

# HAM

AN ARGUS SPECIALIST PUBLICATION

NOVEMBER 1988 £1.40

# RADIO

# TODAY

## BRITAIN BACK ON THE BANDS!

## All British Navico 2m mobile on test



FRG-9600 computer interface to build  
MICROPHONE amp with AGC project  
JRC HF rig and CTE 2m Handy on test

## NEW BEARCAT

### IT'S HERE AT LAST!

Bearcat's latest high technology scanner is now available in this country. It covers 10 mtrs, 6 mtrs, Airband, High Band, UHF and 950MHz.

The UBC 200XLT is the hand held scanner with the latest facilities - 850-950MHz in 12.5KHz steps, 200 memories in 10 Banks.

Super LCD Backlight for discreet listening in the dark, detachable Nicad pack, C.W. charger @ £249.00 (£5.00 P&P).

**ONLY LIMITED STOCKS AVAILABLE  
OUR NEXT DELIVERY IS IN  
TWO MONTHS**

# RAYCOM

COMMUNICATIONS SYSTEMS LTD

TEL: 021-544 6767

## SUMMER SPECIAL OFFERS WHILE STOCKS LAST

Icom ICR7000 + Royal 1300	£899.00
Icom IC3200E 25W Dual Band Mobile	£399.00
BJ200 Mk2 Handheld AM/FM Scanner	£199.50
Sony ICF2001D SW Receiver plus Airband	£289.00
Sony ICF600DS Super SW Receiver	£199.00

## SCANNERS

YAESU FRG9600 from the company who specialises in fitting extra options, as supplied to Government departments and professional bodies. We also upgrade existing models, please call for more details, prices, delivery and information.

Yaesu FRG9600 Basic Model Improved 'S' Meter + Sens	£465.00
Yaesu FRG9600/RWC Mk2 60-950MHz 'N' Connector Fitted	£495.00
Yaesu FRG9600/RWC Mk5 HF 100kHz-950MHz Active Mixer	£625.00
Yaesu PAL Video Unit for above	£77.50
Icom ICR7000 25M-2GHz superb quality professional Rx	£859.00
Icom ICR7000/AH7000 Receiver plus Matching Discone	£937.50
Kenwood RZ 1 New 500kHz-950MHz Wide and Narrow AM/FM POA	£139.00
Fox VHF-UHF Multi Function Mobile Scanner FM only	£139.00
Uniden-Bearcat UBC 50XL VHF-UHF 10ch H/held Scanner	£95.00
Uniden-Bearcat UBC 70XL VHF-UHF 20ch Miniature H/held	£179.00
Uniden-Bearcat UBC 100XL VHF-UHF-Airband H/held Scanner	£189.00
Uniden-Bearcat UBC 175XL VHF-UHF-Airband Desk-Top	£175.00
BJ200 Mk2 VHF-UHF-Airband-Military Airband H/held	£199.50
AOR 2002 25-550, 800-1300MHz Desk-Top/Mobile AM/FM	£469.00
Sony Air 7 Top Quality VHF-Airband Handheld Scanner	£245.00
Package deal on above Mk3/5 FRG9600 c/w AH7000 discone, G5RV, PA4 AC PSU, complete receiving station HF-UHF including delivery UK mainland. Add £100.00 to above price.	

**PACKAGE DEAL AVAILABLE ON ALL MAKES.  
IF IT'S GOOD, WE STOCK IT!**

## A new concept in Amateur Radio . . . uniden 2830

It's here at last! A beautifully-made processor-controlled full feature 10w (20w PEP) multimode transceiver with LCD readout and all functions necessary to work DX with Sporadic E and in the forthcoming sunspot maxima and also for transverting to the VHF and UHF bands. Work out the facts . . . how much is a Two Metre Multimode? How much is the Uniden 2830 Ten Metre Multimode and a 2 metre transverter? With the Uniden 2830 you can have two bands for the price of one, with 10 watts on each band and all modes including CW. \* S.A.E. for copy of Review.

### Features

- \* All modes, AM/FM/USB/LSB/CW
- \* LCD readout of frequency/functions
- \* CW with Sidetone
- \* FM bandwidth compatible with VHF/UHF
- \* 10Watts continuously variable o/p AM and FM
- \* Scanning feature, up and down steps on mic.
- \* Selectable frequency steps, 10kHz, 1kHz, 100Hz
- \* Ten metre band selectable in 500kHz steps
- \* Build-in VSWR meter and protection circuit
- \* Superb receiver sensitivity -3uV FM

Just TEN of the many reasons for choosing the UNIDEN 2830

THIS PRODUCT IS EXCLUSIVE TO RAYCOM. WE ARE THE U.K. DISTRIBUTOR. WHOLESALE ENQUIRIES WELCOME

### 10 metre band amateur transceiver



**£279.00**  
£10.00 post  
and packing

Matching transverters  
2M transverter £169.00  
6M transverter £189.00  
Package Deal: 2M + 2830

£399.00 Post £10

## HANDHELDS

* Extended Receiver coverage available, call for details	
YAESU FT727R/FNB4A 2.5W (5W) DUAL BANDER. C/W CHRGR	£395.00
*YAESU FT723R/FBA10 2.5W (5W) 2MTRS	£299.95
*YAESU FT73R/FNB10 2.5W (5W) 70CMS C/W CHARGER	£299.95
*ICOM MICRO 2E 2.5W 2MTR HANDHELD WITH CHARGER	£209.00
ICOM 32E DUAL BANDER	£399.00

Many other types of handheld stocked, please enquire.

## SHORT WAVE RECEIVERS

Yaesu FRG8800 Short Wave 100kHz-30MHz all Mode + Mem	£589.00
Yaesu FRG8800/FRV8800 as above with VHF Conv. fitted	£679.00
Icom ICR-711 Top Grade Communications Receiver	£799.00
Sony PRO80 HF/VHF Handheld Scanner c/w accessories	£345.00
Sony 2001D Short Wave/Airband Receiver	£249.00
Sony SW1 Micro Short Wave/Airband Receiver	£249.00

Many more makes and models in stock. PLEASE CALL FOR PRICES.  
DELIVERY COSTS and any advice or information, or send large SAE. (Insured post and packing £10.00. Carrier £12.50).

## MOBILES

YAESU FT211RH 45W 2MTR MOBILE WITH FREE 1/4 WAVE ANT	£339.00
YAESU FT212RH NEW 45W 2MTR MOBILE DVS FEATURE OPT	£349.00
*ICOM IC28E 2MTR 25W MOBILE WITH FREE 5/8 ANTENNA	£359.00
ICOM IC48E 70cm 25W	£428.00
KOM KC3200 Dual Band 25W	SPECIAL £399

Compare our prices!

Many other types and makes stocked, please enquire.

## PORTABLES

FT290RMK2 2.5W MULTIMODE STANDARD ACCESSORIES	£399.00
FT290RMK2 2.5 WATT M/M AS ABOVE C/W NICADS CHRGR	£425.00
FT290RMK2/FL2025 (STD) WITH 25W LINEAR AMPLIFIER	£489.00
FT690RMK2 6MTR 2.5W MULTIMODE STANDARD ACCES.	£399.00
FT690RMK2 6MTR 2.5W M/M AS ABOVE C/W NICADS CH	£425.00
FT790RMK2 NEW 70CM 2.5W MULTIMODE DUE OUT SOON	£499.00

## ANTENNAS & ACCESSORIES

NOW AVAILABLE AT RAYCOM: CUSHCRAFT, BUTTERNUT, HY-GAIN ANTENNAS, JAYBEAM, TONNA, MET, HAM-M ROTATORS, Call for full details, prices, availability and delivery costs.

ICOM AH7000 SUPER 250-1300MHz DISCONE £79.50  
G5RV HALF SIZE HF ANTENNA ready to use £16.50  
G5RV FULL SIZE HF ANTENNA ready to use £24.50  
G8KW-TYPE 7 1MHZ TRAP DIPOLE KIT SO239 £24.50  
G8KW-TYPE AS ABOVE FOR USE WITH 75 OHM £23.50  
G8KW-TYPE 2X 7.1 TRAPS ONLY. LESS CABLE £9.95  
RAYCOM AIRBAND-VHF SIX ELEMENT DISCONE £12.50  
RAYCOM DISCONE VHF 60-600MHz 8E SO239 £29.50  
SUN KG209 SE2M 5/8 MOBILE TILT-OVER 25X £14.50  
RAYCOM CAST GUTTERMOUNT C/W SO239/COAX £8.50  
GAMMA TWIN 2 METRE SLIM JIM KIT inc. instr. £14.50  
RAYCOM/RWC HB9CV 2 METRE 2E MINI BEAM £12.50  
RAYCOM/RWC HB9CV 70CM 2E MINI BEAM £8.95

The above popular products POST FREE.  
(UK mainland only)

## YAESU FT 747GX

**£649.00** including our  
FREE fitted MOD Board!

We improve the reciprocal mixing performance by up to 15dB which gives you receive performance of higher priced rigs! Only available from Raycom, buy it elsewhere if you want SECOND BEST! YAESU IS STILL BEST VALUE FOR MONEY!

ALL CURRENT YAESU AND ICOM HF RIGS STOCKED, CALL FOR A DEAL!

## ROYAL 1300 WIDEBAND DISCONE

Following the huge success and popularity of the 25-1300MHz, wideband discone antenna - Icom AH 7000 & Welz - Diamond D109 with transmit facilities on VHF-UHF amateur bands, Raycom decided to persuade a UK manufacturer to make a "BRITISH COPY!" at a very competitive price!

COMPLETE WITH PROFESSIONAL CABLE & CONNECTORS AT ONLY £65.00  
P&P £5.

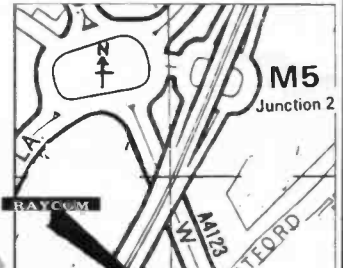

CALL IN,  
EASY TO GET TO,  
EASY PARKING

Opening hours 9am-5.30pm 6 days, late nights  
Thursday & Friday till 7pm. We stay open later!

## ORDERING INFORMATION

ALL PRODUCTS WE ADVERTISE ARE NORMAL STOCK ITEMS. OUR NEW MAIL ORDER DEPARTMENT CAN NOW DESPATCH MANY ITEMS SAME DAY, BUT PLEASE ALLOW UP TO 14 DAYS. DELIVERY TIME IS SUBJECT TO CARRIAGE METHOD. IF ORDERING BY MAIL PLEASE INCLUDE CARRIAGE AND STATE YOUR DAYTIME TELEPHONE NUMBER. ALL PRODUCTS OVER £750.00 CARRIAGE FREE. PLEASE ALLOW TIME FOR PERSONAL CHEQUES TO CLEAR. PLEASE CALL BEFORE ORDERING AND FOR MORE INFORMATION

PLEASE TEL: 021 544 6767

**RAYCOM COMMUNICATIONS SYSTEMS LTD.**  
INTERNATIONAL HOUSE, 963 WOLVERHAMPTON ROAD  
OLDBURY WEST MIDLANDS B69 4RJ  
Telephone 021 544 6767. Fax 544 7124. Telex 336483 Identi-G

**RAYCOM gives you MORE  
PURCHASING POWER!**



FOR FAST SERVICE PHONE IN YOUR ORDER WITH ANY MAJOR CREDIT CARD OR IN MOST CASES WE CAN OFFER YOU INSTANT CREDIT OF UP TO £1,000.00 (SUBJECT TO STATUS. RAYCOM ARE LICENSED CREDIT BROKERS. APR 29.8%, SUBJECT TO VARIATION. FREE CREDIT ON CERTAIN PRODUCTS AT M.R.P. PRICES, 50% DEPOSIT AND SIX MONTHLY PAYMENTS. PLEASE TELEPHONE FOR MORE DETAILS AND APPLICATION FORMS.

**NEW INFOLINE 0836 282228**  
available 5-9pm (weekdays only)



FOR THE BEST IN AMATEUR RADIO

THROUGH YOUR CONTINUOUS AND VALUED CUSTOM, RAY WITHERS COMMUNICATIONS LTD. HAS MOVED AND EXPANDED TO ENABLE US TO OFFER YOU EVEN BETTER SERVICE AND PRICES - STILL WITH THE RAYCOM GUARANTEE, BEST EQUIPMENT, BEST SERVICE, BEST PRICES, BEST BACK-UP, AND PLENTY OF PARKING FACILITIES AND EASIER TO GET TO! WE NOW BOAST THE BEST CENTRAL FACILITIES IN THE COUNTRY, WHY NOT POP ALONG AND SEE THE LATEST TRANSCEIVERS, SHORTWAVE/SCANNING RECEIVERS AND ACCESSORIES? MOST OTHER PRODUCTS ADVERTISED IN THIS MAGAZINE ARE AVAILABLE AT RAYCOM, AND DON'T FORGET OUR EXCLUSIVE PRODUCTS AND MODIFICATIONS!

# HAM RADIO CONTENTS

## TODAY

VOLUME 6 NO 11 NOVEMBER 1988

**Editor**  
Dave Bobbett, G4IRQ  
**Technical Illustrator**  
Jerry Fowler  
**Advertisement Manager**  
Selina Gayle  
**Classified Sales Executive**  
Evelyn Coombes

**Published by:**  
Argus Specialist  
Publications Ltd  
**Distributed by**  
SM Distribution Ltd  
**Printed & bound by:**  
Chesham Press Ltd.  
Chesham  
Surrey

**Design by**  
ASP Design Studio  
**Editorial and Advertising  
address:**

Ham Radio Today  
ASP Ltd  
1 Golden Square  
London W1R 3AB  
Tel: 01 437 0626

*(please mark your letter for the  
appropriate department)*

**Subscriptions and back issues:**  
Ham Radio Today Subscription Dept,  
Infonet Ltd, 5 River Park Estate,  
Berkhamsted, Herts HP4 1HL  
Tel: (04427) 76661/4

**Subscription rates:**  
UK £15.60, Europe £20.10,  
Middle East £20.30, USA \$30,  
Far East £22.00, Rest of World  
£20.60. Airmail rates on request.

**USA Subscription Agent:**  
Wise Owl Worldwide Publications,  
4314 West 238th Street,  
Torrance CA90505

ARGUS  
PRESS  
GROUP

Member of the  
Audit Bureau  
of Circulation



Ham Radio Today is normally published on the first Friday in the month preceding cover date. The contents of this publication including all articles, designs, plans, drawings and programs and all copyright and other intellectual property rights therein belong to Argus Specialist Publications Limited. All rights conferred by the Law of Copyright and other intellectual property rights and by virtue of international copyright conventions are specifically reserved to Argus Specialist Publications Limited and any reproduction requires the prior consent of the Company © 1988 Argus Specialist Publications Ltd. All reasonable care is taken in the preparation of the magazine contents, but the publishers cannot be held legally responsible for errors. Where mistakes do occur, a correction will normally be published as soon as possible afterwards. All prices and data contained in advertisements are accepted by us in good faith as correct at the time of going to press. Neither the advertisers nor the publishers can be held responsible, however, for any variations affecting price or availability which may occur after the publication has closed for press.

## REGULAR COLUMNS

RADIO TODAY .....	5
What's happening	
READERS' LETTERS .....	8
Don't shut the repeaters	
RADIO TOMORROW .....	38
What's next in your region	

## FEATURES

RADIO PROPAGATION AND THE SUN PART 5 .....	32
And in conclusion, some predictions . . .	
BOOK REVIEWS .....	42
UNDERCOVER OPERATIONS .....	

## REVIEWS

NAVICO AM1000 2m MOBILE .....	16
The all-British mobile unveiled	
SPECTRUM 2m PREAMP KIT .....	6
A neat and versatile unit in ready-made or kit form	
JRC JST-135 HF TRANSCEIVER .....	43
Do everything for a mere £1195	

## CONSTRUCTION

EXTERNAL MIC AMP WITH AGC .....	12
More flexible mic and modulation control	
FRG 9600 CAT INTERFACE .....	21
A neat and versatile unit in ready-made or kit form	
FREE READERS ADVERTISEMENTS .....	50
RETAIL NETWORK .....	55
CLASSIFIED ADVERTISEMENTS .....	56
ADVERTISEMENT INDEX .....	58

FOR AMATEURS

**R. N. Electronics**  
**6 & 4m TRANSVERTERS**  
**NEW**

**Additions to our range**

ALL PRICES INCLUDE V.A.T.

- 144/50MHz TRANSVERTER  
25w p.e.p. £179 + £4 p&p
- 28/50MHz TRANSVERTER  
25w p.e.p. £199 + £4 p&p
- 144/70MHz TRANSVERTER  
25w p.e.p. £239 + £4 p&p
- 144/70MHz TRANSVERTER  
10w p.e.p. £199 + £4 p&p
- 28/70MHz TRANSVERTER  
10w p.e.p. £199 + £4 p&p
- 7dB ATTENUATOR  
£22 + £2 p&p
- SWITCHED 10m RECEIVE  
CONVERTER 2m I.F.  
Ideal for crossband  
£45 + £2 p&p
- RECEIVE CONVERTERS  
2m, 4m, 6m, 10m  
with 2m or 10m I.F.  
£39 + £2 p&p

PROFESSIONALLY DESIGNED EQUIPMENT

MARKET LEADERS IN 6 METER TRANSVERTERS

MADE IN ENGLAND

# ANNOUNCING

## A NEW DIMENSION IN 2m F.M. MOBILES

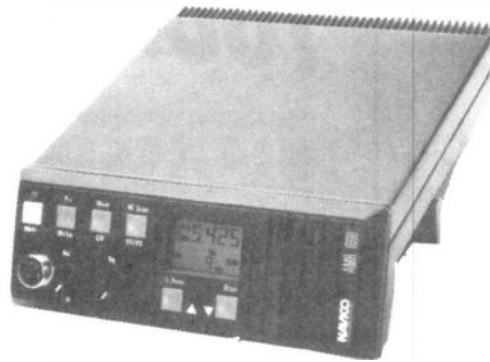

**NAVICO**

DESIGNED FOR TODAY'S AMATEUR.  
VARIABLE MOUNTING POSITION FOR  
THE MODERN CAR. EASY TO USE YET  
PROVIDING EVERY FEATURE NEEDED  
FOR THE EXPERT OR BEGINNER.

- ★ BRITISH BUILT
- ★ 5W or 25W
- ★ DUAL VFO
- ★ FULL REPEATER OPERATION

**£247.25**

INCL VAT + £4 P&P

- ★ FULL SCANNING VERSION

**£299** INCL VAT + £4 P&P

**AVAILABLE FIRST AT LEICESTER RALLY**  
**(28th and 29th October)**

FROM

**R. N. Electronics**

37 LONG RIDINGS AVE  
HUTTON, BRENTWOOD  
ESSEX CM13 1EE

FOR DETAILS:  
0277 214406

# HAM RADIO TODAY

**WISH YOU WERE  
BETTER INFORMED?**



- |                                       |                   |
|---------------------------------------|-------------------|
| 12 issues UK                          | £16.80            |
| 12 issues Europe                      | £21.30            |
| 12 issues Middle East                 | £21.50            |
| 12 issues Far East                    | £23.20            |
| 12 issues Rest of the World<br>or USA | £21.80<br>\$32.00 |

Air Mail Rates Given on Request

Send this form with your remittance to:  
INFONET LTD., 5 River Park Estate,  
Berkhampsted, Herts. HP4 1HL



-----  
 Please begin my subscription(s) to **HAM RADIO TODAY** with the  
 I enclose my cheque/postal order for £..... made payable to Argus Specialist Publications Ltd.  
 or debit £..... from my Access/Barclaycard No.                       
 valid from..... to..... issue.  
 NAME (Mr/Mrs/Miss).....  
 ADDRESS.....  
 Postcode.....  
 Signature.....  
 Date.....  
 Please use BLOCK CAPITALS  
 and include postcodes

# RADIO TODAY

## Sony Launch £250 Alarm Clock!

Well not exactly, but seeing as it took the latest Sony press release nearly two months to fight its way from darkest Staines to the HRT offices here in central London we thought that one of the facilities on the new ICF-SW1S, ie. its alarm clock, might be of use in the future!

You will not doubt also be delighted to know that — and here we quote a Sony News Release 'Sony has a proud tradition in radio technology, introducing the world's second (but by far the more successful) transistor radio were introduced in 1957 and 1958 before Sony moved on to the Integrated Circuit (the IC of the product code) in 1967.' So now you know!

For those old die-hards amongst us who prefer the English language, here is a resume of the new radio. Measuring

only 109×70×22mm the SW1S employs a PLL design offering an LCD readout and ten memories covering 159 to 29999kHz AM and also FM broadcast band. Tuning is in 5kHz steps for shortwave, with no SSB facility being provided or a fine tune control for off frequency stations. IF filtering is limited to one bandwidth and the audio output is claimed to be 250mW, which is quite reasonable considering that the unit is powered from two AA cells.

The approach taken by Sony is that some listeners want to buy a simple package which requires no further outlay, to this end the SW1 comes as part of a £250 'kit' fitted inside a plastic case which also holds a universal 3V mains adaptor, an active antenna and its controller plus a pair of miniature earphones. And the alarm clock? Well that's built into the radio. Further details from: Sony (UK) Ltd, Sony House, South Street, Staines, Middlesex TW18 4PF.

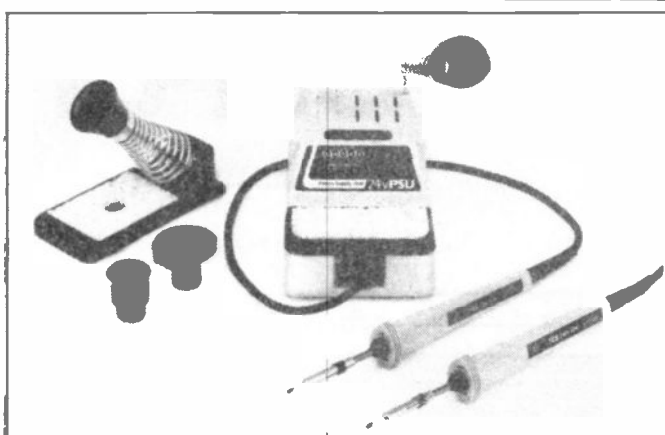

## Antex Antics

Antex Electronics have just introduced the new TCS24 and TCS240 low cost temperature controlled soldering irons. Tip temperature can be set at any level between 200 and 450°C with fast warm-up times in the order of 60 seconds to achieve a working temperature of 350°C. Both versions incorporate a thick film ceramic element which contributes to the  $\pm 2^\circ\text{C}$  temperature stability, and both use surface mount components to implement a temperature control system which is built into the soldering iron handle.

In fact the only difference between the two irons is that whereas the TCS240 is designed to operate directly off a 240V AC mains supply, the TCS24 requires a 24V AC supply such as the standard Antex unit which also incorporates both a soldering iron stand and a wipe sponge. Current prices for the new irons are £32.77 for the TCS240, £35.65 for the TCS24 and £41.97 for the 24V AC PSU unit. Further details from: Antex Electronics Ltd, Mayflower House, Armada Way, Plymouth PL1 1JX. Tel: (0752) 667377.

## PEAKS AND PLAINS AWARD

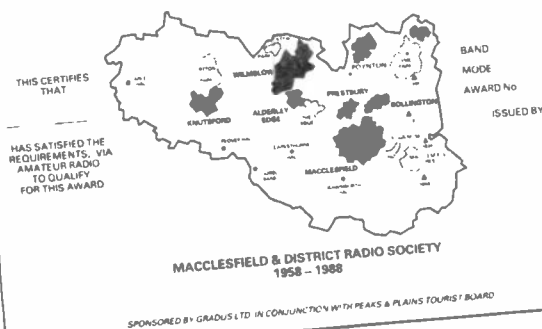

## Macclesfield Club Plainly at its Peak

Now that the Macclesfield DRS has reached the ripe old age of thirty, its members decided that the event couldn't go unnoticed — to wit we now have the 'Peaks and Plains Award'. The requirements for the award are that applicants have worked or heard 10 stations in Cheshire plus either of the MDRS club stations (GIMWS or G4MWS)

plus any one of the special event stations which MDRS will be running during 1988.

A log extract, countersigned by any other licenced amateur showing the contacts for any date after 1st January 1988, should be sent (together with £1.50 or four IRCs for non UK stations) to: R Thornley, GINUS, 270 Hurdsfield Road, Macclesfield, Cheshire SK10 2PN.

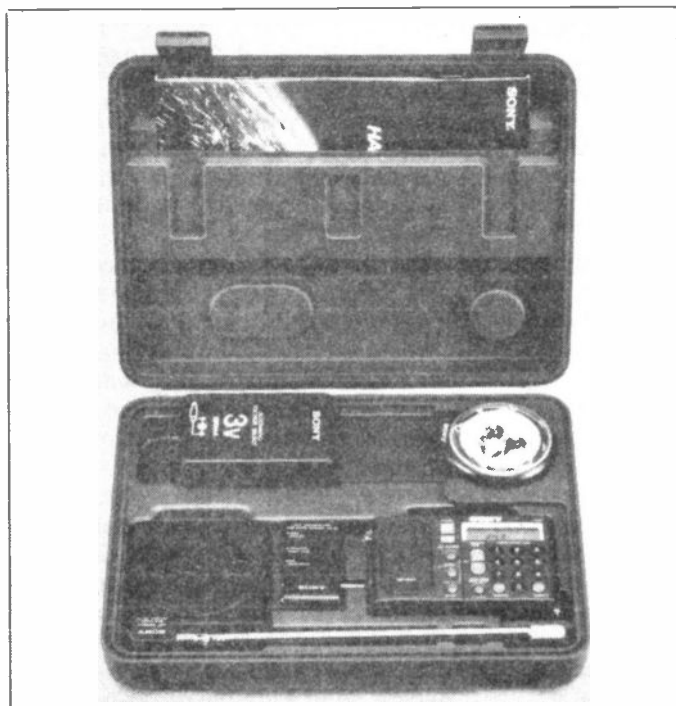

# Spectrum 2metre Amp Kit RP25



A good two metre preamplifier can give a considerable improvement to many rigs enabling them to bring in stations which were not readable before and improving the readability of others. Even though many of the

interested in the Spectrum Communications Unit. This offered amongst its features a variable gain control which would allow the signal levels to be reduced if it became necessary. The preamp also offered

## *Less power is as vital as more power, according to Ian Poole G3YWX*

rigs on the market today may not need a preamp there are still a very large number of old and sometimes not so old rigs which can be livened up with some form of preamp.

However, it is best to be careful about the way in which preamps are used. It is quite possible to degrade the performance of a receiver if there is too much gain. I can still remember having a contact with a station who was using not one but two preamps. It was hardly surprising that he not only told me I was 58+++ , but also spluttering up and down the band! I did check with a local two metre station whose receiver uses a VFO and not a synthesiser. To my relief he confirmed that my signal was clean.

This little episode proved to me that too much of a good thing is not always an advantage. So when I was looking around for a preamp for my trusty old TR7010 I was very

a noise figure of 1dB, transmit/receive switching, availability in kit form (or made up if necessary) and the possibility of a neat case for it. With a specification like this it seemed to fit the bill.

### **The Circuit**

The circuit of the preamplifier itself is fairly straightforward. It uses a single 3SK88 FET to give it a noise figure of around 1 dB which should be more than adequate for most stations. In addition, a variable gain control is incorporated which works by altering the bias voltage on the second gate of the FET.

There is quite a lot of protection around the FET with both the input and output being protected by pairs of back to back diodes. This should ensure that any voltage spikes either from the aerial or transmitter do not reach the device and destroy it.

In addition to the protection for the FET itself there is also a very useful 'idiot' diode placed in series with the supply to prevent any damage if the inevitable happens and the two supply leads are connected the wrong way round. There is also a resistor and zener diode combination in the supply intended to prevent damage if a voltage in excess of 16 volts is applied to the unit.

Transmit receive switching is accomplished using a relay. This may seem like rather a 'low tech' approach at first sight but it does avoid the losses which the use of PIN diodes introduce. The switching can be activated by RF from the transmitter, when a small amount of RF is rectified and amplified so that the relay is switched and a warning LED is also turned on. If DC switching is required the supply to the preamp can simply be removed during transmit as the unit operates in a straight through mode without any supply, and the change over relay is only activated during receive — giving a 'fail-safe' facility.

### **The Kit and Construction**

The kit was contained in two packs. The first of these consisted of the double-sided board with all its associated components as well as the actual circuit diagram, board layout and a few simple instructions. The second pack contained the metalwork and included the box with screws and the SO239 connectors for the rear panel. There were also instructions for wiring up the unit to the box. This pack constitutes the optional 'hardware' part of the project.

The assembly of the board was fairly straightforward, the layout plan of the board enabled the component positions to be located without any difficulty. It was found that the best way of building up the board was to decide upon a logical order in which

to insert the components; for example, insert all the diodes first, then the capacitors, the resistors and so forth. The main point to watch is that one of two capacitors and the emitter of a transistor are soldered to both sides of the board, which is necessary because these connections are used to earth some tracks on the track side of the board to the earth plane.

The last component which should be soldered in is the 3SK88 and when this is done care must be taken to ensure that it does not suffer any damage from static. This may seem a little excessive since the device is protected internally, however, in recent years manufacturers using static sensitive devices have started to take even more care with them. This is because it has been found that static may not destroy a device straight away but just cause its life to be reduced. Having completed the board it is well worth checking everything over. It is all too easy to press ahead building the unit quickly and making the odd mistake, a few minutes can save time later.

Installing the board into the box was quite simple. The only real precaution to take is to ensure that the star washers are used where electrical connections are required. The construction of the preamp did not take too long and the average constructor ought to be able to put the unit together quite easily in an evening although a newcomer might take a little longer.

### Setting-up and Operation

Once the unit had been built and installed in its box it was fully checked out and it was found that it was short of gain, having only 10dB instead of the specified 20dB. There were two reasons for this first being that the decoupling capacitor near the output inductor was not soldered to both sides of the board (This proves that it is worth checking everything!) and the second was found to be the output coil. This could not be adjusted properly and gave the best output when the core was fully out, on looking at the circuit diagram it was noticed that the value of one of the capacitors in the tuned circuit was 12pF whereas its value on the layout diagram and the value of the capacitor supplied was 15pF. A swap

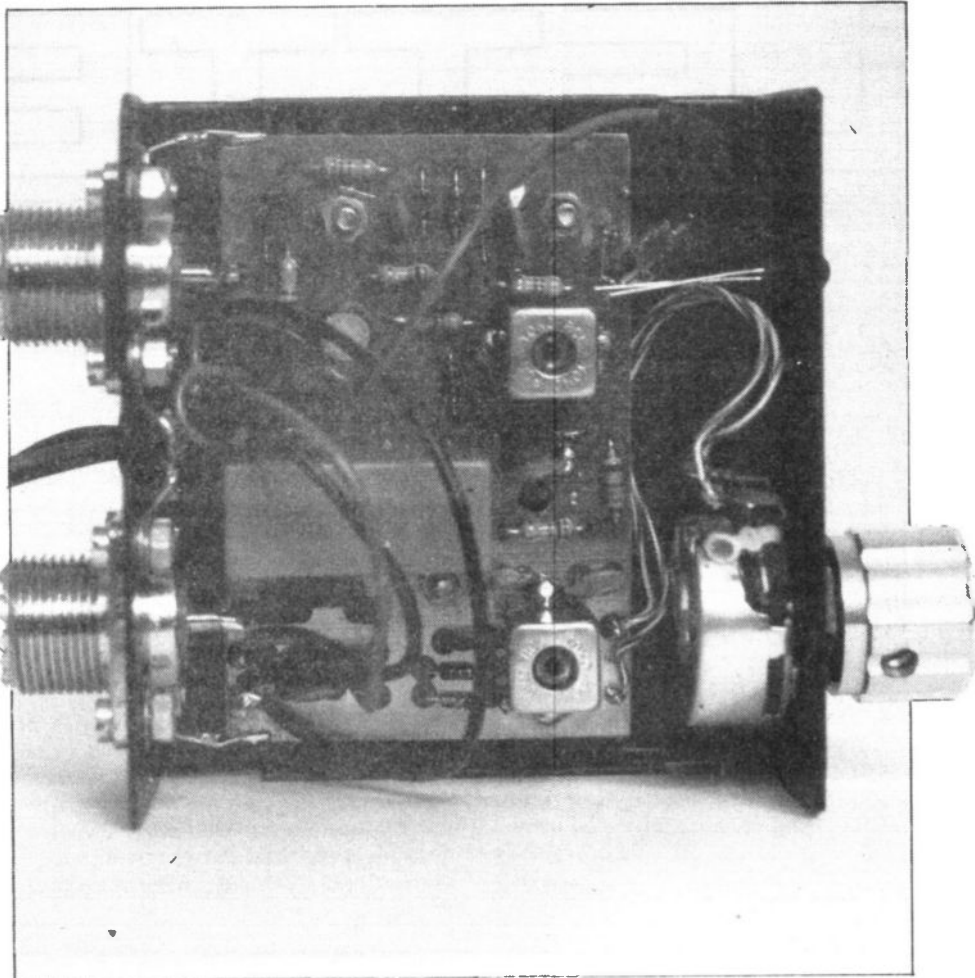

to a 12pF capacitor fixed the problem and the gain rose. Spectrum Communications were advised about the problem and they should have rectified it by now. When adjusted the preamp response was reasonably flat. It gave just over 20dB over the whole band, and it was flat to within about a dB.

Once connected to the transceiver the unit operated well. The preamp gave a useful amount of gain and brought weak stations up out of the noise so that they were comfortably readable. It was also useful to be able to reduce the gain when there were stronger signals around. On the transmit the RF switching worked well, stations reported that there was no sign of a delay at the beginning of syllables when the relay changed over. However, I must admit that my personal preference is to use DC control of the switching to prevent the relay changing over all the time when there are speech pauses. This can, of course, be arranged without any difficulty.

### Final Comments

Once the unit was finished it gave a good account of itself. It was enjoyable to build in the first place, and the finished article looked quite neat from the outside as well as the pcb inside the box. The problems which were encountered should have now been rectified and anyone buying a kit ought to have no difficulties in making it.

The preamp can be bought in a number of configurations. The cost of the PCB kit is £14.75, the PCB built is £22.75, the boxed kit is 25.00 and the boxed unit built is £35.50. These prices include VAT and postage. There are also similar preamps for 4 and 6 metres at exactly the same price. The RP25 is available from: Spectrum Communications, Unit 6B, Marabout Industrial Estate, Dorchester, Dorset. Telephone: 0305-62250.

*My thanks go to Spectrum Communications for answering questions during the preparation of this review.*

# LETTERS

## Letter of the Month

### Shut is no help

I read the reply to GIPDA's letter (HRT Aug 1988) suggesting that repeaters should be shut down. Experience in Birmingham (for the problem is not confined to London) shows that shutting them down does not solve anything.

The most abused repeater is GB3BM, which was switched off for a week in July. This didn't stop the abuse, the unlicensed operators just moved to GB3AM. The Leicester repeater, GB3CF, is also being abused, and the GB3RS news is often jammed. There is no specific time when the jammers, "shut-ups" and other IQOs aren't around. I have even heard them at 2am.

There are many people in the Midlands who are so fed up that they would readily form a lynch mob if given the address of one of these boors. The only people who find the jammers are amateurs, of course. It appears that the DTI couldn't care less.

**Paul O'Connor G1ZCY**

*I remember when 'LO started in London it was jammed pretty much from the start, which put me off repeaters straight away. Repeaters farther from cities do seem to suffer less, though.*

*Perhaps the answer would be for everyone to ignore the IQOs. Some at least would give up eventually when they no longer had the satisfaction of confirmation that they were upsetting anyone.*

### Pirate aid

I read with interest your article "Myers Prosecution", and fully agree with the very heavy sentences given. There are enough disasters occurring in the air, and so many near misses that one cannot tolerate any interference to the difficult job air traffic controllers are doing. But what I can't understand is why, oh why the people that sold Mr Myers his equipment are not brought to justice too. And who did the work on his radios to allow them to transmit on these frequencies?

There is too much hypocrisy in the trade of the so called amateur fraternity, too many traders in for a fast buck.

Don't tell me one can sell a Trio 930 and an FT102 to a non licensed person and hope they are going to behave themselves, and only use it for receive. I myself have witnessed in a major Birmingham emporium an 11m user buying a FT102 asking the owner of the shop is this radio would work on the CB frequencies, and the immediate reply was "it is easy enough to re-crystal your radio. We can do it for you for £50".

Some firms offering to "up rule"

your 11m to ten keep the old crystals and sell them at rallies, enabling someone else to be a pirate. Of course both firms are also legally responsible because they allowed Myers and the like to operate without licenses and outside the proper boundaries of radio hobby.

Japanese manufacturers have for a very long time produced radio amateur equipment that transmits outside the amateur bands with ease. Some radios are in fact designed with pirates in mind, and only the removal of one diode or so will allow the pirates to have a ball. The emporiums are aware of it, and some of them very keen to do the job for them, allowing pirates to break the law.

It is about time they are treated as accomplices and stop giving a bad name to a wonderful hobby that does so much good on other accounts.

Thanks for your wonderful magazine, and a very honest editorial.  
— **G4UPG**

*The Myers case was an exceptional one (I hope). Generally the interference caused by pirates is of considerable annoyance, but causes no risk to life or limb. It is presumably because of the danger caused that the penalty was so substantial.*

*I agree that if anyone modified the equipment for Mr Myers, assisting him to carry out his piracy, then in a fair world he (or she) should be brought to book. It is one thing to sell equipment which transmits on unauthorised frequencies, but can be modified for legal use (eg an old SSB CB rig), but it is quite another to deliberately modify legal equipment for illegal use. This argument applies equally to the modification of an FT102 for CB use, though the likely consequences of this are less serious than causing interference on aeronautical frequencies. Such actions are probably illegal, and I would hope that they would result in prosecution if sufficient evidence were available. — G3YZW.*

### Rag to riches

I have already purchased a high quality handheld scanner and have found scanning to be a fascinating hobby. Having examined many of the specialist publications, Ham Radio Today is in my opinion by far the best and most informative.

I was interested to read the review of the Bearcat BC50XL 10 channel scanner in HRT's April edition. Having read the article and looked at the illustrations, I was impressed and will almost certainly go out and buy one as a backup to my PRO 32A.

I was originally going to buy the Realistic PRO 38, which has identical features to the BC50XL, but having read HRT's review of the BC50XL, I discovered that the PRO 38 is over £30 more expensive. I can now start saving for a decent antenna.

I would be interested to hear of any "scanning clubs" that have been established in the UK.

— **Andrew Blackwell**

*We regret that Ham Radio Today cannot reply to queries individually. Every month we publish a section of the most interesting. We will endeavour to answer straightforward queries about the back issues index if readers enclose an SAE and much patience. It helps if letters and back issue enquiries arrive on separate sheets of paper, although the same envelope can be used.*



## From South to North

In the days of John Clarricoats and May Gadsden the 'Bull' (former name of Radcom) was received the day following publication, and even when I lived in India before WW2 the 'Bull' was generally delivered by sea mail quicker than the RSGB and postal authorities manage to deliver Radcom in the UK in 1988.

After all these years, the RSGB have not made any concrete effort to eliminate abuse of repeaters in spite of having a large paid staff operating expensive equipment in an expensive office block. The Wireless Institute of Australia operates with a very small staff, some only part time, yet they successfully pressed the Department of Communications to take action against a person for abuse of repeaters and as a result a licence was cancelled in 1987. Earlier a person was sent to prison for six months for a similar offence after the WIA had asked for action to be taken.

Surely with wages, rents and property prices in the south of England, particularly in the London area, rising annually at an alarming rate, it makes sense to move the RSGB headquarters from Potters Bar to the north of England where members would get far more value for their subscriptions, and have a headquarters more central to all members instead of London area members only.

Some readers will be aware that the parent of the RSGB was the London Wireless Society. It still appears that most Council members and salaried staff consider it is a London organisation with provincial members paying for the privilege of supporting their Society.

After considerable pressure from RSGB members outside the London area the Council have at last agreed to hold the 1988 AGM in Manchester. It is now up to as many members as possible to attend this meeting and press for headquarters to be moved to a less expensive location, say in the north midlands, and more suitable for the majority of members to visit.

The most efficient part of the RSGB is the QSL Bureau run by voluntary labour.

— **W G H Metcalfe, G6VS/VK2EZA**

## No satisfaction

As a serious short wave listener for the past 30 years, I am slightly offended by the attitude of the author of Listening On. Perhaps not offended so much a surprised.

The remarks on the Drake R2 and R4 and even on the HRO I could take with a pinch of salt, but while I freely

admit the AR88 is old, it is still one of the finest receivers ever made.

Yes, it required, like all older communications receivers, a certain skill to use. Where is the satisfaction in pressing a button on a Japanese black box? Satisfaction is knowing that you, not some gizmo inside the box, has found the station you require.

No, gentlemen and ladies, I'm afraid for me the black boxes rob me of all the old magic that short wave listening consisted of. The sheer joy of radio can still be sought using my '88 or an Eddystone receiver.

You may be right in thinking I'm living in the past, but it was a past that required me to think and use my brain, not just my finger.

— **R J Shaw**

PS I am a serious DXer and SWL and in my time I have had through my hands a great many receivers including Yeasu, Trio and Icom equipment, so I can talk from experience. I guess I'm just old fashioned. By the way, the HRO came from drawing board to full production in five months, and was said to have been produced in a "hell of a rush". HOR was considered to be an unsuitable designation, so National named it HRO, or so I read in the American CQ magazine.

*The advance of technology has reduced the involvement of most amateurs with the technical aspect of their rigs. Many modern boxes are in one sense impersonal marvels of technology. Even if you understand their functioning in detail, there is little that you can do in the way of repairs or mods, and less in the way of building comparable equipment. Partly for this reason, there is less feel for what is going on.*

*Using older (well made) equipment seems to give the amateur a better "feel" for what is happening. It's like comparing a vintage car with a modern one. They both have their place. — G3YZW.*

## Transmission losses

Would it be possible for you to put the following list of stolen gear into your magazine? The gear was stolen from the QTH in East Lothian on Thursday 15th October last year, and was the only stuff taken.

I hope this shows up somewhere and I get it back as I am/was in the process of modifying it.

Thanks for the great mag.

Superstar 360FM, serial No. 13001007, 7 band. Some mods. Rubber stamp marking on inner speaker panel. Three position toggle switch in place of channel 9 to give Alfa channels. Covers up to 10MHz.

Multimode 2, no front panel, no TX, no RX audio but sigs OK. Possibly red paint on knob area.

Two Pye PocketPhone 70 three-channel UHF handhelds, one bodymount and without mic/speaker, other handheld with internal mic/speaker, both without batteries and ultra violet marked.

200 watt linear amp, unpainted silver aluminium, name not known but uses two MRF454 transistors. Very heavy duty power leads with 15A fuses. Ultra violet marked.

If any items are found contact the number below or phone the police and give details.

— **Robert Veal (0875) 613793.**

I am a late starter on the Alpha Transceiver project (HRT September — November 1984). I would be grateful if you could advise on where I can purchase the Jackson 6/30:1 4511 DRF tuning drive. Most of the leading suppliers have only heard of the more common 6:1 4511 DAF. Please help.

*Specific tuning drives are always difficult to track down. Could anyone who knows a supplier for this one drop us a line? — G3YZW.*

## £10 FOR THE LETTER OF THE MONTH

You've got a gripe about the bandplans, or you're sick of being wiped out by next door's microwave. Or maybe you've been bowled over by the excellent service from your local radio shop.

Whatever you've got to say about amateur radio say it here in the letters column and you could win yourself £10 for writing the letter of the month.

Send your epistles to: Letters Column, Ham Radio Today, ASP Ltd, 1 Golden Square, London W1R 3AB.

# ICOM

## NEW! IC-228E 2 Meter FM Transceiver



Actual  
size

### Features:

- Multicolour Liquid Crystal Display.
- 25 Watt output.
- 20 Memory channels.
- Scanning.
- Call and priority function.
- Compact size.
- HM15 microphone supplied.

Take a close look at this easy to use and compact VHF Mobile Transceiver. It's unique orange, red and green LCD highlights the numbers and letters for easy viewing. With a 25 watt output from a custom designed power module and a extra large heatsink, this transceiver does not get too hot under your dashboard.

Each of the 20 memory channels can store frequency, offset and direction, in fact all the information to work simplex or a repeater. The memory scan function will scan the memory channels and with the skip function

miss those you choose. The program scan will scan all frequencies between two programmable limits. The call channel ensures that your favourite frequency is within easy reach, and with the priority watch the call channel or memory channels can be monitored every five seconds.

This transceiver provides you with so many features, its small compact size and simple front panel design make it a superb mobile transceiver. See the IC-228E or the IC-228H 45 watt high power version at your local ICOM dealer.

### Icom (UK) Ltd.

Dept HRT, Sea Street, Herne Bay, Kent CT6 8LD. Tel: 0227 363859. 24 Hour.

Count on us!

# DUAL BAND.

## NEW! IC-3210E Dual Band FM Mobile



If you are newly licensed or just undecided about which band to operate first, then the new ICOM IC-3210 is just the answer. This dual band FM transceiver is ideally suited for the mobile operator. Transmit on one frequency and receive on the other and you're operating full duplex. It's just like talking on the telephone.

The simple and well laid-out front panel ensures quick and easy operation of all its many functions. A great convenience when driving. Optional accessories available are the UT40 tone squelch board, HS15 + SB mobile microphone and switch box SP8 external speaker and PS45 AC power supply.

### Features:

- Full crossband duplex.
- 20 double-spaced memory channels.
- Built-in duplexer.
- 2 call channels.
- 4 priority watch functions.
- Programmed, memory and selected band memory scan.
- Variable LCD backlight intensity.
- Tone squelch and pocket beep functions (optional).
- 25 watts out put.

**Helpline:** Telephone us free-of-charge on 0800 521145, Mon-Fri 09.00-13.00 and 14.00-17.30. This service is strictly for obtaining information about or ordering Icom equipment. We regret this cannot be used by dealers or for repair enquiries and parts orders, thank you.

**Datapost:** Despatch on same day whenever possible.

**Access & Barclaycard:** Telephone orders taken by our mail order dept, instant credit & interest-free H.P.



# MIC AMP WITH AGC

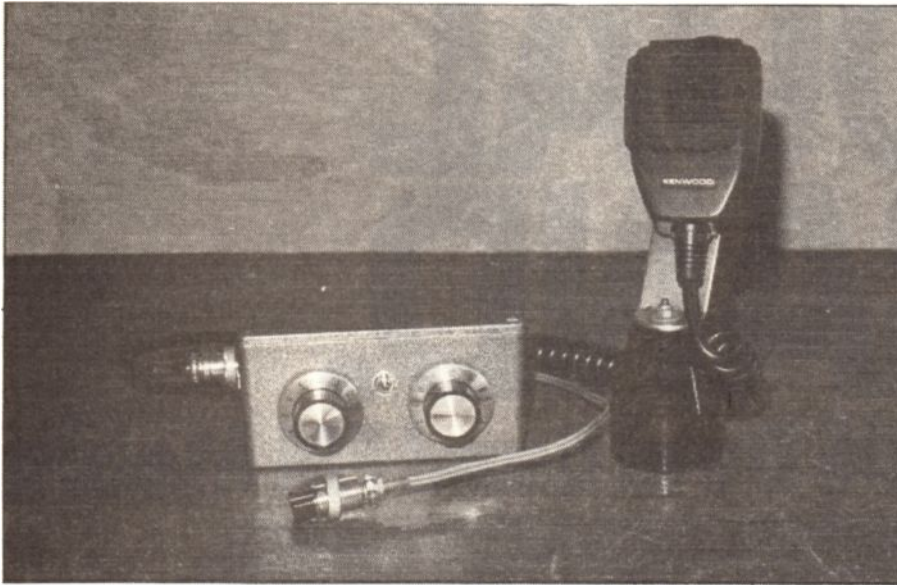

Photo 1. Fig 4. The amplifier using a fist microphone on a stand.

An external microphone amplifier with agc has several advantages even when used with the microphone supplied with the transmitter. It enables a peak modulation level to be set so as to avoid overdriving and the level will be maintained when speaking at different distances from

using home made equipment. The curves agree closely with the manufacturer's data sheet allowing for a slight loss in the input buffer stage. It can be seen that the output remains constant at about 90mV rms for microphone inputs between 1mV and 100mV.

## *John Stebbings G4BTV finds that distance is no handicap with an external mic amp*

the microphone or when turning away from it as one does for some reason. The result is a greater average output which will give a slight increase in intelligibility under poor conditions. The interchange of microphones, with different impedances and sensitivities, and transmitters needing different inputs is easier. A fist microphone with its own push to talk switch (PTT) can be used on a stand as a desk unit using the amplifier's PTT switch.

The design and construction are both simple since only a single integrated circuit with the addition of a transistor buffer stage is required. Fig. 1 shows the characteristics of the amplifier as tested by the writer

One problem likely to be encountered is RF from the transmitter getting into the circuit and causing instability. The original version was constructed on Veroboard; but in spite of making all the usual choking and decoupling arrangements, the trouble remained. It was not until the circuit was rebuilt on a single-sided copper clad board, as a ground plane, that success was achieved — and this is the method which will be described.

### **The Circuit**

Fig. 2 shows the circuit. Two input sockets are provided. SK1 is a

standard 4-pin socket for microphones incorporating a PTT switch and SK2 is a 3.5mm jack socket for a boom or desk unit having no PTT switch. SW1a switches on the 9V battery supply while SW1b shorts the PTT line to earth and switches on the transmitter. With this arrangement of a single switch the first microphone switch does not switch on the amplifier. All operation must be done with SW1.

However, if it is desired to have the fist microphone switch operational, then two separate switches may be fitted. Then, in order to conserve battery power when receiving, it would be necessary to work both switches when changing over.

Input to Q1 gate is decoupled at radio frequencies by the RF choke, the ferrite bead, and the 1nF feed through capacitor. The purpose of Q1 is to provide a high input impedance, limited only by R1, so as to allow both high as well as low impedance microphones to be used. The input impedance of the following integrated circuit amplifier is low at about 150Ω and as it is configured as a source follower, there will be no gain. In fact, there will be some loss due to operating the stage at low current so as to minimise battery drain.

The source resistance RV1 is the input gain control to IC1 which is an SL6270 having internal agc. The input is taken to pin 4 and the output from pin 8, R2 and C3 at pin 1 form a timing circuit to set the attack and decay times of the agc. Capacitor C5 limits the low frequency response below 300Hz and the output is blocked to DC by C7 and reduced to a useable level by the potential divider R4 and RV2, the latter setting the output level. Resistor R5 limits the load on the transmitter input when RV2 is at its minimum setting. The various feed-through capacitors and ferrite beads are necessary to eliminate pick up of RF when transmitting.

A 9V PP3 battery is used as the power supply and this is reduced to 6.2V by R6 and stabilised by ZD1, a 6V battery could be used without stabilisation in which case R6 and ZD1 could be omitted. The output and PPT line are taken via twin coax cable to a 4-pin microphone plug PL1, and while Pin 3 of SK1 is shown connected to earth this arrangement might not suit all transmitters and might have to be left disconnected. The handbook should be consulted on this point.

### Construction

The circuit is built on a piece of single-sided copper clad board 90x70mm copper side uppermost. The terminal posts are a mixture of 1nF feed through capacitors and feed through insulators all of which are soldered in. This requires a powerful soldering iron of about 60W and is preferred by the writer to a printed circuit for one-off projects since it is quicker to produce and more easily modified.

Fig. 3 shows the open layout with no attempt at miniaturisation. IC1 is mounted on the underside of the board in a holder with the holder pins projecting through the 1mm holes (see Fig. 4). The holes were jig drilled

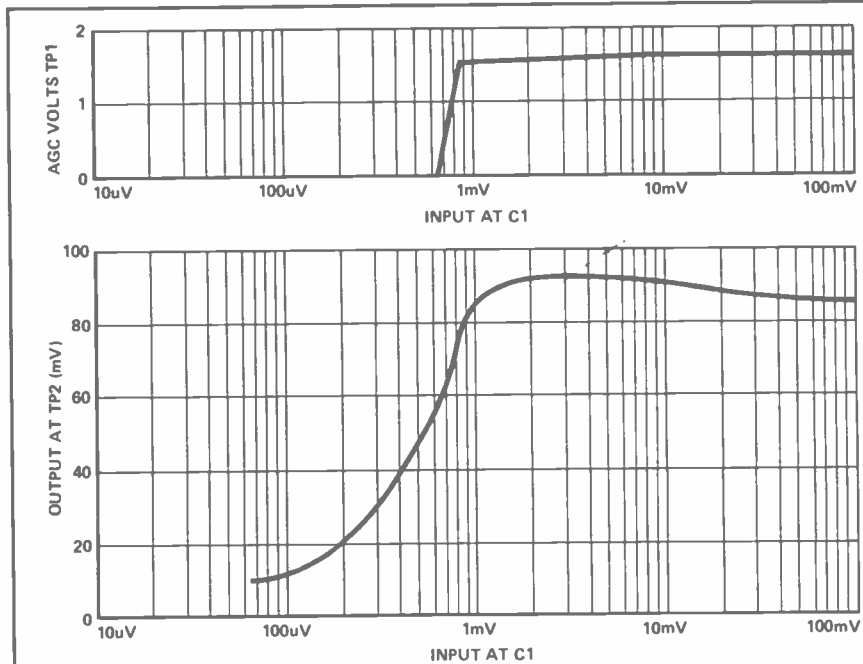

Fig 1. Input/output curve of the complete amplifier and its agc characteristic.

using a small piece of Veroboard and were then spot drilled on the copper side to provide insulation. A spot of glue secured the IC holder to the board and connections to the fine pins of the holder were made by pushing a wire down the hole alongside a pin and then soldering to it. Pin 6 was an exception as it needs to be bent over and soldered to the

earth plane.

For ease of use TP1 and the battery supply rail may be taken to 1mm sockets mounted on the output end of the box. These allow setting up and testing of the battery without having to remove the lid. It should be noted that the braid of the PTT coax cable is not earthed at the C10 end to avoid the formation of an earth loop.

Fig 2. The circuit diagram. Tr1 provides a high impedance in put for all types of microphone. VR1 and VR2 are the input and output gain controls respectively.

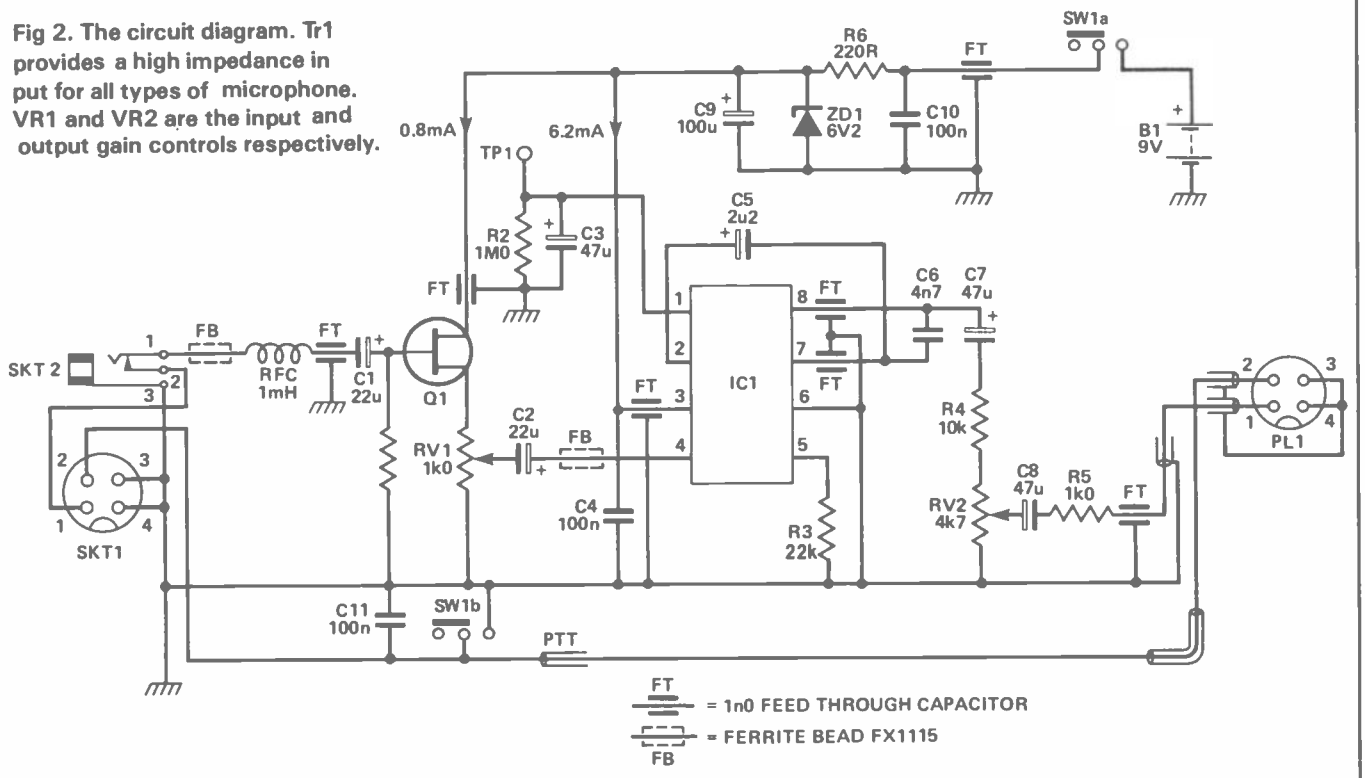

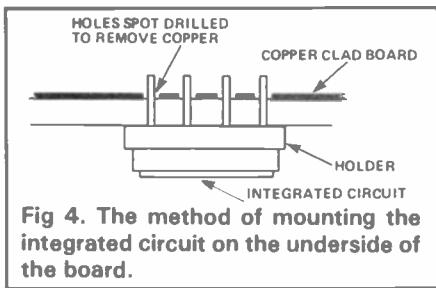

### Adjustments

Although the setting of RV1 and RV2 would appear to be a simple operation, this did not prove to be the case. Much care was needed to get satisfactory settings involving a lot of trial and error. RV1 is used to control the input from the microphone so that IC1 is just giving maximum output at TP1 while talking at the maximum distance – say 30cm. At any greater distance background noises and room resonance may become intrusive. RV2 is used to reduce the 90mV output from IC1 to a level which will modulate the transmitter to its maximum power without overdriving.

These two operations may be carried out independently and, once done, the two dial readings will apply to that particular microphone and transmitter. Any change in one will

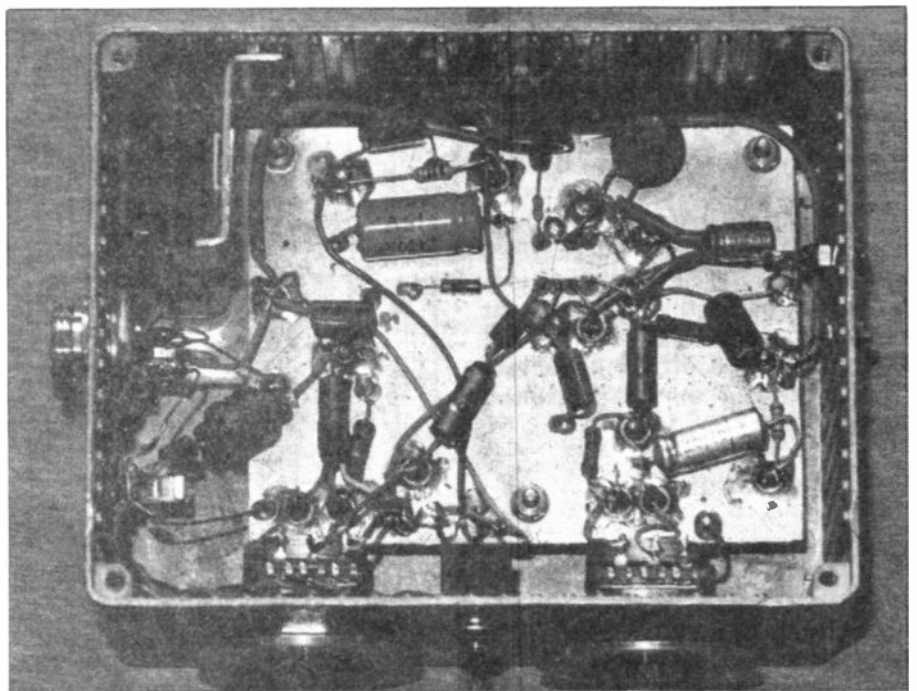
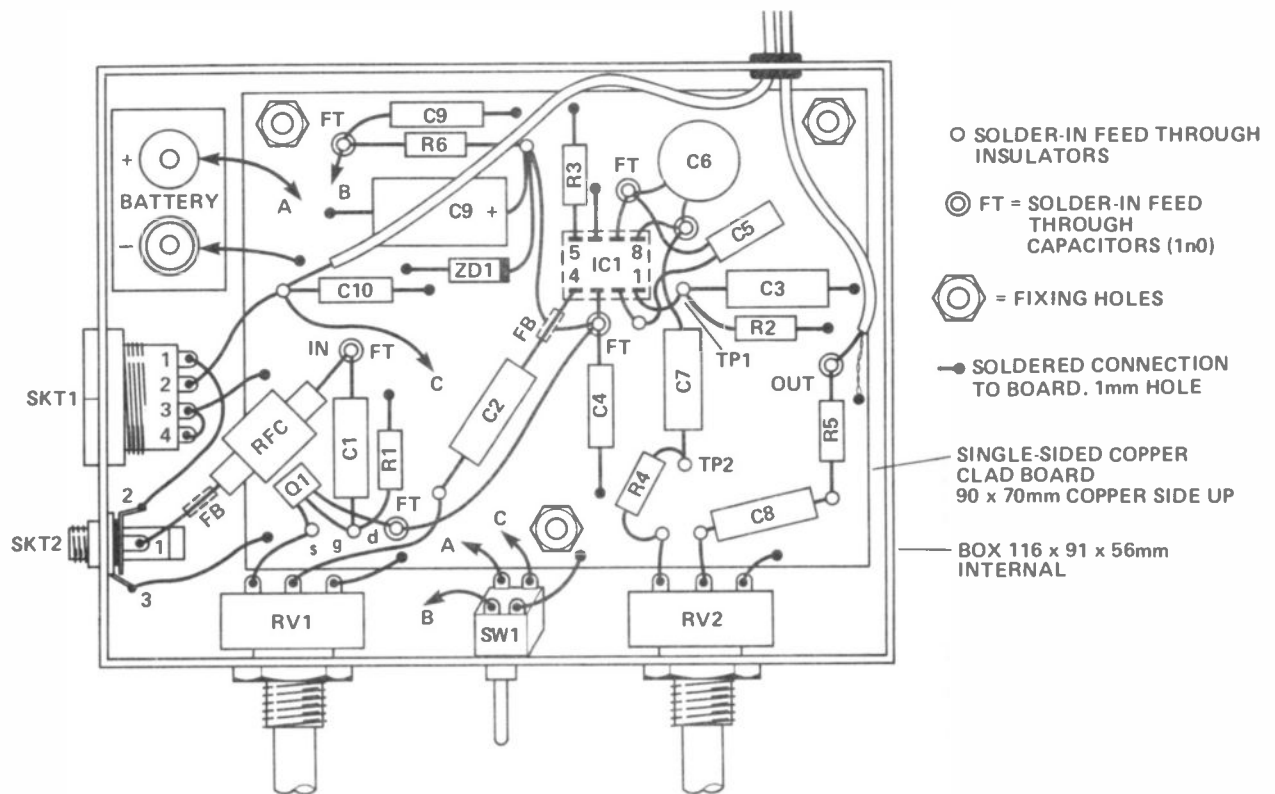

**Photo 2. The interior of the amplifier.**

require a change in the corresponding gain control. Thus a table of settings may be prepared for a number of pieces of equipment any two of which may be used together using the recorded settings. With this adjustment the input can range over 40dB (100 times) while the transmitter output remains constant.

(A) To set RV1. Set up the transmitter to work into a dummy load. A high impedance voltmeter is desirable at TP1 since this is a high impedance point (1MΩ) and it is necessary to detect the onset of the 1.5V agc. First set RV1 and RV2 to zero then, while talking into the microphone at 30cm distance,

**Fig 3. The layout showing the copper clad board with interconnected components mounted on the box.**



gradually increase RV1 until the voltage at TP1 kicks up. This is by no means as simple as it sounds! Try whistling (not too loud) using different frequencies, different words, clicks, and breath intake. After a while an apparently satisfactory setting will be found. Then by moving further away, check that the setting is not too sensitive. Note the RV1 dial reading for that particular microphone.

It will be found that the delay time at TP1 is long so that once the voltmeter has kicked up, it will take ages to reduce to zero which makes testing rather tedious. This can be overcome by temporarily shunting TP1 to earth with a 27k resistor after each trial. *Do not leave it in place.*

(B) To set RV2. Leave RV1 at the previous reading. If the transmitter has its own mic gain control set this to half way. Gradually increase RV2 while talking at 30cm until the Tx alc meter peaks to the maximum allowable level. Again check by talking further away. Also try close up when the Tx output should remain the same. Note RV2 reading for that

transmitter.

If difficulty is found in fully modulating the transmitter R4 may be shorted or reduced in value to increase output.

Finally the ultimate test was on the air and I have had the assistance of many patient and helpful stations who have commented on transmissions with and without the amplifier.

## Components

### RESISTORS

R1, R2	1M
R3	22k
R4	10k
R5	1k
R6	220
RV1	1kΩ pot carbon lin.
RV2	4.7kΩ pot carbon lin.

### CAPACITORS

C1, C2	22μF 15V elec.
C3	47μF 15V elec.
C4, C10	0.1μF 15V disc or poly.
C5	2.2μF 15V elec.
C6	4.7nF 15V disc or poly.
C7, C8	47μF 15V elec.
C9	100μF 15V elec.
7 off	10nF Solder-in feed through capacitors.

### SEMICONDUCTORS

ZD1	6V2 400mW Zener
Q1	2N3819
IC1	2N6270

### MISCELLANEOUS

RFC	1.0mH radio frequency choke.
Ferrite beads	2 — FX1115.
IC holder	8-pin
S1	Miniature DPDT toggle switch.
SK1	4-pin microphone socket.
SK2	3.5mm jack socket.
PL1	4-pin microphone plug.
11 off	Solder-in feed through insulators.
Box	Aluminum die-cast 116×91×56mm.
Knobs	2.



**D A T O N G**  
ELECTRONICS LIMITED

Clayton Wood Close  
West Park  
Leeds LS16 6QE  
Tel: 0532 744822

## For products you can rely upon to give amazing results

For information on **Active Antennas, RF Amplifiers, Converters, Audio Filters, the Morse Tutor and Speech Processors** send or telephone for a free catalogue and selective data sheets as required.

All our products are designed and made in Britain.

Orders can be despatched within 48 hours subject to availability.



— VISA AND ACCESS WELCOME —



# British 2m mobile

## REVIEW

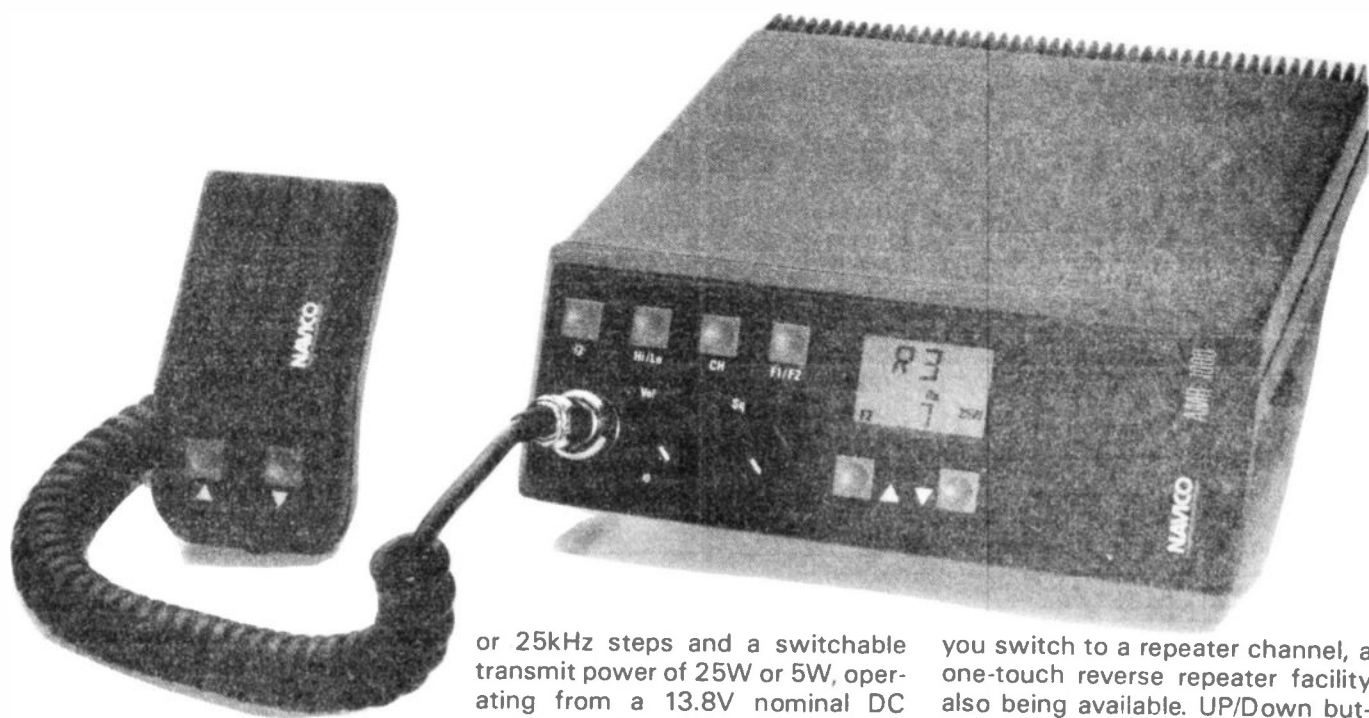

At the NBC exhibition this year a newcomer to amateur radio made a spectacular appearance, the company in question being the British marine electronics firm of Navico. At the show they proudly launched their offerings for the 2m FM amateur market in the shape of the AMR1000 and AMR1000S transceivers, offering a number of features for the British and European markets that could make Japanese 'black boxes' appear rather limited. For a price of £247 for the AMR1000 or £299 for the AMR1000S (the two are identical apart from the latter having extra scanning and programming facilities), they could certainly become very popular. The HRT review team (of course) have done it again with a world first review, and here we put them through their paces . . .

### Features

Each set gives transceive operation on FM over the 144-146MHz range with user-selectable 12.5kHz

or 25kHz steps and a switchable transmit power of 25W or 5W, operating from a 13.8V nominal DC supply requiring approx. 5.5A. Their styling is typically European, sleek and modern to match a variety of installations without looking out of place. The front panel is reversible to allow mounting on a table top or under a car dashboard, or with the panel reversed to allow positioning above the operator, for instance in an HGV cab installation. This feature would also enable the set to be used in more unusual positions, for instance mounted onto the car's central column next to the front seat. A front panel mounted speaker is fitted to improve readability over the more usual lid-mounted speakers one often finds nowadays.

The front panel sports a large multi-function LCD, as well as giving a frequency indication. A novel feature of the set is the direct readout of all repeater and simplex channels in the more sensible form of 'R6' or 'S20' in place of the frequency, a single button switching between the two. In Channel mode, the required -600kHz repeater shift is automatically programmed for you as soon as

you switch to a repeater channel, a one-touch reverse repeater facility also being available. UP/Down buttons on the fascia and the fist mic allow frequency or channel change. When pressed in transmit mode these provide a manual 1750Hz tone for repeater access. An 'intelligent' auto-toneburst is also provided, where a short 1750Hz tone is given on repeater channels only if no carrier has been present on the channel for at least a few seconds.

To cater for European use, repeater channels R8 and R9 may be user-programmed for selection in addition to S8 and S9, and the extra French repeater channels of FR8b, FR9b, and FR10-14 may also be user-programmed for selection. Two digital VFOs are provided, a single button switching between the two, so that one may be left on S20 while the other is left on your local repeater or net channel. The AMR1000 always comes up on 145.500MHz (the calling channel) on switch-on, providing a starting reference for tuning on the move.

Beneath the frequency/channel readout on the LCD is a digital S-meter, showing 1-9 together with 9+20 and 9+40 to give an indication



of the received signal level. Adjacent to this is shown the selected transmit power level of 5W or 25W, TX or RX mode, and which digital VFO (F1/F2) is in use. A front panel mounted button switches the LCD backlight illumination on and off for night time use.

## AMR1000S

In addition to the above features, the AMR1000S offers a more sophisticated variety of programmable options. As well as the direct readout of simplex and repeater channels, ten memory channels are also provided for local net use and the like. All memory or VFO simplex/repeater channels may be scanned for activity if required, and with suitable pre-programming the scan may search for an empty channel. A complete band scan may be initiated, in which up to 50 user programmed frequencies may be inhibited from selection to prevent the set locking up on beacon frequencies and so on. Alternatively, a limited band scan may be selected, searching between the two frequencies entered into the two digital VFOs (F1 and F2). A priority scan mode allows brief sampling of a pre-programmed channel while operating on another frequency, the scan locking onto the priority channel when active. The priority scan may also be used in conjunction with other scan modes if you like the hectic life!

The scan rate may be pre-programmed to between 10 channels per second and 1 channel every two seconds, and the scan 'hold' time between 4 seconds and 20 seconds before scan resume, or the scan may be set to hold until the received signal disappears. The auto toneburst length may be set to between 100ms and 1 second, and the time delay before auto-toneburst initiation to between 4 seconds and 20 seconds. Alternatively this facility may be inhibited. Other programmable features are in the level of LCD illumination and speaker audio muting for quiet use with data communication. In the AMR1000S, and EEPROM (electrically erasible programmable read only memory) is used to memorise the user-programmed features of the set, such as frequency, memory channels etc., so that when powered up it always retains the programmed

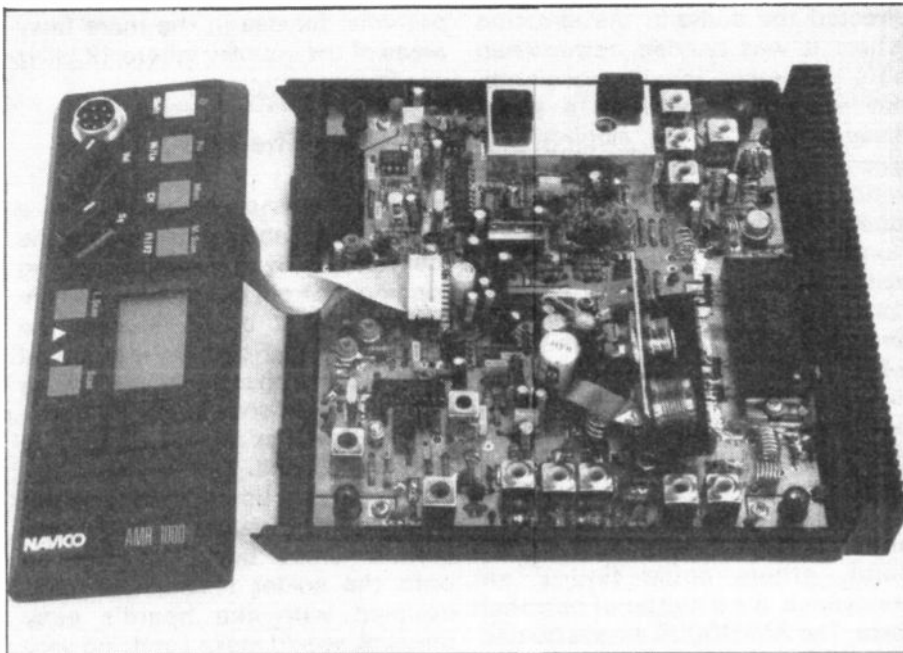

settings. There is, as a result, no need to start changing lithium backup batteries in years to come.

## Accessories

Each set comes supplied with a tiltable mounting bracket, plug-in fist mic and holder, fused DC power lead and a well presented A5 size operating instruction booklet. Optional extras are a mains power supply, DC-DC switched mode power supply (for 24V HGV use for example), internal and external extension loudspeakers, a telephone style handset, and a range of mobile and base station aerials. Navico have also promised a VOX-controlled hands-free microphone unit with some novel operating features in the near future.

## On The Road

Shortly after its launch, I received an AMR1000 unit for evaluation, and a few weeks later following an invitation to visit Navico's factory I drove away with the AMR1000S model. A good deal of operation using both rigs was possible although this was mainly done with the AMR1000S due to the extra features.

Using the set while driving was simplicity itself. I rarely needed to take my eyes off the road. The microphone mounted up/down buttons were very easy to use for frequency

change, the moulded volume and squelch knobs similarly were easily located by feel. Mounted above the centre of my dashboard, the set required just a quick glance to check exactly where on 2m I had ended up on when tuning or scanning. In the May HRT article *Mobile Radio Safety* I stated that an ideal synthesised 2m FM rig would have "a two digit readout of channel number, automatic repeater shift on repeater channels, and one-touch reverse repeater operation". Looking at the Navico rigs, what more can I say!

In QSO, reports of my transmitted audio were very good, with plenty of punch and little distortion, although one or two stations reported a slightly tippy response. I appreciated the "intelligent" auto toneburst. Even though I enthuse about mic-mounted tone buttons, which the Navico rig has, this type of toneburst makes operation more fumble free, especially if you prefer to use one of the many types of replacement boom or neck-slung microphones which don't come with a tone button.

On receive I found the set extremely sensitive; for example when driving around my local area I could hear distant repeaters with ease. There was enough audio from the internal speaker for use in a family type saloon car, but drivers of more noisy vehicles would undoubtedly find an extension speaker beneficial. The sloping front panel certainly

directed the audio in the direction where it was needed, rather than onto the carpet as with many sets, but at first I found it a slight disadvantage as the sloping LCD glass reflected daylight from my car window. Shifting the rig's position cured this. At night I found the LCD illumination just enough for readability without distraction; however, none of the controls were illuminated and I often had to try to remember which button performed which function. Because the AMR1000 always powers up on 145.500MHz, I found that by quickly switching off and then back on again I was always placed on the calling channel. This could be of use to some amateurs as a tuning point, others could find it an annoyance. It's a matter of personal taste. The AMR1000S always comes up on whichever frequency you have decided it should power up on.

I often used the set on long journeys having similarly long periods of QSO (I'm a natural woffler, sometimes I never stop!), and even though the set's rear heatsink became quite warm I found no problems of transmit power slumping or frequency shift. The receiver squelch was very sensitive, allowing very weak signals to stop the rig scanning if required. I found the digital S-meter of limited use, for two reasons: firstly, rather more than a quick glance is required to check the receive strength, in a similar manner to the difference between using a digital and analogue multimeter. I feel a bargraph display would have been better. Secondly, most received signals indicated at least S9, hence there was little difference in readout most of the time, although this was mainly due to the generally good signal levels I received in normal use.

At home, I powered the set up from a stabilised mains PSU and coupled various external aerials up to check how the set performed in a radio hostile environment. Using the rig in close proximity with my 2m packet radio station, which was automatically transmitting away merrily at the bottom of the band, showed the set to be very good indeed at strong signal tolerance. Similarly, tuning 12.5kHz off strong local signals gave an excellent rejection, with even the modulation sidebands of the other stations well down in level, showing the set has

potential for use in the more busy areas of the country where 12.5kHz use is commonplace.

### Inside The Box

The set is constructed from a sturdy two-piece die-casting for the main chassis, with a plastic moulding forming the front panel. A large single printed circuit board housing the analogue and RF circuitry is mounted directly to the chassis, smaller boards housing the control and interconnection facilities being fitted to the front panel itself.

The main board uses discreet components throughout, each component number being silk screened onto the solder resist. This fact, coupled with the board's easy removal, would make servicing very easy indeed, a stark contrast to many other sets on the market. Adjustments such as TX high and low power level, and the deviation control, are also clearly identified enabling easy location by the user.

The receiver uses a pair of bandpass tuned circuits feeding a dual gate MOSFET front end amplifier, three further bandpass circuits follow to feed a single gate FET mixer. The resultant first IF of 21.4MHz is filtered by a pair of monolithic dual crystal filters, and a standard IF subsystem IC takes care of the second mixer, IF amplification at 455kHz and demodulation, a multi-pole ceramic filter providing a degree of further selectivity here.

On transmit, the VCO is directly modulated at final frequency, buffered and amplified before being applied to a block PA module to achieve the 25W RF power level. A multi-section low pass filter provides harmonic suppression, a PIN diode switching network giving TX/RX aerial changeover. A single-chip synthesiser and separate ECL prescaler provide control of the VCO in 12.5kHz steps, this being serially programmed by the microprocessor controller mounted on the front panel section.

### Laboratory Tests

The receiver sensitivity, as found on air, was very good; the intermodulation rejection (ie rejection of off-channel mixing products from strong stations) was likewise quite

good, especially in view of the sensitivity. However what certainly made me check my signal generator settings was the outstanding 12.5kHz adjacent channel rejection. This excellent result should allow you to operate quite happily using the in-between 12.5kHz channels in the presence of strong stations on either adjacent channel. The blocking performance of out-of-band signals was similarly excellent, which will soon be very important as government users have already started to occupy frequencies on either side of our already overcrowded 2m band. The S-meter dynamic range was far better than most FM rigs, but most of this occurred at weak signal levels, again confirming the air test results.

The transmitter was very clean indeed in terms of its harmonic output, the power output was well regulated above 13.8V, and gave only a slight reduction on high power with reduced supply voltages. The deviation was accurately set at just below the 5kHz absolute maximum level.

### Conclusions

A British made 2m transceiver to be launched on to the market *must* be good to be able to compete with the numerous foreign-made offerings available. I'm very happy to say that in my opinion the Navico rig meets this goal. The manufacturers have certainly done their homework well. Not only does it out-perform its competition on technical grounds but it offers many very useful operating features not found on other rigs, and sells at what appears to be a very competitive price. I found this set one of the easiest to use on the move, enabling me to keep my eyes on the road rather than having to look at what the rig was doing.

It is not a micro-miniature unit, neither does it have flashing LEDs galore. If this is important to you, you may be disappointed. It does however have smooth styling with controls that do not need tiny fingers to operate. Whether the AMR1000 or the AMR1000S would suit you best is purely a personal choice; many users certainly don't want their set zooming off frequency automatically while others who travel around different areas appreciate these extra facilities to search out people to talk to.



**Laboratory Results  
(AMR1000S)**

**Receiver**

<b>Sensitivity:</b> Input level required to give 12dB SINAD
<b>0.124uV pd</b>

<b>Adjacent channel selectivity:</b> Measured as increase in level of interfering signal, modulated with 400Hz deviation, above 12dB SINAD ref. level to cause 6dB degradation in 12dB on-channel signal.	
+12.5kHz	67.0dB
-12.5kHz	65.5dB
+25kHz	81.0dB
-25kHz	79.5dB

<b>Blocking:</b> Increased over 12dB SINAD level of interfering signal modulated with 400Hz at 1.5kHz deviation to cause 6dB degradation in 12dB SINAD on-channel signal.	
+100kHz	95.4dB
-100kHz	96.0dB
+1MHz	104.0dB
-1MHz	102.5dB
+10MHz	>115dB
-10MHz	>115dB

<b>Intermodulation rejection:</b> Increase over 12dB SINAD level of two interfering signals giving identical 12dB SINAD on-channel 3rd ordinary intermodulation product.	
25/50kHz spacing	73.5dB
50/100kHz spacing	73.5dB

<b>Maximum audio output:</b> Measured at 1kHz on the onset of clipping	
3ohm load	1.47W RMS
8ohm load	1.08W RMS
15ohm load	850mW RMS

<b>Squelch Sensitivity</b>
<b>Threshold</b> 0.068uV pd (3.5dB SINAD)
<b>Maximum</b> 0.135uV pd (120dB SINAD)

<b>Image rejection:</b> Increase in level of signal at first IF image frequency over level of on-channel signal to give identical 12dB SINAD signals.
<b>91.5dB</b>

<b>S-Meter Linearity</b>		
Indication	Sig. Level	Rel. Level
S1	0.054uV pd	-12.0dB
S2	0.057uV pd	-11.5dB
S3	0.072uV pd	-9.5dB
S4	0.101uV pd	-6.5dB
S5	0.112uV pd	-5.6dB
S6	0.142uV pd	-3.6dB
S7	0.173uV pd	-1.8dB
S8	0.180uV pd	-1.5dB
S9	0.214uV pd	0dB ref
S9 + 20dB	0.617uV pd	+9.2dB
S9 + 40dB	2.490uV pd	+21.3dB

<b>TX Power and Current Consumption</b>				
Freq MHz	Power	10.8V Supply	13.8V Supply	15.6V Supply
144MHz	High	21.8W/5.80A	26.2W/5.95A	27.1E/5.96A
	Low	5.10W/2.50A	5.25W/2.58A	5.20W/2.55A
145MHz	High	21.9W/4.75A	25.1W/5.70A	25.2W/5.65A
	Low	4.65W/2.45A	5.00W/2.55A	5.00W/2.51A
146MHz	High	20.8W/4.85A	23.5W/5.60A	23.6W/5.50A
	Low	4.45W/2.40A	4.60W/2.45A	4.55W/2.45A

<b>Harmonics/Spurii</b>	
2nd Harmonic	-81dBc
3rd Harmonic	-87dBc
4th Harmonic	< -90dBc
5th Harmonic	-88dBc
6th Harmonic	-89dBc
7th Harmonic	< -90dBc
Spurii	< -90dBc

**Peak Deviation**  
4.79kHz

**Toneburst Deviation**  
2.81kHz

# CAP.CO

**STAY TUNED FOREVER WITH A CAP.CO.ATU - ONCE BOUGHT - NEVER REPLACED**

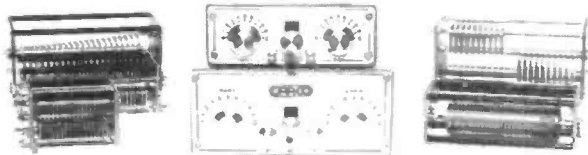

## ANTENNA TUNING UNITS

SPC-300 D 1Kw p.e.p. £225.00  
 SPC-3000D 1Kw p.e.p. £325.00

ADD £5.00 p&p

## CAPACITORS

CAP-25S S GANG 250 pfd. £15.50  
 CAP-25T T GANG 250 pfd. £18.95  
 CAP-10S S GANG 500 pfd. £21.95  
 CAP-25D DIFF 500 pfd. £18.95

ABOVE CAPS HAVE 2.5mm plate spacing rated at 8Kv.  
 ADD £2.00 p&p

CAP 31S S GANG 250 pfd. £17.95  
 CAP 31T T GANG 250 pfd. £22.95  
 CAP 12S S GANG 1200 pfd. £25.95

ABOVE CAPS HAVE 4.5mm plate spacing rated at 12Kv.  
 ADD £2.50 p&p

ROLLER COASTER - £2.00 p&p £22.95  
 BALUNS 4:1 - £2.00 p&p £16.50  
 AERIAL KIT + £1.00 p&p £5.30  
 TURNS COUNTER - £1.00 p&p £22.50

## THE GENUINE MAGNETIC LOOP ANTENNA A RARE TECHNOLOGICAL BREAKTHROUGH

The Magnetic Loop Aerial is totally different from any other aerial. It relies solely on the magnetic portion of the electromagnetic wave to operate. It filters out all unwanted noise via 180° phase shift between the magnetic and the electrical wave, exactly what is required from 1 to 14MHz where the electrical noise is virtually unbearable.

Depending on the model used and within the bounds of the frequency designated for that model, the Control Box enables the user to operate the antenna from the lowest to the highest part of the frequency with no gaps.

There are various models of loops - typically 2 antennas and 1 Control Box is required to cover the whole HF frequency range from 1 to 30 mcs. A reduction of £50.00 is allowed for two aeriels. Prices range from £79.95 for the receive Loop to £456.00 Power ratings for these versions are from 100-200 watts.

The Commercial versions, power rating 500 and 1000 watts come complete with Automatic Controller which selects the frequency you require.

- It has a very high Q
- A radiation resistance of approx. never more than 800 mill ohms
- Has a bandwidth from 3KHz to 50KHz
- It has an SWR of 1.1 at the very least, 1.1 to 1 on most bands
- Will operate at virtually ground level
- The loop has a vertically polarised radiation pattern containing both very high and very low angle radiation (ideal as a DX antenna)
- Does not require an Antenna Tuning Unit
- Depending on the model used it only occupies from 80cm to 4mt of space
- It is ultra compact, light and waterproof
- Planning permission is not necessary

Receiving only Loop - ideal for S.W.L.

PLEASE WRITE INCLUDING SAE FOR FURTHER DETAILED INFORMATION

Our equipment is guaranteed, unique and as such protected by registered designs and copyright. Our policy is one of continual research and improvement therefore current specifications are subject to change without notice.

**Unit B6, Peel Rd Ind. Estate  
 Peel Road, West Pimbo,  
 Skelmersdale, Lancs WN8 9PT**

# NEVADA

**THE UK'S SCANNER SPECIALISTS**

**JUST ARRIVED THE NEW  
 BLACK JAGUAR MkIII**

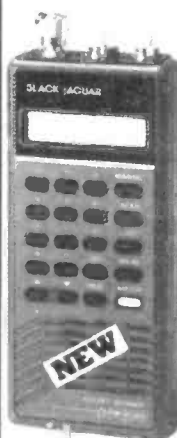

Switchable between AM/FM.  
 Base & mobile charging  
 Frequency range -  
 26-30MHz, 60-88MHz  
 115-178MHz, 210-260MHz  
 410-520MHz

**£235**

**200 XL  
 Bearcat**

Hand held scanner  
 with 200 channels.

Memory scan covering -  
 66-88 Mhz, 118-174 Mhz,  
 405-512 Mhz, 806-956 Mhz.  
 Complete with carrying case,  
 earphone and charger unit.

**£249<sup>00</sup>**



**Bearcat 210 XW**

NEW Base station scanning Rx  
 with 20 channel memory scan  
 covering: 30-50MHz,  
 136-174MHz, 406-512 MHz.

**£179<sup>99</sup>**

**50 XL  
 Bearcat**

A super NEW low cost  
 handheld scanner with  
 10 memories and covers -  
 12 Volt or mains.

66-88MHz, 136-174MHz,  
 406-512MHz

**£99<sup>99</sup>**

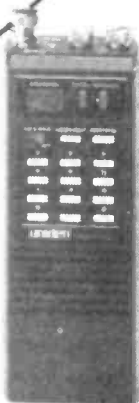

**Bearcat 800 XLT**

40 Channel Base Scanner  
 Covers: 29-54MHz, 118-174MHz,  
 406-512MHz, 806-912MHz  
 Complete with AC adaptor

**£229**

**70 XLT  
 Bearcat**

Pocket size scanner  
 with 20 memory scan  
 covering 66-88 Mhz,  
 118-174 Mhz, 406-512 Mhz  
 Complete with carrying case,  
 earphone and charger unit.

**£149<sup>99</sup>**



**NEW 580 XLT  
 Bearcat**



100 Memory channels covers:  
 29-54 MHz, 118-174, 410-512 MHz

**£199** Requires 12V DC supply

**NEW  
 BUMPER  
 CATALOGUE  
 Includes £20  
 worth of  
 vouchers**

**USE YOUR CREDIT CARD FOR IMMEDIATE DESPATCH**

**HOTLINE (0705) 662145**

**NEVADA COMMUNICATIONS  
 189 London Road, North End,  
 Portsmouth PO2 9AE. Telex: 869107**

# Yaesu FRG-9600 Cat Interface

The Yaesu FRG 9600 is a high specification VHF/UHF scanning receiver. The standard model covers the frequencies 60-905MHz without any gaps, and can be programmed with up to 100 memory channels. It has an internal microprocessor and

port as standard so was chosen as the host for a simple low cost interface unit. This, together with the controlling software accompanying this article, gives full computer control of the receiver for less than £10. Although most micros lack the

uses voltages of  $\pm 6V$ , or  $\pm 12V$  to represent binary data. A binary 0 would be represented by a  $+12V$  signal, and a binary 1 by a  $-12V$  signal. The serial port on the BBC micro conforms to the RS423 standard in which voltage levels of  $\pm 4V$  are specified and the data protocol used is the inverse of that of the RS232 standard, ie  $+4V$  represents a 1 and  $-4V$  represents a 0 — although in practice, the BBC micro generates  $\pm 4.6V$  signals. The task of converting data from a parallel to serial format is performed by the 6950 Asynchronous Communications Interface Adaptor (ACIA) chip. This transmits the logic high and low signals as a train of pulses, along a single wire as shown in Fig.1 and the data may be transmitted at 7 or 8 bit blocks.

The serial system is an asynchronous one. Put simply, this means that the two devices that are talking to each other are not running at the same speed so, in addition to the data bits, extra control bits are sent with each byte to tell the receiving device where a byte of data stops and starts. There are several possible combinations of these control bits. The parity bit is used as a simple error checking mechanism, and if used may be set to odd or even parity whilst the stop bit can be one, one and half or two bits long. Another parameter which can be varied is the speed at which the serial data can be transmitted. The

## *Michael O'Reilly's low cost interface gives control of the Yaesu FRG 9600 from a microcomputer*

can be operated in a variety of user programmable scanning modes. It also features Yaesu's Computer Aided Transceiver (CAT), serial computer interface system which allows the user to control the functions of the radio from an external microcomputer, thus greatly enhancing the versatility of the receiver.

Unfortunately, simply connecting a microcomputer's serial port directly to the CAT interface may not have the desired results as Yaesu have chosen to use a data format for their system which is unlikely to be available directly on any micro. The manufacturer does make a range of interfaces for a number of popular micros, but these cost around £75, and the RS232 interface unit does not feature an analogue to digital converter (ADC) which is required for external monitoring of signal strength. However, the BBC micro has such an ADC

facility required to support the signal strength function, the unit could be built in 'short-form' for use with other micros where the appropriate data format is available.

### **Serial Interface and the CAT system**

Within an eight bit micro, character data is manipulated in bytes with each byte consisting of eight binary digits with 1s represented by  $+5V$  or logic high signals, and 0s by  $0V$  or logic low signals. These TTL signals are transmitted around the circuitry within the micro along eight parallel wires known as a bus. Before this data can be transmitted any distance to an external device, it has to be converted from a parallel, to a serial format. Most microcomputers are fitted with a RS232 serial interface for this purpose.

The RS232 standard typically

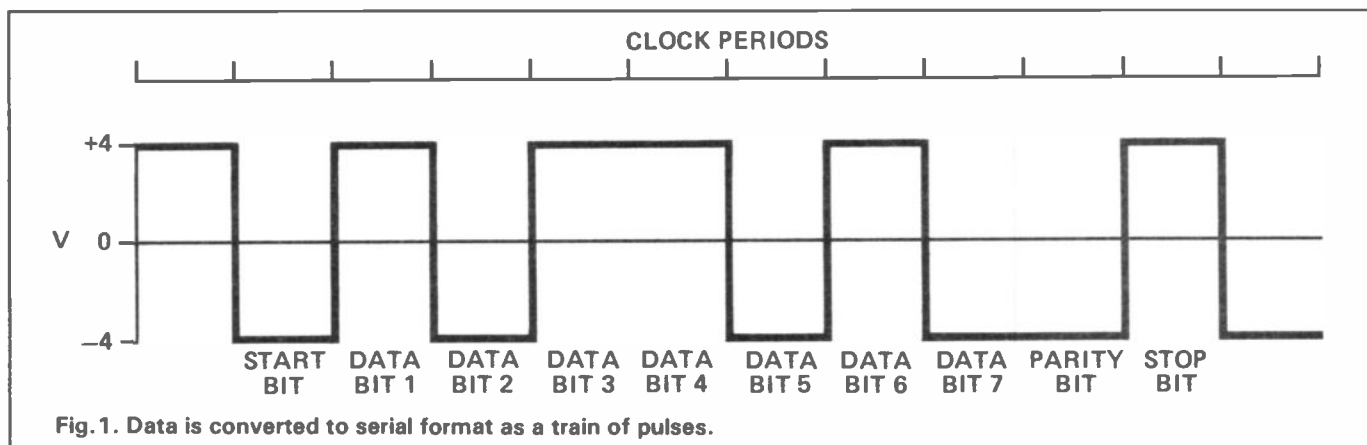
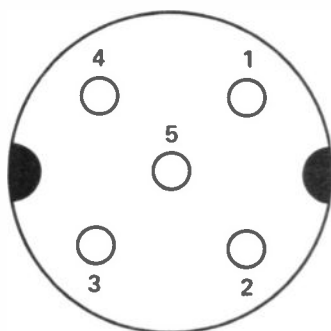

Fig.1. Data is converted to serial format as a train of pulses.

PINOUT FOR BBC MICRO  
RS423 PORT



1. DATA IN (NOT USED)
2. DATA OUT
3. CTS } TO BE LINKED
4. RTS }
5. 0V

Fig.2. The BBC micro uses a 5-pin DIN connector.

PINOUT FOR FRG-9600  
CAT INTERFACE

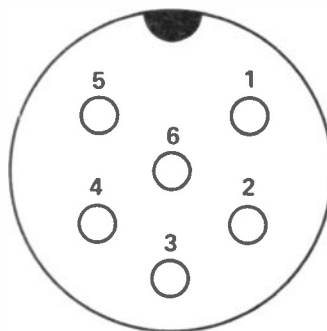

1. GROUND
2. NO CONNECTION
3. SERIAL DATA IN
4. NO CONNECTION
5. S-METER
6. BUSY (NOT USED)

Fig.3. The CAT interface uses a 6-pin DIN connector.

data format required by the CAT system is eight data bits, with two stop bits and no parity (ie no error checking). Data has to be sent to the receiver at 4800 bits/sec (Baud) and the signals must also be at TTL voltage levels, ie 0V and +5V, but the sense of these voltages must be the reverse of that used by the RS423 system as the scanner uses 0V to represent "mark" or logic high, and +5V to represent "space" or logic low.

The BBC micro's serial interface is accessed via a 5 pin (domino) DIN connector (Fig.2 shows the pin-out) where in addition to the data line, the interface also has a Ready To Send (RTS) and Clear To Send (CTS) line. Because the serial port is a bidirectional system which allows the micro to both send data to, and receive data from another device, the CTS and RTS lines are used to inform the transmitting device whether or not the receiving device is ready to accept data. If it isn't, the transmitter must wait until it receives an "all clear" signal from the receiver before transmitting data. This is called handshaking.

The CAT serial interface operates in a unidirectional fashion, ie data is sent out from the BBC computer, but no serial data is returned from the scanner. Therefore in this application the CTS and RTS lines are linked together, so that the computer can send out a continuous stream of instructions, without receiving any handshaking signals from the receiver so no use is made here of the

RS423 Data In pin. The CAT interface is accessed via a six pin DIN connector, located at the rear of the receiver as shown in Fig.3. Instructions in the form of serial data are sent to pin 3 of the CAT connector while pin 5 is connected to the S-meter of the receiver. By monitoring the voltage on this pin, it is possible to determine the signal strength of the received station. Pin 1 is ground and the signal on pin 6 indicates a "busy" state but no use is made of this signal here.

The default data format of the BBC's serial port is 8 data bits, with no parity, and 1 stop bit, the baud rate defaults to 9600 bits/sec and logic high is represented by +4V and logic

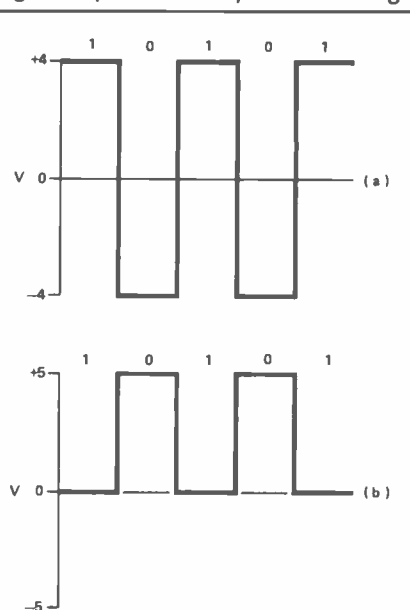

Fig.4. The signal is inverted to match the receiver's logic protocol.

low is -4V. Clearly there are a number of changes that have to be made to the data coming from the BBC micro, before it can be sent to the receiver. The data format has to be changed, the speed at which it is transmitted has to be reduced, and the voltage levels have to be altered. Finally the signals must be inverted, to comply with the logic protocol used by the receiver (see Fig.4). All these changes may look a little daunting, but they can be achieved quite simply. The data format and speed can be changed under software control and both the voltage levels, and signal inversion can be achieved by a simple piece of hardware.

### Hardware — Data Section

The circuit diagram for the interface unit is shown in Fig.5 and consists of two sections, namely the serial interface circuit which is shown on the left of the diagram, and the analogue (S-meter) interface on the right. The circuit is powered from the +8V 200mA DC outlet provided at the rear of the receiver and this is brought down to +5V, by a 78L05 (5V 100mA) voltage regulator fitted to the interface. This device also protects the receiver from excessive current drain. The unit is constructed on a 7cm x 4.5cm piece of Vero-board, and then mounted in an aluminium enclosure. Except for the power cable, all connections between the interface, the computer and receiver were made with screened multicore cable, and the appropriate plug. A twin unscreened cable was used to connect the circuit with the 8V supply.

The serial interface is a simple transistor switch circuit, with an LED on the input line, to indicate when data is being transmitted. The signal is fed from the data-out pin of the RS423 connector, to the base of transistor Q1. When the signal is logic low, no current flows to the base of the transistor, the transistor is switched off, and the output is held at +5V by the pull up resistor R4. When the signal changes to logic high, the LED lights up, current flows through the base of Q1, and the transistor is turned on, bringing the output down to 0V, thus reversing the logic of the signal and changing the voltage levels.

Resistors R2 and R3 bias the base of transistor Q1 to just below

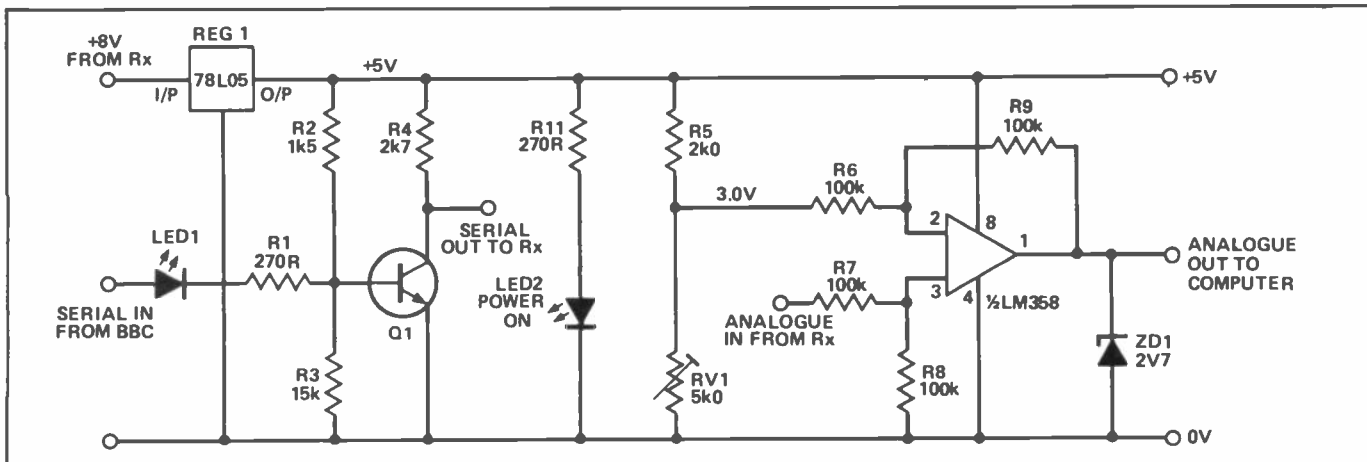

Fig.5. The circuit of the CAT interface, in two sections.

the point of conduction, although in practice the circuit will operate without these, due to the speed of switching, and the tolerance of the serial system. Pin 5 of the RS423 port should be connected to the round rail of the interface circuit and in addition,

pins 3 and 4 should be linked together — this can be done at the plug end of the connecting cable.

### S-meter section

The analogue interface takes the voltage from the CAT S-meter pin and reduces it to a suitable voltage range

for the BBC's analogue port. This is calibrated to convert voltages in the range 0 to +1.8V, into digital values which can then be manipulated by suitable software. Unfortunately I have come across a problem with the voltage levels produced by the S-meter, which are unresolved at the time of writing. I had been advised by the dealer that the voltage range which should appear on the S-meter pin of the FRG9600 is 0 to +2.5V. Upon checking my receiver, I found that it gave voltages in the range +3.1V to +4.7V, with a strong signal giving +3.1V and no signal giving +4.7V. When I queried this with the dealer, they informed me that they had tested all the other sets they had in stock, and found that these gave the same voltage levels as mine.

The CAT interface uses half a dual op-amp, chosen because of its ability to operate with inputs and output down to its negative supply voltage. The circuit has unity gain (non-inverting) and simply subtracts a presettable offset of nominally 3V from the input signal.

This is not required in cases where the S meter output voltage starts at 0V. For example, if the S meter voltage is from 0 to 2.5V, then a potential divider using 1k in series and 1k5 to 0V would set the voltage to a suitable range for the ADC input of the BBC computer to handle. A 2V7 zener, in parallel with the 1k5 resistor, should still be used to protect the input of the computer. Note that in this example the S meter voltage is proportional rather than inversely proportional to the signal strength, and the program should be modified accordingly, as described in the section on the program listing. The

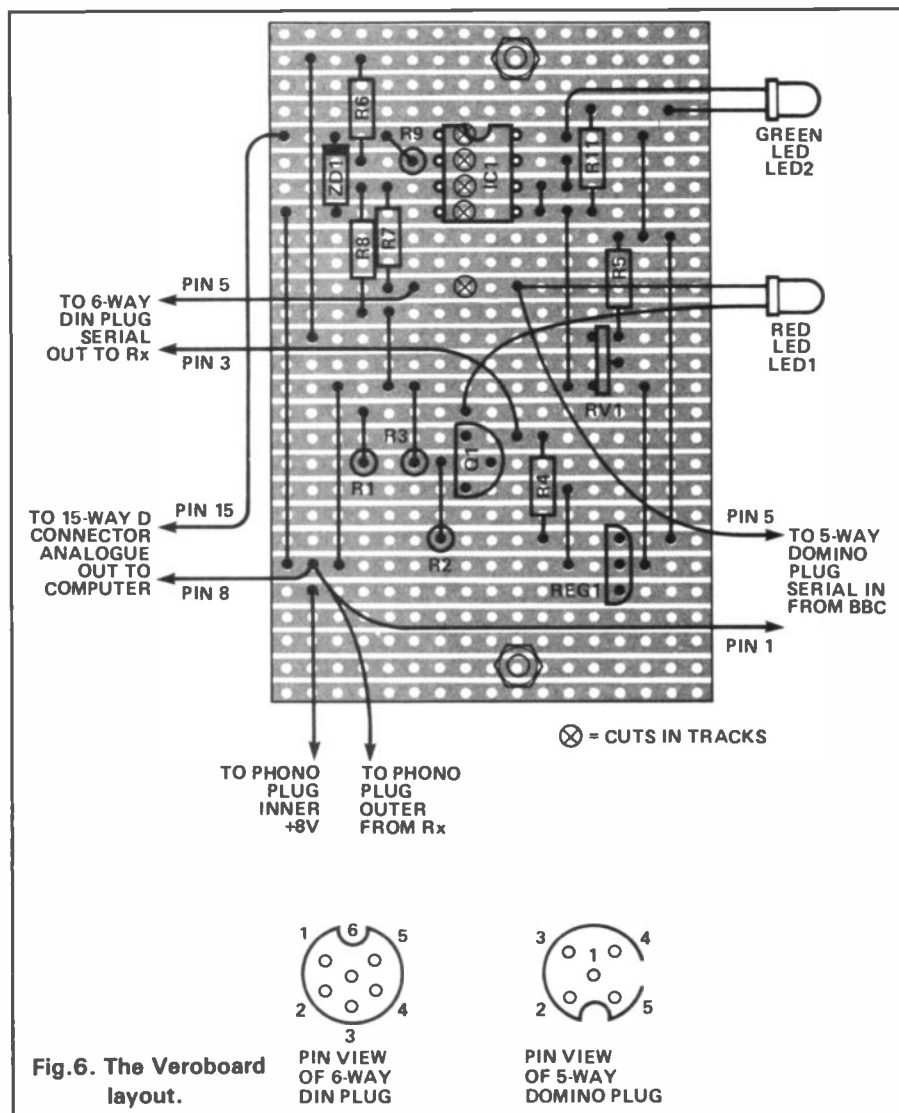
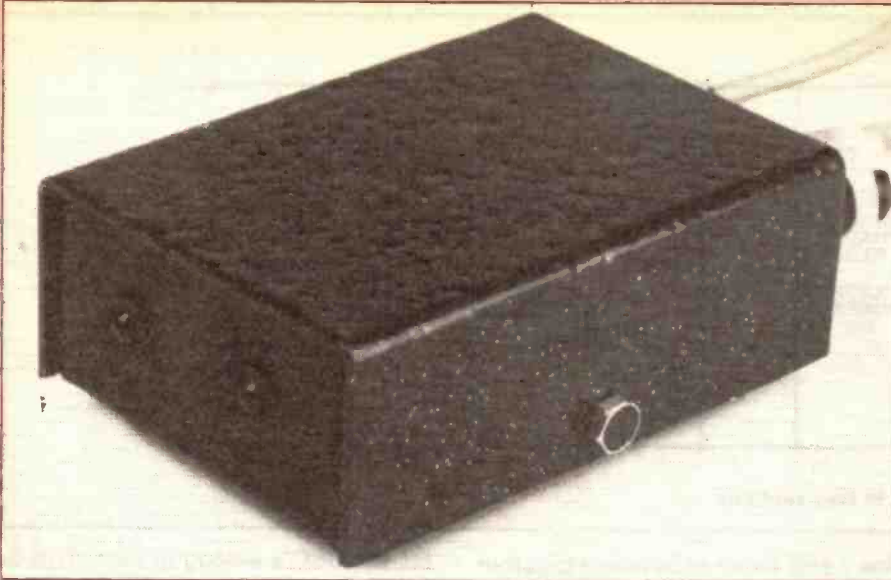

Fig.6. The Veroboard layout.



differential amplifier is based on the LM358 op amp which is a dual device on an 8 pin dil chip. It has the ability to operate from a single rail supply, and its output can swing down to ground. R5 and RV1 form a potential divider network, which should be adjusted to give 3.0V on the inverting input of the op amp. The signal from the CAT S-meter pin is applied to the non-inverting input, and the difference between the two potentials

appears on the output. A 3.1 to 4.7V input voltage range, should give 0.1 to 1.7V out, thus taking good advantage of the resolution available on the BBC's analogue port. In practice some fine tuning of the voltage may be required and this can be done by adjusting the variable resistor RV1, while switching between a strong broadcast station and no station, until a reasonable output signal range is achieved. A zener diode is placed

across the output to the BBC's analogue port so as to protect the ADC chip from a lethal voltage. Although calibrated to operate between 0-1.8V, the chip can take up to 5V before damage will occur, hence the choice of a 2.7V device. The output should be connected to pin 15 of the analogue port but note that this is marked as channel 0 in the BBC Microcomputer User Guide pin out diagram, but is referred to as channel 1 when using the ADVAL command to read its value! Pin 8 of the A/D port should be connected to the interface ground rail as should pin 1 of the CAT connector.

### Software

Before running the demonstration program, it is desirable to calibrate the analogue port. The BBC's analogue to digital converter has four channels in all, but we only require one in this application. Each of them can be interrogated using the ADVAL command which will return a value in the range 0 to 65520, changing in steps of 16. *(The reason for this strange arrangement is that the BBC Micro was designed to take 'high resolution' A/D chips which weren't*

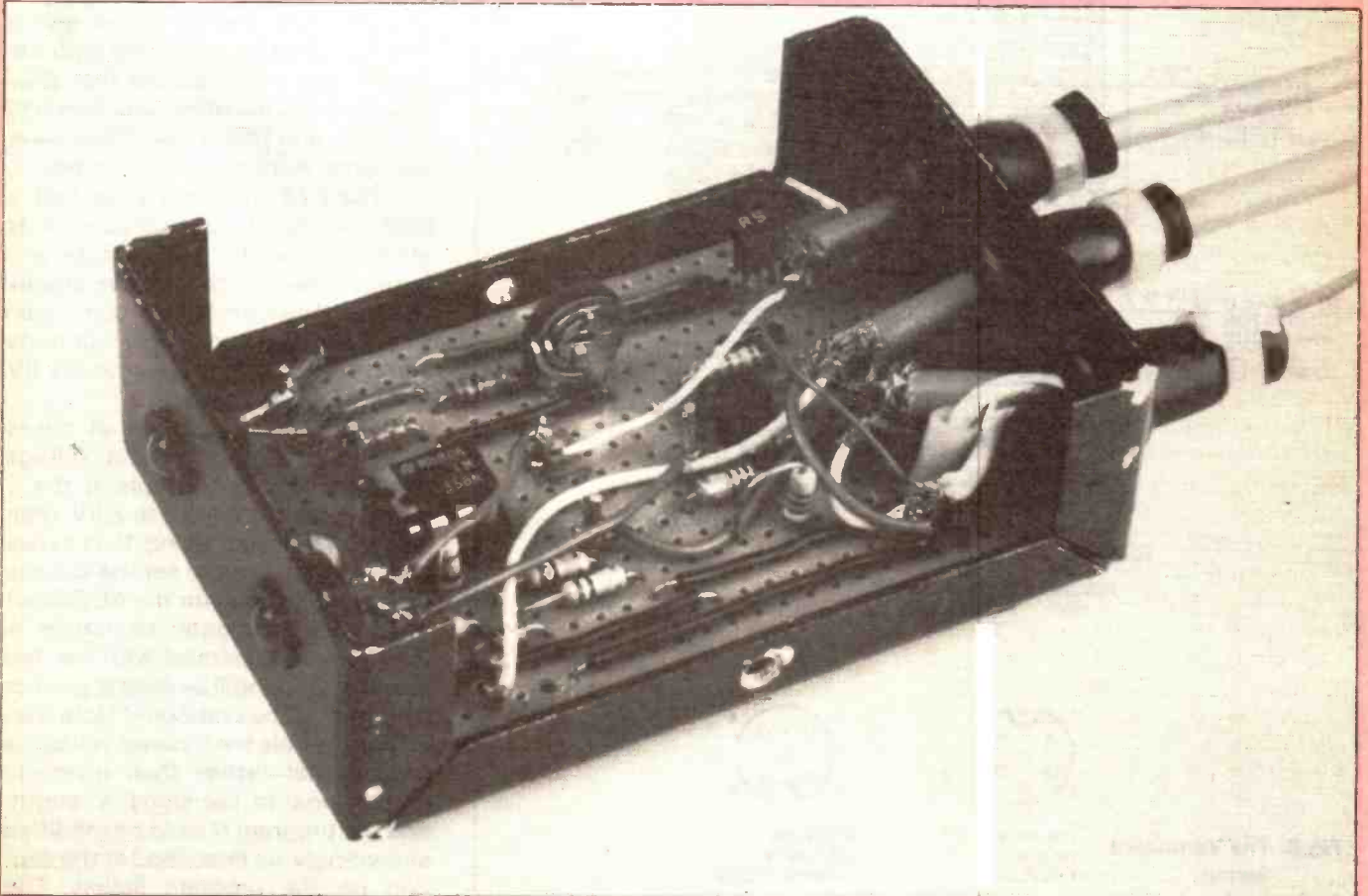



```

10 REM *** FRG 9600 DEMO CONTROL PROGRAM ***
20
30 REM *** INITIALISE VARIABLES ***
40 ConvertFac=330:A$="":A=0:DIM BYTE(5)
50
60 REM *** ENABLE ADC CHANNEL 1 ONLY ***
70 *FX 16,1
80
90 REM *** MODE COMMAND DATA ***
100 DATA "14","15","16","17","10","11"
110 MODE 6
120
130 REM *** REQUEST REQUIRED FREQ RANGE & VALIDATE ***
140 REM *** NB MUST BE BETWEEN 60 & 905MHz ***
150 PRINT :PRINT "FRG 9600 CONTROL PROGRAM": PRINT
160 INPUT "ENTER START FREQ (MHz)",StartFreq
170 IF StartFreq <60 THEN PROCError(1):GOTO 160
180 IF StartFreq > 905 THEN PROCError(1):GOTO 160
190 INPUT "ENTER FINISH FREQ (MHz)",FinishFreq
200 IF FinishFreq <60 THEN PROCError(1):GOTO 190
210 IF FinishFreq>905 THEN PROCError(1):GOTO 190
220 IF FinishFreq < StartFreq PROCError(2): GOTO 160
230
240 REM *** SELECT STEP SIZE & MODE ***
250 INPUT "STEP SIZE (kHz)",StepSize
260 IF StepSize <0.1 THEN GOTO 250
270 PRINT:PRINT "SELECT DESIRED MODE":PRINT
280 PRINT "1 - AM-N"
290 PRINT "2 - AM-W"
300 PRINT "3 - FM-N"
310 PRINT "4 - FM-W"
320 PRINT "5 - LSB"
330 PRINT "6 - USB"
340 REPEAT:A$=GET$:A=VAL(A$):UNTIL A>0 AND A<6
350 M=0:REPEAT:READ ModeString$:M=M+1:UNTIL M=A:RESTORE
360
370 REM *** PAD STRING WITH DUMMY BYTES ***
380 ModeString$=ModeString$+"00000000"
390
400 REM *** CONVERT FREQ MHz -> kHz ***
410 StartFreq=StartFreq*1000
420 FinishFreq=FinishFreq*1000
430
440 CLS: PRINT:PRINT "SCANNING IN PROGRESS"
450 PRINT TAB(5,5)"START FREQ: ";StartFreq
460 PRINT TAB(5,6)"FINISH FREQ: ";FinishFreq
470 PRINT TAB(5,7)"STEP SIZE: ";StepSize
480
490 REM *** SEND OUTPUT TO RS423 PORT ***
500 REM *** & SET BAUD RATE TO 4800 ***
510 *FX 3,1
520 *FX 8,6
530
540 REM *** SET CONTROL REGISTER OF 6850 ACIA CHIP ***
550 REM *** 8 DATA BITS, 2 STOP BITS, NO PARITY ***
560 OSBYTE=&FFF4:A%=156:X%=50:Y%=0
570 CALL OSBYTE
580
590 REM *** SEND MODE DATA TO RECEIVER & PAUSE ***
600 PROCSendChrBytes(ModeString$):FOR T=1 TO 50:NEXT T
610 REM *** SCAN SELECTED FREQUENCIES ***
620 FOR Dial= StartFreq TO FinishFreq STEP StepSize
630
640 REM *** ? PAD FREQ STRING WITH LEADING ZERO ***
650 REM *** THEN PREFIX WITH "SET FREQ" COMMAND BYTE
660 FreqString$=FNPAD(Dial):FreqString$="0A"+FreqString$
670 PROCSendChrBytes(FreqString$)
680 SigStrength=FNSmeter
690
700 PROCDisplay(Dial,SigStrength)
710 REM *** PAUSE BEFORE MOVING TO NEXT FREQ ***
720 FOR T=1 TO 125:NEXT T
730 NEXT Dial
740 END
750
760
770
780 DEF PROCError(N)
790 IF N=1 THEN PRINT "ERROR: Frequency out of range"
800 IF N=2 THEN PRINT "ERROR: Start Freq higher than Stop"
810 PRINT "PLEASE RE-ENTER"
820 ENDPROC
830
840 DEF PROCSendChrBytes(CommandString$)
850 P=1
860 FOR B=0 TO 4
870 BYTE$="&"&MID$(CommandString$,P,2) :P=P+2
880 BYTE(B)=EVAL(BYTE$)
890 NEXT B
900
910 REM ***SWITCH OFF OUTPUT TO SCREEN ***
920 *FX 3,7
930
940 REM *** SEND BYTES TO RECEIVER ***
950 FOR I=0 TO 4:PRINT CHR$(BYTE(I)):NEXT I
960 REM *** RESTORE SCREEN ***
970 *FX 3
980 ENDPROC
990
1000 DEF PROCDisplay(DialReading,MeterReading)
1010 @%=&020410
1020 PRINT TAB(5,10)"FREQ (MHz): ";DialReading/1000
1030 @%=&020010
1040 PRINT TAB(5,11)"SIGNAL STRENGTH: ";MeterReading
1050 @%=&10
1060 ENDPROC
1070
1080 DEF FNPAD(Freq)
1090 Freq=Freq*100
1100 Freq$=STR$(Freq)
1110 IF LEN(Freq$)=7 THEN Freq$="0"+Freq$
1120 =Freq$
1130
1140 DEF FNSmeter
1150 REPEAT:UNTIL ADVAL(0) DIV 256 =1
1160 SigStrength=ADVAL(1) DIV 16
1170 SigStrength=SigStrength DIV ConvertFac
1180 REM *** INVERT S-METER VALUES ***
1190 SigStrength=(10-SigStrength)+1
1200 =SigStrength
1210
1220 REM *** PROGRAM END ***

```

available at the time — nothing came of this 'future-proofing' so the original chip increments in steps of 16. — Ed). The bigger the voltage on the port, the bigger the number will be and dividing the number by 16 will give a range of 0-4095, in increments of 1. The maximum value will be obtained by a signal of 1.8V so assuming the open circuit voltage range produced by the receiver is 3.1 to 4.7V, and the differential amplifier subtracts 3V. Therefore, the highest ADVAL value obtainable will be less than 4095.

Some users may be happy to record signal strengths in these arbitrary units, however, converting them into a scale of 1-10 would mimic

the values displayed on the receiver's S-meter. In order to do this it is necessary to find a calibration factor, which will convert the readings to the correct range. A crude approximation can be obtained by setting up the receiver and interface, then running the following one line program:

```

10 REPEAT:PRINT TAB(5,5)
ADVAL(1) DIV 16:REPEAT:A$:UNTIL
A$<>"":UNTIL FALSE

```

This will show the value being sent from the analogue part of the interface and pressing a key will update the display. The receiver can be manually tuned to broadcast stations

of different signal strengths, and a table made of the ADVAL value for each value on the S-meter scale. From this table it is possible to determine a calibration factor that will give values in the desired range of the S-meter scale. Once the factor has been obtained for a particular receiver and interface, it can be incorporated into the control software — in the prototype this was found to be 330.

### Program Listing

Listing 1 shows a demonstration program for controlling the receiver via the interface unit. The software is

all in straightforward BASIC, and does not use any "illegal" programming tricks. It should therefore work on any of the BBC family of microcomputers. The program asks the user to specify a range of frequencies to be scanned, by entering a start and finish frequency. The user is also asked what step size to use, and which mode the receiver should be set to. The control code to set the mode is then sent to the receiver, followed by a series of commands which cause the radio to scan through the selected frequency range, reading and displaying the signal strength at each frequency step.

Line 380 sets the variable `ModeString$` to the appropriate "mode set" code; the string is then padded with eight trailing zeros which ensures that the string conforms to the format of five bytes required for each CAT interface instruction. Next, the frequency entered by the user in MHz is converted to kHz in lines 400-420.

The section of code, between lines 490-550, sets the serial port to the required data format — as mentioned earlier, the serial port is controlled by the ACIA chip. Within this chip is a control register, and by altering the value stored in the register, it is possible to alter the data format used by the port. This is achieved by using an `Osbyte` call provide specifically for this purpose. Readers interested in the details of how the ACIA's registers are organised, are referred to the Advanced User Guide for the BBC Micro. Now that the serial system is set to the correct data format we can start to send instructions to the receiver.

Line 600 calls the procedure `SenChrBytes`, with the actual parameter set of `ModeString$`. `PROCSendChrBytes` scans along the string sent to it, taking two characters at a time and converting them into their hexadecimal equivalent, using the `EVAL` instruction. The five bytes generated are stored in the array `BYTE`, ready for transmission to the receiver. The second part of the procedure sends the five bytes out to the receiver interface, using the `PRINT` instruction. Control then returns to the main body of the program, where a delay loop is executed. Because the system is being used in a unidirectional fashion, it is necessary to pause before sending the next instruction to the

receiver. If the instructions are sent out from the computer too quickly, the CAT interface will not be able to cope with them, and they will simply be ignored. The optimum length of pause was determined by trial and error.

Having set the receiver to the desired mode, we can now start scanning the desired range of frequencies. At line 620, a `FOR NEXT` loop is used to generate the values of the frequencies to be scanned, these are assigned to the variable `Dial`. At each increment of the loop the value of `Dial` is converted into a string and padded with leading zeros, to give a string 4 bytes long. The padding is done by the function `FNPpad`. The CAT "set frequency" byte (&0A) is then added to the string, which is sent to the receiver by `PROCSendChyBytes`. After tuning the receiver to the desired frequency, the signal strength is sampled and this is done by the function `FNSmeter` by reading the value on channel 1 of the analogue port. The value is then converted to a figure in the range of 1 to 10 by the conversion factor which is set in line 40, and will need to be adjusted to the appropriate value as described above. Finally the signal strength value is inverted (eg a value of 8 is converted to 3) which is necessary because the voltages generated by the S-meter pin on the CAT interface *increase* as the signal strength *decreases*. This inversion is not required in cases where the S meter voltage from the rig is proportional to the signal strength. To remove the software inversion simply omit line 1190. In line 700 `PROCDisplay` prints the current frequency and signal strength on the screen, the program then pauses at line 710. The process is then repeated for each value of `Dial` until the `FOR NEXT` loop comes to its final iteration.

### Possible Extensions

As it stands this program is not very useful. It simply demonstrates the programming required to control the receiver, and it is not intended to be a complete working program. It has been written in a modular style, with each of the main functions performed by procedures or functions and it is left to the reader to use these as a guide to writing his or her own program, which can be customised for the individual's own particular

needs. For example the screen display is very simple, and a more attractive display could be employed. Some suggestions for other additions to the basic control program are given below.

- 1) Programming the computer with the time, and recording the time of transmissions.
- 2) Monitoring the cassette recorder motor control to record transmissions, switching the recorder on when a signal is detected, and off again when the signal drops.
- 3) Monitoring activity over a range of frequencies, storing frequency and signal strength data to disk. The data could then be plotted out in the form of a histogram of frequency against signal strength or the number of times a signal is found on a particular frequency. It would also be possible to monitor a beacon on one frequency over a period of time, and plot a graph of signal strength against time.
- 4) Setting up of a priority frequency. Monitoring the priority frequency at regular time intervals, stopping there when a signal is found. Then returning to the original one at the end of transmission.

Finally, a word about RFI. Despite its many virtues, the BBC micro is infamous for it. One of the main reasons for the high levels of RFI is the computer's lack of a metal enclosure, and one of the most popular suggestions is to spray the inside of the plastic case with a nickel based, RFI shielding, aerosol spray.

### COMPONENTS RESISTORS (ALL 0.25W)

R1 270R  
R2 1K5  
R3 15K  
R4 2K7  
R5 2K  
R7 R8 R9 R10 100K

R6 5K CARBON TRACK VERTICAL  
PRESET

DIODES  
LED1,2 STANDARD 0.2IN RED LED  
ZD1 ZVO ZENER

SEMICONDUCTOR  
REG1 78L05 + 5V REGULATOR  
Q1 BC 547  
ICI LM358 OP AMP

# ALTRON COMMUNICATION EQUIPMENT

ALWAYS CHOSEN BY PROFESSIONALS AND DISCERNING RADIO AMATEURS.

COMPACT LATTICE TOWERS  
SLIMLINE TUBULAR MASTS

Telescopic—Tiltover, Fixed—Mobile from 3M to 60M. Over 50 Models, suitable for a wide range of civil and military applications such as:

- Radio Communications
- Amateur Radio
- CCTV and Surveillance
- Meteorological Monitoring
- Aero & Marine Nav Aids
- Flood Lighting etc.

Purpose designed using 4-5m and 3m section modules for low retracted heights and cost effective shipping. Engineered to B.S.I. standards and hot dip galvanised to BS729 for protection. Wind loads are based on BS CP3 CHAP V PT 2 1972 for wind speeds up to 100mph/160kph. (BS 8100).

## ANTENNAS

AQ6-20 "SPACE SAVER", THE COMPACT 4 BANDER THAT IS DIFFERENT. 2, 3 OR 4 ELEMENTS 6, 10, 15 AND 20M.

Unique Fully Sealed Coils.

Hi'Q—Close Coupled capacity hat loaded Yagi with optimized performance. Ideal for small spaces. Send for full Spec. sheet. NOW!

QUALITY  
RELIABILITY  
KNOW HOW

WE DESIGN—WE MAKE—WE SELL—DIRECT.  
At manufacturers prices—you get best value.

SEND S.A.E. FOR FURTHER DETAILS AND PRICES OF ALTRON PRODUCTS.

H.P. TERMS

**ALLWELD ENGINEERING**

Factory 6, 232 Selsdon Road,  
South Croydon, Surrey, CR2 6PL.  
Tel: 01-680 2995 (24 hr) 01-681 6734



**Bredhurst**  
electronics

SITUATED AT SOUTHERN END OF M23  
EASY ACCESS TO M25 AND SOUTH LONDON  
WE ALWAYS STOCK A GOOD SELECTION  
OF FREQUENCY REFERENCE BOOKS

### HF RECEIVERS

		£ (c&p)
Lowes	HF 125	375.00 (—)
Icom	IC R71	855.00 (—)
Kenwood	R2000	595.00 (—)
Kenwood	VC10 VHF Converter	161.94 (—)
Kenwood	R5000	855.00 (—)
Yaesu	FRG 8800	639.00 (—)
Yaesu	FRV 8800 VHF Converter	100.00 (—)

### HF TRANSCEIVERS

Kenwood	TS 940S	1995.00 (—)
Kenwood	TS 930S	1695.00 (—)
Kenwood	TS 440S	1138.81 (—)
Kenwood	TS 140S	862.00 (—)
Yaesu	FT 747GX	659.00 (—)
Yaesu	FT 980	1795.00 (—)
Yaesu	FT 757GX II	969.00 (—)
Yaesu	FT 767GX	1550.00 (—)
Icom	IC 735	979.00 (—)
Icom	IC 751A	1500.00 (—)

### ANTENNA TUNER UNITS

Yaesu	FRT 7700 Short wave listening	59.00 (2.00)
Yaesu	FC 757AT	349.00 (—)
Kenwood	AT 230	208.67 (—)
Kenwood	AT 250 auto	366.00 (—)

### Featured transceiver Yaesu FT 747GX



LOW COST,  
HIGH QUALITY,  
HF MOBILE

£659.00

### VHF HANDHELD RECEIVERS

Signal	R537S "Airband"	69.51 (2.00)
Sony	Air 7	249.00 (—)
Sony	PRO-80 Receiver	349.00 (—)
	AM/FM/SSB 115KHz-223 MHz	

### VHF SCANNING RECEIVERS

Icom	IC R7000	989.00 (—)
Yaesu	FRG 9600M 60-950 MHz	509.00 (—)
AOR	AR 2002	487.00 (—)
Signal	R535 "Airband"	249.00 (—)

### 2M TRANSCEIVERS

Kenwood	TH 205E Handheld	215.26 (—)
Kenwood	TH 215E Handheld	252.13 (—)
Kenwood	TH 21E Handheld	189.00 (—)
Kenwood	TR 751E 25w multimode	599.00 (—)
Kenwood	TS 711E base station	940.00 (—)
Kenwood	TM 221ES 45w FM Mobile	317.30 (—)
Kenwood	TH-25E Handheld	258.00 (—)
Yaesu	FT 211RH 45w FM Mobile	309.00 (—)
Yaesu	FT 290R II Multimode	429.00 (—)
Yaesu	FT 23R Handheld + FN B10	254.50 (—)
Icom	IC 2GE Handheld	265.00 (—)
Icom	IC 02E Handheld	279.00 (—)
Icom	IC 28E 25w mobile	359.00 (—)
Icom	IC 275E base station inc. P.S.U.	1069.00 (—)
Icom	IC 320E 2M/70cm FM mobile	499.00 (—)
Icom	Micro 2 Handheld	242.00 (—)

### 70cm TRANSCEIVERS

Kenwood	TH 41E Handheld	218.00 (—)
Kenwood	TS 811E base station	1095.00 (—)
Kenwood	TH 405E Handheld	273.18 (—)
Kenwood	TH 415E Handheld	298.85 (—)
Yaesu	70cm module for FT 726R	349.00 (—)
Yaesu	FT 73R Handheld + FNB10	274.50 (—)
Icom	IC 04E Handheld	318.00 (—)
Icom	IC 475E base station inc. P.S.U.	1185.00 (—)
Icom	IC 48E FM Mobile 25w	455.00 (—)

### STATION ACCESSORIES

MC 50	Desk Microphone	46.08 (2.00)
MC 60A	Desk Microphone with Pre-amp	88.22 (2.00)
MC 35S	Mobile Microphone with Control Box	52.67 (1.00)
MC 35S	Hand Microphone 4 pin	21.72 (1.00)
MD 1B8	Base Microphone	79.00 (1.00)
MC 43S	up/down Hand Microphone 8 pin	22.22 (1.00)
CS 100	Mobile Speaker	13.50 (1.00)
LF 30A	Low Pass Filter 1kW	32.26 (2.00)
SF 40	Mobile Speaker	21.06 (1.00)
HS 7	Miniature Headphones	15.80 (1.00)
HY77	Light de Luxe Headphones	19.99 (1.00)
HS 5	Deluxe Headphones	37.54 (1.00)
VS 1	Voice Synthesizer Module	32.26 (1.00)
GC5	ICOM World Clock	43.00 (2.00)
AEA	PK 232 6 Mode Terminal Unit 26	269.95 (3.00)
CD600	CW and RTTY De-coder	215.14 (2.50)
KPC2	Kantronics Packet Communicator	159.00 (2.50)
Kent Morse Key Kits		29.50 (2.50)
Kent Twin-paddle Morse Key Kits		38.50 (2.50)

### ANTENNA BITS

HI-Q Balun 1:1 5kW PEP	13.95 (1.00)
Bricomm Balun 4:1 1kW	13.80 (1.00)
Bricomm 7.1 MHz Epoxy Traps (pair)	10.95 (1.50)
Self Amalgamating Tape 10M x 25mm	4.25 (0.75)
1 piece polyprop Dipole centre	1.60 (0.25)
Small ceramic egg insulators	0.65 (0.20)
Large ceramic egg insulators	0.85 (0.20)

### CABLES ETC.

URM 67 low loss coax 50 ohm per metre	0.75 (0.25)
UR 76 50 ohm coax dia. 5mm per metre	0.30 (0.10)
UR 70 70 ohm coax per metre	0.35 (0.10)
UR 95 50 ohm coax dia. 2.3mm per metre	0.40 (0.10)
4mm Polyester Guy Rope (400kg) per metre	0.25 (0.10)
50 metres 16 swg hard drawn copper wire	6.95 (2.00)
75 ohm Twin Feeder Light Duty per metre	0.20 (0.10)
300 ohm Slotted Ribbon Cable per metre	0.32 (0.10)

ICOM

YAESU

Mail Order & Retail.



**BREDHURST ELECTRONICS LTD.**

High Street, Handcross,  
W. Sussex RH17 6BW (0444) 400786

TELEPHONE:  
(0444) 400786

IF THE EQUIPMENT YOU REQUIRE IS NOT LISTED  
PLEASE TELEPHONE FOR DETAILS.



# A.R.E. COMMUNICATIONS

## STANDARD C500 DUAL BAND HANDIE



Still continuing to be our best dual-band handheld, the STANDARD C500 offers facilities envied even by our Commercial users. 2m and 70cms. full duplex operation with receive coverage on 138 - 169.995 MHz and 420 - 469MHz.

**SPECIAL LEICESTER EXHIBITION PRICE: £349**

## YAESU FT736R QUAD BAND MULTIMODE

The King of UHF/VHF base stations, the FT736R has all the facilities any discerning user may need, plus the two most important features: uncompromised receive performance and a clean transmitted signal.

ARE's continued policy of direct importing guarantees you an unbeatable price including excellent part-exchange deals.

**SPECIAL LEICESTER EXHIBITION PRICE: ASK AT THE SHOW**



## YAESU FT747GX "ECONOMY" HF TRANSCEIVER



An HF transceiver with built-in general coverage receive. All mode, including FM as an option, for less than the price of a 2m multimode?

Offered without am or cw filters at a super discounted price of £579

## YAESU FT767GX HF + 2m + 6m + 70cms

Despite being YAESU's most expensive transceiver for HF operation, it continues to outsell all other HF equipment marketed by A.R.E. All band, all mode, built-in automatic tuning unit, power supply, general coverage receiver, digital power/SWR meter, full 100w output, optional 2m/6m/70cms modules, which just plug in.

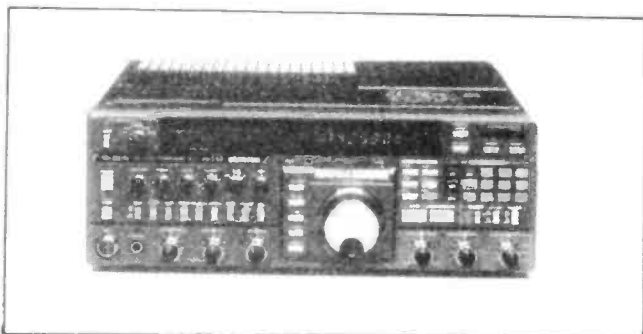

**SPECIAL LEICESTER EXHIBITION PRICE: £1,369** including MH1BB scanning mic.

Also available with one or all VHF modules fitted at a discounted price.

## ICOM IC32E DUAL BAND HANDIE



Direct competition to the STANDARD C500, the ICOM IC32E offers excellent facilities utilising all existing ICOM accessories. Ideal for the IC2E/O2E owner. Similar specification to the C500.

**SPECIAL LEICESTER EXHIBITION PRICE: £369**

**ARE**  
Tel: 01-997 4476

## KENWOOD TS790G TRIPLE BAND MULTIMODE BASE STATION

At last KENWOOD have updated the long-standing TS780S. The latest addition to the KENWOOD product range, the TS790G offers an excellent specification over the 2m/70cms/23cms amateur band. The new TS790G is simple in operation, but offers excellent performance for the VHF user. Operating on 12 volts DC, it is available with the matching PS31 power supply

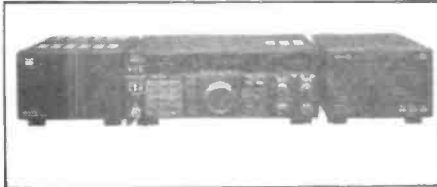

and SP31 speaker. Viewing for the first time can be made at the LEICESTER EXHIBITION.

**SPECIAL LEICESTER EXHIBITION PRICE: WAIT AND SEE!!**

## KENWOOD TS680S/140S HF TRANSCEIVERS

Available with or without 6 metres, the TS680/40 is an ideal upgrade from your dusty FT101ZD!

**SPECIAL LEICESTER EXHIBITION PRICE: TS680S £879 - TS140S £799**



## KENWOOD TS440S HF TRANSCEIVER

Quickly becoming a major seller in the A.R.E. product range, the TS440S offers 100w output between top band and 10m. FM is fitted as standard. Auto tuning unit is optional extra.



**SPECIAL LEICESTER EXHIBITION PRICE: £1,029 or with antenna tuning unit £1,189**

## UNIDEN/BEARCAT BC200XLT SCANNER

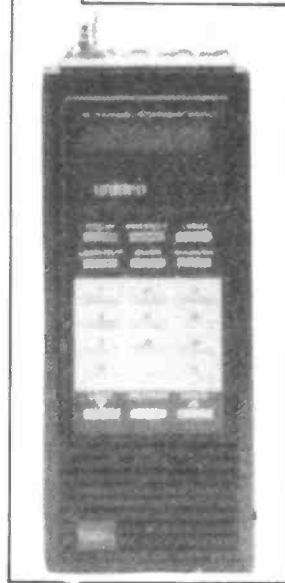

A purpose built handheld scanner, the new BEARCAT BC200XLT offers frequency coverage and specification previously unavailable. **Frequency range 66 - 88MHz: 118 - 174MHz: 406 - 512MHz: 806 - 956MHz (Cellular Band).**

200 fully programmable channels, auto am/fm selecting makes the BEARCAT 200 an instant success.

**SPECIAL LEICESTER EXHIBITION PRICE: £219** including nicad pack, mains charger & free VHF/UHF Frequency Guide.

## JRC JST135 HF TRANSCEIVER

The latest offering from the Japan Radio Co., the JST135 is available for the radio amateur who appreciates quality engineering. Imported direct, bypassing any European distributor. A.R.E. COMMUNICATIONS continue to offer this excellent

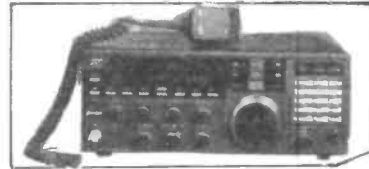

transceiver at an unbeatable price. Visit our stand at the LEICESTER SHOW for details.

**Opening hours Monday - Friday 9.30-5.30. Saturday by appointment.**

## A MESSAGE FROM THE GUV'NOR

"We are often referred to by the 'official' UK Distributors as 'Grey Importers'. Perhaps a change of colour would be appropriate - may I suggest GOLD - because our massive savings in purchase price, which we pass on to you, puts GOLD back into your pockets. We are effectively cutting out the middle-man by importing direct from our agents in Japan. (who are usually found NIPPING AROUND TOKYO IN HONDAS, RATHER THAN SWANNING AROUND IN AEROPLANES, MERCEDES OR ROLLS ROYCES). Both Brenda and myself spend the majority of our time contacting agents throughout the world securing supplies of Japanese

products, including famous brand names such as YAESU and KENWOOD, at far better prices than those offered to you by the European distribution networks. Our continued policy of direct importing will always guarantee you better prices. You may also have noticed that our product range is increasing - this is largely due to the tremendous support we get from our customers. Remember, the more you purchase, the more we can purchase and the better prices will be. Come along to our stand at the LEICESTER EXHIBITION where myself, Brenda, Martin and Brian will give you a warm welcome - and unbelievable discounts."

73 Bernie G4AOG



A.R.E. Communications Limited, 6 Royal Parade,  
Hanger Lane, Ealing, London W5A 1ET, England  
Fax: 01-991 2565

Tel: 01-997 4476

# The JST-135 from JRC



Those who know the NRD-525 receiver will recognise the family resemblance of the JST-135; actually the NRD-525 and JST-135 look identical because they are clearly meant to mate together as an ultimate station. And what a transceiver the JST-135 has turned out to be. It would be impossible to list all the features which make it so outstanding, because so much of the engineering does not appear to the casual view, but take it from me, the JST-135 is destined to become a landmark in equipment design and performance.

The construction of the transceiver follows that of the NRD-525 in using individually screened and mounted plug in vertical boards; an expensive way to build, but JRC try to build to a standard of quality, not down to a price — and it looks terrific when you peek inside.

The measures taken to ensure signal quality include using the same semiconductor devices in the transmit driver stage as those in the PA; not for simplicity but to allow them to be run in Class A. The result is exceptional linearity, improved signal quality, and of course cancellation of second harmonic distortion products. The PA itself is followed by a three section Chebyshev filter, which may not interest you particularly but is all helps the reduction of harmonic radiation, and that is certainly of interest to the station trying to operate on the frequency of your third harmonic . . .

If putting frequencies into memory is your pleasure, you have 200 to go at, with each memory storing frequency, mode, agc time constant, RF attenuator setting, and IF bandwidth. Should be enough for almost anyone. All mode? certainly, with USB, LSB, CW (full and semi break-in), AM, FSK and FM. There is even an optional ECSS unit if you want to dig out rare broadcast stations in a band full of half megawatt propaganda sources.

The receiver side (100kHz to 30MHz) has had the same dedicated attention as the transmitter, and there are some intriguing features such as the optional automatic notch system which grabs an interfering signal, throttles it as birth, and then hangs on to it whilst you tune around so that it causes no more pain and distress. (How did he do that George?).

The range of optional facilities is comprehensive, but an amazing amount of interest was shown at the RSGB show at NEC in the working demonstration of NFG-230 automatic aerial tuner. So what? there are other tuners on the market. True, but this one is fully waterproof, offers virtually instantaneous tuning of a dipole or wire aerial and is meant to be mounted where tuners ought to be — at the feedpoint of the aerial system, out there in the wind and rain.

These brief comments are only a taste of what the JST-135 can do. For more complete information, why not send off £1 for our pack containing details of all the equipment we stock, and make a particular request for the JRC range, or indeed any other equipment which takes your fancy.

The first shipments of the JST-135 have come and gone to happy homes. More are on the way, but there is already a waiting list, and as you read the review of the JST-135 in this magazine, you may get some idea of why this particular transceiver is going to be in such demand. On an even happier note, we sharpened out pencils and did some hard negotiating, with the result that the price of the basic JST-135 has come down to £1,195 including VAT. This just has to be the best buy ever. So one soon.

73

John Wilson  
G3PCY/5N2AAC

<b>JST-135</b>	<b>HF all mode transceiver .....</b>	<b>£1195</b>
<b>NBD-520</b>	<b>Matching 35A psu .....</b>	<b>£299</b>
<b>NFG-230</b>	<b>Auto ATU .....</b>	<b>£599</b>

Glasgow: 4/5 Queen Margaret Road.

Tel. 041-945 2626

Cardiff: c/o South Wales Carpets, Clifton Street.

Tel. 0222 464154

Darlington: 56 North Road.

Tel. 0325 486121

London: 223/225 Field End Road, Eastcote, Middlesex.

Tel. 01-429 3256

Cambridge: 162 High Street, Chesterton.

Tel. 0223 311230

Bournemouth: 27 Gillam Road, Northbourne.

Tel. 0202 877760

Note: All our shops open Tuesday to Saturday inclusive.

**FREE** Information is free; only the Post Office demand payment for handling it — and the Penny Black is no longer used. Send us £1 to cover Post and Packing and we will return not only the full colour Kenwood catalogue, but details of any particular rig you mention and lots of other information including latest prices.



**TM221E** The 45 watt wonder for 2 metres. Common sense facilities, ease of use, and a massive 45 watt output make the TM221E probably the most wanted FM mobile around. All this and an amazing receiver. All you need in a compact package, including all channel spacings (5, 10, 12.5, 15, 20 and 25 kHz). P.S. It also has a 70 cm brother, the TM421E, and a remote controller available for operating them both together.

TM221E ... £317.30 (carr. £8)      TM421E ... £352.84

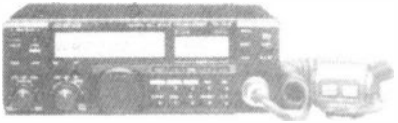

**TS711E** Called by many "The perfect 2 metre Base station", the TS711E is as close to perfection as state of the art can make it. All mode operation, full band coverage, continuous tuning or step tuning for FM channels. Two separate VFOs, 40 memories storing frequency, mode, repeater shifts, even whether or not you need a tone burst. Optional voice synthesiser, the list of features is almost endless. (And it too has a 70 cm brother, the TS811E).

TS711E ... £940 (carr. £8)      TS811E ... £1094



**TR751E** Versatile 2 metre multi mode mobile or fixed station, the TR751E again shows that Kenwood magic touch in making a complex transceiver so easy to use. Virtually a miniature version of the TS711E, the TR751E set new standards of performance at its introduction, and has continued to win friends ever since, continuing as it did the line started by the TR9000 and TR9130. (And, you guessed, it has a 70cm counterpart, the TR851E).

TR751E ... £599 (carr. £8)      TR851E ... £699



**RZ1** To be perfectly honest, the RZ1 came as a surprise to most people. Kenwood have come up with a mobile monitor receiver covering 500 kHz to 950 MHz designed to fit in a standard car radio slot, and the RZ1 seems to have everything. Direct frequency entry, manual tuning, 100 memories, readout of station name on display, scanning, stepping, AM/FM modes, unbelievable ... Of course this level of facilities does not come cheaply, but the RZ1 really adds a new dimension to the wide range monitor market.

RZ1 ... £465



**TS940S** Top of the range, the TS940S has everything the discerning HF operator requires. Amateur bands from 160 to 10 metres, together with a general coverage receiver tuning from 150kHz to 30MHz. Operating modes USB, LSB, CW, AM, FM, FSK. Forty memory channels, each effectively a separate VFO. Easy keyboard frequency entry. Leadership in the field. The TS940S is the transceiver everyone wants to own one day.

TS940S ... £1995 (carr. £8)



**TS140S** Kenwood common sense. The TS-140S shows the way to go in balancing performance, operating features, and ease of use; all at an attractive price. All modes are provided, USB, LSB, AM, FM, and full BK CW for the hot operators. The TS-140S offers everything you ever needed, but it doesn't break the bank balance. Every TS-140S we obtain is instantly sold, and when you have tried one out, you know why.

TS140S ... £862.00 (carr. £8)



**R5000** Virtually the receive section of a TS940S, the R5000 is probably the best HF receiver available right now. Notice the family resemblance to the TS440S which gives it a clean, easy to operate look, and of course Kenwood have applied all their ergonomic skills to make you "at home" the moment you begin to use the R5000. All mode of course, and has an optional internal VHF converter which extends you to 108-174MHz.

R5000 ... £875 (carr. £8)



**TL922** You Brute. If it wasn't for all the safety interlocks I would operate my TL922 with all the covers off, just to admire the sheer engineering beauty of the innards. The TL922 is THE linear amplifier, and once you own it you will never part. The effortless ease with which the TL922 produces RF power has to be experienced to be believed, and it is probably the world's most sought after station accessory.

TL922 ... £1495 (carr. £8)

## LOWE ELECTRONICS LTD.

Chesterfield Road, Matlock, Derbyshire DE4 5LE  
Telephone 0629 580800 (4 lines) Fax 0629 580020

Name .....  
Address .....

Post Code .....  
**FREE INFO.**  
Don't forget £1  
to cover postage.  
H.R.T.

# Radio Propagation and The Sun Part 5

You would be amazed at the number of amateurs who just sling their RF into the air and hope that it comes down somewhere interesting. Sometimes it does, but more often than not it doesn't. You can often hear them on two metres bemoaning the

*On a reasoned basis, foretell a future event.*

The better your understanding of propagation together with the most accurate and up to date information, then the more precise will be your predictions. And no; this isn't a cop-

On the night/sunrise side F layer nighttime ionisation is still in operation and the D layer hasn't yet reformed. Ionospheric absorption is at a minimum (because there's no D layer, and, as you'll remember from previous parts, ionospheric absorption is the limiting factor for working to DX) so HF signals can propagate extraordinarily long distances on very little power.

On the day/sunset side the D layer is beginning to break up and the F<sup>1</sup>/F<sup>2</sup> layers are beginning to combine into the nighttime F layer. Again, ionospheric absorption reaches a minimum and low power, or low frequency signals can propagate very long distances, usually along the line of the terminator.

## *The Sun, the Earth and everything — the story continues...*

fact that 'the band is dead', while the operators with more savvy smile knowingly to themselves. Before we get stuck into an explanation of smoothed sunspot counts, solar flux units, etc, I thought it would be interesting to discuss the 'Idle Jack' approach to propagation prediction — although perhaps prediction isn't really the right word to use.

The simplest way to suss out what's happening is to listen to the band. Simple yes? Again, you'd be amazed at how many people never bother! This isn't really predicting, but at least you know where the paths lay, because you can hear them. Beacons form invaluable tools in the arsenal of the 'Idle Jack' predictor, whether on HF, VHF or UHF. But don't make the understandable mistake of thinking that because you can hear a beacon you're going to work someone in that country. The beacon will only tell you that a path exists.

Of course listening to beacons and/or the bands isn't really predicting because it's after the fact. To successfully predict propagation requires that you should understand something about the driving mechanisms of the phenomenon, which should be the current situation if you've been reading Parts One to Four of *Propagation and the Sun*. And never forget that it is a prediction you will be making! Collin's English Dictionary defines prediction as:

out for me when things go wrong for you!

### **HF Propagation**

The problem with HF propagation predicting is that there are so many variables which must be taken into account for consistent accuracy. You may of course ignore some of them and accept that although the results will not be as good, they can be used to predict trends. Let's take a look at some of the variables which come into play.

There are four basic types of ionospheric variation, these are:- Day/Night — Summer/Winter — Geographical — Cyclic.

### **Day/Night**

The rotation of the Earth is responsible for day and night, and for moving the locations of the transmitting and receiving stations into and out of areas of ionospheric ionisation. As a rule, ionisation is greatest during the hours of daylight, and least during the hours of darkness.

Earth's rotation is also responsible for that fascinating propagational phenomenon, the Grey Line is (can there really be anybody?), here is a brief explanation.

The Grey Line represents the twilight zone between night and sunrise, on one side of the Earth, and day/sunset on the other. the technical term of it is the Earth's Terminator (1).

### **Summer/Winter**

Seasonal variations, such as summer and winter, affect HF propagation because the position of the sun with respect to any fixed point on the Earth changes during the year. Ionisation of the D,E and F<sup>1</sup> layers in particular is very interdependent on the position and elevation of the sun, which is greatest in summer and least in winter.

During the winter, the F<sup>1</sup> and F<sup>2</sup> layers combine at a reduced height. In the summer, intense ionisation causes the atmosphere to swell upwards, increasing its depth. The F<sup>1</sup> and F<sup>2</sup> layers separate into two distinct areas again. The height of the F<sup>2</sup> layer is a vital component in any calculations used to discover the Maximum Usable Frequency, and its changing height throughout the day/night, winter/summer has to be included in the calculations.

### **Geographical**

The amount of ionisation reaching the Earth varies by geographical area. Ionisation is most intense within equatorial regions, and weakest around the poles. Additionally, the Earth's magnetic field interacts with the ionospheric layers



(nobody knows exactly how yet). The Earth's magnetic field is weakest in equatorial regions and strongest at polar latitudes.

### Cyclic

The major force causing changes within the ionosphere is the eleven year sunspot cycle, and associated increases/decreases in the solar wind. Eventually we may also add the variations of the twenty-two year solar magnetic cycle, solar oscillations and the yearly alterations in the Earth's magnetosphere to this four-item list of ionospheric variations.

### Sunspot Data

Having discussed the variables involved with changes in the ionosphere, let's now have a detailed look at how this data is presented and recorded.

Radiation from the sun is responsible for the formation and maintenance of layers in the Earth's atmosphere which reflect/refract radio waves. We commonly refer to them as D, E and F layers, in ascending altitude order. The ability of these layers to reflect radio waves varies in direct proportion to activity on the sun. Sunspots are mainly responsible for changes in solar activity.

### Counting the Spots

Sunspots have been under observation for hundreds of years; Galileo himself was blinded (*see warning in Part One*) after continuously looking at the sun through his telescope over a number of years. In the eighteenth century detailed records of the observed number of sunspots began to be regularly recorded. They simply looked at the sun and counted the number of spots seen.

Today, the same basic method is still used, although now there are added refinements which improve the accuracy of the observations. Simply counting the number of spots seen does not allow for the experience of the observer, his/her geographical location and seeing conditions or the quality of their optical observing equipment.

### Spotting the Count

An astronomer called Rudolph Wolf was intensely interested in the

sun, and was for a time director of the Zurich Solar Observatory. He quickly realised the value of collecting solar data from observatories around the world. Unfortunately, at that time there was no standard method of counting or recording sunspots. He invented a system whereby reports from around the world could be sent to the Zurich Observatory, in a standard format. Wolf's method took into account the experience of the observers, the sophistication of their observing apparatus and also made a vital distinction between single spots and groups.

Wolf's method was a formula, which I've represented using the following:

$$DSN = k(10sg + ts)$$

Where 'DSN' is the Daily Sunspot Number — (sometimes also known as the 'Wolf Number.')

'sg' is the observed number of sunspot groups.

'ts' is the total number of sunspots seen (whether in groups or singly.)

'k' is a constant assigned to remove differences between observers and observatories.

The multiplication of 'sg' by a factor of ten was done by Wolf to add weighting to the number of sunspot groups. He correctly deduced that solar activity depended more on sunspot groupings rather than individual spots.

The value of 'k' was worked out by the Zurich observatory for each participating observatory, and was arrived at statistically by evaluating each contributor's data against a standard. 'k' took into account the experience of the observer/observatory and the relative sophistication of their equipment. Once established the value of 'k' was always used to establish the DSN from a particular observatory.

As you might gather from this rather involved method of establishing how many sunspots are visible on the sun, the Wolf method of working out the Daily Sunspot Number is more of an index to solar activity rather than a simple count of spots seen. Assuming that the Zurich Sunspot Count was eighty, you wouldn't necessarily see eighty spots on the surface of the sun!

In 1981 responsibility for establishing the daily sunspot count was shifted from Zurich to the Sunspot Index Data Centre — SIDC in Brus-

sels. Today, sunspot data are usually proceeded with the letters SIDC.

### Counting the Counts

Wolf's method of reducing sunspot data to a common standard made things much simpler when comparing daily data. However, even working to this standard still wasn't good enough for plotting or recognising longer term patterns. The problem was that even a smoothed daily count still showed very large fluctuations which completely masked long term solar activity.

Yet another formula was introduced, which once again took the daily smoothed Zurich Sunspot Number and smoothed that over a twelve-month period. This rather large and complicated second formula (the details of which I won't burden you with) removed much of the 'noise' from the system. Once the wild fluctuations were removed, the eleven year basic spotted and included in further calculations, allowing astronomers to predict what the likely count would be for the coming month.

This second smoothing is the one we're more familiar with, as it is usually reported in *RadCom* each month. EG. '*SIDC smoothed count for June was —. The predicted count for July is —.*' Plotting these monthly numbers on a graph is an interesting pastime, and they will show you the trend as we head towards maximum.

### Summary

Solar observatories around the world collect sunspot data and pass this on to the Sunspot Index Data Centre in Brussels. They then publish the smoothed monthly sunspot number, and usually make a prediction for the month to come. If I've given the impression that forecasting ionospheric conditions is now purely a mechanical process, with in-built accuracy, and all with total reliability then I must change that because it's far from the truth!

At the time I'm writing this — June '88, we are experiencing very high monthly smoothed sunspot counts which do not agree with where we should be on cycle 22. Many rather eminent people firmly believe that we are much more advanced along cycle 22 than was previously thought, and that the maximum of cycle 22 will be

occurring some twelve — to eighteen months earlier than previous estimates!

While not wishing to argue with my 'betters', I would respectfully beg to differ. We definitely bottomed out of cycle 21 in 1987 — at least all my charts and recorded data suggests that we did! I don't believe that we're only a year or so away from cycle 22 maximum. My theory for the rather drastic increase in recent solar activity is that the sun has now entered one of its periodic very active phases. (See *solar oscillations in Part One.*)

I predict that the maximum for cycle 22 will smash all previous records, with sunspot numbers well into the 250-300s. And that's really sticking your neck out!! (Of course, if I'm right, you do realise that you'll never hear the end of it!)

The point is, we still don't know enough about the driving forces on the sun to predict with any long term accuracy. The explanation I've detailed in previous parts concerning the creation and maintenance of sunspots etc represents the most up to date data I could lay my hands on. Even Jacobs and Cohen in their most excellent book — *The Shortwave Propagation Handbook* freely admit that they don't know how sunspots are created or maintained! By the time you read this, there could be new discoveries which will possibly make us rethink our present understanding!

### The Solar Flux

As previously stated, the SIDC sunspot count is more an index to current solar activity rather than a physical count of the number of spots. Another method of discovering the current state of solar activity is to measure the Solar Flux. Having read Parts One to Four of *Propagation and the Sun*, you will know that the sun emits radiation from sound waves right up to gamma rays.

The solar flux is the amount of radio energy emitted by the sun, measured within the frequency range 2600 to 2800MHz. (Fig.1) During times of low solar activity, the radio energy emitted at these frequencies is very low. Conversely, during very active times the sun sends out large amounts of radio energy at 2.8GHz.

Measuring the solar flux offers a more immediate guide to solar activity, and, as it varies only slowly

Fig.1. Solar flux is radio energy.

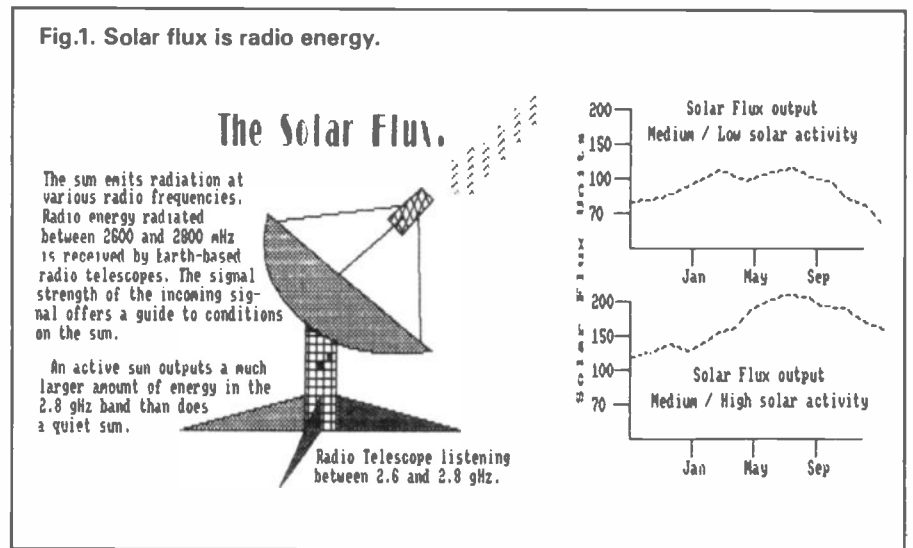

over a number of days, can be used for short term propagation predictions. (See computer program, later.) There is an approximate linear relationship between sunspots and the solar flux, usually expressed in the following formula:-

$$SF = 73.4 + 0.62 \times DSC$$

Where SF = Solar Flux and DSC = Daily Sunspot Count.

For example, a solar flux of 80 translates to a Daily Sunspot Count of approximately 21.  $SF - 120 = DSC$  of 72.  $SF - 180 = DSC$  of 137.  $SF - 200 = DSC$  of 156. The relationship is clear, and generally speaking, the higher the solar flux, then the 'better' the HF propagation.

### K and A Indices

Finally, two more numbers which get bandied around willy-nilly are the A and K indices. The solar wind bombarding the Earth not only contains heat, visible and ultra violet light, but additionally various types of radiation, some of it extremely lethal!

Certain types of radiation (see Part Two) can upset the Earth's magnetosphere, causing magnetic storms, aurorae and local magnetic variations. The amount of disruption of the Earth's magnetosphere varies according to solar activity, and if we measure directly the amount of these disruptive particles in the solar wind we also get a fairly good idea of the activity taking place on the sun.

Various observations do measure particle radiation within the solar wind every three hours, concentrating on the magnetic aspect of its electro-magnetic construction. The results of the measurements are known as the A Index. (Fig. 2 (a)) Loosely, an A index of less than ten indicates a fairly quiet ionosphere, and, consequently low solar activity, whilst an A index of greater than thirty indicates possible storm/auroral conditions, attributable to high solar activity.

Whereas the A index is produced by measuring directly the particle

Fig.2a. Measurements are taken every three hours.

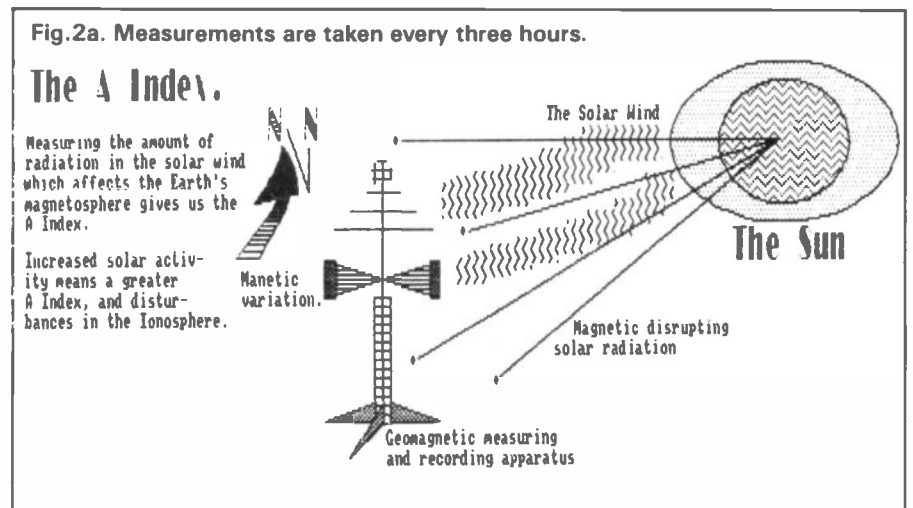
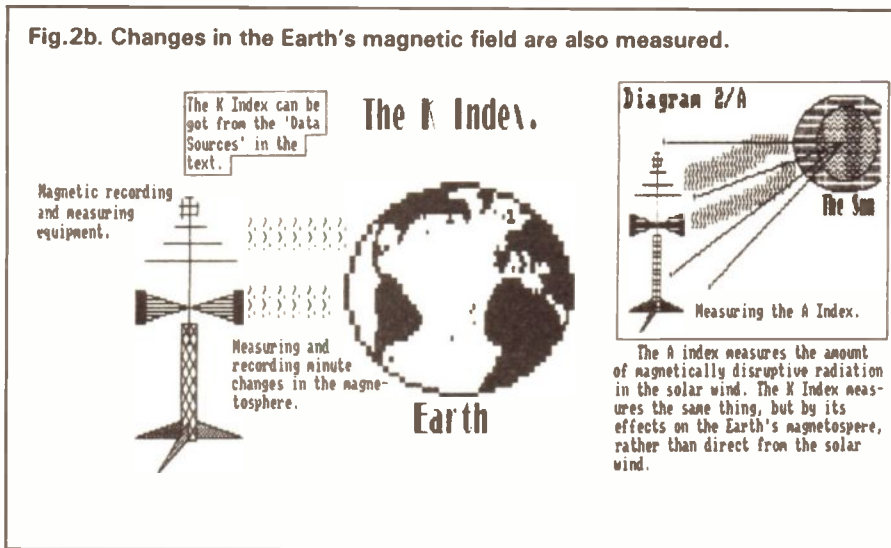

Fig.2b. Changes in the Earth's magnetic field are also measured.



radiation within the solar wind, the K index is produced by measuring minute changes in the Earth's magnetic field. Different routes to the same goal. Instead of measuring the radiation directly, the K index measures the effects of the radiation. (Fig. 2 (b))

The end result is much the same, a guide to solar activity. A K index of less than three indicates a quiet ionosphere, while a K index of greater than four indicates possible storm/auroral conditions. Table 1 shows the relationship between the A and K indices.

Both the K and A indices are measures of geomeric activity, rather than ionospheric activity. However, as the cause of variations in the Earth's geomeric activity is the solar wind (and ultimately the sun), we can use this data to understand what's happening to the sun, based on the effects on Earth.

So, that explains the various data used in the calculations of HF propagation. Next we look at the rather more meaningful items of Critical and Maximum Usable Frequencies. But firstly let's look at how we can measure what's happening in the ionosphere.

### Measuring the Ionosphere

During the 1920s two American physicists took the discoveries of Kennelly, Heaviside, Appleton *et al* one stage further. They transmitted short bursts of radio frequency energy straight up into the ionosphere, and received an echo back. Plotting the time delay between transmission and reception, they were able to accurately state the

height above the Earth of a radio reflecting layer. Further experiments showed that above a certain frequency the signal was no longer returned to Earth.

Additional investigations around the world also noted the (then) rather startling fact that the highest frequency reflected back to Earth by the ionosphere varied according to activity on the sun, the time of day,

eclipse. Fig. 3 shows what happened to the radio output from the sun as measured on Earth during the eclipse. The link between sunlight and the ability of the ionosphere to return radio signals had at last been made, and propagation prediction was born.

The basic method of ascertaining the critical frequency, by pulsing rf vertically up into the ionosphere, hasn't changed much since the experiments of Tuve and Briet in the 1920's. Only now, the equipment is far more sophisticated, encompassing satellites, helium filled balloons carrying *ionosondes*, aircraft and terrestrially based radio telescopes. And now for some definitions of terms.

### Critical Frequency

Solar data, such as sunspots, solar flux etc, tells us what the state of the ionosphere *should* be. A kind of theoretical prediction, even though it's based on direct observation. The data doesn't tell us much about what conditions are actually like in the ionosphere. To discover that we have to use more direct methods, and measure the critical frequency.

Table One. Relationship between the A and K Indices

K	0	1	2	3	4	5	6	7	8	9
A	0	3	7	15	27	48	80	140	240	400

the season of the year and the geographical location of the station making the ionospheric soundings. And, in some way that nobody could quite fathom out, ultra violet radiation seemed to be the driving force behind variations in the soundings.

Then someone had the rather novel idea of pointing a radio telescope at the sun during a total solar

Critical frequency refers to a wide band of High Frequencies, which when transmitted vertically up into the ionosphere are reflected back again. Above a certain frequency (which is dependant on solar activity) the signal is not reflected back. (Fig.4) The highest possible frequency is transmitted vertically into the ionosphere, and reflected

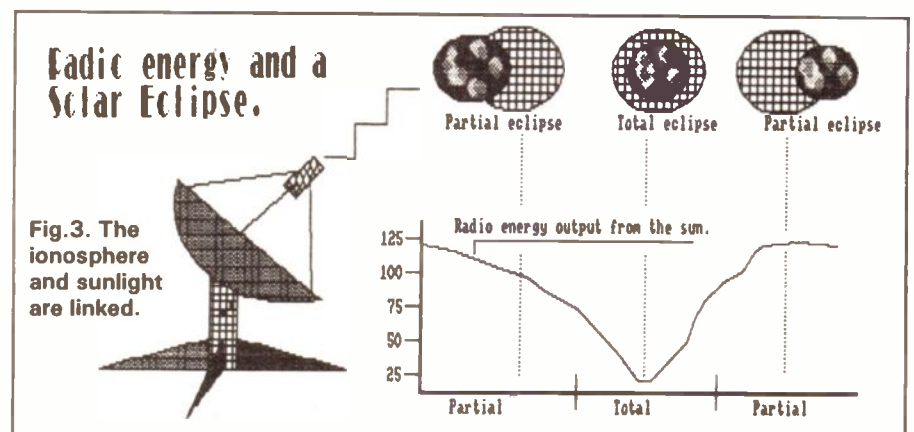

back down again is nominated as the critical frequency.

The critical frequency is used as datum to calculate the MUF — Maximum Usable Frequency. Intrinsically, it cannot be of any use to radio amateurs because it is only a measure of vertical radiation. Not many amateurs are interested in RF which lands a few feet away from their transmitters! This is yet another 'MDQ simplification, as the E and F<sup>1</sup> layers each have their own critical frequency.

### Maximum Usable Frequency

The MUF is a calculated value, just how it's calculated we'll return to shortly. MUF is the frequency which will propagate a radio signal over a given path, with the minimum of ionospheric absorption. It is usually expressed as a frequency, eg. 9MHz or 14.6MHz. You should always aim to work as close to, or just slightly below the MUF. Operating well below the MUF means that your signal will suffer much ionospheric absorption, and therefore attenuation. Operating above the MUF means that your signal will not be reflected back down to Earth.

### Calculating the MUF

The three-cornered formula for MUF calculation is: critical Frequency, height of the F<sup>2</sup> layer and the distance to the target country. This is easier to understand if you have a look at Dia.5. The formula for calculating the MUF is:-

$$f = f_a \sqrt{\frac{D^2}{4h^2}}$$

Where D is the distance to the target country.

f<sub>a</sub> is the critical frequency.  
h is the height of the F<sup>2</sup> layer.

(Note! D and h must be in the same units, mile or kilometres).

Knowing the critical frequency, the height of the F<sup>2</sup> layer and the distance to the target country, it is a simple calculation to discover the MUF. But! note these important points about the MUF.

i) As the MUF is directly related to the critical frequency, it will fluctuate according to: day/night, summer/winter, geographical and solar activity.

ii) Power plays no part in MUF calculations. The ionosphere either reflects a signal or it doesn't.

Fig.4. Above a certain frequency the transmission is not reflected.

### Critical Frequency

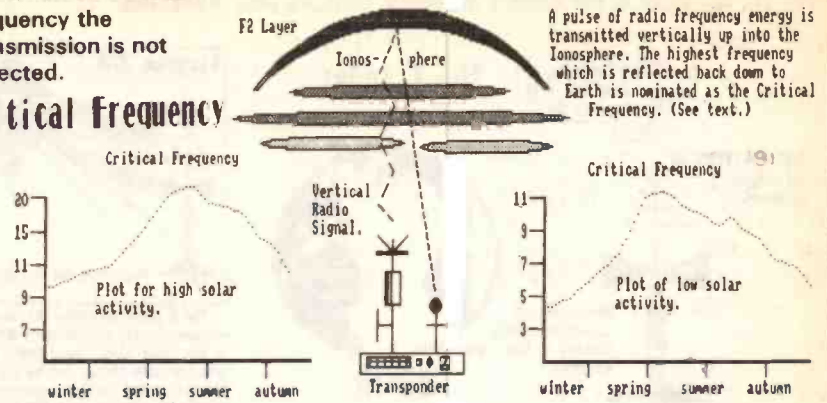

iii) MUF calculations are only valid for single F layer hops. That's not to say that your signal stops dead after that! It's just that other factors take over, such as multiple hops between the ionosphere and the Earth.

iiii) The MUF varies according to the distance you want to work to.

computers. Dragon 32, BBC and Commodore 64. They should translate with a minimum amount of altering to any other computer.

### Home Brew Predicting

To aid you in making your own propagation predictions I've included two computer programs. Program One calculates the MUF and the Optimum Frequency based on the MUF formula given earlier. Program Two offers more limited features, but can be used to predict auroral possibilities. The programs are written in bog-standard Microsoft Basic, and have been test driven directly from the printouts on the following

### Program One

This program works out the predicted median MUF and the optimum frequency. The predicted median MUF is good for approximately 50% of the wanted time period. The optimum frequency should be good for 90% of the time. Operating on frequencies between the MUF and the optimum frequency should ensure safe arrival of your RF in the target country.

Program One is based on the formula given earlier for working out the MUF, however, there are some added routines. To save you a lot of

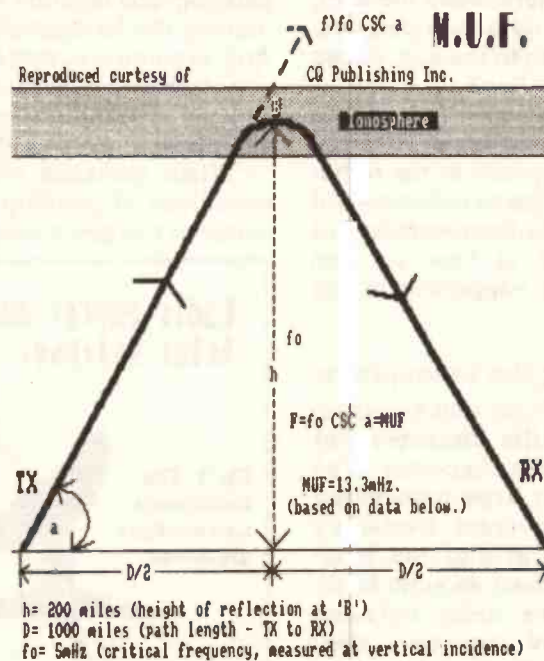

time and trouble discovering the height of the F layer, and the distance to the target country, I've included two routines in the program which work this out for you.

### Height of the F Layer

The heights of the F layer in the program were worked out statistically using data from cycle 20, and then averaged out for each month of the year. Of course, this is not as accurate as getting hold of the information for yourself — (See *data sources*, below). If you can get the height of the F layer for yourself, then you can dispose with the sub-routine from lines 2000-2260. Replace them in an INPUT statement, using the variable 'H'.

Line 4050 is the heart of the program, it calculates the MUF. Although some computers have a neat decimal rounding command, others don't. Line 4055 rounds the decimal places to two. Line 4060 calculates the optimum frequency. When you have the program into your computer and fully debugged, enter the following test data.

### Test Data

Enter 5mHz as the critical frequency, select 'APR' for the height of the F layer (200 miles) and select a distance of 1000 miles. If all's well, the MUF should be 13.4mHz and the optimum frequency should be 11.39mHz.

### Program Two

This second program uses the solar flux and the readily available 'K' Index of geometric activity to work out what the prevailing ionospheric conditions are. For example, whether the band conditions are 'good' or 'bad'. Unlike Program One it doesn't offer you a choice of frequency. The program asks for the solar flux data and the K index, then outputs a message like: "Band conditions are expected to be excellent. Auroral probability is 20%".

### Every possible disclaimer!

These are not sophisticated predicting programs. Also, Program One assumes a low angle of radiation from your aerial. Something you must ensure in practice. The programs were written to encourage you to make further studies of propagation, and also make use of all those

redundant computers cluttering up people's lofts. There is endless scope for improving them. But having said that, in their present form they will work, and will be useful. The solar/geometric data needed by both programs to function properly can be got from any of the sources listed in the *Data Sources* section.

### Data Sources

The Standard Frequency Station WWV in Boulder, Colorado transmits geometric and solar activity at 18 minutes past each hour, using phone. If you haven't got an HF receiver, try telephoning them on 303-499-8129!

Radio Australia (9655kHz) broadcasts daily sunspot counts, solar flux units and geometric data daily. But note that this is a day behind!

*Radio Communication*, journal of the Radio Society of Great Britain, publishes HF band predictions for the month ahead. The RSGB also broadcasts solar/geometric data during their Sunday morning radio broadcasts via GB2RS.

Marconi Radio Propagation Services also provide solar/geometric data. Write to them at Baddow Research Lab, Great Baddow, Essex. CM2 8HN.

"Geoff Watts DX Newsheet" carries solar data and propagation predictions. This invaluable HF operator's tool is now distributed by the RSGB on a subscription basis.

### Endbits

Well, that concludes the series. I hope it's been as enjoyable for you to read as it has been for me to write. It seems to have caused quite a stir judging by the comments and discussions I've had on Two Meters recently! One particular point has cropped up several times. It is... "ow do yer know???"

How do I know for instance that energy takes a million years to journey through the radiative zone? Well, to answer that requires an explanation of scientific methods. Don't Panic! I won't be long. Sciences which are based on observation require special methods.

What happens is this. An astronomer or physicist formulates his/her theory. There are exacting requirements for this theory. It must (a) cover all the known facts thoroughly, and (b) make a prediction about the

subjects future behavior. When and if these conditions are met, then the theory is accepted as the best possible answer we have at that time. Note, that doesn't make it true? because the proposed theory only covers the known facts.

Once the theory has been accepted, then scientists set about proving it, using all the equipment at their disposal, such as making computer models etc. Thanks to satellites and solar observatories, we have discovered more about the sun during the last two decades than the previous five hundred years.

### Footnote

(1) Terminator. The terminator is the dividing line between day and night. It is the same as the Moon's terminator, the line that marks the lit/unlit sides when at half phase. However, because the Moon has no atmosphere, its terminator is much more sharply defined than Earth's, where our thick atmosphere produces a twilight zone around the terminator.

### Acknowledgements and Thanks

My sincere appreciation and thanks to CQ publishing for permission to reproduce Fig. 5 and the MUF/sunspot formulae.

My thanks to John Huggins BSc. Cert Ed. GODZX, for his help with the Basic formula at line 4050 in Program One, and working out the heights for the F Layer. Also to the Editor of HRT for his help and advice with the series. Thanks to Linda Simonian of the Amateur Astronomy Centre for all her help.

### Further reading

I cannot recommend the *Shortwave Propagation Handbook* by Jacobs and Cohen too highly. It has now become the standard reference work on the subject. Published by CQ Publishing Inc. (If enough people hassle the RSGB they may get a stock in.

*Amateur Astronomy*. Consultant Editor — Colin Ronan. Pub. Newnes ISBN 0-600-35667-1. £9.95p.

*The Astronomy Encyclopaedia*. General Editor — Patric Moore. Pub. Mitchell Beazley. ISBN 0-85533-604-8. £14.95.

The *ARRL Handbook* (latest issue). Pub. ARRL.

# RADIO Tomorrow

- 2 Oct** Blackwood & DARS: Welsh Amateur Radio Convention. Oakdale Community College, Blackwood, Gwent. Details from B. Davies, GW3KYA, 16 Vancouver Drive, Penmain, Blackwood, Gwent NP2 0UQ. Tel: (0495) 225825.
- 3 Oct** Todmorden DARS: Surplus equipment sale. 8pm. Queen Hotel, Todmorden.  
Welwyn-Hatfield ARC: Junk sale. Details from Jef G6YIQ. Lemsford Village Hall, Brocket Rd, Lemsford.  
Stourbridge & DARS: Natter/On-air night. Robin Woods Centre, Beauty Bank, Stourbridge.  
Braintree DARS: Construction evening. 7.30pm. Braintree Community Association Centre, Victoria Street (next to Bus park), Braintree.
- 4 Oct** Fylde ARS: Talk 'Computers — what's on the horizon' by S. Williamson G3WGU, The Kite Club, Blackpool Airport.  
Stevenage ARS: Construction evening.  
Worksop ARS: Natter night.  
South Powys ARC: Demonstration of RTTY/'Mailbox'.
- 5 Oct** Wirral ARS: AGM.  
Willenhall DARS: Night on the Air (HF).  
Norfolk ARC: Informal meeting 7.30pm at 'The Norfolk Dumpling', The Livestock Market, Harford, Norwich.  
Cheshunt DARC: Talk 'Reviewing and lack of VHF Activity'. Church Room, Church Lane, Wormley, Nr. Cheshunt, Herts. 8pm.
- 6 Oct** Mid-Sussex ARS: Informal meeting.  
Pontefract DARS: RSGB night with Martin G3ZXZ. 8pm. Carleton Community Centre, Carleton Rd, Pontefract.  
Vale of Evesham RAC: GOEMS on his US Visit.  
Horsham ARC: Autumn junk sale. 8pm. The Guide Hall, Denne Road, Horsham, Sussex. Details from Phil Godbold on Steyning 814516.  
Yeovil ARC: Talk 'Biasing Bipolar Transistors' by G3MYM 7.30pm at The Recreation Centre, Chilton Grove, Yeovil. Details from David Bailey G1MNM, 7 Thatchem Close, Yeovil, BA21 3BS.
- 7 Oct** Loughton DARS: Rainbow & Dove Field weekend planning night. Loughton Hall, Rectory Lane, Loughton, Essex.  
Coventry ARS: AGM.
- 11 Oct** Rugby ATS: Activity night. 7.30pm. Cricket pavilion, BTI Radio station, 'B' building entrance, A5 Trunk Rd, Hillmorton, Rugby.  
Dorking DRS: Talk 'Shortwave listening' by John G6ZOV.  
Workshop ARS: Junk sale.
- 12 Oct** Cheshunt DARC: Natter evening. Church Room, Church Lane, Wormley, Nr Cheshunt, Herts.
- 8pm.  
Norfolk ARC: 7.30pm at 'The Norfolk Dumpling', The Livestock Market, Harford, Norwich.  
Darenth Valley RS: Demo 'Slow Scan TV by G1JEC 8pm, Cockenhill Village Hall, Swanley, Kent.  
Farnborough DRS: An evening on the air 7.30pm, Railway Enthusiasts Club, Hawley Lane, Farnborough. Details from Tim Fitzgerald G4UQE on Camberley 29321.  
Wirral DARC: Chairman's night, 8pm, Irby Cricket Club, Irby Mill Rd, Irby, Wirral.
- 13 Oct** Mid-Sussex ARS: Junk sale, bring & buy.  
Pontefract DARS: Committee meeting. 8pm. Carleton Community Centre, Carleton Rd, Pontefract.  
Yeovil ARC: Talk 'QRP on 50MHz' by G3MYM, 7.30pm at The Recreation Centre, Chilton Grove, Yeovil. Details from David Bailey G1MNM, 7 Thatchem Close, Yeovil BA21 3BS.
- 14 Oct** Coventry ARS: Night on the air & morse tuition.  
Wimbledon DARS: AGM 7.30pm in St. Andrews Church Hall, Herbert Rd, Wimbledon, London SW19. Details from Tom Mansfield G3ESH, 16 Fir Grove, New Malden, Surrey KT3 6RH. Tel: 01-942 1418.
- 17 Oct** Todmorden DARS: Natter night. 8pm. Queen Hotel, Todmorden.  
Welwyn-Hatfield ARC: Construction — Design an audio amplifier by Norman G3BYG. Knightsfield Scout HQ, Opp Ingles, Welwyn Garden City.
- 18 Oct** Stourbridge & DARS: G3ZOM with QRP QRV. Robin Woods Centre, Beauty Bank, Stourbridge.  
Fylde ARS: Informal meeting. The Kite Club, Blackpool Airport.  
Midland ARS: AGM.  
Rugby ATS: Talk 'Weather satellites' by Dave Young G8VXB. 7.30pm. Cricket pavilion, BTI Radio station, 'B' building entrance, A5 Trunk Rd, Hillmorton, Rugby.  
Worksop ARS: Natter night.  
South Powys ARC: Social evening.  
Chichester DARC: Junk Sale. 7.30pm St. Pancras Hill, St. Pancras, Chichester.
- 19 Oct** Wirral ARS: Talk, 'First aid' by Bill Davies G4YWI.  
Willenhall DARS: Natter night.  
Norfolk ARC: Informal & Committee meeting, 7.30pm at 'The Norfolk Dumpling', The Livestock Market, Harford, Norwich.  
Cheshunt CARC: Equipment evening — testing. Church Room, Church Lane, Wormley, Nr. Cheshunt, Herts. 8pm
- 20 Oct** Mid-Sussex ARS: Talk.  
Pontefract DARS: Talk 'Satellite TV' by Richard

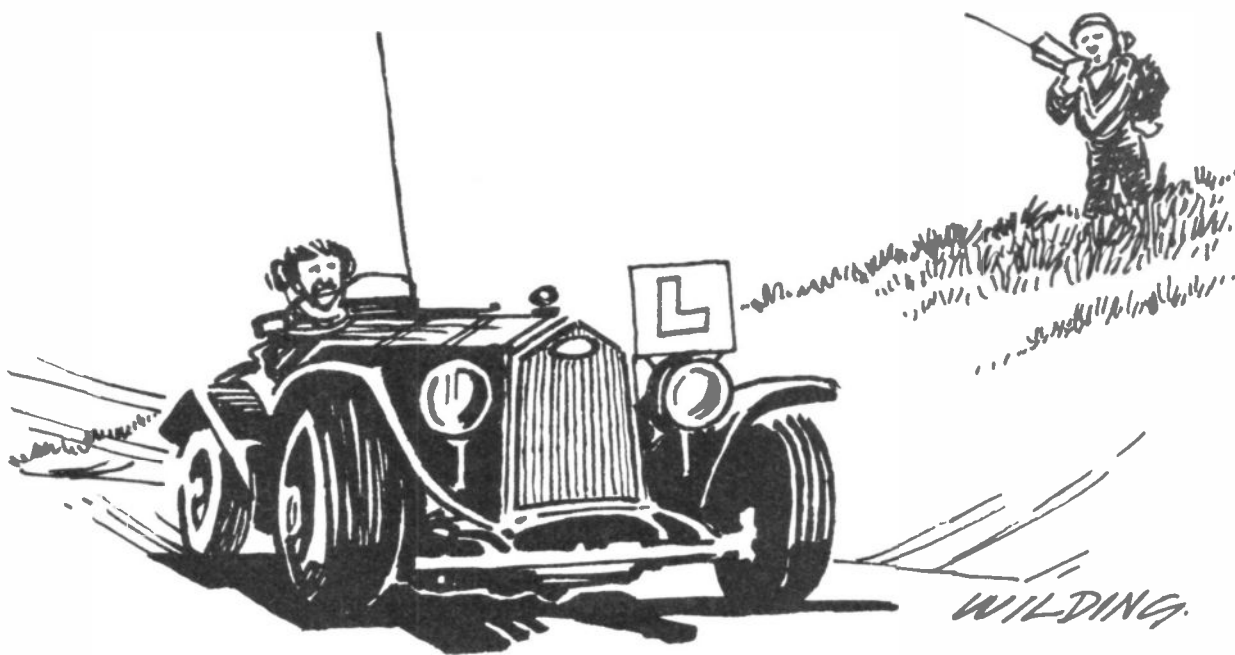

"ERSE DOWN ABIT, YOU'RE GOING TOOFAST."

- |               |  |                  |   |
|---------------|--|------------------|---|
|               | G4FB. 8pm. Carleton Community Centre, Carleton Rd, Pontefract.   |                  | Church Hall, Herbert Rd, Wimbledon, London SW19. Details from Tom Mansfield G3ESH, 16 Fir Grove, New Malden, Surrey KT3 6RH. Tel: 01-942-1418.                                |
|               | Yeovil ARC: Talk 'How the Z Match Works' by G3MYM, 7.30pm at The Recreation Centre, Chilton Grove, Yeovil. Details from David Bailey G1MNM, 7 Thatchem Close, Yeovil BA21 3BS. | <b>28/29 Oct</b> | <b>Leicester Amateur Radio Show at Granby Halls.</b>  |
|               |  | <b>31 Oct</b>    | <b>RSGB City of Bristol Group: AGM. 7.30pm. Small Lecture Theatre, Queens Building, University of Bristol.</b>  |
| <b>21 Oct</b> | Loughton DARS: Rainbow & Dove Field weekend planning night. Loughton Hall, Rectory Lane, Loughton, Essex.  | <b>1 Nov</b>     | <b>Fylde ARS: Equipment sale. The Kite Club, Blackpool Airport.</b>   |
| <b>25 Oct</b> | Stevenage ARS: Committee evening.<br>Worksop ARS: AGM.   |                  | Stevenage ARS: Computer evening.<br>Worksop ARS: Natter night.  |
| <b>26 Oct</b> | Cheshunt DARC: Natter evening. Church Room, Church Lane, Wormley, Nr Cheshunt, Herts. 8pm.   | <b>2 Nov</b>     | South Powys ARC: HF Propagation.<br>Wirral ARS: Chairman's night.<br>Willenhall DARS: Night on the air.   |
|               | Norfolk ARC: 'PSE QSL OM' -- bring your fave or unusual QSLs. 7.30pm at 'The Norfolk Dumpling', The Livestock Market, Harford, Norwich.  |                  | Norfolk ARC: Informal meeting 7.30pm at 'The Norfolk Dumpling', The Livestock Market, Harford, Norwich.   |
|               | Darenth Valley RS: Surplus Sale; 8pm. Crockenhill Village Hall, Swanley, Kent.   | <b>3 Nov</b>     | Cheshunt DARC: Talk by David Evans, G3OUF. Church Room, Church Lane, Wormley, Nr. Cheshunt, Herts. 8pm.   |
|               | Farnborough DRS: Surplus equipment sale 7.30pm. Railway Enthusiasts Club, Hawley Lane, Farnborough. Details from Tim Fitzgerald G4UQE on Camberley 29321.                      |                  | Mid-Sussex ARS: Fireworks on the air.<br>Pontefract DARS: Talk 'Contest Operating' by Dave G4OSY. 8pm. Carleton Community Centre, Carleton Rd, Pontefract.                    |
|               | Wirral DARC: Club Homebrew Competition 8pm Irby Cricket Club, Irby Mill Rd, Irby, Wirral.  |                  | Vale of Evesham RAC: 'St Kilda -- the island on the edge of the world' by G3WBR.  |
| <b>27 Oct</b> | Pontefract DARS: On the air night. 8pm. Carleton Community Centre, Carleton Rd, Pontefract.  |                  | Horsham ARC: Talk 'Know your sporadic E' by G3NAQ. 8pm. The Guide Hall, Denne Road, Horsham, Sussex. Details from Phil Godbold on Steyning 814516.                            |
|               | Yeovil ARC: Natter Night 7.30pm at The Recreation Centre, Chilton Grove, yeovil. Details from David Bailey G1MNM, 7 Thatchem Close, Yeovil BA21 3BS.                           |                  | Yeovil ARC: Talk 'The Full Wave Dipole' by G3MYM. 7.30pm at The Recreation Centre, Chilton Grove, Yeovil. Details from David Bailey G1MNM, 7 Thatchem Close, Yeovil BA21 3BS. |
| <b>28 Oct</b> | Wimbledon DARS: Talk 'Weather Satellites' by Steve Cook G8CYE 7.30pm in St. Andrews  |                  |   |

- 4 Nov** Loughton DARS: Rainbow & Dove Field weekend planning night. Loughton Hall, Rectory Lane, Loughton, Essex.
- 5 Nov** Rugby ATS: Fireworks and Barbecue, details from G8TWH QTHR.  
BARTG: AGM Issues included will be possible name change of group. Refreshments provided and further info from Ian Brothwell, G4EAN, 56 Arnot Hill Road, Arnold, Nottingham NG5 6LQ. Tel: (0602) 262369. 2pm at the Churchill Room, London House, Mecklenburgh Square, London WC1.
- 5/6 Nov** **2nd North Wales Radio Rally at Canolfan Abercony Centre, Llandudno, N. Wales. Further details from Tony Wilkinson GWPVU, 1 Langly Close, Penrhyn By. Llandudno LL3 3LN on (0492) 49121 or 75666/ Edward Shipton GW0DSJ on (0745) 36939.**
- 7 Nov** Todmorden DARS: Visit & Demo by Lowe Electronics. 8pm. Queen Hotel, Todmorden.  
Welwyn-Hatfield ARC: Construction competition. Lemsford Village Hall, Brocket Rd, Lemsford.  
Stourbridge & DARS: Natter/On Air night. Robin Woods Centre, Beauty Bank, Stourbridge.
- 8 Nov** Rugby ATS: Activity night. 7.30pm. Cricket Pavilion, BTI Radio Station, 'B' building entrance, A5 Trunk Rd, Hillmorton, Rugby.  
Dorking DRS: Talk 'Antennas for HF' by Graham G4WOT.  
Worksop ARS: 'Call my Bluff' Maltby visit Worksop.
- 9 Nov** Cheshunt DARC: Natter evening. Church Room, Church Lane, Wormley, Nr. Cheshunt, Herts. 8pm.  
Norfolk ARC: In trivial pursuit of radio — a quiz. 7.30pm at 'The Norfolk Dumpling', The Livestock Market, Harford, Norwich.  
Farnborough DRS: 23rd AGM. 7.30pm. Railway Enthusiasts Club, Hawley Lane, Farnborough. Details from Tim Fitzgerald, G4UQE, on Camberley 29321.  
Wirral DARC: Club Tech Topics. 8pm. Irby Cricket Club, Irby Mill Rd, Irby, Wirral.
- 10 Nov** Mid-Sussex ARS: Talk.  
Pontefract DARS: Committee Meeting. 8pm. Carleton Community Centre, Carleton Rd, Pontefract.
- 11 Nov** Wimbledon DARS: Talk 'The Noise bridge and its use' by George Cripps, G3DWW. 7.30pm in St. Andrews Church Hall, Herbert Rd, Wimbledon, London SW19. Details from Tom Mansfield, G3ESH, 16 Fir Grove, New Malden, Surrey KT3 6RH. Tel: 01-942-1418.
- 15 Nov** Fylde ARS: Informal meeting. The Kite Club, Blackpool Airport.  
Rugby ATS: Talk & live demo of Packet Radio by John Theodorson G4MT & Neal Rimmer G4JTY. 7.30pm. Cricket Pavilion, BTI Radio station, 'B' building entrance, A5 Trunk Rd, Hillmorton, Rugby.
- 16 Nov** Worksop ARS: Natter night.  
South Powys ARC: Social evening.  
Willenhall DARS: CW night on the air.  
Norfolk ARC: Informal meeting. 7.30pm at 'The Norfolk Dumpling', The Livestock Market, Harford, Norwich.
- 17 Nov** Mid-Sussex ARS: Informal meeting.  
Pontefract DARS: Talk 'PCBs' by Dave Wilcox. 8pm. Carleton Community Centre, Carleton Rd, Pontefract.
- 18 Nov** Loughton DARS: Rainbow & Dove Field weekend planning night. Loughton Hall, Rectory Lane, Loughton, Essex.
- 20 Nov** Bridgend DARC: Rally. Bring & buy, morse tests, bar. Talk-in on S22. 11am onwards (10.30am for disabled persons) at Bridgend Recreation Centre, Angel St, Bridgend, Mid-Glamorgan. Details from Mike Butler GW6XCG on (0656) 724041.
- 21 Nov** Todmorden DARS: Natter night. 8pm. Queen Hotel, Todmorden.  
Welwyn-Hatfield ARC: Member soap-box. Knightsfield Scout HQ, opp. Ingles, Welwyn Garden City.  
Stourbridge & DARS: Winter surplus sale. Robin Woods Centre, Beauty Bank, Stourbridge.
- 22 Nov** Stevenage ARS: Committee meeting.  
Dorking DRS: Illustrated talk 'John's travels — 2nd edition' by G3AEZ at Ashcombe School.  
Wirral DARC: Talk 'Thank God for the Diesel' by Dr D Postlethwaite. 8pm. Irby Cricket Club, Irby Mill Rd, Irby, Wirral.
- 23 Nov** Cheshunt DARC: Natter evening. Church Room, Church Lane, Wormley, Nr. Cheshunt, Herts. 8pm.  
Norfolk ARC: Talk 'Early Days of SSB' by Ken Thompson G3AMF. 7.30pm at 'The Norfolk Dumpling', The Livestock Market, Harford, Norwich.  
Farnborough DRS: Chairman's evening. 7.30pm. Railway Enthusiasts Club, Hawley Lane, Farnborough. Details from Tim Fitzgerald G4UQE on Camberley 29321.
- 24 Nov** Pontefract DRAS: On the air night. 8pm. Carleton Community Centre, Carleton Rd, Pontefract.
- 28 Nov** RSGB City of Bristol Group: Annual home construction contest together with ballot for best lecture of 1988. 7.30pm. Small Lecture Theatre, Queens Building, University of Bristol.
- 29 Nov** Rugby ATS: Test gear night. Radio station, 'B' building entrance, A5 Trunk Rd, Hillmorton, Rugby.  
Worksop ARS: Natter night.
- 30 Nov** Norfolk ARC: Informal & Committee Meeting. 7.30pm at 'The Norfolk Dumpling', The Livestock Market, Harford, Norwich.  
Wirral DARC: Social & Presentation evening. 8pm. Irby Cricket Club, Irby Mill Rd, Irby, Wirral.



## TX-3 RTTY/CW/ASCII TRANSCIVE

The high performance, low cost system

Split-screen, type-ahead operation, receive screen un-wrap, 24 large memories, clock, review store, call-sign capture, RTTY auto CR/LF, CW software filtering and much more. Needs interface or T.U. **BBC-B/Master** and **CBM64** tape £20, disc £22. **Spectrum** tape £35, +3 disc £37 inc. adaptor board (needs interface/TU also).

For **VIC** we have our RTTY/CW transceive program. Tape £20.

## RX-4 RTTY/CW/SSTV/AMTOR RECEIVE

This is still a best-selling program and it's easy to see why. Superb performance on 4 modes, switch modes at a keypress to catch all the action. Text and picture store with dump to screen, printer or tape/disc. An essential piece of software for trawling the bands. Needs interface. **BBC-B/Master**, **CBM64** tape £25, disc £27. **VIC20** tape £25. **SPECTRUM** tape £40, +3 disc £42 inc. adaptor board (needs interface also). The **SPECTRUM** software-only version (input to EAR socket) is still available £25, +3 disc £27.

**TIF1 INTERFACE** Perfect for TX3 and RX4, it has 2-stage RTTY and CW filters and computer noise reduction for excellent reception. Transmit outputs for MIC, PTT and KEY. Kit £20 (assembled PCB + Cables, Connectors) or ready-made £40, boxed with all connections. Extra MIC leads for extra rigs £3 each. State rig(s). Interface only available with Tx-3 or Rx-4 software.

**WORLD AND UK/EUROPE LOCATOR** Maps, great circles, distances, bearings, contest scores. Lat/Long, locators. NGR, hundreds of place names. **BBC-B/MASTER, ELECTRON ONLY** tape £10.

**LOCATOR** Distances, bearings, contest scores. Lat/Long, Locators. **SPECTRUM, CBM64, VIC20**, tape £7.

And for the **BBC-B/Master, SPECTRUM, ELECTRON, CBM64, VIC20**.

**MORSE TUTOR** 1-40 wpm. Learn by ear, practice using random letters, punctuation, words. 40 plain language texts supplied or type your own. With learning guide, tape £6.

**LOGBOOK** Date, band, mode, call and remarks. Instant callsearch. Log printout. Tape £8.

**RAE MATHS** Unlimited practice and testing for the exam calculations. Tape £9.

All **BBC** and **CBM64** programs are available on **DISC** at £2 extra.

**NEW!! PEP BOARD** Converts any RF power meter to read pep. Assembled and tested pcb + mounting kit and instructions £12.

Prices include VAT and P&P, 1st Class inland, airmail overseas, normally by return. Eire, C.I., BFPO deduct 13%.

## technical software (HRT)

Fron, Upper Llandwrog, Caernarfon LL54 7RF.

Tel: 0286 881886



## SPECTRUM COMMUNICATIONS

MANUFACTURERS OF RADIO EQUIPMENT AND KITS

### CB TO FM CONVERSION BOARDS

For rigs with LC7137 and TC9119 to give 29.31 to 29.70MHz. Built and aligned board SC29 £18.50, or send your rig and we'll fit it £31.50 inc p&p, £35 inc p&p for base rigs. For rigs with MM55108 use SC29F board £15 or £28 fitted.

### MULTIMODE CB CONVERSIONS

Send your rig and we'll convert it. 80CH rigs converted to give 28.01-28.80 or 28.41-29.70MHz depending on type. £55.00. 120CH rigs converted to give 28.01-29.70MHz, £62.00 for mobiles and £65.00 for base rigs. 200CH rigs in 4 bands of 50CH give 28.01-30.00MHz £45.00, others, Nato 2000 £52.50, Superstar 2000 5x40CH £77.00 Colt 1600 £65.50. All prices inc carriage.

### FM CONVERSIONS FOR YAESU AND KENWOOD

For rigs with Am £71.00 boards or £115.00 fitted, rigs without AM £81.00 boards or £125 fitted. Add £16.00 for valve only rigs. State rig type when ordering.

### RECEIVE PREAMPS

2, 4, 6, or 10 metres RF switched and DC sensing. 100W power handling, gain panel adjustable 0-20dB NFdB on 2m, 4m, and 6m, 35dB on 10m. 13.5V negative ground operation. Excellent performance at a reasonable price. Types RP2S, RP4S, RP6S and RP10S. PCB kit £14.75, PCB built £22.25, boxed kit £25.00, built and tested £35.50.

### TRANSVERTER

Single board 1/2W out for 2m or 4m or 6m 10m drive 25m W-500mW. Types TRC 2-10, TRC 4-10 or TRC 6-10. PCB kit £39.00, PCB built £54.00, boxed kit £54.00, built and tested £83.25.

### TRANSVERTER

Receive converter and 2.5W transmit converter in single boxed unit. 10m drive, 10-100mW unbuffered, types TRX 4-10H and TRX 6-10H, boxed kit £60.00, built and tested £99.50. Buffered types for use with 10m rigs giving 6dBm drive. TRX4 — 10B and TRX6 — 10B, boxed kit £68,000, built and tested £115.00 with Interface unit for use with 2m drive 1/2w-5w types TRX4-2l and TRX6-2l, boxed kit £68, built and tested £115.00.

### FREQUENCY MOD — DEMOD BOARD

Converts AM only synthesised rigs with 455KHz IF to FM. Type FM455, PCB kit £8.25, PCB built £12.25.

### NOISE SQUELCH

Mute rig when noise is too high. Allows reception of weak signals between noise bursts. PCB kit £9.50, PCB built £14.00.

### TRANSMIT AMPLIFIERS

Linear single stage, gain 10dB, 30W output, ideal for FT290, FT690, etc. RF switched and DC sensing, types TA2S1, TA4S1, and TA6S1, PCB kit £33.00, PCB built £40.25, boxed kit £39.00, boxed built £49.50.

### TRANSMIT AMPLIFIERS

Linear two stage 1/2W in 20/30W out, unswitched, suitable for Meon. Types TA2U2, TA4U2, and TA6U2. PCB kit £41.25, PCB built £52.50, boxed kit £45.00, boxed built £59.25. Switched version for use with Spectrum transverter, types TA2S2, TA4S2, and TA6S2, PCB kit £47.00, PCB built £60.00, boxed kit £58.25, boxed built £72.50.

VAT and p&p inc prices. Delivery within 14 days subject to availability. 24 hr answering service. Shop times: 9am-1pm & 2pm-5pm Tues-Fri. 9am-1pm & 2pm-4pm Sat. Closed Sunday & Monday.

Unit B6 MARABOUT INDUSTRIAL ESTATE, DORCHESTER, DORSET. TEL: 0305 62250

## ENTERPRISE ERA RADIO APPLICATIONS LTD.

Unit 26 Clarendon Court  
Winwick Quay  
Warrington  
WA2 8QP  
Telephone:  
(0925) 573118

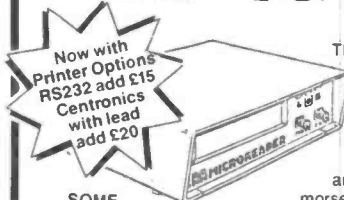

Now with  
Printer Options  
RS232 add £15  
Centronics  
with lead  
add £20

The **MICROREADER** is a totally self-contained system for reading CW and RTTY. Simply plugs into the headphone socket of your radio and displays text on the built in LCD display. No computers, program tapes or interfaces are required. Fully automatic and simple to use. Available with built-in morse. **TUTOR** that sends random groups, full control of speed spaces etc plus auto repeat. Plug in your key and see what you actually send!

SOME  
QUOTES!

G4IJE Sept 87 Review "bargain of the century"; Excellent/outstanding EI9EJ; A very good buy — G2DRT (RSGB Council); Amazing on CW, even better on RTTY - G0HWA; Damn clever — Home Offic Telecoms; Excellent standard of construction — G1CQV. We could fill the page!

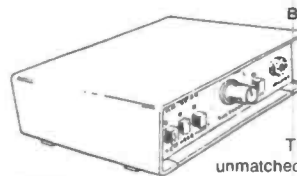

**BP34 PROFESSIONAL COMMUNICATIONS AF BANDPASS FILTER**  
Designed by Dieter Fritsch  
DJ3NB/VK3BGJ/GOCKZ

This filter is a no compromise design with an incredible 34 orders of filtering. The result, a level of performance that is unmatched in this country or any other come to that!

MORE  
QUOTES!

"Too good for radio hams" — G30GQ; 40 Mtrs CW very impressed — Rev G. Dobbs G3RVJ; Better than all the knobs on the TenTec G6SX.

For further information, write or call **Bill Green G8HLZ**

Also available from:  
RAS (Nottingham) or  
Caledonian Software  
(Edinburgh)

All prices include VAT & p/p.  
Full 12 month guarantee.

Standard Microreader . . . . £119.95  
With Tutor . . . . . £134.95  
BP34 Filter . . . . . £94.50

# BOOKS

## An Introduction to Satellite Television by F A Wilson

Although not directly related to amateur radio activities, there has been a growing interest over the past few years — and specifically in recent weeks — in the subject of satellite TV. With the spectre of £200 home reception systems now appearing the interest in SatTV is very much on the up and up, and Babani seems to have got its timing just right with their latest offering.

The book consists of nine main chapters and these are supplemented by eleven appendices which serve to collect all the supporting mathematical and design data together in the one place. Chapter 1 deals with the fundamentals of satellite operation, beginning with what a satellite is, a short history of satellite development and then moving on to give a general outline of a typical satellite TV installation before closing with a brief mention of encryption, payment systems and planning considerations for dish aerials. Essentially, in the UK this consists of no planning permission being needed as long as the dish is less than 90cms in diameter, is the only one on the premises and does not project above the roof line.

Chapter 2, ominously entitled 'Initiation' is in practice a brief introduction to the concept of scientific notation and the metric system, followed by a taste of radio theory concerning decibels and the radio spectrum. This latter aspect is further developed in Chapter 3 which considers signal polarisation, propagation and choice of frequency for satellite operations before Chapter 4 takes up the 'Signal Processing' story by explaining such notions as amplification, oscillators, modulation and mixing.

Chapters 6 and 7 address the methods by which satellites are placed into orbit and also provide a bit more detail concerning the hardware which is up there; covering actual transmission frequencies, the operating principle of the 'Travelling Wave Tube' (sometimes referred to by less-than-kind RF engineers as a twit!), and introducing antennas and satellite coverage footprints. Having established an outline of both the ground receiving equipment and the satellite itself, the book then moves on to a brief explanation of TV receiver principles.

The earlier chapters tend to be rather short and none is more than 5 pages long — this is no bad thing as they are really preparing the reader for Chapter 8 where, building on the preceding information, the book gets down to the nitty gritty of dish design. Here, the accurate focussing advantages of a parabolic cross-section dish over that of its spherical companion are explained and both primary focus and offset fed dishes are covered. At this point the mathematical content of the text takes an upward lurch and, whilst this shouldn't present much of a problem to the patient RAE holder, it could look a bit intimidating to the uninitiated. However, just as you can't make an omelette without breaking eggs, it is a fact of life that you can't explain satellite principles without resorting to some mathematics and the book presents this aspect in as simple a way as possible.

Having successfully leapt that hurdle, the remainder of Chapter 8 turns its attention to path loss, dish size and signal noise; both receiver generated and that derived from local interference.

Chapter 9 is very much the practical part of the book,

giving general advice on the selection, siting, sighting and design of a dish and how to make use of a polar mount. Local magnetic variation is explained in detail together with its relevance for accurate 'sighting' of the final installation and the importance of using high quality cabling between aerial and indoor receiver, plus pointers on selecting the right satellite receiver are given.

The book constitutes an ideal introduction to the world of satellite TV, providing the uninitiated with just the right amount of information to gain a clear picture of what it is all about. Once the basics have been grasped, the extensive appendices come into their own by providing information omitted from the text for reasons of clarity and providing further detail and reference sources for those who would want to take the subject further. In short — recommended reading for any potential satellite TV buff.

*An Introduction to Satellite Television* by F A Wilson is published by Bernard Babani (publishing) Ltd of London and costs £5.95.

## Dial-Search by G Wilcox

Now in its fifth edition *Dial-Search* is a slim 46-page, A5 booklet which provides a comprehensive list of British and European Medium Wave stations with details of frequency, wavelength, language, name of programme; transmitter and its power, broadcasting hours, and British timings. In addition, there are longwave and shortwave listings but one of the most extensive lists is the UK frequency list for medium wave, detailing both timing and alternative frequencies. An index to British local stations and their frequencies is also given.

In addition to the many listings, there is a section on 'Making the Most of Your

Portable' which explains how to align a radio on the correct bearing for best reception, and how to tune in and identify the transmissions. All this is related in an informal but rather long-winded way, and although there are helpful notes to explain the correct terminology for each of the descriptions, these are referred to as 'foot-notes' yet appear within the body of the text. Such topics as calibration, harmonics and interference in Q-code are also covered in this particular section.

The writer voices his opinions on pirate radio and, what he terms 'so-called Free Radio' stations then moves on to explain how things stand in broadcasting at present with regard to UK regulations. One particularly useful little section, however, is 'Spot the Tune' which contains the musical notation for several European radio stations to aid identification. It is worth noting that the notation of eighty signature tunes and interval signals is given in the fourth (preceding) edition of this publication and apparently this is still available.

Two fold-out maps are included with *Dial-Search* — one of European broadcast stations on a mercator projection, with details such as high ground and borders clearly drawn in. The other map is of the British Isles and contains the same information but also details forecasting areas around the coasts.

To sum up this publication, the information given is quite extensive, the maps are very good, and there are spaces left in relevant places for the reader to add his/her further information — but on the negative side, the lay-out is confusing and amateurish, changing style and format in a rather awkward way from listing to listing. Although appreciating the difficulties of keeping costs of publications such as this down, at £3.25 (plus 35p p+p) I would expect a more professional effort.

# JRC JST-135 Transceiver REVIEW

JRC radio equipment is normally found sitting in the radio shacks of ocean-going tankers and for many years their equipment has been thought of with high esteem by professionals and amateurs alike. It certainly is a lucky (or wealthy) SWL that has the NRD-525 receiver in their shack, but what's this . . . an all-mode do-everything JRC HF transceiver for £1195? The HRT review team came away from JRC UK distributors laden with boxes, itchy fingers at the ready!

## Features

The JST-135 gives transceive operation on all HF amateur bands, with a user-variable transmit power of 150W maximum. It operates from a 13.8V DC supply, drawing 35A max. on transmit, and a matching mains supply is available for £299. The receiver section allows general coverage reception to let you listen over its entire 100kHz to 30MHz tuning range with CW, LSB, USB, AFSK, AM and FM mode being avail-

able. An optional ECSS unit is also offered for synchronous AM reception. A high dynamic range upconversion receiver is used to help cope with the ever-increasing power rat-race on the HF bands, other QRM-rejection features provided are a variable level dual pulse-width noise blanker to

## *JRC radio hear is for pros . . . but here's a do-it-all transceiver*

suppress over-the-horizon radar as well as next door's motorbike, a variable receiver IF shift, a tunable IF notch, receive attenuator, selectable AGC and three IF filter bandwidths. An all-mode receiver squelch allows quiet monitoring of net frequencies or FM channels.

Both full and semi break-in operation on CW is provided, with a variable level 800Hz sidetone provided from the sets internal speaker. On SSB, VOX (Voice-Controlled

Transmit switching) is fitted, with variable gain, delay, and preset anti-vox controls; an audio speech compressor may also be switched in as required, this operating on SSB, AM and FM. A separate transmit low-level output is provided on the rear panel for transverter use, this facility disabling the transmit power amplifier on command.

The early review sample came with the 18 and 24MHz amateur bands inhibited from transmit. When trying to find out which internal links to modify, it was with a slight amount of mirth that we found the entire multi-million Japanese JRC plant had closed down for their annual summer holiday over the review period! Hence we could not try these bands, we *do* know however that a general coverage transmit version is available for the professional market, so the capability *is* in there somewhere!

## Tuning

The JST-135 offers similar tuning and direct keypad frequency entry

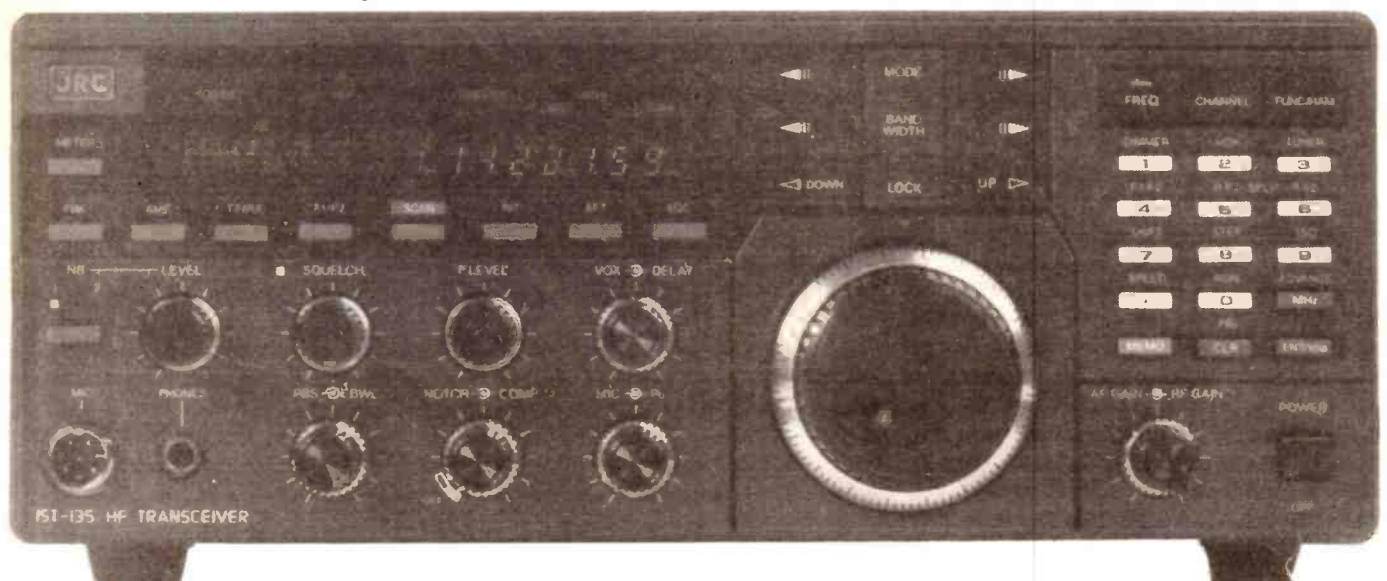



etc. With the new UK licence regulations allowing remote operation of our main station by radio control, this means that with suitable interfacing you could be happily sitting by the fireside in winter having a radio and computer controlled QSO with your equipment in the outside shack! As well as this of course, it would allow automatic tuning for unattended SWL tape recording purposes, and for the digital wizz-kid amateurs direct recording of time, frequency, mode, S-meter level etc. into the computer, all you need do is enter the call sign and out pops a QSL card to put in the bureau.

facilities to the virtually identical NRD-525 high performance receiver, and may indeed be optionally linked to operate with it as an external receiver if required by using a £99 interface linking cable. Two digital VFOs are provided, each with a 10Hz minimum step size and these may be used independently or in split Tx/Rx mode as required for DX chasing. A further programmable Tx offset frequency may also be programmed for 10m repeater use or when transverting. The VFO tuning step size may be independently programmed for CW/SSB, AM, and FM, the main tuning knob allowing fine control while the adjacent panel-mounted UP/Down buttons give coarse tuning steps. The Up/Down controls are also brought out to the eight pin mic socket, allowing Up/Down switching using microphone mounted buttons if required. A front panel mounted 'Lock' button gives protection against accidental frequency shifts.

A total 200 memory channels are available, each storing frequency, mode, bandwidth, attenuator on/off and AGC time constant. Memories may be automatically scanned if required, the scan pausing when the received signal level either exceeds or falls below (as required) a preset signal level controlled from the front panel. Any frequency range between two programmed channels may also be similarly checked for activity. A white and red fluorescent display gives an indication of the tuned frequency, mode bandwidth, AGC time, memory channel etc, together with a digital bar type S-meter doubling as a multi-function meter on transmit, this indicating transmit

power, reflected power, ALC level and PA DC supply current. The meter may also be switched to act as a centre tuning discriminator on FM receive. The entire display and front panel LED indicators may be dimmed for night-time use, or completely inhibited providing 'covert' operation!

### Digital Control

The rear panel of the set has a number of multi-way D-type connectors for ancillaries and amongst these is the facility for an optional RS232C computer control port. This allows control of many of the set's functions, adjacent connections giving two audio line inputs, receive audio output both squelched and unsquelched, Tx switching, mic mute

### User Defined Functions

A set of preset functions may be programmed into the transceiver by the use of the numeric keypad. These control the preset repeater shift and direction, addition of an optional transmit sub-tone on shift for 10m repeater use, subtone frequency, transverter output on/off, any CW BFO pitch ranging from 200Hz to 1.5kHz, frequency display with LSB/USB shift, RF front end band-pass filter in/out, the optional RS232C baud rate, keypad bleep on/off, 10Hz/100Hz display resolution, scan pause selection, and enable/disable of frequency change during transmit.

The set is housed in a grey metal wrap-round case, and measures 33mm(W) x 130mm(H) x 391mm(D),

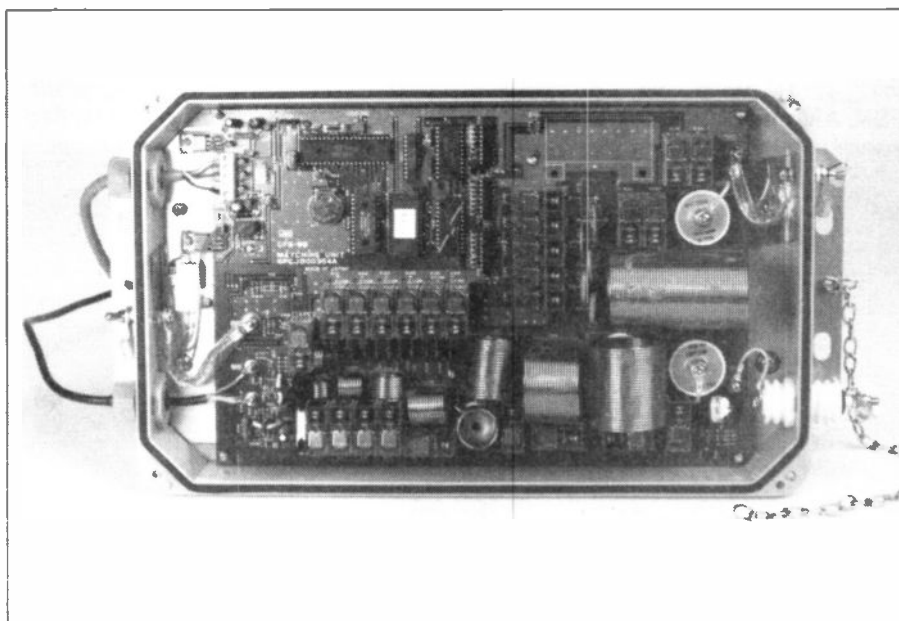

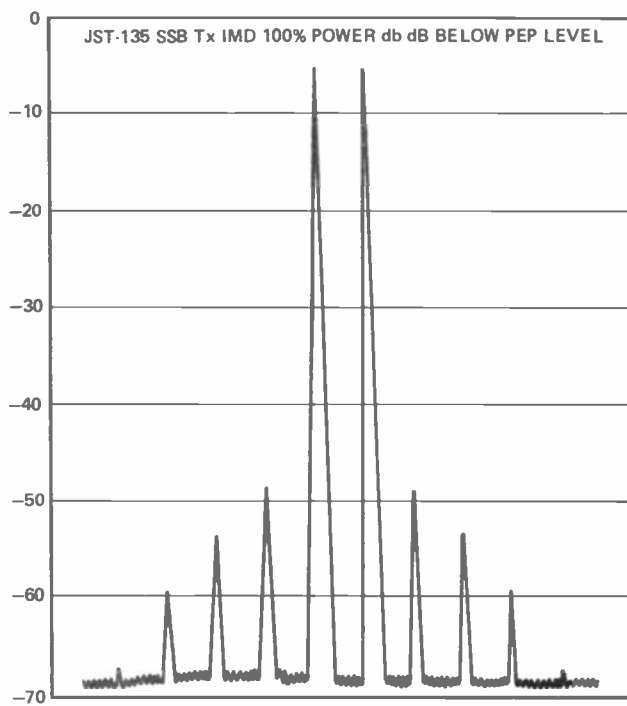
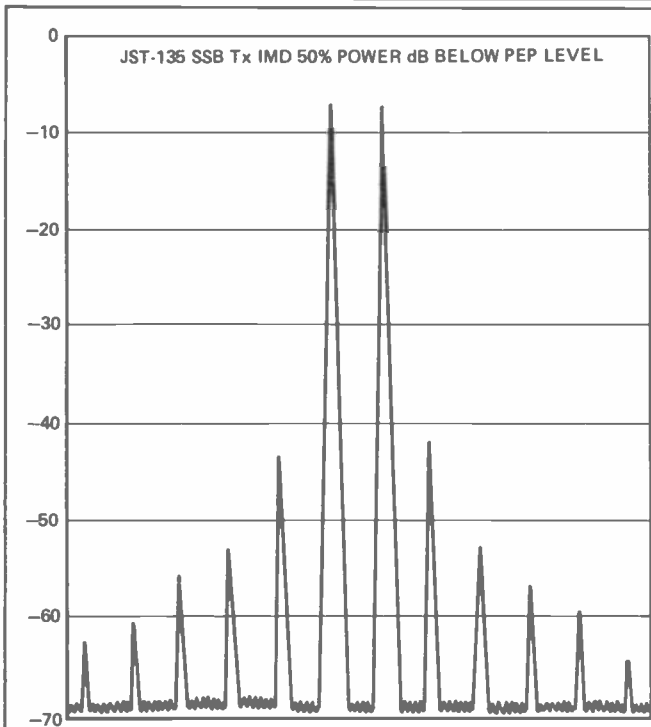

weighing 8.5kg. It comes supplied with a heavy duty DC power lead, spare fuses, accessory and CW key plugs, and a comprehensive user instruction manual. The latter even informs the user on the type of lithium memory backup battery used and how to replace it when it eventually goes flat, hence saving expensive carriage charges to the dealer for what is essentially a simple soldering job taking a few minutes to do.

### Options

As mentioned, various options are available that plug into the set, such as the variable bandwidth control, ECSS unit, IF notch filter and RS232C interface modules. The notch follow unit enables you to manually tune the notch filter to reject an interfering carrier, from when on it will retune this setting as required if you QSY up to 10kHz. The

variable bandwidth control acts in CW/SSB and AM modes, allowing you to reduce the effective selectivity bandwidth of the IF filters. As well as the supplied internal filters of 2kHz, 6kHz and 12kHz, optional filters of 300Hz, 500Hz, 1kHz, 1.8kHz and 2.4kHz are available. A CTCSS (Continuous Tone Controlled Squelch System) board provides generation of any standard sub-audible tone frequency for 10m FM repeater use, some repeaters requiring this tone to enable talkthrough operation. A high stability crystal oscillator is also available for the perfectionists.

External accessories range from a remotely controlled 2kW linear amplifier to a JRC morse key, encompassing a matching external speaker, DC power supply, manual and remote automatic aerial tuning units, headphones, fist and desk microphones, and a transceive cable set.

### Inside The Box

The interior of the set is a pure delight, a very high standard of construction being used. Several large plug-in boards are used for most of its functions, the number depending upon the fitted options, each being slotted into the main body of the equipment. These are the receiver



front end, IF filtering bandwidth control (option), IF amplifier, ECSS unit (option), notch follow (option), direct digital synthesizer, analogue synthesizer loop, central processing unit, and the CTCSS/RS232C options. The front panel houses the control interface PCB, the rear panel the transmitter power amplifier, low pass filter, and fan-cooled heatsink.

Extensive screening is used both in between individual PCBs and between circuits on the boards themselves to give a high degree of isolation between stages. A standard analogue synthesiser using three switched VCOs (Voltage Controlled Oscillators) is used to generate the local oscillator, tuned in 100kHz steps, a mixed low frequency signal generated by a DDS (Direct Digital Synthesiser) giving interpolation in 10Hz steps. A further DDS is used to generate the required BFO signals for each mode.

Varicap-tuned front end filtering within relay switched band ranges is used, providing optimum out-of-band rejection rather than fixed wideband ranges as found on many other HF sets nowadays. A pair of 2SK125 FETs are used in parallel in the front end, this arrangement increasing the overall transconductance and hence dynamic range; a further pair of 2SK125s then follow in the balanced mixer to provide a first IF of 70.455kHz, an analogue synthesiser derived 70MHz oscillator then mixing down to the second IF of 455kHz. On all modes apart from FM, a third IF of 89kHz is employed for final demodulation. On transmit, a pair of 2SC2879 transistors are used in push pull for the PA, a further single 2SC2879 being used as the driver. A bank of relay switched elliptic low pass filters provide harmonic rejection.

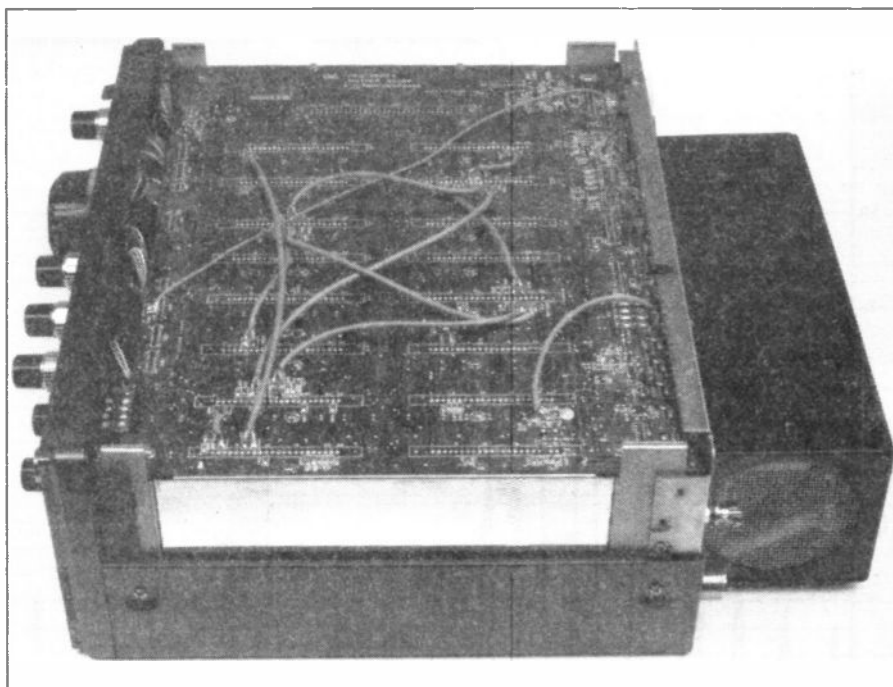

### Automatic Remote Aerial Tuner

The optional NFG-230 ATU was also supplied for review, this being a weatherproof remote unit designed for mounting at the aerial feed-point and currently costing £599. A large insulated aerial connector and adjacent ground lug are fitted to the top of the tuner and a 20m control lead emerges from the bottom of the unit for connection to the rear panel of the JST-135, together with a short 50 ohm coax input lead terminated in a PL-259 connector and a further ground lug. The whole unit measures 420mm(H) x 225mm(W) x 100mm(D).

Inside the unit are a total of 25 high-speed relays, switching fixed coils and capacitors into circuit under microprocessor control. The tuning

unit is claimed to match any 5 to 1000ohm resistive mismatch together with a capacitive component of greater than 150pF, with an average switching time of 2-4 seconds, the maximum power handling capability being 200W. A memory facility may also be used, where stored matching parameters may be automatically recalled for pre-set frequencies giving a switching time of 50mS or less.

This arrangement of having an ATU at the aerial feed-point itself is the ideal in my opinion, preventing radiation and RF voltage problems along the feed coax. We can't all put up monster aerials on towers, and often the use of a long wire coupled to an ATU in the shack presents high levels of RF inside the building that quite happily find their way into all manner of domestic appliances such as TV and video equipment, often guaranteeing to cause neighbourly 'friction'. Placing the aerial and ATU well away from these devices, coupled to a non-radiating feedline down to the shack can often work wonders.

### On The Air

After marvelling at the sheer feeling of quality of the set, I couldn't wait to have my first tune around on the air. The first thing I noticed was that the bands seemed very quiet. Having had a thorough digest of the

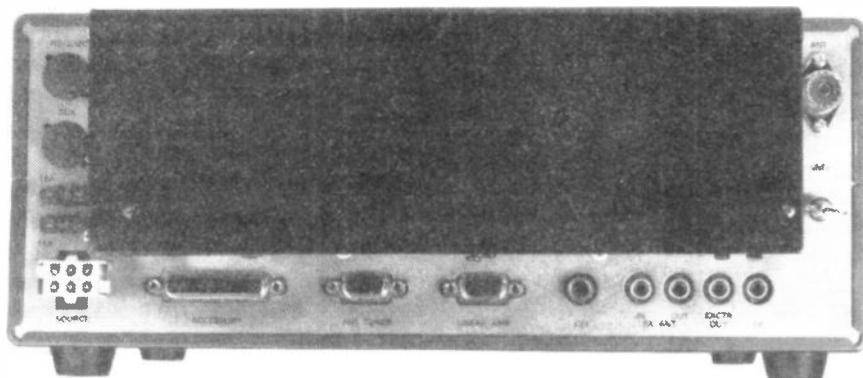

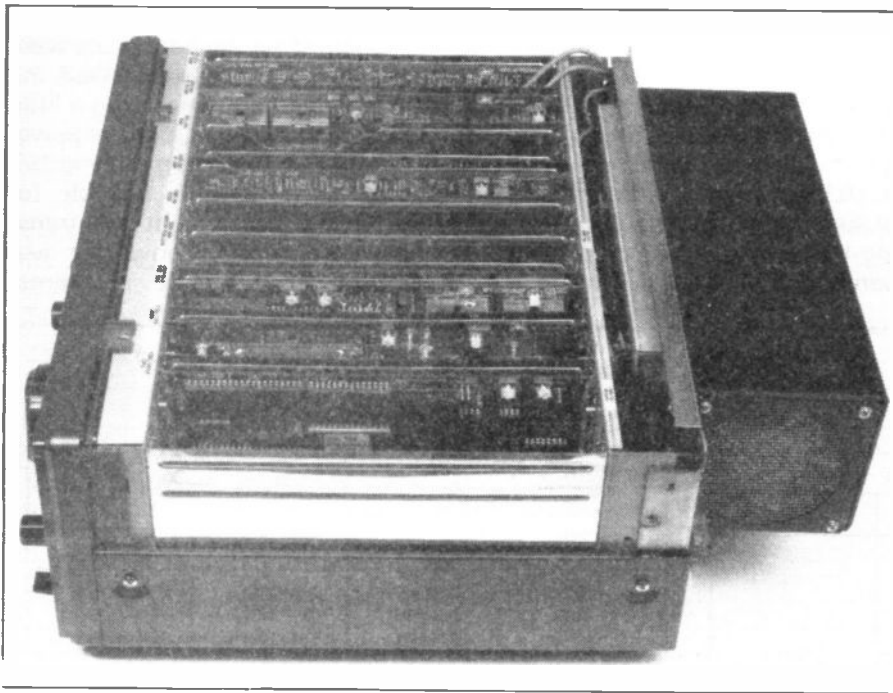

manual, I set off again, on 80m . . . no problem, a reply with the first call. Following this, I tuned to the crowded 40m band and gave the receiver a careful check against my usual high performance HF transceiver. Both sets received exactly the same stations, but the general 'mush' level was that much lower on the JST, showing that its front end was not creating all the internal mixing signals we have come to know and hate on today's bands.

Further tests over the review period of several weeks confirmed this, it isn't often I come across such good performance. I must however say that the AGC attack time seemed rather slow, and on carefully tuning into a strong signal a degree of 'pumping' was very evident before it settled down, the S-meter 'overshooting' in level confirmed this. I eventually found the best results were obtained by switching the AGC off and using the manual RF gain control when possible.

The 10Hz steps of the VFO were excellent for fine tuning, although it took me a while to get used to pressing the Up/Down buttons whenever I needed to get from one part of the band to the other. Similarly changing band required a number of button-pressing operations. However by storing frequencies and relevant modes in the set's numerous memories, I found I could always operate

in 'memory' mode, using the mic Up/Down buttons for channel switching, the main tuning dial then automatically QSYing from these as required.

### Can You Hear Me Mother?

On transmit I received exceptionally good audio reports, my signal having very little 'spreading' due to distortion products generated in the PA. The thermostatically controlled fan on the rear panel was very quiet in operation, the panel itself keeping very cool. By the amount of heat coming from the exhaust grille during ragchews the fan certainly seemed to be doing its job well. Netting on CW was very easy, as well as the 800Hz sidetone the set has a facility for quickly generating the BFO frequency in use with the user-programmed CW offset, allowing a quick button push to be used to 'zero beat' for accurate netting.

On switching from transmit to receive, the AGC recovery time was again noticeably slow, switching the AGC to 'fast' decay giving an improvement here. I also found this essential when using data communication modes such as Packet or AMTOR. However in the set's favour, I found the frequency stability excellent, tuning to the 14.105MHz bulletin board frequency enable 100% reception over several days without the

need to retune even once. I also appreciated the 'line' input on the rear panel, together with the facility for microphone muting using an external switching line, this enabling a one-switch changeover between more 'Mundane' modes.

### Remote Aerial Tuning

I tested the remote ATU by stringing up a wire dipole for 20m in the loft of my two-storey house, and connecting the ATU onto this. Tuning to the middle of 20m and pressing the 'Tuner' button on the keypad in 'function' mode caused the set to transmit a carrier for several seconds prior to finding a match, which I stored together with the operating frequency in the set's memory. Repeating this operation in the lower and upper sections of the band enabled me to operate with the transmitter seeing a VSWR of less than 1.5:1 across the band. Although this arrangement could not compete with my tower-mounted HF yagi, the loft dipole/ATU did slightly out-perform my external W3DZZ trapped dipole, its balun feedpoint being at the apex of my house!

As a further test, I tried the same dipole on 80m, 40m, 15m and 10m, the ATU matching each frequency to the totally non-resonant aerial every time, although sometimes taking about 20 seconds to do so. Again by storing these settings in memory, a rapid QSY from band to band was possible, the ATU switching itself to the required match instantly. When trying to find a match, the tuner was noticeably noisy in operation due to the many relays chattering away, although the good weatherproof sealing helped keep the noise down, but only a short click or two was evident in 'memory' mode. If the unit was bolted to a wall or mast, this could be rather noticeable.

### Laboratory Tests

The first thing I measured was the dynamic range of the receiver, by injecting two off-channel signals from my low-noise cavity tuned signal generators via a hybrid combiner, to examine the level of internal mixing produced. I had great difficulty doing this as the JST-135 had such a good performance it was almost beyond the limit of the best test equipment available. The blocking performance was very good too, and when trying

to measure the image rejection I decided to call a halt when I reached over 110dB, with thoughts of professional rather than amateur performance levels going through my head!

The receiver selectivity was very sharp, however this was limited below the -70dB level by the analogue synthesiser reciprocal mixing noise which is disappointing. Very

slight spuri at -88dB were noted at +/-100kHz caused by the synthesiser reference frequency, these falling to -95dB and +/-200kHz and -97dB at +/-300kHz. I didn't find any close-in spuri whatsoever which is very good, although this is not surprising due to the synthesiser loop being mixed with a lower frequency DDS, hence removing the

need for multiple analogue loops.

On transmit the harmonics were generally reasonably suppressed, the 40m second harmonic being a little poor though. Using an external power supply (rather than the matching JST supply which is only suitable for intermittent use) I kept the transmitter running on full power for over 20 minutes with no problems,

## LABORATORY RESULTS RECEIVER

Sensitivity Input level required to give 12dB SINAD			
Freq. MHz	SSB/CW	AM	FM
1.8	0.226uV pd	0.610uV pd	--
3.5	0.173uV pd	0.485uV pd	--
7.0	0.201uV pd	0.550uV pd	--
10.05	0.198uV pd	0.501uV pd	--
14.0	0.257uV pd	0.835uV pd	--
18.0	0.263uV pd	0.760uV pd	--
21.0	0.305uV pd	0.790uV pd	--
24.5	0.284uV pd	0.775uV pd	--
28.5	0.308uV pd	0.805uV pd	0.655uV pd
29.5	0.305uV pd	0.805uV pd	0.655uV pd

Blocking: Measured as increase over 12dB SINAD level of interfering signal, unmodulated carrier (SSB, intermediate selectivity)

Spacing	Level
+/- 50kHz	99dB
+/- 100kHz	103dB
+/- 200kHz	108dB

3rd Order Intermodulation Rejection Increase over 12dB SINAD level of two interfering signals giving identical 12dB SINAD on-channel 3rd order intermodulation product

Spacing	Level
75/159kHz	95.5dB
150/300kHz	95.5dB

### S-Meter Linearity, SSB/CW, 14.25MHz

Indication	Sig. Level	Rel. Level
S1	--	--
S2	4.35uV pd	-30.3dB
S3	5.42uV pd	-28.4dB
S4	8.59uV pd	-24.4dB
S5	12.3uV pd	-21.3dB
S6	20.4uV pd	-16.9dB
S7	43.0uV pd	-10.4dB
S8	76.2uV pd	-5.5dB
S9	143uV pd	0dB Ref
S9 + 10dB	401uV pd	+9.0dB
S9 + 20dB	1.25mV pd	+18.8dB
S9 + 30dB	4.08mV pd	+29.1dB
S9 + 40dB	11.1mV pd	+37.8dB
S9 + 50dB	29.7mV pd	+46.3dB

### S-Meter S9 Level

Freq. MHz	Sig. Level
1.8	147uV pd
3.5	111uV pd
7.0	126uV pd
10.05	114uV pd
14.0	143uV pd
18.0	153uV pd
21.0	198uV pd
24.5	187uV pd
28.5	176uV pd
29.5	174uV pd

Measurement Point	Bandwidths & Mode Setting		
	SSB (Inter)	AM (Inter)	AM/FM (Wide)
-3dB	2.25kHz	5.63kHz	11.24kHz
-6dB	2.34kHz	7.705kHz	13.12kHz
-60dB	4.95kHz	14.43kHz	23.67kHz

Image Rejection Increase in level of signals at the first IF image frequency (+140.91MHz), and the IF frequency itself (70.455MHz), over level of on-channel signal to give identical 12dB SINAD signals.

Freq. MHz	Image Rej	IF Rej
1.8	>110dB	84.5dB
3.5	>110dB	87.0dB
7.0	>110dB	85.5dB
10.05	>110dB	83.0dB
14.0	>110dB	85.0dB
18.0	>110dB	86.0dB
21.0	>110dB	82.5dB
24.5	108.5dB	83.0dB
28.5	103.5dB	82.5dB
29.5	103.0dB	82.5dB

## TRANSMITTER

Maximum TX Power		
Freq. MHz	Power	Indicated Power
1.8	146W	150W
3.5	149W	150W
7.0	150W	150W
10.1	151W	150W
14.0	153W	130W
21.0	151W	124W
28.5	152W	115W
29.5	149W	115W

Tx Harmonics				
Freq. MHz	2nd	3rd	4th	5th
1.8	-62dBc	-70dBc	<-75dBc	<-75dBc
3.5	-67dBc	-65dBc	<-75dBc	<-75dBc
7.0	-47dBc	-60dBc	<-75dBc	-72dBc
10.1	-54dBc	-62dBc	<-75dBc	<-75dBc
14.0	-58dBc	-60dBc	<-75dBc	<-75dBc
21.0	-61dBc	-59dBc	-68dBc	<-75dBc
28.5	-64dBc	-63dBc	<-75dBc	<-75dBc
29.5	-64dBc	-63dBc	<-75dBc	<-75dBc



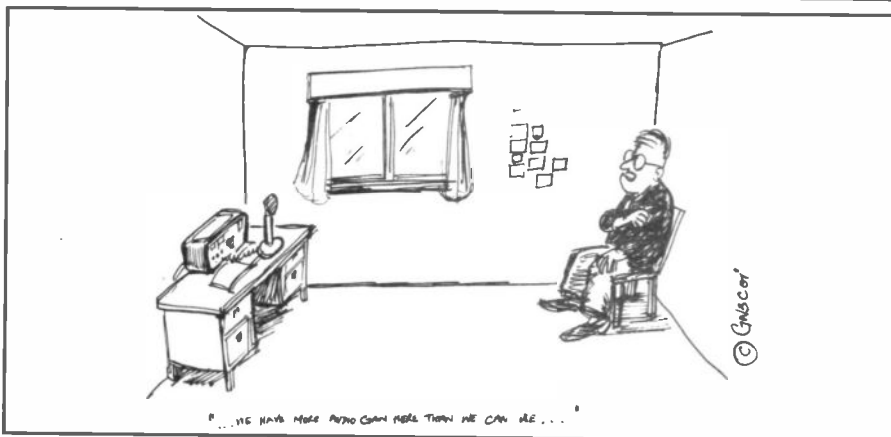

although the cooling fan exhaust air was getting rather hot towards the end! The two-tone intermodulation distortion, a measure of the linearity of the PA and hence the close-in 'splatter level', showed a truly excellent result from a 12V solid state PA. I was very impressed, although these did not significantly improve as I would have expected with a reduction in output power. Deliberately overdriving the microphone input didn't give any degradation in the width of the signal.

For the AMTOR and Data buffs, I

measured the Rx to Tx switching time as 19mS, the Tx to Rx time being slightly shorter at 17mS. This should be more than adequate for most purposes as well as allowing high speed CW full break-in operation for skilled brass pounders.

### Conclusions

The JST-135 out-performs several other often significantly more expensive transceivers in terms of its receiver strong signal handling performance, this fact often being the

limiting factor in most amateurs' stations. The 150W transmitter also gives more power than many other sets, coupled with a linear PA capable of continuous transmission if required. The reciprocal mixing due to the analogue synthesiser loop lets down the set's otherwise excellent performance, however to be fair this is a common limitation with most gear currently on the market, and no problems were experienced during on-air tests.

In my view, the JST-135 offers excellent value for money. A wide range of operating functions are available, coupled with numerous memory channels with a direct QSY facility from each to greatly improve the ease of operation. A number of plug-in options are available to provide more flexibility if needed, including computer control, the average amateur may upgrade the set as interest or need arise rather than face a hefty transceiver cost to start off with.

*My thanks go to Lowe Electronics, who are the UK JRC distributors, for the loan of the review transceiver.*

## K W TEN-TEC LTD ARGOSY II NOW MADE BY KW IN THE UK



**ARGOSY II - 100 WATTS SSB/CW  
MOBILE, PORTABLE OR HOME STATION**

### CENTURY 22

**NOW MADE BY KW IN THE UK**  
50 WATT, 6 BAND CW TRANSCEIVER COMBINING EXCELLENT PERFORMANCE, RELIABILITY, OPERATIONAL SIMPLICITY, AND LOW COST

### ALSO FROM KW

THE PARAGON 200W SYNTHESIZED TRANSCEIVER, THE CORSAR II 200W TRANSCEIVER FRITZEL BALUNS. H.F. BEAMS & VERTICALS NOW IN STOCK - FROM CUSHCRAFT, BUTTERNUTT, HYGAIN, MFJ PACKET RADIO UNITS AND ATU's etc. HYGAIN ROTATORS. VHF BEAMS & VERTICALS.

### K W TEN-TEC LTD

VANGUARD WORKS, JENKINS DALE, CHATHAM, KENT ME4 5RT  
Tel: (Medway) 0634-815173; Telex: 965834

Books for radio amateurs

AERIAL ACCESSORIES AND MASTS

JAYBEAM AMATEUR ANTENNAS

APPOINTED DISTRIBUTOR

OSY OLD MAN TO

INSTANT HP AVAILABLE

**RIGS, ANTENNAS, SWR BRIDGES, POWER SUPPLIES, TEST GEAR, COMPONENTS, MORSE KEYS, COAXIAL CABLES, ROTATORS, MICS, PLUGS AND SOCKETS, SWITCHES**

Call us on (0533) 553293  
OR COME AND LOOK AROUND AT  
26/28 Braunstone Gate, Leicester

## R.A.S. (NOTTINGHAM)

G6XBM  
G1RAS  
G8ULS

**Radio Amateur Supplies**  
Tel: 0602 280267



Visit your Local Emporium  
Large selection of New/Used Equipment on Show

#### AGENTS FOR:

F.D.K.  
AZDEN  
ICOM  
YAESU  
ALDICO  
KENPRO

#### ACCESSORIES:

Wala Range  
Microwave Modules  
Adonia Mics  
Mutek Pre-Amps  
Barenco Mast Supports

DRAE products  
BNCs Linear and  
PSUs

Agents for VODAPHONE & CELLNET

**AERIALS:** Tonna, Halber, Jaybeam, New Diamond Range of Mobile Whips  
Bring in your secondhand equipment for sale

JUST GIVE US A RING

Monday: CLOSED Tuesday-Saturday: 10am to 5pm

3 Farndon Green, Wollaton Park, Nottingham NG8 1DU  
Off Ring Rd. between A82 (Derby Road) & A800 (Ilkeston Road)

# Free Readers Ads!

## FOR SALE

**SONY ICR480**, 6 band, MW and 5 Shortwave bandspread; pocketable; LED tuning, indicator, case, £25. Hitachi WM20 shortwave Transverter, 13-19 metres, 9 band; all pushbuttons; for car radio or base use, £20. BSR 8 track stereodeck, £6. — G4IOF, QTHR. 01-722 7040.

**GLOBAL AT1000** antenna tuner used once, brand new, still boxed, £60 inc P&P. Also four Airband Crystals 120.50, 124.20, 133.60 and 133.70, for DR600-R512 Scanners; all four £5 or £1.50 each. — Ring Walsall (9022) 644054.

**YAESU FT790R** Nicads and Charger, boxed as new, £300. Pye Olympic (FM) 12 channel, four channels fitted, speaker and mic converted to 4 mtr, £80. Tristar 747 multimode CB converted to 10mtr, £80. — Gravesend 357795.

**COLOUR** Genie Computer, RTTY/CW split screen type ahead, tunicator, b/w TV, recorder, ready to go on air. Hardly used, £120 ono. — Phone Noel 0473-49139, Ipswich, G3ZLN.

**TRIO** General coverage Receiver 9R-59DS 550kHz-30MHz, good condition with manual, £65. Photocopy Instruction Manual for the National H.R.O., £3. Wanted: Faxi or similar with Printer etc, must be in good condition. — Telephone GW5DP, 0244 816435.

**TONNA** 9 element crossed for 2 metres, £35. MM Transverter 28MHz-70cms, £69. QTHR. — Tel (daytime) 0423 68954, extn 262, G4IUF, Mike.

**IC R70** Communications Receiver, 0-30MHz, AM/SSB/CW/RTTY/FM P.B.T, RIT, NOTCH R.F. gain, dual/AGC/VFO, N.B/M/Pre-Att, AD-270 active/A 0-30MHz, good condition, like new, £550 ono. — 49 Gaythorne Road, West Bowling, Bradford 5, BD5 7ES.

**STEPHEN JAMES** MkII Antenna Tuner unit (A.T.U.) in-

cludes plugs, £30 ono. — Tel: 061-748 9604 about tea-time, weekends and mid-week.

**FOR SALE** Electronic Components: 5v Regulators, Diodes, Transistors, Capacitors, Resistors, PCB Pin Connectors, Heatshinks, Fuses etc (several items available in bulk quantity). — For full details, Mr D Griffiths, 2 Lodge Hill, Caerleon, Newport, Gwent NP6 1DA (0633) 420218.

**COLLINS 75SI** RX Waters filter, no mods or marks, excellent condition £220. Eddystone 840C RX, unmarked, £55. KW204 Transmitter, factory performance, appearance, recent 6146 Bs, £140. All superb equipment. Carriage, insurance paid. Open to offers. — Telephone 022989 635 any time. Wanted Collins 75S3.

**TRIO TS700G** 2M Base Station Multimode, SSB/CW FM/AM Transceiver, complete with Vox unit, Trio Base Mic and instructions, V.F.O. or fixed channel operation, vgc. £225, buyer collects. — Brian G4TGN 897 3794.

**TS520S** External V.F.O., workshop manual, spare tubes, Shure 404C microphone, all showroom condition, reluctant sale, £400 ono. Car needs new gearbox. AR8BD, working, manual, needs slight attention, £50 ono. — Please write D.G. Burt, 14 Mulberry Close, Eastbourne BN22 0TU.

**LATTICE TOWER**, Aluminium, very lightweight, four sections to make 22ft. Tower wall mounting, ideal for side of garage etc. Would easily make 30ft with stub mast. Transportable by car. Buyer to collect. Bargain £40 no offers. — Tel. Cambridge 0223 845093.

**934 MHz UNIACE** model 400 with Crestbyte variable pre-amp, Yagi and Colinear antennas, £125. — 01-578 7069.

**SONY ICF2001D** vgc plus unused AN-1 active antenna, both boxed, £275. Yaesu FRG-7 vgc £125. Kokusai

MF455 10AZ121 2kHz SSB mechanical filter with matching transformers, unused, £22 ono. — Tel. (021) 778 1719, evenings.

**JAYBEAM** 108MHz-136MHz beam antenna, 4 element, £20, £5 postage. Antenna rotator 70kg load with control box, overload protection, £20 plus £7 postage due to weight of item. — Tel. Chris 0226 288760, 9 Wade Street, Pogmoor, Barnsley, South Yorkshire.

**TRIO TR751E** 2mtr multimode, ideal home or mobile, boxed, mint, £450. — Wormley, Surrey 042879 3017.

**TRANSVERTER** 2 metres to 70cms, repeater shift plus satellite bands, has been used successfully on Oscar 10, as new £100. Also 19ELE 70cms horizontal tonna £15 and 19XY 70cms tonna crossed tonna £15. Antennas to be collected. — Tel. Cambridge 0223 845093.

**TRIO TW4000A** 2mtr 70cms, boxed, £350 ono. 2 mtr Beam Rotator, £60 ono. — G1MUU, 021 458 5502.

**SONY ICF-200ID** 150-29999.9 AM USB LSB 76-108 FM 116-136 Air, six months old, mint condition, £250. — Phone Southampton 0703 464368, Sunday to Wednesday.

**FRG 8800**, mint condition, £425. 35A 13.8V regulated power supply, crow-bar, current limit protected, £75. 2200V 300mA power supply, ideal for 813 linear, £40. 30 amp 13.8V power supply, as above, £60. Telequipment 50MHz dual beam scope, £300. — Phone 0375 378783 (Grays, Essex).

**FT 902 SM TRANSCEIVER**, all options, superb rig: FV 901 DM ex VFO 40 mins and scanning; Welz VSWR and power bridge RMS and Pep 1K. Sem-noise Bridge, new: Transistor Tester G80. rotator 60lb max, Buttean & 1 40-80 Vert new; 9ELE 2 mtr Yari Tonna new; 70cm Colinear. Required, 9405/9305 4405 or 4305. — 0704 880345 or WHY.

**TELEQUIPMENT S32** Service-scope instruction manual, price £20. Wayne Kerr Autobalance universal bridge type B641 with service manual, operating manual and all leads. Price £50. APT regulated power supply type TCVO550 0-50V, price £10. — Phone 0235 816947.

**KENWOOD R2000** Communications receiver with Yaesu FRT7700 A.T.U. and service manual, as new, £350 ono. — Bob Sharp, Rosneath, Scotland. Tel. 0436/831/765, after 6pm.

**TOKYO HY-POWER** 6m SSB/CW, trans, IOW mic, boxed as new, unwanted gift, £250 ono. Yaesu FT301S HF filter, vgc, boxed £375 ono. — Tel. (0305) 813202.

**PRO-30 SCANNER** 16 channel 88-512MHz hand-held, hardly used, excellent condition, £150 ono. Also pair of Burndept VHF radios, set to simplex. Offers please. — Call Gref 01-253 5764, after 5pm.

**YAESU 270RH** dual band 144/432MHz, as new with voice synthesizer, boxed and perfect £360. Boat outfit, complete 2hp Yamaha, 8'3" dinghy, trailer, oars, life jackets, lighting board, £325 ono. WHY? — Bolton (0204) 852786.

**TS940S** fitted internal A.T.U., mint, £1700, save £700 on list. MC60A desk mike pre-amp up/down £60. SP940 speaker, 3 filters, 2 inputs, £62. All matching. VS1 voice synthesiser £23. Manuals, original cartons. — G4IOF, QTHR. Tel. 01-722 7040.

**YAESU FT 690** Mk2 boxed as new, sell for £275 ono. May take 690 Mk1 or TR9000 plus cash or swap for mint FT77, 707 WHY. — Phone Bob Luton (0582) 401881.

**FOR SALE** or swap, 2 K.V.A. Generator 230/115V 8.7/17.4A for HF transceiver or 2mtr multimode. Genny in good working order, 5hp Briggs and Stratton engine. Markon generator. — Phone Toney Wincanton 33271, G1RSF QTHR.

**SEPARATES** Trio 599S TX (dark front), Trio 599 custom special with 144MHz and 50MHz converters. Good cond, £299 or will separate. — Phone (0280) 703512 (Brackley).

**FOR SALE:** FL2100B Linear Amp, new cond, little used, £450 no offers. — G3HRM. Tel. 0942 870329.

**FOR SALE:** Standard C8900 2mtr FM 10 watt, mint £125. Also Yaesu FTV707, no module, mint £45. KW2000B vgc, new valves £220. Wanted A.T.U. ratd at 1kW with built-in meters. KW109 Drake MN2700 or similar. — Phone Coventry 450476.

**ITEMS FOR SALE:** Signal R537S air-band RX case and whip, battery charger, the lot £45.50. Microwave 144MHz converter, as new, £35.50. Packer VHF-UHF Wavemeters £30 each. Topband converter £16, exchange Trio P2000, VC 10 fitted for Icom IC-R71E. Will take IC-R70 if in good overall condition. — Tel. 0272 828586, anytime.

**SONY 7600D**, with PSU frequency guide, vgc £100. Radiomobile CB202 10mtr FM Transceiver with Nevada TC35DX amplifier £65. Jaybeam 4 ele 2mtr quad loft use only, £20. High resolution EMI monitor metal case, 56cms screen £30. — Tel. evenings 04893 6687, Hampshire.

**KR-400RC ROTATOR** £90; two element three band "Western" £50; Eight element crossed Yagi for 2mtrs, £20; 16ft thick wall ali tube £10; 24ft ali tube with 3in bore steel tube £25. All perfect with cables. — G3OAR QTHR. Ring 0924 270024.

**COMMODORE64 + PSU + Datasette**, RX4 tape and interface, books and tapes, £175 ono. — Tel. (0666) 823490.

**SALE OR SWAP:** Scanner receiver, realistic PRO2021, 68-88 108-136, 138-174, 380-470, 470-512 MHz, scans 200 selected channels, 240/12v, perfect, boxed, as new, £125 or swap for hand tuned multi band receiver. — Phone Les 0803 770531, South Devon.

**70cms 100w LINEAR** amp microwave modules, ex cond, £250 ono (nearly £400 new!).

**VHS Video Recorder**, Telefunken VR520 with band 1 (50MHz), DXTV + band and our VHF CH21-68 up converts band 1 + 3 to CH36, will record all bands 1 + 3 and VHF, very good indicator for 2m openings, in ex cond, £150 ono. 23cms 6W LMW PA (800MW in) £35. — G8GXP, 0924-278699, evenings only.

**RACAL RA17L**, comes with a very rare FRO 1002A digital frequency readout unit. RA63 single sideband adaptor RA237B low frequency converter and dual diversity daptor in racal steel cabinet, almost new condition. Also spare Racal steel cabinet for Racal receiver. £500 to lot. — Tel. 0306 711953, afternoon.

**TRIBANDER 3** element full size for 10, 15, 20m, £160, good condition. Monobander for 10/11m £25. £175 for both. Oldish Rae Course with 20 books. Free to collector or swap any of these for W.H.Y. — Contact Mick, G4XMH, on (0602) 736441, 24 hrs.

**EDDYSTONE EC10** with power pac, £55, in perfect condition. — 0283 221870, between 6pm and 10pm.

**FOR SALE:** Grundig Satalite 650, receiver mint £275 ono. — Phone 0306 711953, afternoon.

**FOR SALE:** Yamaha Two manual organ in perfect condition, £900. Exchange for Yaesu FRG 8800 or any RX/TX that covers 160-10 metres. Darkroom equipment, exchange for good marine RX. — Phone Londonderry 46871, after 7pm.

**VERTICAL ANTENNA**, HF 6 bnd, DX 6V, 26' high, £70. — 061-748 2915.

**TRIO R2000** Receiver + converter, boxed, £525. AT1000 ATU, £35. Datong FL1 III £85. AMT II complete interface + cart + power pack for '64' £175. Tec software RX4 prog with tape + module £20 ono. TBI + approx 60ft cable £75. Tonna 2 mtr crossed + rotator £35 ono. — 0256 882 825.

**TRIO TH41E** 70cm FM handheld trans, plus S/Mike, all mint, boxed, £165 ono. Yaesu CPU2500R 2m FM mobile/base trans keyboard, mic, vgc, £150 ono. — Tel. Weymouth (0305) 813202.

**FOR SALE:** SPC 3000 ATU £80. — Ring 0908 566266, after 6pm.

**FDK750X** 2m multimode, extended RX, dual VFO, 1-10W, boxed plus 8 ele Jaybeam and rotator £250. KDK2025 2m FM 5-25W, memory scan, extended RX £90. Lafayette 11mtr multimode, suitable for 10mtr conversion, boxed £75. — Tel. Basingstoke (0256) 472365, evenings.

**FOR SALE:** ICOM IC735 HF transceiver. Zetagi 25 amp power supply. Nevada TM1000 ATU 1.8-30MHZ, all items less than 5 months old and used for listening only. £800 the lot. — Tel. 0963 70178.

**TRIO TS520S HFSSB TCVR** is still for sale due to time waster. AT200 ATU and DG5 digital display/frequency counter, prefer no split, £450. Free HF antenna if buyer collects. — Contact Phil, GMOGNM QTHR, 0309 31082. Genuine reason for sale.

**YAESU FRG7000**, mint, boxed manuals £210. Commodore 64 computer, 1541 disc drive, 801 pringer, 1701 monitor, much software, many discs, £400 ono. Full C64 RTTY CW ASCII AMTOR micropatch software terminal, together £100. — Phone G0FGX, 03646-233.

**FOR SALE:** Telereader CWR 675-E decoder RTTY Daudot ASCII with 5½" green screen monitor plus 13.8v power supply, in new condition, £225 ono. — (0672) Marlborough 52571.

**BENCHER IAMBIC** Paddle, black base, as new, £42 inc p&p. Please write with SAE or Phone No. first to — Terry Grice, G4PSL, 162 Holly Avenue, Wallsend, Tyne and Wear NE28 6PL.

**FRG7** for sale. General coverage RX, good condition, incl manual and digital readout mod, £140. — Ring 0226 56131, after 6.30pm.

**FOR SALE:** Sony portable video outfit, SLF1UB recorder, TTF1UB tuner timer, HVC3000P camera, 3 nicad packs, vgc, £800 ono. — GOCCU, Bristol 721744, anytime.

**FOR SALE:** FTDX560 with speaker, base mike, £275, required new PA valves to bring back up to legal limit. At the

moment 200 watts on CW, other than that in good order. — Tel, eve after 5.30pm, 01-556 7759.

**GRC9** ex US military TX/RX with hand and mobile generator, also antenna and manual, £110 ono. — Mike G4PFG. Tel. 0379 852687.

**UNIDEN BEARCAT 50XL** scanner, hand held, as new, six months old, £70 ono. — Tel. 0633 810276.

**YAESU 101ZD** 12 band Mk3, mike, fan, excellent condition, original packing, gift for £425 or exchange with cash for Trio TS530SP. Grandstand CB base stn, probably best legal homebase available, £75. — Phone 0745 4995, North Wales.

**RX BARLOW** Wadley 500kHz to 30MHz continuous AMLSB, USB CW, crystal controlled, portable battery mains. Little used, for sale £150. — Tel. 0304 202834.

**SONY ICF2001D**, boxed with PSU, mint condition, £260. — Tel. 0602-305661.

**FOR SALE:** ICOM IC255E 2 metre transceiver, 1 watt 25 watt output, Wood Douglas pre-amp, £175. new b.n.o.s. power supply 12/12A 13.8V, £75. GP144 1 ant. The lot £250. — Tel. 0246 36496.

**FOR SALE:** Standard C5800 VHF multimode + Trio PS430 power supply, scanning mike and mobile accessories, £300. — Phone 01-310 1691.

**FOR SALE:** Bearcat Scanner UBC175XL, vgc, £135 ovo. — Peter, G3JXR, 0908 642398.

**YAESU FT790** 70cm multimode £285. Matching Yaesu 7010 linear £60. ICOM 290E 2 metre multimode 10 watts £285. Realistic PRO-2001 scanner 68-88, 144-174, 430-512, mics, sixteen memories plus band scanning, £90. — G1BWW, Doug, 0462 711722 (Herts).

**6 METRE** Multimode transceiver Yaesu FT690 Mk2 plus 15W linear, only used 3 weeks, £315. 250Hz 8 pole CW filter for FT101E £25. Hy-gain TH2 Mk3 2 element tri-bander with Balun, £85. — Phone 0273 462696, any time.

**YAESU FRG7700M** and FRV7700 with handbooks, perfect condition, £295. Telequipment S32A scope with handbook, £65. — 01-474 2476.

**FOR SALE:** Tokyo Hy-power micro7 70cms 3 channel 200mW handi. Xtaled RB10 & 432.800MHz 2 sets nicads, £80 ono. Also Scooper MR110 10 channel mobile scanner fitted 2 metre xtals £25 ono. — GOCCU Bristol (0272) 721744, anytime.

**SALE, TEN TEC** Century with magnetic circuit breaker plus crystal calibrator and electronic keyer built in. Little used, indistinguishable from new, £245. Also Hamgear super preselector and ATU, £25. — Phone Jeff 0484 645923.

**SILENT KEY** sale. FDK750X multimode, IC27E Fm mobile, ICO2E h/held R1000 RX, SRX30RX Yaesu FRV7700 VHF converter. sota 2mtr 40 watt amp. TR2400 h/held complete with STI bse, AEC twin meter SWR bridge. G4MH mini beam. Offers. — Phone 0343 45824, after 6pm, to GM4ILS.

**FT-726R** with two metre, 70cms, HF and satellite modules plus YM48 microphone, £850 or separately. 70cms module £135. Satellite module £40, HF module £180. No offers. — Mike G1XMG, 51B Brownhill Road, Catford, London SE6 2HB. 01-461 5398.

**FT73R** 70cm handheld 425/450 MHz FTS12 CTCSS board installed, soft case, two aerials, slow charger and NC-29 base charger, MH-18A2B SP/mike, spare nicad case. All in original packaging and manuals included, £280. — Phone Tom 01-582 7444 e/w, GOJSV.

**RAD COMM** dates: May 80-Sept 85, 12 for £8 + postage. Govt surplus wireless equipment handbook £5. Six languages, German, French, Italian, Dutch, Norwegian, Spanish, £10 each. Two speakers 10 $\frac{3}{4}$ " x 9 $\frac{3}{4}$ " x 6 $\frac{3}{4}$ ", £14. The maccome 7E as new, £79 + postage. 12 volt £7. Nickel-cadmium battery charger can be used with Max 7E. — 01-548 6111.

**SCOPE TECTRONIC** dual beam DC-1MHz manual, large heavy 22kg, £40. Buyer collects. — G1OKQ, Tunbridge Wells, Kent. 0892 45456, after 6pm.

**RTTY G4IDE ZX81** with programme on Eprom, proper keyboard, metal cased, with terminal unit, £50. KW Viceroy SSB TX, 80-10 mtrs, £30. Stolle rotator, £9. B44 ex-WD transceivers £10 pair. — Tel. Ipswich 689982.

**TRIO TH21E** two metre handheld, with charger, soft cae, speaker, mike and spare nical pack, £170. ICOM R70 communications receiver with FM, £500. HF converter, £35. No offers. — Mike, G1XGM, 51B Brownhill Road, Catford, London SE6 2HB. 01-461 5398.

**ICOM 1200E** 23cms Fm mobile/base, as new, perfect £460. Datong SRB2 'Woodpecker blanker' unit £65. Kenwood HC-10 digital world clock £50. ICS/AEA CP1 'computer patch' RTTY unit, tuning variable shifts etc, perfect. — Phone Paul G3XHF, (0293) 515210 (QTHR).

**PRINTER "Star SG10"** suitable for BBC computer, £150 ovno. FRG8800 communications Rcvr in mint condition, £425. 35A fully protected power supply 13.8V regulated, £75. EHT 2200V 300MA power supply, ideal for 813 linear, £40. — Phone 0375 378783. Grays, Essex.

**FT101B** £250. Kenwood remote VFO for 120V(s) or 130, £60. Mint, never used. Sony mini communications and FM broadcast RX cont coverage to 29.9MHz. £109. — GW3COI, Abersoch 2675.

**IC-H16 HANDHELD** 120-180 MHz similar to ICO2E, complete with BP3, BP5, BP8 Sp/mike, two aerials, two soft cases, BC3 charger, carry strap, suit amateur marine or PMR. All in original packaging with manuals. £350. — Phone Tom GOJSV, 01-582 74444, e/w.

**FT-757GX** All mode transceiver with general coverage receive plus matching FP-757HD heavy duty power supply. Two years old, little used, good condition. Original cost over £1000. Bargain at only £550. Tel: Bristol (0272) 844133 after 6pm.

**BREMI BRS35** 10A 13.8V PSU £20. Ham International HS 150 15A 13.8V PSU £25. Sell or excellent Sommerkamp

**FT767DX (FT707)** with fist mike, two pwr bands, owners manual, workshop manual, four spare crystals, many spare parts for 160 mtrs. Cash £375 or exchange for 25 watt 2mtr multimode base rig (Trio or Icom). — Contact G4XPP QTHR (no phone). Write please.

**SONY 7600D** receiver with PSU, boxed, £110. Manual and wave book. — 0207 560171.

**CBM 64** 1541 drive C2N cassette with software £225. Yaesu FL2100Z HF linear, vgc, £600. Yaesu FT780R 70cms m/mode, £325. Shack clearance, lots to go. SAE for list. May take p/x, WHY?. — Call Martyn G4SUI QTHR 0924 495916.

**DATONG** model DF1 radio direction finding unit for mobile use, complete with four  $\frac{1}{4}$  wave whips and four mag mounts for 2 metres. Literature included, £225. — Phone Tom GOJSV, 01-582 7444, e/w.

**FOR SALE:** HF5 vertical antenna. Also HF5R radial kit, both items brand new 3 months ago, never even been used at all. Reason for sale just bought tri-bander antenna, so must go. Sell only complete for £130 ono. — Tel. Scotland, Midcalder 880345, anytime.

**FT757GX YAESU** transceiver, excellent condition, £55. FP757 power supply £65. RN electronics, 6 metre, 25 watt transverter, unused, £135. Icom 720A transceiver with general coverage, £495. LA1000, no tune HF amplifier, 1.2kW, very compact, £450. — Tel. 0534 54186, after 6pm.

**JAYBEAM TB2** Mk3 antenna Tri-band 10-15-20, good condition, £120 ono. Tel. 0272 892627, GOJLI.

**SELLING CBM64C** with many extras. Am looking for information on any weather sat programs/hardware to use with Amiga A500. — Write to Lynn, 2 Ashby Road, Melbourne, Derbyshire DE7 1ES.

**IDEAL STARTERS** Rig, Trio TS510 5 band HF TCVR, 100 watts out C/W Ps 510 PSU/speaker £200 ono. Wanted Transverters for 144 MHz and 70MHz with 28 MHz IF. — Phone Andy on Dartmouth (08043) 5320.

**FT102** superb condition and performance. In original box with instructions £585. FC700 ATU (matches FT102) used two months only cost £150. Accept £95. BNOS LP50-3-50 amplifier £145. Global AT1000 S.W.L. ATU £45. GOJFM Tel: (Brixham) 0803-882281

**TRIO TR2300** 2M FM transceiver with matching VB2300 10 watt power amplifier. Carrying case. MB2 mobile bracket. Charger, microphone. NiCads. Manuals £140. Sentinel 2M Linear. 10 watts in, 40 watts out. Switchable. Pre-amp £45. Tel: Stafford 44964

**REALISTIC PRO 2004** scanner as new £300. Yaesu FT690 II £300. Yaesu YO901P £400. Yaesu FV901 £160. Commodore 128D with disk drive and data cassette £350. Philips 752 as new, in box, £140. — Call Martyn on 0924 495916, evenings to 9pm.

**FDK MULTI 750** 2m transceiver, all mode 10 watt, £200. 2m 50 watt linear amp, £50. Realistic Pro-31 UHF VHF 10 channel scanner £80. — Phone 0235 24379, between 6pm and 7pm.

**YAESU YC500E** frequency counter, top model, 0.02ppm, mint, boxed, £195. Bird throline type 43 with 50W 200-500MHz; 100w 100-250MHz; 100w 2-30MHz elements. Mint, boxed, £280. Tel. 0904 768545. G8QS.

**R107 ARMY SET**, good working order with original handbook. In transit case, clean and unmodded, £85. Telephone for list of test equipment, early mags, etc. — Tel. 01-462 4614.

**FT708** £160; **FT208** £125; both with spare nicad and speaker mic. Charger £5. Mobile mic (Heatherlite) £15. All vgc. — Martin G1DLK, (0908) 503414.

**JAYBEAM 108MHz-136MHz** beam antenna, 4 element, £20, £5 postage. Antenna rotator 70kg load with control box, overload protection, £20 plus £7 postage due to weight of item. — Tel. Chris 0226 288760, 9 Wade Street, Pogmoor, Barnsley, South Yorkshire.

**TRIO TR751E** 2mtr multimode, ideal home or mobile, boxed, mint, £450. — Wormley, Surrey 042879 3017.

**WANTED**

**FV101DM YAESU** external digital VFO wanted. "Name Your Price". Must be in perfect condition. Cash available. — 051 339 3433, or 26 The Paddock, Great Sutton, South Wirral L66 2NW.

**WANTED, YAESU FC707 ATU** and FP707 power supply. — Tel. 061 366 0130.

**WANTED TS530S** or similar equipment, in exchange deal for 3½" Myford Lathe plus many accessories. — Details, Geoff, 41 Penn Grove, Norwich NR3 3JZ. Telephone Norwich 406331.

**WANTED, urgent, handbook** for Yaesu FRG7 or copy will do. — Tel. Little Cherrington 202, Oxon, after 8pm. Also wanted ERA micro reader, will pay £70.

**WANTED: W.W.2 German** ex-service gear. Parts description, WHY? Swap or cash, will collect. For sale or swap BC-348 command TX & RX. W.S.58, W.S.38, W.S.19, 628RO. — Tel. 010-452-801875.

**WANTED: Service manual** or photocopy for ITT M5 Star Radio Telephone (3 CH UHF FM). — Please contact Andy 0604 48551, G6REG QTHR.

**WANTED: R1155 case.** 19 set 'B' set tank aerial base. Any 19 set parts. 38 set AFV and power supply. AR88 receiver. — G4DVH QTHR. Tel. 0229 54466.

**WANTED: Circuit Diagram** for Stalker IX multimode transceiver. Also wanted, all band ATU. — Phone 074 577 655.

**WANTED: TX SSB** to cover 3.5-3.8 M/cs, anything considered or WHY?. Must be cheap (but willing to pay carriage). — Contact Peter 0287-34397 (daytime).

**WANTED: Sony CRF330** or Sony CRF320 for cash. Also RF9000, RF8000 world radios. — Tel. 0462 33690.

**WANTED: YR-901 CW/RTTY** reader. Also the SP-901 ex/speaker for the FRG7700, most urgent. — Contact M Dunn, 50 Coventry Avenue, Grimsby, Sth Humberside DN34 5EQ.

**WANTED: HF transceiver** FT77, FT707, TS120, TS130, Argosy would also consider FT101, TS530 or similar. Also interested in Heathkit HW7,

Century 22 or similar. — GM4SVM (0786) 75834.

**WANTED: Any Ham International TX/RX**, preferably a multimode Mk1 or II. Must be in full working order and in good condition. Don't hesitate, call; cash waiting. — Tel. Gary on (0504) 46313, after 6pm.

**WANTED: Yaesu FV707 DM (VFO)**, with leads and manual if poss. I have a DNT 40 CNL CB with in-built mains unit or cash. — Details: Syd, Bursledon (042121) 4333, evenings after 19.00 till m/night.

**WANTED: Icom R71** for cash or part exchange Trio 2000 with VC10 VHF converter and cash. — 01-556 5131.

**WANTED: Mobile car** mounting bracket for Yaesu FT290 Mk1. If anyone has one to sell please telephone — Paul Davis on 021-352-1378. Someone always in, so please leave a number for me to get back to you; thank you.

**URGENTLY WANTED: 2** element 10mtr Yagi antenna, such as the HB10F2T by Tet or HB9CV or the G2BAR model also considered. Aerial must be in good condition, strong made etc. No CB antennas please. Your telephone calls most welcome. — Tel. Midcalder 880345.

**WANTED: Ham Radio Today** 1983/84 Jan 1983, March 1983, May 1983, June 1983, Aug 1983, Sep 1983, Oct 1983, Dec 1983, Jan 1984, May 1984, Nov 1984 and informatin on transverter for HF from 2 metres. Help. — Rick, 156 Runley Road, Luton. Phone 29329.

**CIRCUIT DIAGRAMS** or manuals required for National NCX-5 Tncvr. Photocopies welcomed. Basket case for spares would also be useful. — GUOJCI. Phil Horsepool. Le Petit Ruisseau, Vazon, Guernsey. 0481-57166.

**WANTED: Circuit or manual** on Han Internaitonal LA120 solid state linear, urgent. — Reg, 0904 768545.

**WANTED: Dummy load,** 200 watts and 75 ohms. Also oscilloscope, general purpose and modest spec. Full details and prices to — G4LJ, Douglas Brewer, 28 Hillcrest, Downham Market, Norfolk. Tel. Downham Market 383537.

**WANTED: 2m high gain** antennae EG 19ele/16ele

Tonna or 14ele parabeam or 12ele ZL special. Also wanted is HF mini-beam and SWR/power meter up to 400 watts. — Andrew, 30 Maple Road, Horfield, Bristol BS7 8RH.

**QUALITY COMMUNICATION** Receiver rquired with VHF. Possible to collect South England. — Please telephone Lymington, Hants 0590 76603.

**ILR IN BATH (Avon)** is boring, wish to receive Captial Radio in London, 100 miles away. Have high massive aerial. More information appreciated. — Summer address: B. Ramsden, 64 Glenhall Road, Woodford Green, Essex IG8 0DL. Reasonable postage refunded.

**CONSTANT voltage charger** required for the rado spares lead/acid 12V-5.7Ah sealed battery. Could someone check out a "Seavoice" RT-100, for me? More details if you were to phone — Mike Evans, anytime, (01) 505 6303 or write to 120 Loughton Way, Buckhurst Hill, Essex IG9 6AR.

**WANTED: Eddystone models** 940 and 880/2 receivers. Must be in mint condition and fair price. Will collect. — Rogers, 07356 2476.

**WANTED: Circuit diagrams** or handbook for Dymar 980 H/h or E.R.O. MR405, both low band AM. All expenses refunded, also wanted any low band AM H/h gear or VHF FM by Youth Organisation, i.e. limited funds! — Contact Martin, Reading 875358.

**WANTED: Station accessories** for Yaesu FT901DM. Please write stating price and condition. Postage or collection arranged to — 10 Apple Tree Road, Stanfree, Bolsover, Chesterfield, Derbyshire.

**WANTED: AR88LF 0-30MHz** RX + (Handbook) (GW1GAX) QTHR. Also wanted: any Racal TX or RX and Racal equipment, working or not, with price accordingly. — Telephone Aberaeron (0545) 570839, anytime.

**WANTED: ATV KW107** any condition. — Norman, Leeds 663846, 23 Moor Allerton Avenue, Leeds.

**EXCHANGE**

**SWAP RB4 Crystals** for RB14 for PFI's. — Phone 0305 67526.

**MICROWAVE** Modules 1296MHz transvertor 144MHz I.F., as new, £160; would exchange for 144 to 432MHz transvertor. Motorola UHF base station £100. Similar VHF base £100. — 0354 740441 (Cams).

**EXCHANGE** Diawa Search 9 2m receiver with 9volt power pack for good HF receiver ATU or will purchase ATU if available. — L Rogers, 07356 2476.

**EXCHANGE** or Sale, Sony ICF 2001 receiver 150kHz-30MHz AM/SSB 76-108MHz FM scan, direct entry, memories, etc. Used very little, still in box + PSU + manual, £160 or KW2000 or sim. WHY? or good II metre equipment. — R. McClurg, 26 Edenvale Ave, Eden Carrickfergus, Co. Antrim BT38 7NP.

**EXCHANGE, Sale, Trio 9130** 2m multimode, excellent, for FT290R11, would take FM unit with cash adjustment. LS102 + cash or good quality Camara, Nikon 301, OM40, FX103, etc or sell 9130 £325. T Waters, 42 Tregundy Road, Perranporth, Cornwall TR6 0EF.

**EXCHANGE: DTC382** Dataterminal & communications teleprinter, all built in interfaces, vgc; for HF communications RX 1.8 to 30.0 MHz. — Apply D.W. Montgomery, 18 St Danys Close, Sth Killingholme, Grimsby, Sth Humberside DN40 3X. All enquiries answered.

**EXCHANGE: 'C'** mount TV zoom lens, Xitex (USA) RTTY, PC Board drives teleprinter, RS232, swop for computer bits. — J Brown, 45 Marlborough Avenue, Falmouth, Cornwall TR11 4HS.

**EXCHANGE: RTTY set up.** 48K Spectrum Interface I microdrive Scarab Interface and cassette TU1000 terminal unit plus Gifty RTTY microdrive cassette. Plus all leads, booms etc. Boxed. For Icom or Trio handheld 2mtr or 70cm with charger. — Write to, G4XPP QTHR.

**EXCHANGE/SALE: Heathkit** ET3400 microprocessor trainer, microprocessor course, plus experimental components. Exchange amateur radio receiver/transceiver, WHY? or sell £200. — Phone 034282 2843, after 8pm. Also wanted circuit for Pye W30AM.

# Free Readers Ads!

**Buy, sell or exchange your gear through our free service to readers.**

1. These advertisements are offered as a free service to readers who are not engaged in buying or selling the same equipment or services on a commercial basis. Readers who are should contact our advertising department who will be pleased to help.
2. Advertisements will be inserted as and when space becomes available.
3. The insertion of advertisements will be on a first come, first served basis, subject to condition 2. As a result, it will not be possible to guarantee the insertion of a particular advertisement into any particular magazine.
4. Readers should either write out their advertisement in BLOCK CAPITALS or type it. The first word will appear in bold.
5. The magazine cannot accept any responsibility for printers' errors in the advertisements. However, we will do our best to ensure that legibly written advertisements are reproduced correctly. In the event of a gross error, at the Editor's discretion, a corrected version of the advertisement will be printed (at the advertiser's request) in the earliest issue in which space is available.
6. The magazine or its publishers will not accept responsibility for the contents of the advertisements, and by acceptance of these

conditions, the advertiser undertakes to indemnify the publisher against any legal action arising out of the contents of the advertisement.

7. The magazine reserves the right to refuse to accept or to delete sections of advertisements where this is judged necessary. Illegal CB equipment is not acceptable unless specified as suitable for conversion to amateur or legal CB frequencies.

8. Advertisements are accepted in good faith; however, the publisher cannot be held responsible for any untruths or misrepresentations in the advertisement, nor for the activities of advertisers or respondents.

9. Advertisers must fill in their names, addresses and (if available) telephone number in the space provided, and sign the form to indicate acceptance of these conditions (forms returned without a signature will not be used).

10. All that is to be reproduced in the advertisement should be entered into the space provided on the form printed in the magazine. A photocopy is only accepted if accompanied by the corner of this page. All advertisements must give either a telephone number or address for respondents to contact or both — these must be included in the advertisement.

11. Advertisements must be 40 words or less in length including the address or phone number information. Telephone numbers normally count as two words, exchange or exchange code plus number.

Name .....

Address .....

.....  
 .....

I accept the conditions above.

Signature .....

Send this form to: Free Readers Ads, Ham Radio Today,  
 1 Golden Square, London, W1R 3AB

**ENTER YOUR ADVERTISEMENT HERE:**

# HAM RADIO TODAY

Lineage: 54p per word VAT inclusive (minimum 15 words) **Semi Display:** (minimum 2cms) £8.35 + VAT per single column centimetre. **Ring for information on series bookings/discounts.** All advertisements in this section must be prepaid. Advertisements are accepted subject to the terms and conditions printed on the advertisement rate card (available on request).

## CLASSIFIED



01-437 0699 Ext 292. Send your requirements to: Ham Radio Today Classified Department, ASP Ltd., 1 Golden Square, London W1R 3AB.

### ACCESSORIES



Tel: 061-445-8918 061-434-5701 061-446-2437  
Fax: 061-445-0978 Tlx: 666762 PAMACO G

### WHOLESALE DISTRIBUTORS OF CB

WE DELIVER NATIONWIDE - OPEN EVERY DAY, SUNDAY 10-2.  
Pama House, 433 Wilmslow Road, Manchester M20 9AF

Giant range of CBs and accessories, contact us today for very fast, friendly service, competitive prices, widest range and latest CB products.

### COURSES

#### RADIO AMATEUR LICENCE

Start training now for the following courses. Send for our brochure — without obligation or Telephone us on 06267 79398

HRT16

- NAME \_\_\_\_\_
- \_\_\_\_\_
- \_\_\_\_\_
- \_\_\_\_\_
- Radio Amateur Licence
  - City & Guilds Exam 271
  - Micro-processor
  - Introduction to Television

Radio & Telecommunications Correspondence School,  
12, Moor View Drive, Teignmouth, Devon TQ14 9UN.

### FOR SALE

#### MRZ COMMUNICATIONS LTD

##### MRZ MICROWAVE MOBILE ANTENNA

Desk DC supply and base for Icom portables

Icom business —

TA Amateur — Marine — Air

UK and Export



#### MRZ COMMUNICATIONS LTD

Newcastle under Lyme

Tel: (0782) 619658

7 day service



**VHF ACTION RECEIVERS**  
Specialist hand-compact VHF monitor receivers for 10/mid/hf band detection + 10/11m Hear Hams, Aircraft, Public Services, Marine, Local 2-Way and much more!  
All 53-175MHz signals. Squelch, VFO facility etc European origin. Special Price £2950 inc p&p  
Prompt dispatch from  
**TAYLOR RADIO, 8 EMMERSON ST, CROOK, CO DURHAM**

#### 10 METER ENHANCEMENT IS HERE

ALL NEW AR-3500 ALL MODE MOBILE TRANSCEIVER - NOW AVAILABLE IN THE UK!  
MANY FEATURES INCLUDE: DIGITAL FREQUENCY READOUT - 28/30MC/S - AM, FM, USB, LSB, CW - SCANNING - SPLIT FREQUENCY OPERATION - AND MANY MORE.

S.A.E. FOR FULL DETAILS TO:  
**PETE JENKINS GO ECK (HR),  
43 GREEN LANES,  
WEST EWELL, EPSOM,  
SURREY KT19 9TW.**

### SURPLUS

#### ELECTRO DISPOSALS

2000 sq ft of surplus equipment and components

**Lonlas Workshops,  
Skewen, Neath,  
South Wales.  
Tel: 0792 818451**

### PERSONALISED LEISUREWEAR

#### T-SHIRTS & SWEATSHIRTS

by **Interprint**

MINIMUM ORDER - ONLY 12  
FREE DESIGN SERVICE

Other Top Quality  
Personalised Products

Sports Shirts, Ties, Hats, Lighters, Bags,  
Stickers, Badges, Aprons, Tea-towels.

Write for free colour brochure to:

**INTERPRINT Dept. HAM  
CRAVEN ARMS,  
SHROPSHIRE SY7 9NY.**

**TEL: (05882) 2703 & 2502**

SRI PAGER XTALS S20, S22, S23 £2.00 each + 20p P+P/NEW REEDS 123, 136, 928Hz £3.50 each + 50p P+P XTALS 4 433, 4 9152, 5 0688, 15 00MHz £1.00 each + 20p P+P  
8 POLE XTAL FILTER NDK 10F 15DG 10 7MHz/15KHz BW, £9.50 + 50p P+P  
SCANNER VOX AUTO RECORDS ON CASSETTE £5.00/£7.00 BUILT + 50p P+P  
**ELECTROKITS, 15 Kings Road,  
Sutton Coldfield, W. Mids, B73 5AB.  
Tel: 021-354-5409**

**AWARDS SEEKER.** Read computer printed booklet detailing over 350 awards. Send £5, Sue Squibb, G1TZU, 36 Frognaal Gardens, Teynham, Sittingbourne, Kent ME9 9HU.

### KITS

#### NEIGHBOURHOOD WATCH BURGULAR ALARM D.I.Y. KIT

will offer a professional system at a DIY price  
Ham mini beam 10, 15, 20 meters. Part integrated circuits, transistors, diodes, valves, resistors, etc.  
Service Manual and parts for spectrum and Amstrad  
Send a 8" x 5" SAE for list.

**M.J. SEWARD (Mail Order)  
St. Olafs Road, Stratton,  
Nr. Bude, Cornwall.  
Telephone: 0288 4892**

### MISCELLANEOUS

Heathkit U.K. spares and service centre. Cedar Electronics (HR), Unit 12, Station Drive, Bredon, Tewkesbury, Glos. Tel: 0684 73127.

**TO ADVERTISE HERE  
01-437 0620**

### QSL'S

**QSL CARDS.** Your own design on blank postcard (drawing, cartoon, rubdown letters) printed; 500 — £20. Our designs with your details also available. Send sae for details/samples: D J Mackinder GLDWP, The Ham Press, 5 Mill Cottages, Mill Road, Caversham, Reading, Berks RG4 8DP.

### SELL YOUR GOODS IN HAM RADIO TODAY

**ADVERTISE  
HERE FOR  
RESULTS**

## ACCESSORIES

### WHOLESALE

CB radios, aerials & accessories delivered to your shop. Contact for price list.

Parma House, 433 Wilmslow Road, Manchester M20 9AF. only 3 min. from M56



OPEN EVERY DAY, SUNDAY 10-2.

**NATIONWIDE DELIVERY DEALERS** contact us today for very fast, Friendly Service, Competitive Prices, Widest Range & Latest CB Products.

Tel: 061-445-8918 061-434-5701 061-446-2437  
Fax: 061-445-0978 Tlx: 666762 PAMACO G

### KITS & HOBBIES

GET READY FOR THE WINTER CONSTRUCTION SEASON WITH A NEW KIT FROM

#### KANGA PRODUCTS

KITS FOR THE AMATEUR  
BUDDING AMATEUR OR THE LISTENER  
R.F. ACTUATED SIDETONE GENERATOR £5.95  
DUMMY LOAD KIT (100 WATT) £7.95  
CRYSTAL MARKET KIT £9.95  
FREQUENCY COUNTER/DIAL £19.95  
SINGLE BAND RECEIVER £19.95  
THE 'ONER' HF TRANCEIVER £25.00  
DUAL BAND RECEIVER (20 & 80) £35.95  
(Some kits are supplied semi-complete)

Please add 85p P&P  
Send a large SAE for free catalogue

**KANGA PRODUCTS**  
3, Limes Road,  
Folkestone CT19 4AU

### AERIALS

#### T.A.R.

#### COMMUNICATIONS

For all Aerials & Lashing equipment

We are famous for the G5 RB antenna and the 5 7. & 12 element ZL

For Retail or Mailorder contact -

**TAR COMMUNICATIONS**  
King William St., Stourbridge  
W. Midlands. DY8 4EY

0384 390944

NEW GM AERIALS NOW AVAILABLE

### AERIALS

## TENNAMAST SCOTLAND

TENNAMAST ARE FAST BECOMING THE NAME FOR WIND UP TILT OVER MASTS.

THEY ARE: EASY TO OPERATE - SAFE TO USE - SLIM AND ELEGANT - SUIT-ABLE FOR HF AND VHF. DESIGNED AND BUILT PROFESSIONALLY BY ENTHUSIASTS FOR ENTHUSIASTS.

PLEASE WRITE OR TELEPHONE

TENNAMAST, SCOTLAND, Mains Road, Beith, Ayrshire KA15 2HT. Tel: (05055) 3824

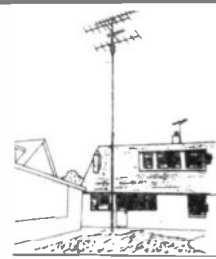

24 HOUR ANSWER SERVICE

### EQUIPMENT

## USED AMATEUR EQUIPMENT?

Buy, Sell & Exchange!

SELLING? I pay the BEST POSSIBLE PRICES for your Clean Used Equipment!

BUYING? I have the BEST SELECTION of top Quality Used Equipment Available!

For the Deal You've been looking for.

Phone Dave. G4TNY

On 04024 57722 or 0836 201530

9am to 7pm, Monday to Saturday.

Or send SAE for lists.

### G4TNY AMATEUR RADIO

132 Albany Road, Hornchurch, Essex RM12 4AQ

82% of our readers frequently use this section when deciding what to buy — to find out how you can take advantage phone: 01-437 0626

### COMPUTER SUPPLIES

#### Disks & Ribbons

3" CF2	£1.90
3.5" DS unbranded	£0.90
5.25" Memorex branded SS/DD	£0.60
5.25" 96 tpi DS, unbranded, labels etc.	£0.35
Vision 10 storage box 5.25" or 3.5"	£1.05
Imagewriter	£2.95
Citizen 120D	£3.50
Epson MX/RX/FX80	£2.75
Epson MX/RX/FX100	£3.10
Cannon PW 1080A	£2.69
Epson LX 80/86	£2.50
Kaga Taxan	£2.69

Please add 15% VAT carriage free.

T-systems Ltd.,  
The Signal Cabin,  
61 High Street, Orpington,  
Kent BR6 0JF  
Tel: 0689 22196

### GENERAL

## USED AMATEUR EQUIPMENT BOUGHT, SOLD & EXCHANGED

S.A.E. for latest list, second hand price guide, updated monthly. Useful guide for buying/selling £2. ATU mods add top band to SEM KW etc. £650.

Call Martyn G4SUI Geefor Enterprises, 112 Leeds Road, Mirfield, West Yorks. Personal callers by arrangement. Tel: (0924) 495916

### TERMS & CONDITIONS

#### CLASSIFIED ADVERTISING TERMS & CONDITIONS

Our terms for new advertisers (semi-display and lineage) are strictly pro-forma payments until satisfactory reference can be taken up (excluding recognised advertising agencies). Cheques and P.O.'s should be crossed and made payable to ARGUS SPECIALIST PUBLICATIONS LTD. and sent together with the advertisement to:

"The Classified Dept.,  
No. 1 Golden Square,  
London W1R 3AB.

There are no reimbursements for cancellations. Advertisements arriving too late for a particular issue will be inserted in the following issue unless accompanied by instructions to the contrary. It is the responsibility of the advertiser to ensure that the first insertion of every series is published correctly, and corrections must be notified in time for the second insertion, otherwise the publishers will not accept any liability or offer any reduction in charges.

All advertising sales are subject to Government Regulations concerning VAT. Advertisers are responsible for complying with the various legal requirements in force eg: The Trade Descriptions Act, Sex Discrimination Act and the Business Advertisements (Disclosure) Order 1977.

Full Terms & Conditions of Advertising available on request.

### WANTED

## Billington Valves

Valves Transistors I.C.'s.  
Usually the lowest prices ...  
Rarities our speciality.

Wholesale + Export enquiries welcome.

20lb (9kg) of resistors, capacitors, potentiometers etc. etc. 1930's-1960's £10 + V.A.T. delivered.

We wish to purchase a small quantity of valve types PX4 + PX2S (or equivalents) also types KT66 KT88, we'll also buy valve collections, transistors + shop clearance.

For quotations contact: **Martin Billington**,  
39 Highland Road, Horsham, W. Sussex RH13 5LH.  
Phone 0403 864086.  
Fax 0403 210108. Telex 87271

### SURPLUS EQUIPMENT

#### D & D ELECTRONICS (Kennington)

The sort of shop you used to see in Lisle St. All sorts of surplus supplies, so come along and browse or send SAE for info. sheets.

3a Braganza Street,  
London SE17 3RD  
Tel: 01-793 0054  
(Open 6 days a week)

To advertise here  
call Mark Linacre  
☎ 01-437 0699



# RETAIL NETWORK

## AVON

**AMDAT**  
**THE PACKET RADIO EXPERTS**  
 Authorised dealer for   
 CROFTERS, HARRY STOKES ROAD  
 STOKES GIFFORD, BRISTOL BS12 6QH  
 0272 699352/559398

## KENT

**ICOM (UK) LTD.**  
**ELECTRONICS**  
 Unit 8, Sea Street, Herne Bay, Kent  
 Tel: (0227) 369464  
 Telex: 9651791 com G  
 Fax: 0227 360155  
 Open Mon.-Sat. 9-5.30pm.  
 Lunch 1-2.

## TYNE & WEAR

**ALYNTRONICS**  
 For all amateur communications equipment and accessories authorised dealers for  and   
 129 Chillingham Road, Heaton, Newcastle Upon Tyne, NE6 5XL. Tel: 091 276 1002.  
 Open 10am-6pm Tues-Fri 10am-5pm Sat  
 Access & Visa accepted

## BIRMINGHAM

**HEWARD'S HOME STORES LTD.**  
 (Est. 1963)  
 822/4 Kingstanding Rd., Birmingham B44 9RT.  
 Tel: 021-354 2083  
 G4RJM with over 40 years in The Radio Trade  
 Ham Equipment urgently wanted!  
 Open: Mon-Sat 9-6

## LANCASHIRE

**AMATEUR ELECTRONICS/HOLDINGS G3LLL.**  
 YAESU JAYBEAM DRAE DATONG BLACK STAR COUNTERS  
 ETC FT 101 EXPERTS  
 6JS6C 6KD6 12BY7A Original type approved valves & our own Double Balanced Mixer and new band WARC Kits for original FT 101 MK1-F  
 S A E List Full Yaesu range 15 mins Junction  
 31 M6 Free parking. Call and consult G3LLL without obligation. Holidays? Phone check we are open before calling  
 45 JOHNSON STREET BLACKBURN BB2 1EF  
 (0254) 59595. CLOSED THURSDAY.  

## YORKSHIRE

**ALAN HOOKER ELECTRONICS**  
 42 Netherrall Road,  
 Doncaster  
 Tel - 0302 25690   
 Large stocks of electronic components

## BIRMINGHAM

**RAYCOM COMMUNICATION SYSTEMS**  
 International House,  
 963 Wolverhampton Road, Oldbury,  
 Warley, West Midlands B69 4RT.  
 Tel: 021 544 6767  
 Opening hours 9-5.30pm Late nights Thurs.-Fri.  
 Send just £1.00 (refundable against purchase)  
 for latest catalogue + our exclusive products & used list.

## LONDON

**ARE COMMUNICATIONS LTD.**  
 For Yaesu Icom and Kenwood.  
 Phone us for the best deals on all communication Equipment.  
 No. 6 Royal Parade, Hanger,  
 Ealing, London W5.  
 Tel: 01-997 4476

## SCOTLAND

**JAYCEE ELECTRONICS LTD**  
 JOHN GM30PW  
 20 Woodside Way, Glenrothes.  
 Fife KY7 5DP  
 TEL: 0592 756962  
 Open Tues-Sat 9-5  
 Quality secondhand equipment in stock. Full range of TRIO goodies Jaybeam - Microwave Modules - LAR 

## CHESHIRE

**FAST AND FRIENDLY SERVICE**  
**WHOLESALE CB**  
 PAMA HOUSE,  
 443 Wilmslow Rd,  
 Manchester  
 M20 9AF  
 061-445 8918  
 061-434 5701  

## ADVERTISERS

Capture the readers in your area  
 Contact Mark Linacre  
**01-437 0626**

## WALES

**SMC/TMP ELECTRONICS**  
 UNIT 27, PINFOLD WORKSHOPS,  
 PINFOLD LANE, BUCKLEY, CLWYD.  
 TEL: 0244 549563  
**FOR ALL YOUR AMATEUR EQUIPMENT AND ACCESSORIES.**   
 OPEN TUES, WED, FRI 10am-5pm  
 SATURDAY 10am-4pm OTHER DAYS BY APPOINTMENT

## DEVON

**AGRIMOTORS**  
 Merton CB & Radio Centre  
 Merton Garage & Post Office, Merton,  
 Nr. Oakhampton EX20 3DZ. Tel: (08053) 200  
 Open 6 days 9-6. Lunch 1-2.15. Closed Thurs. 1pm.  
 (Sundays by appointment)  
 Specialists in 934MHz  
 Supplies of all 27MHz and 934MHz equipment  
 Amateur Radio Stocked.

## SUSSEX

**G.W.M. RADIO LTD.**  
 40/42 Portland Road, Worthing,  
 Sussex Tel: 0903 34897  
 Constantly changing stock of interesting items for callers. Receivers, test equipment, components etc. Communications receivers - Racal RA17 £15.  
 Eddystone 730/4 £110, plus carriage.  
 NOW IN STOCK.

## N. WALES

**NORTH WALES AMATEUR RADIO MART**  
 AMATEUR RADIO - CB RADIO - MARINE RADIO - P.M.R.  
 25 ABBEY STREET  
 RHYL  
 Open Monday-Saturday: 11am-5.30pm  
 All repairs and accessories available ex stock Mail order welcome  
 Tel: 0745-51579

## HAMPSHIRE

**NEVADA** Communications  
 Ham Radio - CB Radio - Scanning Receivers.  
 Fast Mail Order Service.  
 Send £2 for our bumper catalogues (includes £2 voucher)  
**HOTLINE (0705) 662145**  
 189 London Road, North End, Portsmouth PO2 9AE

## SUSSEX

**BREDHURST ELECTRONICS LTD**  
 HIGH ST., HANDCROSS,  
 WEST SUSSEX.    
 TEL: (0444) 400786  
 Situated at the Southern end of M23. Easy access to M25 and South London. Open Mon-Fri 9am-5pm except Wed 9am-12.30pm. Sat 10am-4pm. **YAESU**  
 MAIL ORDER KENWOOD RETAIL

Ring  
**MARK LINACRE**  
**FOR DETAILS OF**  
**ADVERTISING RATES**

# ADVERTISERS' INDEX

Allweld.....	27
ARE.....	28
Bredhurst.....	27
Capco.....	20
Datong.....	15
ERA Communications.....	41
Elliot Electronics.....	49
ICOM UK.....	10
KW Communications.....	49
Leicester Amateur Radio Show.....	IBC
Low Electronics.....	OBC, 30
Nevada.....	20
RAS Nottingham.....	49
Raycom.....	IFC
RN Electronics.....	4
Spectrum Communications.....	23
Technical Software.....	41

## CLASSIFIED COUPON

**Rates: Lineage 54p per word (VAT inclusive), minimum £8.10 semi-display £8.35 + VAT per single column min. size 2cm x 1 column. No reimbursements for cancellations. All advertisements must be pre-paid.**

HAM RADIO TODAY, CLASSIFIED ADVERTISEMENT  
 DEPT, No 1 GOLDEN SQUARE, LONDON W1R 3AB

PLEASE DEBIT MY ACCESS/BARCLAYCARD NO

EXPIRY DATE -



--	--	--	--	--	--	--	--	--	--	--	--	--	--	--	--	--	--	--	--	--	--	--	--	--	--	--	--	--	--	--	--	--	--	--	--	--	--	--	--

FOR SALE   
  SOFTWARE   
  WANTED   
  EQUIPMENT   
  AERIALS   
  OTHERWISE STATE

Name .....

Address .....

..... Daytime Tel. No: .....

Signature .....

..... Date .....

★★ **THE LEICESTER** ★★  
**AMATEUR RADIO**  
**SHOW COMMITTEE**

★★★★

INVITE YOU TO THE  
**NATIONAL**  
AMATEUR RADIO AND ELECTRONICS  
**EXHIBITION**  
AT THE  
**GRANBY HALLS**  
**LEICESTER**



**ON**  
**FRIDAY AND**  
**SATURDAY**  
**OCTOBER**  
**28th and 29th**  
**10.00 am-6.00 pm**

**BRING & BUY**  
**STAR RAFFLE**

Admission — ADULTS £1  
*Concessions for*  
*Children and O.A.P's*

**Enquiries to Frank G4PDZ on 0533 553293**

# Listen to the World on the HF 125 SHORT WAVE RECEIVER

The HF-125 short wave receiver was conceived, designed and is "Made in Britain" for the DX enthusiast. Its ability to perform on a crowded band with strong adjacent stations was a major consideration in its design. The HF-125 is also easy to use, the controls being simple and sensible. Essential bandwidth filters which are often options on other equipment are fitted as standard. Unnecessary frills are not included and their omission is deliberate. The result is an affordable receiver.

The HF-125 has continuous coverage from 30 kHz to 30 MHz. Operating modes are AM, USB, LSB and CW. An optional board (D-125) adds FM. The HF-125 comes complete with a comprehensive range of bandwidths. For the morse enthusiast a 400Hz audio filter is included as standard.

Operating the HF-125 is refreshingly simple. The controls are logical in use and a large back-lit liquid crystal clearly displays the operating frequency.

Two buttons, one marked up, the other down, select the correct megahertz and you tune to the required frequency using a large heavy knob with a thoughtfully provided finger recess. The tuning rates relate to a simple design concept of two stations per knob revolution on each mode. As well as providing the optimum tuning rate whilst you are carefully looking for a weak signal, the HF-125 automatically increases its stepping increment as the knob rotation speed increases. The result is an extra rapid frequency shift to a new part of the band. There is also an optional keypad controller (K-125) for even quicker frequency selection.

To further enhance reception other facilities are included. A noise blanker is permanently in circuit to deal with vehicle ignition interference, 20 dB of attenuation can be switched in when required and an



HF or LF cut tone control can be applied to the audio output. The HF-125 provides its owner with outstanding performance.

Connections are included for both 50 and 600 ohm impedance aerials (So-239 and a terminal block). The receiver has jack sockets on the rear panel, one for an external loudspeaker and the other for tape recording.

The HF-125 operates from 12 volts DC and, as such, is suitable for use from an external battery whilst caravanning or boating. For home use an AC mains adaptor is supplied with the receiver. For truly portable listening, in the garden or on a hilltop, an internal rechargeable battery, charger and active whip aerial option (P-125) is available as well as a tough protective carrying case with shoulder strap (C125). Operation on a fully charged Nicad pack is around 10 hours.

Compact and lightweight, the HF-125 is 255mm wide, 100mm high and 200mm deep, a portable high performance short wave receiver.

HF125 .....	£375.00 Inc VAT, carriage £8.00
D125 .....	£59.50 Inc VAT, carriage £1.00
K125 .....	£59.50 Inc VAT, carriage £1.00
P125 .....	£69.51 Inc VAT, carriage £2.50
C125 .....	£23.85 Inc VAT, carriage £2.50

**LOWE ELECTRONICS LTD.**  
Chesterfield Road, Matlock, Derbyshire DE4 5LE  
Telephone 0629 580800 (4 lines)

**SHORT WAVE IS OUR SPECIALITY**