

10

Have You Got Your Binding Cases for Volume 1?

1<sup>s</sup>/<sub>3</sub><sup>d</sup>

# HARMSWORTH'S WIRELESS ENCYCLOPEDIA

## For Amateur & Experimenter

ELE—FIL

CONSULTATIVE EDITOR  
**SIR OLIVER LODGE, F.R.S.**

THIS PART CONTAINS  
**Special Articles by Sir Oliver Lodge**

*ELECTRONS IN THEORY AND PRACTICE  
ELECTROSTATIC CAPACITY  
MODERN THEORIES OF THE ETHER  
Illustrated with Special Photos and Diagrams*

**Many 'How-to-Make' Articles**  
EXPERIMENTER'S VALVE PANEL  
FAN AERIALS  
FAULTS AND FAULT FINDING  
FILAMENT RESISTANCES

**With 161 New Photos and Diagrams**

**VALUABLE PHOTOGRAVURE PLATE:  
FAULTS & HOW TO FIND THEM**

*J. LAURENCE PRITCHARD, F.R.Ae.S., Technical  
Editor, with expert editorial and contributing staff*

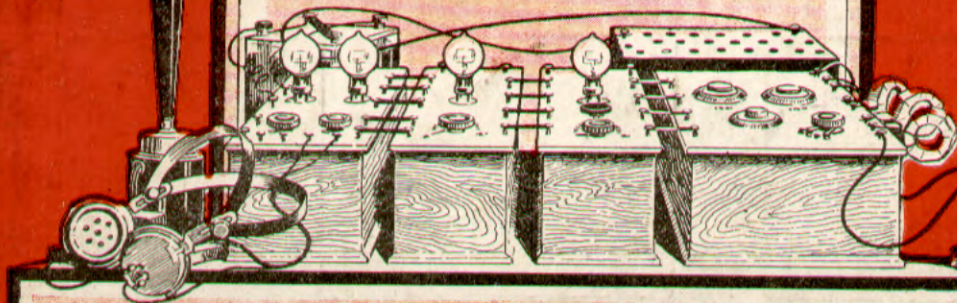

The Only ABC Guide to a Fascinating Science-Hobby

# A Pictorial Tour of the World for a Penny a Day

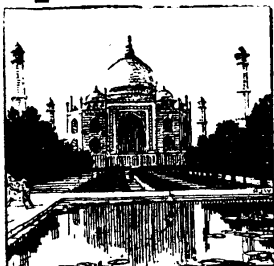

The Wonderful Story of the Countries and Chief Cities of the Globe, written by one hundred and thirty leading Travel Writers of TO-DAY.

**5,000 PHOTOGRAPHS**  
including 400 most sumptuous  
**COLOUR PLATES**



COUNTRIES OF THE WORLD is a magnificent new art publication which deals with every part of the Globe by means of descriptive articles (alphabetically arranged) as fascinating to read as they are instructive. Illustrated throughout by photographs beautifully printed on fine paper, with at least eight full-page COLOUR plates in each part, it stands unrivalled as a pictorial work. Buy parts 1, 2 & 3 TO-DAY.



## COUNTRIES OF THE WORLD

Fortnightly Parts

1/3 each

**PARTS 1, 2 & 3 NOW ON SALE**

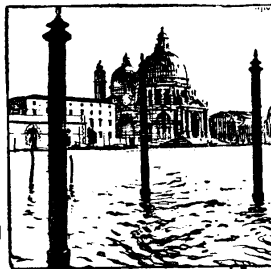



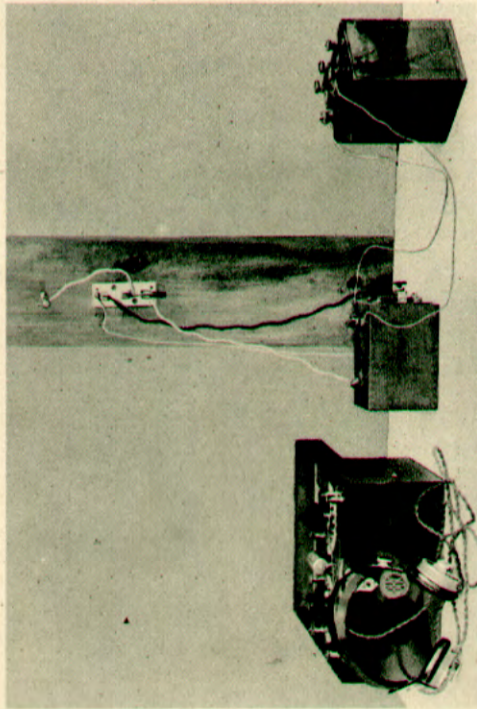

Fig. 1. How to test aerial insulation with a sparking coil connected to the lead-in wire. Leakages are indicated by a brush discharge, or direct sparking to earth

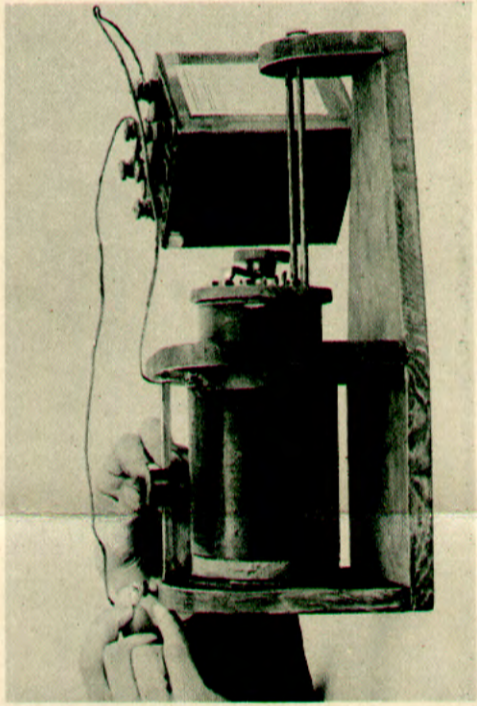

Fig. 2. Continuity of contact in a loose coupler primary is tested with a flashlight bulb. A break in the wiring or imperfect contact is shown by the lamp going out

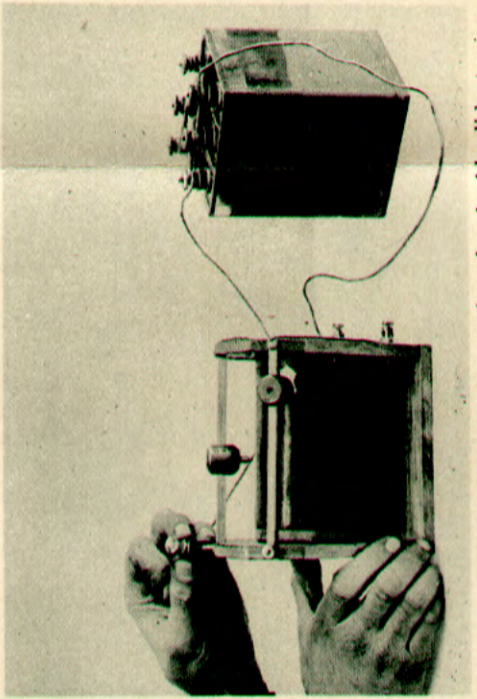

Fig. 3. To test the contact paths of a double-slide tuning inductance a piece of paper is placed under one slider contact while the other is tested

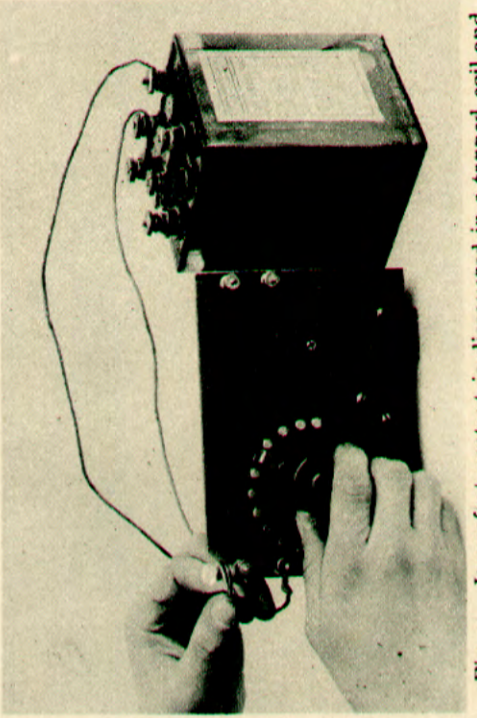

Fig. 4. Imperfect contact is discovered in a tapped coil and switch by a bulb and battery. The light becomes spasmodic if contact is imperfect, or goes out if broken

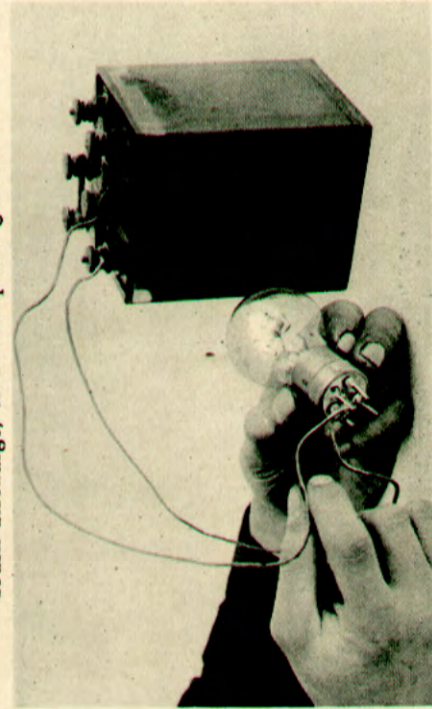

Fig. 5. When a valve filament is sagged, or is broken, so that it touches the grid, a battery across the grid and a filament leg reveals the fault by the lighting of the filament

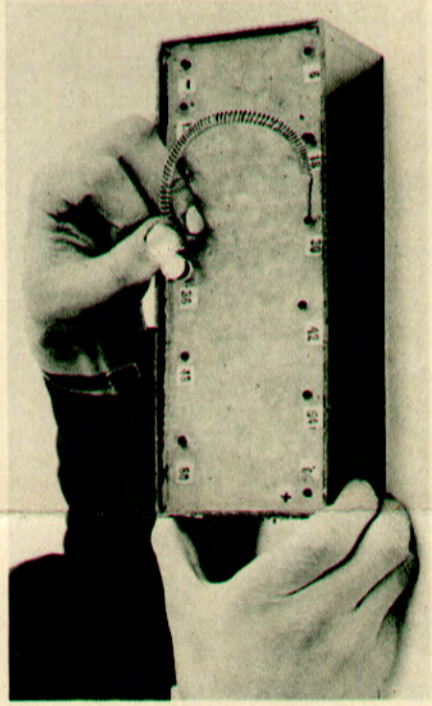

Fig. 6. Faults are detected in a high-tension battery with a 44-volt bulb and a coil of resistance wire. One tap of 6 volts is taken at a time



Fig. 7. Continuity of winding in a high-frequency plug-in transformer is tested by making connexions to opposite legs. A click will be heard if the windings are sound

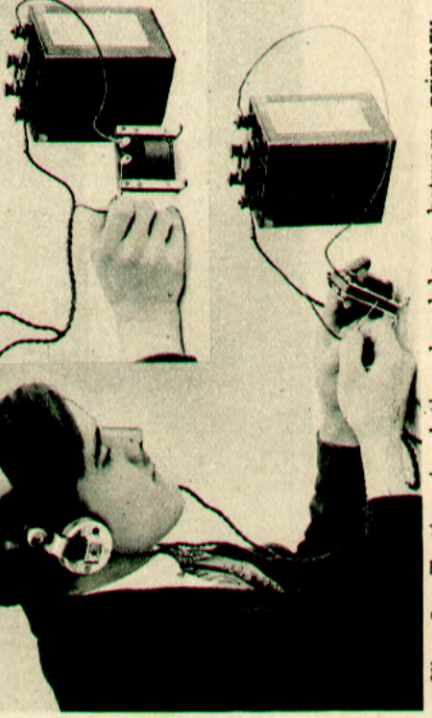

Fig. 8. Testing insulation breakdown between primary winding and core of a low-frequency transformer. Fig. 9 (inset). Primary winding continuity is tested in a similar way

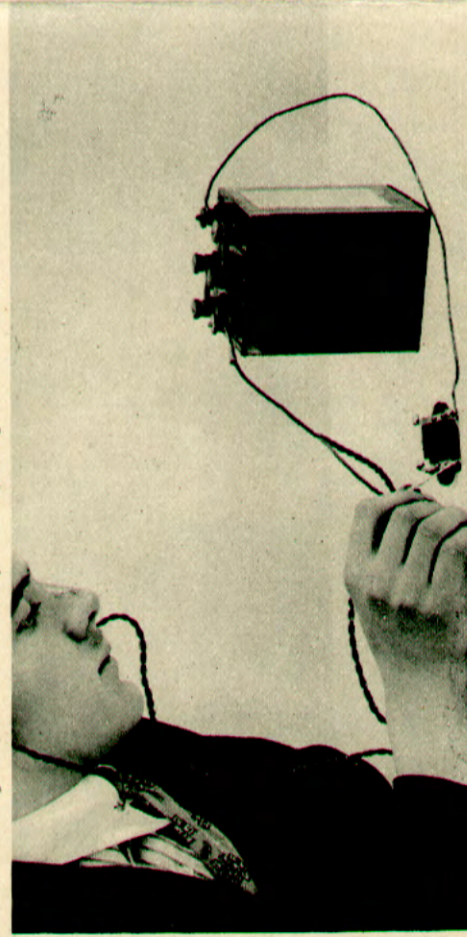

Fig. 10. Testing insulation of a condenser. The condenser (without grid leak) is placed in series with a battery and telephones. A loud click indicates faulty insulation

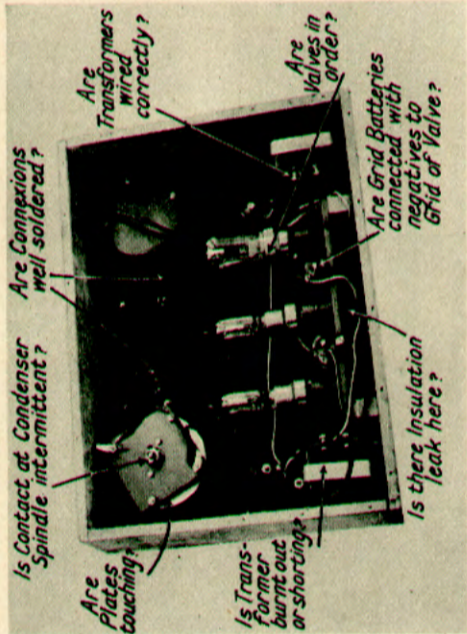

Fig. 11. Faults arise in unsuspected places. Here are a few possible defects in a three-valve set

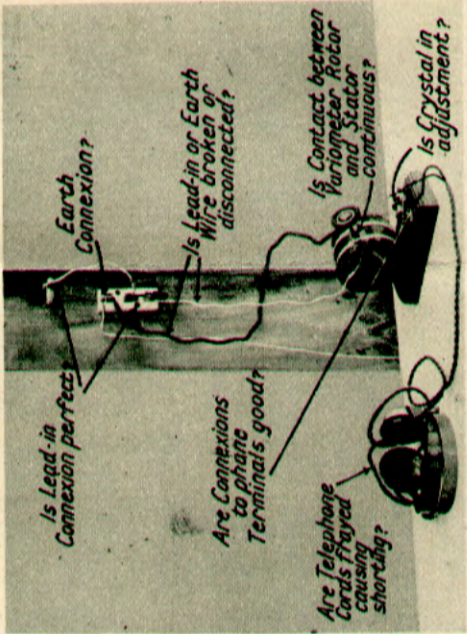

Fig. 12. Simple crystal sets are not always satisfactory. Faults may be found as shown here

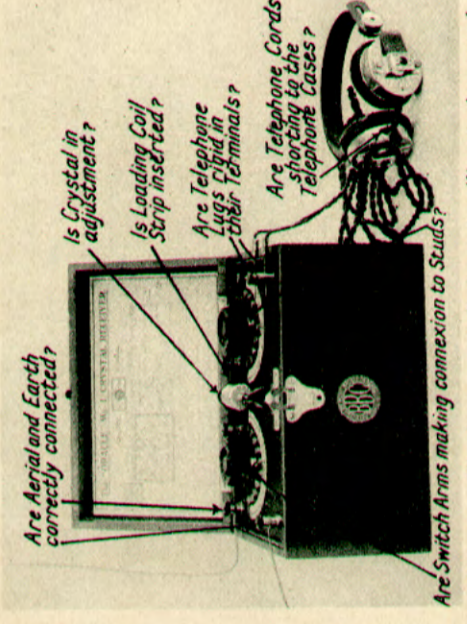

Fig. 13. The best crystal receiver will not give good signals without proper connexions and adjustments

**FAULTS AND FAULT FINDING: PHOTOGRAPHIC DEMONSTRATIONS OF METHODS TO EMPLOY TO DETECT LEAKAGES, BAD CONNEXIONS, AND OTHER DEFECTS IN RECEIVING APPARATUS**



a magnetic force to act at right angles to the electro-lines or lines of electric force. The combination of the movement of the lines of electric force and the lines of magnetic force at right angles forms the electric wave.

With the discharge across the gap the electro-line A B ceases to exist, and the next electro-line closes up to the gap. It is assumed that the momentum is so great that the ends of the line cross the gap before the middle portion, and ultimately a loop is formed, as shown in Fig. 3. The next step in the formation of the loops is shown in Fig. 4, and finally, as in Fig. 5, the loop breaks, and two portions, E and F, are formed. The breaking is due to the fact that there comes a moment when the lines are moving parallel to themselves, so that there is no magnetic field created. The process is repeated, new electro-lines are formed on the same basis as Fig. 2, until ultimately the electro-lines take the shape shown in Fig. 6, where a series of loops are shown thrown off.

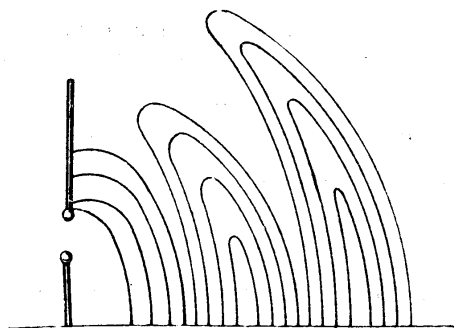

ELECTRO-MAGNETIC RADIATION

Fig. 7. Only the upper halves of the waves in Fig. 6 are shown, since the lower end of the aerial in this case is represented as being earthed.

A simple vertical aerial is considered

By this time a cylindrical sheet of lines of electric force has become detached, and is travelling outwards, and the charges on the oscillator are now being reversed in sign. The electro-lines still remaining on the oscillator begin to contract again as the next spark passes, and the whole process is repeated. The cylindrical sheets of lines of electric force become more and more flat as they move outwards. They are clearly sheets, because the motion takes place symmetrically all round the gap, and the ultimate plane of the sheets is at right angles to the direction they are moving away from

the oscillator. At the same time, magnetic lines of force are generated, and these lines are at right angles to the electro-lines, so forming circles whose planes are at right angles to the plane of the paper in Fig. 6. When the cylindrical sheets of electro-lines have moved so far away from the oscillator that they have become, for all practical purposes, planes, the magnetic lines of force are then perpendicular to them and also to the direction of motion.

Fig. 7 shows electro-magnetic radiation in the case of a simple vertical aerial. The lower end of the aerial is here supposed to be perfectly earthed, so that the aerial and the earth may be considered to form the opposing plates of a condenser. The source of the alternating current is not shown for the sake of clearness. Since the lower end of the transmitting system is earthed, only the upper halves of the waves, shown in Fig. 6, are produced, giving the appearance of Fig. 7 for the electric lines of force.

The same general system of propagation takes place in any form of electro-magnetic radiation, loops being formed and detached. When one form of aerial is a better radiator than another, it simply means that it is better able, due to the disposition of the electro-lines, to form the loops than other forms of aerial. See Electron; Electrostatic Field; Quantum Theory; Waves.

**ELECTROLYSIS.** Electrolysis is the term used to denote the decomposition of a compound substance, usually liquid, into its component parts by means of a current of electricity. Water, for instance, can be split up into its components, hydrogen and oxygen, by electrolysis. The instrument usually utilized for performing the experiment is known as a voltameter. This consists of a U-tube joined at the bottom by a third tube having a thistle-funnel top. Two platinum electrodes are fixed, one in each leg of the U itself, near the bottom. At the top of each leg of the U tube a tap, with a nozzle-shaped outlet to the atmosphere, is fixed. The thistle funnel on the third leg is placed considerably higher than the taps on the other tubes.

The voltameter is filled up to the level of the taps with water, which should be slightly acidulated to ensure good conduction of electricity. The electrodes are connected to a battery, preferably an accumulator, one to each pole of the



latter. A rheostat may be placed in series if the water-acid solution has too low a resistance.

Immediately upon closing the circuit gas begins to form round the electrodes, oxygen being delivered from the positive electrode and hydrogen from the negative. Water ( $H_2O$ ) is, of course, composed of two parts of hydrogen to one of oxygen, and it is in this proportion that the gases are liberated. As the gases have a very much greater volume than the water from which they were formed, they push the fluid down the U tube and into the thistle funnel at the top of the third leg.

This method of splitting up water by electrolysis is, however, purely a laboratory experiment, and is of no commercial value, being far too expensive in current consumption and slow in operation.

Electrolysis is frequently met with in various forms in wireless and general electrical work. For instance, one method of pole finding is by dipping two iron or copper wires, the polarity of which is to be found, in acidulated water. The wire which is surrounded by bubbles, or on which fresh copper is deposited, when current is passing is the negative. Again, the electrolytic condenser functions solely by means of electrolysis. The gas deposited on the plates polarizes them and gives the back E.M.F. like a gas battery. See Accumulator; Daniell Cell; Primary Cell.

**ELECTROLYTE.** Name given to the liquid used in a primary cell. There are many kinds of electrolytes, depending upon the types of primary cells used and their electrodes. In the Leclanché cell the electrolyte consists of a solution of sal-ammoniac in water, and the electrodes are carbon and zinc. The bichromate cell has a solution of bichromate of potash in a mixture of sulphuric acid and water. The Fuller cell is a bichromate cell with two electrolytes, one in an outer jar consisting of strong bichromate of potash solution with about 15 per cent of sulphuric acid added, and the other, in an inner porous jar, consisting of dilute sulphuric acid.

The well-known Daniell cell is also a double electrolyte cell. In the inner, porous vessel dilute sulphuric acid or dilute zinc sulphate solution is used, and in the outer a saturated solution of copper sulphate. In the Grove cell the electrolytes are dilute sulphuric acid and con-

centrated nitric acid. The Edison-Lalande cell has a saturated solution of potassium oxide or caustic potash as an electrolyte instead of the usual acid.

In the so-called dry cells the electrolyte consists of a moist paste, enabling the cells to be carried about without risk of spilling their contents. See Accumulator; Battery; Cell; Dry Battery; and under the names of the various primary cells.

**ELECTROLYTIC CELL.** Name given to a cell in which an external electromotive force is passed through an electrolyte. The action is similar to that of a primary cell. The electrolyte separates into ions, and at each of the electrodes one of the substances of which the electrolyte is composed accumulates. The substances may combine chemically with the substance of the electrode or with the electrolyte. Thus, if a solution of silver nitrate is used as an electrolyte, one electrode is covered with a deposit of silver, and at the other electrode nitrogen peroxides are released. These combine either with the electrode or with the water of the electrolyte to form nitric acid and oxygen.

The electrolytic cell forms a convenient way of measuring the amount of current. The amount of silver deposited upon the electrode depends only upon the amount of current. One ampere of current deposits 0.001118 gramme of silver per second from a solution of silver nitrate, and this current is the legal standard of the ampere (*q.v.*).

**ELECTROLYTIC CONDENSER.** The electrolytic condenser in its simplest form consists essentially of two metal plates or electrodes contained in a sealed glass tube. This tube is filled with an electrolyte. Upon the passage of current through the condenser a gas is formed round the electrodes, polarizing them and opposing the current.

Perhaps the greatest use to which electrolytic condensers are applied is as a protective agent against a phenomenon frequently found in high-voltage work, known as "voltage surges." Three distinct classes of surge are met with, these being:

- (a) High voltage and high frequency.
- (b) High voltage and low frequency.
- (c) Low voltage and high frequency.

Quite the most common form is (a), particularly in wireless work, and this type is dealt with fully below.

These surges, which may be due to the effects of lightning or other cause, take the



form of a sudden rush of pressure, building up to a voltage value many times greater than the normal voltage of the line, whatever apparatus is in use, and, as may be expected, would easily cause insulation breakdown were not steps taken to counteract the trouble at its source.

A surge of this character takes the form of a wave, and a surge caused by lightning, for instance, has a wave front practically vertical, which means that the pressure

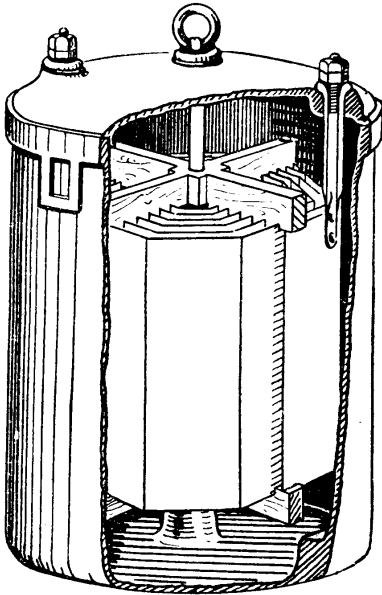

**ELECTROLYTIC CONDENSER**

Cut away to show the interior is a modern electrolytic condenser. Note the method of construction

rise is absolutely instantaneous. The factor of safety possible in insulation is usually limited by manufacturing cost and considerations of space, so that external protection against surges such as this is essential.

The electrolytic condenser possesses peculiar characteristics which render it ideally suited for the purpose of protecting apparatus from surges. An illustration of a modern electrolytic condenser is given in a cut-away view in the figure which shows the internal design.

The electrodes consist of two plates, of spiral formation, of aluminium wound together round a vertical axis. This method is adopted in order to secure a maximum surface with a minimum amount of edge, as the edges are the weakest points in an electrolytic

condenser. They form points where leakage may readily occur. One electrode is negative and the other positive. The whole of the container is filled with a special electrolyte. Upon current attempting to pass through the electrolyte, one electrode becomes completely surrounded with an insulating gas and aluminium compounds.

The resistance of this gas is of an extremely high order, and this increases as the pressure rises, until a certain critical pressure occurs. When this point is reached, however, it suddenly breaks down, resulting, of course, in the current passing readily from one electrode to the other via the electrolyte. As one side of the condenser is connected to earth, the current merely passes straight to earth without causing any damage.

As soon as the surge is passed, conditions in the condenser become normal again, *i.e.* it returns to its proper function as a condenser pure and simple. It will thus be seen that the electrolytic condenser forms an automatic safety device, certain in action and requiring a minimum of attention.

**ELECTROLYTIC DETECTOR.** A detector which converts high-frequency current into a direct current capable of causing sounds in an ordinary telephone receiver. There are several forms of electrolytic detectors. In one, the most usual form, a very fine platinum wire, a thousandth of an inch or less in diameter, is sealed in a glass tube, so that one end projects from the tube. The end of the wire dips into a small cup containing a solution of nitric or dilute sulphuric acid.

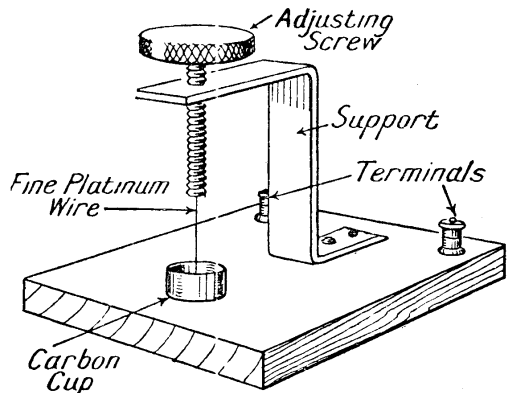

**PLATINUM WIRE ELECTROLYTIC DETECTOR**

Fig. 1. By means of this device high-frequency current is converted into direct current capable of causing sounds in a telephone receiver



Fig. 1 shows a diagrammatic view of an electrolytic detector. The wire is controlled in position by an adjusting screw, so that it may be lowered just to touch the acid in the carbon cup. The wire is so fine that the point of it curls up as it reaches the surface of the acid, as shown in Fig. 2.

The action of the detector is not yet fully understood. Fessenden has advanced the view that the action is thermal, while Rothmund, Lessing, and others, have come to the conclusion that the effect is due to a depolarization action caused by the high-frequency currents. It is more probable that the second view is correct.

In another form of electrolytic detector two vessels containing liquid are connected by an extremely fine tube. A battery of two or three dry cells is used to keep the current flowing, the terminals of the detector being placed in the two vessels. The cells are connected to a potentiometer so that the voltage applied to the detector can be varied. The potentiometer is adjusted until a faint hissing sound is heard in the telephone in circuit with the detector, battery and potentiometer. When this sound is heard, the detector becomes very sensitive to high-frequency currents, a sharp click being heard in the telephones when a momentary current is received via the aerial.

Electrolytic detectors are not so sensitive or stable as crystal detectors, which superseded them before they came into extensive use.

**ELECTROLYTIC INTERRUPTER.** An instrument for breaking up very rapidly an electric current in order to produce an intermittent current of high electro-motive force, as in the case of the induction coil. Interrupters are of various kinds, hammer, mercury, turbine, and others, the electrolytic variety having been first introduced by Dr. Wehnelt in 1898. Wehnelt proceeded on the discovery that, with a large lead plate placed in dilute sulphuric acid

as a cathode, and an anode formed by a thick platinum wire protruding very slightly beyond a glass or porcelain tube in which it is tightly fitted, it is possible, by inserting this combination in the circuit of a primary coil, to produce rapid intermittency in the primary current.

The effect is due to the formation of bubbles on the platinum, causing a temporary stoppage of the current flow. The automatic destruction of the bubbles again completes the circuit. By regulating the extent to which the platinum protrudes from the tube, the frequency of the break can be adjusted. There have been later modifications of the Wehnelt break, some of the more recent patterns having several platinum anodes.

In the Caldwell interrupter no platinum is used, but the principle is the same. Two electrodes are enclosed in a glass vessel having a small hole in it which can be more or less closed by a tapered glass plug, and are immersed in dilute sulphuric acid. As less current is required by this pattern a finer regulation of the coil to the current can be obtained. The Caldwell interrupter will also work with an alternating current.

While hammer and mercury turbine breaks can only be arranged to give from about 10 to 50 or 60 interruptions per second, electrolytic breaks will under some conditions give up to 1,000 interruptions per second. If the secondary terminals of induction coils are connected to spark balls placed a short distance apart, the discharge with an electrolytic break has a flame-like character resembling an alternating current arc. The electrolytic break is preferable for Röntgen ray work, as it gives less flickering, but its advantages are not so marked in the case of wireless. See Hammer Break; Mercury Jet Interrupter.

**ELECTROLYTIC RECTIFIER.** Device for changing alternating current into direct current by means of a solution or electrolyte and suitable electrodes. Such rectifiers depend upon the property of certain chemicals and solutions, combined with certain electrodes, to permit a flow of current to pass in one direction only. The electrolytes and electrodes are phosphate of ammonium and aluminium alloy and lead. Instead of these two electrodes, iron and aluminium-zinc could be used with the same electrolyte.

The wireless experimenter will find a rectifier of alternating currents extremely

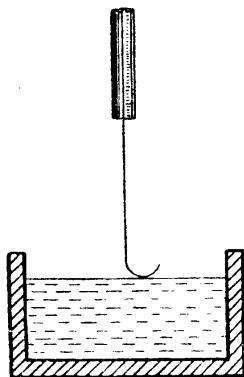

ACID EFFECT ON WIRE

Fig. 2. When the platinum wire of an electrolytic detector comes in contact with the nitric acid the effect shown above takes place



useful. A large proportion of the electric lighting current is alternating, and must be rectified before it can be used for charging accumulators.

An electrolytic rectifier can be easily made by the amateur out of simple materials. A wide-mouthed jam jar, or an ordinary glass battery jar as used for bichromate batteries (*q.v.*), is used to hold the solution, in this case a solution of sodium or ammonium phosphate. A cover should be cut to fit the top of the jar, and may be made of wood or ebonite. This cover should be drilled to take the electrode terminals, and should be grooved

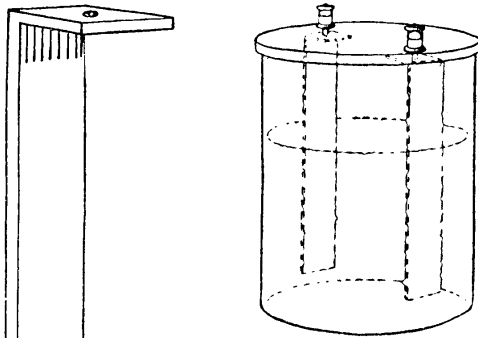

#### ELECTRODES OF HOME-MADE ELECTROLYTIC RECTIFIER

Fig. 1 (left). One end of the electrode is bent and drilled. Fig. 2 (right). The two electrodes are here seen in position in the rectifier, the terminals being attached to the bent portions

on the underside to fit tightly on to the top of the jar. In this way it serves not only as a support for the electrodes, but also to prevent the solution evaporating. If wood is used it will be found better to immerse it in boiling paraffin wax to protect it from the fumes of the electrolyte.

The electrodes are either iron and aluminium or lead and aluminium. They may both be cut out of thick sheet metal, and should be about an inch and a half wide and reach to within an inch and a half of the bottom of the containing jar. The electrodes should be bent at right angles, as shown in Fig. 1, and a hole drilled through the smaller part of the bend to take the terminal. The hole may be tapped to receive a screw or simply drilled a trifle larger than the

shank of an ordinary telephone terminal. The terminal will be held quite firmly in position by the nut underneath the cover.

Fig. 2 shows the two electrodes in position and the completed rectifier. The terminals are passed through the holes in the covers and in the electrodes, and held in position by a nut screwed firmly down. The solution of sodium phosphate should come about three-quarters of the way up the electrodes.

The action of the rectifier may be observed as follows: If the positive pole of a battery is connected to the lead or iron electrode and the negative pole to the aluminium electrode, the battery current flows through the cell in a normal way. If the connexions are changed over, however, so that the current is passing in the other direction through the rectifier, oxygen is given off at the aluminium electrode. This combines with the aluminium electrode to form a coating or film of aluminium oxide. This latter substance is an insulator, and as a result the passage of the current is stopped.

The action of the rectifier, in other words, is to allow a current to pass in one direction only. The rectifier, in fact, is an electric valve, and that is why it is so useful when dealing with alternating currents.

If the rectifier is connected to an alternating current supply, it allows the current to flow in one direction only. Every alternation of the current which makes the aluminium electrode positive is stopped, so that the alternating current entering the rectifier issues from it as an intermittent direct current.

For ordinary accumulator charging the usual alternating current voltage will have to be stepped down with a step-down transformer, or the rectifier will have to be placed in series with a number of lamps for the same purpose. Fig. 3

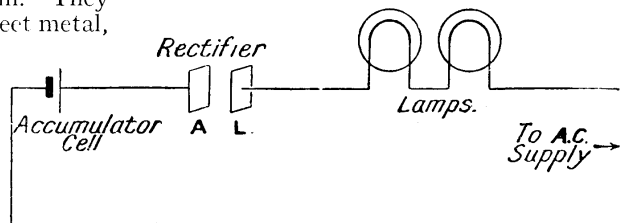

#### ELECTROLYTIC RECTIFIER IN CIRCUIT

Fig. 3. Two lamps are shown in series in this circuit, and A is the aluminium electrode and L the lead or iron electrode of the rectifier

shows a circuit diagram, and the reader is referred to the heading Accumulators for details of lamp resistances and also to the heading Charging Board. A and L in Fig. 3 are the aluminium and the lead or iron electrodes of the rectifier respectively. Fig. 4 shows the con-

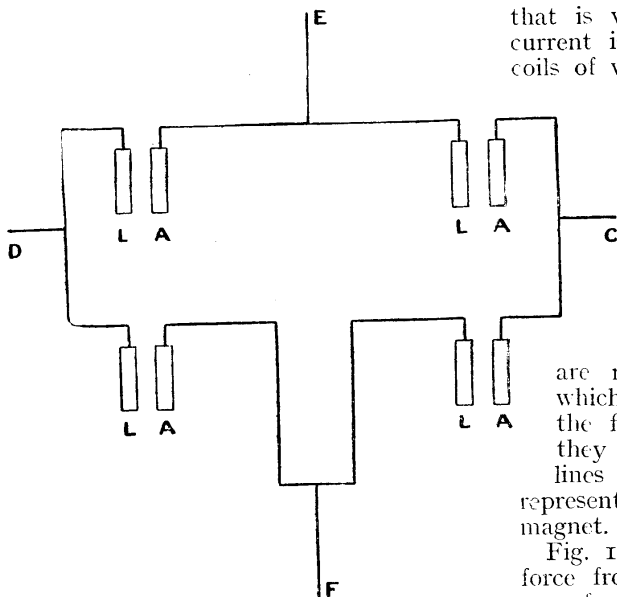

#### CONNEXIONS OF A FOUR-CELL RECTIFIER

Fig. 4. Alternating current is connected at E and F and direct current at D and C. The lead and aluminium electrodes of the four cells are shown at L and A.

nections for a four-cell rectifier. L and A in all cases represent the lead or iron and aluminium electrodes. E and F are the connexions for the alternating current, D and C those for the direct current, D being negative and C positive.

Four cells should be used as a rule and a step-down transformer or a lamp bank to reduce the voltage. It will be found after a certain amount of use that the solution gets exhausted, and the jars should be thoroughly cleaned out and fresh solution put in. Before this is done the electrodes and the jars should also be cleaned. The rectifiers should be watched when in use, as the solution may get hot, in which case it will not work so efficiently as when cold. See Accumulator; Charging Board; Transformer.

**ELECTRO-MAGNET.** A bent or straight piece of soft iron or similar magnetic material magnetized by the passage of an electric current through a coil of

insulated wire surrounding it. It ceases to be a magnet when the circuit is broken.

Before the principles of the electro-magnetic, or electro-dynamic machine, as it is more usually called, can be understood, it is necessary to have some conception of the meaning of Lines of Force.

When an electro-magnet is energized, that is when a suitable unidirectional current is allowed to flow through the coils of wire surrounding it, a magnetic field is created, which acts in a definite direction along lines which are called lines of force. This may be easily illustrated by the following experiment. Take a straight bar magnet such as is used in Post Office telephone receivers. Place it on a flat table and cover it with a sheet of thin paper.

A number of fine iron filings are now sprinkled over the paper, which may be gently tapped to help the filings to take up the position they desire. The filings will form lines about the poles of the magnet representing the lines of force of the magnet.

Fig. 1 shows the radiation of lines of force from such a magnet. It will be seen from Fig. 1 that the lines of force tend to meet in the middle, thus forming with the magnet itself a complete circuit. This is in fact what happens. Every line of force passes out from the north pole of the magnet and returns into the south pole. The same experiment may be carried out with an electro-magnet (see pages 824 and 825), and with the exception of one difference the results will be the same. The second experiment shows the difference is a greater concentration of the lines of force around the ends of the electro-magnet, as may be seen in the positions taken up by iron filings.

The reason of this greater concentration is that the soft iron of which the electro-magnet is composed offers less resistance to magnetic change than does a steel magnet. This magnetic resistance is called reluctance. A body that offers little reluctance to the path of lines of force is said to have a high permeability, which expression is equivalent to "conductivity" in electricity. Soft iron has a greater permeability than steel.

Up to a certain limit the greater the current passing through the magnet windings



and the more turns of wire comprising the windings, the more powerful and also the more numerous will be the lines of force resulting. This limit is called the point of saturation and indicates a maximum output of lines of magnetic flux,

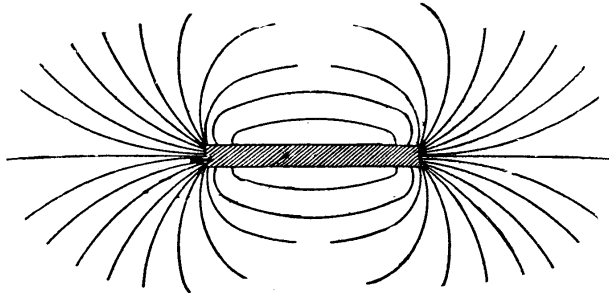

LINES OF FORCE OF A MAGNET

Fig. 1. Magnets radiate lines of force as represented above. It will be seen that there is a tendency for these lines to meet in the middle, forming a circuit or electro-magnetic path

at which state no benefit will be obtained by any further increase of current.

In order to make the best use of the lines of force from both poles of a straight electro-magnet, it is common practice to double the magnet round into a U or horseshoe shape. This practice is usual in electric bells, buzzers, telephone receivers of the watch type, and many other applications in electrical work, including, of course, the dynamo and similar electrical machines.

An example of this type of magnet is shown in Fig. 2, and is suitable for operating a relay or an electric bell, or similar mechanism. In the electric bell this horseshoe effect is obtained by riveting the two pole pieces into a soft iron casting, which is designed in the majority of types to form a support for the end of the vibrating armature and also to hold a post to which the

bell is secured. The electric bell and buzzer show the necessity for rapid demagnetization

A suitable arrangement is provided on the vibrating armature for securing electrical contact when the instrument is at rest. When, therefore, an electric current is made to energize the electro-magnet it attracts the armature, which causes the circuit to be broken. The electro-magnets, being made of soft iron immediately lose their magnetism, and consequently release the armature, which again makes contact. The buzzer is a very similar arrangement, but relies on its own more rapid vibrations to create sound.

In order to increase the rapidity of demagnetization, which is an important feature in many instruments or machines based on electro-magnetism or electro-magnetic induction, the magnets are often built up of laminations of soft iron stampings, which are bolted or riveted together.

The majority of electric telegraph receiving instruments depend upon the U-shaped electro-magnet in relays, Morse inkers, and other types of apparatus. In all cases the principle is the same, that of an iron armature arranged to do a certain work when attracted by the lines of force from an electro-magnet.

This principle is also incorporated in many electrical measuring instruments and meters, as the number of lines of force and their strength increase as the current increases.

An isolated example of electro-magnets having permanently magnetized cores of steel is found in the telephone receiver. This practice is standard in all types of telephone receivers, including wireless

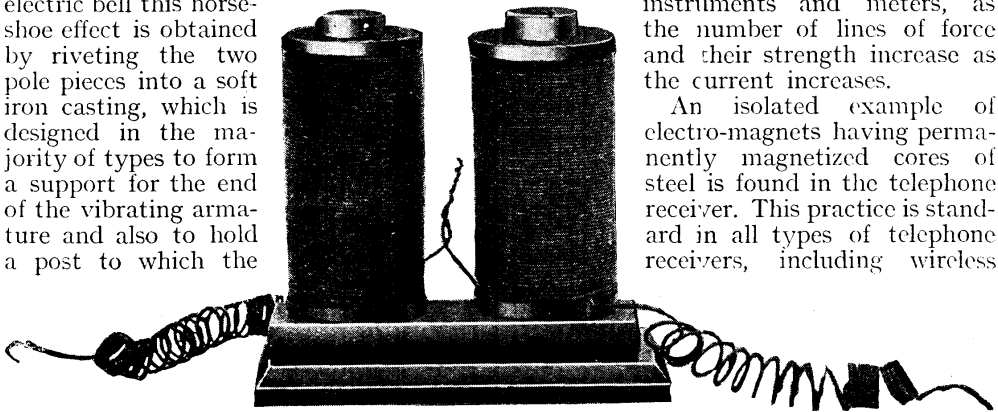

ELECTRO-MAGNETS SUITABLE FOR A MORSE INKER

Fig. 2. Electro-magnets, as illustrated, are suitable for a Morse inker, relay, or an electric bell. The wire is wound on boxwood bobbins, slipped over and fixed to two soft iron cores, which are in turn riveted to a cast-iron back plate

headphones and loud speakers. The object of permanently magnetizing the magnet cores is to give the diaphragm a permanent pull towards them, which results in greater sensitivity of movement.

Probably the best-known use of the electro-magnet is in the dynamo and motor. With these machines, especially the latter, rapid demagnetization is essential, and to secure this end the armature, and very often the field magnets, are built up of stamped laminations of soft iron bolted or riveted together. As electro-magnetic induction enters very largely into the principles of these machines, the subject is more fully dealt with under the heading Induction. See Dynamo; Generator; Induction.

#### **ELECTRO - MAGNETIC INDUCTION.**

Induction of an electrical current in a conducting circuit by means of the variation in a magnetic field of the lines of force which are linked with that circuit.

In 1831 Faraday, proceeding from the discovery that a current can be induced in a conducting wire simply by moving the latter in the neighbourhood of a magnet, eventually established the basis of the definition given above. His investigations have been summed up in the statement that if a conducting circuit is placed in a magnetic field, and if, either by variation of the field or by movement or variation of the form of the circuit, the total magnetic flux of the circuit is varied, an electro-motive force is set up in that circuit which at any instant is measured by the rate at which the total flux linked with the circuit is changing. What is known as Faraday's law of electro-magnetic induction is expressed as follows: The induced electro-motive force round any circuit is the rate of the decrease of the total flux of magnetic induction through the circuit. The theory of electro-magnetic induction was further developed by Neumann and Weber, and, at a later date, by Clerk-Maxwell. See Induction.

#### **ELECTRO-MAGNETIC RADIATION.**

Term used for the propagation or radiation of electro-magnetic waves through the ether. The subject is dealt with in this encyclopedia under the headings Electro-lines; Transmission; Wave, etc.

**ELECTRO-MAGNETIC RELEASE.** An electro-magnetic release is an automatic device fitted to a motor starter to prevent damage to the machine should the current

fail and then come on again suddenly with the starter in the "on" position.

Motor starters are variable resistances of the stud type, the resistance on each stud being cut out by the switch as the brush moves towards the full current position. A spring is fitted to the handle in order that it may fly back of its own accord. When the switch arm has reached the "full on" position, however, it is held there by an electro-magnet. This magnet is energized by the motor current. Therefore it only functions when that current is actually passing.

Should the current fail for any reason, the device becomes de-energized, with the result that the spring immediately returns the handle and the switch arm to the "off" position. In this position it is impossible for any damage to be done to the motor through the supply suddenly coming on again. The device is commercially known as a "no-volt release," and is a standard fitting to all motor starters. See No-volt Release.

#### **ELECTRO-MAGNETIC UNITS.**

Electrical units based on the centimetre, gramme, and second as the fundamental units. Electricity, or the effects of electricity, may be measured in two ways. By one the quantity of electricity is measured by the force it exerts upon another static or stationary quantity of electricity. By the other by the force a quantity of electricity exerts upon a magnetic pole when flowing through a near-by conductor. The first is the electrostatic system of measurement and the second the electro-magnetic, and both systems are in use. Maxwell showed that the ratio of the electrostatic units to the electro-magnetic units is identical with the velocity of light, or the velocity of the propagation of an electro-magnetic impulse through space, identically the same thing.

In the electro-magnetic system of units a unit current is defined to be one which, when flowing in a conductor of unit length, exerts a unit force upon a unit magnetic pole placed so as to be one centimetre from all parts of that circuit. In other words, the conductor is the arc of a circle, the unit of length is one centimetre, and the unit of force is one dyne (*g.v.*). This unit current is nearly 10 amperes.

The unit of resistance is that resistance which permits a unit current to flow through a conductor when there is a unit difference of potential between the two



ends of the conductor. The unit of resistance is one thousand millionth of an ohm.

The unit of potential is defined as follows. A unit difference of potential is said to exist between the ends of a conductor when it requires one erg of work to be done to move a unit quantity of electricity from the end at the lower to the end at the higher potential. It is one hundred millionth of a volt.

The unit of quantity of electricity in the electro-magnetic system of units is the quantity of electricity conveyed by the unit of current in the unit of time. It is equal to 10 ampere-seconds.

The unit of capacity of a conductor is measured by the quantity of electricity required to charge it to unit potential when it is infinitely removed from all other conductors. It is  $10^{15}$  mfd.

The above units, it will be noticed, are scientific, and not practical units. They are either too large or too small for practical work, and the actual units used are the ampere, the volt, the ohm, and the microfarad. See C.G.S.; Electrostatic Units; International Units; Units.

**ELECTRO-MOTIVE FORCE.** The force which causes an electric current to flow, or tend to flow, from one point to another due to a difference of potential between those points. It is usually abbreviated to E.M.F. The potential difference which a primary cell or any other generator of electricity is able to maintain between its terminals when these terminals are not connected by a wire, *i.e.* the total electrical pressure which the generator is capable of exerting, is its electro-motive force. The electro-motive force of a generator of electricity may therefore be defined as its capacity for producing electrical pressure or potential difference. Such a potential difference might be measured by the deflection produced in an electroscope or an electrostatic voltmeter, or other electrical measuring instrument. The precise cause of this force and the conditions appertaining to it are at present not fully understood.

Electro-motive force can, however, be measured and calculations made concerning it, and its presence is made apparent by certain well-known phenomena, such as the ability of a machine to perform some useful work when energized by an electric current.

The practical unit of electro-motive force is the volt, which is a term used to

define that electro-motive force which will cause a current of one ampere to flow through a resistance of one ohm.

The volt is equal to 100,000,000 C.G.S. units of electro-motive force, and may be considered as the pushing power that moves or tends to move electrons from one point to another—in other words, the power that causes the electricity to flow.

When electro-motive force does work a current is produced, and the practical unit of the current is one ampere, or  $\frac{1}{10}$  C.G.S. unit; and when a current flows for a known time a quantity of electricity is utilized. Quantity of electricity is defined by the coulomb, the practical unit of which is a current of one ampere flowing for one second, and is equal to  $\frac{1}{10}$  C.G.S. units.

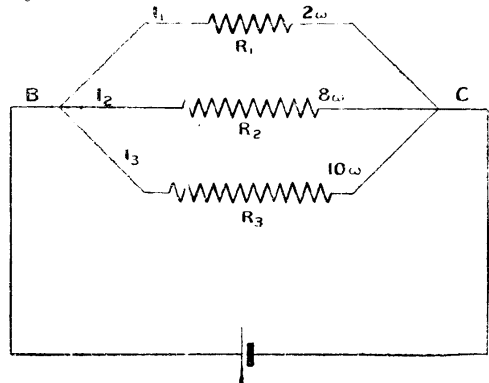

#### CALCULATION OF E.M.F. BY KIRCHOFF'S RULE

Fig. 1. This diagram illustrates how the E.M.F. of distributed currents from a common source may be calculated

Electricity in the form of a current passes more freely through some substances than others; consequently, there is a resistance to the flow of the current, and the unit of this resistance is designated the ohm, equal to  $10^9$  C.G.S. units. The ohm is defined as the resistance to a current of one ampere maintained by one volt.

In wireless work there are often very small amounts of current to be dealt with, and in such cases it is customary to use such prefixes as milli, one-thousandth, micro, one-millionth, to the designation; for example, millivolt, that is, one-thousandth of a volt.

The relationship of electro-motive force, current, and resistance are defined by Ohm's law, as in any active electric circuit these factors are always present. In general terms Ohm's law states that: "In an active electric circuit the current

is equal to the electro-motive force divided by the resistance," and, further, that the current is directly proportional to the electro-motive force and inversely proportional to the resistance.

By transposition the law can be set out thus:

(A) The current is equal to the electro-motive force divided by the resistance.

(B) The electro-motive force is equal to the current multiplied by the resistance.

(C) The resistance is equal to the electro-motive force divided by the current.

From the relationships set out above the current could not be calculated, but by the choice of the proper units an equation can be formed thus:

$$C = \frac{V}{R}$$

where C = current measured in amperes, V = electro-motive force measured in volts, R = resistance measured in ohms.

This only applies to steady currents; the effects of inductance and capacity modify the conditions.

An example of the application of the foregoing as applied to a steady current, such as that given from a filament-lighting battery, may be taken as follows:

Suppose a battery to have a resistance of 3 ohms and an electro-motive force of 2 volts sends a current through the wiring at the back of a panel through a filament resistance of 5 ohms, what is the current?

Applying the first rule, (A), above,  $C = \frac{V}{R}$  and filling in the values thus:

$$C = \frac{2}{8} = .25 \text{ amperes.}$$

It is necessary to notice that whatever is included in the circuit forms a portion of it, and its resistance has to be included. Hence, to be exact, the resistance of the battery, resistance coil, and the resistance of the wires has to be included and totalled, but it is customary to neglect the resistance of the very small amount of wire included in the circuit of the average receiving set.

Conditions are somewhat different when the circuit is complicated by distributing the current over several conductors all originating at a common source, and ultimately returning to the source.

Suppose the current to leave a battery by the positive terminal and branch in

three directions, passing through three resistances and ultimately reuniting and returning to the negative side of the battery, as shown diagrammatically in Fig. 1, then the solution can be found by application of Kirchoff's rule. This states that "If a current divides at a point, the sum of the resulting currents is equal in amount to the original current."

In the diagram suppose there is a current of one ampere entering at B, and let the potential difference between the points B and C, due to the resistances  $R_1, R_2, R_3$  of the various parts, be V volts. Then, by Kirchoff's rule, we have

$$C = C_1 + C_2 + C_3 \dots (1)$$

where  $C_1, C_2, C_3$  are the currents in the conductors whose resistances are  $R_1, R_2, R_3$  respectively.

Since the potential difference between B and C is V volts, it is also the potential difference between the beginning and end of each of the conductors.

$$\text{Therefore: } C_1 = \frac{V}{R_1}$$

$$C_2 = \frac{V}{R_2}$$

$$C_3 = \frac{V}{R_3}$$

$$\text{also } C = \frac{V}{R}$$

where R is the total resistance of the circuit. Substituting these values in equation (1) we get

$$\frac{V}{R} = \frac{V}{R_1} + \frac{V}{R_2} + \frac{V}{R_3}$$

$$\text{or } \frac{I}{R} = \frac{I}{R_1} + \frac{I}{R_2} + \frac{I}{R_3} \dots (2)$$

dividing both sides of the equation by V.

As a practical example, suppose the resistances are 2, 8, 10 ohms respectively. Then

$$\frac{I}{R} = \frac{I}{2} + \frac{I}{8} + \frac{I}{10} = \frac{29}{40}$$

$$\text{or } R = \frac{40}{29} \text{ ohms} = 1 \frac{11}{29} \text{ ohms,}$$

and the currents flowing in each of the branches, are respectively,

$$\frac{V}{2}, \frac{V}{8}, \frac{V}{10} \text{ amperes.}$$

When an electro-motive force moves a quantity of current round a circuit at some known rate, power is developed,



and the electrical unit of power is known as the watt, that is, the power developed when one volt produces a current flow of one ampere, that is, one coulomb per second.

Now when a certain power is utilized for a certain time an amount of energy is available, and may take the form of kinetic or potential energy. In wireless work the former can be illustrated by the current flowing through the filament of a valve, that is, electricity in motion. Examples of the latter are found in condensers and accumulators, where electrical energy is stored up when they are charged. The practical unit of electrical energy is the joule, and is the amount of energy produced by one watt acting for one second.

From the foregoing examples it should be appreciated that electro-motive force is a great fundamental phenomenon of electricity, and that is made manifest in many ways. It may be likened to the force that causes water to flow through a pipe, which in hydraulic work is spoken of as pounds, and in electrical work as the electro-motive force measured in volts. The rate at which a given quantity of water could be forced through a pipe depends on the size of the pipe and the pressure upon it, a greater pressure being needed to force a given quantity of water through a small pipe than a large one. Similarly with electricity a greater voltage is needed to force a given amount of electricity through a small conductor than a large one of similar material. The term level in hydraulic work is analogous to potential in electricity. Similarly the terms electro-motive force and voltage are analogous to the hydraulic expressions "difference of level" and "pressure."

#### E.M.F. measured by Potential Difference

The difference of potential is analogous to the difference in level of water, and in the electrical sense means the voltage difference between two given points, and is, in other words, a measure of electro-motive force.

Similarly, the pressure on the water may be obtained in many different ways—for example, a pump could be driven by a steam engine, or the water could be allowed to fall under the action of a natural force such as gravity, or the water could be heated and thereby set in motion. In the same way there are several ways in which electrical pressure can be

obtained. Of these there are three that are employed extensively.

In the first example an engine is used to rotate a conductor or series of conductors in such a way that the conductor is cut by magnetic lines of force, such an arrangement taking practical shape as a dynamo or generator (*q.v.*).

In the second case, two dissimilar metals or other substances may be immersed in a liquid, such taking practical form as primary or secondary batteries.

In the third example, two dissimilar metals may be placed in contact and the junction between them heated, examples being found in electrical measuring instruments, such as the ammeter and wavemeter, and in detectors, such as the tellurium-zincite couple used in some receiving sets.

The most powerful electro-motive force is generated by the first method, the second for the storage of relatively small amounts of potential energy, while the thermo-electrical generation of electro-motive force is generally restricted to the smallest currents, almost infinitesimal in magnitude.

In the last two examples the electro-motive force can be considered roughly as being generated in a regular and steady manner by the juxtaposition of the elements; but in the case of a generator the electro-motive force is not so produced, but is the result of induction between two or more parts of the machine, because a rotating part of the machine, carrying a conducting coil of wire associated with it, cuts a magnetic field usually set up by an electro-magnet. The linking of this flux induces an electro-motive force in the conductors, and when this electro-motive force is impressed on a closed circuit, it will force an electric current through it—in other words, there is a transference of electrons.

The laws underlying the generation and functions of an induced electro-motive force are dealt with under the heading Induced E.M.F. The formulae for electro-motive force, as given for steady currents, do not apply in their entirety to an induced or to an oscillating electro-motive force, and similarly with the differences in a circuit when inductance and capacity are included in it. See Ammeter; Back E.M.F.; Electricity; Electroscope; Galvanometer; Induced E.M.F.; Induction; Voltmeter



**SIR J. J. THOMSON, O.M., F.R.S., THE DISCOVERER OF THE ELECTRON**

Originally given as the name of the supposed atom of electricity, the full discovery of the electron as the fundamental unit of negative electricity was made by Sir Joseph Thomson towards the end of the nineteenth century. In this photograph Sir Joseph Thomson is seen inspecting large transmitting valves with water-cooled electrodes, valves which, like all valves used in wireless work, were made possible by his researches on the electron

*Photo. Western Electric Co., Ltd.*

## THE ELECTRON IN THEORY AND PRACTICE

By Sir Oliver Lodge, F.R.S., D.Sc.

Here our Consultative Editor, who has himself carried out original work on electrons, explains clearly and simply the theories of the electron and their relation to atomic and molecular theory, with particular reference to the thermionic valve used in wireless reception and transmission. See also Electricity ; Proton ; Valve ; Waves

Electron was a name given long ago to the supposed atom of electricity by Dr. Johnstone Stoney, in anticipation of its future isolation and complete discovery. That electricity was discontinuous or atomic, like matter, was half suspected by both Faraday and Clerk-Maxwell, mainly on chemical grounds. For the facts suggested that during electrolysis (*q.v.*) a definite and apparently indivisible unit of electricity belonged to each atom and travelled with it. Chemists also, with their monads, diads, triads, etc., virtually, though perhaps unconsciously, assumed that the electric charge responsible for chemical affinity existed in numerable units—that is, in units which could be counted.

The full discovery of the electron was ultimately made by Sir J. J. Thomson, in the closing years of last century, when he measured and, so to speak, weighed the particles in the torrent of cathode rays in a Crookes' tube, and showed that exactly the same particles were obtained whatever kind of matter existed in the tube. The electric charge on these particles proved to be negative ; and so the electron is the fundamental unit of negative electricity.

The real nature of the electron is not yet known, but is believed to be a definite and peculiar modification of the ether of space. Lines of electric force radiate from it in all directions ; that is, each is provided with an electric field which extends to an unlimited distance. For this reason they repel each other, with a force inversely as the square of the distance.

The unit of positive electricity was discovered later, mainly by Rutherford. It is called a proton (*q.v.*), not an electron, and in many respects appears different. But its electric charge is the same, only opposite in sign. Protons, too, repel each other, but attract electrons with an equal force. Their combination is electrically neutral and constitutes an atom of ordinary matter.

For methods of determining the charge and mass of electrons, books must be referred to, such as "Electrons," by

Lodge, or "The Electron," by Professor A. E. Millikan (University of Chicago).

The most accurate determination of the charge on an electron was made by Professor Millikan in America, his method being to get it to enclose itself in a minute globule of water, visible as a mist globule in a horizontal microscope, and then, by applying and measuring a vertical gradient of potential, to determine the strength of the artificial electric field which was just sufficient to counterbalance gravitation and prevent the globule from falling.

Similar determinations have been made by many other methods, chiefly by comparing the magnetic and electric deflexions of cathode rays (Fig. 2); and they all agree to two significant figures. Millikan's measurement gives for the charge of an electron  $4.77 \times 10^{-10}$  electrostatic unit ; or, what is the same thing,  $1.59 \times 10^{-19}$  of a coulomb.

### What Does the Electron Consist of ?

For the size of the electron we are partly dependent on the theory of Sir J. J. Thomson as to the nature of electric inertia, which he promulgated so long ago as 1881, showing that an electric charge simulated one of the properties of matter by adding to the apparent mass of the charged body an amount which, with a body of any ordinary size, is absolutely negligible. But the mass really depends on the energy of the charge. In fact, according to the theory of relativity, matter and energy are interchangeable.

So by making the body small enough, the charge becomes so concentrated that its potential rises to a considerable amount, and the energy—and therefore the mass—has a value of some importance. Experiments have since confirmed the suspicion that the whole mass of an electron is dependent on its charge ; in other words, that it consists of electricity and nothing else. That being so, the size of an electron can be reckoned, at any rate, approximately. Though what precisely is meant by its size will be better understood when we know more about its constitution. Meanwhile, the speck or volume which



it occupies is usually thought of as a little sphere  $10^{-13}$  centimetre in diameter; so that a hundred thousand of these spheres would have to be put side by side to equal the diameter of an atom; and yet an atom is so small that ten million atoms side by side would only equal one millimetre. The electron is therefore almost inconceivably small, much smaller in volume than it is in mass. In mass it is about the eighteen-hundred-and-fiftieth part of the lightest known atom; but in volume it is less than the hundred-million-millionth part.

The series of spectrum lines belonging to the simple X-ray spectra of exceptionally small wave-length, represented in Fig. 1, is what enabled Moseley to count the electrons in the atom, and to form the atoms into a regular numbered series, from hydrogen 1 to uranium 92. A few steps in that staircase were vacant, as far as our knowledge went at the time; but some have been filled up since, because their place in the series enabled the properties of these missing elements to be predicted, and thus served as a clue to their discovery. One step was filled up in 1923 by the discovery of hafnium; three more steps remain to be filled up, and then the series will be complete. Examined closely—though not, of course, in the diagram—the lines represented in Fig. 1 are seen to be compound, having a fine structure; and this structure can be accounted for on theoretical grounds.

Nevertheless, in no atom are there very many electrons, never more than a

hundred, and sometimes only one. The number depends on the nature of the chemical element, and for the most part determines that nature. It is obvious, therefore, that they do not fill the bulk of the atom. The atom is mostly empty space, and this accounts for its extreme porosity, when projectiles comparable to electrons in size are driven through it. A sufficient layer or thickness of a dense substance, like platinum, will stop electrons, even when travelling with the speed of cathode rays; and their stoppage generates the peculiar kind of radiation, of excessively high frequency, called X-rays, discovered by Röntgen in 1895.

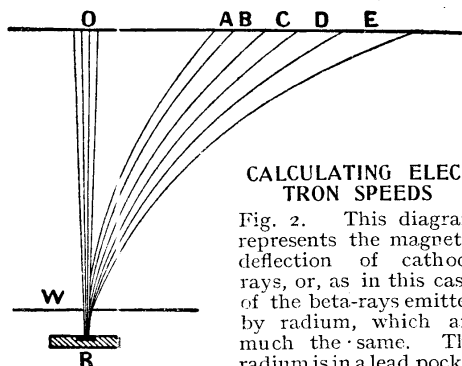

**CALCULATING ELECTRON SPEEDS**

Fig. 2. This diagram represents the magnetic deflection of cathode rays, or, as in this case, of the beta-rays emitted by radium, which are much the same. The radium is in a lead pocket at R. Its rays pass through a small hole or window, W, and normally strike the screen at O. But when a perpendicular magnetic field is applied the rays are bent aside into circular arcs, by an amount depending on their speed, and reach the screen at A B C D E. The amount of their deflection enables the speed of the particles (electrons) to be calculated.

Ti				
V				
Cr				
Mn				
Fe				
Co				
Ni				
Cu				

**X-RAY SPECTRUM LINES FROM WHICH ELECTRONS WERE COUNTED**

Fig. 1. Diagram of the X-ray spectrum lines, skilfully obtained and interpreted by Moseley, for the successive chemical elements titanium, vanadium, chromium, manganese, iron, cobalt, nickel, copper. They enabled him to count the electrons in the atom. They evidently form a series, or what may be called a staircase, each spectrum containing a pair of similar lines, with gradually diminishing distances between them

It seems impossible in a diagram to illustrate the size of electrons as compared with atoms; but one can show in diagrams (Figs. 3-6) their supposed arrangement in atoms, though these do not rightly represent their size. The diagrams (Figs. 7-11) represent some of the peculiarities of the simpler atoms; though they must not be taken as pictures. The atoms of the chemical elements increase in complexity as the series is ascended. More elaborate diagrams (Figs. 12 and 13) were given of some of them by Professor McLennan in his Presidential Address to the British Association at Liverpool, 1923. In that representation the two helium electrons are shown revolving in different planes; and this group is repeated in all the higher atoms. Another set of diagrams illustrate the assemblage of atoms into molecules (Figs. 14-17); and in this sort of way it

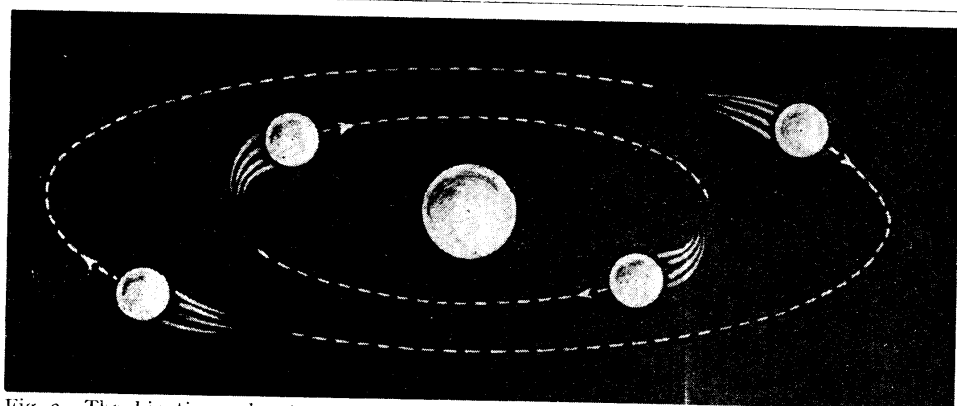

Fig. 3. The kinetic or planetary arrangement of electrons in the atom, according to which the electrons revolve round the nucleus as the planets revolve round the sun; worked out by Sir E. Rutherford and Professor Bohr

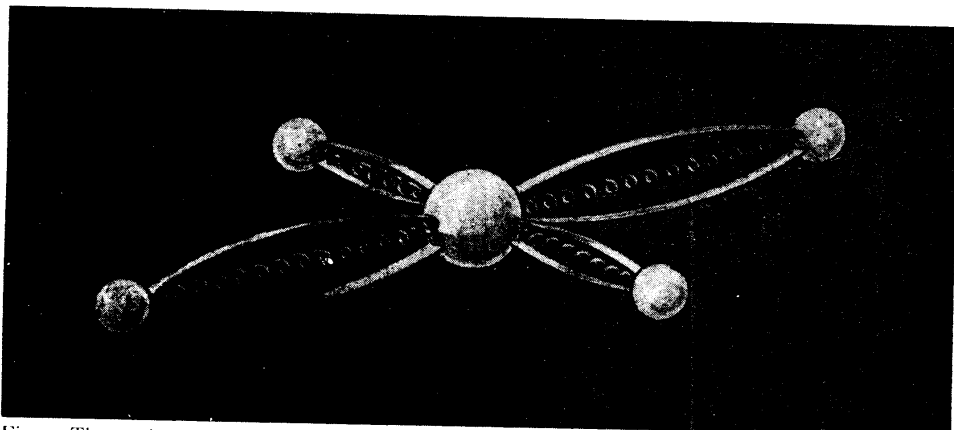
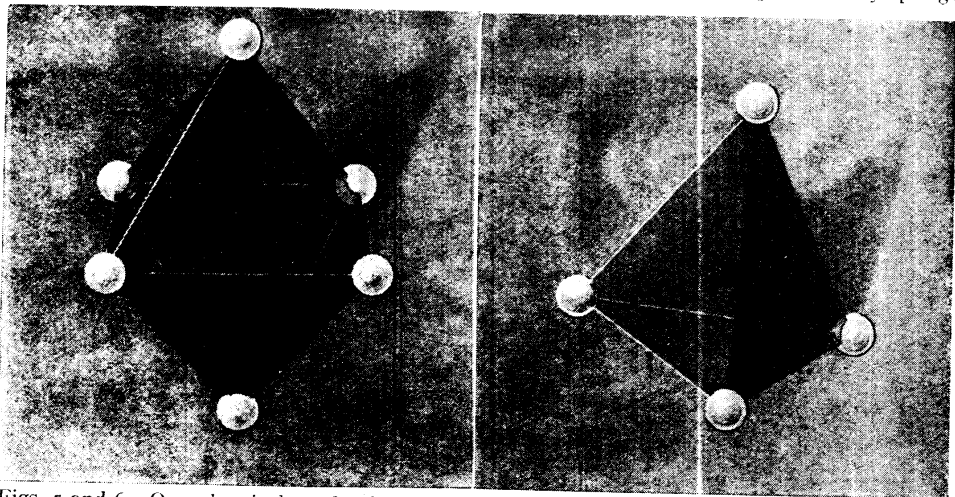

Fig. 4. The static system of representation, associated chiefly with Professors Langmuir and Lewis. The repulsion and attraction of the electrons and the nucleus are here represented by springs



Figs. 5 and 6. One chemical mode of representing the grouping of electrons within the atom. On the left the atom of oxygen is represented, and on the right the atom of carbon. All these representations, as Sir Oliver Lodge points out, are on no proper scale. If an electron were shown by a dot the size of a full stop, the atom would have to be about 80 ft. in diameter

THREE WAYS OF REPRESENTING ELECTRONS IN ATOMS ACCORDING TO MODERN THEORY

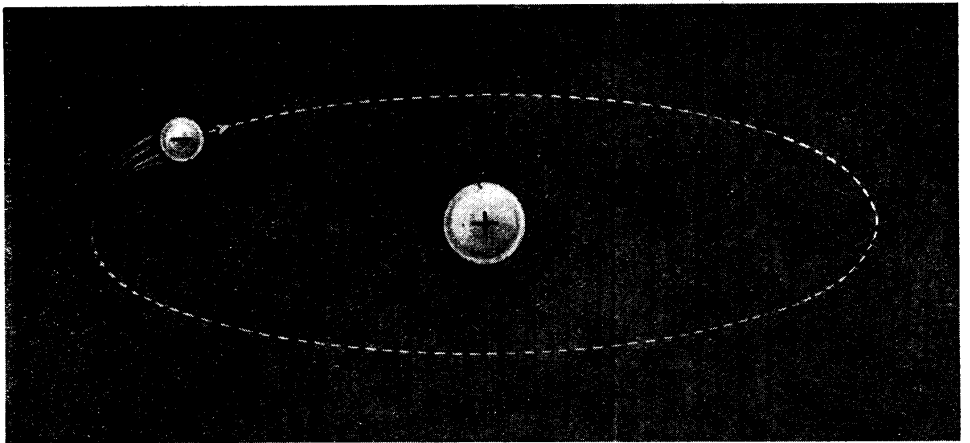

Fig. 7. Diagrammatic representation of the normal hydrogen atom, the simplest of all the atoms. It consists of a negative electron revolving round a positive nucleus. Its orbit is dotted

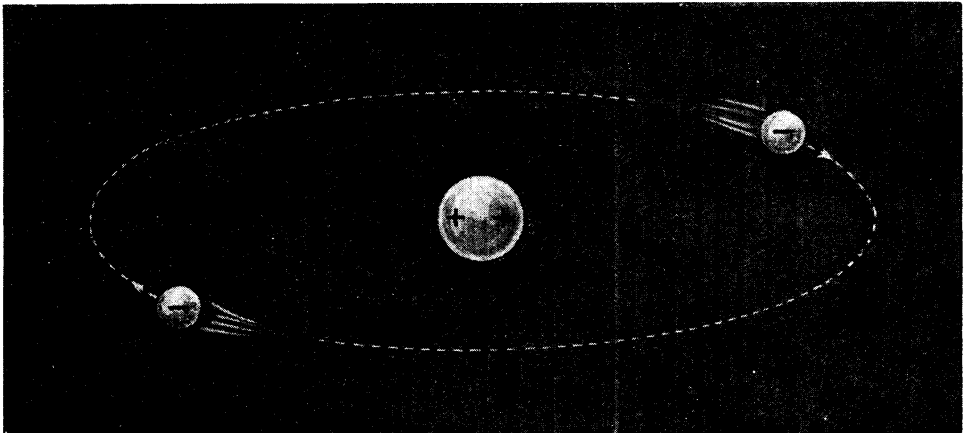

Fig. 8. Diagram of a normal helium atom, with two negative electrons revolving round a doubly charged nucleus

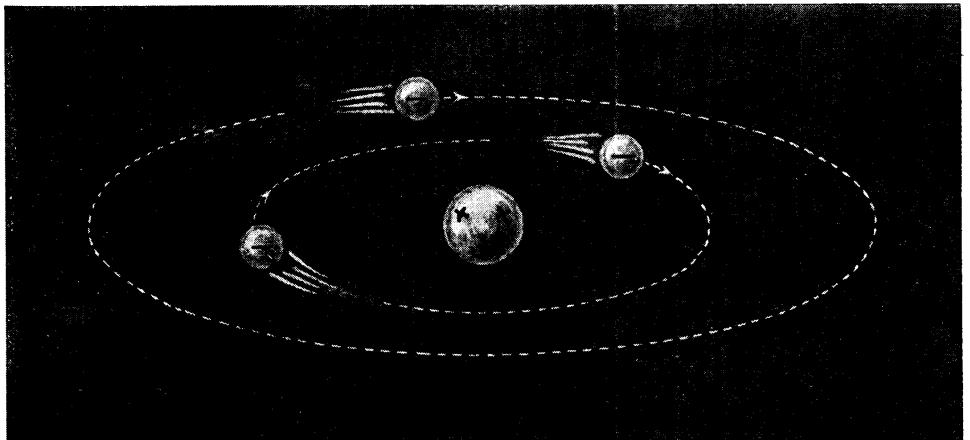

Fig. 9. Diagram of a lithium atom, with a trebly charged nucleus, and with an extra electron revolving outside the group seen in the helium atom, conferring on the atom (lithium) strong chemical properties

DIAGRAMMATIC REPRESENTATIONS OF SOME OF THE SIMPLER ATOMS



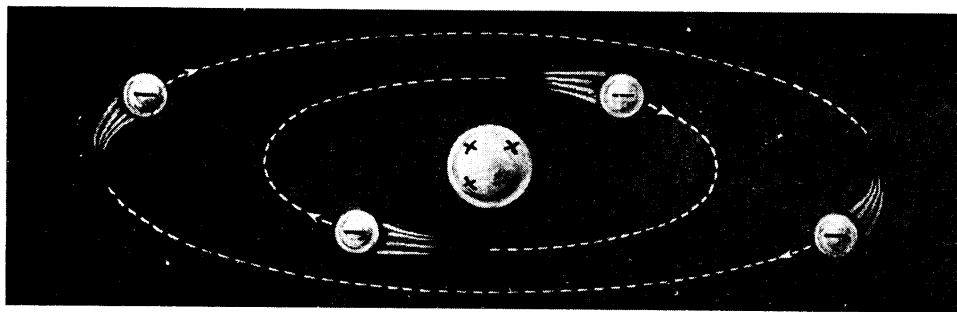

Fig. 10. The "solar system" method of representing the atom of beryllium, a quadruply charged nucleus with four revolving electrons

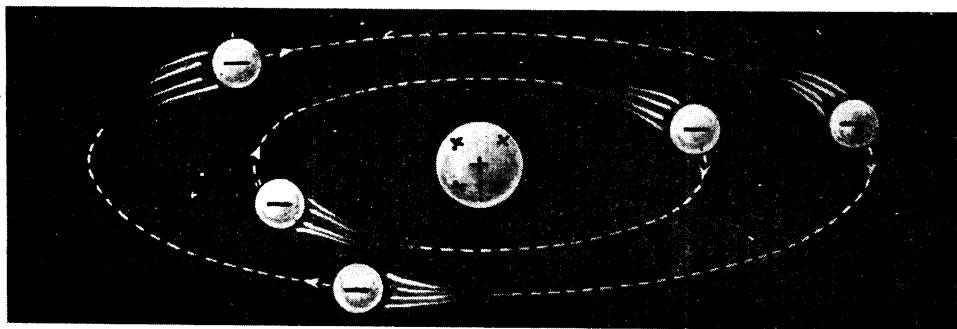

Fig. 11. The atom of boron. Its arrangement is similar to that of beryllium, but the charge on the nucleus is fivefold, and five electrons revolve round it

#### FURTHER DIAGRAMMATIC REPRESENTATIONS OF SOME OF THE SIMPLER ATOMS

appears that the familiar materials that we know are built up. The structure of complicated molecules and of crystals can also be represented in a similar diagrammatic form. The models shown in Figs. 14-17 are due to Sir William Bragg. But in these models the dots do not represent electrons, but atoms; and the grouping shown represents the structure of a molecule or of a crystal, and not of an atom at all. It is, however, by means of X-rays that structures of this kind have been analysed and confirmed.

#### Smallness of an Electron

To get an idea of the size of an electron, look at any of the full stops on this page; their diameter is just about the hundredth of an inch. If that represents an electron, an atom must be represented by a globe 80 ft. in diameter, which would be an exceptionally large and lofty room. The number of atoms required to build up a grain of mustard seed, or a pin's head, is still more enormous, something like  $10^{25}$ .

The smallness of the atoms of matter is proverbial; even the biggest

is hopelessly beyond the power of any microscope; so the comparison between an electron and an atom made above sufficiently emphasizes the exceeding smallness of an electron. A proton is no bigger—some think that it is even smaller—but if we take it as the same size as an electron, and try to depict an atom of hydrogen to scale, we shall have to put a full stop here, and another full stop at the end of the passage, 40 ft. away. Hence we cannot really make any reasonable picture of a hydrogen atom to scale.

Other atoms are of about the same size, but they have 2, 3, 4, or anything up to 92 electrons, instead of 1. Their supposed arrangement in some simple atoms, as now on good grounds surmised, is exhibited in the diagrams; but a representation of their extreme smallness has had to be given up as hopeless, for if properly drawn the specks would not be visible without a microscope on any scale which would bring the atom on to the paper.

Electrons and protons are responsible for all electrostatic fields, and for the phenomena studied under frictional

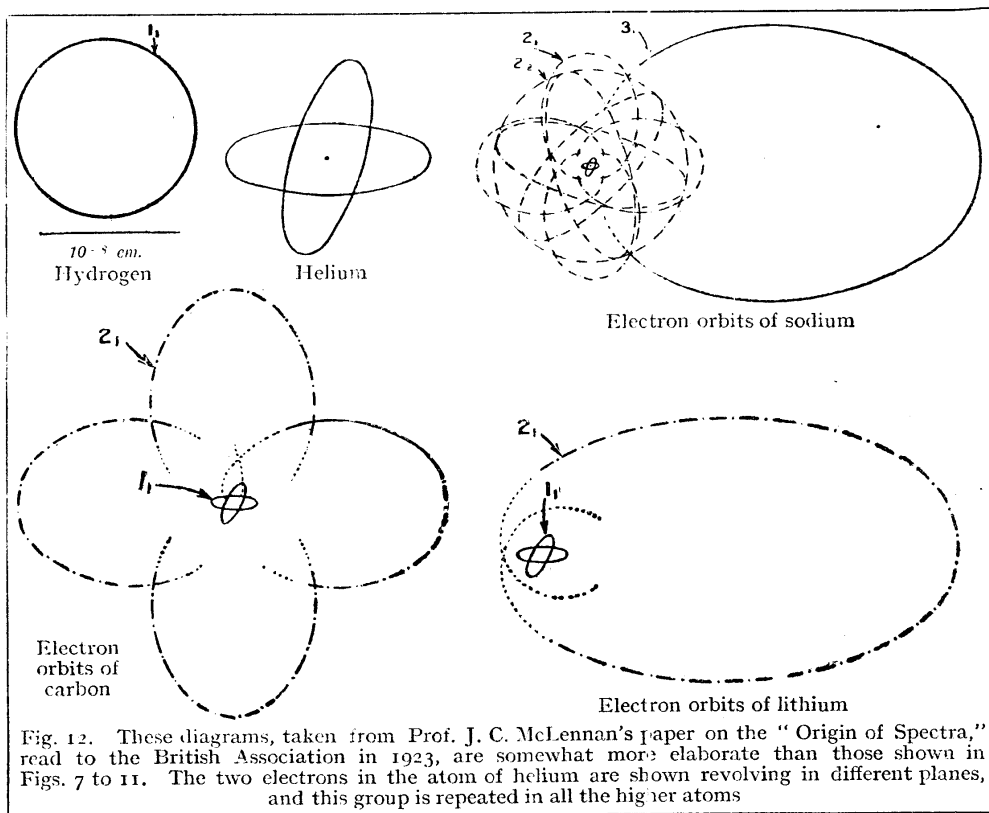

Fig. 12. These diagrams, taken from Prof. J. C. McLennan's paper on the "Origin of Spectra," read to the British Association in 1923, are somewhat more elaborate than those shown in Figs. 7 to 11. The two electrons in the atom of helium are shown revolving in different planes, and this group is repeated in all the higher atoms

#### McLENNAN'S DIAGRAMS OF ELECTRON ORBITS IN THE SIMPLER ATOMS

electricity. For friction is able to separate them, increasing the number of electrons in the rubber and decreasing it in the rubbed, or vice versa; so that one always becomes positive, the other negative—though this will not be observed to the full extent unless both rubber and rubbed are insulated; mounted, for instance, on insulated handles. The process goes on, however, more or less in every case of friction, so that the running belts of machinery sometimes emit sparks. In dry weather, small sparks can be noticed when brushing hair or removing clothes. And the brushed hairs may be seen to stand apart, repelling each other, because they are similarly charged. If things are damp, the charges, though equally produced, do not remain for observation.

Travelling electrons are believed to be responsible for all electric currents, whether they flow in solids, liquids, or gases; except that in a liquid they are not quite free, but carry the atoms with them. Any substance in which the electrons are fixed

and unable to move is a non-conductor or insulator.

In metals they move with peculiar ease, so that metals are good conductors. Some liquids insulate, others conduct. Gases all insulate, unless they are ionized, *i.e.* split up into units which can travel, and which are therefore called "ions." The usual ion is a charged atom, sufficiently free to be capable of locomotion with its charge. But anything is said to be ionized when electrons are liberated, whether associated with atoms or not.

Ultra-violet light has the property of liberating electrons when it falls upon clean metals and other substances, such as the green leaves of vegetation. As a result of this loss of negative electricity, insulated things might acquire positive charge in sunlight. Electrification is known to influence vegetable growth, but the effect is most marked in clean metals, such as bright zinc.

It was also found, by Guthrie and others, that red-hot metals emitted

electric charges, a phenomenon specially studied by Professor O. W. Richardson, and called by him "thermionic emission." It is a kind of evaporation of electricity from bodies at a sufficient temperature; and this is the property made use of in the filament of a valve (*q.v.*).

Some substances emit electrons at a lower temperature than others; and if the filament is coated with these substances, the valve is efficient at a low temperature, and is sometimes called a "dull emitter" (*q.v.*).

The mass of an electron is exceedingly small, much less than that of an atom of matter. Whether it is subject to gravity is uncertain; but if it is, it would take 1,850 electrons to weigh as much as one atom of hydrogen, which is the lightest known form of matter; and 200 times this number to weigh as much as an atom of lead.

The high charge and low mass of an electron makes it exceedingly tractable. It obeys every electric force with extraordinary promptness. One volt difference of potential would confer upon it a velocity of 400 miles a second; 100 volts would give it ten times this velocity, the speed attained being proportional to the square root of the difference of potential applied.

It is this tractability or docility which confers upon electrons their remarkable quickness in a vacuum, and enables them to follow the most rapid variations and alternations in the guiding electric charge, such as may be supplied by an aerial, or otherwise, to the parts of a valve. When the grid above them is negatively charged they are repelled and driven back whence they came. But whenever, even for a moment, the grid is in the positive phase, they are attracted vigorously up to it, and by their momentum may pass through it and reach the positive plate above. The fraction of a second required for the control of electronic motions is almost in-

finitesimal. For even the  $\frac{1}{1000}$  part of a volt will make them move with a velocity sufficient to carry them 12 miles in one second. So that in the small space of a valve the response is practically instantaneous.

The rule to find the velocity of an electron, when the step of potential is given down which it is projected, is a simple one, namely:

$$\left. \begin{array}{l} \text{The velocity of elec-} \\ \text{trons in kilometres} \\ \text{per second} \end{array} \right\} = \left\{ \begin{array}{l} 600 \text{ times the square} \\ \text{root of the number} \\ \text{of volts applied} \end{array} \right.$$

To find the wave-length of the radiation emitted, when an electron projected by a given number of volts is suddenly stopped, is also quite simple:

$$\left. \begin{array}{l} \text{The wave-length in} \\ \text{centimetres} \end{array} \right\} = \left\{ \begin{array}{l} 12.4 \times 10^{-9} \text{ divided} \\ \text{by the number of} \\ \text{volts} \end{array} \right.$$

But this last is applicable to the production of X-rays by the torrent of cathode rays in a well-exhausted bulb, and is not specially applicable to wireless problems.

By applying magnetic fields to sources of light, such as a sodium flame, Professor Zeeman, of Amsterdam, proved that the particles responsible for light were electrons. That is to say, that the mass

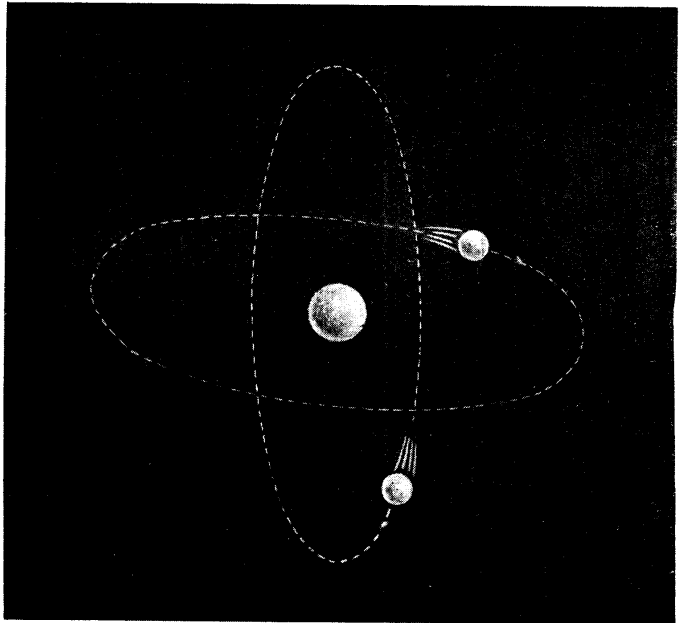

ELECTRONS IN THE ATOM OF HELIUM

Fig. 13. Adapted from Prof. McLernan's diagram, this drawing shows how the two electrons in helium probably rotate in orbits on different planes. See also Fig. 8



of the actual radiator was thousands of times smaller than any atom of matter. And Larmor proved, mathematically, that whenever an electron was accelerated, that is to say, when it was started into motion or suddenly stopped, it must radiate. Hence to generate radiation, all that is wanted is to clash or strike an atom with sufficient vehemence to cause its electrons to vibrate. The most direct way of doing this is to expose a target of some heavy metal, say platinum, to the torrent of cathode rays in a vacuum tube. Every electron thus suddenly stopped emits a pulse of what are called X-rays. But to generate visible light other less direct and less accurately controllable methods have at present to be used; the simplest method being to supply energy to a solid until its atoms vibrate violently, so that the body becomes what we call red or white hot, which simply means that it has begun to emit some visible varieties of radiation. And the radiation is found to increase with the fourth power of the temperature, reckoned from absolute zero.

#### Summary of the Theory of Electrons

Thus, we may summarize and say:

That stationary electrons are responsible for electric charges;

That travelling electrons are responsible for electric currents;

And that vibrating or otherwise accelerated electrons are responsible for radiation of all kinds, including light; that is, for generating waves in the ether of space. And no other kinds of ether waves are known.

But the waves so generated may have very different lengths (*see* Waves).

In any electric oscillator the electrons are surging to and fro, generating a current with all its magnetic properties while in mid-transit at the middle of the conductor, and being reflected as an electric charge at either end. They are thus in a state of vibration, but vibration of great amplitude—an amplitude or extent comparable to the whole length of the conductor. Accordingly the waves emitted are also comparable to that length.

A single isolated wire, for instance, in which the electrons were oscillating from end to end would be analogous to a stretched string emitting its fundamental note. The length of such a string is half a wave-length. And, similarly, a single straight wire is about half the length of

the wave it emits. If a wire is earthed at one end, matters are a little more complicated; it may be likened to a stopped organ pipe, which is a quarter wave-length.

The whole process of emitting waves, from an electric oscillator in general, has been worked out on electro-magnetic principles: the magnetic as well as the electric conditions of the circuit have to be taken into account, especially self-induction of inductance (*q.v.*) and electrostatic capacity (*q.v.*).

#### Hertz Oscillatory Waves

The theory of a linear oscillator like an aerial was worked out by Hertz, who discovered this method of producing waves in free space. It can here only briefly be said that the wave-length of any oscillator is  $2\pi$  times the geometric mean of its inductance and its capacity, both being expressed in terms of length.

For instance, suppose the inductance was a millihenry, which is a length of 10 kilometres, and the capacity was a millimicrofarad, which is a length of 9 metres, the geometric mean of these two lengths, that is the square root of their product, would be 300 metres; and  $6\frac{2}{3}$  times that will give the wave-length for the radiation emitted from such an aerial. About a mile and a quarter.

In dealing practically with radiation, therefore, we need not consciously attend to what the electrons are doing; and indeed most things about radiation were known before the electron was discovered. Nevertheless, it is well to remember, at times, that it is the motion of electrons that we are utilizing, not only in valves, but in all the other phenomena made use of in wireless telegraphy.

**ELECTRON RELAY.** This is a term which is sometimes used for a three-electrode valve. *See* Valve.

**ELECTROPHORUS.** An instrument invented by Volta by which mechanical work is transformed into an electrostatic charge by the aid of a small initial charge of electricity.

The figure shows the ordinary standard type of electrophorus. It consists of a metal plate called the sole plate; a layer of some insulator, as glass, ebonite, or resin; a metal disk, called the cover, smaller than the sole plate, and an insulating handle or rod of glass or some other insulating material. The metal disk may be lifted from the sole plate by the

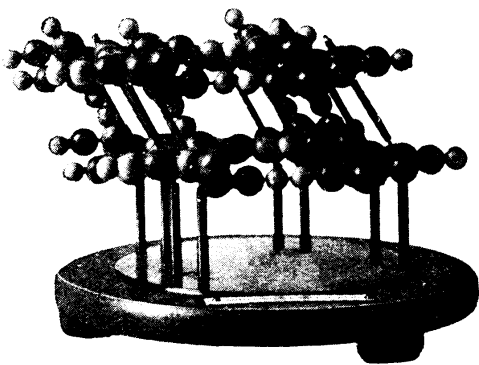

Fig. 14. Model of the structure of ice, showing the hexagonal arrangement which is the basis of the six-rayed snow crystal. Each oxygen atom has four hydrogen neighbours, and each hydrogen atom two oxygen neighbours

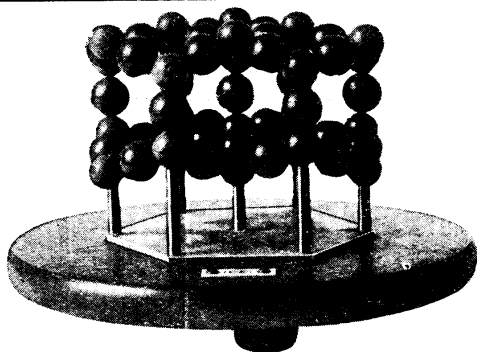

Fig. 15. Model of diamond structure, showing how each carbon atom lies at the centre of gravity of its four immediate neighbours. The actual distance from atom centre to atom centre is 1.54 Ångström unit. An Ångström unit is the hundred-millionth of a centimetre

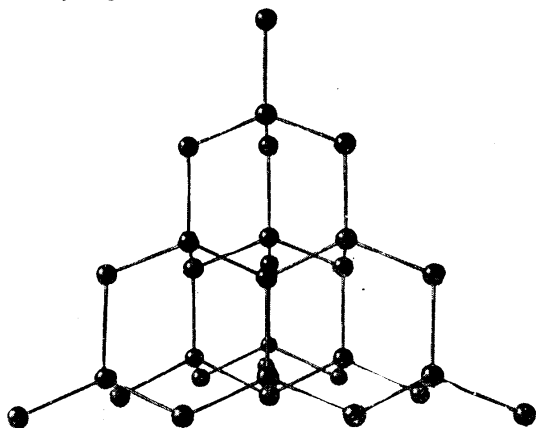

Fig. 16. Model of racemic acid, showing eight molecules, four of which would rotate the plane of vibration of light waves in one sense and four in the opposite sense

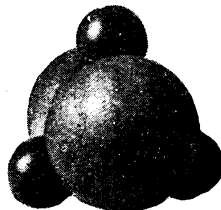

Fig. 17. Model showing the structure of ruby. An enlarged model of the ruby molecule is at one side, and shows the arrangement of the two aluminium and three oxygen atoms of which it consists

#### SIR WILLIAM BRAGG'S MODELS OF ATOMS AND MOLECULES, SHOWING ATOMIC STRUCTURE

insulating handle. The apparatus is used as follows. The resin base is rubbed with fur or dry woollen cloth to electrify it. The resin base is actually negatively electrified.

The metal plate is then placed on the base, and by induction a positive charge is developed on the lower surface of the plate and a negative charge on the upper surface. If the upper surface is now

touched with the finger, so earthing it, the negative charge is dissipated, and the metal plate is left positively electrified. A metal pin, as shown in the photograph, is often provided. It passes through the insulator to the sole plate, so earthing the upper plate automatically as the cover is put down on the resin. This charge may be communicated to any insulated

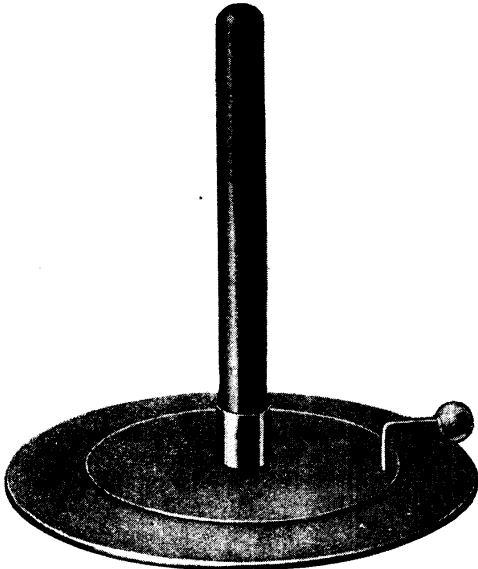

#### STANDARD TYPE OF ELECTROPHORUS

Mechanical work is transformed into electrostatic energy by this instrument. It was the forerunner of the influence machine used for the same purpose

*Courtesy J. J. Griffin, Ltd.*

conductor at a lower potential so totally or partially discharging it. The process may be repeated a large number of times, and so an electric charge can be accumulated and given to another conductor.

The initial charge is due to the mechanical energy expended in rubbing the resin, and is afterwards supplemented by the mechanical energy expended in lifting the cover. The electrophorus is important since it was the forerunner of the influence machine by which mechanical work is converted into electrostatic energy.

**ELECTROSCOPE.** An instrument for testing the electrical condition of a body with regard to static charges.

A very conventional and easily constructed type is found in the pith ball electroscope, which merely consists of a small sphere, usually of elder pith, on account of its extreme lightness, suspended by a silk thread from an insulated stand. On being approached by the body under investigation, a movement of the ball towards it will take place if this body is in a state of electrification, but the ball will remain motionless should the body be neutral.

It is essential that the pith ball itself be uncharged before carrying out the above test. All forces are mutual, and

attraction would occur between a charged pith ball and a neutral body, giving a false impression of the condition of the latter if the presence of a charge on the ball was not known.

Much more sensitive and reliable in its action is the gold-leaf electroscope. In construction this instrument usually consists of a bell-shaped glass jar, as shown in Fig. 1, through the neck of which passes a carefully insulated metal rod, terminating externally in a brass knob or flat circular disk. At the other end, inside the jar, is a cross-piece from which are suspended two finely beaten gold leaves. Normally, they hang parallel to one another at a small distance apart, but under the influence of a charge will diverge. In order to shield the gold leaves

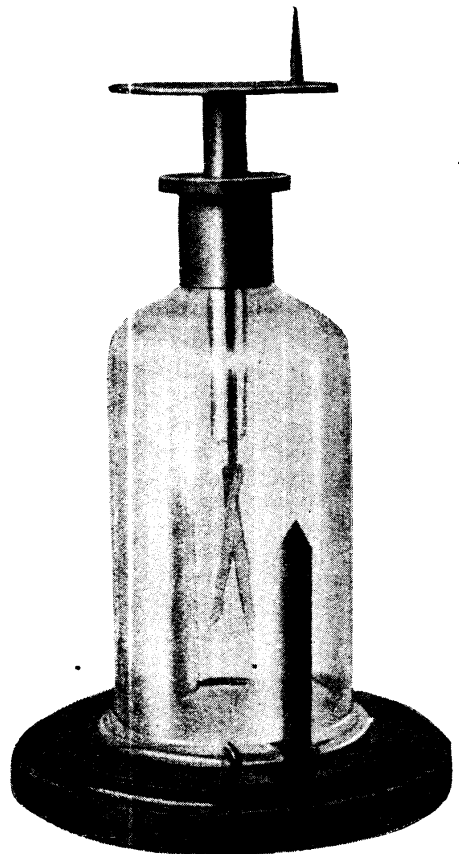

#### BENNET'S ELECTROSCOPE

Fig. 1. Through the neck of this bottle-shaped container is an insulated metal rod with a brass disk at one end, and at the end inside the container a cross-piece to which is attached a pair of gold leaves. These gold leaves indicate the presence of a charge by diverging

*Courtesy J. J. Griffin, Ltd.*



from the influence of any charge other than that which is desired to affect them through the proper channels, viz. the brass knob or disk, the inner side of the jar is usually coated with strips of foil. These are so placed that they allow observation of the leaves, and arrangements made to connect them and to earth them.

A double purpose is served by this coating of foil. Should a very strong charge be imparted to the electroscopes, the leaves would be caused to diverge with such violence that they would run the risk of being wrenched from their support. To prevent the possibility of this accident, the width of the jar and the length of the leaves are so regulated that in a case of divergence beyond a safe distance they come in contact with the earthed coating, lose their charge, and collapse to their normal position.

As a comparative measure of potentials, this instrument may be employed when dealing with fairly high voltages, and a scale placed behind the leaves so as to observe and compare the angle of their divergence. A modification, however, occurs in the condensing electroscopes, which supplies a means of proving the existence of a difference of potential between the two terminals of a cell. A condenser of large capacity is connected across the disk and cage, as shown in Fig. 2. The condenser is first given a charge by means of the cell, which is then disconnected. The next step is to raise the upper plate of the condenser so that

the capacity of the lower one is greatly decreased; and the consequent rise in potential of this lower plate will be found sufficient to cause a divergence of the leaves. In actual practice it is usual

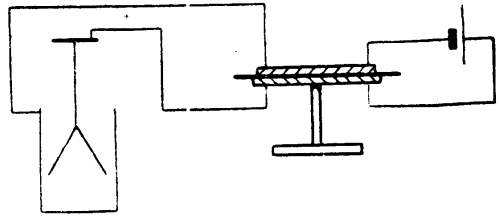

CONDENSING ELECTROSCOPE

Fig. 2. How the electroscopes may be used with a condenser is illustrated in this diagram, in which is represented a test to find the difference of potential between the terminals of a cell

to leave the connexion between the upper plate and cell intact during the course of the experiment and only disconnect the other lead from the lower plate. As the electroscopes indicates potentials both above and below zero equally, it is immaterial which terminal is connected to the plates.

A very simple means of testing the insulating properties of a substance is to charge an electroscopes until the leaves are fairly wide apart and connect one end of the article to be tested to the disk and the other end to earth. The rate of collapse of the leaves, due to leakage of charges, will indicate whether the substance is a good or poor insulator.

## ELECTROSTATIC CAPACITY AND HOW TO CALCULATE IT

By Sir Oliver Lodge, F.R.S., D.Sc.

In this article our distinguished contributor explains in simple but scientific language the meaning of the term capacity, so far as it concerns the amateur in wireless, and gives clear examples how to calculate the electrostatic capacity of aerials. Reference should also be made to allied headings, such as Capacity; Condenser; Electricity; Units, etc. See also Aerial

When a conductor is charged with electricity, its potential rises. And if the quantity of electricity supplied to it is doubled, the potential is doubled too. The ratio of the charge to the potential is called the *capacity* of the body. There is the same sort of thing in heat. The more heat is supplied to a body, the higher grows the temperature. And the ratio of the amount of heat supplied, to the consequent rise of temperature, is called its thermal capacity. The thermal capacity of a body naturally depends on its size, or, rather, its weight; but it also depends

on its material. And that part of the capacity which depends on the material is called "specific," meaning the capacity per pound or per gramme of that material. The specific capacity of lead is one thing, of iron another, and of water is greater than either.

In this respect thermal capacity differs from electric capacity. Electric capacity does not depend on the material of the conductor, but, as Faraday showed, on the nature of the material surrounding the conductor. A conductor in air has one capacity; but if plunged in a vessel

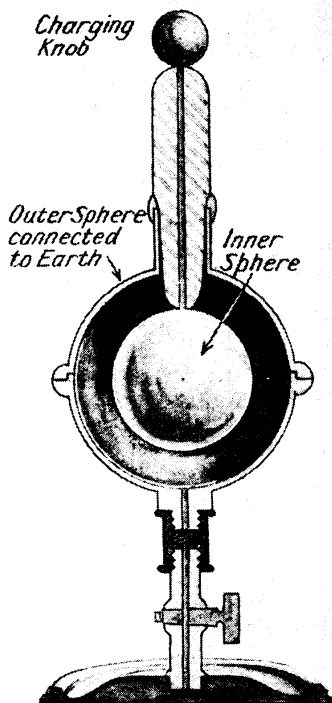

Fig. 1. Faraday's original apparatus for measuring the specific inductive capacity of different substances. The substance to be tested is placed between the spheres

of oil, or melted resin or pitch, or some other insulator, it has another and greater capacity. Hence there is a specific inductive capacity for each insulating material, which can be ascertained by experiment.

In addition to that, however, the capacity of a body changes not only by reason of the insulator surrounding it, but also by reason of conductors in its neighbourhood. If it is brought near the earth, for instance, or near a wall, its capacity increases. And this increase of capacity is calculable from the geometrical conditions, that is, when the shape and distance of bodies are known.

In some respects therefore, electrical capacity is less simple than thermal capacity; since the latter has wholly to do with properties of materials, and the former is dependent on geometrical conditions as well.

To take the simplest case, that of an isolated sphere: the moon, for instance, or a brass ball far away from anything else. A charge on it is measured by the repulsive force. it can exert on a similar equal force at a given distance, in accordance with what is called Coulomb's Law. The electrical force varies inversely with the square of the distance, just like gravitation does. But force is always equal to gradient or slope of potential. From

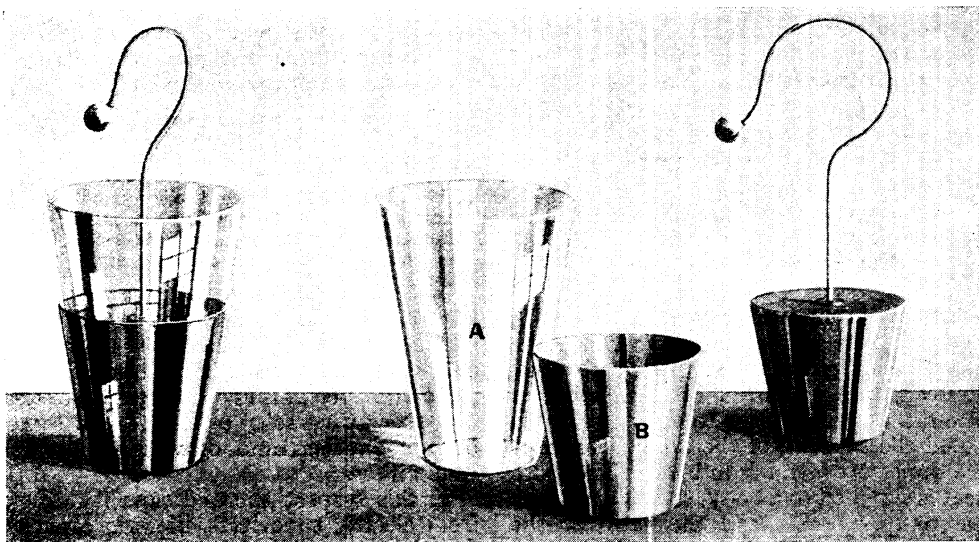

#### LEYDEN JAR WITH MOVABLE COATINGS

Fig. 2. This apparatus emphasizes the importance of the dielectric. A, B, and C, being packed together as shown on the left, can be charged as a Leyden jar. With an insulating handle they can then be taken apart, separately as A, B, and C, being then apparently discharged. But when the parts are put together again, a strong spark can still be got between B and C, showing that the charge really resided on the glass, A, the coatings merely acting as conductors

this it follows, though not quite obviously, that the electric potential at any point near a charged body is equal to the charge divided by the distance, *i.e.* the simple distance of that point from the charge.

Assuming this, and applying it to the case of an isolated sphere, let us ask, What is the potential of its centre? The charge resides wholly on the surface; hence the centre is at a distance from that charge equal to the radius of the sphere. Consequently the potential is  $Q/r$ . And since the body is a conductor, and the electricity at rest upon it, its potential is uniform, or the same throughout. This  $Q/r$  therefore gives the potential of the conductor. And if you want to know its capacity, you simply divide the quantity by the potential; and you get  $r$ . That is, the capacity of an isolated sphere is equal to its radius, and can be expressed in centimetres, metres, miles, or any other units of length.

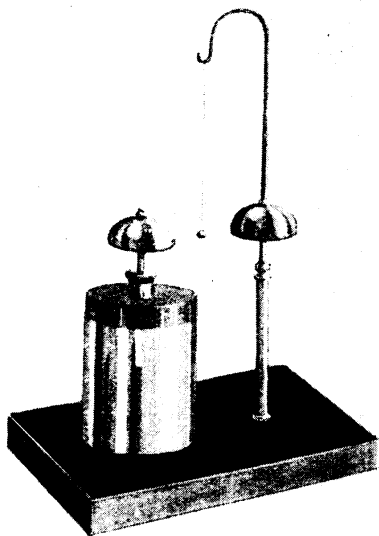

#### DISCHARGING BY ALTERNATE CONTACTS

Fig. 4. Apparatus for illustrating the discharge of a jar by alternating contact. The insulated knob oscillates between the bells connected with the inner and the outer coatings, for a long time, carrying a charge from one to the other, until the whole is nearly discharged

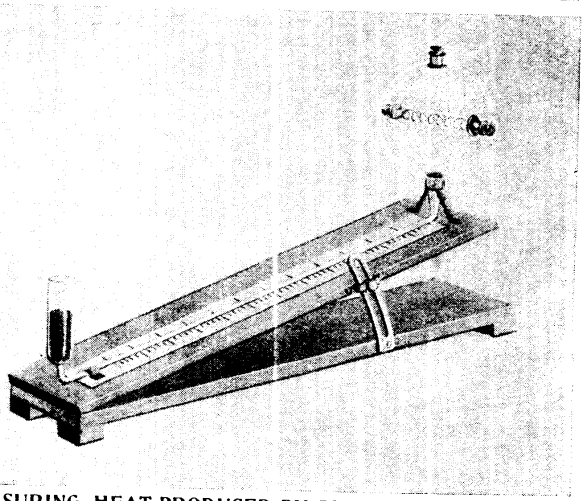

#### MEASURING HEAT PRODUCED BY CONDENSER DISCHARGE

Fig. 3. Riess's thermometer for illustrating the heat produced when a condenser or Leyden jar is discharged through a wire: the air in the bulb expands, and drives liquid in the stem quickly downwards by an amount which may be measured

It may be asked, How can a capacity be a length? And the question is a very proper one. The capacity depends not on the body itself, except as regards its size and shape: it depends essentially on the properties of the material surrounding it. The material surrounding the moon is the ether of space. The material surrounding a brass ball is the ordinary atmosphere. The two surroundings do not differ appreciably in this respect. They both have practically the same specific inductive capacity. But unfortunately its value is unknown. It is accordingly called  $K$ . And when we speak accurately, we ought to say that the capacity of an isolated sphere is  $Kr$ , that is,  $K$  multiplied by the radius of the sphere.

But for practical purposes we cannot deal with an unknown quantity. The simplest plan is to assume it 1, or unity, and proceed with the memory of that perfectly gratuitous and arbitrary assumption at the back of our minds. This is the basis of the electrostatic system of measurement. And when a thing is expressed in electrostatic units, the meaning is that the unknown quantity  $K$  has been arbitrarily called 1. The worst of it is that we get so used to doing this that we are liable to forget the assumption altogether. The convenience of the assumption is that it enables us to specify our measurements in a simple manner.

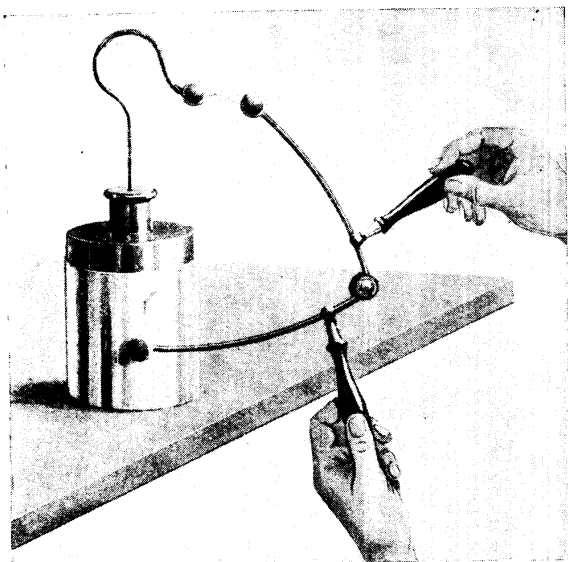

**DISCHARGING THE LEYDEN JAR CONDENSER**

Fig. 5. Ordinary method of taking a spark from a Leyden jar, the tongs touching the outer coating first

Now put an outer hollow globe round the inner sphere of Fig. 1. It can be done, and actually used to be done, by applying to it two brass hemispheres bigger than itself, and suspending it symmetrically in the hollow. And it can be charged through the suspending rod. If the outer shell is earthed, the inner globe will now be found to have a much greater capacity than before. The charge on it has, so to speak, pulled up from the earth an equal quantity of opposite electricity, and the two charges face each other across the insulating space.

If we now reckon the potential of the centre of the sphere, it will be  $\frac{Q}{r}$  due to the one charge, and  $-\frac{Q}{r'}$  due to the other. Consequently, the potential will be

$$Q \left( \frac{1}{r} - \frac{1}{r'} \right) = Q \frac{r' - r}{r r'}$$

and hence the capacity (quantity  $\div$  potential) of the globe, now that it is

surrounded by an outer shell of radius  $r'$ , is

$$C = \frac{r r'}{r' - r}$$

Now, looking at this, we see that  $r' - r$  is the thickness of the insulating space or dielectric separating the two conductors, which we may call  $z$ ; and if this space is very thin—that is, if the spheres nearly fit— $r r'$  may be called  $r^2$ . So the capacity of such an arrangement as this, which is familiar to electricians as a condenser, is  $\frac{r^2}{z}$ .

Now, the area of a sphere is  $4\pi r^2$ . Hence we may specify the capacity of the spherical condenser as

$$\frac{A}{4\pi z}$$

And this result is general; for it does not really matter whether the condenser is spherical or not, provided the dielectric thickness is uniform. This expression, which is really  $KA/4\pi z$ , gives the capacity of any Leyden jar when the  $K$  for its glass is known. It will do equally well

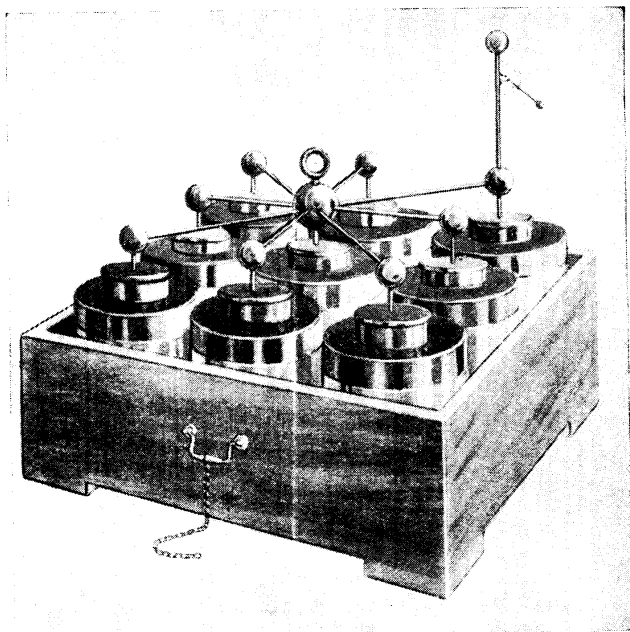

**BATTERY OF LEYDEN JARS**

Fig. 6. Battery of Leyden jars in parallel, with an electroscopic indicator showing how much they are charged, and with a chain connecting the outer coatings to earth



for a pair of flat plates in a condenser, one earthed, the other insulated, each plate being of area  $A$ . So the capacity of a condenser in general is

$$\frac{A}{4\pi z}$$

provided only air or ether is between the plates. If, however, some other substance is used as the insulator or dielectric, such as glass or mica or paraffin or oil, we must multiply this value by the specific inductive capacity of the material relative to air, as determined by Faraday, and may thus get four or five times the air value. This numerical factor has to be determined by experiment for different materials and is usually recorded among the data characteristic of different substances.

When you want to make a condenser of great capacity you naturally make the area big and the thickness small. You therefore take a number of sheets of tinfoil and interleave them with, say, sheets of tissue paper soaked in molten paraffin. You then connect the alternate sheets of tinfoil so that half of them may be charged plus, and half of them minus; say, half of them insulated, half of them earthed.

And now, having a great capacity, you may supply a considerable quantity of electricity to the insulated half without the potential rising much. Accordingly, it is customary now to work with a different set of units. The electrostatic unit of quantity, that we have been employing hitherto, is too small, the electrostatic unit of potential is too big, for convenience. The electrostatic unit is 300 volts, and we should more commonly be dealing with one or two or a dozen volts. Quantity, again, or charge, would naturally now be supplied by a current, a current of so many amperes or milliamperes, lasting for a given time.

Suppose that, having constructed a condenser as above described, we pump into it 10 milliamperes during 100 seconds, or, what is the same thing, one ampere for one second, we should have accumulated in it a practical unit of quantity

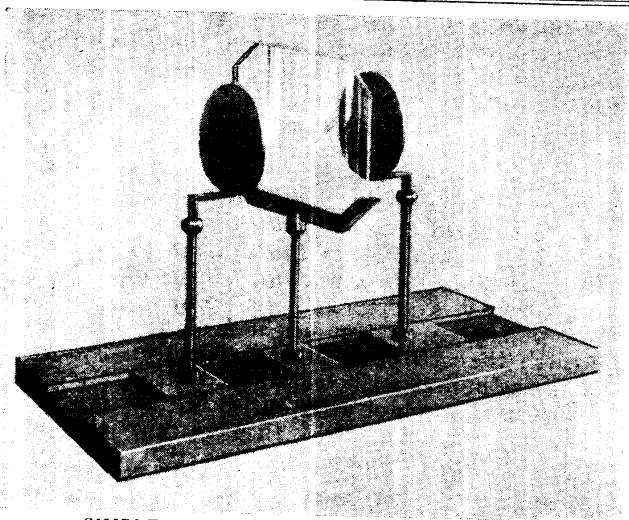

**SIMPLE FORM OF VARIABLE CONDENSER**

Fig. 7. An early form of condenser of variable capacity, with or without a glass insulator between the movable plates, known as Aepinus' condenser. The capacity is increased by bringing the plates close to the glass

called a coulomb, which from the electrostatic point of view is enormous. If we found that the condenser potential had only risen by one volt, and were sure that it had not leaked, we should know that it must have an immense capacity, a capacity which is called a farad, very much greater than we ever have to deal with in practice.

But if, instead of pumping in an ampere for a second, we supply another condenser with a microampere for a second, and found that equally to have risen by one volt, we should naturally say that its capacity was a microfarad. And if, instead of rising by one volt, it had risen by 100 volts, we should know that the capacity was  $\frac{1}{100}$  of a microfarad. For, as always, capacity is measured by the ratio of the quantity supplied to the rise of potential caused. One coulomb by one volt equals one farad.

But the full treatment of these practical or engineering units does not belong to electrostatics. Electrostatic capacity is most easily expressed as a length, or, more accurately,  $K$  times a length. And the capacity of every condenser can be expressed as a length; since  $\frac{A}{4\pi z}$ , that is, an area divided by a thickness, is necessarily a length.

If we ask what length corresponds to a microfarad, we shall find that the answer

is 9 kilometres. That can be remembered, and the explanation sought later. 1 mfd. = 9 kilometres =  $9 \times 10^5$  centimetres.

Imagine an isolated sphere 18 kilometres or about 12 miles in diameter; its electrostatic capacity is a microfarad.

For wireless purposes the chief area that we have to treat electrostatically is the aerial. If you imagine this as a great horizontal plate, or network of wires so close together as practically to form a plate, of area  $A$ , and at height  $h$  above the earth (the earth being either sufficiently conducting in itself or being supplied with a sufficient network of wires buried in the soil to make it conducting), then we can apply the usual formula, and say that

the capacity of that aerial is  $\frac{A}{4\pi h}$ . For instance, suppose the aerial is 500 metres long, 20 metres wide, and elevated 10 metres above the earth, its capacity will be  $\frac{10,000}{4\pi}$ , or, say, about 800 metres. This is a large capacity, but not a large fraction of a microfarad, about  $\frac{1}{12}$  of a microfarad. Still, that is a very big aerial.

#### Simple Calculations of Aerial Capacity

An amateur aerial is not likely to be of this shape at all. It may be only a single isolated wire. Now a wire is a cylindrical conductor; and its geometry is not so simple as that of a sphere. A formula can easily be given for its capacity; but it involves logarithms. Such formulae will be found under the heading Capacity (*q.v.*). But our object here is to put the matter as simply as possible.

The thickness of the wire does not vary much matter. The material does not matter at all, so far as capacity is concerned. What chiefly matters is its length, and also its proximity to neighbouring objects, like buildings. Its capacity increases whenever those are near it. In that case, though it is insulated, it is not isolated. Such extra capacity has no particular advantage and no particular disadvantage. An aerial is not wanted as a condenser, but as a radiator. The loftier it is, therefore, and the freer from obstruction, the more effective it will be in radiating its waves away into space.

An ideal aerial would be an elevated wire of sufficient conducting power, reaching up to a great height, and then expanding into a sort of capacity area; the higher the

effective capacity the better. Expansion at the top is not often feasible, however. Great height is not often feasible either. The aerial at the Eiffel Tower is almost ideal in this respect, and accordingly has remarkable sending power. The way to make an estimate by eye of any given aerial, especially if its dimensions are known, is explained in the concluding portion of this article.

To calculate the capacity of a single isolated wire, of length  $l$  and diameter  $d$ , one can work out the arithmetic of the following expression, which is obtained after the same sort of fashion as that of the spherical condensers above, only the geometry is less simple:

$$\frac{l}{2 \log_e \frac{2l}{d}}, \text{ or, what is the same thing, } \frac{.217l}{\log_{10} 2l/d}$$

To indicate how this comes about, we may note briefly that the force from a charged wire of infinite, *i.e.* great, length does not vary inversely as the square of the distance, but inversely as the distance. And, accordingly, the potential no longer varies inversely as the distance, but as the logarithm of the distance. That is how logarithms come in. And when quantity is divided by potential, in order to get capacity, they stay in. The gradient of  $\log r$  is  $\frac{1}{r}$ ; just as the gradient of  $\frac{1}{r}$  is  $\frac{-1}{r^2}$ . The bearing of this cryptic remark will become apparent after sufficient study.

#### Arithmetic of a Single-Wire Aerial

On doing the arithmetic of the above expression, in what units will the answer come out? In the same units as were put in, *viz.* in whatever units the length was expressed. For the denominator portion is merely a number. All that we must be careful about in that, is that the length and diameter must be expressed in the same unit, so that the length part cancels; otherwise you cannot take a logarithm. You can only take a logarithm of a number. A tabular logarithm, *i.e.* one given in the ordinary tables, which are to the base ten, must be multiplied by 2.3026, or, say, 2.3, in order to convert them into natural logarithms, such as occur in Nature. For Nature knows nothing about the base ten—which, in the last resort, is dependent upon the accident of our having ten fingers, and on early historical methods of counting; and is, in many respects, inconvenient, though it is too late to change.

**To Estimate the Capacity of an Aerial.** Aerials can be made in innumerable shapes. But the original Marconi aerial, of a single vertical, or nearly vertical, wire suspended from a high post by an insulator, and earthed at its lower end, is one that is very likely to be used, with slight modifications, by an amateur, and in its simplicity it has advantages. To estimate the capacity of such an aerial, the simplest plan is to take it as  $\frac{1}{20}$  of its length. It may be expressed in centimetres, or feet, or any units of length you please.

It is unfortunately rather customary to specify it in micromicrofarads, which are not a convenient unit, though they are approximately of the order of a centimetre. Or else it is specified in fractions of a millimicrofarad, which is equal to 9 metres—a capacity greater than that of most amateur aerials. Accurately, each micromicrofarad is .9 of a centimetre—that is, 10 micromicrofarads equal 9 centimetres, which is just near enough to be confusing. Besides, centimetres are so much handier to work with. To convert a capacity expressed in micromicrofarads into centimetres, you only have to multiply it by .9. That is to say, subtract about 10 per cent of its numerical value; a centimetre being the larger unit of the two, and, therefore, a given capacity being expressed by a smaller number in centimetres.

The first rough estimate of a vertical wire is  $\frac{1}{20}$  of its length. It will depend a little on the thickness of the wire, and still more on how near objects, such as buildings, are to it. These always tend to increase its capacity. And  $\frac{1}{20}$  of its length will, therefore, be an underestimate. Prof. Fleming finds that it is well to add ten per cent to the calculated value, in order to allow for the effect of the earth, which is inevitably not very far away from a part of the wire. This comes to the same thing as measuring it in micromicrofarads and then calling them centimetres, without reduction. In practice, it will be found that a wire suspended from any building, such as a chimney, although stretched quite free from it, but hanging down near it, will have a capacity not much less than six per cent of its length, instead of five per cent, as above estimated for a fairly free wire.

If a wire, instead of being vertical, is horizontal, the influence of the ground is more marked; and, at any height likely to be adopted in practice,  $\frac{1}{16}$  of its length,

or six per cent, is not a bad rough estimate. If, however, any part of the wire is in a building, hanging free in a moderate-sized room, for instance,  $\frac{1}{12}$  of that part of its length would be a fair guess at its capacity. Hence, if an aerial has three portions, one part in a building, one part nearly vertical and one part horizontal, we might take  $\frac{1}{16}$  of the length for the horizontal,  $\frac{1}{20}$  of the length for the vertical, and  $\frac{1}{12}$  of the length for the internal portion, and add them together for the total capacity. Any wire coming through an earthed tube will have a greater capacity; and to estimate that the sizes of tube and wire must be known.

I have said that all the above fractions will depend to some extent on the thickness of the wire, but they change only very slowly with that thickness, and if the length and thickness of the wire increased together, so that if one was doubled the

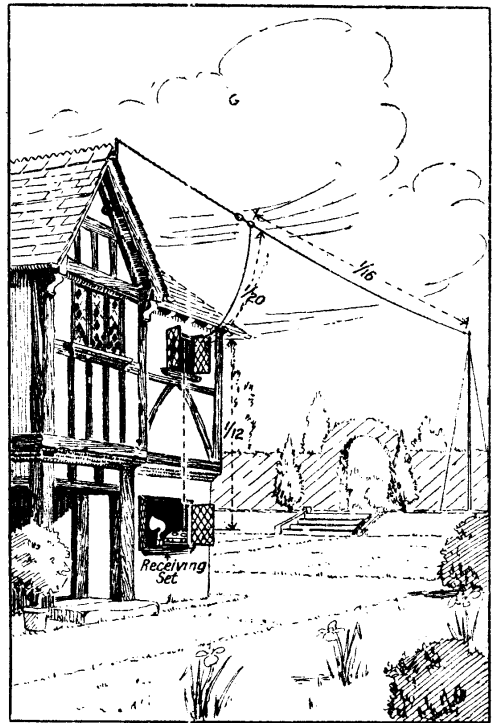

#### ELECTROSTATIC CAPACITY OF AN AERIAL.

Fig. 8. Considering a single-line aerial of the type illustrated, it is roughly estimated that about  $\frac{1}{16}$  of its horizontal portion,  $\frac{1}{20}$  of the vertical part, and  $\frac{1}{12}$  of the internal section added together give the total capacity. The existence of extra capacity effects is often overlooked by amateurs, who do not sometimes appreciate the result of erecting their aerials in close proximity to the roof or house wall

other was doubled too, no change would be made in these fractions. They may be taken as roughly correct for a wire 5 metres in length, and  $\frac{1}{10}$  of a millimetre in diameter. If the length is made 50 metres and the thickness 1 millimetre, the fractions will remain the same—that is to say, still  $\frac{1}{10}$  of the length will be a rough approximation of the capacity for an isolated vertical wire,  $\frac{1}{16}$  of the length for an isolated horizontal wire, and  $\frac{1}{12}$  of the

yard apart. In that case we might expect the capacity to be doubled. It is not quite doubled; it is about  $1\frac{3}{4}$  what we should estimate for each wire separately. Professor Fleming has made experiments on the actual capacity of multiple wires, and his treatise must be referred to if more exact details are wanted. Really, the capacity of an aerial ought to be measured by experiment, since that would take all the circumstances into account. It is impracticable to calculate them all, and not worth while. But it is useful to be able to make a rough estimate of what the capacity will be.

Another common form is four wires arranged at the corners of a square, being kept apart by a cross-piece of wood or other material. Assuming that the wires are two or three feet apart, the combined capacity will be, roughly, between  $2\frac{1}{2}$  and  $2\frac{3}{4}$  that of each wire separately; and by using a factor like that some useful notion is obtained of what capacity to expect in a given case.

**Capacity Specification.** Interpreting capacities as lengths, we may say:

- 1 micromicrofarad = .9 centimetre
- 1 millimicrofarad = 9 metres
- 1 microfarad = 9 kilometres

while the length equivalent to a farad would reach far beyond the moon—twenty-four times the distance of the moon, or one-sixteenth of the journey to the sun.

The figure 9 which enters into these relations is rather a nuisance, but is inevitable. It comes in because the square of the velocity of light is involved; and as that velocity in c.g.s. measure involves a 3, its square naturally contains a 9. Suppose the wire were 9 metres high, its capacity would be  $\frac{1}{10}$  of 9 metres, that is,  $\frac{1}{10}$ , or .05, of a millimicrofarad. To get a single-wire vertical aerial of a whole millimicrofarad capacity, it would have to be 180 metres, or about 600 feet high.

But we must now consider this matter a little more strictly, and show how to calculate the capacity on orthodox principles.

**Examples of Aerial Capacity Calculation.**

We have said that to get the capacity of an isolated wire of length  $l$  and diameter  $d$  we have only to calculate

$$\frac{l}{2 \log_e \frac{2l}{d}}, \text{ or, } \frac{.217l}{\log_{10} \frac{2l}{d}}$$

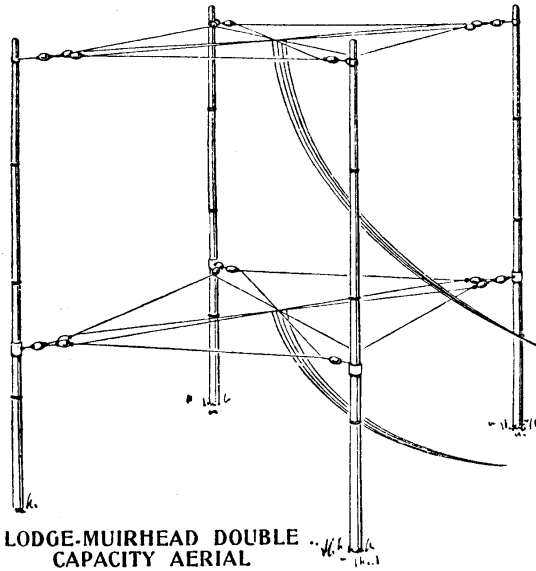

**LODGE-MUIRHEAD DOUBLE CAPACITY AERIAL**

Fig. 9. Diagrammatic view of Lodge-Muirhead aerial at Elmers End, with two insulated capacity areas, one above the other, not connected to the earth at all, but arranged like the two coatings of a Leyden jar, or any other condenser, but far apart. By this means very precise tuning can be obtained: there are no variations of earth resistance to give trouble. Each capacity area is in the form of a Maltese cross, with the corners insulated, and connexion is made, with the centre of the cross only, by a multiple wire of fine strands. This design has special advantages; and though it would not be used for long-distance signalling, it gives very satisfactory results. The lower area should not be on the ground, but at a best height above it, as shown

length for a wire fairly isolated in a large room.

If the isolated vertical wire is much thicker, say ten times as thick, so that the 5 metre length is a millimetre thick, then instead of taking 5 per cent of the length, we must take 6 per cent. That is the kind of difference made by a tenfold increase in the thickness.

**Multiple-wire Aerials.** Very often an aerial, instead of being a single wire, is a pair of wires in parallel, kept apart by distance pieces, say, a foot or two or a



It does not matter what units  $l$  and  $d$  are measured in provided they are expressed in the same units and the capacity will come out also in the same units—that is, in units of length. To interpret that in millimicrofarads is easy enough in the light of what has been said.

Thus, suppose that the length is 60 ft., and that the diameter is  $\frac{1}{10}$  in.; the above fraction is

$$C = \frac{217 \times 60}{\log_{10} \frac{1}{10}} = \frac{13.02}{\log_{10} 14400} = \frac{13.02}{4.16} = 3.13 \text{ ft.}$$

which is just about  $\frac{1}{20}$  of the length of the wire. This equals about 1 metre; so the capacity will be  $\frac{1}{2}$  millimicrofarad.

Or, take another example, using the upper of the two formulae above. Let the length of the vertical single aerial be 40 metres and the diameter .8 millimetre.

$$\text{The capacity } C = \frac{40 \text{ metres}}{2 \log_{10} \frac{8000 \text{ cm.}}{.08 \text{ cm.}}} = \frac{40 \text{ metres}}{2 \log_{10} 10^5} = \frac{40 \text{ metres}}{23}$$

which, again, would practically be  $\frac{1}{20}$ , or 5 per cent, of the length; for a little extra allowance must always be made for the inevitable partial neighbourhood of the earth. Interpreting this into conventional units of capacity, we must

divide by 9, and we find that it equals  $\frac{40}{207}$  or, say,  $\frac{1}{5}$  of a millimicrofarad.

If the wire is very thin, say, .008 centimetre, its capacity would be rather less, but not much less: we should then, theoretically, have to divide the length by 27 instead of by 23. Or, conversely, if the wire were thick, say 8 millimetres, which would be a thin rod, we should have to divide the length by 18.4 to get the capacity. So in any practicable case we can estimate the capacity of a vertically arranged single wire as round about  $\frac{1}{10}$  of its length, with a 10 per cent addition for the neighbourhood of the earth.

**Capacity of Horizontal Wire.** The capacity of a horizontal wire is reckoned similarly, only then the denominator of the fraction contains four times the height above the ground instead of twice the length of the wire.

Suppose a horizontal wire at an elevation of 30 ft., of diameter  $\frac{1}{10}$  in., and of any

length  $l$ , what would be its capacity. The formula is

$$C = \frac{l}{2 \log_{10} \frac{4h}{d}} \text{ or } \frac{l}{4.6 \log_{10} \frac{4h}{d}}$$

All we need reckon is the denominator.

$$\text{Now } \frac{4h}{d} = \frac{120 \text{ ft.}}{\frac{1}{40} \text{ in.}} = 57,600;$$

$$\text{So } \log_{10} \frac{4h}{d} = \log_{10} 57,600 = 10.96$$

And the capacity is  $\frac{l}{22}$ ; one twenty-second of its length. Every centimetre of this length is practically a micromicrofarad.

But the wire for a horizontal aerial would probably be somewhat thicker; if it was  $\frac{1}{4}$  in. thick, instead of  $\frac{1}{10}$  in., the denominator would become 16 instead of 22.

Consider a four-wire aerial with the wires a yard apart, each wire 1 millimetre diameter, and the whole arranged either vertically or horizontally at half its length above the ground, say, 10 metres high and 20 metres long. Each wire, if alone, would be likely to have a capacity roughly estimated as its length divided by  $4.6 \times \log_{10} 40,000$ , which is 21. So the capacity of the whole would be about  $2\frac{1}{2}$  times the length of the aerial divided by 21; that is, 2.4 metres, or, roughly, about an eighth or ninth of the length of the wire grouping. If the wires were further separated, say, by 2 yd., or if it were a cage aerial, the combined capacity would be rather greater, and might be three times that of a single wire.

It is very convenient to express capacities as lengths, and inductances also as lengths; for then the square root of the product of these two lengths, that is, their geometric mean, gives a length proportional to the wave-length at once, and only requires multiplying by  $2\pi$ , or, roughly, by 6, in order to give the wave-length itself in the same length units, whatever they are. But it will always be found that the capacity is expressed by a small length, while the inductance is expressed by a big one. One may be in metres, while the other may be in kilometres. But whether they are expressed in metres, or centimetres, or feet, or yards, matters nothing, so long as one always writes down the unit of measurement after the figures.

**ELECTROSTATIC FIELD.** This field may be defined as the region surrounding a charge or system of charges in which electrical phenomena occur, and represents the area over which potential energy is stored in the form of an ether strain. As in the case of magnetic fields, it may be investigated by examining the density and direction of lines of force, but whereas it is a simple matter to obtain a graphic representation of the former by the usual iron filings map, certain difficulties arise which preclude the possibility of exploring a static field in a similar experimental manner with any degree of ease.

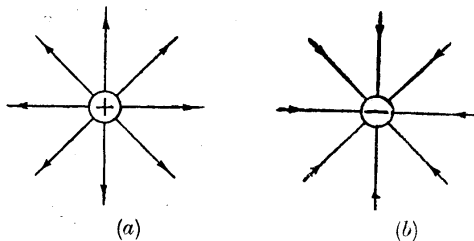

#### INSULATED AND ISOLATED FIELD

Fig. 1 (a). Being insulated and isolated, the charge is uniformly distributed over its entire surface and the lines of force are radial. In (b) negative lines of force are represented, as compared with positive lines in (a)

The accompanying diagrams give an idea of the fields produced by various combinations of charges. The simplest case is that of a sphere which is both insulated and isolated. Under these conditions, the charge on it will be uniformly distributed over its entire surface, and may be considered to act as though situated at a point at the centre of the sphere. The resultant lines of force will accordingly be radial, being continuations

of the radii of the sphere from its surface outwards, as shown in Fig. 1.

In most other cases the lines will be curved. The field due to two charged bodies will illustrate this effect, Figs. 2 (a) and (b). As will be noted from the diagrams, the direction, or rather sense of direction, of the lines is taken to be from positive to negative, and the direction of the resultant force at any point on one of them is represented by the tangent to the line of force at the given point, from which it should be clear that no two lines can ever cross one another.

It is generally supposed that the medium through which the lines of force pass acts as a straining force along their length, so that they tend to shorten themselves wherever possible. This tension is accompanied by a pressure at right angles, causing the lines to separate; this will explain their curvature. The result of these two forces is such that like charges repel and unlike attract.

As will be shown, the strength of the field is dependent upon the value of the charges producing it and the nature of the dielectric. Its effects become less marked as the distance from the charge increases, as may be noticed from the diagrams, where it can be seen that the lines of force are less dense in areas remote from the discharge.

In considering from a mathematical standpoint the properties of the field, it is convenient to assume that the charges to which it is due act at points, and that any new charge introduced into the field is of

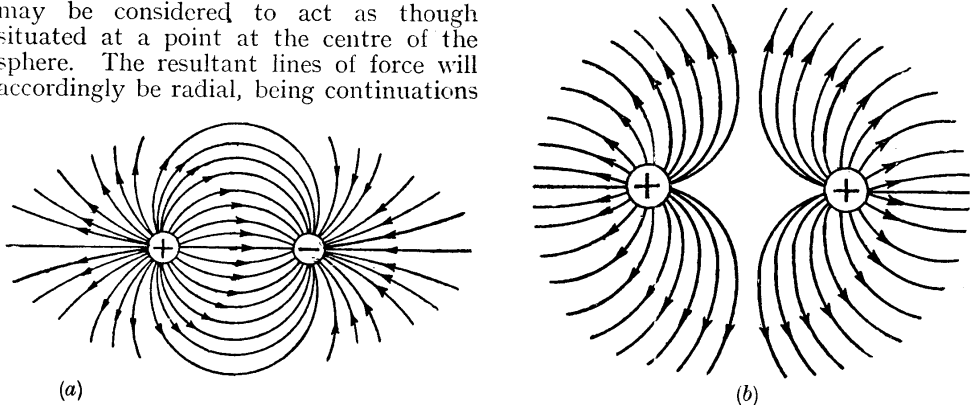

#### ELECTROSTATIC FIELDS IN WHICH LIKE AND UNLIKE POLES MEET

Fig. 2. Two charged bodies are responsible for an electrostatic field, and two cases are shown in which (a) is a field due to unlike poles, positive and negative, and (b) like poles. It will be seen in (a) that the lines of force have a tendency to meet at the negative pole; but in (b) the lines of the separate poles repel each other

extremely small dimensions, so that no inductive effects occur whereby the original charges are disturbed and the forces exerted on the new charge may be considered to be those of the field such as it was before the introduction of the new charge. This conception simplifies the mathematics considerably, and in the following discussion of potential and intensity it is assumed.

The potential at any given point in a field is defined as and measured by the amount of work required to be done on a positive unit charge in moving it from infinity to that point. From this it may be taken that the difference of potential between two points is represented by the work performed on a similar charge when moved from one point to the other. It can be proved that the potential  $V$ , at a point  $P$ , situated in the field due to a charge  $q$ , at a distance of  $r$  from it, is numerically equal to the charge divided by the distance. This may be expressed

$$V = \frac{q}{r}$$

If  $P$  is situated in a system of charges,  $q, q', q'',$  etc., distant  $r, r', r''$  from them, its potential due to the combined charges is found by calculating that due to each one and adding the results,

$$V = \frac{q}{r} + \frac{q'}{r'} + \frac{q''}{r''} \text{ etc.}$$

The force or electro-motive intensity of a static field at any point is measured by the force exerted by the field on a unit charge situated at that point. By Coulomb's law of inverse squares, the force between two charges is proportional to the product of the charges, and inversely proportional to the square of the distance between them. If it is decided to base calculations on the C.G.S. system, this may be expressed

$$F = \frac{q q'}{r^2} \text{ dynes . . . (1)}$$

where  $F$  is the force,  $q$  and  $q'$  the charges in electrostatic units separated by a distance  $r$  cm. in air. If the charges are similar the force will be one of repulsion, if opposite, one of attraction. The substitution of another dielectric for air will modify the expression, which will become

$$F = \frac{q q'}{K r^2} \text{ dynes . . . (2)}$$

where  $K$  is the specific inductance capacity of the dielectric.

Consider, again, the above definition of intensity. By substituting in (1) unit charge for  $q$ , we have

$$I \text{ (Intensity)} = \frac{q}{r^2} \text{ dynes per electrostatic unit.}$$

As in (2) the immersion of the charges in another dielectric than air will give

$$I = \frac{q}{K r^2}$$

See Electricity ; Electrolines.

**ELECTROSTATIC INDUCTION.** Induction arising from static charges. Electrostatic induction or influence is important, as it is the principle underlying one of the most essential pieces of apparatus of either a transmitting or a receiving system in wireless, namely, the condenser. The observation of the effects consequent upon the presence of static charges provided the means of studying these principles.

Imagine a charged and insulated conductor,  $A$ , to be brought into the vicinity of an uncharged and insulated conductor,  $B$ .

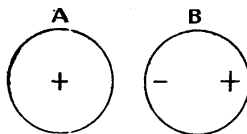

**THEORY OF ELECTROSTATIC INDUCTION**

Two insulated conductors are represented by  $A$  and  $B$ .  $A$  is positively charged and  $B$  uncharged. The potential in both cases is similar. The two are brought into near vicinity, whereupon inductive displacement occurs. The near side of  $B$  becomes negative and the far side positive. Several theories exist as to the reason of this displacement

A potential similar to that of  $A$  is impressed upon  $B$ , and an inductive displacement occurs whereby two distinct and opposite charges are induced at the ends of it. The sign of the charge nearer to  $A$  will be dissimilar to that of  $A$ , while that of the far side will be similar, as in the diagram.

It should be understood that  $B$ , as a whole, has received no charge, and will revert to its former condition on being withdrawn from the influence of  $A$ . Several theories exist in explanation of these results, of which two will be given.

In dealing with the first it is assumed that if a body has an excess of electricity it is positively charged ; if a deficit, negatively. Now, the potential at any point in the dielectric surrounding a charge becomes weaker as the distance from it increases. Thus, the potential due to  $A$  at a point on the right-hand side of  $B$  is lower than that

on the left-hand surface, and the supposition is that this difference of potential causes a flow of electricity from left to right, leaving the near side deficient of its normal amount, *e.g.* negative, and making the far side positive by supplying it with a further store of electricity.

Considered from the point of view of the modern electron theory, a positively charged body is presumed to be deficient of its normal number of electrons, while a body with an excessive number constitutes a negative charge. A, being positive, will endeavour to recover its normal state by attracting electrons towards itself, and thus an abnormal number will be caused to accumulate on the near side of B, making it negative, and leaving the other side short of its proper complement, *i.e.* positive.

An actual and permanent charge may be induced on B if, while under the influence of A, a connexion is made between B and earth. (Note.—If it is desired to test for the presence of this charge, the earth connexion must be broken before the body is removed from the vicinity of A, otherwise the charge would return to earth.) Working on the basis of the first theory, the positively impressed potential of B, due to A, is reduced to zero by earthing it. This state of affairs could only be the result of electricity leaving B, so that it becomes deficient of its normal amount, and by definition is now negatively charged.

According to the electron theory, before B is earthed its right-hand side, being positive, has a deficit of electrons. This shortage will be made good by a supply of electrons flowing in from earth, with the result that B has now a normal number on its right-hand side and, already possessing an excessive quantity on the left, will consequently, as a whole, have a surplus. In other words, it is now negatively charged.

The application of these principles with regard to the condenser may now be considered. Referring once more to the conductors A and B, the negative charge now induced on B will tend to reduce the positive potential of A, which accordingly must be given a further supply of electricity if it is desired to maintain it at its original potential. Thus the final effect of the presence of B is to permit a larger quantity of electricity to be imparted to A without increasing its

potential. The electricity is said to be condensed, and the whole arrangement is called a condenser.

These results will be further intensified as the distance between the two conductors diminishes, and by the substitution of a dielectric of higher specific inductive capacity than air. It should not be imagined that B must necessarily remain connected to earth. This is merely a means of producing as large a charge as possible opposite to that of A. Similar effects would result if B were an insulated body negatively charged by other means than induction, though perhaps they would not be so marked. B might even be insulated and uncharged. As explained earlier, the inductive displacement due to A producing a negative charge on the surface of B, near to itself, would tend to cause these condensing effects. See Capacity; Condenser; Electricity; Electrostatic Capacity; Electrostatic Field.

**ELECTROSTATICS.** Name given to that branch of the science of electricity which is concerned with electricity at rest or with electric charges, and more particularly with the measurement of such charges. The science deals with such phenomena as that exhibited by a glass rod rubbed with a piece of silk, the effects of an electric charge on one body upon a neighbouring body, and the like. See Condenser; Dielectric; Electricity; Electrophorus; Electroscope, etc.

**ELECTROSTATIC UNITS.** Electrical system of units based upon the definition of the unit of electric quantity in the C.G.S. system of units.

In the electrostatic system of units the unit quantity of electricity is defined as that quantity of electricity which, if placed on a small sphere, will repel an equal quantity of electricity of the same sign on a similar sphere with a force of one dyne when the distance between the centres of the spheres is one centimetre.

The spheres in the above definition are assumed to be in a vacuum. Otherwise the distance between the spheres must vary with the dielectric to give the force of one dyne. It equals  $\frac{1}{3 \times 10^{-9}}$  of a coulomb.

The potential at a point is measured by the work which must be done in bringing a unit quantity of electricity up to that point from an infinitely great distance.



The unit is equal to 300 volts. The unit current of electricity is the quantity of electricity which flows across a section of a conductor in unit time, *i.e.* one second. This unit is 0.000333 of a microampere.

The unit of capacity of a conductor is measured by the quantity of electricity required to charge it to unit potential when it is far removed from all other conductors. The capacity of a conductor in electrostatic units is measured in centimetres when air is the dielectric, and is measured in centimetres multiplied by the dielectric constant when any other

medium is employed. It equals  $\frac{1}{9 \times 10^5}$  of a microfarad.

The resistance of a conductor in electrostatic units is equal to the quotient of the potential difference between its ends and the current flowing through it, assuming there are no internal sources of electromotive force. It equals  $9 \times 10^5$  megohms. See Electricity; Electromagnetic Units; Units.

**ELEMENT.** Word used in several senses. In chemistry it is used for those substances which as yet have not been decomposed by any method of analysis. Such elements are hydrogen, helium, carbon, gold, and so on. With the discovery of the electron and the modern electrical theories of matter, the opinion of scientists is veering round to the statement that all the elements are multiples of hydrogen. At present there are between eighty and ninety of the so-called elements.

In a primary cell the two electrodes are often known as the elements. See under the names of the various elements; Atom; Electron; Quantum Theory.

**EMANATION.** In wireless a term synonymous with emission, to denote the throwing off of electrons from a body.

**EMERY CLOTH.** The name of a sheet of linen one face of which has been coated with emery powder. It is made in various grades, designated in various ways by different manufacturers, but generally No. 0 is fine, and No. 2 or No. 3 a coarse grade. The coarseness or grade is represented both by numbers and by letters. For example, FF cloth is a very fine grade. Another fine cloth is known as 120, the latter figure roughly representing the number of grains of emery per square inch, or the number of meshes in the sieve

through which it could be passed in the powder form. The coarser the grade the larger the particles of emery used in its preparation.

In using emery cloth it is important to begin with a relatively coarse grade and finish by progressive use of finer grades, as a better surface results from such a procedure than by commencing with a fine cloth and continuing the polishing process for a longer time.

The wireless experimenter will mostly use emery cloth in the finishing stages of construction, and in general it is as well to use new and coarse cloths on the roughest steel parts and reserve a well-worn piece of cloth for final finishing of brass or fine steel work. Another point is to use a grade of cloth suitable to the material to be worked, and as a rough guide the finer grades will be best for brass or aluminium, and the coarser grades for iron or steel.

The emery can be applied to the work in a variety of ways, but a good plan in almost all cases is to cut the sheets into four as soon as they are purchased, as the stock size of emery cloth is too large for comfortable use, but if the sheet is folded into four, as shown in Fig. 1, the resulting pieces are convenient in size and economical in use. Exceptions to this rule are when the work to be polished is circular in section, when a long strip is more useful, as it can be passed around the work and the two ends held in the hands, as shown in Fig. 2, and one hand pulled back while the other moves forward, repeating this back and forward movement as rapidly as possible. When the work can be mounted and rotated in a lathe, as illustrated in Fig. 2, the polishing process is greatly

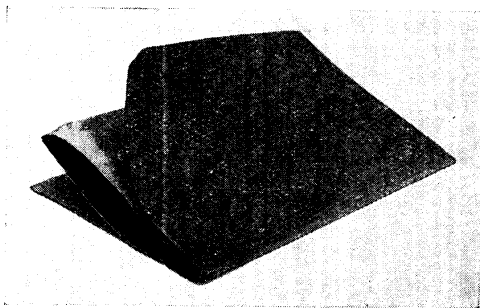

HOW TO FOLD EMERY CLOTH

Fig. 1. Various degrees of coarseness are known and referred to in making, buying and using emery cloth. An example is illustrated to show how the cloth is folded into four to cut to convenient size

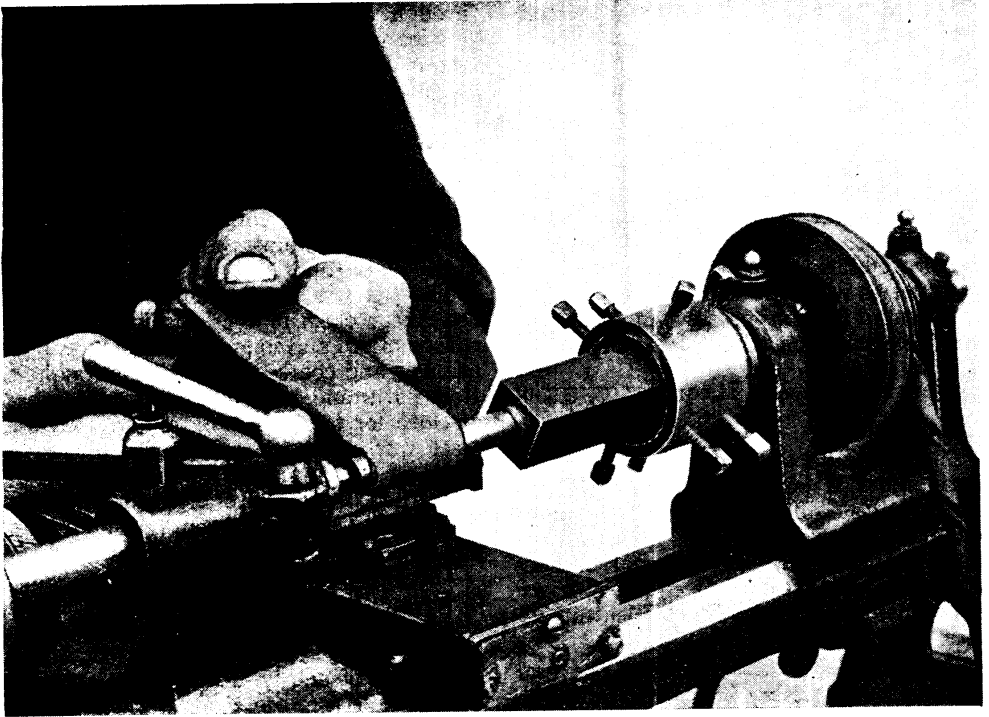

POLISHING A METAL ROD WITH EMERY CLOTH

Fig. 2. For polishing circular objects, such as metal rods and the like, a piece of emery tape or cloth cut into a strip should be used. If a lathe is obtainable the operation may be carried out with far greater facility as illustrated

speeded up. If much of this work is to be done it is best to purchase a roll of emery tape about 1 in. or so in width, and cut pieces from it as occasion requires. When using emery on metals it is generally used dry in the early stages and lubricated with oil in the finishing stages. When emery cloth is used for matting the surface of ebonite it is generally lubricated with oil or water.

Always keep emery cloth free from grit and dirt, as any particles of grit that may become embedded in the cloth will speedily scratch and spoil the finished surface. See Filing; Glass Paper.

**EMERY PAPER.** Expression generally used to describe a sheet of stout paper coated with emery. The same expression is also somewhat loosely applied to emery cloth, in which the emery is applied to a fabric such as linen instead of paper. For general purposes, the ordinary emery as sold in sheets is the most convenient, and is obtainable in different grades from superfine to coarse, the different makers having various designating numbers and lettering, those most commonly employed

being No. 000 for the superfine, and No. 2 for the coarse, the intermediate numbers indicating their grades.

Emery paper is chiefly used in wireless work for smoothing the surface of metals, and for matting the surface of ebonite. In use, the paper may be folded into four and simply rubbed on the work, keeping the fingers about the centre of the pad. A better plan is to cut the sheet into four pieces and wrap one of them around a small block of wood or card, and use this as a rubber. This has the advantage that the resulting surface is more flat and true than is the case when the rubber is not employed, due to the fact that a much more even and steady pressure can be applied.

The paper may also be applied to disks or wooden rods, the latter of any convenient shape to suit the work in hand with one end fashioned into the form of a handle. The paper is simply glued to the stick with ordinary Scotch glue, and is ready for use as soon as the glue has set. The disks are usually mounted on a small polishing head, and the emery paper glued to the face of the disk. The machine is then set in

motion and the work to be polished is applied to the revolving surface.

For other work, a strip of emery paper may be glued around the rim of the disk, or preferably on the face of a leather strap fixed round the disk itself; the article to be polished is applied to the revolving disk. This allows a certain amount of resiliency, and generally results in better work. The disk should be run as fast as possible when polishing metal, and slowly when it is required to put a fine surface on ebonite or similar material.

For a good appearance it is desirable to rub the emery paper in a regular manner on the surface of the work, as this makes a kind of grain on the metal which looks very effective if well done. For the highest polishes the paper used should be a fairly coarse grade at the start, and the surface worked up by the use of finer grades, and finally with the superfine grade, using a well-worn piece that is free from grit or dirt, as the least trace would scratch the surface at this stage.

The wireless experimenter should keep a small piece of emery paper handy for such uses as the polishing of the slider bars of a sliding contact inductance coil. This may be used as illustrated to ensure the best electrical connexion between the slider and the bar. To make spindles such as those used on condensers and filament resistances fit nicely in their bushes, a small piece of fine emery paper can be wrapped around a flat stick and the stick rubbed over the surface of the spindle while the latter is slowly revolved by the left hand.

After using emery paper on a piece of work always take the greatest care to remove all traces of the emery, as it is a powerful abrasive, and will continue to cut the metal unless and until it has all been removed by washing with petrol or oil and the work wiped quite clean.

**EMERY POWDER.** Name given to a very hard greyish-black to black powder, obtained by grinding corundum. The latter is a mineral oxide of aluminium ( $Al_2O_3$ ), and usually contains a very small quantity of magnetite or hematite. It is ground into various degrees of fineness, and graded partly by sifting and partly by deposition processes. The very finest grades of emery powder are known as flour emery, owing to their resemblance to that material, the particles being exceedingly fine and soft to the touch.

The general uses for emery powder are for grinding the faces of metallic objects. It is also used for polishing and grinding, and is then applied by mops and buffs of various patterns. For hand work it may be used on a leather or a buff stick. The latter is a piece of shaped wood faced with chamois leather.

Emery powder may also be used for matting surfaces of various materials, such as, for instance, ebonite and glass. In both cases the emery powder is sprinkled over the surface to be treated, moistened with water, and the matting performed by vigorous rubbing, either with a piece of material such as a knob of glass or with a block of wood.

**E.M.F.** This is the standard abbreviation for electro-motive force, the force

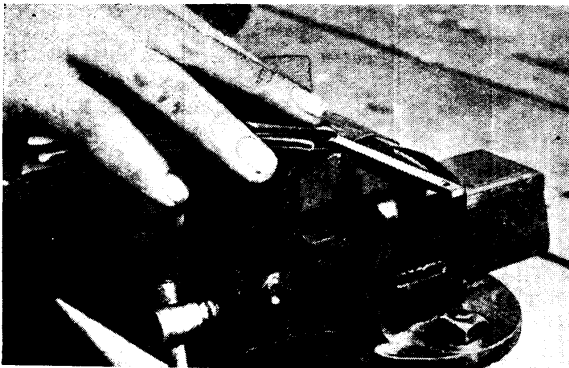

METHODS OF USING EMERY PAPER AND EMERY POWDER

(Left.) Fixed in the vice is a slider-bar for an inductance coil, and the operator is in the act of polishing with emery paper. It will be seen that the paper is folded and is being applied diagonally across the work. (Right.) Emery powder is used as a means of cleaning. This illustration shows a brass plate being treated. The powder is applied with a rag

which causes an electric current to flow or tend to flow from one point to another, due to a difference of potential between those points. See Electro-motive Force.

**EMISSION.** In wireless this term usually refers to the emission of electrons from a body. When the filament of a three-electrode valve is heated, for example, there is emitted a stream of electrons. A definite number of these are emitted per second for each centimetre of length of the filament, and the number depends upon the temperature, rising rapidly as the higher temperatures are reached. The flow of these electrons between the filament and the plate or anode of a valve is controlled by means of the grid (*g.v.*), and this enables signals to be read. See Anode; Electron; Filament; Grid; Valve.

**EMISSION CURRENT.** In a transmitting valve the emission current is the name given to the product of the valve current multiplied by the anode voltage. It gives the power to which the valve is designed. Transmitting valves are usually rated as being of so many watts. See Valves for Transmission.

**E.M.U.** This is the standard abbreviation for electro-magnetic units, based on the definition of the unit magnetic pole. See Electro-magnetic Units; Units.

**ENAMELLED WIRE.** Expression used to describe a conducting wire, the outer surface of which has been coated with a special insulating enamel. This material is extensively used in wireless work for the winding of inductances, magnet windings, transformers, and the like. When carefully used, the enamel is remarkably durable and efficient, and the material has the advantage that it occupies very little space.

When using enamelled wire, it is highly desirable to prevent it from being injured and to avoid sudden bends, as this is almost certain to break down the insulation.

When purchasing enamelled wire, an effective and simple test is to pass the wire across the thumbnail into a U shape, and to straighten it out two or three times in succession. If of good

quality, the wire should stand up to this test without the enamel breaking, but if of poor quality the enamel is almost certain to break or crack, or in bad cases pull off the wire altogether. See Copper Wire.

**END CHEEKS.** Upright end supports for an inductance or other coil of the type built up on a baseboard and supported by uprights at each end. Such end cheeks are customarily made of hardwood, and by various methods which are detailed in the constructional articles in this Encyclopedia, such as Coil, Condenser, etc.

A typical example is illustrated, which shows the uprights fitted to a disk of

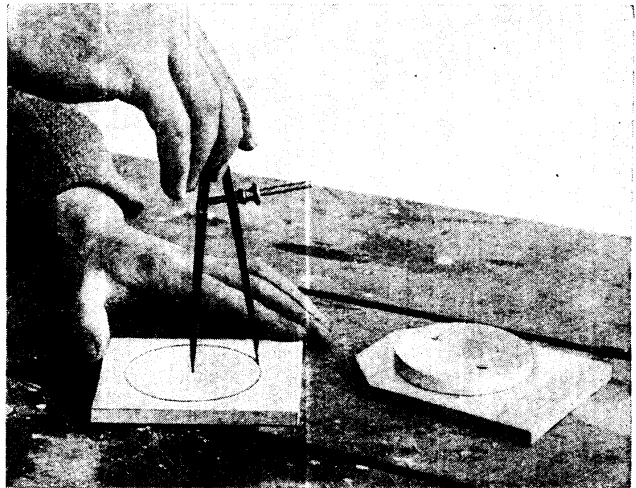

PREPARING END CHEEKS FOR A COIL

End cheeks are used to support inductance or similar coils. They are either grooved for the reception of the former of the coil, or have pieces of wood fitted similar to the one shown

similar material glued and screwed to it. This disk fits into the bore of the tube used as a former for the coil, and is cut to shape by marking out an odd piece of wood with a pair of compasses and then sawing to shape.

The edges should be cleaned up smoothly, and should be fixed to the upright part so that the grain of the one runs in contrary direction to that of the other. Brass screws should be used in preference to iron or steel, for the reason that they are non-magnetic. To improve the insulation value the wood must be perfectly dry and should either be impregnated with boiling paraffin wax or thoroughly well varnished.

**ENDODYNE.** Term used to describe reception by means of local oscillations, when the latter are generated by a part of

the main receiving gear instead of by a separate apparatus, as in the case of the separate heterodyne. See Heterodyne.

**ENERGY.** Capacity to do work. Energy is something that is given to a body by doing work upon it, as when a book is raised and placed upon a bookshelf, or a wheel is spun round. The energy is given out when the body itself performs work. Thus if the bookshelf breaks, the book falls, and in falling does work.

Energy is of two kinds, potential and kinetic. By potential energy is meant the power a body has to do work in virtue of its position or condition. Thus the book on the bookshelf has potential energy, and once the support of the shelf is removed the book does work due to its motion as it falls to the ground. A ball suspended by a string has potential energy, and this energy is given out when the string is cut, the amount of work it performs depending upon the mass of the ball and the distance through which it falls. Water in a tank raised off the ground, a compressed spring, the weights of a grandfather clock, are all examples of potential energy. All these bodies are so situated, as it were, that they are acted upon by forces which produce motion when the restraining force is removed, and work is done. For that reason energy is sometimes spoken of as stored work.

The potential energy of a body is measured by the product of the force tending to produce motion and the distance through which the body is able to move. Thus, if the book is on the bookshelf eight feet off the ground, and it weighs two pounds, it has 16 foot-pounds of potential energy. Energy, it will be observed, is expressed in the same units as work. The work done in raising the book off the ground and placing it on the bookshelf is 16 foot-pounds, and this is exactly the potential energy of the book. It is, in other words, the amount of work stored in it due to its position.

Kinetic energy is the energy of a body due to the fact that it is in motion. A railway train, a motor car, a flywheel spinning round, a current of air, and the book on the bookshelf when it is falling, all possess kinetic energy. The kinetic energy of a body is measured by the product of half its mass and the square of its velocity. Expressed in symbols, if  $E$  is the kinetic energy in foot-pounds,  $M$  the mass of the body, and  $V$  its velocity, then

$E = \frac{1}{2}MV^2$ . The mass of a body is its weight divided by  $g$ , the acceleration due to gravity, so that the above result may be expressed as  $E = \frac{1}{2}WV^2/g$ , where  $W$  is the weight of the body.

Where there is any conversion there is always energy. Thus in a primary cell the chemicals of the cell act upon the electrodes. Here chemical energy is released and converted into electrical energy. The controlling of energy is of the utmost importance in human affairs, and though some forms of energy are easily controlled, others are not. Thus a rotating flywheel, the falling of water, etc., are forms of energy which can be controlled and converted into useful work.

Light and sound and heat are other forms of energy which are not easily converted into useful forms of energy. Heat is the most useful of the three, but it is extremely wasteful. In converting one form of energy into another, heat is often generated, and this, as a rule, is so much waste power.

There is a very important law of energy which is known as the conservation of energy. This is a statement that the amount of energy in the universe remains constant. Potential energy can be converted into kinetic energy, as may be seen from the falling book already quoted, but the total quantity of energy remains constant despite the change. A steam engine converts heat energy into mechanical energy, and the striking of a bullet on a rock converts mechanical energy into heat energy. But nothing is lost in the conversion, although the energy may be dissipated in such a form that it is not usable. See Electron.

**ENGRAVING.** The art of cutting lines or patterns on the surface of metal or other materials. In wireless, engraving is chiefly restricted to cutting the names of various parts of the apparatus, or the lines for calibration of a dial or scale.

Engraving is generally performed professionally with special engravers' machines, but the amateur can obtain fairly satisfactory results by the use of the regulation engraver's tools, of which the chief is the graver, or burin. This is a rectangular tool tapering from the handle end to the point, which is curved over at an angle to form a lozenge-shaped head. The single projecting point is used as the cutting edge. The handle is generally of a small button shape, and made of hardwood.



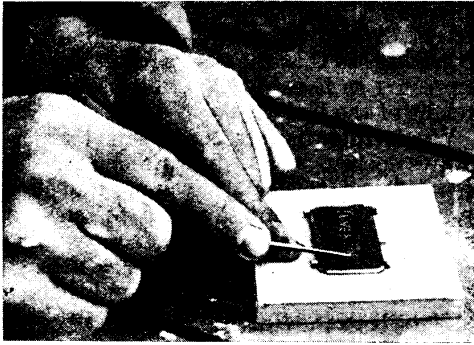

#### HOW TO HOLD A GRAVER

Fig. 1. Engravers using a graver hold the tool in the right hand, as illustrated, and guide its movement by the first finger of the left hand

The tool is used by grasping the handle in the palm of the hand and holding the graver between the first finger of the right hand and the thumb, as in Fig. 1, and guiding it with the first finger of the left hand.

Experience alone gives dexterity in the manipulation and use of the graver, but as a primary exercise the amateur may take a piece of ebonite or brass, and draw upon it with a sharp-pointed pencil the lettering to be engraved. Then holding the graver in the right hand, and resting the wrist lightly on the smooth surface, the incisions are made by sliding the tool forwards over the surface of the material, bringing just sufficient pressure to bear to cause the point to dip in slightly, thus removing a smooth, fine chip of the material.

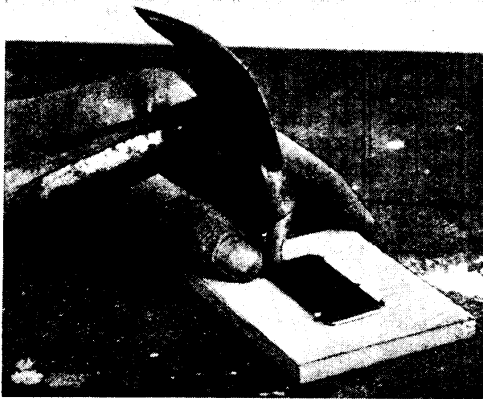

#### FIXING A PLATE FOR ENGRAVING

Fig. 2. Before commencing operations with the engraving tool the work should be securely held. The method illustrated is suitable for plates and similar small objects

The plate should be fixed, with brads, as shown in Fig. 2, to the bench while the engraving is in progress, or preferably to a small block of wood, which can be clamped to the work table. It should be moved about in various directions, so that the principal cuts are always made by simply pressing forwards, and always with a sliding motion.

When it is desired to cut away the ground of a name plate, for example, a tool known as a scorper is used. This is a U-shaped section tool ground to a cutting edge terminating at the curved portion. Consequently, it removes the metal and leaves the surface slightly hollowed. By working the wood in various directions and finishing off with a flat or straight tool it is possible to cut away the background to a nicety.

The amateur will be well advised to commence on simple things, and acquire proficiency in engraving a plain block lettering. A variety of other tools are used by engravers, but they are of little interest to the experimenter.

When the incisions are made in ebonite, it is customary to fill or colour them with white or some other light-coloured pigment, which is simply brushed on, and as soon as the paint has begun to set the surface of the ebonite may be wiped clean with a rag and the paint in the incisions allowed to dry. On brass or copper the filling may be black, and applied in a similar manner. Celluloid, bone, ivory, and the like may be engraved with the same tools and in a similar way.

**E.P.S. BATTERY.** The abbreviated form of the manufacturer's name, the Electric Power Storage Co., Ltd., whose accumulators are based primarily on the inventive powers of Faure, Sellon, and Volkmar.

The plates are made on the grid principle, with antimony-lead made in moulds in such a way that the holes in the plates are made corical in shape, with the small end of the cone inwards. These holes are formed from each side of the plate, and the space in the centre has a perforated lead strip across it.

The filling is a paste of red lead or minium ( $Pb_3O_4$ ) and dilute sulphuric acid for the positive, and for the negative litharge ( $PbO$ ) and dilute sulphuric acid, or a solution of magnesium sulphate. During the process of manufacture the paste is pressed into the grids and dried.

After the plates have been hardened by immersion in dilute sulphuric acid they are formed by charging the positive plates with a strong current for a duration of some forty-eight hours.

The negative plates are formed with a twenty-four hour charge. Glass separators are generally used with these accumulators to prevent short-circuiting when the cells have been set up ready for use. There are many types of E.P.S. accumulators, made in various capacities and forms adapted to station and other storage-battery work. See Faure Plates.

**EQUAL HETERODYNE.** The condition in heterodyne or beat reception which exists when the amplitude of the incoming and of the local oscillations is the same. In practice it is generally found that the maximum strength of signals is not associated with this condition, and that "optimum heterodyne" is only obtained when the strength of the local oscillations is increased beyond equality. See Heterodyne.

**EQUIPOTENTIAL SURFACES.** Surfaces on which the potential is equal. The study of equipotential surfaces is important as supplying a means of examining the field of forces due to a charge and the manner in which the surrounding dielectric is strained.

Imagine a small insulated sphere holding a charge of electricity to be placed in such a position that it is entirely remote from, and unaffected by, the influence of other charged bodies. In these circumstances its charge will be uniformly distributed over the whole of its surface, and it may be assumed that the force exerted by it acts as though the charge were situated at a point in the centre of the sphere.

It may be proved by mathematical reasoning that the potential at any point in the space surrounding the sphere is equal to the amount of the charge divided by the distance between the point in question and the centre of the sphere. Let  $Q$  units of electricity reside on a

sphere,  $A$ , as shown shaded in the figure, and imagine a point,  $P$ , situated  $R$  units of length away from its centre. The potential at  $P$  will therefore be  $\frac{Q}{R}$ .

Similarly, the potential at all points at a distance of  $R$  will be  $\frac{Q}{R}$ .

Now, a sphere whose centre coincides with that of  $A$  will provide a surface any point on which will be equidistant from  $A$ , and in view of what has just been stated this surface must therefore be an equipotential one. If the radius of this sphere is  $R$ , the potential on any part of its surface must be  $\frac{Q}{R}$ . In a similar way, another sphere may be imagined, of radius  $R_1$ , and the potential at all points of its surface will be  $\frac{Q}{R_1}$ .

In order to visualize better the system of surfaces which can thus be set up, a plane may be taken passing through the centre of a number of concentric spheres, giving a diagram of rings spreading outwards in ever-widening circles.

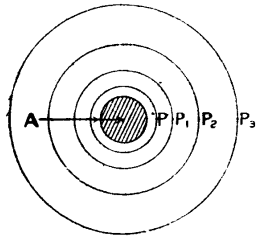

**SYSTEM OF EQUIPOTENTIAL SURFACES**

These surfaces are separated in such a way that it requires unit quantity of work to move a unit quantity of electricity from one to the next

It is convenient to assume that each surface is at such a distance from its neighbours that it requires unit quantity of work to be performed on a particle charged with unit quantity of electricity in order to move it from one surface to the next towards  $A$ . In other words, unit difference of potential exists between each surface. The distance separating each one is not constant, but increases as the distance from  $A$  increases.

Suppose  $V$  to be the potential at  $P$ . Then, as unit difference of potential exists between each surface, the potential at  $P_1$  will be  $V-1$ , at  $P_2$ ,  $V-2$ , and so on. Assume the charge on  $A$  to be unity. As already stated, potential equals charge divided by distance, or

$$V = \frac{Q}{R}$$

but  $Q = 1 \therefore V = \frac{1}{R}$

or  $R = \frac{1}{V}$

similarly  $R_1 = \frac{1}{V-1}$  and  $R_2 = \frac{1}{V-2}$

This is a harronical progression series.

It should be clear that as the charge is considered as acting at a point, the lines of force due to it, being radii of the sphere, must cut the surfaces at right angles. If they cut them at any other angle, one component of each line of force would necessarily be along the surface, and in moving a particle from point to point on the surface, work would be done against the force exerted by A. But, by definition, when work is done, potential is altered, and the impossible case of differences of potential existing on an equipotential surface would present itself. The lines of force cannot, therefore, cut the surface at any other angle than a right angle.

The above ideal case of an isolated sphere is perfectly straightforward, but the influence of other charged bodies complicates matters to a large extent, and gives a complex outline to a system of equipotential surfaces, but in general it may be taken that the lines of force cut them at right angles.

The surface of a conductor must in all cases be an equipotential one. Even if differences of potential did exist in the first place, the resulting flow of current from point to point would restore equilibrium.

**ERG.** The unit of work in the centimetre, gramme, second system of units. It is the measurement of the amount of work done by a force of one dyne acting on a body through a distance of one centi-



**COMPLETE ERICSSON HEADPHONES**

Fig. 1. This brand of headphones is well known among amateurs. Adjustable aluminium headbands are provided. The earpieces are on a universal joint to allow complete adjustment to the head of the wearer

metre. Ten million ergs are called a joule (*q.v.*). See C.G.S.; Horse-power; Units.

**ERICSSON HEADPHONES.** Name of a well-known brand of headphones expressly designed for wireless reception purposes. The external appearance of one

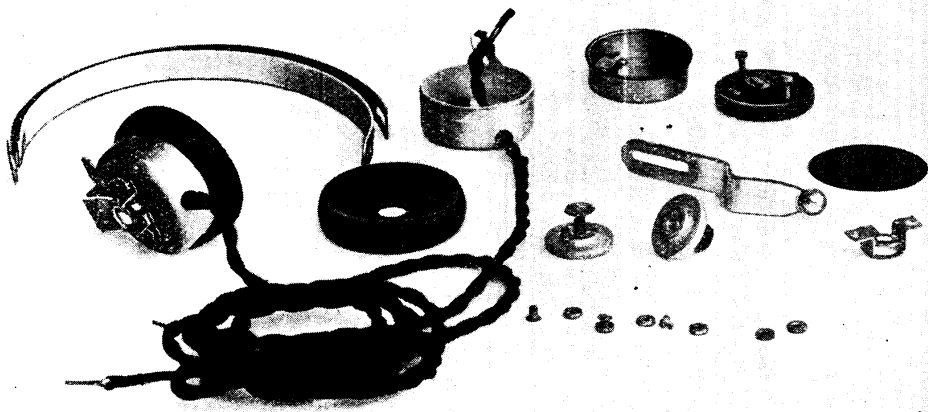

**DISSEMBLED COMPONENTS OF A PAIR OF ERICSSON HEADPHONES**

Fig. 2. On the left of this photograph will be seen the aluminium headband and one complete earpiece. On the right an earpiece has been taken to pieces to show the diaphragm, magnets, adjusting screws and other parts

pattern is illustrated in Fig. 1, and the component parts in Fig. 2.

The headbands are of aluminium, and are made adjustable by means of screws on the side supports. The same material is used for the exterior pad of the ear-pieces, which are attached to the side supports by a simple form of bolt or universal joint. This permits the ear-pieces to adjust themselves comfortably to the operator's head.

The magnets and pole pieces are made up as a separate unit, and are enclosed within a casing, thus separating the telephone mechanism proper from the outer casing and separating it from the connecting wires, which are attached to the terminals on the underside of the inner case. The magnets are of the pattern customary in this class of instrument. The diaphragm is of stalloy. Both the diaphragm and the inner case are held in their places by an ebonite outer cap, which screws on to the thread on the outside of the external casing.

#### ERICSSON MICROPHONE TRANSMITTER.

The Ericsson carbon microphone transmitter is an instrument for converting sound waves into electrical impulses. The instrument is shown in the photograph. The mouthpiece, or trumpet, is of spun metal, heavily nickel-plated to prevent corrosion from the damp breath of the speaker.

Attached to the back of the trumpet is a circular metal case of large diameter, and about  $\frac{1}{4}$  in. maximum thickness. This case, made in two pieces held together by three screws evenly spaced round the rim, is rounded out towards the centre to form a hollow cavity. A diaphragm is sandwiched between the two halves of the case and insulated from it by rings of non-conducting material. The whole is fixed by the three screws. A piece



ERICSSON  
MICROPHONE

Sound waves are converted into electrical impulses by carbon microphone transmitters of this kind  
*Courtesy British L. M. Ericsson Co.*

of fine-meshed copper gauze is attached to the rear of the trumpet immediately in front of the diaphragm, but not touching it.

The rear half of the diaphragm case contains a carbon disk, technically known as the back plate, and is arranged some hundredths of an inch from the diaphragm. The front surface of the back plate is not flat, its surface area being increased by small indentations over its entire surface. The space between the back plate and the diaphragm is loosely packed with fine carbon granules. One connexion is made from the diaphragm and the other from the back plate.

The microphone is mounted upon a fluted ebonite handle, having a slotted projection at the top to enable it to be hung conveniently from a wall or other hook. Flexible leads are brought from the diaphragm and back-plate connexions, through the ebonite handle, these being of a convenient length to attach to the set.

The normal resistance of the instrument is 30 ohms, and the makers recommend that a current of 0.15 ampere be used to obtain the best results. On the operator speaking into the mouthpiece, the diaphragm vibrates backwards and forwards, the vibrations varying in frequency and amplitude in exact accordance with the sound and loudness of the speaker's voice.

This action of the diaphragm compresses the carbon granules to an extent proportionate to the vibrations. The compression of the granules in this manner varies their resistance, the latter being much lower when the granules are under compression, and vice versa.

It follows, therefore, that if a current is applied from some perfectly steady source, such as a battery, and providing the resistance of the external circuit is constant, the resistance variations in the microphone itself will cause a proportionate variation in current strength. Hence the current impulses are as identical in frequency, amplitude, and wave form as the limitations of the diaphragm for recording speech vibrations allow.

In the event of the microphone losing its efficiency as a reproducer, it is possible that a slight tap on the diaphragm will immediately effect a cure, for it occasionally happens that the granules pack or stick together, and the action of tapping loosens them. See Microphone: Transmission.

**ERSKINE-MURRAY, JAMES.** British scientist. Born at Edinburgh, October 24th, 1868, Erskine-Murray was for six years associated in study and research with Lord Kelvin at Glasgow University. He afterwards went to Trinity College, Cambridge, as a research student, and from 1896 to 1898 was assistant professor of physics and electrical engineering in the Heriot-Watt College, Edinburgh. In 1898 he became experimental assistant to Marconi, and in 1900 lecturer and demonstrator in physics and electrical engineering at University College, Nottingham. In 1905 Erskine-Murray became lecturer in electrical engineering at the George Coates

Technical College, Paisley, and the same year became a consultant on radiotelegraphy. From 1907 to 1911 he was lecturer in that subject at the Northampton Institute, London.

Erskine-Murray is a past president of the Wireless Society of London, and the author of several books on wireless. During the Great War he was in charge of the wireless instruments and experimental work in the Royal Air Force.

**E.S.U.** This is the standard abbreviation for electrostatic units, units based upon a definition of the unit quantity of electricity. See *Electrostatic Units*; *Units*.

## THE ETHER: MODERN THEORIES AND THEIR APPLICATIONS

By Sir Oliver Lodge, F.R.S., D.Sc.

Here our distinguished Consultative Editor discusses, largely from the point of view of his own original work on the subject, the modern theories of the Ether, its characteristics and the part it is understood to play in the transmission of electromagnetic waves—whether light, wireless, or other waves. The associated article *Waves* should be consulted, and the general headings *Electricity*; *Electrons*, etc.

When it was discovered that the constitution of matter was atomic—that is to say, that it only existed as individual particles, separated from one another by intervals of space—the particles nevertheless not being entirely separate, but exerting on each other attractive and repulsive forces—a difficulty was felt about how those forces could be transmitted from one to the other, so that a body could appear to act at a distance from where it really was, without any connecting link.

When matter was regarded as continuous, the difficulty did not arise. A universal contact-action could be postulated. And yet it was perceived, even then, that the particles of matter could not really be in contact, since compression was possible. And when matter was either expanded or compressed, the distance between the ultimate particles, whatever they were, must vary. Still the difficulty could be slurred over, on the analogy of elastic materials, until Newton discovered the law of universal gravitation, which showed that the forces of bodies were exerted not only in their immediate neighbourhood, but over immense distances of apparently empty space.

Newton realized clearly that action at a distance of this kind, across empty space, could not be tolerated as a physical explanation, and he went so far as to say that no one with a sound instinct for natural philosophy could rest in such an

idea. Accordingly he was driven to the conclusion that space was not really empty, but was filled with an unknown medium capable of transmitting gravitational force; and the same medium could then be appealed to for the transmission of electric and magnetic forces, with which also he experimented. Anyone watching the behaviour of a piece of iron near a magnet, and feeling the pull, must be struck by the exertion of force across an intervening space, and it was found that this force could act equally well in a vacuum as in air.

Newton therefore proposed to call this hypothetical medium "ether," a term which had been in use before for any impalpable and subtle substance, and which is still, rather confusingly, used by chemists for certain liquids which are more mobile and more easily vaporized than water. The term "ether" as now used by chemists has a definite connotation, and is applied to a group of chemical substances allied to the alcohols, but in a further state of oxidation. This chemical use of the term, however, is entirely distinct from the supposed universally-connecting medium postulated by physics, and called, when discrimination is necessary, 'the ether of space.'

There is no analogy or connexion between the two terms at all, nothing but an antique historical link. It is a case of one name for two entirely different things: and

there ought never to be an excuse for any confusion. But this note seems necessary, because, in the minds of uneducated persons, confusion there sometimes is.

Attempted theories of light soon brought ideas about the ether into prominence, and experiment began to give us information about light which Newton never possessed. Newton's view of light was that it consisted of particles shot out by luminous bodies, which conveyed their energy like projectiles, and produced the various known effects by their impact.

Certain phenomena, however, subsequently discovered, and now studied under the names interference and polarization, and certain other metrical facts relating to the velocity with which light travels in water and other dense substances, brought Newton's Corpuscular Theory into discredit, and gradually replaced it by the Undulatory Theory: a theory which was supported and gradually established by those great natural philosophers, Thomas Young in England and Augustin Fresnel in France. All subsequent discoveries in optics have substantiated the wave theory of light, until it holds the field; though in quite recent times, and subsequent to the beginning of the twentieth century, a few new facts have been observed which suggest certain curious modifications and ideas which are too novel and too speculative to be referred to further here.

#### Early Theories of the Ether

Before the middle of the nineteenth century Faraday's researches in electricity clearly required an ether for their explanation. He drew attention away from charged conductors and other material objects, and concentrated it upon the intervening spaces; so that for a time electricity seemed divorced from matter and to be a thing *sui generis*, much more closely associated with the ether.

Then came Clerk-Maxwell, who, early in the latter half of the nineteenth century, absorbed Faraday's views, and threw them into brilliant and comprehensive mathematical form, uniting electricity and magnetism in one comprehensive scheme, and ultimately being led to perceive that light also was included in the same scheme. In other words, that an ether possessing electric and magnetic properties must also have the power of

transmitting waves, and that electromagnetic waves must travel with the velocity of light.

As a result of all this work we know that the ether is responsible for the whole of optics as well as for electricity and magnetism, that it acts as the universal connecting medium, and that everything transmitted by it is conveyed at one definite uniform speed, which has been ascertained experimentally, and is  $3 \times 10^{10}$  centimetres, or 300,000 kilometres, or about 186,000 miles, per second. This appears to be the one constitutional velocity in the ether, and possibly the one constitutional velocity in the universe.

Experimentally, it is possible to measure this speed. If a spark or a flash is made at one place, and if the light from it is received and reflected back by a mirror at another place 93 miles away, the returning light, on arriving at the sending station, having travelled a distance of 186 miles in all, will arrive after an interval of one-thousandth of a second. This can be proved with great precision by the use of revolving slit wheels and other mechanical devices, and there is no sort of doubt about it. It is the most solid metrical fact about the ether that we know.

#### All Ether Waves Travel at the Same Speed

It has further been proved that whatever the size or the intensity of waves—whether they are a hundred miles long or a millionth of an inch short, whether they are violent or feeble—they all travel at the same identical pace. The only circumstance that can modify this rate of travel is the interposition of matter.

In air they go very slightly slower than in vacuo: in water they go at three-quarters the speed. In denser material, like ordinary glass, they go at two-thirds of the speed; and in a very dense transparent substance, like diamond, at two-fifths of the speed; this speed-ratio, inverted, being called the refractive index of the substance.

This fact it is which confers upon lenses their converging properties, and makes them available for telescopes and microscopes. Upon that fact also depends the photographic camera, and the eye itself; our vision being dependent on the image-forming power of the cornea and the crystalline lens.



It must be understood that no transparent substance is able itself to transmit light. It is able to obstruct it and make it slower, but all transmission must be done by the ether, which therefore permeates all transparent bodies. Electrical phenomena show that it permeates conducting bodies too, that it is an absolutely continuous medium, without gap or interval in its vast continuity. It is responsible for the cohesion with which separate atoms cling together, and therefore for the strength of materials, and all the other phenomena of engineering. And the old view of Newton, that it must be responsible for gravitation too, is really confirmed by the most recent discoveries of Einstein, which have shown that a gravitational field modifies the ether in its neighbourhood sufficiently to cause a perceptible effect on the velocity of light. So that an enormous mass like the sun acts as a feeble converging lens.

Discoveries made during the present century have directed attention back from the ether, and the space surrounding bodies, to their interior also, and have shown that electricity is not so remote

from matter as had been thought. These discoveries have shown that the atom of matter, though a reality, and a definite unit which can be weighed and measured, is not an ultimate unit; that it is composed of electrical particles; and that, as far as we know, these electrical particles or corpuscles or electrons are the fundamental unit of which the atom of matter is composed. The electrons in an atom, though separated by considerable spaces in proportion to their size, are united and welded together into a system by their electrical forces transmitted through the ether, just as the planets round the sun are similarly welded together into a system by their gravitational forces.

But if matter is composed of electricity, the question naturally forces itself on our consideration: What is electricity composed of? What *are* these electrons and protons, that represent all we know of negative and positive charges? We can work out all their phenomena, and understand what they are doing, and analyse their motions by means of the spectroscope, and in fact build up a most extensive theory, in which light, electricity, magnetism, and matter, play their appointed parts. But when we ask what relation these apparently ultimate units bear to the ether of space, we are at present brought up against a stop. The question must be answered some time, but we cannot answer it now.

We can only surmise that these electrical specks are really composed of ether in some peculiar kind of motion, not yet formulated. The ether is not subject to locomotion; that is only a property of matter. But the ether may be in a state of whirling or vortex motion; and it is to some such kind of circulation, circulating in a fine-grained manner with the velocity of light, that the natural philosophers of the near future will look to explain, not only those forms of energy we have been speaking of, but the nature of matter itself.

When we say that matter is probably ultimately composed of ether, we do not mean that it is not specifically modified. The properties of the modified ether may differ in many respects from what is called "free ether"; just as the properties of ice and of steam differ from those of liquid water, though nevertheless it is true to say that fundamentally and ultimately both ice and steam are modified water.

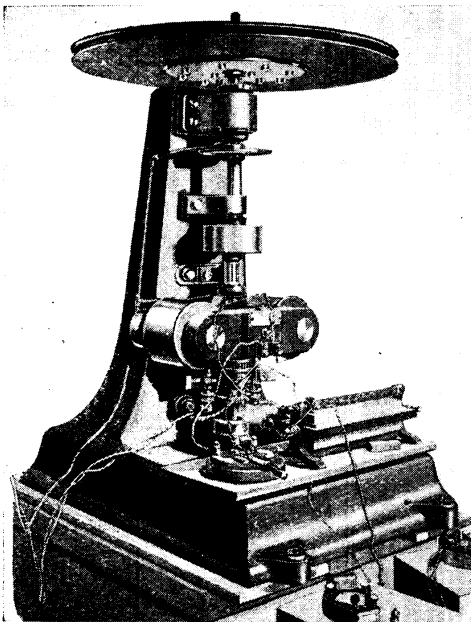

**MACHINERY FOR LODGE'S ETHER TEST**

Fig. 1. This machine, designed and used by Sir Oliver Lodge in his ether experiment, consisted essentially of a pair of steel disks, 3 ft. in diameter, directly coupled to a motor capable of revolving them at 6,000 revolutions per minute. Round the whirling disks optical apparatus shown in Figs. 3 and 4 was arranged

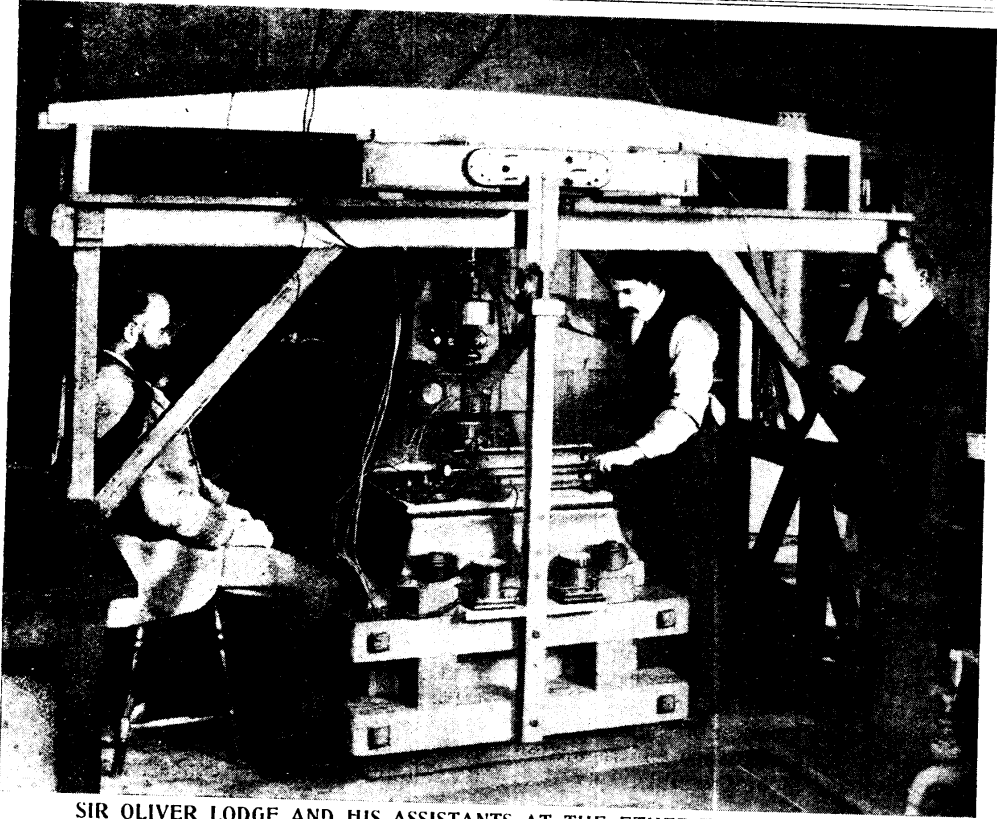

**SIR OLIVER LODGE AND HIS ASSISTANTS AT THE ETHER-TESTING MACHINE**

Fig. 2. The test devised by Sir Oliver Lodge was intended to show whether there was any sort of mechanical connexion between matter and the ether. Between the whirling disks seen in Fig. 1 a parallel beam of light (which by the Clerk-Maxwell theory consists of electro-magnetic waves in the ether) was split in two, and projected by means of mirrors in opposite directions. If the ether were slightly dragged round by the rapid motion of the disks, one half of the beam of light would have been retarded and the other half accelerated. In the result the idea of ether drag was negatived

Meanwhile we know that electrons can freely move about in metals, and can be projected across a vacuum, but that their motion is obstructed by air and many other substances, which are therefore called insulators. In a wireless aerial electrons are surging up and down, and by these large-scale oscillations are generating waves in the ether; which waves break off and travel out with the velocity of light, mainly in a more or less horizontal direction, until some of them are absorbed by a similar aerial device at a distance, and are there reconverted into electronic surges, though much feebler in intensity. Such electric oscillations are called Alternating Currents (*q.v.*), and more must be said about them under the head Waves.

Meanwhile we can realize that in wireless telegraphy we have a new and

artificial method of utilizing the extraordinarily perfect transmitting powers of the ether, and that we are thereby supplementing the power, long ago possessed by man and most animals, of utilizing the ether for conveying information from a distance.

Information can thus be conveyed because any perturbation or modification of the waves, emitted from the sun or other luminous source, caused by bodies upon which they fall, is able, through the extraordinary mechanism of the eye and the skill acquired by long ages of hereditary interpretation, to give us information about the nature of those bodies. All that we directly receive is a succession of ripples or tremors in the ether; but from these we are able to make inference about the bodies which have emitted them, and also about the other non-luminous bodies which have received and scattered and otherwise

modified them. In no other way do we apprehend a landscape: in no other way do we apprehend colour. And all the beauty and complexity of visible objects is conveyed to us by ripples in the ether of space.

This is ancient history; and this power, possessed by the human race, they have been so long accustomed to that they take it for granted, and do not realize the wonder of it. Yet if anyone were to say that by studying the ripples in a harbour he could tell all the boats in the harbour, and where they were situated, and what shape they were, and how close together, we should be sceptical. Nevertheless, that, and much more than that, is what we have learned to do, without a moment's hesitation, by means of ripples or tremors in the ether.

And now, by new methods and by artificial receiving instruments, we are able to deal with larger waves for which we have no sense organ at all, and to pick up out of the ether waves which can be interpreted as signals and music and speech, and in time to come we know not how much else: for it is as if we had almost acquired a new sense for the exploration of the universe.

There are many reasons for regarding the ether as incompressible. It acts

phenomena, again, point to a notable massiveness in the ether. Moreover, matter is so extremely porous, its atoms consist so largely of empty space—analogueous to the empty spaces in the solar system between the planets—that any density possessed by matter must be exceedingly small, a mere, almost infinitesimal, fraction of that belonging to the continuous ether.

So far from the ether being evanescent and ethereal in the poetic sense, it is probably the most substantial reality, perhaps the only substantial reality, that exists in the material universe. The poetic spelling of its adjective must be abandoned in physics, for it suggests erroneous ideas. Truly ethereal properties are made use of in every department of science.

The ether is not matter; and yet it belongs to the material or physical universe. There is nothing occult or ideal about it, except its non-appeal to our animal-derived senses, and the perfection of its properties compared with those of what is sometimes spoken of as "gross matter"; meaning by that term the molecular aggregates, completely interpenetrated by ether, with which everyone is familiar, and with which we have the illusion of being solely concerned.

The ether transmits vibrations at a definitely measurable speed: it allows itself to be harnessed in the service of man at every electrical station: it not only conveys light and telegraphic messages, it illuminates our houses, drives our electric motors, and propels our trams. For no mechanical pull or push is transmitted to them by the trolley-pole, which runs freely, and only establishes ethereal connexion with the overhead wire; which, again, is not subject to mechanical stress,

except that due to gravitation. In short, we are continually dependent on ethereal processes, in ways of which we as yet can hardly dream.

Before Maxwell, the only waves that were known all belonged to the class of upheaval waves, like those on the sea, compression waves, like those of sound, and transverse waves, like those conveyed by an elastic solid. Take a long shaft or rod, miles in length; then take hold of one end and twist it to and fro. The

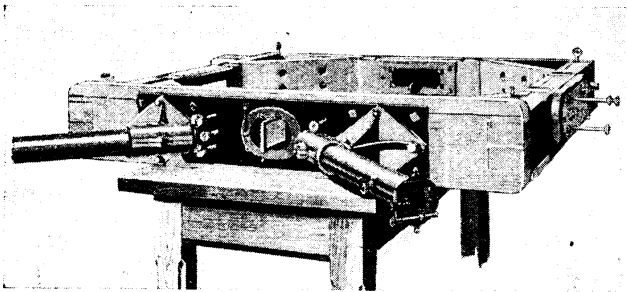

OPTICAL FRAME FOR THE ETHER MACHINE

Fig. 3. This frame, placed round the whirling steel disks, supported the mirrors, telescope, and collimator. It is seen in plan view in Fig. 4

not by compression, but by distortion. Every disturbance in it appears transverse, of the nature of pure shear, without any change of bulk; indeed, if it be really continuous, compressibility can hardly have any meaning.

If, then, an electron is composed of ether, we can form an elementary estimate of what, if it were matter, we should call its density: for the mass and volume of an electron are known, and their ratio is very great, comparable to  $10^{12}$ . Magnetic

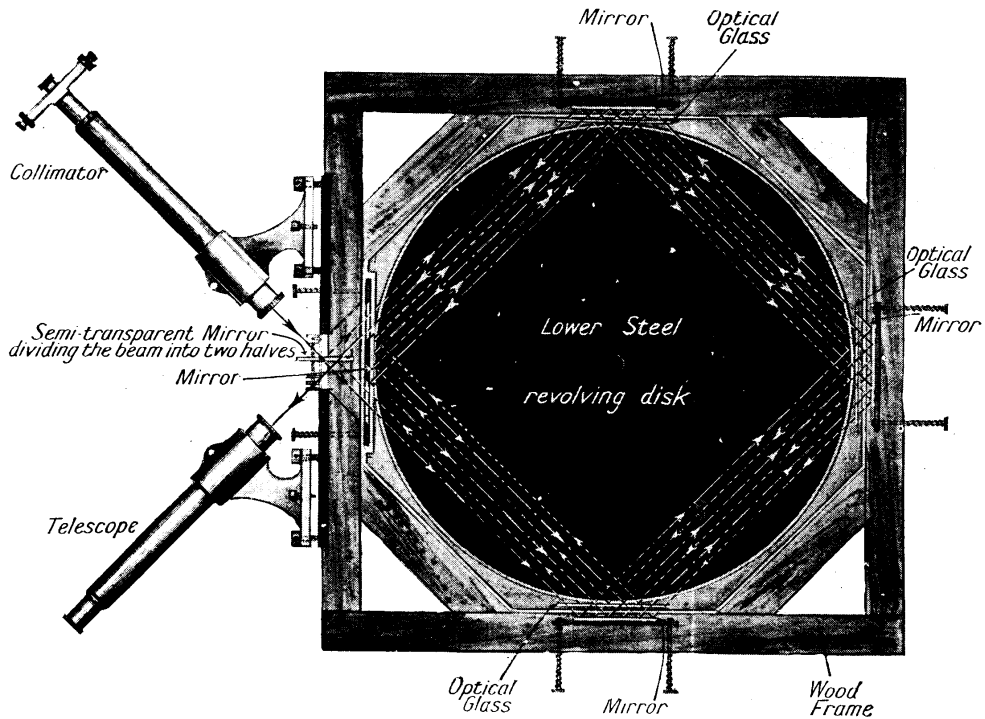

PLAN VIEW OF OPTICAL FRAME OF LODGE'S ETHER MACHINE

Fig. 4. In this view the upper whirling disk has been removed to show the path of the split beam of light, which was reflected in opposite directions by mirrors three times round the square between the two disks shown in Fig. 1. The two halves of the beam, meeting again in the observing telescope, would show, by a shift in the interference bands, whether the ether had been dragged perceptibly by the revolving disks. From the negative results, Sir Oliver Lodge concluded that moving matter does not disturb the ether through which it passes

torsional vibrations will travel along the rod at a definite and known pace, depending on its material. These are transverse waves, just as the waves of the sea are transverse waves of another kind. The particles themselves are not moving in the direction of propagation, but at right angles to it; in the case of the twisted rod they are moving round the axis and back again. Certain phenomena in light, especially polarization, show that light consists of transverse waves. And accordingly, if they were to be dealt with on mechanical principles, the ether which conveyed them would have to be likened to an elastic solid. And many attempts were made to devise an elastic-solid theory of the ether. But they failed. And not until Clerk-Maxwell formulated his theory, which explained them not mechanically but electrically, was the nature of light understood.

Nevertheless, the idea of an elastic-solid structure for the ether survived a long

time; it was likened to jelly and pitch, and other such substances; and yet it was difficult to explain how things could move freely through it while yet it had a rigidity like that of a solid. Hence it was often taught that the required properties of ether were incompatible with each other.

The difficulties were real enough; there were contradictions; but Clerk-Maxwell's theory removed them. There is no excuse now for anyone to say that the ether is endowed with incompatible qualities, or to doubt its existence. Things move through it without friction: it has no imperfections that we know of: it does not dissipate energy, as matter does: it has none of the properties of molecular structure. It is perfect and continuous and uniform. It is, however, thrown into vibration, and otherwise perturbed, by the peculiar configurations which here and there exist in it as electrical specks, and which in their aggregate appeal to our senses as what we call "electrons" and "matter."

Because the ether does not appeal to our senses, it does not follow that it is not a substantial entity. It is probably much more substantial than matter, which is likely to be only a modified portion of it. It is of ether that we and all other material bodies consist. And ultimately the whole of the phenomena of the material universe will be explained in terms of ether and its special kind of circulatory motion.

That is a prediction, but not a baseless prediction: and time will ultimately show how far it is true.

#### Lodge's Ether and Matter Experiment.

The illustrations (Figs. 1-4) give interesting details of Sir Oliver Lodge's important and elaborate experiment, made 1892-1897, at Liverpool University, to ascertain whether there was any sort of mechanical connexion between ether and matter; in other words, whether when bodies such as the earth moved through space they dragged any ether with them, or whether the motion of matter in ether was perfectly free and without a trace of friction.

The general idea of the experiment is to arrange a parallel beam of light so that it can be split into two halves, which are then sent, by properly arranged and perfect mirrors, along the sides of a square contour, in opposite directions, in a narrow channel between two steel disks (Figs. 3 and 4). The beams of light subsequently reunite and produce interference bands, which are visible in a micrometer telescope. The steel disks are then whirled violently, like a gigantic teetotum, by being attached directly to the axle of a 9 h.p. electric motor set vertically on

end. The machine itself, with the whirling disks at the top, is seen in Fig. 1, and the complete apparatus, with Sir Oliver Lodge and his assistants, in the photograph (Fig. 2). The optical part of the apparatus, which was placed round the whirling disks, is seen in Fig. 3, and in plan in Fig. 4. The interference bands are carefully watched to see whether any shift occurs, owing to one half the beam of light being accelerated and the other retarded; which is an effect that is bound to occur if the ether between the disks is at all carried round by their rapid motion. The effect could have been observed within a microscopic distance of the disks.

The answer given by the experiment was that, although the disks were revolving so fast as to be in danger of flying to pieces, they exerted no drag upon the ether at all; not even when they were electrified, nor, again, when they were replaced by a revolving electro-magnet.

The great and well-known experiment of Michelson and Morley, so often referred to, had suggested that perhaps the ether near the earth was entangled and travelled with it. Lodge's experiment negatives this, and shows that the Michelson-Morley experiment must be otherwise explained. It also, in the hands of H. A. Lorentz and Einstein, inaugurated the inception of what is now the momentous theory of relativity. On this theory no experiment can ever be made which will show a result of the earth's motion through the ether of space; and on this theory the results obtained by Michelson and Morley and by Lodge would be expected. These experiments rank among the fundamental experimental supports of that theory.

**ETHOPHONE.** The Ethophone is the name given to a series of broadcasting receivers manufactured by Messrs. Burndept, Ltd. Instruments of all types, from the simplest crystal set to the four-valve set, are made under this name.

Fig. 1 is a photograph of the "Popular" model Ethophone. The tuning arrangements on this model are very simple, being merely two variable condensers and one vernier. The filament resistance is fixed to the correct value, no adjustment being necessary. The switch in the centre of the panel is for switching off or on the low-tension or high-tension batteries, as required. The valves and high-tension battery are arranged inside the cabinet, it being possible to see the filaments when

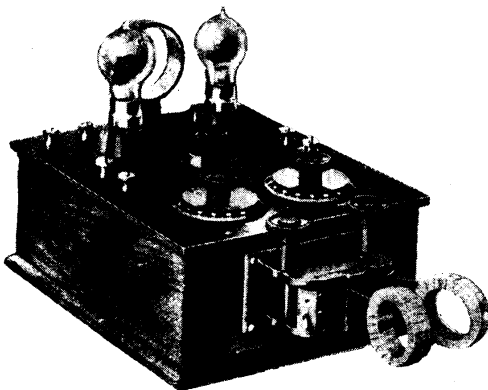

"POPULAR" ETHOPHONE

Fig. 7. Constructor's set No. 2 is one of the Ethophone instruments and much simpler than that in Fig. 6. It has a H.F. valve and detector, and is sold in parts

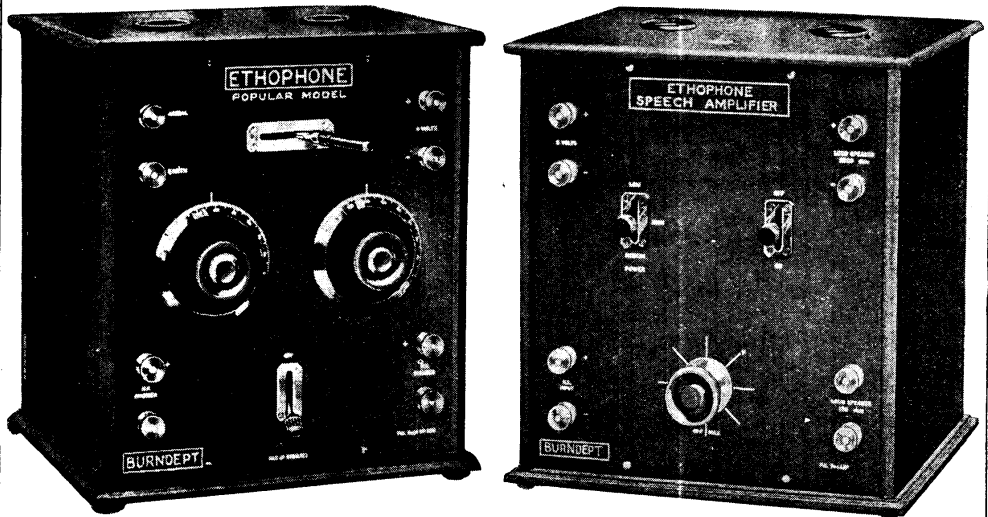

Fig. 1 (left). Specially constructed for broadcast reception is a two-valve "Popular" model. Fig. 2 (right). Another unit to add to Fig. 1 is an Ethophone two-valve speech amplifier

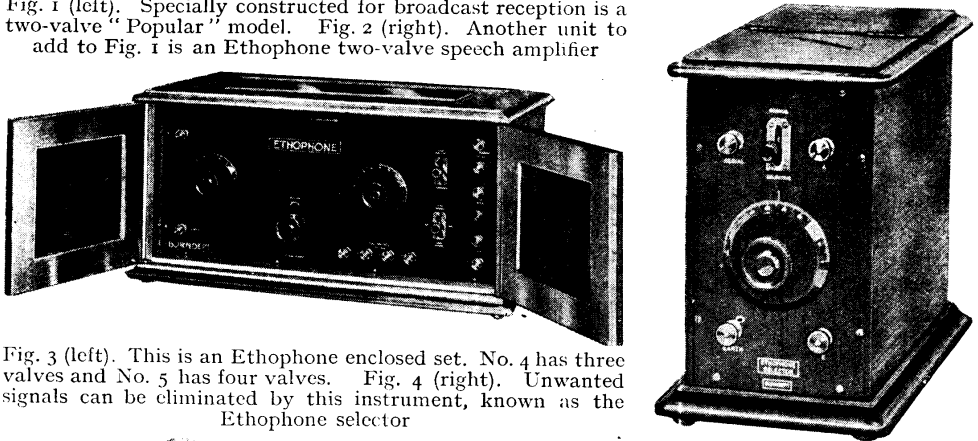

Fig. 3 (left). This is an Ethophone enclosed set. No. 4 has three valves and No. 5 has four valves. Fig. 4 (right). Unwanted signals can be eliminated by this instrument, known as the Ethophone selector

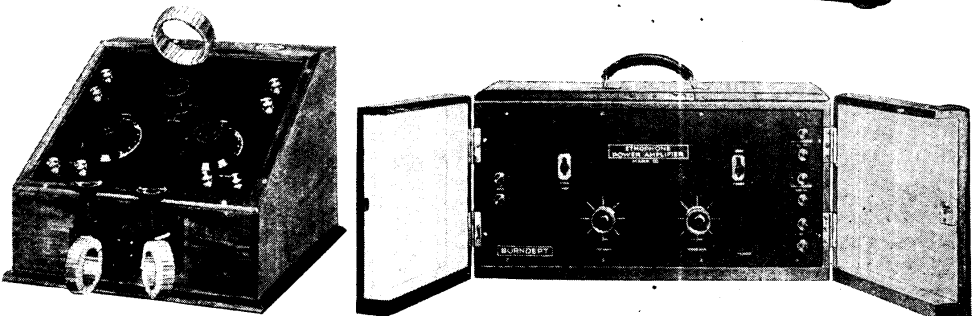

Fig. 5 (left). This is the Home Constructor's set No. 3, which may be built by the amateur. Fig. 6 (right). Made specially portable is an Ethophone power amplifier. Two L.S.2 valves are used

ETHOPHONE RECEIVER CABINETS AND PORTABLE SETS

alight through the gauze "windows" at the top of the cabinet.

The wave-length of the instrument is restricted from 300 to 500 metres, which is ample to cover the British broadcasting

wave-length band. Fig. 2 is the speech amplifier which is made specially for use with the "Popular" model Ethophone. This instrument is designed with a view of reducing distortion over the whole



frequencies of speech and music. The electrical arrangements in this amplifier are unusual, in that two different kinds of valve are used. The first is an R and the second an L.S.3, the latter being a power-amplifying valve for medium power work.

Of the two key switches fitted, the first is a three-way switch, arranged so that three varying degrees of amplification may be obtained at will, whilst the second is to switch off both low-tension and high-tension batteries when not required. A high-tension of 120 volts is fixed inside the cabinet.

The "Ethophone" is shown in Fig. 3. Externally, Nos. 4 and 5 are just the same, but the former is a three-valve instrument only, the latter having four. Tuning is accomplished on two condensers and a variable anode reactance coupling. The two-valve power amplifier is illustrated in Fig. 6, and employs a circuit which is stated to give results of high power, free from distortion, without the use of grid-biasing batteries. Another unusual feature is that the anode current does not pass through the transformers, thus obviating any risk of the windings burning out. A high-tension battery of 150 volts and two L.S.2 power-amplifying valves are necessary with this instrument.

The Ethophone selector, shown in Fig. 4, is an instrument designed for the purpose of eliminating unwanted signals, on the filter circuit principle. It is connected across the aerial and earth in place of the set, the set itself being connected to the output terminals of the selector. The central switch allows it to be cut in or out as desired by the user.

The method of operation is as follows: Tune in the interfering station to its maximum on the receiving set while the selector switch is at normal. Switch over then to "selective," and then rotate the dial on the selector until the interfering station is not heard. This done, the desired station may be tuned in on the ordinary receiver in the usual manner. By this means stations on wave-lengths very close indeed to the desired one may be by-passed, and will be unheard by the operator.

Fig. 5 shows the Ethophone home constructor's set, No. 3. It is supplied in parts for the experimenter to build up himself, and contains one stage of radio-frequency amplification,

tuned anode, coupled, and a detector followed by one stage of note magnification. The wave-length that may be received can be increased to any desired degree by inserting coils of various values.

Fig. 7 shows the No. 2 set for the wireless amateur. This is also sold in parts, and is a simpler set to construct than that shown in Fig. 5. It contains a detector valve and one stage of high frequency.

**ETHOVOX.** Trade name of a loud speaker made by Burndept, Ltd. One model, illustrated in Fig. 1, is adaptable to most valve sets with sufficient power

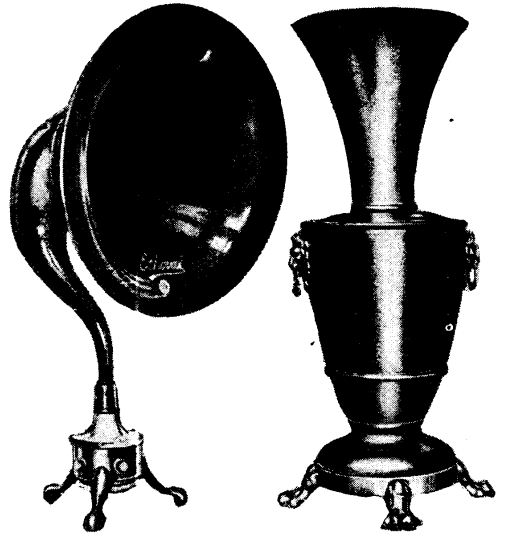

#### ETHOVOX LOUD SPEAKERS

Fig. 1 (left) Standard Ethovox loud speakers have tone-control devices. Fig. 2 (right). Ornamental patterns are also made. This is an example in antique brass and mahogany

*Courtesy Burndept, Ltd.*

to actuate a loud speaker. The instrument is connected to the receiving set by two wires as if it were a telephone, and to the same terminals on the set. The mechanism is contained in the base, and a choice of windings is provided of 120 ohms for use with a telephone transformer, and 2,000 ohms for plain circuits. The pattern illustrated stands 26 in. high, and has a flair, or opening, at the end of the trumpet of 15 in. diameter.

In effect the speaking mechanism is a large-size telephone receiver, but specially designed for the purpose, and with the addition of a tone-control device which is actuated by a knurled wheel seen

immediately beneath the diaphragm case. When this wheel is rotated and the instrument is playing, the tonal qualities are adjustable to the nature of the music or speech, with the result that the tones of the singer are rendered in a most natural manner. Brass bands and instrumental music are similarly effective.

When the customary appearance of a loud speaker is objected to, the claims of the Ethovox Grand are most apparent, as the appearance is that of a Greek vase, as shown in Fig. 2. The whole of the case is made of french-polished Honduras mahogany, with antique brass fittings. The tone qualities are nearly perfect, as there is very little metal in the construction, and the mahogany gives that mellow tone usually associated with an old violin. See Loud Speaker.

**EUREKA RESISTANCE WIRE.** Name given to a proprietary brand of iron resistance wire. It is largely used in wireless for the construction of many forms of resistance, as the filament resistance and the potentiometer.

The following table is useful in calculating the amount of Eureka wire required for a given resistance, and, con-

versely, the ohmic resistance of the wire per yard.

Size S.W.G.	Resistance per yard in ohms.
14	·1339
16	·2094
18	·3718
20	·6613
22	1·093
24	1·770
26	2·645
28	3·014
30	5·575
32	7·350
34	10·128
36	14·840
38	23·808
40	37·184
42	53·564
44	83·664

**EVACUATED VESSEL.** Term sometimes used for any vessel from which nearly all the air or gas has been exhausted.

**EVER-READY BATTERY.** Trade name of a range of dry batteries and accumulators manufactured by the Ever-Ready



TYPES OF EVER-READY DRY BATTERIES

Fig. 1 (left). The electro-motive force of this dry cell is 1·5 volts, and it may be used with most dull emitter valves. Fig. 2 (middle). This type of cell is inert when bought and has to be filled with water. It may be stored for a long time, and is very useful for experiments. Fig. 3 (right). Dull emitter valves may employ a L.T.<sub>3</sub> Ever-Ready battery, as illustrated. Its three terminals permit of 3 or 4·5 volts being tapped. The size is well adapted for fitting in cabinets

Battery Co. They are extensively employed for many wireless purposes, and made in a large range of sizes and types, each adapted for some particular purpose.

The "E" type is a cylindrical dry cell,  $6\frac{1}{2}$  in. high and  $2\frac{3}{8}$  in. in diameter, with an electro-motive force of 1.5 volts, specially suited for energizing the filament of Weco-valves, and under normal conditions one such cell will last approximately 90 hours when employed for the filaments of Weco-valves.

A larger cell, of longer life, especially intended for the supply of current to the filaments of dull emitter valves, is the L.T. 3 pattern illustrated in Fig. 3. This is suitable for G. E. C. M. O. type D. E. R. valves and B. T. H. type B. 5 valves. It measures  $6\frac{1}{2}$  in. in height,  $4\frac{1}{2}$  in. wide and  $2\frac{7}{8}$  in. deep, and is therefore very suitable for placing within a cabinet of a self-contained set. This range of cells is fitted with three insulated terminals, one of them the negative terminal, the other two at 3 and 4.5 volts tappings respectively.

A very efficient battery is that known as the L.T. 1, especially suitable for use with Weco-valves, and when used for one such valve has an approximate life of 1,000 hours and the electro-motive force is 1.5 volt. The cell weighs about 18 lb., is  $7\frac{1}{2}$  in. high and  $8\frac{7}{8}$  in. wide and  $4\frac{5}{16}$  in. deep. It is fitted with two insulated

terminals and a webbing carrying-strap as illustrated in Fig. 5.

Larger batteries are also made with an electro-motive force of 3,  $4\frac{1}{2}$ , and 6 volts, adapted to the requirements of various standard valves. For high-tension work the battery illustrated in Fig. 4 is typical, and is a 66-volt cell, and has tappings at every three volts. Other patterns are made with and without intermediate tappings and with an electro-motive force range of from 16 to 108 volts. They are sold with a sealed lid, which should be intact when the battery is obtained, as evidence that the battery has not been used.

Ever-Ready accumulators are also available for general purposes. One pattern is in a celluloid case, and others in ebonite cases, which are contained in a polished hardwood outer case. Each cell has a separate pair of terminals and is of the unspillable type.

A useful cell is that known as the Ever-Ready inert type, one example of which is illustrated in Fig. 2, and known as type "T." These cells have an electro-motive force of 1.5 volts, and possess the characteristic that they are inactive when purchased. They are rendered active by pouring water through the filling tube. As a stand-by for wireless work they are very useful, as they can be stored in an inert state for considerable periods, and

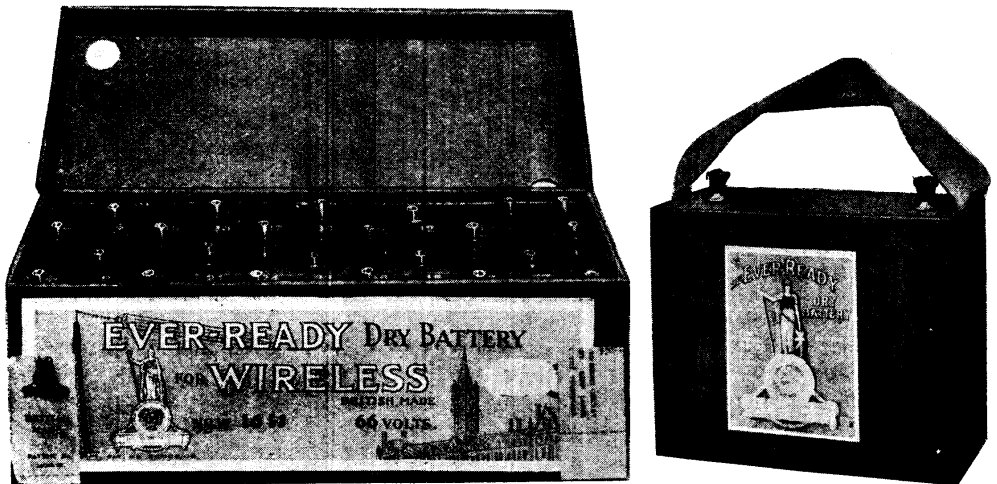

**HIGH-TENSION AND LONG-LIFE EVER-READY BATTERIES**

Fig. 4 (left). Tappings in steps of three up to 66 volts may be taken from this high-tension battery, which is composed of Ever-Ready dry cells. Wander plugs are used for making connexion. Fig. 5 (right). Used with Weco or similar valves, an L.T. 1 battery of 1.5 volts has a life of 1,000 hours. It weighs about 18 lb. and is provided with a strap for carrying

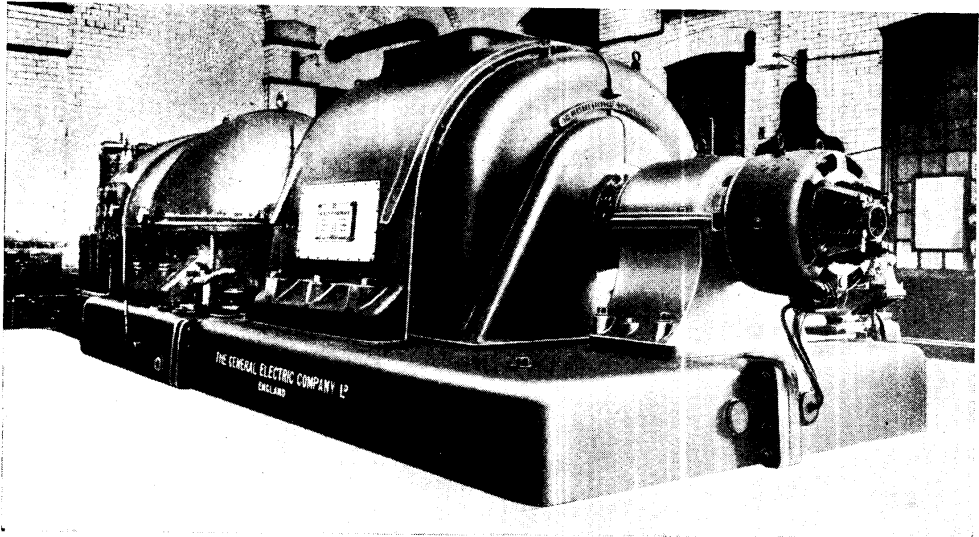

#### EXCITER COUPLED TO TURBO-GENERATOR AND ALTERNATOR

Fig. 1. Direct-coupled to a large alternator is the exciter on the right, while the turbo-generator is fitted on the opposite side of the alternator and is visible on the extreme left. The machine is a product of the General Electric Company. Only the larger broadcasting stations use apparatus of this size, such as 2 LO. London

when required for use have only to be filled with water, when they immediately become active. These cells are also very useful for portable sets, especially for supplying current for sets in use on holiday trips.

**EXCITER.** A small direct-current dynamo subsidiary to the main alternating machine and used for exciting its field magnets. The exciter is usually built as a part of the alternator, but it may also be an entirely separate unit.

Fig. 2 shows an exciter fitted on a bracket carried from the bearing of a large alternator, and directly coupled to the main shaft at the slip-ring end. Arrangements are made to provide special cooling for the exciter. In Fig. 1 is seen a view of the exciter, with the complete alternator and the direct-coupled turbo-generator used for driving the machine. Most exciters are compound wound and fitted with inter-poles. See Dynamo; Generator.

**EXIDE BATTERY.** Trade name of a well-known battery manufactured by the Exide Storage Battery Co. Storage batteries are made under this name with a choice of different varieties and voltages, suitable for wireless work generally. One pattern is illustrated and is known as the H.T. Accumulator. It consists of a series of two-volt cells connected together in

series to give any reasonable high-tension voltage.

These little cells are treated in exactly the same way as the average high-grade

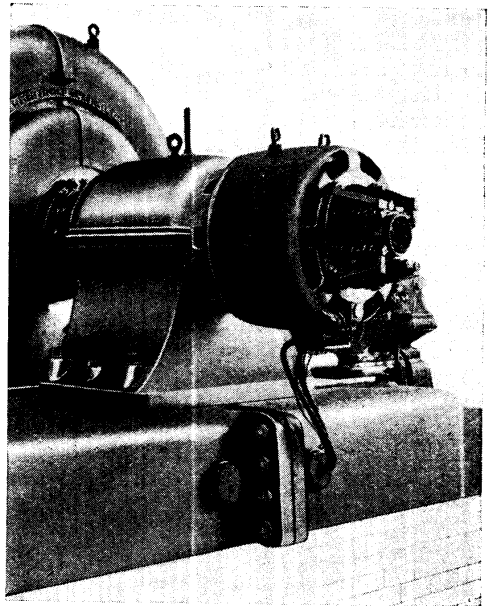

#### CLOSE VIEW OF EXCITER

Fig. 2. This view of the exciter shows more clearly the attachment and construction. It is mounted on a bracket attached to one end of the main bearings at the slip-ring end

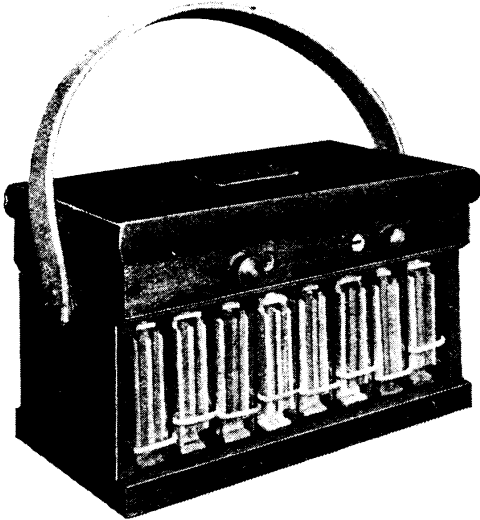

**EXIDE H.T. ACCUMULATOR**

Storage batteries of this kind are well known among wireless amateurs. This consists of a number of 2 volt cells connected in series. The Exide H.T. accumulator has a very long life storage battery cell. They are charged and recharged as required, and have the merit that, once installed, they have an exceedingly long life for ordinary high-tension current purposes, as they can be recharged from time to time as requisite. See Accumulator.

**EXPERIMENTAL LICENCE.** In order to experiment in wireless telegraphy, to use for experimental purposes wireless apparatus, it is necessary to hold a licence from the Postmaster-General, who has a monopoly over all postal, telegraphic, and telephonic communications. It is against the law to use wireless apparatus of any description without being in possession of a licence.

The advent of broadcasting altered the conditions of the licensing problem, and special forms of licence had to be evolved to cater for these new conditions, resulting in the broadcast licence and the constructor's licence respectively for the purely broadcast listener and the broadcast listener who wishes to construct his own set.

When these new licences were issued certain conditions were laid down for the existing and future experimental licence holders, but these were subsequently revised, and the situation now is as follows:

The experimental licence is open to all who wish to conduct bona fide experiments

in wireless reception or with any of the auxiliaries of wireless reception. The applicant must satisfy the Postmaster-General that he is a proper person to conduct such experiments, and must produce evidence of British nationality and references as to respectability and character. Apart from, and in addition to, these essentials, the applicant must convince the authorities that he wishes to conduct genuine experiments with a definite object in view. A general statement such as that it is desired to experiment in wireless telegraphy is not sufficient.

Accompanying any application must be attached a diagram and general description of the aerial arrangements for the reference and approval of the authorities, who have the power to refuse altogether or modify the design as submitted—their main object in all this being that the experimenter shall not cause interference either to his neighbour or any Government station. The whole installation is subject to inspection by agents of the authorities at any reasonable time, and any message, no matter of what nature, which is read by means of the apparatus in question must be kept secret.

The fee payable in respect of an experimental licence is 10/- per annum. It was originally prescribed that holders of this licence would be forbidden to listen to broadcast unless an extra 5/- per annum was paid. This condition, however, has been revoked, and those already in possession of experimenters' licences will not be required to pay the extra fee.

The initial procedure to be followed by those who wish to obtain an experimental wireless licence is to apply to the Secretary, General Post Office, London, E.C.; stating briefly this desire, and requesting that the necessary form be sent. This form is more or less self-explanatory, and states definitely what the applicant has to do and what conditions have to be fulfilled in order to qualify for the licence.

Of considerable assistance to the applicant are the various radio societies to be found all over the country, and the aspirant is recommended to join one of these societies, whose assistance and guidance can be obtained in all matters appertaining to experimental wireless. In some cases difficulty is experienced in satisfying the authorities that the applicant possesses the necessary qualifications, and here the

radio society can be of invaluable assistance, in some cases actual instruction by a series of lectures being undertaken by the society for the benefit of prospective applicants.—*Leslie McMichael, M.Inst.RadioE.*

See Licence.

**EXPERIMENTER'S VALVE PANEL.**

The prefix experimenter's or experimental to wireless apparatus in general means that the set referred to is adaptable to a variety of different circuits without the necessity of materially altering the disposition of the components or their wiring on or under the panel. By such arrangements it is possible for the experimenter to test a number of circuits without difficulty or delay, as in substance all that has to be done is to connect the terminals on the panel in the desired manner, and to add any additional apparatus required for the circuit.

In the accompanying diagrams, Figs. 1 to 10, are given the details and dimensions for a single valve panel that is speedily adaptable to a simple detector valve panel, a low-frequency amplifier, or note magnifier, a high-frequency amplifier, and a detector with reaction coupling

to the aerial tuning inductance. The set is applicable to other circuits than those suggested.

The dimensions need not be adhered to strictly, and will in any case have to be modified to suit existing components that may be available, or those that are purchased for the purpose. The sizes given and the arrangement of the parts generally follow the usual lay-out of a well-designed set.

The panel measures 6 in. square, and should be cut from a piece of ebonite  $\frac{1}{4}$  in. thick, well matted on either side, and preferably mounted on a simple framing or in a shallow case, such as those described in the article on Cabinets. Mounted on the panel are a valve holder or valve legs, a filament resistance, grid leak and condenser, a switch and a series of terminals and shorting slips.

The theoretical wiring of the panel is shown in Fig. 1, as seen from the front of the panel.

The use of the panel as a detecting unit is illustrated in Fig. 2, where the tuning is effected by plug-in coils and a variable condenser across the aerial tuning inductance. When employed as a note

magnifier, the circuit is arranged as in Fig. 3, and this shows the different terminals which have to be connected

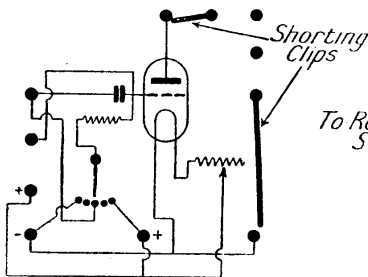

Fig. 1

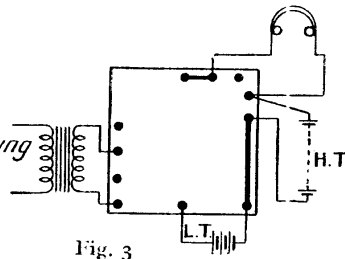

Fig. 3

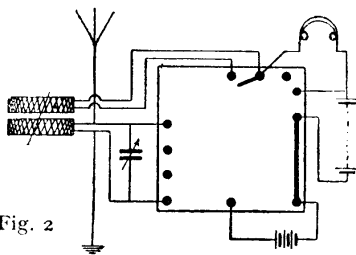

Fig. 2

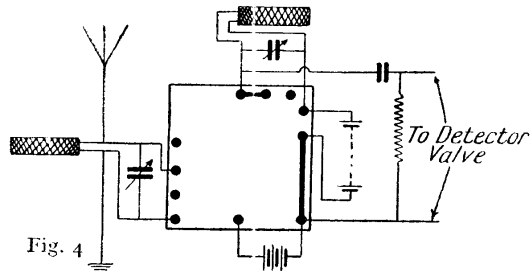
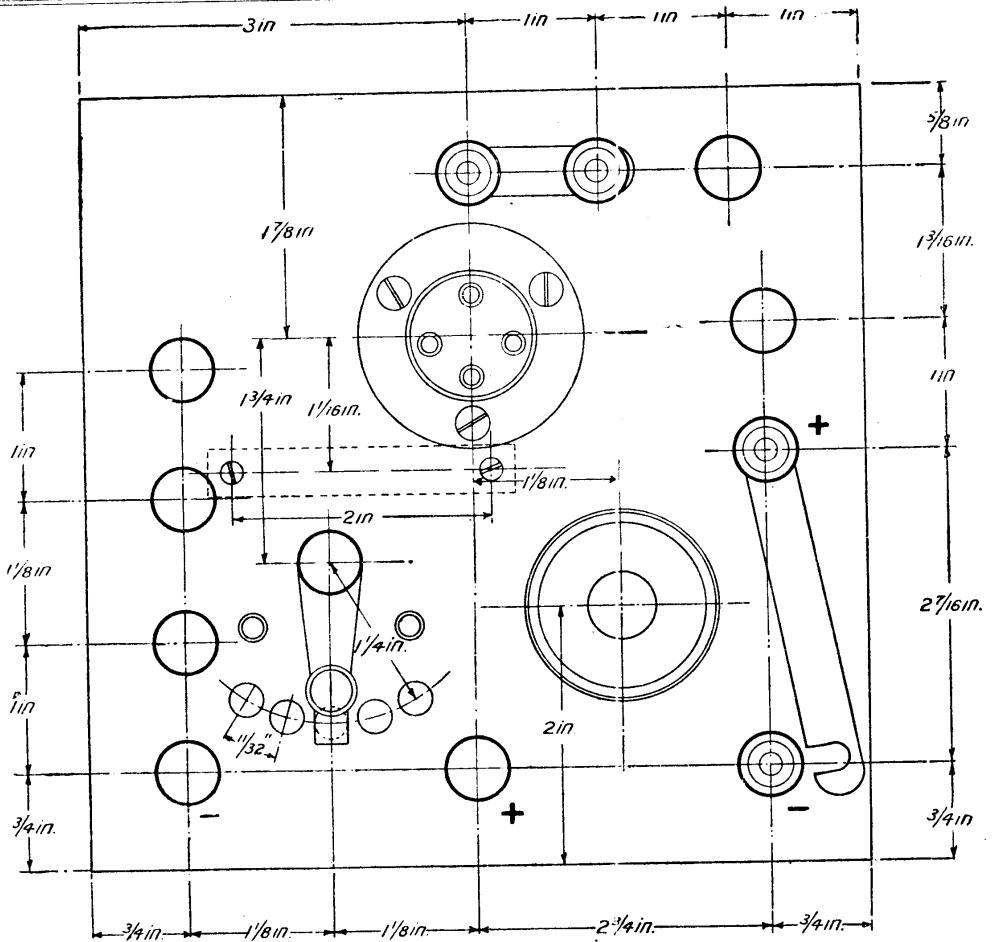

Fig. 4

**EXPERIMENTER'S VALVE PANEL AND SOME OF ITS USES**

Fig. 1. This diagram is of the front of the panel and shows the method of wiring. Fig. 2. Wired up in this way the panel may be used as a detector. Fig 3. With this arrangement the panel becomes a note magnifier. Fig. 4. Wiring from this diagram, the same panel may be used as a high-frequency amplifier with tuned anode coupling to detector valve





**DIMENSIONS OF FRONT OF EXPERIMENTER'S VALVE PANEL**

Fig. 5. Being interchangeable, the panel should be made carefully and accurately, and the terminals should be of a serviceable type. The underside of the terminals should be left long enough for connecting by nuts, as the wires are not soldered. Dimensions given above should be strictly adhered to. Good ebonite should be used, and positive and negative terminals marked with tablets which can be removed, and not by engraving

to make this circuit. The important point is that no alteration is made to the panel itself; the only differences between these two and the next illustrated circuit, Fig. 4, lie in the connexions. These alterations are made solely by connecting the wires to the appropriate terminals, and as the diagrams show the face of the panel, the relative terminals are easily distinguished. The shorting clips are shown by a thick line.

Several such panels could be made and connected together with additional parts, and a two or three-valve set easily connected up. As an example a detector as shown in Fig. 2 could be connected to the note magnifier in Fig. 3 by connecting the

telephone leads to the input side of the transformer as shown in Fig. 3, thus making a two-valve set.

As such sets will be used for many purposes, it is essential to make all the connexions well, and to use only the very best components. The positions of all the parts are shown in Fig. 5, together with the leading dimensions.

The first step is to mark out the panel and drill the required holes, and mount the filament resistance. This should have a value of 7 ohms resistance, and a convenient size is some 2 1/2 in. diameter. The grid leak is a Dubilier or Mullard 2 megohm, mounted in clips alongside a Dubilier type 600A fixed condenser with

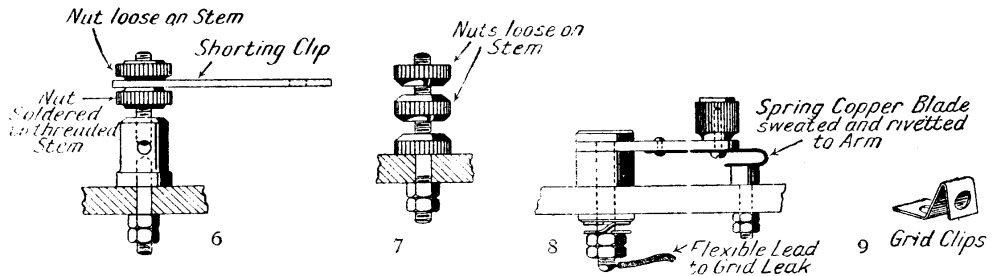

**METHODS OF CONTACT IN EXPERIMENTER'S VALVE PANEL**

Fig. 6 (left). Top nuts of the terminals are loose, but the bottom nut of this type is soldered. The underside is held by two octagonal nuts. A shorting clip is shown attached. Fig. 7. Another type of terminal is shown with the two nuts loose on the stem. Fig. 8. A suitable form of switch is illustrated. In this case the flexible lead is soldered. Note the spring copper contact blade. Fig. 9. An example of grid clip is shown. This may be either strip copper or thin brass

a value of .0002 mfd. The leak is connected to a specially made switch, so arranged that the leak can be connected either in parallel with the grid condenser or to the positive or negative side of the low-tension battery. Two blind studs are provided so that there is no risk of a short circuit when the switch arm is moved.

This arrangement has proved very successful and useful in practice, as it provides a rapid means for changing the polarity of the grid leak. Alternatively a variable grid leak and condenser such as the Filtron combination may be used in place of the fixed value condenser and leak.

The shorting clips are made from flat strip brass, with a hole in one end and a slot in the other, as shown in Fig. 5. There are two effective ways of fixing them to the terminals, and the illustrations, Figs. 6 and 7, show the details. In Fig. 6 a telephone terminal is used as the base, and the customary screwed part removed and a short stud substituted. This is provided with two knurled nuts, and the arm arranged between them so that it can swing, a perfect connexion being made by tightening the nuts when the arm is in place. The alternative plan is to use the pattern of terminal shown in Fig. 7

and grip the arm between the two nuts on the terminal.

Details of the switch arm are given in Fig. 8, and show the short stout contact arm, with a springy copper contact blade attached to it by riveting. A small ebonite control knob completes the switch arm. The pivot bearing is made from a long screw with a large diameter head. The lower part of the screw has a spring washer and two lock nuts to regulate the

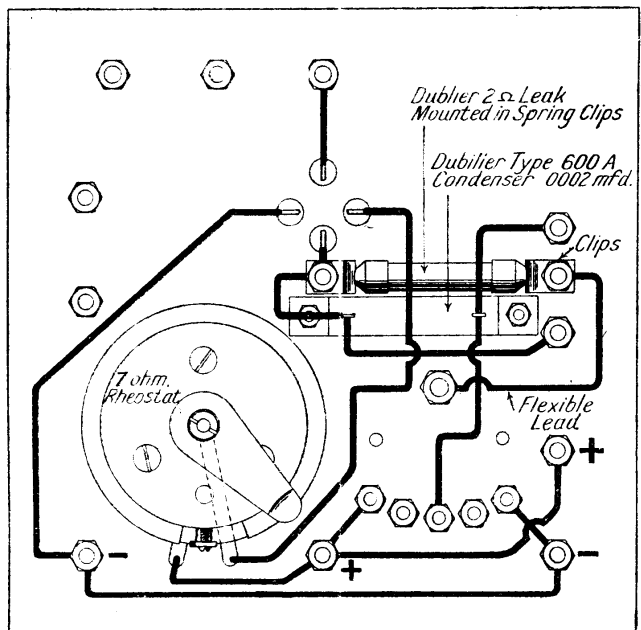

**CONNECTING WIRES BENEATH THE PANEL**

Fig. 10. The position of all the wiring is shown approximately in this diagram of the rear of the experimenter's panel. Comparison can be made with the front diagram (Fig. 5). Wiring is shown in thick lines. Note the position of the grid leak, and the shortness of connexions

pressure. To keep the arm at the correct height an ebonite or brass bush is placed between the underside of the arm and the top of the panel, the length of this bushing being determined by the height of the contact studs and the depth of the contact blade. The proportions shown in Fig. 8 are about correct, and should be followed.

The grid clip shown in Fig. 9 is quickly bent to shape from a strip of copper or thin brass and drilled with holes as shown, one set to hold the leak, and the other to fasten the clip to the base, which should be of ebonite about  $\frac{1}{4}$  in. thick.

The connecting wires beneath the panel are seen in Fig. 10, and all should be carried out with No. 20 gauge tinned copper wire covered with insulating sleeving. The connexion from the moving arm of the switch to the end of the grid leak clip is best made of flexible wire, such as a single piece of flex from an odd piece of good lighting flex. The flex is soldered to the bottom of the switch spindle, as shown in Fig. 8, and should be well and neatly carried out to ensure a perfect connexion.

**EXPLORING COIL.** An exploring coil, also commonly called "search coil," is an essential part of direction-finder apparatus. It consists of a coil of insulated wire wound on a rotatable former. The former is surrounded by two

stationary coils known as field coils, which are set at right angles to each other. The exploring coil is connected through an air core transformer to a closed oscillatory circuit. The position of the exploring coil is located on a dial on the exterior of an ebonite panel by means of a spindle and arm attached to it. The connexions of a search coil in a radiogoniometer, the complete instrument of which the exploring coils form part, are shown on page 229 under the heading Bellini-Tosi Aerial. See also Direction Finder.

**EXTENSION HANDLES.** Expression applied generally to a variety of proprietary and other fittings attached to movable controls in a wireless set, particularly condensers and the like. The purpose of an extension handle is twofold: first, enabling the controls to be regulated from a distance, thus minimizing hand capacity effects; and, secondly, giving a finer means of adjustment.

In most cases extension handles are made of ebonite, and Fig. 1 shows three typical patterns. These are simply ebonite rods, either plain or with knurled grips at one end, and a screwed shank or plain plug at the other end, to enable the latter to be fitted to the boss of the control knob, somewhat in the manner illustrated in Fig. 2. Here a plain ebonite handle is

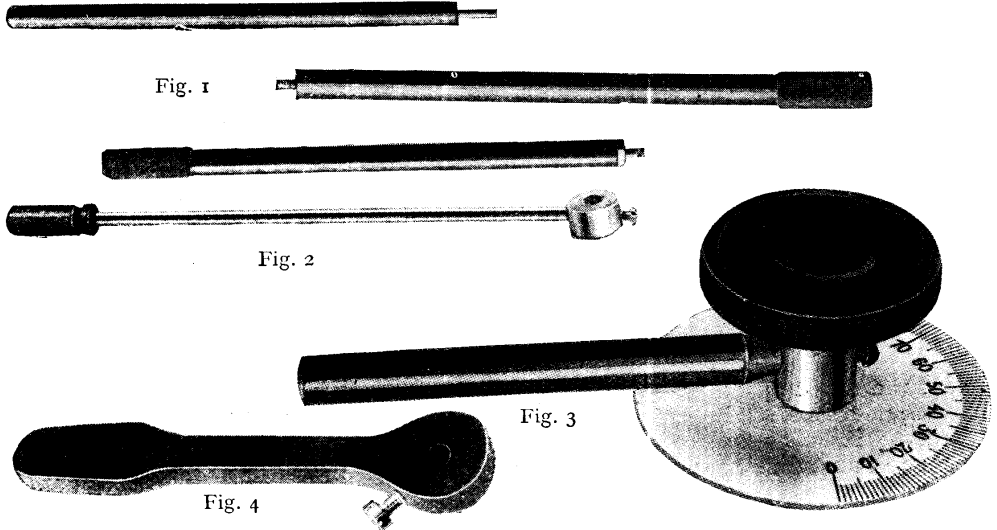

#### EXTENSION HANDLES USED WITH WIRELESS APPARATUS

Fig. 1 (top three). Three types of simple handle for minimizing capacity effects. These are used for tuning devices. Fig. 2. Variable inductance coil holders may be operated by a handle of this type. The rod is of brass and the handle ebonite. Fig. 3. Fitted to a knob and dial is an extension handle, the end of which is cone-shaped, and held in position with a set-screw. Fig. 4. An easily made ebonite handle, as illustrated, is adaptable to many uses.

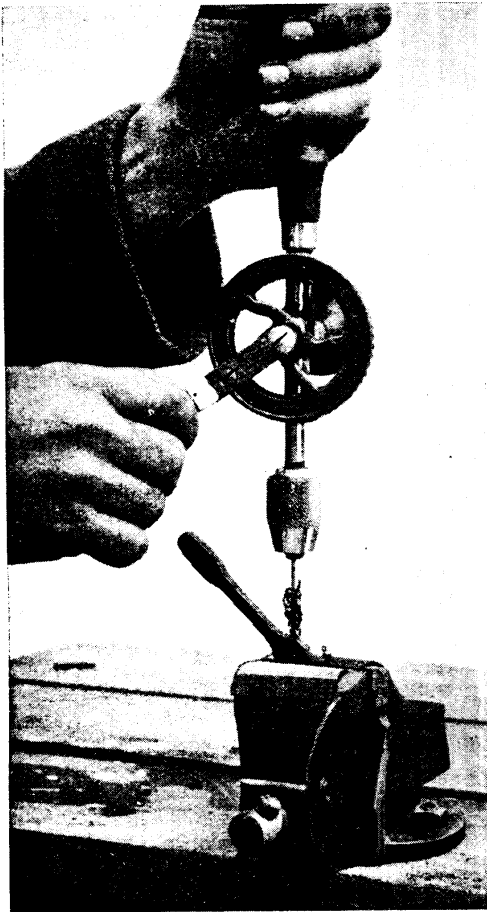

#### MAKING AN EBONITE EXTENSION HANDLE

Fig. 5. Copper clamps are used to protect the ebonite from damage in the vice. The operator is drilling a hole at an angle for the set-screw seen in position in Fig. 4

made cone-shaped on the inner end, and fitted in a tapering hole in the boss of the condenser knob, and secured by a small set-screw, the head of which bears against the boss of the knob and draws the extension handle firmly into its place, thus holding the whole perfectly secure.

This is an important item, as unless the handle is quite rigidly attached to the spindle there will be a certain amount of back-lash and shake, which will make tuning difficult.

Another type of extension handle is illustrated in Fig. 3. This consists of a length of brass rod, at one end of which is fitted a boss with a hole drilled through the centre, into which the spindle fits direct, the spindle being secured by means of a

set-screw, as seen in the illustration. An ebonite knob is fitted to the opposite end of the brass rod, this knob being shaped as shown, or in any other convenient manner.

The experimenter can construct a very efficient extension handle from ebonite, and the illustration, Fig. 4, shows such a handle made from  $\frac{1}{4}$  in. ebonite. This is cut out roughly to shape from ebonite sheet by means of a hack-saw, and then filed to shape, finishing off with a fine file to the desired pattern, preferably with a boss formed at one end, and a species of knob at the other. A hole is then bored in the centre of the boss to fit on the required spindle, and a further hole drilled and tapped for a small set-screw, as can clearly be seen in the illustration, which shows the set-screw partly screwed in.

Fig. 5 shows the method adopted for drilling the set-screw hole by means of a small hand drill. The boss of the handle is held firmly between the jaws of the vice, while copper clamps are placed over the jaws of the vice to minimize the damage occasioned to the ebonite by screwing the vice up tightly. The set-screw hole is then drilled in the usual way, after which it is tapped to suit the set-screw to be used. It is always preferable to mat the sides of the ebonite sheet in such a construction, with the aid of a fine file or emery cloth.

Such an extension handle has the effect of greatly minimizing current losses and capacity, as a much greater resistance is offered by the whole handle being made of ebonite than if the rod and boss were made of metal and only the knob constructed of ebonite.

**EXTERNAL CIRCUIT.** Name given to any circuit where useful work is done by electric currents generated by a dynamo or any other form of generator of electric currents. The name is given in contradistinction to the internal circuit of a generator of electric current, which circuit includes an electrical path or wiring inside the apparatus. Both circuits are dependent on each other, as each forms part of one complete circuit.

**EXTRA CURRENT.** An electrical difference of potential manifested in a circuit when an applied electro-motive force is suddenly decreased or stopped. This extra current is due to the self-induction of the circuit in which the applied electro-motive force is flowing. The self-induction of a circuit is the back pressure, which tends to stop the current

producing it. This is known as Lenz's Law.

The disadvantageous effects of extra current are illustrated in the induction coil unless special effects are provided to guard against it. When the current in an induction coil primary is suddenly broken by the contact breaker, a high self-induced electro-motive force is induced in that winding sufficiently powerful to jump the platinum points of the contact breaker. This allows the "extra current" to flow, which prevents the rapid demagnetization of the coil.

When the applied electro-motive force is suddenly cut off, as distinct from a gradual decrease of current, the induced electro-motive force in the secondary windings is very much greater. Incidentally, the spark of the self-induced electro-motive force is very damaging to the platinum points, which would be soon pitted and burned if the spark were not diverted. This is accomplished by shunting a condenser of large capacity across the points of the instrument. The self-induced electro-motive force is thus made to charge up this condenser and the bad effects of self-induction avoided. See Inductance; Lenz's Law; Self-induction.

**EYE.** A small opening formed at one end of a rod, bar, or rope. Examples are found in wireless work in the form of an eye on the end of a strainer used for supporting the guy wires of an aerial mast, as the ring formed on the end of a halyard. An eye can also be formed on the end of a strip or plate of metal such as is attached to wireless masts to form a point of attachment for the guy-ropes and other fittings. When the shank of the eye is screw-threaded, the fitting is known

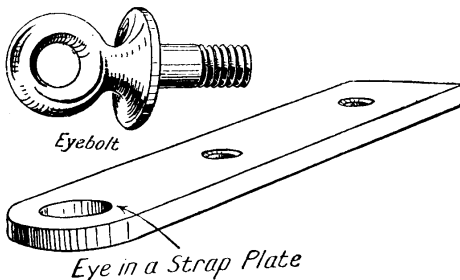

#### EYES USED FOR WIRELESS PURPOSES

Two kinds of eye are illustrated. The top example is used in apparatus such as dynamos and heavy parts. Eyes are also made in metal strips, as in the strap plate shown, or guy-rope attachment plates for aerial masts

as an eyebolt, as shown in the figure. Examples of this are often found on the top of dynamos and other electrical machinery, for lifting purposes. Eyebolts are extensively employed in aerial mast systems.

The method of making an eye in metal, and particularly in rod metal, is described in the article on Forging. The eye in the end of a rope is formed by means of a spliced joint and usually, to prevent the rope fraying or wearing, a hollow ring, known as an eyelet, or thimble, is worked into the eye, the rope being bound around it and spliced. See Forging.



**FADING.** Fading is the name given to a phenomenon evidenced by the variation of the strength of radio telegraphic or telephonic signals.

It has long been known that the strength of a signal is not the same during all hours of the day and night, and that at certain periods the variation in strength is greater than at other periods. The signal strength is fairly constant during the daytime, and again during the night-time, although

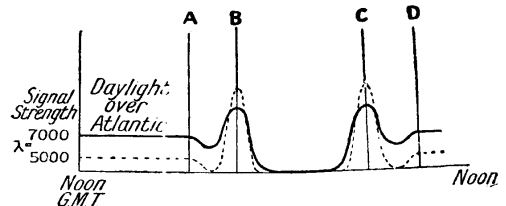

#### SUNRISE AND SUNSET EFFECTS ON SIGNALS

Fig. 1. Two wave-lengths are given in the curve representing observations at the two stations at Clifden and Glace Bay. A is observed at Clifden at sunset; B, Glace Bay at sunset; C, sunrise at Clifden; D, Glace Bay at sunrise

generally signals are stronger during the dark hours. Between the light and dark hours, however, there is a period, *i.e.* sunset and sunrise, during which the strength of signals varies considerably. This variation of strength ranges from many times greater to many times smaller than the normal intensity.

In a paper read by Senatore Marconi before the Royal Institution, some curves were shown illustrating the variations of the strength of signals transmitted at Clifden and received at Glace Bay. The curves (see Fig. 1) show the variations at sunset and sunrise of signals on two wave-

lengths, *i.e.* 5,000 metres and 7,000 metres. It will be seen that at the sunset at Glace Bay, and again at sunrise at Clifden, the signals reach their maximum strength. Again, the signals undergo the maximum variation during the two periods of advancing twilight and dawn across the Atlantic.

Fig. 2 shows the variation in signal strength of Clifden when received at

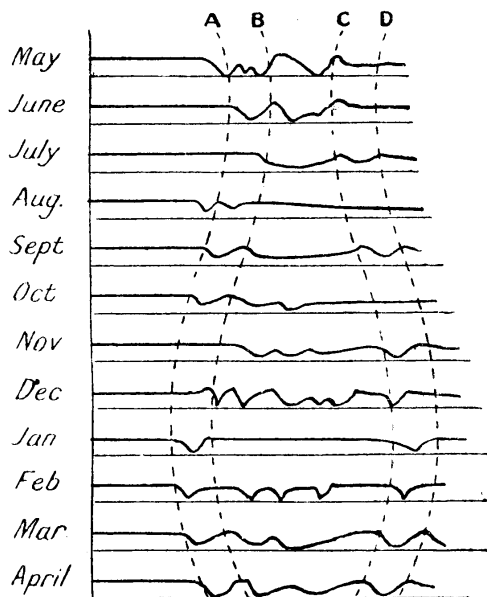

#### MONTHLY TESTS OF DAYLIGHT EFFECT

Fig. 2. Twelve monthly tests of fading gave the results plotted in the above curve. From this the seasonal effects can be realized. A represents sunset at Clifden; B, sunset at Glace Bay; C, sunrise at Clifden; and D, sunrise at Glace Bay

Glace Bay over a period of twelve months, the readings being taken on the first day of each month

A possible explanation of fading has been put forward by Dr. Eccles. His theory is that owing to the degree of ionization being due to the intensity of the sunlight, a surface of equal ionization will be near the earth where the sun is on the meridian, rising away from the earth where the sun is rising or setting.

Thus a circular band round the globe is formed by the regions which are changing from the night level to the day level. The twilight band moves with the sun, and when over the transmitting or receiving station it acts as a partial reflector, and produces the increase in signal strength. When the band has moved to a position

between the two stations, this causes a decrease in signal strength, due possibly to electrical disturbances.

As there is almost conclusive proof that reflection of the transmitted wave is the cause of fading, it is only to be expected that the readings of signal direction required for direction and position finding taken at the periods of sunset or sunrise should be erratic, and this is found to be the case in practice. Bearings taken during these periods show a marked variation of direction, and the greater the variation of signal strength the greater does the variation of direction become. See Distortion.

**FAHRENHEIT.** Name of a thermometer invented by G. D. Fahrenheit. On the Fahrenheit scale the freezing point of water is  $32^{\circ}$  and the boiling point  $212^{\circ}$ , a difference of  $180^{\circ}$ . In the centigrade thermometer the freezing point of water is  $0^{\circ}$  and the boiling point  $100^{\circ}$ . The relation between the two scales is given by  $5F = 9(C - 32)$ , so enabling degrees in Fahrenheit to be converted to degrees on the centigrade scale and vice versa.

**FALLON CONDENSER.** Trade name for a series of variable condensers suitable for amateur experimental work. Figs. 1 and 2 show two  $\cdot 001$  mfd. condensers. One is protected from dust, etc., by a celluloid case, and the other is suitable for panel mounting. The latter instrument has an aluminium shield plate beneath the dial to minimize body capacity effects.

The movable plates are carried in metal to metal bearings, the lower one being adjustable by a screw movement. The standard vane spacing for these condensers is  $\frac{1}{8}$  in. Contact from the moving vanes is obtained by a strip connexion which is pressed upon by a Thackeray washer. The natural spring of this washer is also utilized to obtain the requisite stiffness of motion, which is essential if the instruments are mounted upon a vertical panel.

The Fallon duanode condenser consists of two separate variable condensers mounted together, but insulated from each other, the movable vanes of both being on the same spindle. The capacity of each individual condenser is  $\cdot 0002$  mfd. The two condensers are equal in capacity, and are therefore suitable for use in high-frequency circuits where it is desirable to tune two transformer windings or anode coils simultaneously. The instrument may be used for ordinary purposes,



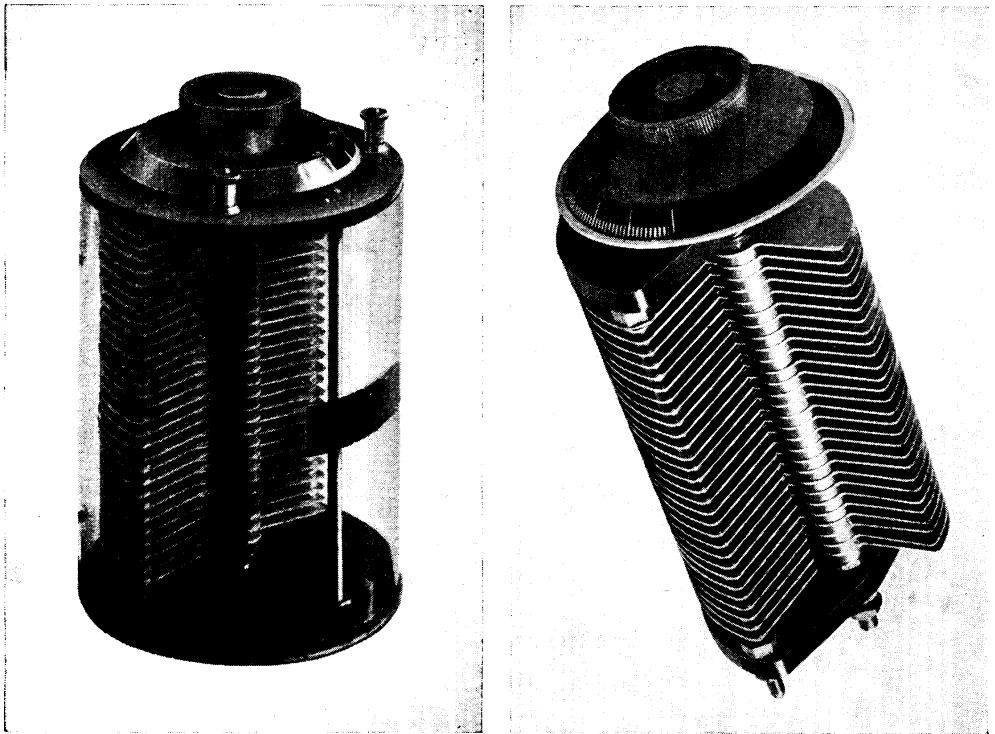

FALLON VARIABLE CONDENSERS FOR EXPERIMENTAL WORK

Fig. 1 (left). Enclosed in a celluloid case is a variable condenser of  $\cdot 001$  mfd. capacity. Connexions are made to terminals on the top of the case. For amateur experimental work a condenser of this kind is particularly suitable. Fig. 2 (right). Another form of the condenser in Fig. 1 is illustrated. This has no outer case, and is designed for panel mounting. An aluminium shield plate is placed beneath the calibrated dial for the purpose of minimizing capacity effects.

either or both halves as required. Different capacities of  $\cdot 0001$ ,  $\cdot 0002$ , and  $\cdot 0004$  mfd. may be obtained, according to whether the two halves are connected in series or parallel. See Condenser.

**FAN AERIAL.** Whilst a single wire is often used to form a good aerial for reception, it is not as a rule suitable for transmission, for as the aerial current is increased, so must the number of the aerial wires be, unless there are to be serious losses in the aerial.

From the earliest days in wireless telegraphy it was realized that a good radiating aerial was one which had a considerable proportion of its area at a good height above the ground.

One of the first aeriels used by Marconi consisted of a strip of wire netting, suspended by an insulator from a mast (Fig. 1). This was succeeded by the true fan aerial, consisting of an elevated capacity suspended from a triatic between two masts (Fig. 2), each wire being attached to an insulator suspended from

the triatic. This type of aerial gives with a simple construction and the use of two masts only an aerial having a much larger capacity at the top than at the bottom end.

Marconi elaborated this type for his first transatlantic station, which was situated at Glace Bay in Nova Scotia.

Four fan aeriels were suspended from four triatics, attached to four masts arranged in the form of a square, as shown in Fig. 3, so that a four-sided fan, or inverted pyramid, was formed.

This type of aerial radiates equally well in all directions.

It is known that if the aerial wire is long compared with its height, and if it is extended parallel with the surface of the ground, that it will radiate more in one direction than in another. A fan-shaped aerial, such as Fig. 2, may be bent over the triatic, and extended to a second triatic, as shown in Fig. 4; it then becomes a flat-topped fan aerial. If the horizontal portion is considerably

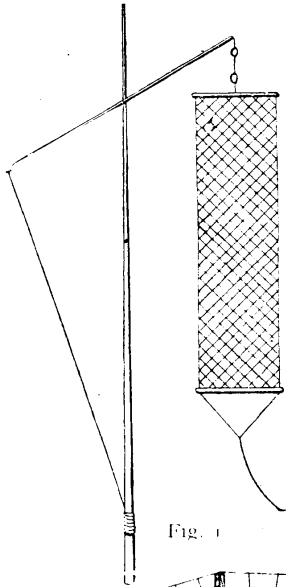

Fig. 1

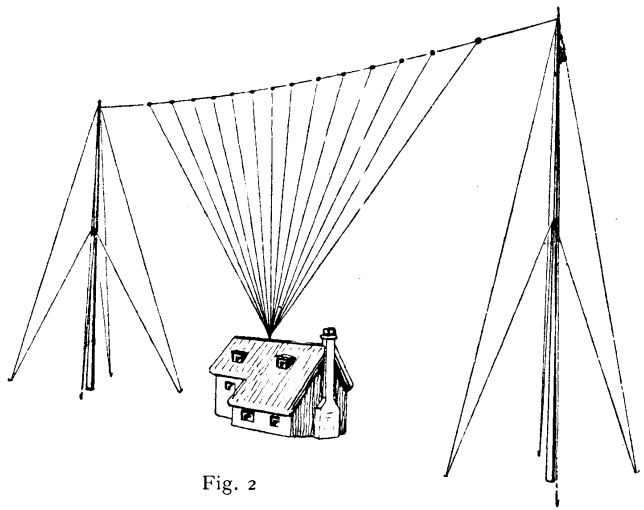

Fig. 2

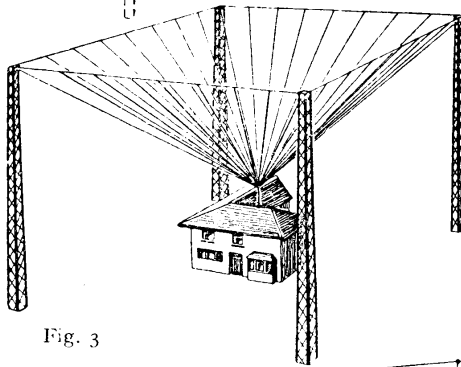

Fig. 3

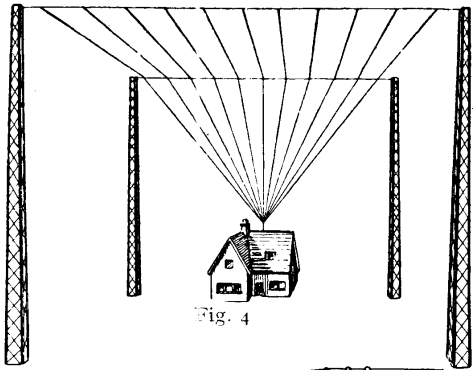

Fig. 4

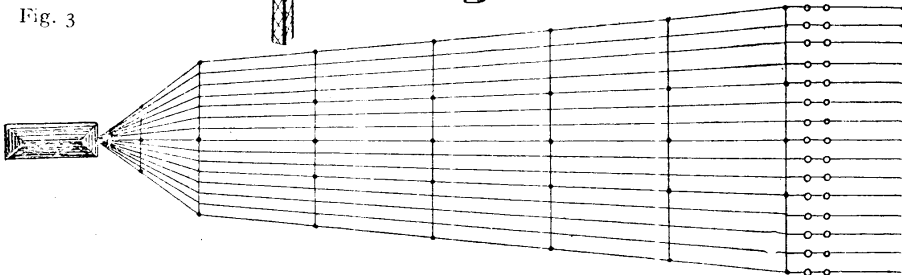

Fig. 5

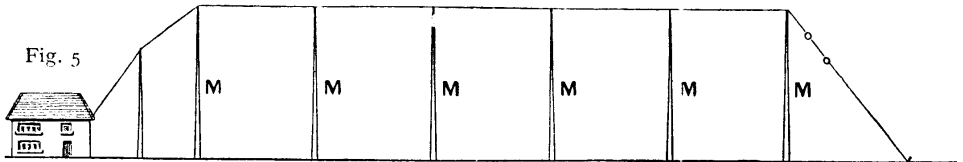

Fig. 1 (left). Suspended from an insulator is a strip of wire netting. This was used by Marconi in early days of wireless. Fig. 2. Known as a true fan aerial, this type has much greater capacity at the top than at the bottom. Fig. 3. Glace Bay station first used this form of aerial for Marconi's transatlantic service. Fig. 4. This is a combination of the aerial in Fig. 2 and a flat-top horizontal wire aerial. Fig. 5. Plan and elevation diagrams, showing the construction of large fan aerial used by the Marconi stations at Glace Bay, Nova Scotia, and Clifden, Ireland. These stations work together as a regular transatlantic service. The masts are about 300 ft. in height. Some thirty-two wires are used in parallel, each being about 2,600 ft. in length

EXAMPLES OF FAN AERIAL FOR EXPERIMENTAL AND COMMERCIAL PURPOSES

extended it becomes the directional, slightly fan-shaped aerial which was used for the second Marconi transatlantic station at Glace Bay and Clifden. This type is shown in Fig. 5.

In high-power stations the area covered by the aerial is often one of considerable size. The Marconi transatlantic stations, situated at Clifden in Ireland and Glace Bay, Nova Scotia, used a type of aerial which is similar in plan view to a nearly closed fan, as shown in Fig. 5, in which M, M, M, etc., are masts of some 300 feet in height, the tops of which are joined together by steel wire ropes (triaties), which pass over blocks at the mast heads. Suspended from the triatics, by means of long porcelain rod insulators, are the aerial wires, which for a station of the size of Glace Bay and Clifden would be some thirty-two wires in parallel, each wire being of  $\frac{7}{16}$  silicon-bronze, and some some 2,600 feet in length.

Each wire is connected at one end to the lead-in insulator, and at the other to a series of porcelain insulators, after which a wire tail is taken from the insulator to an anchor in the ground.

The aerial wires are arranged so that they will pull through the insulators, so that by means of the tails each aerial wire may be adjusted individually, whilst by means of the triatics the whole system may be raised or lowered.

Such a type of aerial is excellent for a high-power station using long waves and requiring a high capacity semi-directional aerial.

The predetermination of the capacity of a fan aerial is of considerable importance. Prof. G. W. O. Howe gives formulae for this purpose.

Take the case of an aerial consisting of many parallel wires. Let the number of the wires be  $n$ , the mean distance between them  $d$ , and the length of each wire  $l$ , whilst the radius of the wire is  $r$ .

If  $\rho$  is taken as the surface density of the charge in electrostatic units per square centimetre, then the average potential of the multi-wire aerial will be obtained in absolute electrostatic units from the formula:

$$V = 4\pi r \rho \left( n \log_e \frac{l}{d} + \log_e \frac{d}{r} - B \right)$$

Whilst the capacity of the same type of aerial may be calculated in electrostatic units from the following formula:

$$C = \frac{nl}{2 \left( n \log_e \frac{l}{d} + \log_e \frac{d}{r} - B \right)}$$

B depends on the number of wires used to form the aerial, and is given in the following table:—

Number of wires = $n$ .	Value of B
2	0
3	.46
4	1.24
5	2.26
6	3.48
7	4.85
8	6.40
9	8.06
10	9.80
11	11.65
12	13.58

The formulae given above are for the flat-top aerial, and are only accurate when the length of the aerial is a large multiple of its width. It takes the average value of the potentials at the mid points of the wires. The potential so obtained is rather greater than the true potential, and a more accurate formula is

$$V = 4\pi r \rho \left( n \left( \log_e \frac{l}{d} - 0.307 \right) + \log_e \frac{d}{r} - B \right)$$

A still more accurate formula for the capacity, using the same symbols as above, is

$$C = \frac{nl}{2 \left\{ n \left( \log_e \frac{l}{d} - 0.309 \right) + \log_e \frac{d}{r} - B \right\}}$$

where B has the same meaning as before. The capacity is given in electrostatic units, and is reduced to microfarads by dividing by 0.9.

For those who are aiming at the greatest possible accuracy in such calculations the expression  $\left( \log_e \frac{l}{d} - 0.309 \right)$  in the last formula should be replaced by

$$\text{Sinh}^{-1} \left( \frac{l}{d} \right) - \sqrt{1 + \frac{d^2}{l^2}} + \frac{d}{l}$$

From these formulae it will quickly be found that the capacity of a number of parallel wires is not equal to the sum of each wire taken separately, but is much less.

Professor Howe has given a very useful table of the capacity of parallel wire aeriels. The table on the next page gives the capacity in microfarads per metre, and neglects the influence of the earth.

CAPACITY OF FAN MULTI-WIRE AERIALS						
No. of wires	$\frac{d}{r}$	$\frac{d}{r} = 20$	50	100	150	300
2	100	11.14	9.41	8.35	7.84	7.24
	250	10.20	8.73	7.88	7.46	6.82
	500	9.60	8.29	7.51	7.12	6.55
	1000	9.05	7.88	7.19	6.82	6.26
3	100	13.60	11.15	9.78	9.15	8.20
	250	12.69	10.49	9.29	8.71	7.84
	500	12.07	10.06	9.94	8.40	7.61
	1000	11.48	9.66	8.63	8.14	7.39
4	100	15.58	12.50	10.82	10.03	8.92
	250	14.60	11.88	10.35	9.64	8.60
	500	13.94	11.45	10.03	9.36	8.40
	1000	13.45	11.07	9.71	9.00	8.16
5	100	17.28	13.61	12.00	10.77	9.50
	250	16.28	13.06	11.23	10.39	9.18
	500	15.60	12.60	10.90	10.12	8.99
	1000	15.09	12.22	10.62	9.82	8.79
7	100	20.2	15.37	13.05	11.90	10.40
	250	19.28	14.81	12.67	11.58	10.13
	500	18.52	14.42	12.37	11.34	9.97
	1000	17.98	14.15	12.10	11.14	9.77
10	100	24.1	17.71	14.70	13.28	11.41
	250	23.1	17.10	14.38	13.00	11.21
	500	22.4	16.80	14.10	12.82	11.04
	1000	21.7	16.47	13.85	12.61	10.92
12	100	26.2	18.9	15.45	14.08	11.97
	250	25.3	18.4	15.13	13.78	11.77
	500	24.6	18.04	14.92	13.61	11.65
	1000	24.0	17.70	14.65	13.42	11.48

**FAN ANTENNA CONNECTOR.** A small but useful appliance for connecting the multiple leads from a multi-wire aerial to the common lead-in that connects it to the instrument. The appearance of a device of this nature, which can easily be made by the amateur, is shown in Fig. 1, and consists of two ebonite plates spanned by five brass bars, to which the wires are attached.

The shape and dimensions of the side plates are shown in Fig. 2, and a piece of ebonite, at least  $\frac{1}{4}$  in. thick, should be marked and cut to shape. A second piece is cut from the first as a pattern, and both of them clamped together in a hand vice, which can then be gripped in the vice, as in Fig. 3, and the holes drilled through both pieces at the same time, thus assuring accuracy.

The next step is to prepare five cross-bars, as shown in Fig. 4, making them 1 in. between the faces of the shoulders. If a lathe is available these cross-bars can be

turned to shape very quickly, otherwise they are made from valve sockets, by tapping the hole for the valve leg and screwing a short piece of screwed rod into it. To make the joint quite secure it should be well soldered.

Holes are drilled across the middle part of the cross-pieces, as shown in Fig. 4, to take the connecting bars, which are simply short lengths of  $\frac{3}{8}$  in. diameter brass rod, which are passed through the holes and soldered as shown in Fig. 5. The single cross-bar at the lower end has a larger hole drilled in it to take the ends of the four wires. The outer plate of ebonite is then fixed to the ends of the cross-pieces and the nuts screwed home.

When a lathe is used and the cross-bars are turned from the solid bar, the shanks that pass through the side plates are secured with washers and by riveting.

When the connector is completed, it is wired to the aerial by turning the ends of the wires around the four cross-bars and

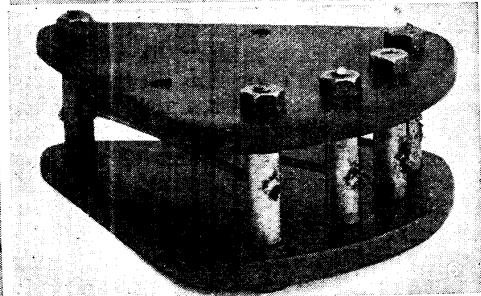
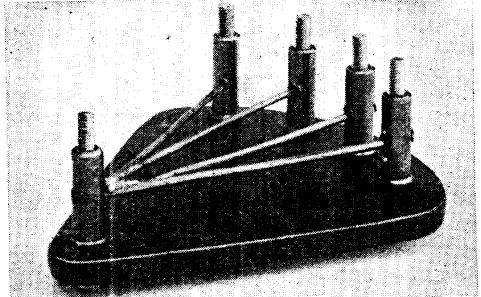
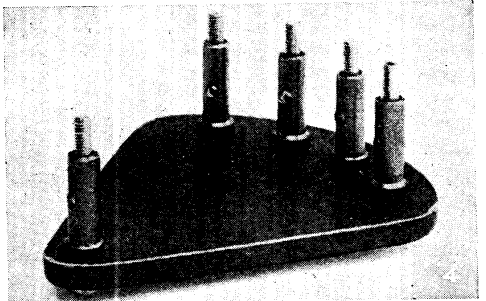
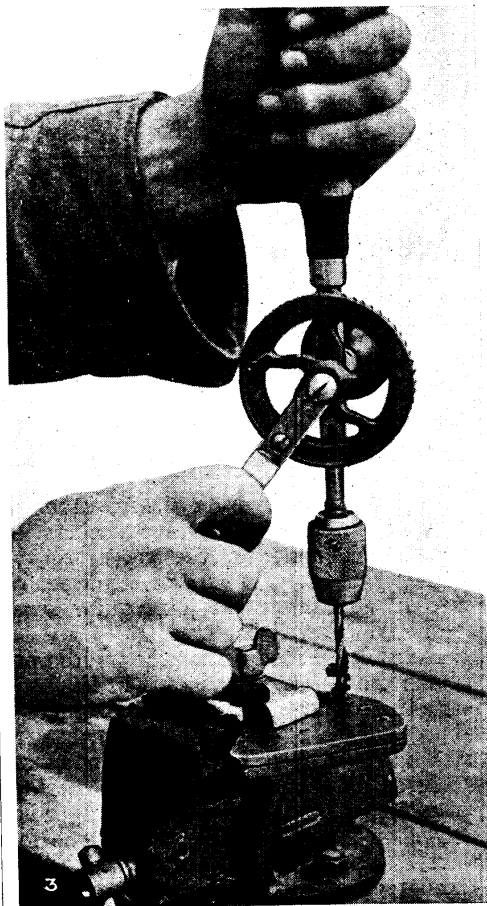
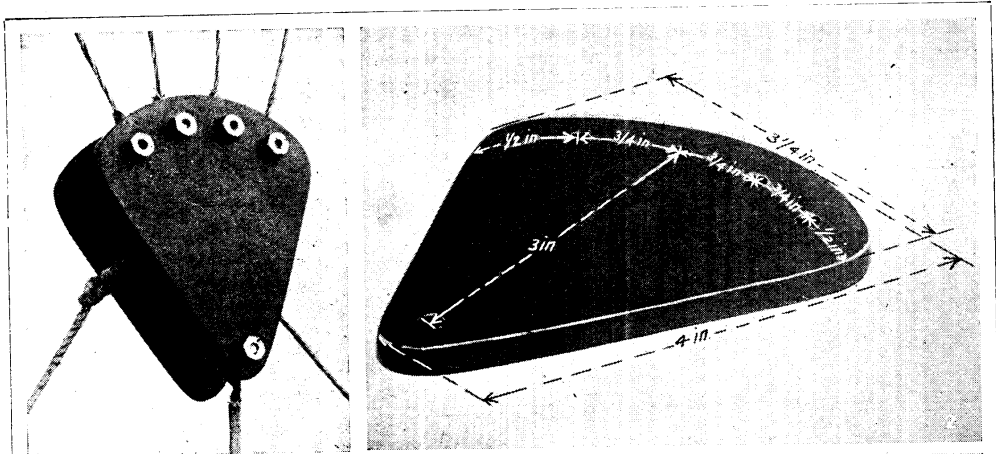

Fig. 1. Spaced apart are two pear-shaped plates. The broad end holds the aerial leads, and the bottom a common lead to the instrument. Fig. 2. Details of one of the side plates of the fan antenna connector. The material is ebonite  $\frac{1}{4}$  in. thick, cut to shape and drilled to dimensions given. Fig. 3. Both plates are drilled together to ensure accuracy of fit for the spacers. The ebonite plates are held in a vice and pierced with a hand drill, as illustrated. Fig. 4. Cross-bars and spacers are shown fitted to one side of the connector. Fig. 5. Connexions are made from the cross-bars to the lead-in connector by metal bars. These are soldered. Fig. 6. Cross-bars are held by nuts. This view shows the fan antenna connector complete

METHOD OF MAKING A MULTIPLE-WIRE CONNECTOR FOR FAN ANTENNA

soldering them securely. The single lead-in wire is connected to the single cross-bar by twisting it around the bar and securing by soldering.

The wires ought to be sufficiently well attached to take the pull of the aerial without relying on the solder, which is only used to make a perfect electrical joint. Two holes can be drilled in the side plates to take a light cord or cords, which are fixed at the lower end to the aerial mast or other point of support. Their purpose is to relieve the lead-in wire of any strains due to the wind, and generally to keep the whole in position.

If desired, the whole can be filled in with insulating composition, such as Chatterton's compound, such treatment making an almost perfect joint, as the surfaces of the metal being protected from the elements, there is little risk of oxidation and the consequent falling-off of signal strength.

**FANNING.** Descriptive term applied to the spreading endwise of the outermost negative plates in the cells of an accumulator. A result is a change in the evenness of the discharge between an affected plate and the corresponding positive plate, with a consequent reduction of the capacity of the cell. This fault is associated with loose packing of the plates and their separators. It is more liable to occur in large stationary accumulators where there is an appreciable gap between the outermost negative plate and the adjacent wall. The explanation of the "fanning" effect lies in the fact that the two end negative plates are used only on their inner faces, the outer surfaces being inert as regards chemical changes during the charge and the discharge of the accumulator. The result is that any expansion due to increasing porosity of the active mass of the negative plate affects the inner side only, and the plate bends outwards at the weakest part, near the lug. Fanning occurs usually early in the life of the accumulator, if it takes place at all. The photograph shows the effect of fanning on accumulator plates.

**FARAD.** Unit of electrical capacity. The international farad is the capacity of a condenser charged to a potential of one international volt by one international coulomb of electricity. It is one thousand-millionth of an electro-magnetic unit of capacity. The farad is too large a unit for most practical work, and the microfarad, or the millionth part of a farad,

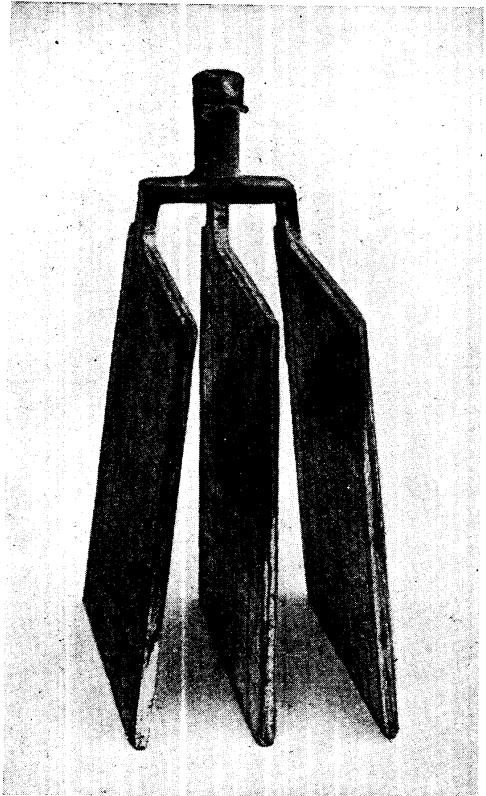

ACCUMULATOR PLATES FANNING

Chemical changes taking place on the inner sides of the outside negative plates sometimes cause this fault owing to their outer faces being inert. When plates spread out in this way the fault is known as fanning

is more commonly used. Nine hundred thousand electrostatic units of capacity equal one microfarad. See Capacity; Electro-magnetic Units; Electrostatic Units; Units.

**FARADAY, MICHAEL** (1791-1867). British chemist and physicist and electrical pioneer. Faraday was the son of a blacksmith, and was born at Newington Butts, London, September 22nd, 1791. He became assistant to Sir Humphry Davy at the Royal Institution, and there quickly showed his genius as an experimenter and original observer. He became a director of the laboratory, and in 1833 he was made Fullerian professor of the Institution for life.

Faraday was one of the most remarkable men of the nineteenth century, and left his mark on many branches of science. In electricity he made the discovery of magneto-electrical induction, the



MICHAEL FARADAY

Born the son of a British blacksmith, Michael Faraday became President of the Royal Society. His scientific genius and his brilliant experiments made him world-famous. Magneto-electrical induction was discovered by Faraday. Wireless science owes more to his work than can be easily computed

*Photo, Emery Walker*

forerunner of the modern dynamo. In 1833 he proved that electricity from different sources was identical, and the following year came the discovery of equivalents in electro-chemical decomposition. Nearly every year saw some brilliant discovery or observation on the part of Faraday, any one of which would have made him famous.

In 1838 he announced the results of his researches on electrostatic induction, and in the same year he showed the relation between electric and magnetic forces. In 1845 he published a full description of the properties of diamagnetic bodies, and in 1846 magnetic rotary polarization.

Faraday was one of the most brilliant experimenters ever known, and many of the suggestions in electrical science which he put forward are being followed in the twentieth century. He died at Hampton Court, August 25th, 1867.

### FARADAY DARK SPACE.

The Faraday dark space is a thin diaphragm of the order of  $\frac{1}{16}$  of an inch in thickness which is noticeable under certain conditions between the glow discharges from electrodes in what would now be called a soft vacuum, but was called by Faraday "a high rarefaction." In fact, until the advent of the hard thermionic valve, which required perfect bombardment to produce its very hard vacuum, any tube exhausted of air even to the moderate extent which is usual in electric lamps was regarded as a high vacuum.

Faraday first discovered this phenomenon when working with the electrodes mounted in a tube which was connected to an air pump, and capable of having its vacuum readily adjusted. He later on showed that the dark space discharge could exist also in air at normal pressure, and in gases other than air.

There is a very full report of the experiments on the dark space in "Experimental Researches in Electricity," by M. Faraday (Vol. I), from which much of the following is obtained.

Two brass rods, each  $\cdot 3$  in. in diameter, were mounted in a glass jar (Fig. 1) so arranged that they might be adjusted from without. The glass jar was connected to an air pump and the air much rarefied. The two brass rods were adjusted so that their ends were in contact, whilst the other ends of these rods were connected to the influence machine. The machine started, and the ends of the rods then moved apart. It was observed that at the moment of separation a continuous glow came round the end of the negative rod, the positive terminal remaining quite dark. As the rods were farther separated a purple haze or stream was noticed on the end of the positive rod, and proceeded outwards towards the negative rod. The glowing stream elongated as the distance between the two electrodes was increased, but it never quite joined the glow round



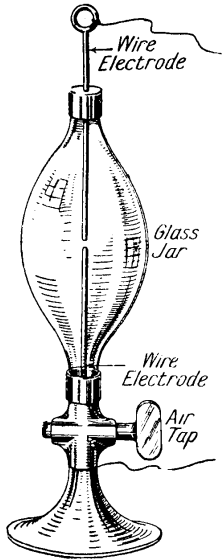

Fig. 1. Faraday's apparatus for demonstrating his "dark space." It consists of a glass jar containing two adjustable rods in a partial vacuum. An electric discharge between the rods included a "short dark space"

the negative wire, there was always a "short dark space" between about  $\frac{1}{16}$  or  $\frac{2}{20}$  of an inch, which was apparently invariable in its extent and position relative to the negative rod, nor did the negative glow vary. Whether the negative end was inductive or inductuous, the same effect was produced (see Fig. 2).

Faraday's next experiment was to replace the wire electrodes by balls, these being mounted in a large air-pump receiver.

The two electrodes were connected as before and the air exhausted. First, sparks passed between the balls, then as further air was removed the sparks became a brush discharge, which in its place gave way to a luminous stream, whilst later on a glow was noticed on the balls, with the dark space as before.

Faraday remarked that when the ball was large and he was using a high vacuum, with a powerful action from the machine, "the ball would be covered over half its surface with glow, and then under hasty observation it would seem that there was no dark space." This he showed, however, is only a deception, caused by the overlapping of the convex end of the one glow within the concave glow of the other.

He stated that the dark space is probably connected with the two different forms of discharge which take place at the positive and negative terminals; "it is probably connected with their differences when in the form of brush, and is perhaps even dependent on the same cause."

"Further, there is every likelihood that the dark parts which occur in feeble sparks are also connected with these phenomena. To understand them would be very important, for it is quite clear that in many experiments, indeed, in all that I have

quoted, discharge is taking place across the dark part of the dielectric to an extent quite equal to what occurs in the luminous part."

In later experiments he considers the question of a dark space in a discharge in air, and asks the question: "Can one particle of air effect discharge to another without becoming luminous." He is quite familiar with non-luminous discharge between air and conductors, and states that non-luminous discharge by carrier currents of air and other fluids are also common enough, but these are not cases in point, for they are not discharges between insulated particles. The apparatus used is illustrated in Fig. 3.

Faraday states that in place of connecting the inductive ball directly to the



+

GLOW DISCHARGE OF FARADAY DARK SPACE

Fig. 2. Proceeding from the positive electrode toward the glow which surrounds the negative electrode is the glow discharge. Faraday's dark space is the non-luminous space between the two discharges

discharger, it was connected through a Leyden jar, and he remarks that whenever a sonorous or luminous spark passed between the balls this (Leyden jar) was charged, but when no sonorous or luminous spark passed the condenser was not charged, and he concludes: "under these circumstances, therefore, discharge even between the air and conductors was always luminous." But in other cases it is almost certain that dark discharge can take place across air.

Using rounded rod .15 in. in diameter, giving a good negative brush, he found that when a smaller wire was brought near at a certain distance a glow came on the positive wire, and a current of air passed from the positive wire to the negative, whilst the negative brush diminished in size as the positive glow came on. "Hence I conclude that dark disruptive charge may occur, and also in the luminous brush the visible ramifications may not show the full extent of the disruptive discharge."

"It is possible even that there are such things as dark discharges, analogous in form to the brush and spark, but not luminous in any part."

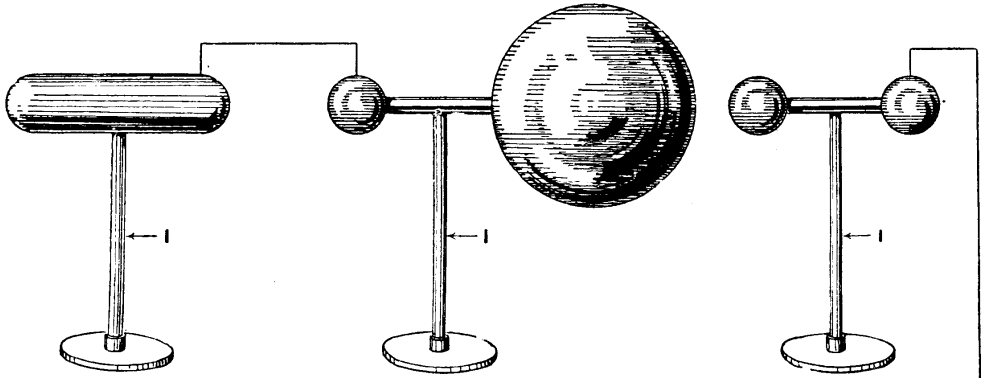

FARADAY'S APPARATUS FOR TESTING THE "DARK SPACE" IN AIR

Fig. 3. Faraday first used an arrangement as illustrated for testing the dark space in air. Mounted on three wooden bases are rods or stems, I, I, I, of an insulating material. Arranged on the top of these stems so as to be spaced as required are spherical bulbs and the cylinder, which are shown wired. The bulbs and cylinder are of metal

These experiments of Faraday are important in that they were the original experiments which led to Crookes's discoveries of discharge in vacuum tubes and ultimately to the study of electronic discharge in valves. They were the first steps on the road travelled by Clerk-Maxwell, Crookes, Fleming and others to modern broadcasting.

**FARADAY'S LAWS.** Laws of electro-chemistry first enunciated by Faraday. These laws are two, and may be stated as follows: The first is that the amount of chemical decomposition which takes place in a given time in a cell or voltameter is proportional to the total quantity of electricity which passes in that time. The second is that if the same current flows through several electrolytes the masses of the ions liberated are proportional to their chemical equivalents.

Faraday enunciated and proved experimentally many laws of electricity and magnetism of the highest value to science, but those dealing with electrolysis are the two most usually referred to as his laws.

In electro-magnetism he also enunciated the following two important laws:

When a closed circuit in which a current is flowing is free to move in a field of magnetic flux it sets itself so that the number of lines of magnetic induction through the circuit is the greatest possible.

The second law states that if there is any variation in the magnetic flux linked with a closed circuit, an electro-motive force is induced in the circuit proportional to the rate of change of the flux. See Electricity; Electro-chemical Equivalent; Electro-magnetic Induction; Flux; Induction; Magnetism.

## FAULTS: HOW TO FIND THEM IN RECEIVING SETS

### What to Do when Reception Fails or Weakens, Specially Illustrated

In this section, illustrated with a plate in photogravure, the amateur experimenter is told what to look for when his set does not work. He is shown how to test it in various ways, step by step. The article should be read in conjunction with the many headings in the Encyclopedia dealing with the construction of receiving sets, as Amplifier; Crystal Receiver; Four-valve Set, etc.

There are so many locations of faults in wireless receiving sets that it is intended in this article to take each particular section of the apparatus individually, and by dealing with faults most likely to occur in it, to reduce the field for investigation until, by this process of elimination, the fault has been found.

Bad design or incorrect values are not, therefore, dealt with to any great extent,

since it is assumed that reasonable care is exercised in choosing a circuit.

Here the following points are considered:

(1) Faults likely to occur in any section of the apparatus.

(2) Various tests for fault finding, and indications, by the behaviour of the set, of the probable trouble.

(3) How to repair faults, or references to articles dealing with their repair.

Very simple apparatus may be used for testing various components and connexions.

One arrangement which is useful for testing connexions or a coil or circuit having a low electrical resistance consists of an accumulator and a  $4\frac{1}{2}$  volt pea bulb, such as is used in pocket flash-lamps. A fairly long flex wire is connected round the screwed portion of the bulb, and the free end of the wire attached to the accumulator. Another flex wire is taken from the accumulator terminal to give a difference of potential of four volts with which to light the bulb. The free end of the wire is connected to the apparatus to be tested. The rounded contact of the bulb is now available to test the continuity of any desired coil or section of the apparatus, which will allow the bulb to light if electrical continuity exists in it.

This test is frequently applied to low-resistance circuits, and will be referred to as Test No. 1.

**How to Use Telephones for Tests**

Where the resistance of a piece of apparatus under test is high, telephone receivers may be substituted in place of the bulb. Continuity in this case is indicated by a click in the telephones when the circuit is made or broken. The experimenter should not confuse this click with a faint click caused by the induction between two coils. This latter click is heard even when one telephone terminal is placed on the battery. A better test for insulation leakage is made by using the high-tension battery where this current flows through the circuit under test, as very often a leak that shows up under a high tension will not appear under a low-tension test. This test with the high-tension battery is not to be recommended where telephones are used, and, if necessary, should only be used as a last resource.

Fault finding with telephone and accumulator is called Test No. 2, and is used in an exactly similar way to test No. 1.

**Faults in Crystal Sets.** By far the most common trouble with crystal sets lies in the crystal itself. Before any further investigations are made, the experimenter should satisfy himself that the crystal is sensitive. Crystals deteriorate with time and their sensitivity with dust and damp.

Where the crystal is set in Wood's metal, or other metal having a low melting point, it should not be heated to excess. This

may be obviated by melting the metal in the crystal cup, and inserting the crystal when the metal becomes plastic again. A common fault when mounting crystals is to hold them in the fingers. This should be avoided, as the natural greasiness of the hand leaves a thin film of oil on the surface of the crystal which destroys its sensitivity. The crystal should be held in forceps or tweezers.

When it is suspected that the surface of the crystal is at fault, it may be scraped with a clean knife blade. The crystal must be rigidly held by the Wood's metal, and not merely kept in place by the cat's-whisker or the other crystal where a combination detector is used. Resetting will put this trouble right. Where other methods of holding the crystal, such as the screwed cup, are adopted, lack of electrical contact is sometimes occasioned by oxidized or insufficient contact. In the former case, the cup or screw ends should be cleaned with fine emery paper, and the latter fault may be remedied by selecting a larger crystal, or tightening the screws.

It is not often that the ball and socket movement, or similar arrangement for varying the position of the cat's-whisker on the crystal, fails to make perfect electrical contact, but when it is very loose, or blackened by oxidation, trouble may occur here. Emery paper or a screw-driver to tighten these parts will generally put matters right. Test No. 1 is applicable here to ensure that this part of the set is functioning correctly.

**Faults in Double Crystals**

Where double crystals are used, they must be matched according to the known combinations, such as the Perikon combination, composed of the crystals zincite and bornite. It is not possible to pick any two crystals at random.

As a general rule, if the crystal or its method of mounting is suspected of being imperfect, a good test is to replace the whole with another detector of known reputation. If there is still no response in signals, look for possible faults in aerial, earth, tuning methods, and telephones.

**Aerial and Lead-in Wire Faults.** Failure in aerials or lead-in wires may be summed up under two general headings :

- (1) Short-circuiting to earth.
- (2) Lack of continuity.

The former may be divided again into eight most common faults :

- (1) Aerial fallen down.
- (2) Aerial touching earthed object as guttering, trees, etc.
- (3) Incorrect attachment of cord and aerial wire to insulators.
- (4) Dirty or cracked insulators.
- (5) Poor insulation generally.
- (6) Staple driven through lead-in wire.
- (7) Lead-in tube cracked and containing water or moisture.
- (8) Insufficient length of lead-in tube causing surface leakages.

Lack of continuity in aerial or lead-in wire may be occasioned by

- (1) Bad connexion between aerial and lead-in wire.
- (2) Bad connexion on lead-in tube.
- (3) Aerial or lead-in wire broken.

In every one of the foregoing faults the remedy suggests itself. The more difficult problem is to find the leakage or breakdown. One method is to use a sensitive galvanometer placed in series with a suitable battery between the aerial and earth terminals. If a deflection of the galvanometer needle is observed the fault must be traced to its source by moving the apparatus and applying tests in different parts of the aerial circuit.

**Faults in the Aerial and Lead-In**

A very effective way of locating aerial and lead-in faults is shown in Fig. 1 on the plate facing this page. The aerial lead-in is connected to a sparking or induction coil secondary terminal, while the earth lead is joined to the other secondary terminal. The coil is then connected up to a suitable battery. The aerial will then be subjected to considerable electrical strain, and faulty insulation will be detected by a passage of sparks from the weak point.

If this test is made at night, tests for brush discharge may be carried out. A brush discharge is a leakage of electricity from a sharp point into the atmosphere. A large brush discharge is denoted by a radiation of short purple lines, forming a glow of light from a point, while a minor discharge is shown by a pinhead of light.

This type of leakage may be found in the free stranded ends of an aerial, or at the connexions of the lead-in wire to the lead-in tube. The trouble may be remedied by cutting or filing off the sharp points and soldering these wire ends to the main wire.

**Earths.** Bad earths are a prevalent cause of trouble and unfortunately, faults

are difficult to detect. A comparative method of testing an earth is to make another earth and compare the results of each in the receiving set, and it should be observed if any improvement is effected when both earths are connected to the set. An earth wire should be of large cross section and well insulated to the point where it is permanently earthed.

It must be remembered that the earth wire is equally a part of the aerial tuning system as the aerial and lead-in wire. If the earth wire is not well insulated, it may make intermittent contact with the earth in one or more places before it is finally earthed. The result of this is that the wave-length of the set is rendered variable and unstable. In the majority of cases a water main constitutes a good earth, and where this is used the point of attachment should be inspected. Test No. 1 may be applied to make certain that electrical contact is perfect between the water pipe and the earth wire.

In the case of an earth consisting of a buried plate or metal object, it should be seen that the soil in the vicinity is not dry. If several pails of water thrown over the ground improve the loudness of the set, a wetter soil should be chosen in which to bury the earth plates.

**Faults in Earth and Tuner**

A common fault with earth plates is that they are not sufficiently large to carry away the earth currents quickly enough. Bury two or more extra plates in the vicinity, but not nearer than three feet to the original one. Solder leads from these to the existing earth wire at the point where it enters the ground. This increased area, if giving improved strength to signals, will indicate that the original plate was too small.

**Tuning Connexions.** The faults in aerial tuning circuits are common to both crystal and valve receivers, and are dealt with under one heading.

No hard and fast rules can be laid down with regard to the connexions of the tuner, but in general practice, in crystal sets, the aerial side of the tuner connects with one side of the crystal, and the earth side of the tuner with one side of the telephones. The other side of the telephones joins the unattached side of the crystal detector.

In standard valve practice the aerial side of the tuner, where high-frequency amplification is used, connects with the

grid of the first valve. Where this valve is the detecting valve, the grid leak and condenser intervene between these parts. Reference should be made to High-frequency Amplification later in this article.

**Variometer.** A common fault in variometer tuning lies in imperfect connexion between the stator and the rotor. This may be checked by applying Test No. 2.

Trouble from this source is indicated if an intermittent click is heard in the telephones on revolving the rotor. If no click at all is heard suggesting a permanently broken circuit, the rotor should be tested alone and then the stator separately until the fault is located. If a connexion is broken and is too short to mend, no harm is done in taking off one whole turn. It is sometimes found that owing to considerable resistance to rotation the rotor will not revolve, but allows the knob and spindle to rotate. This would give one fixed wavelength. The fault may be located by removing the panel, on which the variometer is mounted, from the cabinet, and ascertaining that the rotor and its knob or handle revolve together.

**Inductance Slider Failures.** Single and double slider inductances are subject to a common fault. It is often found that electrical contact is not established along the whole length of the coil. Sometimes the slider knob does not function, owing either to the plunger being stuck in its guide, or because the spring is not sufficiently powerful to make contact with the wire if the latter chances to be a little farther away from the slider rod in one particular place.

Occasionally the insulation is not entirely removed from the path of the slider contact, and may be removed with a small knife blade. Any of these faults may be traced by applying Test No. 1. This test is illustrated in Fig. 2, where the primary of a loose coupler fitted with a single slider contact is under examination.

Where a double slider is used, one slider should be tested at a time, the slider not being tested being pushed to one end, with a piece of paper placed under the plunger to prevent contact with the coil. Fig. 3 illustrates a double slider under test for continuity of contact.

**Duo-Lateral Coils.** Trouble is occasioned in duo-lateral coils, when they have seen considerable service, by faulty connexions at the end of the coil. This may be traced by Test No. 1, and the remedy effected by

disassembling it and rejoining the broken wire. Another fault to which the duo-lateral coil is subject is loose connexion at the plug and plug socket where these fit the coil holder. The effect of opening out the split plugs slightly with a thin-bladed knife will ensure a better fit and repair the fault.

**Basket Coils.** The only usual trouble experienced with basket coils is an occasional breakdown due to connecting wires being broken. These points should be tested, as with honeycomb coils.

**Testing Tapped Inductances.** Tapped inductances may be tested, as shown in Fig. 4, by applying Test No. 1 for continuity of current, by connecting the pea bulb and battery connexions to aerial and earth

terminals, providing there is not a series condenser in the circuit. If this exists, the test should be made on the side of the condenser in contact with the inductance. The stud switch is now rotated over every stud individually.

In some inductances the end of the coil is taken to the centre of the stud, as in Fig. 14. In this case the test given is not applicable, as, despite a lack of connexion to any particular stud, the bulb would still light. The test is effected by connecting to the aerial terminal and each stud individually, the contact arm being placed on the stud

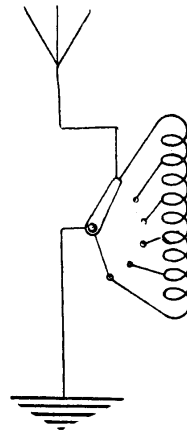

TAPPED COIL TROUBLE

Fig. 14. Trouble is sometimes found where a tapped coil has one end wired to a switch centre arm, and this should be tested

giving maximum wave-length.

If at any stud the light fails, that section of winding should be examined in detail. Two faults likely to occur are, firstly, the wire joining the stud and the section of coil to which the stud is normally connected is broken at the point where it leaves the coil. This is often occasioned by a sharp bend, which causes a brittle wire to break. Secondly, this wire may be making bad contact under the nut holding the slot.

Care should be taken to see that every trace of any foreign material is removed

from the space between contact studs. In cases where the connexions from the tapped inductance have been soldered to the stud ends, there is a great probability that the space between the studs will be filled in with the soldering paste used. Even if this paste were not a conductor it would assist in the collection of dust and dirt between the studs, which materially helps surface leakage. The studs may be scrubbed with a small tooth-brush soaked in petrol. An alternative plan is to use a sharp-pointed tool capable of pushing a rag between the studs.

Both the front and back of the panel on which the stud switch is mounted should be treated by either of these methods. If washers are used at the back of the studs, care should be taken to see that they are at least  $\frac{1}{8}$  in. from their neighbours on either side. A fault common to some types of stud switch, owing to insufficient spring on the contact arm, is that contact to a stud slightly below the level of the others is missed. This trouble may be suspected if a buzzing sound or a continuous "running up" noise is heard in the telephones. Test No. 1 is applicable to determine this point.

The experimenter should always look for trouble where electrical contact is made between a fixed and a moving contact, or between two moving contacts. In stud switches it is preferable to solder a flexible lead to the end of the spindle holding the contact arm rather than solder to the spindle bearing. This will obviate the moving contact between the spindle and the bearing. In the majority of moving contacts a phosphor-bronze washer is used to secure tension between it and its bearing, and it should be seen when testing that the nut or nuts performing this function are quite tight and the spring washer is still under compression.

**Variable Condensers.** The variable condenser affords an example of the moving contact, and this part should receive special attention when testing. An even more common fault with variable condensers is shorting of the plates. This may be tested by applying Test No. 1, and remedied by very carefully straightening the bent plate or plates. A strip of clean rag should be passed between the plates to make certain that dust is not spoiling the dielectric.

**Valves.** Valves are liable to breakdown from several causes, and usually there is

no remedy that the experimenter is able to apply. A valve ceases to function sometimes because one of the legs is making imperfect contact in its valve socket. This can be traced by moving the valve about while in the valve holder. In one position it may work correctly, and in others appear quite useless. Open out the split legs of the valve slightly. If this does not remedy matters, try a fresh valve, and if still the same thing happens it will be advisable to change the valve holder.

#### Why a Valve Fails

It sometimes happens that a valve, although not touched in any way, will suddenly cease to function although the filament is still alight. A tap with the finger may start it working again, and the trouble not recur for some considerable time. Usually, however, it indicates that a replacement will soon be necessary.

Occasionally the experimenter is puzzled with a very weird fault with a valve. The symptoms are that although the filament resistance is completely turned off the valve is still alight, and, yet more strangely, the tappings of the aerial tuning inductance form the filament resistance. It will be found to be that the filament has broken, and that it has curled up sufficiently to make contact with the grid. As one side of the low-tension battery is coupled to the grid circuit via the aerial tuning inductance, a circuit is formed, allowing the filament to function although broken. Fig. 5 on the special plate shows a test for the location of this trouble.

A somewhat similar trouble is caused occasionally by the grid accidentally touching the anode, which fault may be tested by applying Test No. 1.

**High-tension Batteries.** After a battery has seen considerable use it often gives rise to crackling noises in the headphones. It may be only one or two isolated cells in the battery that are giving trouble. Each cell, or group of cells forming one tapping, may be tested individually with a pea bulb of a pocket lamp. Where tappings are made to every three cells, a short spiral of resistance wire should be used in order to avoid burning out the bulb. This test is shown in Fig. 6, where the faulty bulb can be short-circuited by a wire between the two tappings of the cell.

If a high-tension battery is subjected to a sudden knock, its continuity may be broken. This is evidenced in a receiving set by a lack of click in the telephones when the battery plugs are inserted. The test for the remedy of this fault is similar to that adapted for finding a run-down cell. This latter fault may be minimized by shunting a large fixed condenser of about 1 mfd. capacity across the battery.

Faults in the use of a high-tension battery should be carefully avoided by checking the voltage in use with the voltage of the valve recommended by the makers. If two distinct types of valves, requiring different anode voltages, are used in a set, different high-tension taps will be necessary. Too high an anode voltage is manifested by a blue glow inside the valve, and also a high-pitched whistle sometimes occurs.

A voltmeter may be used for test purposes in place of the bulb, but it must be remembered, whichever method is used, that the battery will not stand up to a big discharge, and all tests should be as short as possible. It is important to see that the high-tension battery is connected the right way round.

With the standard receiving valve, having a filament requiring from 4 to 6 volts, an accumulator is most often used. Providing it is connected to the set the correct way round, there is little possibility of fault. A voltmeter should be used to see that the accumulator is not running down, failure of which will result in loss of signal strength, although the diminished brilliance of the valve may not be noticed. The accumulator should be recharged before the voltage drops to 1.8 volts per cell.

With dull emitter valves dry batteries for filament heating are commonly used; they must be replaced when the voltage falls too low to work the valve effectively.

**Loud Speakers.** Apart from bad design or incorrect values of the set, causing howling or distortion in the loud speaker attached to it, the loud speaker does not often give trouble. If reception is good in the headphones, yet poor or entirely absent in the loud speaker, the leads to the latter and also the connexions at both ends should be carefully examined and, if faulty, replaced.

Many loud speakers have adjusting devices, and it should be seen that the regulating knob or handle is correctly

adjusted to secure greatest volume of sound without distortion. An insulation breakdown, either internal or by a frayed end of the connecting flex touching the case, is detected by a squealing noise when the frame of the instrument is touched. The latter is easily remedied, but the former requires the attention of the manufacturers, or an expert in rewinding.

**Telephones.** The faults in loud speakers are common also in telephones. The telephone cords are prone to give trouble by shorting when frayed at the ends. This is manifested by clicks when the cords are moved, and is best remedied by replacing them, or cutting and reconnecting.

**Faults in Sets.** Although faults occurring in sets have been largely exhausted under the particular components in which they are likely to occur, trouble often arises during the assembly stages. Chief among these are:

- (1) Wrong connexions.
- (2) Short-circuiting.
- (3) Broken or imperfect connexions.
- (4) Electrical leakages.
- (5) Unsuitable value or arrangement of components.

(1) Testing for wrong connexions when a set under construction is just finished should always be done thoroughly before the valves and batteries are connected to the apparatus. A wire from the positive high-tension battery, inadvertently joined to either of the filament legs of a valve, will burn out the filament and thus ruin the valve before it is known that any wrong connexion exists. It is therefore advisable, even after checking the wiring with the circuit diagram, to proceed with the caution indicated in the following paragraphs.

Insert the valves (or valve) into their respective valve holders, and connect up a suitable low-tension battery, such as a dry battery or accumulator, to its correct terminals. Turn up the filament resistances, if any, and ascertain that the low-tension circuit is correct. This is indicated by the valves lighting and varying in brilliance with the rotating of the filament resistance control. Assuming this is correct, add the high-tension negative wire to its correct terminal. This is usually connected either to low-tension negative or positive.

A suitable length of wire is now connected to the high-tension positive terminal of the set with the other end at present



disconnected. The filament resistances are then turned on till the valves light. They are left in this position and the low-tension battery disconnected. The free end of the high-tension terminal wire is cautiously approached to the lowest tapping—*i.e.* 3 or 6 volts—of the high-tension battery, at the same time keeping one eye on the valves in order to withdraw the high-tension positive wire should the valves commence to light.

Having ascertained the circuit is in order, a higher tap on the high-tension battery may be selected. The latter part of this test is now repeated with the low-tension battery connected and the valves just alight. The caution displayed at this stage of testing is well justified if it results in saving the life of even one valve.

**Possible Varieties of Wrong Connexions**

Other forms of wrong connexions may result in a shorting of the high-tension battery, which will be found to spark considerably when connexion to it is made or broken. This would result in damage to the apparatus and the ruin of the battery. A better test for the fault finding than the spark method just referred to is to put a small lamp in series with the battery when connecting-up. Intermediate taps should be selected as before, with the object of saving the lamp should a fault in wiring or a short circuit exist.

A fault in the wiring of a set, if not shown by the valve or the high-tension battery test, is often indicated by an entire absence of signals or a steady, howling noise in the telephones. A fault that has been found common in the wiring up of a set is to omit the connexion from the earth to high-tension negative, which is usual in the majority of sets. In the case of a valve circuit having a closed secondary circuit, this wire is generally omitted, and alternatively joined to the side of the secondary tuning arrangements opposite to the side connected to the grid.

If a set wired in this way is found to howl, this trouble is often cured by connecting the high-tension negative wire to earth, in addition to earthing the primary. Other possibilities of wrong connexions will be found under the appropriate heading of each valve unit.

(2) Short-circuiting of two or more wires occurs occasionally when the wiring of a set is carried out by the "anti-capacity" method. This expression is used to indi-

cate wiring with uninsulated wires of thick gauge which are first bent to their required positions and then soldered, their own strength and rigidity being sufficient to keep them in place. It is obvious that each wire of such wiring must be kept well away from any other wires, allowances being made for accidental bending and vibration.

Whichever method of wiring is adopted, it should be seen that wires are cut off close to their terminals. This is particularly necessary in wiring up contact studs and valve holders, where very little space exists between connexions. Another form of short-circuiting is caused by the frayed ends of two flexible wires both touching a metal object, such as a low-frequency transformer core or casing.

(3) Broken or imperfect connexions. The former is usually indicated by the lack of signals or a continuous howling in the telephones. All joints should be inspected and Test No. 1 applied to the apparatus in various parts. During this test valves and batteries must be removed. The test is also useful in locating a loose connexion, which is usually shown up when the apparatus is shaken, which results in clicks and noises in the telephones. In a crystal set, a broken connexion causes a humming or running up noise in the telephones, testing for which may be done with a lamp and battery.

**How to Detect High-Frequency Leakages**

(4) Electrical leakages have been mentioned in connexion with tapped inductances. They also occur in other parts of wireless sets, especially where the distance between two insulated conductors is small. Valve holders are found to collect foreign material, often detected by an occasional snapping noise, similar to an electrical discharge in the telephones. To minimize trouble from leakages, insulation should be effected by using best quality ebonite and matting it on both sides. Terminals should be spaced as far apart as possible. Electrical leakages are most harmful to the efficiency of a set when they occur in circuits at radio-frequency.

Leakages may be tested by putting a wet finger in various parts of the panel while the set is working. A click will be heard in the telephones when the finger intercepts a source of leakage. The experimenter is referred to "tapped inductances," dealt with earlier in this article,

where suggestions for eliminating leakages between studs are given. These hints are equally applicable to valve holders and other parts of apparatus where space between conductors is limited.

(5) Unsuitable value or arrangement of components is a prolific cause of failure, even if the components and connexions to

In receiving sets embodying resistance or tuned anode coupling, the method of connecting the grid leak is important. Normally, the grid leak is shunted across the grid condenser, and combined grid condensers and leaks are marketed in this form. This position will not suit, however, in the methods of high-frequency amplification mentioned. The grid leak may be wired from the grid side of the condenser to high-tension negative.

This arrangement is shown in Fig. 15, where it will be seen that if it were placed across the grid condenser a path would be provided for the steady anode current, which would adversely affect the operation of the grid by giving it a strong positive bias. This change should be remembered when converting a transformer-coupled high-frequency amplifier to either of the above couplings.

Fig. 7 on the plate shows the method of testing a plug-in transformer. The two faults likely to be met with in this type of transformer are lack

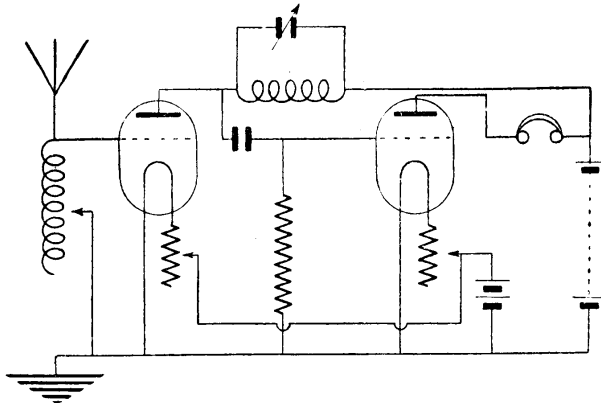

**WHERE A FAULT IN WIRING MIGHT OCCUR**

Fig. 15. Correct wiring of a grid leak in a two-valve circuit is shown. Tuned anode and resistance-coupled high-frequency amplification are included in the circuit. It sometimes occurs that the grid leak is shunted across the grid condenser, but in this type of circuit such an arrangement is wrong, and the circuit as shown is correct

of continuity in either of the windings, and contact between the two due to imperfect insulation. The transformer should also be tested for continuity of winding. In this case the two legs directly opposite to each other are chosen.

When testing insulation a breakdown is indicated by a loud click when adjoining legs are touched with the testing wires. Telephones are necessary in tests with apparatus having a high electrical resistance, for the resistance would be too high to permit the passage of current required to light a testing lamp.

A common fault in high-frequency circuits is in the use of unsuitable switches having a large self-capacity. For this reason ordinary telephone switches should not be used. Where it is desired to control high-frequency amplification by means of switches, those designed for minimum anti-capacity effect should be selected; and, when testing, it should be seen that the points of contact are perfectly clean and that each is making good electrical contact. In a high-class anti-capacity switch the points of contact are often made of platinum riveted to the contact

**Faults in High-frequency Amplification.** Where high-frequency amplification is effected by the tuned anode method with plug-in duo-lateral coils, the tuned anode coil needs to be larger than that used in the aerial tuning circuit. The reason for this is that it must tune to the same frequency as the aerial and aerial tuning coil. The extra inductance of the tuned anode coil must equal the inductance of the aerial itself. It will be found that tuned anode amplification is very critical in adjustment, and thus the selection of the correct value coil in this application is essential to good results.

Exactly the same rule applies to the aerial primary and secondary coils where a closed circuit is used for tuning. The secondary coil will need to be rather larger in order to tune to the primary, the wave-length of which is increased by the fundamental wave-length of the aerial.

arms. It should be seen that these are all intact. It is specially important in high-frequency amplification to see that grid and anode connexions are as short and straight as possible, as long wires tend to reduce the efficiency of a set to a very considerable extent.

**Valve Detector.** The grid condenser in a valve detector circuit may be of incorrect value, and the use of a variable grid condenser to correct this fault is to be recommended as a very useful addition to wireless apparatus. Fig. 10 on the plate shows a method of testing a grid condenser, or indeed of any fixed condenser, where it is thought the insulation is at fault. A loud click will be heard in the telephones if the plates are touching through faulty insulation.

A better test, although not recommended for the telephones, is to use a high-tension battery in place of the accumulator shown.

In detector circuits a grid leak of too high a resistance is detected by a continuous series of clicks in the headphones. It should be changed for a smaller one. A similar phenomenon is sometimes caused by the use of too large a reaction coil when coupling back the anode of a detector valve to the grid circuit for re-magnification.

**Low-frequency Amplification Faults.** Three faults are liable to occur in low-frequency transformers. The primary may be burned out through the passage of too great a current through its windings. Testing for this trouble, which is evidenced by lack of continuity, is shown in Fig. 9. The other two main faults are due to breakdown of insulation. The transformer should also be tested for insulation leakage to the secondary windings. A somewhat more common fault is an insulation leak from the primary windings to the core of the transformer. This is indicated as shown in Fig. 8. In each of these tests

the telephone replaces the pea bulb, as the resistance of the transformer would be too high to pass sufficient current to light the bulb.—*W. W. Whiffin.*

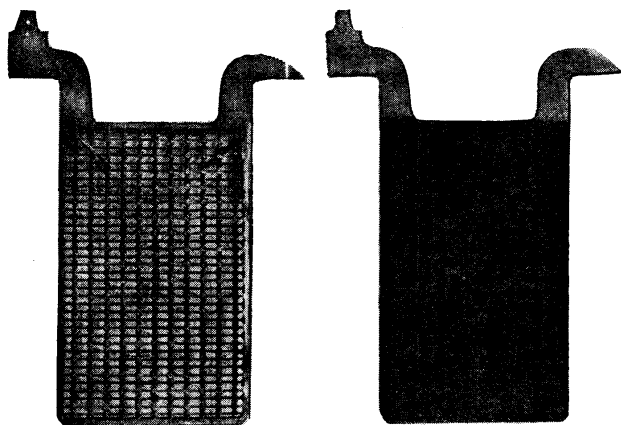

FAURE NEGATIVE PLATE AND GRID

Fig. 1. On the left is shown the grid before pasting, and on the right the complete negative plate. The grey lead composing the active material is really the same colour as the grid itself

*Courtesy Hart Accumulator Co.*

**FAURE PLATES.** A "pasted" plate used in making the positive and negative plates of secondary batteries or accumulators. The earlier Planté type of plate consisted of lead. Camille Faure (France) and Charles F. Brush (U.S.A.) found independently that the time-consuming and expensive method of forming plates is reduced and plate weight could be lessened by applying oxides of lead to the surface of the plate in a paste form.

Litharge (PbO) was used for the negative plate, and red lead (Pb<sub>3</sub>O<sub>4</sub>) on the plates to become positive. The pastes

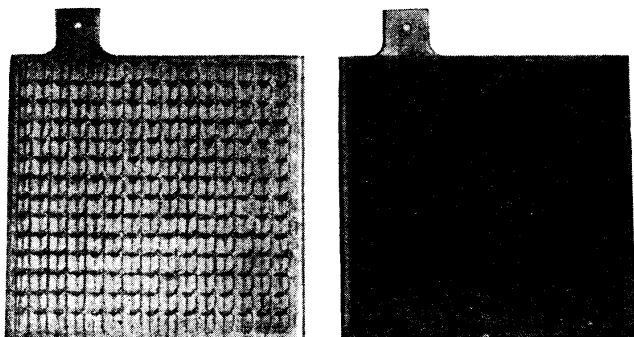

FAURE POSITIVE GRID AND PLATE

Fig. 2. Chocolate-coloured lead peroxide is used in making the complete plate shown on the right, and this gives it its dark appearance. The grid before pasting is shown on the left

*Courtesy Hart Accumulator Co.*

were made with a mixture of sulphuric acid (1 part) and water (4 parts). This sets quickly, so that only small quantities are made at a time. These early Faure plates buckled badly and shed their active material quickly in use, and the various forms of grid patterns were invented to eliminate these troubles. The foundation of a modern Faure-type plate consists of a skeleton or grid of lead-antimony alloy (containing usually about 4 per cent of antimony and 96 per cent lead), as shown in Figs. 1 and 2 on the left. Grids of pure metal are not used, as the pasting is now done mechanically, and the soft metal would bend. See Accumulator.

**Fe.** This is the chemical symbol for iron. It is contracted from the Latin name for the metal, ferrum. See Iron.

**FEED BACK.** The term "feed back" is applied to any radio-telegraph circuit in which one part of the circuit is coupled to another part in order to transfer some part of the energy in the one circuit to the other circuit.

When a three-electrode valve is used for detecting or amplifying radio telegraphic or telephonic signals, the circuit can be divided into two principal parts, *i.e.* the grid or "input" circuit, and the plate or "output" circuit. If these two circuits are not coupled together except through the inappreciable capacity of the valve, the energy in the output circuit is controlled by the voltage applied to the input circuit and the amplification constant of the valve. If, however, some of the energy of the output circuit is introduced back into the input circuit, then the amount of energy in the output circuit will be increased, the increase being governed by the amplification constant of the valve.

The two circuits can be coupled in such a way that:

- (1) The radio-frequency component in the output circuit reacts on the input circuit and increases the grid voltage change, and so produces greater amplification, or starts and maintains the circuit in an oscillating condition.
- (2) The audio-frequency component in the output

circuit can be introduced into the input circuit to produce a second amplifying effect.

The method for coupling for radio-frequencies (1) is generally by means of two coils, the one in the input circuit and the other in the output circuit, so mounted that they electro-magnetically affect each other, which effect can be varied at will. Fig. 1 shows the method

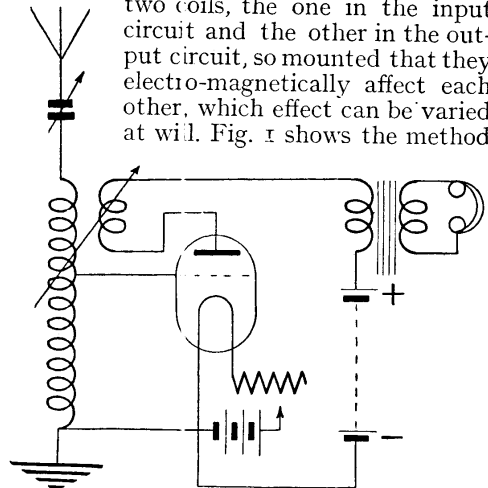

**PLATE AND GRID OF FEED-BACK CIRCUIT**

Fig. 1. Coupling of plate and grid is shown in this circuit for amplification and continuous-wave reception. If used for generating local oscillations the telephone transformer is disconnected and the plate and coil connected direct to the high-tension battery

of coupling the two circuits by this means. This method is adopted when a three-electrode valve is required to act for the

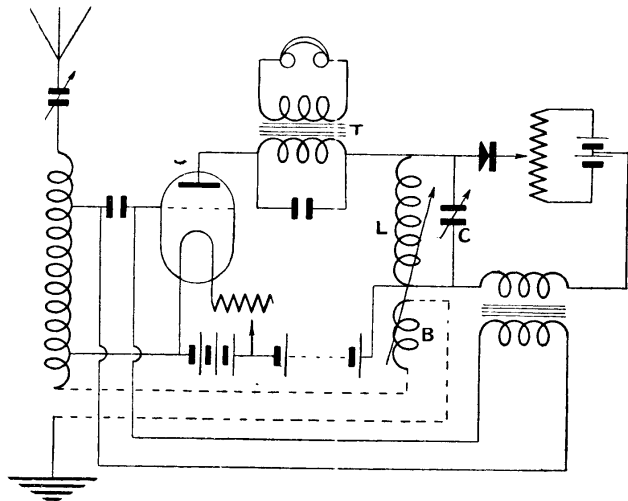

**HIGH- AND LOW-FREQUENCY FEED-BACK CIRCUIT**

Fig. 2. Both high and low frequency are introduced into this circuit, one valve being used for the two forms of amplification. The aerial circuit and closed circuit, LC, can also be coupled by the coil, B. A crystal rectifier is used

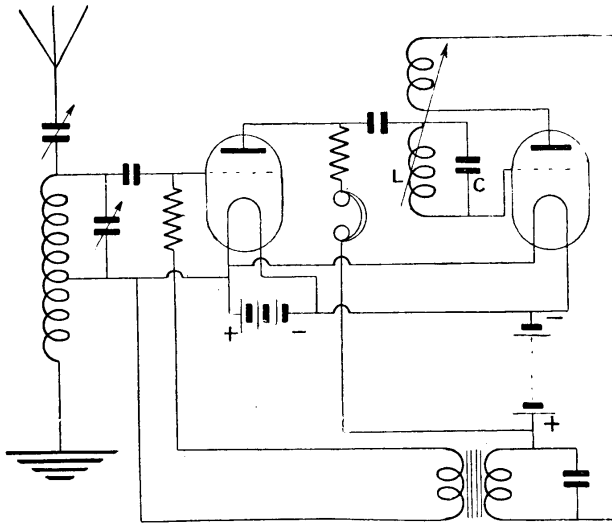

**FEED-BACK AND REACTION COUPLING**

Fig. 3. Connexions of a two-valve set are given in this diagram, which shows the method of reaction coupling with feed-back effect. High-frequency oscillations are amplified by the first valve

reception of continuous waves by the heterodyne method; for detecting and amplifying spark or telephone signals, and for setting up continuous oscillations in a detector circuit in order to receive continuous waves by the autodyne method.

The second method of coupling, *i.e.* for audio-frequencies (2) is generally by means of an iron-cored transformer, one winding of which is connected in the output circuit, and the other winding in the input circuit.

Fig. 2 shows the method of connecting a valve and crystal rectifier for "feed back," or double magnification. With this method the radio-frequency oscillations induced in the aerial circuit are applied to the grid, and set up corresponding radio-frequency impulses in the filament-plate circuit. These radio-frequency impulses set up radio-frequency oscillating currents in the closed circuit LC, which are rectified by the crystal. The rectified radio-frequency impulses are then smoothed out by the inductive action of the iron-cored transformer, thus producing in the transformer windings a varying direct current of audio-frequency. These audio-frequency impulses are then introduced into the grid circuit and cause amplified impulses in the plate circuit, which act through the telephone transformer, T.

Still further amplification can be obtained by means of a coil connected in the aerial circuit and coupled to the circuit

LC. The extra coil is shown by dotted lines in Fig. 2. By means of this coil the oscillating current in the circuit LC is transferred to the aerial circuit and increases the voltage of the incoming signal.

The crystal in Fig. 2 for rectifying can be replaced by a valve. Fig. 3 shows the connexions for a two-valve set in which the first valve acts first as an amplifier of the high-frequency oscillations. The second valve acts as a detector, the rectified impulses being led back via an iron-cored transformer to the grid of the first valve, this valve then acting as a low-frequency magnifier. The low-frequency magnified signals are then passed to the telephones. Still further

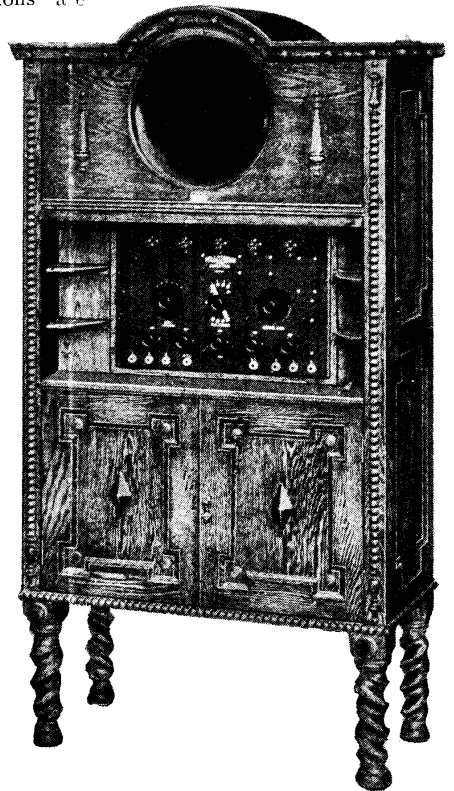

**FELLOPHONE SUPER-FIVE SET**

Fig. 1. Embodied in a Jacobean oak cabinet is a five-valve set and loud speaker. Three stages of low-frequency amplification are added to a detector and high-frequency amplifier

*Courtesy Fellows Magneto Co., Ltd.*



FELLOPHONE SUPER-TWO SET

Fig. 2. Two valves are employed in this set. One is used for high frequency and the other is a detector with reaction. Selectivity is obtained by coupling the tuned anode coil

*Courtesy Fellows Magneto Co., Ltd.*

amplification can be obtained by coupling the plate circuit of the second valve to the closed oscillating circuit LC. See Armstrong Circuit.

**FELLOPHONE.** Trade name for the receiving sets manufactured by the Fellows Magneto Co., Ltd. The apparatus ranges from a simple crystal set to the elaborate cabinet seen in Fig. 1, known as the Fellophone Super Five. It is carried out in Jacobean style, and the oak cabinet incorporates a loud speaker, the flair or trumpet mouth being ingeniously disposed in the upper part. The centre panel is occupied by the receiving set proper, which includes one stage of high-frequency amplification, a detector valve, and three stages of L.F. amplification.

The two-valve set illustrated in Fig. 2 is a sloping-fronted cabinet, with an ebonite panel whereon are mounted the controls. One high-frequency valve and one detector valve are employed, with reaction as permitted by the P.M.G. Coupling to the tuned anode coil is used.

**FERRIE, GENERAL GUSTAVE.** French wireless expert. Born at St Michel de Maurienne in 1868, he first took an interest in wireless after watching the experiments of Marconi in 1899, at Wimereux. He started the following year the French military radio-telegraphic service, and was a delegate for France in 1904 to the International Electrical Congress at St. Louis, and in 1912 to the International Radio-

telegraphic Conference in London. In 1920 he was appointed a member of the Inter-Allied Wireless Technical Committee.

General Ferrie is the author of many books and papers on wireless telegraphy and telephony, and has received many honours from scientific societies and governments for his work on wireless.

**FERRO-MAGNETIC SUBSTANCES.** A term applied to certain elements and compounds which, like iron, are strongly attracted by magnetic fields of force. These are iron, nickel, and cobalt, and, to a less extent, manganese, also the alloys of carbon and iron forming different kinds of steel, as well as iron oxides and salts. The ferro-magnetic metals retain only a slight magnetic attraction when heated, becoming paramagnetic. On the electron hypothesis, atoms consist of a central positive core, or nucleus, with concentric shells of negative electrons equal in strength to the positive charge. Magnetic properties are considered to be due to a lack of symmetry in the distribution of electrons in the inner electron shells of the atom



GENERAL GUSTAVE FERRIE

An illustrious soldier of France, General Ferrie occupies a prominent position among the foremost wireless experts of Europe. His writings are rich in scientific data, and the progress of wireless research on the Continent has received considerable aid from his experiments

The oxides and sulphides of the magnetic metals show large variations in their magnetic properties. Magnetite ( $\text{Fe}_3\text{O}_4$ ), an oxide of iron regarded as made up of the oxides  $\text{FeO}$  and  $\text{Fe}_2\text{O}_3$ , is much more magnetic than either of them, which is also true of the corresponding sulphur compounds. Variation in changes of temperature produces great changes in magnetic properties of a ferro-magnetic element. Four types of iron, each with characteristic magnetic properties, are obtained in succession at definite transition points of temperature on heating iron. When the magnetizing influence is removed a soft iron almost wholly loses its magnetization, but steel may retain about one half of its original magnetization as permanent or residual magnetism.

**FESSENDEN, REGINALD AUBREY.** Canadian-American wireless expert. Born at Milton, Canada, October 6th, 1866, and educated at New York and Port Hope, Ontario, Fessenden became inspecting engineer to the Edison company, New York, and afterwards professor of physics and electrical engineering at Western University, 1892. Professor Fessenden is the author of a well-known system of wireless, and below are briefly described some of the patents bearing his name.

In 1906 and 1907 Fessenden invented a number of microphone transmitters which carried heavy currents for long periods, and also a heavy current telephone relay, which allowed the controlling of heavy currents by means of small currents originating in an ordinary microphone circuit or coming from a telephone line.

One of these transmitters was called by Fessenden a trough transmitter. It consisted of a soapstone annulus to which were clamped two plates having platinum-iridium electrodes. Through a hole in the centre of one plate passed a rod attached at one end to a diaphragm, and at the other to a platinum-iridium spade. The two outside electrodes were water-jacketed. This form of transmitter required no adjusting, all that was necessary being to place about a teaspoonful of carbon granules in the centre space. It was able to carry as much as 15 amperes continuously without articulation falling off, and had the advantage that it never packed.

By a combination of the trough transmitter and a differential magnetic relay, Fessenden produced a transmitting relay for magnifying very feeble currents. An

amplification of fifteen times is possible without any loss of distinctness.

Fessenden is also responsible for a duplex system of wireless telephony, and the heterodyne method of reception is due to him. Fessenden has written largely on wireless subjects, and is one of the leading authorities on both transmission and reception. See Heterodyne; Microphone.

**FIBRE.** The name given to a variety of fibrous materials. As applied to wireless work the word is practically restricted to a hard vulcanized composition containing hemp, cotton cellulose, and raw hide, but chiefly paper chemically treated and compressed.

As an insulator it has some value, but is not so good as bakelite or ebonite, but can be employed advantageously for handles and knobs, and as bases for less important parts or those only subject to low-tension currents.

Fibre is obtainable in various colours, but is generally black or red. It is somewhat hygroscopic, and readily absorbs moisture, but does not disintegrate under the action. Fibre is liable to buckle in the thinner sheets when damp.

Fibre is readily obtainable in the form of sheets, rod, and tube, and is easily turned, drilled, and tapped. In general, it can be treated on the same lines as ebonite, but with the advantage that it is not so affected by heating as the latter.

Washers are speedily made from fibre by merely punching them out with a wadpunch, as shown in Fig. 1. The fibre is placed on the top of a post of wood, the punch held firmly on it and driven home with a sharp blow from a heavy hammer. The small central hole can be punched cleanly with a smaller but similar punch. These washers make effective insulating washers when placed under the heads of terminals, around the openings in a valve panel, and so forth.

Rectangular and other shaped pieces of fibre are cut from sheet with the aid of a strong and sharp penknife, guided by a steel rule or straight edge, as illustrated in Fig. 3; the fibre need not be entirely severed by the knife, as if it is cut about half-way through the sheet is speedily broken asunder by bending the fibre over sharply. Sheet fibre used as an electrical insulating medium can be applied to the surface of wood cases and panels with some advantage. It is best secured with small



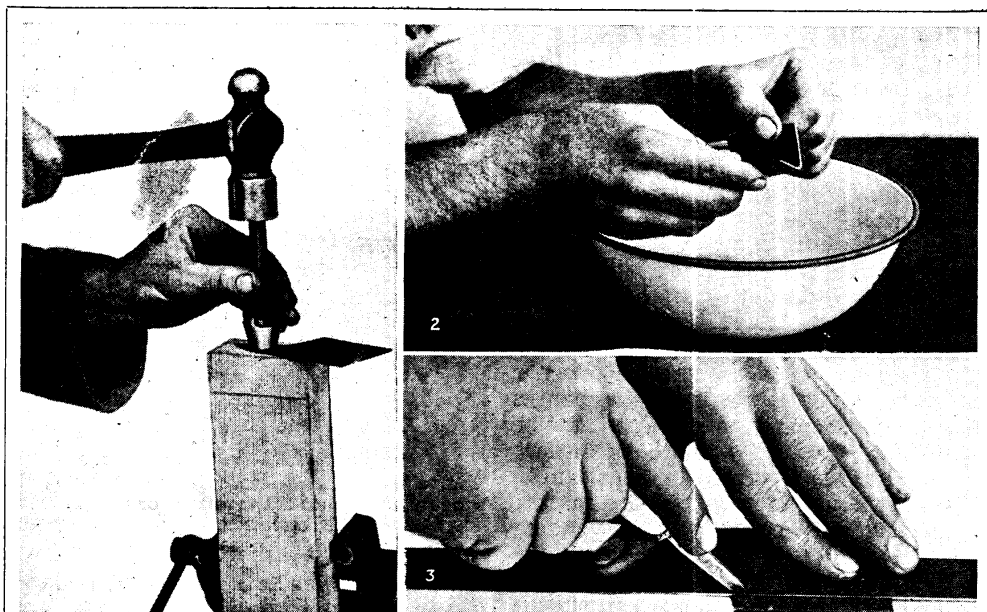

#### HOW TO CUT AND MAKE ANGLE PIECES IN FIBRE

Fig. 1. Fibre is a tough material with insulating properties which can be used for many purposes by the wireless amateur experimenter. It is not difficult to work. This photograph shows how a small fibre disk is cut with a wood punch. By using two wood punches of different gauge a fibre washer can be cut. Fig. 2. Boiling water is used to soften the strip, which is submerged for a few minutes. The strip which is to be bent can be placed over the edge of a rectangular block and pressed over with the fingers. It is then allowed to harden, precaution being taken to hold the material in the bent position. Fig. 3. Many instances occur in which small fibre strips are invaluable for insulation purposes, and the way to cut a fibre sheet is illustrated. The operator is pressing firmly upon a steel rule to guide the knife by which the fibre is cut half-way through. The strip is then broken off.

screws or pins, but if a glue is preferred, one composed of shellac and methylated spirit can be employed, but the underside of the fibre must be well roughened to afford sufficient grip.

One advantage of fibre is that it can be bent to simple shapes without difficulty if the piece to be bent is first immersed in boiling water and the bending accomplished while the fibre is still hot. The method is illustrated in Fig. 2, and shows a bowl of boiling water and a small piece of sheet fibre being bent to an angular shape, such as may be needed for the insulation of some part of a receiving set. Rod and stick fibre is turned in a lathe to curved or other forms, and all joints made by screwing or push fits, as there are no effective ways of sticking fibre securely with an adhesive.

Fibre has a natural dull polish, but this may be improved with the aid of very superfine polishing abrasives, such as rottenstone or fuller's earth applied with a little lubricating oil. See Ebonite.

**FIELD MAGNET.** Usually a core of soft iron surrounded by a winding of insulated wire. When a current of electricity is passed through the winding, a magnetic state is set up which results in a grouping of magnetic lines of force, generally known as a magnetic field. Alternatively, the term is used for a permanent magnet, used for the same purpose.

Field magnets are most extensively employed in the various types of machine used for the generation of currents of electricity, especially of the type where another but moving coil of wire is arranged to cut the lines of force in the magnetic field.

To set up such a magnetic field it is customary to employ two or more field magnets with opposite polarities, and spaced a distance apart, the whole so proportioned that the resulting magnetic field between the poles is of the required nature and value.

The cores of such field magnets may or may not form an integral part of the

machine, and are made both in the form of castings, and also from laminations of sheet iron according to the nature and purpose of the apparatus.

Field magnets made from permanent magnets are used on small machines of the magneto type, but do not yield such a high flux density as a separately excited field magnet.

The design of field magnets for dynamo and generator work is dealt with under the heading Generators (*q.v.*).

**FIELD REGULATOR.** A field regulator is a device for varying the strength of the field magnets in a dynamo or electric motor, by virtue of which certain changes in the performance of the machine may be conveniently brought about. Applied to a generator, any increase in the strength of the magnetic field in which the armature is rotating will cause a corresponding increase in its terminal voltage, assuming the speed to remain constant; consequently the field regulator forms a most convenient means of adjusting the exact terminal voltage, or indirectly the current delivered to the circuit, without having to alter the setting of the governors on the engine or varying the sizes of any pulleys on the shafting.

In the case of an electric motor, the field regulator is used to bring about speed changes without altering the terminal volts. If the field strength is weakened, the motor armature speeds up in order

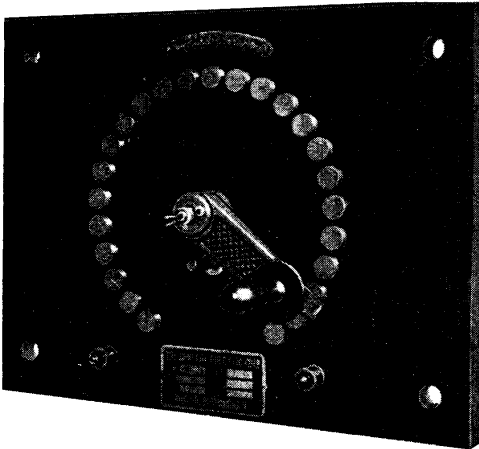

#### DYNAMO OR MOTOR FIELD REGULATOR

Fig. 1. Speed of a shunt-wound motor is regulated by this means. The studs are wired to a resistance coil, one end of which is connected to a terminal beneath the contact arm. The contact arm is wired to the other terminal. These two terminals are wired to the circuit in Fig. 2

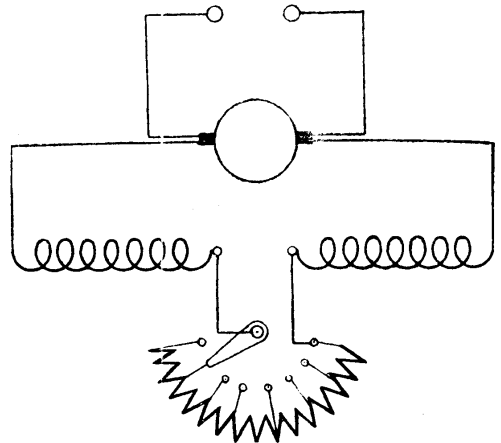

#### FIELD REGULATOR IN CIRCUIT

Fig. 2. Generator voltage is controlled by the employment of a field regulator or field rheostat inserted in the circuit as illustrated by this diagram

that it may generate the same counter-electro-motive force as before, and, conversely, if the field is strengthened, the speed of the motor falls because the counter-electro-motive force is now obtainable at a lower speed on account of the armature running in a stronger field.

The "field" of a generator or motor is, of course, due to the magnetizing effects of a number of turns of wire wound around the poles and carrying a current. The ampere-turn effect so obtained can only be varied by changing the value of the current flowing round the coils, since the number of turns constituting the exciting coils cannot, from the nature of things, be varied while the machine is in active service; neither can the resistance of the exciting coil itself be changed from within, since this is a function of the length and gauge of wire which is used in the coils.

The only method, therefore, of varying the ampere-turn effect is to include in the external circuit of the exciting coils an additional variable resistance, by which control of the actual current passing through them is obtainable either by hand operation or by automatic devices of some kind or another.

In a shunt-wound generator the terminal voltage depends upon the speed and the field strength for any given machine, and if, therefore, it is impracticable to alter the speed, the volts can be adjusted simply by manipulation of the field regulator, also known as a "voltage control," a "field

resistance," or a "field rheostat," which is shown in the form of a diagram (Fig. 2).

In their commercial shape field regulators take the form either of "stud" type resistances, in which a contact lever passes over a large number of contact studs on the face of a slate base, between which are connected resistance units suited to the work they have to perform (Fig. 1); or they may consist of a single endless coil of resistance wire wound spirally on an insulated supporting base, over which a sliding contact finger passes. This is the "sliding" type of resistance, and naturally gives much finer gradation, since the number of steps is increased to an almost infinite extent, as the slider passes from wire to wire, instead of from unit to unit in a more or less jerky manner. There is still another regulator used when exceptionally fine adjustment is required, in which a sliding contact traverses a spiral of resistance wire in the manner of a screw thread progressively from one end to the other; this is known as the "vernier" type regulator.

The field regulator is used with shunt-wound motors as a convenient means of regulating the speed within reasonable limits. Its position in the circuit is exactly the same as in Fig. 2. A motor is supplied, usually with a constant terminal voltage, and therefore the armature runs at a constant speed, subject to reasonable changes in load, all the while the field strength is constant. When the current supply is derived from the public mains it is, of course, impossible to change the terminal voltage to alter the speed of the motor, but it is perfectly practicable to alter the field strength by the insertion of such a field regulator as described; and in this way the armature may be caused to run faster as the field strength is diminished until a point is reached where sparking becomes injurious or the motor fails to develop sufficient torque.

From the wireless point of view, the chief use of field regulators is to provide a convenient means of regulating the charging rate of a dynamo used to recharge accumulators. When the dynamo is run up to a critical speed its electro-motive force balances the opposing electro-motive force of the accumulator. On increasing the dynamo speed the resulting slight increase in electro-motive force is sufficient to pass a considerable charging current, since once the back electro-motive force of

the cells is overcome the charging current is only limited by the extremely small internal resistance of the cells themselves and the connecting cables; hence the need for providing means for a sensitive and fine adjustment to the dynamic voltage. Further, as the charging proceeds the back electro-motive force of the accumulator is continually rising, calling for a proportionate increase in the charging voltage in order to maintain the same rate of charge; and still another effect that comes into operation is the heating up of the dynamo field coils themselves, which increases their own resistance slightly and weakens the exciting power they had when cold. All these changes can be met by adjustments to the field regulator, and, consequently, it is a very necessary part of the equipment.

Other devices have been brought out from time to time which eliminate to a greater or lesser extent the human element, some depending for their operation upon a contact lever passing over a graduated resistance controlled by a solenoid, the excitation of which is affected by changes in the generator voltage. Others depend upon a vibrating contact which short circuits field resistance for a greater or longer interval according to the conditions at the moment, the vibrations taking place at a sufficient rate to smooth out any noticeable irregularities and remove the lag due to time constants.

**FIELD RHEOSTAT.** The terms field rheostat, field regulator, or shunt regulator are all synonymous, meaning simply a variable resistance for the purpose of controlling the amount of current passing through the shunt exciting coils of a dynamo or motor. The method of connecting in circuit, and the principles upon which it operates, are explained in the article Field Regulator.

Since the field rheostat is connected in series with the field circuit, its carrying capacity in amperes must be proportioned to the maximum current flowing, and also its total resistance usually bears some definite relation to the resistance of the field coils whose excitation it is used to control. For small generators used for charging wireless accumulators it will be sufficient to provide from one-third to one-half the total ohms of the shunt field circuit in the field rheostat and to employ the same gauge of resistance wire throughout, the gauge being chosen to suit the

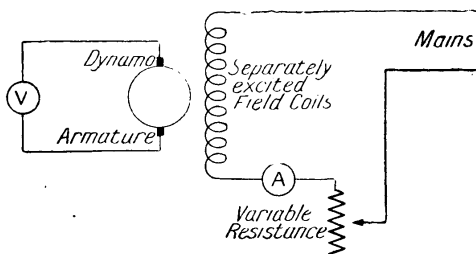

#### ARRANGEMENT OF A FIELD RHEOSTAT

Fig. 1. Readings are taken for a saturation curve by this method. The generator is run at a constant speed with the fields separately excited

maximum current ever carried by the field circuit with a temperature rise not exceeding  $100^{\circ}\text{C}$ . ( $212^{\circ}\text{F}$ .)

As a matter of fact, the current passing through the rheostat varies with every adjustment made; and it is never called upon to carry the maximum current the fields would take with the extra resistance "all out." And when all the additional resistance is included in the field circuit, the current drops to only a fraction of its maximum value. Consequently, the resistance wire need not be of so large a gauge in the last steps of the rheostat as in the first steps. A continuous tapering down of the gauges between successive contact studs, however, would entail too much complication; and, in practice, all working conditions can generally be met quite satisfactorily by adopting a two-to-one taper, that is, by making the first half of the resistance wire of such a gauge as to carry full shunt current with the specified temperature rise, and the second half of a smaller gauge that will give the same temperature on one half the full shunt current. This has the advantage of reducing the weight and cost of the wire employed, since the reduction of gauge naturally entails a reduction of length and weight and effects a saving in all ways.

The design of field rheostats can be carried out on more accurate lines if a saturation curve of the dynamo is first obtained. The method is to run the generator at a constant speed with the fields separately excited, as in Fig. 1, and modify the current passing through the field windings by means of a variable resistance, the values being noted by a low-reading ammeter for each successive reading. As the fields are excited to an increasing extent the open-circuit volts at the dynamo brushes are read off and tabulated against the associated field

current, and a curve is afterwards plotted, Fig. 2, with volts as ordinates and ampere turns as abscissae, the latter figures being arrived at by multiplying the actual number of turns in the whole of the field coils by the current passing through them for the time being.

With the aid of the saturation curve so obtained, it then becomes quite a simple

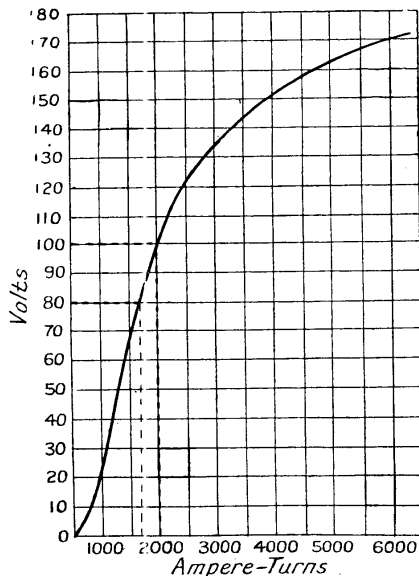

SATURATION CURVE OF A DYNAMO

Fig. 2. Field rheostats can be more accurately designed by first making a saturation curve. The curve above is given as an example

matter to design a field rheostat which will give any desired range of voltage regulation. For instance, let it be required to reduce the voltage of the dynamo from which the characteristic curve has been taken to the extent of 20 per cent. On referring to Fig. 2, the curve shows an open-circuit voltage of 100 with an excitation of 2,000 ampere turns. A reduction of 20 per cent in the voltage brings us to the point marked 80 on the curve of volts, and the corresponding point to this figure on the abscissae is 1,700 ampere turns.

A twenty per cent regulation, therefore, is effected by reducing the excitation from 2,000 ampere turns to 1,700 ampere turns, and assuming a constant terminal voltage of 100, and also, for sake of example, that the number of turns of wire in the field coils is 1,000, the current will need to be reduced from 2 amperes to 1.7 amperes. The resistance of the coils themselves may be taken as a constant value for purposes

of this calculation. Let the latter figure be 50 ohms, then, since  $R = \frac{E}{C}$ , and the re-

duced value of  $C$  is 1.7 amperes,  $R = \frac{100}{1.7} = 58.8$  ohms. The total resistance of fields and rheostat together is therefore 58.8 ohms, of which the coils alone account for 50 ohms, therefore the value of the added resistance in the field rheostat must be  $58.8 - 50 = 8.8$  ohms.—*A. H. Avery.*

See Filament Resistance; Resistance.

**FILAMENT.** Word used in several senses. In one application it refers to the thin wire or thread acting as the conductor in an incandescent lamp, which, by glowing brightly, acts as a source of light.

In the case of the thermionic valve the filament generally is a metal wire very thin and customarily made from tungsten. It may be considered as the cathode and the plate as the anode in the valve, as the filament is primarily required in this connexion as a means of supply of electrons. This is because certain materials when heated have the property of throwing off electrons.

Of the metals most suitable for the requirements of the filament of a wireless valve, tungsten is one of the foremost. Other metals are used for the same purpose in some valves, including thoriated tungsten, tantalum, and platinum coated with lime. The filament consists of a straight or looped length of wire fused into a glass supporting member within the valve, and connected to opposite terminals on the outer side of the valve base.

By generally accepted custom these terminals are located opposite each other, the terminals of the grid and anode wires are at right angles to the filament terminals and unequally spaced, whereas the filament terminals are equally spaced about the centre of the valve base, or cap.

Filament wire as produced at the Osram works may be as small in diameter as .015 mm., and is obtained by a chemical reduction method, as tungsten cannot be smelted in the same way as other metals. By the chemical process the tungsten is obtained in a powder form. This is compressed and heated, and is then in the form of a small ingot of brittle metal. It is then subjected to a current of electricity, which almost fuses the metal, thus turning it into a silvery-like metal bar, which is subsequently swaged or drawn at a definite heat and, after further treatment,

is drawn through dies of diminishing diameter until the desired size is obtained. An ingot originally measuring 20 cm. long and 7 cm. square can be drawn down to .015 mm diameter, and would measure some 20 miles in length.

In the process of manufacture the filament is sealed or welded to the supports within the valve body after the anode and grid have been placed in position. To ensure uniform filament length, and consequently filament voltage within close limits, the welding is done on a special spot welding machine, so arranged that the weld points are uniform for all valves of similar type.

To ensure a good and useful life from the filament there are several important processes in manufacture that have to be carefully studied and observed, particularly in connexion with the exhaustion of the gases.

The filament wires in the earlier valves, and also those still in extensive use, give off the electronic bombardment when heated by voltages in the neighbourhood of 4 to 6 volts, but the recent advances in the science of thermionic valve construction enable a greater electronic emission at a lower temperature to be given off from a thoriated tungsten wire, and this heat can be obtained from voltages as low as 1.8 to 1.0 or less. To ensure long life it is important that the thoria in the thoriated tungsten be brought to the surface of the filament when the latter is at a temperature too low to give off any appreciable tungsten emission.

As a practical matter, therefore, it is important never to subject a low-temperature valve to a higher voltage than that stated by the makers, as to do so will inevitably ruin the valve by reducing the electronic emission of the filament, and also reduce the effective life of the valve itself. This in the general type of valve, as used in amateur receiving sets, may be taken on a conservative basis as some 500 hours' burning. One of the greatest advantages of the low-temperature or dull emitter valves is the possibility of successfully using dry batteries as the source of electro-motive force.

These can now be obtained specially proportioned for this work, and consequently, if used in a normal way, there is little risk for the filament. When an accumulator is employed, on the other hand, there are the fluctuations of voltage

consequent on the recharging and discharging to be considered, and the customary way of judging the filament temperature by the brightness of the filament is a most unscientific and unreliable method. A better plan is to use a good voltmeter or other instrument, and be guided by the indications thereon.

Other useful precautions are to employ a reliable filament fuse and a filament rheostat or resistance of suitable proportions for the valve and voltages to be dealt with. See Anode; Grid.

**FILAMENT BATTERY.** Expression used to describe all types of batteries used for energizing the filament of a valve employed in receiving from another wireless apparatus. The size and nature of the battery will vary according to circumstances and the current required from it. In the case of high-efficiency valves such as the Weconomy, a single dry cell with a capacity of a little over one volt is sufficient. With dull emitter valves of the D.E.R. type two good-sized dry cells connected in series will supply sufficient current for many hours' working.

In some multi-valve sets a large dry battery may be employed with a voltage appropriate to the valves in use, but it will be necessary that the battery be fully large enough to supply sufficient current to keep the valves in operation at full power.

For power amplification purposes it is generally preferable to fit a storage battery or accumulator, the voltage of which should be appropriate to the valves in use, and may vary from single cell with

a capacity of two volts upwards, six volts being the usual limit. The size of these accumulators should be as large as space permits. They then provide a more steady supply of current, and do not need such frequent recharging.

Storage batteries and dry batteries for filament-lighting purposes are sometimes used to supply two or more different voltages to the same receiving set. For example, four volts may be needed with a particular valve used for the high-frequency amplification, while only two volts will be needed for the rectifying valve. Generally, when this is done, a separate tapping is taken from one of the terminals of a cell forming part of the battery, but this practice should be avoided, as it inevitably causes one of the cells to be discharged before the remainder, which makes recharging difficult, with the result that the accumulator is speedily rendered useless because one or two of the cells will fail owing to the augmented load. A better plan is to use entirely separate cells. See Accumulator.

**FILAMENT FUSE.** Specific title for all manner of low-value fuses applied to the filament circuits of wireless valves, as a means of protecting them from a sudden excess of current.

The purpose of a filament fuse is exactly the same as the fuses used in a house-lighting circuit; that is, to protect the filaments of the lamps from sudden rushes of current that would otherwise burn them out.

Valves employed in wireless work are expensive to purchase, and it is very prudent to use a small fuse in the filament circuit, as if the fusible material is of a sufficiently low melting point and properly proportioned, the excess of current will melt the metal before the current rises to a dangerous value through the filament of the valve, so protecting it from injury.

It is obviously necessary that the fuse be very reliable, and that the chosen value be appropriate to the valve in use at the time, especially as there are now so many different valves in use, with varying current consumption values. A typical and reliable pattern is illustrated in Fig. 1, and consists of an ebonite base with two upstanding metal pieces, one with a cup-like portion, the other with a spring-pressed cup at the end of a short spindle. Between these two is located the fuse in a small cartridge. As can be seen from

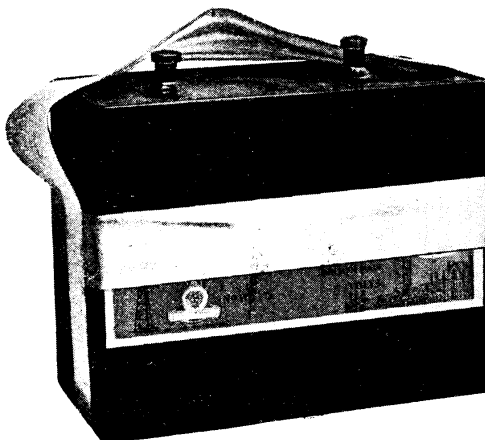

**FILAMENT-LIGHTING BATTERY**

Dry batteries for filament lighting are not necessarily of this size. This is a large size dry battery, and suitable for a power amplifier

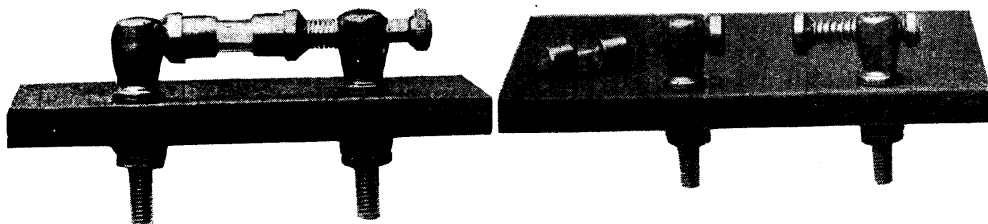

#### FILAMENT SAFETY FUSES AND HOW THEY ARE MOUNTED

Fig. 1 (left). Filament fuses are used to protect the filaments of valves from being burnt out by any sudden excess of current. The fuse can be mounted on the front or back of the panel in the manner illustrated. Fig. 2 (right). If too high a voltage is allowed to pass in the filament circuit, so causing the filament fuse to break down, a new fuse is quickly and easily replaced by pulling out the spring-gripping device, which is also the means of contact

*Courtesy Radio Communication Co., Ltd.*

Fig. 2, this can be removed or changed at will by drawing back the spring-pressed plunger and releasing the fuse element. The fuse is located in the positive side of the filament circuit by connecting the wires to the terminals of the fuse, the circuit being completed through the fuse itself.

**FILAMENT RESISTANCE.** Resistance interposed in the filament-lighting circuit for the purpose of controlling and regulating the voltage provided for the filament-lighting battery. In the general use of the words, a filament resistance is a small variable resistance instrument, but the expression may be applied to any suitable resistance. The resistance element is usually a coil of resistance wire, and examples are made in which the composition material is used as the resistance element. Other resistance-controlling methods adopted in a filament circuit include the barretter.

To vary the value of the resistance it is customary to provide an adjustable contact arm, which can be traversed along the length of the coil of the resistance wire. One end of the coil is connected to one side of the circuit—for example, the positive terminal of the filament-lighting battery—the other end of the coil of wire being free.

The function of the contact arm is to pick up the current after it has passed through the desired amount of resistance wire and convey it to the filament of the valve. There are many patterns of filament resistance on the market, of which some are illustrated.

Fig. 1 shows a very simple pattern, suitable for panel mounting. This comprises a circular disk or former of ebonite about  $\frac{1}{4}$  in. thick and  $1\frac{3}{4}$  in. diameter, bushed in the centre with a brass bush which supports a short spindle, one end fitted to the contact arm and the other with a knurled

ebonite knob. A coil of resistance wire encircles about  $300^\circ$  of the former, one end being fixed to the former by a small screw, and the other fitted with nuts and a stud for attachment to the connecting wire.

A somewhat similar attachment is shown in Fig. 2, and is made by the Fuller United Electric Co. This comprises a rectangular-sectioned coil of resistance wire and a neat, strong, brass contact arm rotatable by means of an external ebonite knob. Two terminals are fitted for contact purposes. The Igranic pattern filament resistance illustrated in Fig. 3 is on a different system, and comprises a U-shaped bracket or support which can be attached to the back of the panel or in any convenient position. In this case a circular former is firmly mounted on a spindle which, when rotated by means of an external ebonite knob, rotates the coil of resistance wire. Contact is effected by means of an insulated flat strip metal contact arm, which bears lightly on the periphery of the resistance wire. Thus a particularly smooth and easy movement of control is obtained, with a strong and robust construction.

Fig. 4 illustrates another example of a filament resistance, comprising a circular ebonite base, which carries a movable spindle and short contact arm, which wipes over the edge of a narrow, flattened coil of resistance wire. Connexions are then made through connecting strips provided with screws for attachment to the wires. To ensure the most perfect adjustment for the filament voltage, several different patterns of resistance giving delicate control are manufactured, a typical example being that illustrated in Fig. 5.

In this case the main resistance follows the general lines already mentioned, with the addition of a small central spindle



passed through the main spindle terminating at the outer end with a small knob, and on the inner end with an ebonite disk, upon which is mounted a single turn of resistance wire. This makes contact with a second contact arm, and adjustment of each is provided by rotation of a small knob. In use, rough adjustments are obtained by turning the large knob, and the final delicacy of adjustment is obtained by turning the small knob.

This class of resistance is of great value in multi-stage amplifying circuits, especially regenerative and dual-amplification circuits. A continuously variable resistance combination is shown in Fig. 6, mounted on the back of an ebonite panel. In this class the resistance wire is coiled round a drum, which can be rotated by an external knob. A strong brass contact piece is forced into engagement with the coil of resistance wire, and the pad piece has screw threads formed upon it corresponding to the pitch of the resistance wire, which may virtually be considered as a very fine screw thread. Consequently, when the knob is rotated the contact arm is screwed along, thereby giving more delicacy of adjustment, and an absolutely continuous variation of resistance from a minimum to a maximum.

#### Combined Switch and Resistance

Contained within an ebonite casing on the inner end of the resistance framework is a simple switch, which is actuated by pulling a knob bodily in or out, thereby making or breaking contact as desired. This forms a single pole switch, and consequently this resistance combines two functions, that of a switch and that of a normal resistance. The arrangement of parts is such that the state of the resistance is not affected when the knob is pulled in or out, since as it rotates, the drum and the moving contact arm slide in unison, any variation of the resistance value being obtained only by rotation of the knob.

The ordinary type of filament resistance should have a resistance of 5 ohms, but when a low voltage or dull emitter valve is used it is then necessary to have a somewhat higher resistance, of the order of 7 to 8 ohms, especially when the set is converted for use with Weconomy valves, or others of particularly low voltage, the current supply for which may have to be taken from a 2 volt accumulator or

dry cell. In general it is preferable to use independent resistances for each valve.

In some circuits one resistance controls two or more valves, and when this is the case the resistance value should be increased proportionally.

The circular type of resistance already illustrated is usually the most adaptable for amateur receiving sets, but there is no reason why a straight pattern with a slider should not be used. They are far more serviceable when mounted upon a baseboard or on the outside of a panel, as there is otherwise the necessity, with many patterns, to provide a long slot through the panel to allow the slider knob to be moved backwards and forwards.

#### Special Points in Resistance Design

In a form of resistance made by the Marconi Scientific Electric Co. a rectangular resistance coil is employed, and contact is effected by rotating a long rod carrying a helical-shaped contact bar, which is virtually a screw thread with a very long pitch. The actuating knob may then protrude from the panel front, and is rotated in a similar manner to the circular pattern of resistance.

The means of insulation of filament resistances should be of good quality, and when any appreciable current is to be handled by them, they may be prevented from overheating by interposing asbestos or other heat-resisting material between the resistance and the back of the panel, especially if there is any chance of the filament heating. Alternatively, the resistance coil can be mounted on porcelain or china extended between two insulated posts, or in any other convenient manner which provides the maximum of insulation, both electrically and thermally.

Points to note when purchasing any resistance are that the value of the resistance is appropriate to the purpose, that the contact arm moves smoothly over the resistance coil, and without setting up any suspicion of noise or jerkiness, as this will become much more apparent when the resistance is put into use in the set. Any jerkiness of movement will cause microphonic noises in the valve, and also make it difficult to effect a fine adjustment.

The former ought to be of good quality ebonite or other efficient insulating material, and all connexions well made, and the terminals be of adequate size, and preferably fitted with soldering tags.

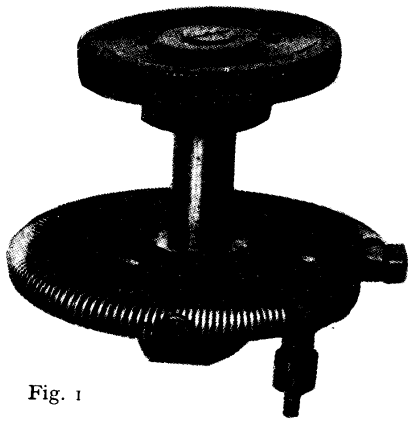

Fig. 1

Fig. 2 (a)

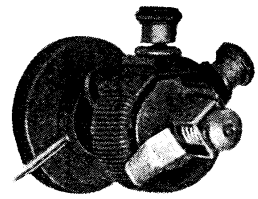

Fig. 2 (b)

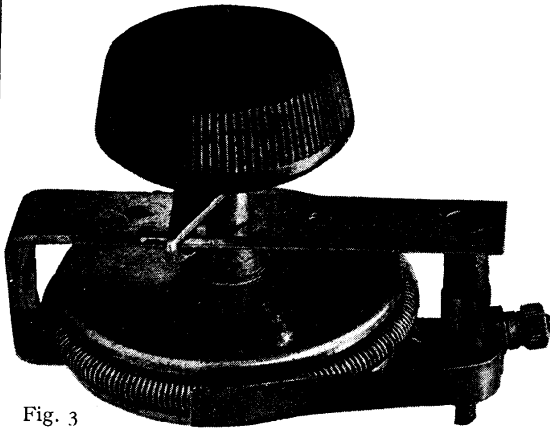
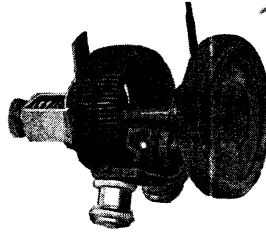

Fig. 3

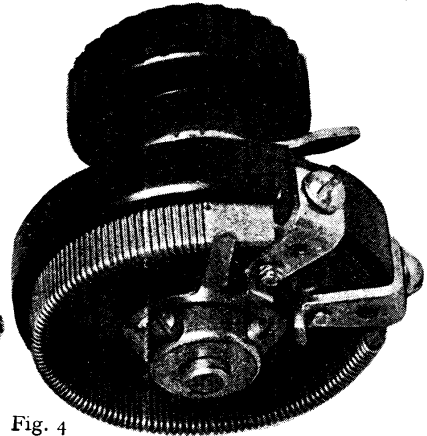

Fig. 4

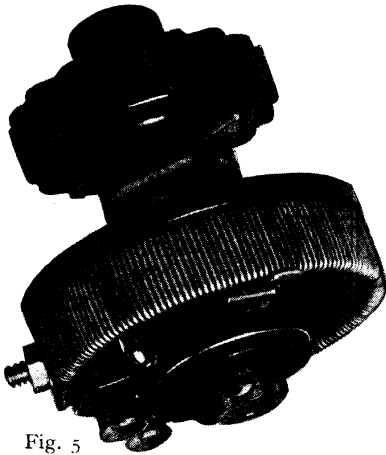

Fig. 5

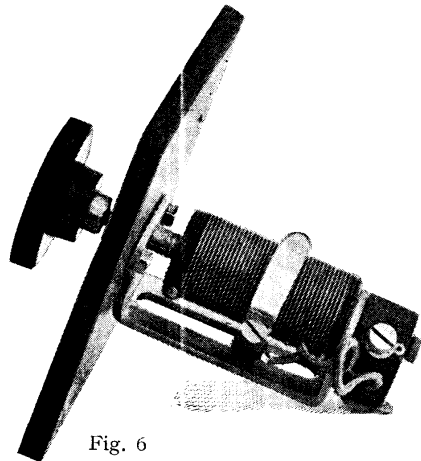

Fig. 6

Fig. 1. Standard pattern filament resistances of this type are suitable for panel mounting. Fig. 2 (a and b). Front and back views of a rheostat made by the Fuller United Electric Co., showing rectangular section coil. Fig. 3. Another type of filament resistance for panel mounting, made by Igranic Electric Co., Ltd. In this case the coil is rotated and the contact arms remain stationary. Fig. 4. Connexions are made in this case by connecting strips. Fig. 5. Vernier adjustment can be made with this rheostat, which has a single wire on the lower ebonite disk. Coarse adjustment is made in the usual way. Fig. 6. This rheostat is continuously variable. The contact arm moves along the wire instead of across it

SIMPLE BUT EFFECTIVE TYPES OF VARIABLE FILAMENT RESISTANCES

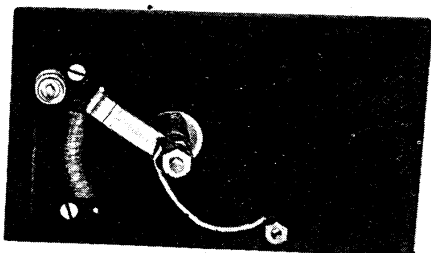

Fig. 7. Details of the back of the panel of an easily made rheostat, showing contact arm

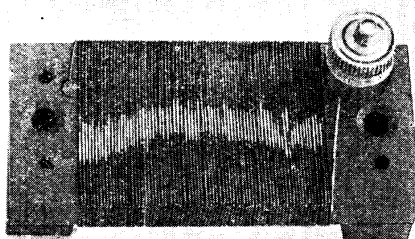

Fig. 8. Resistance wire is wound on a former with a flat surface and connected to a terminal

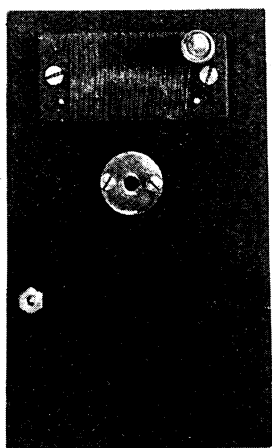

Fig. 9. Components of the contact arm are shown disassembled, also a view of the back of the panel. Fig. 10 (inset). The turning knob and contact arm are seen assembled

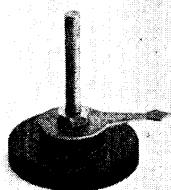
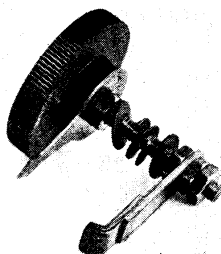

Fig. 11. Front of the panel. The terminal on the right connects the switch arm

EXPERIMENTER'S HOME-MADE FILAMENT RESISTANCE

The coil should taper at the starting end to act as a cut-off.

The experimenter is sometimes in need of a special type or value resistance, and one method by which such a resistance can be made is illustrated in Figs. 7 to 11. This type is intended for back of panel mounting, and the arrangement of the parts as seen from the back is illustrated in Fig. 7. The intention in this case is to subsequently fit a valve holder to the square space on the ebonite panel and make it into a self-contained unit.

The principle adopted is that of a rectangular-sectioned coil with a simple contact arm movable across it by rotation

of the control knob. The first step is to determine the required resistance value in ohms, and select a length of Eureka (*q.v.*) or other resistance wire that will give this value. The length of the resistance wire is the chief factor in determining the length and breadth of the former whereon to wind the wire, but as this is rectangular the dimensions are readily calculated by measuring the total distance around the former, and dividing the required length of resistance wire by this amount. The answer is the number of turns that must be taken to wind the wire on to the former.

The length required for this will depend on the gauge or thickness of the wire.

These particulars, as well as the length of wire required for a given resistance with any particular gauge of wire, will be found in any table of resistance wire values. It should be noted that the resistance of a thin wire will be greater for a given length than a thicker wire, consequently a choice of thicknesses is possible. The finest adjustments are found when the resistance is longest, consequently it is preferable to have as long a coil as reasonably possible, as the range is thereby increased.

When the length of the resistance coil is known, an extra amount must be allowed for the former to permit it being fitted in place, and for this purpose an amount of  $\frac{3}{8}$  in. at each end will suffice. In the example illustrated the resistance value is approximately 8 ohms. The former is made from ebonite, and measures 1 in. in width and  $2\frac{1}{4}$  in. long, and is illustrated in Fig. 8.

One end of the coil is secured to the former by inserting it into a hole therein and stopping it with insulating compound, the other end terminates at the small terminal which is screwed to the former. Two small strips of ebonite are fixed to the underside of the former and secured with two small screws, as shown in Fig. 9. The bushing for the spindle is shown in position, and the remaining components detached. The bush is an ordinary pattern with a flange and secured to the panel with two small brass screws tapped into it.

The contact arm, shown separately in Fig. 10, is a standard arrangement as described in detail under the heading Contact Arm (*q.v.*).

The spindle may be a length of screwed rod, one end equipped with a knob and pointer, the other with a laminated contact blade, perfect contact being maintained by the spring washers which are located between the pointer and the face of the panel.

The exterior appearance is shown in Fig. 11, and consists merely of a knob and pointer and a terminal for the connexion wire. If preferred, either or both terminals can be fitted to the back or to the front of the panel, as may be most convenient.—*E. W. Hobbs.*

. See Resistance; Rheostat.

**FILES AND FILING.** A file is a hand tool used to remove the surface from metals and other hard materials. It is virtually a series of saw-shaped teeth cut

on the surface of a strip of metal. All the points of the teeth face in one direction, towards the end of the file opposite to the handle. The teeth vary in their depth and spacing, and this determines the relative roughness of the cut, as it is called.

All files are made in several different cuts, somewhat differently designed by various makers, but for amateur and experimenters' purposes the fine, or smooth, files are sufficiently fine in the cut for all ordinary smooth filing. A second or middle-cut file for the intermediate work, and a rough-cut file for the preliminary roughing down of the work, are also wanted. Files are further described by their shape and length.

Several types are illustrated and named in Fig. 1, and may be taken as a useful selection for a beginner, but it is desirable to have some of the principal files in several sizes and cuts. A selection should include 6 in., 8 in., and 10 in. hand flat files in all three cuts; one or two half-round files in 8 in. and 10 in.; half a dozen assorted 6 in. square, round, and three-square, or triangular-shaped, files; and one or two knife files, warding files, and pillar files. The names sufficiently describe most of these files, but a hand flat is a flat file with parallel sides and one safe edge.

This means that one edge is smooth, and does not have teeth cut on it, but the other side is cut with single teeth. The broad faces of most files are cut with two sets of teeth inclined at an angle to each other to make the file cut more freely. A knife file is tapered in cross section, and used for opening slots and such work. Warding files are thin flat files used for cutting narrow slots. Pillar files are simply narrow hand flat files, but are very useful in wireless work owing to their narrow form. A riffer file is curved, and used chiefly for filing the curved forms sometimes met with in the construction of variometers in ebonite and other materials. They are also invaluable when filing into a curved and hollowed part of the work.

Handles can be of any shape that suits the worker's hand. Essentials are that the handles be very securely attached to the shank by heating the tang of the file and forcing it into the handle, and completing the fixing by standing the file

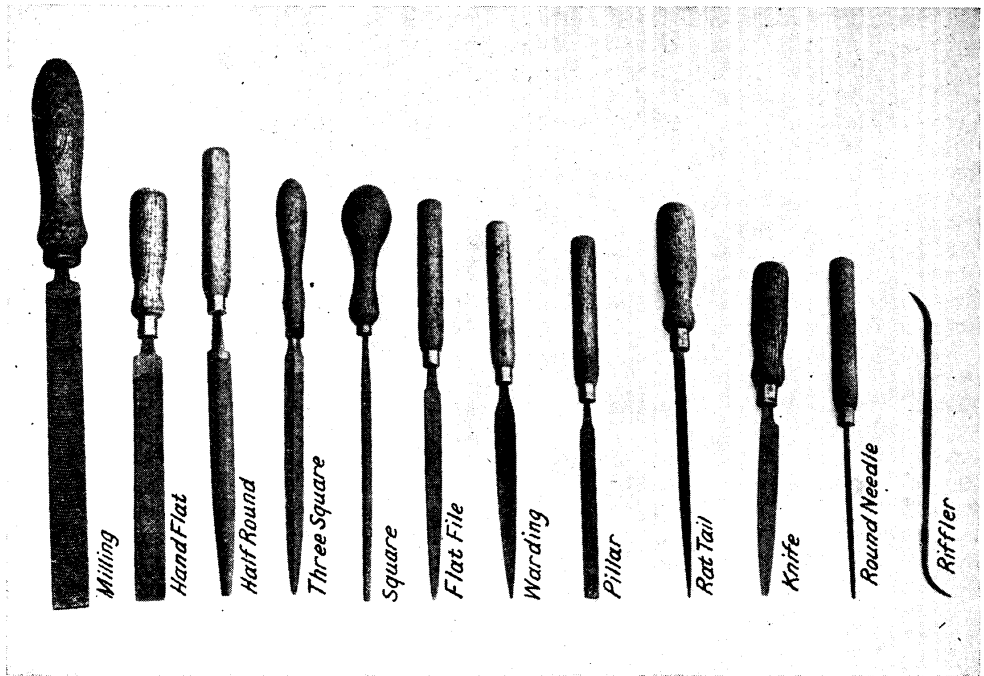

#### SUITABLE FILES FOR AMATEUR WIRELESS WORK

Fig. 1. Every amateur wireless worker uses files of different types in the course of constructing cabinets, components, and sets. This list will be found useful for reference by non-professional users who may not know the various files by name or by sight

point downwards on the bench and driving the file handle down with a hammer or mallet. The better plan with a file is to hold the handle in the right hand with the file pointing upwards, and strike the handle on the bench, this forcing the file down into the handle without risk of breaking the file.

All work to be filed should be held securely in a vice, and for comfort the top of the vice should be on a level with the worker's elbow when standing erect. The actual filing operations are similar whatever the material to be filed, but in these notes it is assumed that work is being carried out on mild steel.

The correct position for filing is found by the worker standing in front of the bench, taking a half pace backwards with the right foot, and a half pace forwards with the left foot, thus bringing the body about 45 degrees to the bench edge. The vice should be to the right of the body for normal work. The file is then gripped in the right hand, by the handle, with the thumb on the top of the handle, as shown in Fig. 2, and the left hand should grip the point of the file. The face of the file should be flat on the surface of the work.

The point of the file is gripped in the palm of the left hand and held there by the finger tips also, as shown in Fig. 2. The next point to observe is that a file only cuts on the forward stroke, that is, when it is pushed away from the body. Consequently, commencing from the inner side of the work, that nearest the worker, the file has to be pressed into contact with the work and pushed over it with sufficient force to cut off a series of chips.

On the return stroke the file should be very slightly raised above the surface of the work, so that it glides over it and does not rub perceptibly. It is important not to rub the file backwards and forwards over the work, as this will only make the worker tired. Further, it blunts the file at a rapid rate.

The third step in filing correctly is to keep the face of the file flat and to move it in a flat plane. Try and imagine that the file glides in an invisible groove, and that the bottom of the groove is quite level and straight. This will help to acquire the correct knack in filing flat. The path of the file should be in a straight line, except in certain cases as illustrated later.

BACK NUMBERS OF ALL PARTS ARE STILL ON SALE

## HARMSWORTH'S WIRELESS ENCYCLOPEDIA

### Contents of Part 11

Among the extraordinarily varied contents of Part 11, with its 76 articles on practice, theory and construction in wireless work, illustrated with 190 new "action" photos and diagrams, will be

"How-to-Make" articles on:

#### Forging for Amateurs

Easy methods described and illustrated with 10 photographs showing the amateur how he can make his own small forgings for aerial and other fittings without heavy apparatus

#### Four-Valve Set

One of the series of special receiving sets described throughout the ENCYCLOPEDIA. This is a unit set, graphically illustrated with 17 "action" photos and diagrams

#### Frame Aerials & How to Make Them

This type of aerial is becoming of increasing importance in wireless reception. Here its principles are clearly demonstrated, the best varieties are illustrated, and full instructions given for making them. 18 photographs and diagrams

#### Frame Aerial Receiving Set

This is a splendid self-contained set with no external connexions. It is portable, and will work a loud speaker up to 200 miles. Illustrated with a photogravure plate, 27 new photographs and diagrams

#### Gauges for All Purposes

In many branches of wireless constructional work exactitude in dimensioning is essential. Here the careful experimenter is told what gauges are required for every kind of work, and shown graphically how to use them by "how-to-do-it" photos

Part 11 will also contain a large number of sections dealing in simple but precise manner with wireless theory. Among these articles will be

#### THE FLEMING VALVE

By Professor J. A. Fleming, F.R.S., D.Sc.

The original thermionic valve and its uses described by its inventor, one of the great British pioneers in wireless work

#### FORCE, FOSTER BRIDGE and FREE OSCILLATIONS

By Sir Oliver Lodge, F.R.S., D.Sc.

Three of the graphically written articles on electrical theory connected with wireless communications for which our Consultative Editor is so well known. Here matters which in other hands might be abstruse and difficult of comprehension are made clear to every amateur

## SPECIAL BINDING OFFER

By the Publishers

The Publishers of the WIRELESS ENCYCLOPEDIA are prepared to undertake the actual work of binding the loose parts into volume form for those subscribers who are unable to get this done to their satisfaction locally

Conditions which must be observed:

Only fortnightly parts in good condition—free from stains, tears, or other detachments—can be accepted.

The parts to be bound must be packed securely in a parcel (eight parts constituting a volume), containing the name and postal address of the sender clearly written, and posted direct to the publishers' binding department, or handed to a newsagent, the subscriber being liable for the cost of carriage in both cases.

If the parcel is sent direct to the publishers the cheque or postal order in payment for binding-cases and actual work of binding should be enclosed in a separate envelope, together with a note mentioning how many parts have been dispatched and what style of binding is desired. The cheque or postal order should be sufficient to cover the full amount of the binding charges in respect of the actual number of parts sent in ONLY.

The name and address of sender should be given in the letter as well as in the parcel, and the letter containing cheque or postal order must not be put in the parcel: post it separately.

#### THE STYLE

To bind eight parts in the publishers' *Dark Blue Cloth* binding-case, with full gilt back, top edges of the leaves "sprinkled," the inclusive charge will be 5/6 (2/- for the binding-case and 3/6 for the actual binding and cost of packing and return carriage)

All cheques or postal orders must be made payable to The Amalgamated Press (1922) Ltd., and crossed "Bank of England Law Courts Branch."

Address all letters and parcels to—

WIRELESS ENCYCLOPEDIA Binding Dept.,  
The Amalgamated Press (1922) Ltd.,  
Bear Alley,  
Farringdon Street,  
London, E.C. 4.

Terms for the Trade on application to the above address.

SOUTH AFRICAN readers should apply to: Central News Agency, Ltd., JOHANNESBURG (or branches)

AUSTRALASIAN readers to: Messrs. Gordon & Goch, Ltd., MELBOURNE (or branches).

CANADIAN readers to: The Imperial News Co., Ltd., TORONTO (or branches)

PART 11 ON SALE EVERYWHERE TUESDAY, MARCH 25



**BIND VOLUME 1 NOW**  
 and use the Publisher's Special  
**BINDING CASES**

**BLUE CLOTH**  
 (As Illustrated)

**2/-**

(Plus 6d. extra postage in British Isles)

This binding case (the only authentic binding for the "WIRELESS ENCYCLOPEDIA") is very handsome and extremely durable. You can safely keep it in your workshop, for it has been made to withstand hard usage. Have your parts of "WIRELESS ENCYCLOPEDIA" bound up now and keep the volume by you for reference. You can obtain the binding case through any newsagent or bookseller. If ordered direct from the publishers 6d. extra must be enclosed to cover cost of postage and packing. All prices mentioned apply to Great Britain only.

See overleaf for Particulars of the  
 Publisher's Special Binding Scheme

