

ONLY £2.50

www.hi-fiworld.co.uk

hi-fi

APRIL 2001

£2.50

WORLD

& computer audio

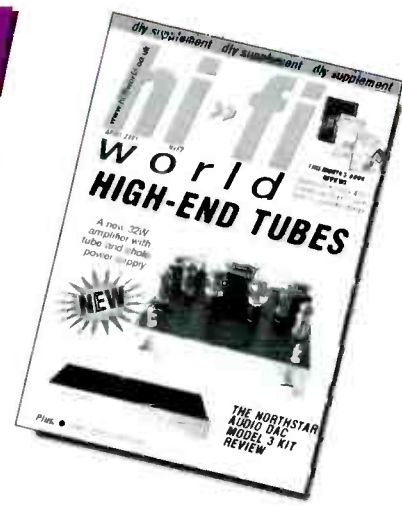

SHARP LOOKING

Sharp's 1-bit digital amplifier and SACD/CD player.

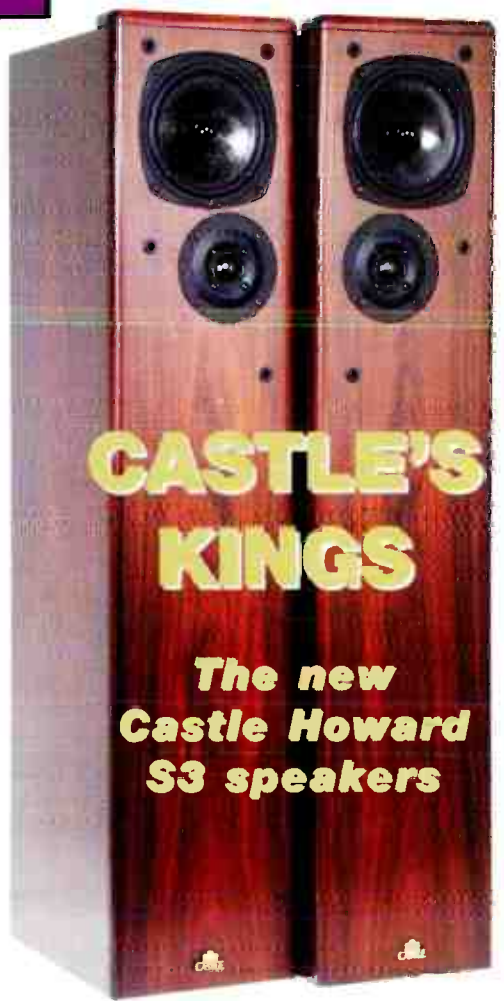

CASTLE'S KINGS

The new Castle Howard S3 speakers

plus

- New Naim CDS CD player
- Linn Katan bookshelf speakers
- Arcam A85 integrated amp
- Sony CDP-XBT40E CD player
- Chario Cygnus speakers
- Uison Research S6 valve amp
- Feature: The Return of Vinyl?

Computer Audio World

- Meridian M8000 USB One
- Media200
- Klipsch ProSound 2.1 speakers
- Philips Auro 5A 120

COMPETITION win a Linn Klassik system & Katan speakers

+ 100s of classified ads full of secondhand bargains!!!

APRIL 2001

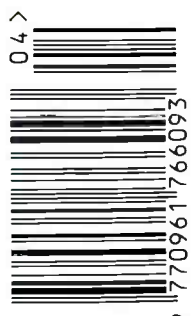

9 1770961766093

marantz®



Marantz combines the CD-17 CD player, the ST-17 tuner and the PM-17 amplifier to create something really special. All products have a solid metal casing and use state-of-the-art technology. Hi-Fi sound with no compromises.

The Premium Series by Marantz is available exclusively at the following premium dealers:

Aylesbury, Northwood Audio 01296 428790. Bath, Moss of Bath 01225 331441. Paul Green Hi Fi Ltd 01225 316197. Beckenham, Musical Images Ltd 020 86633777. Birmingham, Music Matters Ltd 0121 4292811. Bolton, Empire Electro (Cleartone) Centre Ltd 01204 531423. Sound & Vision 01204 861861. Bradford, Empire Electro (Cleartone) Centre Ltd 01274 575000. Brentwood, Audio T 01277 261730. Bloxwich, Sound Academy 01922 473499. Camberley, Trufi (Camberley) Ltd 01276 686414. Cambridge, Systems 01223 461518. The Audiofile (Cambridge) Ltd 01223 368305. Canterbury, Canterbury Hi Fi Centre 01227 765315. Cardiff, Sevenoaks Hi Fi Centre 029 20472899. Carlisle, Peter Tyson Hi Fi Centre 01228 46756. Coventry, Frank Harvey Hi Fi Excellence 024 76222622. Derby, Superfi 01332 360303. Edgeware, Musical Images Ltd 020 89525535. Edinburgh, Hi Fi Corner 0131 5567901. Enfield, Audio T Ltd 020 83673132. Gateshead, Lintone Audio 0191 4774167. Glasgow, Loud & Clear Ltd 0141 2210221. Grimsby, Manders Hi Fi Ltd 01472 351391. Harrow, Harrow Audio 020 88630938. Hounslow, Musical Images Ltd 020 85695802. Huddersfield, Huddersfield Hi Fi Centre 01484 544668. Ipswich, Sevenoaks Hi Fi Centre 01473 286977. Jersey, Sound Engineering 01534 21735. Kings Lynn, Martins Hi Fi 01553 761683. Leeds, Superfi 0113 249075. Leicester, Leicester Hi Fi Ltd 0116 2539753. London Central, Musical Images Ltd 020 74971346. Sevenoaks Hi Fi Centre 020 78377540. Hi Fi Experience Plc 020 75803535. Spatial Audio & Video 020 76378702. London North, Superfi 020 74881300. Bartlets Hi Fi 020 76072296. London South, Nicholls Hi Fi 020 88525780. Hi Fi Confidential Ltd 020 72337225. Francis of Sireatham 020 87690466. Manchester, Practical Hi Fi Ltd 0161 8398869. Superfi 0161 8351156. New Malden, Grandix Sound & Vision 020 83360012. Unilet Sound & Vision 020 894 29567. Newbury, B&B Hi Fi 01635 32474. Newcastle Upon Tyne, Global Hi Fi Centre Ltd 0191 2303600. JG Windows Limited 0191 232 1356. Norwich, Martins Hi Fi 01603 627010. Nottingham, Superfi 0115 9412137. Oxford, Oxford Audio Consultants Ltd 01865 790879. Parkstone, Movement Audio 01202 380018. Plymouth, Sevenoaks Hi Fi Centre 01752 226014. Portsmouth, Now That's Hi Fi 023 928 11230. Preston, Practical Hi Fi Ltd 01772 883958. Ramsey, Island Compact Disc Centre 01624 815521. Reading, B&B Hi Fi 01734 507134. Redhill, TruFi 01737 766128. Sevenoaks, Sevenoaks Hi Fi Centre 01732 459555. Sheffield, Moorgate Acoustics Ltd 0114 2756048. Shrewsbury, Shropshire Hi Fi 01753 252065. Slough, Frasers Hi Fi Video 01753 520214. St Leonards on Sea, Adams & Jarrett (Retail) Ltd 01424 337165. St Neots, Audio Vision 01480 471115. Stratford upon Avon, Stratford Hi Fi Ltd 01789 414533. Swansea, Audio Excellence 01792 474608. Tunbridge Wells, Sounds of Music Ltd 01892 539595. Home Media 01892 525666. Watford, Sevenoaks Hi Fi Centre 01923 212736. Witham, Sevenoaks Hi Fi 01376 501733. Woking, Bartlets Hi Fi 01483 771175. Worthing, Phase 3 Hi Fi 01903 245577. Wrexham, Clwyd, Aston Gate Audio 01978 364500. York, Vickers HiFi 01904 629659. Also at selected branches of John Lewis Plc.

The ultimate combination

Telephone: 01753 680868 Internet: www.marantz.com

Browsing through the day's newspapers before my Sunday lunchtime snooze, I came across something that woke me from my slumbers like forceful slap around the chops. Vinyl is back with a vengeance, apparently. With sales of vinyl albums up a staggering 41% in the year 2000 compared to the previous year, it looks extremely promising, especially when CD album sales were up a 'mere' 15%. Okay, so the total sales figures are slightly different but it's still heartening to us record players. And, according to the same source a predicted 70% of the British public have turntables, so eat your words big Japanese corporate types who predicted vinyl's demise!

Of course, since the dance boom of the early nineties, sales of vinyl have always been guaranteed. This must be much to the chagrin of most consumer electronics companies, apart from Technics of course which has a popular little model called the SL-1200 out there in clubland. Apparently though, it's not just dance music that's creating the growth.

In the audiophile world, many enthusiasts soon tired of CD's nasties and ran crying back to their tonearms and turntables, guilty of a wayward dalliance. Now it seems the same is true of the public in general, and I for one can second this observation. Friends and acquaintances who dumped their turntables for something more domestically pleasing now plead for a Sunday lunch invitation, to which they'll arrive laden with dusty LPs recovered from the loft. It's an afternoon with the GyroDec they're after, rather than my food and company, not that I was under any misapprehensions in the first place! It may appear that I'm teaching granny to suck eggs but the advantages of vinyl over CD are numerous. Not least in the bass, and those in the dance music business realise this. I have a selection of various drum 'n' bass 12" 'singles' which question the structural security of my house on a regular basis. DJs won't touch anything with more than one track per side with a barge pole, so LPs become collections of 12" singles. A whole 'side' is available for one track and the result is high level cut with

enormous groove excursions, often giving awesome sound quality.

The new high resolution formats are sold on the premise that they'll bring a new dimension to audio; the idea being that you'll be brought closer to live music and therefore glean more emotion from it. I disagree. I've experienced excellent performances from both two channel SACD and DVD-A, but neither conveys a sense of 'being there' more than the old Decca analogue late 50s and 60s recordings. They have a sense of a live performance with minimum takes, and include such accidental luxuries as stage shuffles, subsonic rumbles of passing lorries and even 'off-stage' birdsong! More and more classical music fans are discovering through these vinyl recordings that the old ones are superior.

Never underestimate the power that the film industry has on the masses - it also appears the Big Screen is helping to enhance vinyl's lure to the movie watchers. Both 'High Fidelity', adapted from Nick Hornby's novel of a music obsessed record collector and the new Tomb Raider film in which the delightful Angelina Jolie possesses a Clearaudio Master Reference turntable, are helping to bring back vinyl. Just think, when these titles are available on DVD thousands will be exposed to turntables and records. It could even lead to the masses dumping their DVDs for Project Debuts or LPI2s. Okay, maybe that's one step too far, but who said home cinema doesn't have its place? ■



Simon Pope

HI-FI WORLD

SUITE G4, IMEX HOUSE
KILBURN PARK ROAD
LONDON, NW6 5LF

www.hi-fiworld.co.uk

Contact Numbers
Mon-Fri 9am - 5pm

General Editor
Simon Pope
tel/fax +44 (020) 8786 8141
e-mail: editorial@hi-fiworld.co.uk

Computer Audio World Editor
David Price
e-mail: editorial@computeraudio.co.uk

Graphic/Advertising Designer
Faiza Chunara
tel: +44 (020) 7625 3129
fax: +44 (020) 7328 1844
e-mail: adproduction@hi-fiworld.co.uk

Production/Photography Editor
David Noble
tel: +44 (020) 7625 3134
fax: +44 (020) 7328 1844
e-mail: classifieds@hi-fiworld.co.uk

Advertising & Marketing Manager
Amanda Sweeney
tel/fax +44 (020) 8864 4760
e-mail: advertising@hi-fiworld.co.uk

Accounts
Michael Ogazi
tel: +44 (020) 7625 8032
fax: +44 (020) 7328 1844

Credit Control
Louise Palfrey
tel: +44 (0) 1923 270833
fax: +44 (0) 1923 260588
e-mail: subscriptions@hi-fiworld.co.uk

WORLD AUDIO DESIGN
Technical Manager - Nick Lucas
www.worldaudiodesign.co.uk
tel/fax: +44 (0) 1908 218 836
e-mail: nick@worldaudiodesign.co.uk

Publisher
Noel Keywood
e-mail: publisher@hi-fiworld.co.uk

Private & Trade Classified Ads
tel: +44 (020) 7625 3134
fax: +44 (020) 7328 1844
e-mail: classifieds@hi-fiworld.co.uk

Subscriptions & Back Issues
9:30am - 12:00 noon
tel: +44 (0) 1923 270833
fax: +44 (0) 1923 260 588
e-mail: subscriptions@hi-fiworld.co.uk

Distributed by
Comag Magazine Marketing,
Tavisstock Road, West Drayton,
Middlesex UB7 7QE
Tel: +44 (0) 1895 444 055

Printed by
Southern Print, Dorset
Tel: +44 (0) 1202 622 226

All unsolicited submissions and goods are at the owner's risk. We accept no responsibility for such submissions, nor do we undertake to return them.

No material may be reproduced from this magazine without the publisher's written permission.
© Audio Publishing Ltd



how we test the products

- Hi-Fi World has its own advanced test laboratory and acoustically treated listening room.
- Hi-Fi World has a dedicated in-house team of experienced listeners. We review thoroughly by extensive auditioning, rather than by quick-fire group listening tests.
- Hi-Fi World's engineering team designs a wide range of products in-house. No other hi-fi magazine is so expert and dedicated.

- £ ——— NICE PRICE - Represents
- 👂👂👂👂 EXCELLENT - Superb sound
- 👂👂👂 ——— VERY GOOD
- 👂👂 ——— ADEQUATE - Room for improvement
- 👂 ——— POOR - Seriously flawed. Forget it!
- 👂 ——— Half ginses are added for those products that we feel are between categories

contents

reviews

cd/dvd players

SHARP DX-SX1H SACD PLAYER AND SM-SX1H



1-BIT DIGITAL AMPLIFIER 10
This hot new combination from Sharp represents the latest cutting edge technology. Simon Pope and Noel Keywood listen in.

SONY XB740E 23
Here's the latest UK player from the Japanese giant. Dominic Todd checks out the £200 disc spinner.

NAIM CD 5 26
We welcome the new entry level from Salsbury's finest. David Price Naims the tune.



loudspeakers

CASTLE HOWARD S3 24
Noel Keywood checks out this updated version of an old HFW favourite.



amplifiers

UNISON RESEARCH S6 14



David Price listens to this classy looking valve amp from Italy. Will it sound as good as it looks?

LINN KATAN 21
Here's Linn's new replacement for the popular Tukan. Simon Pope listens in.



ARCAM A85 40



Top integrated in the new DiVA range from Arcam, the A85 has some interesting features. Simon Pope does the honours.

accessories

LOUDSPEAKER CABLES 66



Simon Pope listens to the latest cables designed to make your 'speakers sing.

features

VINYL'S RETURN? 34
Noel Keywood highlights the recent resurgence in vinyl sales. Is the LP back for good?

IN-CAR NIRVANA 37
David Price takes to the road with music courtesy of Nakamichi.

NEW TECHNOLOGY? 43



David Price writes exclusively on the latest development in two channel audio.

OLDE WORLDE 67



This month it's the turn of Pioneer's PL600X - the "people's turntable".

regulars

WORLD NEWS 6



Our round up of the latest products and gossip in the audio world

NEXT ISSUE 9

COMPETITION 19



Win a Linn Classik/Katan system worth over £1,600 in this month's bonanza giveaway.

READERS LETTERS 44
Hi-Fi World's team reply to your letters and e-mails.

COLUMNS 65, 69, 71
The World team get to grips with issues facing both the industry and hi-fi alike.

SUBSCRIPTIONS 59



Hi-Fi World is second to none for news and reviews. Subscribe today!

HI-FI WORLD KITS 60

World Jio *design*

Check out all the latest kits, and Christmas discounts.

SPECIALIST HI-FI DEALERS 72

Got a problem? - see a specialist.

HI-FI WORLD LIBRARY 76

A comprehensive selection of titles covering audio, valve amplifiers, loudspeakers, solid state electronics and more.

DIAL-A-DEALER 78

Who sells what, and where to find them.

MEET YOUR MAKER 82

Who makes what, and how to get in touch.

WORLD FAVOURITES 83

Components which we know to be truly worthy of audition.

CLASSICS 88

Our list of products that have stood the test of time.

MARKETPLACE 91

MEASURED PERFORMANCE 111

READERS CLASSIFIEDS 119

The definitive place to find classic audio components.

ADVERTISERS' INDEX 130

computer audio world

MARIAN MARC2/USB-ONE 51

A full blown 24bit, 96kHz PC soundcard for peanuts, plus the world's most useful PC audio gadget for notebook pilots...



WINDAC32 55



A great little bit of digital audio extraction freeware you can get off the net...

KLIPSCH PROMEDIA 2.1 57



America's king of horns has gone multimedia - we test the result!

PHILIPS RUSH SA-126 58

From Europe's largest consumer electronics giant comes this very special MP3 walkie...

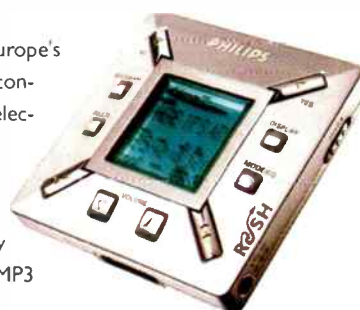

world news

||> SPIN DOCTORS



Fans of the evergreen Technics SLI 200 series of turntables (of which there are a great many, and deservedly so) will be interested to hear that there's a veritable visual feast at <http://mdma.mit.edu/1200/>. Alternatively, those after serious amounts of information on the Technics Direct Drive turntable family should point their browsers at

<http://www.backspin.org/turntables.html>

||> ELECTRONICS GIANTS LINK TO CYBER DEALERS

As the internet becomes an unavoidable addition to everyday life, so companies are adapting to life on-line. Philips, for example, are currently flourishing in the development of hard disc and internet technology. At the opening day of the CES show in Las Vegas the Dutch electronics giants announced they are to launch an online marketing strategy that will apparently link customers to over 60,000 Philips dealers around the world. The company have signed a deal with an American software company, iMediation inc., after European trials to deal with online

purchasing. It will let customers view products and contact dealers.

It seems that Philips have learned a lesson from another electronics giant Sony. Last year they announced they were to launch their own website, SonyStyle.com which would put them in direct competition with their dealers. After much wailing and gnashing of teeth from their dealers Sony are apparently reviewing and reworking their on-line strategy, although the SonyStyle website is still in operation.

||> ROTEL GO HIGH RES



Rotel are the latest company to announce the launch of a DVD-A player. At present only available in the US, the RDV-1080 is a descendant of their CD player design and employs the use of Rotel's Balanced Design engineering in the new format. The machine, priced at \$1,500, will play DVD-A, DVD-V CD, CD-R/RW and CD-V discs. Featuring the latest specification LSICs (large scale integrated circuits) and 24bit/192 kHz DACs, the 1080 will "easily handle" stereo PCM,

Dolby Digital, dts, and MPEG audio formats. Rotel's distributors in the UK, Gamepath said they expect the player will not be available on these shores until "at least three months' time". UK price has yet to be confirmed but expect the usual pounds-for-dollars equivalence.

Gamepath Ltd.
28 Heathfield
Stacey Bushes
Milton Keynes MK12 6HR
Tel: 01908 317707
www.rotel.com

||> CYRUS ICONOGRAPHY

It was only a matter of time before Cyrus joined its erstwhile partners Mission on the ever lengthening list of NXT licensees (over 210 at the last count!). The new Cyrus Icon is both the company's first NXT flat panel speaker system, and the very first use of the technology in a high end hi-fi application.

Not all NXT panels are created alike of course, and with the budget available to them commensurate with a \$5,000-per-pair loudspeaker, Cyrus's engineers have been able to create a bespoke mid-hi NXT panel drive unit of very high quality. Supporting this is a moving coil bass reflex woofer giving a 10-octave range in total. Cyrus claims that the Icon's NXT panel technology improves on the many benefits found in the



best high-end electrostatics, like speedy attack transients and hear-through transparency. The new 'speakers should be in British shops by the time this issue goes to press.

Cyrus Electronics:
Ermine Business park
Huntingdon
Cambs
PE29 6XY
Tel: 01480 435577

||> 'UNIVERSAL' CHIP LAUNCHED

A new high resolution DAC from Texas Instruments makes the universal high resolution format audio player one step closer. The giant electronics company, makers of Burr-Brown DACs, announced the launch of a chip DAC designed for high resolution professional and domestic applications. This includes CD, DVD-A/V and SACD players and A/V receivers, as well as professional products such as mixing consoles. This relatively inexpensive chip, the PCM1738, employs the company's new Advanced Segment DAC design and is capable of 24bit resolution and 192kHz sampling rate, but it can be used in any application that uses between 16-24bit data and up to 200kHz sampling. As well as having an external digital filter mode, it also possess a DSD decoder interface for SACD playback. You never know, it could force both Sony and Matsushita to sit around the table!



NO HINT OF HISS



On a Hi-Space™ recordable MiniDisc, you can cut, paste, divide, erase and record a million times. One thing alone will never change. The digital quality of the recording. Just pure sound, no hiss.

TOMORROW'S MEMORY TODAY



Web Site: www.hi-space.com - E-mail: info@hi-space.com
UK Office - Tel: 020 8961 9906 - Fax: 020 8963 0737

World Radio History

▶▶ DIGITAL DEBUT FROM CHORD



Chord Electronics are claiming a "world first" with their new DAC64. Professing to be the only 64bit/up to 384 kHz stereo digital to analogue convertor on the market, it uses fourth generation Pulse Array DAC technology and the 64 bit filter is also accompanied by an all new receiver chip. The DAC64 has Chord's unmistakable industrial build of the E range and has 3 inputs

(coaxial, balanced XLR and fibre optical) along with outputs for both RCA phono and XLR balanced. A RAM buffer switch that operates at three different levels is also included. Expected to be joined soon by Chord's first CD player and an A/V processor, the DAC64 will be priced at £1,900.

Chord Electronics
The Pumphouse
Farleigh Bridge
Farleigh Lane
East Farleigh
Kent ME16 9NB
Tel: 01622 721444
www.chordelectronics.co.uk

▶▶ DOLBY AT CES

January's CES in Las Vegas was the venue for Dolby Laboratories to showcase its new consumer electronics technologies, spanning home theatre, computer and online audio, DVD-Audio and virtual surround sound: Pro Logic II is Dolby's new generation of Dolby Surround which turns any existing stereo mix into surround, as well as also making existing Dolby Surround mixes sound more like discrete 5.1-channel surround.

As well as working with CDs, Dolby Surround-encoded VHS tapes, MP3s and radio broadcasts, Pro Logic II is claimed to not introduce the artefacts created by other matrix decoding technologies. DVD-Audio using MLP (Meridian Lossless Packing) allows 5.1 channels of 24-bit/96 kHz resolution audio on a single DVD.

Dolby Headphone is a clever signal processing system claimed to make conventional stereo headphones realistically portray the sound of a Dolby Digital five-speaker playback system.

AAC (Advanced Audio Coding) is the new audiophile coding technology that many see as the logical successor to MP3, since it is both 30 percent more space efficient than MP3 and sounds better too!

▶▶ EC ON THE TRAIL OF THE 'BIG FIVE'

The long-standing problem of CD price fixing in Europe looks like it's to be tackled at last. The music biz's 'Big Five' (Universal, Sony, Warner, EMI and BMG) are being closely investigated by the European Union antitrust team. They are considering the fact that the quintet could have conspired to keep software prices in Europe at an excessively high level, some of the highest in the world. It is suspected by the European Commission that competition between the publishers has been discouraged in a sort of unofficial, 'gentlemen agreement'.

A selection of retailers have apparently been

asked to submit purchasing data to the European Commission for perusal.

The investigation is at an early stage. It could apparently take up to two years before a decision is reached.

This new EC investigation was launched after a similar action in the United States, by the Federal Trade Commission, which resulted in the abandonment of the previous Minimum Advertised Price scheme for recorded music in May last year. It also resulted in many lawsuits against major record labels.



▶▶ A NEW SPIN FROM NAD

Still much in the two channel hi-fi business, NAD have announced details of another new affordable CD player. Hoping to continue their tradition of value for money CD spinners, the new C521 will be priced at £200. As usual the company's emphasis is on sound quality rather than esoteric bodywork and in an attempt to achieve this goal they have included "sophisticated circuitry" behind the typically modest front panel.

It features a buffered coaxial output that is also isolated from the convertor by a transformer. Attention has also been paid to the output impedance which NAD claim is a precise 75Ω to ensure easy matching. Number crunching is dealt with by a 20bit Burr Brown chip

chosen for its "excellent low level linearity and detail retrieving capability".

Lenbrook UK Ltd.
Unit 2, Old Wolverton Rd.
Old Wolverton
Milton Keynes MK12 5NP
Tel: 01908 319360
www.lenbrook.co.uk

STAGE RIGHT

Hot on the heels of the 5 Series from Naim comes their new phono stage designed to "keep vinyl in fashion well into the twenty-first century". The Stageline is actually the company's first stand alone, outboard phono stage that was designed to partner the 5 Series amplifiers. Power to the Stageline comes from special sockets on either the Nait 5 or Nac112, or for increased performance, from a separate Naim power supply such as the new Flatcap 2. Available in both Moving magnet and Moving Coil versions, the Stageline is priced at £175.

Naim Audio
Southampton Rd.
Salisbury
Wilts SP1 2LN
Tel: 01722 332266



JUST ADD TV!

Denon have launched a complete surround system that could well be the best bet to get mass market appeal. The company's new AV-F100 mini components surround system is the first of its kind to be supplied with flat panel discrete NXT 'speakers. Consisting of a DVD-V player, home cinema receiver and multichannel power amplifier, each measuring only 270mm x 84mm x 250mm (w,h,d) the AV-F100 is based on the popular D-F100 mini system and comes finished in champagne gold.

Denon have worked closely with Mission to create the compact NXT 'speaker system, consisting of five flat panels and a powered subwoofer. The output of the power amp is 25W per channel, with 50W for the subwoofer. The complete system including the 'speakers and all cables is £1,200. The system is also available for £750 without the 'speakers and the 'speaker package is available separately for £450.

Denon UK Ltd.
Tel: 01753 888447

next issue

Here's a small selection of the audiophile delights that await you next month.

KENWOOD DV-FR9030 DVD-A/V PLAYER

This is the first DVD-A player to cross Hi-Fi World's portals. See what we make of this £700 'budget' option from Kenwood next month.

SONY SCD-555ES SACD/CD PLAYER

This brand new SACD player from Sony sits in the 'affordable audiophile' ES series. Will it turn out to be as impressive as its siblings?

PLINIUS 8100 INTEGRATED AMPLIFIER

From the land of the All Blacks and Kiwis comes this powerful bruiser. Will it turn out a Jonah Lomu or a dead sheep?

Sharp



Maestro of the mainstream Sharp has turned its hand to high-end audio with a £6,000 SACD/CD player and 1-bit amp package. Simon Pope investigates. . .

It's fair to say that '£6,000' and 'Sharp' rarely appear in the same sentence, especially when the former is attributed to a product from the latter. However, don't rush down to the optician just yet, as your eyes haven't deceived you. This isn't Sharp's first venture into high end digital audio - that came with the launch of its first digital amplifier at £10,000 last year. It's still a slap around the chops to see Sharp venturing into the higher realms of digital engineering, though. The Japanese giant has already made a name for itself in the world of MiniDisc portables - which have been very well received thanks to

their excellent sound quality - but the high-end is a different ball park. They've entered it in form of the DX-SX1 SACD/CD player and SM-SX1 1-bit digital amplifier, and done it with an undeniable sense of style.

The styling of both amplifier and SACD player is a weird mix of edgy, hi-tech minimalist modernism combined with a nod to audiophile credibility. What first attracts the eye is that protruding lilac item from the front of the amp, that looks like it was designed for use on a rather large-lipped woman. It's actually a volume control, and one that will be used, as amazingly, there's no remote for the amplifier.

This, according to Sharp is apparently because any type of remote attributed to an amplifier in its native Japan is seen as a downgrade from true high-end status. Strange one this, as you'd imagine sound quality would be the true mettle of a high-end product, wouldn't you? This fetching lilac colour is spattered across both products and is actually quite appealing. Other stylish touches are the mirrored front panels, complete with easy to use metal buttons (with natty blue-lit surround on the amplifier to identify the input in operation).

However, it's round the back



Entry

where we find the true claim to fame of this combination. In what is a first in any domestic product, the SACD player can be linked to the amplifier via a 13 pin connector which transmits the SACD Bitstream data. This opens the door to a problem - namely piracy - a hot potato as far as new digital formats are concerned. To accommodate this, Sharp has designed the connector as bi-directional, so that the amplifier recognises the SACD data from the connection and vice versa (a sort of 'handshake') which results in a short delay whilst each reacquaint themselves with each other in SACD mode. The connector will only transmit SACD data information, so connection for CD playback has to be made via one of the bog-standard' digital inputs also found to the rear of the amp - both optical and coaxial as well as a Toslink output. One pair of 'speaker terminals are present, and they're a bit of a nuisance, as 4mm plugs cannot be inserted into either the ends or the titchy 2mm hole found in the main screw shaft, so bare wire is the order of the day.

The DX-SX1 SACD/CD player is, to the best of my knowledge, the first from outside the Sony/Philips camp. It's supplied with a remote control (obviously no stigma when it comes to players, then) which is a basic plastic job found with most budget CD players and nothing much else in the

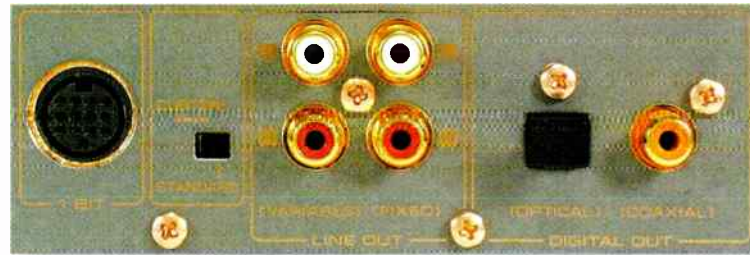

way of surprises. The usual outputs (except the aforementioned 1-bit job) are present, including a variable analogue option.

THREE O'CLOCK SHARP!

First, a warning. If you give this combination a listen, make sure you're using high sensitivity 'speakers - a minimum of 88dB to be safe, more like 90dB to get the best results. Whilst using a pair of Quad 988 electrostatics (just for the hell of it, at 83dB!) gleaned perhaps the most detailed performance, it was severely lacking in grip and punch with the volume set at 3 o'clock! A change to KEF's Reference One -Two floorstanders was called for. Although quoted at 50W per channel, our measurements show that at 8 ohms the best the SM-SX1 could muster was 15W, and it's not a valve 15W either, so the sound isn't full and rich!

Once partnered satisfactorily, I started with Orbital's 'In Sides' on CD. This is a nice, clean recording with a wide frequency range, and



the Sharp combo picked up on the intricate detail in the mix. It's a very forward and exact sound that some will find cold. But the lack of warmth is substituted for a detailed and clean sound that many associate with high-end audio. It's exciting as well, rhythms are strong and fast but lacking in clout (thanks to the puny output of the amplifier). If you crank it though, you'll get a roughish sort of digital sound that verges on the harsh, especially at climaxes. This was demonstrated best with the guitar rumpus of Green Day. Although separation and image depth were good, and the drums were analysed with excellent detail, vocals and guitars on the heavier tracks were edgy and blurred around the edges.

Moving on to SACD with the

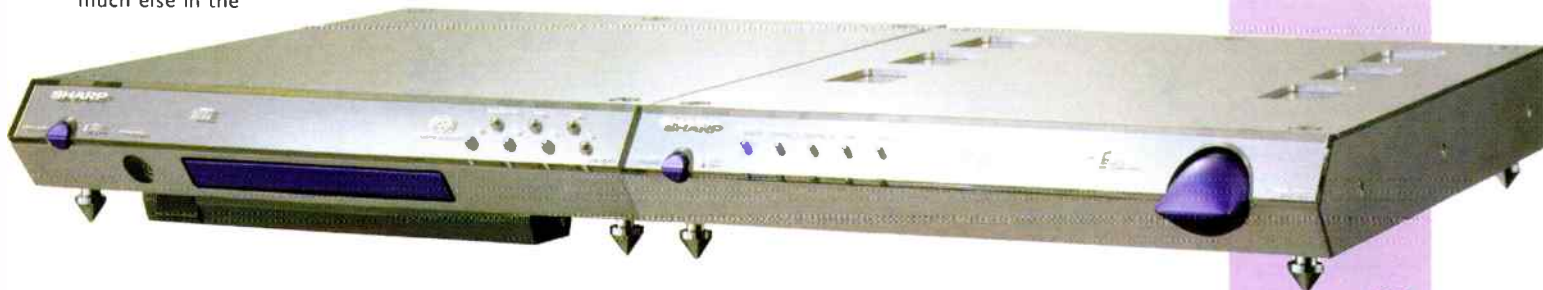

See, hear and feel the Castle difference



With a selection of 7 models and 9 beautiful real wood finishes, there's a lot of choices to make. But when you realise there's a Castle loudspeaker to suit most rooms and high fidelity aspirations, including AV applications, you'll come to appreciate the Castle difference. Go create the best looking sound around.



Castle Acoustics Limited, Park Mill, Shortbank Road, Skipton, North Yorkshire BD23 2TT, England.
Tel: +44 (0)1756 795333 Fax: +44 (0)1756 795335 Email: sales@castleacoustics.co.uk www.castle.uk.com

1-bit connection in operation, I fed a Harmonia Mundi disc of Beethoven's third piano concerto into the player. Again detail and presence were highlights, with phrasing of the violins brought to the fore through sheer detail. Knowing that woodwind instruments are one of SACD's selling points, I wasn't that surprised to hear realistically flighty flutes and rich yet light clarinets and bassoons bobbing away to the rear of the mix, but I was impressed with the way the Sharp combo delivered it. Another SACD in the shape of Clare Martin's 'Take My Heart' on Linn Records again had the Sharp delving the detail depths. Martin's vocals were precise and forward but again erred to the shrill at climaxes, due more to the amp, I fear, than the recording or SACD player.

There's no mistaking the detail and insight this combination brings

to music, but to keep up with the similarly priced opposition, Sharp need to do better, especially in the amplifier technology. Admittedly the digital amp phenomenon is still in its infancy but people expect more clout and drive from an amp than the SM-SX1 can deliver at present. Using the two of them as separate components, I found the SACD player the better of the pair, with insight and detail retrieval up there with the best, although its CD sound is a bit harsh compared to SACDs. The amp suffers from lack of power and coldness, especially at high volumes, but still matches the DX-SX1 in the low level detail department.

It's hard to imagine what kind of market Sharp is after here, apart from those with a high disposable income, of course. It's a mixed bag. Dyed-in-the-wool audiophiles will treat the digital amp process with a certain amount of trepidation, as it's still in the early stages and

can't deliver the power that many need to match their existing equipment. And more mundanely perhaps, they won't go for its 'minimalist space age' look. Those who crave that studious, analytical quality in hi-fi (neck brace, hot-spot types) may well warm to its coldness, whereas those who like music with emotion may want more. Whatever. It's an important product as far as both hi-fi and Sharp are concerned and they should be praised for having the guts and confidence to go for it. ■ ▲

Sharp DX-SX1 SACD/CD player £2,700
Sharp SM-SX1 1-bit amplifier £3,300

Sharp Electronics UK Ltd.
Sharp House
Thorpe Rd
Newton Heath
Manchester
M40 5BE
Tel: 0161 205 2333

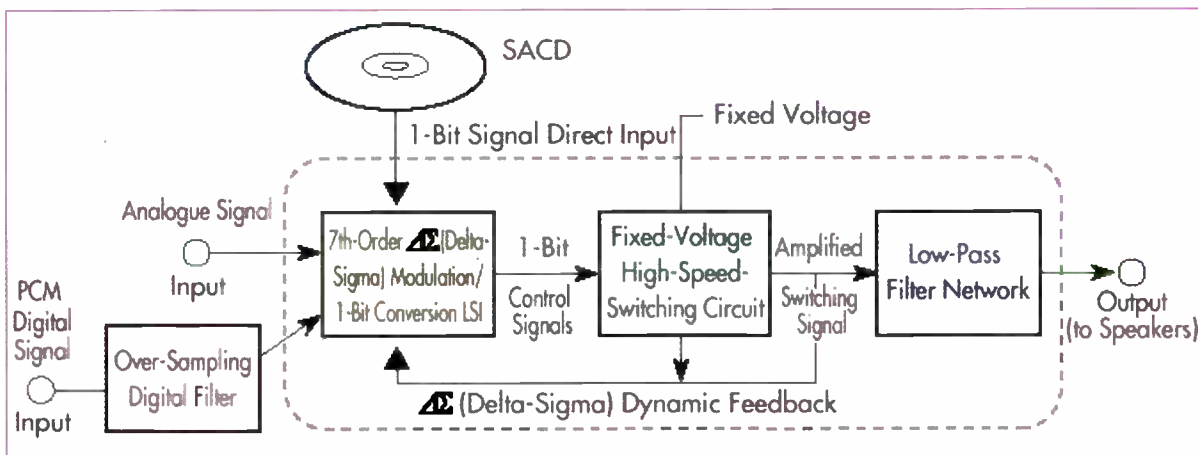

HOW SHARP'S DIGITAL 1-BIT AMP WORKS

Sharp's SM-SX1 uses the concept of the class-D operating system, but employs 1-bit signals to control switching of the fixed voltage power instead of the usual PWM signals of other digital designs (which have an analogue-like width on the time axis and are used to control the switching in ordinary class-D). A delta-sigma Dynamic Feedback circuit feedbacks fluctuations of

voltage power to a 7th order delta-sigma modulation LSI chip and corrects the 1-bit signal in real time. The amplifier creates the 1-bit signal faithful to the input data by sampling delta-sigma modulation.

As the diagram to the left shows, the control signal is fed from the LSI chip to a high speed switching circuit and results in the amplified switching signal being finally fed to a low pass filter network. This large filter converts the digital switching signal into an

analogue signal and is fed out to the 'speakers'. This process means there's no analogue amplification from the signal input right through to the 'speaker outputs'.

Digital amps benefit from power efficiency due to their relatively simple ON/OFF switching operation. Incoming data in effect controls the DC power supply level, so box size is kept to a minimum but with maximum efficiency - both good selling points for many of today's consumers. ■ ▲

World Verdict



Super clean and detailed, but lacks both power and raw emotion. High price ensures a limited customer base.

Measured Performance
see page 111

the single life

David Price has a swinging time with Unison Research's brand new S.6 parallel single-ended integrated tube amplifier.

Unsurprisingly, Hi-Fi World often gets labelled a 'valve magazine' thanks to our penchant for little glass bottles that glow in the dark. As a result, we're regularly contacted by tube amp manufacturers and distributors asking for a review. We duly find ourselves agreeing, then listening and measuring the review sample, then pulling the review - simply because it isn't good enough to feature, let alone recommend.

The trouble is, standards are often shockingly bad in the wonderful world of valves. There are a lot of chancers and fly-by-nighters who lash up old textbook designs with poor quality components and charge a fortune in the hope of making a fast buck. Time and time again we come across this sort of product, and are then forced to refuse it 'the oxygen of publicity', lest some poor sod buy one! So it takes a good one to make it to print.

It's all the better then when we find ourselves reviewing decent valve amps. Having been long in the game, we can tell when something's a lemon or a plum. And years of reviewing experience has taught us that anything from Unison Research invariably falls into the latter category. This Italian manufacturer of over fifteen years experience never seems to do a duff amp. Moreover, every new creation seems even more special than the last. The £1,600 S.6 is no exception to the rule.

Handmade with a heavy gauge metal chassis, stainless steel baseplate and the best solid hardwoods finished

with natural organic lacquers (not just for effect, because as well as looking great, the timber damps the chassis too), it's a sight for sore eyes. Unfortunately its brick outhouse construction will give you a sore back too - much of its 330x450x200mm, 25kg bulk is taken up by its hefty output transformer and mains power supply.

The S6 is an integrated amplifier, meaning you get a volume control and source selector (complete with mad precision-turned stainless steel knobs), a tape monitor and a full wireless remote control. To those tube users who feel lucky to have an on-off switch, this thing feels as sumptuous as a Maserati Biturbo with all the options. You even get a metal valve guard as standard, which hinges up and down effortlessly for easy access and doesn't impede air circulation. Very classy, so it's a shame the power switch is a rather Heath Robinson affair stowed round the back next to the IEC mains input socket.

Unusually at this price, the new Unison is a parallel single-ended design, producing a very substantial 35W (claimed - see our measurements) per channel. The preamp stage uses two direct coupled ECC82 triodes, while three EL34EHs per channel handle the power amplification duties. The output tranny is a bespoke Unison Research affair that's hand wound at the factory, and taps for both four and eight ohm 'speakers are fitted.



The designers claim the shortest possible signal paths have been used, and all connections to the outside world are gold plated for the best electrical contact.

Unison recommend switching the amp on with the volume control set to minimum, which will hardly fill high end speaker owners with confidence, but the good news is that if you forget to heed the advice (which of course I did the second time I powered her up) you should be greeted with little more than a dull thud. Just as well for me, considering a single tweeter in my reference Yamaha NS1000Ms costs over £200! Those in the know will doubtless be questioning my sanity by now - 'what the hell's he doing using those things with a valve amp?' Well, you'd be right - the Yams have a highish 91dB sensitivity (therefore go loud with relatively little power) but are big, bad muthas in terms of the load they present to a power amplifier. Their impedance drops low enough to trip the protection circuitry on half decent transistor monoblocks (Audiolab 8000Ps, Naim NAPI 60s), so any valve amp that can drive them is definitely of the hairy chested variety. Much to my approval, you can

Clearly
we've
moved on



The original Q Series won so many awards that it was tempting to leave well alone.

So we changed it.

We improved the Uni-Q® driver array with an acoustically purer polypropylene midrange cone, and a high frequency unit with a more powerful magnet for greater accuracy at high volume. We fine-tuned the crossovers for even smoother response, and mounted them directly to the bi-wire

terminals for optimum signal transmission.

The gorgeous new front baffles are contoured to eliminate edge diffractions, and finished to match the cabinets* in Natural Cherry, Dark Apple or Black Ash.

And the end result? All the acoustic transparency of the original, with an even sweeter, more open sound.

There's no such thing as perfection - but now, you can get pretty close.



Q
SERIES
Point • Two



MODELS SHOWN ARE THE Q SERIES POINT TWO COMPRISING MAIN PICTURE MODEL Q65 - GROUP PICTURE Q85, Q15, Q35, Q55, Q65, Q95 KEF AND UNI-Q ARE REGISTERED TRADEMARKS. UNI-Q IS PROTECTED UNDER GB PATENT 2 296929 U.S. PAT. NO. 5,548,657. WORLDWIDE PATENTS PENDING. FOR DETAILS ON KEF Q SERIES 2 PLEASE CONTACT KEF AUDIO (UK) LIMITED, DEPT HFWR79, FREEPOST MA1332 ECCLESTON ROAD, TŶŴIL, MAIDSTONE, KEN. ME15 6BK. FREEPHONE 0800 7315620 www.kef.com

*MODELS Q25, Q65 AND Q65 ONLY

WorldRadioHistory



► count the S.6 in that category!

Of course, I've come across a few tube amps that have performed the miraculous feat of not going pop at the merest whiff of my Yams. I reviewed a mad Russian Omak push-pull design back in 1995 and that didn't bat an eyelid, but then again it was probably once part of a Soviet radio transmitter back in the 1930s - it certainly looked that way! Unlike the Omak though, the Unison neither looks nor sounds quite as agricultural. Fed by a Michell Delphini phono stage, the result was quite the opposite. Kicking off with an innocuous bit of power pop, Blondie's 'Union City Blue' instantly impressed. Even at low volumes I found the S.6 extremely listenable - music flowed out of the speakers in an effortlessly organic way. Aside from the unusually clear, hear-through acoustic, I most enjoyed Debbie Harry's voice, which was amazingly direct and up-front, yet so clean and unsullied.

In other respects, the S.6 was just as satisfying. Obviously coloured, there's definitely that EL34 sepia tint that you also hear on other similarly aspirated amps. It is, however, more a patina than a full-on blind, as the Unison lets you discern a wide variety of tonal flavours. While lacking the sheer hear-through transparency of more expensive AudioNotes, you nevertheless get an inkling of how real music can sound if it's spared transistors. Lead guitars had a rough, grainy feel which contrasted Debbie's earthy vocals and the saccharine sound of those hi-hat cymbals. Rather than smoothing out or hardening up everything, the S.6 you left in no

doubt there were shades inbetween, which is an impressive feat for anything anywhere near its price.

Indeed, it proved a joy with a whole range of acoustic music. Female vocals are where parallel single-ended tubes excel, as the Unison so ably demonstrated. Kate Bush's 'December Will Be Magic' was gripping from start to finish - I felt 'direct coupled' to that voice, which wafted louchely out of my speakers with an eerie presence. Then I put on some classic R&B in the shape of Soul II Soul's 'Keep On Moving' and - hey presto - the Unison worked its spell again. It was like you could swim in those harmonies...

What then of the other things which amplifiers must do, such as keeping control of proceedings? Well, considering this is a tube amp and not a brace of Naim NAPI35s, it did an admirable job. Frankly, you're not going to get transistor levels of dynamics and grip from valves - even the very best can't match a good mid-price tranny amp like the Cyrus 7/PSX-R I had on standby. But many similarly priced tube amps are far inferior to the S.6 in this respect.

Go back to the beginning of 'Keep on Moving' and the opening bass sequence is - let's be honest here - loose and a trifle overblown - but it does manage to retain a coherent sense of rhythm that even many solid-state amplifiers lack. Although hardly the grippiest of basslines, it

somehow syncopates rather successfully with the looped snares further up the frequency spectrum. Again it's that 'ole PSE magic - cue up 4Hero's 'Universal Love' and the intricate snare/hi-hat/rim-shot patterns come over wonderfully lucidly. They do with Naim amps too, but somehow both products get there from completely different starting points. Despite having less obvious grip, the Unison manages to cohere the music's rhythms together like few products at any price.

Okay, so bass is a bit woolly, soundstaging a little constrained, imaging a touch vague and the overall dynamics curtailed. Yes indeed, the S.6 suffers all these trad tube maladies, yet it still manages very successfully to transcend them thanks to its strengths elsewhere. Its strong, confident power delivery, wide tonal palette, sweetness, warmth, rhythmic alacrity and deliciously clean, open sound more than compensate. Indeed, you could say Unison Research's S.6 is valves without tears. One of the few tube amps around that will drive difficult loads



reasonably loud, it can confidently be slotted into most home hi-fi systems and work straight out of the box. Thus installed, you'll soon start to appreciate its obvious talents, and yet you won't miss your previous solid state amp too much either. Matched with reasonably sensitive loudspeakers and a clean, neutral source, this thing could well prove a revelation. At the price, it's easily the best tube amplifier I've heard, and is a good enough all-rounder to make even hardened transistor users sit up and listen. Heartily recommended. ■ ▲

UNISON RESEARCH S.6 £1600
UKD23,
Richings Way, Iver,
Bucks
SL0 9DA
Tel: 01753 652669
www.ukd.co.uk

World Verdict
£★★★★★
Beautifully built and voiced amp offering a taste of the high end at a reasonably affordable price. Superb value for money.
Measured Performance see page 111

A lot of changes - and still rather a lot of money.



Speakers as universally revered as our Reference Series are a tough act to follow. After all, what can you do to improve on excellence?

Rather a lot, as it happens. Take the high order crossovers, for example. They've been completely redesigned, using advanced polypropylene capacitors for even greater lucidity. And every crossover is further fine-tuned to match the parameters of each individual drive unit. We even found ways of making the drivers themselves with greater precision to iron out the slightest sonic imbalance.

Having perfected the acoustics, we turned to aesthetics. Hence the choice of five stunning contemporary finishes - exquisitely book-matched veneers, now including Cherry and the highly figured pale Albina Burr, with corners carefully radiused to eliminate residual edge diffractions. In all, literally hundreds of painstaking improvements were made.

So many small improvements can make a big difference to sound quality - and these do. You'll find the Reference Series~Two vastly more accomplished than its illustrious predecessors. Sweeter. Purer. Even more lavishly detailed.

Like all the best things in life, they still don't come cheap - but to anyone who really appreciates sound, they're better value than ever.



REFERENCE SERIES



Some people
still travel by car

Power output (continuous into 8 Ohms) 140 Watts per channel Voltage Gain +25dB Input Impedance 18kOhms Frequency response 1.5Hz and 100kHz Mains supply 100V, 115V, 230V (50 or 60Hz) Case dimensions - NAP 500 160mm x 430mm x 374mm Case dimensions - Power supply 76mm x 430mm x 300mm

Test drive the new
NAP 500 power amplifier

London

Billy Vee Sound Systems, Lewisham, 020 8318 5755
Grahams Hi-Fi, N1, 020 7226 5500
Oranges and Lemons, SW11, 020 7924 2040

Near London

Infidelly, Kingston-upon-Thames, 020 8943 3530

South

Audio Designs, East Grinstead, 01342 314569
Audio T, Reading & branches, 0118 958 5453
Jeffries Hi-Fi, Brighton, 01273 609431
Phonography, Ringwood, 01425 461 230
Soundcraft, Ashford, 01233 624441

East

Rayleigh Hi-Fi, Chelmsford & branches, 01245 265245

West

Audio Excellence, Bristol & branches, 0117 926 4975

Midlands

Creative Audio, Shrewsbury, 01743 241924
New Audio Frontiers, Loughborough, 01509 264002
Overture, Banbury, 01295 272158

North

Acoustica, Chester & branches, 01244 344227
Audio Counsel, Cheadle, 0161 428 7887
Audio Counsel, Oldham, 0161 633 2602
Audio Images, Sheffield, 0114 273 7893
Fortissimo, Manchester, 0161 834 2545
Linton Audio, Gateshead, 0191 477 4167
Zen Audio, Hull, 01482 587397

Wales

Audió Exceñenóe, Cáróñff & branches, 029 2022 8565



www.naim-audio.com

naim
WORLD CLASS HI FI



CAMARGUE
SERIES



Camargue Satellite Camargue Front Camargue Center Camargue Front Camargue Satellite



THE idyllic landscape of southern France, known for its wild horses, has been the inspiration for our finest loudspeaker series. Good food - good wine - luxury. Imagine the best chefs, the finest ingredients, - a feast. This is how the Camargue series was created. Our development team had no constraints, no time limits, no economic limits.



Eltax UK · 4 Warren Yard · Wolverton Mill · Milton Keynes MK12 5NW
Tel.: 01908 226464 · Fax: 01908 226434 · e-mail: office.uk@eltax.dk

www.eltax.com

HI-FI WORLD'S

GREAT COMPETITION GIVEAWAY

WIN A FANTASITIC LINN CLASSIK/KATAN COMBINATION WORTH OVER £1600 IN THIS MONTH'S GREAT COMPETITION GIVEAWAY!

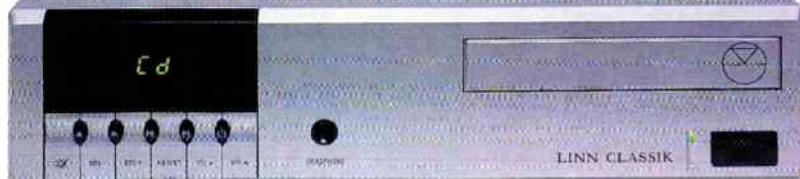

There's a lot of hot talk about all-in-one hi-fi systems, and here's a product that proves it! While it's true to say that many integrated audio solutions aren't much cop, there are designs around like Linn's Classik that will radically assault any preconceptions you might have.

Launching this baby was a very brave move by the established Scottish hi-fi manufacturer. Not only has the company entered a market niche that many others have assiduously avoided 'on pain of death', but by putting out a product focussed as much on convenience and usability as it is on sound quality, it solemnly risked its purist audiophile credentials.

All this meant that the Classik had to be right first time, which it most obviously is. Not only do you get a wealth of facilities, including a proper CD player, tuner and amplifier, in a case the size of a shoebox, but it sounds the business too.

As a self contained hi-fi system, the £995 Classik has all you need for great sound out of the box. Lurking inside its beautifully hewn metal casing is a CD player with a Delta Sigma DAC, plus a 75W amplifier with extensive input options, a headphone output, twin sets of speaker terminals for biwiring, and even a decent pair of 2.5m speaker leads terminated with plugs! There's also an AM/FM tuner with 80

user definable presets and a digital signal strength meter. Then there's the remote control unit that offers everything from Treble, Bass and Balance controls to independently switched Listen and Record selectors. There's a digital clock with timer and sleep functions, which also controls a switched AC outlet on the back panel. This, Linn points out, means your Classik can wake you to music in the mornings and brew up your coffee too!

In short, it's awash with sensible, useful, real world facilities for music listeners - but hey audiophiles, don't let that put you off! Sound is top notch too - better than any equivalently priced separates system. This is because Linn's designers have extensively used circuitry from its widely acclaimed, mid nineties range of 'entry level' hi-fi separates - the £800 Mimik CD player and £749 Magik-I amplifier! The Classik proves conclusively that less really can be more.

In his review of the Classik in November 2000's Hi-Fi World, David Price concluded that its sound was superb. "You get an extremely finely etched midband with loads of detail. Strings are smooth and refined, voices powerful and immediate. Drums - especially snares and rim shots - machine-gun out from the recorded acoustic with a verve that an equivalent separates system simply

can't match. Best of all, the Classik frames all this action beautifully, giving the impression of a song on the move, of building up to a climax rather than just ambling along."

To complement the Classik, we're offering a pair of Katan loudspeakers and matching stands worth over £600. An attractive two-way bass reflex design, they feature a new dome tweeter with a neodymium magnet for a clean, open sound, plus a new custom polypropylene bass/ midrange driver with a strong die-cast chassis and dual field shaping magnets for an extended bass response. A high specification crossover ensures accurate music reproduction across the frequency range, and high quality internal cabling deliver optimum signal clarity to each drive unit. The Katans are fully shielded and can be easily configured as passive or active loudspeakers by Linn's clever reversible-link connection boards.

To win this superb Linn hi-fi combination, simply answer these questions on a postcard, and send it to the following address before March 31st, 2001. The lucky winner will be picked out of Hi-Fi World's now threadbare baseball cap. ■ ▲

Competition Questions

[1] What type of DAC does the Classik use?

- [a] Delta Sierra
- [b] Delta Sigma
- [c] Dark Sierra
- [d] MASH and peas

[2] The power output of the Classik is?

- [a] bangin'
- [b] kickin'
- [c] mingin'
- [d] 75W per channel

[3] Katan is the name of what, exactly?

- [a] a rare mutation of the Tunisian Dinar bird
- [b] an erstwhile Hi-Fi World scribe
- [c] a Linn loudspeaker
- [d] James Tiberius Kirk's titular nomenclature

[4] Linn Products' website address is?

- [a] www.linn.co.uk
- [b] www.hi-fiworld.co.uk
- [c] www.computeraudio.co.uk
- [d] www.spacer.net

Please send all entries to:

April Competition
Hi-Fi World
Freepost LON3478
LONDON
NW6 6YR

Eager audiophiles should keep Saturday June 9th free. At an exclusive central London venue Linn Products in conjunction with Hi-Fi World will be demonstrating both a top spec CD12 system and an LP12 system. It's your chance to compare the company's flagship £12,000 CD player to the world's reference turntable. Top staff members of both Hi-Fi World and Linn will be in attendance and we hope to hand over the prize to the lucky winner of the above competition. It's an event that no hi-fi enthusiast should miss! See next month's issue for further details of how you can attend this exciting event.

CONGRATULATIONS!

...to Mr. William Jones of Rotherham, the winner of our February competition. A pair of Mission 783s are on the way!

Superclock



- 2ppm accuracy master clock.
- Fast rise time resulting in greater data accuracy retrieval.
- Negligible levels of power supply and data related jitter.
- Greater dynamics and detail at all frequencies.
- Spacious 3-D presentation.
- Natural texture of instruments and vocals.

plus

Alps, Analog Device, Black Gate, Burr Brown, Caddock, DACT, Elma, Elna Silmic, Holco, Intertechnik, Linear Technology, Multicap, Nichicon, Panasonic, Pro-Cap, Vampire, Vishay and many more.

Modification service available for CD players, DVD, amplifiers and loudspeakers, etc. Why not contact us to see how this service can be adapted to suit your requirements?

AUDICOM

Tel: +44 (0) 1646 685601

Fax: +44 (0) 1646 685602

E-mail: Info@audiocom-uk.com

www.audiocom-uk.com



O-Power Discrete Regulator



- Wide bandwidth, ultra-low noise DC regulation
- Extremely fast transient response.
- Improved bass definition, solidity and rhythm.
- Greater midrange focus and clarity.
- Improved dynamics and detail at all frequencies.

THE NEW AFFORDABLE PHONO AMPLIFIER FROM TRICHORD RESEARCH

DINO



- Moving Coil
- Moving Magnet
- Switchable Gain
- Switchable Loading
- Super Regulators
- Discrete Output Stage
- Upgradeable Power Supply

Tel: +44 (0) 1684 573524

Fax: +44 (0) 1684 577380

WWW.TRICHORDRESEARCH.COM

ATOMIC KATAN

Will Linn's new entry-level standmounting loudspeaker fend off the best of the rest? Simon Pope gives the Katan a blast.

First came the Kan, then the Tukan, now it's the turn of the Katan to fly Linn's bookshelf loudspeaker flag. The Katan was launched with the Ninka, a large infinite baffle floorstander that recently impressed us with its bass depth and taut, fast sound. It also looked much better than the company's previous efforts. This also goes for the Katan. Gone is the 'square' appearance of the Tukan, and in its place is an attractive tapered cabinet with fixed metal grilles over the drivers - far better than the old granny's tights that had to be stretched over the Tukans with the aid of an elastic band!

The Katan is a two-way bass reflex design (unlike the closed cabinet Ninka) featuring a new dome tweeter with a neodymium magnet, plus a new polypropylene mid/bass unit with a strong die-cast chassis and dual field shaping magnets. The drivers are fully shielded to ensure placement next to a television for A/V applications. Like the Ninka a choice of reversible connection boards beneath the inputs link the terminals for either single or bi-wire passive and bi-amped active playback, where the inputs will link directly to the drive units and bypass the crossover.

Described as a bookshelf, wall mount or standmount 'speaker, I found the Katan worked best between four to eight inches from a rear wall. Another trait of the Katan I noticed, which our measurement confirmed, was that they need a bit of power to drive them. 4W valve amps are not the order of the day here, so I used Linn's own LK85 power amp and a 200W Meridian 557 power amp to glean the best

from them. I would recommend a minimum of 60W per channel, otherwise you may find your amp gain set at 3 o'clock! These 'speakers perform best with punchy rock or pop such as Green Day's 'Dookie' or Blur's 'Best Of', both of which I played through Meridian's 206.24 CD player. What I heard was a fast and vibrant sound similar to the Ninka, but lacking the obvious bass depth of the floorstanders - although there's lower bass here than the Tukans could muster. The sound was also a tad thinner, in that vocals lacked a bit of warmth and guitars could sometimes sound edgy. What these 'speakers did exceptionally well was keep time and deliver the music with excellent staging and clarity. There's no woolly bass flab found in many other reflex designs here - even when close to a rear wall, there was very little boom, although there is some 'bloom'. Tracks like Blur's furious 'Song 2' sounded grippy and controlled, with a terse, visceral presence.

Moving to classical chamber music in the form of Borodin's string quartets on vinyl, the Katans showed a good sense of detail but phrasing wasn't absolutely the best, due to a little greyness present that drained acoustic instruments of their natural timbre. This didn't distract too much from the performance but it wasn't as accomplished a sound as the larger and slightly softer sounding Ninkas. Orchestral music like Stravinsky's Rite Of Spring, while exciting and forceful, suffered from a closed in sound that couldn't escape the boxes, despite being perfect in imaging and detail. But orchestral fullness in the recording (Boulez with the Cleveland

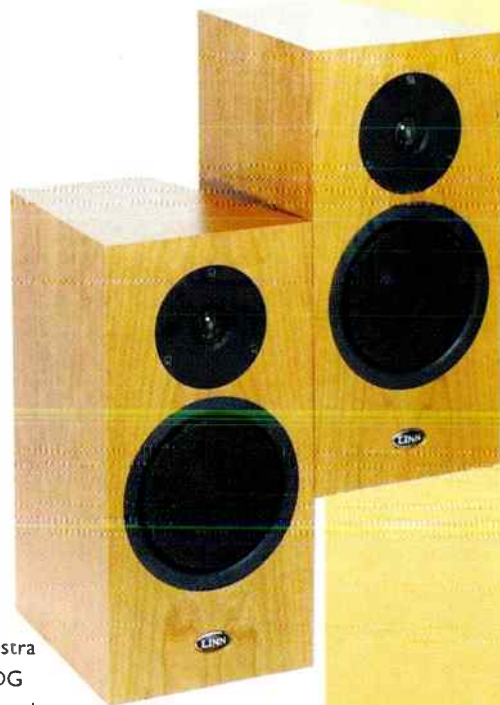

Orchestra on a DG CD) was lost somewhere along the line.

Like many Linn products, the Katans are excellent rock 'speakers with oodles of punch and excitement. Used with at least 60W of power they'll sound fluid and controlled, giving life to anything you wish to chuck at them. Like previous Linn 'speakers, they don't quite give classical music their full attention but will still sound highly detailed, if not over-warm. Overall I'd say they're an improvement on the slightly thin sounding Tukan, and well worth a listen if this is the sort of 'speaker you're looking for. ■ ▲

Linn Katan £600 (black) £635 (white, cherry and maple)

Linn Products Ltd.
Floors Rd., Waterfoot
Glasgow G76 0EP
Tel: 0141 307 7777
www.linn.co.uk

World Verdict



Exciting and attractive little 'speaker with detail and punch. Better with rock than classical.

Measured Performance
see page 111

THE SPIRIT OF MUSIC



New from Elac - the CL512.
Designed in Britain, precision built in Germany.
Model shown £1300. Prices from £159

Distributed by
Sennheiser UK Ltd. **FREEPOST**, High Wycombe, Bucks HP12 3BR.
Brochure Line: 0800 652 5002 Fax: 01494 551 550
email: info@sennheiser.co.uk Web: www.sennheiser.co.uk

ELAC Electroacoustic GmbH, Rendsburger Landstr. 215, D-24113 Kiel,
Tel: +49 (431) 64 774-0 Fax: +49 (431) 68 21 01 Web: www.elac.com

Sound looks

cameo

Inner value



WHAT HI-FI? August 2000

"The Myriad is a fine sounding system,
as you might expect from this brand."

MYRYAD

Myriad distribution by Sennheiser UK Ltd. **FREEPOST**, High Wycombe, Bucks HP12 3BR.
Brochure Line: 0800 652 5002 Fax: 01494 551 550 email: info@sennheiser.co.uk www.sennheiser.co.uk

Mechanical Engineering

Dominic Todd listens to Sony's latest CD player for the UK market. Will it see of the £200 competition?



Let's get the bad news out of the way with first. Unlike its big brother, the 940, the new Sony CDP-XB740E is not a Super Audio Compact Disc (SACD) player. Perhaps that's asking too much for a player costing £200 at this stage in its development. Neither does it feature Sony's intriguing fixed laser transport, whereby the disc passes over the laser rather than vice versa. However, Sony hasn't been idle in improving their QS range CD player. The removal of the headphone socket and associated PCB and level control should make for less interference inside the machine. Sony also claims an upgrading of capacitors, resistors, wiring and damping materials. A glimpse inside shows typically neat construction, although don't expect Marantz KI Signature quality components on the cheap, despite improvements. This is also Sony's cheapest machine to feature their 24bit variable coefficient digital filter, allowing the user to subtly adjust tone characteristics. Key rivals include the

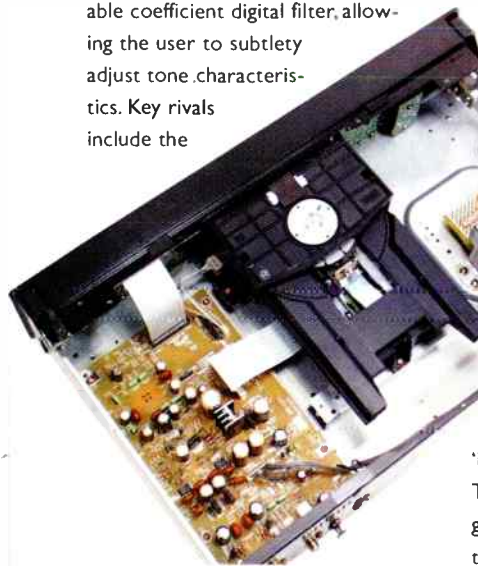

Kenwood DPF-3030 (£180), NAD C520 (£170) and Cambridge D500 (£200).

The dynamic, but slightly bright 'Absent Minded Friends' by Moloko set the ball rolling. Immediately apparent was a strong taut bassline that successfully gave the track suitable bounce. Separation was good even through the more complex passages. Less impressive was a 'glassy' element to vocal reproduction, which spoiled otherwise fine projection. As I've found before with Sony products, changing the filter setting didn't have a profound effect upon the over all balance. Setting 2 emphasised the slightly harsh treble reproduction, whilst setting 3 simply appeared to veil the music. In short, I found the filter at its best left in the 'std' position.

Turning back the clock, my next choice of disc was Nina Simone's 'Why (the king of love is dead)'. As anyone familiar with the song will testify, it's an emotionally charged performance. Sadly though, the 740 failed to truly capture this. Technically, with regards to price, the piece was extremely well presented. The sound staging showed a fine lack of constraint with particularly fine height of sound apparent. 'Red Spaces' by Lobe (from the Swim Team label) suited the Sony to a far greater extent. The Ambient nature of the track allowed the 740 to excel at

what it's best at. The upper bass response was particularly strong, and whilst real bass weight was absent, I've yet to hear a CD player at anything like this price do better.

The brilliantly titled 'Lucille Has Messed Up My Mind', by the inimitable Frank Zappa provoked a mixed response. The track was transparently reproduced with fine percussion detail in particular. No complaints about the timing, either, with the strong upper bass driving the piece through with gusto. Less good, however, was the vocal performance. It was rather blandly portrayed, missing out on subtle nuances of voice.

I've no doubt that the Sony would give many years of faultless, consistent performance, yet musically it's something of a mixed bag. If your tastes are focused more toward the Classical or Dance genres, then there's much to recommend the 740. Fine timing, a spacious sound stage and good definition are the main attributes. However, for those who listen to a vocal based source of music, it's rather less convincing. By no means a bad machine then, but just make sure you get a listen to the opposition before taking the plunge. ■ ▲

SONY CDP-XB740E £200

Sony UK Ltd.
The Heights
Brooklands
Weybridge
Surrey
KT13 0XW
Tel: 01932 8160

World Verdict



A good player well worth audition but suits ambient instrumental music better than vocal.

Measured Performance
see page 111

HOWARD'S

Noel Keywood listens to Castle's latest 'speaker in the Classic series, a revamped version of an old friend.

▶ **T**he arrival of Castle's new Howards in the office was greeted with anticipation by me. The Howard is one of those long standing designs with a set of qualities I like. Each new iteration is not only a welcome chance to reacquaint myself with this entertaining floorstander, but also an opportunity to see just how Castle might have moved the game on. Castle are obviously happy with the design too, since it's now up to version three, full name Howard S3.

It was stimulus I needed to spend a few hours sorting out my much loved but slightly feared 300B valve amplifier, because the Howard is something of a 'perfect load' as far as amplifiers are concerned. As such it's a great match for a valve amplifier, but equally perfect for transistor amplifiers too - just one of its strengths. It will get the best from any amplifier and is one of the few loudspeakers currently available that can do so. The Howard might not look radical, but underneath its conventional exterior Castle have built a clever and advanced loudspeaker that in the past has delivered fine results. I looked forward to testing this new version.

At 992mm the Howard is tall. Luckily it is narrow at 210mm and not too deep either, at just 320mm. So it doesn't loom large in the room and consumes little real estate. Behind a small front grille lie just two drive units in a normal enough arrangement comprising bass/midrange and tweeter. But there's grille in the top panel too and here things get interesting. The top unit handles most of the audio range and fires up at the

ceiling. Bouncing sound off the ceiling adds some height to the sound stage, making it seem more expansive and also more solid and plausible, I found. But that's not all. This upward firing unit also drives a long bass line that ports onto the floor, beneath the loudspeaker. This novel arrangement is responsible for the Howard's fine bass and excellent load characteristics.

In a nutshell then, the Howard is a high quality two-way, with augmented bass and stereo imaging. It might sound simple but there's a lot of special cabinetwork that you become aware of when unpacking; these 'speakers are heavy, weighing 25.5kgs (56lbs) apiece. Each cabinet has a large port in its bottom face that exhausts onto a plinth. The plinth must be screwed to the bottom of the loudspeaker, spacers holding the two apart by around 4mm to allow the port to 'see' the outside world. Large spikes can be screwed into the base to aid stability.

Two sets of shielded heavy duty terminals cater for bi-wiring. There are no links to allow the use of a single cable. The crossover networks use a couple of very large iron-cored inductors, high quality capacitors glued down and hard wiring. Castle solder all connections, even to the drive units. It's a high quality crossover, thankfully not so complex as to be riddled with components. The cabinets are beautifully finished, in keeping with the high overall standard of quality adopted for the Howard, since this is their flagship model in the Classic range.

I measure loudspeakers before listening to them - and measurement



says a lot. Castle tell me their carbon fibre drive units are a new design over which they've spent a lot of time. Working with a soft dome tweeter the new drivers give an exceptionally flat frequency response and doubtless Castle are proud of this. It's an approach fast becoming popular amongst U.K. manufacturers - if they can boast extreme accuracy, why not? My observation on this, drawn from my own experiences designing our kit loudspeakers, is that it gives a glassy bright tonal balance. Orchestral strings are moved forward and given a more prominent role in a performance, with some edginess at times creeping in, probably from a 5kHz peak attributable to the 'whizzer cone' Castle use. However, the Howards have real transparency and stage depth. From the Righteous Brothers singing You've Lost that Loving Feeling through to Toni

END?

Braxton's Spanish Guitar, vocalists come over as full in body and healthy in voice. Instruments are layered backward in the mix and choirs fill the room convincingly. The upward firing drivers help embody singers by strengthening central images, whilst also lifting the sound stage. They also fill the room with sound, making the Howards sound equally good whether you're sitting, standing - or even out of the room! Apart from being very insightful and detailed the Howards paint an expansive picture that conveys an impressive sense of scale. This is uncommon and a feature of the 'speaker that sets it apart. From Rock through to Classical these loudspeakers sound nothing other than impressive; there's little like them.

Creating a sense of scale demands good, deep bass too. The Howards have this in plenty. Their quarter wave transmission line gets low and notes step down with real authority. It's always a treat to hear a good, large speaker almost breathe bass into the room, bass so low you feel it gently moving the fabric of your surroundings. Cesar Franck's intriguing Choral No2, played on the organ of the Basilica of Saint Sernin, Toulouse, through these 'speakers had the sort of grandeur that makes this work complete, the organ majestically stepping down to its 16ft pipes which the Howards reproduced as a 32Hz rumble that seeped through the building. Impressive stuff.

I knew from measurement though that there was likely to be some box colouration from a broad peak in the output of the upward firing driver, and this was so. Modern digital recordings in particular, like George Michael's Roxanne from Songs from the Last Century sounded a little box bound. From Eddy Grant's Electric Avenue, spinning at 45rpm, to the very clean, close-miked and powerful digital recording of the Overture of Wagner's *Reinzi* from Teldec, kick

drum to kettle drum had the Howard sounding a trifle coloured. It can be over excited, Mission's Cyrus 7 solid-state amplifier getting more power out of the low impedance bass section than my valve 300B amplifier, producing a fruitier sound as a result. As loudspeaker cabinets get bigger and loading arrangements more complex, colorations like this tend to creep in. It's a small price you pay for the Howard's complexity.

Castle have pursued an interesting design aim with the Howard. This is a loudspeaker wrought to present music with a sense of scale; it's not just a bigger box with more drivers,

like so many top of the range models. Using quality components in a beautifully made and finished cabinet, the Howard S3 was better than ever. It remains one of the most accurate, entertaining and revealing of the large loudspeakers. ■ ▲

Castle Howard S3 £1349.00
 Castle Acoustics
 Park Mill Shortbank Road,
 Skipton
 North Yorkshire
 BD23 2TT
 Tel: 01756 795333
 Fax: 01756 795335
www.castleacoustics.co.uk



World Verdict



Tuneful deep bass, see-through clarity and spacious imaging mark out the Howard S3 as a first class loudspeaker. It produces music on an impressive scale and is hugely entertaining.

Measured Performance
 see page 111

SALISBURY

As soon as you spin a disc, you'll hear that Naim's CD5 is a Compact Disc player at the height of its powers, says David Price.



Regardless of fad or fashion, Naim has ploughed its own furrow for over twenty five years. If buyers, dealers and reviewers want to come on board that's fine, but the company has never once pandered to the hi-fi business's whimsical ways.

The Naim sound holds that rhythmic and dynamic accuracy is paramount, and all else is secondary. It's something they once shared with LInn. Of the two, Naim has been its stronger proponent. As well as making audio equipment, Naim has become something of a hi-fi paradigm. In the same way most motorists know the difference between, say, a Volvo and a BMW driver, so audiophiles talk in terms of 'Naim owners'. A cliché maybe, but I challenge you to go into someone's house, notice a brace of NAP135s, and not know how they like their music!

Naim styling always struck me as something of a missed opportunity. It wasn't as if the company was skimping on the looks to invest money elsewhere - because the build of the higher end stuff (such as the CDX 1 reviewed last year) is supreme. It's just that the company seemed either unconcerned or even wary of 'styling' its products lest

people start buying them because they looked nice - perish the thought!

Well, the advent of the NAP500 was obviously an important moment. Not only did it represent a nod to the high end, but also introduced a new aesthetic template which Naim's lesser models have gone on to adopt. The entry level '5' range - as someone once said - wears it well. My first encounter with the sculpted contours of the fascia, divided into three clearly delineated regions, was courtesy of the NAIT 5 - and what a happy occasion that was. With its die-cast Zinc and aluminium (58.4x432x301mm) casework, and tactile, backlit control buttons. The CD5 is no less impressive to look at and touch.

The quality continues inside. Naim has paid great attention to the stability of the RF signals read by the laser, resulting in a suspended transport and low mass magnetic puck clamping system. Paths between critical components are said to be as short as possible, and meticulous attention has been paid to earthing and mains issues.

There are fourteen low-noise, regulated power supplies on the CD5 main circuit board, separate digital and analogue transformer windings

plus additional screening to reduce the intrusion of RF interference.

Mechanical engineering is no less thorough - aside from that beautifully hewn, low resonance casework, there are 'low-energy-transfer' feet, physically decoupled circuit boards and a CDX-style glass reinforced front loading drawer mechanism.

Finally, as with all other Naim products, you can add a Flat-Cap, Hi-Cap or even a Super-Cap external power supply to be connected to the analogue circuitry.

SOUND QUALITY

Generally, when people talk about Compact Disc players, they think in terms of two generic types - 'smooth' and 'lively'. The former often have a drooping frequency response and get their inoffensive sonics simply because they don't excavate much of the dynamic and timing information on the disc. The latter may seem to do great things in the detail department, but this is often because of the artificial edge their noise and distortion adds.

To understand the CD5, you have to think beyond this. In one respect it's very slick, with no piercing upper midband nasties whatsoever. Yet in another way it is amazingly fast and engaging - not because of any added

THRILL

digital hash, but rather down to its supreme grip and speed. It treads a brilliantly judged path between the blood-on-the-carpet dynamism of eighties multi-bit, and the slickness of nineties Bitstream.

Scritti Politti's 'Lover to Fall' is a complex exercise in sequenced drum programming, to which some pretty elaborate keyboard patterns are added. The result is an intricate piece of pop that can all too quickly become a torture track for some CD players. Indeed, even at the CD5's price point, many players just gloss over many of the song's rhythmic and dynamic intimacies. I can count only two players at this price point which have successfully negotiated it to date - Arcam's FMJ CD23 and Meridian's 506.24. Well, now there's a third.

When a note starts, the CD5 will be the first player in its price bracket to tell you about it. Likewise, that note's sustain and decay are carried superbly too. All this information is then sewed together in a fantastically coherent and natural way, giving a tremendously engaging sound.

Indeed, while the Naim lacks the almost unipivot-like (I hope this analogy still means something even to non-vinyl users!) fluidity of the Arcam and the wonderfully warm, open and expansive soundscape of the Meridian, it blows both into the weeds in its ability to impart this song's deliriously complex rhythmic inflections. Crank the volume up, sit back and prepare to be amazed - it's a gas!

Winding my way through my CD collection, I was amazed by the wealth of detail the CD5 threw out. Compare two average thousand pound CD spinners using Grace Jones' 'My Jamaican Guy' and one might sound a little more communicative than the other, but generally the differences aren't huge. But the Naim proved no ordinary Joe - positively bursting with stuff I'm sure I hadn't heard before (little bits at the back of the mix, subtle



rhythmic shifts and flurries), it didn't have me entertained and amused so much as transfixed.

And still it gets better. While it's undoubtedly the most transparent sounding machine in its price point, the CD5's party trick is the way it sews all this mass of information together in a way that makes complete sense. Some have called it clinical - but I don't think this is fair - it isn't just an efficient communicator but a gifted performer in its own right. It's both technically accomplished and in tune with the music's emotion. This is why it works so well with so many different types of music - from T Rex's 'Cosmic Dancer' to Michael Hedges' 'Aerial Boundaries'.

Such is the essence of the CD5. It's a Naim and it sounds like one - it isn't as neutral or impassive as, say Copland's CDA289, or as even handed and level headed as the Meridian 506.24. Its bass isn't the most natural and organic sounding - indeed it can sometimes sound a little synthetic - but it's as tight and supple as you'll get under two grand. It doesn't have an awful lot to tell you about the tonal and textural delights of a recording either, but its capacity to move and groove you is



simply sublime.

Another beautifully designed, manufactured and voiced product from Naim then. Easily the most thrilling listen at or anywhere near the price, it's wonderfully presented and screwed together, and frankly I'm surprised by how close it comes to its far more expensive CDX brother I reviewed last year.

If you're interested in 'the Naim sound', there's never been a more compelling reason to get down to a dealer to experience it for yourself. ■ ▲

Naim CD5

£1125

Naim Audio
Southampton Rd

Salisbury

Wilts

SPI 2LN

Tel: 01722 332266

World Verdict



Superbly built, reasonably priced and with a fantastically exciting yet sophisticated sound, the CD5 is one of Naim's best products yet.

Measured Performance
see page 111



J A Michell | Gyrodec SE Turntable **£974.95**

Founded in Borehamwood by mechanical engineer John Michell. For over thirty years, Michell Engineering have been at the forefront of quality audio, with world-wide appreciated products like the GyroDec and Orbe Turntables.

In the early eighties, the revolutionary GyroDec Turntable, with its elegant and effective suspension system, was introduced. The **Gyro SE** is a smaller and cheaper package that retains the classy sound of the GyroDec and can be upgraded to the full GyroDec specification by adding a plinth and dustcover. **Price includes Rega RB300 Tone Arm**

CYRUS

CD7 CD Player **£799.95** 7 Integrated Amplifier **£699.95**

The new **CD7** combines the latest transport developments with 24-bit DAC technology. The CD player can be easily upgraded by adding the external PSX-R power supply.

The 60 Watt **Cyrus 7** is a powerful integrated amplifier and system controller that can be upgraded in many directions. This flexible unit will form the cornerstone of your system and provide access into Cyrus' Audio Visual and Multiroom systems.

Whether you want a high quality music, multiroom or audio visual system, there is a Cyrus system to fulfill your needs.



MISSION



782 bases its performance on a 165mm Nomex bass unit fitted to a reflex enclosure that extends low frequency output to reach the lowest fundamental of bass guitar - an astonishing performance for such a graceful and compact cabinet.

783 houses a larger 200mm bass unit with massive motor system, capable of floor shaking, yet tightly controlled low frequency extension. Both use Keraform midrange drivers for outstanding clarity and midrange detail coupled to superb dynamic range together with the smooth and finely detailed Mission silk dome tweeter.

780 and **781** are the pinnacle of Mission's research into creating a three dimensional soundstage. extensive bandwidth and dynamic range from the smallest possible cabinet dimensions. The **780** is diminutive in form but massive in its sonic capabilities. Its 130mm Keraform bass unit is carefully matched to a novel reflex enclosure for full bodied bass extension, the qualities of Keraform produce a dynamic and ultra detailed midrange. In the **781** a 165mm Keraform driver takes advantage of a larger, stand mount cabinet to extend bass performance and increase efficiency whilst maintaining that superb midband transparency and finely detailed treble.

Cyrus Selection

5 Integrated Amplifier	£499.95
FM7.5 FM Tuner	£399.95
PSX-R Power Supply	£349.95
Smart Power Amplifier	£549.95
APA7 Mono Power (ea)	£949.95
AV5 AV Processor	£999.95
CLS70 Loudspeakers	£799.95

Mission 780 Series

783	£999.95
782	£699.95
781	£499.95
780	£299.95

Please Note: Some products may not be available at all outlets. Advertisement valid until at least 14th March 2007, L&OE.



more entertaining

World Radio History



ARCAM

DiVA Series

CD72 CD Player	£399.95
DV88 DVD Player	£899.95
A65 Integrated Amplifier	£369.95
A75 Integrated Amplifier	£429.95
P75 Power Amplifier	£299.95
P85 Power Amplifier	£499.95
T51 Tuner	£279.95
AVR100 AV Receiver	£799.95



DiVA CD92 CD Player **£849.95**
DiVA A85 Integrated Amplifier **£699.95**

Arcam's quest for higher performance, has led to the development of the new *DiVA* series, the most complete range of high performance home entertainment equipment ever launched by a specialist audio manufacturer. Innovative design and production techniques have enabled Arcam to build on established values of excellent sound quality and value.

The *DiVA* series comprises, two CD Players, three Integrated Amplifiers, two Power Amplifiers, an AM/FM Tuner, a high performance DVD Player and Arcam's first Home Cinema Receiver. All models are available in either silver or black.



Please Note: Price Excludes STAE1 Stands.



ACOUSTIC ENERGY

AE1 Series II **£699.95**

In 1988 the original AE1 was launched. Designed to satisfy the needs of the professional audio sector of the market, by offering great accuracy, precise stereo imaging, dynamics, and transparency coupled with high power handling and linearity. The AE1 quickly acquired a global reputation with musicians, recording artists and studio engineers.

Subsequently the AE1 won the British Hi-Fi Award for Best Speaker in 1991 and 1992, and acclaim within the hi-fi press grew world-wide.

Unrivalled in its class the AE1 is renowned for superb bass, speed and dynamics.

The **AE1 Series II** retains these qualities and provides greater clarity, transparency and harmonic timbre, coupled with a larger stereo sound stage and increased sensitivity.

Critical matching of the voice coil and metal-cone have improved the mid-range, allowing for a much simpler, short path crossover network achieving gentle first order acoustic slopes and a seamless blend between the drivers.

The crossover features upgrades to the internal wiring and Industrial grade encapsulation is also applied to the total crossover assembly eliminating resonance, microphony and increasing power handling.

ROKSAN

Kandy is the starter system from Roksan. Without compromising its high-quality sound performance, the *Kandy* system offers a complete musical experience at a very affordable price. Its CD player, tuner and amplifier are all designed and built to the exacting specifications for which Roksan are renowned.

Minimal, stylish, ultra-modern, this system is available in a choice of unique colour panels, a complimentary feature to any modern interior.

Also Available: *Roksan Caspian Series*



World Radio History

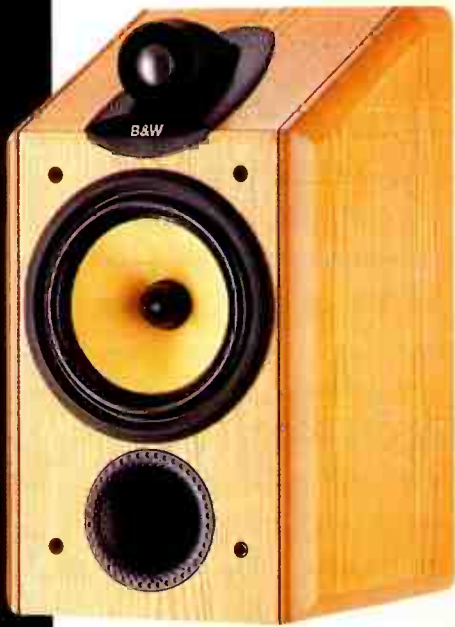

CDM™NT Series

The CDM™NT series from B&W combines the unbeatable sound purity of their highly acclaimed Nautilus 800 Series and the classic looks of their predecessors, the CDM SE. Complete in both looks and sound quality, this is one of B&W's finest loudspeaker ranges to date. The CDM™NT Series is available in a choice of beautifully finished real wood veneers.

CDM™NT Selection

CDM™1NT	£749.95
CDM™7NT	£1249.95
CDM™9NT	£1799.95
CDM™CNT Centre	£399.95
CDM™SNT Surround	£749.95

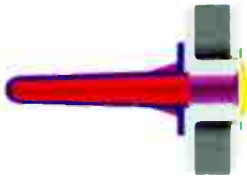

Nautilus Tapered Tubes
The most effective way of absorbing unwanted sound from the back of the drive unit.



Kevlar Cones The same properties that make Kevlar the right material for bulletproof vests also benefit the design of wide bandwidth drivers.



Flowport™ Technology
Golf ball aerodynamics theory points the way to lower distortion reflex ports.



LINN
the only sound™

Founded in 1972, independent precision-engineering company. Linn Products Limited, specialise in top performance sound reproduction.

Linn's first product was the revolutionary Linn Sondek LP12 Turntable. 25 years later it is still, for many, the reference Turntable. Today, Linn's hi-fi range includes over 50 products including CD Players, Tuners, Amplifiers and Loudspeakers.



Classik CD Receiver £999.95

The **Classik** is an alternative to the sound and looks of mass market compact systems. Designed to be useful throughout the home, the Classik is simple and stylish with all the advanced features needed to satisfy the most demanding hi-fi enthusiast or discriminating music lover.

The Classik combines an extensive and flexible control system, high quality CD, Tuner, and powerful Amplifier, capable of driving any Loudspeakers, in a single, compact package and is available in a choice of colours.



Genki CD Player £994.95

The **Genki** is a versatile, high performance CD Player combining value and multi-zone flexibility. With both fixed and variable outputs, the Genki can be connected to a Pre Amplifier in the conventional way or, using its local volume control, connected directly to a Power Amplifier. **Features include:** HDCD playback capability, Delta-Sigma digital-analogue conversion, carefully implemented low-noise circuitry to deliver pitch accurate sound, surface mount electronics for optimum signal routing and layout and Linn proprietary Brilliant silent power supply technology.

Pekin AM/FM Tuner £544.95

Integrating the knowledge gained from developing other Linn Tuners such as the Kremlin, the Kudos and most recently the Classik, the **Pekin** AM/FM Tuner takes it one step further, to produce a powerful and truly musical performance to the unique standards that you expect from Linn.

Features include: 80 memory pre-sets, upgradeable software, fully screened low-noise circuitry, high overload margin and high sensitivity, low noise switchmode power supply and two audio outputs.



Linn Selection

Ikemi CD Player	£1949.95
Majik Integrated Amplifier	£694.95
LK85 Power Amplifier	£494.95
LK 140 Power Amplifier	£749.95
Katan Speakers	£634.95
Ninka Speakers	£894.95
Kolektor Pre Amplifier	£494.95
Wakonda Pre Amplifier	£794.95



more entertaining

World Radio History



MUSICAL FIDELITY

Musical Fidelity's A-Series is a ground-breaking range of CD Players, Pre-Power and Integrated Amplifiers. The whole series has received enormous acclaim and has won many hi-fi awards worldwide.

X-Ray CD Player	£749.95
X-A2 Integrated Amplifier	£449.95
A3 Pre-Amplifier	£999.95
A3 Power Amplifier	£999.95
A300 Integrated Amplifier	£1399.95
A3 Tuner	£599.95
HT600 5 Channel Power Amplifier	£1999.95
HTP Surround Processor	£1999.95



A3 CD Player **£799.95**
A3 Integrated Amplifier **£849.95**



MONITOR AUDIO Gold Reference Series

Monitor Audio has been designing and manufacturing high quality British Loudspeakers since 1972. In the mid-eighties, the R852MD was launched utilising Monitor Audio's unique C-CAM™ Metal Dome Tweeter. It sounded significantly smoother and more musical than its rivals and formed the basis for a whole new generation of Monitor Audio Loudspeakers. The company has been at the forefront of Loudspeaker technology ever since.

The new **Gold Reference** Series introduces advanced Drive Unit technology and the highest standards of engineering currently available. Each cabinet is hand crafted from 22mm thick MDF, using mirror matched veneers. Multiple internal bracing is positioned at critical resonance nodes to eliminate flexing and audible cabinet artifacts.

ARCAM FMJ

Arcam's approach to hi-fi has always been to provide the best combination of performance and price in the hi-fi separates market. The FMJ series not only continues this tradition but also evolves and extends it.

It quickly became apparent to Arcam's design team that the significant performance improvements gained from using more advanced chassis and casing materials and a solid metal front panel, could be taken further by revisiting the mechanical design of the units.

All FMJ products have finely textured, 8mm thick, aluminium machined front panels. These panels are then "sealed" by baking them in industrial ovens to ensure the durability of their high quality finish. Even the control knob on the A22 Amplifier is turned from solid aluminium before being given the same finishing treatment.

The **CD23** benefits from a second power supply transformer. This, like the power supply transformers used in nearly all Arcam amplifiers, is a toroidal transformer. Whilst being expensive compared to the alternatives, toroids are known to dramatically improve the audio performance of many hi-fi products. In this product, both transformers are custom made for Arcam and are used to supply the analogue and digital circuits separately.



Please Note: Some products may not be available at all outlets. Advertisement valid until at least 14th March 2001. E&OE



who are **sevenoaks?**

Founded as Sevenoaks Hi-Fi in the summer of 1972, the original shop, in the market town of Sevenoaks, Kent, quickly gained a reputation for offering a wide range of products at competitive prices, and providing excellent service.

Exciting new technologies like compact disc, meant that throughout the 1980's there was considerable interest in hi-fi and Sevenoaks were able to grow. By 1990, the company was established as one of the leading independent hi-fi specialists in the country.

More stores were opened and a number of the original shops were relocated. In 1995 the important decision was made to change the name to Sevenoaks Sound & Vision, reflecting the wide appeal of new audio visual products.

After twenty-eight years of trading, the company has more than forty outlets nationwide, and is for many of the UK's leading manufacturers of electronics and loudspeakers, their largest and most successful retailer.

solutions

The people at Sevenoaks appreciate that customers have a choice. This appreciation has meant that over the years Sevenoaks have had to adapt.

As new products and technologies have arrived, the staff have been trained to ensure that they can explain the issues, simply and informatively.

This orientation to customer service remains, and the implementation of a company charter is one example of this commitment.

By staying true to the original ideals of offering a wide range of the latest products, at competitive prices, and providing superb service in pleasant surroundings, Sevenoaks are able to listen, recommend, demonstrate and supply the products that best suit the needs of their many customers.

As the world becomes a more complex place and people search for entertainment and relaxation, Sevenoaks Sound & Vision believe that whatever the requirement, they have the solution.

solutions

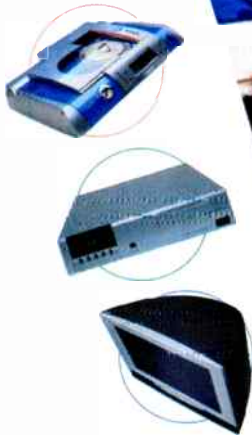

DVD Video is a great way of enjoying movies at home

brochure

available in all outlets





scotland and north

- Aberdeen** 491 Union Street **01224 587070**
- Edinburgh** 5 The Grassmarket **0131 229 7267**
- Glasgow** 88 Great Western Road **0141 332 9655**
- Hull** 1 Savile Row, Savile Street **01482 587171**
- Leeds** 112 Vicar Lane **0113 245 2775**
- Liverpool** 16 Lord Street **0151 707 8417**
- Manchester** 69 High Street, City Centre **0161 831 7969**
- Newcastle** 19 Newgate Street **0191 221 2320**
- Preston** 40-41 Lune Street **01772 825777**
- Sheffield** 635 Queens Road, Heeley **0114 255 5861**

midlands and east

- Bedford** 29-31 St Peters Street **01234 272779**
- Cambridge** 17 Burleigh Street **01223 304770**
- Ipswich** 12-14 Dogs Head Street **01473 286977**
- Leicester** 10 Loseby Lane **0116 253 6567**
- Lincoln** 20-22 Corporation Street **01522 527397**
- Norwich** 29-29a St Giles Street **01603 767605**
- Nottingham** 597-599 Mansfield Road **0115 911 2121**
- Oxford** 41 St Clements Street **01865 241773**
- Peterborough** 36-38 Park Road **01733 897697**
- Wltham** 1 The Grove Centre **01376 501733**

midlands and west

- Birmingham** 12 Queensway Arches, Livery Street **0121 233 2977**
- Bristol** 82b White Ladies Road, Clifton **0117 974 3727**
- Cardiff** 104-106 Albany Road **029 2047 2899**
- Cheltenham** 14 Pitville Street **01242 241171**
- Exeter** 28 Cowick Street **01392 218895**
- Plymouth** 107 Cornwall Street **01752 226011**
- Swansea** 24 Mansel Street **01792 465777**
- Worcester** 2 Reindeer Court **01905 612929**

london and south east

- Brighton** 57 Western Road, Hove **01273 733338**
- Bromley** 39a East Street **020 8290 1988**
- Chelsea** 403 Kings Road **020 7352 9466**
- Crawley** 32 The Boulevard **01293 510777**
- Croydon** 369-373 London Road **020 8665 1203**
- Epsom** 12 Upper High Street **01372 745883**
- Guildford** 73b North Street **01483 536666**
- Holborn** 144-148 Grays Inn Road **020 7837 7540**
- Kingston** 43 Fife Road **020 8547 0717**
- Maidstone** 96 Week Street **01622 686366**
- Reading** 3-4 Kings Walk Shopping Centre **0118 959 7768**
- Sevenoaks** 109-113 London Road **01732 459555**
- Southampton** 33 London Road **023 8033 7770**
- Southgate** 79-81 Chas& Side **020 8886 2777**
- Swiss Cottage** 21 Northways Parade, Finchley Road **020 7722 9777**
- Tunbridge Wells** 28-30 St Johns Road **01892 531543**
- Watford** 478 St Albans Road **01923 213533**

new outlets

Towards the end of 2000, new outlets were opened in **Edinburgh, Lincoln, Liverpool** and **Nottingham**.

Each outlet has dedicated their main demonstration room to the concept of home cinema. Built to the exacting THX specifications set-down by Lucasfilm, and using specially designed audio visual loudspeakers arranged so that they mimic the array found in a cinema auditorium, they are able to demonstrate the new extended surround formats being found on many of the latest DVD video releases.

All our outlets may be contacted via e-mail at the following address:

insert outlet@sevenoakssoundandvision.com. There are only two exceptions, these are: swiss.cottage@sevenoakssoundandvision & tunbridge.wells@sevenoakssoundandvision.



With the introduction of their 'entry-level' **Five Series**, which includes the CD5 CD Player and Nait 5 Integrated Amplifier, Naim Audio have enhanced their long established reputation still further.

All the models are built to the same exacting standards as those in their 'audiophile' range, and feature the hallmark 'idiosyncrasies' that make Naim Audio products so uniquely popular.

The Five Series provides a simple upgrade path, ensuring musical satisfaction for many years.

Naim Audio Products, including the Five Series, are available in **Bedford, Birmingham** and **Exeter**.



super audio cd

SACD is a superior performance format, developed by Philips and Sony, the original inventors of the Compact Disc.



New Dual Layer SACD Discs will facilitate a seamless transition to the benefits of the new format, although SACD is fully compatible with existing CD software.

The very latest processing technology used in SACD will allow recorded music to be reproduced at a much higher level.

Super Audio CD Players are available through all outlets of Sevenoaks Sound & Vision.



VINYL REVIVAL

Is vinyl really making a comeback? Noel Keywood looks at new figures from the music biz that suggest it is. Meanwhile, other formats plummet. . .

► I was intrigued to see a report on BBC Breakfast News giving healthy coverage to a vinyl revival. The story was that vinyl sales were on their way up, fuelled by Scratching and Dance.

In the past, vinyl revivals have been more a case of wishful thinking than anything else. I've written about them when things looked encouraging, only to see LP sales sink inexorably shortly afterward. The vinyl LP sells in miserably small quantities these days and I've come to see 'revivals' as little more than the last twitches of a dead format. It's true that the music business hastened the LPs demise but all the same, for the average Joe or Jane, the fragility of a stylus was a serious impediment to a wild Saturday night in. There's no real, serious chance of a major vinyl revival; the CD is just too convenient. People are as likely to go back to spinning LPs as they are to wearing Terylene.

All the same, I was intrigued. The Beeb report and another in the Observer newspaper were triggered by third-quarter (July-September) 1999 trade delivery figures from the B.P.I. which certainly looked good but were more likely a blip rather than a trend, I supposed when I inspected them some months

ago.

The B.P.I. have just released fourth-quarter (Oct-Dec) results for 1999 and they suggest that vinyl's popularity seems to be more than a blip, even if it is not a full blown revival. Healthy survival is more like it. There are other stories to be told from these figures as well. Vinyl isn't the only medium in flux.

level, down from a peak of 91m reached in 1975.

By way of contrast, CD sales currently stand at 177m and have just risen 9%, so the CD remains enormously popular. Since third-quarter LP sales were up 34% it looks like the LP is gathering strength again, which raises the question: who is buying it and why?

Quarterly Analysis by Format

BPI

		Oct/Dec 1998	Oct/Dec 1999	Oct/Dec 2000	% Change 1999-00
7" Singles	Units (000)	192	201	128	-36.3%
	Value (£000)	£195	£281	£114	-59.4%
12" Singles	Units (000)	1,332	1,991	2,081	+4.5%
	Value (£000)	£2,936	£4,175	£4,356	+4.3%
Cass Singles	Units (000)	5,554	5,449	3,682	-32.4%
	Value (£000)	£5,021	£5,702	£3,961	-30.5%
CD Singles	Units (000)	15,215	14,167	11,256	-20.5%
	Value (£000)	£25,791	£29,672	£23,427	-21.0%
Total Singles	Units (000)	22,293	21,808	17,147	-21.4%
	Value (£000)	£33,943	£39,830	£31,858	-20.0%
LPs	Units (000)	569	690	976	+41.4%
	Value (£000)	£1,776	£1,790	£2,956	+65.1%
Cassettes	Units (000)	13,265	7,825	4,262	-45.5%
	Value (£000)	£48,878	£32,080	£16,267	-49.3%
CDs	Units (000)	69,903	71,770	82,705	+15.2%
	Value (£000)	£370,573	£393,006	£429,589	+9.3%
MiniDisc	Units (000)	124	175	77	-56.0%
	Value (£000)	£925	£1,265	£533	-57.9%
Total Albums	Units (000)	83,861	80,460	88,020	+9.4%
	Value (£000)	£422,152	£428,141	£449,345	+5.0%
Total Value		£456,095	£467,971	£481,203	+2.8%

BPI trade delivery figures for Oct-Dec 2000

The latest BPI figures we show here list an apparently spectacular 41.4% rise in LP sales, reaching a new annual total of 3.2million. LP sales bottomed out in 1996 at 2.4m and have been bumping along at that

The answer to this is to be found in the Dance market where 12in vinyl singles sales have been on the increase for many years now, amounting to nearly 8.5m last year, up 22%, the highest figure since 1995.

That's a lot of records and a trip down Oxford Street to the Megastores showed long lines of Dance vinyl in racks. It's got a high profile where there's space for it.

Most of these discs spin at 33rpm, unlike the 12in singles of the 1980s, which spun at 45rpm. However, just to confuse matters some of them also spin at 45rpm and rotational speed isn't clearly marked. I bought a 'single' (Cevin Fisher, It's a Good Life) that spins at 33rpm one side and 45rpm the other! As Simon Pope points out in his editorial this month, when running times are short, cutting engineers will allow massive groove excursions, making for dramatic sound quality.

It's curious that rotational speed suddenly seems to have become unimportant to a generation of buyers. Here, it seems, the market isn't constrained by old practices and ways, appealing instead to a new user not weaned on pernicky belt drives where changing speeds is a 'get out and get under job', but on the Technics SL1200 which moves effortlessly from 33 to 45 rpm at the flick of a switch. The only problem with this hypothesis is that a new Technics SL1200 M3D costs a cool £600 or

so, whilst the outgoing model is £400. This turntable apart, it isn't clear what the Dance crowd use to play their vinyl, other than budget turntables lying around the house, remnants from an old midi-system, or newcomers like the Project Debut, as well as Far East cheapos like Limit and Sherwood. It's a peculiarly ill defined market at present, but with 8.5million discs finding their way into UK homes last year there are more turntables being used now than for a long time. The BPI tell us that "the UK singles market was second only to Japan and was 6% larger than North America's". Something is going on out there.

What about 33rpm LPs? The Oxford Street Virgin Megastore had none in their entrance and just a desultory collection elsewhere. They still think MiniDisc is about to get big, judging by their displays. Wakey, wakey.

HMV had a healthy stock of LPs. I guessed around 40% of current releases were covered, looking at lines of LPs stacked alongside CDs in the crucial entrance area. The B.P.I. told me that in 1999 30% of the top 500 acts were available on vinyl, so quite a lot of effort still goes into

producing LPs and HMV is the place to go for them. This is likely due to HMV's historic link with EMI, who still press LPs at Hayes, Middlesex - and make a fine job of it. If there are no LPs in your local shop then it's quite likely down to their stocking policy, rather than real availability. LPs are a minority interest now, they are heavy and take up space, so you may have to travel for them.

Prices of LPs hover around the £15 mark, sometimes rising to £25. HMV had some vinyl LP classics in their racks but they were distributed into musical categories around the edges of the store mostly, so if you choose to visit these superstores you will have to search around.

The curious story of vinyl's revival isn't being repeated elsewhere. Prerecorded MiniDisc sales are plummeting, and so are pre-recorded cassette sales, both down over 40%.

It's looking good for the LP. Dance singles appear to be re-introducing a whole generation to the turntable and vinyl disc. The dramatic sound quality of 12in singles, especially at 45rpm, is likely a factor in all this. If the LP does survive because of the single it'll be a surprising conclusion to a long drawn out decline.



SPINNING A SINGLE

well designed. The SL1200 can cope with 33 and

give a great sound, it will also impose little wear or damage. Poor cartridges sound bad and damage discs when they mistrack.

Good cartridges come from Shure, Ortofon, Stanton and Goldring.

Nowadays, many amplifiers lack a phono stage. The low output of a cartridge needs extra amplification and equalisation. Budget external phono stages are available from QED (tel: 01276 451166) as the battery/mains Discsaver and NAD (tel: 01908 319360) as the mains powered PPI. Naim, Linn, Project, Cyrus, Roksan, Musical Fidelity and Michell make quality external phono stages, and World Audio Design make an all-valve phono stage kit. ■ ▲

Top of the tree for DJ and Dance use is the SL1200 LTD turntable shown here, recently superseded by the SL1200 M3D. The SL1200 was originally aimed at the hi-fi market, but complex direct drives never caught on. It's fast-start motor suited DJ use though, and it has a pitch control and a cueing light, conveniences not found elsewhere. The arm is sturdy yet light, with a removable headshell, so even in this crucial and difficult area the SL1200 is

45rpm singles easily.

Hi-fi turntables mostly run at 33 and 45rpm, but the ease with which speed can be changed varies. Some decks virtually have to be dismantled to change speed.

Whilst hi-fi decks are less suited to heavy use than budget DJ decks, they come fitted with a better cartridge. Here we come down to the issue of sound quality. A Project Debut deck comes with an Ortofon already fitted and this will not only

MUSIC MATTERS

THE FINEST HI-FI AND HOME CINEMA



PLEASE CONTACT ONE OF OUR BRANCHES TO ARRANGE A DEMONSTRATION OF B&W CDM NT LOUDSPEAKERS AND ARCAM DIVA ELECTRONICS, INCLUDING THE STUNNING DV88 DVD PLAYER, TO EXPERIENCE A COMBINATION OF EXCELLENT SOUND AND PICTURE QUALITY WITH SUPERB AESTHETICS!



Music Matters stock one of the widest ranges of hi-fi and home cinema products including Chord, Copland, Cyrus, Denon, Dynaudio, KEF, Krell, Marantz, Meridian, Mission, Musical Fidelity, Pioneer, REL, Ruark, Sonus Faber, Tag McLaren, TEAC and Yamaha. All of our branches offer excellent demonstration facilities and we pride ourselves in providing friendly and un-biased advice. We are members of BADA and CEDIA to give the best support to our customers, accept all major credit cards and can arrange finance including interest-free on selected items. (Written details on request. Licenced credit broker. APR 0%.)



363, HAGLEY ROAD, EDGBASTON, BIRMINGHAM, B17 8DL. TEL: 0121 429 2811
93-95, HOBS MOAT ROAD, SOLIHULL, WEST MIDLANDS, B92 8JL. TEL: 0121 742 0254
9, MARKET STREET, STOURBRIDGE, WEST MIDLANDS, DY8 1AB. TEL: 01384 444184
10, BOLDMERE ROAD, SUTTON COLDFIELD, B73 5TD. TEL: 0121 354 2311
344, UXBRIDGE ROAD, HATCH END, MIDDLESEX, HA5 4HR. TEL: 020 8420 1925

Open Tuesday to Saturday 10.00 - 5.30. Late night Thursday until 6.30 (except Stourbridge).

Does your rack sing along?

Create a quiet space with *cd-str5*!



"I do like the *cd-str5* feet." "Bass stays firm and nimble, while the midband gains warmth and fluidity."

Jimmy Hughes writing in Hi-Fi Choice, issue 210, January 2001

Damping resonance for better sound.

www.hi-fi-accessories.com

cd-str5, liked by Jimmy Hughes & highly rated by Stereo and Audio, Germany's leading HiFi magazines. £59, set of four isolating feet. No-risk money back guarantee.

Information and orders:

cd-str5, 1 Mortimer Cottages, Leominster, Hfds. HR6 9TG

Tel: 01 568 708 739 cd-str5@talk21.com



ORANGES & LEMONS

Juicy fruit from London's freshest hi-fi / home cinema retailer. Free home installation + credit cards. 0% credit finance available (subject to status).

ARCAM, B&W, CABLETALK, CASTLE, CHORD CO, DENON, EPOS, KEF, LINN, MARANTZ, NAD, NAIM, NEAT, QUAD, REGA, ROKSAN, ROTEL, ROYD, RUARK, SOUNDSTYLE, STANDS UNIQUE, YAMAHA

Our Sixth succulent year

**THE INNOVATIVE
AUDIO RETAILER**

0171-924 2040

61/63 WEBBS ROAD, CLAPHAM, SW11

www.orangesandlemonshifi.com

ICE COOL

Not all in-car entertainment is created equal.

David Price reviews Nakamichi's latest CD-45 car CD tuner.

If you're anything like me, the mere thought of 'car hi-fi' sends you into a spiral of depression. No matter how hard you try, it seems almost impossible to find any half-decent sounding hardware or a dealer with more than two working brain cells.

Nakamichi will be familiar to Hi-Fi World readers as the purveyor of top quality cassette decks, but did you know it also does serious in-car entertainment?

The CD45z tested here is the second in the company's CD tuner range and retails for £450. Anyone familiar with Nakamichi cassette decks will find its simple, fuss-free ergonomics as delightful as that famous name. The front panel isn't the easiest to attach or detach, but once on it has a reassuringly solid, mechanical feel to it. The unit also comes with a classy looking wireless remote control, which will doubtless delight the back seat drivers of this world.

The middle of the fascia is dominated by the rotary volume control. Rubber edged and silky smooth in action, it's a delight to use and far superior to the up-down buttons used by certain other brands. There are also dual purpose buttons for Mute (Clock), FM/AM (RDS EON), RDS mode and Sound Tuning (Loudness). When pressed, the latter offers a menu of Balance, Fader, Bass, Mid and Treble tone controls.

Once you've set the tone controls to suit your car's acoustics (mine needed very little trimming at any frequency), you can appreciate the CD-45's very special sound. I've tried

a range of CD head units in the past (Alpine 7840, Clarion 9575Z, Kenwood KRC-7080) and the Nakamichi sounds by far the most transparent.

Poor DACs are the bane of low and mid price CD tuners - many manufacturers skimp on the quality in order to bankroll showroom-friendly

features like motorised faceplates, neon light shows and what have you - and this explains the grey, cold, transistory sound you get from so much in-car stuff. In this respect, the CD-45 is a class above almost all its price rivals. Sliding Goldie's 'Angel' into the disc loader, I got a remarkably clean, detailed and even handed sound. Female voices - always the acid test - were brightly lit but not coarse, hi-hat cymbals were crisp and spry yet never harsh. Imaging was bold and soundstaging deep with a very low noise floor - the acoustic seemed to fall back much further than I've heard from other CD tuners.

While not quite up to the dizzy heights of the CD player, the tuner section is a conscientious effort. FM sound isn't that far removed from CD, with a very clean and detailed flavour and sharply defined stereo imaging. With a quoted 15dBf (IHF) sensitivity, it isn't the most flexible I've tried - with my car's twig at least, the CD-45z struggled to receive BBC Radio 4 on stretches of the M4 that

my previous budget Sony took in its stride. AM was superb - with a strong and full bodied sound, it was one of the best performers I've heard in-car.



The amplifier section is excellent too - 4x43W isn't going to blow out your windscreen, but it's easily enough to shift large amounts of cabin air. Impressively, it showed few signs of strain even near its highest volume setting,

and never let go in the bass as cheaper designs invariably do.

If there's any criticism I can make about the CD-45, it's that it's almost too good for the money. Its £450 retail price makes it just about cheap enough to be slotted into your dashboard in lieu of your standard radio/cassette. Only then will you realise how hopelessly inadequate your standard speakers are, so you could find yourself spending a lot more. Other grumbles? If like me you use dark blue/green dye CD-Rs from the likes of TDK, you may find the Nakamichi mistracks near the end of the disc. Use light dye blanks, though, and it'll play flawlessly. Oh, and if only it had CD Text and Radio Text like Kenwood. Still, if ever there was car audio designed to be heard and not seen, Nakamichi's CD-45z is it. ■▲

Nakamichi CD-45z £450

BBG Distribution
Unit 3 Barrett Way Tudor Rd
Middlesex HA3 5QS
Tel: 020 8863 9117
www.bbgdistribution.co.uk

World Verdict



With sound quality that wouldn't disgrace a decent domestic hi-fi, plus superb build and ergonomics, this is one of the most desirable car CD tuners around. Expensive, but superb value nonetheless.



A3 RANGE.

MACHINED, MIL-SPEC ALUMINIUM
FRONT PANEL.

TWENTY-FOUR CARAT GOLD
PLATED FITTINGS.

REMOTE CONTROLLED.

PHONO STAGE.

POWERFUL, ROBUST, BUILT.

MUSICAL FIDELITY

A3 RANGE: INTEGRATED AMPS, PREAMPS, POWER AMPS, TUNER, CD PLAYER AND HOME CINEMA DECODER. FOR DETAILS OF YOUR NEAREST STOCKIST RING 020 8900 2866.

Swing low sweet Chario

From the shores of Italy comes the new Constellation Cygnus from Chario. Will Simon Pope be star struck?

Chario makes a wide variety of loudspeakers, from affordable budget 'department store' designs to the upper echelons of high-end esoterica. It has three basic model ranges, comprising Reference, Constellation and Academy, in ascending order of price and sound. The last Charios we heard were the £1,200 Academy Millennium I - sophisticated and cultured stand-mounters in the archetypal Italian mode. This time it's the turn of the visually arresting £1,000 Cygnus from the Constellation series, which is the smaller of two floorstanders in the range.

As we've come to expect from an Italian 'speaker of this money, the cabinet is both beautifully built and attractive to the eye. Its sides are constructed from three panels of solid hardwood intricately joined together, whilst the rest of the cabinet is formed from Medite, including the bottom plinth to which the cabinet is joined by Medite feet. These gaps between cabinet and plinth are not solely aesthetic but normally involve an attempt at bass reinforcement, in the form of either a downward firing port or bass drive unit. In this case it's both, making the Cygnus a three-way bass reflex design. All drivers are made by Chario (proving it's no simple 'potting shed' outfit) - the 130mm mid/bass units are constructed from doped paper and the tweeter a 20mm silk dome model. Spikes are provided to attach under the plinth.

Using a Meridian 506.24 CD player, Cyrus 7 integrated and Meridian's 502/557 pre and power

amps I started the listening with Mahler's 6th symphony played by the Vienna Philharmonic under Pierre Boulez on DG. First impressions were of an innate smoothness and richness to the sound in which strings, especially violins, were treated with a sympathy bereft of many 'speakers on the market. The opening movement starts with a brisk, menacing march, the cellos and double basses pulsating fiercely, with the theme on the violins. The Charios showed power and depth in the bass but also a smidgen of bloom, which although not distracting was nevertheless obvious. This, I felt, was due to the down firing port rather than box boom.

Highs were handled well with a warm and very sweet sound, woodwind instruments rich and full and high percussion sparkingly fresh but not over bright. They sounded very much at home with a few of Beethoven's middle quartets played by the Quartet Italiano on a 1970s Philips analogue recording. String tone and phrasing were brought to the fore and again the balance between instruments was superb. These attributes together with the fine overall tonal balance, showed the Cygnus to be an accomplished classical music speaker which is able to handle large scale music commendably well despite its relatively small box volume.

Moving to the rock sounds of Skunk Anansie's 'Weep', the Charios handled Skin's vocals with aplomb. The slightly rich nature of these 'speakers brought a certain fruitiness to the voice which was great. What

let them down however was their lack of speed with bass and drums - I felt they needed a large espresso to kick them into life. While open guitar lines and cymbals sounded fresh and clean, the bass felt like it needed to catch up with the upper parts. This same effect happened again with Underworld's admittedly fast and pumping bassline in 'Push, Upstairs' from 'Beaucoup Fish'.

Here's a loudspeaker voiced for classical chamber and orchestral music, with a smooth sophistication matched by a clean and detailed midrange. I enjoyed my time with them, and would declare them well worth a listen if you preferences lean this way. ■ ▲

Chario Constellation Cygnus £1,000

Musical Design Company
Tel: 01992 573030



World Verdict



Enjoyable, smooth sounding and finely put together. Good with classical but sound a tad loose with bass heavy music.

Measured Performance
see page 111

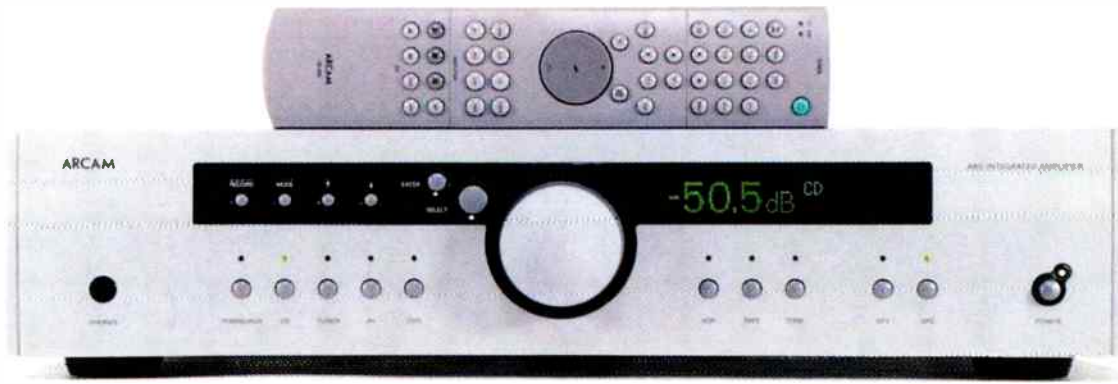

PRIMA

Simon Pope takes the romantic lead with Arcam's A85, top of the range integrated amplifier in their new DiVA series.

"The past couple of years have been difficult ones for manufacturers. With declining sales in some sectors of the two-channel separates market many have felt the need to expand their product range to encompass A/V products. The audiophile likes of Musical Fidelity, Roksan and now the "UK's leading manufacturer of hi-fi electronics", Arcam are turning their attention to DVD players, processors and multi-channel amplifiers. However not forgetting their audio stereo roots, the launch of Arcam's DiVA series (Digitally integrated Video & Audio) sees the company producing not only an audiophile DVD player and AV receiver but also a seven-strong two channel product range.

This new range of products features a radically new look from the company always associated with a high quality sound from somewhat staid looking components. Arcam called on the services of out-of-house industrial designers to work on the new range. Consequently, the new DiVA series (available in either black or silver) has a sleek and stylish look more akin to their flagship FMJ range than the grey box Alpha products. Dare you brand them 'boring' now?

Arcam have always regarded amplifiers as the heart of any hi-fi since they started making them back in the mid-seventies and that tradition continues. The DiVA series

contains a total of five two channel amplifiers, two power amps and three integrations, of which the A85 is the top dog. An awesome amount of electronic design work has gone into the range, most of it masterminded by the company's new head of R&D, a certain Johnny Reckless (I jest not!). If ever a name was destined for rock stardom, it's his. Instead he turned his talents to audio design and now heads up a sixteen-strong team at Arcam's HQ in Cambridge.

The flagship A85 integrated is the only one of the three to feature a comprehensive display window, necessary for all the hi-tech facilities it's veritably stuffed full of. There's undoubtedly a lot of very clever stuff going on here, thanks to the use of a microprocessor based control system which gives awesome flexibility to the A85. There are a total of seven inputs, each one of which has adjustable sensitivity and can be assigned its own bypassable tone control setting. This feature can make the switching between a CD player to Radio 3, for example, less an agonizing trauma and more a sensuously seamless integration. A slight exaggeration perhaps but you hopefully understand what I'm getting at.

Further luxurious delights are found when altering the volume control. With the current obsession for everything 'oversize' - hotel beds, restaurant plates and cutlery, etc. -

the beautifully clean dot matrix window displays the volume level (in minus dBs) in an impressively large numerical display. Although not too large to make the whole effect 'Fisher Price' style, if it's not to your liking it can be changed to a more 'sensible' bar graph display. Those like me, who like to live dangerously though, will love the chunky numbers - especially when you hit 'mute' on the sleek remote and the display counts down (or rather, up?) to -73dB in a flash. Sublime!

The A85 has a totally new circuit design for both the pre and power sections. The whole amp is direct coupled from the input to output with no capacitors in the signal path. The heart of the power supply is a weighty toroidal transformer which gives a quoted output of 85W per channel into 8Ω and 130W into 4Ω. Being a newly conceived series for the future, Arcam have made sure that future formats will be properly served and SACD and DVD-Audio can be fully appreciated through the A85. There are two remote switchable pairs of 'speaker outputs and a Headphone output. An optional MM/MC phono stage is available and pre-amp outputs are provided which can be supplied in a three channel version for multichannel use.

SOUND QUALITY

You may well have realised by now the A85 immediately impresses with



DONNA

its facilities and looks but at the end of the day, the proof of the pudding is in the eating and it was time to get the A85 cooking.

Diving straight in at the deep end without arm bands, I treated the A85 to a bit of an onslaught courtesy of Rage Against The Machine's latest earbashing, 'Renegades'. The album is well mastered with awesome use of compression and level. Pearl Harbour had nothing on it and I'm glad to say the Arcam had the neighbours politely popping round for a quick, friendly chat. The pounding kick drum of the scorching rap-metal track 'Pistol Grip Pump' was delivered with a powerful dead thump, and the bass guitar was as tight as the proverbial duck's rear quarters - and deep to boot. This amp certainly has life. Vocals (or rather shouts) were clean and forceful and the blazing guitars showed a detailed and open midrange. All this power and drive had perfect control however, I never once thought the express would derail.

Calming both myself and my neighbours down I next fed Miles Davis's seminal 'Kind Of Blue' into the Meridian 506.24 CD player. What followed was an aptly cool and refined performance. Again bass was tight and well controlled below

Davis's barren blowing in 'So What'. The trumpet kept smooth and lyrical, rather than raspy but when Coltrane's silky tenor entered via the left channel, I felt the sound was just a tad colourless. Presence and phrasing were perfect but a little warmth which sometimes benefits this sound was missing. Apart from this there was nothing to fault and the A85 did its job well.

Classical orchestral music in the shape of Tchaikovsky's fifth symphony with the Oslo Philharmonic under Jansons on Chandos records showed up the superb sound staging of the A85. Here was depth and breadth in abundance as the timpani thumped well back in the mix and the double basses growled from stage left. Rhythms were powerful and exact, driving the music on excitingly, whilst the lyrical nature of instruments such as the opening clarinets of the first movement was brought to the fore. Again a little more instrumental colour could have been present but frequency balance was good and the sound nice and open.

CONCLUSION

This is a fine integrated for the money that merits a serious

demonstration if you're in the market for a sub-£1,000 integrated. It has excellent control and poise with power enough to easily drive all but the very toughest.

It suits all types of music well but will deliver rock, dance and jazz a tad better than classical due to a slight greyness to the sound that could restrict the true timbre of some instruments. It's a trait of solid state amps though. I'm comparing the Arcam to more expensive power and valve amps, and in many other respects, such as sound staging, it's excellent.

For an integrated under £1000, little can touch it musically apart from Musical Fidelity (slightly more transparent) or Audio Analogue (slightly more lyrical). With a wide range of facilities and good upgrade potential, this is an ideal all rounder. 

ARCAM A85 £699.90

A&R Cambridge Ltd
Pembroke Avenue
Denny Industrial Centre
Waterbeach
Cambridge
CB5 9PB
Tel: 01223 203203
www.arcam.co.uk

World Verdict

Exciting integrated with detail, poise and control that can compete with the best under £1,000. Excellent facilities and upgrade potential.

Measured Performance
see page 111

DESKADEL

When only the best will do!

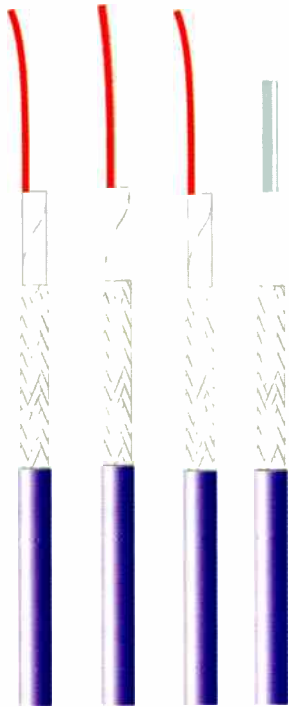

Conductor
Reference Cables
and Connectors
in PURE gold and PURE SILVER

Worldwide Distribution

Wire & Insulation Tel/Fax: 00-44-1-942-887171

Agents

1	Arbelos	Switzerland	Tel: 00-41-718586282
2	Analogue Audio	Netherlands	Tel: 00-31-306044342
3	Audio Synthesis	United Kingdom	Tel: 00-44-1159224138
4	Deskadel International	Belgium	Tel: 00-32-3-8892231
5	Ginsa Electronics	Spain	Tel: 00-34-932005055
6	Lothar Hoffman	Germany	Tel: 00-49-60298107
7	Christou Laertis	Greece	Tel: 00-30-1773208
8	Lowveld Audio	South Africa	Tel: 00-27-137511485
9	Samhouse	Hong Kong	Tel: 00-852-254457

DESKADEL

MOERPLAS 53 2870 PUJRS - BELGIUM

Telephone: +32 3 8892231 Fax: +32 3 8609181

web: <http://www.deskadel.com> e-mail: kdelaet@deskadel.com

van den Hul[®]



THE LINK BETWEEN
TECHNIQUE & EMOTION

Loudspeaker cables

£13.49/m
CS122 Hybrid
Best Buy What Hi-Fi?
★★★★★ Awards '00

£23.99/m
Teatrack Hybrid
Bi-Wire CS122 Hybrid

£49.99/m
The Optocoupler
Best Buy What Hi-Fi?
★★★★★ Awards '00

Pure Linear Structured Carbon and LSC hybrid cables are unique to van den Hul

Interconnect cables

£79.99/0.8m pair
D102III Hybrid
Product of the year
(interconnects)
What Hi-Fi? Awards '99
Best Buy What Hi-Fi?
★★★★★ Awards '00

First Ultimate
£269.99/0.8m pair
★★★★★ What Hi-Fi?
Sept '00

£49.99/0.8m pair
PB5 Hybrid
Best Buy Hi-Fi Choice
March '99
★★★★★ What Hi-Fi?
October '99

£239.99/0.8m pair
Integration Hybrid
"Wonderfully realistic" Hi-Fi World
"Highly recommended" - Feb '01

£64.99/0.8m pair
Orange Source
★★★★★ What Hi-Fi?
May '00

For more information on our extensive range of cables please contact

van den Hul UK

Imex House 6 Wadsworth Road Greenford Mdsex U B6 7JJ Tel: 020 8997 4280
e-mail vandenhukukl@hotmail.com

campaign audio design "Love Hertz"



Getting a better, more involving sound often means spending a lot of hard earned money. It's such a waste, because every system can benefit from our cables and accessories, at a fraction of the cost of some new "black box". Here are some of the ways we can help.

We have Linear Crystal Oxygen Free Copper interconnects (£12.48) up to High Purity Silver balanced cables (£99.00) and high definition

loudspeaker cables in Silver Plated Copper or Pure Silver. Our mains cables add weight, power and scale, and with non-inductive RF filtering (£10.00) and over-voltage protection (£3.00) enhance performance still further. Gold plated AV cables, both RF (£19.95) and OFC Seart with PTFE insulation (£19.21), help bring picture quality in line with NICAM sound resolution.

We also have a cure for your noisy fridge or central heating motor (£3.50), enabling you to throw away your big mains noise suppressor, which has been giving you that "sat upon sound" for years. There's lots we can do to bring you closer to the emotion and energy of the performance. So confident are we, that we offer a 21 day money back guarantee.

Ring or write for details:-

CAMPAIGN AUDIO DESIGN

Llandudno Road (HW)

Cardiff CF3 3PG

Tel: - 02920 779401

Website: <http://business.virgin.net/cad.cables/>



Trade and International Enquiries Welcome.



New Format War Beckons

Hi-Fi World reports exclusively on RDA. A fascinating new development that promises to give the latest audio formats a run for their money.

There's no doubt that digitally downloadable music is fast becoming the format of choice for today's technology-conscious music buyers. Not everyone is convinced that this is progress however, which is why a group of hardcore hi-fi nuts has come up with a new format designed to redress the balance. RDA (Retro Digital Audio) is claimed to satisfy the needs of unreconstructed audiophiles who grew up listening to music 'the proper way'.

The brainchild of a consortium of 1970s hi-fi journalists intent on enjoying pure, perfect sound forever, RDA's technical spec reads like a trip down memory lane - 44.1kHz oversampling with 16bit words on a 30cm optical disc.

The RDA Consortium's Technical Director Mike Spike, ex-editor of 'Audio Stack'

magazine, told us that the new format offers the best of all possible worlds. "Well first, it's on a disc" he commented, "which means reviewers can get on mailing lists for free music again. Ever since MP3 was invented, the record companies stopped all that and we had to buy our own bloody music again!"

Asked why RDA had 'gone back' to Philips' original 16/44 digital audio specification developed back in the seventies, Spike replied: "Well, like we all said at the time, it's pure perfect sound forever. I'll never forget when I

first heard 'Dark Side of the Moon' on CD back in '83 - it was so realistic I thought I was going mad, with spiders crawling up me back and all that."

Another 'interesting' aspect of RDA is that it uses old fashioned, twelve inch discs. How so? "Well, at the time CD replaced vinyl, many of us had grave reservations about the format's ability to fully reproduce subtle information and details like the gatefold sleeves found on seminal

industry. While some companies have been gearing up to produce state-of-the-art flash memory-based audio devices, others see the format as affording them another opportunity to make stuff people don't want to buy anymore.

Britain's major manufacturers, gave a mixed reaction. A spokesperson for one major UK hi-fi manufacturing business commented "Och, we've no plans for an RDA player as yet but you can bet your

elk's backside that if we had, then ours would be better than anyone else's, Jimmy" A London based manufacturer, famous for its cylindrical shaped power amps said, "Well, of course dear boy, if it's popular we'll have a ten strong range of players out by next Wednesday". A Huntingdon based pipe and slipper manufacturer was out



Scoop spy shot - note the player's extensive retro styling cues, extending to the tonearm-style laser pickup and wood veneer plinth-encased DAC

classic rock albums. I mean, 'Trick of the Tail' in a jewelcase? What were they thinking of?"

"By combining the best characteristics of the Compact Disc and Vinyl LP, we believe that music buyers will abandon that stupid downloadable crap and flock back to disc-based audio in droves. I mean, why download 'Crime of the Century' on your computer when you can buy it on double gatefold RDA for only £26.99?"

News of RDA has caused a mixed reaction within the British hi-fi

to lunch when we called, and one Salisbury company asked if the format permitted the use of DIN plugs.

Many experienced hi-fi industry observers believe RDA is just what hi-fi needs. "Thank God for RDA," said I'm D' Istortion of 'What Rack?' magazine, "it's just what we all need to have a good old barny amongst ourselves while no one else is listening." Bill Others, a leading audio public relations supremo said, "It's big, it's fun, it's sexy, it's very you, darling. Ermm... can I have a receipt for that please?" ■ ▲

letters & e-mails

Visit our website at www.hi-fiworld.co.uk or send your e-mails to letters@hi-fiworld.co.uk

Every letter we print wins a superb prize including Precious Metals interconnects and a **FREE** subscription to **Hi-Fi World** for the best letter of the month!!

LETTER OF THE MONTH

READING AND WRITING [1]

Do CD players read discs differently? The reason I ask is because we have three CD players in our house, and my TEAC VRDS-7 sometimes will not even play new CDs, and absolutely never CDs from a library. My daughter has a Technics 490G and it gladly plays anything you throw at it, likewise my son's cheap TEAC. I find it hard to believe that, as a service person told me, it's just a question of changing the laser on my machine. My local record shop owner laughed when I told him about my problem. He told me that in his experience the same machines from the same companies reacted very differently regarding their reading abilities. I use Colgate toothpaste with baking powder to clean the unreadable CDs, and sometimes it works, sometimes it doesn't. Can you help?

Greg,

Greg, do us a favour and keep the baking soda in the kitchen and the Colgate on your toothbrush! The chemical and abrasive properties of the two together is more likely to ruin your hi-fi than clean your discs!

There are several reasons why your TEAC isn't reading discs properly. The most obvious cause is a dirty laser lens - this happens to all players but is aggravated by smoky or dusty air in your listening room, not to mention baking soda particles. There are fixes - easiest is to buy an Audio Technica CD Lens Cleaner (there are others available, but we've found this to be the best), dab a bit of fluid onto it, load it into your player and give it a spin. It doesn't work with all transports, but when it does, it works well.

Better still, clean your lens manually. Disconnect your VRDS-7 from the mains, remove the case and taking care not to touch ANY of the electronics inside, gently clean your laser lens with a cotton bud dipped in Isopropyl alcohol in a circular motion. Then dry it with the other end of the cotton bud, put the case back on and try it now. This often works wonders, and can actually drastically improve your CD player's sound even if it isn't mistracking. If it's still faulty then it's likely that either the laser is dying or the transport alignment is out - either way it's an expensive trip back to the importer



or manufacturer. As your VRDS-7 is a decent player though, I'd say it was worth fixing.

If you ever need to 'power clean' CDs, the easiest way is to squirt some washing up liquid on them, run them under the hot tap until all the grease, fingerprints and congealed toothpaste has come off, then wipe them dry with a soft cotton towel in a radial motion with your index finger, from the inside of the disc going outwards. Really stubborn marks should get a second cleaning with the aforementioned Isopropyl alcohol. For CDs with just a few marks on, the above is too

Store your discs like this and you could end up with some skipping!



ARCAM

Visit www.arcam.co.uk

for Arcam news, product information, technical support and advice on how to get the best from your system

Arcam, Pembroke Avenue, Waterbeach, Cambridge, CB5 9PB, England
Tel: +44 (0) 1223 203203 Fax: +44 (0) 1223 863384
support@arcam.co.uk www.arcam.co.uk

drastic - best just blow on the disc so it mists up, then wipe the moisture off in a radial outwards motion with a clean cotton towel. **DP** ■

DP's right about the baking soda and toothpaste. It's a bit of an old wives' tale, along with Brasso. Whilst great for polishing your gnashers, CDs are a little more sensitive to the stuff. I speak from experience. Although previously believed to be a quick fix for problem discs, applying baking soda and toothpaste to my once-cherished 'Rage Against The Machine' disc resulted in disaster and the only use for it now is as a street-wise, in-car accessory to be dangled below the rear view mirror.

If your disc is shot to pieces anyway then give it a try as a last resort, but otherwise stick to more conventional methods. Like good old vinyl, prevention is the best cure. Using them for drinks coasters and playing frisbee with the dog will soon result in a skipping disc. Giving you CDs a regular wipe over with accessories such as Ross's Disc Wipes (cheap, available from dealers and some High St. stores) will help preserve your discs shelf life. **SP** ■

There are several reasons for your Caspian being all at sea. First, the lens could be dirty - see the above query for an answer. Second, the unit could be faulty - after you've cleaned the lens it would be worth going back to your dealer with the player for him to check it. Three, you're playing the wrong sort of CDs - many CD players simply don't like CD-Rs, thanks to their lower reflectivity. Some brands and colours of CD-R are better than others, but the darker (blue) dyes used by Sony and TDK can rub some machines up the wrong way, especially towards the end of the disc. The answer is to copy your CD-Rs onto higher reflectivity CD-R media (just do a direct disc copy with your CD-R in the CD-ROM and a fresh blank in the CD writer). The best thing is to try out several brands and colours, to see which suits your Roksan best. Also, at all times avoid the 80 minute blanks, which are simply more than many hi-fi CD players can cope with.

As for speakers, it sounds like you're looking for a high quality, mid price solution that's not too big or imposing. Mission's 782 (£700) is an ideal choice, thanks to its compact, small-footprint dimensions and high efficiency. The former is important considering your room size and the latter an essential qualification considering your Alabaster's modest power output.

Alternatively, B&W's CDMINT (£750) is the latest evolution of what, for my money at least, has been a very impressive speaker. With its high tech Kevlar mid-bass unit it's very sensitive, a very musical listen at low levels, and being a standmounter won't over drive your room either.

DP ■



Mission's 782 - slim yet powerful

RM TRANSPLANT SURGERY

I have an AR EB101 turntable which I am unable to use at the moment as the wiring in the arm is faulty. I am unsure whether to have the wiring replaced in the arm, replace the arm with a new one or replace the whole turntable. I'd appreciate your thoughts. My budget would be up to £100 for the first two options or £250 for the last. If you think the first option is most appropriate, do you happen to know any reputable firms in the north west? Thanks for an excellent magazine, and in anticipation of your kind assistance.

Peter Steele

It depends what you want to do with your vinyl - is it a primary source, or something for the, erm, weekend? A quick fix would be to get Origin Live (tel: 02380 442183, net: www.originlive.com) to rewire the arm with standard Litz cable for a very reasonable £38. This would be a small improvement on the original arm, but if you really wanted a noticeable difference, you should go for a standard Rega RB250 at £109.

Fitting the RB250 to your AR is certainly possible - indeed it will go on most decks. If you can't find a pre-drilled Rega armboard (try asking some local dealers), then you should remove the old arm and drill a single 24mm hole in the armboard, with a 222mm gap from the centre of the arm pivot to the centre of the platter spindle. When working out the position, remember the length of the arm from its mounting hole centre to the end of the headshell is 245mm, and the rear arm overhang is 50mm to the end of the counterweight stub.

When mounting it, the tip of the stylus should be 240mm from the pivot. In approximate terms, the armboard mounting hole should be such that the cartridge stylus will overhang the record centre spindle by around 17-19mm for an arm that is of 229-250mm. Check this by swinging the stylus over the record spindle. For your reference, here are the RB250's vital statistics:

Effective length:	240 mm
Overhang:	17.24 mm
Offset angle:	22.92 deg
Mounting distance:	222.76 mm
Effective mass:	11 grams

When you've drilled your hole and bolted in the new Rega, you may

READING AND WRITING [2]

Recently I squandered my hard-earned money on a Sonneteer Alabaster amplifier and Roksan Caspian CD player. Whilst I think the equipment is good, the Caspian will only play about two thirds of my discs properly. This is unlike my now defunct Meridian which would play nearly everything, including those from my attempt to transfer vinyl to CD via the computer. Is the Caspian usually this fussy, or could mine have a fault?

My main query however relates to my next step in the upgrade, the purchase of 'speakers and cables. I've started looking and already am getting confused by the advice given. Generally it seems the more expensive the 'speaker, the more power they like to perform at their best and I generally listen with low to moderate volumes. Do you have any recommendations? I don't mind floor or stand mounted but would prefer something that can be placed reasonably close to a wall. I mainly listen to older pop music, with forays into folk classical and country in a room about twelve feet square.

P.V. Rackett



EXPAND YOUR MIND

THINK EMTEC MEDIA



Behind every EMTEC disc media product lies state-of-the-art technology and the same commitment to quality and value that made BASF leaders in tape media.

Now EMTEC brings you a complete range of CD-R, CD-RW, DVD and MD products for the digital age. These are available in a range of capacities.

Whether you need to expand your music collection or your data storage, EMTEC disc media always delivers mind blowing results.

www.emtec-group.com

World Radio History



**EMTEC
BASF**

Upsample CDs to SACD sound quality. Decode any digital audio signal. Plug in room equalisation. Drive the power amp direct - no preamp. This CD player is future proof.

One-Box

CD upsampling

The new **ACCUPHASE DP75V** is the answer to "should I wait for DVD-A?" **DON'T**. It may be years before there's a full library of music - if ever.

Make the most of the CDs you have now and will buy for years to come. **UPSAMPLE** them all to 24bit/192kS/s and decode any future DVD or SACD recordings. Even drive the power amp direct with the built-in **DIGITAL VOLUME CONTROL** - all in one box.

Upsampling creates natural, three-dimensional sound. Notes gain **CHARACTER** and are better defined in time and space. Music takes on more meaning and **COHERENCE**.

Think of the DP75V as a versatile, upgradeable, **DIGITAL PREAMP**, with a built-in CD transport. Switch digital inputs and control volume from the remote as normal.

Add **PLUG-IN BOARDS** for analogue inputs and to cope with future developments, eg a SACD transport.

Even correct the room and system response with the transparent Accuphase DG28 **DIGITAL EQUALISER**.

Music through the DP75V is rich, seductive and **INVOLVING**. Listen for hours without fatigue. This player delivers the future of digital. It sounds **ANALOGUE**.

Customers say we make some of the best sounds they have ever heard, so you know we can do the same in your home. Our advice will take account of your best components and guide you where change is needed, in stages you can afford.

You **AVOID EXPENSIVE MISTAKES**, enjoy music along the way and save money in the long run.

JUST LISTEN AND YOU'LL KNOW

The
Right
Note

Music in its home

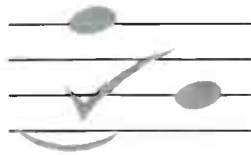

BATH

01225 874728

CD: ACCUPHASE, ADVANTAGE, AUDIO SYNTHESIS, BALANCED AUDIO TECHNOLOGY, dCS ELGAR, DELIUS AND PURCELL, MERACUS, PASS, SUGDEN, WADIA. **VINYL:** BASIS, CLEARAUDIO, CROWN JEWEL, DNM, GRAHAM, THE GROOVE, LEHMANN, MICHELL, SUMIKO BLUE POINT SPECIAL, TRANSFIGURATION. **AMPLIFIERS:** ACCUPHASE, ADVANTAGE, BALANCED AUDIO TECHNOLOGY, CAT, DNM, GAMUT, NAGRA, PASS, SONNETEER, SPECTRAL, SUGDEN. **LOUDSPEAKERS:** AUDIO PHYSIC, BKS, ETHOS, LUMLEY, NEAT, TOTEM, VERITY AUDIO. **TUNERS:** ACCUPHASE, MAGNUM DYNALAB. **CABLES:** ARGENTO, CHORD CO., DNM, HOVLAND, NORDOST, SILTECH, SPECTRAL, YAMAMURA CHURCHILL ETC. **SUPPORTS:** STANDS UNIQUE, VIBRAPLANE ETC.

strength
in depth

REL

01656 768777

www.rel.net

be left with an unsightly hole where the AR arm once sat. You can cover this by making up a large circular plate washer of black card or aluminium. If the VTA is wrong, try making a spacer from a tap washer, or buying the rather more elegant Origin Live VTA adjuster for £48. This done, you'll have a fine sounding deck capable of taking a very good cartridge such as a Dynavector DV10X4 high output MC (£199), which would be your next logical step.

Alternatively, your third option would be to find a used Systemdek IIxe/RB300 for around £250, which would give you a marginally better and more upgradeable deck. Personally I'd install a Rega into the AR and then buy a decent cartridge, leaving the field open to start saving my pennies for an LP12 Basik or Michell GyroDec SE. ■ DP



2 TONEARM WITH TAP WASHER (COURTESY OF REGA)

II ► SWEET AND LOW

I am currently in the wilderness that is the complete upgrade of my Hi-Fi. To date I have been satisfied, and restricted due to cash flow, with a budget system that cost me about £100. This then started to sound a little flat and dull in comparison to others I stumbled upon and so I decided to upgrade. After some demos and reading pretty much all the opinions available I have decided to go for an Arcam CD72 with an Arcam A65 or A75. This sounds great in the demo room but I have a problem. The room in my flat where the new kit is to sit is 14 by 12 feet, with concrete walls and floor. The problem is that I play most of my music at reasonable 'family' levels in what is a small room so most of the speakers people recommend with this type of system are large and don't really show their true colours until played at higher volumes. Large isn't a problem in itself, I reckon I could get the KEF Q35.2's past my girlfriend's aesthetically critical eye. So my request is some advice in what I should look for in a speaker for low to medium volumes, and some specific sets for me to try out. Also does the power

of the amp have any bearing on this? If you think I should try a different set up entirely my budget is £1000 for a CD, amp and speakers.

Thanks for any help you can provide

James Benfield

Hi James. You're right to say that not all 'speakers come into their own at low levels. And the ones that do, such as Quad's £3,500 ESL-988s are well off target, price-wise. The fact is that 'speakers that deliver superlative detail and presence at low levels unfortunately rarely come cheap. For my taste you'll need something with ideally excellent detail and a good bass response - tight and pronounced rather than merely deep and boomy. Sticking to standmounts, you could always try out a pair of Mission's cracking 780s at £300. Whilst these aren't particularly high sensitivity (which will give you good presence at lower levels), they are exceptionally well detailed thanks to their Keraform ceramic bass/mid drive unit and will convey many important aspects of the music whilst played at lower levels. Another standmount to try for exceptional detail and speed is the SuperZero from NHT which has an audiophile sound that's well beyond the humble £275 price tag. These both take a bit of driving, so the A75 would be a better option here but the sonic rewards would more than make up for the extra few quid spent on the amplifier.

However, it's not always the case that floorstanders will possess too big a sound for your room. If you're only playing at low to medium levels there should be little problem. What you do need though is good balance throughout the whole frequency range. If you can push the boat out a little Tannoy's Revolution r3s are a nice choice but are also £550. However, these have a well balanced sound with little coloration and boom due to the solid cabinet and will be a good match for your Arcam system. Although we haven't yet reviewed the CD player or amps you have in mind, I have heard them all in demos and have spent a long time with the top of the range A85 and know them to be of high quality. Whatever your choice, try to get a home demonstration. This will confirm if you can live with a certain sound or not. ■ SP



II ► HANDS ACROSS THE WATER

As a recent transplant from that other English speaking country to the west (not Ireland or Canada) I have had the pleasure of getting familiar with all sorts of audio gear (or 'shiny things' as my wife would have me call them) I had only previously seen in magazines. In moving across the pond I had to part with many toys that would be incompatible or difficult to work with the different electrical grid.

As I begin rebuilding my system I have found your magazine most helpful. Recently I acquired a Rega Planar 2 with a RB300 arm. Sadly the included cartridge (Linn K5 most likely) is sans stylus. Could you suggest where I might find a replacement stylus (K9 or K18) or recommend something different? My last set-up was an AR ES-101 (classic and well regarded American table) with a Shure V15 MR of late '80s vintage. I would like something good but reasonably priced. While my present record collection is somewhat limited I plan to start mining car boot sales in search of the jazz, blues, and classical that I have come to appreciate. I would also like to stick with an MM as it will be more easily compatible with my present kit. If there could be one word I would like to use to describe my desire in a cartridge it would be 'accurate'. If you can help me in my search you will gain a happy and loyal reader.

Richard Oelerich

Greetings to our wondrous, sun-drenched country Richard - hope you enjoy your stay. Unfortunately 'accurate' budget moving magnet cartridges are as rare here as in your neck of the woods - better to think in terms of the least inaccurate! You already have a fine deck, so you'd do well to treat it to a Goldring 1042 cartridge for around £120, which is a step up even from the likes of a Linn K18. A high output MM with a very high quality stylus profile, it has a smooth, sweet and detailed sound that also happens to boast a very lively, punchy nature. Having used one on a Planar 3, I know them to suit the relatively dry and clinical tonality of the Regas.

This done, get your tonearm's counterweight modded by Origin Live (see 'ArmTransplant Surgery' for contact details), and site your deck on a Base SP01 sub-table (£70). Don't just do car boot sales by the way, but look also to record fairs, which are a tremendous source of vinyl bargains. You can find details of fairs in your area in publications like 'Record Collector'. **DP** ■



Goldring's little gem!

AND FINALLY... NINETIES NIGHTMARE?

My system comprises a Marantz CD52SE CD player, Pioneer A400 amplifier and Mission 780SE 'speakers. Where do I go from here? It's time for an upgrade, but I've only just come back to hi-fi since the early nineties when I originally bought the system. I like a powerful, punchy sound. I was thinking about the new Marantz CD6000OSE, which I've just heard at a dealer. The salesman told me CD players have come along massively since mine, and that I should upgrade to a Bitstream model like this. I also have an old Dual CS505 turntable and Nakamichi BX300 cassette deck. I'd like better sound from my vinyl - which everyone keeps telling me sounds better than CD, but not to my ears! Also, the Nakamichi is my pride

and joy, but I'm thinking about getting into MiniDisc because of the easy CD copying and editing facilities. How would something like Sony's MDS-JB940 compare to my Nak?

**Rod Carr,
Via email.**

Where you should go depends on how much money you've got. Your dealer is a little confused - your CD52SE is actually a

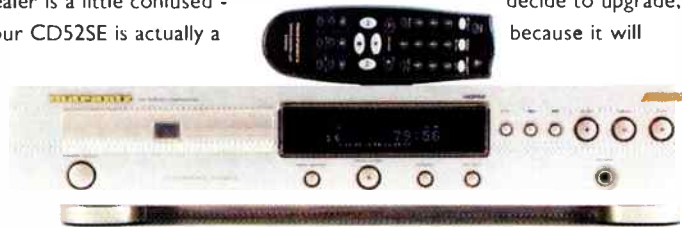

Bitstream design. (The CD50 before it was Marantz's final multibit budget player). The difference between it and the CD6000OSE is surprisingly small - of course CD players have evolved, but the largest limiting factor on your CD52SE's performance was not the available technology back in 1992, but the cost cutting going inside what was ostensibly a budget Philips machine. Put the two together and you'll hear a little more detail, a less brightly lit treble, and maybe slightly stronger dynamics, but all this really doesn't justify an upgrade (I'm sure Mr. Ishiwata would disagree!)

No, what you need is one of the latest crop of thousand pound players, which are a real step up from the budget designs (of today and of yore). Buy an Arcam FMJ CD23 and you'll hear a far smoother yet more musically involving sound, with a much more natural - dare I say it 'analogue' - presentation. Any lesser player and you'd get an upgrade but it probably wouldn't be such a 'sea change' that the Arcam (or Meridian's 506.24, which has a slightly softer, fuller sound) would bring.

As for the rest of your system, the A400 is still an excellent budget design - excepting its mediocre onboard phono stage. With a deck of your Dual's modest calibre, you're not losing too much, but upgrade it and you won't hear the benefits. I'd recommend you think about your future plans. If you're keeping your amp then buy a decent phono stage such as LFD's superb Mistral (£300). You can then buy a Rega Planar 3/Goldring 1042, or a more expensive deck, at your leisure. If you do plan on changing amps, Naim's

NAIT 5/StageLine would be the one given your musical preferences and the need for a top class phono stage. This would also compliment the softer sounding Meridian or Arcam CD source. Your 'speakers are actually still pretty good for what they are, and should be upgraded last of all - come back to us for a recommendation on these when you decide to upgrade, because it will

depend on how your system has evolved. Finally the Nakamichi vs. MiniDisc debate. No, if it's still properly set up and serviced, a Sony 940 would struggle to beat it. If you got a £600 (discounted) Sony MDS-JE55ES, that would be another matter entirely. Still, there's no doubt MD is brilliant for editing and compilation making - if this is your primary consideration then 940 is perfectly adequate. It's an excellent sounding machine for under £300, just not the equal of your Nak. Good luck! **DP** ■

Another option would be to sell the lot and splash out for a new trio of components. I'd go for a pair of Mission's new £300 781 standmounts featuring Aerogel 'Keraform' ceramic mid/bass drivers. These will give you plenty of drive and punch and have a especially good midrange. A good match for these would be (if money allows) the excellent new £700 A85 inegrated amplifier from Arcam, which has plenty of power (85W per channel) and control, along with great styling and an abundance of features plus an optional phono MM/MC stage to boost your vinyl sound. My option for a CD player to go with these two is either the new Arcam CD 72 at £400 or the Sony SCDXB940 which gives you the added option of SACD for just £500.

This will give you a complete system for less than £1500 that will last you at least until it's time to upgrade in another ten years or so. As for the Nak, how much do you want for it? **SP** ■

WHERE TO FIND US

BASINGSTOKE 01256 324311
2 Feathers Lane

BRENTWOOD 01277 264730
30 Crown Street

BRISTOL 0117 926 4975
65 Park Street

CARDIFF 029 2022 8565
134/136 Crwys Road

CAMBERLEY 01276 685597
173-175 London Road

CHELTENHAM 01242 583960
38 Winchcombe Street

CHESTER 01244 345576
88/90 Boughton

ENFIELD 020 8367 3132
159a Chase Side

EPSOM 01372 748888
15 Upper High Street

EXETER 01392 491194
156 Sidwell Street

GLOUCESTER 01452 300046
58 Bristol Road

HIGH WYCOMBE
01494 558585
30-32 Castle Street

LONDON: W. HAMPSTEAD
020 7794 7848
190 West End Lane

OXFORD 01865 765961
19 Old High Street, Headington

READING 0118 958 5463
4 Queens Walk
Broad Street Mall

SOUTHAMPTON 023 8025 2827
10-12 Hursley Road
Chandlers Ford

SWANSEA 01792 474608
9 High Street

SWINDON 01793 538222
60 Fleet Street

TUNBRIDGE WELLS
01892 525666
6 High Street

WORCESTER 01905 619059
Independence House
The Trinity

All shops are closed on Mondays



For the very latest information
please check our web sites:
www.audio-t.co.uk
www.audio-excellence.co.uk

[www.audio-t.co.uk]
[www.audio-excellence.co.uk]

audio

EXCELLENCE

audio T

THE BEST OF BOTH WORLDS

Audio Excellence and Audio T have joined forces to bring you the benefits and security of buying from a larger dealer, yet each of our stores is run as an individual specialist shop. Our staff are enthusiastic and friendly, with the knowledge and experience to satisfy your expectations. Plus, we haven't forgotten that buying hi-fi should be as much fun as listening to it!

CUSTOM INSTALLATION

If you want your Hi-Fi equipment neatly and attractively integrated into your home we can plan out the system to be installed, the choice of the equipment to be used, where it will be installed in your home and how it will be connected. Call us for advice on how you can enjoy music all round your home.

- 55 YEARS JOINT EXPERIENCE
- 3 YEAR GUARANTEE ON HI-FI SEPARATES
- FULL DEMONSTRATION FACILITIES
- PRICE PROMISE
- 10 DAY EXCHANGES
- 30 DAY NO COST PENALTY UPGRADES
- PART EXCHANGES
- INTEREST FREE OPTION ON SALES OVER £250*
- HOME LOANS AND HOME DEMONSTRATIONS
- EVENING DEMONSTRATIONS BY APPOINTMENT

For your **FREE** copy of **MUSIC AT HOME**,
The Ultimate Guide 2001

FREEPHONE 0500 101501 (quote ref HPW2)

or visit our web site at www.music-at-home.co.uk

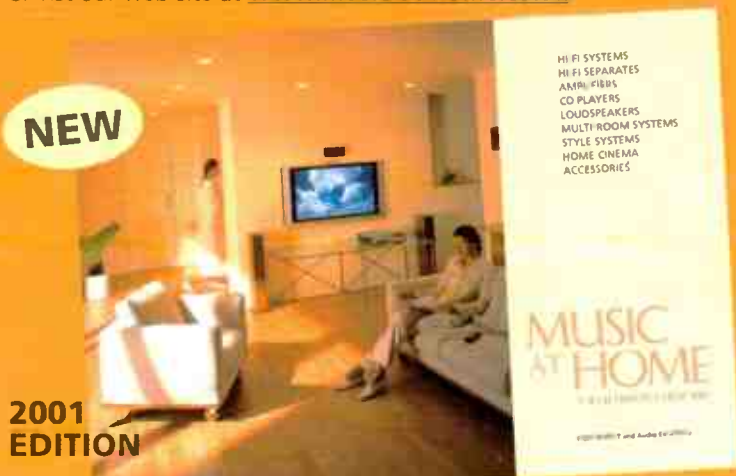

World Radio History

Products we sell
include:

ACOSTIC
ENERGY
ALR/JORDAN
ARCAM
AVI
BAW
BOW
BRYSTON
CASTLE
CELESTION
CHORD
ELECTRONICS
CURA
CYRUS
DAVIS
DENON
DENSEN
DYNAUDIO
DYNAVECTOR
ELAC
KEF
LINN
LOEWE
MARANTZ
MERIDIAN
METZ
MICHELL
MILLER
& KREISEL
MISSION
NAD
NAIM
NAKAMICHI
ONKYO
PANASONIC
PIONEER
PMC
PRIMARE
PROAC
PROJECT
QUAD
REGA
REL
ROKSAN
ROTEL
RUARK
SENNHEISER
SHAHINIAN
SONANCE
SONY
SYSTEMLINE
TAG McLaren
TALK
ELECTRONICS
TANNOY
TEAC
WILSON
BENESCH
YAMAHA

Not all products
are stocked by
every shop so
please check with
your local branch
before travelling

*Subject to status.
Written details on
request

www.computeraudio.co.uk
advertising@computeraudio.co.uk
editorial@computeraudio.co.uk
news@computeraudio.co.uk



contents

Marantz

MARC2/USB-One 52-53

A full blown 24bit, 96kHz PC soundcard for peanuts, plus the world's most useful PC audio gadget for notebook pilots...

WINDAC32 55

A great little bit of digital audio extraction freeware you can get off the net...

Klipsch Promedia

57

America's king of horns has gone multimedia - we test the results

Philips Rush

SA-126 58

From Europe's largest consumer electronics giant comes the very special MP3 walkie

REAL NEWS

MP3 portables are all the rage right now, but they're looking increasingly likely to be replaced by wireless handheld 'PalmPilot' type devices with music recording and replay software programmed into them. Texas Instruments has announced it is to collaborate with RealNetworks to provide Internet multimedia solutions for next generation wireless and digital audio devices. Streaming and downloadable audio and video capability will be embedded into the next-generation of wireless consumer devices.

TI says that the forthcoming third generation (3G) of DSP-based Internet appliances such as portable Internet audio players, mobile handsets, and personal digital assistants will be able to watch breaking news, listen to music and receive the latest entertainment updates via the RealAudio and RealVideo formats. Over seventy portable digital audio players from the likes of Sony, Samsung and LG Electronics already incorporate TI's TMS320C5000 series of DSP chips.

The company also announced that its RealJukebox software will be the exclusive music management software for forthcoming new range of Secure Digital (SD) Memory Card devices, including their two e-wear portable audio players that Computer Audio World exclusively previewed in February. The software will let consumers record CDs or download music to their RealJukebox then transfer it to their Panasonic SD portable music players. The new devices will be available in the US from February, with Europe to follow later. See www.real.com

ICE COOL

Although we've been reading about car MP3 players for a while now, Kenwood's £500 Z919 is the first to reach Britain's High Streets. Packed with features, including FM/AM radio (with full RDS EON facilities) and CD player with CD Text, it also plays MP3 files recorded as data files from your PC's CD-RW. As you can fit around 650 MP3 files onto one disc, it's obviously ideal for the state of Britain's roads.



World Radio History

SANYO FIRST WITH AAC

Dolby Labs has just announced that Sanyo's AAC-equipped SSP-PD7 digital portable will be on sale in Europe and the US soon. The device, as previewed in February's Computer Audio World, uses Dolby's Advanced Audio Coding to provide higher-quality sound while using around thirty percent less storage space. It supports playback in both AAC and MP3 formats, and includes CD-ripping software, which allows users to encode CDs in AAC format. Dolby says that since AAC encoding at 96 kbps can exceed the quality of 128kbps MP3, the player can store more songs than MP3-only playback devices on the bundled 32MB MultiMediaCard flash memory card. It also supports Liquid Audio's Secure Portable Player Platform (SP3) format that allows for the secure distribution of digital music to portable devices in accordance with SDMI guidelines. Users can access over 120,000 high-quality music tracks from hundreds of websites, as well as extras such as lyrics, liner notes, and album art. For more information about AAC, check out www.aac-audio.com.

LABTECH PULSE 415

This new £65 American sub-and-sat package is dead simple to use - just plug the 5W satellites and PSU into the 15W subwoofer, and go. Bass is punchy, treble clear and undistorted. You get reasonable detail and lively dynamics considering the budget price, too. For more information, point your browsers at: www.labtech.com.

THE NEW MINIS

Sony's SRS-Z500 are a dinky pair of active desktop speakers designed for MD or MP3 portables. The 6W amplifier is well up to the job and you get basic facilities like the usual volume and power on-off controls, plus magnetic shielding for near-monitor use. Good mini mobile music makers, but for raising the roof look elsewhere. You can contact Sony UK on: 01932 816400.



FIREWIRE BURNING

Sony's new CRX1600L CD burner is the very first FireWire CD writer to market. Its i.LINK (which is Sony's trademarked name for the FireWire IEEE 1394 interface) offers 12x CD-R burning, 8x CD-RW writing and 32x CD-ROM capability. There's a 4 MB buffer - which might be regarded as quite modest considering its writing speed - plus standard RCA phono audio outputs at the back and a quoted 150ms access time. Watch out for a full review soon!

2's COMPANY

Marian isn't a brand familiar to UK audiophiles, but its new Marc 2 digital audiocard could easily change that. David Price spends some time with it.



For just £199, this German-made Marian Marc 2 PC soundcard offers the full 24bit, 96kHz digital monty, which at a stroke puts it far closer to true audiophile status than any of its price rivals currently available in the UK. Here's a card for the serious audiophile, rather than gamers.

Designed as a 'mastering soundcard for PCs', the Marian offers a fearsome set of specs, considering its pocket money price tag. Build quality isn't anything to shout about - the board design looks pretty run of the mill apart from that innocuous little Crystal Semiconductors CS8427 DSP chip in the middle of the card. All the same, it offers full 24bit stereo (2-channel) line inputs and outputs via 1/4 inch stereo jacks, plus full stereo digital inputs and outputs using either optical (TOSLINK) or electrical coaxial connections.

There's a direct 'Digital Audio' CD input (running at 16bit, 44kHz) and Marian's SyncBus which lets you daisy-chain several cards together for multichannel recording and playback. Oh, and it also happens to be available for the Mac platform, too!

Quoted specs are 95dB signal to noise ratio and THD of 0.005% at 90dB! Frequency response is quoted at 20Hz-40kHz at 96kHz sampling.

INSTALLATION

It's pretty straightforward to fit, sitting in a PCI connector, held tight by a single screw through the end bracket to the rear casing. If applicable it can be connected the 2-

pin S/PDIF out of a CD-ROM drive. Next, the drivers go in. Insert the supplied CD-ROM into your machine, point the wizard to the marian\drivers\marc2\win9x\english directory and Windows copies the driver files and installs the card. This done, the Marc 2 Manager appears in the Windows taskbar.

The bundled manager software is some of the best I've tried. Unlike a worryingly large amount of the stuff that comes with soundcards, this actually lets you set levels without resort to Windows' resident Volume Control - which can be a hassle to find and use.

The Marc 2 Manager lets you monitor all your ins and outs, and set levels. High resolution peak meters that point from -60dB to 0dB are included, along with stereo faders working from -72dB to +18dB, a channel link (to fade up/down both channels simultaneously) and a mute.

Optical, coaxial and internal CD direct digital inputs can be selected, as well as digital output monitoring.

Last but not least is the Automatic Latency Adjustment, which manages system resources so the card's digital audio buffers don't get overloaded by the CPU.

PERFORMANCE

Sound quality was generally very good. Superb in some areas and just okay in others, it's best characterised as extremely fluid and well extended. Playing 16/44 CD audio and A-B the Marian's onboard DAC against my Cambridge Audio DACMagic 2, the

Marian comfortably outperformed it in a number of areas. This was a good sign, as most soundcards I've auditioned over the years are comprehensively inferior.

Kicking off with Thin Lizzy's 'The Boys are Back in Town', the Marian struck me by its subtle musicality. Where the reference DAC sounded rigid and wooden, the Marc 2 let the song flow along much better, giving the impression of a musical event involving real musicians rather than just a bunch of sequencers. Soundstaging was better too - whereas those famous guitar power chords felt boxed in with the Cambridge, the Marian let them hover in space more. Stage depth wasn't quite as wide, but it nevertheless felt more natural and airy.

Lou Donaldson's 'Alligator Bogaloo' again had the Marian sounding more fluid and beguiling with the beat ebbing and flowing better. Better still, there was a far more tangible atmosphere around the drum kit, with the ride cymbals in particular far better carried. By comparison, the DACMagic sounded as if a curtain had been placed over the speakers. The only area where the latter comprehensively outclassed the Marc 2 was in the bass - the Cambridge has quite firm and solid low frequencies, compared to which the Marc seemed a little

ONE LOVE

Marian's USB-ONE 'high performance digital audio interface' is another winner

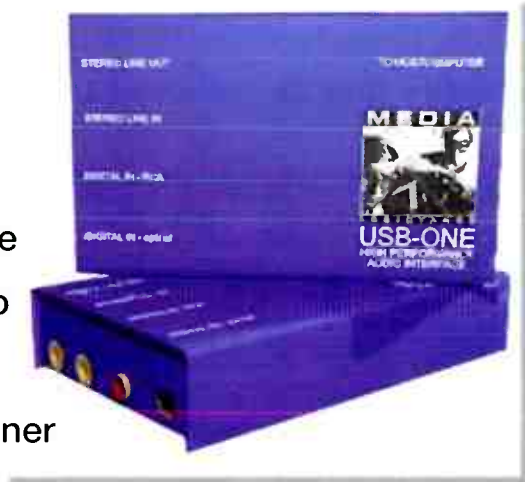

from the German company, says Nick Tate.

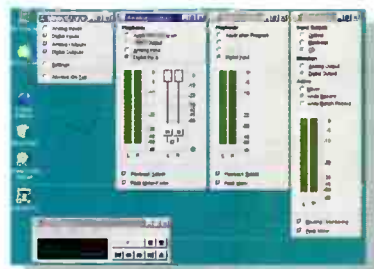

▶ lightweight and uncommitted.

Middling bass apart, this is one of the most analogue-like digital soundcards I've heard. Switch to 24/96 resolution and things get even more natural, with a truly expansive soundstage, spacious treble and smooth, detailed midband. With an extremely open and liquid sound playing CDs, and great potential for better things at higher sampling frequencies, Marian's new Marc 2 really is a cut above almost every other price rival. The only other consideration is Guillemot's superb MaxiSound ISIS, which is the one to get if a breakout box (with its myriad inputs and outputs) is important. If on the other hand, the 24/96 option could be useful to you in future, go for this with a clear conscience. It's one of the very few budget cards around which is perfectly comfortable in the company of decent hi-fi. ■ ▲

MARIAN MARC 2 £199
www.etcetera.co.uk

World Verdict



Excellent budget audiophile product that brings real hi-fi performance to your PC, with the option of 24/96 recording and playback to boot.

This small blue metal box of tricks, of fairly agricultural appearance, is one of the most handy computer audio gadgets I've seen in a while - especially if, like me, you're a confirmed notebook PC user who takes his music with him wherever he goes. The thing is, the soundcards in most computers - especially notebooks - are, in a word, pants. By plugging the USB-ONE into your Universal Serial Bus (fitted to every PC since around 1996), you have a direct line to the digital audiostream whizzing around your motherboard. This then means you can record digital audio straight to your hard drive (from CD, DAT or MD) without having to buy a soundcard with a digital in. Cool, huh?

You can also get high quality analogue into your PC via the USB-ONE's built in A/D converter - which is much better than most of the rubbish on budget soundcards.

Want to record some of your friend's records? Simple, just bring your notebook round to his place

and run a lead from the Tape Outs on his amp to the USB-ONE. Click on Cool Edit (or suchlike), and suddenly you've got well over ten hours of recording time on your average hard drive at 16/44 resolution! When you've drowned your poor little PC in WAV files, you can play them back through the USB-ONE's internal DAC, which again is a very respectable sounding device that's probably far better than the one in your computer.

I just loved this thing. It installs perfectly, works flawlessly and has a very open and smooth sound right across the frequency spectrum. Those internal A/D and D/A converters are classy items. At a stroke it turns your computer into another hi-fi source component, which is very handy if like me you've got half your vinyl and most of Napster on your hard drive! I want one. ■ ▲

MARIAN USB-ONE £139
www.etcetera.co.uk

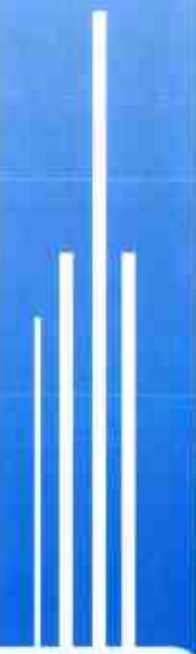

World Verdict



In a word - brilliant. Many computer audiophiles will find this the most useful thing since food was invented.

Ortofon



Pro-Ject

The year is 2001, the age of .com, poor service and fast turnover.

At Henley Designs we feel that things should be done differently. Customers should be treated with respect by staff who not only care, but who possess a knowledge and interest in the products they sell.

Our aim is to have a nationwide team of elite dealers who are able to offer advice, demonstrate and set up Pro-ject and Ortofon equipment. As a customer you should feel valued and comfortable during your purchase. As an owner, the value should continue through your pleasure in the music and its reproduction.

A limited number of dealers have been selected for their exceptional standards in customer service. Their staff have been trained by ourselves to ensure the highest level of expertise and at least one member of staff from each store is fluent in all aspects of our products.

We are proud to recommend the following dealers who have demonstrated their commitment and deserve the title:

Centres of Excellence

Town	Dealer	Telephone	Store Expert
Aldridge	Sound Synergy	01922 457926	Clive
Ashby De La Zouch	Zouch Audio	01530 414128	Mick
Bedford	Richards A/V	01234 365165	Dave
Brentwood	Audio T	01277 264730	Paul
Bristol*	Audio Excellence	0117 9264975	Jason
Cambridge	The Audiofile	01223 368305	Malcolm
Cardiff	Sevenoaks S&V	01222 472899	Chris
Colchester	Grayston S&V	01206 577682	Alan
Coventry	Frank Harvey	0247 6525200	David
Doncaster	The Hi-Fi Studios	01302 727274	Jeff
East Grinstead*	Audio Designs	01342 314569	Niel
Edinburgh**	Russ Andrews	0131 5571672	Drew
Euston, London	Kamla	0207 3232747	Moss
Helston, Cornwall	Sounds Perfection	01326 221372	Nigel
Holborn, London	Sevenoaks S&V	0207 8377540	Matt
Kidderminster**	Midland Audio Lx	01562 822236	Jon
Leeds	Sevenoaks S&V	0113 2452775	Chris
Lincoln	Sevenoaks S&V	01522 527397	David
Manchester	Sevenoaks S&V	0161 8317969	Sam
New Malden, Surrey	Unilet	0208 9429567	Vernon
Newbury*	B&B Hi-Fi	01635 32474	John
Nottingham	Notts Hi-Fi Centre	0115 9248320	Andy
Reading*	B&B Hi-Fi	0118 9583730	Dave
Salisbury*	Salisbury Hi-Fi	01722 322169	Paul
Southampton*	Phase Three	0238 022843	Dave
Swansea	Sevenoaks S&V	01792 465777	Craig
Tuxford, Notts**	Chantry Audio	01777 870372	Nigel
Warrington**	Doug Brady	01925 828009	Dean

* Pro-ject only
** Ortofon only

For a full dealer list and more information contact:
Henley Designs Ltd, Unit 10 Moorbrook, Southmead Industrial Park, Didcot, Oxon, OX11 7HR
Tel: 01235 511166, Fax: 01235 511266. E-mail henley.designs@virgin.net, WWW.henleydesigns.co.uk

SMALL WONDER

In the USA Klipsch are known for large loudspeakers. David Price checks out their move into multimedia with the Promedia S2.

The Klipsch name will be familiar to a good many dedicated audiophiles. An American company famous for its horn-loaded hi-fi loudspeakers, including the uniquely spectacular, high-end Klipschorn, the company now makes everything from home cinema to pro audio designs.

Founder Paul Klipsch designed a charismatic range of speakers focussed on reproducing transients and dynamics - hence his propensity for horn loading. The Promedia 2.1, it is claimed, carries the tradition to the computer audio sphere.

There are many reasons why baby active speaker systems should work well. By letting the separate subwoofer perform most of the air shifting duties, the satellites can be made small and narrow. This saves on the largest fixed cost in loudspeakers - the cabinet. The aurally sensitive presence region is handled by satellites, which are less prone to resonances that muddy the sound. Because the drive units are smaller, the mid-bass driver can be mounted closer to the tweeter, better approximating a point source.

Done properly, this all results in a clean, tight sound with great imaging and soundstaging. However, successful integration between a subwoofer and satellites isn't easy to do. Many systems end up sounding hopelessly disjointed. What then of these baby Klipsches?

For the £170 asking price, build is good. Compared to all other price rivals currently on the market, the 2.1s seem better put together and finished. Even the VideoLogic Siroccos, which are amazingly sturdily built for the money, possess a finish which looks home made by comparison. The system comprises the 240x248x260mm subwoofer with its single 165mm doped paper drive

unit, plus two 220x105x144mm two-way satellites using tiny paper coned mid/bass drivers and horn loaded plastic dome tweeters. The left satellite has controls for master system and subwoofer volume, plus an 'auxiliary/MP3' input and 3.5mm headphone jack. Usefully, the satellites feature removable grilles.

The sub is ported as you'd expect, and has spring-clip terminals on the back to connect up the satellites. One of the satellites has a built-in flying lead which plugs by its 3.5mm minijack into your computer soundcard or CD portable (or any other line level source). The sub also contains the amplifier, which is said to feature discrete linear output transistors and high current power section. It gives the system a claimed output of 2x35W, plus 135W from the sub (peak music power).

From the moment they were powered up, the Klipsch system impressed. Sound is fantastic for the money. Indeed, my problem was that I stopped listening to them as budget multimedia designs and started scrutinising them like they were a £1,000 pair of hi-fi speakers! Super clean, open, fast, rhythmic, dynamic and musical, they're remarkably engaging performers considering their price tag. I put them on the end of my Sony MZR-90 MiniDisc player (via the Line Out) and couldn't stop listening. Essentially, the Klipsch system gives a dry, detailed sound that's slightly mid-forward. The rhythm guitars on Chic's 'Le Freak' were really pulled out of the soundstage and projected beautifully. Likewise vocals imaged

strongly forward of the mix with tremendous confidence - you rarely hear hi-fi speakers do this so well. Treble wasn't splashy at all, but of course lacked the tonal variety of more expensive hi-fi loudspeakers. Best of all, the Klipsch system drove the room, effortlessly shifting air like a pair of Martin Logan hybrids. I got true 3D soundstaging and oodles of low level detailing. The result was a sound far bigger, punchier and more engaging than you'd ever think possible from three small boxes.

With my pedantic hat on, I have to say the sub is the least successful part of the package. Don't get me wrong, it isn't one of those hideous boom boxes, it's just that you have to be careful with both positioning and the level control to stop it from sounding disjointed. I used just a touch of boost, whereupon the whole system sang. Thus tuned, it crossed over pretty seamlessly - although there was always a very slight upper bass dip before the sub stepped in. Any more sub level and things boomed, without filling out the upper bass region appreciably more.

Overall though, it's thumbs aloft for this Klipsch system - I've heard worse hi-fi speakers at twice the price. It goes loud without strain, is clean, musical and dynamic, drives rooms well and always raises a smile. Short of VideoLogic's Sirocco, perhaps, there's no other £200 multimedia speaker that even comes close. ■ ▲

Klipsch Promedia 2.1 THX £170
Klipsch UK Ltd. Tel: 0131 333 5179
www.klipsch.com

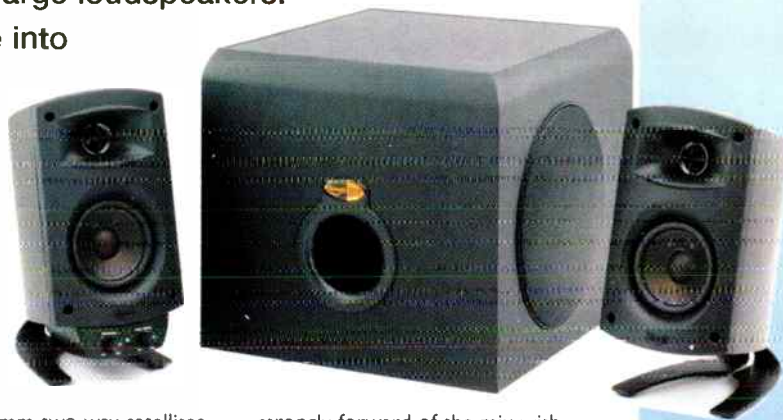

World Verdict



Extremely musical and bags of fun, these sound far better than they've a right to considering their modest price.

mercury mX

E V E R Y B I T B E T T E R

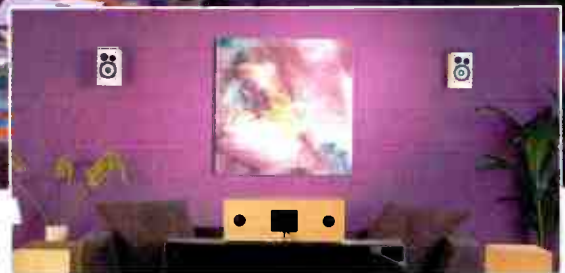

HomeEntertainment
AWARDS 2000
WINNER
MERCURY MX1
BEST SPEAKER
FRONT - OR - REAR



Tannoy monitors are highly sought after across the world in the professional music recording industry. We have also supplied many famous film production studios ever since sound made its way into the movies. This know-how from satisfying the worlds most discerning listeners goes into the new Tannoy Mercury mX range. Great speakers for hi-fi and home cinema. Speakers that are every bit better than the rest.

TANNOY
THE ANIMO-SOUND GAMERS

For free literature on the mercury mX range from Tannoy, call 01753 680868 www.tannoy.com

RUSH RELEASE

It's taken a long, long time for Philips' much publicised Rush SA-126 Digital Audio Player to reach the shops. At last, David Price gets a chance to give it the treatment.

This is getting boring. Having played with the Rush now for a week, I can confidently say it's the best MP3 portable I've yet to review. It's boring because the world's electronics manufacturers have been on a strong learning curve with this particular type of product since the first Diamond Multimedia Rio PMP300 hit the shops in Summer 1999. This has meant that each successive design seems to knock the former off the top spot, and ends up in me writing dramatic stuff like this.

In the case of the Rush though, it definitely has the feeling about it of being more than a bit special. And so it should - it's the first digital walkie from one of the world's leading - if not the leading - consumer electronics giants. To wit, it would be surprising if it wasn't a significant development on one of the many 'me-too' MP3 portables from Korea. So it's easily the best all rounder I've come across, usurping the other leading contenders by quite a margin. And that includes Sony's first Digital Walkman, Samsung's YP-E64 and s3's latest Rio 600, too!

Why do I like it so much? It has the most potent combination of build quality and small size I've seen. Most impressive of all though is the sound quality, which is the stuff of real hi-fi. I remember reviewing Philips' first ever DCC portable back in 1995, and being impressed by its clean, smooth, sweet and sophisticated sound and marvelling at its modest proportions. Six years on, the Rush weighs a fraction of its size and sounds just as good - transpotters will doubtless point out the DNA that MP3 shares with the now-defunct DCC!

It weighs 50g and measures 70x 70x 17mm, takes two AAA batteries. It comes with a standard 64MB SmartMedia card, which gives around an hour of decent quality MP3 music.

Build and finish is superb - with a metallised plastic case and a classy centrally mounted alphanumeric display. It's got lots of info, including a handy 'MB FREE' feature as well as the usual track name, track number, elapsed time, bitrate, battery and play mode.

The pack contains AC adapter, stereo in-ear headphones, both parallel port and USB connection cables, a Flash Memory card and what Philips call a 'stylish pouch'!

Moving swiftly on, you also get RealNetworks' RealJukebox on CD-ROM, complete with a clumsy patch for it to work on Win98 systems - bizarrely there are no drivers as yet for Win ME or NT. Installation was simple enough, the USB drivers auto-installed without a fuss and the RealJukebox software handled file transfers relatively painlessly, taking around 25 seconds to download a three minute audio track.

Sound quality is superb for a portable of any format - even driving Musical Fidelity XA-200 monoblocks direct (via the Rush's headphone output and digital volume control) through my Yamaha NS-1000M loudspeakers - it sounded very smooth and open. Think of a Philips CD player and you get the picture - on the warm side of neutral but still quite dry and detailed in a 'Teutonic' way.

Hefner's 'Residue' (at 256kbps) was a fine showcase for the Rush's talents. Bass was lithe but not light - there's no added oomph but neither is it artificially anaemic - instead you get a nicely rounded bottom end with decent extension and a touch of warmth. Midband is impressively detailed, but not in an overt, in-your-face way as with Sony's ATRAC3-powered NW-MS7 or s3's Rio 800. Instead, the Philips puts all the pieces together in an unusually



organic and cohesive manner. Rhythms aren't as punchy and vivid as the Sony, but the player still boogies just as well. Treble

is very slick and sweet, with none of the swimmy quality I got from the Sony MS Walkman. At high bitrates (192kbps or higher) you'd be forgiven for thinking you were listening to a good budget CD player.

I've got just three criticisms. The first is that there's no backlight on the display, the second is the annoying RealJukebox software and the third is that (unlike s3's Rio 600 and others) the Rush doesn't seem to offer downloadable codecs, meaning its future compatibility with AAC and WMA is questionable. Sticking with MP3, the standard RealJukebox MP3 ripper only records at up to 96kbps (unless you buy the full retail version) and doesn't have the great sounding Fraunhofer MP3 codec as standard. In this respect, bundling MusicMatch Jukebox would have been so much better. Still, this can all be got round or lived with - the fact remains that the Philips Rush offers the best sound, size and build combination yet created! ■ ▲

Philips SA-126 £230
www.philips-electronics.com

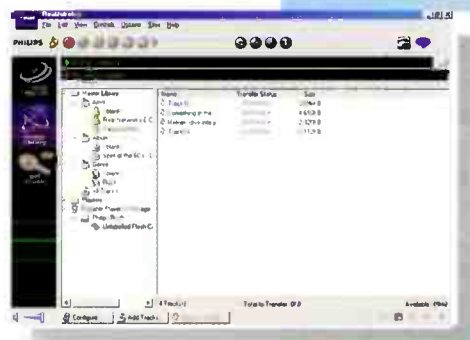

World Verdict



Fantastic sound, beautiful build and small size put it head and shoulders above all that came before it.

probably the best

NEW DEMONSTRATION ROOM NOW OPEN AT 12A SPRING GARDENS, NEWPORT PAGNELL,

KEL84 VALVE INTEGRATED AMPLIFIER KIT

This is our brand new low cost, beginner level amplifier kit, featuring the popular a pair of EL84 valves in push pull configuration per channel, providing 15 watts into an 8 ohm load, plenty for most medium sensitivity loudspeakers. The output transformers are Ultra Linear, keeping distortion down to a minimum. Up front we have the ECF80 valve a extremely smooth pentode/triode tube. The Kel84 has an extremely low hum level, to solid state standards. The kit is based on a printed circuit board. We have given the kel84 a high class look with a 3mm anodised front panel and our famous chrome custom made knobs. The amplifier has the capacity to receive 5 line level inputs, plus one monitor input, with a tape output included, all controlled from the front panel. Both the phono sockets and 4mm banana socket speaker terminals are the gold plated. The Kel84 mains switch is, positioned at the rear of the amplifier and is

easily accessible, the mains is received via an IEC lead, an earth post is also positioned at the back.

This kit is suited to the beginner in that the instructions now include pictures as well as diagram, making them very easy to follow. At a UK price of £250.00 all inclusive you cannot ignore this kit. Simon Pope says, "The quality that can be gleaned from this amp is a fine introduction to the joys of the valve sound. The KEL84 will highlight all the intricacies and depth of detail in your favourite recordings whilst retaining a warmth and fullness. This combination of both detail and warmth is almost the exclusivity of pure valve amps and is rare at this price point." The Kel84 weighs in at 10kg. External dimensions with valves are 300mm(w) x 270mm(d) x 150mm(h).

£250



KIT88 VALVE INTEGRATED AMPLIFIER KIT & KAT88 VALVE POWER AMPLIFIER KIT

Here is the amazing KIT88. The circuit is similar to that of the ever popular KEL34 with a few changes to incorporate the Tesla, JJ branded KT88 power tetrode. This is a pure Class A push-pull design providing 36 watts into an 8ohm load. Gary Devon has come up with a gem of an output transformer (E1). Combined with the KT88 it offers a virtually unmatchable result for a valve amplifier. Frequency response measured 11Hz to 75kHz, separation 71dB, noise 96dB, sensitivity 400mV and distortion 0.03%. "As valve amplifiers go, the KIT88 is one of the best measured performances I have ever come across", says Noel Keywood. Jon Marks says, "The KIT88 pulled a series of surprisingly fast, meaty basslines out of its trickbag when dealing with Suzanne Vega's Nine Objects Of Desire album. As if

this wasn't enough, the mid and treble were nice too - cymbals had a deliciously natural, golden shimmer without sounding soft, and vocals were extremely transparent and crisply defined. KIT88 didn't hang around when it came to exploring the virtues of its four output valves on numbers such as 'Leaves' and 'Suspect Sustain' from Cirrus' Land's End Jazz CD. Saxophone had a wonderfully smooth, realistic character, and acoustic guitar mixed speed with harmonic richness to very impressive effect. Asian Dub Foundation and Moloko showed no sign at all of the sluggish, woolly bottom-end and poorly-delineated bass beats that most valve amps are to blame for. Which makes the KIT88 an all-round, high-end bargain." Weight 16kg, external dimensions with valves are 330mm(w) x 300mm(d) x 190mm (h).



£425

KaT88 upgrade kit now available £140

KaT88 VALVE POWER AMPLIFIER KIT

£440

KIT88 upgrade kit now available £150

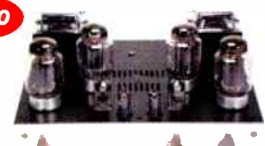

KIT88 VALVE INTEGRATED AMPLIFIER KIT

ALL NEW SERIES II MODULAR PRE-AMP KIT

The PRE-II is a valve pre-amplifier with six inputs, tape monitor and two sets of output sockets. It utilises a high quality line driver transformer and x5 gain. The PHONO-II is a dedicated valve phono stage that incorporates a step up transformer for MC users. Finally,

PSU-II is a power supply unit that feeds both the PRE-II and PHONO-II.
Power Supply Unit (PSU-II) £175.00
Pre-amplifier (PRE-II) £175.00
Phono Stage (PHONO-II) £100.00
Moving coil step-up transformer £70.00



300B PSE MONOBLOC KIT

Our Parallel Single Ended amplifiers offer the ultimate sound quality, featuring two of the beautifully linear 300B directly heated triode in the output stage (per monobloc) pushing out 20 watts into an 8 ohm load. At the front we have a 6AU6 pentode and the famous ECC82 as the driver valve and the kit utilises a 5U4 rectifier valve for the power supply in combination with a 10H choke, giving an extremely quiet supply. For the mains and output transformers we have used the E1 type. Feedback is

switchable for all those purist out there and the kit is totally hard-wired. For those that require valves we provide the superb Tesla 300Bs, Russian 5U4s and European 6AU6s & ECC82. Simon Pope says, "Not to put too fine point on it, the sound these monoblocs create is among the finest that can be encountered in hi-fi." Our 300B PSE kit bears an affordable price of £795.00 (UK price) excluding valves. Each monobloc weighs 23kgs., external dimensions with valves: 25cm(w) x 38cm(h) x 22cm(d) per monobloc.



£795.00

KEL80 MONOBLOC AMPLIFIER KIT

Following the success of our budget KEL34 40watt kit amplifier, we have come up with a 'bigger brother' design. The output stage utilises two pairs of TESLA EL34 pentodes in parallel-push-pull mode, allowing KEL80 to turn out 80 watts into an 8ohm load. Heading up the input stage we have the wonderfully linear Russian 6AU6 working into an American 5687 phase-splitter. KEL80's output transformers are 4ohm and 8ohm tapped. With an input sensitivity at

around 380mV for full output, it will happily partner both passive and active pre-amplifiers. It is easy to assemble. Simon Pope says, "The proof of the pudding is in the eating and the KEL80 is a feast for the ears, with solid bass attack, lightening fast reactions, that emphasises musicality as well as power, at 590.00 GBP a pair, a definite valve winner. Each monobloc weighs 12kgs., external dimensions with valves: 14cm(w) x 8cm(h) x 43.5cm(d).



£590 A pair

HD83 VALVE HEADPHONE AMPLIFIER KIT

The HD83 is our new headphone amplifier, a beautifully simple design using Mullard ECL83 valves, a triode and power pentode housed in the same envelope. It works directly from any source, be it CD, tape, tuner etc., or from an amplifier's tape out or pre-amp sockets. The circuit utilises high specification output E1 output transformers that will drive any headphone load from 16 ohms to over 300 ohms depending on how the secondaries are

wired up. The HD83 is a single-ended design with the power pentode wired up in triode configuration for that added purity and is a quiet as a mouse. For sound quality Jon Marks says, "The bass is punchy and controlled without becoming artificial, while treble has the crispness of the best solid-state, with the tonal purity, delicacy and speed associated with valves. External dimensions 18cm(w) x 30cm(l) x 8cm(h) weight 4kg.



£175

parts directory

mains transformers & chokes

Kel84 mains transformer
1.5 inch stack, 90mm(h) x 80mm(w) x 95mm(d) drop through fitting with zinc cap
Secondaries: 0V-240V, 300mA, 3.15V-0V-3.15V, 5.5A, suitable for 120/240V operation
KIT88/KaT88 mains transformer
120mm dia x 60mm(h)

Secondaries: 195V-0V-195V, 450mA/0V-27V, 100mA/3.15V-0V-3.15V, 9A, suitable for 120/240V operation
300B PSE mains E1 transformer
130mm(h) x 95mm(w) x 115mm(d), drop through fitting with zinc cap
Secondaries 380V-0V-380V, 180mA/150V-0V-150V, 25mA-0V-5V, 1.2A-0V-5V, 1.2A-0V-5V, 3A-3.15V-0V-

3.15V, 0.4A suitable for 120/240V operation
Kel80 mains toroidal transformer (encapsulated)
130mm dia x 65mm(h)
Secondaries: 195V-0V, 195V, 390mA/0V-27V, 100mA/3.15V-0V-3.15V, 5.5A, suitable for 120/240V operation
HD83 mains toroidal transformer
80mm dia. x 35mm(h)

Secondaries: 0V-165V, 75mA/3.15V-0V-3.15V, 1A, suitable for 120/240V operation
PSU-II mains toroidal transformer
80mm dia. x 35mm(h)
Secondaries: 0V-270V, 60mA/0V-10V, 2A, suitable for 120/240V operation
TRANS1 mains toroidal transformer
95mm dia. x 50mm(h)

Secondaries: 0V-370V, 150mA/0V-6.3V, 3.5A
300B E1 choke 65mm(h) x 70mm(d) x 80mm(w) open frame fitting, 10H, 180mA
Kel84 E1 choke
0.5 inch stack, 40mm(h) x 35mm(d) x 70mm(w) clamp fitting, 1H, 250mA
PSU-II E1
40mm(h) x 35mm(d) x 70mm(w) clamp fitting, 15H, 20mA

KIT34 mains transformer
2.5 inch stack, 120mm(h) x 115mm(w) x 95mm(d), drop through fitting with zinc cap, Secondaries 365V-0V-365V, 300mA/0V-5V, 6A/3.15V-0V-3.15V, 7.5A, Suitable for 120/240V operation.
KIT34 choke
1.25 inch stack, 65mm(h) x 105mm(w) with fitting holes x 60mm(d), clamp fitting, 2.5 H, 350mA

diy kits in the world

MILTON KEYNES, BUCKS MK16 0EE- CALL FOR DETAILS ON 01908 218 836

KIT34 VALVE INTEGRATED AMPLIFIER

The Kit34 is a 32 watt stereo valve integrated amplifier. Featuring a pair of EL34s, in push-pull mode, per channel, with an ECF80 pentode/triode as input/phase splitter. The power supply is valve rectified (2 x 5U4) incorporating a heavy duty choke to achieve exceptional smoothing. The output transformers are 14% Ultra Linear tapped to keep distortion down to its lowest level and the kit is totally hard wired utilising 3 tag boards. It offers 5 line level inputs, plus, a tape in

and tape out, all controllable from the front. As you can see the Kit34 looks amazing, a true classic in the making. Simon Pope says, 'The Kit34 carries a true valve signature. It has everything you could ever want and more from a tube amp, a absolute winner. Weight 22kg. External dimensions with valves fitted - 390mm(w) x 360mm(d) x 210mm(h)



NEW KIT

£495

KLS10 HIGH TECHNOLOGY COMPACT MONITOR

Our mini-marvel uses an Audax carbon fibre bass/midrange unit, married to the world's most advanced tweeter, the piezo-electric gold dome HD3P from Audax. KLS10 offers high performance from a small package. The main 'speakers are designed to work alone, or with a dedicated subwoofer to extend their bass. Alone, they are suited to near-wall mounting and can be tuned by port adjustment to suit personal taste and

location. They are easy to drive and need just 30-60watts. KLS10 is unique. Technically advanced, yet compact and relatively inexpensive. There is little to match it. Sensitivity 89dB 1W/1m. 15mm MDF, internal volume 9Ltrs. external dimensions 19cm(w) x 31cm(h) x 23cm(d). Drive units & Crossover KIT £394.00 Drive units only £358.00



£394

KLS10 GOLD SUBWOOFER

Designed to compliment KLS10 Gold stand mounters by providing a deep and open bass. The subwoofer is inexpensive, easy to build, comprising a simple crossover network to a high quality 8 inch Aerogel dual voice coil unit. A must for all KLS10 Gold customers. Sens. 89dB.

volume 25 litres. external dimensions 28cm(w) x 43cm(h) x 34cm(d). DRIVE UNIT & CROSSOVER KIT £149.95 Drive unit only £71.00



£149

KLS9 TWO WAY FLOORSTANDER

Here's a storm for you - KLS9, with its BB4 alignment bass cabinet and Audax High Definition Aerogel 8in bass/midrange unit. Designed by Noel Keywood to possess optimal bass damping and a clean step response. Aided by a teensy bit of bass lift, KLS9 really thunders: it will re-arrange your furniture. But it does not waffle, falling silent when there's no bass in the music. Aided by a high power 1in fabric dome tweeter, KLS9 is

detailed, evenly balanced and images superbly. It is an easy 12ohm load and is 88dB sensitive. For amps up to 60W. Easy to build and great for beginners. Internal volume 70Ltrs, 18m MDF external dimensions 25cm(w) x 93cm(h) x 40cm(d). Drive units & crossover kit £230.00 Drive unit pack £160.00



£230

KLS3 Gold Mk II

ADVANCED TECHNOLOGY
THREE WAY LOUDSPEAKER

KLS3 Gold uses the latest version of Audax's innovative oval gold dome piezo electric tweeter, giving it the sweetest and most extended treble. Married to a 4in. carbon fibre cone midrange driver for neutral and clear reproduction, and a powerful 8in. bass driver for superb depth, this is our top-of-the-line reference 'speaker. Sensitivity

90dB at 1W/1m. 25mm MDF, internal volume 60Ltrs, external dimensions 26cm(w) x 100cm(h) x 35cm(d). Drive Unit & Crossover kit £575.00 Drive Unit Pack £450.00



£575

Upgrade your KLS3s to Gold status. Includes latest oval gold dome piezo tweeter and all components.

£330

capacitors, potentiometers & upgrade kits

- a. BLACK GATE 220uF, 50V electrolytic
- b. BLACK GATE 4700uF, 16V electrolytic
- c. JENSEN 0.47uF, 630V paper in oil capacitor
- d. LCR 22.5uF 440Vdc polypropylene capacitors (wire leadouts radial) 100mm(h) x 45mm diameter
- e. ANSAR 22.5uF 630Vdc polypropylene capacitors (wire leadouts radial) 85mm(h) x 45mm diameter

- f. ALPS blue audio grade 50K or 100K dual log potentiometer 8.5mm diameter fitting hole

Kit88 upgrade kit

- 4 x Jensen 0.47uF, 630V
- 4 x Black Gate 220uF, 50V
- 2 x Black Gate 4700uF, 16V
- 1 x 100K alps pot

Kat88 upgrade kit

- 4 x Jensen 0.47uF, 630V
- 4 x Black Gate 220uF, 50V
- 2 x Black Gate 4700uF, 16V

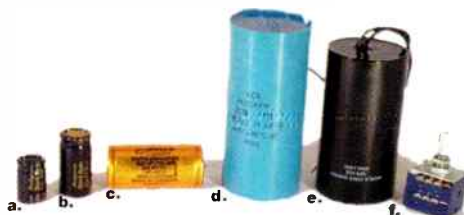

output transformers

- Kit84 E/I Ultra Linear push-pull output transformer 1.25 inch stack, 76mm(h) x 65mm(w) x 76mm(d) Primary-secondary 8K with 12.5% UL tap - 8ohms, max o/p-15watts, max current 150mA valves EL84 etc
- Kit88/Kat88 E/I push-pull output transformer

- 80mm(w) x 95mm(l) x 100mm(h) Primary-secondary 10K - 8ohms, max o/p-40watts, max current-160mA valves-KT88, 6550 EL34
- Kit34 E/I 14% tapped Ultra Linear push-pull output transformer 2 inch stack, 80mm(w) x 95mm(l) x 100mm(h), drop through fitting with zinc cap. Primary-secondary 6.4K, 14% UL taps. Secondary 8ohm, max

- output 24watts, max current 150mA, valves EL34, 6L6, 6CA7
- Kit80 E/I parallel-push-pull output transformer 95mm(w) x 115mm(l) x 133mm(h) Primary-secondary 4 6K - 8 & 4ohms, max o/p-80watts, max current-250mA valves-EL34, 5881, 6L6
- HD83 E/I single ended output transformer 40mm(w) x 50mm(l) x 55mm(h) Primary-secondary 4K - 4 x

- 64ohms windings, max o/p-1watts, max current-25mA valves-ECL83 etc
- Pre-II E/I driver transformer 80mm(w) x 60mm(l) x 65mm(h), 6:1 step down transformer, max current-10mA valves-6922 etc pre-amp stage
- printed circuit boards
- Kit84 Printed Circuit Board

- 280mm(w) x 135mm(l) x 1.6mm(d)
- Kit88/Kat88 Printed Circuit Board 140mm(w) x 310mm(l) x 2.4mm(d)
- Kit34 Printed Circuit Board 140mm(w) x 310mm(l) x 2.4mm(d)
- Kit80 Printed Circuit Board (a pair) 120mm(w) x 215mm(l) x 2.4mm(d)
- HD83 Printed Circuit Board 140mm(w) x 160mm(l) x

- 1.6mm(d) PSU-II Printed Circuit Board 105mm(w) x 130mm(l) x 1.6mm(d)
- PRE-II Printed Circuit Board 105mm(w) x 130mm(l) x 1.6mm(d)
- PHONO-II Printed Circuit Board 105mm(w) x 130mm(l) x 1.6mm(d)
- Tag board 2 x 16 connections (hard wiring) 40mm(w) x 140mm(l) x 3mm(d)

parts directory

World Audio Design



DSP5000 - a classic

Meridian Audio loudspeakers combine digital signal processing with powerful built-in amplifiers. This provides the greatest performance from the neatest cabinets with perfect control.

Our brilliant Windows® based setup software makes installation easy. Connect a digital source direct or any other source via our surround controllers for the finest stereo and up to seven channels of surround sound.

Meridian, the classic solution.

Meridian Audio Limited

Stonehill, Stukeley Meadows
Huntingdon, England PX29 6FX
Tel 44 (0)1480 434334
Fax 44 (0)1480 459934

Meridian America Inc

3800 Camp Creek Parkway
Building 2400, Suite 122
Atlanta GA 30331
Tel (404) 344 7111
Fax (404) 346 7111

<http://www.meridian-audio.com>

BOOTHROYD STUART
MERIDIAN



order on our website @

www.worldaudiodesign.co.uk

amplifier kits description

Ki734 valve integrated amplifier kit (with valves)
 Ki734 valve integrated amplifier kit (without valves)
 Kel84 valve integrated amplifier kit (with valves)
 Kel84 valve integrated amplifier kit (without valves)
 PSU II power supply unit module
 PRE II pre-amplifier module
 PHONO - II phono stage module (with valves)
 Moving Coil step up transformers
 Ki788 Valve integrated amplifier kit (with valves)
 Ki788 Valve integrated amplifier kit (without valves)
 Ki788 upgrade kit
 Ka788 Valve integrated amplifier kit (with valves)
 Ka788 Valve integrated amplifier kit (without valves)
 Ka788 upgrade kit
 HD83 Valve Headphone amplifier kit (with valves)
 Kel80 Valve Monobloc amplifier kit (with valves)
 Kel80 Valve Monobloc amplifier kit (without valves)
 300B PSE Valve Monobloc amplifier kit (with valves)
 300B PSE Valve Monobloc amplifier kit (without valves)

order No.

Ki734-K240/120 (with valves)
 Ki734-K240/120 (without valves)
 Kel84-K240/K120 (with valves)
 Kel84-K240/K120 (without valves)
 PSU - II - K240/120
 PRE - II
 PHONO II
 MC - step up (pair)
 Ki788-K240/120 (with valves)
 Ki788-K240/120 (without valves)
 Ki788 upgrade
 Ka788-K240/120 (with valves)
 Ka788-K240/120 (without valves)
 Ka788 upgrade
 HD83-K240/120 (with valves)
 Kel80 -K240/120 (with valves)
 Kel80 -K240/120 (without valves)
 300B PSE-K240/120 (with valves)
 300B PSE-K240/120 (no valves)

qty

(inc vat & carriage)
 £495.00
 £430.00
 £250
 £225
 £175.00
 £175.00
 £100.00
 £70.00
 £440
 £325
 £150.00
 £425
 £310
 £140.00
 £175
 £590
 £520
 £1070.00
 £795.00

overseas

(exc. vat & carriage)
 £420.00
 £365.00
 £215
 £195
 £150.00
 £150.00
 £85.00
 £60.00
 £375
 £275
 £130.00
 £365
 £265
 £120.00
 £150
 £500
 £445
 £910.00
 £680.00

loudspeaker kits

KLS3 Gold mkII Drive Units
 KLS3 Gold mk II Drive Units + Crossover Kit etc
 KLS9 Drive Units
 KLS9 Drive Units + Crossover Kit etc
 KLS10 Drive Units
 KLS10 Drive Units + Crossover Kit etc
 KLS10-Subwoofer Drive Units
 KLS10 Drive Units + Crossover Kit etc

order No.

KLS3G-D
 KLS3G-C
 KLS9D
 KLS9C
 KLS10D
 KLS10C
 KLS10-subD
 KLS10-subC

qty

(inc vat & carriage)
 £450.00
 £575.00
 £160.00
 £230.00
 £358.00
 £394.00
 £71.00
 £149.00

overseas

(exc. vat & carriage)
 £392.00
 £500.00
 £140.00
 £200.00
 £311.00
 £343.00
 £61.00
 £130.00

parts description

Ki734 transformer set
 Ki734 mains transformer
 Kel84 E/I mains transformer
 Ki788/Ka788 mains toroidal transformer
 Kel80 mains toroidal transformer(encapsulated)
 HD83 mains toroidal transformer
 PSU-II mains toroidal transformer
 TRANS1 mains toroidal transformer
 300B PSE E/I mains transformer
 Ki734 E/I choke
 Kel84 E/I choke
 300B PSE choke
 PSU-II E/I choke
 Ki734 E/I UL push pull output transformer
 Kel84 E/I push-pull output transformer
 Ki788/Ka788 E/I push-pull output transformer
 Kel80 E/I parallel-push-pull output transformer
 HD83 E/I single ended output transformer
 Pre-II E/I driver transformer
 300B PSE E/I output transformer
 Kel84 Printed Circuit board
 Ki788/Ka788 Printed Circuit Board
 Kel34 Printed Circuit Board
 Kel80 Printed Circuit Board
 HD83 Printed Circuit Board
 PSU-II Printed Circuit Board
 PRE-II Printed Circuit Board
 PHONO-II Printed Circuit Board
 Tag board 2 x 16 connections (hard wiring)
 Alps blue audio grade 50K dual log potentiometer
 Alps blue audio grade 100K dual log potentiometer
 LCR 22.5uF 440Vdc polypropylene capacitors
 Ansar 22.5uF 630Vdc polypropylene capacitors
 Jensen 0.47uF 630Vdc paper in oil capacitor
 Black Gate 220uF 50Vdc electrolytic
 Black Gate 4700uF 16Vdc electrolytic
 K5881 chassis
 Kel34 chasis
 650V safety gloves (a pair)

order No.

Ki734 Tset
 Ki734 - mains T
 Kel84 - mains T
 88 - mains T
 Kel80 - mains T
 HD83 - mains T
 PSU-II - mains T
 TRANS1
 300B - mains T (each)
 Ki734 - choke
 Kel84 - choke
 300B - choke
 PSU-choke
 Ki734 - O/P T (pair)
 Kel84 - O/P T (pair)
 88 - O/P T(pair)
 Kel80 - O/P T(pair)
 HD83 - O/P T(pair)
 PRE-II - driver T(pair)
 300B - O/P T (each)
 Kel84 - PCB
 88 - PCB
 Kel34 - PCB
 Kel80 - PCB(pair)
 HD83 - PCB
 PSU-II - PCB
 PRE-II - PCB
 PHONO-II - PCB
 TAG
 ALPS - 50K
 ALPS - 100K
 LCR - 22.5U
 ANSAR - 22.5U
 JEN - 0.47U
 BG - 220U
 BG - 4700U
 K5881 - CHAS
 KEL-CHAS
 SAFETY GLOVES

qty

(inc vat & carriage)
 £250.00
 £100.00
 £50.00
 £75.00
 £70.00
 £35.00
 £35.00
 £25.00
 £100.00
 £45.00
 £15.00
 £35.00
 £18.00
 £130.00
 £80.00
 £130.00
 £170.00
 £85.00
 £70.00
 £120.00
 £22.00
 £37.00
 £12.00
 £47.00
 £18.00
 £18.00
 £18.00
 £18.00
 £18.00
 £18.00
 £3.50
 £11.00
 £11.00
 £10.00
 £16.00
 £20.00
 £12.00
 £16.00
 £55.00
 £40.00
 £10.00

overseas

(exc. vat & carriage)
 £210.00
 £85.00
 £43.00
 £55.00
 £52.00
 £25.00
 £25.00
 £17.00
 £85.00
 £38.00
 £13.00
 £30.00
 £16.00
 £50.00
 £70.00
 £104.00
 £136.00
 £65.00
 £54.00
 £102.00
 £19.00
 £32.00
 £10.00
 £39.00
 £15.00
 £15.00
 £15.00
 £3.00
 £9.00
 £9.00
 £8.50
 £13.00
 £17.00
 £10.20
 £13.60
 £45.00
 £32.00
 £9.20

order information

NAME: _____
 ADDRESS: _____

 POST CODE: _____
 COUNTRY: _____
 TEL. (DAY): _____

(240/120 option - delete the voltage NOT required. If you wish for a built item, please phone for a quote / Valves included except where otherwise stated)
 If you would like a data sheet on any of the kits, please write a 'D' in the qty box

WARNING - World Audio Publishing Ltd accept no responsibility for kits, parts or modifications made or supplied by third parties. Order on our website www.worldaudiodesign.co.uk
 Please send your completed order form to:

Far East Distribution

overseas price & details

24 hour Credit Card Hotline: Tel: 01908 218 836

I enclose cheque/postal order for £_____ made payable
 to World Audio Publishing Ltd. I wish to pay by Mastercard / Visa / Switch / Solo.
 Please debit my account no:

_____ (_____)

Expiry Date: _____ Signature: _____
 (Switch/Solo only) Valid Date: _____ Issue No. _____



World Audio Publishing Ltd, 1 Spring Gardens, Foxwell, Pagnell, Milton Keynes, Bucks MK16 6EE, UK. Tel: 01908 218 836. Email: worldaudio@worldaudiodesign.co.uk

Millennium Hi-Fi & AV, 137 Jalan Pendekar 2, Taman Skudai Baru, 81300 Skudai, Johor DT, Malaysia

Tel: 07 554 5171 - Fax: 07 554 7645 - email: mha8@pd.janng.my

Please allow for your own local import taxes (custom duties) and for carriage charges, which must be added to the net price.

METHODS: **World Radio History** money order in Sterling Mastercard or Visa

wanted

Sevenoaks Sound & Vision is the UK's largest independent supplier of hi-fi and audio visual equipment with stores throughout the country. We have opportunities throughout the country for forward thinking, self-motivated managers and staff but specifically in the following stores:

- Bristol** • Assistant Manager and Sales
- Kingston** • Sales (Possible Part-Time Position)
- Liverpool** • Senior and Junior Sales
- Preston** • Sales
- Sevenoaks** • Sales
- Southgate** • Senior Sales
- Watford** • Sales
- Witham** • Manager

If you have experience within the hi-fi and audio visual market or electrical retail supply field, excellent customer service skills, are self-motivated, enthusiastic and looking for fresh challenges within an established and progressive retail chain, we'd like to hear from you.

All applications should be in writing together with a current CV to:-

Janys Ness • Personnel Manager
 Sevenoaks Sound & Vision
 109-113 London Road
 Sevenoaks
 Kent
 TN13 1BH

Or call our recruitment number
01732 466214



AUDIOVECTOR

The new improved range of Audiovector M Series speakers are now available...

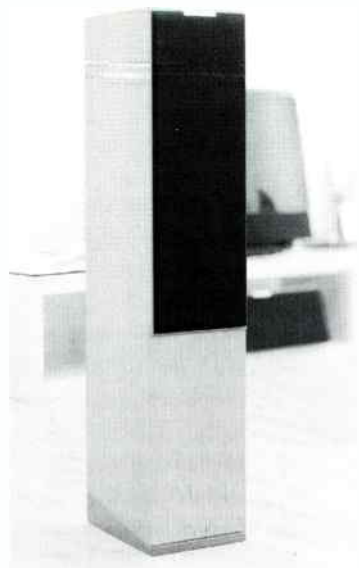

Call us to arrange a demo or visit our website at:
www.audiovector.co.uk
 and view the entire range of Audiovector speakers from just £329 (per pr) to over £4,000

Example prices (for Black Ash):
 Bookshelf/stand mounts
 M1 (bi-wire/bi-amp) £649.95/pr
 M1 Signature £1,179.95/pr
 Floorstanding speakers
 M2 (as "Recommended" by Hi-Fi Choice) £999.95/pr
 M3 (tri-wire/tri-amp) £1,199.95/pr
 M3 Super £1,699.95/pr

Post to: Glaive Limited, Unit 7, Wren Industrial Estate, Coldred Road, Maidstone, ME15 9YT Tel/Fax: 01622 664070 Web: www.audiovector.co.uk
 Please send me info on Audiovector speakers

Name:
 Address:

 Post code: HFW0012

MICHELL ORBE

A SYMBOL OF PRECISION

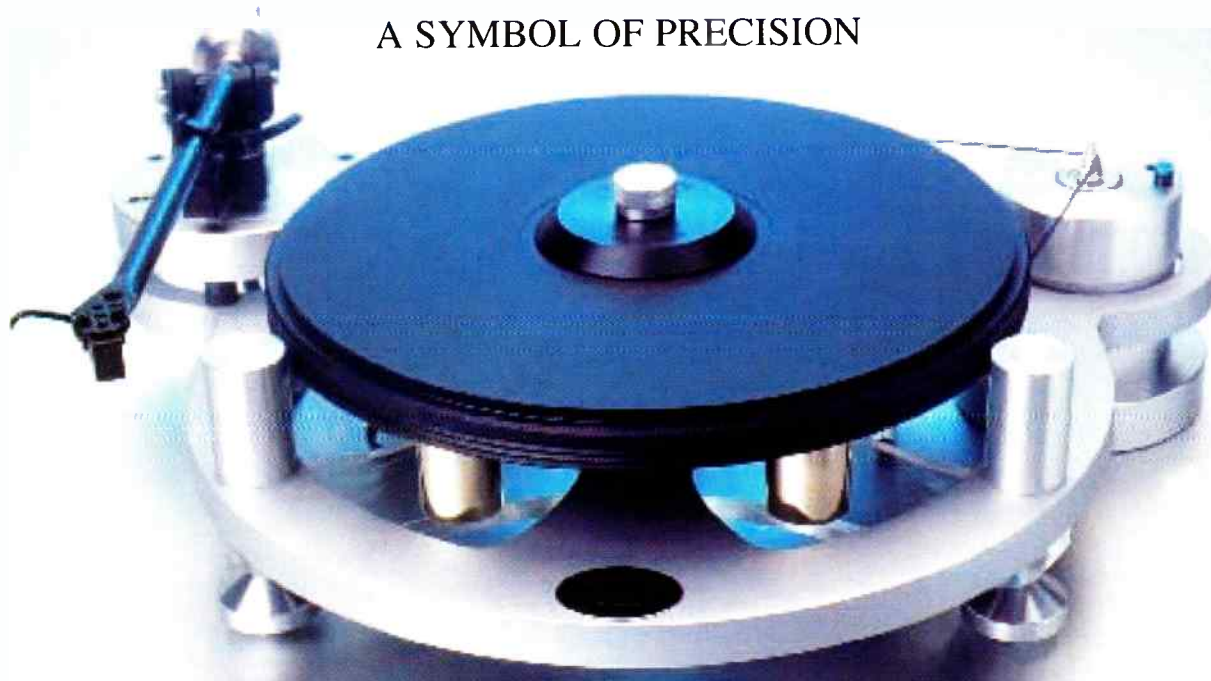

★★★★★ **WHAT HI-FI?**
 June 1999

Michell Engineering Ltd, 2 Theobald St, Borehamwood, Herts, WD6 4SL
 Tel: 0208 953 0771

My year started with a bang. It was the fuse of my 300B amplifier blowing at switch-on and I knew from experience it meant trouble. Valve amps sound wonderful, but they're like old cars - characterful but unreliable. At least, by modern standards. Worlds apart in technology but unusually close in sound is the Cyrus 7 amplifier I've also grown partial to and comparing them is interesting. The Cyrus sits quietly on the shelf, in its small, black unassuming case. Not so 300B; it is a majestic monster that demands attention. When the fuse starts going, however, I look at it in fear.

In spite of designing and building valve amplifiers over a lifetime, I still quake at the thought of repairing my beloved 300B. It's the push-pull design we released in our 4th DIY Supplement, August 1993. From the outset this was one difficult amplifier to make work properly. I conceived it with Tim de Paravicini to be as simple but near-perfect as possible and it is the basic concept of this amplifier that makes it special.

However, 300B push-pull (as I call it to set it apart from our recent single-ended) was always a hairy design that pushed the limits. The main source of fear is its internal power (HT) line that runs at 550V. Sensible designers try not to work at voltage levels this high because high voltage parts are expensive - and because when something goes bang, it does it big-time.

How I remember slaving over the power supply of this amplifier with designer Andy Grove, trying to get it right. This experience taught me to respect 550V much more than the usual 350V or so valve amps run at. Massive blue sparks would crackle through the tortured GZ34 rectifier valves we tested as they gave up under the strain. I looked on in awe and trembled a little every time I had to haul the power supply board out, testing the HT line repeatedly to make absolutely sure, beyond any shadow of a doubt, that the capacitors had discharged. I know that being hit by 550V is like being hit by a truck.

I was reminded of the power behind this supply every time a test prod slipped,

shorting HT to ground. There'd be a massive flash and bang, bits of PCB track would evaporate, burn marks scar the board and weld holes appear in the prods. I'd fly backwards in fright.

In spite of the difficulties we succeeded in getting 300B working stably and, with a sense of satisfaction, I wrote up our experiences in the September 1994 issue of Hi-Fi World. Development had taken a year.

Although the amplifier was expensive at £850, because of all the special parts, it sold well. With good justification in my view because this still remains one of my favourite amplifiers. I absolutely love listening to music through 300B. Lacking feedback, it has the most open, spacious sound I have ever heard.

This time around it looked like the diodes had gone again, but after struggling

” In spite of designing and building valve amplifiers over a lifetime, I still quake at the thought of repairing my beloved 300B.

upstairs to my workshop with all 20kgs (44lbs) of the beast there was seemingly nothing wrong. I cleaned the power supply board and inspected it for tracking or arcing. Yet again I managed to discharge the electrolytics accidentally, which produced a vicious flash and bang. I decided it was time to get serious and fit the bleeder resistors that were always meant to be there; we just hadn't bothered on this prototype.

This gorgeous power amplifier is now back working again, sitting on the concrete base of an empty fireplace where it gets a good, cool draught and, if disaster does strike, it will not set the house alight! After all these years I still view it with a little suspicion, even though it was carefully designed to run safely at 550V. We even had power supply special capacitors made, flashover tested to 800V.

In spite of its idiosyncrasies, I wouldn't live without 300B. There's a healthy 'thrum' at switch on and it sits there glowing heartily all day long, fed by a KLPP1 valve preamplifier. This is a

real battleship of an amplifier, King George V scale - not a toy! The Cyrus takes up a fraction of the space, produces more power and almost no heat. How enormously sensible it is, proof that you don't need to suffer for a great sound. It's modern, clinical efficiency isn't intriguing though. Visitors might love listening to it, but they won't see it. Not so 300B: visitors gawp.

With 300B, size is deceptive though. The circuit was designed to be as simple as possible: there are just four amplifying devices in each channel. The circuit arrangement uses no fewer than five transformers and two chokes, hence its weight and size. Cyrus 7 is far more complex.

Readers often ask what we use at home. I hesitate to mention 300B because it is hair-shirt and unavailable commercially now. Something like this means little to most people. That's another reason I'm thankful for Cyrus 7. It is the nearest solid-state equivalent, sounding smooth, detailed and atmospheric. It has firmer and more lucid bass too, if not the sense of deep spaciousness of 300B.

Cyrus 7 has more power too but in terms of loudness there's no choice: 300B gives much louder bangs. This is the amplifier for me! ●



Noel Keywood

Cables Talk

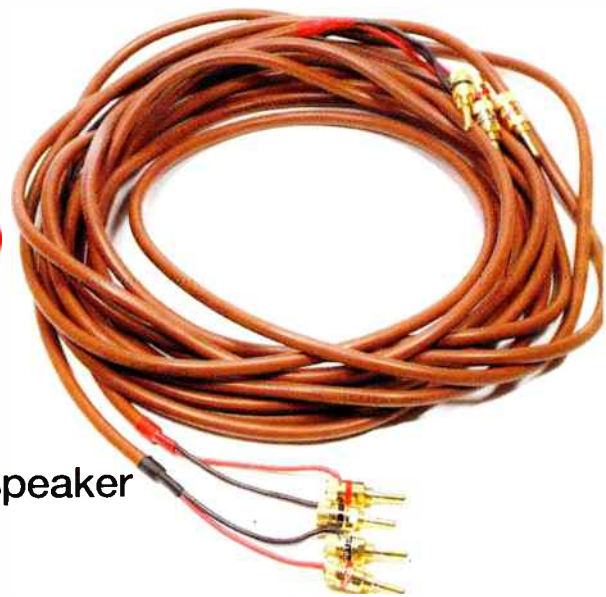

Simon Pope listens to two single wire loudspeaker cables priced under one hundred pounds.

SONICLINK AST-150
£4.00 PER METRE/£48.00
TERMINATED 3 METRE PAIR

Not the catchiest of names or the most fetching of colours (it's also available in white as well as the brown we had), but the price is most definitely right. Under fifty quid for two three metre runs is good value from any company but from cable specialists SonicLink it's great.

The AST-150 employs the company's Aero Space Technology (AST) that uses "advanced materials developed for aerospace applications". It's a two core cable with plated conductors - an attempt to reduce high frequency distortion - with a not too chunky diameter of 7.5mm. Each core consists of thirty 0.2mm tinned copper strands. The cable is terminated with 'sandwich' type plugs.

A performance of Harris's English church anthem 'Faire Is The Heaven' as sung by the excellent Cambridge Singers on Collegium Records showed this cable's excellent transient attack. I find choral music a good test for cables - it showcases their abilities with detail retrieval, high frequency response and the sense of air and space. The AST-150 fared well, with an immediate and realistic presence. Where it let itself down slightly was in the upper voices, where sopranos sounded a little shrill at climaxes and consonants a tad sibilant.

Moving to Rock from the Foo Fighters, the SonicLink proved fast and grippy, with tight, controlled rhythms. Bass was a little thinner than I'd expected but what it lacks in bass

depth it makes up for in detail.

Overall, it's fine value for money. Little at this price gives as much detail, but thanks to its forward sounding or dullish systems, where it will quicken the sound. An excellent value buy and a big step up from the budget stuff.

SonicLink
 Tel: 01332 361390

KIMBER CABLE 4PR
£94 TERMINATED 3 METRE PAIR

Like SonicLink, Kimber's products range from this, their cheapest terminated 'speaker cable, to the dizzy heights of the Select range (the KS-3038 being £6,300 for a 2.5 metre pair!). So, you'd expect some high-end experience to trickle down to the lower end of the price spectrum. The 4PR is no spring chicken and has been in existence since 1979 but is still going strong. It has the familiar knitted conductor look of the more affordable models, this time in black and brown - 4 of each. The conductors are made from high-purity copper and the cable is terminated with Kimber's excellent little 4mm banana plugs or PostMaster spades. Starting the ball rolling with Harris's 'Faire Is The Heaven', the 4PR had a well balanced sound. The cable brought warmth and smoothness to the acoustic and the phrasing of the choir was also highlighted. There's a fine sense of lyricism and line, with smoothness and transparency by the bucket.

A nice open midrange was present in male voices, plus a good sense of space. There was little sibilance in female voices and no shrill edge at high notes or climaxes.

With the Foo Fighters there wasn't the same sense of immediacy as with the SonicLink, the emphasis being more on musical cohesion. Everything was very well put together, so to speak, the drums integrating beautifully with the bass guitar and Dave Grohl's vocals were strong and lyrical. The various guitar layers were all conveyed with clarity, and the whole performance shone in terms of staging and imaging. This cable is twice as much as the SonicLink and what you get for the extra money is more cohesion and lyricism. The sound isn't mechanical or dry, but open and extremely well balanced across the frequency spectrum. Bass is also good and taut. An excellent all round buy that will fit well into most systems up to £2,000. ■ ▲

Russ Andrews Accessories Ltd.
 Tel: 01539 825500



Perfect Pitch



Pioneer's classic PL600X turntable was an ideal 'people's turntable' for the late seventies - it's just a shame no one noticed, says David Price.

The PL600X found itself somewhat overshadowed by Pioneer's 'sexier' products when it was introduced back in 1980. It was unashamedly fully automatic, the Japanese not seeing the need for fiddling around with the cueing lever if they could possibly avoid it.

Back then, in Britain at least, fully auto turntables were about as fashionable as Michael Foot's duffel coat. This was because unless the automatic mechanism was done meticulously well, it invariably wrecked the sound. True to the spirit of Pioneer's high end products however, the PL600X's was executed perfectly. Everything from the actuation motors to the microswitches were of the highest quality, which was completely in keeping with the rest of the deck's engineering.

Indeed, you just can't help but be impressed by the build of this

deck. The tonearm is a beautifully crafted stainless steel S-shaped affair with a rigidly mounted counter-weight, with the tightest and smoothest bearings you'll find on an auto deck. This, and the heavy, dynamically balanced cast aluminium alloy platter and thick rubber mat are isolated from the deck's all-aluminium plinth and steel base using Pioneer's clever 'coaxial' suspension system. This means the arm, platter, bearing and motor hang from rubber coated internal struts (not dissimilar to SME's Model 30), immune from the vibrations the platter and base pick up.

The bearing housing is a robust alloy casting which encloses a finely machined spindle, and the motor a brushless, slotless linear design with a Phase Locked Loop Quartz circuit that keeps wow and flutter down to a quoted 0.02% WRMS - a figure comparable to Technics' broadcast-quality SP10/II.

A tell-tale sign of a classy turntable is its bass. When the low frequencies sound unusually deep and powerful - AND tight and fast - you know you're listening to something that's been properly engineered. The PL600X is just such a deck. With an

amazingly crisp attack-sustain-decay envelope, you can hear bass strings being struck with tremendous speed and then falling off naturally, like few turntables of any vintage. It makes for an extremely enjoyable sound which only today's best high end belt drives come anywhere close to bettering.

In other areas though, the Pioneer isn't so hot. Thanks to its low tech tonearm the midband isn't as transparent as today's top decks, and treble's a bit ragged too. Factor in its inability to handle major dynamics and it's clearly flawed in absolute terms. It's still great fun to listen to though - like many other high end Japanese decks of its day, it's always an involving performer.

These days, PL600Xs are few and far between in Britain. An unloved deck that originally sold for £250 in 1980 (nearly as much as a Linn Sondek LP12 at the time) is never going to be abundant. But if you're looking for a cheap automatic disk spinner, then any Pioneer PL200, 300 or 400 is worth a look, not to mention the PL512, PL514, PL516 and PL518 that preceded them.

Pay between £40 and £100, depending on model and condition. The arm can be replaced with a Dynavector DV10x4 (to the high enders) or Audio Technica AT110E (to the budget decks) to improve things. Then you'll have a reliable disc spinner that will run your flash new CD player uncomfortably close! ■ ▲





15th ANNIVERSARY

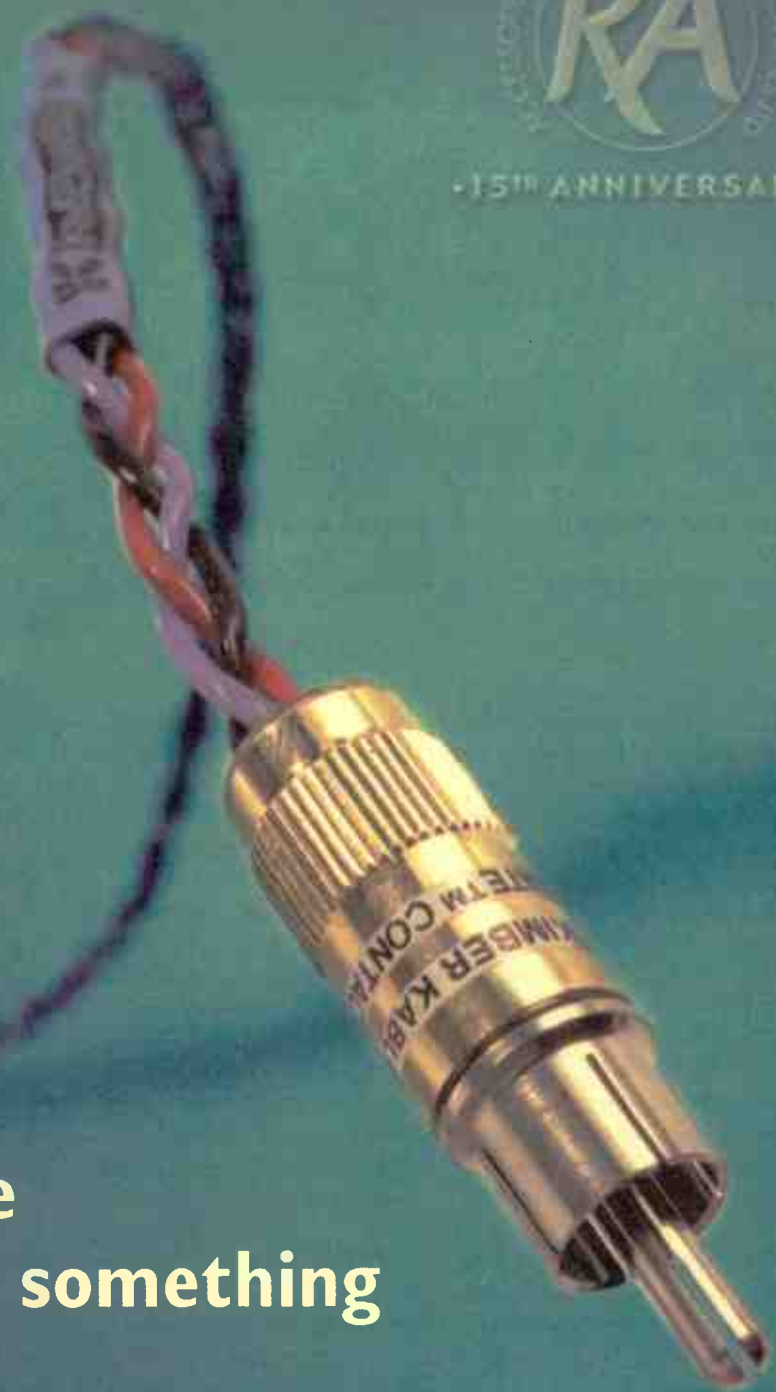

Why settle for
anything else
when you can **OWN** something
this good!

PBJ Interconnect
with Ultraplate™ phonos

200 Ohm 0.5m Juke

"Assured sound, solid and natural bass, and
clear, bright, excellent performance all round"

Richard Black, Hi-Fi Choice
Issue 186, March 1999



"for the best cables, CDs and accessories"



Sole UK Distributor
for MEMBER KABLE

Mail Order Direct on UK Freephone **0800 373467** quoting ref: AHW31 and request a catalogue

Cable Upgrade Scheme • Lifetime Guarantee • 30-Day Home Trial • Expert Advice

RUSSELL & ANDREWS ACCESSORIES LTD, FREEPOST MWWRKA WEMDA, LAB 92A

PO Box 101529, 825 20th Ave, Dallas, TX 75210-0152, USA. Tel: +44 (0)1534 831111. Fax: +44 (0)1534 831112. Email: info@russandrews.com www.russandrews.com



Ever walked into a hi-fi shop and asked the sales assistant for something, only to be greeted by a look of abject bemusement? I have, and it happened several times in one day, too.

I wasn't asking for an idler pulley screw for a Garrard AP75 turntable, or a stylus guard for a 1977 Shure M76-5. Disc clamping mechanisms for the later B version of Marantz's early CD63 CD player weren't on the shopping list either. In fact, what I wanted was completely new, current and recently released - a Super Audio Compact Disc. "You wot, mate?", was the general consensus of opinion in the five Bristol hi-fi shops I asked.

The first problem was most sales assistants' failure to understand basic English. Although I'd simply asked, "do you sell SACDs?", three out of the five dealers assumed I meant the hardware rather than the discs I was actually looking for. Considering that most trained hi-fi salespeople know the distinction between CDs and CD players, this confusion seemed a bad omen, and I was not wrong.

Although two of the five dealers sold SACD players, my request for software to play in them provoked a reaction tantamount to me having just teleported in from the planet Tharg. "You sell SACD players, don't you?", I meekly enquired. "Yes sir", they replied. "Then do you sell the discs?", I asked, "Err.. no." They might as well have replied, "of course we bloody don't, stupid".

Next came the false dawns. Several suggested I try the Virgin Megastore in Broadmead, but the kid on the desk just said, "you wot, mate?" Another suggested a specialist record shop, to which I energetically went with high hopes. "Do you sell SACDs?", asked I. "What, you mean those audiophile things with Dire Straits and that on?", the guy replied. The implication that I wanted to buy 'Money For Nothing' was bad enough, but that the fact that the guy had a smile on his face when he said it was too much. In the interests of journalistic enquiry, I swallowed my pride and nodded.

He went over to his CD rack and picked out an HDCD. Doh!

Okay in hindsight I'll admit that breezing into high end hi-fi shops that sell high end SACD players and asking for high end discs to play in them was naive. Ironically, the most helpful store was Richer Sounds, where someone suggested Vivante. Quite right too, because Vivante does sell SACDs, and even bothers to keep some in stock. This, in the software-starved world of Super Audio, is a right royal feast.

All in all, it took me the best part of five hours pounding the rainy February streets of Bristol to come up with a big fat zero. Which is why I can see the new format having rather an uphill struggle. Click on Vivante's website (www.vivante.co.uk) or even Sony's (www.sony.com/sacd) and

“ what stands between SACD and success is getting the bloody music.

you'll find there's actually a half decent selection of titles, it's just getting them that's the problem.

While audiophiles like us delight in DSD's stratospheric bandwidth and stonking dynamic range, what stands between SACD and success is getting the bloody music. Time after time, the great listening public has proved that avail-

ability and price is all a format needs for success. Napster, lest we forget, has had over thirty million downloads and practically as many satisfied customers. As far as SACD's concerned, judging by my Shanks's Pony-based market research, you can divide that figure by around one million.

Let's do a quick reality check here. You can buy a decent CD player for £200, and a second-hand turntable from Loot - that will sound better than most CD players at any price - for half that. You can get vinyl for 50p an album at a car boot sale or record fare, CDs for not much more, and if you happen to own a computer you can have MP3s of any music you ever wanted for free. By any draw of the cards then, SACD features a bit of an uphill struggle.

"But it sounds great", I hear you cry. And so it does, in the same way that TVRs are top fun to drive and a Yamaha R1 is no slouch on the open road. But that isn't where most people are at, or ever will be. If the general public is even going to aspire to listening to SACD, it must first be able to experience the software in the flesh. Pounding the streets is for journalists, not music fans. ●



David Price

Why settle for
anything else
when you can **OWN** something
this good!



UK's UK Distributor
for KIMBER KABLE



"for the best cables,
CDs and accessories"

Mail Order Direct
on UK Freephone
0800 373 467

quoting ref: AHW41
and request a catalogue

Cable Upgrade Scheme
Lifetime Guarantee
30 Day Home Trial
Expert Advice

Russ Andrews Accessories Ltd.,
FREEPOST NWW881A,
KENDAL, LA8 9ZA.

Tel: +44 (0)1539 825500

Fax: +44 (0)1539 825540

E-mail: AHW41@russandrews.com

www.russandrews.com

The Purifier from £250

"...the Purifier gives the music a cleaner, quieter background, allowing you to hear low level detail more clearly... it is highly effective and will greatly reduce mains disturbances."

Hilary Hughes, Hi-Fi Choice, Oct 2000.

The Power & The Glory

How to Upgrade Your Mains

Essential reading for anyone who wants to hear the best music their system can deliver. Call and request your free copy quoting ref: AHW41



definitive audio

Living Voice • Lowther • Vitavox • Electrofluidics • Art Audio • Border Patrol
Canary • DNM • MF • Sugden • Wavac • Western Electric • Resolution Audio
Wadia • Michell • Nott'm Analogue • SME • Ortofon • Van den Hul



...land of opportunity
and adventure...

Sale of part exchanged and ex-dem items

	Sale	New
SJS Electroacoustics Model1 pre-amp. Immaculate - rare.	£700	£1000
Audio Innovations P2 phono stage, with full Border Patrol conversion; inc. Hovland film & foil capacitors and choke power supply. Very rare and very special.	£1000	--
Art Audio VP-Special pre-amp with phono stage. Full conversion with Hovland film and foil caps and Panasonic potentiometer.	£850	£1450
Art Audio VP-S pre-amp. Standard.	£600	£1150
Audio Innovations Series 1000 monos. Serviced and re-valved.	£900	£2000
Croft Series V monos.	£600	£1500
Art Audio Diavolo. Special chrome finish, Hovland film and foil caps throughout. Border Patrol MB psu (£1000). Great opportunity.	£3500	£5500
Cary 805c mono blocks. 845 single ended.	£4500	£8500
Linn LK 140 monos + Kolector pre-amp.	£1000	£2000
Art Audio Quintet monos. Chrome.	£1800	£2400
Unison Simply 4 integrated amp.	£800	£1600
Nottingham Analogue Mentor turntable base. Two arm mount version. Green marble finish.	£1900	£2600
- if with 12" Nottingham Analogue carbon fibre tonearm (ex dem).	£2500	£3600
Living Voice Avatar. French polish finish refurbished - spotless.	£2100	£2500
Living Voice Auditorium, cherry.	£900	£1500
Living Voice Avatar OBX-R ex-dem, cherry.	£3000	£4000
Hefios Model 1 CD player - new	£1200	£1500
Hefios Model 2 CD player - new	£900	£1200
B+W 620i loudspeaker	£200	£400

AMEX VISA MASTERCARD

Tel 0115 973 3222 Fax 0115 973 3666

internet: www.definitiveaudio.co.uk email: shout@definitiveaudio.co.uk

pear audio

presents

Shahinian DYNAVECTOR Well Tempered

Stockists and Information from
**Pear Audio Ltd. 7 Prospect Place,
Alnmouth, Northumberland, NE66 2RL**
Tel: 01665 830862 Fax: 01665 830051

The compulsive spend of the New Year has just struck again. Christmas for me means work. Whilst I'm something of a party pooper at just the time of year all my friends are letting go of their inhibitions, money and waist lines, at least I've plenty of readies left for the new year.

Last January a new car was order of the day, the year before a new house. This time around something had to be done about the hi-fi.

It was the house that left the hi-fi in something of a sorry state, especially when it came to vinyl. My beloved Roksan Xerxes and Artemiz were scarified in order to pay the moving costs. A worthy NAD 533 (aka Rega Planar 2) has played host since. The trouble is it hasn't really played host at all. In fact it's played very little!

As good as the NAD is as a budget deck, it never encouraged me to go racing down to the record shop to pick up the latest realises on vinyl. Instead I focused upon CD. Something had to be done. The trouble was, buying a first home two years ago and just having paid seven hundred quid for car insurance, didn't leave me quite as flush as I'd hoped. Still, I reasoned that £300 should be enough to get a decent improvement upon the NAD if I scoured the second hand pages. Perhaps it wasn't quite enough to get something as good as the old Roksan, but it would be a challenge to see just how close I could get.

The scarcity of kit at this time of year didn't bode well, yet a solution appeared right under my nose. At the shop I manage there were two Ariston RD90 Superieur decks, both in a rather dilapidated state. They'd been there for longer than I have (at least seven years now), and I'd often thought about attempting to rejuvenate them. Neither had tonearms so a listen was out of the question. A review in another magazine gave the 90 a mere "good" for sound quality. Still, if the price was right I was tempted.

After a little convincing my boss of the delapidated state of them, forty pounds later my winter project had begun! I'd bought both the units, but one of them had shed its plinth and broken a motor housing clamp. It was a sorry sight, but at

least it had an armboard. The other unit was in one piece, so I decided that it would be the one to play host to the other's generous donations.

Finding a power supply proved surprisingly easy. Once I knew that I needed a 24V 800ma thing-a-me-whatsit, I simply went down to Maplins and asked for one. Admittedly the "Sunpower" PSU probably isn't a patch on the original, but it did the job of revolving the RD90 without going pop! Total cost was so far £55.

The hunt for a tonearm proved rather trickier. The SME fitting limited my

” Last January a new car was order of the day, the year before a new house. This time around something had to be done about the hi-fi.

choice severely to an SME, Audio Technica or Odyssey. The latter two were ruled out on the grounds of scarcity, so an SME it had to be. No bad thing really as the boys at Scale Model Engineers makes some pretty tasty contraptions. The trouble came in finding one. As much as I'd have loved a 309 (or better), finding one for less than £450 proved impossible. This would have completely blown my budget, and as tempted as I was, I decided to turn to the decidedly vintage 3009. I say vintage, but this World Favourite is still actually made today! No need to buy new though, as there are plenty around second hand and superb build quality and parts availability ensures longevity.

Although familiar with

the arm I hadn't quite realised just how many incarnations they'd been making, choosing one was difficult. I settled on a fixed head 3009 Improved. Partly because I've always preferred fixed heads for their extra rigidity (and I rarely change cartridges anyway), and partly because it was the only one Classique Sounds of Leicester had left! I bought it there and then for a reasonable £95. The Ortofon MC15 Super came off the NAD to complete the deck.

Putting it all together took about 9 hours, much cursing and several trips to the hardware shops to buy the necessary Allen keys and nuts and bolts, but the end result is pretty good. Whilst I'd be the first to admit that, by modern standards, it's a little weak at frequency extremes, and it doesn't have quite the solidity of soundstage as the Roksan, listening to vinyl has become a real pleasure once more. There's plenty more I can do to tweak the performance. For half the price of my original budget you could say that I'm "well pleased". In fact I'm just off down to the record shop now! ●



Dominic Todd

LONDON

SPECIALIST HI-FI DEALERS * SPECIALIST HI-FI DEALERS * SPECIALIST HI-FI DEALERS

AudioVenue
the symbol of security

~ ONCE IS NOT ENOUGH ~



Nakamichi REIO Receiver

X-PI00 & X-AS100 pre/power amplifier

Ortophon S10 Cartridge

► Export Orders Welcome ► Home Demonstrations
 ► Multi-Room Design & Installation Service

'We at AudioVenue are committed to providing an unrivalled service together with state of the art equipment to achieve the ultimate in home entertainment, so whether you are buying, selling, exchanging or just looking for unbiased advice, ensure your first call is to AudioVenue.

Components from £120 - £72,000
 0% Credit available. Written quotations on request. Subject to status.

Tel Fax +44 (0)181 707 4849 Mobile: +44 (0)973 471 426
 email: info@audiovenue.co.uk



think audio think...
Auditorium

0171 384 3030

THE HI-FI SHOP 112 NEW KINGS ROAD LONDON SW6

Soundcraft
 INSTALLATIONS

VISIT THE LEADING HI-FI DEALER IN THE SOUTH EAST
 "SEE & HEAR THE DIFFERENCE REAL HI-FI MAKES"

LINN NAIM ARCAM REGA
 HELPLINE: 01233 624441

~~AUDIO CONCEPT~~

27 BOND STREET, EALING
 LONDON W5 5AS
 TEL. 081 - 567 8703

Audio Analogue, Art Glass, Ash Designs, Avik, B&O, B&W, Cabletalk, Chord Company, Creek, Denon, Epos, Harman Kardon, Infinity, KEF, Lat, Marantz, Musical Fidelity, NAD, Nakamichi, Nordost, Orelle, Onkyo, Primare, Quad, Roksan, Rotel, Ruark, Sennheiser, SonicLink, Sound Style, Stands Unique, Strightwire, Supra, Tag McLaren, Target, Teac, Thorens, van den Hul.

10 - 6 pm Mon., Tues., Friday, & Sat.
 Late night Thur. closed Wed.

Two demonstration rooms.
 Free local delivery and installation.
 Repairs and Services

O'Brien Hi-Fi



ARCAM • ANTHEM • AUDIOGRAM • AUDIO RESEARCH • AUDIO TECHNICA • BEYER • CABLETALK • CHORD • CREEK • DENON • DENISEN • JADIS • JECKLIN • MICHELL • MUSICAL FIDELITY • NAD • NAIM • OPERA • PRECIOUS METALS • QED • REGA • ROGERS • ROYD • SENNHEISER • SILTECH CABLES • SME • SONNETER • SONUS FABER • TEAC • THORENS • TRANSPARENT CABLES • UNIONSON • RESEARCH • WILSON

MARTIN LOGAN COPLAND

Clearance • Second Hand • Ex Dem Equipment • Details on request

0% Instant Finance Available
Without deduction of interest

New Demonstration Rooms • Free car parking • Major Credit Cards
 Personal Expert • Mail Order • Installation Service • Repair facilities
 5 mins walk Raynes Park BR • 20 mins Watlington
 5 mins from A3 (Raynes Park B28 Jct) • 25 mins to Epsom

60 Durham Rd, West Wimbledon, London SW20 0TW
 Est. 1966
 Tel. (0181)946 1528 Fax (0181)946-0331

INSTANT 0% FINANCE AVAILABLE
 SERVING LONDON FROM BATTERSEA

ORANGES & LEMONS

Juicy fruit from London's newest, freshest hi-fi/home cinema retailer. Telephone demonstrations or just pop in. All the usual, i.e. friendly and efficient service, free home installation + credit cards.

THE INNOVATIVE AUDIO VISUAL HI-FI RETAILER. ARCAM, CABLETALK, CHORD CO, DENON, EPOS, MARANTZ, NAD, NAIM, REGA, ROKSAN, ROTEL, ROYD, RUARK, SOUND-STYLE, STANDS UNIQUE, YAMAHA

NOW IN OUR FIFTH FLAMBOYANT YEAR.
 020-7924 2040
 61/63 WEBBS ROAD, SW11
 Visit www.orangesandlemonshifi.com

ZEBRA

18-24 Brighton Road,
 South Croydon
 CR2 6AA
 0181 688 2093

NORTH

FRANK HARVEY
 HI FI EXCELLENCE

The Midlands Largest Choice of Specialist Hi Fi & Home Cinema

163 Spon Street, Coventry
 Tel: 01203 525200
 Web: http://frankharvey.co.uk

For real choice and the largest range of Hi Fi & Home Cinema products in the Midlands

Acoustic Energy - Atacama - Arcam - Audio Quest - Alphason - Apollo - Bang & Olufsen - B & W - Castle - Cable Talk - Celebration - Chord - Cynos - Definitive Technology - Denon - IXOS - Kef - Marantz - Meridian - Monitor Audio - Miller & Kreisel - Mission - Michell Gyrodek - Musical Fidelity - NAD - Optimum - Panasonic - Pioneer - Quad - QED - REL - Rega - Rotel - Sennheiser - Sharp - Tag McLaren - Target - Teac - Tannoy - Thorens - Van Den Hul - Yamaha

Much more in store on 3 Floors with 3 dedicated Hi Fi demonstration rooms of the very best Hi Fi.
 Plus our new Home Cinema Room. Very nice Staff and excellent coffee. Appts Req.
 Opening Hours 9-30 to 5-30, Tues to Sat. Closed all day Monday

INVEST IN OUR EXPERIENCE

CYMBIOSIS
 AUDIO & VISUAL SOLUTIONS

6 HOTEL STREET
 LEICESTER
 TEL: 0116 262 3754

ARCAM • ACOUSTIC ENERGY • CASTLE • CHARIO • CURA
 CHORD CO. • DENON • LINN HI-FI & KNEKT • LOEWE
 LUTRON • MUSICAL TECHNOLOGY • NAIM • NORDOST
 REGA • REVOX • ROTEL • TAG MCLAREN • WADIA

"Customer care at it's best"

e-mail: shop@cymbiosis.com
 website: www.cymbiosis.com

BADA
the symbol of security

Basically Sound
 NORWICH • NORFOLK

Arcam, Audio Analogue, Cabletalk, Chano, Chord Co, Denon, Epos, Naim Audio, ProAc, Rega, Royd, stax, Talk Electronics, Teac, UKD Opera, Audio Note and many others

The Old School
 School road, Braiton Ash
 Nr Norwich, Norfolk, NR14 8HG
 Tel (01508) 570829

BADA
the symbol of security

IRELAND

VALVES & TUBES

SPECIALIST HI-FI DEALERS * SPECIALIST HI-FI DEALERS

KRONOS HI-FI
 7 Scotch Street Centre,
 Dungannon,
 N. Ireland BT70 1AR.
 Tel. 01868-753606
 http://www.kronoshi-fi.
 demon.co.uk
 Open Mon-Sat 9.30-5.30, closed Wednesdays.
 Agencies include: Absolute Sounds, Arton,
 Audion, Audiomeca, Cadence, Denon, Elton,
 Frameworks, Harman Karbon, JBL, Kabelwerk,
 Klipsch, Living Voice, Lyra, LFD, Marantz,
 Mitchell, MIT, Musical Fidelity, Nottingham
 Analogue, Oracle, Orelle, Roksan, Rotel, Ruark,
 Silver Sound, SME, Sonic Link, Triangle, Trisorb,
 Unison, UKD, VPI, Wilson Benesch, Yamaha.

Hearing is Believing

CLONEY Audio
30 years of Experience

55 Main Street,
 Blackrock,
 Dublin.

Tel: (01) 2889449/2888477
 Open Tues - Sat 10 am to 6 pm.
 Thur - Fri 10 am to 6 pm.

Arcam
 B&W
 Tag McLaren
 Castle
 Meridian
 Classé
 Copland
 Marantz
 Jadis
 Naim Audio
 Sony
 REL

CVC Chelmer Valve Company
For audio valves

Buy CVC. PREMIUM HI - FI valves direct from us.
 All valves processed for improved performance.
 We also have stock of MAJOR BRAND types inc.
 MULLARD, GEC, BRIMAR, RCA, GE, PHILIPS, etc.

130 New London Road, Chelmsford, Essex, CM2 0RG
 Tel. 01245 265865/355296 Fax. 01245 490064
 e-mail sales@chelmervalue.com

MISSION
 YOU MUST LISTEN TO MISSION

THE HI-FI SHOP

AUDIOLAB,
 B&O, B&W,
 CASTLE,
 MERIDIAN,
 MICROMEGA,
 ROTEL

OPEN
 TUES-SAT
 10-6

PHONE:
 (01232) 327604
 BELFAST

MAIL ORDER

RA Russ Andrews
 Hi-Fi Accessories
 Mail Order Direct

The Power & The Glory
 How to Upgrade Your Mains

Essential reading for
 anyone who wants to hear
 the best music their
 system can deliver.
 Call and request your free
 copy quoting ref: AHW41

UK Freephone
0800 373467

Russ Andrews Accessories Ltd.,
 FREEPOST NWW881A, Kendal LA8 9ZA
 Tel: +44 (0)1539 825500 Fax: +44 (0)1539 825540
 E-mail: AHW41@russandrews.com
 www.russandrews.com

VINYL

MUSONIC STYLII
 SPECIALIST MANUFACTURER &
 SUPPLIER FOR MORE THAN 40 YEARS
 REPLACEMENTS & ORIGINALS
 MANY OBSOLETE/78 VERSIONS
 PICK-UP CARTRIDGES
 & RECORD ACCESSORIES

For prices tel fax or mail to
MUSONIC (UK) LIMITED
 Unit 13 The Wenta Business Centre Colne Way
 Watford Hertfordshire WD12 4ND
 Tel: 01923 213344 Fax: 01923 213325
 E-mail: sales@musonic.co.uk Website: www.musonic.co.uk



VISA

REPAIR & DIY

TECHNICAL & GENERAL
 THE ORIGINAL TURNTABLE SPECIALIST

for the Great Classical Turntable, Arms, Cartridges, Styli

CONNOISSEUR • GARRARD • GOLDRING •
 LENC0 • ORTOFON • SHURE • S.M.E. •
 THORENS • WATTS

All available Genuine spares and our own
 re-manufacture of obsolete parts

NO ILLUSORY 'IMPROVEMENT' NO DUBIOUS
 OR HARMFUL 'MODIFICATIONS'

Cartridges and stylis, correct radius diamonds, for early
 recordings - 78s & Lps

TECHNICAL & GENERAL
 P.O.Box 53 Crowthorough, East Sussex TN6 2BY
 Tel: 01892 65 45 34

THE DIRECT DISC
 VINYL VINYL VINYL

Thousands of records always in stock.
 + a full range of sought after compact discs.
 Extensive search service for wanted albums.
 Comprehensive 96 page full catalogue available at £1.50
 Telephone / Fax 01992 447764
 Or visit our web site on www.walrus.co.uk

SERVICES & CONSULTANTS

Front End Problem?
 contact
The Cartridge Man

It doesn't have to cost an arm and a
 leg to get the best - listen to my
 Koetsu - and Decca -eater.

Also agents for Croft, Hadcock,
 E.A.R, Michell &
 Moth.

plus cartridge re-tipping service
020 8688 6565
 Website: LISTEN.TO/THECARTRIDGEMAN

atv

- Service & Repairs
- Valve & transistor amplifiers
- Vintage valve Radios
- Hi-Fi VCR's
- Valves Tested

ATV SERVICES
 LEATHERHEAD
 01372 456921

TO REACH
78,000 READERS
CALL AMANDA
NOW ON
0208 864 4760

"SYSTEM HARMONISING"
 Balance your Sound Reproduction System
 and extract its **full** potential.

Three-Dimensional Natural Swedish Recordings
 OPUS3 ("Eric Bibb") PROPRIUS ("Cantate Domino")
 PROPHONE ("Jazz at The Pawnshop") Swedish
 Society. ("Jussi Björling")

OPUS3/PENTACONE
 4, Cross Bank Road, BATTLEY, W.Yorks.
 Tel FAX: 01924 445039 Email: Peter@pentacone.freecore.co.uk
 http://www.go.to/pentacone

STUDER REVOX
 SALES, SERVICE, SPARES
 SERVICE & REPAIR OF
 A77, B77, A700, PR99 &
 36 SERIES
 HI-FI SPARES TO ORDER
 SERVICED MACHINES IN
 STOCK
 APPROVED CONVERSIONS
E.M.A.S
 TEL: 01246-275479
 FAX: 01246 550421

WORLD LIBRARY

WE HAVE OVER 40 TITLES ON OFFER!!!

LOUDSPEAKER BOOKS



Theory and Design of Loudspeaker Enclosures by J. E. Benson
Covers infinite baffle, reflex, passive radiator etc. in great detail with a highly mathematical approach, making it unsuitable for beginners but highly authoritative for experienced designers.
244pp 6" x 9"
Paperback Code: 1140
£23.95 + £2.50 P&P (UK)

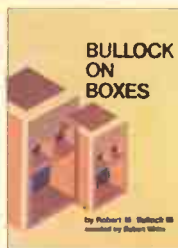

Bullock On Boxes
by Robert M. Bullock III.
Using Thiele-Small parameters clearly, it offers lots of helpful tables and graphs to get to grips with the sizing of the box and port of a reflex loudspeaker.
72pp 8 1/2" x 11"
Paperback Code No. 1100
£12.95 + £2.00 P&P (UK)



The Loudspeaker Design Cookbook, 6th edition (new) - by Vance Dickason
This best seller offers up-to-date design information for the home constructor. It uses modern Thiele-Small theory and parameters.
185pp 8 1/2" x 11 1/2" Paperback
Code No. 1090
£25.00 + £4.00 P&P (UK)



Electrostatic Loudspeaker Design and Construction by Ronald Wagner
Step by step guide to the design and construction of a full range electrostatic loudspeaker, including basic operating principles. Strongly recommended for those wanting to either build, repair and/or restore, or who are just interested in electrostatics.
243pp 7" x 9 1/2"
Paperback Code No. 1080
£16.95 + £3.25 P&P (UK)



Testing Loudspeakers+
by Joe D'Appolito
Joe D'Appolito, loudspeaker designer and consultant, has written the definitive text on testing loudspeakers. Dr. D'Appolito brings his expertise to the subject and provides you with a hands-on discussion of testing drivers and systems. He brings you the theory and physics behind loudspeaker testing in this volume.
Paperback Code No. 1580
£24.95 + £2.50 P&P (UK)



Audio Amateur Loudspeaker Projects
A collection of the 25 best speaker articles published in the Audio Amateur throughout the 1970s, this popular book is proof that great designs are never out of date. This volume is a rich source of theory, practice and design.
135pp 8 1/2" x 11" Paperback
Code No. 1550
£16.95 + £2.50 P&P (UK)



Advanced Speaker Designs
by Ray Alden
One for the mathematical minded with all the equations one would need for speaker design. Driver parameters are discussed. Sealed & Vented Enclosures have a chapter to themselves. Crossover design is covered as well as measuring speakers. At the rear there are seven projects that rely upon American sourced drivers (Radio Shack). The book offers concise technical explanations of how speakers work.
128 pp 230mm x 150mm
Paperback Code No. 1680
£14.99 + 2.00 P&P (UK) £3.50(europe) & £5.00 rest of world



Loudspeakers: The Why and How of Good Reproduction
by G.A. Briggs
An easy to understand book on building loudspeakers, using empirical techniques that pre-date computer analysis. Strongly recommended for beginners.
88pp 5 1/2" x 8 1/2"
Paperback Code: 1070
£10.95 + £1.50 P&P (UK)



Horn Loudspeaker Design
by Mr J. Dinsdale
A collection of papers by Mr J. Dinsdale, that discuss the design and theory of this wonderful breed of loudspeaker. The book contains detailed drawings of numerous design, including some Lowther classics. Also, included with the book is a 3.5inch floppy disc with straight forward software to assist in the design process. A serious reference for those with an interest in horn speakers.
112pp paper back & 3.5 floppy disc
210mm x 300mm Code: 1730
£29.50 + £2.50 P&P (UK)

AUDIO ELECTRONIC THEORY BOOKS



Scroggie's Foundation of Wireless & Electronics by Roger Amos
A classic text based on his experience since the dawn of the electronic age. It covers both the theory and practical aspects of a huge range of topics from valve technology, and the application of cathode ray tubes to radar, to digital tape systems and optical recording techniques.
400pp 234 x 156mm Paperback
Code No. 1590 £19.99 + £3.00 P&P (UK)



High Performance Audio Power Amplifiers by Ben Duncan
This handbook links analog electronics, acoustics, heat and music technology; high-end hi-fi and professional PA and recording studio use; theory, modelling and real-world practice; design and repair; the old and the new, the mainstream and the specialised.
288pp, 234x156mm, Hardback
Code No.1460 £40.00 + £3.25 P&P (UK)



Understand Amplifiers by Owen Bishop
Here's a readable introduction for those with little previous knowledge of the subject. The theme of amplification is central to many branches of electronics. The book describes amplifier types, how they work, their properties, advantages and disadvantages, and applications. Amplifiers are treated with the minimum of mathematics and lots of illustrations.
Paperback Code No. 1560
£16.99 + £2.50 P&P (UK)



Inventor of Stereo - The Life and Works of Alan Dower Blumlein
by Robert Charles Alexander
At last! An authoritative biography of one of the seminal figures in electronics. In addition to inventing stereo, Blumlein made significant contributions to, recording, television, cable and radar. A well informed work, a must for all enthusiasts.
448pp 234mm x 156mm Paperback
Code No: 1660 £14.99 + £2.50 P&P (UK)



Electronics made Simple
by Ian Sinclair
This book covers the basic theory and principles of electronics. A good read for the beginner.
Code No 1420 £12.99 + £2.00 P&P (UK)



Build your own High-End Audio Equipment
by Elektor
Build your own High-End Audio equipment contains construction projects for solid state preamplifiers and power amplifiers, active cross-over filters, an active subwoofer, a mono/stereo compressor and a headphone amplifier.
Code No. 1390
£14.95 + £2.25 P&P (UK)



MAKING SENSE OF SOUND by Alvis J. Evans
This is an excellent compact introduction to audio technology in all it's forms. Covering the basic concepts of sound itself, hi-fi hardware, amplifiers and how they work, distortion, recording and reproduction, new sound concepts, noise, the principles of radio transmission and reception, A/V technology and much much more. Beginners will find this a brilliant starting point to further their hi-fi knowledge.
108 pages, 225mm x 150mm Paperback
Code No. 1690 12.99 + 1.50 P&P (UK)



Practical Electronic Fault-Finding and Troubleshooting by Robin Pain
This book explains the basic techniques needed to be a troubleshooter, using only basic equipment: a digital multimeter and an oscilloscope. Simple circuit examples are used to illustrate principles and concepts fundamental to the process of fault finding.
240pp 235mm x 156mm Paperback
Code No. 1430
£19.95 + £2.25 P&P (UK)



Build your own Electronic Test Instruments
by Elektor
This book contains designs for 17 measuring instruments, seven generators and analysers, ten miscellaneous instruments and a number of test ancillaries and auxiliaries. The designs range from a simple multicore cable designs contain a special printed circuit, drawing of which are given in an appendix.
Code No. 1400 £15.95 + £3.25 P&P (UK)



Back to Basics Audio by Julian Nathan
A first class reference book covering electrical principals, meters & measurements, amplifiers, transmission lines, sound waves & decibels, loudspeakers, tape recorders, transformers, PSUs, mixers, acoustics, audio cabling, assembly methods, installation planning and home cinema. An excellent read.
344pp, 234 x 152mm Paperback
Code No.1610 £27.50 + £2.25 P&P (UK)



The LP is Back!
by Audio Amateurs
Your complete guide to LP care and maintenance designed to offer you everything useful for those who love and enjoy this older music medium. This covers the theory and care of LPs and the electronics and mechanics of its players.
154pp Paperback Code No.1620
£8.00 + £1.50 P&P (UK)



The Joy of Audio Electronics
by Charles Hansen
This is a fail-safe guide to the pleasures of hands-on electronic construction. This book covers test and measurement projects, how to build simple kits, safety issues, the workplace, theory and resources. A must for the beginner who plans to build more advanced electronic projects in the future.
124pp Paperback Code No.1650
£10.50 + £2.25 P&P (UK)

ORDER 4 BOOKS & OVER & PAY ONLY £7.00 P&P (UK ONLY)

VALVE BOOKS



The Beginner's Guide to Tube Design

This book takes a comprehensive look at tube audio design. It explains how vacuum tubes work and how to design with them. Rozenblit covers stabilisation and testing, a description of 13 famous and classic amps and preamps and how to work effectively as a designer. A hands-on guide to construction techniques, tools and choosing components and tubes is provided. 1997. 132pp., 8 1/2" x 11"
Paper back Code No. 1340
£15.50 + £2.25 P&P (UK)



Mullard Tube Circuits for Audio Amplifiers
Includes full designs for eleven power and control amps, including 5-20, using valves. Begins with a four chapter tutorial on getting the best sound from valve amplifiers.
142pp 8" x 10"
Paperback Code 1030
£13.95 + £1.50 P&P (UK)

Radio Designers Handbook 4th Edition

This is a classic reference handbook for all who are interested in the design and application of audio amplifiers and radio receivers, and deals with basic principles and the practical design of all types of classic audio amplifiers, radio receivers and record-producing equipment up to the invention of the transistor, covering valves, valve testing, general theory and components; audio and radio frequencies; power supplies, design of complete AM and FM receivers, and reference information.
1498pp 216mm x 138mm
Hard back Code No. 1600 £35.00 + £6.00 P&P (UK)

70 Years of Radio Tubes and Valves

Outlines the evolution of radio receiving tubes and the part they played in the domestic radio receiver. A reference for those interested in the history and development, and collectors alike.
256pp 8 1/2" x 11" Paper back
Code: 1050 £24.95 + £3.50 P&P (UK)

Modern High-End Valve Amplifiers Based on Toroidal Output Transformers

Explains the whys and wherefores of toroidal output transformers at various technical levels, starting with elementary concepts and culminating in complete mathematical descriptions. The schematic diagram of a valve amplifier often appears to be very simple at first glance, but anyone who has built a modern valve amplifier knows that a lot of critical details are hidden behind the apparent simplicity. These are discussed extensively, in connection with designs for amplifiers without output powers ranging from 10 to 100 watts. Finally, the author gives some attention to a number of special valve amplifiers, and to the theory and practice of negative feedback.
170mm x 240mm Hard back, 250 pages. Code No. 1670
£24.95 + £2.50 P&P (UK)

Principles of Electron Tubes

A textbook for beginners starting with the basics of how a vacuum tube actually works. Shows how a simple circuit is designed including amplifiers, transformers and power supplies. A must for both enthusiasts and hobbyists.
398 pp 6" x 9" Paperback Code No. 1010
£27.95 + £3.00 P&P (UK)

An Approach to Audio Frequency Amplifier Design

Seventeen circuits from 5 to 1100watts - General Electric Co. High quality amp. designs using KT66s, KT88s, DA100s etc. Includes two valve pre-amps complete with phono stages.
126pp 6" x 9" Paper back Code No. 1020 £19.95 + £1.75 P&P (UK)

AUDIO ANTHOLOGY BOOKS

Audio Anthologies - When Audio Was Young

Volume One: May '47 to Dec '49
Contents: 9.5W, 5W and 6.5V 6AS7G amps., 30W 300B amp., valve FM tuning indicator, 30W 211 power amp., cathode follower amp. using 6V6, an adaptation of the Williamson amp., valve phono pre-amp., several horn and reflex loudspeaker designs.
Code No. 1150 £14.95 + £2.00 P&P (UK)

Volume Two: Jan '50 to Jul '55

Contents: Ultra linear 6L6 design and operation of the Williamson, a direct coupled amp., Williamson type amp using 6A5s, 40W 845 push-pull amp., valve phono and line pre-amps., valves and loudspeaker damping, design and construction of reflex, horn loudspeakers.
Code No. 1160 £14.95 + £2.00 P&P (UK)



Tube Amplifiers

The most beautiful tube amp book in the world. No specs. no test. just 215 gorgeous four colour photos of 65+ amps with a short description of each. Including a 12 page explanation of the history of tubes and tubeamps. Appendix with addresses with tech. data.
160pp 9 1/2" x 12"
Hard back Code No. 1310
£47.95 + £5.50 P7P (UK)



Electronic Universal Vade-Mecum

This Data book comprises 5693 valves divided into 442 groups. A comprehensive book which contains connection details, operating parameters, load lines and example circuits.
Hard back Code 1060
£49.95 + £ 8.50 P&P (UK)



Valve & Transistor Audio Amplifiers

This is J.L. Hood's greatest work yet, describing the milestones that have marked the development of audio amplifiers, from the earliest valve amp to the latest solid state design. It is the complete world guide to audio amp design. Other contents: active & passive components, amplifiers, pre-amplifiers and power supplies.
Paperback 250pp., 156mm x 232mm
Code No. 1530 £19.99 + £2.50 P&P (UK)



Audio Amateur Power Amp Projects

This illustrated handbook features 26 of the best articles on power amps from 1970-89. Authors from six countries offer an array of designs to provide almost any level of high-quality audio power needed by the resourceful amateur who prefers the pleasure of building his or her own equipment.
205pp., 8 1/2" x 11" Paper back
Code No. 1300 £14.95 + £2.25 P&P (UK)



Sylvania Technical Manual

This 13th edition contains data on more than 3300 electron tubes and semiconductor devices. Reprinted here without the TV picture tube section, this manual contains detailed information on Sylvania's devices including charts and diagrams. A master index is found in the front of the book for reference.
516pp Paper back 140mm x 216mm
Code No. 1700 £16.95 + £3.50 UK p+p



The Williamson Amplifier

Offers practical advice on how to build and set up the amplifier for best results.
40pp 8 1/2" x 11"
Paper back
Code No. 1040
£9.95 + £1.50 P&P (UK)

Electronic Valves in Audio Frequency Amplifiers

Originally published in 1954 by Philips, this book encourages amp. builders to experiment with design elements. Discussing the use of valve data, the function of different amplifier stages and includes detailed descriptions of eight designs. A wealth of practical data, measurements and interesting features will be found. A very good read.
Paperback 147pp Code No. 1520 Price £12.95 + £2.00 P&P (UK)

Volume Three: Aug '52 to Jun '55

Contents: Simple valve phono stage, transformer less amplifier using 6082, 20W 5881 amp., 10V 6V6 amp., stereo valve pre-amp., high quality valve phono stage, a pre-amp for the Williamson, low distortion tone control pre-amp., binaural or stereophonic, transistor phono amp., corner & concrete horn loudspeaker.
Code No. 1170 £14.95 + £2.00 P&P (UK)

Volume Four: Jul '55 to Dec '57

Contents: 18W 5881 amp., 4W single-ended tweeter amp., budget 11W amp., versatile bass/treble control, transistor theory, transistor pre-amp., transistor techniques, battery powered transistor phono pre-amp. and loudspeakers explained.
Code No. 1180 £14.95 + £2.00 P&P (UK)



Audio Reality

A little read that investigates conductors skin effect, impedance, interconnects, speaker cables, balanced lines, transmission lines, power cords, isolation transformers, damping systems, tubes, acoustics and much more. Also, Includes 6 excellent detailed valve design projects, 80watt OTL, 25watt OTL, grounded grid pre-amp., 150watt amp., 6550 5E amp. and a grounded grid cascode phono preamp.
Paperback 128pp Code No 1640
Price 21.50 + 2.25 P&P (UK)



Build your own Audio Valve Amplifiers

This book covers construction projects for preamplifiers, power amplifiers and two amplifiers for musical instruments aimed at the practical audio/hi-fi enthusiast, it offers much information on the operation of electron tubes, while the first chapter gives a short history of the thermionic valve.
paperback, 251pp, 235mm x 133mm
Code No. 1320 £14.95 + 2.25 P&P (UK)

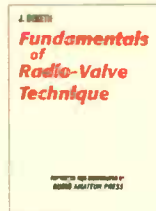

Fundamentals of Radio-Valve Technique

This is part of the philips technical series written in 1947 it was one of the most authoritative and comprehensive treatments of the nature and function of the vacuum tube.
534pp 6 1/2" x 9" Paper back
Code No. 1630
£21.50 + £2.50 P&P (UK)



Getting the most out of Vacuum Tubes

From the cover, "Types and causes of tube failures, what to expect from tubes, testing methods and all about tube maintenance programs." This book is intended to offer explanations of why tubes fail and what to do about it. Discussions of catastrophic and degenerative failures; selecting tubes and tube types and testing and predicting tube performance.
160pp Paper back, 140mm x 216mm
Code No. 1710 £13.95 + £2.00 P&P (UK)

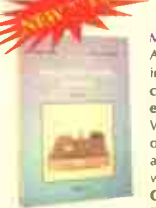

Manuale Hi-Fi a valvole Schemario 2

An Italian publication with all circuit diagram in standard conformation, therefore, all circuits are easy to follow. This book is dedicated to self makers and to Hi-Fi tube engineers. With a wealth of circuit diagrams from some of the best valve amplifiers, pre-amplifiers and phono equipment producers in the world. Including, Audio Research, Altec, Conrad Johnson, Art Audio, Luxman, Carver, Dynaco, Electrovoice, Leak, MacIntosh, Marantz, Quad, Radford, Quick Silver, numerous OTL designs, Verdier, VTL and Western Electric. Well worth the money.
208pp, paperback, 210mm x 300mm
Code No. 1720 £44.00 + £4.00 P&P (UK)

Valve Amplifiers

This book allows those with a limited knowledge of the field to understand both the theory and the practice of valve audio amplifier design, such that they can analyse and modify circuits, and rebuild an amplifier. Constructional techniques are also provided so readers can build from scratch designs that actually work.
374pp 6 1/2" x 9 1/2"
Paperback Code No. 1330
£25.00 + 2.75 P&P (UK)

Volume Five: Jan '58 to Dec '59

Contents: Stereo valve multiplex decoder, 7W EL84 amp., valve active crossover and 20W treble amp/50W bass amp., monaural, binaural, monophonic and stereophonic explained, heterodyne FM multiplex adaptor, transistor pre-amp., 60W EL34 amp., high power audio amps, hi-fi loudspeaker enclosure.
Code: 1190 £14.95 + £2.00 P&P (UK)

Volume Six: Jan '60 to Dec '61

Contents: Transistor pre-amps., feedback techniques, the coming of FM stereo, FM multiplex adapters, Tape recorders; distortion, frequency response and noise, 120W 6550 amp., loudspeaker efficiency.
Code No. 1200 £14.95 + £2.00 P&P (UK)

ORDER FORM

Please send (Code No.) _____ (enter codes clearly)

Pay: World Audio Publishing Ltd. £ _____ or debit my Mastercard/Visa/Switch/Solo (Card No) _____

Expiry date: _____ (Switch/Solo only) Valid Date: _____ Issue No. _____ Name: _____ Signed: _____

Delivery Address: _____

Tel: (Day) _____ Please return to: W.A.P. Ltd. 12A Spring Gardens, New Port Pagnell, Milton Keynes, MK16

0EE. ENGLAND TEL/FAX: 01908 218836 Website: www.worldaudiodesign.co.uk E-Mail: nick@worldaudiodesign.co.uk

Please contact us for overseas P&P charges. Allow 28 days for delivery. All orders subject to availability. If further space is required please attach separate sheet.

ORDER 4 BOOKS & OVER & PAY ONLY £7.00 P&P (UK ONLY)

BEDFORDSHIRE

RICHARD'S AUDIO VISUAL 4 Greyfriars Bedford. Tel: 01234 365165. Stockists of: Arcam, Audioquest, Beyer, B&W, Bose, Cable Talk, Celestion, Cyrus Denon, Heybrook, Marantz, Mission, Moth, Nakamichi, Ortofon, Pioneer, Pro-Ject, Quad, REL, Rotel, Royd, Ruark, Sennheiser, Sound Style, Systemdek, Target, Teac, Thorens, van den Hul & more! Expert friendly service: Listening room, Pioneer Reference Point, Visa / Access.

BRISTOL & BATH

THE RIGHT NOTE Tel: (01225) 874728. Just think: most audiophiles listen for most of the time to systems that are 'not quite right'. Are you happy with yours? Forget the reviews and trying to put together a system like a patchwork quilt with the 'best' bits around. Its our job to do the assessing, you judge our results. We'll help you to plan a system for the future, even if you spread the purchases. Leave the 'up-grade-itis' behind, save money and enjoy music all the time. Just listen, and you'll know. CD: Acuras, Audio Synthesis, Classe, DCS, Enlithened Audio Design, Meracus, Orelle, Wadia, XTC. Vinyl: Basis, Crown, Jewel, Graham, Michell, Sumiko, Transfiguration. Amps: Acuras, Audio Sculpture & more. Speakers: Audio Artistry, Audio Physics & more. Tuners: Fanfare, Magnum Dynalab & many more. Cables: Chord, DNM, Silver Sounds & more. (Credit Cards Accepted).

VAUDIO HiFi Consultants: 36 Druid Hill, Stoke Bishop, Bristol. BS9 1EJ. Tel: 0117 968 6005. ATC, AVI, Alon, Audio Analogue, Audiomeca, Cadence Valve, Chord Amps, Electrocompaniet, Harman Kardon, Heybrook, Jamo, LFD, Lyra, Opera, Ortofon, Pink Triangle, Ruark, Mark Levinson, Michell, REL, SME, Shearpe, Sonic Link, Sugden, Townshend, Triangle, Unison Research Valve Amps. Home Cinema demonstrated including, A/V Amps, DVD Players, Video Projectors and Screens. Demos by appointment only. Home trial facilities. Free installations. We are not a shop.

BUCKINGHAMSHIRE

TECHNO SOUND/ AUDIO INSIGHT 7 Granville Square, Willen, Milton Keynes. MK15 9JL. Tel: (01908) 604949. Audiophile Hi-Fi and Home Cinema Specialists. All major brands stocked from Arcam to Yamaha. Meridian Digital Home Theatre dealer. Custom home cinema and multi room installation. 4 dem rooms and expert advice. Audiophile CDs, LPs and LaserDiscs to buy. Open late on Fridays.

NORTHWOOD AUDIO 98 Cambridge St, Aylesbury, Bucks HP20 1BA. Tel: 01296 428790. Selected sounds from Acoustic Energy, Alchemist, Audio Meca, Audio Note, Boston, B & W, Cabletalk, Castle, Celestion, Chord, The Chord Company, CR Developments, DNM Virtual Reality, Denon, DPA, Epos, Exposure, Gyrodek, Harman Kardon, Heybrook, Kef, Klipsch, Marantz, Micromega, Monitor Audio, Moth, Musical Technology, NAD, Nakamichi, Pioneer, PMC, Proac, Rega, Rel, Rose, Rotel, Ruark, Stax, Tannoy, Teac, Talk Electronics, Thorens, Triangle, Tube Technology and a range of quality pre-ripped equipment. Export orders welcome. - The ultimate Hi-Fi Specialist experience... a mere phone call away.

CAMBRIDGESHIRE

THE AUDIO FILE 41 Victoria Road, Cambridge. Tel: 01223 368305. 'For the best in British Hi-Fi and Home cinema entertainment'. Visit or call to arrange a dem with products from: Audiolab Arcam, Linn, Naim, Rega, Cyrus, Absolute Sounds, Kef, Sony, Yamaha, Rel, Quad, Ruark, Denon.

THE HI-FI COMPANY PETERBOROUGH The region's largest range of enthusiast hi-fi. Arcam, Audiolab, B&W, Cyrus, Denon, KEF, Kenwood, Krell, Marantz, Martin Logan, M&K, Meridian, Mission, NAD, NAIM, Pioneer, Quad, REL, Rotel, Yamaha and many more. Excellent hi-fi and A/V demonstration facilities. Part exchange welcome. Huge selection of top quality, carefully used equipment, telephone for mailing list. 35-42 COWGATE, Peterborough. Phone: (01733) 341755 Fax: (01733) 358141.

CHESHIRE

ACOUSTICA 17 Hoole Rd, Chester CH2 3NH. www.acoustica.co.uk. Tel 01244 344227. All that's best in HiFi & Home Cinema from quality manufacturers including Naim, Rega, Arcam, Musical Fidelity, Rotel, Selego Projectors, Kef, Ruark, Densen, Primare, Teac, JM Lab, Nakamichi, Quadraspire, Celestion & Crimson. We offer friendly, helpful advice, interest free credit & trade-in facilities, and deliver & install systems throughout Cheshire, Merseyside & North Wales. Opening hours are Tuesday to Saturday 10.00 until 5.30, evenings by arrangement

ACTON GATE AUDIO 4 Ruabon Road, Wrexham, North Wales. Tel. 01978 364500. Audio Visual Specialists. Arcam, Audio Analogue, Bose, B&W, Celestion, Castle, Denon, Harman Kardon, Jamo, Marantz, Michell, Mission, Onkyo, Pro-Ject, Musical Fidelity, NAD, Micromega, Myrad, QUAD, Radford, Rotel, Ruark, Tannoy, TDL, Teac, Thorens, UKD, Unison Research, Yamaha, DSP Club Member, Demo Room, installation service, Easy Parking and Motorway access. All major credit cards accepted. 9.30 - 5.30 daily. Closed Sunday & Monday

DOUG BRADY HI-FI Kingsway Studios, Kingsway North, Warrington, WA1 3NU Tel 01925 828009 Fax 01925 825773. Visa, Mastercard, Lombard Tricity, 2 dem rooms, home trial. Agencies include: Arcam, Tag McLaren, AVI, B&W, Castle, Caspian, Chord Electronics, Exposure, Harbeth, Heybrook, Krell, LFD, Michell, Meridian, Musical Fidelity, Monitor Audio, Naim, Nautilus 800 series, Pink Triangle, ProAc, Roksan, SME, Wilson Benesch, XTC and many more.

PRACTICAL HI-FI 88 Bridge Street, Warrington, WA1 2RF. Tel:- 01925 632179. See our main entry under Preston, Lancs.

REPLAY AUDIO CONSULTANTS Tel/Fax 0161 202 9922. Cheshire's alternative hi-fi specialists. Honest advice and personal service. We can demonstrate Alchemist, AVI, Henly, Heybrook, LFD, Michell, Moth, Musical Fidelity, NAD, Neat, Origin Live, Ortofon, Pink Triangle, Royd, Sonneteer, Totem, Trichord. Demonstrations by appointment in Chester or in your own home. Delivery & installation available. Mastercard, Visa, Switch, Delta

SWIFT HI-FI St. Annes Parade, Wilmslow. 01625 526213. Aura, B&W, Denon, Kenwood, Marantz, Nad, Pioneer, Rotel, Systemdek, Tannoy, Revolver, J.P.V., M. Short, Mission, Celestion, Technics, Audiolab, Castle. Open 9.30-6. Dem room. No pressure BADA member.

CORNWALL

SOUNDS PERFECTION 'Cornwall's most exclusive Audio retailer'. Agencies include: Alchemist, Audio Analogue, Audio Note, Audio Spectrum, Border Patrol, Boston, Electrocompaniet, Elemental Audio, Henley, JM Labs, Michell, Monitor Audio, Musical Fidelity, Ortofon, Parasound, Sonic Frontiers, Primare, Project, Nordost, Philoshophy, REL, Tsunami, S.M.E., Sugden, Stands Unique, Teac, Vienna Acoustics, Triangle, Trichords, Tara Labs, Sonic Link. Home Demonstrations by Appointment. Tel/Fax: 01326 221372 Mobile 0468 754353. E-mail: soundsperfection@mailcity.com

CUMBRIA

PRACTICAL HI-FI 106 English Street, Carlisle, CA3 8ND Tel:- 01228 44792 See our main entry under Lancaster.

DORSET

MOVEMENT AUDIO 588 Ashley Road, Poole, Parkstone, Dorset BH14 0AQ. Tel: (01202) 730865. Arcam, Audiolab, B&W, Celestion, Cyrus, Denon, KEF, Marantz, Meridian, Michell, Micromega, Pioneer, Ruark, Shearpe Audio. 2 Dem rooms. Listen to the available choice and decide at your leisure - no pressure, no obligation. Our staff enjoy music, with our choice of products, you can too! Service Department. Free installation. Home trial facilities. Access, Visa, Amex, Diners Card. Credit facilities available. Open Mon-Fri 10-6. Sat 9-6

MOVEMENT AUDIO 336 Wimborne Road, Winton, Bournemouth, Dorset, BH9 2HH. Tel: (01202) 529988/520066 Arcam, B&W, Denon, KEF, Marantz, Meridian, Mission, Pioneer, Sony, Yamaha. Full dem facilities available, also home dem. Friendly expert advice. Service Department. Free installation. Home trial facilities. Access, Visa, Amex. Open Mon-Fri 9-5.30

DAWSONS OF WESTBOURNE Home Cinema Specialists. Main agents for Bang & Olufsen, Harman Kardon, JBL, REL, Mordaunt Short, Sony, Technics and TDL. Demonstration facilities include our unique Dolby pro-logic system comparator for the ultimate way to choose the perfect system. Also on demonstration large screen televisions from Thomson, sony and Ferguson with video projectors from Sharp and Selego. Dawsons, 23 Seamoore Road, Westbourne, Bournemouth 01202 764965

SUTTONS HI-FI 18 Westover Road, Bournemouth, Dorset. Tel. 01202 55512. You will find the very latest in superb Hi-Fi facilities with stocks to include: Arcam, Cabletalk, Celestion, Denon, DTS, KEF, Linn, Marantz, Meridian, NAD, Pioneer, QED, Rotel, Sennheiser, Sony, Sound Organisation, Tag McLaren, Target, Teac, Technics, Yamaha, and many more. If you're serious about Hi-Fi you've probably heard of all these brands and probably heard of Suttons too! We've been around for over 45 years. Please call for expert knowledge and friendly advice.

WEYMOUTH HI-FI 33-35 Maiden Street, Weymouth, Dorset DT4 8BA. Tel (01305) 785729. Arcam, Aura, B&W, Denon, Kenwood, Marantz, Micromega, Musical Fidelity, Panasonic, Quad, Sony, Technica, Yamaha. Dem room. Friendly professional advice. Only quality hi-fi dealer in Weymouth area. Service Department. Free installation. Home trial facilities. Access, Visa, Amex, Switch, Delta Mastercard. Interest free credit. Instant credit. Open Mon-Fri 9.30-5.30 Sat - 9.30-5.30

ESSEX

GRAYSTON SOUND & VISION 33 Sir Isaac's Walk, Colchester. (01206) 577682. Alchemist, Arcam, B&W, Boston Acoustics, Castle, Denon, Harman Kardon, KEF, Linn, Loewe Opta, Meridian, Michell, Musical Fidelity, Philips, Pioneer, Project, Rotel, Sennheiser. Superb demo rooms, free regional delivery and installation. Regular musical and surround evenings, home demonstrations. Excellent credit facilities.

GLOUCESTERSHIRE

THE RIGHT NOTE - Bath. For specialist advice and home demonstrations. See BRISTOL & BATH.

HAMPSHIRE

AUDIO T. 2-12 Hursley Road, Chandlers Ford, Hants, SO53 2FU. Tel Southampton (02380) 252827/265232. Three Hi-Fi and two Home Cinema/Dolby Surround Sound Demonstration Rooms, one with Projection TV and an 8' wide screen. Brands stocked include ARCAM (incl. Xeta), Audiolab, Audioquest, Celestion, Cyrus, Denon, Gradient, Infinity, KEF, Marantz, Meridian, Mission, Polk, Quad, Rotel, Selego, Sennheiser, Soundstyle, Tannoy, Target Audio, Thorens, & Yamaha. Established 1969, we offer a 2-year Guarantee covered by our own well-equipped Service Dept. We have a large FREE car parking facility and we are located within 3 miles from Junction 14 (M3/M27 Interchange) and Junctions 13 (M3) and 5 (M27). Closed Mondays, except in December. Late Night: Thurs to 8pm. BADA Founder Member. All deposits fully covered by BADA Bonding

NOW THATS HI-FI 32 Arundel Street, Portsmouth Tel: (01705) 811230. Pioneer, Yamaha, Marantz, Kenwood, Mission, TDL, REL, Attacama and much more. Laserdisc and AC3 specialists. Accessory center at 24 Arundel Way, Portsmouth. Tel. (01705) 811618

HEREFORDSHIRE

ENGLISH AUDIO 37 Whitecross Road, Hereford, HR4 0DE. (01432) 355081. Arcam, A.T.C., B&W, Castle, Cura, Cyrus Centre, Denon, Dynaudio, JM Lab, KEF, Marantz, Mission, Musical Fidelity, MVL, Naim, ProAc, Pink Triangle, Pioneer, Project, REL, Rotel, Ruark, John Shearpe, Stax, System Audio, Tag McLaren, Teac, Vienna Acoustics, Wadia, and Yamaha. Single speaker dem room, home trial facilities, free installation, service dept, Access/Visa, Credit arranged. Open Mon-Sat, 9.30-5.30pm. BADA members.

HERTFORDSHIRE

ACOUSTIC ARTS LTD 101 St. Albans Road, Watford, Herts. Tel: (01923) 245250. Fax: (01923) 230798. Audio Research, B&W, Boston, Castle, Celestion, Chord, Copland, Denon, Densen, DPA, Jadis, KEF, Krell, Marantz, Martin Logan, Michell, Micromega, Rel, Roksan, Ruark, SME, Sonus, Faber, Theta, Thorens, Wilson. 4 demonstration rooms. Purpose built AV studio. Credit available. 100 yards from Watford Junction station. Open Tues-Sat 10-5.30 (Thursday open by appointment until 8pm).

AUDIO FILE (THE) 27 Hockerill Street, Bishops Cleeve, Herts. Tel. (01279) 506576. Please see main ad under Cambridgeshire.

AUDIO FILE OBJECTIVE 37 Tower Centre, Hoddesdon, Hertfordshire, EN10 8UD. Tel: 01992 478666 Fax 01992 440431. Selected British and specialist brands. New, Ex-dem, and S/H. Mail order Hi-Fi Purchased. Free Parking.

DARBY'S OF ST. ALBANS. 6 Market Place, St Albans, Herts. Tel: (01727) 851596. Hertfordshire's premier Hi-Fi/Audio Visual specialists established 1946. Full Home Cinema demonstration suite. Whether your needs are large or small, we stock it all; Arcam, Yamaha, Quad, Denon, Sony, Bang & Olufsen, Pioneer, REL, KEF, Mission, Ruark, Celestion, Polk, and many more. Free planning service. Free Delivery and basic installation. Full workshop facilities. Open 9-6 Mon-Sat.

KENT

ASHFORD SOUNDCRAFT HI-FI 40 High Street, Ashford. Seeking music lovers, male or female, any age, to share common interest in musical Pro-aktiv Hi-Fi Systems, Multi Room of Home Cinema. Attractive unusual equipment in unusual setting, your place or ours, we guarantee lasting pleasure. Open Mon-Sat. Appointment Service or just pop in. Tel (01233) 624441

DOVER HI-FI 43 High Street, Dover. Tel: 01304 207562. Suppliers of quality hi-fi equipment including: Arcam, Akai, B&W, Denon, Jamo, Mordaunt Short, NAD, Panasonic, ProAc, Quad, Rotel, Ruarc, TDL, Technics, Tannoy. Part exchange. Listening room. Service and repairs. Credit facilities. Access/Visa. Open 6 days 9-5.30.

KIMBERLEY HI-FI 193 Broadway, Bexleyheath, Kent. Tel. 020 8304 3272. Sep dem rooms, Denon, Technics, Kenwood, Aiwa, NAD, Dual, Wharfedale, Mission, Marantz, Tannoy, Castle, Monitor Audio, Heco, Jamo, Cerwin Vega and many more.

MATRIX HI-FI SHOWROOM - 65 Darenth Road, Dartford, Kent DA1 1LU. Tel: 01322 292391, Fax: (01322) 229908. Email: Matrixcomputers@compuserve.com Hi-end, Home Dem, By appointment, over 30 years experience, for enquiries or a chat, give us a ring.

LANCASHIRE

ADVENTURES IN HI-FI 5, Bishopgate, off Hallgate, Wigan, WN1 1NL. Tel 01942 234202. For the best hi-fi and home cinema products from quality manufacturers including Naim, Rega, Cyrus, NAD, KEF, Denon, Dynavector, Rotel, Shanhinian, JM Lab, PMC, Project, Quadraspire, Seleco and Sanyo projectors. We offer friendly advice, excellent demonstration facilities, 0% finance, free delivery and installation throughout the North West. Opening hours 10.00 - 5.30pm Tuesday to Saturday evenings by appointment.

CLEARTONE 235 Blackburn Road (1/2 mile from city center on the A 666 Blackburn Road) Bolton, Lancs BL1 8HB Tel: (01204) 531423. Bolton's biggest Hi-Fi superstore. Every top brand & all the best buys at guaranteed unbeatable prices. Aiwa, Akai, Arcam, Audioblab, B&W, Bose, Castle, Celestion, Denon, Hitachi, Infinity, JBL, JVC, KEF, Kenwood, Marantz, Meridian, Mission, Mordaunt Short, NAD, Parasonic, Pioneer, Rotel, Sony, Tannoy, TDL, Technics, Toshiba, Yamaha. 2 dedicated Hi-Fi Demo rooms and 2 AV Demo rooms, no appointments necessary. Service department, free installation, home trial facilities, free parking, Access, Visa, Amex, Diners. Interest free credit. Open Mon-Wed 10.00-6.00, Thurs-Fri 10.00-7.00, Sat 9.00-6.00, Sun 11.00-5.00

MARTON MUSIC 5 Masterson Ave. Read, Burnley, BB12 7PL. for audition of the best stereo and surround sound equipment from BRYSTON (20 yr guar), MYRYAD, PMC, RUIARK, YAMAHA, and the latest WILMSLOW-HART electronics, in a comfortable demonstration room through commercial and custom-built speakers including Transmission Line, Open Baffle and Reflex designs. Home demos encouraged for complete satisfaction. Also main agent for Liberty Audiosuite loudspeaker/audio measurement system, ETF4.0 room measurement system and LSPCAD room/box design/crossover package. Call Tony Seaford anytime for an appointment, a chat or free advice on 01282 773198 (fax 776413), or e-mail 106505.251 @compuserve.com.

PRACTICAL HI-FI 43 Friargate, Preston. Tel:- 01772 883958. The audio visual specialist, expert advice, instant demonstrations, best prices, instant free credit, part exchange welcome. Extended warranty. Stockists of Yamaha, Castle, Teac, NAD, Lexicon, Arcam, Kenwood, Denon, Sony, Technics, Onkyo, Marantz, Pioneer, Mission, Kef, Celestion, B&W.

PRACTICAL HI-FI 84 Penny Street, Lancaster, LA1 1XN Tel:- 01524 39657 - See our main entry under LANCASHIRE

PRACTICAL HI-FI 33/35 Knowsley Street, Bolton, Lancs Tel:- 01204 395789 - See our main entry under LANCASHIRE

PRACTICAL HI-FI 81 Whitegate Drive, Blackpool, FY3 9DA Tel:- 01253 300599. See our main entry under LANCASHIRE

ROMERS HI-FI, 94-96 High Street, Rishton, BB1 4LQ. Suppliers of quality hi-fi equipment including: Linn, Arcam, Cyrus, Quad, Yamaha, Mission, Ruark, Sony, Monitor Audio, NAD, Onky, Bose, Castle, Nordost, Straightwire, Panasonic, Pioneer, Loewe, TDL, JVC. Target, stands Unique. Specialists in multiroom installations. Access/Visa/Switch. Credit facilities. Open 9.00 - 5.30 Mon-Sat (5.00pm Wed & Sat). Tel: 01254 887799 Fax: 01254 876866

LEICESTERSHIRE

CYMBIOSIS 4 Hotel Street, Leicester, LE1 5AW Tel: (0116) 2623754. Email: shop@cymbiosis.com. Arcam, Acoustic Energy, Cable Talk, Castle, Chario, Chord Company, Cura, Denon, Linn Hi-Fi, Linn Knekt, Loewe Televisions, Lutron Lighting, Musical Technology, Naim, Nordost, Projekt Furniture, Rega, Revox, Rotel, System Audio, Tag McLaren, and Wadia. Multi room design & Installation Service. 4 listening lounges, Installation Service, Finance Available. Open 10-5.30 Monday to Saturday.

LEICESTER HI-FI 6 Silver Walk, St Martins Square, Leicester LE1 5EV. Tel: (0116) 2539753. Fax: (0116) 2626097. Arcam, B&W Nautilus, Mission, Cyrus, Marantz, Pioneer, Quad, Tannoy, Copland, Pink Projects, Michell, Technics, Rotel, Rogers, Yamaha, Acoustic Energy, Chord Electronics, Teac, Miller & Kreisel, DPA, Talk Electronics, Greig Loudspeakers, E.T.C. 4 Listening areas over 3 floors. We can demonstrate, deliver and install. Including A V and Multiroom. Credit Facilities. All cards taken, open 6 days 9.30-5.30.

STEREO SHACK 1-3 Guildhall Lane, Leicester. Tel: (0116) 2530330. Fax: (0116) 2626097. Yamaha, Kenwood, NAD, Mission, Teac, Aiwa, Cerwin Vega, Pioneer, TDL, Thorens, JBL, Rotel, Celestion, Jamo & many more. We are A.V. specialists, 2 dem. rooms. We can demonstrate, deliver and install. Credit facilities and all cards taken. Open 6 days 9.30-5.30

LONDON

BABBER ELECTRONICS SERVICE CENTRE 158 Lxbridge Road, West Ealing, London, W13 8SB Tel: 020 8579 6315. Alkali, Aiwa, A&R, Celestion, Dual, Goodmans, Harman Kardon, JBL, JVC, Kenwood, Marantz, Panasonic, Sennheiser, Sony, ES range, Tannoy, Technics, Wharfedale, Yamaha and many more. Auth. Service Dept. Credit Facilities. Open 10.30 - 5.30 Mon-Sat.

BILLY VEE SOUND SYSTEM 248 Lee High Road, Lewisham, London SE13 5PL Tel: 020 8318 5755/020 8852 1321. Arcam, Denon, Marantz, Linn, Mission, Naim, Tag McLaren, Pioneer-DVD, Rega, etc. 2 domestic style listening lounges. Appts required, service dept, home trial facilities. Interest free credit. Access, Visa, Amex cards accepted. Opened Mon-Sat 10-6.30, Closed Thursdays.

CHOICE HI-FI Tel. 020 8392 1959. Specialist dealers in high end quality second-hand equipment. All main brands in stock including, Krell, Audio Research, Wadia, Mark Levinson, Sonus Faber, Linn, Naim, SME & many more. Generous price given on trade-in. Part exchange welcome. Also dealers for Trichord, SME, Gamma, Trilog, Lumley, Boulder & many more.

INFIDELITY 9 High Street, Hampton Wick, Kingston-upon-Thames. Tel: (020) 8943 3530. for full details see entry under SURREY

HIFI EXPERIENCE 227 Tottenham Court Road, London W1, 020 7580 3535. Arcam, Audioblab, Mission, Cyrus, Quad, Celestion, Kef, Meridian, Rogers, Tannoy, Yamaha, TDL, Thorens, Marantz, Nakamichi, Musical Fidelity and many more. Open 10.00-7.00 Mon-Fri, 9-6 on Sat. Service dept. Credit facilities, delivery and free installation.

K J WEST ONE 26 New Cavendish St., London W1M 7LH. 020 7486 8262/63. Fax 020 7487 3452. Two hi-fi & two home cinema dem studios. Appts pref. Home trial. Installation by arrangement, Service dept. Major credit cards. Interest free credit on selected items. Major brands stocked: Arcam, Audio Alchemy, Audion, Audioblab, Audio Research, B&W Castle, Chord, Copeland, DPA, Epos, Graaf, Harbeth, KEF, Klipsch, Krell, Lexicon, Marantz, Martin Logan, Meridian, Michell, Micromega, Mission, Musical Fidelity, Nitty Gritty, Pink, ProAc, Quad, Rel, Rotel, Orelle, Sonus Faber, Stax, Tannoy, Theta, Union Research, Wilson Benesch. Open 6 days.

THE LISTENING ROOMS 161 Old Brompton Road, London SW5 0LJ. (020) 7244 7750/59. Fax (020) 7370 0192. Linn, Quad, Meridian, Nakamichi, Arcam, Audioblab, Acoustic Energy, SME, Audio Research, Krell, Wadia, Theta, Apogee, Martin Logan, Pioneer, Tannoy, Syntec, Stax, Pink Triangle, Michell, Monitor Audio, Yamaha, Marantz, KEF, Bose, Celestion, Epos, Mission, Denon, Neat Petite. Mon-Sat 10-6pm.

ORANGES AND LEMONS 61-63 Webbs Road, Battersea, SW11. Tel: 020 7924 2040. Visit www.orangesandlemons.hifi.com Juicy fruit from London's freshest Hi-Fi / Home Cinema retailer, our sixth succulent year. Telephone demonstrations, or just pop in. All the usual, i.e. friendly and efficient service, free home installation, credit cards, 0% credit finance available (subject to status), plus...all the very best from Arcam, Cable Talk, Castle Acoustics, The Chord Co., Denon, Epos, Kef, Linn, Marantz, NAD, Naim Audio, Neat, Quad, Rega, Rolan, Roly, Rnyd, Ruark, Soundstyle. Stands Unique, Yamaha and more.

THOMAS HEINITZ LTD 35 Moscow Road, Bayswater, London, W2 4AH. Tel:020 7229 2077. Fax: 020 7227 9348. Email: info@thomasheinitz.com. Web site: www.thomasheinitz.com. Established in 1952. Thomas Heinitz has a long history of providing the best music and AV systems available. We continue to offer the highest standard of service in the most relaxed atmosphere. Whatever your needs, from multiroom and home cinema to a high quality stereo system, we offer consultation, design specification, architect liaison and installation in order to ensure your system is tailored to your exact requirements. For quotes contact our manager Johnny Drum.

TIME & TUNE For TV, video, Hi-Fi, and in-Car Hi-Fi. We are dealers of: Aiwa, Bose, Hitachi, Jamo, Kenwood, Marantz, Mitsubishi, Nad, Panasonic, Pioneer, Sony, Technics. For these and more come and see us at Time & Tune, 218-220 Whitechapel Rd, London. E1 1B). Or call 020 7377 2000.

GREATER MANCHESTER

ADVENTURES IN HI-FI 5, Bishopgate, off Hallgate, Wigan, WN1 1NL. Tel 01942 234202. See our main entry under LANCASHIRE

PRACTICAL HI-FI 65 Bridge Street, Manchester M3 3BQ Tel:- 0161 839 8869 See our main entry under LANCASHIRE

SWIFT OF WILMSLOW, 4-8 St. Annes Parade Wilmslow. Tel (01625) 526213. Aura, B&W, Denon, Kenwood, Marantz, NAD, Pioneer, Rotel, Tannoy, Revolver, JPW, Open 9.30-6.00pm. 2 dem. rooms. No pressure!

MERSEYSIDE

ACOUSTICA 17 Hoole Rd, Chester CH2 3NH. Tel 01244 344227. See our main entry under "Cheshire"

MIDDLESEX

MUSICAL IMAGES 45 High Street, Hounslow, Middlesex. Tel:(020) 8569 5802. Fax: (020) 8569 6353.

MUSICAL IMAGES 173 Station Road, Edgware, Middlesex. Tel. (020) 8952 5535 - Fax. (020) 8952 5535. Most brands available - see full page advert. Interest free credit, ask for details. Demo rooms. Repairs & Service. Sunday opening - Open all week A Home Cinema Specialist. Mail order. Part exchange.

OPAL DESIGNS LTD Rockware Business Centre, 5 Rockware Avenue, Greenford, Middlesex, UB6 0AA. Tel: (020) 8930 7972. Fax (020) 8970 7976. Email: jas@opal.co.uk. Home Page: www.opal.co.uk. High-end Audio & Home Theatre Consultants. Authorised dealers: Mark Levinson, Proceed, Linn Hi-Fi, Linn Knekt, Runco Projectors, Faroudja, Stewart Film Screen, Revel Loudspeakers, Stax, Wilson Audio, Martin Logan, Sonus Faber, MIT, Transparent, B & W. Mail order welcome. Credit cards accepted. Phone for latest brochure.

RIVERSIDE HI-FI 422 Richmond Road, East Twickenham, Middlesex, TW1 2EB. Tel: 020 8892 7613 Fax: 020 8892 7749. www.riversidehifi.co.uk Arcam, Bose, B&O, Castle, Copland, Denon, Krell, Marantz, Martin Logan, Michell, Monitor Audio, Musical Fidelity, NAD, Pioneer, Project, Rel, Sonus Faber, Sony, Tag McLaren Audio, Tannoy, Teac, Theta, Wilson. Finance available. Subject to status. Written details available on request. Export orders welcome. UK mail order available. 3 demonstration rooms. All major credit cards. Open 10am-5.30pm Mon-Sat.

NORFOLK

BASICALLY SOUND The Old School, School Road, Bracon Ash (Nr Norwich), Norfolk, NR14 8HG. Tel:(01508) 570 829. Stockists of the following leading Hi-Fi: Arcam, Audio Analogue, Beyer, Denon, Dynavector, Epos, Grado, Naim, ProAc, Rega, Royd, Sennheiser, Talk Electronics, Teac and more. Bada members. 2 comprehensive demo rooms.

NORTHAMPTON

CLASSIC HI-FI At Classic Hi-Fi we cover the best in quality sounds. Be it a question of taste, a question of balance or a question of price, we're the ones to help. We stock: Marantz, Nad, Pioneer, Roksan, Yamaha, Heybrook, LFD, Sugden, Rotel, Kenwood, B & W, Kef, Rogers, Monitor Audio, Musical Fidelity, Tannoy, Shearpe Audio, Royd, Audio Alchemy, Teac and many more. For more details call: 01536 310855

LISTEN INN 32 Gold Street, Northampton, NN1 1RS Tel: 01604 637 871. The World's Finest Hi-Fi from Arcam, Audio Analogue, Chord Company, Copland, Denon, FMJ, Fujitsu, KEF, Krell, Linn, Loewe, Martin Logan, Meridian, Miller & Kreisel, Nares, Roksan, Yamaha, Proac, Rega, Rotel, Sennheiser, Sonus Faber, Wilson Benesch, Yamaha. Dedicated Viewing & Listening Rooms, Friendly Staff, Fresh Coffee, 7 Full Years Warranty, Part Exchange Welcome, Free Car Parking, Interest Free Credit, Members of BADA. Open 10am-5.30pm (Closed Thursday).

NOTTINGHAMSHIRE

CASTLE SOUND & VISION 48-50 Maid Marian Way, Nottingham, NG1 6GF Tel: 0115 958 4404. Nottingham's leading hi-fi, multi room and home cinema store, serving the whole of the East Midlands. Brands stocked include: Alchemist, Audio Valve, Bose, Boston Acoustics, Castle Acoustics, Chord Electronics, DMP, Denon, Jolida, KEF, Klyne, Linn, Linn Knekt, Lexicon, Loewe, Monarchy, Musical Fidelity, Naim, Nordost, Pink

DIAL-A-DEALER

Triangle, Pioneer, Project Turntables, Precious Metals, REL, Rega, Revox, Selec Projectors, Sheffield Lab, Solidsteel, Sony, Stand Unique, Stereophile, Talk Electronics, TEAC, Wavac, Wilson Benesch and XLO. Large showroom including purpose built home cinema room as well as three demonstration rooms. Home demonstrations and a full installation service available, including multiroom systems. Open 10.00 am - 6.00 pm Tuesday, Thursday, Friday and Saturday; 11.30am - 7.30pm Wednesday. Appointments out of normal shop opening hours can also be arranged.

NOTTINGHAM HI-FI CENTRE 120-122 Alfreton Road, Nottingham. Tel: 0115 9786919. Multi-room specialists. Hi-Fi, Home cinema. All leading brands stocked. Three superb demonstration areas. Two year parts and labour guarantee. Home trials. On site service facility. Full delivery and installation service. Easy free parking. BADA Dealer. Established 1968. Mon-Sat 9.00-5.30

OXFORDSHIRE

OVERTURE HI-FI, 3 Church Lane, Banbury, Oxon OX16 8LR. Tel (01295) 272158. Email sales@overture.co.uk Website: www.overture.co.uk Arcam, Bose, Cura, Denon, KEF, Linn Products, Miller and Kriesel, Mission, NAD, Naim Audio, Yamaha. For sensible unbiased advice, call Oxfordshire's audio experts. Superb demo facilities. No appts. necessary. Home Cinema, Plasma TV, Projectors, Lutron Lighting, MultiRoom and Commercial installations. Access/Visa, instant credit. Mon-Fri 10-6, Sat 9.30-5.30.

SHROPSHIRE

ADAMS & JARRETT Hi-Fi and Home Cinema Specialist. Phone or visit us at 6-18, Norman Road, St. Leonards-on-Sea, E.Sussex. (01424) 437165/432398. Stockist of quality equipment including: Audio Innovations, Meridian, KEF, Ruark, Marantz, NAD, JBL, Royd, Dali, Jamo, Onkyo, Rel, Traget, Cable Talk, Technics, TDC, Yamaha, Kenwood. Air conditioned listening rooms, on site service and repair facilities

SHROPSHIRE HI-FI St Michael Street, Shrewsbury, Shrops. SY1 2ES. Tel. 01743 232065. Stockists of Musical Fidelity, Mordaunt Short, Sony, Kenwood, Pioneer, Rotel, Denon, B&W, Proac. Audio Visual. Products available. Open 9.30 - 5.30pm Mon-Sat.

STAFFORDSHIRE

ACOUSTICA 114 Wolverhampton Rd, Stafford ST17 4AH. www.acoustica.co.uk. Tel 01785 258216. All that's best in HiFi & Home Cinema from quality manufacturers including Naim, B&W, Musical Fidelity, Rotel, Selec Projectors, Kef, Ruark, Densen, Primare, Teac, JM Lab, Nakamichi, Quadraspire, Celestion & Crimson. We offer friendly, helpful advice, interest free credit & trade-in facilities, and deliver & install systems throughout Staffordshire & the Midlands. Opening hours are Tuesday to Saturday 10.30 until 6.00, evenings by arrangement.

SOUND OF MUSIC The alternative Hi-Fi shop. 01270 214143. A.K.G., A.V.I., Alchemist, B.C.D., Blueprint, Castle, Chord Co., Deva, Dynaudio, Dynavector, Electrocompaniet, John Shearn, Kef, Lexicon, Linn, Loewe, Michell, Myrrad, Nordost, Ortofon, Project, Projekt Stands, Q.L.N., Restek, Roksan, Stands Unique, Teac.

SUFFOLK

AANVIL AUDIO, Tel/Fax 01359 240687 Mobile 0467 404874 Music from the Sound Foundry! Suppliers of: [Audio Physics]: loudspeakers, Adyton: amplifiers, Meracus: CD transports, players, DAC's pre and power amplifiers, Yamamura Churchill: cables and accessories, ART: Accessories Mail Order Accessories/CD's Cable/Amp Stock Clearance: Phone or fax for further details and ex-demo hardware offers. Most major credit cards accepted.

ANGLIA AUDIO The Street, Hessest, Bury St Edmunds, Suffolk, IP30 9AZ. Tel. 01359 270212. "Hi-Fi and speaker centre dedicated to quality hi-fi since 1971. Open 10-6. Closed Weds and Sundays. Evening and Sunday Demos by appointment.

AUDIO IMAGES 128 London Road North, Lowestoft, Suffolk, NR32 1HB. Tel: 01502 582853. Arcam, Accurus, Castle, Rotel, Moth, Triangle, QTA, Sugden, Denon, Yamaha, Mirage, M & K, Definitive, Musical Fidelity, plus the incredible Rothwell range. Refreshingly different selection. Dem Room, Professional AV installer's from budget to high end. Full credit facilities. 9.30 to 5.30 Mon & Sat - 9.30 to 6.00 Tues to Fri.

EASTERN AUDIO 41 Bramford Road, Ipswich, Tel. 01473 217 217. Fax 01473. 215705. Quad, Arcam, Audiolab, Meridian, Mission, Denon, Rotel, Marantz, NAD, Sony, Rogers, Nakamichi, Systemdek, Technics, Celestion, B&W, Tannoy, Morel Thorens and Top Tape. Also stock a wide range of accessories. usual credit facilities. A BADA dealer.

STOWSOUNDS Audio Consultants, Stone Farm, Borough Lane, Great Finborough, Stowmarket. Tel: 01449 675060. We offer genuine impartial advice and demonstrations of quality audio equipment, racks and accessories. Demonstration by appointment here or in your own home. Some ex-demo and second-hand equipment. Phone for a consultation, demonstration, or price lists and product information.

SURREY

INFIDELITY 9 High Street, Hampton Wick, Kingston upon Thames, Surrey KT1 4DA. Tel. 020 943 3530. Email: infidelity@compuserve.com - Web Address: infidelity.co.uk Stockists of: Linn, Naim, Arcam, Meridian, Rega, B&W Nautilus, Neat, Proceed, Royd, M&K, Rotel, Stax, Shahinian, Dynavector. Open 10.30 - 7.00 Tues - Fri, 10.00 - 6 Sat.

SPALDINGS HI-FI 352-4 Lower Addiscombe Rd., Croydon, Surrey, CR0 7AT. 0181 654 1231/2040. 3 dem rooms and home dem. Free installation/credit. Meridian, Linn, Naim, Quad, Arcam, Audiolab, Mission, Denon, Tannoy, Marantz, Ruark. Mon-Sat 9-6, Tues 9-8, . Service dept. (3 Dem rooms incl. A.V. 0% credit).

SUSSEX (EAST)

ADAMS & JARRETT For the best Audio Visual Specialist with friendly helpful staff phone or visit us at 6-18 Norman Road St. Leonards-On-Sea. East Sussex. Tel. 01424 437165/432398. Copland, Castle, Denon, Densen, Dynaudio, Jama, Kef, Kenwood, Marantz, Meridian, Musical Fidelity, NAD, Onkyo, Primare, Rel, Rotel, Ruark, Tannoy, Technics, Yamaha. Interest free credit available subject to status. Visa, Mastercard.

WARWICKSHIRE

SOUNDS EXPENSIVE 12 Regent St, Rugby, Warwicks CV21 2QF. Tel: 01788 540772. Agents for: Arcam, Audiolab, B&O, Castle, Celestion, Denon, Dual, Kef, Mission, Marantz, Meridian, Pioneer, Quad, Rotel, Sony, Tannoy, Yamaha & many more. 2 year warranty on all hi-fi separates. 2 Demonstration rooms. Home Trials, All Major Credit Cards Accepted, Mail Order Welcome. Ring Now For Keenest Prices. Open Monday - Saturday 9-5.30. Closed Wednesday. If We Haven't Got It It's Probably Not Worth Having.

WEST MIDLANDS

ACOUSTICA, 114 Wolverhampton Rd, Stafford ST17 4AH. See our main entry under "STAFFORDSHIRE".

MUSIC MATTERS

Birmingham - 363, Hagley Road, Edgbaston, B17 8DL. Tel. 0121 429 2811.
Solihull - 93-95, Hobs Moat Road, B92 8JL. Tel. 0121 342 0254.
Stourbridge - 9, Market Street D48 IAB. Tel. 01384 444184.
Sutton Coldfield - 10, Boldmere Road, B73 5TD. Tel. 0121 354 2311.
Arcam, Alchemist, Apollo, Audioquest, Audio Research, B&W, Cable Talk, Castle, Celestion, Chord, Copland, Cyrus, Denon, DPA, JBL, Kef, Krell, Marantz, Martin Logan, Meridian, Musical Fidelity, Panasonic, Pioneer, REL, Rotel, Ruark, SME, Sennheiser, Sonus Faber, Tag McLaren, Teac, Theta, Yamaha etc. Classical CD's available at Birmingham only. Demonstration rooms, service and installation. BADA member. VISA / MASTERCARD / AMEX / SWITCH. Open: 10-5.30 Tuesday to Saturday. Late night Thursday till 7.00 (not Stourbridge).

FRANK HARVEY HI FI EXCELLENCE 163 Spon Street, Coventry, CV1 3BB. Tel: 01203 525200. Web Site: http://www.frankharvey.co.uk. Much more in store on 3 floors with 3 dedicated Hi-Fi demonstration rooms of the very best Hi-Fi. Plus our new Home Cinema Room. Appts Req. Open 9.30 to 5.30, Monday to Saturday. Authorised agencies include: Acoustic Energy, Atacama, Arcam, Audio Quest, Bang & Olufsen, B&W, Castle, Cable Talk, Celestion, Chord, Cyrus, Definitive Technology, Denon, KEF, Marantz, Meridian, Monitor Audio, Miller & Kriesel, Mission, Michell Gyrodek, Musical Fidelity, NAD, Optimum, Panasonic, Pioneer, Quad, QED, REL, Rega, Rotel, Sennheiser, Sharp, Tag McLaren, Target, Teac, Tannoy, Thorens, van den Hul, Yamaha. Interest free credit and part exchange. Wide screen TV, Projection and Multi room specialists.

SOUND ACADEMY For the Midlands. The Parade, Sutton Coldfield, Tel. 0121 321 2445 & High Street, Bloxwich, Nr Walsall, (sharing the ASDA shopping centre) Tel 01922 493499. Hosts 4 private studios plus a Home Theatre Cinema with Tube & LCD Projectors. The best in hi-fi from Naim, Arcam, Audiolab, Chord, Meridian, Monitor Audio and many more. So... if you've taken time to read this, please let us make you welcome. Phone 0121 321 2445 for Sutton or 01922 493499 for Walsall. Call in and to browse our exciting display of hi-fi and home cinema equipment. Mail order available. interest free credit S.T. Status. Open 6 days, 9am to 5.30pm. Please call for late night. Expert Advice, Cable Dressing and Installation.

WILTSHIRE

SALISBURY HI-FI LTD, 15 Catherine Street, Salisbury, Wiltshire SP1 2DF. Tel (01722) 322169. Arcam, B&W, Celestion, Denon, KEF, Kenwood, Marantz, Meridian, Micromega, NAD, Ruark, Sony, Yamaha, 2 Dem rooms. Friendly, relaxed atmosphere. Professional advice. Home dem available. Service department, Free installation. Home trial facilities. Access. Visa, Amex. Interest free credit. Instant credit. Open Mon-Sat 9-5.30.

THE RIGHT NOTE - See under BATH & BRISTOL heading.

WORCESTERSHIRE

MAX - MIDLAND AUDIO X-CHANGE 181 Franche Road, Kidderminster, Worcs. DY11 5AD. Phone: 01562 822236 • Mobile: 0421 605966 • Email: john.roberts20@virgin.com Analogue Hi-end specialist • Open Monday to Saturday 9.30 to 6.00 • Part exchange always welcome • Evening demos arranged by appointment • Service facilities • Free delivery, Suppliers and installers of high quality audio systems, including: Audio Note • Basis • BAT • Densen • Dpa • Electrocompaniet • Mark Levinson • Michell • Nagra • Pass • Primare • ProAc • Rega • Revel • Roksan • SPM • Sugden • UKD • Unison Research • Wadia. Access. MasterCard, Visa and Switch.

YORKSHIRE (EAST)

THE AUDIO ROOM 2 George Street, Hedon, Hull, HU12 8JH. Tel: 01482 891375. HiFi - Home Cinema - Multiroom. Authorised agents for: Linn Products, Cyrus, Musical Fidelity, B&W, AVI, Marantz (including premium), Denon, NAD, Royd, Quad, Helios, Nakamichi, Tannoy, Sonic Link, QED, Quadraspire, Stands Unique, Soundstyle, CableTalk, Grado, Sound Organisation, Exposure, Talk Electronics and more. Open Mon-Sat 9am-7pm, 0% Finance Available, 4 Demonstration rooms, home demonstrations available, friendly relaxed atmosphere guaranteed.

ZEN AUDIO 35 George Street, Hull Tel. 01482 587397. "Comfortable listening rooms; Home dems; Personal, friendly service; Free installations. Agencies include: Arcam, Audiolab, Atacama, Audio Innovations, Audio Note, Audion, Alchemist, B&W, Cable Talk, Chord CO, DPA, Densen, Denon, DNM, EAR, Exposure, Fi-Rax, Harbeth, Heybrook, Impulse, KAR, KEF, Michell, Micromega, Monitor Audio, Musical Technology, Myrrad, NAD, NAIM, Pioneer, REL, Rehdeko, Rotel, Royd, Ruark, Shearpe Audio, Stands Unique, Sugden, Spondor, Sonic Link, TEAC, TDL, Tube Technology, Vivanco and many others.

YORKSHIRE (SOUTH)

THE HI-FI STUDIOS Doncaster Sunnyfields, Doncaster, DNS 8SA. Tel: (01302) 781387/391193, Fax: (01302) 781387. HI-FI, HOME CINEMA AND MULTI-ROOM EXPERTS Musical Fidelity, TAG McLaren, Electrocompaniet, ProAc, Ruark, Castle, TEAC, Unison Research, John Shearpe, T & A, Impulse Horns, Monitor Audio, Harbeth, Alchemist, Michell Turntables, Nottingham Analogue Studios, Blueprint, Audio Analogue, Exposure, Living Voice, Densen, Celestion (A Series only), Opera, Audio Physic, Trichord Research, Nordost, Stands Unique, Stax Electrostatics, Ortofon, Goldring, REL Subwoofers, Yamaha AV, Proceed Digital Cinema. Viewing and demonstration by appointment. Home trials and free installation. Access/Visa and credit facilities. Phone for more information. 10-8pm Tues - Fri, 10-6pm Sat, Closed Monday.

MOORGATE ACOUSTICS 8 Westgate Chambers, Rotherham Tel: 01709 370666, 184 Fitzwilliam Street, Sheffield Tel: 01142 756048 - Audio Alchemy, Atacama, Arcam, Audio Lab, Audio Quest, Bayer, Bose, Canon, Castle, Cyrus, Celestion, Denon, Jamo, John Shearn (Amplifiers), Linn, Marantz, Mission, REL (Sub Woofers), Rogers (Speakers & Amplifiers), Royd, Sennheiser, Spondor, Tannoy "D", T.D.L., Technics, Yamaha. Demo rooms (6), Home Cinema, Access, Visa, Switch, Interest free credit (details available upon request), up to 5 years guarantee.

SOUND ORGANISATION YORK, 2b Gillygate, York YO3 7EQ. Tel (01904) 627108. Carefully chosen Hi-Fi and AV equipment includes Arcam, B&W, Denon, Linn, M&K subwoofers, Naim, Rega, Rotel, Royd, ect 3 dem rooms incl. Home Cinema and Multi-room facilities. Service Department. Home installations. Instant Credit and major credit cards. Closed Mondays. Phone for chat and more details.

YORKSHIRE (WEST)

HUDDERSFIELD HI-FI CENTRE 4 Cross Church St, Huddersfield, (01484) 544668. B&W, Cyrus, Kenwood, Denon, Rotel, Arcam, Musical Fidelity, Quad, Audio Lab, Marantz, Mission, ect. Dem facilities - appointment reqd. Mon-Sat 9-5.30, Thurs 9-8. Closed Wed. Free installation, credit facilities. Access. Visa

Huddersfield Hi-Fi Centre Halifax 3-5 King Cross St, Halifax. 01422 366832. Audio Analogue, Arcam, B+W, Castle, Cyrus, KEF, MF, Mission, NAD, PRO-AC, Sugden, Quad, 2 Dem rooms Mon - Sat 9.5.30 closed Thursday. Credit facilities.

Premier Audio Wakefield (01924) 255045. A brand new company offering a range of exciting Audiophile products carefully selected and professionally demonstrated. Equipment includes Audio Synthesis, Chord Company, Classe, cable Talk, DPA, EAD, Exposure, Harbeth, Kora, Mirage, Myryad, Orelle, Trichord and many others. demonstration facilities, Home demonstrations & Free installation. Part Exchange & used equipment Available. telephone for details and opening offers.

-----SCOTLAND-----

CENTRAL

COLIN MACKENZIE'S HIFI CORNER 52 Gordon Street Glasgow 0141 248 2840. Rose St Edinburgh 0131 220 1535, 1 Haddington Place, Edinburgh 0131 556 7901 and 44 Cow Wynd, Falkirk 01324 629011. Audiolab, Cyrus, Sound-Bytes, Meridian, etc. Most major Brands stocked. Free five year guarantee on all loudspeakers, keen prices.

JAMES KERR & CO., 145 Bath St, Glasgow 0141 226 5711. Glasgow's oldest established hifi specialist, now at new larger premises.

LOTHIAN

COLIN MACKENZIE'S HIFI CORNER 52 Gordon Street Glasgow 0141 248 2840. Rose St Edinburgh 0131 220 1535, 1 Haddington Place, Edinburgh 0131 556 7901 and 44 Cow Wynd, Falkirk 01324 629011. Audiolab, Cyrus, Sound-Bytes, Meridian, etc. Most major Brands stocked. Free five year guarantee on all loudspeakers, keen prices.

JAMES KERR & CO., 145 Bath St, Glasgow 0141 226 5711. Glasgow's oldest established hifi specialist, now at new larger premises

MUSIC MILL 72 Newhaven Road, Edinburgh EH6 5QG. Tel: 0131 555 3963 Fax: 0131 555 3964. Audio Research, Copland, Naim Audio, Krell, Roksan, Rotel, DNМ, Marantz, AVI, Martin Logan, Pro-Ac, Wilson Audio, Wilson Benesch Theta Digital, Transparent Audio, Alchemist, Quadraspire, Stands Unique. Listening Rooms, Free Parking, Full Workshop, Delivery and Installation. Open Mon-Sat 10-6.00 pm. Please phone for a map or contact Raoul, John, Mark, or Mike.

GRAMPIAN

HOLBURN HI-FI 441 Holburn Street, Aberdeen. Tel: 01224 585713. Arcam, Audiolab, B&W, Celestion, Denon, Dual, Epos, Heybrook, ION, Kenwood, Creek, Marantz, Meridian, Mission, Cyrus, M.S., NAD, Nakamichi, Pioneer, QED, Quad, Revox, Rotel, Ruark, Tannoy, Technics, Wharfedale, Yamaha. 9.30-5.30 Mon-Sat.

STRATHCLYDE

COLIN MACKENZIE'S HIFI CORNER 52 Gordon Street Glasgow 0141 248 2840. Rose St Edinburgh 0131 220 1535, 1 Haddington Place, Edinburgh 0131 556 7901 and 44 Cow Wynd, Falkirk 01324 629011. Audiolab, Cyrus, Sound-Bytes, Meridian, etc. Most major Brands stocked. Free five year guarantee on all loudspeakers, keen prices.

KEVIN GALLOWAY AUDIO., Audio Physics, Accuphase, Audion, Basis, DCS, JM Lab, Pink Triangle, Electrocompaniet, Sugden, Nagra, Tara Labs. Nationwide delivery and installation. Demonstration by appointment. Tel: 01563 574185. Fax: 01563 573207.

JAMES KERR & CO., 145 Bath St, Glasgow 0141 226 5711. Glasgow's oldest established hifi specialist, now at new larger premises

LOUD & CLEAR 520 St Vincent Street, Finnieston, Glasgow G3 8XZ. Tel: (0141) 221 0221 or visit us at www.loud-clear.co.uk. Glasgow's finest and friendliest Hi-Fi store, combining knowledgeable advice with specially selected products and the best of service. Three comfortable demonstration rooms, full service and installation facilities, interest free credit on selected products. Product lines include Naim Audio, Exposure, Alchemist, Rega, Tag McLaren, Musical Fidelity, Marantz, Denon, Rotel, Acoustic Energy, KEF, KEF Reference, Monitor Audio, Tannoy, ProAc, VdH, Chord Co., DNМ, Ash Design, Stands Unique. Open Tues-Sat 10am-6pm, Thurs till 7pm. Complimentary parking at PC World, Finnieston Street.

STEREO STEREO 278 St Vincent Street, Glasgow, Tel: 0141 248 4079
Email: Stereo@cix.compulink.co.uk
We will supply the most musical sound for your budget and if you take the time to visit us we will take the time

to return the compliment with free installation of your chosen equipment. Open 10-6.00pm closed Sunday, Tuesday Installation Nation-wide Interest free credit available.

AUDIO NOTE SALON Five dem rooms in Glasgow's peaceful west-end; free parking, relaxed atmosphere, serious equipment. Unique in the north, we specialise in Audio Note (entry level to Ongaku), Bow Tech and Mark Levinson, speakers include ProAc and Zingali. Large second-hand stock and cost-effective cables. Established 1979 as the original Music Room, we invented the dem room, matching, and consultancy rather than selling hyped gear. We save you a lot of disappointment. See our full page and half-page ads in this issue. Visit us online. [HYPERLINK http://www.audiosourc.co.uk](http://www.audiosourc.co.uk)
www.audiosource.co.uk . Phone or fax for advice, info sheets, lists, or appointment.
Phone 0141-357 5700, Fax: 0141-339 9762.
E-mail HYPERLINKmailto:jack@audiosource.co.uk
jack@audiosource.co.uk .

-----WALES-----

NORTH WALES

ACOUSTICA 17 Hoole Rd, Chester CH2 3NH. Tel 01244 344227. See our main entry under "Cheshire".

ACTON GATE AUDIO 4 Ruabon Road, Wrexham, North Wales, Tel. 01978 364500. See our main ad under Cheshire.

GLAMORGAN (SOUTH)

SOUND DR. JULES SWANSEA. 01792280 061. Call now for price list, UK or overseas. Hi end new and pre-owned hi-fi at an affordable price. Home trial prior to purchase. Reliable courier service and repair service. Friendly and enthusiastic advice, day or evening seven days a week. A service to suit you.

-----IRELAND-----

AUDIO AUDIO HIFI SPECIALISTS 15 Mansfield Heights, Portlengone, Co. Antrim, N. Ireland BT44 8JR. Telephone 01266 822128/ Fax 01266 822128. Products include Totem, Sugden, Denon, Ortofon, Project, Alchemist, QED, Chord Co., Arcam, Quadraspire, Audioquest, Rega, Soundstyle, Apollo, Grado, Ixos, Sonace, Optimum, Acoustic Energy, Tangent, Mighty Mighty, Sound Organisation, Jamo. Free installation. Please ask about our FREE customer care package.

CLONEY AUDIO 55 Main Street, Blackrock, Dublin, Tel.2889449/2888477 Fax. 2834887. Products include: Arcam, Classe, Philips, B&W, Naim Audio, Meridian and others. Open Tues/Sat 10am-6pm. Thurs/Fri 'till 9pm Closed Mondays.

DUBLINN HI-FI 38 Augier Street, Dublin 2. Tel: (00 353) 1 4785205. Fax: (00 353) 14785219. We all have two ears and one mouth - use them accordingly. We only stock the best products, based on performance and reliability - not reviews or sales patter. Call Mark or drop in for a listen. Three single speaker demo rooms. Free delivery and installation. Full service department, Open Mon-Fri 10-7, Sat 10-6

-----NORTHERN IRELAND-----

KRONOS HI-FI 7 Scotch Street Centre, Dungannon, BT70 1AR. Tel: (01869) 753606. Fax: 753006. Email: David@KronosHi-Fi.demon.co.uk website <http://www.KronosHi-Fi.demon.co.uk> We have one of the largest ranges of quality Hi-Fi in Ireland. Our agencies include Absolute Sounds, Apogee, Audion, Audiomeca, Blueprint, BOW Technology, Cadence, Copeland, Denson, Frameworks, Harman Kardon, Helios, JBL, Kelly, Kimber, Klipsch, Living Voice, Lyra, LFD, Marantz, Michell, MIT, Musical Fidelity, Nottingham Analogue, Oracle, Orelle, QLN, Rogers, Roksan, Rotel, Ruark, Silver Sounds, SME, Triangle, Trichord, Unison, UKD, Wilson Benesch, YBA and much more. Demo rooms for Hi-Fi and A.V. Free installation, home demos and home trial. Access and Visa. Credit including instant and interest free. Multi-Room specialists. Open Mon-Fri 9.30-5.30. Closed Wed. Sat 10-5. We are also open any evening by appointment.

VINYL/RECORD MAIL ORDER

AUDIOPHILE UK LTD 214 Station Road, Addlestone, Surrey, KT15 2PH. Specialists in high quality, new and used vinyl & CD. Telephone order: 01932 701248 Fax order: 01932 701162. E-mail order: sales@audiophile.co.uk. Order your copy of our free monthly flyer and get the most up to date information on new releases plus the thousands of mint used LPs we hold in stock. As well as this we stock interconnects, record cleaning materials, isolation feet and many more accessories. Callers welcome by appointment. Hours Mon - Fri 9.30am-5.30pm and occasional Saturdays.

ABERGAVENNY MUSIC 23 Cross Street, Abergavenny, S. Wales. NP7 5EW Tel: 01873 853394 9am - 5pm Monday-Saturday.
E-mail: abermusic@compuserve.com. All major credit cards accepted. Abergavenny Music is a specialist classical music shop carrying a wide stock of CDs & Tapes. We regret we do not stock vinyl. Please phone for prompt personal service. Any item in stock can usually be posted on same day. First class free p&p. We welcome any enquiry or order.

DIVERSE VINYL 10 Charles Street, Newport, NP20 1JU. Tel/Fax: 01633 259661/256261.
Email: sales@diverse-music.co.uk Probably the most varied and impressive selection of brand new LPs you'll find anywhere: international new releases, reissues and audiophile products. Also UK distributor of the Disco Anti Stat LP Cleaning Device. Call for a free catalogue, or visit www.diverse-music.co.uk

SILVERNOTE PO Box 158, Cheshunt, Herts, EN7 6UH Always wanted: Vintage and Modern Equipment, Records & CD's. Tele/fax Steve on 01992 620905.

VINYL DEMAND Stockists of VPI record cleaning machines and the widest range of audiophile vinyl in the UK - at the best prices. Living Stereo, Verve, Mobile fidelity, Decca, Absolute Analogue, Testament, MCA, DCC. Also a vast range of analogue accessories. Phone 01425-654545 or Fax 01425-654400 for orders or catalogues.

VIVANTE - Unit 4, 60 High Street, Hampton Wick, Surrey KT1 4DB. Tel: 0181 977 6600. Fax: 0181 977 4445 One of the UK's largest importer and distributor of audiophile and conventional vinyl is now operating a mail order service specialising in jazz and classical reissues. Labels include Decca, London, Deutsche Gramophon, Archiv, EMI, Telefunken, Testament, Verve, MPS, Milestone, Fantasy, Pablo and more. Extensive catalogue available. Access/Visa accepted.

WOODSTOCK RECORDS. The regions largest new and used vinyl specialist catering for all musical tastes - classical; jazz & blues; rock; sixties; indie; funk; soul; reggae; soundtracks; disco, deep house; hip hop; drum & bass; breakbeat; electronica and much much more. Plus extensive 7" section and a wide range of accessories. Internet site coming soon! Shop details: 22 Heritage Close, St. Albans, Herts AL3 4EB Tel/Fax 01727 846 907.
E-Mail: woodstockrecords@LineOne.net
Shop hours: Mon 10.30-6.30 Sat 9.30-5.30

-----VINTAGE-----

AUDIO CLASSICS. 18/20 Chapel Green Road, Hindley, Wigan, WN2 3LL. Tel: 01942 257525. Fax: 01942 207089. Mobile: 0585 476574. Hi-Fi bought, sold, repaired and renovated. Mail order and vintage specialists. Please see our main ad (look under the ad index to find) for further information.

-----EX DEMONSTRATION-----

AFFORDABLE AUDIO. (NORTHAMPTON) Pre-Owned Hi-Fi Specialists. 168 Wellingborough Road, Northampton, NN1 4DU. Tel/Fax 01604 231261 or Tel: 01933 273281 Mobile: (0370) 877893.
Email: sales@affordable-audio.co.uk
Website: www.affordable-audio.co.uk Urgently required: compact disc collections, hi-fi separates, especially Linn products, Naim Audio, Cyrus Electronics, Musical Fidelity, Quad Electronics, almost anything British/American. Cash waiting, part exchange welcome. We also stock lots of audio accessories, compact discs, vinyl, DAT players. All equipment is sold with warranties. All Credit Cards accepted. Please phone anytime for stock update.

AUDIO CLASSICS. 18/20 Chapel Green Road, Hindley, Wigan, WN2 3LL. Tel: 01942 257525. Fax: 01942 207089. Mobile: 0585 476574. Hi-Fi bought, sold, repaired and renovated. Mail order and vintage specialists. Please see our main ad (look under the ad index to find) for further information.

CHOICE HI-FI/HI-FI EXCHANGE Open 10am-8pm. 7 days by appt. Tel: 0181 392 1959/1963. Fax: 0181 392 1994. Agents for Acoustic Energy, Alon, ATC, Boulder, Bryston, Chord, Forsell, Gamma, Van den Hul, Lumley, Rockport, SME, Soundstyle, Straight Wire, Target, Trichord, Trilogy, VPI, XLO and many more. We offer: generous part exchange, your equipment purchased, show room/dem room, single speaker dem room, trade in policy, credit card facilities, mail order, export service, finance available.

**TO ADVERTISE IN DIAL A DEALER
PLEASE CALL
AMANDA SWEENEY
ON 020 8864 4760**

welcome to

world favourites

Here's a list of products that are a good buy. We've tried to cater for a range of tastes, identifying strong products in every area. We're agnostic so you'll find a wide range of products, from valve pre-amps through to MiniDisc players. Products marked * are recently out of production but make a good second-hand buy.

Prices shown are those at the time of the review



Roksan Caspian CD player
Solid as a ROK

COMPACT DISC

ARCAM FMJ CD23 £1100
This British-built player is extremely versatile. Controlled and detailed with a musical insight that few match. (Jul 2000)

CAMBRIDGE CD4SE* £200
A touch soft in the treble but outstanding in every other respect. (Feb 98)

KENWOOD DP-3080/II* £180
Has great clarity and presence for the price. Not as naturally expressive as the CD4SE though. (Feb 98)

LINN KARIK III* £1775
Under rated and overlooked, the final Karik was a gem. Superb transport gives a brilliantly tight, grippy dynamic sound, albeit tonally rather dry.

MARANTZ CD-17 KI-S £1100
The Marantz excels in all areas. Without doubt this is one of the most involving CD players on the planet. Build quality is also exemplary. (Sep 97)

MARANTZ CD-63 MKII KI-S* £400
Similar to the CD-63SE but more powerful bass and an all-round smoother sound. The famous KI tweaks pay off again. Whether or not it is still pre-eminent against the vastly improved competition is a matter of opinion.

MERIDIAN 506 20-BIT* £1100
Very detailed and revealing player. More cerebral than visceral sounding, however. (May 95)

MUSICAL FIDELITY X-RAY £800
Commonsense sturdy CD player of exceptional ability. Clear and detailed with high quality internal processing system. The X-Ray is inclined to show up poor recordings, but it's only doing its job! (Feb 99)

NAD S500 £1000
This dynamic top of the range Silverline spinner delights with any type of music. Exciting, sophisticated sounding and highly recommended. (Jun 2000)

ROKSAN CASPIAN £895
The Caspian has a smooth, slightly bright sound with some of the clearest treble in the business. Very engaging, dynamic character. (Aug 97)

ROTEL RCD 951 £300
HDCD capability at a midrange price. Plain Jane looks but solid construction. There is some higher than average measured distortion which may take the edge off this otherwise tempting product. (Aug 99)

COMPACT DISC TRANSPORTS

SONIC FRONTIERS TRANSPORT £6999
Cutting-edge design and technology combine to make this one very desirable product. The only problem is the fantasy hi-fi price. (Sep 98)

TEAC P-30 £2500
Cheap it isn't, but then it sounds like a million digital dollars. Nothing short of superb. (Jun 97)

TEAC VRDS-T1 £600
Excellent mid-price silver disc spinner with a powerful, expansive and warm sound. Easily beats most sub-£1000 designs. A good choice for the budget concious who want the best. (Feb 95)

CD TRANSPORTS

CAMBRIDGE AUDIO DACMAGIC 3* £99
Superb value for money with extensive facilities and solid, detailed sonics. Upgrades any sub-£300 player.

DCS ELGAR £8500
Future-proof convertor which will handle 24/96 and 24/192. Extremely open and natural performer. (Nov 97)

DPA LITTLE BIT 3* £299
A taste of the high end on a budget. Rich, clean, punchy sound transforms budget CD players.

MIDIMAN FLYING COW £299
Excellent as a DAC and doubles as an ADC for archiving to CDR. (Jun 98) Great value, as is junior version Flying Calf at £109. (Feb 99)

MUSICAL FIDELITY X-DAC* £300
A bargain for normal CDs and even better with HDCDs. (Nov 97)

SONIC FRONTIERS PROCESSOR 3 £6999
Quality never comes cheap! This DAC oozes class and when matched with the Transport 3 is certainly up with the best. (Sep 98)

TURNTABLES

LINN SONDEK LP12 BASIK £1100
Off the pace these days in many respects but still an extremely sweet and engaging listen with a quintessentially analogue sound.

MICHELL GYRODEC SE £775
Exquisitely built, infinitely upgradeable deck that gives true high end sound at mid-fi prices.

MICHELL ORBE £2000
Fantastically capable all rounder with commanding, powerful, detailed sound that gets the best from almost any arm and cartridge. Supreme build, brilliant value. (Apr 95)

ORIGIN LIVE STANDARD (KIT) £145
Good in standard form with AC motor; frighteningly good with a DC motor and battery PSU.

PINK TRIANGLE TARANTELLA £680
Not only does the Tarantella have more style than a catwalk full of models, it also combines PT's usual clarity with real authority. (Oct 97)

PRO-JECT DEBUT £110
Straight out of the box and onto the shelf! Nothing short of a bargain. Vinyl's never had it so good, so cheaply!

REGA PLANAR 2 £214
Brilliant starter deck with extremely polished manner. Better built £274 Planar 3 is a great all-in-one package that eats mid-price CD players for breakfast.

ROKSAN XERXES X £1295
DSU or XPS 3.5 power supply £150/170 extra. Excellent pitch stability from a new Swiss motor and outboard power supply. Very tight bass, fine dynamics and revealing clarity. (Jan 97)

SYSTEMDEK IIX900*/RB250 £330
A fine all-rounder and easy to upgrade too. More depth and breadth than Rega Planar 3. (Sep 94)

VESTAX BDT-2000 £225
A stylish looking deck with infinitely variable speed 16-90 rpm DC belt drive and built-in MM phono stage. Good value, with plenty of chassis room for alternative arms, if required. (Sep 99)

TONEARMS

HADCOCK 242 SE £649
Latest of a long line of unipivot arms. Added mass makes the 242 suitable for both low compliance MCs and straw-in-the-wind high compliance types. Revised geometry and chromium plating completes a first-class job. (Jun 2000)

NAIM ARO* £975
Truly endearing and charismatic performer - wonderfully engaging mid-band makes up for softened frequency extremes

REGA RB300 £180
Some may prefer the simpler RB250 at £130. Detailed, tight, rhythmic sound but tonally rather grey and cold-sounding. Still excellent value, though.

Audiophile candy

MAIL ORDER HI•FI ACCESSORIES



FREE PLEASE CALL

GREAT SELECTION

CALL: 0870 241 246 9

For more information contact:

Audiophile Candy

P.O. Box 7274 • Tadley • RG26 5FR
tel: 0870 241 246 9 fax: 01256 851486
e: theteam@audiophilecandy.com

five star
performance
in audio equipment support

Hi Fi Choice

An earth-shattering upgrade
for your Hi Fi system
Best Buy September 1999

Customer Selection

The BASE platform
must rank as
one of the great
bargains in
Hi Fi

WHAT HI FI?

extract from June 1999
This nicely finished platform
works superbly and for sheer
value for money, the Audiophile
BASE 01 takes top honours.
★★★★★

Top Accolades for BASE Audio Supports

Stereo (Germany) Feb 97 **Maximum** ★★★★★
Hi Fi World Feb 98 **Outstanding** ★★★★★
What Hi Fi July 98 ★★★★★
Home Entertainment Oct 98 ★★★★★
Stereoplay (Germany) Feb 99 **Outstanding** ★★★★★
What Hi Fi June 99 ★★★★★
Hi Fi Choice Sept 99 **Best Buy**

AUDIOPHILE FURNITURE LTD

The Square, Forest Row, East Sussex RH18 5ES
Tel: 01342 826262 Fax: 01342 824845

Total customer care

1. Expert, impartial advice on all aspects of audio & video, given by trained staff
2. Products specially selected for quality, performance and value
3. Personal demonstrations - Listen before you buy!
4. A home delivery and installation option - for optimum performance



BADA
BRITISH AUDIO DEALERS ASSOCIATION
the symbol of security

BRITISH AUDIO DEALERS ASSOCIATION

P.O. Box 229 London N1 7UU Phone: 0171 226 4044
Fax: 0171 359 7620 E-mail: bada1@compuserve.com

For further information please see our web site: <http://www.bada.co.uk> or ring for our information pack

BADA acknowledges the support of the following Associate Members: Alphason, The Chord Company, Dolby Labs, Heybrook, Jamo, KEF, Kenwood, Meridian, NAD, Pioneer, Polk, Sennheiser, Sony, Vivanco

Total peace of mind

1. A 10-day purchase exchange programme (returns as new & excluding special orders)
2. BADA's Free extended 2-year Guarantee on all new hi-fi and home cinema separates
3. The option to transfer the Guarantee to any one of 120 BADA members nationwide
4. Deposits safeguarded by the BADA Bonding Scheme

Home Demonstration Specialists
Hi-End Audio & Home Theatre

Multi-Room Design & Installations
Export Orders Welcome

Unbiased Advice & Support
Part-Exchange Available

AudioVenue
Bespoke Audio Visual Consultants

www.audiovenue.com



X-P100 & X-AS100
pre/power amplifier



Musical Fidelity A3 & A300
integrated amplifier



Proceed AVP
processor



Krell KAV 3001
integrated amplifier



Musical Fidelity A3
cd player



Tact Millennium MKII
digital amplifier



Copland CDA 289
cd player



Sonus Faber
Grand Piano
Speakers



Martin Logan
Prodigy
Electrostatic Speakers

Ex-Demo
Equipment
Available

Tel/Fax: +44 (0)20 8707 4849 Mobile: +44 (0)7973 471 426 email: info@audiovenue.com

Ranges available: Audio Analogue • Audio Research • Acoustic Research • AidErikamp • BCD Engineering • Bryston • Bose • Baw Technologies • Bellucci Designs • Bøston • Chord • Copland • Clearaudio • Dual • Final • Graaf • Krell • LAT • Mirshell Engineering • Monitor Audio • Musical Fidelity • Martin Logan • Nad • Nordost • Nakamichi • Opera • Parasound • Primare • Proceed • Project • QED • Revel • REL • Sonus Faber • SME • Stands Unique • Stand Design • Straightwire • Sunfire • Tact Audio • Thule Audio • Target • Transparent Audio • Theta • Unison Research • Wilson Audio • Wilson Benesch and other leading components and accessories.

Prices shown are those at the time of the review



Musical Fidelity X-Cans2
Warm, sumptuous, sweet sound

SME 3009SII £309
Once state of the art, but no longer. Weak at frequency extremes and detail, but its legendary serviceability makes it a cult in Japan. Can be picked up for peanuts second-hand. (Jan 93)

SME 309 £689
A down-market version of the IV and V with aluminium arm tube and detachable headshell. Tight, neutral sound with good tonality, but lacks the IV's pace and precision. Like the older SME 3009 series, this arm is also available in 10" and 12" versions. (Jan 93)

CARTRIDGES

AUDIO TECHNICA AT-110E £30
Great starter cartridge that's refined, detailed and musical beyond its price. Best value MM under £50

GOLDRING 1012GX £74
An accomplished MM with a solid bass, slightly forward midband and clean transients. Very reasonable price for such an able performer. (Jul 93)

DNM MICA £185
Better than Goldring's 1042 and costs only £135 on trade-in. An assured and transparent MM. (Feb 98)

DYNAVECTOR DV20X-H £299
The best modern budget MC combines deliciously sweet sound with fantastic get-up-and-go. High output version works a treat with valve phono stages too.

MUSIC MAKER £575
When mated with a good quality arm, this hand finished high-output pick-up gives an ear-boggling account of itself. Very high compliance ensures maximum information retrieval. An absolute (grain orientated) gem. (Feb 99)

ORTOFON MC 7500 £2000
Conclusive proof that there's hope for the world. It's a long time ago now but this high-priced favourite still earns its niche - CD lovers would die if they heard it. (May 94)

ORTOFON MC 15 SUPER II £140
Not quite as good as the dearer Supremes but the Super II is a splendid introduction to the joys of moving-coil cartridges.

GOLDRING 1042 £130
One of the best Moving Magnet cartridges going, with beautiful treble and muscular bass. New low price makes it a bargain.

ORTOFON ROHMANN £1000
In a way it's MC 2000 meets MC 7500 with great tonal strengths and a dynamo sound. (Apr 96)

INTEGRATED AMPLIFIERS

AUDIO ANALOGUE PUCCINI SE £595
This superbly-built Italian integrated has a lucidity and control which leaves others nowhere. Sound stage a wow. (Dec 97)

AUDIOLAB 8000a £495
Well rounded integrated with smooth and detailed sound plus a huge feature count. Great build makes later versions a top used buy.

DENON PMA-250SE £160
It might not have bags of grunt but the Denon can sound exceedingly natural and open. (Feb 97)

McINTOSH MA6800 £3735
The MA6800 not so much plays music as takes control of it, with effortless bass drive. (Sep 95)

MISSION CYRUS 2 £299
Classic eighties minimalism combines arresting styling with clean, open, lively sound. Further upgradable with PSX power supply.

MUSICAL FIDELITY X-CANS2 £160
Warm, sumptuous, sweet sound h/phone amp. gives startling results with a decent set of headphones.

NAIM NAIT 3 * £575
Superb rhythms and dynamics make for great music making, but tonally monochromatic. Super optional phono stage makes it ideal for vinyl junkies.

ROKSAN CASPIAN £695
Smooth, warm integrated with remote control that works happily into most 'speakers. (Dec 97)

SONNETEER ALABASTER £995
Builds on the strengths of the Champion with ample control, colour and drive. (Oct 97)

PHONO STAGES

CREEK OBH-8 SE £180
Punchy, rhythmic character with oodles of detail makes this a great budget audiophile product.

LFD MISTRAL PHONO STAGE * £300
The Mistral has a warmth and involvement that make many pricier stages sound overpriced.

MICHELL DELPHINI MONOBLOCS £1995
Analogue tour-de-force gives supremely clean, detailed and finely resolved sound with breathtaking dynamics. Great value, even at this price.

MUSICAL FIDELITY X-LP £125
One of the famous MF X series. Full marks throughout for clarity and detail. Switchable between MM and MC. Indestructible build! (May 99)

PRO-JECT PHONO BOX £39
Not the last word in many respects but a thoroughly honest piece of work. Inexpensive introduction to all that vinyl has to offer. MM and MC provision plus choice of two impedances.

ROKSAN ARTAXERXES X £950
With the Atessa PSU the Artaxerxes X MM/MC stage still shines. Great stage depth, neutrality and tonal colour. (Oct 97)

Billy Vee

SOUND SYSTEMS

248 Lee High Rd, London SE13 5PL (Mon - Sat 10am to 6.30pm Closed Thurs & Sun)

SAME NAIM, BUT A WHOLE NEW GAME

Call 020 8318 5755 to find out more...

Sometimes it just happens, a new range appears to replace existing products that have already carved and enviable reputation for affordable excellence and you think, Oh no - how can it be better? And it is! The new 5 Series is right here, right now. Call Paul or Patrick for more info, a leaflet or more importantly an audition, you won't be disappointed - promise!

- Local delivery and installation included in purchase price
- 3 year warranty for all 5 Series products - part exchange available
- Deferred and Interest Free Credit available at 0% APR - Call for details.
- Complete Naim range available for audition inc NAP500 & NBL



Featured - CD5 Player (Top) £1125 & Nait 5 (Bottom) £799

world favourites I

SONNETEER SEDLEY £399

Combines transparency and fine dynamics with excellent rhythmic ability. (May 98)

PRE-AMPLIFIERS

AMC 1100 £150

Suffers from un-defeatable tone controls but an extremely good value piece of kit. Partners the similarly budget level AMC 2200 power amplifier, also at £150. Comfortable beginners' choice. (Mar 99)

AUDIO ANALOGUE

BELLINI £475

Showcases AA's characteristic mix of clarity and musicality and blasts the competition. (Apr 98)

CHORD CPA1800 £1800

Clarity, insight and control are second to none - an addictive mixture. (Mar 98)

CROFT VITALE £350

A modestly priced valve pre-amp with exceptionally transparent performance. MM phono stage plus three line stages are standard. Volume controls are separate for each channel, thus giving balance adjustment. A remarkable item in all respects. (Feb 2000)

XTC PRE-1 * £1000

Almost valve-like in its smoothness, the level Pre-1 is warm and seductively clear. (Nov 96)

POWER AMPLIFIERS

ARCAM 9 * £400

With 70W on tap, the 9P will drive most loudspeakers with a spacious and detailed sound. Good bass welly too. (Dec 96)

CHORD SPM400 £1400

There's a sense of effortless power to the Chord that gives music real scale and presence. (Mar 98)

MARANTZ MODEL 9 * £8000

Authentic reproduction monoblocs still more than cut the sonic mustard. Highly expensive and highly sought after. (Mar 97)

MICHELL ALECTO £1989

Crisp, clean and beautifully controlled with gorgeous styling. Partnered with the £1650 Orca this is a superb winning combo. (Oct 98)

MUSICAL FIDELITY X-A200 £1000/pair

200W of high-end monobloc power in a grooved tube. (Aug 98)

NAIM NAPI80 £1060

Partnered with a NAC82, this has classic Naim control, and a superbly rhythmic presentation.

TUNERS

CAMBRIDGE T500 £180

An extremely engaging tuner with a performance at odds with its low price. Not exactly a Troughline, but you may not notice... (Feb 99)

CREEK T43 £399

Excellent detail, separation and dynamics. A great little tuner and unbeatable at this price. (May 98)

MARANTZ ST17 £600

A positive dreadnought of a tuner. Sweet and refined but with a heavy punch when needed. A tuner of this quality demands a decent aerial. (Jul 99)

MISSION CYRUS FM7* £300

Clear and lucid sound puts it up with the best. Superb build too. (Apr 94)

NAIM NAT03 £595

The NAT03's warm, atmospheric sound is further proof of Naim's proficiency with tuners. (Sep 93)

SONY ST-SA3ES* £250

Beguiling RDS tuner for the sonically discerning. Good ergonomics and sensitive too. (Apr 97)

CASSETTE DECKS

AIWA AD-S750* £200

Sonically a very decent machine at the price. Comes fitted with Dolby B, C and the dead handy Dolby S. (Apr 96)

AIWA AD-S950* £300

A stable transport, superb head and Dolby S make the AD-S950 an excellent all-rounder. (Feb 95)

KENWOOD KX-3080* £160

A simple deck, but excellent-quality head and transport give top quality sound. (Oct 96)

PIONEER CT-S740S £430

A great piece of engineering from Pioneer, with first-rate sound. (Jun 96)

YAMAHA KX-580SE* £250

The 'SE' tag is more than a marketing gimmick. Sound is solid and clear with Dolby S. (Sep 97)

LOUDSPEAKERS

CASTLE EDEN £469

Impressively vice-free 'speakers that offer great transparency and involvement. One of a select band that simply makes music regardless. (Mar 97)

EPOS ES12 * £495

Strong, punchy bass is allied to finely detailed, articulate midrange and sparkling treble. (Oct 96)



Kef Cresta I loudspeakers
A very musical sound.

KEF CRESTA I £100

Delightfully sophisticated presentation for the price. Won't blow the roof off, but will deliver a very musical sound. (April 2000)

KLIPSCH HERESY II £1100

An outstanding high sensitivity loudspeaker with midrange and treble horns coupled with infinite baffle 12" bass driver. Effortless, fast and accurate. (May 99)

MISSION 752 * £495

Cracking mid-price mini towers combined HDA drive units and metal dome tweeters with surprisingly warm results. Benign load characteristics makes them great for valves.

MISSION 771 £170

Characteristically fast, punchy Mission sound from the Aerogel mid/bass and silk-dome tweeter. (Jul 98)

Billy Vee

SOUND SYSTEMS

248 Lee High Rd, London SE13 5PL (Mon - Sat 10am to 6.30pm Closed Thurs & Sun)

MIDI STYLE, HI-FI PERFORMANCE!

Call 020 8318 5755 to find out more...

Got something new for you,

the man from Sugden said. A choice piece of engineering he held in one hand. The first of the Bijou range and did it sound good! Now, the rest is here and if you want small elegant boxes that please the eye, satisfy the soul and fit in a small space. This is for you, Yorkie bar Hi-Fi. Come and have an audition - and be amazed

- Local delivery and installation included in purchase price
- 3 year warranty for all Bijou Series products.
- Deferred and Interest Free Credit available at 0% APR - Call for details
- Masterclass & A21 series also available for audition



CD Master Player £1249

Head & Ampmaster £1148

QUAD ESL 63* £3450
A reference against which all other loudspeakers are judged, the '63s have superb imaging and genuine transparency.

TANNOY AMS8* £2700
Bold sounding pro active monitor with solid bass, clear midrange and delicious treble. (Aug 96)

TANNOY MERCURY m2* £140
A true audiophile bargain which embarrasses many more expensive boxes. Never mind the price, let your ears decide. (May 97)

MINIDISC PLAYERS

KENWOOD DM-9090 £500
One of the best MD players yet. ATRAC 4.5 gives clean and very musical recordings from this Kenwood. (Jan 98)

SONY MDS-JB930Q £250
Great mid-price machine that adds better build and facilities to the '530's already excellent sonics.

SONY MDS-JA50ES* £1300
This Sony can put the wind up Nakamichi cassette decks when used with better blank MDs. (Apr 98)

SONY MDS-JE55ES
MiniDisc recorder £520
The best sounding MD deck made so far, thanks to awesome build and heroic ATRAC-DSP Type R coding.



Alesis Masterdisk
A glimpse of the future

SONY MDS-JE510 £300
An impressive sound and unmatched convenience make this MiniDisc player an excellent buy.

DIGITAL RECORDERS

ALESIS MASTERDISK £1400
A groundbreaking hard disc recorder with a built-in CD drive. An amazing bit of kit, and a glimpse of the future. (July 2000)

KENWOOD DMF-9020 £500
An excellent tool for home recording, combines convenience, superb sound and a fair price. (Aug 99)

MARANTZ DR-17 £1100
Probably the best sounding CD recoder on the market. Built like a brick out house with a true audiophile sound. HDCD compatible. (July 2000)

PHILIPS CDR-765 £360
One of the first twin deck recorders/players that boasts high speed dub facility. Playback could be warmer, but still a bargain. (Oct 99)

PIONEER PDR-555RW £480
Excellent mid-priced CD recorder that both plays and records with equal panache. (Oct 99)

SONY TCD-8 DATMAN* £599
Super clean and detailed sound makes this an amazing portable. Not as robust as it should be though.

DVD PLAYERS

DENON DVD-5000 £1600
Monster build, as you'd expect at this price. Facilitates and gadgets galore and drop-dead high end looks. A very smooth and sophisticated sound, although not as good as similarly-priced CD players. (Mar 99)

PIONEER DV-717 £700
Well built and a solid performer, with a 'true' 24/96 digital output. Facilities in abundance and a controlled, exciting way with CD replay. Shame it lacks a Dolby Digital decoder! (Sep 99)

SONY DVP-S725 £490
One of the best buys in the DVD market. Available in a dodgy white case, but the facilities and performance more than make up for this. Excellent with both music and visuals, and a whole host of up to the minute facilities to keep you occupied. (Mar 2000)

HEADPHONES

JECKLIN FLOAT MODEL TWO £99
Wonderful panel-like and open sound from these esoteric-looking headclamps. Do not wear in public unless you like being made a fool of!

SENNHEISER HD-490 £50
Good value cans with an exciting and bassy sound. Everything one should look for in headphones at a sensible price.



Nordost Blue Heaven
A simple and effective upgrade

INTERCONNECTS

CHORD COMPANY CHAMELEON 2 £90/m
One of our favourite favourites, the Chameleons are musical performers with a smooth yet open sound.

DNM RESON £40/m
Neutral and transparent, and a steal at forty quid!

NORDOST BLUE HEAVEN £150/m
Some of the fastest and most transparent cable around. A simple and effective upgrade.

VAN DEN HUL ULTIMATE THE FIRST £260/0.6m
Carbon interconnects that help you forget the electronics and concentrate on the music. Miraculous transparency.

LOUDSPEAKER CABLE

CHORD COMPANY RUMOUR £9.95/m
The Rumour is our reference at the price. Tight and tuneful bass mixed with air and space results in a cracking cable for the money.

DNM RESON £6.95/m
This cable has a transparency of sound that's rarely heard at the price. Excellent value for money.

NORDOST BLUE HEAVEN £375/3m pair
This isn't cheap, but it sounds absolutely fab. An open and spacious sound that simply carries music.

Billy Vee

SOUND SYSTEMS

SAVE ££££'S ON OUR DISPLAY CLEARANCE

SOME AS NEW WITH 1 YR WARRANTY. 24HR DEL ONLY £5. CHECK AVAILABILITY BEFORE ORDERING

CALL SALES: (020) 8318 5755 or 8852 1321 - 248 Lee High Road, London, SE13 5PL

0% APR is available on purchases of more than £660. Please call for details. * Prices Correct at 12/12/00 E&OE

AVI Biggatron Speakers	(599.00)	£449.00	Naim Nait 3R Amp (1Yr G/tee)	(799.00)	£599.00
Linn LK85 Power Amp S/H (1Yr G/tee)	(499.00)	£375.00	Naim AV1 Surround Procs E/D (2Yr G/tee)	(1835.00)	£915.00
Linn Mimik CD Player S/H (1Yr G/tee)	(875.00)	£475.00	Naim CDX CD Player E/D (2Yr G/tee)	(2335.00)	£1639.00
Linn Kairn Preamp S/H (1Yr G/tee)	(1400.00)	£800.00	Naim NAC 82 Preamp S/H (1Yr G/tee)	(2360.00)	£1650.00
Linn Keilidh Spkrs Rosenut inc Stands	(985.00)	£729.00	Naim NAP 250 Power Amp S/H Old Style	(1350.00)	£949.00
Linn Kaber Passive S/H(1Yr G/tee)	(2000.00)	£795.00	Naim NAP 135 Power Amps S/H (1Yr G/tee)(3610.00)		£2690.00
Linn Isobarik Aktive Speakers (1Yr G/tee)	(3500.00)	£995.00	Naim SBL Passive Speakers S/H (1Yr G/tee)(2475.00)		£1595.00
Naim CD3 CD Player S/H (1Yr G/tee)	(949.00)	£550.00	Naim SNAXO 2/4 Crossover S/H (1Yr G/tee) (770.00)		£475.00
Naim NAC 72 Preamp E/D (1Yr G/tee)	(790.00)	£499.00	Nakamichi DR3 Cass/Deck S/H	(449.00)	£249.00
Naim NAP 140 Power Amp E/D (1Yr G/tee) (815.00)		£569.00	ProAc Tablette 50 Speakers	(599.00)	£350.00
Naim NAP 180 Power Amp S/H (1Yr G/tee) (1155.00)		£849.00	ProAc Response 2 Spkrs S/H (1Yr G/tee)	(1995.00)	£1250.00
Naim CDI CD Player S/H (1Yr G/tee)	(1650.00)	£929.00	Rotel RB991 Power Amp (2Yr G/tee)	(650.00)	£489.00
Naim NAC 92/90 Pre-Power S/H (1Yr G/tee) (978.00)		£675.00	Rotel RB981 Power Amp (2Yr G/tee)	(400.00)	£299.00

World classics

CASSETTE

NAKAMICHI DR-2

A great machine with Nakamichi's legendary heads. The lowest cost 'true' Nakamichi at the time, retailing for £600.

NAKAMICHI CR-7

The last of the great ones, and definitely the best Nakamichi ever (yes, better than a Dragon)

YAMAHA TC-800G

Early classic in serious cassette. Its ski-slope looks got it a cult following once it had ceased to be simply ugly.

CD PLAYERS

MERIDIAN 207

Beautifully-built two-box with pre-amp stage. Very musical although not as refined as modern Bitstream gear. No digital output.

PIONEER PD-91

Built-to-last player with easy upgrade routes for modifiers. Not knockout as it stands but get one cheap and have a go!

CAMBRIDGE CD1

The first two box player with weighted mechanics and even an optional Dropout/error counter. Radical and effective at the time - a classic.

AMPLIFIERS

LEAK POINT ONE, TLI2 & TLI10

Ancestors of hi-fi, consequently expensive nowadays. As with all vintage valve stuff, overhauling is de rigueur before use, using original parts if possible.

LEAK PRE-AMPS

Line of 'good for their time' pre-amps. Use of EF86 pentode valve for high gain rules out ultra performance. Not the highest-fi.



Garrard 401
A legendary turntable.

LEAK STEREO 20

Excellent workaday classic valve amp. In good order the 20 will not disgrace itself. Various upgrades are available from specialist repairers.

LEAK TLI2+

Plentiful monobloc equivalent of Stereo 20. Reasonably inexpensive and a tweakers' dream. Genuine valve hi-fi on a budget.

NAD 3020

You can't argue with success! NAD's budget transistor integrated gave thousands their first taste of hi-fi and remains great value.

QUAD 33/303 PRE/POWER

Great style and construction, also bullet proof. Warm and wooly sound, but easy going. A good introduction to early transistor audio classics.

QUAD 22/II PRE/POWER

One of the all-time classic valve amplifiers. Unusual circuit but it works beautifully. 22 pre-amp not up to today's standards.

SUGDEN A21

Seventies transistor integrated has an eminently likeable smoothness and musicality. Limited inputs via DIN sockets.

TECHNICS SE-A5 Mk2

Nice transformer and electronics, shame about the casework. With tweaking, this 150watter can sound sweet.

LOUDSPEAKERS

KLIPSCHORN

Not exactly plentiful or cheap but a splendid beast. For efficiency they have seldom been equalled. Space hungry!

LEAK SANDWICH

Rather warm sounding big infinite baffle but cheap with it. With a reasonably powerful amp can sound quite satisfying.

LOWTHER PM6A

High quality full-range driver; still manufactured. High sensitivity, as fitted to many classic horn designs.

MAGNEPLANAR SMGa

Touch dry in the bass but a technological loudspeaker with genuinely musical abilities.

MISSION 770

Father of the 77 range which continues to this day. Well mannered with a warm sound and a kind load to amplifiers.

QUAD ESL57

Unrivalled. Properly serviced there is nothing like them. Their natural presentation may make them caviar to the general.

YAMAHA NS1000M

Hi-tech favourites of the Japanese and Americans. Viewed more warily in the UK but can give excellent results.

TANNOY GRF & AUTOGRAPH

Folded horn monsters which certainly sound good if you have the space. For Tannoy vintage see HFW November 1998.

WHARFEDALE SUPER 8 RS DD

Ideal experimenters' driver. High sensitivity ~14,000 Gauss magnet and extended frequency range. Inexpensive too!

TANNOY YORK, LANCASTER

Many similar models of infinite baffle or reflex design. Not the last word in tautness but the drivers work well in modern cabinets.

VINYL

ACOS LUSTRE

Very honest piece of kit, well made and easily adjusted. Vinyl beginners could do very much worse.

ALPHASON HRI00S

First class arm, up to present-day standards. Buy carefully, though, as there's no service available now.

ARISTON RD11

A one-time king of turntables very similar to the Linn LP12. Now deposited but worth a look at the right price.

LINN AXIS

Uncomplicated, lower-price version of the famous Sondek. Less expensive than some of its stablemates.

GARRARD 301 & 401

Legendary turntables, once fairly plentiful. Excellent back-up available; many different custom plinths available. High quality.

GOLDRING LENCO 88 & 99

Great deck for the kitchen table enthusiast. Garrard fans won't look at 'em but cheap and capable. Servicing available.

HADCOCK 228

Recently out-classed by Hadcock's updated 228 Special Edition but a proper hi-fi arm for all that. Makers still service.

MICHELL FOCUS ONE

20 years and still going strong. Early runner in the 'modern' turntable cycle with a first class arm. Factory servicing available.

SHURE M75

Recent line-contact improvements have left the M75 behind but the wide range of needles make it a handy tool.

SME 3009 IIS

Everlasting classic tone-arm. Spares permanently available from SME. No longer the last word but peanuts second-hand.

THORENSTD124

Best classic deck ever? Judging by the prices they fetch it's possible - 78rpm too!

THORENSTD150

Mid-price deck with a keen following. No real difficulty with servicing - novices may find the suspension system unnerving.

TRIO L-07D

Knockout heavyweight from 1980 with stainless bearing and 11lb platter! Not a give-away and beware! - spares scarce.

TUNERS

LEAK TROUGHLINE (ORIGINAL)

Interesting ornament but no longer hi-fi. Limited coverage of 88MHz to 100MHz only.

LEAK TROUGHLINE II & III MONO

Arguably the best-sounding tuners ever. Adaptation for stereo easy via phono multiplex socket.

LEAK TROUGHLINE III STEREO

Excellent tuner with indifferent stereo decoding circuit. Best when adapted to use modern outboard decoder.

MARANTZ ST-8

Possibly the ultimate Tardis console, including an oscilloscope for checking the strength of signal. Expensive even now.



Trichord Research

Tel: +44 (0)1684 573524
Fax: +44 (0)1684 577380

Convert your CD player to a high performance transport with our Digital Output Board
Genesis Mk3 CD Player, Digital Turntable CD Transport, Pulsar Series One DAC with HDCD
High performance 75 ohm Digital Interconnect suitable for CD and DVD Transports
Upgrade your CD player with Clock 3 and dedicated Power Supply
Mains Conditioners, Cables and Accessories

Visit our Web Site @
www.trichordresearch.com





A selection of our ever changing offers for sale (all fully guaranteed)

Equivalent New Price Sale Price

A selection of our ever changing offers for sale (all fully guaranteed)

Equivalent New Price Sale Price

AMPLIFIERS		
Audio Research LS-8 Valve Pre. MINT / Boxed / Manual	1450.00	895.00
Metaxus Charisma Pre. (M.M./M.C. Phono-Stage) MINT/Boxed (Sounds Superb)	1600.00	695.00
Rega Hal Pre. / 4 x Exon Power-Amps. (Phono / Remote) (250 Watts Per Channel Bi-Amp) MINT / Boxed / All Cables (May Split)	3390.00	1795.00
Counterpoint SA-1 Valve Pre-Amp / Phono-Stage (Dual-Mono) VGC (Bargain)	1000.00	+ 299.95
Golden Tube SL-50 Remote Int. Valve Amp. MINT / Boxed / Manual	1100.00	695.00
Krell K5A-50 Class A Power-Amp. VGC	2500.00	+ 850.00
Audio Innovations Series 800 Anniversary Power Amp. MINT / Boxed	1500.00	695.00
Naim NAC-92 / NAP 90.3 Pre. / Power (M.M. J-Boards) MINT / Boxed	975.00	695.00
Naim Hi-Cap (Inc. Snaic 5) (New-Style) MINT / Boxed	720.00	450.00
Linn LK-1 Pre. + Dirak Power Supply. (M.M. / M.C. Phono-Stage) VGC / Boxed / Manuals	N/A	275.00
Linn Pretek Pre. (M.M. / M.C. Phono-Stage) VGC	400.00	179.95
Croft Vitale Valve Pre-Amp. (M.M. Phono-Stage) The NEW Pre-amp. (Superb at this price) Available to Special Order Only (Selling Very Well And Delivery Times Now Approx. 10-Days) NEW Standard		350.00
*Deluxe (Timber Fascia / Brass Control Knobs) (Matching "Musica" Power Amp. Now Available: Please Phone For Details)		400.00 *
Moth Series 30 Active Pre. / Power-Amp. (2 x 30 Watts) MINT / Boxed (Black Ash Version)	600.00	269.95
Quad 77 Pre / 77 Power / Remote Control Station. (2 Sets in Stock) MINT	1750.00	899.00
Quad 33 Pre-Amp. VGC / Boxed / Manual	N/A	79.95
Quad 405 I Power-Amp. VGC / Boxed	N/A	189.95
Audiolab 8000A Int. Amp. MINT / Boxed / Manual	500.00	329.95
Meridian 101B (M.M. Boards) (Black) MINT (Rare Black Version)	N/A	149.95
NAD 106 Pre / 906 Power (Six Channel Power-Amp) GC	880.00	399.95
Musical Fidelity XA-200 Mono-Blocs (2 x 200 Watts) MINT / Boxed (Black-Gate Upgraded) VGC / Boxed	1200.00	695.00
Musical Fidelity "The PreAmp" (Balanced-Out Etc.) MINT / Manual	280.00	129.95
Musical Fidelity B-1 (2 x 40 Watts Int.) VGC	300.00	119.95
Rotel RB-990 BX Power-Amp. (2 x 200 Watts) VGC / Manual	600.00	329.95
AMC 3050A (2 x 45 Watts / Full Remote Etc.) MINT / Boxed Etc.	300.00	+ 119.95
NAD 3020i (2 x 25 Watts Int. / Phono-Stage) MINT / Boxed	180.00	99.95
Pioneer A-300 X Int. MINT / As New	230.00	119.95
Creek CAS 4040 Int. MINT / Boxed	180.00	99.95

DIGITAL		
Teac P-500 / D-500 (Transport & DAC) VGC	1200.00	549.95
Meridian 602 Transport / 606 D.A.C. (MSR Remote Control Station.) MINT / Boxed / Manuals	3100.00	1195.00
Meridian 203 D.A.C. (Bitstream) VGC	500.00	129.95
Rotel RCC-955 (5-Disc Multi-Player / HDCD) (2 in Stock) MINT / Boxed	525.00	249.95
Technics SL-PS 840 (Remote Etc.) MINT	420.00	229.95
Technics SL-PS 490 (Remote Etc.) MINT / As New / Boxed	100.00	79.95
Q.E.D. Digit / PS.U. (Digital to Analogue Converter) VGC	150.00	59.95
AMC CD-9 (Remote) MINT / Manuals / Digital Out	250.00	99.95
Audio Alchemy Data-Stream Transceiver (Powered C.D. Connection) AS NEW	200.00	99.95
Arcam Alpha GC / Digital Out Etc. / No Remote	350.00	129.95
Arcam CD-67 II Original SE (Remote / Digital Out) VGC	350.00	169.95
Soundstream (Krell) DAC-1 18-Bit DAC NEW / Unused	400.00	249.95
DPA Little Bit (DAC) Digital To Analogue Converter MINT	520.00	189.95
Harman Kardon HD-7500 (Remote) VGC	350.00	99.95
Sony CDP-XE 900E (Remote) MINT / AS NEW	300.00	139.95
NAD Monitor 5000 (Digital Out) VGC	310.00	99.95
Musical Fidelity X-24K 24-Bit DAC MINT	300.00	179.95
Pioneer PD-91 Reference MINT / Boxed / Manuals	1000.00	449.95

VINYL		
Linn Sondek LP-12 (Afrosmosia) Valhalla / Alphason HR-1005 / Goldring Electro II Boron M.C. MINT	1500.00 +	595.00
Linn Axis / Basic Plus / Ortofon MC-1 Turbo M.C. MINT / Boxed / Manual	600.00	329.95
Garrard 401 (Motor-Unit) VGC	N/A	175.00
ADC 1600 Direct-Drive / Ortofon VM5-20E Cartridge VGC	300.00	99.95
Musical Fidelity XL-P2 (Mono-Bloc Phono-Stage / X-PSU) NEW and Superb (M.M. / M.C.) (Switchable Impedance) (Ex-Display)	NEW	379.90
Audio Alchemy Vac-In-The-Box. M.M. / M.C. Phono-Stage / Power-Station-One PS.U. VGC	250.00	119.95
Monacor SPR (M.M. Phono-Stage) NEW / Excellent Value	N/A	29.95

Lots of Vinyl in Stock and always WANTED. Record-Cleaning Service Available. Your Records Cleaned to Perfection on Moth Machine For £1.00 Each Including New Inner-Sleeve. (Maximum 10 at a time please) - Turntables / Tonearms / Cartridges (M.M. / M.C.) "Urgently" Required... Also any "interesting" Vinyl Accessories. Clamps, Protractors, Stylus Scales, Cleaning Devices etc

affordable-audio will happily "build" Systems to your individual requirements, and if you purchase three or more components, i.e. (C.D. Player, Amplifier, & Loudspeakers), we will give you a 15% Discount on the total price! Please enquire for further details.

MISCELLANEOUS		
Sony DVP-5715 Remote DVD Player (Multi-Region) MINT / Manuals	500.00	269.95
Sony DVP-8725D Remote DVD Player (Multi-Region) MINT / Boxed / Manuals	600.00	289.95
Kenwood SS-3300 Remote Pro-Logic Processor (Centre / Rear Amps) MINT/Boxed	250.00	89.95
Mordaunt Short Decoder One (Dolby Pro-Logic Decoder) MINT / Boxed Etc:	400.00	79.95
Kef Q-75C Uni-Q Centre Speaker MINT	200.00	129.95
Mission 77C Centre Speaker MINT / Unused	200.00	149.95
Technics SB-LV500 Rear-Surrounds MINT	200.00	139.95
Musical Fidelity X-PSU Power-Supply Upgrade For X-Series MINT	140.00	90.00
Pearl Coolers (8 x EL-34 Valve Coolers / Dampers) MINT	64.00	40.00
Target B-4 Gloss Silver Stand (Glass Shelves) NEW Slight Second	230.00	189.95
Target B-4 Gloss Silver Stand (Glass Shelves) NEW Slight Second	243.80	199.95
Target TT-2 (2-Shelf Spiked Stand) VGC (4 In Stock) Each	N/A	40.00
Target TT-2.5 (4-Shelf Spiked Stand) (Same As TT-2 Above But With Two Additional Half-Shelves For Naim / Cyrus Etc.) VGC	N/A	N/A
Target TT-1 Wall-Support Shelf (For Turntables Etc.) VGC	N/A	N/A
Sound Organisation 5-Shelf / Glass MINT	180.00	119.95
Foundation Heavy 24" Spiked Stands VGC	N/A	49.95
Target R-1 (4-Column Heavy Stands) MINT	280.00	189.95
Target H5-60 Piano-Black Spiked L.S. Stands NEW	105.80	89.95
Target HM-50 Spiked L.S. Stands NEW	90.30	79.95
Target SP-60 Spiked Stands MINT	60.00	35.00
Target 24" Spiked Stands (Electric Orange) MINT	90.00	50.00
Stands For LS-35a, Kans or Pro-Ac Tablettes Etc: GC	N/A	40.00
Monacor SPS-35 Spike Kit (Gold or Anodised Black Finish) 'speaker Spikes NEW (Per 4)	9.95	9.95
Monacor SPS-45 Spike Kit (Small) Loudspeaker Spikes (Per 4)	NEW	7.95
Monacor SPS-65 Spike Kit (Large) Loudspeaker Spikes NEW (Per 4)	NEW	9.95
Roni LSS 2 (2-Way Speaker Switch-Box)	NEW	18.95
Roni 4 m.m. Banana Plugs (Gold Plated) (Screw-Type, No Soldering) Per Four	NEW	6.95
Roni Optical Line Cables (C.D / Minidisc to D.A.C. Etc.)	NEW	10.00
Audio Source Twin-axial Digital Incon. 0.7 Metre / MINT	45.00	25.00
XLO/VDO Digital Incon. 4 Metres / MINT / Boxed	70.00	39.95
Monacor 75 Ohm. Digital Incon. NEW	N/A	8.95
Nexera Gold 5-Pin DIN To 4 Phono NEW	N/A	9.95
Monacor SPS-20 Anodised Adjustable Polished Cone Equipment Supports (Superb Spike System at a very good price) (Black Anodised Or Gold Finish) Set of 4	NEW	19.95
XLR Cannon Line-Sockets (Gold-Plated) High-Grade XLR NEW	Only	5.95 Each
discwasher CD Radial Cleaner VGC / Boxed	N/A	12.00
Parastatic Disc Preener VGC	N/A	5.00
John Michell Engineering "Sweep-Arm" MINT	N/A	20.00
Monacor Power Concept Incons (0.8M. / 1.5M)	NEW	9.00
Excellent Value Interconnects NEW Only 7.95 0.8M. or 10.95 1.5M. (Blue And Black)	NEW Only	3.50
Van den Hul CS-122 L.S. Cable 2 x 2 Metres Terminated	NEW Only	1.25
affordable-audio Bi-Wire L.S. Cable (In Brown or White)	NEW Only	1.25
79-Strand L.S. Cable (Black-Round-Section or White-Flat-Section)	NEW Only	1.25
Monacor DC-100 Carbon-Fibre Brush NEW (Essential)	NEW	5.95
Various Plugs (RCA / DIN / Cannon Etc.) Various NEW / 5/H P.O.A.		

PRODUCT OF THE MONTH
Star Product
Audio Research LS-8 Vacuum-Tube Pre-Amplifier.
In MINT Condition With Boxes And Manuals /
Recent New Valves
Latest Retail Price £1,450.00 - affordable-audio price £895.00
Please Contact Paul For A Genuine Bargain...

TUNERS		
Quad 77 FM (Bus) VGC	700.00	375.00
Quad FM-3 Stereo Tuner VGC / Boxed / Manual	N/A	99.95
Revox A-76 FM VGC / Boxed / Manuals	N/A	179.95
Sugden DT-48 FM (Digital Display / Pre-Sets) Fair Condition	N/A	149.95
Sony STS-117 FM Digital Tuner MINT / Manuals	140.00	79.95
Q.E.D. T-231 VGC	N/A	49.95
Luxman T-88 V VGC	N/A	85.00

RECORDING EQUIPMENT		
Pioneer CTS-5505 (Dolby S Etc.) MINT / Manual		250.00
Denon DRM 550. (HX-PRO Etc.) MINT / AS NEW	160.00	89.95
Denon DR-171 (Variable-Output / Mic. Inputs) GC	N/A	50.00
Nakamichi RX-202E (Auto-Reverse Mechanism Etc.) VGC	N/A	369.95
Marantz SD-53 (HX-Pro Etc.) MINT	200.00	99.95
Aiwa ADF-640 (3-Head / 2-Motor Etc.) MINT		300.00
Sharp MDMS-200 (Portable Mini-Disc Recorder / Headphones / Power Supply) MINT / Manuals	300.00	129.95

LOUDSPEAKERS		
Quad ESL-63 Electrostatics (Afrosmosia / Brown Cloth) Circa '83 MINT / Manuals		3450.00
Kelly KT-3 (95dB / Bi-Wire Etc.) MINT (Cash Sale)	1300.00	600.00
DynAudio Contour 1.1 (Cherry) MINT / Boxed / Manuals	880.00	549.95
Audio Note ANE / D. (94dB / 150 Watts / Bi-Wire Etc.) Rosewood L.S. And Stands VGC / Boxed	1769.00	850.00
Audio Note ANK / D. (92dB / 100 Watts / Bi-Wire VGC / Boxed	620.00	329.95
Meridian M-3 Active Monitors (Black 101B Pre Available, Please See Amplifier Section) MINT / Long-Lead Kit / Stands	1000.00 +	329.95
Rega Ela Floorstanders VGC	300.00	179.95
Ref Strata II 60 Watts Active Sub. (2 In Stock) VGC / Manuals (Each)	600.00	329.95
B&W DM-603 Floorstanders VGC / Manuals	550.00	299.95
Spendor BC-1 BBC Monitors GC / Original Trolley Stands	N/A	189.95
System 959 Reference Monitors (Cherrywood) MINT	1500.00	750.00
Kef Q-55 Floorstanders MINT / Boxed	500.00	349.95
Arcadyis ASC Stand-Mount MINT	400.00	229.95
Royd Minstral / Bases MINT (Rosewood)	300.00	159.95
Mission 752 Freedom (Silk-Dome Tweeters Etc.) VGC	650.00	349.95
Mission 730 Floorstanders GC / Cabinet Marks	N/A	179.95
Mission 780 Minis (Bi-Wirable) (Black) GC	250.00	109.95
Linn Kaber (Black) GC / Boxed	2000.00	575.00
Mordaunt Short Festival III MINT	350.00	119.95

Lots of Loudspeaker Cables in Stock, both New & Used

PLEASE VISIT OUR WEB-SITE (UPDATED DAILY)
WWW.affordable-audio.CO.UK
E-MAIL: Sales@affordable-audio.CO.UK

***** GOOD HIFI SEPARATES WANTED *****
 Phone anytime with your wants, stock changing daily. All equipment is sold with warranties.
Don't forget we can offer mail order.
All major credit cards accepted.
 We welcome part-exchange on any of the above.
 Affordable Audio is always keen to buy, (or part-exchange) Good quality Hi-Fi separates in good condition. Especially top British manufacturers products!



We can also sell your equipment for you on a commission basis.
(Lowest rates/best return)
(Please phone Paul for details!)

www.hi-fiworld.co.uk

hi-fi

WORLD

& computer audio

WELCOME TO OUR MARKET PLACE

Here are a wide variety of specialist hi-fi products and services.
Keep an eye open for regular advertisers, who know the market and serve
their customers in a friendly and reliable manner.

Apex Acoustics

Audio Consultants

	WAS	NOW
Cyrus DAD 3Q 24 bit CD Player	900.00	585.00
Cyrus Hark Rack 5 Shelf	500.00	275.00
Micromega Data/DialogueCD/Transport	3750.00	1850.00
Sony 777 ES SACD Player	1700.00	1350.00
Cyrus 7 Integrated Amp	700.00	450.00
Manley Stringray Valve Integrated 50watt	1895.00	1725.00
Manley Purist PreAmp Valve	1645.00	1115.00
Conrad Johnson PV10A Pre & MV55 Power	3290.00	1550.00
Roksan L2.5 Pre S1.5 Power DS1.5 PSU Silver	3835.00	1550.00
Sonus Faber Concertinos Walnut	599.00	399.00
Monitor Audio Studio 12's Cherry	1500.00	450.00
Einstein Octopus 8 Way Mains Blocks		
Ex Demo Black	199.00	149.00
Chrome	229.00	179.00
BCD Mains Cables 1m Ex Dem	99.00	75.00
Ecosse Reference MA2 Interconnects		
Maestro 1m Ex Dem	155.00	125.00
Ecosse Reference MS2.3S/Cable		
Factory Terminated Ex Dem 2x3m	165.00	130.00

More stock available Phone for details

NEW EQUIPMENT FROM:

BLUEROOM, EINSTEIN, ECOSSE, FUTUREGLASS,
MANLEY LABS USA, VERITAS, VDH.

Phone Steve Mosedale 01527 450500

Fax 01527 450320

E-Mail Apexsnm@aol.com

VINTAGE VALVE AUDIO & CLASSIC HI-FI

for sale at the next

National Vintage Communications Fair

HALL 11 • NEC • BIRMINGHAM

Sunday 29th April 2001

10.30am - 4pm • Admission £5*

*includes FREE NVCF 2001 Fair Guide (while stocks last)

— Early Entry from c.8.30am @ £15 —

BARS • RESTAURANTS • GREAT DAY OUT!

VINTAGE VALVE AMPLIFIERS

PRE-AMPS • TUNERS • LOUDSPEAKERS

RECORD DECKS • RECORDS (78s to CDs)

GRAMOPHONES • HI-FI BOOKS & MAGS

VALVES • COMPONENTS & SPARES

VINTAGE RADIOS • TRANSISTORS

EARLY TVs • TELEPHONES etc. etc.

plus all MECHANICAL and ELECTRICAL

ANTIQUES & COLLECTABLES

Stalls from £45 • Bookings/Details: (01392) 411565

NVCF, Spice House, 13 Belmont Road, Exeter, Devon EX1 2HF

web <http://www.angelfire.com/tx/sunpress/index.html>



Choice hi-fi you choose

Choice hi-fi make it easy for you to fulfill your sonic dreams. Quality hi-fi is not just about expensive brandnames. It's about aspiring to the very best sound, about choosing your ideal system from the widest selection in the country, in a unique no-pressure environment.

your choice

- Acoustic Energy
- Advantage
- Alon
- ATC
- Audible Illusions
- Audio Physics
- B.A.T
- Boulder
- Bryston
- Cary
- C.A.T.
- Chord
- Clear Audio
- Denon
- DNM
- Dynavector
- Eggleston Works
- Electrograph Delphi
- Genelec
- Gryphon
- Graham
- Helios
- J M Lab
- John Shearn
- Krell
- Lexicon
- Loewe
- Mark Levinson
- Mitchell Eng.
- Musical Fidelity
- NEC
- Nordost
- Oracle
- Plinius
- P.M.C.
- Primare
- Quadraspire
- Seleco
- REL
- Rockport
- Roksan
- Ruark
- Shahinian
- SME
- Straight Wire
- Sugden
- Tara Labs
- Teac
- Thule
- Totem
- Transfiguration
- Trichord
- Trilogy
- Van den Hul
- VPI
- Wilson Audio
- Wilson Research
- YBA

H I - F I

HOME
CINEMA

MULTIROOM
INSTALL

RESELL

New this month

POWER AMPLIFIER

	Our Price	Original Retail Price
Naim Nap 250	£795.00	£ -
Cary SLA 70 mk II	£1,450.00	£2,250.00
YBA 2 Alpha amp (DT, HC)	£2,295.00	£3,050.00
Audio Refinement Complete Amp	£695.00	£895.00
Audio Research VT200	£7,795.00	£9,998.00
Audio Research Ref 600 mk II	£29,995.00	£ -
Tag Maclaren F3-601 int.	£495.00	£800.00
YBA Passion Monoblocks	£On Dem	£8,995.00

PRE AMPLIFIER

BAT VK3i	£995.00	£1,795.00
Mark Levinson 3805	£3,995.00	£6,495.00
Naim Hi Cap	£350.00	£ -
Cary SLP 50	£795.00	£1,195.00
YBA Pre 1 Alpha & psu mm/mc	£On Dem	£4,900.00

SPEAKERS

B & W Nautilus 804	£1,995.00	£2,500.00
B & W CDM 1 se + Stnds	£495.00	£700.00
JM Lab Electra 905	£On Dem	£1,195.00
Avalon Ascents	£6,995.00	£12,000.00

CD PLAYERS & DACS

Thule Spirit CD 150B	£On Dem	£899.95
Audio Refinement CD Complete	£650.00	£875.00
Wadia 860	£5,495.00	£8,500.00
Teac P30	£1,995.00	£2,500.00

TURNABLES, ANALOGUE, VARIOUS

Voyd Reference/ IO Limited/psu/ reference psu/ step up	£12,999.00	£25,000.00
Plinius 14 Phono	£1,995.00	£2,750.00
Transparent Audio Music Wave Ultra Plus XL Bi-Wire	£2,100.00	£3,200.00
Cary PH301 MM/MC	£995.00	£1,695.00
Koetsu Red K Sig	£1,295	£2,000.00
Michell Orbe	£1,395	£2,000.00
SMEV Gold (Silver wired)	£1595.00	£2,500.00

AV COMPONENTS/TV/Plasma

Harmon Kardon AVPI	£250.00	£ -
Pioneer CLD 2850 Lazerdisc	£250.00	£ -
Thule PR250B DTS/ Dolby	£On Dem	£1,549.95
Thule PA250B 5 Channel Amp	£On Dem	£1,549.95

Pre amplifiers

YBA Passion Pre + mc	£On Dem	£5,595.00
Boulder 2010 Pre	£p.o.a.	£25,000.00
Conrad Johnson PV10 al	£795.00	£1,100.00
Plinius 16L	£2,800.00	£3,200.00
Krell KSL pre	£1,295.00	£ -
Audible Illusions LI	£1,795.00	£2,000.00
C.A.T. ultimate reference Pre Amp Int/ Phono Stage	£5,195.00	£5,750.00
Tube Tech Seer Pre Amp	£650.00	£935.00
Audible Illusions P3A Pre MM/MC	£On Dem	£3,140.00
Audio Research LS9	£1,995.00	£2,500.00
Electrocompaniet EC 4.5 (new)	£895.00	£1,195.00
Exposure VII	£295.00	£600.00
Exposure XI pre XII psu	£795.00	£1,500.00
Jeff Rowland Consumate + phono (3box)	£3,750.00	£8,000.00
John Shearn Phase 6 Pre	£695.00	£900.00
Mark Levinson No 28	£2,250.00	£4,000.00
Meridian 541 Dolby Surround	£650.00	£1,095.00
Naim 42.5	£195.00	£450.00

Quality speakers

JM Lab Micro Utopia	£On Dem	£3,300.00
JM Lab Mini Utopia	£On Dem	£4,500.00
JM Lab Mezzo Utopia	£On Dem	£7,300.00
B & W Nautilus 801	£6,995.00	£8,500.00
Sonus Faber Guarneri + Stand	£3,895.00	£5,500.00
JM Lab Electra 915.1	X-Demo	£1,895.00
Audio Physics Tempo III	£On Dem	£2,000.00
Jamo Concert 8 Anniversary Piano Black	£1,395.00	£1,850.00
Cadence Arca	£6,995.00	£10,000.00
Naim SBL's	£1,695.00	£2,225.00
BC Acoustics Tibre	£795.00	£1,100.00
ClaraVox Magnifica	£9,500.00	£14,500.00
B & W CD M7	£695.00	£1,000.00
BC Acoustics Araxe	£895.00	£1,195.00
Ensemble Speakers PA1	£995.00	£2,000.00
Acoustic Energy AE1 P BK + Stnd	£795.00	£1,500.00
Acoustic Energy AE120	£350.00	£500.00
Alon Adriana (new)	Special	£10,000.00
Alon V MK III	Special	£5,500.00
Audio Physics Caldera	£On Dem	£10,000.00
Audio Physics Libra	X-Demo	£4,799.00
Audio Physics Rhea Sub	£2,350.00	£3,099.00
Audio Physics Spark	£On Dem	£1,749.00
Audio Physics Steps	£On Dem	£999.00
Audio Physics Virgo	X-Demo	£3,295.00
Electrocompaniet Qube	£895.00	£1,400.00
Jamo SW3105 active sub	£495.00	£800.00
Orelle Swings	£795.00	£1,200.00
Rogers ABI Sub (new)	£450.00	£598.00
Rogers LS3/ 5A Black (new)	£575.00	£798.00
Rogers LS55 (new)	£330.00	£430.00
Wilson Cubs	£4,995.00	£6,000.00
Wilson System 5.1	£8,500.00	£18,000.00

Power amplifiers

YBA Passion Stereo	£On Dem	£5,995.00
Krell FPB 300c	£8,500.00	£10,000.00
Krell FPB 200c	£7,500.00	£8,500.00
Sunfire 300 Power Amp	£1,795.00	£2,400.00
Sugden Master Class	£1,995.00	£3,000.00
Plinius 50s	£On Dem	£3,000.00
Krell FPB 250M Monoblocks	£7,990.00	£10,796.00
Krell FPB 200	£4,750.00	£7,000.00
Musical Fidelity XA50 Monos	£350.00	£500.00
Plinius 250 mk IV	£Dem	£6,000.00
Audio Note Kasi	£14,950.00	£30,000.00
Cary 805c	£on-Dem	£8,250
Lavardin Model IS Integrated	£1,495.00	£2,200.00
Boulder 500 AE	£3,495.00	£5,500.00
John Shearn Ref 5 Mono blocks (as new)	£1,395.00	£1,700.00
Audio Note Neiro (as new)	£7,995.00	£16,500.00
Audio Note Ongaku (new)	p.o.a.	£45,000.00
Audiolab 8000 S	£550.00	£800.00
Burmester 850 Monoblocks	£1,295.00	£3,000.00
Cary 300 se LX20 Monoblocks	£On Dem	£5,250.00
Cary 572 SE Monoblocks	£1,950.00	£2,350.00
Counterpoint SA12	£795.00	£1,400.00
Exposure IX Power supply	£795.00	£1,500.00
Exposure VIII	£450.00	£700.00
Jadis Defy 7 MK III	£2,000.00	£4,790.00
John Shearn Reference Phase 2 Integ.	£575.00	£799.00
John Shearn Reference Phase 3 Power Amp	£550.00	£749.00
Kenwood L1000C pre/ L1000M Power Amp	£1,495.00	£2,500.00
Krell FPB 300	£6,500.00	£9,990.00
Krell FPB 600	£8,995.00	£12,900.00
Meracus Intrare 6 (int) X-Demo	£1,795.00	£2,000.00
Sugden AUS1	£995.00	£1,500.00
Pioneer A300 Int	£90.00	£180.00
Quad 77 Intergrated	£450.00	£900.00
YBA 3x Pre/PWR	£1,495.00	£2,400.00

CDplayers DACS

Boulder 2020 dac	£p.o.a.	£24,000.00
California Audio Lab Sigma II dac/Delta Transport	£1,495.00	£2,400.00
Meracus Tahto CD player	£1,195.00	£1,495.00
Cyrus Dac Master &	£450.00	£899.00
Cyrus Disc Master	£495.00	£899.00
Forsell Air Ref Transport MKII	£4,995.00	£8,000.00
Helios Model 3	£495.00	£700.00
Krell KAV 250 CD	£1,895.00	£2,599.00
Krell KAV 300 CD	£2,750.00	£4,290.00
Krell KPS 255c	£18,995.00	£23,498.00
Marantz CD14	£1,295.00	£1,600.00
Mark Levinson 30.5/31	£11,500.00	£24,000.00
Mark Levinson No.39	£4,250.00	£5,000.00
Meridian 565	£1,495.00	£2,500.00
Micromega CD 3.1	£95.00	£1,995.00
Musical Fidelity X-ACT	£95.00	£130.00
Oracle CD 2000 Transport	£p.o.a.	£7,299.00
Pink Triangle Da Capo	£795.00	£1,595.00
Teac P500	£395.00	£600.00
Theta Data II Transport AT + link	£1,995.00	£4,000.00
YBA CD Integre	£On Dem	£1,095.00

AV components

Denon AVC A1D AV Processor/ Amplifier	£1,195.00	£2,000.00
---------------------------------------	-----------	-----------

TELEVISIONS & DVD PLAYERS BY LOEWE

Loewe DVD	£On Dem	£495.00
Loewe Aconda	-	POA
Loewe Planus	-	POA
Loewe Xelos	-	POA

PLASMAS

From NEC	-	POA
From Electrograph Delphi	-	POA

Turntables & analogue

TURNABLES/ ANALOGUE/ VARIOUS

Nackamichi DR 3	£225.00	£400.00
Ortofon MC7500 Cart. (new)	£1,395.00	£2,000.00
Nakamichi 202E	£295.00	£600.00
Tom Evans - The Groove	£On Dem	£1,500.00
Clear Audio Reference Mc phono stage X-demo	£1,695.00	£2,065.00
Rega Planer 3 + Hi Fi News Out Board Power Supply	£320.00	£423.00
Roksan 10 Turntable with Artimix Tone ARM (black)	£1,995.00	£3,200.00
Clear Audio Symphono phono stage X-demo MM/MC	£640.00	£740.00
Clear Audio Evolution + ARM	£995.00	£1,475.00
Helios Cylene Tonearm/ ANS 6 Wire	£895.00	£ -
Lavardin Reference Phono	£ -	£2,500.00
Michell Syncro RB300	£450.00	£ -
Musical Fidelity XLP2	£395.00	£495.00
Oracle MK V Turntable	£p.o.a.	£4,199.00
Pink Triangle PT Too Ref Bearing/platter/ clamp	£395.00	£950.00

Clearance items

Micromega Tempo 2 Integrated	£395.00	£900.00
Pink Triangle Ordinal 1307	£395.00	£900.00

tel: 020 8392 1959 & 020 8392 1963
fax: 020 8392 1994 info@choice-hifi.com

Open from 10am to 8pm by appointment.
All previously cherished items, second hand or as new are guaranteed
We accept all major credit cards. Finance available subject to status

www.**audio-shed**.com

Probably the UK's best on-line hi-fi shopping centre

Free phone

Free advice

Free delivery

Free install

Free thinking

Some things in black & white do make sense

Free yourself

0800 169 7079

S/hand and ex-demo clearance items - April '01

CD Players & DAC'S	Was	Now
Audio Note DAC 3 Signature Ex -Demo	2850	1495
Densen Beat 400 CD player HDCD S/H	1280	899
Kenwood 9010X Clock 3 moded Transport S/H	N/A	249
Mark Levinson 31.5 Transport S/H	9500	5999
Mark Levinson 39 CD Player (9 months old) S/H	4999	3999
Monrio 18B2 DAC Ex-Demo	950	399
Rega Jupiter Transport/I/O DAC Ex-Demo	975	750
Resolution Audio D92 24/96 Dac/Processor Ex-Demo	1500	949
Resolution Audio VT960 DVD Transport Ex-Demo	3500	1899
Roksan DP2T Transport S/H	1295	599
Roksan DA2 DAC S/H	599	299
Roksan DS5 PSU S/H	579	399
Theta Digital Pearl Transport S/H	1349	899
Theta Digital Progeny DAC S/H	1099	649
Theta Digital Pro Prime II DAC S/H	1699	599

Turntables Tonearms & Cartridges	Was	Now
Basis 1400/RB250 (New & Boxed)	1200	899
Basis 2000/RB300 (New & Boxed)	2000	1599
Benz Micro Ruby (New & Boxed)	1500	799
Dais Turntable Motor Unit Only S/H	N/A	199
Heybrook TT2 Belt Drive Turntable S/H	N/A	99
Lehmann Black Cube Phono Stage (New & Boxed)	399	299
Linn Sondek LP12/Black/Rega RB200/Goldring1020 S/H	N/A	379
Linn Sondek LP12/Afro/Lingo/Ekos S/H	3000	1099
Mantra Manticore Reference/Musician/Eroica) S/H	2100	695
Nottingham Analogue Paragon 1 Linear Tracker Tonearm S/H	1600	349
Naim Flat Cap PSU S/H	370	250
Rega RB250 Orgin Live Modification S/H	300	159
Roksan Arterxerxes MK1 Phono Stage S/H	495	195
Roksan DS 5 Attesa PSU Ex-Demo	549	399
Roksan Radius 3 Turntable (98) Ex-Demo	470	250
Roksan Xerxes Piano Lacquer XPS 1 (SME Cut) S/H	1295	399
Trio K500/SME 3009/E77 S/H	N/A	150

Preamplifiers	Was	Now
Audio Research LS9 Remote Solid State (Ex-Demo)	1999	1399
Densen DM20 Preamplifier Ex-Demo	1380	899
DPA Enlightenment New Style Ex-Demo	799	449
Graaf GM13.5 II Valve Preamplifier Ex-demo	4000	2999
Michell ArgoHR/Hera S/H	N/A	475
Naim Audio 32 MM/MC Preamplifier S/H	N/A	99
Quad 33 Preamplifier S/H	N/A	45

Amplifiers	Was	Now
Audio Analogue Puccini SE S/H	635	449
Audio Note P1SE Ltd Edition (Silver Wired) S/H	1600	849
Audio Note P2SE Valve Power Amplifier S/H	1499	795
Audiolab 8000S Integrated S/H	900	499
Audion Sterling Integrated Line Ex-Demo	799	399
Bartolomeo Transperenza ST140 Power Amplifier S/H	1500	695
Bow Technologies Wazoo XL S/H	2499	1895
Graaf 50/50 Push Pull Power amplifier (New&Boxed)	2100	1695
Graaf GM100 (New&Boxed)	4450	3299
Graaf GM20 OTL S/H	2950	1995
Quad II Anniversary Mono Valve Power Amplifiers Ex-Demo	6000	1999
Rega Big Brio Amplifier Ex-Demo	298	199
Rega Maia Power Amplifier Ex-Demo	475	349
Sugden SP30 Class A Stereo Power Amplifier S/H	950	599

Loudspeakers	Was	Now
Audio Note AN-K/SP Light Ash Loudspeakers Ex-Demo	1070	629
Audio Note AN-Z Two Floor standers (Black) Ex-Demo	549	395

Midland Audio X-change is looking for good used British & American Hi-fi

cash paid call John Roberts on 01562 822236

Loudspeakers (Con't)	Was	Now
B&W CDM1SE Cherry Loudspeakers S/H	599	399
Diapason Karis Walnut 2 Way Monitor (New&Boxed)	1250	950
Indigo Centre Ex-Demo	199	129
JM Lab Colbalt 807 Cherry Ex-Demo	595	425
JM Lab Colbalt 815 Dark Cherry Ex-Demo	950	749
Martin Logan SL3 Hybrid Electrostatics S/H	3400	2495
Royd Sourceror Walnut S/H	650	379
ProAc Tablette 2000 Light Oak Ex-Demo	695	450
VelodyneTX810MK2 Subwoofer S/H	695	379
Yamaha NS1000M Black S/H	1200	595

Cables & Accessories	Was	Now
Air Sus Cherry Platform Ex-Demo	169	99
Audio Research BL1 Balanced Converter S/H	888	399
Audio Sculpture 2m RCA Interconnect Ex-Demo	380	149
Bow Technologies Wand Remote S/H	349	199
Deskadel 1M Interconnects WBT/RCA S/H	300	150
Einstein Octopus 8 Way Mains Block (Ex-Demo)	199	149
G- Flex isolators (New & Boxed)	199	75
Lindsey Audiophile 2m Satin RCA Interconnect New	495	199
Madrigal HPC 2m Balanced Interconnect Ex-Demo	310	149
MIT MH750 2X21ft Speaker Cable S/H	N/A	699
Nordost Red Dawn 1M Balanced Ex-Demo	330	199
Shakti On Lines (New&Boxed)	85	45
Shakti Stones (New&Boxed)	195	120
Slate Audio Stands 21" S/H	489	199
Tara Labs Master RSC Gen II 3m Balanced S/H	1250	499
Target 5 Tier Silver Stand MDF Shelves Ex-Demo	249	145
Vdh Skytrack 2X4M Bi-wire Speaker Cable S/H	75	39

Tuners & Tape Decks	Was	Now
Fanfare FT-1 FM Tuner S/H	1399	599
Cymbol C DAB Digital Tuner (Ex-Demo)	1000	750
Magnum Dynalab FT101 Analogue Tuner (New&Boxed)	850	679
Rega Radio R Tuner (Ex-Demo)	350	249
Roksan Caspian Tuner AM/FM (Ex-Demo)	599	399
Yamaha CT7000 Silver Tuner S/H	N/A	399

Suppliers and installers of High Quality Audio Systems

- 47 Laboratory : Graff
- Accuphase : Gryphon
- Audio Note : Lavardin
- Audio Research : Mark Levinson
- Avid : Martin Logan
- Basis : Michell
- Cabasse : Nagra
- Cardas : Primare
- Clearaudio : ProAc
- Conrad Johnston : Rega
- Copland : Resolution Audio
- Dcs : Sonus Faber
- DNM / Reson : Spectral
- Einstein : SPM
- Electrocompaniet : Sugden
- Final : UKD
- Finite Elemente :

www.midlandaudiox-change.co.uk

call John Roberts Tel / Fax 01562 822236

181 Franche Rd • Kidderminster • Worcs • DY11 5AD

e-mail sales@midlandaudiox-change.co.uk

Mobile 07721 605966

Grandjix

Sound & Vision

71 HIGH STREET, NEW MALDEN
SURREY, KT3 4BT

TEL: 020 8336 0012
FAX: 020 8336 2703

TEL: + 44 (0) 20 8336 0012
FAX: + 44 (0) 20 8336 2703

WORLDWIDE MAIL ORDER

14 DAY HOME TRIAL - EXCHANGE SYSTEM • FULL DEMONSTRATION FACILITIES •
0.0% INTEREST FREE CREDIT (subject to status) • PART EXCHANGE WELCOME • MON TO SAT

CLEARANCE BARGAINS

		WAS	NOW			WAS	NOW
ACOUSTIC ENERGY AEGIS 2	XD	£250	£179	NAKAMICHI CR-4E	SH	LOTS	£229
ACOUSTIC ENERGY AEGIS 3	XD	£350	£250	MARANTZ CD6000	XD	£250	£179
ARCAM ALPHA 7 SE CD	NEW	£300	£249	MARANTZ CD6000 KI	XD	£500	£399
AUDIO ANALOGUE BELLINI	XD	£495	£389	MARANTZ CD6000 OSE	XD	£300	£225
AUDIO ANALOGUE DONIZETTI	XD	£595	£395	MARANTZ DR6000 CDR	XD	£500	£379
AVI NUNEUTRON	XD	£499	£389	MARANTZ PM6010 OSE	XD	£230	£169
AVI BIGGATRON	XD	£600	£469	MARANTZ PM6010 OSE K.I.SIG	XD	£400	£299
AVI S2000 MC 24-BIT CD	XD	£995	£695	MARANTZ SR5000	XD	£500	£349
ALR JORDAN NO 4	NEW	£1200	£719	MONRIO ASTY CD	XD	£700	£495
ALR JORDAN TAKE 2	NEW	£1700	£995	MUSICAL TECHNOLOGY OSPREY	SH	£250	£125
ANTHEM INT2 AMP	XD	£1800	£995	MUSICAL TECHNOLOGY PM15	XD	£475	£229
ATC SCM10 YEW	XD	£1240	£849	MYRYAD CAMEO SYSTEM	XD	£1500	£995
AUDIO ANALOGUE PAGANINI	XD	£750	£599	NAD C520 CD PLAYER	XD	£170	£129
AUDIO ANALOGUE PAGANINI CD	XD	£750	£569	PROJECT 1.2	XD	£200	£149
AUDIO ANALOGUE PUCCINI R	XD	£575	£459	ROTEL RA-931 MK2	XD	£189	£139
B+W P4	SH	£675	£399	ROTEL RA-972	XD	£450	£349
CASTLE HOWARD S2 MAHOGANY	XD	£1299	£799	ROTEL RB 971 MK2 PWR	XD	£250	£179
CASTLE SEVERN 2 SE	XD	£699	£499	ROTEL RC971	XD	£175	£129
CHARIO ACADEMY ONE	XD	£1450	£799	ROTEL RC1070	XD	£350	£259
CHARIO ACADEMY TWO	XD	£1700	£919	ROTEL RCD951	SH	£375	£269
CHARIO ACADEMY THREE	XD	£8500	£3995	ROTEL RCD991	XD	£825	£599
CREEK OBH-11	XD	£129	£89	SONIC FRONTIERS TRANSPORT 3	XD	£7000	£4500
CRIMSON 610c PRE	SH	£450	£250	SONNETEER ALABASTER	XD	£900	£599
CRIMSON 620c PWR	SH	£450	£250	SONNETEER CAMPION	XD	£600	£399
CRIMSON 630c MONOBLOCKS (PAIR)	SH	£850	£450	SONUS FABER CONCERTO W	XD	£945	£729
DIAPHASON ADEMANTES III INC STANDS	XD	£2450	£1795	TANNOY MX2	NEW	£150	£99
ELECTROCOMPANIET ECI-3	XD	£999	£749	TANNOY MX3	NEW	£230	£149
HARMAN KARDON AVR200	XD	£400	£249	TANNOY REV R1	NEW	£199	£129
JBL XT120 (BEECH)	XD	£400	£299	TANNOY REV R2	NEW	£400	£265
JBL XT140 (BEECH)	XD	£500	£379	TANNOY REV R3	NEW	£550	£399
KEF Q35	SH	£350	£125	TANNOY CANTERBURY 15HE	XD	£8500	£4995
KENWOOD DPF3030-S	XD	£180	£129	TEAC AV H500	XD	£380	£249
KENWOOD KAF303R-S	XD	£250	£175	TEAC REFERENCE 300	XD	£599	£449
LINN CLASSIK 2	XD	£995	£749	TEAC REFERENCE 500	XD	£799	£599
LINN GENKI CD	XD	£995	£749	TEAC V8030S TAPE	XD	£650	£489
LINN KEILIDH (BLACK)	XD	£750	£579	TEAC V6030S TAPE	XD	£550	£399
LINN KOLEKTOR PRE	XD	£495	£375	TEAC P30 TRANSPORT	XD	£2500	£1729
LINN LK 85 PWR	XD	£495	£375	TEAC VRDS 10	SH	£799	£299
LINN PEKIN TUNER	XD	£545	£429	UKD SIMPLY TWO	SH	£1000	£599

EX = EX DISPLAY, SH = SECOND HAND, NEW = BRAND NEW BOXED

MASSIVE CABLE CLEARANCE NOW ON ... **UP TO 50% OFF** CABLETALK, AUDIOQUEST, IXOS, QED, VAN DEN HUL, NORDOST, SONICLINK AND MORE.
CALL FOR DETAILS

ATC SCA2 PRE + ATC SPA2-150 PWR AMP C/W
REMOTE CONTROL, EX DISPLAY
NEW £6519 CLEARING AT £4560

AGENCIES INCLUDE: ACOUSTIC ENERGY • AUDIO ANALOGUE • AVI • ATC • ANTHEM • APOLLO • ATACAMA • AUDIOQUEST • ALPHASON • BEYER • CASTLE • CABLETALK • CREEK • COPLAND • CYMBAL • CHARIO • DIAPHASON • EPOS • ELECTROCOMPANIET • GRADIENT • HARBETH • HARMON KARDON • HEYBROOK • IXOS • INFINITY • JBL • JAMO • JM LAB • KRELL • LINN • LOEWE • MARANTZ • MICROMEGA • MICHELL • MUSICAL TECHNOLOGY • MYRYAD • MONRIO • NAD • NORDOST • OPTIMUM • ORTOFON • OPERA • PIONEER • PANASONIC • PRECIOUS METALS • PROJECT • QED • ROTEL • REDGUM • RESTEK • SME • SHURE • SONY • SONUS FABER • SENNHEISER • STANDS UNIQUE • SOUND ORGANISATION • SONICLINK • SONIC FRONTIERS • STAX • SOUNDSTYLE • SONNETEER • SUGDEN • TANNOY INC PRESTIGE • TDL • TEAC • TECHNICS • TOTEM • TOWNSEND • UNISON RESEARCH • VAN DEN HUL • VIENNA ACOUSTICS • YBA AND MORE

WE REGRET WE ARE UNABLE TO MAILORDER MARANTZ AND LINN PRODUCTS

WILLIAMS HART ELECTRONICS

HART ELECTRONIC KITS TRADED FOR OVER 30 YEARS



NEW LAYOUT

80Watt Mosfet Stereo Power Amp Kit
110Watt Mosfet Monoblock Power Amp Kits

ONE OF THE BEST AMPLIFIERS YOU WILL HEAR! Regardless of price
ON DEMO @ Wigan, Southend, Peterborough and Burnley



Single Ended Class A Valve Sound
15Watt Power Amp modules

FOR THOSE WHO WANT THAT VALVE
MIDBAND BUT BASS AND TREBLE TO MATCH



ACTIVE R/Control SUBWOOFER MODULE £177.30



Range of speaker Kits
Passive and Active

TO CLEAR: WILMSLOW PRESTIGE SPEAKERS finished in dark oak £1699

Advertise your Hi-Fi on my website (£2.50 admin charge)
Also: Award Winning Phono Stage Kit, Active Crossover Modules, Speaker Drive Units,
M Cap Capacitors, Cadlock Resistors, Remote Control Volume and much more.

WEB SITE www.williamshart.com

e-mail: williamshart@classicfm.net

or Tel/Fax for catalogue 01942 253647 121 Long Lane, Hindley Green, Wigan, WN2 4XD

PERSONAL VISITORS SHOULD PHONE FIRST TO AVOID DISAPPOINTMENT

Run by former Technical Director of Wilmslow Audio



MANTRA AUDIO Specialist Suppliers of Audio Accessories www.mantra-audio.co.uk

CARTRIDGE SELECTION STYLUS

Goldring	1006	£65	£46 EX	£46
	1012 GX	£84	£62 EX	£62
	1022 GX	£112	£77 EX	£77
	1042	£130	£93 EX	£93
	Eroica LX/H	£121	£84 EX	
	Elite	£232	£163 EX	

EX - Exchange price for a Goldring
Any make/model of cartridge accepted

Audio Technica

AT 95 E	£23		£15
AT 110 E	£28		£16
AT OC 9 ML	£315	£237 EX	

Denon

DL 110	£79	£62 EX	
DL 304	£210	£179 EX	

Grado

Prestige Black	£46		£25
Prestige Gold	£140		£78

Ortofon

510 Mk II	£34		£19
MC 15 Super II	£130	£110 EX	
MC 25 FL	£227	£193 EX	
MC 10 Supreme	£304	£258 EX	
MC 20 Supreme	£382	£323 EX	
MC 30 Supreme	£452	£385 EX	
Rohmann	£837	£742 EX	

Shure

SC 35 C	£35		£27
V 15 V XMR	£285		£190

REPLACEMENT STYLUS

Swiss Quality Oiamond Styli		
ADC XLM Mk III		£15.00
Akai AN 5, AN 80		£11.00
AN2, AN 70		£13.00
Dual DN 145 E, DN 165 E		£15.00
Goldring G800 Super E		£15.00
JVC DT 55, DT 60		£11.00
National EPS 24 CS, P 30 D, P 33 D		£11.00
Ortofon FF 15 E II, VMS 20 E II, OM 20		£15.00
Pioneer PN 210, PN 220, PN 240		£11.00
Shure N 75 C, SC 35 C,		£11.00
N 75 ED T2, N 75 EJ T2		£13.00
N 95 ED, N 95 EJ, N 75 3 (78)		£15.00
VN 35 E		£18.00
N 95 HE, N 97 HE, VN 35 HE		£25
Sony ND 142 G, ND 150 G, ND 155 G		£11.00
CN234		£13.00

*** OVER 500 STYLUS TYPES STOCKED ***

Order direct from our
Secure Online Catalogue

HEADPHONE SELECTION

GRADO		
Prestige Series	SR-60	£77
	SR-80	£93
	SR-125	£139
	SR-225	£186
	SR-325	£279
Reference Series	RS-1	£609
	RS-2 (new)	£439

ALL CARTRIDGES SUPPLIED BY MANTRA AUDIO ARE GUARANTEED
AUTHENTIC NEWLY BOXED ORIGINALS AND CARRY A FULL
DISTRIBUTORS AND MANUFACTURER'S WARRANTY
EX - designates factory exchange price against any Audio Technica, Denon,
Goldring or Ortofon moving coil cartridge

MAIL ORDER (1-10 DAYS) PRICES (INC P&P) + INSURANCE FOR UK DELIVERY -£5 FOR EUROPE DELIVERY & £10 FOR
USA/WORLDWIDE DELIVERY TO COVER INSURANCE ON ORDERS OVER £50 VALUE



Tel/Fax (01757) 288652 e-mail: enquiry@mantra-audio.co.uk



MANTRA AUDIO (HFW), 22 GARTH AVENUE, NORTH OUFFIELD, SELBY, NORTH YORKS YO8 5RP



Vacuum Tubes for Audio Are Back!

Glass Audio brings together
yesterday's tube with today's
improved components, voltage control,
and the exciting new Soviet tubes,
to make smooth sound in your
livingroom possible again!

YES!

Please send my first issue of *Glass Audio*. I'll pay just \$45.00 for six issues (1 year); \$80.00 for 12 issues (2 years) of the best information on tubes to be found anywhere. I understand that my satisfaction is guaranteed!

Name _____

Street & Number _____

City _____ Postal Code _____

Country _____ REMIT IN US \$ DRAWN ON A US BANK ONLY. PRICE GOOD THROUGH DECEMBER 31, 1995.

We Accept MC/VISA.

Glass Audio

PO Box 176, Dept. HFWS, Peterborough, NH 03458-0176 USA
Phone: (603) 924-9464 or FAX 24 hours a day (603) 924-9467

WILLIAMS HART ELECTRONICS

HART ELECTRONIC KITS TRADED FOR OVER 30 YEARS



NEW LAYOUT

80Watt Mosfet Stereo Power Amp Kit
110Watt Mosfet Monoblock Power Amp Kits

ONE OF THE BEST AMPLIFIERS YOU WILL HEAR! Regardless of price
ON DEMO @ Wigan, Southend, Peterborough and Burnley



Single Ended Class A Valve Sound

15Watt Power Amp modules

FOR THOSE WHO WANT THAT VALVE
MIDBAND BUT BASS AND TREBLE TO MATCH

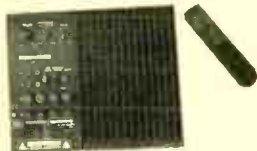

ACTIVE R/C Control SUBWOOFER MODULE £177.30



Range of speaker Kits
Passive and Active

TO CLEAR: WILMSLOW PRESTIGE SPEAKERS finished in dark oak £1699

Advertise your Hi-Fi on my website (£2.50 admin charge)
Also: Award Winning Phono Stages Kit, Vintage Transistor Mixers, Speaker Drive Units,
M Can Capacitors, Caddock Resistors, Remote Control Volume and much more

WEB SITE www.williamshart.com e-mail: williamshart@classicfm.net

or Tel/Fax for catalogue 01942 253647 121 Long Lane, Hindley Green, Wigan, WN2 4XD

PERSONAL VISITORS SHOULD PHONE FIRST TO AVOID DISAPPOINTMENT

Run by former Technical Director of Wilmslow Audio



MANTRA AUDIO

Specialist Suppliers of Audio Accessories
www.mantra-audio.co.uk

CARTRIDGE SELECTION STYLUS

Goldring				
1006	£65	£46 EX	£46	
1012 GX	£84	£62 EX	£62	
1022 GX	£112	£77 EX	£77	
1042	£130	£93 EX	£93	
Eroica LX/H	£121	£84 EX		
Elite	£232	£163 EX		

EX - Exchange price for a Goldring
Any make/model of cartridge accepted

Audio Technica			
AT 95 E	£23		£15
AT 110 E	£28		£16
AT OC 9 ML	£315	£237 EX	

Denon			
DL 110	£79	£62 EX	
DL 304	£210	£179 EX	

Grado			
Prestige Black	£46		£25
Prestige Gold	£140		£78

Ortofon			
510 Mk II	£34		£19
MC 15 Super II	£130	£110 EX	
MC 25 FL	£227	£193 EX	
MC 10 Supreme	£304	£258 EX	
MC 20 Supreme	£382	£323 EX	
MC 30 Supreme	£452	£385 EX	
Rohmann	£837	£742 EX	

Shure			
SC 35 C	£35		£27
V 15 V XMR	£285		£190

REPLACEMENT STYLUS

Swiss Quality Diamond Stylus		
ADC	XL/M Mk I	£15.00
Akar	AN 5, AN 60	£11.00
	AN2, AN 70	£13.00
Dual	DN 145 E, DN 165 E	£15.00
Goldring	G800 Super E	£15.00
JVC	DT 55, DT 60	£11.00
National	EPS 24 CS, P 30 D, P 33 D	£11.00
Ortofon	FF 15 E II, VMS 20 E II, UM 20	£15.00
Pioneer	PN 210, PN 220, PN 240	£11.00
Shure	N 75 C, SC 35 C,	£11.00
	N 75 ED T2, N 75 EJ T2	£13.00
	N 95 ED, N 95 EJ, N 75 3 (78)	£15.00
	VN 35 E	£18.00
	N 95 HE, N 97 HE, VN 35 HE	£25
Sony	ND 142 G, ND 150 G, ND 155 G	£11.00
	CN234	£13.00

*** OVER 500 STYLUS TYPES STOCKED ***

**Order direct from our
Secure Online Catalogue**

HEADPHONE SELECTION

GRADO		
Prestige Series	SR-60	£77
	SR-80	£93
	SR-125	£139
	SR-225	£186
	SR-325	£279
Reference Series	RS-1	£609
	RS-2 (new)	£439

ALL CARTRIDGES SUPPLIED BY MANTRA AUDIO ARE GUARANTEED
AUTHENTIC NEWLY BOXED ORIGINALS AND CARRY A FULL
DISTRIBUTORS AND MANUFACTURER'S WARRANTY
FX - designates factory exchange price against any Audio Technica, Denon,
Goldring or Ortofon moving coil cartridge

MAIL ORDER (1-10 DAYS) PRICES (INC P&P)* INSURANCE FOR UK DELIVERY -£5 FOR EUROPE DELIVERY & £10 FOR
US/WORLWIDE DELIVERY TO COVER INSURANCE ON ORDERS OVER £50 VALUE

Tel/Fax (01757) 288652 e-mail: enquiry@mantra-audio.co.uk
MANTRA AUDIO (HFV), 22 GARTH AVENUE, NORTH DUFFIELD, SELBY, NORTH YORKS YO8 5RP



Vacuum Tubes for Audio Are Back!

Glass Audio brings together
yesterday's tube with today's
improved components, voltage control,
and the exciting new Soviet tubes,
to make smooth sound in your
livingroom possible again!

YES!

Please send my first issue of *Glass Audio*. I'll pay just \$45.00 for six issues
(1 year); \$80.00 for 12 issues (2 years) of the best information on tubes to be found
anywhere. I understand that my satisfaction is guaranteed!

Name _____

Street & Number _____

City _____ Postal Code _____

Country _____

REMIT IN US \$ DRAWN ON A US BANK ONLY. PRICE GOOD THROUGH DECEMBER 31, 1995.

We Accept MC/VISA.

Glass Audio

PO Box 176, Dept. HFWS, Peterborough, NH 03458-0176 USA
Phone: (603) 924-9464 or FAX 24 hours a day (603) 924-9467

Granddix

Sound & Vision

71 HIGH STREET, NEW MALDEN
SURREY, KT3 4BT

TEL: 020 8336 0012
FAX: 020 8336 2703

TEL: + 44 (0) 20 8336 0012
FAX: + 44 (0) 20 8336 2703

WORLDWIDE MAIL ORDER

14 DAY HOME TRIAL - EXCHANGE SYSTEM • FULL DEMONSTRATION FACILITIES •
0.0% INTEREST FREE CREDIT (subject to status) • PART EXCHANGE WELCOME • MON TO SAT

CLEARANCE BARGAINS

		WAS	NOW			WAS	NOW
ACOUSTIC ENERGY AEGIS 2	XD	£250	£179	NAKAMICHI CR-4E	SH	LOTS	£229
ACOUSTIC ENERGY AEGIS 3	XD	£350	£250	MARANTZ CD6000	XD	£250	£179
ARCAM ALPHA 7 SE CD	NEW	£300	£249	MARANTZ CD6000 KI	XD	£500	£399
AUDIO ANALOGUE BELLINI	XD	£495	£389	MARANTZ CD6000 OSE	XD	£300	£225
AUDIO ANALOGUE DONIZETTI	XD	£595	£395	MARANTZ DR6000 CDR	XD	£500	£379
AVI NUNEUTRON	XD	£499	£389	MARANTZ PM6010 OSE	XD	£230	£169
AVI BIGGATRON	XD	£600	£469	MARANTZ PM6010 OSE K.I.SIG	XD	£400	£299
AVI S2000 MC 24-BIT CD	XD	£995	£695	MARANTZ SR5000	XD	£500	£349
ALR JORDAN NO 4	NEW	£1200	£719	MONRIO ASTY CD	XD	£700	£495
ALR JORDAN TAKE 2	NEW	£1700	£995	MUSICAL TECHNOLOGY OSPREY	SH	£250	£125
ANTHEM INT2 AMP	XD	£1800	£995	MUSICAL TECHNOLOGY PM15	XD	£475	£229
ATC SCM10 YEW	XD	£1240	£849	MYRYAD CAMEO SYSTEM	XD	£1500	£995
AUDIO ANALOGUE PAGANINI	XD	£750	£599	NAD C520 CD PLAYER	XD	£170	£129
AUDIO ANALOGUE PAGANINI CD	XD	£750	£569	PROJECT 1.2	XD	£200	£149
AUDIO ANALOGUE PUCCINI R	XD	£575	£459	ROTEL RA-931 MK2	XD	£189	£139
B+W P4	SH	£675	£399	ROTEL RA-972	XD	£450	£349
CASTLE HOWARD S2 MAHOGANY	XD	£1299	£799	ROTEL RB 971 MK2 PWR	XD	£250	£179
CASTLE SEVERN 2 SE	XD	£699	£499	ROTEL RC971	XD	£175	£129
CHARIO ACADEMY ONE	XD	£1450	£799	ROTEL RC1070	XD	£350	£259
CHARIO ACADEMY TWO	XD	£1700	£919	ROTEL RCD951	SH	£375	£269
CHARIO ACADEMY THREE	XD	£8500	£3995	ROTEL RCD991	XD	£825	£599
CREEK OBH-11	XD	£129	£89	SONIC FRONTIERS TRANSPORT 3	XD	£7000	£4500
CRIMSON 610c PRE	SH	£450	£250	SONNETEER ALABASTER	XD	£900	£599
CRIMSON 620c PWR	SH	£450	£250	SONNETEER CHAMPION	XD	£600	£399
CRIMSON 630c MONOBLOCKS (PAIR)	SH	£850	£450	SONUS FABER CONCERTO W	XD	£945	£729
DIAPHASON ADEMANTES III INC STANDS	XD	£2450	£1795	TANNOY MX2	NEW	£150	£99
ELECTROCOMPANIE ECI-3	XD	£999	£749	TANNOY MX3	NEW	£230	£149
HARMAN KARDON AVR200	XD	£400	£249	TANNOY REV R1	NEW	£199	£129
JBL XT120 (BEECH)	XD	£400	£299	TANNOY REV R2	NEW	£400	£265
JBL XT140 (BEECH)	XD	£500	£379	TANNOY REV R3	NEW	£550	£399
KEF Q35	SH	£350	£125	TANNOY CANTERBURY 15HE	XD	£8500	£4995
KENWOOD DPF3030-S	XD	£180	£129	TEAC AV H500	XD	£380	£249
KENWOOD KAF303R-S	XD	£250	£175	TEAC REFERENCE 300	XD	£599	£449
LINN CLASSIK 2	XD	£995	£749	TEAC REFERENCE 500	XD	£799	£599
LINN GENKI CD	XD	£995	£749	TEAC V8030S TAPE	XD	£650	£489
LINN KEILIDH (BLACK)	XD	£750	£579	TEAC V6030S TAPE	XD	£550	£399
LINN KOLEKTOR PRE	XD	£495	£375	TEAC P30 TRANSPORT	XD	£2500	£1729
LINN LK 85 PWR	XD	£495	£375	TEAC VRDS 10	SH	£799	£299
LINN PEKIN TUNER	XD	£545	£429	UKD SIMPLY TWO	SH	£1000	£599

EX = EX DISPLAY, SH = SECOND HAND, NEW = BRAND NEW BOXED

MASSIVE CABLE CLEARANCE NOW ON ... UP TO 50%
OFF CABLETALK, AUDIOQUEST, IXOS, QED, VAN DEN
HUL, NORDOST, SONICLINK AND MORE.
CALL FOR DETAILS

ATC SCA2 PRE + ATC SPA2-150 PWR AMP C/W
REMOTE CONTROL, EX DISPLAY
NEW £6519 CLEARING AT £4560

AGENCIES INCLUDE: ACOUSTIC ENERGY • AUDIO ANALOGUE • AVI • ATC • ANTHEM • APOLLO • ATACAMA • AUDIOQUEST •
ALPHASON • BEYER • CASTLE • CABLETALK • CREEK • COPLAND • CYMBAL • CHARIO • DIAPHASON • EPOS •
ELECTROCOMPANIE • GRADIENT • HARBETH • HARMON KARDON • HEYBROOK • IXOS • INFINITY • JBL • JAMO • JM LAB •
KRELL • LINN • LOEWE • MARANTZ • MICROMEGA • MICHELL • MUSICAL TECHNOLOGY • MYRYAD • MONRIO • NAD • NORDOST •
OPTIMUM • ORTOFON • OPERA • PIONEER • PANASONIC • PRECIOUS METALS • PROJECT • QED • ROTEL • REDGUM • RESTEK •
SME • SHURE • SONY • SONUS FABER • SENNHEISER • STANDS UNIQUE • SOUND ORGANISATION • SONICLINK •
SONIC FRONTIERS • STAX • SOUNDSTYLE • SONNETEER • SUGDEN • TANNOY INC PRESTIGE • TDL • TEAC • TECHNICS • TOTEM •
TOWNSEND • UNISON RESEARCH • VAN DEN HUL • VIENNA ACOUSTICS • YBA AND MORE

WE REGRET WE ARE UNABLE TO MAILORDER MARANTZ AND LINN PRODUCTS

Special Offer 1



Rogers E-40a Improved Pure class 'A' valve amplifiers. Special IMPROVED version by Audio Note UK. You get the stunning sound quality of the original E-20a but with double the power output! Improvements include factory pre-set bias adjustment, gold plated input / output connectors and world renowned Audio Note sound quality.....

These very high quality, stylish integrated amps feature four line inputs plus a high quality phono stage. The E-40a Improved is suited to low, medium and high sensitivity loudspeakers, and of course it's the ideal amplifier for driving the LS3/5a and AB-1 combination.

Superb value: 40 watts per channel of top quality pure class 'A' amplification at a bargain price (the last list price was £ 1,898.00 !).
VERY RARE AND COLLECTABLE !

Brand new and supplied in sealed boxes, with 12 months warranty:

each: £ 1,088.00

Special Offer 2

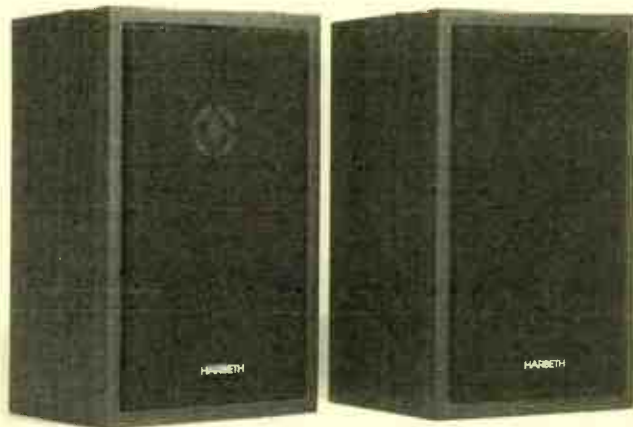

Harbeth LS3/5a special Rosewood Limited Edition Version (Alan Shaw signature).
Brand new and supplied in manufacturers sealed boxes with 12 months warranty

per pair: £ 688.00

Please note: These are the very rare and collectable final production run version of the LS3/5a loudspeaker, featuring gold tweeter mesh and lucky '8' suffix serial numbers, originally built for the demanding Far Eastern markets. Limited stocks, so don't miss out on this extra special offer.

Available exclusively from *Stirling Broadcast*.

Add a pair of AB-1 bass extenders in Rosewood for only £ 338.00

Special Offer 3 Amazing value package deal:

Rogers E-40a Improved with Harbeth LS3/5a Limited Edition Rosewood and AB-1 bass extenders in Rosewood (original price for this combination was £ 3,257.00 !)

Package price: £ 1,998.00

Stirling Broadcast Charter Alley, Basingstoke, Hants. RG26 5PX

Phone: 01256 851001 Fax: 01256 851144



Golden Dragon

Precision Audio Tubes

Please enquire for any tube not listed. We have an inventory of over 2,500 different types in stock.

Golden Dragon High Quality Pre-amplifier Tubes

12AT7A/E81CC/ECC81	£ 6.95
12AU7A/E82CC/ECC82	£ 6.95
12AX7A/E83CC/ECC83	£ 6.95
12BH7A	£ 9.95
6DJ8/E88CC/ECC88	£10.95
6SN7GT/ECC33	£ 8.95

KT66R	£69.95 pr
KT88R	£69.95 pr
6550WA	£67.95 pr

Golden Dragon Special Quality Pre-amplifier Tubes

E81CC-01	Gold Pins Low Microphony Low Noise	£10.50
E82CC-01	Gold Pins Low Microphony Low Noise	£10.50
E83CC-01	Gold Pins Low Microphony Low Noise	NEW £ 9.50
E88CC-01	Gold Pins Low Microphony Low Noise	£14.50

Golden Dragon Power Tubes

	Matched Pair	Matched Quad	Matched Octet
EL34 Super	£25.00	£50.00	£100.00
EL34M	£25.00	£50.00	£100.00
E84L (special quality EL84)	£12.50	£25.00	£50.00
EL156 Octal	£75.00	£150.00	£300.00
6L6WGB	£25.00	£50.00	£100.00
KT66	£25.95	£52.00	£104.00
KT66 Super	£65.00	£130.00	£300.00
KT88	£57.95	£116.00	£232.00
KT88 Special (Gold plated)	£67.95	£136.00	£272.00
KT90	£65.00	£130.00	£260.00
KT90LX	£75.00	£150.00	£300.00
350B	£29.95	£60.00	£120.00
6L6GC	£19.95	£40.00	£80.00
6550A	£42.95	£86.00	£172.00
6550A Special (Gold plated)	£64.95	£130.00	£260.00
50CA10	£84.95	£170.00	£340.00
807	£25.00	£50.00	£100.00

Golden Dragon Triodes

	Singles	Per matched pair	Per matched quad
2A3 4 pin	£22.50	£50.00	£100.00
2A3 Octal	£22.50	£50.00	£100.00
211	£28.50	£60.00	£120.00
811A	£11.50	£25.00	£50.00
845	£36.50	£75.00	£150.00
805	£36.50	£75.00	£150.00

Golden Dragon T300B Range

300B Super	£79.00	£160.00	£320.00
4.300B	£84.00	£170.00	£340.00
4.300B LX Super	£124.00	£250.00	£500.00

We have a vast range of tubes available from manufactures all over the world including rare and vintage types. an 80 page booklet of valves available is updated monthly and can be provided at a cost of £2.50 per copy U.K. £4.00/\$7.00 rest of world or you may telephone our Sales Desk for a prompt quotation.

Prices exclude VAT and Carriage. Please add carriage charge of £2.50 for UK orders and VAT at 17.5%

P.M. COMPONENTS LTD, Selectron House, Jenkins Dale Industrial Estate, Chatham, Kent. ME4 5RD

Tel 01634 848500. Fax 01634 848676, e-mail: 101650.2424@Compuserve.com

The Valve. Golden Dragon



Simply, The Best.

For more information contact:

PM Components Ltd, Selectron House, Jenkins Dale Industrial Estate,
Chatham, Kent. ME4 5RD

Tel 01634 848500, Fax 01634 848676, e-mail: 101650,2424@Compuserve.com

THE EMPORIUM

28 St Nicholas Street, Diss, Norfolk IP22 3LB

Tel/Fax: 01379 650744 email: emporium@dircon.co.uk www: www.emporium.dircon.co.uk

VALVE AMPS		COST PRICE		MUSICAL FIDELITY MASO class A monoblocks		CD & DACS		
ART AUDIO QUINTET stereo power amp	1500	700	NAD 114	270	450	ARCAM DELTA 170 transport	750	275
AUDIO INNOVATIONS 500 integrated with phono	1000	500	NAIM 140 new style	150	125	ARCAM 9 cd player	900	500
AUDIO INNOVATIONS 200 integrated	4200	2100	NAIM NAC 32	150	300	AUDIO ALCHEMY DIGITAL DRIVE 3 transport	700	325
AUDIO NOTE P4 monoblocks 18 watts	1500	750	NAIM SNAPE	each	350	AUDIO NOTE DAC ZERO valve dac 24 bit	5500	2800
AUDIO NOTE p2se power amp	1500	750	NAIM NAP 90 / NAP 90	each	350	AUDIO NOTE DAC 4.1s latest spec	5000	2800
AUDIO NOTE P2 phono preamp	1500	750	NAIM 32/110 old style	each	350	CAMBRIDGE DISCMAGIC II TRANSPORT	1000	100
AUDIO NOTE ZERO pre/monoblocks silver finish ex dem with full warranty	3500	1000	NAIM NAC125 75	each	400	COUNTERPOINT DA10 SE/11 top transport /dac combo	800	200
AUDIO RESEARCH SP14 pre	7250	1200	NAIM mc phono boards 40 pounds/pair suit 32, 42, 62, etc	each	400	DENON DCC1520 old heavy weight wrtg variable output	700	300
AUDIO SILVER NIGHTS	4000	1600	NAIM 160 power amp very old style	each	400	DPA bigger bit	5000	1750
AUDIOM GOLDEN NIGHTS	900	450	NAIM 250 very old style but rebuilt by Naim in 1998	each	400	KRELL DT10 krells best ever transport 3 years old	9000	2800
AUDIOM PREMIER line preamp	1500	750	NAKAMICHI 13 integrated amp	each	140	LUXMAN VALVE CD PLAYER	700	350
AUDIOM REFERENCE pre amp with phono, old but good	1500	750	PINK TRIANGLE PIP TWO PRE-AMP two box with dry cell psu serviced last year	each	2000+	MERIDIAN 206 DAC7 CD PLAYER	375	375
BEARD BBA100 line preamp	1000	500	QUAD 34/306 pre/power amp grey	each	606	MERIDIAN 203 dac	500	150
CONCORDANT EXHILIRANT line pre	1000	450	QUAD 44/405 MkII	each	350	NAKAMICHI DRAGON 7 WITH DRAGON DAC one of the sexiest ever cd players only 200 ever made	8500	3500
CONRAD JOHNSON PV10A pre with phono, boxed	2000	800	QUAD 33/303	each	150	PINK TRIANGLE CARDINAL CD TRANSPORT boxed	1000	200
CONRAD JOHNSON PREMIER 11A power amp 70 watts per channel 6 months old mtnt, upgraded op valves, boxed	3750	2500	QUAD 522 power amp	each	150	QUAD 66 cd player	300	350
CONRAD JOHNSON PV5 PREAMP with phono	2000	800	QUAD 77 pre carbon with system remote mint boxed	each	1100	QED DIGIT dac	50	50
COUNTERPOINT SA100 100 watt valve/mosfet hybrid excellent sound	2000	700	SONUS FABER musica	each	1600	REGA Jupiterio CD TRANSPORT/DAC	1050	650
EDISON pre/power	375	375	SUGDEN P28 POWER 100 WATTS 200	each	1800			
GAMMA ERA REFERENCE preamp with phono	3500	1500	TECHNICS SU-C2000SE-A2000 PRE POWER, 200 watts	each	1800			
GAMMA RHYTHM REFERENCE	3000	1000	THRESHOLD SL10 and CAS 2 pre/power	each	1900			
GOLDEN TUBE AUDIO SE 40	600	300	TOCA 22 class A power amp	each	500			
HBC "BEASTIE" 211 single ended amp	1500	750						
HBC "black beastie" NOW AVAILABLE	1650	825						
LUXMAN CL 33/MSQ 3600 valve pre/power	3000	1500						
MELOS 222 two box pre with phono	3000	1500						
MELOS 333 line preamp two box	3000	1500						
MORE FIDELITY 3008 single ended stereo power amp	2200	1100						
ORANGE PREAMP	1000	500						
SONIC FRONTIERS SFM 160 MONOBLOCKS	5500	2500						
SONIC FRONTIERS SF5 40 POWVER AMP	2000	800						
TRILOCY 948 Stereo power amp	3500	1500						
VAC AVATAR new, remote controlled	1500	600						
VTL MONOBLOCKS 1500 600								
TRANSISTOR AMPS		COST PRICE		MUSICAL FIDELITY MASO class A monoblocks		CD & DACS		
ALBARRY AP4(mms)S 508 PRE/POWER	850	450	NAD 114	270	450	ARCAM DELTA 170 transport	750	275
ARCAM DELTA 290 amp remote	500	250	NAIM 140 new style	150	125	ARCAM 9 cd player	900	500
ARCAM ALPHA 109 3 channel power amp	2350	1150	NAIM NAC 32	150	300	AUDIO ALCHEMY DIGITAL DRIVE 3 transport	700	325
AVI S2000MPS2000MM pre & monoblocks 150 watts	1100	550	NAIM SNAPE	each	350	AUDIO NOTE DAC ZERO valve dac 24 bit	5500	2800
AVI INTEGRATED	1000	500	NAIM NAP 90 / NAP 90	each	350	AUDIO NOTE DAC 4.1s latest spec	5000	2800
AUDIOLAB 8000CP pre/power grey colour	1300	650	NAIM 32/110 old style	each	350	CAMBRIDGE DISCMAGIC II TRANSPORT	1000	100
AUDIOLAB 8000C pre nice late black	1000	500	NAIM mc phono boards 40 pounds/pair suit 32, 42, 62, etc	each	400	COUNTERPOINT DA10 SE/11 top transport /dac combo	800	200
Bose 1801 250W	25000	10000	NAIM 160 power amp very old style	each	400	DENON DCC1520 old heavy weight wrtg variable output	700	300
CELLO PALETTE MIV multi input version with Master psu	2350	1175	NAIM 250 very old style but rebuilt by Naim in 1998	each	400	DPA bigger bit	5000	1750
CHORD SPH800	2350	1175	NAKAMICHI 13 integrated amp	each	140	KRELL DT10 krells best ever transport 3 years old	9000	2800
CYRUS 3	100	50	PINK TRIANGLE PIP TWO PRE-AMP two box with dry cell psu serviced last year	each	2000+	LUXMAN VALVE CD PLAYER	700	350
CYRUS ONE	100	50	QUAD 34/306 pre/power amp grey	each	606	MERIDIAN 206 DAC7 CD PLAYER	375	375
DNMP 2 pre with 3 boards and upgraded by audiocomp with oscons etc	450	225	QUAD 44/405 MkII	each	350	MERIDIAN 203 dac	500	150
EPA DSP2005 pre amp	1000	500	QUAD 33/303	each	150	NAKAMICHI DRAGON 7 WITH DRAGON DAC one of the sexiest ever cd players only 200 ever made	8500	3500
Electrocompaniet pre/power original 25W class A	500	250	QUAD 522 power amp	each	150	PINK TRIANGLE CARDINAL CD TRANSPORT boxed	1000	200
ELECTROCOMPANET ECP1 phono stage mm/mc	1000	500	QUAD 77 pre carbon with system remote mint boxed	each	1100	QUAD 66 cd player	300	350
EXPOSURE X31 remote pre, boxed as new	1400	700	SONUS FABER musica	each	1600	QED DIGIT dac	50	50
HEYBROOK C3/P3 Pre/Power with Tiak cases	100	50	SUGDEN P28 POWER 100 WATTS 200	each	1800	REGA Jupiterio CD TRANSPORT/DAC	1050	650
HITACHI HMA7500 power amp	100	50	TECHNICS SU-C2000SE-A2000 PRE POWER, 200 watts	each	1800			
KELVIN LABS class A integrated with phono stage nice	3200	2000	THRESHOLD SL10 and CAS 2 pre/power	each	1900			
LAVARDIN IT line integrated	5700	3500	TOCA 22 class A power amp	each	500			
LAVARDIN AP/PA pre/power 1 year old ex demo	2000	1000						
LFV LS1/PA1 some upgrades done	1000	500						
LINN LK1/LK280	800	400						
LINN MAJIK	1000	400						
LINX STRATOS 100watt monoblocks	1000	400						
MARK LEVINSON PH12 pre	3500	900						
MERIDIAN 10/1103 pre/power	1000	500						
MERIDIAN 551 integrated amp	1100	450						
MERIDIAN 541 PRECESSOR/PRE	1350	675						
MICHEL ARGO 100 line level pre	2000	1200						
MONARCHY 100se 100 watt monoblocks single ended class A boxed as new	300	150						
MOTH 60 WATT power amp wood mint boxed	775	387						
MUSICAL FIDELITY Dr Thomas	100	50						
MUSICAL FIDELITY SYNTHESIS	450	225						
MUSICAL FIDELITY PREAMP/TYPHOON/TYPHOON	150	75						
MUSICAL FIDELITY A1 classic class A amp	300	150						
MUSICAL FIDELITY A100 as above but with more power								

Are you making the right connections?

Send for Britain's biggest catalogue of specialist cable and connections. All available by mail order. Phone 020-8942 9124 or clip the coupon for your Free copy

CUSTOM CABLE SERVICE
PO Box 4007, London SW17 8XG

Please send me your FREE Custom Cable Catalogue

Name _____

Address _____

Postcode _____

NO FURTHER INFORMATION REQUIRED

Send to: Custom Cable Service
PO Box 4007
London SW17 8XG

HEW 04/01

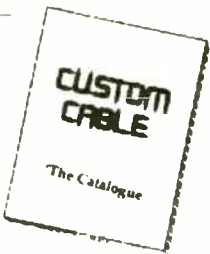

Sound Investment

If you have invested expertise and money in building up a sound system to your own unique specifications, then why compromise with indifferent housing units? Fi-Rax offers a new dimension in audio visual racking - from a range of standard designs to the flexibility to custom create a unit to suit your particular sound system and lifestyle.

- *High quality aluminium construction.
 - *Finishes available to your choice.
 - *Fully adjustable 6mm glass shelving.
 - *Sound isolation on shelving/feet.
 - *Custom created to suit your system.
 - *Free delivery throughout the UK.
- Fi-Rax - a sound investment for those who want the best from their equipment.

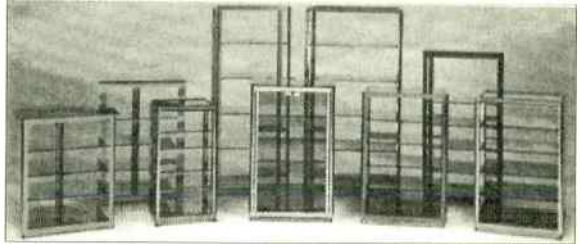

Audio Visual Furniture

For further information or a free brochure contact: JEM Distribution, Springfield Mills, Spa Street, Ossett Wakefield WF5 0HW. Tel: 01924 277626 Fax: 01924 270759

**PREVIOUSLY OWNED
AND EX DISPLAY
HI-FI EQUIPMENT**

36-38 Park Rd, Peterborough. PE1 2TG
Tel 01733 897697
www.sevenoakshifi-peterborough.co.uk

"MUSICAL FIDELITY M3 IN STOCK - GET ONE WHILE YOU CAN !"

PREVIOUSLY OWNED EQUIPMENT

Acoustic Energy AE120 (beech)	£ 349.00
Arcam Alpha 8 CD	£ 249.00
Audiolab 8000 A	£ 279.00
Audiolab 8000 LX	£ 279.00
Aura T-80 tuner (gloss black, £350)	£ 179.00
Cyrus III	£ 299.00
Denon TU 425 RDS tuner	£ 99.00
Kef Model 100C centre speaker	£ 199.00
Linn Axis /K9	£ 199.00
Manticore Mantra RB250	£ 299.00
Naim SBL (upgraded)	£ 999.00
Talk Electronics Storm 1 Int. amp (£500)	£ 299.00
Talk Electronics 4 System (pre/psu, monoblocs, £2650)	£1499.00
Yamaha DSPE492 add-on processor with 6ch input	£ 119.00

EX DISPLAY EQUIPMENT

AE1 II NEW!! Cherry or Rosemah	£ 699.95
AVi Nuneutron (cherry)	£ 399.00
Castle Pembroke (cherry, £500)	£ 399.00
Rotel RCD 951 CD player (£375)	£ 299.00
Rotel RCD 971 CD player (£475)	£ 399.00
Talk Electronics Cyclone 1 Int. amp (silver, £600)	£ 499.00
Talk Electronics Thunder 1 CD (silver, £600)	£ 499.00
Talk Electronics Thunder 3 CD (silver, £1000)	£ 849.00

All "previously owned" equipment comes with a minimum of 3 months warranty, and all "ex display" equipment comes with a minimum of 12 months warranty. These warranties cover parts and labour but not carriage costs.

IAN HARRISON HI-FI

TEL: 01283 702875

9am-9pm

INCLUDING SUNDAYS

HI-FI AT DISCOUNT PRICES. FREE NATIONWIDE DELIVERY

TRADE IN YOUR OLD MOVING COIL CARTRIDGE & SAVE UP TO 45% OFF THE RRP.

CARTRIDGES & STYLII	TOPEARMS	CASSETTE DECKS	COMPACT DISC
DENON SHURE AUDIO TECHNICA GOLDRING SUMIKO TRANSFIGURATION LONDON (DECCA)	ROKSAN SOUTHER GRAHAM MOTH CLEAR AUDIO	PIONEER TEAC SONY DENON YAMAHA MARANTZ TASCAM	PIONEER TEAC SONY DENON YAMAHA MARANTZ
	TURNTABLES	DAT	TUNERS
	ARCAM MICHELL CLEAR AUDIO	TASCAM SONY FOSTEX PANASONIC	SONY DENON PIONEER YAMAHA MARANTZ
	HIFI FURNITURE		DVD
	APOLLO SOUND STYLE PROJEKT SOUND ORGANISATION ALPASON	MINI DISC	SONY DENON
LOUDSPEAKERS		SONY DENON	AMPLIFIERS
HARBETH SONY ROYD	CABLES	CDR	DENON MARANTZ PIONEER SONY SONIC LINK & OTHERS
	ARGENTO AUDIO SONIC LINK AUDIOQUEST VAN DEN HUL GOLDRING OED ORTOFON NORDOST	REEL-REEL	
HEADPHONES		STUDER TASCAM	
SENNHEISER BEYER SONY AKG GRADO AUDIO- TECHNICA			*ALL GOODS ARE BRAND NEW & BOXED WITH FULL U.K. GUARANTEES. NO EX/DEM OR EX DISPLAY GOODS. NO GREY IMPORTS.
TEST CASSETTES	BLANK TAPES / DISCS	ACCESSORIES	
TEST CD'S TEST RECORD OPUS 3	TDK SONY MAXELL BASF	DISCWASHER MILTY OED GOLDRING TDK	MAXELL SONY ANTIFERRE MAXVIEW PIVOTELLI
*PHONE OR WRITE FOR DETAILS	AMPEX JVC SCOTCH FUJI		

PLEASE PHONE TO CONFIRM PRICE & AVAILABILITY PRIOR TO ORDERING. GOODS ARE NOT SUPPLIED ON APPROVAL. SORRY, NO GENERAL CATALOGUES. PLEASE PHONE OR WRITE FOR SPECIFIC REVIEWS, BROCHURES OR PRICES.

MAIL ORDER ONLY FROM: IAN HARRISON, 7 MILL HILL, REPTON, DERBY, DE65 6GO. TEL: 01283 702875. 9am - 9pm INCLUDING SUNDAYS.

WANTED

**HI-FI
& accessories
any make, any age**

BUY · SELL · TRADE

OPEN 7 DAYS 10am - 8pm

Please bring official ID with address & signature when selling or exchanging

MUSIC & VIDEO EXCHANGE

56 Notting Hill Gate, London W11

☎ 020 7792 3474

480 Fulham Rd (Broadway), London SW6

☎ 020 7385 5350

95 Berwick St, Soho, London W1

☎ 020 7434 2939

www.buy-sell-trade.co.uk

LARGE SELECTION ON SALE

ALSO BUY, SELL, TRADE MUSICAL & PHOTOGRAPHIC EQUIPMENT

Audio Synergy



LIMITED AVAILABILITY

The HeadMaster is a new headphone pre-amplifier manufactured by SUGDEN. Not only will it satisfy the demands of headphone users, it is also a high quality Class A pre-amplifier with three inputs, tape-out/pre-out and is fully relay switched. The case construction is solid aluminium plate, finished in superb black chrome.

Contact us now for further details
Audio Synergy Limited
Tel. 01924 406016
email audiosynergy@easynet.co.uk

NEWS FLASH! ERGO headphones now available in the UK. Made in Switzerland these headphones are simply the best. Prices start from £149.00 for the Model 1.

We are best known for our single-ended 300B power amplifiers and power supply upgrades for valve amplifiers, but did you know that we supply complete systems, new and used equipment, and components? We also provide support and servicing for Audio Innovations valve products. For full information visit www.borderpatrol.net or ring 01273 276716.

passion, grace & fire

www.borderpatrol.net

Selected products from:

BorderPatrol • Living Voice • SME • Audio Note • Cartridge Man • Goldring
Western Electric • Electrofluidics

BorderPatrol Brighton UK
Tel/Fax +44 (0)1273 276716
e-mail: bp@borderpatrol.net
www.borderpatrol.net



BorderPatrol

Sound Music

S Nakamichi CMS 5 System (XD) - £300 **S**
A Nakamichi Soundspace 5 (XD) - £375 **A**
L Nakamichi Soundspace 8 (XD) - £700 **L**
E Musical Fidelity XAS 100 (XD) - £650 **E**
E Musical Fidelity Explorer (XD) - £450 **E**
E Linn LK140 Power Amplifier (XD) - £545 **E**
E Linn LK100 Power Amplifier (SH) - £300 **E**
E Linn Keilidh Speakers (Black)(SH) - £325 **E**
E Proac Studio 150 Speakers(SH) - £700 **E**
E Roksan Kandy CD Player (XD) - £350 **E**
E Roksan Kandy Tuner (XD) - £275 **E**
E NAD Turntable (XD) - £150 **E**

Energy Encore A.V. Sub&Sat Speaker Set (XD) - £850
 Myryad Cameo System (Tuner/CD/Amp)(XD) - £1150
 Myryad MDP500 Pre-amplifier Processor (XD) - £1150
 Myryad T70 5 Channel Power Amplifier (XD) - £375
 Myryad MC100 CD Player (XD) - £550
 Castle Howard S2 Speakers (SH) - £650
 Loewe Planus + Base 32" Wide Screen 100 Hz - £1200
 Rega Planet CD Player (SH) - £250
 Musical Technology Kestrel Speakers (XD) - £350
 AVI Nu-Neutron Speakers (Cherry)(XD) - £350
 Teac 500 VRDS9 CD Player(XD) - £350
 John Shearne Phase 2 (XD) - £350
 Kof RDM 2 Speakers (XD) - £250

Sound Of Music, 93-95 Nantwich Rd
Crewe, Cheshire. CW2 6AW
Tel.:01270 214143 Fax:01270 254143

Orpheus Audio

**We are proud to introduce "Oxygen"
 a single-ended, pure class A triode power amplifier
 with volume control unbelievable at £595 new,
 "the closest approach to the original emotion"**

TURNTABLES	
Acoustic Solid The Solid One (40kg Brand New)	£1850
VPI TNT Junior & JMW Memorial 12" Arm & Lyra Lydian	£2900
Technics SL-1200 Ltd (Black & Gold)	£550
CD PLAYERS	
Heart (Holland) CD5000 Valve CD-Player (Brand New)	£299
Heart (Holland) CD6000 Valve CD-Player (Brand New)	£449
Meridian 203 DAC	£100
Kinshaw Overture DAC	£70
PRE AMPLIFIERS	
Michell Argo with Hera power supply	£300
QED Reference (Upgraded)	£200
POWER AMPLIFIERS	
Alchemist Forsetti APD20AM MKII	£800
Oxygen (single-ended, Class A Triode) Brand New	£650
Cabasse AM1000 Monoblocks	£1000
Conrad-Johnson Sonographe SA250	£550
INTEGRATED AMPLIFIERS	
EAR V-20	£1850
Accuphase E-202	£350
Magnum Class A SE	£450
Musical Fidelity A-X1	£350
NVA 9 Box Amplifier	£850
Triangle TB60	£850
LOUDSPEAKERS	
Chario Academy 2 (Walnut)	£1000
Apogee Centors	£550
Lowther Bior 200 (DX2 drive units)	£550
Proac Response One	£550
Sonus Faber Signum with A/Stands	£1350
Cybasse Skiff 301 (Beech)	£950
Cybasse Parella 401 (Bubinga)	£550
B&W Matrix 2 Ss (Black)	£450
B&W DM 70 Electrostatics	£600
Triangle Scalene (Black)	£300
JBL LX-90 (Black Ash)	£300
CASSETTE DECKS	
Nakamichi 1000 ZXI	£1000

All the above come with 12 months warranty
 tel: 01257 473 175
 evening calls welcome
 e-mail: sales@orpheusaudio.co.uk website: www.orpheusaudio.co.uk
 For a full list of our agencies please see: **ORPHEUS AUDIO**
 (GREATER MANCHESTER) in the DIAL-A DEALER Section

RETRO REPRODUCTION



The Outstanding V20 Integrated Amp

*****EXCLUSIVE SCOTTISH DEALER*****
for
E.A.R./Yoshino, Croft, Cary, Nottingham Analogue, Creek, Triangle, B.C. Acoustique



Small but perfectly formed MC3

RETRO REPRODUCTION
Is now offering a restoration service for Quad & Leak valve amps at very reasonable prices phone for more details

V20
Introducing Tim De Paravicini's latest masterpiece, the outstanding V20. Using no less than 20 ECC83 triodes operating in Class A with no overall feedback, the result is the most natural and uncoloured sound available today.

HI-FI NEWS: Ken Kessler: 'What I think we're witnessing here is Tim De Paravicini's finest moment and that's scary, when you consider that even his disasters are better than most designer's triumphs!'

WHAT HI-FI: Verdict *****

Leading French magazine Diapason voted the V20 Amplifier of the year. To hear what all the fuss is about phone now for a personal home demonstration

Used Equipment For Sale

- Linn Bask turntable with Akto tone arm £175
- Naim 62.5 Pre unit £175
- Meridian in-ride pre with CD & 2 phono inputs housed as new £150
- Meridian 303 DAC £125
- Alchemie Kraken int. amp 2 wks old £225
- KEF Concerto speakers £175
- Celestion Dition 44 speakers £125
- Krell KAV/3000 housed out new £1595
- Micromega TDAC & T Drive housed £695
- Quad 34, mant, boxed £195
- Quad 405, excellent condition £185
- Linn linc& arm, excellent condition £295
- Musical Fidelity T1 FM tuner, £145
- Marantz CD75 £75
- Cary 572 SL mono blocks, housed £1495
- Goldmund Parallel tracking focamtr.
- Model SL5, housed £495
- Gamma Rhythm integrated amplifier £795
- Audio Research SI 7 preamp, as new £795
- EAR V20 integrated amp (origam price) £1795
- Klyne SLK 1 Moving coil step up £295.00
- Chimron Pre & Power 2 years old £375.00
- Naim Nait 3 int amp £195.00
- Mission 753 Freedom black £195.00

- Arcam 9 int amp with matching 7 Tuner fully remote £490.00
- AMC Subwoofer fully adjustable £195.00
- Tannoy 10" Gold with Lockwood Studio 1 cabinets £395.00
- 1 another Arcam with D160-4cc: unit £390.00
- VPI Turntable with TNT Platter, Motor unit, Bearing & Outward line (Conditioner, Piano Black) £1250.00
- AA&R Cambridge A60 Amp £75.00
- AA&R Cambridge Power Amp £125.00
- Arcam Alpha 7 Tuner £175.00
- NTC Tower 124 Janned Power Amp £995.00
- NTC Single ended Class A Remote Pre £595.00
- EAR R34P £235.00
- Meridian 200 Transport with Triched Clock 3 System £395.00
- Concealart Quad Mini Conditioner £495.00
- Quad 77 Power Amp With 77 Pre & Remote £695.00
- Gamma Rhythm 211 int valve amp with phono stage S.M.E. 89 tone boxed new £495
- Trinity valve MC head amp £195
- Tube Technology Prophet 2 box int and pre with phono stage £795
- Orly's integrated amp with Tuner £295
- Near Field loudspeaker black boxed £150
- Mission Cyrus 2 1st edition (mint) £250
- Demon CA202 DP-3000 DD Turntable £195
- Luxman Z501 Class A Power Amp £895
- ATC SCM 20 spks walnut £595
- Heybrook Sealed Ribbon Tweeter rosewood £225
- Michelle QC power supply £195
- Audio Research H250 power amp 20k 6550 Avesare £350
- Tannoy III LZ 10" Monitor goods £45.00
- Fisher x 100 Integrated valve amp £145
- Rodgers Cadet III valve amp mint £145
- EAR R44 L valve line stage £275
- Pye FM Tuner valve with rose gold finish £95
- Leak Stereo 60 mint & professionally rebuilt £595
- Meridian 602 Transport £695
- Meridian 601 PR1/DAC £695
- Meridian 604 Tuner £950
- Meridian 605 Mono blocks £50
- Leak Stereo 30 amp mint £350
- Quad II pair various £500.00
- Leak T11 2x pair £495.00
- Revox B77 Open Reel mint £125.00
- Dynaco Stereo 80 valve Power Amp £375.00
- Triode ultra linear, Syre old (mint) £395.00
- Quad 405 MK II Power Amp £125.00
- Naim T2 Pre £125.00
- Naim L40 Power £195.00
- Sugden A21 INT Amp £125.00
- Sugden R21 Tuner £195.00
- Sugden C51, P51, R51 £295.00

CROFT PRODUCTS
Croft's new Vitali Valve Pre with Phono Stage an ideal partner for Vintage Amps or an upgrade from solid state £350.00

Producing the very best from vinyl has long been a black art and it's no wonder with so many permutations involved. Most people agree that Moving Coil cartridge design is technically superior than the Moving Magnet but demands much more from it's ancillaries, especially the phono stage

E.A.R./Yoshino have just launched the MC3 Cartridge Transformer with a hand width of 3Hz-100kHz facilities for a wide range of quality cartridge outputs and twin isolated earth terminals for maximum noise reduction.

The MC3 captures all the subtleties from the most complex recording without resorting to thrusting or spitting it out. Its extreme clarity and graceful presentation makes for a superb vinyl experience.

ART DUDLEY: Leading American hi-fidelity critic. I'm impressed with the MC3, and from a musical point of view, I think it's worth every penny of the price. Those of you who have tube-based systems & can afford it should pester your local dealer until he lets you take one home and try out Value/Quality *****

- AR 60 INT Amp £95.00
- T21 Tuner £95.00
- Spendor LS 35A £395.00
- Musical fidelity A1 (20w) £295.00
- Arcam DC-300A Power Amp £950.00
- Linn Wakonda with tuner + MC Stage £995.00
- Audio Research classic 90 BRAND NEW! bargain £1995.00
- Audio Golden Knight 808 Mono blocks-NEW £400.00
- Cary SLP44 Pre-Amp with superb Phono stage -outboard £1195.00
- PSU (mint) NEW £400.00 SELL FOR £1195.00
- Counterpoint SA 900 Pre - the ultimate Valve Pre Amp (very rare) £1495.00
- Audio Research SP-9 Pre Amp £695.00
- Audio Research D-115 MK II Valve Power £1195.00

DUE IN:
Tannoy 15" Red's with Chassis
Tannoy 15" Gold's
(Tannoy Original III LZ with Rebs)

NOW DEMONSTRATING
LEN GREGORY'S AMAZING MIXING IRON CARTRIDGE ON THE NEW NOTTINGHAM ANALOGUE CARBON SPACE ARM

New Showroom now open
28a Haddington Place Edinburgh EH7 4AF
Phone/Fax 0121 558 0890 Open 11.00am - 5.30pm - closed Monday & Sunday

HARMONIC TECHNOLOGY SINGLE CRYSTAL CABLE
NOW IN STOCK *AT LAST I HAVE A CABLE TO DO ALL THE THINGS THE MANUFACTURE CLAIMS AND AT A RIDICULOUS LOW PRICE* PHONE FOR MORE DETAILS



01376 521132
0802 483698
CHELMSFORD, ESSEX
E-MAIL: soundstage@netlineuk.net
BY APPOINTMENT ONLY

PRE-OWNED EQUIPMENT

- ARCAM XETA 2 WITH 5.1 INPT MODIFICATION £399
- AUDIOLAB 8000C PRE AMP £299
- CHORD RUMOUR 2x6M £89
- CREEK A52 POWER AMP £399
- CYRUS STRAIGHT LINE INTEGRATED AMPLIFIER £279
- DEFINITIVE TECHNOLOGY BP-1 DI-POL: SURROUND SPEAKERS £199
- DEFINITIVE TECHNOLOGY BP-2 DI-POL: SURROUND SPEAKERS £349
- DENON DCD-820 CD PLAYER £149
- DENON DRM-12HR CASSETTE DECK £179
- DENON DRS-810 3-HEAD CASSETTE DECK HORIZONTAL LOADING £199
- DUAL CS 505-4 TURNTABLE £129
- EPOS ES12 DARK CHERRY WOOD £349
- GOLDRING EROICA MC CARTRIDGE £60
- KEF REFERENCE 103/4 LOUDSPEAKERS £595
- KEF CODA 71 LOUDSPEAKERS BLACK ASH £59
- KEF CODA 75E LOUDSPEAKERS BLACK ASH £99
- KENWOOD KAV3700 AV AMP £99
- LFD PA2 POWERSTAGE POWER AMP £895
- LINN AKITO TONEARM £229
- LINN AVS103 AV PRE-AMP AC3-RF BUT NOT DTS INCL HANDSET £2495
- LINN VALHALLA POWER SUPPLY £99
- MARANTZ CD14 CD PLAYER BLACK £895
- MARANTZ CD67SE CD PLAYER BLACK £179
- MARANTZ RC2000 LEARNING REMOTE WITH BOX AND INSTRUCTIONS £119
- MERIDIAN 500 CD TRANSPORT £795
- MERIDIAN 566 CD DAC 20-BIT £795
- MERIDIAN 518 DIGITAL PROCESSOR £695
- MONITOR AUDIO R252 LOUDSPEAKERS £79
- MONITOR AUDIO STUDIO 20SE LOUDSPEAKERS ROSEWOOD £895
- NAIM CD2 CD PLAYER £1395
- NAIM CD3 CD PLAYER £595
- NAIM NAIT 3 WITH PRE-OUT MOD £479
- NORDOST OCTAVA LOUDSPEAKER CABLE 2x5M 4MM TERMINATION £25
- NVA PHONO 2 MC PHONO STAGE WITH TWIN PSU SUPPLY UPGRADE £449
- NYTECH OBELISK CA102 INTEGRATED AMPLIFIER £99
- PARTINGTON A460 LOUDSPEAKER STANDS-BRAND NEW £79
- QUAD 34/306 PHONO PRE/POWER £429
- QUAD ESL-63 WITH SHORT STANDS-BLACK-IMMACULATE £1495
- REGA PLANAR 2/RR250 TURNTABLE £149
- RUAR CRUSADER II SPECIAL ORDER YEW VENEER 2 WEEKS USE ONLY £1999
- RUAR DIALOGUE REFERENCE SPECIAL ORDER YEW FINISH £299

PROFESSIONAL RECORD CLEANING SERVICE - KEITH MONKS MACHINE - PLEASE RING FOR FURTHER DETAILS AND PRICES.
THREE MONTH WARRANTY ON ALL ITEMS
WWW.SOUND-STAGE.CO.UK

IAN EDWARDS
MAKERS OF FINE HAND
MADE FURNITURE



Elegant Storage Solutions
for
Hi-Fi's, Books, LP's, CD's
Any veneer supplied
Special orders welcome

To celebrate 30 Years in the business we have a
VERY SPECIAL OFFER for the readers of HI-FI WORLD
on unit pictured above
£250 for white or simulated teak
£400 for selected wood veneers



The Old Chapel
282 Skipton Road
Harrogate • N. Yorks
HG1 3HB

Tel: 01423 500 442
Fax: 01423 705 200

www.iansbespokefurniture.co.uk
Ian Edwards supports the Woodland Trust

cartridges

denon
dnm
goldring
lyra
ortofon
sumiko

cables

audioquest
cable talk
chord company
dnm
heybrook
ixos
kontak
lfd
nordost flatline
ortofon
qed
sonic link
trichord
van den hul
xlo

headphones

beyer
ergo
grado
jecklin
sennheiser
stax

stands

alphason
frameworks
sound org'n
something solid
soundstyle
stands unique
target

accessories

audioquest
creek
densen demagic
dishwasher
earmax
goldring
ixos
kontak
michell
milty
monarchy
moth
musical fidelity
nordost
pixall
qed
rms
shure
trichord
zerostat

hardware

atc
audio physic
audio synthesis
b+w Technology
densen
harbeth
michell
nva
nordost
primare
qln
royd
sequence
sugden
teac
thorens
totem
trichord

audio, cables and accessories available by post

(post
haste)

phone, fax or write

for latest price list

/ newsletter

Second hand & ex dem deals

Audiophysic Spark 2 loudspeakers. Cherry veneer. Excellent condition. boxed. Originally sold by Signals, one owner S/H (£1700) **£850**

Unison Research Simply 845 integrated triode line level valve amplifier. Boxed, excellent (£2950) **£1500**

Meridian 200 CD transport (Trichord DOB & AES/EBU output fitted) **£385**

DPA Little Bit DAC **£95**

Royd Doublet loudspeakers. Black stained veneer. (£585) ex demo (new model due) **£395**

new deals (while stocks last)

Sugden

Audition C with remote control and equalisation SRP £1000 available at **£725**
Audition P (matching power amplifier to allow bi-amping) SRP £549 available at **£430** - or buy both together for **£1100**.

ATC

SCM 20 SL loudspeakers. New in ANY veneer (see below). RRP was £1999, available for **£1050** if purchased with ATC amplifier, **£1300** on their own. Finishes available: black ash, cherry, rosewood, yew, walnut, burr walnut, birdseye maple, antique oak, ebony.

SCM 20SL towers in walnut, rosewood or black ash:
Passive **£1800** Active **£3000**

SCM 50 SL in walnut, black ash, rosewood, ebony or burr oak:
Passive **£3200** Active **£5200**

Nordost Blue Heaven Rev 1 5m pair bi-amp RRP £680 available @ **£475**

Nordost Blue Angel interconnects ex demo, no boxes:
1m pair RCA **£50**
1m pair XLR balanced **£60**
1m pair 5 pin DIN to 2 Phono **£50**



hi-fi for grown-ups



MUSONIC STYLI

**SPECIALIST MANUFACTURER &
SUPPLIER FOR MORE THAN 40 YEARS**

REPLACEMENTS & ORIGINALS

MANY OBSOLETE/78 VERSIONS

PICK-UP CARTRIDGES

RECORD/TAPE/CD ACCESSORIES

**WHY NOT TRY US AND HEAR THE
DIFFERENCE !!**

For prices tel/fax/e-mail to:-

MUSONIC (UK) LIMITED
Unit 13 Wenta Business Centre Colne Way
Watford Hertfordshire WD24 7ND

Tel: 01923 213344 Fax: 01923 213355

E-mail: sales@musonic.co.uk

Website: www.musonic.co.uk

VISA Trade and Export enquiries welcome



SUPRA[®]

Supra cables are manufactured to exceptional standards of quality in our very own factory near Gothenberg in Sweden - in tune with nature & in tune with your needs.

Interconnects

EFF-ISL "Hi-Fi Choice Best Buy"

fitted with locking gold-plated phono's (0.75m) **£79.95/pr**

EFF-IX - same cable as EFF-ISL but fitted with non-locking phono's (0.75m) **£69.95/pr**

EFF-IXLR - same cable as EFF-ISL but fitted with XLR connectors (0.75m) **£89.95/pr**

Digital Cables (1m)

DAC-XLR 110ohm AES/EBU cable **£44.95ea**

EFF-ID co-ax digital cable **£44.95ea**

Fibre optic cables(1m)

ZAC (Available in 3 versions TosLink>TosLink, 3.5mm>TosLink or 3.5mm>3.5mm) **£29.95ea**

X-ZAC (Hi-End TosLink>Toslink) **£59.95ea**

Classic Series Tin-plated speaker cables (unterminated)

Classic 2.5mm **£2.49/m**

Classic 4mm **£3.95/m**

Classic 6mm **£4.95/m**

Quattro 4x4mm biwire cable **£8.95/m**

(All Classic cables are multi-stranded OFC - Classic 4mm is a 'What Video Best Buy')

Ply Series low inductance OFC speaker cable

Ply 2.0 **£4.95/m**

Ply 3.4 **£6.95/m**

Ply 3.4/S **£7.95/m**

(Both Ply 3.4 are "Hi-Fi Choice - Recommended" cables)

LINC Series Installation Speaker Cable (shielded)

LINC 4.0 **£4.95/m**

For a catalogue, complete the coupon and post to our address. E. & O.E.

Most interlinks cables are available in other lengths. New range of scart + s-video cables now in stock. See website or catalogue for details.

Supra Retailer websites: www.custom-cable.co.uk
www.supradirect.co.uk

Post to: Glave Limited, Unit 7, Wren Industrial Estate, Coldred Road, Maidstone, ME15 9YT Tel/Fax: 01622 664070 Web: www.supracables.co.uk
Please send me info on: Supra

Name:

Address:

Post code: HFW0004

ipswich (01473) 655171
signals bucklesham
ipswich suffolk IP10 0DY
fax (01473) 655172
email: enq@signals.uk.com
signals.uk.com

UPGRADE YOUR TURNTABLE

"If you are thinking of upgrading your system..the Origin Live dc-motor kit should be high on your list for consideration" TNT AUDIO internet magazine April 2000.

"The single most important upgrade you can ever make to any record deck concerns the motor drivenothing can compare you for the shock of going DC, in a word Gobsmacking" COMMON GROUND MAGAZINE

"Its value is nothing short of tremendous" LISTENER MAGAZINE

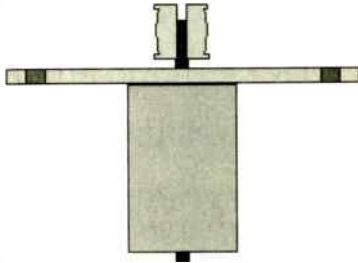

Whether you own a Linn Valhalla/Lingo, Rega or any other deck, the results of upgrading to the Origin Live dc motor and power supply are simply astounding. This high grade motor kit is designed as a drop in replacement for almost all turntable motors. Decks benefiting so far from this ultimate of upgrades include Linn, Roksan, Michell, Systemdeck, Rock etc. With a 12 Volt power supply it is safe and easy to fit. Guidance instructions are provided. At £250 (add £25 for fully soldered and tested regulator board) with money back guarantee this is a bargain out of all proportion to it's value in terms of performance. An optional, larger purpose made transformer is also available as an add on at £175

AURIOS ISOLATION MOUNTS



"highly recommended" March 2001

HI-FI WORLD

With the AuriOS, I am now (finally) consistently hearing what I've always wanted out of audio"

STEREO TIMES

"unbelievable until you've heard the difference"

SOUNDSTAGE

Placed under Turntables, CD Players, Amplifiers, Loudspeakers etc these amazing devices dramatically upgrade the sound of your Hi-Fi. Reviewers who try them won't be without them. The investment made in the AuriOS will last a lifetime. They reflect excellent value in terms of outstanding performance which is only possible through expensive production techniques and the finest engineering available.

The AuriOS (MIB) mounts are £197.50 GBP for a set of 3 mounts (carriage is an additional £5.50 within the UK and will be quoted for outside). One set of 3 mounts normally supports one item of equipment.

Make cheques payable to Origin Live and send to address shown We can take credit card orders if you wish. Remember there is a no risk money back guarantee if not entirely satisfied.

ORIGIN LIVE TURNTABLE KITS

Standard & Ultra

Now you can save money and build your own high performance deck. The budget kit version is offered at £195, and the ultra version at £279. Both decks come with a full set of drawings and guidance instructions. The kit allows for your creativity or there are optional parts that will enable you to assemble a tried and tested design within 1-4 hours. This is probably the easiest kit you will ever make.

"this Vinyl front end had my jaw heading towards the floor with the solidity and transparency of the music it was making"... "the standard came up with crystal clear images set in a broad sound stage"... "With all these goodies in place, the standard would give turntables at the £1200-£1400 mark a hard time."

HI-FI WORLD SUPPLEMENT

"is exceptionally easy to build and professional in both sound quality and appearance"

HI-FI NEWS SUPPLEMENT

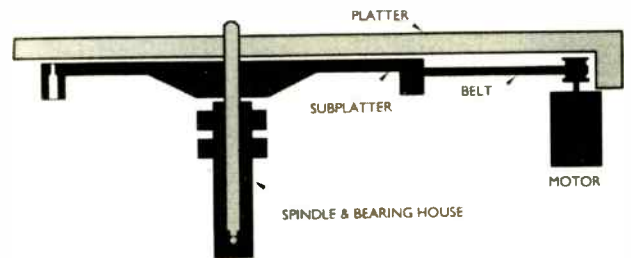

TURBOCHARGING YOUR REGA ARM

"Nothing less than total dynamite" HI-FI WORLD

If you are the proud owner of any Rega arm, why not utterly transform it into the league of super arms with the Origin live structural modification:- £75 inc post & packing.

This modification will enable your Rega to perform at a level exceeding that of arms costing over £1200. Rewiring with high grade litz cable is also offered at an additional £70, and external rewiring is £70.

"I have to say the Rega modifications turn this humble arm into a real Giant killer. Gone is the rather grey, sterile sound of the cooking Rega. Instead, tonal colour is fresh, dynamics have great speed and impact, and the sound stage is huge." HI-FI WORLD SUPPLEMENT NOV 97 (structural modification to a RB250) WHAT HI-FI gave this modification a 5 star rating.

For arm modifications we normally return your arm in 2 - 3 day

CROSS SECTION OF ARM END

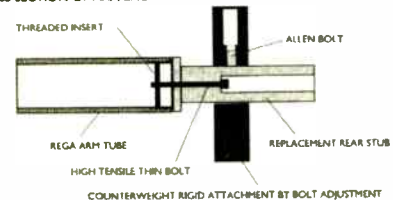

For further information contact
Origin Live, 87 Chessel Crescent, Bitterne,
Southampton, SO19 4BT
Tel: 02380 442183 / 578877 - Fax: 02380 398905
Email: origin.live@virgin.net

WEBSITE: <http://www.originlive.com>

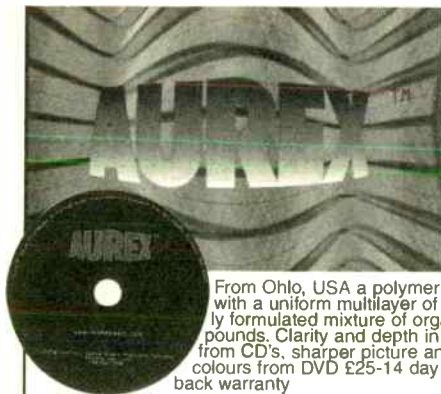

From Ohlo, USA a polymeric, mat with a uniform multilayer of a specially formulated mixture of organic compounds. Clarity and depth in music from CD's, sharper picture and brilliant colours from DVD £25-14 day money back warranty

Taperwise flat speaker cable

418 -★★★★★ WHAT-HIFI, What Hi Fi Ultimate Hi Fi Guide

Sunfire Corporation

....from the mind & soul of Bob Carver



CLASSIC TUBE PRE AMP, optional all valve phono stage (MM/MC) with CD input (reverse RIAA equalisation)



STEREO POWER AMPLIFIER 300 wpc HEXFET with no heat sinks

FIVE CHANNEL POWER AMP 200 wpc x 5 - HEXFET with no heat sinks
THEATRE GRAND PROCESSOR PRE-AMP- phono stage, tuner, Dolby Digital, DTS, auto source sensing, intelligent remote

2700 watt TRUE SUB-WOOFER 11 inch cube 18Hz
Patent No 4218660 & 4484150
2700 watt SIGNATURE SUB-WOOFER 13 INCH CUBE 16Hz



4 Arundel Road Kingston UponThames
Surrey KT1 3RZ
Tel: 44 (020) 8241 9826
Mobile: 020 8264 0249
Fax: 44 (020) 8241 0999
E-Mail: weere@cablenet.co.uk

AUDUSA & Co



AC-2 POWER CORD

"For the money, that's no mean feat"
HI FI WORLD June 99

"compare against product costing ten times as much or more, then decide"
AUDUSA & CO

AC-2 Power cable - Silver clad, Teflon insulated at 10awg; this is the largest gauge of power cord we know of. The design of our shielding system effectively eliminates interferences from RF and EMI sources. Fitted with a MK Tough plug and IEC or Fig of eight connector. European connectors also available. Solder connections with Wonder Solder. 2ft £56, 3ft £68, 4ft £78, 6ft £99. Other lengths to order. 4, 6 and 8 way all steel distribution boxes with 3 ft of cable & MK Tough plug 4way £161, 6way £194, & 8way £226.



Hi-Fi World Aug 99
"gained speed, control & involvement. Improved cohesion and musicality"

LAT International Cables - now with **SILVERFUSE** conductors. Silverfuse is a near alloy of silver and copper. It is not silver plated or silver clad. The Silverfuse process starts with seven nines OFHC copper wire with a diameter that is slightly larger than the required size. It is then pulled through a trough of molten silver. The wire with a silver deposit, is then forced through a compacting die where it is subject to tremendous pressure. The silver and the high purity copper are fused together into a near alloy. The compacting fusion also reduces the wire diameter to the desired size. No idling subsequently occurs with this process. The result provides for the benefits of silver; which are excellent definition and clarity, with the high purity copper benefits of warmth and mellowness. Interconnects analogue IC200, IC100, IC80, digital DI-20, video V1-6 and Component Video, Speaker Cable SS1000, SS1000 Biwire, SS800 and SS800 Biwire and Mains cable AC-2.

For further information visit our website:
www.audusa.com or www.audusa.co.uk

AUDIO MATTERS

NEW EX-DEM & PART EXCHANGE
EQUIPMENT FOR SALE
020 8255 0572/0973 436135

	LIST	SALE
Alchemist Forsetti pre + power	£2398	£POA
Alchemist Kraken Anniversary MkII	£599	£POA
Alchemist Forsetti R/C Int Amp	£1250	£650
Alchemist Genesis monoblocks	£1500	£695
Anthem CD player (5 star What Hi-Fi)(ex/d)	£1699	£899
Audio Research D240 Mk.II	£3500	£1195
Audion Black Shadows 845 valve monoblocks	£4000	£POA
Audion Silvernight 300B monoblocks	£2250	£POA
Audio Alchemy drive 3 + V3DAC + 3PSU	£1649	£759
AVI S2000MP Pre + Rata PSU	£1450	£750
AVI S2000 Monoblocks	£1400	£750
Chario Academy 1 solid walnut (ex/d)	£1299	£800
Chario Academy 2 solid walnut (ex/d)	£1649	£1100
Conrad Johnson PV10AI. Pre	£1095	£595
EAR 859 pwr. amp	£1599	£750
Krell Kav 300I	£2495	£POA
Krell KSA 80 pwr. amp	£3498	£1495
Krell KSA 250 pwr. amp	£6700	£2500
Krell KSL pre amp	£2298	£995
Krell KAV-S Prologic, AC3, DTS, THX PRE	£13500	£6500
Macintosh 7106 6ch. THX pwr. amp	£4000	£1999
Meridian 207 CD + PRE		£350
Proac Response 4 spks	£12000	£3995
Pass Aleph LFP PRE	£3800	£2195
Quad ESL63 + Stands	£3500	£1395
Spendor SP7/1 spks.	£1995	£650
Tannoy D700 spks. rosewood	£2500	£1250
Theta pearl transport + Progeny dac	£2448	£1250
Wadia 23 CD Player	£2980	£1495

Wazoo integrated amp from Bow Technologies now on Dem

A NEW RANGE OF VIENNA ACOUSTICS SPKS. NOW ON DEM - ALSO
PERREAUX EQUIPMENT AVAILABLE ONLY FROM AUDIO MATTERS
ON DEM -

Alchemist, Anthem, Audiomeca, Audion Valve Amps, Cadence Spks., Chario, D.P.A.,
Goertz cables, Monarchy, Ortofon, Pink Triangle, Project T-T, Sonic Frontiers,
Triangle Spks., Trilogy Valve Amps, Vand den Hul.

VISA/MASTERCARD ACCEPTED



PROGRESSIVE AUDIO



2 Maryland Court, Rainham, Kent, ME8 8QY
Telephone / Fax No. 01634 389004

WEBSITE: www.progressiveaudio.co.uk E-MAIL: dave@progressiveaudio.co.uk

We have the following ex demonstration and part exchange items for sale :

- TEAC P30 CD Transport, one week old! £1995. S/H.
- AUDIONOTE AN E/D loudspeakers. Rosewood with matching stands. £995. S/H
- REGA Jupiter /lo CD Transport and DAC with digital interconnect. £795. S/H.
- Van den Hul First Ultimate interconnect. 1m set. £225. S/H.
- GRAAF GM 20 OTL valve power amp. £2250. S/H.
- DENON AVC-A1D AV Processor/amp. 4 months old. Mint. Boxed. £1150. S/H.
- SONUS FABER Solo centre speaker. Black. Unused. £425. S/H.
- NORDOST Quatrofil Reference interconnects. 1.5 m (x2) £875 PER PAIR. X/D
- CHORD 1400B Mono block power amps. Black. As new. Boxed. £5500. S/H.
- VERITAS H3 Horns. Piano black. As new. £4600. X/D.
- VERITAS 7's. Piano Cherry. With stands. As new. £995. X/D.
- VERITAS 20'S. Piano Black. With stands. As new. £1250. X/D.
- UNISON RESEARCH simply Four valve amp with Simply phono stage, Mint £1425 X/D
- BLACK Rhodium interconnect. 1.5m Boxed as new. £795. S/H.
- ALON Petite loudspeakers. Walnut. As new. Boxed. £850. X/D.
- ALON 1 loudspeakers. Walnut. Excellent condition. Boxed. £795. X/D.
- ELEMENTAL Audio monolith. (£499) £300. X/D.
- ELEMENTAL Audio speaker stands (the best ever ?) £1500 new. £850. X/D.
- ANALYSIS Epsilon ribbon loudspeakers. Good condition. Boxed. £3495 new. £1250. S/H.
- TRIANGLE Alcante loudspeakers. Excellent match for valve amps. Black. Mint. Boxed. £650. S/H.
- SUGDEN SDD1 CD transport. Mint. Boxed. £495. X/D.
- MICHELL Argo HR Line pre amp. With Hera P/S. £650. X/D.
- MICHELL Iso HR.phono stage. With Hera P/S. Excellent condition. £495. S/H.
- ETALON phono stage. M/M and M/C. New £1500. £650. X/D.
- ORIGIN LIVE Conqueror loudspeakers. Cherry. As new. Boxed. £1250. X/D.
- ORIGIN LIVE Sovereign loudspeakers. Cherry. Good condition. £650. X/D.
- ACOUSTIC SOLUTIONS "Eight" loudspeakers. Oak. As new. With stands. £1200. X/D.
- SUGDEN A2La (Line only) integrated amp. mint £525 S/H
- EXPOSURE PreX1X and Power XV111 amp combo. Comes with 1m balanced interconnect. Mint. £725. S/H.
- LINN Kaber loudspeakers with stone stands. £825. S/H.
- ROKSAN Caspian Integrated amp. Excellent condition. Boxed. £495. S/H.
- MICHELL Mycro/Rega RB250 (with ortofon cartridge) Mint. £525 S/H
- MUSE Model eighteen subwoofer. £1500. S/H.
- ROTEL 965 CD player. £125. S/H.
- ARCAM CD9 CD Player (just serviced by Arcam) Mint. £525. S/H
- UNISON RESEARCH 845 Mono blocks. Mint. Boxed. £1995. S/H

**NOW ON PERMANENT DEMONSTRATION THE
TOTALLY AMAZING SUGDEN MASTERCLASS CD
PLAYER. AT £2500 THIS IS AN ABSOLUTE SNIP!
PHONE NOW TO BOOK YOUR DEM.**

RESERVE YOUR COPY TODAY!

Complete this form and hand to your local newsagent

Please reserve/deliver* (delete as appropriate) Hi-Fi & Computer Audio World on a regular basis, commencing with the next issue, until further notice.

Name _____

Address _____

Signed _____ Date _____



Distributed to the newstrade by

COMAG
MAGAZINE MARKETING

STOWSOUNDS

Stownfarm Borough Lane, Great Finborough, Stowmarket, Suffolk, IP14 3AS

We have the following equipment to clear:

	WAS £	NOW £
Alchemist Nexus CD	599	480
Atacama Audio Rack 6 shelf	200	140
Atacama Speaker Stands		from 40
Creek 4330 integrated	279	235
DPA Enlightenment Pre amp	795	550
DPA Enlightenment DAC	825	600
DPA Renaissance CD	995	700
Exposure 21 Pre amp	1100	900
Exposure 18 Power amp	1000	800
Exposure 25 integrated	1100	950
JM Lab Tantal 515	499	375
JM Lab Cobalt 810	799	600
JM Lab Electra 905	1199	999
Linn Numerik DAC	1500	950
Linn LK100 Power amp	750	500
Linn Wakonda Pre amp	650	400
Magnat Needle floorstander	479	300
Magnat Vector 55 floorstander	399	225
Magnat S1 sub and satellite	249	195
Micromega Sage 4 CD	600	400
Mordant Short MS 30i	350	200
NAD 310 integrated	110	80
Neat Petite cherry	795	575
Rogers LS4a	-	150
Sonneteer Byron CD	795	600
Sonneteer Alabaster integrated	900	700
Sonneteer Campion integrated	600	500
TDL RTL 3	-	200
Trichord Revelation CD	800	575
Yamaha DSP E492 Processor	-	175

Various interconnects, supports, cables at reduced prices.

Phone for details

Sale of CDs. Phone for latest list.

TEL: 01449 675060



HEATHERDALE AUDIO LTD.



HEATHERDALE PRE-OWNED GUARANTEED EQUIPMENT EXPORT FACILITIES AVAILABLE

SPEAKERS

Meridian A500 Speakers £595
 KLH Speakers £195
 Heybrook Prima Speakers £125
 Epos ES11 Speakers £245
 Thiel 7 2 Birds Eye Maple £395
 Linn Isobarik Wrth Stands £395
 Audionote ANE-SE (Rosewood) F Vener £375
 Kel 101-2 speakers £250
 Mission 782 Loud Speakers (Stand mount model)
 Selection of Thiel ex Demo Speakers. All with 10 year guarantee
 MAIN DEALER FOR ORCHID SPEAKERS

PRE AMPS

Mark Levinson ML26 with Phono-Stage £2495
 Arcam Delta 110 Digital Pre-Amplifier £345
 Classe CP35 remote pre-amp balanced £595
 AVI S2000MP Pre-Amp with phono-stage £495
 Burmester 785 with phono-stage £895
 Z System digital pre-amp £2750
 Audio Research phono 1 phono stage MM & MC £795
 Exposure 21 Pre-amp NEW with remote £990

AMPLIFIERS

Chord SPM 1000B Amplifier £595
 Krell KBL Pre-Amplifier £195
 Krell KSA 100S boxed mint £125
 Rogers E40a Integrated Amplifier with phono-stage (NEW) £245
 Exposure 1112-Super 8 £395
 Audionote P4 Monoblocks £395
 Adcom GFA 5300 Power amp £375
 Pioneer precision integrated amplifier £250

CD PLAYERS & TRANSPORT

Cec TL Zero Mk2 CD Transport £5500
 (cost new £12300) 2 months old (Stereophile Class A1 recommended)
 Denon DCD660 CD Player £95
 Mark Levinson ML37 CD Transport £2695
 DAC S £2495
 Mark Levinson ML35 DAC £995
 PS Audio Ultralink Digital Processor £2995
 Cello Reference DAC £1595
 LFD DAC 3 £1295
 Audio Synthesis DAX

202 FINDON ROAD, WORTHING, WEST SUSSEX, BN14 0EJ
 TEL: 01903-872288 OR (AFTER HOURS) 07860 660001 FAX: 01903-872234
 e-mail: heatherdale@hifi-stereo.com / www.hifi-stereo.com

MISCELLANEOUS

Pioneer F93 Tuner Bowed Mint £595
 2mint C2 GE Balanced Interconnect (£550) ONLY £1995
 Nakamichi BXC cassette deck (just serviced) £295
 Teac A-33405 Tape recorder £595
 Selections of MIT cables available at discounted prices £995
TURNTABLES, CARTRIDGES & TONEARMS
 Linn LP12 with Rega Tone-Arm and Avondale PSU £495
 SME V Tone-Arm Mint/Boxed £995
 Luxman PD 282 Turntable £295
 Technics SLD2 Turntable £75
 Helius Silver wired tonearm £75
 VPI TNT Turntable £995
 Thorens TD125 Turntable £295

FOR THE CONNOISSEUR

Mark Levinson ML26 with Phono-Stage £2495

NOW DEMONSTRATING THE MARK LEVINSON 383 INTEGRATED AMP

WE NOW OFFER 0% FINANCE (subject to status)

PLEASE PHONE TO ARRANGE AN AUDITION

VISA - SWITCH - MASTER CARD AND DISCOVER CARDS
 MAIN DEALERS FOR MARK LEVINSON, THIEL AND ABSOLUTE SOUNDS
 WE TAKE PART EXCHANGE ON NEW & USED STOCK AND BUY IN FOR CASH



Soundcraft HiFi

At 40 High Street, Ashford, Kent. TN24 8TE

Clearance! Ex-dem & Re-sale stock March Sale 2001

Hi-Fi Separates

Arcam Xeta II amp	£199	Musical Fidelity X-Plora	£499
Arcam AV50 Amplifier	£550!	Marantz CDR 4050 Recorder	£299!
Audiolab 8000A Amp	£299	Marantz Ki Sig 6010 Amp Gold	£350!
Audiolab 8000-CDM	£499	Marantz Ki Sig 6000 CD Gold	£450!
Linn Karik CD	£799	Naim CD-3	£650
Linn Kairn Phono Pre-amp	£999!	Naim NAC-92 Pre/NAP-90 Pwr	£650
Linn Mimik CD	£599	Nait II Amplifier	£299
Linn Majik amp (used)	£450	Quad 34 Pre/ 306 Pwr amps	£399
Linn Kolektor Pre-amp	£399	Quad 66 CD Player	£299
Linn LK-140 Pwr-amp	£550	Rega Radio (still boxed)	£150
Linn Keilidh Speakers	£500	Rega Planar 25 Turntable	£550!
Linn Ikemi CD Player	£1599	Rotel RCD-971 CD Player	£299
Musical Fidelity A2 CD	£249	Rotel RC-970BX/RSP960-AX	£299
Musical Fidelity X-A1 amp	£399	Sony ST SA3ES Tuner	£199

Our exciting range includes: Arcam, Ruark, Linn (CD12 in stock) Loewe TV, Naim, Rega, Rotel, Musical Fidelity, PMC, B&W (includes Nautilus) & Chord Electronics.
HOTLINE: 01233 624441 Fax: 01233 640333.

AV Separates

Arcam AV-50 Amplifier	£199	Pioneer NS-DV1AV System	£999
H/K AVR-65 DTS/AC-3 Amp	£499	Rotel RDV-985 DVD	£400
H/K AVR-45 Amp Receiver	£399	Selecto SVT-195CRT Projector	£1499
Naim AV-1 Processor	£799	Yamaha RXV-795 Amp/Rec	£499
Marantz DV-4100 DVD Player	£299	Yamaha RXV-395 Amp/Rec	£199
Pioneer DV-626 DVD Player	£299	Yamaha DSP-492 Processor	£149
Pioneer DV-535 DVD Player	£199	Yamaha RXV 496RDS Amp/Rec	£249

Check our web site: www.soundcraftkent.ltd.uk

PREVIOUSLY CHERISHED HI-FI

Ear 509 Mono Blocs - Valve	999.00	Rothwell Rubicon Power Valve Amp	849.00
Marantz CD-17K1 - Signature - 3 months old	799.00	Celestion A2 speakers cherry	999.00
Marantz PM-17K1 - Signature - 3 months old	699.00	Michell Gyro Deck RB300 arm bronze	1,199.00
Marantz PM-6010K1 - Signature - 3 - months old	250.00	Michell Orca Pre Amp with Large Power Supply	1,399.00
Bill Beard BB100 Valve Amp	650.00	QED Passive CD Pre Amp Alps Pot.	60.00
Kef 104/2 Speakers black Ash	625.00	Project 2.9 Record Deck with Ortofon cart. cherry	449.00
Magner Planer Sma - mint blk/rose	289.00	Audio Innovations Line Pre-Amp Valve	175.00
Mordaunt-Short MS201 B/Shelf Loudspeakers	150.00	DPA- DSP50S Pre-Power-Phono (MC,MM)-PSU- with 500s Black Link Speaker Cable -black Link inter con. very good condition-sounds superb.	950.00
Linn Classic various colours	995.00	Precious Metals Coppertech Delta	59.00
Linn Keosa Floor Standers	499.00	Precious Metals Silvertech 52 Signal	81.00
PMC Tb2 Stand Mount Speakers - cherry	299.00	Precious Metals Silvercoppertech 102 Signal	110.00
Quad FM3	95.00	Precious Metals Silver SS200 Signal	187.00
Castle Howard S2 Pair	690.00		
Rothwell Indus Passive Pre Amp Stepped Cont.	449.00		



• NEW HI-END HI-FI

• VINTAGE HI-FI FOR SALE & WANTED

MICHELL - ALCHEMIST, CELESTION, QED, AUDIOQUEST, TARGET - ETC...

NEW AND VINTAGE VALVES - INTERCONNECTS & SPEAKER - OFC & SILVER

WEALTH OF KNOWLEDGE SPANNING OVER 30 YEARS, FOR ENQUIRIES OR

A CONTROVERSIAL CHAT, ASK FOR DAVE OR LEE.

PHONE: (01322) 292391

FAX : (01322) 229908

E-MAIL: MA TRIXHI-FI@HOTMAIL.COM

WEB: WWW.MATRIX-CS.CO.UK

FREE -EASY PARKING

SHOWROOM -

65 DARENTH ROAD

DARTFORD

KENT DA1 1LU.

TEL: 01428-651554

P.G. Hi-Fi

FAX: 01428-654592

Buying & Selling Vintage HiFi, Valves,
Classical LP Records & Spare Parts.

Quad

All spares available for
Quad II and Quad 22

Quad QA12P (pair) very rare	£1400
Quad 303 (bit scruffy)	£ 50
Quad QCI Pre-amp (early model)	£120
Quad QC II Pre-amp	£ 40
Quad FM1 Tuner	£ 40
Quad II mains transformer	£100
Quad II output transformer	£100
Quad II output transformer (100v line)	£ 50
Quad II choke	£ 30
Quad II Fuse Holder	£ 7
Quad II chassis + wiring loom	£ 35
Quad ESL57 Electrostatic Speakers Bronze. Excellent Condition	£600

Please phone for details of other
Quad/Leak/Garrard spares

Leak

Leak TL12.1 (pair)	£1500
Leak TL12+ (single)	£150
Leak Stereo 20	£250
Leak Stereo 60	£550
Leak Troughline 3 Tuner (Mono)	£ 75

Most Models Of Leak Mono +
Stereo Pre-Amps In Stock.

Colton MC101 arm	£ 30
Garrard 301	£150
Garrard 401 (Mint)	£175
Nakamichi 610 Pre-Amp	
620 Power-Amp/630 FM Tuner	£500
PYE HF5/8 Amps (pair)	£450
SME 3009 III + Fluid Damper	£100
Tannoy HPD15" gold crossover (single)	£ 50
Teac C-2 Cassette Deck (3-Head)	£200
Technics SLD-202 Turntable (No Lid)	£ 25

WANTED
LARGE COLLECTIONS OF CLASSICAL LP'S

Cartridges

Moving Magnet

Audio Technica AT13A (used/good)	£ 10
Shure V15II (no stylus)	£ 10
Pickering TL2S (boxed/unused)	£ 20
Decca London Gold (boxed/unused)	£200

Moving Coil

Ortofon SPU-TE used/good	£150
--------------------------	------

Valves (G E C Mullard etc.)

PX25, KT66, ECC81/B4 EF80	
Many Others. Please Phone For Details.	

Valve Alert

Mullard ECC81 Genuine N.O.S.	
Blue Box. made in England	each £8
G.E.C. PX25 (single)	£120

Valves Used/Tested

ECC81 Mullard	£4
ECC83 Mullard	£8
ECC83 Telefunken	£8

Valves N.O.S.

ECC84 Mullard	£6
ECC84 Brimar	£6
EF80 Mullard	£5
ECC81/CV455 Mullard	£10
ECC81/CV4024 Haltron	£5
ECC81/CV4024 White Box?	£5

Photocopies Of Circuit Diagrams
+ Vintage Hi-Fi Literature
Spare Parts For Quad + Leak -
Transformers etc. Garrard 301 spares

Speakers

Celestion 12" bass drive units (pair)	£ 10
Goodmans Midax Horn Units (pair)	£ 50
Goodmans Axiom 150 12"/15 ohm /15 watt (single)	£ 50
Wharfedale W12/RS/PST 12" 15 ohm (pair)	£75
Wharfedale Super 8 RSDD 8" 15 ohm (pair)	£75

NEW
SENNHEISER
EVOLUTION
REVOLUTIONToday's generation of recording artists and musicians now has a better
alternative in high performance headphones with the introduction of theall-new Evolution Headphone Series by
Sennheiser. Combining outstanding clarity and
performance with sleek, sophisticated design and
a surprisingly affordable price point, the Sennheiser
Evolution Headphone Series is the ideal choice for up-and-coming performers
who have long sought to bring Sennheiser's technical excellence and sound
quality to their own home and studio listening environments.The Evolution Series consists of three dynamic headphone units: the EH1430,
EH2200 and EH2270 offering durability, versatility and the rich, full sound you
expect from Sennheiser. All units incorporate 3.5mm and 6.3mm (1/4") jacks.

EH1430 our price £19.95 EH2200 our price £49.95

EH2270 OUR PRICE ONLY £79.95

SENNHEISER HEADPHONE SPARES FOR
MOST MODELS ALWAYS IN STOCK — CALLNEW SENNHEISER WIRELESS
HEADPHONES NOW AVAILABLERS30 Sennheiser's entry-level model for those who want to listen to great
sounding music and enjoy freedom of movement. Incorporates a special filter
to protect against interference from TV sets. Our price £69.95RS40 Excellent sound reproduction and extended listening comfort thanks
to fabric-covered ear pads. When placed on the transmitter, the battery is
automatically recharged in the headphone. Our price £79.95RS60 Our first RF wireless headphone with surround sound! Can be
switched on and off as desired. An SAW input filter eliminates RF
interference for undisturbed listening. Our price £119.95RS80 The flagship of the new RS series delivers accurate, dynamic music reproduction. Features
specially optimised transducers as well as HiDyn™ noise reduction. Our price £159.95

FULL DETAILS AND MUCH MORE IN OUR ON-LINE CATALOGUE OF QUALITY COMPONENTS AND ACCESSORIES AT

www.strachan.ndirect.co.uk

STRACHAN ELECTRONICS

9 CROALL PLACE, EDINBURGH, EH7 4LT

Tel: 0131 556 9549 E-mail: strachan@ndirect.co.uk

INFIDELITY

9 High Street, Hampton Wick, Kingston Upon Thames, Surrey, KT1 4DA
Tel: 0208 943 3530 Fax: 0208 943 4509

SALE LIST February 2001

Amplifiers

			NEW PRICE	SALE PRICE								
Rega Luna	integrated amp	ex-dem	£375	£285	Arcam Alpha 8	integrated player	ex-dem	£400	£250			
Rega Brio	integrated amp	new	£298	£265	Arcam 85E	integrated player	ex-dem	£500	£375			
Rotel R5X 965	A/V integrated amp	ex-dem	£950	£725	Rotel RDV 985	DVD player	ex-dem	£600	£395			
Densen Beat B100	integrated amp	ex-dem	£700	£495	Nakamichi DVD 10s	DVD player silver	ex-dem	£600	£495			
Densen Beat B200	preamp R/C	ex-dem	£1000	£750	Loudspeakers							
Densen Beat B300	power amp	ex-dem	£800	£595	Rega ELA	floor-standing oak	ex-dem	£535	£425			
Linn Wakonda	preamp - line	s/hand	£795	£550	Rega Jura	floor-standing	ex-dem	£465	£325			
Linn Majik phono	integrated amp	s/hand	£845	£545	Musical Technology							
Linn LK100	power amp	s/hand	N/A	£385*	Harrier	floor-standing oak	ex-dem	£635	£485			
Linn Majik phono	integrated amp	ex-dem	£845	£645	Naim 5BL	floor-standing walnut	s/hand	£2465	£1595			
Naim Nait3 R	R/C integrated amp	new	£800	£695	Naim 5BL	floor-standing beech	ex-dem	£2465	£1795			
Naim Nait 3	integrated amp	s/hand	£650	£450	Naim 5BL	floor-standing black	s/hand	£2465	£1295*			
Naim NAC72	preamp	s/hand	£790	£275*	5shahinian ARC	floor-standing light oak	s/hand	£2000	£1095			
Naim NAP140	pre/power amp	s/hand	£815	£495	Stands & Headphones							
Naim NAP180	power amp	s/hand	£1155	£750*	Stands Unique	Midi Tower Ash finish	ex-dem	£279	£195			
Naim HiCap X 2	power supply	s/hand	£760	£375/ £425*	Stands Unique	Sound Tower 10 cherry	ex-dem	£400	£295			
					HNE Nautilus 805	stands black granite finish	ex-dem	£450	£295			
Meridian 501/556	pre/power amp	ex-dem	£1690	£1195	Ash Design Cosmic 4	A/V stand maple	new	£569	£469			
					Stax Lambda Nova / SRM-T1	Selectrostatic h/phones	s/hand	£1195	£795*			
					Sennheiser HD580/Lucas	Dolby surround + h/ph	new	N/A	£225			
					Sennheiser Lucas processor	Dolby surr. Processor	new	N/A	£95			

CD & DVD Players

Naim CDX	integrated player	s/hand	£2335	£1800
Densen B400	integrated player	ex-dem	£1280	£950
Linn Klassik black	CD/tuner/amp	s/hand	£995	£750
Linn Mimik	integrated player	s/hand	N/A	£495
Arcam Alpha 85E	integrated player	s/hand	£500	£350
Arcam Alpha 9	integrated player	ex-dem	£800	£595

Turntables

Roksan Xerxes	Turntable and PSU	s/hand	N/A	£575
Ortofon Jubilee	moving coil cartridge	new	£1250	£850

* Items being sold by us on the owner's behalf
ALL THE ABOVE ITEMS ARE SUBJECT TO AVAILABILITY

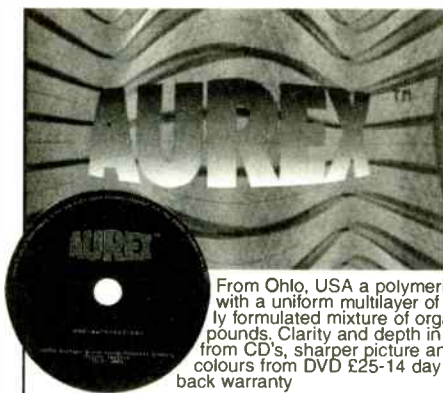

From Ohio, USA a polymeric, mat with a uniform multilayer of a specially formulated mixture of organic compounds. Clarity and depth in music from CD's, sharper picture and brilliant colours from DVD £25-14 day money back warranty

Taperwire flat speaker cable

418 -★★★★★ WHAT-HIFI, What Hi Fi Ultimate Hi Fi Guide

Sunfire Corporation

....from the mind & soul of Bob Carver



CLASSIC TUBE PRE AMP, optional all valve phono stage (MM/MC) with CD input (reverse RIAA equalisation)



STEREO POWER AMPLIFIER 300 wpc HEXFET with no heat sinks

FIVE CHANNEL POWER AMP 200 wpc x 5 - HEXFET with no heat sinks

THEATRE GRAND PROCESSOR PRE-AMP- phono stage, tuner, Dolby Digital, DTS, auto source sensing, intelligent remote

2700 watt TRUE SUB-WOOFER
11 inch cube 18Hz
Patent No 4218660 & 4484150
2700 watt SIGNATURE SUB-WOOFER 13 INCH CUBE 16Hz



4 Arundel Road Kingston UponThames
Surrey KT1 3RZ
Tel: 44 (020) 8241 9826
Mobile: 020 8264 0249
Fax: 44 (020) 8241 0999
E-Mail: weere@cablenet.co.uk

AUDUSA & Co



AC-2 POWER CORD

"For the money, that's no mean feat!"
HI FI WORLD June 99
"compare against product costing ten times as much or more, then decide"
AUDUSA & CO

L A T INTERNATIONAL

World Class Cables Made in U.S.A

AC-2 Power cable - Silver clad, Teflon insulated at 10awg; this is the largest gauge of power cord we know of. The design of our shielding system effectively eliminates interferences from RF and EMI sources. Fitted with a MK Tough plug and IEC or Fig of eight connector. European connectors also available. Solder connections with Wonder Solder. 2ft £56, 3ft £68, 4ft £78, 6ft £99. Other lengths to order. 4, 6 and 8 way all steel distribution boxes with 3 ft of cable & MK Tough plug 4way £161, 6way £194, & 8way £226.



Hi-Fi World Aug 99
"gained speed, control & involvement. Improved cohesion and musicality"

LAT International Cables - now with **SILVERFUSE** conductors. Silverfuse is a near alloy of silver and copper. It is not silver plated or silver clad. The Silverfuse process starts with seven nines OFHC copper wire with a diameter that is slightly larger than the required size. It is then pulled through a trough of molten silver. The wire with a silver deposit, is then forced through a compacting die where it is subject to tremendous pressure. The silver and the high purity copper are fused together into a near alloy. The compacting fusion also reduces the wire diameter to the desired size. No dioding subsequently occurs with this process. The result provides for the benefits of silver; which are excellent definition and clarity, with the high purity copper benefits of warmth and mellowness. Interconnects analogue IC200, IC100, IC80, digital DI-20, video V1-6 and Component Video, Speaker Cable SS1000, SS1000 Biwire, SS800 and SS800 Biwire and Mains cable AC-2.

For further information visit our website:
www.audusa.com or www.audusa.co.uk

MEASURED PERFORMANCE

LOUDSPEAKERS

CASTLE HOWARD S3

The forward firing drive units of the new Howard provide a flat measured frequency response down to 150Hz, within very tight limits of 1dB or so, on axis or just a little above. Below 150Hz output drops suddenly from the forward unit, but all the same reaches down to 40Hz, -5dB.

An upward firing unit works from 5kHz right down to 63Hz, measurement showed. As frequency decreases sound becomes less directional and below 200Hz its contribution to forward energy will increase, helping raise the apparent -5dB level loss below 150Hz.

Unfortunately, the upward firing unit peaks strongly at 300Hz, due to a cabinet effect, meaning colouration will be apparent from this unit. Since its output is reflected from the ceiling I'd expect the Howard to work best in a room with some ceiling height, say 8ft or more, otherwise the reflected energy might be very strong.

The upward and forward firing drivers are identical. Our analysis of upward firing output shows the parasitic centre cone of this driver peaks sharply at 5kHz. There's a peak at this frequency in the forward response too which is almost certainly responsible for some sharpness in the Howard's sound. Ideally, the parasitic centre cone of this driver should be made less resonant or a notch filter used to control this peaking, to smooth the sound.

The top firing driver is loaded by a long tapered line that vents onto the floor. The vent peaks at 63Hz and rolls off slowly below this frequency, extending output down to 25Hz and lower. In a big room it will give very deep bass; in a medium room it will drive the modes well - especially the height mode - to make things shake.

CHARIO CYGNUS

A noticeable feature of the Cygnus is a strong treble peak in its frequency response at 16kHz. Although it looks serious, it is so narrow that response only starts to lift at 10kHz. Whether this sort of thing is audible or not depends very much upon the music played, since if there are no strong harmonics at 10kHz or above then equally there will be no audible effect. Put on a recording with strong harmonics, something like closely

The impedance curve of this loudspeaker is superb. An impedance curve says a lot about a loudspeaker (and the skills of its designer). Perfect flatness is a design goal rarely achieved. We managed it once at Hi-Fi World with a quarter-wave transmission line design (DIY Supplement No 14, April 1995) but I have never since returned to the transmission line. The Howard S3 behaves very similarly. What's more, not only have Castle engineered a flat bass impedance, but they've knowingly kept the impedance curve flat right up to 20kHz.

A flat impedance curve means many things. Down at the bass end it means the drive unit is seeing optimum acoustic loading, with near-perfect damping. So we can expect smooth, tuneful and tight bass. I know from experience of course the Howard produces this.

Absence of sudden impedance changes also means that as a load this loudspeaker is largely resistive, so it doesn't return energy to the amplifier. With feedback amplifiers, as all solid-state designs are, the Howard is not driving the amplifier in a way most do - something I can't help feeling accounts for more problems than we know about.

Finally, measured with pink noise the Howard is an exact 8ohm load - perfect for valve amps and easy for transistor amps too. The only downside of this high impedance is that it limits sensitivity a little. Castle claim 88dB but I measured 86dB, a reasonable if not exceptional figure.

Because the Howard drives a room's height mode strongly and reflects energy from the ceiling too, listening room height is important. This loudspeaker is likely to suit rooms with high-ish ceilings. The forward response is very flat, my only slight

miked guitar, and a peak like this will become suddenly noticeable as a sharp edge - almost a sting in the sound. For most of the time the Cygnus' are likely to sound quite normal in balance though.

The two visible drivers are aided by a downward firing unit in the base of the cabinet. Measurement showed this unit added nothing to bass extension though, unlike a port. Forward response of the Cygnus reaches down to 40Hz, with

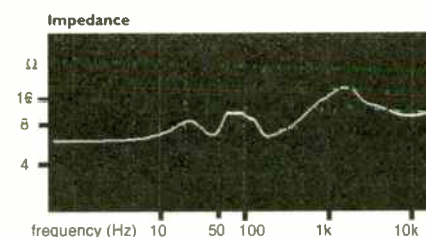
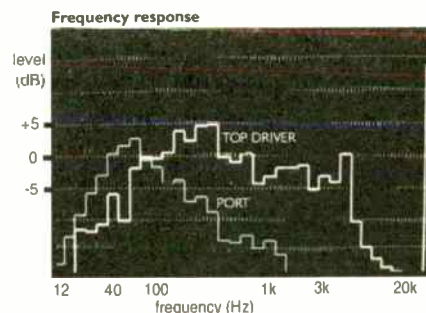
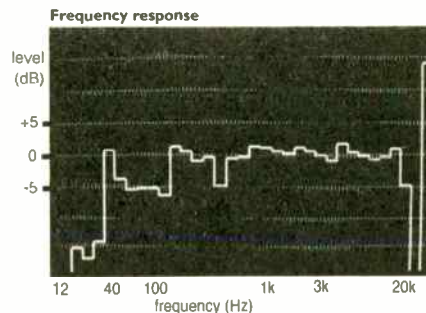

reservation here being perfect flatness to 20kHz often results in a glassy type of brightness and the 5kHz peak doesn't help. As a load the Howard is one of the easiest going on the loudspeaker market today so it will get the best from amplifiers.

The Howard might look trad but it sets out to do much more than most expensive loudspeakers and achieves its goals with success. This is an interestingly different loudspeaker, very well engineered, even if there are a few minor blemishes that could be tackled. **NK**

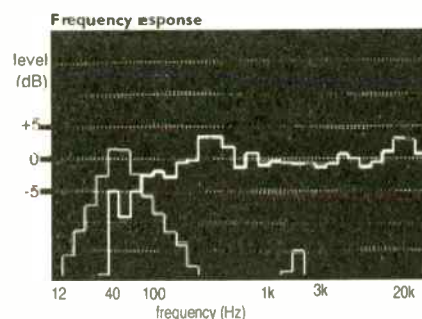

V.A.T. No.
729580013



QUALITY USED
EQUIPMENT.
BOUGHT, SOLD, PART
EXCHANGE

TEL/FAX
0121 747 4246



URGENTLY REQUIRED
LINN, NAIM,
MERIDIAN, QUAD,
CASH WAITING

	RRP	NOW £
ACCUPHASE E306V INTEGRATED 1 MTH OLD	3300	1995
ALCHEMIST FREYA PRE	1000	495
ALCHEMIST GENESIS MONO'S	1500	795
ART AUDIO DIAVLO 300B SE CHROME & GOLD	4500	2295
ATC SCM 10 BLACK	1000	495
AUDIOPHILE BASE SYSTEM 5 TIER FULLY LOADED	700	395
AUDIOLAB CDM TRANSPORT	1400	695
AUDIOLAB DAX 24 BIT	1100	495
AUDIOSTATIC DCI ELETROSTATICS	3000	1295
AUDIO NOTE ANV INTERCONNECT	180	95
AUDIO SYNTHESIS DAX DECADE BALANCED	4000	2495
AUDIO SYNTHESIS TRANSCEND TRANSPORT	1200	395
AUDIO RESEARCH SP14	4000	1295
AUDIO RESEARCH CLASSIC 60	3500	1695
AVI S2000 MM POWER AMPS	1400	850
AVI S2000 MT TUNER	900	550
CARDAS CROSS 2 X 2.5 MTRS SPEAKER CABLE	720	450
COPLAND CTA 401	1700	995
DIAPASON ADAMANTES 11 + STANDS	2250	1395
DYNAUDIO CONTOUR 1.8 MK11 ROSEWOOD	1900	1095
EQUATION 2 SPEAKERS PIANO BLACK	3500	795
KEF 20B SUBWOOFER	350	195
KRELL KST 100	3500	1495
KRELL KSL BALANCED PRE	2500	895
KIMBER KC1 INTRCONNECT	100	50
LEXICON CP2 PROLOGIC PROCESSOR	1200	150
LINN ISOBARIKS DMS WALNUT CANNONS + STANDS	N/A	495
LINN LP12 CIRKUS ARMAGGEDON TRAMPOLIN	N/A	895
AKITO DENON DL304	N/A	995
LINN LP12 LINGO ITTOK LV111 TROIKA	N/A	995
LINN LP12 CIRKUS ARMAGGEDON TRAMPOLIN	N/A	1295
ITTOK LV111 TROIKA	N/A	1295
LINN KABER AKTIV WALNUT + CROSSOVER	2640	795
LINN 5110 SMALL SURROUNDS	200	125
LINN LK 100	650	350
MARK LEVINSON NO 28 + HIGH GAIN PHONO	4000	1695
MARTIN LOGAN QUESTS (NEW PANELS)	5500	2295
MERIDIAN 263 DELTA SIGMA DAC	750	195
MERIDIAN 506 20 BIT	1100	695
MICHELL ALECTO MONO'S MK11	2000	1395
MICHELL ORCA + LARGE PSU	1660	1095
MICHELL DELPHINI + LARGE PSU	900	595
MIT 330 PLUS INTERCONNECTS I MTR X 2	300	150
MUSICAL FIDELITY X ACT	200	125
MUSICAL FIDELITY X10 D	150	75
NAIM CD 3.5	1100	695
NAIM 62 OLD STYLE	N/A	150
NAIM 42	N/A	75
NAIM 160	N/A	350
NAIM 160 (RECENT SERVICE)	N/A	450
NAIM SBL WALNUT LATEST DRIVERS BOXED MINT	2465	1095
NAIM 90/2	450	250
NAIM ARMAGGEDON	645	450
NEAT MYSTIQUE CHERRY	750	350
PINK TRIANGLE EXPORT LIGHT OAK	1000	295
QUAD 57 BRONZE	N/A	450
QUAD ESL 63 ROSEWOOD TRIM BLACK GRILL'S + STANDS	3800	1395
QUAD 99 PRE	800	495
REVOX B226 CD VARIABLE OUTPUT	1100	350
REL STENTOR 11 BLACK	1800	995
REL Q50	375	195
ROKSAN CASPIAN INTEGRATED	800	450
SONUS FABER MINIMA AMATOR	1600	795
SONY ESPRIT TAN 900 MONOBLOCKS	8000	995
TANNOY ARDENS 15 INCH DUAL CONCENTRIC	N/A	795
THETA TLC	230	150
TRANSPARENT MUSIC WAVE 2/4 FT	280	150
TRANSPARENT MUSIC WAVE PLUS 2/10 FT		
SPADES 2 MTHS OLD	530	295
WADIA 860X LTD EDITION SILVER	7500	5495
YBA 2 POWERAMP	2300	895

OPEN MON-SUN 10.00 TO 8.00
Website: www.centralaudio.co.uk
E-mail: tony@centralaudio.co.uk



listening
rooms

PHONE FOR LATEST LIST

	RRP	SALE
NEW, ED-DEM AND CLEARANCE ITEMS		
AUDIO RESEARCH D130	1995	1195 S/H
AUDIO RESEARCH LS2		795 S/H
MICHELL ALECTO STEREO		1150 D
CYRUS 3i INT AMP	598	329 D
CYRUS SL INT AMP	400	279 D
ARCAM ALPHA 10 AMP	800	599 D
ARCAM ALPHA 8R AMP	350	259 N+D
ARCAM ALPHA 7R AMP	280	229 N+D
ARCAM ALPHA 9P P/AMP	400	300 N
ARCAM ALPHA 10 DAVE +(SURROUND SOUND) 10 CHANNEL P/AMP	2498	1595 D
SONUS FABER MUSICA AMP (BOXED AS NEW)	2295	1295
MUSICAL FIDELITY XA1	480	295 N+D
KRELL KAV500i INT AMP	5498	4295 D
CAMBRIDGE CD2	-	129 S/H
CAMBRIDGE P55 AMP	-	79 S/H
M/F DIGILOG DAC	-	69 S/H
MONITOR AUDIO 14 SPKRS	-	159 S/H
MISSION 701 SPKRS	160	119 N
SONUS FABER ELECTA AMATOR INCSTONE WOOD STANDS, MINT	-	1495 SH
Linn 5140s	2150	1495 D
LINN KABER	1995	695 D
MISSION X SPACE SPKRS	199	149 N+D
NEATE MYSTIQUE	735	499 D
CYRUS DAD 1 CD	400	150 D
CYRUS DAD 3 CD	598	349 D
CYRUS DAD 1.5 CD MINT	400	239 D
CYRUS FM7 TUNER	400	279 D
THETA CHROMA DAC HDCD	899	495 D

D = EX DEMONSTRATION, N = NEW, S/H = SECOND HAND

THE LISTENING ROOMS LTD

161 OLD BROMPTON ROAD LONDON SW5 0LJ

TEL: 0171 - 244 7750/59 FAX: 0171 - 370 0192

www.listeningrooms.com E-mail: tlr@dial.pipex.com Mon-Sat 10-6pm



Hi-Fi Audio Consultancy
Sales and Service

	Was	Now
Arcam Xeta 2 A/V Processor	S'Hand	£250.00
Arcam Delta 90 Amplifier	S'Hand	£175.00
Arcam Alpha 5 Amplifier	S'Hand	£230.00
Arcam 9 Amplifier	Ex Dem	£500.00
Arcam Alpha 10 Amplifier with Dave module	Ex Dem	£1650.00
Arcam Alpha 10P/3 channel power amp	Ex Dem	£850.00
Arcam Alpha 9 P Power amplifier	Ex Dem	£400.00
Arcam Alpha 8 P Poweramplifier	Ex Dem	£250.00
Arcam Alpha 7 Amplifier	Ex Dem	£280.00
Arcam Alpha 8 R Amplifier	Ex Dem	£350.00
Arcam Alpha 8 Tuner	Ex Dem	£250.00
Arcam Alpha 7 Tuner	Ex Dem	£230.00
Arcam Alpha 8 SE CD Player	Ex Dem	£500.00
Arcam Alpha 9 CD Player	Ex Dem	£800.00
B & W DM 601 S1 Loudspeakers	S'Hand	£200.00
B & W DM 620 Floorstanding Loudspeakers	S'Hand	£150.00
Bose 501 Mk 2 Loudspeakers	New	£600.00
Castle Inversion 15 Various finishes	New	£425.00
Castle Harlech S 1 in Birch	New	£900.00
Castle Inversion 100 in Cherry	Ex Dem	£1950.00
Denon AVR 1800 Dolby Digital Receiver	Ex Dem	£450.00
Denon AVR 2800 Dolby Digital Receiver	Ex Dem	£600.00
Denon AVR 3800 Dolby Digital Receiver	Ex Dem	£800.00
Elac EL 140 Loudspeakers Black	S'Hand	£800.00
Kef Q 65 Floorstanding Loudspeakers Rosewood	Ex Dem	£800.00
Kef Q 70 Floorstanding Loudspeakers Black	Ex Dem	£600.00
Logic DM 101 Turntable, RB 300arm ATF3 Cartridge	S'Hand	£850.00
Marrantz CD 63 SE Cd Player	S'Hand	£350.00
Meridian 541 A/V Processor	Ex Dem	£1000.00
Musical Fidelity Preamp 8 in Chrome	S'Hand	£175.00
Quad FM3,303 Poweramplifier,33 preamplifier	S'Hand	£150.00
Quad 405 Mk 1 Poweramplifier	S'Hand	£175.00
Rotel RC 972 Preampifier	New	£225.00
Sony STS 730 ES Tuner	S'Hand	£100.00
Yamaha MDX 595 Minidisc Player	Ex Dem	£230.00
Yamaha DSPA 2 Dolby Digital Amplifier	Ex Dem	£1000.00
Yamaha DSPE 492 Processor	S'Hand	£250.00
Yamaha DVDS 795 DVD Player	New	£450.00
Yamaha RXV 795a RDS Dolby Digital Receiver	Ex Dem	£600.00

12 Regent Street, Rugby, Warwickshire, CV22 5LP
Tel: 01788 540772 Fax 01788 542170
www.soundexpensive.co.uk

unevenness related to floor effects. Bass may sound a bit uneven because of this.

Although impedance measures 4ohms up to 300Hz, meaning the speakers draw bass current from an amplifier, sensitivity was low at 84.6dB. A powerful amplifier with good current handling is needed. There's a large rise in imped-

ance across the midband, signalling reactance and energy storage. All in all, this loudspeaker is not an easy or well tailored load.

The Cygnus looks a little unimpressive in its measured performance. It has no particular strengths and some small weaknesses. **NK**

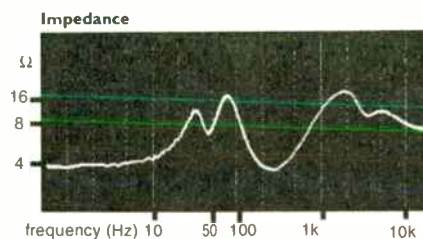

LINN KATAN

There are a few obvious features characterising the bass/midrange performance of the Katan. The overall response is lumpy by modern standards, meaning it will be 'characterful'. From an engineering point of view this doesn't look so good, but from a listeners view it may well give the Linn something other 'speakers don't have. There's no lift at low frequencies to add body to the sound and bass rolls off smoothly and steadily. Both factors suggest a fairly damped system intended for use close to a (rear) wall. Well damped 'speakers work best with a powerful amplifier possessing grip; the result is a fast, tight sound that suits Rock in particular.

The response lumpiness is due to three effects. There's a peak 160Hz that signals the presence of a box effect, meaning there'll be some colouration in there somewhere, likely most audible with deep male vocals, as well as bassoon, string bass, etc. The port whistles at 1.25kHz, seen as a peak in port output, and this again reflects back into forward response. The bass/mid gets peaky at its upper limit, a common enough problem.

The port is tuned to 52Hz but extends output down to a useful 30Hz, so in larger (18ft) rooms the Katan might

excite a length mode quite well to give some strong lows.

The crossover region shows some lift or peaking in the bass/mid driver's response plus slow take up from the tweeter. I'd expect a little sharpness to be heard from that peak. Upper treble might sound a little thin or divorced, but the tweeter is smooth and not given too great a role, so it shouldn't be prominent. Overall the Katan has a balanced response characteristic that's quite flat.

Overall impedance, measured with pink noise, measured out at exactly 8ohms. Together with a resistive nature this makes the Katan quite an amenable load as far as any amplifier is concerned. Unfortunately, it is very insensitive, partially as a result of high impedance, producing just 82dB SPL from one watt of input. This means a powerful amplifier with plenty of voltage swing is still needed for good volume, around 100W being likely usable.

The Katan is no triumph of loudspeaker engineering but it's basically accurate and will likely have a fast, tight sound with good bass. Used with a powerful amplifier, on firm stands close to a rear wall the Katan should give a distinctive sound. **NK**

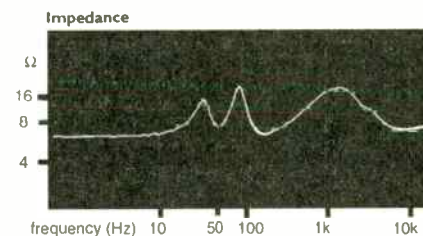
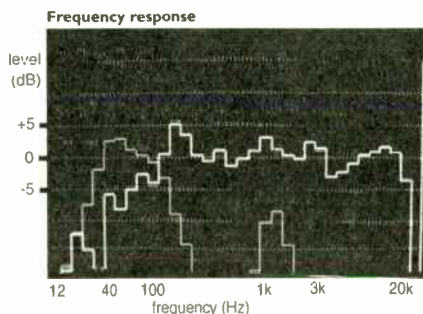

AMPLIFIERS

ARCAM DIVA 85 AMPLIFIER

Producing 105W into 8ohms and 156W into 4ohms, the Arcam 85 amplifier has plenty of grunt. Better still, it stayed more linear than many designs as current was drawn, so the output stage will cope with today's low impedance loudspeakers rather better than many, giving plenty of volume and staying relaxed sounding whilst doing so. The only small blemish was a rise in high frequency distortion at low output levels, something that can be avoided these days. With a trace of third harmonic measuring 0.02% this should not be a problem though.

Input sensitivity was unusually low at 700mV. Whilst modern sources usually give a volt or more of output, old cassette

decks and tuners only manage 300mV or thereabouts. The Arcam will be fine with modern items then, but will not match older product. As a result of low gain, noise was low too.

Frequency response stretched from 4Hz-88kHz, plenty enough for SACD and DVD-Audio.

This is a tidy amplifier with plenty of power for modern loudspeakers. It should sound smooth enough too, but it does not match 'legacy' sources. **NK**

Power	105watts
CD/tuner/aux.	
Frequency response	4Hz-88kHz
Separation	75dB

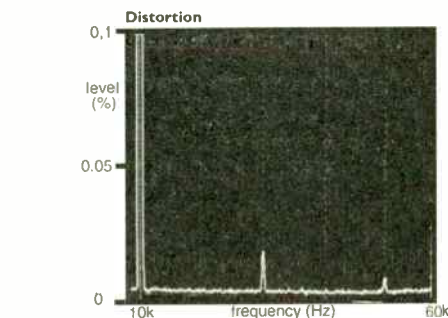

Noise	-113dB
Distortion	0.02%
Sensitivity	700mV
dc offset	2.71mV

CLASSIQUE SOUNDS. (LEICESTER) INC. *ONETHING* VINTAGE HI-FI & VALVE SPECIALIST

FOR SALE PRE/POWER AMPLIFIERS

Radford MA15 MK2 mono valve amplifiers X 2 consecutive serial Nos C/W SC2 pre-amplifier. Mint cond.	£1900
NVA A60 mono power amplifiers X 2. Good cond.	£ 799
NVA A60 stereo power amplifier. Good condition.	£ 295
NVA P80 passive pre-amplifier. Good condition	£ 199
Pair huge Advant GI-A565 mono amplifiers. Good cond.	£ 995
Alchemist Forsetti pre-amplifier. Mint. Boxed	£ 850
Quicksilver Line stage valve pre-amplifier. Stunning	£ 599
Hafler SE100 pre-amplifier. MM/MC. 2 outputs	£ 125
Pair Meridian 605 mono amplifiers. Good condition.	£ 950
Assemblage L1 Valve pre-amplifier. Some frontiers	£ 399
Musical Fidelity Pre-8 pre-amplifier. Mint. Boxed	£ 175
Arcam Alpha 3 amplifier. Mint. Boxed/Instructions	£ 100
Exposure IV power amplifier. Excellent condition	£ 595
AudioLab 8000E pre-amplifier.	£ 199
Int 5PI pre-amp & Spare MC board / X Pak 2 Power supply & Nexus Sain-40 power amplifier. Mint. Boxed	£ 450
Quad 605 MK1 power amplifier. Excellent condition.	£ 399
Musical Fidelity P7A Pre-amplifier. Mint. Boxed	£ 225
Leak stereo 50 valve power amplifier. Very rare	£ 495
Arcam Alpha 2 amplifier. Good condition.	£ 89
Pair Heathkit MA12 mono valve amplifiers.	£ 249
Quad 34 pre-amplifier. Grey finish's pin din. Boxed	£ 195
Yamaha DSP580 Dolby prologic digital sound field processor. C/w centre and rear spks & remote. Mint. Boxed	£ 250
Oxford Acoustics Mistral int amp. Cost £450.	£ 149
Sugden Optima 140 int line amp/remote. Ex con. Bxd	£ 275
Quad 903 power amp. Ex cond. Serviced. New caps	£ 195
Townsend 600E pre-amplifier with mm/mc phono	£ 125
Musical Fidelity The Pre-amplifier with MM/MC	£ 199
Technics SHGE70 Graphic Equaliser. 12 presets.	£ 80
Cambridge P25 integrated amplifier. Ex condition	£ 99
Exposure IV power amp. Dual mono / regulated	£ 899
Ruel RB970 BX power amplifier. Mint	£ 300
Sony TA-F8000E integrated amplifier. £2500. Mint	£ 300
Arcam Zeta 1 Pro logic Cinema amp. Cost £999.00	£ 450
Quad 33 pre-amplifiers	£ 75
TVAac line level valve pre-amplifier. Mint. Boxed	£ 350
Scott 410A integrated transistor amplifier.	£ 99
Leak Stereo 20 valve power amplifiers from	£ 200
Marantz PM6010SE int amp/remote. Mint. Bxd	£ 140
Arcam Alpha 2 amplifier. Mint. Boxed/instr	£ 95
Comosuz/Sugden stereo valve pre/power amp. Mint	£ 249
Quad 11 Various. Price depends on condition.	£ 90A
Sugden C51 pre-amplifier. Excellent condition	£ 99
Pioneer A40 amplifier. Ex condition. Boxed.	£ 125
Quad 44 pre-amplifier with 5 pin din and MC board	£ 200
Naim Nac 42.5K pre-amplifier with MC board	£ 195
Sugden A48 amplifier	£ 90

TURNTABLES

Veid THE VOYD: 3 motors & outboard PSU.	£ 799	NVA phono 2 MC pre-amp + 2 X PSU. Awesome	£ 499
Thorns TD125/Audio Technica 1100 arm/plinth	£ 250	Roksan series XB2 PSU. Black finish RB250	£ 550
Rega Planar 2 turntable RB250.1. Ex condition. Boxed/£120	£ 199	Revolver Table / Linn Bask + & AT. Mint. Bxd	£ 169
Michell Focus One with Linn Bask LVA arm. Ex con	£ 199	Rega Planar 2 c/w rega RB200 arm Wood plinth	£ 95
Luxman P1277 Direct drive turntable.	£ 170	Trio KD550. Direct drive turntable.	£ 95
Dunlop Systemdeck Turntable Complete with Syrius 2	£ 299	pick up arm the original & the best. Excellent condition	£ 299
Arson RD110 turntable. Cut-out for SME. Bx'd	£ 75	Technics SL150 3D deck. Cut-out for SME. arm	£ 150
Thorns TD166BC Deck only. Cut-out for SME. Bx'd	£ 150	Thorns TD125 in SME 3000 plinth. Cut-out for SME.	£ 60
Arson RD80 turntable. C/W Linn Bask LVA. Boxed	£ 149	Garrard 301 & 401 motor units all serviced from	£ 125

SPEAKERS

Quad ESL57 speakers. All fully serviced with full 3 months warranty. Hear what ESL57s should sound like. From	£ 750 pr
Pair Quad ESL57 spks. Fully rebuilt. 4 x Recon bass & 2 recon treble units. All new electronics. 12m warranty	£ 1199
Naim Intro speakers in black ash. Mint. Boxed	£ 450
Paradigm mini monitor speakers. As new. Boxed	£ 100
Pair of Meridian Short performance 860 speakers. Mint condition. Piano black finish. Boxed. Cost £1895	£ 899
Celestion Ditton 25 in. teak. Very good condition.	£ 139
Townsend Glastonbury 2 speakers. Ex condition	£ 899
B&O Beovox 3800 speakers. Nice sound. Large	£ 49
Kel 127 tweeters. Pair of.	£ 50
B&W DM220 slight cabinet marks. Boxed	£ 79
Celestion Ditton 44.	£ 80
Meridian Short MS20 Pearl. Black finish. New	£ 169
Richard Alan monitor speakers. Good condition.	£ 125
Cambridge R50 transmission line speakers. Rare	£ 259
Heybrook Heylins. Black. Boxed. Ex condition	£ 199
Kel kat 62 with B139/B110 Scans-peak D2005 9300	£ 295
tweeters. Expensive X overs. Gut wrenching base. Awesome	£ 295
Rogers I.56 speakers in teak. Mint. Boxed	£ 125
Pirate stands for Snell J speakers. Black	£ 100
Speaker SF2/5. Black finish. Boxed/Instructions	£ 95
Kel Cresta 2. Black. Mint condition. 4 months old.	£ 110
Russ Andrews. Torlyte speaker stands. Cost £599	£ 249
Heybrook HB1 speakers. Priced to sell	£ 50
Bose powered Acoustimats 3 spks. Unused/boxed	£ 295
Dynalab 2.8 reference speakers. Cost \$1200. Unused	£ 450
Ruark Sabre. Black. Mint. Boxed	£ 170
Heybrook HB2 speakers. Teak finish	£ 100
Snell J2 speakers. Black finish. Ex condition. Boxed	£ 495
Bose 301 MK3. Unused. Boxed. Mint. Black finish	£ 249
Pair Rogers Studio 5 speakers. Rosewood finish	£ 250
Meridian Short MS3.10. Mint. Boxed. Black finish	£ 40

OTHER ITEMS

Sugden SDT1 & SDA1 Transport & Dac/remote	£ 849	Quad rack for 44/405/mst.	£ 40
Naim CD3.5 CD player. Mint. Boxed	£ 749	Sony pro walkman WMD6C with leather case. Mint	£ 200
Quad PM4 tuner. Late model. Grey finish.	£ 199	Spare arm tube for SME series 3. New. Unused. Boxed	£ 55
SME 3009 Series 3 Tone-arm. Mint. Boxed	£ 149	Senheiser HD500 MK2 Headphones. Unused. Boxed	£ 55
Soundstyle Rack. 4 shelf. 4 legs. Black finish. Ex	£ 120	Teac TR450 tuner. AM/FM synthesized/RDS. Boxed	£ 69
Linn Tuner. Mint. Boxed. Very unusual. Cost £549	£ 249	Quad FM2 Valve tuner. Nice condition. Rare.	£ 160
National Panasonic 205C-11 low impedance stereo	£ 59	cartridge complete with SME style headshell. Unused. Boxed	£ 59
Arcam Alpha 5 cd player. Mint. Boxed/remote	£ 195	Phillips 100 cd player. The first. Good condition.	£ 100
Denon DC1700 CD player. Cost £650. Boxed.	£ 100	Denon DC1700 CD player. Cost £650. Boxed.	£ 100
Marantz CD 50 CD player. Ex condition. Boxed	£ 80	Marantz CD 50 CD player. Ex condition. Boxed	£ 80
Leak troughline 3 stereo tuner. Fully serviced	£ 195	Revox B772 2 speed reel-reel player. Ex condition	£ 395
Leak stereo/tuner. Similar to Troughline.	£ 35	Leak 2300 tuner. Serviced by One. Thine. Mint	£ 49
Marantz CD52 MK2 CD player. Mint. Boxed	£ 99	Audax HD-13D 34H tweeters. New old stock.	£ 25
Sugden T48 tuner. Sounds superb.	£ 95	Arcam Black Box 50DAC Unused Cost £480. Mint	£ 240
Meridian 203 MKV B&S DAC. Mint. Boxed	£ 160	Thio KT80L synthesized tuner. AM/FM. Bx'd	£ 75
Haddock tone-arm with Linn arm-board	£ 149	Technics SL-PS620A CD player/remote.	£ 75
Quad 34 moving coil module. Mint. Boxed	£ 40	SME 3009 tonearms from	£ 95
Technics Class AA 3 head cassette deck. Dolby B/C	£ 80	HN pro. Adjustable Bias control. Good condition.	£ 80
Airwa NT950 tuner. Boxed. Full w/aw/cw/w tuner	£ 75	Avantec Blamini Lcp3/BX/B11 AM/FM tuner. Serviced	£ 150

QUAD ESL57 PANELS/SERVICING ETC

Reconditioned Quad ESL57 speakers from only £700.00 pr. Why spend £4000+?
Have your ESL57s refurbished for only £349.00/Pair. Ring for full details.
Exchange/recon ESL57 bass panel £120. Treble £100. ESL63 panels £110. Refurbished.
New socks for ELS63s £38 pr. Many other spare parts available. Please ring.
"Classique Sounds servicing restores the Quads to a position where they can hold their head high", Jon Marks. HI-FI WORLD. April 1999
Full servicing facilities available.

Troughline tuner service & realignment £95.00. (excludes valves. Rarely needed). Subject to tuner being in a serviceable condition, with no major faults or modifications.

TRANSLUCENT. (some what of a bargain) Hi Fi World. Jan 1999
PURE SILVER INTERCONNECT CABLE
99.99% pure silver conductors. Quality gold plated RCA phono plugs.
Half Metre terminated £60.00 One metre terminated £80.00
7 day money back guarantee if not better than existing cable. Regardless of price or quality

One Thing Main cable - Class 1 RFI suppressed. Silver plated conductors
Voltage spike protection, only...£55.00

NEW EARLY YOSHINO EQUIPMENT

Ear 834P MM/MC phono stage with/without volume.	Brand new. Boxed at only £529
Ear 834P MM phono stage. No volume control.	Brand new. Boxed at only £379
Ear 834L Line only valve pre-amplifier. Amazing.	Brand new. Boxed at only £479

301/401/124 PLINTHS (lets the Garrards inherent quality show through) Hi-Fi World. Oct 98
Plinths @ only £199 unfinished or £299 finished (venered)
Awarded 4 Globes October 98 (HI-FI WORLD)

WANTED Vintage and modern hifi eqpt. Part exchange welcome.
Tel/Fax 0116 2835821 or 0802 213740 (Mobile). Callers by appt only
Opening times 10.00am-6.00pm Mon-Friday. 10.00am-2.00pm Saturday.
Classique Sounds, 61 Aylestone Drive, Aylestone, Leicester. LE2 8QE

Cable Talk

Interconnects & Speaker Cables

1994		Best Speaker Cable
1995	 	Best Interconnect & Highly Recommended Speaker Cable
1996	 	Best Interconnect & Best Speaker Cable
1997	 	Best Speaker Cable & Highly Recommended Interconnect

Interconnects Speaker Cables

Doesn't Your System Deserve The Best?

FOR FURTHER INFORMATION

Please telephone, fax or write to

Cable Talk,

Unit J, Albany Park, Camberley, Surrey, GU15 2PL

Tel (UK ONLY): FREEPHONE 0800 - 100 - 6868

TEL: (+44) (0) 1276 686717. FAX: (+44) (0) 1276 686353

(CT HFV 0401)

diverse vinyl

01633 256261 / 259661

10 Charles Street Newport South Wales NP20 1JU.
sales@diverse-music.co.uk

Forthcoming Releases

Arab Strap	The Red Thread	25/02	£TBC
Beastie Boys	Sounds Of Science		£TBC
Bob Marley/Wailers	Natty Dread/Live (SV)		£18.50
Bonnie Prince Billy	Ease Down The Road	25/02	£TBC
Captain Beefheart	Grow Fins Volume 3		£TBC
Richard Thompson	Action Packed (Best Of) 2LP		£17.90
David Bowie	Man Who Sold The (SV)		£TBC
David Bowie	Diamond Dogs (SV)		£TBC
Erykah Badu	Mama's Gun		£15.90
Fun Lovin Criminals	Logo	26/02	£TBC
Led Zeppelin	3 & 4 (Classic Records)		£25.90
Rubbles Vois 13 -15	Psyche Reissues	01/03	£16.90

THIS MONTH'S FEATURED NEW RELEASES
GEORGE HARRISON "ALL THINGS MUST PASS"
30TH Anniversary Re-issue with 5 extra tracks - 3LPs £25.90
THE WHO "LIVE AT THE ISLE OF WIGHT FESTIVAL"
First time on vinyl for this classic live set - 3LPs £29.90

Other New Stock And Recent Releases

Al Green	Simply Beautiful	£12.90
Beatles	1 - WHILE E STOCKS LAST	£18.90
Charles Lloyd	Discovery	£10.90
DCC - Queen	Night At The Opera	180g £26.90
Genesis	Duke (SV)	£18.90
Gram Parsons	Lost Recordings(65-66)	£15.90
Ibrahim Ferrer	Salson (Early Recordings)	£15.90
Impressions	Young Mods Forgotten Story	£12.90
JJ Perrey	The In Sound From Way Out	£13.90
Johnny Cash	American 3 Solitaryman	£11.90
Ornette Coleman	Live At Prince Street	£10.90
Paul Simon	You're The One	£16.90
Queens Of Some Age	Rated R	US LP £14.90
Sonics	Here Are/Boom	Each £12.90
Stephen Malkmus	(Ex Pavement)	£12.90
Captain Beefheart	Trout Mask Replica	£22.90
Tortoise	Standards (Warp)	£TBC
Tubby Hayes	Introducing Tubbs	£10.90
Turin Brakes	The Door	£TBC
Unicorn	Uphill All The Way	£12.90

PLUS WE NOW STOCK THE DISCO ANTISTAT LP WASHING DEVICE - PRICE £39.99 (Ask For Details!)

P & P £1.00 1st LP: 50p each Additional LPs (up to 5 LPs)

Call For Rates On Larger Orders. 24hr Service Now

WWW.DIVERSE-MUSIC.CO.UK

SHARP DIGITAL AMP

Digital amplifiers would have been on the market some time ago were it not for their problems, the worst of which are distortion, as well as high frequency rubbish (above 20kHz) so strong as to produce radio interference. I looked forward to testing Sharp's new digital amplifier, hoping to see how they had managed to overcome these difficulties. I got a shock.

In spite of its size and weight the SM-SX1H amplifier produced just 15W into 8ohms. It didn't like 4ohms, protection circuits kicking in quickly to limit output current. However, it produced 30W and would manage this with short term music peaks into a low load. Because current limiting kicks in so quickly, and because most loudspeakers these days are 4ohms at low frequencies, the Sharp may well trip out if pushed too hard.

Since the amplifier got warm I can only assume efficiency is low, around the 50% mark, where Cirrus and Zetex are claiming 90%. As Sharp's amplifier approached clip RF noise on signal peaks grew, becoming fierce at clipping (overload). It looked grim on the oscilloscope, as our time domain shot (fig 1) shows, and it looked evil on the spectrum analyser (fig 2). As this amplifier moves into output overload it produces up to 0.5V of hash above 50kHz (fig 4), so will transmit RF interference from the speaker leads. It's a classic digital amplifier problem and Sharp have found no solution.

At low levels the SM-SX1H produces large amounts (1%) of low order distortion (fig 3). As signal level increases the distortion pattern changes, harmonics extending further up the audio band, level measuring around 0.25%. As full output is

approached progressively more high frequency rubbish is produced.

I'd expect these levels of distortion to be audible. Perhaps surprisingly, the highest level produced - 1% at 1W - is likely to be least audible, because it is innocuous second harmonic. The real problem is both the appearance of high order distortion harmonics and the horrible way the distortion pattern modulates. It's the latter effect that ensures audibility and will probably result in roughness. Of course, with just 15W available this amplifier needs unusually efficient loudspeakers if it is not to be driven into clip.

Noise output was high, the signal-to-noise ratio being a miserable -76dB, even though there was little overall gain, input sensitivity measuring a poor 600mV. This amplifier generates noise in its output stage, whereas noise in conventional amps comes primarily from the input stage.

With its low power, low efficiency, high levels of distortion and strong RF interference Sharp have produced no advances here. Cirrus, Zetex and Linn have digital amplifiers with better specifications. By normal standards it looks very poor, to the point of being unacceptable as a hi-fi amplifier. **NK**

Power	15watts
CD/tuner/aux.	
Frequency response	7Hz-51.5kHz
Separation	65dB
Noise	-76dB
Distortion	1.3%
Sensitivity	600mV
dc offset	4/1mV

UNISON S6 AMPLIFIER

Getting power from a single-ended amplifier is hard work. They're only 30% efficient or so, meaning you have to dissipate lots of plate power to get much output power. Unison have stacked three EL34s in parallel in the S6 to get goodly current through its output transformer. And the problems don't end there. The transformer core must be massive to survive d.c. magnetisation and be able to handle low frequency power. My tests inevitably probe this aspect of performance, an SE being quite a different animal to a push-pull. Output power was high at 24W in the mid-band, but the S6 could manage only 20W at 40Hz, going into quite severe clipping asymmetry. Its high frequency performance was fine however, with no output limitation at 10kHz.

Frequency response was a wide 6Hz-63kHz with a smooth roll-off at high frequencies. The transformer looked quite

good in this area. Unison have given the amp good sensitivity, yet it has low hum too, always something of a difficulty with valves, since high gain plus high input impedance tends to result in hum unless great care is taken. At 1.3mV or so this will not be a problem though.

Single-ended amps produce distortion of course, but it usually does not rise with frequency. This is how the Unison measured, our analysis showing no less than 0.8% distortion at 10kHz, one watt output. However, it is all second-harmonic and there's no sign of higher order distortion here, unlike a transistor amp. Since second harmonic is innocuous, resulting only in a lightening of timbre at levels of 3% or more, the subjective impact of such distortion is not great.

The S6 is a well designed single-ended producing as much power as is possible without getting impossibly large. **NK**

Power	24watts
CD/tuner/aux.	
Frequency response	6Hz-63.7kHz
Separation	65dB
Noise	-94dB
hum	1.4/1.3mV
Distortion	0.7%
Sensitivity	200mV

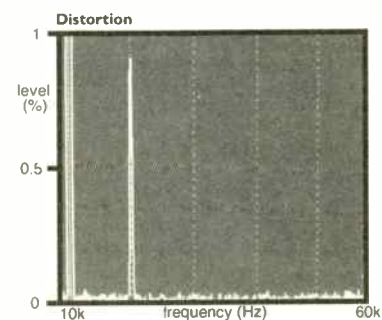
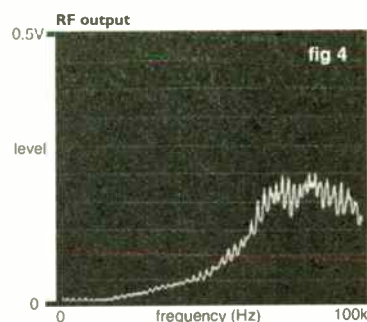
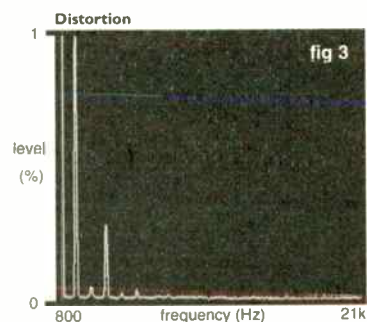
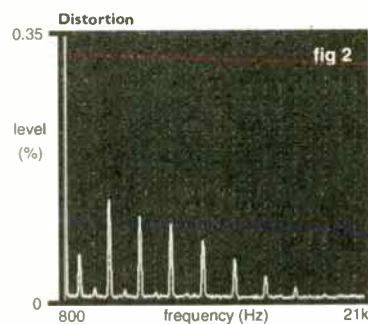
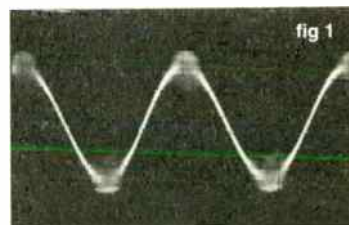

WILLIAMS HART ELECTRONICS

HART ELECTRONIC KITS TRADED FOR OVER 30 YEARS



NEW LAYOUT

80Watt Mosfet Stereo Power Amp Kit
110Watt Mosfet Monoblock Power Amp Kits

ONE OF THE BEST AMPLIFIERS YOU WILL HEAR! Regardless of price
ON DEMO @ Wigan, Southend, Peterborough and Burnley



Single Ended Class A Valve Sound
15Watt Power Amp modules

FOR THOSE WHO WANT THAT VALVE
MIDBAND BUT BASS AND TREBLE TO MATCH



ACTIVE R/Control SUBWOOFER MODULE £177.30



Range of speaker Kits
Passive and Active

TO CLEAR: WILMSLOW PRESTIGE SPEAKERS finished in dark oak £1699

Advertise your Hi-Fi on my website (£2.50 admin charge)
Also: Award Winning Phono Stage Kit, Active Crossover Modules, Speaker Drive Units,
M Cap Capacitors, Caddock Resistors, Remote Control Volume and much more

WEB SITE www.williamshart.com e-mail: williamshart@classicfm.net

or Tel/Fax for catalogue 01942 253647 121 Long Lane, Hindley Green, Wigan, WN2 4XD

PERSONAL VISITORS SHOULD PHONE FIRST TO AVOID DISAPPOINTMENT
Run by former Technical Director of Wilmslow Audio

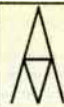

MANTRA AUDIO Specialist Suppliers of Audio Accessories www.mantra-audio.co.uk

CARTRIDGE SELECTION STYLUS

Goldring				
1006	£65	£46 EX	£46	
1012 GX	£84	£62 EX	£62	
1022 GX	£112	£77 EX	£77	
1042	£130	£93 EX	£93	
Erica LX/H	£121	£84 EX		
Elite	£232	£163 EX		

EX - Exchange price for a Goldring
Any make/model of cartridge accepted

Audio Technica				
AT 95 E	£23		£15	
AT 110 E	£28		£16	
AT OC 9 ML	£315	£237 EX		

Denon				
DL 110	£79	£62 EX		
DL 304	£210	£179 EX		

Grado				
Prestige Black	£46		£25	
Prestige Gold	£140		£78	

Ortofon				
510 Mk II	£34		£19	
MC 15 Super II	£130	£110 EX		
MC 25 FL	£227	£193 EX		
MC 10 Supreme	£304	£258 EX		
MC 20 Supreme	£382	£323 EX		
MC 30 Supreme	£452	£385 EX		
Rohmann	£837	£742 EX		

Shure				
SC 35 C	£35		£27	
V 15 V XMR	£285		£190	

REPLACEMENT STYLUS

Swiss Quality Diamond Stylus				
ADC	XLM Mk III			£15.00
Akai	AN 5, AN 60			£11.00
	AN2, AN 70			£13.00
Dual	DN 145 E, DN 165 E			£15.00
Goldring	G800 Super E			£15.00
JVC	DT 55, DT 60			£11.00
National	EPS 24 CS, P 30 D, P 33 D			£11.00
Ortofon	FF 15 E II, VMS 20 E II, DM 20			£15.00
Pioneer	PN 210, PN 220, PN 240			£11.00
Shure	N 75 C, SC 35 C			£11.00
	N 75 ED T2, N 75 EJ T2			£13.00
	N 95 ED, N 95 EJ, N 75 3 (78)			£15.00
	VN 35 E			£18.00
	N 95 HE, N 97 HE, VN 35 HE			£25
Sony	ND 142 G, ND 150 G, ND 155 G			£11.00
	CN234			£13.00

*** OVER 500 STYLUS TYPES STOCKED ***

Order direct from our
Secure Online Catalogue

HEADPHONE SELECTION

GRADO				
Prestige Series				
	SR-60			£77
	SR-80			£93
	SR-125			£139
	SR-225			£186
	SR-325			£279
Reference Series				
	RS-1			£609
	RS-2 (new)			£439

ALL CARTRIDGES SUPPLIED BY MANTRA AUDIO ARE GUARANTEED
AUTHENTIC NEWLY BOXED ORIGINALS AND CARRY A FULL
DISTRIBUTORS AND MANUFACTURER'S WARRANTY
EX - designates factory exchange price against any Audio Technica, Denon,
Goldring or Ortofon moving coil cartridge

MAIL ORDER (1-10 DAYS) PRICES (INC P&P)+ INSURANCE FOR UK DELIVERY -£5 FOR EUROPE DELIVERY & £10 FOR
US/WORLDWIDE DELIVERY TO COVER INSURANCE ON ORDERS OVER £50 VALUE

Tel/Fax (01757) 288652 e-mail: enquiry@mantra-audio.co.uk
MANTRA AUDIO (HFV), 22 GARTH AVENUE, NORTH DUFFIELD, SELBY, NORTH YORKS YO8 5RP



Vacuum Tubes for Audio Are Back!

Glass Audio brings together
yesterday's tube with today's
improved components, voltage control,
and the exciting new Soviet tubes,
to make smooth sound in your
livingroom possible again!

YES!

Please send my first issue of *Glass Audio*. I'll pay just \$45.00 for six issues
(1 year); \$80.00 for 12 issues (2 years) of the best information on tubes to be found
anywhere. I understand that my satisfaction is guaranteed!

Name _____

Street & Number _____

City _____ Postal Code _____

Country _____

REMIT IN US \$ DRAWN ON A US BANK ONLY. PRICE GOOD THROUGH DECEMBER 31, 1995.

We Accept MC/VISA.

Glass Audio

PO Box 176, Dept. HFWS, Peterborough, NH 03458-0176 USA
Phone: (603) 924-9464 or FAX 24 hours a day (603) 924-9467

CD PLAYERS

SHARP DX-SX1H SACD

I tested this player via its digital connection through Sharp's 1-bit SM-SX1H amplifier, also tested in this issue, because the two will almost certainly be used together. The performance of the amplifier swamped the player in some areas, notably distortion and noise.

Being noisy, the amplifier's noise floor dominated, giving a poor signal-to-noise ratio, but this is how it would be in practice.

Likewise, distortion levels were high until harmonics disappeared under noise, making the -90dB impossible to glean in a realistic fashion. So the CD player doesn't benefit from its advanced SACD specification. The idea is that, by being converted to analogue in the amplifier's output stage there'll be no analogue degradation of the signal within the amplifier. This is a rather notional benefit though, when the final conversion process is so flawed.

Frequency response of the player dis-

played a little treble lift at 20kHz, as our analysis shows. This is likely to brighten its sound a little.

The measured performance of Sharp's SACD player looks none to good when paired with the DX-SX1H digital amplifier, but it's the amplifier that dominates matters. **NK**

Frequency response	4Hz-21.25kHz	
	left	right
Distortion		
-6dB	0.7	0.7
-30dB	3	3
-60dB	10	11
-90	-	-
Separation	left	right
1kHz	68	68
20kHz	67	67
Noise		-76dB

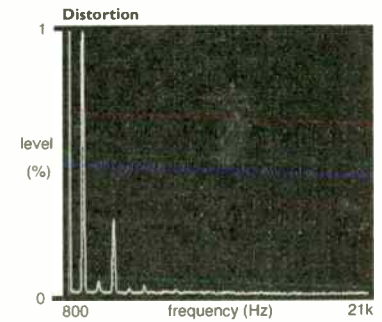
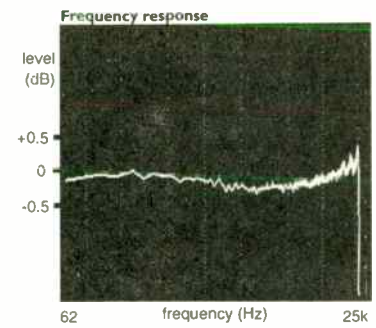

NAIM CD5 COMPACT DISC

Although Naim are known for their forceful sound, with powerful bass and unabashed treble, when it comes to CD they choose to round things off a little at the top end. Our convolved impulse frequency response analysis of the CD5 clearly shows this at far right, where above 10kHz there's a gentle roll off up to the cut-off point of 20.8kHz (-1dB) for this player. Perhaps it's their roots in analogue LP that persuade them to this course, although it's common enough amongst U.K. designed CD players. The roll off isn't great and the consequence not dramatic either, but it does tend to give a slightly easier to cope with treble presentation from CD than super-flat responses, which come across as bright. This is not to say the Naim will sound either dull or warm, since the roll off is too small.

CD players invariably extend flat down to 4Hz and Naim's was no different here, working right down to subsonic frequencies.

Nowadays digital-to-analogue converters are pretty linear and here the player showed it is well equipped. Distortion was minimal right down the dynamic range of the machine, from full output at 0dB with a figure of 0.009% to -90dB where it rises, with 16bit, to 29%. It's the -30dB to -60dB range that seems to be most important, even though most music these days is compressed up to the 0dB to -30dB range to avoid digital distortion. Our analysis of

distortion at -30dB shows a small amount of energy in 4th and 5th harmonics, but rms level of all harmonics up to 20kHz measured a low 0.02%, as good as 16bit CD gets.

The distortion analysis shows a fairly low noise floor which helps matters. Down at -60dB the player was again respectable, producing a 0.38% thd figure, which is up with the best. This results in a healthy 109dB EIAJ dynamic range figure.

Output was a normal 2.15V and channel separation high at 113dB. The Naim CD5 measures well in all areas; it should give a smooth sound, and likely an impactful one. **NK**

Frequency response	4Hz-20.87kHz	
	left	right
Distortion		
-6dB	0.009	0.009
-30dB	0.015	0.018
-60dB	0.4	0.38
-90	29	28
Separation	left	right
1kHz	113	112
20kHz	106	105
Noise		-105dB
with emphasis		-105dB
Dynamic range		109dB
Output		2.15V

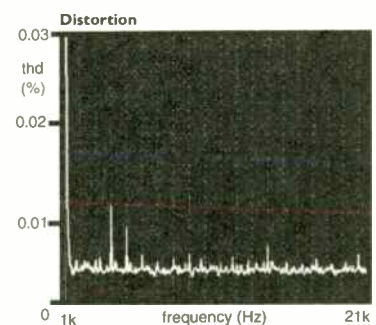
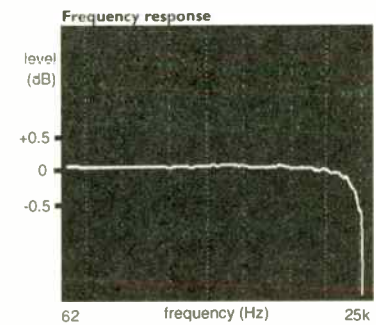

Oxford Audio Consultants Ltd.

OUR SUPERB SERVICE IS THE SAME REGARDLESS OF PRICE



Now Demonstrating



Ex-Demonstration & Previously Owned Equipment

SALE LIST - February 2001

WILSON AUDIO SYSTEM 6 BLACK AS NEW	£13995	SH
SONUS FABER GUARNERIS AS NEW	£3995	SH
NAIM SBL BLACK EX DEM PASSIVE	£1495	XD
PATHOS ACOUSTICS TWIN TOWERS AMPLIFIER	£2795	SH
MARTIN LOGAN SL3 LOUDSPEAKERS LIGHT OAK	£2195	SH
THETA JADE	£1795	SH
OPERA CALLAS GOLD SPEAKERS MAHOGANY	£695	SH
KRELL 300 I INTEGRATED AMP EX DEM	£1995	XD
KRELL DT10 CD TRANSPORT	£3995	SH
THETA PROBASIC 3a D/A CONVERTER	£1995	SH
KRELL KRC PREAMPLIFIER	£2995	SH
TRANSPARENT ULTRA SPEAKER CABLE 20FT	£1495	SH
NAIM 180 POWER AMP	£795	SH
NAIM CDI CD PLAYER	£ 795	SH
NAIM 92/90 PRE/POWER AMP EX DEM	£750	SH
JADIS ORCHESTRA CD PLAYER	£795	XD
JADIS ORCHESTRA AMPLIFIER	£ 795	XD
KRELL KAV300 CD PLAYER EX DEM	£2995	XD
KRELL KAV300CD AS NEW	£3450	
RUARK TALISMAN	£250	SH
VIDIKRON HELIUS PROJECTOR		
- OUR DEMONSTRATOR	£6995	XD
UNISON RESEARCH SMART 845 - our demonstrators	£1995	XD

0% INTEREST FREE CREDIT
Licensed Credit Broker

REFER TO OUR WEBSITE FOR THE LATEST UPDATED SALE LIST.

Agencies include: Audio Analogue, Audio Research, Audio Technica, BOSE, B&W, Cable Talk, Castle, Copland, Denon, Graaf, Goldring, Jamo, Jadis, KEF, Koetsu, Krell, Lexicon, Loewe TV & Video, Lyras, Marantz, Martin Logan, Michell, Musical Fidelity, MRS, NAD, Naim, NEC Gas Plasma Screens, Nordost Cables, Onkyo, Opera, Ortofon, Pioneer, Proac, Project, QED, REL Subwoofers, Rotel, Speckercraft, Sennheiser, SME, Sonus Faber, Sonance, Stands Unique, Siac, Target, TAG McLAREN, TEAC, Theta, Thorens, Transparent Cables, Unison Research, van den Hul, Vidikron, Wilson, Yamaha.

TAX-FREE EXPORT SERVICE
MAIL-ORDER AVAILABLE ON MANY ITEMS

Cantay House Park End Street
Oxford OX1 1JD

Telephone: Oxford (01865) 790879
Facsimile: Oxford (01865) 791665

E-MAIL: Oxford.Audio@btinternet.com
WEBSITE: www.oxford-audio.co.uk



HICAM

CHERISHED PRE-OWNED HI-FI EQUIPMENT SOLD,
PURCHASED, P/X.

WE URGENTLY REQUIRE NAIM, MERIDIAN, AUDIOLAB,
LINN EQUIPMENT

MAIL ORDER ALWAYS A PLEASURE

DESCRIPTION	PRICE	£
AUDIOLAB C PRE AMP		195
AUDIONOTE EL SPK MINT INC STANDS BOXED	1780	925
ALCHEMIST NEXUS APD32A 24 BIT CD PLAYER NEVER USED	599	495
TARGET R4 SPEAKER STANDS	325	275
ALCHEMIST TS-D1 24 BIT DAC	299	225
AVI S2000MC 24 BIT CD PLAYER	999	895
ALPHASON AKROS 2 SPEAKER STANDS BOXED	65	40
AV1 S2000 MM MONOBLOCKS	1399	1195
AVI S2000MT11 AM/FM REFERENCE TUNER	899	725
DALI EVIDENCE 870 FLOORSTANDING SPEAKERS	1299	999
EAR MC3 MC TRANSFORMER	629.95	495
DALI ROYAL MENUET MK2 CHERRY FINISH	399.95	295
DALI EVIDENCE C70 CENTRE SPEAKER	399.95	325
HEYDROOK QUARTET ROSEWOOD FINISH	550	300
LAT AC2 6 WAY DISTRIBUTION BLOCK 3 FT	194	170
LAT AC2 POWER CABLE 3 FT	65	55
SME V ARM MINT/SEALED BOX	1243	1150
TALK ELECTRONIC THUNDER 1 CD PLAYER	599.95	495
MICHELL GYRODECK SE/RB300 MINT BOXED	950	875
MICHELL ARGO/HERA PRE/PSU		325
TALK ELECTRONIC CYCLONE 1 INT AMP R/C	599.95	495
MICHELL ALECTO MONOBLOCKS	1989	1599
MICHELL ORCA PRE AMP	1286	1100
MONRIO ASTY INT AMP MINT/BOXED	425	275
NAIM 180 POWER AMP		725
NAD C320 INT AMP/REMOTE MINT	200	125
NAIM SBL LOUDSPEAKERS WALNUT FINISH	2100	895
NAIM SBL LOUDSPEAKERS BLACK/BOXED	2100	795
MARANTZ CD 63	300	150
TANNOY MERCURY M3 SPEAKERS BLACK/BOXED	230	150
LINN INTEK INT AMP/BOXED		150
MERIDIAN 501 PRE/ MSR		450
PRECIOUS METALS SILVER SIGNAL 202B BALANCED	430	350
PRECIOUS METALS SILVER SIGNAL 204 INTERCONNECT 1 METRE	430	350
PSB ALPHA 6 ACTIVE SUBWOOFER	499.95	425
PROJECT CLASSIC/PROJECT9/510 CHERRY MINT	450	325
REGA BRIO INT AMP		180
PROJECT PERSPECTIVE/PROJECT 9 ARM BOXED MINT	750	525
PSB ALPHA ZERO SUB ACTIVE	199.95	160
LINN LK 280/LINN PRETEK BOXED		400
STAX SRS 2020 MK2 EARSPEAKERS	395	325
TARGET MX100 SPEAKER STANDS PIANO BLACK	79	60
TRICHORD RESEARCH 500 POWERBLOCK	299	265
SUMIKO BLUE POINT SPECIAL MC	249	195
SONETEER THE BYRON CD PLAYER	795	645
SONETEER THE SEDLEY PHONO STAGE MM/M/C	399	325
LYRA LYDIAN BETA MC CARTRIDGE	599	495
SONICLINK RED EARTH 1 METRE INTERCONNECT	300	225
SONICLINK 8 WAY DISTRIBUTION BLOCK 2 METRE CABLE	225	175
EAR 834P MM/MC PHONOSTAGE	529	450

AGENTS FOR,

ALCHEMIST, AVI, CRIMSON, EAR, DALLDNM, LAT, LOGIC, MICHELL,
ORTOFON, OPTIMUM, PSB, PROJECT, PRECIOUS METALS,
SNELL, SONNETEER, SONICLINK, SUNFIRE CORP, TARGET,
TOM EVANS, VIDIKRON, TRICHORD RESEARCH

OPEN MON-SUN 10AM-6PM
FOR FURTHER DETAILS: TEL 01726 74474 / FAX 01726 70774
MOBILE: 07973 233 380
E-MAIL: HICAM1@FREEINETNAME.CO.UK
OR VISIT OUR WEBPAGE HICAM.CO.UK

SONY CDP-XB740

Sony CD players have always possessed a better measured performance than any other except those from Philips. Both companies seem to take it as a matter of pride that, as inventors of this universally used medium, they set the performance standard. In this player, however, Sony give users an option of four filters, each of which alter frequency response and impulse behaviour.

Sonys generally measure ruler flat, so it isn't surprising that the STD (standard) position on this player was flat and gave the widest bandwidth (i.e. the best response figure). I measured the upper limit of this filter at 21.3kHz.

The next filter, number 1, gave an early roll off, reaching just 16kHz. This will give a softer, warmer sound than usual from CD.

Filter number 2 really gave more of the same, as our analysis shows - namely an early roll off, but this time with a little treble lift - to brighten things up a little perhaps. The response limit was 15.5kHz.

Filter No 3 looked good, giving a nice smooth response without ringing, right up to 19kHz. This looks like the best to me. However, bright CDs might be best played with filter 2 or 3 This player certainly gives enthusiasts plenty of options.

At -30dB our analysis shows there's absolutely no distortion or quantisation noise. The noise floor is low too, leading

to a fine set of distortion figures right through the operating range, from 0dB down to -90dB. Only the -60dB result can be improved upon these days, or low levels smoothed out with a processing scheme like Kenwood's DRIVE. The XB-740 will sound clean, there's no doubt about that.

Output was high at 2.38V, +1.5dB above the 2V standard, giving this player a bit more apparent oomph in any side by side comparison. All other figures were perfect.

The XB-740 measured extremely well in all areas. Like all Sony players it will likely sound clean and bright in STD, but the choice is yours. **NK**

Frequency response	4Hz-21.3kHz	
Distortion	left	right
-6dB	0.005	0.005
-30dB	0.017	0.017
-60dB	0.41	0.4
-90	29	28
Separation	left	right
1kHz	116	116
20kHz	91	92
Noise	-106dB	
with emphasis	-106dB	
Dynamic range	109dB	
Output	2.3V	

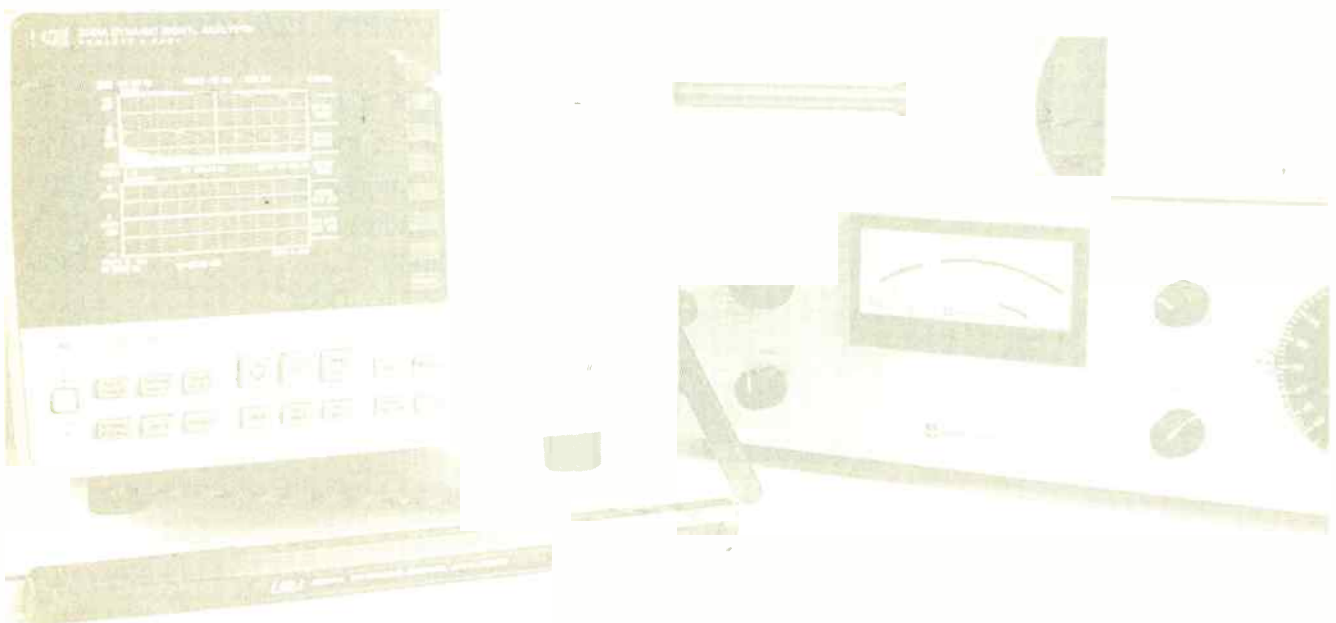
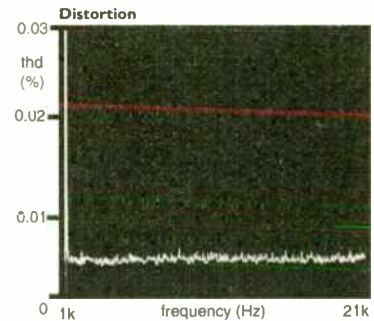
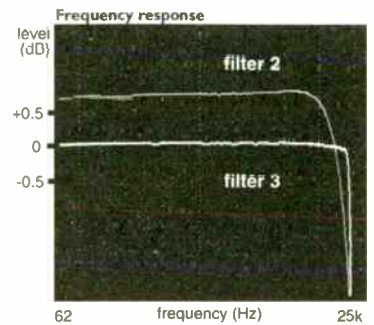
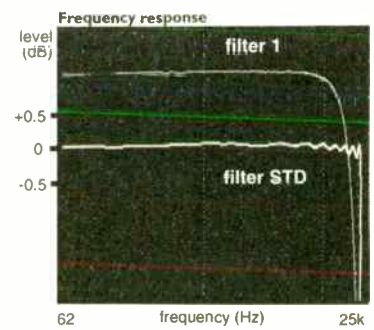

MUSICAL IMAGES

PRODUCT		LIST	NOW
ACOUSTIC ENERGY AE 105SE Speaker	EX/DEMO	£350	£225
ACOUSTIC ENERGY AE 509 Speakers	EX/DEMO	£850	£425
ACOUSTIC ENERGY AE520 Speakers	EX/DEMO	£1,000	£500
ARCAM ALPHA 10 DAVE	EX/DEMO	£1,650	£825
ARCAM ALPHA 10 Amp	EX/DEMO	£800	£600
ARCAM ALPHA 10 Power Amp	EX/DEMO	£600	£425
ARCAM ALPHA 1 Amp	EX/DEMO	£230	£175
ARCAM ALPHA 8RE Amp with remote	EX/DEMO	£350	£275
ARCAM ALPHA 8 Power Amp	EX/DEMO	£250	£175
ARCAM ALPHA 9CD CD Player	EX/DEMO	£800	£600
ARCAM DELTA 90 Amp	S/H	£300	£120
AVI POSITRON Speaker	EX/DEMO	£900	£600
BOSE 501 Black Speakers	EX/DEMO	£600	
CELESTION KINGSTONE Speakers	S/H		£500
CHORD CPA2200 Silver Pre Amp	EX/DEMO	£2,740	£2,200
CHORD DSC1100 Silver DAC inc Tragger	EX/DEMO	£2,815	£2,300
CHORD SPM1000B Black Power Amp	EX/DEMO	£2,920	£2,100
CHORD SPM5000 Silver Power Amp	EX/DEMO	£15,000	£10,000
CYRUS SL Amp	S/H	£400	£150
DEFINITIVE TECHNOLOGY			
CLR1000 Centre Speaker	S/H	£900	£300
DENON AVC A1D AV Amp	S/H	£2,000	£1,250
DENON AVC 2800 AV Amp	S/H		£250
HARMAN KARDON AVR80&APD303 AV COMBO	S/H		£700
KEF TDM45 Subwoofer	S/H	£800	£550
LINN KLOUT Power Amp	S/H		£1,200
MARANTZ MM500 Power Amp	S/H	£350	£100
MERIDIAN 500CD CD player	S/H		£600
MERIDIAN 565 AV Processor	S/H		£750
MICROMEGA DVD DVD Player	S/H	£1,500	£500
MUSICAL FIDELITY XA-1 Amp	EX/DEMO	£480	£400
MUSICAL FIDELITY XA-1 Amp	S/H	£480	£320
MUSICAL FIDELITY XPRE Pre Amp	S/H		£400
MUSICAL FIDELITY XRAY CD Player	S/H	£800	£500
NAD 917 AV Tuner/PRE Amp	EX/DEMO	£550	£300
NAD 533 Turntable	S/H		£150
NAD C320 Amp	S/H	£200	£110
NAIM CD 3.5 CD Player	EX/DEMO	£1,112	£1,000
NAIM FLATCAP Power Supply	EX/DEMO	£370	£330
NAIM NAC 3 Amp	S/H	£600	£425
NAIM NAC 92R Pre Amp with remote	EX/DEMO	£690	£590
NAIM NAP 90/3 Power Amp	EX/DEMO	£487	£420
NHT VS1.2 Black Surround Speakers	S/H	£400	£200
NHT VS1.2 White Centre Speaker	S/H	£200	£100
PRIMARE A20 Amp	S/H	£700	£500
ROTEL RB985 Power Amp	S/H	£625	£400
TAG McLaren PA10 Pre Amp	EX/DEMO	£850	£500
TUBE TECHNOLOGY UNISIS Stereo			
Power Amp	S/H	£3,000	£1,500
YAMAHA DSPA3090 AV Amp	S/H	£1,300	£650

Special Kef Reference Old Range Demo Offer

KEF MODEL 1 Rosetta Speakers	NEW	£1,550	£1,075
KEF MODEL 1 Classic Rosewood Speakers	NEW	£1,450	£950
KEF MODEL 1 Black Speakers	NEW	£1,350	£875
KEF MODEL 2 Rosetta Speakers	NEW	£2,150	£1,425

PLEASE VISIT OUR SHOWROOMS OR
CALL OUR HOTLINE NUMBER FOR DETAILS.
HURRY, THESE ARE ONE-OFF ITEMS!!

SEE IT! HEAR IT! BUY IT!

HOTLINE NUMBER:
020 7497 1346

14-18 Monmouth Street, Covent Garden, London WC2H 9HB
E-Mail: sales@musical-images.co.uk

Beckenham **Edgware** **Hounslow**
0208 663 3777 0208 952 5535 0208 569 5802

NOT VALID WITH ANY OTHER OFFERS OR PROMOTIONS E&OE



SOUNDS PERFECTION



THE SOUTHWESTS PREMIER RETAILER

e-mail:- nigel@soundsperfection.co.uk
web:- www.soundsperfection.co.uk

AUCTION THE FOLLOWING PRODUCTS HERE:-

ALCANTARA * ARCADIS * AVA * AVIA * AUDIO ANALOGUE * AUDIO DESIGNS * AUDIO NOTH * AUDIOQUEST * AUDIO SPHERICAL * AUDIO * BORDERS PATROL * BOSTON ACOUSTIC * CABLE TALK * CENSTON * ELECTROCOMPANIE * GRATE * HENLEY DESIGNS * JAM LABS * JAMICON * JAR HILL * MONITOR AUDIO * MUSICAL FIDELITY * NAKAMICHI * ORTOFON * PARASOUND * PHILOSOPHY CABLES * PRIMARE * PROTECT * REAL ACOUSTICS * SAIL * SONIC FRONTIERS * SONIC LINK * STANDS UNIQUE * STRAIGHT WIRE * SUGDEN * TARA TABS * TARGET * TEAC * TEFAL * TRIANGLE * TRICORD * TUNING * UNISON RESEARCH * VIKING ACOUSTICS

FULL HOME THEATRE DEMONSTRATIONS AVAILABLE

SECONDHAND & EX-DEMO PRODUCTS

AUDIONOTE ONGAKU BOXED ONLY	£17,995
AUDIONOTE AN-S MK II MOVING COIL TRANSFORMER	£2,795
PARASOUND 2500 PROCESSOR MINT BOXED HARDLY USED ONLY	£1995
AUDIONOTE QUEST MONO BLOCKS EX DEMO	£1995
ELI ELECTROCOMPANIE EMC 1 CD PLAYER MINT BOXED EX DEMO	£1,749
ELECTROCOMPANIE FC46 PRE AMP MINT BOXED (THE BEST ONE)	£1095
AUDIO SPHERICAL ARTIMIS FLOOR STAND SPEAKERS MINT EX DEMO	£895
PARASOUND 1800 PROCESSOR MINT BOXED NEARLY NEW	£795
AUDIO INNOVATIONS SERIES III 50W MONO BLOCKS BOXED MINT	£895
MIRIDIAN 500 TRANSFORMER MINT BOXED WITH SYSTEM REMOVED	£845
TRIANGLE ZAVS BOXED HARDLY USED ONLY	£795
MUSICAL FIDELITY X-RAY CD PLAYER MINT BOXED	£525
CYRUS III AMP/FILTR * PSX POWER SUPPLY BOXED ONLY	£495
AUDIOLAB 8000S INTEGRATED AMP BOXED	£495
CYRUS DAD 3Q CD PLAYER MINT BOXED	£449
MUSICAL FIDELITY XAS 100 POWER AMPS (2 OF 1)	£449
VIKING ACOUSTICS HAYDEN'S MINT BOXED IN BLACK	£429
AUDIONOTE DAC 1 MINT BOXED ONLY	£375
UNDERSTANDS WING-G HIRSHAND MARBLE SHIVES MINT	£375
AUDIO ANALOGUE PUCHINSE AMP MINT BOXED	£325
MISSION 753 SPEAKERS MINT ONLY	£325
MIRYAD MC100 INTI GRAFID AMP III R/R C BOXED	£249
ARCADIS BABY 2 FLOOR STANDING SPEAKER EX DEMO	£279
AFCHEMIST KRANKEN AMP III R	£249
MACORMACK LINE PRE AMP	£195
V&B THE SECON BALANCED FM INTR CONNECT BOXED NEW	£179
MUSICAL FIDELITY ELECTRO L20 PRE-AMP ONLY	£179
MUSICAL FIDELITY X PRE	£195

FOR FRIENDLY ADVICE AND 7 DAY'S A WEEK 8AM TO 10PM
PHONE NIGEL 01326 221372 OR MOBIE 0498 554357
MAIL ORDER THROUGHOUT UK

The HiFi Centre 

4 Ruabon Road, Wrexham LL13 7PB
Tel. 01978 364500

email: sales@acton-gate.com
website: www.acton-gate.com

*Spring sale of ex-display and
customers' equipment*

Micromega Stage 1 CD	£175
Musical Fidelity A300	£1050
Quad 606 (Russ Andrews)	£300
Quad 44 (Russ Andrews)	£275
Audiolab CD8000	£350
Quad 99 pre & cd Ex.Disp.	£1125
Arcam alpha 9 cd	POA
Quad 606 II boxed mint	£400
Rotel 951 cd Ex.Disp.	£275
Quad 77 integrated	£280
Quad 50e (pair)	£350

Stock constantly changing - many other offers

Special Internet offer
 see page 130 for details

Dealers must not advertise in the Private Classified section.
 Monthly consecutive insertions will be considered Trade
 advertising. The Publisher reserves the right to judge submissions.

RUARK SOLSTICE (Black Piano Lacquer) £2900 ono. Tel: 01622 721 011 or 07973 899 651 (May (I))

ROGERS STUDIO ones teak plus stands £300. LS3/5A's 15 ohm walnut plus stands £300. Audio Synthesis Passion pre-amp £200. Tel: 01303 211 461 (Apr)

CONRAD JOHNSON Premier-Two pre-amp. Top of the range, original classic noisy transformer. Manual and circuit info. Suit enthusiast. Bargain £250 ono. Cost £3000 approx. Part-Ex for Meridian CD Transport taken. Tel: 01509 215 230 (Apr(I))

RUARK SOLSTICE (Black Piano Lacquer) £2900 ono. Tel: 01622 721 011 or 07973 899 651 (May (I))

LOWTHER ACOUSTAS - originals - Finnish Birch throughout. Professionally renovated, dark oak with dud PM6s. Renovation cost=£1200 For Sale @£495. Quad II stereo complete. Recent original specification overhaul @£450. Also half price DX3 drivers. Tel: 01483 268 804 or Email: info@hornutopialoudspeakers.co.uk (Jun(I))

FOR SALE: Linn LK1/LK2-75 including leads and remote £500, Linn Isobarik speakers (DMS) including stands & 2x7metres of Linn K20 cable (terminated) £550.0, Can demo. Tel: 01582 702 007 (Apr(I))

WANTED: Linn Isobarik speakers, bi-wireable or preferably with external crossovers, with stands, will collect. Tel: 07808 391 667 (Apr(I))

CYRUS 'PRE' & Cyrus 'Power' Amplifiers. Stunning - see original reviews. Immaculate Condition. Original receipts / manuals. £550 pair (cost £1100). Tel: 0113 265 0118 / 07966 233 363. E-mail: rioboc@aol.com (Apr(I))

LINN KLOUT Power amp, latest spec Mint Condition boxed, POA. Nakamichi BX300E cassette deck, serviced, offers. Tel: 01920 424 831 (Apr(I))

ACOUSTIC PRECISION Eikos speakers £390 (cost £800). Atacama stands £45. Tom Evans 'Micro Groove' phono stage £340 (cost £700). Ion Oberlisk 2 £150. 10 metres Monolith 20/20 cable £250. Tel: 020 8952 2044 (Apr(I))

MISSION 752 loudspeakers (not Freedoms), black ash, boxed with spikes. HFW recommended, sweet, warm sound. VGC, £195. Sony CDP-X557ES flagship CD player (18kgs) with Trichord Clock 3 mod, export model, wooden side panels. Mint, boxed, superb multibit sound for £295. Can arrange carriage - Tel: 07887 656 866 or Email: JP@spacer.net. (Apr(I))

HI-FI YEAR books wanted. Tel: 01507 328 420 (Apr(I))

SUGDEN A21A pure Class A integrated amplifier, titanium finish, MM/MC phono stage, immaculate condition, boxed, (cost £1000) accept £675. Sugden CD21 CD Player, latest titanium finish, very musical, detailed sound, immaculate condition, boxed (cost £1000) accept £675. Tel: 01429 290 213 (Hartlepool) (Apr(I))

MICHELL ISO + Hera £260 ono. Monitor Audio Studio 12, mint £470 ono. Meridian 105 monoblocs £330 ono. Luxman LV 105-U £200 ono. JVC DDVR77 cassette £50 ono. Tel: 0793 911 6779 or Email: alexkirkham@yahoo.com (May(I))

QUAD 33, 303, FM3 Academy Sound modified (phono sockets, upgraded components/wiring). High quality, dedicated mains cables/interconnects. Unmarked, mint condition. Original packaging/manuals. £425. Tel: R.Richards 01639 641 043 (Apr)

CD TRANSPORT - Kenwood DPX-9010 £140. DAC - Deltac (DPA) Little Bit £110 excellent condition. Pair £240. Includes Sonic Link digital coaxial and Chord Company Interconnect. Email: andy@brechin77.freeserve.co.uk Tel: 01224 896 449 (Apr(I))

WANTED: QUAD 10L speakers. Tel: 01883 627 185 (Apr (I))

AUDIOLAB PPA phono amplifier v.g.c. £495 ono. 1xos 103 x 1 metre £15 Cable Talk Reference 2x 1 metre £50. Tel: 01224 483 642 (evenings) or Email: barmonte@aol.com

RUARK PROLOGUE One speakers, special matched pair in cherry. Sound Byte loaded, mint, boxed, (£950) £400. Benz Micro MC Silver cartridge 50 hrs use, boxed (£165) £85. Tel: John 01889 881 984 (Apr(I))

NAIM HI-CAP five months old, boxed and in mint condition £490. Upgraded to Supercap. Tel: Chris 07773 341 145 (Apr(I))

NAIM CD5 player complete transport power supply remote control, boxed immaculate £1950. Tel: 01752 509 236 (Apr (I))

LUMLEY M75 monoblocks piano black £700. Roxsan Xerxes plus Rega RB300 arm £300. MSB Link 2 24/96K DAC £250. Origin Live modified Rega RB250 £150. Tel: Chris 01263 861 435 (Apr (I))

JEFF ROWLAND Model 2 power amplifier very good condition £2000. Mark Levinson CZ-GEL-I XLR interconnection cable 5m length £450. Tel: 0117 956 5361 (Apr(I))

NAIM 82 preamp. M.C. boards. Mint, boxed £1400. Hi-Cap, new style, mint, boxed £400. Linn Lingo boxed £200. Tel: 01638 668 299 (Apr(I))

We are best known for our single-ended 300B power amplifiers and power supply upgrades for valve amplifiers, but did you know that we supply complete systems, new and used equipment, and components? We also provide support and servicing for Audio Innovations valve products. For full information visit www.borderpatrol.net or ring 01273 276716.

passion, grace & fire

www.borderpatrol.net

Selected products from:

BorderPatrol • Living Voice • SME • Audio Note • Cartridge Man • Goldring
Western Electric • Electrofluidics

BorderPatrol Brighton UK
Tel/Fax +44 (0)1273 276716
e-mail: bp@borderpatrol.net
www.borderpatrol.net



BorderPatrol

Sound Music

S Nakamichi CMS 5 System (XD) - £300
A Nakamichi Soundspace 5 (XD) - £375
L Nakamichi Soundspace 8 (XD) - £700
E Musical Fidelity XAS 100 (XD) - £650
Musical Fidelity Explorer (XD) - £450
Linn LK140 Power Amplifier (XD) - £545
Linn LK100 Power Amplifier (SH) - £300
Linn Keilidh Speakers (Black)(SH) - £325
Proac Studio 150 Speakers(SH) - £700
Roksan Kandy CD Player (XD) - £350
Roksan Kandy Tuner (XD) - £275
NAD Turntable (XD) - £150

Energy Encore A.V. Sub&Sat Speaker Set (XD) - £850
Myriad Cameo System (Tuner/CD/Amp)(XD) - £1150
Myriad MDP500 Pre-amplifier Processor (XD) - £1150
Myriad T70 5 Channel Power Amplifier (XD) - £375
Myriad MC100 CD Player (XD) - £550
Castle Howard S2 Speakers (SH) - £650
Loewe Planus + Base 32" Wide Screen 100 Hz - £1200
Rega Planet CD Player (SH) - £250
Musical Technology Kestrel Speakers (XD) - £350
AVI Nu-Neutron Speakers (Cherry)(XD) - £350
Teac 500 VRDS9 CD Player(XD) - £350
John Shearne Phase 2 (XD) - £350
Kef RDM 2 Speakers (XD) - £250

**Sound Of Music, 93-95 Nantwich Rd
Crewe, Cheshire. CW2 6AW
Tel.:01270 214143 Fax:01270 254143**

Orpheus Audio

We are proud to introduce "Oxyzen"
a single-ended, pure class A triode power amplifier
with volume control unbelievable at £595 new.
"the closest approach to the original emotion"

TURNTABLES	
Acoustic Solid The Solid One (40kg Brand New)	£1850
VPI TNT Junior & JMW Memorial 12" Arm & Lyra Lydian	£2900
Technics SL-1200 Ltd (Black & Gold)	£550
CD PLAYERS	
Heart (Holland) CD5000 Valve CD-Player (Brand New)	£299
Heart (Holland) CD6000 Valve CD-Player (Brand New)	£449
Meridian 203 DAC	£100
Kimshaw Overture DAC	£70
PRE AMPLIFIERS	
Michell Argo with Hera power supply	£300
QED Reference (Upgraded)	£200
POWER AMPLIFIERS	
Alchemist Forsen APD20AM MKII	£800
Oxyzen (single-ended, Class A Triode) Brand New	£650
Cabasse AXI1000 Monoblocks	£1000
Conrad-Johnson Sonographic SA250	£550
INTEGRATED AMPLIFIERS	
EAR V-20	£1850
Accuphase E-202	£350
Magnum Class A SE	£450
Musical Fidelity A-X1	£350
NVA 9 Box Amplifier	£850
Triangle TB60	£850
LOUDSPEAKERS	
Chario Academy 2 (Walnut)	£1000
Apogee Centors	£550
Lowther Bior 200 (DX2 drive units)	£550
Proac Response One	£550
Sonus Faber Sygam with A/Stands	£1350
Cabasse Skiff 301 (Beech)	£950
Cabasse Farella 401 (Bubinga)	£550
B&W Matrix 2 SE (Black)	£400
B&W DM 70 Electrostatics	£600
Triangle Scalene (Black)	£300
JBL LX-90 (Black Ash)	£300
CASSETTE DECKS	
Nakamichi 1000 ZXL	£1000

All the above come with 12 months warranty
tel: 01257 473 175
evening calls welcome
e-mail: sales@orpheusaudio.co.uk website: www.orpheusaudio.co.uk
For a full list of our agencies please see **ORPHEUS AUDIO**
(GREATER MANCHESTER) in the DIAL-A-DEALER Section

Special Internet offer
see page 130 for details

YBA 2 PREAMP and mains filter (£1700 new) £650. View specification at www.phlox-electronique.fr. Musical Fidelity CDT valve CD player £375. X10-D The Missing Link £75 Rotel RC970 BX and two RB970BX's £295. Tel: 01282 867 819 (Apr/I)

TAGMcLAREN PA20 preamp, TagMcLaren monobloc's 125M, two Kimber high current power cords (3 feet) Wattgate plug and Nordost Blue Heaven speaker cable x 3 metres terminated. All mint condition, boxed with manuals, reasonable offers. Tel: 01423 881 260 (Apr/I)

CYRUS TWO amplifier and PSX in non matching cases good condition £175. Tel: 01306 880 574 (Dorking) (Apr/I)

PHILIPS CDR 870 compact disc recorder £185. Videologic DRX 601E DAB tuner £250. Linn Majik amplifier. Line £435. All boxed. Tel: 01932 785 065 (Surrey) (Apr/I)

SUMIKO BLUE Point Special, few hours use, still under warranty £150. L.F.D. integrated Zero £290. Epos ES 14 speakers £240. P.S. Audio 4.6 £220. Tel: 01202 429 353 weekdays after 4.30 (Bournemouth) (Apr/I)

WANTED J.M. Reynaud speakers, Offrende preferred, or Trente, mint condition. Stands optional. Tel: Bernard 020 7730 7332 or 01189 343 818 (Apr/I)

EPOS ES30, 4 months old, 150 watts per channel, light cherry finish, cost £2500 selling for £1500. Immaculate condition, immaculate sound. Tel: 01892 527 971 (Apr/I)

TECHNICS SP 10 Mk 2 decks in good order £400. SME 3009 arms no cartridge £75. Part manual and circuit diagram checked can be seen working. Tel: 07802 403 851 (Apr/I)

GAMMA AEONS 211 valve monobloc's late champagne facia model. 20 watt SE silver construction. Excellent sound quality 2 years old £1395 ono. £4999 new. Tel: 02392 662 772 after 6pm (Hampshire area) (Apr/I)

SUGDEN MASTERCLASS phono stage tremendous sound from the masters of class A amplification. As new, 4 years unexpired Sugden warranty £800 ono (cost £1250). Demo will convince. Tel/Fax: 0113 284 3770 (Leeds) (Apr/I)

CYRUS PREAMP + XPA amp. £200 Cyrus. 3 DADQ CD. Updated 24 bit £400. Tel: 020 7253 3883 daytime, 020 7278 8371 evenings (Apr/I)

SPENDOR SPZ/Z speakers black bi-wirable with purpose made stands £500. Tel: 01733 810 516 (Peterborough) (Apr/I)

CHAMELEON RUBY balanced unbalanced power amp 200 wpc £450 ono. Pair Transparent Music Link balanced interconnects £150 ono. Rebuilt Quad 405 power amp phono inputs £250. Tel: 01302 370 578 (Apr/I)

AUDIOLAB 8000P S/N 209D50223 boxed £380 (ovno). Croft Epoch Elite S/N 351 boxed £500 (ovno). Interconnects: Chord Solid (0.5m) Van Den Hull The First (O.G.M.) £30 each pr. Black Slink (0.5) £50 pr. Tel: 01823 324 243 (Apr/I)

MUSICAL FIDELITY A300 amp mint condition/new £950. Creek CD 43, mint condition £350. Pioneer Elite Pro Logic receiver hi-fi amp/tuner, mint condition £250. Heybrook HBZ's average condition £35. Marantz CD63 SE mint condition £100. All boxed. Tel: 020 8959 3611 ext 233 (Apr/I)

LINN KUDOS tuner, as new £400. Pink Triangle LPT record deck, Origin Live RB300, Ortofon MC15 II, £480. Michell Iso phono pre-amp £220. World Audio Design 5881 PSE valve amp £300. Tel: 01252 870 861 (Apr/I)

ATC SCM 50 SLA active speakers. Latest SL drivers, immaculate piano black £3800 (list £7000+), A.V.I. preamp/monoblocks £1300. Music Labs pre/power £1200 (list £3000+) Tel: 020 8875 9696 day 020 7937 0856 evenings 07768 738 372 mobile (Apr/I)

REGA PLANAR 3 turntable with RB300 arm and Elys cartridge. Three months old, boxed, as new £295. Project phono stage £30. Tel: 01428 713 146 Hants/Surrey (Apr/I)

EXPOSURE 25 integrated amplifier mint £600 (£1100). Neat Petite Mk1 good £250. B+W CC6 Mk1 centre mint £120 (£200). Neat Critique Mk1 excellent £150. Tel: Rod 020 8689 8750 (Apr/I)

LOWTHER ACCOUSTA Auditoriums. Rare horn design with two PM2C's per cabinet. Walnut veneer, compact floor standers £450. Dulci 4 wpc SE poweramp upgraded £160. Together, £575. Tel: 01709 555 403 (Rotherham) (Apr/I)

TAGMcLAREN CD 20R £800. DAC 20 £800. PA10 pre £450. 125m monoblocks x 2 £1600. B+W 604 S2 speakers £650. Naim Flatcap £250. All above boxed as new. Contact 07880 770 179 (Apr/I)

SONY AMPLIFIER TA-FB 920 E £95. Sony CD player. CDP-XB 920E £95. Kimber PBJ CD interconnect £30. Kimber Hero CD interconnect -11dB £55. Kimber 4TC pair speaker cables 15ft £110. Tel: 01634 363 374 (Kent) (Apr/I)

AUDIOLAB 8000S/8000P excellent condition both boxed with instructions £795 ono. Moth Series 30 phono stage £140. Trichord Digiwire BNC/BNC £25. Tel: 01908 260 112 (Apr/I)

PINK TRIANGLE Anniversary turntable, rosewood, SME 309, Ortofon MC 3000 MkII, +£4000 new, only £995. Helius Syrius I loudspeakers, light oak, non-parallel sided cabinets, 4 x 8" bass each. Cost £2850. Bargain £500. Pink Triangle Pip II preamplifier excellent phono stage. 3 box. Battery PSU. Cost £3500. Sell for £995. Tel: Harry 07974 784 638 (Devon) (Apr/I)

AUDIO RESEARCH Ref 2 preamp (black) boxed as new £6200. Audio Research PH2 phono stage (black) boxed £1100. Tel: 020 7702 4984 after 6pm (Apr/I)

DYNAUDIO CENTOUR 1.3a Mk II cherry speakers 16 months, boxed, mint (£1200) £849. Rotel RCD99L (AE) CD player HDCD compatible remote boxed 5 months old (£825) £549 Tel: 07747 762 672 or 0115 952 1820 (Nottingham) (Apr/I)

Classified Ads

S/hand and ex-demo clearance items - April'01

CD Players & DAC'S

	Was	Now
Audio Note DAC 3 Signature Ex -Demo	2850	1495
Densen Beat 400 CD player HDCD S/H	1280	899
Kenwood 9010X Clock 3 moded Transport S/H	N/A	249
Mark Levinson 31.5 Transport S/H	9500	5999
Mark Levinson 39 CD Player (9 months old) S/H	4999	3999
Monrio 18B2 DAC Ex-Demo	950	399
Rega Jupiter Transport/Io DAC Ex-Demo	975	750
Resolution Audio D92 24/96 Dac/Processor Ex-Demo	1500	949
Resolution Audio VT960 DVD Transport Ex-Demo	3500	1899
Roksan DP2T Transport S/H	1295	599
Roksan DA2 DAC S/H	599	299
Roksan DS5 PSU S/H	579	399
Theta Digital Pearl Transport S/H	1349	899
Theta Digital Progeny DAC S/H	1099	649
Theta Digital Pro Prime II DAC S/H	1699	599

Turntables Tonearms & Cartridges

	Was	Now
Basis 1400/RB250 (New & Boxed)	1200	899
Basis 2000/RB300 (New & Boxed)	2000	1599
Benz Micro Ruby (New & Boxed)	1500	799
Dais Turntable Motor Unit Only S/H	N/A	199
Heybrook TT2 Belt Drive Turntable S/H	N/A	99
Lehmann Black Cube Phono Stage (New & Boxed)	399	299
Linn Sondek LP12/Black/Rega RB200/Goldring1020 S/H	N/A	379
Linn Sondek LP12/Afro/Lingo/Ekos S/H	3000	1099
Mantra Manticore Reference/Musician/Eroica) S/H	2100	695
Nottingham Analogue Paragon 1 Linear Tracker Tonearm S/H	1600	349
Naim Flat Cap PSU S/H	370	250
Rega RB250 Orgin Live Modification S/H	300	159
Roksan Artexerxes MK1 Phono Stage S/H	495	195
Roksan DS 5 Atessa PSU Ex-Demo	549	399
Roksan Radius 3 Turntable (98) Ex-Demo	470	250
Roksan Xerxes Piano Lacquer XPS 1 (SME Cut) S/H	1295	399
Trio K500/SME 3009/E77 S/H	N/A	150

Preamplifiers

	Was	Now
Audio Research LS9 Remote Solid State (Ex-Demo)	1999	1399
Densen DM20 Preamplifier Ex-Demo	1380	899
DPA Enlightenment New Style Ex-Demo	799	449
Graaf GM13.5 II Valve Preamplifier Ex-demo	4000	2999
Michell ArgoHR/Hera S/H	N/A	475
Naim Audio 32 MM/MC Preamplifier S/H	N/A	99
Quad 33 Preamplifier S/H	N/A	45

Amplifiers

	Was	Now
Audio Analogue Puccini SE S/H	635	449
Audio Note P1SE Ltd Edition (Silver Wired) S/H	1600	849
Audio Note P2SE Valve Power Amplifier S/H	1499	795
Audiolab 8000S Integrated S/H	900	499
Audion Sterling Integrated Line Ex-Demo	799	399
Bartelomeo Transperenza ST140 Power Amplifier S/H	1500	695
Bow Technologies Wazoo XL S/H	2499	1895
Graaf 50/50 Push Pull Power amplifier (New&Boxed)	2100	1695
Graaf GM100 (New&Boxed)	4450	3299
Graaf GM20 OTL S/H	2950	1995
Quad II Anniversary Mono Valve Power Amplifiers Ex-Demo	6000	1999
Rega Big Brio Amplifier Ex-Demo	298	199
Rega Maia Power Amplifier Ex-Demo	475	349
Sugden SP30 Class A Stereo Power Amplifier S/H	950	599

Loudspeakers

	Was	Now
Audio Note AN-K/SP Light Ash Loudspeakers Ex-Demo	1070	629
Audio Note AN-Z Two Floor standers (Black) Ex-Demo	549	395

Loudspeakers (Con't)

	Was	Now
B&W CDM1SE Cherry Loudspeakers S/H	599	399
Diapason Karis Walnut 2 Way Monitor (New&Boxed)	1250	950
Indigo Centre Ex-Demo	199	129
JM Lab Colbalt 807 Cherry Ex-Demo	595	425
JM Lab Colbalt 815 Dark Cherry Ex-Demo	950	749
Martin Logan SL3 Hybrid Electrostatics S/H	3400	2495
Royd Sourceror Walnut S/H	650	379
ProAc Tablette 2000 Light Oak Ex-Demo	695	450
VelodyneTX810MK2 Subwoofer S/H	695	379
Yamaha NS1000M Black S/H	1200	595

Cables & Accessories

	Was	Now
Air Sus Cherry Platform Ex-Demo	169	99
Audio Research BL1 Balanced Converter S/H	888	399
Audio Sculpture 2m RCA Interconnect Ex-Demo	380	149
Bow Technologies Wand Remote S/H	349	199
Deskadel 1M Interconnects WBT/RCA S/H	300	150
Einstein Octopus 8 Way Mains Block (Ex-Demo)	199	149
G- Flex isolators (New & Boxed)	199	75
Lindsey Audiophile 2m Satin RCA Interconnect New	495	199
Madrigal HPC 2m Balanced Interconnect Ex-Demo	310	149
MIT MH750 2X21ft Speaker Cable S/H	N/A	699
Nordost Red Dawn 1M Balanced Ex-Demo	330	199
Shakti On Lines (New&Boxed)	85	45
Shakti Stones (New&Boxed)	195	120
Slate Audio Stands 21" S/H	489	199
Tara Labs Master RSC Gen II 3m Balanced S/H	1250	499
Target 5 Tier Silver Stand MDF Shelves Ex-Demo	249	145
Vdh Skytrack 2X4M Bi-wire Speaker Cable S/H	75	39

Tuners & Tape Decks

	Was	Now
Fanfare FT-1 FM Tuner S/H	1399	599
Cymbol C DAB Digital Tuner (Ex-Demo)	1000	750
Magnum Dynalab FT101 Analogue Tuner (New&Boxed)	850	679
Rega Radio R Tuner (Ex-Demo)	350	249
Roksan Caspian Tuner AM/FM (Ex-Demo)	599	399
Yamaha CT7000 Silver Tuner S/H	N/A	399

Suppliers and installers of High Quality Audio Systems

47 Laboratory	Graff
Accuphase	Gryphon
Audio Note	Lavardin
Audio Research	Mark Levinson
Avid	Martin Logan
Basis	Michell
Cabasse	Nagra
Cardas	Primare
Clearaudio	ProAc
Conrad Johnston	Rega
Copland	Resolution Audio
Dcs	Sonus Faber
DNM / Reson	Spectral
Einstein	SPM
Electrocompaniet	Sugden
Final	UKD
Finite Elemente	

www.midlandaudiox-change.co.uk

call John Roberts Tel / Fax 01562 822236

181 Franche Rd • Kidderminster • Worcs • DY11 5AD

e-mail sales@midlandaudiox-change.co.uk

Mobile 07721 605966

www.midlandaudiox-change.co.uk

Midland Audio X-change is looking for good used British & American Hi-fi

cash paid call John Roberts on 01562 822236

Special Internet offer
see page 130 for details

QUAD ESL63 excellent £1000. Gradient subs £700 or both £1600. Tel: 020 8510 9237, Mobile: 0973 228 095 (Apr/I)

THETA DIGITAL, surround processor, RF, circle surround, Dolby digital, DTS, excellent condition, can demonstrate, new July 99, boxed (new £5000+) £3750. Three Ecosse reference monocrystal MS2 balanced interconnects (new £350) £200. Tel: Paul 020 8804 9293 (Apr/I)

SONY WM-D6C Walkman professional with ECM 909 stereo microphone excellent condition little used £150. Tel: 01274 491 962 Bradford (Apr)

FOR SALE, genuine Cambridge Audio R50 transmission line loudspeakers in superb condition and lovely sound. Also Sony CDP XE530 CD player hardly used. Tel: 01463 811 779 (Apr/I)

LEAK FM Troughline 3 mono tuner, Radford FM7 stereo tuner, Quad FM3 stereo tuner, Quad 33 Meridian p/amp also Sansui Sony A&R Cambridge Mission 771 amplifiers chokes available for vintage amps EMI BTR2 ex BBC offers. Tel: 0131 332 7536 (Apr I)

FOR SALE – Audio Research L.S.7 valve preamp, mint condition, boxed with manuals £700. Tel: 01752 787 459 (Apr I)

EPOS ES22 floor standing speakers. Dark cherry veneer. Boxed in immaculate condition £700. Tel: Day 020 8774 4248 evening 01483 486 442 (Woking, Surrey) (Apr/I)

MERIDIAN 101 preamp (black) rare. 105 monoblock power amps (black) 104 tuner (brown) all mint. Can demo amps £325. Tuner £75. Together £350. Tel: 01279 724 804 evening, 01442 286 740 daytime (Herts) (Apr/I)

PINK TRIANGLE PT TOO, Rega RB300, AT 37E £375. Leak Troughlines 2+3, mono, teak case £70 - £80. Leak Stereo 30+ teak case £35. Naim CDi remote £25. P.Metals Alpha £15. Tel: 01722 334 694 (Apr/I)

EPOS ES15 £400. Monitor Audio Studio 2SE £300. Musical Fidelity Nu-Vista interconnect 1.2m £60. QED Silver Spiral £40. D.N.M. speaker cable 4m bi-wired terminated £85. Chord Cobra 2 £25. Tel: 07967 646 089 (Apr/I)

CELESTION DITTON 33 speakers all veneered, excellent condition £50. KEF104 homemade speakers £80. Leak Sandwich 250 speakers £60. Designwise Glen speakers £25. Leak Mini-Sandwich speakers £40. Tel: 01379 898 676 evenings and weekends (Suffolk) (Apr/I)

TEAC TI transport £300. Quad 34, 405 MkII, FM4 £400 ono. Onkyo Grand Integra DX-G10, 27 kilo, 18bit, 8x o/sampling, very rare (£1700) £550 ono. NAD C160 pre 218 THX power 200wpc new 2 year G'tee (£1280) £850. NAD 533 T/Table (£230) £110. Musical Fidelity 24/96kHz DAC £150. Ixos Ixotica interconnect (£200) £90. Marantz CD12 remote, brand new £65. Will do deal with Quad 66 or 99 Series. Wanted: Hoods for B&W 801 in brown. Tel: 0121 742 2015 (Apr/I)

AVI 2000MM 150 watt monobloc power amplifiers £650. AVI FM tuner £290. Meridian 201 preamplifier and 209 remote £240. B & W P4 speakers £340. Harbeth bass speakers/stands for HLP3 and similar £120. Tel: 01892 536 919 (W.Kent) (Apr/I)

MICROMEGA DUO CD3 and Duo Pro DAC total quality in sound, build and looks, mint, boxed with manuals, less than third original price £750. Tel: 01892 538 126 or 07836 234 347 (Apr/I)

DENON DCDS 1011 14kg CD player £650 (£1300). Denon PMAS1011 30kg top quality integrated amplifier incorporating quality MM/MC phonostage £700 (£1400). Straightwire Maestro 2 interconnect (Stereophile recommended) £100 (£250). All excellent condition boxed with instructions. Tel: 01582 881 149 (Apr/I)

INFINITY MODULUS 50 speakers piano black EMIT ribbons matching shot filled stands £320 (£1000 new). Technics SL7 turntable new cartridge and spare stylus £200. Technics EPC-205Mk3 cartridge £150. Tel: 01387 263 252 (Apr/I)

PLINIUS 8150 integrated amp 150 watts, 16 months old, mint, boxed £1195. Sugden AV51 DAC £545. EAD T1000 transport £545. Both boxed, mint, sale due to upgrade. Tel: Paul 01283 716 443 (Apr/I)

PROAC RESPONSE speakers, Target stands, absolute mint condition, cost £1500, accept £700 for quick sale. Tel: 01204 393 606 (Apr/I)

HEYBROOK QUARTETS, boxed, black/walnut, matching stands £430 (£800). Linn Isobariks, stands, teak, boxed £450 ono. Mission 770's offers. DPA white Slink, metre pairs £25 each. Tel: 0151 480 3566 Email: Bob.Hignett@Instem-lss.co.uk (Apr/I)

AUDIO SYNTHESIS Passion Vishay passive preamp £345. Micromega Duo 3.1 Acutrans CD transport acrylic top loader stunning £525. Celestion SL600s with heavy master stands £400. Tel: 07909 697 060 or 0118 981 5681 (Apr/I)

LINN LK1 preamp £140. Ruark Sabres speakers £140. Linn Kusound speakers stands £40. Marantz CD50 £90. Aiwa 1800 cassette deck £40. Creek stereo tuner £50. Yamaha PS70 subwoofer £130. Vgc. Tel: 020 8406 4460 (Croydon) (Apr/I)

LINN: PRO-KAIRN slimline 'Brilliant' £700. Late spec Isobariks + Active/Dirak £600. LK140, Sep 2000, £600. 5103 processor pre-amp (silver) July 2000, £3300. All boxed, excellent condition. Tel: 01622 858 085 (Apr/I)

LINN KARIK transport and Numeric DAC (mark 2) with boxes, cables and remote £950. 1 metre pairs of gold phono terminated Kimber KCAG £200, Van Den Hul 501 mk2 £50, 102mk2 £50. Tel: 0141 945 1993 (Apr/I)

MONITOR AUDIO Silver 7's in Rosema £250. Rel Strata II subwoofer £350. Marantz CD 67 MkII £120. Arcam 8R 8P amplifiers £400. All items boxed. All 18 months old. All excellent condition. Tel: 07976 574 728 (Apr/I)

CLASSIQUE SOUNDS. (LEICESTER) INC ONE THING VINTAGE HI-FI & VALVE SPECIALIST

FOR SALE PRE/POWER AMPLIFIERS

Radford MA15 MK2 mono valve amplifiers X 2 consecutive serial Nos 1/AV SC4 pre-amp. Mini cond.	£1500
NVA A80 mono power amplifiers X 2. Good cond.	£ 799
NVA P80 passive pre-amplifier. Good condition	£ 199
Alchemist Forestry pre-amplifier. Mint. Boxed	£ 599
Quicksilver Line stage valve pre-amplifier. Stunning	£ 599
Pair Meridian 005 mono amplifiers. Good condition.	£ 990
Musical Fidelity Pre-S pre-amplifier. Mint. Boxed	£ 175
Exposure 1V power amplifier. Excellent condition	£ 505
Mini SPL pre-amp & Spare MC board / X Pak 2 Power supply	£ 450
Quad 606 MK1 power amplifier. Excellent condition	£ 399
Leak stereo 50 valve power amplifier. Very rare	£ 495
Pair Heathkit MA12 mono valve amplifiers	£ 249
Yamaha DSP-590 Dolby prologic digital sound field processor. C/w centre and rear spkrs & remote. Mint. Boxed	£ 250
Oxford Acoustics Mistral int amp. Cost £450.	£ 149
Quad 303 power amp. Ex cond. Serviced New caps	£ 195
Musical Fidelity The Pre amplifier with MM/ MC	£ 199
Cambridge P25 integrated amplifier. Ex condition	£ 99
Rotel RB970 BX power amplifier. Mint.	£ 99
Arcam Zeta 1 Prologic Cinema amp. Cost £999.00	£ 450
T/Vac line level valve pre-amplifier. Mint. Boxed	£ 350
Leak Stereo 20 valve power amplifiers from...	£ 200
Arcam Alpha 2 amplifier. Mint. Boxed/mstr	£ 95
Quad 11 Various. Price depends on condition	£ 90
Power A400 amplifier. Ex condition. Boxed	£ 195
Naim Nic 42.5K pre-amplifier with MC board.	£ 90

TURNTABLES

Wood THB VOFDE 3 motors & outboard PSU	£ 799	NVA phono 2 MC pre amp + 2 X PSU. Awesome	£ 499
Thorens TD125/Audio technica 1100 arm/plinth	£ 250	Roksan series X152 PSU. Black finish/RB250	£ 550
Rega Planar 2 turntable/RB250. Ex condition. Boxed	£ 120	Revolver Platable / Linn BasiK + VT. Mint. BXD	£ 69
Michell Ficus. One with Linn BasiK. Linn arm. Ex con	£ 199	Rega Planar 2 c/w rega RB200 arm. Wood plinth	£ 195
Lusmaa PD277. Direct drive. Ex cond.	£ 170	Rega K2 PS50 Direct drive turntable	£ 170
Denon System Deck Turntable. Complete with Syntr 2 pick up arm. The original & the best. Ex condition	£ 350	Arison RD110 turntable. Cut-out for SME. 3009	£ 150
Thorens TD110 turntable. Cut-out for SME. BsdC	£ 149	Thorens TD1125 in SME. 2000 plinth. Cut-out for SME	£ 60
Thorens TD1163C Deck only. Cut-out for SME. BsdC	£ 149	Garnant 301 & 401 motor units all serviced in situ	£ 125

SPEAKERS

Quad ESL57 speakers. All fully serviced with full 3 months warranty. Hear what ESL57s should sound like from	£ 750 pr
Pair Quad ESL57 spkrs. Fully rebuilt. 1e 4 Rec on bass & 2 recon treble units. All new electronics. 12m warranty	£1199
Naim Intro speakers in black ash. Mint. Boxed	£ 450
Pair of Meridian Short performance 860 speakers. Mint condition. Phono black finish. Boxed. Cost £1895	£ 899
Celestion Diton 25 in. teak. Very good condition.	£ 139
B&O Beovox 3800 speakers. Nice sound. Large	£ 49
B&W DM220. Slight cabinet marks. Boxed	£ 79
Meridian Short MS20 Pearl. Black finish. New.	£ 259
Cambridge R50 transmission line speakers. Rare	£ 259
Kel Kit 62 with H1-891110 Scanspeak. D2995 9300 tweeters. Expensive X Covers. Gut wrenching. Base. Awesome	£ 295
Rogers LS6 speakers in teak. Mint. Boxed	£ 125
Spendor SP2/3. Black finish. Boxed/instructions.	£ 595
Sony Andrews Tority speaker stands. Cost £599	£ 249
Base powered Acoustimas 3 spkrs. Unused/boxed	£ 295
Rusk Sabre. Black finish. Mint condition	£ 170
Snell J2 speakers. Black finish. Ex condition. Boxed	£ 295
Pair Rogers Studio 5 speakers. Rosewood finish	£ 480

OTHER ITEMS

Sugden SDT1 & SDM1 Transport & Disc/remote.	£ 849	Quad rack for 44/405/m4	£ 40
Naim CD13.5 CD player. Mint. Boxed	£ 749	Sony pro walkman WMD6C with leather case. Mint	£ 200
Quad PM4 tuner. Late model. Grey finish.	£ 199	Spare armature for SME series 3. New. Unused. Boxed	£ 55
SME 3009 Series 3 Tone-arm. Mint. Boxed	£ 149	Schreiber HD350 MK2 Headphones. Unused. Boxed	£ 55
Scanspeak Rack. 4 shelf. 4 legs. Black finish. Exe	£ 120	Teac TR450 tuner. AM/FM synthesized/RDS. Boxed	£ 69
Linn Tuner. Mint. Boxed. Very unusual. Cost £549	£ 249	Quad FM2 Valve tuner. Nice condition. Rare.	£ 160
National Panasonic 20FC11 low impedance stereo cartridge complete with SME style headshell. Unused. Boxed	£ 59		
Arcam Alpha 5 cd player. Mint. Boxed/remote	£ 195	Phillips 100 cd player. The first. Good condition	£ 100
Aiwa AD-750 Dolby B/C S/H/Ls pro Cassette. Mint.	£ 75	Denon DCD1700 CD player. Cost £650. Boxed	£ 100
Aiwa AD14370 cassette deck. Dolby B/C. HiSpn. Bsd	£ 40	Marantz CD 50 CD player. Ex condition. Boxed	£ 80
Leak singleline 3 stereo tuner. Fully serviced	£ 195	Revox B77/2. 2 speed reel-reel player. Ex condition	£ 395
Leak stereo/tuner. Similar to Troughline	£ 35	Leak 2300 tuner. Serviced by One Thing. Mint.	£ 49
Marantz CD52 MK2 CD player. Mint. Boxed	£ 99	Audax HD 11D 34H tweeters. New old stock	£ 25
Sugden F48 tuner. Sounds superb	£ 95	Arcam Black Box S/DAC. Unused. Cost £480. Mint	£ 240
Meridian 203 MKV B/S DAC. Mint. Boxed	£ 160	Tro K1880L synthesiser tuner. AM/FM. Black	£ 75
Hendek tone arm with Linn arm-board.	£ 149	Technics SL 15620A CD player/remote	£ 75
Quad 34 moving coil module. Mint. Boxed	£ 40	SME 3009 tonearms from	£ 95
Technics Class AA 3 head cassette deck. Dolby B/C	£ 119	HiX pro Adjustable digital control. Good condition	£ 80
Aiwa XT950 tuner. Boxed. Final w/MS. CW. tin...	£ 50	Arcam Black Box B/MC. AM/FM tuner. Serviced	£ 150

QUAD ESL57 PANELS/SERVICING ETC

Reconditioned Quad ESL57 speakers from only £700.00 pr. Why spend £4000+?
 Have your ESL57s refurbished for only £349.00/Pair. Ring for full details.
 Exchange/recon ESL57 bass panel £120. Treble £100. ESL63 panels £100 Refurbished.
 New socks for ELS63s £38 pr. Many other spare parts available. Please ring.
 "Classique Sounds servicing restores the Quads to a position where they can hold their head high", Jon Marks. HI-FI WORLD. April 1999
 Full servicing facilities available.

Troughline tuner service & realignment £95.00. (excludes valves. Rarely needed). Subject to tuner being in a serviceable condition, with no major faults or modifications.

TRANSLUCENT. (somewhat of a bargain) Hi-Fi World. Jan 1999
PURE SILVER INTERCONNECT CABLE.
 99.99% pure silver conductors. Quality gold plated RCA phono plugs.
 Half Metre terminated £60.00 One metre terminated £80.00
 7 day money back guarantee if not better than existing cable. Regardless of price or quality

One Thing Main cables. Class I RFI suppressed. Silver plated conductors.
 Voltage spike protection, only... £55.00

NEW EAR/YOSHINO EQUIPMENT

Ear 834P MM/MC phono stage with/without volume.	Brand new. Boxed at only £529
Ear 834P MM phono stage. No volume control.	Brand new. Boxed at only £379
Ear 834L Line only valve pre-amplifier. Amazing.	Brand new. Boxed at only £479

301/401/124 PLINTHIS (lets the Garrards inherent quality show through) HI-FI World. Oct 98
 Plinths @ only £199 unfinished or £299 finished (sencered)
 Awarded 4 Globes October 98 (HI-FI WORLD)

WANTED Vintage and modern hi-fi eqpt. Part exchange welcome.
 Tel/Fax 0116 2835821 or 0802 213740 (Mobile). Callers by appt only.
 Opening times 10.00am-6.00pm Mon-Friday, 10.00am-2.00pm Saturday.
 Classique Sounds. 61 Aylestone Drive, Aylestone, Leicester. LE2 8QE

Cable Talk

Interconnects & Speaker Cables

1994 Best Speaker Cable

1995 Best Interconnect & Highly Recommended Speaker Cable

1996 Best Interconnect & Best Speaker Cable

1997 Best Speaker Cable & Highly Recommended Interconnect

Interconnects Speaker Cables

Doesn't Your System Deserve The Best?

FOR FURTHER INFORMATION

Please telephone, fax or write to

Cable Talk,

Unit J, Albany Park, Camberley, Surrey, GU15 2PL

Tel (UK ONLY): FREEPHONE 0800 - 100 - 6868

TEL: (+44) (0) 1276 686717. FAX: (+44) (0) 1276 686353

(CT HFW 0401)

diverse vinyl

01633 256261 / 259661

10 Charles Street Newport South Wales NP20 1JU.

sales@diverse-music.co.uk

Forthcoming Releases

Arab Strap	The Red Thread	25/02	£TBC
Beastie Boys	Sounds Of Science		£TBC
Bob Marley/Wailers	Natty Dread/Live (SV)		£18.50
Bonnie Prince Billy	Ease Down The Road	25/02	£TBC
Captain Beefheart	Grow Fins Volume 3		£TBC
Richard Thompson	Action Packed (Best Of) 2LP		£17.90
David Bowie	Man Who Sold The (SV)		£TBC
David Bowie	Diamond Dogs (SV)		£TBC
Erykah Badu	Mama's Gun		£15.90
Fun Lovin Criminals	Loco	26/02	£TBC
Led Zeppelin	3 & 4 (Classic Records)		£25.90
Rubettes Vols 13 -15	Psyche Reissues	01/03	£16.90

THIS MONTH'S FEATURED NEW RELEASES

GEORGE HARRISON "ALL THINGS MUST PASS"
 30TH Anniversary Re-issue with 5 extra tracks - 3LPs £25.90
THE WHO "LIVE AT THE ISLE OF WIGHT FESTIVAL"
 First time on vinyl for this classic live set - 3LPs £29.90

Other New Stock And Recent Releases

Al Green	Simply Beautiful	£12.90
Beatles	1 - WHILE STOCKS LAST	£18.90
Charles Lloyd	Discovery	£10.90
DCC - Queen	Night At The Opera	180g £26.90
Gesheis	Duke (SV)	£18.90
Gram Parsons	Lost Recordings(65-66)	£15.90
Ibrahim Ferrer	Salson (Early Recordings)	£15.90
Impressions	Young Mods Forgotten Story	£12.90
JJ Perrey	The In Sound From Way Out	£13.90
Johnny Cash	American 3 Solitaryman	£11.90
Ornette Coleman	Live At Prince Street	£10.90
Paul Simon	You're The One	£16.90
Queens Of Sone Age	Rated R	US LP £14.90
Sonics	Here Are/Boom	Each £12.90
Stephen Malkmus	(Ex Pavement)	£12.90
Captain Beefheart	Trout Mask Replica	£22.90
Tortoise	Standards (Warp)	£TBC
Tubby Hayes	Introducing Tubbs	£10.90
Turin Brakes	The Door	£TBC
Unicorn	Uphill All The Way	£12.90

PLUS WE NOW STOCK THE DISCO ANTISTAR LP WASHING DEVICE - PRICE £39.99 (Ask For Details!)

P & P £1.00 1st LP; 50p each additional LPs (up to 5 LPs)

Call For Rates On Larger Orders. 24hr Service Now

WWW.DIVERSE-MUSIC.CO.UK

Special Internet offer
see page 130 for details

UNISON RESEARCH Simply Four triode mode integrated amplifier. Extremely natural sound. Excellent condition £895. Simply phono stage £270. Tel: 01484 712 947 evenings (West Yorkshire) (Apr/I)

AVI NEU-NEUTRONS marble & steel stands £300. Arcam Delta 70.3 CD £200. Quad 77 amp £300. Wanted: Linn Kairn Karik 3 Grado SR 60's or SR80's Linn Pekin 0121 246 0486 (Apr/I)

CARDAS GOLDEN Cross speaker cables, 2m pair, single-ended spades, not run in yet, runner-up Stereophile 'Product of the Year' (December 2000) (£2k) £900. Tel: 020 7715 8374 (May/I)

CLASSIC COLLECTORS items. 1964 Philips EL330 cassette. As new, boxed, never used, offers. Technics SL7 LP sized linear tracking turntable, little used marvel £250. Decca Export Gold, damaged £30. Tel: Norman 01702 527 983 (Apr/I)

NAIM NAIT3 with MM phono board £295 ono. Naim Nait1 £120 ono, Rogers LS7 BBC speakers £150 ono. Meridian 204 tuner £295 ono. All very good. Tel: Nick 01733 896 581 (Peterborough) (Apr/I)

AUDIO INNOVATIONS valve power amps: 800 Mk1 £275, Series 200 Mk2 £195, Nikko transistor poweramps 40wpc Class A 100 volts £175 each with transformers. Celestion Ditton 33 speakers, teak, £35. Tel: 01202 767 873 (Apr/I)

QUAD ESL57 two pairs, £400, £550. Meridian 602, 606 £900. Tel: 0121 459 9616 (Apr/I)

QUAD ELS63 Afromosia and brown, as new condition, serviced in 1993. Serial Numbers 11171, 11172. Hi-Fi World review tells you all you need to know. O.I.R.O. £1100. Tel: 0121 745 6516 (Birmingham) (Apr/I)

R.M.S. REVELATION speakers £850. Oydseus valve amp £550. Metexa pre £395. Revox H11 cassette deck £600 ono. Acoustat Electrostatics £350. Arcam 9 amp £300. Arcam 5 CD £150. Rel Q50 £200. Tel: 01626 774 246 (Apr/I)

LEAK 2075 speakers £375. Immaculate condition. Quad 303/405 pre-amp £275. Recently serviced by Quad. Please call 0121 707 0791 evenings (Apr/I)

B&W CC6 S2 Centre speaker £75. Target Hi-Fi stand, 5 glass shelves, cost £240, bargain £110. Volt 10" bass unit £45. All items excellent condition. Tel: 01604 661 052 (Apr/I)

KOETSU RED, boxed, original stylus, 300 hours £495. Koetsu Black £275. Linn Isobarik tweeters (latest) 3 as new £75. Linn Keltik/Kaber tweeters (3) £95. Naim 250, boxed £550. Tel: 00 3531 295 4076 (Apr/I)

AUDIO SYNTHESIS DAX DAC and Roksan ROK1 transport. The classic combination. Both excellent condition £1350. Tel: 01823 443 825 (Taunton) (Apr/I)

LINN AXIS Akito £250. Roksan Tabriz £75. Both boxed, excellent. JBL centre speaker, excellent £35. Connoisseur BD101 (12" platter) SME 3009, good, £70. Tel: 01344 750 440 (Bracknell) (Apr/I)

NAKAMICHI BX100E cassette deck, very little use, immaculate condition, excellent performance. boxed with instructions £130 ono. Tel: 01625 260 903 (Stockport) (Apr/I)

AUDIOSTATIC ES 100s Electrostatic (full range) speakers, black, Kimber 8TCM and base weighted/spiked modified for even greater fidelity, total cost £3100+, sell £1500. Pink Triangle D.C. supply, needs service £400. Tel: 0141 954 8030 evenings (Apr/I)

WANTED: 4TH ORDER passive crossovers and speaker stand mounting panels for Linn Isobariks. Tel: Dave 0115 953 2621 (Nottingham) (Apr/I)

ROGERS SPEAKERS pair of original BBC monitors, 15 ohm £500. Pair of Sonic Link Red and Silver Pink interconnects £25. Quad 405, good condition £150. Tel: 07721 470 286 (Apr/I)

MARANTZ CD10 CD player Trichord Clock modifications perfect condition £300. Roksan Attesa ATDP3 CD transport fitted Audicom Superclock with Sumo Theorem Two DAC balanced and unbalanced outputs, brilliant sound £400. Tel: 01633 279 173 (Apr/I)

NAIM NAP90 £299. NAC72 £375. Castle Harlech light oak immaculate £499. Tel: Steve 01793 643 930 or 07971 605 383 (Swindon) (Apr/I)

PROAC RESPONSE ISC loudspeakers in rosewood and in mint condition, boxed, instructions, (£1350) with dedicated Target loudspeaker stands (£230), £800 ono. Tel: 01508 499 586 after 4pm (Apr/I)

REVOX B77 Stereo tape recorder hi-speed, fully serviced by Audio Labs Leeds October 2000 and according to them is in perfect condition and running to Revox specifications. £575. Tel: 0113 281 2693 (Apr/I)

GUIDELINES FOR BUYING AND SELLING SECOND-HAND EQUIPMENT

FOR THE BUYER

1. Not everyone is honest - Buyer Beware!
2. Accept no verbal guarantees.
3. Have you heard the item or something similar? If not, why do you want it?
4. Don't pretend to have knowledge - it's your fingers that will get burnt!
5. Is it working? If not, why not?
6. Has it been modified and, if so, have notes been kept?
7. Was it any good in the first place?
8. **Don't send cash!**
9. If you are in the slightest doubt, arrange an audition (see point 4). If it's too far, wait for another time.
10. Either buy it or don't: vendors are excruciatingly impatient with 'consultation' exercises.

FOR THE VENDOR

1. Not everyone is honest - Seller Beware!
2. Make no verbal guarantees.
3. Even 'nearly new' is still second-hand. If the manufacturer's guarantee is no longer in force, your price should reflect this.
4. There is very little intrinsic value in second hand hi-fi: it's only worth what someone will pay for it.
5. The best guide to pricing is last month's Classifieds: that a 'classic' was worth £xxx a year or two ago is no guide. Values fall as well as rise.
6. Amateur second-hand dealing is not a big money game: you win some, you lose some.
7. Be prompt with despatch. If in doubt about buyer's bona-fides, either wash out the deal or send C.O.D.
8. There will always be time-wasters; be tolerant within reason!

Classified Ads

Classified Ads

Oxford Audio Consultants Ltd.

OUR SUPERB SERVICE IS THE SAME REGARDLESS OF PRICE



Now Demonstrating



Ex-Demonstration & Previously Owned Equipment

SALE LIST - February 2001

WILSON AUDIO SYSTEM 6 BLACK AS NEW	£13995	SH
SONUS FABER GUARNERIS AS NEW	£3995	SH
NAIM SBL BLACK EX DEM PASSIVE	£1495	XD
PATHOS ACOUSTICS TWIN TOWERS AMPLIFIER	£2795	SH
MARTIN LOGAN SL3 LOUDSPEAKERS LIGHT OAK	£2195	SH
THETA JADE	£1795	SH
OPERA CALLAS GOLD SPEAKERS MAHOGANY	£695	SH
KRELL 300 I INTEGRATED AMP EX DEM	£1995	XD
KRELL DT10 CD TRANSPORT	£3995	SH
THETA PROBASIC 3a D/A CONVERTER	£1995	SH
KRELL KRC PREAMPLIFIER	£2995	SH
TRANSPARENT ULTRA SPEAKER CABLE 20FT	£1495	SH
NAIM 180 POWER AMP	£795	SH
NAIM CDI CD PLAYER	£ 795	SH
NAIM 92/90 PRE/POWER AMP EX DEM	£750	SH
JADIS ORCHESTRA CD PLAYER	£795	XD
JADIS ORCHESTRA AMPLIFIER	£ 795	XD
KRELL KAV300 CD PLAYER EX DEM	£2995	XD
KRELL KAV300CD AS NEW	£3450	
RUARK TALISMAN	£250	SH
VIDIKRON HELIUS PROJECTOR		
- OUR DEMONSTRATOR	£6995	XD
UNISON RESEARCH SMART 845 - our demonstrators	£1995	XD

0% INTEREST FREE CREDIT

Licensed Credit Broker

REFER TO OUR WEBSITE FOR THE LATEST UPDATED SALE LIST.

Agencies include: Audio Analogue, Audio Research, Audio Technica, BOSE, B&W Cable Talk Castle, Copland, Denon, Graaf, Goldring, Jamo, Jadis, KEF, Koetsu, Krell, Lexicon, Loewe TV & Video, Lyr, Marantz, Martin Logan, Michell, Musical Fidelity, MRS, NAD, Naim, NEC Gas Plasma Screens, Nordost Cables, Onkyo, Opera, Ortofon, Pioneer, Proac, Project OED, REL Subwoofers, Rotel, Speakercraft, Sennheiser, SME, Sonus Faber, Sonance, Slands Unique, Stax, Target, TAG McLaren, TEAC, Theta, Thorens, Transparent Cables, Unison Research, van den Hul, Vidikron, Wilson, Yamaha.

TAX FREE EXPORT SERVICE
MAIL ORDER AVAILABLE ON MANY ITEMS

Cantay House, Park End Street
Oxford OX1 1JD

Telephone: Oxford (01865) 790879

Facsimile: Oxford (01865) 791665

E-MAIL: Oxford.Audio@btinternet.com

WEBSITE: www.oxford-audio.co.uk

HICAM

CHERISHED PRE-OWNED HI-FI EQUIPMENT SOLD,
PURCHASED, P/A.

WE URGENTLY REQUIRE NAIM, MERIDIAN, AUDIOLAB,
LINN EQUIPMENT

MAIL ORDER ALWAYS A PLEASURE

DESCRIPTION	PRICE	£
AUDIOLAB C PRE AMP		195
AUDIONOTE EL SPK MINT INC STANDS BOXED	1780	925
ALCHEMIST NEXUS APD32A 24 BIT CD PLAYER NEVER USED	599	495
TARGET R4 SPEAKER STANDS	325	275
ALCHEMIST TS-D1 24 BIT DAC	299	225
AVI S2000MC 24 BIT CD PLAYER	999	895
ALPHASON AKROS 2 SPEAKER STANDS BOXED	65	40
AV1 S2000 MM MONOBLOCKS	1399	1195
AVI S2000MT11 AM/FM REFERENCE TUNER	899	725
DALI EVIDENCE 870 FLOORSTANDING SPEAKERS	1299	999
EAR MC3 MC TRANSFORMER	629.95	495
DALI ROYAL MENUET MK2 CHERRY FINISH	399.95	295
DALI EVIDENCE C70 CENTRE SPEAKER	399.95	325
HEYBROOK QUARTET ROSEWOOD FINISH	550	300
LAT AC2 6 WAY DISTRIBUTION BLOCK 3 FT	194	170
LAT AC2 POWER CABLE 3 FT	65	55
SME V ARM MINT/SEALED BOX	1243	1150
TALK ELECTRONIC THUNDER 1 CD PLAYER	599.95	495
MICHELL GYRODECK 3E/RB300 MINT BOXED	950	875
MICHELL ARGO/HERA PRE/PSU		325
TALK ELECTRONIC CYCLONE 1 INT AMP R/C	599.95	495
MICHELL ALECTO MONOBLOCKS	1989	1599
MICHELL ORCA PRE AMP	1286	1100
MONRIO ASTY INT AMP MINT/BOXED	425	275
NAIM 180 POWER AMP		725
NAD C320 INT AMP/REMOTE MINT	200	125
NAIM SBL LOUDSPEAKERS WALNUT FINISH	2100	895
NAIM SBL LOUDSPEAKERS BLACK/BOXED	2100	795
MARANTZ CD 63	300	150
TANNOY MERCURY M3 SPEAKERS BLACK/BOXED	230	150
LINN INTEK INT AMP/BOXED		150
MERIDIAN 501 PRE/ MSR		450
PRECIOUS METALS SILVER SIGNAL 202B BALANCED	430	350
PRECIOUS METALS SILVER SIGNAL 204 INTERCONNECT 1 METRE	430	350
PSB ALPHA 6 ACTIVE SUBWOOFER	499.95	425
PROJECT CLASSIC/PROJECT9/510 CHERRY MINT	450	325
REGA BRIO INT AMP		180
PROJECT PERSPECTIVE/PROJECT 9 ARM BOXED MINT	750	525
PSB ALPHA ZERO SUB ACTIVE	199.95	160
LINN LK 280/LINN PRETEK BOXED		400
STAX SRS 2020 MK2 EARSPEAKERS	395	325
TARGET MX100 SPEAKER STANDS PIANO BLACK	79	60
TRICHORD RESEARCH 500 POWERBLOCK	299	265
SUMIKO BLUE POINT SPECIAL MC	249	195
SONETEER THE BYRON CD PLAYER	795	645
SONETEER THE SEDLEY PHONO STAGE MM/MC	399	325
LYRA IYDIAN BETA MC CARTRIDGE	599	495
SONICLINK RED EARTH 1 METRE INTERCONNECT	300	225
SONICLINK 8 WAY DISTRIBUTION BLOCK 2 METRE CABLE	225	175
EAR 834P MM/MC PHONOSTAGE	529	450

AGENTS FOR:

ALCHEMIST, AVI, CRIMSON, EAR, DALLI, DALLI, LOGIC, MICHELL,
ORTOFON, OPTIMUM, PSB, PROJECT, PRECIOUS METALS,
SNELL, SONETEER, SONICLINK, SUNFIRE CORP, TARGET,
TOM EVANS, VDH, XLO, TRICHORD RESEARCH

OPEN MON SUN 10AM 6PM
FOR FURTHER DETAILS: TEL 01726 74474 / FAX 01726 70774
MOBILE: 07973 233 380
E-MAIL HICAM1@FREENETNAME.CO.UK
OR VISIT OUR WEBPAGE HICAM.CO.UK



hi-fi Trade Ads

world

Special Internet offer
see page 130 for details

Dealers must not advertise in the Private Classified section.
Monthly consecutive insertions will be considered Trade
advertising. The Publisher reserves the right to judge submissions.

WANTED - EARLY HI-FI LOUDSPEAKERS

Tannoy, Lowther, Parmeko, Voigt,
Vitavox, RCA WE etc

TURNTABLES

Garrard, BBC301, EMT SME,
Ortofon, Decca, etc.

VALVE AMPLIFIERS

AEI, EMI, Leak, Rogers, PYE-
Quad, WE etc

AUDIO VALVES

DA30, KT66, KT88, PX4, PX25,
PP3/350, WE300

CLEAR CRYSTAL SYSTEMS

John Petrie-Baker
Tel: 020 7328 9275

VINTAGE WIRELESS COMPANY LONDON

Website: www.

vintagewirelesslondon.co.uk

Buy-Sell-Exchange. Vintage wireless and classical audio. Repairs, spares, restoration, modification to all valve equipment. Quad II, Leaks etc, shipped worldwide, best prices, call us at 17 Bell Street, London, NW1 5BY.
Tel: 020 7258 3448
Fax 020 7258 3449
Email: vwirelesslondon@aol.com
(Jul/1)

AFFORDABLE VALVE

COMPANY Model EL34. Powerful 40 watts Class A valve amplifier. Mr Andrew Everard in Gramophone Magazine "delivers a sound that's both smooth and refined...allied to a good degree of clarity and finesse." Richard White in Hi-Fi World review "soothing rocked by EL34's powerful bass end...very good value for money." Richard Black in Hi-Fi Choice "it's a classic valve sound...warm and cuddly...vocals are generally lifelike and involving." Comprehensive 1 year guarantee. Free colour literature. Free delivery. 1 month home trial. Guaranteed to improve your hi-fi system or your money back. New £600 New. Credit cards accepted. Telephone 01634 373 410 anytime. Website: www.affordablevalvecompany.com (Apr01)

ATTENTION! SUMO Polaris Power Amplifier. Includes extensive modifications carried out by Audiocom UK. Mods include: DNM Slit Foil capacitors, REL Multicaps (PPFX-S) input coupling caps. Kimber Kap & Elna Silmic de-coupling caps, Vishay metal foil film resistors, Kimber TC internal wiring, Audiocom custom-made mains cable. SUMO RRP £850, modification value £750, sounds superb! First to dem will buy. Usual Audiocom Warranty. £995.00, absolutely no offers. Tel: 01646 685 601 (Apr/1)

RELEASE THE full potential of your digital Source with active CD/DVD upgrades from Audiocom. Available are the highly acclaimed SUPERCLOCK master clock with Super-low noise power supplies and the Q-power discrete regulator. Check our web site for product news, reviews, DIY features, & classifieds: www.audiocom-uk.com. Tel: 01646 685 601 (Apr/1)

MARK LEVINSON 23.5 power amp. Rec't service. Mint. boxed £2600. Naim NAC82 £1600. Audio Technica OC9 cartridge, brand new, unused £360 - £230. Audio Research SP14, Boxed inc. Manual. mint £1250. Audio Research SPI1 MK11 Superb pre amp, Rcn't A/S service £1450. Cyrus Disc & Dac master Mint, boxed as new (£1800) £670. Deltac Black Slink, 6 mtr, WBT's £400 ono. Deltac Black Slink, 3.75mtr, WBT's £150. Heybrook HBI 2000, beech, dem'd once, immaculate £130. Krell KSA 80 power amp, Boxed, mint £1450. Meridian 209 r/c £30 ono. Naim SBL's new style bass units, walnut, mint condition, spare gasket kit, boxed £850. Nordost Blue Angel balanced cables, 1mtr £70 ono. Quad 77 remote control brand new £300 - £150. Rotel dem stock; sealed boxes: Rotel RCD 971 - £350. Rotel RA931 £145. Transparent Link 100 new £95. Transparent The Wave 12ft speaker cable, new £170. Please telephone Jules on 01792 280061 Email: sales@sounddrjuleshifi.co.uk Web: www.sounddrjuleshifi.com (Apr/1)

HIGH-END-AUDIO - Amplifiers - Cello Encore 50/50 monos £3700. Cello 150/150 monos £5700. Krell KAV 300i (remote) £1795. Krell Kav 500i (remote) £3795. Gryphon Antileon (Denmark) (£10k) £6500. McIntosh 6500AC £2600. Mark Levinson No.27 amplifier £1995. Krell KSA 2005 £3250. Pre-Amplifiers - Krell KSP-7B pre-amp with phono/PSU £1295. Krell KRC HR/PSU £3600. Mark Levinson No26 S £3000. - CD Players - Theta Pearl CD Transport £995. Theta Miles Symentricks transport £1795. Wadia 6i CD Player £2000. Wadia 860ix (silver) £5700. Vincent™ CD S3/pre-amp, heavy) £2000. Tel: 020 7349 9675 or 0958 607 613 Cadeias Mondelo Transport/DAC (piano/blk) + marble £2000. Krell Kav 300 CD £2500. Cello Reference DAC (£4350) DCS Elgar DAC £6500. Theta Casanova processor £3500. Audiomeca Mamphisto CD (Transport) £1300. Audiomeca Ambrosia (DAC) £1295. Theta Ds Pro Prime (DAC) £900. Burmester 939 CD (Chrome) £1995. Wadia 27i (DAC) (£8.5k) £4500. Gryphon Tabu CD player £2700. - Speakers - Martin Logan SL3 Electrostatics £1850. Martin Logan CLS2 Electrostatics £2700. Final 0.4 MkII Electrostatics £1850. AudioStatics 300RS Electrostatics (2 metres) £1200. Tel: 020 7349 9675 or 0958 607 613 (Apr/1)

AUDIOJOY CO. Transfiguration Temper Supreme, as new £1000. Michell Delphini phono monoblock pair as new £1000. VDH The Second Interconnect 1m £140. Harbeth P3ES cherrywood boxed mint £400. Tel: 020 8363 4963 (Apr/1)

VOODOO ISOLATION systems, Airtek launched at the London Show 2000. Airtek is an air suspension platform designed for use under all Audio Electronics, benefits gained, tighter extended bass, cleaner more detailed treble, better imaging, a more open natural presentation. Price £149, 14 day money back guarantee if not satisfied. For more information Tel: 01643 822 128 9am-9pm Mon-Sun (Apr/1)

NAGRA T-AUDIO two track four speed £3000. Nagra IV stereo £1200. Nagra E-mono £400. Studer B67 VU portable three speed £850. Revox PR99 high speed £650. Tel: 01246 235 024 Fax: 01246 550 421 (Apr/1)

REVOX PR99 MkIII high speed in serviced condition £850. Technics SLP1200B pro CD player £550. Studer A710 cassette £450. Revox B760 tuner £450. Revox B77 HS £550. Tel: 01246 235 024 Fax: 01246 550 421 (Apr/1)

LINN GENKI, Kolektor, LK85 £1500. Arcam Delta 270 CD £250. Arcam 7CD £200. Rega XEL speakers £550. Rotel RSP966 processor £450. M + K VX100 £575. Linn Intek £200. Sound Cinergy 01922 457 926 (Apr/1)

SJS ARCADIA 7W PSE 2A3 valve power amp £2750 (£4500), SJS Arcadia 18W PSE 300B power amp £3450 (£5500). SJS Arcadia Model I line preamp £750 (£1000), buy direct from the manufacturer with a Warranty. Rare Snell A2 loudspeakers £1850. Call Simon on 0161 439 0727 (Apr/1)

CASH WAITING for the following valves: ECC31; ECC32; ECC33; ECC34; ECC35; ECC81; ECC82; ECC83; EL34; EL37; EL84; GZ32-GZ34; KT66-KT88; PX4; PP3/250; AC044; PX25; PP5/400; DA30, DA60. Amplifiers: Quad I and II; Leak TL10; TL12+; 12.1; PYE; RCA; Rogers Cadett; Rogers loudspeakers 15 ohm and any other working not working vintage amp. Tel: 020 8343 0533 or 07901 976 441 Email: altofidelity@infinito.it (Apr/1)

APOGEE CENTAUR Minor speaker, as new £650. Musical Fidelity Pre 3x + 2xP140x poweramps £550. Arcam Alpha 9 CD (new) £550. Ruark Talisman 2 (black) £350. Densen B400 CD (new) £800. Tel: 01952 502 097 (Apr/1)

VALVE PREAMPS! Best selection of sensibly priced valve amplifiers in England. Tel: Audio Classics. Tel: 01942 257 525. Email: audioclassics@hotmail.com

ARCAYDIS

HAND CRAFTED SPEAKERS TO SUIT
ALL MUSICAL TASTES AND POCKETS

ARCAYDIS ASC

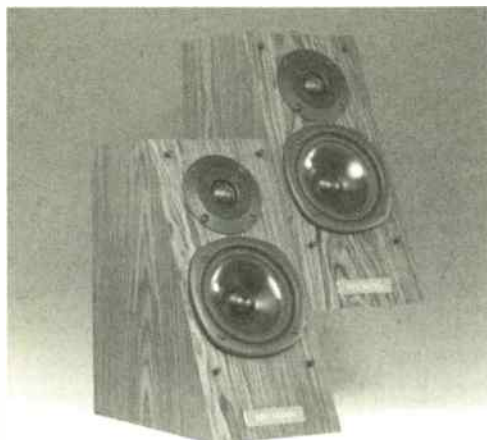

*As reviewed by Richard White
Hi-Fi World June 99*

ARCAYDIS AS2



*As reviewed by Simon Pope
Hi-Fi World October 99*

Unit 4 -19 Lisle Avenue, Kidderminster, Worcs, DY11 7DF
Tel: 01562 865 788 Fax: 01562 865466

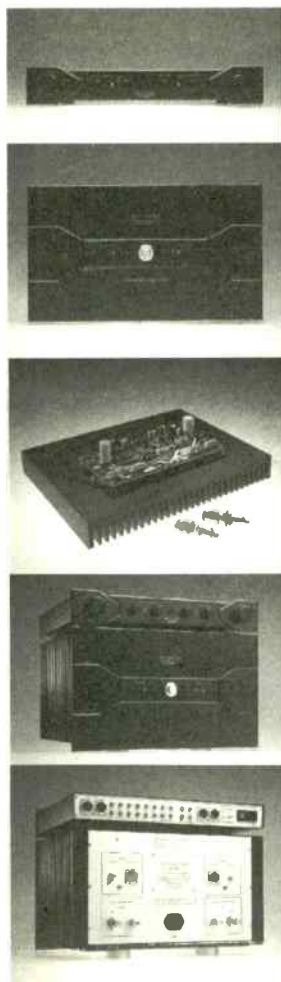

SUGDEN audio products



Masterclass from the original CLASS A company

New products from Sugden

Wide-bandwidth d.c coupled high current class A power amplifier and matching pre-amplifier. Available as a stereo power amplifier you can upgrade or balanced monoblocks.

Handcrafted from the finest materials and components, Sugden guarantee to add an extra dimension to your listening pleasure. Our superior wide-bandwidth designs will increase the dynamic range and sonic accuracy of your audio system - without fatigue.

With over thirty years experience in design and manufacturing Sugden has become a reference for reviewers, musicians and audiophiles around the world. Prices start at £549.00 for the Audition series so why settle for anything less?

J. E. Sugden & Co Limited
Valley Works, Station Lane, Heckmondwike,
W. Yorks. WF16 0NF
Tel. 01924 404088 Fax 01924 410069
Email jesugden@compuserve.com

SUBSCRIPTIONS



UK SUBSCRIPTION £27

VISIT OUR WEBSITE: www.hi-fiworld.co.uk

Get your issue of **hi-fi world** straight to your door!

Get to our amazing classified ads first and grab a bargain!!

Run by dedicated hi-fi engineers and enthusiasts, Hi-Fi World has become famous for its informative reviews and radical kit designs.

OVERSEAS SUBS RATES

Surface Mail	£40
Airmail Europe	£50
Airmail Middle East & South-East Asia	£60
Airmail USA, Canada, Australia, Japan, Korea & China	£70

MISSED AN ISSUE?

Back issues also available at a cost of £3.50 only (includes P&P), payment by cheque only - overseas please contact us for details. Send cheque to: Hi-Fi World, Freepost LON3478, London, NW6 6YR.

Credit Card Hotline Monday - Friday 9.30am - 12.00 noon: Tel: +44 01923 270 833 Fax +44 01923 260 588

By post: Make cheque or postal order payable to: Audio Publishing Ltd, sent in an envelope marked: Hi-Fi World, Freepost LON3478, London, NW6 6YR

HI-FI WORLD SUBSCRIPTION FORM

I would like to pay by cheque made payable to Audio Publishing Ltd. Credit Card Airmail Surface Mail

Please debit my VISA/MASTER/SWITCH Card No. (Switch card issue No. _____)

Expiry Date: _____ Cardholder Signature: _____



Name _____ Address _____ Delivery Address (if Different) _____

Post Code _____

Daytime Tel: _____

Start Issue _____



classified ads order form

Dealers must not advertise in the Private Classified section. Monthly consecutive insertions will be considered Trade advertising. The Publisher reserves the right to judge submissions

SPECIAL OFFER
Book a private or trade classified advert, and get one months FREE internet advert

In a rush to get your advert published? Why not use our Instant Internet Advert to get on our website immediately. Only £15 per week (7 days)

RATES :

Maximum length per advert is 30 words, each additional word is 50p extra. Telephone and model numbers are treated as one word, i.e. Quad 303= two words. Please tick the box for the advert required

*Free internet adverts are published three weeks AFTER the magazine has been published

Instant Internet Only Advert Private or Trade published immediately	£15 per week	<input type="checkbox"/>
Private magazine advert plus *FREE internet advert	£10 per month	<input type="checkbox"/>
Private magazine advert display black box plus *FREE internet advert	£15 per month	<input type="checkbox"/>
Trade magazine advert plus *FREE internet advert	£10 per month	<input type="checkbox"/>
Trade magazine advert display black box plus *FREE internet advert	£15 per month	<input type="checkbox"/>
Please tick here if you DO NOT WANT your FREE internet advert <input type="checkbox"/>		

Please write or type your advertisement copy in block capitals with one word per box.
Please continue on a separate sheet if necessary.
WE WILL ACCEPT PHOTOCOPIES OF THIS FORM

1	2
3	4
5	6
7	8
9	10
11	12
13	14
15	16
17	18
19	20
21	22
23	24
25	26
27	28
29	30

Name _____
Address _____
Post Code _____
Daytime Tel: _____

Please debit my VISA/MASTER/SWITCH Card No. (Switch card issue No. _____)
Expiry Date: _____ Cardholder Signature: _____

I enclose a cheque/postal order for £ _____ Made payable to: Audio Publishing Ltd.
Send in your private classified ads with our NEW Freepost service. No need for a stamp!
Send this form together with your payment in an envelope marked:
Hi-Fi World, FREEPOST LON3478, LONDON NW6 6YR

ADVERTISERS INDEX

Acton Gate Audio	118
Affordable Audio	90
Apex Acoustics	91
Arcaydis	128
Audio Com	20
Audio Matters	105
Audio Shed	93
Audio Synergy	100
Audio T	50
Audio Vector	64
Audusa	105
Billy Vee	85,86,87
Cable Talk	112
CAD	42
Castle Acoustics	12
Central Audio	110
Choice Hi-Fi	92
Classique Sounds	112
Comag	106
Custom Cable	99
Vintage Fair	91
Definitive Audio (Brighton)	101
Definitive Audio (Notts)	70
Deskadel	42
Diverse	112
Elac	22
Eltax	18
Emporium (The)	99
Emtec	46
Glaive	103
Glass Audio	96
Grandix	95
Heatherdale	106
Ortofon	54
Hi-Cam	116
Ian Edwards	102
Ian Harrison	100
Infidelity	108
Jem Distribution	99
Kef	15,17
Listening Rooms	110
Mantra Audio	96
Marantz	1FC
Matrix	107
Meridian	62
Michell Engineering	64
Midland Audio Exchange	94
Mission	BC
MPO	7
Music & Video Exchange	100
Musical Fidelity	38
Musical Images	118
Musonic	103
Myryad	22
Naim Audio	18
Origin Live	104
Orpheus Audio	101
Oxford Audio Consultants	116
Pear Audio	70
PG Hi-Fi	107
PM Components	98
Progressive Audio	105
Rel Acoustics	48
Retro Repro	102
Russ Andrews	68, 70
Sevenoaks	28,29,39,31,33
Sevenoaks	64
Signals	103
Soundcraft	106
Sounds Expensive	110
Sounds Of Music (Crewe)	101
Sounds Perfection	118
Soundstage	102
Stirling Broadcast	97
Stowsounds	106
Strachan	107
Sugden	128
Tannoy	56
The Right Note	48
Trichord Research	20, 89
UKD	1BC
van den Hul	42
Williams Hart	96

Advertisers Index Classified Ads Order Form

DEADLINE FOR MAY 2001 ISSUE IS TUESDAY 6TH MARCH 2001
DEADLINE FOR JUNE 2001 ISSUE IS WEDNESDAY 4TH APRIL 2001

UNISON RESEARCH

For a lifetime of musical enjoyment



S6

Single-ended integrated amplifier.
33 watts pure Class-A
Beautifully styled, impeccably built.
Enchanting, natural sound.

SR1

Integrated amplifier.
The grace of triode tubes.
The power and control
of solid state.
80 watts dynamic Class-A



For more information on the range of Unison Research Products please contact:



23 Richings Way, Iver, Bucks, SL0 9DA, England
Tel: 01753 652 669 Tel: 07000 853 443 Fax: 01753 654 531
www.ukd.co.uk email: nick@ukd.co.uk

*models illustrated: S6, £1600. SR1, £1250

HEARD, BUT NOT SEEN.....



IMAGINE....

A DISCREET
LOUDSPEAKER
SYSTEM THAT
ADAPTS TO ANY LIVING
SPACE, WITH A ROOM
FILLING SOUND FOR BOTH
MOVIES AND MUSIC.

IMAGINE NO LONGER.....FS2.

SERIES

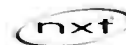

Trade Mark of New Transducers Limited

MISSION. HUNTINGDOON, PE29 6EY ENGLAND. TEL: 01480 451777 FAX: 01480 432777
EMAIL: INFO@MISSION.CO.UK HTTP://WWW.MISSION.CO.UK