

# hi-fi+

Issue 34  
£3.95

REPRODUCING THE RECORDED ARTS

## High-end cable...

## ...is it just a load of Jacksons?



9 771465 595011



# A new name A proven pedigree

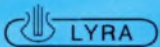
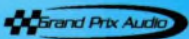

**STAX**



**Sumiko**

**THIEL**

Symmetry may be a new name in hi-end audio distribution but it's a company with an impressive heritage. Founded by the driving force behind the highly esteemed 'Path Premier', Symmetry brings to the market 16 years of specialist experience in distribution, technical support and customer service.

We share your passion for the world's leading audio products. We're equally passionate about applying our insight and expertise to ensure you get the very best from your system. Whether you're seeking assistance with components, installation, system matching or simply some advice, our expert opinion is always on hand. Symmetry – a new name, built upon sound principles.

t: 01727 865488

e: [info@symmetry-systems.co.uk](mailto:info@symmetry-systems.co.uk)

w: [www.symmetry-systems.co.uk](http://www.symmetry-systems.co.uk)

# Hi-Fi+ e-edition

**Editor**  
Roy Gregory

**Contributors**  
David Ayers  
Chris Binns  
Mark Childs  
Richard Clews  
Dave Davies  
Dennis Davis  
Sian Drinkwater  
Richard S Foster  
Simon Groome  
Jason Hector  
Andrew Hobbs  
Jimmy Hughes  
Jason Kennedy  
Scot Markwell  
Paul Messenger  
Reuben Parry  
Alan Sircom  
Chris Thomas

**Photography**  
Simon Marsh

**Cartoonists**  
Dave Davies  
Thomas Divita

**Cover**  
After Jackson Pollock

**The Editorial Office**  
can be contacted at  
Hi-Fi+ Editorial  
Unit 12, Albany Business Park  
Cabot Lane  
Poole, Dorset  
BH17 7BX  
United Kingdom  
Tel. (44)(0)1202-659380  
Fax. (44)(0)1202-659540  
Net. [www.hifiplus.com](http://www.hifiplus.com)

**Design**  
Creative Byte  
Poole, Dorset  
Tel. 01202 690990  
E-mail. [info@creativebyte.co.uk](mailto:info@creativebyte.co.uk)

**Printed By**  
JPS Litho Ltd., Poole

Hi-Fi+ is published eight times  
a year by; Hi-Fi+ Publishing Ltd

**Advertising**  
Rebecca Bird  
Tel/Fax. 0208 763-1277  
Email. [sales@hifiplus.com](mailto:sales@hifiplus.com)

All Rights Reserved.  
Not one word of Hi-Fi+ may be reproduced without the written consent of the Editor. We are perfectly happy to co-operate, but we don't want quotations to appear out of context.

ISSN 1465 5950

In an exciting new development for hi-fi+, we are pleased to be able to offer, in partnership with Newsstand.com, an electronic edition of the magazine. The e-edition is identical to the print edition, except that is downloaded from the internet directly into your computer, where you can read it at your leisure. Copies can be bought singly, or as a subscription. And although they're priced in US dollars, they work out as roughly equivalent to the UK printed copy prices. Of course, exchange rates may change that!

So, how does it work? You can reach the Newsstand.com web-site either via our own site at [www.hifiplus.com](http://www.hifiplus.com), or directly at [www.newsstand.com](http://www.newsstand.com). There you have the option to purchase a single copy or a subscription. To access the magazine, you need to download the free Newsstand reader, which controls access to the e-editions. Once that is done, simply follow the instructions to download the copy. Obviously a complete magazine is not a small file, so the download can take a little while, especially for those using dial-up connections. Once downloaded, the magazine is accessed through the reader software. This allows you to see the magazine as if it is laid on the desk in front of you, to turn pages, to make searches, and to directly access any web links imbedded into the text of the magazine, or in the advertising. The reader allows you to zoom into the page as required. Connection to the internet is not required once the download has been made, unless you wish to click on any of the imbedded links.

If any current reader is worried that hi-fi+ will change because of this new initiative, let me assure you that we are first and foremost a print magazine, and we will continue to produce the print copies to the same standard. What appeals to me as a publisher about the e-edition is that it is an electronic facsimile of the print magazine, and not an entirely different animal. Also, it enables us to embark on a programme of making back-issues available in the same format, including those which are no longer in stock in print form. We also intend to have the e-edition available on CD for those who would prefer not to download from the internet, including back issues. As these become available, we will let you know.

Newsstand is one of the leading suppliers of print media e-editions and it is great to be working with them, allowing Hi-Fi+ to be read by even more people. While the folks at home in the UK are able to obtain Hi-Fi+ relatively easily, in many other parts of the world logistics make it hard to come by, late arriving or expensive. Just look at the subscription rates in our advertisement to see what I mean. The rates for Europe and the rest of the world are very high solely due to the cost of postage. With the e-edition you can purchase hi-fi+ anywhere in the world on the same day that it hits the shops in the UK, and at near enough the same price. There is no need to go scouring the shops looking for it, you can order from the comfort of your own home. If you subscribe, then you will be informed by email when each issue is published, complete with instructions from where it can be downloaded.

Despite the fact that I (normally) prefer my music in analogue rather than digits, I am very pleased to be able to offer Hi-Fi+ in digital format. To all our future new e-edition readers I say 'Welcome aboard'.

**David Ayers**

Publisher, Hi-Fi+





**BELOW**  
 FRESCO CENTER / REAR CHANNEL  
 MOSAIC LOUDSPEAKERS  
 GROTTO SUB WOOFER

**LEFT**  
 PRODIGY LOUDSPEAKER

**BOTTOM**  
 CLARITY LOUDSPEAKER



# MARTIN LOGAN

**ABSOLUTE SOUNDS'** commitment to Martin Logan has been rewarded with a line of hybrid electrostatic speakers so comprehensive that it now encompasses every permutation of home theatre and audiophile performance, and a price band from entry-level to cutting edge. Because of their sheer beauty - both aural and visual - the Statement Evolution 2, Prodigy, Odyssey, Ascent i, Aeon i and Clarity have established hybrid electrostatic technology as the obvious choice for those who want state-of-the-art sound without suffering a profusion of ugly boxes.

All of the speakers are immediately recognisable as Martin Logan products because of the peerless, oft-imitated, room-friendly appearance, with the captivating see-through panels and furniture grade finish. Best of all, the sound is as clear as the panels themselves. This year, in recognition of its astonishing performance and sensible price, the Clarity - the 'baby' of the line - won the coveted EISA award, proving that the Martin Logan look and the sound are acknowledged across Europe.

For the new season, Martin Logan has applied its years of experience to even smaller, room-friendlier systems suitable for a wider range of applications, by launching a second hybrid technology called ATF. Martin Logan had already demonstrated its skills with home theatre applications with the Theater i and Cinema i centre-channel models, the Script i main and surround speakers, the awesome Descent self-powered subwoofer and its baby sister, the Depth.

Thanks to ATF, an even wider audience can savor the Martin Logan experience. The ultra-compact Fresco hybrids can be used horizontally or vertically, wall- or shelf-mounted above or to the sides of plasma or other flat-screen display, while the Mosaic and Montage floor-standing models have the look of a 'baby Clarity'. Even the subwoofer's size has been addressed: the new ATF designs work wonderfully with the Grotto, literally a miniature Depth!



EYE TO EAR  
 CO - ORDINATION

**absolutesounds Ltd.**  
 58 Durham Road, London SW20 0TW  
 T 020 8971 3909 F 020 8879 7962  
 www.absolutesounds.com  
 info@absolutesounds.com









*for the love of music...*



Avalon Acoustics

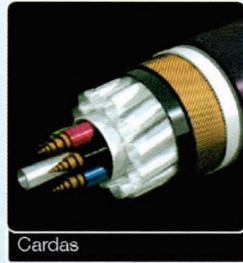

Cardas



Karan Acoustics



conrad-johnson



Esopower



Tri-Planar



McCormack



Avalon Music Systems

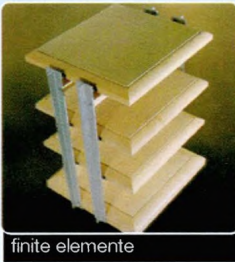

finite elemente



Muse Electronics



Kuzma



Reimyo by Harmonix



Magnum Dynalab



Harmonix



Acustica Applicata (DAAD)



Benz-Micro

### HiFi Show & AV Expo 2004

Please visit us at the Lancaster Suite, Renaissance Hotel, Heathrow  
24 September (trade), 25-26 September (public) 10am – 6pm

Acustica Applicata (DAAD) • Avalon Acoustics • Avalon Music Systems • Benz-Micro • Cardas  
conrad-johnson • Esopower • finite elemente • Harmonix • Karan Acoustics • Kuzma • Magnum Dynalab  
McCormack • Muse Electronics • Reimyo by Harmonix • Tri-Planar

*Distributed Exclusively by*

# AUDIOFREAKS

DISTRIBUTORS OF FINE AUDIO + HOME ENTERTAINMENT EQUIPMENT

tel: 020 8948 4153 fax: 020 8948 4250 email: info1@audiofreaks.co.uk [www.audiofreaks.co.uk](http://www.audiofreaks.co.uk)



KEF UNI-Q® LOUDSPEAKERS

Go on,  
you deserve it.



REFERENCE SERIES



KEF's legendary Reference Series has always been different. As the name implies, it's about an absolute standard. Objectively verifiable performance, not marketing hype.

The latest range raises the benchmark higher than ever. With a performance envelope that extends way beyond the limits of human hearing, they're crammed with technologies found nowhere else. Radical new UNI-Q® point source arrays, with elliptical dome tweeters. Titanium dome Hypertweeters™. Ultra-low distortion motor systems. Adjustable boundary control - the Reference Series bristles with high end technologies like a hand-built GT. As accurate as a Swiss chronometer. Exquisitely crafted like a Savile Row suit. None of them cheap, admittedly - but in terms of pleasure, worth every penny.

The Reference. Created by KEF because only KEF can.

[www.kef.com](http://www.kef.com)

ADAMS AND JARRETT  
ST LEONARDS ON SEA  
TEL: 01424 437165

CYMBIOSIS  
LEICESTER  
TEL: 0116 2623754

GLOBAL HI FI CENTRE LTD  
NEWCASTLE UPON TYNE  
TEL: 0191 2303601

HOME MEDIA LTD  
MAIDSTONE  
TEL: 01622 676703

LOUD AND CLEAR  
GLASGOW  
TEL: 0141 221 0221

MUSICAL IMAGES  
BECKENHAM  
TEL: 0208 6633777

MUSICAL IMAGES  
COVENT GARDEN, LONDON  
TEL: 0207 4971346

MUSICAL IMAGES  
EDGWARE, MIDDLESEX  
TEL: 0208 9525535

MUSIC MATTERS LTD  
BIRMINGHAM  
TEL: 0121 429 2811

PRACTICAL HI FI  
MANCHESTER  
TEL: 0161 839 8869

PRACTICAL HI FI  
WARRINGTON  
TEL: 01925 632179

SEVENOAKS SOUND & VISION  
PETERBOROUGH  
TEL: 01733 897 697

SEVENOAKS SOUND & VISION  
SEVENOAKS  
TEL: 01732 459555

SEVENOAKS SOUND & VISION  
WITHAM  
TEL: 01376 501733

STRATFORD HI FI  
LEAMINGTON SPA  
TEL: 01926 888644

UNILET SOUND AND VISION LTD  
NEW MALDEN  
TEL: 0208 942 9567



KEF REFERENCE SERIES



KEF AND UNI-Q ARE REGISTERED TRADEMARKS. UNI-Q IS PROTECTED UNDER GB PATENT 2 236929 AND U.S. PAT. NO 5,548,657. WORLDWIDE PATENTS PENDING.  
FOR FURTHER INFORMATION PLEASE CONTACT KEF AUDIO UK, DEPT V, FREEPOST MA1332, ECCLESTON ROAD, TOVL, MAIDSTONE, KENT ME15 6BR. FREEPHONE 0800 7315620.





# Incoming!

Please address letters to the Editor at Hi-Fi+, Unit 12 Albany Business Park, Cabot Lane, Poole, Dorset, BH17 7BX.  
or via the web-site at [www.hifiplus.com](http://www.hifiplus.com)

Dear Sir,

I would like to compliment Chris Binns for his informative article on Field Coils. He laments, however, that field coil technology is nowadays confined to full range drivers mounted in corner horn cabinets. His research is incomplete, however. Shindo Laboratory of Japan, renowned for their exceptional electronics as well as for their modifications of the legendary Garrard 301, manufacture a two way field coil loudspeaker: the Latour. The speaker comes in two varieties: one in which only the tweeter is a field coil and another in which both the woofer and tweeter are field coils. Needless to say, the speaker is as admired for its extraordinary way with music as are the more well known Shindo electronics. I hope to be reviewing a full field coil pair myself in the not too distant future.

Give a listen, Chris. I doubt very much that you will long for a field coil version of the Nautilus 800. Indeed, field coils and B&W constitute a union in violation of the natural order – at best.

Good work.

**Jules Coleman**, New York and Connecticut, USA

Via e-mail

*Dear Jules*

*Thank you for your communication regarding the article on field coils - it is always good to get some response, and part of the reason for writing it was with the hope of provoking feedback from other people who have more knowledge on the subject than myself! As you probably gathered, my technical knowledge in this particular area is somewhat insubstantial; as for advanced magnetic theory, forget it. (Although that doesn't seem to have been a problem for quite a lot of loudspeaker designers...) I do know that Kevin Scott of Living Voice loudspeakers is currently experimenting with some more 'real world' drive units from the Far East, and I look forward to hearing the results. As for a Nautilus with field coils, it was the most provocative contender I could think of while my tongue was firmly in my cheek.*

*Regards*

*Chris Binns*

Dear Sir,

I have just finished reading an article in Issue 32 by Chris Thomas on the Aurum Cantus Leisure 2 loudspeakers and I

have to say that his conclusions and comments appear to be rather contrary to how I have found them.

I purchased my speakers direct from China many months back at which time I do not think there was a UK distributor, but as you can imagine, I paid only one third of the price, which is irrelevant to the point I am making.

Chris states that although the higher frequencies via the ribbon tweeter were extremely good he appears to lay blame at the mid/bass unit for any below par performance. He also states that the ribbon has been voiced a little too smooth by not accentuating the high-end by rolling it off early which could be one of the reasons for impressive driver integration. I don't see why that would be as this is at the top end of the ribbons frequency when surely the integration between woofer and tweeter would take place at the lower end of its range.

I also cannot concur his findings on the soundstaging of these speakers, describing them as having a little left/ right and central information with no real front to back depth. I have all of these in spades.

The fact that Chris also criticises the Aurums as having a noticeable weakness of being easily confused when asked to do too much work leads me to the conclusion that he might well have had a pair of speakers in the same condition that I got mine and that is with all the driver retaining allen screws loose. Once tightened down the performance snapped into focus and presented me with all the attributes that Chris found lacking in his review. Hmmm!!

Having said all that, on a more positive note, thank you all for a really great magazine the quality of the content and presentation are second to none.

Regards,

**John Clark**

*And response from Chris*

*Dear Mr Clark,*

*Thanks for the response to the review. Sorry that we disagree on the attributes of the Aurums, but let me try and answer a few of your criticisms. Firstly, are we absolutely sure that the Aurums that I reviewed and those that you have are exactly the same speaker with the same drivers and crossover, given the difference in their age? If we assume that they are then the differences we perceive may be partly down to run-in periods which are a constant bone of contention for reviewers.*

► *If you look closely at the picture in the magazine you may notice that the ribbon is a little strangely aligned and obviously not right. Funnily enough you couldn't tell when listening but, in the interests of fairness, I had to reject the pair in the photograph as the unit clearly had a problem. This pair had done the rounds and were well run in. So I had to ask the importer to source me another pair at shorter notice than we both would have liked. These were run for over 100 hours before I started to listen to them so perhaps they need many, many more hours of normal use before they really loosen up. I went on the importers recommendation. As for the integration issue, I think you have misunderstood me. Speakers that have really extended high frequency responses often, as they grow more directional with frequency, sound to me as if the hf becomes disconnected, sitting atop the sound, and this can leave the drivers sounding a little disjointed, whereas speakers like the Aunum Cantus, the Neat Petite and even the splendid but defunct Red Rose R3 with their smooth and relatively unextended top end, invariably sound as if the integration between the units is subjectively more balanced and rounded.*

*As for my comments on the soundstaging, lack of depth and the tendency to grow a little flustered under pressure, you may be right. The speaker bolts were certainly not as loose as yours were, but perhaps I should have put a bit more torque on them. But it might also be that I was asking quite a lot of them by using a CD player and cabling which presented them with a level of rhythmic and tonal subtlety that they couldn't totally resolve.*

*At the price you seem to have paid you obviously have a bargain, but let's not forget that the model I reviewed is going to cost over £1000 with a decent stand in the UK and that means that a beautiful cabinet is not enough and they really have to do the business musically.*

*Finally I have to say that you and I may like different things and may even perceive music in a different way. This makes neither of us right or wrong. The main thing is that we all love listening to music and its message extends beyond what equipment we choose to use.*

*Regards*

*Chris Thomas*

Dear Sir,

I am writing following your review of the Lentek Integrated Amplifier. This had been one of the designs that had been on my "wish-list" as a young lad, along with the likes of the Meridian 101/105, Naim Nac32/Nap 250, Michaelson & Austin TVA1X and much other high-end kit. I saw one in excellent condition for sale last year and decided to buy it, although I had not been sure how I was going to explain to my wife why I had bought yet another amplifier I was not going to use. "I wanted one twenty years ago, couldn't afford it then but can now" isn't really much of a reason - but she humours me.

I connected it up solely with the intention of making sure it worked, the plan being to consign it to the loft along with my other bits of old kit to await the house move that would enable me to have enough space for different systems dotted around the place. However, as usual in life, things were not to be so simple. Whilst I thought that it would sound at least respectable, I was surprised at just how good it actually was. So much so, that as I listened further over the next few evenings, I found myself for the first time in 16 years considering deserting Naim for another make of amplifier.

It possessed my Naim system's (102/Napsc/HiCap/250) good points of speed and precision, coupled with a sweeter midrange and much improved depth and width to the soundstage. The only area where I felt the Naim remained superior was in absolute bass power. Well I thought, if one amp sounds this good, what would they be like bi-amped - especially as the pre-out, power-in sockets would make this so easy. Luckily, I knew that the person that I had bought the first one from had another in equally as good condition, which I managed to acquire.

It was obvious within minutes of listening to the Lenteks bi-amped that I would have to seriously think of forsaking my Naims. All the previously noted good points were there coupled to a greater solidity in the bass and with instruments that seemed to be locked in their own space making detail so much easier to make out. Even my wife whose eyes normally glaze over when asked to listen to different equipment expressed a preference for the Lenteks.

I previously had no desire to move away from the Naims, which are fantastic amps (I wouldn't have upgraded through the range over the years had they not been). Nor did I have any pre-conceived idea that the Lenteks would be an upgrade (there being no influence from rave reviews or any price-led expectation). They were after all, ancient compared to the Naims, which although not the most recent designs were still reasonably new.

Consequently I could not fall into the trap of expecting to hear an improvement, which can sometimes delude one into thinking that the new equipment makes a bigger change than it actually does. In fact, despite the fact that I was trying to convince myself that the far more expensive (and remote controlled!) Naims must be better, my ears were telling me that in my system at least this was not so.

So the change was made and the Naims sold. Since then, certain people have been somewhat incredulous when I have sung the praises of the Lenteks, most never having heard of them. Maybe now, armed with your review they will believe me and see that I haven't gone mad after all.

Yours sincerely

**Kevin Kennedy**

Via e-mail





tel: 020 7724 7224 fax: 020 7724 4347 email: contact@walrus.co.uk web: www.walrus.co.uk

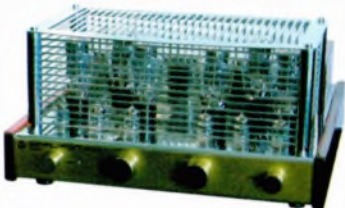

Amplifon WL25 (left): 28W/channel using 6P3, £795  
Amplifon WT40 (centre): 40W/channel using 6C33, £1995  
Amplifon WT30 II (right): 31W/channel using 6H13, £1395

Amplifon is proving to be a huge success both with reviewers and customers alike - we are delighted! Now made in the EC (a warm welcome to our Polish neighbours is in order), this range of three models, all superbly built, all featuring automatic biasing, and all with large, wide bandwidth toroidal output transformers suitable for 4 or 8 Ohms, offer superb value for money. Sound quality is reminiscent of the best classic designs of the past, but modern circuit techniques and transformers give an authority of presentation and power reserve often lacking in older designs. Truly modern classics!

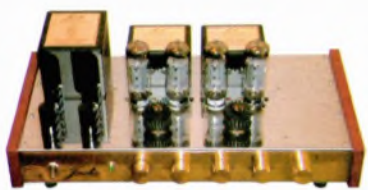

The Jadis Orchestra Reference (left) from France, at £1699 - Output of 40W/ch using KT90s, and even featuring that long missed attribute, tone controls - my, takes me back!



The Consonance M100S (right), £1595, is proving to be a reviewer's favourite, offering a delicacy which is a speciality of the 300B output valve, giving here 25W/channel.



For people who prefer the authentic Star Trek look, the Shanling STP80 (left) fits the bill perfectly! With superb build quality, remote control, digital level indicator, 35W/ch output, all for a mere £1295. Oh, it sounds good too, by the way.



The Audiovalve Assistant 20 (yes, it is spelt like that) is a little gem from Germany, with a very musical performance - sweet as a nut, we say, 30W/ch output, in a neat chassis, for £1600.



The Musical Fidelity Trivista DAC: We have secured some of the last remaining UK stock of this brilliant device. An utter bargain for £1200 - and, as they say, once it's gone, it's gone! Don't delay - pick up the phone now.



Cawsey may not be the best known cable (others spend more on advertising) but it's quite possibly the best sounding. We have been selling these Australian made silver interconnects for several years and can recommend them without reservation. From £250 to £900 per metre set.



Slinkylinks are solid silver air dielectric cables with the latest bullet plugs, fantastic sound at an amazingly low price: £195 for a 1.2m set!

*Slinkylinks*



air tangent amazon amphion amplifon apollo furniture argento audible illusions audio physic audiovalve breuer dynamic brinkmann cabasse cartridge man cawsey chord electronics clearaudio clearcover consonance decca london dnm duevel dynavector ear yoshino ecosse final lab graham slee hadcock heart incognito infinity isolda jadis jbl k2 klimo koetsu korato lavardin loricaft lyra michell engineering morch musical fidelity nordost nottingham analogue opus 3 origin live ortofon papworth project rega revolver ringmat roksan shun mook shanling shelter slinkylinks sme sonneteer spendor stax sugden sumiko lannoy tci cables tivoli audio tom evans townshend audio transfiguration trichord trigon van den hul voodoo wireworld xlo

# Home Truths



by Jimmy Hughes

Acting for the camera is not the same as acting for the stage. Every actor knows this, and wouldn't dream of performing in a manner that wasn't appropriate. But do musicians making recordings have a similar understanding of the difference between playing for an audience live, and playing for the microphone? In the case of classical musicians, the answer in many cases would seem to be a resounding "No!"

I once bought a CD of Schumann's intimate piano piece *Papillons* (Butterflies) performed by a world-famous pianist, only to be greeted by the sound of a huge overpowering Steinway piano being played loudly as though to fill a massive concert hall. Is that appropriate? In some ways, yes. The pianist in question would certainly sell out most concert halls throughout the world, and would therefore be used to playing in big venues which required him to play with plenty of power and weight.

So, you could argue that the recording represents the way he sounds when heard live. But, is such an approach valid when making a recording? With the Schumann CD mentioned, the recording engineers could've helped by miking the piano at a greater distance to create a sense of space and depth. Even so, the piano was still being played far too forcefully for what is essentially a miniature.

Schumann's piano music is a case in point. Most of it is intimate and personal. Even big works like *Davidbundlertanze* or *Kreisleriana* are surprisingly conversational and introspective, with the composer speaking to you on a one-to-one basis. Much of Schubert's piano music is the same. It's not 'public' music, but a one-to-one encounter between composer and listener. It's fragile and easily damaged by inflation.

In the booklet that accompanied his 1970 Deutsche Grammophon set of the sonatas, the great German pianist Wilhelm Kempff had this to say about Schubert. "Most of his sonatas ought not to be subjected to the glaring lights of huge concert halls. They are confessions of an extremely vulnerable spirit. Or more correctly, monologues, often whispered so softly that the sound

does not carry in a large hall. Schubert reveals his innermost secrets to us in pianissimo".

It's an historical accident that we listen to classical music in concert halls. In Schubert's time, many of his works for solo piano, his songs and chamber works, would have been heard in private performances held in large rooms.



So listening at home, either alone or with friends, is arguably closer to the composer's intentions that sitting in the Royal Festival hall and hearing the music live.

Sadly, very few classical musicians really 'play to the microphone' in the way that film actors act to the camera. Many, perhaps the great majority, play as though they were in a large hall and having to project their sound to its farthest reaches. This is fine if you're at a live performance and sat well back from the stage in a big hall. But it's not easy to record such a sound. The microphone does not 'hear' sound in the way the ear does. Place a microphone sixty or so feet back in a large hall, and all you'd get



*See it.  
Hear it.  
Feel it.  
For the  
first time.*



*The Chord  
SPM14000.*

*Ultimate mono  
power amp.*

**W**e just can't help ourselves.  
Not one, not two, but three new  
product launches all at one show!

Come and experience them for yourself,  
and see our full range of exquisite  
hand-made audio products at the  
Hi-Fi Show & AV Expo, September  
24th - 26th, Concorde Suite,  
Renaissance Hotel. Alternatively,  
please contact us on 01622 721444,  
email [sales@chordelectronics.co.uk](mailto:sales@chordelectronics.co.uk),  
or visit [www.chordelectronics.co.uk](http://www.chordelectronics.co.uk)

**UK PREMIERE**

SPM 14000 ULTIMATE MONO POWER AMPLIFIER

CFA 3400 STEREO PRE AMPLIFIER

SPM 2400 FIVE-CHANNEL POWER AMPLIFIER

Hi-Fi Show & AV Expo, September 24th - 26th,  
Concorde Suite, Renaissance Hotel.

**CHORD**

Chord Electronics Limited

▶ is a muddy swimmy sound lacking any sort of clarity.

Some of the greatest 20th century pianists rarely (if ever) received technically good recordings. Arthur Rubinstein was one. Vladimir Horowitz was another. When these two keyboard legends were still alive and making recordings, I used to greet each new release with a mixture of hope and dread, hoping that the sound would be good, but dreading that it wouldn't. Even when Horowitz made his final recordings for Deutsche Grammophon, there were problems with the sound.

At the time I put the problems down to a lack of engineering competence on the part of the RCA and CBS technicians. Later I realized there was far more to it. True, the contemporary LPs often failed to reflect the full quality of the original mastertapes (carefully remastered CD re-issues have confirmed this), but some of the blame is down to the pianists themselves, and the way they played.

Put bluntly, neither Rubinstein nor Horowitz had a sound that was particularly microphone friendly. For whatever reason, the sound they made live did not transfer itself to tape and disc. In the case of Horowitz, his sound was simply too big, too powerful. It taxes the dynamic range of even the best equipment, and needs to be experienced at a distance so that hall and piano sound intermingle.

To create an appropriate result for recording, a performer needs to listen to the sound as it comes through the speakers. Trouble is, there's a huge disparity between what a pianist might hear while playing the

piano, and what someone sitting 15 or 20 rows back in the hall hears. There's still a massive difference between the sheer body and presence of sound heard live, and the same thing reproduced through speakers. It must be difficult (if not impossible) to objectively listen to yourself playing via a recording, and then go back and adjust your playing so it sounds 'better' when reproduced.

That said, pop musicians seem to manage it. Through my Chinese wife, I've been introduced to the singing of a Chinese pop singer the late Teresa Teng (Den Li Gun). Now, she's got a truly beautiful voice; one, moreover, that's very microphone friendly. When she sings her voice caresses your ears, it's so sweet and expressive. Yet she's equally capable of singing dramatically and powerfully should the song demand such an approach. She's not a bland faceless singer, far from it.

She never makes an ugly sound. The technique is fabulous, effortless, it all sounds incredibly easy. When I listen to her, I feel certain she knows exactly how her voice is going to sound when reproduced, and she sings accordingly. Her phrasing is perfect. I can't understand the words, but through the music I comprehend everything. I'd love to hear a classical singer tackle the songs of Schumann or Schubert like Teresa Teng!

People talk about the way the camera 'loves' certain photogenic movie stars. Monroe was like that, you almost never see a bad picture of her. Well, for me, the microphone loved the voice of Teresa Teng. The sound she makes is gorgeous - totally musical, so much so, I want every recording she made! It's how music should sound. ▶+

# Music Matters



by Alan Sircom

The quest for high-end without high-end prices mentioned last issue continues, and the first results are mixed at best. On the one hand, the base-line level of performance continues to improve; on the other, the performance of these decent products is too bland for genuine high-end

commendation.

I discovered that we need those idiosyncratic products of yesteryear. And we need them at all price levels. While I've not looked into every nook and cranny, it seems there is no NAD 3020 or Wharfedale Diamond ▶



► for the download generation. There is no giant-killing Dual CS-505, that does almost everything wrong but manages to turn in an exciting sound in the process.

Of course, idiosyncratic products continue to be made... but in most cases they cost. At the low end, the vast majority of products are extremely safe performers. They all work evenly well with one another and you no longer need to carefully match product with product to get a sound that works. But, if you don't get the lows of poorly matched products, neither do you get the highs of fantastic synergy. For the most part, everything at the low-end is so... blah!

I blame the CE mark, that mid-90s Euro-chummy ruling to prevent us from playing with products that pollute the world with electromagnetic interference. To sell a legitimate product in Europe these days, it has to have been tested to reach a minimum standard of electrical competency. It may be entirely unconnected to the CE mark, but after the introduction of the testing protocols, budget products suddenly became bland.

Of course, a return to the days when a new product could try to electrocute you, throw you across the room, melt your speaker cables or set fire to the curtains is not recommended (and, in case you are wondering, all of these things have happened to me as a direct result of reviewing products in the pre-CE days). There's a level of exciting that's not worth craving for. Nevertheless, some of the excitement of the old days would be a welcome change, just perhaps not that sort of excitement.

But is the modern world of budget hi-fi really so bland? I've found a few gems, of course. One of the most significant is the Mordaunt-Short Avant 902 loudspeaker. This is essentially a very cheap loudspeaker (certainly by Hi-Fi+ terms) but one that's built as much to fulfil certain sonic requirements than filling a particular price bracket. This is one of those now sadly rare budget speakers that comes to life the better the quality of other components used with it. So, it's perfectly acceptable to use the Avant 902 bookshelf on stands that cost considerably more than the speaker, being driven by a system that would normally be used with speakers costing £1,000 and up.

In high-end terms, the speaker is desperately rolled off and uneven, but this is what we should expect from a speaker that tries hard but doesn't cost a fortune. Instead, what you get is a speaker that is articulate and slightly coloured, but makes a sound that is distinctive enough to count. It's the perfect antithesis to the blandly neutral or the artificially exciting sounds of most budget speakers.

Then, there's the big surprise; the Philips range of DVD/SACD players, which start at around £150. These

are surprisingly good at making music (especially the more expensive 963SA), even on CD. And Cambridge Audio produces a good range of sonically neutral, detailed products without the huge price tags. But otherwise the ultra budget part of the market is mostly free of the sort of products with great audio redeeming quality.

In a way, the problem is with us, not the products. Back in those classic days of 20+ years ago, a decent sounding budget system of separates could be had for under £400. In real terms, that £400 is worth around £800-£900 in 2004 money. The problem is, we still want to buy a system for £400... and we still can. If you spend £800-£900 on a system today, you get a system with the start of high-end performance, often with the same names you might have purchased 20+ years ago.

Perhaps today's 'starter' systems should be considered 'pre-starter' systems; with a notable few exceptions, the sub-£800 system components should be considered less than a first rung on the ladder but some form of interphase between micro systems and real separates, allowing someone to upgrade to the good stuff later.

Of course, this is a modern fallacy, known as the 'No True Scotsman' or 'Shifting the Goalposts' fallacy. If we fail to classify starter separates as 'real' separates, it's possible to extend the list of 'not-real' separates to include everything that isn't in your own system (or your dream system). So we rely on the term to define the product; 'separates' assume individual components are separated from their rivals, by means of separate power supplies, phono cables and such.

So, why should cheaper components be classed differently from the better class of separates costing more? This may be a controversial opinion, but the sound quality of the cheapest separates components is not substantially better than that of the better class of integrated units. Those little Denon and Onkyo all-in-one systems turn in a blinding performance for the money; they may not be upgradeable and don't offer much for the person wanting to fill a living room the size of Lichtenstein, but within their own specific parameters, these products work exceptionally well and are better integrated than many of the separates components at the price.

Now this poses a problem for the next generation of hi-fi. If the Dual/NAD/Wharfedale selection of 25 years ago didn't sound as good as a similarly priced 'music centre' of the same period, a generation of hi-fi upgraders (who traded in their Dual decks for Rega Planar 3s and then just kept on upgrading) simply wouldn't have existed. Those budget systems are still all-important after all these years.





GRANDE

NOVA

ALTO

DIVA

## UTOPIA BERYLLIUM

MICRO

CENTER

SUB



GRANDE UTOPIA BERYLLIUM: A WORLD REFERENCE

*Winner Golden Sound and Grand Prix awards - Stereo Sound magazine, Japan.*

*A remarkable tour de force - Hifi News magazine, UK.*

*The finest loudspeaker on the planet? Possibly - Stereophile magazine, USA.*

 **Focal.JMlab**  
the Spirit of Sound



# Chord Signature



reviewed: issue 28 - 2003

- Heavy gauge high purity multi-strand copper conductors
- Low density foam polyethylene dielectric
- Unique dual layer high frequency shielding structure
- Non-compression aluminium clamping system
- Factory terminated

No matter what your system, the innovative design of Chord Signature Speaker Cable will transform the sound and really bring your music or soundtracks to life. If you are passionate about music, listen to the Chord Signature series of interconnects and speaker cable and find out just how much you have been missing.

Twenty years of experience, obsessive attention to the finest detail and a real commitment to producing high performance products, make all Chord interconnects and speaker cables a vital component of any hi-fi or home cinema system.

Used and recommended by manufacturers, retailers, hi-fi magazines and recording studios throughout the world, Chord cables are chosen for the dramatic improvements they can bring to any level of system.

Highly compatible, dynamically balanced, detailed, coherent and musically involving, Chord interconnects and speaker cables are stocked by the all the best hi-fi retailers.

To find out more visit  
[www.chord.co.uk](http://www.chord.co.uk)  
or call +44 (0)1980 625700

THE  
**CHORD**<sup>TM</sup>  
COMPANY

MOVING SOUND & VISION<sup>TM</sup>

# Tales from the disk-world...

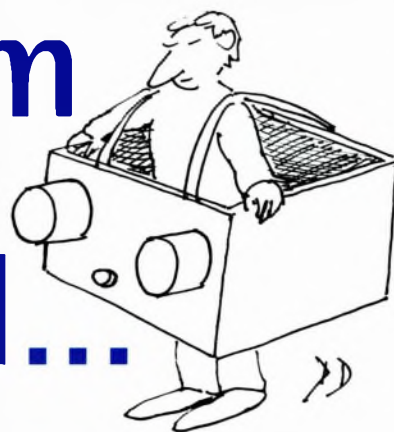

by Jason Hector

The magazine's recent mailbag demonstrates just how self-important and impervious to well-aimed criticism some hi-fi web-forum contributors can be. I have contributed to internet-forums for many years. Starting out with the Naim Audio site then PinkFish Media and Audio Asylum (URLs at the end). So whilst I agree with several of Roy's comments I think that there are also some very real, good points about the forums as well. I am going to try to present some of these good aspects and provide any of you thinking of venturing into this jungle for the first time the equivalents of a machete and insect repellent ... Dr. Livingstone, I presume? ...

**Diversity:** One of the first things that will strike you is the sheer diversity of opinion. Ask a question about which speakers you should be thinking about to complete your system and the first 10 replies will recommend seven or eight different brands. Two people will tell you to forget the speakers and look at your source, amplifier, cables or racks and one will advise you to forget about the boxes and buy some more music! In reality of course these can all be valid suggestions but many will not be applicable to you at this time. For example the speakers recommended may not work close to a wall as you desire, or are not available in your country. Similarly source first and better amps before speakers can make sense, but it depends on the system and technology involved. Buying more music is of course always great advice but if your old speakers don't work in your room it's not the suggestion you want or need to hear! So lesson one is to ask detailed questions to earn detailed and cogent responses. It is also a really good idea to check the archives and forum search engines to find out what has already been posted. Nobody wants the same discussion for the twenty-first time.

**Experience:** Another key lesson is that just like life, some advice of the advice offered is of superior quality – and a lot isn't. Which is another way of saying that there is plenty of information out there but very little knowledge, and just like life the person shouting loudest is not necessarily the one to listen to. If you want useful advice from a forum it is important to watch the posters for a while (often known as lurking) and try to get a feel for the people offering consistently realistic advice that you can see the sense in. And, just as importantly, who don't seem to have too much of a vested interest. Similarly try to ascertain which people are speaking from germane experience. Some posters will have tried the product in question in a suitable environment over a decent period of time as opposed to the guy reporting the findings of his brother's, friend's uncle who heard it at a show five-years ago. Of course the advice will often be given without those caveats. The positive flip-side to all of this is that you can receive some really good advice from a wide range of sources and experiences and it is hard to see where else a similar breadth of opinion is available.

**Sceptics and Disciples** (and I use the word disciple precisely because of its religious connotations): It seems that the more detailed and finely drawn the discussion the more likely you will be to find somebody who treats an idea or product like a religion. So whether it is the ultra-orthodox vinyl users, those tied up in cables, the ones aglow with valve fever or those who follow the one true mains route, they each believe they are the only ones who have the right answer. A lesser form of forum fundamentalism is the forum clique. Every forum has a couple and it is a bit like being at school (junior school!). Non-members are of course belittled and the clique ►



► looks after its own. I tend to try to avoid them, as Groucho Marx might have said "I wouldn't dream of joining a clique that would have me as a member". They will never tire in their efforts to convert anybody that will read their posts. Fortunately (and at times unfortunately) for all concerned, for every evangelist there will be a nay-sayer. For every subjectivist there is an objectivist knocking at your door armed with his meter and ABX bible. So the key here is balance, and the best forums have a good balance of contributors. If everyone pulls in the same direction then there is no debate and the experience is far too anodyne to be of more than passing interest.

**Wars:** All of this belief in one's own importance tends to lead to battles between the various camps. The usual seed for a long drawn out argument that often descends into insults and petty name calling is something that at first seems innocuous. One or two people will lay claim to an absolute opinion (stand X is the only option and should be bought regardless of all other constraints). They won't move an inch – then all hell breaks loose. 100 posts later and nothing other than contributors stress levels will have changed. The key when dealing with this is to try to ignore it and not be drawn into the massive long running and repetitive arguments that always ensue ... unless you are really bored and want to stir up the natives. And I won't even go into the subject of stirrers, shakers and general wind-up artists...

**Silly names:** Anonymity is one of the big problems with web forums. With anonymity to hide behind people seem encouraged to talk nonsense and to let themselves overreact in a manner they wouldn't dream of outside of the internet. Either that or they are used to nights in casualty. Generally the more ridiculous the name the less the weight should be placed on the poster's words. But even here there is a counter-point to be made and I am sure there are several people posting to sites under assumed names that cannot post in any other way because of work restrictions or perceived clashes of interest and often it would be a shame to lose these valuable contributions. (They'd be a lot more valuable if those clashing interests were transparent!!! Ed.)

With all of the above looking pretty negative you might well wonder why you'd bother? I think it is time to stress some of the good parts of the forum experience, starting with ...

**Music rooms:** Usually the best section of a forum is the music room (the Naim forum has a particularly fine example). As the name suggests these are areas where the music is discussed. In these separate spaces you rarely find the sort of anger and animosity you find in the Hi-Fi rooms. There are always regular posters with

encyclopaedic knowledge (and record collections to match) and a handy recommendation for the next time you are shopping for something new to play.

**Enthusiasm:** The enthusiasm that people have for music reproduction in the home is, perhaps, the most important aspect that makes participating in the forums enjoyable. I guess this enthusiasm can often be the root cause of the frayed tempers that afflict the Hi-Fi rooms, but with the number of really dedicated dealers on the wane and the whole industry declining it is important not to underestimate the raw passion for audio reproduction displayed on these forums.

**Moderation and self-policing:** One thing that RG failed to point out in his previous articles is the role of the moderators and the self-policing of the forum. The moderators have the power to remove posts and people, usually after the offender has been reported by the forum participants or is consistently spouting argumentative nonsense and libellous comments. This backed up self-policing (and the fact that no two people agree, so if a product is attacked there will always be somebody that leaps to its defence!) keeps the best forums working extremely smoothly and restricts the damage that can be achieved by an individual with a grudge. People entering a forum with a mission to disparage either a product or a shared opinion are very quickly spotted and very quickly, and sometimes politely, asked to moderate their own posts or leave.

**Friends:** If you are really lucky you may find a few kindred spirits posting. I have made several good friends through the various forums on which I've posted, in a range of countries. At the end of the day it is for this reason alone I can forgive almost all of the crap that also happens on the forums.

So if your appetite has been whetted, point your browser at some of the following and remember it's just a bit of fun, isn't it?

PinkFish Media forum, the modern flat-earthers choice with good used section:  
<http://www.pinkfishmedia.net/forum/>

Audio Asylum, huge, general forum with a wide range of contributors and a strong US presence. One of the oldest and most respected forums out there, although possibly a bit daunting for first timers:  
<http://www.audioasylum.com/>

Naim Audio forum, mainly Naim HiFi but excellent music room and general room (the Padded Cell):  
<http://naim-audio.infopop.net/>

A light-hearted introduction to Naim forum life:  
<http://comedylimp.com/naimfaq/forum.htm> and  
<http://comedylimp.com/naimfaq/forum2.htm>



# Absolute Analogue®

Address: PO Box 30429, London, NW6 7GY

Tel / Fax: +44 (0)20 8459 8113

Email: [Absolute\\_Analogue@email.msn.com](mailto:Absolute_Analogue@email.msn.com)

Website: [www.absoluteanalogue.co.uk](http://www.absoluteanalogue.co.uk)

## Nordic Concept Signature / Reference

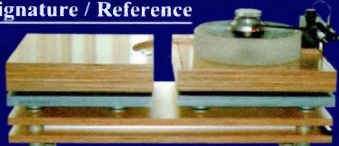

"...very much a state of the art contender"  
*Roy Gregory, Editor, Hi-Fi+*

## Reference 3A Dulcet

The extraordinary loudspeaker from Reference 3A.  
Small in size, immense in performance.



NEW! Plinius SA-201  
power amplifier

NEW! Plinius CD101  
CD player



## Aurum Cantus Leisure 3SE

Finished to the same superb standard as the Leisure 2SE, the Leisure 3SE has a slightly larger cabinet and superior drive units, leading to significantly enhanced performance.



Please visit our website  
for more details

# Direct sale bargain!

## The Nordic Concept Artist turntable

- One of the few real bargains in high-end hi-fi.
- A simplified version of the acclaimed Nordic Concept Reference.
- Alternative construction techniques lead to significantly reduced manufacturing costs but still amazing performance.
- Unlike the Reference, the artist is designed specifically to be sold **direct** by the distributor rather than via dealers.
- The result is truly high-end performance at a fraction of the normal cost.
- The picture shows the Artist with the Nordic Concept unipivot arm. Also available is the Nordic Concept air-bearing arm.

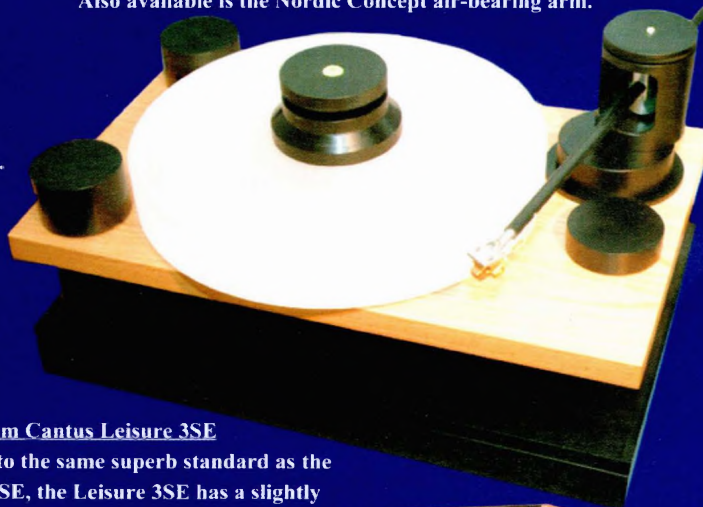

# Get it right!





# Blind Listening To Cables...

## Can we hear the differences and if so, does it tell us anything?

by Roy Gregory

Hi-fi has, and always has had, more than its fair share of sacred cows: ideas or beliefs that become articles of faith for their advocates. Amongst the most vociferously attacked and defended is the whole issue of cable sound, with available views running the gamut from “all cables sound the same” through to “you should spend the lion’s share of your budget on cables and rely on basic electronics”. The truth, as is so often the case, lies somewhere in between, but we have garnered considerable criticism for our interest in the whole topic of cables, how to get the best out of them and just how much it makes sense to spend. Along the way many of those critics have rather missed the point, mistaking exemplars for advocacy, and the attempt to develop a general approach or strategy for individual product promotion. There are those incensed by the cost of the cabling we use, and those who think the whole exercise is lunacy. In short – expensive leads are a rip-off that make little or no difference and we’re all delusional.

Difficult to resist then, the opportunity to put all these things into some sort of context, and what better way than blind listening? After all, those who are most sceptical of cable quality are also the most vocal advocates of blind testing – and vice versa. The opportunity then, is not to simply test the validity of those claims made for the sonic benefits of superior cabling, but to examine the whole issue of blind listening itself. In other words, to test the test – to consider what it tells us but also what it doesn’t. After all, a key issue with any methodology is the influence that it itself exerts over the process.

### How the test was done...

The problem of course, is in devising an appropriate test or set of tests. Way back in Issue 1 we carried out a similar

exercise with budget leads – with notable success. As a result, I opted to use a development of the same format, employing the same checks and balances.

The basic set-up involves a blind, panel test, subsequently repeated with the same test products but a different system, thus allowing us to compensate for and also investigate the issue of system matching. Sounds simple but it’s not without its complications. The test group consisted of five



expensive cable sets as well as a budget combination, the intention being to assess the audibility of differences between cables, as well as whether or not the expensive cables out-performed the basic pairing. Secondly, there was a spread of price and approach, with different materials and constructions in an effort both to maximize the sonic differences and see

to what extent the cost/performance equation held true. The tests themselves involved a panel of three listeners who sat en bloc. It would have been better to conduct separate listening but it would have been unwieldy to say the least. The sessions took all day as it was! Instead we simply banned any discussion during the testing in an attempt to prevent undue influence.

For each test series, the panel were first played one of the expensive cables, without its identity being revealed, to set a level of expectation from the system and act as a control. The six samples were then played, each one with three different pieces of music, the control set appearing for a second time. The first of the six was marked as a 10, each following sample being marked up or down in comparison.

This differential marking system gets over the issue of establishing a scale for what is, after all, a completely arbitrary judgement, indicating as a primary response ►



▶ preference as opposed to rating. In terms of relative performance, it's a far more meaningful gauge. On the second series we adopted the same approach but a different running order and choice of initial control as well as the different system.

In both cases we went to great lengths to ensure that the identity of the cables was concealed, and whilst the drapes between the speakers and in front of the system would have had their own influence on the sound, they're an unavoidable evil if blind testing is to be achieved.

The scores were entered on pre-printed response sheets, along with comments regarding the listener's response to each cable. These written notes deliver a valuable expansion to the simple numerical scores, often helping to explain apparent anomalies.

### The systems used...

The systems chosen were designed to be both sonically and qualitatively different, in an attempt to both eliminate or at least reduce the possibility of system dependency as well as examine the audibility of cable differences in lower resolution as well as high-end systems.

The first system used consisted of the following equipment:

- Burmester CD001 CD player
- Hovland HP100 valve pre-amp
- Hovland RADIA solid-state power amp
- ProAc Tablette Reference 8 Signature loudspeakers
- IF Designs Tallis loudspeaker stands

The system was placed on a Quadraspire rack and powered up using a Shunyata Hydra distribution system and power leads, chosen on the grounds of their performance and the fact that they are 'neutral' as regards the interconnects and loudspeaker cables under test, thus avoiding any unwanted synergy between mains and signal cabling. The speakers were single wired and all interconnects were single-ended. Although this is the simplest possible configuration, the variety of different plugs and spades on offer made the change overs far from straightforward.

The more modest system comprised:

- Burmester CD001 CD player
- Sugden a21 integrated amplifier
- Royd RR2 floor-standers

I opted to employ the same CD player as it meant that I only had to keep one digital source connected, preventing possible problems of interaction. The systems were set-up on a Thursday in the large listening room at Phonography in Ringwood, the tests taking place the following Monday when the shop was closed. This ensured that everything was well warmed through and ready to go once the panel assembled.



### The music...

As described, we used three selections for each set of blind tests. First up was the fragile delicacy of Janis Ian's 'At Seventeen', chosen for its natural, unforced, open and detailed sound. Whilst just about any system should sound good on this, it's adept at revealing tonal and spatial license, especially to familiar yet particular voice. This was followed with 'Hey, Bossa Nova' from the incomparable Elvis. An excellent and extremely busy recording this revealed the ability of the cables to keep everything separate yet in time and in proportion. Any propensity to exaggerate, especially in the bass, wreaked havoc on the musical integrity and dance rhythm of the track. Finally, we heard the Adagio ma non troppo from the XRCD of the Dvorak *Cello Concerto*, with Gregor Piatigorsky and the BSO under Munch. Perhaps the least obviously demanding of all, this track ruthlessly reveals inner instrumental texture, intra-instrumental balance and the control of tempo. It's languid pace conceals an inner tension and vitality built on the relationship between soloist and orchestra. The phrasing should be perfection, with Piatigorsky's mastery obvious to all. Sadly, this isn't always the case...

On the second set of tests, the Janis Ian track was replaced by Aimee Mann song 'How Am I Different?' as much to relieve boredom as anything else. However, this did have the effect of presenting the modest a21 with some seriously deep and unruly bass to contend with, creating a situation in which the cables with greater bandwidth and dynamic range risked running into trouble by asking too much of the system. A classic conundrum if you're going to use expensive cables with basic electronics.

The other two tracks remained the same, at the

▶ panel's request, their informative character and the accumulated experience with them being both useful and something of a safety blanket, continuity in an otherwise blind environment.

### The listeners...

As it fell to yours truly to spend his day on hands and knees behind the systems, I was excused listening duties, which meant finding three willing victims, I mean volunteers... But who? This question is absolutely critical to both the outcome and validity of the tests, defining what they do and do not tell us. Experience and familiarity will play a huge part in the responses garnered, as well as the listener's attitude and approach to the test program. Issues of reliability and repeatability of data are also dramatically influenced by the choice of listener, key considerations considering the relative lack of time available to us. To really iron out the variables you'd need to use more systems, more rooms, different times of day and periods between sessions, and far more sophisticated controls. Fine if you've got a government research grant, but somehow I don't see cable sound as a burning issue at No.10, despite Tony's dodgy taste in music. Major vote winner? I suspect not... Especially when compared to crushing the infamous Dr. Evil and his dark cohorts, along with a place on the World Stage to go with it. Bitter? Me? I just can't help feeling that a bit of cable research would at least have been a lot cheaper! And think about all those volunteers...

Enough of this silliness, just who did we choose, co-opt or coerce?

Being based just north of Salisbury, Nigel Finn from the Chord Co. was too good a prospect to miss. And before you cry foul, let's remember that although the Chord Signature cables are included in the test, it is blind listening, allowing us to examine how Nigel would mark his own designs!! He gamely accepted this potential banana skin, thus representing somebody who not only spends a lot of his day and earns all of his living from listening to cables, but someone who has an unhealthy interest in the sound of solder. He was by far the most experienced listener on the panel, both in terms of the subject and the methodology involved.

Nigel's home system consists of Roksan and Chord Electronics front-ends feeding a Bonnac pre and two

Bonnac stereo power amps which are used to bi-amp a pair of KEF Reference 201s or RDM1s. Various super-tweeters and subs also make occasional appearances, whilst the cables are an ever changing mosaic of Chord Co. prototypes.

The ever-willing Jason "What Parapet" Hector was also happy to oblige. As an electronics research engineer by day, this was new ground for him. Yet, as a reviewer on the magazine, he hears far more equipment than most people. However, coming from a ruler flat background before cresting the subtle rise that finds him inhabiting his current Well-Tempered, Dynavector, Shahinian world, cables have always been a proscribed subject as far as he's concerned: NACA5 good – Kimber 8TC better... But that's about as far as it goes. The sort



of exotica under test here are generally greeted with a slightly bemused smile and a well developed sense of scepticism. Perfect for my purposes...

Third lamb to the slaughter, the unsuspecting Kevin Russell, engineer and salesman at local emporium Salisbury Hi-Fi, who had absolutely no idea what he was letting himself in for. His home set-up consists of a Meridian 506/24 CD player and 501 pre-amp, driving his own valve power amp and a pair of ART STOne speakers. Cables are Chord Chameleon and Odyssey. Again, the shop stocks none of the cables under test.

This trio of (fairly) willing participants gives the panel a nice cross section of attitude and experience, both in terms of the subject matter and the actual activity of blind listening. More importantly, from my point of view, not one of these listeners uses the Nordost Valhalla cables that nearly half of our reviewers rely on, and which lie at the root of so much of the vitriolic outrage directed our way. Fine, let's put our opinions to the test and see whether the Valhallas would perform under blind listening conditions as well as we think they do when we know their identity.

### The cables...

As mentioned earlier, we selected cables to offer a cross section of materials and technology, construction and price, ranging from where high-end designs start right the way up to the dizzy heights of the Nordost Valhalla. In each case we obtained two sets of interconnects ▶



▶ and a 5m pair of single-wired speaker cables. In the mix I wanted to include our benchmark designs, by way of corroboration and confirmation of our faith in their performance and value. But along the way it was essential to provide credible competition. The designs selected and the rationale behind them is laid out below:

Nordost Valhalla (1m pr, £2195;  
5m spkr, £4296)  
Nordost (UK) Ltd.  
Tel. (44)(0)1352 730251  
Net. www.nordost.com

So much has been written in these pages regarding Valhalla that it seems superfluous to add more. It acts as the cable of choice for CT, CB and myself, as well as SG if only he could lay his hands on some. Undeniably expensive, it employs Nordost's mono-filament construction and multiple silver-plated copper, solid-core conductors.

Siltech SQ-110 and LS-188  
(1m pr, £1430; 5m spkr, £6300)  
RT Services  
Tel. (44)(0)1235 810455  
Net. www.siltechcables.com

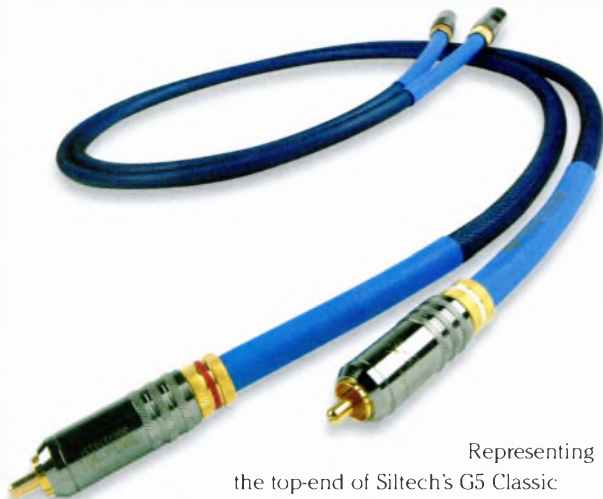

Representing the top-end of Siltech's G5 Classic series (there's a more expensive Signature range) this beautifully presented cable is a price match for Valhalla. The conductors are drawn from a silver/gold alloy, which is unique as far as I'm aware. Construction is a closely guarded secret but is claimed to offer significant benefits when it comes to the rejection of magnetic and RF interference. It appears to comprise a

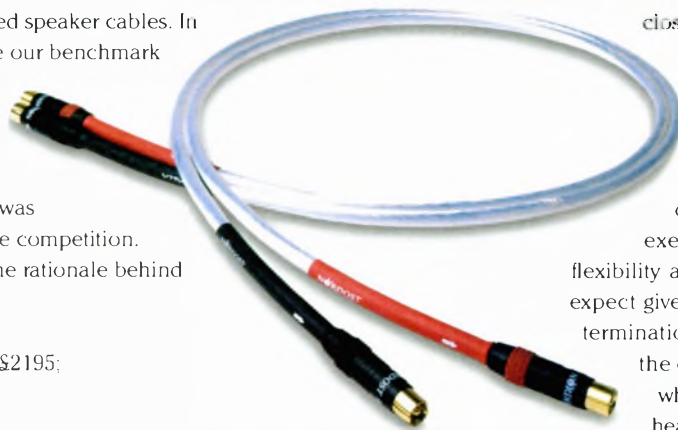

close twisted solid-core configuration combined with a sophisticated shielding arrangement. All terminations are from WBT and the quality of fit and finish is absolutely exemplary. Fit, finish and flexibility are all superb, as you'd expect given the source of the terminations and the pedigree of the conductors. The packaging, which always seems to be a headache for cable designers, is both effective and intelligent as well as being suitably individual. It rounds off the classy presentation perfectly.

Stereovox Symmetry  
(SEI-600 1m pr, £1695; 5m spkr, £8770)  
Tel. (44)(0)1727 865488  
Net. www.symmetry-systems.co.uk

These leads are the latest product from US cable designer Chris Sommovigo, the man behind the superb Illuminati digital leads. They are extremely unusual in that they represent a totally clean sheet approach to the problem, with even the plugs and terminations being specifically designed and

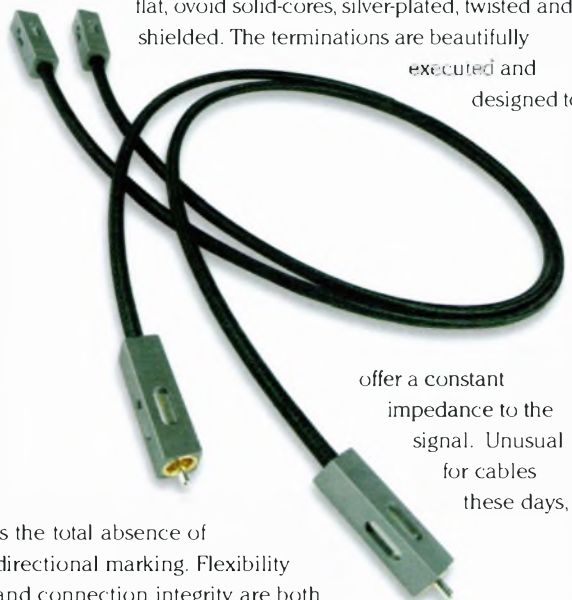

manufactured for the purpose. Conductors are flat, ovoid solid-cores, silver-plated, twisted and shielded. The terminations are beautifully executed and designed to offer a constant impedance to the signal. Unusual for cables these days, is the total absence of directional marking. Flexibility and connection integrity are both excellent, which is just as well given the bulk and weight of the speaker cable. The leads are packed in cymbal cases which is both simple and

► effective. It's a neat touch that's indicative of the lateral thinking that pervades all aspects of the design.

Audience Au24  
(1m pr, \$401.60,  
5m spkr, £1591.20)  
Metropolis Music  
Tel. (44)(0)1892 539245  
Web. [www.audience-av.com](http://www.audience-av.com)

Audience's Au24 cables offer a dramatically different face to the high-end cable world. Yet they arrive with excellent recommendations and an internet reputation as a Valhalla beater, which certainly suggests they should be taken seriously. The more so given their comparatively modest price (we are talking high-end cables here!). The simple, solid copper cores are designed to minimize inductance and eddy current resistance, while the incredibly straightforward, even minimalist construction follows many of the low-mass tenets that have proved so effective over the years. In fact, Audience have done their best to eliminate any superfluous parts or purely cosmetic elements, on the basis that every time you add additional sleeves or dressing, you can hear it. They're right too! The end result is an almost impossibly thin lead that's as basic in appearance as you can get. Despite the minimalist plugs, connections are very tight indeed, while the springy nature of the leads makes any excess something of a handful.

Chord Signature  
(1m pr, £500; 5m spkr £1150)  
Tel. (44)(0)1980 625700  
Net. [www.chord.co.uk](http://www.chord.co.uk)

Chord's Signature cables might be the company's flagship products but are still only entry level in high-end terms. In technological terms they represent the new trend toward designs based on microwave cables, promising exceptional sound quality for their price. They also represent another of our benchmark products and as such it will be interesting to see how they stack up. In constructional terms, this is another minimalist, low-mass

design, despite the comparatively bulky conductors. The construction is absolutely first class with extremely neat finishing and considerable care given to matching materials and conductor surfaces. Hence the use of silver plated copper conductors and plugs in combination with silver solder.

Connections are positive without being so tight as to damage socketry, but these cables are very springy indeed, making neat dressing a nightmare. The speaker cable is colossal and if the red and black colour-way upsets your sense of aesthetics, it's also available in an all black finish.

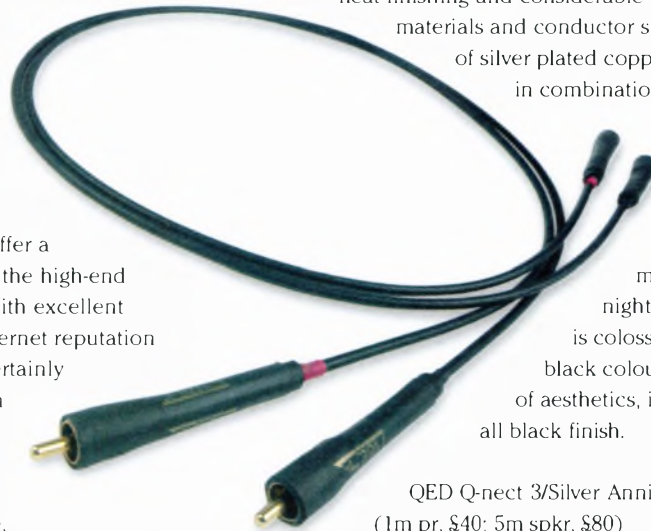

QED Q-nect 3/Silver Anniversary  
(1m pr, \$40; 5m spkr, \$80)  
QED Audio Products  
Tel. (44)(0)1483 747474  
Net. [www.qed.co.uk](http://www.qed.co.uk)

At less than a tenth the price of the next nearest competition, you might well wonder what the QED cables are doing in this group. The answer is simple: I want to know whether people can hear the difference between cheap and expensive cables when they don't know what they're listening to. As such, the three-times What Hi-Fi Award winner represents the people's choice. The basic, stranded speaker cable and shielded twin-ax interconnect use silver-plated copper conductors and offer neat, mass-produced style terminations. Practicality is excellent with the interconnects being flexible and the speaker cables offering a cross-section almost as slim as the Au24. It's

hard to criticize the presentation given the price, although the proof will be in the listening.

### Listening Results

The response sheets for the panel were collected and collated to create the table laid out below. The running orders have been corrected to make it easier to follow individual cable performance, although the results are still separated into first and second groups and by listener. ►

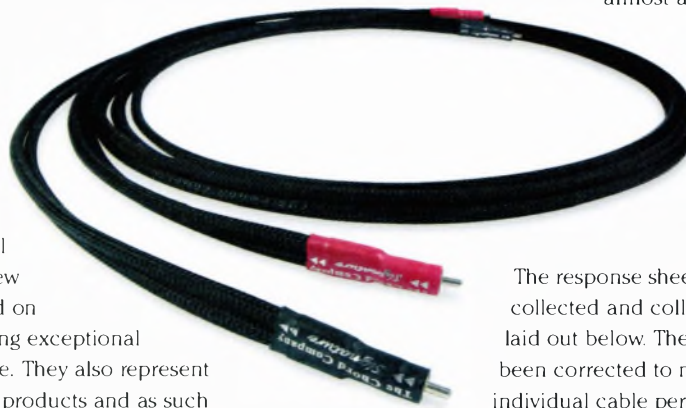



► Scores by Listener

CONTROL	TEST GROUP 1 STEREOVOX			TEST GROUP 2 CHORD		
	NF	JH	KR	NF	JH	KR
SILTECH	10	10	10	15	16	15
	10	10	10	10	11	9
	10	10	10	11	9	13
NORDOST	18	18	18	14	16	16
	13	12	12	15	15	15
	16	16	16	14	13	14
QED	12	16	11	10	11	12
	15	14	15	6	7	6
	12	13	13	8	7	10
AV24	16	18	10	10	10	10
	12	15	8	10	10	10
	18	16	11	10	10	10
CHORD	15	15	13	15	16	13
	13	14	13	14	14	15
	16	14	13	15	15	15
STEREOVOX	15	15	15	12	12	12
	12	12	12	7	8	8
	17	17	15	10	10	10

In the first group, the Siltech was the first cable scored, whilst in the second it was the Au24, accounting for their straight 10 scores. You can handle this raw data in a number of different ways. Initially, I ranked the cables by overall preference, totaling the scores for each listener and then rating them accordingly. Adding together those ratings then produces an overall ranking for each cable, based on the combined preferences of the panel across both systems and all musical selections. However, one thing became clear almost immediately. The Siltech finished dead last in the first session and a very close third in the second! The result in the first round was also by far the most concerted verdict, with the ranking agreeing across all three listeners. What do we conclude from this? Well, the Siltech cables and the Hovland electronics obviously don't get along. This kind of incompatibility is always a possibility with cables and has occurred with a vengeance in this instance. That's why we used two different systems. In this case, the response is to rely on the second set of scores, doubling them up to create an adjusted result, adding it to the results table as an additional entry.

Rankings by Listener and Overall

CABLE	RANKING					TOTAL	
NORDOST	1	1	1	2	2	3	10
Adj. SILTECH	-	-	-	1	3	3	14
CHORD	4	2	4	3	2	1	16
STEREOVOX	2	4	1	(4	5	4)	20
Au24	3	5	3	6	3	4	24
SILTECH	6	6	6	1	3	3	27
QED	5	1	5	5	6	6	28

The final consideration is the question of total scores, or points awarded. Whilst the scoring system is preference based rather than numerical in nature, used in conjunction, the two results present a fuller picture.

Overall Rankings and Total Points Awarded

CABLE	TOTAL SCORE	BY RANKING
NORDOST	272	1
CHORD	258	3
STEREOVOX	219	4
Adj. SILTECH	218	2
Au24	214	5
QED	199	7
SILTECH	198	6

Conclusions

Well, the first and most obvious result is the clear preference exhibited by all listeners for the Nordost Valhalla. Topping the ratings both in terms of rankings and points scored, our benchmark top-end cable accumulated only four faults (in equestrian speak) with a total of ten against a theoretical minimum of six! That's an impressive performance by any standards and an emphatic justification for our faith in its abilities.

Equally apparent (and reassuring) is the audible gap between the expensive cables and the budget QED. Indeed, barring a single aberration (that we'll get to later) the gap would have been even wider. Ignore the spurious Siltech results in the first round and it finished plum last in five out of six cases. This is hardly surprising given its price and shouldn't be taken as a criticism of QED or its products. However, it ►

► does rather undermine the notion that cable differences are inaudible or unimportant. And yes, I'll admit that there's a certain satisfaction in hoisting the blind-listening/all cables sound the same brigade on their own petard.

But perhaps the most gratifying performance comes from the Chord Signature, our "mid-price" benchmark. Ranked a solid third on preference (behind the Nordost and Adjusted Siltech) that places it well beyond its price level. Look at its accumulated points and it gets even more interesting, scoring a solid second, well ahead of the pack, reflecting the consistency of its scoring across all listeners and genres. Again, this underlines the "subjective" results achieved in the observational review. Which is nice.

And talking of consistency, the results themselves are remarkably consistent across the range. Both the major aberrations detected were reflected in every listener's notes, the Siltech's system incompatibility being particularly obvious. Less sonically apparent was a flaw in the first round listening with the Au24. The first two tracks were negotiated with ease, the cable scoring highly. But once we reached the Dvorak things fell apart alarmingly, a fact that was picked up by every listener. Unfortunately, the Au24 was first up in the second session, which meant that I'm unable to tell whether this is a system or program related effect. However, the accuracy with which it's mirrored in the numbers is impressive, reinforcing just how audible differences in system and cable performance are, even under blind conditions.

So much for the highlights, the real detail and quality is in the stitching. Dig a little deeper and interesting patterns begin to emerge that start to throw some light on the influence of the process itself. I've already mentioned the Siltech result and its effect on the initial, overall outcome. Now let's take a look at the Stereovox scores. On the face of it, especially considering the price of these cables, they represent a poor return. Yet, having listened to these cables in isolation I'd consider them worthy of far higher marks – a judgement based on the same criteria applied to the Nordost and Chord reviews whose outcome was so emphatically reinforced by the blind-testing. Why the discrepancy?

I think it has a lot to do with the nature and sonic character of the Stereovox cables. Compared directly to the more obvious sounding competition they can sound almost muted. They don't exhibit overt or ear-catching strengths such as impressive dynamics or dramatic transparency. But listen

longer and you realise that they have a sense of balance and integrity that brings an unforced coherence to music. It's a quality that emerges gradually and is far from apparent in straight A/B comparisons (although A/B/A listening does prove more revealing – as always). This effect becomes even more apparent under blind-listening conditions, actually exaggerating the responses of the listeners. Sure, you can devise a different blind-test, and with more time and resources you could certainly develop a superior test protocol, but this instance does tend to underline the potential pitfalls in blind-testing. Reading through the listener's comments you can see the cable's character emerging in the repeated use of words like 'even', 'unforced' and 'easy', but it's hard to interpolate these into the numerical scores unless you use a far more complex points system, which has related problems all its own. Certainly, keeping things simple should aid consistency and repeatability and that seems to be reflected in our results.

Now let's take that a stage further and examine the single biggest anomaly in the whole test series. How can the same listener mark the QED as best in one series of tests and worst in the next? Yet that's exactly what JH managed to achieve. Of course, he could just be deaf (after all, he is a reviewer) but looking at his other results reveals much greater consistency, as well as the fact that he picked up on the Siltech and Au24 anomalies also identified by the other listeners. This suggests that the responsibility lies elsewhere.

Read the accompanying side-bar and it'll give you some insight into the thought processes that governed the marking. Indeed, my biggest criticism of blind-listening is that it transforms the exercise into one where listeners attempt to identify products rather than identifying their characteristics. It's a subtle shift but a vital one, rearranging the listener's priorities. Read Jason's own description and you can begin to see just how unsettling and threatening having all your established benchmarks removed can be. Rather than freeing the listener it tends to pressurize them, undermining their confidence. As a research scientist by trade, JH responded by reverting to type. The end result was to recast the exercise, at least to start with, as a sophisticated form of pin the tail on the donkey.

Now, if we combine that with the particular sequence of events, we can start to see where that first round score

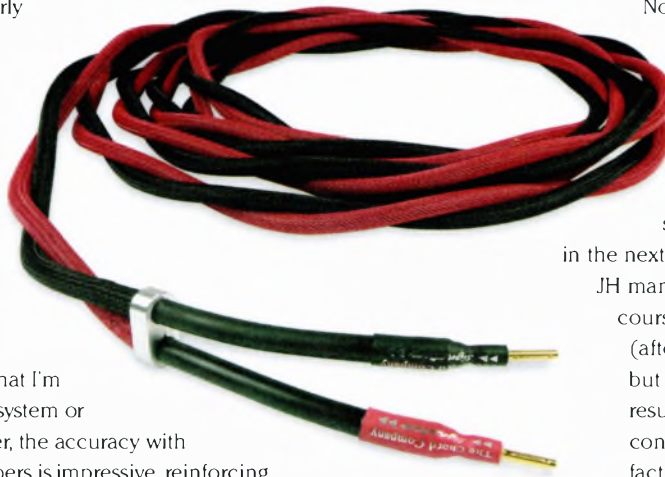



## Fear And Loathing In Ringwood...

by Jason Hector

It is always with some trepidation that I put myself forward for these sorts of tests. (I can't say that I noticed! Ed.) Will I identify the cheap cable? Will I be consistent with my opinions? Will I hear any differences at all? Well the last worry soon evaporated as the cables were swapped around and it was clear that each set had marked performance differences. But until you've sat there, with nothing to see and none of your usual reference points that you start to realise just how deeply this sense of apprehension lies. It was further stoked by the nature of the tests; comparative listening is not something I do day to day. Normally I set a system up and try to get a feel for the whole of its presentation rather than worrying about how it compares to anything else. And I do that over numbers of albums rather than just a few tracks! In the first run through all of the cables were fresh to our ears and there was a tendency, in my case, to always try to compare the current cables under test to the previous cable rather than awarding it an absolute score. This made the ordering more important than perhaps it should have been. The tendency is to try to identify the cable and then mark

it, rather than simply respond to what you're hearing. It's that confidence thing again... When you have a better feel for the boundaries, as we did second time around, then each cable becomes more isolated and its comparative performance easier to discern.

With my working background I also have a tendency to over analyse, or go into scientist mode and again this led to some confusion in the first run through with too much focus on small parts and not enough on the whole. Another way of saying that I was listening for that specific drum strike or backing vocal rather than the way it was integrated into the rest of the piece. The second time round I was more relaxed (lunch and a pint of Ringwood bitter helping) and interestingly, as the gaps between the cables were perceived as more obvious this in turn led to more confidence in my opinion.

The general thrust of the results speak for themselves and I feel confident that using these cables over time at home, with my music in my system, would lead to even larger differences between the cables becoming ever more obvious. Whether that would result in the same ordering is a different question. I can't help feeling that there are performers here that would do better under those circumstances – and not just the cables!

► came from. Remember, this is right at the start of the process, and it's an unfamiliar system. The control cable was the Stereovox, followed by the Siltech which really didn't suit the system at all. Next came the Stereovox again, then the QED. That makes a running order of solid-core, under-performing silver and again, solid-core. Each subsequent disappointment builds on the last, increasing the tension and pressure. Imagine the palpable sense of relief, having been marking down the unfamiliar and unimpressive, when something familiar and multi-stranded hove into earshot. After all, of the assembled cast, this is the closest thing in technological terms to the cables Jason runs at home. Trouble is, this was no donkey – it was an ass. Somehow the image of a drowning man grabbing a passing life-belt swims, unbidden into my mind. Under the circumstances, a degree of relieved over-reaction is understandable.

After that, things settle down a bit, although the absence of stranded cable thump and smear still undermines the subsequent results. But some sense of orientation is beginning to assert itself and the scores for the last three cables are beginning to hit a groove. This is reinforced

by the post-session debrief which helps establish some way-marks in the wilderness. The second series results are far more representative. This time, the QED appears after the Nordost, which rather puts it in context.

Now compare this to the consistency of NF, far more familiar with both the subject matter and methodology.

He was even able to reliably identify cable configurations in many cases. Likewise, KR arrived unburdened by expectation and unfamiliar with most of these products to the point of never having heard of most of them. Identity was something of a side issue. All of which leads us to the biggest intangible in blind-testing – the listeners themselves. Compensating for variations there is well beyond the scope of any test that either this or any other magazine could devise and fund. JH is probably feeling a

little bruised and not a little embarrassed by all this. Well, he shouldn't. What his experience usefully demonstrates is the hidden-psychology that governs blind-testing. Revealing this facet is if anything, more important than the other results put together. Next time you're thinking of writing in to demand blind-listening tests, just bear what it reveals in mind. ➤+



# Tube technology...

## PM Components launch a set of cables intended specifically for valve electronics.

by Roy Gregory

Cables, especially expensive cables, have always attracted considerable suspicion from the buying public, dealers and reviewers alike – much of it well founded. Indeed, there's more snake-oil involved in and outrageous claims made on behalf of cables than any other product category. Yet, as our blind test demonstrates, well-chosen cables make a real and very worthwhile contribution to system performance. Indeed, they're a vital part of the whole. Yet, as the test also shows, price in itself is no guarantee of a good result, and even cables that perform brilliantly in one context can underperform dramatically in another. Then of course, there are those that never perform: And that doesn't relate to price either. Time for a cautionary tale...

We recently received for review, a set of cables (two different interconnects and a set of speaker wires) that arrived with quite a story. A story that depends in turn on a theory that states that valve amps sound better than solid-state amps because they deliver signals much quicker. The problem is that the market is dominated by solid-state designs, which means that accessories such as cables are designed around the "slower" sound of those amps, thus handicapping valve products. Because of this, the designer postulates, there's a requirement for cables intended specifically for use with valve electronics.

Now, let's be clear: this is his theory, not mine, and I'm not sure I accept it or even the assumption on which it's based. However, bear with me. After all, companies like Transparent have been making valve optimized cable sets for some time, so while the reasoning might be flawed the requirement certainly already exists.

The next leap of faith demanded is that the way to make a good cable is to use a variety of conductive materials, sizes and lengths within a single conductor. This they say, major cable producers are not prepared to do because it's costly and time consuming. But all you valve owners can breathe a huge sigh of relief, because our lone hero is prepared to hand-build cables with tube electronics in mind. Who better to distribute these technological marvels than an established valve distributor? Our intrepid designer approached just such a company, who, having no experience with cables took the claims on trust and forwarded samples to one of their dealers for comment. "Very good" came the response "but

no track record". So, not being slow on the up-take the distributor devised a promotional plan. Armed with a good story and independent corroboration, they really went to town on the spiel including all the original claims made by the manufacturer. And just to ensure success, they decided to offer valve owning potential purchasers the chance to compare the cables to "conventional designs costing twice as much" with a money back guarantee extending for 28 days if you "are not 100% convinced".

Now this, dear reader, is just too good to miss. Here's a specific claim that we can put to the test, from a manufacturer making a product which a large percentage of the world's population don't believe can possibly make an audible difference. And let's be honest, there's nothing like a particularly verbose and nebulous piece of marketing hyperbole to provoke a suitably self-righteous response from the press.

So, who's right and who's wrong? The proof of the cable is in the listening and with that in mind I dutifully assembled an all valve set-up with the distinct possibility of egg impacting face in the not too distant future. However, I needn't have worried, as subsequent experience proved my scepticism to be well founded. Armed with a Rogue Audio Magnum 99 pre-amp and Model 90 stereo power amp, I acquired an armful of equivalently priced cabling from The Chord Co. for comparison, and CB by way of corroboration.

The distributor had supplied both their cheapest interconnect, (£59.95 for a metre pair) and the mid-priced model (£174.95) for review. There's also a top-end model which costs £599.95 but we didn't hear this. By way of comparison I had Chord's Chameleon (£110) and Chorus (£200) Interconnects, and all leads were terminated with RCA/Phonos. As regards speaker cables, this got a little more complex. Chord supplied Odyssey at £17 a linear meter, as well as a doubled up set of the same. The valve specific speaker cable was vastly more expensive, at £1699.95 for the five-metre, single-wired pair, so we also had Chord's Signature speaker cable on hand, although in practice, the precaution proved unnecessary.

The Chord cables are all either established models or have been recently reviewed so I'll not dwell on them. However, the "valve" cables are worthy of some discussion. ►



► The cheaper interconnect appears to be a basic co-axial design and is terminated with rather nasty ProFi Gold plugs which are pretty enough but have no place on a cable at this price. The mid-price model also employs a flexible co-ax cable. But once again, a severe question mark rests over the choice of termination, in this case, cheap copies of the WBT locking collet design. Even the original didn't sound that great and these replicas are way, way off the sonic pace.

Which brings us, finally, to the speaker cable, a bulky but surprisingly lightweight construction sheathed in the ubiquitous black nylon netting. Fitted with 4mm plugs, the speaker end featured removable tips, presumably to allow replacement with spades, although these weren't supplied. It seems like a nice idea but why only at the speaker end? And why use such a nasty, basic design? Any break in the signal path has to be really well engineered if you are not going to hear it. I can't see these qualifying in that regard. The sprung sleeves that shroud the tips mean you can't even get them tight! Unfortunately it's all downhill from here. The pair of cables supplied were around five inches different in length: A small thing, but so easy to get right – especially at £1700 a pair. What's more, deeper investigation revealed that far from containing a host of different conductors the leads appear to be constructed from three runs of basic, Shark wire speaker cable plaited together. This silver-plated copper, PVC insulated cable is available from RS for around £4 a metre. Unfortunately, the manufacturer's claim to use silver cable seems to be untrue. What's more, he also claims that there are two copper conductors in the cable to enhance bass performance: We could find no sign of them and believe me, we looked. Likewise, we could find no evidence of the claimed doubling back of individual strands within the interconnects. Given that the core conductors and shields are constructed from uninsulated strands, I'm not sure what it would achieve anyway. Instead, these certainly appear to be utterly conventional, machine made cables. Final nail in the coffin has to be the termination which is amateurish in the extreme. The standards of soldering were worse than mine – and that's saying something.

Still, as I observed earlier, the pro is in the listening and this wouldn't be the first time that someone in the marketing department got a bit carried away, so the various cable combinations were duly run from CD player to pre-amp and pre-amp to power amp, each with its own speaker cable. The combination of the basic interconnects with the "valve" speaker cable was, I'm afraid to say, musically disastrous. Far from releasing the speed supposedly inherent in valve amplification it resulted in a thick, congested and tubby sound, reminiscent of the disjointed bass and clogged mid-range that marks out a truly bad tube design. Combine that with a whiney quality to the upper mid and the results were actually pretty unpleasant. Upgrading the

interconnects to the mid-price model offered greater focus, detail and separation whilst failing to generate any real improvement in musical coherence or communication. The sound remained a horribly muddled and slothful mess, the more expensive interconnects delivering more information but the system making no more sense out of it.

Well, you don't have to be a genius to point a finger at the speaker cable. Sure enough, replacing it with the five-metre pair of Odysseys transformed the system, introducing a sense of rhythmic coherence and flow, timing and definition in the bass and top-to-bottom evenness. It's been a long time since I heard a cable as bad and as musically destructive as these "valve" speaker cables. As good as cables at twice their price? All I can do is wonder what on earth the designer has been listening to. The Odysseys are a tenth of their price and performance wise it really is no contest.

Which brings us to comparisons with the Chord interconnects. I'll not labour the details but the conclusions were clear. The basic interconnect really doesn't cut it and is easily outperformed by the sort of blister-packed cables available at half its price (and which it so resembles). The mid-price model is a far better option. You can hear a good cable struggling to get past those God-awful plugs, but the lack of a decent, matching speaker cable seriously undermines its appeal. A coherent combination from the likes of Chord costs less and delivers much more music. In this regard the Chorus/Odyssey set-up was a notable success. We even tried the "valve" leads in a solid-state set-up, where ironically they were no better but at least they were less offensive.

Once I'd assembled my facts I duly contacted the distributor for comment. In fairness, they were appalled, followed up our investigation with questions of their own and a decision to drop the product like a hot brick. Good for them. But whilst I can understand them falling into this, seduced by a product which claimed to complement their existing range and serve their customer base, what does it tell us about the dealer who listened to these leads and the magazine that's already reviewed them?

Why make such a point about the performance (or lack of it) with these cables? This industry suffers enough grief for the price of the cables we sell and which magazines review so enthusiastically. And that's without the specious BS that companies indulge in to promote their designs. All we need is a few more products like this one and the cynics will have a field day. The one thing that these leads do prove is that not just anybody can source a cable, terminate it and then market it successfully. Perhaps the distributor in question should stick to valves – it's definitely what they do best. Hopefully the designer/manufacturer will find something else to occupy his time.





Boulder 2010 Preamplifier



metropolis music



Acoustic Zen



BAT VH600se

Hovland HP200 Preamplifier / Radia Solidstate Power.

Copulare

Music Tools

Lumley Lampros Concert Grand



Kharmo Ceramique 3.2



Boulder 1050 Mono amplifier

For real music lovers.



Hovland Sapphire



Advantage Monoblocs

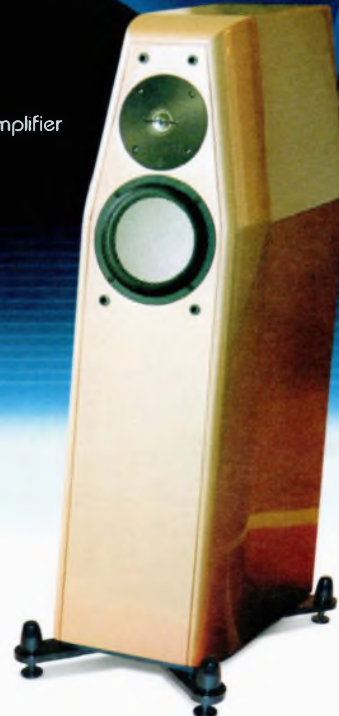

[www.metropolis-music.co.uk](http://www.metropolis-music.co.uk)

Tel. 01892 539245 Fax. 01892 616383

6 London Road, Tunbridge Wells, Kent. TN11 1DQ





# Firm Foundations...

## Equipment racks from finite elemente, Voodoo Isolation, Arcici, Hutter and Clearlight Audio

by Roy Gregory

Right from the word go we've paid rather more attention to racks and supports than most other magazines. It's a natural extension of the belief that whilst people tend to concentrate on the electronics and other active elements in the system, the peripherals that ensure their conditions of operation are actually just as important in the great scheme of things. It's a bit like a Ferrari, which contains a fabulous engine and superb suspension. It's dynamic elements might be the best you can get, but without the right tyres, petrol and road surface, they're going nowhere fast. Well, when it comes to your hi-fi system, instead of road, fuel and rubber, think mains cables, signal cables and supports. That's why we think that racks are an important, and more importantly, an oft overlooked element in a successful system.

We've placed our faith in various different models over the years, and different listeners have their own favourites. That means that very often, even if the same writer has reviewed two different racks, it has often been with different equipment, so generalized conclusions have been hard to reach. With that in mind, and given the recent emergence of several new or updated designs, I felt it was about time to establish just how our benchmarks relate to each other and also, the competition. Time in fact, to gather them all under a single roof and listen using the same equipment. Which is, as I soon discovered, easier said than done. For one thing, the darn things take up so much space. For another, what system are you going to use than can flit quickly from one rack to another without having to be disconnected and then warmed up again?

Well, the answer to the first question comes in the form of self-denial. Just don't do them all at once. So, with that in mind I devised the following methodology. I first assembled five subjects for testing, which is about as many additional racks as I can accommodate in the house at any one time. These are all large, four-shelf racks, capable of

accommodating substantial equipment. I also had a SoundStyle three-shelf unit to represent the real world and what people tend to end up taking home from their dealers. It's a classic welded steel and glass design, prettier than most, much prettier than some. A pair of racks were set up and leveled, standing next to each other with enough space to walk behind them. This way, the system could be pulled through the back of one and placed on the other, allowing fairly quick comparisons as well as long-term appreciation. Once I'd got the measure of a rack, with the system on the other one it could be removed and replaced with the next in line, thus maintaining an overlapping continuity throughout the circular operation.

Of course, this whole plan depends on having a readily portable yet stable system. The one I selected is essentially simple, with a one-box CD player and an integrated amp. But it must also be of sufficient quality to show differences

between the various supports. I selected the Burmester 001 top-loading CD player, placing it on the top-shelf for obvious reasons. This was fed into a Cyrus Integrated amp and PSX-R combination – two boxes but a lot easier

to handle than a full-width pre-power set-up. Speakers were the Audioplan Kontrast IIII, an excellent match with the Cyrus amp. Cabling was Nordost's Valhalla throughout, with the introduction of the Thor mains distribution unit proving a single point mains connection, easing the transfers and filling the bottom shelf.

Assembling the cast of thousands (of nuts and bolts that is) was a slightly more troublesome affair. I settled on the following line-up. The resident finite elemente Pagode HD-03 Master Reference racks were

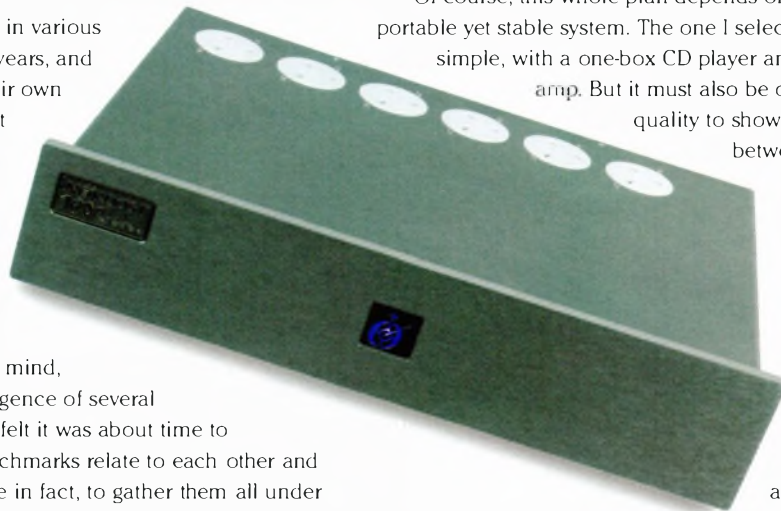



► joined by the Clearlight Audio Aspect and the Hutter RackTime, representing most of our current benchmarks. Alongside them I placed the Voodoo Isolation rack and the highly rated Arcici Junior Suspense from America, both air-suspended designs, although rather different in detail. These will be followed by a second group comprising the finite elemente (for continuity – and besides, it lives here), the Grand Prix Racing rack, the Naim Fraim, the latest incarnation of the Townshend and anything else that comes to mind or crops up in the meantime.

So, in no particular order, this is how they faired...

### The Voodoo Isolation Natural Rhythms Rack System

The Voodoo rack is a logical extension of the company's isolation platform. The rack essentially consists of four separate platforms, each with its own air isolated support surface. These are clamped between two substantial side panels, the top and base being fixed but the intermediate levels being adjustable for both spacing and number. Thus, those with many, slim units to house can simply build more shelves, closer together to keep things (relatively) compact. The clamping system is simplicity itself. There are three vertical slots in each side plate through which you screw long, mushroom headed allen bolts in order to clamp the shelf unit. It provides infinite adjustability at the cost of some awkwardness when it comes to construction and leveling.



However, once the bolts are tightened you end up with a sturdy enough structure.

Despite the relatively large footprint of this rack (590 x 500mm) the main support surfaces are a significantly smaller 430 x 360mm. The top shelf measures a rather larger 490 x 460mm, while the space between the side panels is 538mm. Each intermediate shelf is a little over 50mm deep and the total height of the rack is 1050mm. Not overly heavy and lacking conventional spikes it's easy to move about and position.

The base is a double layer sandwich on the under-side of which Voodoo have placed three, fixed, domed oak feet. There's no provision for leveling the rack as a whole. However, each shelf can be laterally leveled using the two air bladders that support it. That's except for the top shelf which uses three bladders, allowing leveling in both planes making it more suitable for mechanical devices such as CD and record players. However, customers can order any combination of shelves with two, three or even four bladders, at a small extra cost. Whilst this arrangement requires each shelf to be leveled separately, which is a bit of a pain initially, they do retain their level over time, making for a stable long-term support. The Presta HP valves used don't seem to bleed even small amounts of air. Bolts aside, the entire structure is metal free, a central theme with Voodoo's designs. The review sample arrived clad in a rather fetching Maple veneer that certainly seems to suit the current domestic dictates. ►

## ► The Arcici Junior Suspense Rack

Like the Voodoo rack, the Arcici is a suspended design, but that's as far as the similarities go. In the Voodoo, each item of equipment is individually supported, sitting atop the platform while the combination of the unit's mass and the air pressure establishes the fundamental resonance. This works fine unless the unit involved is very light or very lopsided.

Arcici adopt a different arrangement in which the suspension system is pre-loaded by its own mass, and in which the majority of the load is suspended below and thus hanging from the spring medium. This makes for an inherently stable arrangement and one with a guaranteed low resonance to maximize isolation. Arcici's realization of this ideal is both simple and elegant. A space frame is constructed from two wooden trays, bolted together using aluminium angle uprights. The top tray supports three inner tubes spaced one front and two back, and all adjustable from valves on the rear face (although with a square footprint you can orientate them more conveniently if you wish).

These are inflated to support a large slab of steel that must weigh 40 kg or so.

Holes in the base of the top tray align with holes in the four corners of the steel slab. Threaded rods are passed up through these and retained by nuts that sit into rubber washers seated in



dimples in the top of the steel plate, thus allowing a flush top surface which is capped off by a cosmetic plastic moulding. The four suspended rods have large nuts spaced along their lengths and these interface with slots cut in slabs of Perspex in order to create and support the intermediate shelves. The review sample had three shelves although I believe a four-shelf version simply called the Suspense is also available. Corner braces on the underside of the bottom tray are hidden by another cosmetic cover and support threaded, floor friendly feet for leveling the frame as a whole. The three valves being so close together make for easy leveling of the suspension, although ditch the cheap pump supplied in favour of a quick release mini-pump from your local cycle shop. But for me, by far the best part of this design is those supporting nuts. Having used "adjustable" racks that use threaded studs and nuts to position and level the shelves, I can attest to the time consuming pain in the ass this approach represents. I groaned aloud when I first set eyes on the Arcici's rods – but that was because I hadn't RTFM. Once I'd scoured the instructions I realized that these were in fact Speed Nuts, each with a button built into its side.

Press this and they simply slide freely. Respacing the shelves is a simple case of press and slide, with the twisting option still available for fine-tuning.

The review sample arrived with oak wood-work and black uprights. That didn't really do it for me I have to say, and with the clear shelves I'd definitely go for an all black frame which would suit the overall aesthetic rather better. Still, that would be easy enough to arrange.

The top surface is 595mm ►



▶ square, the usable space on the internal shelves is 500mm square, which allows accommodation of even the bulkiest equipment, a fact underlined by the total load rating of 270kgs. The internal vertical space available is 745mm, with the three 17mm shelves taking up only 51mm of that. It's an extremely space efficient set-up, with very little of its 960mm height lost to the structure itself.

Leveling is critical as the flexibility of the suspended section means that it must hang vertically so as not to foul the spaceframe's uprights. Fortunately, the threaded glides that support the frame make it easy to adjust the position and attitude of the rack, while the spaceframe itself, whilst sturdy, is surprisingly light once you remove the pre-loading plate. Assembling the rack in situ is by far the best option, but once constructed you can still maneuver it fairly easily, especially if there's two of you. My only problem throughout an extended review period was that one of the bladder junctions developed a leak, drooping one corner of the rack. Easy enough to fix, the biggest pain was having to unload the entire system to do it. I'd also like to see the use of Presta (high-pressure bicycle type) valves rather than the less reliable and more easily contaminated Schraeder (car type) valves. It's a small thing but it will reduce the number of top-ups the rack will need.

### The Clearlight Audio Aspect rack

This design (and the other two racks still to be described) will be familiar from earlier issues. That and its inherent simplicity means that it requires rather less physical description. The basic structure is a rigid tripod, constructed from three frames, each cut as one piece from a sheet of MDF. These are connected at their vertical edges by strips of suitably profiled hardwood, fastened securely together with small allen bolts. My early sample has these positioned on the outer faces, although current versions bolt through from inside, make for a much neater



appearance. The resulting spaceframe is very light and surprisingly rigid, as well as being virtually devoid of metal. The simplicity of its six-part structure with its mutual clamping also offers a well damped and spread resonant character which is a key point to the design. The downside is that there is no adjustability built into the shelf spacing. The fixed frames offer supports of 480mm by 400mm, with two vertical spaces of 160mm and one of 220mm. Your only choice is whether the large space goes at the top or the bottom.

The shelves themselves are the really clever bit. Spaced from the frame by small rubber blobs, they consist of an MDF surface with a snail shaped groove routed out of it and filled with Clearlight's RDC disruptive material. This makes for an incredibly inert support, with a very

well distributed and low-level resonant signature.

The review rack was used with standard shelves in all but the top position, where a heavy-duty, double thickness sandwich version (540 x 445mm) was employed. Constructed from two standard shelves glued face to face, these are available as an option in the internal positions too.

Leveling the rack is achieved using the three RDC cones mounted on threaded posts in the underside of the

hardwood corners. The rack itself is simplicity itself to move and position, one reason why it remained my support of choice for so long.

### The Hutter RackTime rack

As used by JH, the RackTime is a versatile and extremely effective support with superb standards of finish. The simple structure is based on U-section shelves constructed from laminated wood in which the grain is variously orientated to help disperse resonance. These are separated by aluminium uprights that actually comprise rods inserted into close fitting sleeves. It's a simple and inherently non-resonant

► solution that allows the manufacturer to offer an almost infinite variety of shelf spacings and widths. Anything that's not in the standard range can be built to order. The bottom shelf is spiked to the base-board, which is in turn spiked to the floor. It's vital to get these two elements rigid and level if the rack is to perform at its best.

The review sample's shelves offer support surface dimensions of 540mm wide (600mm external) by the standard 475mm deep. However, as discussed, there's a host of width options, up to a massive 1640mm, with just about anything possible in between. And if one of the six superb (and I do mean superb)



standard veneers doesn't suit then the furniture factory that produces these racks will match a supplied sample, at a price.

Once built, the rack is almost impossible to move so don't even try. This one you need to get right from the start. But one practical upside is that the various spacer sizes and the stacking construction make it easy to adapt the Hutter to future upgrades (although less so if you've specced a special finish – which is worth considering). There are also a range of storage and different shelf options available that are beyond the scope of this review but are outlined in the product literature.

## The finite element Pagode HD-03 Master Reference rack

Reviewed as recently as Issue 27, I'll skate over the intricacies of the HD-03. A spiked, hardwood frame supports extruded aluminium uprights, tied together by lateral, hardwood struts near their tops. These uprights support the shelf units by means of horizontally threaded cones that are wound out to meet dimples drilled into the aluminium surfaces. Once secured (and they do go incredibly tight) these are locked in place with jimmy bars and threaded collars. It's a fiddly system until you get used to it, but more than any other I've used, it guarantees useable adjustment of spacing with extreme rigidity.

The frames that support the shelves are constructed from solid hardwood, with extensive bracing that also contains the specially designed parasitic resonators used to tune each shelf. These are factory set across a range of differential values and whilst in theory they could be changed, I've certainly never felt the need. The actual support surfaces are fairly small (515mm by 465mm) compared to the rack's substantial 700mm by 550mm footprint, indicative of the substantial structure. The shelves are supported on small, adjustable spikes that engage cups sunk into the frames' bracing. The rack is difficult to move single-handed, and once leveled on its four spikes is essentially locked in place. However, you can substitute finite's superb Cera-Base feet for the spikes, which both sounds and looks better. More on that next time, for now I'll concentrate on the standard set-up.

Essentially a set of modules that can be factory configured to create a number different racks, finite element offer the HD series with a choice of the 600mm wide shelf units

supplied for review, 750mm ones, or even 1120mm if you must (add an extra 100mm to allow for the uprights when calculating total width).

The uprights are available in 600mm and 850mm heights. There is also a special, heavy-duty top level available to support turntables or equipment weighing up to 150Kg, while two different sizes of single layer amp stands are offered. Standard finish is maple in

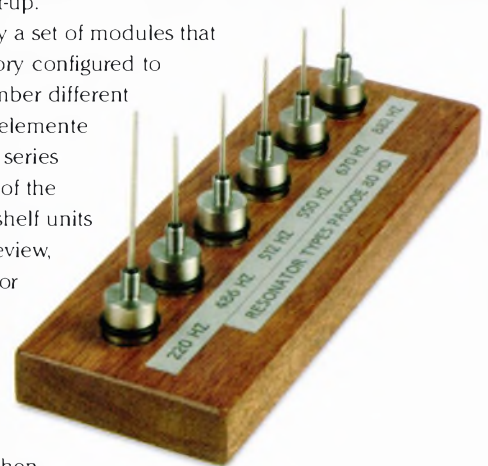



▶ natural or black, but special finishes are also available to order, assuming that you are prepared to both pay for them and wait for delivery.

### Listening to Furniture!

Having spent considerable time with all of these racks, both individually and in the context of these direct comparisons, it came as no surprise that all of them offer a significantly better performance than the SoundStyle control. What was more surprising was the breadth of the gap. Where the steel and glass construct sounded forced, edgy, exaggerated and uneven, every rack in the test group sounded significantly better balanced, with more natural, detailed and expressive presentation, greater bandwidth and far better soundstaging. But the killer difference was in the sense of flow and rhythmic subtlety, the binding element that ties the instruments together. The pacing of music was far more natural, the sense of ensemble greater, the contrasts between instruments within the same piece far more obvious. It's an effect I've come to take for granted, so long have I been using superior isolation. It was quite a shock to have the benefit removed and realise just how hollow, false and contrived the system sounded as a result. The first and most obvious conclusion is that any of these racks is worth the price in pure performance terms. As to how they sound (and they do sound quite distinctive, one to another), well, that's another matter...

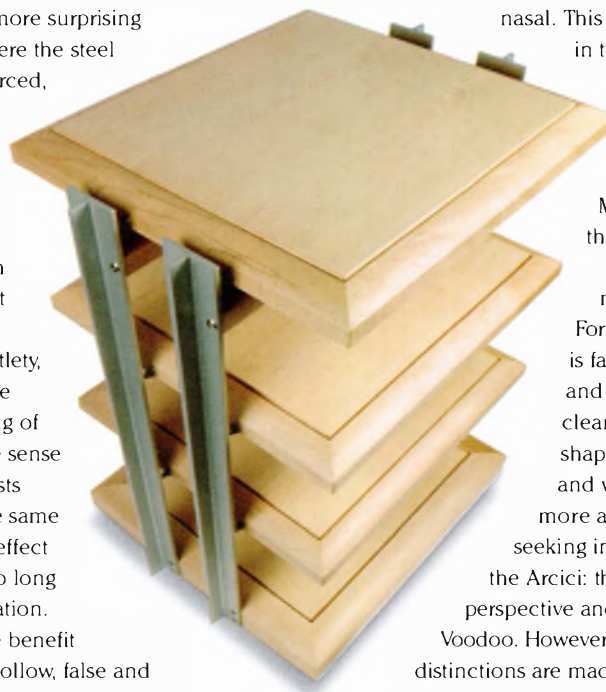

### The Suspended Designs

The Voodoo and the Arcici, perhaps not surprisingly, sounded more similar than they did different. Characterized by their easy, unforced and remarkably even presentation they really allow recordings to breathe and the music to speak for itself. There are no nasty energy spikes to pep or drive the bass, and tempi are particularly varied and expressive rather than one paced and metronomic. That's not to say they lack rhythmic involvement; indeed, quite the opposite. What they do is open whole vistas of rhythmic sophistication that escape less effective stands where the energy spectrum of the structure imposes itself on the energy spectrum of the music.

However, there are differences between them, and these too, I suspect, reflect the materials used. The Arcici offers superior transparency, separation and low-level detail. While neither can be described as dynamically challenged, the Arcici shows better discrimination of low-level dynamics and the inner harmonic texture of notes. In contrast, the Voodoo offers a slightly more rounded view of events, but one that shows a sweeter, richer tone and wider, more natural range of instrumental colours. In contrast, the Arcici sounds lean, a little pinched and at times, even slightly nasal. This combined with a slightly shut-in top-end which smoothes and rounds aggressive sounds, makes for a slightly velvety quality that often affects Perspex turntables. Musically the implications are that the Voodoo tells you what is being played, while the Arcici majors on how it's being played. For example, Piatigorsky's bowing is far more apparent, the shape and accent of individual notes far clearer on the Arcici. The overall shape of phrases and the structure and weight of the work as a whole is more apparent on the Voodoo. Those seeking inner detail and focus will favour the Arcici: those who prefer a more natural perspective and tonal palette will opt for the Voodoo. However, bear in mind that these distinctions are made within the broader qualities that link these designs. As different as they are, they still exhibit a distinctive 'suspended' thumbprint.

### The Rigid Designs

The Clearlight Aspect rack is the lightest and simplest of the group and in many ways this is reflected in the uncluttered clarity of its sound. It's extremely even, top to bottom, with a leanish balance and tight, neat presentation. Tonal range is good, albeit not in the class of the suspended Voodoo, but this aids the excellent focus and separation. Delineation of depth is fair rather than outstanding, and dimensionality again doesn't match the suspended designs, images being a little flat and 2D in comparison. However, that covers the downsides. The upsides are that this rack adds very little of itself to proceedings, allowing superb dynamic discrimination and pitch definition. Pace is quick and driven, giving music plenty of life and energy, a stark contrast to the fluidity of the Voodoo, but valid in its own right and preferred ▶

► by many a listener. The ability to let you hear into a performance whilst retaining the overall sense and structure is rare, and beautifully balanced in the Clearlight. The price you pay is the slight leanness and the diminished sense of spatial separation, both of which rob music of some of its scale and power, a small price to pay for the intelligibility and perfect proportion of its perspective.

The Hutter is the big-boned and muscular brother to the Aspect's delicacy and lightness of touch. Richer and tonally more sophisticated, the RackTime has a wonderful sense of natural weight and presence, underpinned by a subtle mid-prominence. Separation and detail suffer in the name of substance and keeping that sense of body where and when it should be. The result is a smooth and engaging sound that tracks the shape and structure of the musical performance as a whole rather than the separate dynamic strands. Pace and timing are more relaxed and fluid than the Aspect, a presentation that works well with the power and colour of the RackTime. Big and bold, it carries the dramatic sweep and scale of a performance with emotive grace and purpose.

### The finite elemente tuned solution

Sonically at least, the finite elemente rack holds the middle ground, its sophisticated tuning system seemingly offering the mechanical isolation of the suspended racks combined with the sure-footed steadiness of the rigid designs. Tonal colours are rich and natural, timing subtle and persuasive, but it's the dynamics that are the key to the stand's performance and which tie the other elements, impressive as they are, together. The delineation of micro-dynamic detail allows the stand to hold firm control of the different strands in the music without ever seeming to do so. Thus, it can be delicate and spacious as well as rich, swelling and powerful, all without changing gear, simply by virtue of its control over energy levels and density. The spiked base provides a firm foundation that's reflected in the stability of the expansive soundstage, while the tuning prevents unwanted spikes or imprecision in the pitch and pacing of bass lines. Orchestral bass in particular, floats and breathes very nearly as well as the suspended racks but offers a firmer foundation than either, with more explosive

power when required. Toms and bass drum are particularly impressive, with volume, pitch and texture rather than a simple booming thud.

### An interim conclusion – of sorts...

While we can dwell on the precise sonic qualities of these various racks, the real lesson is in their collective superiority over the common-or-garden steel offerings. Second, and just as important, is the degree and nature of the differences between these racks. I was surprised to discover just how wide the performance gaps were. Okay, so we've all done ABA listening with a couple of different designs, but it's not until you get half a dozen in the same place that the extent and musical subtlety of the differences really becomes apparent. The differences between the various racks are just as big, and in their own way, just as important, as the differences between the cables we've just been listening to.

Varying dramatically in price, these designs underline both the fact that you don't need to spend a fortune to achieve superior performance, and that you can go one better if you do. Simplicity is a virtue but so too is well founded engineering, the finite elemente HD-03 making a compelling case for its sophisticated approach, and standing as a compelling benchmark for the next round of contenders.



#### Arcici Junior Suspense Rack

Price: £1695  
Supplier: The Audiophile Club  
Tel. (44)(0)20 8882 2822  
Net. [www.audiophileclub.co.uk](http://www.audiophileclub.co.uk)

#### Voodoo Isolation Natural Rhythms System

Price: £1436  
Supplier: Voodoo Isolation Systems  
Tel. (44)(0)1643 841 244  
E-mail. [voodootek@hotmail.com](mailto:voodootek@hotmail.com)

#### Clearlight Aspect Rack

Price: £550  
Supplier: HiFi for Sale  
Tel. (44)(0)870 241 2469  
Net. [www.hififorsale.com](http://www.hififorsale.com)

#### Hutter Racktime Basic 2

Price: £606  
Supplier: Phonography  
Tel. (44)(0)1425 461230  
Net. [www.hutter.co.at](http://www.hutter.co.at)

#### finite elemente Pagode Master Reference Rack

Price: £2800  
Supplier: Audiofreaks  
Tel. (44)(0)208948 4153  
Net. [www.audiofreaks.co.uk](http://www.audiofreaks.co.uk)



# WORLD CLASS AUDIO



Imported & Distributed by Audiocraft in the United Kingdom



Lavardin  
France



Solid State  
Amplification

amphion  
Finland



Loudspeakers

Rogue Audio  
USA



Vacuum Tube  
Amplification

Marten Design  
Sweden



Loudspeakers

Dartzeel  
Switzerland



Solid State  
Amplification

Hi-fi show, Heathrow, 24-26 September 04, Gatwick Suite

Also introducing Jorma Design



Cabling systems, Sweden

# the AUDIO CONSULTANTS

FINE TWO CHANNEL AUDIO SYSTEMS



#### SME Series M2 tonearm.

Wonderful engineering for this price. A much better sound than we expected at £613. Cartridge shown is the excellent new Lyra Argo at £849.



**Amphion Xenon loudspeakers** Fast and articulate with neutral tonal balance. Slim floorstander which does not mind walls. £2500.



**Unico** Hybrid integrated amplifier, 80wpc. Line only version £900, with phono stage £950.



**Acoustic Arts Player 1.** A superb sounding CD player, very detailed without being forward. 24BIT/96kHz 8 times oversampling, great build quality. £3750



#### Sugden Bijou Series.

An exceptional high-end sound in a compact life-style design. CDMaster, Headmaster and Ampmaster £2647 in total. FMMaster tuner (not shown) £949



**Clearaudio Balance Reference Phono Stage.** Completely dual mono in design with widely adjustable cartridge loading and amplification to suit all MCs precisely. Exceptional soundstaging performance, accurate tonal balance outclassing many more heavily marketed designs. A must-hear for discerning vinyl reproduction. £2390



**EAR 509 mono amplifiers.** The anniversary edition of this classic EAR amplifier. 100wpc of pure valve sound. EAR 509: From £5998 per pair



**Pathos New Classic One.** This valve hybrid amplifier has many of the qualities of the Logos but at an affordable price £1325.

ACCUSTIC ARTS ▶ AMPHION ▶ ART ▶ AUDIO PHYSIC ▶ AVALON ▶ BEL CANTO ▶ BENZ-MICRO ▶ CARDAS ▶ CLEARAUDIO ▶ CONRAD-JOHNSON ▶ DALI ▶ EAR/YOSHINO EXPOSURE ▶ LYRA ▶ MCINTOSH ▶ MONO PULSE ▶ NORDOST ▶ NOTTINGHAM ANALOGUE ▶ OPERA ▶ PAGODE ▶ PATHOS ▶ QUADRASPIRE ▶ ROGUE AUDIO SME ▶ SHANLING ▶ SHUN MOOK ▶ SUGDEN ▶ TRANSFIGURATION ▶ UNISON RESEARCH ▶ VIRTUAL DYNAMICS ▶ WADIA

Conveniently located between Reading and Basingstoke, we are approximately 15 minutes drive from either Junction 12 on the M4 or Junction 6 on the M3. Free and easy parking, outside the building. We have a home evaluation scheme for those who might find this method more convenient.

7 Comet House, Calleva Park, Aldermaston Reading, Berkshire RG7 8JA

T 0118 981 9891  
E info@audioconsultants.co.uk  
[www.audioconsultants.co.uk](http://www.audioconsultants.co.uk)

*Demonstrations by appointment, Mondays to Saturdays 10:00 to 18:00. It is advisable to call us before visiting.*

*Part exchange welcome. Ex-demonstration and previously owned equipment listed on our website.*





# Avalon Eidolon Diamond Loudspeaker

by Roy Gregory

There's an old adage in hi-fi; it's the mid-range that counts. After all, that's where 90% of the musically important information resides. But, look at just about every state-of-the-art contender in the loudspeaker stakes and the emphasis seems to be on ever increasing bandwidth, personified at the (il)logical extreme by monster, four cabinet systems such as the Wilson WAMM and original Infinity IRS, with their separate woofer towers. Indeed, if money and space present no barriers then pursuing bandwidth ceases to be a problem. But bandwidth in and of itself is of no great value. In the same way that a badly adjusted sub-woofer does more harm than good, extending the frequency extremes of any speaker is only any use if the benefits are tied to and reflected in the mid-band.

On the surface, Neil Patel of Avalon broke all the rules with the Eidolon Diamond; marketing rules that is. For a full-range speaker, intended to tackle the best of the competition (the company does produce a true flagship in the shape of the Sentinel, although it's a rare beast) the Diamond is too small, too cheap and visually indistinguishable from its cheaper sibling of the same name. And this from a company whose speakers are already smaller, more discrete (and rather more elegant) than the opposition. Indeed, a cursory glance might well suggest that the only difference between the Eidolon and the Eidolon Diamond is the latter's inclusion of a diamond diaphragm tweeter – for which virtue, a £10000 difference in cost seems like a high price to pay. However, as soon as you

think about the implications of the change you'll realise that it's far from a straight swap. The 25mm inverted ceramic dome tweeter used in the standard Eidolon extends out to a -1.5dB point at 34kHz, well beyond the supposed limits of audibility. But the new 19mm solid diamond diaphragm extends that upper limit to 100kHz. As recent experience with sub-woofers and super-tweeters has shown, extension at one end of the audio spectrum must be balanced at the other.

With this in mind, consider what happens when you insert the diamond tweeter into an existing design. Suddenly, it loses its balance and musical coherence, which is exactly what happened when Avalon first played with these drive-units. And it's not just a question of extension either. There's the issue of quality to consider: speed, resolution, distortion and dynamic range all come into play. The end result demanded a total redesign, with only the ceramic mid-range driver surviving unscathed. A new, far more powerful motor was developed for the 280mm Nomex/Kevlar bass unit, delivering increased speed and resolution, as well as an extra 2dBof extension. The cabinet, although outwardly identical had to be redesigned with new internal bracing to accommodate the changes in low-frequency output. The cross-over had to be completely reconsidered and the internal wiring has now been optimized for each specific bandwidth.

The Eidolon Diamond retains the downward firing position for its reflex port, venting into the carefully sculpted plinth, where you'll also find a single pair of screw terminals to accept speaker cables. The grille is intended to be left in place for listening, and to that end is lined with carefully contoured acoustic felt. The badge carries a small faux



(Swarowski?)

"diamond", tweeter

aside, the only outward distinction between the two Eidolon models.

All of which makes a simple upgrade from the Eidolon to the Diamond impossible. They really are two quite distinct designs. However, the visual continuity of the Avalon speakers is an important clue to the family continuity that carries over into their sound. Listen to the Diamonds and you're listening to a perfect extension of the performance





► envelope defined by the Ascendant: But not, maybe, in the way that you might think. Indeed, your first reaction might well be that the Diamond delivers less! In fact, the big speaker possesses the same astonishingly natural tonality and understated, almost self-effacing modesty in its musical presentation. Just more so – no, make that much, much more so.

The majority of high-end, high-priced speakers wear their achievements very much upon their sleeves.

"Look at my bass

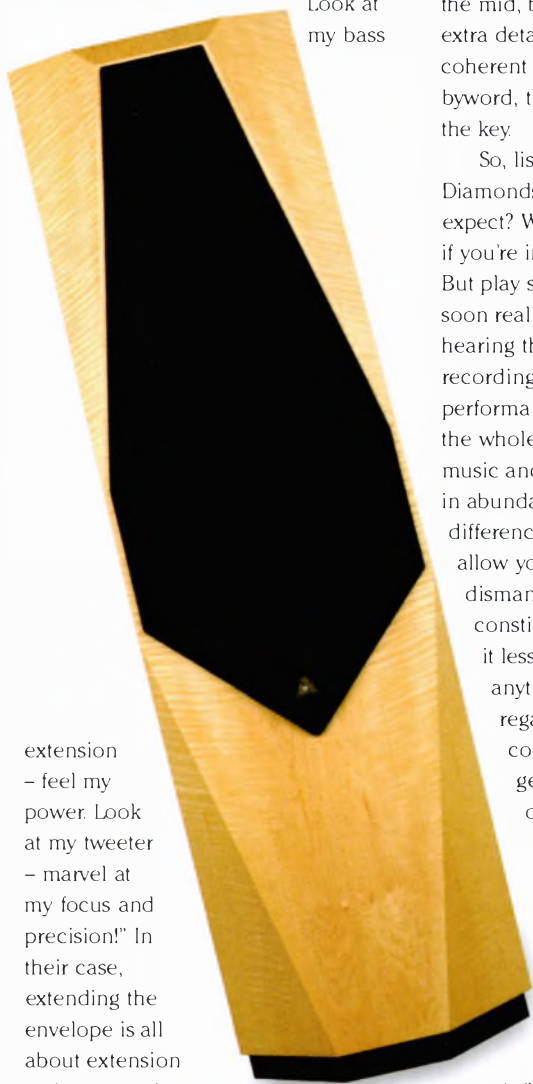

extension – feel my power. Look at my tweeter – marvel at my focus and precision!" In their case, extending the envelope is all about extension at the top and bottom, an approach that tends to rather overshadow the mid-band and undermine musical coherence. The

Diamond is a fish of an entirely different flavour. It starts from the premise that to improve the breed you must first improve the mid-range, which as we know means extending the frequency extremes. But in this instance the extension is all about continuity. Listening to the Diamond it's hard not to conclude that it uses a single full range driver. Far from being obvious or explicit, the effects of the extra bandwidth are heard not just in the superior resolving power in the mid, but in the way that all the extra detail is integrated into a single, coherent whole. If continuity is the byword, then it's coherence that's the key.

So, listen to music on the Diamonds and what should you expect? Well, first, don't be surprised if you're initially rather underwhelmed. But play something familiar and you'll soon realise that you're not actually hearing the system – not even the recording. What you're hearing is the performance. What's more, while it's the whole that counts, listen into the music and you'll find familiar detail in abundance, just more so. The difference is, as deep as the speakers allow you to look. They never, ever dismantle the recording into its constituent parts, and never make it less than it is. You can play anything on these speakers, regardless of age, quality or condition, and still expect to get every last ounce of music off the disc.

There are a number of elements at work here, but they are all built on the Diamond's astonishing ability to resolve tiny shifts in dynamic level within and between signals.

This micro-vibrational definition allows the simplest possible separation of musical instruments and strands. So precisely are the harmonic identities and

## The System and Set-Up

At a lowly 87dB efficiency, 4 ohm impedance and with a 24Hz –1.5dB low-frequency contour, the 100 or so Watts available from my usual Hovland RADIA was always going to struggle. Fortunately I had on hand the Conrad-Johnson Premier 350, reviewed elsewhere in this issue – delivering 350 Watts a side of c-j's best ever power. To this the importer added the exceptional new Conrad-Johnson ACT II line-stage to go with the Kuzma and Wadia front-ends. In a fit of even greater generosity, he also provided, for a frustratingly short period of time, his own preferred match, the Karan Acoustics KAM 1200 mono-blocks. Frustrating for the exceptional performance delivered as well as the exceptional effort involved in relocating them. After the delivery trip I was rather hoping that the return journey might prove sufficiently daunting to inhibit their early removal. I sadly misjudged the situation – and the symptoms of withdrawal. Branko duly appeared at the door on the due date, but the effort was worthwhile, the memories that remained, haunting in their presence and reality.

The Diamonds themselves are smaller, visually speaking, than their dimensions suggest, even in the pale finish of the beautifully hand cut, curly maple veneer on the review pair. At a substantial 68kg each, they're a two-man lift, but the careful faceting of the sloping front baffle minimises their domestic impact, and whilst they need space behind them they're less demanding in this respect than you might expect. I listened with them closer together than I usually place speakers, and with minimal toe-in. The bottom-mounted terminals make for especially neat cable routing, while the combination of the smooth plinth and Avalon's extremely pointed cones make fine positioning and secure floor coupling an absolute doddle.

structures of instruments reproduced that their position and contribution is never in doubt. So the peculiarly wistful quality of the trombonium/ ►

▶ flugelhorn combination that provides the brass backing to Janis Ian's 'At Seventeen' is not just instrumentally identifiable, but the purpose behind the off-beat choice makes perfect sense. The beautifully phrased and skillfully muted lines integrate seamlessly into the song,



underpinning the vocal, accentuating the feel and mood of the plaintive lament, yet at the same time enhancing the fragile beauty of the music itself. It's a telling performance.

Likewise, the shipyard soundscape that opens Jackie Leven's 'Defending Ancient Springs' is a single cohesive whole rather than a patch-work of spot-lit sounds. The fizz of the welding torch and the striking of rivets are instantly identifiable, as are the ships horns and the rolling swell and crash of the waves. But it's the remarkable inner detail of these sounds that brings them so naturally and convincingly to life. The curling tumble of the breaking wave, the metal on metal strike of hammer on rivet head, the echoing vastness of the giant shed. Yes, it's a collage, and in reality there are electronics and speakers that will dismantle and pull it apart for you, defining each and every individual element. Yet the Diamonds have an uncanny ability to weld the elements together, making sense of them as they do so. There's no shortage of musical detail – indeed, quite the opposite, and I've heard no other speaker that makes such convincing use of the detail it passes, or passes as much as the Diamonds. It's almost as if they have a sixth sense that

separates out the musical notes along with their intent.

Alongside that resolution comes vanishingly low distortion. A precursor for any speaker that has ambitions regarding musically natural presentation, the Diamond excels in this regard. The effect is to make the speaker far less critical of volume: So much so that you'll find yourself listening much quieter than normal. The Avalons will happily go as loud as you are ever likely to want and do it gracefully too, especially with the Karans doing the driving, but you simply don't feel the need. You no longer find yourself seeking that perfect balance between dynamic range and edgy distortion. Instead, the relationships within the music stay constant, pretty much regardless of level, while headroom benefits accordingly.

By now it should come as no surprise that the Diamonds are as near sonic invisibility as you're going to get. Regardless of the recording (even classic, left/right Impulse jazz records) it's impossible to locate the speakers with your eyes closed. The soundstage is as wide, deep and tall as the electronics allow, while good orchestral recordings are spectacular. The Ricci *Carmen Fantasie* on Decca SXL2197 not only made the most of the soloist's passion and energy, it wrapped him in a huge and beautifully defined soundscape, that extended way beyond the boundaries of the room. Scale and perspective were exceptionally natural, images within the soundstage stable and beautifully proportioned. With the Karan amps in particular, the sense of a tangible, enclosed volume of energized, almost electrified air, transported me effortlessly to the performance, recreating the venue and the tension and atmosphere of a live event.

Now I can't comment on the acoustic accuracy of the experience as I have no idea where it was recorded (Watford seems like a fair guess from the sonic and circumstantial evidence) and it certainly wasn't a live event. But what this experience reflects is the extent to which the Diamonds retain the frisson and creative tension within a performance. They extract the same levels of drama and compulsion from studio recordings that you

normally only achieve with the best, one-take live performances. In many respects this is the most telling difference between what the



Eidolon Diamond delivers and the competition leave out.

So far I haven't really talked ▶



▶ about treble and bass or the breadth of dynamic range. Frankly, I don't intend to, as to do so dissects and fundamentally misunderstands what this speaker is all about. I'm tempted to describe them as sufficient, but rather than the stellar praise that's intended, I suspect many a reader will interpret that as a backhanded compliment. So, a few examples should suffice. Bass, whether electronic a la Jackie Leven, acoustic in an orchestral context or upright and plucked, is perfectly defined in pitch and pace. It's transparency, texture and the way in which it can breathe and pulse, floating on an acoustic cushion rather than wobbling along the floor, means that it integrates seamlessly and exactly as it should. And just like reality, it's there when it should be rather than a constant, rumbling presence. But perhaps the best indicator of its depth and transparency is the convincing character and scale of the soundstage. You simply don't get that impression of an enclosed volume unless you have deep, deep bass: You don't get the air and tension within the acoustic unless that bass is transparent.

Likewise the treble is unobtrusive, its quality apparent in the ease with which it can separate tambourine rattles and bead cymbal work (a detail I'd never heard before on Dolly Varden's *The Dumbest Magnets*) without shouting about it or making it obvious. The Diamonds never highlight or exaggerate detail – it's simply there if you look for it, subconsciously convincing if you don't.

The widest dynamic range is



scaled with grace, even the excessive, explosive demands of the Milanov/ Bloerling *Tosca* on RCA failing to phase the effortless presentation of the speakers or disturb the stability of the soundstage. At this extreme, the

Diamonds can't match or even really approach reality – and those speakers that can pay a heavy price in other regards. Instead they are content to keep everything perfectly proportioned, preserving the illusion and thus your enjoyment. All of which tells us what the Eidolon Diamond can do, but not how it does it. I can't talk about the minutiae of design (and

Avalon are understandably reluctant to do so) but I can talk about the mechanics of reproduction. Let's use the Yepes/Argenta *Concierto De Aranjuez* (Alhambra SCLL 14000) as an example. The opening of the Second movement normally wows listeners as it unfolds a vast and beautifully captured acoustic. Well, the Diamonds do it a little differently. The space is there and so is the sense of anticipation, but what pierces you is the poise and perfection of Yepes' first notes. So many systems simply give you a series of strummed chords as a precursor to the haunting melody that we're all anticipating. That's the danger with works that are so familiar. But the Diamonds, by placing each note within the strum, precisely against the next and against the

orchestra laid out beyond, establish a sense and root to the repeated notes, making the transition to the melody both a natural step and an artistic release. The shape and spacing of the notes that follow is precisely rendered, the artistry in Yepes' playing coaxing the poignant air to dramatic life. Once again your attention is drawn to the superb playing rather than the spectacular recording.

The secret lies in the degree of resolution delivered by the Diamond. Notes expand from a black background of zero energy, their exact character and shape defined against the silent backdrop, each one complete with the complex energy patterns that create its harmonic identity and texture. That background serves as the zero axis for each



and every note, regardless of level. It's why every instrument can retain its individuality no matter how many are playing, even when it's quiet and they're ▶

► loud. So even in full cry, the orchestra never swamps or blurs Yepes' playing. Likewise, the subtle percussion work that embellishes tracks becomes exactly that, neither lost nor exaggerated. The ability to precisely define distinct energy levels, right across the soundstage, is what brings magic to the musical performance, coherence to the event. You can, and should, point a finger at the partnering electronics, but that misses the point. The Diamond is capable of resolving the information they pass, and I suspect, more of the same. In that, it's unique in my experience. The Ascendants pulled the same trick, their sound less tonally influential than their partnering electronics. The Eidolon Diamond elevates that ability to whole new levels, staying ahead of some of



the best amplification out there. As such it places a heavy burden on partnering equipment, yet

I've heard it sound startling with amps as (comparatively) prosaic as the Ayre Acoustics designs. Balance is what matters, and an even top-toe performance – just like the speakers. That way you can be sure of getting everything on offer without upsetting the apple cart.

Which brings me to a final point. The musical insight, the drama, the communication that flows so effortlessly from the Diamond makes your life so easy that listening becomes devoid of any fatigue. You can hear so much so easily, you can play at lower levels, you don't have to tolerate or filter out incipient distortion, that you can simply enjoy performance after performance. Comparing different readings of the same work takes on a new fascination as the speaker reveals the subtleties of inflexion and technique. It provides a window into the artistic soul of the music.

As I said at the start, Avalon's Eidolon Diamond breaks all the rules. Along the way it banishes the sonic bombast and macho aesthetics that have dominated high-end loudspeaker design for the last two decades. It is domestically discrete yet squeezes every last ounce of bandwidth and musical performance out of its three-way format. It's finished to a standard that has to be seen and felt to really be appreciated. It disappears musically, leaving no mark on the

performance. If you want a speaker that's both musically convincing and natural, so much

so that you can't hear it trying, then look no further: Transducer? It's a time and space machine. There might be a speaker out there that can bring more music into your home, and sit you closer to the performers, but if there is I haven't heard it. Diamonds are supposed to be forever – this could be the last speaker you ever need to buy. ►+



#### TECHNICAL SPECIFICATIONS

Type:	Three-way reflex
Drive Units –	
High-frequency:	19mm concave diamond diaphragm tweeter
Mid-range:	90mm concave ceramic midrange
Low-frequency:	280mm Nomex-Kevlar bass unit
Bandwidth:	24Hz-100kHz $\pm$ 1.5dB
Efficiency:	87dB
Impedance:	4 Ohms nominal (3.6 Ohms minimum)
Dimensions (WxHxD):	300x1088x425mm
Weight:	68kg each
Prices:	£3300

#### UK Distributor:

Audiofreaks  
Tel. (44)(0)20 8948 4153  
E-mail. info1@audiofreaks.co.uk

#### Manufacturer:

Avalon Acoustics  
Net. www.avalonacoustics.com



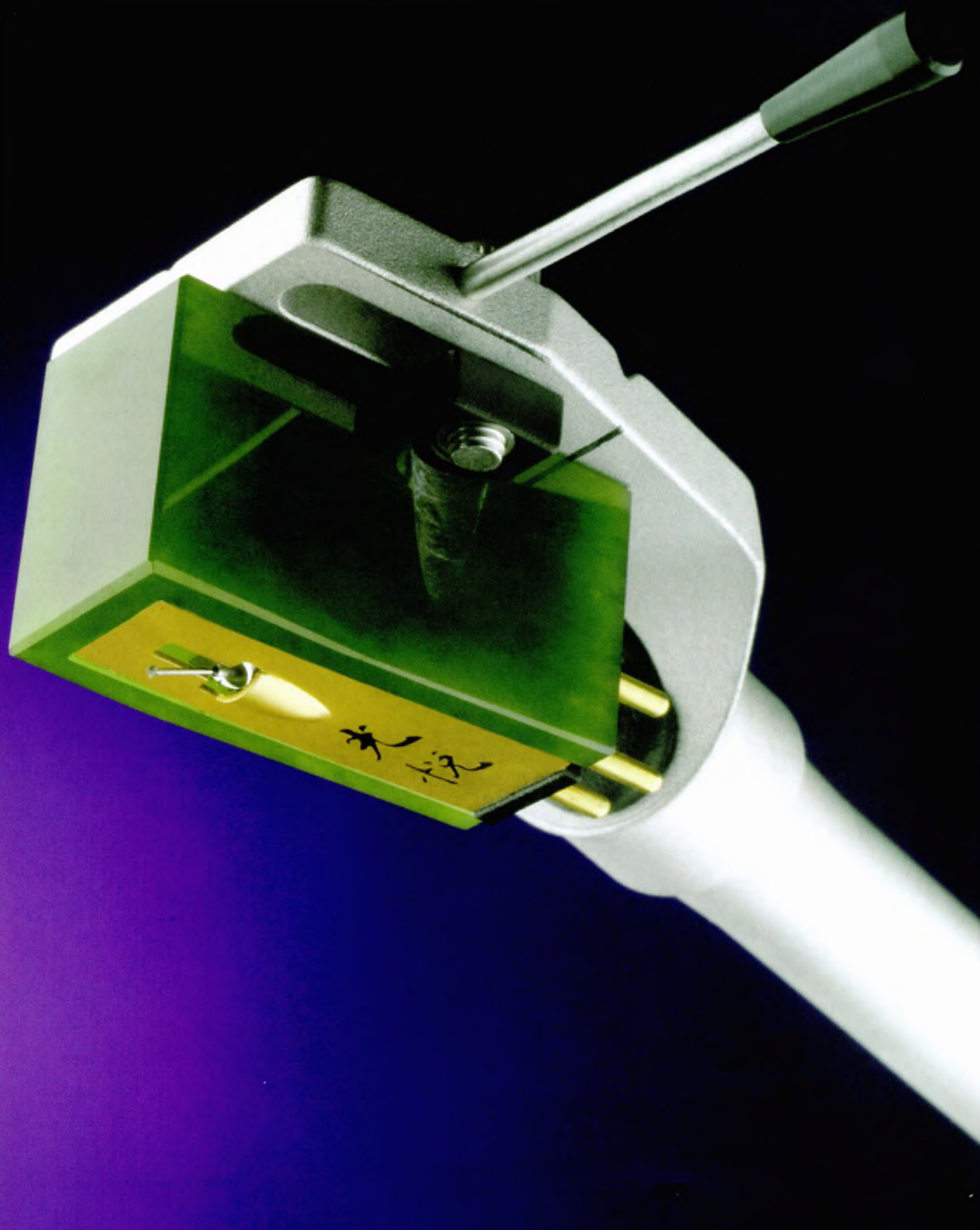

# Koetsu Jade Platinum Moving Coil Cartridge

by Roy Gregory

There are certain products that stick in the memory, products that constitute waymarks on an individual's hi-fi learning curve. For yours truly, the first of these, and one that really knocked me sideways, was the Kiseki Lapis Lazuli. Obscenely expensive, it also had an intimacy and natural sweetness that literally took my breath away. Further listening revealed a smoothness and absence of grain that banished all trace of the mechanical act of dragging a rock down a plastic trench, and it was this that removed the system from the listening experience. The communication and natural flow of the music brought performers to life, vocals and instruments a vivid construct in front of you.

To say the Lapis left a lasting impression is an understatement – as you can tell from the above. The intervening years and the many cartridges that have crossed my path since then, have failed to produce a performer to match it. Indeed, nothing has come close – until the arrival of this Koetsu, the Jade Platinum. Listening to the rapid scat of Ella singing 'Rockin' In Rhythm' there's an easy grace and flow to her vocal gymnastics that makes musical sense of the verbal nonsense. There's body and substance and physical volume to her voice and presence, and a layering of the orchestra arrayed behind her that gives each instrument a physical dimension and separates it from the one behind. And this on a mono recording. Now the concept of depth on a mono disc isn't exactly news, but I've never heard it quite so vividly or dramatically apparent. The sound of the Jade Platinum is sweet and open, powerful

and solid, yet above all, it's unforced. At no time do you hear it impose itself on musical proceedings, at no time does it shout, "hey, look at me!"

In fact, the only thing that's even slightly clumsy about the Koetsu Jade Platinum is that name, but I'll forgive it because there's actually a logic to it. The current Koetsu range can be divided into two layers. On the one hand there's the Black, Red, Red K Signature and Urushi Black, all of which use copper coils. There are also an Urushi Gold that uses silver plated coils and a Vermilion that's a hybrid of the two. The second tier consists of four cartridges (the wooden bodied Signature, called the Pro IV in the US, the Jade, Onyx and Itagawa) all of which use platinum coils, hence the distinction.

Coil material aside, there's not much to distinguish the Jade from its many predecessors. Externally at least, it's a case of plus ça change, and anybody who has ever handled a Koetsu will suffer instantaneous déjà vu as soon as they're handed the familiar wooden box. Remove the snug fitting lid and everything is exactly as you expect to find it. The Jade is exactly the same size and shape as the 80th Anniversary that dates back nearly 20 years. Apart from the green shade of the semi-precious stone used for the body, the two cartridges are visually indistinguishable. Whilst such continuity is rare in the rapidly evolving world of hi-fi, the comfort factor it bestows comes with its downsides too. In this case, these

are purely practical. Koetsu have never supplied even rudimentary spec sheets or instructions with their cartridges, they've never colour coded the pins or supplied fixing hardware. Well, the Jade Platinum is no exception in this regard, although you do get the simple and extremely effective plastic stylus guard that's graced every cartridge they've ever produced. I wish other manufacturers would take note – after all, they've only had a quarter of a century to catch on.



But one extremely welcome change becomes apparent as soon as you start to install the Jade. Koetsu have finally threaded the mounting holes. Praise be; this not only makes the whole job a lot less fiddly and nerve racking, it also makes it far safer. The problem with semi-precious bodies on cartridges is that they can crack, as many an owner has discovered in the past. And the principal cause of failure? Use an even slightly oversize nut or bolt and as you tighten it down it



▶ contacts and stresses the cartridge body and – the fat lady’s finished up and long gone. The new arrangement makes such worries a thing of the past, as well as making all adjustments possible from above the headshell, keeping nasty metallic tools well away from that vulnerable cantilever. If you think I’m laying this on a bit thick then you try making microscopic adjustments to someone else’s six-grand cartridge or, even worse, your own. Six-grand? Ahhh yes, that’s the other thing the Jade and Lapis have in common – they’re both obscenely expensive.

Value is of course, in the eye of the beholder and the ear of the listener. In an industry that routinely seems to charge ludicrous sums of money for quite prosaic products, price is no guarantee of quality or even content, and nowhere is the variation on offer more apparent than with cartridges. Flagship models vary in price from the \$3000 Lyra Titan all the way up to the

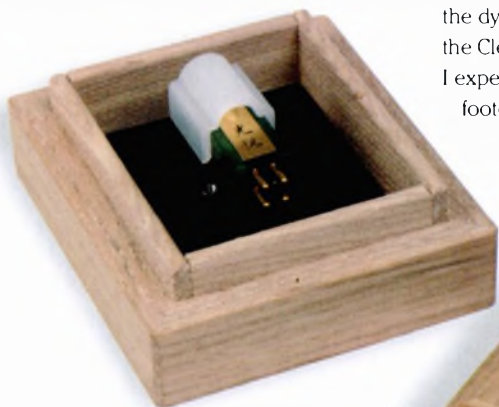

\$7500 Clearaudio

Insider Reference and beyond. I mention those particular cartridges because they’re the ones in residence and the context in which I listened to the Jade. They also serve to underline, when compared to the Koetsu, just how critical the transducers are in a system when it comes to defining its balance and strengths.

I ran the Jade in one wand of the JMW 12.5, mounted on the latest VPI TNT VI. Slated for imminent review,

the IV incorporates the double motor and flywheel assembly from the HRX, making for better sound and more manageable dimensions. I put the Titan in the other wand, allowing swift changes of cartridge with optimized VTA, while the Clearaudio Master Reference record player was also on hand for comparison. It was a fascinating experience and my initial impressions of the Koetsu were not just confirmed but reinforced. This really is an astonishing cartridge.

The sound of the Jade is immediately recognizable for its effortless presence and grace. Sonically arresting it also easy on the ear, a neat trick if you can pull it off. Playing familiar tracks like the Yepes/Argenta *Concierto De Aranjuez* underlines the focus and absolute dynamic resolution of the Lyra, the dynamic range, speed and drama of the Clearaudio. Switching to the Koetsu I expected the smooth flow and sure footed musical lines, the rich tonal balance and

solid sense of presence. What I wasn’t prepared for was the focus, precision and transparency, the dynamic control and tension that this cartridge delivers almost as an afterthought, so unobtrusively does

it slip below your guard. I’d instinctively recognized the stamp of musical greatness, but it was the direct comparisons against the competition that revealed the secrets of the Jade’s success.

Of course, just like those other cartridges the Koetsu offers its own particular strengths, traits I’ve already alluded to. It can’t match the flawless energy mapping of the Titan or the explosive fireworks of the Insider, but what’s shocking is just how close it gets. Why isn’t that more obvious when you first listen

to the Jade? Because of the utterly seamless way in which the Koetsu grafts these capabilities onto the musical core of its performance.

But I’m getting ahead of myself here. Right from the dawn of high-end history – and Koetsu were there, one of the founding fathers – the “Big K” sound has been synonymous with power and rich, vivid tonal colours. Now, whilst few people complained about the sheer presence and musical heft on offer, there were those who found the sumptuous tonal balance altogether too much of a good thing, the redolent harmonics spreading and clogging the finer detail and textures in recordings. Thus was born the legendary “armchair ride” – big, rounded, comfortable, and if you wanted to get personal, a shade overstuffed. It was a character that was itself exaggerated by the circumstances



## ▷ Set-up And Settling In...

The square body and reasonably long cantilever of the Jade Platinum makes alignment an absolute doddle, while the depth of the body requires a little extra height from the arm. Just make sure that, whilst it's fine to use the blunt nose to get things there or thereabouts, you get your eye-line underneath the cartridge and use the cantilever for final tweaking. I used the superb WallyTractor, dedicated to the JMW 12" geometry to get things spot-on, having done a quick and dirty set-up with the JMW jig. The difference was far from subtle... To compound the problem, the Jade is very sensitive to VTA easily revealing a five graduation shift on the JMW's vernier scale. Not quite as critical as the "now it's right – now it's not" Titan, the window is still pretty narrow. You'll hear it in the rhythmic integrity of the music and particularly the way percussion work integrates with the whole. As both VTA and VTF affect overhang, you'll need to go back and recheck your set-up. I tracked this sample at 1.78g with no problems at all, a setting that delivered firm bass and a lightness of touch. Again, you'll need to suck it and see. Just believe me when I say that all the fiddling and faffing will be worthwhile. Interestingly, Koetsu apparently recommend little or no anti-skating force, an approach that

mirrors the design philosophy of the JMW precisely. Whilst I can't comment on the long-term effects of this, I will note that none of the cartridges I've run in the 12.5 are showing signs of lopsided wear or off-set cantilevers, while Koetsus are justifiably renowned for their longevity. Just as well given the price of replacement! Whilst the manufacturer and distributor both favour higher loadings, I prefer the Jade loaded down. Your preference will depend on personal taste, the phono-stage you use and overall system balance. Just don't be afraid to experiment. Output is on the low-side for a Koetsu, I'd guess around 0.35mV (but that is a guess), although this doesn't seem to influence the feeling of power and substance it generates. The Jade required next to no running-in, with ten or so LP sides opening out the sound a little and releasing the really low-level information. Music breathed that much more convincingly, and again, you notice this after a side or so of warm-up after the cartridge has been standing idle. Whilst I've tended to concentrate on acoustic recordings, simply because they play to the Koetsu's strengths, its musical integrity is equally appropriate to all forms and genres. Everything from embarrassing rock albums to girl and guitar has graced the TNT's platter – all to equally enjoyable effect. I've yet to throw anything at the Jade that it and I didn't enjoy.

of the time. The American propensity for feeding the Koetsu's healthy output straight into the medium gain phono-stages then current on valve pre-amps like the Audio Research SP3, 8 or 10 generated huge soundstages as a result of the 47K loading, a situation which did nothing to help control excesses in the generator.

Fast forward to the present day and cartridges like the Red K Signature have cleaned up their act, exhibiting far greater detail and evenness across the range, whilst retaining their innate sense of musical flow and natural dynamics. It makes for a musically engaging and convincing package. You still get the sheer presence and authority, extensive soundstage and emotional charged presentation that built the Koetsu

reputation, but now it's tempered with a more balanced overall perspective. It's an easy progression to understand and one that appeals to the causal logic we like to see in events.

So how do we explain the Jade Platinum? For make no mistake, the performance of this latest offering is fundamentally more advanced than that of the Red K Sig, musically speaking, elevating proceedings to a whole new level. Its transparency and dimensionality are astonishing, both in terms of individual images and the acoustic as a whole.

The music emerges from a black silence that acts as a reference plane for spatial location and scale as well as dynamic resolution. It imparts an authority and poise to each note, so that its shape and level and duration can be precisely understood. It's this sense of control and stability that enables the Jade to bind the rich harmonics it generates so effortlessly to the spine of the musical and rhythmic fundamentals. Where the Titan sets out precisely defined steps in energy level and shape between individual notes, the Koetsu follows, equally sure footed but adding the cloth and texture of the instrument's harmonic character, the weight that carries the music's momentum. That inner energy makes changes in dynamic level and density all the more telling, and here again, whilst the Clearaudio shifts faster and is quicker through the dynamic range, it can't match the emphatic power and solidity of the Koetsu.

But the really special thing about the Jade Platinum is just how harmoniously all these different elements co-exist. The secret lies at the lowest level, built on

an amazing ability not just to retrieve the tiniest dynamic and musical details, but to keep them in balance. So, the ability to resolve shifts in the precise level of, and between, each note, coupled to the superb

reproduction of harmonic structure and texture, provide the building blocks on which the music is founded. When the Jade tracks dynamics it does so with a natural solidity and warmth in stark contrast to the pared away speed we so often find in overtly fast or detailed cartridges. When it delivers power and impact it does so without additional weight that clogs inner detail or slows response. ▶





## Past Imperfect...

At the start of this piece I waxed lyrical about the Kiseki Lapis Lazuli, rose tinted spectacles lodged firmly in place. It's a cartridge that shares so much in common with the Koetsu, physically and sonically that it's hard, indeed wrong, to ignore the parallels. Semi-precious bodies, low compliance, high mass and pre-micro-ridge stylii add up to a considerable coincidence. Then there's the astonishingly natural flow and life of the music they make, the effortless with which they reproduce the entire envelope of the performance and their lack of any mechanical intrusion. You simply listen to the players.

Yet, if I look at these two cartridges dispassionately then it's hard to ignore the Koetsu's superiority. It's more naturally balanced, undoubtedly more accurate, it suffers not the KLL's spot-lit upper mid, nor its forward and slightly weighted bass response. The Koetsu outperforms my memory of the Kiseki in every important aspect save one: the KLL offered an intimacy and immediacy that made it more initially impressive and a little livelier. Not as natural,

not as accurate but just a shade more direct. Which brings us to the obvious difference between these two cartridges. The KLL used a diamond cantilever compared to the Jade's boron. What then if I told you that Koetsu offer as a special order option, a diamond cantilever on their platinum range. It costs around 35-40% more depending on model, which is no small consideration, but consider this: The Jade Platinum is the most musically satisfying cartridge I've been lucky enough to enjoy. Happy? I'm ecstatic. But the grass is still greener and, given my history, the lure of that diamond is hard to ignore. What price the possibility of perfection? Or will the diamond cantilever be too much of a good thing, tipping the carefully established balance of the standard Jade? It's more than just a possibility, but it's one that I'll at least get to investigate. In a fit of ill-considered generosity the importer rashly promised a diamond model to review. Don't hold your breath - these things don't just happen along. And don't worry about me. I can easily console myself with the Jade while I await developments. If patience is a virtue then the Koetsu Jade Platinum might yet make a saint of me.

which this cartridge expunges record damage. Cleverly, the top-end response is mirrored at the bottom where the bass is just a shade softer and less crisply defined than the Insider's. It's a price worth paying to retain that preternaturally convincing sense of balance.

This Koetsu sounds so unforced and devoid of edge that it can at first seem unimpressive. Until that is, you compare it with other cartridges, at which point you realise just how exaggerated they sound: How violently they bend the shape and colour of reality. Music with the Koetsu just is... And what it is, is the most natural reproduction of recorded sound I've yet experienced. The low-level integrity and continuity completely banishes any sense of the mechanics of reproduction. You simply can't hear it working. Perspectives are realistic, dimensions and scale of images completely in proportion. Tonality is natural, dynamics just so. It's not just a complete package it's the real deal. But reality is a double-edged sword and just as the reality of its reproduction carries a powerful bite, so does the reality of its price. Mind you, there really are times when six-grand sounds like a bargain, and one of them is all the while you're listening to the Jade Platinum. ➤

▶ With this inner balance comes, delivered almost by default, correctness of colour, dynamic smoothness and the natural pacing and placing of notes. Over-voiced recordings sound just that, but instead of detracting from the experience the Jade reveals the reasoning behind it. Play the Starker *Bach Suites* (so brilliantly transferred by Speakers Corner) and you are definitely up close and personal with the maestro and his instrument. But instead of being over-powered you simply marvel at the harmonic complexity of the cello, the poise and precision of Starker's playing, the sheer energy and emotive swell he generates. It's a front-row seat and now you realise why those cost extra. You also realise that this is a genuinely fast and detailed transducer, meaning that it actually makes use of and integrates

that speed and information, rather than simply scattering it like fairy dust, aiming to decorate and impress. The Jade Platinum allows music to flow and breathe like a living thing, imbuing it with the humanity that holds our attention.

This ability to identify and cleave directly to the core of the music, regardless of type, is another natural consequence of the Koetsu's inner balance, but it also reflects a careful tailoring of the response. The top-end is slightly rolled, a response that robs the reproduction of the last frisson of air and tension so dramatically portrayed by the Titan. But it also robs even the most aggressive surface noise of bite and edge reducing it to a background irritant, far from the plane of the music. It's almost ghostly the way in

### TECHNICAL SPECIFICATIONS

Type:	Low-output moving-coil
Output:	0.35mV
Tracking Force:	1.8g
Cantilever:	Boron
Stylus Type:	Fine-line
Weight:	14.5g
Stylus Guard:	Yes
Price:	£5995

#### UK Distributor:

Absolute Sounds

Tel. (44)(0)20 8971 3909

Net. [www.absolutesounds.com](http://www.absolutesounds.com)

# Tube Shop COM



**TUBES! TUBES! TUBES!**

Golden Dragon

They're now considered essential as far as I'm concerned, and bring new meaning to the term "simply the best!"

Roy Gregory - Hi-Fi+ magazine issue 28.



Tube Rings  
by Duende Crattura

## NEWARRIVALS@THESHOP



Dragon Tails

Worlds 1st Audio Cables designed purely for Vacuum Tube Hi-Fi equipment  
...more details @ [www.tube-shop.com](http://www.tube-shop.com)

For all your vacuum tube needs  
[www.tube-shop.com](http://www.tube-shop.com)

or call us on  
0870 9220404



[www.tube-shop.com](http://www.tube-shop.com)

### 'S' series

S3e

S5e

S6e

S8e

S9e

SR5

CS5

CS9



**Walls without boundaries**

Don't be contained, be entertained

Prepare for deeper, wider, higher

Let the technology work, hear the music

Reset your definition of exceptional

Experience sound without limits

Enjoy the Spendor magic

**Spendor Audio Systems Ltd**

Tel +44 (0)1323 843474

Fax +44 (0)1323 442254

[info@spendoraudio.com](mailto:info@spendoraudio.com)

[www.spendoraudio.com](http://www.spendoraudio.com)







SS1  
POWER

BOSTON

SS1  
POWER

# The Bryston 7B SST mono power amplifier

by Chris Binns

## Power corrupts...

When it comes to amplification, I do not really have many prejudices. Solid state, valve, class A, OTL, bi-polar... While there are people out there who will only listen to one particular genre (and no doubt vehemently slag-off any other approach... you know the sort) I have a fairly open mind. If I did not have the burden of writing about hi-fi equipment I would undoubtedly classify gear into one of two camps; like or dislike, regardless of the technology. Professional etiquette, however demands a third category; good (or interesting... whatever) but not for me. For example, there are some amplifiers of quite modest output that I love the sound of - how about the Leak Stereo 20 - which do a lot to uphold the idea that it is easier to design a good sounding low powered amp than a big one, but in practice, my requirements are not sympathetic. A few Watts are

not enough. While I can get excited about certain aspects of higher efficiency loudspeakers, I tend to find their shortcomings less than easy to live with, particularly



in the long term, while the desire for an extended bass response preferably without a large cabinet unfortunately means that the third factor in the acoustic equation, namely efficiency, goes out the window. To make matters worse, there are occasional times when I still like to put the cats out, crack open a beer and scare myself with the appropriate music.

So, in the cold light of day the loudspeakers I would choose to listen to require a bit more than a handful of Watts.

Having established that, I rarely get excited by the prospect of mega powerful amplifiers (certainly not since I was a teenager\*) and there have been too many disappointments along the way that support the theory that the bigger it is the worse the sound. Strange then, that the Bryston 7B's should prove an exception as it is categorically the most potent amplifier I have used in a domestic system. Not that I am that surprised, as having lived with the 14B ST for a while I knew to a certain extent what to expect, and there were attributes to that amp's performance that put it in a class of its own, certainly at its asking price.

## No, it really is a domestic amplifier.

When Bryston first started making amplifiers, they were not aiming at the professional market. The products might have appeared that way, but don't forget that in America (and Canada, from whence they

\* I will probably never forget in the late seventies, working in a recording studio and demonstrating to other bemused engineers that the Naim 250 (seventy Watts per channel) sounded way louder than their beloved professional BGW rated at ten times the output.



► come) the most important thing that a piece of hi-fi had to do was look butch, preferably with handles on. It just so happened that due to their robust build and general ruggedness, a number of them found homes in professional situations, surviving admirably and, I suspect also sounding considerably better than the competition. Thus their reputation grew rapidly. This I can verify, as I bought a 4B in the late seventies –

amplifier, if not a full blown PMC monitoring system.

The 7B is effectively a mono-blocked 14B. As such, it uses virtually the same circuitry whereby each channel consists of two amplifiers running in a bridged configuration, and as the 14B is mono all the way to the mains socket, on the surface of it there would seem to be little difference between it and a pair of 7B's. Output power is specified the same, although the mono-block does have a higher thermal capacity allowing greater

Bryston and the Naim NAP 500) interesting things can happen; it allows for the possibility of greater power output with a potential reduction in noise and distortion, a factor that seems to be regaining credibility these days. (For the record, the quoted figure on the 7B is 0.0001% THD.)

A little smaller than the 14B and thus somewhat easier to manoeuvre, the 7B is still pretty substantial; it is available with 19" rack mounting and handles or a neater more domesticated front panel in either black or silver. While no great beauty to look at, it is functionally elegant; the front panel having



(which incidentally, I still have; and while it has never been serviced still does a stalwart job when it comes to parties, band practices and the like) which sounded way better than most of the muscle amplifiers of the period. In this country, their distribution by PMC loudspeakers seems to have been a symbiotic and highly successful relationship in both the domestic and professional markets, a feat which very few companies can claim to have pulled off. Most recording studios that I have been in have had at least one Bryston

headroom when driving hard into difficult loads, and there is the option of placing the unit close to the loudspeaker with minimal speaker cable and running long signal interconnects. Bridged configuration has had its fair share of criticism recently, and I have never been entirely convinced when it is offered as an option for 'mono-ing' a stereo chassis for more power. But when it is employed from the ground up as a circuit concept (such as the

a small membrane switch for power up and a status LED, this is red during start up while the amplifier is muted, green for normal operation, orange indicates thermal shutdown and flashing red informs you of clipping. Rear panel connections are pretty much what you would expect with balanced input via a combination XLR / 1/4" ►

▶ jack, switchable to single ended RCA's, both these inputs can be set for nominal one, or two volt input sensitivity. A single set of practical binding posts are provided for loudspeaker output, crucially coloured blue and red; being a bridged design, it is important to remember that neither side of the loudspeaker is earthed. Mains input is via a standard IEC connection, and there is a remote

neat, with minimal wiring, and Bryston make a point of the fact that the boards are hand soldered to avoid exposing them to the thermal shock that a flow soldering machine would inflict. This, they feel would compromise reliability. That is important if you are going to offer a twenty-year guarantee.

during which time (under quiescent conditions) the heat sinks become slightly warm to the touch. While they are not class A amplifiers, each unit will draw 215 Watts from the wall at idle, and running at full power this elevates to nearly 2 kilowatts (!), so I was glad to have recently replaced wall sockets and wiring in my listening room. But all this talk of extreme levels of power is creating the wrong impression. The 7Bs do not immediately impress. Or at least,



not in the way that you might expect; there is no sense of a big muscle bound amplifier straining at the leash or waiting to erupt and bombast you with vast slabs of noise. To put it another way, it is not afflicted with the sort of clumsy 'heaviness' that seems to come with the territory of so many powerful amplifiers. It sounds light, open and airy...and

dark. Before you condemn me for spouting complete bulls\*\*\*t, let me explain. The sound of the Bryston is not bogged down by a thick glutinous quality; it is remarkably fast and tactile, aided and abetted by a lack of smearing or coloration of any sort, hence light of touch. It is possible to be mildly disappointed by the fact that on first acquaintance there is nothing in the sound quality that hints at the tremendous reserves of power available, in fact, the 7B sounds a little lightweight in the bass...And then it hits you. The effect is like adding another octave of bass extension to your loudspeakers. ▶

power up option, requiring the application of 4 – 12 volts. The power switch is actually a breaker that will trip in the case of severe overload (although quite what constitutes that, I don't know) and it should be noted that the amplifier is not powered up in any way until the front panel control is activated. Internally, construction is supremely

Sixteen hand selected bi-polar complementary output transistors are fed from discreet circuitry (the company does not favour IC's) and a massive power supply, which from memory has slightly more reservoir capacitance than the 14B.

### Uh oh, there goes the neighbourhood...

The 7B sounds pretty lousy until it has had 20 minutes or so to warm up;



**ST and SST**

Complicated? The emergence of the ST versions of Bryston's long established models was more than just the addition of a couple of letters after the model number. Extensive research that was initiated with the multi-channel 9B to reduce noise and distortion due to the close proximity of the mains transformers found its way into other models, starting with the 14B. With the addition of new, higher spec output transistors this effectively became a new design, ST being the initials of Stuart Taylor, the man responsible for the work. The 7B ST however, continued to use the original metal can output transistors, until the introduction of an SST version updated these to bring it into line with the 14B ST. Across the board, power supplies have been slightly beefed up with a marginal increase in rail voltage (hence the 14B SST now falls into line) but (and I quote from the designer) with an amplifier of this power output the differences are marginal.

▶ while the ability to pitch extremely low notes is awesome. The Bryston does not waste time with the exaggeration of 'mid-bass' waffle, but when there is something genuinely there, it is reproduced with breathtaking results.

And the darkness?

**It's not so much what you play as what you don't play...**

I remember this as advice given to me by one of the elder statesmen of the art in my early days of doing session guitar work; it is often more productive to be economical. In common with amps like the Naim NAP 300, there is a finely etched quality, a cleanliness to sounds that serves to highlight the space in between them, which together with the ability to stop and start with no overhang results in a 'black canvas' from which music emerges, effectively giving a higher contrast and more impact to music. But where the power

reserves really come into their own is with the way in which the amplifier exerts its influence over the loudspeakers. Rather like the teacher you had at school that never had to raise his voice to instil discipline, but had the whole class totally and utterly under control through respect, the 7B's are about grip and control. Kick drum had quite incredible impact, while it was possible to play certain highly dynamic recordings at higher than normal levels, as the bass cone was on such a tight leash that the danger of mechanical overload was actually diminished. Talking of such things, I never had the opportunity to try the Bryston's with something like the Revel Salons, which I think would have sounded sublime, or the JMLabs Nova Utopia, where the general level of tightness at the bottom end would have tidied up a slightly unruly performance in my room. During the time that I lived with the 7B's, I cannot deny that there were occasions on which I explored the excitement of playing suitable music at pretty high levels, and there was always the temptation to show off to friends, but more often than not it was playing music quietly that was most rewarding. Possibly the Bryston lacked some of the romance of a good valve amplifier, and one acquaintance argued that it lacked a certain ability to involve you with the music quite as effectively, but I was always drawn back by the cleanliness and lack of smearing that gave everything great articulation and speed, with real detail to string instruments and voices. It seems mildly crazy to describe the 7B as delicate, but that is often how it came across... an iron fist, but with a velvet glove on.

There are differences between the 7 and the 14B. The 7 has an ever so slightly tighter bass response, which in itself might go unnoticed under a lot of conditions, were it not for the fact that it slightly alters your perception of what is going on elsewhere. I suspect

the differences are subtle enough to make a decision between the two system led, i.e. you will opt for mono blocks over a stereo chassis for practical rather than sonic reasons, the ability to site the amps near the loudspeakers, for example. But, it is just possible that the 14 gives the impression of having a little more flow with music, seeming a little bit warmer in the midrange; as I have said, a result I suspect that has more to do with a different perception generated by the slight difference in bass performance rather than anything else.

The 7B SST is a terrifically good amplifier. Its generous power abilities allow almost universal application, but forget about that, it is far more to do with the fact that you really wouldn't know that it was a big amp. It suffers none of the flaws that often afflict the breed, and if it lacks some of the organic warmth of a low powered valve amp, it makes up for it by having a sense of purpose and authority that is rarely achieved elsewhere.

Just think of it as a little amp with unlimited headroom... 

**TECHNICAL SPECIFICATIONS**

Type:	Solid-state bi-polar mono-block power amp
Power output:	600 Watts / 8 Ohms 900 Watts / 4 Ohms
Input sensitivity:	1 or 2 Volt switchable
Input impedance:	50 K Ohms single ended 20 K Ohms balanced
Distortion:	<0.005% at rated output
Damping factor:	Over 300 at 20 Hz
Dimensions (WxHxD):	483 x 133 x 320
Weight:	22 Kg ea.
Finishes:	Black or silver, with or without handles
Price:	£3000 ea.

**UK Distributor:**  
Professional Monitor Company Ltd  
Tel. (44)(0)870 444 1044  
Net. www.bryston.ca

# audioSalon

## The Return of the King

Having defined the high-end 30 years ago Mark Levinson continues to push the envelope today. Now relocated in its excellent new factory techniques from the reference products are now available from entry level products. UK prices take advantage of the present exchange rates. There has never been a better time to make the ultimate move. We will be pleased to arrange an appointment to inspect and audition these distinguished products. Hi-Fi is a jungle, but there is one that is the king.



390s



320s



431/432

tel 0141 333 9700 | info@audiosalon.co.uk | www.audiosalon.co.uk  
 audio salon ltd, the townhouse, 4 park circus, glasgow, g3 6ax, scotland

# www.audiophileusa.com - The Supreme Source For Your Musical Inspiration!



Worlds Finest Quality Used & Sealed LPs - Tel: 916-990-9321





6 CHANNEL CONTROL VALVE AMPLIFIER CVA 306

COPLAND

CD

TAPE

POWER

TAPE

SUB

L BACK

L FRONT

CENT

R FRONT

R BACK

POWER

AUDIO LEVEL

COPLAND  
6 CHANNEL POWER AMPLIFIER CVA 535

AMPLIFIER  
COPLAND  
6 CHANNEL POWER AMPLIFIER CVA 535

# Copland CVA306 Six-Channel Pre-amp and CVA535 Five-Channel Power Amp

by Alan Sircom

The problem with home cinema is the home cinema system! From a musical standing, there's nothing worse than a home cinema processor introducing high-frequency nasties from the digital processing and video switching into the amplifiers. If only there was a way of getting the benefits of multi-channel sound without all that multi-channel nonsense in the way. Fortunately, there is...

Scandinavian electronics specialist Copland is one of the few companies that has approached the concept of multi-channel entirely correctly from the audio viewpoint. Its £1,400 CVA306 pre-amplifier and £2,000 CVA535 five channel power amplifier are entirely directed at making a fundamentally musical sound from five channel systems. Why? Because there is no in-built digital processor, no video switching and nothing to get in the way of the sound quality; instead, the nearest you get to sound processing are half a dozen ECC83 valves.

The logic is unassailable. Most DVD-Audio or SACD players have built-in digital decoding, which can also handle Dolby Digital and DTS surround sound from DVD-Video. If this is built into the player as standard, why replicate the processing in the amplifier stage? Of course, there are also some high-end DVD-Video players which do not include a multi-channel processor and these become untenable as surround sound players for the CVA306.

Doing without processing in the pre-amplifier does mean installation is slightly different from the multi-channel norm. Instead of establishing the speakers by means of test tones and digital delay-lines, all you have are a series of front panel level potenti-

ometers. These adjust the volume level of each channel separately, effectively acting as a sort of six-channel balance control. Carefully negotiated, this works surprisingly well, although two issues immediately spring to mind. First, it suggests the speaker distance should be constant, with the listener sitting in the centre of a proscribed circle of speakers, each one the same distance (the radius of that circle) from the listener. This means the volume levels fine-tune the sensitivity problems that may occur when using six not-exactly-identical speakers in the system. Secondly, and perhaps just as significantly, the six front-mounted pots make an irresistible target for addicted knob-twiddlers, especially for children. If you've spent hours getting the balance exactly correct, make a note of the settings... you can guarantee they will be changed.

Aside from the row of pots, the CVA306 is an exercise in simplicity, especially compared to other six-channel devices. Just a source selector, a tape monitor button, a power button and a master volume control complete the control count, while the display is just a series of illuminated source lights. The back panel also shows just how basic (in all the right ways) the CVA306 is; as well as the six-channel input phono block, there are stereo phono inputs for five audio sources, one tape output, a pair of high-quality phonos for stereo only output and six phono outputs for connection to the CVA535. Aside from a pair of 12V remote trigger mini-jacks, that's it. The stereo audio outputs could be used to deliver stereo sound to a second system, but remember there is no processing going on at all in this pre-amplifier; if your multi-channel player is

not configured to output in stereo, all you will hear through the stereo output is the left and right channel components of a six-channel mix. Similarly, playing a two-channel source through the six channel outputs will not turn it into multi-channel sound; the centre, rear-left, rear-right and sub-woofer will all simply not have any signal to cope with.



Many associate the Copland name with valves but forget the company makes

hybrid products too, so don't expect valves in both products. Copland considers valves to be a useful addition to the sound quality in key areas in the pre-amp stage, but for power amplification the company is FET-friendly. Of course, people also associate valves with weight, thanks to dirty great power and output transformers needed to use EL34s properly. In this case, though, the CVA306 (which uses an ECC83 in each channel) is considerably lighter than the modular and massive solid-state CVA535.

Sadly, specifications in home cinema have become specious, with almost every manufacturer squeezing their el-cheapo receivers to deliver '100Watts' in some form or another. Often, this only occurs by pushing a single channel at 1kHz and accepting some 10% distortion. But, it means those who deliver honest, real world statistics ▶



▶ are left looking rather insubstantial by comparison. So, in that spirit, the realistic 5x 125W per channel delivery of the CVA535, when expressed in home cinema style, delivers something in the region of 125kW (PMPO) with the wind in its sails.

The power amplifier is even more simple than the pre-amplifier. Aside from the on switch,

there are LEDs to denote which channels are in operation, or alternatively a single standby LED. Then, there are three different warning LEDs; the one marked 'TE' is the temperature indicator which kicks in when the amp overheats; the one marked 'DC' kicks off when more catastrophic failures in the DC circuit occur. These are often accompanied by the 'pro' light, which means the protection circuit has switched in. At least, we assume these LEDs deploy; despite being used during the hottest days of the year which generated an amplifier you could cook lunch on, the CVA535 stayed within its working envelope at all times.

Often, hi-fi amp makers build a modular power amp circuit that can be used in blocks for different amplifier configurations. Many make a feature of it, implying the amplifier is like a computer, slotting power amp cards into a modular motherboard like a computer geek might plug in a new SCSI card. But, an amplifier is not a computer and Copland are well aware of the difference. The CVA535 is not a modular design; everything is built on a single circuit board like a traditional amplifier and the product reflects that

in its sound quality.

Unlike the pre-amp, the CVA535 can be connected in balanced or single-ended mode, with little toggle switches to move between phono and XLR operation. You can even auto-engage the power amplifier by running a trigger signal from pre to power using the mini-jack socket.

It's probable that the Copland

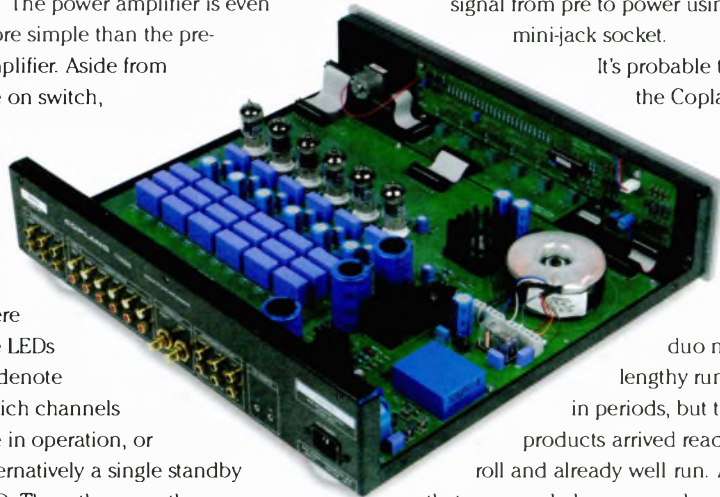

duo need lengthy running in periods, but these products arrived ready to roll and already well run. All

that was needed was a weekend of settle-down time and everything was at its best. Copland does not mention running-in times in the manual, but from experience, I would suggest they will improve considerably over a month or so of playing from new. There is something intrinsically right about the performance of the Copland, both in two and five-channel mode. The absence of processing makes for a sound that is more like good stereo of old, which means directness and charm that are almost unattainable in anything with a processor.

Paradoxically, this is most obvious with two-channel material. Stereo CD replay on most processors sounds like an afterthought; perhaps the reason why people add Dolby Pro-Logic II or DTS Neo:6 decoding to stereo sources is because they feel they need to help the

stereo sound along. No such impetus is apparent here. Instead, you want to listen to stereo in stereo and appreciate the lack of gunk between the disc player and the loudspeakers. This creates a good sense of stereo sound-staging, even with the extra speakers in the room, and manages to sound surprisingly like a Copland CSA29 when used in this mode. Ideally, it would be better to have some form of ability to switch out the power amplifiers not in use when playing stereo, but at least they're whisper quiet.

The smoothness of the valves coupled with the clout of the power amplifiers and the overall detail of the Copland system all combine beautifully in multi-channel, too. The overall presentation is large, enhancing speaker size and blending speaker to speaker perfectly, or at least as well as the steering algorithms in the player itself. It's a dynamic sound, although perhaps not dynamic enough for the home-cinema die-hards, who seem



intent on making even the most quiet passage sound like John Woo directing a shoot-out in a cannon factory. But for more level heads, this has the energy in reserve to cope with the scale of an orchestra in multi-channel without closing down the image in the process. That alone sets the Copland duo apart from the vast majority of multi-channel amplification. ▶

► It's perhaps not the most neutral presentation, but the sound quality introduced is benign and euphonic. Those valves in the pre-amplifier do add a sheen to the sound, which is rich and satisfying but will not satisfy the "warts 'n' all" school of listening. This may also make the sound too rich and satisfying for those who have spent the last few years listening to home-cinema amplification scream out hi-fi sounds. If you have reprofiled your hearing with steely-bright and brash home-cinema sounds, this refined delicate sound may seem a bit laid back.

Where home-cinema types will be impressed is the vocal clarity and articulation this duo present. Voices stand proud of the centre speaker, full-bodied, visceral and completely correctly sized. Anything that can decode Johnny Depp's slurred mockney accent in *Pirates of the Caribbean* deserves praise.

But it's DVD-Audio and SACD replay that really justify the Copland's existence. The lack of digital processing in the pre-amplifier, coupled with the harmonic enhancement of the tubes and the sheer heft of the power amplifiers is the perfect vehicle for showing off what multi-channel music can do. The sense of seamlessness from speaker to speaker is more profound than conventional multi-channel systems and the palpable solidity to the images produced in every channel makes you realise the format can affect the listener in a more profound way than we usually give it credit for. Suddenly, multi-channel does to stereo what stereo did to mono; it manages to liberate the sound from one end of the room, seemingly without losing anything in the process.

The system favours neither SACD nor DVD-Audio, although its warm and rounded tones might suggest a bias against SACD. Instead, it presents both equally well with excellent detail retrieval and a satisfying presentation

that just makes the five channels blend comfortably with two in the same system. In particular, the atmospheric sounds of *Dark Side of the Moon* are delivered with such natural insight that you think the recording has always been performed in multi-channel and the stereo replay was simply an oversight.

Multi-channel music rarely sounds this



comfortable; it usually sounds like a bolted-on afterthought compared to stereo. This is the exception to that rule.

There is only one stumbling block, but it might be a real problem depending on your viewpoint. In a world where DVD-Audio and SACD extend the frequency range covering everything from DC to light (well, almost), this Copland duo is firmly ensconced in the traditional 20Hz-20kHz range. Like most high-end products, the Copland products are over-engineered and will exceed their cited frequency range, but they are not the sort of products that can parse 100kHz signals from SACD players. There are those who argue that we don't really need this extension, as few speakers have much information above 30kHz and if you are male, over 30 and have ever been to a gig, your ears cannot hear much above 15kHz anyway. Nevertheless, recent experience with supertweeters suggests otherwise, and those who insist on choosing wide-bandwidth amplification for their wide-bandwidth digital sources will pass up the Copland duo on principle.

This is a shame, for they are missing

a trick. The Coplands may not have the numbers required to allow bats to listen to Mahler, but performs wonderfully within the sort of parameters we humans can process. It might be tempting to hook up just the power amp to your existing processor, and whilst the results might be good enough, you'd be hearing a lot less than half the potential. It's the unforced, unprocessed and dynamic sound of the duo that makes you realise just how excitingly natural surround sound can be. If you have a disc player that processes the sound in camera, hook the CVA306 to the 5.1 channel outputs and match that with the CVA535. You won't be sorry! ➤

#### TECHNICAL SPECIFICATIONS

##### CVA 306

Type:	6-channel valve pre-amp
Tube Complement:	6x 12AX7/ECC83
Output Voltage:	Rated 2V; max 40V
Input Sensitivity:	Less than 300mV (output 1V)
Input Impedance:	25 K Ohms
Output impedance:	Less than 600 ohms
S/N Ratio:	More than 95 dB
Dimensions (WxHxD):	430 x 110 x 390mm.
Weight:	8 kg
Price:	£1499

##### CVA 535

Type:	6-channel solid-state power amp
Rated Output:	125 W / channel at 8 ohms
Frequency Response:	20-20 kHz $\pm$ 0.2dB
Input Sensitivity:	1.4V for rated power
Input impedance:	100 kOhms (single ended inputs) 12 kOhms (balanced inputs)
S/N Ratio:	More than 103 dB
Dimensions (WxHxD):	430 x 168 x 420mm.
Weight:	30 kg
Price:	£2249

##### UK Distributor:

Absolute Sounds  
Tel. (44)(0)20 8971 3909  
Net. [www.absolutesounds.com](http://www.absolutesounds.com)

##### Manufacturer:

Copland  
Net. [www.copland.dk](http://www.copland.dk)



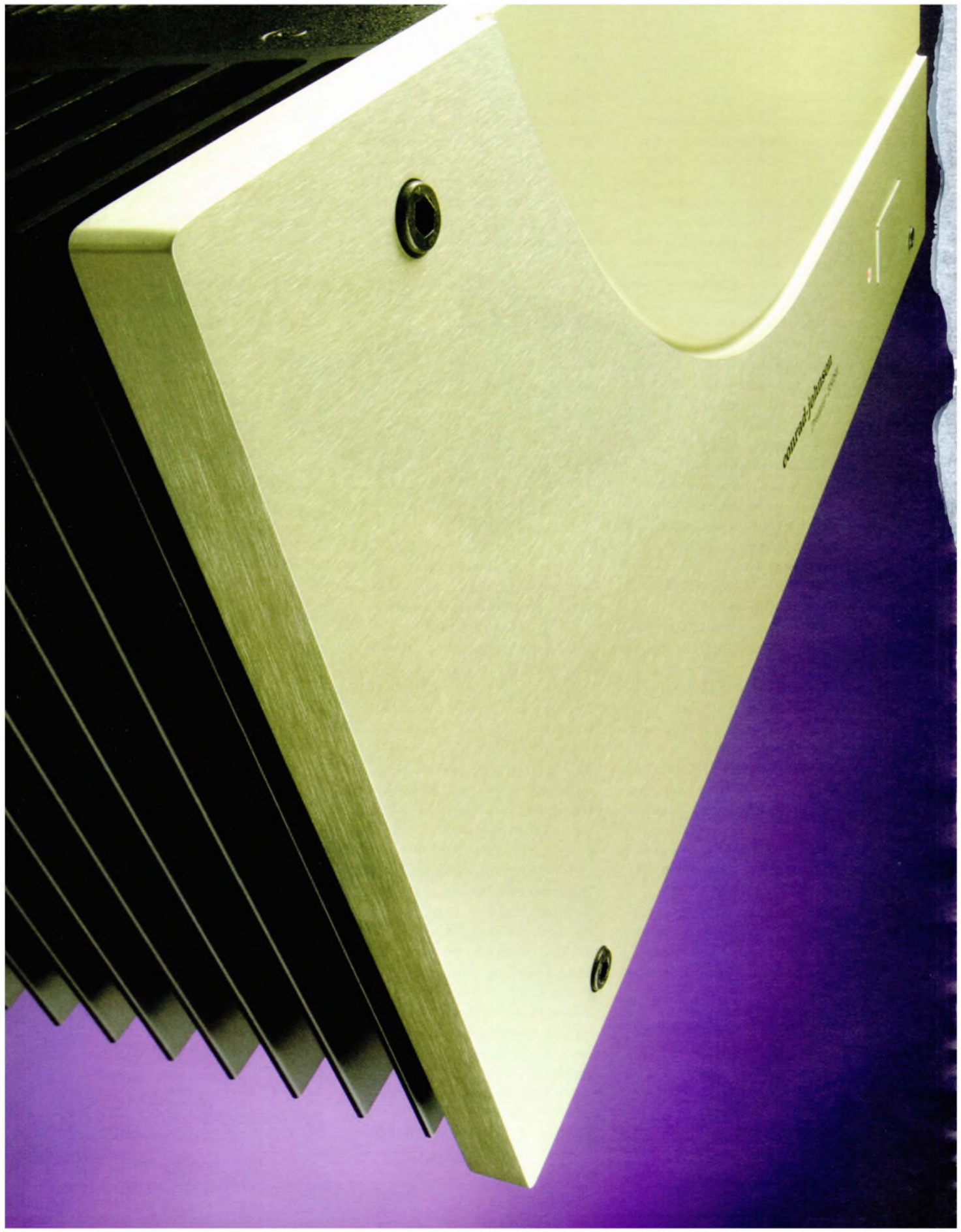

*country-jobs.com*  
www.country-jobs.com

# conrad-johnson Premier 350 Solid-State Power Amplifier

by Roy Gregory

Every so often a company (if it's lucky or particularly inspired) will hit a purple patch. Well, currently conrad-johnson are basking in a prolonged lavender glow. First came the MV60SE, followed by the awesome Premier 140, both exceptionally accomplished and refined products at their respective price levels, combining tonal and textural finesse with a real sense of power. Of course, these valve amps are exactly what c-j are best known and most respected for, the latest in a long line of front-rank thermionic pre- and power amps. Which is why the mischievous glint in Bill Conrad's eye was so intriguing when he first introduced me to the Premier 350. "The best amp we ever made" he stated, in that measured, understated way of his – the kind of manner that you ignore at your peril. And you know what? He's right. But the real surprise is that the 350 is a solid-state design.

Outwardly there's nothing terribly exciting about the Premier 350. It's a large, bluff block of an amplifier, whose proportions give it a compact, solid appearance that belies its considerable weight. 85 lbs is awfully heavy for a solid-state amp, even one this powerful. Yes, I've had heavier units at home, but they've tended to be either pseudo-Class A or the kind of products that come wrapped in ostentatiously styled casework, probably machined from a single billet of grain orientated and hand selected aerospace alloy. I'm sure you're familiar with the kind of thing to which I'm referring...

In stark contrast, the plain exterior of the c-j could not have been more straightforward. To say that form follows

function misses the point, especially when compared to the competition. The simple, heavy gauge casework is devoid of embellishment. Even the heat-sinking is confined to the left-hand side of the chassis where most manufacturers would double it up for aesthetic reasons if nothing else. Besides, physical separation of dual-mono circuitry is at least visually congruent and a picture's worth a thousand words. c-j have ignored even this most basic of marketing imperatives. Indeed, the lopsided appearance is echoed in the actual balance of the amplifier, the massive, offset mains transformer making it an even more obstreperous beast to manhandle. Heat-sinks and a single row of cooling slots in the top-plate aside, there's nothing else to look at. Even the rear-panel is a model of practicality and almost Trappist minimalism. You get a 20Amp mains input, RCA/phono signal socketry and single pairs of basic, gold-plated binding posts for each channel. That, and a deeply unfashionable row of rail fuses is your lot. The front-panel is similarly Spartan, with nothing but an on/off switch and a power LED. The single, curved groove and the textured relief area it encloses are the sole concessions to styling, the sweep of the arc echoing the offset heat-sink.

So, no balanced inputs, bi-wiring options, fancy terminals boasting more gold than a rap star. No handles, intricate CNC work, meters or intelligent status displays. If any product ever embodied the ethos of "Less is more" then this is The One.

And that logic carries over to the bits that actually matter: the insides.

Despite being c-j's latest power-amp, the actual circuit on which the 350 is based is the very first solid-state layout that Bill Conrad devised. It just took him a while to get it to work! Boy, was the perseverance worthwhile. Twenty or so years on, what we find is an amplifier that on the inside, just like the outside, is easier to define in terms of what it lacks. For a start, you get an FET voltage gain-stage, a bi-polar output-stage and that's your lot: that's two stages where most solid-state designs would boast four or five. The only other transistor amps that I'm aware of with this direct a circuit topology are the late, lamented Pass Labs Aleph single-ended designs, making this a rare beast indeed. Another thing missing is global feedback, along with local feedback within the driver stage. Add that to a rated output of 350 Watts per channel and this c-j is unusual to say the least.

c-j chose FETs for the voltage gain-stage on the basis of their extremely low odd-order harmonic distortion, further protecting their audio performance with dedicated, fully regulated power supplies. However, for the output stage, the lower output impedance characteristics of bi-polar designs offer greater control over real-world loudspeaker loads, delivering greater dynamic control, transparency and harmonic texture, especially at low frequencies. Component quality is, as you'd expect, exemplary, with a mix of critically selected polypropylene, polystyrene and, above all the recently introduced proprietary



► Teflon (PTFE) capacitors, laser trimmed metal-foil resistors and specially selected internal wiring.

I can't argue with any of this, especially given the amplifier's performance. However, c-j's almost dogged resistance when it comes to the visible trappings of audiophilia is beginning to compromise utility. I'd like to see slightly nicer input socketry, but I'll take what I'm given on the basis that we all know that good looks and good sound don't necessarily travel hand in hand. But those binding posts need to go. Fine, only fit one set, but at least provide a transverse

4mm entry for those people who need to attach more than one set of cables for bi- or tri-wiring. The choice here is between compromise within the connector and compromising the connection itself. There are better alternatives out there and this amp truly deserves them. That minor, personal gripe aside, the 350 is c-j's normal model of common-sense and practicality. The only thing you need to watch out for is that like their other designs it phase inverts. No problem if you're using a c-j pre-amp but reverse the speaker connections if you're not. Simply hook it up, switch it on and you're away.

I used the 350 with the Hovland HP100 and Tom Evans pre-amps, and chose to drive Living Voice OBX-R2, Perigee and Audioplan Kontrast IIII loudspeakers. I also wheeled in the ProAc Tablette Reference Eight Signatures, with frankly astonishing results. Cabling was Nordost Valhalla

with Wadia 861SE and Kuzma Stabi Reference, Triplanar, Lyra Titan front-ends. Like any good amplifier, the c-j will benefit from a decent support and I placed it on the bottom shelf of one of my Pagode HD Master Reference racks.

With all the boring bits out of the way we can finally get to the fun – and, boy, was this amp fun. Hovland's RADIA arrived in my system like a breath of fresh air, managing to combine the musical benefits of a small amp with the headroom

perspex, its beautifully deliberate styling a statement in itself as well as a stark contrast to the 350's prosaic exterior. But sonically they could be brother and sister. The c-j is better at being a big amp, not quite so good at being a small one, but you'd only pick up on that in a direct comparison between the two. In use it is astonishingly free of the drag and slurring, the earthbound quality, that betrays the lurking potential in so many large amps. And make no mistake – this is a genuinely

powerful beast, capable of delivering awesome levels from each and every speaker I used it with, even the demanding Avalon Eidolon Diamonds. With the more modest demands of the Perigees and Audioplans, headroom was effectively limitless, for the first time

exposing the limitations of the RADIA in this regard. With the little ProAcs, the sheer scale and weight of the delivery belied the size and bandwidth limitations of the speaker, yet hook-up the OBX-R2s and the 350 is agile and fleet of foot enough to match the efficient speakers' rhythmic dexterity and textural subtlety. So often, these virtues are mutually exclusive that to find them coexisting in such seamless harmony is both unusual and exciting. The kind of performance in fact that sends you scabbling back through your record collection, looking for old abandoned gems to disinter. The sort of performance that has you hauling this ungainly lump round to friend's houses, despite the physical effort that entails!

But, and if that wasn't enough, the c-j adds its own, specific quality ►



and lack of strain that comes from a big amp: the precision, detail and resolution of a solid-state design with the tonal and dynamic evenness and energy of a valve amp. As such it escaped the fingerprint of either technology and set new standards for musical honesty and the invisibility of its contribution. It provides stern competition for visiting amplification, so imagine my surprise when the sound of the Premier 350 proved to be a lot more similar to the RADIA than it was different.

Now, part of that surprise lies in the fact that the two amps, placed side by side, simply look so different. The RADIA is all cool silver and frosted

▶ to the mix, over and above the performance of the RADIA. It's partly grounded in the company's traditional virtues of tonal warmth and harmonic accuracy, partly in the copious power on tap and the speed with which it's delivered, but what the 350 brings to musical performances is a sense of absolute stability and graceful authority. If you want to hear it at work, look no further than a piano piece. Playing the recent Speakers Corner 180g re-issue of the legendary Byron Janis Rachmaninoff *Piano Concerto No. 3* (Mercury SR90283, Dorati and the LSO) the notes

are crystalline and definite without ever becoming brittle, his variations of pace and key pressure effortlessly captured and encompassed, yet without dynamic constriction.

Just as you think his playing can't get any louder, that the system can't cope, it steps up to a new level and intensity. And even when the score is heavily biased to the right-hand there is no lack of authority or stability underpinning the playing: The piano is never swamped by the orchestra, its power and primacy never called into question. Instead the careful balance of power and delicacy that elevates this performance is beautifully captured, the sheer range of the solo instrument, the brooding potential of the orchestra.

This authority, stability and headroom delivers a spectacular soundstage, whether from studio artifice or natural acoustic space. The shipyard soundscape that opens Jackie Leven's 'Defending Ancient Springs' is delivered with an astonishing sense of

space and depth, yet with presence, focus and detail to the individual sounds. His voice is uncannily natural, the stability and dimensionality of the image adding significantly to the illusion (and enjoyment). Stereo spectaculars, like the Gregorio Paniagua recordings on Harmonia Mundi (not just *La Folia* but the others, too) are even better. Their spatial qualities are exploited to the full, yet the 350's tonal accuracy, harmonic weight and coherence binds the



(occasionally bizarre) elements into a single convincing whole, elevating the performance still further.

It's this ability to cut to the core of a recording, fastening on its strengths and buttressing them that makes the 350 so musically satisfying. You want dimensionality, you got it – but you get tonal and textural support at the same time to reinforce the effect. You want power and dynamic impact – you've got that too. But alongside it you get micro-dynamic subtlety and rhythmic agility to enliven and bind the quieter passages into the whole. Play Felix Slatkin's *Young Person's Guide...* recently (and beautifully) repressed

by Cisco and whilst the performance doesn't match the poise of Britten or the recording the spatial precision and transparency of Decca, the 350 brings the presence and gusto, the wonderfully warm energy of the American orchestra to the fore. There's no mistaking the combination of mischief and the heady joy of making a really loud noise that suffuses this reading. Cerebral? Maybe not – but then this is *The Young Person's Guide...* Slatkin doesn't miss the point and nor, just as importantly, does the c-j.

Don't go getting the idea that this is a broad-brush performer.

Its micro-dynamic

definition and the accuracy with which it renders harmonic structures keeps even the quietest contributions to the whole quite distinct

and identifiable,

even under the most vociferous support. Once

again, this detail and insight supports and enhances both the ease with which you hear what's going on and the recording's ability to convince and transport your attention. Back to the Jackie Leven and the synth bass that opens the album sounds like two interwoven tones on the RADIA. There are four or even five on the c-j. That might not seem important, but the added texture and physical volume that imparts breathes life into the music, critical to this most human of performers. It's a small thing and just one example, but multiply it many, many times across the many recordings you own and suddenly, the effect on your listening experience, the return you get from your system is dramatically transformed. The 350 ▶



makes most amps sound flat and two-dimensional (spatially and tonally). As such it advances the musical reality and communication of almost any system, which is after all, exactly what it's supposed to do.

The notion of an amp that combines the best qualities of valves and solid-state is more a cliché than an audio grail. The 350 transcends that false goal, delivering greater musical balance than either or both combined. Along with the RADIA it sets new standards for audio

indeed is, genuinely expensive. But it's also a bargain. Considerably cheaper than c-j's previous flagship, the Premier 8, it handily outperforms that amplifier. But the important thing is the way in which it does it; not by simply offering more of the same for less money, but by extending the breadth across which it delivers musical balance and insight.

There are fast amps

and indeed, all power amps. I'm very lucky – I've got the RADIA at home. But that doesn't mean that I'm not going to miss the Premier 350 when it goes. "Best" is in the ear of the hearer, but the sheer fact that the c-j has exposed the first chinks in the Hovland's armour demands both respect and affection. Big and powerful yet naturally intimate; versatile, communicative and capable all at the same time, the Premier 350 should need no help from me. Listen, and you too will be besotted. ➤

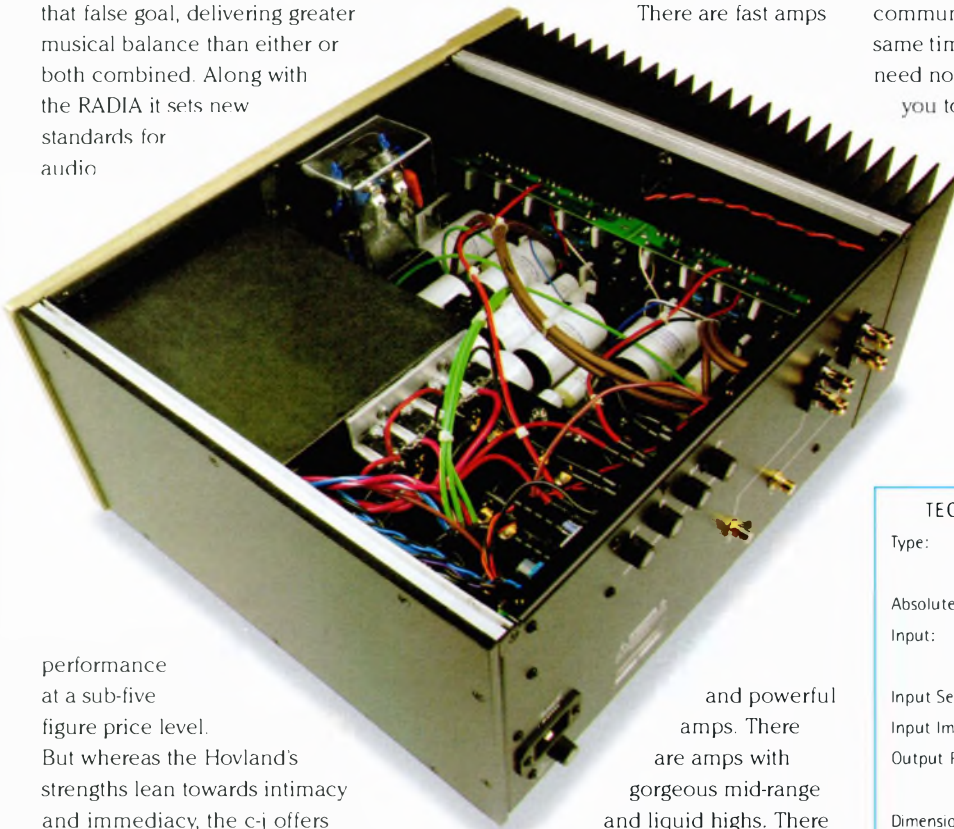

performance at a sub-five figure price level.

But whereas the Hovland's strengths lean towards intimacy and immediacy, the c-j offers power and grace under pressure as well as natural tonality and harmonic discrimination that broaden your system's musical compass and banish listening fatigue. The problem comes in trying to place it in context.

That this is the finest amplifier that conrad-johnson have ever produced I am in no doubt. It's also one of the best amplifiers that's ever enjoyed long term residence in my system. Have I heard better? Yes I have, but never at less than three times the price, and that's the point I'm trying to get across. The Premier 350 might seem, and

and powerful amps. There are amps with gorgeous mid-range and liquid highs. There are amps with thunderous bottoms and others with expressive constipation. The real strength of the Premier 350 is not just its lack of a single real strength, but the number of strengths that it can elevate and offer at once, without ever drawing attention to them and thus itself.

I've been relying on the RADIA for some time, but it's nice to know that the Hovland amp isn't the only game in town. Both the RADIA and the conrad-johnson represent a new benchmark for solid-state design –

#### TECHNICAL SPECIFICATIONS

Type:	Solid-state power amplifier
Absolute Phase:	Inverting
Input:	1 pr single-ended RCA/phono
Input Sensitivity:	1.1V
Input Impedance:	100kOhms
Output Power:	350 Watts per channel into 8 Ohms
Dimensions (WxHxD):	475 x220 x 390mm
Weight:	38kg
Finish:	Champagne gold front panel with black casework
Price:	£8000

#### UK Distributor:

Audiofreaks

Tel. (44)(0)208 948 4153

Net. [www.audiofreaks.co.uk](http://www.audiofreaks.co.uk)

#### Manufacturer:

conrad-johnson inc.

Net. [www.conradjohnson.com](http://www.conradjohnson.com)



“There may be better value propositions around to upgrade your system but if there is I haven't heard them...A fantastic product then from Origin Live and this particular audiophiles dream review tool.”

TNT AUDIO MAGAZINE

“The best tonearm I've heard”

HIFIWORLD

## The ultimate performance for your deck

The supremacy of vinyl quality over digital is set to continue - especially with the spectacular levels of performance now available through the new Origin Live tonearms. If you are in the slightest doubt as to the groundbreaking nature of these arms and their ability to transform your turntable's performance, we suggest you investigate the reviews and arrange an audition. Shown above is the new “Linn fitting” base with built in VTA adjuster, making the arms quick and easy to fit to LP12s among others. We guarantee all arms above the Silver to outperform any other arm regardless of price or your money back.

### Tonearms

Conqueror - £2500 Illustrious - £1570 Encounter - £970 Silver - £599 OL1 from - £124

Origin Live, Unit 5, 362b Spring Road, Sholing, Southampton SO19 2PB  
Tel / fax: 02380 578877 E mail: info@originlive.com

[www.originlive.com](http://www.originlive.com)

Winner of Stereo Times magazine Most wanted component of 2004 award



“Simply stated, the Origin Live Illustrious tonearm / Aurora Gold turntable produce the best musical results of any turntable I've ever heard, regardless of price...It sets a new reference”

STEREO TIMES

“...the Ultimatum is an exceptional achievement in every respect.”

Hi Fi Choice



*Ultimatum*

by neat acoustics

+ 44 1833 631021 [www.neat.co.uk](http://www.neat.co.uk)







# Perigee FK-1F Hybrid Ribbon Loudspeaker

by Roy Gregory

Ribbon drivers have been around pretty much as long as people have been making hi-fi. The Kelly tweeters were the first commercially viable product, at least as far as the UK was concerned, way back in the late '50s. At the same time, the French Orthophase loudspeaker used 24 identical drivers to create a full-range design – albeit at the ruinous cost of \$200. And that's for one speaker back in 1959! But, the inherent simplicity of the approach meant that enthusiasts had been tinkering with their own designs since the late 20's. And in that simplicity lies both the appeal of the technology and its problems. Inherently light, the ribbon diaphragm is blindingly quick, but the basic structure allows limited potential for mechanical damping. And that puts tremendous pressure on the choice of materials and accuracy of manufacture.

The first company to really take the commercial bull by the horns was Apogee Acoustics. With the economic pressure cooker of the '80s fuelling the explosion of high-end audio, Jason Bloom thought the time was ripe and he was right. Back in 1985 (I think it was) and the full-range

Apogee Scintilla reached these shores. John Atkinson, then editor of HFN-RR before *Stereophile* saw the light, graced it with a front cover and no fewer than three, independent reviews in a single issue. As a display of editorial backbone that takes some beating, but it also reflects the inherent fascination with ribbon speakers.

By coincidence, it also marks the start of the Perigee story. Apogee went on to produce a whole range of speakers, both pure ribbons and hybrids, but clashed with Magneplanar over the design of their ribbon tweeter, a protracted case they ultimately lost. It was enough to close the company in 1998, which left a lot of owners out there without any support. Australian Graeme Keet took on the task of producing replacement ribbons for the existing Apogee designs

– not as simple as it first seemed. However, the knowledge and experience gained encouraged him to develop his own driver and it's this that graces the Perigee FK-1F. Keet's ribbon is based on a sophisticated laminate, computer cut for accuracy.

It is mounted to the back of a solid aluminium billet, CNC machined to time-align the ribbon with the dynamic drivers it partners. And “partners” is the right word, as the ribbon was designed from the ground up to match the chosen Peerless bass drivers. These are six and a half inch units, using a molded plastic cone selected for their speed and dynamic response,

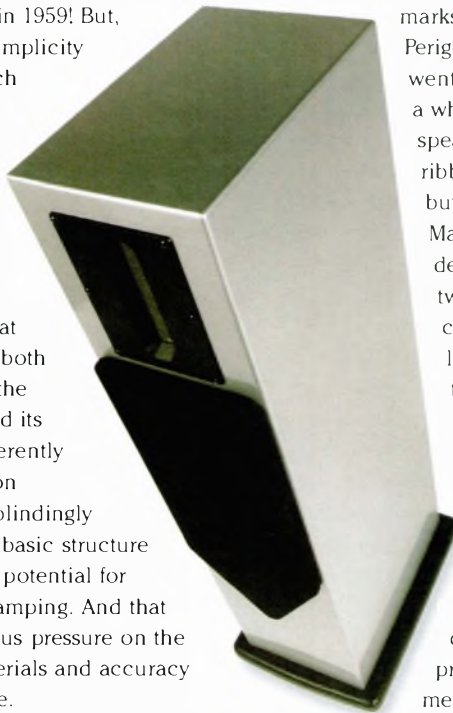

always a thorny issue when designing a hybrid. Whether you use a ribbon or an electrostatic unit for the higher frequencies, the crossover to a conventional moving-coil driver is always a potentially problematic one, and not just because of the difference in speed. What people often overlook is the difference in dispersion characteristics



▶ between the dipole upper frequencies and cone bass. This provides an all too audible aural cue to the cross-over point, especially as it so often occurs in or around the critical mid-range.

Perigee have responded to the problem in two ways. Firstly, the ribbon has its own rear chamber in the cabinet, which is combined with careful design to help absorb the rear output of the driver, killing the back wave, whilst also hopefully preventing re-radiation through the surface of the ribbon itself. Secondly, by designing the ribbon unit specifically to work with the chosen bass drivers, they have managed to eliminate both resistors and matching transformers from the cross-over network, thus ensuring maximum energy transfer. Likewise, the other crossover components comprise high tolerance polypropylene capacitors and resin dipped inductors, in order to further reduce cross-over losses and microphony. Sensible five-way binding posts are provided for bi-wiring, hard fastened to the crossover components by copper sheet. The internal cable is selected copper, stranded for the ribbon and solid-core for the bass. The ribbon driver extends down pretty well, especially given its size, but the crossover still occurs around the 1kHz point, making its engineering particularly critical.

The cabinet is a massive, fairly bluff looking affair, constructed throughout from

25mm MDF. As well as the separate mid/tweeter chamber, it is effectively braced by a horizontal divider that closes off the bottom quarter of its volume. Remove the plinth bass and you'll find a large diameter grub-screw allowing access to the void this creates. The 10kg of sand that the designer recommends you fill it with adds considerable stability to the tall cabinet, as well as helping to counter balance the 5kg ribbon assembly built into its top. Two large diameter, rear-facing ports provide bass loading, and whilst it's hard to tell with the

naked eye, they are different

lengths to help spread the port resonance and smooth the low-end response.

The review pair arrived in a well-executed piano black lacquer, while we photographed the other standard finish which is silver. However, for a small extra charge you can have pretty much any colour you like. The front baffle is fitted for grilles although none were supplied, and frankly, I can't imagine anyone buying a pair of these speakers and compromising performance in such a way. Besides, the fragile tweeter ribbon is protected by a tough, integral mess shield so even that concern is unfounded. The end result of the considerable

effort and attention to detail that's gone into the Perigees is a substantial, even imposing speaker that is more purposeful than attractive.

But pick it up and the considerable mass (even without the sand filling) is reassuring, while the electrical



characteristics speak volumes about the designer's past experience with Apogees. At around 92dB efficient and a flat four ohm load, the Perigees offer a stark contrast to the power hungry American panels. But don't assume you can hook up simply anything to them and expect the best results.

The FK-1Fs' possess a speed and immediacy that's at once impressive and appealing. There's an obvious transparency and complete lack of grain to the sound, while the solid cabinet and low-loss cross-over makes them sound more energetic than the numbers suggest. There's also a top-to-toe coherence that belies their hybrid nature. Confronted with a hybrid design there's something inside every reviewer that makes them go hunting for the crossover point. I've seen a lot of hybrids and, contrary to popular belief, I'm just as human as the next guy; Once I spot that tell-tale discontinuity there's no escaping it. It niggles and it gnaws away at me undermining my enjoyment, drawing my attention. It's why I've never, ever owned a hybrid speaker. There are those that have impressed me, but when it comes time to part with my own money...

I just couldn't help myself. ▶

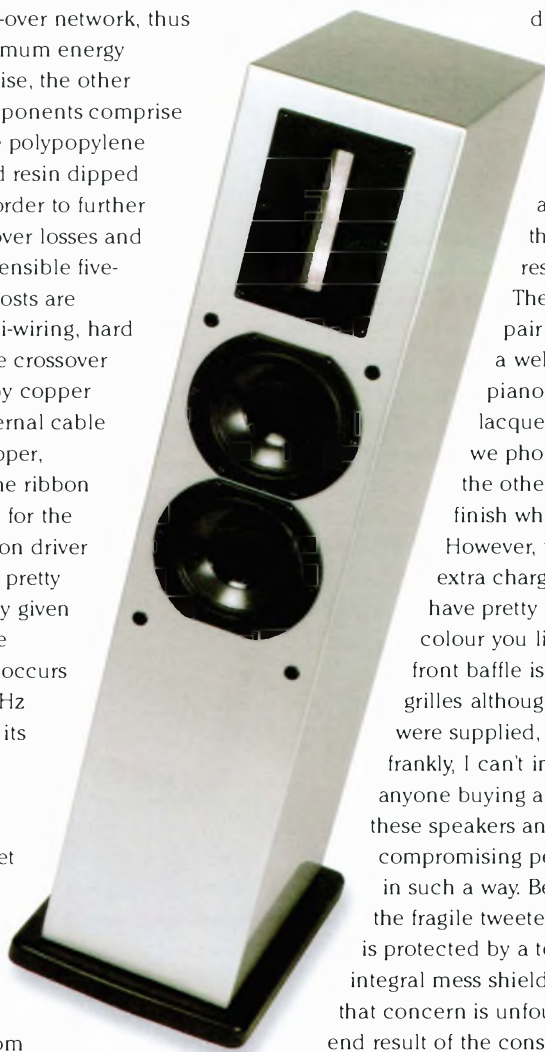

## Replacement Apogee Ribbons

Graeme Keet started out, as noted, producing replacement ribbons for the many Apogee models. Well, it's a side of the business that continues, with Reality Audio offering the service in the UK. The new ribbons are cut using the same computer controlled system as the ones in the Perigee tweeter, a fact that makes them far more accurate and consistent than the hand cut items originally fitted. As such, replacing the older ribbons with the new represents both a repair and an upgrade. As well as this Reality can offer owners of Caliper and Duetta speakers the Signature upgrade. That, plus a complete set of new ribbons will set you back around £1200, which seems pretty reasonable to me. Full details of the ribbons can be found at [www.apogeeribbons.com](http://www.apogeeribbons.com), while Apogee owners might well be interested in the resource and support site [www.apogeespeakers.com](http://www.apogeespeakers.com). It's nice to see people providing back-up for such an expensive product range once the company has gone.

► Out came the Starker *Bach Suites*, and sure enough, there's the crossover, slap-bang in the middle of the Cello's range. But, and here's the surprise, it really wasn't that intrusive or distracting. Extensive experimentation nailed down its nature: a tonal shift as the signal passes to the ribbon, introducing a sheen or brilliance to instrumental colours that's absent lower down the range. However, it's much more noticeable in the first half-hour of listening, diminishing as the drivers warm through. More importantly, there's no noticeable shift in instrumental scale or position through the cross-over. I'm speculating here but my guess is that the consistent energy levels through the critical frequencies are playing a big part here. Couple that to the ear's tonal adaptability and the absence of dispersion/placement/scale

anomalies that normally draw attention to cross-over points and the unobtrusive nature of the Perigee's design begins to make sense.

But be warned, because of the tonal nature of the shift, both speaker placement and the selection of driving electronics needs to be made with care. Any looseness or added flab at the bottom end will tend to exaggerate and warm the lower-mid, widening the gap between the drivers. Importer Jon Oakey provided a pair of granite slabs to go between speakers and floor, which certainly helped bottom-end linearity, and mid-range coherence as a result. A good thing, as the FK-1Fs will go both deep and loud. He also suggested that a slightly greater listening distance (rather than my near near-field set-up) should offer better integration, although I was unable to try this. Space to the rear wall is critical, as is having the speakers absolutely upright. A spirit level is essential here. In my room I actually preferred them tilted very slightly back, but that will depend on listening distance and the height of your seat. What you must do is get the angle and attitude of each identical. Toe in was minimal, allowing you to see plenty of each inner face. When you get all that right, you lose the slightly thrummy quality to cello and the chestiness that

infects voices. What remains is glorious.

Driving the Perigees with either the RADIA or the Conrad-Johnson Premier 350, each fed by the Vibe/Pulse or Hovland HP100, the overall coherence of the signal chain was just what the speakers ordered. Admittedly these are expensive ancillaries, but the FK-1Fs never failed to do them justice. Other electronics proved less successful, the speakers only too happy to reveal their character or shortcomings – especially any unevenness or roll-off, top or bottom. Fortunately it's quality that counts here rather than

quantity, which is just as well, because buying a lot of quality will cost an awful lot of money. The RADIA and Prem 350 both represent bargains in this respect. If the budget doesn't stretch that far, a decent integrated is probably the way to go, the Moon I-5 or Lavardin IT springing to mind. Likewise, a coherent cable loom will be essential, and whilst I stuck with Valhalla, the importer reports excellent results with the Vertex AQ products. I think Chord Signature represents a sensible minimum in this instance, which further underlines the quality ►





► of these speakers.

So, once you've got the system AND the set-up right, how do they sound? That quick, immediate quality is their hallmark. Voices and instruments are contained in a well-defined acoustic space, although emphasis is on the players rather than the acoustic boundaries.

The tonal character of the ribbon driver brings an etched, spot-lit quality to the stage which whilst it might not be strictly accurate is certainly attractive. The bass is tactile and deeper than you at first think, a function of its speed and agility. Deep bass lines like the ones that underpin 'Single Father' (from Jackie Leven's *Defending Ancient Springs*) are sure footed and tuneful, while the bass thuds that open his fabulous cover of 'You've Lost That Loving Feeling' have a visceral foundation that takes you by surprise.

Those low-frequencies provide a solid foundation for the stable and beautifully separated mid-band, although overall, there's a lightening of tonal colours that robs Jackie's voice of some texture and substance. What you are trading here is quick, agile dynamics for the last word in harmonic textures and development. It's a balance that plays to rock, pop and large scale orchestral music while leaving itself more exposed on simpler acoustic and jazz material. The space and dynamic scaling of the Johanos/Dallas *Symphonic Dances* is impressive indeed, the tonal subtlety and voicing of Narcisco Yepes' guitar less so. You pay your money and takes your choice – just

look at your record collection first.

I've dwelt on the contrasting strengths and weaknesses of the Perigee speakers at some length – which creates the danger of a negative sounding review. Well, that's far from the case. It's just that the particular balance of compromise with this

speaker is quite distinct from its many price peers. What you are actually getting is a wide-bandwidth speaker with superb dynamic speed, transparency and the best executed crossover I've come across in a hybrid design. Most ribbon or ribbon hybrid speakers tend to be fragile,



inefficient or awkward (for which read expensive) to drive. They often come with extortionate price tags. The Perigees suffer from none of these failings, and in material terms

alone, it's hard to argue with the content given the price. They also go loud. Pretty much as loud as you're likely to want. As such, the FK-1Fs make a serious stab at delivering the theoretical advantages of their technological blend whilst neatly avoiding the many possible pitfalls. Their real strength lies in the fact that they actually make accessible AND useable, the benefits of ribbon technology. Like any technology that comes with its own strengths and weaknesses, but at least you now have the option to decide for yourself whether it's for you. If so, then practical, capable and chock full of serious engineering the Perigees represent a highly enjoyable bargain. Apparently, there's a full range model in the offing. Now that I'd like to hear...



#### TECHNICAL SPECIFICATIONS

Type:	Ribbon/moving-coil hybrid
Bass Loading:	Twin port differential reflex
Drivers:	1x Perigee laminated ribbon mid-tweeter 2x Peerless 165mm fiber coned bass
Crossover:	1kHz
Bandwidth:	28Hz - 22kHz ±3dB
Impedance:	4 Ohms
Sensitivity:	92dB
Dimensions (WxHxD):	285 x 1100 x 410mm
Weight:	40kg each
Finishes:	Black or silver as standard. Other colours to order.
Price:	£5000

#### UK Distributor:

Reality Audio

Tel. (44)(0)121 356 2697

E-mail. [realityaudio@bopenworld.com](mailto:realityaudio@bopenworld.com)

MM AND MC

SELECTABLE GAIN

SELECTABLE LOADING

INDEPENDENT SUPPLY

## TRICHORD RESEARCH

Granville, Blackmore End  
Hanley Swan, Worcestershire WR8 0EE

Tel/Fax: +44 (0)1684 311600  
[www.trichordresearch.com](http://www.trichordresearch.com)

## DELPHINI Mk2

High performance phono amplifier

NOW AVAILABLE WITH THE REVOLUTIONARY  
'NEVER-CONNECTED™' NOISE REDUCING  
POWER SUPPLY TECHNOLOGY

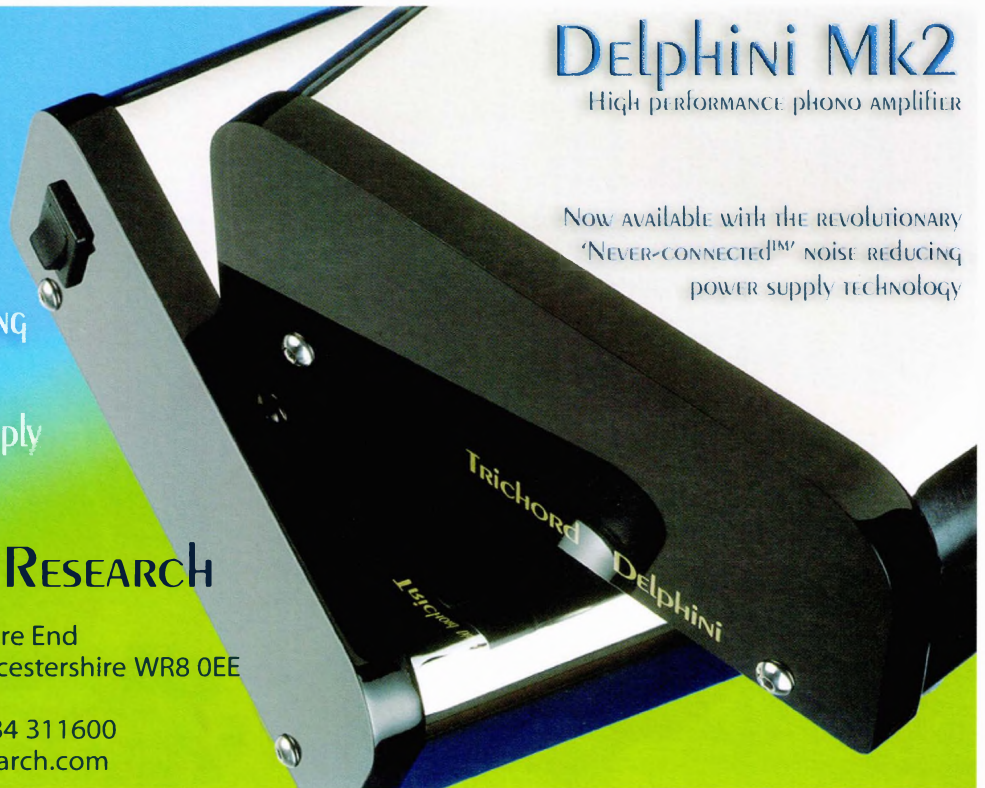

## definitive audio

### *land of opportunity and adventure*

Definitive Audio creates a quality of musical experience that is irresistible. We achieve this using some of the world's most ingenious contraptions and by employing a value system that places musical considerations above all others.

Our inventory includes the tantalising KSL Kondo amplifiers from Japan. There is the M7 Line, M7 Phono, M77 Ongaku, Neiro Integrated and of course the extraordinary Gakuoh. We also have a range of single minded amplifier designs from, amongst others, Border Patrol, Art Audio and Sugden.

Our Aladdin's cave of analogue treasures includes 12 choices of moving coil cartridge, along with the Kuzma Airline, Triplanar 6 and SME Series IV and V tonearms. Keeping these company is an enviable selection of turntables that includes the Kuzma Stabi Reference and the unequivocal SME Model 30.

And, of course, you will find the complete range of Living Voice loudspeakers including the internationally celebrated Avatar OBX-R2.

More importantly we have an attitude and an intent that breathes new life, interest and fascination into your relationship with music. Call us for an informal chat or to arrange an appointment.  
(+44) [0]115 9733222

For a comprehensive listing of part exchanged and ex-dem equipment, go to our website and click on "stuff"



Tel 0115 973 3222 Fax 0115 973 3666  
internet: [www.definitiveaudio.co.uk](http://www.definitiveaudio.co.uk) email: [shout@definitiveaudio.co.uk](mailto:shout@definitiveaudio.co.uk)





# Reference 3A Dulcet Loudspeaker

by Chris Thomas

In every area of hi-fi and at every price level there are world-class products, so putting together a great system should be just an exercise in identifying them, right? The audio market has never been so full of quality hi-fi and there must be thousands of combinations of equipment available that can be lashed together to make a decent and enjoyable sound. Long established audio companies have, in some cases lost some of the high ground where pure performance is concerned to smaller and more specialised manufacturers and brilliant though some of their products are, none of these established companies make the best of everything. It's not hard to understand how easy it is for a dealer to sell an upgrade as opposed to shifting the goalpost and explaining that the law of diminishing returns is about to bite into the posterior with considerable force and that now might be the time to broaden ones horizons somewhat. And I am not talking exclusively about the top-end of the market either. Over the past few years I have met many people who have been slavishly treading an established upgrade path and then found themselves staring rather dejectedly at a financial brick wall as it slowly sinks in that the cost of their next step is going to be financially ruinous. And those dealers that do encourage their customers to think outside the envelope will probably be suggesting equipment that will likely be unknown to them and this tends to make people nervous. Even during my time in retail there were many occasions when I demonstrated a superior sounding

system often at less cost. But the customer, despite agreeing, normally went for the equipment they knew as they had either seen it many times in the press or their mate had one and as we all know, mates just love us to make the same mistakes as them.

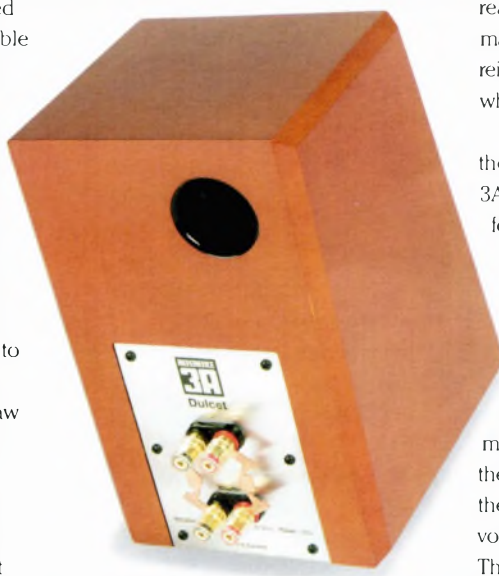

But the fact is that there are some really exceptional products out there and these stand out because they fulfil the desire of those who really need to have music and not necessarily hi-fi as a part of their life. That is how the trail to audio heaven often starts. The problem is that quite often, somewhere along the way, the hi-fi attributes and even the lifestyle image of the equipment gradually becomes more important than the music and we buy into upgrades for silly reasons. These are the first steps on the road to nowhere and most of us have trodden it at some time or another. On too many occasions,

it seems to me, the improvements on offer are just way too expensive for the rewards gained and throwing money at a problem doesn't always get the instant results you are looking for. Ask Roman Abramovich. (I'm staying well out of this one! Ed.) But this is where your dealer really does have some serious input to make because occasionally we all need reining in somewhat and reminded of what's important both in music and life.

I mention the above only because the miniscule Canadian-made Reference 3A Dulcet is one of those products that forces you into a re-evaluation of any preconceptions or bias that might have started to creep into your view of what a really good music system should be all about. It's a simple formula and it has been worked a thousand times. Take a small box, make it rigid, and perhaps fit a port and then bolt in a pair of drivers. Connect them through a simple crossover, et voila; a pair of mini-monitors are born. There are any number of such designs on the market including some very good ones but there are also many that range from bad to merely competent and these days, that's just not enough. To be really notable and worthy of serious consideration it just has to be musically special and believe me, this speaker is. It is however relatively limited in its application as it is a small box and despite its excellent sense of size and musical scale, does its best work in small rooms. Having said that I should add that it would work superbly in about 75% of the listening rooms of friends and associates that I am familiar with, many of whom use speakers that I think ▶



▶ are too big to be really useable or appropriate though I would stress that this is a personal opinion. There is little to suggest from their appearance that the Dulcet is anything other than a very nicely made small box design. You take a look at the cabinet and that tiny mid/bass driver and think that, however good the resolution, bandwidth and imaging are, it will always sound like a small speaker and that it will simply not have the body, bandwidth and range of tonality to intrigue, especially at lower levels. You might well think that the lowish 87dB efficiency points toward it being a bit of a power sponge that takes a lot in and puts very little out. But you'd be wrong.

The bevel-edged cabinet, with its sloping, time aligned baffle is superbly solid and non-resonant. The two drivers, which are mounted in a mirror image configuration comprise a 27mm textile domed tweeter and a very special 100mm mid-bass unit fitted with a huge phase plug and designed specifically for the Dulcet by Reference 3A supremo Daniel Dehay by using multi-layer, variable density materials. To the rear of the cabinet there are two pairs of WBT-type connectors and a pair of solid copper jumpers for those without bi-wire cabling. Very close to the top of the rear panel is a 55mm port that spirals down to the rear of the bass chamber reducing, it is claimed, back wave interference from the driver.

As with other Reference 3A designs there is no multi component crossover to speak of, just a single oil-filled capacitor before the tweeter to keep all those unwanted bass frequencies out and that means that the bass-mid

unit is driven directly by the amplifier which, depending on the model in question, may or may not be a good thing. Crossovers give them and they take them away but, not being a crossover designer, I think life is too short to debate their pros and cons in the vain hope of a definitive answer as to their ultimate desirability. But if you are wondering if there



are any noticeable anomalies apparent, particularly around the natural crossover point between the drivers I would have to say none that seem to matter or get in the way of the speaker fulfilling its musical role.

I doubt that the frequency response is anything approaching flat but then nor are any of our listening rooms.

Siting them is easy; just don't place them closer than about 18 inches from a rear wall. They require a suitable stand and though the manufacturer has a rather expensive ready-made design in their catalogue these were not supplied with the speaker so I had to improvise. Fortunately, despite the fact that the JM Labs Micro Utopia stands have a bigger top plate than ideal, I found the height to be perfect and followed the manufacturer's advice of four blobs of Blu Tac with a central line of the same running front to back. As always you will need to

make micro-adjustments yourselves though I found that despite recommendations for zero toe-in I preferred them a with just a few degrees which knitted the soundstage together to give a quite stunningly open view of the music. They don't seem particularly difficult to drive and I had excellent but understandably quite different results with both the solid-state Moon i-3 integrated and the valve/solid state hybrid the Pathos Classic One.

Congratulations to the designer for allowing the tweeter the benefit of some serious high frequency extension as the majority of similarly sized speakers are rolled off somewhat earlier so as not to emphasize the limitations at the other end of the bandwidth. And what an excellent unit it is when fitted in the Dulcet. Full of strength and subtlety and superbly textural, it also has enormous speed and impact when needed and integrates so well with the bass/mid driver that the music never sounds rhythmically disjointed. The whole speaker



immediately exudes an air of confidence and it can cope with seriously complex music without feeling rushed or confused. Even heavy-duty percussive pieces are handled with surprising ease. From top to bottom they are tremendously coherent time-wise and this just draws you into wanting to play more and more music. The Dulcets feel as if the absence of

a crossover has removed the shackles from the drivers and allowed them a sense of dynamic and rhythmic freedom. The music pours from them in an endless flow with no sense that the sound has been shaped or tidied up around the edges to make them more ▶

► broadly acceptable and when you couple this with their sense of velocity and start/stop abilities you realise that they are cashing in big time on all the attributes that smaller speakers traditionally have. They seem a few dB more sensitive than they really are. This is largely due to the fact that they have striking presence and impact and can seem quite forward,



especially on vocals where they are always impressively articulate. But their presentation, as I learned, is largely influenced by the nature and characteristics of the driving amplifier. Swap the Moon for the Pathos and the singer takes a step back but the sense of communication and involvement doesn't and neither does the feeling of solidity and stable focus. There is much more sheer tonal warmth than I was expecting and the thin, lean clarity that I might have anticipated is replaced by an extraordinary palette of colourful tonality and harmonic richness that is extremely rare from such a small speaker. On *Alison Krauss Live with Union Station* it was easy to enjoy that bluegrass nasal tone she sings with without that associated feeling of it being on the edge of microphone distortion that I have come to associate with this disc. And where the spiky jangle of three acoustic guitars can make

this album seem superficially detailed on other speakers, here I was just listening to Dan Tyminski standing over to the right playing that big old Martin Dreadnought and marvelling at the tone of the instrument itself and at his tremendous intonation and sense of anchored rhythmic progression as he guides the band through the chord progression. And if any proof were needed as to Jerry Douglas' genius, the Dulcet is more than capable of allowing

you to isolate him in the mix and just follow every delicious movement of that slide. You'll hear that his subtlety, feeling of space and ease and freedom within the tempo is nothing short of beautiful. And the scale of the music is superb. It is undoubtedly an audio cliché to say it but just close your eyes and you could easily believe that you were listening to a speaker several times larger and it is this sense of soundstage stability, scale and overall instrumental and vocal separation that is one of the things that sets the Dulcet apart and allows you so effortlessly into the music.

You will be amazed at the quality, quantity and pitch control down in the bass, which maintains that vital sense of rhythmic coherence with the rest of the bandwidth that is another huge and vital attribute of this speaker. Not since the Red Rose R3 have I been so impressed with the low frequency performance of such a small box design. Being relatively limited in real extension and having such a rigid and quiet cabinet allows it to start and stop instantly with a real sense of snap and precision. And the resolution and sheer weight is excellent too and remains so right down to late night listening levels where the sound doesn't collapse feebly back into the box. It will also take some hard driving though this is successful only up to a point. Push it too hard and the bass will begin to compress and lose shape and the treble will grow ragged. But this is most certainly not what the Dulcet is all about and though

it will play rock with power and impact it doesn't really move enough air, so head bangers should look elsewhere.

I see the Dulcet as something of an antidote to the more complex designs that are out there. You will of course need an excellent source, amplifier and a quality cable loom to allow them to reach anything like their true potential. And there is an argument which suggests that anyone who can accommodate a speaker of this size and type could probably manage a bigger design in a larger cabinet. All these are questions for the individual, but I guarantee you that no matter what level of equipment you are used to, you will enjoy listening to music through these little things and you won't waste too much time analysing why. And that is what it's all about. Isn't it?



#### TECHNICAL SPECIFICATIONS

Type:	2-way, rear reflex port
Drivers:	
Bass/mid -	100mm multi-layer, variable density composition.
Tweeter -	27mm textile dome.
Sensitivity:	87dB
Impedance:	6ohms nominal
Power Handling:	80 watts rms
Dimensions (HxWxD):	300x190x240mm
Weight:	7 kg each
Finishes:	Two available. 3 polyester layers over stained maple. Black or what looks like red cedar to me, as the review pair
Price:	£1695 a pair.

**UK Distributor:**  
Absolute Analogue  
Tel. (44) (0) 208 459 8115

**Worldwide Distributor:**  
Divergent technologies  
Ontario, Canada  
Net: [www.Reference3a.com](http://www.Reference3a.com)





# B&W 704 and 705... A tale of two speakers

by Paul Messenger

Should you be contemplating a new pair of speakers, you might well be checking out one or other of the models produced by the biggest player in the field. B&W makes several ranges of speakers, but these essentially boil down to three series primarily oriented towards the hi-fi customer. There's the 'budget' vinyl-covered 600 S3 series, and the upmarket hi-tech Nautilus 800 series, both of which have been established for a number of years. Splitting the difference between these extremes is the latest range to emerge, the 700s effectively replace the CDM NTs, and promising to deliver much of the 800 series' performance at a substantially lower price.

Not surprisingly, they've been very successful, but there are three stereo pairs to choose from, and picking the best pair to go for is a far from straightforward decision. The 705, 704 and 703 have much in common, all sharing the same cunning enclosure shape, and the same externally mounted, tube-loaded tweeter. Where they differ is mainly in size, price, and in driver configuration.

This review focuses on the two less expensive models – the £900/pair 705 and the £1,400/pair 704. These share the same bass/mid driver as well as tweeter, the difference being that the 704 is a floorstander, with an extra bass-only driver operating alongside and augmenting the bass/mid driver in a two-and-a-half-way.

(For the record, the 703 is the daddy of the range, a full three-way design priced at £2,000/pair and featuring one of B&W's 'surroundless' FST midrange drivers, operating above a pair of bass-only drivers.)

The core question that we're addressing here is how the two less expensive models compare, and whether the 704 is worth the extra £500 it costs over the 705. Although the actual price difference is £500, in practice some of that will have to go towards the cost of a suitable pair of stands. One could spend the whole lot on the stands of course (though not many models run to that sort of money) or less than £100 for a pair of budget examples. In practice the Kudos S100 stands used for this review (and sadly no longer currently available) used to cost about halfway between those extremes, so in this case the combination of stands-plus 705s will work out somewhat less expensive than the 704s – but not that much.

Let's start off with a full description of the 705. Direct successor to the CDM-INT, it's a simple two-way, and uses an evolution of the same external tube-loaded tweeter.

The former's rather boxy and chunky lines have

been replaced by an altogether sleeker, sharper and more streamlined look, albeit without the soft, radiused edges of the previous model. All five visible faces are covered in a high-class real wood veneer, either in the attractive cherrywood applied to our samples, or in maple, American walnut, 'rosenut' or black ash. With an all up weight of 9.5kg, it all feels very solidly built.

The enclosure is particularly cleverly shaped and constructed. The front and top surfaces are made from a single piece, bent into a curve at the junction. The curved top surface is also tilted at a quite pronounced angle, and the back is narrower than the front, so the whole enclosure is front-to-back tapered. These various measures have several consequences. Most importantly, the only parallel surfaces that remain are the front and the back, an arrangement that will help to 'spread' reflections and 'defocus' internal standing waves. The curved single-piece front/top not only ensures great mechanical stiffness, its shape will reflect the tweeter output in a dispersed manner across a very wide vertical angle.

The top-mounted tweeter not only provides wide all round distribution for the high frequencies, without the edge-diffraction effects that occur with panel mounting, but because it's set back an inch or so behind the line of the front panel, the voice coils of the tweeter and the bass/mid driver are more or less equidistant from the listener, improving integration through the

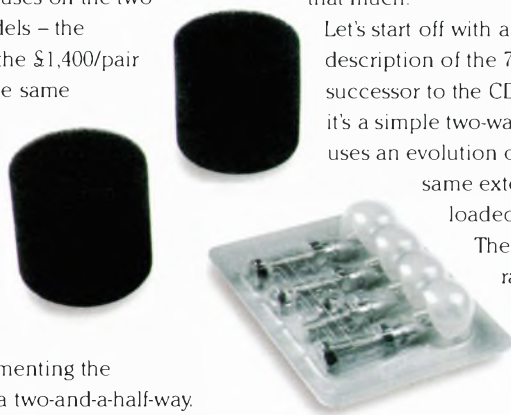



► crossover region. There's a clip-on mesh-front cover for the tweeter, but the very delicate diaphragm is still vulnerable to damage because the grille is rather easily detached accidentally.



The 25mm alloy dome tweeter is loaded at the rear by a long tape red 'transmission line' tube, so that the soundwaves generated are absorbed rather than reflected. The 165mm cast-frame bass/mid driver has a yellow woven Kevlar cone 120mm in diameter. Improving on earlier examples by applying lessons learned during development of the upmarket Signature 805, it features what B&W calls a 'balanced drive' motor, with better magnetic field symmetry and reduced variations in inductance.

A front 'Flowport' shaped port with 'golf-ball' dimples to reduce turbulence reflex-loads the main driver, and a foam bung is supplied to block this if preferred. Twin terminal pairs provide bi-wire or bi-amp capabilities.

In terms of basic content, the 704 consists of a 705 with built in passive sub-woofer. The 705's stand-mount

enclosure is effectively extended down to the floor, the larger, lower section being used to accommodate a purposeful looking, port-loaded 165mm bass driver. It's not quite that simple – in fact the 704 is slightly deeper than its smaller sibling, and there are also changes to the crossover network feeding the bass/mid and treble drivers to take account of the extra bass. It also places the port that loads the bass/mid driver and the upper, smaller sub-enclosure on the back instead of the front panel, allowing the bass-only driver to be mounted higher than would otherwise be possible.

Said bass unit has a 120mm diameter Kevlar-reinforced paper cone, further stiffened by a dome that's nearly as large as the cone.



It also features the 'balanced drive' motor used in the bass/mid driver. Both ports use B&W's 'Flowport' technique,

and foam bungs are supplied to block either or both of these if the bass end sounds too strong in the specific room. With an all up weight of 21kg, the whole thing feels very solidly built, and sits securely on



well-seated, shiny spikes. Twin terminal pairs provide bi-wire or bi-amp options, and our samples were finished in a dark American walnut real wood veneer, with the same options listed above. It's no surprise to find that there are considerable similarities between the in-room far-field measured responses of the two models through the midrange and treble, or that the main differences are found in the relative level of bass output of the two designs.

Of the two, the floorstanding 704 is the more neutral and well balanced model by a significant margin, delivering an impressive overall in-room balance that holds within very respectable +/-5dB limits right across the audio band. With the port tuned to an unusually low 28Hz, ultimate

▶ bass extension is particularly impressive here – if arguably a little too strong in the bottom octave – and the bass region as a whole is smoother than average under our particular room conditions, if a little lean through the



upper bass and lower mid-band, with the speakers mounted well clear of walls, and the ports left open. The mid-band proper is quite smooth and flat, while the upper mid, presence and treble is slightly downtilted and restrained. Sensitivity is pretty damn close to the claimed 90dB, though the load here is quite demanding, as it dips to a little below 4 Ohms at low frequencies, where the two cone drivers are operating in parallel.

Predictably perhaps, the 705 is similar to the 704 in the mid and top, alongside significantly less bass energy. Placed clear of walls it also shows evidence, on the far-field in-room

averaged plots, of a significant peak at 300Hz, which turned out to be a function of the room and siting therein, rather than the speaker per se. Below that point the bass is dry and about 4dB too light, but nonetheless pretty well extended down to around 30Hz. It seems most unlikely that there will be any need to block the 40Hz-tuned reflex ports here, and some close-to-wall reinforcement might well be preferred – though this is also liable to increase the mid-band coloration to some degree. Sensitivity is just a fraction below that obtained with the 704, but on this occasion the load is rather less demanding of amplifier current, staying comfortably above 5 Ohms throughout.

Auditioned using a wide selection of high quality equipment and ancillaries, most of the work was done using Naim CDS3 and Burmester 001 CD players, a Linn/Rega hybrid record player and a Magnum Dynalab MD102 tuner, feeding a Naim NAC552/ NAP500 amp and using Vertex AQ and Chord Signature speaker cables.

The first and most abiding impression with both these speakers is their effectiveness in avoiding the sort of 'boxiness' that usually

afflicts conventional monopole box loudspeakers. Both speakers have very refined enclosures, which are notable not only for the lack of midrange boxiness, but also because cabinet wall colorations seem very well controlled, ensuring the bass stays clean and clear. That said, and despite the considerable commonality of engineering content, the two models do have very distinct characters, and each possesses its own particular charms, alongside similarly distinctive limitations.

The 705 is noteworthy for its lightness of touch and freedom from time-smear. It sounds coherent, communicative and lively, with a notably sweet, well controlled and tidy top end. Voices are clean and well projected, with very

little coloration and no trace of thickening or chestiness. However, the mid-band does rather tend to dominate the proceedings here, because although the bass is qualitatively fine and dandy, it's also a little too lightweight and restrained quantitatively.

Placing the speakers back against the wall proved a bit of a mixed blessing. It does add worthwhile extra weight to the bottom end, as one would expect, but it also rather spoils the overall evenness, adding a little too much mid-bass 'thump' without the warmth and power that provides the real drive and impetus to bass guitar playing, for example, or the true harmonic ▶





richness of orchestral cellos. A third alternative is of course to mount the speakers close to the wall and block the ports with the supplied foam bungs, though this didn't seem ideal either in this case, as the bass warmth and 'punch' seemed, if anything, even more lacking.

One is therefore caught between stools here. Speaking personally I preferred to keep the 705s

away from the wall, where their sound might be a little lightweight overall, but which seemed to bring out their excellent overall agility and spaciousness to best advantage. However, in another room and system, the effects of bass/room interaction might well be different, so it's always worth experimenting with placement in situ, rather than assuming that what works best in one situation will necessarily apply elsewhere.

But, although the bass is undoubtedly a little light in weight and warmth, it's also engagingly quick and lively, and agile enough to stay well clear of the mid-band information. The mild mid-dominance that results brings an engaging close-up intimacy to both male and female voices, as well as the smaller and more delicate acoustic instruments, such as the vibraphone that sometimes features in jazz/blues combos.

Unlike its baby brother, the 704 suffered no placement dilemmas

under my listening conditions. Placed well clear of walls and with the bungs consigned to the shipping cartons, it delivered a superb bass-to-mid balance with such a low coloration signature the speakers themselves simply seemed to disappear from the proceedings and leave just the soundstage to fill the end of the room. Monteverdi's *Vespers* are not part of my normal listening repertoire,

but the Prom performance, captured by Magnum Dynalab, amplified by Naim and reproduced by 704s, was quite magical in the way it seemed to transport one to the Royal Albert Hall, and drag one's attention into this ancient Venetian music.

This speaker has a big, smooth sound, bringing a convincing sense of scale to the proceedings, alongside a well judged modicum of restraint through the upper registers. It's an easy speaker simply to ignore, as it goes about its business with superior neutrality and smoothness, and little

obvious drama.

Reason suggests that the 704 is the better of the two B&Ws, and it's certainly the better balanced model. But reason isn't the only arbiter when it comes to music reproduction, and I found my emotions tugging me more towards the smaller stand-mount, simply because listening to it somehow seemed more fun. Bonnie Raitt,

singing 'Baby of Mine', somehow sounded sexier and more 'real'.

Although a top class two-and-half-way floorstander like the 704 is one of the better ways of delivering a genuinely full bandwidth sound from a relatively simple and very neatly packaged loudspeaker, they never seem to have quite such good overall time-coherence as the two-way stand-mount. It might well be to do with the roll-off that's applied to the bass-only driver, that inevitably involves a measure of phase shift stretching up into the lower mid-band. It might be to do with the fact that there's two or three times as much enclosure surface area to add its inevitably delayed coloration contribution to the whole. Or it might be because the stand-mount allows sound from the main drive unit to pass under (as well as around and over) the loudspeaker, rather than rolling down the front to the floor. Whatever the reason, the most obvious effect seems to be a mild degree of extra thickening and 'chestiness' with male speech. Professor Laurie Taylor, host of Radio 4's *Talking Aloud*, who doesn't have the best microphone technique around, definitely sounded more congested via the 704s than the 705s, and somewhat less expressive at the same time.

But if that's the downside of the 704, the upside is the splendid sense of scale it brings to material with plenty of bass content, whether orchestral in origin, or more modern and synthetically in nature. Whereas the 705 can deliver a pretty persuasive and satisfyingly crisp 'thump', the 704 adds genuine scale, superior texture analysis and true gravitas to the proceedings. Massive Attack's *Mezzanine* illustrated this perfectly. It was listenable enough with the 705s, but only the weight and warmth of the floorstander could really bring out the dark and moody



► magnificence of this fine album. And it definitely needed the 704s to put the Massive into the Attack.

The situation was less clear cut with the Grateful Dead's live acoustic album *Reckoning*. Phil Lesh's 'walking' bass lines are particularly impressive here, and while the full weight of the 704s is welcome enough, the superior timing and coherence of the smaller, simpler 705s puts forward an equally strong case for consideration. Both speakers fall a little short of the ideal here, it has to be said, but this particular album illustrates very clearly the contrasting qualities of each.

Indeed, it's much more interesting – and arguably also more relevant – to take two related speaker designs such as these and compare the way they perform, than to review a solitary model in isolation. These two models both come from B&W, which is the biggest and most successful UK brand when it comes to specialist hi-fi speakers, and also the company that puts the most resources into research and development.

It's therefore no surprise to find that these middle-range models incorporate a number of unusual technical features which directly influence the sound they produce.

The external tweeters have notably wide sound dispersion, as do the narrow cabinets for the

bass/mid drivers, so although these are by no means omni-directional designs, the speakers will still interact quite strongly with the listening room, going some way towards creating the sort of 'solid' images which will help create the impression that the musicians are there in the room. The consistent dispersion and asymmetric enclosure shapes

will help minimise any 'boxy' character and promote precise stereo imaging, aided by the time-alignment of tweeter and midrange.

These two models share very similar characters through the mid-range and treble, with fine transparency alongside a modicum of restraint through the presence. Some might prefer a sound that's a little less laid back, but this does have the advantage of avoiding any aggressive tendencies when the volume is turned up.

Despite the top end similarities, substantial differences through the bass region do result in striking contrasts in overall character. The 705's relative lack of bass in fact results in a rather mid-dominant sound, which along with its the two-way simplicity gives a lively, bouncy sound, though the lack of bass warmth and weight is better suited to small scale material, and probably to smaller rooms too. The 704 is a much more neutral and powerful sounding

proposition, well suited to large scale and heavy music, but with a little less overall coherence. ►+



#### TECHNICAL SPECIFICATIONS

<b>704</b>	
Type:	21/2-way floorstander
Drive units:	1x 25mm alloy dome HF 1x 165mm woven Kevlar cone bass/mid 1x 165mm paper/Kevlar cone bass
Bandwidth:	40Hz - 25kHz +/-3dB ref axis -6dB at 30Hz and 50kHz
Sensitivity:	90dB spl (2.83Volts @ 1m)
Nominal impedance:	8 Ohm (min 4.1 Ohms)
Power handling:	50W - 150W into 8 Ohms, unclipped programme
Crossover:	150Hz, 4kHz
Dimensions (HxWxD):	957 x 222 x 319 mm
Weight:	21kg
Price:	£1400/pair
<b>705</b>	
Type:	2-way stand-mount
Drive units:	1x 25mm alloy dome HF 1x 165mm woven Kevlar cone bass/mid
Bandwidth:	45Hz - 25kHz +/-3dB ref axis -6dB at 43Hz and 50kHz
Sensitivity:	89dB spl (2.83Volts @ 1m)
Nominal impedance:	8 Ohm (min 4.5 Ohms)
Power handling:	50W - 120W into 8 Ohms, unclipped programme
Crossover frequency:	3.7kHz
Dimensions (HxWxD):	420 x 222 x 290 mm
Weight:	9.5kg
Price:	£900/pair
<b>Manufacturer:</b>	
B&W Ltd.	
Tel.	(44)(0)1903 221500
Net.	www.bwspeakers.com



final opus 204 speaker

*final*

**FINAL LABORATORY**  
 8-2 tenouyama fukozu kota nukata  
 aichi japan 444-0124  
 tel/fax : 81-564-63-3279  
 http://www.finallab.com  
 mail@finallab.com

always final audio research

final daruma insulator

Would you use this to power your car?

**You can buy online!**

**Feed your system with clean power with the PS Audio power Plant and hear the concert hall...**

Treat your system to the best solution to mains problems; Power fluctuations, spikes and noise.

**How is this possible?**  
 Simple, the power is regenerated providing you with clean power. No mains cleaner can lay claim to the virtues of the P S Audio mains regenerators or cleaners.

**Multiwave II (£220) upgrade** for existing power plant owners delivers another improvement to the power plant instead of sine wave which is limiting

**NEW P500**  
*it's so cute it fits on hi-fi racks!*

**Try one in your system with our 14 day home trial**

Stronger £ means lower prices.

**Ultimate Outlets**  
 £ 330-£370

<b>P300</b>	now £1400
<b>P500</b>	now £1850
<b>P1000</b>	now £2800

**PS Audio**

Distributor of Quality and affordable high end hi-fi and home theatre equipment

Tel: 020 7435 1222 Fax: 020 7435 1300 Email: admin@psaudio.co.uk Website: www.psaudio.co.uk 392 Finchley Road, London, NW2 2HR.

**This Tempo flies!**  
**A major upgrade for a legendary loudspeaker from Audio Physic ...**

**Tempo** fugit!

Considering loudspeakers in the £2k region? – we believe the latest Audio Physic **TEMPO** is the new reference.

In 1986 the first Tempo set new mid-price standards for clarity, pace, dynamics and the Audio Physic speciality:

**HOLOGRAPHIC IMAGING.**

The new Tempo 5 is neat and svelte with stunning performance, drawing on the research and design work done for the landmark £8k Audio Physic **AVANTI**.

The cabinet is a masterpiece of elegance and **RIGIDITY** to curb colourations from resonance. Curved side panels minimise internal standing waves that muddle the bass and blur mid-range detail.

AP's "PUSH-PUSH" design places bass drivers back-to-back in the **SIDES** of the cabinet to cancel vibrations and allow a narrower front baffle for domestic acceptance and wonderful imaging.

An important bonus: Audio Physic have included a **DAMPED TERMINAL PANEL** to block energy being transmitted through the speaker cables back into the system.

Customers say we make some of the **BEST SOUNDS** they have ever heard, so you know we can do the same in your home. Our advice will take account of your best components and guide you where change is needed, in stages you can afford. You **AVOID EXPENSIVE MISTAKES**, enjoy music along the way and save money in the long run.

**JUST LISTEN AND YOU'LL KNOW.**

**The Right Note**

*Music in the home*



**BATH**  
 01225 874728  
 or NEW lo-call  
 0845 230 7570

CD: ACCUPHASE, ACCUSTIC ARTS, AUDIO SYNTHESIS, BEL CANTO, DCS (ELGAR, DELIUS, PURCELL, VERDI, VERONA), WADIA. VINYL: AVID, BASIS, CLEARAUDIO, DNM, GRAHAM, THE GROOVE, LEHMANN, MICHELL, ORIGIN LIVE, SUMIKO BLUE POINT SPECIAL, TRANSFIGURATION. AMPLIFIERS: ACCUPHASE, ADVANTAGE, BEL CANTO, CAT, DNM, GAMUT, HOWLAND, NAGRA, TACT AUDIO, SONNETER, SPECTRAL. TUNERS: MAGNUM DYNALAB. LOUDSPEAKERS: AUDIO PHYSIC, DALI, ETHOS, NEAT, TOTEM, VERITY AUDIO. CABLES: ARGENTO, CHORD CO., DNM, NORDOST, SILTECH, VERTEX AQ, YAMAMURA CHURCHILL ETC. MAINS: ACCUPHASE, VERTEX AQ. SUPPORTS: ARCICI, STANDS UNIQUE, VERTEX AQ

**TIME TO BRING OUT ALL THE MUSIC HIDDEN IN YOUR LPs AND CDs**

BY ADDING TO YOUR SYSTEM ALL OUR RINGMAT AND STATMAT PRODUCTS, AND BE SURPRISED HOW MUCH MUSIC WAS HIDDEN AWAY ALL THOSE YEARS.

**FOR ALL MUSIC and AUDIO VISUAL SYSTEMS**

You need our Statfeet, Ringmat Feet, Ringmat Domes, Ringmat Anti-Resonance Platforms\*, Ringmat Stereo & Digital Interconnects, Tonearm\*, Speaker & Power\* Cables \*to be released soon, plus our Xtra Large, Xtra Heavy Duty Feet and some surprise new products and ideas

**FOR CD, SACD and DVD SOUND (& PICTURES)**

You also need our CDi Blue Statmat for your player

**FOR VINYL LOVERS**

You need to start with our Anniversary Ringmat on your turntable platter

**TO FIND OUT MORE** and read the reviews in the leading UK and international hi-fi magazines, visit [www.ringmat.com](http://www.ringmat.com) or call us on 01277 200 210

**RINGMAT SECURE ONLINE STORE NOW OPEN**

All released products **Now Available at the Click of a Button**  
**EASY, FRIENDLY, SECURE. Visit [www.ringmat.com](http://www.ringmat.com) and click on BUY ONLINE**

**RINGMAT DEVELOPMENTS**

PO Box 200 Brentwood Essex CM15 9FB GB

Call: 01277 200 210 or visit: [www.ringmat.com](http://www.ringmat.com) for information and contact

**PUTTING SOUND INTO FOCUS**

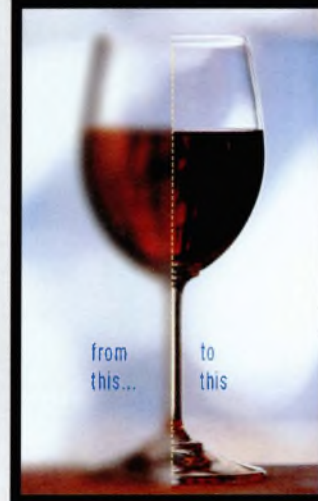

**RINGMAT**



*Renaissance  
Amplification*

Balanced Audio Technology

**VKPS**  
Balanced Phono Stage

# Four Phono-Stages

## The Bonnec, Sutherland Ph.D, BAT VK-P5 and Renaissance Music Re-Performance

by Jimmy Hughes

Go back 20 or so years, and outboard phono-stages were comparatively rare. Every integrated amplifier or pre-amplifier had its own built-in phono-stage; indeed, in the days when LP was the dominant source, the quality of the phono-stage largely defined an amplifier's sonic performance. But, as the '80s wore on, and CD gained an ever-increasing hold on the market, things changed; amplifiers began to appear for use with line-only sources. With many listeners moving away from LP to CD only, this made sense. After all, why make someone pay for a phono-stage they're never going to use...

Meanwhile, for those still committed to LP being able to choose from so many outstanding outboard phono-stages means being able to get the best from vinyl sources regardless of the amplifier chosen. For example, someone with efficient horn loudspeakers can select a low-powered single-ended tube amp without having to worry about whether or not its built-in phono-stage is comparable in quality to its line-level inputs. Obviously, it costs more to buy an outboard phono-stage. But, once you've got a really good one, there's no reason to change it, even if upgrading the amplifier later.

In many ways, producing a good phono-stage is perhaps the most difficult challenge an electronics designer can face. Because the output voltage of a typical moving-coil cartridge is so low, things like circuit layout, component quality, and power

supply noise assume far greater significance. Metaphorically, it's like holding up a powerful magnifying glass so that every fault and limitation is emphasised and exaggerated.

Small design details that might pass unnoticed at line level become hugely significant with signals of a few microvolts. Some years ago, one respected electronics whizz told me he'd learnt an incredible amount during the development work on his outboard phono-stage – knowledge that helped him greatly when it came to designing the line-stage and power amp – enabling both to perform far better.

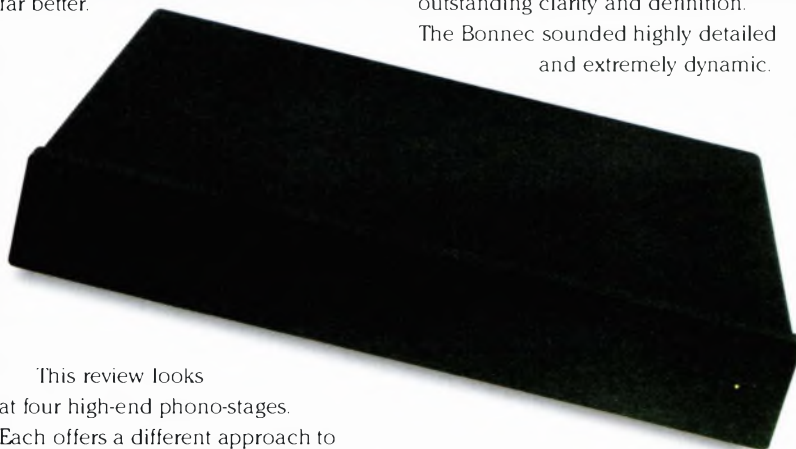

This review looks at four high-end phono-stages. Each offers a different approach to the challenges presented. But perhaps unexpectedly, something all four have in common is – considerable size and weight! In a couple of cases this approaches 10kg, and one is a massive 13kg – surprisingly hefty – and heavier, dare I say, than some integrated amplifiers. It's clear that considerable effort has been spent on every aspect

of design, all to enable LP records to deliver peak performance. Speaking personally, I never cease to marvel at the (seemingly) endless level of quality possible with vinyl; the better the playback equipment, the better it sounds...

### Bonnec Fono

This was the first of the four phono-stages I tried, and straightaway it impressed with a combination of brilliance and immediacy. The musical presentation was very clean and focussed, with excellent detail and outstanding clarity and definition. The Bonnec sounded highly detailed and extremely dynamic.

It was very holographic too, creating a big out-of-the-boxes soundstage that sounded impressively free and lively. Transients were crisp, and the music was portrayed with plenty of energy and verve. Rhythmically, the Bonnec sounded fast and articulate. There was a keen sense of the notes



▶ starting and stopping, creating a suitably brusque 'abrupt' dynamic quality where appropriate.

Background noise is very low, and the music emerges from an impressive 'dark' background. Tonally, the presentation is notable for its vibrant brilliance and sparkling



detail and attack.

Although I'd not describe the sound as rich or warm, neither is it cold or hard. For all that the presentation is sharp and detailed, the tonal balance is actually quite smooth and sweet. It's an attractive engaging kind of sharpness, rather than being unpleasantly forward and 'in your face'. There's the focus and precision of CD, but with a smoother nicer feel.

The Bonnec's in its element on fast high-energy music; anything with strong driving rhythms and crisp articulate detail. It sounds lively and engaging, making sure the music retains its tempo and presence. Which isn't to say it fails to perform on a subtle classical piece or a quiet jazz number – it can sound beautifully smooth and relaxed too. It's just that it's particularly good when it comes to music that requires speed and dynamics. It engages your heart by making the music sound fresh and immediate.

Playing Joe Sample's LP *Carmel* demonstrated this perfectly. Sample's acoustic piano has a brilliant pearly sort

of ring to it, so that the high notes came sailing out of the speakers.

Whereas the Sutherland phono stage (see below) tended to direct your attention to subtle changes of tone colour and dynamics – the interplay between the musicians – the Bonnec

emphasised drama and passion, giving more of a driving, forward-moving, 'live performance' feel to the proceedings. It makes the music sound fast and exciting.

The Bonnec is designed for both MC and MM cartridges, with separate inputs for each and a selector switch on the back. Input and output socket are gold-plated RCA phonos. Although in reality a fairly big heavy unit, it's actually the Kate Moss of the group, weighing a 'mere' 7kg. The casework is made from aluminium, and there are twin

torroid mains transformers fitted inside an internal metal box, employed for screening purposes. There's no loading option, but gain is variable via pre-set pots on the back of the unit. Maximum gain is around 60dB, so there's ample sensitivity for the great majority of MC pickups. Note as well, that the Bonnec

phono-stage is also available as an internal option on the company's Timpano pre-amp. You lose the separate, dedicated power supply so possibly a little performance, but you lose the box too, making it something of a bargain at £1500 on top of the pre-amp itself.

Price: £2250

Supplier: U-phonic

Tel. (44)(0)141 585 8844

Net. www.bonnec.com

### Sutherland Ph.D.

In many ways, this was the most intriguing and unusual of the four phono-stages. Its principle point of discussion is the use of batteries for the power supply – namely 16 chunky D cells. Given my remarks earlier about the sensitivity of phono-stages to power supply irregularities, this is very interesting. The makers assert that all AC power supplies create noise - true. But, they go further, saying that - even if the mains supply from the wall were perfectly quiet and noise-free, there's still the problem of self-generated noise from other electronic components:

In particular, the power amplifier. Given



the nature of the problem, designer Ron Sutherland came up with a noise-free battery supply.

But batteries have their own limitations - a finite lifespan; ▶

▶ reduced performance with age. They either need regular recharging or replacing. In the case of the Ph.D, there's no mains supply, no built in battery charger. Instead, ordinary Alkaline batteries are prescribed. Interestingly, there's no power on-off switch. The phono-stage powers up automatically when a signal is presented. In practise you hear sound within a few of seconds of the stylus touching groove. When you stop playing music, the phono-stage shuts down after about half an hour of no activity. Battery life is said to be around 800 hours – which means about 10 months' use assuming three hours listening each night.

Whether or not it's due to the battery power supply is difficult to say, but the Sutherland Ph.D. turned out to have a very distinct



sound – quite different to the

other phono-stages. There was a deliciously open natural quality that was quite unmistakable. The other phono-stages were very good, but by comparison to the Sutherland they all had a 'signature'; not necessarily an unpleasant signature, but something added. In visual terms it was like looking at several pictures, each with a slight colour cast, and then seeing one without; suddenly the difference is very obvious. My guess is that the battery supply is responsible for this sonic difference, since it ties in with the sort of sound produced by other battery-powered components in my experience.

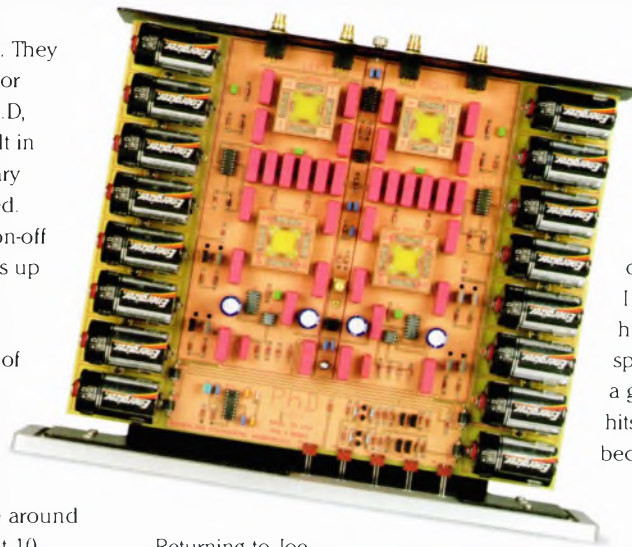

Returning to Joe Sample's jazz classic *Carmel* – see the remarks made about this album in the Bonnec review above – it's impressively recorded, with a bright lively sound that's very dynamic and detailed, the sort of LP that sounds good on most systems. I've got an original American copy, and it's beautifully cut at a nice high level.

The Sutherland brought out the tonal brilliance of the piano, and the crisp impact of the percussion, sounding sharp and immediate. Maybe the sound wasn't quite as brilliant and upbeat as the Bonnec, but it was crisp and detailed by any standards.

However, there was a more important difference. Although the Sutherland sounded immediate and articulate, at the same time, it had a hard-to-describe naturalness none of the other phono-stages quite matched. It's as though the Sutherland preserved more of the individuality of each tone colour, creating a sound that was both vivid and subtly varied. Of course - everything's relative; while listening to the other phono-stages on their own, I felt each one sounded natural and realistic once each had settled in and my ears had adjusted. But nonetheless, the Sutherland had

something extra.

You consistently got a much better idea of specific tonalities and timbres, rather than everything and everyone heading in the same general direction. This individuality, I feel, the hallmark of great hi-fi. When you sense each specific tone colour as (say) a guitarist solos, or a drummer hits the skins, the music becomes more interesting and special – more personal and individual. It's easy to hear, yet hard to convey in a few words. Another way of putting

it is to say that things just sound 'right'. There's suddenly an effortless natural quality that feels accurate and authentic.

In all the conventional hi-fi aspects the Sutherland Ph.D. performs superbly well. It sounds clean, focussed, sharply detailed, and very articulate. At the same time there's superb naturalness and a complete lack of exaggeration and false drama. Actually, for all I've said, I do think there might be some listeners who prefer other phono-stages – in much the same way some people like spicy food or strong colours. The Sutherland is perhaps too refined for some palates; those seeking maximum

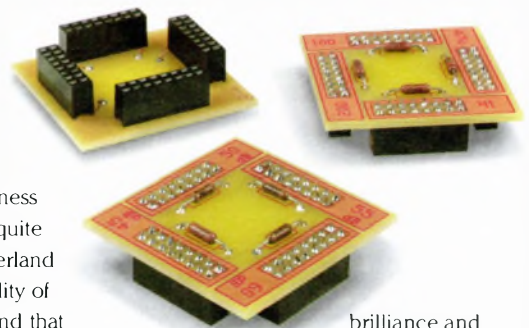

brilliance and excitement might find other phono-stages more impressive and engaging.

But if naturalness is what you want, and you can listen beyond the obvious, the Ph.D. is something extra special. You really feel you want to turn it ▶



► up loud – not because the sound lacks presence or punch, but because it's so effortlessly smooth and natural. Even when it's loud it doesn't sound 'loud'. There's no sense of



aggression or edginess. Yet there's no lack of brilliance either – it's not as though the sound is soft and rounded off. It's genuine naturalness – hard to describe – impossible to replicate.

Playing a brightly recorded compressed DMM LP pop album (Roxette – *Look Sharp!*) I was very taken with the way the Sutherland reduced the metallic edge of the recording. Sure, it still sounded bright; sure, there was plenty of forwardness. But the sound had much greater sweetness than I'd previously experienced. Voices sounded surprisingly smooth and natural, with a clean extended high treble and full liquid mid-band. Bass was firm and well-balanced, with good definition and pitch differentiation – interesting, as this album often sounds somewhat bass-shy.

In many respects the Sutherland produces a very tube-like sound - very open, very smooth, very liquid. At the same time there's the speed and attack of good solid state. Bass is deep and powerful, with good definition and impressive weight. The top-end is beautifully smooth and silky. But it's the mid-band that steals the show – very liquid and effortlessly natural. There's no hint of exaggeration, which gives the whole sound a very natural realistic feel.

Internally, the Sutherland is laid out on a single circuit board in dual monaural style. The 16 batteries are laid

out eight per side, and the circuit is a mirror-image layout. The use of high-value storage capacitors ensures that power supply impedance remains low as the batteries age. There's a quick and simple system for altering cartridge loading and gain. Loading values offered

are 100, 200, 1000, and 47000 ohms, with gain settings of 45dB, 50dB, 55dB, and 60dB. If these values were not suitable, it would be possible to customise the loading boards to produce a different result. The adjustments are made by re-orienting small, square sub-boards piggy-backed onto the main board, one each per channel for gain and loading. It's an elegant and extremely effective solution to a thorny problem.

Build quality is excellent, and having the plug-in board arrangement to alter cartridge



gain and loading is both simple and intuitive. However, you do have to remove the top plate to gain access. Noise is very low. Having a battery supply means that hum should be completely non-existent – and it is. But background hiss is very low too, and the music emerges from a quiet inky-

black background. Powering up from cold, the unit takes little or no time to settle down. In use it runs very cool, and the makers claim there's no 'warm-up' time.

I thought there might've been a slight sonic improvement after about five or ten minutes of use. But that could be imagination! The unit sounded so good the moment it came on, that anything more was simply a bonus. The chassis is made from thick 12 gauge steel. So it's a heavy old unit, weighing in at almost 15Kg. Don't drop it on your foot... This is a remarkable weight, given that there's no mains transformer. Mind you, the batteries (16 in total) weigh quite a bit.

Price: \$3000

NB. The Ph.D is supplied direct from Acoustic Sounds. Importing one to the UK or Europe will attract both import duty and VAT which will be collected by the deliverer before you receive the unit.

Supplier: Acoustic Sounds Inc.

Tel. (1)785 825 8609

1 800 716 3553 (Toll Free)

Net. [www.acousticsounds.com](http://www.acousticsounds.com)

### Balanced Audio Technology VK-P5.

The odd man out among the group, the VK-P5 offers a balanced output and an all tube design. No less than ten valves are used; eight 6922s and two 6SN7s. It's comfortably the biggest of the group, and the second heaviest - weighing around 13Kg. Maximum

▶ gain is 56db – a little lower than usual – but sufficient for all but the lowest output MC cartridges. To cater for most eventualities, it's possible to alter cartridge loading from 47k Ohms to 100 Ohms. Intermediate values of 1k Ohms and 10k Ohms are also possible. You can add extra capacitance too – 100pF, 470pF, and 1000pF – though this typically has little or no effect on low impedance MC pick-ups; it's more effective with high impedance MM types.

Being a tube design, the VK-P5 inevitably raises certain expectations – or should that be prejudices? Would it live up to the typical warm/smooth/rich valve stereotype?! In some ways, yes... I felt it gave an immensely likeable sound; warm and smooth certainly describe the effect, but it sounded detailed and clear too, with outstanding definition and clarity. It's certainly impressive (in all the right ways) when you first listen to it. But the experience deepens as time goes on. It produces a deceptively subtle and finely shaded sound. Detail is excellent, but often it's implied rather than underlined. The VK-P5 is exceptionally easy to listen to; it soothes and caresses the ear. But don't be fooled; it's very much an iron fist in a velvet glove.

One of the stranger LPs I played during the tests was a disc called *Phases of the Moon* consisting of Chinese traditional music. It's an analogue recording made in China during the late '70s, but issued in the UK on CBS. I've actually had the disc for over 20 years, and the music's very nice, very atmospheric, and extremely varied – from quiet solo instruments to a small orchestra. But to be honest, although the album made a positive impression musically, I didn't think the sound was anything particularly special when I first heard it. However, over the years it's miraculously got better and better

as my LP playback equipment has improved. I now realise that the recording is actually rather good – extremely natural and well-balanced, with excellent soundstaging, realistic depth, and a very believable ambience.

Playing this LP via the VK-P5, I was immediately struck by the overall smoothness and naturalness of the sound. There was a lovely liquid quality that made even quite 'busy' strenuous



passages sound natural and relaxed. Yet, plucked instruments had real impact, despite sounding smooth tonally. One of the things I like about this recording is the sheer variety of all the different sounds. The dynamic range is very wide, and the range of moods extremely varied. One minute a single instrument will be playing quietly, and then more and more join in, creating a vivid kaleidoscope of tonalities and textures.

What really impressed was the way the VK-P5 managed to sound vivid and immediate, while at the same time retaining a lovely effortless quality. Sudden abrupt changes in the music were conveyed with absolute naturalness – for example, a sharply-plucked string would have presence and bite, yet sound perfectly integrated and effortlessly natural. In other words, detail wasn't being pulled out and thrust at you all the time; dynamic

contrasts were recreated without the sort of false exaggeration that can sound impressive in the short term, but quickly tires long-term.

On the debit side, the VK-P5 proved slightly noisier than the other phono-stages in the test. For the most part, the noise wasn't obtrusive; when playing music, it was well below the noise floor of all LP records. But, compared to the others, the VK-P5 produced a gentle 'shush', mainly mid-band noise with a softish high frequency hiss. With the

Transfiguration Aria cartridge used for the tests, the noise would not be noticeable unless you were hyper-critical of such things. If you were, a higher output cartridge – one in the 0.5mV region or more would help.

The VK-P5 is provided with a balanced output via XLR sockets. To use it with an unbalanced input, you'd simply connect up to either one of the two 'hot' pins with ground. But if you were able to use the VK-P5 balanced, it would improve sound quality over the unbalanced option. I was able to do this, and felt it increased depth and transparency, as well as giving a slight increase in fine detail and spaciousness. Balanced working gives a 'bigger' sound – not just louder, but larger with increased presence. I used a transformer to create a balanced input. But if instead you partnered the BAT with an amplifier than had an electronic balanced input, you would enjoy an increase in gain of approximately 6dB compared to unbalanced working.

Price: £1515

Supplier: Metropolis Music

Tel. (44)(0)1892 539245

Net. [www.metropolis-music.co.uk](http://www.metropolis-music.co.uk)



► **Renaissance Amplification Music Re-Performance moving-coil phono-stage.**

Weighing in at almost 10kg, the Renaissance Amplification phono-stage wasn't quite the heaviest of the group – but it's still a remarkable weight when you consider it has an outboard power supply! What makes it so heavy? It's a combination of thick steel casework, and – get this! – transformer coupled inputs AND outputs. A quick look inside reveals dual-mono construction, with left and right channels completely separated. There are a couple of smallish printed circuit boards with a handful of components on each; very minimalist. In part that's because the active elements use ICs, but it's the simplest of the four units on test by a country mile.

Under the lid there are two round metal boxes, each containing an input transformer, and two smaller torroid transformers that couple to the output – a most unusual arrangement. Amplification and RIAA correction are accomplished by use of the aforementioned ICs. The outboard power supply is fairly light in weight, and keeping it separate from the phono-stage eliminates the possibility of mains hum. It should also help reduce some of the effects of mains noise. Perhaps for this reason, the Renaissance had certain qualities and characteristics in common with the Sutherland Ph.D. Tonally, there was a similar openness and naturalness. But added to this was an extra sense

of weight and power.

The Renaissance Amplification Music Re-Performance phono-stage sounded exceptionally focussed and very cohesive. It offers a superbly detailed, lucid presentation, with excellent clarity and definition.



Bass sounded full and weighty, with impressive power and solidity. The overall impression was of a smooth well-balanced presentation that offered space and depth while remaining focussed and open. The sound was natural and unforced despite

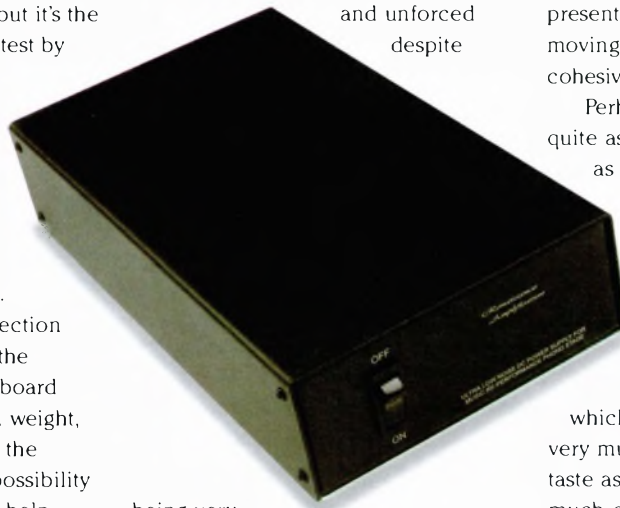

being very detailed and articulate.

The high treble sounded very clean and smoothly integrated with an open liquid mid-band. Bass was full-bodied and powerful, with impressive weight. Transient attack

was strong and clean, with excellent portrayal of dynamics. The tonal balance was lucid and crisp; tactile and sharp, rather than warm and beguiling. Yet the sound remained easy on the ear. It wasn't hard or brash, despite being brilliant and exciting.

Time and again what impressed was the cohesiveness of the sound – the way everything held together. On percussion, for example, there was transient excellent attack – a proper sense of (say) stick hitting metal or skin. But, for all that the sound was sharp and immediate, the ear was never assaulted by an uncoordinated welter of leading edges; there was no loss of control. Even during difficult complex passages, the music held together rhythmically. The overall presentation was fast and forward-moving, but very integrated and cohesive. It's a potent mix!

Perhaps the Renaissance wasn't quite as relaxed and natural-sounding as the Sutherland but it remains a close call. The mix is slightly different. The Renaissance trades a little relaxed sweetness and ease for added bite and immediacy.

But so what? It's very hard to say which one's better – which one's right. Ultimately it's very much a question of personal taste as to which is preferred. Also, much depends on your hi-fi system and the sort of music you listen to. It's akin to liking a front-row seat, or one a bit further back. The main thing is, the Renaissance always sounds believable and convincing. Musically, there's a 'rightness' about it that's very engaging and involving. ►

► It proved capable of subtle delineation on *Phases of the Moon*, managing to hold the various disparate elements together. While it could be delicate and refined on a solo instrument, it retained control when the music grew in complexity and scale. Speaking personally, I'm very keen on transformer coupling for this reason – if it's done properly one should notice important gains in cohesiveness and solidity; the music should sound much more focussed and firmly-placed in terms

to alter gain or change cartridge loading – it's 40 ohms as standard – although it wouldn't be difficult to solder resistors across the input terminals to change the loading if this were desired. Gain is quite high – around 68dB – ensuring plenty of output. Noise levels are very, very low, and the music emerges from a clean quiet background.

Price: £1495  
 Supplier: Integrated Engineering Solutions  
 Tel. (44)(0)2380 905020  
 Net. [www.highendaudio.co.uk](http://www.highendaudio.co.uk)

combination of smoothness, warmth, brilliance, and lucidity. It has a lovely naturalness that, once heard, is quite irresistible. It's not the most exciting, though! You can't have everything...

But the Renaissance impressed too, with its combination of naturalness and brilliance, giving a sound that offered much of the Sutherland's warmth and smoothness with extra bite and attack. It produced a very lucid cohesive sound that ensured maximum detail without losing control and becoming messy. Very quiet too, and extremely clean-sounding - like the best CD player you never heard..

For sheer lushness, the Balanced Audio Technology VK-P5 took a lot of beating. It produced an extremely smooth yet lucid sound that was open and very well balanced. Being all-tube, it proved slightly noisier than its solid-state rivals – though it should be noted that the noise produced (mainly a soft mid-band hiss) would usually be lower than the noise floor of most LP records. You'd ideally need to look elsewhere if using very low-output cartridges like the Ortofon MC7500.

I liked the Bonnac very much. The first of the four I listened to, it immediately impressed with its combination of brilliance and lucidity. It's exciting to listen to, and superbly immediate. It really conveys the driving energy of the music, making listening an almost tactile experience. It's somehow smooth and refined, in a brilliant sort of way – if that makes any kind of sense! There's never a dull moment with this phono-stage..

Or in their own ways, the others tested here. You pay your money and you take your choice, but for once you're guaranteed a result whichever way you jump.



of soundstaging. Aside from all that, it's a simple elegant way of boosting the low output of an MC cartridge without incurring noise penalties. Providing the transformers used are up to the job, there are many benefits and very few drawbacks.

The Joe Sample album sounded very crisp and detailed, yet natural and extremely open too, with excellent attack and impressive impact. Again, the sound was satisfyingly solid and focussed, creating an impression of clarity and weight. Sonically, the instruments really do materialise between the speakers – you almost feel you could reach out and touch the piano or the drums - it's that tactile.

Unlike some of the other phono-stages there appears to be no option

## Summary

When faced with four products as good as this, it's hard (and not necessarily useful or sensible) to choose a "winner". Frankly, I'd be very happy to live with any of the four. But if backed into a corner, I'd probably go for the Sutherland Ph.D – choosing it for its sheer truthfulness and subtle tonality. It really plays to the strengths of analogue, producing a winning





'Superb amplifier with bags of power and genuine resolution, one of the best music appreciation devices available.'  
 BorderPatrol P20, Jason Kennedy Hi-Fi Choice Summer 2002.

'.....for the first time in my experience, I'm listening to an amplifier with the linearity and directness that are supposed to be single-ended's great virtues'  
 BorderPatrol SE300B  
 Roy Gregory Hi-Fi+ issue 8.



**BorderPatrol**

Tel/Fax 00 44 (0)1242 717171

e-mail bp@borderpatrol.net

www.borderpatrol.net

**"Listen up, and don't skip over this section, 'cos I'm about to reveal the biggest improvement in my hi-fi system for a decade."**

- Paul Messenger, Vertex AQ Review, Hi-Fi+ Issue 29

**vertexaq**

Want to know more?  
 Visit [www.vertexaq.com](http://www.vertexaq.com)  
 or contact the following dealers:

The Right Note Bath  
 01225 874728

Acoustic Arts Watford  
 01923 245250

Audio Destination Tiverton  
 01884 243584

Hazlemere Audio High Wycombe  
 01494 865829

Progressive Audio Rainham  
 01634 389004

Midland Audio X-change Birmingham  
 01562 731100

Kevin Galloway Audio Kilmarnock  
 01563 574185

**Heatherdale**  
 audio limited

202, Findon Road,  
 Worthing, BN14 0EJ

Pre-owned Equipment Available with Guarantee  
 Export Facilities Available. Visit our Web Page [www.hifi-stereo.com](http://www.hifi-stereo.com)  
 Main dealer for Mark Levinson Reference products

**SPEAKERS**

Tannoy Monitor Gold 12" in Lancaster size cabernets £795  
 Rel Strata 3 Sub Woofer (ex-demo) £750  
 Revel F50 Speakers (New) £4495  
 Audio Physics Tempo Speaker £995  
 Eltax Symphony Floor Standing Speakers £99  
 Orchid LWO Speakers Ex Demo £2495  
 Eltax Floor Standing Liberty 5-Speakers £140  
 Acoustic Research 338 Stand Mount Speakers £275  
 Warfedale Diamond II Speaker £60  
 Revel F30 Loudspeakers Ex Demo were £2995 now £2395

**PRE-AMPS**

Proceed PAV Pre Amp £1395  
 Conrad Johnson 16LS Pre Amp £3995  
 Naim Nac 92 Pre Amp £350  
 Sony 1000 ESD Digital Pre Amp £150

**AMPLIFIERS**

LAB 47 Gaincard Amp 25wpc (unused) (retail £1260) £895  
 Lab 47 Power Supply for Gaincard (unused) (retail £1520) £995  
 Mark Levinson 431 Power Amp (our demonstrator) List Price £5995 Our Price £4995  
 Mark Levinson 20.5 Ref Mono Blocks Immaculate Condition + Boxed £4995  
 Mitchell Alecto Amplifier £695  
 Mark Levinson 383 integrated Amp £4495  
 Boulder 102 AE Power Amp £1595  
 Adcom GFA 5300 Power Amp £350  
 Musical Fidelity P180 Amps with MF 3A Pre Amp with PSU £995 now £695  
 Hafler DH-200 Amp £125  
 Advantage integrated Amp £1495

**DVD**

Yamaha DVD-S795 £145

**DACS**

Mark Levinson 36s dac £1995  
 CEC DX51 mk2 DAC w/ CEC TL5 Trans £1995

**CD PLAYERS & TRANSPORTS**

Roksan Attezza CD Transport with ROC DA1 DAC and ROK DS4 PSU £895  
 Accuphase DP67 CD Player Unused £2995

**MISCELLANEOUS**

Selection of high quality Kontak cables, balanced & single ended  
 Shunyata Xdemo 3m Lyra Speaker c/w Spades w/locking Connectors was £1500 £995  
 Stax SR007 Omega Ref (SR117) £1995  
 Stax 40/40 Headphones £850  
 Audio Note (Kondo) Digital Silver Litz Cable, 1m, Boxed, Mint Condition, Price New £700, Our Price £475

Lektrapacks CDM-820 Multisystem Converter £125

**TURNABLES, CARTRIDGES & TONEARMS**

ZYX R100FSL (0.24mv) silver coils (unused) (retail £780) £550  
 Pro-Ject RPM 6B Turntable (unused) no cartridge fitted (retail £500) £350  
 Selection of Brand New Discounted Cartridges  
 Rega Planar 3 Turntable/RB250 £195

We now offer 0% finance (subject to status).  
 Please phone to arrange an audition  
 Main Dealers for Mark Levinson, Thiel, & Absolute Sounds  
 Switch, Mastercard, Visa Diners Club, American Express

Tel: 01903 872288 or Evenings 07860 660001  
 Fax: 01903 872234  
 E Mail: [heatherdale@hifi-stereo.com](mailto:heatherdale@hifi-stereo.com)

# Hazlemere Audio

If you *value the best*  
(rather than just the most expensive)

Spectral



*Cables*

Avid  
Siltech  
Spectral

*Speakers*

ART  
Peak Consult  
Reference 3A  
Verity Audio

*Digital*

dCS  
Opus 21 (new from Resolution Audio)  
Orpheus  
Oracle  
Metronome

*Amplification*

DNM  
Lamm  
Nagra  
Orpheus  
Plinius  
Renaissance  
Spectral



*Supports*

Avid  
Clearlight  
Kinabalu

*Avid Acutus Turntable*

*Vinyl*

Avid  
Garrard  
Lyra  
Oracle

*Power supply*

Accuphase  
Isotek  
Jaya  
Loricraft

Audio Analogue  
Creek  
Ecosse  
Fanfare  
Gamut  
Harmonic Technology  
Ortofon  
Piega  
SME  
Sugden  
Triangle

For an appointment (day or evening) call High Wycombe

**(01494)  
865829**

## LAMM INDUSTRIES, INC.



[www.lammindustries.com](http://www.lammindustries.com)



Quite simply... the world's best audio electronics

**Distributed in the U.K. by:**  
Integrated Engineering Solutions Ltd.  
(023) 8090 5020 (tel.)  
(023) 8070 4073 (fax)  
[info@highendaudio.co.uk](mailto:info@highendaudio.co.uk)  
[www.highendaudio.co.uk](http://www.highendaudio.co.uk)



*M1.2 Reference*  
pure class A  
power amplifier

**NEW**

*a continuation of the Lamm tradition*

**Analogue?**  
Digital?

### The best of all worlds...

Digital?  
Analogue?

Enjoy your choice of recorded music to the full, courtesy of the world's best audio electronics  
Phono stages by Lamm and IES provide the full glory available from your vinyl collection  
Realise the full potential of CD with players and transports by Metronome Technologie  
Hear the best of all worlds with preamplifiers and power amplifiers by Lamm and IES

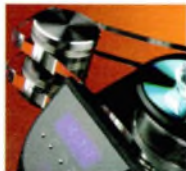

Meet us at the Hi-Fi Show & AV Expo 2004, Syndicate Rooms 4 & 5, Park Inn, Heathrow, 24<sup>th</sup> to 26<sup>th</sup> Sept  
UK distributor for the world's best audio electronics  
Integrated Engineering Solutions Ltd - 023 8090 5020 [www.highendaudio.co.uk](http://www.highendaudio.co.uk)



# pear audio

presents

**Shahinian**  
**DYNAVECTOR**  
**Well Tempered**

Stockists and Information  
 from:

Pear Audio Ltd.  
 7 Prospect Place, Alnmouth,  
 Northumberland, NE66 2RL  
 Telephone: 01665 830862  
 Fax: 01665 830051

## The Cartridge Man

We sell our own MusicMaker cartridge, digital stylus force gauge and digital turntable level. We also carry a limited range of valve equipment - Croft, E.A.R. - and pick up arms - Hadcock, S.M.E. Ortofon, Graham Slee Projects and a few other high quality products.

We also rebuild classic valve equipment, giving you a choice as the level of specification. We have in stock a range of original Mullard valves, including the sought after EL 34's. Also available is a turntable setting up service, this is free when you purchase one of our cartridges as is our Test Record.

We don't believe that quality is necessarily synonymous with massive amounts of 'dosh', we encourage customers to purchase second-hand items where appropriate. Sound quality come before cosmetics. Remember it doesn't have to cost an arm and a leg... And don't forget our cartridge rebuild service.

88, Southbridge Road, Croydon, CRO 1AF. tel/fax; 020 8688 6565. [www.thecartridgeman.com](http://www.thecartridgeman.com)

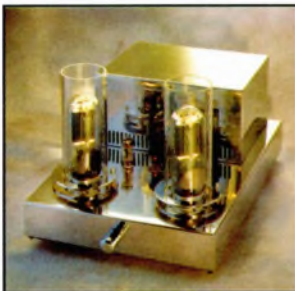

**Art Audio**

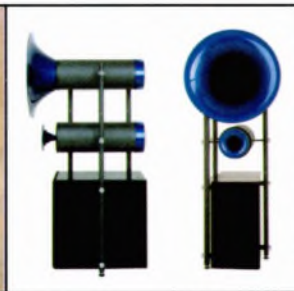

**Avantgarde**

**Hear Here**

Call to audition, or for our "Beginners' Guide to Valves"

Tel: 020-8875 9696 or 07768 738372  
 Email: [hearhere@onetel.com](mailto:hearhere@onetel.com)



SPEAKER INSULATOR BASES

C H A I R · M A N

*Darrell Strub*

(310) 824-4811  
 FAX: (310) 824-5543

914 WESTWOOD BLVD SUITE 193  
 LOS ANGELES, CA 90024

# Size Matters...

by Jason Kennedy

In an ideal world the truly remarkable ATC SCM150A SL would be a domestically desirable loudspeaker,

however in an age when speakers like the LS3/5a are considered quite big enough thank you, this would seem to be a pie in the sky dream. All right, these ATCs are big but no bigger than a chest of drawers or small fridge – most homes have space for them. More and more homes make space for enormous tellies too. I've been to a number of houses belonging to wealthy individuals where the living room is dominated by a 42inch plasma TV, but finding the 5.1 channel surround sound speakers to go with it takes a bit of effort. Usually there are some of those plastic Bose things lurking in discreet locations with a plastic 'subwoofer' sitting somewhere behind the sofa. The sound that

emanates would be embarrassing for a transistor radio but in an era when interior décor has been elevated to a religion, the only sound source allowed in the modern home is a virtually invisible one. The irony is that when you're not watching them TVs are considerably less attractive than most loudspeakers.

Now even I have some difficulty in describing these ATCs as the sort of attractive objects that would positively

enhance a stylish interior, but if you have reasonably capacious room there's no reason why they shouldn't



fit in. In their domesticated veneered form they have a retro appeal that any music lover should be proud of.

Back in the day, or the seventies as they're known, larger speakers were quite popular things, the Sandwich coned Leak, JBLs and numerous Wharfedales each took up more living room space than a whole home theatre in a box. In some respects this was because the speaker was considered to be the most important

part of the component chain.

Unfortunately a certain Scotsman figured out that by challenging this

hierarchy with a source first approach he could make lots of money. Along the way he produced some small speakers that while hideous in many respects did seem to appeal to the more masochistic audiophiles. But even Linn made a decent size loudspeaker in the shape of the Isobarik. What is most regrettable about modern fashions is the way that they exclude 'proper' sized speakers that have internal volume that is equal to the difficult job of reproducing wide band, wide dynamic range music at a volume level that is adequate to a fully immersive musical experience. These ATCs are that speaker precisely, they make no concessions to styling

and are as ever with the brand rather less expensive than they should be – can you imagine Naim or Linn producing an active loudspeaker of this size for less than twice what's being asked here?

Measured TV style, diagonally across the baffle, the 150s are smaller than a 42inch screen but take their depth into account and you have what it takes to make a 150 litre box. The difference between this





▶ speaker and its 50 litre stablemate the SCM50A is quite astonishing. I had expected a similar sound with better bass extension; after all, the tweeter is the same 25mm dome with a silver voice coil and a double magnet system. Ditto for the midrange dome, a hand-built Super Linear design with a 75mm soft dome. It's only the 15inch doped carbon reinforced paper bass cone in place of the 50's 9inch unit that separates the two.

Perhaps surprisingly the active power amplification and electronic crossover pack on the back of the SCM150A SL mirrors that on the SCM50 with its 350 watts of combined power. Three separate power amps (50 watts to the tweeter, 100 watts to the midrange and 200 watts to the bass unit) operate in class A up to two thirds output.

These speakers may be able to deliver 118dB but they are immensely sophisticated. This is not a brute even if it might look like one in all black Pro guise. It's a highly revealing speaker that does for your record collection what no amount of remasters could hope to. It reveals what the music is all about by exposing aspects of recordings that seem so obvious that you can't understand why they weren't clear or at least noticeable before. One example is Joe Walsh's track 'Dreams'. The vocals on this are recorded separately in mono in each channel, they are used individually and together to great effect and the SCM150A SLs make the fact blindingly obvious, yet previous power amp/speaker combinations have never made this clear.

It could be because the speaker has a level of distortion/coloration that is way below the norm and combines



this with a breadth of bandwidth and dynamic range that allows the music to breathe. All the power and majesty of Beethoven's *Fifth* (Gardiner) can be appreciated without a sense that the speaker is clamming up when the level rises – it makes the hairs stand up on the back of your neck.

Having so much volume to work with makes this a naturally very capable design when it comes to providing energy. Play something lively and powerful and you know precisely all about it. Inevitably one is tempted to play everything just that little bit louder as well, simply because it's so much fun. And of course some records sound better than others and this is more obvious than usual,

Richard Thompson's *Old Kit Bag* is simply stunning recording and a good example of the superiority of vinyl.

Zappa's *Apostrophe* on CD is flat and not a little brash, but you can still hear a lot more than usual, the guitar on the title track is pure filth.

I could go on but the bottom line is that the SCM150A SL is a phenomenal speaker and one of the main reasons for this is that it is of a decent size. You can't beat physics if high fidelity is the goal, so damn compromise and set your sites on genuine home entertainment. ▶✚

#### TECHNICAL SPECIFICATIONS

Type:	Three-way, active loudspeaker
Drive Units:	
Tweeter:	25mm soft dome, silver voice coil, double magnet system
Midrange:	Soft Domed SM75-150S
Bass:	375mm (15inch) with additional voice coil spacers Super Linear Magnet Systems
Amplification:	350watt proprietary three-channel amplifier with 4th order electronic crossovers
Output Level:	Capable of up to 118dB continuous Power Output
Finishes:	Professional Black, Black Ash, Cherry, Walnut, Yew and Rosewood real wood veneers.
Price:	£11,600
Manufacturer:	ATC Loudspeaker Technology Ltd, Tel. (44)(0)1285 760561 Net. <a href="http://www.atc.gb.net">www.atc.gb.net</a>

# Romeo or Juliet?

## The Townshend TA 565 and McCormack UDP-1 universal digital disc players

by Alan Sircom

*Two products, both alike in modification,  
In fair Hi-Fi+, where we lay our scene,  
From Pioneer footing break to new  
appellation,  
Where designer outline makes designer  
styling pristine,  
From forth the CAD programs of these  
two foes  
A pair of star-cross'd players spring to life;  
While Wattle contended Confederate Rose  
Do with their aspect peak their  
makers' strife.  
The cheerful passage of their  
disc-mark'd test,  
And the continuance of their  
makers' gauge,  
Which, but their execution,  
nought could best,  
Is now the two thousand words'  
traffic of our page;  
The which if you with patient  
eyes attend,  
What here shall miss, our toil shall  
strive to mend.*

OK, so this is no Romeo and Juliet and I am no Shakespeare, but this pair of star-cross'd players from Townshend and McCormack need a prologue. Both the TA 565 and the UDP-1 have been reviewed in previous issues of Hi-Fi+ and there is no sense going over old ground. But both products were only reviewed in their stereo guise and these are multi-channel players as much as stereo performers. How do the two shape up?

In many respects comparing the two is almost pointless; they aim at different targets and make different sounds for entirely different markets. Additionally, in reality, it's unlikely that

people thinking of buying one would (or should) countenance the other; although similarly priced, the players simply move in different circles.

The TA 565 is likely to feature in what could be classed as the 'New Wave Of British Hi-Fi' – partnered with the likes of Tom Evans or Border Patrol electronics. The McCormack (with its Mod Squad and now c-j lineage) is classic High-End material and will be used in systems with famous name equipment from the established US high-end.



The two approaches rarely conjoin, except in rare products like Jadis.

But on the surface at least, the similarities seem compelling. In the titanium finish, there is only £100 between the McCormack and the Townshend, with the UDP-1 costing £2,800 and the TA 565 £2,700. Under the caseworks, they are pretty similar, too. They are both based upon Pioneer universal DVD players, with similar circuitry inside. Of course, basing a player upon a Pioneer should be

considered little more than a blank canvas, a bit like saloon car racers basing their racing cars loosely upon a standard rep-mobile, and these players bear only scant similarity to the base Pioneer model.

There are standard points of interest across these models; places where both manufacturers have modified the basic Pioneer concept in their own sweet ways.

Both have addressed the power supply; McCormack building their own circuit board populated with expensive components in the same box as the rest of the player, while Townshend effectively removes this section into a separate housing. Similarly, both have addressed the analogue output stage of the player in their own way, replacing or hot-rodding the existing electronics in order to bring the Pioneer in line with the ethos of the company involved. There's no shame in this; some of the best products in history have taken an existing product and revolutionised it



Why is live music so different to ordinary stereo?  
**Dynavector**, famous for its cartridges for over  
 25 years, think they know the answer and so have  
 developed their SuperStereo Adapters Adp-2 and  
 Adp-3, an easy addition to your audio system.

"extraordinarily convincing" ... "simply sounds more natural.."  
 on the Adp-2 by *Hi-Fi Choice magazine*  
 and  
 "Indispensable for listening to music"  
*Stereo Sound*, Japan.

Adp-2 (£895) and Adp-3 (£1,495), info & sales direct from:



**Dynavector (SuperStereo)**



Tel/Fax: (01202) 767873  
 E-mail: [dynavector@onetel.com](mailto:dynavector@onetel.com)  
 Net. <http://web.onetel.com/~dynavector>

**Voodoo Isolation systems**  
 hand crafted audio furniture,  
 for music lovers only.



PNEUMATIC ISOLATION PLATFORMS. INTEGRATED RACKS  
 SPEAKER PLATFORMS AND STANDS. EXCELLENT REVIEWS  
 A CHOICE OF REAL WOOD FINISHES. CUSTOM WORK UNDERTAKEN.  
 ALSO THE RANGE OF EXCELLENT SILVER ARROW CABLES.  
 TEL +44 (0) 1 643 841244 E-MAIL [voodooolek@hotmail.com](mailto:voodooolek@hotmail.com)  
 DEMOS BY APPOINTMENT.

Analysis-Plus  
 Audia  
 Audion  
 Audio Physic  
 Avid  
 Ayre  
 Bel Canto  
 Chapter Audio  
 Chord  
 Isol-8  
 Monitor Audio  
 Moon  
 Musical Fidelity  
 Primare  
 Tannoy  
 Thiel  
 Totem Acoustics  
 Tube Technology  
 Vertex-AQ  
 and many more

**Audio Destination**  
 DEVON'S AUDIO SPECIALISTS

Want to hear your music come to life?  
 Come and hear what we can do



Free advice in a relaxed & friendly atmosphere  
 2 demonstration rooms · Childs play area  
 Home demonstrations - 0% Finance available  
 Mon-Sat 9am-5pm - Out of hours appointments  
 t: 01884 243584 [www.audiodestination.co.uk](http://www.audiodestination.co.uk)  
 Mike & Caroline look forward to seeing you  
 32B B mpton St eet, Tiverton, Devon EX16 6AH

No other machine does it better.  
 and that's a promise.

**HW16.5**

"The Worlds best-selling record cleaning machine."



01579 363603

[info@cherished-record-company.co.uk](mailto:info@cherished-record-company.co.uk)

[www.cherished-record-company.co.uk](http://www.cherished-record-company.co.uk)

the stunning new valve tuner from  
**synthesis**

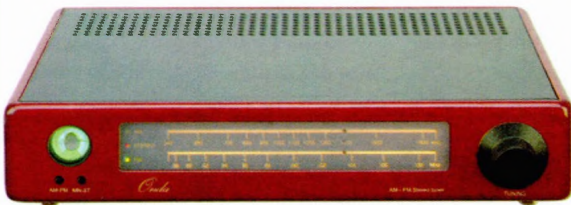

With the best choice, advice & service  
 For all that is real Hi-Fi & Home Cinema

AUDIO IMAGES IS THE SHOP. CALL NOW ON 01502 582853  
 128 LONDON ROAD NORTH, LOWESTOFT, SUFFOLK. NR32 1HB

**audioimages**

**Infidelity**  
 INDECENTLY GOOD HI-FI

Buying hi-fi should be a delight.

If choosing your new hi-fi in a civilised and relaxed  
 atmosphere from a well-chosen selection of genuine  
 performance equipment appeals, then we are for you.  
 Bring along your own records or CDs, we'll provide the  
 coffee, and hear the difference we can make.

9 High Street, Hampton Wick,  
 Kingston upon Thames, Surrey KT1 4DA

Telephone: 0208-943 3530



Open: 10am - 6pm, Tues - Sat (inclusive)



naim  
focal jm lab  
cyrus  
accuphase  
spectral  
pathos  
unison research

krell  
audio research  
sonus faber  
proac  
linn  
nordost  
siltech

the audio room  
2 george street, hedon, hull, HU12 8JH  
tel: 01482 891375  
www.theaudiroom.co.uk  
open: mon - sat, 9am - 6pm

## SHUNYATA RESEARCH

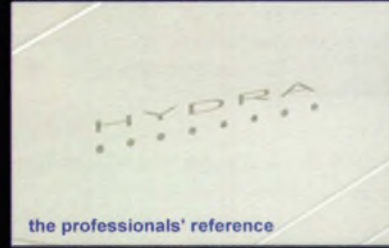

the professionals' reference

UK representation

AUDIO ATMOSPHERE  
29 Drake Avenue Penkridge Staffordshire ST19 5UA  
tel 01785 711232 stuart@audioatmosphere.com  
WWW.AUDIOATMOSPHERE.COM



For people who love music...and custard

3 Gibb Terrace, Gibb Street,  
Custard Factory, Digbeth, Birmingham B9 4AA.  
Tel: 0121-224-7300 Web: www.griffinaudio.co.uk



## TIME TO TRY ...



Stockists of:  
Naim Audio  
Conrad Johnson  
Accuphase  
J M Lab  
Dynavecator  
Rega Research  
Cardas  
Totem Acoustic  
Sugden  
Unison Research  
Quadraspire  
Wadia  
Dynaudio  
and others ...

Audio Republic, 78 Otley Road, Headingley, Leeds, LS6 4BA  
Tel: 0113 2177294 www.audio-republic.co.uk



## Music Matters

The finest hi-fi, Home Cinema and Multi-room systems -  
from a selected range of suppliers

On demonstration:

Arcam. Audio Net. Base. Bowers & Wilkins.  
Chord. Cyrus. Dynaudio. Epos. Isotek. KEF.  
Living Control. Marantz. Meridian. Musical Fidelity.  
Naim. PMC. Project. Rel. Wilson Benesch

And much, much more.....

Demonstrations available by appointment  
020 8420 1925

344 Uxbridge Road, Hatch End, Pinner, Middlesex HA5 4HR  
Open Tuesday - Saturday 10am - 5:30pm



## Midland HiFi Studio

[Tel/Fax. 01902 380083]



9 Finchfield Rd West,  
Finchfield, Wolverhampton WV3 8AY



\* NEW WEBSITE \*  
www.midlandhifistudio.co.uk





▶ (Carroll Shelby, for example, took a little-known British sports car, added a massive Ford engine and created the AC Cobra, and someone recently had the bright idea of mixing the humble baseball cap with the famous Burberry pattern to produce an icon of modern British chav-wear).

But this really isn't about the specification of the products; you'll need to check back through previous issues of Hi-Fi + for the

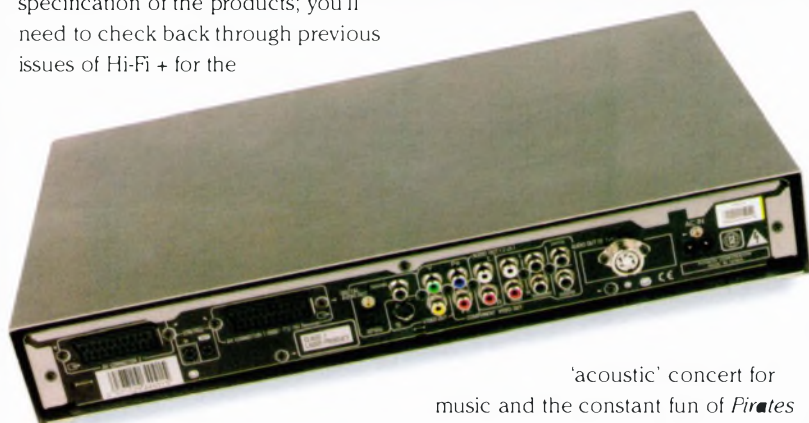

specifics.

Nor is this a test of the stereo sound of both products. The performance of both has been well covered in previous tests. No, this is a specific comparison of the multi-channel performance of both in DVD-Audio, DVD-Video and SACD flavours, and whether products like these (from what can be classed as traditional two-channel specialists) really mean that its time for stereo fans to start circling the wagons.

The first – and possibly most important – port of call is DVD-Video replay. This may seem odd in a magazine dedicated to music reproduction, but the bulk of your music in surround sound will likely be in this format. Aside from the tiny collection of classic albums garnered from the American on-line sources for DVD-Audio and SACD ([www.highfidelityreview.com](http://www.highfidelityreview.com) is the best source of information for US releases. It makes the multi-channel music market seem almost buoyant) this is about your lot. So, most of your operas will have video content, most of your music will come with videos attached

and most of your surround sound will be Dolby or DTS encoded – it's a fact of life simply because these DVDs can be purchased in the local HMV shop and DVD-Audio and SACD cannot.

From the outset, it's clear that both players are doing very different things to the same recordings, in this case the obligatory Eagles' *Hell Freezes Over*

'acoustic' concert for music and the constant fun of *Pirates of the Caribbean* for movies. Oh, and the Baz Luhrmann *Romeo + Juliet* (naturally). The picture performance is not greatly changed from one player to the other – both are good products from the pre-digital video connection days (that is, 2002/2003, with products



without HDMI or DVI-D digital links). There is a slight picture advantage to be had with the Townshend player; the McCormack seems to produce pictures on a par with standard Pioneer players, while the Townshend seems to add a little more layering to the image. Such differences are fractional, however, and neither product should be chosen on the basis of picture alone, especially when a HDMI-equipped Arcam or Denon will out-picture both players for a fraction of the price.

The sound quality in DVD-Video marks out the first big changes. The players begin to develop their own characters rapidly. Townshend's player is exceptionally clear, tight and detailed, where the McCormack makes a more rounded, warmer sound. This is no small difference: the two are radically different in tone. Both seem exceptionally good at articulating vocals through the centre channel, making them hang in space with a sense of solidity and physicality that makes you think people are really in the room with you. It's just that the McCormack focuses on the physicality of the sound and the Townshend highlights the informational content. Both make the hairs on the back of your head raise up, but do so for very different reasons.

Once you shift to dedicated multi-channel music sources, these differences become all the more apparent. DVD-Audio first. Here the McCormack delves into the inner structure of the sound from all channels, presenting the sound with ease and precision, but with an all-pervading sense of musical coherence. In contrast, the Townshend presents the music with extended detail, marking out individual elements in

the sound with unparalleled almost military precision. In other cases, this would mean the McCormack is soft and spongy sounding and the Townshend bright and soulless. Fortunately, both players are above this; they are both musically communicative and both detailed, just with slightly different accents. All genres of music on DVD-Audio were used, but

▶ perhaps *Riders on the Storm* by the Doors highlighted the differences the best of all. Here, the distant storm in the rear channels placed the accent on the storm in the McCormack and the falling rain in the Townshend.

SACD continued to highlight the differences in the same manner. The Townshend was the more immediately detailed of the two, the McCormack the more natural.

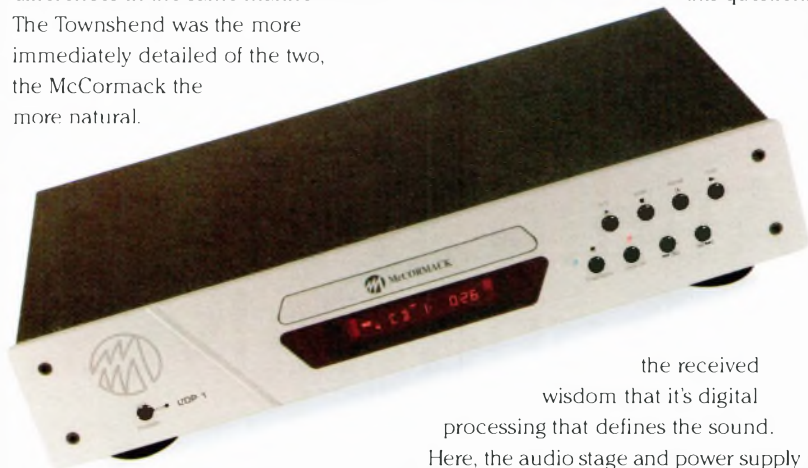

*Tangled Up In Blue* by Bob Dylan was as if played in two different mixes, but ultimately the detail won out. The McCormack player made the entire performance desperately musical, but if you want to know exactly who's playing what and where in the mix (it's a complex piece of music), the Townshend delves deeper and higher into the upper registers, too. It remains a trade-off, however.

Between the two, the Townshend is the better SACD replay device, the McCormack is superior at playing DVD-Audio. This might reflect simple national prejudices – American multi-channel music enthusiasts favour DVD-Audio over SACD, while the British (Max Townshend may be Australian by birth, accent and character, but anyone who's made their home in the shadow of Hampton Court becomes British by default) seem to favour SACD. In fairness, the Townshend is no slouch at DVD-Audio and the McCormack is good at SACD,

too. It's merely if you gravitate toward SACD, you might steer Townshend-wards, but if DVD-Audio takes your fancy, McCormack is the way to go.

It is remarkable how two entirely different sounds can be garnered from essentially the same Pioneer gubbins; this questions

the received wisdom that it's digital processing that defines the sound. Here, the audio stage and power supply (the main changes to both players) effectively re-draw the Pioneer's performance. Neither sound like a Pioneer, neither sounds like the other and both sound exceptionally good in their own right. If you are expecting a multi-channel Wadia, neither product really fits

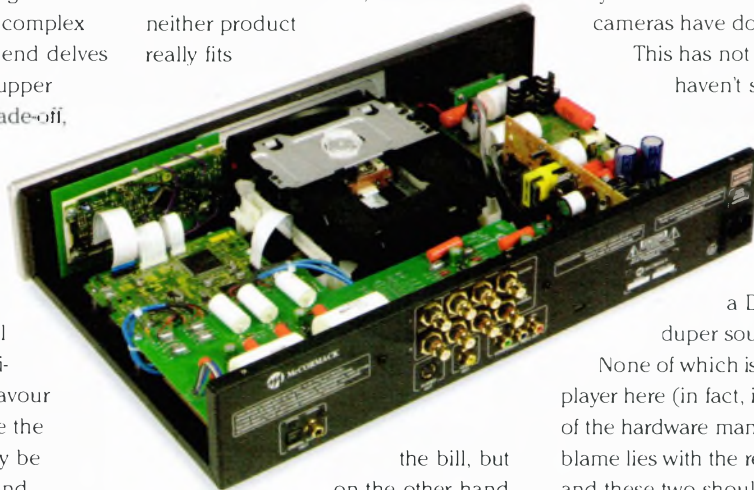

the bill, but on the other hand, no other universal player acts like a multi-channel Wadia either.

Ultimately, these are excellent players, indicative of some of the best possible performance from the multi-channel formats that money can buy.

Yes, a dedicated single-format player (like the Krell SACD Standard or the Meridian 800 Reference DVD-Audio player) will sound considerably better than any universal player. Also, in absolute terms, the lack of the latest digital video outputs does prove a stumbling block when connecting to high-end plasma screens or DLP projectors (currently the best connected player is the £900 Denon DVD-3910). But these are trivial concerns when compared to the flexibility of the sound of both players.

This is not a test of CD performance, but it's worth noting that both are very good CD players in their own rights, and the CD performance follows in the same vein as the multi-channel sound. But you already know this if you've read the previous tests of the players. Why this is important is because multi-channel music simply ain't happening and it is likely that the bulk of replay will be from CDs playing in two-channel mode. A couple of years ago, hi-fi industry types hoped that DVD-Audio and SACD would stem the migration to home cinema and that they would do for music what digital cameras have done for photography.

This has not happened. People haven't switched over to multi-channel music and music on DVD is a DVD-Video of music videos, not a DVD-Audio super-duper sounding version.

None of which is the fault of either player here (in fact, it's not the fault of the hardware manufacturers at all; the blame lies with the record companies) and these two should both be applauded for digging up the best possible sound from the largest variety of formats. This is likely the shape of the specialist player from here on in. CD transport mechanisms will become increasingly hard to find, as most ▶



► will support some kind of DVD replay. So, most players over the next two or three years will have to deliver good CD sound from DVD technology. Fortunately for McCormack and Townshend, that hurdle has already been taken.

There is just one last question... which one would I choose to own? Ultimately, my system is directed more toward the classic High-End sound and in context, the McCormack is the better suited player. But the Townshend sound

is beguiling, like a multi-channel Rock in directness and precision. Perhaps that would ultimately mean, if I ended up with the Townshend, everything else would start changing to keep up with it... and I would make the change happily. It almost requires two separate systems; one for the enticing, articulate McCormack and another for the exacting bandwidth of the Townshend. In other words... I kind of want to own both players.

*A glooming peace this morning  
with it brings;  
The sun, for sorrow, will not  
show his head:  
Go hence, to have more talk  
of these sad things;  
Some shall be pardon'd,  
and some punished:  
For never was a story of more woe  
Than that both these products did  
have to go.*



# Euro Audio Team KT88 Diamond valves

by Chris Binns

When twenty years ago, the MO valve company closed its doors for the last time at the Hammersmith plant and production of valves ceased, they could hardly have foreseen the way in which the market was to regenerate steadily to the apparently quite healthy state that it is in today. By 1984 the general world demand for valves was at an all time low, and most other companies had already stopped production; the MO Co. were I think the last people making valves in this country. Their last shot at the audio industry involved marketing the KT66, 77 and 88 under the Gold Lion banner (with a suitable increase in selling price), but there were not enough companies making thermionic equipment to make it viable, and demand from the military was dwindling fast as communication equipment became solid state. Since that time, the KT series of valves (which unlike valves such as the EL34 were at that time manufactured solely by MO) have reached iconic status while the KT88 in particular has become

something of a legend, and ostensibly a benchmark for other manufacturers to aspire to. In more recent years numerous companies have been making product that is advertised as 'an exact copy' or 'built to the original MO specification', some allegedly using the



original machinery from the English factory (which is possibly true) while one company advertises a British made KT88, to the best of my knowledge this is at the present time, fiction.

So, was the original KT88 all that it was cracked up to be? Maybe it is worth putting a few things in perspective regarding the venerable status of the MO KT88. It was introduced in 1957 as a more powerful relative of the popular KT66, and at a time when 25 Watts was considered a lot, its capabilities must have seemed formidable with outputs of up to a hundred Watts from a single pair, the only competition being the American made 6550 from companies such as RCA, Sylvania and GE (not to be confused with the British company GEC who were parent company of MO). See the side bar for more details of the differences and similarities between these two important audio valves.

While the general standard of manufacturing, and more importantly quality control of the KT88 was pretty good, performance did vary. Take for example the CV labelled military version(s) of the valve; it is rightly assumed that examples of these have a tighter specification as they

► were often used in demanding applications such as driver valves in transmitters and radar. What is less well known is that rather than creaming off the best samples from a production run, the military version was manufactured in a different part of the factory to a higher tolerance. Sometimes part of the machinery of the main production line would break down, and a portion of the military specified valves would be diverted and labelled as commercial stock; these were significantly superior to the standard product. Either way, the KT88 maintained a reasonable standard throughout its production which left one hell of a void when it ended. With interest in thermionic technology at an all time low, the available alternatives were either the aforementioned 6550's from GE, Philips or Sylvania, or Chinese bottles labelled KT88 which often behaved more like fire crackers than valves; using them in powerful amplifiers was a hazardous and frequently damaging experience. Even assuming that the new valves fired up okay, often they would prove unstable with time, and suffer a short life span, expiring in a fit of sparks and usually smoke as your treasured amp went up as well. (But I should mention companies such as Gold Aero, who fastidiously tested NOS (new old stock) and other such valves to provide a viable alternative for the thermionically inclined audiophile.)

Two things happened to improve the situation to its current healthy status; there was a resurgence of interest in valves for audio use in the late eighties, and the change in the political situation in and around Russia meant access to stock that had hitherto

remained hidden. While there was no direct Soviet replacement for the KT88, it was not long before the factories that had been producing valves for the military were persuaded that it would make good commercial sense to produce one, and there is now a wide selection available. As a (sometime) user of large power amplifiers that were designed around a dozen original MO KT88's. I have tried most of these different breeds. It is testament to the healthy situation



that I have been meaning to carry out an extensive report for the magazine on current 6550 / KT88's for quite some time, but such is the extent of available valves it has become a daunting and unmanageable prospect.

But it was fairly obvious from the first time I saw them that the EAT valves were rather special. Everything from the packaging through to the individual certificate of performance smacks of

quality and care, and if at times it seems like overkill, consider that quite a high percentage of valve failure is due to mechanical damage through bad handling. The bottles themselves look equally as impressive, with an internal construction that would appear to be identical to the MO original; externally, the glass envelope is slightly more elongated in shape while the base is one piece plastic rather than metal shrouded.

EAT stands for Euro

Audio Team, and it is a cooperative effort from several countries, the mission being to produce the best possible valves. Parts are made in a division of the original Tesla factory in Prague, the assembly and detailed testing is carried out in Switzerland. The KT88 is a fairly recent and welcome introduction as EAT have to date been specialising in large triodes for SE use such as the 52B and 32B, the result of recent development by Alesa Vaic, as well as the traditional 300B. The company is confident enough in their product to provide a full one year guarantee for each valve, an unprecedented step as far as I know, and one which goes a long way to ameliorate spending out on specialist product.

Assessment of the valves was carried out in two stages. Doing any kind of direct A/B comparisons was always going to be difficult owing to the time involved in running in, settling and biasing issues, and almost impossible when using the twelve valves required by the big amplifiers. To enable comparisons to be carried out I opted to first try a quartet of ►



► the EAT's in a Rogue Audio Model 90, kindly loaned by Kevin Walker of Audiocraft. This amplifier runs a pair of 6550 / KT88s in ultra linear to provide a nominal 90 Watts, and the straightforward biasing arrangement enabled a fairly swift substitution to gauge relative performance. Also present at these listening sessions were RG and Nigel Finn of the Chord Company.

The Rogue comes supplied with good quality Electroharmonix 6550s, a Sovtek sourced valve which has been recently gaining a good reputation and is used by

while the treble had detail and clarity that had not been there before. The overall increase in focus and transparency was remarkable. Nigel suggested that it made the original tubes sound 'shagged' (which they weren't), and the disappointment was intense when we returned to them. To put things in perspective, I had a set of Svetlana KT88's that I have been recently using, and to date have been my choice of the readily available valves. Differences between them and the Electroharmonix were interesting but minor, while there was a similar leap in performance

### KT88 versus 6550

While developed independently on both sides of the Atlantic, the KT88 and 6550 are broadly speaking, electrically (and pin out) compatible, although there are differences in the internal construction. The KT88 has slightly higher ratings in terms of absolute voltage (800 as opposed to 600 Volts on the anode) but the dissipation and electrical characteristics are similar. Although the 6550 is classed as a pentode, and the KT88 a tetrode (i.e. one less electrode) there is an explanation for this. During the time of development, Mullard were applying for a patent on the 'pentode', where the inclusion of a fifth electrode (sometimes called the suppressor grid) connected to the cathode was used to collect stray electrons and reflect them back to the source. The KT - standing for kinkless tetrode - incorporated a form of beam shaping that actually amounted to another electrode to achieve a similar result, but avoided infringement of the patent. As for the sonic differences, these days I suspect that there is more difference between different manufacturer's product than between the KT88 and 6550 per se. To confuse the issue further, some suppliers will produce an identical batch of valves and label them according to the market demand; I have had an example of each from the same manufacturer, and breaking them open revealed that they were absolutely identical.



quite a few manufacturers in their products. This particular set were probably at their optimum, having been used for 40 to 50 hours. Substituting the EAT KT88's was something of a revelation; even without the luxury of warming up the difference was quite startling. I think Roy summed it up by saying that it sounded as if we were listening to an amplifier at three times the price, which was no exaggeration. Indeed, had someone told us that the EATed Rogue was the next model up the range it would have presented a perfectly reasonable proposition!

The EAT's had an authority that seemed to enhance every aspect of the performance; the bass was firmer, deeper and much more articulate, the mid was more open and spacious,

with the EAT's in situ. The acid test involved a set of original MO KT88's that I have clung on to for many years, really to use as a comparison in such circumstances as this, and as such, I would say that they are about half way through their life. While they sounded pretty good, superior to the Svetlana's and Electroharmonix, they could not manage the sheer exuberance and taughtness of the EAT's. It did occur to me however, that while there had been a general consensus that the EAT's were just 'better' in every respect, the character of the MO's was a shade more laid back and therefore less obviously impressive. Another comparison suggested that this was true, but they could not match the

EAT's for colour, texture and in particular, definition.

The next evaluation took place over a longer period using twelve of the EAT valves in the big amplifiers described earlier. The demands here are a little different from the Rogue amp as the valves are potentially pushed a bit harder with 550 Volts on the anodes, while matching seems to be an important criteria when it comes to absolute sound quality, and not just under static conditions. Using the EAT KT88's in these proved to be every bit as dramatic as the previous session, perhaps even ►

► more so. While I have never been disappointed with the bottom end of these 250 Watt amplifiers, it has never been a match for something like the Bryston. The use of the EAT's was startling in this respect, and the grip and bite exerted on the loudspeaker was much improved, to the extent that the amplifier would go considerably louder into difficult and inefficient loudspeakers; once again the result was a better amplifier. Musically, it felt as if several layers had been removed, and the slight sense of vagueness that has always been there diminished to imperceptible levels, with a real improvement in definition, a factor facilitated by what looked to be extremely close matching of the valves. Going back to the Svetlana's or Sovtek's was very disappointing.

There is no doubt that the EAT

valves are extremely good. The big question is that at ninety pounds per piece (and an extra three pounds apiece for matching) – roughly three times the price of say, a Svetlana – are they worth it? Judging by what I have heard, the answer is very definitely, yes. On performance alone, I think the results speak for themselves, while the security of a full years warranty makes it a considerably safer investment. What I cannot tell you at this stage is how long they will last, and how well they will stay matched over that time period. But so far, the indications are good, and I will certainly be following this aspect up.

So, you are looking for the best? Original MO KT88's are still available – just – at highly elevated prices, and I reckon you might be able to get a supposedly unused pair on ebay for

around £250.00. There will be no guarantee; they will almost certainly not be matched, and it's unlikely they will sound as good as the EAT's.

Truly a worthy successor to the esteemed British king. ►+

Price:  
£90 ea. with matched pairs  
as standard  
Quartets and beyond - £3 extra/valve

Contacts:  
UK Distributor  
Art Audio (UK) Ltd.  
Tel. (44)(0)11 5963 7795

Manufacturer  
Euro Audio Team  
Net. [www.euroaudioteam.com](http://www.euroaudioteam.com)

## Spikes 'n things...

by Chris Thomas

I believe it was Linn Products who first introduced us to the concept of spiking the base of speakers and stands and this particular mechanical interface has dominated the world of speaker design virtually unchallenged over the past 20 years or so. There are a few exceptions, like the Shahanian range that use alternatives like castors, but by and large you will find spikes of one type or another under most speakers and even under most equipment racks.

Spikes are good when siting speakers on carpets as they will force their way through to form a tighter connection with the floor beneath, but if your listening room uses a hard flooring such as wood, then there is little alternative but to stick with the spiked arrangement, using floor

protectors to prevent obvious damage. I have tried several different makes of protectors and was quite surprised at how much audible difference there was between them. The best of those I have tried are unquestionably the Naim Chips that I still use beneath my Fraim equipment rack. They are quite large in diameter and are in fact rather good even with a carpeted floor, as the weight of the stand/speaker is usually sufficient to give a decent foundation for support.

But I started to consider alternatives shortly after receiving the JMLabs Micro Utopia Be for review last year. The stands, although pre-drilled for spikes, arrived without any. But there was a rubber lip around the taps so I sat the stand and speaker on those on my wooden floor to run them in a little

before I could locate a suitable set of spikes. The speaker sounded really excellent for the few days it took me to locate an appropriate set. So good in fact that I was quite happy to leave them decoupled from the floor by rubber, but the allure and promise of a big performance hike proved too much to resist and I fitted the spikes, sat them on the Chips and eased back, waiting for the improvements. None were forthcoming. The sense of scale and depth that the Micros had established just collapsed and all of the musical perspective flattened. Now the entire image was set in stone in a flat plane between the speakers and that simply wonderful tweeter had lost quite a bit of its texture and sheer breadth. In a sense there were improvements but





▶ these were all Hi-Fi in nature. The bass was now tighter and firmer and there was an edge and sharpness to the instrumentation that wasn't there before. But the music had lost its rhythmic ease and swing to some extent and the character of the speaker had changed so much that it had me a little perplexed.

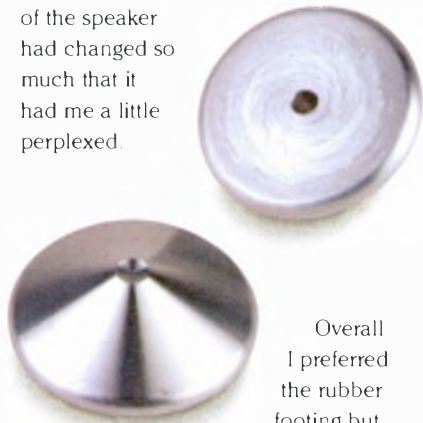

Overall I preferred the rubber footing but there were small

aspects of their performance with spikes that lead me to the conclusion that there must be another way. It also had me looking at the small rubbery dimples between the speaker and the stand and wondering if there was some improvement to be had there also.

When the Eben speakers arrived I had real problems with their wobbly spike arrangement so the importer offered to supply a set of the Cold-Ray feet. This aluminium three-piece design employs a decoupling ball between two cups, one of which screws into the speaker/stand while the other presents a fairly large footing to the floor. It didn't take too long to realise that this was sounding like a really promising compromise. There are two balls available, one metal and the other ceramic. I only tried the ceramic but the increase in musical stability without that disappointing loss of depth and scale was intriguing. Fired up with an evangelistic enthusiasm I fitted the

Cold-Rays to the JMLabs stands. It sounded like I had expected the spikes to sound. The good aspects of the rubber footing were maintained but the edge and rhythmic drive were tighter and much more incisive. This seemed like the answer all right and I even began to think about how I might adapt them for the Fraim when the importers representative had to nick them back for some reason or another. I told him that I would not let him into the house if he couldn't supply me with a non-spikey alternative and to his absolute credit he turned up with a few sets of Pulsar points which could be screwed into the stand bases.

Pulsar points are available in both aluminium and titanium so, given the choice, I went for the titanium. Well, you would wouldn't you? Strange, isn't it that the best sound is so often achieved with the most expensive raw materials.

Why can't someone make the discovery that the best sounding rack is made from a combination of old bits of wood and chipboard instead of aluminium, titanium and expensive sheets of glass?

Wow! What a difference. The Pulsar points were a really significant and obvious improvement over everything else I had tried.



In comparison the spikes/chips arrangement made the Micros sound as if they were broken and the

Cold-Rays were instantly relegated to second place. Now the Micros could really sing. The music had never sounded so strong and firmly grounded. The whole of the bandwidth became useable and there was such an increase in the dynamic agility of the system that I could scarcely believe it. All that I knew to be special about the Micro Utopia was being fulfilled and the slight softness in the bass that I had always been aware of was all but gone. The amplifier seemed to have a firmer grip on the speaker and that sense of front to back depth had returned with a vengeance.

To me, one thing has become abundantly clear and that is that spikes and floor protectors are not the way to go if you have a wooden floor.

No, I'll amend that statement and add that this is only applicable, at the moment, to my particular set of circumstances, purely because I haven't tried it anywhere else and nor have I tried it with the



▶ far cheaper aluminium versions as yet. My particular order of preference puts the standard spike/protector combination as the least desirable. I would rather use the rubber dimples. The Cold-Rays are a worthwhile improvement and fairly reasonably priced as are the aluminium pulsar points but the titanium versions are very pricey, though if you have a very expensive pair of speakers, justifiable. Given the differences in speakers and stands there seems no reason to suppose that any one solution will be universally applicable, but I am convinced that there are really worthwhile benefits to be had by moving away from spikes which seem to me to be fitted by manufacturers largely out of habit.



respect for the Moon has grown. I eventually liked it when I reviewed it, but it has such a ludicrously lengthy warm-up period that it has just got better and better over the months since. Ever so gradually the resolution has become finer and more focussed from top to bottom and any

trace of excessive brightness have all but vanished though it still retains its excellent sense of lively dynamics. It is also very coherent time-wise and constantly reminds me of the olive-cased "Naim" sound as it is unfazed by

whatever polyrhythm you

throw at it. It has a light

anything that interested me. There was nothing that grabbed your attention about it at all; in fact it was a little insipid and uninspiring. It was the Sven Goran Eriksson of amplifiers. But now I am an admirer, not of Sven, but of the i-3 which strikes me as having just about everything you could reasonably expect for the £1695 that it costs. It does a very credible job with all sorts of speakers, responds well to superior source components and it is one of the very few amplifiers around which seems equipped to play

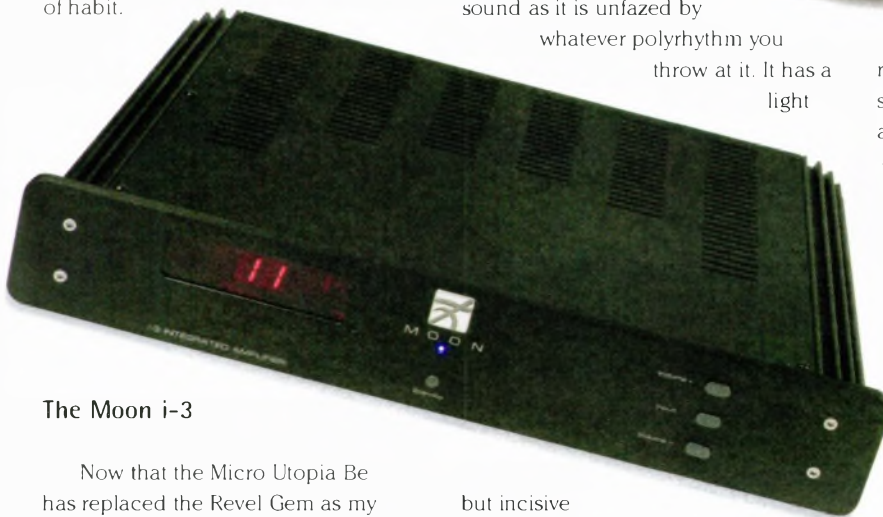

### The Moon i-3

Now that the Micro Utopia Be has replaced the Revel Gem as my permanent home speaker I am getting to spend more time with amplifiers that the Gems would have been unmoved by. The Micros are a much easier proposition to drive and I have been thoroughly enjoying them and several other speakers powered by the Moon i-3 integrated that I reviewed several issues ago. As time has gone by my

but incisive touch too and is far more detailed and intricate than first seems the case. When you plug in an i-3 from cold you will most likely be unimpressed. I was completely unmoved by it for several days and had more or less written it off as just another transatlantic amplifier which spoke a different musical language to

rock music. Where so many err on the side of politeness and seem intended to neither fright nor excite, the little i-3 is punchy and edgy when the need arises and it has the speed of attack and recovery to pull it off without losing its sense of composure and control. It may not be the last word in audio refinement but it is very powerful with a claimed output of 100 watts per channel and it can use much of this power to good effect though it will grow a little flustered and brittle if you ask too much of it. Add to this the fact that it runs very quiet both electronically and mechanically and also remains cool to the touch even after some heavy use, without ever missing a beat and you might wonder if, at this price point, it is worth the extra expenditure on a separate pre/power combo.





“Without doubt  
the best sounding  
show in the UK”

S. P. Kerr

Audio  
Works



MANCHESTER & SHEFFIELD

ACOUSTICA  
Hi-Fi & HOME CINEMA

*Doug Brady Ltd*

INTERNATIONAL  
**smarthouse**

WHAT'S NEW IN  
**SOUND**  
AND VISION

**hi-fi+**



- **Very low in hassle fats!** Train, coach or plane right to the door!
- **Car nut!** Just off the M56, Junction 5. Couldn't be simpler. Room for 500 cars.
- **Spine shiverer!** The best sounding Sound & Vision show in the UK.
- **Goodies!** Free programme and magazines for all visitors.
- **Add on's!** Whole range of weekend attractions.
- **Atmosphere!** One of the North's friendliest Hotels.
- **Anti rip-off!** Entrance just £5 with one of our Privilege Tickets – valid for both days.
- **Shopoholic!** THE selling show, masses of bargains and show specials
- **Gizmo's!** All the very latest product releases
- **Added value!** As well as Hi-fi, Home Cinema and Custom install: add In-car Hi-fi and PC Media.
- **Kiddys Capers!** Yup – their very own non-stop cinema and games section.
- **Stretch Limo!** Nope, we can't do that but we are working on All-in Coach packages from a number of locations, which will include a trip to the Concorde Museum etc.

FOR DETAILS OF THE LONDON, MANCHESTER, SCOTLAND SHOWS OR THE UK HIGH FIDELITY REGIONAL  
ROADSHOWS ORGANISED BY CHESTERFIELD COMMUNICATIONS, CONTACT: ROY BIRD

TEL: 01829 740650 FAX: 0845 280 0065 MOBILE: 07810 697123

E-MAIL: roy@chestergrp.fsnet.co.uk WEBSITE: www.chestergroup.org



Experience

filtration



For Superior filtration qualities in line Connections

Experience Filtration Ltd · PO Box 6155 · Derby · DE24 0ZZ · ENGLAND  
Tel: +44 (0)1332 757 068 · Fax: +44 (0)1332 572 713  
info@experiencefiltration.com · www.experiencefiltration.com

# ULTIMATE Power Distribution

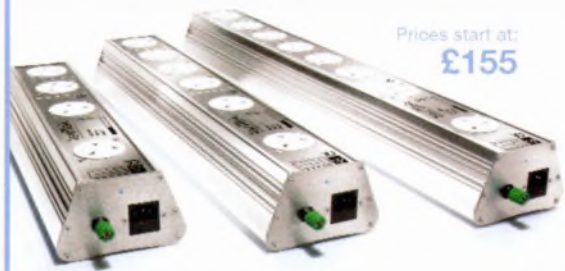

Prices start at:  
**£155**

Multi award winning mains filtration and power management company, IsoTek<sup>®</sup> have released a new series of Multi-Way filter & distribution strips. These stunning units reinforce IsoTek's<sup>®</sup> commitment to the pursuit of excellence at every level.

Sales enquires: 01635 291357

**IsoTek<sup>®</sup>**  
www.isoteksystems.com

Manger Speakers ● ASR Amplifiers ● Cables

## ASR Basis Exclusive Phono Stage

Two piece battery powered phono preamp. Gain adjustable from 32dB to 66dB, infinitely adjustable loading from 5 Ohms to 50kOhms. Extremely low noise floor with explosive dynamics.



"rhythmic snap; among the deepest, cleanest, most dynamic bass I've heard; midrange and high frequency transparency without etch, grain or brightness. I absolutely love the ASR Basis Exclusive!"

Michael Fremer - Stereophile - October 03



103 zerobox



swing



109 zerobox



t: 0161 304 0099 m: 07970 908 619

e: info@manger-audio.co.uk

www.manger-audio.co.uk

## 10 WAYS TO IMPROVE YOUR SBLs

- 1) A Biamp option
- 2) Hand matched components
- 3) Jensen paper and foil inductors
- 4) Audyn capacitors
- 5) High performance PCB
- 6) Aluminium standalone housing
- 7) Silver plated OFC internal cabling
- 8) Sorbothane PCB mountings
- 9) Oak cone feet
- 10) Caddock resistors

(\*audiophile plus version)

The new biampable Audio42 passive Crossover – ten easy ways to improve your SBLs all in one go.

**AUDIO**

**42**

A new perspective for inquisitive ears

For more information [www.audio42.com](http://www.audio42.com)

High performance passive crossovers for: Hi-Fi SL2, SBL and soon a range of other fine speakers.



# hi-fi+

REPRODUCING THE RECORDED ARTS

## Back Issues

If you missed out on earlier issues of Hi-Fi+, and want to complete your collection, you can order them by calling

**+44 (0)1202 659380**

or by visiting our website:

**www.hifiplus.com**

Issues 1, 5, 6, 9, 12, 14, 26, 27: **SOLD OUT**

Issue 2: £4.75 All other Issues: £3.95

Postage & Packing:

UK: free Europe: £1/magazine Rest of World: £2.50/magazine

UK orders are sent by Parcel Post, please allow 2 weeks for delivery  
Overseas orders are sent by air mail



## Keep your hi-fi+ magazines in immaculate condition with these specially designed protective binders.

We've had many requests from readers for binders to protect their magazines, and finally, after something of a wait we are happy to announce their arrival. Made from solid polypropylene each one will hold approximately eight issues and they cost **£5 each, or £3 to subscribers, with £1.50 p&p per order.**

You can order yours by calling **(44)(0)1202- 659380** or via the website at **www.hifiplus.com**

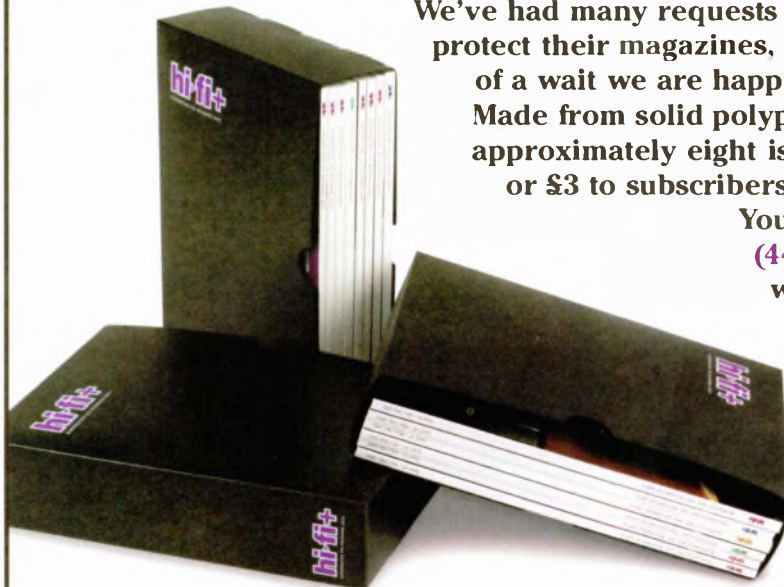

# hi-fi+

Hi-Fi+, Unit 12,  
Albany Business Park,  
Cabot Lane, Poole, Dorset  
BH17 7BX,  
United Kingdom

# Upwardly Mobile

## The changing faces, formats and fortunes of Mobile Fidelity Part 1

by Reuben Parry

Mobile Fidelity Sound Lab, to quote its full and rather grandiose name ("Mo-Fi" or "MFSL" for short), began life at least as an audiophile record label, back in 1977 with the production of half-speed mastered LPs using original master tapes as the source material. Many of its now famous titles are quite collectable and continue to command high prices when they appear on dealer lists or internet auctions. The label's founding father, Brad Miller (1939-1998) was a producer and engineer who had cut his teeth in the late 1950s and early 1960s on recordings that featured the sounds of steam locomotives. These early efforts with titles like an awe inspiring *Highball* and *Under Thundering Skies* were released by his own Mobile Fidelity Records company. Now, while it's easy to be rather superior and amused by these sound effects recordings, they did show a commitment from the very beginning to advance the cause of LP reproduction. Consequently, the half-speed and Ultra High Quality Records (UHQRs); high fidelity cassettes; compact discs (including the groundbreaking Ultradisc 24k gold CDs that first appeared in 1987) and even those 200g ANADISQ LPs pressed in the mid-1990s continued to follow an innovative and singular pathway towards a kind of sonic nirvana. Or at least they did until 1999 when their main distributor went bankrupt and we all thought that Mobile Fidelity had closed its doors forever.

If anything, this unexpected ending added to a sense of mystique that has always surrounded their releases.

Inevitably of course as the retailer stocks diminished the better remaining titles like Joe Cocker's *Sheffield Steel* began to fetch premium prices. Putting your finger on exactly why audiophiles talk in such hushed and

reverential tones about them is not always clear. Certainly, the precise cutting processes and advanced mastering techniques, vinyl compounds and lacquer plating methods of the early years led to some great sounding LPs. The Mo-Fi release of Pink Floyd's *Dark Side of the Moon* became an anthem all over again in the early 1980s and it has remained a sought after second hand purchase ever since. Then there was the publicity over extraordinary licensing agreements which



allowed them the use of original master tapes in outstanding projects like the thirteen LP Beatles collection and a beautifully presented sixteen LP Frank Sinatra box that were released in 1982 and 1983 respectively. They certainly raised the company's profile both amongst the audio community and farther afield. On top of it all were those highly prized UHQR limited edition "super vinyl" LPs that continue to command jaw-dropping sums in today's marketplace. Added to this were the Gold Ultradisc CDs and a GAIN Mastering system, which applied those technical black arts to a digital format. They substantially advanced the cause beyond just an evocative and perceived "elevation in status" found in the clever terminology emblazoned on the packaging for these ▶



► transfers. Even the 1994 return to record production with the 200g ANADISQ pressings (ANADISC? The logo is far from clear), which I personally regarded as something of a *cul de sac*, tapped into the resurgence of interest in vinyl. It is perhaps only when you draw all these factors together that the aura of greatness becomes understandable. It certainly hints at why there was that universal feeling of shock when they ceased trading. But what did we really lose? If the truth were known by the dawn of a new Millennium their greatest successes



were in the past and the crop of then current releases had a tired and more than predictable look about them.

However, because of the worldwide Mo-Fi brand awareness and having such a good reputation for quality, it was probably only a matter of time before a keen eyed entrepreneur stepped forward to pick up the pieces and re-launch the label. This process was started when Jim Davis of Chicago based Music Direct bought not only the propriety mastering chain but all the intellectual property rights associated with the Mobile Fidelity Sound Lab name as well. Now it would have been the easiest thing in the world to exploit an existing brand's reputation and qualitatively damn the torpedoes. Yet this never seems to have been a part of the agenda. From the outset their efforts were directed at ensuring that both the analogue

and digital formats were developed to the limits of current technology. To that end they focused on expertise, bringing a technical and engineering team mainly of former MFSL stars back together. The masterstroke (please forgive a tired play on words) was the return of the acknowledged half-speed mastering guru, Stan Ricker, to the fold in 2002. Later that year the Tim de Paravacini designed GAIN 2 Ultra Analogue LP cutting system was installed and after exhaustive testing they were ready to rock and roll once again. These efforts further demonstrated the tremendous commitment towards achieving the best sounding analogue and digital software around.

When they finally arrived, hot off the press, the first new titles were interesting for a number of reasons. These just happened to be three Patricia Barber discs: *Café Blue* (UDSACD 2002), *Modern Cool* (UDSACD 2003) and *Nightclub* (UDSACD 2004) which all appeared on an Ultradisc UHR (Ultra High Resolution) GAIN 2 Direct Stream Digital Hybrid SACD format. That's quite a mouthful and it is one I definitely don't intend repeating in a hurry! Anyway, this format was introduced shortly before the demise of the old Mobile Fidelity label with their Duke Ellington *Blues in Orbit* disc, so obtaining the mastering chain was essential if its bedrock

sonic strengths were to be



employed.

The "Pat Barbers" though are much cuter choices than you might think, both from a musical and revenue generating perspective. She is the audiophile darling of the moment: A mysterious, brooding, heavily ironic and intelligent jazz diva that has been beautifully recorded in

atmospheric and suitably dark yet crystal clear sounding acoustics. This is a performer and the kind of performance that really taps straight into the heart of the audiophile psyche. Throw in a tight and empathic set of supporting musicians and you have from this

► musical perspective a winning formula. Importantly, too, the resolution, detail and ambience achieved by these SACDs are quite outstanding – and that applies not only when they are played on a high-end system but with the less costly real world equipment that most of us use as well. I've even heard impressive results from modest entry level kit, but I digress. Although Patricia Barber's recorded works are not particularly to my liking (I happen to prefer her live performances which bring a welcome lightness, less tense and untroubled persona to the mike) I do understand why these studio recordings have and continue to beguile so many of you. I also know that while an army marches on its stomach, a record label (especially when it's a specialist one) survives only on a healthy cash flow and that the commercial success of these early releases was an imperative if Mobile Fidelity were to flourish. These early victories have helped to grow the business, generated a distribution agreement with Koch Entertainment and ultimately financed what I consider to be a far more intriguing catalogue of SACD and 180g vinyl releases that encompasses the jazz and blues, classical and popular music genres.

Generally the old Mo-Fi records and CDs proved to be something of a barometer for the tastes and predilections of the American audience, which was only fitting for a Stateside based label. This in the past led to a few unusual and unanticipated transfers entering the catalogue and I have

always wondered how and why such bemusing and thoroughly undistinguished albums as the Bee Gees'

*Talalgar* and Emerson, Lake & Palmer's *Pictures at an Exhibition* or *Tarkus* were recut as half-speed mastered LPs.

(The shrieks of outrage from all you ageing prog rockers will, of course, be forward directly to RP!) However, my feelings concerning the latest selections of musically interesting and significant recordings is far more positive. The label appears to be genuinely repertoire driven. Musically, there is tremendous consistency of quality in the recordings chosen for re-issue.

I detect no makeweights amongst their ranks. In fact, alongside the solid

but essential heavy hitting discs from

the distant past such as *Steamin' With The Miles Davis Quintet*, *Soultrane* or John Lennon's *Imagine* is a raft of recent and genuinely exciting material featuring the likes of Primus, Aimee Mann, Los Lobos and Alison Krause.

They, together with some top classical titles, give

their catalogue a really balanced look. But I still want to look at some of those familiar big titles first. I have to ask myself "do they come any bigger than the iconic *Imagine*?" (MFSL 1-277). I don't think so.

Cosmetically this LP exudes quality from the tactile heavy card outer sleeve and gold embossed limited edition numbering right down to an anti static inner liner and printed lyric insert complete with credits. Retaining this old Mobile Fidelity look for the LPs and digital discs gives a reassuring sense of brand continuity. In the engine room the tapes used for this half-speed

mastered edition are those that were re-mixed at the Abbey Road Studios in the Autumn of 1999 under





► Yoko Ono's personal and exacting supervision. The mastering process itself lifts another veil to present the uncoloured, highly detailed but transparent sound that really knits together the musical information that has always been present in this source material – and what a fabric it is to work with. An accessible John Lennon pop album, rather than one of those impenetrable collaborations with his Mrs, combines a healthy sense of romance and politics in that immense utopian anthem of a title-track; rips hard and fast into Paul McCartney's ribs with 'How Do You Sleep?' Really rocks to 'Gimme Some Truth' and then lets you swoon with a touching ballad like 'Jealous Guy'.

Another artistically satisfying and distinctive release not least for its striking cover shot of a shaven headed

Issac Hayes bedecked in gold

jewellery is his hugely

influential album from 1969,

*Hot Buttered Soul* (MFSL

1-273 & UDSACD 2005).

There are only four tracks:

'Walk On By', Hyperbolic-

syllabicsesquedalyimistic,

'One Woman' and an

eighteen minute 'By The

Time I Get To Phoenix', but

these are jam-packed with

shimmering orchestrations,

layered vocals and bold,

sophisticated soliloquies.

This is Hayes at his best:

deeply soulful, resonant and

rhythmic. Really at a peak

before the style descended

into the self-parody that

characterised later albums

like *Black Moses*. Krieg Wunderlich's vinyl re-master is an

extremely revealing piece of work. It consciously creates

a virtue in retaining all the existing ticks, pops, flutter and

drop outs found on the master tapes, because to remove

them would have adversely affected the musical integrity

of these performances and also placed a question mark

against the honesty of these transfers. The SACD format

too is extremely well suited to such a congested and

complex musical kaleidoscope. It sorts out these sparkling

arrangements recorded for Stax at John Fry's Ardent

Recording Studio in Memphis, accommodates them

and puts the whole thing back together with purposeful

ease. The results translucently pour instrumental details,

including the strings, trombones, trumpets and saxes,

throughout the soundstage, yet draws together the

recording as a satisfying whole without exposing any



of the vocal overdubs and vivid mixing of slap echoes and reverb on the Hayes vocals to undue attention.

A digital solution could have pulled this production apart and left the pieces dangling, but there's nothing at all fragmented about this presentation. It also provides some clues as to why the classical recordings that I intend to talk about later sound so stunning.

Before I lustfully indulge in an overview of those classical discs and some remarkable pop releases I want to look at an important tier of recordings for any re-issue label: the jazz titles. I was particularly keen to hear how the GAIN 2 (Greater Ambient Information Network) mastering process would enhance the mono Prestige tapes of Miles Davis, John Coltrane and Sonny Rollins.

As I don't have a dedicated mono cartridge at home,

I do like to have my re-issued mono recordings as digital discs whenever this is possible. A classic Miles Davis set will always be a winner and *Steamin'* (UDSACD 2019) with a stellar line up of John Coltrane (tenor sax), Red Garland (piano), Paul Chambers (bass) and Philly Joe Jones (drums) finds them all at the very height of their vibrant improvisational powers. This Mobile Fidelity treatment more than does them justice and sonically knocks the Analogue Productions versions (LP and gold CD)

into a proverbial cocked hat. The technical sophistication behind this SACD transfer cannot be underestimated. Neutrality, bandwidth (up to and beyond 60kHz or so the publicity says), tonal accuracy, instrumental solidity and the security of their individual images within the soundstage are all products of this remarkable mastering system. It effortlessly synthesises an essence of the precise, deft and quite brilliant nature of the interplay between John Coltrane and Miles Davis on a track like the Thelonious Monk penned, 'Well, You Needn't'. Here, and elsewhere on 'Diane', 'Something I Dreamed Last Night' and 'Surrey With A Fringe On Top', there is a palpable and powerful sense of the ensemble that clearly developed before and during the sessions at the Rudy Van Gelder Hackensack, New Jersey Studios way back in 1956. This is a charming and essential musical characteristic

► that is brought to the fore in this release.

There's more of the hard bop tenor playing Coltrane to be found on a warm and gloriously focused *Soultrane* (UDSACD 2020). Following hard on the heels of *Lush Life* this 1958 mono recording with the Red Garland Trio places his lonely, cascading sheets of sound and that enviable degree of control against a relaxed and intimate working ensemble. The engineering and resolution of some fine instrumental detail is better than heard with *Steamin'* and the results on two contrasting numbers: a seminal 'Russian Lullaby' or the emotive and very pretty ballad, 'I Want To Talk About You' is spectacular to say the least. This transfer digs really deep into these sets and retrieves the articulate and extremely fluid tenor sax solos as well as the internal rhythmic security generated by the combination of Paul Chambers' bass, Arthur Taylor's drums and Red Garland's languid piano. They also get their own opportunities to stand alone and shine. But I'm still trying to get my head around how these musical images can be so beautifully separated yet in the very same breath or series of notes hang together in a way that makes perfect harmonic and melodic sense. Solid rhythmic grooves are there too, for that extended exploration of an opening Basie tune, 'Good Bait', which combines exciting flourishes for the solos and intelligent dialogues throughout a memorable mood setting performance. Jazz is a living, breathing and evolving form and this transfer vividly gives it all the oxygen that it needs to heat the blood and fire the imagination. Reproducing the natural instrumental tonal colours and natural balances is only half the battle. To do this with such detail and clarity and not allow the transfer to slip into the dark and clinical realm inhabited by so many other analogue to digital transfers is an immensely rewarding musical and acoustic experience.

Sonically pitching up somewhere between the Davis and Coltrane discs is another hard-bop band who play as though their very lives depended upon it, they are the Clifford Brown-Max Roach Quintet. A precocious Sonny Rollins joined them in the November of 1955 and there

then began a series of amazing Prestige sessions. During the following year between March and May he recorded three masterpieces: *Tenor Madness*, *Saxophone Colossus* and first of all, *Sonny Rollins Plus 4* (UDSACD 2006) the latter with Clifford Brown, Max Roach, Richie Powell and George Morrow backing him. This is a recording that you really need to own if you want to make complete sense of the other two. He (Rollins) begins by placing an authoritative stamp on proceedings with the self-penned opening and closing numbers 'Valse Hot' and 'Pent-Up House'. The young tenor had come of age. A waltz-like 'Valse...' with its tenderness, swinging flow and melodic solo restatements shows great delicacy, while 'Pent-Up...' delivers an exciting and knock about display from both horn men. Rollins, a natural virtuoso and soloist

par excellence allows his imagination, forcefulness and occasional but contrasting moments of genteel sentimentality to roam. Those sorties and flights of fancy up and out there alone soaring through a full range of tenor sax notes and emotions are exquisite. This approach on a standard like Irvine Berlin's Count Your Blessings is intriguing and the bounce of his reading and a warmth present in that tape is ably recreated for this transfer. Yet Rollins also shows us his growing maturity as a performer especially through the tight and rewarding relationship

forged with Clifford Brown. It finds this eminent trumpeter asking the most searching and inventive of questions. The sidemen in the rhythm section are also very comfortable with this aesthetic. Pianist Richie Powell, who is often regarded as the least accomplished of the group, puts in one of his strongest and most sympathetic of sets and Roach's stick work and the secure timing and swinging bass lines of George Morrow are finely etched on my memory. *Plus 4* is an illuminating and thought provoking album that reveals the direction and subtle nuances of one of the best quintets of the day. The sonic properties when compared to these considerations are secondary but not inconsequential when they open out the stretched Sonny Rollins chords.

The release that I am least comfortable with (from ►

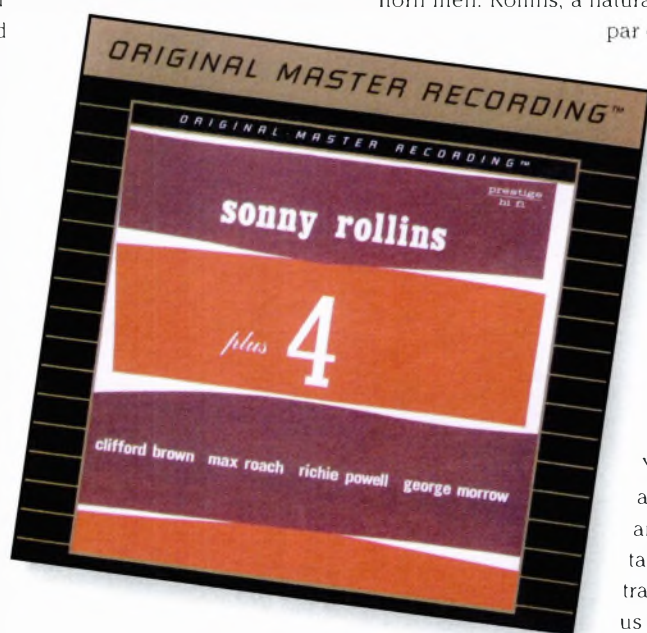



► a repertoire perspective) is Jim Hall's *Concierto* (UDSACD 2012). More than anything this is about personal taste. Twee mid-Seventies jazz guitar is not much to my liking and when compared to those Prestige giants talked of earlier, it's certainly found wanting. To my mind *Concierto* with a nineteen minute Don Sebesky arrangement of the Rodrigo *Concierto De Aranjuez* as its centrepiece is one of those smart but quite tenuous jazz/classical crossovers that never fully realises the potential of either genre. Eventually it wears paper-thin. Yes, Hall's guitar has an attractive voice (even the colourful Spanish guitar overdubs are sympathetically done) but he's not a classicist and his technical limitations in that department must have tempered the ambitions for this music. Consequently, this is a performance built solely on the lovely melodies and I am not sure that this is sufficient. On the pure jazz side of the coin he brings a sustained elegance and consistency to the table. There's nothing flashy about his approach, yet behind numbers such as Cole Porter's 'You'd Be So Nice To Come Home To' or his own 'Two's Blues' and 'The Answer Is Yes' he can be a little fussy. Hall may be a subtle and refined guitarist, but he is perhaps one who just lacks that last ounce of emotional drama. However, this sextet which features a lyrical Chet Baker on trumpet, Ron Carter's fine bass playing, the sympathetic keys of pianist Roland Hanna, Paul Desmond's sweet toned alto sax and some clean Steve Gadd drumming works extremely well together because they form such a really tight unit. Their musicianship and camaraderie throughout is faultless. The more musically significant part about this CD is an expansion of the listing beyond those four original numbers recorded in 1975 to include another five Rudy Van Gelder engineered tracks. These are Duke Ellington's 'Rock Skippin' and the Johnny Andrews/Carlos Chavez penned 'Unfinished Business' coupled together with three alternative takes in 'You'd Be So Nice', 'The Answer is Yes' and 'Rock Skippin'. For fans these will be priceless.

I want to end the first part of this Mo-Fi overview on a slightly different note with an absolute diamond.



The R.L Burnside *First Recordings* disc (UDSACD 2026) captured back in 1968 by George Mitchell is an unadulterated blues masterpiece. What a sound! What an immense talent! What an inspired choice! Such presence, such emotion-dripping lyricism and such wickedly cut and refreshing blues grooves rarely make it into the audiophile catalogue. These moody Burnside northern Mississippi rhythms are spiced up with robust and knowing vocals that twist and turn through every classic blues victim of circumstance you might happen to know. Cheatin' women? We've got them in an opening 'Just Like A Bird Without A Feather'. Self-pity and good old-fashioned misery? That would be 'Sat Down On My Bed And Cried'. Dirt floors, peeling clapboard and a yard littered with bits of broken and rusting Chevy? Well, it could be any number of the remaining tracks that vividly recreates a corn liquor taste or sweat soaked smell of rural apathy, decay and despair. You can also feel the languid rolling gait of a travelling musician with that enduring beat and wandering tactile guitar licks of 'Walkin' Blues' and 'Hobo Blues'. The clarity, honesty and stark simplicity of a vibrant and responsive acoustic enhance this deliciously depressing subject

matter even further. This recording goes beyond atmospheric and while you may not like the characters scratching out a meagre existence in these songs, Burnside still makes you feel for them nonetheless. There are also two very different bonus tracks bolted on to this SACD, both of which were cut thirty years after the *First Recordings*. One, 'Come On In' is a powerful live electric groove dominated by rugged vocals worn and cracked by a lifetime's experience. The other is an irrelevant electronic dance remix of 'Rollin' And Tumblin'. The original (scroll to track five) is the way you want to hear this song – a stark, exposed and pared down to nothing country blues stunner.

Next time the focus will be on the popular and classical music genres. So prepare yourselves mentally, physically and spiritually for a superb series of releases.



# Record Reviews

## How To Read Them

The information contained in the record reviews is presented in the following way. Albums are identified by label and serial number. Beneath this you will find one or more icons which denote the available formats for the recording. The first icon refers to the format reviewed.

The ratings at the bottom of each review reflect the reviewer's opinion of the recording quality, and musical merits of the album. You'll soon realise that a great many musically significant albums offer less than wonderful sound. Don't let it put you off! For your information the scale rates a standard, good quality pop recording as slightly below average.

The reviewers are identified by their initials.

They are:- Chris Binns, Pete Christie, Dave Davies, Roy Gregory, Jason Hector, James Michael Hughes, Jon Maple, Reuben Parry, Dave Ayers, Andrew Hobbs, Chris Thomas, Mark Childs, Simon Groome, Michael Mercer, Richard Clews, Sian Drinkwater, Richard S. Foster.

### Key to Icons

-  CD
-  Gold CD
-  HDCD
-  XRCD
-  Double Disc
-  DVD
-  SACD
-  Hybrid SACD
-  MultiChannel SACD
-  120g LP
-  150g LP
-  180g LP
-  Availability As S/H LP
-  Vinyl Double Album
-  45rpm



Eliza Gilkyson, Ad Vanderveen,  
Iain Matthews

### More Than A Song

Perfect Pitch PP008 

Fifteen songs, five penned by each of these three guitar picking wordsmiths play across a range of emotions with love's fragile, rewarding and contrary states at the core of tracks like 'Fall Into The Night', 'Rerun Matinee' and 'All The Way'. While their string chords carry rhythm, melody and tune before them on an album that drips with acoustic simplicity these remain carefully crafted songs which are punctuated by a scoring for piano, harmonica, dobro and mandolin that extenuates the sentiment behind the lyrics. Outside of these romantic entanglements are smartly observed tales about tightly knotted self delusional binds in 'A Beautiful Lie', those endemic small town small minded attitudes of 'Sing Sister Sing' and that selfish and single minded world when you're 'Home On The Highway'. Airy, lightly rocking country vocals ease you through all of these dilemmas including a sad, punishing and apocryphal Iain Matthews story, 'Lamb In Armour'. A musically rewarding, intelligent and intuitively played body of work in which these mature yet differing song writing styles are arranged in a complementary and thoughtful way that bears closer and closer examination.

RP

RECORDING 

MUSIC 





Graham Coxon

### Happiness in Magazines

EMI 5775192 

On the surface, *Happiness in Magazines* appears to be an extension of Blur's early efforts. Tracks such as 'No Good Time' and 'Freakin' Out' convey a youthful exuberance reminiscent of old favourites such as 'Popscene'. A familiar Blur-like sense of humour is also evident in the album's lyrics which display a childlike quality through the use of consciously contrived rhymes. A prime example of this can be found in 'Hopeless Friend' when Coxon sings, "Come on inside and drop your coat/ Wash your hair you smell like a goat". But in between all this fun and frivolity lies a darker side to Coxon's work full of insecurity and self doubt. 'All Over Me' is a particularly unsettling number with its near-violent imagery ("You washed my hair in bright red water/ You really thought I was dead") and haunting string section. 'Girl Done Gone' has a bluesy, melancholic feel to it, whilst 'People of the Earth' is a brash, vitriolic attack on contemporary British society. *Happiness in Magazines* represents a musical return to form for Coxon and is an album which has a wider appeal than its assumed Blur fanbase. The content of this record implies that he has some way to go before he conquers all of his demons, but the end product is that *Happiness in Magazines* sounds exactly like what it is; Blur with added life experience.

SD

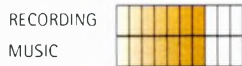

Henry Butler

### Homeland

Basin Street Records BSR08022 

Now here's a gem. Henry Butler is a blind New Orleans pianist who incorporates a host of styles in his music. He's been playing professionally since the age of 14 and has recorded a clutch of fine albums for corporate giants like MCA and Atlantic, as well as some of the finest independent labels, including Blacktop and Alligator. For his second album on Basin Street he's enlisted the help of some of Louisiana's most respected musicians including native Mississippi bluesman Vasti Jackson on guitar, and bought in ex-Soul Asylum frontman Dave Pirner as producer. Butler's piano style tilts a cap to Professor Longhair and Dr. John. He calls it a 'percussive style of playing that no one else is doing; similar to a stride, but a lot more rhythmic and syncopated'. Make of that what you will; suffice to say the boy can play a bit, as well as being a dab hand at writing a tasty tune or two. There's plenty of evidence of those piano skills on the instrumental boogie-woogie 'Henry's Boogie', but he also turns in fine singing performances throughout the record, especially on the honey coated ballads 'The Way we loved' and 'I Stand Accused'. Reference points? Dr. John, The Meters, Al Green and The Neville Brothers should give you a rough idea where he's coming from. Stick it on at parties and watch it lighten up the evening.

AH



Janis Ian

### Billie's Bones

Cooking Vinyl COOKCD 285 

On the reverse of these liner notes is a four-verse extract from a book of Janis Ian poems published in 1968. The poem is entitled *Billie's Bones*. Its images of the skull beneath the skin are reminiscent of John Donne's metaphysical poetry but I think Ian had other peerless artistry in mind, that of the great Billie Holiday. Understandably she is revered on the opening title track. Yet there is a huge tension developed between this musical genius and the fragile human story beneath it. The tone is reverential, the images beautifully morbid and the allusions to flesh, decay, secrecy and those bleached white bones hint at the prostitution, drug addiction, cruelty, humiliation and racial prejudice Holiday experienced during her life. But she was a survivor and it's clear that this musical legacy empowers Janis Ian's song writing when she tells us that "When the wind blows from the east, I can taste her on my tongue and the grave is lined and paved with all the songs we never sung". The lyricism in this and another eleven deeply personal songs like 'My Tennessee Hills', 'Paris In Your Eyes' and 'Save Somebody' reflects upon home, her loves and the social responsibilities she feels through a style that moves away from the smooth pop of *Revenge* to embrace folk genre storytelling.

Supplier: [www.trackrecordsuk.com](http://www.trackrecordsuk.com)

RP

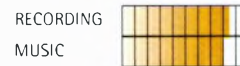



Jeff Buckley

## Grace

Columbia 475 928 2 (CD)

It's hard to believe a whole decade has passed since the release of this seminal work; in many ways Buckley's debut still sounds as current and mesmerising as it did back in '94. Released at a time when grunge ruled the alternative rock roost, *Grace* was an album which went against the tide of sneering vocals and greasy hair, and tapped into a more sensitive style of music.

It begins with the sublime 'Mojo Pin', gradually building to a crescendo full of raw and fragile emotion, before gliding into the album's title track. One moment vulnerable ('*Lover You Should've Come Over*'), the next passionate ('*Eternal Life*'), *Grace* is an album rich in diversity and packed with personal lyrics about the torment of young love. Buckley even manages to make the cover tracks sound as though he's lived through every minute. Similarities between Jeff and estranged father Tim are clear to hear, despite Jeff's desire to be recognised in his own right. To a large extent he achieve this, and today's artists frequently site Jeff and not Tim as a major influence; quite an achievement when you consider *Grace* was the only complete album released in his lifetime. Yet it is undeniably a thing of rare and astonishing beauty, made all the more poignant by the tragic, early demise of its creator and leaving behind a legacy of frustratingly, unfulfilled potential.

SD

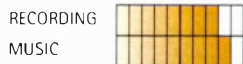

Tori Amos

## Welcome to Sunny Florida

Epic 516288-2 (DVD) (CD)

This near three-hour DVD, was recorded live at Advice Amphitheatre, Florida on September 4th 2003 at the back end of Tori's "Scarlet's Walk" tour. Amongst her more recently penned material is a reprise of classic songs like 'Cucify', 'Professional Widow', 'Hey Jupiter' and 'Cornflake Girl'. Interestingly, the DVD comes with a six-track 33-minute CD entitled *Scarlet's Hidden Treasures*. These are songs that she cut for but didn't include on the previous year's album. It's another unmistakably strong and deeply personal set built around her vocals (sometimes layered) and the superbly played piano. Of Course "Amos" and "autobiographical" have always walked hand-in-hand and an opening 'Ruby Through The Looking-Glass' is no exception as it spot welds together unlikely religious imagery, allusions to Lewis Carroll's *Alice* and those typical anxieties of twenty first century womanhood. She also wears a pretty big political heart on her sleeve with a pastoral and spiritual backdrop for 'Indian Summer' contrasted against an openly critical view of the current US Presidency. The worldwide wave of post-9/11 unrest is a recurring concern and lyrics about the bombings played out daily on our TVs are wed to images of a girl coming of age in 'Seaside'. It is yet another of those songs that leave you feeling an acute loss of innocence.

Supplier: [www.trackrecordsuk.com](http://www.trackrecordsuk.com)

RP

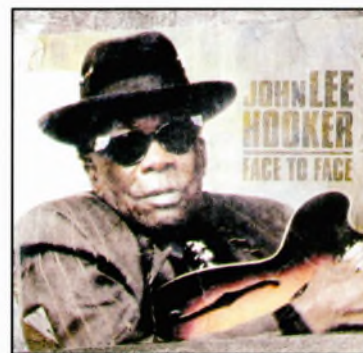
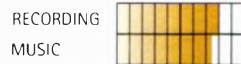

John Lee Hooker

## Face To Face

Eagle Records EAGCD265 (CD)

The great old man's last recording session capitalises on a foot tapping tempo, lead picking guitar and an unmistakably robust vocal technique which continues to exude the very same urbane sophistication on each of these fifteen tracks that it did for much of the preceding half a century. For most of this classic blues material including 'Dimples', 'Mad Man Blues' and 'Face to Face' Hooker is joined by the likes of Van Morrison, Elvin Bishop, Johnny Winter and George Thorogood. The guitar licks, sometimes smouldering, sometimes rip-roaring burn the house down. And while JLH no longer "boom, boom, booms" like he used to, that doesn't really matter because there's still no less feeling behind these songs. Whether it's a slow introspective pot boiler like 'It Serves Me Right To Suffer' or in the discovery of that last little bit of self respect within 'Up And Down' there's just no let up in his emotional intent. Even the soulful side of the John Lee Hooker blues makes one of its timely entrances with those deep, richly sonorous vibrato textures on 'Six Page Letter' and in a duet alongside Zakiya Hooker that rhythmically nails 'Mean Mean World' and a closing 'Rock These Blues Away'.

RP







Jon Cleary

Pin Your Spin

Basin Street Records BSR09022 

If you're an English musician and you place yourself in an environment where there are more talented musicians per square inch than anywhere else in America, you need to be damn good. Jon Cleary did just that and it speaks volumes for his talent that not only has he been welcomed with open arms but he's now considered one of Louisiana's most respected and revered pianists. Bonnie Raitt's a huge fan (Cleary's a member of her touring band), as are Taj Mahal and BB King. He doubtless makes a good living as a sideman but he's also got plenty to offer as a frontman, as this disc attests. Right from the off *Pin Your Spin* makes its intentions known: to get every sinew in your body moving and grooving to an ace band who just want to funk the living daylight out of you. I guess you can expect nothing less with titles like 'Agent 00 Funk', 'Funky Munky Bizniz' and 'Zulu Strut'. Even when the band take their foot off the pedal they still maintain the groove; 'Smile In A While' and 'Oh No No No' being cases in point. The instruments marry together with effortless ease to create the most delightful rhythms – it's impossible to keep still when you're listening to it. Legendary producer John Porter has given the recording a big, full sound which is best appreciated turned up loud!

AH

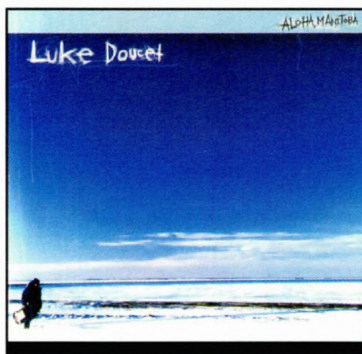

Luke Doucet

Aloha Manitoba

Six Shooter Records SIX01 

This is the debut solo release from Canadian guitarist and songwriter Luke Doucet. He is the much lauded front man for Veal, an intriguing and critically acclaimed motorcycle-hillbilly-rock trio, who adopts a slightly different persona here for *Aloha Manitoba* which is instrumentally another one of those beautiful pared back to nothing albums. His wilful and highly polished guitar playing stretches the strings and the range of images, while Bazil Donovan's bass and Barry Mirochnick on drums rhythmically underpin this lean and countrified sound with no little skill, dexterity and subtlety. Songs alluding to striking individuals in 'Rasputin', 'Vanessa', 'Pedro' and 'Leroy' vie with that tangled baling twine of 'The Defector' and 'Another Woman'. Their lyrics have bite and the melodies are strongly strung across a dozen tirelessly worked vignettes that never leaves you weary or saddle sore. Luke's calm, attractive and leather softened vocals eases the passage for the troubled and often personal material found in a track like 'Outlaws', but without glossing over an intelligent and gritty subtext. Consequently, Doucet's musical reputation as the lost love child of a KD Lang and a Tom Waits is from all the evidence here, totally justified.

Supplier: [www.hotrecords.uk.com](http://www.hotrecords.uk.com)

RP

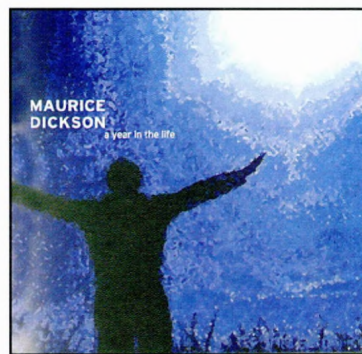

Maurice Dickson

A Year In The Life

Mo Music MO 006CD 

*A Year In The Life* is Maurice Dickson's sixth solo album in a career that began in his native Northern Ireland way back in 1975. He started out in blues/rock bands singing a mixture of his own compositions and well chosen covers, a good way of supplementing his day job as an engineer. In 1979 he decided to place his trust in lady luck, so he packed a sleeping bag and left to seek adventures across Europe and North Africa as a full time working musician. The experience taught him things way beyond the confines of the formats he was used to.

*A Year In The Life* is not a blues album. It's not country, folk or world music either, more an amalgam of everything rolled into one. Dickson has an acute ear for a teasing hook and a great way with melody and lyrics. The first six songs are low key affairs, acoustic led but fleshed out with subtle string arrangements, not unlike Paul Brady's quieter moments. The next two have a Pogues-like bounce to them, whilst 'The Road To Basra Parts 1 and 2' are cinematic, moody instrumentals. 'Spirit Of The Music', with its tribal drumming, could be off a Peter Gabriel album and 'The Journey' is Christy Moore. colliding with Ladysmith Black Mambazo.

Definitely worthy of your attention.

AH





Tift Merritt

## Tambourine

Lost Highway (CD)

Tift's debut album *Bramble Rose* was a magnificent way to open her account, a heartfelt Americana classic in the vein of those early Emmylou albums. It rightly received gushing praise and heralded the arrival of a bright new talent.

Here was an artist confident in her own skin; a singer blessed with a voice of astonishing intensity who made the art of song-writing look incredibly easy. The big question: could she follow it up with the notoriously difficult second album? Well here's that second album, and the good news is... it's even better than the first.

*Tambourine* moves with a racing pulse, it contains more upbeat songs which have been immersed in a stew of hard driving soul; southern soul that is, of the Dusty and Aretha variety. George Drakoulias (the man who gave those early Black Crowes albums their swagger) was installed in the producer's chair and he's added a certain toughness to Tift's sound. The beautiful heartbreakers are still in evidence (witness 'Plainest Thing', as good a ballad as anything in Emmylou's repertoire) but it's tracks like the pumping gospel rocker 'Shadow In The Way' and the horn driven 'Your Love Made A U-turn' (with its heavy stax vibe) that are at the centre of this album being. American music doesn't get any better than this - they'll still be buying it 25 years from now.

AH

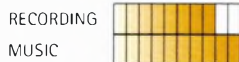

Ron Sexsmith

## Retriever

Netwerk America 5783082 (CD)

You'd be hard-pressed not to be won over by the pervading loveliness of Ron Sexsmith's eighth offering. An album both uplifting and melancholic in equal measures, *Retriever* has the potential to make you both smile and cry.

These conflicting emotions are evident in the juxtaposition of the tracks. For instance, the life-affirming energy of 'From Now On' is closely followed by the heartbreaking 'For the Driver'. With assistance from the likes of Neil Primrose (Travis) and Ed Harcourt, Sexsmith is able to subtly shift through a range of styles; sometimes soulful ('Whatever It Takes'), at other times alt-country ('Hard Bargain'). The use of strings also works well, serving the purpose of adding another layer to songs such as the down tempo 'Tomorrow In Her Eyes'. But Sexsmith is perhaps at his best on tracks such as 'Dandelion Wine', with minimal accompaniment allowing his honey-warm vocals to be heard to full effect.

*Retriever* is essentially an album about lost love, regrets and then doing it all over again. With its infectious melodies and soothing lyrics, Sexsmith's latest is the perfect soundtrack to a late summer's afternoon.

SD

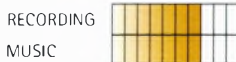

Tom Ovans

## Tombstone Boys, Graveyard Girls

Floating World FW021 (CD)

Tom's earlier albums are notable for their rough-hewn, sometimes overwrought vocals and an abrasive social commentary. These new songs with titles like 'Great Big Lie', 'Revolution' and 'Before I'm Dead' continue to pack a powerful punch.

Often taking its form from one of those "road to nowhere" journeys either across the underbelly of America or through those seedy downtown bars that are populated by immorality and self-loathing. These vivid images sickeningly suck the wind from out of you with their depressing sense of attrition. The unrelentingly shots to the body always seem to find soft yielding flesh. Is there a knock out blow? No. We, like lost souls condemned to purgatory, cannot escape this cycle of suffering. The difference between *Tombstone Boys, Graveyard Girls* and his earlier outings are the higher production values employed. Personally, I find them a distraction. They inevitably draw you away from the lyrical gristle and this can momentarily dilute and even sanitises the Ovans message. Yet always lurking in the background are those scowling snarling observations such as 'Young girls scream, critics rant while all the f\*\*kers zip up their pants' (It's Hard) that snap your head back with their horrendous moments of clarity.

RP

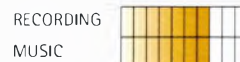





Shelley Campbell

Blue Ridge Reveille

Nettwerk 303662 (CD)

Every Once in a while a new artist appears on the music scene, someone with a talent you just can't ignore – welcome Shelley Campbell. Already feted in her homeland, Canadian Campbell has got what it takes to be a very big noise in alternative country; great songs, a hauntingly beautiful voice, a top notch band and oodles of sex appeal. Her father was an evangelist who spent a lot of his time working with the native American Mohawk nation. He would take the young Shelley with him, so although she grew up under the canopy of Christianity it was far from a blinkered upbringing. Once into her teens She hit the highway, spending time with the homeless and later busking in Vancouver – all good experience for a young women looking to discover her reason for being. Recorded in her kitchen, *Blue Ridge Reveille* contains 14 magical moments in time; Songs so beautiful, uplifting and wise they transport the listener. One of the Album's many highlights, 'Is it you?' could easily have been added to the cowboy junkie's legendary *Trinity Sessions* without sounding out of place. Campbells vocal style is a mixture of the junkies' Margo Timmins and Nanci Griffith, blended to a twang that's all her own; once married with her intoxicating songs it becomes a heady brew of inescapable beauty. She's coming to the UK in the Autumn... Better make sure you're there.

AH

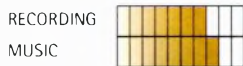

Michelle Shocked

Captain Swing

Mighty Sound (CD)

This re-release of an expanded *Captain Swing* CD is to be welcomed because its radical musical journey seems to have much more in common with today's diverse Americana sound than it did on its debut back in 1989. Of course Michelle's flair for political statements in songs such as 'God Is A Real Estate Developer' and 'Cement Lament', or bravery when tackling tough subjects like abuse in 'My Little Sister' have an undiminished relevance. But it is the inclusion of seventeen additional tracks, nine of them acoustic demos (most of which reprise the original track listings) that are of real interest. They are in stark contrast to those original jazzy productions and their heavily produced and swinging horn sections. Instrumentally these are beautifully recorded demos pared back to a guitar or guitar and fiddle. The effect is to heighten the impact of her acute social observations. There are also several live tracks including 'Worth The Weight' and 'Poll Tax Song' that reminds us of how well she can work a crowd. A real find, though, are two songs with 'Dollar Bill: The Titanic' and 'Old Paint'. These herald the folk and fiddle tunes heard later on *Arkansas Traveller*. Now that Michelle has regained complete artistic control over this back catalogue, I guess we can expect more and even deeper insights on this extraordinary singer/songwriter's early career.

RP



Theresa Andersson

Shine

Basin Street Records BSR10012 (CD)

In New Orleans Theresa Andersson is a Goddess. In 2003 she was given 'The Big Easy Award for Best Female Artist' and has won Offbeat's 'Best Of The Beat' award six years running for her violin playing. For reasons that are blatantly obvious she is also regarded as something of a sex siren. Not bad for a woman who was born in Sweden and who never intended to play a violin! I first became aware of her when she backed Anders Osborne on his 1995 album *Which Way To Here*, a classic of its type which unfortunately tumbled into obscurity (as so many great albums do). She released her debut album *No Regrets* on her own label in 2002, which cemented her reputation as an artist in her own right, and now follows it up with *Shine*, a pop/rock effort with a rootsy, southern sheen. She's dragged along some influential friends for the ride; Neville Brothers drummer Willie Green (inspiring throughout), Anders Osborne, top session pianist Jon Cleary and legendary Louisiana guitarist Sonny Landreth. Andersson's vocal style leans toward Cheryl Crow territory and her songwriting is catchy and incisive, with strong, insightful lyrics. Memorable melodies and punchy choruses are there in abundance but tend to come through stronger after the third or forth listen, so don't be too hasty to judge; give it time and it'll work its magic.

AH

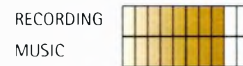

# art loudspeakers

designed and manufactured in Inverness, Scotland

To hear the new **Impression 2** loudspeakers or any of the other ART models, please call or visit one of the following specialist Dealers:

Acoustica, Chester	01244 344 227
Acoustica, Stafford	01785 258 216
Adventures In HiFi, Wigan	01942 234 202
Audio Consultants, Reading	0118 981 9891
Audio Salon, Glasgow	0141 333 9700
Divine Audio, Market Harborough	01536 762 534
Mazelmere Audio, High Wycombe	01494 865 398
HiFi Corner, Glasgow	0141 226 5711
HiFi Corner, Edinburgh	0131 220 1535
HiFi Corner, Edinburgh	0131 556 7901
HiFi Corner, Falkirk	0132 429 011
Laser Audio, Kilmarnock	01563 540 292
Moorgate Acoustics, Sheffield	0114 275 6048
Sounds Perfect, Dundee	01382 226 592
The Audio Republic, Leeds	01132 177 294
The Audio Room, Hull	01482 891 375
The Audio Works, Cheadle	0161 428 7887

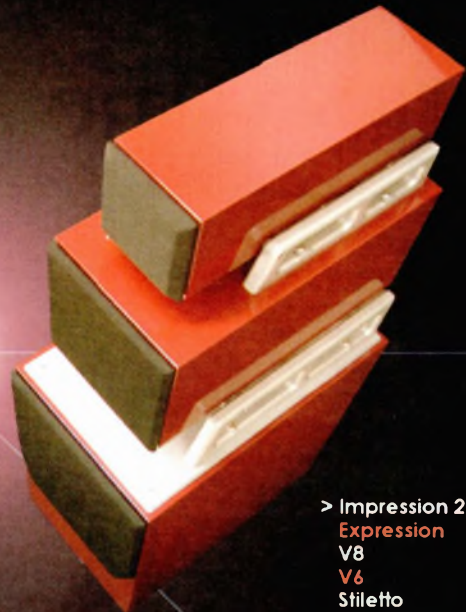

> Impression 2  
Expression  
V8  
V6  
Stiletto  
Skibo  
Skibo CC



tel/fax +44 (0) 1292 319 416 | [contact@loudspeaker-art.com](mailto:contact@loudspeaker-art.com) | [www.loudspeaker-art.com](http://www.loudspeaker-art.com)  
overseas (ANJ International Ltd. Hong Kong) tel 00 (852) 218 00 88 | [anji@yardway.com.hk](mailto:anji@yardway.com.hk)

## Audio Reference

DISTRIBUTORS OF FINE AUDIO EQUIPMENT

[www.audioreference.co.uk](http://www.audioreference.co.uk)  
**01252 702705**  
[info@audioreference.co.uk](mailto:info@audioreference.co.uk)



Amp-2



HALCRO



Acapella



Stello



Virtual Dynamics



Shakti



Gamut

See us at the Hifi Show & AV Expo 2004  
Rooms 1076/78 Renaissance Hotel.

ACCUSTIC ARTS ACAPELLA CAT CLEARAUDIO GAMUT GRAHAM HALCRO  
SHAKTI SHUN MOOK STELLO TRANSFIGURATION VIRTUAL DYNAMICS



# The History Man

# The Art of Lili Kraus

by Richard S. Foster



I've discussed my love for the French School of Pianism however my fondness for pianists does go beyond that world. How could you not like Glenn Gould's Bach – all humming aside? I've mentioned two of the great Russian pianists of yesteryear, Maria Yudina and Tatiana Nikolayeva whose playing must be heard, probably most easily in

the compact disc format. There is the great Rumanian pianist, and also one of my favourites, Clara Haskil, whose playing is simply divine. Her ability to perform as a soloist, a duo or with an orchestra is just about unequaled. Perhaps in the future I will talk more about Ms. Haskil, but not now. Now is the time for Lili.

Born in Budapest, Hungary on March 4, 1903, Lili began her first piano lessons at the age of six. Actually her first choice was to play the violin, but this was vetoed by her mother Irene. After two years of lessons, she entered the Budapest Royal Academy of Music. Two of Ms. Kraus' teachers included the great Zoltan Kodály and Bela Bartók! She graduated with first class honors in 1921 and then moved shortly thereafter to Vienna where she continued her studies with Edward Steuermann and the great Artur Schnabel. In 1925 Kraus was given her Professorship at the Vienna Conservatory and taught there for the next six years.

After a period of teaching in Vienna, she and her husband moved to Germany. (Please note that as a teacher, she also appeared in concert in the European community, including performances in London). In Germany she began an active concert appearance schedule and developed an exceptional reputation as both a soloist and artist in chamber recordings of music by Mozart, Beethoven and Haydn.

Kraus and her husband had converted from Judaism to Catholicism in the early 1930's, but the political climate was getting uncomfortable for anyone with any Jewish heritage and so the family – she had a daughter born in 1930 and a son in 1931 – moved to Italy. In 1934 she

formed a duo with the virtuoso, Szymon Goldberg. Kraus had already developed an exceptional reputation for her Mozart and there were some fabulous recordings of the Kraus-Goldberg duo of several Mozart piano-violin sonatas.

(She actually made her first recordings for Odeon in 1934). It was in 1936 when they embarked on their first world tour as a duo. They stayed in Japan for at least six weeks. Their stops included visiting Indonesia, Sri Lanka, France, Portugal, back to England and then on to the Netherlands. Needless to say, the tour was a phenomenal success. Once again the political climate, this time in Italy, became unfavourable for Kraus and her family and



on this occasion in 1938, they moved to England, to Betteshanger on the estate of a Lord Northbourne. Through various friends, they were introduced to the Minister of Finance and Immigration of New Zealand, Walter Nash. Having renounced their own citizenship and being stateless, Nash suggested they become New Zealand citizens. This was a difficult time in her life and thank goodness the Kraus' had the friends they did and were able to obtain travel documents from the British Government. Another tour had been scheduled and so New Zealand would have to wait another year. I learned a fascinating anecdote about Kraus' British documents when I read the wonderful biography of Lili by former student and now a Professor at the University of Texas, Steve Roberson. (*Lili Kraus*: ISBN 0-87565-216-6, highly recommended.) When the family went to obtain their documents, there was a clerical error when putting Lili's birth date in the records. The clerk mistakenly copied her true date-of-birth which was 1903 yet wrote 1908. It was not until very late in life that Kraus acknowledge this error.

Between 1934 and 1940, Kraus and the Kraus-Goldberg Duo recorded some exceptional performances for

▶ Odeon. The solo performances by Kraus include various works by Mozart, Bartok, Haydn, Schubert and Beethoven. Her recordings with Goldberg included six Mozart sonatas as well as several Beethoven sonatas. In the mid 1930's the Duo recorded three wonderful Haydn Trios with the great Argentinian violoncellist, Anthony Pini. These are stunning performances. All of this 78rpm material above has been released on early LPs by American Decca. The Mozart *Sonatas* were issued in a "long box" as DX 103 and the Haydn in the same form as DX 104. In the late 1990's, Music and Arts (CD 665) issued the Mozart and Beethoven's *Sonatas* on a compact disc, but I believe it's now out of print.

In early 1941, the Kraus family was living in Bali. During one of her tours, because of the events in Europe, the family decided it was 'safer' to stay with so many of their European friends in this area of the then called Dutch East Indies. Quoting from Roberson's book, "On December 7, 1941, the South Pacific suddenly changed when the Japanese attacked the U. S. Navy base at Pearl Harbor. On December 8, the Netherlands declared war on Japan and the Japanese invasion of the oil-rich Dutch Indies soon followed. When Bali fell, Kraus, Mandl (her husband), and the children went back to Bandung, which the Japanese quickly captured. On February 15, 1942, "Fortress" Singapore, bastion of British colonial dominance in the southwest Pacific, fell to the Japanese and the back of European resistance was broken. By March 8, Java was conquered and the Dutch surrendered. Escape was now impossible for Kraus and her family." It would be another year before Kraus and her husband and children would all be separated and imprisoned. Clearly this was not an easy time and although the commander of the camp knew who Kraus was (and had her give recitals), she also had to work with the other prisoners. Sometime in mid 1944 the famous Japanese conductor

Aida paid Kraus a visit and brought her some additional food and graciously asked if there was anything he could do to make her life more bearable. Using his influence he arranged to have the family brought together and moved to a fenced in area where they lived in a single-car garage.

He also arranged to have an old piano brought to her. She and her family would not experience freedom until mid August of 1945, more than two years after their imprisonment. In 1945 the family travelled to Sydney, Australia and finally in 1946 moved to New Zealand. This was home for a while, but as world events settled, she began touring once again.

The time in the internment camp did take its toll on her playing and although her reviews were passable, they weren't as glowing as her earlier performances. It took several years for her to bring her

style back to its pre-war condition. During a tour in Europe, her reviews were not favourable and it was a period in her life filled with melancholy. While on a tour in South Africa, she made contact with the chairman of the music department at Stellenbosch University in Capetown. She accepted an eighteen-month appointment to the piano faculty as artist-in-residence. This was just the period she needed to not only teach but to bring her skills to where

she felt they should be.

This time also totally restored her confidence. On November 6, 1949, she made her debut recital at New York's Town Hall. In the audience was her former teacher and mentor, Artur Schnabel. The recital was a spectacular success and with this renewed

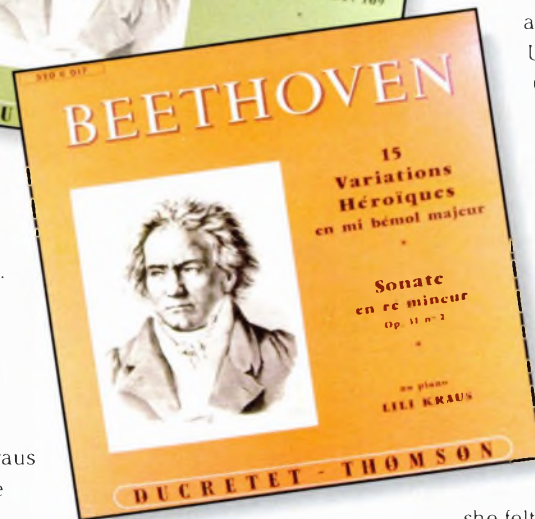



► confidence as well as critical acclaim from the newspapers, her love affair began with the United States. Her world tours began again, even to Japan on several occasions, and she would record some fabulous performances in Paris for Les Discophiles Français in the early to mid 1950's. It would not be until 1967 that Kraus and family would move permanently to the United States. Initially living in New Jersey, she became artist-in-residence at Texas Christian University in Fort Worth. Kraus had previously been a judge there at the first Van Cliburn International Piano Festival in 1962 and again in 1966. Eventually she moved to Fort Worth. Tours continued, teaching continued, fame continued. She would be with us until late 1986.

Kraus left a massive legacy of recordings. She recorded for Odeon, Les Discophiles Français (which became part of French EMI [Pathé-Marconi]), Ducretet-Thomson, Columbia (Epic) and Vanguard in the US, MMS in Switzerland and in the 1970's a handful of records for an educational company, Educo also in the US. My personal favourites are all the Odeon works that were re-issued on American Decca, a sheer wealth of playing that sounds as if it comes directly from heaven. I'm also partial to her Ducretet-Thomson recordings of Beethoven, Mozart and Haydn, but the real jewels in this period are the recordings she made for Les Discophiles Français. There are Schubert piano sonatas, Mozart piano sonatas complete on eight wonderful records, as well as the violin and piano sonatas, also complete, with Willi Boskovsky playing the violin. There are several Beethoven *Sonatas* with Boskovsky and there is also a very rare recording of two Mozart *Piano Concertos* with Boskovsky conducting - this issued as DF 176. Kraus performs concertos *K271* and *K466* as Boskovsky leads the Orchestre de Chambre du Wiener Konzerthaus.

In the United States, many of these were released in the mid 1950's by the Haydn Society. Her Mozart sonatas were also released again by Music and Arts in a five compact disc set, CD-1001.

Music is a very personal affair. While there are many artists that excel with a particular repertoire, i.e., Lefebure's Bach, Tagliaferro's penchant for composers of the French and Spanish schools, Marcelle Meyer's legacy of French composers including Ravel, Debussy and Chabrier (also on Les Discophiles Français), for me Mozart is Kraus and her contemporary, Clara Haskil. There is something that this artist brings to Mozart that I hear no where else. It's indescribable, but it touches me deeply. Haskil also is right up there for me, but again, Clara is not what I'm writing about today.

I'm a Mozart person. There is not enough Mozart for my collection

because there are so many great performances of individual works by various artists. For example, as much as I love Marcelle Meyer, her rare Discophiles Français seven inch recording of *K330* does nothing for me, but my mind changed about Meyer when I heard the performances released on *L'Archet*

*D'Or: OR V*, the limited edition series from Glenn Armstrong. He found this Mozart in Switzerland, and it's fabulous. His series offered by subscription only, offers some of the finest and rarest performances by a variety of artists and should not be missed by any music lover.

The finest *K330* I've ever heard is by the great French teacher and pedagogue, Lazare-Levy on Ducretet-Thomson. I find it unique because this is the only time I've ever heard this work where the artist leaves nothing of him/herself with the composition. It's Mozart as if Mozart was playing and I find this interpretation to be the most superior single ►



► performance I've ever heard. It is just so simple, but I can guarantee that it contains only what Mozart wrote: A unique recording indeed.

Lili adds soul and her life experiences to the music. You can tell how much she loves what she is doing. Her notes are clear, precise and her tempi seem perfect. Her tone is perfection itself. Mozart with soul. What more could you ask for? Part of the enjoyment of these works on this French label is the sound quality they offer. There is absolutely no doubt about the Steinway piano she is using. From the very first note on DF 91 starting with *Variation K 398*, you are captured and mesmerized, and just to keep you in your seat, the following selection is *K330!*

I don't know what the French engineers did (I believe many if not most of these recordings were engineered by the great André Charlin) but it's sheer magic. Charlin is to these recordings as Wilkinson is to Decca, Parker to EMI, Layton to RCA and Fine to Mercury. The man was a genius. He was able to capture the sound of a piano, in my opinion, better than anyone else ever did or has since. He worked not only for DF, but also for Ducretet, Lumen and eventually his own label, Charlin.

Kraus performed some of these works for Odeon that were released later on American Decca as I mentioned earlier. There is clearly a difference in her style. While I prefer the Odeon recordings for technique, there is no doubt the sound of the French recordings is literally 'Manna from the Gods'. She also performed these works for the US Columbia subsidiary, Epic. For me, they do nothing. Yes, the playing is excellent, but the sound is too tinny and thin. This spoils my pleasure. For me, Mozart is an ethereal experience and really

puts me in another place, but the sound has to be a major component. This is, for me, one of the joys of mono-phonics listening. All tube equipment was used from start to finish and although my head tells me it's 'flavoured', my soul tells me it's right.

Lili Kraus was a very special artist. She endured events in her life that most of us cannot even

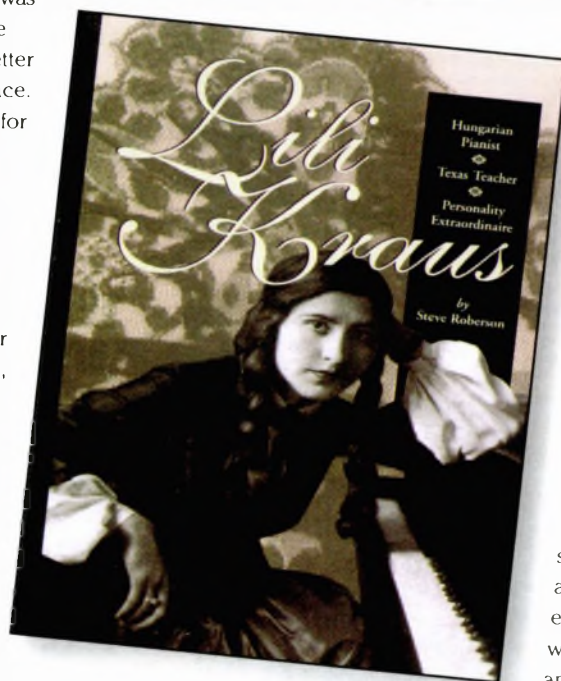

begin to comprehend. Everything I've read about her describes her as a wonderfully vibrant and outgoing personality. For someone to have lived and experienced what she did in her lifetime and still be able to touch the soul of so many listeners, is nothing short of a miracle. Do spend some time and try and find her recordings. Perhaps the French recordings are not going to be readily available in record form, but they do exist on Compact Disc and there is so much out there. She's an artist you owe it to yourself to explore. The journey is well worth the riches that await and will reward you.





## PINEWOOD MUSIC of Winchester and Taunton

### JADIS

A living legend of gold and stainless steel that delivers the awe, the shock and the humanity of music. Once heard, a Jadis can never be forgotten.

### KRELL

Krell's Resolution Series of loudspeakers set a new standard for clarity, delicacy and attack in beautifully finished biwired cabinets. Superb value.

### ORACLE

The vinyl legend that remains a world standard in its 25th year, a sculptural work of art that looks as beautiful as it sounds.

Agencies include: Krell, Sonus faber, Martin Logan, Jadis, Oracle, Koetsu, Lyra, Copland, Pathos, Audio Research, Unison Research, Transparent, Chord Company, BCD, finite-elemente, Futureglass

**Winchester: 01962 776808**  
**Taunton: 01460 54322**  
**Mobile: 07860 351113**  
**e-mail: brianriv@mac.com**

**DEMONSTRATIONS AVAILABLE 7 DAYS A WEEK**

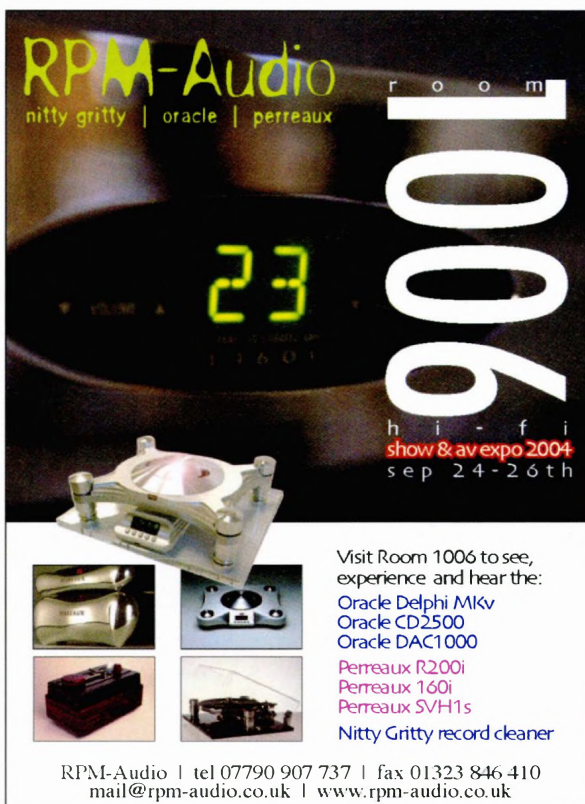

**RPM-Audio**  
nitty gritty | oracle | perreaux

**room 1006**  
h i - f i  
show & av expo 2004  
sep 24-26th

Visit Room 1006 to see, experience and hear the:

- Oracle Delphi MkV
- Oracle CD2500
- Oracle DAC1000
- Perreaux R200i
- Perreaux 160i
- Perreaux SVH1s
- Nitty Gritty record cleaner

RPM-Audio | tel 07790 907 737 | fax 01323 846 410  
 mail@rpm-audio.co.uk | www.rpm-audio.co.uk

## Townshend

### Maximum Supertweeter.

"Great performance, engineering and build make them this year's essential high - end audio accessory." Verdict ●●●●● Hi Fi World Feb '04.

"I still have my Maximum supertweeters, thank goodness. But I have tried living with them switched off and, believe me, it felt like masochism."  
 Hi-Fi News March '03.

But, whatever the explanation, truth is you don't need bat-like hearing or ultra-wide bandwidth recordings to enjoy the subjective benefits of super tweeters. The effect is there for all to hear on the vast majority of recordings, be they new or old, digital or analogue, mono or stereo. Hi-Fi + April '04.

Compact design placed on your speaker.

Stands available for use with curve-topped speakers, e.g. B&W, Wilson Benesch, Sonus Faber, etc. Fantastic upgrade for Quad EL5s!

Supplied with 1.5m 'DCT' Deep Cryogenic Treated Litz connecting cables.

Adjustable level control to suit speakers with sensitivity 76 to 105dB/W.

Coming in at 10kHz; 30kHz - 90kHz response +/- 3dB.

Townshend Audio, Hampton Court. Tel +44(0)20 8979 2155  
 www.townshendaudio.com  
 Made in England



Visit us in room 1026, Renaissance Hotel. See the TA565 universal player on demonstration with the new Anniversary Rock turntable & Excalibur pick-up arm all through the Townshend System using the Glastonbury III Speakers.

2 Star Lane, Ringwood, Hants, BH24 1AL  
 Tel: 01425 461230 Fax: 01425 472054



...Join the dots!

*phonography*

Arcam, Rega, Rotel, Naim, Densen, Royd, Shahinian, Dynavec, Ortofon, Cura, Dynaudio, Chord, Quadraspire



**47 LABORATORY @ THE HI-FI SHOW & EXPO 2004 SYNDICATE ROOM 21**  
 WWW.MIDLANDAUDIOX-CHANGE.CO.UK SALES@MIDLANDAUDIOX-CHANGE.CO.UK

T. 01562 731100  
 F. 01562 730228  
 M. 07721 605966

**Vinyl**

- Audio note TT-1 & IQ3
- Rega Planar range
- SME tonearms
- Opus Continuo & Cantus
- Project RPM6 & RPM9
- Roksan Radius 5
- Michell Gyrodek mkV

**CD Players**

- Audio Note Dacc 1 Sig
- Shanling CD1100
- Sugden CD21 player
- Heart CD6000 valve output

**Amplifiers**

- Audion Silver Night 300B SE
- Icon Audio integrated amps
- Verdier Control B pre amp
- StoetKit valve amps and kits
- Cut Loose Audio amplifiers

**Speakers**

- Living Voice range
- ProAc Reference D38
- Graves Audio Koronglay
- Reithm nom speakers
- PMC GB1 FR1 & GB1's
- PHI/HP drive units
- ProAc Studio 100

**Cables/Accessories**

- Chord Signature cables
- Silver Arrow cables
- Something Solid supports
- Voodoo Airtech Isolation
- Isotek GII mains filters

And many more

**Featured product: Something Solid XR**  
 After years of development Something Solid, a well respected, but little known audiophile stand manufacturer, have developed this outstandingly high performance rack.  
 Based around a solid steel skeleton from which each shelf is individually suspended and tensioned using braided polymer cord. The shelves themselves are made from a combination of materials including end grain balsa and carbon fibre pads.  
 The purpose of the design is to efficiently remove and dissipate vibration, therefore isolating any equipment placed upon it.  
 The four tier rack as shown costs £650, with even further isolation available when the revolutionary Missing Link feet are fitted instead of spikes (for an additional £100).



**Noteworthy Audio**  
 36 Buckingham Street, Aylesbury, Bucks, HP20 2LH. Tel: 01296 422224  
 www.noteworthyaudio.co.uk



# hi-fi+ Subscription Form

In order to ensure prompt arrival of your copy of hi-fi+, it is safest to take out a subscription. This lasts for a year, or 8 copies, and means that your magazine is delivered to your doorstep immediately it is published. No more fruitless journeys in search of audio enlightenment, and no more worries about missing an issue.

In order to apply, simply fill in the form, legibly (!), and drop it in the post.

**UK, Western Europe & Rest of the World:**

**One Year Subscription / 8 Issues**  
 Within the UK, \$28.50 Western Europe, \$39.50  
 For the rest of the world (excluding USA/Canada) \$52.50

**Two Year Subscription / 16 Issues**  
 Within the UK, \$48.00 Western Europe, \$70.00  
 For the rest of the world (excluding USA/Canada) \$96.00

**Contact:**  
 hi-fi+ Subscriptions, Unit 12 Albany Business Park  
 Cabot Lane, Poole, Dorset BH17 7BX, UK

**Or call:**  
 Andrea Chick on Tel: 44 (0)1202-659380  
 or Fax: 44 (0)1202-659540

**Via the web: www.hifiplus.com**

**USA & Canada:**  
**One Year Subscription / 8 Issues**  
 USA, \$65.00 US Canada, \$72.00 CN

**Two Year Subscription / 16 Issues**  
 USA, \$130.00 US Canada, \$144.00 CN

**Contact:**  
 US: DirectMag, PO. Box 2165, Williamsville, N.Y., 14231  
 Canada: DirectMag, 695 Westney Rd. S, Suite 14, Ajax,  
 Ontario, L1S 6M9

**Or call:**  
 Tel: Toll Free 1-877-474-3321 or Fax: 1-905-619-2903

**Via the web: visit DirectMag @ www.magamall.com**

**ABOUT YOU:**

Title .....

Forename .....

Surname .....

Address .....

.....

Country .....

Postcode/Zipcode .....

Daytime Tel .....

I would like my subscription to start from issue: .....

One Year  Two Years

**PAYMENT:**

UK  Europe  Rest of World

Cheques to be made payable to Hi-fi+ Publishing limited.  
 (drawn on a UK bank)

US  Canada

Checks to be made payable to DirectMag.

Visa  Access/Mastercard

Card No .....

Expiry Date .....

Switch

Card No ..... Issue No .....

Expiry Date .....

Signed ..... Date .....

How did you hear about us?  
 shop  web  airlines  friend  other .....





**Le Violon Vagabond**

**Graf Mourja/Natalia Gous**

Harmonia Mundi HMC 901785 (CD)

Those expecting a release of standard violin repertoire will have to look elsewhere. It may include music by Tchaikovsky, Paganini and Sarasate that will be familiar to most listeners, but the remainder of this astonishing disc contains treasures as far from the over-recorded fare that these kinds of releases usually carry, as you are likely to find. While they may not be regarded as masterpieces, there are some 20th Century gems here. This recital also exhibits the wonderfully natural talents of violin virtuoso Graf Mourja, who's playing balances perfectly between that of the classically trained musician and a gifted Gypsy performer, bringing each piece to life without the slightest hint of mannerism or over-exaggeration. He plays the familiar as well as anyone, while his expressiveness paints a kaleidoscope of hues that outshines most others in the more folk-orientated works. The opening *Danses populaires roumaines* by Bartók is a perfect example of this, with his extraordinary performance simply surpassing any other on offer. With enthusiastic support from pianist Natalia Gous, and excellent engineering, this CD will both surprise and delight all but the most cynical music lover, and has to be one of the most entertaining albums of the year.

SG

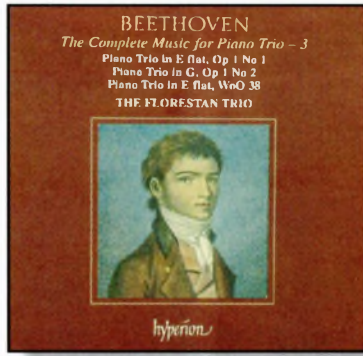

**Beethoven**  
**The Complete Music for Piano**  
**Trio, Vol. 3**  
**Florestan trio**

Hyperion CDA67393 (CD)

This is the third volume of a complete, four-disc, set of Beethoven's works for piano trio planned by the wonderful Florestan Trio and Hyperion; and like the first two it is an entirely first-class issue. It comprises three trios: *Op. 1, Nos. 1 and 2*, and *38. The Op. 1 Trios* were first published shortly after the composer's move to Vienna, and became immediate hits with the Austrians, despite Haydn not being totally enthralled by them all. The first two from that set are among the youthful Beethoven's most endearing works, and are totally charming and positively engaging. Here they are given the most enthralling of performances: full of elegance and sophistication. This ensemble are probably the finest current interpreters of this repertoire on modern instruments, and their superb playing supplies some extra vigour and wit. Simply listen to the alluring panache of the opening movement of the *E flat major trio* and the two glittering *presto finales* of both the *Op. 1 trios*, and you will here some of the most superb chamber music on CD. With Hyperion's very good sound, this has got to be a winner and has therefore got to receive a firm recommendation.

SG

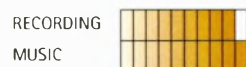

**Vivaldi's Cello**

**Yo-Yo Ma/Amsterdam Baroque**  
**Orchestra/Koopman**

Sony Classical SK 90916 (CD)

Many will be familiar with Yo-Yo Ma's deep, luscious sound, but even though the instrument used on this CD is the same 1712 Stradivarius that featured on the *Simply Baroque* albums, the sound is far more intimate, more refined and restrained, with a rasping tone. Ma wanted to restore the original timbre of the instrument, so the Stradivarius has been returned to its original set-up, with a baroque bridge and gut strings replacing the more-modern articles. The results certainly bring Vivaldi's cello music to life, but there is a lack of independence to Ma's performance. There is more of a sense of the soloist being drawn further into the orchestra; with Koopman and his charges performing much more on equal terms. This is a far more natural presentation and the music comes across as particularly elegant and sensitively conveyed. Apart from three concertos for cello, there are also a few transcriptions of works that Vivaldi originally composed for other instruments or voice, with mixed results – the *largo* from the *Four Seasons' Winter* is rather lacklustre – but generally this disc is successful, with a number of superb renditions of sometimes poignant, occasionally humorous, but always engaging music.

SG

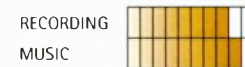



**Haydn**  
String Quartets Op. 64 No. 5, Op.  
76 No. 2, and Op. 77 No. 1  
Jerusalem Quartet

Harmonia Mundi HMC 901823 

I have always had an especially high regard for Joseph Haydn's chamber music. There is a particular maturity that Mozart never fully achieved, although that is not to dismiss the younger composer's work; it is just that there is a wonderful rightness to Haydn's compositions. This disc features three of his greatest quartets performed by the youthful, yet already internationally renowned, Jerusalem Quartet, who play with a professionalism way beyond their years. The rhythmic qualities of the *Lark Quartet* are almost hypnotic, while the first violin soars above in the most persuasive manner. Generally their tempos are on the fast side, but even in the quicker movements their accuracy and precision are such that there is only an added sense of liveliness, but they never allow the resulting excitement to overwhelm the music's charm. Their tone is most ravishing, helped by the vivid, yet warm recording, with no hint of glare in the highest notes; only a natural grittiness and vibrancy that add presence to each performance. In fact the Jerusalem Quartet present these three works as if newly discovered, exhibiting their own individuality to each, but still managing to display a wonderful maturity without ever bordering on the conventional.

SG

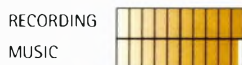

**Penderecki**  
Violin Sonatas Nos. 1 and 2/  
Miniatures/Cadenza for Solo Violin  
Bieler/Tichman

Naxos 8.557253 

Krzysztof Penderecki's early compositions display a strong Shostakovichian influence, and this is no better demonstrated than in his *First Violin Sonata*, written at the age of twenty. The piece lasts for around seven and a half minutes, during which its three wonderfully condensed movements exhibit all the repartee and distinctive themes of the Russian master's writing. The *Second Violin Sonata*, receiving its premier recording here, also recalls Shostakovich, but this time more particularly his *Eighth String Quartet*. Its five movements produce a large palette on to which the Polish composer has painted with rhapsodic freedom. This is particularly true of the work's structural centrepiece, the thirteen-minute *adagio*, which experiences several moments of climatic expression. Between the two sonatas come the three *Miniatures* and the *Solo Cadenza* that Penderecki originally added to his viola concerto. Throughout all the performances Ida Bieler plays with dynamic enthusiasm. Her commitment is tremendous, producing the most ardent of interpretations, and pianist Nina Tichman most ably accompanies her. Naxos' engineering is superbly balanced, with neither instrument too prominent, and there are some fine notes to accompany the disc, making this a release that easily deserves my full recommendation.

SG

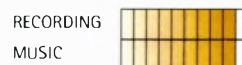

**Léonardo de Vinci - L'harmonie  
du monde**

Quentin/Azéma/Doulce  
Mémoire/Raisin Dadré

Naïve E 8883 

Among his many other talents, Léonardo de Vinci was a skilled and talented musician, especially on the plucked string instrument known as the lira da braccio: devising and recounting impromptu poetry. Many of the composers of the music featured on this recital of 15th Century works are anonymous, but there are others that will be familiar to early music specialists. All originate from places that Léonardo either lived or travelled, and the selection is a fascinating group of secular and non-liturgical sacred pieces. Throughout, but especially in the purely instrumental works, there is a particular clarity, with no overcrowding of texture and a wonderful display of timbre. The playing emphasises various points of style, enhancing the differences between music from the varying places of origin, while the songs are attractive, especially the anonymous *Deh quanto è dolze*, impressively sung by Anne Azéma, whose renditions of the Italian songs are particularly fine - although Anne Quertin's more straightforward and unornamented French songs are also of a very high standard. While such a concept for an early-music recital is not the most innovative, the resulting disc is certainly a most welcome and satisfying issue.

SG

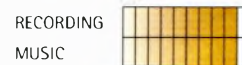



**VIVA AUDIO**  
 The best triode amplifiers in the world  
 Built by hand in Italy. Available in the UK from  
[www.emporiumhifi.com](http://www.emporiumhifi.com) Tel: 01379 870873

## Oranges & Lemons

Hi-Fi,  
 Home Cinema  
 & Multi-room  
 Specialists

**020 7924 2040**  
[www.oandlhifi.co.uk](http://www.oandlhifi.co.uk)  
 61 Webbs Road, Battersea, SW11 6RX  
 email: [oranges.lemons@virgin.net](mailto:oranges.lemons@virgin.net)

## Radlett Audio

EST. 1978

**THE HIGH-END SPECIALIST SINCE 1978**

ATC, Audio Analogue, Avantgarde,  
 Ayre, Bryston, Copland, EAR, Isotek,  
 JM Lab, Lyra, Mark Levinson,  
 Naim Audio, Notts Analogue, PMC,  
 ProAc, Rega, Revel, Roksan,  
 Sonus Faber, Stax, Spendor, Sumiko,  
 Wadia and lots more.

9 Holywell Hill, St. Albans, Herts, AL1 1EU  
**Tel: 01727 855577**  
 Fax: 01727 858727

For the very best deals on  
 the finest products available, visit:

[www.sounds-of-music.co.uk](http://www.sounds-of-music.co.uk)

there's no finer sound.

>cartridges  
 lyra  
 orofon  
 sumiko  
 >cables  
 chord company  
 nordost  
 >headphones  
 grado  
 stax  
 >hardware  
 atc  
 audio pro  
 creek  
 epos  
 harbeth  
 lexicon  
 michell  
 naim audio  
 neat acoustics  
 nottingham  
 parasound  
 primare  
 sme  
 trichord

naim  
 +  
 nordost  
 +  
 neat  
 (& nottingham analogue  
 too) =  
 signals  
 hi-fi for grown-ups

l p s w i c h ( 0 1 4 7 3 ) 6 5 5 1 7  
 w w w s i g n a l s . u k . c o m  
 Buckle sham Ipswich IP10 0DY

Living Voice Loudspeakers  
 Tom Evans Audio Design  
 Resolution Audio  
 Neat Acoustics  
 Border Patrol  
 DNM/Reson  
 Audio Physic  
 LFD Audio

the sound prac'tice.  
 architects of extraordinary  
 2 channel audio systems

[www.thesoundpractice.com](http://www.thesoundpractice.com)  
[surgery@thesoundpractice.com](mailto:surgery@thesoundpractice.com)

tom tom audio

The largest selection of mint, pre-loved  
 Naim Audio components on the planet.

- 12 month guarantee
- Help & advice
- Mail order
- Dem facilities
- Open 7 days
- Products tested

[www.tomtomaudio.com](http://www.tomtomaudio.com)  
[tunes@tomtomaudio.com](mailto:tunes@tomtomaudio.com)

**Tel: (01727) 893 928**



**Haydn**  
String Quartets Op. 64 No. 5, Op. 76 No. 2, and Op. 77 No. 1  
Jerusalem Quartet

Harmonia Mundi HMC 901823 

I have always had an especially high regard for Joseph Haydn's chamber music. There is a particular maturity that Mozart never fully achieved, although that is not to dismiss the younger composer's work; it is just that there is a wonderful rightness to Haydn's compositions. This disc features three of his greatest quartets performed by the youthful, yet already internationally renowned, Jerusalem Quartet, who play with a professionalism way beyond their years. The rhythmic qualities of the *Lark Quartet* are almost hypnotic, while the first violin soars above in the most persuasive manner. Generally their tempos are on the fast side, but even in the quicker movements their accuracy and precision are such that there is only an added sense of liveliness, but they never allow the resulting excitement to overwhelm the music's charm. Their tone is most ravishing, helped by the vivid, yet warm recording, with no hint of glare in the highest notes; only a natural grittiness and vibrancy that add presence to each performance. In fact the Jerusalem Quartet present these three works as if newly discovered, exhibiting their own individuality to each, but still managing to display a wonderful maturity without ever bordering on the conventional.

SG

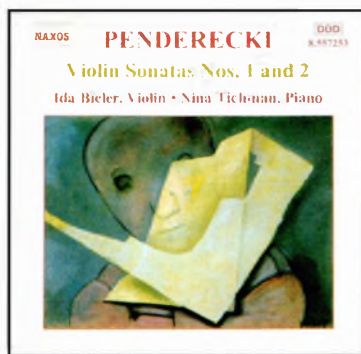
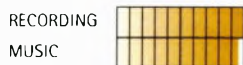

**Penderecki**  
Violin Sonatas Nos. 1 and 2/  
Miniatures/Cadenza for Solo Violin  
Bieler/Tichman

Naxos 8.557253 

Krzysztof Penderecki's early compositions display a strong Shostakovichian influence, and this is no better demonstrated than in his *First Violin Sonata*, written at the age of twenty. The piece lasts for around seven and a half minutes, during which its three wonderfully condensed movements exhibit all the repartee and distinctive themes of the Russian master's writing. The *Second Violin Sonata*, receiving its premier recording here, also recalls Shostakovich, but this time more particularly his *Eighth String Quartet*. Its five movements produce a large palette on to which the Polish composer has painted with rhapsodic freedom. This is particularly true of the work's structural centrepiece, the thirteen-minute *adagio*, which experiences several moments of climatic expression. Between the two sonatas come the three *Miniatures* and the *Solo Cadenza* that Penderecki originally added to his viola concerto. Throughout all the performances Ida Bieler plays with dynamic enthusiasm. Her commitment is tremendous, producing the most ardent of interpretations, and pianist Nina Tichman most ably accompanies her. Naxos' engineering is superbly balanced, with neither instrument too prominent, and there are some fine notes to accompany the disc, making this a release that easily deserves my full recommendation.

SG

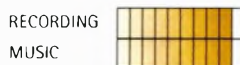

**Léonardo de Vinci - L'harmonie du monde**

Quentin/Azéma/Douce  
Mémoire/Raisin D'adre

Naïve E 8883 

Among his many other talents, Léonardo de Vinci was a skilled and talented musician, especially on the plucked string instrument known as the lira da braccio: devising and recounting impromptu poetry. Many of the composers of the music featured on this recital of 15th Century works are anonymous, but there are others that will be familiar to early music specialists. All originate from places that Léonardo either lived or travelled, and the selection is a fascinating group of secular and non-liturgical sacred pieces. Throughout, but especially in the purely instrumental works, there is a particular clarity, with no overcrowding of texture and a wonderful display of timbre. The playing emphasises various points of style, enhancing the differences between music from the varying places of origin, while the songs are attractive, especially the anonymous *Deh quanto è dolze*, impressively sung by Anne Azéma, whose renditions of the Italian songs are particularly fine - although Anne Quertin's more straightforward and unornamented French songs are also of a very high standard. While such a concept for an early-music recital is not the most innovative, the resulting disc is certainly a most welcome and satisfying issue.

SG





**VIVA AUDIO**  
 The best triode amplifiers in the world  
 Built by hand in Italy. Available in the UK from  
[www.emporiumhifi.com](http://www.emporiumhifi.com) Tel: 01379 870873

## Oranges & Lemons

Hi-Fi,  
 Home Cinema  
 & Multi-room  
 Specialists

**020 7924 2040**  
[www.oandlhifi.co.uk](http://www.oandlhifi.co.uk)  
 61 Webbs Road, Battersea, SW11 6RX  
 email: [oranges.lemons@virgin.net](mailto:oranges.lemons@virgin.net)

## Radlett Audio

EST. 1978 CONSULTANTS

THE HIGH-END SPECIALIST SINCE 1978

ATC, Audio Analogue, Avantgarde,  
 Ayre, Bryston, Copland, EAR, Isotek,  
 JM Lab, Lyra, Mark Levinson,  
 Naim Audio, Notts Analogue, PMC,  
 ProAc, Rega, Revel, Roksan,  
 Sonus Faber, Stax, Spendor, Sumiko,  
 Wadia and lots more.

9 Holywell Hill, St. Albans, Herts, AL1 1EU  
**Tel: 01727 855577**  
 Fax: 01727 858727

For the very best deals on  
 the finest products available, visit:

[www.sounds-of-music.co.uk](http://www.sounds-of-music.co.uk)

there's no finer sound.

>cartridges  
 lyra  
 ortofon  
 sumiko  
 >cables  
 chord company  
 nordost  
 >headphones  
 grado  
 stax  
 >hardware  
 atc  
 audio pro  
 creek  
 epas  
 harbeth  
 lexicon  
 michell  
 naim audio  
 neat acoustics  
 nottingham  
 parasound  
 primare  
 sme  
 trichord

naim  
 +  
 nordost  
 +  
 neat  
 (& nottingham analogue  
 too) =  
 signals  
 hi-fi for grown-ups

l p s w i c h ( 0 1 4 7 3 ) 6 5 5 1 7  
 w w w s i g n a l s . u k . c o m  
 Bucklesham Ipswich IP10 0DY

Living Voice Loudspeakers  
 Tom Evans Audio Design  
 Resolution Audio  
 Neat Acoustics  
 Border Patrol  
 DNM/Reson  
 Audio Physic  
 LFD Audio

the sound prac'tice.  
 architects of extraordinary  
 2 channel audio systems

[www.thesoundpractice.com](http://www.thesoundpractice.com)  
[surgery@thesoundpractice.com](mailto:surgery@thesoundpractice.com)

tom tom audio

The largest selection of mint, pre-loved  
 Naim Audio components on the planet.

- 12 month guarantee
- Help & advice
- Mail order
- Dem facilities
- Open 7 days
- Products tested

[www.tomtomaudio.com](http://www.tomtomaudio.com)  
[tunes@tomtomaudio.com](mailto:tunes@tomtomaudio.com)

**Tel: (01727) 893 928**



## Brain

### Hiromi

Telarc SACD-63600 

Don't judge this album by the opening track alone. 'Kung Fu World Champion' is an all out electronic assault, a tribute to Bruce Lee and Jackie Chan, and with its driving percussion and lighting fast keyboard runs is hugely enjoyable. It's such a gear change when the trio move to relatively straight ahead jazz for track two that my initial reaction was to check the sleeve to be sure it's the same band. Fronting a very accomplished trio – Tony Grey or Anthony Jackson (bass), and Martin Valihora (drums), Hiromi Uehara is an outstanding musician. She composed all the numbers here, and most range between eight and ten minutes so the band really have the chance to stretch out. This really is an album that rises above the mass of mediocre jazz releases, packed full of surprises and superbly played. The band is extraordinarily tight and eloquent making it very difficult to choose a favourite track although after just a few plays I'm becoming very fond of the title number, almost a mini symphony in its 8.59 minute life. Hiromi's solo piano piece 'Green Tea Farm' is also hugely engaging.

Telarc have done the band proud with a full-bodied, spacious and dynamic recording that's great in the plain vanilla CD layer and better still in SACD. Hiromi was a new musician to me. I'll now seek out her other Telarc release *Another Mind*.

DD

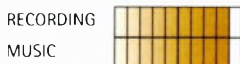

## Babatunde Olatunji

### Love Drum Talk

Chesky SACD275 

This CD, originally released and Grammy nominated in 1998, is the tenth in the Nigerian percussionists 'drums of passion' cycle. Based around his own experiences, it encompasses unbridled passion, romantic love and doomed passion. Olatunji's words are sung in Yoruba, his tribal language, and he transmits the message even more eloquently via the battery of drums that surround him. Just listen to the nine-minute title track with pattering percussion building and building as the musician comments on the unspoken dialogue between male and female dancing partners. Or to the opening track 'Sare tete wa', with its plea to an estranged lover. Olatunji is backed by a vocal trio and an array of musicians including guitar, mandolin, bass and more percussion. It's the leader that shines centre-stage but the band adds the essential fuel to his engine. Personally though, I could do without the occasional interjections such as 'very nice' and 'I like it' from the vocalists. The production is excellent, one of Chesky's best and although the CD layer is outstanding the SACD adds a whole other dimension, more dynamic, spacious and three dimensional, bringing this delightful heart warming experience right into your listening room. Play loud and enjoy!

Supplier: [www.vivante.co.uk](http://www.vivante.co.uk)

DD



## John Fremgen, Shelly Berg, Pete Erksine

### Pieces Of String

Viewpoint VP0011 

Viewpoint is a small privately owned company with a bespoke studio in Austin, Texas. Their recordings are now distributed by Mike Davis of Woodside Electronics. This band was a very pleasant surprise. There's nothing too sophisticated here, just an accomplished trio romping through some standards and a couple of their own compositions, but the beauty of this set is in its very simplicity. Their storming take on Monk's 'Little Rootie Tootie' opens the album and captures your attention with crisp percussion followed by piano and bass in unison, belting out the main theme, before some lovely playing from Berg (piano) taking a more melodic approach than Monk's staccato original. An eight-minute take on 'A Nightingale In Berkeley Square' gives scope for a fine solo from Fremgen (bass). And so it goes. Each number is strong and the band are clearly enjoying themselves. Viewpoint allowed the musicians more freedom than many a larger label would and it shows in this fine album. They use vintage Neumann mikes, Telefunken tube pre-amps and the like and they've done a superb job here. To pick just one instrument, the double bass actually sounds very close to the real instrument, with the requisite body and presence that is sadly lacking in the vast majority of recordings.

DD

Contact: [m.davis@virgin.net](mailto:m.davis@virgin.net)

Tel: +44 (0) 1758 741026)







**Kapustin  
Piano Music**

Marc-André Hamelin

Hyperion CDA67433 

Russian composer Nikolai Kapustin trained in that country's great piano tradition, and while his works may include lines and structures from that school, his music is pure jazz; but written in classical form. This should not come as too great a surprise when you realise that the two forms are the most virtuosic styles of keyboard playing and composition to come out of the last century, and he has therefore been able to amalgamate the styles of Scott Joplin and Oscar Peterson with those of Rachmaninov and Scriabin without any sense of incompatibility. In line with the best jazz composers, Kapustin is a great melodist, writing fine music, while utilising other forms of composition to achieve his own fusion of styles: in a similar way to Gershwin. Marc-André Hamelin simply flies through the music, ignoring any technical difficulties with the most marvellous command and virtuosity. He adds an ebullient playfulness to many pieces, exhibiting the most tremendous sense of enjoyment. In all, this second disc of Kapustin's marvellous music from Hyperion is the most exceptionally satisfying discovery, which I hope will result in the label's complete exploration of this very talented composer's most colourful work.

SG



**Ella Fitzgerald sings the Duke  
Ellington song book**

Ella Fitzgerald, Duke Ellington and his Orchestra

Speakers Corner/Verve MGV 4010-4  

Speakers Corner received well deserved plaudits for their superb Ella Fitzgerald *Gershwin Songbook*, a sumptuous re-issue that sounded as good as it looked. On the surface, the *Ellington* box-set might not seem to have the luxurious quality of the *Gershwin*, but that's more about quantity than anything else. The book might be thinner and there's no extra disc, but don't let that fool you. From the beautifully reproduced box to the double gatefold inners, the weight of the art-paper booklet to the quality of the printing, this is in every way, the partner and counterpoint to the *Gershwin* set. The difference is in the music. If the *Gershwin* is all about show tunes and popular song, this is about scat and jazz. The repertoire needs no introduction and nor does Ellington's orchestra. The cutting and pressing are up to the superb standard we've come to expect from Speakers Corner while the performances are sublime and superbly served by the vintage Verve mono sound. Ella received plenty of criticism from narrow-minded jazz fans for recording the song books. Well, there's nothing to criticize here as she struts imperiously through the whole range of styles. This is the perfect accompaniment to the *Gershwin* box and every bit as essential.

RG



**Portrait of Bill Evans**

Various

JVC VICJ 61171 

Evans is undoubtedly one of the most well-loved and well-known jazz pianists in history. He recorded prolifically, appearing on many landmark albums both in his own name and perhaps most famously, played a key role in what many regard as the greatest jazz album of all time, Miles Davis' *Kind of Blue*. This album draws together a rich selection of his admirers, all of whom have a profound respect for the man.

With a cast list that includes Herbie Hancock, Dave Grusin, Bob James, and Elaine Elias, accompanied by the likes of Jack DeJohnette and 'others' as the sleeve proudly proclaims, this could be a real curates egg. Fortunately that's not the case and this is a remarkably cohesive set. Sure, there are standouts here – take Bob James reading of his own 'Under The Influence' which features fine ensemble playing and some great and uncredited horn playing in addition to James' sprightly finger work – but the whole album is of a very high standard. Grusin's take on the Evan's classic 'Waltz for Debby' evokes more than a whiff of the man himself. The album closes with 'Ghost Story' Herbie Hancock's improvisation on Chopin's *C Minor Prelude Opus 28* that truly does raise the ghost of Evans and provides a fitting close to this set. The recording is full-bodied, dynamic and a credit to the XRCD24 process.

DD

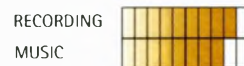

vivante

**Going to the show? So are we!**

Come down and see us on **Stand 25**. All the latest and best vinyl, SACD, CD, XRCD, DVDA and DTS titles loads of special offers. A warm welcome is guaranteed. We look forward to meeting you. **Enjoy the show.**



**Vivante Productions Ltd**  
Unit 6, Fontigarry Busines Park,  
Reigate Road, Sidlow, Nr. Reigate, Surrey,  
RG2 8QH. United Kingdom

Tel: +44 (0)1293 822186

Fax: +44 (0)1293 820509

sales@vivante.co.uk

www.vivante.co.uk



# ADVERTISERS INDEX

Absolute Analogue	17	Final Lab	84	Pinewood Music	130
Absolute Sounds	2	Focal JM Lab	13	Radlett Audio	134
ART Loudspeakers	125	Griffin Audio	101	Ringmat	85
Audio42	111	Hazlemere	95	RPM Audio	130
Audio Consultants	39	Hear Here	96	Signals	134
Audio Craft	38	Heatherdale	94	Sounds of Music	134
Audio Atmosphere	101	Hififorsale.com	111	Sendor Audio Systems Ltd	51
Audio Destination	100	Infidelity	100	Strub	96
Audio Images	100	Integrated Engineering Solutions	95	Symmetry	IFC
Audio Reference	125	KEF	5	The Cartridge Man	96
Audio Republic Ltd	101	Lamm	95	The Chord Company	14
Audio Room	101	Manger Audio	111	The Emporium	134
Audio Salon	57	Metropolis Music	29	The Right Note	85
AudioFreaks	4	Midland Audio Exchange	131	The Sound Practice	134
Audiophile International	57	Midland Hifi Studio	101	Townshend Audio	130
B&W	OBC	Music Matters	101	Trichord Research Ltd	73
Border Patrol	94	Neat Acoustics	67	Tube Shop	51
Cherished Records	100	Nordost	IBC	Ultimate Sonics	84
Chesterfield Communications	110	Noteworthy Audio Ltd	131	Vertex AQ	94
Chord Electronics	10	Oranges & Lemons	134	Vivante	137
Definitive Audio	73	Origin Live	67	Voodoo Isolation Systems	100
Dynavector Superstereo	100	Pear Audio	96	Walrus	8
Experience Filtration	111	Phonography	130		





Joan Baez

In Concert

Cisco-Vanguard: VSD 2122 **180g** **2**

Vanguard's third Baez LP is a compilation from several venues offered up as an "in concert" album, although you can't really tell that this recording was taped in several locations. Baez is clearly, both to my mind and those of the audience and folk song lovers of the day, the absolute High-Priestess of Protest. If that offends you, forget about her politics, just sit back and enjoy another aural treat from Messrs. Pincus and Gray. The album is a stunner. I've compared it to my original black label, early StereoLab copy and it's way better. Once again, what was once great, is now glorious.

Her voice is magnificent. The remastering has dramatically lowered the noise floor and although there is plenty of ambient information to go around, you are catapulted to the location(s) where these tapes were made. The audience is wonderfully quiet and it's always amazed me how civilized and polite they were. True respect offered to their artist by the attending public. Cisco has done us a big favour re-issuing this recording, so don't hesitate to buy this gem. You'll receive a wonderful 'audiophile' treat: a voice that is stunningly beautiful, and a live concert venue. I wish I were there! Highest recommendation.

RSF

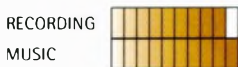

Britten, Dohnanyi  
Young Person's Guide...  
Variations On A Nursery Tune

Slatkin, Concert Arts S.O.

Cisco/Capitol SP8373 **180g** **3**

There is and always has been a prejudice amongst classical listeners when it comes to the indigenous repertoire. The music of your home country, so the story goes, can only really be played by a conductor, and preferably an orchestra too, that shares the composer's nationality. I'll admit I've often thought the same – but about Finnish music rather than English.

So deeply ingrained is the dogma that many an eyebrow will be raised at Cisco's decision to re-issue Slatkin's *Young Person's Guide...* especially given the options available from the composer himself and the pantheon of great, British conductors. But listen and you'll hear, that Robert Pincus' faith is well founded. Where the likes of Britten and Boult give us a perfectly poised and rather academic view, Slatkin is a bundle of life and exuberant energy, offering a performance full of mischief and humour. It sits well with the music and its aspirations, offering a vibrant, engaging quality. It's an approach that is less effective with the subtler textures of the Dohnanyi, but the price is worth it for the Britten alone, along with the silent surfaces and superb cut. Suspend your disbelief and enjoy. It's what this music was written for.

RG



The London Howlin' Wolf Sessions

Speakers Corner / Chess Records.

CH-60008 **180g** **1**

Make no bones about it – I'm a HUGE blues fan and all those who know me, know that's a fact. With all the great music available in the Chess catalogue, I can't wait for some of those titles to be released, and I was most impressed with the *Muddy Waters sings Big Bill Broonzy*, issued earlier in the year by SCR.

Here's the lineup: Up front, the incomparable Howlin' Wolf. The other artists, well they're more than just okay; Eric Clapton, Steve Winwood, Bill Wyman and Charlie Watts to name a few, with the great Hubert Sumlin sneaking in there too. Whilst there's a certain fascination with the crossover/combination of rock and the original bluesmen, it's not normally my thing. I prefer my blues a little more on the 'raw' side, however this album offers an interesting Rock slant on great blues tunes played by master musicians. The songs are all traditional ones, written mostly by the Wolf(Chester Burnett) and the superb Willie Dixon. This really is a fine album, a comment which has probably confused you totally. It's a bit of a love-hate thing, but I can tell you this: If I were at a friend's house and he put this record on his 'table, I'd buy it. You should too. It's classic Wolf... with a solid rock undercurrent. Very Strongly recommended.

RSF

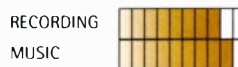





# Old Gold...

## Revival in the US re-issue ranks

by Richard S. Foster

When it comes to re-issues, I've written much of late on the subject of Speakers Corner, but from where I sit on the continental USA, our home market is also pretty vibrant. Maybe it's rising to the challenge, or maybe it's indicative of the generally rude health of the vinyl revival, but after the demise of DCC and Mo-Fi, we seem to be emerging into a new spirit of optimism. At the forefront of this new-old wave are six key players. There's Sam Passamano (late of DCC Compact Classics) and Bill Straw (Blix Street Records). Straw and Passamano recently created S&P Records and they have the very talented Steve Hoffman as their mastering engineer. These guys have a long history together which goes back to the 1980's at MCA Records. Next up is the iconoclastic Robert Pincus of Cisco Music who uses the skills of that master cutter, Kevin Gray from AcousTech Mastering. And of course number six is Chad Kassem. We've discussed Chad in detail in other articles and so I'll devote my time to the others. (I'm also not discussing Mobile Fidelity as RP is reporting on them, while SG will be reviewing the latest 200g 'non Groove-Guard' offerings from the doyen of US vinyl re-issues, Classic Records.)

Hot on the trail of the driving force behind this new surge of activity, I spoke with Passamano and Hoffman of S&P and Pincus of Cisco. I learned much from all three of them, but before I share, a little history is in order. Cisco Music, headed by David Fonn their President – who is still in charge – was just about the only company



bringing 180 gram vinyl into the North American marketplace in the mid 1980's and in fact they alone brought these products to the CES as late as 1990. Think about it. No one else in the Western World was offering 180 gram vinyl. Everyone had gone digital. This is before Speakers Corner, Classic Records, etc. If truth be told, prior to Pincus' arrival at Cisco, Fonn was using Kevin Gray in the

late 1980's for Cisco's

Japanese clients (making Japanese dance records). So the choices made are not Pincus' alone... David Fonn is very much involved, but as President he has other duties which obviously keep him away from the day to day business of record re-issues.

Kevin Gray is involved in a wide variety of assignments for a number of companies, but he's the cutting engineer of choice for Pincus (and Fonn), and as has been discussed in these pages, they've delivered the goods in spades. Cisco's own releases are stunning. I've commented most favorably on their re-issues from the Vanguard catalogue – Joan Baez, Doc Watson, The Weavers. Even the Brits are getting in on the show with RG loving their Slatkin *Young Person's Guide*... Who'd have thunk it! In each and every case, the re-issue betters the original. One of Pincus' quotes sums up his philosophy, "If you can't cut a better record than someone cut in 1962, then you have a major problem."

Cisco is a relatively new player in the re-issue game. They've given us not only the Vanguard material, but

► don't forget the fabulous job they've done in bringing back to life some other great Capitol releases besides Slatkin's Britten. There's Milstein's Dvorak and Glazounov as well as a superb mono of June Christie. Two records you may need to be reminded about again are the Urania release of Prokofiev's *Symphonic Suite of Waltzes, op. 110* and *Gypsy Fantasy* with Hans Schweiger conducting the Kansas City Philharmonic Orchestra and also Mozart's *Symphony No. 35 in D major (K. 385)* "Haffner" coupled with Witt's *Symphony in C major, "Jena"*, Thomas Nee is conducting the New Hampshire Festival Orchestra. (Personally I think the Witt, although previously unreleased, could have stayed that way). I think the Mozart is absolutely stunning

I also think our own RP reviewed this issue and we seem to disagree about the Mozart and Witt. Well, it will make for an interesting discussion one of these days between Reuben and me.

Pincus was brought into Cisco in late 1997 to sell the pre-existing audiophile records the company was handling at the time: the King Super-Analogue editions and the Three-Blind Mice jazz re-issues. For the next two and some half years this was his function, but that changed when King got out of the re-issue market. Pincus' passion, which he felt he now had an opportunity to explore, was to re-issue some great recordings in Cisco's own name.

The readership must keep in mind how difficult it is to get giant companies to agree to allow titles to be re-issued. Not only do you have to deal with the corporate structure, hierarchy and politics, there are often issues with artists (who may be re-issuing certain projects of their own from their previously released albums, estate permission from deceased artists and other such issues). This is not easy work. One thing I learned from all three gentlemen is that they are keeping many balls in the air

at any one time but that this is the only way they can make it happen. It's a minefield that has to be very carefully traversed. Legalities and ownership as well as what is available make the re-issue marketplace one heck of a tough business for manufacturers to be in.

Pincus' own feelings about re-issues are that first the record has to be a title he likes. Then he has to think about the title's ability to sell (don't forget there are commitments required in their licensing agreements to 'guarantee' a certain quantity). Of course, you have

to add to the mix when you finally have

approval, the condition of the tape. There are times when you are legally able to release an album, but the tape

is just not of the quality you feel you require to put your name on. All in all, I think Pincus is doing a great job of digging and doing his homework in bringing us some fine sounding, musically worthwhile re-issues. Considering what Cisco has released in a short period of time, they are to be truly complimented for bringing us some great music.

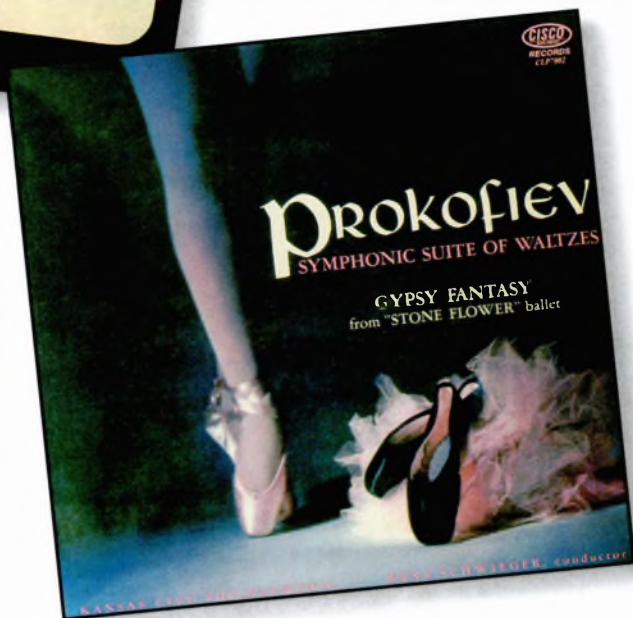

One thing about Robert Pincus – he certainly has his own point-of-view and extremely strong convictions.

Given what they've done, I see great things happening in the future. He's orchestrated some



► fabulous sounding re-issues and I can hardly wait for what tomorrow will bring.

Talking to Sam Passamano and Steve Hoffman is somewhat like wearing your most comfortable pair of slippers: It was easy and relaxed. It was a nice experience for me listening to these two industry experts talk about their business. These guys have worked together for longer than they'd probably like to think about, however it makes for a twosome capable of finishing each other's sentences. They really click, connect and are 100% on the same wavelength. Ask them what this re-issue business is about and why they're doing this and you get one word: Music.

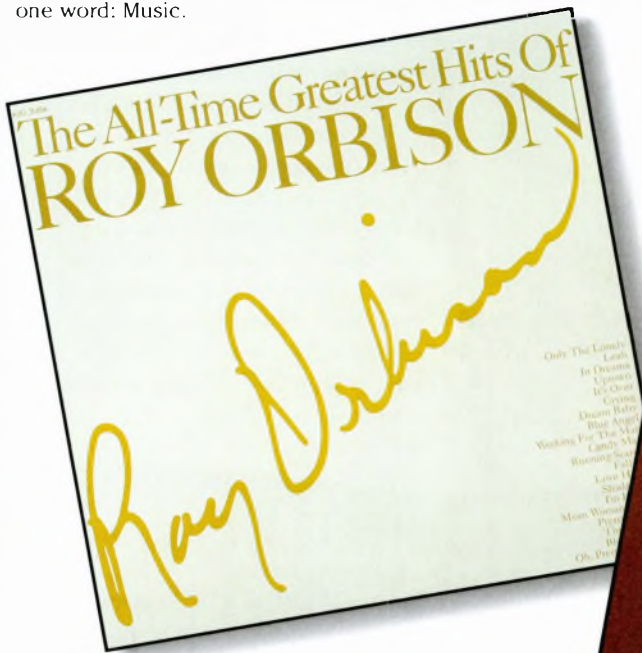

The goal for S&P is to re-issue classic titles by legendary artists that sound great and are fine additions to everyone's collection. Hoffman feels they should be selective and release, as he puts it, 'little jewels'. Titles that may have been neglected. Some beg for re-mastering, some are just really great records, but what this means for them is high quality for everyone, not just audiophiles, while they get to feel they're doing the best they can.

According to Passamano the re-issue market is very fluid. Things are changing all the time. There are a lot of labels (majors) as well as independents re-issuing products. Some are available and some are not. They spend a fair amount of time looking in the marketplace to see what's out there and what they feel should be released. First and foremost they're both music lovers to begin with. If something hasn't been in the market-

place for some time, they're going to seriously look at releasing it.

They put lists together, not only for vinyl but for their CD business as well. They'll compare the lists and make the decisions they feel will be best suited for the end user. When the decisions have been made, the appropriate company is approached and perhaps they will ask for eight titles and wind up with three. It's a very difficult business as I've mentioned already.

You can imagine approaching a company with a really great idea and all of a sudden they acknowledge just what a great idea it is – but then they could turn and say, "Hey, maybe we'll do it ourselves." Tough stuff!!

The business is built on relationships and with the history these two gentlemen have, it's allowed them inroads to companies others could only dream of working with. They have done their homework in how to make the corporations feel at ease with royalty payments, mechanical licenses,

how the artwork

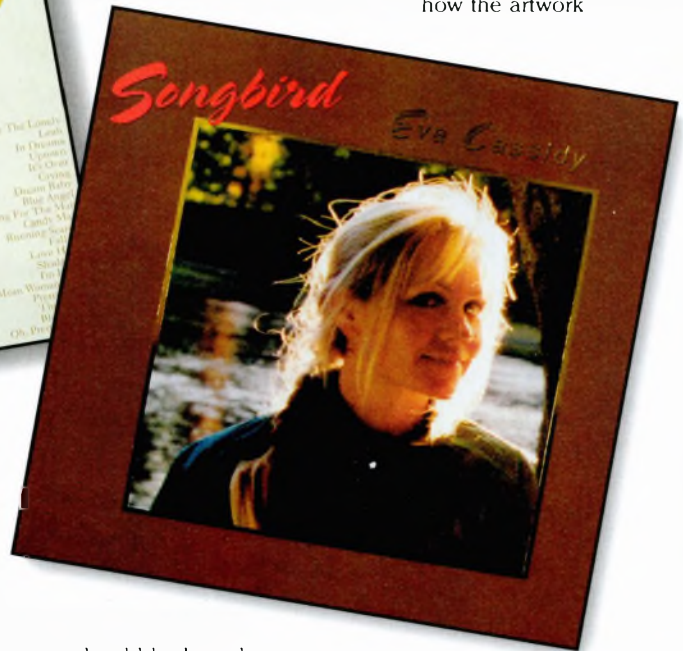

should look, and that the end product sounds right. Having been doing this for a number of years and because of their hands on involvement, the companies are more at ease knowing their products are with people who will do it right: Track record counts.

No matter how easy this sounds, it's always a struggle and because they're not part of the majors there is a very guarded approach by these corporations in handing out their precious tapes to "outsiders." In the end, the corporations do realize S&P is enhancing their product and know it's going to get top-shelf treatment. ►

► The common theme that continues to weave through these discussions is that the process takes a very long time. From the point that they put in their requests for titles until the answers come back yea or nay, takes many months. And that's only the start. This is not the kind of business for everyone.

The climate, when working with the majors is always changing as mentioned earlier. Certain artists may change labels and they do have a strong say in the process. For example, if you're wanting to do a particular album, but the artist is doing a box-set (which may or may not include that album, but only some tracks from the album) everything is on hold until that box-set comes out. Many times the same titles are



resubmitted quite often and although they may get rejected the first six or seven times you request it, perhaps on the eighth submission you're granted approval.

There is no doubt that S&P sees the re-issue market bringing in new consumers, the younger market that the hi-fi industry so vitally needs.

Maybe they hear a song such as 'Pretty Woman' in a film. That turns them on to Roy Orbison and some of them will choose the luxury presentation of the S&P *All-Time Greatest Hits* album. Once you're buying quality vinyl, a quality replay chain is the next logical step.

However, S&P is interested in re-issuing in both formats, CDs and LPs and in both mono and stereo. We're going to see a nice variety in the future. At this point in their growth, they're excited about bringing some really great material to the marketplace. Another

common theme I've learned is that these guys, all of them, really want to release material they like... not just something that will make money. Sometimes they hit on a title that takes off and brings a greater return than expected while perhaps a lesser title, although important to the re-issuers doesn't do as well; it all works out financially in the end. It's a refreshing view on a part of the industry that was in danger of becoming mired in cynicism.

Passamano sees the vinyl market growing and feels it's very exciting. He feels there is a market for Hoffman to breathe new life into some of the great titles and this is a real turn on. Which means it's a great time to be a vinylholic. Meanwhile, Hoffman feels that sometimes the master tapes are not in the condition he would like and says that they occasionally need to be massaged to bring them up to the quality he is interested in before putting his name on the re-issue. It underlines the quality (as opposed to slavish authenticity) aspect of their approach.

In the last issue I went off the deep end about the Orbison re-issue. Well, the same can be said about their efforts with the two Peggy Lee albums, the Dave Mason *It's like you never left*, Eva Cassidy's *Songbird* and the soon to be released Nat King Cole, *Just one of those things*. There is no doubt about S&P releasing a quality product. The business these gentlemen are in is very difficult, competitive, but the product they offer is nothing short of stunning.

Hoffman and Passamano are really music historians. They know their stuff and I think you can be assured they're confident they know all the songs, they know the right versions and this is so important when you go into the studio. The tape may say "Master" but that really doesn't mean it's the real deal. Add to this that so many of the majors are keeping the titles to themselves. They want to do it themselves. (Whether they ever will or not is another story, as are the results if they do. Sometimes, like in the case of the two Doors releases from Universal/Elektra, we get lucky.)

Some of the projects they told me they're working on are quite exciting. Yet time and again I heard these two discuss working on one particular title or another and receiving tapes from the 'giant': The minute they put them on, they realize they've received the wrong version. So they call them up and tell them, "You sent us the wrong tape." The giant says "What do you mean? It's the master." And then you can only imagine the back and forth until Hoffman and Passamano smooth the waters and get exactly what they were seeking. Sometimes this doesn't make them any friends... ►



▶ but again, in the end, the giant is happy with the results because of the trust that's been built over time. In the very end everyone is a winner.

This is also a costly business to operate. After all they go through to get approval, then comes the up front funding to the majors. That's when the work really begins on whatever project you've received approval for. It takes quite a long time to recoup your financial outlay. It's just not the kind of business you're guaranteed a home run ever time you step up to the plate. It's tough. Damned tough.

I asked the question about the longest, shortest and average time it takes to get 'approval'.

The longest . . .  
Jethro Tull's

*Aqualung*

– seven years!

Normally it takes  
a couple of months.

The fastest were the  
Peggy Lee releases.

Passamano's  
contribution is clearly  
the business contact-  
negotiation side  
of the endeavor.

Once approval is  
granted, Hoffman then  
has to dig in and find  
the right tape(s). It's not  
as easy as you think.

I won't bore you with  
the infinite tiny details of  
what they have to go through with the majors to  
keep the artwork original: don't put bar codes on  
the front of the jacket, don't put 'parental advisory  
stickers' on the front of the shrink wrap and a dozen  
other details none of us ever think about.

Each major has its own way of doing things.  
This is the key to the success of the operation:  
knowing what minefields there are and how to  
traverse them. The majors are all tightly controlling  
and quite often, as in the case of Capitol, although  
it is more expensive, there is better cooperation  
when Hoffman books time in their historic studio.  
Although you may still be an outsider, it gives  
Capitol a greater feeling of control. The upside  
is that he can get his hands on the right tapes  
much faster.

I hope this gives you some insights into not just  
what these re-issue companies have to go through to

get us these products but also what motivates their  
choice of material. It's a tough business, but when you  
put a Joan Baez, *Farewell Angelina* or the Slatkin  
Britten on your turntable, I'm sure you'll agree that  
it's well worthwhile. The level of commitment required  
also makes you appreciate why the breadth of materials  
and variety of titles on offer has improved so dramatically  
of late. The easy life merchants who think that every  
audiophile is dying to buy yet another version of *Jazz*  
*At The Pawnshop*, this time on single-sided, 45rpm,

numbered discs have long moved  
on to greener pastures and faster  
bucks, leaving behind those who  
really care.

My thanks to Robert, Sam and  
Steve for both their insights and  
their time. Good luck to all of you  
guys and keep them black disks  
coming! Oh, and the silver and  
gold ones too. . .



# NORDOST

MAKING THE CONNECTION



Valhalla



Shiva

Vishnu

## Nordost (UK) Limited

Unit 7, Aber Park Industrial Estate,  
Aber Road, Flint, Flintshire, CH6 5EX.

Tel: 01352 730251 Fax: 01352 731273

Email: [sales@nordostuk.com](mailto:sales@nordostuk.com)

## Nordost Corporation

200 Homer Avenue, Ashland,  
MA 01721, USA.

Tel: (508) 881 1116 Fax: (508) 881 6444

Email: [sales@nordost.com](mailto:sales@nordost.com)

Please visit our website at:

[www.nordost.com](http://www.nordost.com)





**B&W** Bowers & Wilkins

> *ABSORBED*

With every beautiful note  
I'm where I want to be

THE NEW B&W

704



[www.bw700.com](http://www.bw700.com)  
For your virtual tour of the B&W 704 and 700 Series please visit our site, or call +44 (0)1903 221 500

