

hi-fi+

Issue 20 - Nov / Dec 2002
UK £3.95

REPRODUCING THE RECORDED ARTS

Something for the Weekend?



▶ Fancy Dress

B&W 800 & Signature 805
Vienna Acoustics Schoenberg

▶ Hot Tickets

conrad-johnson PV14L & MV60-SE
Audio Research SP16 & VS55

▶ Analogue Cocktail

Clearlight Recovery Basic
Rega P9
Kuzma KC-REF Cartridge
47 Labs Miyabi Cartridge

▶ Viennese Whirl

Hi-Fi in the Austrian capital...



REPRODUCING THE RECORDED ARTS

Issue 20 - Nov / Dec 2002

30 YEARS of performance classics

Throughout the history of Mark Levinson there have been many milestone products. Among this illustrious group are the JC-1 phono preamplifier (1972), LNP-2 preamplifier (1975), ML-1 preamplifier (1977), ML-2 mono power amplifier (1977), our first ever "Reference" component, the No.20 monaural power amplifier (1986), and the legendary No.30 Reference Digital Processor (1991) and No.32 Reference Preamplifier (1999). These products, even at the time of their introduction, were obviously destined to become classics. In many cases, these now classic components were considerably more expensive than virtually any other product in their class, and often offered fewer features (or less power) than competing products. Yet, they became classics. These and other now legendary Mark Levinson components shared one extraordinary trait: they outperform everything else in their product category. Performance, above all, is the primary motive for owning a Mark Levinson product – and exceptional performance is the most significant reason for owning a Mark Levinson No.40 Media Console. The No.40 is poised to establish new standards for connoisseurs of multi-channel audio and video.

We believe that the No.40 is perhaps the most remarkable product we have built in our 30 year history of innovation and market leading performance – it is surely destined to take its place among our classic designs.



mark
levinson®

MADRIGAL AUDIO LABORATORIES

1972 - 2002

PATH
Premier

PATH Premier
Dorner Road, Thame Industrial Estate, Thame, Oxfordshire OX9 3UD
Tel: +44 (0) 1844 219000 Fax: +44 (0) 1844 219099
Email: premier@path.co.uk

mark
levinson®
MADRIGAL AUDIO LABORATORIES
1972 - 2002

Editor

Roy Gregory

Contributors

David Ayers
Chris Binns
Mark Childs
Pete Christie
Dave Davies
Simon Groome
Jason Hector
Andrew Hobbs
Jimmy Hughes
Jason Kennedy
Scot Markwell
Paul Messenger
Reuben Parry
Peter Russell
Alan Sircom
Chris Thomas
Phil Ward

Photography

Simon Marsh

Cartoonists

Dave Davies
Thomas Divita

Design

Creative Byte
U12, Albany Business Park
Cabot Lane, Poole, Dorset
BH17 7BX

Printed By

Offset Colour Print Ltd.
Southampton

Hi-Fi+ is published six times
a year by; Hi-Fi+ Publishing Ltd

The Editorial Office

can be contacted at;
Hi-Fi+ Editorial
Unit 12, Albany Business Park
Cabot Lane
Poole, Dorset
BH17 7BX
United Kingdom
Tel. (44)(0)1202-659380
Fax. (44)(0)1202-659540
Net. www.hifiplus.com

Advertising;

Rebecca Bird
Tel/Fax. 0208 763-1277
Email. sales@hifiplus.com

All Rights Reserved.
Not one word of Hi-Fi+ may be
reproduced without the written
consent of the Editor. We are
perfectly happy to co-operate,
but we don't want quotations
to appear out of context.

Editorial

Happy In Heathrow

Well, who would have thought it? The Hi-Fi Show & AV Expo 2002 at Heathrow is now three days finished, and I am sitting here composing a piece about how much I enjoyed being there. More than that: there with an officially sanctioned stand of our own. Turn back the clock 12 months, and I was not a happy puppy. Not only had hi-fi+ been unilaterally banned from the show, but the show itself had reached its nadir. Frankly, it had ceased to be of any use to the hi-fi industry in general, and in particular to IPC Media (owners of Hi-Fi News) who organise the show. Something had to be done.

It is to the organisers credit that they decided to involve the industry in a series of meetings designed to address the problems with the show, and that they listened to what was being said. The result being that the show was moved out of the Hammersmith Novotel Hotel and back to the much more suitable hotels at Heathrow, and that the arrangement and allocation of stands was re-organised. It also meant that hi-fi+ were able to take up the offer of leasing a stand, an offer that was also available to the other hi-fi magazines.

So now the new style autumn show has passed, and the overall feeling amongst the exhibitors was very upbeat. Attendance appeared to be up, although Sunday was as usual, a little quiet. Most people seemed to be reporting a brisk trade, and certainly from our own point of view the show was a great success. There is no doubt that I will be looking to re-book our stand for the 2003 show, and it would be nice to see some support from the other magazines.

David Ayers





Martin Logan Home Speaker Package
Home Cinema Choice Award Winner 2002
Best speaker package over £1000

right Descent
Sub Woofer

far right Odyssey
Hybrid Electrostatic
Loudspeaker System

below Theater
Hybrid Electrostatic Channel
Speaker Center



MARTIN LOGAN

eye to ear co-ordination



ABSOLUTE SOUNDS' commitment to Martin Logan has been rewarded with a line of hybrid electrostatic speakers so comprehensive that it now encompasses every permutation of home theatre, and a price band from entry-level to cutting edge.

Prodigy, Odyssey, Ascent and the best selling Aeon are the models marking a new era for Martin Logan. Having mastered the art and science of creating hybrid systems, with the awe-inspiring Statement Evolution 2, Martin Logan has applied the same skill to smaller systems suitable for a wider range of applications.

All speakers are immediately recognisable as Martin Logan products because of the peerless, room-friendly appearance, with the captivating see-through panels and furniture-grade finish. But it is sound as clear as the panels themselves, which mark the Prodigy, Odyssey, Ascent and also the best-selling Aeon for those purists with limited space as children of the Statement.

To provide a selection for all home entertainment needs have also been joined by the new Theater and Cinema centre-channel models, the Script, the Scenario and the awesome Descent self-powered subwoofer, to create the awards winning Home cinema loudspeaker system able to grace any size or shape of room.



absolutesounds ltd.
58 Durham Road, London SW20 0TW
T 020 8971 3909 F 020 8879 7962
www.absolutesounds.com
info@absolutesounds.com

Contents

Equipment+

Regulars

- 5 News
- 7 Columns
- 19 Letters
- 23 Hi-Fi News Heathrow Show Report

Equipment Reviews

- 38 B&W Nautilus 800 Loudspeaker
- 42 Signing On...
B&W go Signature with the 805
- 46 B&W Nautilus 805
Signature Loudspeaker
- 52 Conrad-Johnson PV14L and
MV60-SE Amplifiers
- 56 Audio Research SP16 and
VS55 Amplifiers
- 62 Metronome T1-i CD Player
- 66 Dynavector L200 Pre-amplifier
- 72 Rega P9 Turntable
- 76 Clearlight Recovery Basic Turntable
- 82 Kuzma KC-REF
Moving-Coil Cartridge
- 85 47 Labs/Miyabi
Moving-Coil Cartridge
- 90 JMLabs Electra 926 Loudspeaker

The Real Deal

– budget gear that works

- 94 LFD Zero LE Mk. II
Integrated Amplifier

Shop Talk – the Viennese scene

- 100 System Review – Trenner and Friedl
Dizzy loudspeakers play with the
Mace electronics
- 104 Interview with Peter Gansterer,
President of Vienna Acoustics
- 108 Vienna Acoustics Schoenberg
Loudspeaker

Audio Smorgasbord

- 114 More spherical speakers, but this
time from Gallo Acoustics, a
cartridge demagnetiser and all you
ever wanted to know about the
evolution of hi-fi aesthetics (but
should probably be afraid to ask).

Music+

Music Reviews

- 124 Pop and contemporary
music reviews
- 131 Jazz reviews
- 134 Classical music reviews
- 137 Audiophile music review
- 140 Tales of the riverbank...
Acoustic Sounds revitalise
the Riverside label

Departments

- 112 Back Issues and Binders
- 112 Subscriptions
- 139 Advertisers Index

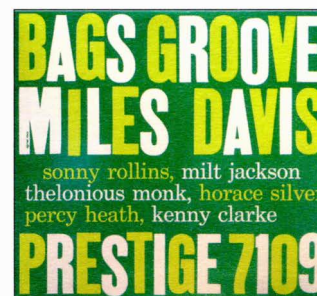
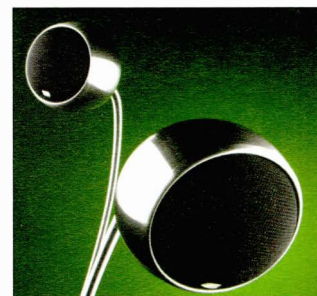

EXPERIENCE THE CHORD EFFECT!

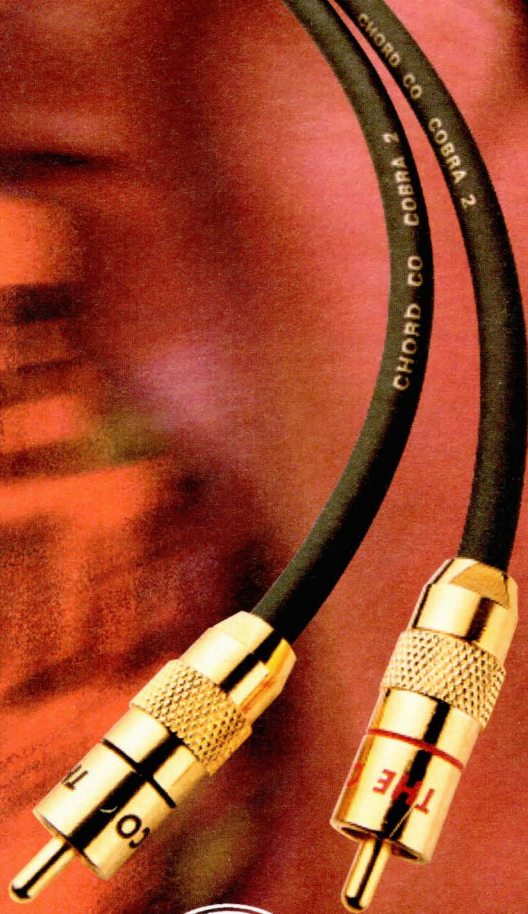

The first time you hear
your sound system with
Chord interconnecting cables
will be the first time you've
really heard it.

Be warned - the effect can
be shattering.

Your eyes and ears will be
opened. Your music will
never sound the same again.

Specify Chord cables -

Hear the light!

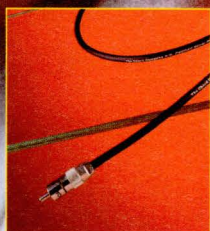
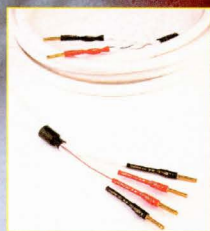

FOR SALES AND INFORMATION CALL: 01722 331674
FAX: 01722 411388 E-MAIL: CHORD@CHORD.CO.UK OR VISIT US AT WWW.CHORD.CO.UK

Karan International Contacts

In our last issue we inadvertently published a pre-edited version of the news piece carrying contact details for those interested in the excellent Karan Acoustics range of electronics. Potential customers or international distributors can contact Branko Bozic of Audiofreaks at:

Tel. (44)(0)208-948-4153
Fax. (44)(0)208-948-4250
E-mail. info1@audiofreaks.co.uk

If you are unaware of this brand then you'll find mention of it in this issue's Heathrow Show report, where the KA S 270 power amp was contributing to the superb sound in the Audiofreaks room. For an in depth appraisal you could also turn to the review of the KA I 180 integrated amp in Issue 15. ▶+

Zyx Cartridges Now Cheaper

Price reductions are always welcome, and the Zyx cartridges reviewed in the last issue have now been re-priced by importer Audio Atmosphere. The RS30H, originally tagged at \$700 now costs £550, while the more expensive R100FSH, originally £1700, loses a massive \$400 to bring it down to £1300, and a lot closer to the £1200 Lyra Helikon that represents its main competition.



Further details from:
Audio Atmosphere
Tel. (44)(0)1785-711232
E-mail. stuart@audioatmosphere.com
Net. www.audioatmosphere.com ▶+

Upcoming show dates for your diary...

Autumn's upon us and that means that the show season has started in earnest. Manchester and Dublin (which has to rank as one of my all time favourites) are well established, and now they're joined by the Glasgow date, two weeks gone by the time you read this. These regional shows are going

from strength to strength, following in the footsteps of their Great Granddaddy, the Bristol event, which takes place each February. Freed of the constraints imposed on a major international event, they are rather more characterful, and some enthusiasts would say, more interesting too! ▶+

The Manchester Hi-Fi Et Home Cinema Show

@ The Hilton Hotel, Manchester Airport
Saturday the 16th – Sunday the 17th of November 2002
10am – 6pm Saturday, 10am – 5pm Sunday
Admission: £6 on the day, with discounts
for advance booking. On site parking, £2.50 for 4 hours.
Further Information from: www.chestergroup.org

Sound And Vision 2002

– Belgium's High End Show
@ Hotel RADESKI – Boulevard d'Avroy, 69 4000 LIEGE – Belgium
November 22nd (evening from 6pm to 10pm), 23rd and 24th
(from 11am to 7pm). Admission: €5
Contact: La Galerie du Son – Pascal Devillers
Phone: +32 4 2210050. E-mail: info@galerieduson.com

The Cloney Audio Dublin Hi-Fi Show 2002:

@ The Burlington Hotel, Donnybrook, Dublin 4
November the 9th and 10th, 10am – 6pm,
Admission: €5
For further information:
Tel: (00353 1) 2889449, (00353 1) 2888477
www.cloneyaudio.com

Bristol Sound and Vision 2003

@ Marriott Hotel, Lower Castle St. Bristol
February 21st to 23rd, 2003 (From 10am to 5pm)
Admission: £7, £3.50 concessions,
accompanied children free.
For further information: www.bristolshow.co.uk

Walrus Systems

11 New Quebec St, London W1
020 7724 7224



amazon
amphion
apollo furniture
argento
audible illusions
audio note
audio physic
avantgarde
breuer dynamic
brinkmann
carfrae
cartridge man
cawsey
chord electronics
clearaudio
croft
decca london
dnm
duevel
dynavector
ear yoshino
es lab
final lab
gamut
graham slee
haddock
incognito
klimo
laverdin

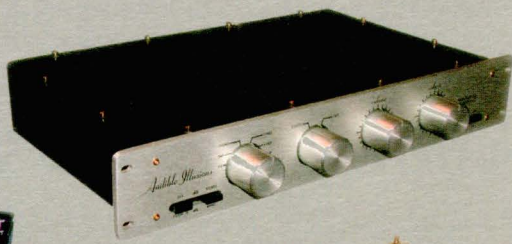
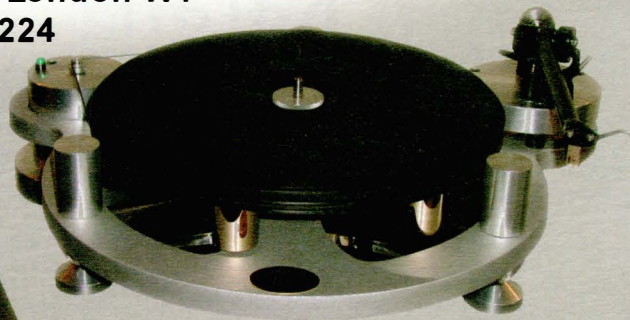
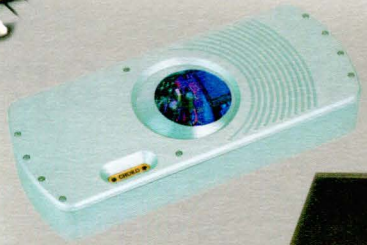

loricraft
lyra
michell engineering
morch
musical fidelity
nordost
nottingham analogue
origin live
ortofon
papworth
phy cables
pink triangle
pluto
rega turntables
ringmat
shun mook
sme
spendor
stax
sugden
sumiko
tannoy
tci cables
tivoli audio
tom evans
townshend audio
transfiguration
trichord
van den hul
verdier

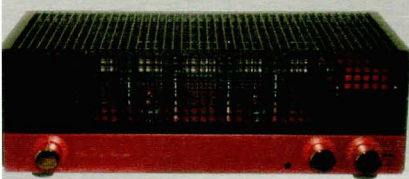

fax: 020 7724 4347 email: mail@walrus.co.uk web: www.walrus.co.uk

Home Truths



by Jimmy Hughes

Some people have a dream. I have a nightmare. It's this. Someone comes and does a Through the Keyhole style expose on my LP and CD collection. What they find reflects badly on the sanity of the victim. Of course a collection mirrors the taste of its owner. Mine's no different. How could it be otherwise? I chose every single recording. However, when I look through what's there, even I'm baffled by some of the things that ended up on the shelves. It just doesn't make any sense...

I mean, why four versions of *Lucia di Lammermoor*? I don't even like the work. And what about all those frothy inconsequential operas by Bellini? Agreed, ten different versions of *Carmen* is a bit of an indulgence. But at least it's good music and worth hearing; it's a piece I do actually like. But works like Donizetti's *L'Elisir d'Amore* or *La Fille du Regiment* actually irritate - half an hour, or so, and I get twitchy and restless. So how/why did they end up on the shelves?

Simple dear boy. Such bizarre choices can nearly always be linked to what was on special offer the day I visited the record shop. Throw in attractive cover art (especially on LP) and that's it - hooked! Faced with a disc I actually want selling at top-price, and something else vaguely interesting in the Sale at half-price, I sensibly choose the latter. It would break my heart to pay top price for a disc when newly released, only to find it at half price a few months (or years!) later.

Okay, I'm exaggerating. But joking aside, there's actually a serious point being made. If you're aiming to build a comprehensive music collection, letting price dictate the course of your buying activities isn't a bad way of going about things. It's clearly scads better to buy something for £2.99 in the sale, than £16.99 when newly-released. And, like a punter studying form, with a bit of experience you can learn to spot the discs likely to be on special offer. Mind you, nowadays that's virtually everything...

For example, bet your last 50p on any new set of Verdi's *Falstaff* being likely to bomb. Every new recording released in the last twenty-plus years has flopped commercially. So, no surprises to see the recent DG set with Bryn Terfel and Claudio Abbado on special offer, quickly followed by Sir John Eliot Gardiner's Philips account. Even I've stopped

buying stuff like this (oh yeah?); things must be getting desperate out there.

So, letting price be your guide is no bad thing. Except that, taken too far, you may end up with a lop-sided collection. I know; it happened to me. I'm not thinking of the 41 different LP versions of Stravinsky's *Rite of Spring* I seem to have acquired - after all, it's a work I love, and nearly every recording has some interesting light to shed on the music. It's having multiple recordings of works I don't particularly like that's tricky to explain.

In my defence I can only say I was buying for future times - getting something today I might perhaps hopefully like (maybe) in possibly five or ten years time. With a deleted recording, you may have to buy now - or risk never having another opportunity to acquire said disc. The same applies when buying LPs and CDs secondhand; hesitate and you may never see that rare wonderful title ever again. There are any number of LPs in my collection that I only saw once - the time I actually bought them.

Speaking personally, I'm not a great opera fan, yet seem to have acquired an opera collection to die for. Why? Well - I thought, hoped, and for a while actually believed, I'd one day grow to love opera. Inevitably there were quite a few operas I did become rather friendly with. So it wasn't a total waste of time and money. But it's still only perhaps 20% of the total number of opera sets in my collection. Trouble is, you can never tell when a work will suddenly fire your imagination.

Sometimes it takes years before a piece suddenly 'clicks'. A recent example for me is Schumann's song cycle *Liederkreis Op 39*. Usually it's coupled with Schumann's other great cycle *Dichterliebe* - a work of passionate inspiration and genius that moves and excites me every time I hear it. And so it came to pass that last year's HMV Sale (Know HMV - Know Poverty) saw Olaf Bar's famous EMI coupling of the works being sold off at the absurdly silly irresistible bargain price of just £3.99.

That's four quid for a disc that usually retails at £16. Being unable to pass by a bargain, I bought it and played it two or three times. Then, suddenly, the miracle occurred. *Liederkreis* clicked. It's a subtler piece than *Dichterliebe*. The latter is more extrovert and impassioned, whereas *Liederkreis* is more inward looking - despite the heady

► intoxication of the final song. Also, the melodic content of *Dichterliebe* is more obviously catchy - I think so anyway.

Lucky I gave *Liederkreis* one more chance - the music connected, made sense, and I was in heaven. Now, having finally had a breakthrough with *Liederkreis*, I can't see why the hell it took so long. I mean, it's hardly complex or difficult in the way that (say) Berg's opera *Wozzeck* is complex and difficult. Now there's a work I've struggled with! To make matters worse, *Wozzeck* lasts the best part of two hours - so it's a whole evening's listening.

Of course, the appreciation of great music can't be rushed. But the difficulty is knowing in advance which works are worth giving time to. Suppose you listen to a piece three or four times and it makes no impression. Do you play it another three or four times in the hope it suddenly metamorphoses into one of your all time favourites? After all, it might just happen. The things that grow on you slowly often end up being the ones most loved.

Alas, you might give it extra time, and still feel much the same. As more and more demands are made on people's leisure periods, it becomes harder and harder to justify 'wasting' time on something that gives no return. Unfortunately, great classical music is not something you listen to for quick easy gratification. Agreed, there's the Classic FM stuff - the famous tunes everyone knows. But, great music demands commitment from the listener if its depths are to be appreciated.

Some pieces of music are indestructible; almost regardless of how badly they're played, their greatness seems to shine through. Other pieces need special pleading; only in a highly sympathetic performance is their true worth apparent. Yet when everything's right - performance, sound, the listener's mood - even a new and fairly 'difficult' work can produce a deep and lasting first impression.

One of my luckiest bargain basement buys was Liszt's neglected choral work *Via Crucis* - the 1986 Philips recording with Reinbert de Leeuw. I happened on a copy of the LP in a deletions rack for a couple of quid, and (why not?) decided to try it. What a find! The music had a spiritual depth and inwardness entirely unexpected. Having bought the disc with the expectation of playing it perhaps once or twice (if that), I found myself listening to it over and over again.

Apparently, not long before he died, Liszt offered *Via Crucis* and some other choral pieces to a publisher, gratis - only to have the music returned. It seems even then you couldn't give the work away - a tradition that's lasted to the present day. Eventually I got the de Leeuw recording on CD - again, cheap, as a deletion. But before doing so I actually bought two other (deleted) performances on CD. However, in neither case was the experience of the music anywhere near as moving or profound.

It's hard to say what was missing. Outwardly the

performances seemed sensitively played and well-sung. But there's something extra in Reinbert de Leeuw's version. It's like he really believes in the work; understands it from the inside. Hearing de Leeuw on Philips, I'd acclaim *Via Crucis* a masterpiece; no question. Yet, had I first encountered the music in either of the CD versions I bought subsequently, I'd have (wrongly) dismissed the work as disappointing and frankly second-rate.

It's all about mood, atmosphere, and colouring. Liszt was hardly a great melodist, but in *Via Crucis* he creates a deeply moving response to the 14 Stations of the Cross. Each section is a profound meditation on Jesus' suffering - a series of brooding slow movements. It's not a piece you can approach from the outside, so to speak. Clearly, for Liszt, the composition of *Via Crucis* was an act of deep religious faith.

For the Sixth Station, which deals with Saint Veronica who wipes Christ's face with a cloth only to find His likeness left on its surface, Liszt borrows the famous old chorale tune Bach uses in his *St Matthew Passion*. It's an inspired choice, giving colour to a work that's otherwise almost stark in its plainness and simplicity. The music is austere and deeply deeply serious. The writing (for choir with piano or organ) is simple but at the same time intense, cohesive, and highly concentrated.

Somehow, de Leeuw draws a sense of narrative and meaning from music that in other hands sounds rather empty and formless. It's as though he understands exactly what Liszt was trying to convey in the piece. Almost as if he had a composer's insight into the precise meaning of each note. In my experience it's rare to find an interpreter so totally inside a piece of music

It was a lucky purchase. However, given a more pragmatic approach to choosing LPs and CDs, I'd never have bought *Via Crucis*. Were I a gambling man, I'd have said the odds were stacked against it being a memorable work. But, because it was cheap, I wasn't overly worried if it turned out to be shite. Even the act of buying it served a purpose; filling a 'gap' in the collection - another work to chalk off the Pieces I Haven't Yet Got A Recording Of list.

Interestingly, my next-door neighbour John buys records in a similar fashion, frequenting Charity shops and the like. His collection is marvellously varied and wide ranging. In other words, all over the bloody place. He finds the most exquisite things - often for just a few pounds. It might, for instance, be a beautifully presented boxed set of 30 LPs devoted to the *History of Gregorian Chant*, tantalisingly labelled Vol 1 - 24 hours of dirge-like unaccompanied singing. And 9 more sets to collect. Great!

But that's the trouble with obsessive record collecting. It's not just about hunting stuff down and buying it; you've also got to play it when you get home. Sometimes half the fun is going out and seeing what you can find - and how cheap you can get it. Actually having to listen to it all ►

bwspeakers.com

Explore the new B&W CDM NT Series.

Genetic engineering.

The new CDM™ NT. Notice any resemblance? Believe us, you will. The B&W CDM NT Series is a speaker range spawned from the most advanced audiophile DNA: a perfect blend of our multi award-winning CDM SE Series and our world-leading Nautilus™ Technology. That's the same technology found in our flagship Nautilus speaker and in our acclaimed Nautilus 800 Series, as chosen by Abbey Road Studios.

The breeding is impeccable, the listening experience unequalled. Audition the new CDM NT Series soon at your B&W dealer.

Call +44 (0)1903 221500 for details.

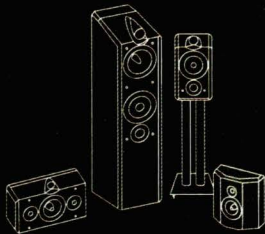

B&W Bowers & Wilkins

dCS Elgar Plus and Purcell

dCS Elgar Plus and Purcell with IEE 1394 interface are the cutting edge of digital technology

And at Midland Audio X-change you can now experience up sampling into the DSD data stream.

That's right, take your normal CD collection and transform it into master tape quality, by using a dCS Verdi Transport and using the IEE 1394 "Fire wire" output into a dCS Purcell Up sampler IEE 1394 compatible. Up sample into DSD and then send the signal to a dCS Elgar Plus. The result is the closest to master tape quality we have heard.

This system also plays SACD at a level, which is unsurpassed by any other player, or combination we have tried.

Phone John Roberts for an insight in what is achievable with any dCS product.

MAX
Midland Audio X-change

The Sonus Faber Cremona

Lute Design 3 way floor standing speaker, the Cremona project is a tribute to the city that is the custodian of the art and traditions of lute making, and the source of inspiration for this wonderful loudspeaker system.

32 individual pieces of solid and laminated maple, finished in an eco-friendly medium gloss.

Suppliers and installers of High Quality Audio Systems

47 Laboratory

Accuphase

ATC

Audio Physic

Audio Research

Avalon Accoustics

Avid

bel canto

Benz Micro

Cardas

Clearaudio

dCS

Densen

DNM/Reson

Electrocompaniet

Finite Elemente

Graaf

Gryphon

J M Labs

Kuzma

Lavardin

Mark Levinson

Martin Logan

Michell

Nagra

Primare

ProAc

Rega

Siltech

Sonus Faber

Spectral

Nordost

Sugden

Transparent Audio

Verity Audio

Wadia

Audio Research CD3

What sets the CD3 apart from the so-called "combination" players on the market - whether DVD or SACD based - is that the CD3 is designed to do one thing superbly: that is, to play back normal "redbook" music CDs, CD-R and CD-RW discs with maximum fidelity and full musical expression. The CD3 will not play back DVD video, DVD audio or SACD-only discs because it is our firm belief that the convenience of multi-format playback sacrifices sonic performance in the CD format. The engineering focus of the CD3 is to maximise performance with the prevailing music format by keeping the overall player design simple, reliable and optimised for the one task it must accomplish. Class A J-FET analogue output stage. Massive regulated power supplies - using industry-leading capacitors for both bulk supplies and bypass components and damping techniques of a proprietary nature have been used to extend to the CD3's remarkable range of performance characteristics.

Nagra PL-L

One of the most respected names in the world of professional Audio, Nagra has a forty year history of producing leading edge electronics for the recording industry. Their move into high end audio was a welcomed surprise, and their gear has met with rave reviews. Many listeners requested a line stage preamp, and Nagra listened. The PLL will interest many, not only because of the great sound, but also for the new found convenience of full remote controllability. Balanced outputs are available as a option. As with all Nagra equipment, expect superb Swiss craftsmanship and meticulous attention to detail. Nagra takes great pride in introducing the ultimate preamp, the PL-L, line input cousin to the PL-P. The PL-L combines the unmistakable sonic excellence of the PL-P with the convenience of remote control for those whose source components do not include Phono. The features of the PL-L include four selectable inputs, one for balanced and three unbalanced, dual output zones, each with two unbalanced outputs. An optional balanced output is available as well.

call John Roberts Tel **01562 822236** - 181 Franche Rd • Kidderminster • Worcs • DY11 5AD
e-mail sales@midlandaudiox-change.co.uk - Fax **01562 750246** Mobile **07721 605966**
www.midlandaudiox-change.co.uk

► afterwards is a chore you can do without. Ken Kessler recently wrote about all the still-sealed CDs and DVDs he had at home - not review copies, but things he'd actually gone out and bought and never opened. Thanks Ken; I thought it was only me...

Anyway, you can now perhaps more readily understand why some really serious record collectors actually get rid of their hi-fi completely. There's so many advantages to doing so. It raises much needed cash to buy expensive rarities, and at the same time increases space for storage. The more you think about it, the more it makes sense...

Editor's note. Shortly after writing the above piece, Mr Hughes was apprehended outside his local record shop clutching two

sets of Verdi's Falstaff conducted by Claudio Abbado and John Eliot Gardiner respectively, adding to the nine versions (five on LP, four on CD) already in his collection. When asked to sing a few notes of the score, to demonstrate how well he knew it, he was unable to do so. He did claim to have heard the work, and said the plot had something vaguely to do with Shakespeare.

Pressed to give a reason for purchasing said sets, he was heard to mumble something regarding 'only a couple of sealed copies left'; 'if I don't buy now, I might never see either cheap again'; 'it was playing in the shop when I went in and sounded quite nice'. None of which seemed particularly convincing. Fortunately Mr Hughes' wife is preparing to beat a more plausible answer out of him, and is believed to be confiscating his credit cards... RG.



Speakers Corner

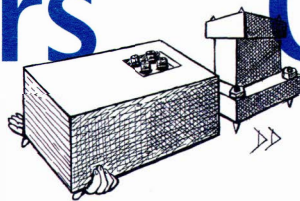

by Paul Messenger

Elsewhere in this edition I review B&W's Nautilus 800, an exceedingly impressive speaker but also one that might be a little too laid back for some tastes. The reason may have something to do with the concept of 'acoustic squareness', which B&W proposes as part of the rationale for basing its midrange driver diaphragm on a single woven sheet of Kevlar.

Most drive unit cones are 'homogenous'; that is, like moulded plastic or paper, they have the same consistency throughout. B&W's Kevlar cones, however, start out as a square of woven fibres imbedded in a plastic matrix. With a homogenous cone, sound waves travel out from the voice-coil centre to the periphery, and do so in the same way in every direction. As frequency rises, there'll come a point where the cone will start to flex and bend, and the outer edge will start moving in the opposite direction (ie out of phase) from the central portion. This 'breakup mode' will cause a dramatic reduction in net output.

However, this breakup scenario is very different – indeed, altogether more benign – when the cone is based on a single sheet of a woven matrix (such as Kevlar). Such a material is no longer homogenous because a woven fabric is constructed from mutually perpendicular warp and weft fibres. Crucially, the cone stiffness is less along the directions of the fibres than across the diagonals (known as the bias). This creates four 'fast-tracks' interspersed by four 'slow-

tracks', making the circular diaphragm 'acoustically square'.

When such a cone starts to flex, instead of the whole edge going out of phase with the centre, it goes into so-called octopole bell modes, with eight alternating segments around the periphery flexing out of phase with one another. These effectively cancel each other out, generating little net output, while piston-like radiation continues to be generated from the central portion of the diaphragm. Furthermore, as the frequency rises, so the central radiating portion of the cone steadily shrinks, reducing output level somewhat, but helping maintain a constant and consistently wide dispersion.

That's the theory at least, though in practice it seems that output well off axis may be rather less than predicted, presumably because the octopole edge effects do actually interfere to some degree with the sound distribution from the centre. This could well explain the loss of presence energy, which I invariably find with B&W's larger Kevlar-cone drivers when measured under far-field conditions, because the further one moves back from the speakers, the greater the contribution of off-axis room-reflected components in the total mix.

Hybrid Bi-Amping

Two years ago in this column, I described Harman's interesting new RABOS speaker technology. Now I've had a chance ►

▶ to try it, and am rather more impressed than I expected to be, especially by the relatively simple Infinity Intermezzo 2.6. This compact stand-mount sells for £1,500, which is pretty hefty for such a small speaker. But it's strikingly original in a number of respects, and different from anything else on the market. Whether it will spawn imitators is harder to call, but it's certainly a leading contender for any 'Biggest Sounding Little Speaker in the World' award.

In order to do the RABOS thing (of which more later) it's necessary to apply electronic 'active' equalisation, which means it's necessary to build at least one power amp into the speaker. This isn't, however, a full 'active' speaker (like Meridian's delightful little M3, for example), in which each drive unit has its own power amp and the crossover (plus any equalisation and protection) is done electronically ahead of the power amp stages. Nor is it a pro-style 'powered' speaker, with a single built in power amp driving a conventional passive crossover and drive units.

Rather it's a hybrid, a built-in power amp for the bass driver effectively automatically converting the speaker to bi-amplified operation. You connect it in the normal way to a regular power or integrated amplifier, but this amplifier only has to drive the tweeter (and the network feeding it), which should make its life a whole lot easier, and significantly enhance sound quality. This 'auto-bi-amp' upgrade is of course particularly appropriate with a two-way speaker such as this, and probably wouldn't confer the same advantage with the four-way floorstanding Intermezzo 4.1T.

The 2.6's deep-anodised alloy diaphragm drivers, similar to those found in less expensive Alphas, are just about the most conventional of this speaker's ingredients. The rest is much more radical, featuring a switch-mode power supply 250W amp codenamed BASH (for Bridge Amplifier Switching Hybrid). Despite inherently high efficiency, some waste heat is inevitable, so some heatsinking is necessary, so Infinity adopts the 'full metal jacket' approach, casting the entire enclosure from alloy. The tooling costs must be pretty scary, but these have fallen in real terms in recent years, and Infinity's global marketplace brings economies of scale. Furthermore, casting allows irregular and curved shapes, which look attractively distinctive and help avoid the standing waves created between the parallel faces of a rectangular box. Careful front baffle shaping provides optimum tweeter loading too.

Shaped cast alloy casework, strategically rib reinforced, should give excellent stiffness without taking up too much internal volume. I doubt it can match the self-damping properties of organic wood-based materials, and there does seem to be plenty of vibration going on in the enclosure here, but I suspect the net result is probably to impart a rather different overall 'character' to the sound. Certainly it's a good sounding speaker by any standards, though I did feel the

bi-amping might have made the top end a little more transparent and delicate, and suspect that 'sub-audiophile' crossover components may be responsible here.

The RABOS thing is both intriguing and not a little puzzling. This Room Adaptive Bass Optimisation System involves inserting a single, adjustable parametric equaliser filter – a 'suck circuit' to its friends – ahead of the power amp driving the bass/mid driver. The avowed intention is to use this filter to 'notch out' the most intrusive of the bass modes created by the interaction between the speakers and the room. (Whether that's what actually happens, I'm less sure!)

The difficulty in executing RABOS is that every room is different, and indeed will react differently according to where the speakers are placed. The 'notch' therefore has to be adjustable for three different parameters – the frequency at which the filter acts, the width (or spread) over which it operates, and how deep the notch needs to be to cancel out the room peak.

The tricky part, however, lies in developing a system that enables the customer (or dealer, or company rep) to identify the most disruptive room mode in the first place. This is far from easy, involving a test CD, sound level meter, graph paper, a special protractor, and several pages of the instruction manual. I have to say I found it all quite daunting, and feel this is a classic instance where a video showing someone working through the set-up procedure might be helpful. In fact, Harman sent down the excellent Reuben to do the RABOS thing. And since I wasn't feeling too technological that day, I happily let him get on with it.

For more than a decade I've carried out basic in-room swept sinewave measurements on literally hundreds of different loudspeakers. These consistently show two main bass reinforcement modes in my particular room – one at about 30Hz, the other around 53Hz. Both were evident with the pre-RABOS Intermezzo 2.6, but also showed very little difference after the RABOS filter was applied, which was confusing. I was also puzzled to find that Reuben had tuned the notch filter to 46Hz.

However, despite these apparent contradictions, introducing the filter did bring a significant sonic improvements, most obviously in the way it made the speakers sound less boxy, opening up the soundstage and bringing a greater sense of scale and coherence to the party.

Exactly what's happening here I haven't quite figured out just yet, and suspect the filter may have as much to do with manipulating the bottom end phase relationships as in modifying the amplitude response. My relationship with this intriguing speaker is therefore very much 'work in progress', but whatever's actually going on, this is still undoubtedly one of the more interesting and creative designs to emerge in recent years.



Ortofon



Pro-Ject



The new
**Pro-ject
RPM9**

Exclusively at
**Centres of
EXCELLENCE**

Town

Aberdeen
Aldridge (West Mids)
Ashby De La Zouch
Basingstoke
Bedford
Birmingham (Solihul)
Birmingham (Edgbaston)
Brentwood
Bristol
Bristol
Cambridge
Cardiff
Castleford
Chester
Colchester
Darlington
Doncaster
Dunstable
East Grinstead
Edinburgh
Edinburgh
Exeter
Glasgow
Harrow
Helston, Cornwall
Hitchin, Herts
Huddersfield
Hull
Ipswich
Ireland (Dungannon)

Dealer

Sevenoaks Hi-Fi
Sound Cinergy
Zouch Audio
Audio T**
Richards A/V
Music Matters
Music Matters
Audio T
Radford HiFi
Audio Excellence
The Audiofile
Sevenoaks S&V
Eric Wiley
Audio Excellence
Grayston S&V
Hi-Fi Experience
The Hi-Fi Studios
Technosound
Audio Designs**
Hi-Fi Corner
Russ Andrews*
Sevenoaks S&V**
Glasgow Audio
Harrow Audio**
Sounds Perfection
David Orton A/V
Huddersfield Hi-Fi
Sevenoaks S&V
Sevenoaks S&V
Kronos Hi-Fi

Town

Kidderminster
Leamington
Leeds
Leeds
Leicester
Lincoln
London (East Sheen)
London (Euston)
London (Holburn)
Maidenhead
Manchester
Manchester
New Malden, Surrey
Newbury
Newcastle
Norwich
Nottingham
Oxford
Peterborough
Rainham (Kent)
Reading
Reading
Salisbury
Sheffield
Southampton
Swansea
Swiss Cottage
Warrington
Worthing
Yeovil

Dealer

Midland Audio*
Stratford Hi-Fi
Sevenoaks S&V
Yorkshire Audio**
Leicester Hi-Fi
Sevenoaks S&V
Choice Hi-Fi
Kamla
Sevenoaks S&V
Audio Venue
Practical HiFi
Sevenoaks S&V**
Unilet
BBB Hi-Fi**
Lintone Audio
Sevenoaks S&V
Notts Hi-Fi Centre
Oxford Audio
Sevenoaks S&V
Progressive Audio
BBB Hi-Fi**
Audio T*
Salisbury Hi-Fi**
Moorgate Acoustics
Phase Three**
Sevenoaks S&V
Sevenoaks S&V
Doug Brady*
Phase Three
Mike Manning*
Vickers Hi-Fi

* Ortofon only
** Pro-Ject only

For a full dealer list and more information contact:

Henley Designs Ltd, Unit 11 Moorbrook, Southmead Industrial Park, Didcot, Oxon, OX11 7HP
Tel: 01235 511166, Fax: 01235 511266, E-mail info@henleydesigns.co.uk, WWW.henleydesigns.co.uk

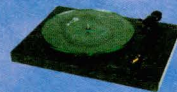

the AUDIO CONSULTANTS

SOPHISTICATED SYSTEMS • ELEGANT SOUNDS

1. Gryphon Audio Adagio CD player

Very sophisticated sound and elegant appearance. Dual mono design. £4300



1

2. Avalon Symbol loudspeaker

The soundstage and imaging that you would expect from this manufacturer but in a compact design. The new maple finish at £3795



2

2. Resolution Audio Opus 21 CD player

Very transparent, very detailed player. Separate CD drive with fast track access. Tremendous sound at this price. £2850



3



4

4. GamuT D 200 dual mono power amplifier

An extremely lucid and controlled sound. £3250

5. SME Model 10 turntable/Series IV tonearm

One of our best selling combinations consistently over the last few years. A first class, high-end sound at an affordable price. Turntable £2644. Tonearm £1127. Cartridge shown is Transfiguration Spirit Mk3. £950

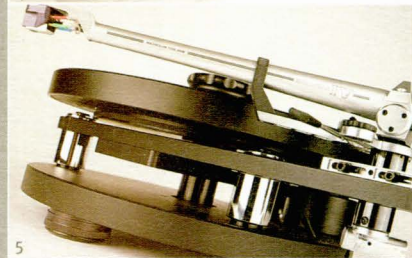

5

6. Unison Research Unico R

100wpc integrated valve-mosfet amplifier. As you would expect, a remarkable sound from this valve amplifier manufacturer. £750 With phono stage £800



6

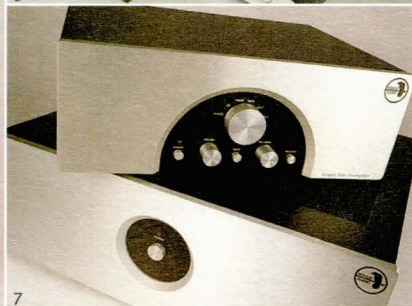

7

7. Rogue Audio valve amplification

Tremendous sound and build quality at this price point. The Model 66 pre-amplifier with phono stage costs £1295. The Model 88 stereo power amplifier 60wpc from matched 6550 valves. £1495

8. Kuzma Stabi Reference turntable £4000.

A true reference vinyl front-end in all respects. Triplanar VI tonearm £3350. Clearaudio Accurate cartridge £2750



8

Aloia • Avalon Acoustics • BCD • Beauhorn • Benz-Micro • Cardas • Clearaudio • Clearlight Audio RDC • conrad-johnson Diapason • EAR/Yoshino • Final • Gamut • GRAAF • Gryphon Audio Designs • Heart • IsoTeck • Kuzma • Lavardin • Living Voice Lyra • Magnum Dynalab • Nordost • Nottingham Analogue • Opera • Pagode Equipment Supports • Red Rose • Resolution Audio Rogue Audio • SME • Shun Mook • Transfiguration • Triangle • Tri-Planar • Tube Technology • Unison Research • Wadia

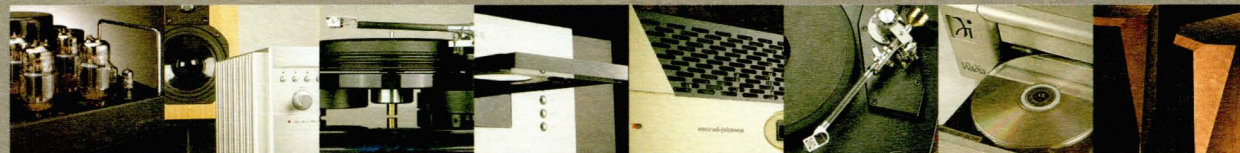

Our new premises have free and easy parking, immediately outside the building. Conveniently located between Reading and Basingstoke, we are approximately 15 minutes drive from either Junction 12 on the M4 or Junction 6 on the M3. The new unit has 2 demonstration rooms, which will make assessing our select range of prime audio products even easier.

We have a home evaluation scheme for those who might find this method more convenient.

7 Comet House, Calleva Park, Aldermaston Reading, Berkshire RG7 8JA

T 0118 981 9891
E info@audioconsultants.co.uk

Demonstrations by appointment, Mondays to Saturdays 10:00 to 18:00. It is advisable to call us before visiting.

Part exchange welcome. Ex-demonstration and previously owned equipment listed on our website.

www.audioconsultants.co.uk



Big Boy's Toys

by Scot Markwell

Scot Markwell is a reviewer for The Absolute Sound magazine, but more importantly, he's Harry Pearson's personal set-up man. That gives him unprecedented access to the Highest-End. Not just listening to it but working with it, optimizing it, having to shift it about. Scot's a big guy, but that just matches his sheer musical enthusiasm. I've asked him to keep us abreast of events in the US high-end, highlighting the contrasts with the UK market. He's going to start in on triodes ...Ed.

From what I can gather by reading audio magazines and talking with those I know who live there, the triode scene in the UK is fundamentally different than in America. On the UK side of the pond, the odd Croft or parallel SET amp may have more than a single output tube, but here, triode amps positively bristle with the darn things. Sure, one can find any number of integrated or mono and stereo power amps at Hi-Fi shops all across Britain, but the likes of which we have here in America, see and take as a matter of course, do not seem to be at all commonplace in the UK. While I have only visited a few times, always too briefly, if the conversation turns to big American triode amps, the discussion is always lively.

Take AtmaSphere Music Systems. Ralph Karsten, owner and chief designer, has been manufacturing direct-coupled, differential-circuit valve amplifiers for about 13 years, using a special version of an OTL (Output TransformerLess) circuit called the Circlotron. Think big and ugly Croft with lots more tubes and a better disposition. Karsten is a (fairly) normal-looking Minnesota fellow who leans a bit to the Native American side in his mode of dress. He hang-glides over the countryside on thermals with the eagles whenever he can, somehow managing to build amps when his feet are on the ground. He is quite outspoken in his views, and at the drop of a hat will willingly espouse his personal philosophy of design and implementation of all things amplifier. He uses anywhere from eight 6AS7 output triodes in a set of his (60 watts apiece) M60 monoblocs (\$4,650.00/pair) up to forty in a set of his big 220 wpc MA-2 MK II.2 mono OTLs (\$27,200.00/pair).

Even more (many more) in his gigantic upcoming MA-3 amps (very expensive!), which will be seriously big and bulky (and hot: all of Karsten's designs are pure Class-A). Some folks say that AtmaSpheres are homely beasts, as well,

but I prefer to be charitable and describe them as rather industrial-looking. OK, so you might never look at one of Karsten's amplifiers as just another pretty face, but they get the job done, and in a mighty musical way. One of the neat tricks that AtmaSphere amplifiers can do is managing to conjure up, seemingly from nowhere, more air and life into almost any system. Upon substituting a Karsten amplifier for almost any other, especially a solid-state design, the first thing noticed is an absolutely uncanny sense of dimensionality and space. It is as if he borrowed some of the fine edge detail from a recording's sonic images and transformed it into spatial cues and instrumental body. Upon closer listening, however, you realize that the detail is still all there; it is just that now there is a stunning sense of ambience and liquidity that was simply not there before. Debate all you want, but AtmaSphere amps simply sound as if they have more, well, er, atmosphere.

Or take Valve Amplification Company (VAC). Kevin Hayes (resident self-taught boy-genius), while a bit more on the demure side as a man, and a lot more on the classic and artistic side as a (chassis) designer, is a hard-nosed perfectionist and complete fanatic when it comes to squeezing the most out of his multiple-triode valve designs. A solid 300B advocate, the Florida-living Hayes refuses to give in to the notion that this venerable tube cannot be made to kick ass and take names in both power and frequency response, never mind driving actual "normal" loudspeakers. His Renaissance Series of amplifiers are both beautiful to look at and fantastic to listen to. The Renaissance 140 monoblocs' eight-each 300Bs (140 wpc of push-pull Class A1 power per amp) are housed in beautifully executed machined aluminum chassis, complete with integrated valve covers and a hand-rubbed black paint finish. Refined and powerful, with a sense of old-world elegance and class, the VAC Renaissance Signature 140 (\$18,000 each) amps make music in beautiful, saturated colors, with all of the natural harmonic structure, warmth, liquidity, and naturalness of the real thing, while never putting a bad foot forward. Slightly forgiving of less-than-perfect recordings, they nonetheless are incredibly revealing of all electronic components upstream from them. But to put on a record or CD and hear these big, beautiful amps pumping out anything from



► Rachmaninoff to Rocky Horror is an experience that can prove very addictive (and expensive) if one falls for the charm of Hayes' sonic vision.

Not as sonically pure of heart nor aesthetically clean of line, but still positively aglow with valves and able to play music with more sheer authority and control than any other valve design I have heard are Luke Manley's (the only English chap in this picture...) Vacuum Tube Logic (VTL) amplifiers, manufactured in Chino, California. With 24 (count 'em) 6550 output valves and three power supplies in a double-decker chassis configuration per side, and weighing in at 250 lbs. (over 113 kg!) each, VTL's largest monobloc amplifier, the MB-1250 Wotan (\$27,500/pair), lays claim to being the most powerful production valve amp ever made for the (home) music lover. With 1250 tetrode watts per monobloc, or 600 watts each in triode, the Wotan MB-1250 has the authority and reserve to drive just about any speaker, anywhere, any time. And still do the knitting and take out the trash. His MB-750 "Brunhilde" amps (\$16,500/pair), half the size and weight of the Wotans use the same basic design and components as their hefty 1250 brothers, but get by with "only" twelve 6550s per similarly-designed chassis. The "smaller" MB-750 musters a clean 750 watts per channel in tetrode mode, and about 300 per in triode, the toggling of operative mode in either amplifier as easy as a flip of a switch in the back of the unit. With a more "big & bold" sound than either the AtmaSphere or VAC amps, these monsters are more able than either of the other two to control more difficult speakers and deliver true-to-life levels without even breathing hard. While not quite as open in some ways as the AtmaSpheres or as liquid and wonderful as the VACs, the big VTLs nonetheless manage to achieve a remarkable level of finesse for such brutes, as well as rhythmic and dynamic vitality that valve offerings of lesser grunt simply cannot deliver.

On the other side of town (literally) from VTL lives another tetrode/triode valve manufacturer, Manley Labs, now owned and operated by the ex-wife of David Manley (Luke's dad), EveAnna. With a bit of a different twist, most of Manley Labs' gear is turned out strictly for the professional recording community. They make a slew of studio compression devices, mics and mic preamps, as

well as all manner of effect boxes, special DACs and so forth, all using vacuum tubes. Quite successful in their niche catering to the recording industry, Manley Labs also manufactures a line of what EveAnna calls "Hi-Fi" gear for the home playback enthusiast, including preamps, a state-of-the-art phono section, integrated amps, and basic monobloc power amplifiers. Everything is tubed. Her Manley 500 (\$12,000/pair) and Neo-Classic 250 (\$9000/pair) amplifiers offer 500/275 tetrode/triode watts per mono unit and

250/100, respectively. Again switchable

between modes with just a flip, these amps offer perhaps a little more of a "vintage" sound than the big VTLs, and, though hardly slouches, ultimately not quite as much muscle. But they are more than adequate to drive most speakers, and are champions at conveying authentic tonal colors and musical weight, be it orchestral or rock-and-roll.

In the end, all of these products are, on the surface, rather impractical devices; they all take up more than their fair share of listening room real estate, suck down rather prodigious amounts of electricity, and produce a sometimes staggering amount of heat. They are all quite heavy and none, save perhaps the VACs, are very much of a pleasure to look at.

Not quite the perfect thing for most households in the UK,

admittedly, which may go a long ways towards explaining why none of these companies seem to have done well there over the years. So why do we darn Yanks dream up and fabricate these giants and eat them up like so much candy? Because they work, and work well. To a man, as it were, they all reach down deep and play music the old-fashioned way, with gusto and heart and raw, gut-wrenching power, painting big pictures in broad strokes, as if their life depended on it. To hear any of these brawny beauties playing in a great system, warmed up and in the groove, either with digital or vinyl, is to understand why some folks are more than happy to share their space and their lives with these multi-valve triode music machines.

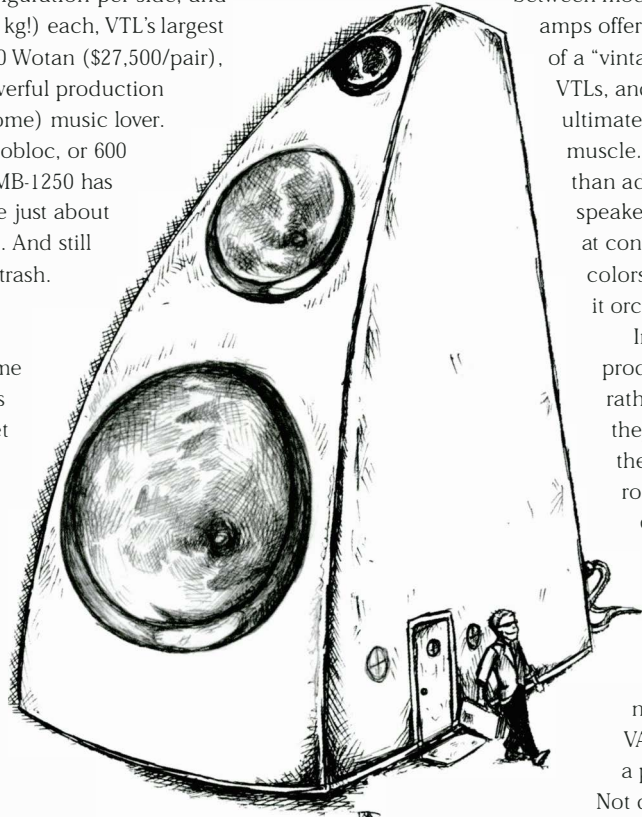

The World's Finest Sound and Vision Systems



Expert Multi-Channel and Multi-Room Installations - Nationwide



*Visit our West End store to see an incomparable selection of hi-fi components
plasma screens and projection systems*



*West **kj** One*

KJ WEST ONE

26 New Cavendish Street London W1G 8TY Phone: 020 7486 8262/3

www.kjwestone.com

VALHALLA

"Special. Very special indeed. I was genuinely impressed by the SPMs, feeling that they established new standards in many important areas. The Valhallas have just rendered them obsolete as any sort of reference. 'Tis ruined that I am."

Roy Gregory Hi Fi + Issue 9

NORDOST (UK) Ltd

Unit 7, Aber Park Industrial Estate,
Aber Road, Flint, Flintshire CH6 5EX

Tel: +44 (0) 1352 730251

Fax: +44 (0) 1352 731273

Email: sales@nordostuk.com

NORDOST CORPORATION

200, Homer Avenue,
Ashland, MA 01721, USA.

Tel: (508) 881 1116

Fax: (508) 881 6444

Email: sales@nordost.com

Please visit our web site at:
www.nordost.com

hi-fi+
**EDITOR'S
CHOICE**

EDITOR'S
CHOICE
hi-fi+
NEWS

AWARD
WINNER
hi-fi+
NEWS

hi-fi+
**PRODUCT
of the
YEAR**



Incoming!

*Please address letters to the Editor at Hi-Fi+, Unit 12 Albany Business Park, Cabot Lane, Poole, Dorset, BH17 7BX.
or via the web-site at www.hifiplus.com*

Dear Sir,

Thank you for a very fine magazine, one that I appreciate and enjoy very much.

I would like to suggest a type of article in the magazine: Hi-Fi+ visits a reader. From time to time the magazine maybe could feature such a type of article or interview?

You have been doing stuff of this kind before, amongst others the Living Voice interview, the Spectral interview and the Laverdin interview, and it makes very interesting reading. I think it would be interesting to read about other readers too, and their way to Hi-Fi Nirvana, and it could lend variety to the magazine. I am sure there would be inspiration to find in stuff like that: Just an idea.

I would also like to encourage you to do a review of the revised/updated Densen Beat B100 Mk.5 integrated amplifier. This is a very interesting amp in a price category that makes it relevant to a lot of people, I think.

Maybe the Densen Beat B-200 pre-amp and B-300 power-amp deserve a review too? An interesting pair. And maybe for the 'Real Deal' pages, reviews of the Pioneer PD-S 707 and Denon DC-D 1450 CD-Players - these are the machines that get the next generation started with hi-fi.

Thank you for your attention.

Best Regards

Bjorn Overgaard

Denmark

Dear Sir,

Whatever you do, don't listen to that guy who asked for fewer reviews of contemporary music (issue 19)! This is how the rot sets in. I'm a "born again" hi-fi enthusiast, largely thanks to your magazine. Many years ago, when a student, I had a little system consisting of a Rega P2, a Quad II/22 and some Tangent speakers. I listened to vinyl because that's all there was and I amassed a collection of some 1000 or so LPs. I was a true "lights out and let yourself go" listener.

Various moves, and then a family, meant this modest system was relegated to the attic. I did get a cheapo CD system in the 80s but did not often listen in other than background mode. This didn't worry me as I found nothing

in the 1980's or 90s which really hit the spot musically. I had come to the conclusion that (a) the old faithfuls (Stones etc.) were all past it and (b) the youth of today had nothing to say and no talent whatsoever. My blackest moment came when I heard a bit of T.Rex played in the film Billy Elliot. In the '70s I thought this sounded awful but now, in comparison with the current stuff, it sounded pretty good.

For a period of about 15 years I had purchased the odd CD but was always disappointed. I tried Oasis, Blur... you name it. A couple of years ago, I decided that the kids were old enough to keep their hands to themselves and I now had the house to myself once a week, so I decided to invest in a good CD set-up and do a bit of real listening (thus restoring some mental balance).

I was very out of touch with current hi-fi trends so I bought a few magazines to help me up the learning curve. It goes without saying that I found your own tome by far the most informative and entertaining (it's the only one to which I have subscribed - and I bought all the back issues). The things that struck me at once were the high cost of everything (my budget was a mere £1000) and the fact that cables and supports were now all part of the equation. Anyhow, I auditioned a few bits of gear starting with a Linn Classic which I eventually bought, finding nothing that sounded nearly as good at the price. Small beginnings, I know, but we've all got to start somewhere (I had to overcome some extreme internal prejudice to accept the fact that I found this to be better sounding than any of the "separates" I listened to).

I installed this and started listening to my modest CD collection which consisted mainly of re-issues of the vinyl output of the Beatles and Stones etc. Over the next few months, I read the magazines looking at reviews of kit which I hope one day to afford. But a strange thing happened. I found the same musical material kept cropping up in the equipment reviews. So I started reading the music reviews in HiFi + and made a few tentative purchases. Lo and Behold, a whole new musical world opened up for me. I forgot about saving to buy new kit and spent it on music. I have you to thank for introducing me to the likes of Dolly Varden, Eels, Laura Cantrell and (even) Nelly Furtado. Sure, there have



▶ been a few misses but, I reckon, about 90% have hit the spot. I remember reading an interview with Jeff Beck in which he told of the first time he heard Miles Davis' *Jack Johnson* soundtrack. He went into the house and said to his wife "there IS hope." Well, my tongue is only partially in my cheek when I say this has been a life changing experience (it's certainly restored my faith in contemporary music if not humanity as a whole). I can't afford the gear but I can afford a few CDs and your "Pop and Contemporary" music reviews are of far more value to this reader than all the items about multi-grand components which I can't afford.

So please, please ignore Mr. Powell's opinions. I can't believe that anyone would want less of something. I would not presume to request less classical reviews (even though I have heard very little that I like). To paraphrase his own words - is he having a laugh? If so it's at my expense.

Yours

Clive Robinson

PS. What happened to Roy Gregory's "Playing the System" experiments in issue 14? I reckon my next move might involve a Monarchy power amp into LV Auditorium speakers which I'd love to hook up directly to a Wadia 301. Has anyone tried this? What other front ends would fit the bill? Why don't you do some features on getting a high end system for a modest price by taking an unconventional approach?

They will happen but have been derailed by the non-arrival of the HW19 Junior, and the advent of the Scout. Mind you, the 301 straight in is an interesting thought... Ed.

Dear Sir,

I'm hoping that I'm not in the minority when I write in to say that I would be furious if you chopped your record reviews from HI-FI+, as suggested by Robert Powell's letter in issue no 19.

One of the reasons that I've kept buying your magazine since issue No.1, is because of the excellence and quantity of the record reviews section. The reviews have often guided and informed me of the excellence and quality – or – otherwise- of C.D.'s and vinyl, that I may not even have considered looking out for on the shelves or ordering from a specialist.

Certainly nobody on either National press or Radio would have highlighted the sonic delights of Jennifer Warnes' *The Well*, to me.

Another magazine – Hi-fi News- that used to run an excellent review section has almost disappeared from the circulation figures, since it started chopping

the reviewing columnists and I'd hate to see your beautifully photographed and produced magazine descend to the monosyllabic utterances of that previously esteemed publication.

If you need more editorial pages, ask your readership which they prefer – the 'show' coverages, which offer no known benefit to either dealers or distributors or punters and the restaurant reviews, likewise. I do eat out often but never met anyone at my favourite seafood restaurants – The Port Gaverne Hotel or The Seafood Restaurant, Padstow, both in Cornwall – who read about restaurants and was guided to them by a member of Audiophiles Anonymous!

Best Wishes for the next 20 issues.

Yours faithfully

D Webster

Devon

Dear Editor,

I am appalled at the type of attitude, dominant in the hi-fi industry, which was displayed in the letter from Robert Powell in Issue 19. He breathes a 'sigh of relief' at the news that there will be less pop and contemporary music reviews. While not a fan of pop music, contemporary music covers a very wide spectrum, and I am very interested in many of the genres which this encompasses - for example drum & bass, electronica, digital hardcore, avant garde noise, ambient, death metal, grindcore, as well as the more established 'audiophile' genres such as classical, jazz, blues, rock, and so on. Does this eliminate me from the audipohile community? Does this mean I couldn't possibly be interested in hi-fi, or the quality reproduction of music? I thought that hi-fi was first and foremost about a love of music, which is, after all, a pretty broad area.

As a young (25) audiophile, I find a certain amount of resistance to 'other' forms of music, apart from the genres which are already accepted in the hi-fi community. It also staggers me that there is also an alarming lack of people of my age group who are becoming interested in hi-fi, something which has been mentioned several times in hi-fi magazines over the years, although the articles didn't have the insight to come up with the blatantly obvious reason why - musical elitism. Don't get me wrong, I'm not asking for reviews of modern, underground, diverse music forms, just a step away from the general musical ignorance and tunnel vision of the average audiophile - which includes the hi-fi press.

Yours truly,

Richard Steels

Derby



*So you think you've
heard music?*



Think again.

The Chord DAC64. The world's first 64-bit digital-to-analogue converter.

Regarded by the press as 'stunning', the DAC64 is result of our innovation and engineering excellence, and will deliver new levels of sound quality from any digital source.

Each solid aluminium unit is hand-built to uncompromising standards to your specification.

So, to unlock the real potential of music, please contact us on 01622 721444, email sales@chord.softnet.co.uk, or visit www.chordelectronics.co.uk



Chord Electronics Limited

evolution

Cyrus' legendary amplifiers have evolved!

Back in 2001, Cyrus began a project to evolve our integrated amplifier designs to incorporate technologies researched over the last five years. After many months of acoustic tuning and detailed electrical re-evaluation lasting more than a year, we are proud to announce the arrival of our evolutionary new Cyrus 8. This extraordinary amplifier sets new standards and strengthens Cyrus' position at the leading edge of what's possible in audio design today. For the full story on how our amplifiers have evolved, please visit our website at www.cyrusaudio.com.

The logo for Cyrus, featuring the word "CYRUS" in a stylized, metallic, sans-serif font with a blue and silver gradient. The letters are slightly shadowed to give a three-dimensional appearance.

Advanced Audio and Video Systems

Cyrus Electronics
Huntingdon, Cambridgeshire, PE29 6XY

Tel: +44 (0)1480 435577
Fax: +44 (0)1480 437715
email: info@cyrusaudio.com

www.cyrusaudio.com

integrated
Cyrus 8

Going Home...

The London Hi-Fi Show 2002

by Roy Gregory

As the curtain came down on the 2002 London Hi-Fi Show the overwhelming response was one of relief: Relief for the organisers, relief for the exhibitors and blessed relief for the visitors. After three years spent in the claustrophobic purgatory of the Hammersmith Novotel, during which the show declined to a shadow of its former self, it's started on the long road to recovery with a return to its spiritual home at the Heathrow Renaissance / Ramada / Penta (or whatever it's called this year). Also following the pattern of the last Heathrow show, exhibits were spread across two adjacent sites, the Meridien joining the party, and whilst its position across the busy Bath Road isn't ideal, it does mean a higher proportion of larger rooms.

The result of all these changes was an upbeat mood amongst exhibitors that carried over to the general public. Indeed, a good time was had by all, helped by the large number of new and interesting products on view. And view is the appropriate word, with an increasing number of exhibitors opting for predominantly static displays. The result is that it's easier to talk to designers and get a good look at new products, while those who are playing music suffer a lot less competition. Indeed, noise pollution was mercifully absent (save for the ill-advised Bedroom Bedlam DJ feature, which certainly lived up to its billing).

Seen...

The sheer range of new equipment on offer was mind-boggling, and whilst I abhor those show reports that do nothing but list the exhibits, there's a real danger that that could happen here. Still, I'll try to sort the wheat from the chaff...

Source Components

Analogue continues its rude revival, with new turntables on show from DPS, Nottingham Analogue, Origin Live, Clearlight and Max Townshend. GT Audio were showing the DPS design from Germany. It employs a plinth laminated from mixed materials (including cork, Perspex and birch ply) mounted to a Granite plinth. The acrylic platter rides on an inverted ruby ball bearing and is driven from

a mechanically separated motor housing, with its own external power supply. The result is a compact and rather elegant unit with a distinctly seventies aesthetic and a very different approach. Price is around £1800 with a Berger synchronous motor, or £2500 with the optional DC drive.

GT also announced the reappearance of the Garrott Brothers cartridge designs. Built by a Garrott trained engineer and using the original plant and parts the range consists of two MMs in the familiar A&R bodywork, and a pair of moving-coils. Prices start at £270, and further information is available from GT Audio (44) (0) 1895-833099, sales@gtaudio.com.

Path Premier announced major additions to the Lyra cartridge line-up, with the Lydian Beta being replaced by the £495 Dorian, joined by the bright blue £849 Argo which slips in below the Helikon (now £1195). At the other end of the range, we will finally see the long awaited Parnassas replacement, in the shape of the titanium bodied Titan (£2995). The flagship should be available by the time you read this, with the cheaper models following before Christmas. (44) (0) 1844-219000, premier@path.co.uk.

Nottingham Analogue launched the new Horizon turntable, a non-suspended skeletal design (if something that looks like its built round



▶ a solid ingot could be described as skeletal) complete with base board and RB250 tonearm for the all in price of £528.75. Personally I'm not entirely sure about the aesthetics, but that normally ensures that the product goes on to become a resounding success! It certainly offers an alternative to the existing range of sub £600 players, and hopefully we'll get to review one soon. (44) (0) 1773-762947.

be available by the time this hits the news stands. (44) (0) 208-979 2155.

Meanwhile, South coast mavericks Origin Live unveiled their Resolution turntable and Encounter arm. The deck employs a complex, composite structure for its sub-chassis, suspended on pre-set springs so that despite appearances, set-up is simplicity itself. The other interesting development is the use of a hollowed out acrylic platter.



The irrepressible Max Townshend turned up on Sunday sporting the all new Rock Reference Master, an £11000 monster with battery power and remote control VTA! It also has studio looks, three speeds and the obligatory snout trough at the front end of the all new Excaliber arm. Perhaps more relevant to the general public is that Max finally has the finalised metal work for his long awaited super-tweeters, so they'll

This has spokes to ensure rigidity and a thick band of material around the periphery for fly-wheel effect, besides looking pretty spectacular (so long as you aren't actually playing a record of course. Motor is a DC unit driven by a dedicated external supply and price for the 'table is £1979.

However, more impressive is the matching Encounter tonearm. This is a Rega mount compatible design that uses a threaded column and collar to allow VTA adjustment.

This mount comes as part of the deck and is compatible with all single hole Rega arms. But unlike the companies' other tonearms this is no simple modification of an existing design. Instead, designer Mark Baker has applied the knowledge gained from that exercise to an all-new product based around a massive, one-piece bearing housing. The arm-tube and headshell are extensively machined from carefully selected and highly specified materials. All in all, constructionally speaking, it wouldn't be out of place on a battleship, whilst its medium mass makes for wide compatibility with moving-coil cartridges. It's priced at £970 which makes it extremely competitive, whilst for those who simply have to spend more there's the £1570 Illustrious model (and that is a battleship!). (44) (0) 2380-578877, www.originlive.com.

Loricraft showed a further development of the Garrard 601 first seen in Frankfurt, looking very sexy in its dark wood finish and sporting an RDC armboard. (44) (0) 1488-71307, www.garrard501.com. Moth showed new versions of the deservedly popular Incognito re-wiring loom designed to be straight replacements for the internal connectors in arms using 5-pin detachable leads (Linn, SME etc). (44) (0) 1234-741152, www.britishaudio.co.uk

But the most impressive analogue debut was Kuzma's new Air Line air-bearing linear tracker. Using the



▶ same inverted bearing as the Rockport arm, but running at 4-bar, it also employs a massive, tapered aluminium armtube and milled from solid headshell. This thing is so solid it looks like a piece of military hardware (and you know how much those boys spend on their toys). It also offered simple and effective VTA adjustment which I'd prefer to see graduated in some way, although as a prototype there's still time to put that right, along with a neater solution to the cabling which is already in the works. Priced at around £4500 including a serious compressor, which looks like a bargain against the prices charged for the competition, this looks like being a serious contender in the Best Arm stakes. As with all air-bearings, its dimensions and in this case mass (2kg), makes the choice of matching turntable critical. LP12 owners need not apply! The arm sounded wonderful in the exceptionally musical Audiofreaks room, but more on that later. www.kuzma.net



Digitally speaking, the big news came (perhaps not surprisingly) from Pioneer, who announced second generation multi-standard players, with the DV-656A coming in at £400! However, it's the new, circa £900 DV-757Ai that will get all the attention. Multi-standard, it also incorporates an IEEE1394 digital interface, more commonly known as FireWire within the computer industry. This runs from all formats except DVD-A, although that will be enabled as soon

as final copy protection protocols are settled, allowing digital transfer of hi-bit information onward into an appropriately interfaced system. The technology is fully CPPM compliant, and thus represents a huge step towards integration of high-quality digital home audio, entertainment and information systems. The DV-757Ai should be available towards the end of the year, the proposed roll-out being in October. (44) (0) 1753-789500, www.pioneer.co.uk.

Amplification

There was something of an American invasion at Heathrow, proving that even if the country hasn't transcended its fear of flying then its high-end audio products certainly have! Path Premier showed a pair of new stereo amplifiers from Levinson, replacing the existing 334, 335 and 336. Styled after the No 32 Reference pre-amp and 434 and 436 mono-blocks, the 200 Watt 431 and 400 Watt 432 deliver more power for less money than the models they replace, although final pricing is yet to be fixed.

But biggest news on the amplification front (at least as far as Path are concerned) is the long anticipated arrival of the Ayre electronics in the UK. Highly regarded Worldwide, I've yet to hear a bad word said about these sleek and stylish designs, their immaculate build quality and reliability a match for their pristine performance. The bad news has always been that this quality doesn't come cheap – until now. New for Heathrow were what almost amounts to a budget range, starting with the CX-7 CD player and AX-7 line integrated, balanced, 60 Watt amplifier, each costing £2950. Okay, I know that's not exactly pocket money but it is shed loads cheaper than the state-of-the-art kit. And the good news



is that the fit and finish of the new, more affordable range doesn't seem to have suffered one iota, making this some of the most impressive looking product in its price range. As well as the CD and integrated, there's also a pre-amp and stereo and multi-channel power amps, the last being a modular unit that that starts with two channels at £2995, with each additional channel up to six costing another £1249.



RT Services showed the Spectral DMC15, eagerly awaited replacement for the DMC12, priced at £4250, while Ultimate Sonics are now importing the highly regarded Edge Electronics amplification. They were running the battery powered Signature 1 pre-amp at £8950 and the NL10 laser biased stereo amplifier at £10800. (44) (0) 1235-810455, info@rtsaudio.co.uk : (44) (0) 20-7435-1222, sales@ultimate-sonics.com.

Fighting back for the Brits, Chord Electronics launched the Choral series, a complete system built into the svelte but solid casework of the DAC64. The decoder has been joined by the ▶

► Symphonic phono stage (c.£2000), Prima line stage (c.£2400, £2750 including the Touch screen System remote) and the Mezzo 30 Watt power amp (c.£2350). Offering fully balanced connection at every stage, the units are beautifully constructed, typified by the relay operated loading and gain adjustments available on the phono-stage, indicated by small LEDs viewed



through the curved top-window. The final element is a rack constructed with slotted, curved end panels that space and tilt the units to show them to maximum advantage. It's a diminutive tour de force, but as John Franks is quick to point out, the downsizing has nothing to do with a drop in quality. In fact, further reductions in the physical size of surface mount components mean that, for example, the entire driver stage of Chord's bigger amps has made it into the Mezzo, an interesting option for those who don't need the power of the larger models or find their sound rather muscle bound. I can foresee the reviewer feeding frenzy now. www.chordelectronics.co.uk.

Further down the price range, although they'd claim giving little away in quality, Creek announced major changes to their product line. The existing 43 series will be superseded by the 50 series with improved internals but just as importantly, sleek new silver exteriors that at last mean that the Creek

components give nothing away to their competition when it comes to looks. The IA50 integrated amp (£600) is joined by the CD50 (£700) and the T50 three wave band tuner (£500), all with cosmetics to match the more expensive 53 series.

The P53 pre-amp, first mentioned in our New York show report and built around an innovative, high-quality discrete resistor volume control, will be available in December at a price of £1500. It will be accompanied by the A53 balanced input and bridgeable power amp (£1200) and the similarly priced five band T53 tuner that includes a DAB option. Likewise the OBH series of expansion boxes have been streamlined and cosmetically improved, meaning that 20 years after the 4040 first saw the light of day, Creek have a focussed and really competitive product range that is carving itself an enviable reputation. The new developments can only strengthen that position. (44) (0)020-8361-4133, www.creekaudio.co.uk.

Naim, fresh from the success of the 5 Series and the launch of the NAC 552 pre-amp, offered up the restyled and engineered 200 series. I'll leave the overall impressions to JH save for one

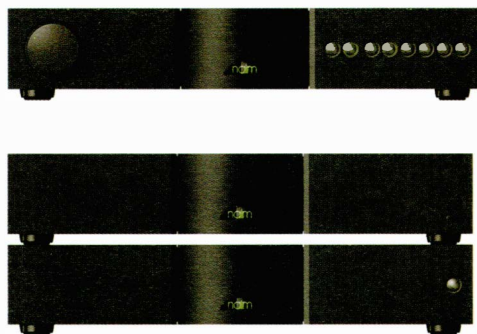

comment. The new CDS3 is an exquisite product that takes Naim's triptych chassis to its logical aesthetic extreme. The centrally mounted transport lid is a work of art, and finally, Naim have produced a top-flight CD player that actually looks like the money.

The revised version of Lavardin's legendary IT integrated amplifier has finally arrived, the IT 2K2 (Audiocraft), and was joined by other continental offerings from Germany and Italy. Award for cutest product on show definitely goes to AvanteGarde for their compact integrated amplifier. Remote control, 30 Watts and balanced line outs for those wanting to use it with the Solo active speakers, it should retail for less than £1500. (GT Audio). Meanwhile, Mel Audio were continuing the long tradition of Italian companies producing distinctive yet elegant products. I'm not sure about the UFO look of the circular CD player with its cookie jar lid over the top-loading transport, but the long slabs of beautifully milled aluminium that encase their amplifiers reek quality. Add the distinctive, tapered knobs and you have a really stylish package. The amplification starts with a 21 Watt integrated whose grip and control belie its modest rating. Even really awkward speaker loads don't phase it, and its promise suggests that this is definitely a brand to watch. (39) (0)522-433368, www.melaudio.com.

The Briston 14B gave CB a serious case of the I wants when he reviewed it a few issues ago. Now, the midrange models have benefited from a mid-life make-over, with improved cosmetics, controls, measured performance, reservoir capacitance and output power, meaning that those who don't need the 14B's 600 Watt output can investigate its qualities in more modest quantities. For example, the 150 Watt 3B SST weighs in at £1725. (44) (0)870-444-1044, www.briston.ca

But perhaps the biggest surprise of the show was in the Eminent Audio room. There I spied a sleek amplifier combination, all clear Perspex front panels over clear anodised aluminium casework, with nicely turned knobs, looking just like it was fresh off the ►

Forest

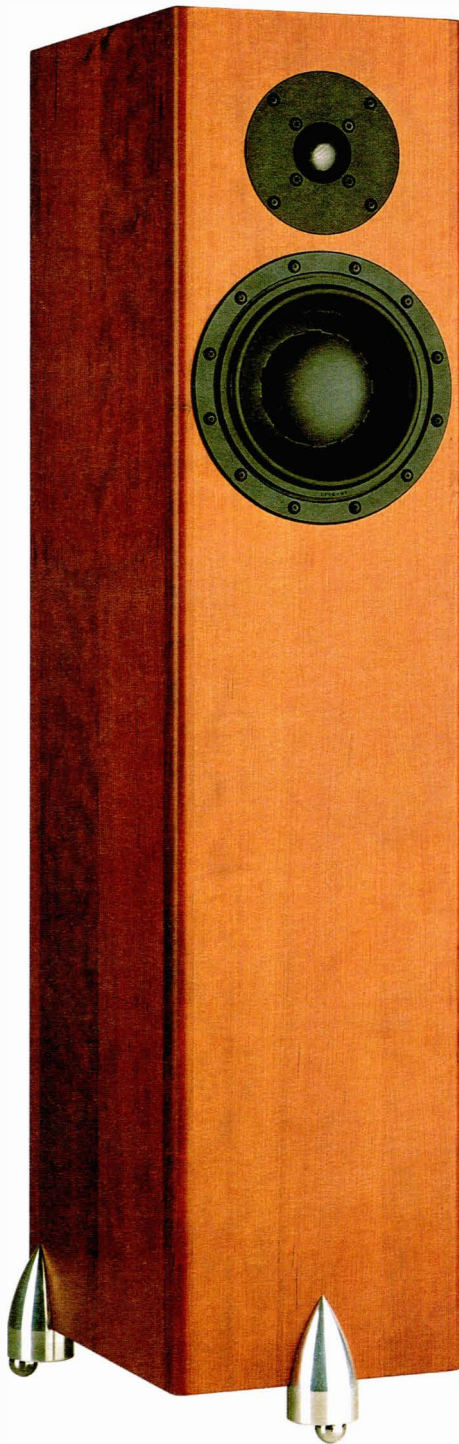

Totem has spared no expense in making the Forest one of the best speakers available at any price... It's a two-way floor standing model that is surprisingly affordable, considering that it is a true super-speaker. The woofer and its aluminium dome tweeter, allow it to cover the full auditory range. Those aren't mere paper specs, either! The response is down only 6 dB at 28 Hz, a frequency most speakers can't reach. Its lock-mitred monocoque chassis, its slanted rear baffle, and its fine hand-crafted construction place it above lesser speakers of its size and price. Much of this is invisible, though by no means inaudible. As usual with Totem speakers, the fine wood veneer is also placed inside the cabinet, to equalise forces on the two sides of the walls. Why it's called the Forest? Well, where would you expect to find a totem? Well, a forest would be a good place to begin your search. However, a forest also imbues mystery, quietness and unpredictable, unexplainable power. In a real forest you are surrounded with sound, which can suddenly appear, surprise and then disappear. It can happen anywhere around you. Let the Totem Forest surprise you in the same way...

To receive information on our full range of products, please send your address to info@joenit.com or call 003215 285585

London Area

Cornflake.co.uk, LONDON, Tel: 0207 6310472
Rayleigh Hi Fi, LAKESIDE, Tel: 01708 680551
Thomas Heinitz, BAYSWATER, London, Tel: 0207 2292077
Audio-T, READING, Berkshire Tel: 01189 585463

South East

Rayleigh Hi Fi, RAYLEIGH, Essex, Tel: 01268 779762
Rayleigh Hi Fi, CHELMSFORD, Essex, Tel: 01245 265245
Audio-T, TUNBRIDGE WELLS, Kent, Tel: 01892 525666
Rayleigh Hi Fi, SOUTHEND, Essex, Tel: 01702 435255

The North

Audio Republic, Headingley, LEEDS, Tel: 07932 682440
Romers Hi Fi Great Harwood, Lancs Tel: 01254 887799
The Audio Room, Hedon, Hull Tel: 01482 891375



TotemAcoustic.com



United Kingdom Distributor
wim.verellen@joenit.com
Belgium Tel: 0032 15 285 585

► plane from Italy. Imagine then my surprise when I discovered that these are new offerings from none other than that offender against all things aesthetic, Glenn Croft. The Vita line stage is an all valve, remote control unit based on a pair of ECC83s and a single ECC81. It costs £900. The matching Twinstar power amp is a hybrid design with solid-state outputs, zero feedback and Croft's new Transvalve circuitry, an approach that mimics both the topology and hardwired construction of a classic valve amp. The Twinstar delivers 45 Watts of stereo power and costs £1700. (44) (0) 1746-769156, www.eminentaudio.co.uk.

Finally, and leading on to speakers, Red Rose introduced the Spirit system, consisting of simplified versions of the Rosebud/ Rosette. General appearance is similar, although the Spirit LS1 speakers lack the high quality, high gloss finish of their more expensive clones. But don't get the idea that this is a shabby or second rate set-up. You still get real wood veneer and the IA1 35 Watt amp retains the cute, vertical format, although, if anything the control layout is both more logical and more attractive. But the best bit is the price: amp, speakers and a 15' pair of speaker cables for £1999. (44) (0) 1992-573030. www.mdc-hifi.co.uk.

Loudspeakers

British loudspeaker launches are something of a tradition at Heathrow, and this year was no exception. KEF announced the new XQ series that slots in between the established Q and Reference ranges, offering a high quality stereo platform with a "life style" aesthetic and the option to expand it to a full surround set-up. The thing that sets this apart from other ranges claiming similar benefits is the

coherence of the range as a whole. Not only do each of the four models employ identical Uni-Q drivers, they also inherit the hyper-tweeter first employed in the Reference models. Add to that identical cabinet profiles around these driver arrays and the tonal character and dispersion of these speakers should be as near identical as possible, a seriously underrated consideration when it



comes to maximising the performance of 5.1 systems. (44) (0) 1622-672261. www.kef.com.

Both Mordaunt-Short and Monitor Audio showed revised ranges with

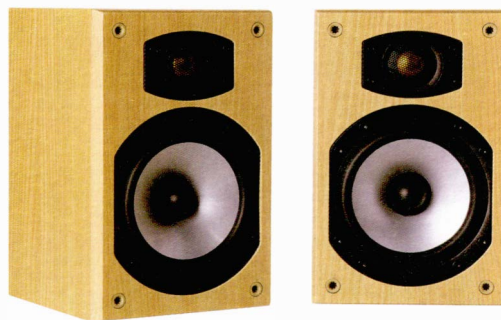

updated aesthetics. The new Bronze models from Monitor Audio are a good example of this, with looks that bring them into line with the more expensive Silver (also redesigned and improved) and Gold ranges. But the changes are more than just cosmetic. The drivers have been further refined, and the bass unit now features eight-point mounting and a vented motor, which combined with a revised port design are claimed to improve bass linearity and clarity. We'll be looking at models from both manufacturers in due course to see how they effect the status quo in the vital budget

sector, but if you can't wait, you can find additional information at www.monitoraudio.co.uk or www.mordauntshort.com.

The big news from Tannoy is the availability of the super-tweeter from their Eyriss range as a standalone unit, the ST-50. Costing £600 a pair, it can be matched with a variety of speaker models and is switchable between 85, 89 and 93 dB sensitivity and 14, 16 and 18 kHz crossover points. The -6dB point is out at 54 kHz, with claimed useable output extending to 100 kHz. (44) (0) 1236-420199. www.tannoy.com.

But the most impressive new range on show came from Wharfedale. A couple of years ago, the curved, boat shaped backs to the cabinets were a must have for serious high-end contenders after the fashion was set by the B&W Nautilus series. ►

GamuT

www.gamutaudio.com

D200 • D100 • C100
 D200 • D100 • C100
 D200 • D100 • C100
 D200 • D100 • C100
 D200 • D100 • C100
 D200 • D100 • C100



Recreating the entire musical event with all its light, colour and detail.

the absolute sound: "...in some respects, it's hard to beat for any amount of money", ...and... "the GamuT D200 has the best soundstaging I've yet heard from any amp ... superb width, depth and layering ..."

In the UK HiFi News wrote: "Through all types of music the GamuT D200 shows spectacular three-dimensional layering of the stereo sound stage." ...and... "excellent retrieval of ambience and an accurate rendering of the space around instruments."



the absolute sound says of the CD-1: "...what the Gamut does let you hear, on disc after disc, is the music" ...and... "The music lover says, this thing is a joy and, for the money, a dream."

For more information:

UK Distributor on **01252 702705**
 or email: info@audioreference.co.uk

Visit our new web site:

www.audioreference.co.uk



Sendor S9



Sendor S8



Sendor S6

Sendor S6 "Excellent all-rounders that demand an audition" Jul 02
 Sendor S8 "Stunning loudspeakers that deliver everything that their price demands"
 Sendor S9 "Great sense of timing and gorgeous bass" Jan 02

Available now at your Sendor Dealer
 For full information contact:

Sendor Audio Systems Ltd
 Station Road Industrial Estate
 Hailsham East Sussex
 BN27 2ER
 T+44 (0)1323 843474
info@sendoraudio.com
www.sendoraudio.com



Take two...

by Jason Hector

This year's return to the Renaissance and Meridien hotels at Heathrow airport was a relief to the vast majority of exhibitors and visitors alike. Of course, living South of London made it a hellish journey by train and tube for me, but for every inconvenienced visitor there must have been a dozen or more happier travelers! Spreading the show across two hotels is always a compromise but at least it gave access to many more, larger rooms, and the courtesy buses did sterling work ferrying people between the locations.

It was a shame that both Meridian and Path Premier felt that a static display was a better solution than a compromised room. Path Premier avoided a dem of their usual high quality because they could not find a decent room that they could work with for a number of years, although I understand this will be sorted out for next year. It was disappointing to miss more exposure to the big Madrigal system, but as Nigel Crump (Path Premier) rightly said "better no sound than a bad sound" ... I just wish a few other exhibitors had taken this advice. Path were displaying a new brand for them, Ayre Acoustics, and very good it looked too. The CD player will be reviewed in an issue or two, and from the care and execution of the casework and the press about these products I doubt Path have backed a dud.

Meridian had brought a large selection of their products to reinforce their technical leadership position. They seem five or more years ahead of everyone else, at least in the UK. Not really surprising given their commitment to multi-channel systems and their major interest in the early

adopting US market.

On to the brands that were actually demonstrating their wares, and I will concentrate on the rooms that made a sound that I particularly enjoyed, and who managed to avoid playing plinky-plonky audiophile crap ...

As ever those tell it straight Sugden guys were making an excellent sound with the Bijou series of electronics driving a small pair of stand mounted Pro-acs. The star of this system is the new Class A amplifier, good for a massive ... 16W. The amplifier is pretty much a cube built in the distinctive and over engineered Bijou style casework, but with the corner connecting posts extended to create a stylish, dedicated rack system. The sound was very clean with plenty of purity across the midrange but what impressed me most was the drive and dynamics on offer from such a low paper power rating. To be honest this system could be on anybody's audition list, almost regardless of budget, but if you are after superior sound from a gorgeous yet compact product the Sugden really is in a class of its own. www.jesugden.co.uk

If one room was really showing the way it was Neat Acoustics. Demonstrating their new Ultimatum range of speakers, Neat were using two large Dynavecator power amplifiers in a bi-amp format. CD sounds were from the Resolution Audio Opus 21 and vinyl from a Roksan Xerxes with Dynavecator DrT XV1 cartridge, so this was not a cheap system. But they were more than happy playing any music (Metallica to Right said Fred) at any volume (mainly loud!). Personally I think this more than demonstrates the faith Neat have in their product. In less than ideal situations the system was unbreakable and very tight in the bass. Dynamics were extremely impressive, giving a visceral connection to the music. A couple of people I spoke to had a slight concern

about the deep bass lagging slightly but I am sure this was a room mode, probably the large cupboard doors at the rear moving with every transient. The Ultimatum range starts with a stand-mount speaker which will retail for £2900 and this is followed up with four floor-standers each one4 having a larger cabinet and adding more drive units. These drivers and the cabinetry were of a very high quality and the veneer of the speakers at the show was lacquered to a brilliant finish. All of the speakers feature one or two upward firing super-tweeters and that tight deep bass can be at least partly explained by the isobaric loading used for the bass drivers. Detail was well resolved and the speakers offer low distortion demonstrated by the lack of fatigue when listening at serious levels. They will, however, require some powerful amplification to give their best. Expect a review of one of the range from yours truly in the next few issues. www.neat.co.uk

Naim Audio went all out to scare the competition senseless by launching a completely reworked middle

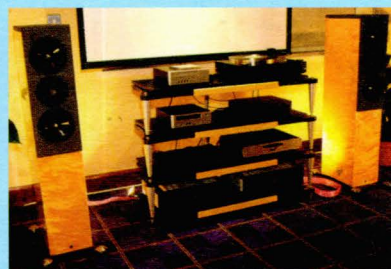

to their range of equipment. Everything they make is now in the new and improved livery pioneered with the NAP500 and 5 series, and best of all the logo has been retooled and looks miles better. First off, lets hear it for the Sources ... well the CDX has been replaced with the CDX2 (not original naming, but

► The Wharfdales are built in China from real wood veneered 18mm MDF They use Kevlar bass/mid units and decoupled soft dome tweeters and are heavily braced both laterally and vertically. In the floorstanding Evo 30 model, the twin bass-mid drivers are separately loaded and isolated by a diagonal, bracing baffle. The two and a half way design uses reflex loading for the bass end and



sealed box for the mid-band. Spikes and terminals are heavy duty, indicating care and attention to peripheral details. And prices? The bookshelf Evo 8 costs just £250, while the Evo 30 weighs in at £650, and if the sound of the latter at the show is any indication, the parts and features package is more than matched by the sonic performance. (44) (0) 1480-447700. www.wharfdale.co.uk.

The Gallo spherical satellites enthusiastically reviewed elsewhere in this issue are finally joined in the UK by the Due model, two globes arranged around the excellent CDT cylindrical tweeter with its 120 degree dispersion. System sensitivity is 93 dB and bandwidth extends down to 60 Hz, where you have a choice of the active, cylindrical subs covered by the review, or an identical looking passive version, the MPS1. Sound quality is extremely good, building on the already excellent performance of the baby Nucleus models, and these are a credible alternative to more conventional ►

what did you expect?). It is still upgradeable with a new XPS. Both have been reworked with the CDX2 featuring a new transport, digital filter and DAC. The CDS2 is also being replaced with the CDS3 although the actual device wasn't ready for the show so we had to satisfy ourselves with an empty box. The CDS3 is still a top loader but the transport has been moved to the center front and it simply looks "right"; form, function and all that. The CDS3 will not be the top dog in the Naim CD line up for long, with hints being dropped about a forthcoming ultimate Naim Audio CD player, codename the CD555. Both the X2 and S3 CD players feature outputs to phono sockets so the trend started with the NAC552 is continued. In fact all of the pre-amplifiers above the NAC112 feature line level inputs via phono sockets. Talking of pre-amplifiers they have all been reworked too. The 102, 82 and 52 have been replaced with the 202, 282 and 252 respectively. Again the devices are not just cosmetically changed. The tried and tested circuit has been extensively refined and lessons learnt developing the 552 have been applied to these devices, including isolation of the circuit boards. None of the new pre-amplifiers will accept the plug in Phono cards seen in almost all previous Naim pre-amplifier products. Instead all feature a socket which can power a Stageline or Prefix phono-stage. Finally the power amplifiers: the 180, 250 and 135's have been succeeded by the 200, 250 and 300 respectively. Yep, the 250 continues (could Naim really not make a NAP250? Like Linn stopping the LP12) although it is massively different to the old one with a huge transformer that must take up 60% of the case space. (Just a slight exaggeration then Jason. Ed.) Perhaps the most interesting unit was the NAP300, a two box design resembling a chopped down 500 rather than the mono-block 135s.

All of these products were on display in a form of audiophile porn gallery with their lids off and innards on show. Seeing the interior of the NAC552 in the flesh you can start to understand its price tag. Also on static display was a smaller center speaker that will retail for approximately £1000 and will be better suited for a lower end Naim AV system.

Naim did not just have a static display. They were also demonstrating an AV system, and a two-channel system with the new CDX2, XPS, 252, Supercap and NAP 300 into SL2s. The sound of the new components does retain the virtues of the older boxes. Whether they are miles better however is impossible to tell with the room restricting absolute quality. That said I thought the SL2 speakers were sounding much better than at Bristol earlier in the year. The AV demonstration was the more impressive in many ways, with a very, unusually, musical result when playing the Fab Four's re-mastered Yellow Submarine DVD. Nothing was overblown unlike most of the other AV systems which seemed to want to deafen the audience. Hidden away in the AV room was another new product, the NAPV145 a mono amplifier based on the NAP250, to get the right number of amplifier channels in a 5.1 setup. Expect a Naim Sub woofer soon along with at least one DVD player. www.naim-audio.com.

PMC Bryston were also showing a good quality AV system. The new subwoofer was very impressive. Plenty of weight and speed from a compact and, best of all, narrow enclosure. The sound had subtlety as well as power and depth when playing some gentler DVDs.

Star of the show for me though was the Audiocraft room. Here we had a relatively cost effective system consisting of a Rogue Audio 99 Magnum pre-amplifier and M120 Magnum mono-block power amplifiers driving a pair of Amphion

speakers. The source was the Metronome CD player reviewed in this issue, so total system cost was about £10000. Along with the Sugden bijou room, this system offered the best sound per pound of the show and, like the Neat and Sugden rooms, they have enough faith in their product and their ability to set them up to play any music. This system demonstrated that it's not just the flat earth brands that have a monopoly on musical pace, rhythm and timing. This system rocked with the best, even playing my torture disc, Smog - Dongs of Sevotion (sic.) and specifically the track 'Bloodflow', which plain sounds boring on a poorly integrated system. The Audiocraft system got it all right, tracing the tempo shifts with ease and keeping the sense of menace and tension building throughout the song. I managed to cadge a listen to the system early on Sunday morning when few other rooms were operational. A return visit demonstrated the problems the mains can cause when lots of boxes and screens are hanging off of it. With the second audition the noteworthy clarity of the system was compromised to some extent, the system was still good but in the morning it had been excellent. I will be trying my hardest to get this system home to test my findings a little more.

How would I sum up this Hi-Fi show? Well overall with the exception of the rooms above and a few others, if I was an average punter trying to decide between a new hi-fi and a Jet ski / car / kitchen / round the world holiday, I don't think the hi-fi would have gained that many points. Sad but true, it's a conclusion that must take into account just where this show started from - which was the disaster at Hammersmith last year. This was a major league improvement on that. If the organisers can continue that trend then we will finally be getting somewhere.



speakers at their price of £600 each. (44) (0) 1555-666444. www.networxgroup.co.uk.

Another long awaited return to these shores came in the shape of the elegant Audiostatic loudspeakers. The familiar Wing model has been joined by the smaller and cheaper Wing A that employs the same drive unit membrane and electronics package in a cheaper baffle arrangement. Prices are £4850 for the wing, while the A version costs £3250, and both are available through new distributor Audiography, Tel. (44) (0) 1444-870400, www.audiography.co.uk.

Racks

I realise that furniture doesn't get a look in to most show reports, but hey, we're nothing if not different. In fact, there were several impressive new developments, but the most interesting of them came from Solid Tech and Grand Prix Audio. The first of these is a skeletal unit based on extruded aluminium uprights held together by height variable cruciforms constructed from aluminium brackets and wooden struts. The resulting X shaped levels then support the equipment either on ball bearings that sit

AUDIO ILLUSION

23 Langley Broom
Langley, Berkshire, SL3 8NB
2 mins, June 5 off the M4)
TEL: 01753 542761
FAX: 01753 772532
(Open: 10am - 8pm (Mon-Sat -
By Appointment Only)
www.audioillusion.co.uk
audioillusion@btinternet.com



EVERYTHING MUST GO
MASSIVE CLEARANCE SALE
AT PRICES NEVER TO BE REPEATED
ALL ITEMS SOLD WITH A WARRANTY
ALL MAJOR CREDIT CARDS ACCEPTED
MANY ITEMS HALF PRICE OR LESS!!!!
STRAIGHT AUDIO / HOME THEATRE!!!!



ACCESSORIES, ETC.

FI-RAX STAND: 6 Shelf, Smoked Glass Shelves & Side Panels, Aluminium Constr. (Black Gloss with Gold Trim) Ex.Demo/Mint £ 500 £ 149
TARGET STANDS: Many-give us a call Ex.Demo/Mint Call Call
MONDIAL: MAGIC BOX - Improves your Picture! **NEW/Sealed** £ 99 £ 49

ACURUS

A250: 250W Stereo Amplifier (Black) Ex.Demo/Mint £1400 £ 850
A200X3: 3-Channel (3x200w) Power Amp. (Black) Ex.Demo/Mint £1600 £ 975

AERIAL ACOUSTICS (see pictures below for some of the models)

Model 5: Bookshelf Monitors-Pair (Maple) Ex.Demo/Mint £2900 £1495
Including Special Stands
Model 7B:** Floorstanding Speakers-Pair (Cherry) Ex.Demo/Mint £5000 £2500
Plus Special Pinths
Model 10T: Reference Loudspeakers-Pair (Santos Rosewood) including Special Pinths (Stereophile Reference listed) Ex.Demo/Mint £8700 £4350
CC3B:** Centre Speaker (Natural Cherry) Ex.Demo/Mint £1800 £ 900
SW12:** 400W Active Remote Control Subwoofer with Parametric Equalizer (Rose Walnut) Ex.Demo/Mint £4800 £2400

RETAIL SALE

AVM

V2: Remote Pre-Amplifier (Black) Ex.Demo/Mint £1175 £ 595
M2: Mono Power Amplifiers - Pair (Black) Ex.Demo/Mint £1975 £ 995pr

CAIRN / EZO

K5.5:** (5 x 100w) Multi Channel Amplifier, 6 Transformers, Bal. In/Outputs (Silver) Ex.Demo/Mint £1500 £ 849

NANDA Face Nord: Pre-amplifier, 2 Analog Chan. Ex.Demo/Mint £1000 £ 499
Dual Mono, 3 Transformers, Bal In/Outputs (Silver)

ARIA: Integrated Amplifier - Remote (Silver) Ex.Demo/Mint £ 450 £ 225

CHORD

DAC 64: D to A Converter (Silver) Ex.Demo/Mint £1900 £1350

MIRAGE

AVS-500:** Full Home Theatre Pack (Black L'ette) Ex.Demo/Mint £ 399 £ 210

FRX-S8:** Active Subwoofer (Black) Ex.Demo/Mint £ 249 £ 140

HT-3: Spec.Stands for AVS-200 Satellites (Black) Ex.Demo/Mint £ 50 £ 25

OM-C2:** Centre Speaker (Piano Black) Ex.Demo/Mint £ 599 £ 349

OM-R2:** Rear Speakers - Pair (Piano Black) Ex.Demo/Mint £ 440 £ 220

PIEGA (P Series - see picture above)

S3: Satellites with Wall Brackets, Pair (Aluminium) Ex.Demo/Mint £ 499 £ 250

S4: Floorstanding Speakers - Pair (Aluminium) Ex.Demo/Mint £1095 £ 550

S4C: Centre Speaker (Aluminium) Ex.Demo/Mint £ 440 £ 220

P4L:** Floorstanding Speakers - Pair (Aluminium) Ex.Demo/Mint £1695 £ 850

P SLB 1:** Subwoofer (Aluminium) Ex.Demo/Mint £1850 £ 925

P4C:** Centre Speaker (Aluminium) Ex.Demo/Mint £ 840 £ 430

P4XL:** Floorstanding Speakers-Pair (Aluminium) Ex.Demo/Mint £2210 £ 1105

P5: Floorstanding Speakers (Aluminium) Ex.Demo/Mint £2450 £ 1295

** AWARD WINNERS / 5 STAR BEST BUYS !!!!!!!

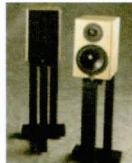

A Product
That Does Absolutely
Nothing - Except
Let The Music
Come Through

Boulder



METROPOLIS
music

Tunbridge Wells, Kent Tel: 01892 539245 • Fax: 01892 616383

► in grooves in the top of the struts, or suspension feet that slot over them, allowing the feet to slide. It's an interestingly minimal basis to which you can add additional isolation if necessary, either with the optional feet, or by suspending the cruciforms themselves. Contact Ultimate Sonics for further information.

At the other end of the spectrum, certainly as far as cost goes, Path Premier offer the Grand Prix Audio racks. With the cheapest four-shelf option starting at £2495 and prices shooting up from there as you start exercising options, this is for the seriously committed only, but the construction is interesting none the less. The rack employs uprights constructed from a variety of aerospace alloys (they can be lead filled if you want) with decreasing coercivity as you move away from each shelf and designed to lead energy away from the equipment. These are held in a triangular arrangement by carbon fibre space frames, decoupled by compressed Sorbothane. These support glass shelves, again supported on Sorbothane pads, but this time matched to the weight of the supported component. The spikes on the bottom of each pillar are suitably savage, and for the well heeled there's the option of carbon-kevlar shelves (at a mere £849 each)!

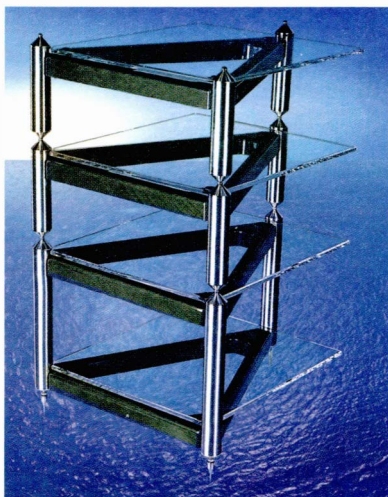

It's a sophisticated, multi-stage approach to equipment support and we'll be investigating its benefits as soon as we can prise a review sample out of the importer's grasp.

Software

Big story of the show was the arrival of the first fruits of Classic Records' co-financed collaboration with Peter Gabriel's Real World studio. Mike Hobson was proudly clutching 200g pressings of not just

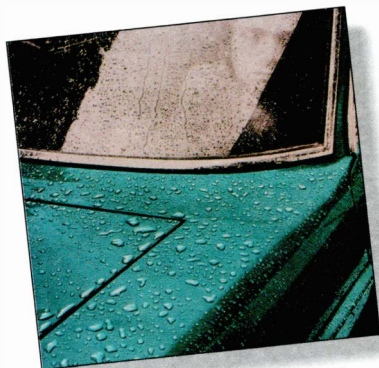

the first solo album but also the latest, *Up*. The interest of the studio in the project makes this a first for a pop re-issue and promises great things, especially when you consider the sheer density of Gabriel's music, and the demands it places on systems and storage media.

Elsewhere, Diverse Records have announced their second project, a 180g vinyl issue of the latest Dolly Varden album *Forgiven Now*, possibly (hopefully!) followed by its predecessor *The Dumbest Magnets*. And Naim, following on from the Image Hi-Fi sponsored vinyl issue of their latest Charlie Haden / Chris Anderson recording *None But The Lonely Heart*, had 180g pressings of the Forcione / Sciubba collaboration *Meet Me In London*.

And finally, Warners seem to have got their act together on the DVD-A front, with a

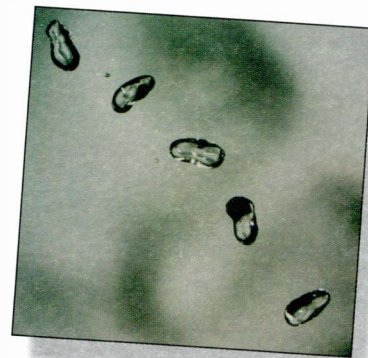

whole raft of re-issue titles now available. Mind you, they've some serious catching up to do, with SACD leading them in terms of new issues as well as the quality of their re-issues. They've nothing to compare with the appeal of the Rolling Stones back catalogue.

...and Heard

Which brings us to the best of the sounds on offer and it reads like a list of the usual suspects: return to Heathrow, return to form. So, in order of seniority...

I didn't make Absolute Sounds' ticketed demonstration (although I did spy a very cute smaller brother to the Martin Logan Descent sub-woofer, the Depth, with a price of £1998, and the VS110, bigger brother to the VS55 reviewed in this issue). But that doesn't mean that I missed out on sweet sounds. Sonus Faber's new Cremona Auditor, a two way stand-mounter related to the floor standing Cremona, was making very impressive noises on the end of a Copland CDA822 CD ►



▶ player and Jadis DPL2 / DA7 combination. It looks fabulous, has an equally fabulous matching stand, and nearly the bandwidth and authority of the Electa Amator, but without the latter's ruinous load and inefficiency. The music was open, stable and really breathed: so much so that I returned to this room three or four times, finding it equally impressive on each occasion. With an asking price of £2149 plus £399 for the matching stands, looks to die for and sound to match, this is one seriously desirable little box. (44) (0)208-971-3909. www.absolutesounds.com.

Audiofreaks can be relied on for an oasis of musical calm amidst the mayhem and this year was no exception. Source was the Kuzma Stabi Reference turntable, the aforementioned Air Line tonearm and KC-REF cartridge (there was a Muse CD / DVD player on hand too, but with Franc in the room his new baby seemed to be getting most of the airtime). Pre-amplification was courtesy of a conrad-johnson Premier 15 S2 phono stage and Premier 17 LS line stage. These fed the immensely impressive Karan Acoustics KA S 270 power amplifier and Avalon Opus Ceramique loudspeakers. Cabling was Cardas Golden Cross throughout whilst



support was provided by the elegant finite elemente Pagode Signature and HD Master Reference racks. I haven't actually totted this little lot up, but it comes to a lot, okay? It also provided the most spacious, natural and engaging sound of the show, no doubt in part due to the use of a full suite of Acoustic Applicata room treatment. Going to such lengths is unusual at a UK hi-fi show, but it's hard to argue with the results. If I'd had to choose a single room to spend the three days of the show in then this would have been it. (44) (0)20-8948-4153. www.audiofreaks.co.uk

Audio Reference had two rooms which, whilst they suffered sonic problems at least hinted at what was possible from the equipment they contained. The larger space contained the enormous Gamut amplifiers, themselves dwarfed by the seven foot columns of the Nearfield Pipedream speakers and the two accompanying, cylindrical sub-woofers. I was seriously impressed by these a couple of years ago in New York. There they were in a tiny hotel bedroom yet, driven by the VAC amplification, still managed to offer awesome scale, power, transparency and an almost palpable

Acustica Applicata

Those familiar with Tube Traps will not be surprised to learn that Acustica Applicata used to build the American designs for the European market, and they learnt a thing or two along the way. Their own version of the Abfusor recipe is a far more subtle and refined device, working at a wider bandwidth and with a more sophisticated range of set-up possibilities. Rather than a half and half reflective / absorptive split, the DAAD towers use a porous, diffractive surface on their hard side, and it only covers a quarter of the surface of the larger units. By adjusting the precise orientation of the towers you can focus their effect. But perhaps the most important innovation is the fact that these off-white columns with their blond-wood end caps are remarkably domestically acceptable: Incredible given their size, but true nonetheless. Which makes them a first in the world of room treatment. They also offer three discrete levels of treatment, each built on the one below, and a free planning service that matches the necessary towers to the dimensions and layout of the user's room. It's a comprehensive and considered package that should be considered by anybody with a serious interest in room treatment. Towers start at £199 each for the DAAD 2, rising to £379 for the largest DAAD 4, and each complete tower can consist of either one or two individual units. That means a starter kit will probably set you back around a £1000, which is pretty small beer in the context of many of the hi-fi systems out there. Don't underestimate the impact of your room on the sound of your system. The DAAD devices attack that problem at source.

presence. Ironically, in the much bigger room they occupied at Heathrow, they only suggested their former magnificence, although by Sunday they were finally beginning to come together.

More successful were the Cabasse Karas, large 4-way floorstanders which swamped their much smaller environment. Using the companies' triple concentric TC22 driver in its distinctive spherical enclosure, backed by an upward firing 12" (I think) bass driver, they offer -3dB extension to 35Hz and 93.5dB sensitivity. They also managed to extract a musical performance from the Halcro amplifiers, which is a first in ▶



ULTIMATE SONICS

DISTRIBUTORS OF QUALITY & AFFORDABLE HIGH END HI-FI AND HOME THEATRE EQUIPMENT

The Ultimate Solution for all electrical mains problems – Hear the difference

PS Audio Power plant

AC regeneration
- the most
sophisticated
solution
available

from
£1745



Ultimate Outlet

£385



New high
current Ultimate
Outlet from PS Audio
- reduces mains noise and
improves sound quality.
Innovative circuitry means it
performs like no other

Synergistic research

£240



Best in test - Hi-Fi Choice
Reviewed by Jimmy Hughes

£160



£155



xStream Digital

PS Audio Lab Cables - as always, the affordable option



£420

250W stereo 8 Ohms
500W stereo 4 Ohms
1800W stereo 4
Ohms
Built-in Power Plant

The Classic 250
will be recognised as one of
the world's finest power
amplifiers

£4290



£1550



HCA-2 Amplifier
150W per channel into 8 ohms
225W per channel into 4 ohms
Built in High Current Ultimate Outlet
The coolest running stereophile class A rated amp
- will drive ANY loudspeaker ever made

Try one in your system - 14 days no obligation trial

For more product information visit our web site at www.ultimate-sonics.com
Check out our pre used pages on the web for bargains

Tel: 020 7435 1222 Fax: 020 7435 1300 Email: sales@ultimate-sonics.com

▶ my admittedly limited experience. The sound, driven from the Clearaudio Master Reference turntable and Shun Mook cartridge was notable for its linearity and absence of false emphasis or exaggeration: Just nice, lively, direct music. This, and my recent experience with the Cabasse iO / Jupiter combination suggests that there's gold in them thar hills. I think I'll be playing closer attention to Cabasse in future. (44) (0) 1252-702705. www.audioreference.co.uk.

Moving on from the established high-end importers we reach the newcomers, fast risers and new faces.



First up is Audiocraft, one time dealer but now an importer with a small but extremely select portfolio and a burgeoning reputation for offering exceptional performance at approachable prices. Opting this year to show the upgraded Magnum versions of the surprisingly affordable Rogue Audio valve amps from the US, driving the Amphion Xenon floorstanding speakers, source was the Metronome T1 CD player, the latest version of which graces our cover this issue. My notes say "rhythm and timing enough to satisfy a Naim owner" and sure enough, both JH and PM mentioned to me how much they'd enjoyed the sound. Taut, dynamic, detailed and organised, it still managed to breathe life into recordings. Dispelling the myth that suggests that all valve amps are soft and turgid, this system

proves just how much you can get out of a well designed valve circuit without it costing the earth. We reviewed the standard Rogue Audio 99 pre-amp and M120 mono-blocks back in Issue 10, when they seriously impressed that ultra cynical valve aficionado CB. Rest assured that both the Magnums and the Amphion speakers are slated for early attention. What's more, this was one room where they'd play anything you asked them to, the system's performance more than justifying the confidence of its designers. (44) (0) 1895-253340. kevinwalker@genie.co.uk

Reality audio were playing the interesting Perigee ribbon hybrid speakers (compact and beautifully finished) with the Cawsey amplifiers from Australia. This modular system employs compact predominantly Class A power amps with remote power supplies. Although a single supply can be used to power up to five individual output stages, in this instance they'd



really gone to town, driving the speakers actively with four output stages each with its own dedicated supply. Pre-amp, cabling and mains filters also came from Cawsey, ensuring system coherence. And although the name might be new to you, those audio eclectics at Walrus Systems have been quietly importing (and raving about) the cables for four years. The sound of the system as a whole was detailed, transparent and blindingly quick. Its lucid presentation was extremely impressive and I'm looking forward to a closer acquaintance with the individual elements.

So finally we get to what was for me

the most interesting demonstration of the show. In their Classe Audio room, B&W had enlisted Tony Faulkner to demonstrate his LSO Live DSD recordings direct from hard disc. The results, replayed via Classe amps and two pairs of B&W CDM7 floorstanders, were out of all proportion with the cost of the system involved, giving a tantalising glimpse of the capabilities of SACD. Huge dynamic range and superb differentiation of energy levels and shifts within the orchestral picture made for a riveting listening experience, helped of course by the quality of the orchestra and recording. But what's even more interesting is that the LSO Live recordings, the Orchestra's own discs are available on CD for £5. The Shostakovich 10 has already sold 14000 copies and come November there'll be matching SACD issues too, for £10 a throw! This could be both the future of high-resolution digital audio and recorded classical music, all rolled into one.

Available from all decent record dealers these LSO Live discs seem set to cause the biggest ructions in classical recording since the advent of Naxos, cutting the record companies out of the equation and throwing the Orchestras a financial



life-line. Now all we need to do is find something to do a similar job for the hi-fi industry and we can all relax a bit. Come to think of it, the rejuvenated Heathrow show, if it can continue to build and improve on this foundation, could be a step in just that direction. Here's hoping... 

Doug Brady Hi-Fi



Wilson Benesch
Arc Loudspeaker

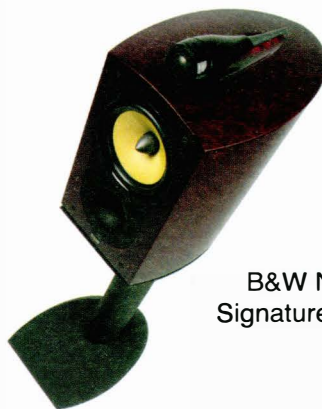

B&W Nautilus 805
Signature Loudspeaker

Wilson Benesch & B&W Nautilus: two of the most outstanding ranges of stylish high performance loudspeakers.

We also stock ProAc, Castle, Monitor Audio (new S6 and S8).

Just in! : New range of models from CHord Electronics, Naim Audio, Musical Fidelity, Rotel, Arcam, NAD.

Demonstrations by appointment plus home trials. 0% Credit available

Kingsway Studios, Kingsway North, Warrington. WA1 3NU.

Tel: 01925 828 009 Fax: 01925 825 773

Email: doug.brady@doughbradyhifi.com Website: doughbradyhifi.com

"Probably the best tonearm in the world"

Hi-Fi World 2002



Origin Live Tonearms

"The Silver 250 is the very best tonearm I've ever heard....the £599 price tag is laughably low....could probably charge five times this amount....words can't express how good this is - one of the designs of the decade"

Hi-Fi World 2002

"There may be better value propositions around to upgrade your system but if there is I haven't heard them....A fantastic product then from Origin Live and this particular audiophiles dream review tool."

TNT Audio 2002

Very occasionally new products appear that are so advanced as to render all previous benchmarks obsolete. People believe our new range of tonearms are just such products and we invite you to experience an unprecedented leap in your system performance - regardless of your current tonearm. Arrange for an audition now.

Silver - £599

Encounter - £970

Illustrious - £1570

All products carry a full no risk money back guarantee and are available via your nearest Origin Live dealer or by direct mail order.

For more information visit our website or contact us at:

Origin Live, Unit 5, 362b Spring Road, Sholing, Southampton, SO19 2PB, UK
Tel/Fax: 02380 578877 e-mail: originlive@originlive.com

www.originlive.com



B&W Nautilus 800 Loudspeaker

by Paul Messenger

Following on from the original – and highly successful – 1998 launch of its Nautilus 800 series, B&W has added three more models to the range. 2001 saw a new top-of-the-line 800, available in either standard 'Nautilus' real-wood veneer (£11,000/pair), or the luxury high gloss grey tiger's eye or red bird's eye 'Signature' finish shown (£16,000), while 2002 brings a very pretty Signature version of the little stand-mount 805.

Some of the differences between the new models and the originals are purely cosmetic, to do with the fancy high-gloss cabinetwork. But the new models also incorporate a number of important engineering changes, reflecting some of the lessons learned by B&W's well-staffed research department since 1998, and these are claimed to enhance both the measured performance and the sound quality.

Aesthetically speaking, this 800 looks like a cross between the 801 and the 802, which means it's comfortably the best proportioned of all the Nautilus – where the 801 looks a bit tubby and the 802 slightly top-heavy, this 800 looks just right, in the way the bass section supports the large teardrop-shaped midrange enclosure which is common to all three.

The reason for the differently shaped bass enclosures is that the bass driver complement varies between the three. The 801 uses a single 15-inch, which inevitably makes the bass enclosure rather four-square and 'tubby'; the 802 has a pair of 8-inch bass drivers, allowing the bass enclosure to be nice and slim, but necessarily somewhat taller too. This 800 splits the

difference, featuring a pair of 10" bass drivers that require the bass 'commode' to be just 8cm or so wider than the head unit, and give a much better proportioned speaker in consequence.

Let's compare the 800 and the 801 in rather more detail, highlighting the differences which are responsible for the considerable £2,500 price hike for the newer model. For starters, each of the 800's 10" bass drivers uses the same magnet as the 801's solitary 15", so the bass drivers themselves are effectively doubled, as is the actual bass 'drive' for a similar total cone area.

The midrange driver now uses a more compact rare-earth magnet (Neodymium-Iron-Boron), reducing the acoustic reflection signature of the motor assembly, while an increase in top plate thickness improves consistency and reduces distortion. The central 'bullet' polepiece extension is now aluminium alloy.

Modifications to the tweeter include a 'crowned' voice-coil bobbin and silver-plated pole-piece, extending the -6dB rolloff point to 50kHz.

Considerable work has gone into improving the crossover network. All inductors are now air-cored, and improved custom polypropylene capacitors are used. New Palladium-plated WBT terminals feed

the bass drivers with heavy gauge cable. Why Palladium? It won out over Rhodium, Silver and Nickel in a four-way subjective shoot-out.

Although the 800 bass enclosure's size and shape would seem to offer good inherent stability, in fact this is further enhanced by a large and capacious plinth. Accommodating either spikes or coasters, this gives a huge 56x37cm stability footprint, though its prime task is to house the crossover network, keeping it well clear of the speaker drive units, and providing plenty of room to space out and orient the individual components for best performance. A large 'FlowPort' is set into the base of the enclosure, firing into a gap between plinth and bass box.

One of the most convincing indicators to the extra engineering content built into the N800 may be seen in a 20 per cent greater total weight over the 801, from an already very considerable 104kg up to an almost incredible 125kg – almost incredible because this is by no means a dramatically large or bulky loudspeaker.

Doubling the bass drivers is part of it of course, but when looking around B&W's new Worthing factory recently I spotted a completely 'empty' 800 bass enclosure, and tried to lift it up. Yes, I could move it alright, but considering this was just the MDF shell, I was nonetheless amazed at how heavy it was, partly through the sheer thickness of the side/back wrap and front baffle, but also through the complex 'matrix' of reinforcing members which further brace and stiffen the enclosure in every conceivable direction.

Although this review has so far ▶



► focused on the differences between the new 800 and the earlier 801 and 802 models, it wouldn't do to overlook the numerous and dramatic technical innovations which were first introduced on the latter two models, and which remain important ingredients in the 800.

All are three ways, and the most radical elements concern the midrange reproducer, which is housed in its own massive teardrop-shaped enclosure, made from an epoxy-ceramic compound called Marlan.

This is decoupled mechanically on a rubbery elastomer gasket from the bass enclosure, and positioned in such a way as to provide some time-alignment. From the outside it promotes wide sound distribution, while the internal shape, combining a sphere and cone, acts as a natural absorber to rearward radiation, without the need for hysteretic damping materials.

Because this is a three-way, the midrange driver doesn't need to undergo the large excursions needed to reproduce deep bass frequencies, and this has allowed B&W to opt for a very unusual 'free edge surround' type of driver. In a two-way design, the surround has to perform a number of somewhat contradictory tasks. It's required to locate and centre the edge of the cone at all times, create a gas-tight seal, and also absorb some of the sound waves travelling out from the voice-coil to the edge of the cone, but the normal rubber roll will also tend to reflect back some of the latter. Freed from any need to provide large to-and-fro excursions, in place of the usual roll surround B&W uses a fixed rubber gasket which is expressly designed to absorb midrange frequencies.

Several of the features incorporated into the midrange section are also adapted and applied to the tweeter too.



This also has its own enclosure, again mechanically decoupled from and time-aligned with the rest. In this instance the enclosure consists of a long tube, which absorbs the rearward output from the 25mm metal diaphragm.

Using simple, steady state sinewave measurements, the measured in-room frequency balance looked very similar to the trend I'd found with the 801 a few years earlier, while the impedance likewise showed a determinedly current-hungry load. Registering a low 3 Ohm load from 90 – 200Hz indicates a speaker which is not too well suited to low power SET or OTL valve amps, though the 800's high 92-93dB sensitivity is some recompense, and I had no problems at all with the meaty 100W Steinhart Fidelio.

The frequency balance is quite smooth, though not entirely neutral. Low bass extension is prodigious, output in my listening room averaging around +3dB through the bottom (20-40Hz) octave. In contrast to this very full low bass, the mid-bass (centred around 65Hz) is a little lean, and as a consequence the sound tends to have a little too much weight and not quite enough 'punch'.

Above the bass zone (which is very much controlled by interaction with the particular listening room and the siting of the speakers therein), the midband is impressively flat and smooth, from 85Hz up to 1.5kHz. Then there's some 3dB loss of output through the presence zone (2-5kHz) (typical of B&W's larger Kevlar drivers under my far-field conditions – see Boxout). The tweeter here comes in

at a highish 4kHz, and is again smoother and flatter than most, though its output is a little stronger than the presence level.

It's some years since I had 801s at home, but my memory is of a speaker that I respected, for a number of reasons, but never quite learned to love. It had a delightful midrange, to be sure, but was a tad too 'heavy' and laid back for my personal taste.

During the time I had the 800s – which was several months, as I was in no hurry whatsoever to return them to their owners! – I spent a morning down at B&W's research facility in Steyning. The guys there set up a comparison between 800, 801 and 802 – something that's tricky to organise at home – driving a pair of gigantic Mark Levinson No. 33 Reference mono-blocks from a Naim CDS II via a passive pot. The 801 and 802 are decent enough speakers in their own right, to be sure, but I was amazed how obviously and immediately superior the 800 sounded, with dramatically superior dynamic range resolution, and substantially less apparent time-smear.

The 800 might nearly replicate the measured in-room balance of the 801, but sonically it's an altogether different

animal. It's tauter, tighter, firmer and altogether more accomplished in supplying a genuinely deep and wide dynamic range, in creating genuine musical tension, and defining leading edges.

It didn't take me long to come to the conclusion that this speaker was definitely casting a spell over me, and I could all too easily fall in love.

Unquestionably a magnificent beast, the 800 will take anything you throw at it, responding with total unflappability and an impression of almost infinite headroom. And while it does lack a little presence energy and bass 'punch', this character seemed far less obvious ►

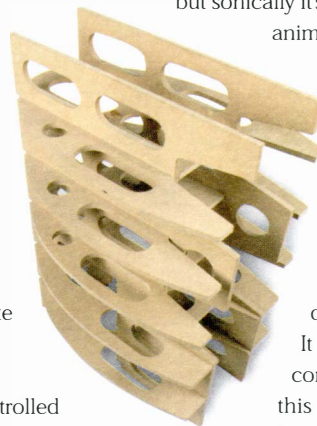

▶ than it had been with the 801, and the 800 sounded altogether more neutral in consequence. This is still a speaker that responds well to being worked hard, but it's altogether happier and more articulate than the 801 when operating at whisper-quiet levels too.

Of its type – by which I mean a conventional 'direct radiator' (or monopole box) loudspeaker – I reckon this is the best loudspeaker I've yet spent quality time with at home. It has a quite prodigious dynamic range and loudness capability, fundamentally good neutrality, a splendid freedom from boxiness with outstanding imaging and focus, plus fine transparency.

However, I'm deliberately including that 'of its type' qualification, because there are several distinct types of speaker – panels, horns, omnis, for example – all of which will give similarly distinctive results in practice, at least in part because of the different ways and different degrees to which they interact with the listening room.

Listen to a pair of loudspeakers and you will hear a combination of the direct sound from the speakers, plus the reflection of some of that sound from the walls, floor and ceiling. For example, omni-directional speakers, which spray the sound around in all directions, tilt the direct-to-reflected ratio in favour of the latter, so that the net sound involves a relatively large contribution from the listening room. The panel or 'dipole' speaker represents something approaching the opposite condition, its 'figure-8' radiation pattern tending to minimise the room interaction

'Direct radiator' speakers, like B&W's Nautili, which effectively split the room interaction difference between the omni and the dipole, probably represent the

best all round compromise. They're certainly by far the most popular type of hi-fi speaker around, and not without reason. A 'less interactive' speaker will tend to give superior imaging, but will create a less powerful illusion of actually bringing the musicians into the room, and vice versa.

Over an extended period of some months, my respect for the Nautilus 800 continued to grow. Their massive weight proved a tad awkward for a reviewer who has to change speakers frequently, but in truth the only real practical difficulty I encountered arose from the equally massive magnetic fields generated by those bass drivers, and the consequent difficulty of maintaining the colour purity of the 36-inch Panasonic TV that normally sits between my front speakers. No other speaker has given me quite as much trouble as the 800s in this regard, though with a little patience and care I cracked it.

Most of my listening was done using my regular Naim-based (NAC 52/NAP 500) system, which seemed to work very well, though I did try a number of other components along the way, and found the 800s as revealing as they were entertaining. At one point, and for all too short a time, I managed to borrow a second NAP 500 and bi-amp the 800s, and was quite surprised at how much obviously better they sounded with the extra power amp. This does perhaps imply that this is a difficult load to drive, yet even the little Croft Red Shift seemed to do OK, despite its minimal power, providing one didn't attempt to push it too hard.

The superiority of Naim's NAC 552 over the NAC 52 was very obvious, for example, and I got good results with other high quality pre/power combos too, valve and solid state alike. Steinhart's

100W valve device showed considerable authority, and the speaker simply took 700W of Audionet power in its stride.

Powerful magnetic fields apart, there's little to complain about this hugely entertaining loudspeaker, which definitely represents a major step forward from the 801 and 802, and must surely represent something close to the start of the art for direct radiator designs. Perhaps the bass is the best bit, because no other hi-fi speaker I've encountered can kick it with the very best in-car subs like this. But all three sections – bass, mid and treble – show exceptionally creative engineering, and all are pulled together into a coherent whole by an unusually well crafted crossover network. ➤+

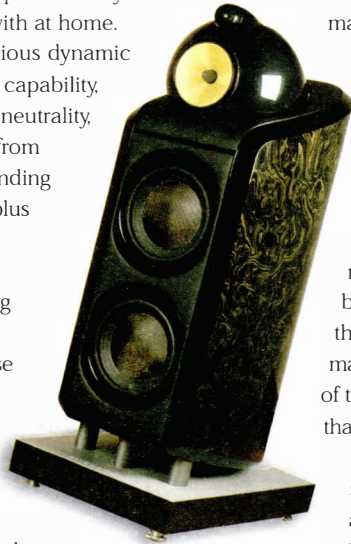

TECHNICAL SPECIFICATIONS

Type:	Full range three-way vented-box loudspeaker
Driver complement:	1x 25mm wide-band alloy dome tweeter, tube-loaded, 1x 150mm free-edge woven Kevlar cone midrange 2x 250mm paper/Kevlar cone bass
Sensitivity (ref 2.83V):	91dB (claimed); 92-93dB (measured)
Impedance:	8 ohms nominal (3 ohms minimum)
Frequency range:	-6dB at 25Hz and 50kHz -3dB at 32Hz and 42kHz
Dimensions (WxHxD):	Overall 45x 120x65cm Plinth 45x65cm
Weight:	125kg each
Finishes:	Bass enclosure: choice of real wood veneers
Mid/treble sections:	high gloss black
Plinth:	matt black, brushed silver alloy
Price:	£11,000 £16,000 Signature finishes

Manufacturer:

B&W Loudspeakers Ltd
Tel. 01903 221500
E-mail: info@bwspeakers.com
Net. www.bwspeakers.com

Signing On...

B&W Discuss the Genesis of the Signature 805

by Jason Kennedy

With the Signature 805 B&W has done a lot more than put a shiny lacquer over a nice veneer, even though this was all the Japanese market place seemed to want. So I went down to the company's Steyning research labs to find out exactly what they had done to extract such a stunning performance from such a relatively modest loudspeaker. Present for the round table forum were Senior development engineer John Dibb, development engineer Steve Pearce, Electro-acoustic development engineer Tom O'Brien and laboratory guru Peter Fryer. Just to make sure they didn't let any cats out of the bag we were chaperoned by PR and marketing manager Danny Haikin.

JK. Apart from the change in resolution the two 805s sound as if they have a different balance, is that the case?

John. It's slightly different, but measurement wise very little, the Signature is slightly more sensitive and the midrange is half a dB up relative to the bass - which makes it sound a touch less tubby.

JK. So there's other reasons why the Signature sounds different?

John. Lots of reasons; firstly it's tuned slightly lower, the upper bass (c100Hz) is down and the lower bass (40Hz) has been raised which tightens up the early harmonics on bass instruments and makes them sound much more realistic.

JK. Why didn't you do that with the original?

John. Listening to the two we felt that it could be less warm in that region. A lot of people have commented that it sounds more extended and it is more extended

but leaner or drier. The 100-150Hz region is down relative to the mid which gives a drier, if you want to use that awful term, faster, bass.

Tom. There's probably other factors which give it faster bass, it's got a little bit more shove, or magnet strength, albeit not a lot.

John. If you lift the second and third harmonics of the bass that makes it sound faster and that's what's happened. As far as changes from the original are concerned - we've gone to a copper clad pole piece (on the mid/bass driver) which effectively reduces the inductance of the coil and drastically reduces distortion, particularly the nasty sounding third harmonic distortion.

JK. Why did you do this with the Signature and not originally?

John. It's a more recent discovery that's significant enough to warrant holding back for the next level of product.

Steve. It also changes the frequency response so it couldn't have been done as a running change without altering the crossover so it wouldn't be a case of switching drivers.

John. Reducing the inductance changes the response of the driver so you get a lot more top end out of the driver. Requiring a change of crossover. The drawback with the copper cladding is that it significantly increases the magnetic gap. Which results in a substantial reduction in flux density, hence the 38% bigger (in volume) magnet which goes a little further than making up for the increased gap, and gives a slight increase in flux density. So you have more control and therefore tighter bass.

Tom. It effectively improves the impulse response.

Peter. It grabs hold of the coil better!

John. That plus the lower tuning is what's tightened up the bass. The DC resistance has stayed the same. ▶

► **JK. Has it become easier to drive?**

John. It's slightly more efficient, we're talking about half a dB in sensitivity. We've also been looking at the impregnation and coating on the back of the cone which have given us improvements in the top end response, to the extent that we can now use a first order crossover as opposed to a highly damped second order. Originally it was second order with a high resistance value on the shunt component, which means it's not a true 12dB/octave filter, it's a bit more gentle than that.

JK. Does a first order filter give you a steeper roll-off?

John. No, each order that you have gives a 6dB/octave roll-off. A true second order filter would give you 12dB/octave but if you add some resistance in there, to prevent ringing it softens the knee of the curve giving a more gradual roll-off before becoming true second order. The capacitor that used to be used for this has now gone and there's just a single air core inductor rather than iron core.

JK. So the reason for using a first order crossover is that it has less components?

John. There's no chance of a resonant circuit because there's only one component, secondly there's an inherent distortion in iron cores and there's no distortion in an air core. So any distortion from the crossover itself has been eliminated. This has reduced midrange distortion to 0.15%.

JK. The crossover point is quite high up, 4kHz, why?

John. With a Kevlar cone because you get this effectively reducing diameter you don't get the beaming problems of other cone materials, so if you can get reasonable dispersion at 4kHz and not have any nasty coloration then why not? The problem you have with a unit that does beam badly and you bring the crossover point down you get a big jump between a cone that is directional at that frequency to a tweeter that has very wide dispersion, and you get a big jump in directionality, we get much more gentle transition. Your ear is most sensitive around 2kHz so you definitely don't want the crossover to be as low as that.

Tom. That's where most people tend to be most sensitive, 1.5 to 3kHz at the most.

Peter. It's the critical speech region, there's a lot of theoretical work showing that if you keep the directivity more or less constant over this region the speaker tends

to sound better.

Steve. Woven cones work differently to pistonic cones. Over a sixty degree arc we get very good uniformity of off axis response but in a more reverberant field compared with other systems, with say a 2kHz crossover, they have more energy off axis, way off axis, which means that you can hear more of the room.

Tom. So you are effectively getting more direct and less reverberant sound, in the critical midrange frequencies.

John. With Kevlar you lose output from the outer ring of the cone as frequency increases, so at the crossover you're changing from a relatively small effective cone area to the tweeter whereas with a lot of units you're changing from something of six inches in diameter to a tweeter, there's a more sudden change.

Tom. You can see that in off axis responses. We think off axis is important and we try to roll-off the response smoothly and evenly.

Peter. So that's why it's [the crossover] higher up!

Steve. Another great benefit is that you're not hammering your tweeter as hard, you're putting less power into the tweeter and less power means less compression and lower distortion.

John. The tweeter is the same in effect as the one on the Signature 800, the only difference is that the models which have the Nautilus head have a larger tweeter casing, but the internals are exactly the same. We use silver plating on the pole piece which has a similar effect of cutting inductance as the copper does on the mid/bass unit. Thereby reducing distortion and extending the top end up to 50kHz. We've gone to a metal coil former which is crowned over and bonded directly onto the rim of the dome rather than butting it up as is usual.

Tom. We used to have a Kapton former which was bonded to the edge of the dome, but now the aluminium former reinforces the edge of the dome which stiffens it.

John. The Kapton was a less stiff former that had a shear transfer, now it's literally pushing on the edge. Because the first resonance in the dome is in the lip this stiffening has pushed the first resonance from 26 to 32kHz. Which means the -6dB point is above 50kHz because there's more energy getting into the coil. It's effectively become a supertweeter.

Tom. The voice coil is copper clad aluminium to keep weight down.

JK. What about the crossover components?

John. The crossover is very different in terms of the construction of the components. On the standard model we use ICW capacitors, 250 volt polyprop

▶ which were among the best at the time of the 805s inception. When Steve was doing the Signature 800 we had it in our minds that very low loss capacitors would be a good thing and ICW came back with a different configuration of cap that reduces the distances between the end caps, which means that the diameter has to increase. They have solid copper end caps. Then the idea of series wound caps came along, which is like two caps in one which also sounds better. The problem is that for a given value you need four times as much film, so they end up being huge and these were too big for the Signature 805. What we did for this model was we went back to the same construction but not series wound, and slightly polyprop thinner film but still double metalised. Which gave it the same improvement.

The other area is the sound of resistors. In the 801/802 we used Vishay thick film resistors clamped onto heatsinks but we've now found some better sounding resistors called Caddock from America. Which are even smaller.

Steve. The Vishays themselves are non inductive so they're a huge step up from the normal wire wound things, so a bit like we moved the frequency response of the tweeter up with the silver we also think that the inductance of resistors has a bearing on the bandwidth and perceived sound quality.

JK. Why should resistors make a difference?

John. It's possible that because you have inductive values in a resistor this could interact with capacitance here and there and cause ringing, if you think about what difference it can make if there is inductance in a resistor it's got to be that it interacts with something else. It's not high enough to really roll off the top end.

Tom. It will roll the extreme top end off. It's like capacitors we listen to them and we choose the best ones but with traditional measurement techniques there's no way of knowing why. There's no response difference, there's no distortion difference and the difference in losses can't be measured either. But when it comes down it we don't know why these differences exist on a technical level but on an empirical level it's easy to distinguish differences. What's really bizarre is that depending on what point the capacitor is in the crossover different designs work better than others, there is no universal cap that sounds best in all applications, the same goes for resistors.

JK. Has this inspired you (Peter) to try and find a way of measuring what's going on here?

Peter. No. The instruments that exist don't go down low enough in terms of distortion and I don't think it's a distortion thing anyway. I personally think it's an energy storage effect giving the signal out at the wrong time, it can be 90dB down but the fact that it's coming out at the wrong time is what we're picking up.

Tom. Another theory is that it's to do with compression. With transients caps have to absorb a lot of energy which heats them up and using components with more film in means they can cope with the energy more easily.

John. We generally feel that the lower the losses the better a component will sound, because it's storing less energy. But by listening to lots of caps we've found that in some cases a lossier polyester cap will sound better than a polyprop because the position in the crossover is also critical.

JK. So a big crossover must take ages to get right?

Tom. Steve and I spent maybe a year listening to caps and resistors for the Signature 800.

John. The other factor is microphony. With the static charges between the films in a capacitor where the film is incredibly thin there's going to be enough force in the electrostatic charge to move them.

JK. It has been suggested by your competitors that Kevlar is less than impressive in terms of stiffness to weight.

Peter. Of course it is, that's the way it works, they don't understand it. If you put too much goo on it you make it just like a rigid thing that rings like a bell, you have to have exactly right amount of goo on it so that it breaks up in exactly the right way so that the outer regions cancel out. You've got it exactly right otherwise it doesn't work.

Tom. Kevlar has high internal damping, unlike say carbon fibre which is stiffer and lighter but less damped and it doesn't work well for us.

Peter. Once you get the doping precisely right you have a break up pattern that is beneficial to the end result, a matter of knowing how to get the desired result out of the material.

Tom. Getting back to the 805s, we've also changed the bullet (in the mid/bass cone) material from plastic to metal. And it sounds better. It improves the linearity of the driver in a similar way to the copper on the pole piece only outside the pole. Being a big lump of

▶ aluminium the new bullet is (slightly) conductive and it linearises the inductance and keeps it constant in and out. Steel has a modifying effect on the magnetic gap and copper has too much effect but aluminium seems to be just about right, it's mechanically stronger and deader.

DH. I should point out that we can't supply replacement bullets to existing 800 series owners.

JK. Why did you choose to Signature the 805 rather than any other model in the range?

Tom. It started in Japan, they wanted a better looking bookshelf.

John. They didn't want the Signature sound they just wanted the Signature look, high gloss everything, but we don't do that. I'd hoped that we'd eventually convert the whole range to Signature status.

DH. That's not going to happen, absolutely not, there will be no other Signature models.

JK. So you'll incorporate these upgrades into the next 800 series if and when that is produced?

DH. Yes, a long way off in the unseen future we anticipate using these advances along with other currently secret ones in an as yet unplanned range.

JK. What are you doing at the moment?

DH. We're working on subwoofers, 800 series product to go with speakers like the 805 and the rest of the range.

JK. Is there going to be a Signature sub?

DH. I don't know?

Tom. I think someone wants one, the Americans.

DH. The purpose of these Signature products is our 35th anniversary.

Steve. That was last year!

DH. Yeah, we started last year.

John. At the Tokyo show every single person I spoke to asked when are you going to do a Signature 804.

DH. And the answer's never.

JK. Have you ever considered using samarium cobalt as a tweeter magnet?

John. No we jumped straight to neodymium, I think Neodymium is better, any magnet that is an electrical conductor should in theory be lower distortion than one that isn't. That's why alnico is a good material.

JK. Do you have any plans for supertweeter?

Peter. We have plans to extend the range of our existing tweeter, we believe in existing tweeters going high not putting supertweeters on we think that's a basket of worms.

Tom. Not a mere can of worms, a can's too small!

John. We feel that a crossover at 10 or 15kHz is absolutely not the thing to do.

Steve. Also a lot of so-called supertweeters don't have the range of our existing tweeter

John. It's very important to cover the region of 3kHz right up to as far as it goes with just one unit. It's entirely possible to do.

Tom. You can't get two units close enough to crossover at 15kHz or 20kHz without introducing distortion, and you've got another load of crossover components.

Peter. There are lots of good reasons for making your existing tweeter go as high as possible and lots of bad reasons for adding a separate supertweeter.

John. A poor supertweeter is going to sound worse than nothing at all.

JK. Is Beryllium a good tweeter material?

Peter. Yes.

JK. Would you use it

Tom. We've had a play with it.

John. Beryllium's hard to get, they're shipping it all to Iraq!

Peter. We've recently got some Klippel measurement tools which separates the causes of distortion into their different causes, one of which is suspension linearity, another is the inductance and the third is the magnetic linearity, you can separate them out and find which is the most important part. We can now well precisely tell the effect of things like copper plating the pole piece. You can see the actual curve of how things change as the cone goes in and out.

Tom. With the bullet, before we'd tried aluminium and thought it sounds better, but not until we put it through the Klippel test did we realise it gave the flattest inductance response of all the alternatives we'd tried.

Peter. Changing inductance as the voice coil moves in and out causes distortion and makes the HF roll-off, so if you get rid of it you get rid of the distortion and the roll-off which is a major improvement.

Steve. You also get less compression because you get more sensitivity.





B&W Nautilus Signature 805 loudspeakers

by Jason Kennedy

Bowers and Wilkins' Nautilus speaker project (otherwise known as The Snail) was largely the work of one engineer, Lawrence Dickie, and the indulgence of the then owner of the company Robert Trunz. At the time it must have seemed like tremendous folly but in retrospect the Nautilus has proved extremely useful to the brand regardless of how many pairs were actually sold. The inverse horn or tapering tube technology that Dickie developed has filtered down to B&W's entry level range while the profile raising that the Nautilus's dramatic appearance brought to the company must have been worth the cost of five years of research and development alone.

Dickie has now left the company in search of speaker systems with even greater fire power, I believe PA specialist Turbosound is now utilising his talents, but his legacy lives on at B&W's Steyning research labs. I went down to talk to the guys there about the work that has gone into the Signature version of the most diminutive Nautilus model the 805, and you can read what they said in the accompanying interview.

Prior to the S805 the Signature process was most recently applied to the company's current flagship the Nautilus 800, indeed the first version of that model was the Signature 800, the regular N800 following almost immediately. But the difference between regular and Signature 800 is solely one of finish. The difference between plain and Signature 805 is far greater, and whilst a shinier finish is all that Japan,

the main market for this model, really wanted, the guys at Steyning managed to use this particular project as a vehicle for all their new discoveries. What the S805 represents is the step between the original N800 series and its successor, as and when that appears.

The transformation produced by the various changes to both drive units and crossover have made quite a significant impact on the sound of this loudspeaker. B&W has no plans to offer Signature versions of any of its other N800 series models, which is a great pity as a Signature 802 is an extremely appealing idea. I pick the 802 because in most domestic environments it is, for my money, the best of the N800s. The 801 offers deeper bass but has a balance that suits larger rooms and recording studios but not many homes. I lived with the 802s for six months or so around the time of their launch and found the experience a highly gratifying one. I've not used many alternatives that offer the degree of power, transparency and neutrality of that design, and the notion of increasing its resolution in the fashion of the Signature 805 has tremendous allure. But B&W is not the country's

biggest loudspeaker maker for nothing, and it's not for me to suggest how best to make a profitable range of products.

But to really get a handle on what's been going on let's start first with the standard Nautilus 805, a heavily engineered standmount

which incorporates only the high frequency driver and tapered tube from its more ambitious siblings.

Because the Kevlar mid/bass driver has to cover such a relatively wide band it doesn't have the vanishingly slim foam surround of the Nautilus mid-range driver but a more conventional rolled rubber

suspension to allow greater driver excursion. It's a fairly compact design with a beautiful curved cabinet that is devoid of parallel surfaces inside and out so standing waves should not be a problem inside the box. The curves also make it inherently stiff, a state of affairs further enhanced by the Matrix structure inside. The mid/bass section is reflex loaded with one of B&W's trademark anti-turbulence golf ball dimpled ports. The twin terminals are chunky WBT affairs that are supplied with bridging cables though these were not used. I also eschewed the aesthetically matching stands in favour of a stone design made by HNE

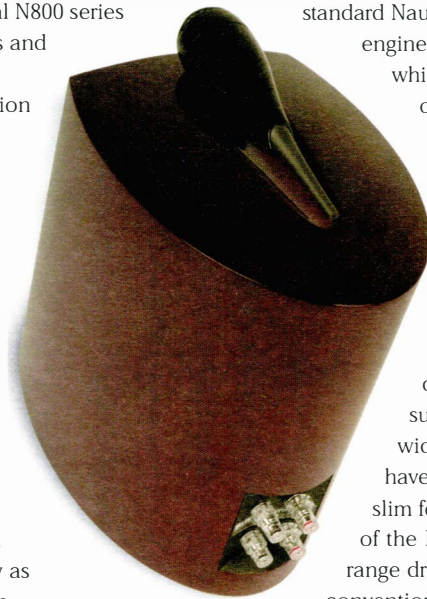

specifically for this speaker. To get the best from this speaker it pays to remove not only the main grille but also the mesh tweeter cover which is magnetically attached.

The last time I had this speaker at home it came fairly hot on the heels of the aforementioned 802, which was not the right order to hear these speakers in.

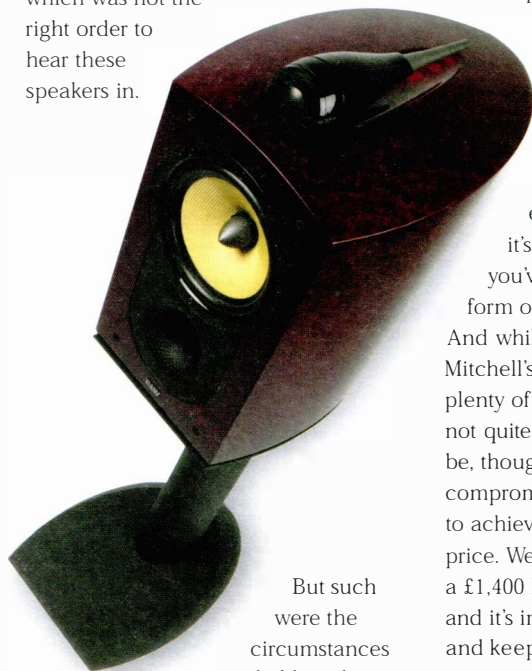

But such were the circumstances and although it made a good impression the result was certainly overshadowed by the remarkable capabilities of its big brother. This time around it followed the less ambitious but still substantially bigger Focal-JMLab Electra 926 into the room and suffered rather less as a consequence. It clearly didn't compete in terms of bandwidth or dynamics but when it came to resolution in the mid and top the step down was not so dramatic. In fact I found a lot to enjoy in the standard N805, it has a good grip on timing, and you can throw just about anything at it and it remains coherent and engaging. A current favourite is Captain Beefheart's *Lick My Decals Off Baby*, the title alone is entertainment enough but the music is probably amongst his best as well. Rhythmically dense and

difficult to enjoy with components that mess up leading edges, something that cannot be said of the N805 which takes its musical invention and lets it gel into a cogent whole that's delightfully entertaining.

They are highly sensitive to the scale and acoustic of the material, revealing differences between recordings with ease and making good use of reverb both natural and artificial. They could perhaps have a bit more sparkle and life, some tracks don't seem as energetic as they might but it's hard to be sure that what you've heard before wasn't some form of distortion however euphonic. And while voices such as Joni Mitchell's on the *Mingus* LP have plenty of presence and scale it is not quite as focused as it could be, though you'd have to make compromises in other areas to achieve as much at this price. We are talking about a £1,400 loudspeaker here and it's important to try and keep things in context, the design choices are always going to be limited and the fact that the N805 doesn't leave you wondering where detail has gone is a tribute to its design.

It is in fact very transparent and makes no bones about revealing the shortcomings of hard- and software alike, Him's *Out There* revealing decent energy levels alongside rather frazzled highs on vinyl - I fear that the Grasshopper needs attention - not even high end cartridges last forever it seems! They're fussy about cable too, preferring an unbalanced Living Voice Potato Wire connection between pre and power to an old Deltec balanced

lead. They encourage you to turn up the volume too but this is mostly to try and release dynamic energy rather than their having a better balance sound at high levels. In fact they sound best at medium and moderate levels, which is not the case with the 802 for instance which sounds a lot better at full tilt. The 805 is clean and quick on its feet with good low level resolution and no obvious coloration, it's capable of producing plenty of air and acoustic space if not the low frequency foundation to go with it and it really appreciates a high resolution drive.

Moving over to the Signature 805 is a bit like going from 400 to 100 ASA film,



it's the same picture but there is far less grain - you get a smoother, richer and more solid sound that makes the more affordable speaker sound like its smoothing over the fine detail of the music. The effect is to make the N805 seem more focused and clean but in fact it's a softer focus, and you can't hear the nuances that make up the signal. The Sigs peel away a layer of the veil to reveal a richer sound with deep, vibrant tonal colour, precisely exposed transients and remarkable levels of detail. It's almost a shinier sound such is the extra vibrancy.

Even less sophisticated recordings reveal new layers of detail as a result, I'm thinking of Eminem's *Marshall Mathers* LP unfortunately not actually on LP but pretty fast and fluent nonetheless. Here the Sigs' ability to stop and

▶ start with alacrity means that more of the profane but occasionally insightful lyrics can be appreciated, and the wacky sound effects come through in full effect. Oddly enough it sounds less aggressive through the Sigs, which is probably another facet of the relative increase in resolution. Well made recordings with acoustic instruments offer up further riches, the attack and decay of the guitar notes on John Fahey's *Let Go* sitting right there between the speakers as if they were real, exposing the shifts of light and dark within the music, this really is a superb piece of music and it's a crime that it's so hard to find on vinyl.

Joni Mitchell's mid seventies voice though no match for its purity in her *Blue* period makes up for it with more character, the superb 'Drycleaner from Des Moines' (from *Mingus*) tripping along with a spring in its step, full of pizzazz and a gorgeous soprano sax from Wayne Shorter. Massive Attack's 'Inertia Creeps' was one of the few tracks that had me pining for a bigger speaker, the bass weight and dynamics being not quite as powerful as they can be. They go deep though, I don't think it's a room mode but you can get some surprisingly low stuff out of the S805, I hadn't noticed Lambchop's Karl Wagner tapping a slow, heavy foot on 'Flick' from *Is A Woman* before. It sounds like he's sitting on a stage or a suspended wooden floor.

The Sigs are even more fussy about your ancillaries than the Nautilus, and I found CDs rarely shone the way

that vinyl did. This is not least because my turntable is a lot more ambitious than the Sony SACD and Eikos CD players I have. It would have been nice to have been able to hang onto Max Townshend's nytro powered Pioneer DV-747A long enough to use it with these. Not only does it play a remarkable CD but it lets DVD-A and SACD fly as well. And when you've got high res software you actually want to listen to but no decent player life can be tough!

But I had fun with CD through the B&Ws nonetheless, they picked out the best track on EST's new *Strange Place For Snow* while I wasn't really listening and made

me pay attention.

Peace Orchestra's

Reset is not as good as the original but it has some entertaining moments, namely the lovely squelchy bass on 'Marakesch' which reveals that a speaker doesn't

have to plumb the depths to make satisfyingly grunty, round bass notes that will keep even a basshead happy. A more audiophile SACD recording on the Red Rose label is Mark Levinson and his sister in law, him 'playing' various gongs and her reciting the '23rd Psalm'. This reveals some of the grit and earthiness that the N805 smoothes over, the voice is rich and soft with a touch of nerves while the attack and prolonged decay of the bronzeware shimmers off into the distance. You certainly appreciate the extended high frequency response of this model when something which is rich in harmonics comes along.

Fortunately all this transparency

makes the music more interesting as well as making it aesthetically pleasing, the small things really do count in music just as in life and a small loudspeaker when its executed with this much attention to detail does a very good job of making that clear. I haven't heard a more complete or revealing standmount and I suspect it'll be a while before I do. The Signature 805 is a lot more than a shiny Nautilus, it's a landmark product in its own right.

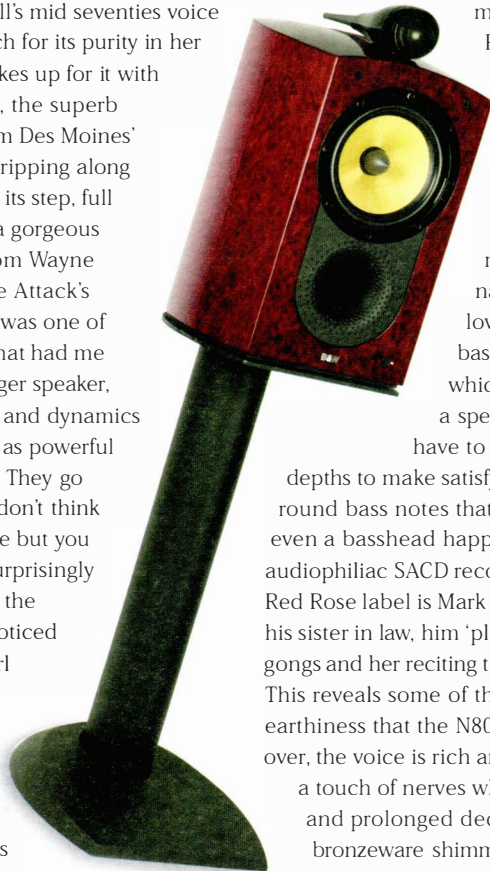

TECHNICAL SPECIFICATIONS

N805/S805

Single figure indicates the same for both models

Type: 2-way vented-box system

Dimensions (WxHxD): 238x 415x344mm

Net Weight: N805/S805 9kg/9.5kg

Freq. Range N805: -6dB at 42Hz and 30kHz

-3dB at 49Hz and 22kHz

Freq. Range S805: -6dB at 42Hz and 50kHz

-3dB at 49Hz and 42kHz

Sensitivity: 88dB SPL (2.83V 1m)

Nominal Impedance: 8 ohms

(minimum 4.6 ohms)

Power Handling: 50 - 120W into 8 ohms

Tweeter: 25mm metal dome

Woofer: 165mm woven

Kevlar® cone

Finish N805/S805 black ash, cherrywood,

red stained cherrywood/

grey or red tiger's eye

(all real wood veneer)

Crossover Frequency N805/S805:

3kHz/4kHz

Price N805/S805 £1,400/£2,250

Manufacturer:

B&W Loudspeakers

TEL. (44)(0)1903 750750

www.bwspeakers.com

**NOW, FOR THE FIRST TIME,
HEAR SOUND REPRODUCED AS IT WAS MEANT TO BE**

VINYL IMPERATIVE

Correct alignment and support of the LP on the platter is the most important aspect of vinyl reproduction.

The new *Anniversary Ringmat*, at £70, is THE pre-eminent record mat for virtually all turntables.

Further improvements can then be achieved by using:

- *LP Blue Statmat* and *Statcap*, at £45, to remove static;
- *Ringcap MkII*, at £15, to remove vibrations emanating from the centre of the record;
- *Ringmat Spacers* to provide an improved interface between platter and record, to remove resonance from your turntable and platter and to fine tune stylus rake angle/VTA.

All these can also be purchased in one fell swoop as the *Ringmat Support System* for £210.

DRAMATICALLY IMPROVE YOUR CD, SACD and DVD SOUND

For digital sources, the *CDi Blue Statmat*, at £37.50, will totally transform playback.

**FROM ILLUSION TO REALITY WITH RINGMAT AUDIOPHILE CABLES
SIMPLY, THE FINEST CABLES FOR LINKING-UP YOUR HI-FI SYSTEM**

Our *Pure Signal Interconnects* from £105 per stereo pair and *Pure Power Speaker Cable* from £25 per mono metre are the finest, most affordable cables available to you.

"So dropping them straight in... immediately after the Valhallas probably wasn't the kindest thing I could have done! Surprisingly, the Ringmat leads stood up remarkably well, which speaks volumes for their musical balance, evenness and coherence. ... and that's quite a feat when you consider the extent to which the Valhallas embarrass the vast majority of even the most expensive competition."

Roy Gregory *HI-FI+* Issue 19 Sept-Oct 2002

PLUS, THE BEST ISOLATION PRODUCTS AVAILABLE

Protect all your equipment, including your TV and speakers, from static, by using a *Statfoot*, from £10, underneath each one. *Ringmat Feet* and/or *Ringmat Domes*, our isolation "soft feet" approach from £17.45, must also be used if you want the best sound (and picture).

NEW PRODUCT LINE-UP, PRICE LIST and MONEY-BACK GUARANTEE

Call us for details or visit our Website: www.ringmat.com.

RINGMAT DEVELOPMENTS

PO Box 200 Brentwood Essex CM15 9FB GB

Call: 01277 200 210 Visit: www.ringmat.com or Email: enqhf+@ringmat.com

SEE YOU AT THE MANCHESTER HI-FI SHOW 16 - 17 NOVEMBER

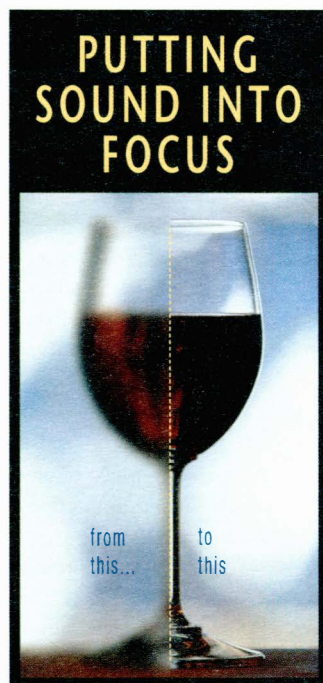

RINGMAT

high-end audio tamed

stoneaudio



hi-fi



home cinema



multi-room



www.stoneaudio.co.uk
order on-line or call 0845 126 0500

Avantgarde horns for the masses



Introducing the new Avantgarde Solo loudspeaker. True Avantgarde performance in a small affordable package. Price from £3350 a pair.

Distributors for: Allaerts MC Cartridges, Avantgarde Acoustic, DPS turntable, Garrott Brothers cartridges, Lindemann, LYS, Ocellia loudspeakers, Relaxa, PHY-HP, Schroder tonearms, TRON, J.C. Verdier.

G T AUDIO

5 Upper Road, Higher Denham, Buckinghamshire, England. UB9 5EJ
Telephone: 01895 833099 email: sales@gtaudio.com

www.gtaudio.com

definitive audio

CANARY AUDIO



CA608-LV
Integrated Amplifier
Hi-Fi Plus *Editor's Choice*
Hi-Fi Plus *Product of the Year*

The results are simply astonishing. The majestic sense of graceful power belies the modest rated output, bringing drive and purpose to music on demand and a palpable delicacy where required. The presence and substance of the music is independent of level, and for once the images and soundstage are consistent through dynamic shifts. ...The CA608 might start life as the baby in the Canary range, but get it modified and you turn it from a domestic pussy cat into a Bengal Tiger!

Roy Gregory

LIVING VOICE



Auditorium Avatar
Hi-Fi Plus *Editor's Choice*
Hi-Fi Plus *Product of the Year*
Hi-Fi Choice *Editor's Choice*

"The Avatar is a near perfect balance of size, bandwidth, efficiency and tonal refinement. Its slim lines and small footprint deliver a genuine 94db sensitivity, and excel when it comes to delivering the scale, vibrance and colour of the music. Its unobtrusive quality allows it to cut straight to the heart of a performance, unlocking the music trapped in the recording, whilst its refinement makes it equally at home with both basic and surprisingly expensive amplification."

Roy Gregory

Tel 0115 973 3222 Fax 0115 973 3666

internet: www.definitiveaudio.co.uk email: shout@definitiveaudio.co.uk
Living Voice · Vitavox · Electrofluidics · Art Audio · Border Patrol
Canary · DNM · Sugden · Wavac · Lyra · Monarchy · Western Electric
Wadia · Michell · Stax · Tom Evans · Nottingham Analogue · EMT
Kuzma · Resolution · Benz Micro · Tri-planar · SME · Van den Hul



conrad-johnson

volume

ph aux tuner cd video aux2

source epl theater

mute

25 25

standby

conrad-johnson PV14L Line-stage and MV60-SE Power Amplifier

by Roy Gregory

No lesser person than Harry Pearson said recently that conrad-johnson had never built an unmusical product. He was lamenting a growing trend within the US high-end towards a sterile, high-definition sound, long on information and very short on soul. Whether recent events in Fairfax, Virginia are a reaction to that state of affairs or pressure from UK importer Audiofreaks, I couldn't possibly comment but c-j have seen fit to revise the excellent PV14L whilst at the same time ringing the changes on the recently introduced and highly regarded MV60. And whilst the changes are relatively minor (other than a switch from EL34 to 6550C output tubes in the MV60) I'm glad to report that they are wholly beneficial and extremely musical.

The PV14L is a relatively slim (it does contain valves!) remote control, zero-feedback line-stage. Also available is a matching EV1 vacuum tube phono-stage, offering 49dB of gain that makes it compatible with moving-magnet and the more energetic moving-coil cartridges (you can read about it in Issue 12). Just don't expect to use a low-output Ortofon. These are thoroughly modern designs. Those of you expecting cranky operation, fluctuating performance and constant tweaking can think again. The PV14L requires no such alchemical procedures or consideration. In fact, the only glitch in an otherwise faultless performance was caused by my inability to read the instruction manual. Although the power LED comes straight on when you first power-up the unit, you need to cycle

through the standby mode to activate the outputs. Simply press the power button, the LED flashes for 90 seconds and then hey presto, you're up and running. It's a simple but very sensible precaution that prevents the unit passing any potentially damaging DC while its valves warm-up, and it sets the tone for what is a versatile and no-nonsense design.

The 14 offers a total of seven single-ended line-level inputs, including an External Processor (or tape) Loop and a Theatre

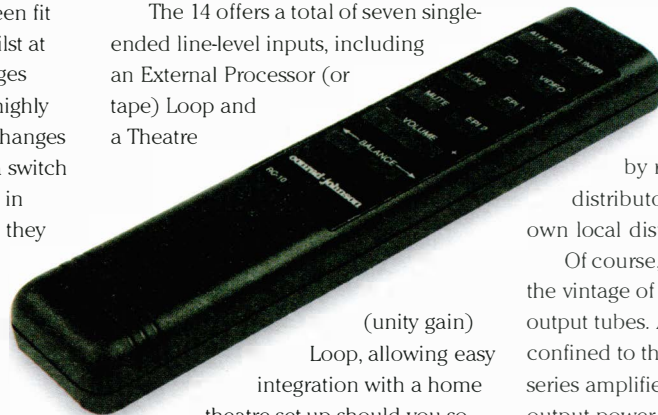

(unity gain) Loop, allowing easy integration with a home theatre set-up should you so desire. There is also, of course, a single pair of single-ended main outputs. Front panel push buttons allow you to select sources and volume or mute the unit, while decent sized LEDs allow you to keep track of the levels, across the 100 available 0.7dB steps. The small plastic remote control wand might not seem very impressive but it is clearly laid out and operates from a decent range of distances and angles, putting it way ahead of an awful lot of the heavyweight, hewn from solid competition. It also adds a simple and effective balance control to the range of facilities on offer.

All of which is identical to the original incarnation. The changes are all internal, amounting to a significant

increase in power supply capacitance. The circuit consists of a single gain stage that uses a 6C4 valve, linked to a DC coupled output stage that provides an output impedance of less than 200 Ohms. The gain stage provides 22dB and the unit is phase inverting, which means that most of you will have to reverse your speaker connections to restore absolute polarity. The designation of the PV14L remains unchanged, while original units can be updated for a small charge by returning them to UK distributor Audiofreaks (or your own local distributor).

Of course, it's rather easier to discern the vintage of an MV60: just look at the output tubes. Adopting 6550s, previously confined to the companies' Premier series amplifiers, offers an increase in output power, now rated at 65 Watts per channel. It also moves the design closer, at least conceptually, to the now discontinued Premier 11. Otherwise things are pretty much as before: the same ultra-linear output stage, the same option to internally reconfigure the valves for triode operation, the same user adjustable fixed-bias arrangement. Once again, there are small but significant changes in the power supply componentry associated with the revised bias voltage requirements, and its these along with the output tubes that define the SE model. These changes are essential for correct operation of the 6550 output tubes, so don't be tempted to try a straight substitution! I won't labour the amp's physical details as they can be found in the original review, ►

► back in Issue 16

I used the c-j combination in my US based system, to which c-j are just as local as Naim are to my UK address. Sources are the Wadia 861 and a VPI Aries Scout/Dynavector DV-20X combination, with phono amplification provided by a Tom Evans Audio Design Micro Groove or Musical Surroundings Phenomena.

Speakers are the two-way floorstanding Audioplan Koncepts, while the mains cabling and distribution comes from Russ Andrews. Interconnects and speaker cables are all Nordost Valhalla. Hook up was perfectly straight forward, and both units performed faultlessly from the word go.

What was immediately obvious was that both these products have improved significantly over their original versions. The combination now offers far greater overall transparency, a weightier, fuller balance and an even better sense of musical flow. The sound of the PV14L has gained resolution and focus whilst retaining its spatial, tonal and above all, musical virtues. Likewise, the MV60-SE still has the refinement and colour that made the original 60 so engaging, but adds significant weight and authority to the mix. There's a subtle loss of mid-range delicacy (an EL34 forte) but it pales into insignificance against the gains made at the frequency extremes. This is now a fulsome, entertaining and musically resolute set-up, whose performance has been lifted into quite another league.

That new sense of drive and purpose is most obvious on rock and pop music: the better the recording the greater the benefit. A track like 'Forest Fire'

(Lloyd Cole and The Commoions *Rattlesnakes* LCLP1) depends absolutely on the momentum provided by the combination of drum patterns and the mobility of the bass line. They build and combine into a series of ramped plateaux that underpin the building instrumental fills. But, just like a building, the extra structure and substance

need a firm foundation to offer any strength. The density and dynamic scale of the song might increase, but without authoritative low frequency pace and placement it will lack the power that can make it so compelling.

That the c-j amplification can do the necessary where so many systems fail is impressive enough, but what's really impressive is the way in which it achieves it in such an unobtrusive way, without disturbing or intruding on the more subtle shadings of musical

reproduction. With what might be described as more rhythmically explicit systems there's a tendency to push the track, forcing the pace and collapsing the soundstage. Cole's vocal steps forward and the band all pile in behind: But not on the c-j. There's no sense of congestion at all. The soundstage is wide and very deep, the drum kit situated right at the back, but most importantly of all, the vocal steps back slightly into

the same acoustic as the band. It's an impressive display of musical coherence, always a forte of the original MV60 but now extended and improved upon by the revised PV14L/MV60-SE combination.

As I said, it's an effect that's most obvious on rock and pop music, but once you've recognised it you'll discover both it and its importance to all musical forms. The Du Pre Elgar *Cello Concerto* (EMI ASD 655) suffers a similar tendency to over-

voicing the solo instrument, but the c-j combination manages to keep things beautifully in perspective. Du Pre is always separate and 'out-front' but once again her instrument is held within the overall soundstage, its relationship with the orchestral choirs behind it stable and consistent. It doesn't wander, swell or step forward with level; it doesn't get lost or submerged in crescendos. But what I really admire is the ability to combine the complex tonality and substance of the instrument with an innate sense of pace and weight that tracks the phrasing and deft changes of tempi in this most emotive of performances.

So large-scale recordings take on a new sense of breadth, stability and power, emerging from an expansive ►

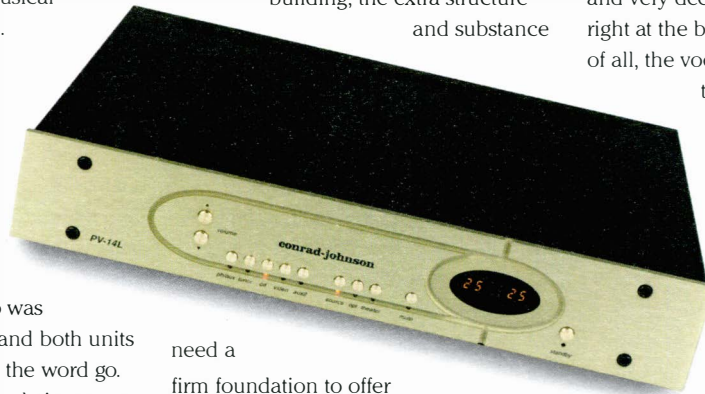

▶ soundstage that extends beyond the speakers and back, where appropriate, behind the rear wall of the listening room. And all this from a relatively modest vinyl front-end. Switching to smaller musical forces replayed on the Wadia brings home the increases in transparency, speed and resolution that are contributing to those big pictures. Playing *Charlie Byrd Live At Blues Alley* quickly shows just how immediate and intimate the conchie-ys can sound when called on to do. Completely un-phased by the complex rhythmic patterns woven by the accomplished trio on stage, they capture the chemistry of the live performance and the appreciation of the audience. For once the applause even stays in front of the performers. The eight and half minute exposition of 'Water To Drink' is a case in point. Byrd's strummed ripostes to his fast picked melodic riffs are full of direction and purpose, and even the extended solo interventions of brother Joe on Bass and Chuck Redd on drums never lose the distinctive rhythmic pattern of the deceptively simple opening theme. The end of that drum solo demonstrates the point perfectly as the guitar sounds a single note, rests for a couple of bars and then slips effortlessly into step with what you take to be the faltering final steps of the drum break. Suddenly you're shifted into a powerful restatement of the main theme, everything called back into line by the deft placement of that single note.

This is clean, uncluttered music from small acoustic forces; exactly the sort of thing that any system should thrive on. It's also three musicians who know each other playing at the top of their game in what's close to a home venue. That's exactly what you hear - the easy creative tension that comes with familiarity and confidence in each other's abilities. You can appreciate the space that the

musicians give each other, but most of all you can appreciate their artistry. You simply don't worry about the system because its faults and failings never

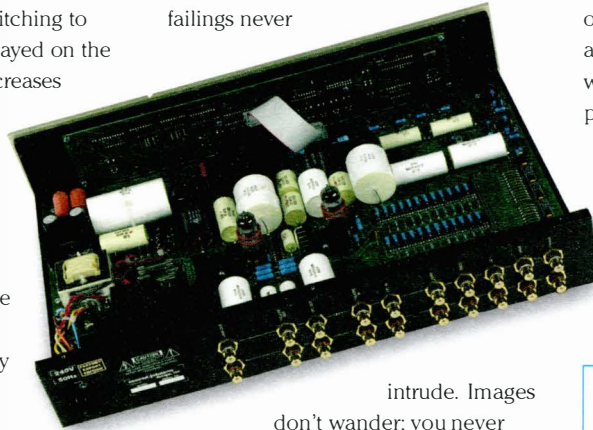

intrude. Images don't wander; you never have to grope for the pitch or placement of a note. And the perspective is uncannily convincing. The size of the instruments and their height off of the stage (especially the cymbals) on the Charlie Byrd disc is captured perfectly, adding significantly to the believable presence and intimacy of the performance. Use these amplifiers with a pair of speakers that don't bend the power envelope out of shape and you'll probably never hear the limitations unless you actively go looking for them. Such is their balance of virtues that if you simply use them to play music you should enjoy a long, extremely satisfying (and trouble free) relationship.

I first encountered the original PV14L in combination with the Premier 11A power amp. It was a superbly musical set-up, albeit one that would beguile listeners rather than blowing them away. The arrival of the MV60 moved the sound even further in that direction, imparting added delicacy and sweetness to proceedings, with a more natural and even less "impressive" presentation. It was a sound that would seduce the connoisseur but also one that was less than obvious in its considerable virtues. However, the recent revisions to these two units have changed all that. The increased focus, dynamic grip and authority at frequency

extremes have served to throw open the window onto the musical performance. Sacrificing none of the musical coherence and naturalness of the originals, these new c-j products extend and reinforce those virtues to the point where I'd expect the MV60-SE to outperform the Premier 11, which is praise indeed. Owners of original units should consider upgrading them at the earliest possible opportunity. Prospective purchasers should definitely seek them out. In combination they certainly underline HP's point. ➤

TECHNICAL SPECIFICATIONS

PV14L Line-stage

Type:	Vacuum tube, remote-control line-stage
Valve Complement:	2x 6C4
Gain:	22dB
Inputs:	5x line-level
Outputs:	1pr RCA phono
Loops:	1x EPL (Tape) 1x Theatre (Unity Gain)
Input impedance:	>39 Ohms
Output impedance:	<200 Ohms
Dimensions (WxHxD):	483x85x365mm
Weight:	6.8 kg
Finish:	Gold
Price:	£2200

MV60-SE Power Amplifier

Type:	Fixed bias, ultra-linear valve amplifier
Valve Complement:	2x 12AU7A, 2x 6SN7, 4x 6550C
Input Sensitivity:	0.8 V
Input Impedance:	100 Ohms
Output Power:	65 Watts into 4 Ohms (30Hz - 15kHz)
Dimensions (WxDxH):	17.6 x 7 x 13.25
Weight:	20kg
Finish:	Champagne gold with black metalwork
Price:	£2995

UK Distributor:

Audiofreaks
Tel. (44)(0)208 948 4153
Fax. (44)(0)208 948 4250
Net. www.audiofreaks.co.uk

Manufacturer:

conrad-johnson Inc.
Net. www.conradjohnson.com



6550E

BIAS

LEFT

BYP

V2

MODEL V-2000 HIGH DEFINITION

The Audio Research SP16 pre-amplifier and VS55 power amplifier

by Chris Binns

Autumn. Season of mist and mellow fruitfulness...and a time when it is something of an asset to be using valve amplifiers. During the summer, long listening sessions could become a little stifling with the heat of a dozen KT88's, but now seem like a welcome benefit as the colder evenings draw in. As it happened, I was saved from the trauma of moving 250 odd pounds of resident thermionic amplification by the arrival of the Audio research SP16 and VS55, which unlike most boxes that bear the ARC name were suspiciously easy to carry, but hey, this is supposed to be Audio Research on a budget. Budget? Somehow the words don't sit comfortably together, after all this is the company that along with distributor Absolute Sounds has played a major part in establishing the high end movement in this country. Apart from a brief (and relatively unsuccessful) foray into solid state electronics, Audio Research has always been inextricably linked with thermionic technology, which usually means big and heavy – hence my surprise at the weight of the two boxes in front of me, but of course the VS55 is physically the smallest power amplifier that the company have made. By their standards, fifty watts per channel might not seem like a massive amount when you make 200 Watt mono blocks, but these days it amounts to a pretty healthy output. The accompanying SP16 pre amp is not short on features either, being a fully fledged unit with a phono section.

The launch of any new product from Audio Research should be of interest, and the idea of some of that legendary performance on the cheap is a highly attractive one. But with a price tag close on to five thousand pounds for the pre

and power amp before you, I think the term budget is overstating the mark a bit. Lets settle for 'more affordable', as to date the majority of Audio Research gear has been out of reach for all but the lucky few. There are many landmark designs that mark the history of the company, and they must be credited for rejuvenating the interest in valves during the more bleak times when most people regarded tubes as redundant technology. The SP6, 8, 10 and 11 preamps along with the D79, 115 and 250 power amplifiers (to name but a few) have all achieved legendary status over the last two decades. That amounts to one hell of a heritage behind the latest products, particularly when you bear in mind that there are an awful lot of early ARC products out there that are still in daily use. The company will happily service any of their products and bring them back to original specification.

In the past Audio Research units have always had an unmistakable visual identity, instantly recognisable regardless of size or age. This combination is a little different. While the SP16 pre amp retains the distinctive brushed aluminium front panel, it is disconcerting not to see the machined knobs and curved handles that have been a familiar hallmark for so many years. Instead, there are two recessed panels one of which contains LED's for function and volume indication, the other a row of small press buttons similar to the CD player. The lack

of rotary controls is compensated by a full remote control system; somewhat easier to implement as the volume control and all switching is electronic. The handset, although small, is well laid out and surprisingly ergonomic, and covers all the functions available on the pre amp plus one extra – a mono switch, a feature that I find very useful. It also works over a reasonable range – one of my continual gripes about audio equipment is the number of

manufacturers who provide a remote, but require you to be standing directly in front of the machine to use it, thus negating the whole concept.

The SP16 is well equipped with input and output options, the four line

inputs are

complimented by two

independent cathode follower outputs, the low output impedance of these offers a degree of immunity to cable matching and loading with multiple power amplifiers. There is a tape output, but no dedicated input and thus no loop facility, but I should imagine that there are very few people still using three head tape machines these days. There is however a processor input that bypasses all front panel controls to allow use with an AV system.

Also available as a line only unit, the standard SP16 incorporates a phono stage that utilises three of the six selected ECC83 valves within the unit. Input sensitivity is specified at 1 millivolt. That means moving magnet or high output moving coil cartridges, both ▶

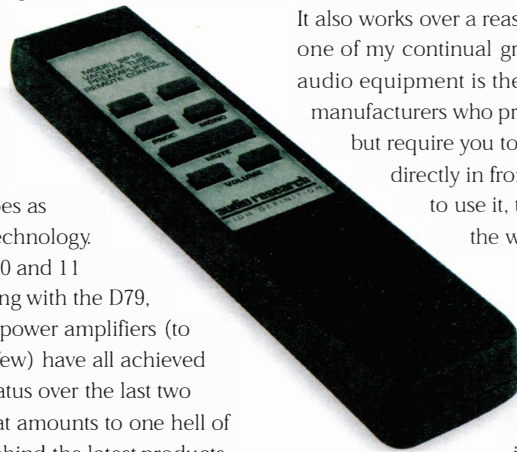

► of which seem to have limited appeal these days. Clearly the potential purchaser must decide how important vinyl replay is going to be, opting either for a high output cartridge (like the Cartridge Man's Music Maker or one of the Benz models) or a standalone phono stage. But, as is often the case, the paper specifications don't tell the whole story.



Internally, the SP16 is well made, constructed on a single substantial PCB with plenty of good quality components in evidence, while there are no less than eight regulated power supplies for the valves.

The VS55 represents a new look for Audio Research. Built on an open chassis (to date all of the companies amplifiers have been fully enclosed) visually it represents a classic, more traditional approach, with the transformers at the back, and the valves projecting up through a milled aluminium top plate. A pure valve design (not a hybrid as some ARC products have been) there are a total of four Electro-Harmonix 6550 output tubes complimented by three Svetlana 6N1P double triodes, a Russian valve along the lines of (an educated guess) an ECC88. While not the most visually adventurous of designs, its compactness gives it a certain amount of charm and it didn't take long for the household felines FB (that's fat bastard) and FBS

(fat bastard's sister...) to appreciate a new source of accessible warmth. With just a power switch on the front, the back panel connections comprise the phono inputs (balanced operation is not provided) 4 and 8 Ohm loudspeaker outputs via binding posts that favour spade connectors (they are not 4mm plug friendly) and a standard IEC mains input socket. Also located here is a set of sockets for bias measurement;

in conjunction with the pre – sets accessible through the top plate quiescent current adjustment is both simple and straightforward. Which if I am honest, was never an easy process with previous Audio Research designs, involving as it did a certain amount of foraging around inside amongst 450 Volts – certainly not a job to be attempted after going to the pub.

While the VS 55 might be somewhat scaled down, there are enough familiar features to the circuit to make it undeniably Audio Research. Each channel consists of a pair of 6550s operating in pentode mode, a configuration that the company has used for many years, but dispensed with in the VT series of amplifiers in favour of the more common ultra-linear connection. The screen supply is not regulated. A point of interest – I couldn't help noticing that the output transformers do have an unused tap for the screen grids, indicating that UL operation could

have been an option. In common with all other Audio research designs, the cathodes of the output valves are connected to the secondary of the output transformer (i.e. the loudspeaker), a configuration that can allow the valve to exert more grip particularly at low frequencies.

Substituting the SP16/VS55 combination straight into my system presented two potential problems – I doubted that the Helikon cartridge that I am using would have enough output at 0.5mV for the phono stage, and was worried that the VS 55 would run out of steam with my not so efficient loudspeakers.

While I could not pretend that it was an ideal combination, the pick up input was quiet enough to allow the use of medium output cartridges, and I managed to achieve respectable levels with the system as it was, certainly enough to establish that its performance was equal to the rest of the pre-amp. As for driving the loudspeakers, the VS 55 showed a surprising amount of grunt for fifty watts

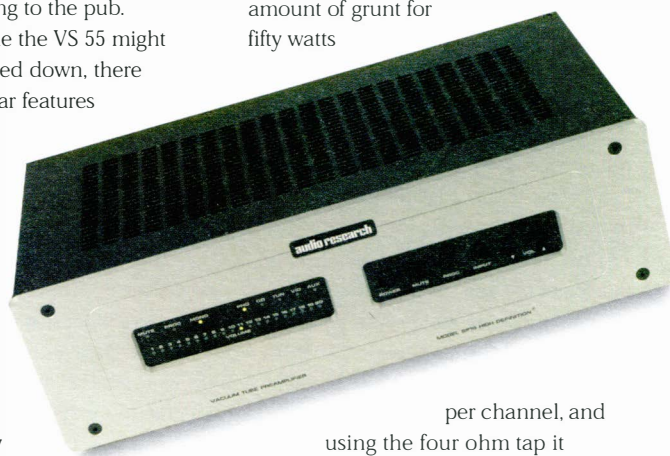

per channel, and using the four ohm tap it sounded very much at home under all but the most excessive of conditions. To wit, it reminded me very much of the older D70 and 115 amplifiers that I owned; there is a boldness to the presentation that gives an air of authority when reproducing music.

As a combination, the two units never failed to produce an enjoyable sound. Concentrating more on ►

► musical flow rather than fine detail, the effect was more pronounced via the phono input where results were perhaps a bit lush, too much of what people think of as the 'old fashioned' valve sound. But then the cartridge was hardly an ideal match.

Via the CD input, I got much more of an idea of what the SP16 / VS55 was capable of. Underpinned by an impressive amount of rhythmic drive – always a forte of earlier ARC amps – the soundstage was big and wide, and what it lacked in precision was made up for in sheer enthusiasm. "Refined but not stuffy; a nicely formed balance between accurate portrayal of colour and texture without stifling the music" is one of the things I wrote down after a prolonged listening session. While the top end was smooth and detailed, there was a hint of 'glassiness' that would manifest itself as a slightly edgy



quality on vocals and occasional strings, irrespective of volume. Experimentation showed it to be more a character trait of the pre-amp than system mismatching, and quite possibly some different cables would disguise the effect. I also felt that the volume control was a bit coarse at lower levels, making precise adjustment difficult, but on the positive

side channel balance was excellent all the way through.

A lot of the Audio Research's success comes down to disguising its shortcomings.

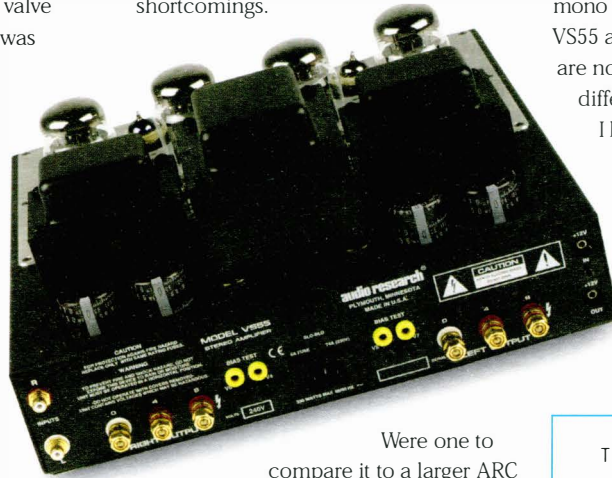

Were one to compare it to a larger ARC system, I think you would notice that the smaller amplifier could not achieve the bandwidth that some monster amps are capable of, but listening to it in isolation you would never guess, as the VS55 in particular doesn't try to do what it can't. Rather than wasting energy on trying to reach the lowest depths of the bass register, it just provides loads of impact at a point where it

matters, and for that reason

I can see it as being an ideal partner for many smaller loud-speaker designs.

In many ways the SP16 / VS55 combination is a great success, as it certainly does what the manufacturers intended by offering classic Audio Research performance at a more affordable price. The validity of the phono stage is academic as there is the line stage version available for £500 less. But don't ignore the internal option if your cartridge possesses a healthy output; it's capable of exceptionally musical results.

However, the problem facing these units is the considerable amount of competition in the market place. For example a pair of Rogue Audio M120 mono blocks cost a little less than the VS55 and are twice as powerful. But they are not Audio Research, and are quite different in the way they sound.

I have, with very few exceptions, always liked the sheer authority and musical flow of the ARC sound. The SP16 and VS55 continue that tradition, and represent the cheapest way of achieving it: exactly as intended. ➤

TECHNICAL SPECIFICATIONS

SP16 pre-amplifier

Line inputs: -

Sensitivity: Not stated

Impedance: 50K Ohms

Phono input: -

Sensitivity: 1 mV

Input Impedance: 47 K Ohms

Rated output: 2 V

Valve compliment: 6 x ECC83 / 12AX7EH

Dimensions (WxHxD): 17.75 x 5.2 x 10 inches

Weight: 12.6 lbs

Price: £2,499

LS55 power amplifier

Input sensitivity: 1.1 Volts for rated output

Input impedance: 100 k Ohms

Power output: 50 Watts per channel

Frequency response: 1Hz – 60 KHz

(-3dB points @1 Watt)

Valve compliment: 4 x 6550 3 x 6N1P

Dimensions (WxHxD): 14 x 7 x 14 inches

Weight: 32 lbs

Price: £2,699

UK Distributor:

Absolute Sounds

Tel. (44)(0)208 971 3909

E-mail. (44)(0)208 879 7962

Net. www.absolutesounds.com

Manufacturer:

Audio Research Corporation

Net. www.audioresearch.com



Reference Audio

An honest high quality range of loudspeakers available in any finish.

- True Hard Wired Crossover
- Full Frequency Spectrum
- High Quality WBT Connectors

The Loudspeaker Manufacturing Company Ltd.
 181 Robin Hood Lane, Chatham
 Kent. ME5 9NJ
 Tel: 01474 854208
 Fax: 01474 854902
www.referenceaudio.co.uk

your perfect partner

WA WILMSLOW AUDIO

Loudspeaker specialists for almost 40 years

- Range of replacement drive units from Vifa-Scanspeak, Peerless, Morel etc, for use in AR, Gale, Heybrook, IMF, KEF, Mission, ProAc, Rogers, TDL plus many others.
- Comprehensive stock of components, capacitors (Ansar, SCR & Hovland), QED cable, damping and grille materials.
- UK's largest supplier of kit loudspeakers - all on demonstration

Phone today for your **FREE** catalogue or check out our Website.

WILMSLOW AUDIO
 50 Main Street, Broughton Astley, Leicester
 Tel: 01455 286603 Fax: 01455 286605
 Website: www.wilmslow-audio.co.uk



Russ Andrews
 Mail Order Cables & Accessories

FREE UK DELIVERY



FREE catalogue!

Don't buy new equipment! What you have is much better than you think! Our NEW catalogue will show you how to release the full potential of your system.

For your free copy just call UK FREEPHONE
0800 373467
 and quote AP112

FREE info downloads at: www.russandrews.com
 Russ Andrews Accessories Ltd., FREEPOST NWW881A, KENDAL LA8 9ZA
 Tel: 00 44 1539 825500 Fax: 00 44 1539 825540
 E-mail: AP112@russandrews.com

Infidelity

INDECENTLY GOOD HI-FI

Buying hi-fi should be a delight.

If choosing your new hi-fi in a civilised and relaxed atmosphere from a well-chosen selection of genuine performance equipment appeals, then we are for you. Bring along your own records or CDs, we'll provide the coffee, and hear the difference we can make.

9 High Street, Hampton Wick,
 Kingston upon Thames, Surrey KT1 4DA
Telephone: 0208-943 3530

Open: Tues - Fri 10.30am - 7pm
 Saturday 10am - 6pm.



Enjoy music more

*Renaissance
Amplification*



**METRONOME
TECHNOLOGIE**



L A M M

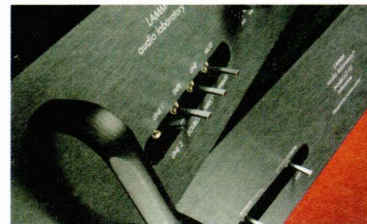

High End Audio Roadshow

A series of demonstrations in comfortable venues throughout the UK.

Convincing musical re-performances by PLAYBACK systems featuring Lamm, Metronome Technologie, Reference Audio, Renaissance Amplification and other PLAYBACK partnership recommended components.

November 23rd and 24th - Holiday Inn, High Wycombe (junction 4, M40)

December 7th and 8th - Hilton, Warwick (junction 15, M40)

Free admission to all music lovers. For full information please contact:

Integrated Engineering Solutions Ltd - 023 8090 5020 audio solutions - 07787 543031

Audiocraft - 01895 253340 Hazlemere Audio - 01494 865829

www.highendaudio.co.uk

High Performance Audio Systems.

Bel Canto

Es Lab

dCS

Audio Note

Pink Triangle

Spectral

JM Labs

SME

Verity Audio

Accuphase

Lavardin

Siltech

Quad

Metronome



Metronome
CD player

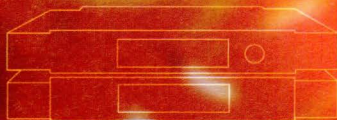

Kevin Galloway
AUDIO

t (01563)_574185
e info@kevingallowayaudio.co.uk
w www.kevingallowayaudio.co.uk

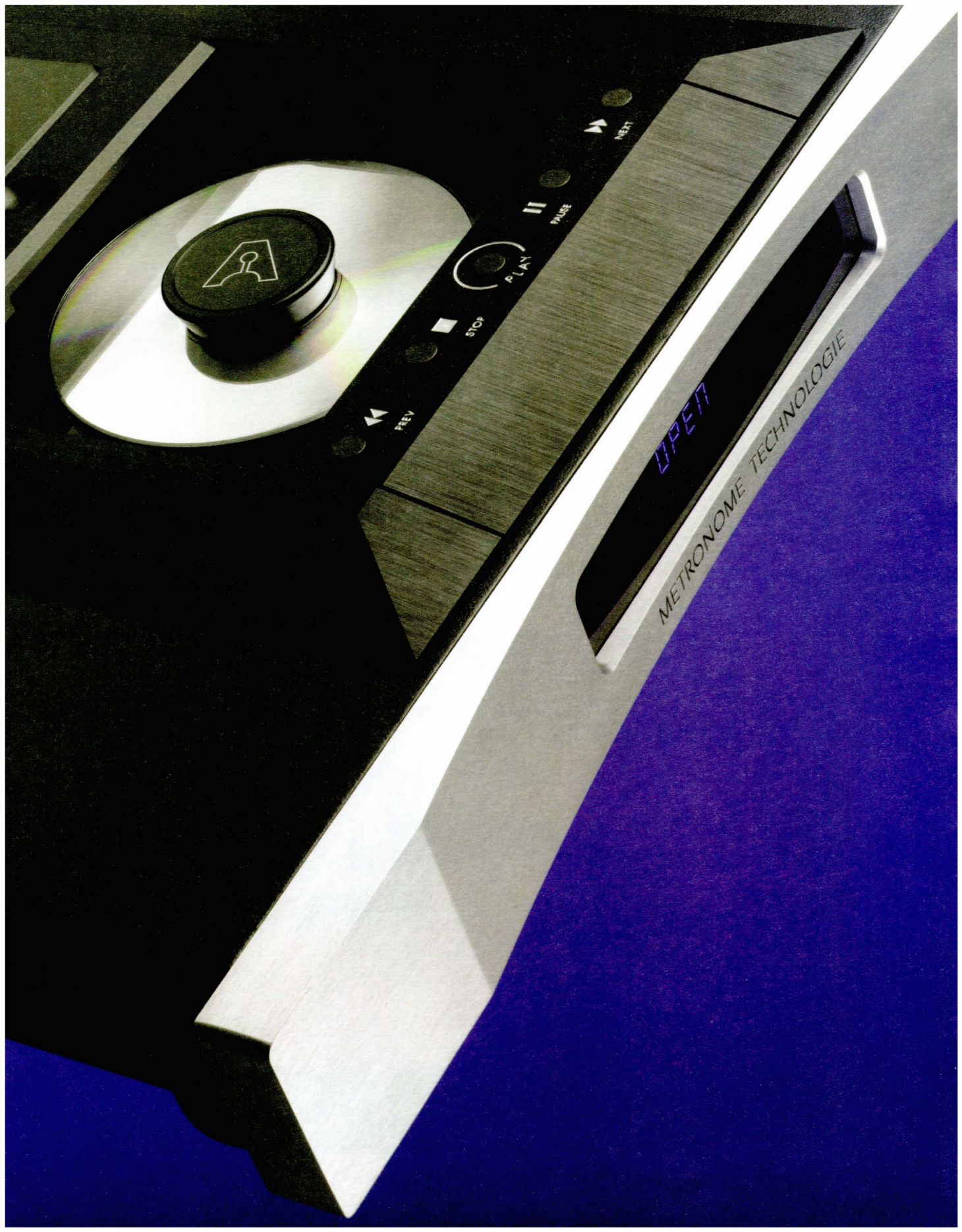

0:07
METRONOME TECHNOLOGIE

Metronome T1-i Compact Disc player

by Chris Thomas

French manufacturer Metronome are a new name to the UK audio market and if you have heard of them it is likely to be because you have seen a picture of their striking CD transport, the extravagantly designed Perspex and metal Kalista. But, as a prelude to the imminent arrival of this intriguing piece of audio art I have spent the last six weeks or so living with Metronome's less flamboyant model, the T1-i. This is a slimline 2-box integrated CD player with a separate power supply that is based around the Phillips CDM 12 Pro transport mechanism. I like top-loaders a little more every time I use a front tray-loading machine. Because, unless it is done really well, like on an Accuphase or Mark Levinson, where the budget allows the manufacturer the chance to engineer it properly, the cheapo flimsy plastic trays that come rattling out of most machines are often both horrible to use and, being adjacent to the motor unit, another potentially resonant part of the design that the top loader is immune from.

The only potential downside being access, which means that you need to site it on the top of a rack. This Metronome conceals its transport behind a beautifully engineered metal sliding door mechanism that would have been so easy to get wrong. But here it is spectacularly right, being substantial yet satisfyingly smooth to use as it glides its way along damped rollers before clicking shut and allowing the disc to be read. The transport buttons too have been well thought out, feel great and lay

just in front of the door. And just as you are beginning to think that these guys really know what they are doing when it comes to the all important aspect of engineering those parts of the machine that are most frequently touched, you take a look at the remote and it is a rather cheap off-the-shelf looking device that admittedly does the job well enough (at least it has a numeric keyboard), but perhaps should be more interesting, individual and tactile for a machine of this price, design and class. But don't mind too much as even the splendid Accuphase machines use unimpressive, plastic remotes too. It is really only when you start to actually use the machine on a continuous basis that the biggest problem presents itself. I always thought that the display would be one of the easiest things to get right

and yet it is, without doubt, one of those design aspects that is more often that not very, very wrong. The T1-i is an object lesson in how not to design a CD display. As far as I can see there are two aspects to be considered. First, the size of the digits which ought to be BIG, or at least big enough to see and in the case of the slimline Metronome

should actually utilise the whole of the available window. Secondly the colour and for this I refer to the two best displays I have used, that of the Naim and Mark Levinson which are green and red respectively. With both of these machines I can tell, at a glance, from any part of the room, which track is playing and not surprisingly I find this of critical importance. I sit about 12 to 14 feet and off-axis from where the equipment is sited and, without binoculars, I could not begin to see the track numbers on the T1-i's display, at any time of the day. This

weedy, skeletal blue readout is mounted behind a glass/plastic cover which is so reflective that the merest shaft of sunlight renders it once again illegible and when you have to keep wandering over to within a few feet of the machine to check track status it is hardly endearing. When a display is right you never notice it, when it is wrong, like here, it becomes a major source of irritation. Oh, and on a machine like this, it should also be switchable through on and off.

Right, moan over, it gets much better from here because, display apart, this is an impressive performer. It is based around the familiar Phillips CDM 12 Pro transport as used in my own player, the Naim CDS 11. Both Naim and Metronome modify the transport quite heavily for their own purposes, not least in the way that it is mounted. ►



► Where Naim float the mechanism on its own sprung suspension system the T1-i is solidly bolted to a Methacrylate board beneath the sliding door, atop the machine. Metronome claim the use of internal "hard" suspensions, which is probably another way of saying that it is mechanically decoupled. Like the Naim though, the Metronome uses a magnetic puck to secure the disc in place.

The T1-i is an upsampling player that receives the output from the transport at 16 bit/44.1Khz and upsamples it to 24 bit/96Khz. It also has digital outputs for an external processor which, with the machine in standard form, outputs at 44.1 though the review machine had the optional rear panel switching for 96 kHz output as well and this comes either as standard or a dealer-installable retro fit. The rear panel carries digital outputs as AT&T, AES/EBU and SPDIF connections. It also accommodates balanced and single ended analogue outputs. In an attempt to eliminate the problems associated with noisy on-board power supplies the Metronome utilises 4 separate transformers in its slim outboard power supply which deal individually with the motor and servo of the transport, the D/A stage and the rather academic display.

You can't ignore the build quality as the whole machine is impeccably made and finished from 2mm steel with an attractive 1-inch thick aluminium bowed front panel. It sits on 3 Delrin feet but comes equipped with 3 cones of the same material, which sit neatly within the feet to give minimal 3-point contact with the chosen support. Metronome regards these as *de rigeur*, but I would prefer to think of them as an option rather than mandatory. When the T1-i first arrived I was unaware of their presence

as they were cunningly concealed within the packaging so I used the machine coneless for a week or so before discovering and installing them. There are unquestionably significant, but subtle sonic variations available with them in place, but I think that individual systems and support materials demand a suck it and see approach.

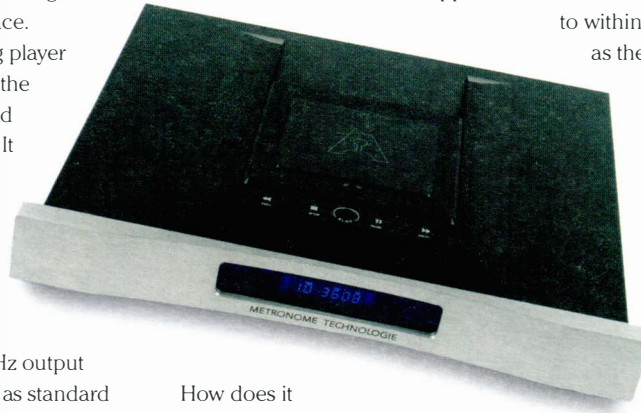

How does it sound? In three words – lush, seamless and smooth. First impressions, after only an hours warm-up (this was a previously run-in machine), were of a broad, if not massive, bandwidth, a little soft at the frequency extremes

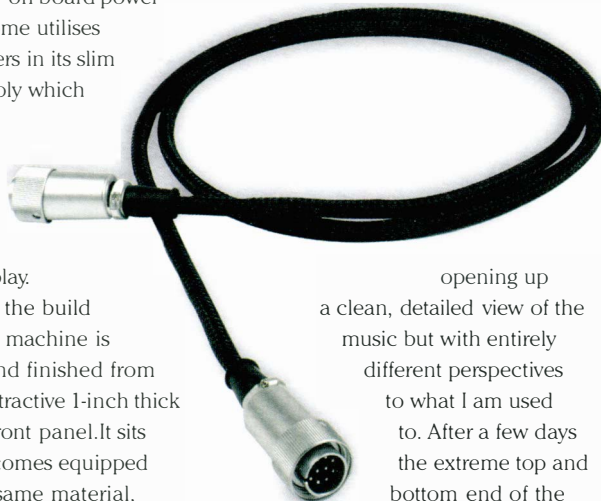

opening up a clean, detailed view of the music but with entirely different perspectives to what I am used to. After a few days the extreme top and bottom end of the useable frequency response had gathered strength and though I thought the machine a little slower than I am used to I began to realise that this was a subtle by-product of the shape and scaling of the musical presentation rather than any rhythmic

deficiencies. As the source of a system comprising of a Spectral DMC-12 /DMA 100 driving a pair of Revel Gems the Metronome was in its element and able to show off its remarkable powers of spatial resolution and tonal shading. It never imposes the music on you by projecting instruments and voices forward of the plane of the speakers to within a few inches of your face,

as the Naim manages. Instead it frames the musical whole, like a painting, with great depth and front to back stability, inviting you to sit back and gaze into the picture. And the longer you look, the more you will see. Because this Metronome is one of those products that is so musically well balanced that it shows no real weaknesses across the whole bandwidth. In other words, there is no area that stands out as being inferior to any other. It has a firm, deep and well controlled bass which flows up through an impressively broad and confident midband right through to the top end which is silky and textural enough to remind me of the sound that flows from the top Focal tweeters.

With its Bossa-nova swing beat, Lyle Lovett's 'Her First Mistake' from *The Road To Ensenada* (MCA 11409) is such a fine piece of studio production work that it sounds quite impressive even on the cheapest of systems. But it has been so well thought out and miked-up that each instrument contains a sense of breathy tonality and depth that only really becomes apparent when you hear it on a player of the Metronomes resolute abilities. The blending of the acoustic guitar and rock solid bass drives the song along at a fair old lick. But nothing is snatched at, nothing hurried. The song just appears to open out and swing, helped by the drum and percussion patterns and that lush expanding cymbal sound which is ►

► so glossily metallic and vital to the sheer energy of the tempo. When the snare is hit it has impact and great speed. It starts and stops perfectly with clarity and precision. It may seem a couple of b.p.m.'s slower than the Naim but it is so well controlled that it feels entirely in time with itself, right across the bandwidth and manages this without compromising any of its undoubted tonal shading abilities. It just sets the stage from the first bar, fixes the vocal and instrumentation in space and that's is where it stays throughout the whole of the song. The soundstage is wide and has the sort of front to back depth that I usually associate with the Mark Levinson players. But is perhaps a little leaner and less weighty, dynamic, energetic and imposing than the ML or the Naim. I noticed this when I played *Paseo de los Castanos* by Tomatito, one of the new wave of artists who are pushing the discipline of

flamenco guitar playing into new areas. This is one of

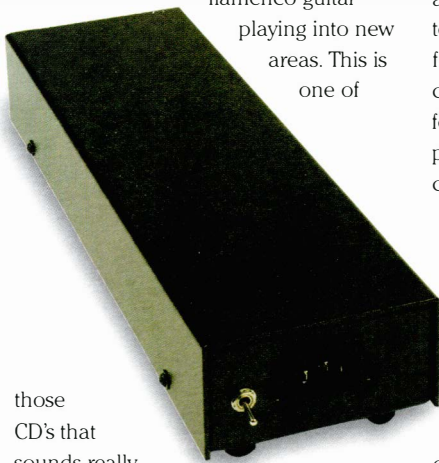

those CD's that sounds really awful on cheap players. The occasionally brutal speed of the playing leaves most systems struggling over each notes attack and complex leading edge often with a loss of pitch. Flamenco guitars are low string-tension devices set up with deliberately shallow playing actions to allow each

note, when pushed, to slap back onto the fretboard and not ring with the unimpeded harmonic clarity of a classical instrument. This opens up a whole world of percussive possibilities for the virtuoso and is one of the reasons why lesser systems struggle so woefully when confronted with the "little tomato"



and his contemporaries.

The Metronome did a pretty good job but didn't have quite the sense of ease and flow that I was expecting and as a consequence the musical message had less power and just lacked that intensity and rhythmic anticipation that I am used to. It's probably unfair to draw too much from such comparisons as the Naim costs over 30% more but I couldn't help feeling that this, and other similar discs pushed the T1-i to the limit of its considerable resolving power.

I really cannot imagine anybody actually disliking this CD player's view of music, but I can certainly see it being underestimated in a dem room when being compared to a pushier and overtly dynamic competitor. It's unspectacular way of opening the ear to tonal contrasts; dynamic shifts and small touches of musicianship grow on you over a period of time. And just when you think you understand its full repertoire it will surprise you by illuminating a distant strand of the performance that you hadn't noticed before and when you piece it all together then new musical possibilities arise. For me, this is one of

the greatest things about recorded music, that the small can have such a great relevance to the whole.

Overall its operation is flawless. It has the feel of an expensive machine, largely due to that beautifully damped sliding door but it is also one of the slowest machines I have tried when it comes to reading discs or processing commands though this is not a problem. What is a problem is the display and the only thing I can think is that this somehow slipped through the design studio while everyone was having one of those long French lunches. If they fixed that, then I could happily live with the rest.



TECHNICAL SPECIFICATIONS

Type:	CD player with separate power supply
Drive:	Phillips CDM 12Pro with custom mods.
Digital outputs:	1 x SPDIF (RCA), 1 x ATT/ST (fiber optic), 1 x AES/EBU (XLR) Optional digital outputs Additional switchable up-sampler (44.1 to 96Khz) Analog outputs balanced (XLR) and unbalanced (RCA)
Power supply:	4 transformers with 8 regulators on the transport and converter.
Finishes:	Silver or black aluminium
Dimensions:	70x450x375mm-CD player 65x95x230mm-power supply
Weight:	32lbs for the 2 pieces.
Price:	£3995

UK distributor

Integrated Engineering Solutions
Tel. (44)(0) 23 8090 5020
E-mail info@highendaudio.co.uk

Manufacturer

Metronome Technologie, Toulouse, France
Net. <http://www.acoustic-precision.com>

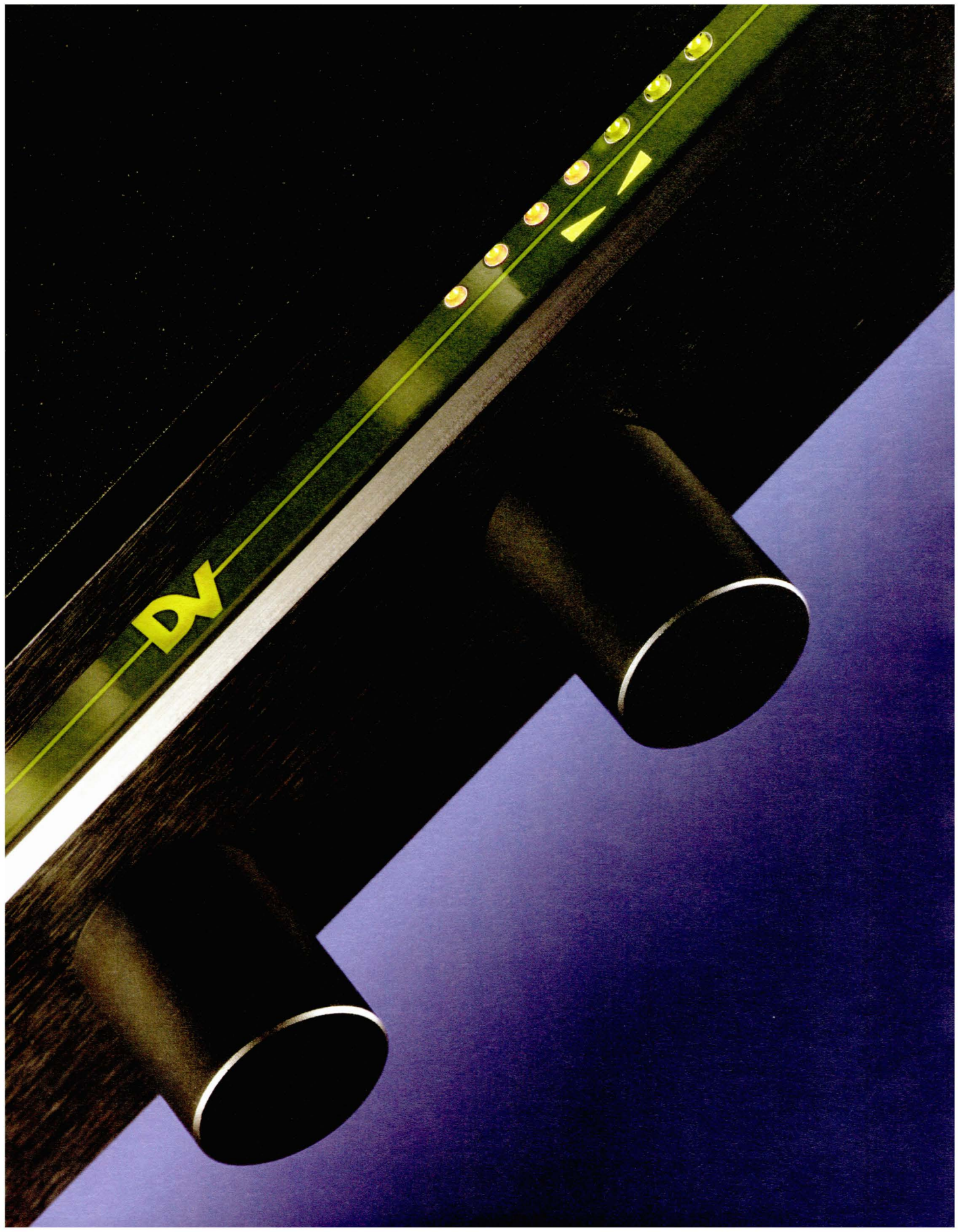

Dynavector L200 Pre-amplifier

by Jason Hector

Pre-amplifiers have featured heavily in this magazine recently with four serious devices reviewed in the last issue alone. I think all the copy is justified since this is one, often overlooked, area where it is really easy to screw up the sound of what could otherwise have been a decent system. A poor pre-amplifier seems to send the power amplifier such a weedy signal that it compromises the latter's capability to drive the speakers.

A pre-amplifier should offer some key features to work well, and I am not talking about inputs and remote control. A pre-amplifier, assuming it is not a balanced device, should have a high input impedance so that a wide range of source components can be plugged into it and give their best. It should also offer a low output impedance to cope with the input impedance of the power amplifier and any interconnect cable. The pre-amplifier should be a wideband device because we don't want to lose any information at the extremes, and similarly it should offer a fast rise time (the time it takes for the output to follow the input). And it should do all this with a minimum of distortion, independent of voltage fluctuation and across 4 or 5 decades of frequency band. The pre-amplifier is a hard design task! In reality some of the above can be compromised for a perceived sound quality improvement. So valve preamps often have poor input and output impedance but the benefits of using valves is felt by many to outweigh the loss of compatibility

with some devices. Naim Audio pre-amplifiers are known to curtail the bandwidth to give their power amplifiers a tailored signal that they are designed to operate with. But this Dynavector pre-amplifier attempts to cover all the bases and uses some novel technology in the attempt.

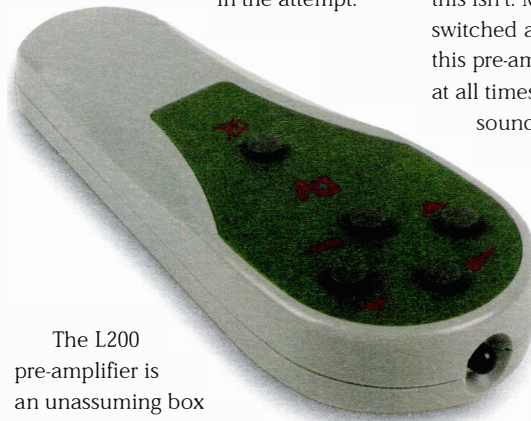

The L200 pre-amplifier is an unassuming box from the Australian / New Zealand Dynavector brand. Connected to, but not the same as Dynavector (Japan) who make the cartridges, tonearm and Super Stereo units, they are actually the parent brand's Antipodean distributors. It has been designed to match the HX75 amplifier I reviewed a few issues ago and my listening has been almost exclusively with these two as a pairing. At the time of the HX75 review I thought the L200 a good pre-amplifier but not the last word at the price with the HX75 was the real star of this particular show. Recently the L200 has been reworked to include remote control and the grounding has been changed so that the pre-amp's analogue circuitry floats. Whatever the changes

the sound quality has been lifted a long, long way.

The folded aluminium box is uh... functional. Two knobs round the front and a load of phono sockets behind. Very basic and well executed it might be, but a beautiful lifestyle product this isn't. Mains input is via the usual switched and fused IEC socket and this pre-amp is designed to be left on at all times and really benefits from it, sounding pretty poor from turn on. The front panel is a piece of thick, machined aluminium, and is broken up by a strip sitting above the control knobs which indicates the input selected and the volume setting. The volume is illustrated with a row of LED's which are actually too coarse to be much use. The two knobs on the front panel control volume and source selection via the pre-amps central micro-processor. To change source just rotate the selector and the relevant LED lights: no noise is heard as there are no relays clacking away inside. Keep turning and the unit cycles through the inputs and the mute setting. The ultra-cute remote control allows remote volume, source selection and an instant mute control. The reception angle is pretty good and the codes are based on the RC5 set. The volume control is a discrete step device and I found the volume steps a little too crude, often wanting a setting between the available levels. I am assured that this is being

▶ looked at. My biggest gripe however is the paucity of inputs: three inputs plus a tape loop is simply not enough in these multi source AV days. CD player, LP spinner, tuner, tape but what about VCR, digital TV box and DVD player? Perhaps this misses the point. This pre-amplifier is a purist two-channel device, designed to deliver sound quality above all other fripperies and that is how it will be judged in this review, but that's not to say more inputs wouldn't still be appreciated!

the good straight girls album I was immediately struck by the beauty of her voice. The subtle inflections are details that are also part of the musical message. With this pre-amplifier we don't have to worry about the timing of the band; it is all presented for us in a natural, organic way. The musicians are not forced to work together by the system, they manage it perfectly well by themselves. Piano, that problem instrument, is well presented. The range is continuous both in volume and from left to right hand and the percussive element is very well handled. The Dynavector input stage does seem to flatter CD players and really

a record I always want to hear on a new system. In places it is very simple but the rhythmic complexity is always there, ready to expose any system that tries to hurry things or slow it down, and if the bass lags at all, well forget playing this album altogether: You'll just miss the whole point of most of the songs. I guess it is no surprise that the phono-stage works well with Dynavector cartridges but with its particular mix of virtues I am sure it will flatter other makes equally well. With the phono-stage on board the L200 offers serious value for money.

The L200 does not use standard audio electronic components. It features a number of op-amp IC's, as opposed to the normally preferred discretes, as gain devices. Input switching is achieved with analogue IC switches which are purely electronic relays. The advantage of these devices is that they do not contain any moving parts so do not degrade over time and use. Dynavector claim they do not generate as much noise as the usual devices. Jonathon Davies, the designer of this pre-amplifier seems to get access to unusual components and isn't afraid of using them in innovative ways. The volume control is a case in point. Rather than using a variable resistor or resistor ladder Jonathon uses an all electronic device to adjust the volume which, like the input selector switches has no moving parts and so will not degrade the way a traditional track and wiper pot would. It's also non-microphonic, a definite and potentially huge advantage. The pre-amplifier output stage is capable of driving difficult loads and is really a small power amplifier in its own right and, according to the importer, easily capable of driving a pair of headphones: big horns and no power amplifier anybody? Much is made of the use of thick, ultra pure

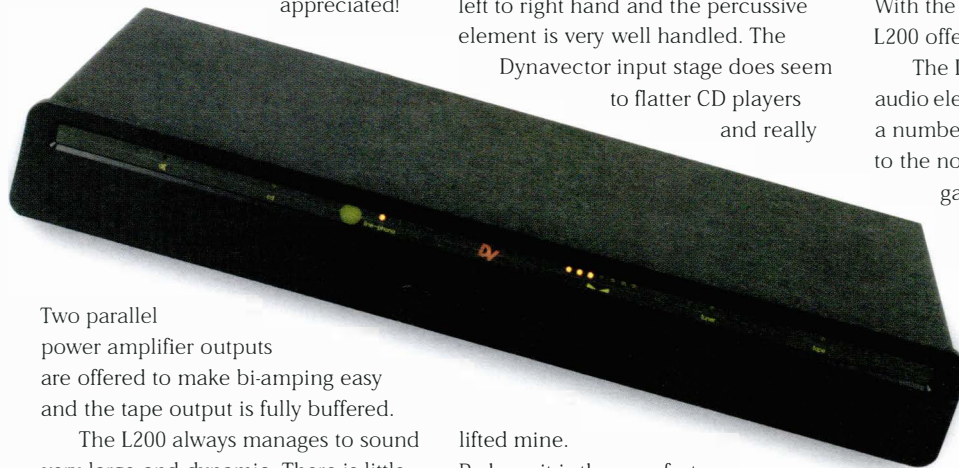

Two parallel power amplifier outputs are offered to make bi-amping easy and the tape output is fully buffered. The L200 always manages to sound very large and dynamic. There is little truncation of space or notes with this device. Coupled to the HX75 we have a super musical result for sensible money. The bass is very powerful, avoiding the tendency toward a one note bass response sometimes seen at this price. It is pretty obvious that the L200 was developed in the company of the superb bass and control of the Dynavector power amplifiers and in this area it does punch well above its weight. Stereo imaging is impressive. The performers exist in their own space where the recording allows and there is plenty of depth. Almost all of my listening was with my Shahinian Obelisk speakers but the L200 and HX75 really demonstrated how good the Epos M12's I reviewed in the last issue are. They responded with real verve to the clean signal from the Dynavector pre and power amplifiers. Listening to Susan Werner's *Last of*

lifted mine. Perhaps it is the very fast devices, the voltage overhead or the high input impedance of the circuits but whatever the techie explanation, it really works. A plug in phono-stage (the P50) is also available for the L200. I tested this with an LP12 carrying a Naim Aro and the low output Dynavector 17D2 cartridge. The phono-stage provides ample gain for the low output Dynavector and was silent in operation. Even at high volume settings the level of hiss was barely audible even up close and personal to the loudspeakers. The phono performance is superb, keeping to the themes of excellent musical integration and the big powerful sound exhibited by the line section of the L200. Detail resolution was excellent with instrument timbre beautifully portrayed. A good example of this is the album *Home Burns* by Orange Can which has become

▶ Australian copper in the circuit boards and lead free high silver content solder is used throughout. The L200 is DC coupled avoiding capacitors in the signal path and the active devices are carefully matched.

On to Jeff Martin's *Still* album, which should have been titled music to go mad to. Often simple songs, close miked vocal over an electric guitar but with incredible intensity. Everything is delivered by the L200 and the palpable menace of songs like 'The hangman'



pervades the room. Again it is back to the subtle infection of the voice, the interaction with the guitar and the ability of the L200 to let them work off of each other as intended. Roddy Frame's *Surf* is an even simpler album. Every track is just Mr. Frame and his acoustic guitar. The most impressive effect of listening to these albums is that you are allowed to visualise the performer as he plays and sings the songs. There is a sense of realistic scale that I normally only find in much more expensive components. The guitar is guitar sized and the vocalist doesn't end up either miniaturised to absurdity or stretched to become some sort of giant.

With something a little more powerful we can really test how the preamplifier can cope with complex multi layered instrumentation. So on with Metallica and the *Black* album.

By now many of you reading this may be questioning the suitability of this pre-amplifier to play classical music. Well, have no fear, the tonal purity I mentioned earlier makes classical music a pleasure. Just remember where I say Metallica you should feel at ease substituting full scale and dense orchestral music. When I talk about Nick Drake or Emmy Lou Harris you should think of small-scale chamber or similar. Overly simplistic? Probably, but bear with me. Even with Metallica powering through the system like a dose of salts the L200 never seems to suffer from congestivitus.

This is something of a surprise at the price. I would expect it to

struggle more with really dense recordings or powerful crescendos, but it seems to stay in control and let only the right stuff through without sounding like it is holding the music back too much. Drums are very realistically portrayed, start and stop as intended with plenty of weight and power.

I tested the pre-amplifiers timing and rhythmic abilities with my torture disc *Smog* and *Dongs of Sevotion* which is a surprisingly difficult album for any hi-fi system to play. Several of the songs, but particularly *Bloodflow*, do not offer a consistent tempo. The band is constantly accelerating the pace and then backing it right up. This can happen like a Ferrari, from

one note to the next, or like a Trabant, over tens of seconds. I don't fully understand how some systems can get it so wrong. They sound clear and fast but all of the suspense and tension is lost in their "one speed" interpretation. I think it comes back to an ability to time the leading edges of notes across the whole frequency band. Some brands, Naim Audio being the most obvious, get this absolutely right. Suffice to say the Dynavector was also spot on here. The result is an edge of the seat ride through the song. You are dragged along and emotionally drained by the end of the album. This is exactly what a system should do, and to do it with a pre-amp this modestly priced is impressive indeed. As a line-stage the Dynavector L200 easily justifies its price. Add in the phono-stage and it becomes a real bargain. And bargain pre-amps are rare indeed.



TECHNICAL SPECIFICATIONS

Type:	Solid state pre-amplifier
Remote Control:	Source selection, volume control and mute
Line Inputs:	3 single ended
Outputs:	2 single ended in parallel
Phono stage:	Optional MM/MC (replaces one line input)
Tape loops:	1 (buffered)
Input sensitivity:	200mV for 2V output
Dimensions (WxHxD):	440 x 220 x 60 mm
Weight:	6kg
Finish:	Black
Price – L200:	£1200
P50MM:	£140
P50MC:	£150

UK Distributor:

Pear Audio
Tel. (44)(0)1665-830862
E-mail. john@pearaudio.com

Dynavector presents its SuperStereo processor Adp-2, an easy addition to your existing system.

"...the whole (listening) experience is dramatically lifted, with a huge increase in instrumental weight and warmth and overall space ..."

Roy Gregory, Hi-Fi +

"...extraordinarily convincing
...simply sounds more natural ..."

Paul Messenger, Hi-Fi Choice

The Adp-2 processor costs £795 (plus carriage) and is available from:

Dynavector (SuperStereo)

Tel/Fax. 01202-767873

E-mail. dynavector@onetel.net.uk

Net. <http://web.onetel.net.uk/~dynavector>

Radlett Audio

EST. 1978

CONSULTANTS

THE HIGH-END SPECIALIST SINCE 1978

ATC, Audio Analogue, Avantgarde, Bow, Bryston, Copland, EAR, Lyra, Mark Levinson, Naim Audio, Notts Analogue, PMC, ProAc, Proceed, Rega, Revel, Roksan, Isotek, Sonus Faber, Stax, Spendor, Sumiko, Wadia and lots more.

9 Holywell Hill, St. Albans, Herts, AL1 1EU



Tel: **01727 855577**

Fax: **01727 858727**



This Autumn
Don't be Blue
Try Something New
from
audio republic

☎ 0113 2177294

stockists of



Shahinian
Dynavector



and others...

audio republic
78 Otley Road
Headingley
Leeds
LS6 4BA

www.audiorepublic.co.uk

pear audio
presents

Shahinian
DYNAVECTOR
Well Tempered

Stockists and Information
from:

Pear Audio Ltd.

7 Prospect Place, Alnmouth,
Northumberland, NE66 2RL

Telephone: 01665 830862

Fax: 01665 830051

THE AFFORDABLE PHONO AMPLIFIER

FROM TRICHORD RESEARCH

only £299.00 inc VAT (complete with TOROIDAL PSU)

DINO

Moving Coil
Moving Magnet
Switchable Gain
Switchable Loading
Super Regulators
Discrete Output Stage
Add a 'Dino+' PSU for true high end performance
Dino complete with Dino+ combination - £498.00 inc VAT



tel: +44(0)1684 573524
fax: +44(0)1684 577380

www.trichordresearch.com

hi-fi+ PRODUCT of the YEAR

Great products, just rewards...

Distributed by:

WOLLATON AUDIO

▲ Klyne Model 7 Line and Phono stage

▲ Monarchy Audio SM70 Power Amp

Monarchy Amps, Transports and DIPs • Klyne Pre-Amplifiers • Aliante Loudspeakers
Audio Valve Amplifiers • Solidsteel Hi-Fi Furniture
Kochel Horn Loudspeakers • Wavac Amplifiers • XLO Cables & Interconnects

Telephone: 0115 852 3858
e.mail: audio@wollaton.demon.co.uk



The Rega P9 Turntable

by Chris Binns

I'm sure we have all said things that we later regret, and of course sometimes one's past actions come back to haunt you. For example, about twice a year I bump in to an old friend of mine who, back in the days when I was a fiery twenty something old, witnessed my mouthing off with a degree of passion about the then new format of CD. Having been asked for my opinion, and fuelled no doubt by a considerable amount of beer, I tore into the new format with some enthusiasm, and stated quite categorically that it sounded lousy (correct) would never take off (incorrect) and was unlikely to supersede records (fill that one in yourself). Now, whenever I bump in to William in polite company, after a drink or two a mischievous streak emerges within him and he cannot resist embarrassing me by proclaiming loudly to the whole room that here is the man that thought CD would be a flop - and thank God I am not an investment banker...

I could quite easily wipe the smile from his face. I know that he recently went to buy a turntable from Argos for his midi system, only to be told that they were out of stock – they are selling so many that they are on back order for several months. I gather also that Project are having difficulty in keeping up with demand for the Debut turntable at £120. So it would seem that record players are once again no longer the unique province of condemned hi-fi nuts.

Which must be great news if you are a turntable manufacturer.

In the days when the Linn LP12 was the turntable to aspire to, if you couldn't

afford that the then hierarchy (or was it the press?) dictated that the starter system was the Dual 505, and the only other turntable worth considering between it and the Linn was a Rega Planar 2, or 3. At a time when Naim Audio would not consider selling you an amplifier unless you had a Linn, Rega were the only other manufacturer to be similarly blessed; a starter Naim system was often partnered with a Rega turntable.

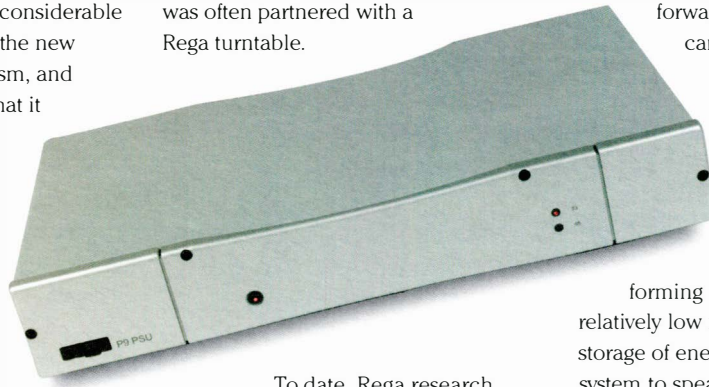

To date, Rega research has been renowned for producing innovative and cost effective products many of which have defined what can be achieved for a certain price. The undoubted success of the turntables has been followed by a range of electronics, most notably the Planet CD player (by far the most satisfying budget machine that I have heard), and of course their most successful product ever, the RB 300 tone arm. While capable of impressive results that have seen it partnered with some highly expensive kit, it remains something of an icon in terms of price versus performance. Perhaps this is why Rega have always had what could be interpreted as a mildly contemptuous attitude toward the high-end, and have tended to steer clear of it. Not that the P9 would be regarded by today's standards as high-end, but it does represent the

companies most ambitious and expensive turntable so far.

The family bloodline runs strong, and thus the P9 looks similar to the less expensive P25 and others in the line up. It is compact, and by comparison to some of the competition appears almost 'lightweight', due to its small size and construction. Personally, I love it –

I think it is refreshingly straightforward and elegant. The P9 carries forward the company philosophy of rigid construction, consisting of a plinth that is fabricated from a lightweight material coupled to the main assembly at three points,

forming a skeletal construction of relatively low mass ensuring minimal storage of energy. There is no suspension system to speak of to isolate the arm and platter - Rega argue that such a system causes more problems than it solves, and that the benefits of a degree of vibrational immunity are outweighed by a more complex and uncontrolled dissipation of mechanical energy that would result in a smearing of music reproduction. The rigidly mounted motor drives the metal sub-platter via two small round section belts, thus cancelling out any small inaccuracies that would be apparent with a single one. The platter itself is made from a ceramic oxide material that is compressed and then fired, the result being so hard that it can only be shaped and ground to size using diamond.

The RB1000 arm that is fitted to the P9 is a derivative of the fabled 300. Visually, it is distinguished by the highly polished arm tube (thus dispensing with the extra mass of the paint finish), ►

▶ while the original plastic moulding that formed the cueing and bias adjustment has been replaced with a superior machined metal assembly. The single threaded collar mounting arrangement has been substituted by a three point fixing arrangement, however this is not compatible with the standard Linn type. Less obvious is the new wiring, which now runs unbroken from the cartridge pins to the phono plugs, and the bearings, with a claimed tolerance of under 1 micron. This is an incredible

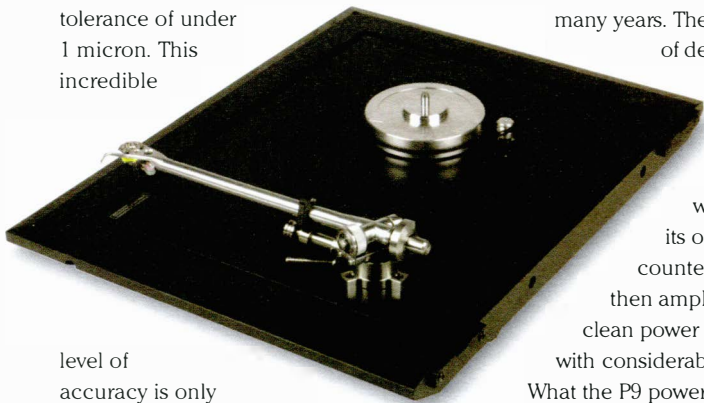

level of accuracy is only attainable by a selection process; the bearings of an RB300 are pretty damn close anyway, and by picking the best out of the thousand units that they produce every month, Rega are able to offer incredible precision for the assembly of the 1000.

That would more or less be that as far as the turntable goes. But perhaps one of the most interesting points about the P9 is the power supply. While the last few years have seen considerable development in this area, the importance of providing a clean stable and supply for the motor cannot be overestimated. Rega however, have taken things one stage further. The P9 uses a variation of the Philips / Impex motor, the type of which has appeared on a large proportion of high quality turntables over the last three decades - a fact that often surprises me. Why? Well no disrespect to Philips, but in the flesh it hardly comes across as a piece of precision engineering - rather the opposite in fact, as it appears rather cheap and nasty. However, there must

be something about it, it has been used for a long time with undeniable success by many manufacturers. A 24 pole synchronous design, it is available with different voltage specifications, but all require a bi-phase 50Hz AC supply, effectively two 'rails' out of phase with one another to work correctly. This can be achieved easily enough from the household mains with the use of a single capacitor, and indeed this was the case for most turntable designs for

many years. The development of dedicated supplies usually involved synthesis of the 50Hz waveform (and its out of phase counterpart), which is then amplified to provide clean power for the motor, with considerable benefits.

What the P9 power supply does that is of particular interest is allow adjustment of the relative phase between the two supplies, to my knowledge for the first time. The benefit of this is that one can literally iron out any vibration produced by the motor inherent in its design, and more importantly allow individual control over variation between samples, which by all accounts is quite considerable. The result is a lower level of mechanical noise from the motor; touch the motor casing while it is running and you cannot detect any vibration, which is not the case with other turntables I have used. What this amounts to is killing the problem at its source, and since there is virtually no vibration there is no requirement for any mechanical isolation from the rest of the turntable.

To say that the P9 falls out of the box ready to use would not be too much of an understatement. The unit came supplied with Rega's own Exact cartridge, a refined moving magnet design that unfortunately I was unable to try as I didn't have a mm input stage handy. Were it not for having to change the cartridge, the P9 would have been up and running in under five minutes. I was reminded of the owners card that used to come with the Planar three, that ended a set of simple instructions by stating something along the lines of 'why are you reading this when you could be listening to music?' ... Well, Rega always were a little bit different in their approach. I ended up using the Lyra Helikon. This did throw up a minor problem, in so much as it highlighted Rega's continuing view that VTA is unimportant; despite the refinements with the RB1000 height adjustment can only be achieved through the use of spacers. With the original RB300 the use of one large spacer at least maintained the mechanical integrity of the arm mounting, the new arm requires three washers, one under each

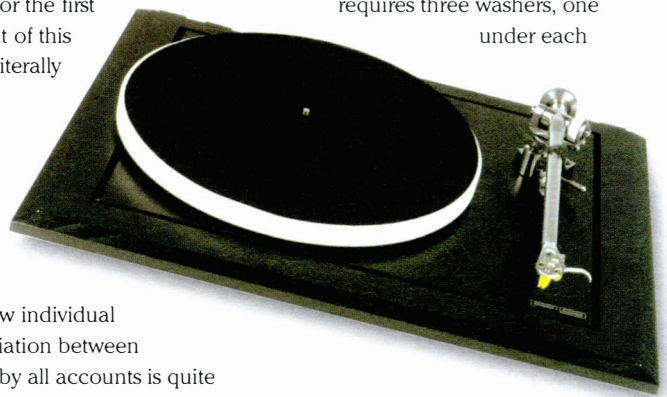

mounting hole. The result is a little inelegant to say the least, although I can't put my hand on my heart and say that I was aware of it detracting from the performance. The solution would be a machined plate to match the arm base - expensive, but on a turntable of this calibre, worthwhile.

Being a rigid design, one aspect of the P9 that I was worried about was acoustic feedback, and

► I figured that positioning was going to be crucial. Placing the unit on a Sound Organisation table with a glass top, I was at first disconcerted by the thumps that issued through the speakers whenever I touched the deck. Years of using turntables such as the Linn whereby you can thump the plinth as hard as you like (assuming it is correctly set up) with no audible result has made me immune to this. But during use, even at high volumes I was never aware of the sound being compromised, quite the opposite in fact.

From the very first track I played, I was struck by the sheer amount of energy coming off the record. There was a vital urgency and exuberance to music that was at times quite startling and never short of excitement. I spent several very happy evenings digging up old records that had always sounded a bit dull and lifeless, playing them on the P9 gave them a shot of adrenalin with the result that the recordings sounded clean, fresh, and very fast.

Rhythm and timing were particularly impressive, while drums and percussion as a whole came over particularly well. What was also apparent was a confidence, a sure footedness that made music accessible and enjoyable, while there was detail coming out of the grooves that I had not heard before. From the taught bass through the punchy mid range and into the exceptionally clean, clear cut treble, music was reproduced with real precision and clarity, and if that all sounds like too much of a good thing, it managed to do this without resorting to the sort of clinical anaemia that can ruin ones involvement with the music. Record noise was particularly low, and this combined with the absence of low frequency rubbish greatly enhanced the

impact of music, helped considerably by the superior tracking ability of the cartridge that the RB1000 allows.

Larger scale orchestral works benefited from the highly stable presentation, and the image presented was both deep and wide with plenty of detail regarding positioning and acoustic space. The only drawback was that sometimes the sense of urgency that proved so exciting with rock music prevented more gentle passages from developing at

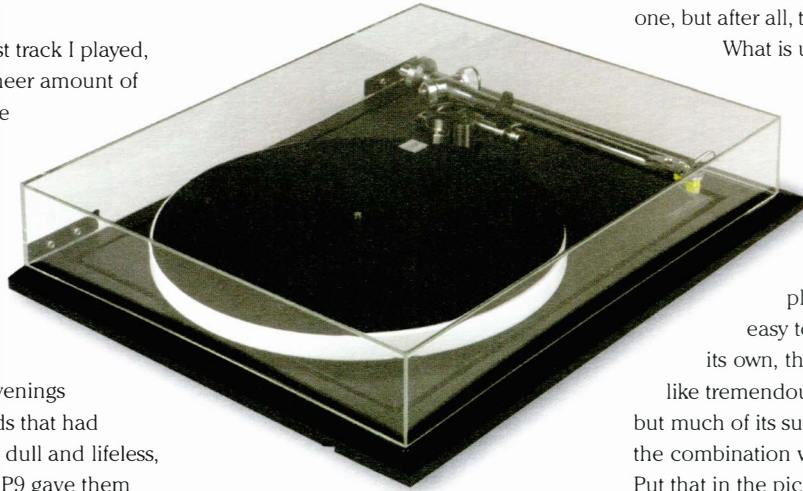

their own pace – I felt that the P9 was a little insensitive when it came to slower, thoughtful music, robbing it of some flow and sense of feeling, as if it were impatient to get to the end. It occasionally sounded as if the extreme bottom end needed filling out a bit to slow things down and allow more of an atmosphere to develop.

This was highlighted to some extent by a comparison with the Clearlight Recovery Basic that RG is reviewing in this issue. The sound from these two turntables was very different, and I have to admit that a Lyrita recording of Herbert Howells string quartet sounded more comfortable on the Recovery, while it lacked a bit of grace when played on the P9. But then the Clearlight could not manage the sense of urgency recreated when playing a Talking Heads album. It was while

we were listening to both turntables that it occurred to me that the combination of the Helikon and the P9 might be responsible for the slightly forward balance. The Lyra, while being very civilised, is a lively and exuberant performer with a degree of 'snap' in the mid range, much like the Rega. I will be interested to try some different cartridges and report back.

The P9 is a startlingly good turntable. It could well be that its slightly 'up front' performance will not appeal to everyone, but after all, that is a matter of taste.

What is unquestionable is that it retrieves an awesome amount of information from the record, which it presents it in a thoroughly enjoyable fashion plus, it is refreshingly easy to use. Viewed on

its own, the P9 might not look like tremendous value for money – but much of its success comes down to the combination with its power supply. Put that in the picture and it would seem as if the reputation Rega have for producing high performance products at reasonable cost is intact, even enhanced. 

TECHNICAL SPECIFICATIONS

Speeds:	33 and 45 RPM
Dimensions (W x H x D):	
Turntable:	480 x 120 x 370mm
Power supply:	430 x 70 x 270mm
Weights:	
Turntable:	9.5Kg
Power supply:	7Kg
Finishes:	Cherry, Maple, Black
Price:	£2248

Manufacturer:

Rega Reasearch Ltd
Tel. (44)(0)1702 333071
Fax. (44)(0)1702 432427



Clearlight Recovery Basic Turntable

by Roy Gregory

It was once said that all a turntable had to do was turn at 33 rpm and do it quietly, yet it's a problem that has tantalised hi-fi designers for upwards of 40 years. Indeed, that deceptively simple statement nicely sums up the essential conflict that confronts anybody setting out to build a record player. On the one hand you want good speed stability, which requires close coupling of the motor and platter. On the other you need to isolate the stylus groove interface from any potential source of spurious vibration, and chief amongst those is of course the motor. In other words you are seeking an intimate connection to something that you are also mechanically isolated from. It's the theoretical push-me-pull-you of the hi-fi world, and it has tested the ingenuity of some of our most successful designers.

There have been two traditional approaches to the problem. In one, you mass load the motor in an attempt to stop it vibrating, and then place it physically remote from the chassis that supports the platter. In the other, you suspend the platter relative to the motor, isolating it by dint of the suspension medium. The problem with the latter is that although it is effective in eliminating structure born vibration, it suffers from having to connect the motor to the platter with a belt. This belt not only transmits vibration itself, but effects the speed stability of the system in unpredictable ways. Let's face it, a fixed motor driving a heavy mass that wobbles like a jelly, via an

elastic band, hardly constitutes a stable relationship.

But there's a second, less obvious issue. Use a stiffish belt to prevent oscillation in the system and the mass of the platter can drive the motor out of synchronicity, at which point it starts to vibrate like a spin dryer.

Of course, many of these problems are a result of the industry obsession with the shoddy little Impex AC synchronous motor that seems to have been a permanent fixture in most belt drive turntables since AR introduced the three point suspension. Only a few, invariably expensive designs have ever really sought to use an inherently superior motor, perhaps the most obvious being the last of the Rockport turntables. Which is what makes both the Clearlight and the Rega designs reviewed here so fascinating. But whilst the Rega sets out to eliminate the problem at source by preventing the motor from vibrating in the first place, the Clearlight adopts a mechanical approach to the same issues.

I've been using the Clearlight Recovery, the Basic's big brother, for quite some time. It's a sophisticated and carefully considered beast, but

also an expensive one to produce, the deck alone costing the wrong side of three thousand pounds. The brief with the junior was to produce a deck that would retail for a more approachable price while retaining most of the virtues of the more expensive design. It called for exactly the sort of inventive engineering solutions and lateral thinking that Clearlight are famous (or should that be notorious) for.

The first thing that you'll notice about the Basic is that it arrives complete with a rack. Well, almost... It's actually built into the rack, the top shelf becoming the bottom half of the turntable's sandwich plinth. Of course, we all know how important a turntable's support can be to its sound, a factor reflected in the design of the full-on Recovery, which uses a pair of top shelves from the Aspect rack for its own plinth. When you consider that, then the Basic becomes a logical extension of the approach.

Other than that, the recipe stays pretty much the same as before, at least from the outside. The two slabs of the split plinth are separated by Sorbothane pads, the lower one supporting the motor, the upper the arm and

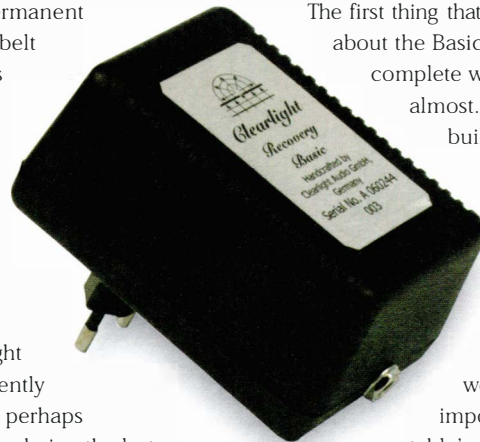

► main bearing / platter assembly. Put the two turntables next to each other and the family resemblance is obvious. The cost cutting is concealed inside. Gone is the expensive composite platter and novel standing bearing, replaced by a thick acrylic unit, rotating on an inverted bearing and running on a ceramic ball. Gone too is the sophisticated external power supply, which is the first hint of the clever arrangement adopted for the drive system.

The Basic is, at least in terms of drive dynamics, essentially a solid plinth design. Therefore, the critical factor becomes belt tension and the risk of the platter driving the motor rather than the other way round. The Clearlight's solution is both elegant and simplicity itself. The RDC motor pod contains the DC motor and all the electronics to allow you to switch between 33 and 45, and fine-tune each speed. It in turn stands on two threaded legs that locate directly onto small Sorbothane pads. Two legs? Yes, and they are positioned towards the platter side of the motor housing, meaning that the housing topples outwards, away from the platter. The platter is driven by a peripheral belt, actually a loop of nylon fishing line. Hooking this over the drive pulley lifts the motor pod to the vertical, but gravity ensures that belt tension stays constant, even if tiny variations in motor speed try to alter it. As I said, simple and elegant. The only downside is that the length of the belt is absolutely critical, but there's a knack to tying it off that you get the hang of pretty quickly, and once it's right it stays that way.

The Basic is generally supplied with the Incognito Rega tonearm, for which an RDC base, including a simple post and collar VTA arrangement, is provided. The magic damping compound crops up in the plinth too, the slabs each consisting of two pieces of MDF bonded together, their inner faces routed

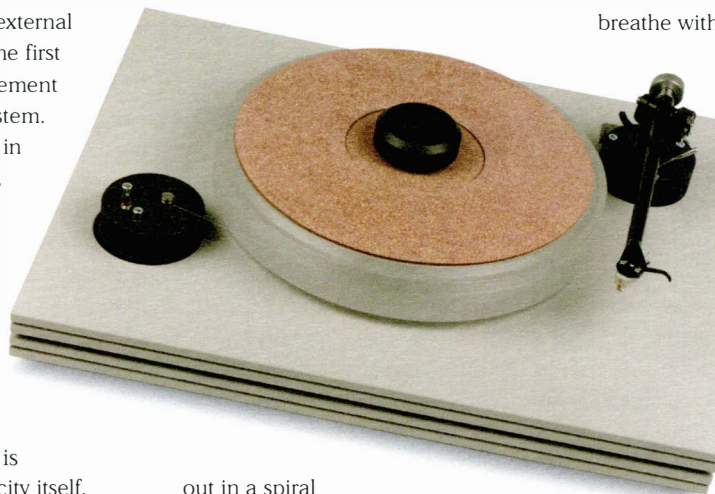

out in a spiral pattern and filled with RDC. I used it exactly as supplied and ran it with a Lyra Helikon, a cartridge that works exceedingly well in the Incognito arm.



Set up is perfectly straight forward, the most time consuming part being the building of the Aspect rack. For those who already own a rack, Clearlight or otherwise, you can buy the Basic on its own, for which eventually it has threaded studs fitted

to take RDC cones. However the message is clear. It's going to sound best on its own rack and that's how you should aim to use it.

The sound of the Basic is pure Clearlight with the hallmark linearity and open neutrality that characterises all the companies' products. It's an unforced character that allows music to breathe with a life of its own. Playing a record like the Martzy

Kreutzer Sonata on Coup d'Archet really makes the most of this quality. The mono recording already offers superb timing integrity, but on the Recovery Basic the space and time afforded the instruments reveals the expressive nuances of the playing, the superb understanding between

Martzy and Antonietti. Walter Legge might have dismissed Antonietti as an unworthy accompanist for a player of Martzy's talent but here you have clear evidence that the whole was much greater than the sum of the parts.

It adds credence to the suggestion that Legge was guilty of listening with his trousers rather than his ears.

What you gain from the Basic is a sense of poise and stability that serves acoustic music wonderfully well. Its tonal neutrality is central to this, delivering the character and identity of individual instruments, identifying their contributions without you having to grope for them. It makes listening easier and more of an appreciative rather than a deductive process – vital to being able to fully relax and enjoy the music. ►

▶ The question mark with any turntable that excels in this regard comes with more up-beat material. Playing 'Die Tanzerin' from Ulla Meinecke's album *Wenn Schon Nicht Fur Immer Dann Wenigstens Fur Ewig* (RCA PL70932), with its combination of space and sporadic percussive transients demonstrates that although the Basic doesn't possess the transient snap and leading edge definition of some turntables, it's never in any doubt as to where a note starts and just as importantly, where it

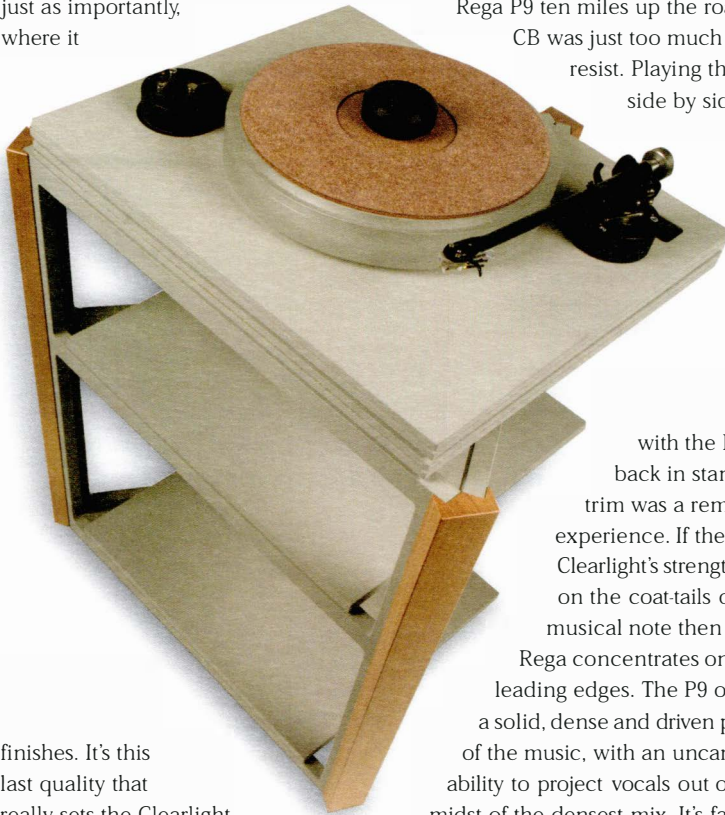

finishes. It's this last quality that really sets the Clearlight apart from the crowd. Its ability to let you hear the harmonic development and decay of a note is remarkable, close to the performance delivered by the full-on Recovery.

The nice thing is that you have voicing options with the Basic as I discovered. Because I use the Aspect racks at home I was able to experiment with the support arrangement. What I discovered was that using the Basic's

conical feet and then placing it onto an additional heavy duty RDC shelf rather than directly onto the rack's frame, supported on the small rubber feet provided, delivered a noticeably crisper, richer and more solid sound with greater weight and presence. I couldn't detect any downside to this (other than the obvious additional cost) and I'd recommend it as a standard first upgrade to all Basic owners.

We don't often indulge in comparative reviews but having the Rega P9 ten miles up the road with CB was just too much to resist. Playing the two side by side,

with the Basic back in standard trim was a remarkable experience. If the Clearlight's strengths ride on the coat-tails of the musical note then the

Rega concentrates on the leading edges. The P9 offers a solid, dense and driven picture of the music, with an uncanny ability to project vocals out of the midst of the densest mix. It's fast and furious, exciting and at times edgy. In comparison, the Basic sounds far more laid back, with a relaxed, open presentation, even from top to bottom and without the Rega's emphasis. The differences are such that they play to the music chosen. Early Blondie? The Rega will capture the drive and energy, the latent aggression in the music. The Clearlight will sort out the dense, overlapping layers, but it will lack that last frisson of excitement.

But change to an acoustic recording and the Basic's strengths come into their own. The open stable picture allows the music to bloom and swell in a natural space, making the Rega sound forced and hurried, almost clumsy in comparison. CB concluded that you'd almost need both, depending on which record you wanted to play at a given time. My response was rather different. I'd like to hear the Basic with the RB1000 tonearm on it. Best of both worlds? I think it just might be. But even without that option, the Recovery Basic represents exceptional value for money, including as it does a market leading £600 rack in a package that redefines the subtlety, neutrality and musical coherence available at this price. If you value a natural, unflustered musical perspective and a turntable that allows the music to speak for itself, then the Clearlight Recovery Basic gets an unequivocal recommendation. ➤+

TECHNICAL SPECIFICATIONS

Type:	Filament drive, composite plinth turntable
Speeds:	33 and 45, user adjustable
Motor Type:	DC
Tonearm:	Incognito RB300
Lid:	None supplied
Rack:	Clearaudio Aspect
Finishes:	Black or grey nextel
Dimensions (WxHxD):	660 x 860 x 570mm
Price :	Basic System (without tonearm) in black - £1995 Basic Turntable only - £1595 Grey finish - £50 extra

UK Distributor:

Aktiv Distribution (Isotek)
Tel. (44)(0)1635-291357
E-mail. isotek@aktivdistribution.co
Net. www.isoteksystems.com

FREE Hi-Fi Upgrade

hififorsale.com Ltd's AudiophileCandy
2003 accessories catalogue

Our NEW Edition Features:

- A massive selection of class leading audio accessories from manufacturers throughout the world
- Overviews and advice from leading industry experts
- The Latest Industry News
- 'Your Views' letters page
- Over 65 full colour pages featuring over 350 products



AudiophileCandy 2003 is your **FREE** essential guide to the very best in audio accessories.

Grab Your Copy NOW

For your **FREE** copy of our latest catalogue visit www.audiophilecandy.com and fill in our contact form or call;

0870 241 246 9

Advertise your old Hi-Fi for **FREE** on-line at www.hififorsale.com, or pick up an audio bargain. Every month we have over **30'000** visits and **1.8 million hits!** - What are you waiting for?

DON'T RACK YOUR BRAINS

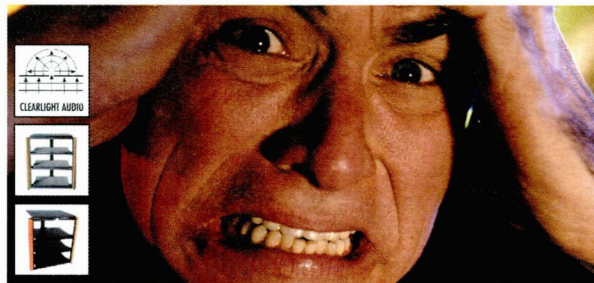

RACK YOUR HI-FI



"But how does it sound? Wonderful...The absence of resonant smearing allows the music to flow in an open, communicative and unforced manner." - **Hi-Fi+**



"A top performer with matching price tag. Stunning neutrality and laid back with it, detail and control were always in abundance." - **Hi-Fi Choice**



"It simply clarified music heard from equipment sited on it. The definition of an acoustic guitar's plucked harmonics was perceptibly, and repeatedly, improved, and there was less smearing of instruments in the soundstage." - **Hi-Fi News**



"The Aspekt works well with a wide range of equipment from Rega's £300 Brio amp through to our reference Krell set-up." **Verdict:** One of the best equipment supports around. If your system justifies the outlay give it a go. - **What Hi-Fi?**



TRY AN ASPEKT RACK TODAY
SIMPLY CALL: 0870 241 246 9

Amazing, but true. All acoustic recordings – voices, strings and, yes, even triangles – sound better if the system can produce really deep bass. Why does it matter?

Deep bass – for triangles??

You will take a major step towards greater **REALISM** if your system can produce really deep, clean bass – for all types of music. **HALL AMBIENCE** is underpinned by the **SUB-HARMONICS**. Reproduce them well and mid-range fills out. Music comes to life, as colours brighten when the sun shines.

But excess bass spoils everything, clouding the critical midrange and slowing rhythm. The deeper your speakers go the more likely your room will suffer **BOOM**. Add most sub-woofers and it gets worse.

THE ANSWER is a "smart" sub-woofer which can be controlled for volume, phase and frequency at *both* ends of its range: especially at the bottom to **DRIVE THE ROOM** cleanly, even cancelling boom.

The **AUDIO PHYSIC LUNA** does this, and its servo control means it never slows the music. You get power in the bass, but also glorious imaging – in the **MID-RANGE**. Now everything is tight, clean, fast – and natural.

Reviewing its big brother, the Rhea, US magazine *Stereophile* said, "In my small room the Rhea made the illusion of a large venue believable..."

Customers say we make some of the **BEST SOUNDS** they have ever heard, so you know we can do the same in your home. Our advice will take account of your best components and guide you where change is needed, in stages you can afford. You **AVOID EXPENSIVE MISTAKES**, enjoy music along the way and save money in the long run.

JUST LISTEN AND YOU'LL KNOW.

The
Right
Note

Music in the home



BATH
01225 874728

CD: ACCUPHASE, ADVANTAGE, AUDIO SYNTHESIS, BALANCED AUDIO TECHNOLOGY, dCS (ELGAR, DELIUS, PURCELL AND VERDI), RESOLUTION AUDIO, SUGDEN, WADIA. **VINYL:** AUDIO SYNTHESIS, BASIS, CLEARAUDIO, DNM, (THE) GROOVE. GRAHAM, LEHMANN, MICHELL, STRATOSPHERE, SUMIKO, TRANSFIGURATION. **AMPLIFIERS:** ACCUPHASE, ADVANTAGE, BALANCED AUDIO TECHNOLOGY, CAT, DNM, GAMUT, HOWLAND, NAGRA, SONNETEER, SUGDEN. **LOUDSPEAKERS:** AUDIO PHYSIC, BKS, ETHOS, NEAT, TOTEM, VERITY AUDIO. **TUNERS:** ACCUPHASE, MAGNUM DYNALAB. **CABLES:** ACOUSTIC ZEN, CHORD Co., DNM, HOWLAND, NORDOST, SILTECH, YAMAMURA CHURCHILL ETC

Winning Hand!

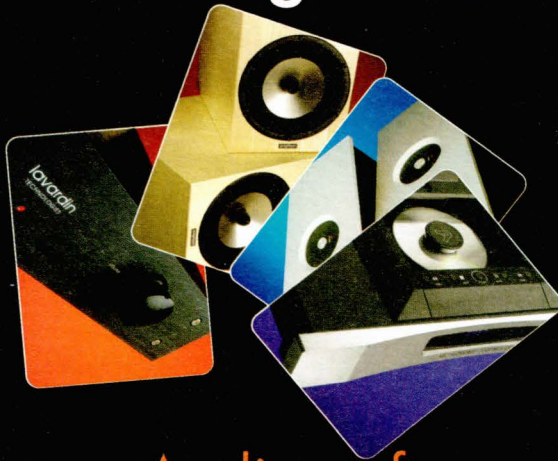

Audiocraft

Systems that include Amphion, Rogue Audio, Metronome & Lavardin

Call 01895 253340 to request an information pack
Fax 01895 238238 Email kevinwalker@genie.co.uk



ARE YOUR SPEAKERS
DEMANDING BETTER
WORKING CONDITIONS ?

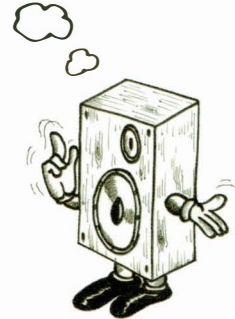
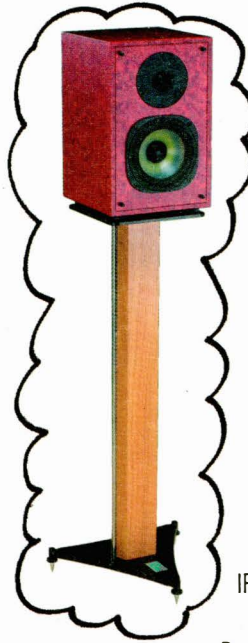

IF Designs Speaker Stands

www.ifdesigns.co.uk
Brochure Request: 0870 744 1382
email: innovation@ifdesigns.co.uk

PURE
by VideoLogic

DAB digital radio
Digital Audio Broadcasting

Third Generation DAB Digital Radio Tuners



EVOKE-1



DRX-701ES

sales@pure-digital.com • Tel: +44 (0)1923 277488 • www.pure-digital.com

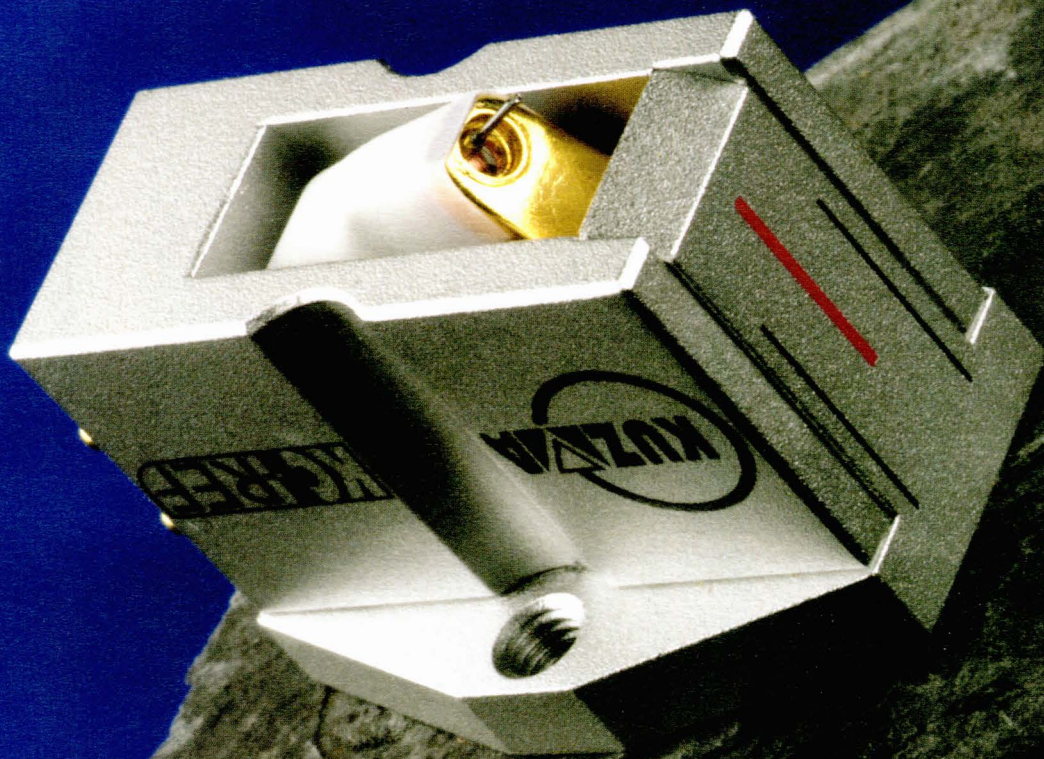

Kuzma KC-REF Moving-Coil Cartridge

by Roy Gregory

Barely a week seems to go by without the appearance of a new high-end cartridge, or a new one from an established manufacturer. In this case you're getting a little of both. Kuzma have long been recognised for the excellence and value of their turntables and tonearms, products that first reached the UK around 20 years ago. Now, Franc Kuzma has completed his analogue front-end by offering his first cartridge, a low-output moving-coil. Actually embarking on in-house cartridge manufacturing at this point in time would constitute confidence verging on the foolhardy. Instead, analogue old-boy Franc did the sensible thing and used his extensive contacts to tap into the vast experience in cartridge production that exists in Japan. That's where the KC-REF is built, to his exacting (and slightly unusual) specification. Made in Japan this is very much a Kuzma product.

It's an attractive and beautifully built cartridge. Not many pick-ups can stand blowing up to full-page size, what looks intricate held in your hand all too often appears crude close up. But not the Kuzma, its superbly machined aluminium body and carefully shrouded stylus assembly are the very model of a precision instrument. And it's not just a pretty face. As soon as you set up a VPI JMW tonearm you can instantly appreciate that Harry Weisfeld has incorporated all the features that he

always wanted in the arms he'd used before. In exactly the same way, the KC-REF is clearly the product of an analogue aficionado, and it's a joy to set-up. The connecting pins are colour coded and the mounting holes tapped. You get two sets of different length allen bolts for mounting, and a nice square nose that helps with initial

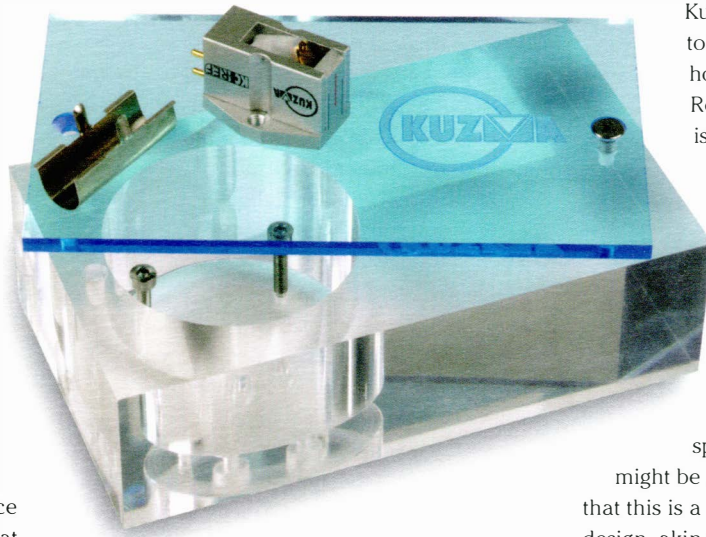

alignment. The flat bottom likewise helps establish initial vta. You even get a safe and simple to use stylus guard. In fact, the only complaint I can possibly make is that the cantilever itself could be a little more visible, rather than tucked under the unit's nose. Final alignment gets a bit tricky compared to the likes of Lyra and Clearaudio with their more exposed cantilevers, but that's really splitting hairs, and if it wasn't for the sheer practicality of the package as a whole it wouldn't even have occurred to me.

Internally, the KC-REF is as particular as it is sensible on the outside. The generator uses samarium

cobalt magnets, a soft iron armature and oxygen free copper coils. The cantilever is formed from aluminium clad boron and is tipped with an elliptical stylus rather than the more fashionable micro-ridge type. Output is a healthy 0.5mV, generous for a low-output design, and compliance is a low 9 cu, ideal for the heavier than average effective mass of Kuzma's Stogi Reference tonearm, but equally at home in the Tri-planar. Recommended loading is 100 to 2000 Ohms, and tracking weight 1.8 to 2.0g. I settled on 1.9g, which offered the best balance between life and solidity, although even at the lower limit tracking was never an issue.

Read those specifications and you might be forgiven for assuming that this is a rather old fashioned design, akin to something like a Supex. Certainly it stands in stark contrast to the likes of the Lyras, both technologically and sonically. Listen to the Kuzma immediately after listening to something like the Clearaudio Accurate and your first impression could easily be that it lacks speed and clarity, virtues in which the Clearaudio excels. But that only goes to show the dangers of direct comparison and first impressions. Sure, comparison tells you what the differences are, but not which is better or more natural, with exaggeration in particular catching the ear. Listen longer and you'll realise that this is exactly what's happening with the KC-REF. It's unforced and even presentation

▶ might sound dull initially, shorn of all the fashionable moving-coil fireworks, but the longer you listen the more you'll appreciate its easy grace and unfailingly natural balance.

Take speed and pace as examples. There's none of the obvious zip that you get from some cartridges. The KC-REF doesn't sound overtly fast. But listen to the easy loping bass lines on *Farmers Market Barbeque* and you'll soon appreciate that the notes are perfectly placed, their pitch and the steps between them immediately clear to hear. The gentle plod of 'St Louis Blues' never drags for an instant, the bass line slotting unerringly into an easy groove that carries the track beautifully, and it's then that you realise that the Kuzma's neither fast nor slow: it's spot on. Carry through to an up-beat track like 'Lester Leaps In' and it picks up its skirts with the best of them.

Why then the first impression? Most fast sounding products achieve the effect by paring away instrumental weight and curtailing harmonic development. The Kuzma does neither, exhibiting none of the leanness or etching that can sound so impressive on first acquaintance. Instruments portray their correct character and sound, their speed appropriate to their frequency, so that bass notes do develop slower than bells or other high-frequency instruments. It creates a soundstage in which instruments are correctly placed and inter-related, and in which they don't wander or step forward. Indeed, the Kuzma's soundstage is one of the most natural that I've come across, with excellent perspectives and decent depth without that false, ultra focussed high-definition quality favoured by some high-end companies. By getting the harmonic and spatial relationships between instruments correct, the structure and chemistry of the original performance is preserved.

Listening to the KC-REF is a remarkably easy and relaxing

experience exactly as it should be. Part of this is down to its innate balance of instrumental forces. It gets weight and speed spot-on and that means that it also delivers power. Not the kind of slap you in the face dynamic impact that CD so loves, the instantaneous bang that pins cinema goers into their seats. This is the deep-seated swelling solidity that reminds you just how many people there are in a symphony orchestra, and just how much acoustic power they can actually generate. It has far more to do with convincing on a musical level than any number of artificial, short, sharp shocks. Ask it deliver the drum cannonades from *Gladsome Humour And Blue* and it'll not disappoint in terms of weight and impact. But it integrates the drum set into the musical fabric, its contribution into the music, rather than simply firing the beats at you out of the blue.

There are, however, provisos to extracting this level of performance from the Kuzma: One concerns the loading, the other the vta. Despite having a theoretically less extreme stylus profile the KC-REF is extremely sensitive to correct vta. Not tonally, which is the assumption that people tend to make, but rhythmically. This cartridge needs to run ever so slightly nose down. Run it level and it'll sound dull and disconnected, musically disinterested. Conversely, run it too high at the back and things start to sound forced and hectoring. Of course, the Tri-planar and JMW tonearms make optimising vta a piece of cake. Unfortunately, they're the exception to the rule, but to put this in perspective, the ideal performance window in the Tri-planar encompasses around ten units on its micrometer scale! And that's not very much – at all. When it comes to loading, the manufacturer's recommendations are spot-on. It'll depend a little on the system, but I'd go lower rather than higher, with the KC-REF matching the 100 Ohm setting on my Groove perfectly. Less damping

again led to a lazy and slightly bloated sound.

In other words, don't be fooled by the warmth of the sound or the less than extreme stylus profile. You can get it wrong with the Kuzma just as easily as you can with any of today's other top-end cartridge designs. Because that's exactly what the KC-REF is. It might not enjoy a prestige name, or the price-tag that goes with it, but you'd be a fool to dismiss it. Anybody seeking a top-flight transducer to complete a serious analogue front-end should add it to their list. It combines the tonal qualities of Ortofon's MC7500 with the musical coherence of a Dynavector and the power and solidity of a Koetsu. Nor does it lack detail or definition. Placing musically natural presentation firmly ahead of the merely hi-fi spectacular, Kuzma's first cartridge is one for the connoisseur.



TECHNICAL SPECIFICATIONS

Type:	Low-output moving-coil
Output Level:	0.5mV
Compliance:	9 cu
Cartridge Weight:	9 g
Coil Material:	Oxygen free copper
Cantilever:	Aluminium clad boron
Stylus Profile:	Elliptical
Tracking Force:	1.8 – 2.0 g
Recommended Loading:	<100 Ohms
Price:	£2000

UK Distributor:

Audiofreaks
 Tel. (44)(0)208-948-4153
 E-mail. info@audiofreaks.co.uk
 Net. www.audiofreaks.co.uk

Manufacturer:

Kuzma Ltd.
 Net. www.kuzma.net

47 Labs / Miyabi Moving-Coil Cartridge

by Roy Gregory

47 Laboratories have built a reputation as purveyors of products that are small but beautifully formed. It's impossible not to be impressed by the exquisite execution they bring to their diminutive yet slightly kooky designs, be it the Flatfish CD player or the arch simplicity of the Phonocube head-amplifier. Which is just as well given the astronomical pricing in a market where value is all too often calculated by pounds weight. So I was hardly surprised to discover the nicely understated cylindrical wooden box that arrived mummified inside enough bubble-wrap to create a Tate Modern installation. The discrete calligraphy on the lid reinforces the impression of quality, which only increases the shock when you twist off the lid to reveal the cartridge inside.

In a world awash with increasingly exotic cartridges, it's hard to imagine a less impressive looking beast: especially when you consider the \$XXX asking price: especially when you sit it side by side with the perfectly formed Kuzma KC-REF which I had for review at the same time. We are talking plastic body, flip down stylus guard, open shoulder mounting and slot head screws! Aesthetically we're back in Shure land, circa 1975 – and we're not even talking V15, nearer your M75.

So, whilst it might be the 'small

but beautifully formed' tendency that's caught the public eye (and ear), it's definitely the 'dare to be different' mode that's operating here. In fact, I don't know why I'm surprised at all. 47 Labs have a habit of challenging

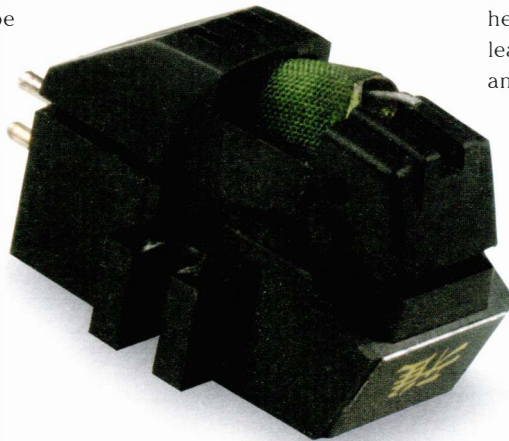

conventional wisdom, so why shouldn't they treat milled from solid cartridge bodies and the associated overriding concerns with structural integrity with the same disdain they reserve for massive power amplifiers, exotic cabling and CD players that it takes two people to lift? The interesting thing is that once you get over the initial 'someone stole my expensive cartridge and substituted a cheap, plastic bodied moving-magnet' shock of first sight and look a little closer, you begin to realise that there's more here than meets the eye.

Okay, there are no tapped holes for mounting allowing the fiddly struggle with nuts and bolts an unwelcome return to the arena of cartridge set-up, but the top-plate has been carefully sanded smooth to allow a proper interface with the headshell. The nasty stylus guard at least does a job during installation and can then be discarded as per 47's recommendation. The pins aren't colour coded (which is one of my pet hates) but reading the instructions that arrived by e-mail I learnt that neither are they anchored! Too much rotational force when it comes to attaching stylus tags and you risk snapping the hair fine internal wiring, so double check that you've got the layout right before you start installation.

The generator assembly is beautifully shrouded too, which further hints at the care that's actually been lavished on this otherwise mundane looking device. You see, just like their electronics, the 47 Labs cartridge adopts a rather more sophisticated approach to the question of structural resonance than simple, solid mass. Whether it can conjure a stellar performance from such an unlikely looking source is both the proof of their pudding and the challenge to those preconceptions that make it seem so unlikely in the first place.

For some reason (and despite ►

▶ my initial concerns) the cartridge slotted straight into the JMW headshell with nary a pause for adjustment. Either it was fluke or the air earth currents were in perfect alignment. Even the nuts and bolts were less than their troublesome norm, and rarely have I had a cartridge up and running quite so quickly. Mind you, was I glad of the JMW's easy VTA adjustment. Few cartridges I have used exhibit quite such a gulf in performance between just about and absolutely spot-on, and few are quite so misleading on first listen.

Correctly set-up the 47 Labs has one of the most tactile and expansive sounds I've ever heard, but it also sounds initially dull and shut in at the top. Raise the back of the arm and you get more high frequency energy but you lose the acres of space and rhythmic ease, replacing it with a forced, congested and mechanical balance. So, spectral balance familiar: musical presentation lousy. Work back down the arm height scale and first the high frequency hash disappears and then the soundstage starts to expand, bloating at first before settling into a focussed and transparent whole. Which is when you realise that along the way you might have lost high frequency energy but you've lost no high frequency information. The music's all there, as is the air and space, it's just not as obvious (or exaggerated) as it is with most cartridges.

In fact, the key to the 47's performance is that sense of space; space that allows the music to breath.

As I've already said it's an incredibly tactile performer which says an awful lot about its way with tonal colour and harmonic structure. Combine that with an incredibly natural soundstage perspective and a sense that there really is a place for everything and that everything's in its place and you have all the ingredients for magically convincing reproduction.



Du Pre's cello (Elgar *Cello Concerto*, Barbirolli and the LSO, EMI ASD 655) has a wonderfully vibrant solidity and presence, sat firmly in front of the massed ranks of the LSO, inside a wide, deep and tall acoustic space. The sweep of bow on strings and the music as a whole is equally breathtaking in this most quint-essentially English of performances, a quality that is beautifully and emotively captured. But, although instruments are wonderfully separate, it's not the sort of pinched, etched separation that leaves music carved from solid and just about as animate. Instead, the images are superbly scaled and localised, with volume

and body rather than hard edges. Much of the separation is tonal, a capability that I first noticed with the Lamm L2 Reference pre-amp, a unit that lacked the resolution of its rivals, yet managed to effortlessly surpass them in terms of instrumental identification and separation. The 47 Labs cartridge pulls the same trick.

Surface noise is there but so distinct and separate from the recorded information that it really has to get nasty before starting to intrude.

If you want microscopic analysis and detail uber alles then there are plenty of cartridges that you'll prefer to the 47: They're the ones that dissect

music and put it on a slide for you. But if you value coherence, integration and the bigger musical picture then this cartridge should be right at the top of your list. Its wide-open perspective allows music to breathe, while its unforced, unexaggerated and natural sense of organisation keeps everything perfectly in proportion. I haven't mentioned dynamics yet, but in many ways they offer more of the same. The smooth refinement of the sound lacks the gritty ▶

► immediacy of an Insider or the ultra resolution of the Lyras, but it also lacks any artificial edge. It's a smoothness that can easily lull you into a false sense of security, because when the music gets big on you it really does. Whether it's the massive swelling heavens of the Elgar, the crash bang crescendos of the Massenet *Le Cid* (Fremaux, CBSO EMI Studio 2 Stereo Two 350) or the insistent, driving beats that propel 'Shotgun Down The Avalanche' (Shawn Colvin *Steady On*) or Lloyd Cole's 'Forest Fire' the 47 rises mightily to the occasion. It tracks musical density and energy levels with the same unflustered aplomb with which it lays out an orchestra or defines the limits of a recording studio. When the groove says more that's exactly what it gives you, without ever seeming to reach the end-stops. It's an ability that lets it shift effortlessly from the scale and drama of a full orchestra to the finesse and dynamic agility of a Mozart *Clarinet* trio and on to big band jazz or rock without breaking stride. It's the music that dominates proceedings rather than the transducer that's doing the tracking.

It's weird how products seem to arrive in groups where one reveals something new to you and then others underline it. First came the Lamm L2 Reference, then the c-j PV14L and MV60-SE. At the same time I received the Kuzma KC-REF, a cartridge that set new markers for naturalness of presentation, markers that now serve as way-points on the path to where the 47 Labs is at! The way in which all these products dovetail is fascinating. The tonality

and harmonic structures of the Lamm appear again in the 47 Labs, along with the spatial coherence and natural perspectives of the c-j. The Kuzma stands astride the trio, more recognisably related to accepted standards, and arguably as a result, offering the most carefully balanced performance of all. But the character and ethos of each of these products is reflected in the others, and it's the



taste of live performance that you hear. Using the 47 Labs in combination with the connie-js played to the strengths of each, creating a whole much greater than the (considerable) sum of the parts. Together they offered such direct access to the gestalt experience of the original performance that the standard hi-fi considerations were rendered utterly irrelevant. You'll notice that I haven't said that it was just like being there, the standard hi-fi cliché. I didn't need to be there because the system

bought the music to me. It might seem like a subtle distinction but once you hear it you'll appreciate just how fundamental it really is.

The 47 Labs cartridge is a difficult one to encapsulate simply because it challenges so many of our precepts regarding the relative importance of those things that together we consider hi-fi. Some of those things are to do with the way it sounds, some to do with the way it looks. It doesn't come with a USP, a story or a pitch. It doesn't obviously excel in so many fashionable respects, but it's exactly the lack of any obvious influence that makes its music so engaging and convincing. That it is music is unmistakable, and perhaps that says it all. ➤+

TECHNICAL SPECIFICATIONS

Type:	Low Output Moving-Coil
Output Level:	0.2mV
Internal Impedance:	2 ohms
Cantilever:	Aluminium
Stylus Profile:	Elyptical
Weight:	13g
Price:	€4,500 (£2,830 + VAT)

European Distributor:

Konus Audio Systems (Sarajevo)
Tel. 00 387 61 171641
Fax. 00 387 33 201066
Net. www.konusaudio.com

Manufacturer:

Haruo Takeda for 47 Laboratories

At the Manchester Hi Fi Show: Hilton Manchester Airport: Room 164
16th & 17th November 2002

"..Neat's
ULTIMATUM
deserves
recognition
as amongst
the very best
there is.."

Hi Fi + April 2002

Ultimatum

neat acoustics + 44 1833 631021

music to the *n*TH degree

www.neat.co.uk

Lumley

LAMPROS

*Designed for the purist,
the music lover and the rest
of the family*

Any colour
and any wood finish



Distributed by: Metropolis Music, 6 London Road, Tunbridge Wells, Kent, TN1 1DQ
Tel: 01892 539245 Fax: 01892 616383

Distributors for Boulder, Passlabs, B.A.T. Advantage, Hovland, Burmester, SAT, VTL, Sound Lab, Kharma, Meadowlark, Copulare, Acoustic Zen

High quality Hi-Fi and AV cables from:

Black Rhodium, Chord, Clearlight, DNM Reson
Hificables, Nordost, QED, Van Den Hul

Other products from:

AudioPlan, Black Rhodium, Clearlight, Densen
GP Audio, RDC, Resolution Audio, Ringmat, Shure
Vibrapod

- Expert advice
- Exceptional prices
- Exceptional service
- Free UK delivery

web: www.hificables.co.uk tel: 01273 269789

Heatherdale

● audio limited

**202, Findon Road,
Worthing, BN14 0EJ**

Pre-owned Equipment Available with Guarantee

Export Facilities Available. Visit our Web Page www.hifi-stereo.com

Main dealer for Mark Levinson Reference products

<p>Now Open Brand New Mark Levinson Listening Room</p> <p>SPEAKERS</p> <p>Audio note AN J SP speakers £650 Mission 782 (stand mount model) (Black ash) £150 ATC SCM 50A activespeakers £3495 Tannoy Kingdom 12 x demo speakers £3495 Pro-ac studio 1 speakers mk 2 £395 Castle 7 speaker £295 Audio Physics tempo speakers £995 Revel Ultima sub 15 with LE1 sub EPOA £1495 Epos ES30 speakers £1495 Jean-Marie Reynaud Offrand Speakers £1495 Thiel SCS 2 Speakers £1495 (Walnut Finish) (Brand New) (Normal Price £2395) £1595 Audio Note AN J SP Speakers £650 Orchid LWO Speakers (ex Demo) £2295</p> <p>PRE-AMPS</p> <p>Naim Audio NAC 82 Pre Amp with Toft Pre amp (fully balanced) £595 NAD 114 Stereo pre amp £99 Naim Nac 42.5 pre amp £150 Exposure 21 pre amp (remote) £750 Musical Fidelity MVT pre amp £395 NAP SC Power Supply £1495 Exposure 111 & 12 Pre Amp and Power Supply £650</p>	<p>Adcom GTP 450 Tuner/Pre Amp £350 Oakley High-end valve Pre Amp (similar to Conrad Johnson) £650</p> <p>AMPLIFIERS</p> <p>Nakamichi PA 5 stasis power amp £695 Naim Audio NAP 90 Power amp £395 Arcam xeta one integrated amp (pro logic) £595 Sirius D200 power amp - mint condition £195 Audiolab 8000 A integrated amp £245 AVI S2000Mi integrated amp (Ex demo) £750 Naim Audio NAP 180 Power Amp £795 (Brand New, Sealed, Boxed) EPOA Bow Wazoo Integrated Amp £1995 (Brand New) normal price £2500 Adcom GFA 5300 Power Amp £350 AVI Integrated Amp (ex demo) £750 Krell KST 100 Power Amp £1695 Nakamichi Stasis Power Amp £695</p> <p>CD PLAYERS & TRANSPORTS</p> <p>Pioneer PD 9700CD player £250 Krell Kav 300 CD Player £1995 Marantz CD 63 CD Player £3195 Marantz CD 72 mk2 SE CD Player (mint) £295 CEC TL1 CD Transport Belt Drive (Gold Finish) (Normal Retail £5000) £2650 Krell KAV 300 CD Player £1995</p>	<p>DACS</p> <p>Sonic Frontiers SFD1 £895 Digital Processor Theta Chroma HDCD DAC £775</p> <p>MISCELLANEOUS</p> <p>Nakamichi ZX1 1000 Cassette Deck (fully serviced) £1495 Luxman K331 W double Cassette deck £150 Nakamichi cassette deck 1 £395 Nordost Red Dawn BI Wire Speaker £1995 Cable 3M Set £499 Harmonix Record Clamp £195 Audio Note ANS7 MC transformer with phono stage £8495 Target Heavy duty speaker stands £195 Nakamichi BX300E 3 Head Cassette Deck £295 Nakamichi RX202E Cassette Deck £275 Quadrashire Q4 Oak Wall Shelf £120 Synergistic Research Coax Resolution Reference Interconnect (With Active Shielding) £250 Mark Levinson ML25s Phono Stage (with Power Supply) £3495 Rotel RQ970 BX Phono Stage £99 Stax SRS404 (SR404 & SRM006T) Head Phones (Normal Retail £1195) £750 Stax SR007 Omega Ref (SA007 Head Phone & SAM007T Dual Triod) (Normal Retail £2295) £1750</p> <p>Shun Mook Record Clamp (Normal Retail £1660) £995 Heybrook Signature System (CD Player, Pre Amp & Amp) £995</p> <p>TURNABLES, CARTRIDGES & TONEARMS</p> <p>Audio research PH3 Phono stage £1495 Eminent Technology Air Bearing Tonearm with Magnesium Wand c/w Pump £1695 Helius Silver Wired Tonearm £995 Verdier Ebony Wood Arm Board (Normal Retail) £425</p>
---	---	---

We now offer 0% finance (subject to status).
Please phone to arrange an audition
Main Dealers for Mark Levinson, Thiel, and Absolute sounds
We accept Switch – Mastercard – Visa Diners Club – American Express

Tel...01903-872288 or Evenings...07860-660001
Fax...01903-872234
E Mail address; heatherdale@hifi-stereo.com

Linn

Naim

Rega

Shahinian

Dynavector

Anthony Gallo

Acram

Royd

Quadraspire

Stax

Tivoli

Themescene

Viewtec

Iso Blue

Loewe

For people who love music

To celebrate the launch of some new and sweet sounding audio components from two of our favourite manufacturers we are holding two musical evenings this winter.

On Monday the **25th November** we will be firing-up the fantastic new range from Naim Audio including the Nac 282 pre-amp CDX2 CD player and Nap 250 power-amplifier.

On Monday **December 2nd** we will showcase the long awaited Linn Klimax Kontrol pre-amp, Klimax twin power-amp and the legendary Sondek CD 12 CD player. We will also have on show Linn's Classik Movie System and Themescene movie projector.

Demonstrations will be at **7.15pm** and **8.30pm**
If you would like to come along, give us a call

Griffin Audio, 94 Bristol street, Birmingham, B5 7AH

☎ 0121-692-1359 email - griffinaudio@fsbdial.co.uk



JMLabs Electra 926 loudspeaker

by Jason Kennedy

Every now and again a hi-fi brand takes me by surprise. Focal-JMLabs is one such. Up until a recent factory visit I had tended to bundle the brand alongside other French speaker specialists such as Cabasse and Triangle, medium scale with a good range but nothing out of the ordinary. However, after an exhaustive tour of the facilities it's not hard to see why the brand commands 25% of the home market and is naturally keen to raise its profile in an important market like ours. The factory is enormous, probably about the same scale as the UK's biggest, B&W, employing 250 people and building an enormous range of drive units in-house. There are over 250 Focal drive units the majority of which are used in the brand's in-car and domestic loudspeaker ranges. Despite a recent 200 percent increase in production capacity Focal still can't make enough drive units to encourage OEM customers. At present they have only ten including Wilson Audio and more recently Neat Acoustics, but there are no plans to expand on this front.

Based in St Etienne near Lyon in South-East France the company was started by Jacques Mahul in 1980. He recently brought most of the company's facilities together under one roof but this still leaves a high-end cabinet making facility three hours away and the W cone manufacturing in a Government run facility elsewhere in the town. Its R&D facilities are pretty substantial as well, an engineering team lead remarkably enough by a young English ex-hi-fi hack Dominic Baker (some of you might remember him from a stint at Hi-Fi World in the early nineties). Dominic worked initially at Tannoy before joining Focal-JMLab three years ago. Now he is involved in the entire loudspeaker range and is directly responsible for models

like the Electra 926 and the brand's Utopia flagships.

The heavyweight Utopias are undergoing substantial changes as you read this and next year will see the unveiling of the complete Utopia II range. So far only the mighty Grande Utopia Be has been revealed, and if you've got £45,000 languishing in your building society I'd suggest you book a demonstration forthwith: they're pretty impressive.

The Electra range sits on the next rung down from Utopia and consists of three floorstanders, a so-called book-shelf model, two centre channels, a surround design and a subwoofer. The Electra 926 is the smallest floorstander but it's no shrinking violet. Standing over a meter high and weighing in at 36kg it's a serious loudspeaker by any standard. Our sample is in the Signature finish with red cherry veneered side panels and 'granite' central section. The finish on the side panels is quite heavily scored with natural grain marks which when they are coated in an egg-shell lacquer gives a result that almost looks unnatural. Apparently the French like their veneers to look really woody but to English eyes the effect, ironically, is almost the opposite.

There's no doubting the build quality however, one glance at the Gamma principle construction on a cut-away sample is enough to tell you why they're so heavy. The front baffle is 50mm thick for a start, two inches in old money, and it's reinforced by three cross braces that divide the cabinet up internally and provide a sealed enclosure for the midrange driver. Two of these braces sit directly behind the

bass drivers, providing a rock solid mechanical connection between driver and cabinet.

The unusual profile of this and other Focal cabinets is designed to create a time-aligned wavefront at a typical listening position. Instead of the more conventional alignment of driver centres by tilting the front baffle backwards, Focal has come up with the Focus Time system that's designed to present a coherent wave front at a specific 'focal length'. In effect this puts the ideal seating position 3.5m in front of the speakers.

This distance is not specified in the unusually comprehensive set up notes but virtually everything else is, including preferred wall coverings behind speakers and listener, an example of the ideal

ratio of wall lengths to room height should you feel

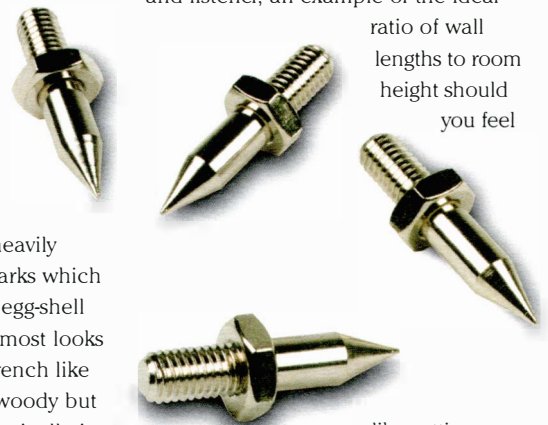

like getting purpose made housing

for your speakers and some surprisingly complex equations for speaker placement in the room. Only Audio Physic has produced instructions that are this complete in my experience. The Electra 926s are a little heavy to experiment with extensively so these notes came in handy when setting up these speakers on my Townshend Seismic plinths.

The Focal drive units on this speaker consist of a pair of seven inch

▶ woofers with 130mm cones, a six and a half inch midrange with 120mm cone and a 25mm inverted dome tweeter. All three cones are of Focal's preferred W variety. This is a sandwich design consisting of a structural foam core laminated with woven glass on one or both sides. The name W is derived from verre-verre (or glass-glass), yes they could have made it clearer, VFV might have been more obvious, though not a lot! Still never mind, it's the hand made, high stiffness to weight ratio of the result that counts.

The high frequency drive unit is a Tioxid 5 unit that, as with all Focal tweeters sits the other way up to every one else's. It's claimed that this allows greater efficiency and a lower roll-off point - the hand over from the midrange occurs at a lower than usual 2.5kHz. The coil is attached to the curved part of the dome rather than its edge as occurs with normal dome tweeters, the theory being that less energy is dissipated into the suspension this way. The tweeter and its neighbouring drive units are tied together with what Focal calls an OPC or optimum phase crossover, but the significance of this, beyond the fact that it brings the mid to treble cross-over down to a point below which the midrange driver would start to beam, is not entirely clear.

Enough about the theory, what about practice - do all these claims add up to anything if you want to enjoy your record(ing) collection. After all hype is not something that's hard to come by in

this game. Fortunately I'd say that these Electras do warrant time and attention with a decent system and some first rate music. One example being The Cinematic Orchestra's latest production, *Everyday*, which combines danceable jazz with some great tunes and makes for excellent late night listening. In the Electra's hands one is made fully aware

of the low frequency power on tap

at one end of the spectrum and the metallic nature of cymbals and brass at the other. In the middle things get even more interesting, vocals are remarkably well served by the mid-range driver and lyrics are precise and clear cut. The album contains

Root's Manuva's finest work so far, 'All Things To All Men', a reflection of urban living through somewhat less than rose tinted glasses. There's a

lot of soul on show and these speakers make no bones about it. They also serve the bass playing rather nicely, twin drivers always help - after all there's more radiating area, and if it's grunt you are after then more is usually more. Bass

from the Electra 926 is deep, controlled and powerful and seemingly a good reflection of what's on the recording. This one can establish by the variety in tone and character of instruments and voices on different discs.

Whereas it's pretty well impossible to know what the absolute sound of each recording is without having sat in the mastering studio, it is safe to assume that recordings will vary quite considerably. Variables include which microphones, recording techniques, mixing desks, monitoring systems etc were used in their creation, and that's to ignore the tastes of the producer and mastering engineer. The combinations are myriad, therefore any system that makes one recording sound much like the rest is not exactly high fidelity. These speakers do a particularly good job of revealing variations in imaging, compression, tonal colour and timing within recordings. They are remarkably transparent and responsive to intonation and nuance of playing. Which means they are equally adept at exposing the limitations of accompanying hardware; I had to hastily install a cartridge before some friends came round for a session one evening and could have done a better job, something that became abundantly clear early on and had to

be rectified on the spot wasting valuable

sessioneering time!

Likewise the filter settings on a Sony SACD player were less easily trifled with.

By which I mean you swiftly become aware of their effect whereas with other speakers they often seem quite subtle at first.

One aspect of the performance of audio equipment that intrigues me more than most is dynamics or energy. Few components are adept at producing this intrinsic ▶

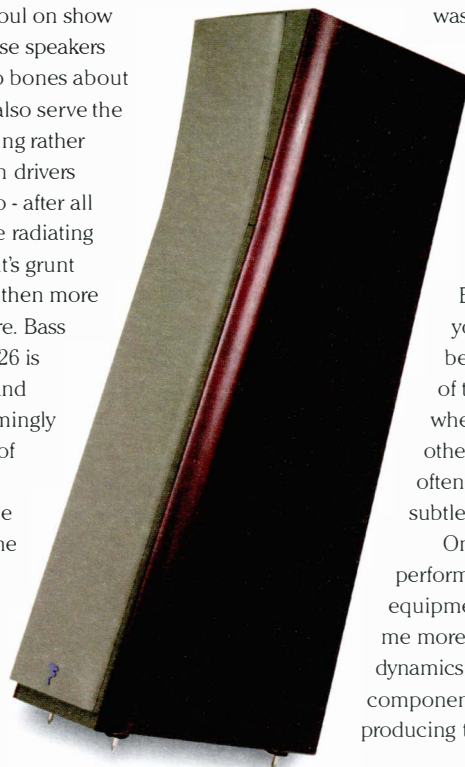

▶ element of music and those that do often have distinct limitations in other areas. The best example is the horn loudspeaker, when well executed a horn is by far the most dynamically powerful form of loudspeaker but making one with an even vaguely flat response is extremely difficult. At the opposite end of the speaker scale you have compact, low sensitivity designs that barely produce genuine energy however many Watt's you stick in the back. Then you get a better than average direct radiator like these Electras which are highly revealing of degrees of compression in recordings but which urge you to jack the volume up just that little bit more to hear things at their best. A speaker like the Living Voice Avatar OBX-R on the other hand, seems to dig out the energy in every recording and produce an engaging sound at relatively low listening levels. They still sound better louder but you don't feel quite the same urge to nudge the volume. The Electras are more revealing of the range of compression in recordings. You don't get the same energy levels overall but you get more obvious variations in energy level.

There's certainly no shortage of dynamic range either, the LSO Live recording of Shostakovich's *11th* practically blowing me out of my seat when this piece had built up from its subtle beginning into the towering inferno of the climax. The way it deals with high levels so effortlessly is also very gratifying. Few alternatives offer this bandwidth and dynamic range for the money.



The Electras are no slouches when it comes to transient speed either. They stop and start with remarkable precision, this is clear whatever you play but when there's a good deal of bass energy in the program it's hard to ignore. Eminem's unwholesome but strangely compelling 'Kill You' from the *Marshall Mathers* LP features a big bass note followed by momentary silence which these speakers revel in, cutting the note in its tracks and leaving a sonic void that is heavy with rapidly decaying bass harmonics. I guess tight would describe the bass performance, and indeed that from the rest of the range.

Imaging performance is highly dependent on how you angle the speakers but once they're dialled in things snap into focus. The speakers' size makes it hard for them to disappear sonically. You don't get the air and space of say the B&W Signature 805, but you get precise instrument placement between the boxes and in a bigger room I suspect they would blend more easily into the soundscape.

Most of my listening was done with LP and CD but I played a few SACDs for good measure as well. One particularly fine example of the art is *Gaudeamus*, a choral piece recorded in a church by Tom Jung of DMP records. The female voices on this regularly challenge the high frequency performance of loudspeakers, leading many to break up in a less than appealing manner. The Electras coped admirably, capturing the sound of the venue with ease and presenting the singers in a relaxed and natural fashion. It could have been a bit more open but in many respects it felt like a more realistic rendition than I've heard for

some time.

The Focal-JMLab Electra 926s represent tremendous value for money. The build quality is exemplary and while the styling might be a little Gallic for some tastes it's pretty restrained given the size of the box. Performance is very strong in many important respects and it's hard to think of many other speakers that could compete in terms of bandwidth, transparency and speed. I didn't have a valve amp of suitable grunt to try but imagine that they would sound rather gorgeous with a stiffly supplied 25+ Watter. As it is I used Border Patrol pre-amplification and Gamut power amplification to remarkable effect. It's the sort of speaker that leaves you wondering how much better it's siblings in the Utopia range sound, but how on earth am I going to get them up the stairs?



TECHNICAL SPECIFICATIONS

Type:	3-way, bass reflex
Tweeter:	25mm inverted Tioxid dome
Midrange:	6.5inch W cone
Woofer:	2x 7.5inch W cone
Bandwidth:	(+/-3dB): 38Hz - 23kHz
Sensitivity:	91dB
Impedance, nominal/minimum:	8/3.6ohms
Recommended amplifier power:	30-175w
Dimensions (HxWxD):	1083x250x417mm
Finishes:	Classic - black satin/anigré, Technic - granite/black cherry, Signature - granite/red cherry (shown)
Price:	£2,149

UK Distributor:

Focal-JMLab UK
Tel. (44)(0)121 616 5126
E-mail. info@focal-jmlab.co.uk
Net. www.focal-jmlab.fr



The Real Deal

LFD Zero LE Mk.11 Integrated Amplifier

by Chris Thomas

When you talk to the people at LFD you feel as if you are in the Hi-Fi business of two decades ago. There is no talk of the bottom line, margins, or of the scaling down of components to produce cheaper amplifiers. They don't feel the need to have a product at each price point or to swamp the audio-buying public with the "big new idea" or the revolutionary circuit design that yields such miraculous results. There is no sealed box inside each amplifier with the word Magic printed upon it. These guys are music enthusiasts first. The talk is of sound quality and how best to achieve it and they are just as fastidious whether talking about their bigger amplifiers or the budget Zero LE model. This solid-state amplifier has been in Mk11 guise for almost a year now. But, talk to LFD and they will tell you that it utilises the same main board as the original, it is just that the quality of components they are now able to source have improved to such an extent that they felt it should become a model 11. And, being LFD, they are quite happy to update earlier amplifiers, if they feel it is worth it for the customer. They even publish their own charter outlining their aims and values.

I doubt that anyone is going to buy this amplifier for its startling good looks or what it can do for their image.

People are going to buy it for its sound quality alone and that is precisely how it should be. And they will certainly get no argument from me because this little, relatively inexpensive amplifier is an impressive performer and, I kid you not, is actually more engaging and interesting to listen to than many others I have heard costing more than twice as much. The review sample

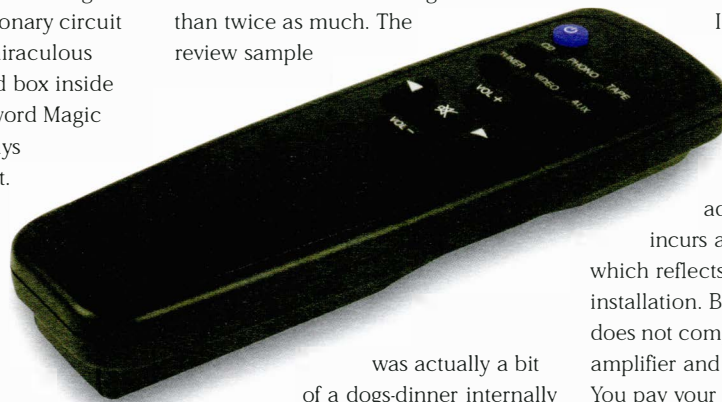

was actually a bit of a dogs-dinner internally as LFD had retro-fitted a self-powered a remote control volume control to it and I believe it had done the rounds a bit. There are two basic finishes available and this was the one with the Corian front panel and chrome knobs. Functional is probably the best way to describe it. It has 5 line inputs and one set of tape in and outs though there is the option of a phono stage, which can accommodate both moving magnet and moving coil cartridges. All rear panel inputs are via phono sockets though there are unusually, two sets of speaker terminals per channel for bi-wiring. Unfortunately these are awkwardly bunched into one corner of the rear panel making them

a little difficult to access with the unit in situ, due to the rear overhang of the casing. So 4mm plugs are a necessity and don't even think about using the connectors as binding posts or a short will surely be on the cards.

The remote control is a decent little plastic unit, entirely acceptable on an amplifier of this price.

It only operates the volume, and not input selection though I believe there are plans in hand to include this is, plus the addition of the remote also incurs a hefty £200 extra cost which reflects the complexity of the installation. But, according to LFD it does not compromise the sound of the amplifier and sleeps when not in use. You pay your money... as they say.

This was my first exposure of any LFD product that I can remember and there is always that feeling of anticipation when encountering a new manufacturer as to whether you will be rewarded with a pig or a prince when it is fired up. I normally get the machine running with whatever system I have set-up at the time, just to see that all is working. I hardly think that anyone would consider driving a pair of Revel Gems with the little LFD, but that was how I first heard it, being sourced by the impressive Metronome T1-i CD player, reviewed elsewhere in this issue. Not only was it working but it was doing a quite remarkable job. The speed, control and sheer

► exuberance of the sound took me by surprise. It is rated at 60 watts per channel, and feels like it has power to spare, even with such relatively inefficient transducers as the Gems. There was no rhythmic “dumbing-down”: in fact the LFD was among the fastest and sharpest amplifiers I have heard driving the little Revels. The limitations were there as well, but for a system so obviously unbalanced, it was surprisingly enjoyable.

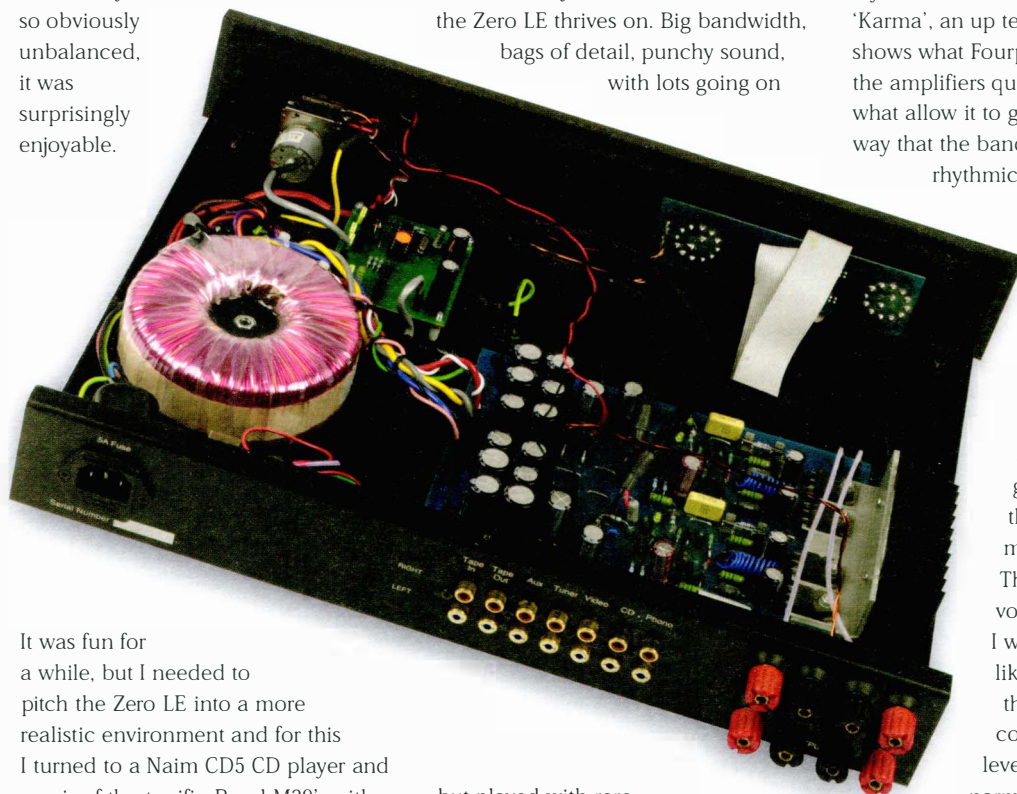

It was fun for a while, but I needed to pitch the Zero LE into a more realistic environment and for this I turned to a Naim CD5 CD player and a pair of the terrific Revel M20's with an interconnect from LFD and a set of Naim NACA5 speaker cables.

This proved to be a great little system and though I wouldn't rate neutrality as one of its strengths, in fact it was quite forward and in your face at times yet was always light in touch and rhythmically intriguing. This all stems from LFD's interest in the amplifier's speed of response and subsequent recovery. The ability to swing large transients without smearing what comes next is not uncommon in small, inexpensive amplifiers, but it is often at the cost of tonality and colour.

And any musician will tell you that the breadth of the tonal palette and subtle variations within are all prerequisites in an instrument for it to be emotionally expressive and, in this respect, amplifiers are no different. But let's start with the new Fourplay CD, *Heartfelt* (BMG 63916-2) which is their best for a while and the multi-track recording is pretty good too. This is exactly the sort of music that the Zero LE thrives on. Big bandwidth, bags of detail, punchy sound, with lots going on

but played with rare subtlety by top quality musicians. Never so well illustrated as the relationship between drum and bass which is at the heart of so much of what they are about. From the opening bars of the first track the LFD shows really sharp control and confidence with the way it maintains great space between the percussion and the bass, allowing the silence between them to create a real sense of physical distance. Gradually the guitar chops in another rhythmic suggestion then the whole thing hangs suspended for a brief moment before

three big snare shots and the band pours into the main body of the tune. Often, even on systems a lot more expensive than the one I had assembled around the LFD, this musical preamble just wafts by as an intro to the main event, but the impact and vitality of this amplifier really captures that rhythmic tension that releases into a gallop after the snare. My favourite track at the moment is 'Karma', an up tempo shuffle that shows what Fourplay do best. Again, the amplifier's qualities of control are what allow it to get to grips with the way that the band are able to shift rhythmic and harmonic

emphasis as a single entity and without any jolt to the musical flow whatsoever.

Push the system too hard though and a bit of confusion does set in and when you get to a certain level the music ceases to make as much sense. This happens at lower volume settings than I would have ideally liked but, to be fair, these were at considerably louder levels than I would normally listen. But I tend to think that most music almost decides its own

volume level where it sounds most right. At these higher levels there is also a noticeable hardening of the sound overall, but especially at the top end, which, despite its other qualities, is never a paragon of smoothness. I hadn't noticed it so much with the Gem and the silky Metronome, but the M20's certainly left it more exposed to a steely greyness at times.

One thing that the Zero LE does have is resolution beyond its price ►

▶ and its forwardness tends to emphasise this. Benito Madonia and Antonio Forcione's album *Vento Del Sud* (Naim cd050) can sound like a bloke who has smoked too many cigarettes and an acoustic guitarist. But, as I have often mentioned, Antonio understands the dynamic potential of his instrument and has an enviable sense of volume and a very expressive way of addressing the strings and frets. A lot of his most delicate moments come when he is playing at his quietest and as he drops the volume you tend to listen harder and it pulls you in a little deeper. But the contrast between the

the fact that the sound can be a little brittle at times, especially when pushed and tonally bleached as well. Violins, string sections and vocals are leaner and thinner than ideal and there is undoubtedly a bit of high frequency emphasis present which requires that a certain amount of thought goes into partnering equipment. If you listen primarily to classical music where you would gladly trade a bit of that sheer transient grip for

a compromise needs to be reached. At this end of the market you are not going to find too many amplifiers that offer anything like tonal neutrality. Come to think of it even £5K a box hi-fi doesn't do that. All manufacturers offer their version of events and LFD are no different. I feel about the Zero LE in much the same way that I felt about the small Exposure 2010 amplifier that I tried several months ago. They are both exceptionally good but different amplifiers for the price that are, above all, great fun to listen to and any criticisms of their performance must be fairly balanced against their price. Personally, I think that the non-remote version is the real bargain and I can easily imagine it doing sterling work in the right system. As a first upgrade to a serious amplifier it gets a big thumbs-up. ▶+

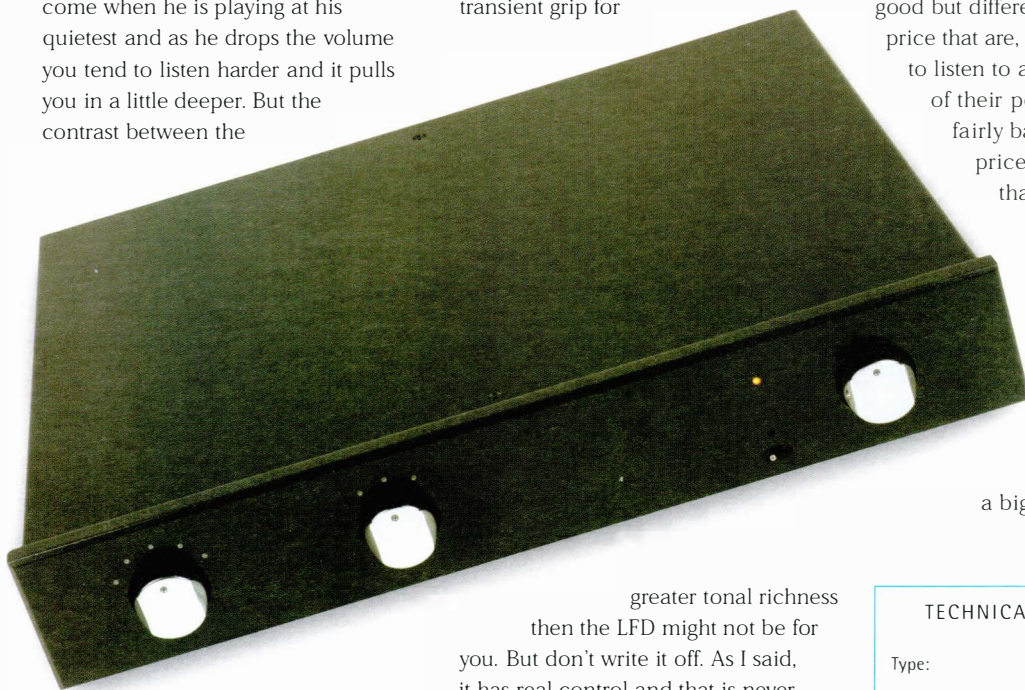

raw, gravely vocal and the tonal sweetness of the guitar are one of the things that gives the album its appeal to me and the space in between the two is also vital for the music to have a sense of drama and presence. The transparency of the Zero LE allows you to see through the music as the closely miked guitar leads and embellishes each tune. And the resolution is well up to allowing you to appreciate the pure physical mechanics of playing the instrument like the different vibrato or the variations in plectrum technique.

So what about the downsides, I hear you ask? Well, you can't ignore

greater tonal richness then the LFD might not be for you. But don't write it off. As I said, it has real control and that is never a bad thing, whatever music you are into. Also, there are a number of £1K speakers out there that could benefit from an amplifier with such an energetic sense of drive. And I don't really want to bag this LFD as just a speed merchant that only really works on thunderously rhythmic music with a driving pulse. Surely a good amplifier is just that and should be at home on all sorts of music. When I think of the very best products I have ever heard, they were just as enjoyable, and even beautiful, on the slowest adagio as they were on electro-funk. It is just that, at this price you cannot have it all and

TECHNICAL SPECIFICATIONS

Type:	Single box solid-state integrated amplifier
Inputs:	5 line-level inputs plus tape loop with optional mm/mc internal phono stage available.
Speaker connections:	2 pairs per channel (4mm sockets)
Power:	60 watts per channel
Dimensions (WxHxD):	430 x 65 x 340mm
Price:	£799 non-remote £999 remote

Manufacturer:

LFD Audio, 7 Lancaster Gardens West,
Clacton-on-sea, Essex CO15 6QG.
Tel. (44) 1255 42533
Fax. (44) 1255 221069

audiocounsel

Firstly we love music. Then we select the best equipment to reproduce it.
For the best sounds and the best service; audiocounsel; where Customers and Music matter.

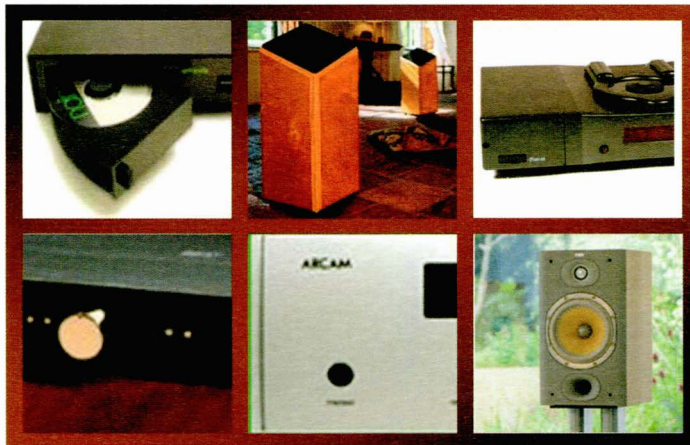

ARCAM, B & W, CHORD COMPANY, DENON, DENSEN, DYNAVECTOR, ISOBLUE, NAD, NAIM, PROJECT, REGA, ROTEL, SHAHINIAN, QUAD

12-14 Shaw Road Oldham Lancs. Phone:- 0161 633 2602
Plus NEW SHOP 26 High Street Cheadle SK8 1AL Phone:- 0161 491 6090

Hazelmere Audio



art loudspeakers



Spectral

Digital

dCS
Opers 21 (new from Resolution Audio)
Oracle
Metronome

Amplification

DNM
Nagra
Plinius
Renaissance
Spectral

Power supply

Accuphase
Isotek
Loricraft

Vinyl

Avid
Garrard
Oracle

Speakers

ART
Talon
Verity Audio

Cables

Nirvana
Siltech
Spectral



Avid Acutus Turntable

If you *value the best*
(rather than just the most expensive)

For an appointment (day or evening)

Call High Wycombe **(01494) 865829**

Audio Analogue • BKS • Creek • Crimson • Ecosse • Epos • Fanfare • Divergent Technologies
Gamut • Harmonic Technologies • Ortofon • Sugden • Triangle • Unison Reseach

**Bocchino Audio
High-End Connectors**

Brenda™ Phono Plugs



Gold-plated, High Conductivity phono plugs and chassis sockets

Visit our website:
www.bocchino-audio.co.uk
and make your purchase online!

www.supradirect.co.uk
The 1-stop website for discounted
Supra cables and connectors.

Featuring:

- Best Buy AV3 component video cable
- Best Buy AV6 RGB scart cable
- Best Buy X-ZAC fibre optic cable
- Best Buy Rondo 4x2.5T bi-wire cable

Bocchino and Supra products will also be on sale at: The Manchester Hi-Fi Show
Hilton Manchester Airport
16th-17th Nov 2002
Just visit the Audio Atmosphere room.

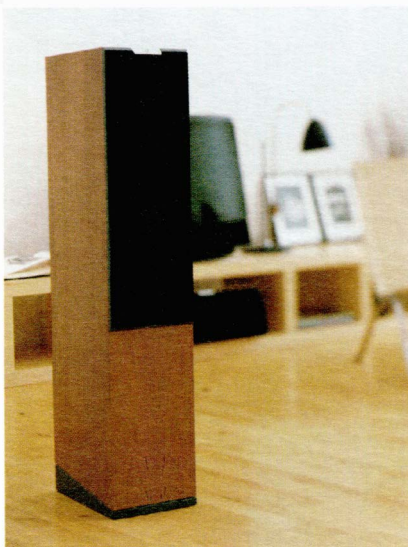

Audiovector M3 Signature shown above. Other products include bookshelf, centre channel and active subwoofer models.

Visit our website or clip the coupon for details and prices to be sent to you.

Post to: Audiovector UK, Unit 7, Wren Industrial Estate,
Coldred Road, Maidstone, ME15 9YT Tel: 01622 201983
Web: www.audiovector.co.uk

Name:

Address:

Post code:HFP0212



AUDIOVECTOR

Call us to arrange a demo
or visit our website at:
www.audiovector.co.uk

or visit us in the
**Audio Atmosphere
demo room**

at:
**The Manchester Hi-Fi &
Home Cinema Show
Hilton Manchester Airport**
on
16th-17th November

**We'll have some very
Special Show Discounts
on all show models.**

Introducing
the ea series
of amplifiers by ECS

Whether it's music or film the EA series will enhance your passion.
A range of amplifiers designed by enthusiasts for enthusiasts.

- Mono Bloc & Stereo versions
- 200w per channel
- Transformer balanced inputs
- Unbalanced audiophile gold phono connectors
- Ultra low impurity PCB copper track
- Zero inductance components used in critical paths
- Ultra low tolerance and inductance components used throughout
- Ultra short audio signal path
- Hand selected audio grade components
- 3 years parts and labour warranty

See & Hear us at the
Manchester show 2002.
Room 164

Contact us for more info and
for your nearest dealer.

ECS Ltd
020 8932 7995
020 8743 8880

'A' audiosolutions
Northern England
dealer for
"THE CARTRIDGE MAN"

Music Maker Cartridge - now in MK11 improved guise with no price increase - demonstrations by appointment.

NOW AVAILABLE IN THE UK FROM OPUS 3 OF SWEDEN THE CONTINUO TURNTABLE

Manufactured from 25kg of acoustically inert material. Designed to reproduce music with all the subtleties of timbre, timing and acoustics intact at a price that is very affordable. Available with Hadcock 228SE and Music Maker Cartridge.

GRAHAM SLEE projects distributor/dealer

KORATO amplification - UK dealer

Also UK distributors for
GOLDPOINT BARTOLUCCI KIWAME JJ

Amplifier rebuilds and custom built using best quality components.

Telephone - **01977 798844**
E-Mail - Audiosolutions@aol.com



Shop Talk...

by David Ayres

The Brief:

To build a well balanced system using Austrian hi-fi components

The System:

Rega Jupiter CD Player
Mace Audio Digital Pre-amp
and Stereo Power Amp
Trenner and Friedl Dizzy
Loudspeakers

Unlike recent system reviews, this one doesn't come from a dealer but a country. In this case, and in keeping with our theme, it's Austria, a country that all too often gets categorised as a national suburb of Germany (much to the annoyance of the fiercely independent Austrians). Their hi-fi is, as we shall see, equally distinctive. As the system was to be mid-priced, and based around the Dizzy (as in Gillespie) speaker from Trenner & Friedl, I asked Andreas Friedl to put together a set-up which he felt would deliver the musical goods. To this end he sourced the amplification from Mace Audio of Vienna, and the racks from Naim favourite Hutter. Cabling was from American company Cardas, for the simple reason that Trenner & Friedl speakers are wired internally with Cardas, and cable mixing is a black art at best. Finally no appropriate CD transport could be obtained from Austria, so the excellent Rega Jupiter CD

player was chosen.

Levering the system into my pied-à-terre in Vienna proved to be as troublesome as I had anticipated, not the least because the whole system turned up when I was only expecting an early delivery of the speakers. I somehow doubt that poor Andreas was expecting to be roped into moving all the furniture round my living room when he agreed to this review. By contrast, connecting up the system couldn't have been easier. With only a digital interconnect between the Jupiter and the Mace digital pre-amp, a pair of interconnects between the pre and power, and single wire speaker cables, from start to finish took a mere half an hour.

The power distribution board was supplied by Herr Friedl and is not commercially available, and the Mace power leads may or may not become available in the future. For the purposes of the review I substituted the basic Rega mains lead with one from Audioplan, and I used the Ringmat Statmat throughout the listening tests.

The Rega Jupiter was enjoyed by RG in Hi-Fi+ issue 14, but in that review it was being used as a player and not a transport. In the context of this system however, the DAC duties were performed by the Mace digital pre, and so much of

what was written there is irrelevant, but suffice it to say that RG would not have enjoyed listening to the Jupiter as a player unless the transport was well sorted. The Jupiter is simple enough to use, just lift the 'Starship Enterprise' lid, pop in the CD (and Statmat), close the lid and press play. The inclusion of CD Text is a natty feature that some people will find useful, but slightly frustrating



is the lack of a standby mode.

I'm not sure why Rega haven't fitted this feature, as the player, even when used as a transport, takes about an hour to warm up to peak performance, and when left fully powered the display beams out at you permanently - very annoying!

I have to say I was very struck by the looks of the Mace digital pre. Unlike the stereo power amp which is a dull black lump, the slim lines and the black finish contrasted by the inset silver fascia panel and control knobs looks classy and understated. The display is unfortunately a bit garish, but as it automatically powers down a few seconds after any control action this is not really an issue. Apparently there is a very attractive remote to go with this pre-amp, but it was not



► supplied for the review. Luckily the Rega remote would happily control the volume, although not the input selection, however as this was a single source system that was also not a problem. Internally this pre-amp is quite a sophisticated beast in terms of use of modern technology. As a digital pre-amp it contains a DAC and sample rate converter (up-sampler). Although up-sampling is the latest must have digital technology, it's certainly no guarantee of quality, and like everything else in hi-fi, it's not what you use but how you use it that counts

All other control functions are also software based, and the information required to perform these functions is sent via the two knobs on the front panel, or via the remote. There is also an internal menu

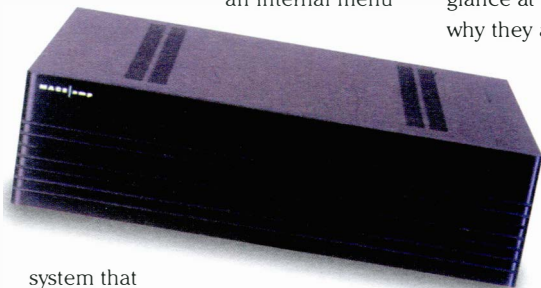

system that allows you to control items such as maximum volume, channel balance, input naming etc. The other slight problem I had was that the first few steps in the volume control were not fine enough, something that I am assured has now been rectified. I am hoping to bring a sample of the pre-amp back to England for further evaluation, as there are a number of features in it which are not covered in this review, and I also had no opportunity to compare the digital inputs against the analogue inputs due to a lack of suitable interconnects and time.

Power amp duties were performed by the 110W/channel Mace stereo power amp. Mace also make a mono-block version, but as the Dizzy is an

easy load, and as the listening room was only 6m x 4m x 3m, it was felt that the stereo version would be plenty sufficient for the job at hand. So it proved to be, as I had headroom to spare throughout the review period.

Trenner & Friedl's Dizzy speaker is their new baby floorstander, currently enjoying much success in



Japan and Switzerland. The approximate sterling equivalent price at the time of writing is just under £2,000, which puts them into first upgrade category. A quick glance at the Dizzy will not show you why they are more expensive than the current glut of sub £1,000 floorstanders, as they have only a single bass-mid unit and a single tweeter per speaker. The cabinets themselves are well finished, but have none of the currently fashionable sculpting or radiused edges.

In fact the only thing that marks them out from the crowd on first appearance is the brushed aluminium baffle. Look more closely however, and you will see that the two drive units are of very high quality, and the cabinet work is to a very high, and thus expensive, standard. Also the baffle is of an expensive to build sandwich construction used to cut down on destructive vibration. Where some manufacturers opt to open the window wide with the use of more and bigger drive units to give more bass, T&F



keep the window the same size but fit optical quality glass by the use of fewer but higher quality drive units. At this price you pay your money and take your choice. One noticeable concession to pricing comes in the form of the binding posts, which are quite fiddly and don't accept banana plugs. I found it quite difficult to fix the spade terminated Cardas cables, and they were never as firmly clamped in place as I would have liked.

By contrast the binding posts on the Mace amp were chunky and easy to reach, allowing a good purchase on the spades. To be honest this is a minor criticism.

The Dizzys are a bass reflex design, and are very successful in driving the listening room. As the one I was using had a length exactly double that of the height, I had some trouble positioning them so as not to cause standing wave problems. The initial positioning caused a major suck out at around 50Hz, and I eventually used them a little closer to the wall than I would have normally liked in order to achieve the best compromise. Having heard the Dizzys elsewhere I know that the final result was not quite as good as can be achieved in a better shaped room. However, it is worth

bearing in mind that the Dizzys do like room to breathe, and it would be best to hear them at home before purchasing – so no change there then.

Fortunately all the equipment apart from the Rega was fully run in, so all I had to do was put a CD on silent repeat play for a couple of days before starting the listening sessions. The first impression was one of extreme clarity and openness, without any treble harshness. This was not because of any ►

▶ treble rolloff however, in fact the high end was extremely extended. Taking 'Whole Lotta Love' from the re-mastered *Led Zeppelin II* CD as an example, on many systems the guitar break is harsh and piercing, yet with this system this simply was not the case. Yes it was sharp as it's meant to be, but not unpleasant and painful as it so often is. Another immediate impression was the sheer wealth of detail presented to the listener, not in terms of



a welter of leading edges, but in terms of the micro dynamics that make well played acoustic guitar so engaging. Listening to T&F's own demo CD of a locally recorded flamenco guitarist, I could hear how each note was played, the individual emphasis given to each phrase. Another CD where this level of clarity shone out was *Welenga* by African Griot, Wes Madiko. On the title track this astounding journeyman singer breathes and croaks his way around the words in a manner unexpected by the western ear, and the system produced every breath and vocal contortion with ease, allowing unfettered access to a style of singing that is at odds with the UK norm.

Playing 'Mein Hertz Brennt' from Rammstein's *Mutter* CD shows up the system's limitations. Here we have a band who like to throw out gobs of deep rich guitar, something that requires a large amount of lower mid / upper bass power. This is a track that should have real visceral impact, but on this system this impact was muted. To be honest I wasn't surprised, as to achieve the correct result requires

6.5" bass / mid-range drive unit per side. This was very much a case of me taking the speakers beyond their envelope rather than the amps, which never revealed any sign of strain, even with my heavy hand on the volume control. In the end I felt that the system made a better stab at this track than I had any right to expect, and that's because it kept everything clear and intelligible and rhythmically sound. On some systems this track will have the impact, but all mushed up into a thick soupy mess, a product of quantity over quality. I know which compromise I prefer.

From that you might get the impression that this system is lacking in bass, and it's true that some systems of this size and price go deeper. However there is a rhythmic intensity to the bass akin to listening to a Naim system that makes you forget about any lack of lower frequencies as you are

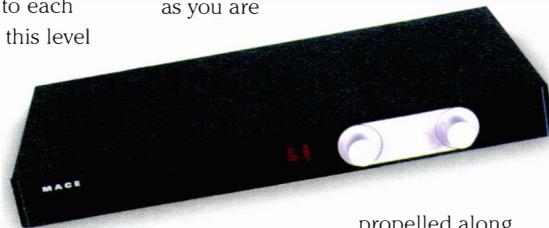

propelled along by the music's sheer fleetness of foot. Yes it's true that certain musical genres, as exemplified by the Rammstein, will occasionally expose it, but in the main the clarity and insightfulness of the performance will win you over every time. Listening to the Supercussion reading of *Spartacus* reviewed in the last issue showed that although the last ounce of weight might be missing, the timbre and decay of the percussion is all faithfully reproduced. In addition the system simply refused to be forced into harshness by struck metal percussion, such as bells and tuned pipes, which quite frankly is a rare achievement at this price range.

I thoroughly enjoyed my music

during the course of this review, and I was sorry to see the system go. For most musical genres it produces a clear and enjoyable window onto the music, and for voice and guitar it is outstanding. It's difficult to think of a similarly priced alternative that offers the same degree of refined clarity and intelligible, coherent information. I hope that these amps and speakers make their way over to the UK, as anyone other than a total metal head who is in the market for a system at this price should hear what they can do. One final point, late night listening with this system is a real possibility even if you live in a flat because, as I found out, it remained musical and involving right down to the penultimate stop on the volume control, and there's not many times that you can say that. ▶+

Mace Audio

Styria-Hifi-Vertrieb
Peter Haidinger
Thoneben 108
A-8132 Semriach
Austria
Net. www.maceaudio.at

Product: Digital Pre
Price: €3,540

Product: Stereo Power
Price: €2,590

Trenner and Friedl

Friedl KEG
Steinberg 107
A-8052 Thal
Austria
Tel. (44) (0) 664 4424105
Net. www.trenner-friedl.com

Product: Dizzy
Price: €2,542
Nextel finish: €2,750
Veneered finish

All Prices Are Exclusive Of VAT

Interview – Peter Gansterer of Vienna Acoustics

by Roy Gregory

RG. When did you start Vienna Acoustics?

PG. The company was founded in '89. I was playing around with loudspeakers, had a background in acoustical engineering from university. I started together with a partner, and we jumped right in.

We bought ground and built the factory. Right from the start I felt that it was important to have on the complete process. We took products to CES in '91 and there was some interest from international distributors, but most importantly from the best US distributor in my opinion, and that is Sumiko. In '98 the previous company was bought out by the present one, Vienna Acoustics GmbH, which brought us a new director, and that has been vital to the growth of the last three years. She looks after marketing and business for the whole world, and now I only have to worry about research and development. Project strategy, product development, trying things out, trying to develop better drivers and better matching, crossover components.

Loudspeakers seem to be pretty easy, and in theory they are, but when it comes to sound they are a very complex thing consisting of so many influential parts. Every resistor, every capacitor, every brace, where it is placed in the cabinet has a huge influence on the sound. In a three way speaker in particular, the crossover has a huge effect.

It's something we really concentrate on, judging the natural sound of a component. You can get the same capacitor from three different suppliers – same type, same material, same value, same voltage – but switching between them you sometimes think that one tweeter

has been switched off!

It's unbelievable, but easy to demonstrate. There is something that is very important here. What a designer develops in this hi-fi world often has very little to do with what the customer ends up buying. What the customer buys is often no better than a lottery. The designer might refine his product over several years, refining it and refining it. Then it

goes to series production. If the crossover is out-sourced then if the components are even a little bit different the result is a totally different sound. The drivers that are ordered are just the same. Drivers are finely tuned mechanical devices so that in an order of 1000 pieces you have huge tolerances. The designer works with tiny

changes in crossover values, 0.1 or 0.2dB, that make huge differences in the sound of the speaker. Then you get drivers in that are + 2dB. This is what really costs money. It's not the driver itself that is expensive, it's all the work that goes into matching it to the proper specification so that the customer actually receives the product as it should be.



► **RG.** So is it fair to say that consistency is the root of what you are trying to achieve?

PG. What we do is that when I have finished my development of the speaker I make an absolutely 100% copy of it and this then goes to the production facility. Whatever leaves the factory has to match that within very close tolerances, and we have closely defined standards for this. So if we have a production run of sixty pieces of a particular model, first we take out the Reference and measure it.

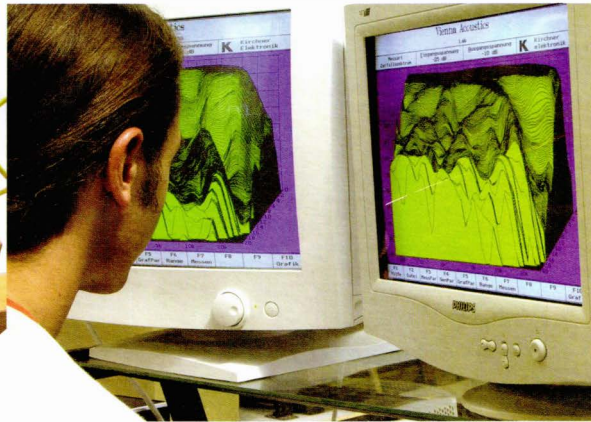

That eliminates environmental variation such as temperature, humidity, any variation in the driving amplifier. Each new speaker then has to match it. How do you achieve this? In a number of ways. First we measure each and every driver and categorise them: -1dB, +0.5dB, 0dB, and we have the crossovers built to correct them. Initially about 30% of the new speakers will not meet tolerances. By looking at their measurements, waterfall plot etc. we can then adjust these so that their performance is corrected. What we are looking for is an absolutely parallel frequency response to the Reference. We don't mind if it is 0.3dB louder so long as it is perfectly parallel. Of course, the two speakers in a pair must match.

RG. Where do you source your drivers from?

PG. The drivers are sourced from a number of companies, but mainly Scanspeak followed by SEAS. Together with

them I have done a lot of development work.

RG. And do you have preferred materials for drivers?

PG. Yes. For midrange drivers we have developed our own material which is XPP. The material we use is KPE from Japan, the lightest of all the thermoplastics. It has good inner damping but we add a little more by adding a certain percentage of polypropylene. That's why our cones are transparent.

The second material we use is paper: air-dried paper cones, usually filled with carbon fibres. That's where the rippled surface on our drivers comes from. They are also good for mid-range. I absolutely do not like metal and you'll never find metal drivers in our speakers – at any frequency, tweeters or bass drivers.

For bass drivers we adapt the way we use the materials that I like, because for bass drivers one thing is vital – the stiffness of the cone. So we can use stiffer versions of the paper cones with carbon fibres, and we also use a sandwich of carbon, honeycomb, carbon which is self damping. It has a resonance, but only in the mid-band, so it's not a movement resonance – you can't hear it. In the Mahler we cross over at 70 Hz.

We only produce two-way systems and what we call two-way systems with integrated sub-woofers:

The bass drivers are always filtered out by 100 or 110Hz. This is the highest frequency at which they ever work.

Otherwise they mess up the mid-range. Now what we are doing is developing our own bass-driver,

absolutely unique to us. We use XPP for the cone, but reinforced with moulded radial ribs. This cone is produced from our own tool here in Austria, and then sent to SEAS who build it into drivers. These ribs prevent bending and ensure that the driver behaves like a piston. Computer analysis also showed us the importance of ►

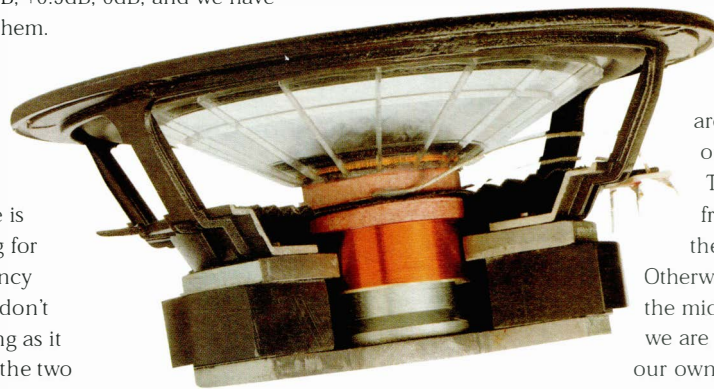

▶ the two ring ribs as well. The final structure is really incredibly rigid.

For tweeters we still try a lot of things. The latest unit we tried was a pure carbon tweeter which was very promising, with extension to 60kHz. In these days of DVD-A and SACD this is an issue, although I have to say that I'm very disappointed by the pricing of the discs. It's killing the new formats. Even at the recent hi-end show in Frankfurt almost nobody talked to me about it. I see the potential in SACD for example, but when I talk to the public who buy high-end audio, it's no issue. For the present we still haven't found anything that we prefer to silk dome tweeters, hand coated in a special way, and with careful shaping of the air gap behind the dome. And we've also developed our own neodymium tweeter, which is very good.

Cross-overs, we use the finest components, but everyone will tell you that!

RG. And cabinets?

PG. Ah, cabinets. When I develop a speaker design I am only concerned with sound quality. But we have to realise that if we are to deliver that quality to the customer then our products will always have to be at a certain price. Because of that we have to be concerned about the cosmetics. It's not enough to simply convince the customer with the sound. They have also to see a difference, and that means using nicely proportioned cabinets with a range of really well finished real wood veneers. We also use ten layers of lacquer, and have a special technique which only we use, for wrapping the veneer around curved cabinet edges, which makes a really big difference to the appearance.

Much more like solid wood. People like the finish of our speakers very much and we have achieved very high consistency with it.

But more important for us is how they are constructed, which is with massive front and rear baffles. We never go under 40mm of thickness. With the bigger models it's 50mm. And the carcass is very heavily damped and braced, using finite element analysis and an accelerometer. That defines where we place the braces, which is actually much more important for the side panels than massive construction. The bracing also comes from our policy of separate enclosures for the mid-range drivers.



RG. So you use internal baffles that double as braces?

PG. Exactly. Also, extensive listening tests that we conducted when we started the company demonstrated the importance of keeping the front baffle narrow. If you want to develop good sound-stage depth then it's important to avoid early reflections, and that includes diffraction from the baffle edge.

RG. If I was to characterise your speakers then I'd have to say that you've built your reputation on essentially traditional designs, but incredibly carefully executed. Yet the latest model, the Schoenberg seems like a complete departure.

PG. Yes and no. We feel that we have some highly innovative thinking in our existing range, but that it doesn't necessarily show. In marketing and management meetings we are always talking about the future and the

▶ new designs really come from the emergence of multi-channel. Over 50% of our speakers in the US go into home-theatre systems, so we started to think, if you have two Mahlers or Beethovens at the front, a centre speaker and two Haydns for the rear, isn't that a bit much for a living room. Fine for hi-fi enthusiasts but what are women going to say to that? So our conclusion was that the first thing that we could do to help was get the



speakers out of the room space and back closer to the wall. That's something that we could do that would really help. The first product we did like this was called Waltz, a shallow speaker that could be placed in a number of ways with a very simple mounting bracket. It was very successful.

But it also presented a technical problem. We use very thick MDF so it is impossible to get internal volume from a slim enclosure. This made me consider what other material we might use. Aluminium is ideal. Extremely rigid even when it's thin. The problem is that it rings, especially when you have a cabinet that's shaped almost like a bell! We counteracted this by splitting the cabinet in two. We joined the two halves with MDF which will already damp them, but we covered each contact surface between the Aluminium and the MDF with a special rubber, for even greater damping. The result is really good. Very dead. You'll never find a wooden cabinet that behaves this well.

So this was the technical solution, but we still needed to develop more bass. In order to do this we looked at the interaction between the crossover and the drive unit.

You can model any driver as a composite of resistors, capacitors and inductors. By combining these values with the values of a filter contained in the crossover, you can alter the performance parameters of the driver to the ones you want. This means that we can trick the speaker into producing more bandwidth. So the little Berg surround speaker works down to about 80Hz.

The next thing to do was develop a small tweeter.

Most neodymium tweeters are so small that there's almost no air gap behind the diaphragm. By using a three part magnet and small mechanical dampers, we are able to both vent the diaphragm and roll off the tweeter's lower output smoothly and quickly, making for a far simpler cross-over. To do this needs a very long throw, so the tweeter is a very special driver, but also a very expensive one as it has to be built to incredibly tight tolerances.

The Schoenberg floorstander is the only model in the range that's reflex loaded. It uses a twin port system in a two and a half way



arrangement, so each driver is individually ported, with the ports hidden in the edge of the 'wing'. The system can be built up using any combination of the models, even five Bergs and the sub-woofer, because of the symmetry of the smaller designs they can all be used horizontally or vertically, and have the brackets included to let you do this. It makes a very versatile and domestically acceptable product line, both in terms of price and placement.



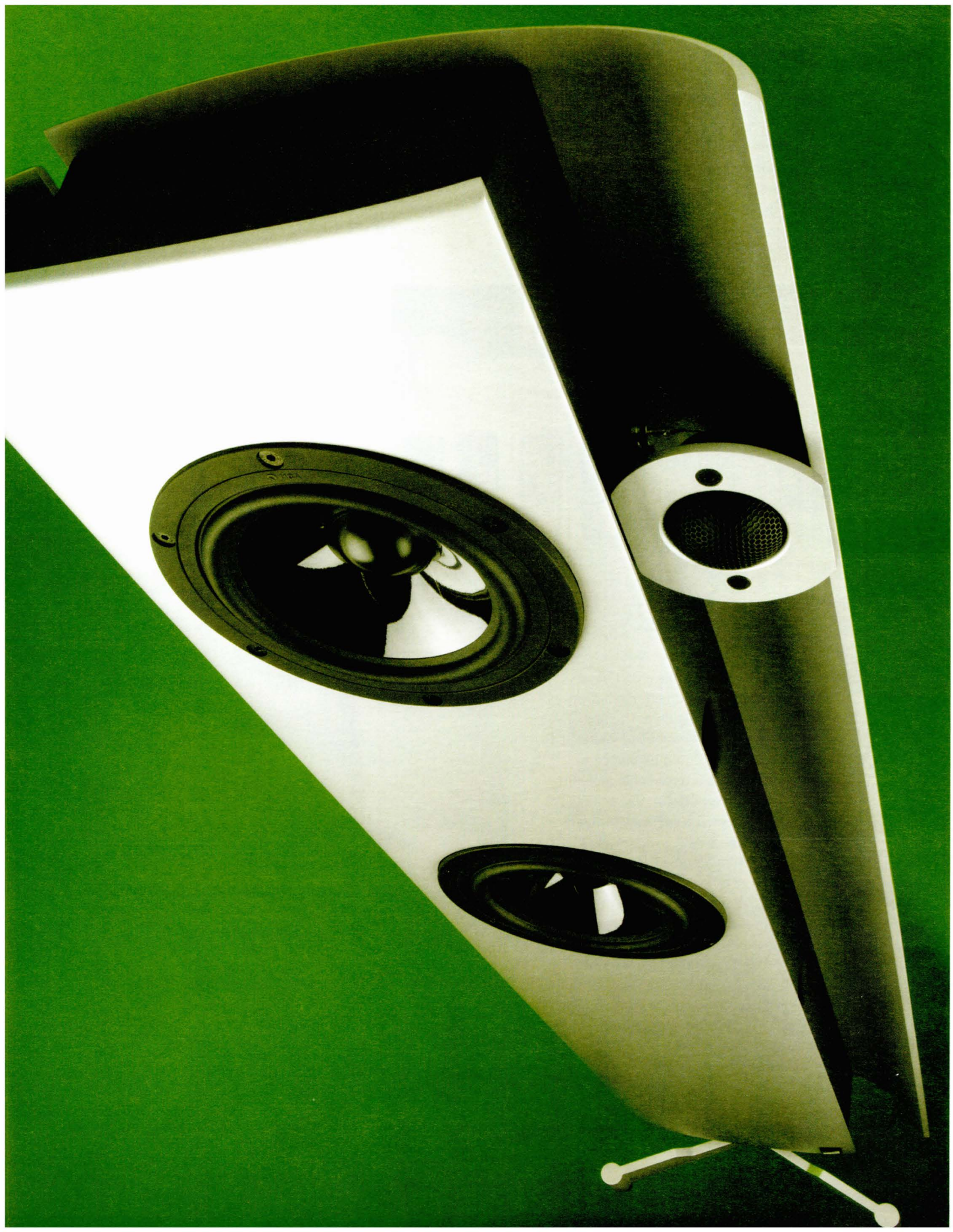

Vienna Acoustics Schoenberg Loudspeaker

by Roy Gregory

Vienna Acoustics have built an enviable reputation based on a range of exquisitely finished box speakers, each named after one of the great classical composers. But the quality of the finish and the conservative styling has tended to distract from the attention to detail and innovation that's gone into the designs. Now we have something of a departure, in the futuristically shaped and appropriately named Schoenberg, a tall, slim speaker with clear designs on the lifestyle market. Indeed, it comes with smaller siblings using the same clamshell cabinetry to offer centre and surround options, complete with some of the neatest and best executed mounting hardware I've ever seen.

But there's far more here than a pretty face and a few well engineered fixings, and the first shock comes when you pick up the speakers. If you are used to the flimsy construction of built to a price 'designer' speakers, the weight of the Schoenberg will come as a surprise. As will the obvious substance and rigidity of the cabinet. Built around two curved and carefully radiused aluminium plates, these speakers are seriously solid. The almost airfoil section that results has the effect of looking a lot slimmer than it actually is. In fact, the two 110mm bass drivers are full depth units built onto substantial cast baskets with equally impressive

magnets attached: No puny slimline drivers here.

Likewise, the small faceplate of the soft-dome tweeter conceals a single point fixing and flying leads and plugs that connect into their own little sockets. Blown tweeter? Changing it is a matter of moments involving a single allen key. The black rubberised bodywork that joins the clamshell together is heavy and well damped, the vertical infills on each side carrying the twin reflex ports and the single set of speaker terminals respectively. The lack of a bi-wire option isn't a cost cutting exercise. It merely reflects Vienna Acoustics' preference for single wiring.

The speaker is supported

on an extremely rigid cruciform stand, with large, bullet shaped spikes anchoring it to the floor. The stand's thick

top-plate bolts to the base of the speaker with four large allen bolts, increasing the overall air of solidity. Indeed, once placed, for such a tall and apparently

slim enclosure, the Schoenberg is astonishingly stable.

Listening to the Schoenbergs is an equally surprising experience.

They reward your efforts in lugging them into place with a rich, weighty presence that once again belies their slender appearance. But the bass power and substance isn't the kind of bloated, exaggerated, subterranean, single note excess that typifies cheaper floorstanders with AV pretensions. It's got pitch, shape and drive to compare with its more conventional competition, and a refreshing freedom from the bands of thickened opacity that infect the lower reaches of too many MDF cabinets. That clean, uncluttered sound carries over to the rest of the range, the mid-band clarity and treble integration making the speaker sound much smaller than it is – in the manner of a mini-monitor.

The result is an agile, direct sound that's underpinned with sufficient authority to give it a real sense of purpose. Eleanor McEvoy's carefully crafted and beautifully sung songs can sound lazy simply because of their sparse instrumentation and subtle rhythmic patterns. But play them on the Schoenbergs and you'll soon realise just how much feeling and insistent direction drives them along. It's not the songs that are lazy, it's the pace and bass timing of systems that should do better. ▶



▶ The ease with which the Vienna Acoustics speaker delivers musical energy and delineates the tiny shifts in level that carry the expressive input of the musicians make it sound far more efficient than its specifications suggest. It's an indicator as to just how rigid the Schoenberg's structure really is. It actually sounds as if the energy

you put in comes straight out as music – all of it.

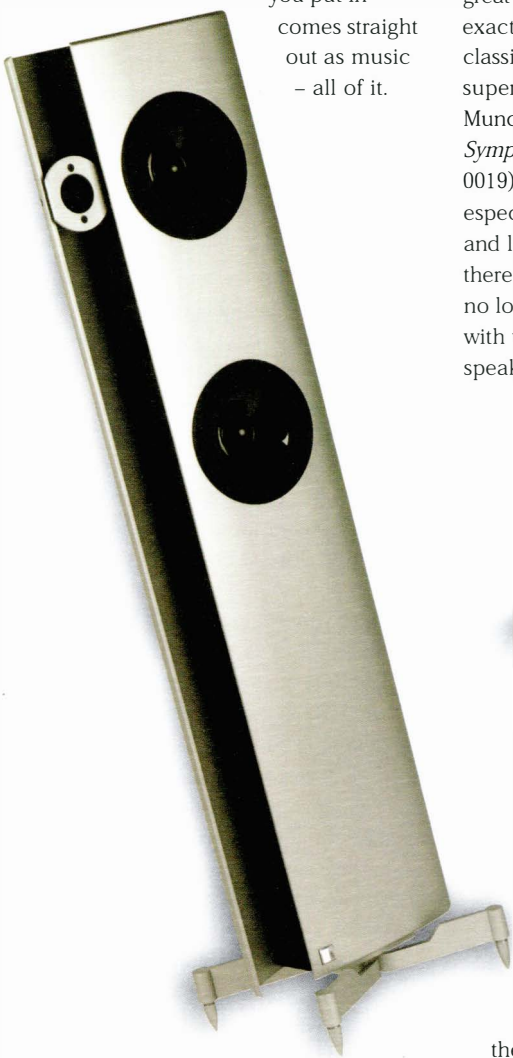

and immediacy can leave less than wonderful recordings sounding a little exposed, some singers a little throaty. This last effect, far from being intrusive actually brings a little life and character to recordings that can all too often do with the help. But even great recordings don't exactly suffer, with classical works like the superb XRCD of the Munch BSO *Eroica Symphony* (JMCXR-0019) sounding especially dynamic and lively. Indeed, there's absolutely no loss of scale with these speakers,

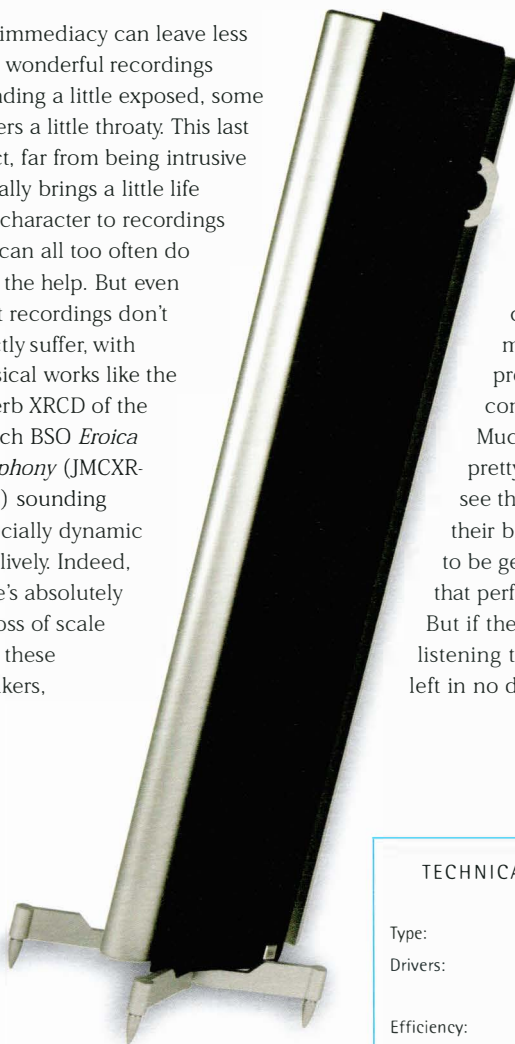

unlike so many lifestyle products that rely on inadequate sub-woofers to deliver what weight and authority they can muster.

Stereo, under-pinned by that firm foundation, is good but only if you get the toe-in exactly right, which kind of sums up this speaker's biggest problem. It looks like one thing but it's actually quite another. It looks like a lifestyle product but it performs as a serious piece of hi-fi, and is just as demanding as any other top notch speaker that costs well over a thousand pounds.

The Schoenbergs' clever cabinets give them striking looks as well as a serious sonic advantage over equivalently priced MDF boxes. That benefit is clear in their clean and uncluttered musical directness, their presence, drama and communicative quality. Much more than just a pretty face (and you should see the tiny Berg model!) their big problem is going to be getting people to take that performance seriously. But if they get as far as listening then they'll be left in no doubt.



TECHNICAL SPECIFICATIONS

Type:	Two and a half way reflex.
Drivers:	1" Silk Dome HF 2 x 6" XPP Bass-Mid
Efficiency:	91dB
Impedance:	4 Ohms
Bandwidth:	-33dB 44Hz and 25kHz
Dimensions (WxHxD):	268x1050x90mm
Weight:	13.5 Kg
Finish:	Silver
Price:	£1500

UK Distributor:

Henley Designs Ltd
Tel. (44)(0)1235 511166
Net. www.henleydesigns.co.uk

Manufacturer:

Vienna Acoustics
Net. www.henleydesigns.co.uk

Even dense, anthemic tracks like 'Forgiven' (Echo and the Bunnymen, *Evergreen*) don't phase it, retaining their stately pace and momentum without getting bogged down.

If there's a flaw to the Schoenbergs' presentation it's that their directness



Sounds of Music

BUYING HI-FI? THERE'S ONLY ONE WAY!!!

I believe there is only one way to successfully buy hi-fi. You must try and test any item selected for evaluation in the comfort of your own home in the environment you know. No demonstration room can tell you how the sound will be in your own home. There are so many factors that contribute to different sounds even in rooms that are identical in size - carpets, furniture, wall paintings, even wall paper makes a difference.

Our unique extendable one months trial system has to be the best way of all. It will almost definitely cost you less in the long run. Couple this with the largest selection and choice of some of the worlds very best hi-fi products, the very best service and advice, many years of experience (since the 1960's) and the results have to be the best available anywhere.

BUY WITH CONFIDENCE NOT REGRET

Call me for our company brochure and product leaflet and full details of the best way to buy hi-fi. *John Jeffries**

UPGRADE SCHEME

Buy today and get a written guarantee that if you upgrade your system by 100% within two years, we will give you 75% of your original purchase price of any single item or complete system. Please ask for details and conditions of this amazing scheme.



NEW SHOWROOMS NOW OPEN - 4 FLOORS OF THE WORLDS BEST HI-FI



Sounds Of Music 10-12 Chapel Place / 6 London Rd, Tunbridge Wells, Kent. TN1 1YQ / TN11DQ

Tel: 01892 547003 / *545688 Fax: 01892 616383

www.sounds-of-music.co.uk

Acapella, Acoustic Zen, Avantgarde, Argento, Audio Synthesis, Advantage, Audience, Audio Physics, Apollo, Aloia, Audio Note, Audio Analogue, A.V.I., A.T.C., Acoustic Energy, Aremo, Atacama, Base, Balanced Audio Technologies, Black Rhodium, Boulder, Bow, Bose, Burmester, Cabasse, Covertent Audio Technology, Copland, Celestion, Copulare, Clear Audio, Clearlight Audio, Dunlavy, Echo-Busters, Eggleston Works, Electrocompanient, Gamut, Graham, Grado, Halcro, Harbeth, Hovland, Jamo, JM Labs, Kharma, Koetsu, Krell, KEF, Klipsch, Lumley, Lyra, Lamn, L.A.T., Lavardin, Meadowlark, Marantz, Martin Logan, Mitchell, Neat, Nordost, Opera, Optimum, Ortofon, Orchid, Parasound, Pipedreams, Plinius, Project, Passlabs, Pro-ac, Pink Triangle, Primare, QED, Quad, Rel, Renaissance, Rogue Audio, S.A.T, SME, Shure, Sennheiser, Spondor, Sound Lab, Soundstyle, Sumiko, Steinhart, Straight Wire, Sonus-Faber, Stands Unique, Teac, Theta, Tannoy, Townshend, Transparent, Transfiguration, Unison Research, Van Den Hull, Veritas, Wisdom, Wilson, Wadia.

HI-FI 2002 **CLONEY Audio**

The Dublin Hi-Fi Show
Burlington Hotel
 Ireland's Premier Home Entertainment Event

November 9th - 10th
10am - 6pm
Admission €5.00

Featuring
The very latest in home entertainment systems
Hi-Fi • Multi-room • Plasma
• LCD Wall mounted TV
 +
Great Show Offers!
 +
Live Music

The Dublin Hi-Fi Show
Hi Fi 2002
 November 9 & 10
 Burlington Hotel

Organised by Cloney Audio
For details please call +353 1 2888 477

FREE DRAW
 €16,000 worth
 of Nordost
 Cables

hi-fi+
 REPRODUCING THE RECORDED ARTS

Back issues

If you missed out on earlier issues of HiFi+, and want to complete your collection, you can order them by calling

+44 (0) 1202 659380
 or by visiting our website:
www.hifiplus.com

Issues 1,6,9 and 14 - **Sold Out**, Issue 2 - \$4.75
 Issues 3-19 - £3.95.

Postage & packing: UK - Free. Europe - £1/magazine.
 Rest of World - £1.50/magazine.
 UK orders are sent by Parcel Post,
 please allow 2 weeks for delivery.
 Overseas orders are sent by surface mail.

Keep your hi-fi+ magazines in immaculate condition with these specially designed protective binders.

£5 each, or £3 to subscribers, with £1.50 p&p per order.



ABOUT YOU;

Title _____
 Forename _____
 Surname _____
 Address _____

 Postcode _____
 Daytime Tel _____

PAYMENT;

UK Europe Rest Of World

One year Two year

Cheques to be made payable to Hi-fi+ Publishing Limited.
 (drawn on a UK bank)

Visa Access/Mastercard

Card No _____

Expiry Date _____

Switch

Card No _____ Issue No _____

Expiry Date _____

Signed _____ Date _____

hi-fi+ **Subscription Form**

In order to ensure prompt arrival of your copy of hi-fi+, it is safest to take out a subscription. This lasts for a year, or 8 copies, and means that your magazine is delivered to your doorstep immediately it is published. No more fruitless journeys in search of audio enlightenment, and no more worries about missing an issue.

In order to apply, simply fill in the form, legibly(!), and drop it in the post. Oh, and we won't supply your details to the double glazing or insurance industries. You can rest safe in the knowledge that the only junk mail you'll receive has been sent by us!

And the cost of all this peace of mind?

One Year Subscription / 8 Issues

Within the UK, \$28.50 For the rest of Europe, \$37.25
 For the rest of the world, \$46.00

Two Year Subscription / 16 Issues

Within the UK, \$48.00 For the rest of Europe, \$65.00
 For the rest of the world, \$80.00

Contact:

hi-fi+ Subscriptions, Unit 12 Albany Business Park
 Cabot Lane, Poole, Dorset BH17 7BX

Or call;

Jayne Gage on Tel. 44(0)1202-659380
 or Fax. 44(0)1202-659540.

Via the Web;

www.hifiplus.com



The Fastest Growing Show In The UK !

Saturday 16th – Sunday 17th November 2002
The Hilton Manchester Airport

Why you should be there...

- The fastest growing Hi-fi and Home Cinema Show in the UK returns for it's 3rd year
- Bigger and better
- Same venue, same dates, more sponsors, more exhibitors, better value
- This year sponsored by Hi-fi Plus, Hi-fi Choice and Smarthouse
- 60% of stand space already allocated

New for 2002

- **Visitor presentations every 30 minutes** So you can plan your day
- **Custom install** The modern way to total pleasure
- **Lecture theatre** Varied subjects every hour
- **Fantastic sponsor demonstrations** Watch our website and press for details
- **Outside OB unit** Bringing the outside inside
- **Bring & play** Hear your own vinyl
- **Free magazines** Increasing the shows value
- **Giveaways** Everyone gets one
- **Cafe 'meet relax' area**
- **And for the kids...** Playstation 'par excellence' fully equipped giant screen that will completely blow them away
- **Plus our normal free show programme and competitions**

Discounted Ticket £4 - Available before 31/08/02

Advance Tickets £5 - Available before 01/09/02 - 08/11/02

Both available by e-mail, fax or letter to: CCL Chesterfield Communications Ltd, Events House, 1 Chester Road Tattenhall, Chester CH3 9AE Tel 01829 770884 Fax 01829 771258

The show also features a new trade entrance hall and a defined area for home entertainments.

The show will open from 10am – 6pm on Saturday 16th and 10am – 5pm on Sunday 17th.

Admission on the day will be just £6 with upto 4 hours parking for just £2.50 (the same as '01)

Further up to the minute information will be available at our website www.chestergroup.org, please email us with your comments, and tell us what you would like to see at the show.

hi-fi+

HI-FI CHOICE

smarthouse

Exhibition organisers

CCL Chesterfield Communications Ltd, Events House, 1 Chester Rd Tattenhall, Chester CH3 9AE
Tel 01829 770884 • Fax 01829 771258 • Mob 07810 697123
Email : roy@chestergroup.fsnet.co.uk or carl.tydd@monitorgroup.co.uk
Website: www.chestergroup.org





The Gallo Acoustics Nucleus Micro Speakers

by Roy Gregory

When I reviewed, and was entertained and amazed by the performance of the Cabasse iO spherical speakers in Issue 19, I hardly expected it to open a can of worms. But in passing I mentioned the even smaller and even cuter Gallo Acoustics speakers from the USA. No sooner had I put fingers to keyboard than the Gallos landed on these shores, necessitating a rapid phone-call to the new importer, and the equally rapid arrival of review samples.

Of course, small, spherical speakers are hardly news these days, but the Gallos are a bit different. Firstly, Anthony Gallo has been building spherical speakers for longer than anybody I know, with the possible exception of Cabasse. Secondly, his designs have always been aimed at the quality end of the market: his original UK distributor was after all, Absolute Sounds. Thirdly, these come with the cutest sub-woofer I've seen in a long time.

The Nucleus Micro speakers employ a single, "full-range" driver, housed in a 4" metal sphere. That's about the size of a large orange. The front face is rounded out by a black grille, on the back is a pair of small 4mm binding posts. Gallo employ a proprietary technique to extend the low-frequency

bandwidth of their speakers, claiming -3dB points at 80Hz and 18kHz from the diminutive units, along with a system sensitivity of 89dB. You get a choice of eight different anodised or paint finishes.

The matching MPS-150 sub-woofer is an unusual twin enclosure design housed in circular, tub like housings. One holds the amplifier and active cross-over electronics, the other a downward firing 10" pulp coned bass driver with a large, convex roll surround. The unusual arrangement offers a couple of benefits: already compact, the units can also be placed

next to each other, roughly halving their height, which can be a real boon when it comes to discrete siting. You can also connect an additional speaker unit to the electronics module should you feel the need for extra bass reinforcement. It makes for a versatile and extremely user friendly package, a quality that's extended by the comprehensive controls. These include the standard variable level

and crossover controls, along with a constantly variable phase control, sweeping from 0 to 180 degrees. There are connections for both high and low-level inputs, and an auto power mode that switches on the unit when it senses a signal.

The final part of the equation consists of mounting hardware for the Micros. In its simplest and most elegant form this consists of a pair of thick rubber O rings that simply prevent the spheres rolling about on a handy flat surface. There are also optional wall brackets, and the slender "Wall Flower" stands supplied for review. These consist of a sturdy, weighted disc base (not tapped for spikes) and a hollow tubular upright that will accept the supplied 18 gauge solid-core speaker cable. All in all it's an impressive, elegant and discrete system. Oh, and there's a 5.1 option too, as you might imagine.

However, it's the two-channel performance that I'm interested in, and that's really quite surprising. The Gallo set-up lacks the warmth, weight and scale of the Cabasse



Reality Check!

HEGEL
MUSIC SYSTEMS



AUDIO ATMOSPHERE

www.audioatmosphere.com
stuart@audioatmosphere.com
01785 711232

Paul Hynes custom amplification

Exceptional designs, exceptional power supplies,
exceptional components, truly exceptional performance
call 01931 712822 for details



50W mono-otl-ocl balanced SE bridge amplifier

mike manning audio

— the home-entertainment specialists —

For the Best in Hi-Fi & Home Cinema

**DENON-PIONEER-YAMAHA-NAD
ROTEL-NAIM AUDIO-M&K
REGA-DENSEN-DEF'TECH
B&W-LOEWE (TV/VIDEO)
PROJECTORS, PLASMA etc**

**Demonstration Lounges
Home Installations
Service Facilities**

Yeovil

01935-479361

**110, Middle Street, Yeovil
Closed Mondays**

Taunton

01823-326688

**54, Bridge St, Taunton
Closed Tuesdays**

The Cartridge Man

We sell our own MusicMaker cartridge, digital stylus force gauge and digital turntable level. We also carry a limited range of valve equipment - Croft, E.A.R. - and pick up arms - Hadcock, S.M.E. Ortofon, Graham Slee Projects and a few other high quality products.

We also rebuild classic valve equipment, giving you a choice as the level of specification. We have in stock a range of original Mullard valves, including the sought after EL 34's. Also available is a turntable setting up service, this is free when you purchase one of our cartridges as is our Test Record.

We don't believe that quality is necessarily synonymous with massive amounts of 'dosh', we encourage customers to purchase second-hand items where appropriate. Sound quality come before cosmetics. Remember it doesn't have to cost an arm and a leg... And don't forget our cartridge rebuild service.

88, Southbridge Road, Croydon, CRO 1AF. tel/fax; 020 8688 6565. www.thecartridgeman.com

► iO/Jupiter system, which if space isn't a constraint still offers the better sound for your money. But it also lacks its large satellites and even larger sub-woofer. The Cabasse option will never, ever be as discrete as the Gallo: nor will it have that astonishing "all that sound out of those tiny speakers" appeal either. Because, make no mistake, this system offers exceptionally good sound regardless of the aesthetic and stylistic considerations. Think of it as a thousand pound speaker system and treat it accordingly and it will repay your confidence handsomely.

Of course, like any sub-sat system the Gallo rewards time and care spent on set-up and integration of its elements. I ran it via the high-level inputs, hanging it on the end of Tom Evans/Hovland Sapphire amplification, and never felt cheated in any way. The sound is characterised by its lively agility and wide open sound-stage. Vocals are nicely focussed and held central, but it's the easy micro-dynamic tracking of the tiny shifts and inflections that really brings them to life. Whether it's Anne McCue or Shawn Colvin there's a directness and communicative quality to lyrics

that is at once engaging and rewarding. Okay, so Steve Earle might lose a little gravel and the last crate of whisky, but he loses not one jot of grit or vitality, purpose or communicative power. That's the trade-off you're making. There are plenty of conventional speaker systems that'll give you more weight, but few that'll match the textural and informative nature of the Gallo Micros. Adjust the sub with the requisite care and even the absolute weight issue will be a close call (as Stewboss proved). Instead it's more a question of balance, with the Micros favouring detail, life and clarity over the last word in harmonic development.

It's an effect that's beautifully illustrated by the Albert Fuller recital of Bach harpsichord music (Reference Recordings RR-2105). Playing *The Well Tempered Clavier, Book Two*, you are presented with a capacious and beautifully focussed soundstage with the instrument solidly presented and clearly angled across it. The structure and symmetry of the piece is immediately apparent, as are any slight hesitations in the playing. The sound is complex and burnished bright, just as it should be, although it's also a little quick, the notes decaying a shade too soon, the resonance of the instrument's body a little

short compared to the fulsome richness of a speaker like the (far more expensive) Living Voice Avatar OBXs. Overall the tone has a slightly silvery shade, but it's difficult not to be entranced by the sheer clarity of the tiny globes.

If you have need of a system that is at once discrete and musically engaging, majoring on communication, clarity and transparency, then look no further. Indeed, if it's the latter qualities that you prize then the Gallo Micros could easily be your speaker of choice regard-less of type. Don't confuse these with the six in a box toys that everybody and their wife seems to be offering these days. This is a genuine hi-fi speaker. All it needs is someone to treat it that way. ➤+

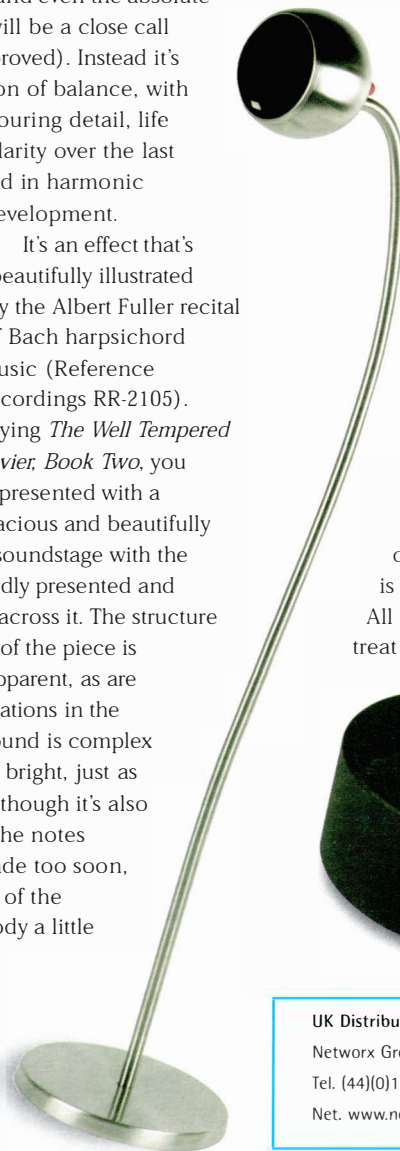

UK Distributor:
Network Group
Tel. (44)(0)1555 666 444
Net. www.network.co.uk

Audio Images

With the best choice, advice & service.
For all that is Real Hi-Fi and Home Cinema



*The World's finest CD
player now in stock*

Audio Images is The shop. Call now on 01502 582853
128 London Road North, Lowestoft, Suffolk NR32 1HB.

audio rapture

01359 240687
www.aanvilaudio.com

No artificial colours
or flavousings

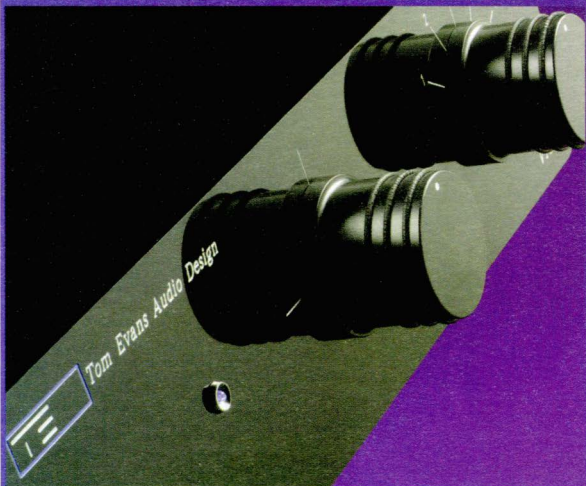

Tom Evans Audio Design
tel/fax: 01443 833570

Experience
FILtration



HAS GROWN

Experience Filtration Ltd · PO Box 6155 · Derby · DE24 0ZZ · ENGLAND
Tel: +44 (0)1332 757 068 · Fax: +44 (0)1332 572 713
info@experiencefiltration.com · www.experiencefiltration.com

The Benz-Micro Aesthetix ABCD-1 Cartridge Demagnetiser

by Roy Gregory

Audiophiles have long been aware of the benefits of purging spurious magnetic fields from within the components that constitute their systems. Devices to do the job are as simple to acquire as any of a number of CDs that carry the necessary sweep signals for replay, thus degaussing the entire playback chain from player to speakers. However, simple as this approach is it's limited in two ways: the efficiency of the method itself, and the fact that it necessarily excludes arguably the most critical component of all – the moving-coil pick-up.

Of course, there have always been hand-held electronic devices available, with a demonstrably superior performance to the simple CD, but they've always been expensive, and possibly as a result of that, supply has been unfortunately erratic. Perhaps the best known are those that come from Gryphon who produce a pair of such units, one for system use and the other dedicated to moving-coil phono cartridges. (Don't even think of applying one of these to a moving-magnet!) Of course, analogue audiophiles could always turn to the Cardas Sweep Record, a 12" black vinyl equivalent to the various CDs, but one that suffers the same caveats as its digital counterparts: cost-effective but with a limited capability. Nevertheless it's the option that I've been relying on for the last few years, an essential part of my system set-up and routine maintenance regimen.

But I recently received a neat hand-held alternative from Aesthetix via Benz-Micro. This small box is simplicity itself to use: just connect your arm leads to the sockets provided, press the power button (lighting its LED) press the



activate button, which lights its LED, and wait for the light to extinguish. The de-mag cycle takes a little over a minute. Then you simply turn the Aesthetix off and reconnect your arm leads to your phono-stage. It's straight forward and completely failsafe.

It's also extremely effective. Even after using the Cardas Sweep Record, the Aesthetix delivered a further clear improvement. And clear is the word. If you've never experienced degaussing you'll be startled by the improvement it produces, but perhaps the nicest thing about this particular tweak is that it's firmly based in theoretical physics. After all, the careful arrangement of a coil that moves relative to a magnetic field is the operational basis of all moving-coil cartridges. Hence the name. Therefore it should be equally apparent that the build up of additional, spurious magnetic fields within the generator assembly will distort the resulting output. In practice that distortion takes the form of muddy bass and a clouding of inter instrumental space within the soundstage.

Using the Aesthetix offered obvious improvements in transparency, focus and immediacy. The whole sonic picture was cleaner, clearer and crisper, especially in

the dynamic sense. But it's the low frequencies that really benefited. I used 'Shotgun Down The Avalanche' from Shawn Colvin's album *Steady On* as my testbed. (You only get one go at this so you need to be careful how you approach it.)

The improvement in bass pitch, attack and texture brought new drive and impetus to the music, while small details like the sleigh bells that mark the end of the first verse were far more clearly defined both as sounds and in space. The increase in overall transparency was more than simply cosmetic, delivering a similar benefit in leading edge definition and the rhythmic and placement advantages that go with it. It's like the whole band have suddenly tightened up, receiving an injection of creative electricity. It's the sort of change that lifts the whole system and makes it so much more rewarding to listen to. And that's after treatment with the Cardas disc. A repeat performance in a different system and without the benefit of pre treatment with the vinyl option merely served to underline just how effective the Aesthetix is.

With an asking price of £199 this little box of tricks should be considered an essential accessory by anybody spending over £700 on a cartridge. Used regularly (I reckon once a week is sensible in a heavily used system) it will quickly justify its purchase in the best possible way. By increasing the pleasure delivered by your system every time you sit down to listen. ➤+

UK Distributor:

Audiofreaks
Tel. (44)(0)208 948 4153
Net. www.audiofreaks.co.uk

Sound Design

- Classic Audio and Hi-Fi Design

by Phil Ward

Seems to me that the petrolhead and muso communities have for too long had the lion's share of coffee table books. I even own a couple of them - hidden appropriately away in a bookshelf. We audiophiles, however have had to make do with, well, not a lot really. There's always been a few technical books that might for a moment have strayed onto the coffee table (The Loudspeaker and Headphone Handbook anyone?), but nothing covering our particular enthusiasm that the disinterested would for a moment be tempted to pick up and browse. Well nothing till now.

David Atwood's good looking book is a delight. I showed it to another contributor to Hi-Fi+ whose face, as he turned the pages, lit up as would that of a 12 year old kid with a new Scalextric catalogue. This particular contributor probably ought to remain nameless because part of the reason for his innocent grinning at the book was that he'd either once owned, or still owned (slowly degrading into its constituent elements in the garage), at least half, it seemed, of the products pictured. It's not a compulsive disorder, really. Binns could give it up anytime he wanted. Honest.

The book covers a big subject - the design and development of domestic audio products from 1945 to the present day but does so with a fine balance between technical and aesthetic concerns: Issues which,

despite the protestations of the occasionally blinkered among us, have never really been separable anyway. It's full of little snippets of information, many I was previously unaware of, too.

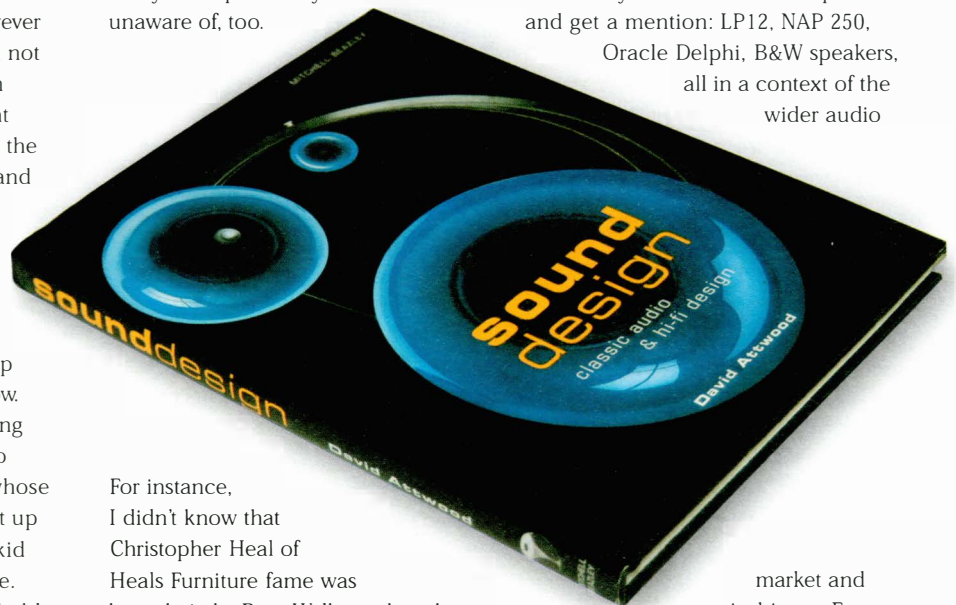

For instance, I didn't know that Christopher Heal of Heals Furniture fame was brought in by Peter Walker to breathe over the original Quad ELS. Walker was perhaps the first UK manufacturer then to appreciate how aesthetic industrial design skills could contribute to audio products (shame so many manufacturers still don't get it).

There's also a fine sense of the cultural context in which the products developed, that perhaps we tend not to appreciate in the big picture. And it's fascinating to see how little, especially in terms of product aesthetic, is truly new. There's a Braun SK4 "radiogram" from 1956 (yes, Binns once owned one) pictured and described that, other than including a turntable,

could so easily have come out of a contemporary European design house a few weeks ago.

And what about the contemporary? Well many of the icons win a place and get a mention: LP12, NAP 250, Oracle Delphi, B&W speakers, all in a context of the wider audio

market and its history. Even, right up to date, the Apple iPod a page or two away from the Jadis JA80s. At last: an audio book you can leave lying about without fear of embarrassment. ➤+

Sound Design -
Classic Audio and Hi-Fi Design

By David Atwood,
published by Mitchell Beazley
ISBN 1 84000 506 8

SELECTED USED & EX-DEM ITEMS

All Fully Tested With Warranty

- ◆ TURNTABLES & ARMS WANTED
- ◆ HI-FI BOUGHT FOR CASH
- ◆ COMMISSION SALES
- ◆ HIGH-END REPAIRS & SERVICE

VINYL REPLAY

DUNLOP Systemdeck 3 / Basik LVX / KS	£750	£379
MICHELL ISO HR Phono Stage Ex-dem	£895	£696
MICHELL Gyro (Like new)	£829	£695
MICHELL ISO/HERA Phono Stage	£895	£448
MICHELL ISO HR/HERA Phono Stage	£895	£480
REVOLVER Turntable + Linn LVX arm	£380	£148
ROKSAN Xerxes + RB300 + PSU	£1500	£600
SME 10A with 309 Tone Arm Ex-dem	£3410	£2896
STAX System SR303/SRM313 (Mint)	£850	£648
VOYD Reference inc arm	£14,995	£6000
WILSON BENESCH Full Circle (Mint)	£1995	£1495
WILSON BENESCH ACT 1 Tonearm	£1200	£594

CD • DVD

ARCAM Alpha 6 CD	£750	£458
ARCAM Alpha 6 CD + Clock 3	£850	£458
ARCAM Alpha 8 CD	£450	£248
ARCAM Alpha 9 (HDCD)	£800	£420
ASSEMBLAGE DAC2		POA
AUDIO ALCHEMY V1 + PSU	£489	£169
AUDIO ALCHEMY V3 DAC + PSU	£900	£549
AUDIO MECHA Kreatura Trans	£1500	£648
AUDIO MECHA Damnation + Upgrade	£1250	£599
CYRUS dAD3Q		£498
DPA PDM 1 DAC	£1000	£438
KRELL KPS 25 CD/Pre	£24,998	£16,996
LINN Karik CD	£1850	£1098
LINN Ikemi CD Ex-demo	£1950	£1694
MERIDIAN 203 DAC	£499	£228
MERIDIAN 263 DAC		£398
MERIDIAN 500 Trans	£1400	£798
MICROMEGA DAC 1		£320
NAIM NAC CD3.5	£1300	£798
NAIM CDS Mk2 Ex-dem	£4165	£2924
NAIM CDX Ex-dem	£2470	£1724
NVA Emotive Statement (Must be seen!)	£2200	£998
ORELLE DA10T Trans	£900	£450
PINK TRIANGLE Cardinal (Trans)	£1250	£550
RADFORD WS1 CD Player	£999	£358
REGA Planet	£500	£350
REGA Jupiter Ex-dem	£1000	£658
REVOX B225		£348
TAG CD120R (Trans)	£2200	£1100
TEAC VRDS 10 (CD Player)		£450
TEAC P500 (Trans)	£850	£400
THETA Gen Pro IV	£4500	£2400
THETA DATA Basic	£2400	£1100
THETA Pro Basic IIIA (DAC)		£1990
THETA Pro Time II	£2000	£995
THORENS TD C2000(Trans) + TDA2000(DAC)	£2000	£1198
TRICHORD Super 1 DAC + PSU	£1800	£1298
WADIA 8 Tran+DDE12 DAC *****	£7500	£3600

AMPLIFIERS • TRANS

ARCAM Diva P75 Ex-demo	£320	£254
ARCAM Diva P85 Ex-demo	£530	£424
AUDIO ANALOGUE Puccini SE	£700	£498
AUDIOLAB 8000C (Pre)	£600	£290
BAT VK40	£4950	£2600
CYRUS Pre	£700	£358
CYRUS Power	£700	£358
CYRUS III		£358
CYRUS PSXR		£228
DENON AVP-A1D Digital Pre-amp	£2500	£1299
DENON ADV 700 Ex-demo	£750	£644

DEVA 250 Integrated + Matching Power	£1000	£450
EXPOSURE 7/8 pre & Power		£400
HARMON KARDON AVR85 AV Rec	£1000	£498
JEFF ROWLAND C.3 (pre-amp)	£4990	£2490
JEFF ROWLAND Consumate (pre-amp)	£4000	£2196
KRELL KSL (Pre) Inc Phono Stage	£2990	£1350
KRELL KSA 100	£1990	£1000
KRELL KAV250A	£3698	£2490
KRELL FPB650 Mono's. 5 available, price each	£14,000	£8000
LFD LS1 Pre-amp	£1900	£500
LFD Zero Integrated		£400
LINN Wakonda (Inc Phono) Ex-demo	£945	£844
LINN LK140 Ex-demo	£750	£644
LINN LK1		£350
LINN Kairn Pre	£1700	£1098
MARK LEVINSON 27.5 Power *****	£6000	£3998
MARK LEVINSON 380 *****	£4495	£2990
McINTOSH MX 132 Pre/Processor Ex-dem	£7990	£4996
McINTOSH MC7108 8 Channel Ex-dem	£2549	£1996
MERIDIAN 201 Pre	£760	£329
MERIDIAN 557 ex demo	£1625	£1294
MERIDIAN 563 Ex-dem	£700	£446
MERIDIAN 518 Digital Processor Ex-dem	£985	£646
MICHELL Argo + Hera		£598
NAIM NAC 32 (Modified)	£600	£294
NAIM NAC 72 (Inc M/C board)	£1000	£454
NAIM NAP90 (Power)	£600	£378
NAIM NAP90 (Power)	£600	£400
NAIM Hi-Cap (New style)	£780	£498
NAIM Hi-Cap (Ex-dem)	£794	£554
NAIM Super-Cap (Ex-dem)	£2450	£1714
NAIM NAC 102 Pre (Ex-dem)	£1210	£844
NAIM NAC 82 Pre (Ex-dem)	£2500	£1754
NAIM NAP 180 Pre (Power)	£1220	£854
NAIM NAP 250 Pre (Power)	£1910	£1334
QUAD 66 Pre/remote		£450
REGA Elicit	£750	£498
REGA Cursa (Pre) Ex-demo	£1000	£638
REGA Exons (Monoblocks) Ex-demo	£750	£498
ROTEL RC971 (Pre)	£450	£248
ROTEL RB98 (Monoblocks)	£800	£498
TALK ELECTRONICS Storm (Intgtd)	£650	£370
TESSERA Pre	£1500	£798
THETA Casanova Pre Ex-dem	£4478	£3596
VERITAS P400 Power *****	£3000	£2496

VALVE AMPLIFIERS

AUDIO INNOVATIONS		£748
AUDION Silver Knight 300B Mono's	£2250	£1390
AUDIONOTE M2 Pre	£1000	£600
AUDIO PRISM Debut (Red Rose)	£2800	£1700
AUDIO PRISM Mantissa (Red Rose)	£3000	£1800
AUDIO RESEARCH LS2 Pre	£2800	£1798
AUDIO RESEARCH LS12 Pre	£3200	£1500
AUDIO RESEARCH LS15 Pre	£2995	£1996
AUDIO RESEARCH BL1	£699	£496
AUDIO RESEARCH LS8 Pre-amp	£1800	£1196
AUDIO RESEARCH VT50 Power Amp	£3499	£2496
B&W DM801 (Rosewood)	£1500	£749
CARY CAD300SE monoblocks (As new)	£5000	£3998
CONRAD JOHNSON PV11 Pre	£1600	£999
CONRAD JOHNSON PV14L Pre (3hrs use!)	£2200	£1590

CONRAD JOHNSON 15 Phono Stage	£4500	£2650
CONRAD JOHNSON Premier 17 Pre	£4750	£2750
CONRAD JOHNSON Premier 8 Monoblocks	£16,000	£9750
CONRAD CTA 301Pre	£1299	£899
CR DEVELOPMENTS Carmelo (Pre)	£900	£428
EAR 859 (Integrated)		£1648
GOLDMUND Mimesis 6 Amp Ex-dem	£2900	£1726
GOLDMUND Mimesis 4 Tuner Ex-dem	£6100	£2996
GRAAF 13.5 Blt Pre Ex-dem	£3950	£2996
MICHAELSON Odysseus 40w Int	£1150	£699
MAGRA PL-L (Line Level Pre) (Mint)	£5395	£4395
PAPWORTH TVASO	£2000	£1198
PATHOS Twin Towers	£3250	£2495
PM COMPONENTS Monoblocks	£3000	£1498
WELBORN LABS Monoblocks	£1500	£998

CASSETTE • TAPE

NAKAMICHI CR2E Cassette	£600	£300
NAKAMICHI DR10 Cassette	£400	£298
REVOX D36 Reel to Reel		£348
REVOX E36 (Reel to reel)		£298
REVOX B710 Mk2		£548

LOUDSPEAKERS

ACOUSTIC ENERGY AE 3 (Inc stands)	£1700	£748
ARIEL ACOUSTICS Model 8's (stands) Ex-dem	£5679	£3996
AUDIONOTE AN/E (Inc stands)	£2900	£1748
CASTLE Chester (Blk)	£900	£475
CHORD CEL 301	£3500	£1498
DALI 400	£800	£400
GAMMA ACOUSTICS Epoch 5	£3000	£998
HALES Signature System 2	£4000	£1848
HHB Circle 5's (Active)	£900	£430
IMPULSE H7 (Black)	£1000	£480
INFINITY Modulus (Inc stands)	£600	£390
LINN Kaber (Black)	£2000	£780
LINN Kaber (Rosewood) ACTIVE	£2500	£1350
MAGNA PLANAR 1a Imp	£1400	£850
MAGNA PLANAR MG111A	£3500	£1195
MARTIN LOGAN Aeries i	£2295	£1595
MARTIN LOGAN SL3	£3399	£1995
MARTIN LOGAN CLS (2) Ex-dem	£6998	£4496
McINTOSH LS320 (Speakers) Ex-dem	£1790	£1296
MEADOWLARK Shearwater	£2990	£1990
MERLIN TSM-SE (Mint)	£1600	£1148
MISSION 754P (Rosewood)		£698
MORREL Bass Master (Oak)	£1600	£728
NAIM Credo Ex-dem	£1425	£994
PINK TRIANGLE Ventral		£950
PROAC Studio 1 Mk2		£350
PROAC Response 1.5 (Rosewood) Ex-dem	£1970	£1596
QUAD ESL63 (Black)	£3500	£1400
REGA Naos Ex-dem	£998	£798
REGA ELA Ex-dem	£750	£414
REGA XEL (Black)	£990	£640
REL Q100 Sub	£750	£448
ROKSAN Ojan (Ex-dem - Mint)	£1000	£590
RUARK Equinox (Black)	£2200	£1400
RUARK Equinox (Rosewood)	£2000	£1195
RUARK Logrhythm (Sub)		£498
SNELL J3 High Sensitivity Monitors	£770	£449
SNELL Type E2		£698
SONUS FABER Grand Piano (Ex-dem)	£1699	£1399
SONUS FABER Concertino (Ex-dem)	£599	£529
SONUS FABER Electra Ex-dem	£1789	£1349
SOUNDLAB Dynastats	£3200	£1400
TANNOY Precision 40	£1000	£490
TRIANGLE Icare	£1500	£748
WILSON Cub (Black Laminate) Ex-dem	£5495	£3496
WILSON Cub (Gloss) Ex-dem	£6890	£3996

The Hi-Fi Company's

Trading Station

35 Cowgate
Peterborough PE1 1LZ

Much More Always Available
Please Check Our Web Site
hifitradingstation.com

ALL ABOVE ITEMS IN STOCK
AT TIME OF GOING TO PRESS

PHONE: 0870 608 8211

audiotrader@talk21.com

OPEN: Tues - Sat: 10am - 5.30pm

MOST CREDIT CARDS ACCEPTED
FOR NEXT DAY DELIVERY



Northwood Audio

Now on demonstration

- AudioMeca Mephisto II
- Audio Note CD2.1x
- Exposure 2010 range
- JM Labs Micro Utopia
- Isotek mains products
- Marantz SA-1 SACD
- Merlin Cables
- PMC DB1 loudspeakers
- Pure DAB Digital radio
- Quad ES11 speakers
- Shanling CDT-100
- Talk Electronics Thunder 3.1 Upsampling CD

98 Cambridge St,
Aylesbury, Bucks
Tel: 01296 428790
www.northwoodaudio.co.uk

cartridges
lyra
ortofon
sumiko
>cables
chord company
nordost
van den hul
>headphones
grado
stax
>hardware
atc
audio physic
densen
epos
harbeth
imerge
in focus
michell
primare
red rose
sme
sugden
trichord

**the stunning new
ATC SCM 20 active
loudspeakers**

get close to them, together with
some other fine products, at

signals

ipswich (01473) 655171
fax (01473) 655172
www.signals.uk.com



TSA THERMIONICS

- *Interconnects
- * Quality Mains Cables
- * High End Rebuild Service
- * Build-To-Order Audio Manufacture

****Pre-Qll...Love the sound****
(Josh Abbey, Recording Engineer to Russell Watson)

Total Systems Audio
Telephone: 0161 740 3076
www.tsa-thermionics.com



THE INNOVATIVE
HI-FI, HOME CINEMA
AND MULTI-ROOM
RETAILER/INSTALLER

ORANGES & LEMONS

Friendly and efficient service 0% Finance available
JUICY FRUIT FROM LONDON'S FRESHEST RETAILER

ARCAM B&W CABLE TALK CASTLE CHORD CREEK
DENON EPOS LINN MARANTZ NAD NAIM NEAT PMC
QED REGA ROKSAN ROTEL RUARK STANDS UNIQUE
SOUNDSTYLE YAMAHA XANTECH and many others

020 7924 2040
61/63 WEBBS ROAD, SW11
website: www.oandlhifi.co.uk

BADA the symbol of security

Isolation systems
Voodoo

AIRTEK Pneumatic Isolation Platforms
for electronics, turntables & Speakers (excellent reviews)
NATURAL RHYTHMS Equipment Rack System with unique
cable isolation System, all hand crafted in our workshops in a
variety of real wood veneers. Custom service available.

The **Voodoo** 99.999% solid silver power cord,
Interconnect cables, solid silver, & copper fitted with bullet plugs
Quality Mains Power Cords £49.95 Credit Cards Taken,
Tel, **Voodoo** on +44 (0) 1643 841244, voodootek@hotmail.com

SOUTH WEST ANALOGUE
Have all **Voodoo** equipment on demonstration along
with SME-TUBE TECHNOLOGY- MICHELL
NOTTINGHAM ANALOGUE - LORICRAFT/GARRARD
CROFT - various cartridges, ORTOFON , VDH
Second hand equipment, Record cleaners/cleaning service.
Perspex lift off covers, Major credit cards.
Tel +44 (0) 1643 851351,
graham@southwestanalogue.fsnet.co.uk



Music Matters

The finest hi-fi, Home Cinema and Multi-room
systems - from a selected range of suppliers

Including
Arcam, Base, Bowers & Wilkins, Chord, Cyrus, Dynaudio
Epos, KEF, Living Control, Marantz, Meridian,
Musical Fidelity, Project, Rel, Sonus Faber,
Wilson Benesch

And much, much more.....

Demonstrations available by appointment
020 8420 1925
344 Uxbridge Road, Hatch End, Pinner, Middlesex HA5 4HR
Open Tuesday – Saturday 10am – 5:30pm

BADA the symbol of security

SECOND/HAND - EX DEM OR
SPECIAL CLEARANCE LINES

**YOU'LL ALWAYS
GET THE BEST DEALS**

FROM

www.sounds-of-music.co.uk

LOG IN NOW

OR CALL 01892 539245

Vynoodle
Classical Music on Vinyl

SEE US
AT THE
MANCHESTER
SHOW



Catalogue
01332 760587

List online at www.vynoodle.co.uk

new audio FRONTIERS

hi-fi retail



The Isoblue stand
a new reference



Now on demonstration
the amazing Naim NAP 500

Dynavector moving coil
cartridges, the best there is



43 GRANBY STREET
LOUGHBOROUGH
LEICESTERSHIRE
LE11 3DU

TEL: (01509) 264002
FAX: (01509) 219900

E-mail:
naf@replete.freemove.co.uk

STOCKISTS OF LEADING HI-FI

- A careful selection of the best Hi-Fi to suit most budgets.
- Two comprehensive listening rooms.
- Expert advice on building a system.
- Expert advice on improving existing systems.
- Home installation service.
- Call in for more information or a demonstration.
- 0% Finance Available on request.

Basically Sound

NORWICH • NORFOLK

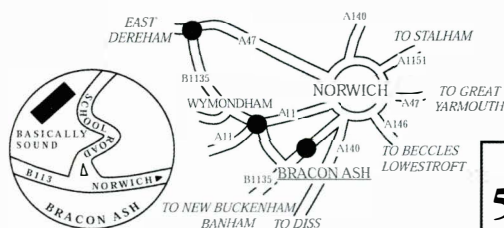

01508
570829
CLOSED MONDAYS
AND SUNDAYS

Basically Sound of Norfolk, The Old School, Bracon Ash, Nr. Norwich, Norfolk NR14 8HG
www.falcon-acoustics.co.uk

AUDIO ANALOGUE • BEYER
BRYSTON • CABLE TALK
CREEK • DENON • EPOS
FINAL • GRADO • JM LAB
NAIM AUDIO • OPERA • PMC
PROAC • QED • REGA • ROYD
SENNHEISER • SOUNDSTYLE
STAY • TALK ELECTRONICS
TEAC • TARGET XLO
UNISON RESEARCH
VIENNA ACOUSTICS
AND MANY MORE



Record Reviews











How To Read Them

The information contained in the record reviews is presented in the following way. Albums are identified by label and serial number. Beneath this you will find one or more icons which denote the available formats for the recording. The first icon refers to the format reviewed.

The ratings at the bottom of each review reflect the reviewer's opinion of the recording quality, and musical merits of the album. You'll soon realise that a great many musically significant albums offer less than wonderful sound. Don't let it put you off! For your information the scale rates a standard, good quality pop recording as slightly below average.

The reviewers are identified by their initials. They are:- Chris Binns, Pete Christie, Dave Davies, Roy Gregory, Jason Hector, James Michael Hughes, Jon Maple, Reuben Parry, Dave Ayers, Andrew Hobbs, Chris Thomas, Mark Childs, Simon Groome.

Key to Icons

-  CD
-  Gold CD
-  HDCD
-  XRCD
-  Double Disc
-  SACD
-  Hybrid SACD
-  MultiChannel SACD
-  120g LP
-  150g LP
-  180g LP
-  Availability As S/H LP
-  Vinyl Double Album

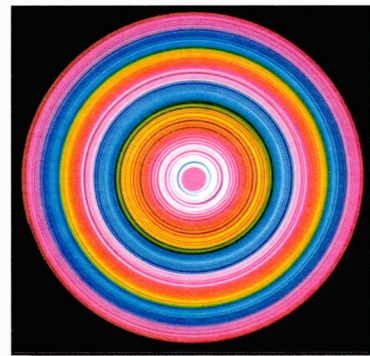

The Music

The Music

Virgin CDHUT76 

One of the most hotly anticipated releases this year, *The Music* is the debut album by the band of the same name. After two 'proper' single releases *The Music* have already built a solid reputation and seem to be succeeding in the charts. Which is odd given this album is not very good. *The Music* have several mind-blowing instrumentals, bongo-driven pounders that build up into a frenzy of guitar and feedback before breaking out into (real) dance anthems. However none of these are featured on the album. Instead the album treads the ground where *Baggy* once roamed. *The Music* seem to have thrown off the psychedelic experimentalism and instead simply written a collection of Manchester standards. Instead of sounding like a blast of raw talent *The Music* is a lesson in studied chart flirting. It's not a bad album, by no means. *The Music* still represent a young band that passionately believe that guitar music has a lot more to give. More than that, *The Music's* skill lies in arranging songs so that the slightest change in sound can give entire new direction to song, sending a rock standard spiraling into a funk freestyle. The problem is that this album is too conservative, it just fails to excite. But then again, *The Music* are rapidly becoming this years press darlings, which won't do them, or any other current British guitar band, any damage.

MC

RECORDING
MUSIC





Oasis

heathen chemistry

Big Brother Rkided 25

Another Oasis album and another disappointment. I know I shouldn't get my hopes up, but I can't help it. The excitement that they might possibly recreate *Possibly Maybe* is always present. But yet again they fall short. In fact Oasis are not the same band that wooed us back then. Only the brothers Gallagher remain of that initial line up, and as such 'Heathen Chemistry' should be judged, not against an album eight years its senior, but against their closest rivals in the charts today. But it's this comparison that disappoints; it's all just a little comfortable; this is an album to put your feet up to. But lets not get too scathing, there are some real gems here. The singles do what singles should, the quiet numbers make the world seem like a better place, and the track-three stunna 'hung in a bad place' sees Oasis capture (albeit far too briefly) some of the flame they once held aloft. The problem is, instead of turning into a louder version of Doves, Oasis have turned into slower version of Kula Shaker. Whilst we wait for the regeneration that one day must surely come, I shall go back to listening to guitarist Gem's old band, Heavy Stereo, where I can get the same homages to Gary Glitter, but without the grit taken out.

MC



Dave Alvin and The Guilty Men

Out In California

Hightone Records : HCD8144

In 1980 Dave Alvin, along with brother Phil, formed the much loved Blasters, probably the best 'unknown' band in America at the time, and even formed their own particular style of playing which they dubbed 'American Music' – a potent blend of R & B, Country, Blues and Rock n' Roll. Four albums and five years later Dave Alvin left to pursue a solo career, releasing a string of fine recordings – *Blue Boulevard*, *Museum of Heart* and the stunning *King of California* being particularly noteworthy. Which brings us nicely to this little gem, a live album recorded in August 2001 at The Blue Café, Long Beach and January 2002 at the Neighbourhood Church, Pasadena and featuring 76 minutes of Dave Alvin and his brilliant band in their natural habitat. The Band, comprising of Alvin (Guitar and vocals), Bobby Lloyd Hicks (Drums), Gregory Boaz (Bass), Joe Terry (Keyboards), Chris Gaffney (Accordian), Rick Shea (Mandolin & Pedal Steel), Brantley Keams (Fiddle), John 'Juke' Logan (Harmonica) and Greg Leisz (Dobro) are one of the hottest around in the USA at the moment and the interplay between them is a constant joy to the ears. The way they blend Alvin's 'Little Honey' with the old blues chestnut 'Who do you love' borders on the mercurial. *Out in California* is the best type of live album – one that makes you wish you'd been in the audience.

AH

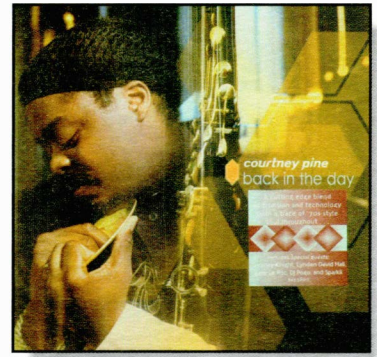

Courtney Pine

Back In The Day

Blue Thumb Records LC 00383 543 580-1

Pine needle. Even before dropping into that opening groove I had my suspicions aroused by those sleeve notes proclaiming this to be, "A cutting edge blend of tradition and technology with a trace of '70s style soul throughout". This sounded an awful lot like a disclaimer to me. Anyway, the man picks up pretty much from where his 1997 release, *Underground*, left off. Hip-hop rhythms flow from the MC Mello and Blak Twang raps, which, when coupled to those DJ Sparkii drum programs and the scratchy turntable edges of DJ Pogo, once again illuminate Courtney Pine's desire to align jazz much more closely within a pop context. These, and earlier frequent collaborations with the likes of Mica Paris, serve as a prologue for this album. Here, it's the presence of London Community Choir members on a Joan Armatrading cover, 'Love and Affection', or those Beverly Knight and Eska Mtungieuzi lead vocals for tracks like 'Inner State (Of Mind)' which redevelop those soulful moments. However, Pine's classy sax and keyboard playing songs like Curtis Mayfield's 'Hardtimes' are too often overshadowed by a misguided pursuit of the soulless, showy and quite paradoxical samples, scratches, programs and raps. In my opinion, if you have half a mind to buy *Back In The Day*, then you've clearly made ample intellectual provision.

RP



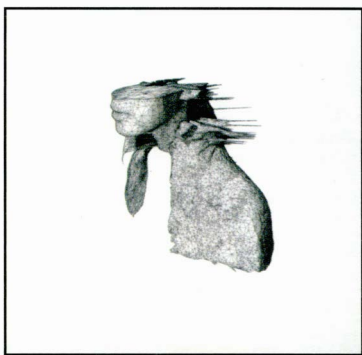

Coldplay

a rush of blood to the head

Parlophone 7243 5 40504 2 8

I never liked Coldplay. I'd seen them live a few times, and heard *Parachutes* more than enough, and I found them bland, repetitive and boring. Which is why *a rush of blood to the head* came as such a surprise. Where their debut was self-conscious, vain and lacking in variety (both in style and pace), Coldplay's second long-player is brim full of relaxed self-confidence. The album benefits greatly from a more careful assembly, so whilst *Parachutes* sounded like the same song played twelve times, *a rush of blood...* is a coherent collection of songs that swells and retreats naturally over fifty-four minutes of life re-affirming music. The change could not be more dramatic. This is a beast of an album that lifts Coldplay firmly onto the pillars of the great, standing them alongside the most obvious neighbours: U2 and REM. The orchestration and the recording perfectly complement the songs, adding life and movement to what would otherwise be slightly stodgy album tracks. Chris Martins vocals also sound more natural and less considered, giving a greater emotional payload, and a slightly raw punch when needed. All in all this is a superb album that deserves a good concentrated appraisal. It might also be noted that, after being so pleasantly surprised by this album I returned 'Parachutes' to the Hifi, and found it just as dull as ever.

MC



Boo Radleys

Kingsize

Creation CRECD228

Most people will forever associate the Boo Radleys with their three minute sugar-pop anthem 'Wake Up', but the Boo Radleys were actually consistently one of the most progressive and creative bands of the nineties. They acted as an indicator for the general state of the music industry, whilst the Boo Radleys still existed all was not lost, there remained some hope for the UK music scene. And then, in January 1999, the Boo Radleys split. Catalyzed by the commercial failure of their final album they turned in, and went their separate ways. Which was singularly odd, because *Kingsize* was by far the best thing they ever recorded. For all the previous albums intentional experimentation, Martin Carr just couldn't hide the fact that whenever he turned his attention to music, classic tunes would appear, as if from nowhere. No matter how much he tried to hide it, Boo Radleys albums brimmed with classic hooks. But *Kingsize* didn't hide it. The album brought together Carr's skillful arrangement, Sice's soulful and the bands constant experimentation with technology and for the first time in their career produced a homogenous entity. Alongside the big guitars and choruses lie songs of reflection and contemplation, *Kingsize* pulls everything the Boo's had been working on for years into one bite size package. Their genius will be much missed.

MC



The Blind Boys Of Alabama

Higher Ground

Real World CDRW107

Close harmonies not really your thing? Gospel send you screaming from the room? Pedal steel conjure up nightmarish images of Tammy Wynette? Well, now's the time to put aside your prejudices, 'cos if you don't you'll be missing out on a musical trip you really want to be taking. And while you're about it put aside your preconceptions too. I sincerely doubt that this is even remotely like any Gospel album you've heard before. The Blind Boys Of Alabama have been singing together for over sixty years! They are backed here by the multi-talented Ben Harper along with Robert Randolph and The Family Band. The material is eclectic (traditional Gospel through to Prince) but it's the wonderful, understated arrangements, the confidence to leave so much space that makes this so special: That and the range of styles on offer. There's the wonderful chuggy guitar riff that underpins 'Higher Ground', one any metal band could be proud of. Then the upbeat funk of 'I May Not Can See'. Throw in stellar performances of 'People Get Ready' and 'Many Rivers To Cross' and you begin to get the picture. These are great voices, singing from the heart, and it's that passion that illuminates this disc. Swallow your scepticism and enjoy.

RG





Beth Nielsen Chapman

Deeper Still

Sanctuary Records SANCD 122 CD

Beth Nielsen Chapman is one of the strongest singer-songwriters to come out of Nashville in recent times. Her silky lyricism in tightly woven ballads like 'World Of Hurt', 'Deeper Still' and 'Sleep', despite their romantic and spiritual under-currents, is often pierced by intense moments of pain, longing or loss. Love is the regenerative force here. One, that has in the past provided Beth with a degree of solace, proves once again to be the determining thread for this release. She is joined on six of a dozen songs by either John Hiatt, Vince Gill, John Prine, Bonnie Raitt or Emmylou Harris – artisans who do not lightly pledge their allegiances. They, too, like Joni and Jennifer, have wholeheartedly embraced those indistinct boundaries of a new wave in country/folk music. Part of that has been the adoption of increasingly sophisticated production values. *Deeper Still* is little different. Vocal overlays, synths and string arrangements, dulcimer, Native American flutes and sampled sounds – all vie for our attention on an album so awash with these bold primary colours that it's easy to lose sight of much softer tonal shades. These simpler pleasures are revived for tracks like 'All For Love' and 'Feathers Bones And Shells', where the writing for acoustic piano and guitar draws you more deeply within the temperamental fabric. Musically, decorative and emotionally, draining.

RP

Supplier: Cherished Record Co. 01579 363 603

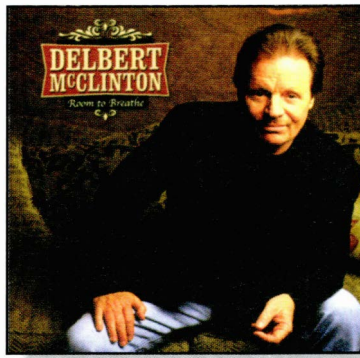

Delbert McClinton

Room to Breathe

New West – NW6042

With his last Album (The excellent *Nothin' Personal*) and this latest offering on the Indie label New West, it would appear that Delbert McClinton is enjoying some kind of musical rebirth with the record buying public.

In truth McClinton has always been revered by his fellow musicians and it's the likes of Trisha Yearwood, Martina McBride, Garth Brooks and Vince Gill that have been helping to pay the bills by covering some of his songs.

Room to Breathe features 12 more penned with long time writing partner Gary Nicholson, former NRBQ guitarist Al Anderson and Benmont Tench from Tom Petty's Band. Opener 'Some Kind of Crazy' sets the stall out, a swampy rocker featuring some fine Harmonica Blowing from McClinton, following hard on its heels is 'Smooth Talk', A Mid-paced bump and grinder with a real Stonesy feel. 'Lone Star Blues' reels in a whole host of Texan Superstars on backing vocals, but one of my personal favourites is 'The Rub', a Half spoken/half sung jazzy shuffle containing some lovely horn arrangements and subtle harmonica from McClinton. Every Delbert Album has a big ballad and *Room to Breathe's* is 'Don't want to love you', an achingly beautiful lament with a lush string arrangement. It might very well be McClinton's umpteenth album, but *Room to Breathe* has the freshness and vitality of a debut recording and could very well be his best yet.

AH

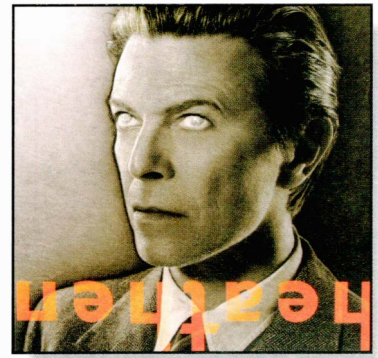

David Bowie

Heathen

CD ISO / Columbia 508222 1

It says in my little book of generally held beliefs that David Bowie hasn't made a great album since *Scary Monsters and Super Creeps*, although I am never one to be swayed by general opinion when it comes to music, but then I liked *Earthling* which may make me officially mad. Having said that, even I have to admit that with the release of *Heathen* the book will have to be rewritten because this time round Bowie has really brought everything together. On his latest album you will not only find consistently good musicianship, excellent arrangements, and great tunes, but also for the first time in ages he has produced something which is actually very commercial.

Bowie has gone back to Tony Visconti for his production and arrangements. Their partnership was responsible for most of the high spots of Bowie's career, and it can surely be no coincidence that the resulting album is excellent. Listening to *Heathen* is like hearing little kisses to the past throughout, a touch of 'Space Oddity' here, a little 'Hunky Dory' there, even, dare I say it, a smattering of Tin Machine. Unfortunately the CD is somewhat coarse sounding, so buy it on vinyl if you can, but even if you can't, if you've ever liked Bowie then you won't be disappointed.

DA



REGISTER WITH US NOW & GET A
PRESHOW DEAL
A WHOLE DAYS PARKING AT £2.50

hi-fi+
2002
& Home Cinema
THE MANCHESTER HI-FI SHOW
Hilton Manchester Airport
16 & 17 November 2002

Now In It's Third Year, One Of The Highest Quality Shows In The UK

Naim
Definitive Audio
Creek/Epos
Hifi Plus
UKD
Diverse
Hifi Choice
Black Rhodium
Exposure
Smarthouse
Rega
HNE
Direct Disc
hifisale.com Ltd.
Integrated Eng
Border Control
Activ Distribution/IsoTek
Metropolis Music
Larc
Romers
Absolute Sounds

Music Works
AudioCom
A.R.T
Audio Atmosphere
Owl
Wilmslow Audio
Ecosse
Quadraspire
Wilson Benesch
Audio Works
Audio Counsel
Nutwood Music Co
Red Line
Wentworth
Michell Eng
AudioNote
Reference Audio
Garrick
Audio Reference
Ringmat
'A' Audio Solutions

AudioCraft
CSE
AMC
Cherished Records
Ultimate Sonics
Emotive
Chord
Vivante
Arcaydis
Brady's
Vynoodle
Neat Acoustics Ltd
Walrus
Audusa
Crane
Dali loudspeakers (FBI) etc.

Please note this list relates to actual exhibitors. For an upto the minute list - see our website, email us, fax us or telephone

Show Features

Over 60 Exhibitors • Latest Technology • Lectures • Live Entertainment • Look & Buy

Advance Tickets 01/09/02 - 08/11/02 Only £5

Advance tickets can be reserved on line now, simply visit, www.chestergroup.org

Show Seminars

We will be having regular lectures throughout both days of the shows. Visit our website to pre-register via email, or fax or phone. Also register your main areas of interest.

Show Directions

Visit our web site or ring 0161 435 3000 for show directions

Don't Miss These Exciting Events

The N. Ireland Hi-Fi & Home Cinema Show - Stormont Hotel Belfast - 8/9 March '03
The Heathrow High Fidelity Show - The Renaissance Hotel - 29/30 March 2003

All Intellectual Rights Reserved

hi-fi+

HI-FI CHOICE

smarthouse

Exhibition organisers

CCL Chesterfield Communications Ltd, Events House, 1 Chester Rd Tattenhall, Chester CH3 9AE
Tel 01829 770884 • Fax 01829 771258 • Mob 07810 697123

Email: roy@chestergp.fsnet.co.uk
Website: www.chestergroup.org





Lee Morgan, Sonny Clark, Doug Watkins, Art Taylor

Candy

Classic/ Blue Note 1590 

Mention Lee Morgan and most people will immediately respond with his classic *The Sidewinder* but his legacy is much greater than that fine album; he played on Coltrane's *Blue Train*, with Art Blakey's Jazz Messengers, and has released many great albums under his own name. This '58 release is one of them. Supported by the superbly propulsive rhythm section of Sonny Clarke, Doug Watkins and Art Taylor, Morgan delivers a cracking, hard driving set. There are no weak numbers here, but 'All the Way' brings the best from Morgan's gentler side and the nicely titled 'Who Do You Love I Hope' showcases the strengths of the band with some great piano from Clark and crisp, driving percussion from Taylor. Morgan really was a superb trumpeter, brash, dynamic and confident yet able to conjure up real subtlety (a skill he was to improve still further in the '60's), when required.

This album is another argument in favour of Classic's mono re-issues. The quality and power of the music making override any issues as to the absence of stereo and if anything the mono recording delivers more weight and dynamics than your average stereo.

A lovely album, lovingly handled by Classic and strongly recommended.

DD

www.vivante.co.uk

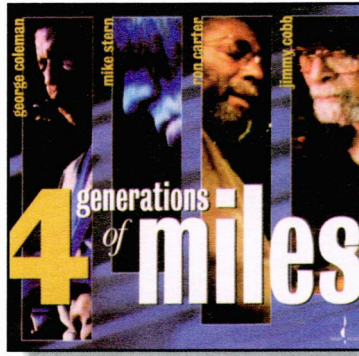

George Coleman, Mike Stern, Ron Carter, Jimmy Cobb

4 Generations of Miles

Chesky JD238 

This live set brought together four generations of Miles' sidemen for a one-off concert in New York. Given the huge stylistic changes in Miles' music in the decades represented by these players tenures with him – ranging from *Kind of Blue* through to Davis' final albums – this could have been a mess. It's a credit to the professionalism of all involved that it's actually a fine set. The youngster here is Mike Stern, more laid-back than his work with Miles' '80's bands, but his Telecaster cuts a really distinctive line throughout with some particularly fine playing in 'On Green Dolphin Street'. Jimmy Cobb is the last surviving member of the *Kind of Blue* band and it's particularly poignant when the band launch into 'All Blues' from that classic album. Sure nobody's breaking barriers here but they're certainly enjoying themselves and that comes across with conviction.

Coleman's tenor playing is great throughout; just listen to 'Blue in Green', his fluid tones wringing the emotions from this lovely autumnal piece. The recording quality is good with a tangible and happily non-intrusive sense of the audience, and each instrument well caught although I'd have liked a little more weight to bring out Carter's bass playing more fully. Recommended.

DD

www.vivante.co.uk



Eden Atwood

The Bossa Nova Sessions

Groove Note GRV1012-1 

I'd not heard of Atwood before this, her debut album for Groove Note. Shame on me since she's clearly talented and has previously released four albums for Concord (about which according to the liner notes she's not too enthusiastic), before dropping from the music scene for a while.

This set marks her return and Atwood does a fine job in her interpretations of this selection of standards taking in Jobim's 'He's a Carioca' 'Meditation' and of course 'Girl from Ipanema'. The set also includes a version of Lennon & McCartney's 'Fool on the Hill', not exactly a Bossa standard but I suppose we have Sergio Mendes to blame for that. Atwood has a fine, sultry voice that she brings to great effect particularly on the slower numbers like 'Meditation'.

This is an excellent debut for Atwood but there are really two stars at work here; Bill Cunliffe's excellent arrangements and superb piano playing throughout really lift the set above the ordinary. Coupled with yet another superb recording and pressing from Groove Note (even more evident in the bonus 45rpm disk included with the album), this is a winner. My only quibble is that the pure Bossa numbers were recorded in English rather than the original Portuguese; to my ears at least this would sound even more sensual but maybe that's just the dirty old man in me!

DD

www.vivante.co.uk

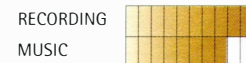

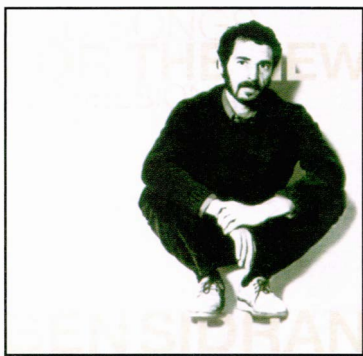

Ben Sidran

Old Songs For The New Depression

Go Jazz 60492 

I'm a long-time fan of Sidran's stretching back to my purchasing a pressing of *Bop City* in '83. This album dates from a year earlier but for some reason and despite its great title I've missed it 'til now. What a mistake. Dedicated to Hoagy Carmichael (along with Mose Allison, a major influence on Sidran), this is billed as 'nine pieces of new music, road tested at concerts and clubs...and forged in front of live audiences'. This shows, since the ensemble playing from Sidran and a strong band including Marcus Miller, Buddy Williams and Richie Cole, is spot-on. The band's enjoyment just leaps out of the speakers and Sidran's lyrics in turn wry and as in 'Old Folks' his Carmichael tribute, nostalgic, are put across with conviction. The recording quality is acceptable, a bit two-dimensional, but the quality of the music making quickly overrides any audiophile concerns. For me this highly enjoyable album is best summed up by the lyrics of 'Turn to the Music': 'When your high hopes don't materialize, and you're looking at life right between the eyes, you got no gas in your tank, you got no chicken in your pot, your best friend aint so friendly now, and your best girl, she aint so hot, why don't you turn (turn turn) to the music...you can count on that'. Enough said!

DD



Young Man With A Horn

Miles Davis

Classic/ Blue Note LP 5013 

This beautifully presented mono 10" album in its thick card sleeve looks and feels like an original but for its immaculate appearance and superb pressing. There's something about jazz, particularly of this vintage (the set was recorded I think, there's no indication on the label, in the early '50's), that cries out to be played on vinyl and boy, does this re-issue bear this out. Who needs stereo when you have music making of this calibre recorded with a punch and realism that perfectly evokes the original sessions? Fronting a fine band including Jay Jay Johnson, Jackie McLean, Oscar Pettiford and Kenny Clarke, everyone is in superb form as they tear through the six numbers here. Standouts are 'Wouldn't You?' (with great horn playing from Johnson and McLean), 'Yesterdays', the lightning paced 'Chance It' with some superb soloing from all and, well actually they're all standouts and a great snapshot of one of the world's greatest musicians early in his career. The recording is solid, weighty and dynamic. I suspect that these Classic 10"ers, given that originals are as rare as hen's teeth, are going to be highly collectable. Now where's my wallet?

DD

www.vivante.co.uk

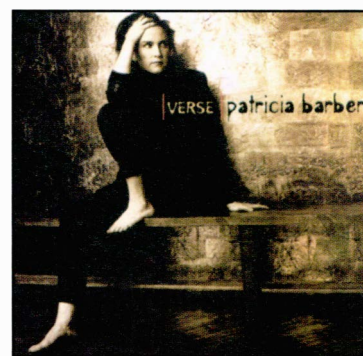

Patricia Barber

Verse

Blue Note/ Premonition 7243 5 39856 2 

Barber is a bit of a 'love her or hate her' artist. I don't fit this category in that I really like her when she's doing her straight-ahead stuff, but some of her more 'poetic' offerings do set my teeth on edge. The opener to this album 'The Moon' is a classic case in point with Barber intoning 'Should I leave Erebus to his own device? What chaos when the curtain rises...' , but just when the lyrics had me reaching for the 'next track' button, some cracking playing kicks in; deep, deep acoustic bass, great bluesy trumpet, crisp, dynamic percussion which just kept me listening. Faster paced stuff like 'Lost in this Love' hook you into the groove straight away. And so it goes, but on balance the poetic overspill is always offset by her funkier moments and by great playing from all throughout the set. This really is a cracking band and with the likes of Joey Baron on drums, Dave Douglas on trumpet, and Michael Arnpol on bass it can't fail. With an exemplary weighty and dynamic recording I declare this curates egg good!

DD

www.vivante.co.uk



Live At Blues Alley

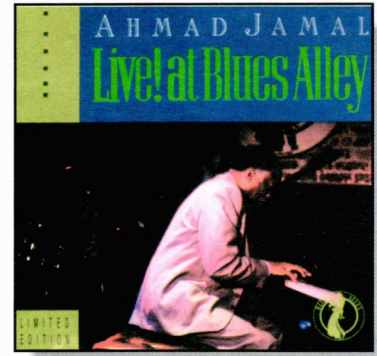
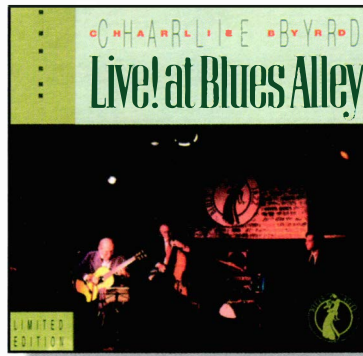

Charlie Byrd

Live at Blues Alley

Blues Alley Music Society BAMS CD 1 10002 

Ahmad Jamal

Live at Blues Alley

Blues Alley Music Society BAMS CD 1 10005 

Georgetown is Washington DC's fashionably bohemian area, with the University rubbing shoulders with designer shops, craft galleries and trendy restaurants and deli's. And right at its heart, just off the junction of Wisconsin Avenue and M Street, is one of the capital's premier blues and jazz venues, Blues Alley. With a suitably seedy exterior, its cosy interior, laid out to tables and a bar so that patrons can enjoy the club's creole cuisine, has been host to a rare array of America's leading musical talent. Everyone from Dizzy Gillespie to McCoy Tyner and Stanley Turrentine have graced the tiny stage, while the club also acts as home and hearth to the Blues Alley Music Society, devoted to the active promotion of all forms of jazz. Boasting a masthead of patrons that looks like a who's who of modern American jazz, the Society can call on the likes of Gil Scott-Heron, Wynton Marsalis, Tony Bennett and Wayne Shorter for participation and support. You get the picture. So, when the Society decided to release a series

of limited edition live recordings (with 2500 of each title) the roster of available talent read something like an A&E man's wet dream. And if the series title sounds familiar then you'll probably be thinking of the Eva Cassidy disc of the same name. Cassidy, a DC resident, was a regular at the tiny venue, and yes, that's exactly where the tape emanated from. The best of her various discs, it's a fair pointer to what's on offer from the jazz titles. I chose two at random, and having listened to them I'm going back for the rest!

The Charlie Byrd disc features the guitar trio of Byrd, brother Joe on bass and Chuck Redd on drums. It's a tight unit that know each other inside out, and a great set features rare Byrd vocals and highlights with 'Water To Drink' and the beautiful 'Shiny Stockings'. The recording captures the warm intimacy of the venue, with exceptionally natural perspectives and scale (if your system's really together you'll pick the vertical separation of the individual elements that make up the drum kit!). Dynamic and quick, it's both immediate and musically convincing. Combine that with the quality of the performance and you've a disc to cherish.

Ahmad Jamal's set is full of typically staccato piano runs and stabbed chords. Backed by bass, drums and percussion it's a busy, complex and ever shifting musical pattern that's woven with all the skill and elan that you'd expect of this masterful performer. The recording isn't in the same class as the Charlie Byrd, lacking the dynamics and transparency of that disc, but it's still way better than average: Just listen to 'Serena' to get my point. The busy piano lines leave so little space,

but the subtle support of drummer David Bowler never gets stifled or confused: Likewise the rolling electric bass of James Cammack. It's a musical tour de force, and it's captured live and intact for your considered consumption.

The full range of five titles is available from the Blues Alley Music Society web-site at www.bluesallemusicsociety.org at the bargain price of \$15.00 a disc, which is under a tenner in God's own currency. The Dizzy disc is a double, but you should see the artwork. So great music meets a worthy cause which makes purchase a no-brainer. Buy now before the rush exhausts the limited supply.

RG

www.bluesallemusicsociety.org

Charlie Byrd

RECORDING
MUSIC

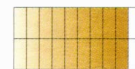

Ahmad Jamal

RECORDING
MUSIC



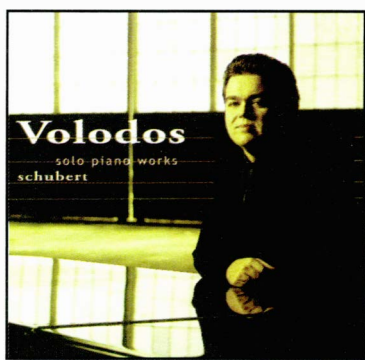

Schubert
Piano Sonatas D157 and D894,
and Der Müller und der Bach

Volodos

Sony SK 89647 **CD**

Arcadi Volodos is a great pianist. It is just disappointing that he can sometimes play with an utter lack of sensitivity. On this recording he performs with sublime gentleness, exhibiting great concentration, especially in the long *Piano Sonata in G major, D894*. In the opening movement Volodos never appears too measured, but creates undulating rhythmic waves that, despite a hint of mannerism, reveal expressive warmth. No one plays this piece quite like Mitsuko Uchida, and he may not manage the same profound understanding that she does, but nevertheless achieves a performance of tremendous elegance. There is a certain richness of tone, helped by the wonderful acoustics of Vienna's Sofiensaal, with Sony's engineers capturing every detail, highlighted by the recording's considerable dynamic range, while the piano is portrayed realistically in size. But it is Volodos who steals the show, although he leaves out the ornate flourishes from the Second Movement that Uchida manages with ease, although this is only a minor point. While the other works on this disc may not be in the same league as the D894 Sonata, this recording is recommended for some wonderful virtuosity and a sublime performance of one of the great works for solo piano.

SG

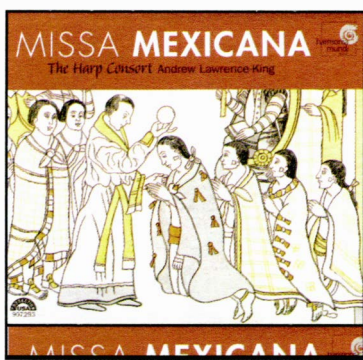

Missa Mexicana

The Harp Consort/Lawrence-King

Harmonia Mundi HMU907293 **CD**

With a number of vibrant styles, this is an utterly enthralling release. While the core of the music may be a parody of a Mass by Padilla, rather than an exact re-enactment, each movement offers a taste of the colourful liturgical music of the New World during the 17th Century. The polyphonic *Mass of the Renaissance* is brought together with dance-like religious settings and a selection of popular Hispanic dances, jácaras and songs by thrumming gamba, guitars, harp and theorbo, colourful bajón (bassoon), organ, psaltery, sackbut and shawm, and various percussion, including conch shell, rain-stick and small bells. This intoxicating blend reveals the complex cultural amalgam of the Americas at the time, and shows how the solemn splendour of the church was mixed with driving rhythms to attract congregations. The Harp Consort, under the direction of Andrew Lawrence-King, appear totally uninhibited by the music, and deliver inspired playing that is technically commanding, yet improvisational. The resulting performance is expressive, sensual and stylish, and Harmonia Mundi's engineering is also of a very high order. This outstanding disc is a revelation - incomparable with anything else available - and should not be missed. You will be totally captivated from start to finish.

SG



Liszt - Six Grandes Etudes de Paganini/Franz Schubert's Märsche für das Pianoforte übertragen
Hamelin

Hyperion CDA67370 **CD**

In 1832, Liszt heard Paganini perform at the Paris Opéra. Such was the impression made on the young composer that six years later he produced a set of transcendental studies based on Paganini's *Caprices*, but included the famous version of the *Campanella Finale* from the violinist's *B minor Concerto*. They were written to produce keyboard playing to match the great violinist's virtuosity, and although revised by Liszt in 1851 to make them more logical and less decorous, they remain a severe test of the pianist's adroitness. Marc-André Hamelin is a pianist with such technique, managing to make them sound undemanding, leaving the listener in awe. But, he also instils them with style and wit, bringing each piece to life, and therefore surpassing the accounts of all before him. Hamelin is also successful in the Schubert *March Transcriptions*, but the competition is stronger here. He demonstrates reverence for the earlier composer, using his technical prowess to vividly portray each piece, producing a performance from the top draw. With Hyperion supplying sound of a pretty high order, revealing a natural vibrancy that is enhanced by the acoustics of Henry Wood Hall, this is a thrilling recital, with some dazzling piano playing.

SG



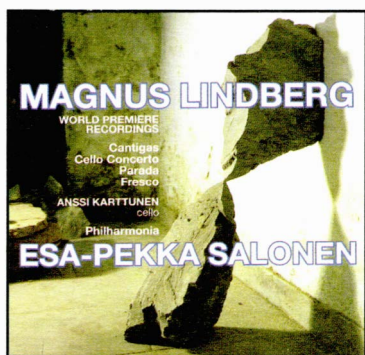

Lindberg
Cantigas/Cello
Concerto/Parada/Fresco
Karttunen/Philharmonia
Orchestra/Salonen

Sony SK 89810 

Finnish composer Magnus Lindberg is now recognized and admired as a popular composer, with concerts of his work never failing to stimulate. This CD contains four world premiere recordings of his later works. Each is a near-continuous onslaught of sound, with solos integrated into the overall orchestral picture. The opening *Cantigas* is a set of five cycles that explore tempo interactions, and blends tempestuous polyrhythmic brass and a number of harmonic shifts with a brutally demanding oboe solo, performed with assurance by Christopher O'Neal. The *Cello Concerto* is a radical single-movement work, requiring a soloist of supreme agility and virtuosity, which is perfectly executed by Anssi Karttunen. *Parada* and *Fresco* feature more rapid passages superimposed over harmonic developments, but still revealing the composer's solid foundations of musical structure. Directed by Lindberg's most devoted follower, Esa-Pekka Salonen, the Philharmonia plays each piece with total enthusiasm. Vividly recorded in Sony's DSD sound, the dynamic form of this music may be too much for some to take all at one sitting, but for those willing and able to withstand eighty minutes of aural bombardment, as one overwrought crisis of sound becomes a new climax, there is much to entertain and interest the listener.

SG



Haydn – String Quartets,
Op. 63, Nos. 2, 4 and 5

Quatuor Mosaïques

Naïve Astrée E 8875 

Having recorded a couple of delightful Mozart discs, the Quatuor Mosaïques return to continue their evolving and distinguished Haydn series with this release. Again they are stylish, with their trademark assurance and refinement, their wonderful precision, and the vivid textures they fully exploit to enlighten each piece. Yet these individual hallmarks never overwhelm the character of and their authority over the music. They possess great enthusiasm and verve, with pliant rhythms and a wonderful sense of direction that allow for some thrilling climaxes. Haydn employed some irregular phasing, interwoven with pauses, that the ensemble use to fully utilize the potential comic character of each work, bringing them to life, especially when Erich Höbarth plays almost capriciously in the minuet of the Lark Quartet. The recording is superb, revealing the quartet's wonderfully resonant instruments in a beautifully natural acoustic, with a nice sense of space around each performer, allowing one to listen to each individual's playing. While there may be great competition, especially from the Lindsays, the Mosaïques possess superior cadence and poise, and fully reveal how these relatively little known works can be illuminated to become masterpieces, making this an extremely enjoyable CD of demonstration quality music making and sound.

SG



Arias for Farinelli

Genaux/Akademie für Alte Musik
Berlin/Jacobs

Harmonia Mundi HMC901778 

Carlo Broschi detto Farinelli was a superstar of his generation, a castrato who continues to motivate and intrigue with films, novels and other fictionalised reports enhancing his reputation as the epitome of the Baroque vocal art. With no castrati available to make this recording, this collection of arias associated with Farinelli are re-created by mezzo-soprano Vivica Genaux. Although countertenors have traditionally been used in this territory, she has all the virtuosity to negotiate the embellished lines, enabling her to create expressive effects by use of ornamentation in the same way that the 18th Century master did. Her astounding agility, colourful daring and accuracy of pitch show why this music suits the right mezzo. She maintains expressive and interpretive composure throughout, judging each note and each exquisite trill perfectly. Her artistry is simply dazzling. She is admirably accompanied by René Jacobs and the eloquent Akademie für Alte Musik Berlin, who are responsive to every nuance of the music. The playing is precise, with a wonderful tone and incredible energy when required. With informative notes and superb, natural sound that reveals every texture, this release is the complete package, creating a wonderful listening experience, and a superb vocal display.

SG



3 legendary artists...

Ella Fitzgerald, Nelson Riddle and his Orchestra:

ELLA FITZGERALD SINGS THE GEORGE AND IRA GERSHWIN SONGBOOKS

You can't go wrong with a Gershwin tune! - how often this statement was heard at Ella Fitzgerald's concerts, regardless of whether she performed with a bigband, in a duet with Joe Pass, or at the Jazz at the Philharmonic jam sessions. But one thing's absolutely certain: everyone, all the musicians and every single member of the audience knew the song. Ella surpasses herself in such numbers as "The Man I Love", "Let's Call The Whole Thing Off" and "They Can't Take That Away From Me". In songs like "Boy! What Love Has Done To Me", or the ragtime "Real American Folk Song", she can express her humour to the full. The arrangements by Nelson Riddle, who had re-orchestrated Frank Sinatra albums, are crafted to perfection. They explore to the full the big band sound behind the rhythm group and Ella's voice which was at its absolute peak in the 60s. The recording and mix-down were perfect - and so is this new release with five LPs, a 10" promo, a hard-cover book about George and Ira Gershwin, and five prints by Bernard Buffet!

Speakers Corner. Verve MGVS6082 180g 5LP + Bonus 10 inch disc + book + prints £95.00

'Musically essential, qualitatively superior and beautifully presented this is a dream release for all Ella fans. Serious record collectors everywhere should be reaching for their flexible friends music lovers should too, if ever there was a record that everybody should own this is it. I'd give it 11 if I could.'

Roy Gregory. Hi - Fi + magazine



John Coltrane:

The Heavyweight Champion - The Complete Atlantic Recordings

The first thing we should know about this limited edition box set is that John Coltrane was only on the Atlantic label for less than 3 years. In that short time, over just 14 sessions, Coltrane changed the face of jazz forever and cemented his reputation as one of the most inventive saxophonists and creative composers to ever be committed to tape.

The albums show just how diverse Coltrane's playing could be - from soft and gentle romantic ballad playing to fast and furious improvisation that at times seems difficult to follow but always keeps you listening intently. Yet you always know it's him when he plays, no matter the style he chooses.

This beautifully presented 180 gram 12 LP box set contains all the material Coltrane recorded for Atlantic, plus a double LP of studio outtakes. The set contains a deluxe 12" x 12" colour booklet detailing the albums and John Coltrane himself. A must for all jazz lovers.

Amongst the 12LPs are: *Giant Steps; Bags & Trane; Coltrane Jazz; The Avant Garde; Coltrane Plays The Blues; My Favourite Things* and *Olé Coltrane*.

Atlantic. RHM1 7784 180g 12LP + book £150.00

Jimi Hendrix:

The Hendrix Experience 8LP Box Set

This 8LP Box Set is the crown jewel in the Hendrix Experience release programme, consisting as it does of 56 previously unreleased recordings. In all, over 4 hours of rare and never-before-heard Hendrix music.

The Box Set consists of:

- Rare alternate takes of Hendrix classics such as Purple Haze, Hey Joe, Stone Free and a powerful instrumental version of Little Wing
- Unique interpretations of songs by his favourite artists, including Sgt. Pepper, Like A Rolling Stone and Johnny B Goode
- Fine live recordings made in Paris, Stockholm, Maui, Los Angeles, Monterey and The Isle Of Wight
- The lavish box is covered in purple velvet imported from France
- The unpublished front cover photo is printed on holographic paper, and the Hendrix logo is made of gold foil and heat stamped onto the front of the box
- Each 180g LP comes in its own colour sleeve with rare pics and track listings
- The 12 x 12" 40 page colour booklet contains rare photos by Linda McCartney, Karl Ferris and Dave Sygall

MCA 180g 8LP + book £100.00

available from:

vivante

Unit 6, Fontigarry Business Park, Reigate Road,
Sidlow, Nr Reigate, Surrey RH2 8QH. UK.

tel: +44 (0)1293 822 186

fax: +44 (0)1293 821 965

email: sales@vivante.co.uk

web: www.vivante.co.uk

...3 stunning box sets

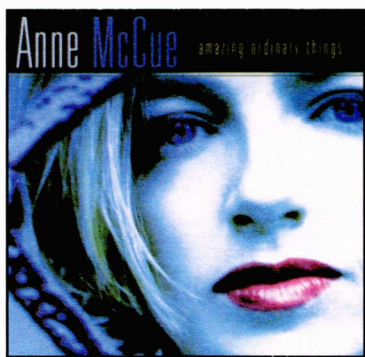

Anne McCue

Amazing Ordinary Things

Relentless Records M2R2 0554

Aarrgh! I know exactly how a werewolf feels. Much as I despise them, much as I've tried to totally eradicate them, the odd hippy sympathy still manages to lurk unbidden in my soul, ready to emerge at the most unexpected and potentially embarrassing moments. What am I to make of an album that reminds me of some weird Sally Oldfield meets Judy Tzuke amalgam? What am I to make of the fact that I like it? In fact, I really like it. All that vocal purity; all that sheer musical beauty; it should be cloyingly sick making but instead I find myself coming over all whimsical.

Of course, the quality of the recording helps, playing straight into the hands of such beautifully concordant melodies and hooks. Then there's the raw appeal of the only live track here, 'Love We Made'.

Oh what the hell. Why bother with excuses? If you like the kind of pure female vocals that tinkle like falling drops of mineral water, if you like them sympathetically recorded and you can stomach the inherent naivete that seems to be an obligatory accompaniment, then dive right in. Wallow about, you'll love it.

RG
www.vivante.co.uk

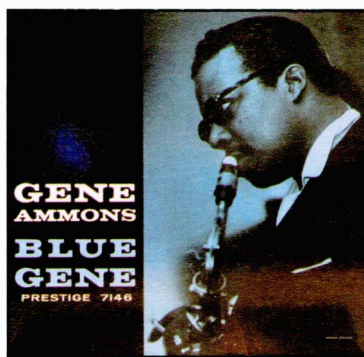

Gene Ammons All Stars

Blue Gene

Acoustic Sounds/Prestige AAPJ 192

Blue Gene is a superb mono Prestige recording of a soulful and deeply blue Gene Ammons landscape - one that leaves you yearning for more. Terrific close support for his rich and aggressively shaped tenor sax lines comes from that formidable presence of Idriss Suliman heard in those soaring trumpet notes and through the forceful soloing of Pepper Adams on baritone sax. Even in the sultry and more relaxed closing, 'Hip Hip Tip', they still cut across an acoustic like a proverbial knife through butter. Van Gelder's recording of these soloists (and that goes for Mal Waldron's piano, too) is unswerving - which is not to say that he neglects the talents of a rhythm section that includes Arthur Taylor (drums), Doug Walkins (bass) and Ray Barretto (conga). Their beat zips along for 'Scamperin'; goes on to provide those subtle shifts in mood that underpin the "blowers" on an alternately happy and sad title track, and then perfectly picks out that funky, finger-clicking tempo for, 'Blue Greens' N Beans'. The engineering, its sense of proportion and priority on each of these four very different jams, is dangerously good. While a solid RTI 180gram pressing reassuringly completes this package. Highly recommended.

RP
Supplier: Cherished Record Co. 01579 363603

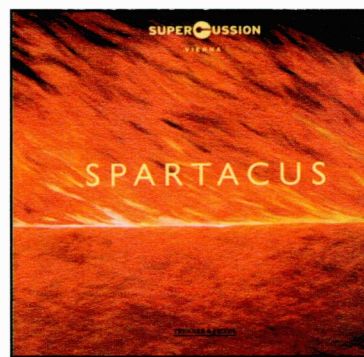

Spartacus

Supercussion

T&F CD 1

Supercussion are an ensemble garnered from the percussion sections of the finest Austrian orchestras, but before you run screaming at the thought of yet another audiophile percussion disc, let me assure you that this disc is for the music lover rather than the musical pyromaniac. The core piece on this CD is Khatchaturyan's sparkling short work *Spartacus*, the first movement of which is familiar to millions as the theme to The Onedin Line. Sensitively arranged for Supercussion by Bruno Hartl, the first timpanist at the Vienna Philharmonic, the ensemble manages to convey all the textures of an orchestra via the use of an incredible array of percussion instruments. Much of the success of this arrangement lies in the use of the marimbaphone, an electrically augmented marimba variant that allows sustained textures, aping the original string sections. Add to this the skill and sensitivity of the eight musicians and the result is a bold and ultimately satisfying slant on this popular classic.

The recording itself was made using a simple twin pair of mikes, and the balance was achieved by careful positioning of the players in the studio. There are no edits, what was played is what you get, and despite the (very) occasional fluffed note this approach adds no end to the vitality of the finished work. At last a percussion disc for people who like music - more please.

DA
www.supercussion.net



THE NATURAL CHOICE FOR HI-FI UPGRADES



GARRICK
FOR THAT NATURAL SOUND



Hand crafted stone products to your exact requirements

- Speaker Stands
- Hi-fi Racks
- Plinths
- Top Weights
- AV Racks

Tel: 01202 591922
www.garrickstone.com

SEE US AT THE MANCHESTER SHOW

the sound sanctuary



The only choice for music lovers looking for the highest quality sound.

Naim, Linn, Rega, Musical Fidelity, Chord Electronics and Wilson Benesch plus esoteric audiophile brands such as Wavac, Klyne and Monarchy.



Castle Sound & Vision, the region's leading hi-fi, home cinema and multi room specialists

48 - 50 Maid Marian Way Nottingham NG1 6GF Tel: 0115 958 4404
www.castlesoundvision.com

ADVERTISERS INDEX

Advertiser	Page	Advertiser	Page	Advertiser	Page
Audio Solutions	99	GT Audio	51	Pear Audio	70
Aanvil Audio	118	Garrick	139	Pure Digital (formerly Videologic)	81
Absolute Sounds	2	Griffin Audio	89	Radlett Audio	70
Audio Atmosphere	116	Hazlemere	98	Reference Audio	60
Audio Consultants	14	Heatherdale	89	Ringmat Developments	50
Audio Counsel	98	Henley Designs	13	Russ Andrews Accessories	60
Audio Illusion	32	Hififorsale.com	80	Signals	122
Audio Images	118	Hificables.co.uk	89	Sounds of Music	111 & 123
Audio Reference	29	IF Designs	81	Sounds of Music (Boulder)	32
Audio Republic	70	Infidelity	60	Sounds of Music (Lumley)	88
Audiocraft	81	Intergrated Engineering Solutions	61	Spendor Audio Systems Ltd	29
Audiovector/Bocchino Audio	99	Joenit	27	Stone Audio	50
B & W Loudspeakers	9	Kevin Galloway Audio	61	The Cartridge Man	116
Basically Sound	123	KJ West One	17	The Chord Company	4
Castle Sound & Vision	139	Midland Audio Exchange	10	The Right Note	80
Chestergate Exhibitions	113 & 130	Mike Manning Audio	116	Tom Evans Audio Design	118
Chord Electronics	21	Music Matters	122	Total Systems Audio	122
Cloney Audio	112	Naim	IBC	Trading Station	121
Cyrus	22	Neat Acoustics	88	Trichord Research	71
Definitive Audio	51	New Audio Frontiers	123	Ultimate Sonics	35
Densen	OBC	Nordost (UK)	18	Vivante	136
Doug Brady Hifi	37	Northwood Audio	122	Voodoo Isolation Systems	122
Dynavector Superstereo	70	Oranges & Lemons	122	Vynoodle	123
European Circuit Solutions	99	Origin Live	37	Walrus	6
Experience Filtration	118	Path Premier	IFC	Wilmslow	60
		Paul Hynes	116	Wollaton Audio	71

Tales Of The River Bank

Acoustic Sounds revisit the Riverside Label

by Reuben Parry

Last year's exclusive deal struck between Acoustic Sounds/Analogue Productions and Fantasy Records has placed within Chad Kassem's reach a wonderful opportunity to cherry pick the very best albums from amongst their highly regarded Original Jazz Classics titles. The artist rosters from these Contemporary, Prestige and Riverside labels of the Fifties and Sixties reads like a "who's who" of jazz, and in this first batch of 180-gram and Super Audio CD releases there's a fine cross-section of styles and personalities from which to choose. Miles Davis and Sonny Rollins are very well represented in the analogue transfers of *Cookin'*, *Saxophone Colossus* and *Way Out West*. These masterpieces, together with the Bill Evans' *Waltz for Debby* and Chet Baker's *Chet*, have made it on to a classy SACD format with a little help from Ed Meitner and the EMM Labs' latest third generation Analogue-to-DSD converters. The full array of mastering skills, courtesy of a legendary Doug Sax, are also brought into play here.

I have already touched upon three of these 180-gram RTI virgin vinyl cuts – *Bags' Groove*, *The Contemporary Leaders* and *Blue Gene* – as single record reviews, but there are also four stunningly individual Riverside label reissues spanning the years 1959 to 1961, that I thought would make an interesting article in their own right. The four LPs, in no particular order, are: *The Little Giant* – Johnny Griffin, *Thelonious Alone In San Francisco* – Thelonious Monk, *Sunday At The Village Vanguard* – Bill Evans Trio, and the only blues album release to

date in this series, John Lee Hooker's *That's My Story*. However, before diving headfirst into these inviting waters, it's perhaps worth recalling the origins of this famous record label.

Riverside Records was founded in 1953 by Orrin Keepnews and Bill Graver. Although they were later to be well known for their strong advocacy of modern cutting edge jazz, the label did begin life as a home for a more traditional sound, yet as new recordings were released, they never completely lost sight of those roots. However, by 1955 Thelonious Monk, still reeling from the aftershock of a trumped-up charge for drugs possession and a subsequent six-year performance ban within New York City, was signed by the sympathetic executives at Riverside. The fruits of the association can be heard in those truly great albums like *Brilliant Corners* and *Monk's Music*. Monk, working with the likes of Gerry Mulligan and Clark Terry, was able to reveal his unique rhythmic sense and exposed piano style to a much broader audience.

In 1956 Mundell Lowe introduced the twenty-seven year old Bill Evans to the label for a successful debut as leader on *New Jazz Conceptions*. It was here, five years later, that he cut the grooves for those defining LPs, *Sunday At The Village Vanguard* and *Waltz For Debby*. The roster was even further strengthened when in 1958 Riverside hooked up with that blues-soaked sax of Cannonball Adderley. From then, until the label's demise in 1963, he released fourteen titles – amongst



► them was of course a highly regarded collaboration with Bill Evans – *Know What I Mean*. By the end Adderley has cold-forged that entirely new “Jazz-Soul” genre. He was also responsible for getting the guitarist Wes Montgomery a Riverside contract to record the series of trio albums which were to eventually establish him as one of the foremost players of his generation. Even an old war-horse like Earl ‘Fatha’ Hines was given a new lease of life at Riverside. His 1961, *A Monday Date*, was a worthy prelude to a succession of

from original Riverside tapes.

I thought quite hard about the sequence in which these LPs were to be reviewed. A strictly chronological approach appealed to my personal sense of orderliness and I hoped that this might also better reveal something of the shifting artistic undercurrents, as well as detect any refinements made to a Riverside sound.

Launching itself on to the platter first was a New York recording taped in the August of 1959: *The Little Giant*, Griffin’s third Riverside album, while being more carefully framed than his earlier efforts, still goes a long way towards confirming that Johnny G was the living, walking and sax blowing embodiment of a quart in a pint pot. Short of stature and big of breath, he, together with Eddie ‘Lockjaw’ Davis, developed a whole sub-genre of tenor playing built around their burgeoning reputations as the “tough tenors”. But, importantly, this LP also reveals Griffin’s growing maturity as a jazz performer. Fellow horns, Blue Mitchell (trumpet) and Julian Priester (trombone), combine remarkably well with his distinctive tenor sax style to create a full-bodied, lucid, wholly integrated and exciting sound. Griffin leads this sextet, not by the nose but through example.

Three of these six quite intriguing numbers flow from the pen of Norm Simmons, who, like Griffin, built an enviable reputation at home in Chicago. Johnny G has an obvious affinity for his intricately scored, ‘Olive Refractions’, ‘The Message’ and ‘Venus and the Moon’. Each arrangement lends itself to the improvisational skills of these accomplished horn men. Typically, on his own solos, Griffin gives a pocket battleship of a performance. Agile and dextrous, yet packing that muscular punch of a fifteen inch round, these powerful and richly toned interludes (to continue a naval analogy) pierce the lightly armoured superstructure of a tune with lightning velocity. Then they detonate deep within, and successive notes tear at it’s innermost workings in a series of secondary explosions. When these guys get going it’s a case



acclaimed concert and recording dates which relaunched his career later in the decade. When Riverside’s visionary flame was extinguished in 1963, it was Fantasy Records who obtained the rights to these recordings. Consequently, in the 1970s, many of these famous titles resurfaced on their Milestone and Original Jazz Classics labels. It is a splendid catalogue from which to draw reissue material and this first batch of titles are a more than fair representation of what is available. Substantial, heavyweight RTI pressings are the bonus here. Though, I believe I am correct in saying that these LPs have been manufactured using the Fantasy Records metalwork instead of being remasters taken

▶ of “smell the cordite and hear those chords really burn”. The rhythm section, Albert Heath (drums) and the dependable Sam Jones (bass), are definitely no slouches either. But with all the fireworks going off in tracks like Saxie Dowell’s ‘Playmate’, that hoarse and often blistering treatment by the horns needs an antidote, one which is cleverly provided through plump swinging bass lines and a catchy beat. The subtle Jack Higgins engineering techniques intelligently manoeuvre these musicians in a variety of ways. Tenor sax, trumpet and trombone sound incisive rather than strident. While a well-proportioned Sam Jones bass ripens in this warm acoustic. Nor is the flawless Wynton Kelly piano work neglected. Backlit, as opposed to spotlight, his fresh and inventive approach (so admired by Miles Davis) is solidly presented. The recording even manages to paper over cracks in the weakest of these tunes – a worn out, exotic and two-paced Babs Gonsalez number, ‘Lonely One’.

A couple of months later, on October 21st and 22nd 1959 to be exact, our Riverside production team of Orrin Keepnews and engineer Reice Hamel, were now to be found practising their darkest arts in an empty meeting hall on the West Coast. Here they awaited that first visit to San Francisco by one Thelonious Monk. The recording of this, his second unaccompanied Riverside album (after the 1957 release of *Thelonious Himself*) proved to be a far less fragmented affair. Whereas, *Thelonious Alone in San Francisco*, was taped over just two brief sessions on consecutive afternoons, with just one of its ten tracks requiring more than a single take; his earlier New York piano solos were characterised by a whole agonising series of takes. *Alone in Frisco*, though, remains as one of those rare, seamless and smoothly executed recordings of a great musician at the peak of their powers.

Having striped this hall, the music and even their recording equipment down to bare essentials, a profound sense of being “alone” was developed and then further reinforced through an unusual set of anecdotal personal circumstances. A first visit to a strange city. His wife left behind recuperating in Los Angeles after major surgery,

and a bizarre opening on the previous night at the Black Hawk, where Monk was the only member of his quartet to show up for the first two sets, were the physical and psychological preparations for these challenging themes of loneliness on this LP.

Unaccompanied, those Monk compositions more familiarly heard as quartet pieces, such as the ballad, ‘Ruby, My Dear’, a contemplative ‘Reflections’, or an introspective ‘Blue Monk’, are here shown in an entirely new light. He quietly, but firmly, establishes a subdued mood. Adopting an approach that reveals a bluer side

to these tunes. Yet, in the final analysis, he never truly detaches himself from their natural warmth. His affectionate playing on a classic Irving Berlin number, ‘Remember’, and the wry lyrical humour evident throughout ‘Round Lights’, are the nicely timed and weighted relief that’s drawn out from some intricately woven patterns.

The acoustic and a secure and centrally located piano image complements the whole tone of this album. There is nothing flashy or

inflated about their reproduction of these typically Monk-ish chords. They would probably sound even better as a mono cut, and there is a school of thought which says that for the recording of a soloist “mono” is all you really need. That said, this is a piano recording I wanted to return to again and again, and each time I did, well, there was a stubborn rebuttal of any criticism. Another attraction is the length and variety present within these Monk improvisations. Seven of them last less than four minutes, which suggests that those nimble-fingered visualisations never slip into a dangerously self-absorbed exorcism of demons. If you were to think of an LP side as a set, then both sets here are precise, tightly controlled and beautifully played.

On February 9th 1960, back within the boundaries of New York City, Orrin Keepnews and Jack Higgins were reunited for an album from a bluesman who occupies a pivotal position both in the adoption of the blues form by white bands, and as a prime mover

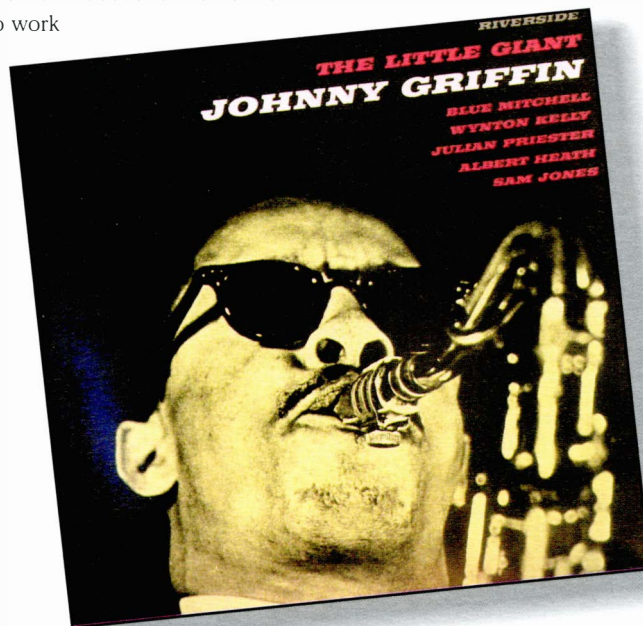

► in the transition from urban blues to R&B. *That's My Story* was John Lee Hooker's second LP for Riverside after *The Country Blues*, his debut the previous year. Here, however, that gravelly voice and those unconventional, thumping rhythms are given an added dimension with the inclusion of Cannonball Adderly's rhythm section of Sam Jones (bass) and Louis Hayes (drums) on nine of these twelve tracks. Freed from those hefty burdens of having to solely provide a beat, Hooker can draw that much more deeply upon his emotional strengths – an approach that was to broadly popularize this medium. Never restricting himself to that strict twelve-bar structure also enabled JLH to loosen the bindings of a blues tradition and, instead, increasingly treat these tunes as feelings rather than a form.

This is certainly evident right from the stark realism of an opening, 'I Need Some Money', right through to those threatening lyrics of side one clincher, 'Gonna Use My Rod', which simply drips with bile as Hooker tells a friend to stop messin' with his wife.

Hooker is, of course, one of the great emotion-stirring singers. He has terrific powers of vocal projection and an immense rhythmic presence which makes this, his personal take upon those concerns that have preoccupied generations of bluesmen, so utterly convincing. While sensitive to poverty, inequality and the woes that befall men and women, he is also an honest social chronicler in songs like, 'Democrat Man', which at the time must have given this album a topical political slant. He is, too, as the title track seems at pains to remind us, a time-served wandering musician. A man who, though steeped in the tradition of his forebears, still brings an indelibly fresh perspective to these themes. The suitably meaty recording gets right into this gristly material. That voice, its distinctive textures, and the power and resonant full-bodied delivery, are all expertly revealed – as are those exposed and sinuous guitar chords, and that ever so determined and unyielding beat. True, the very bottom end of the recording does roll off a little, but its' decline is progressive rather than sudden, and it could always be argued that an absence of "snap" down in the boiler-

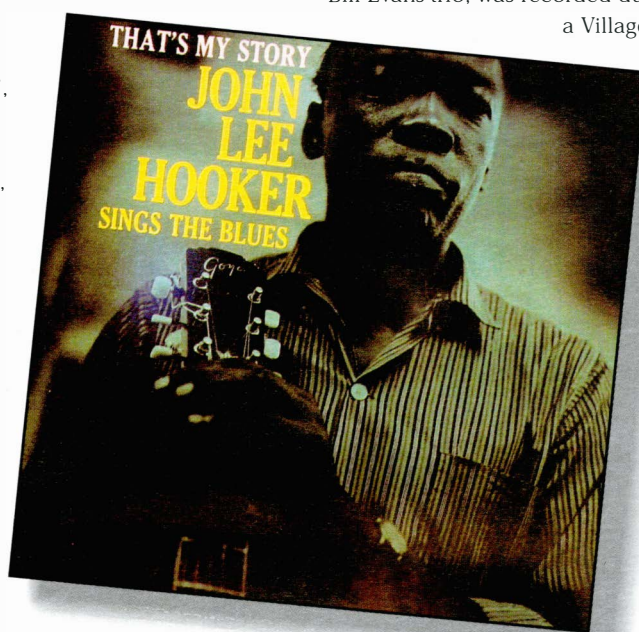

room actually promotes JLH's trademark "boom".

When compared to the technical niceties of Monk's San Francisco sessions, *That's My Story* has an advantage where overall warmth is concerned, but lacks the impressive inner detail and that degree of authority which allows even those decaying piano notes to retain their shape and form. Monk's piano image is a crisply cut dress uniform while JLH pulls on a much-loved cable knit sweater. These sartorial differences are not lost on the listener. Though in a way both are appropriately attired for their respective workplaces.

The last in this quartet of Riverside tales is a legendary, *Sunday at the Village Vanguard*. This, the first of two Riverside albums spotlighting the brilliance of that first Bill Evans trio, was recorded during their final day of a Village Vanguard engagement

on June 25th 1961. It is everything a live jazz recording like *Jazz At The Pawnshop* should have been, but isn't.

Where to begin? Well, I think an appropriate starting point is the relationship between the principals. Bill Evans, piano, Scott LaFaro, bass and Paul Motian, drums had been performing as a trio since 'Fifty-Nine and that sense of inseparability permeates this session. The programme here may only extend to a mere six songs, but when five tracks

run to between six and nearly nine minutes in length, it always allows sufficient time for musicians of this calibre to stretch out, explore, improvise and personalise all these tunes in a unique and fulfilling way. To that end, a sense of ensemble, that congenial joining of these like-minded players, with their perfect phrasing, sublime solos and inspired levels of creativity, comfortably eases this LP (on a musical basis at least), into that frequent and over used "definitive" category.

Much of this is down to Evans who was one of the most important and influential of modern jazz pianists. He is at his lyrical, melodic and impressionistic best. These methods employ a wide variety of subtle tonal colours in a distinctively softer approach to harmony than was heard from his peers. This comes across most

► strongly on the Miles Davis, 'Solar', that Cole Porter standard, 'All Of You', and in an arresting version of George and Ira Gershwin's, 'My Man's Gone Now'. When listening to the Gershwin, you can hear that underlying root of a chord carried by those compelling LaFaro bass solos, while Bill Evans only retains an essence of these tones when he delivers the same chord. This generous style of piano playing became known as 'rootless voicing' and Evans generally cradles, strokes and lovingly caresses a beautiful exposition with it. Naturally, the poignancy generated and distilled from these magical performances

is heightened by a knowledge of those tragic events which overtook this album. Only ten days after putting these tapes in the can Scott LaFaro was dead, killed in a road accident at the tender age of twenty-five. The essence of a live jazz trio, so faithfully captured by this recording, was a fitting requiem in itself.

Nor should the presence of two LaFaro compositions, 'Gloria's Step', and a closing, 'Jade Visions', be regarded as sentimental inclusions. They are here on merit. 'Gloria's Steps', for example, are underpinned by dynamic and swinging Paul Motian brush strokes which provide a rhythmic backdrop for some terrific bass and piano solos. 'Jade Visions', meanwhile, is a sensitive vignette, gently teasing out an oriental, lime-coloured hue that conjures up additional images of petite and delicately featured young women.

The only track not yet touched upon in this set is a Frain-Hilliard, 'Alice in Wonderland'. Do not be put off. This is unrecognisable as music originally penned for the Walt Disney film. The liner notes clearly point to a "reworking of a piece of trivia and banality" that

showed improvisation and versatility at its' finest.

Acoustically? There is plenty of inner detail throughout, including all those extraneous "you are there" audience noises from the Vanguard. Clinking glasses, background chatter and applause, (even on tracks like 'Alice', where it's more prominent), can only be described as atmospheric and never intrusive. Here, as elsewhere, this Dave Jones recording presents piano, bass and drums within a nicely balanced, transparent, yet intimate and

full-bodied soundstage. Pretty good for a "live" outing. It needs to be all these things and more because the Nick Webb master of this LP recut at Abbey Road for ALTO EDITION some five or six years ago, is an exceptionally good one.

Musically, all four pressings can be closely grouped. It's a tight old hierarchy here but, as they say, "it's a dirty job and someone's got to do it". On piano, Monk ahead of Evans? Or, vice versa? These are the toughest of calls and their differing styles just don't make



this any easier. The debate is fairly open, and where within it do you place the big blowin' Griffin sax or that booming Hooker blues? All of these musicians and their performances are significant and, in the end, the following pecking order was as much determined by the impact of the sidemen on these LPs as anything else, perhaps giving a self-reliant Monk an advantage over the others. Sonically, the grading has been simpler and these strong RTI cuts, whatever their source, can be safely recommended. Records to treasure. ✚

Supplier:
Cherished Record Company 01579 363 603

Griffin



Monk



Hooker

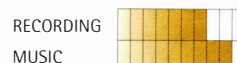

Evans



SEE WHERE IT TAKES YOU

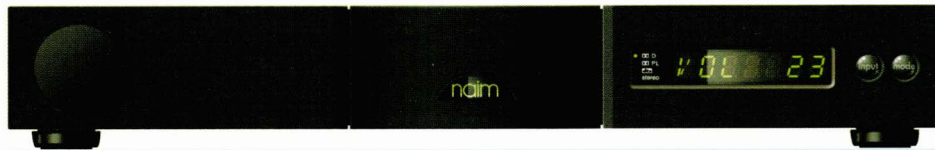

SERIES
5

Introducing the latest addition to the Series 5, the Naim AV2 (Audio Video) processor. It not only enhances anything you listen to, it makes everything you watch come to life. People talk about 'Surround Sound', at Naim we immerse you.

THE ULTIMATE ENTERTAINMENT SYSTEM

WORLD CLASS HI FI

For your nearest stockist call +44 (0)1722 332266. Or visit www.naim-audio.com

BEAT
Densen Audio Technology

Stop

Pause

Play

Open

BEAT B-400

Acoustic Arts
Walford
Tel. 01923 245250

Adams and Jarrett
St. Leonards on sea
Tel. 01424 437165

Audio Counsel
Oldham
Tel. 01616 332602

Hi-Fi Studios
Doncaster
Tel. 01302 725550

**Kevin Galloway
Audio**
Kilmarnock
Tel. 01563 574185

**Midland Audio
Exchange**
Kidderminster
Tel. 01562 822236

Mike Manning
Taunton
Tel. 01823 326688

Mike Manning
Yeovil
Tel. 01935 479361

New Audio Frontiers
Loughborough
Tel. 01509 264002

Phonography
Ringwood
Tel. 01425 461230

Progressive Audio
Gillingham
Tel. 01634 389004

Radfords
Bath
Tel. 01225 446245

Radfords
Bristol
Tel. 01179 441010

Signals
Ipswich
Tel. 01473 655171

Zen Audio
Hull
Tel. 01482 587397