

HOBBIES WEEKLY

IN THIS ISSUE

	Page
Contemporary Furniture for the Doll's House	353
A Lady's Sewing Cabinet and Work Table	355
Soldering Techniques	356
A Two-Tier Test Tube Rack	358
How to Fix those Screws	359
The Sopwith Camel Single-Seater Scout	360
Make a Warm-Air Drying Cabinet	362
Replies of Interest	364
A Pair of Small Bookends	367



SEPTEMBER 7th 1955

VOL. 120

NUMBER 3123

The first of a series of articles on making—

THE illustration shows the first of a series of articles showing how to make contemporary furniture for dolls' houses. We already list two wallets of furniture in our Handbook and these are extremely popular. Although there is not quite the demand for the ultra-modern designs, we are sure that they will appeal to enough readers to warrant their inclusion in *Hobbies Weekly*.

Popular Scale

The scale chosen is approximately $\frac{1}{2}$ in. to 1ft., which is suitable for a medium or large size doll's house with a room height of not less than 6ins. Room height could extend to anything up to 9ins. and still be in keeping as far as scale is concerned. Of course, there is no need to be particular about exact

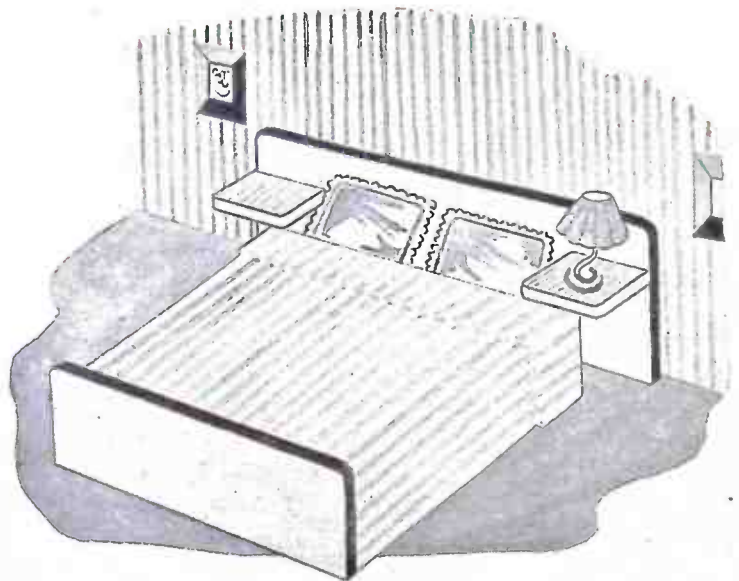

CONTEMPORARY FURNITURE FOR THE DOLL'S HOUSE

scale in everything. The main requirement is for the overall size to be more or less in proportion with the room.

In this issue we give details of how to

make up a double bed complete with headboard. The mattress part is shown full size in Fig. 1, and is cut from $\frac{3}{8}$ in. wood. The small shelf is also cut from

$\frac{3}{8}$ in. wood and is shown full size in the same diagram. Note that two shelves are required, one on each side of the bed. The headboard and foot of the bed

All correspondence should be addressed to The Editor, Hobbies Weekly, Dereham, Norfolk

*For Modellers, Fretworkers
and Home Craftsmen*

4^D

A LADY'S SEWING CABINET AND WORK TABLE

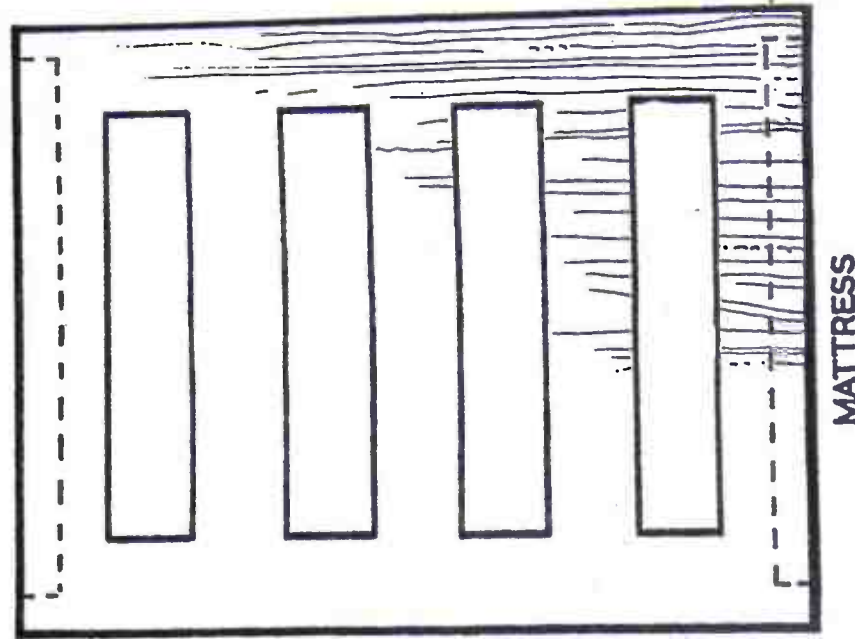

Fig. 1

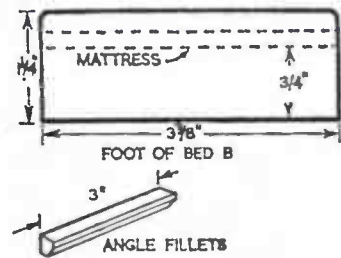
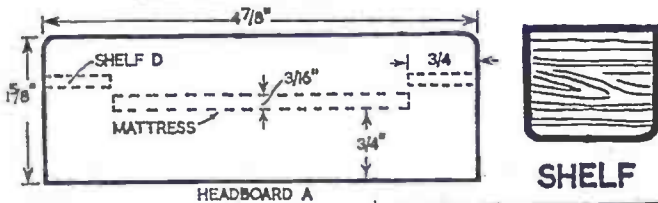

Fig. 2

are shown in Fig. 2. Sufficient measurements are shown for you to be able to draw them out full size. The dotted lines show the positions of the mattress and the shelves. Cut both headboard and foot from 3/4 in. wood.

The mattress should be pinned and glued to the headboard and foot, and two pieces of angle fillet are glued underneath for added strength.

Finish

Much of the contemporary furniture is left in the natural wood and we suggest this is a good finish for the

dolls' furniture. It would also look well painted with plastic enamel paint in a pastel shade. The wood must be well cleaned with fine-grade glasspaper before the paint is applied, and if two or more coats are needed, a light rubbing before applying the next coat will improve the appearance. (M.h.)

Continued from page 357

Soldering Techniques

untinned surfaces, or .001 in. with tinned surfaces (R). Such gaps will fill by capillary action, if the joint faces are clean and the solder hot enough.

Electrical joints are about the easiest to make in one sense. They usually involve the easiest metals to solder, such as copper, tinned copper, or brass. On the other hand, great care is often needed to avoid damaging insulation or components with the heat of the iron, and in making truly neat connections.

Stripping insulation of wires is the first problem. Wire cutters can be used, or a knife (S), but take care not to cut into the wires themselves. After cutting nearly through the insulation, it can be pulled off to expose a short length of bare wire. Plastic insulation is best removed by 'cutting' with the tip of a hot iron and then pulling off.

The exposed wires should be clean and ready for tinning, which is done as shown in (T). If the wires are enamelled, this must first be scraped off carefully, as

otherwise the solder will not adhere.

Having tinned the end of the wire it should now be held on the terminal with one hand, the iron loaded with solder, and then pressed over the joint. The solder should flow readily to cover the joint, when the iron can be removed. Continue to hold the wire until the solder has frozen. The real secret of success is clean terminals, tinned wire, and a really hot iron applied for the minimum amount of time necessary to make the solder flow over the joint. And do not put more solder than necessary on the joint.

Finally, a word or two about soldering leads to dry batteries. This is very difficult to do properly unless the battery terminal, or case, is properly cleaned with a file. If the battery is intended for short-term use only, then it is permissible to use a corrosive flux to ensure a good joint. Otherwise rely on good mechanical cleanliness produced by filing and a resin-cored solder (U).

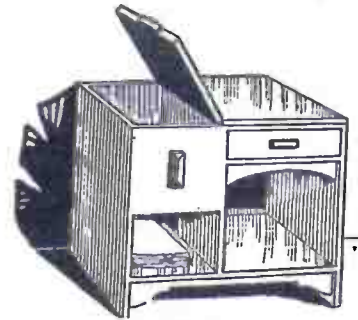

Fig. 1

THIS useful piece of furniture would be the delight of any lady, as it considerably aids the problems of sewing. Moreover, its construction is well within the limits of the average handyman. The article consists of a large cabinet for holding material that is being made up, and when the lid of this is lowered, this and the table top

In Fig. 2 are all the necessary measurements for making, and in Fig. 3 a section through the drawer giving further constructional help. The two ends (A) are 24 ins. long by 13 ins. wide

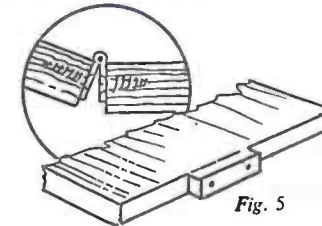

Fig. 5

by 1/2 in. thick, and they are grooved for the main floor (B). One end is also grooved for the tongues on front and back (D). The top of the right-hand end and also the centre partition (C) is

two parts (D) and that tenons are cut along the bottom to fit into the mortises cut in floor (B). There are two stiffening rails, one long one to go under the edge of the floor (B) to which it is counter-sunk screwed and glue-blocked as shown in Fig. 2. The second stiffener is under the rail (E), and its shaping can be determined by the radius line of 18 1/2 ins. shown. The detail Fig. 4 shows how all

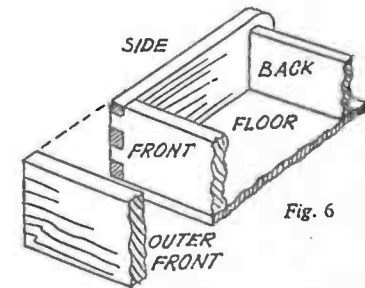

Fig. 6

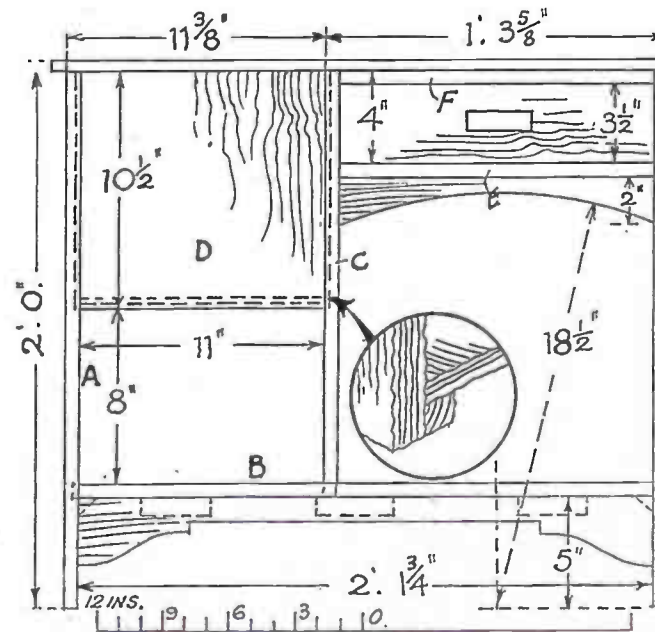

Fig. 2

alongside will form a very convenient cutting-out table. A drawer for cottons, etc., is provided and space for pattern books, etc. is arranged for beneath the cabinet.

slotted to take the cross-rails (F). The rail (E) is also slotted into the above and in the centre partition, all as shown in detail Fig. 4. It will be noted that (C) is grooved on the left face to take the

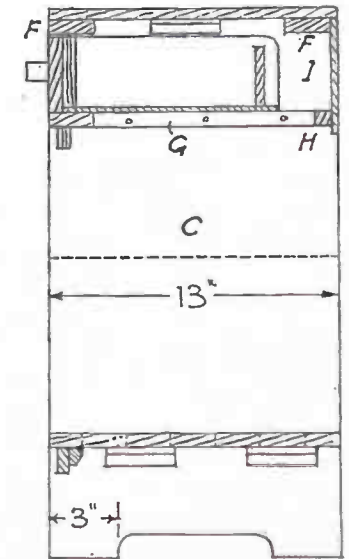

Fig. 3

the parts are grooved and cut before assembling.

The floor of the box may be of plywood 1/2 in. thick, and set on four

Continued on page 359

SOLDERING TECHNIQUES

By R. H. Warring

TECHNIQUE is all important in making good soldered joints. One of the principal considerations is that the solder should 'run' or wet the surface to which it is being applied. If a blob of molten solder is run on to a piece of metal which has been lying around in the workshop for some time, it will just collect in the form of a blob, which, when solidified, can be picked off quite easily. In other words, the solder has not wetted the metal, and has little

iron will 'carry' a considerable amount of solder to the joint. An untinned iron will carry no solder at all, except any which you are lucky enough to balance on the end of the bit.

If cleanliness is the first of the rules of soldering, the second is correct iron temperature. If the iron is too cold it will not completely melt the solder, but

solders, except for the difference in bit temperatures required. Solders with an even lower tin content are of little use to the amateur. 30/70 solder, for instance, is used for fuses, motors and dynamos; and 20/80 solder for lamps and dynamos.

It will generally pay to use 60/40 solder for most model work where soft-soldered joints are to be made. This gives a minimum temperature which is over 40 degrees less than 40/60 solder, and it will be better suited

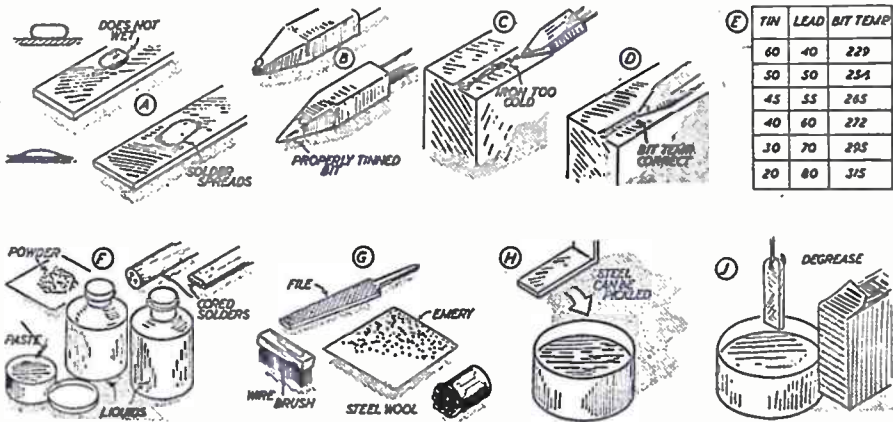

or no adhesion to it (A). On the other hand, if the metal surface is clean and/or flux has been applied, the solder will spread out over the surface, and this time will be difficult, or even impossible, to pick off when cold.

The same remarks apply to a large extent to the soldering iron as well as the metal to be jointed. If the iron is dirty, it will still melt solder pressed on to the

will keep it in a pasty state. It can be applied to the work, but the result will be unsatisfactory (C). With the iron at the correct temperature the solder will 'run' on a clean joint, which is the ideal.

There are quite a number of different types of solder and each one has a definite minimum temperature for satisfactory performance. The lower the tin content of the solder, the higher the

to electric irons. The latter are widely used today and frequently misused, or do not give a satisfactory service. The reason for the latter is almost invariably the result of operating the iron on a sub-standard voltage. The majority of electric irons are rated for 230-240 volts and tend to give indifferent results on much lower voltages. The actual supply voltage may be appreciably less than the

bit, but the solder will not stick. It will roll up into blobs and drop. With a clean iron the solder will actually amalgamate with the copper of the bit, spreading out over the surface and 'tinning' it (B). More and more solder can then be added and will cling to the tinned bit until quite a large blob is hanging suspended, which can be transferred to the work surface. A well-

temperature needed (E). In this table the temperature of the bit is given in degrees Centigrade. Tin costs five to seven times the price of lead, so the higher the tin content of the solder, the greater its cost. Thus 60/40 solder is used for high-quality work, and is more expensive than 40/60 solder. There is not a great deal of difference in the performance of these two particular

nominal figure at certain periods, too. Thus using a 230 volt iron on what is supposed to be a 200 volt supply is bad enough; but at a peak load period the actual supply voltage may be as low as 180 volts. No wonder, therefore, the iron does not heat up properly.

The third rule of good soldering is to use the proper flux for the job. There are a variety of fluxes available—some in

powder form, some as pastes, some liquids. In addition there are 'cored' solders which contain the flux in the solder itself (usually a resin-type flux) and do not need any other flux in use. Cored solders are particularly useful for soldering electrical connections (F).

Broadly speaking, fluxes are of two main types—those which are 'active' and those of a passive nature. An active flux, as the name implies, pro-

duces a definite chemical reaction of a corrosive nature, which may be excellent from the point of view of cleaning the surfaces involved, but cannot be left to remain active once the joint has been completed. Hence active fluxes have normally to be neutralised or washed off after completing the joint. They should be used only when necessary, and never for electrical connections. As a rough working rule, an 'active' flux is generally advantageous when soldering steel, or where complete cleanliness of the joint is difficult to achieve. Otherwise use a 'passive' flux which has no corrosive after-effect.

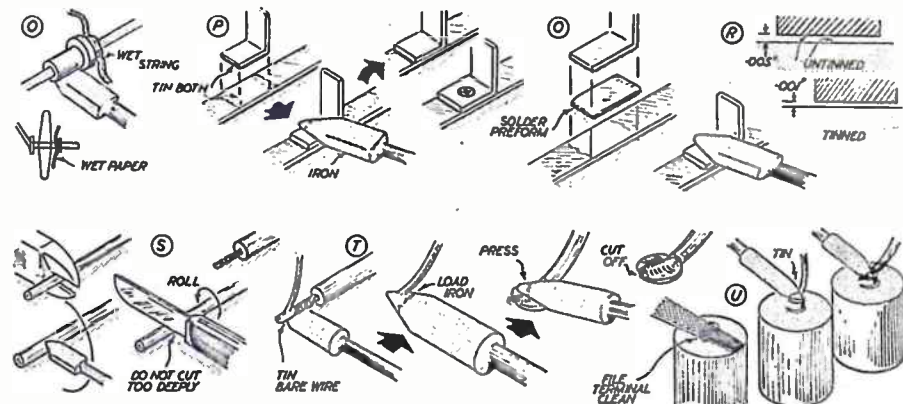

These rather elaborate cleaning methods mentioned may not be necessary in every case. Quite often a rub with emery paper or a file is all that is necessary to produce a surface satisfactory for good soldering; but it is as well to know how to tackle a really dirty surface, should the need arise.

Steel is not considered by many people to be a good subject for soldering. If the steel is properly clean, however, and an active flux is used, like Baker's fluid, perfectly satisfactory joints can be made with a minimum of trouble. A gas-heated iron is often preferred for such jobs, particularly if 40/60 solder is used.

Thus the stages in joining two steel wires are:—Clean the joint surfaces thoroughly (K) (and after cleaning do not finger, nor delay the actual soldering), tin (L), bring the joint surfaces together (M), and fuse with more solder.

If the steel is clean, it will tin readily after being brushed with flux. Hold the iron under the wire, apply the solder to the top and it should run over the fluxed area. If the solder is sluggish, the iron is not hot enough. If the solder does not wet properly, then the surfaces are not properly clean.

Where steel articles are concerned and the surface has rusted, pickling in a 50-50 mixture of hydrochloric acid and water is most effective (H). The steel should not be left in the acid any longer than is necessary to remove the rust, otherwise the surface may become etched and pitted. It should then be rinsed in hot water and dried thoroughly straight away.

Besides getting the surfaces chemically clean (i.e., free from oxides, scale and

other products of natural corrosion), it is also necessary to make sure that they are free from grease. Solder will not wet a greasy surface and even fingerprinting an otherwise clean article may produce this undesirable effect. Degreasing can be accomplished very simply by dipping in a hot solution of household detergent, swilling around, and then withdrawing, rinsing in warm water again and drying (J).

Capillary Action

In completing the joint (M), load the iron with solder and apply to the underside of the joint. The solder should then be drawn up into the joint by capillary action. Touching the

produces rapid cooling but may result in a brittle joint.

It is a great help with jobs like this to make up some form of simple jig to hold the parts to be soldered (N). Even binding the two pieces together with fuse wire will do. Any sort of simple jig (or holding the parts together in a vice) leaves both hands free, one to manipulate the iron and the other the solder.

Sometimes the wetting action of solder on a good clean surface can be a disadvantage as well as an advantage. In this case a binding of wet string or a mask of wet paper can be used to stop solder flowing past this point (O). The string or paper can easily be removed after the joint is completed.

Diagram (P) shows a method of soldering on a bracket. Both joint surfaces are generously tinned, brought together and a hot iron placed on top. An additional blob of solder may be added to the upper facing joint surface before bringing the two together for a stronger joint. Alternatively a 'preform' of solder may be used (Q). This is a piece of solder of the shape of the joint, sandwiched between the two and subsequently melted by the heat and pressure of the iron. The joint surfaces in such cases only need very light tinning, or even none at all if thoroughly clean and well fluxed.

For maximum joint strength, the gap between the joint faces which is filled with solder should be .005in. with

● Continued on page 354

A TWO-TIER TEST TUBE RACK

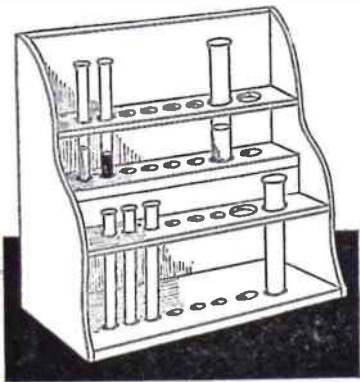

Fig. 1

PROBABLY no chemical laboratory fitting comes in for so much use as the test tube rack. While the usual one-tier type is easy to make from odd pieces of wood, a little more work and material will produce a much superior article, such as the two-tier design shown in Fig. 1.

The lower tier is intended for the temporary holding of tubes during tests. If it is desired to keep the contents of any tubes for observation, they can be transferred to the upper tier and

owing to its higher resistance to water. Fig. 2 shows the general construction. The back (A) is cut from $\frac{1}{2}$ in. wood, 13 ins. by 11 $\frac{1}{2}$ ins. Also cut from $\frac{1}{2}$ in. wood are (B) 4 ins. by 11 $\frac{1}{2}$ ins.; (E) 2 ins. by 11 $\frac{1}{2}$ ins.; (D) 1 $\frac{1}{2}$ ins. by 11 $\frac{1}{2}$ ins. Wood $\frac{1}{4}$ in. thick is needed for (C) 1 $\frac{1}{2}$ ins. by 11 $\frac{1}{2}$ ins.; and (F) 2 ins. by 11 $\frac{1}{2}$ ins.

The broken lines in Fig. 3 indicate the centre lines for positioning the holes and hollows. In (C) six holes $\frac{1}{4}$ in.

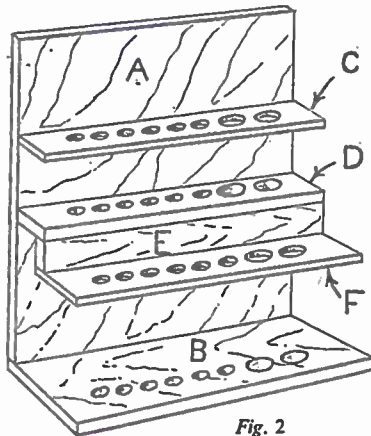
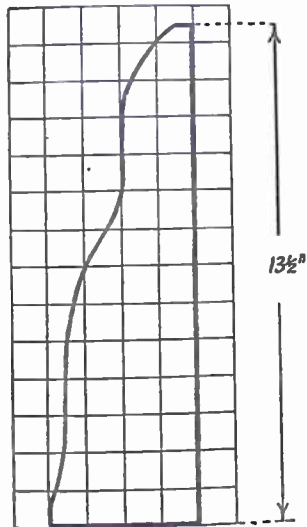

Fig. 2

cut from $\frac{1}{2}$ in. wood. The wood is marked off in 1 in. squares and the cutting line drawn on as shown in Fig. 4.

(A), (B) and the ends should first be assembled. (B) is screwed to (A) with brass screws. To avoid marring the ends with screws, they should be fitted to the rack with glue. A few fine fret nails or panel pins will strengthen the whole and be inconspicuous.

The top of (C) lies 3 $\frac{1}{2}$ ins. below the top of (A) and is fixed in with glue and fret nails—two at each end and a few



1" SQUARES

Fig. 4

along the back of (A). (D), (E) and (F) should be fastened together as a complete component before fixing in the rack. (F) is screwed to (E). Glue and fret nails serve to fasten (D) to (E).

When the glue is dry (D) is screwed to (A) from the back, the top of (D) lying 7 ins. from the top edge of (A). The edges which abut on the ends are previously coated with glue. Fret nails through the ends make the whole rigid. (L.A.F.)

EVERY CAR THAT PASSES—YOU WILL FIND THE INDEX MARK ALPHABETICALLY ARRANGED IN WHERE'S THAT CAR FROM? Price 9d. from all Booksellers or from the Publisher. (11d. postage) RALEIGH PRESS, EXMOUTH

How to Fix those Screws

ALTHOUGH a well-fitted wood-screw should remain secure and tight, this is not always the case. If it is fitted in something which is subject to much vibration or shock, in time it may work loose.

Unless you want the trouble of having to tighten it up quite often, a locking device is needed and there are several ways in which it can be done. Screws that have to be taken out occasionally will receive different treatment to those which are permanent fixtures.

Fixing Permanent Screws

The simplest way of fixing the permanent type is to drive a staple or bent wire across the slot as shown at (A) or a brad driven in to one end like (B). When the screw is sunk below the surface of the wood, a slot can be cut and a piece of wire laid across the slot and soldered in, and this method is also useful if you do not want to

puncture the wood with the points of a staple. This is shown at (C).

A very neat and secure job is made by cutting a circular or square sink a little larger than the countersink and gluing

When the screw has to be withdrawn occasionally a slightly different technique must be adopted. File a small semi-circular nick in the side and insert a tiny lock-screw (E).

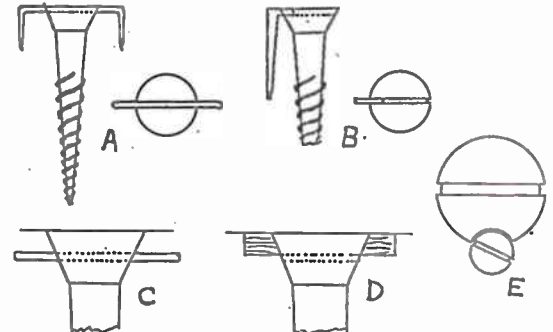

in a plug (D). When nicely done with the same kind of wood, it could be practically invisible.

These methods are only suggestions, and can be modified to suit your own problem and the materials available. (A.F.T.)

Continued from page 355

Lady's Sewing Cabinet

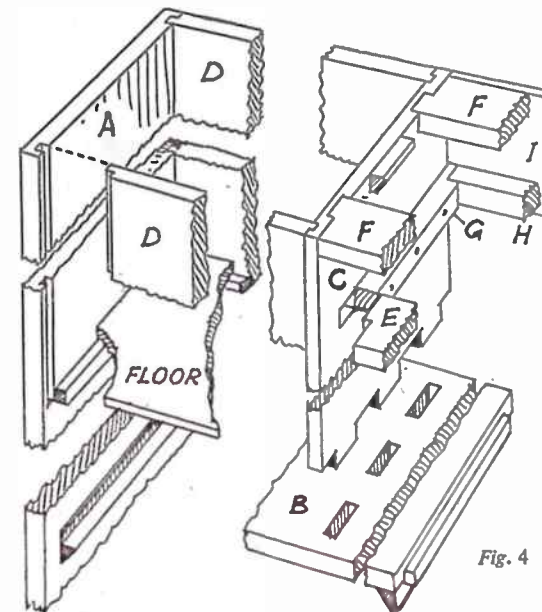

Fig. 4

screwed inside the sides and along the back (I). This latter consists of $\frac{1}{2}$ in. plywood fixed to the back of rail and to (H), see Fig. 4 and Fig. 3. The top of the table, on the right, is $\frac{1}{2}$ in. thick and may be of plywood, as is also the lid of the cabinet alongside. The top is screwed to the rails and glue-blocked as seen in Fig. 3. The lid is, of course, hinged to the top as in the detail Fig. 5. On the left of the lid is screwed a block of wood to act as a lift when opening it (Fig. 5).

Making the Drawer

The drawer is made up as shown in the sectional diagram Fig. 6. The sides and the front are half-lapped and glued together and the back nailed a little way in from the back edge as shown to make a firm hold. The $\frac{1}{2}$ in. plywood floor is screwed over the frame and the outer front then attached, screws being put through from the back to run well into the outer front. The drawer might well measure 8 ins. clear inside front to back, while the length should be carefully ascertained from actual measurements taken from the drawer opening.

If objection is taken to the exposed edges of the plywood lid and its neighbour, then a half-round beading could be glued and nailed on with small sprigs. Beneath diagram Fig. 2, a scale has been added, this will be found useful for getting further measurements in addition to those already included. (S.W.C.)

labelled. As the bases of these tubes are clear of the mouths of those in the lower tier, the behaviour of the contents can be noted at a glance, without having first to lift out the test tubes.

The rack can stand against the wall at the back of the bench, or be hung from the wall by means of eye plates. For preference, hardwood should be used,

diameter are drilled, starting 1 $\frac{1}{2}$ ins. from the end and allowing $\frac{1}{2}$ in. between each. The two 1 $\frac{1}{2}$ ins. diameter holes are also spaced $\frac{1}{2}$ in. apart. The hollows in (D) are spaced similarly and should be gouged $\frac{1}{2}$ in. deep. The holes in (F) and the hollows in (B) are spaced similarly along the centre line.

The ends of the rack should now be

$\frac{1}{2}$ in. square fillets as seen in the cut-away section in Fig. 4. The top cross-rails should be $\frac{1}{2}$ in. thick and let in half way

into the thickness into the right-hand side and into the partition (C). Drawer runners (G) and (H) must be glued and

A TWO-TIER TEST TUBE RACK

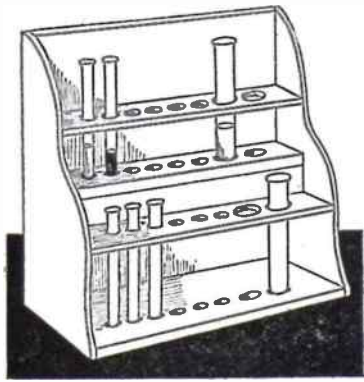

Fig. 1

PROBABLY no chemical laboratory fitting comes in for so much use as the test tube rack. While the usual one-tier type is easy to make from odd pieces of wood, a little more work and material will produce a much superior article, such as the two-tier design shown in Fig. 1.

The lower tier is intended for the temporary holding of tubes during tests. If it is desired to keep the contents of any tubes for observation, they can be transferred to the upper tier and

owing to its higher resistance to water. Fig. 2 shows the general construction. The back (A) is cut from $\frac{1}{2}$ in. wood, 13 ins. by 11 $\frac{1}{2}$ ins. Also cut from $\frac{1}{2}$ in. wood are (B) 4 ins. by 11 $\frac{1}{2}$ ins.; (E) 2 ins. by 11 $\frac{1}{2}$ ins.; (D) 1 $\frac{1}{2}$ ins. by 11 $\frac{1}{2}$ ins. Wood $\frac{1}{2}$ in. thick is needed for (C) 1 $\frac{1}{2}$ ins. by 11 $\frac{1}{2}$ ins.; and (F) 2 ins. by 11 $\frac{1}{2}$ ins.

The broken lines in Fig. 3 indicate the centre lines for positioning the holes and hollows. In (C) six holes $\frac{1}{2}$ in.

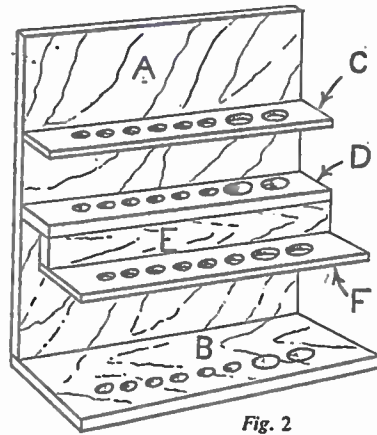

Fig. 2

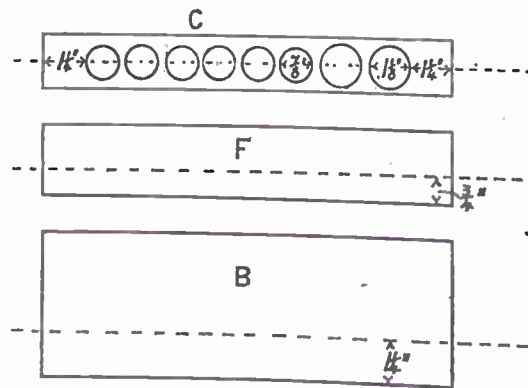

Fig. 3

labelled. As the bases of these tubes are clear of the mouths of those in the lower tier, the behaviour of the contents can be noted at a glance, without having first to lift out the test tubes.

The rack can stand against the wall at the back of the bench, or be hung from the wall by means of eye plates. For preference, hardwood should be used,

diameter are drilled, starting 1 $\frac{1}{2}$ ins. from the end and allowing $\frac{1}{2}$ in. between each. The two 1 $\frac{1}{2}$ ins. diameter holes are also spaced $\frac{1}{2}$ in. apart. The hollows in (D) are spaced similarly and should be gouged $\frac{1}{2}$ in. deep. The holes in (F) and the hollows in (B) are spaced similarly along the centre line.

The ends of the rack should now be

cut from $\frac{1}{2}$ in. wood. The wood is marked off in 1 in. squares and the cutting line drawn on as shown in Fig. 4.

(A), (B) and the ends should first be assembled. (B) is screwed to (A) with brass screws. To avoid marring the ends with screws, they should be fitted to the rack with glue. A few fine fret nails or panel pins will strengthen the whole and be inconspicuous.

The top of (C) lies $\frac{3}{4}$ ins. below the top of (A) and is fixed in with glue and fret nails—two at each end and a few

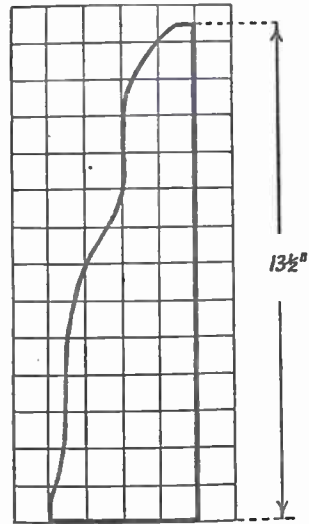

1" SQUARES

Fig. 4

along the back of (A). (D), (E) and (F) should be fastened together as a complete component before fixing in the rack. (F) is screwed to (E). Glue and fret nails serve to fasten (D) to (E).

When the glue is dry (D) is screwed to (A) from the back, the top of (D) lying 7 ins. from the top edge of (A). The edges which abut on the ends are previously coated with glue. Fret nails through the ends make the whole rigid. (L.A.F.)

EVERY CAR THAT PASSES—YOU WILL FIND THE INDEX MARK ALPHABETICALLY ARRANGED IN WHERE'S THAT CAR FROM? Price 9d. from all Booksellers or from the Publisher. (1 $\frac{1}{2}$ d. postage) RALEIGH PRESS, EXMOUTH

How to Fix those Screws

ALTHOUGH a well-fitted wood-screw should remain secure and tight, this is not always the case. If it is fitted in something which is subject to much vibration or shock, in time it may work loose.

Unless you want the trouble of having to tighten it up quite often, a locking device is needed and there are several ways in which it can be done. Screws that have to be taken out occasionally will receive different treatment to those which are permanent fixtures.

Fixing Permanent Screws

The simplest way of fixing the permanent type is to drive a staple or bent wire across the slot as shown at (A) or a brad driven in to one end like (B). When the screw is sunk below the surface of the wood, a slot can be cut and a piece of wire laid across the slot and soldered in, and this method is also useful if you do not want to

puncture the wood with the points of a staple. This is shown at (C).

A very neat and secure job is made by cutting a circular or square sink a little larger than the countersink and gluing

When the screw has to be withdrawn occasionally a slightly different technique must be adopted. File a small semi-circular nick in the side and insert a tiny lock-screw (E).

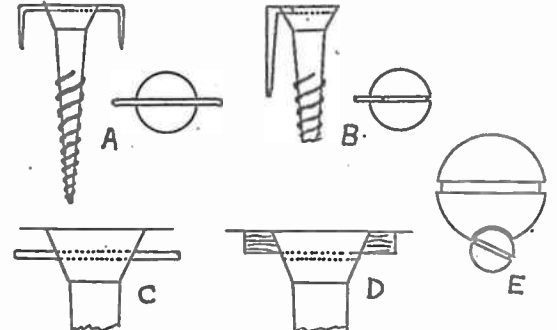

in a plug (D). When nicely done with the same kind of wood, it could be practically invisible.

These methods are only suggestions, and can be modified to suit your own problem and the materials available. (A.F.T.)

Continued from page 355

Lady's Sewing Cabinet

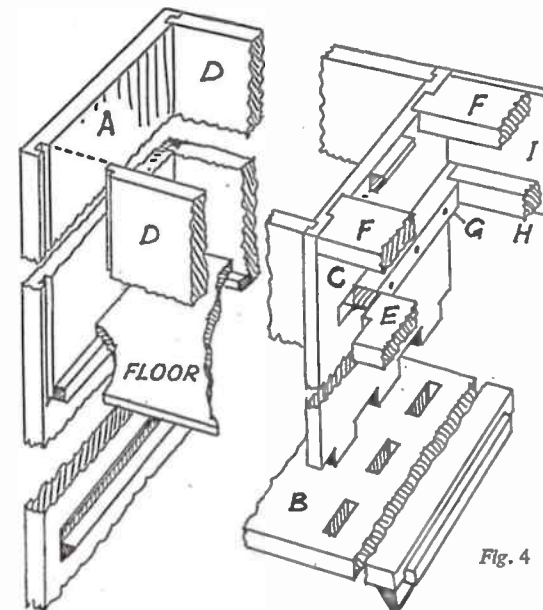

Fig. 4

$\frac{1}{2}$ in. square fillets as seen in the cut-away section in Fig. 4. The top cross-rails should be $\frac{1}{2}$ in. thick and let in half way

into the thickness into the right-hand side and into the partition (C). Drawer runners (G) and (H) must be glued and

screwed inside the sides and along the back (I). This latter consists of $\frac{1}{2}$ in. plywood fixed to the back of rail and to (H), see Fig. 4 and Fig. 3. The top of the table, on the right, is $\frac{1}{2}$ in. thick and may be of plywood, as is also the lid of the cabinet alongside. The top is screwed to the rails and glue-blocked as seen in Fig. 3. The lid is, of course, hinged to the top as in the detail Fig. 5. On the left of the lid is screwed a block of wood to act as a lift when opening it Fig. 5).

Making the Drawer

The drawer is made up as shown in the sectional diagram Fig. 6. The sides and the front are half-lapped and glued together and the back nailed a little way in from the back edge as shown to make a firm hold. The $\frac{1}{2}$ in. plywood floor is screwed over the frame and the outer front then attached, screws being put through from the back to run well into the outer front. The drawer might well measure 8 ins. clear inside front to back, while the length should be carefully ascertained from actual measurements taken from the drawer opening.

If objection is taken to the exposed edges of the plywood lid and its neighbour, then a half-round beading could be glued and nailed on with small sprigs. Beneath diagram Fig. 2, a scale has been added, this will be found useful for getting further measurements in addition to those already included. (S.W.C.)

The Sopwith Camel

Single-Seater Scout

By D. G. Norton

PERHAPS the most famous of all World War I aircraft, the Camel, built by the Sopwith Aviation Co., which is now the Hawker Aircraft Co., appeared in France in 1917 at a period when the Royal Flying Corps (as the R.A.F. was then known) was experiencing a difficult time fighting against superior German aircraft. The Camel was a tremendous success and did an immense amount of work. It carried twin Vickers' machine-guns,

German aircraft. The recognition features were distinctive. A flat top wing, with a large amount of dihedral on its bottom wings. It could climb to 12,000ft.

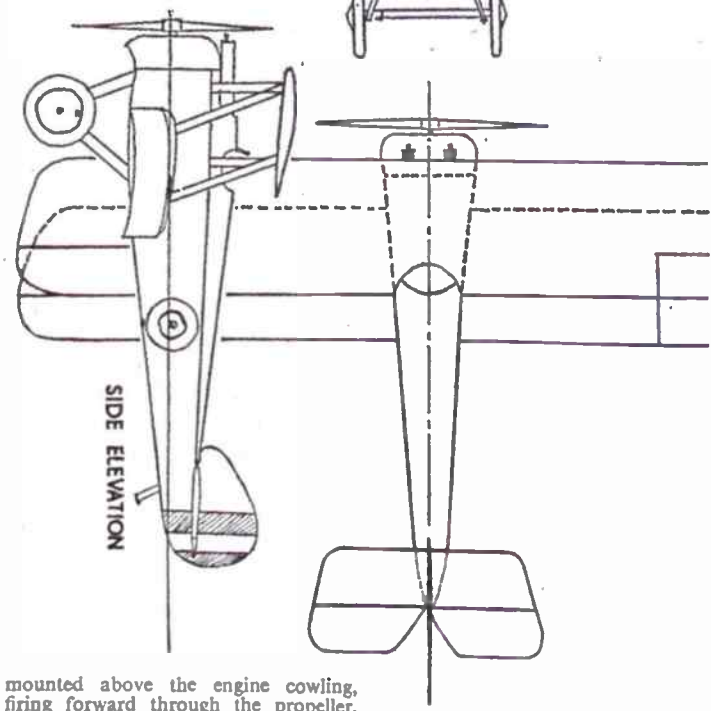
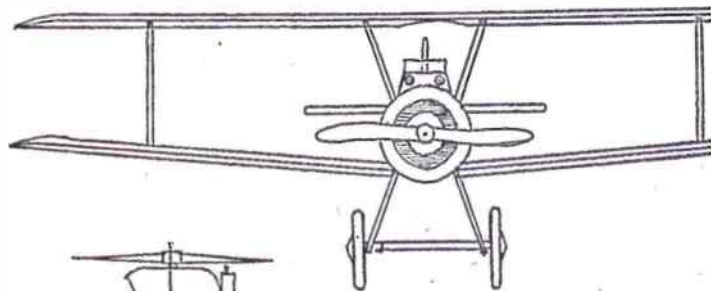

PLAN VIEW

mounted above the engine cowling, firing forward through the propeller. The machine had a reputation for being tricky to fly, and there is no doubt that it had many dangerous habits. But as soon as a pilot had mastered it, it became a weapon to be reckoned with, and accounted for more than 2,000

in twelve minutes, and at that height fly at 115 m.p.h. Its wing span was 28ft. and length 18ft. 9ins. It was powered, in its later form, with a Bentley rotary

engine (a rotary engine being one that turned with the propeller). The flying endurance of the Camel was 2½ hours, in which time it used 26 gallons of petrol.

Building a Scale Model

The plan is drawn to a scale of 1/72nd, or 6ft. to the inch. All the models in this series are to the same scale, and are very inexpensive to build.

Here is a list of the materials required. A block of balsa 2½ins. by ½in. by ½in. for the fuselage; a sheet of balsa 4½ins. by 2ins. by 3/32in. for the wings; for the tail units a sheet of balsa 3ins. by



Fig. 1

Engine cowling

1½ins. by 1/32in.; for the struts (interplane, centre-section and undercarriage) thin sheet metal from coffee, biscuit or other food (this will be found extremely useful and should be cut with thin-nosed metal cutters or a pair of old scissors. Reference will be made later to other parts such as guns, wheels, propeller and engine cowling.

Balsa wood is recommended for the wood parts, since it is easy to work, but before painting it should be treated with a good coat of clear dope rubbed in well with the fingers, then, when dry, the surfaces should be smoothed with fine glasspaper. This will give the balsa wood a smooth finish that will receive coloured dope satisfactorily.

The following is a rough guide to the tools most likely to be needed: A small bradawl or pointed instrument for making holes; thin-nosed metal cutters or an old pair of scissors; a small file (this will be very useful for shaping); small long-nosed pliers; a tube of balsa cement; a ruler measuring in 1/10th, 1/12th and 1/16th of an inch, a razor blade (one-sided, for preference) and glasspaper.

These tools are sufficient for all the models in this series.

Construction

Trace the side elevation of the fuselage (leaving out the engine cowling), place the tracing against the block of balsa and pinprick the outline. Then

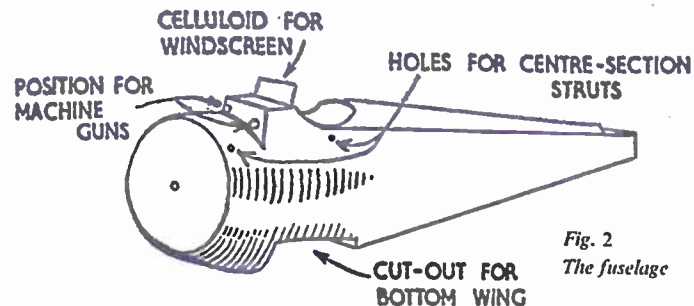

Fig. 2

The fuselage

mark it in with a ball-point pen or a pencil.

Carve or file the side elevation of the fuselage, then draw a centre line along the top surface of the block and mark in the plan view of the fuselage. File away the surplus wood. All that remains is the final shaping of the fuselage. Before you do this, glue on the engine cowling. (See Fig. 1.) The engine cowling can be turned on a lathe or made by hand (see note at the end). The cowling, glued in place, will act as a guide for obtaining the roundness of the front part of the fuselage. The bottom is flat, but the top continues its rounding to the tail-plane. Note that there is a flat-topped hump in front of the cockpit. This has the machine-guns glued to the front of it. (See Fig. 2.) Mark in the position of the cut-out for the bottom wing (see Fig. 2), and with file and razor blade, remove the surplus wood. The cockpit can be hollowed out. For this you will require a small drill, or you can paint the cockpit area black. Holes should be made for the centre section and undercarriage struts.

Draw the plan of the wings on to the sheet of balsa and cut them out. Glasspaper the leading and trailing edges until you achieve the aerofoil section shown in Fig. 3. The bottom wing should be prepared (see Fig. 4), so that it will fit into the cut-out in the bottom of the fuselage. Shallow holes are made in the wings for the interplane and centre section struts. Fig. 5 gives you the exact size for these struts, and also those for the undercarriage. The tail-plane and rudder are made in a similar way to the wings. Wheels can be made from ½in. linen buttons and painted; machine-guns from short lengths of ¼in. dowel, and the propeller may be cut out from thin card.

Assembly

Before you glue the bottom wing into place, it should be given its correct dihedral. Hold the wing between your finger and thumb about 6ins. over a candle flame and, very gently, bend it until the correct dihedral is obtained. Then glue it beneath the fuselage in the



Fig. 3

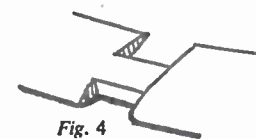
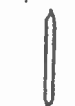

Fig. 4



INTERPLANE STRUT
4 REQUIRED



CENTRE-SECTION STRUT
4 REQUIRED



UNDERCARRIAGE
2 REQUIRED

Fig. 5

cut-out. Glue the centre-section struts into the holes in the fuselage, and then fix the upper wing on top of them, purely as a trial. The wing should rest ¼in. above the fuselage (not the machine-gun housing). You may have to adjust the centre-section struts to obtain the correct distance between the wing and fuselage. When you are satisfied, glue the interplane struts into the bottom wing, adjusting them for correct stagger (their forward slope) and then glue on the top wing to centre

section and interplane struts, making sure that all struts are correctly in line, both from the front and side. Glue the undercarriage struts into place, adjusting them to their correct position (the track should be 7/10th of an inch). Thread the axle (a piece of florist's wire is excellent for this) through the holes, put the wheels on, add a touch of glue on the ends of the axle, or burr the wire to keep the wheels in place.

Rudder and tail-plane are now glued in place and the tail skid, which is a short piece of wire, is glued into the fuselage, beneath the tail-plane. Glue the machine-guns into place, and fit the propeller with a pin.

Painting

The Sopwith Camel was painted dark green on all upper surfaces, and cream on the under surfaces. The engine cowling was painted silver. Interplane and centre section struts were varnished and were almost the colour of yellow ochre. (This can be obtained in poster colour, and if a touch of Seccotine is added, the paint will take well on metal.) The undercarriage was black. The wheel discs and propeller may be any colour and the

rudder red, white and blue, with the red at the end.

Night fighter Sopwith Camels were painted dark green on all surfaces.

Take care with your painting, remembering that two thin coats are better than one thick; and make sure that all surfaces are smooth and free from finger marks. The modeller will find that the transfers of cockades from model shops will be most useful. Two cockades are on the top wing, two on the bottom wing and one on each side of the fuselage midway between the cockpit and the tail.

Celotex Perforated Hardboard

CELOTEX LIMITED, who were the first people to introduce the completely packaged pegboard in Britain, have now entered the perforated hardboard field. Their Five-Star Hardboard, which is a rigid high-density wood fibre board, is now available in perforated form.

The Celotex Five-Star Perforated Hardboard, which will conform to

what is accepted now as standard measurements—lengths 4ft., 6ft., 8ft. and 12ft., with perforations of ¼in. diameter at ½in. centres—is a double-sided board—on one side it has a smooth surface providing an ideal base for the applied finishes required in certain decorative schemes, and on the other it has a 'canvas' texture which is much sought after.

Make a Warm-Air Drying Cabinet

By A. F. Taylor

PROBABLY one of the most useful accessories to the enthusiastic photographer is a cabinet in which films and also prints can be put to dry.

It is well known that the chief drawback to the drying process is the dust particles which float about in the atmosphere and delight to stick on to any wet surface. Large specks of dust can make ugly marks on the negatives, and when these have to be enlarged, they are a real nuisance. Therefore, anything which will reduce this menace and help to produce better photographs is sure to win approval from the keen photographer.

Not only does the drying cabinet, described in this article, help to combat the dust menace, but the warm air element accelerates the drying process. Under damp weather conditions this will be found invaluable, and besides drying films, the cabinet can be used equally well for prints.

The heating element is a small electric light bulb housed in the base. This warms up the air as it enters through a filter near the bottom, and as warm air rises, it helps to dry the film.

Individual Requirements

The size of the cabinet will depend on several factors all of which must be determined by individual requirements. The length of the film governs the height, while the number of films which the cabinet is required to hold will decide the width. Quite thin plywood is suitable for the construction, which should not present any difficulty nor take up much time to make.

The cabinet described and the measurements quoted will prove a very useful size. It is suitable for films up to about 24ins. long. Although designed for two films, it could hold three, but there is a risk of the films touching and sticking together should the cabinet be knocked accidentally.

For the sides two pieces 36ins. long, 5½ins. wide and ¼in. to ⅜in. thick will be needed, while the back and front are 36ins. long, 9ins. wide and the same thickness as the sides. The top and base are thicker, and it is on to these that the sides and back are fastened. Two pieces of wood 8½ins. long, 5½ins. wide and ¼in. thick will serve well.

Reference to the drawings will show two circular holes cut in the sides. These are for the cold air to enter at the bottom, and after being warmed, it passes out at the top.

In order to keep out any dust particles

these holes are covered with a piece of muslin which acts as a filter. It is quite simple to glue this in position on the inside. A better and stronger finish is obtained if a thin ply rim is glued over the muslin, and this should be about 3ins. in diameter, with the 2ins. hole cut in the centre.

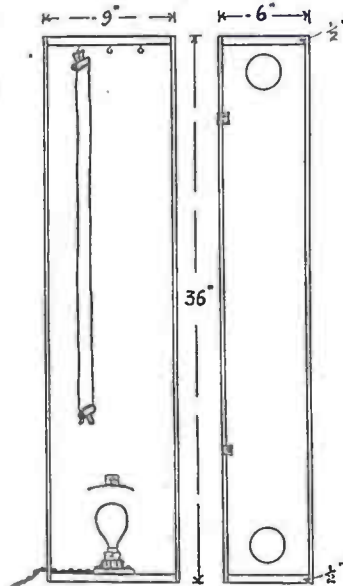

After fixing the filters the cabinet can be assembled, gluing the sides and back to the top and base. Panel pins may be used to strengthen at the top and base, and corner strips used down part or all of the length.

The front of the cabinet is a door fixed with two or three small brass

CHILDREN'S MOBILES

FOUR different designs for novelty mobiles for children have been produced by Philmar Ltd., London. They are 'Super Circus', 'Pixies', 'Favourite' and 'Round-up', and working on them provides hours of interest. When assembled and suspended from the ceiling the animation of the various figures provides an absorbing fascination. The kits cost 7/11 each.

hinges. There may be some difficulty in fixing the hinges with ordinary wood screws owing to the thinness of the wood. It is, therefore, much better to use small bolts for the job.

Screw a suitable bulb-holder to the centre of the base and lead the wires through a small hole in the corner. The heat of a 25-watt bulb should be sufficient for most purposes, and an even smaller wattage may be found to do the job quite well. It is not advisable to use too large a bulb, as the heat generated may do considerable damage to the film by melting the gelatine instead of drying it.

It is an advantage to fit a deflector lin. or 2ins. above the bulb to break up the heat waves and disperse them more evenly over the area of the cabinet. Although this is not essential, the effect of a deflector should be tried out before deciding whether to discard it or not. It will be found useful if too much heat is produced by the bulb near the lower end of the film.

The form for the deflector can best be found by experiment, and will most probably be semi-circular as shown in the sketch, although a straight piece will be quite effective. Any highly polished sheet metal such as tinfoil, chromium, or copper about 4ins. wide, and extending from the back to within about 1in. of the front door is fixed to the back with a small wood screw or bolt.

Suspend Films from Hooks

Two or three small brass hooks screwed into the top will complete the dryer, the films being suspended from these with spring-type paper clips. To keep the films straight another clip is fastened to the bottom end, and if this is not sufficient, a small weight can be attached.

Much longer films can be accommodated by hanging both ends on the two top hooks, but it is a better plan to hang them straight if possible. If much work is done with long films, it would be better to build a taller cabinet.

Good clean plywood should not need any further attention, but if the inside of the cabinet is given a coat of varnish, it will be easier to wipe out occasionally to keep it free from dust.

One final word of warning is necessary — do not put in any films that are dripping wet, especially if no deflector is used, as this may result in a cracked bulb. Remove as much moisture as possible with a rubber wiper first before hanging them up to complete the process in the dryer.

The all-British board with a 1001 uses

CELOTEX
FIVE-STAR HARDBOARD

KITCHEN FITTINGS
WALL PANELLING
TOYS
PARTITIONS
PELMETS
CUPBOARDS
FURNITURE
CEILING PANELLING

BATH PANELS
STAIR CASING
FLUSH DOORS
HOBBIES
CABINETS
SHELIVING

Ask for it by name. Every sheet carries a FIVE-STAR label

Made in Great Britain with all-British materials by
CELOTEX LIMITED
North Circular Road, Stonebridge Park, London, N.W.10
Telephone: ELGar 5717 (10 lines)

REPLIES OF INTEREST

Cost of Recording Equipment
CAN you tell me whether the price of recording equipment is high? What roughly is the cheapest price, and could it be operated by anyone? Is a licence necessary? (C.D.—Wrexham.)

THE price of good recording equipment is quite high; no licence is required. The modern tape recorder is possibly most suitable. You will see these advertised in many periodicals. Various tape units, etc., are also advertised in radio and technical periodicals such as *Practical Wireless* and these enable a recorder to be made up at rather less cost than the ready-manufactured type. The cost depends on the specifications of the equipment, type of microphone, etc., and will usually lie between about £15 to £80.

oil, spirit or water medium, according to preference. Experience with pigments on hardwoods would make it appear that water is best. The requirements are whitening, chrome green and lamp-black. First grind the whitening with the chosen medium, work in enough chrome green to give a fairly full colour and then tone with lampblack. As chrome green varies somewhat, a little ultramarine may be needed to increase the grey tone. It is important that genuine chrome green be used; this consists of chromic oxide, whereas some so-called chrome greens are mixtures of chrome yellow and Prussian blue. The stain is rubbed into the wood with a cloth pad. After drying, smoothing can be done in the usual way.

Tinting Wood
COULD you give me the formula of the chemical, and the method used, to give sycamore and maple the grey-green tint to make it known as Greywood or Harewood? (D.H.—Colne.)

WHILST the required tint could be obtained by the alternate application of dilute water solutions of the dyes Nigrosine and Brilliant Green, a colour faster to light will be achieved by using a pigment base. This can be used in an

Repairing a Drum
CAN you tell me how to repair a bass drum? I am an instructor of a children's jazz band and last week the skin got broken. I have some old skins of another drum which I could use for patching. What adhesives do I use, and how do I apply same? (R.M.—Mountain Ash.)

PROBABLY the best way to approach the repair of a drum skin is first to remove it entirely, lay it out flat and draw the broken parts as nearly into proper position as possible. Skive

the joint edges and thin them out taperwise, and put clean paper under this part. Prepare a suitable size patch, corresponding in shape to the damaged area but overlapping about 1in. all round, and similarly skive the edges. Apply an even film of good glue, such as Le Pages fish glue, to the joint faces, and when about to get tacky, lay the patch flat and even in place. Leave to dry under pressure applied by weights on a smooth board, or the like, put a clean piece of paper over the patch. When quite dry and hard, refix the drum skin in the usual way. It is, of course, probable that the tonal quality will, in any case, be depreciated by any repair.

Mounting Colour Photographs
PLEASE tell me the best way to mount colour photographs such as Dufay, for viewing against light. I am not referring to transparencies for projection. (L.S.L.—Amersham.)

WE would advise that several methods of mounting transparencies for viewing by transmitted light exist. A type of ready-made frame is available, in packets of 25, into which the films can be inserted. A cheaper method is to employ square cover-glasses, the film being sandwiched between two of these, and the edges secured together all round by self-adhesive tape. Thin tinfoil masks, with square aperture, can be obtained to include with the films, to give a square frame. These items and others of like nature may be obtained from large photographic dealers. Cheapest of all are paper masks, at 2/- per 100, with glasses at about 6/- for 50, or cardboard frames with glasses at about 7/- per 25.

The New Coronet Flashmaster



30%
 The easy-to-use Camera

Simple, economical, yet scientifically up-to-date, this eye-level viewfinder camera takes twelve 2 1/2 in. sq. photos on 120 roll film. Everset shutter plunger threaded for cable release, and protected by safety slide. Synchronised for flash, with two sockets into which Coroflash unit can be plugged. Complete with smart, securely fixed carrying strap. From most chemists or photographic dealers, or write direct.

TO CORONET LTD. DEPT. HW, SUMMER LANE, BIRMINGHAM 19
 Please send free booklet 'Photography is Fun'

NAME

ADDRESS

Croid

The finest glues for every handicraft

Whatever your handicraft or hobby, use the Croid Glue recommended for it, and you will obtain completely satisfactory results. Croid—the strongest glue in the world—is obtainable everywhere.

AERO GLUE a pure hot glue of great strength in tins from 1/3 (4 oz.) to 4/6-, and the Home Outfit 4/- complete.	UNIVERSAL GLUE a general purpose cold liquid glue. Handy size tube 1/-, 8oz. tin 2/6. Specially recommended for sticking laminated plastics.
---	--

See Croid in the 'Do-it-Yourself' T.V. Programme London Commercial, Sat. Oct. 1st at 5.15 p.m.

Croid GLUES OF QUALITY
 THE BEST NAME IN ADHESIVES

CROID LIMITED, Imperial House, KINGSWAY, LONDON, W.C.2

Miscellaneous Advertisements

200 STAMPS free. Genuine offer. S.A.E. for approvals.—W. Self, 36 Fairfield, Boro Green, Kent.

£5 to £20 weekly earned at home running your own Mail Order business. Complete Course 5/6.—Courses, 28(HB) Dean Road, London, N.W.2.

BUILD your own TV and learn about its operation, maintenance and servicing. Qualified engineer-tutor available whilst you are learning and building. Free Brochure from—E.M.I. Institutes, Dept. HW58, London, W.4. (Associated with H.M.V.)

STOP SMOKING!! Quick guaranteed remedy. Free Testing Sample!!—Triumph Remedies (H3), Exeter.

'PAINTSPRAYING' HANDBOOK (1954 Ed.). Covers Car, Industrial & Flock Spraying. 3/6, post free, including catalogue of our Cellulose and Synthetic Paints and all Allied Sundries and Plant Hire.—Leonard Brooks Ltd., 81 Oak Road, Harold Wood, Essex.

STAMPS FREE—Empire Packet including Pictorials and Victorians with approvals.—Robert J. Peck, 7A Kemp Road, Bournemouth.

SWISS MUSICAL Mechanisms for cigarette boxes, etc., 18/- post free. S.A.E. for illustration and list of tunes available.—Dept. HW, Metwood Accessories, Church St., Wolverton, Bucks. (Trade supplied.)

GENUINE Swiss Musical Movements. Limited Quantity 17/- each plus 9d. post/pkg.—Richardson & Forder, 5 Chapel Place, White Hart Lane, London, N.17.

PLYWOOD—HARDBOARD—at amazing low prices. Send S.A.E. for samples and prices to—N. Gerver, 10 Marc Street, Hackney, London, E.8.

KUKLOS ANNUAL. Indispensable cyclist's handbook. Tours, resthouses, money-saving hints, 2/10, post free.—Burrow, Publishers, 2 Imperial House, Cheltenham.

PLYWOOD; large sizes, 14 lbs. 10/- delivered (Express) C.W.O.—H. Leader (1920), Gosford St., Middlesbrough.

TRANSFER graining paper—oaks, walnuts; samples 1/-; complete range 3/-; roll 16/10.—H. Decano Co., 20 Clarendon Rd., Jersey.

100 DIFFERENT stamps free! Request 3d. upwards discount approvals. Wants lists welcomed.—Bush, 53 Newlyn Way, Parkstone, Dorset.

SPECIAL offer—50 different stamps, plus Mint Packet of British Empire Pictorials to applicants for my approvals.—P. E. Bentham, 40 Little Glen Rd., Blaby, Leicester.

HYPNOTISM—Rapid, inexpensive, guaranteed methods. S.A.E. details.—Albert Killford, 157 Kirkewhite Street, Meadows, Nottingham.

BRITISH Colonials, all periods, bargain prices. One country or mixed selections on approval. Discount allowed.—L. Newell, 6 St. Mary Road, Walthamstow, E.17.

LOOK! Free stamp tweezers valued 1/6. Send 2d. requesting 25% discount approvals.—H. Rowley, 50 Waylen Street, Reading.

NEW— for you!

MODELLING IN PYRUMA PLASTIC CEMENT

PRICE 6d

This BOOK OF MODELS

MODELS of every kind from one plastic ready-to-use material—PYRUMA! This book with new methods—new ideas—shows you how to acquire simple skill in making many types of permanent models listed below. And pages in full colour show how your models of animals, buildings, figures, etc., can be painted in natural tints.

SANKEYS PYRUMA PLASTIC CEMENT

Pyruma is supplied, plastic and ready for immediate use, in air-tight tins, obtainable from your local Ironmonger, Hobbies shop or Art material dealer, from 1/6d. upwards. Finished Pyruma Models can be baked or air dried to stone hardness ready for colouring after simple treatment. Send 6d. in stamps with the coupon below for the book which shows how to make MODEL RAILWAYS, STATIONS, SIGNAL CABINS, FARM COTTAGES, SHIPS, FIGURES, ANIMALS, ASH-TRAYS, BOOK-ENDS, MODEL FURNITURE, PLAQUES, RELIEF MAPS, ETC.

COUPON

To: **J.H. SANKEY & SON, L^{TD}**
 Estd. 1857
 Dept. H, ILFORD, ESSEX

Enclosed 6d. in stamps for PYRUMA MODELLING INSTRUCTION BOOK addressed to:
 NAME (Block letters)

ADDRESS

ELECTRIC SANDER POLISHER



5/-
DEPOSIT

The I. & G. Electric Sander Polisher does the job ten times faster than by hand with no effort. Sands wood, furniture, burnishes metal, polishes cars, furniture, silver, A.C. only 220/250v. State your actual voltage. Cash 75/-. Or send 5/- deposit and 6 monthly payments of 13/6.

This U.50 BLACK & DECKER KIT

for ONLY £1 deposit
CASH PRICE £9.17.6



With this Kit you can clean, buff, burnish, grind and drill. Comprises Sander Polisher, Rubber pad, Lambawool bonnet, 3 sanding discs, one 1" chuck, Allen key, wax and polish. Cash £9.17.6, or £1 deposit and 8 monthly payments of 25/-. With chuck, becomes all-purpose drill. Can also be used as driving unit for lathe and saw attachments. Fully suppressed. State your actual voltage.

Send for complete list of Tools

BARGAIN DISTRIBUTORS

(Dept. 124), 5 Silver Street, Luton

ELECTRIC PAINT SPRAYER



4/-
For deposit

Cash 75/-. Or 4/- deposit and 6 monthly payments of 13/6

Paint easily, evenly, twice as fast with the Burgess Electric Sprayer. Sprays paint, varnish, etc. Complete with sturdy glass container, flux, nozzles for ceiling spraying and extra nozzle discs for different liquids. A.C. mains - state your actual voltage. Fully guaranteed. Leaflet free

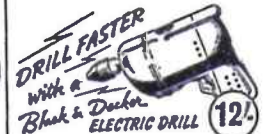

DRILL FASTER
with a
Black & Decker
ELECTRIC DRILL

DEPOSIT

A first-class tool, the Black & Decker U-1 Portable Electric Drill saves hours on home and workshop jobs. Drills wood, steel, brick, etc. Steel capacity up to 1". Also drives sanding discs, polisher pads, etc. Weighs 3 1/2 lb. Fully suppressed. £5. 10. 6 or 12/- deposit and 6 monthly payments of £1. Sent on receipt of the deposit. A.C./D.C. motor, voltages 110 to 250. State your actual voltage.

THE 'ROYAL CHARLES'

is the latest design in Hobbies wide range of models of famous old-time galleons. Obtain your design FREE with

HOBBIES 1956 HANDBOOK

Containing 152 pages packed with interest for the fretworker, modeller and handyman

Now on sale (2/-) at newsagents, etc., or 2/3 post free from
Hobbies Ltd., Dept. 99, Dereham, Norfolk

STOP SMOKING

Any Man or Woman In the World May Now Stop Smoking Quick and Sure

To Prove It. A Free Trial Package Sent Sealed To All Who Write
If you want to stop smoking, this should be just the thing you need. Simply send your name and address to Mr Brian Hussey, Dept. HD/4, The Triumph Remedies, Exeter, and he will send, absolutely free of charge, a trial package of our remedy to show how it is used and how it will quickly conquer the habit of smoking, also full directions how to use it, free advice, and everything needed to aid you in overcoming the habit quickly and certainly. No matter what else you have tried or how many times you have failed, this time you will succeed. Please send name and address now—as this free offer may never appear again.

SIMPLE FRETWORK

A PAIR OF SMALL BOOKENDS

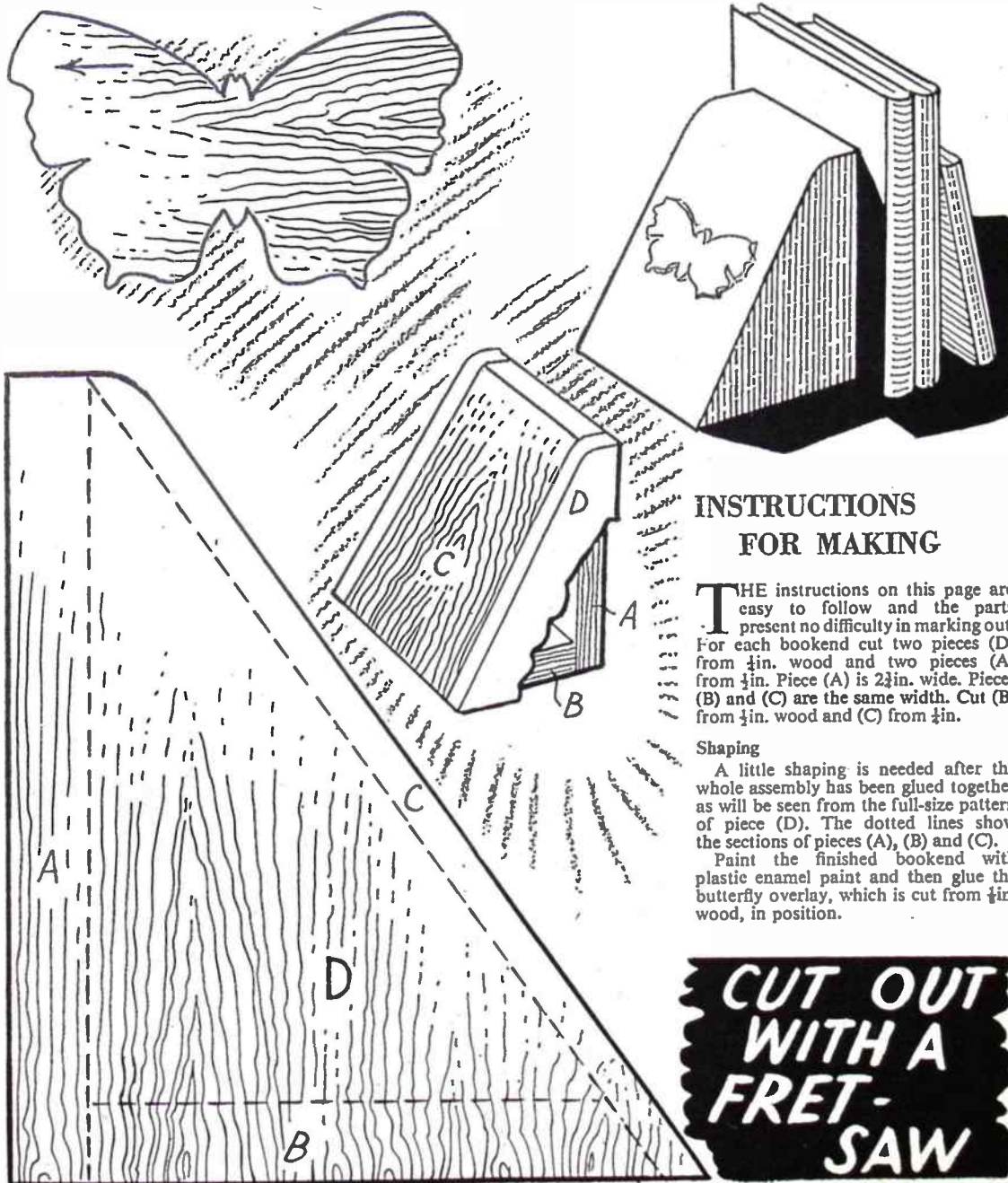

INSTRUCTIONS FOR MAKING

THE instructions on this page are easy to follow and the parts present no difficulty in marking out. For each bookend cut two pieces (D) from 1/4 in. wood and two pieces (A) from 1/4 in. Piece (A) is 2 1/4 in. wide. Pieces (B) and (C) are the same width. Cut (B) from 1/4 in. wood and (C) from 1/4 in.

Shaping

A little shaping is needed after the whole assembly has been glued together as will be seen from the full-size pattern of piece (D). The dotted lines show the sections of pieces (A), (B) and (C).

Paint the finished bookend with plastic enamel paint and then glue the butterfly overlay, which is cut from 1/4 in. wood, in position.

CUT OUT WITH A FRET-SAW

THE SUPER MODERN FLIGHT LIEUTENANT HANDLESS WATCH

NO DEPOSIT
No Glass, No Dial, No Hands. Built for strength, fitted "Aircraft" shock resisting movement. Lever "Aircraft" escapement. Anti-magnetic. Handsome chrome case. Expanding bracelet 12/6 extra if required. Time shown by revolving figures. Send 2/6 for pack., reg., etc. 7 Days approval. If satisfactory send 7/6, then pay 8 payments of 10/- within 8 months. Guaranteed. Cash price 79/6. Non luminous night dial 6/6 extra.

GERMAN PRISMEX BINOCULARS

6 LENSES x 40mm COATED LENSES. Popular Squat Model No Deposit CASH PRICE 69/6
For wide field viewing, finest value for German Prismex Binoculars. 5 1/2" x 4 1/2". Bending Bar for eye adjustment, centre focus. Splendid magnification, 3D viewing. Clear Bloomend lenses, wide angle. Sports and holiday use, day and night lenses. Lightweight model. With case lanyard and leather straps. Send 2/6 for pack. & reg., etc. 7 days approx. If satis. send 4/6, then 8 pmts. 9/- in 8 months. CASH 69/6. LISTS, TERMS, Headquarters & General Supplies Ltd. HOBWICK/68, 196/200 Coldharbour Lane, Loughboro Junc., London, S.E.5. Open Sat., 1 p.m. Wed.

ENFIELD EASIFIND

A unit of 14 Transparent Plastic Trays each 7 1/2" x 2 1/2" x 1" deep, swivelling outwards for easy access. Ideal for all craftworkers (jewellery, flowers, etc). Each tray supplied with 2 movable partitions providing 42 compartments for only 8 1/2" x 6" bench space. Complete Unit. 49/6

Cash with order or C.O.D. (Carriage paid). Callers welcome at each branch. Write today:—ENFIELD TYRE COMPANY, 123-5 Baker St., Enfield, Middx. Enfield 2982 Branches: 1058, Christchurch Road, Bournemouth and Castle Lane, Market Street, Torquay.

A GRAND BOOK FOR ALL THE FAMILY. The "Kaylee Year Book of Bright Ideas". A really helpful guide to home planning, decoration, Hobbies, toys, etc. Showing famous Kaylee Transfers in brilliant colours, and most effective uses. From "Hobbies" stockists 1/- or direct. KAYLEE TRANSFERS Postage 3d. LTD., (HW) Long Eaton, Nottingham

DO YOUR OWN CHROMIUM PLATING

COMPLETE OUTFITS 10/- and 25/- EACH
Guaranteed! this product has the British Good Housekeeping Certificate! Send P.O. now for complete outfit, or 4d. in loose stamps for details and plated sample to—
O. DUTCH & CO., 81 Monkham Lane WOODFORD GREEN, ESSEX

Micromodels

MADE IN ENGLAND
MODEL MAKING IN CARD

SET TR 1
4 MDLS. 2/6

HAMPTON COURT SET
ARC XXI

Send stamped addressed envelope for Illustrated List of 100 Models, Authentic, Architectural, Mechanical, Railway, Maritime, Aero, etc. etc.

MICROMODELS LTD.
3 (H) Racquet Court, Fleet St., London, E.C.4

MATCHBOX-SIZE crystal sets. All parts, crystals, instructions, complete 3/6, post free. —Bailey's, 44 Stanley St., C. Oldham.

It's a family affair...

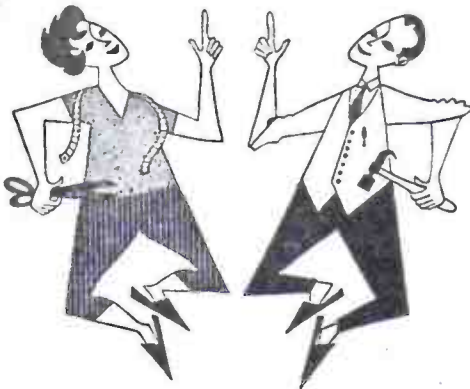

Here is your great opportunity to see how to do it yourself. Skilled advice on all the latest craft ideas and methods. See and buy the newest tools, materials and equipment. Wide range of unusual hand-made gifts to choose from. Fashion parades. Daily demonstrations by experts of every kind of handicraft and hobby at this most fascinating of all exhibitions.

More details in POPULAR HANDICRAFTS, on sale now 1/-

DO-IT-YOURSELF

3RD INTERNATIONAL
HANDICRAFTS, HOMECRAFTS AND HOBBIES

EXHIBITION

FRETWORK · MODEL-MAKING · RUG-MAKING · TOYS
LAMP SHADES · WOODWORK · BASKETRY · POTTERY
NEEDLEWORK · WEAVING · LEATHERWORK, ETC.

EARLS COURT

SEPT. 22—OCT. 1

Admission: 2/6, Children 1/-

Open daily (except Sunday) from 10 a.m.—9.30 p.m.

NEW!

EXPERIMENTAL KITS

LEARN THE PRACTICAL WAY

Here is home study of the most effective kind under expert tutors. There is no better way of studying for an examination for a career in industry or starting a new hobby. Our Practical courses comprise the most modern methods of postal tuition, combined with a practical kit of parts (which is supplied upon enrolment and remains your property).

COURSES FROM 15/- A MONTH

COURSES WITH KITS INCLUDE: Radio, Television, Mechanics, Electricity, Chemistry, Photography, Carpentry; also Draughtsmanship, Commercial Art, Amateur S.W. Radio, Languages, etc.

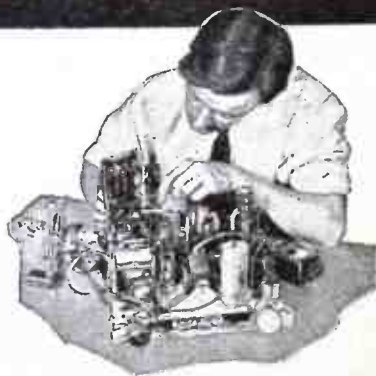

POST THIS COUPON TODAY

E.M.I. INSTITUTES, Dept. 31X, Grove Park Road, London, W.4. Please send me your free book.

Subject(s) of interest

NAME

ADDRESS

7/9/55.....C.51

EMI INSTITUTES

The only Postal College which is part of a world-wide Industrial Organisation.