

HOBBIES WEEKLY

IN THIS ISSUE

	Page
Climbing Frame and Chute	193
Care of Milk Bottles	194
Radio Control Receiver	195
Magic with a Camera	197
A Casket for Scents	197
Model Railways	198
Shipmodeller's Corner	200
Make Lifelike Masks	201
The 'Great Harry'	201
Rowing Machine	202
An Attractive Letter-Rack	204
Is This Your Problem?	206
Patterns for Scents Casket	207



JUNE 27th 1956

VOL. 122

NUMBER 3165

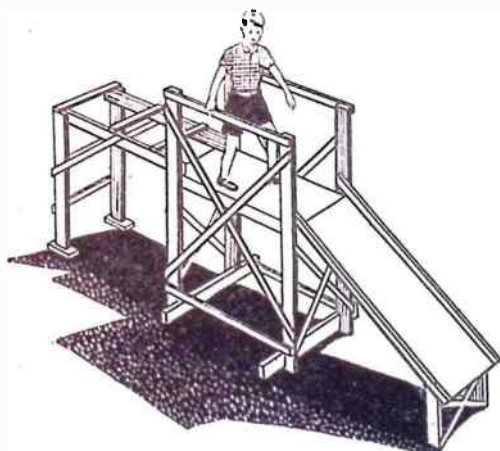

UP - ACROSS - and DOWN

Grand fun for the youngsters

CLIMBING FRAME AND CHUTE

A CLIMBING frame and chute not only provides exercise, but gives the opportunity for fun on a 'slide' in one's own garden. The children will be delighted with it.

The measurements shown on the illustrations are not critical, but serve as a guide, particularly to overall measurements. Sizes may be modified to suit timber already available.

Commence by making the main framework shown in Fig. 1. The four uprights are 72ins. high and are joined to the two base pieces as shown by the inset diagram. The two supports for the platform are fixed 27ins. down from the

top. Strengthen the framework by means of cross-braces of 1½in. by ½in. and ties of 1½in. by 1in. material.

**Diagrams showing
measurements and
assembly on page 194**

The ladder is shown in Fig. 2. The uprights are cut from 4in. by 2in. wood and are stood on 1in. thick blocks. It is secured to the main framework by means of bolts and nuts.

The chute is constructed from a framework of 2in. by 1½in. and 1½in. by 1in. wood, covered with ½in. hardboard. The overall length is 66ins. and the width 24ins. The feet at the front are strengthened by means of cross-braces as shown in Fig. 3, and bolts and nuts are again used for fixing.

The whole assembly, apart from the chute, should be given a good coat of wood preservative such as Cuprinol, or can be painted. Two or three coats of green paint will be sufficient to give protection against the weather. The chute should be given a coat of clear varnish. (M.h.)

All correspondence should be addressed to The Editor, Hobbies Weekly, Dereham, Norfolk

*For Modellers, Fretworkers
and Home Craftsmen*

4½^D

PAGE 193

CLIMBING FRAME AND CHUTE

See page 193

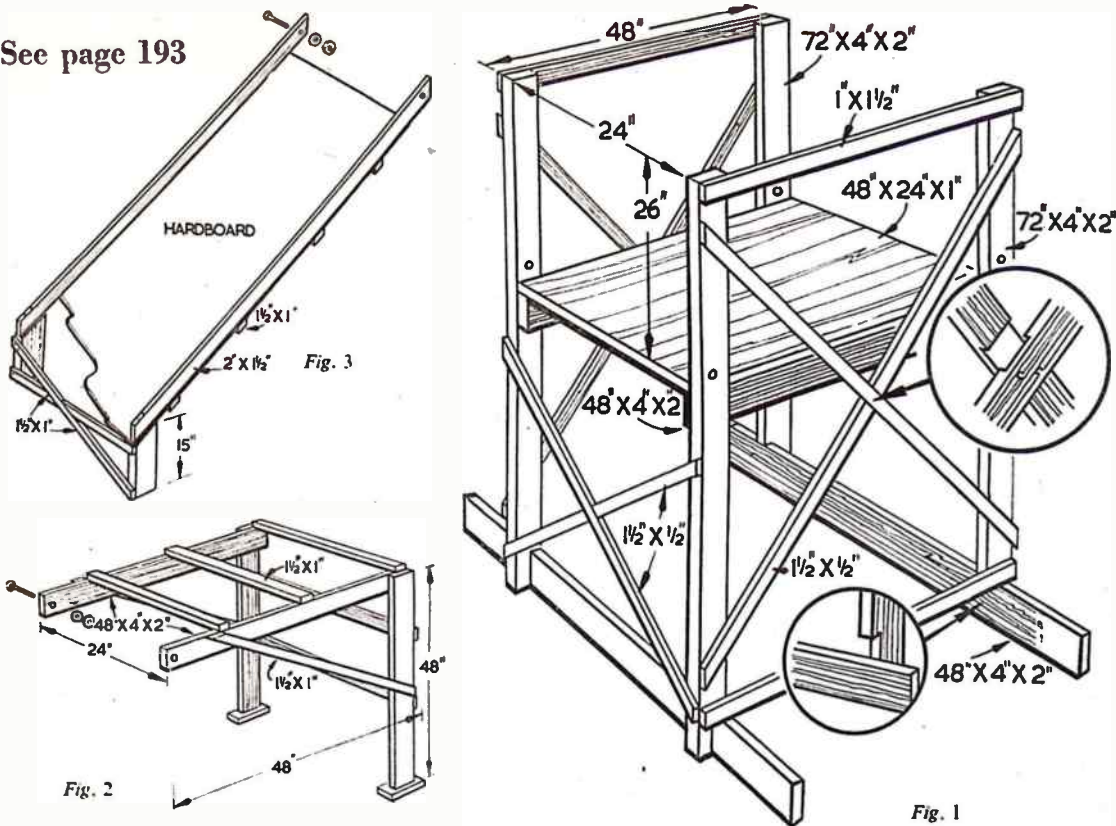

Care of Milk Bottles

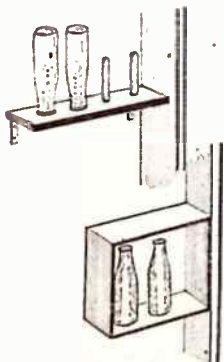

WHEN milk bottles are empty and stood outside they often get knocked over with consequent breakages. The fresh supply arrives and gets knocked over, or the birds wait to have a peck. Why not make two simple containers and save all this trouble?

A simple holder can be made with 4in. by 1in. board which you can get for about 4d. a foot, cut length. Make the cabinet just large enough to take two or three bottles with only sufficient clearance to enable you and the milkman to get the bottles in and out. Line the back with a small panel of hardboard and fix it inside the porch or any convenient spot.

For the outgoing bottles you can fix a special shelf with 3in. brackets just

long enough to take three or four bottles. Cut some short lengths from an old broom-handle or dowelling and screw these through from the base of board as shown and the bottles will then rest safely upside-down and also drain.

Odds and Ends

WHEN wearing new shoes rub your heels and feet with methylated spirit — this prevents blisters.

An old motor tyre turned inside out and cut to size makes a good seat for a small child's swing.

The central part of the tread of an old cycle tyre makes an ideal band for a tennis court marker of the belt type, and will last for years. (R.L.C.)

Radio Control — Part 4

RECEIVER FOR THE BOAT

THE manner in which a model boat can be controlled by radio has been explained, and the receiver dealt with here is intended for use with the transmitter already described. Dimensions in the receiver have been reduced as far as practicable, so that it can be accommodated in a small model of 14ins. to 16ins. or so in length. Hobbies 'Patricia' (Design No. 3096) is a suitable boat for light control equipment and a receiver such as this.

The actual receiver itself is only 2½ins. by 1½ins. by about 1in. deep, but it will be remembered that a relay, batteries, and other items also have to be carried in the model. In the launch mentioned it is necessary to remove the passenger seat to accommodate the receiver. In this, or any other model boat, it is very helpful to have batteries, relay and receiver covered by a light cabin, which can be lifted off for adjustments. This will mean changing the open type of boat into a cabin-type launch, but very little work will be re-

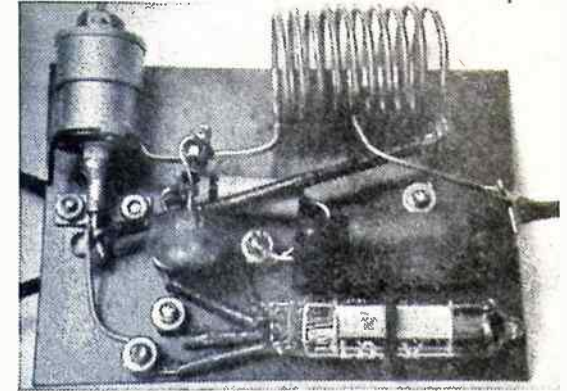

COMPONENTS LIST

- Hivac XFG1 valve.
- 8-10 megohms, ½ or ⅓ watt carbon resistor.
- 50pF mica fixed condenser.
- 30pF air-spaced concentric trimmer.
- 001μF fixed condenser.
- Miniature 50,000 ohm potentiometer.
- Small on/off switch.
- Paxolin, wire, nuts and bolts.

two 22½ V deaf-aid batteries in series, and these are a little smaller than a matchbox. To keep weight low, the batteries are placed in the bottom of the boat.

The receiver circuit is such, that when the signal from the transmitter reaches it, the valve current drops, allowing relay contacts to close. A meter able to read currents from about 0-2mA is required to set up the receiver initially.

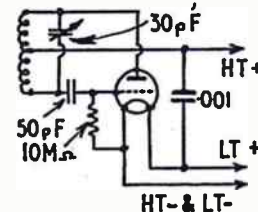

Fig. 1—Circuit of control receiver

Coil

This should be wound carefully as directed, to avoid trouble in tuning in the transmitter, as if the coil is different, it may not tune the correct wavelength. A piece of 18 S.W.G. enamelled or tinned-copper wire is pulled out straight, and freed from kinks. One end is

from the object, and pulled out until it is between ⅞in. and 1in. long, all turns being evenly separated.

A short piece of 18 or 20 S.W.G. wire is then soldered on to the middle of the centre turn. This is best done by cleaning and tinning both the end of the wire, and the coil turn, then holding the wire in position and applying the heated iron. The joint must not touch adjacent turns,

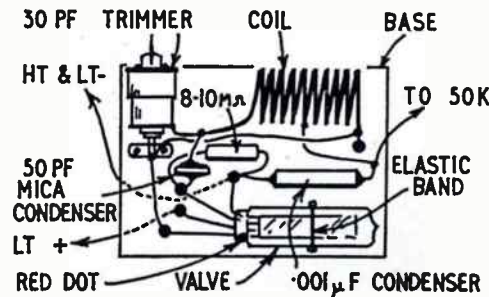

Fig. 2—Wiring plan, showing all connections

quired to do this, as a rule, and the hull itself will not need modifying.

A single valve is used in the receiver, being a gas-filled triode made by Hivac for this purpose. It requires a 1½ V dry cell for filament supply, and a miniature 45 V H.T. battery. The latter voltage can conveniently be supplied by wiring

clamped in a vice, or otherwise anchored. An object ⅜in. in diameter is then taken, and the wire wound upon it, the object being rotated in the hands, and powerful tension kept on the wire. Ten turns are necessary, with straight pieces about ⅜in. long at each end for connections. The coil is then removed

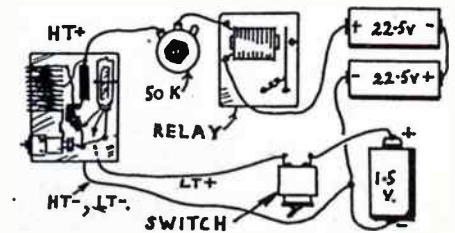

Fig. 3—Battery connections

or the set cannot function.

Receiver Base

This is a piece of thin Paxolin 2½ins. by 1½ins. If a larger boat is being used, dimensions may be increased a little, to give more space for connections, etc. A number of small 6 or 8 B.A. bolts are

necessary, to anchor leads, and the Paxolin is drilled for these in advance, in accordance with Fig. 2, which shows the completed receiver with all connections.

The small air-spaced trimmer is fixed to a small bracket bolted to the Paxolin, and one end of the coil is soldered to the outer tag of this condenser. The centre-tap goes straight to the larger fixed condenser, and the other end of the coil is formed into a loop, and bolted to the baseplate, a lead going from this to the second tag (centre) of the trimmer.

A short piece of elastic passed through two small holes helps to hold the valve in place. The latter is the Hivac XI G1, easily obtainable by post if desired. It has a red dot at one side, to show the anode lead, and must be positioned so that this dot comes in the position in Fig. 2. The other leads are then taken in turn, exactly as in the wiring diagram.

Three short flexible leads are taken from the points indicated. One is for L.T. positive, one for L.T. negative and H.T. negative together, and one for H.T. positive (via relay and control resistor). A switch is included at any convenient point in the L.T. circuit, and should always be 'off' except when the model is functioning.

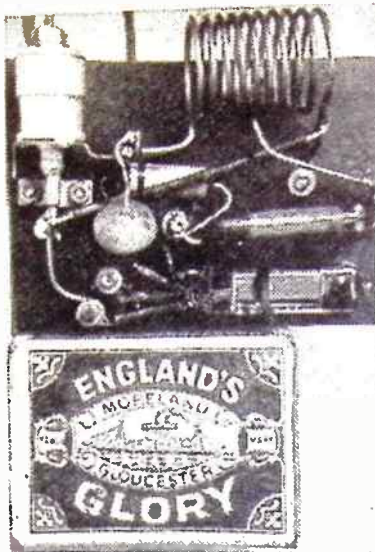

Receiver compared with matchbox to indicate size

been properly adjusted. Fortunately this is not difficult, but, nevertheless, it is most important. With poor adjustment, control may be unreliable at even a few feet range, while with best adjustment a single valve set of this kind can be controlled at distances of 500yds. or even more.

Adjustments are of three kinds. (1) Tuning the receiver accurately to the transmitter. (2) Adjusting 'quenching' so that the maximum drop in anode current arises when the transmitter is switched on. (3) Setting relay so that it operates reliably with the change in anode current obtained.

Critical Tuning

Tuning is usually easy to accomplish. The transmitter is switched on, and set to its proper frequency, as has been explained. A meter able to read up to about 2mA is then wired in series with H.T. positive at the receiver. The receiver is taken near the transmitter, and the trimmer rotated until the anode current, as shown by the meter, dips. A piece of ebonite rod or tube, with the end cut to shape, will be necessary to rotate the trimmer. When the approximate tuning position has been found, the set can be carried to a little distance, and tuned exactly, this being the point where the meter shows *least* current. Tuning will be quite critical, the meter pointer dropping as the correct spot is approached, then rising again as it is passed. Subsequently, slight re-tuning will only be required when any change is made to the aerial, or its position.

Reliability of operation, and proper control over a distance, will only be obtained when the set and relay have

off. A helper is thus needed, to switch on and off, while subsequent adjustments are made, if the model is to be controlled at anything near maximum distances. The valve anode current should not exceed $1\frac{1}{2}$ to 2mA with the transmitter off. The 50,000 ohm resistor is adjusted to assure this is so. The lower the current, the greater the life of the valve. However, relay adjustment becomes more critical, and range falls. The maximum current is thus best set to around the lowest figure which will give control over the range wanted.

Setting the Relay

Finally, the relay has to be set so that it opens and closes each time the transmitter is keyed. To do this, adjust the contact screws so that the armature is as near the magnet pole as possible, without actually touching, as this is the most sensitive position. The transmitter is then switched off, and the armature return spring adjusted in tension until the magnet *just* holds the armature down. When the transmitter is switched on, the armature will then be released. The movement of the armature in this direction should also be very small, so that when anode current rises (transmitter off) the armature is at once drawn down again. Maximum range will be that distance at which the fall in current is no longer sufficient to release the armature, so that control of the model ceases.

Final Adjustments

For initial testing indoors it will be satisfactory to adjust the 50K control until the anode current is 1mA with transmitter off, and adjust the relay until it is *just* held down by this current. Using the 1-valve transmitter already described, with no aerial on it and the H.T. voltage reduced to 30 to 45 V, the receiver can be controlled at 5 to 10yds. (When the H.T. voltage is increased and transmitter aerial added, range will be vastly greater, of course.) It is not very satisfactory to make final adjustments near the transmitter if the latter has its full aerial, and is working at full power, as the signal is then very powerful. As a result, the receiver may work satisfactorily, but no longer do so when the model is at a distance. For this reason final adjustments should *always* be made with a weak signal. Out-of-doors, this can be done by carrying the model to a distance. Indoors, this is impossible, so a very small H.T. voltage can be used on the transmitter to obtain a similar effect. The receiver should be in the boat for final adjustments, with all batteries, etc., exactly as when ready for sailing.

(Transmitter and receiver have now been covered and in Part 5 of this series F. G. Rayer will describe a steering unit for the boat.)

Easy when you know how

MAGIC WITH A CAMERA

By S.H.L.

ALTHOUGH the effect produced may be called trick photography, the following method can be used to advantage in making amusing pictures, showing your friends in two positions on the same print.

There is no alteration to the background whatever, no mirrors are used, there is no awkward processing technique involved and it can be done with

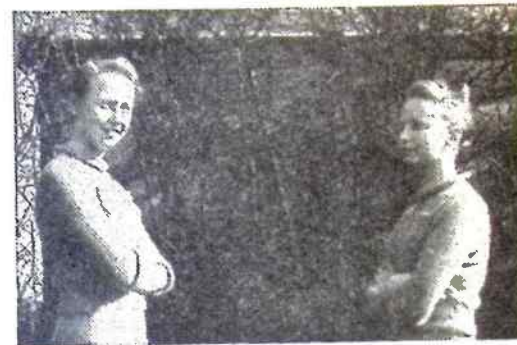

Neither twins nor sisters!

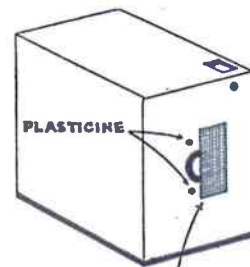

BLACK PAPER
SHOWING PAPER FIXED IN POSITION

camera on the same side as the open half of the lens. With the camera firmly

BACKGROUND

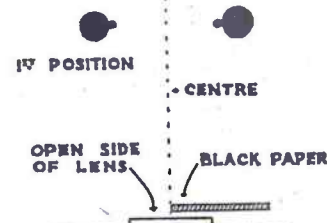

ARRANGEMENT OF CAMERA

in position and your subject correctly placed take the first snapshot. Without moving the camera reverse the piece of black paper, so that it covers the half just used. To do this, if you have used Plasticine, take another piece of paper, and fit in position to the existing one, which is then removed. If you have made a tube, all you have to do is to turn it round. The film must not be wound on yet.

The subject can now take up a position on the other side and the second exposure made. When both of the exposures have been made wind on the film for the next shot.

In the illustration, the subject was placed at the extreme sides of the picture area to show that the background has not suffered in any way, nor is there any line revealing where the black paper was placed over the lens.

A Casket for Scent



The size of the casket depends upon the scent bottle, but the dimensions shown will be right for average sizes. Pieces (A) and (D) are cut from $\frac{1}{4}$ in. wood, (B) and (C) from $\frac{1}{8}$ in. or $\frac{1}{16}$ in. The small diagram on the pattern page shows the general construction.

Patterns on page 207

Use small hinges let into pieces (C) and (B), or alternatively use tape hinges. Fix the overlay on the top with glue and clean up ready for painting.

Give two or three coats of plastic enamel paint to provide a good finish.

If you cannot find a bottle of scent to fit the shape shown, it is a simple matter to fix a new shape by drawing round the bottle. (M.p.)

YOUNG fretworkers can make excellent gifts from odd pieces of fretwood. The small scent casket shown here can be made up in a few hours and with little outlay. Of course, you need a small bottle of scent, and, by the way, make sure that you buy mother's favourite.

necessary, to anchor leads, and the Paxolin is drilled for these in advance, in accordance with Fig. 2, which shows the completed receiver with all connections.

The small air-spaced trimmer is fixed to a small bracket bolted to the Paxolin, and one end of the coil is soldered to the outer tag of this condenser. The centre-tap goes straight to the larger fixed condenser, and the other end of the coil is formed into a loop, and bolted to the baseplate, a lead going from this to the second tag (centre) of the trimmer.

A short piece of elastic passed through two small holes helps to hold the valve in place. The latter is the Hivac XI G1, easily obtainable by post if desired. It has a red dot at one side, to show the anode lead, and must be positioned so that this dot comes in the position in Fig. 2. The other leads are then taken in turn, exactly as in the wiring diagram.

Three short flexible leads are taken from the points indicated. One is for L.T. positive, one for L.T. negative and H.T. negative together, and one for H.T. positive (via relay and control resistor). A switch is included at any convenient point in the L.T. circuit, and should always be 'off' except when the model is functioning.

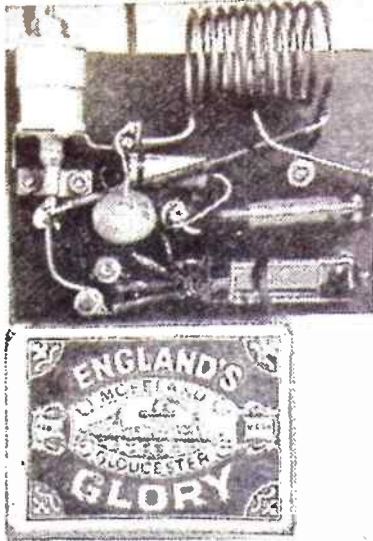

Receiver compared with matchbox to indicate size

been properly adjusted. Fortunately this is not difficult, but, nevertheless, it is most important. With poor adjustment, control may be unreliable at even a few feet range, while with best adjustment a single valve set of this kind can be controlled at distances of 500yds. or even more.

Adjustments are of three kinds. (1) Tuning the receiver accurately to the transmitter. (2) Adjusting 'quenched' so that the maximum drop in anode current arises when the transmitter is switched on. (3) Setting relay so that it operates reliably with the change in anode current obtained.

Critical Tuning

Tuning is usually easy to accomplish. The transmitter is switched on, and set to its proper frequency, as has been explained. A meter able to read up to about 2mA is then wired in series with H.T. positive at the receiver. The receiver is taken near the transmitter, and the trimmer rotated until the anode current, as shown by the meter, dips. A piece of ebonite rod or tube, with the end cut to shape, will be necessary to rotate the trimmer. When the approximate tuning position has been found, the set can be carried to a little distance, and tuned exactly, this being the point where the meter shows *least* current. Tuning will be quite critical, the meter pointer dropping as the correct spot is approached, then rising again as it is passed. Subsequently, slight re-tuning will only be required when any change is made to the aerial, or its position.

The dip in current mentioned will cease when the transmitter is switched

off. A helper is thus needed, to switch on and off, while subsequent adjustments are made, if the model is to be controlled at anything near maximum distances. The valve anode current should not exceed 1½ to 2mA with the transmitter off. The 50,000 ohm resistor is adjusted to assure this is so. The lower the current, the greater the life of the valve. However, relay adjustment becomes more critical, and range falls. The maximum current is thus best set to around the lowest figure which will give control over the range wanted.

Setting the Relay

Finally, the relay has to be set so that it opens and closes each time the transmitter is keyed. To do this, adjust the contact screws so that the armature is as near the magnet pole as possible, without actually touching, as this is the most sensitive position. The transmitter is then switched off, and the armature return spring adjusted in tension until the magnet *just* holds the armature down. When the transmitter is switched on, the armature will then be released. The movement of the armature in this direction should also be very small, so that when anode current rises (transmitter off) the armature is at once drawn down again. Maximum range will be that distance at which the fall in current is no longer sufficient to release the armature, so that control of the model ceases.

Final Adjustments

For initial testing indoors it will be satisfactory to adjust the 50K control until the anode current is 1mA with transmitter off, and adjust the relay until it is *just* held down by this current. Using the 1-valve transmitter already described, with no aerial on it and the H.T. voltage reduced to 30 to 45 V, the receiver can be controlled at 5 to 10yds. (When the H.T. voltage is increased and transmitter aerial added, range will be vastly greater, of course.) It is not very satisfactory to make final adjustments near the transmitter if the latter has its full aerial, and is working at full power, as the signal is then very powerful. As a result, the receiver may work satisfactorily, but no longer do so when the model is at a distance. For this reason final adjustments should *always* be made with a weak signal. Out-of-doors, this can be done by carrying the model to a distance. Indoors, this is impossible, so a very small H.T. voltage can be used on the transmitter to obtain a similar effect. The receiver should be in the boat for final adjustments, with all batteries, etc., exactly as when ready for sailing.

(Transmitter and receiver have now been covered and in Part 5 of this series F. G. Rayer will describe a steering unit for the boat.)

Easy when you know how

MAGIC WITH A CAMERA

By S.H.L.

ALTHOUGH the effect produced may be called trick photography, the following method can be used to advantage in making amusing pictures, showing your friends in two positions on the same print.

There is no alteration to the background whatever, no mirrors are used, there is no awkward processing technique involved and it can be done with

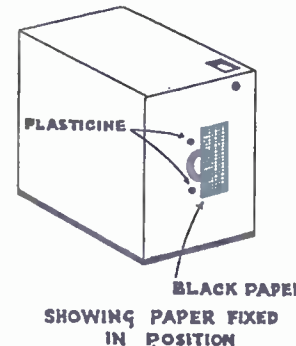

any kind of camera. In the illustration, you will observe that the girls appear on each side of the picture, and this should give you a clue. It is actually two pictures taken on the same film but with a slight rearrangement.

Take your camera into the garden, set it up on a stool, table, or anything firm and have a look through the viewfinder. You will see the normal scene like a small picture in a frame, but for our present purpose we must concentrate on the background. Observe how much of the background is shown in the viewfinder, and in particular, the most central point. If you prefer it, hold a piece of paper covering half of the viewfinder to help you see one side of the picture only, and it is in this section that your subject must take his place.

Before taking a picture we have to arrange for half of the lens to be covered vertically, so that only half of the film is exposed when the snap is made. This may be done in two ways. With a box camera, it is best to stick four round little balls of Plasticine around the rim of the lens to allow a piece of black paper to be attached halfway over the lens. If the camera has a lens with a rim, you may fashion a little tube of paper to fit and gum the covering half to this. Reference to the diagram will clarify this point.

With one side of the lens covered, the subject is placed in position before the

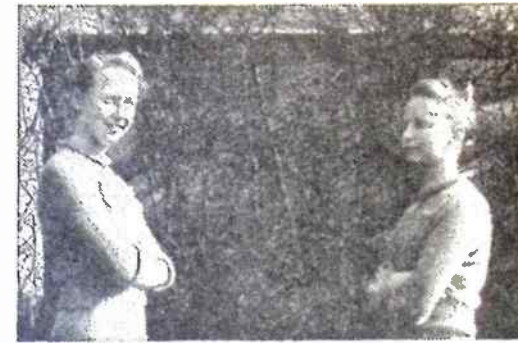

Neither twins nor sisters!

camera on the same side as the open half of the lens. With the camera firmly

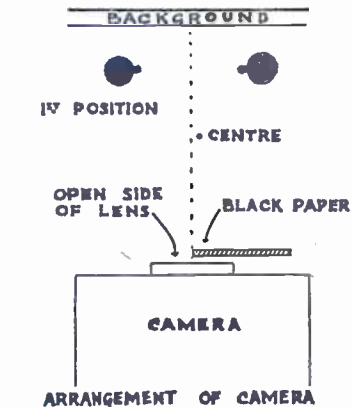

placed take the first snapshot. Without moving the camera reverse the piece of black paper, so that it covers the half just used. To do this, if you have used Plasticine, take another piece of paper, and fit in position to the existing one, which is then removed. If you have made a tube, all you have to do is to turn it round. The film must not be wound on yet.

The subject can now take up a position on the other side and the second exposure made. When both of the exposures have been made wind on the film for the next shot.

In the illustration, the subject was placed at the extreme sides of the picture area to show that the background has not suffered in any way, nor is there any line revealing where the black paper was placed over the lens.

A Casket for Scent



YOUNG fretworkers can make excellent gifts from odd pieces of fretwood. The small scent casket shown here can be made up in a few hours and with little outlay. Of course, you need a small bottle of scent, and, by the way, make sure that you buy mother's favourite.

The size of the casket depends upon the scent bottle, but the dimensions shown will be right for average sizes. Pieces (A) and (D) are cut from ¼in. wood, (B) and (C) from ½in. or ¾in. The small diagram on the pattern page shows the general construction.

Patterns on page 207

Use small hinges let into pieces (C) and (B), or alternatively use tape hinges. Fix the overlay on the top with glue and clean up ready for painting.

Give two or three coats of plastic enamel paint to provide a good finish.

If you cannot find a bottle of scent to fit the shape shown, it is a simple matter to fix a new shape by drawing round the bottle. (M.p.)

Complete Equipment

Fig. 3 shows the manner in which all the parts are wired together, including batteries. A small 50,000 ohm potentiometer is necessary in the H.T. circuit, and is connected between receiver and relay. If space permits, all the items can be assembled on one plywood base-board, fitted with clips for batteries, and with the relay bolted in position. But in the small boat mentioned it is necessary to keep these separate, so that they can be fitted in the various compartments between the bulkheads.

A relay intended for model control is essential, since it will operate with extremely small changes of current, once adjusted. Suitable sensitive relays are also obtainable ex-service, but some of these are rather large, and thus only possible with bigger boats.

Battery leads may easily be secured with a touch of solder. It is essential that the H.T. supply, in particular, should never short-circuit to any other connections or parts, and a layer of insulating tape over the ends of the batteries, covering the bare surfaces, will make these safe.

For sailing on a model boating pond, a range of over 100yds. will seldom be required, and a suitable aerial for short-range control can be made by taking a 9in. length of 18 S.W.G. or similar stiff wire, and soldering this to the coil, so that it stands vertically when the receiver is in the boat.

Reliability of operation, and proper control over a distance, will only be obtained when the set and relay have

Model Railways—Part 5

ADDING TO THE LAYOUT

By E. F. Carter

WITHOUT undue leanings towards one or other of the several brands of 'boxed train set' now on the English market, suffice it to say that the beginner would be well advised to step off on the right foot and choose the brand with which he is assured that he will be able to most faithfully reproduce in miniature a model railway of accurate scale and of operational reality. This momentous decision, so important when future enlargements and improvements are in mind, can only be rationally made by actually examining the various makes in detail and noting just how nearly they approach the ideal.

Track Selection

Should it be desired, of course, a start can be made along entirely different lines, and an embryo layout laid down in scale track, which may be purchased by the yard or half-yard in many differing types and of varying cost. Here again it is impossible to dogmatise as to 'the best', but suffice it to say that the best is not always either the cheapest or the dearest.

The selection of the type of purchased scale track to be used should be largely dictated by the use to which it is to be put. If train running and general model railway operation is to be the main feature of a layout, then, obviously, the trackwork can be made slightly less accurate in detail—fewer sleepers per yard run being used. If, on the other hand, it is aimed to produce a perfectly spectacular model, then the more perfect the trackwork the more perfect the model. It is, as ever, a matter for personal choice and final decision.

Over a period of 28 years of practical modelling in all the smaller scales, the writer has proved without gainsay that it is absolutely essential to ultimate success, both in appearance and operation, that one type of track is used *throughout* a layout. Even a non-standard siding road, though little used, can cause a heap of trouble by derailment if it does not match up with the rest of the 'road'. So make the first choice the last, and be assured of good modelling always.

Now just a few more remarks about planning—remarks made with a view to stressing the importance of matters already touched upon in earlier articles.

Bear strongly in mind that there is not, and will never be such a thing as a 'best' design for any model railway, any more than there is a 'best' of anything else in the engineering world in which things have to be adapted to many differing operating conditions. The best layout for any particular reader is obviously

the one that suits his own conditions best. His model railway is his own personal affair, and quite reasonably, no one else has the right to destructively criticise it in any way. Most certainly they may give advice or offer suggestions, but criticise—definitely no!

In spite of the hundreds of layout plans which have appeared over the years, each of which purports to show the model railwayman just that very layout he needs for his house, one must never overlook the fact that every dwelling is differently arranged, and its owner has to be satisfied because he pays the bills!

The railway companies did not build their tracks in any proportion to their motive-power stock, but the very reverse. Their stations may be many miles apart, and their 100-wagon freight trains

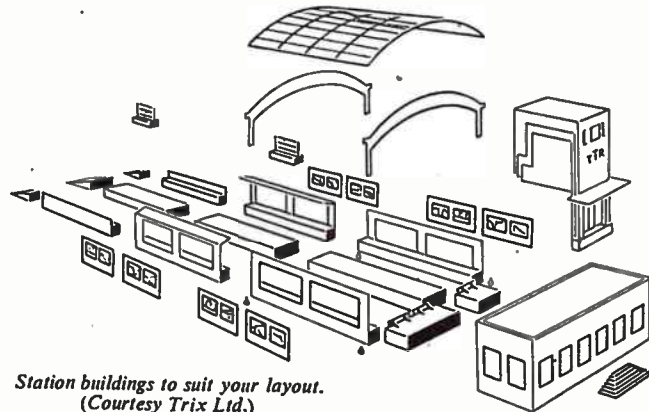

are able to proceed for many miles in one direction without even reducing speed, and yet when we come to the average model railway we find a very altered set of conditions in which many incongruities are accepted without the turning of the proverbial hair. Expresses are run at full speed between stations a train-length apart. 'Princesses' and 'Merchant Navy' engines are to be seen hauling impossibly mixed trains including Pullmans, local, main-line, and freight stock—just a glorious muddle, utterly unreal and unrailwaylike.

Too Much Cramming

There is nothing worth while in trains thus made up. There is nothing to observe, nothing to be proud of—and

why? Just simply because the misguided owner is trying to cram too much 'railway' into too little space.

If one has only a limited area at one's disposal—and that is usually the case, then the only obvious thing to do is to design the line to occupy to the best advantage that available space, and to design it rationally and with the greatest amount of care and thought.

Quart into Pint Pot

It is a truism that model railways aimed at too high an ideal always suffer badly during any subsequent 'shrinkage' processes to which they are subjected in the owner's frantic efforts to get the proverbial quart into the pint pot. The radius of curves are decreased—a very bad policy, pointwork is cramped, station platforms shortened, and many other equally vicious deviations are made from good, wholesome full-sized practice; and all because of the lack of a little foresight and pencil-and-paper

planning before ever an inch of track is laid. The moral is only too obvious.

The reader's first layout must be so arranged that it can always be added to as opportunity offers. Even if it consists only of a simple 'oval' of track, that oval should be laid in such a position on the baseboard or available space that any logical additions or minor alterations can be made easily without lifting the track and commencing afresh.

A model railway should rightly grow, just as the full-sized railways did, from humble beginnings, but by growth it is not intended to indicate the cramming into a small space of as many junctions, crossings and sidings as possible. This is a very common fault with beginners,

and it is quite wrong. In fact, one can learn an important lesson from the real railways, and economise where possible, getting all our effects by the use of as little rail and as few turn-outs as possible; for by so doing, cash will be saved, and at the same time a model will be produced which will look infinitely more railwaylike in every way. In short—little and good.

One must also consider the possibilities of some of the 'boxed train sets' on the market for the erection—and dismemberment—of portable layouts. Most of the track types used in these sets lend themselves to experimentation in that any given track plan—within the limits of the track units available—can be laid and used, and its operating facilities or shortcomings proved without involving anything more difficult than the locking of the track units together. Then on another occasion, an entirely different layout can be tried out, and its value assessed in the light of actual operation.

Most of the different makes of ready-made track units are both electrically and mechanically robust, and within reasonable limits their efficiency is not impaired, no matter how much they are laid and dismembered. So to take full



Fig. 1—Simple single-line passing station advantage of the facility offered by the 'unit' type of track for quick experiment, it is a good idea to get to understand how the various standard track units—the straights, half-straights, the curves and the turnouts—can be best incorporated into any layout design to produce the best and most workable plan. It is then quite an easy matter to fix the track permanently to the baseboard if so desired to produce a real 'permanent way'.

The Double Junction

No doubt, however, during such experiments, the reader will discover that although each of the different track units in these train sets are well thought out and mathematically planned, and that they each fit in perfectly with each other, certain difficulties arise when it comes to reproducing faithfully any given prototype layout owing to the fact that the curved sections are usually of very small radius, and that it is not always possible to reproduce that very essential track set-piece, the double junction.

Unfortunately, there is nothing that can be done about this admitted shortcoming, but as the reader progresses he will no longer be satisfied with seeing an engine and train lurch off at almost right angles from the main line. The use of scale track with curves of larger radius is the only answer to the difficulty.

Fortunately, special track can be pur-

chased of larger radius from several model railway trade firms which will effect a match-up with the various types used in boxed train sets, and with this it becomes possible to really plan additions and alterations to an existing boxed set with some pretence to railway-like practice.

Unit Construction Track

There are other forms of track which can be purchased which are equally suitable for either three-rail, 'Trix', Hornby 'Dublo' and other specified makes. Some of these forms of track are of unit construction in which remarkable realism is achieved, the track being completed with ballast, sub-ballast, sleepers and verge, yet by methods requiring no specialised skill and within the abilities of every owner.

Although secured to main baseboards for use, one form of such track and its ballast can be lifted bodily if it is desired to alter or dismantle the layout; which is an immense advantage to a beginner who may not be too sure of his early track-planning abilities.

Most of these other makes of track are designed with the obvious aim of finding the point at which the ratio of



Fig. 2—Single-line terminal with turntable

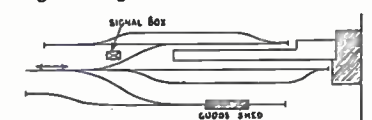

Fig. 3—Single-line terminal with goods shed

realism to purchase price reaches its peak, and in one case the very wide selection of single and double track-bases of various different radii offered allow the prospective builder to plan his layout or to add to his existing boxed train set layout without being tied to any specific curve radius. Moreover, part-curves and any radius and type of pointwork can readily be constructed from the kits of unit parts supplied, no special tools being required for the purpose.

Mention of unit construction track calls to mind that the same principle has been adopted by one firm for the construction of station buildings. By the adroit combination of various building units an unending variety of realistic modern station buildings can be constructed—from the humblest single-line 'halt' platform to the most ambitious of glazed-roof terminus or main-line 'through' station.

However, reverting to track and layout expansion, it may be well to survey British Railway station practice and see

how the full-sized railway atmosphere can best be captured with the means at our disposal.

In the smaller model railway layouts with which we are most concerned, what is known as 'single-line' working is almost a matter of necessity, for the very exigencies of small layout space do not permit of the provision of a regular 'up' and 'down' road. Such single-line working in which trains travel in either direction along a single line of track, can well provide a welcome variant to the more normal two-road ('up' and 'down') working more usual on larger layouts; upon which a single-line branch can be run to a small country-town terminus.

Smallest and simplest of all is the single-line halt platform, at which trains stop to pick up or to set down passengers upon notice being given to the guard at the previous station, or by hailing the train as one would a bus.

Next up the scale of station importance is the single-line platformed station with or without permanent buildings, according to the amount of traffic with which it deals. If passenger traffic is in preponderance, then some simple form of brick or stone-built structure will surely be provided, but if only three or four trains a day stop at the station, the 'waiting-rooms' may well consist of three-sided corrugated

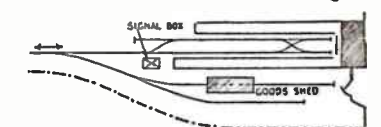

Fig. 4—Single-line terminal—another arrangement

shelters, the tickets being issued on the trains by the guard.

From a point of view of expanding a boxed train set, such stations as these we have considered do not boast any track layout at all, dealing as they do with passenger traffic from either direction, and hence having no need for a goods yard or any turn-outs or cross-overs. But in the case of the single-line, single-platform station located in a scattered suburban area devoid of farming interest, a simple little goods yard would make a pleasant addition to an otherwise rather uninteresting station.

Such a single-line station could well form the objective of a beginner's first addition to his boxed train set. Its laying and habilitation would give ample scope for initiative and imagination, whilst the outlay for the few yards of track and three turn-outs necessary would be quite reasonable. Not only so, the structural work entailed by the small station buildings would give a good idea of what can be done with wood, card, and—patience. Here again, camera and note-book are one's best friends.



AS ship lovers and modellers we like to recognise the ships we see in photographs, illustrations and old drawings and, when on holiday, we get the opportunity of seeing one of the fast disappearing types around our coasts. A knowledge of the wide variations of types of hull form and rig will, moreover, open wide a wonderland of ships from which to choose our next

Fig. 3 is a caravel of the time of Columbus. Two of his ships on the famous voyage of discovery were of this type, the *Pinta* and the *Nina*. The *Santa Maria* was converted to square sail for the voyage.

Fig. 4 is a Spanish treasure frigate. This is one of those out-of-the-way ships that I am surprised more modellers have not attempted. I made one myself

Fig. 6 is a naval cutter of the nineteenth century, being in use during the first half of the century. It is an ideal scale model as even to a large scale, say, standard museum scale of 1/4in. to the foot, it allows very detailed modelling and at the same time does not result in a model that is too large for the average home.

Fig. 7. In this example we come to the latter part of the nineteenth century and find that the number of types of sailing craft is legion, so many and varied are the types of rig, each and every one designed for its own special purpose.

SAILING TYPES

By Whipstaff

The one illustrated by the sketch is a fishing vessel and even this one type has numerous variations, according to the type of fishing and the locality.

Fig. 8. In this we have a topsail schooner, a very graceful and picturesque ship and one which would grace any home. Again there are many variations of type, both in the number of masts and individual rig.

Fig. 9 is a distinctive type, it is an American fishing schooner of the Blue-

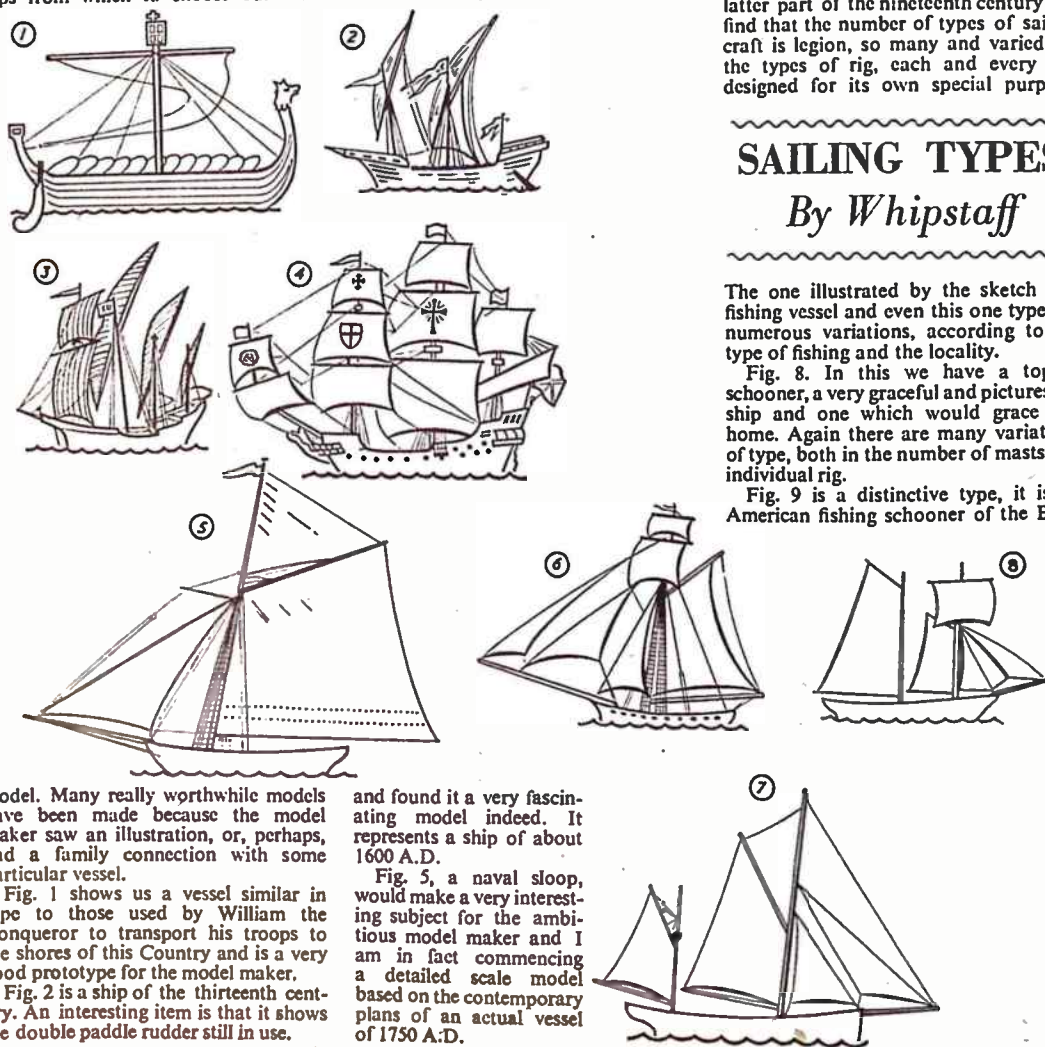

model. Many really worthwhile models have been made because the model maker saw an illustration, or, perhaps, had a family connection with some particular vessel.

Fig. 1 shows us a vessel similar in type to those used by William the Conqueror to transport his troops to the shores of this Country and is a very good prototype for the model maker.

Fig. 2 is a ship of the thirteenth century. An interesting item is that it shows the double paddle rudder still in use.

and found it a very fascinating model indeed. It represents a ship of about 1600 A.D.

Fig. 5, a naval sloop, would make a very interesting subject for the ambitious model maker and I am in fact commencing a detailed scale model based on the contemporary plans of an actual vessel of 1750 A.D.

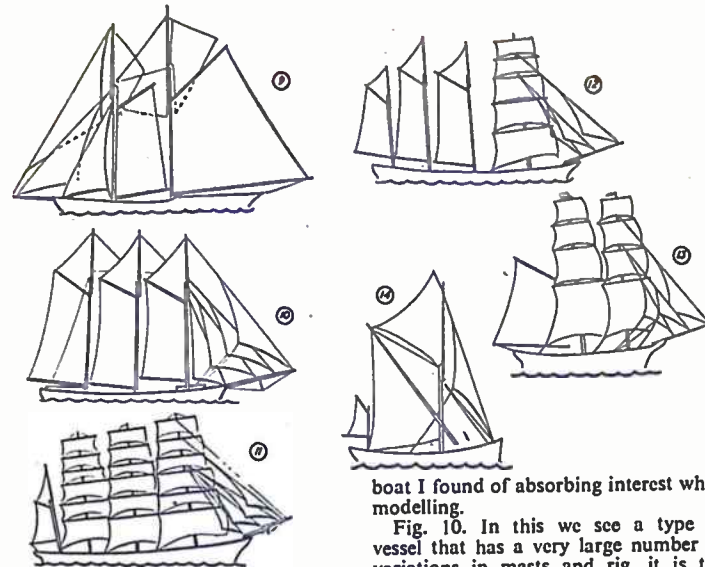

nose type, popularly known by the term 'Gloucester Fisherman'. This is again a

experience of seeing racing yachts in full sail will know, the 'fore and aft' is a most satisfactory sight and makes a graceful model.

Fig. 11. This is one of the variations of the square-rigged sailing ship, in this case it is a barque. One of the most famous of this type was the celebrated *Achibald Russell*. These are models that if well modelled are really satisfying to make and are the aim of the serious modeller.

Fig. 12. The four-masted barquentine is a variation of the square-rig ship, all these variations being very intriguing to make.

Fig. 13 is a brig of the nineteenth century and these are again many and various in type, the prototype not being a large ship, we again have a type that can be modelled in a large enough scale to show all the detail without the finished model being over large. This is also a very suitable type for those who want to make an actual sailing model.

Fig. 14 is an example of what is, perhaps, the last surviving type of sailing vessel to be in trade, namely the Thames sailing barge, always an interesting model to make.

boat I found of absorbing interest when modelling.

Fig. 10. In this we see a type of vessel that has a very large number of variations in masts and rig, it is the very beautiful fore and aft schooner. As anyone who has had the delightful

MAKE LIFELIKE MASKS

MAKING masks has always been a fascinating art among civilised and primitive peoples. Why not try making one? You may create any face, ugly or beautiful, old or young; it is for you to choose and wear.

Measure your face from nose to ear and from temple to chin. Then, using these measurements cut out a brown paper plan. Fit this closely over the face and cut away holes for the eyes and mouth. Place the plan on a large board and draw round the outline. Remove the plan.

Place a large piece of ordinary soft clay within the outline on the board and model the features of your mask, keeping them large and clear and using the paper plan to ensure the eyes and mouth are in the right place. Do not let your clay harden while you are working but keep it pliable. When you have created your model, make the surface as smooth as possible before allowing it to set. This may be done by slightly damping the surface with water and smoothing with the fingers. Allow the clay to harden for twelve hours.

Oil or grease the surface of the hardened clay model. Then mix some flour and water to make a paste. Cut up some strips of butter muslin and soak them well in this paste. Lay the strips over the model, stretching and smoothing them well into the features. Three or more layers of muslin should be applied in order to make a good strong mask.

Allow the muslin to dry out thoroughly before removing from the clay model, but do not dry in front of a fire or any sudden heat, as the muslin may shrink. When the muslin has been removed from the clay, rub the surface gently with glasspaper and bind the edges with adhesive tape.

To paint the mask use water colours, applying several coats of a good flesh colour. When dry, paint in the eyes, eyebrows, lips, etc. Use good thick paint and make clearly marked features. Do not overdo the decoration.

You can paint hair round the mask to disguise the bare edge, or you may add a wig of coloured raffia or wool to fit closely to the face. (D.M.D.)

THE 'GREAT HARRY'

This fine model of The 'Great Harry' was made by Ramesh N. Bulsara, of Jinja, Uganda. A very colourful galleon. The 'Great Harry' carries 36 large and 16 small guns. Kit No. 2262, price 34/6 from branches or Hobbies Ltd., Dereham, Norfolk.

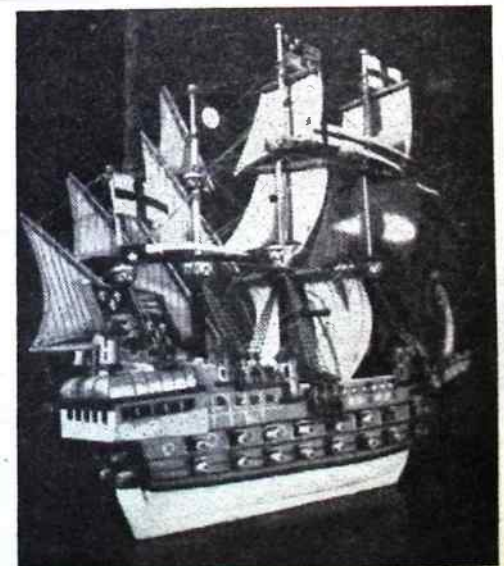

Simple — yet efficient

A ROWING MACHINE

READERS who are athletically inclined or who value the wonderful sense of well being which springs from a state of fitness will, undoubtedly, want to make and use this simple rowing machine, especially as it can be made from easily obtained material at a negligible cost.

A study of Fig. 1 will explain the general idea and construction. Commence with the framework of the base, using 3in. by 2in. or 2in. by 2in. battens, making the rectangular frame 2ft. wide and 3ft. long. Secure with wire nails and strengthen by fixing a 2in. by ½in. cross-batten, as in Fig. 1.

Secure the seat at one end by nailing a piece of wood or planking 2ft. by 1ft. by 1in. Two pieces of 6in. wide planking will serve as a substitute if 12in. wide material is not available. The seat should be covered with a piece of American cloth or odd piece of carpet.

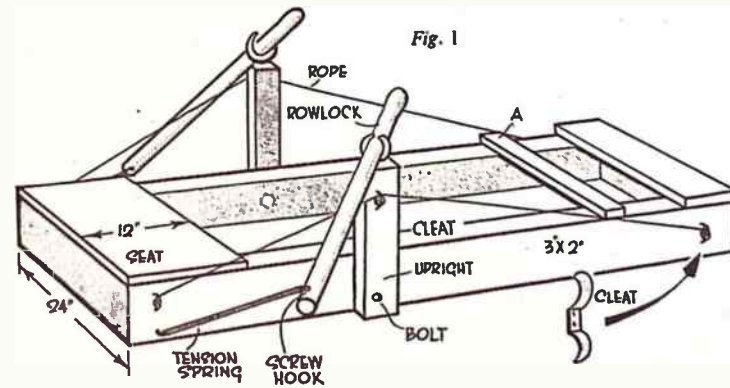

Oars and Rowlocks

The 'oars' may be sawn from an ash handle — of the kind used for garden rakes, or adapted from a suitable tree-branch, each being 18ins. long. If the handle end requires paring down to ensure a comfortable grip, this should be done with the aid of a knife or spokeshave, finishing with glasspaper No. 2 to ensure a smooth finish. About 3ins. space should be allowed between the handle ends when both fitted 'oars' are in a straight line. This will prevent the thumbs from colliding or jarring the 'oars' when doing a work-out.

A cheap pair of second-hand rowlocks with sockets should be purchased from a boatyard or junk-shop.

Mount the sockets on a pair of 2in. by 2in. battens, each 15ins. long,

Described
by D. H. M.

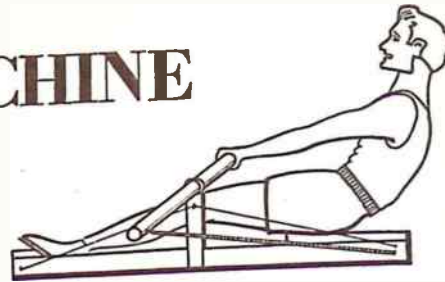

as in Fig. 2. The other end of each batten is now bolted to the side of the base, one on each side of the seat and 6ins. in front of the front edge of the seat. A small cleat is screwed to the outer side of each batten an inch or two below the top. Similar cleats are also screwed to the outside edge of the base, one at the front and one at the rear of each side. A length of linen line is passed from the front cleat around the batten cleat and thence to the rear cleat, thus giving support to each batten.

KEEP FIT—INDOORS

Tension on each 'oar', to imitate the pull in a real rowing boat, is provided by 'expander' springs, which can be obtained at any athletic outfitters at quite a modest price. As an alternative, strong rubber elastic may be used or even discarded inner tubes from car or cycle may be utilised. Each tension spring or band should have one end dropped over a screw hook in the base and the other end fixed to a screw hook near the 'water end' of the 'oar'. Use more than one tension spring or band to each 'oar' if strenuous exercise is favoured, the tension being adapted to suit individual requirements.

When inserting the rowlocks give the pins a smear of oil to assist smooth movement.

As will be seen from the sketch, the rower's feet rest against the end of the base. An additional footrest (A in Fig. 1) can be nailed across to support a user with shorter legs.

When completed, varnish in oak or mahogany, or paint in contrasting colours, such as blue base with white uprights, the 'oars' being left 'natural' or clear varnished.

Quickly Dismantled

Constructed as described, this rowing machine can be quickly dismantled for stowing away by simply unhooking the tension bands, loosening the lines on the cleats and loosening the batten bolts. The uprights will then lie flat alongside the base and the machine with oars can be stowed under the bed if desired, ready for the early morning 'row', or packed away in a comparatively small space.

If a rigid, non-collapsible model is desired, support the uprights with 2in. by ½in. battens in place of the cleats and line, and screw or nail uprights and side supports instead of using bolts.

A 'work-out' of ten minutes each morning should go a long way towards maintaining health and fitness and should assist in taking care of a troublesome waistline.

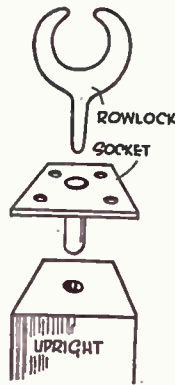

Fig. 2

* GREAT CAMPING OFFER *

RIDGE TENT SENT FOR 4/-

BRAND NEW de luxe 'Safety' Tent. All colours. Complete. Ideal Cyclists.

Campers. Length 7 ft. 3 in. sleeping base x 4 ft. 6 in. wide x 3 ft. 6 in. high x 12 in. walls, all approx. Weight 3½ lb. Cash 42/- or 4/- deposit and 6/- monthly. With fly-sheet 70/6 or 9/3 deposit and 6/9 monthly. Both carr. 2/-. Don't delay, send now. BRAND NEW U.S.A. OFFICER'S SLEEPING BAG

MADE IN THE U.S.A. These are a gen. American issue, not to be confused with spurious imitations on the market. Real 100% wool inner zipped down the front, with an additional free waterproof outer, you can sleep in the open. Comfortable, warm, rolls into easy carrying pack 29/11, post etc. 2/6

WITH FREE OUTER 29/11 Post etc. 2/6

HEADQUARTER & GENERAL SUPPLIES LTD. (HOBWX/14), 196-200 Coldharbour Lane, Loughboro Junc., London, S.E.5. Open Sat.

STAMPS FREE — Empire Packet including Pictorials and Victorians with approvals.—Robert J. Peck, 7A Kemp Road, Bournemouth.

LEARN it as you do it — we provide practical equipment combined with instruction in Radio, Television, Electricity, Mechanics, Chemistry, Photography, etc. — Write for full details to E.M.I. Institutes, Dept. HW.47, London, W.4.

A MONTHLY BARGAIN!
EVERY MONTH there are over 50 MONEY MAKING IDEAS in the novelty-packed 1/- Monthly

GADGETS MAGAZINE

Remember—over 50 easy-to-make Gadgets, Novelties, Gifts and clever devices for every purpose. Many are saleable inventions of extraordinary ingenuity. ANYONE can make them!

Send 1/3 for the current issue, or 7/- for the next six months to: HOME-MADE GADGETS MAGAZINE, 26 Swan House, Kingsbury, London, N.W.9

6 months Subscribers get FREE "LUCKY TALISMAN" key-chain!

100 Different Stamps free! Request 1d. upwards discount approvals. — Bush, 53 Newlyn Way, Parkstone, Dorset.

MAGIC Catalogue and 'Shocking Letter' Trick. 1/-.—DeHempsey, 363 Sandycombe, Kew, Surrey.

PAINTSPRAYING' HANDBOOK (1954 Ed.), Covers Car, Industrial & Flock Spraying 3/6, post free, including catalogue of our Cellulose and Synthetic Paints and All Allied Sundries and Plant Hire.—Leonard Brooks Ltd., 81 Oak Road, Harold Wood, Essex.

ACID-SHARPENED FILES. One dozen assorted specially sharpened files, all types and cuts; ideal for model makers, etc. 12/6 post free.—Phoenix File Co., 22 East Union St., Manchester 16.

SWISS MUSICAL Mechanism for cigarette boxes, etc., 18/- post free. S.A.E. for illustration and list of tunes available.—Dept. HW., Metwood Accessories, Church St., Wolverton, Bucks. (Trade supplied.)

PLYWOOD: large sizes, 14 lbs. 10/- delivered (Express) C.W.O. — H. Leader (1920), Gosford St., Middlesbrough.

GENUINE Swiss Musical Movements. The best and largest selection of tunes in the country, lowest prices 16/3 each. Genuine Thorens Movements, 21/- each. All guaranteed. P. & P. 9d. extra on all orders.—Richardson & Forder, HW., 5 Chapel Place, White Hart Lane, London, N.1.

SWISS musical box movements, only 14/9 post 5 free. S.A.E. for details.—Swisscross, Dept. B., 116 Winifred Rd., Coulsdon, Surrey.

Stick to SECCOTINE — it sticks Regd! — it sticks everything!

KEEP A TUBE IN THE HOME

Sole Manufacturers: McCaw, Stevenson & Orr Ltd., Belfast

Yours for only 8/6d.



Safeguard your copies of 'HOBBIES WEEKLY' The amazing 'EASIBINDER' (Pat.) makes it simple!

With the new EASIBINDER, specially prepared for Hobbies, you can bind each copy of Hobbies Weekly as you get it, turning your favourite magazine into a permanent, easily-consulted library of immense value, and avoiding the delay and despair occasioned when copies are accidentally mislaid or destroyed. Carefully finished in black leather-cloth and gold-blocked on the spine, each binder is strong, serviceable and neat. It will hold two complete volumes (52 copies) and costs only 8/6. Each copy of the magazine is quickly inserted by means of a flexible steel wire, and can easily be removed if necessary. Easy-to-follow instructions with each EASIBINDER. Get one today and take care of your copies of Hobbies Weekly.

NOTE! For those who prefer to bind each volume (26 copies) in the orthodox way, the familiar red binding cases are still available, price 4/6 each, and indexes are published for each completed volume and cost 1/- each. To avoid confusion, however, these items should be ordered separately. USE THE COUPON ONLY TO ORDER EASIBINDERS.

★ One 'EASIBINDER' holds two volumes (52 copies)

★ Easy to use

Post today



To: HOBBIES LTD., Dept. 99, Dereham, Norfolk.

PLEASE SUPPLY EASIBINDERS at 8/6 each. P.O. for is enclosed.

NAME

ADDRESS

Simple woodwork project

AN ATTRACTIVE LETTER-RACK

THE original of this little letter-rack was made in sycamore, but any hardwood of pleasant appearance would be equally suitable.

Four pieces of wood are prepared to the sizes shown in Fig. 1. All wood is $\frac{1}{2}$ in. thick. It must be noted that the grain of the base (which is prepared to $4\frac{1}{2}$ ins. wide) runs from front to rear, and not from left to right.

Do not attempt any shaping at this stage, or it will be impossible to mark out the joints with any accuracy.

By K. Blackburn

First, the back must be dovetailed into the base as shown. Square lines round on both pieces $\frac{1}{2}$ in. from the ends, and mark out the dovetails on the back part. When these have been sawn and the waste removed, draw round the tails onto the end of the base with a very sharp pencil. Square the lines down the base to the shoulder line, and remove some of the waste with a coping saw, finishing off with a chisel.

The distance between back and middle section is $1\frac{1}{2}$ ins. Square the two lines right round the base after checking the distance between them by placing the centre section in position. Square a line round also $\frac{1}{2}$ in. from the bottom of the centre section before marking out the joints with a marking gauge.

Note that the centre part of the upright is cut down only to within $\frac{1}{4}$ in. of

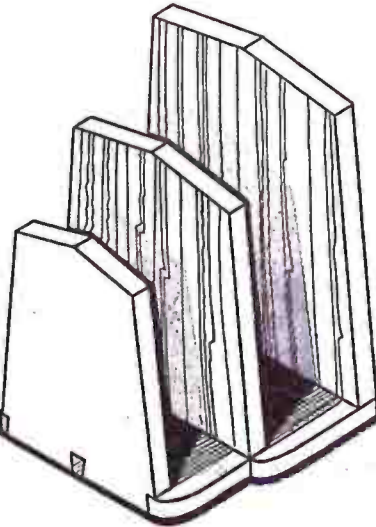

the shoulder line: this raised middle portion will fit into the groove between the mortises in the base. The side pieces, of course, are cut right down to the shoulder line.

The positions of the mortises in the base are marked by placing the centre section flat upon it as shown in Fig. 2. The gauge is then set to each of these four marks in turn, and the joints marked on top of, and underneath, the base.

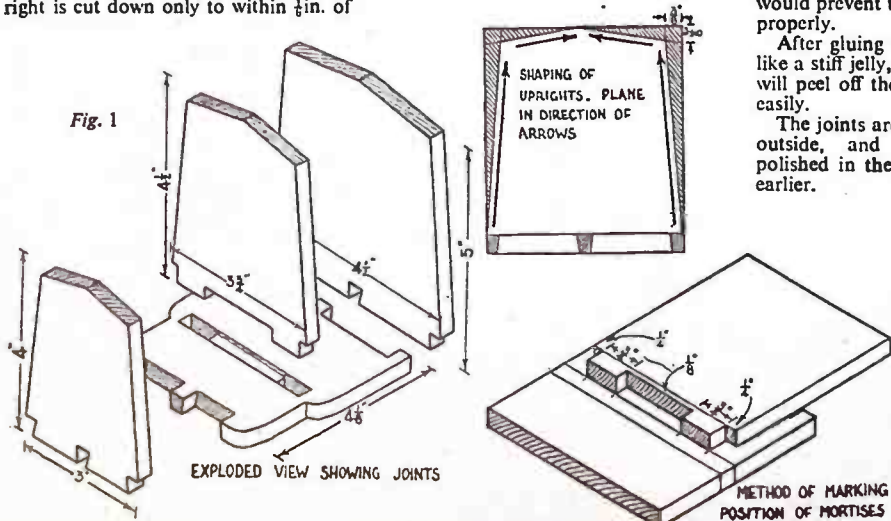

Use a $\frac{1}{2}$ in. chisel for chopping out the mortises, reversing the wood when the mortise is half-way through. Then the $\frac{1}{2}$ in. deep groove is cut between the two mortises with the same chisel.

The front is dovetailed into the base in the same way as the back. Next mark out the shaping on the three upright sections, and plane down to these lines with a finely-set plane, using it in the direction of the arrows in Fig. 2.

These three sections are now fitted into the base, when the shaping on it can be marked with no danger of error. Use a marking gauge for the straight part which has to be cut away, and draw in the curves freehand. The shaping is done with a tenon-saw and a wide chisel, used vertically downwards while the base rests flat upon a piece of waste-wood.

The inner surfaces are then cleaned up with fine glasspaper. Do not glasspaper inside the joints, or their fitting will be spoiled.

Polishing tips

You will find it easier to do the polishing of the inner surfaces before assembly. Give a few brush-coats of French polish, using flour grade glasspaper to rub down between each coat. A few more coats of the same polish applied with a rubber will give a delightful finish. The rubber consists of a piece of cotton-wool (which holds the polish) wrapped in a piece of cloth.

When polishing, be very careful not to allow any polish on the joints, as this would prevent the glue from penetrating properly.

After gluing up, wait until the glue is like a stiff jelly, and you will find that it will peel off the polished surfaces quite easily.

The joints are then cleaned up on the outside, and the outside surfaces polished in the same way as described earlier.

Make Leisure a Pleasure with



This Modern Toy Garage and Service Station makes an excellent gift for a lad. Spacious, and very much like the real thing, it will give hours and hours of real pleasure.

It is easily made up from Hobbies Kit No. 3129, which includes all wood, beading, window material, posters, and a set of petrol pumps, together with full working instructions.

A GRAND GIFT FOR 39/11

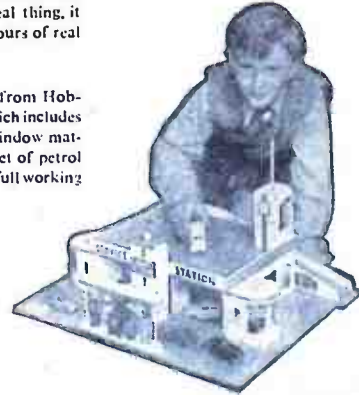

To HOBBIES LTD. DEPT. 99, DEREHAM, NORFOLK
Please send Modern Garage Kit No. 3129 . 39/11
Name.....
Address.....

YOU CAN BECOME A HANDICRAFTS INSTRUCTOR

EXPERIENCE NOT ESSENTIAL

Men who enjoy making things in wood or metal can turn their hobby into a permanent and interesting Career. Short hours, long holidays and security in a job you would really enjoy, can be yours if you become a Handicrafts instructor. Let us send details of the easiest and quickest way to get the necessary qualification.

We guarantee "NO PASS—NO FEE"

If you would like to know about our unique method of preparing you for one of these appointments, write today, and we will send you our informative 144 page Handbook—free and without obligation. Mark your letters "Handicrafts Instructor".

BRITISH INSTITUTE OF ENGINEERING TECHNOLOGY BIET

595 College House, Wright's Lane
Kensington, London, W.8

HARDHITTING ACCURATE

Webley AIR PISTOLS

AIR RIFLES · ACCESSORIES

Write for Catalogue
WEBLEY & SCOTT Ltd., 166 WEAMAN ST., BIRMINGHAM, ENGLAND

PADDLE YOUR OWN CANOE

Hundreds of readers have made their own canoes from plans supplied by Hobbies. Recommended full-size drawings are:—

PBK 14—14ft. 2-seater, 7/6 post free
PBK 10—11ft. single-seater, 5/6 post free
Also 'Dereham' 10ft. rowing dinghy, 8/6 post free

Drawings of paddles and accessories, 2/- post free

HOBBIES LTD., DEREHAM, NORFOLK

Make a good job of it with COLRON WOOD DYE



Any job that's worth doing is worth finishing well. COLRON Wood Dye in any one of its dozen shades gives perfect results—even on softwoods. A single application, wiped on with a soft cloth is sufficient. It doesn't raise the grain, and it's fine for floors!

Send for the COLRON Colour Guide.

COLRON

RONUK LIMITED



PORTSLADE SUSSEX

Replies to Readers Is this YOUR Problem?

Water Proofing a Caravan

I WISH to make a sealing compound which is waterproof, will remain fairly elastic and is reasonably cheap. I intend to use it on the seams and windows of a caravan. (T.F.—S.E.15).

IF the framework of your caravan is mostly wood, make up the following filler, which should serve. Make up a Casco glue mixture in standard proportion and to it add 1½ measures of sifted sawdust, ½ measure flour and ¼ measure whitening. Make only enough for the job as it dries in about four hours and is then useless, becoming hard. Plax, a flexible sealing compound, recommended for this type of job, costs 2/6 a tube from Hobbies Ltd., Dercham, and branches.

Resilvering a Mirror

MY dressing table mirror is getting discoloured on the silvered side. It looks like dampness. Can you tell me of a remedy? (R.H.—South Harrow).

RESILVERING is the only remedy for your dressing table mirror. Clean off the old silver and lay face downwards in a shallow tray. See the back of the mirror is quite clean and apply the following solution. (A) Dissolve 60 grains silver nitrate in one ounce of distilled water and pour into a boiling solution of 48 grains of Rochelle salt in about one ounce water. Cool and filter and make up to 12 fluid ounces with distilled water. (B) Dissolve 60 grains silver nitrate in one ounce distilled water, then add ammonia, drop by drop, until the precipitate is nearly redissolved, and make up to 12 fluid ounces as before. Keep in black bottles, and mix in equal quantities just before using.

Wiring for Electric Fire

CAN you help me with my problem regarding an electric fire — if I connect the negative and positive from the electric light to an electric fire filament on a wooden base, using a metal reflector, will it be safe? (R.W.—Doncaster).

ELECTRIC fires should not be operated from lighting circuits, because there is no earth available here, and the current is not supposed to exceed 5 amps. Official regulations require that a fire be used from a 3-socket outlet. To conform to these regulations, any reflector or other metal-work should be earthed to the earth pin of the main

plug (largest pin). The fire element is taken to the two other pins. 3-core flex will be necessary to do this, so that the required three connections can be made. If the fire is soundly constructed, it can be perfectly safe, if earthed in this way. A protective guard of wire netting or metal bars, close together, and also earthed to the frame, should be fitted in front of the element. Though a 1kW element could be powered from a lighting circuit, it is not safe to do this, so you should use a power point intended for such purposes. One, two or three 1kW elements can be used, according to the heat wanted.

Replacing Tiles

I WISH to replace some bathroom tiles which have come away from the wall. What cement or plaster should I use and how can I remove the hard plaster adhering to the tiles to be replaced? (E.S.—Orpington).

THE removal of old cement from tiles can be to some extent successful by rubbing vigorously with a brick, sprinkling silver sand and water between it and the tile. It is a tedious job, however, and unless the thickness of old cement on the tile renders it impossible, a quicker method would be to ignore it and refix the tile with a special cement, such as Tiluma. The usual cement is one part cement and three parts clean sand, laid on to a thickness of ¼ in.

Recolouring a Fiddle

I HAVE a double bass fiddle with a light colour finish. I wish to strip this all off and put on a very dark or, maybe, black finish to the instrument. Can you advise me what to use to take the colour off. Is there any kind of special varnish or polish to use on this job, as I do not wish to spoil the tone of the fiddle. (L.W.—Consett).

YOU should remove the old varnish with pumice powder, moistened with water and applied on a clean soft rag. Rub down with fine glasspaper and then revarnish with the following. Dissolve in half pint methylated spirit, 2ozs. gum sandarach (juniper gum) and 2ozs. white shellac. Add two tablespoonfuls Venice turpentine and filter through fine muslin. Colour to the desired shade with spirit soluble aniline

TIMELY TIP

Tent 'Pockets'
THERE is usually insufficient space in a tent for enough room to be found for bedside tables on which to place articles such as torches, which are required near to hand. A good idea is to sew a canvas 'pocket' inside the tent at the head of the bed, and there is no reason why the idea should not be extended to the provision of several such 'pockets' to hold other equipment.

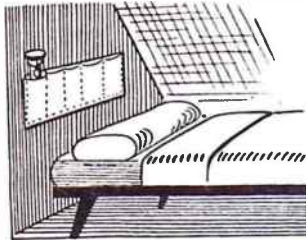

Restoring Polish to table

PLEASE inform me of a method to remove heat stains from a polished table. (W.S.—Nairn).

HEAT marks on a polished surface are very difficult to eradicate. Try rubbing over with turpentine and linseed oil. This will sometimes remove the marks if not too deep. If this fails, a gentle rubbing with methylated spirit on a clean rag pad should prove efficient, after which a coat of clear varnish or a rub with a french polish rubber will restore the original polish.

Removing Cedarwood Stains

I WOULD be grateful if you could advise me how to clean Western Red Cedarwood. My shed has got mud spattered on it, but scrubbing has had no effect. (C.C.—Muswell Hill).

A BLEACHING agent may be effective in removing the stains. Ordinary bleaching powder in water could be tried, or a small handful of borax in half a pailful of hot water. Test on a small portion of the wood first. To help prevent further trouble with such stains, it would be as well to apply a coat of colourless solignum as a protective.

A gift for Mother

See page 197

Patterns for Scent Casket

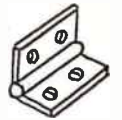
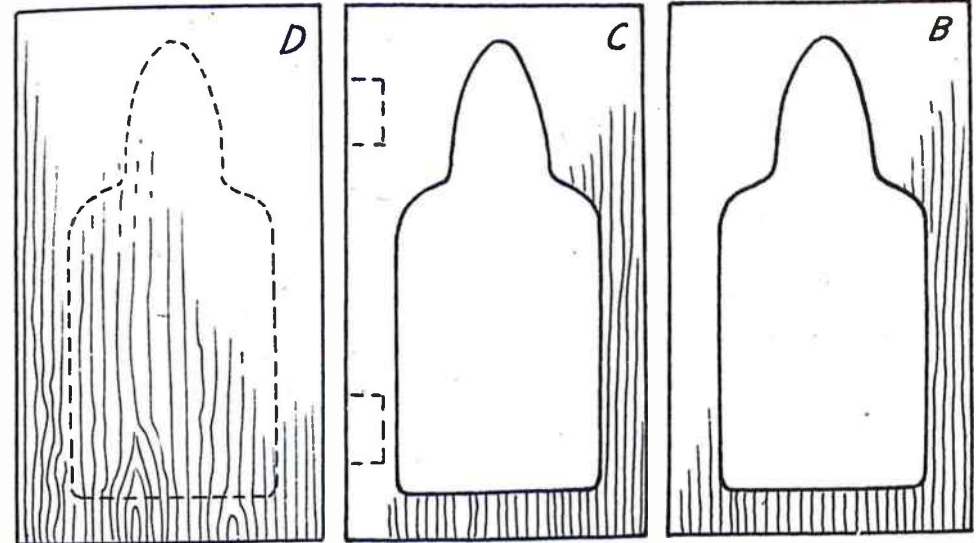

3/4" HINGES

TWO REQUIRED

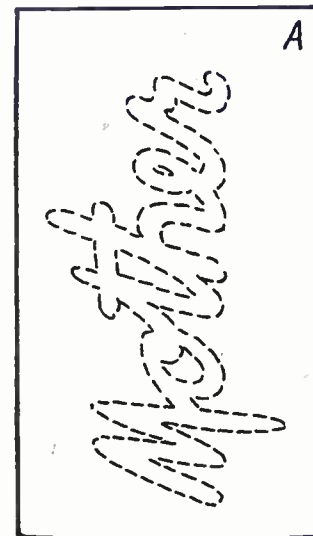

OVERLAY.
CUT ONE 1/8 IN.

Mother

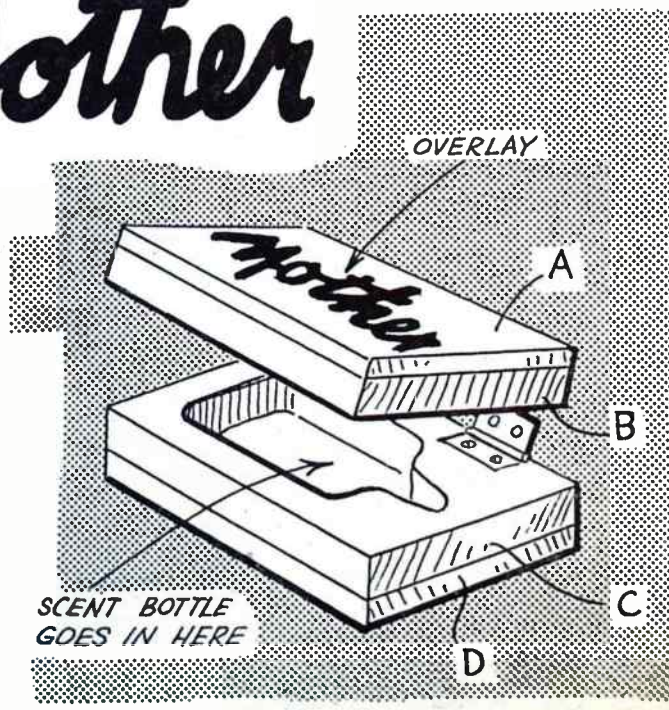

SCENT BOTTLE
GOES IN HERE

USE
YOUR
FRETSAW

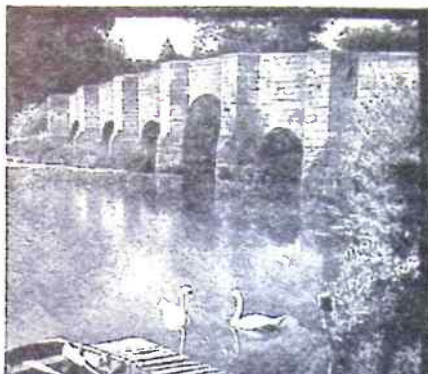

Stopham Bridge, Sussex

ILFORD FILMS

*for faces
and places*

ILFORD FILMS IN BLACK-AND-WHITE IN ALL POPULAR SIZES. IN 35mm. COLOUR, TOO!

NEW!

THE PRACTICAL WAY
of learning RADIO
TELEVISION · ELECTRONICS

- Beginners Radio Course ●
- Advanced Radio ●
- Short Wave Technique ●
- Lesson Manuals ●

Experimental work includes construction of Basic Oscillators, Amplifiers, Deflectors, Power Units, 1, 2 and Multivalve TRF and Super-het receivers.



COMPLETE EXPERIMENTAL COURSES IN RADIO ENGINEERING and SERVICING

An entirely new series of courses designed to teach Radio, Television and Electronics more quickly and thoroughly than any other method. Specially prepared sets of radio parts are supplied and with these we teach you, in your own home, the working of fundamental electronic circuits and bring you easily to the point when you can construct and service radio receivers, etc. Whether you are a student for an examination; starting a new hobby; intent upon a career in industry; or running your own business — these Practical Courses are ideal and may be yours at very moderate cost. With these outfits, which you receive upon enrolment and which remain your property, you are instructed how to build basic Electronic Circuits (Amplifiers, Oscillators, Power Units, etc.) leading to designing, testing and servicing of complete Radio and Television Receivers.

COURSES FROM 15/- PER MONTH

POST THIS COUPON TODAY

To E.M.I. Institutes,
Dept. 31X, Grove Park Road, London, W.4.
Please send me your FREE book on Practical Courses

NAME

ADDRESS

June 27IC74

EMI INSTITUTES

associated with
"His Master's Voice,"
Marconiphone,
Columbia, etc.

Wolf Cub ELECTRIC DRILL AT ONLY £5.17.6



or 8/- deposit
and 6 monthly
payments of 20/6d.

This wonderful Electric Drill is also the power unit for ALL Cub equipment. Drilling capacity: Mild Steel, 1/2"; Hard Wood, 1/2"; with 210 watts input on full load. Complete with 1" three-jaw chuck and Allen key and Sft. of cable. TV Suppressed. State Voltage. ALSO Sanding & Polishing Kit (drill discs, etc.). Cash Price: £6.19. 6 or 22/- deposit and 6 monthly payments of 22/-

Send for Illustrated Brochure

BARGAIN DISTRIBUTORS

ELECTRIC PAINT SPRAYER

4/- deposit
and 6 monthly
payments of 13/6
Cash Price 75/-



Paint easily, evenly, twice as fast with the Burgess Electric Sprayer. Sprays paint, varnish, etc. Complete with sturdy glass container, flexible nozzles for ceiling spraying and extra nozzle discs for different liquids. A.C. mains — state your actual voltage. Fully guaranteed. 96-page booklet supplied FREE with Sprayer. Also Horvell Electric Paint Stripper 30/- cash, or 4/- deposit and 3 monthly payments of 10/-.

Leaflets free.

(Dept 124), 5 Silver Street, Luton



BRANCHES: LONDON

- 78a New Oxford St., W.C.1
(Phone MUSEum 2975)
- 87 Old Broad Street, E.C.2
(LONDON Wall 4375)
- 81 Streatham Hill, S.W.2
(TULSe Hill 3796)

GLASGOW

326 Argyle Street
(Phone CENTral 5042)

Head Office & Factories — HOBBIES LTD, DEREHAM, NORFOLK

MANCHESTER

10 Piccadilly
(Phone CENTral 1787)

BIRMINGHAM

100a Dale End, Birmingham 4

SHEFFIELD

4 St. Paul's Parade
(Phone 24671)

LEEDS

10 Queen Victoria Street
(Phone 28439)

HULL

10 Paragon Square
(Phone 32959)

SOUTHAMPTON

134 High St. (Below Bar.

BRISTOL

30 Narrow Wine Street
(Phone 23744)