

HOBBIES WEEKLY

IN THIS ISSUE

An Inlaid Thermometer	Page 241
Stand for a Cupboard or Bookcase	242
Take Guard with this Cricket Set	243
Books to Read	243
Build a Test Meter	244
Extending the Paint Brush	245
Experiments with Alum	246
Bream afford a Fine Sport	247
The Shipmodeller's Corner	248
Two-Tier Tea Tray	249
Make a Surf-Board	250
Gauges from Scrap	250
Stamp Collector's Corner	252
Pattern for a Metal Boot Scraper	255



JULY 18th 1956

VOL. 122

NUMBER 3168

FREE Design
Inside for—

AN INLAID THERMOMETER

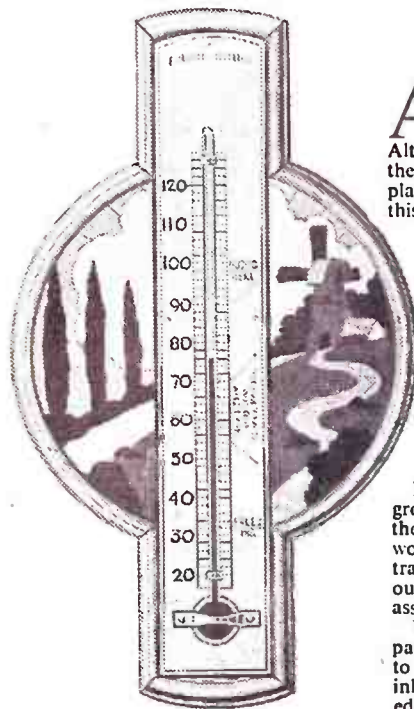

A THERMOMETER set in a coloured wood background makes a pleasing fitting for the home. Alternatively, workers could omit the thermometer fitting and make circular plaques for hanging on the walls from this design.

The picture is made by the fret-saw inlay method, with which most readers are familiar, but the procedure will be described for the benefit of newcomers to whom there is available a leaflet 'Making Pictures in Wood', obtainable free from the Editor. Please enclose s.a.c. The kit for making this design includes sufficient wood for the backing piece and mitred framework, and four contrasting panels of wood for the inlays.

First transfer the shape of the background (piece 1) and the pieces forming the frame (4 to 11 inclusive) to ¼-in. wood. Make sure that *all* parts are traced out on the panel before cutting out. Clean up and lay aside for future assembly.

Now build the picture. Transfer the pattern of the picture and pieces 2 and 3 to the whitewood panel. Pin the four inlay panels together around the outside edge in the waste wood, and drill a hole

near the edge of the picture. With a fret-saw, cut out one shape at a time, allowing the pieces to fall out. When all the cutting has been completed, assemble the pieces according to the keyed picture on the design sheet. The picture is now glued down piece by piece to the background (piece 1). The wood for pieces 2 and 3 can be selected to contrast with the picture.

Scrape smooth

When completely dry, the picture should be scraped (i.e., with a piece of glass) until smooth. Glasspaper may be used for this operation, but it will take much longer. Apply white wax (furniture polish), rub it well in with the fingers, and polish lightly with a duster. Then rub down with fine-grade glasspaper until the surface wax has been removed. From this operation it will be appreciated that the fine dust from the glasspapering, combined with the polish, will begin to fill up the cracks between the pieces. Repeat this process of waxing, polishing and lightly glasspapering until the cracks have been completely filled and the surface is reasonably well glazed. The more often this is done, the

● Continued on page 242

All correspondence should be addressed to The Editor, Hobbies Weekly, Dereham, Norfolk

For Modellers, Fretworkers
and Home Craftsmen

4½^D

PAGE 241

STAND FOR A CUPBOARD OR BOOKCASE

Described by
W. J. Ellson

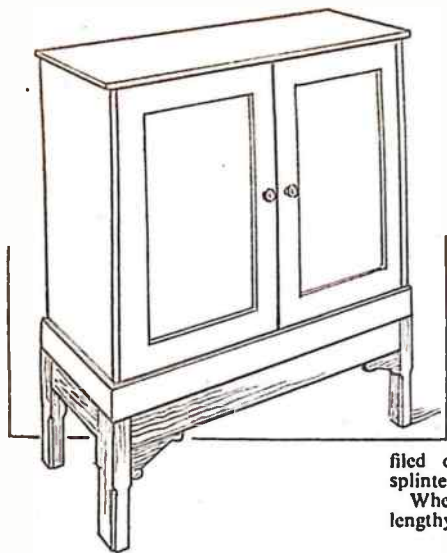

feet or glasspapered off to prevent splintering when the stand is moved.

When the stand has to be rather lengthy to suit a wide piece of furniture,

INCONVENIENCE is sometimes experienced when it becomes necessary to take an article from the bottom compartment of a cupboard, or a book from the lowest shelf of a bookcase. To remedy this a stand is suggested, high enough to elevate the article of furniture, and thus render access to its lower parts much easier.

A simple design of stand is illustrated. It shows a common pattern of cupboard on a stand of 12ins. in height. No dimensions are given, as these must depend on the size of the article to be raised.

The legs are cut from 2in. square timber, and the horizontal rails are 1in. thick. The rails are tenoned into the legs as in Fig. 1. Note that the face sides of these rails should come level with those of the legs, so cut the tenons accordingly as at (A), where the wood is reduced to half thickness, cutting from the face side.

Using 3in. wide timber for the rails, cut the tenons 2ins. by 1/2in. A horizontal section of a corner of the stand is given in Fig. 2. This also shows the corner block, screwed across each corner angle. After gluing up the stand, and allowing it to set hard, screw the blocks across. The blocks can be cut from spare bits of the wood, at least 1in. thick, with a notch cut out to pass over the legs.

Using turned legs will practically complete the stand, but with plain squared timber it will be as well to add some little finish as a decorative effect. A stop chamfer, as shown in the drawing of the finished stand, can be easily planed, and is quite effective. The sharp bottom corners of the legs should be

the corners to impart a finishing effect.

It will be desirable in most cases to add stopping slips at the top of the stand to prevent the article on it from moving. These are cut to the shape at (B) in Fig. 3, and are nailed or screwed to the inside of the rails as in the diagram, and should project about 1/4in. above. As seen at (B) the projecting portion of these stops should be cut to make up any difference between the thicknesses of rails and plinth above.

To fix the stand permanently to the

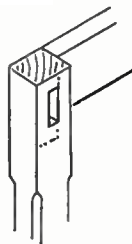

Fig. 1

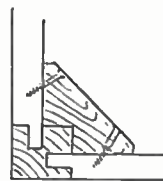
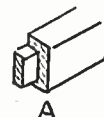

Fig. 2

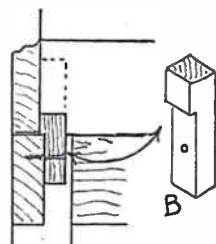

Fig. 3

corner brackets (as seen in the illustration) may be added to break up the space between the legs. These can be cut from pieces of wood 6ins. long and 3ins. wide, and glued and nailed in

article resting upon it so that the whole can be moved as one, the projecting parts of the stops should be made longer as indicated by dotted lines, and screwed to the plinth.

● Continued from page 241

An Inlaid Thermometer

better will be the resulting finish. The final operation will be waxing and polishing only, omitting the glass-papering.

The border strips can now be glued to the outside, trimming where necessary to ensure a perfect fit. The edges can be rounded or left square, as thought suitable. Wax polish the frame and finish off by screwing the thermometer and bracket eye in place.

It will be appreciated that only one set of each shape has been used for making the one picture. Other pictures using different colours of wood can be sorted out from the shapes already cut and similarly made up. Those who wish

to make a number of these inlaid thermometers for gifts, etc., can add extra panels of wood, cutting up to a total of 1/2in. to 1in. thick on a fret-machine.

Full Kit 7/6

A set of inlay panels and a thermometer are included in Kit No. 3168 for making this Design. Price 7/6 from branches etc. or post free from Hobbies Ltd., Dereham Norfolk

A portable wicket

TAKE GUARD WITH THIS CRICKET SET



THE difficulty of fixing stumps in a hard playground or yard can be overcome by using this ready-assembled set, which will stand quite firm on any flat surface. The swivel arrangement at the base allows each stump to fall independently without losing the set positions of the wicket.

The over-all measurements are given

in the side and front views in Fig. 1. Notice that the base is made from 1/2in. mild steel 2ins. wide. It can be riveted or welded together as shown in Fig. 2. The inside measurement of the 'U'-shaped piece is exactly 8ins. and allowance should be made when bending or the measurement will be scant.

The bolt securing the stumps is 1/2in.

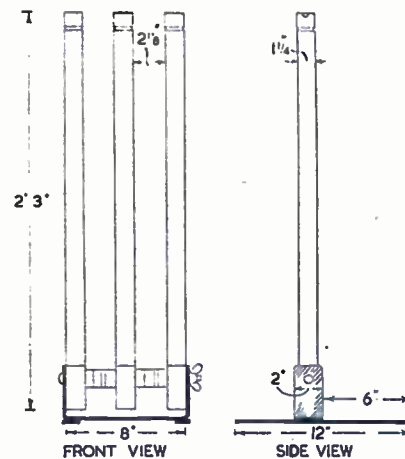

Fig. 1

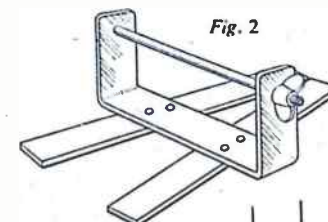

Fig. 2

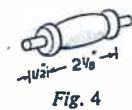

Fig. 4

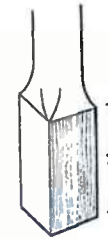

Fig. 3

diameter with about 1in. of thread to take a wing-nut as illustrated. Bore 1/2in. holes in the 'U'-shaped piece 2 1/2ins. from base to allow a generous clearance.

The stumps are shaped from 1 1/2in. square wood 2ft. 3ins. long. Fig. 3 shows how the base is left square for about 3ins. A hole should be drilled in each stump and centred 2ins. from the base. The diameter is 1/2in. to take the 1/2in. diameter bolt.

Circles of wood 1 1/2ins. in diameter act as washers or spacing pieces between the stumps. The total thickness is 2 1/2ins., so that three or four pieces should be cut to make up this thickness exactly.

The bails are shaped from 1in. diameter wood as shown in Fig. 4. The pegs can be shaped from the block, or dowels let in at each end.

Finish off by painting the metalwork green and give the stumps and bails two coats of clear varnish. (M.h.)

Books to Read

Making and Using a Telescope

by H. P. Wilkins and Patrick Moore
MANY would-be astronomers are deterred from obtaining the equipment they need by the feeling that any telescope that is good enough to be useful, is bound to be expensive to buy and impossible to make. The authors, however, show that with no previous experience the handyman can make up his own instrument comparatively cheaply. A start, in fact, can be made by using some old spectacle lenses and rolled-up paper. From this stage the reader is led on to the advanced refracting type, and there is also much guid-

ance in making observations of the moon, the planets and stars.
Published by *Eyre & Spottiswoode (Publishers) Ltd.*, 15 Bedford Street, Strand, W.C.2—Price 12/6.

The Canoeing Manual

by Noel McNaught
THIS contains a mine of information about a sport which is becoming increasingly popular year by year. It describes the legal position in regard to individual touring on rivers, the various types of craft, the advantages of joining clubs, and notes on the different races held annually. There is much good ad-

vice for beginners, and a helpful list of the Canoe Clubs in Britain, which those interested in the sport would do well to contact.

Published by *Nicholas Kaye Ltd.*, 194-200 Bishopsgate, London, E.C.2—Price 10/6.

Making and Repairing Fishing Tackle

by Richard Arnold
THIS is a book for all angling enthusiasts which shows how tackle can be kept in good repair at a minimum cost. How various tackle accessories can be made is also fully explained.
Published by *W. & G. Foyle Ltd.*, 119-125 Charing Cross Road, London, W.C.2—Price 3/.

F. G. Rayer says

BUILD A TEST METER

READERS appear to be interested in constructing a meter with several ranges, so that batteries, and wireless and electrical circuits can be tested. It is quite easy to do this, and to provide any desired ranges. Or the meter may be made up in simple form, and other ranges added later.

Such multi-range meters are built up around a milliammeter, and these can be purchased new, or from ex-service stores, in many sizes and types. They are usually round, but square ones are also made. The shape, naturally, does not influence results in any way. Again, some are flush mounting, and others projecting. The flush mounting type will fit in a suitable hole cut in the panel of

meter is large enough for all ordinary purposes.

In addition to the above (e.g., size and shape of meter,) it is most important that the current required to move the pointer to full scale is known. The most generally suitable type will be a 1mA meter. With this, 1 milliamp (one-thousandth part of an amp) will move the pointer to the end of the scale.

Voltage Ranges

The method used to measure voltages will be clear from Fig. 1, a resistance being wired in series with the meter. If a 1mA meter is used, this resistance must have 1,000 ohms for every 1-volt of the required range. For example, a 5,000 ohm resistor would read 0-5 V,

200 ohms per volt, while a $\frac{1}{2}$ mA (500 microampere) meter would require 2,000 ohms for each volt. This can be kept in mind if a meter of other than 1mA type is to be used.

With high value resistances (K) is used to show 'thousands of ohms'. A 50K resistor is thus 50,000 ohms. It would give 0-50 V with a 1mA meter, or 0-100 V with a 2mA meter. With the $\frac{1}{2}$ mA meter 50K would give 0-25 V, and with a 5mA meter it would give 0-250 V in accordance with the 'Ohms per Volt' ratings explained above.

Ordinary resistors are correct to 20% only. Resistors with a silver band or end are correct to 10%, and those with a gold band are correct to 5%. For much testing, 5% resistors will do well. If it is desired that readings be correct to a higher degree of accuracy, then 1% tolerance resistors may be used, but these cost a little more.

The circuit in Fig. 1 can be used exactly as shown for a single range voltmeter.

Reading Ohms

It is often an advantage to be able to read resistance values. This can be done by using a dry battery, usually contained in the multi-meter case. With normal use the battery will last six to twelve months.

A typical resistance scale is shown in Fig. 2, and will be correct when using a 1 mA meter with a 4.5 V dry battery of the kind used in flashlamps. Meter, battery, test prods, and a resistance which can be set to 4,500 ohms are all wired in series. The prods are held together, and the resistance adjusted until the meter shows 1mA, or Zero ohms. When the prods are parted, the pointer will return to its original position. When they are applied to any resistor or circuit, the pointer will take up a position which shows the resistance on the ohms scale.

It must not be forgotten that the scale shown is only correct for 4.5 V battery and 1mA meter. If a different battery or meter is to be used, the deflections for given resistance values can be worked out from Ohm's Law, and a scale to suit drawn.

Five-Range Meter

Volts and ohms readings are most satisfactory for the majority of tests, and the principles explained can be used to make a meter according to the circuit in Fig. 3. A small case, with Paxolin or Bakelite panel, must be constructed to hold the parts. A 5-way rotary switch is

easily obtainable, but terminals or sockets can be used instead.

Considering the ohms range first, a 4K fixed resistor and 1K variable resistor are used in series, to obtain 4,500 ohms. This saves the meter from possible damage, as if the variable resistor is turned to zero, 4K will still be in circuit. Furthermore, when the dry battery has run down to 4 V, it will no longer be possible to get the meter pointer to Zero. A new battery will thus be necessary, and the errors in ohms readings which would result from a discharged battery cannot arise. For ohms readings, the switch is set to '2' and the scale as shown in Fig. 2 is employed.

With the switch at '1' the meter reads up to 1mA, exactly as if used alone. When it is set to '3' a 10K resistor is in circuit, giving a 0-10 V range. When set to '4' 250K (240K plus 10K) will be in circuit, giving 0-250 V. At '5' a range of 0-500 V will be obtained, 500K in all being in circuit.

It would be possible to wire 10K, 250K, and 500K resistors directly from the switch contacts to positive on the meter, as explained in relation to Fig. 1. However, with high voltages (over 150-250 V or so) it is more usual to wire the resistors in series, as in Fig. 3. This breaks up the voltage existing across the resistors. For up to 250 V it is perfectly in order to use one resistor only. But for 500 V or 1,000 V it is desirable to use two or more resistors in series, the total value coming to that necessary.

Ranges to Use

It will be seen that the voltage ranges can easily be made up to any figure wanted. They can thus be chosen to suit the purpose in view. For example, if battery radio sets are to be tested, there is no point in providing 250 V or 500 V ranges. Instead, it would be better to have a range reading about 0-5 V to test the L.T. batteries.

It is also helpful to choose ranges which fit easily to the meter scale. With a 1mA meter, usually marked as in Fig. 2 (0-1mA scale) it would be very awkward to read, say, 0-6 V or 0-12 V. But 0-10 V could be read off at once, without needing to mark the meter scale. So could 0-100 V. With such a range, '1' would be 10 V, '2' would be 20 V and so on.

If the meter dial is big enough, new ranges can be marked on it, or on this card. Or the actual meter scale may be copied on card, enlarged, and the various voltage ranges marked on this. A glance from meter to card scale will then show the reading. If the meter is opened to fit a new scale inside, care is necessary not to damage the delicate pointer, moving-coil, or hairsprings and pivots.

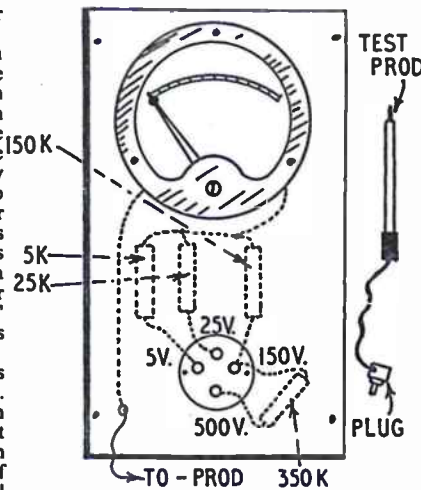

Fig. 4—A 4 range meter

With a 0-5mA meter voltage ranges to suit can be chosen, such as 0-5 V and 0-50 V, etc. If this is done, the meter scale can be left unchanged, and readings will still be easy.

A Four-Range Voltmeter

The arrangement shown in Fig. 4 will be satisfactory for many purposes. A shallow case large enough to hold the

meter and other parts is made, with a Paxolin panel. A 4-socket valveholder allows four ranges to be selected by simply inserting the plug in the appropriate socket. If more ranges are wanted, then a 6-, 7- or 8-socket holder can be used.

With the 1mA meter, 5K gives 0-5 V. For 25 V a 25K resistor is in circuit. For 150 V, a 150K resistor is present. For 500 V only 350K extra is necessary, since 150K is already present, making 500K in all, when the plug is in this socket.

For high voltages, well insulated prods are necessary. These can be bought, or made by passing very stout wire, or thin brass rod, down rubber tubing. Good quality flex, red for positive and black for negative can be soldered on, and slightly larger rubber tubing used to cover the joint.

When an ohms range is provided, battery and 1K variable resistor are in the case, the latter being on the panel. It can then be turned to bring the pointer to Zero on the ohms scale, as explained.

Details of circuit testing have appeared in past issues. But it should be noted that batteries should always be tested when actually working the motor, receiver or lamp, if a correct indication of voltage is to be obtained. In addition, a meter of this type reads D.C. only — this includes batteries, H.T. and other voltages in radio receivers (including mains sets), etc., and is most generally useful.

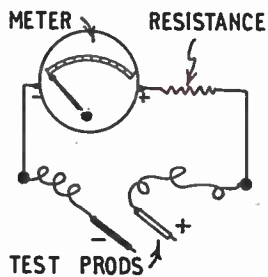

Fig. 1—Circuit for measuring volts

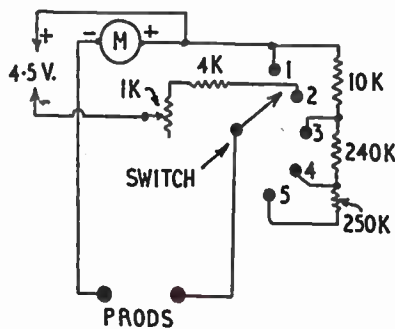

Fig. 3—Circuit for 5 range meter

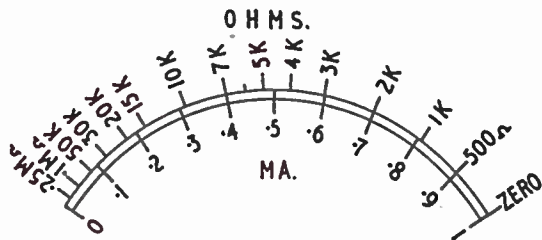

Fig. 2—The resistance scale

the finished test meter, the glass and dial being almost level with the panel. With the projecting type, there is no flange for this method of fixing, and the whole meter stands out from the panel. The flush mounting type is generally most convenient.

The diameter of the meter, or length of its scale, will also appear in the supplier's list. Small meters may be 1 1/2 ins. or so in diameter, with a scale of similar length, while big meters may have scales several inches long. A 2in.

and a 100,000 ohm resistor would read 0-100 V.

To obtain several ranges, it is only necessary to select various resistors. This can be done with a rotary switch, plug and sockets, or simply by taking the resistances to a number of terminals, to which the positive test prod lead can be connected, to select the range required.

If the meter should be a 2mA one, then 500 ohms will be needed for each volt. A 5mA meter would require

Extending the Paint Brush

By
S.H.L

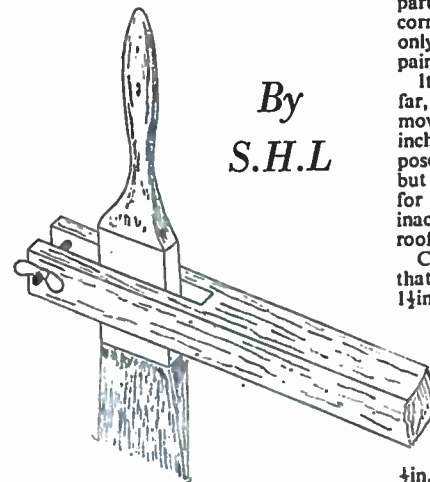

THERE are times when one wishes the paint brush had a longer handle or could be made to extend a little further to avoid moving the ladder so many times. This applies

particularly when one comes to the corner of the house and there remains only a small portion of the spouting to paint.

It can be dangerous to lean over too far, yet it is tempting to try instead of moving the ladder for those few extra inches. It was for this particular purpose that the gadget shown was made, but it has also been found to be useful for painting fallpipes and one or two inaccessible spots on the greenhouse roof.

Construction is extremely simple. All that is required is a 3ft. length of 1in. by 1 1/2ins. wood and a 3/4in. wing nut and bolt. A slot is cut out large enough to accept the brush to be used with an extra 1in. for the bolt. Drill a hole for the bolt first, then a further hole at the base of the slot, cutting away the waste material with a saw. Most brushes are about 3/4in. to 1in. thick and this must be the thickness of the slot.

In use, the brush is fitted into the slot and the wing nut tightened to keep the brush in position. Note that the brush may be set at almost any convenient angle.

EXPERIMENTS WITH ALUM

WHEN we speak of alum we mean potash alum, or, as chemists term it, potassium aluminium sulphate. There are many other alums, some containing aluminium and some not. Potash alum is a double salt and is a chemical combination of one molecule of potassium sulphate, one of aluminium sulphate and twenty-four molecules of water of crystallisation.

Growing a crystal is an interesting experiment and alum is a good chemical to use, for it crystallises easily. Take about 200 c.c. of warm water and stir in as much alum as will dissolve in it. Hang a hair from a glass rod placed across the vessel and weight the end of the hair with a small washer (Fig. 1).

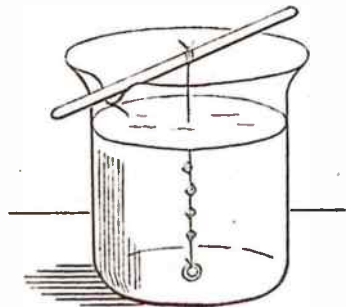

Fig. 1

As the solution cools crystals will deposit on the hair and in the vessel. The next day remove the hair, pour the solution into another beaker, taking care that no crystals pass from the first to the second beaker. Now examine the crystals on the hair, using a magnifying glass if they are very small. Select one which has the form shown beside the beaker in Fig. 1. Remove the others from the hair and replace the hair in the solution as before. Place the beaker in a warm place, such as on a mantelpiece, so that slow evaporation may take place. By daily removing all crystals except the selected one, a perfect crystal of alum will be obtained. Larger crystals may be grown by making a fresh lot of alum solution when the volume of the previous solution sinks too low to be effective. Using similar methods, an American experimenter grew an alum crystal weighing around one hundredweight! Apart from the expense and patience involved, such a huge crystal would be inconvenient to have around, and if you stop at a dimension of $\frac{1}{2}$ in. to 1 in., you will have a specimen which is quite as instructive.

In the last experiment we made use of the water of crystallisation in alum to form a crystal. Now let us see what happens when we remove it. This we do by means of heat. Place some alum in a crucible and heat it. First it melts in its water of crystallisation, then boils as the water is given off. When the temperature reaches a low red heat the alum begins to swell up, rises above the rim of the crucible and forms a startling sort of chemical mushroom (Fig. 2) which even has the spongy texture of the real thing.

Red hot glow

Powder this residue and mix it well with a third of its weight of fine carbon black. Put the mixture in a crucible, cover the crucible with a lid and heat to full redness for about thirty minutes. Turn out the flame and let the crucible grow cold. Remove the lid. The black mass will suddenly glow red hot in a spectacular way. If the air is sufficiently humid at the time it will fall in a shower of sparks when sprinkled out of the crucible. This product is known as Homberg's pyrophorus.

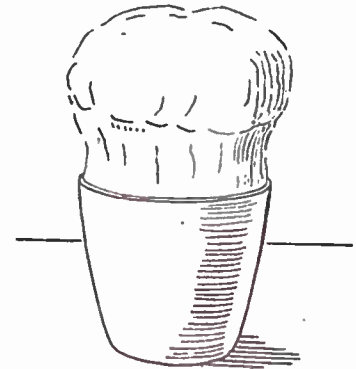
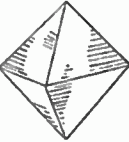

Fig. 2

Alum has proved a useful chemical to the dyer. Let us see why. Make a solution of alum by shaking successive small quantities of the powder with water until no more dissolves. Pour off the clear upper solution from the undissolved residue. Stir ammonia into this slowly until a drop of the mixture turns red litmus paper blue. A bulky white precipitate will have appeared in the liquid. This is aluminium hydroxide. It possesses the property of making many soluble colouring matters in-

soluble by combining with them. This is the reason why alum has been of so much use to the dyeing industry.

Filter off the aluminium hydroxide on a filter made not from paper but from a circle of white cotton cloth. Pour hot water through until one wash water gives no white precipitate with strontium nitrate solution.

Put some of this purified aluminium hydroxide in a test tube and thin it down with water. Add enough cochineal to give a pink tint, warm the mixture and filter it through a filter paper. The filtrate will be colourless, but the residue of aluminium hydroxide in the filter will be coloured pink. It has combined with the cochineal.

If you tried to dye a piece of cotton with cochineal the colour would wash out when rinsed in water. By depositing aluminium hydroxide in the fibre and then dyeing, the cochineal is fast to washing. This principle is used widely to fix colours in cloth and is known as mordanting.

Fixing colours

You can try out the principle very simply. Fill a test tube with alum solution and pour it into a beaker. Stirring well, add, drop by drop, a solution of washing soda (sodium carbonate). Aluminium hydroxide is precipitated, but redissolves as more soda solution is added. At last there comes a point when a slight permanent cloudiness remains. Now add alum solution drop by drop until the solution clears.

If you take a little of this solution and warm it in a test tube a precipitate of aluminium hydroxide immediately appears. Therefore, if we warm this solution on the cloth the aluminium hydroxide will be deposited in the fibre and form a mordant. Soak a piece of white cotton cloth in the solution, drain it and then dry it by holding it in front of a hot fire. Cut a small hole in one corner.

Put this marked and mordanted cloth together with a piece of unmordanted cotton into a beaker containing water which has been strongly reddened by the addition of cochineal. Boil the whole for about ten minutes. Then remove the two pieces of cotton, wash them in several changes of plain water until one wash water is colourless. You will find the mordanted cloth is now permanently dyed, whereas the other is not.

By making the aluminium hydroxide deposit only in certain areas of the cloth, only those areas will take dye.

Continued on page 247

Bream afford a Fine Sport

THE bream is a fish highly esteemed by the 'course' angler, particularly during July, August and September. Last summer, for instance, no fewer than six bream weighing over 5lbs. apiece were caught by an angler in the river Shannon. These big fish gave excellent sport. Larger specimens are not unknown. The record for English waters is one of 13lbs. 6ozs. caught in 1945 from the Castle Lake, Chiddingstone, by Mr. E. G. Costin.

Bream run to a noteworthy size, like carp and barbel. Happily, they are fairly widely distributed, in sluggish rivers, drains, lakes, reservoirs, ponds, canals, meres and the East Anglian Broads. In a well-stocked water you may expect bream to range from 1lb. to 5-, 6- or even 7lbs. and over. These bigger fish are strong and when hooked resist with great determination, boring down to the muddy bottom, or seeking refuge in weeds. One's tackle must be strong, the hook a No. 8 or 10 tied to gut or Nylon of 2x or 3x strength, and the line itself of corresponding quality. The float should be either a porcupine quill or goose quill.

The float is adjusted so that the baited hook lies close to the bottom of the 'swim', or drags just on the bed, an angler nipping on the cast sufficient split-shot to achieve this purpose.

'Finicky' Feeders

With the knowledge to spur him on that it is possible to hook and land a bream that may prove a notable specimen, the angler can afford to ignore the indifferent days when these fish are for some unaccountable reason, 'off their food'. The truth is that bream are uncertain in their habits, and there is no accounting for their 'on' days and 'off' days. They are apparently sensitive to weather influences and react to extremes of heat and cold. A sudden shift of wind may also upset their feedings.

Cold, windy, rainy spells, occurring at intervals during summer, after a period of high temperatures, will often check their appetites. They seem to abhor a quick change from hot to cooler conditions. Often during a heat wave they will be found well 'on the feed', and thus may give good sport when other species are disinclined to 'wine and dine'.

It pays to study bream habits. They are disposed to rove in schools along a waterway. It is possible to pursue a travelling company of bream moving leisurely in a drain or canal, keeping them in sight as they forge ahead. As they wander on their 'summer cruises'

they often stir up the soft mud from the bottom or the sides of the water-course, causing discoloured patches on the surface — these betray the presence of a school moving in formation and questing for food as they go along. Such muddy patches are sure bream signs — watch out for them! If such a patch be found, ground-bait liberally with a ground-bait of soaked bread and bran mixed together thoroughly, or brewer's grains well soaked with warm water and worked in with bread crumbs and bran to a fairly stiff consistency.

The correct bait

Baits for bream are various, namely, worms, maggots, paste, slightly sweetened with honey, creed wheat, stewed barley, wasp grubs (in season), and gravaes.

Another bream sign, well known to old anglers, is the presence of 'sentinel' bream on the surface of the water. Izaak Walton noted this habit, and mentioned it in his famous book.

There are times when the angler trying for bream, sees his float rise out of the water an inch or so and then lie flat on the surface. This is said to be caused by the fish sampling the bait, 'standing on its head' as it were, to nuzzle the succulent titbit on the hook, and then, taking hold and levelling itself again in the water, lifting the hook tackle, causing the float to rise and fall on the surface. In such a case the angler exercises patience until the float moves and is leisurely drawn under, and as it disappears he strikes — and not until then.

Sometimes, instead of muddying the water, bream blow air-bubbles as they

root about at the side of the water; therefore, when you observe such bubbles rising to the surface in a particular place, it is wise to fish there for a while and test it well before moving elsewhere.

During the height of summer some anglers resort to a spot of night-fishing for bream. If you desire a good catch of bigish bream, try angling during the midnight hour. August is a good month for this. Night-angling, however, has its drawbacks. It is, perhaps, better to set your stage beforehand and get on the job at early dawn and stick there trying your luck and hoping that your plans will turn out successful. If you observe patches of buff-coloured muddy water with flecks and bubbles on its surface you can usually settle down to a decent morning's sport — if nothing untoward puts the bream off their appetites in the meantime.

Bream are easily recognised from other fish by their deep, bellows-shaped body, sharply forked tail, large dark-hued fins, and in general colouring — blackish-green on the back, with light-hued underparts.

'Breamflat'

The silver bream, which is a smaller variety, has a flattish instead of rounded body, with silvery appearance. This variety is often called the 'breamflat'. The record for English waters is a specimen of 4lbs. 8ozs., caught at Tortworth Lake in 1923.

Finally, when bream fishing, carry an old towel with you to wipe your hands on after handling — bream are well coated with slime.

Continued from page 246

Experiments with Alum

Here we have the principle of calico printing. Take a few c.c. of the soda-treated alum solution and thicken it by grinding in a little powdered gum arabic. Dip a cork end into the mixture and press it on a small square of white calico. Hold the cloth in front of a hot fire as before until dry and then boil it for ten minutes in cochineal as in the last experiment. On washing the cloth, the only place to have any colour will be the mordant-printed spot. From this simple principle arose all the elaborate and beautiful designs we see on printed fabrics.

As a final interesting experiment you can make use of the purified aluminium

hydroxide left over from the first experiment with cochineal. Dry this in a dish in the oven. Now heat it to bright redness for about an hour in a crucible. The aluminium hydroxide shrinks and loses water, becoming aluminium oxide, which is also known as alumina.

This innocent looking white powder in the bottom of the crucible may look as different from emery, rubies and sapphires as those do from each other. Yet they are all aluminium oxide, the difference in appearance in the last three being caused by their being crystalline and coloured by small quantities of oxides of other metals. (L.A.F.)

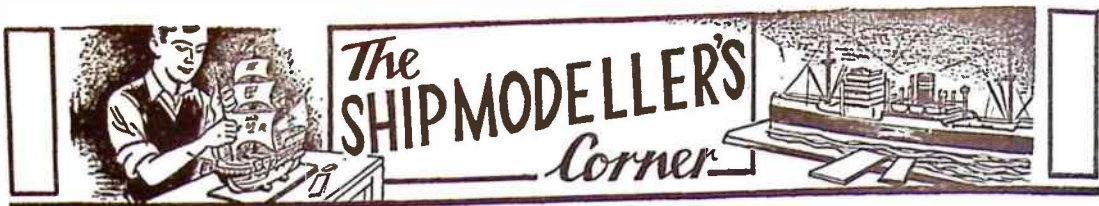

OUR little model represents a vessel favoured by the slave traders during the early part of the nineteenth century. They were at first converted ships and were later designed for the trade. The main consideration was speed and cost, decoration and other non-essentials being cut to the minimum. Armament consisted of one gun, mounted on a pivot.

Commence with cutting the keel and hull pieces (A) and (B). Glue together (A) and (B) in pairs in the usual way and carve to the dotted lines on the keel piece. Note the particularly fine lines to the hull shape, designed for speed, as was the large sail plan.

Cut the deck piece and when glued in place on hull, drill the mast holes at an angle for the rake of the masts, the main at about 8 degrees and the mizzen at 10 degrees. The rake on these vessels was more than normally found.

Cut and fit the bulwarks so that at the bow (front of ship) there is a space of 1/16 in. between the edges to allow for fitting the bowsprit.

Chamfer the bowsprit and glue to the hull or cut a little longer and set in a hole drilled at an angle in the deck.

The deck-house is built up of pieces (C), (D) and (E) as shown.

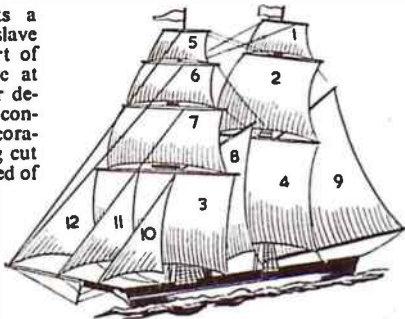

Finished model and sail plan

The hatchway grating need not be a problem. At this scale a very good representation can be made in the following manner. After cutting the hatchway piece, cut a piece of surgical gauze 1/16 in. smaller than the wood all round, this leaves a margin to represent the hatch coaming. Glue on the top of the wood block and give a coat of shellac. When dry, this gives a good imitation of the grating.

Cut out and glue the other two hatchways in position and make the gun platform and pivot. This is done by winding one turn of fine wire or rigging

cord around a piece of 1/16 in. dowel and gluing the resulting ring on the deck. At this scale we will not make the gun platform actually pivot, but fix it in position as illustrated, with three lill pins. Cut off the heads of the pins and drive through the platform one in the narrow end to be driven into the deck in the centre of the circle and the other in the rear two corners of the platform and driven into the deck as close to the wire ring as possible. If a ring of cord has been used they can be driven through the cord, the effect will actually be more realistic in the case of cord, as the two rear supports were actually running on the circular track when the gun was pivoted for firing in any direction.

MODEL SLAVE TRADER

By 'Whipstaff'

The mast tops can be cut in thin wood, or in thin white celluloid, which saves painting as well as giving a stronger assembly, the channels are cut from 1/16 in.

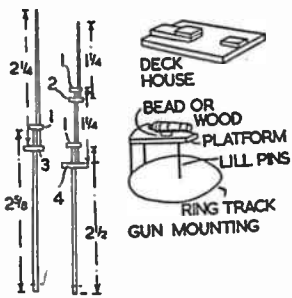
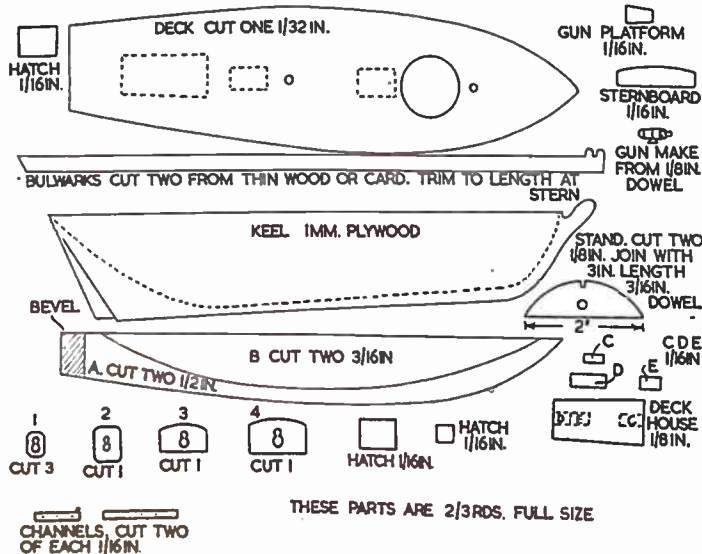

wood and treated with shellac instead of painted. Make the mast assemblies and bind and glue the spars in place. In fixing gaffs and booms on small models, a short length of lill pin inserted in the end of the spar and driven into the mast when gluing in position makes a very strong job of the joint.

The sails in my model were made from good quality cream-laid notepaper fixed to the spars with balsa cement.

Continued on page 249

Handy at all times

A TWO-TIER TEA TRAY

By G. Allen

THIS is an ideal household accessory for those who do not require an elaborate tea trolley but find that a single tea tray becomes overcrowded — particularly when there are guests present.

Chief requirements are some 1/2 in. ply for the trays, 1/2 in. thick timber for the end supports and Formica if you intend to face the trays in the modern style.

Start by fretting out the two end supports. Finish the faces dead smooth and, if desired, round off all the edges.

On the face of each support mark the positions of the tray ledges (C) by

surface of the trays. Ply 1/2 in. thick is used. Mark the angles on the ends of the strips by holding each in position against the edges of the supports and drawing fine pencil lines in the appropriate places. Cut and glue in place.

Before fitting the ornamental handles finish off the unit as desired; by polishing, staining, varnishing or enamelling — having first filled in all holes and cracks

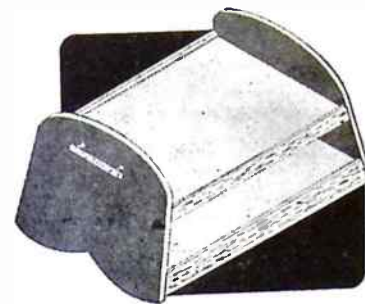

with wood filler. You may consider it a good idea to cut fretwork overlays, using designs already published in *Hobbies Weekly*, and fixing them on the outside faces of the end supports.

The handles themselves, in metal or plastic, can be obtained at a modest price direct from Hobbies, ready for screwing into position, or you may wish to have the entire unit home-made and to cut two from ply and screw them in place from the inside.

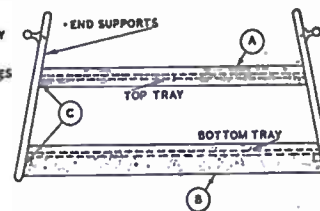
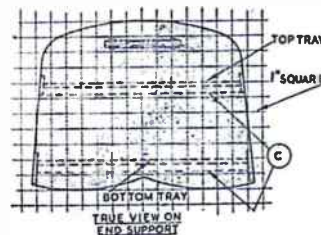

drawing parallel pencil lines 1/2 in. apart. The ledges are cut from 1/2 in. square hardwood. Note that they fall short of the edge of the main supports by 1/2 in. at each side — i.e., the thickness of the side pieces (A and B). Plane one face of each ledge strip at an angle to allow for the eventual lean of the end supports. Glue them in place between the pencil lines and reinforce each by driving three woodscrews through the ledge into the supports.

Inward lean

Next cut the trays from 1/2 in. ply. The bottom one measures 20 ins. by 14 ins.; the top one 18 ins. by 13 ins. Bevel the end edges of the trays to allow for the inwards lean of the supports. Do this with file and glasspaper.

Face each tray with Formica or similar plastic at this stage, using the appropriate glue, and trim flush with the ply.

Glue the trays in position on top of the respective ledges. Fix the bottom one first, leaving the top tray loose on its bearers to act as a guide. When set, glue the top tray. Reinforce by driving panel pins into the edges of the trays through the end supports, making sure that the heads are driven below the surface of the timber.

Now cut and fit the tray sides (A and B). (A) is 1 1/2 ins. wide; (B) 2 ins. wide. Each side protrudes 1/2 in. above the

Continued from page 248

Model Slave Trader

A. BACKSTAYS - BOTH SIDES OF MODEL
B. LIFTS-ON AFT (REAR) SIDE OF SAIL
C. YARD BRACES

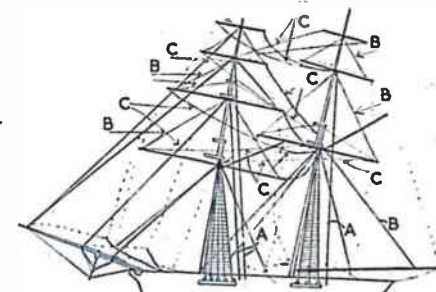

The rigging is simplified for this small model, consisting only of the stays, lifts and braces.

The original ships were plainly painted and lacked any decoration. Paint the topsides black with a white stripe. The stripe can be added by painting a piece of fine cord white and fixing in position when dry with balsa cement. The underwater body is painted coppery red, to represent the copper sheathing of the period.

The spar sizes are as follows: No. 1, 1 in.; No. 2, 1 1/2 ins.; No. 3, 2 ins.; No. 4, 2 1/2 ins.; No. 5, 1 in.; No. 6, 1 1/2 ins.; No. 7, 1 1/2 ins. Gaff for sail No. 9 is 1 1/2 ins., and the boom 2 1/2 ins. The gaff for sail 8 is 1 1/2 ins. This latter sail has no boom, but is held down by the sheets, i.e., the rigging line from the lower corner aft and the tack from the forward corner.

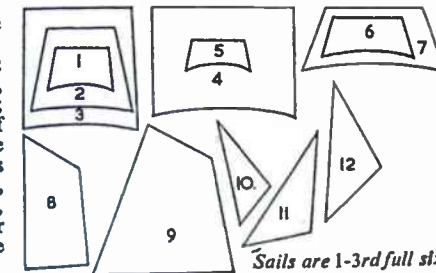

Sails are 1-3rd full size

For Holiday Thrills

MAKE A SURF-BOARD

SURF-RIDING is a sport that is both exciting and exhilarating and one that can easily be learnt. There are many places around our coasts and in the Channel Islands that are suitable for 'the art of surfing', and for quite a modest sum — about 10/- — an excellent board may be made.

Firstly, obtain from the wood merchants a piece of 1/2 in. mahogany resin-bonded plywood, 48 ins. long and 12 ins. wide. It is essential that the ply be resin bonded because this is waterproof. Clean off all edges with a smoothing plane and mark out the curve at the front. Cut near the line with a fretsaw and finish off with a sharp spokeshave. Smooth off the corners and all edges with glasspaper.

Making the bend
So far, the construction of the surf-board has been quite straightforward. The most difficult part is making the bend at the front. This bend upwards should be between 1 1/2 ins. and 2 ins. from the straight.

HINTS ON SURF-RIDING

1. It is best to surf-ride on an incoming tide, when the waves seem to have more power. In any case only strong swimmers should 'ride' away from the shore.
2. Wade out into the sea until waist deep and then turn to face the beach.
3. Hold the surf-board in front of you, sloping upwards about 45° and held firmly into the body about where the top of your bathing trunks will be. In this position wait for a suitable wave.
4. The best waves for surfing are those that are just about to break or those that have just done so. When a wave approaches, glance behind and leap forward just a fraction of a second before it reaches you. Try to jump forward, keeping the front of the surf-board above water and at about the same speed as the wave.
5. The art of surfing lies in three things:
 - (a) Keeping the front of the board above water.
 - (b) Jumping forward at about the same speed as the wave.
 - (c) Judging the right moment when to leap forward.

These three points will be learnt, on the average, in an afternoon. Of course, the more practice you get, the better you will be, and eventually you will probably get a surf-ride every time.

The surf-board described was easily and successfully bent by using a smooth log about 5 ins. in diameter (any similar round and solid object would be suitable). This was held firmly in a vice. The round end of the surf-board was fully immersed in boiling water in a pail and left for about ten minutes, quickly taken out, and bent by hand around the log. Old rags are useful in this operation. Before it was dry the board was firmly held in position and left over-night to allow the curve to set. When dry, the curve will remain in position. On the

MATERIALS REQUIRED
One piece 1/2 in. mahogany resin-bonded plywood.
One piece pine 8 ins. by 3 1/2 ins. by 2 ins.
Brass screws: Two 1 in. Number 8.
Two 1 1/2 in. Number 8.
One 1 1/2 in. Number 10.
Half pint yacht varnish (or enamel paint).
Resin glue (optional but advisable).

is a good idea to make a paper template, or pattern, and trace round this on to the wood. Make the top of the block into a streamline shape, rounding off all corners, and secure by means of

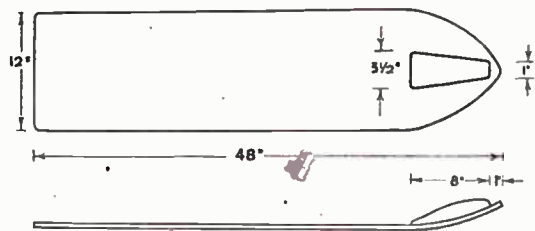

original, the tip of the surf-board was put under the leg of a bench and the back supported in a tilted position by the simple means of placing a chair under it.

The bending operation will have raised the grain of the ply-wood, so it will be necessary to glasspaper smooth again.

Supporting block
A block made from a light wood and shaped on the underneath to the curve on the surf-board will ensure that the board never loses its shape. Make the block from a piece of timber 2 ins. by 3 1/2 ins. by 8 ins. To get the exact curve, it

screwing from the underneath with brass screws. Waterproof resin glue can also be applied.

To finish off the surf-board it is necessary to give it several coats of yacht varnish, glasspapering down in between each coat to ensure a final smooth finish. Of course, the board may be painted, preferably in gay colours, so that it can easily be located if washed out of your hands in the sea.

A surf-board so constructed will give years of service and endless hours of amusement. All that will be required in the way of maintenance is a glasspapering down at the end of the season and a coat of varnish or paint. (A.E.H.)

Gouges from Scrap



THE ribs from an old umbrella can be utilised for making small gouges which are very handy for use in model making or carving. There are usually two sizes of ribs used in umbrellas; these will make 1/4 in. and 1/2 in. radius gouges.
With a pair of pliers break off a 5 in.

length, after cleaning off the paint, and grind the cutting end to an angle of 30 degrees, taking care not to get the metal too hot when grinding, as it will lose its temper and become very soft. Before sharpening with a slip stone, fasten the tool in a handle made of wood. (J.R.)



with **Black & Decker**
it costs so little to do so much

It costs us so little to make our home attractive. Whatever we want — from the bench John's working on, or the little table he's just finished, to extra cupboards in the kitchen — we just make them all with our Black & Decker. Furthermore we made an early start on the Spring-cleaning this year and our Black & Decker was an enormous help de-rusting and preparing doors for repainting — now the old home simply sparkles with spring-newness. And I'd hate to be without Black & Decker for the daily housework. I can whizz through polishing, scouring, oven cleaning — everything. We save so much time and money — it's wonderful.

What a wide choice!
You get value for money and the advantage of free choice when you buy Black & Decker. You can buy the popular 1/2" Drill or the more powerful Sander-Polisher-Drill which will give you an indispensable household and workshop unit in itself. Add low price attachments to it as and when you wish, or select your own choice of tools for a complete electric home workshop to your own particular requirements for only 30/- down.

Black & Decker

ELECTRIC HOME WORKSHOPS

Write TODAY for full details and Saving and Woodturning Hints Booklet

BLACK & DECKER LIMITED · DEPT. 57D. · HARMONDSWORTH · MIDDX



THE Canadian stamp commemorating the 1955 World Jamboree makes one consider some of the stamps and their designs which have been issued, either for a definite Scouting purpose, such as raising funds for a Scout charity, or as a commemorative stamp commemorating some Scouting activity.

This last reason may appear as a rather vague one until one considers, for example, the 1918 stamp from Czechoslovakia, which is the subject of the first illustration. This stamp was issued by the Revolutionary Committee of



Top left: Czechoslovakia. Commemorating the work of Scouts as postmen. Right: Siam. In aid of the Tiger Scouts Fund.

Bottom left: Russia. First Scout Rally. Right: Romania. One of the many Scouting stamps.

Prague, and the distribution of the letters was undertaken by the Scouts, so that these certainly commemorate a Scouting activity. Some of the stamps have an overprint recording the fact that the Scouts took out the post, and these are exceedingly rare, but the specimen can be purchased for a few shillings. It serves as a very good introduction to a Scout collection.

One of the most important of the stamps comprising a Scouting collection would be one of the Mafeking Siege stamps. At first the besieged used the

stamps of the Cape of Good Hope overprinted with the 'Mafeking 3d. Besieged'. Then the stamps of the Bechuanaland Protectorate were so overprinted, and lastly stamps were prepared by a photographic process by a Mr. Taylor. There were two values, the 1d. and 3d. The former showed a picture of Sergt.-major Goodyear on a bicycle and the other showed a head and shoulder portrait of, as he was then, General Baden-Powell. These stamps were, of course, used between 24th March and 17th May, 1900, which was considerably before Scouting, as such, started, though the portrait is that of the late Chief Scout. Scouting was born in Dorset, at Brownsea Island in 1907, when General Baden-Powell took a few boys and told them all about Scouting. Little did he imagine that the movement that was started then would develop into the world-wide affair that it is today.

English overprint

The second illustration has one peculiarity about it. It was issued in 1920 by Siam, or Thailand as it is now called, and there was a premium on each stamp, this going to the Wild Tiger Scout fund. The rather curious thing is that the overprint is in English and not Siamese. But, then, Scouting is English isn't it?

Russia in 1929 gave us the third illustration, that of the Scout with the trumpet, and it was issued to commemorate the first all Russian gathering of Scouts.

Their neighbouring country Roumania has had quite a large number of Scout designs. In many cases these stamps have carried a 100% premium, that is to say, a stamp postage value 2 lei would cost 4 lei, the other two lei going to some Scout fund. The reason why this country has allowed Scout funds to benefit so much from postal charges is shown when one considers the design of the 6 lei value of the 1931 charity stamp. This shows a picture of King Charles II in Scoutmaster's uniform. In 1932 there was a set in connection with the Scouts' Jamboree, and the designs show Scouts in camp, the signaller shown in the fourth illustration, Scouts cooking by a camp-fire and, again, King Charles II. As you see in the stamp illustrated there is a premium of 100%, the cost of postage being 50 bani and the amount to go to Scout funds is also 50 bani.

ISSUES ON SCOUTING

By L. P. V. Veale

Hungary seems to have favoured the Girl Guides rather than the Scouts, and issued four stamps in 1939 to celebrate the Guide rally at Godollo.

Holland, on the occasion of the World Jamboree in 1937, had three stamps forming the set. The lowest value showed a picture of the tender-foot's badge, the 6c. a picture of a drum with the drummer's hands and a background of flags, while the 12½c. had a picture of Hermes — the Greek name for the messenger of the Gods called by the Romans, Mercury. Australia had two jamborees, one 1948-9 and the other 1952-3 Pan Pacific Scouts' Jamborees. The designs were almost identical, the values and the dates being the differences, 2½d. against 3½d. Both these stamps are quite common and everyone should be able to see specimens.

Since the United States of America has been issuing stamps for every possible excuse, it is rather surprising that she has not got a few more examples of Scout stamps. There are only two. In 1952 were issued the 'Boy Scouts of America' stamps showing three American Scouts, the Scout badge and the words 'On my honour I will do my best'. In 1948 the founder of the American Girl Scouts, Juliette Gordon Low, was honoured also on a 3c. stamp, which showed her portrait and also the girl Scouts' badge.

Excellent examples

Moving south into the Caribbean sea we reach Jamaica which issued two stamps to mark the occasion of the first Caribbean Scout Jamboree, 1952. The 2d. value has a map of the Caribbean Sea seen through the Scouts' badge and the 6d. value has the badge resting on a map of the island, each having the portrait of King George VI in a medallion. Readers should endeavour to obtain good specimens of these stamps which have gone up very considerably in price.

The last country that we shall mention is New Zealand, and among her issues you will find two excellent examples of Scout stamps. The first is the 1953 health stamp. The 1½d. postage plus ¾d. premium for the health stamp shows a portrait of a Girl Guide proudly carrying a Guide banner and the 2d. postage plus 1d. premium has a Scout squatting beside a camp-fire cooking. Lastly we come to the two 1944 Health stamps, both of the same design. Her Majesty Queen Elizabeth II as Princess, and Princess Margaret appear both in Guide uniform.

NEW!

THE PRACTICAL WAY of learning RADIO TELEVISION · ELECTRONICS

- Beginners Radio Course
- Advanced Radio
- Short Wave Technique
- Lesson Manuals

Experimental work includes construction of Basic Oscillators, Amplifiers, Deflectors, Power Units, 1, 2 and Multivibrator TRF and Super-heter receivers.



COMPLETE EXPERIMENTAL COURSES IN RADIO ENGINEERING and SERVICING

An entirely new series of courses designed to teach Radio, Television and Electronics more quickly and thoroughly than any other method. Specially prepared sets of radio parts are supplied and with these we teach you, in your own home, the working of fundamental electronic circuits and bring you easily to the point when you can construct and service radio receivers, etc. Whether you are a student for an examination; starting a new hobby; intent upon a career in industry; or running your own business — these Practical Courses are ideal and may be yours at very moderate cost. With these outfits, which you receive upon enrolment and which remain your property, you are instructed how to build basic Electronic Circuits (Amplifiers, Oscillators, Power Units, etc.) leading to designing, testing and servicing of complete Radio and Television Receivers.

COURSES FROM 15/- PER MONTH

POST THIS COUPON TODAY

To E.M.I. Institutes, Dept. 31, Grove Park Road, London, W.4. Please send me your FREE book on Practical Courses

NAME

ADDRESS

July 18 1974

EMI INSTITUTES

associated with "His Master's Voice," Marconiophone, Columbia, etc.



DECRA-LED T.V. demonstrated from B.I.F. LEADED WINDOWS are worth looking into...

for brighter windows that last a lifetime and add pounds to the value of your house. 'Do-It-Yourself' with Decra-Led and transform your plain windows into beautiful Leaded Lights. A 10/- kit contains enough material to convert 3 panes (30 in. x 18 in.) into diamond leaded lights. No glass to cut — no windows to take out. You simply fix Decra-Led to your existing windows.

Full scale working drawings available — send for price list and name of nearest stockist.

From your local dealer or, if unobtainable locally, from: **T. BROWN & CO. LTD., Dept. 1, 50 WOOD STREET, ASHTON-UNDER-LYNE LANCASHIRE. Tel. ASHTON 4076**

Sole Agents for Eire: T. & C. Martin Ltd., 21/24 D'Olier St., Dublin, E.5

RUBBER MOULDS FOR PLASTER WORK

From 1/6 each. Figures, dogs, cats, flights of birds, etc. Moulding Compound for Mould Making, 8/6 per lb. Moulds for Metal Soldiers from 3/- each. Lists supplied.

F. W. NUTHALL
69 ST. MARKS RD., HANWELL, LONDON, W.7

HEAR ALL CONTINENTS With H.A.C. Short-Wave Receivers

Suppliers for over 18 years of Radio S-W Receivers of quality. One-Valve Kit, Price 25/- Two-Valve Kit, Price 50/- Improved designs with Denco coils. All kits complete with all components, accessories and full instructions. Before ordering, call and inspect a demonstration receiver, or send stamped addressed envelope for descriptive catalogue.

"H.A.C." Short-Wave Products (Dept. 22), 11 Old Bond Street, London, W.1

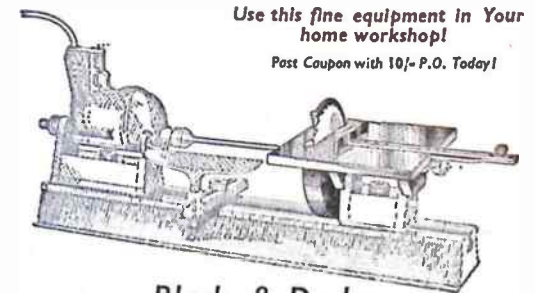

Use this fine equipment in Your home workshop!

Post Coupon with 10/- P.O. Today!

Black & Decker DRILL, LATHE & SAW

Start a home workshop with this famous Black & Decker DRILL, LATHE & SAW outfit. Enjoy the thrill of using this fine equipment. Use this outfit to save and make £££. Outfit consists of powerful high-speed 3/16 in. Drill, Buffing & Polishing Equipment, B & D Wood Turning Lathe and Sawbench attachment with 5in. circular saw.

HOW TO GET THIS OUTFIT. All you have to do to get delivery is to send coupon with first instalment of 10/-; 38 further weekly payments of 10/6 complete purchase. Post Coupon NOW!

10/- and 38 weekly payments of 10/6 or £17.13.6 Cash

To **NEW TRADING HOUSE LTD.**
Dept. O.E.23, 38 Fishergate, Preston, Lancs.

Send one B & D DRILL, LATHE & SAW outfit. I enclose 10/- and will send 38 further weekly payments of 10/6 to complete purchase, under your credit scheme.

Signed

Please PRINT your name and address in margin.

Wolf Cub ELECTRIC DRILL AT ONLY

£5.17.6 or 8/- deposit and 6 monthly payments of 20/6d.

This wonderful Electric Drill is also the power unit for ALL Cub equipment. Drilling capacity: Mild Steel, ½"; Hard Wood, ¾"; with 210 watts input on full load. Complete with ½" three-jaw chuck and Allen key and 5ft. of cable. TV Suppressed, Starck Voltage. ALSO Sanding & Polishing Kite (drill, discs, etc.), Cash Price: £4. 19. 6 or 22/- deposit and 6 monthly payments of 22/-

Send for illustrated Brochure

CHILTON ELECTRIC HOME HAIR 5/- CLIPPER DOWN

Keep short hairstyles smartly trimmed yourself with the Chilton. Gives the professional comb-and-scissors action. Slip comb off and use to tidy neck hair. Useful for children's hair, also for men too busy to visit barber. Plugs into lampholder. Complete with plug. A.C. only. 210/250v. £4.14.6 cash or 5/- deposit and 6 monthly payments of 16/6. 12 months guarantee. ALSO hand clippers 16/-

Send for list of other Bargains.

BARGAIN DISTRIBUTORS (Dept 124), 5 Silver Street, Luton

BETALLER

in 12 days or money back. New gland and spinal discovery increases height 2 to 5 inches. 'I have gained 4½ inches in height. My weight increased from 9-stone 4-lb. to 10-stone 3½-lb.'—P.D. 'Increased 3 inches'—H.G. Guaranteed harmless. Full course 10/- (or \$1.50). Air Mail 16/3. Details 1½d. Sent under plain cover. J. H. MORLEY, 28 (H/159) Dean Rd., London, N.W.2. Practical Courses, all subjects. List free.

KITS for OLD TIME SHIPS

Hobbies range of Ship Models includes Elizabeth Jonas, Cutty Sark, Victory, Playflower, etc. Complete kits of wood, sail material, guns, pulleys, cord, etc., with full-size patterns of parts and planed wood ready to cut out, shape and construct. A fascinating pastime.

Ask for free illustrated lists at Hobbies Branches or from Hobbies Limited, Dept. 99, Dereham, Norfolk.

*** GREAT CAMPING OFFER *
RIDGE TENT SENT FOR 4/-**

BRAND NEW de luxe 'Safety' Tent. All colours. Complete. Ideal Cyclists. Campers. Length 7 ft. 3 in. sleeping base x 4 ft. 6 in. wide x 3 ft. 6 in. high x 12 in. walls, all approx. Weight 3 1/2 lb. Cash 42/- or 4/- deposit and 6/- monthly. With fly-sheet 70/6 or 9/3 deposit & 9/9 monthly. Both carr. 2/-. Don't delay, send now.

BOYS! Be a real DAVY CROCKETT



COMPLETE 4-Piece Outfit
*NO DEPOSIT!
Includes FREE HAT

Includes fringes, and an adjustable belt. Our special secret-waterproofed material to withstand Prairie storms. Hat is real Fur Fabric. Just send 2/6 for post. & pack. If satis. 5 monthly payts. 4/6. Cash 19/11 complete. Ages 4 to 9 and 10 to 13. STATE AGE. DAVY CROCKETT TENTS 21/-, post, etc. 1/6. LISTS CLOTHING, WATCHES, ETC. TERMS.

HEADQUARTER & GENERAL SUPPLIES LTD.
(HOBBY X/16), 196-200 Colindale Lane, Loughboro Junc., London, S.E.5. Open Sat.

LEARN it as you do it — we provide practical equipment combined with instruction in Radio, Television, Electricity, Mechanics, Chemistry, Photography, etc. — Write for full details to E.M.I. Institutes, Dept. HW47, London, W.4.

AMERICAN MAGAZINES. One year's 'Popular Mechanics' 32/-; 'Homemakers' 16/6; 'Homecraft' 18/-. Full list from Willen Ltd. (Dept. 57), 9 Drapers' Gardens, E.C.2.

WHEELS (Hardwood and Rubber Tyred W/Metal). Cot, Pram and Doll's House Fittings and Papers. Beads, Transfers, Prints and other accessories. Stamp for new lists. (Trade supplied.) New address — JOYDEN CO. 91 Peplins Way, Brookmans Park, Herts.

KUKLOS ANNUAL. Indispensable cyclist's handbook. Tours, resthouses, money-saving hints, 2/10, post free. — Burrow, Publishers, 2 Imperial House, Cheltenham.

MODELS. You can make lasting stone-hard models with Sankey's Pyrama Plastic Cement. Supplied in tins by Ironmongers, Hardwaremen and Builders' Merchants. Ask for instruction leaflet.

MAGIC Catalogue and 'Shocking Letter' trick, 1/- — Deltimpsey, 363 Sandycroft, Kew, Surrey.

100 DIFFERENT stamps free! Request 1d. upwards discount approvals. — Bush, 53 Newlyn Way, Parkstone, Dorset.

DO-IT-YOURSELF BOOKS. List free. — S.P. Ltd., 28(H) Dean Road, London, N.W.2.

'PAINTSPRAYING' HANDBOOK (1954 Ed.). Covers Car, Industrial & Flock Spraying. 3/6, post free, including catalogue of our Cellulose and Synthetic Paints and all Allied Sundries and Plant Hire. — Leonard Brooks Ltd., 81 Oak Road, Harold Wood, Essex.

PLYWOOD: large sizes, 14 lbs. 10/- delivered (Express). C.W.O. — H. Leader (1920), Gosford St., Middlesbrough.

GENUINE Swiss Musical Movements. The best and largest selection of tunes in the country, lowest prices 16/3 each. Genuine Thorens Movements, 21/- each. All guaranteed. P. & P. 9d. extra on all orders. — Richardson & Forder, 11W, 5 Chapel Place, White Hart Lane, London, N.17.

STAMPS FREE — Empire Packet including Pictorials and Victorians with approvals. — Robert J. Teck, 7A Kemp Road, Bournemouth.

GOVERNMENT SURPLUS BARGAINS. Inter-room Telephones, comprising 2 self-energised microphone/receivers and approx. 6yds. flex (may be extended if desired). No Batteries needed. Nothing to wear out. Complete 9/6, post 6d. Motors, Transformers, Switches, etc. 3d. stamps for illustrated list. Milligan's 24 Harford Street, Liverpool, 3. Money Back Guarantee.

SWISS MUSICAL MOVEMENTS. Before you buy send 2d. stamp for our illustrated brochure. — Metwood Accessories (Dept. HW), Church St., Wolverton, Bucks. (Trade enquiries invited.)

MODEL RAILWAY MAGIC. The beginner's book 2/6. 'Making a baseboard' 6d. Bargain list 4d. — Southgate Hobby Shop, 1 The Broadway London, N.14.

PRIVATE Christmas Greeting Cards — Agents (either sex) wanted. Sample book of beautiful designs free to enterprising and reliable applicants. Generous commission. Also useful means of raising funds for any scheme. No outlay. Write — British Greeting Card Co., Dept. J, Gate Street, Blackburn, Lancs.

SAN MARINO 1956 DOGS. Fine bi-coloured set sent free to approval applicants enclosing postage. — Yulwontmor Stamps (Dept. H5), 29 Layton Avenue, Mansfield.

BRASS, COPPER, DURAL, ALUMINIUM, BRONZE
ROD, BAR, SHEET, TUBE, STRIP, WIRE
3,000 STANDARD STOCK SIZES
No Quantity too small. List on Application
H. ROLLET & Co. Ltd
LONDON LIVERPOOL MANCHESTER
LEEDS BIRMINGHAM
Since 1896

BARGAIN Marquetry Parcel, 20 best veneers approx. 8 sq. ft., 6/-. Swann Morton craft tool handle, three blades, 2/9 post free. — Kirby's 322 Dennian St., Nottingham.

600 STAMPS free. Stamp for details and approvals. — W. Self, 36 Fairfield, Boro, Green, Kent.

MONACO Wedding. Short set free to all sending for my approvals. — C. S. Berry (Dept. H), 32 Cross Whitehouse Row, Leeds, 10, Yorks.

Job for the handyman
A METAL BOOT SCRAPER

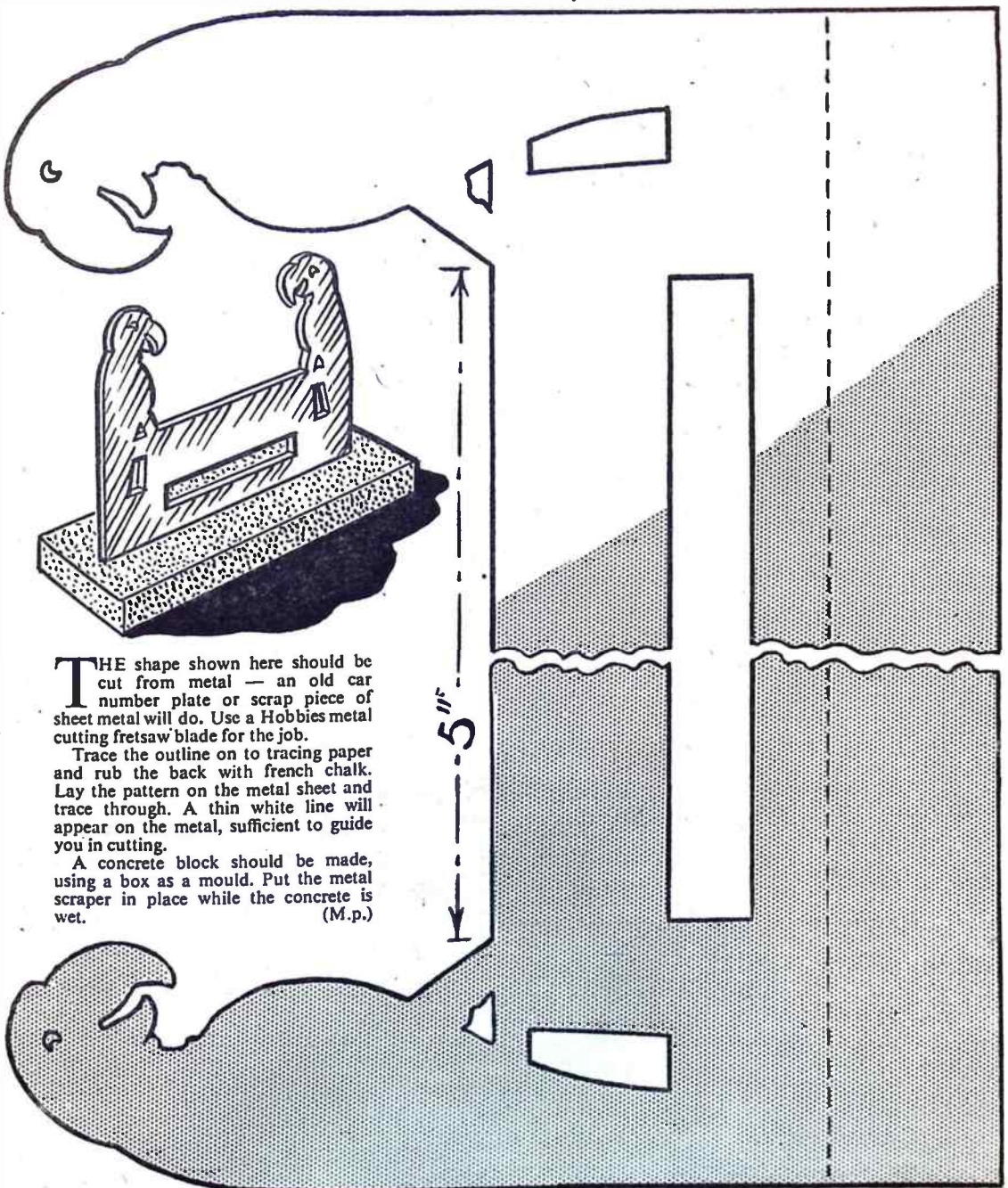

THE shape shown here should be cut from metal — an old car number plate or scrap piece of sheet metal will do. Use a Hobbies metal cutting fretsaw blade for the job. Trace the outline on to tracing paper and rub the back with french chalk. Lay the pattern on the metal sheet and trace through. A thin white line will appear on the metal, sufficient to guide you in cutting. A concrete block should be made, using a box as a mould. Put the metal scraper in place while the concrete is wet. (M.p.)

FREE OFFER TO YOUR FRIENDS

Regular readers of Hobbies Weekly are invited to introduce a friend to this popular magazine, so that they can also enjoy the many interesting features.

All you have to do is to fill in your friend's name and address and that of his newsagent on the coupon below (or on a plain sheet of paper). The Editor will arrange for the newsagent to supply your friend with a free copy for two weeks and then if he likes Hobbies Weekly he can become a regular reader by placing a firm order with his newsagent.

BE A PAL TO A PAL

Fill in the coupon now and make sure he receives two free copies. There is no obligation.

Friend's Name Newsagent's Name

Address Address

This offer is for new readers only. Fill in this coupon or send particulars to The Editor, Hobbies Weekly, Dereham, Norfolk, who will arrange with your newsagent for your friend to receive two free copies.



Look Chaps
See the snaps I've printed!

You, too, can print copies of your own snap-shots at home. It's not at all difficult. With the Johnson Print-a-Snap pack you can make extra prints of the family's favourite pictures in a single evening. Any dimly-lit room will do to work in.

PRINT-A-SNAP PACK

Look what you get for only 3/6: Printing paper to make either 16 2½ x 3½ in. or 24 2½ x 2½ in. prints, developer, fixer, simple printing frame, full instructions and a wallet to keep your prints in. Make this your first step in the fascinating hobby of photography.



At your photo dealer

3/6

JOHNSONS OF HENDON LTD.

Don't just
stick it



FIX it

CERTOFIX liquid glue can cope with all general repairs. It unites wood, glass, metal and almost all substances. It is clean in use; its joints are stronger than the materials it unites.

Make it immovable with

CERTOFIX

Sold at all Woolworth Stores

**If it's worth doing -
it's worth doing well!**

The more you know about your favourite hobby, the more pleasurable - and the more profitable - it becomes. I.C.S. offer you first-class tuition, at home, in your spare time, and at very moderate fees. Time spent now in acquiring this extra knowledge can add to your enjoyment and your earning power in the very near future.

These are just a few of the subjects I.C.S. teach:

- WOODWORKING
- RADIO SERVICING
- ART TRAINING
- SHORT STORY WRITING
- GARDENING
- FREELANCE JOURNALISM
- MOTOR CAR MAINTENANCE

● MAKE THE MOST
OF YOUR HOBBY
WITH

ICS

For further details fill
in this coupon and post
it to us TODAY!

INTERNATIONAL CORRESPONDENCE SCHOOLS
Dept. 87A International Buildings, Kingsway, London, W.C.2

Please send me FREE Book on..... Age.....

Name Occupation

(Block letters please)

Address.....

If your subject is not listed, please state it on the coupon

Coronet
Flashmaster



31/3

The easy-to-use Camera

Simple, economical, yet scientifically up-to-date, this eye-level viewfinder camera takes twelve 2½ in. sq. photos on 120 roll film. Everset shutter plunger threaded for cable release, and protected by safety slide.

Synchronised for flash, with two sockets into which Coroflash unit can be plugged. Complete with smart, securely fixed carrying strap. From most chemists or photographic dealers, or write direct.

TO CORONET LTD., DEPT. HW, SUMMER LANE, BIRMINGHAM 19
Please send free booklet "Photography is Fun"

NAME

ADDRESS