

HOBBIES WEEKLY

IN THIS ISSUE

	Page
Perpetual Calendar -	161
Hints when going after Pike -	162
A Model Transformer -	163
Portable Book Rack -	164
Template for Mounting Prints -	165
A Graceful 'White Swan' -	165
Replies to Readers -	166
Your Bicycle in Winter -	167
Salver for Serving Biscuits -	167
Simple Battery Amplifiers -	168
Simple and Effective Cramps -	170
Formulas for Useful Products -	172
Patterns for a Biscuit Salver -	175



DECEMBER 5th 1956

VOL. 123

NUMBER 3188

An all-the-year-round gift

★ *FREE* design

inside for you

to make this

Galleon

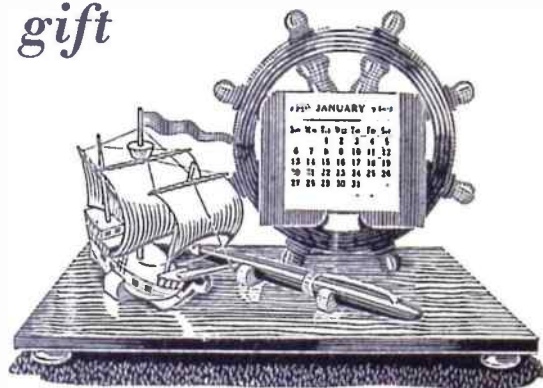

PERPETUAL CALENDAR

THIS charming design for a perpetual calendar with its ship's wheel and galleon motif, will be appreciated by all, especially those who have the 'call of the sea' in their blood. It makes a charming fitment for a desk, sideboard or writing bureau, and is an excellent idea to make up as a gift. A rack is provided to accommodate a pen or pencil, and it is handy to know where one can be found at a minute's notice without searching around.

The makeup of the galleon is quite simple, and contains no elaborate detail.

Particular care must, however, be taken in cutting and finishing the ship's wheel in order to obtain nice symmetrical lines. Uneven shapes would look ugly, particularly in a design of this nature.

Hobbies kit contains all the materials needed for making up the design, including a perpetual calendar which is made of plastic and will give the correct combination of days and months for any year, including Leap Year. Parchment, cord and rod for making the galleon is also provided, together with all the necessary wood.

Trace all the parts from the design sheet on to the thicknesses of wood indicated, and cut them out with a fret-saw. Now shape the ship's wheel by rounding off the spokes, taking note, however, that two square ends are left for gluing into the base. The base, wheel, and pin supports (No. 7) can now be stained and polished. Then make up the calendar holder by gluing pieces 3, 4, 5, and 6 in pairs as shown on the design sheet. When completely dry, the calendar holder can also be finished by staining and polishing.

All correspondence should be addressed to The Editor, Hobbies Weekly, Dereham, Norfolk

For Modellers, Fretworkers
and Home Craftsmen

4 1/2 D

World Radio History

Galleon Calendar Kit

All the wood, parchment for sails and other materials, together with a perpetual calendar set, are contained in Hobbies Kit No. 3188 to make the perpetual calendar. Kits, price only 5/-, from branches or Hobbies Ltd., Dereham, Norfolk, (post free).

The next step is to glue the calendar holder to the wheel in the position shown by the dotted lines on the wheel pattern on the design sheet. The wheel can now be glued into the slots provided in the base. Similarly the pen supports (pieces 7) are glued into the base slots provided. The four No. 19 Hobbies toes can also be added under the base by gluing.

Making up the galleon is the next stage. The diagram for the construction of this is shown at the top of the design sheet. It will be seen that two pieces 9 are glued together and rounded to give one side of the hull, and similarly two

pieces 10 glued together form the other side. These shapes are glued on either side of the keel piece 8, their positions being shown by dotted lines.

On top of this assembly are glued piece 11 (at the bow) and pieces 12 and 13 (at the stern). When the glue is quite set, shape these three pieces to conform to the lines of the hull.

Now shape and glue in position the masts, bowsprit and crow's nest (15). Note that the holes to take the main mast and foremast must be bored in the deck. At this stage, paint the hull according to the key given on the design sheet. The colours here are, of course, only suggested, and can be altered to suit individual tastes or colours available.

Completing the galleon

Next shape the spars and cut out the sails. Glue these spars to the sails and lace them with thin cord to give added strength. The standing rigging can now be added to the masts, and the sails and spars tied in their positions indicated. The sails have a cord tied to each



FOR A FRIEND

corner and these are fixed to any convenient position on the deck by means of small staples made from fret pins with their heads cut off.

Only a minimum of rigging is shown for this is not intended to be an authentic galleon model, but keen modellers can add to it with shrouds, extra running lines, etc.

The 'cradle' which holds the galleon consists of two pieces 14 glued in position to the base after staining and polishing and into this cradle the galleon is glued by the keel.

Simple science experiments

A MODEL TRANSFORMER

IN this series of simple science experiments and models, the only sources of electric current so far mentioned have been primary and secondary cells and batteries. You should now try to make this small model transformer which will enable you to use electricity from the mains at various voltages to suit your various needs. It is

made up from a core of laminated stallo, the yoke is readily removable and the coils are interchangeable.

A suitable U-shaped core and a choke may be purchased from the Electroano Co., B.G.M./Electrano, London, W.C.1, or you may be able to obtain second-hand stallo stampings for the core and choke from Electradix, 218 Upper

Thames Street, E.C.4, or from the Economic Electric Co., 64 London Road, Twickenham. If the stallo stampings are obtained loose it may be necessary to calculate the number required. They are usually sold by the gross and will have to be bolted or riveted together after drilling.

If the core has a cross sectional area of 1 sq. in., eight turns of wire per volt on the input and output coils will be required. If the sectional area is $\frac{1}{2}$ sq. in., then 16 turns per volt are required.

On the primary coil, to be connected to the mains (230 volts), with a core of 1 sq. in. in cross sectional area, 1,840 turns will be required, using No. 26 D.C.C. copper wire. About $1\frac{1}{2}$ lbs. will be needed. This will have a resistance of 48 ohms, and when connected to 230 volts mains, the current flowing will be 4.8 amps.

Thus the primary coil can be connected to any ordinary lighting point.

For the secondary coils, No. 20 D.C.C. copper wire can be used, and $\frac{1}{2}$ lb. should be ample. Numerous secondary coils, each giving different voltages, according to the number of turns, can be made and slipped into position as required on one arm of the core, or a smaller number of secondary coils, each giving a range of voltages can be made as in Fig. 40.

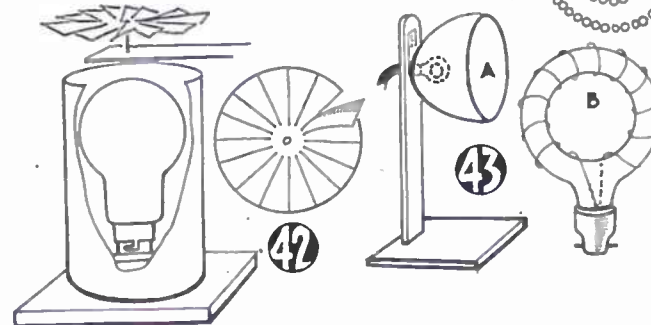
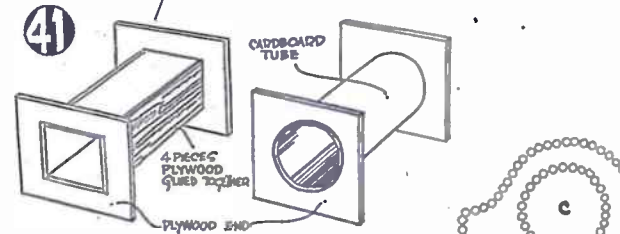
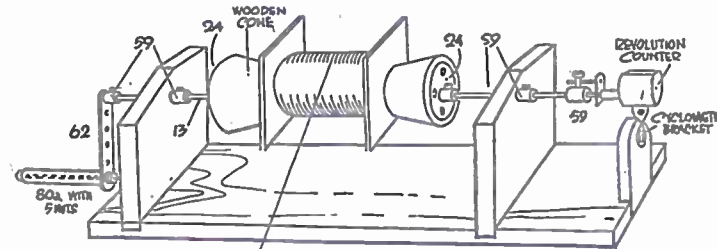
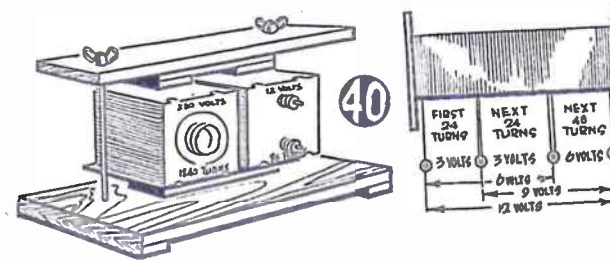

With rod and line

HINTS WHEN GOING AFTER PIKE

PIKE are now well worth seeking. To the end of February these fish may be regarded as the premier quarry of the winter angler. For one thing, the pike is by far the largest of 'coarse' species; then it is of value for the table. Furthermore, pike are widely distributed and one does not need to travel far from home in quest of a little pike-fishing.

Many rivers, lakes, canals, reservoirs, and meres contain samples of these fish from jack of 2 lbs. up to 10 lbs. and 20 lbs., and in some waters specimens of thirty odd pounds are not unknown. Any fair-sized sheet of water may hold one of these coveted 'glass-casers', and this gives an incentive to the sport.

Although the pike has often been exaggerated in more ways than one, this line fish can be a noble one and an exceedingly sporting fish. At times, perhaps, a victim, when landed, can be nasty. More than one angler has had a piece chipped out of his finger by the teeth of a pike, whilst extracting the hook. Wise anglers, therefore, use a pike gag to prop open the rows of recurved teeth in the brutal jaws, whilst a disgorger is being used.

Given a favourable day with pike on the prowl, and they are easily pleased, nothing coming amiss to hungry fish, the angler may offer with equal chances of success live-bait or dead, artificial spinner or plug, a piece of offal, or a bunch of lobs. Nothing tickles the appetite of a big hunger-driven specimen

more than a member of his own kith and kin of tender age. Anglers know this, and those seeking a real big one never hesitate to trim their live-bait tackle with a jack of 1 lb. or 2 lbs. in weight, if they can get hold of one.

Live-baits are always worth trying in winter. Roach, dace, gudgeon, minnows, etc., will all serve to tempt them; such baits as these, on snap tackle, will seldom fail to move a pike that is on the prowl for food at this season. When live baits are hard to get, salted and pickled baits may be used.

Any artificial Devon, minnow, phantom or spoon, deftly swung into the quieter lay-byes and spun slowly home, is very attractive. In shallower waters the plug lure is worth a trial. Thread-line exponents find good sport with pike. Advantages of threadlining are many. When spinning with this outfit the lure can be cast a good distance, a distinct help when the water is clear.

Pike in summer are often lazy and overfed; consequently they lie close amongst the weeds and, when hooked, give poor sport compared with winter pike. The frosts having killed off the weeds, and floods having cleared away the summer debris, the pike's haunts are laid bare and he has to find different quarters.

It is at this period when pike will be found in the quieter waters at the edges of streams, in the slacks at the tails of islands, in the deepish pools where the current has scooped out a hollow under the shelving bank, and similar places. A

live bait floated down into such spots may well attract a lurking pike waiting for the chance of a snack.

Pike are frequently ravenous following a flood, and a visit to the backwaters, dyke-ends, and slacks in a river where it has sought shelter from the galloping current, may prove very profitable. In common with other fish, whilst a flood is raging they experience a period of enforced fasting, and a dace or roachlet floated down into a quiet lay-by at such a time is almost irresistible to any pike taking refuge there, whereas in summer the chances of a pike being in that spot are few. When a flood has gone down and the water recedes into its due bounds again, there comes an excellent opportunity to connect up with fish seeking to make up for their long abstinence.

Pike differ much in their fighting qualities. Those caught in fast waters and streamy rivers are the best 'scrapers'. Usually, however, a hooked pike puts up a lively fight. It is necessary to use a little force in 'striking' a pike when it has taken the baited hook, especially if live-baiting. Owing to the hard bony substance of a pike's mouth and jaws, it is imperative to 'strike' hard after winding up any slack line before driving the hook or hooks home. When spinning for pike the angler strikes immediately the fish grabs the lure, his line being taut. Remember, a pike's mouth is, indeed, a 'case-hardened affair', the roof being especially bony. (A.S.)

clamped to the bench when in use, and one person should turn the handle while another manipulates the wire. A third person should hold the bobbin of wire on a pencil, so that it can revolve freely.

How the Flicker and Smoke effects are produced on an Electric Fire

For this model you will require a piece of thin sheet aluminium, pieces of cardboard and a pin, a 100 watt electric lamp and lamp holder.

You will have seen electric fires that are made to look like coal fires, and an ingenious method is used to obtain flicker and smoke effects. This little model shows how it is done.

With a pair of dividers, mark a circle about 3ins. in diameter on the piece of thin sheet aluminium and then cut it out. In the exact centre (which will be marked by the point of the dividers) make a dent with a punch. Mark and cut the disc into sectors, as shown, turning each sector through an angle of

45°. It is important that all this should be done carefully, or the balance of the disc may be affected.

Next, mount the aluminium disc on a pin fixed point upwards through the end of the cardboard strip which is supported above an electric lamp as shown. Surround the lamp with a cardboard cylinder which has a number of holes cut all round the base as shown. When the apparatus is working you will see how moving shadows produce the impression of smoke rising.

A Model Electric Bowl Fire

The illustration (Fig. 43) shows how you can make an electric fire with a reflector (A) from a motor-car headlamp. You may be able to get one secondhand from one of your local garages for a small sum. The reflector, which should be complete with lamp-holder, can be supported on a wooden stand. It may be necessary to solder a piece of brass to the lamp holder to fix the reflector firmly to the stand.

The small heating element (B) is made by winding a nichrome wire spiral round a former made from a small piece of uralite. The shape of the former should be traced out in pencil on the piece of uralite and holes should be drilled round the lines as shown in (C). The inner circle should be drilled out first. The former can be cleaned up with a file, and should be about the size of a 12 volts lamp when complete.

(D) is the brass cap from a worn-out 6 volts or 12 volts lamp. In breaking away the glass from the cap, care should be taken not to damage the leading-in wires, as the ends of the nichrome wire must be joined to these by twisting the ends together. Lengths of nichrome wire can be obtained from the cheap stores.

The uralite is fixed into the brass cap with a little fire-clay. You must find the voltage required to make the nichrome glow by trial with your transformer coils.

An electric heater made in this way will send radiant heat in any desired direction.

factorily, strip down and prepare for final assembly by glasspapering all pieces to a smooth finish. The rods are glued into their sockets, all surplus glue being removed before it hardens.

On the bottom of each end piece glue a strip of felt. This will prevent scratching when the rack is placed on any polished surface.

When completely dry, rub down once more with fine glasspaper and finish with a coat of clear varnish, or, if preferred, the rack may be stained or french polished.

If, instead of using oak or figured hardwood it is decided to use a cheaper softwood, then the rack may be enamel finished, an attractive effect being obtained by using contrasting colours for the rods and end pieces.

'SELECTA' HOME WORKSHOP

B. ELLIOTT & CO. LTD., manufacturers of machine tools and engineering equipment, of Victoria Street, Willesden, London N.W.10, are now in full production with the new 'Selecta' Home Workshop, the all-in-one unit which replaces manual work, or the necessity of having different kits for different jobs. This amazing yet simple piece of 'do-it-yourself' equipment, makes rip-sawing, mitring, grooving, dovetailing, tool sharpening, scarfing, fly cutting, cross-sawing, cutting large-sheets, sanding, grinding, drilling, polishing and routing just speedy, routine operations well within the capabilities of even the most diffident beginner.

Ensures a neat album

Template for Mounting Prints

THE long winter evenings are with us once again and outdoor photography must, necessarily, be curtailed, but this does not mean that we must put all thoughts of photography out of our minds. Many jobs, which are seldom attempted in the summer, remain to be completed. Negatives can be listed, numbered and filed safely away, printing of all remaining pictures and enlargements of those desired can be done during the long hours of darkness. Mounting of contact prints and enlargements is just the job for a dull wet night, and it is this task that the writer has in mind at this moment.

Have a plan

Any page of a photograph album can be made to look more neat, tidy and attractive with a greater interest value if all the photographs are mounted according to some predetermined plan. To have them arranged in definite sequence, artistically and uniformly laid out in some geometric pattern certainly enhances the beauty of the book. Photographs should be mounted exactly facing each other on opposite pages, as shown in Fig. 1, to avoid pressure imprints which can spoil a photograph that has taken hours to make. To replace a print in an album sometimes leaves a mark on the page that is impossible to remove short of tearing the page out of the book and replacing completely with all new prints. A positioning template accurately made can overcome all these difficulties. It is easy to make and simple to use. Such a device is shown in Fig. 2.

Careful drilling essential

The template may be made of sheet brass, aluminium, thin stiff cardboard, perspex, plywood $\frac{1}{8}$ in. thick, or any other suitable material. First cut to the exact size of the leaves in the photograph album. Then mark out on a plain piece of paper, exactly the same size, the arrangement of photographs required. Several different layouts as shown in Fig. 3 can be drawn and once the positions have been finally decided, the paper should be pasted to the template and the corners drilled right through, using a $\frac{1}{8}$ in. diameter drill. Make a good clean job of this drilling, or the template will defeat its object.

Several templates for different arrangements of prints may be made or one template may serve several different groupings, each being clearly marked by outlines of the prints. To use, it is only necessary to place the template upon the

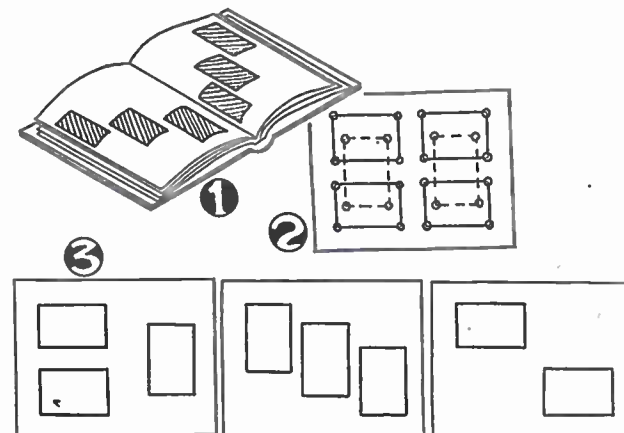

page of the album and prick through the holes desired with a sharp pencil. The corner mounts may then be fixed into position or the prints pasted and placed with all four corners on the pencil dots. These dots, being small,

cannot be seen after the mounts or prints are in position.

The writer has one of these templates made of thin tough card, which has been in use for more than five years, and is still in perfect condition. (T.H.M.)

A Graceful 'White Swan'



This all-electronic cabin cruiser 'White Swan', owned by Mr E. B. Hill, of Sowerby Bridge, Yorks., is 46 inches long and has a beam of 12 inches. The 'White Swan' is powered by 16 Venner lightweight silver-zinc reaction accumulators type H105 (24V. 150 mA) which give seven hours fast sailing on one charge. The total weight of the accumulators is only 11b. 2ozs.

Mr Hill reports that the performance is excellent, with the advantage of no noise or mess usually associated with diesel and petrol running, and that he can be sure of a start every time.

Portable Book Rack

AS a temporary home for library volumes, books from the bookcase in current use and, in fact, any volumes which have been borrowed from friends and have, therefore, no permanent position on the shelves of the main bookcase, this portable book rack will prove of great use in almost any household. It has the great advantage of being very cheap to make and its construction should present no difficulty to the average handyman. Its capacity of about one dozen books is adequate, and its portability is not the least of its many attractive features.

A glance at the illustration will be sufficient to explain the simple construction. The two end pieces (A) should be cut from $\frac{1}{2}$ in. oak or figured hardwood. The rods are cut from $\frac{1}{2}$ in. dowelling.

On the inside of each end piece mark out the centre points of each connecting dowel end. This is best accomplished by drawing a line (C) parallel to the sloping face of the end piece and, at a point on this line 1in. from the base, draw another line at right angles (D) towards the front of the end piece. The first dowel of the back four will have its centre $2\frac{1}{2}$ ins. from the top of the end piece, and the remaining three will descend 1 $\frac{1}{2}$ ins. apart. On the bottom line, and forming the bed of the rack, the front dowel will be centred on the line at a point $2\frac{1}{2}$ ins. from the base, with the remaining two rods of the bed being spaced $\frac{1}{2}$ ins. apart.

Drill the seven holes on each inside face to a depth of $\frac{1}{2}$ in., the diameter of the holes being the same, of course, as

the dowels. Great care must be taken in the drilling to ensure that the bit does not come right through. The actual length of the book rack is not critical. Much will depend upon personal requirements, but for the sake of illustra-

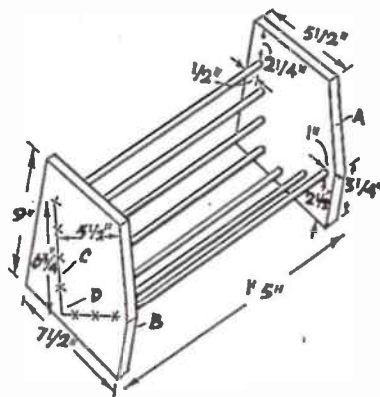

tion, 15ins. has been taken as a suitable length. It is advisable to make a test fitting of the rods after they have been cut into 16in. lengths. Owing to the difficulty of drilling to an exact $\frac{1}{2}$ in. in each case, it may be necessary to slightly adjust the lengths after one side has been fitted. As already stated, the length between the end pieces is not critical, but both end pieces must, of course, fit truly at right angles to the line of the rack when finally assembled.

Having test fitted the rods satis-

Replies to Readers Is this YOUR Problem?

Making 'Glass' Slippers

WE are producing the pantomime *'Cinderella'* with a cast of children, and my greatest difficulty is making 'glass' slippers. Can you help with any suggestions? (W.H.—Falmouth).

YOUR problem is a difficult one and I can only suggest that you improve by gluing Cellophane on the outside of, say, canvas slippers. This would give the appearance of glass and would probably do for your production, and the audience would not appreciate the difference in material. If you adopt this method, be sure to use a balsa cement for sticking, as this is colourless.

Polishing White Beech

I WISH to wax or polish a fruit bowl turned out of white beech and mahogany, without any darkening in colour if possible. Can you please advise me on the best method to do this? (A.G.—Romford).

FOR a wax polish, use one with a basis of white hard wax, in place of the more usual yellow beeswax — this

will help to preserve the contrasting colours of the woods. White hard wax can generally be bought at a paint and colour stores, but if difficulty is experienced in getting it, shred up a hard wax candle in turpentine and gently heat in a water bath until dissolved. Keep contents away from any naked light. Apply wax with a clean rag and change frequently until the gloss comes. If you possess a lathe, fix the bowl to it and while rotating, press the waxed rag hard against it.

Waterproofing Concrete

WOULD you be so kind as to inform me of some chemical formula for waterproofing concrete? (H.K.—Cork).

THERE are several methods of concrete waterproofing. The cheapest and simplest calls for solvent naphtha, aluminium stearate and glacial acetic acid. The first two can be had from a laboratory furnisher or ordered through a dispensing chemist. The third is a dispensing chemist's stock item. Warm to 80 degrees Centigrade (175 degrees

WORTH KNOWING Cutting Dowels

OFTEN when dowels have to be cut off flush the surface of the job on hand becomes pitted with saw or knife scratches and more labour is entailed in glasspapering down to get a smooth surface. This can be avoided by using a hacksaw blade from which the bottom set of teeth have been ground off. Use the blade out of the frame, of course, and wrap a handkerchief round the ends or bind with insulation tape to protect the hands. If much work of this kind is undertaken it would be handy to have two or three blades so prepared.

Fahrenheit) 100 parts by weight of the naphtha. No flames should be in the vicinity owing to the inflammability of the liquid. A good plan is to immerse the vessel partially in a large vessel of water which has just boiled and the flame been extinguished. Dissolve in this 2 to 10 parts by weight of aluminium stearate. Stir in 0.3 to 1.5 per cent by weight of glacial acetic acid. The resulting liquid can be brushed or sprayed on to the concrete and gives good penetration. It may also be stored for further use on other surfaces. Keep it in a well closed tin or bottle to prevent evaporation.

YOUR BICYCLE IN WINTER

SOME of us will be using the bicycle quite a lot during the winter, others will take a pleasure ride occasionally on days when the weather is fine and mild; and quite a few will 'lay up' their machines just as many motorists garage their cars from the end of autumn.

In the first case, the cycle is a means of transport to the daily job in workshop or office. Then keen members of touring clubs see no reason why cycling should not be enjoyed all the year round, and maintain their machines in first-class order throughout the winter to partake of the joys a wheel when opportunities permit. A week-end spin is a grand means of keeping fit.

Equipment hints

It is quite true that the weather is sometimes really impossible, with fog, rain, snow, and icy roads to contend with. Wind, too, can be very troublesome. Roads that are covered with patches of frozen snow and ice make cycling too precarious to undertake with real pleasure. But every day in winter is not like this — there are many week-ends that bring clear, dry days when the roads are less congested than in the summer and cycling is a pleasure.

To get the best out of your winter cycling it is essential to be well equipped and also well protected against the climatic conditions. Wear warm clothing, stout waterproof cycling shoes with good soles, woollen socks. Give the skin breathing room, together with some insulation from the cold, and the outer garments can be adjusted according to the individual need for extra warmth, comfort, and appearance. We might suggest, as being serviceable for winter riding: plus-fours or similar, a wool jersey with polo-neck collar, gauntlet mittens, and a cap that can be pulled well down over the ears if necessary. In case of bad weather developing, a roomy cape, leggings, and sou-wester may be carried in the cycle-bag or pannier. Fortified thus, one can face up to a sudden snow-shower or even a blizzard without dread.

Low gear recommended

For winter cycling a fairly low gear is recommended, either a variable gear or a fixed low gear. On windy days such will, doubtless, be appreciated when riding against the wind. Mudguards should be of a type that is really effective for winter cycling, and the addition of mud-flaps on the guards will help to protect the feet from the mud thrown up by the tyres. These latter should be kept in good condition. Roads are so fre-

quently greasy and messy at this season that non-skidding tyres are to be appreciated. Smooth well-worn tyres are apt to be treacherous on a bad patch of road.

There is no need to forego all the pleasures of cycling during the winter. On a nice bright day a spin in the saddle can be a real pleasure says

A. Sharp

See that your lighting set is in good condition, for you use it a lot more in winter-time than during the remainder of the year. If the lamp is of a pattern that requires an electric battery, carry a new spare one with you. The type of set best for use in winter is the dynamo-driven, but this kind requires some knowledge of its maintenance, and often the necessary occasional repairs require expert skill often beyond the average cyclist. The battery type, therefore, is more popular, for there is little that can go wrong. Such a lighting set if kept clean and well looked after, causes little trouble. The value of really good and efficient lighting in winter cannot be over-emphasised in these days and nights of unending motor transport on the roads. See that your bike lights, front and rear, are effective when out

after dark — your life may depend upon them!

Take great care of your bicycle in winter — it pays to do so. The bearings, the head-races and the hubs, the pivot and exposed wires of caliper brakes should be kept well oiled, and on roller brakes a spot or two of oil will do the lever pivots and stirrup guides no harm. The chain also needs an application of graphite grease, but do not overdo it. A thin film will be sufficient. When lubricating or greasing your machine, always avoid allowing vaseline or other grease and oil to come into contact with brake blocks, rims and tyres.

Keep all bearings and fittings nicely adjusted, and the chain at the correct tension, neither too tight nor too slack. Regularly test your tyres and brakes — particularly the latter. During winter the brakes must be maintained in tip-top condition.

Cleaning after rain

Cleaning your machine after a journey in the rain or under damp, muddy conditions of the road, is most important. Do not be tempted to push the cycle into the shed or wherever you house it until another day. Give it a good wipe down with wash-leather and duster after swilling the mudguards and wheels down with water. Chromium plating will not rust, but is apt to wear off at the edges and corners and the exposed steel will become rusty. A thin film of vaseline occasionally will do the plating no harm. (A.S.)

The thrill of "Build it yourself"

Mobile Crane made with Meccano Outfit No. 3

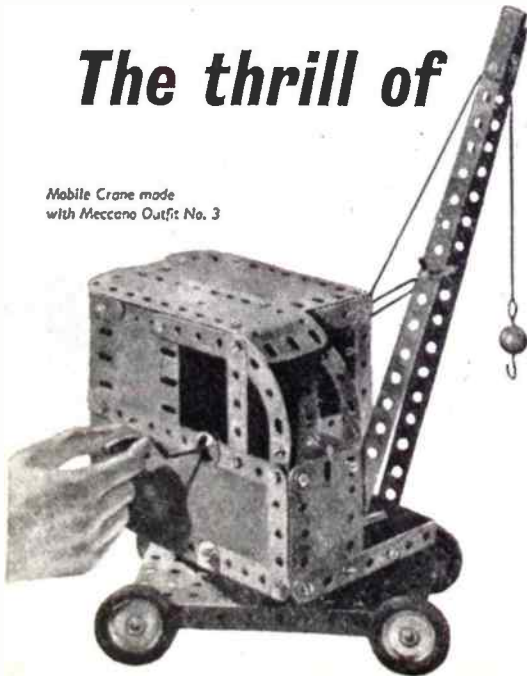

How much better it is to make your own toys! Make them as you want them, and make them work. Make them with Meccano. When you've made and played with one model, you can take it to pieces and build another with the same parts. Meccano grows in interest as you keep adding to your stock of gears, wheels, girders and strips — it is "the Toy that grows with the Boy".

MECCANO

MADE IN ENGLAND BY MECCANO LTD.,
BINNS ROAD, LIVERPOOL 13.

Salver for Serving Biscuits

THIS little tray is intended for use when viewing T.V., especially when you have company. It will accommodate several varieties of biscuits and all can be carried in at once.

in. wood. The sides (B) are 14ins. long and are cut to the depth shown. Glue them to the ends and strengthen by means of pins or screws.

The tray portion is made up of pieces

Patterns are
on Page 175

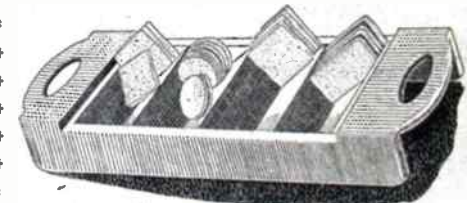

Should you be keen on making these up for sale they should be painted with plastic enamel paint, and particular attention paid to cleaning up the wood. Customers will expect a high standard of workmanship.

The two ends or handles (A) are shown full size, and these are cut from

(C) glued between the sides. Eight of these are required, and they are glued as shown by the dotted lines on piece (B), and the small diagram.

Clean up all surfaces with glasspaper and give one coat of brush polish. This will seal the grain and make painting much easier. (M.p.)

Add power to your radio

SIMPLE BATTERY AMPLIFIERS

THE battery-operated type of amplifier is particularly easy to build, and very few parts are needed. Circuits such as those dealt with here are very simple and inexpensive indeed, and can be used for various purposes — such as increasing the volume from a crystal set or 1-valver, or for record playing with a pick-up.

set, wire a 50,000 ohm resistor across the phone terminals on the set; with the crystal set, this resistor may be 100,000 to 250,000 ohms. Earth on the receiver is joined to L.T. negative on the amplifier. The same H.T. and L.T. battery can do for both receiver and amplifier.

With a crystal set, volume will be much improved. If the crystal set signal

only one valve is required. Greatest amplification will be obtained from a 2 V valve with 120 V H.T., but the small 'all-dry' types, with 67 V H.T., will be satisfactory when less volume is wanted.

As with all other low-frequency coupling circuits, it is absolutely essential that the transformer be of a type intended for this purpose, as mentioned.

By F. G. Rayer

If not, then it may actually cause a reduction in volume, so that resistance coupling would be better.

Two Valves

In some cases a single valve will not provide enough amplification, and two valves may then be used, a simple circuit being shown in Fig. 3. Here, two coupling transformers are indicated, but it is possible to replace either, or both, by resistance coupling, with some sacrifice in volume.

The 1-valve circuits have two Grid Bias connections, and the best bias voltage depends upon the valve and H.T. voltage. It is easily found by trial,

is really good, moderate speaker volume can be expected. Speaker results from local stations can also be expected, at rather greater volume, with the valve-plus-amplifier, which will work like a 2-valver.

First, it should be mentioned that the circuits can be used with a wide range of battery valves. If a 2 V accumulator is to hand for filament supply, 2 V valves will be best, and can be obtained at prices of about 3/- for the triode type, and 4/6 in the pentode type. These require 4- and 5-pin English valveholders. If an accumulator is not desired, 'all-dry' valves can be used. The all-glass miniature types do well, but are relatively expensive, at 7/6 to 9/6 each. They need B7G holders. If valves are to be bought, for 'all-dry' use, then the Octal or Loctal based types are cheaper, at about 5/- to 6/- each, with output pentodes of the 3D6 type costing only 2/6. All these valves use a 1.4 V filament supply, obtained from a standard dry battery, if the filament sections are wired in parallel.

It will thus be seen that the type of valve actually used can be chosen to suit those to hand, or whether an accumulator is available or not.

One Valve

The simplest possible type of 1-valve amplifier is shown in Fig. 1, and it will give a useful increase in signal strength. The input signal is fed to the points (A) and (B).

This circuit is suitable for a crystal set, (A) and (B) going to the phone terminals on the set. Point (B) has to go to the earthed phone terminal.

Or, for either crystal set and 1-valver, condenser coupling may be employed. For this, wire a .01μF condenser from (A) to the phone terminal going to crystal or detector anode. With a valve

Fig. 1—Simple 1-valve amplifier

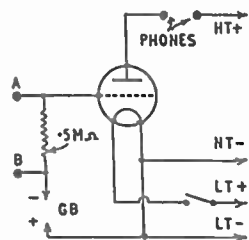

Increasing Output

Transformer coupling will further boost signals, provided the transformer is of the type intended for such purposes. Its ratio can be about 1:3 or 1:5 step-up. A pentode valve will also amplify more than the triode, and these two improvements are used in Fig. 2.

Points (A) and (B) (transformer primary) are wired directly to the phone terminals on the receiver, which may be a 1-valver or crystal set. Only one further connection is necessary — that from valve screen-grid to H.T. positive. As a pentode tends to emphasise high notes, a condenser of about .005μF or .01μF is wired across the speaker, to mellow reproduction.

This circuit is particularly suitable when a speaker is to be operated, and

Fig. 2—Pentode amplifier

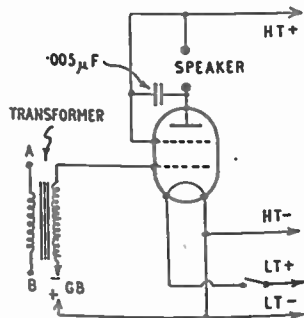

the correct bias being that which gives best volume and clarity of reproduction. Something of about 1½ V to 6 V will usually be necessary, a tapped G.B. battery being best, as even 1½ V may make considerable difference in results. It is essential the polarity shown be followed.

In the 2-valve circuit, two negative bias plugs are used, that marked (1) going into the G.B. battery at about 1½ V or 3 V, and the second (2) at 4½ V to 6 V or so.

If a 120 V H.T. is used, HT1 may go into a 90 V socket, and HT2 in the

120 V socket. With a 60 V or 90 V battery, both leads may be joined and go in the maximum voltage socket.

It is sometimes worth while reversing the two leads taken to the secondary of either coupling transformer, as one particular way sometimes gives best results, e.g. take the original Grid tag to G.B., and the original G.B. tag to valve Grid.

Volume Control

A volume control is desirable with a 2-valve amplifier, and can be provided by wiring in a ½ megohm potentiometer. When resistance coupling is used, this can be wired as in Fig. 4. If a transformer is fitted, wire outer tags of the control to the transformer secondary, and slider to valve grid.

Fig. 4 also shows Resistance Capacity Coupling between valves. This is not quite so loud as transformer coupling, but using a pentode output valve helps restore volume. A circuit such as that in Fig. 4 is particularly cheap to build, as no transformers at all are wanted. With 1.4 V valves, the anode load resistor may be increased from 50,000 ohms to 100,000 or 200,000 ohms, with advantage.

Results to Expect

Greatest volume is obtained with the 2 V type of valve, with the more powerful 1.4 V types giving almost

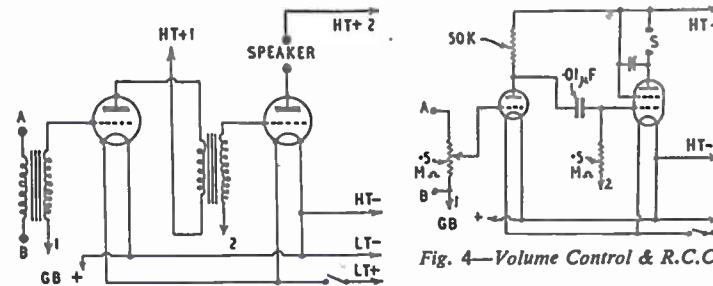

Fig. 3—2-Valve amplifier

Fig. 4—Volume Control & R.C.C.

equivalent results. The miniature 1.4 V valves are also good, but handle less power, especially as a 120 V H.T. cannot be used with them.

To boost signals up to really good phone strength, one valve is sufficient. For moderate speaker results, one valve will do only if the signal applied to the amplifier is good, and it is desirable to use ample H.T., whereas a 45 V or 60 V battery is sufficient for phones.

The 2-valve circuits will give louder results, and are also suitable for 78 r.p.m. records with a general purpose magnetic pick-up. This pick-up would be wired to (A) and (B) in Fig. 4. If Fig. 3 were to be employed, the first transformer is omitted, the pick-up

being connected to GB1 and valve grid. As with other simple amplifiers, Long Playing records cannot be reproduced satisfactorily.

The 1.4 V type of valve is only made in pentode type, in some ranges. In output stages, this can be wired as shown in Fig. 2, but when the valve is required in an early stage, it will be simplest to use it as a triode, by wiring screen grid and anode together. If this is not done it will be necessary to provide a suitable H.T. voltage for the screen grid, by means of a dropping resistor of about ½ to 1 megohm, from H.T. positive, a condenser of about 1μF being wired from screen grid to the H.T. negative circuit.

Finally, it must not be forgotten that any moving-coil speaker must be fitted with the usual speaker transformer, as it cannot operate without this.

From Malta—

The Coronation Coach, Hobbies Design No. 203 Sp., is still a very popular one among keen fretworkers. The model on the right has been finely executed in Perspex by Mr. V. Zarp of Malta. The design and full instructions for making this historic coach, in which reigning monarchs are driven to Westminster Abbey for their Coronation, costs 3/- from branches or by post from Hobbies Ltd., Dereham, Norfolk. A kit for making this model in wood is also obtainable, price on request.

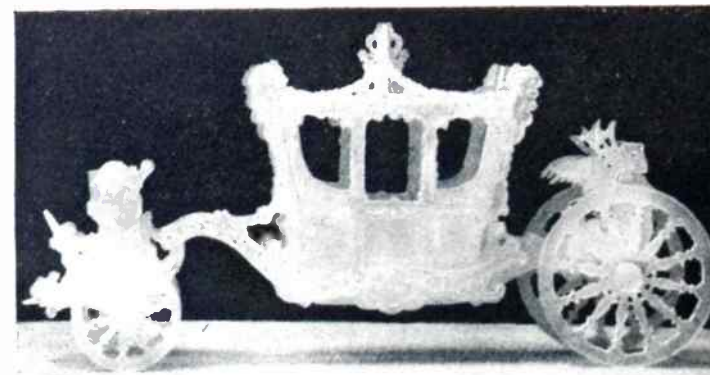

— and India

From India comes the photograph on the left of models made from Hobbies designs by V. K. Govardhan Rao, with the assistance of his brother. Obviously keen workers, their projects range from big ones such as the Tug Climax and St. Paul's Cathedral to small toys and novelties. Hundreds of these designs are detailed in Hobbies 1957 Handbook, which costs only 2/- from branches, newsagents etc. or 2/3 post free from Hobbies Ltd., Dept. 993, Dereham, Norfolk.



Handy for the woodworker

Simple and Effective Cramps

SOME form of pressure is required for all glued work, usually calling for the employment of a cramp. Not all handicraft workers have cramp heads at their disposal, but there are several ways of holding the work tight while the glue sets. The simplest form is a heavy weight, but the work itself may make the application impossible. Rubber bands are often useful for small classes of glued jobs, as for example the repair of broken china. Extending the same idea, we may make extra strong rubber bands from the inner tubes of motor tyres. A visit to a garage will probably enable you to obtain such a tube for a few coppers. Strips may be cut about 1in. across the tube to give a suitable band. Fig. 1 shows a band holding a frame, or you may use it for small boxes or any other light work with every confidence of success.

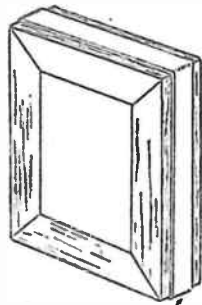

Fig. 1

RUBBER BAND MADE FROM AN INNER TUBE

Fig. 2 shows another form of temporary cramp, quite useful for holding frames while the glue is setting. First of all, take a piece of strong cord, forming a loop round the work. Note that it is essential to provide protective pieces to prevent damage to your work. With the cord looped round the frame, a short piece of batten is inserted between the two cords and twisted round and round. This has the effect of shortening the cord, which tightens, pulling the wood-work together. It will be necessary to fasten the small piece of batten to the frame, or the cord will untwine and release the pressure.

Cramping board

A cramping board is shown in Fig. 3, made from a piece of shelving and two fillets of 2ins. by 1in. batten to the width of the board. The two fillets are fixed by screws as shown. The board itself may be about 2ft. long and, say,

4ins. or 5ins. in width. We also require two wedges to operate the cramping procedure. These should be nicely tapered and cut diagonally from a rectangular piece of 1in. stuff. For use, the work is laid on the board with the straight side of one wedge laid against it. The other wedge is then forced in with the aid of a hammer. Note that if the work is smaller, some additional packing may be used to fill up the space and this may be done on the opposite side of the wedge end.

By S. H. Longbottom

A type of cramping board, very similar in action to the metal cramp heads, is shown in Fig. 4. This is easy to make and has the additional advantage of a movable stock, making the cramp adjustable to all sizes of work. Take a

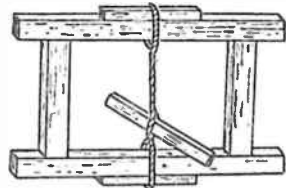

Fig. 2

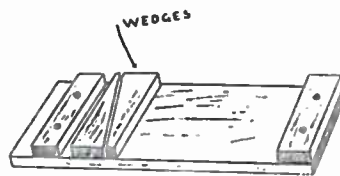

Fig. 3

piece of 2in. by 1in. batten, fixing a short piece of the same material at one end. Down the centre drill several holes at regular distances to take the movable stock, another piece of batten being drilled in the centre for a wing nut and bolt. The bolt must be long enough to pass through the stock and central batten. Use a washer to prevent any damage when tightening. To use the cramp, the work is placed in position, the movable stock adjusted and wedges inserted to provide the pressure as with the previously described board. In this case it is best to insert the wedges at the fixed end.

A modification of this particular type of board is shown in the sectional drawing, where it will be noticed that the work has been fitted between battens on each side. The advantage here is that the work is supported on both sides and is particularly useful when gluing butt joints. If such a board is made it will be realised that the width of the space between the battens restricts the use of the cramp to work of that dimension. If possible, cramps of both kinds should be made, but the first mentioned of this type will prove the more useful for many kinds of work.

Wedging

It will be seen that these cramps rely on the principle of wedging for their success, and, of course, the same principle of the inclined plane is used with the screw, which will be recognised as a sound method of tightening. All the

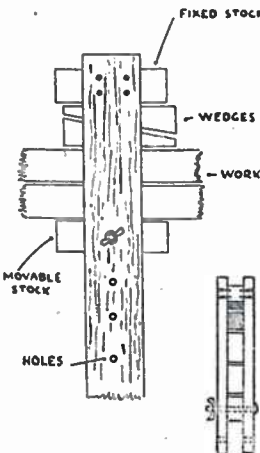

Fig. 4

methods of cramping described here will be found to be effective, although based on this simple idea, and they are all within the reach of every woodworker. Sizes have been given, but if you are concerned with smaller or larger work, it is not difficult to make the necessary modifications. Perhaps it should be mentioned that the wedges must have a gradual taper, allowing the pressure to be applied gradually, and if there is any tendency for slipping it may be because the incline is too severe. This may be remedied, however, by the application of a little powdered resin on the engaging surfaces.

It pays to be fussy...

When you've a gluing job to do, your success will depend very much on the performance of the glue you use. So choose a top quality product—it will cost you very little more and yet will give you the best possible means of doing a really good job. CASCO P.V.A. is just such a glue; and for household repairs, general handicraft work, model making, etc., you can make no better choice.

Here are the special advantages of CASCO P.V.A. Completely ready-to-use (no heating or warming required) . . . extremely clean in use (washes easily from brushes or fingers) . . . quick setting . . . non-staining . . . almost transparent when set . . . glues wood, paper, cloth and leather.



Recommended for

"Build-it-Yourself" with **Easi-Bild** patterns

... for a general-purpose glue, insist on

CASCO P.V.A. GLUE

Obtainable from
Ironmongers,
Hobbies Shops, etc.
Price: 2/- per jar
(approx. 2 oz.)

Manufactured by: LEICESTER, LOVELL & CO LTD · NORTH BADDESLEY · SOUTHAMPTON

DON'T MISS THE REAL THRILL IN PHOTOGRAPHY



Anyone can take a snap; but not many people can print their own photographs. They just don't know how easy (or how much fun) it can be. YOU can do it TODAY.

The Johnson Print-a-Snap pack contains full instructions and all you need to print sixteen 2½ in. x 3½ in. or twenty-four 2½ in. x 2½ in. pictures from your own negatives. It only costs 3/6 and you can use it in any room.

It's so exciting to actually see the picture slowly appearing on the paper, and how envious your friends will be when you show them prints which you have made YOURSELF.



Ask your local photographic dealer for the

**JOHNSON
PRINT-A-SNAP
PACK**

JOHNSONS OF HENDON LTD.
LONDON N.W.4

The Handyman's PERFECT PAINT

Here is a perfect answer for the home handyman's painting problems—easy-to-use Robbialac Lacquer. This versatile finish dries dust-free in 2-4 hours and overnight sets to a diamond-hard glass-like sheen that resists steam and hard wear. It leaves no brushmarks and is the ideal finish for the amateur painter who aims at a professional job. It is sold in handy ½, ¼, ⅓ and 1 pint tins and is available in 24 brilliant colours plus black, white and silver. Ask for it at any good paint shop, cycle shop, ironmonger or hardware dealer.



FREE: Put a 'factory finish on your handiwork. For a free instructional Leaflet send 2d. stamp to Dept. 6L12, Jenson & Nicholson Ltd., Carpenters Road, London, E.15.

ROBBIALAC LACQUER

2-4 HOURS DRY

JENSON & NICHOLSON LTD., CARPENTERS ROAD, LONDON, E.15

Make them at home

Formulas for Useful Products

THE need often arises for an ink which can be used outdoors, such as for labelling bushes or plants. Happily, there is a simple formula to fill the need. The requirements are shellac, methylated spirit, technical grade cresol and spirit soluble Nigrosine.

GARDEN LABELLING INK

To make the ink, warm 2½ fluid ounces of meths. in a vessel, dipping in a pan of hot water (no flame). Stir into this ½ ounce of spirit soluble Nigrosine and keep on stirring until the Nigrosine has dissolved. Let the solution cool and put it into a screw capped bottle. Add 1½ ounces of shellac and shake occasionally until the shellac has dissolved. Stir in 1½ fluid ounces of technical grade cresol. The ink is now ready for use. It produces black characters and is weatherproof.

WATERPROOF DRAWING INKS

Yellow and violet inks of this type can be made at home with the aid of easily obtainable dyes. The ink base consists of a shellac-borax-water solution and is coloured with the appropriate dye.

To make the base, dissolve 0.7 gram of borax in 100 c.c. of hot water and then add 2.8 grams of bleached shellac, stirring until it has dissolved. For a yellow ink, dissolve in this 2.85 grams of Erythrosine; for a violet, 2.85 grams of Methyl Violet. Wash the pen or brush immediately after use to prevent the ink hardening, otherwise subsequent washing will, naturally, be unavailing.

REMOVING ADHESIVE PLASTER

We have probably all suffered while removing an adhesive plaster dressing from our skin. Unless it has been on long enough to have lost some of its adhesiveness, it can only be removed painlessly by destroying this. Fortunately, there is a way. Simply dab a little oil of wintergreen on the plaster, let it spread by absorption and the plaster will peel off easily. Naturally, the oil should not be applied over the wound itself. It is only necessary to apply it where the plaster holds the lint dressing to the skin.

SANDSTONE CEMENT

The broken sandstone pieces should be perfectly dry for this cement to work well. A coat or two of varnish should also be applied and allowed to dry. If the stone can be warmed before spreading the cement, so much the better, for this prevents premature chilling of the cement.

Melt separately in small tins 1 ounce of sulphur and 1 ounce of rosin. Pour

the rosin into the sulphur and immediately stir in 3 ounces of litharge and 2 ounces of powdered glass. Apply to the stone, press the pieces lightly together and leave to set. This cement may be used, too, for filling cracks in sandstone. It stands up excellently to the weather.

BLACK STAIN FOR WOOD

A process for staining wood which gives a durable result and good penetration calls for logwood chips, oak apples and ferrous sulphate. Powder ½ ounce of oak apples, mix with 5 fluid ounces of water and leave the mixture in a warm place for four or five days, making up any water lost by evaporation. Strain the liquid, squeezing out as much as you can from the oak apple residue.

Next boil 1 ounce of logwood chips for two hours with 10 fluid ounces of water, again making up any water lost by evaporation. Strain the liquid and apply hot to the wood. When dry, brush on the oak apple extract three or four times, allowing it to dry between each application. While the last coat is still damp, finish off by brushing with a solution of ½ ounce of ferrous sulphate in 1 pint of water until the full colour develops.

SATINWOOD STAIN

For a useful satinwood stain of the spirit type, place in a bottle ½ pint of methylated spirit, 1½ ounces of turmeric powder and ½ ounce of gamboge. Shake the bottle occasionally during the next three days so as to extract all the colouring matter and then strain through thin cotton for use. Owing to the volatility of meths, the stain should be kept in a well closed bottle.

BRASS LACQUER

Those who have bought modern brass ornaments will have noted that they do not tarnish. This is, of course, because they have been treated with a special lacquer to exclude the air. When this has been properly done, care being taken to cover the edges well, the method is quite effective. You may like to treat other non-lacquered brass ornaments in the same way, so as to dispense with periodical cleaning.

To make a suitable lacquer, place in a screw-topped bottle ½ ounce of turmeric, 1 drachm (¼ ounce) of saffron and 10 fluid ounces of methylated spirit. Shake occasionally during the next three days and then strain through thin cotton into another bottle. Add 1½ ounces of orange shellac, shake now and again until this has dissolved, and the lacquer is ready for use.

COPPER LACQUER

Similarly, copper may be protected from tarnish. In this case the turmeric and saffron may be dispensed with, a solution of 1½ ounces of orange shellac in 10 fluid ounces of meths. alone being used.

COCKROACH DESTROYER

The cockroach nuisance can be dealt with by a simple preparation. Grind together until intimately mixed 1 part of chocolate, 2 parts of flour and 4 parts of borax. The parts are by weight. Sprinkle this mixture about the runs of the insects.

Another good mixture consists of an intimate mixture of equal weights of plaster of Paris and fine oatmeal.

Cockroach destroyers, naturally, work best in detached houses. In semi-detached or terrace houses one kills one's own cockroaches only to find that a fresh supply is forthcoming from neighbours. Shock tactics in the form of neighbourly cooperation is the only real answer here.

CEMENT FOR ELECTRICAL APPARATUS

Where a non-conducting cement is needed, first heat in a tin about 10 grams of yellow ochre until it darkens and is almost red hot. Let it cool. It will now be found to have changed to red-brown. Add 4 grams of this to a melted mixture of 20 grams of rosin and 4 grams of beeswax. The last two should be melted in a tin over a low flame. Finally stir in 0.5 gram of plaster of Paris and use the cement hot.

ARTIFICIAL FLOWER STIFFENER

Those who make artificial flowers from thin cloth will welcome a preparation which will stiffen the petals. Heat up a pan of water not quite to boiling, extinguish the flame and in the water stand an old cup containing 4 fluid ounces of methylated spirit. The water must not be hot enough to cause the meths. to boil. Add 1 ounce of polyvinyl acetate and stir until it has dissolved. Remove the cup from the water and let the solution grow cold. For use, brush or spray all surfaces of the flowers. No flames should be allowed in the area while treating the flowers or during the subsequent drying period, of course, owing to the inflammability of the meths. vapour.

* * * * *
 * Next week we shall give details for making a small shaving cabinet and a charming contemporary stand for flower pots. An article will describe how to copy photographs and there will be a fascinating subject for marquetry lovers.
 * * * * *



SAVE MONEY

with

VALSPAR

2-4 HOUR LACQUER
 High-Gloss WOOD STAIN
 or CLEAR - VARNISH

Paint, Stain or Varnish whitewood furniture with Valspar which produces a brilliant, smooth finish, proof against boiling water, alcohol, petrol, oil and grease.

No knotting, priming or undercoating required — easily applied coat-over-coat. Dries in 2-4 hours.



GOODLASS, WALL & CO., LTD. 179/185 CD17 Great Portland Street, London, W.1

Please send me a free copy of the Valspar Handbook giving full details of all Valspar Paints.

NAME _____
 BLOCK CAPITALS
 ADDRESS _____

LOOK! Take your popular 4" Electric Drill and the **Selecta** (PAT. APP. FOR) HOME WORKSHOP and you have a **COMPLETE "ALL-IN-ONE" UNIT** MADE IN ENGLAND

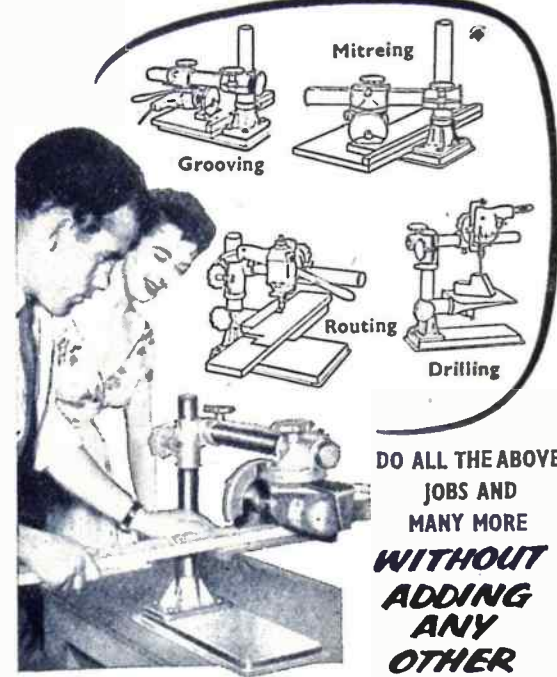

DO ALL THE ABOVE JOBS AND MANY MORE WITHOUT ADDING ANY OTHER KIT!

CASH PRICE £13-10-0 (EXCLUDING DRILL)

YOURS FOR £2-10-0 DEPOSIT

and 8 monthly payments of £1-12-6 (plus 6/- carriage) MONEY REFUNDED IF MACHINE RETURNED WITHIN 7 DAYS

Design a woodworking Pattern for a nest of tables and Win either £50, £25 or £15. Send for details and FREE Entry Form. Closing date December 15th.

POST COUPON NOW

FREE 32 PAGE BOOKLET

Please send me your FREE 32 page Illustrated Booklet

NAME
 ADDRESS

B. Elliott & Co. Ltd. (N.W.D.)
 Victoria Works, Wembley
 London, N.W.10.

BOYS! Be a real DAVY CROCKETT!

COMPLETE 4-PIECE COTTAGE *NO DEPOSIT!

Includes FREE HAT all with fringes, and an adjustable belt. Our special secret-waterproofed material to withstand Prairie storms. Hat is real Fur Fabric. Send 2/6 for post & pack. It suits 5 mthly. payts. 4/6. Cash 19/11. Ages 4 to 7 and 10 to 13. STATE AGE. DAVY CROCKETT TENTS 2/1/- post, 1/6.

1000 YARD DRUMS
Assault Cable WIRE
5366 BARDOLFO POINT

combat field service telephone communication wire on a drum. Rustless as it is PVC covered. Numerous uses include fencing gardens and fields, baling goods and heavy parcels, tough suspension lines for all purposes. Use instead of roping—stronger and almost everlasting. Essential to have around. 1,000 yards per drum, 526 lb. breaking point, 9/11, carr., 3/6. Case of 6 carr. free. A Govt. surplus article cost pounds to make, our price is cheaper than string!

Headquarter & General Supplies Ltd. (HOBW/36), 196-200 Coldharbour Lane Loughboro Junc., London, S.E.5 Open Sat.

THE Tom-Tom WIGWAM

SENT 2/6 FOR CASH 21/- POST 2/6

TENT CONSTRUCTED OF SUPERB "TOM-TOM" COTTON PROOFED FABRIC AND NOT MADE OF NYLON. 4' 3" x 4' 3", height 5' 6". Built with collapsible poles, dismantle swiftly and transport elsewhere. No centre pole. Erect anywhere. A real waterproofed Tent. Holds 4/5 children. ALL AGES. Send 2/6 dep., then 4 mthly. payts. 5/9. Cash 21/- Post 2/6. Waterproof Groundsheet 10/6 if req.

WRIST WATCHES REAL GOLD PLATED FRONT AND BACK NO DEPOSIT

LADIES OR GENTS MODELS 'AIRCRAFT' shock resisting wrist watch. Fitted accurately tested pin-lever movement. Written guar. Cases are REAL GOLD PLATED all over, dials are silvered with gilt raised figs. and hands. Send only 2/6 for packing & registration, bal. 18 fortnightly payts. 3/3. CASH, on strap, 59/6 or LADIES' MODEL 10/- extra. Matching bracelet 12/6 extra. Luminous 6/6 extra. Lists, Watches, etc.. Terms.

MODERNISE YOUR HOME WITH ARNOBOARD

Send 1/6 for R. W. D. Kirkham's comprehensive illustrated book which shows you how; and FREE SAMPLE of Arnoboard, the prefinished plastic surfaced hardboard which works like ordinary hardboard. Finishes include wood grain, tile, marble effects, etc.

Dept. 3, Arnolite Ltd, West Parade, Spring Bank HULL

FREE Stamp Album and 20 stamps. Request approvals enclosing 4d. Additional gifts given. — Beeze, 8 Langland Villas, Mumbles, Swansea.

ORNAMENTS — Brooches, Ashtrays, 'Lady', 'Tramp', etc. 6d. to 3/- each. 10% discount in December. Numerous colour schemes. Write Hat. — D. Chaplin, 26 Cambridge Drive, Lee, London, S.E.12.

JAMAICA KGVI 2/-; cat. 1/6. This high value stamp offered Free to approval applicants enclosing postage. — 'Yulwontmor Stamps', Dept. H5, 29 Layton Avenue, Mansfield.

OO-GAUGE Road Transport scale model kits. Range of over 30 different models. Stamp for illustrated catalogue. — Ash Products, Leiston, Suffolk.

WATCH AND CLOCK REPAIR OUTFIT

The complete Outfit for cleaning and repairing. Comprises: Illustrated explanatory booklet, eye-lens, tweezers, screwdrivers, oil, dusting powder, oilers, also illustrated catalogue, tools and materials. Plus P. & P. 1/- extra. C.O.D. if required. 12/9

The above with additional luminous compounds, jewellers' rouge, dial brush, jewel. 21/-

Plus P. & P. 1/- extra. C.O.D. if required.

ASSEMBLE YOUR OWN JEWELLERY

Selection of facet earrings, pendants, rings, brooches and stones, etc. at fraction of cost. Send S.A.E. now for big illustrated free catalogue. Money back guarantee.

THE BOLSTER INSTRUMENT CO. (Dept. HB45) GOVETT AVENUE, SHEPPERTON, MDDX.

COINS for a few pence each. Send S.A.E. for lists. — Humphries, 5 Cordova Road, London, E.3.

FOR SALE — quantity of Occupational Therapy materials and equipment, surplus requirements of a Local Authority. Looms, leatherwork equipment, needlework and weaving materials. Lists on application to Occupational Therapy Department, Phoenix Chambers, High Street, Bedford.

AMERICAN PUBLICATIONS — 'How to Plan a Home Workshop', 'Toys', '19 Charming Chairs', 'Furniture Designs', 'Novelties', 'Small Furniture Designs', '40 Fine Tables', 'Toys, Games & Playground Equipment'; complete set of 8 books, 15/6 inc. postage. Send for complete catalogue. — Willen Ltd. (Dept. 57), 9 Drapers' Gardens, London, E.C.2.

WHEELS (Hardwood and Rubber Tyred Metal), Cot, Pram and Doll's House Fittings and Papers, Beads, Transfers, Prints and other accessories. Stamp for new lists. (Trade supplied.) New address — JOYDEN CO., 91 Peplins Way, Brookmans Park, Herts.

MAGIC catalogue. T. and Donkey Puzzle 1/- — DeHempsey, 363 Sandycroft, Kew, Surrey.

STAMPS FREE — Empire Packet including Pictorials and Victorians with approvals. — Robert J. Peck, 7A Kemp Road, Bournemouth.

MAKE A RADIO

NO SOLDERING — only a screwdriver and pliers required. Success guaranteed. WINNER crystal set, 12/6 post free. CONQUEROR 1-valve set, 22/6 post free, valve and batteries 15/6 extra. BUILDING INSTRUCTIONS for 10 different sets, 3/6 post free.

Send P.O. 3/6, 12/6, 22/6 or 38/- to: **BLANCHARD'S RADIO** (Dept. H4), 13 GAINFORD GARDENS, MANCHESTER, 10

HEAR ALL CONTINENTS With H.A.C. Short-Wave Receivers

Suppliers for over 18 years of Radio S-W Receivers of quality. One-Valve Kit, Price 25/- Two-Valve Kit, Price 50/- Improved designs with Decco coils. All kits complete with all component, accessories and full instructions. Before ordering, call and inspect a demonstration receiver, or send stamped addressed envelope for descriptive catalogue.

H.A.C. Short-Wave Products (Dept. 22), 11 Old Bond Street, London, W.1

Patterns for —

A BISCUIT SALVER

CUT WITH A FRETSAW

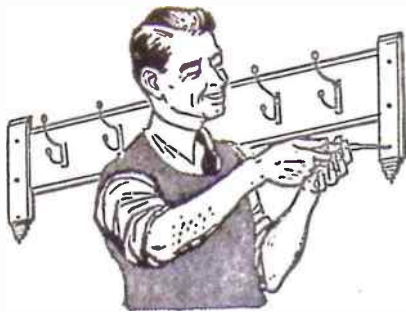

IT'S FAR EASIER WITH RAWLPLUGS!

THE EASIEST WAY of fixing screws in masonry is *still* the world-famous Rawlplug way. Rawlplugs are used by the million in industry! You drill a hole, insert a Rawlplug and screw up your fixture. Far easier, far quicker, far safer than any other method. A Rawlplug Outfit (from as little as 3/-!) contains all you need—Rawlplugs, Rawltool, screws, 16-page 'Hints on Fixing'. Get one today!

HIGH-SPEED MASONRY DRILLING—IN A HAND BRACE!

When drilling brick, tile, stone, enjoy the swift, clean-cutting ease of a Rawlplug DURIMUM-tipped Masonry Drill. Drill right through a wall if you wish—easily and silently. There's nothing 'just as good'—look for the name DURIMUM on the shank.



Rawlplug DURIMUM-tipped DRILLS FROM YOUR IRONMONGER OR HARDWARE DEALER

THE RAWLPLUG COMPANY LTD • LONDON • S.W.7

NEW!

THE PRACTICAL WAY of learning RADIO TELEVISION • ELECTRONICS

- Beginners Radio Course
- Advanced Radio
- Short Wave Technique
- Lesson Manuals

Experimental work includes construction of Basic Oscillators, Amplifiers, Deflectors, Power Units, 1, 2 and Multivalve TRF and Super-het receivers.

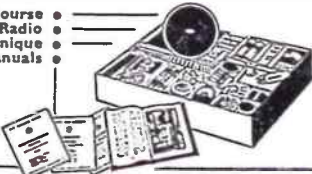

COMPLETE EXPERIMENTAL COURSES IN RADIO ENGINEERING and SERVICING

An entirely new series of courses designed to teach Radio, Television and Electronics more quickly and thoroughly than any other method. Specially prepared sets of radio parts are supplied and with these we teach you, in your own home, the working of fundamental electronic circuits and bring you easily to the point when you can construct and service radio receivers, etc. Whether you are a student for an examination; starting a new hobby; intent upon a career in industry; or running your own business—these Practical Courses are ideal and may be yours at very moderate cost. With these outfits, which you receive upon enrolment and which remain your property, you are instructed how to build basic Electronic Circuits (Amplifiers, Oscillators, Power Units, etc.) leading to designing, testing and servicing of complete Radio and Television Receivers.

COURSES FROM 15/- PER MONTH

POST THIS COUPON TODAY

To E.M.I. Institutes,
Dept. 31, Grove Park Road, London, W.4.
Please send me your FREE book on Practical Courses

NAME

ADDRESS

5 Dec.....IC74

EMI INSTITUTES

associated with
"His Master's Voice,"
Marconiophone,
Columbia, etc.



Easy to apply and quick to dry, these inexpensive lacquers have many uses. They will impart a rich and lustrous finish to models, picture frames, lamp standards, wicker chairs, work baskets, those unsightly water or gas pipes, etc. Fine for dance shoes too!

Be sure to ask by name for
CROWN SILVER LACQUER
AND
GUINEA GOLD LACQUER



Obtainable only from

WOOLWORTHS

THE GALLEON PERPETUAL CALENDAR

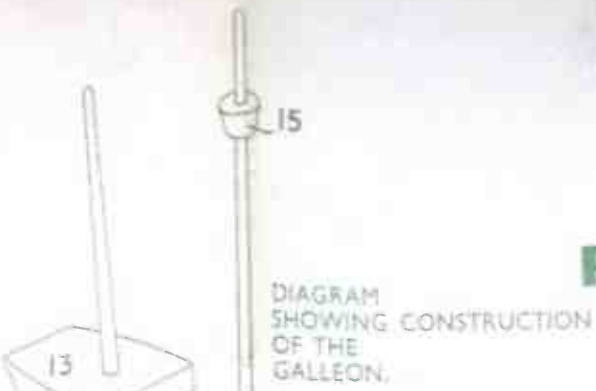
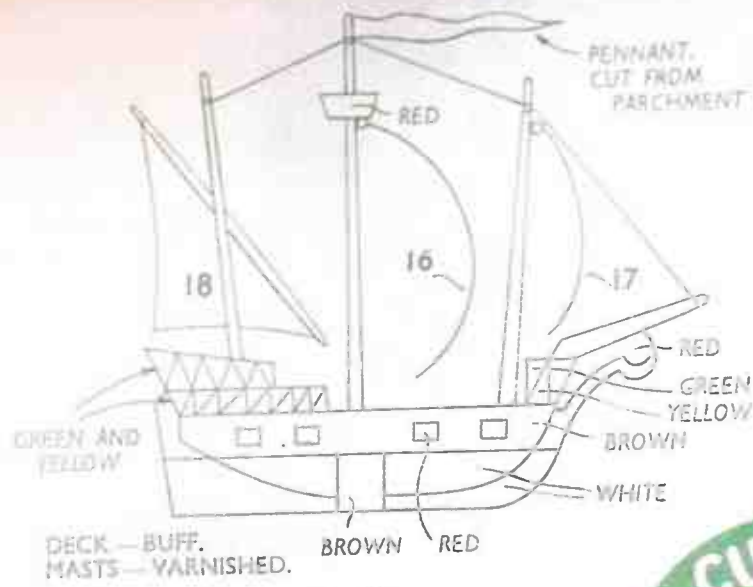

SIZE
7 1/2 in. LONG.
3 in. WIDE.



DECK - BUFF.
MASTS - VARNISHED.

KEY TO PAINTING

NOTE. SPARS AND MASTS ARE SHAPED FROM 1/8 in. ROUND ROD. THE SIZES ARE OBTAINED FROM THE PAINTING KEY AND THE SAILS.

CUT OUT WITH A HOBBIES FRETSAW

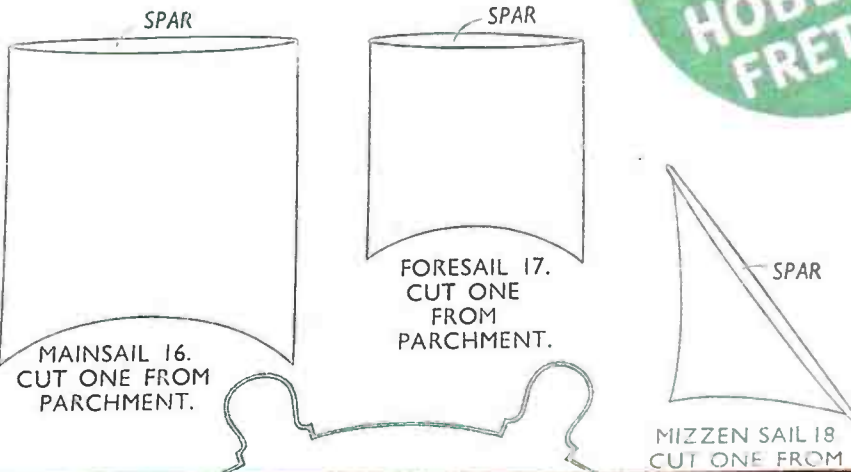

PANELS OF WOOD REQUIRED FOR THIS DESIGN
ONE G4 ONE G2
A KIT OF MATERIALS FOR MAKING THIS DESIGN IS SUPPLIED BY HOBBIES LIMITED DEREHAM, NORFOLK.

Use **Croid AERO** IT'S DESIGNED FOR THE JOB

HOME OUTFIT AERO GLUE

IT'S DESIGNED FOR THE JOB

It gives you the greatest strength with no mixing or preparation. The Home Outfit consists of 8 oz. tin Croid Aero Glue - Hot Water Container - Handy Brush - 4¢ complete.

AVAILABLE FROM ALL BRANCHES OF HOBBIES LTD.

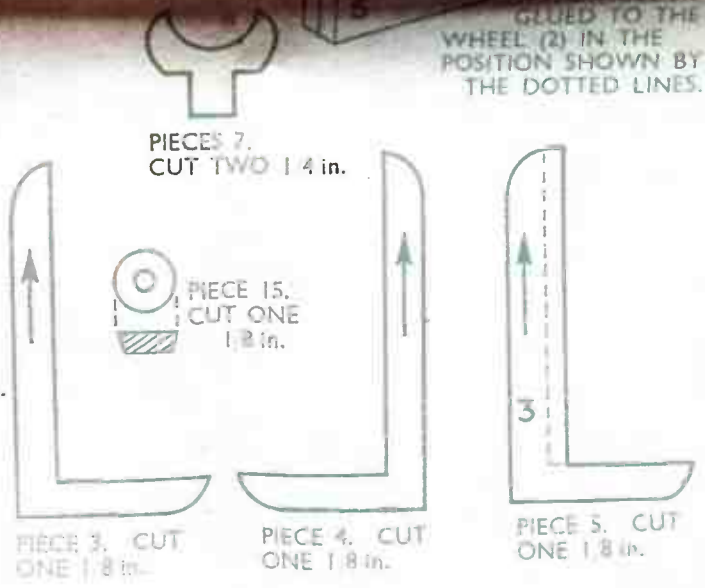
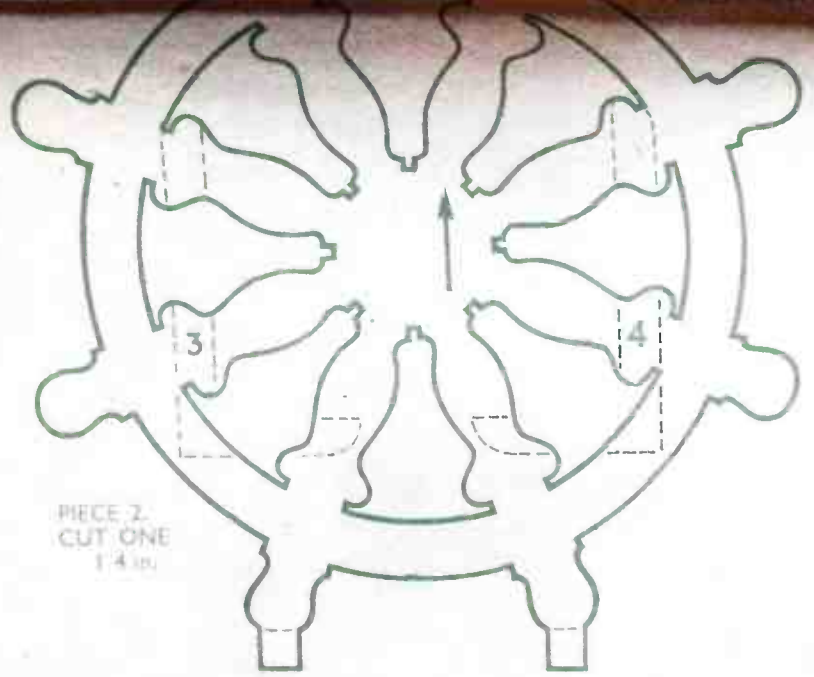

THE ARROWS INDICATE DIRECTION OF GRAIN OF WOOD.

