

HOBBIES WEEKLY

IN THIS ISSUE

	Page
Two Inlay Tea Trays	225
Books to Read	226
A Word in Your Ear	227
Chemistry in the Home	228
Coffee Table in Plywood	229
An Album for Your Records	230
The Kitchen as a Dark Room	231
Lawn Aerator	232
Flower Pot Soil Firmers	232
A Folding Chair	233
Simple Barometer	233
Stamp Collector's Corner	234
A Draught Excluder	236
Make Low-Level Steps	236
Money Box for Baby	239



JANUARY 2nd 1957

VOL. 123

NUMBER 3192

★ **FREE**

*design
for
making*

TWO INLAY TEA TRAYS

WILD GEESE OR SCOTTIE MOTIF



TWO charming tea trays can be made from Hobbies kit No. 3192 at very little cost. The bases measure 15 in. by 10½ ins. which is quite a handy size, and they make an ideal pair.

Of quite modern appearance, the trays are easy to assemble when the pictures have been glued on to the baseboard and polished. The handles consist of dowelling let into shaped pieces of wood attached to the corners, and permit easy handling and cleaning. The base is consequently left completely open, thus allowing for a wipe over to clean. With normal trays, pieces of waste food invariably congregate in the corners, and this design will obviate that.

There is enough material in Hobbies kit to make two complete trays, and the motif for each will be the same. There are alternative designs — the wild geese as in the illustration, and a Scottie dog which is shown by the dotted lines on the design sheet.

 ★ Write to the Editor, Dereham, ★
 ★ Norfolk for a free copy of the ★
 ★ leaflet 'Making Pictures in Wood', ★
 ★ which describes fretsaw inlay. ★

The pictures are made up from the two coloured inlay panels provided, using an OO fretsaw blade to ensure close fitting joints when the pictures are

glued on to the baseboard. The two different-coloured wood veneers give contrasting pictures for the trays. One will be in dark wood and the other light. For instance, on one tray the geese, if this is the motif chosen, will be of dark wood set in a light wood, and the rest of the colouring of the base as in the illustration. On the other tray these colours will be reversed for each section.

First select the design to be incorporated — the birds or the dog. Transfer the outline of this and the background on to the light wood veneer in the kit. Incidentally the veneers are the exact size to cover the base of the tray. The light wood panel is placed on top of the other inlay panel, and the two held

All correspondence should be addressed to The Editor, Hobbies Weekly, Dereham, Norfolk

*For Modellers, Fretworkers
and Home Craftsmen*

4½^D

PAGE 225

securely together by Sellotape placed round the edges as shown in the inset (A) in Fig. 1. This will enable the two to be cut together to give identical sections.

In cutting out, always remember to keep the saw upright so that the various parts interlock together closely. Start cutting from the outside edge in the left-hand bottom corner, continuing to complete the arc, and then cut out the parts of the circles. Continue with the

TWO TRAYS FOR 14/3

A kit of all the necessary wood, round rod, inlay panels, screws etc. for making TWO Inlay Trays can be obtained from branches etc. or post free from Hobbies Ltd. Dereham, Norfolk. Ask for Kit No. 3192, costing only 14/3.

centre piece, to start which a small hole will need to be drilled to insert the fretsaw blade. Do not go completely round the circle, but take out the figure piece by piece thus ensuring that they are held together until the cutting of this section is completed. Now finish the cutting with the right-hand arc and circles.

Place the pictures together in their different shapes, and glue on the plywood base step by step starting at one end and gradually moving along.

When the glue is thoroughly dry, clean up the picture surface with a

scraper (a piece of glass will do), and glasspaper until a smooth surface is obtained all over. Then finish with wax polish working it in with the finger tips. Give several applications and rub down with very fine glasspaper after each. After the final application, polish with a soft duster. Now we turn to the handles, the makeup of which is shown in Fig. 1. The corner pieces (2) are shown actual size on the design sheet, and dowelling is cut to the measurements

indicated. Note that the holes in the end pieces which will hold pieces (3) are drilled, and those for pieces (4) can be cut with the fretsaw. Accurate drilling and cutting is, of course, essential. Assemble the handles and rails by first fixing two corner pieces in which have been inserted dowel (3). The corner pieces are glued and screwed from underneath. Drill first before screwing and countersink the screws. Then add the other corner pieces and dowelling.

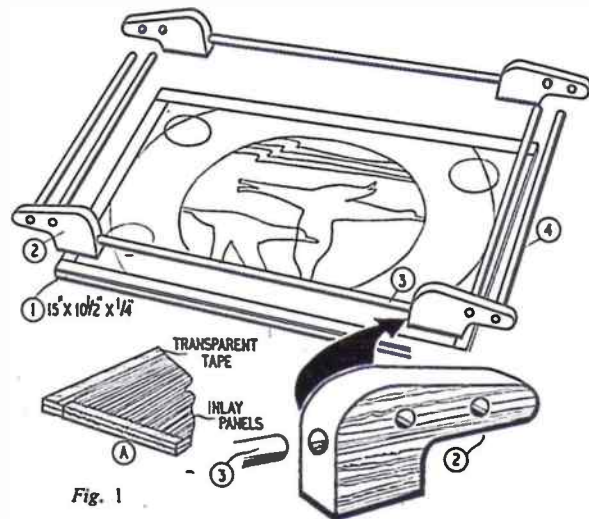

Fig. 1

BOOKS TO READ

Woodworking Tools

by Alfred P. Morgan

THIS is one of the best books on its subject we have had the pleasure of reading. From driving a nail to smoothing and finishing, all stages in the correct use and care of woodworking tools are carefully explained in lucid style considerably helped by hundreds of drawings. Additional chapters on glass cutting, gluing and cramps complete a work which should be available on the workbench of every apprentice and in the hands of all amateur woodworkers. Published by Phoenix House Ltd., 38 William IV Street, Charing Cross, London—Price 15/-.

How to be a Winner at Chess

by Fred Reinfeld

THE author, a player of many years' experience, with a profound sympathy for the legion of 'middle class' chess players has deliberately set out to make this work not only a simple guide to all the many sided aspects of the game but an entertaining, sometimes most amusing, aid to better playing. He has succeeded in smoothing out the wrinkled forehead of the beginner and

in a most unusual approach to the treatment of a subject hitherto almost alarming in its academic severity, has put fun into his teaching without losing any of the thrills of this fascinating game.

Published by Nicholas Kaye Ltd., 194-200 Bishopsgate, London, E.C.2—Price 11/6.

Guide to Broadcasting Stations 1956/7

Compiled by the staff of 'Wireless World'

THIS up-to-date compilation giving the operating details of over 3,000 broadcasting stations of the world will prove of great interest and assistance to the wireless enthusiast, especially as it includes nearly 2,000 short-wave stations with their call signs, arranged geographically and in order of frequency. Operating details of nearly 400 v.h.f. broadcasting and 170 television transmitters are also included. This is an excellent handbook at a modest price.

Published for 'Wireless World' by Messrs. Iliffe and Sons Ltd.—Price 2/6.

A Word in your Ear

From the Editor

A HAPPY NEW YEAR TO ALL OUR READERS — and may everything you undertake during 1957 meet with success. That is the sincere wish of the Editor, his staff, and all the contributors to the columns of *Hobbies Weekly*. Whatever your hobby we shall endeavour to give you bright and new ideas, interesting projects to undertake, and informative articles which we hope will enable all to enjoy their leisure hours in a most profitable manner.

During its 61 years of publication our magazine has introduced many hundreds of new designs and given details of thousands of projects for the handyman and hobbyist to go to work on, but we realise that there is 'nothing new under the sun' and that there are, perhaps, many good and original ideas lurking in the inventive brains or on the workshop benches of our readers. And that is where YOU can help future issues of *Hobbies Weekly* to be even more interesting.

Pet ideas

How about that pet idea for a model — or a gadget — or a piece of furniture? Send it along to the Editor at Dereham, and if it is considered that the majority of our readers would be interested then an article will be prepared so that all can share your 'brain-wave'.

Come to think of it, it wouldn't be a bad idea if we stipulated that each query received by our experts asking for information should be accompanied by an idea for a Hobbies design! But, seriously, we are pleased to give all the help we can with this free service, even though sometimes it involves no little research and no little expense.

It would be appreciated, however, if readers taking advantage of the knowledge of our experts would enclose a stamp for reply and confine their queries to the subjects covered by our magazine. We once received a list of about twenty queries covering a host of subjects from a reader in Dublin. Irish blarney? Anyhow we did our best!

Big surprise

RECENTLY I had pleasure of seeing what a woman can do in the way of model-making — and I was in for a big surprise. Women, of course, do make up our designs and some of them make a really good job of it. But what surprised me in this instance was the subject chosen.

Miss M. E. Ransome of Scole, near Norwich, had chosen our trawler, which

is the design given in *Hobbies 1957 Handbook*, to make up and enter in a Handicrafts Exhibition. You will gather how successful she was by the fact that her entry was awarded 100% marks by the judges.

Intriguing model

This trawler is a replica of those made by Messrs. Richards Ironworks at Lowestoft, and Miss Ransome had taken the trouble to go to this seaside resort in order to perfect the details on the model. It was a really excellent model and would have put the efforts of many a man to shame. Miss Ransome told me that she had made up the model completely with the aid of a Hobbies fretmachine, and that it had had many a successful run on pond, river and boating lake. She was full of praise for the design, buoyancy and endurance of the trawler, and said she was now looking forward to another working model from Hobbies.

Incidentally Miss Ransome had not done any work of this kind for about fifteen years until she was thumbing through the pages of *Hobbies Handbook* on a bookstall and became interested in the picture of the trawler. She says 'The trawler intrigued me, so I bought the Annual and for several days studied the plan. At first sight it seemed a bit complicated, but that only stimulated my interest and I decided to "have a go". It was really a challenge, and out came the fretsaw'.

Miss Ransome adds that she had enormous enjoyment out of making the boat, which also provided her with considerable educational value, as she learnt many things about trawling and drifting. She finally adds that possibly the chief ingredient for making this type of model is patience. As we have always pointed out — 'a thing worth doing is worth doing well' and a model to be proud of gives a very satisfying feeling.

Hobbies 1957 Handbook, which contains a free design and instructions for building this motorised trawler, costs only 2/- from newsagents, etc. or 2/3 post free from Hobbies Ltd., Dereham, Norfolk.

New branch

JUST before Christmas, Hobbies Ltd. opened their 12th branch, at 42 Dean Street, Newcastle-on-Tyne, to serve the needs of all hobbyists and handymen in this very populous area in the north east of England. As in their other branches, all Hobbies kits, tools, designs, and, of course, copies of *Hobbies Weekly* will be available, and the manager, Mr. Derek

★ ★ ★ ★ ★
★ NEXT WEEK ★
★ Many readers have expressed in- ★
★ terest in building their own radio- ★
★ gram and next week we shall give ★
★ details of making the cabinet. ★
★ Subsequent articles by F. G. Rayer ★
★ will describe the circuit, power ★
★ pack, etc. ★
★ ★ ★ ★ ★

L. White will always be pleased to see readers and give helpful advice.

Mr. White has spent a considerable time at the headquarters of Hobbies Ltd. in Dereham, Norfolk, and is well acquainted with the difficulties and problems to be encountered, as he is himself a keen modeller and fretworker. His aim, he says, is "to help the beginner and interest the expert", so I advise all readers in that area to make their way to 42 Dean Street, and take advantage of Mr. White's knowledge.

Competitions

A COMPETITION to test readers' ability at designing and fretcutting will be published in our issue of January 23rd, and we hope to offer similar competitions monthly. Timex watches will be awarded for the best design and execution — one for juniors and one for seniors — and there will be ball point pens for the runners-up. Look out for full details in our January 23rd issue.

Next week we shall publish a Crossword Puzzle for amusement only, and we hope readers will find much interest in solving this. The solution will be given the following week.

Short-cuts

We frequently receive letters from readers asking the price of Hobbies kits in order to make up that particular week's design. This is always given in a panel in the instructions for making, which are printed in the magazine. We thought everyone had noticed that!

Good news for canoe enthusiasts and those who are contemplating making their own craft this year. P. W. Blandford, an expert on such projects, is designing a new model for publication in *Hobbies Weekly* during the spring. More details later.

Thousands of Hobbies Fretwork Outfits were found in the stockings of lucky youngsters this Christmas. Perhaps you were the Good Samaritan who provided the start to such a satisfying and lifelong hobby. Why not carry on the good work by ensuring that the lucky lad gets a copy of *Hobbies Weekly* every Wednesday? We can send each issue by post — 28/6 for a year or 14/3 for six months. A New Year present which will last for a long time.



ROYAL PRINCE

A magnificent 22in. model of Hobbies Royal Prince made by Mr L. Brown of Bradford. Kit No. 247 special for making this galleon costs 62/6 from branches etc. or Hobbies Ltd, Dereham, Norfolk.

CHEMISTRY IN THE HOME

TO many, the word 'acid' conjures up the idea of a sinister liquid which burns holes in nearly everything, fumes threateningly and is only waiting for the chance to do you harm. The culprits responsible for this notion are concentrated sulphuric, nitric and hydrochloric acids which are corrosive and do need handling with care. They happen to be the commonest acids used by handyman and chemist, and so non-scientific folk, naturally, get the idea that all acids must be the same.

Few corrosive

Nothing could be farther from the truth. Of the legion of acids known to chemistry only a few are corrosive. The great majority are inoffensive, many of them being solids. Lemon juice is good for you and every time you drink some you are drinking the citric acid to which it owes its sharp flavour. Vinegar is dilute acetic acid, tea contains tannic acid and a sour apple owes its sourness to malic acid.

Chemistry cannot get along without acids and it is most interesting to prepare at least some of them for oneself, for the experiments take one into all fields of the science.

Hiding under the innocent name 'boracic powder' in many an unsuspecting housewife's cupboard we have one of these 'sinister' acids. Boracic powder consists of orthoboric acid. Generally, it is referred to as boric acid. It is easy to make from borax, for this consists of sodium pyroborate. By adding an acid to its solution, pyroboric acid is set free, but this immediately changes to orthoboric acid.

In 100 c.c. of boiling water in a beaker dissolve 25 grams of borax. Measure out 20 c.c. of concentrated hydrochloric acid in a small measuring cylinder and stir this into the borax solution. Let the liquid cool overnight. White crystals of boric acid separate out. Filter off the acid, wash it with a few c.c. of cold water, and then let it dry on a porous brick until the smell of hydrochloric acid has gone.

To purify

As sodium chloride is also formed in the reaction a little of this will still contaminate the boric acid, despite your having washed it. To purify it, dissolve it in the smallest possible quantity of boiling water, leave it to cool and

crystallise overnight, then filter it off and dry it on a brick. All but traces of the sodium chloride remain in the mother liquor.

Care should be taken in handling the strong hydrochloric acid used in this experiment, and the strong sulphuric acid in those that follow. Should you get any on your fingers, flush it off with water, dab on a thin paste of sodium bicarbonate (baking soda) and water, leave it a few moments and then wash it off.

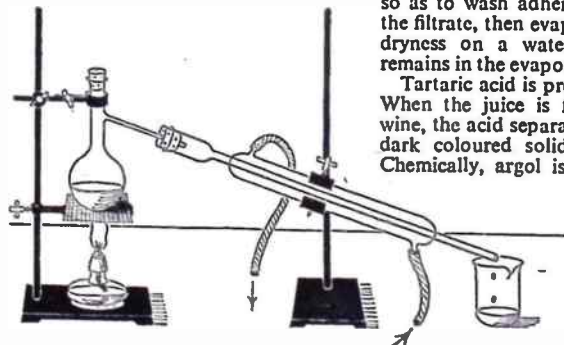

To extract citric acid from lemons, the filtered juice is neutralised with precipitated chalk (calcium carbonate). This forms insoluble calcium citrate which is removed and treated with sulphuric acid. The latter sets free soluble citric acid and forms insoluble calcium sulphate. On filtering off the calcium sulphate, a solution of citric acid is obtained.

Acid from lemons

Heat the juice of four lemons not quite to boiling and filter it. Boil the filtrate and add precipitated chalk little by little until a blue litmus paper dipped in the mixture turns purple. Effervescence occurs during this process owing to carbon dioxide being set free from the carbonate, so use a vessel large enough to cope with the foam. Note the weight of the chalk used. By weighing out a quantity of chalk before the neutralisation and weighing it again after, the amount of chalk used is easily found by subtraction.

Filter off the calcium citrate, wash it in the filter several times with boiling

Making Acids Part 1

water, transfer it to a beaker and stir with about four times its bulk of cold water. To decompose the calcium citrate there must be added a weight of sulphuric acid equal to the weight of chalk you used to neutralise the juice. If you wish to measure instead of weighing the acid, you can base the quantity needed on the fact that 10 grams of concentrated sulphuric acid measure 5.4 c.c.

In grape juice

Add the acid slowly with constant stirring. If the beaker becomes warm, let it cool before adding more acid. Next heat up the mixture in a water-bath, filter off the calcium sulphate formed, fill up the filter several times with water, so as to wash adhering citric acid into the filtrate, then evaporate the filtrate to dryness on a water-bath. Citric acid remains in the evaporating basin.

Tartaric acid is present in grape juice. When the juice is fermented to make wine, the acid separates in the form of a dark coloured solid known as argol. Chemically, argol is impure potassium

hydrogen tartrate. When this is purified we have the household cream of tartar. From this you can prepare the free acid.

Chalk added to a solution of cream of tartar produces insoluble calcium tartrate (which is filtered off) and soluble potassium tartrate. On adding calcium chloride to the filtrate, potassium chloride is formed and more insoluble calcium tartrate (which is filtered off and added to the other portion). On treating the latter with sulphuric acid, soluble tartaric acid is set free and insoluble calcium sulphate formed. On filtering, a solution of tartaric acid is obtained and evaporated.

To 150 c.c. of boiling water add 20 grams of cream of tartar and boil and stir until it has dissolved. Now add precipitated chalk in small portions until a final addition causes no more effervescence. Again allow for the carbon dioxide produced foam by using a large vessel. Filter off the calcium tartrate.

To the filtrate add calcium chloride solution until no more white precipitate of calcium tartrate forms. Filter this off

Continued on page 229

COFFEE TABLE In Plywood

Described by A. F. Taylor



FURNITURE made entirely or almost entirely of plywood is quite popular, and very attractive it can be, too, especially when it is well designed and carefully made. It is strong, easy to cut and fit together, and quite light in weight.

Plywood can be obtained in a very wide variety of woods and in many different thicknesses. The grain of some of these is really handsome, and when

radius of 10ins., then the outside portion is divided into four to make the legs, each side of which will be 12ins. long.

Plywood up to 3/4in. thick can be cut quite well with a fretsaw, using a stout blade provided the work is not forced and the saw allowed to take its time, which will prevent overheating of the metal.

The edges of both top and legs can be left square, but most people prefer to round these, or at least to remove the sharp edges. Only the straight outside edge and the curve of each leg need be rounded, leaving the other straight edge quite square for fixing to the table top.

Glasspaper is probably the best medium to use for rounding the edges of the ply without chipping off any of the layers and spoiling its appearance. Fraying can also occur when using too coarse a saw or trying to cut too fast, and it is, therefore, best to use a medium cut saw, even though it will take longer to do.

The underside of the table is shown in Fig. 2, which gives the position of the legs, together with all necessary measurements. Although it is not essential, it is certainly an advantage to fasten the legs to a block of wood 5ins. square and about 1in. thick, which is shown in the

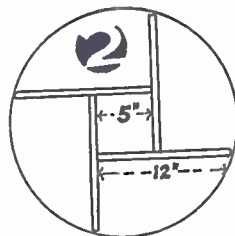
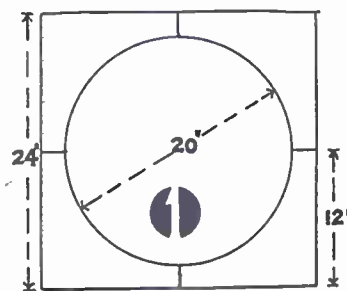

made up and nicely polished, will produce an article you can be proud of, and one that will last for many years.

Plywood is most economical to use and it is often possible to design and make furniture with very little waste. A very good example of this is this coffee table which is, in fact, made entirely from a single square of wood. From a piece 24ins. square you can cut a top 20ins. in diameter, and also the four legs each 12ins. high.

Although 3/4in. wood is thick enough for this size table, it would be better to use 1in. or even 1 1/4in. without making it too clumsy. Choice of wood will largely depend upon the finish it is intended to give, and must be left for the maker to decide.

Fig. 1 shows how to mark out the 24ins. square of plywood. Draw the circular top in the centre of this with a

Continued from page 228

Chemistry — making acids

through the filter containing the first lot of calcium tartrate. Wash this with hot water until one washing shows no precipitate with silver nitrate solution — indicating that the potassium chloride adhering to the precipitate has all been washed out.

Transfer the moist precipitate to a beaker. Dilute 6 c.c. of concentrated sulphuric acid by slowly stirring it into 50 c.c. of cold water, with pauses for cooling when necessary. Add the diluted acid to the precipitate and heat up the whole in a water-bath. Filter off the calcium sulphate, run two or three lots of water through the filter, and evaporate the filtrate to dryness on the water-bath, when solid tartaric acid will

remain.

Provided the legs and block are well glued to the table top, no other form of fixing is necessary, but extra security can be obtained with fine panel or veneer pins, or triangular corner blocks may be glued and pinned in position. Small brass angle brackets screwed on to the legs and top is another form of fixing which can be used if desired.

Well smoothing with fine glasspaper will get the ply into the right condition for whatever finish you intend to use. Clear varnish or french polish are quite good either on the natural wood or after it has been stained. Painting or enamelling are equally suitable, but it is advisable to size the wood first and rub down lightly with a piece of worn glasspaper before painting.

The table can be made in other sizes, and provided you keep to the same proportions, it will be quite strong. You may also like to try making an oval table on the same lines from a piece of wood, say, 36ins. by 24ins. The feet may need placing in other positions, depending on the proportions of the rectangle, but that can be easily arranged when you have cut them out. One side of the legs will be long and the other short, and this will enable you to make either a tall or a short table.

remain.

Acetic acid is produced when sulphuric acid acts on sodium acetate. Rig up a distillation apparatus (see diagram) and in the distilling flask place 22 grams of sodium acetate crystals. Pour on to the sodium acetate 40 c.c. of accumulator acid — which is, of course, sulphuric acid of specific gravity 1.25, Swirl the flask gently to mix the contents, reconnect to the condenser and leave the whole for about fifteen minutes.

Now distil the mixture. Carry on heating until the mixture in the flask is semi-solid. The colourless liquid which distils into the beaker is dilute acetic acid.

(L.A.F.)

AN ALBUM FOR YOUR RECORDS

By
S.H.L.

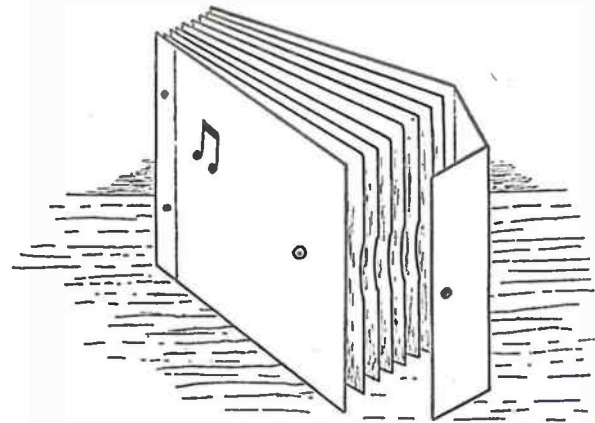

THE best way to ensure a long life for your gramophone records is by making a special album for storage. This not only keeps them dust free, but safe from scratches and breakage.

Making an album is neither difficult nor expensive, and if your record cases are reasonably substantial, you will be able to use them. Alternatively, you may purchase a new set of record cases, made from lightweight card, at almost any record shop. These are much better than some of the paper cases given with the

No doubt it will be appreciated that some allowance must be made for the difference between the thickness of the records in their cases and the much thinner fly leaves. This compensation is provided by the insertion, at several places, of spacers made from strips of medium weight card $1\frac{1}{2}$ ins. wide and the same length as the fly leaves. These act in the same way as washers and give additional strength to the binding. It will be necessary to make some experiment with these spacers before deciding the number required. Pile the records,

slight modification must, of course, be made for those albums required to take the 12 ins. records, or the smaller, new long-playing variety.

The wrap over on the underpart of the cover allows for $1\frac{1}{2}$ ins. in depth, to accommodate twelve records, and a $2\frac{1}{2}$ ins. flap. The card should be scored accordingly, and reinforced inside by paper gumstrip. The flap may have a small press stud fitted or a strap, with a buckle on the other part of the cover. Straps may be fastened to the card by means of bifurcated rivets.

We now have to determine the means of fastening together the covers, fly leaves and spacers. Your stationer will be able to assist here. There are some small, tubular screw bolts available, normally used for fastening together loose leaf files and the like. They are made in many sizes, and you will have to decide which is suitable according to the

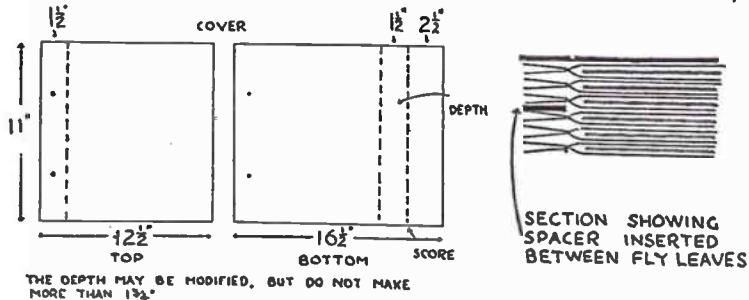

records. In addition, you will need some more lightweight cardboard, of similar quality to the cases, and here you are recommended to buy either manilla folders, or stiffeners, sold by stationers for filing correspondence. The only other requirements are a good quality carton, perhaps obtainable from a shopkeeper, some linen adhesive tape and suitable fasteners for binding. The latter will be mentioned later.

The method is to make several 3 ins. strips from the manilla folders. These are folded in half, lengthways, to make fly leaves and ultimately attached to the cases by the adhesive tape, but not before they have been punched for the fasteners. Cut the strips to the same length as that of the record cases and you will require as many as there are records in the album.

laying the fly leaves at one side, applying light pressure to the latter until the difference in depth is noted. Balance this by adding spacers, which may then be distributed at various points among the leaves. It is better to have the depth of the leaves plus spacers a little greater than that of the pile of records.

We may now turn to the making of the cover.

Here we have one oblong piece of card cut from the carton, measuring $12\frac{1}{2}$ ins. by 11 ins., scored at one end to make a hinge as shown in the diagram. The underpart wraps round the open end of the record cases, forming a flap on the top cover, and measuring $16\frac{1}{2}$ ins. by 11 ins. These measurements provide for $\frac{1}{2}$ in. overlap on all edges, for protective purposes, and for the popular size of 10 ins. record. Some

Ideal for photographers

The Kitchen as a Dark Room

THE kitchen makes an ideal dark-room, and is probably used by the amateur photographer more than any other room in the house, and a great deal of really excellent work is constantly being turned out from such humble surroundings. A small cupboard, such as the dark one under the stairs, might be used, but the absence of running water and bad ventilation makes this a bad choice.

There is generally quite a small window in the kitchen which can be easily blacked out, and as the dark-room is mostly used in the evenings, this should not present any difficulty. When much photography is undertaken, it is a good plan to make a light wooden frame to fit the window, and cover it with one or more sheets of stout dark paper. For occasional use, however, a piece of thick curtain may be pinned round the frame-work. A thick curtain hung over the door is usually sufficient to cover any cracks which may let in the light.

There is one drawback, however, in using the kitchen as a dark-room, and that is the problem of temperature. The amateur photographer knows that the correct temperature for his solutions during development is between 60° and 65° and it is quite easy to maintain them at that level during the summer months.

In winter, however, when freezing point is often reached it is impossible to turn out satisfactory work at so low a temperature, and some means is needed to increase it.

By bringing the gas cooker into service we have easily solved this problem, and are able to carry on with the good work all through the year. There are many points in favour of this arrangement which should appeal to all home photographers.

Check thoroughly

The oven is lit up and the regulo adjusted to maintain the correct temperature. With the door shut there is little fear of light leaking out, but if you are working with panchromatics, have a thorough check up before starting operations. Some gas stoves have an open bottom, and this could cause serious trouble by light reflected from the floor. In most cases a sheet of tin or aluminium can be cut to fit, and will solve the problem. An alternative method is to box in the bottom of the stove down to floor level.

A large tray placed on the top of the stove as shown makes an excellent bench for the dishes of solutions which will be warmed up to the correct temperature by the heat from the oven and kept

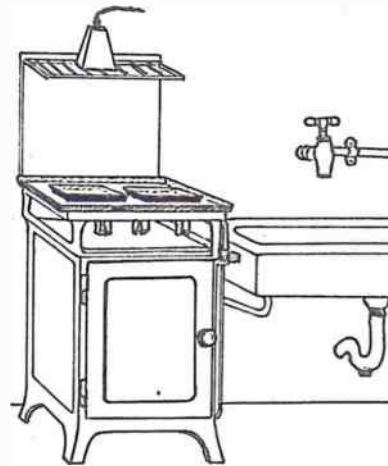

heavy gauge enamelled iron, it will keep warm for quite a while. Additional heat may be obtained by placing the dishes under this tray right on top of the oven, but care is needed so that overheating does not occur.

Instead of using a tray it is a good idea to get a piece of asbestos sheeting cut to fit the top of the oven. This should be about $\frac{1}{2}$ in. thick, and is excellent for maintaining the heat for quite a while.

By A. F. Taylor

If there is a plate rack over the oven, this is a good place for the dark-room safe light, where it will light up the dishes below. The white enamelled back plate will act as a reflector and help to distribute the light more evenly.

Some photographers prefer to tilt the light so that it shines on to the plate and illuminates the dishes by reflected light only. For fast films this is a splendid idea and is well worth trying. Another source of reflected light can be obtained by turning the lamp upwards to shine on the ceiling, which in most cases is white or cream, and this is an even better method when working with ultra sensitive material.

An important point to remember when using the kitchen as a dark-room is that other people may enter when you are in the middle of developing an important picture and switch the light on. Safeguard against this by either fitting a lock or bolt on the inside of the door, or by taking the bulb out of its holder.

Continued from page 230

An Album for Records

and the fly leaves may be attached to the record cases. A piece of adhesive tape is attached on both sides, the fly leaves being fitted so that the folded part meets the edge of the record case. It should also be noted that these fly leaves are attached to that side of the case opposite to the open end. Moreover, although linen adhesive tape has been specified for the job, there are some types of paper gumstrip available which are exceedingly strong and which may do the work equally well. The 'pages' are now ready for fastening between the covers.

It should be mentioned that carton cardboard has not only been specified because of its cheapness, but mainly

because it is flexible. This has been decided after the consideration of the possible use of hardboard, but the flexibility of cardboard will prevent any damage to the records which could be caused by the harder material. For a really smart finish the cardboard must be given some treatment.

There is the choice of two coats of gloss paint, or some imitation leather paper obtainable from a handicrafts store. The paper is pasted on and turned over on to the inside at least for $\frac{1}{2}$ in. A suitable lining paper is then applied, to cover the score reinforcement strips, and leaving a nice margin of the outer binding.

Winter projects for gardeners

LAWN AERATOR

WHEN a lawn, through continual rolling, mowing and normal foot traffic, has become consolidated on the surface, the grass begins to thin and pale, indicating the need for some attention. Aeration is a good way of improving the condition, and here is a simple tool to help you.

Spiked wheels, drawn by small motor tractors are used on large sports grounds. There are also special hollow tined forks, but one made from wood and nails is equally effective. You need two pieces of $\frac{1}{2}$ in. shelving measuring about 10 ins. by 4 ins., a broom handle and some 4 ins. nails.

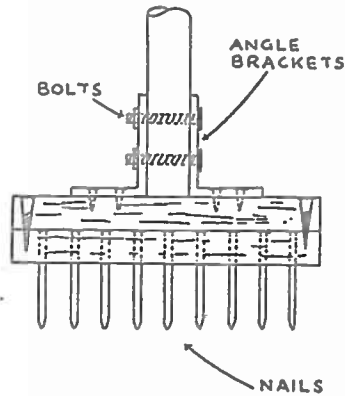

Prepare the two pieces of wood, one of which is to take the nails. Mark out this board as shown in the diagram to accept about one dozen nails evenly spaced. Drill holes, rather smaller in diameter than the nails, to avoid splitting the wood, then drive home with a hammer.

The upper portion, of the same size, is necessary to keep the nails in position, when using the tool, otherwise hard-baked soil would force the nails out of the wood. Drill this top piece and screw to the underpart already fitted with nails. To finish the job, a broom handle is attached by means of angle brackets at each side.

Actual operation of the tool is simple. It is placed on that part of the lawn requiring attention, and pressed in with the foot. If a large area is needing treatment, the best way is to line off with cords, working each lane in turn.

After spiking the turf in this way, it is best to leave the lawn for a full day to allow the air to circulate in the soil, when a top dressing may be given. Heavy soils will be greatly improved by brushing in a mixture of granulated charcoal and sand. This mixture is

brushed well into the turf, so that the holes are filled. Air is permitted to enter and rain will quickly penetrate to all parts via the punctures. Impoverished lawns will be assisted if a little fertiliser is added to a mixture of peat and sand.

It will be appreciated that the punctures made with the aerator have a similar effect to hoeing cultivated soil, by permitting air to get to the roots. But that is not all, for drainage is improved.

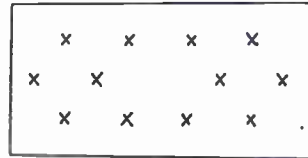

Positions of the nails

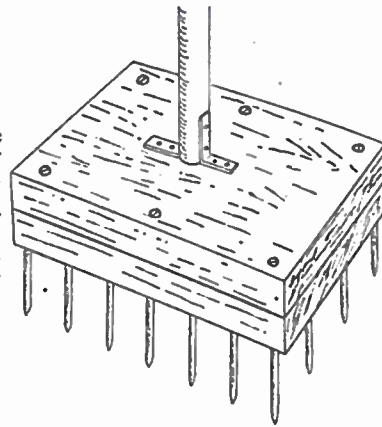

There may be no apparent immediate benefit since the combined action of air, water and fertiliser is usually a slow process, and it will be necessary to repeat the entire operation at intervals if a healthy sward is desired. (S.H.L.)

Flower pot soil Firmers

WHEN sowing seeds in flower pots or seed boxes greater success is generally achieved if the soil is in the proper condition to receive them. Making the soil firm and even is more important than some of us realize, yet a few with 'green fingers' can get anything to grow in any old way.

For the gardener who loves to do everything exactly according to the book we have designed a set of soil firmers which, as the name implies, make the soil firm and of a more even texture than can be done by ramming it in with the fingers.

Soil that is rammed too tight will restrict the drainage, and when the

firmness, but with an open texture, so that the air can penetrate the soil and this can be achieved by using the right firmer. For a flower pot the firmer is round and the most popular sizes are 3 ins. and 4 ins. diameter, while for a seed box it should be about 4 ins. square.

A small pot will need an equally small firmer, but in order to achieve its object efficiently, it should not be less than 2 ins.

Oak, ash or similar hardwoods are most suitable, and should be from $\frac{1}{2}$ in. to 1 in. thick. Drill the central hole about three quarters of the way through for the handle, which can be dowel rod or a piece of broom handle $\frac{1}{2}$ in. to 1 in. diameter and about 6 ins. long. See that it is upright, and is a good tight fit, and it is better not to use glue if you can secure it without.

It may be easier to drill the hole right through, push the handle through the firmer and smooth off level. A better idea however, is to face the end with a tin lid. Choose one with a right angle side and cut your block to fit nicely into this, so that when the handle is fixed, you just push the lid on and fix secure with a few fine pins round the edge.

The same idea can also be applied to a square firmer by cutting a piece of tin about $\frac{1}{2}$ in. larger all round and turning over the edges and tacking on as before.

Round off the top of the handle and well glasspaper all the woodwork. A coat of paint will help to preserve the tool and improve its appearance, but this is not a necessity. (A.F.T.)

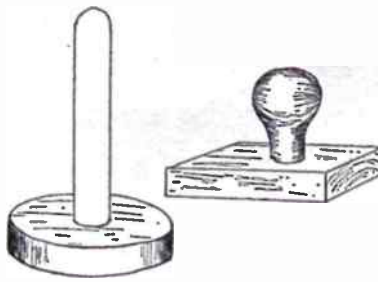

water cannot get away easily, it is liable to rot the seeds before they have a chance to germinate. On the other hand, if the soil dries out badly, there will be greater difficulty for the water to reach solid lumps of consolidated soil.

What is wanted is a certain degree of

For the angler

A FOLDING CHAIR

A CHAIR of this type is useful for fishing expeditions, and is also handy in the garden. Now is the time to get down to jobs like this when the long winter evenings provide time for constructional work.

The chair consists of a stool portion and a folding back. The stool or seat is made up from two separate folding parts shown in Fig. 1. All necessary measurements are shown and it should not be difficult to cut the various pieces to size. Make sure when assembling that

you allow enough clearance for paint or polish on pieces (A).

Pieces (A) are cut from $1\frac{1}{2}$ in. by $\frac{1}{2}$ in. wood and are 22 ins. long. They are tenoned at the top and let into mortises in the pieces (B) and (C) which are both cut from lin. square wood. Piece (B) is $15\frac{1}{2}$ ins. long and (C) 17 ins. The two sections are pivoted by means of screws or rivets.

The two bracing pieces (D) for the front are $17\frac{1}{2}$ ins. long by $\frac{1}{2}$ in., and those for the back are 16 ins. long.

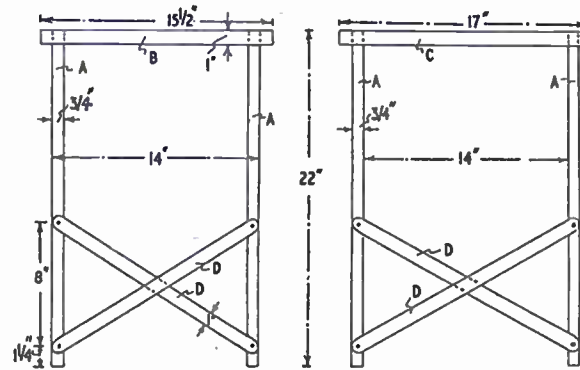

Fig. 1

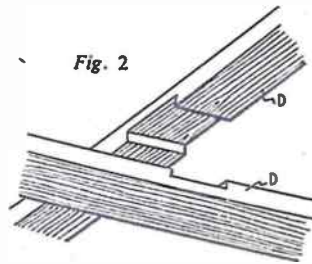

Fig. 2

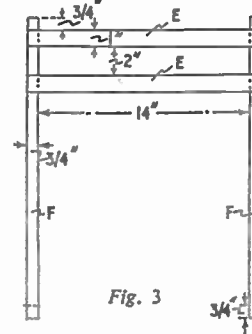

Fig. 3

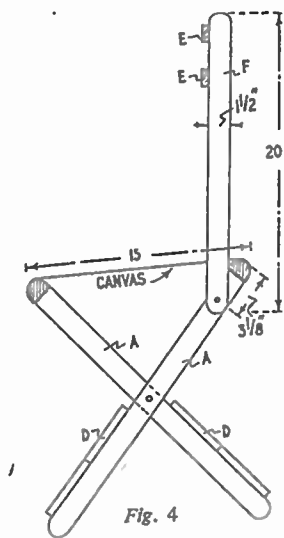

Fig. 4

They are halved together as indicated in Fig. 2. Secure them together and to pieces (A) by means of glue and screws.

The back is shown in detail in Figs. 3 and 4, and is made up from two pieces



(E) and two (F). The cross-pieces (E) are $15\frac{1}{2}$ ins. long by $\frac{1}{2}$ in. by $\frac{1}{2}$ in. They should be glued and screwed to pieces (F), spacing them according to the measurements. The lower ends are bored for round-head screws on which they are pivoted to pieces (A). The measurement in Fig. 4 gives the correct slope for the back and this could be adjusted by trial and error if desired. The projections of piece (C) hold the back support in position.

Cover the seat portion with canvas, allowing the seat to open to about 15 ins. The canvas should be doubled at the ends, tucked under and secured by large-headed tacks.

The chair may be finished off by staining and polishing or by painting. (M.h.)

Simple Barometer

A SIMPLE barometer can be made from an empty vinegar bottle, a glass jam-jar and some water coloured with red ink. Half fill the bottle with the coloured water. Place the jar upside-down over the bottle. Then reverse, so that the jar is standing upright with the bottle standing in it upside-down.

The coloured water will flow into the jar until the level of the water in the bottle is about 2 ins. above that in the jar.

By the rise and fall of the water in the neck, the weather may be fairly accurately foretold. Fine weather will cause it to rise, while a drop may presage rain or rough weather. A ruled card fixed behind the jar enables the rise or fall to be seen more easily. (R.L.C.)



DURING the winter season stamp auctions are taking place all over Great Britain and when a stamp fetches a good price, it is invariably reported in the daily Press. As a result of seeing one of these notices, some people recall that they have some foreign stamps tucked away in a drawer. They fetch them out and wonder if theirs are as valuable as those reported upon as a result of the auction, but the difficulty is to find out.

If the desire is to sell the stamps, then there are two easy ways of solving the problem. Either the stamps can be sent to one of the reputable stamp dealers with a note asking them to make an offer, or they could be sent to one of the auctioneers, asking them to put the stamps in their next sale.

Perfect condition

Two things should be remembered, first, all stamps must be in perfect condition, a torn stamp, even only very slightly torn is valueless and should not be sent; and if the stamps are unused, then they must have all the gum on the back and be perfectly clean. Secondly a stamped addressed envelope should be sent in case the stamps are not good enough to be put into an auction, or in case the firm does not wish to buy them. If the stamps are sent to an auctioneer then it will probably be about ten weeks before the money is received — the stamps have to be entered in the sale catalogue, this has to be printed, etc., so there is bound to be some delay.

If sent to a dealer, then he will probably make an offer by return of post, which, if accepted, would be sent immediately, but if the offer is refused, most firms do not hold their offer open for acceptance at a later date.

Possibly the worry is to know if the stamps are worth sending to either the dealer or the auctioneer, but this worry need hardly arise if the stamped addressed envelope is sent. After all they deal in stamps, and they will decide in a very short time what they are prepared to pay.

If it is purely a matter of the owner wishing to know the value of his stamps, then he must be prepared to buy a catalogue and learn to use it. First of all he must know what a catalogue is. If he looks up a certain stamp in two different catalogues it is quite likely that he will

find slightly different prices in each. A catalogue is really a large price list issued by a firm to let customers know how much they will have to pay if they wish to purchase a certain stamp. It is not likely that they will each have exactly the same stock of stamps, and so some prices may differ very slightly.

Suppose one wants to purchase a certain stamp. You send to a firm quoting the number of the stamp according to their catalogue, or else giving the value, date of issue, etc. They will have to open the letter, send a clerk to the particular stock book, on a particular shelf, in a certain room, and the specimen is found. Now the rent of the room has to be paid, the stock book bought, the shelf has to be put up and also the clerk's wages have to be paid, and these factors have to be taken into account when the price of the stamp is fixed. If you happen to have a stamp priced at 1/- in the catalogue and you wish to sell it, it would be ridiculous to expect 1/- for it. To begin with it is doubtful if the condition is as good as the condition of the specimen priced, secondly, you have no room, shelf, or stock book to provide, yet the firm has quite a lot of money to pay out after buying the stamp, before it is sold again.

We mentioned above about learning to use a catalogue. The point is that there are so many stamps of exactly the same design but having either different colours, watermarks, perforations or even thickness of paper. Each of these factors may have a bearing on the price

We cannot undertake to evaluate stamps for readers, but some helpful hints on this subject are given here by

L. P. V. Veale

of the stamp, so the user must be able to classify a stamp before he can find out the value:

Lastly, one must mention fashion. It may seem remarkable that one must talk about this in connection with stamps, but it is a most important factor if one wishes to sell them. Some countries are popular while others are not. Great Britain, for example, will always be popular, but stamps from some of the foreign countries are far less likely to sell.

Health stamps

Mr. G. L. Donaldson of Auckland, New Zealand, has again been most kind in sending specimens of the 1956 Christmas Health stamps. Not only has he sent an official first day cover clearly stamped 24th Sept., he also sent the most interesting cover shown here. The design of the three health stamps issued this year is taken from a photograph by Mr. J. F. Loudon, the grandfather of Graeme and Peter Wilson, the two boys who are depicted in the photograph. The envelope also bears the signatures of the two boys. As can be seen, the cover was postmarked at the Pakuranga Health Camp.

It seems likely that the sales of these stamps will be a record this year. For example, at Tauranga on the first day £835 worth of stamps was sold, £132 more than was taken at the corresponding first day last year, and Graeme and Peter Wilson helped with the sale. In the Auckland District the total was £4,018 against £3,726 last year. This design is a really nice one.

GRAEME AND PETER WILSON, TAURANGA. PICK N.Z. APPLES



Signatures
G. Wilson P. Wilson



Mr. G. Donaldson,
Canadian Pacific Railway Company,
P.O. Box 1350,
AUCKLAND.

A REPRODUCTION FROM THE DESIGN-WINNING PHOTOGRAPH BY J. F. LOUDON, TAURANGA, WHICH WAS USED TO PRODUCE THE 1956 HEALTH STAMPS.

NEW! THE EASY PRACTICAL WAY of learning RADIO · TELEVISION · ELECTRONICS

COMPLETE EXPERIMENTAL COURSES IN RADIO ENGINEERING and SERVICING

An entirely new series of courses designed to teach Radio, Television and Electronics more quickly and thoroughly than any other method. Specially prepared sets of radio parts are supplied and with these we teach you, in your own home, the working of fundamental electronic circuits and bring you easily to the point when you can construct and service radio receivers, etc.

With these outfits, which you receive upon enrolment and which remain your property, you are instructed how to build basic Electronic Circuits (Amplifiers, Oscillators, Power Units, etc.) leading to designing, testing and servicing of complete Radio and Television Receivers.

COURSES FROM 15/- PER MONTH

EMI INSTITUTES

associated with "His Master's Voice", Marconiophone, Columbia, etc.

- Beginner's Radio Course
- Advanced Radio
- Short Wave Technique
- Lesson Manuals

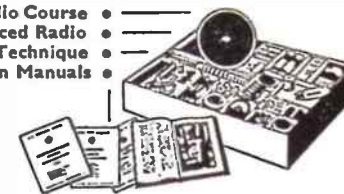

Experimental work includes construction of Basic Oscillators, Amplifiers, Deflectors, Power Units, 1, 2 and Multi-valve TRF and Superhet receivers.

POST THIS COUPON TODAY

To E.M.I. Institutes, Dept. 31, Grove Park Road, London, W.4.
Please send me your FREE book on Practical Courses

NAME _____

ADDRESS _____

Jan 2

1C74

HEAR ALL CONTINENTS With H.A.C. Short-Wave Receivers

Suppliers for over 18 years of Radio S-W Receivers of quality.
One-Valve Kit, Price 25/- Two-Valve Kit, Price 50/-
Improved designs with Denco coils. All kits complete with all components, accessories and full instructions. Before ordering, call and inspect a demonstration receiver, or send stamped addressed envelope for descriptive catalogue.
H.A.C. Short-Wave Products (Dept. 22), 11 Old Bond Street, London, W.1

WATCH AND CLOCK REPAIR OUTFIT



The complete Outfit for cleaning and repairing. Comprises: illustrated explanatory booklet, eye-glass, tweezers, screwdrivers, oil, dusting powder, oilers, also illustrated catalogue, tools and materials.
Plus P. & P. 1/- extra. 12/9
C.O.D. if required.
The above with additional luminous compounds, jewellers' rouge, dial brush, jewels.
Plus P. & P. 1/- extra. C.O.D. if required. 21/-

ASSEMBLE YOUR OWN JEWELLERY

Selection of unset earrings, pendants, rings, brooches and stones, etc. at fraction of cost.
Send S.A.E. now for big illustrated free catalogue.
Money back guarantee.

THE BOLSTER INSTRUMENT CO. (Dept. HBI)
GOVETT AVENUE, SHEPPERTON, MDDX.

12/6! CRYSTAL RADIO

Make the 'WINNER' crystal set—only a screwdriver and pliers required, only 6 screws to fit, no soldering. Kit of parts with building instructions only 12/6 post free. Building instructions alone, 1/-

Send P.O. 1/- or 12/6 to:—

BLANCHARD'S RADIO

(Dept. H2), 13 GAINFORD GARDENS, MANCHESTER, 10

NOW
BIGGER & BETTER!
Than Ever

BIGGER Format
Increased to 10 3/4" x 8 3/8" — no less than 1/3rd extra!
BIGGER Pictures
Whole page illustrations to show more detail!
BIGGER Coverage
More subjects — more features!
BIGGER and Better in every Way!
SEE TO IT NOW!

RAILWAY MODELLER

FROM ALL GOOD MODELSHOPS AND NEWSAGENTS
2/3 direct from

2/-

PECOWAY : SEATON : DEVON Monthly

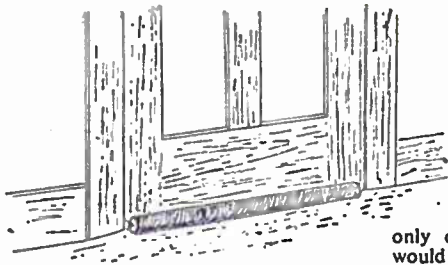

Keep the cold away

A DRAUGHT EXCLUDER

WITH the winter days we begin to seek means of preventing cold draughts as we sit around the cosy fire. And probably some of the worst draughts enter from beneath the door which cannot fit exactly to the floor, especially when the thickness of the carpet has to be considered.

Door draughts can be easily remedied by means of a simple excluder made from a roller and a small piece of some of the rubber backed, felt carpeting now on sale.

Use a broom handle

A broom handle, or something similar, should be cut about 1½ins. shorter than the width of the door and the ends carefully smoothed off with rasp and glasspaper. The next part of the job is covering with the material. This may be rolled on quite simply and fastened either by glue or tacks, but it is far better to spend a little more time on the job, rolling the material round the rod in strips. An average door measures 2ft. 6ins., and the diameter of the roller will be approximately 1in. Allowing for a little overlap to trim away at the ends, you will need a small strip of material 5ins. by 30ins., which should be quite easy to buy as a remnant from any carpet store. This strip is cut into two, making two strips each 2½ins. wide. Needless to say, a suitable colour should be chosen to match the other furnishings.

The strips must be carefully cut so that the edges are perfectly straight, for in winding round the roller we wish the edges to fit perfectly, so that there are no gaps.

Make a preliminary trial of the angle of winding, then fix one end with a tack. This is shown in the diagram. Keep the strip in position by additional tacks at various points or by attaching with some suitable rubber solution. If the latter course is adopted, it is better to apply the solution to the rod and back of the carpeting, as the work proceeds. When the first strip, which should reach the centre, is fully wound, commence with the second strip, winding round the roller until the end. Trim the ends and the roller part is complete. You will appreciate that it is better to use

only one strip of material, but this would involve buying one piece 2½ins. wide by 60ins. long, and it is doubtful whether your carpet store would supply.

We now come to the problem of fixing to the door.

Bore a hole in each end of the roller with a gimlet, fixing stout round-headed screws, but leaving the shank visible. Lay the covered roller on the floor against the outside face of the door, carefully marking the position for two screw eyes which fit into the door and engage with the shanks of the screws.

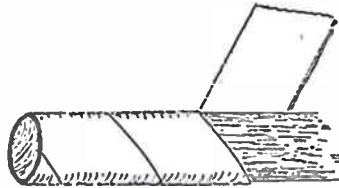

Covering roller with strip

The screw eyes may be fixed to the door and we now remove the screws from the ends of the roller. The roller is placed between the screw eyes and the screws replaced, but this time a washer is inserted to prevent the screw slipping out. It should be mentioned that the screw eyes must have a long shank to meet the radius of the roller, and eyes large enough to allow some play where the roller has to rise to meet the thickness of carpeting inside the room.

An alternative method of attaching the roller to the door, and equally effective, is to make some small brackets. Obtain a pair of 2ins. or 2½ins. angle brackets, laying the roller against the door as before, but this time marking the position for the brackets. One side of the bracket is drilled to accept the roller screw, with a hole large enough to provide the necessary play as mentioned, probably ¼in., and the balance of the bracket is then cut away. A suitable washer will be required as with the screw eye fixing. The angle brackets should also be given a coat of paint to match the woodwork.

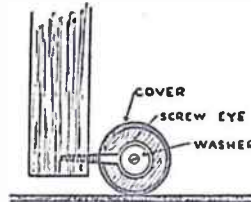

Fix roller with screweyes

Once fixed, these excluders will last indefinitely, and it is quite a simple matter to remove them in summer time for cleaning. Should there be any squeaking in operation, a drop of oil will remedy, or a little touch of grease.

It should be remembered that the excluder is fitted to the outside of the door. In some instances a door may open towards a wall, in which case it would not open fully if the excluder were on the inside. (S.H.L.)

R. H. Warring says

MAKE LOW-LEVEL STEPS

TO save straining yourself trying to reach the top of a wardrobe or a high shelf, make a pair of 'low level' steps to place alongside. Build up from stout wood to the pattern shown, screwing or nailing all joints. Fitted in back panels will give the assembly rigidity. Mount the whole on a ply or hardboard base.

The space underneath the steps is useful storage for shoes (in the bedroom) or cleaning materials, etc. (in the kitchen). Paint or stain and polish to finish, and stick on rubber tread mats as a finishing touch.

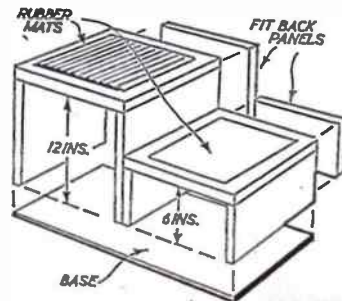

THE FAMOUS BENNETT COLLEGE can train your mind to SUCCESS

WHAT CAREER DO YOU WANT?

Architecture
Agriculture
Building
Carpentry
Chemistry
Commercial Art
Diesel Engines
Draftsmanship
Electrical Engineering
Electric Wiring
Mechanical Engineering
Motor Engineering
Plastics
Plumbing
Quantity Surveying
Radio Engineering
Surveying
Surveyor's Examinations
Telecommunications
Television
Textiles

Accountancy Exams.
Auditing
Book-keeping
Costing
English
General and Commercial Arithmetic
General Education
Geography
Journalism
Languages
Mathematics
Modern Business Methods
Police Subjects
Salesmanship
Secretarial Examinations
Shorthand
and many others
GENERAL CERTIFICATE OF EDUCATION

THROUGH PERSONAL POSTAL TUITION

A FREE book

vital to your career!

Read how the famous Bennett College can help you to success! Send now for this recently published FREE Book, "Train your mind to SUCCESS", which tells you about The Bennett College proven success in postal tuition... and how it can help you to success in your career.



TO THE BENNETT COLLEGE (DEPT. B.62N), SHEFFIELD
Please send me, without obligation a free copy of "Train your mind to SUCCESS" and the College Prospectus on:

SUBJECT
NAME
ADDRESS
AGE (if under 21) Please write in Block Letters

THIS COUPON

COULD BE YOUR PERSONAL PASSPORT TO SUCCESS.

Send it NOW!

Make model buildings —



as simply as this!

A new method—described in a new book on Pyruma Modelling. This shows how to turn empty match boxes into model buildings, by Pyruma 'Plasticraft'. It is one of the many methods of modelling in plastic Pyruma, shown in black and white and full colour pages, which enable you to build and finish in natural colours:—

MODEL FARMS, RAILWAY STATIONS, SIGNAL CABINS, AIRPORT BUILDINGS, DOCKS, SHIPS, FIGURES, ANIMALS, ASHTRAYS, BOOKENDS, DOLL'S FURNITURE, PLAQUES, RELIEF MAPS, ETC.



Is a ready-to-use material, cheap to buy locally, and easy to work by following the Instruction Book offered below. Pyruma dries or can be baked to stone-hard permanence, then painted in natural colours. Sold by local Ironmongers and Hardwaremen, Hobbies shops and Art material Dealers, in airtight tins from 1/6 upwards.

Send Coupon and 6d. P.O. (not stamps) for this NEW Book of instructions to:—

J.H. SANKEY & SON, L^{TD}

Estd. 1857

Dept. H, ILFORD, ESSEX

Enclosed 6d. P.O. (not stamps) for PYRUMA MODELLING INSTRUCTION BOOK addressed to:—

NAME (Block letters).....

ADDRESS.....

.....

CASH **WRIST WATCHES**
REAL GOLD PLATED
 FRONT AND BACK
NO DEPOSIT



LADIES OR GENTS MODELS
 'AIRCRAFT' shock resisting wrist watch. Fitted accurately tested pin-lever movement. Written guar. Cases are REAL GOLD PLATED all over, dials are silvered with gilt raised figs, and hands. Send only 2/6 for packing & registration, bal. 18 fortnightly parts.
 3/8. CASH, on strap, 59/6 or LADIES' MODEL 10/- extra. Matching bracelet 12/6 extra. Luminous 6/6 extra. Lists, Watches, Terms. Complete transmitting and Receiving apparatus for two persons.

AMAZING GOVERNMENT SURPLUS INTERCOM
 MOBILE OR STATIC
 ONLY 12/11
 POST ETC. 2/1

Communicate at distances of a few yards, room to room, or will adapt for use up to a mile, from buildings or over country. Self-voice generating at normal telephone strength due to scientifically wound coils and armature. Sensitive diaphragm. No batteries or electricity—it just works! Send 12/11, post 2/1. Ready for use in 5 minutes.
 Headquarter & General Supplies Ltd. (HOBW/40), 196-200 Coldharbour Lane Loughboro Junction, London, S.E.5

KUKLOS ANNUAL. Indispensable cyclist's handbook. Tours, resthouses, money-saving hints, 2/10, post free. — Burrow, Publishers, 2 Imperial House, Cheltenham.

LEARN it as you do it — we provide practical equipment combined with instruction in Radio, Television, Electricity, Mechanics, Chemistry, Photography, etc. — Write for full details to E.M.I. Institutes, Dept. HW47, London, W.4.

Classified advertisements are accepted at a cost of 6d. per word prepaid. Send P.O. with advertisement to Advertisement Dept., Hobbies Weekly, Dereham, Norfolk

'PAINTSPRAYING' HANDBOOK. Covers Car, Industrial & Flock Spraying. 3/6, post 4d. Catalogue of our Cellulose and Paints and all Allied Sundries 2/6. — Leonard Brooks Ltd., 81 Oak Road, Harold Wood, Essex.

GENUINE Swiss Musical Movements. The best and largest selection of tunes in the country, lowest prices 16/3 each. Genuine Thorens Movements, 22/9 each. All guaranteed. P & P. 9d. extra on all orders. — Richardson & Forder, HW, 5 Chapel Place, White Hart Lane, London, N.17.

WHEELS (Hardwood and Rubber Tyred Metal). Cot, Pram and Doll's House Fittings and Papers. Beads, Transfers, Prints and other accessories. Stamp for new lists. (Trade supplied.) New address — JOYDEN CO., 91 Peplins Way, Brookmans Park, Herts.

GOVERNMENT SURPLUS BARGAINS. Inter-room Telephones, comprising 2 self-energised microphone/receivers and approx. 6yds. flex (may be extended if desired). No Batteries needed. Nothing to wear out. Complete 9/6, post 6d. Motors, Transformers, Switches, etc. 3d. stamps for illustrated list. Milligan's, 24 Marford Street, Liverpool, 3. Money Back Guarantee.

MODERNISE YOUR HOME WITH ARNOBOARD
 Send 1/6 for R. W. D. Kirkham's comprehensive illustrated book which shows you how; and FREE SAMPLE of Arnoboard, the prefinished plastic surfaced hardboard which works like ordinary hardboard. Finishes include wood grain, tile, marble effects, etc.
 Dept. 3, Arnolite Ltd, West Parade, Spring Bank HULL

EVERY CAR THAT PASSES—YOU WILL FIND THE INDEX MARK ALPHABETICALLY ARRANGED IN WHERE'S THAT CAR FROM?
 Price 9d.
 from all Booksellers or from the Publishers (2d postage)
RALEIGH PRESS, EXMOUTH

100 DIFFERENT stamps free! Request 1d. upwards discount approvals. — Bush, 53 Newlyn Way, Parkstone, Dorset.

REEVES PARCELS of plywood are here again. Do it yourself with our well known handy sized panels (various thicknesses) mostly Gaboon and Birch. Quality as good as ever. Parcels in 20/- and 15/- sizes. Send cash for prompt delivery to — Reeves, 33 Front Street, Monkseaton, Whitley Bay.

MODELS. You can make lasting stone-hard models with Sankey's Pyrama Plastic Cement. Supplied in tins by Ironmongers, Hardwaremen and Builders' Merchants. Ask for instruction leaflet.

ASTRO. TELESCOPE KITS 59/6. P/P 3/6
 2in. dia. at 40in. focus. Mag. 53 x linear (equivalent 2809 x area). Shows intricate lunar detail, Saturn's Rings, etc. Self adaptable parts. With large drawings and TEST CERTIFICATE.

ASTRO. TELESCOPES. COMPLETE.
 Superior stoved aluminium, black wrinkle finish. 2in. dia., length 39ins., with 3in. focus eyepiece. Mag. 53 x. Made to order. Price 117/6, carriage including strong stowing cylinder 10/6.

ASTRO. EYEPIECES. High Power 3in. focus. Mag. with above 80 x (6400 x area). Length 5 1/2in., turned brass, 28/- P/P 1/6. Also ideal for reflecting telescopes.
ALTAZIMUTH PORTABLE CLAMP STANDS. For mounting above instruments 32/6. P/P 2/-.

ASTRO. BOOKS, PLANISPHERES, ETC. Large detailed Moon Maps, 28 x 20ins. 5/- P/P 6d.

Send stamp for full particulars and lists in first instance. Telescope and Kit Photos 1/- set (returnable).

HOLMES, WILSON & CO.
 Dept. H, MARTINS BANK CHAMBERS,
 33 BEDFORD STREET,
 NORTH SHIELDS,
 NORTHUMBERLAND

HOBBIES BRANCHES
 LONDON
 78a New Oxford Street, W.C.1 (Phone MUSEUM 2975)
 87 Old Broad Street, E.C.2 (LONDON Wall 4375)
 81 Streatham Hill, S.W.2 (TULSE Hill 8796)
 GLASGOW—326 Argyle Street (Phone CENTRAL 5042)
 MANCHESTER—10 Piccadilly (Phone CENTRAL 1787)
 BIRMINGHAM—100a Dale End
 SHEFFIELD—4 St. Paul's Parade (Phone 26071)
 LEEDS—10 Queen Victoria Street (Phone 28639)
 HULL—10 Paragon Square (Phone 32959)
 SOUTHAMPTON—134 High St. (Below Bar)
 BRISTOL—30 Narrow Wine Street (Phone 23744)
 NEWCASTLE—42 Dean Street, Newcastle 1

SWISS MUSICAL MOVEMENTS. Before you buy send 2d. stamp for our illustrated brochure — Metwood Accessories (Dept. HW), Church St., Wolverton, Bucks. (Trade enquiries invited.)

STAMPS FREE — Empire Packet including Pictorials and Victorians with approvals. — Robert J. Peck, 7A Kemp Road, Bournemouth.

AMERICAN DELTAGRAM PUBLICATIONS. Things to make on your 'Lathe', 'Band Saw', 'Scroll Saw', 'Circular Saw and Jointer', set of four books 10/- inc. postage. Year's subscription 'Deltagram' 12/6. Send for complete catalogue. — Willen Ltd. (Dept. 57), 9 Drapers Gardens, London, E.C.2.

FREE Stamp Album and 20 stamps. Request Approvals enclosing 4d. Additional gifts given. — Beeze, 8 Langland Villas, Mumbles, Swansea.

1700 MARVELLOUS TRICKS. half-quarter price, five different Bargain catalogues. Send 2/- (returnable). — Orlestones, Riverside Road, Shoreham-by-Sea.

TATTOO materials; postal tuition. Tattoo mark remover. S.A.E. — 61 Stanley Ave., Dagenham.

MYSTIFY your friends! With five easily performed tricks for only 2/3 post free. — Kipps, 47 Westbourne Grove, Scarborough.

STOP SMOKING in 3 days or money back. Safe, pleasant, permanent. The only scientific way. No Will Power necessary. 'Conquered the habit in 2 1/2 days'. — F.C. 'Within 2 days I was free from the tobacco habit'. — W.G. 'Was a smoker for 2 years and broke the habit in 2 days'. — F.N. 'I used to smoke 20 a day . . . now I have no desire to smoke'. — J.M. Recommended by 'Health and Efficiency Magazine'. Complete course 6/6 (or \$1.00 bill). Details 2d. stamp. Sent under plain cover. **NATURE REMEDIES**, 28 (H/163) Dean Road, London, N.W.2. Established 1928

Job for the fretsaw

MONEY BOX FOR BABY

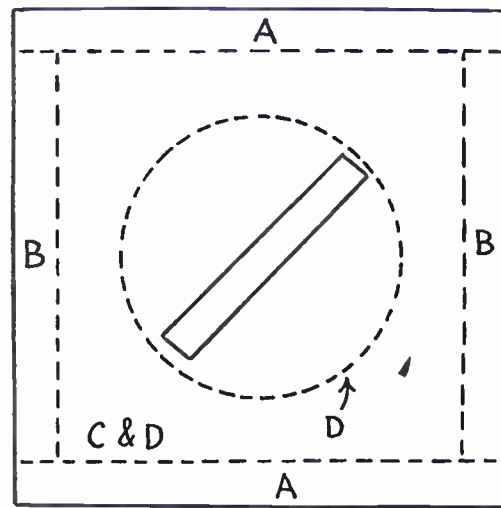

BASE
BROWN PAPER

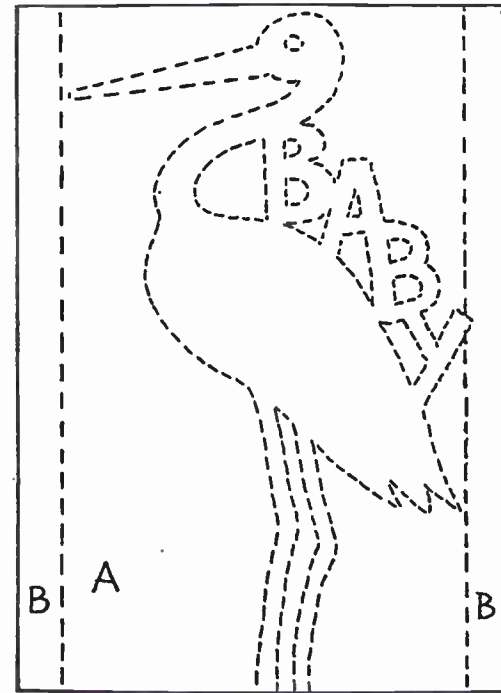

USE this special box for all the gifts of money baby receives. It would be a welcome gift in itself if nicely painted in bright colours.

It consists of two sides (A) and two sides (B), cut from 3/4in. wood. They are shown full size on this page. The top (C) is the same size as the bottom (D), but (C) has a slot for coins and (D) a hole which gives access to the money. Simply paste a piece of brown paper over as shown in the section.

The stork overlay is cut from 1/4in. wood and glued in the position shown by the dotted lines. (M.p.)

TAKE CARE IN CUTTING

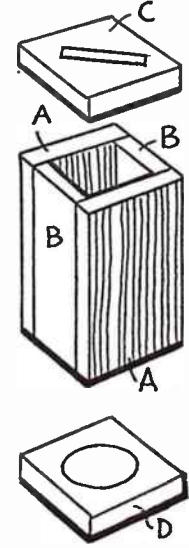

Make Leisure a Pleasure with



Some of our
Kits which can
be made up as
GRAND GIFTS

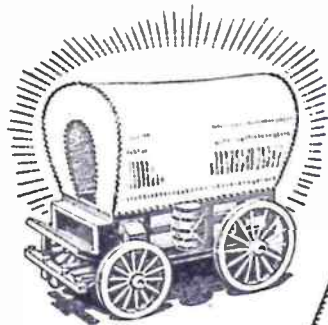

24/6 'Covered Wagon'
Kit No. 3156

**NOVEL,
PRACTICAL
ELECTRIC
LIGHTS**

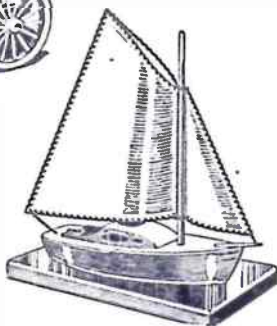

23/11 'Yacht' Kit No. 3110

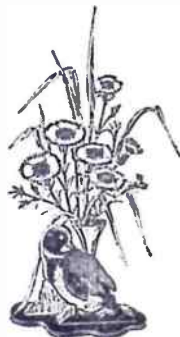

6/9 'Bird' Vase Holders
Kit No. 3140
(for a pair, including vases)



3/6 'Windmill' Egg Timer
Kit No. 3118

**CHARMING
DESIGNS
WHICH WILL
DELIGHT
EVERY
HOUSEWIFE**



Electric Tug 'Climax' Kit No. 251 Special
(including motor and propeller unit) **52/6**

— AND
**THRILLING
JOBS FOR
THE BOYS**



45/- Cruiser 'Crusader' Kit No. 3154
(including motor and propeller unit)

To Hobbies Ltd, Dept. 99, Dereham, Norfolk
Please send kit marked X (all post free)

- | | | |
|--|--|---|
| <input type="checkbox"/> Covered Wagon
No. 3156, 24/6 | <input type="checkbox"/> Egg Timer
No. 3118, 3/6 | <input type="checkbox"/> Tug 'Climax'
No. 251 Spl., 52/6 |
| <input type="checkbox"/> Yacht Light
No. 3110, 23/11 | <input type="checkbox"/> Vase Holders
No. 3140, 6/9 | <input type="checkbox"/> Cruiser 'Crusader'
No. 3154, 45/- |

NAME

ADDRESS

.....

P.O. enclosed for

From Branches,
Stockists etc, or fill
in coupon for one
of these fine kits

TODAY