

HOBBIES WEEKLY

APRIL 2nd 1958

VOL. 125

NUMBER 3257

IN THIS ISSUE

	Page
Child's Swing Chair	433
Firewood Chopping Block	434
A Versatile Power Unit	435
Flat Leg Table	437
The Art of Lettering	438
A Double Nameplate	439
Make Your Own Kite	440
The Dovetail Puzzle	442
Collectors' Club	444
A Case for Drills	447



All correspondence should be addressed to the Editor, Hobbies Weekly, Dereham, Norfolk

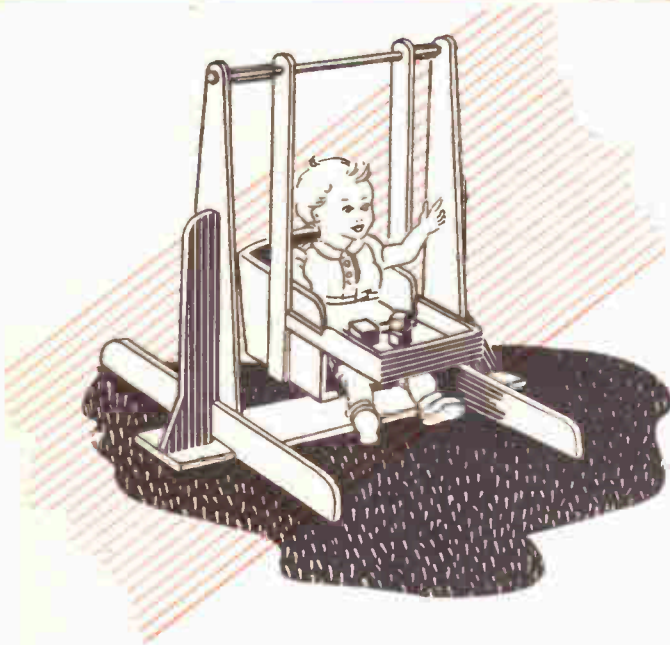

*Keep your youngster
happy—make this . . .*

SWING CHAIR FOR A BABY

BABY can enjoy an occasional swing and also play safely with bricks and toys in the tray provided in this novel swing chair. If suitably painted it can be used outside on the lawn as well as indoors. It is sturdily constructed and the wide base eliminates any danger of turning over.

The parts are all cut from $\frac{3}{4}$ in. wood and the main measurements are shown

in the various diagrams. You will see that there is plenty of scope for improvisation, so that any wood you have in stock may be used economically.

Commence by making the uprights (A) and (B). Glue and screw them together, remembering that there are slots in pieces (B) to take the cross members (C). Next glue (C) in position and then the cross piece (N) (Figs. 1 and 2).

433

The chair and tray (Figs. 3 and 4) are next made up and the tray screwed to the chair as shown in Fig. 3. Note that piece (K) which is the strengthening bar in the tray, also acts as a stop, resting on the projecting portions of pieces (F) of the chair.

The chair and tray are suspended from the rod (M) by means of the arms (D). These are screwed securely to the

FOR ALL HOME CRAFTSMEN
Over 60 years of 'Do-it-Yourself'

WorldRadioHistory

4 $\frac{1}{2}$ ^D

sides of the chair in the position shown in Fig. 3. The length of (D) depends upon the age of the child. They should be long enough to keep the feet off the ground.

The rod (M) should be $\frac{1}{2}$ in. diameter metal and may be threaded at each end to take a nut and washer. Before fixing, insert two lengths of garden hose to act as stops, preventing the swing chair from moving sideways.

Clean up well with glasspaper and give a coat of wood preservative such as Rentokil before applying two coats of paint. Where children are concerned it is preferable to use a synthetic paint rather than one with a lead base. (M.h.)

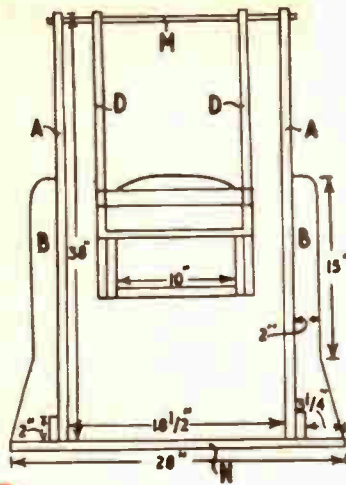

Fig. 1

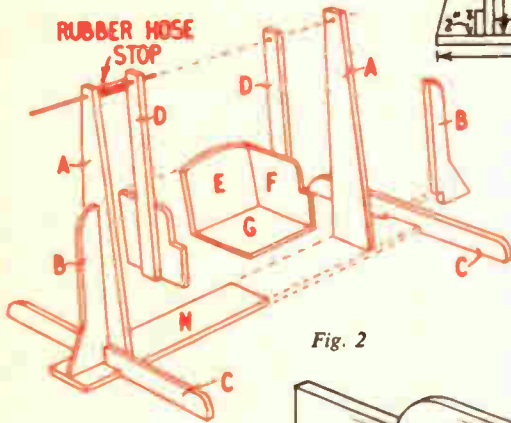
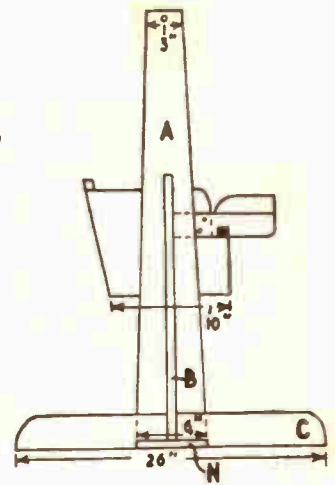

Fig. 2

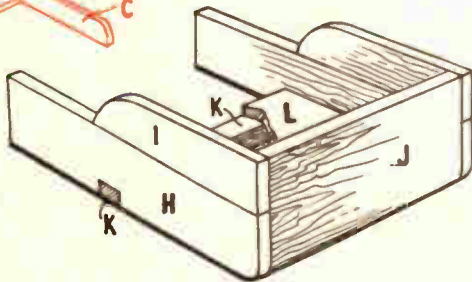

Fig. 4

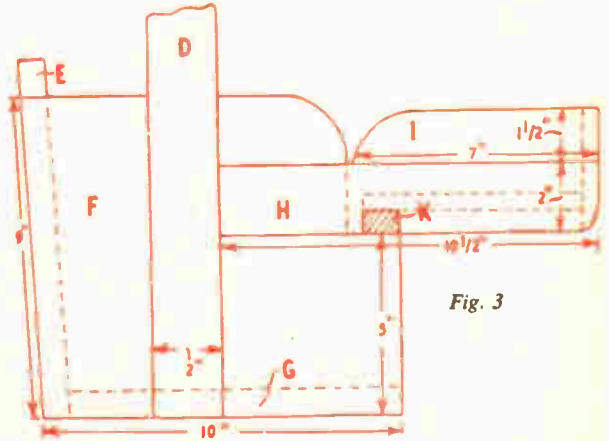

Fig. 3

Firewood Chopping Block

CHOPPING long lengths of firewood into smaller lengths can prove difficult — even risky. This simply constructed chopping board supplies a handy solution to the problem.

Nail a block (B) to the end of a base (A) and a smaller block (C) to the other end of the base. On top of block (C) nail or screw a strip (D) to give an overhanging edge on the inner side, as shown in the diagram.

To use the chopping board insert the stick of firewood under the ledge made by (D), resting the remainder of the stick against block (B). Chop the stick where it rests against (B). (W.J.S.)

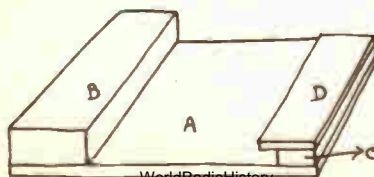

WorldRadioHistory

1958 Competition

April 30th is the last day for receiving entries in Hobbies £200 Fretwork Competition. Make sure your model is received at Dereham, Norfolk, in good time. Remember, there are a host of valuable prizes and entry is free.

A VERSATILE POWER UNIT

A PRIMARY concern of all radio constructors is a source of power supply. Each set demands its own particular power supply, and so one's requirements vary from set to set. Some are battery fed, others are mains fed, and the voltages vary. Many constructors often fancy building this or that set, but are loath to undertake the expense of the power supply merely for experimental work.

The answer here is to build a permanent bench source of power supply that will to a considerable degree supply any set that the constructor might wish to build and try out experimentally.

The unit described here will supply voltages from 45 to 200 at up to 60 mA. Heater voltages can be 6.3 volts at 2 amps, or 2 volts or 1.4 volts. It can be seen that most sets from battery types to domestic mains types can be supplied by the unit. It can be used for experimental purposes, but also for emergencies if the domestic set has a breakdown in its power supply. It is also useful for testing sets that have gone 'dead'.

The cost will be in the region of £2 10s. 0d. but the usefulness of the unit will more than repay the experimenter.

The size of the unit depends on the components used, but in any case it should not exceed say 9ins. by 6ins. by 2½-3ins. for the chassis itself.

The chassis can be made of plywood or aluminium. In the latter case, it is very important to insulate the negative line of the high tension section. This is necessary because some battery sets, such as the conventional four valve superhet 1.4 volt type, connect the H.T. negative to

By
A. Fraser

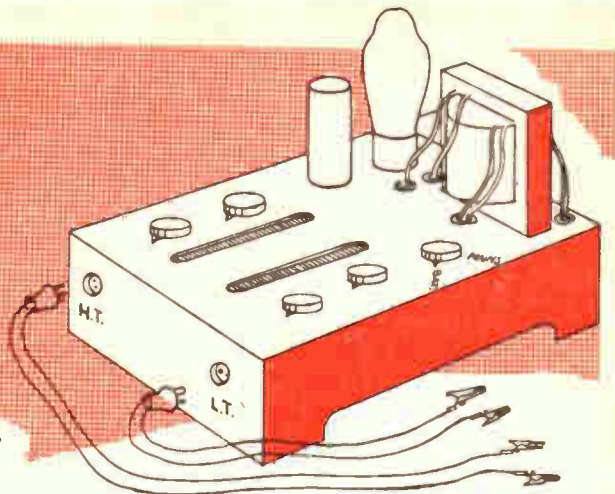

COMPONENTS LIST

Mains transformer, 250 volt 60mA. 6.3 volt 2A, 5 volt 2A. (11/9) (a)
Rectifier valve 5Z4G
E. 32-32mfd. 350 volt working.
J, metal rectifier, 6/12 volt. 1A. F.W. (Bridge) (4/11) (a)
K.K, 6,000 mfd. 6 volt working. (5/6) (a) or 1,000-2,000 mfd.
S, 4 pole, 2 way switch.
F. on/off toggle switch.
Wire-wound potentiometers 3-5 watt:
A (15K), B (100K), C (20), D (100)
Wire-wound resistor, 5 watt:
R (1.5K)
H.T. and L.T. battery socket strips.
H.T. and L.T. battery plugs.
4 Crocodile clips.

(a) Radio Supply, 32 The Calls, Leeds 2.

chassis only through a resistor for bias purposes. If the H.T. negative were earthed to chassis, the bias resistor would thus be shorted and no bias would result. So take care to keep the negative H.T. line insulated. Where the electrolytic smoothing condenser (E) has the outside of the can as negative, then this should not be allowed contact with the

chassis (if this is aluminium). Mount the condenser instead on a strip of paxolin bolted to the chassis.

It should be made certain, also, that the variable resistors (A) and (B) do not earth themselves through the shaft.

To the doubtful, the best way out is to make the whole chassis of plywood or at least the top deck of plywood or paxolin. This will guarantee insulation of the H.T. line.

A complete list of parts required is given separately in the article, and it is best to procure these first before making the chassis, setting them out experimentally to ascertain suitable dimensions.

Note that there are slots cut out in the deck of the chassis, adjacent to the variable controls, as well as a section cut out along the bottom of each long side of the chassis. These are for ventilation, for some heat is given off by the resistances.

The small holes (P), (Q), (R), (M), can be ¼in. diameter, while the cut for the valveholder should be 1½ins. Smoothing condenser cans (E) are generally 1½ins. diameter. The holes for the controls should be ¼in.

The wiring up of the unit should be clear and straightforward from the diagrams, but some observations can be made to help the constructor.

First, H.T. section. The mains transformer has two 250 volt secondary leads, but only one of these is used, the other being ignored. It is passed through the chassis at (P) to join tags 6 and 4 on the valveholder. The (O) volt lead goes through hole (Q) to connect with the outer case of the condenser (E). A soldering tag can be placed under the bolt of the condenser can clip for this purpose. Where the negative pole is not the outer case, but a special tag near the positive tags of the condenser, then the (O) volt lead should be taken to this

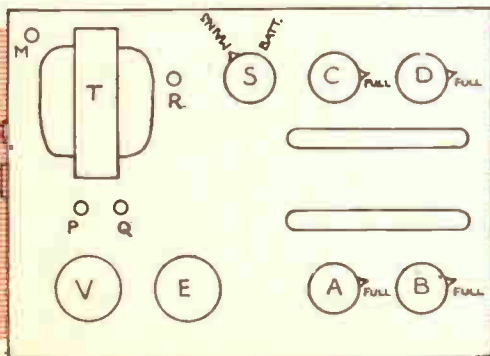

Fig. 1

point. Whichever is the case, join from this point to the negative socket on the end of the chassis.

The tags 8 and 2 are joined to the 5 volt leads of the transformer.

Now turn to the L.T. section. First find the two 6.3 volt leads on the transformer and pass these through the chassis at (R). Then connect them to the centre tags of the switch as shown in Fig. 2. The other centre tags are taken straight to the L.T. socket on the end of the chassis. Take care the right tag goes to the right socket.

The switch connections (outer tags) must be carefully followed, and one must be sure to get the connections to the metal rectifier (J) correct. The input tags are generally green or yellow, while the output tags are usually red for positive to the positive tag of the electrolytic (K), with black for connection to the negative case of the condenser.

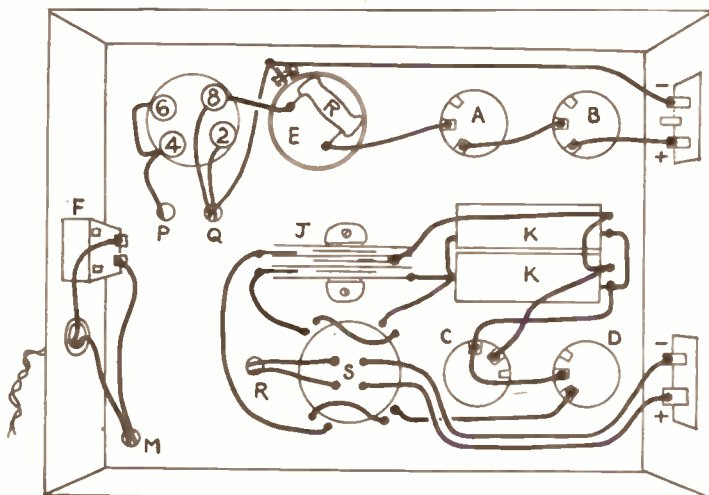

Fig. 2

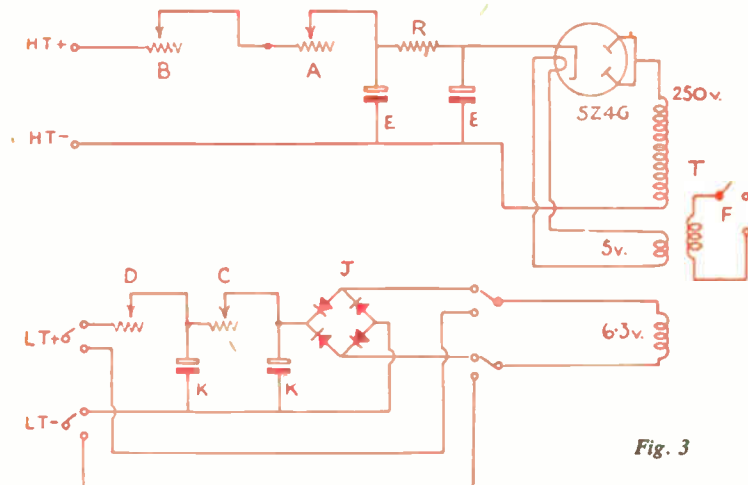

Fig. 3

The electrolytics (K, K) shown in the diagram were 1,000+2,000 types. They were connected together at the bottom of each can for the negative pole. The 1,000 mfd. tags of both cans were joined to form a 2,000 mfd. first positive pole, while the 2,000 mfd. tags were treated similarly to produce a 4,000 mfd. second positive pole. This latter is joined to the left outer tag of variable resistor (C), as shown.

Two condensers

Instead of this method, one could use two separate single condensers of 3,000 mfd. or 6,000 mfd. each (the bigger value is better). In this case, one would have only to deal with two single positive poles, one pole linking the rectifier positive to the centre tag of the variable resistor, with the other pole going to the left-hand tag. The negative ends of the

two condensers are joined, as before, and the black tag of the rectifier is linked to the switch, as shown.

It is essential to take great care in getting the wiring correct. Check as often as possible. See especially that the leads are correct to the appropriate tags of the H.T. and L.T. output sockets.

At the same time see that the leads are right with regard to the plug-in system. The plugs are the normal battery three pin for H.T. and two pin for L.T. With the L.T. the thick pin is the positive, while the H.T. plug has the positive pin on the right (looking at the pin bottoms with one pin below). Make the L.T. positive lead brown coloured and the negative green. The H.T. positive lead can be red and the negative black.

Labels are also recommended at the ends of the leads next to the crocodile clips, to avoid any chance of error.

The operation of the unit can now be described. The L.T. will be dealt with first and we assume a battery set is to be supplied, for example, a four valve 1.4 volt type.

Clip on the crocodile clips to their appropriate points in the set, taking care to avoid any accidental short circuit of the positive clip. To the same points attach the leads of a high resistance meter set to the 3 volt range. This is to measure 1.4 volts correctly.

Switch off toggle (F), and plug in at the mains. (Unit plugged in, but switched off.)

Turn switch (S) clockwise to second position, which switches set to rectifier (J).

Turn controls (C) and (D) fully clockwise so that full resistance is engaged.

Switch on the unit at toggle (F).

Correct setting

Slowly rotate knob (D) anti-clockwise and watch the meter reading. If the knob comes to a stop with the meter reading still inadequate, then start rotating knob (C) anti-clockwise very slowly. When the meter registers about 1.35 volts then this is a correct setting.

This point can be marked and a note made as to the type of set it covers. This will be useful for future reference, so that the unit can be set into operation without recourse to the meter.

The same procedure is adopted for all battery sets, using the meter to get the correct setting for the necessary voltage, and then noting the exact spot and the exact type of set. Each spot can be numbered and a card index employed, indicating the types of set covered.

The H.T. section for battery operation comes next. For this, the heaters of valves in the set must be in operation, either by battery or from the unit.

● Continued on page 437

Unusual and attractive

FLAT LEG TABLE



A LIGHT, useful and yet attractive table made of white pine and five ply wood, has three flat cut-out legs and a shaped shelf.

The round table top is 19ins. in diameter. A five ply wood is used, making this about $\frac{1}{2}$ in. thick. A simple system to draw the circle is to tie a pencil to a piece of string, looped at the other end, the overall length of the string from pencil to end of loop being 9 $\frac{1}{2}$ ins. Loop the string over a drawing pin or small nail inserted in the centre of the wood and swing the pencil around. This method will give a circle with a diameter of 19ins. The top is then easily sawn out. Smooth the edges with a glasspaper block.

A small strip of white pine $\frac{1}{2}$ in. thick and 2 $\frac{1}{2}$ ins. wide is needed for three leg supports; one 7ins. long with a mitred point and two pieces 5ins. long. Placing the table top upside down, mark out a triangle with 16in. sides, one point being at the centre top edge. A line should be drawn through the centre of the triangle from this top point. The 7in. piece of wood is laid 3 $\frac{1}{2}$ ins. from this top point on the centre line. Fasten down to table top with two screws. The two smaller 5in. pieces are screwed down 3 $\frac{1}{2}$ ins. from the two remaining points of the triangle and to jut against the mitred end of the 7in. piece as in Fig. 1.

For the shaped shelf first draw a circle 16ins. in diameter on the five ply wood. In this case the string will be 8ins. long. Within the circle mark a triangle with sides of 13 $\frac{7}{8}$ ins. At each triangle point draw a line on the edge of the circle $1\frac{1}{2}$ ins. each side of point, making the line 3 $\frac{1}{2}$ ins. and saw along

the line to make the flat side of the shelf for the leg. Draw lines connecting the outer points of the three flat sides. These lines should be 12ins. long. Now from the same outer points of the flat sides, draw a line curving in. at the centre from the 12in. line and $\frac{1}{4}$ in. from the original triangle as in Fig. 2. Saw along the curved lines with a fretsaw and smooth edges.

The three legs are 28ins. long and are cut from $\frac{1}{2}$ in. white pine. They are tapered from 2 $\frac{1}{2}$ ins. at the top to 4ins. at the bottom. The very bottom of each leg is shaped with a scoop. Allow $\frac{1}{2}$ in. at each side and curve the middle up to $\frac{1}{2}$ in. at the very centre. 3 $\frac{1}{2}$ ins. from the

top of the leg a drop-shaped hole is cut 12 $\frac{1}{2}$ ins. long, using a fretsaw. This will bring the hole 12ins. up from the centre of the bottom scoop. The cut is $\frac{1}{2}$ in. wide at the top and widens to 1 $\frac{1}{2}$ ins. and waved down to $\frac{1}{2}$ in. It is advisable to draw a paper pattern of this drop-shaped hole and transfer to the legs.

By H. Mills

Drill a hole and saw out with the fretsaw as Fig. 3. Smooth the edges of the wood.

Insert a small screw-eye on the inside of each leg 10ins. up from the centre of the bottom leg scoop. These will hold the shelf.

The legs are next screwed to the top. Lay the table top once again upside down and fit the legs against the supports and screw on with 1 $\frac{1}{2}$ in. slight, countersunk screws, two screws to each leg.

With the table still inverted, slip the shelf under the screw-eyes on the legs and screw on with $\frac{1}{2}$ in. stout screws.

For a finish use a very small quantity of 'Bismark Brown Powder' mixed with a very small amount of water. Brush the stain well into all the wood of the table. Wipe off the surplus with a cloth and cover with a coat of size. To obtain a gloss apply a coat of varnish.

The table is of an unusual pattern and will stand firmly.

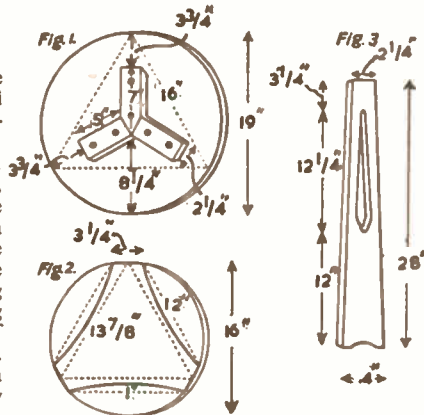

Continued from page 436

VERSATILE POWER UNIT

Connect up the clips to the correct points in the set, also the meter (this time using the 150 volt range. Take precaution against accidental short circuit of the positive lead.

Switch off toggle (F) and plug in at the mains. Turn controls (A) and (B) fully clockwise. Switch on (F).

Slowly turn knob (B) anti-clockwise, watching the meter reading. If the voltage is still not high enough after (B) has come to a stop, then start turning knob (A) anti-clockwise slowly until the correct voltage is recorded.

Note the spots the knobs indicate and enter this and the type of set in the card index, for future reference.

For mains set operation, the switch (S) is turned anti-clockwise to its first position, to cut out the eliminator section and switch the ~~Ward-Leitch~~ straight to

the 6.3 volt winding of the transformer. The knobs (C) and (D) are ignored in this case.

With mains set operation, the H.T. section is as before, only in this case the knobs (A) and (B) will have to be turned fully anti-clockwise to give maximum voltage that mains sets need.

One last warning. Always turn off toggle (F) before plugging in to the mains. Always turn all knobs fully clockwise before switching on. This ensures minimum voltages at the outset, for safety. It would be disastrous to switch on with the knobs inadvertently turned to voltages far too high for the particular set under treatment.

PUZZLEPIC (See page 441)

This unusual angle photograph is of an electric lamp bulb.

Interesting and profitable

THE ART OF LETTERING

THE art of lettering is undoubtedly one of the most interesting hobbies and when tackled in the right manner can be a very profitable one too. Every shop in the country is in constant need of tickets and showcards, while the organizers of concerts, fetes and dances must inform the public by means of posters.

Lettering is soon learnt and proficiency is easily gained with a comparatively short amount of practice. There is no reason therefore why you should not prepare tickets and showcards for your local shopkeepers and get paid for doing it.

If you are not interested in the financial side then why not make a study

The same paper may also be used to make tickets or showcards by pasting it on to a suitable thickness of card. Blank tickets can be bought cut to size, but it is better to get large cards and cut them to the various sizes you will need. They are made in white, black and a wide range of gay colours.

You will need bottles of black and red ticket ink for use with pen or brush work. These can be added to later with pots of showcard paints in an assortment of colours if desired.

Lettering with a pen is much easier than brushwork and can also be executed much more quickly. The hints in this article therefore will be confined to pen-work. Having mastered this technique it

is very suitable for starting with. Dip the pen in the ink and drain off any surplus on the edge of the bottle.

Keeping the working ball flat on the paper start off by doing the simple exercises in Fig. 2 and continue with each stroke until it comes easily, then

By A. F. Taylor

pass on to the next. Join up the various strokes to form letters, and do these in several sizes. Allow the hand and fingers to move freely and try to form graceful shapes. A cramped, jerky movement of the hand will produce badly shaped letters and you will find it very tiring work.

Fig. 3 shows the order in which to do the strokes to form the letters. Practice doing these several times and continue with the alphabet. When making a letter which is formed with a straight stroke and then a curve like capital J and U or

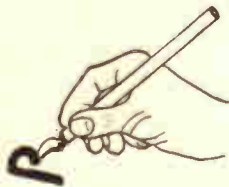

Fig. 1



Fig. 2



Fig. 3

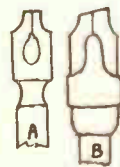

Fig. 4

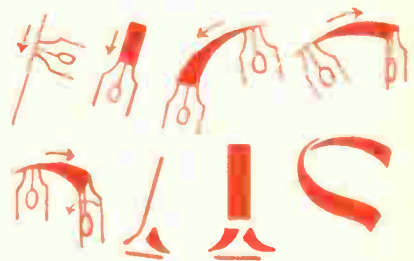

Fig. 5

of the different alphabets and their history, or make a collection of them? It is a most fascinating occupation and can keep you amused for a long time.

Very few tools and materials are needed to start with and a few extras can be obtained as you proceed with the work. It should be remembered however that it does not pay to buy cheap goods, even for practice. Good work cannot be turned out with inferior tools or material and the few pence extra is money well spent.

Ordinary drawing and cartridge paper can be obtained in various thicknesses and the light weight grade is suitable to start with and is quite cheap. Get a smooth surface paper or you may have trouble getting the colour to flow easily or evenly.

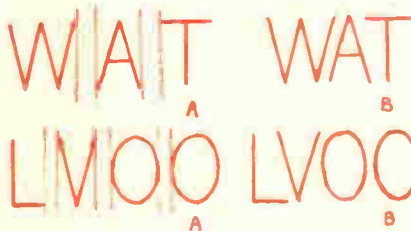

Fig. 6

will then be somewhat easier to use a brush.

There are several types of pen on the market, each of which is made for a particular job — different kinds of alphabets require different shaped pens. That shown in Fig. 1 is a ball point and

a small a, b, h, etc, you will find it easier to pause very slightly at the junction but do not take the pen off the paper. This will produce a better shaped letter, and is shown in Fig. 3 by a line at the junction.

We have just done the Gothic alphabet with a ball pen, now let us try another type which will produce a greater range, including the Roman and Text alphabets. With a square or oblique pointed pen it is possible to make both thick and thin strokes and anything between the two, whereas a ball point pen is capable of only one thickness.

The two pens shown in Fig. 4 will be found excellent for this style of lettering. Both are by William Mitchell, (A) is a square point round hand pen which is made in several widths, while (B) is a

Continued on page 439

A DOUBLE NAMEPLATE

FOR semi-detached houses, especially those with long front gardens, the double nameplate is a real blessing. It saves the postman, tradesman, and visitors much time in searching and is by no means an unsightly addition to the houses. It should be erected as near the centre of the two houses as convenient, and the post should be just tall enough to suit the average person's line of vision.

By W. J. Ellson

At A a half view is given of the nameplate alone, the missing half being identical, with the hand of course pointing in the opposite direction. The length given will suit for most names in common use, but can be lengthened to allow for longer names.

Cut the plate to length, and of course, allow extra for the part attached to the post. For this, a suitable length of 2½ in. sq. timber should serve. It will be noticed that the straight portions of the nameplate are for the actual names, the extra at each end for the hands. These can be drawn on paper and transferred through carbon paper to the wood. Only one hand needs drawing, and it should be transferred to the wood as drawn, the second hand being transferred through the paper, the latter being reversed. Both will then be symmetrical.

The names can be painted on in the usual way if the reader feels confident enough to make at least a passable result, otherwise the careful use of transfer lettering will give excellent results.

A good alternative is to cut the letters in the wood, using sharp chisels of suitable widths. Even a tyro can do a good job here, especially if he copies straight line letters instead of the more conventional type. An example of this form of lettering is shown at (B), and looks quite well.

Pencil in the lettering first, then cut with the chisel on the lines, pressing the tool inwards and at an angle of 45 degrees. Then cut on the inside of the lines, with the chisel at the opposite angle to remove triangular slips of wood to show the shape of the letter. Finish the ends neatly, the result being as at (C).

When lettering is finished, the nameplate can be stained and varnished, or painted. Paint in the lettering with white, or other coloured enamel, to bring into prominence. Any enamel creeping over the lettering to the plate should be

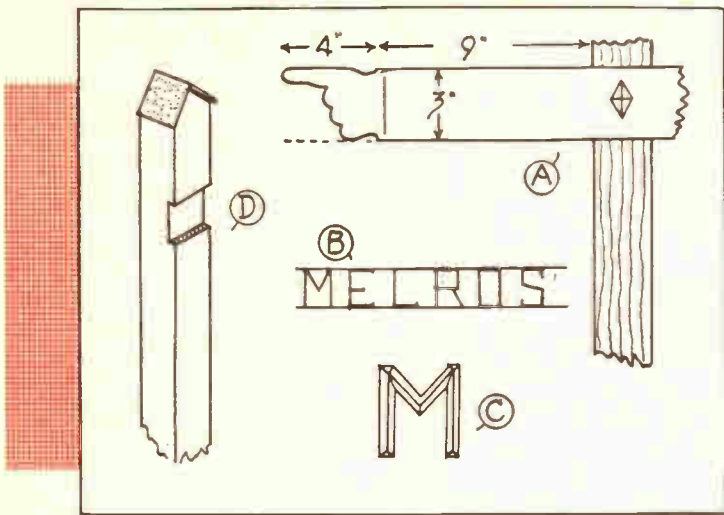

removed as soon as possible with a scrap of cloth, moistened with turpentine.

When cutting the post, allow 2ft. extra for insertion in the ground, and well creosote below ground level against rotting. Cut a groove ½ in. deep, into

which the nameplate can sink and screw the plate tightly in it. Bevel off each side of the top and cover with a piece of zinc, as at (D). Finally, to separate the two names fix in the centre a wood diamond, or similar decoration.

● Continued from page 438

Art of Lettering

wider version but with an oblique end and is called a poster pen.

To produce the thick and thin strokes the pen is held in certain positions as indicated in Fig. 5, which also shows the different strokes necessary to produce the letter. This will need a little more practice, but you will soon find it a good pen to use.

Modern newspapers and magazines contain a wide range of lettering of excellent quality, all of which can be copied. Start off with the easier alphabets and thoroughly master one before passing on to the next.

To make a ticket or poster look nice and attractive good letter spacing is essential. Good spacing is in fact more important than good lettering. Letters should not be spaced in mechanical fashion with an equal distance between them. Optical spacing is what is needed and you should study the work with half closed eyes. This will show up any defects and point out any extra large gaps or black spots.

To make printed matter appear pleasing the letters should be fitted together so that they read clearly. Avoid

gaps between irregular shaped letters by fitting them closer together. Reference to the examples in Fig. 6 will explain this — equal spacing between the letters is shown at (A), while at (B) they have been optically spaced so that they appear equal.

Plenty of practice is the best way to thoroughly master this important branch of lettering. Try out all the letter combinations and keep rearranging them until you are satisfied with their appearance. The mistakes you make while practising will teach you quite a lot — more in fact than whole volumes of instruction.

SOLUTION TO CROSSWORD NO. 14 PUBLISHED LAST WEEK

Across: 3. Flog. 7. Radar. 8. Alas. 9. Stag. 10. Bismuth. 12. Soda. 15. Irish. 18. Coir. 19. Asses. 21. Arena. 22. Abet. 23. Helix. 26. Late. 29. Muttlers. 30. Grim. 31. Wing. 32. Sneer. 33. Sash.
Down: 1. Rapid. 2. Marmion. 4. Laths. 5. Gags. 6. Bald. 9. Stir. 11. Uriah. 13. Oust. 14. Also. 16. Habit. 17. Fall. 18. Cent. 20. Sextant. 22. Alum. 24. Emits. 25. Green. 27. Apis. 28. Eggs.

High flyers these . . .

MAKE YOUR OWN KITE

THERE are several types of kites, ranging from the simple pegtop to the more ambitious box kite. When properly constructed they give hours of pleasure at little cost.

The pegtop

The best known, easy-to-make kite, is the pegtop pattern (Fig. 1). The backbone (A) is a 2ft. length of $\frac{1}{4}$ in. square stripwood. The bow (C) is formed from a 20in. piece of thin split cane or flexible wood. This is bent to a semi-circle, and held in that position by the bowstring (B). The centre of the bow is lashed to the top of the backbone with thin

enable quick adjustments to be made, the kite line is attached to the bridle with a reef knot and a bowline knot. The string tail is twice the length of the kite, and has a few twisted pieces of paper tied to it at intervals.

The Eddy kite

The backbone (A) is a 2ft. length of $\frac{1}{4}$ in. square stripwood shown in Fig. 2. A piece of thin split cane or flexible wood, 2ft. long, forms the cross strut (B). These two are lashed together (X) in the form of a cross, 4 $\frac{1}{2}$ ins. from the top of the backbone. A surround string (D) is run round these sticks to complete the

A bridle (C) and a kite line are fitted, like those for the pegtop. No tail is needed.

The Jet kite

This is a grand flyer seen in Fig. 3. The main centre rib (A) is a piece of split cane or flexible wood, 31ins. long. Two pliable cross pieces (B, 31ins. long and C, 15 $\frac{1}{2}$ ins. long), are also required. The cross piece (B) is fixed 1 $\frac{1}{2}$ ins. from one end, and (C) is 2 $\frac{1}{2}$ ins. from the other end of (A). Use thin twine to lash them

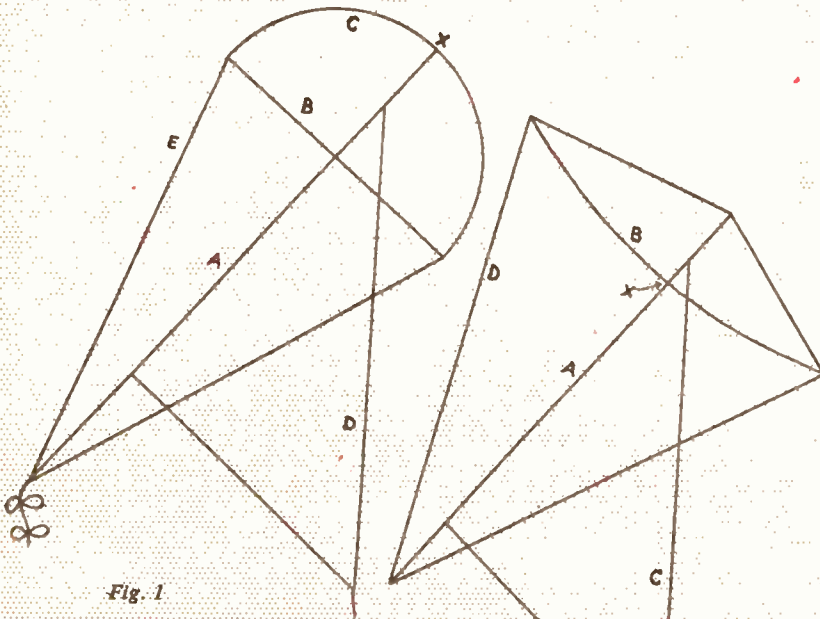

Fig. 1

twine (X). Two strings (E) are run from the ends of the bow to the bottom of the backbone, thus completing the frame. These strings must not be too tight. It is advisable to notch the wooden frame where the strings are tied to it, to prevent them from slipping.

Cover the kite with coloured tissue paper, gummed to the frame, or preferably, fine linen or similar light cloth.

A piece of string (D), double the length of the kite, has its two ends tied to the backbone, one near each end.

The kite line is attached to this bridle, so that the upper arm is shorter than the lower. The best position at which to fix the line to the bridle will be found by practice in flying the kite. To

frame. The ends of the cross strut are bent backwards, and held in position by a bowstring. The distance between the bowstring and the centre of the strut is 2 $\frac{1}{2}$ ins. The bowstring lies clear at the back of the kite.

The covering, of light cotton material, should be wider than the frame. This loose fit will enable the cover to bulge like a sail when the kite is flying.

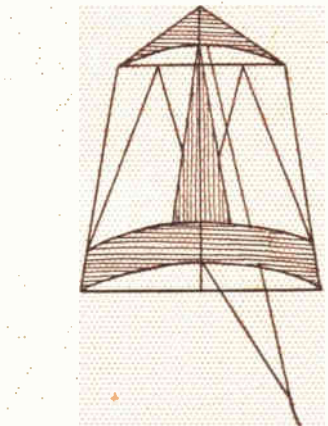

Fig. 3

together. Notch these sticks at the end to receive the string (D), which forms the outline of the frame and braces the parts.

Two cross strings are placed at (E) and (F) 7ins. from each end of the centre rib (A). Further bracing strings are crossed, as at (G) and tied to the cross string (F) as shown at (H), on both sides.

The cross piece (B) is curved upwards to form a bow, the centre of which is

3½ ins. above the string to which its two ends are tied. The shorter cross piece (C) is bent and tied in the same manner. The depth of the curve at the centre is 2½ ins. The centre rib is also tied to form a bow, the depth of the curve at the centre being 1½ ins. All these curves follow the same direction.

The front and rear parts of the frame, between the end and the cross strings, (E) and (F), are covered with tissue paper, indicated in the diagram by shading. This is gummed on to the two

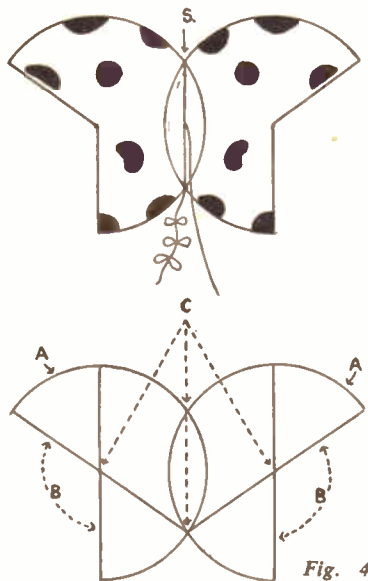

Fig. 4

cross pieces and the strings. The piece of tissue paper (L) is 4 ins. wide at (M), tapering to a point at (N).

The bridle string, 5 ft. long, is fastened to the centre rib (A) at the junction of the cross pieces (B) and (C). Usually the kite line is attached to the bridle at a point where it centres under the cross stick (B).

The Butterfly kite

This is a really lovely kite (Fig. 4) and most graceful in flight. Two 2 ft. 6 ins. lengths of split cane are required. These are bent to a curve as at (A). Tie a piece of strong string (B) to one end of each of these curved sticks, and take the string to a point 3 ins. from the other end.

Tie another string to the free ends of the sticks, and run up to a point 3 ins. from the ends which are already tied. These arched frames are then lashed together (C), so that they overlap, as shown.

Thin strong paper, marked with spots, will make a good covering for the wings. Allow for a 1½ in. margin of paper all round, so that it can be gummed

securely round the edges of the frame-work. Before gumming, cut slits round the edges of the paper, so that it will not wrinkle. A short tail, about 1 ft. long is needed. The kite line is attached to the centre of the butterfly's body, on a piece of string indicated at (S) in the diagram.

The Box kite

This is a great favourite, for it is an excellent flier. All the sizes given in

A bridle of strong string, 7 ft. long, is tied to one of the longerons, 6 ins. from either end. The kite line is attached to the bridle with a reef knot and a bow-line knot (J), to permit adjustments to be made. Usually, the lighter the wind, the shorter the front line of the bridle. When the wind is blowing strongly, it is advisable to tie the line direct on to the longeron, just behind the front band.

(H.R.)

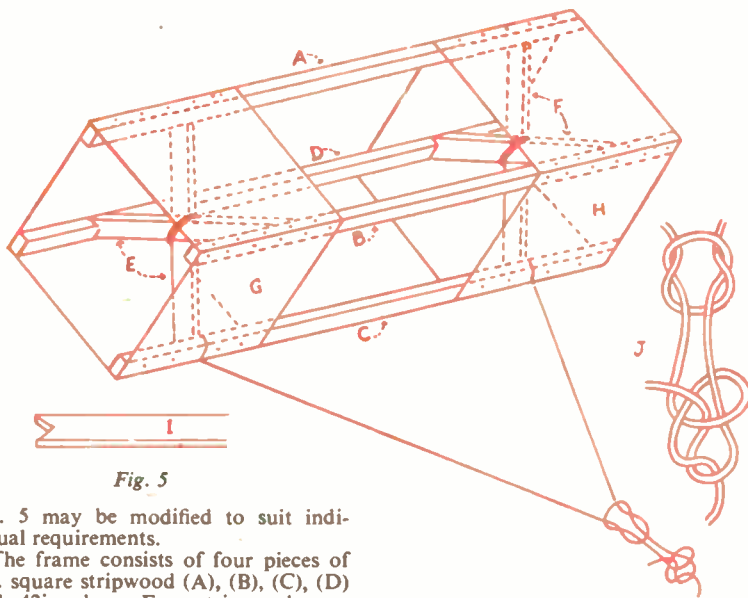

Fig. 5

Fig. 5 may be modified to suit individual requirements.

The frame consists of four pieces of ½ in. square stripwood (A), (B), (C), (D) each 42 ins. long. Four stripwood cross struts (E and F) are required. They are 26 ins. long, ½ in. wide and ½ in. thick. The two bands (G and H) are made from a light cotton material, and are 6 ft. 3 ins. long by 13 ins. wide. When they are hemmed they measure 12 ins. in width. The ends are overlapped and sewn together to make endless bands.

Lay these bands on the table. Iron two creases in them, one where the ends are joined. Fold over again and make two more creases. The four creases on each band will indicate where the four 42 in. struts, or longerons, are fixed. They are tacked on along both sides of each crease.

The important cross struts

The ends of the cross struts are cut to a V-shape. Tape is bound round them, near the point of the cut, to prevent splitting. They are inserted at the centre of each band, as shown. The struts must be a close fit, to keep the bands tight. Lash them together at the centre with thin twine. Small blocks of wood, glued on to the longerons, will keep them in position. A detail of the ends of the cross struts is shown at (I).

★ ★ ★ ★ ★ PUZZLEPIC ★ ★ ★ ★ ★

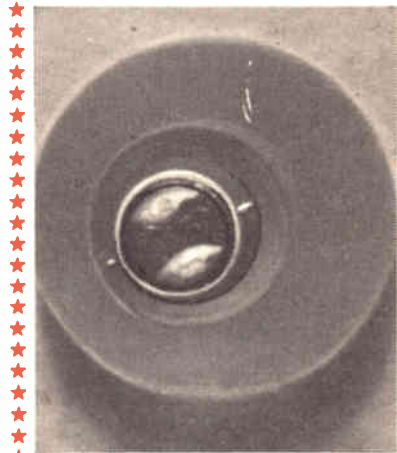

What is it? Pictured is an unusual angle of an article used every day in most homes. Solution on page 437

★ ★ ★ ★ ★

THE DOVETAIL PUZZLE

THE dovetail puzzle is both deceiving and intriguing, for when the parts are fitted together, it appears impossible to construct such a joint. Moreover, the puzzle forms an interesting piece of constructional work within the power of any reader if some care be taken. Fig. 1 shows how the puzzle appears when finished, but although we can only show two sides, it

First of all prepare the block with the dovetail, using a fine tenon saw after scribing in the lines, making a few additional sawcuts to help removal of

diagonal dovetails must be parallel or there may be some difficulty in assembling. When finished the two parts should slide together with only a little pressure, yet not be so loose that the secret will be revealed.

By S. H. Longbottom

By careful measuring and patient work you should be able to produce this tricky puzzle and the secret is to be quite true that the tops of the blocks are square with the sides. You can ensure this by use of a right-angled cutting block in the first stages. It may be mentioned that although this gives the basis of the puzzle as a cube, you may trim off the corners or make into any shape you like, for the principle of locking together will not be affected.

the waste material with a chisel of appropriate size. In view of the fact that the sawcuts are at an angle, it will be helpful to place the blocks in a vice, so tilted that your saw can cut vertically — that is in the normal manner. By

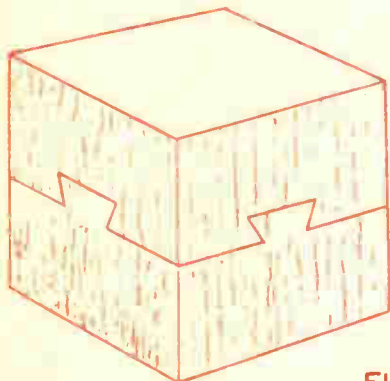

FIG 1

will, no doubt, be appreciated that the dovetail appears on all four sides. The puzzle thus becomes one of separating the parts.

Reference to Fig. 2 will reveal the secret and it will be seen that instead of true dovetails running across the blocks at right angles as may be assumed, construction is such that the joints are diagonal, while a sliding movement in that direction will unlock the two pieces.

You will require a block of wood 2ins. square and at least 6ins. long for ease of working, cut into two equal parts, one being for the raised dovetail $\frac{1}{4}$ in. in depth. Note that this measurement is given for convenience, but if you wish, can be amended to suit your requirements. When the joints have been made and the two parts fitted together, the cube should be trimmed down to measure 2ins. by 2ins. by 2ins.

Careful marking out is essential and after preparing, make sure that the tops of both blocks are square, by testing. Mark a line all the way round the blocks with a gauge $\frac{1}{4}$ in. deep. The dovetails are now marked in as shown in Fig. 3, exactly in the centre of each side and the points joined diagonally. The other part must be similarly prepared as shown in Fig. 4.

following this method you should not encounter much difficulty, and after removal of the waste, clean up with a file, particularly in the corners.

Before proceeding with the other part it will be advisable to test the dovetail with the markings already prepared. And it should be noted that the two

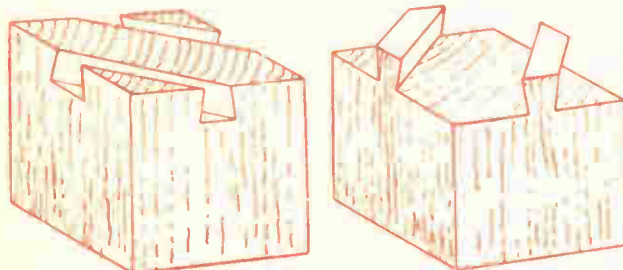

FIG 2



5/8"

1/2"

3/8"

FIG 3



3/8"

5/8"

WASTE TO REMOVE

3/8"

5/8"

FIG 4

★★★★★★★★★★★★★★★★★★★★★
 ★ Next week's free design is for a ★
 ★ mechanical wind vane and bird ★
 ★ scarer — a delightful novelty to ★
 ★ make for the garden. ★
 ★ MAKE SURE OF YOUR COPY ★
 ★ ★★★★★★★★★★★★★★★★★★★★★★



makes you an expert... *easily!*

It's not difficult to be an expert with the BRITFIX/HUMBROL combination... tried to the qualities which the Handyman needs... tested to the requirements of the do-it-yourself man. And—more than ever—produced to give that 'professional' look... That's the way with H.O.C.—you can see-it-yourself when you do-it-yourself!

FOR WORKING IN WOOD OR PLASTICS

Humbrol Art Oil Enamel, a 4-hour lacquer enamel which dries with a brilliant finish. Is most suitable for the handyman about the house, being ideal for touching up all decorative household and workshop utensils.



BRITFIX TISSUE PASTE.
A specially prepared paste for aeroplane tissue providing exceptional adhesion and non-staining qualities.



BRITFIX CEMENT.
The finest all-purpose adhesive made. Transparent, water and heat proof, BRITFIX CEMENT combines rapid drying with the utmost tenacity.

BRITFIX PLASTIC POLYSTYRENE CEMENT.
A high quality polystyrene adhesive, combining quick drying with excellent adhesion. An ideal companion to Enamel

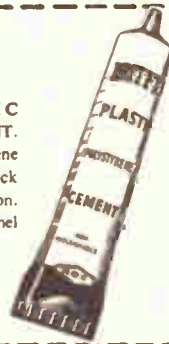

BRITFIX COLOUR DOPES, fast drying, clean and bright, smooth and easy to work with.



HUMBROL INTERMIXABLE PAINTING KIT.
Humbrol Art Oil Enamel Kit—6 intermixable colours in capsule form. An economical method of application for the Handicraft Worker.



the choice of the expert!

Send 10-day for **FREE Humbrol Colour Card,**

THE NUMBER OIL CO. World Radio History, MARFLEET, HULL.



IT'S EASTER AGAIN

By R. L. Cantwell

AT Easter we say goodbye to winter and greet the spring. We also commemorate the resurrection of Christ. Stamp and label collectors may honour the season by depicting the 'Easter Story' in their album.

The illustrations, showing a suggested layout, briefly outline the theme.

In the New Testament Christ is described as the Good Shepherd who laid down His life for the sheep.

'Stamps: Italy 1950. 50 lira violet — Shepherd — 1d. used. Falkland Islands 1952. ½d. green — Sheep — 1d. mint.'

Christ is the world's true Light. Its Captain of Salvation.

'Hungary 1956. 1ft. blue — Miner Holding Lamp — 6d. mint.'

At Rome, Easter Sunday is celebrated with elaborate ceremonials.

The Pope officiates at mass in St. Peter's. From a hall in the adjoining palace of the Vatican he is borne into the church. Seated in his sedia gestatoria, his vestments blaze with gold. On his head he wears the tiara, a tall round gilded cap representing a triple crown, and which is understood to signify spiritual power, temporal power, and a union of both. Beside him are borne the flabelli, or large fans, composed of ostrich feathers, in which are set the eye-like parts of peacock's feathers, to signify the eyes or vigilance of the church. Over him is borne a silk canopy richly fringed.

After officiating at mass at the high altar, the Pope is borne back through the crowded church, and then ascends to the balcony over the central doorway. There rising from his chair of state he pronounces a benediction, with indulgences and absolution. The crowd is



Rock of ages! cleft for me,
Let me hide myself in Thee,
Let the water and the Blood,
From Thy riven Side which flowed,
Be of sin the double cure,
Cleanse me from its guilt and power.

'France 1946. 20f. blue — Rocks — 1d. used.'

There was no other good enough
To pay the price of sin;
He only could unlock the gate
Of Heaven, and let us in.

'Match labels: India 1956 — Key — 1d. mint'

The egg and chicks depicted on the Indian label of 1956 — 1d. mint, and Gallic Cock — Great Britain 1956 — 1d. mint, complete the cameo.

most dense almost immediately below the balcony at which the Pope appears; for there papers are thrown down containing a copy of the prayers that have been uttered, and there is a scramble to catch them.

On Easter Sunday evening the dome and other exterior parts of St. Peter's are beautifully illuminated.

'Stamps: Ireland 1950. 2½d. violet — Statue of St. Peter — 1d. used. Italy 1933. 20c. red — Dome of St. Peter's — 3d. mint. Vatican City 1954. 10 lira red, yellow and brown — Pope Pius X — 4d. mint.'

Some labels issued with chocolate easter eggs, etc., contain useful illustrations — so don't forget to save them.

Be snap-happy with

ILFORD films!



See for yourself what Ilford films will do for your camera. Millions of happy snappers have proved to themselves that Ilford films make all pictures better and good pictures brilliant. So whatever make your camera is, give it a chance to show what it can really do—ask for Ilford films and be happy with every snap.

**CARRY A CAMERA AND TAKE
FACES AND PLACES**

STICK TO



Keep a
tube
in
the
home



**IT
STICKS
EVERYTHING!**

1/- PER TUBE

Sole Manufacturers—

MCCAW, STEVENSON & ORR LTD., BELFAST

A GUITAR for only 65/11

OVERALL
LENGTH
36½ ins.



MAKE IT
WITH A
KIT FROM



Everything needed to make a first class job. Easily constructed with a few simple tools. Thousands in use. Shown on TV.

All wood (including partly shaped neck) materials, fittings, full size plan, six strings, tutor, etc.

From branches, stockists or direct

To HOBBIES LTD., Dept. 99 Dereham, Norfolk.
Please send Guitar Kit No. 3209. P.O. for.....enclosed.

Name

Address

.....

CUPPED PUNCHES

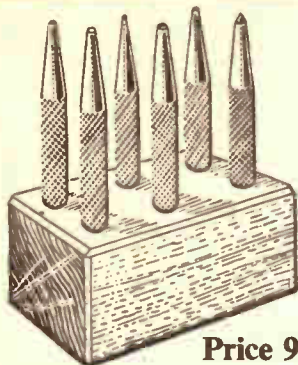

Price 9/6

A set of six round-head punches with polished wood stand. There are five cup or brad punches from $\frac{1}{4}$ in. to $\frac{1}{2}$ in. and one centre punch. A most useful set for the handyman.

From branches or:—

HOBBIES LTD., (Dept. 99), Dereham, Norfolk

STAMPS FREE → Empire Packet including Pictorials and Victorians with approvals. — Robert J. Peck, 7A Kemp Road, Bournemouth.

MAKE a MUSICAL BOX for as little as 21/6. New kits and tunes available. Movements 14/9 post free. Please send 3d. stamp for free illustrated catalogue. — The Swisscross Co., Dept. B., 116 Winifred Road, Coulsdon, Surrey.

FREE stamp album and 20 stamps. Request approvals, enclosing 4d. Additional gifts given. — Beeze, 8 Langland Villas, Mumbles, Swansea.

GOVERNMENT SURPLUS BARGAINS. Inter-room Telephones, comprising 2 self-energised microphones/receivers and approx. 6yds. flex (may be extended if desired). No Batteries needed. Nothing to wear out. Complete 9/6, post 6d. Motors, Transformers, Switches, etc. 3d. stamps for illustrated list. Milligan's, 24 Harford Street, Liverpool, 3. Money Back Guarantee.

BUYING OR SELLING?

Classified advertisements on this page are accepted at a cost of 6d. per word prepaid. Use of a Box No. is 1/- extra. Send P.O. with advertisement to *Hobbies Weekly*, Advert. Dept., Dereham, Norfolk. Rates for display advertising on application.

BECOME trained chiropodist. Quick postal, B.practical. — GRADUATE SCHOOLS, 48a Abbey Street, Accrington.

100 DIFFERENT stamps free! Request 4d. upwards discount approvals. — Bush, 53 Newlyn Way, Parkstone, Dorset.

CHEMICALS AND APPARATUS. Free booklet of 100 experiments with orders over 15/-. Send 3d. stamp for catalogue and details of special offers. — Scientific & Technical Supplies (Notum.) Ltd., Dept. H, 9, Wellington Circus, Nottingham.

HOBBIES BRANCHES

LONDON

78a New Oxford Street, W.C.1

(Phone MU5EUM 2975)

87 Old Broad Street, E.C.2

(LONDON Wall 4375)

81 Streatham Hill, S.W.2

(TULsa Hill 8796)

GLASGOW—326 Argyle Street

(Phone CENTRAL 5042)

MANCHESTER—10 Piccadilly

(Phone CENTRAL 1787)

BIRMINGHAM—100a Dale End

SHEFFIELD—4 St. Paul's Parade

(Phone 24071)

LEEDS—10 Queen Victoria Street

(Phone 28439)

HULL—10 Paragon Square

SOUTHAMPTON—134 High St.

(Below Bar)

BRISTOL—65 Fairfax Street

NEWCASTLE—42 Dean Street

Newcastle-on-Tyne 1

GRIMSBY—88 Victoria Street

EVERY CAR THAT PASSES—YOU WILL FIND THE INDEX MARK ALPHABETICALLY ARRANGED IN WHERE'S THAT CAR FROM?

Price 9d.

from all Booksellers or from the Publishers (2d. postage)

RALEIGH PRESS, EXMOUTH



Brand new Government stock. Completely zipped full length on one side and across the chest and around the head, held rigid with flexible stays that fold flat when packed. Must have cost £4 to make. Comfortable to amazing degree, finest model ever made and at a cost of less than the wool content! Send for one, on money back guarantee. 18/11, post 3/1. Folds up neatly for easy transport. Full length and width, accommodates any size person.



SENT FOR 2/6

SUPERB 'TOM-TOM' COTTON PROOFED FABRIC. NOT NYLON. Height 5' 6". Built with collapsible poles, dismantle swiftly & transport elsewhere. No centre pole. Erected anywhere. A real waterproofed Tent. Holds 4/5 children. SEND 2/6 DEP., then 4 monthly pmts. 5/9. Cash 21/. Post 2/6. Waterproof Groundsheet 10/6 if req. Lists, Tents, Binoculars, Terms.

HEADQUARTER & GENERAL SUPPLIES LTD

(HOBW/4) 194-200 Coldharbour Lane Loughboro Junc., London, S.E.5 Open Sat.

'PAINTSPRAYING' HANDBOOK. Covers Car, Industrial & Flock Spraying. 3/6, post 4d. Catalogue of our Cellulose and Paints and all Allied Sundries 3d. — Leonard Brooks Ltd., 81 Oak Road, Harold Wood, Essex.

MATCHBOX crystal receiver parts and instructions, 3/6. Reception guaranteed. — Write BCM/ALEXTONE, London, W.C.1.

110 DIFFERENT stamps free! Request approvals, enclosing postage. — Banks, 62 Avonlea Road, Sale, Cheshire.

FREE PICTORIAL Packet with approvals. 3d. postage. — Allcock, 74 Tynyparc, Rhiwbina, Cardiff.

STOP SMOKING in 3 days or money back. Safe, pleasant, permanent. The only scientific way. **No Will Power necessary.** 'Conquered the habit in 2 1/2 days'.—F.C. 'Within 2 days I was free from the tobacco habit'.—W.G. 'Was a smoker for 2 years and broke the habit in 2 days'.—F.N. 'I used to smoke 20 a day . . . now I have no desire to smoke'.—J.M. Recommended by 'Health and Efficiency Magazine'. Complete course 7/6 (or \$1.00 bill). Details 3d. stamp. Sent under plain cover. **NATURE REMEDIES**, 28 (H/178) Dean Road, London, N.W.2. Established 1928

APPARATUS & CHEMICALS

For your experiments. Let us help you equip a **HOME LABORATORY**

Beakers, Crucibles, Flasks, Funnels, Gas Jars, Test Tubes, etc.

Booklets:
(including postage)

'Experiments' 1/2

'Formulas' 1/2

'Home Chemistry' 2/10

New edition



Send 3d. Stamp for latest **PRICE LIST**

A. N. BECK & SONS (Dept. H.W.)

60 Stoke Newington High Street, London, N.16

Is This Saw in Your Kit?

You can cut almost anything in wood with this Coping Saw. The blade is 6 1/2 ins. long and can be turned to cut at any angle. No tool-kit complete without one. Get yours NOW.

Buy from any Hobbies Branch or post free from Hobbies Ltd., Dept. 99, Dereham, Norfolk

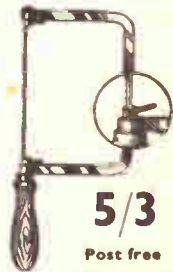

5/3

Post free

A CASE FOR DRILLS

YOU need a few pieces of fretwood, a small hinge and a catch for making this neat case for your twist drills. Provision is made for four sizes, but measurements may be modified to take a greater number if required.

Cut two pieces (A) (top and bottom), two pieces (B) (sides) and one piece (C) (end), all from $\frac{1}{4}$ in. wood. Piece (D) is a

block of $\frac{1}{4}$ in. wood. As seen from the sketch, the case is made in two pieces. The bottom and top are hinged together and the drills housed in piece (D). Use the twist drills themselves to make the holes.

Finish off by painting, cleaning up with glasspaper before giving the first coat. (M.p.)

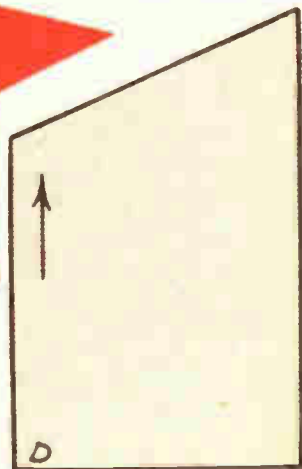
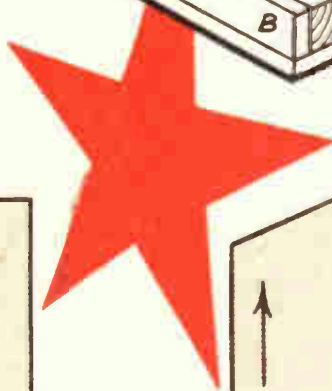
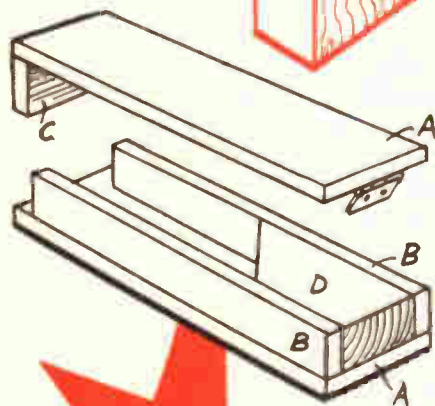
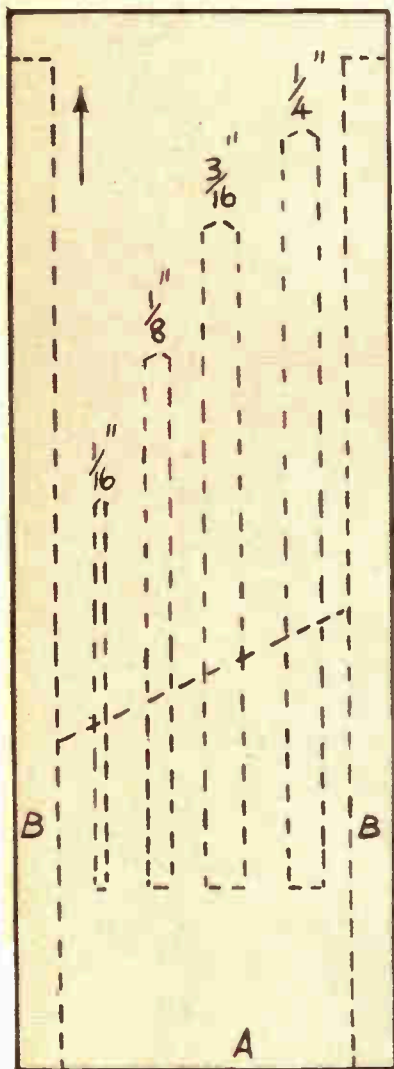
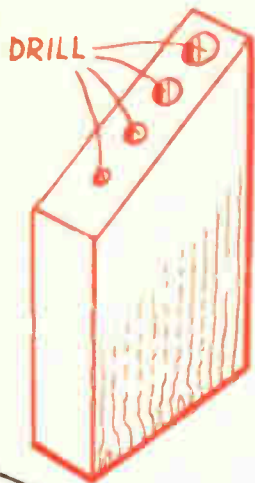

Paddle Your Own Canoe



*... and make
it with the
aid of
full-size
plans from*



BUILDING COSTS FROM ABOUT £7

These plans contain all the information needed to build the canoe and its accessories. The main frames and other shaped parts are drawn full size for tracing direct on to the wood. There are plenty of constructional diagrams, with step-by-step instructions, and a detailed material list. Accessory instructions include the making of paddle, spray cover, trolley, rudder, sailing gear, etc.

All of these canoes are of the decked kayak type and are primarily paddling craft, but sail is useful as an auxiliary and can add to the fun of canoeing. If sailing capabilities are particularly required, PBK 20 is the best selection.

A canvas canoe can be built by the novice with limited equipment, and the average handyman can complete the job in about 40 hours. The structure consists of widely-spaced laths on cross frames, covered with a fabric skin. There are no difficult joints or awkward work. Plywood skinned canoes need more skill and a larger tool kit.

Building costs range from about £7 (for the PBK 10). We do not supply materials for building, but addresses of firms who do so are included with the plans.

DETAILS OF PLANS AVAILABLE

RIGID CANVAS-COVERED

PBK 10. Single seat, 11 ft. long, 28 in. beam, normal max. load 300 lb. The shortest satisfactory canoe. Economical in size and building costs. Room for lightweight kit. Price 11/-

PBK 14. A roomy single for the big man, or a two-seater for an adult and child, or two young people. 14 ft. long, 29 in. beam, normal max. load 500 lb. Popular tourer. Price 12/6

PBK 15. Single seat, 14 ft. 6 in. long, 26 in. beam, normal max. load 400 lb. The enthusiast's fast touring craft. Safe and stable. Suitable for any waters. Price 12/6

PBK 20. Two-seat, 15 ft. long, 32 in. beam, normal max. load 600 lb. Stable and seaworthy. Easily paddled and a good performer under sail. Popular with scouts and youth clubs.

Price 12/6

RIGID PLYWOOD-SKINNED

PBK 16. Two-seater. 16 ft. long, 32 in. beam, normal max. load 700 lb. Flat-bottomed. Safe and robust. Popular for local hire on sea and river. May be left afloat. Price 12/6

FOLDING

PBK 24. Single seat, 11 ft. long, 28 in. beam, normal max. load 300 lb. Similar lines to PBK 10 but longer cockpit. Only canoe which packs into one bag small enough to go on bus.

Price 12/6

From branches or direct (post free)

HOBBIES LTD (Dept 99) Dereham, Norfolk

WorldRadioHistory