

HOBBIES *weekly*

FOR ALL
HOME CRAFTSMEN

Also in this issue :

PORTABLE 4-VALVE
BATTERY SET

PERFECTION IN
PHOTO PRINTING

COLLECTORS' CLUB

HOW TO RELEASE
SWIM VICTIMS

PROJECTS FOR
YOUNGSTERS

MODELLING SHIPS

ETC. ETC.

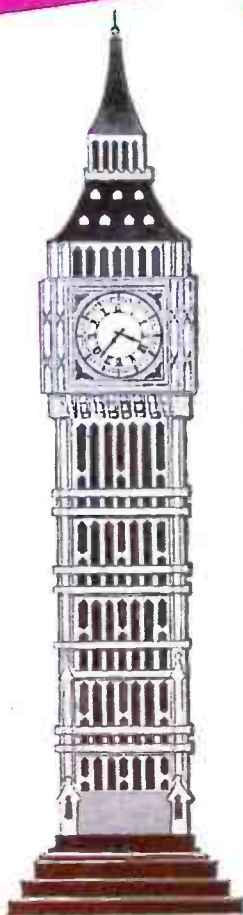

★ **FREE**
Design
Supplement

CIGARETTE BOX MODEL OF
BIG BEN
WITH WESTMINSTER CHIMES

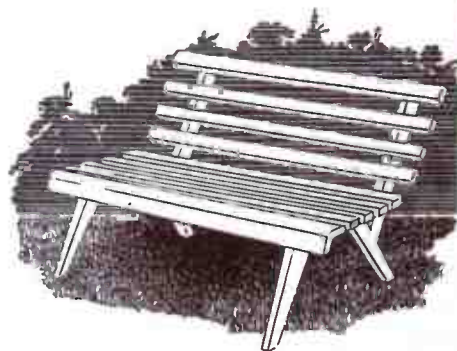

GARDEN SEAT



Up-to-the-minute ideas
Practical designs
Pleasing and profitable things to make

5^p

MARK Antony named July after Julius Cæsar, who was born in this month, and who reconstructed the calendar.

Julius Cæsar is depicted on the 7½ cent Italian stamp of 1929 — 2d. used.

Some July anniversaries are:
5th, 1853, Cecil Rhodes born — Rhodes appears on a Southern Rhodesian stamp of 1940 — 4d. mint.

9th, 1947, Royal engagement (Princess Elizabeth) — Southern Rhodesian stamp of 1947 showing Queen Elizabeth II as Princess — 5d. mint.

13th, 1837, Queen Victoria moved into Buckingham Palace — New Zealand stamp of 1953 depicting Buckingham Palace — 2d. used.

18th, 1947, Indian Independence Bill — Indian stamp of 1947 showing National Flag — 4d. used.

JULY — By R.L.C.

20th, 1944, Hitler assassination plot — Hitler appears on German stamps of 1942.

28th, 1833, Slavery abolished — Spanish Guinea stamp of 1952 depicting Native Man — 2d. mint.

29th, 1883, Mussolini born — Hitler and Mussolini appear on Italian stamps of 1941 — 1d. used.

Now is the time to collect specimens of beautiful or rare plants, which may be preserved in the following manner:

Place the plant, when fresh, between several sheets of blotting-paper, and iron it with a large smooth heater, pretty strongly warmed, till all the moisture is dissipated. The flowers may be afterwards fixed down to the



paper with gum or transparent gum-strip, and then ironed again, by which means they become almost incorporated with the paper. Some botanists prefer to tack the plant in place with fine cotton.

At this season, all potted window plants require to be carefully and liberally supplied with water. Do not allow any to remain in the saucer under the pot.

When window plants are carelessly allowed to become too dry, the earth separates from the sides of the pot, and all the water you may then give escapes through the gap thus formed, without being of any benefit to the roots of the plants. The best remedy is to immerse the pot up to the rim in water for a few minutes, then take it out and let the superfluous moisture drain off before placing it back in the window.

Stamps: Cuba 1955, 4 values depicting flowers in pot — 1s. 9d. mint. Match labels: Yugoslavia 1958, 24 covers depicting flowers and plants — 3s. 0d. mint. Many cheese labels also depict flowers.

'In this month is St. Swithin's day,
On which if that it rain they say,
Full forty days after it will
On more or less some rain distil.'

Finally a holiday stamp — New Zealand 1948, Health — Boy Sunbathing and Children Playing — 8d. mint.

CHILDREN may be taught many Christian principles through the medium of the stamp album. For example, a Red Indian Chief is depicted on an American stamp of 1922 — 14 cent blue — cat. 6d. mint.

Here is a little bedtime talk about Indian names:

The Indians used to give their babies only temporary names. Their real names

NAMING A CHILD



had to be earned when they got older. Thus, some good girl was named Bluebird, Snow Flower, Spring Wind, Sunshine or something else which showed how people felt about her. Boys, when they grew older and joined the hunting parties, were given names such as Brown Bear, Running Wolf, Black Eagle or Thunder Stone.

Something of the kind would probably happen to boys and girls of today if their real naming was left until they had grown at least to a junior age or until they had earned a suitable name. Then we might get names for boys like Helping Hand, Brave Lad, Great Heart, Faithful, or Mouth of Truth, and girls might be called Sunny Smile, Blue Flower, or Hope.

There are, however, a few boys and girls who might not have earned such delightful names as those, and they might have to be called Scowler, Shirk, Unreliable or Cheat.

What do you think would be your name?

Handyman's project

LIGHTWEIGHT SEAT FOR THE GARDEN

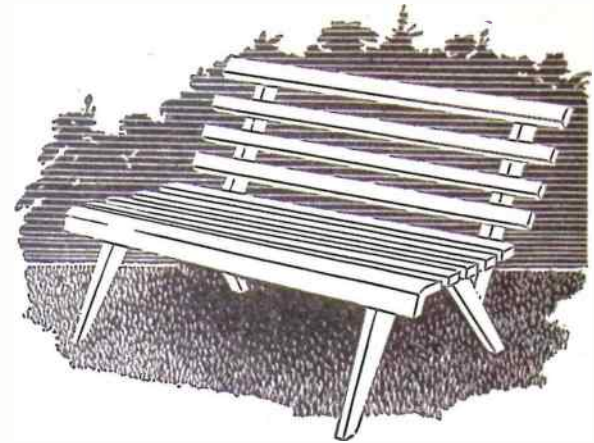

THE construction and weight of this seat makes it easy to move about the garden. One person can carry it without difficulty. Although it is of a streamlined contemporary appearance it is quite sturdy when assembled. The length is 4 ft. 6 in. and the overall height about 32 in.

The seat is formed of two end frames, consisting of pieces 1, 2, 3, and 4, and slats of 1½ in. by 1 in. or ¾ in. wood. The diagram in Fig. 1 shows the general arrangement and Figs. 2 and 3 show how the pieces are assembled. All parts are halved together as shown.

To get the correct sizes of the various pieces it is advisable to draw out the end view full size on a large sheet of grease-proof, or brown paper. The wood can then be marked out accordingly.

Commence by drawing three parallel lines — AB, CD and EF as indicated in Fig. 4. Draw in the three perpendiculars, spaced out as shown. It is now a simple matter to draw in the various pieces from the measurements shown. Start with the back support (1) and then the back leg (2).

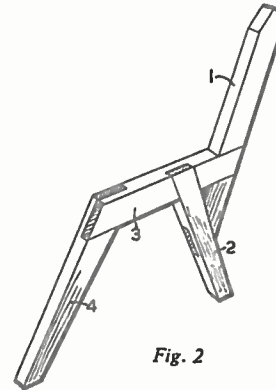

Fig. 2

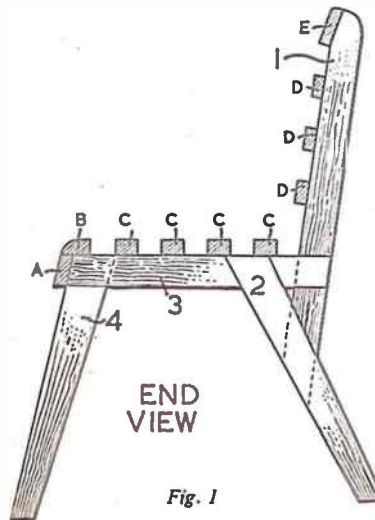

Fig. 1

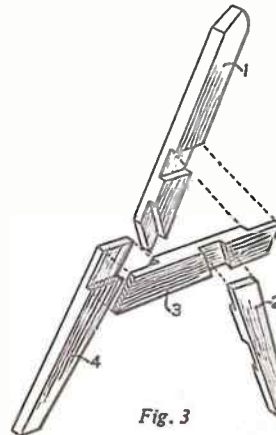

Fig. 3

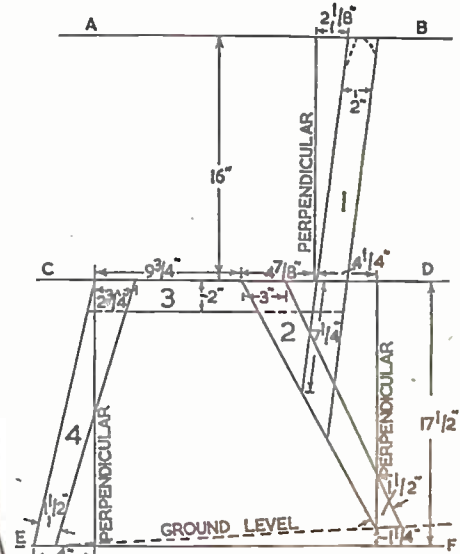

Fig. 4

Finish with the seat support (3) and the front leg (4).

All these pieces are cut from 1½ in. thick timber, and are screwed and glued together. Use waterproof glue and countersink the screws, filling the heads with plastic wood.

The slats are all 4 ft. 6 in. long and are fixed in the following order. A (2½ in. by ¾ in.), B (2 in. by 1 in.), C (1½ in. by 1 in.), D (1½ in. by ¾ in.) and E (2½ in. by ¾ in.). Fix all these with countersunk screws, filling the heads before painting.

Finish off by giving a coat of wood preservative and then a coat of pink primer. One undercoat and one finishing coat of gloss enamel will give a good appearance. (M.h.)



Out with a camera

A PLAN FOR PERFECTION

OUR aim is to produce perfect photographs and while standardisation of processing, films and chemicals goes a long way towards success it is not always realised that we can standardise our exposures to a large extent. With this in view we have devised a simple plan which you can memorise or copy, but some explanation is necessary for you to appreciate the full value.

You should make a point of using one type of film only until you have mastered its characteristics, that is a film of the same make and speed. It is no use thinking that you will get better results by changing to other films. This may be done when you have gained some experience. And not only should you stick to one brand of film but also to one developing formula if you process your own films, otherwise patronise a reliable dealer.

Exposure and speed

Now the modern cameras, even the inexpensive ones, have far more gadgets and aids than the old box camera, and one distinctive feature is that which allows adjustment of the size of the lens aperture. This is the diaphragm which controls the size of the aperture, the latter being indicated by *f* numbers, or stops. This scale of *f* numbers has been so arranged that the exposure is doubled or halved — if made larger or smaller — depending on which way the change is made. For example, *f*/8 is twice as large as *f*/11, while this stop is twice as large as *f*/16, and the larger the number the smaller the opening. We are to use this particular feature for standardising our exposure in conjunction with the speed of opening the shutter, i.e. 1/25, 1/50 or

A perfect print produced from the perfect negative below



1/100 of a second.

You may well ask why exposure plays such an important part, and the brief answer is that we require an exposure which produces a negative capable of enlargement to a fair degree without excessive 'graininess' and without loss of shadow detail. It must not be too thin, it must not be too dense; but oddly

By S. H. Longbottom

enough the ideal negative is one which looks thin and sharp and retains the details in the deepest shadows. Photographs of different negatives reproduced here will illustrate this point.

We should also mention that while the camera is said to make exposures of 1/50

and 1/100 of a second there may be a slight variation, but the way to control this is by using one speed only and either reducing or increasing the aperture. You should now realise that the secret of this plan is to take all your pictures with the camera set at one speed, 1/50 of a second, adjusting the aperture — or *f* number — according to the lighting conditions of the day.

Having explained the basic principles of the plan we are now ready to approach the details. We will assume that the camera is loaded with either a Selo-chrome Pan or Verichrome Pan, it is a bright sunny day and the sun is behind you. Under such conditions you could take a perfect picture, producing the right kind of negative, by making an exposure of 1/50 second at *f*/11. Unfortunately, the conditions do not stay so rigid, but by using the foregoing as a basis we can devise a working arrangement and here is our plan:

1. Set the speed to 1/50 second.
2. With the sun to either side of the camera open stop from *f*/11 to *f*/8.
3. With the sun behind the subject, open up two stops, i.e. from *f*/11 to *f*/5.6. (You should also use a lenshood for this type of shot.)
4. With the sun obscured by a light haze, open up one stop, i.e. from *f*/11 to *f*/8.
5. If the sun becomes obscured by a cloud of a light kind, open up two stops, but if it becomes very dull it is advisable to open by three stops, i.e. from *f*/11 to *f*/4.

Adjustment by aperture is a far more reliable method than adjusting the speed, but it might be as well to give an example. Assume you propose taking a

close-up of your friend, but the sun is covered by a light haze. Here we can ignore the sun position in relation to the camera and we open the lens from *f*/11 to *f*/8, because it is a close-up, and then to *f*/5.6 because of the lighting conditions. This illustration is included purposely to draw your attention to the fact that near subjects require more exposure (a larger aperture) than the distant ones, so we can now express the final basis.

For head and shoulder pictures open up the aperture to *f*/8; for landscapes with foreground subjects close down the aperture to *f*/16; for landscapes close down the aperture to *f*/22.

This plan can be memorised quite simply. Stick to one speed and remember that there is a constant relation-



Negative under-exposed. A larger stop should have been used

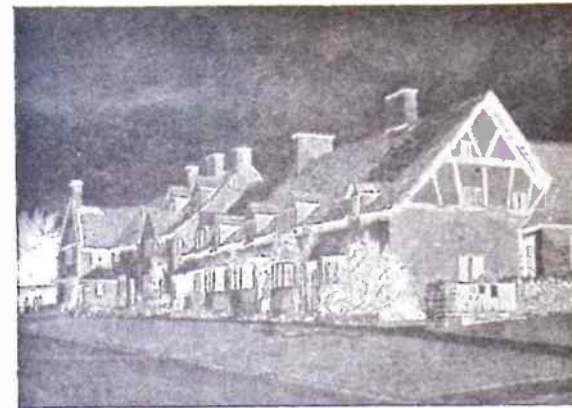

Negative over-exposed by using too large a stop

ship on the aperture scale between each set of lighting conditions. The only time when we diverge from this set of conditions is as just mentioned when dealing with different subjects which demand more or less exposure; that is a larger stop for near subjects and a smaller one for distant subjects.

It is, however, appreciated that different subjects can have a vital effect on the ultimate negative and the wide range we produce may call for an adjustment in the type of printing paper employed. This is an entirely different subject, but for the present we suggest that you examine your camera and acquaint yourself with the advantages of working by means of altering the stops as outlined.

[Illustrations in this feature by courtesy of Ilford Ltd.]

A Simple Sun Awning

HERE is an easily made sun awning which can be quickly put in place or taken down — an advantage in our changeable climate. Designed to be fixed to a wall with hooks, all it consists of is a light wooden frame covered with deck-chair canvas, and supported by cord from above, so that the space below is unobstructed.

The size of the awning depends on individual requirements, but 6 ft. by 4 ft. is reasonable. The frame A is made of 1 in. square wood, jointed as shown in B.

Two metal eyes are screwed into the frame at the front corners. These take the supporting cord for the awning. At

the rear of the frame two large hooks are screwed in place a few inches from each corner. These hooks should have their open ends facing downwards. Two holes are then made in the wall five or six feet from the ground, to correspond with the hooks at the back of the frame. Two large metal eyes are cemented firmly into these holes with the eyes in a horizontal position, so that the hooks fit into them easily (C).

A hook is fixed in the wall four feet above the awning, over which the supporting cord runs.

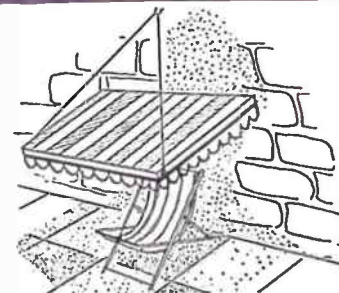
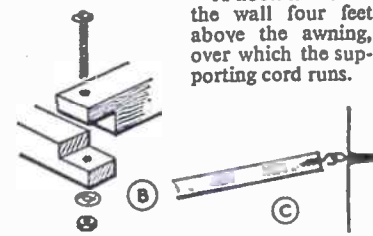

The cover is made from deck-chair canvas, stitched together to give the required width. It should extend 6 in. over the frame at each side and at the front, and is held to the frame with upholstery tacks, the extra canvas at the front and sides being left to hang down.

Strong cord should be used to support the awning at the angle desired, and by slipping the cord off the hook, the awning can be swung down snugly against the wall when it is not in use. (A.L.)

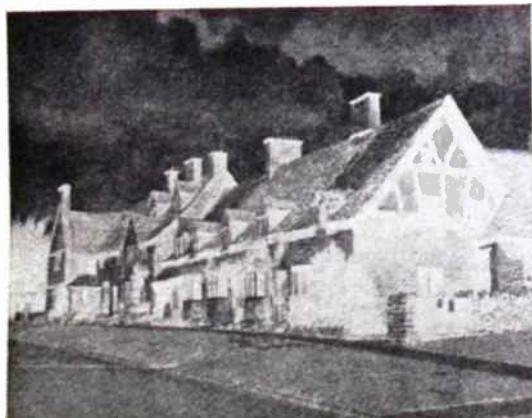

The perfect negative which resulted in the perfect print above.



DESIGN

No. 3324

BIG BEN MUSICAL CIGARETTE BOX

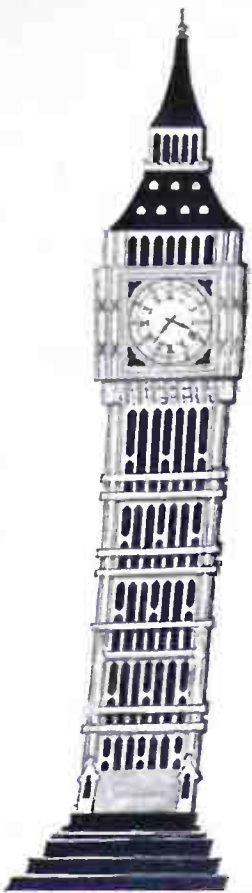

SIZE
16 1/2 in. HIGH
APPROX.

THE ARROWS
INDICATE DIRECTION
OF GRAIN OF WOOD

A KIT OF MATERIALS FOR MAKING THIS
DESIGN IS SUPPLIED BY HOBBIES LIMITED
DEREHAM, NORFOLK.
PRICE ON APPLICATION

Use
Croid UNIVERSAL

IT'S DESIGNED FOR THE JOB

The popular general purpose liquid glue,
used cold for all making and mending
with wood, leather, card, etc. The
best glue for sticking laminated
plastics. Large tube 1/2, 8 oz.
tin 2/10, 16 oz. tin 4/6

AVAILABLE FROM ALL BRANCHES OF HOBBIES LTD



SECTION
OF
HOBBIES
No. 21
MOULDING

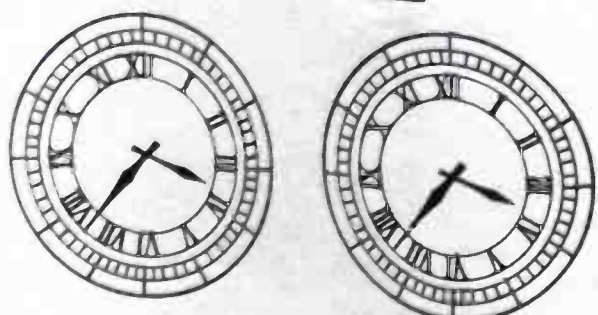

CLOCK FACES.
MARK ON TO
THIN CARD AND
STICK IN POSITION

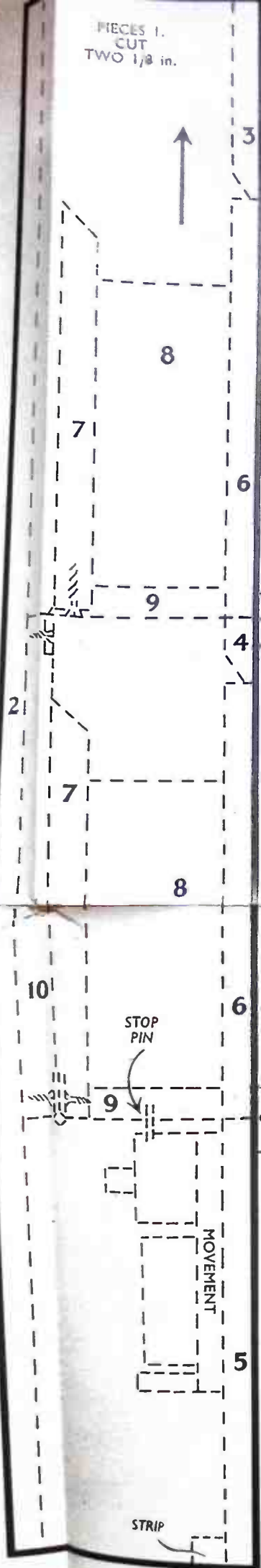
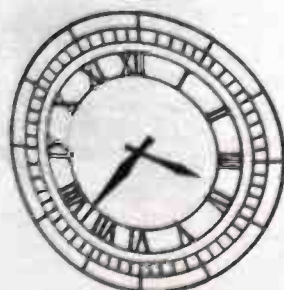

SECTION
PIECES 30.
CUT 24 1/8 in.
CHAMFER TO
SECTION

PIECES 23
CUT 24
1/8 in.

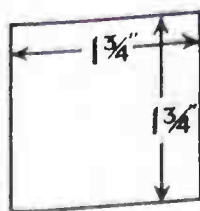

PIECE 25.
CUT ONE 1/4 in.

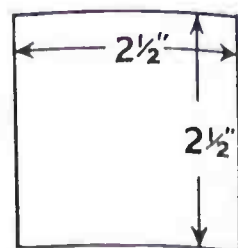

PIECE 24.
CUT ONE 1/4 in.

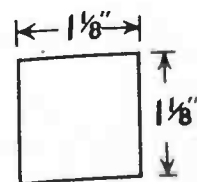

PIECE 26.
CUT ONE
1/8 in.

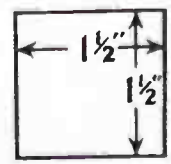

PIECE 25A.
CUT ONE 1/4 in.

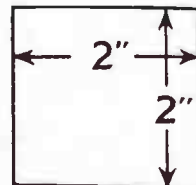

PIECE 24A.
CUT ONE 1/4 in.

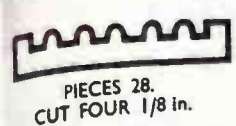

PIECES 28.
CUT FOUR 1/8 in.

PAINT
ON

PRINTED IN ENGLAND

World Radio History

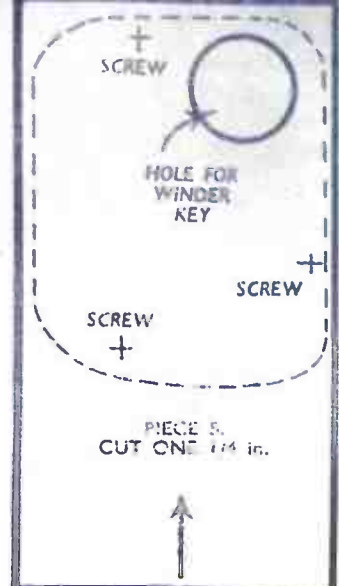

PIECE 5.
CUT ONE 1/4 in.

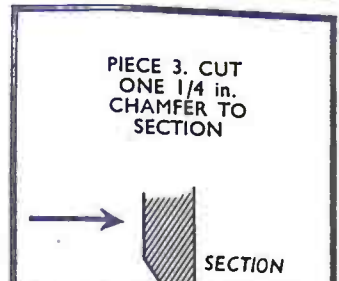

PIECE 3. CUT
ONE 1/4 in.
CHAMFER TO
SECTION



PIECE 4. CUT ONE
1/4 in.

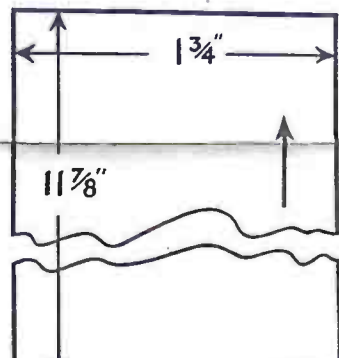

PIECE 2. CUT ONE 1/4 in.
EXTEND TO 11 7/8 ins.

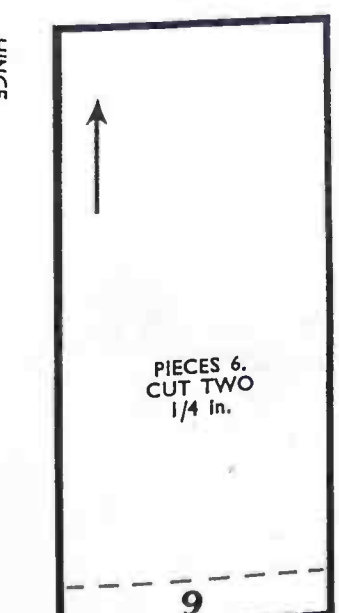

PIECES 6.
CUT TWO
1/4 in.

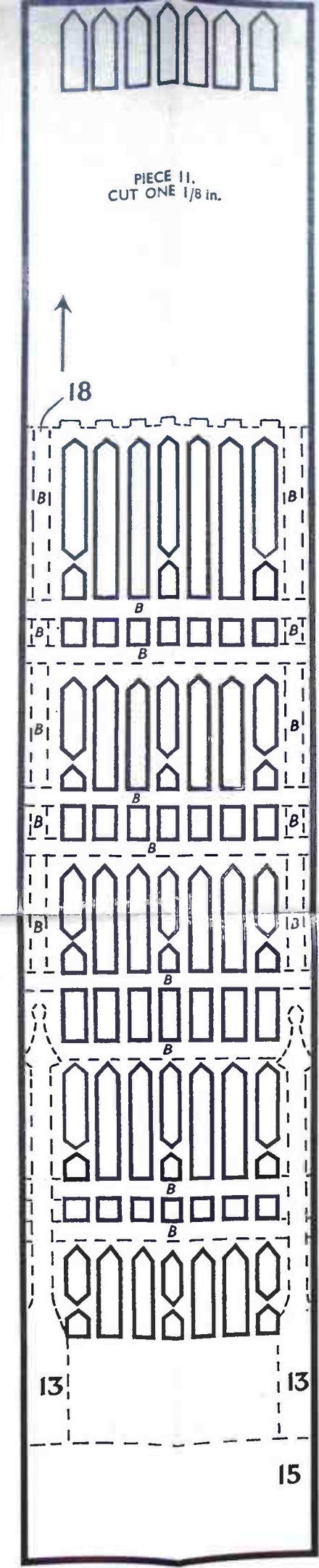

PIECE 11.
CUT ONE 1/8 in.

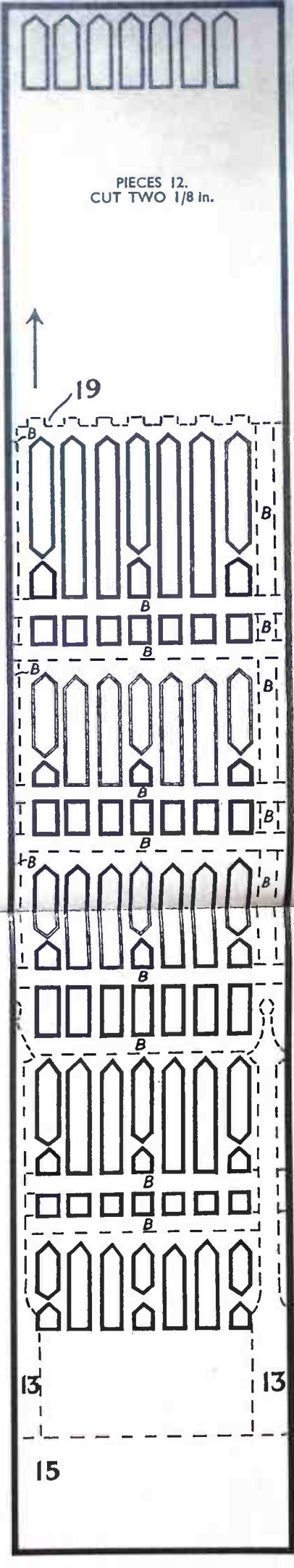

PIECES 12.
CUT TWO 1/8 in.



PIECES 7.
CUT TWO 1/4 in.
CHAMFER TO
SECTION

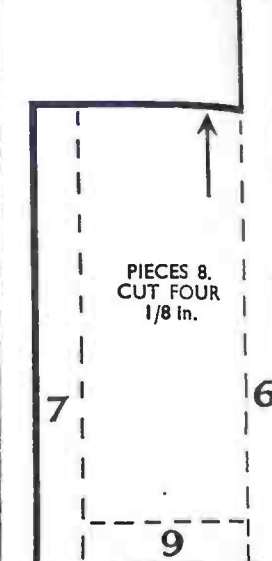

PIECES 8.
CUT FOUR
1/8 in.

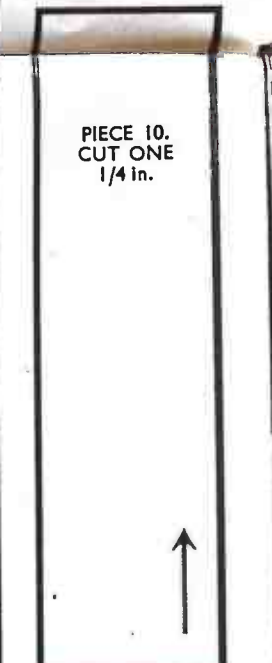

PIECE 10.
CUT ONE
1/4 in.

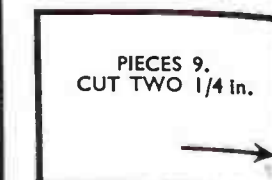

PIECES 9.
CUT TWO 1/4 in.

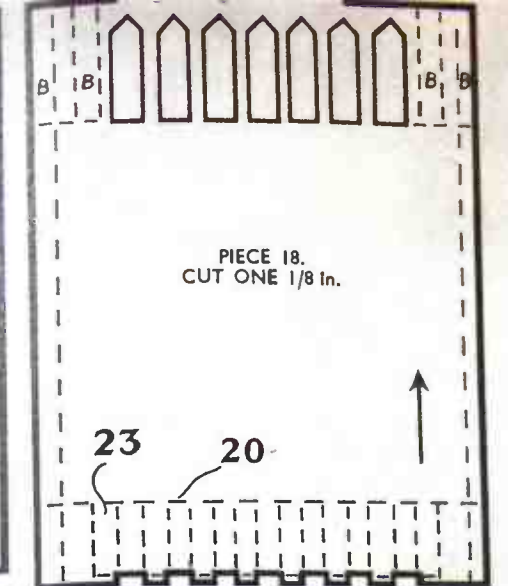

PIECE 18.
CUT ONE 1/8 in.

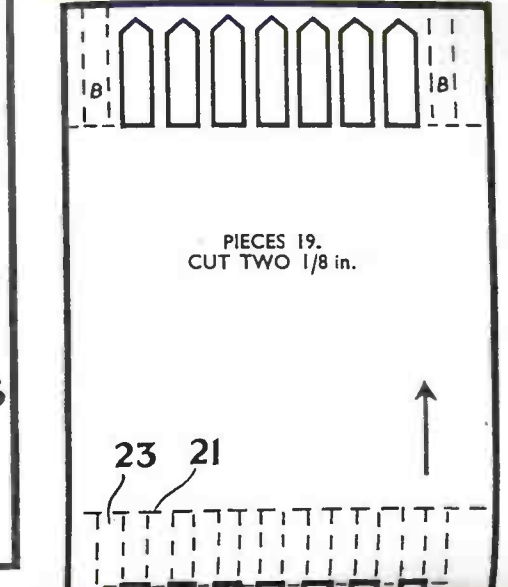

PIECES 19.
CUT TWO 1/8 in.

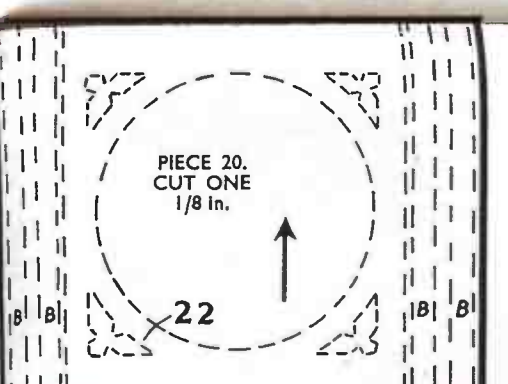

PIECE 20.
CUT ONE
1/8 in.

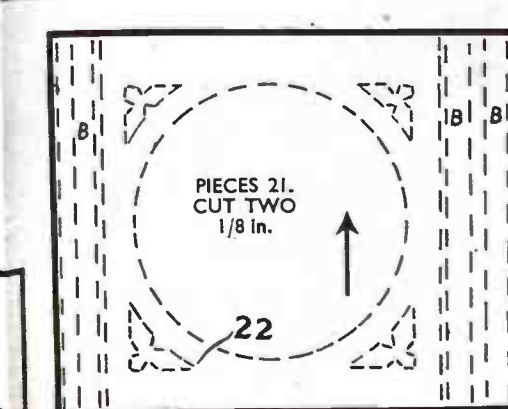

PIECES 21.
CUT TWO
1/8 in.



PIECES 15.
CUT FOUR
1/4 in.

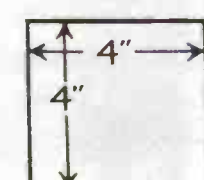

BASE 16.
CUT ONE 1/4 in.

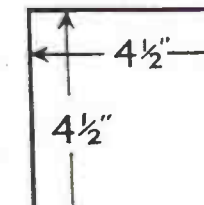

BASE 17.
CUT ONE 1/4 in.

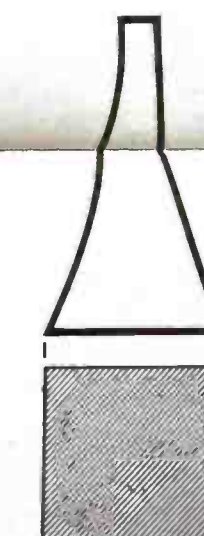

SECTION
PIECE 29.
SHAPE FROM
1 in. SQUARE STRIP

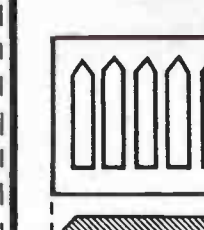

SECTION
PIECES 27. CUT FOUR
1/8 in. MITRE TOGETHER



PIECES 22.
CUT THREE
1/8 in.

A PLAN FOR PERFECTION

OUR aim is to produce perfect photographs and while standardisation of processing, films and chemicals goes a long way towards success it is not always realised that we can standardise our exposures to a large extent. With this in view we have devised a simple plan which you can memorise or copy, but some explanation is necessary for you to appreciate the full value.

You should make a point of using one type of film only until you have mastered its characteristics, that is a film of the same make and speed. It is no use thinking that you will get better results by changing to other films. This may be done when you have gained some experience. And not only should you stick to one brand of film but also to one developing formula if you process your own films, otherwise patronise a reliable dealer.

A perfect print produced from the perfect negative below



1/100 of a second.

You may well ask why exposure plays such an important part, and the brief answer is that we require an exposure which produces a negative capable of enlargement to a fair degree without excessive 'graininess' and without loss of shadow detail. It must not be too thin, it must not be too dense; but oddly

By S. H. Longbottom

enough the ideal negative is one which looks thin and sharp and retains the details in the deepest shadows. Photographs of different negatives reproduced here will illustrate this point.

We should also mention that while the camera is said to make exposures of 1/50

and 1/100 of a second there may be a slight variation, but the way to control this is by using one speed only and either reducing or increasing the aperture. You should now realise that the secret of this plan is to take all your pictures with the camera set at one speed, 1/50 of a second, adjusting the aperture — or *f* number — according to the lighting conditions of the day.

Having explained the basic principles of the plan we are now ready to approach the details. We will assume that the camera is loaded with either a Selo-chrome Pan or Verichrome Pan, it is a bright sunny day and the sun is behind you. Under such conditions you could take a perfect picture, producing the right kind of negative, by making an exposure of 1/50 second at *f*/11. Unfortunately, the conditions do not stay so rigid, but by using the foregoing as a basis we can devise a working arrangement and here is our plan:

1. Set the speed to 1/50 second.
2. With the sun to either side of the camera open stop from *f*/11 to *f*/8.
3. With the sun behind the subject, open up two stops, i.e. from *f*/11 to *f*/5.6. (You should also use a lenshood for this type of shot.)
4. With the sun obscured by a light haze, open up one stop, i.e. from *f*/11 to *f*/8.
5. If the sun becomes obscured by cloud of a light kind, open up two stops, but if it becomes very dull it is advisable to open by three stops, i.e. from *f*/11 to *f*/4.

Adjustment by aperture is a far more reliable method than adjusting the speed, but it might be as well to give an example. Assume you propose taking a

close-up of your friend, but the sun is covered by a light haze. Here we can ignore the sun position in relation to the camera and we open the lens from *f*/11 to *f*/8, because it is a close-up, and then to *f*/5.6 because of the lighting conditions. This illustration is included purposely to draw your attention to the fact that near subjects require more exposure (a larger aperture) than the distant ones, so we can now express the final basis.

For head and shoulder pictures open up the aperture to *f*/8; for landscapes with foreground subjects close down the aperture to *f*/16; for landscapes close down the aperture to *f*/22.

This plan can be memorised quite simply. Stick to one speed and remember that there is a constant relation-

Negative over-exposed by using too large a stop



Negative under-exposed. A larger stop should have been used

ship on the aperture scale between each set of lighting conditions. The only time when we diverge from this set of conditions is as just mentioned when dealing with different subjects which demand more or less exposure; that is a larger stop for near subjects and a smaller one for distant subjects.

It is, however, appreciated that different subjects can have a vital effect on the ultimate negative and the wide range we produce may call for an adjustment in the type of printing paper employed. This is an entirely different subject, but for the present we suggest that you examine your camera and acquaint yourself with the advantages of working by means of altering the stops as outlined.

[Illustrations in this feature by courtesy of Ilford Ltd.]

Exposure and speed

Now the modern cameras, even the inexpensive ones, have far more gadgets and aids than the old box camera, and one distinctive feature is that which allows adjustment of the size of the lens aperture. This is the diaphragm which controls the size of the aperture, the latter being indicated by *f* numbers, or stops. This scale of *f* numbers has been so arranged that the exposure is doubled or halved — if made larger or smaller — depending on which way the change is made. For example, *f*/8 is twice as large as *f*/11, while this stop is twice as large as *f*/16, and the larger the number the smaller the opening. We are to use this particular feature for standardising our exposure in conjunction with the speed of opening the shutter, i.e. 1/25, 1/50 or



The perfect negative which resulted in the perfect print above.

A Simple Sun Awning

HERE is an easily made sun awning which can be quickly put in place or taken down — an advantage in our changeable climate. Designed to be fixed to a wall with hooks, all it consists of is a light wooden frame covered with deck-chair canvas, and supported by cord from above, so that the space below is unobstructed.

The size of the awning depends on individual requirements, but 6 ft. by 4 ft. is reasonable. The frame A is made of 1 in. square wood, jointed as shown in B.

Two metal eyes are screwed into the frame at the front corners. These take the supporting cord for the awning. At

the rear of the frame two large hooks are screwed in place a few inches from each corner. These hooks should have their open ends facing downwards. Two holes are then made in the wall five or six feet from the ground, to correspond with the hooks at the back of the frame. Two large metal eyes are cemented firmly into these holes with the eyes in a horizontal position, so that the hooks fit into them easily (C).

A hook is fixed in the wall four feet above the awning, over which the supporting cord runs.

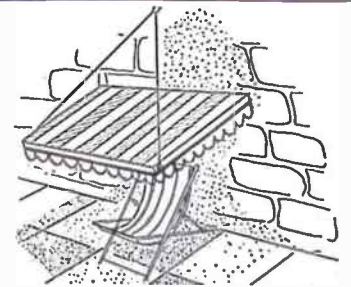
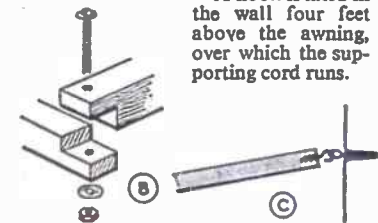
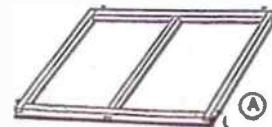

The cover is made from deck-chair canvas, stitched together to give the required width. It should extend 6 in. over the frame at each side and at the front, and is held to the frame with upholstery tacks, the extra canvas at the front and sides being left to hang down.

Strong cord should be used to support the awning at the angle desired, and by slipping the cord off the hook, the awning can be swung down snugly against the wall when it is not in use. (A.L.)

For the medium waveband

MAKE THIS HANDY BATTERY PORTABLE

By
A. Fraser

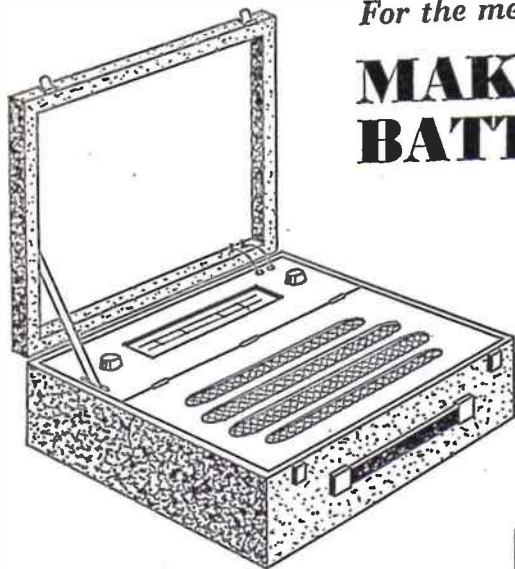

A UNIVERSALLY portable radio set is always useful. Whether one is out in the country, or on a business trip, or laid up in bed, one's favourite programmes need not be missed. Moreover, it is a good standby if ever the family set goes wrong.

The circuit is a conventional superhet, one that has proved popular in recent years, and the use of pre-aligned Intermediate Frequency Transformers makes it as easy to build as any straight T.R.F. set. The novice should have no difficulty in constructing it.

The cost of the whole set should amount to between £5 and £6. For a

little further expenditure a mains unit could be bought (or built) to fit in the case. This unit could be used in the home and the batteries saved for outdoor use.

The set receives only medium waves, but apart from this, it is equivalent to sets in the shops costing three times as much.

The building of the set falls into two parts — the receiver itself and the case to hold it. The receiver should be built first and the case fitted afterwards.

The chassis should be made first. Fig. 1 shows how it should be cut from one

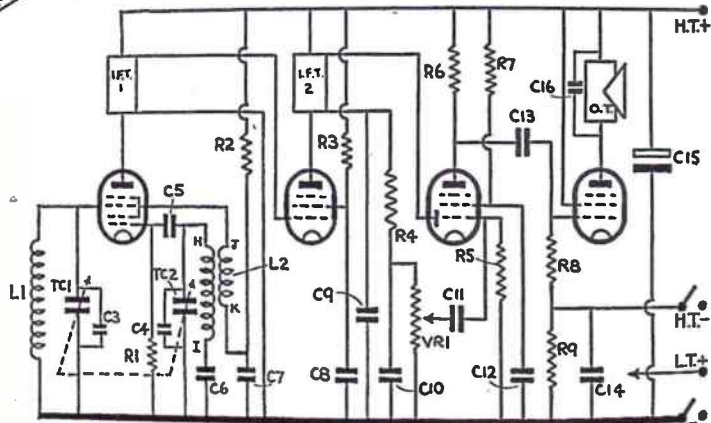

Theoretical diagram

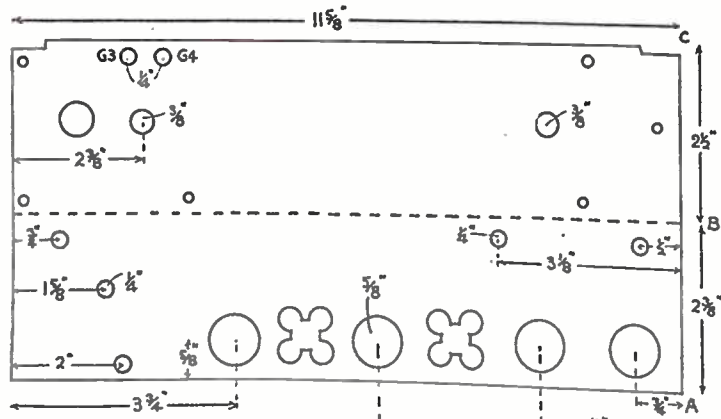

Fig. 1

flat sheet of aluminium. 20 to 22 gauge is most suitable. The thick dotted line indicates where it should be bent at right angles, after the cut-outs have been made. Fig. 2 shows how the main components will occupy the chassis eventually. Take care to bend the sheet in the right direction, as indicated by the letters A, B, C.

When the chassis is ready, the I.F.T.'s and valveholders, etc., can be fitted. Be sure to place these properly so that the pins are in the correct position as shown in the diagram (Fig. 3) of the under-chassis layout.

Tagboard 1 should be a 3-way type (i.e. 3 insulated tags and 1 earthed tag). The earth tag is removed and replaced by an ordinary soldering tag. The board is secured to the chassis by means of a 6B.A. bolt, a nut or washers being used between the chassis and board to raise

it off the chassis. This is to make certain of no accidental contact between chassis and the three insulated tags. The substituted solder tag beneath the 6B.A. bolt is used to earth one of the I.F.T. pins.

Tagboard 2 has 7 insulated tags and 2 earthed ones. The earthed ones are bent out straight and used to bolt the

1 insulated plus 1 earthed tag. Bend over the top of the insulated tag to save depth again. Tag 4 is similar.

Next attach all soldering tags used as earthing points. Bolt tightly down.

Add the volume control/switch on the upper chassis, then the oscillator coil L2, and the trimmers C3 and C4. (See Fig. 5.) Insert the rubber grommets where needed.

Finally add the tuning condenser. This should be a 3-hole front-fixing type, if possible.

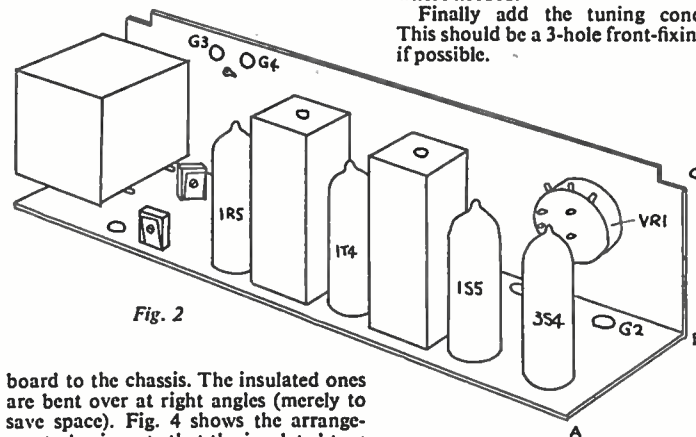

Fig. 2

board to the chassis. The insulated ones are bent over at right angles (merely to save space). Fig. 4 shows the arrangement. Again note that the insulated tags do not contact the chassis. Tag 3 is a

PARTS LIST

- T1, T2, twin-gang tuning condenser (midget).
- C3, C4, 50 pfd. trimmers.
- C6, 470 pfd.
- C5, C9, C10, .0001 mfd.
- C7, C8, C12, .1 mfd. 150-250V. working.
- C11, C13, .01 mfd. 150-250V. working.
- C14, 50 mfd. 12V. working.
- C15, 8 mfd. 150-250V. working.
- C16, .005 mfd.
- R1, 100K.
- R2, 15K.
- R3, 22K.
- R4, 47K.
- R5, 10 meg.
- R6, 1 meg.
- R7, 3-3 meg.
- R8, 2 meg.
- R9, 560 Ω.
- V.R.A., 1 meg. vol. control/D.P. switch.
- L2 Medium wave oscillator coil (e.g. Osrom Q08).
- L1 Medium wave frame aerial (e.g. Osrom QFA2).
- 2 I.F. transformers (pre-aligned) 'Rambler' portable type (obtained from Clyn Radio, 162 Holloway Road, London, N.7).
- Valves 1R5, 1T4, 1S5, 3S4.
- 4 B7G valveholders.
- Midget output transformer to match 3S4.
- 5 in. Elac loudspeaker.
- 2 1/2 in. drive drum, spindle, spring, cord.
- Superec dial (Superior Radio Supplies, 37 Hillside, Stonebridge, N.W.10).
- 3 pulley wheels, 2 knobs.
- 1 H.T. battery plug, 1 L.T. plug.
- Ever-Ready batteries B126 (90V.) AD35 (1.5V.).
- Strap handle, case clips, rubber feet.

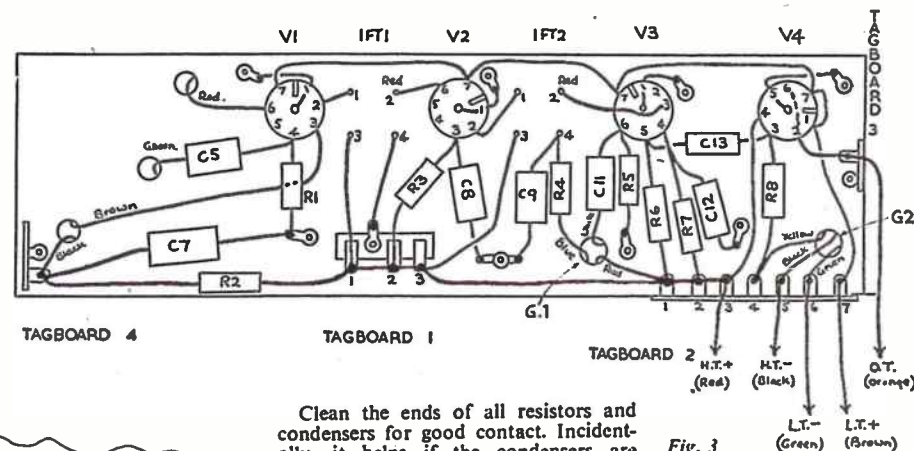

Fig. 3

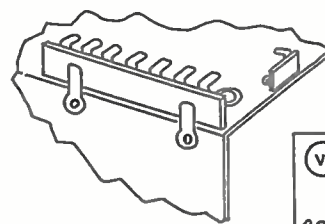

Fig. 4

Clean the ends of all resistors and condensers for good contact. Incidentally, it helps if the condensers are midget types. These cost a penny or two more, but are worth it for ease of wiring.

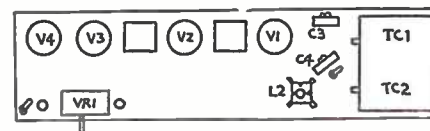

Fig. 5

Detailed instructions for the wiring of the receiver will be given in next week's issue.

MAKING UP BIG BEN (as illustrated) (on front page)

BIG Ben has been indicating the correct time to Londoners for 100 years, and its Westminster Chimes have been heard regularly all over the world almost continuously since midnight on December 31st, 1923, through the medium of radio.

Lovers of modelling and fretwork will welcome this design of the Big Ben clock tower, the capital's famous landmark, while added attractions are the provision of novel compartments or 'pouches' for containing cigarettes and the incorporation of a musical movement. And the tune? Naturally it had to be the Westminster Chimes, which are traditionally associated with the lines:

Lord, through this hour
Be thou our guide,
That by Thy power
No foot shall slide.

The model stands 16½ in. high on a 4½ in. square base. The two cigarette containers in the back work in conjunction — by pulling one knob — by the same action starts off the musical movement. When the cigarette containers are closed the music stops.

Basic details

We have given here sufficient basic details for making a fine model of the clock tower, to which the really keen modeller can add by means of more research and possibly personal observation. We would not say that this is an easy design to master, but it involves some intricate pieces of fretcutting which will be a challenge and source of delight to more experienced workers, especially those who have been asking for something of this nature to 'get their teeth into'.

It should be noted that provision has been made for three clock faces — at the

front and the two sides. Hobbies kit of materials includes specially printed faces on white plastic material. Those not working with a kit should transfer the clock faces from the design sheet on to thin Bristol board or other suitable white card, marking out the numbers, etc., in indian ink.

All detailed parts are shown full size on our extra large design sheet, and full measurements are given in other instances for easy marking out. Trace the appropriate pieces from the design sheet and transfer them to their proper thicknesses of wood by means of carbon paper. Add those parts for which measurements are given, and make sure that all the pieces which go towards the make-up are accounted for on the wood before cutting out with a fretsaw and cleaning up thoroughly with glasspaper.

The assembly

Make a start in the assembly by gluing together the sides 1, front 2, and small back piece 3, as shown in Fig. 1. Remember to chamfer the inside of the lower edge of piece 3 before gluing it in position. Also add a small strip of ¼ in. waste wood by gluing at the bottom.

Next prepare the cigarette 'pouches' as shown in Figs. 2 and 3. Note that pieces

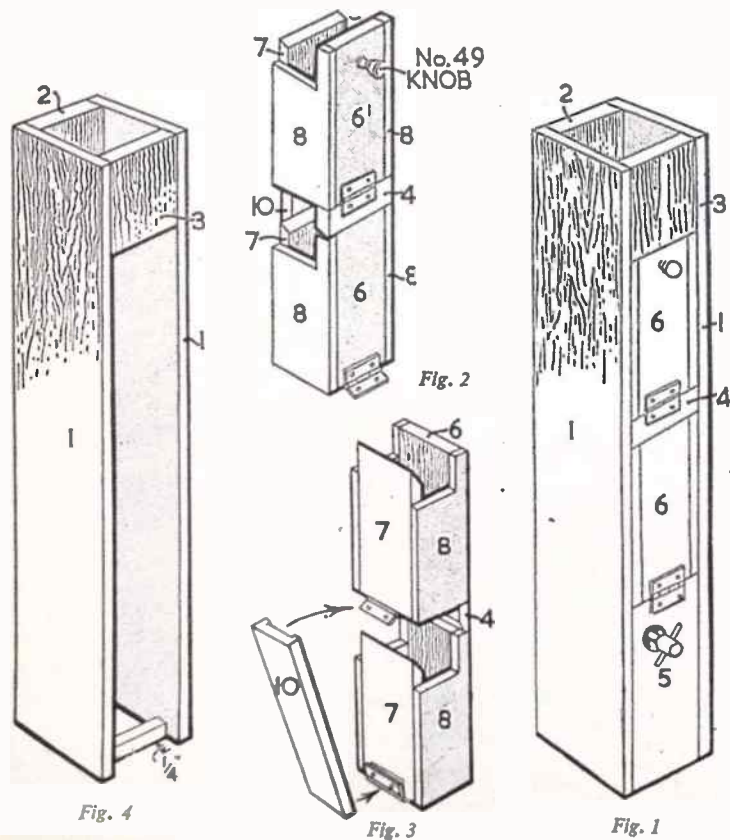

Copyright photograph by permission of Imperial War Museum.

Just like the real thing!

Airfix kits are not just models — they're exact replicas, each series to a constant scale.

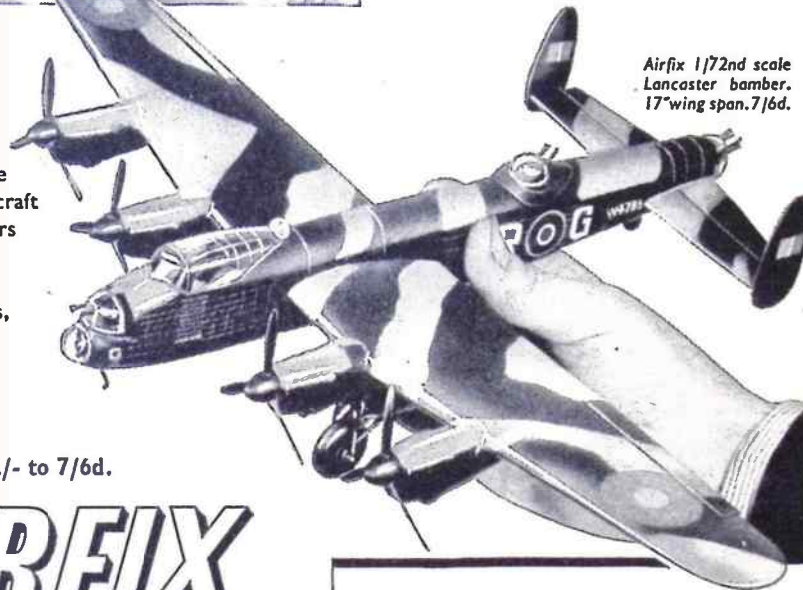

Airfix 1/72nd scale Lancaster bomber. 17" wing span. 7/6d.

There are models galore in the Airfix range! Aircraft from fighters to bombers (all to the same 1/72nd scale), 00 gauge railway accessories, vintage cars, historical ships. Airfix value is unbeatable — ask your dealer for the latest list.

Nearly 100 kits from 2/- to 7/6d.

AIRFIX

THE WORLD'S GREATEST VALUE IN CONSTRUCTION KITS

From Model and Hobby Shops, Toy Shops and F. W. Woolworth



TRACKSIDE SERIES Level Crossing 2/-



VINTAGE CARS 1930 Bentley 2/-

MODEL FIGURES Lifeguard 2/-

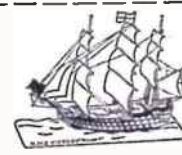

HISTORICAL SHIPS H.M.S. Victory 2/-

STOP PRESS!

Latest Airfix Product

YEOMAN OF THE GUARD

Beautiful 1/12 scale model Beefeater. 2/-

Also new — SEA HAWK jet naval fighter-bomber. 1/72 scale. British or German markings. 2/-



This model farm
cost less than 2/6

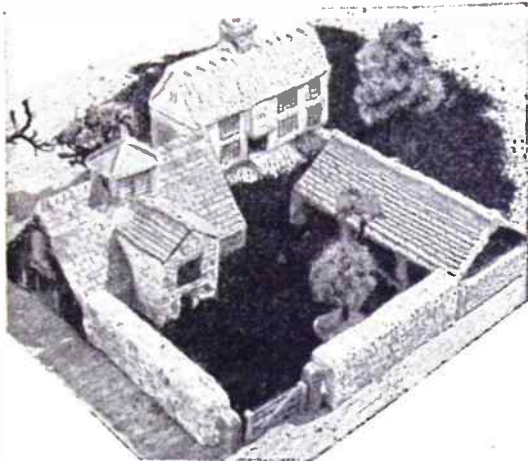

It was made from a half-crown tin of Sankey's PYRUMA — farmhouse, barn, implement shed, walls and gate — and there was still plenty of this grand modelling material left to build many more farm features, by simple methods described in the Instruction Book (see Coupon below). PYRUMA, plastic and ready-for-use, becomes stone hard after drying or baking, and can be painted in natural colours. For permanent modelling —

MAKE IT AND BAKE IT IN



Obtainable from your local Ironmonger or Hardwareman and many Art Material dealers. Ideal for making —

Model Railway Buildings and Accessories, Harbours, Ship Models, Airport Buildings and Features, Houses, Bookends, Ashtrays, Animals and Figures, Plaques, etc.

Post this Coupon today for your Instruction Book

J.H. SANKEY & SON, L^{TD}

Established over a century
Dept. H, ILFORD, ESSEX

Please send ILLUSTRATED INSTRUCTION BOOK with full colour pages on Pyruma Modelling.

Enclosed Postal Order value 6d. (not stamps)

NAME (Block letters).....

ADDRESS.....

BIGGER AND BETTER THAN EVER

7th International Handicrafts and

Do it yourself

EXHIBITION

OLYMPIA

EMPIRE HALL • SEPTEMBER 4th-20th

10 a.m.-9.30 p.m.

Admission 2/6 Children 1/-

GET THERE EARLY
AND MAKE A DAY OF IT

SPONSORED BY DO IT YOURSELF MAGAZINE

HOBBIES FRETSAWS

Not only in fretwork and model making but in a hundred and one woodwork, composition, plastic, leather or sheet metal jobs you'll find a fretframe handy. And the best blade for any is the saw which is made by Hobbies from good steel and the experience of some fifty years of manufacture. Every dozen is distinctly labelled.



BLUE LABEL
8d. doz. 7/6 gross
Grades OO (fine), O, 1, 2,
3, 4, 5, 6

YELLOW LABEL
1/2 doz. 13/6 gross
Grades OO (fine), O, 1, 2,
3, 4, 5, 6

HEAVY SAWS
For Thick Work, Toy
making, etc.
1/6 doz. 17/6 gross

METAL-CUTTING
For Sheet Metal of all
kinds

1/3 doz. 14/6 gross
Fine or medium grade

Obtainable from Ironmongers' Stores and Hobbies Branches, or post free from **HOBBIES LTD., DEPT. 99, DEREHAM, NORFOLK**

The Ideal Target Rifle
for the Young Shot



'JUNIOR' AIR RIFLE

Semi-bead Foresight
14" Machine-cut Rifled barrel
Details on request
Wheel adjustable Rear Sight

WEBLEY & SCOTT LTD., Established 1790
34 Park Lane, Handsworth, Birmingham 21



CERTOFIX liquid glue can cope with all general repairs. It unites wood, glass, metal and almost all substances. It is clean in use; its joints are stronger than the materials it unites.

Sold at all Woolworth Stores

CERTOFIX



BIRMINGHAM
100a Dale End, Birmingham 4

SHEFFIELD
4 St. Paul's Parade

LEEDS
10 Queen Victoria Street

HULL
179 Faransway

SOUTHAMPTON
134 High St. (Below Bar)

BRISTOL
65 Fairfax Street

NEWCASTLE
42 Dean Street

GRIMSBY
88 Victoria Street

BRANCHES: LONDON
78a New Oxford St., W.C.1
(Phone MUSeum 2775)

87 Old Broad Street, E.C.2
81 Streatham Hill, S.W.2

GLASGOW
326 Argyle Street

MANCHESTER
10 Piccadilly

Head Office & Factories—**HOBBIES LTD., DEREHAM, Norfolk**

It's Ready NOW!

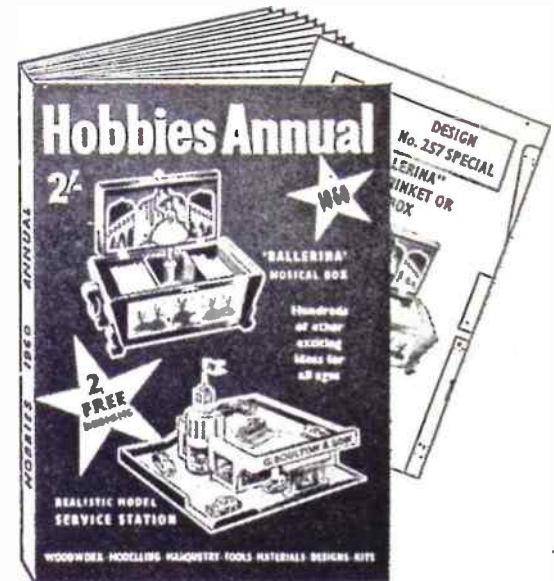

The Annual You MUST Have

The big-value Handbook for the woodworker, handyman, modeller and handicraft worker. 168 pages full of interesting projects — and ONLY 2/-.

TWO FREE DESIGNS WITH EACH COPY

Charming Ballerina Musical Box.
Model Service Station for the modern lad.

Projects include:

- ★ Animated Toys
- ★ Trailer for Tricycle
- ★ Bathroom Drip Dryer
- ★ Blanket Chest
- ★ Coloured Marquetry Picture
- ★ Standard Lamp
- ★ Modern Clocks
- ★ Models etc. etc.

From Hobbies branches, stockists, newsgagents, bookstalls, etc. or send NOW for your copy by post (6d. extra).

To Hobbies Ltd., Dept., 99 Dereham, Norfolk.

Please send copy/copies Hobbies 1960 Annual (2/6 each, post free). P.O. for enclosed.

Name

Address.....

THINKING OF YOUR HOME?

Any handyman can make a success of these projects for the home and save himself pounds. Hobbies kits contain all materials and full instructions for making.

GET YOUR KIT NOW!

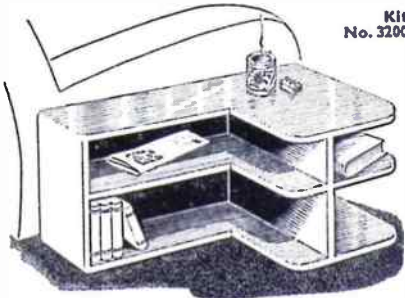

Kit No. 3200

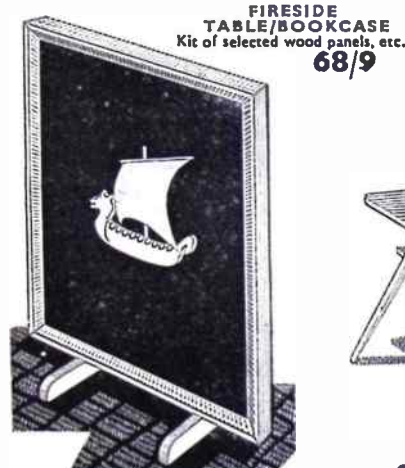

FIRESIDE TABLE/BOOKCASE
Kit of selected wood panels, etc.
68/9

Kit No. 3208
VIKING FIRESCREEN
With ship model in semi-relief
13/6 (post 2/-)



Kit No. 3174
BED TRAY/BOOK REST. A practical two-purpose job
13/6 (post 2/6)

Kit No. 3268



CONTEMPORARY TABLE
Designed to hold a pot plant
24/9 (post 2/9)

Please everybody with these charming pieces of furniture

★ Dozens of similar money-saving kits in Hobbies 1959 Annual. Only 2/- from branches, newsagents, etc., or by post 2/6.



Kit No. 3212
CONTEMPORARY TABLE
With shelf for books, etc. Made in an evening
29/6 (post 3/3)

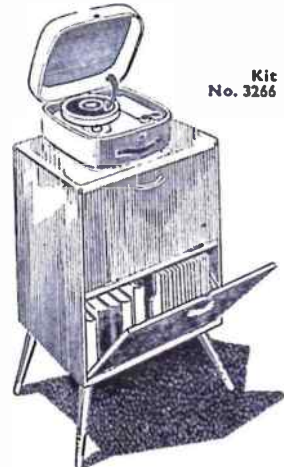

Kit No. 3266

RECORD CABINET AND BOOKCASE. Holds over 200 records, plus books.
65/-

SEND FOR FREE BOOKLET TODAY!

To Hobbies Ltd, Dept. 99, Dereham, Norfolk. Please send free 20-page booklet 'Profitable Leisure', name of nearest Hobbies stockist and items marked X.

Hobbies 1959 Annual (2/6 post free)

Kit No.

Name

Address

U.K. Orders totalling 30/- and over, post free

At this stage piece 4 is quite loose and only connected to piece 6 by the hinge. Piece 4 (and piece 5) will later be fixed between pieces 1, as shown in Fig. 4.

For the present, however, leave the 'pouches' and continue with the assembly of the main body of the model as shown in the broken-away view in Fig. 5. Glue piece 11 centrally to piece 2 and glue pieces 12 on either side. Continue as in Fig. 6, gluing pieces 18 to 11, 19 to 12, and similarly pieces 20 to 18 and 21 to 19.

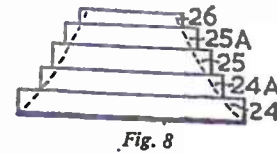

Fig. 8

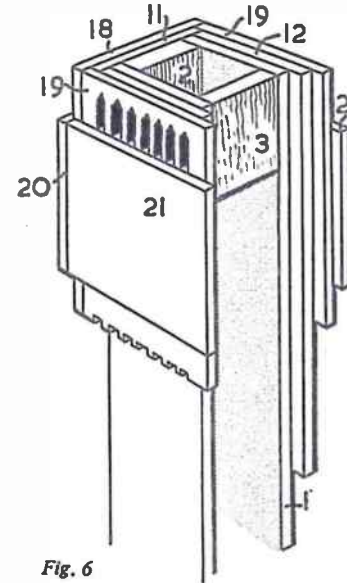

Fig. 6

The make-up of the base is shown in Fig. 7. Pieces 15 are mitred round pieces 11 and 12. The Hobbies No. 21 moulding is mitred round pieces 15 and this assembly is then glued to pieces 16 and 17. The shape of the moulding to use is shown on the design sheet.

Make-up of spire

The pieces which go to the make-up of the main portion of the spire are detailed in Fig. 8. Glue them together and shape off to the dotted line using a rasp, modelling knife, glasspaper, etc.

The four pieces 27 are mitred together and glued to piece 26 (see Fig. 9). Pieces 28 are then mitred round pieces 27. The top spire is shaped as shown on the

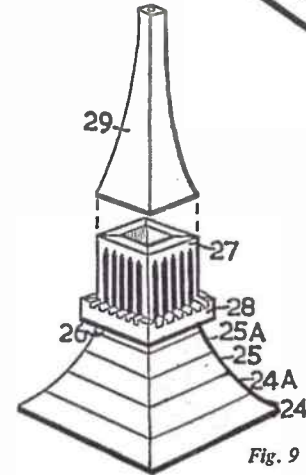

Fig. 9

design sheet from a piece of 1 in. square stripwood, and the top of the spire is drilled to take a Hobbies No. 80 knob.

Continue by gluing pieces 22 in position on pieces 20 and 21 as shown by dotted lines on the design sheet. The buttresses (pieces 13 and 14) can also now be glued in place. The small brackets (23) are glued to pieces 18 and 19 in positions also shown by dotted lines on the design sheet. The dormer windows (30) are shaped and glued to the roof as shown in the finished illustration. The remaining decoration consists of strips of 1/4 in. thick balsa which are shown lettered (B) on the design sheet and glued in their marked positions.

Adding the movement

Now all is ready to add the cigarette 'pouches' and musical movement. Screw the movement to piece 5 in the position indicated by dotted lines on the design sheet. Insert a stop pin (an ordinary household pin or fret pin will do) in the underside of piece 9 so as to engage with the 'butterfly' of the musical movement

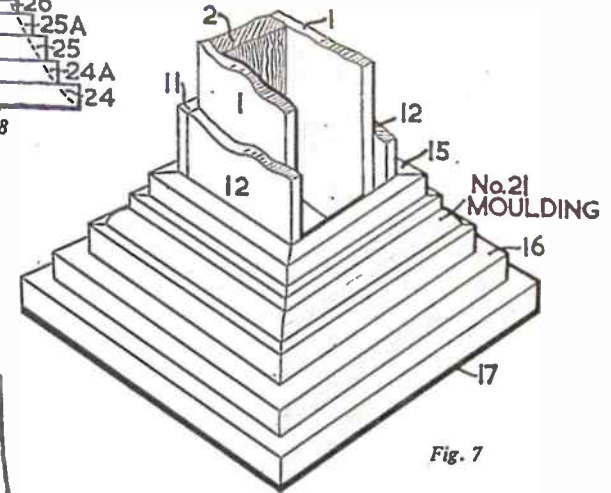

Fig. 7

KIT FOR 14/3

Hobbies Kit No. 3324 for making the Big Ben Cigarette Box contains all wood, moulding and materials, including specially printed clock faces on white plastic. Kits from all branches and stockists, price only 14/3, or by post from Hobbies Ltd, Dereham, Norfolk (post 1/6 extra) The Westminster Chimes tune (movement No. 1) is 14/11 (post 6d. extra), but if desired there are 26 alternative tunes available.

when the 'pouches' are closed, and thus stopping the music. The approximate position of the pin is indicated on piece 1 on the design sheet. Now hinge piece 5 to piece 6 (shown in Fig. 2) and drop the whole assembly into the opening in the back of the tower. Piece 5 will slip down between piece 15 and the 1/4 in. strip. Piece 4 may be glued and pinned through from the sides, whilst piece 5 should be secured by four round-headed screws through the sides. These will give access to the movement.

For finish we suggest stone grey in a matt paint with a darker shade for the roof.

Filling with plastic wood

When filling up cracks and holes with plastic wood, always leave a little sticking beyond the surface to allow for the slight shrinkage which takes place as the plastic wood hardens. Once it is hard, rub down flush with some glasspaper.

METHODS OF RELEASE

THE fourth method of rescue is sometimes known as the 'tired swimmer' and is by far the easiest. This cannot be used for anyone inclined to panic and is in fact, as the name implies, designed to assist a swimmer who has become exhausted or overcome by cramp.

In this method you tell the victim to place his hands on your shoulders as you face him, keeping his arms straight. You then swim by the breast stroke, although you will not be able to bring your hands close together in front. Your partner must not grip your shoulders, but just rest his hands on them as he is pushed



4th. Method "Tired Swimmer"

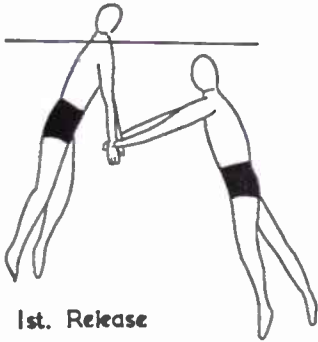

1st. Release

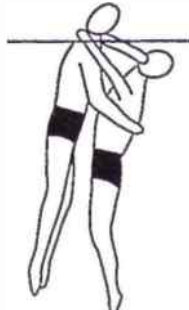

2nd. Release

gently backwards. His legs should be either together underneath you or apart on each side; the latter probably gives a more stable position. If he tends to drift away from you between strokes it does not matter, you will catch up.

Since in this case you would normally approach from the front, you will need to turn him to take him back the way you have come. To do this, after he has placed his hands on your shoulders, you should place your left hand on his left arm, under his shoulder, and gently swim round to the left, using your legs and free hand. You can, of course, use your right hand and swim round to the right.

These methods of rescue should be practised frequently with a friend until you are able to pull one another 20 yds. by each method in turn.

We must now deal with the advised methods for releasing oneself from the clutch of a drowning person. This clutch, proverbially powerful, is, nevertheless, wild and clumsy, although it must never be underestimated. Ideally a drowning person should be approached from behind, using the breast stroke, and should not be given the chance to grab the rescuer. In this case he should be grasped by one of the holds already described. However, if the victim should turn and clutch you from the front, there are in general, three methods of release depending upon how you are gripped. These methods should be practised with

hind your neck whilst he is treading water and facing you. You should then place your right hand on his chin, so that his nose comes between your second and third fingers. Your left hand should be placed in the small of his back. You then push down with your right

By P. R. Chapman

hand and pull with your left, with the result that your partner is pushed under the water, and the grip will be released. In the case of a persistent grip, the nose of the victim is closed by the fingers when he will be forced to release you in order to pull your hand away from his face. Once the release is effected, he is turned on his back as before. This probably sounds unpleasant, but if your partner is a good swimmer himself, he will not mind, and it is only fair to change places! Of course, one is not expected to be gentle with a real drowning person.

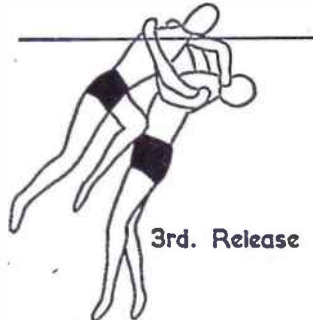

3rd. Release

Third method

If grasped around the body so that your arms are pinioned, the correct method of release is to force up the right arm, putting the hand on the victim's chin, and at the same time, pulling down hard on his right shoulder with your left hand. You should also raise your right knee, pushing it into your partner's stomach (it doesn't hurt in water!). This will force him to release his grip.

In all these release methods, you can reverse the position of your hands if you are left-handed or otherwise prefer it. It is important when practising for the acting victim to grasp firmly and not to let go until he is forced to do so, and all releases should be performed with vigour.

Next: Surface diving for a sunken object.

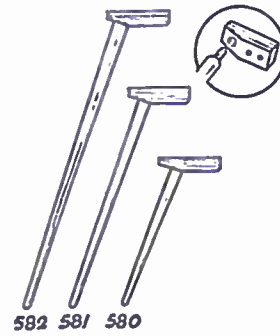

You Can Make a Modern Table in One Evening with these legs



A coffee table, TV table, footstool, etc. . . all can be made in quick time with these Contemporary style legs. Beautifully turned in Scandinavian beech, they can be left in their natural colour, or stained. Each leg is threaded at one end to screw into a hardwood block (see inset) which, in turn, is screwed to the underside of a piece of plywood or suitable material which forms the table top. Simple . . . and a perfect job. The legs are obtainable in three sizes:—10 ins. 2/3 each, 15 ins. 2/6 each and 20 ins. 3/- each. Postage on 3 or 4 legs 1/6 extra. Legs from branches or:

HOBBIES LTD, Dept 99, Dereham, Norfolk

STICK TO SECCOTINE



Sole Manufacturers—

McGAW, STEVENSON & ORR LTD., BELFAST



When you ask for a knife—say X-acto



...they're made to develop your skill!

A man knows that X-acto is right the moment he picks up one of these superb knives. X-acto have three different weights of perfectly balanced handle. 25 interchangeable blades, gouges, routers and punches—all in razor-sharp surgical steel. X-acto's a precise tool. And an all-round tool—right for delicate modelling, right for handyman work around the house. When you ask for a knife—say X-acto.

From Hobby shops & Ironmongers
And ask to see all the other tools in the X-acto range
DUFAY LIMITED
(X-acto Products Division)
14-16 COCKSPUR STREET, LONDON S.W.1

A BULL ROARER



the toy is well known and in Czechoslovakia the Bull-Roarer has been called 'the wolf' after the terrifying noise it makes. Boys in Ceylon whirl Bull-Roarers to scare cattle from the rice fields.

As a toy the Bull-Roarer is ideal, for it is both simple to construct and very effective in use. Merely obtain a flat piece of wood about 3ins. wide and 18ins. long and bore a neat hole in the middle, 1/4in. from one end. Tie on a 10ft. length of strong string to complete the toy. To make your Bull-Roarer work stand in an open place and swing it around you at shoulder level. The wooden blade will soon begin to spin and the air will vibrate with a deep booming or roaring

sound. With such noises, sounding like thunder, the priests and witch doctors of the ancients summoned their gods to send rain for their parched crops.

Experiment with different materials, shapes and sizes, and give your Bull-Roarer an authentic appearance by decorating the blade with brightly painted patterns. A similar toy called a 'Whizzer' can be made, using a 9ins. length of strong wire, a rubber band and a piece of string. Bend the wire to make a U-shape and make little loops in the ends so that the elastic band can be stretched in place across the 'horns'. Tie the string to the base of the U and swing the Whizzer round to produce an eerie sound. (A.E.W.)

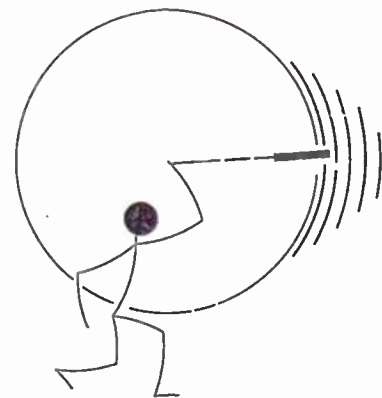

YOU may have seen a Bull-Roarer in a museum. Perhaps it was in the form of a large bat-shaped piece of wood carved and coloured with weird designs and symbols. For thousands of years Bull-Roarers have been used all over the world in religious ceremonies, usually in sacred rites 'to produce rain'. Nowadays the once holy instrument has become a plaything. In the West Indies

Holiday Treasure Hunt

HUNTING for treasure doesn't always mean discovering gold mines or unearthing family fortunes lost for centuries in panelled walls.

One easy and pleasurable way of discovering treasure is to become a spare-time beachcomber. The best time to hunt for treasure on the beach is just after a storm, when all kinds of articles will have been washed up by the sea. Go down for an early morning walk before people are stirring, and you'll be surprised by what you will find.

It is important for beachcombers to understand the law with regard to any valuable articles picked up. There are four classes of articles which are to be found on beaches. First 'flotsam' which is a term used to describe anything which floats and is eventually thrown on to the beach by the waves. Next 'jetsam', which means an article which has been thrown from a ship in distress, and which the tide has eventually brought into shore. The third term is 'ligan'. This means an article fastened to a floating buoy or cork, or a bottle containing a message which sailors may have cast overboard from a ship in distress in the hope that it will be found by some responsible person.

The law orders that anything of value found on a beach which may be described as flotsam, jetsam or ligan must be handed to the police. If the articles

are not claimed within a year, they become the property of the Crown, but, in nearly every case, the person who has found the treasure trove is suitably rewarded.

The fourth class of article which the beachcomber will come across is comprised of things lost by people frequenting the beaches. Many valuables have

been found, particularly after storms. In this case the same rule applies of handing over to the police. But the law does not look on such articles as treasure trove. They are simply things people have lost, unless they have been deliberately buried in some hide-out.

The spare-time beachcomber sometimes gains a good deal more than exercise in his leisurely walk along the beach! (D.D.)

A Tin Telephone

BEFORE the telephone was invented a means of communication along a wire was frequently used. In the old tin-can telephone a string or wire was stretched between the bottoms of two tins. The persons held the tins so that the string was pulled taut between them. When one man used his tin as a

mouthpiece and spoke into it, his companion, who held the other tin to one ear, could hear the words being spoken.

Sound waves travel much better through a tight wire than through air. One version of this device was a quarter of a mile long. Users of this very elementary communications system 'rung' their companions at the other end by banging a metal plate.

To make your own telephone, acquire two identical cocoa or syrup tins. Discard the lids and bore a small hole in the centre of the bottom of each tin. Secure the ends of a long piece of string or thin wire between the two tins by tying large knots or holding the ends in place with matchsticks. (A.E.W.)

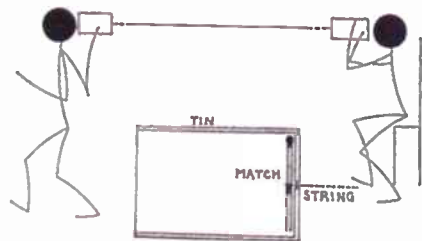

Further Reduced

Brand New Slip into it—soft and comfy—enjoy restful sleep throughout night. No blankets, no sheets, everything in one including special padding for a beautiful soft mattress effect. Light as a feather, it rolls up to a tiny lightweight size. 19/11, post 2/6. Even finished in heavy quality strong material. Really hardwearing. Not a blanket with outer, but genuine quilted. LISTS.

LUXURIOUSLY QUILTED SLEEPING BAGS **QUILTERFOAM**
DAILY 19/11 POST ETC 2/6

These 1500 TELESCOPE SIGHTING-GUN SIGHTS

W.A.R. DEPT. instruments fitted with genuine scientific hand-ground lenses are precision built and graticuled for dead-on sharp shooting accuracy. Made for precision sniper's action they represent an absolute bargain. Actual cost of production, without any profit, £10.0. OUR PRICE only 17/6, post etc. 2/6. If you want to get a precise bead on anything, this is the instrument to do the trick. Limited offer only. Lists, Binoculars, Telescopes. Headquarter & General Supplies Ltd. (HOBY/71) 196-200 Coldharbour Lane, Loughboro Junc., London, S.E.5. Open Sat.

MAKE A MUSICAL BOX for as little as 21/- New kits and tunes available. Movements 13/- post free. Please send 3d. stamp for free illustrated catalogue. — The Swisscross Co., Dept. B, 202 Tulse Hill, London, S.W.2.

100 DIFFERENT stamps free! Request 3d. upwards discount approval. — Bush, 53 Newlyn Way, Parkstone, Dorset.

INTRODUCTIONS to new friends; home and overseas. — V.C.C., 34 Honeywell Road, S.W.11.

HEAR ALL CONTINENTS With H.A.C. Short-Wave Receivers

Suppliers for over 18 years of Radio S-W Receivers of quality. One-Valve Kit, Price 25/- Two-Valve Kit, Price 50/- Improved designs with Denco coils. All kits complete with all components, accessories and full instructions: Before ordering, call and inspect a demonstration receiver, or send stamped addressed envelope for descriptive catalogue. H.A.C. Short-Wave Products (Dept. 22), 11 Old Bond Street, London, W.1

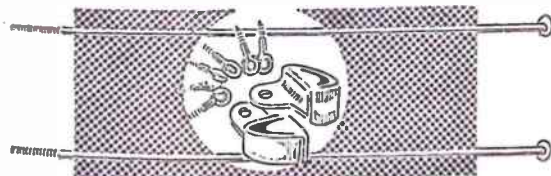

COT FITTINGS (full size)

The fellow handy with tools can make quite easily a drop-side Cot using these fittings. The set comprises two bright steel rods 36ins. long, six heavy-duty screweyes (four plain and two threaded for rods) and two catches. Price 7/9 Set. Post 1/6 From branches or: **HOBBIES LTD., Dept. 99, Dereham, Norfolk**

There was a young man from Penzance—
—who hadn't a clue how to dance!

but he sent for our book
and in no time—just look!

—he's made an amazing advance!

Can't afford private lessons? Learn ballroom dancing at home. Send for exciting booklet *Dance Escort* FREE to readers of *Hobbies*—which explains the dynamic SURE STEP system. Just send name and address to: **ESCORT DANCE INSTRUCTORS** Studio H24, Harrogate (or Rock'n'Roll Course—send 4/6 P.O., or Old Time 8/6, or Cho-Cho 5/6)

WHEELS. (Hardwood and Rubber Tyred Fittings and Papers, Beads, Transfers, Prints and other accessories. Stamp for new lists. (Trade supplied.) New address — **JOYDEN CO., 91 Peplins Way, Brookmans Park, Herts.**

LEARN RADIO AND ELECTRONICS the LNEW practical way! Very latest system of experimenting with and building radio apparatus — 'as you learn'. FREE brochure from — Dept. HW10, Radiostructor, Reading, Berks.

STAMPS FREE — Empire Packet including Pictorials and Victorians with approvals. — Robert J. Peck, 7A Kemp Road, Bournemouth.

BUILD YOUR OWN HI-FI at home! At last, for reasonable cost — the chance to make your own quality HI-FI audio equipment and to gain the knowledge to service and maintain it. FREE brochure from — Dept. HW20, Radiostructor, Reading, Berks.

PERSONS required to make new type fancy cushion covers. Apply, enclosing S.A.E. — Dept. 28, Arnold Trading, 10 Shelley Rd., Worthing, Sussex.

NOTTINGHAMSHIRE COUNTY COUNCIL EDUCATION COMMITTEE

WOODWORK AND METALWORK TEACHERS

If you are interested in becoming a full-time teacher of Handicraft and hold one of the following qualifications in a Woodwork or Metalwork subject —

- (a) Higher National Diploma plus two years' industrial experience,
- (b) Higher National Certificate plus two years' industrial experience, or
- (c) Full Technological Certificate of the City and Guilds of London Institute, plus five years' industrial experience —

write to the undersigned for further particulars of a proposed short training scheme as a qualified teacher on full pay. Basic salary scale £498 15s. 0d. — £945 per annum; industrial experience recognised for starting point on scale. School posts arranged for selected applicants.

Applications of previous candidates will automatically be brought forward for consideration.

J. Edward Mason, Director of Education (Reference T.S.), Education Department, County Hall, West Bridgford, Nottingham.

MODELS. You can make lasting stone-hard Models with Sankey's Pyruma Plastic Cement. Supplied in tins by Ironmongers, Hardwaremen and Builders' Merchants. Ask for instruction leaflet.

KUKLOS ANNUAL. Indispensable cyclists handbook. Tours, resthouses, money-saving, hints, 3/- post free. — Burrow, Publishers, 2 Imperial Houses, Cheltenham.

APPARATUS AND CHEMICALS. Gigantic Appliance reductions. Save pounds! Special offers. Catalogue free. New premises and better service. — Scientific and Technical Supplies (Nottingham) Ltd, 286 Alfred Street Central, Nottingham.

100 DIFFERENT STAMPS Free; if requesting cheap approvals, post free. Send to — G. & B. Arscott (H.W.), 31 Westbrook Avenue, Ashburton, Devon.

A HANDY GLASSPAPER BLOCK

A wooden block with special handlo which holds glass-paper taut and always in place. In two sizes, 3in. price 1/9 (post 6d.); 5in. price 3/- (post 9d.)

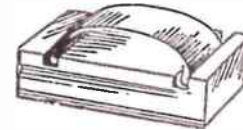

HOBBIES LTD., DEREHAM Norfolk, and all Branches

APPARATUS & CHEMICALS For your experiments. Let us help you equip a HOME LABORATORY

Beakers, Crucibles, Flasks, Funnels Gas Jars, Test Tubes, etc.

Booklets: (including postage)

- 'Experiments' 1/2
 - 'Formulas' 1/2
 - 'Home Chemistry' 2/10
- New edition

Send 3d. Stamp for latest PRICE LIST

A. N. BECK & SONS (Dept. H.W.) 60 Stoke Newington High Street, London, N.16



Mainly for Modellers

IN commencing this series for the benefit of readers who are interested in and love ships, my aim is twofold; firstly to present a picture of how the old shipwrights proceeded to work and their methods of ship building and secondly, to provide details of ship parts and fittings of interest to the model maker.

Readers who follow this hobby of ours should keep these articles and either file them or bind them together when complete, in which case they will form a valuable reference. Often ship plans do not contain sufficient details of fittings or some other forms, in which case a knowledge of the practice and usage of the period for similar ships will enable us to add those missing details as they were most likely to have existed on the original ship.

Many models of vessels like the 'Mayflower', 'Golden Hind', 'Santa Maria', etc. have to be completed on this basis.

I have in mind at the moment the plans I possess, copied from the original builder's drafts, of an 18th-century naval sloop of war. These plans only cover the hull and after several years I am still no nearer obtaining an actual deck or rigging plan. I am, therefore, reconstructing on paper the deck plans and

rigging plans based on my own knowledge and on reference works dealing with the building of this type and period. It is in such cases that I hope the present series will help our readers, who may not have available the sources of information on these subjects.

As an introduction to this fascinating study let us turn to 'Naval Architecture and Shipbuilding' as described by Falconer's Marine Dictionary 1769.

Naval architecture, or the science of shipbuilding, comprehends the theory of delineating marine vessels upon a plane; and the art of framing them upon the stocks, according to the proportions exhibited in a regular design.

It may be divided into three parts.

1. To give the ship such an exterior form as may be most suitable for the service for which she is designed.
2. To give the various pieces of a ship their proper figures, and to unite them into a firm and compact frame, so that by their disposition they may form a solid fabric.
3. To provide convenient accommodation for the officers and crew, and also suitable places of stowage for the cargo, furniture, provisions, artillery, ammunition, etc.

Earliest details

Prior to the 17th century there is no record of any attempt to put on paper the draughts or design of ships. Our earliest record is the valuable MS. found among the property of the great diarist Samuel Pepys. His MS. is entitled 'Fragments of Ancient Shipwrightery' and is the earliest known attempt to set down the details and form of a ship.

As very few of our readers will be likely to be skilled draughtsmen the methods of actually laying out a draught or design will not be dealt with in this series. We shall be working from copies

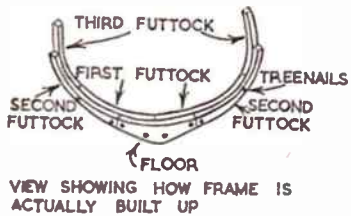
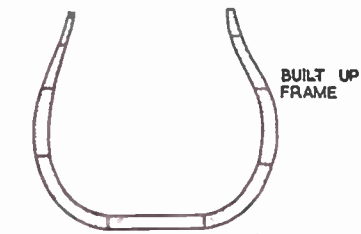

Fig. 1

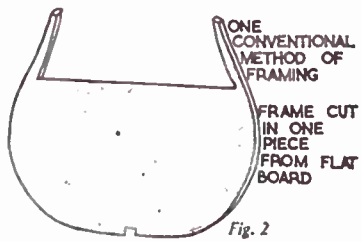

Fig. 2

of actual draughts or commercially available plans, and our purpose, therefore, is to describe and illustrate the various parts that go to the building of a wooden sailing ship.

Building models on what is called the frame system is actually miniature shipwrightery. Several methods are followed by model makers, adopting various conventional means which, although falling short of full-size practice, yet produce the effect aimed at in the particular model.

WOODEN SHIP BUILDING—1

By 'Whipstaff'

In Fig. 1 we have the ship's frame, as actually built up in full-size ship building showing the various pieces that make up the individual frame, while in Fig. 2 we have one of the many conventional ways of framing a model.

In our small survey we will take the ship in sections and look at the same section at different periods of history and at types from different parts of the world. For example, when dealing with the head of the ship in, say, the 16th and 17th centuries we will compare the various national types of bow in the galleon and other types of vessel.

The same method will be followed when considering the stern, decks, etc., and in this manner we will have our information in a form which will be one of easy reference, when we are working out details of our current model.

AGENTS WANTED

Large PRIVATE CHRISTMAS CARD Company has few vacancies for Agents (part time). Tremendous scope and excellent profits to be made by keen agents: wide range, best selling designs, reasonable prices. Write for further details without obligation to:
GARRICK CARD CO.
Dept. 13, Avenham Street, PRESTON, Lancs.

NYLON · P.T.F.E

ROD, BAR, SHEET, TUBE, STRIP, WIRE
No Quantity too Small. List on Application.
BRASS · COPPER · BRONZE
ALUMINIUM · LIGHT ALLOYS
H. ROLLET & Co. Ltd.
6 Chesham Place, S.W.1 SLOane 3443
ALSO AT LIVERPOOL, BIRMINGHAM
MANCHESTER, LEEDS

'SNAP-SHOT' PHOTO FRAME

CUT piece (A) and the strut from $\frac{1}{4}$ in. wood, piece (B) from $\frac{1}{8}$ in. and piece (C) from $\frac{1}{16}$ in. or thin card. Glue (B) to (A), clean up and paint. Cut glass to fit opening in (A). Insert glass, snap-shot, trimmed to size, and piece (C). Paste a piece of brown paper over back. Finally glue the strut to the back. (M.p.)

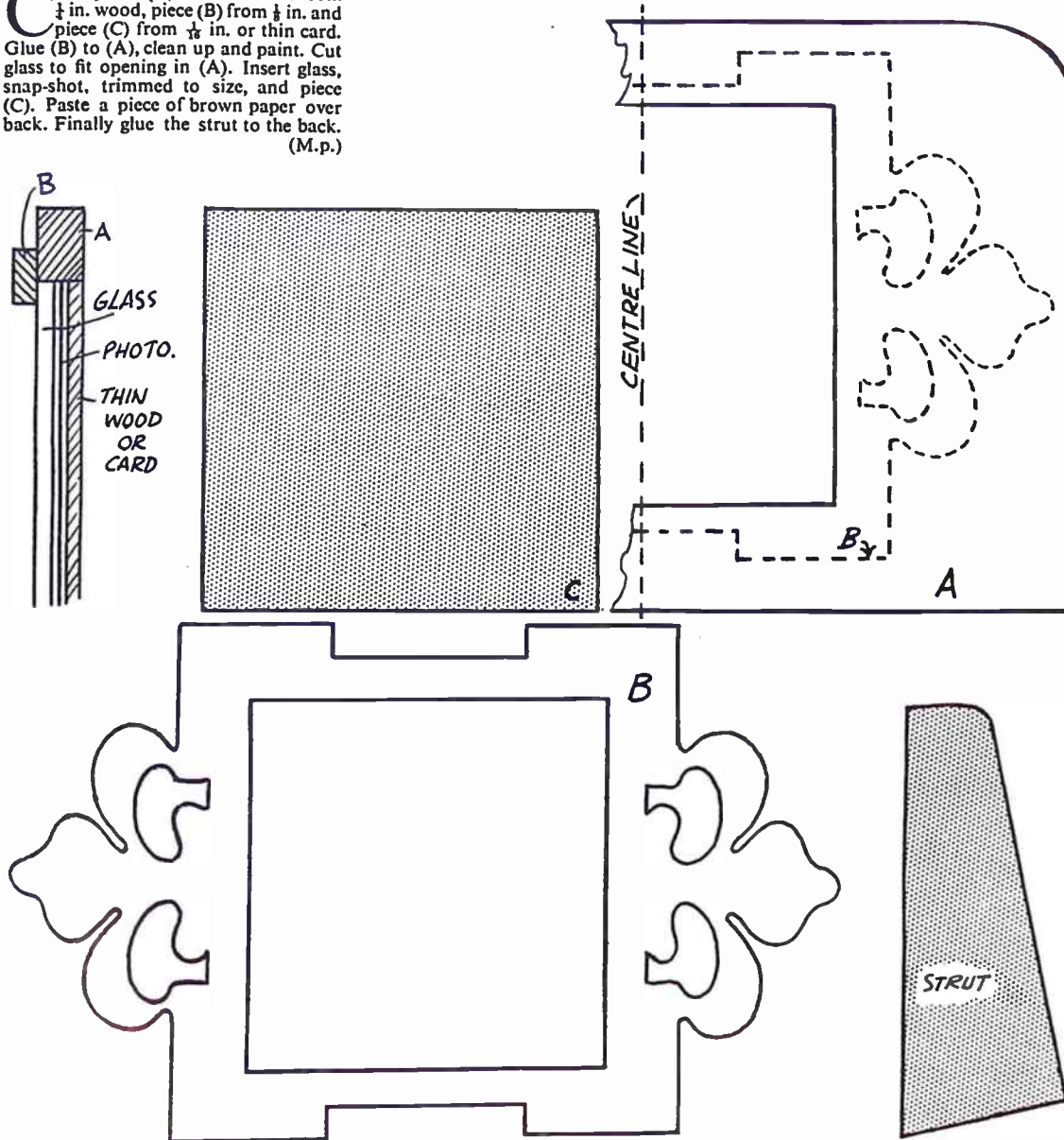
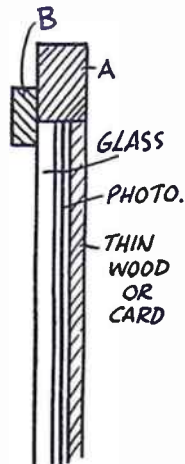

Be snap-happy ... buy **ILFORD**



ILFORD SELOCHROME PAN is the all-purpose film that millions of happy snappers choose. For the very pick of the pictures on holiday — and all summer through — this panchromatic film is the one to ask for. The famous film for Faces and Places



JUST LIKE DAD'S!

You can make this ideal showpiece from Hobbies Kit No. 3300, which contains all wood, materials, etc., and 12 sets of pots and saucers. Hinged roof, window, door. 18 ins. x 12 ins. x 13 ins. high. Only a few simple tools needed in construction.

Kits from Hobbies branches, stockists or post free (see coupon). **39/6**

ALL-THE-YEAR-ROUND INTEREST



MINIATURE GREENHOUSE

A really practical model for the home

For growing cacti, succulents, miniature trees, seedlings, etc., and can be used as a propagating frame.

To **HOBBIES LTD.**, Dept. 99, Dereham, Norfolk

Please send Kit No. 3300 for making Miniature Greenhouse.

I enclose P.O. for 39/6.

Name

Address

.....
.....