

23rd SEPTEMBER 1959 VOL. 128 NUMBER 3328

THE ORIGINAL  
'DO-IT-YOURSELF'  
MAGAZINE

# HOBBIES *weekly*

FOR ALL  
HOME CRAFTSMEN

## ★ *FREE Design Supplement*

Also in this issue:

SHOPPING CART

ICE WARDEN

COLLECTOR'S CLUB

A STRONG AND

USEFUL CHAIR

DELL'S DINING

ROOM PLANS

MICROSCOPES

VARIETIES OF

PORT WINE

ETC. ETC.

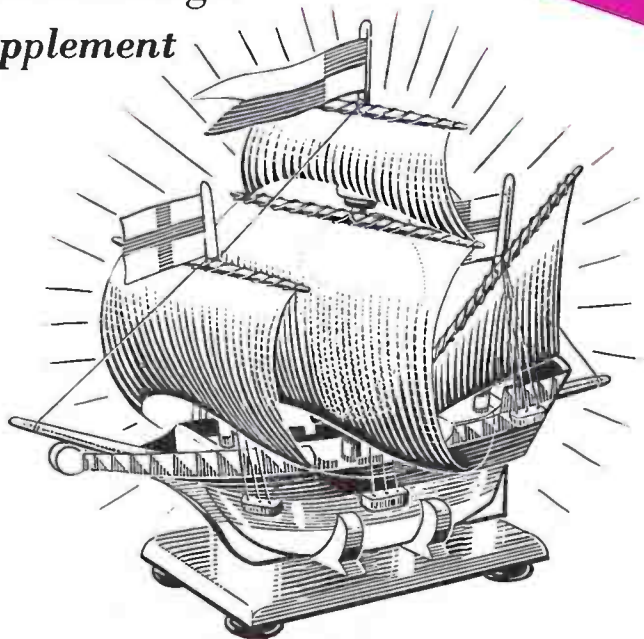

## GALLEON ELECTRIC LAMP



*Up-to-the-minute ideas*

*Practical designs*

*Pleasant and profitable things to make*

World Radio History

5<sup>¢</sup>

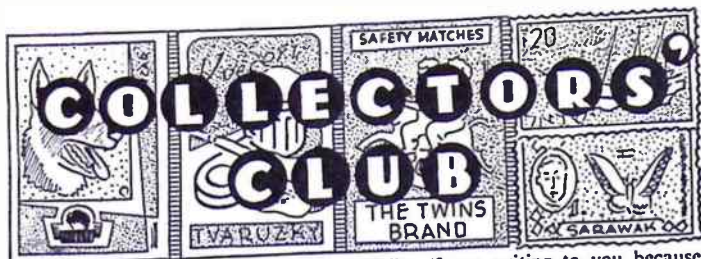

STAMPS and labels of Czechoslovakia are a treasure. Readers seeking a reliable pen friend should write to Jaroslav Ruzicka, Zateckych 4, Praha 14, Nuzle, Czechoslovakia.

Mr Ruzicka wrote recently — 'Although I particularly want hotel labels, I like to exchange all hobby items with readers of your helpful magazine. I will answer all letters received.'

Harry W. Copleston of 1555 Odell St, New York 62, N.Y. America, has formed an 'Hotel Label Collectors Club'. Harry, who is an expert on the hobby, is reputed to possess the world's largest collection.



Roger Smith



Terry Joose

And if you need more friends write to any of the following readers: Robert Vine, De-la-Haye Estate, Bellville, Cape, South Africa (collects stamps and labels); J. Davies, 10 Woodford St, Leichhardt, Ipswich, Queensland, Australia, (collects stamps and match labels); C. A. Buffan, Marie-Postale, Caransebes, Banat, Rumania (collects air mail covers, circusana, stamps).

Here is a Hobbies' family — Mr D. H. J. Holmes of 'The Haven', Whitchurch, Reading, Berks, has four sons aged 9, 7, 5 and 4, all of whom read the magazine, and collect stamps, cheese and match labels.

The illustrations showing new issues of stamps and labels have all been sent by readers mentioned above. (R.L.C.)



Mr Holmes on holiday

He is at present preparing a catalogue of all known labels.

Readers who need English pen friends for hotel label exchange should contact Laurie Gibbs of 37 Derwen Road, Pontardawe, Swansea, South Wales. Laurie has visited many countries and has a large collection of labels, post cards and hotel stationery.

For exchange with Spain write to Arturo Esteban Delgado, Viada 7, Barcelona, Spain.

German exchanges to B. Arzt, Kanstr 123, Berlin-Charlottenburg, Germany.

Female collectors should contact Miss L. K. Stokell, 18 Fisher Place, Cleethorpes, Lincs., England. Miss Stokell, a member of the Poster Stamp Association of Great Britain, has been travelling in Norway, Sweden and Finland, and has many interesting items for exchange.

I have received a letter from Ian C. Heath of Manor House, Dauntseys School, Kittleton-Panell, Nr. Devizes,



## SHOPPING CART FOR GROCERIES

If you live within walking distance of the market and shops this little cart is ideal for transporting your heavier purchases. It is much less tiring than the effort required with laden baskets or bags.

The handyman will find it easy to construct the cart and should have no difficulty in working out the sizes of the various pieces. The diagrams show the main measurements and it will be necessary to draw out the top 1, and the bottom 2, full size as indicated in Fig. 1. Draw the shapes on to  $\frac{3}{8}$  in. plywood making the top 1 in. wide all round.

The holes for the  $\frac{3}{8}$  in. diameter dowels are marked and drilled before the pieces are cut out. Space out the  $\frac{3}{8}$  in. holes equidistantly, making sure that the holes in the bottom 2, are drawn on the radii

drawn through the centres of the outer circles.

Drill a small hole in the corner as indicated in Fig. 1 and insert the fretsaw blade. Cut round the inner shape, keeping the saw upright. This will provide you with the top 1, and the bottom 2.

The dowels are now inserted in the two pieces and are secured with waterproof glue. Dowels are 24 in. long and  $\frac{3}{8}$  in. diameter. The central dowel, however, is longer, allowing for it to extend through the bottom 2, about 9 in. to form a foot upon which the cart will stand square. It may later be trimmed to the correct length according to the size of the wheels used.

The axle consists of a piece of  $1\frac{1}{2}$  in. square stripwood screwed to the bottom and the handle is 1 in. square stripwood shaped as shown in Fig. 2. An extra piece of stripwood (Fig. 3) is glued in place at the top and the excess wood is then pared away with a rasp or knife to give a smooth finish. Fig. 2 shows the axle, handle, and a few of the dowels in position.

The wheels should be rubber tyred and may be obtained from Hobbies Ltd., Dereham, Norfolk, price 4s. 6d. per pair postage 1s. They are 4 in. diameter and should be pivoted to the axle by means of round-head screws. Dowels cost 7d. per 3 ft. length, postage 1s. 6d. on any quantity.

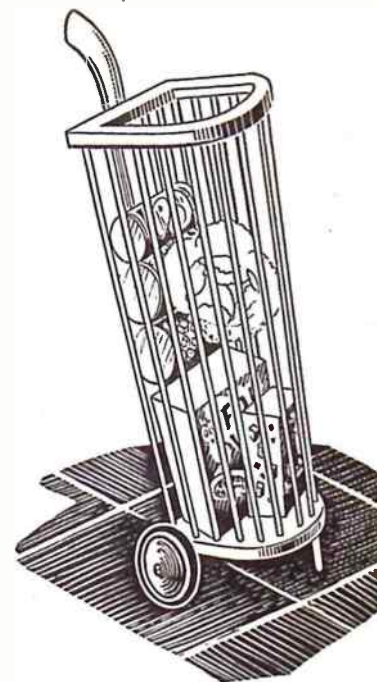

Finish off by cleaning with glasspaper and painting with high gloss enamel. One undercoat and two top coats will give a hard-wearing finish. A rub down with silicon carbide paper (wet) between coats will greatly improve the finish. (M.h.)

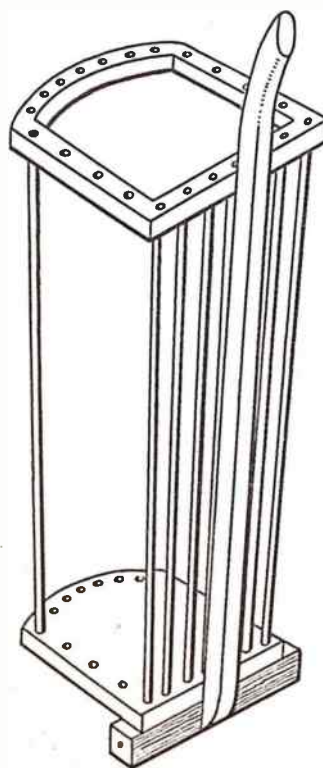
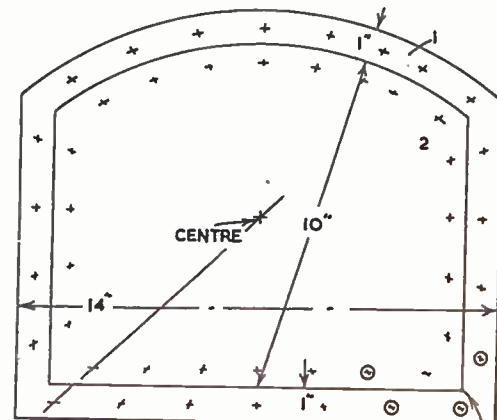

Fig. 2



DRILL HOLE HERE AND CUT OUT WITH A FRETSAW

Fig. 1

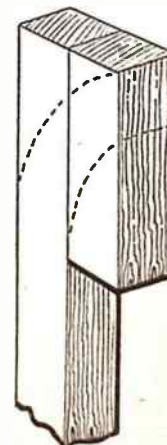

Fig. 3

Illustrated on front page

# GALLEON ELECTRIC LAMP

**A** PICTURESQUE galleon complete with billowing sails and flying pennant makes a delightful show-piece for the home, and we have incorporated into this model a further use as an electric lamp which makes it a very satisfying and worthwhile project.

The lighting from a 60 watt lamp comes from the back of the model, the sails giving a charming diffused effect by eliminating glare and harshness from the light, which at the same time serves to bring out the grand lines of the galleon. It stands  $13\frac{1}{2}$  in. high on its base, and is  $13\frac{1}{2}$  in. wide, making it ideal for use as a TV light, or as a bedside or occasional

lamp. The make-up of the galleon has been simplified so as not to give too much detail in the way of rigging and armament, etc. and it can thus be undertaken with confidence by anyone who is handy with tools.

All the essential parts of the galleon are shown full size on the design sheet and measurements and shapes of other parts, such as spars and pennants, are given in the diagrams. Mark out the various parts on to their appropriate

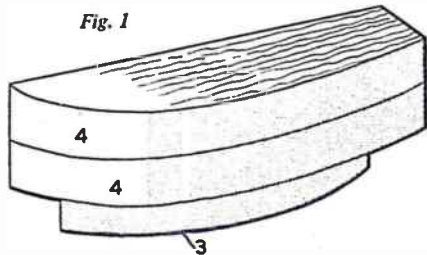

Fig. 1

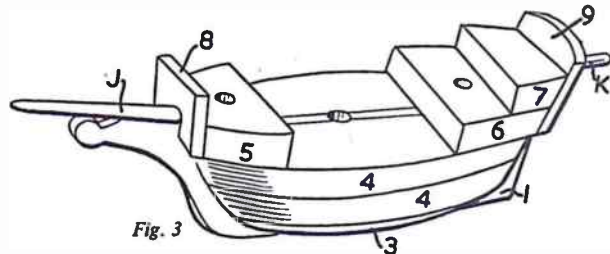

Fig. 3

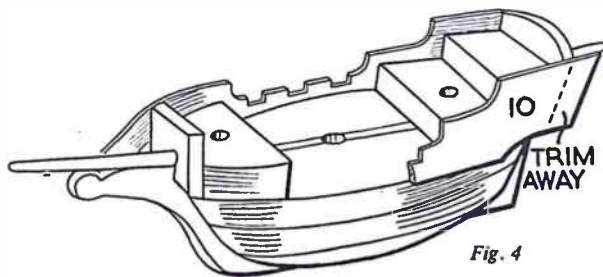

Fig. 4

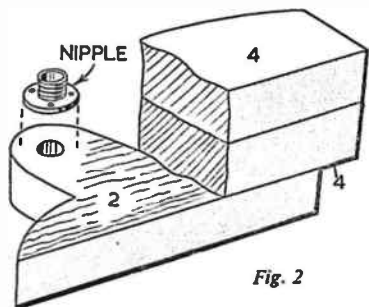

Fig. 2

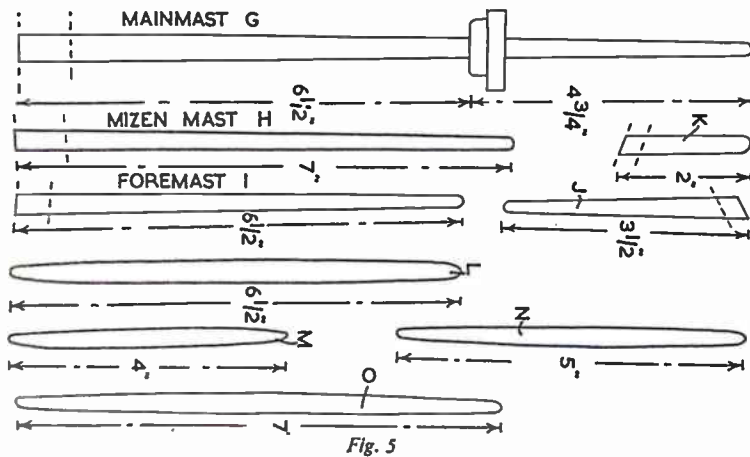

Fig. 5

thicknesses of wood, ensuring that all have been accommodated before cutting out with the fretsaw. Clean up all parts thoroughly with glasspaper.

The assembly of the model should be started by building up the hull, which is in two sections to be placed either side of the keel. The front section (Fig. 1) consists of pieces 3 and 4 and the back section (Fig. 2) consists of pieces 2 and 4 which are glued together. When dry, these two sections should be shaped to conform with the dotted lines on piece 1 on the design sheet. Do this with a rasp, small plane and knife, finishing off well with glasspaper. Note that the projecting portion of piece 2 of the back section on which the electric light fitting will be accommodated is not shaped like the rest of the hull.

Now glue the front and back sections on each side of the keel (piece 1) and continue assembly by adding pieces 5, 6, 7, 8 and 9 as shown in Fig. 3. The further

addition of the bulwarks (10) is shown in Fig. 4. These are glued in place and later trimmed to fit.

The cradle pieces of the stand (11) can next be glued to the base (12) and the insides shaped to the contour of the hull. Add the toes by gluing in the corners underneath the base.

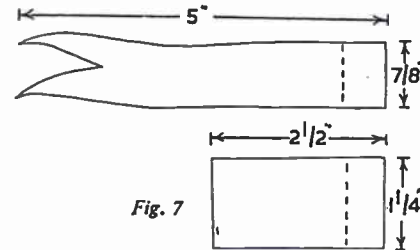

Fig. 7

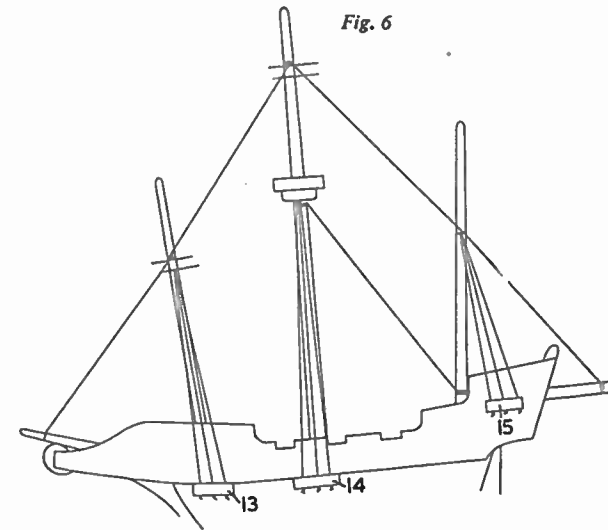

Fig. 6

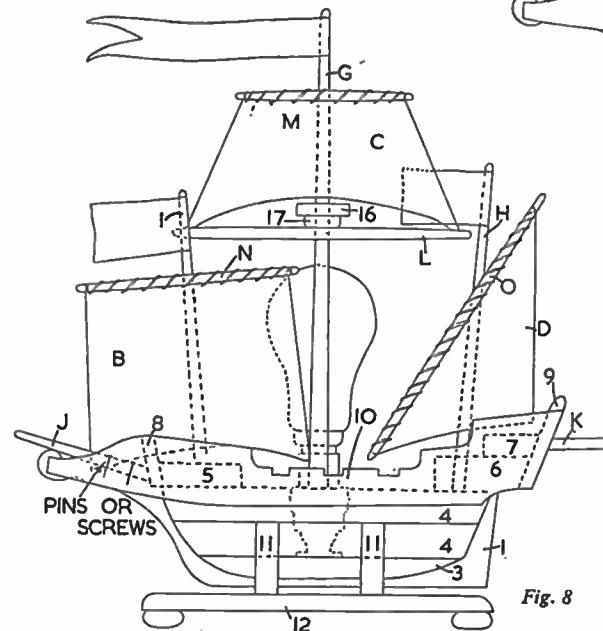

Fig. 8

Now cut out and shape the masts and spars. The mainmast is from  $\frac{3}{8}$  in. round rod and the rest from  $\frac{1}{4}$  in. round rod. The various sizes and shapes are given in Fig. 5. The crow's nest, consisting of pieces 16 and 17, is glued in position on the mainmast.

Bore holes in the deck to take the three masts. Note that the foremast slopes forward and the mizen-mast slopes backwards, the mainmast in the centre being upright. Suggested slopes are shown in Fig. 8. Glue the masts, bowsprit (J) and boom (K) in their re-

spective positions. The bowsprit may be further secured by the addition of a screw or pin.

The channels (pieces 13, 14 and 15) should next be added as shown in Fig. 6. Note that there is no channel 14 at the back. The shrouds and a few standing lines of cord are added as indicated in Fig. 6 by tying off and fixing with a touch of balsa cement.

The sails are shown full size on the design sheet and the pennant and flag shapes can be seen in Fig. 7. These are cut from crinothene. The sails are lashed

by cord to the appropriate spars, which are then tied to the masts (Fig. 8). Attach cords to the lower corners of the sails and tie off to any convenient position, such as on mast or boom, but so as to ensure the desired set to the sails. Flags and pennant should also be fastened in place by cord.

## KIT FOR 18/6

All the wood, materials, electrical fittings, etc., for making the Galleon Lamp are included in Hobbies Kit No. 3328 which costs 18/6. Kits from branches and stockists or by post (2/- extra) from Hobbies Ltd., Dereham, Norfolk.

The nipple to which the lamp holder is attached is screwed to piece 2 (Fig. 2) and flex is threaded through and connected to the holder, which can then be screwed on to the nipple.

Clean up the model thoroughly with glasspaper, removing excess glue, before painting. A suggested colour scheme is that the decks should be buff, lower hull white, and upper hull brown with white and blue decorations on the bulwarks. The stand base can be black and the cradles, masts and spars finished with clear varnish. Flags and pennant can be coloured and decorated as desired. The galleon is fixed in its cradles by means of a screw driven up from underneath the base.

Job for the handyman

# A STRONG AND USEFUL CHAIR

Described by  
A. W. Croot

THIS is a chair for the amateur to make. It has simple lines, is very robust and can be used by little children or adults. It is small enough to fit into the boot of the family car for



in Fig. 2. After cutting out with a hand-saw the legs can be cleaned to size with a sharp plane, rasp or file, smoothing with glasspaper.

The front legs are also in  $\frac{3}{4}$  in. ply and they also extend to provide the front support for the arm rests. The legs can

Continued on page 331

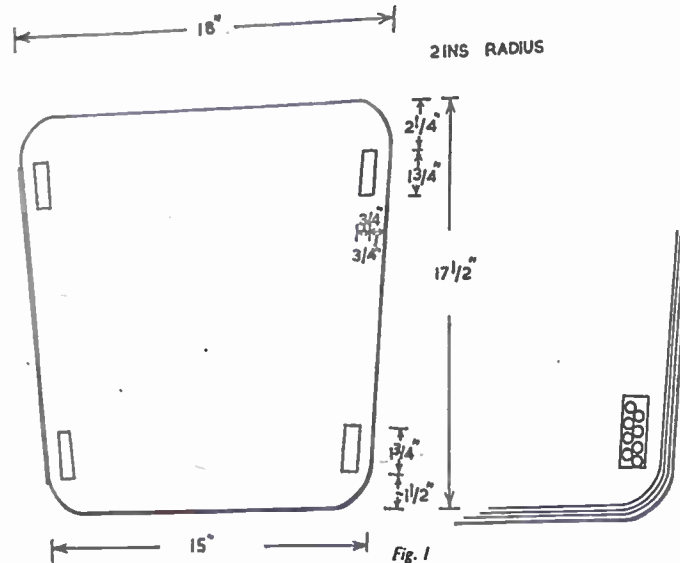

picnics, and can be painted and fitted with cushions to suit existing colour schemes for use indoors.

The material used in the construction of the chair described here is good quality plywood, but almost any hard wood could be used for the component parts with the exception of, perhaps, the seat. The design is well within the scope of the normal home workshop.

### Start with the seat

The seat is in  $\frac{1}{4}$  in. ply and is shown in Fig. 1 along with a method of opening up the leg slots by drilling a series of  $\frac{1}{4}$  in. holes, prior to chopping out with a sharp wood chisel and finishing to size with a suitable rasp. Round the corners (2 in. radius), and smooth with glasspaper.

Fig. 2 shows a back leg which is combined with an upright for the back rest. The two combined back legs and uprights are identical and are in  $\frac{1}{4}$  in. ply. These can be cut from a piece of timber 26 in. by 9 in. Mark out carefully, noting the change of angle shown on the detail

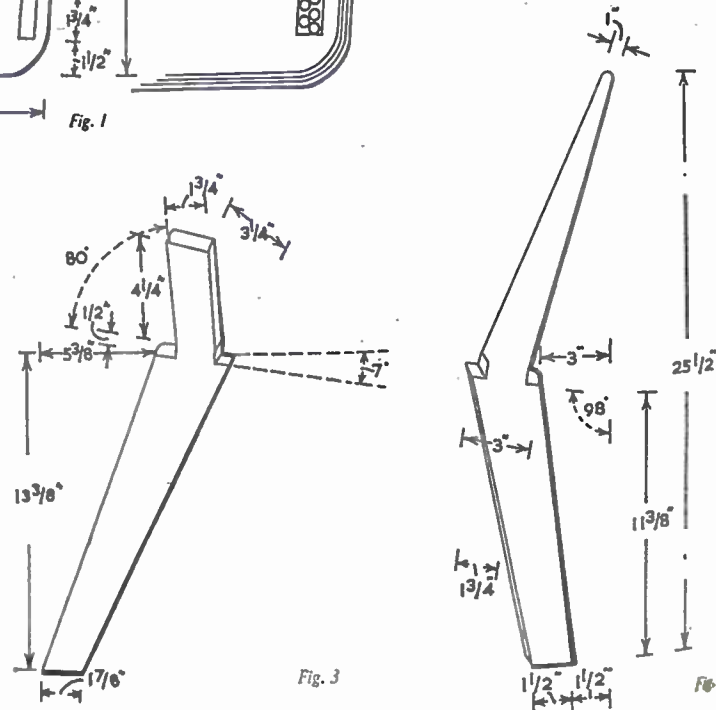

be cut from material 21 in. by 7 in. Note the detail in Fig. 3.

The arm rests, side bracings, and the back rails are in  $\frac{1}{4}$  in. ply (see Fig. 4). For these you will require a piece of ply 18 in. by 12 in.

### Use strong glue

The chair is assembled with strong glue and countersunk wood screws through pre-drilled holes.

Fig. 5 shows the fitting of the legs to the seat and the use of 3 in. nails driven in through pre-drilled holes. The nails have their heads cut off before they are finally driven home. These will ensure that the legs are held quite firmly while the glue is setting and will add considerably to the strength of the chair. Glue and screw the leg bracings to the seat as well as the legs. The arm rests are assembled with the cut out edge inside, thus giving the maximum seat room.

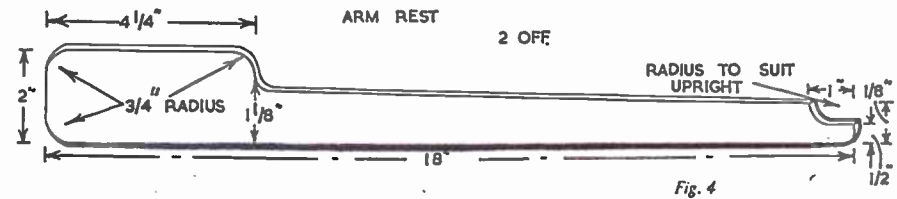
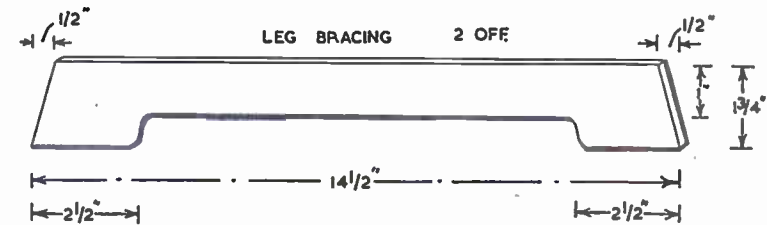
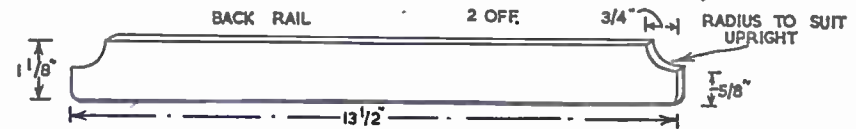
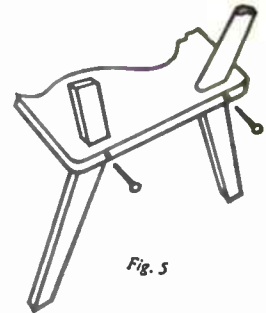

## Impromptu Shooting Gallery

IT takes only fifteen minutes to put together a shooting game that will pass the time pleasantly on a rainy afternoon. The gun is made from a cotton reel, a 3 ins. long strip of elastic and two drawing pins.

Pin the elastic across the hole on one side of the cotton reel, leaving a generous loop of elastic in the middle. Use matchsticks for bullets. Load your gun by pushing a matchstick right through the hole in such a manner that the elastic is also forced through. Hold the stretched elastic and the bullet, at the other end of the hole, between the forefinger and thumb of your right hand, while you steady the cotton reel with your left hand. Take aim, and fire by releasing hold of

the elastic. The tension of the rubber will drive the little missile a considerable distance with some force. Do not shoot at anybody's face!

Targets can be figures of men or animals cut from stout cardboard. Simple outlines look most attractive. Use coloured cardboard if available, and glue the figures to light wooden bases. Line up your targets against a suitable background such as a wall or large board resting upon a chair, and open fire. As a competitive game allow each marksman three shots in turn and score points for hits. For two players why not make the game a battle? Cut out a dozen soldiers each and let there be a gun apiece. Allow good supplies of ammunition and set out

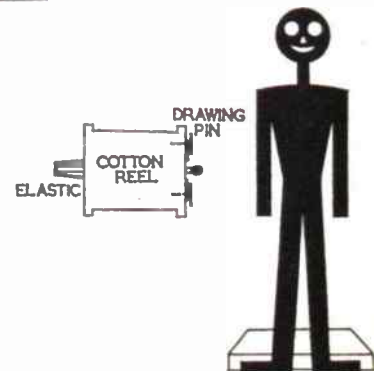

the 'armies' about ten feet apart. Fight on until all the soldiers on one side have been knocked over. (A.E.W.)

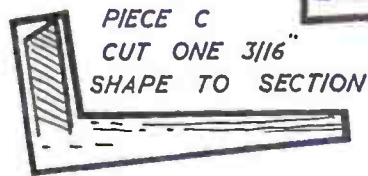
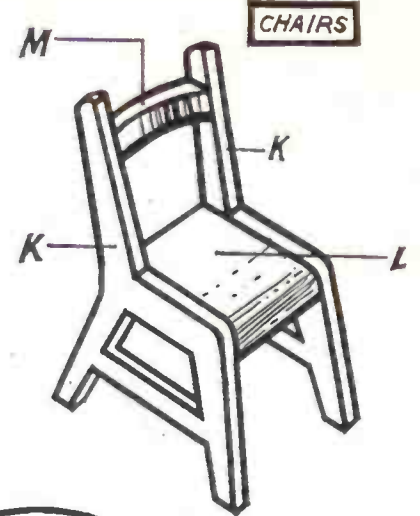
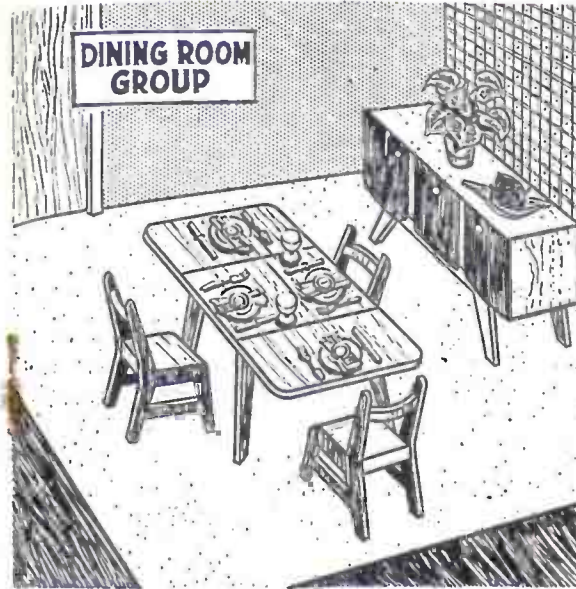
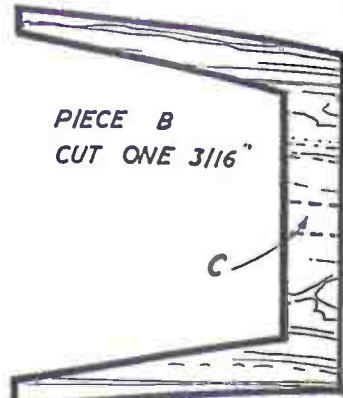
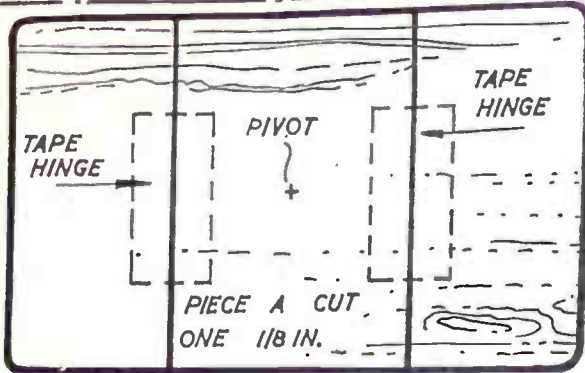

TABLE

PIECES M CUT FOUR 3/16 IN.

PIECES L CUT FOUR 3/16 IN.

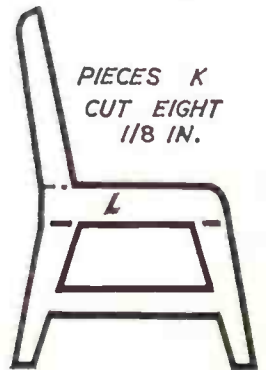
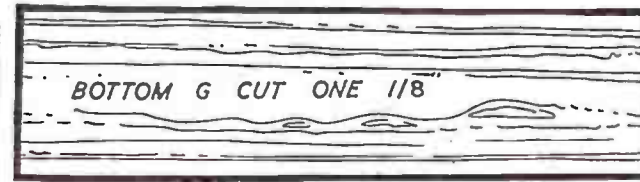
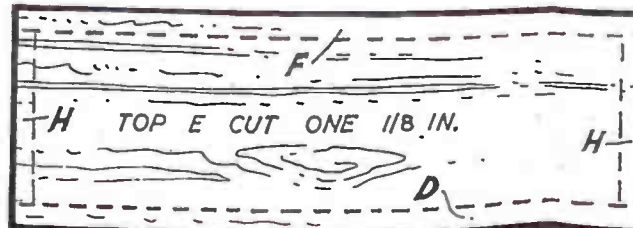
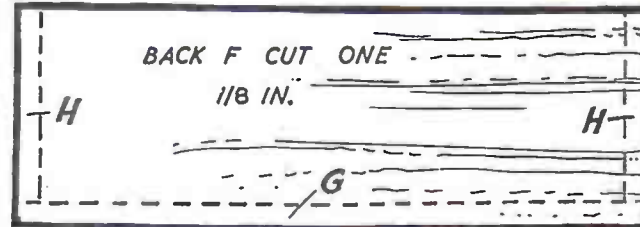
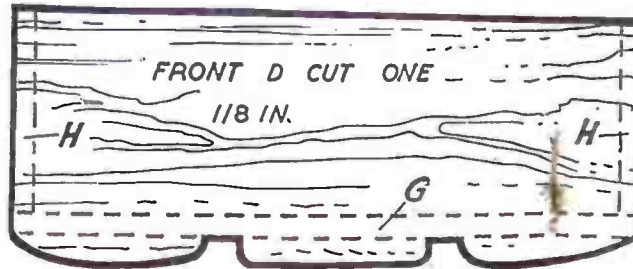
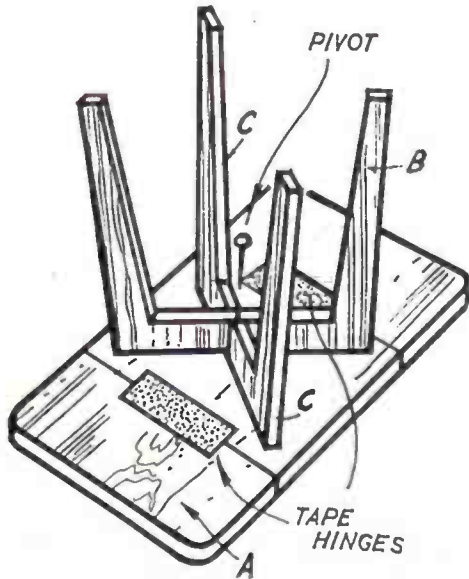

PANELS OF WOOD REQUIRED ONE G3 TWO G2

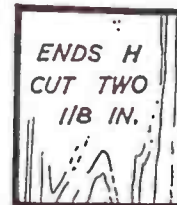
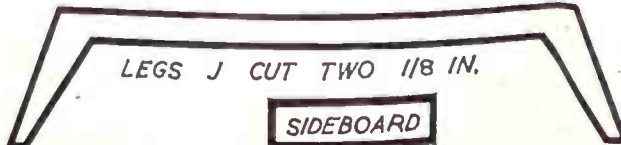

DOLL'S HOUSE FURNITURE PATTERN

PRINTED IN ENGLAND

# FEATURES OF MICROSCOPES

As an introduction to this work on microscopes you should read the chapter on Leeuwenhoek, first of the microbe hunters, in Paul de Kruif's thrilling book 'Microbe Hunters' (Jonathan Cape).

Apparatus required consists of convex lenses of various focal lengths, lens holder, optical bench described in the last article.

Using the optical bench and accessories illustrated in the article on curved mirrors in our issue of 1st July, together with the home-made lens holder illustrated in Fig. 1, you should see how convex lenses form images of various kinds. You should first of all find the focal lengths of the lenses. This you can do quite simply when the sun is shining by measuring the distance between the lenses and the tiny spots of heat and light formed at the foci of the lenses when they are held in the path of the sun's rays.

With a convex lens between A and C (without the mirror of course), and with the screen A at a distance from the lens greater than twice its focal length, move C backwards and forwards until a clear image of the arrow on A is formed on the surface of C, which should be covered with white paper. Place A at a distance equal to twice the focal length of the lens, at a distance less than twice the focal length but greater than the focal length, and at a distance less than the focal length.

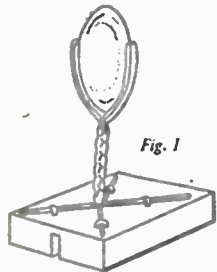

Fig. 1

Fig. 2 indicates the nature of the images formed.

When the object A is at a distance from the lens less than its focal length you will be unable to obtain a real image on the screen C, but if you place your eye near to the lens on the face away from A, you will see an erect and greatly magnified virtual image of the illuminated arrow. The convex lens is being used as a simple magnifying glass or simple microscope.

### Improvised types

Simple microscopes can be improvised in several interesting ways. Obtain a cylindrical glass bottle of fairly good quality clear glass with a smooth surface, fill it with water, and lay it along the printed lines of a newspaper or book.

For examining small objects try using a spherical flask filled with water, a drop of water on the under or upper side of a microscope slide or similar piece of glass, or the lens from a bullock's eye.

### Compound type

A simple model microscope which magnifies about 120 times is illustrated in Fig. 3. The tube A can be made from ebonite, cardboard, brass or tin plate tubing about 25 mm. in diameter and 13 cm. long. B is a short length of tubing, about 5 cm. long, and is a good sliding fit inside A. The tubes should be dead

black on the inside and for this reason ebonite tubing is very suitable. C and D are corks painted dead black, with neat holes cut out with cork-borers. Special optical tubing can, of course, be used for the microscope body.

The objective lens E (that is the lens near to the small object to be examined) is a plano-convex lens, and two plano-convex lenses F and G form a Huyghens eyepiece (named after the designer). E has a focal length of 13 mm. and a diameter of 6 mm. F has a focal length of 3 cm. and a diameter of 2 cm. G has a focal length of 1 cm. and a diameter of 6 mm. The distance between the eyepiece lenses should be about 2 cm. The lens F, if held in a metal tube, can be fixed between three punch-marks and a metal ring.

Suitable cheap lenses can be obtained from various sources. The method of mounting the microscope tube in a simple wooden stand will be clear from the illustration. The upper part of the stand is fixed to the base with a wing nut and bolt so that the microscope can be tilted. The pieces of wood H and K, which are fixed to L with simple housing joints, have holes bored in them to hold the microscope tube firmly. M is a plywood stage, and the slide is held in position by two pieces of clock spring, each fixed to the stage at one end with a small nut and bolt. Where the spring has to be drilled to take the bolt it must be softened by holding it in a Bunsen flame.

N is a sub-stage lamp consisting of a six volt lamp in a small cylindrical tin fixed with a brass strip to the lower part of L. The opening of the tin should be covered with a piece of ground glass and a few holes are drilled in the tin for ventilation. (T.A.T.)

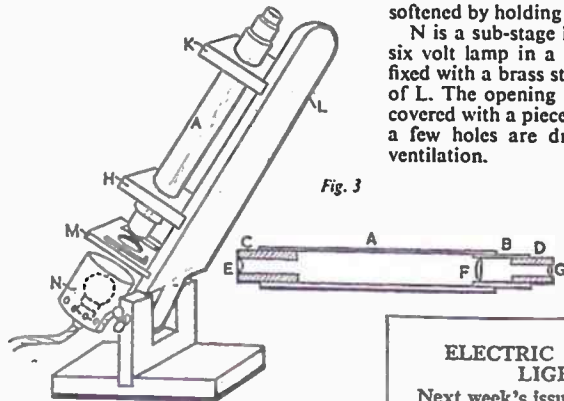

Fig. 3

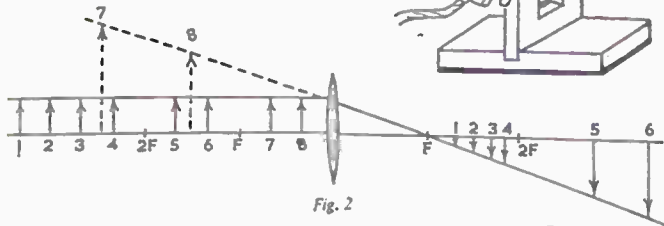

Fig. 2

### ELECTRIC CIGARETTE LIGHTER

Next week's issue will contain full details for making an electric cigarette lighter and plans for building a Hobby Soarer in our model aircraft series.

MAKE SURE OF YOUR COPY

# Be snap-happy ...

# buy ILFORD

ILFORD SELOCHROME PAN is the all-purpose film that millions of happy snappers choose. For the very pick of the pictures on holiday — and all summer through — this panchromatic film is the one to ask for. The famous film for Faces and Places

**BIRMINGHAM**  
100a Dale End, Birmingham 4

**SHEFFIELD**  
4 St. Paul's Parade

**LEEDS**  
10 Queen Victoria Street

**HULL**  
179 Forensway

**SOUTHAMPTON**  
134 High St. (Below Bar)

**BRISTOL**  
65 Fairfax Street

**NEWCASTLE**  
42 Dean Street

**GRIMSBY**  
88 Victoria Street

**BRANCHES: LONDON**  
78a New Oxford St., W.C.1  
87 Old Broad Street, E.C.2  
81 Streatham Hill, S.W.2  
15 High St., Walthamstow E.17

**GLASGOW**  
326 Argyle Street

**MANCHESTER**  
10 Piccadilly

Head Office & Factories—HOBBIES LTD, DEREHAM, Norfolk

## YOU CAN BECOME A HANDICRAFTS INSTRUCTOR

**EXPERIENCE NOT ESSENTIAL**

Men who enjoy making things in wood or metal can turn their hobby into a permanent and interesting Career. Short hours, long holidays and security in a job you would really enjoy, can be yours if you become a Handicrafts Instructor. Let us send details of the easiest and quickest way to get the necessary qualification.

**We guarantee "NO PASS — NO FEE"**

If you would like to know about our unique method of preparing you for one of these appointments, write today, and we will send you our informative 144 page Handbook—free and without obligation. Mark your letters "Handicrafts Instructor".

**BRITISH INSTITUTE OF ENGINEERING TECHNOLOGY**

595 College House, Wright's Lane, Kensington, London, W.8

# BIET

## STICK TO SECCOTINE

*it sticks everything*

Sole Manufacturers—  
**McGAW, STEVENSON & ORR LTD., BELFAST**

## APPARATUS & CHEMICALS

For your experiments. Let us help you equip a HOME LABORATORY

Beakers, Crucibles, Flasks, Funnels  
Gas Jars, Test Tubes, etc.

Booklets:  
(including postage)

|                  |      |
|------------------|------|
| 'Experiments'    | 1/2  |
| 'Formulas'       | 1/2  |
| 'Home Chemistry' | 2/10 |

New edition  
Send 3d. Stamp for latest PRICE LIST

**A. N. BECK & SONS (Dept. H.W.)**  
60 Stoke Newington High Street, London, N.16

# AQUATIC PLANTS



6 ft. deep; 2-3 in. yellow flowers. June to August.

**Orontium Aquaticum.** The Golden Club is a handsome plant that will grow in anything from 4 to 12 in. of water but the soil needs to be at least 18 in. deep, not easily provided except in natural pools. The slender flower spikes, tightly packed with small bright yellow florets, project a foot above the surface.

**Ranunculus Aquatilis.** The Water Crow-foot is a fine oxygenator, equally at home in still pools and fast water, with waving dark green foliage and white flowers. May-July.

**Vallisneria spiralis.** A charming little plant, very much like a water lily in miniature. The small dark green leaves are lightly mottled reddish-brown, and the bright yellow fringed flowers stand an inch or two above the surface. July and August.

## Oxygenating Plants

These much maligned plants — that are usually dismissed by the layman as 'water weeds' — are absolutely essential to the well-being of the water garden. Under the influence of light, they release oxygen without which fish cannot

Oxygenators can be moved from May to July, after July they become too brittle to transplant successfully.

**Callitriche Autumnalis.** An excellent oxygenator, and the only one which remains active during the winter months.

**Ceratophyllum Demersum.** Hornwort. Delicate branching stems densely clothed with whorls of narrow leaves. This variety will flourish in pools that have no soil at all.

**Elodea (Anacharis).** A family of efficient and vigorous oxygenators.

**Canadensis.** The Canadian Pondweed was introduced about 1836 and did not take long to colonise every river, canal and pond in Europe. Although this excessive energy was soon spent, it is still capable of vigorous growth but can be controlled easily in aquaria and pools of moderate size.

**Crispa.** A distinct variety whose stems are very densely clothed with reflexed leaves. An exceptionally good oxygenator.

**Fontinalis Antipyretica.** The Willow Moss is a good oxygenator with soft masses of dark green foliage. It is particularly attractive in running water. The stems should be firmly tied to a

IN addition to the water lilies (Nymphaea) which have already been described, there are several attractive aquatics with floating flowers and/or foliage. They like a turfy loam in which to root and can be grown easily in pots or baskets, with the exception of Orontium. Unless a water depth is mentioned in the description, it may be assumed that any depth of water up to 12 in. is suitable.

## Surface flowering

**Alisma Natans.** A small plant suitable for indoor aquaria such as miniature water gardens and small pools. It has dainty leaves, both submerged and floating, and delicate white flowers.

**Aponogeton Distachyum.** An attractive and unusual plant with forked flower spikes held just above the surface. The flowers, white with black anthers, have a strong scent of May, justifying the name Water Hawthorn. It flowers freely from April to October even in a shady pool, for which it is indispensable. The floating leaves are oval in shape. Water depth up to 18 in.

**Hottotia Palustris.** The Water Violet projects stems 6 to 12 in. above the surface, bearing numerous white or lavender blue flowers. The decorative ferny pale green foliage remains submerged. A first class oxygenator, *Hottotia* is invariably a transplanting risk, and being erratic in growth, is not always available throughout the planting season.

**Nuphar Luteum.** Yellow Water Lily or Brandybottle. It has been said that the finest Nuphar cannot compare with the humblest Nymphaea. However this native plant has its uses in water too deep, too shaded, or with too much current for the Nymphaea. Water up to



Hottonia



Ranunculus



Orontium



Vallisneria



Vallarsia

survive. By competing with them for mineral salts in solution, they keep in check or completely suppress the algae which are responsible for discoloration and clouded water. An adequate supply of flourishing oxygenators is the most important factor in ensuring the clarity and healthy condition of the water. They also provide the ideal spawning medium for fish, and cover for the young fry.

The number required may be calculated on the basis of one plant for every three or four square feet of surface area. With the exception noted below, oxygenators do not require planting in the ordinary sense. It is sufficient to attach the stems to a stone with a rubber band and drop them in the pool, but they can be planted in small pots if desired. Water depth is not important, but plenty of light is essential.

rough stone.

**Hottotia Palustris.** A temperamental plant which is a good oxygenator when established. Described under 'Surface Flowering' plants.

**Myriophyllum Spicatum.** Long stems clothed with finely divided olive green foliage.

**Potamogeton Crispus.** A first class oxygenator with wavy edged seaweed-like foliage, varying in colour from green to bronze.

**Ranunculus Aquatilis.** An excellent flowering oxygenator for either still or running water. Described under 'Surface Flowering plants'.

**Vallisneria Spiralis.** Light green ribbon-like foliage, spirally twisted. The one oxygenator that has a distinct root system and needs planting in the normal manner. Invaluable for aquaria.

## BUYING OR SELLING?

Classified advertisements on this page are accepted at a cost of 6d. per word prepaid. Use of a Box No. is 1/- extra. Send P.O. with advertisement to *Hobbies Weekly*, Advert. Dept., Dereham, Norfolk. Rates for display advertising on application.

**MAKE A MUSICAL BOX** as little as £21/- New kits and tunes available. Movements 13/- post free. Please send 3d. stamp for free illustrated catalogue. — The Swisscross Co., Dept. B, 202 Tulse Hill, London, S.W.2.

**STAMPS FREE** — Empire Packet including Spicorials and Victorians with approvals. — Robert J. Peck, 7A Kemp Road, Bournemouth.

**EXTRA CHEQUES** from writing. Send for 'Ideas for Writers' (free). Scores of suggestions for beginners and others. Typewriter unnecessary. — 'Writers' Ring (H.W.), 5 Edmund Street, Birmingham 3.

**INTRODUCTIONS** to new friends; home and overseas. — V.C.C., 34 Honeywell Road, S.W.11.

**KUKLOS ANNUAL.** Indispensable cyclists' handbook. Tours, resthouses, money-saving hints. 3/- post free. — Burrow, Publishers, 2 Imperial House, Cheltenham.

**100 DIFFERENT stamps free!** Request 3d. upwards discount approvals. — Bush, 53 Newlyn Way, Parkstone, Dorset.

**MODELS.** You can make lasting stone-hard models with Sankey's Pyruma Plastic Cement. Supplied in tins by Ironmongers, Hardwaremen and Builders' Merchants. Ask for instruction leaflet.

**WHEELS** (Hardwood and Rubber Tyred Metal). Cot, Pram and Doll's house Fittings and Papers, Beads, Transfers, Prints and other accessories. Stamp for new lists. (Trade supplied.) New address — JOYDEN CO., 91 Peplins Way, Brookmans Park, Herts.

## REFUND IF NOT WORTH DOUBLE!



TV TABLE & EXTRA LARGE RECORD CABINET

Not only sand polished but also sprayed light or medium WAL-

**NU TONE. NOTE—ROOMY BOOK CASES AT BOTH ENDS** — one converts to Magazine Rack by insertion of sloping panel provided, as illustrated. Amazing offer — 59/6, carr. 6/6 or sent for £1. Balance 6 monthly payments 8/-, plus carr. A well built contemporary piece of furniture to solve your record problem and also ideal as stand for TV, Radio or Record Player. 30" x 15" x 24" high. Modern sliding doors. Room interior, partitioned for classifications, holds up to 200 records (upright for perfect condition). Entirely of seasoned timber. Detachable legs. SEND quickly. LISTS, FURNITURE.

SEND FOR OUR FREE ILLUSTRATED CATALOGUE OF NEARLY EVERY KNOWN MAGNIFICATION. BINOCULARS. TENTS, FURNITURE, ETC. ALL AVAILABLE ON THE EASIEST OF TERMS.

HEADQUARTER & GENERAL SUPPLIES LTD.

(HOBW/81) 196-200 Coldharbour Lane, Loughboro Junc., London, S.E.5. Open Sat.

**LEARN RADIO and ELECTRONICS** the NEW practical way! Very latest system of experimenting with and building radio apparatus — 'as you learn'. FREE brochure from — Dept. HW.10, Radiostructure, 46 Market Place, Reading, Berks.

**GIANTS, Triangles, Victorials, etc.** — 100 Free. Request Approvals. Postage. — Salter, 42 North Rd., Rotherham.

## KITS for OLD TIME SHIPS

Hobbies range of Ship Models includes Elizabeth Jonas, Cutty Sark, Victory, Mayflower, etc. Complete kits of wood, sail material, gun, pulleys, cord, etc., with full-size patterns of parts and planed wood ready to cut out, shape and construct. A fascinating pastime.

Ask for free illustrated list at Hobbies Branches or from Hobbies Limited, Dept. 99, Dereham, Norfolk.

## HEAR ALL CONTINENTS With H.A.C. Short-Wave Receivers

Suppliers for over 18 years of radio S-W Receivers of quality. One-Valve Kit, Price 25/- Two-Valve Kit, Price 50/- Improved designs with Denco coils. All kits complete with all components, accessories and full instructions. Before ordering, call and inspect a demonstration receiver, or send stamped addressed envelope for descriptive catalogue. 'H.A.C.' Short-Wave Products (Dept. 22), 11 Old Bond Street, London, W.1

## TOO GOOD TO MISS — GET IT NOW

The big-value Handbook for the woodworker, handyman, modeller and handicraft worker. 168 pages full of interesting projects — and ONLY 2/-. TWO FREE DESIGNS WITH EACH COPY Charming Ballerina Musical Box. Model Service Station for the modern lad.

Projects include:

- ★ Animated Toys
- ★ Trailer for Tricycle
- ★ Bathroom Drip Dryer
- ★ Blanket Chest
- ★ Coloured Marquetry Picture
- ★ Standard Lamp
- ★ Modern Clocks
- ★ Models, etc. etc.

From Hobbies branches, stockists newsagents, bookstalls, etc. or send NOW for your copy by post (6d. extra).

To Hobbies Ltd., Dept., 99 Dereham, Norfolk.

Please send .....copy/copies Hobbies 1960 Annual (2/6 each, post free). P.O. for ..... enclosed.

Name .....

Address .....

# MAKING PORT WINE

**P**ORT is one of the best known and probably the best liked of all wines. Real port wine comes from quite a small district in Portugal. The red grapes which are used in its manufacture are grown on the banks of the River Douro, not far from Oporto.

The characteristics of a good vintage port are full fruity flavour, rich colour and fine bouquet. It varies in colour from pale rose to deep red, and is often fortified by the addition of brandy.

English grapes are generally too sour and lack the necessary sugar content to make a good port, but there are many other fruits which can be used with good results. If the above characteristics can be matched then we are well on the way to producing an excellent wine.

Some people consider that beetroot will make a good mock port, but it lacks that fruity flavour. This, however, can be greatly improved by the addition of a suitable fruit such as rhubarb.

Although damsons are rather sharp they are probably the best for colour; elderberries, too, will produce an excellent port wine but their bitter taste requires a little toning down.

It is a pity that bilberries are not more plentiful because they are capable of producing a wine very closely resembling port. Blackcurrants will give good results. Having valuable medicinal properties the wine is delicious and should have a strong appeal. Here is how to make it.

## Blackcurrant Port

- 2 lb. blackcurrants
- 2 lb. granulated sugar
- 4 pints water
- ½ lb. rice

Put the blackcurrants and rice into cold water and bring them to the boil. Then continue to boil under gentle heat for about 10 minutes. When cool, strain through muslin and squeeze out as much liquid as possible.

Add the sugar, stir until thoroughly dissolved, and put into bottles. This should start working without using any yeast, and continue for 3 to 4 weeks, when it is ready to be corked down. The wine will be ready for drinking in 6 months.

## Elderberry Port

Elderberries are generally very plentiful in most districts and provide a means of making a cheap port wine.

- ½ gallon elderberries
- 1 gallon water
- ½ lb. wheat
- ½ lb. raisins
- 3 lb. sugar
- 1 oz. yeast

The berries should be quite ripe in order to produce a rich coloured wine. Strip the berries from the main stems (a few small stalks will do no harm) and boil gently in the water for about 20 minutes, then strain. Add the raisins, which are chopped up small, the wheat and sugar and allow these to simmer for not more than half an hour. Add the yeast when cool (at about 100°F) and put to work for 15 days without any more straining.

When fermentation slows down, the wine may be strained and bottled. At this stage the corks must be put in lightly; and pushed in tighter when safe to do so. A richer and deeper coloured wine is obtained by increasing the quantity of berries used, and this can be up to 1 gallon to the same quantity of water.

## Beetroot Port

Owing to the rich port-like colour obtained with beetroot, many people prefer it to any other methods of making mock port. So let's try this well tested recipe.

- 4 lb. beetroot
- 1 gallon water
- ½ lb. barley
- 1 orange
- 1 lemon
- 3½ lb. sugar

Cut up the beetroot into small pieces and place immediately into cold water. Bring to the boil and continue until the colour has been extracted and the beet is tender. Now strain and then add the barley, rind and juice of the lemon and orange, and the sugar. Stir until dissolved, and then boil for a further 15 minutes. Again strain and put into bottles to work, preferably in a warm place.

A small quantity of yeast can be added if it does not start to ferment within a reasonable time but this should not be necessary. The rind of orange and lemon should be cut very thin so that there is no pith, which would give a bitter taste.

## Damson Port

Here is a very simple recipe for making an excellent port-like wine. The large plum-like damsons are best for this brew: also rich dark coloured plums may be used with equal success.

- 4 lb. damsons
- 1 gallon water
- 4 lb. granulated sugar

Cut the fruit in half and pour over them the boiling water. Stir twice a day for a week then strain through several thicknesses of muslin, allowing the juice to trickle through without any

squeezing. Filter the liquid through muslin once again before adding the sugar.

Bottle and put in a warm place to encourage the process of fermentation, which will take about 15 days. Then strain again and bottle up, putting the corks in lightly at first.

There are several fruits giving a pale coloured liquid but which are capable of making an excellent mock port. To give the necessary colour to the wine they require fortifying with a small quantity of blackcurrants, blackberries or elderberries.

Apples of all kinds, including even the crab apple, are ideal for this purpose. Try this well-tried recipe and see how near you can get to the true port wine.

## Apple Port

- 8 lb. apples
- 4 lb. blackberries
- 4 lb. sugar
- ½ lb. raisins
- 1 gallon water
- ½ oz. yeast

Cut up the apples into small pieces without peeling them, but the core should be removed. Place them in a bowl with the blackberries and pour the boiling water over them. Squeeze them between the hands every day for 14 days.

Now strain thoroughly through muslin, add the raisins (well chopped up) and the sugar. Raise the temperature to 98°F, stir in the yeast and allow to ferment for 21 days. After this strain again and bottle with the corks inserted lightly until all fermentation has completely ceased.

## Cherry Port

Black cherries are a really excellent fruit to use for making port wine with. Even the paler coloured cherries can be used although the rich red colour is missing. This, however, can be put right by adding a suitable juice.

- 8 lb. cherries
- 1 lb. prunes
- 1 gallon water
- 4 lb. sugar
- ½ oz. yeast

The prunes are first boiled in part of the water to extract as much goodness as possible, after which they are strained. Cut the cherries in halves and allow them to soak in this juice to which has been added the remainder of the water at boiling point.

A week is usually sufficient time for this part of the process and they should be squeezed twice a day. Strain again, add the sugar and yeast at blood temperature and put to ferment for 14 days, then strain and bottle. (A.F.T.)

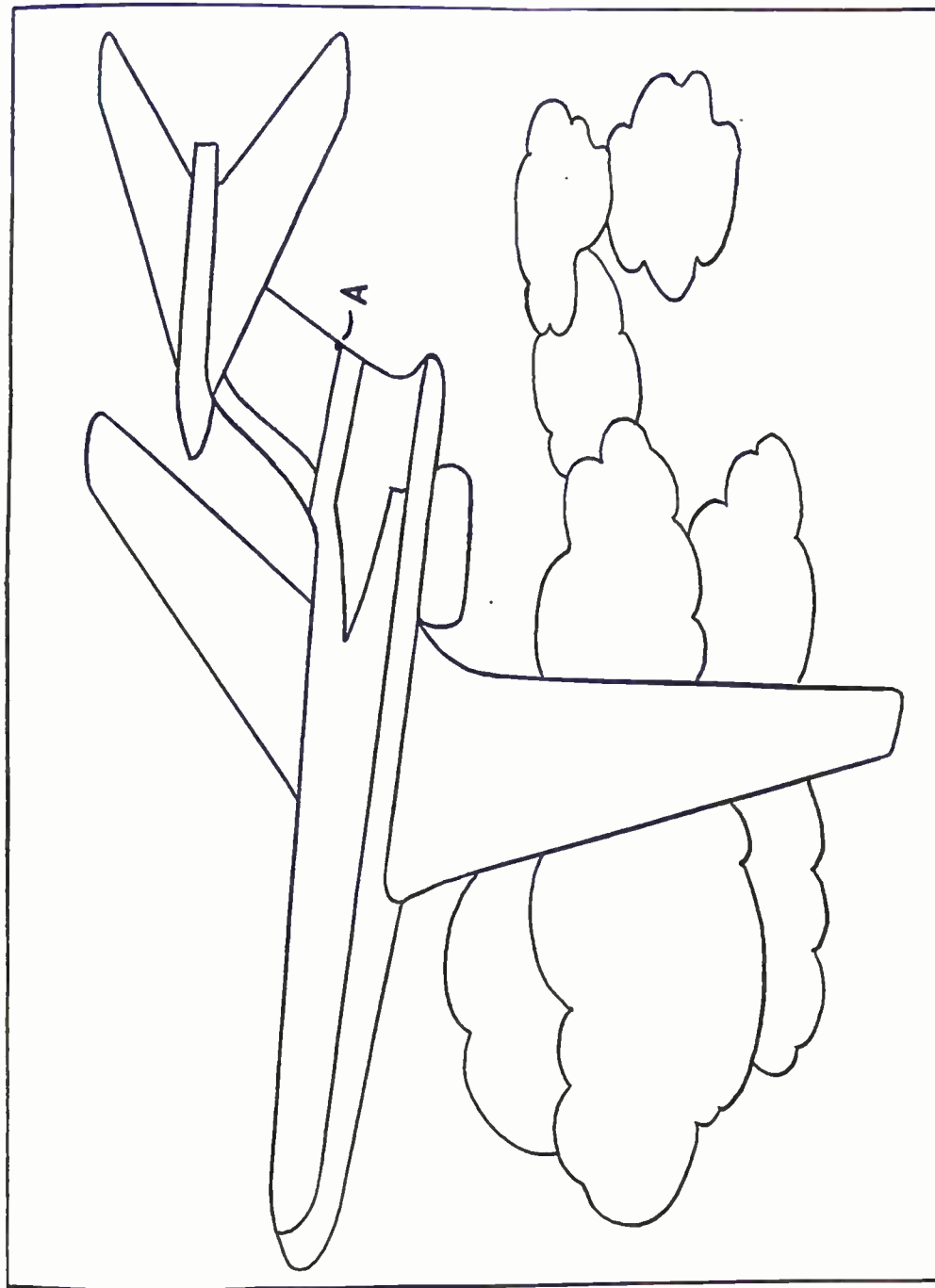

339



Whatever your speciality

You'll get a far better finish—far quicker—

with **NEW FORMULA**  
**HUMBROL**  
**PLASTIC ENAMEL**

**NEW FORMULA**  
**HUMBROL**  
**PLASTIC ENAMEL**

is available in 34 colours—  
matt and gloss

$\frac{1}{4}$  oz tins 8d. Sizes up to  $\frac{1}{2}$  pint  
Handy multiple painting kits 3/- .12/11  
from all good model shops and  
hardware stores.



Specially formulated for the exacting standards of professional model makers, new formula Humbrol gives a superlatively fine finish to wood, metal, perspex, polystyrene, pottery, aircraft tissue and paper.

- *dual purpose: replaces colour dope*
- *dries in one hour*
- *lead free in most colours*
- *proof to diesel fuel*
- *brushes on easier*
- *consistently matching shades*
- *long lasting*

AIRCRAFT  
SHIPS  
GALLEONS  
CARS  
TRAINS  
ARCHITECTURE  
PUPPETS  
MACHINERY  
HANDICRAFTS

**HUMBROL**

A product of the paints division,  
**THE HUMBER OIL COMPANY LTD.**

MARFLEET · HULL · ENGLAND