

3rd AUGUST 1960

VOL. 130

NUMBER 3373

THE ORIGINAL  
'DO-IT-YOURSELF'  
MAGAZINE

# HOBBIES *weekly*

FOR ALL  
HOME CRAFTSMEN

Instructions to make . . .



**BATHING**

**FLOAT**

Also in this issue:

MAKE A TOY  
'TIME-BOMB'

COLLECTORS' CLUB

DEREK ROY'S  
STAY CHOICE

INDIVIDUAL  
CLUB TROPHIES

PHOTOGRAPHING  
HISTORIC PLACES

ETC. ETC.

**PRE-SET  
RADIO  
UNIT**



**TUNES  
THREE  
STATIONS**



*Up-to-the-minute ideas*

*Practical designs*

*Pleasing and profitable things to make*

World Radio History

**5<sup>p</sup>**



**R**OCKETS are not a product of the Atomic Age. They were invented by the Chinese.

During the siege of the city of Kai-fung-fu by the Mongols in A.D. 1232, the Chinese defenders used what they called 'arrows of flying fire'. These were arrows with rockets fastened to them. Such arrows are shown in Chinese manuscripts of a later date.

Other countries soon learned of this new weapon. In 1379, the destruction of a strategic tower by rockets was given credit for an important Italian victory.

## ROCKET MAIL

By 1600, the use of rockets in land warfare had ceased. But they were still used for signalling. They were a favourite weapon with pirates for setting fire to the tarred rigging of ships.

Rockets were revived again in the eighteenth century by a Prince of Mysore, an Indian prince who formed a rocket corps of 5,000 men and inflicted severe losses on the British.

Rockets were used in the Napoleonic Wars. In 1806, Boulogne was badly damaged. In 1807, Copenhagen was almost destroyed by 25,000 rockets. The surrender of Danzig was caused by the destruction of its food stores by rockets.

The last use of war rockets in the nineteenth century was made by the Russians in the Turkestan wars in 1881.

But rockets have found many peacetime uses. Rocket harpoons are used by whaling ships, sky rockets bring joy on 5th November, and most important are the life-saving rockets which shoot lines to shipwrecked vessels.

Germany began experimenting with liquid fuel rockets in 1929 with a view to using them in mail services. The first was successfully launched in February 1931. But it carried no mail.

Reinhold Tiling, an engineer of Osnabrueck, fired the first rocket mail. He had worked in secret and produced a perfect rocket. He had no failures in his public tests. This rocket, with powder as its fuel, was first launched on the shore of a lake near Osnabrueck.

The rocket itself had a streamlined aluminium body, which contained the rocket proper, and four long fins. The fins, or wings, were snapped out like blades of a pocket knife, transforming the rocket into a glider, which reached an altitude of 1,500 to 2,000 ft. The rocket carried 188 post cards bearing the marking '1. Deutscher Postra Ketenstart 15th April 1931 am Dummersee'.

Other types of cards exist, dated 13th November 1932, with a cachet 'Gestart Mit Tiling Rakete', but these

were not carried by any Tiling Rocket.

Gerhard Zucker made many rocket experiments in Germany. His first successful attempt was at Duhnen in April 1933. His rocket had a central steel tube containing the powder rocket and an outer jacket with compartments for the mail.

For this flight, it was planned to prepare covers franked with all the stamps of the first issue of German Rocket Mail stamps and with stamps of the second issue. The authorities cancelled these plans at the last moment. So the mail was flown without stamps.

On the 31st of August 1933, Zucker launched his second mail-carrying rocket from Hasselfelde to Stiege in the Harz mountains. And this time, the 420 letters flown bore stamps. But these first stamps are rare.

In an effort to enlist the interest of the Hitler government in his experiments, Zucker gave his aid to the 'Winterhelp' campaign of 1934. But Hitler was only interested in war rockets and refused to help.

## Post Office names

**T**EA, Coffee, Creamery. Temperance, Whiskeytown and Prosit are a few of the interesting names that have been given to America's 36,605 post offices.

Many post offices have been named after animals, birds, and fish. Georgia and Washington each have a Tiger, and there is a Lionville, Pa. There is both a Horse Shoe Run and a Horse Springs in West Virginia. New York has a Horse-heads and Florida has a Horse Shoe Beach, while Virginia has post offices named Horsepen and Horsey.

Deer is in Arkansas, while six states have an Eagle and four a Turkey. Otter, Montana, and Ottertail, Minn., are also in this category. Eighteen states have post offices named Buffalo, four have Fox and Wyoming and Kentucky have a Wolf. Lamb is also in Kentucky. There is Chicken in Alaska, and Quail in Texas. There is a Duck in West Virginia, a Raccoon in Kentucky, Salmon in Idaho and King Salmon is located in Alaska.

Washington has a Nighthawk. Mississippi has the only Alligator. Louisiana and West Virginia share a Trout apiece and only Iowa has a Swan. There is an Elk in four states. Wyoming has the only Moose. Pigeon is in Michigan as well as West Virginia, and five states have offices named Falcon.

Old Joe is in Arkansas, Truth or Consequences in New Mexico, Fate in Texas, Protection in Kansas, Fame in Oklahoma, and Releif in Kentucky and North Carolina.

Goodnews Bay is a post office in Alaska, and there is a Goodnight in Texas.

# MAKING THE BATHING FLOAT

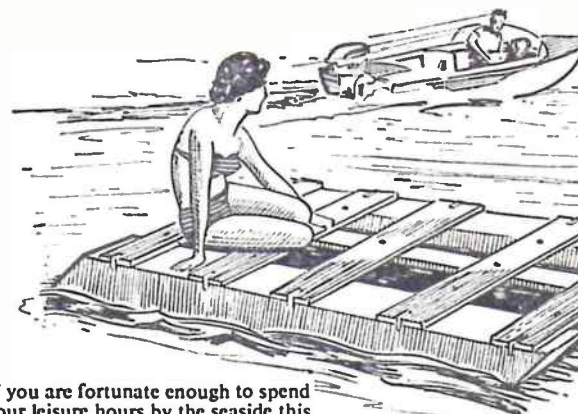

**I**F you are fortunate enough to spend your leisure hours by the seaside this float will give you hours of fun. It can be used for resting while in the water, or may even be used as a diving platform.

batten, as seen in the inset diagram Fig. 3. The four corners of the bulkheads have 1 in. square notches cut to

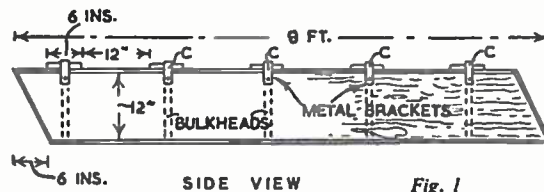

Fig. 1

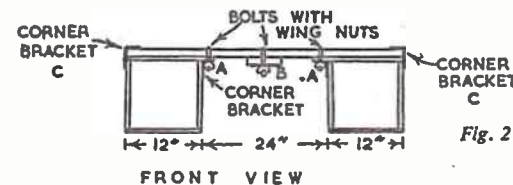

Fig. 2

It is collapsible, the two floats being removed and the centre platform folded. Brackets and wing nuts and bolts hold the float rigid after assembly.

The float consists of two pontoons which are connected by a rigid platform. The pontoons contain a number of water-tight compartments, so that if one is punctured it will not completely upset the buoyancy of the float.

The diagrams in Figs. 1 and 2 give the main measurements and show the positions of bulkheads and brackets. The two floats are 8 ft. long and about 12 in. square. They are constructed as shown in Fig. 3. There are five bulkheads in each pontoon, and these are made from two pieces of  $\frac{3}{4}$  in. thick wood, 6 in. wide and 12 in. long, held together by a  $\frac{3}{4}$  in.

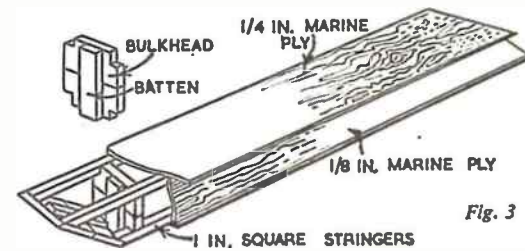

Fig. 3

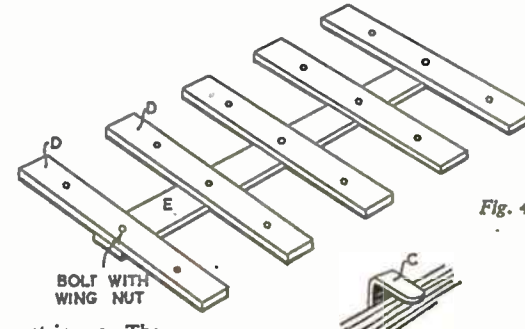

Fig. 4

take the 1 in. square stringers. The joints should be liberally smeared with waterproof glue when assembling.

The stringers go the whole length of the pontoons and are shaped at the ends to provide a slope. Note that the ends may be blocked in by frames made in the same way as the bulkheads.

Pin the stringers to the bulkheads and use waterproof glue liberally to make all joints watertight. The pontoons are now covered with marine plywood, the sides and bottom being  $\frac{3}{4}$  in. thick and the top

about  $\frac{1}{2}$  in. thick. Note that the top overhangs 2 in. on the inside, see Figs. 2 and 3. The plywood is glued and pinned in position, using brass pins.

Metal corner brackets are now fixed at the bulkhead positions, as seen in Figs. 1 and 2. The brackets C are fixed to the pontoons and project 1 in. at the top, as seen in the small sketch Fig. 4. The cross slats D of the platform slip under these brackets, but are not fixed.

The platform is made from 1 in. thick slats 6 in. wide. Pieces D are 4 ft. long and piece E 7 ft. 6 in. long. The cross slats D are drilled and are secured by bolts and wing nuts to the piece E. They are also drilled to take bolts which slip through the plywood top of the pontoons and through the metal brackets A. You will see that to assemble the float the wing nuts may be quickly put in place and tightened.

The whole float should be finished with good quality marine paint, giving

several coats to provide protection against sea water and sunshine. Paddles, if required, may be made from broomsticks or hoe handles and pieces of marine plywood.

Great care should be taken when using the float, and it should be tethered in some way to prevent it drifting out to sea. Non-swimmers should keep within their depth, and should see that the float is in water which can be safely reached by wading. (M.h)



Raymond L. Cantwell  
48. Fourth Avenue.  
Slade Park.  
Headington.  
Oxford.

Frederick Medis of 'Ivanhoe', Jambugasmulla, Muregoda, Ceylon, sent this 'World Refugee' cover issued by Ceylon.

IN the non-habitable type of room, where the Local Authorities will not insist on standards of daylight that must enter or of windows that must open to certain proportions, windows can be dispensed with if the room is only to be used on odd occasions. However, electricity is expensive and you may find it an advantage to fit a simple window to be of value during the long summer evenings.

## 6—LIGHT AND VENTILATION

Undoubtedly, the easiest to install is a cumborio, or the replacing of some of the existing tiles with identical ones made of toughened glass. Unless you have the equipment and ladder experience, the changeover of the tiles is best left to the local builder. It should not be expensive; one or two hours work by an experienced tradesman should see the job through.

The boxing-in, between the rafters on

the room side, you can do yourself. Fig. 1 shows the construction. A top and bottom horizontal member is fitted between the rafters and supported by cross battens. Finally, a sheet of Perspex is screwed, through drilled holes, to the front of the rafters. A light framing of  $\frac{1}{2}$  in. half-round moulding can be

screwed around the perimeter as a finishing touch.

You may prefer to have a hinged frame, so that the sheet of Perspex and the cumborio tiles can be cleaned (see inset).

The area of daylight needed will depend on the size of room. One of 2 ft.

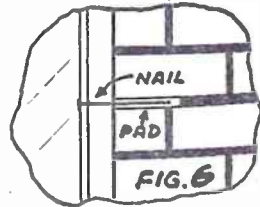
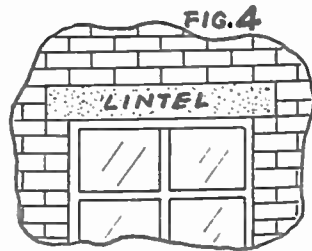
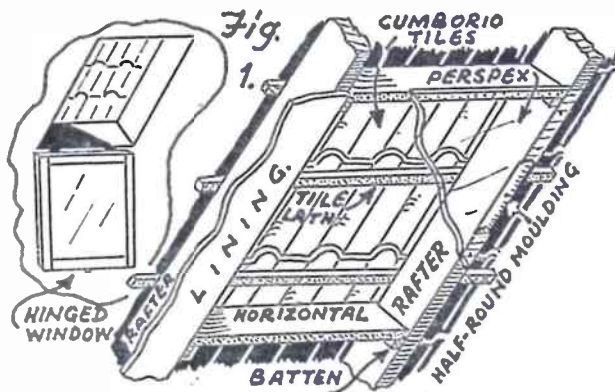

length and set between a pair of rafters may be sufficient. Or one between three rafters may be needed. Two windows on opposite rafter slopes is better still. You will find that even the smallest window will let in quite an appreciable amount of daylight.

Ventilation of some sort is a 'must' in an attic room. Without it you will find the room gets unbearably hot on summer days. The simplest form of ventilation to install is the air brick.

Three bricks, sited high on the existing wall, should be removed, as shown in Fig. 2. You will find it quicker than chopping bricks in half. Also, the

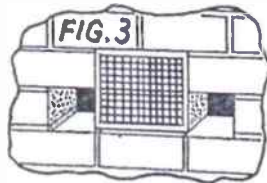
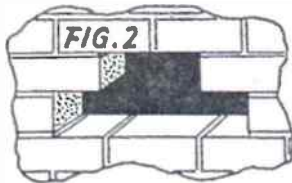

surrounding brickwork is less likely to be disturbed.

The air brick should be bedded in with a 2:1 cement mix, in the position shown in Fig. 3. It is quite simple to cut a brick in half to fill in the two lower gaps remaining. The air brick should sit flush with the outside of the wall. The inside cavity can be tidied with a rendering of plaster, or boxed-in.

A refinement on the room side is to fit a 'hit and miss' ventilator plate. This unit has a series of upright slots which can be opened or closed by the flick of a central knob.

For the habitable room the Local Authorities will insist on a minimum-size window, according to the size of the room. Part of the window must also be able to open. If you refer back to earlier articles in this series, you can calculate what size window you will require. It is wise to make it a little larger than the minimum requirements stated.

As most readers will know, the brickwork above a window is usually supported by a lintel, as shown in Fig. 4. A

wooden lintel can be used if the brickwork over the window does not exceed three courses. It should, however, be of at least 4 in. by 4 in. dimensions. Even so, a wooden lintel, unless made from oak, does not weather too well, and for that reason, a concrete one is always to be preferred.

It is made in a box mould, as shown in Fig. 5. The inside width of the box should correspond with the required width of the lintel, whilst its length should be such that it overrides the window width by at least 4 in. each side.

Reinforcement is provided by the insertion of  $\frac{1}{2}$  in. round iron bars, set to run lengthways down the lintel, as shown. The concrete should consist of a mix of two parts cement, two parts granite chippings, and one part of sharp sand. Do not make a sloppy mix, and tamp it well down when filling the mould. The top surface should be made level by drawing a board across it, resting on top of the side pieces. It should be left for two days to harden, and then the mould dismantled.

The depth of the lintel should be that of two layers of brickwork. Remove these two layers first, and then fit the lintel, bedding it in with a 2:1 cement mix. The area of brickwork that the window will occupy is next removed, and then tidied up, so that the gap made is  $\frac{1}{2}$  in. larger all round than the actual window frame.

At suitable points, the mortar is removed between two bricks and a wooden pad driven in and trimmed off flush with the brickwork. Into these pads will locate the nails that hold the frame to the brickwork, as shown in Fig. 6.

The frame is then set in place on a 2:1 cement bedding. Finally, any gaps around the framework are filled in.

It is best to use metal frames; in fact, some Local Authorities will insist on it. The cill, however, will probably be of timber. Check it before purchasing to ensure that it has a throat-cut running lengthways along its underside. This allows rainwater to drip off instead of doing damage by seeping behind the frame.

## MAKING A TOY 'TIME-BOMB'

BOYS are always fascinated by mechanical toys and delight in constructing simple contrivances which will provide them with harmless amusement. The toy bomb which will explode when it falls upon a hard surface is well known. Here are instructions for making a delayed action device which will effectively detonate percussion caps that are sold for use in toy pistols. You will need a mousetrap, two large flat-topped screws, a rubber suction disc, four tin tacks, and a piece of thin sheet metal, measuring  $1\frac{1}{2}$  in. by  $1\frac{1}{2}$  in., which you can cut from a tin lid.

Strip the mousetrap of its trigger mechanism and bait spikes, leaving only the powerful spring and the stout metal 'snapper'. Fix the screws into the wood,  $1\frac{1}{4}$  in. apart, where the snapper can press upon the middles of the screw heads when it is at rest. Let each of the screws protrude for a  $\frac{1}{2}$  in. above the surface of the wooden base. Use a hacksaw to cut off the points of the screws flush with the bottom of the base. Avoid splitting the hard wood when you put in the screws, by first drilling holes in the proper places.

The delayed action mechanism is quickly assembled. You must start by mounting the suction disc upon the end of the snapper. Push a long thin nail through the middle of the 'ball' at the top of the suction disc, in order to make a straight hole. Gently pull out one side of the snapper where its end is tucked into the spring and slip the suction disc on to the stout wire. Work the disc around the snapper until it is in position midway between where the snapper presses against the twin screw heads. Press the end of the snapper back into the spring and reset the parts of the spring should this

now be necessary. Use the tin tacks to fasten the metal plate across the opposite end of the mousetrap base.

Set the timing device by lifting the snapper and pressing the suction disc against the metal plate. Atmospheric pressure will make the disc adhere to the

By A. E. Ward

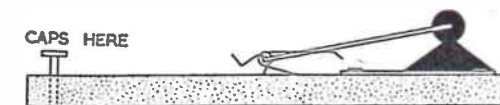
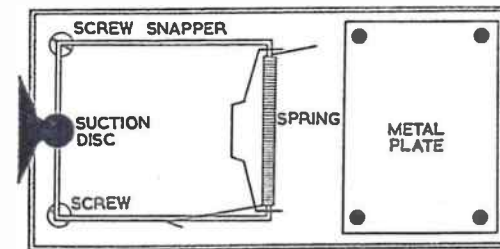

HOW BOMB IS SET

metal. The theory is that, eventually, the great tension of the spring will cause the suction disc to give way and cause the snapper to fly back and strike violently against the twin screws. Percussion caps placed upon the screws will thus be detonated with a loud report. Actually you will probably find that the suction disc will grip the metal so well that it will resist the tension of the spring. You may, therefore, need to make a minute pin prick through the disc in order to let air slowly leak into the space beneath the disc to equalize the pressure on both sides of the rubber. This must be done cautiously, otherwise the disc may lose its grip too rapidly. A time delay of about thirty seconds is convenient and not difficult to achieve.

You may use the toy for all manner of exciting games and practical jokes, but remember that it is not clever, but only foolish, to use apparatus of this sort to annoy particularly sensitive people.

# Getting to know Water Birds

**T**HERE is a wide variety of water birds on our inland waters. Some are native, whilst others have been introduced from abroad. These latter may be frequently seen on ornamental lakes in our parks, although some have made good their escape, and are breeding naturally around the countryside.

*By P. R. Chapman*

For the purposes of description it is convenient to divide the birds into three groups: ducks, geese, and miscellaneous. The ducks most commonly seen are Mallards, Tufted Ducks, Sheld-ducks and Pochards. The Mallard is the aggressive, greedy bird so frequently seen in our parks. To many people Mallard is synonymous with 'duck'. The bird breeds all over the country where there is inland water. The drake is particularly handsome, having a deep green head separated by a white collar from the deep brown breast. The female is a much quieter looking bird, being basically brown, but she has the same bright blue bar, edged with white, on the wings as the drake. In the summer the male bird loses his fine feathers, and resembles the female; he remains in this

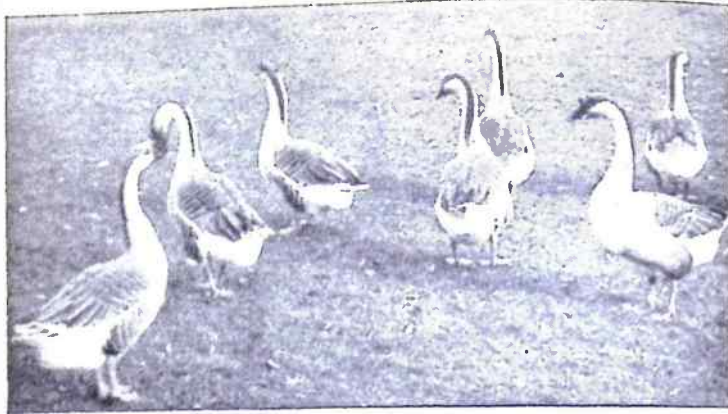

Chinese geese

water, searching for food. The drake is black and white, whilst the female is brownish. In the summer the drake goes into eclipse, and becomes difficult to distinguish from the female. This bird now breeds freely on our inland waters, although a century ago it did not breed here at all. The common Sheld-Duck is a very beautiful bird, being basically white, with a fine bronze band across its breast. The scarlet bill is also very conspicuous. There is very little difference

between the plumage of the duck and drake. Although the Sheld-Duck may be seen in our parks, it is essentially a sea bird, and may be found breeding at suitable localities around the coast, where it has a preference for sandy places. The common Pochard is another diving duck, and it may be distinguished from the Tufted Duck by the drake's chestnut red head. His body is grey, with a black breast and rear; as usual the female is a more drab animal, with a grey body and brown head and breast. This duck may be found on ornamental waters, and in its wild state is scattered all over the country. There is no scientific difference between ducks and geese. Large birds are called 'geese', whilst the smaller ones are known as 'ducks'. The Chinese Goose is a large bold bird often found in parks, where it tends to group into flocks. It is a



Moorhen



A pair of Mallard

'eclipse' state until the end of the year. Little black ducklings can often be seen in the summer, swimming very competently behind their mothers. The Tufted Duck is very frequently seen on the large ornamental lakes in our parks. It gets its name from the crest on the head of the drake. These birds belong to the group of diving ducks, and are often seen with their heads under

between the plumage of the duck and drake. Although the Sheld-Duck may be seen in our parks, it is essentially a sea bird, and may be found breeding at suitable localities around the coast, where it has a preference for sandy places. The common Pochard is another diving duck, and it may be distinguished from the Tufted Duck by the drake's

predominantly brown bird, with a dark brown neck and white throat, and is larger than most of the other geese (with the exception of the Canada Goose). The bright orange feet are very noticeable. The Bar-headed Goose is another bird frequently found on ornamental lakes. It is a smallish goose with a bright yellow bill and two conspicuous black

● Continued on page 317



The finished fireplace

**I** WAS not surprised to get this letter. Derek, the famous comedian, is always helping someone. Derek can tell his friend that the answer is to build a mock-up fireplace of 2 in. by 1 in. framing, and covered with a 'skin' of hardboard. This is then covered with imitation Cotswold walling wallpaper (Crown, 15/- piece). With careful planning, a tailor-made surround can be made to slide in tight

## A 'Stone' Fireplace for Derek

\*\*\*\*\*  
 ★ 'A friend of mine has just re- ★  
 ★ decorated his first-floor lounge. ★  
 ★ He would like to incorporate one ★  
 ★ of those attractive stone fire- ★  
 ★ places but feels it would be too ★  
 ★ heavy for an upstairs room. ★  
 ★ Like the fool I am I promised ★  
 ★ to find a solution. Over to you ★  
 ★ — any suggestions? Yours ★  
 ★ sincerely, Derek Roy.' ★  
 ★

under the existing mantelshelf. Or if the shelf is old, build over it. Knobs and protrusions on the old surround can usually be concealed. Hold the framework together with screws and use panel pins to fix the

*By Ed. Capper*

hardboard. A shelf recess is optional, but it is easily built from boxwood. It is simply a rectangular shape, made to fit into a matching hole cut in the front of the surround and held in position with shelf brackets.

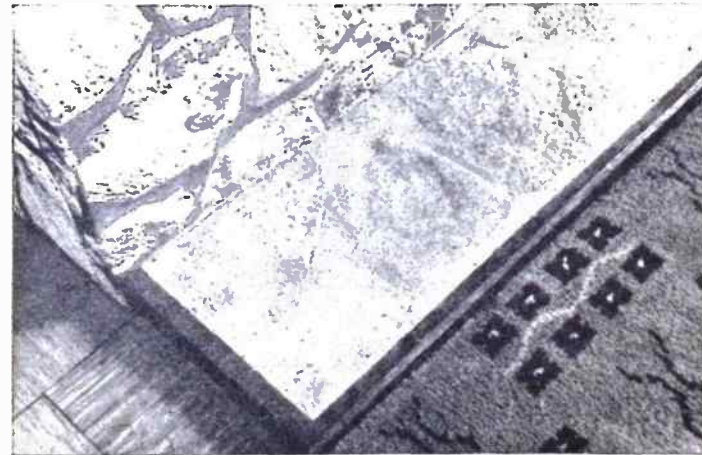

Details of hearth



The pièce-de-résistance is the hearth, for this is laid with real walling stones. Enclose them in a surround of 2 in. by 1 in. planed timber, nailed to the floor. Choose thin stones and bed them in with a mixture of three parts of sand to one of cement. Afterwards, point the joins with the same mixture.

Obviously, a coal fire cannot be used with such a surround. Use an electric fire of the imitation log or coal-burning type. Make the hearth sufficiently wide for the fire to stand 2 in. away from it. If you wish, you can fix a sheet of asbestos on the hardboard front, of the same dimensions as the fire.

Regarding the ventilation previously afforded by the open fire and now lost with the fireplace being boxed-in, if you have an air brick in the room that will be sufficient recompense. If not, cut a small rectangle on the surround front, near the bottom and behind the fire, and cover it with perforated zinc to act as a grille.

## 'Starting Photography'

*By André Page*

**Y**OUR Complete Guide to Starting Photography' is essentially for the beginner, and commences with suggestions regarding the purchase of a camera and how to use it to best effect. In easy stages, and simple language, the reader is taken through all aspects of the hobby, including printing and developing, and colour photography. Published by Fountain Press, 46-47 Chancery Lane, London, W.C.2 — Price 2/6.

# A PRE-SET UNIT FOR YOUR RADIO

**T**HIS unit automatically provides one of three stations, by turning a switch, and is intended for use with an amplifier. Amplifiers used for record playing and other purposes, will give very good results from radio programmes in this way. The pre-set tuning in the radio unit makes this much smaller, and it only has a single knob, for selecting stations. These will usually be Home, Light, and Third Programme.

The output from the unit is such that it may be used with a high-fidelity amplifier, for musical reproduction of better

quality than can be achieved with the usual type of radio receiver. The output is also powerful enough for small amplifiers having as few as two valves, such

By 'Radio Mech'

as was described in last week's issue. This item may be used for records, or for radio with the aid of the unit described here. The radio unit shown is for mains running, but it could be con-

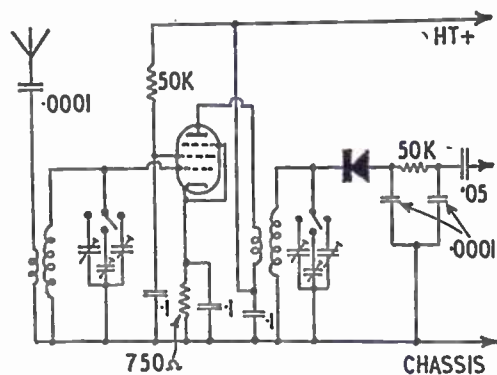

Fig. 1—Tuner circuit

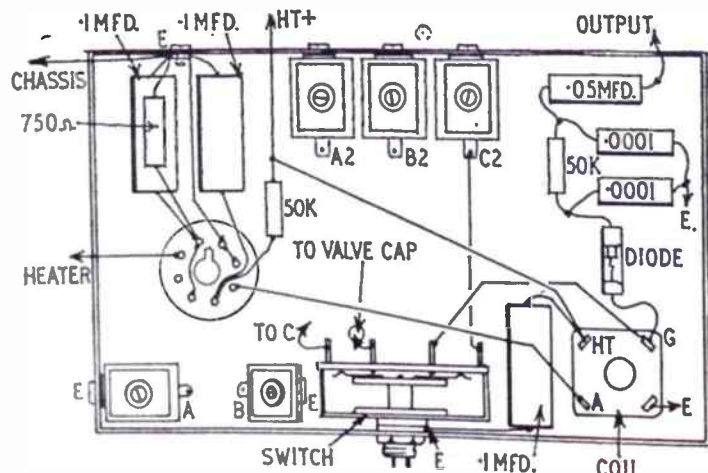
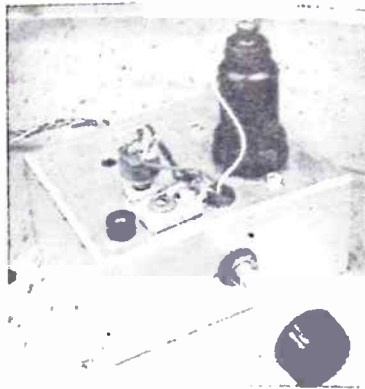

Fig. 2—Wiring diagram of the unit



structed with a battery valve for use with a battery amplifier.

### Unit Circuit

This is shown in Fig. 1, and has a radio-frequency amplifier, followed by a crystal diode detector. Instead of a gang variable tuning condenser, a 2-pole 3-way switch brings in pairs of pre-set condensers, which are adjusted for the stations wanted, then left so that the stations are selected by turning the switch.

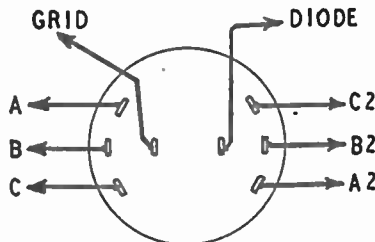

Fig. 3—Connections to the switch

The unit draws current from the amplifier, and is intended to work with A.C. amplifiers having 6.3V. valves. The H.T. positive lead is taken to the H.T. positive circuit of the amplifier. A lead from the valve heater (Fig. 2) goes to the amplifier heater circuit. The radio unit chassis is joined to the amplifier chassis, to complete H.T. and heater circuits, etc.

Any ordinary amplifier will supply the little extra current needed. If sockets are fixed on the amplifier, and the radio unit can be easily disconnected when the amplifier is to be used for records. The on/off switch and volume control in the amplifier work in the usual way, with the radio unit connected.

The valve is a 6K7, 6K7/G, 6K7/GT, KTW63, EF39, or W63. If the unit is to be used with amplifiers with 4V. or 12.6V. valves, or a battery amplifier, a different

valve, with holder to suit, must be used. But nearly all mains amplifiers have 6.3V. valves.

### Metal Chassis

A metal chassis is necessary, and this can be about 4 in. by 6 in., and 1½ in. or 2 in. deep. The switch fits in a hole drilled in the front runner. Many such switches have a small tag, to prevent them turning. If so, a small hole is drilled for this.

The aerial circuit coil must be above the chassis, which screens it from the second coil. It is also convenient to place one or two of the aerial coil trimmers above the chassis.

Any pair of medium-wave coils, with coupling windings, can be used. Dust cored coils give best results. As various makers put tags in different positions, coil tag connections should be copied from the maker's instruction leaflet.

Some coils fix with a bolt; others are a push-fit in the chassis, or fit into a clip. The valveholder is bolted down so that the slot faces the back, as indicated in Fig. 2.

### Wiring Diagram

Wiring up can be done from Fig. 2, the trimmers and switch being left until last. Various points are marked 'E'—all these are bolted tightly to the metal chassis. A flexible lead also goes from the chassis, to connect to the amplifier chassis (H.T. negative and heater return circuits).

If the output lead from the .05mfd. condenser to the amplifier is short, and the amplifier is of fairly small type, ordinary insulated flex will do. But if this lead is at all long, or the amplifier is powerful, a screened lead is necessary. This is made from wire with a screened outer covering (such as is used to connect pick-ups, microphones, etc.) and the braiding is joined to the chassis. This lead should in any case be clear of the wires carrying power to the radio unit, or a mains hum will be heard with the programme.

Two other connections are required from the unit, for heater and H.T. positive. These are of insulated flex.

Good soldered joints should be made. The wire ends of the diode are left full length, and soldered quickly so that heat does not reach the crystal.

Connections for the aerial coil, above the chassis, are not shown. Two tags will be joined together, and taken to the chassis. One tag goes to the aerial. If the aerial is at all long, the .0001μF condenser shown in Fig. 1 should be joined in circuit. A socket can be fitted to the chassis for the aerial to be plugged in, if a flex lead is inconvenient.

One switch tag has a lead which passes through the chassis to the valve cap (see

Fig. 2). This switch tag is wired to the remaining tag (grid) of the coil above the chassis.

### The Pre-set Condensers

It is simplest to test the tuner with only one pair of pre-set condensers wired in, and the switch turned to this position. This will make mistakes in wiring condensers unlikely. The other condensers can then be connected in afterwards.

In Fig. 2, the diode circuit tuning condenser C2 is wired to the switch, and the aerial tuning condenser C, which is above the chassis. A back view of the switch contacts is given in Fig. 3. When the switch is turned fully one way, C and C2 will be in circuit. It is then only necessary to adjust C and C2, with an insulated screwdriver, for best reception of the station which is to be obtained at this switch position.

Another pair of pre-sets, A and A2, then the last pair, B and B2, can then be wired in, from Fig. 3. Turn the switch to its middle position, and adjust B and B2 for the second station. Then put the switch in its last position, and adjust A and A2.

One tag of each pre-set condenser is joined to the chassis. This is most easily done by bolting the tags to the chassis sides, and this will hold the condensers in place. An insulated screwdriver must be used for adjustments.

### Stations to Choose

A radio unit of this kind is not intended for long distance reception, but

for good signals from those more powerful stations which are generally wanted.

If A and A2 are both .0001μF maximum capacity, they will tune in stations between about 200 and 250 metres. If B and B2 are .0002μF, they will cover from about 220 to 350 metres. If C and C2 are each .0005μF, they will tune from about 300 to 550 metres. The main point to watch is that the larger capacity condensers (.0005μF) will not tune to very low wavelengths, while the small condensers (.0001μF) will not reach high wavelengths. It is thus wise to look up the wavelengths of the required BBC stations, or to note where these tune in on the dial of an ordinary radio set. Or it may be impossible to adjust the capacity to a station near the upper or lower limits of the waveband. When coils with adjustable cores are fitted, the position of these cores will alter the wavelength tuned, and this is useful when it is necessary to reach a station at the extreme end of the waveband.

Any fairly short aerial will usually be sufficient. This can often be indoors, and can be a few yards of thin insulated wire near the ceiling.

If the amplifier has no volume control reproduction is likely to be too loud. A 50,000 ohm volume control may then be wired between the 750 ohm resistor and E, in Fig. 2. This will allow the output from the radio unit to be adjusted as needed.

The unit must not be used with A.C./DC equipment in which the chassis is alive to the mains.

## MOVABLE WORKROOM LIGHT

**B**ORE two holes in the wood from the bottom and side so that they meet. Make the channel wide enough to thread through the flex. Fasten the screw eye in the top of the block.

Fasten the two hooks securely in the opposite walls, so that the wire stretches over the work-bench.

Thread the wire through the screw eye, and fasten the wire to the hooks.

Thread the flex through the channel in the wood block and then connect the bulb-holder. Tie a knot in the flex where it enters the wood block, to prevent the bulb holder from dropping down too far.

After connecting to the ceiling rose you can move the light along the wire to the place on the bench that you are using without diffi-

REQUIREMENTS	
2 Hooks.	
1 Screw-eye.	
1 piece of wood — 4 in. by 1½ in. by 1 in.	
Sufficient wire to stretch from one wall to the other.	
Sufficient flex to go along the wire in each direction.	
1 Bulb holder.	

culty. A spring incorporated at one end of the wall-to-wall wire will keep it taut. (R.W.)

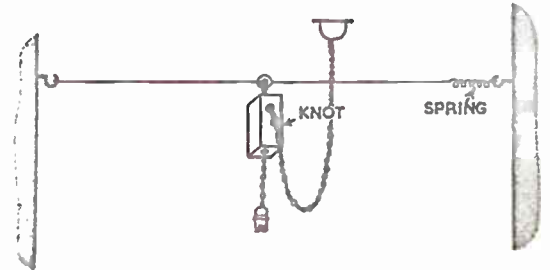

# GET WHAT YOU WANT

**O**LD castles are a 'natural' for the amateur snapper whether they are small and unimportant historically, or still massive, if partly ruined, fortifications.

Wandering along the ramparts, peering through ruined archways, marvelling at the gaunt strength of towered gateways with portcullis and draw-bridge the camera can find enough material to eat away several spools of film. But it's often the castle as a whole that makes the impact on first sight — there's something about a turreted or crenellated wall stark against the surrounding countryside, or dominating a huddle of roof tops, that stirs most snappers.

By E. G. Gaze

So, however many photogenic corners you find in exploring, you probably want the best shot you can of the castle as a whole, especially if it stirs you to stop and look at first sight. The snag is that it's not always so easy to capture with the camera that first impact, that stirring of interest. The brain is selective, and if a scene stirs us in some way to interest then imagination gets to work and we build a picture that's more than merely visual, more than the camera lens can itself record unaided by our own imagination and 'feel' for the scene.

This applies not only to castles, but to any scene that stirs our interest, and if

you can capture some measure of it on your film, then your prints will run truer to the memory picture you carry of the scene as it first struck you. And even if we can't capture it, as amateurs, our prints will be better for having been taken with some forethought instead of a haphazard clicking of the shutter. It's good practice to decide just *why* you

want to snap a scene.

Generalisations are always easy, so let's take some examples.

The three illustrations are all of Manorbier Castle, on the Pembroke-shire coast, raised on high ground between two shoulders of land running to the cliff edges. The snaps were taken at different times, from different angles, in

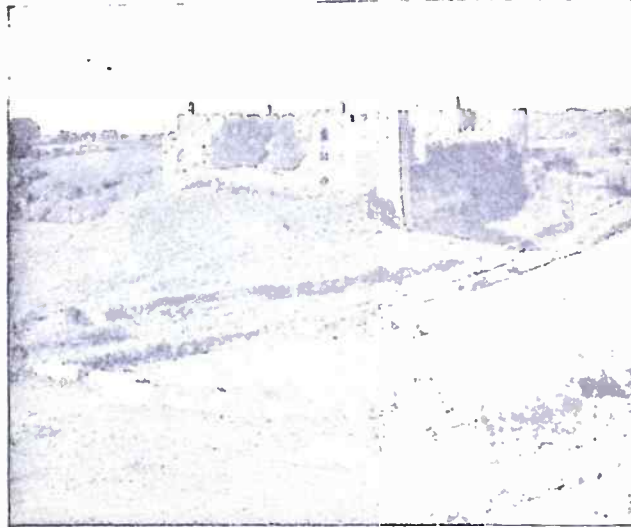

Fig. 1—Castle "just sits in the middle"

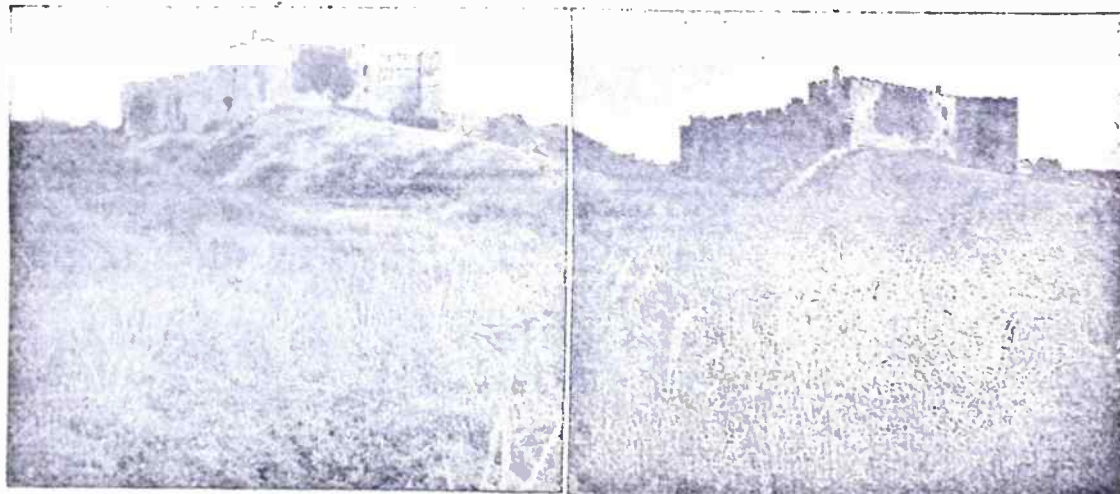

Fig. 2—No contrast, a flat scene lacking impact

Fig. 3—A "harsher" scene than the others

different conditions, but they are all mainly the same scene in different aspects.

**NO. 1 PRINT** — A bright day with scattered clouds, sun at high left, frontish: shadows quite short, not very deep in the overall brightness of the open view. Viewpoint from high land, shoulder to right, so that castle on its mound sits at about eye-level in the viewfinder.

A pleasant enough snap, giving a good view of the castle outline with enough contrast for an impression of a bright, open scene. But, somehow, the castle just sits there, it lacks the 'feeling' of strength and dominance which appealed to the snapper.

**NO. 2 PRINT** — Another attempt to get that 'feeling' of harsh dominance. This time on a day with fairly good lighting, but diffused with over-all clouds. And a new viewpoint — a low angle relative to the castle this time,

with a flattish foreground of reeds and stream growth.

It seemed to give more impression of the castle rising up strongly in its surroundings, but lack of lighting contrast prevents it from standing four-square, the walls are too evenly and flatly lit and as visually drab as the foreground. Flat tones lessen the impact of the snap and cut down the effect of different masses and shapes.

**NO. 3 PRINT** — Another slight change of viewpoint to accentuate the effect of the castle rising up four-square against the sky and dominating its surroundings. Foreground from this viewpoint not so flat but itself of different levels and masses — and both foreground and castle now lit in a strong, lower side-light from the right. Also a stronger sky effect.

Most snappers would discard No. 2 as

too flat and lacking in visual interest for the album. Opinions could easily differ between No. 1 and No. 3 — it depends upon the way the scene struck you in imagination as well as visually. They give different aspects.

But maybe these simple examples show that haphazard snapping doesn't often pay when you can take time to work out just what it is you want to show in your print — and then use viewpoint and lighting to aid your camera lens to record it that way for you.

Just lifting the camera to your eye and clicking won't do, even if it's the most modern automatic camera it doesn't really *think* for you — and the most self-rewarding snaps come from a little thinking. It all boils down to trying to get what you want on your film — even if other folks would like to snap it differently!

## Mysterious behaviour of a Triangle

**T**HE amateur scientist can perform a beautiful experiment to demonstrate surface tension, using quickly-contrived apparatus. You will need three exactly similar shapes cut out of  $\frac{1}{2}$  in. thick sheet balsa wood. As these pieces must fit together perfectly to form an equilateral triangle, you will be advised to draw a full-size plan before you cut them out.

Draw a plan of a triangle, having three 5 in. sides, each  $\frac{1}{2}$  in. broad, and rule lines to join the corners of the two outlines. Thus you will have subdivided your pattern into three identical parts, as illustrated.

Use the plan as a guide when you cut out the three parts with a razor blade from  $\frac{1}{2}$  in. wide strips of the balsa wood. The finished parts should fit together to completely cover the plan. Paint the parts jet black.

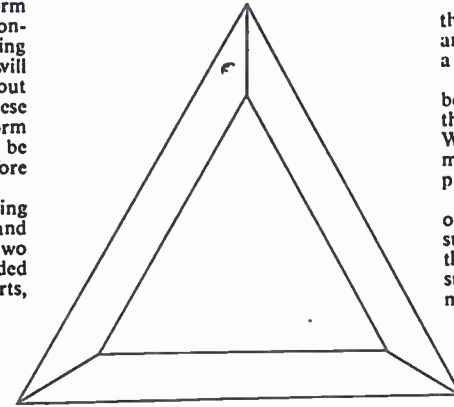

When the paint is quite dry, wash the three shapes in soapy water to remove any traces of grease, and rinse well under a tap.

Float the shapes in the middle of a bowl of water, in such a manner that they cling together to form a triangle. When you splash a drop of oil in the middle of the floating triangle, the three pieces will move apart instantly.

An explanation is not difficult. The oil rapidly spreads out and lowers the surface tension over the water within the triangle. Outside the triangle the surface pull of the water molecules remains the same. Consequently, the stronger force of surface tension outside the triangle pulls the three pieces apart. This experiment was demonstrated by Sir Lawrence Bragg during his popular television lectures on 'The Nature of Things' last Autumn. (A.W.)

• Continued from page 310

## GETTING TO KNOW WATER BIRDS

bars on its white head. The body colour is greyish.

The Canada Goose is the common goose of North America, but is very frequently found in this country, not only on park lakes, but also on various inland waters, where it breeds freely. It is a very large brownish grey bird with a black head and neck, and a characteristic white band around the throat.

The geese mentioned, although common, were all imported at one time. However, there are many geese which are winter visitors to these islands. The

Barnacle Goose may be found feeding in fields near the sea. This bird has a black and grey body, a black neck, and characteristic white face.

The Pink-Footed Goose is another winter visitor. It is a greyish-brown goose with a pink bill and pink feet. Both these last two birds may also be found on ornamental lakes, and these tame birds are much more easily observed than the truly wild ones, which are extremely shy; it is difficult to approach them.

Among the miscellaneous water birds

are the various swans. The Mute Swan with its bright orange bill needs no description, but there are less familiar species to be seen. The Whooper Swan is a regular winter visitor. It differs from the Mute Swan in not having a knob at the base of the bill, and it has a yellow face. This yellow colouration runs down the otherwise black bill.

The Moorhen is a familiar dark little bird with white under-tail feathers. Since they may often be seen wandering around the grassy edges of ponds, their large non-webbed feet may be easily observed. These are among our commonest water birds, and may be found on most inland waters.

The Coot is a little black bird with a white bill, and white patch on the head.

# CHEMISTRY AT HOME

**L**EATHER goods, such as gloves, which have become hard after wet cleaning may be softened by rubbing in a special preparation. It consists of an emulsion of neatsfoot oil (or, if hard to obtain, castor oil), water, oleic acid and triethanolamine.

During the mixing of the ingredients stirring should be continuous and vigorous. There will be needed 44 c.c. of neatsfoot oil, 40 c.c. of water, 5 c.c. of oleic acid and 1 c.c. of triethanolamine.

Mix one-third of the oil with the oleic acid and the triethanolamine. Gradually work in one-third of the water. When an even emulsion is obtained, slowly work in the rest of the oil and finally the remaining water. Stir until complete emulsion ensues.

Softening or 'plumping' of leather is carried out industrially by complete immersion in a thin emulsion under controlled conditions of temperature. The above preparation makes a surprisingly good easy substitute.

**MAGNESIA TOOTH POWDER.** An excellent antiseptic antacid tooth powder can be made by thoroughly mixing 113 grams of precipitated chalk and 85 grams of light magnesia. Next grind in 0.3 gram of thymol crystals until thoroughly dispersed. Make a hollow in the mass of powder and add 0.6 c.c. of oil of cinnamon, and a generous dash of rose perfume. Fill up the hollow and leave for a day or so. Then grind well and sieve.

**MARBLE POLISHER.** High gloss marble articles which have lost some of their lustre may be restored by means of stannic oxide. It is best applied with a chamois leather. Rub the work with the dry powder until the requisite degree of lustre is regained and then brush off well.

**CELLULOID INK.** An ink for writing on celluloid is easily made by thinning a cellulose adhesive with a mixture of equal volumes of acetone and amyl acetate and dissolving in the product a little dye. For blue-black use spirit soluble Nigrosine; for red Safranin; for blue Methylene Blue; for green Malachite Green. This product and its vapour are inflammable.

**WHITE PASTE ADHESIVE.** A good photographic mountant and for general use as a fine paste for paper is based on dextrin. Dextrin quality varies. As pale a variety as is available should be bought. In a water bath heat up 80 c.c. of water to 71°C (160°F). The maintenance of this temperature is important and it should

not be allowed to fluctuate more than a degree either way. Consequently, the addition of the necessary 44 grams of dextrin should be made slowly so as not to cause over-cooling. The dextrin dissolves to a clear solution. Now stir in 1 drop each of oil of wintergreen and oil of cloves. Let the whole cool somewhat and then pour into a wide necked jar.

## SOME PRACTICAL FORMULAS

Screw down the lid and leave aside for a fortnight or so. The dextrin solution slowly thickens to the familiar paste.

**BOOK LACQUERS.** Shabby bindings may be touched up by a variety of special lacquers. One for general use may be made by putting into a screw cap bottle 5 grams of Venetian turpentine, 10 grams of shellac and 40 c.c. of methylated spirit. Shake occasionally until dissolved.

For special work involving white or other pale bindings use 18.3 grams of bleached shellac, 62.5 c.c. of technical grade methyl alcohol (wood spirit) and 0.5 c.c. of oil of lavender. As in the first lacquer, put all into a bottle and shake occasionally until dissolved.

Brush on thinly, leave to dry and give another coat if required. Wash the brush by stirring it around in methylated spirit.

**PAPER WATERPROOFER.** It is occasionally desired to waterproof paper. This may be done with a simple product consisting of 50 c.c. of water, 30 grams of shellac and 13 c.c. of ammonium hydroxide of specific gravity 0.88. First mix the ammonium hydroxide and water in a beaker. Add the shellac and let the mixture stand overnight. Now heat up in a water bath until the shellac has completely dissolved. Stir in enough cold water to make a final volume of 200 c.c. To waterproof the paper, brush on one coat and allow to dry. Then give another coat.

**BLUEPRINT WATERPROOFER.** It is advantageous to have waterproofed blueprints if these are to be used on outdoor sites. Boil up a water-bath and turn out the flame. Put 3.25 grams of rosin, 6.5 grams of paraffin wax and 28.3 c.c. of oil of turpentine into a

beaker or small clean tin and stand this vessel in the pan of water which has just been boiled and the flame extinguished. The solids dissolve as the mixture warms up. Allow to cool somewhat and then pour into a bottle with a well fitting screw cap. For use, take a little of the product on a soft cloth, rub over the blueprint and leave aside to dry.

**GASKET CEMENT.** Where gaskets have to resist superheated steam a special cement is required. This may be made by mixing 5 ounces of water-glass, 1½ oz. of asbestos powder and 1 oz. of dry slaked lime. Owing to the stiffness of the water-glass when cold, it should be warmed and small amounts of hot water used to incorporate the other materials. Apply to the gasket and fix in place. Allow several days to harden.

**GLASS TO METAL TUBE CEMENT.** When glass tubes have to be cemented into steel or brass tubes reliance may be placed on a mixture of glycerine and litharge (lead monoxide). Work enough litharge into some glycerine to produce a stiff paste. Leave the work aside until the cement has hardened.

**CASTING MASS FOR GARDEN ORNAMENTS.** Fancy statues and similar garden embellishments may very satisfactorily be made from a mixture of 2 parts Portland cement, 1 part asbestos powder, 1 part fine sharp sand (quarry sand) and 1 part of stone dust. Mix thoroughly the dry materials and then incorporate water until a mortar-like consistency results. The amount of water can be cut down and hence a harder cast be obtained by adding half an egg-cupful of liquid detergent to each gallon of water. The detergent acts as a wetting agent. The mix is poured into the mould and allowed to set. The casting should then be allowed to dry out under cover before placing outdoors. (L.A.F.)

## 'LETS GIVE A SHOW'

By Bill & Sue Severn

**T**HERE is more in the world of entertainment than watching a cinema or T.V. screen. The younger generation are always 'putting on a show' one way or another. Boys and girls who are interested in theatricals will find this book a mine of information on how to put on a show themselves — whether it is a solo act, or a play involving a full cast and covers all aspects of 'shows', even to costumes and make-up.

Specially adapted, and additional material, by Douglas Houlden and published by Nicholas Kaye, Ltd. 194-200, Bishopsgate, London, E.C.2. Price 15s.

## \* LEARN \* RADIO & T/V SERVICING for your OWN BUSINESS/HOBBY

by a new exciting no-maths. system, using practical equipment, recently introduced to this country.

FREE Brochure from:—  
**RADIOSTRUCTOR**

DEPT. G81. 46, MARKET PLACE,  
READING, BERKS. 3/8

**PERSONS** (either sex). Soft toy assembling. The ideal profitable pastime. Experience unnecessary. Everything supplied. Apply, enclosing s.a.c. Dept. H.W. Cuddlycraft Supplies, East Road, London, N.1.

**LEARN RADIO & ELECTRONICS** the LNEW Practical Way! Very latest system of experimenting with and building radio apparatus — 'as you learn'. FREE Brochure from: Dept. H.W. 10, Radiostructor, 40 Russell Street, Reading, Berks.

**PEN PROFIT.** If you like writing send for 'Writers' Guide' (free). Thousands of words to interest beginner or experienced. Typewriter unnecessary under our system. — Writers' Ring (H.W.), 5 Edmund Street, Birmingham 3.

Further reduced  
Brand New  
Slip into it — soft and comfy — enjoy restful sleep throughout night. No blankets, no sheets, everything in one including special padding for a beautiful soft mattress effect. Light as a feather, it rolls up to a tiny lightweight size. 19/11, post 2/6. Even finished in heavy quality strong material. Really hardwearing. Not a blanket with outer, but genuinely quilted. Refund guaranteed.

**SLEEPING BAGS**  
OCT 19/11  
POST ETC 2/6

SENT FOR 10/-  
The FLIGHT LIEUTENANT  
Genuine NEW  
TENT  
7/11. Plus DUCK carr.  
Waterproofed 1960  
Tents of 8 oz. WHITE  
Duck. Galeproof. Brand new  
surplus to export order. DON'T  
CONFUSE with Tents made from drab material never meant for tentage. This is real thing, withstands anything even in our climate. Approx. 7 ft. 6in. x 6ft. x 6ft., 3ft. walls. Cash £5/19/6, carr. 6/- complete ready to erect, incl. valise. 'Willesdon' Green 42/- ex. Ridgepole if req. 7/6 Fly-sheet 39/6 Rubberised Groundsheet 19/6. These essentials sent on approx. Refund guaranteed. LISTS, TENTS.  
Headquarter & General Supply Ltd.  
(HOBW/16) 196-200 Coldharbour Lane  
Loughboro Junc., London, S.E.5. Open Sat.

100 DIFFERENT stamps free! Request id. upwards discount approvals. — Bush, 53 Newlyn Way, Parkstone, Dorset.

Completely new 54 page Edition  
**WHERE'S THAT CAR FROM?**

Price 1/- (Postage 4d.)  
Of all Booksellers  
or  
RALEIGH PRESS, Exmouth, Devon

### AGENTS WANTED

Large private Christmas Card Company has few vacancies for agents (spare time). Tremendous scope and excellent profits to be made by keen agents; wide range of best selling designs; reasonable prices. Write for further details without obligation to: GARRICK CARD CO. DEPT. 6, AVENHAM STREET, PRESTON, Lancs.

If you have taken a lot of care in making a musical box, be sure to make it worthy by including the best Swiss movement — a REUGE. Prices from 13/9. Wide range includes a charming Dancing Ballerina. Many tunes to choose from. Send for details in free booklet 'Profitable Leisure'. HOBBIES LTD, DEREHAM, NORFOLK

**WORKERS** with sewing machines required for making cushion covers. Regular work guaranteed. Apply enclosing s.a.c., Dept. 28, Arnold Trading, 10 Shelley Road, Worthing, Sussex.

**DO YOU DOODLE?** Then you have creative ability. Read 'MAKE ART PAY' (sent free). This fascinating booklet shows how doodling can be turned to profitable artistry, quickly, easily and with ready sale through us. CLUN VALLEY FEATURES, Castle Gallery, Clun, Shropshire.

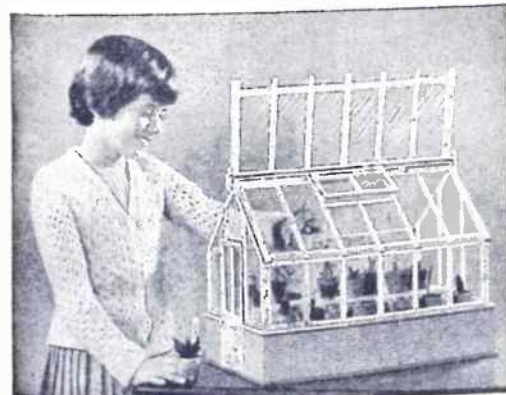

## MINIATURE GREENHOUSE

A really practical model for the home

For growing cacti, succulents, miniature trees, seedlings, etc., and can be used as a propagating frame.

To HOBBIES LTD., Dept. 99, Dereham, Norfolk  
Please send Kit No. 3300 for making Miniature Greenhouse  
I enclose P.O. for 39/6

Name \_\_\_\_\_

Address \_\_\_\_\_

### JUST LIKE DAD'S!

You can make this ideal showpiece from Hobbies Kit No. 3300, which contains all wood, materials, etc., and 12 sets of pots and saucers. Hinged roof, window, door. 18 in. x 12 in. x 13 in. high. Only a few simple tools needed in construction. Kits from Hobbies branches, stockists or post free (see coupon). 39/6

**ALL-THE-YEAR-ROUND INTEREST**

# FIXING GLASS TO WALLS

BECAUSE rimless wall mirrors and glass splash-backs to wash-basins and baths are becoming increasingly popular, the home handyman is often called upon to fix glass to walls. This is normally done with the aid of decorative mirror screws (Fig. 1). These screws are usually chromium-plated, and are provided with detachable domed caps which hide the slotted heads of the screws once they are in position.

Once the glass panel (or mirror) has been obtained, the first thing to do is to bore the necessary holes for the fixing screws. The glass may be taken to a glazier's for drilling, or the home handyman can tackle the job himself if he possesses a suitable drill. If you do decide to do the drilling yourself, then

make sure that the glass is held stable in a fixed position, and is resting on a flat, reasonably soft, surface. An ordinary hand brace and special glass drill will do the job satisfactorily.

Scratch the glass where the centres of the holes are to be with a sharp-pointed tool to provide a guide for the drill. Then make a small ring of putty or modelling clay around the centres of the holes and fill up with turpentine substitute (Fig. 2). This will ensure that the drill is constantly lubricated. Once drilling commences, use the minimum amount of pressure; let the drill do all the work. Be very careful when the drill is just about to emerge at the reverse side of the glass. Sometimes at this stage the drill emerges too quickly, gets stuck, and finally fractures the glass. If possible, drill from both sides of the glass in a similar manner to boring wood. When determining the positions for the holes, care should be taken not to position them too near to the edges.

It is important that the part of the wall to which the glass is to be fixed is perfectly flat. Any irregularities should be smoothed down with glass-paper.

Place the glass on the wall and carefully mark the positions of the holes. The wall should now be plugged to

receive the fixing screws.

If the glass panels are not very heavy then it is quite in order to fix the glass in position with the screws without any further preparation. Where the screws, however, are expected to support large panels of glass, it is necessary to avoid the glass resting directly on to the shanks of the screws. This may be done by wrapping small strips of felt or other soft material around the shanks of the screws, as shown in Fig. 3. Furthermore, in order to cushion the glass against the wall, thin discs of rubber or cork should be positioned between the back of the glass and the wall surface.

When inserting the fixing screws, always proceed cautiously. Immediately some resistance is felt in the glass, screwing should cease. The decorative cover domes should now be fitted to the screw heads, and the job is done.

Finally, when fixing rimless mirrors to walls where they are likely to be subjected to condensation, e.g. in kitchens and bathrooms, then some protection must be given to the silvering at the back to prevent damage from the moisture. This may be done by bedding the mirror to the wall with a mastic compound (to prevent moisture penetrating round the back), and then sealing the exposed edges with a coat of suitable paint.

(F.K.)

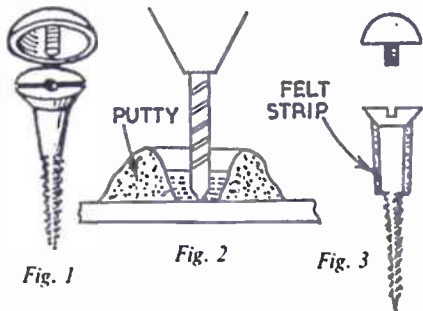

Fig. 1

Fig. 2

Fig. 3

# The Doorbell as a Burglar Alarm

IF your house has an electric doorbell, you can also use it as a burglar alarm. This is very cheap and simple to make, costing only a few shillings.

Basically, all it consists of are two hidden metal strips which are connected to the bell circuit. When the alarm is switched on, the bell will ring whenever the door or window is opened. Any number of doors or windows can be protected, using this device on each.

Two copper contact strips, each 1/2 in. wide and 2 ins. long, are screwed in position as shown in (a) in the top corner of the doorway on the same side as the handle. Midway along their length, a small hole is drilled in the wood behind them, to take a small spring or a ball catch. Adjust the ends of the copper strips by bending them slightly if necessary, so that the springs force them together when the door is opened, and

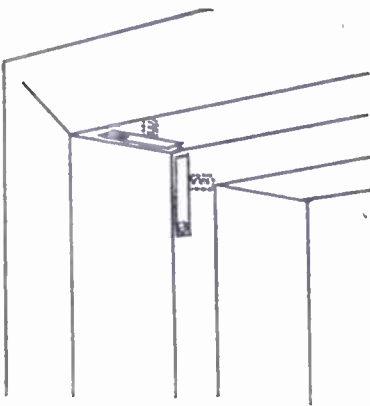

a

make sure that the door forces them apart when it is closed.

Connect a length of thin insulated bell wire to each copper strip at the screw end, and join these wires to the low voltage doorbell circuit as shown in (b).

Insert a small switch in one of the wires at a convenient place between the door and the point where the wires join the bell circuit, so that the alarm can be switched off when it is not required. The doorbell, of course, will continue to function in its normal way.

(A.L.)

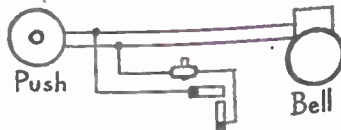

b

# Quick! pass the CERTOFIX

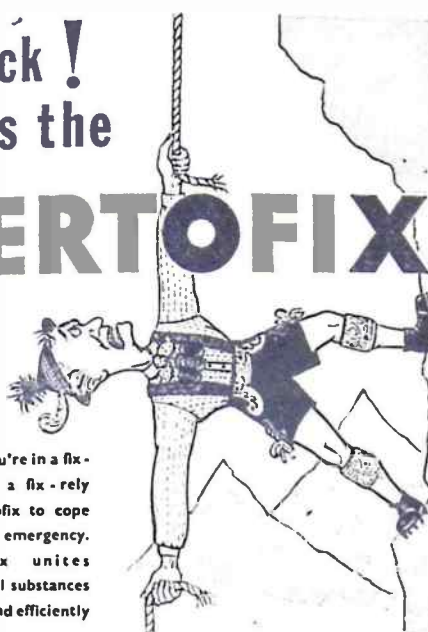

When you're in a fix - or need a fix - rely on Certofix to cope with any emergency. Certofix unites almost all substances cleanly and efficiently

## CERTOFIX FOR ALL YOUR FIXES!

Obtainable at Woolworth Stores

## Webley AIR PISTOLS



High Accuracy  
and Hitting Power  
Perfect Balance  
Robust Construction

Send  
for  
Catalogue

WEBLEY & SCOTT LTD

34 PARK LANE, HANDSWORTH, BIRMINGHAM 21

## why pay MORE?

Coronet roll films - made in all popular sizes - give brilliant results every time - and they are sold at lower-than-usual prices.

ask your dealer for

**coronet**  
ROLL FILMS

CORONET LTD., DEPT. 72 SUMMER LANE BIRMINGHAM 19

## MANY MODELS from ONE TIN!



Pyruma, plastic and ready to use from its tin, can be fashioned into the widest variety of models imaginable. Buildings for your model railway set, houses, ship models, animals and figures, ashtrays and plaques - all of which when set or baked to stone-hardness can be finished in natural colours. Get the Pyruma Model Instruction book - see Coupon, and start making things like those shown below.

## SANKEY'S PYRUMA PLASTIC CEMENT



Made by amateur modellers, this signal cabin and lighthouse show how with Pyruma you can get the effects of tiles, wood, brickwork, chimney pots, concrete - and even the rocks of the sea. The book offered below tells you how. Pyruma is obtainable from your local ironmonger, Hardware Store or Art Material dealer.

## POST THIS BOOKLET COUPON TO-DAY

To J. H. SANKEY & SON, LTD (Dept. HW),  
ILFORD, ESSEX

I enclose P.O. 6d. (not stamps) for a copy of Pyruma Modelling Instruction Booklet, post free to:

NAME .....

ADDRESS .....

(BLOCK LETTERS PLEASE)



# Points from Letters to the Editor . . .

ABOUT two months ago', writes D. C. Catt of 37 Mount Road, Maxton, Dover, 'I decided to make my own guitar, so I sent away for your plans and instructions, and began to build it. I told my school woodwork master that I was making a guitar, and he told me that boys had tried to make some at school but they were not successful.

'I heard a lot of stories of unsuccessful attempts', he continues, 'but I carried on with the work and finished the job. When I compared my guitar with one costing over £6, I found that the tone was as good if not better. People who see the guitar say that it looks and sounds like a professionally-made instrument.'



All praise to the successful achievement of this 14-year-old youth (pictured above) to whom great credit is due for his persistence and determination. His example is also an answer to the oft-met assertion 'Youths ain't what they used to be.' As a matter of fact, thousands of these guitars have been made up quite successfully from Hobbies design in the last year or so, and although, admittedly, it is not a simple project, the success of this young man proves it is, indeed, possible.

Plans for this full-size Spanish guitar, which is 3 ft. long, cost 3/6 (postage extra) and a full kit (No. 3209) can be obtained for 5/6 from all branches, or

by post from Hobbies Ltd, Dereham, Norfolk (post free).

Kind-hearted reader

MR W. SIBBALD of South Woodford, London, has been a keen fret-worker since well before the 1914-18 war. He started with a handframe and graduated to the Roger fretmachine and then on to the Royal, which he bought at our Bishopsgate branch in 1925 for £3. 17s. 6d.

Prices have certainly risen since those days, but the length of service given by the machines is again a tribute to the quality of Hobbies manufactures.

Incidentally Mr Sibbald is another gentleman who has the interests of children very much at heart. He tells me he has made over 2,000 toys and given them to children's hospitals far and wide. He has just completed another batch, which at the time of writing was due to be delivered to another hospital.

Mr Sibbald concludes his letter thus — 'I think I am fit for several years yet to continue making children happy.' When I tell you that Mr Sibbald is eighty-four you will understand that this is a sentiment very much to be appreciated.

Like father . . .

MR P. Gordon Gill, who is a Reserve Inspector in the Police Lines in India, writes in praise of his Gem fretmachine which was given to him as a Christmas present in 1934. It has never given him a

\*\*\*\*\*  
 \* Next week's free design is for \*  
 \* making a charming Stellar Wall \*  
 \* Clock. Make sure of your copy. \*  
 \* \*\*\*\*\*

day's trouble, and has been in continuous use all that time.

Mr Gill's son, after mastering the handframe, is now vying with his father in turning out projects on the Gem machine, and as Mr Gill says, it is difficult to find who is the more interested — father or son.

This is a typical example of how a father can encourage his children to take up an entertaining and profitable pastime, which is a splendid beginning to all do-it-yourself endeavours.

First-day Cover

EACH year Canada produces a limited number of special issues of postage stamps, the designs of which illustrate the growth of the country and the history of the nation.

The Editor has been pleased to receive from Mr William Hamilton, the Canadian Postmaster General, a First Day Cover of the first commemorative stamp for 1960. This depicts the Golden Jubilee of the Girl Guide movement in Canada, and was designed by Helen Fitzgerald of Toronto.

The movement was established in Canada in 1910, the first company being formed in St. Catharines, Ontario. Canada now has the third largest Girl Guide movement in the world, and it also claims the most northerly company in the world — the Aklavik, Northwest Territories group (latitude N. 68°) founded in 1937, many of its members being Eskimos.

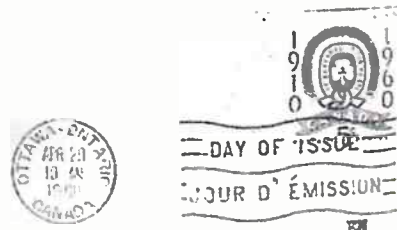

A first-day cover from Canada

# DECORATIVE INKWELL STAND

CUT out the two pieces from 1/4 in. wood, using a fretsaw. Piece B is cleaned up with glasspaper and

glued to piece A. Both are then glass-papered to a smooth finish and are stained and varnished. The inkwell

No. 5662 can be obtained from Hobbies Ltd, Dereham, Norfolk, price 2/6, post and packing 7 1/2d. (M.p)

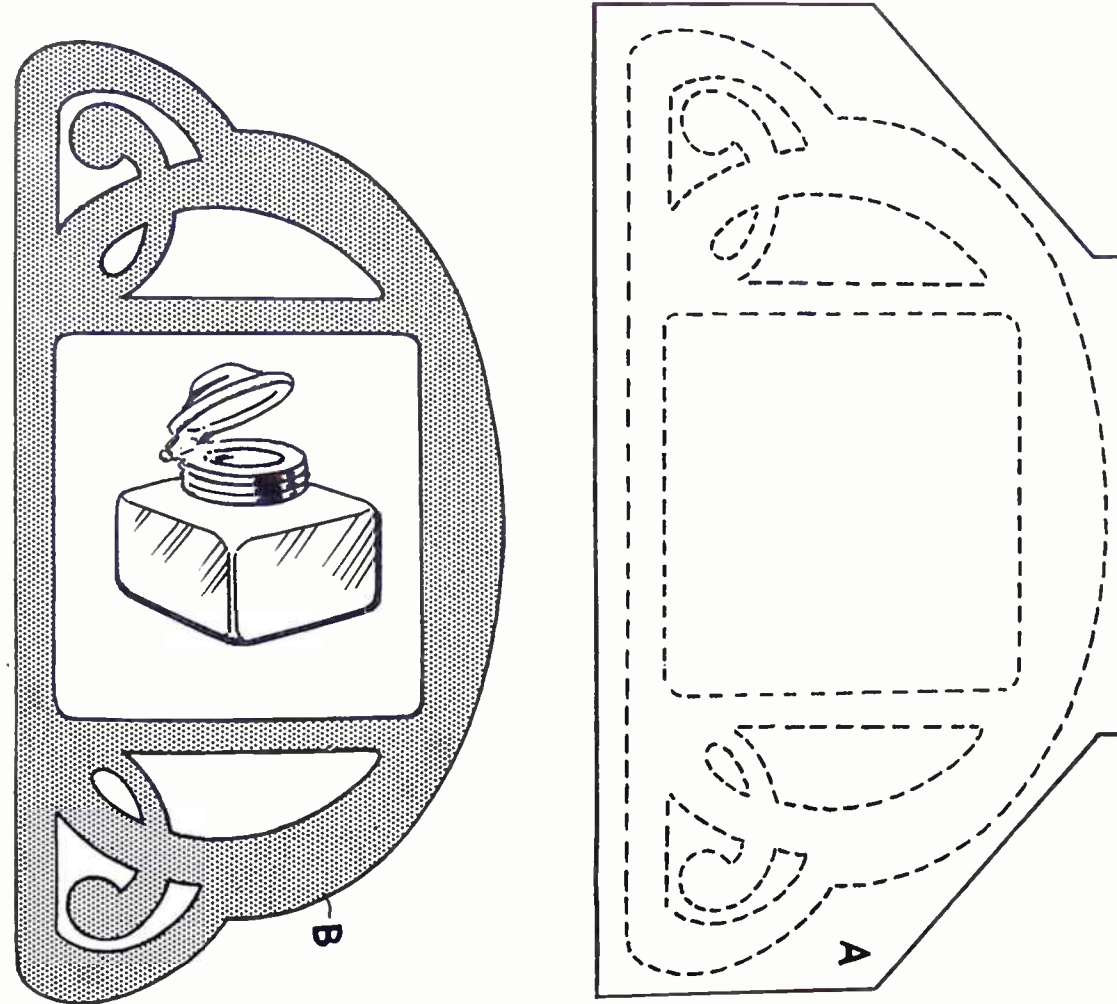

323

Printed by BALDING & MANSELL, LTD., London and Wisbech, and Published for the Proprietors, HOBBIES LTD., by HORACE MARSHALL & SON, LTD., Temple House, Tallis Street, E.C.4. Sole Agents for Australia and New Zealand: Gordon & Gotch (Asia) Ltd. For South Africa: Central News Agency, Ltd. Registered for transmission by Canadian Magazine Post.

READER'S REPLY  
 HW AUGUST  
 1960

# MAKE YOUR OWN

## GUITAR

Kit 3209

All wood (including partly shaped neck) full-size plan, six strings, etc

**57/6**

(Post free)

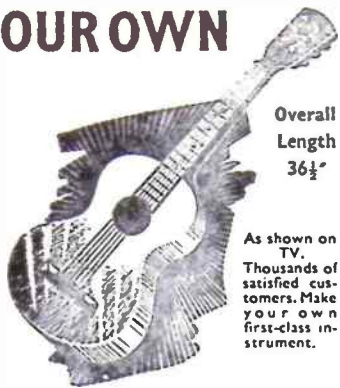

Overall Length 36½"

As shown on TV. Thousands of satisfied customers. Make your own first-class instrument.

From branches, etc., or by post

## UKULELE

Kit No. 3260

Contains all wood, wire, strings, etc., for full-size instrument

**23/9** Post 1/6



To Hobbies Ltd., Dept 993, Dereham, Norfolk. Please send Kit No.

P.O. for enclosed

Name  
Address



# The world's STRONGEST tube glue

STILL ONLY

**1/2**

a large tube

PUBLICATION DATE—AUGUST 1ST

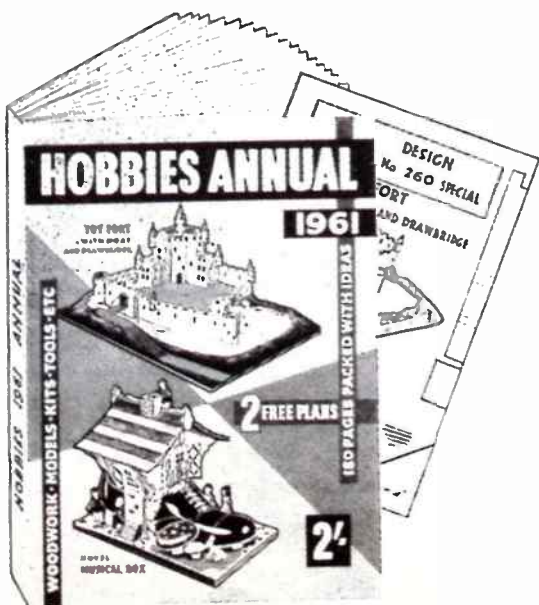

Make sure of your copy of

# HOBBIES 1961 ANNUAL

Enlarged to 180 pages—and still only 2/-

Two free plans with each copy, for making

**TOY FORT** (with moat and drawbridge)

**MUSICAL BOX** (The Old Woman who lived in a Shoe)

Hundreds of exciting projects for all ages

From Hobbies branches, stockists, newsagents, bookstalls, etc., or send NOW for your copy by post (6d. extra)

To Hobbies Ltd., Dept. 99, Dereham, Norfolk

Please send.....copy/copies Hobbies 1961 Annual containing two free plans

Name.....

Address.....

.....

.....

P.O. for.....enclosed

**THE "STELLAR" CLOCK**

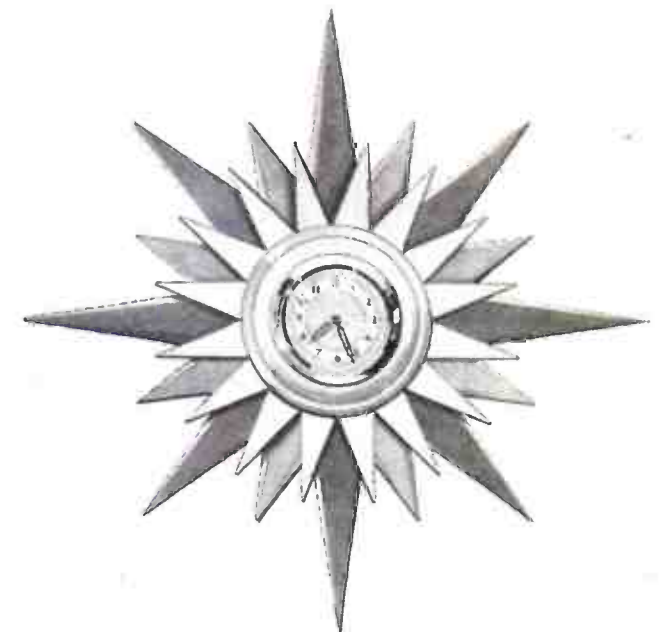

SIZE — 12 ins. DIAMETER (from tip to tip)

PANELS OF WOOD REQUIRED FOR THIS DESIGN  
**THREE Q4**  
 A KIT OF MATERIALS FOR MAKING THIS DESIGN IS SUPPLIED BY HOBBIES LIMITED DEREHAM, NORFOLK. PRICE ON APPLICATION.

**NEW HUMBROL MINI KIT**

Here's the latest addition to the Humbrol range, the new Mini Kit. 6 phials of Humbrol Enamel, and mixing palette; ideal for handicrafts and all small jobs. Buy one today from your stockist!

THE HUMBER OIL COMPANY LTD., MARFLEET, HULL, YORKSHIRE

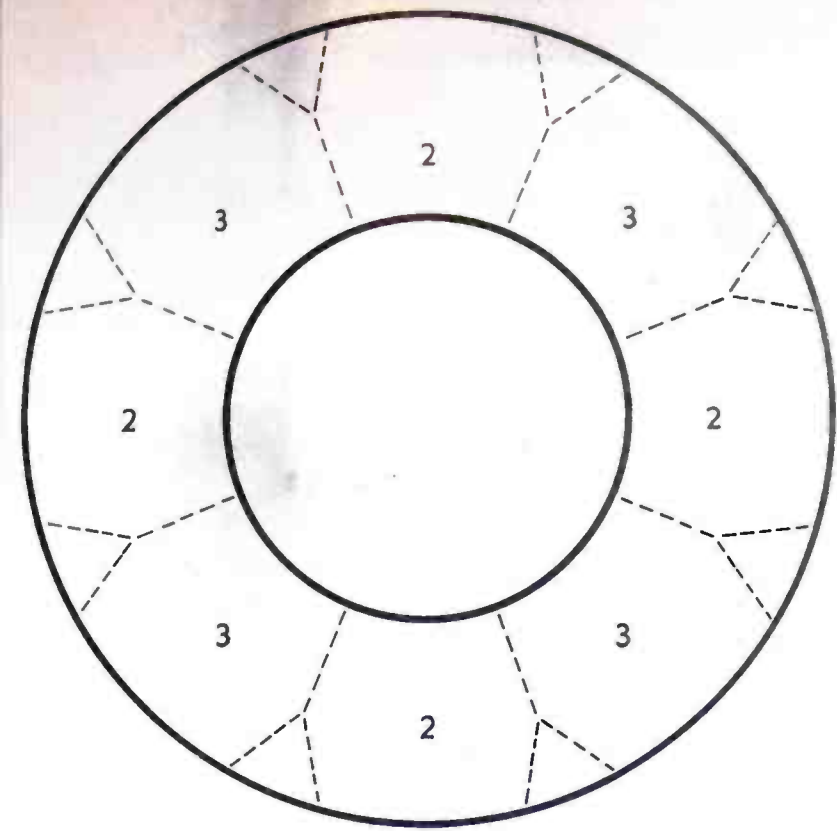

PIECE 1. CUT ONE 1/4 in.



PIECES 2. CUT FOUR 1/4 in.

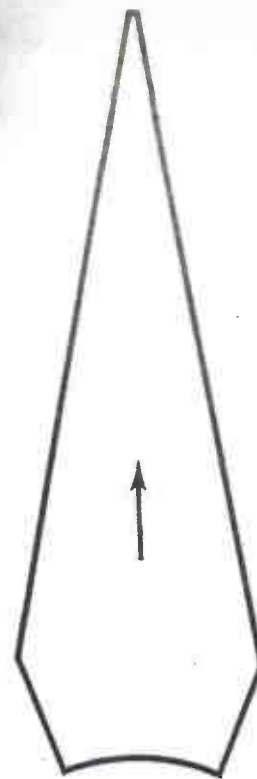

PIECES 3. CUT FOUR 1/4 in.

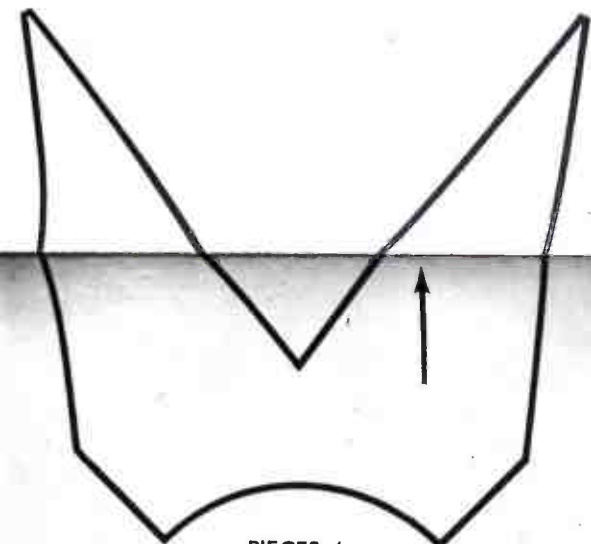

PIECES 4. CUT FOUR 1/4 in.

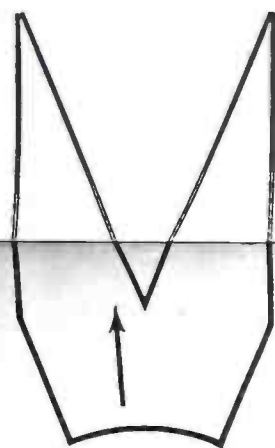

PIECES 5. CUT EIGHT 1/4 in.

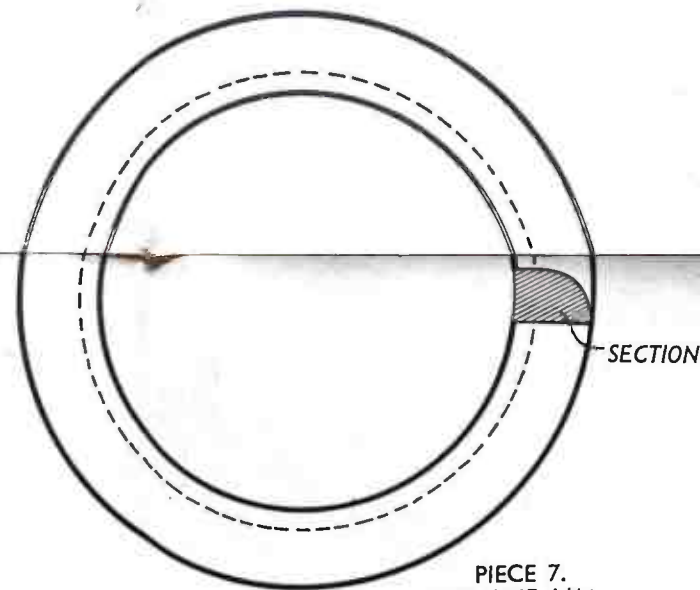

PIECE 7. CUT ONE 1/4 in. SHAPE TO SECTION.

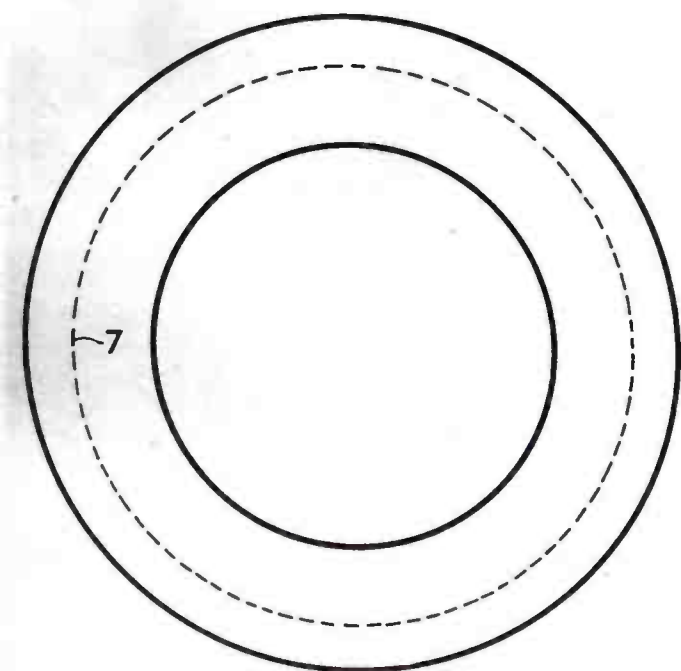

PIECE 6. CUT ONE 1/4 in.

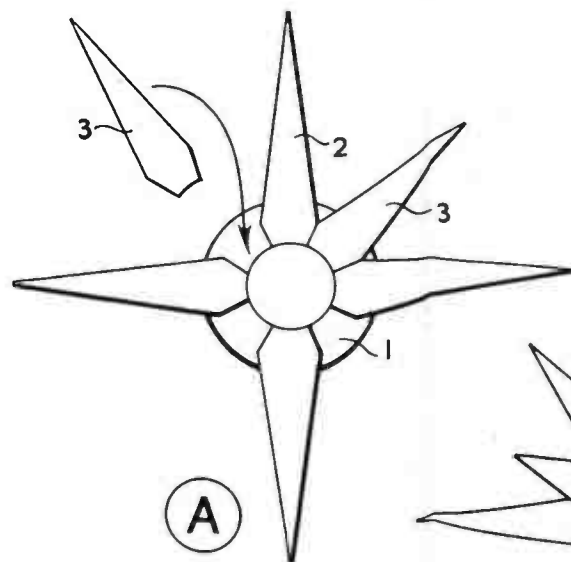

**A**

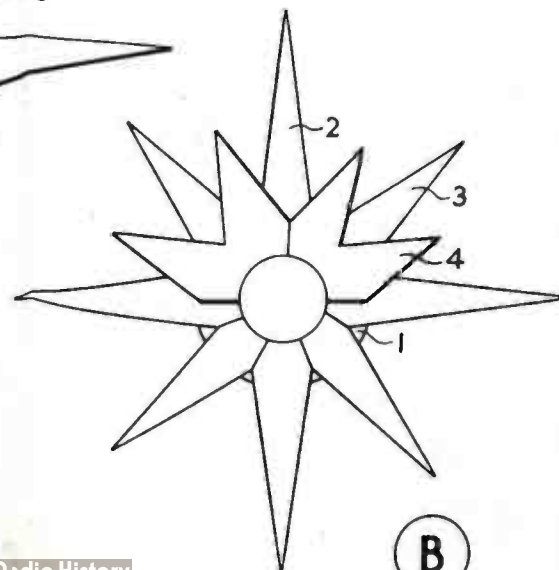

**B**

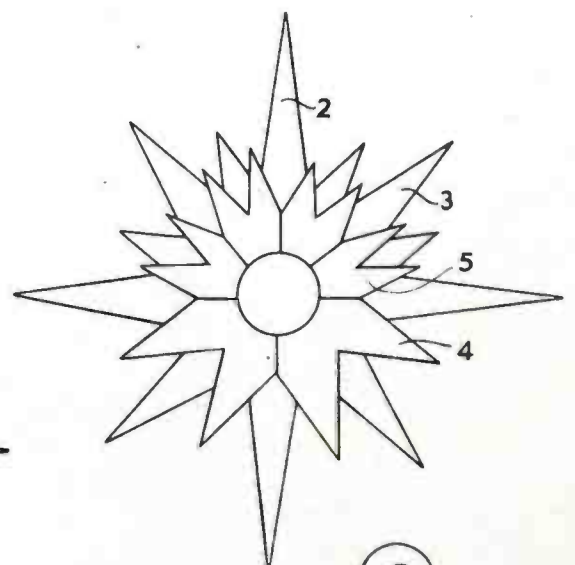

**C**

THE ARROWS INDICATE DIRECTION OF GRAIN OF WOOD.