

10th JANUARY 1962

VOL. 133

NUMBER 344B

THE ORIGINAL
'DO-IT-YOURSELF'
MAGAZINE

HOBBIES *weekly*

FOR ALL
HOME CRAFTSMEN

Instructions for making . . .

Also in this issue:

PATTERNS FOR
A NOVELTY

COLLECTORS' CLUB
— POSTCARDS

RAILWAY
MODELLING

DISC BREAK WITH
SHIRLEY BASSEY

TRANSISTORS—PHONES
AND SPEAKERS

SCIENCE FEATURE
AND PUZZLE

ETC. ETC.



Up-to-the-minute ideas

Practical designs

Pleasing and profitable things to make

5^D



SHIRLEY BASSEY



SHIRLEY Bassey was born in the Tiger Bay area of Cardiff, the youngest of five girls and one boy, and the daughter of a West Indian father and an English mother. The only member of her family to enter show business, she gained her first stage experience when she was only sixteen years old. She joined a show called *Memories of Jolson* — as the soubrette — and toured all over the provinces with it.

'I decided to retire from show business at the delicate age of seventeen, because I did not like it one little bit', says

Shirley. 'It meant too much hard work, I missed my family and got terribly homesick. Then I had an invitation from an old friend of mine, a choreographer. He asked me if I would help him out for two weeks at Jersey with a show. It was my mother who persuaded me to go back to show business. She told me I was miserable and pining for it.

Eventually I gave in and went up to London to start rehearsals.'

After working for about six months in variety she went into the West End of London — in 1955 — to appear at the Astor Club. It was there that Jack Hylton saw her, and he immediately engaged her to appear with Al Read in *Such Is Life* at the Adelphi Theatre.

'I stayed at the Adelphi for eleven months', says Shirley, 'then went into the Café de Paris for eight weeks, and from there made a wonderful trip to America. This took in three weeks at the El Rancho in Las Vegas, five weeks at Ciro's in Hollywood and two weeks at the Marino Riverside Hotel. When I came back to England, in April 1957, I appeared on A.T.V.'s *Sunday Night At The London Palladium* and then followed up with another tour of this country.'

After her variety tour Shirley began her travels again, including Sweden, Monte Carlo and Australia.

A prolific and highly successful recording artiste, Shirley has enjoyed such disc successes as *The Wayward Wind*, *Needle and Thread*, *Banana Boat Song*, *Please, Mr Brown, You, You Romeo*, *Kiss Me Honey*, *Kiss Me, As I Love You*, and *Love For Sale*. Her first record to enter the Hit Parade was the *Banana Boat Song*.

It was in May, 1959, that Shirley Bassey signed exclusively for Columbia who later scored a great disc double by issuing the popular *If You Love Me* and *Count On Me* (DB4344) to mark her 'single' debut and, shortly afterwards, a wonderful 12 in. LP entitled, aptly enough, *The Fabulous Shirley Bassey* Columbia 33SX 1178).



INGENIOUS

This little miss is admiring a model vintage car which was an eye-catching display on an exhibition stand.

Used in the model were: 176 spiral tubes, 5 thermometer cases, 4 pencil cases, 12 reels gummed tape, 4 carving-set boxes, 16 cutlery boxes, 70 jewellery boxes, 15 fancy boxes, 36 pill boxes, 30 cigarette boxes, 100 cigarette cartons, 4 shoe boxes, 26 cereal cartons, 1 sheet laminated board.

All the components were materials in which glues supplied by British Glues & Chemicals Ltd, had been used.

SPEAKERS AND PHONES

TO obtain the best possible results from the circuits so far given, the loudspeaker must be correctly coupled to the output stage. This will make a great difference to the volume obtained, and also to the quality of reproduction.

The output stage transistor will work best when its collector load is of moderately high impedance. Very many loudspeakers are of low impedance, however. If such speakers are to work properly, an output or matching transformer must be used between the transistor and loudspeaker.

The way in which such a transformer is connected is shown in Fig. 14. The winding with most turns is the primary, so that the transformer has a step down ratio. That is, its secondary has less turns than its primary. This brings about the required matching, or impedance transformation, between transistor and speaker.

Output transformers can be obtained to suit the usual 2/3 ohm speaker, when this is used with output transistors. There is then no need to bother about what the ratio may be, provided the transformer is

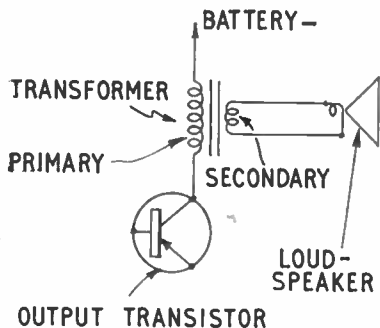

Fig. 14—Output transformer and speaker

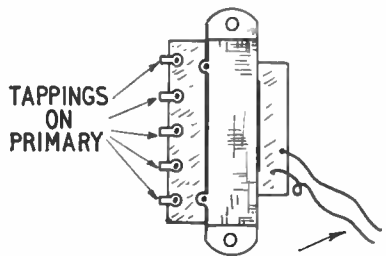

Fig. 15—Transformer used to couple loudspeaker

of reliable manufacture, and actually is intended for the purpose in view.

It may be necessary to find out the correct ratio, to see if a transformer to hand is likely to be satisfactory. If so, the 'optimum load' (that is, best working load) of the transistor should be found, by referring to the transistor maker's information. The optimum load will be in Ohms. The speech coil impedance of the loudspeaker will also be in Ohms. The optimum load is divided by the speech coil impedance, and the square root of the result is found. This is the most satisfactory transformer ratio. As example, suppose the optimum load is 75 ohms, and the speaker is 3 ohms. $75/3 = 25$, and the square root of this number is 5, so the transformer is 5:1 ratio.

Some output transformers, such as those used with valve sets, have a number of tappings, like that in Fig. 15. These tappings will give various ratios. With such a transformer, it is quite easy to find the best tappings by trial. The two leads from the receiver or amplifier (actually from collector and battery negative) are tried on two tags at a time. This can be done by using clips on the leads, and the receiver should be switched off before disconnecting the leads. Those two tags which are found to give best results are used.

Size of speaker

There is no need to use a miniature loudspeaker, except to obtain a small, compact receiver. A somewhat larger speaker, if used instead, will actually give better results.

This means that it is quite in order to use a speaker which is to hand. Sensitive speakers of about 3½ in. to 6 in. diameter, such as were often used in all-dry valve battery sets, will give very good results.

In the same way, there is no need to use a miniature output transformer. It will often be found that an ordinary transformer will be quite satisfactory, even if the ratio is not exactly correct. It may thus be possible to use a speaker and transformer from an old valve set.

When the receiver is to be of midsize, a 2/3 ohm speaker of good manufacture, with the miniature output transformer designed for use with it, can be fitted. Such speakers are often 2½ in. in diameter but even smaller units are available. It will generally be found that very low priced speakers give less sound output than the better quality models.

For best results, any type of speaker must be mounted in a case or cabinet. An opening should be cut of about the same diameter as the speaker cone. This opening may be covered behind with silk. The speaker is then screwed or bolted in place, or otherwise fixed so that it is behind the opening.

Direct connections

Miniature and other speakers may be obtained with windings which can be connected directly to the transistor, so that no transformer is needed. If this type of speaker is used, it is connected directly to the output stage, as in Fig. 16.

If only one circuit is to be built, there is little to choose between this type of speaker, and the 2/3 ohm model, which will need a transformer. The 75 ohm type of speaker saves the need for one component (the transformer). But it is less easy to use the 75 ohm speaker in different circuits, because there will be no means of changing matching, which will be possible when a transformer is present.

The usual types of medium or high impedance phones can also be connected

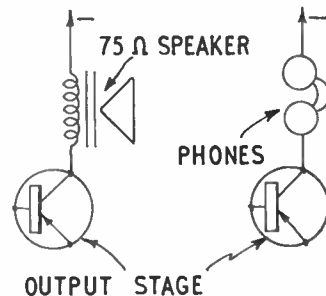

Fig. 16—Direct connections for speaker or phones

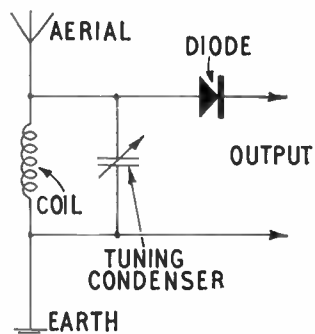

Fig. 17—Simple detector circuit

directly to the output stage, as shown in Fig. 16. If the phones have red and black leads, or polarity markings, take negative to the battery.

Headphones which work well with crystal sets or small valve sets will usually prove satisfactory with a transistor receiver. For general listening purposes a complete pair of phones, with headband, will be most comfortable. If the set is to be carried in the pocket, a single earpiece can be used instead, with a thin flexible lead.

Special phone units, similar to those used with deaf-aids, can also be obtained. If these are of medium or high impedance, they may be connected directly to the transistor, as in Fig. 16. If they are of low impedance, they require a coupling transformer, as in Fig. 14. It is thus generally better to obtain a medium or high impedance unit, so that no transformer is wanted.

Flat tuning

The circuits so far given can provide very good results, either with phones or speaker, but tuning may be very flat. That is, any station (especially a local) will be heard over quite a large swing of the tuning condenser. As a result, one station may interfere with another.

Fig. 17 shows a simple detector circuit, which may give good results. If the aerial is short, no trouble may be experienced. But with a long aerial, or very near a local station, interference may be troublesome. If so, it is necessary to sharpen tuning.

Various ways of doing this are shown in Fig. 18. 'A' is a very easy system, with home-wound coils. The tapping is roughly one-quarter the total number of turns from the earthed end of the coil. There is no need to provide the tapping at any exact point. The nearer it is to the earthed end of the coil, the sharper will tuning become. There will also be some loss of signal strength, so it must not be too near earth.

At 'B' a primary, or coupling winding, is added. This can be done with commercially made coils, or those with Litz (stranded) wire, which would be difficult to tap. The coupling winding can have roughly one-quarter the number of turns which have been used on the tuned part of the coil. That is, roughly 15 to 25 turns, for most medium wave coils, or about 50 turns for a long wave coil. Any fine gauge wire will do.

If the number of turns on the primary is reduced, or this winding is moved farther away from the other winding, this has the same result as moving the tapping towards earth in the circuit 'A'.

The detector can be connected as in Fig. 17. That is, to lead 'X'. But when a transistor amplifier follows, more volume may be obtained by feeding the diode from a tapping, such as lead 'Y' at

'B' in Fig. 18. This tapping can be made as described previously for Fig. 6. That is, it can be at one-fifth the total number of turns from earth. This will also help to sharpen tuning.

Another simple method, needing no change to the coil, is to add a condenser in series with the aerial lead, as at 'C'. This item may be fixed, of about 100pF ($.0001\mu\text{F}$) capacity. Or a pre-set or variable condenser can be used instead. If so, it is adjusted for best results.

The condenser can be added to either of the circuits at 'A' or 'B'. The smaller the condenser value, the sharper will tuning become.

It is not possible to give one 'best' type of aerial circuit, because the kind of aerial used depends on circumstances. For example, if a short rod, or perhaps a few feet of wire, were used, the circuit in Fig. 17 would be satisfactory. This could also do with a short out-door aerial.

But if a longer wire has been erected, it will probably be necessary to use one of the circuits in Fig. 18, to avoid interference from unwanted stations.

Ready-made coils of the kind used in valve sets will often be satisfactory in transistor sets. Suitable coils can also be purchased separately. Coils with dust or ferrite cores will generally give sharper tuning than coils simply wound on insulated tubes.

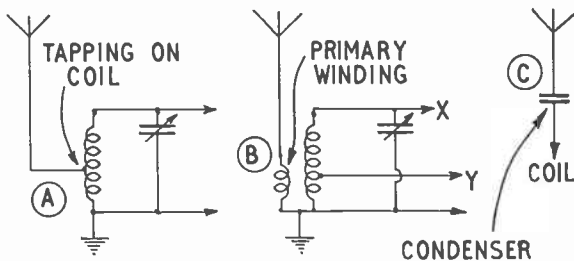

Fig. 18—Three ways of sharpening tuning

With many transistor sets, a ferrite rod aerial is used. This is simply a tuning coil which has been wound on a ferrite rod or slab, as shown in Fig. 6 in a previous article. Such a rod aerial can be fitted by wiring it in place of the coil.

The signal pick-up of the ferrite rod is much smaller than that of an extended aerial. To compensate for this, more transistors have to be used. When building two or three transistor circuits, such as those already described, it is thus best to use some form of extended aerial, even if it is only a few feet long. If used with an extended aerial, a diode detector followed by a 2-transistor amplifier could give adequate speaker reception. But the same circuit, with a ferrite rod aerial alone, might fail to give adequate head-phone volume.

It is for this reason that more complicated circuits are used when the set is intended to work from a ferrite rod alone, and these will be dealt with later.

Transistor types for loudspeaker stages will be described next week.

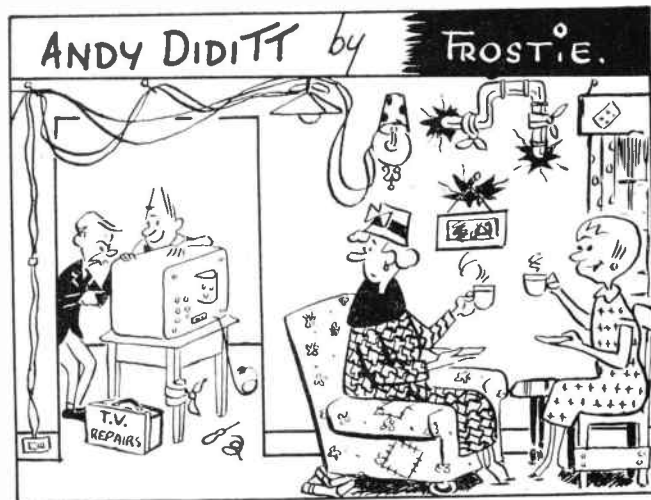

"THE DARLING GETS THE TRADESMEN TO GIVE HIM AN ESTIMATE FOR THE JOB, THEN HE KNOWS JUST HOW MUCH HE SAVES BY DOING IT HIMSELF."

NEW Thoughts
on

RAILWAY MODELLING

MANY readers will be interested in a 'hide-away' type of railway which can be permanently set up, but which will take up the smallest possible amount of space when not in use. We will call it 'the cupboard', for want of a better term.

This will accommodate a fair-sized model railway in any of the smaller scales. I should not recommend it for anything over 'OO' gauge, but for the

Airfix Turntable

I HAVE received from Messrs Airfix several models that I have not had the chance of reviewing before, reports 'F.A.B.'. Firstly, their kit for a turntable makes a very good model indeed. One of the things that folk want to see working is a turntable, and you should try to have at least one on your railway. The Airfix model will accommodate most locomotives. There is no track supplied in the kits, of course — the modeller has to fit the type of track that he is using — but it is very good value, and quite easy to construct. As usual Airfix excel in the amount of detail that they put into a model.

It should not be too difficult to fit some sort of mechanism to turn this table electrically. Perhaps I will explain this in a later article. But for the modeller who wants a turntable, and one that can be quickly made, I recommend this one to you.

Two more tanks have come my way, or at least the kits to make them. One is the Sherman and the other the Churchill. These are of course, companion kits to the German Panther tank which I reviewed earlier, and they are modelled to the scale of 4 mm. to the ft. ('OO' gauge). There are plenty of small parts in both of these, and a very good sheet of transfers. Excellent value for 2/-.

smaller gauges it would be ideal. For the newest 'OOO' gauge it would give ample space for a very nice layout, but of course it could be made any size to suit the space available.

If you will refer to the illustration you will see what I have in mind. It consists of a cupboard made to fit against a wall, of a depth that will accommodate the tallest part of your layout and wide and long enough to take the layout. The cupboard underneath will be useful for the storage of rolling stock, etc, as will the lower cupboard on the right-hand side, although here you should leave room at the top for installing your power pack, etc. The small flap above this last cupboard is for the controllers, and it is suggested that this is in the form of a sliding drawer with the controllers mounted on a board which will slide out when in use. The upper cupboard above the controllers could house any switchboard you might need, and I will describe all this to you when we come to the subject of electrification.

instance it would look nice if reeded hardboard were used. This could be painted to suit the décor of the room, and of course the underside of the baseboard of the railway will have to be covered with the same material so that when the thing is shut it will match into the surrounds. If you are using a plywood, you can get this with a facing

THE 'CUPBOARD'

By F. A. Barrett

of different types of wood, such as oak, etc, and this could be polished if you so desire.

One point must be stressed. The actual board that the railway is on will have to be strong. You could, of course, use a sheet of blockboard, and this would suffice on its own, providing it is thick enough. I would say that 1 in. would be the mini-

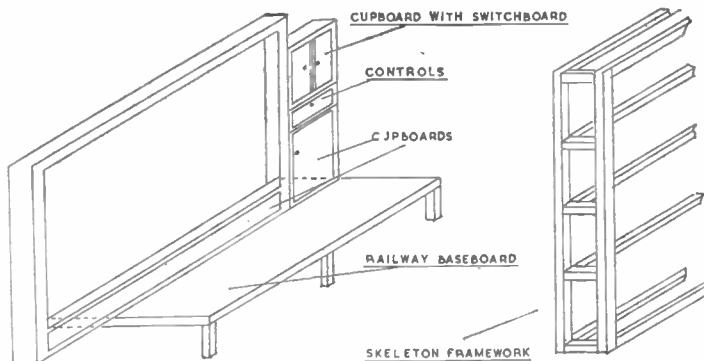

THE CUPBOARD MODEL RAILWAY

On the extreme right I give a sketch of the skeleton framework of the structure. This should be as strong as possible, and I suggest that you make this up of 2 in. by 1 in. battens. I have not put any joints in the sketch but will leave that to your own taste and capabilities. In any case the joints should be strongly made and glued.

The actual framework can be covered with hardboard or plywood. In the first

mum thickness to aim at. On the other hand, if you make up a framework of battens and cover the top with a suitable material, say Weyroc or plywood, and the lower side with hardboard, or whatever you are using for the main cabinet, this will allow you to hide all your wiring between the two layers, and will result in a neater job.

Along the lower edge of the cabinet and the railway baseboard you will want

hinges, and these will look better if they are recessed. A long piano type hinge would be ideal for the job. You will need a couple of locks for the top to hold the assembly shut, and various other hinges, knobs and locks for the cupboards. *Hobbies Annual* should be perused, as there are many fittings there which would be ideal for the job. The long cupboard under the railway should have the door to hinge downward, and small blocks of wood, or short legs will be needed to hold the front of the baseboard off the floor.

It would be as well, if making this type of model railway, to design and make your railway first, on the baseboard, and then build up a suitable cabinet to hold it. If you wish to make this a permanent fixture, you could do away with the cross battens in the back of the cabinet, and using small plates and Rawlplugs, screw it to the wall. But if you want to make it so that it can be portable, then I suggest you plan a free standing unit.

One thing that you could do is to fix up some scenic backgrounds inside the back of the cupboard to line up with the railway. This would give the added effect needed. This design is only to give you an idea of what to aim for. I am sure that you could design something along these lines to suit your own room. It is a definite answer to where to put the railway so that it can be left set up and yet is able to be put out of the way when not in use. One word of warning. Don't forget to remove everything from the tracks, etc, before closing the door.

The essential thing is to make the assembly very strong to avoid warping as this can cause a lot of trouble later on.

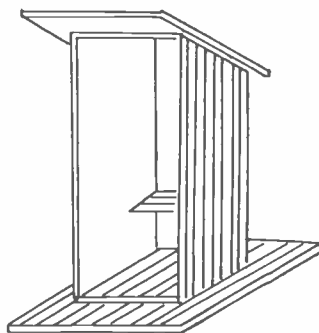

FOG SIGNAL HUT

Now, I propose to give you from time to time designs and instructions for building small items that are of use on the railway, such as platelayers' huts, fogmen's huts, signal cabins and the like, and for this purpose you will need some cardboard. Most stationers sell sheets of this for about 1s. You want something about $\frac{1}{8}$ in. thick, white if possible, and with a smooth texture and surface. I shall give you in every case dimensions in feet, and you will have to measure these to suit your existing railway. For this purpose you will need a scale rule. You can purchase one at your local model shop. There is an excellent one called the ERG scale rule which gives dimensions in feet for the four scales, i.e. 2 mm., 4 mm., 3.5 mm. and 7 mm. If you cannot purchase one I suggest that you make yourself one to suit your own scale.

DIMENSIONS — Sides 3 ft. 6 in. wide, 6 ft. 6 in. high front, 5 ft. 6 in. high rear. Back 2 ft. 6 in. wide, 5 ft. 6 in. high. Door 2 ft. 6 in. wide, 6 ft. 6 in. high. Seat 2 ft. 6 in. by 1 ft. 6 in. Inner floor 2 ft. 6 in. by 4 ft. Inner roof 2 ft. 6 in. by 4 ft. Roof 3 ft. 6 in. by 4 ft. 6 in. Base 4 ft. by 5 ft.

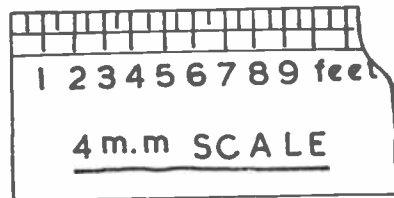

For sake of illustration, let us assume that the scale of your railway is 'OO' gauge, 4 mm. to the foot. Take a length of either thin Perspex or metal and mark off a line every 4 mm. (you will find millimeters on most rules). Then subdivide these 4 mm. marks into half, that is to say, every 2 mm. This you will then give you 6 in. on the model. Mark your 4 mm. spaces 1, 2, 3, and so on, and it would be advisable to make this rule at least 12 in. long. You will then be able to transfer feet to the actual size you require. A small sketch of part of such a rule is illustrated for your guidance. Naturally, if you are modelling in 'O' gauge you will have to make your marks 7 mm. apart for the feet, and 3.5 mm. for the 6 in. lines. For 'OOO' gauge, you would need to make your lines for feet 2 mm. apart and 1 mm. for the 6 in. lines. For T.T.3 scale, the feet lines will be 3 mm. apart, although for all practical purposes this is so close to $\frac{1}{4}$ in. that you could use the scale of $\frac{1}{4}$ in. for models.

A fogman's hut is made of various parts, most of them scored to represent the planking of the wood. This is best done with the card in the sheet before it is cut.

Then cut out the parts, after marking them out, and assemble as follows. Glue the inner floor to one side, and then put the back on, and then the inner roof, and the other side. Next put in the little seat, glue on the roof, and finally glue the whole structure to the floor. I always use a good adhesive such as Britfix Balsa Cement. This dries quickly, and is waterproof and transparent, but don't use too much or else you will have lumps all over the model.

I would suggest that you make up several model huts in one batch. A matt black paint is the correct colour for a fogman's hut. I have also made up these models with a door, in some cases open, and in others shut.

When cutting your card use a good modelling knife and a straight edge, such as a metal rule.

MODELS FOR YOUR LAYOUT

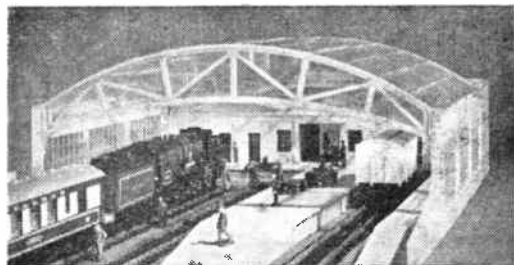

*2nd Class Sleeping Car,
TT gauge, for Triang Railways.
Rovex Scale Models
Ltd, 8s. 11d*

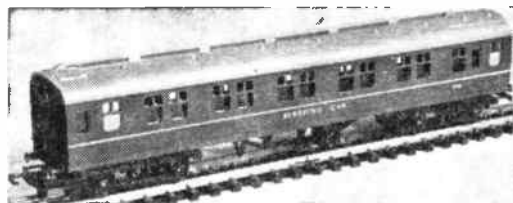

*Hornby-Dublo Terminal or
Through Station, No. 5083.
Meccano Ltd,
price £3 9s. 6d.*

PIXIE POST HOUSE



This Hobbies model of a Pixie House Money Box was adapted for the present purpose as a letter postbox. The action of the money box is that when a coin is inserted a tune is played. Kits for making the money box (No. 3340) cost only 9/5 (post 1/6 extra). Special musical movements are available for insertion with choice of three tunes. Note that kits are *not* available for the Post House described here.

MANY houses make use of a postbox in which letters are left at the bottom of the drive. Of course they could be left in a plain box, but the pixie house shown on the front page looks far more attractive. The idea was suggested to us by a New Zealand reader and we have been pleased to plan construction details.

The house is based on Hobbies design

No 3340, the Pixie House money box, shown at the top of the page. This is a money box which plays a tune when coins are inserted and we have adapted it for use as a post box — without, of course, the musical movement.

Study the diagrams carefully and you will see exactly how the house is constructed. For instance you will see at once that the sides go between back and front. Notice, too, that the letters are inserted at the front through the slot provided and are taken out through the flap in the back. This flap is hinged in place and you can fix a knob and a ball catch if you wish (Fig. 1.) Alternatively, you might prefer to fix a small lock.

The exact shape of the front and back is not particularly important, but they should be more or less as shown in Fig. 2. Enlarge the squares to 1 in. and draw in one square at a time. Note that the ridge piece (D) is halved in position.

Most of the parts are cut from $\frac{1}{4}$ in. fretwood, the exception being the ridge (D) which is $\frac{1}{2}$ in. thick, and the roof timbers which are of $\frac{1}{2}$ in. hardboard. The roof timbers fit into the steps on pieces A and B.

Commence by gluing and pinning the main pieces together as seen in Fig. 3. Slot piece D in position and add the finials. Strengthen by adding triangular fillet in the corners. It will be advisable to use waterproof glue throughout.

The roof timbers are now cut to size and glued in place, overlapping as shown in Fig. 4. Pins can be added for strength.

Other items may be added as indicated. Doors and windows may all be glued in position cleaning off excess glue before it has time to dry.

Details of the mushroom and house name are shown in Fig. 5. Shape the mushroom from softwood such as beech or balsa and bore a hole underneath to take a stalk of the same material.

ALL DIAGRAMS ON OPPOSITE PAGE

Before screwing the base in place you should seal all leaks in the roof with waterproof glue or any proprietary brand of sealer such as 'Bostik'. Give the inside a coat of clear wood preservative and two coats of paint, one undercoat and one finishing coat. Ensure particularly that the edges of the wood and hardboard are well covered with paint.

Treat the outside in the same way, but give at least two finishing coats. Colours will, of course, be a matter of personal choice. Your name or the house name may be painted on the ridge.

The house will, of course, be fixed in some way to a gatepost or even to a tree or shrub. It would be a simple matter to scheme a way of fitting to suit individual needs. (M.h.)

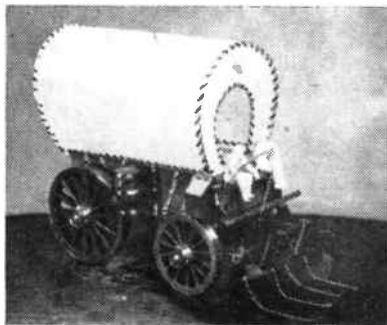

MR Samuel Sommerville of Belfast has forwarded this photograph of a Covered Wagon Electric Light which he has made to his own specification from Hobbies Design No. 3156. This attractive novelty which is 12 in. long by 10 $\frac{1}{2}$ in. high was designed by Hobbies Ltd, to be made in wood and

The Covered Wagon

crinothene, with the lamp concealed in the plastic wagon top. The kit costs 24s. 6d. from all branches, or by post from Hobbies Ltd, Dereham, Norfolk, postage 2s. 6d. extra.

Mr Sommerville, however, has added many embellishments to good effect. On his model the wheels have stainless steel rims, and the hubs consist of the brass ends of old electric light bulbs which fit beautifully. Brass strips have been added to the sides, with brass rivets to match, and the water barrel has also been furnished with three brass hoops. With the main part made from polished light oak, Mr Sommerville says that it makes a beautiful model. His brass fittings also include a small lamp. The whip held in the driver's hand is made from a twig of

a tree from which the bark has been stripped and the wood polished.

With the use of aluminium chain for the horse couplings, Mr Sommerville says that this model has aroused much admiration. Its practical use as a TV or sideboard lamp is also emphasized.

One of the best known British groups were originally called 'The Drifters'. They have since changed to — what? See next week's 'Disc Break' for the story of their fabulous success.

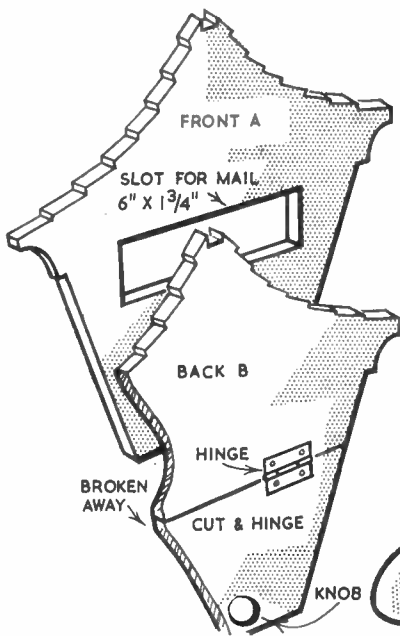

Fig. 1

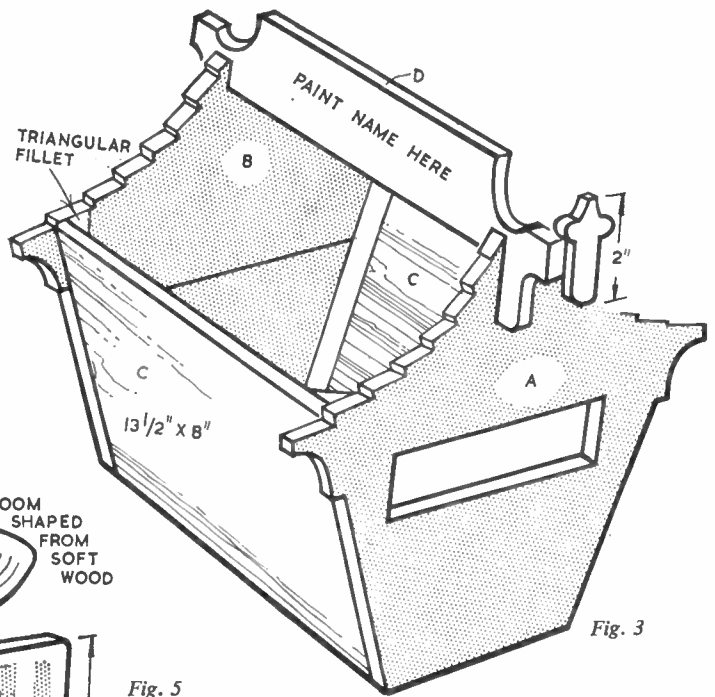

Fig. 3

DIAGRAMS FOR MAKING

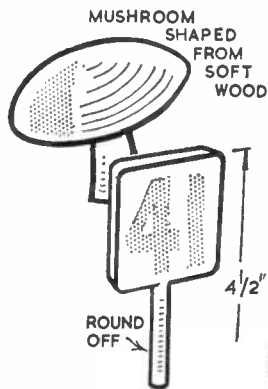
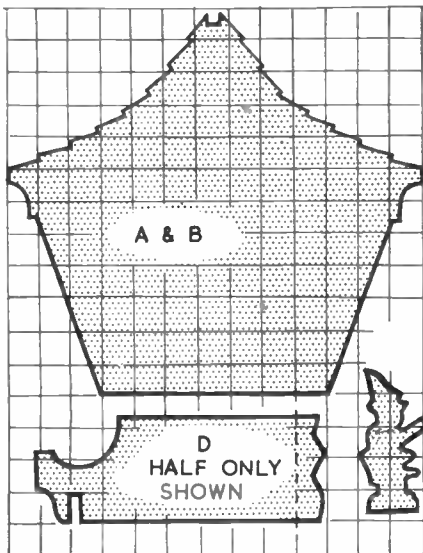

Fig. 5

PIXIE POST HOUSE

Fig. 2



ENLARGE TO 1 IN. SQUARES

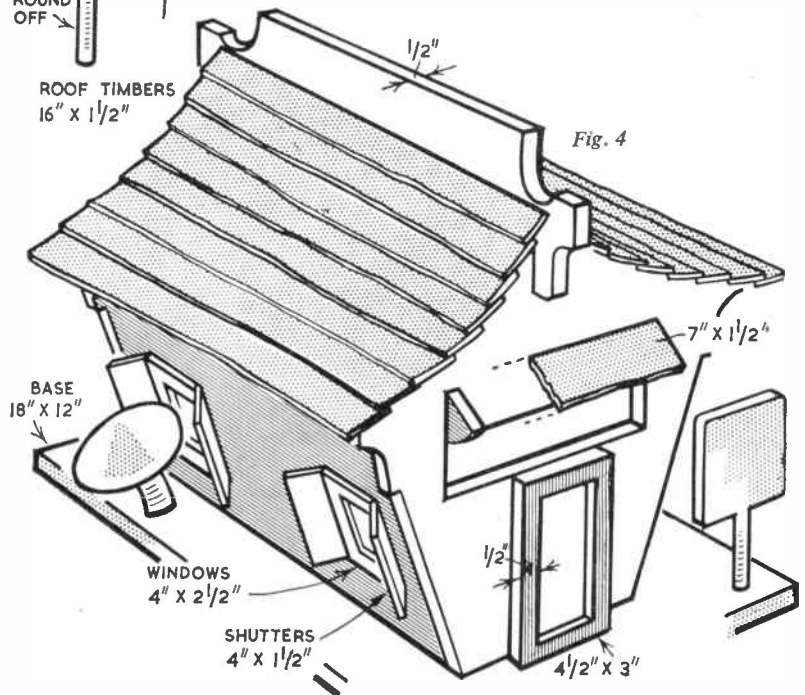

Fig. 4

Raindrops and Thunderstorms

HEAVY raindrops usually herald a thunderstorm. The dry pavement quickly becomes spattered with huge drops, and soon the full violence of the storm is upon us. Generally raindrops are much smaller, but why should this be so? Lord Rayleigh invented a simple means of detecting the presence of static electricity in the air and his experiment will help us to find a solution to the mystery. He arranged for two small jets of pure water to pour from separate vessels, in such a manner that the 'upper' stream fell upon the 'lower' stream.

Rayleigh's tests

Rayleigh was able to demonstrate that the forces of surface tension prevented the little jets from breaking up, and confined them as would tubes or 'skins'. Furthermore he showed that the upper jet would not combine with or flow into the lower stream when it impinged upon it, but that it would actually bounce off. When Rayleigh removed an electrified rod of sealing wax from his pocket, a minute charge of static electricity was generated and a curious thing happened.

The forces of surface tension upon the water jets were overcome and the two streams ran together.

The effect is an extremely sensitive test for static electricity that is really far too delicate for common use. However the phenomenon does help to explain why raindrops are commonly quite small

of water. Leave this solution to settle for an hour before use. To blow a bubble, dip the mouth of the funnel into the solution and blow out the resulting soap film. It will be easy to blow bubbles downwards through the wire rings and to catch the bubbles beneath the wire supports when you raise the funnel afterwards. With practice you will have no trouble in blowing an identical pair of bubbles to hang beneath the rings. Do not let them quite touch each other.

If the bubbles are made to oscillate slightly so that they may hit against each other, they will behave like raindrops falling freely in an ordinary shower and will bounce upon one another without fusing. You will realize that surface tension in the soap films is responsible for the bubbles forming and keeping their nicely rounded shapes. Now produce a charge of static electricity at some distance away from the bubbles and observe how the fragile spheres react.

Static charge

You can obtain a static charge by simply removing a dry stick of sealing wax from your pocket, or from your armpit if you are wearing a pullover. Electricity will also be generated when you run a comb through your hair, rub your hands together, tear in half a dry sheet of brown paper or crumple up a polythene plastic bag. Whichever method you employ to create your static charge, watch the bubbles. The electricity will overcome the tendency of the bubbles to remain separate and they will suddenly shudder and join up as one large bubble in a manner very pretty to see.

Success with this unique experiment is not easy, but a diligent effort will be well rewarded at the end. You will find by experience that the bubbles are incredibly sensitive to the static charge and probably this fact itself will contribute to your difficulties. The amalgamation of the bubbles has been achieved dramatically when a whole class of school children rubbed their hands and when a polythene sheet was ruffled at a distance of twenty feet from the bubble stand. The bubbles will represent the smaller raindrops which can unite and grow larger in the heavily charged atmosphere of a thunderstorm.

HOBBIES 1962 ANNUAL

Supplies of Hobbies 1962 Annual containing free Designs for two projects are running low. We would advise readers to obtain their copies at once. Price is 2/6 post free from Hobbies Ltd, Dereham, Norfolk.

By A. E. Ward

and assume perfectly spherical forms as they fall freely to earth. Each drop is confined by its tight 'skin' of surface molecules and will simply bounce off its neighbours when collisions occur during its descent. In a thunderstorm the falling drops are influenced by the atmospheric electricity and they behave like Lord Rayleigh's static detector and amalgamate to form spheres of abnormal dimensions. The segregating effect of surface tension is defeated by the electricity generated during the downpour.

We are going to illustrate this principle with a beautiful experiment which was described in that classic of schoolboy science: 'Soap Bubbles', by C. V. Boys. You will need to construct a special stand, using a round flat polish tin, a cotton reel and a one foot length of glass tubing which will fit tightly into the hole in the cotton reel. Nail the cotton reel to the tin lid and insert the glass tube in an erect position. Now fill the bottom of the tin with sand or earth and fix the lid assembly firmly on top. The added weight will lower the centre of gravity of the apparatus and give your stand added stability.

Identical rings

Next fashion two perfect 3 in. diameter wire rings by forming the material around a cylinder. The rings should be identical in size and each should possess a 6 in. long 'stem', as illustrated. Twist the ends of the stems together and bend the joined part downwards through 90°. Adjust the arrangement so that the planes of the rings are level and the rings themselves are about 4 in. apart. Fit the twisted stem into the top of the vertical glass tube. You will also need to acquire a plastic funnel roughly 3 in. diameter at the top, to serve as a bubble pipe.

Prepare a soap solution by dissolving a tablespoonful of Lux flakes in a saucer

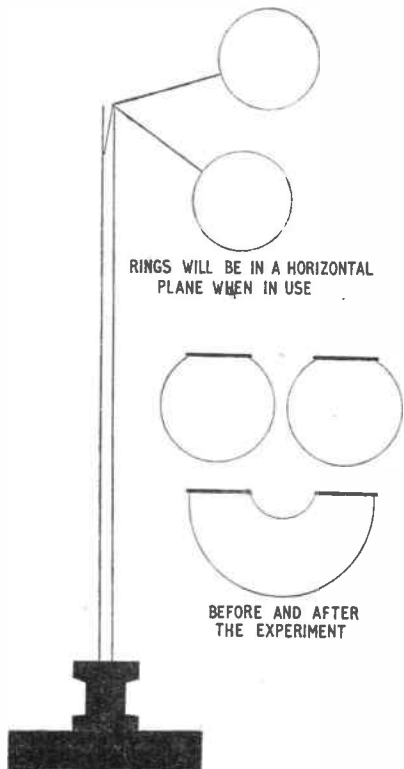

HIKING IN WINTER

PERHAPS you think the countryside a bleak and desolate place on winter days — that there is little to see of interest. But if you have ever hiked across country at this time of year and used your eyes properly, a different story you will tell.

Never put away your hiking gear when winter comes; it is a big mistake. But 'play safe'. That is, go forth prepared for anything you may meet in the shape of muddy paths, slippery slopes, sudden mist and inclement weather.

Strong boots, warm slacks, and thick woolen socks are essential. Take a pull-over and scarf, plus a mackintosh, and 'emergency rations' in your haversack. Remember, many wayside cafes do not open during the winter months, though quite a few Youth Hostels never close down.

Weekly Jaunts

Tramping in winter is not confined to a few cranks. Many clubs have their weekly fixtures, and each weekend finds hundreds of enthusiastic hikers abroad. The usual plan is to take train or 'bus to a certain venue, then do a circular tramp back to the starting point, and train or bus it home. This idea can, of course, be varied, but it is a frequent method adopted by the 'regulars' in winter, chiefly on Sundays. Joining a club is wise advice.

Naturally, with the shortened daylight you have to curtail the mileage actually tramped, and this must be remembered in plotting your course across country. Booklets giving full particulars of local rambles are to be obtained from the booksellers' shops in many provincial towns. If any such are published in your own home town, it will pay you to get one.

Even in winter the rambler will find that there is much wild life about by field and hedgerow. No longer embowered in shady bosage and aglow with gay blossom, the lane in winter is grey-toned save where the remaining 'haws' blush ruby-red in the pale sunlight. Though hedgerows are naked in their undress, the little winding track is attractive to wild creatures.

In these austere days they gather closer; at least many birds do, roving to and fro in flocks. Small birds assemble in social company. Momentary white flashes gleam as parties of bachelor finches scatter across the path; linnets appear in the tops of bushes, to vanish as quickly. Goldfinches are seeking the seeds in the dry heads of thistles under the tangled hedgerow.

Many winter migrants will be noted. Fieldfare, redwing, siskin, goldcrest, brambling, crossbill, and foreign pigeons, smaller than our native ringdove. If the path takes the hiker along the banks of a stream, the grey wagtail will often provide a charming picture, as he flits about the shiny pebbles like some 'animated flower'. The gold of his underparts gleams bright as he spreads his wings to fly. When primly walking on the pebbly strand, his long springy tail in black and white, quivers with his every movement as though it were on a delicate spring.

Long-tailed tits love to roam in family parties and nothing gives more pleasure than to see such a troop of the charming birds in black and white plumage with long dainty tails, flickering amid the bare willow boughs, twittering softly in the grey half-light.

In the low-lying valley, flocks of blackheaded gulls, now lacking their dark-brown hoods (which they will don again in springtime), peewits, starlings, and mixed flocks of finches, fly to and fro by the brimming river. Ducks of various species, mallard, teal, pochard, sheld-duck, wigeon, and shoveller — many of them visitors from the far north — haunt the pools and meres, enjoying the hospitality of our milder climate.

Winter woods are ever beautiful, but if you go forth on a morning after a sprinkling of snow, then the scene is pure Fairyland. A mighty decorator is the snow, when every twig is adorned

and silvered over.

After snowfall, too, the rambler may read much writing on the whitened ground, with the great number of tell-tale markings of birds that hop, birds that walk, and others that do a bit of both. Tiny pencilling of voles and mice and the dog-like pads made by the fox, may all be traced, giving one an impression that there are many more wild-folk about in winter than we imagine.

By moonlight

Have you ever gone out on a winter's evening when the moon shines brightly in a frosty sky, for a short hike across country? It is worth it, for a change! Choose a night when the moon is full, the weather crisp and clear. Take the open fields for preference. Have a hot supper before you start; and you will be ready for a hot drink on your return. But you will enjoy every minute of it.

At no time of year is moonlight so charming and impressive, though you must leave the artificial lights of town and village far behind to appreciate the full glory of the Queen of Night as she walks abroad in her 'silver shoon'.

Some nights the silence is wonderful; yet listen — an owl hoots, a peewit wails, there is a swish of wings as a night-flying bird passes over. From the copse comes the cry of a dog fox questing for a mate, for foxes pair in winter.

Try a moonlit hike; it is a novelty if no more; it is marvellous beyond words.

New Year — new idea!

Make 1962 a year for new activity. Whatever your out-door hobby, you can increase the scope and interest by joining the Y.H.A. Bird watchers, naturalists, photographers, and even train spotters walk or cycle around the country, spending the nights at one of nearly 300 youth hostels in England and Wales. If you're under 16, it costs only 5s. a year to join and 2s. a night at the hostels. (Slightly more for older members). Meals are provided at reasonable prices or you can cook your own. Send this coupon for details.

To Y.H.A., Trevelyan House, St. Albans, Herts.

HW621

Please send me 'Going Places' and details of Y.H.A. membership.

Name

Address

.....

.....

THE MAGIC SQUARE

MAGIC squares have always been the basis of intriguing mathematical puzzles but Fig. 1 shows one which is entirely different. Moreover, we will not only show you how it can produce a mysterious trick but also show how you can evolve similar squares for any desired number.

Normally the magic square is so arranged that the total of the numbers in each row, column and diagonal are the same. In our example we have a different method and although so very simple when you know how it has been evolved there still seems to be some magic.

6	2	11	5	3
10	6	15	9	7
4	0	9	3	1
11	7	16	10	8
9	5	14	8	6

FIG 1

First of all we will describe how to perform a trick. Prepare a square numbered and ruled as in the Fig. 1. Obtain five pennies and 20 squares of paper which are in turn to cover selected numbers and to cover the balance.

Now ask a friend to select any number in the square. This done lay a penny on the number but covering all the other squares with paper squares in the same row and same column. For example, if 9 is selected in the centre of the square we cover that number with a penny, then 11, 15, 16 and 14 in the vertical column, and 4, 0, 3 and 1 along the row with paper squares. We then repeat the process, asking for another selection, laying a penny on same and covering the same row and column with paper squares. This procedure is repeated twice again when you will discover that there is only one square remaining uncovered, so your friend has no other choice for this final number.

Having done this you may turn away and write down the sum of the selected

numbers on a piece of paper, ask your friend to uncover the pennies, make the

By 'Mystifier'

addition and the answer — which you have previously written down — will be 37!

If you stand near to your friend while

the top row starting on the left shows 6 (i.e. $2 + 4$): the 2 is $2 + 0$; and 11 is $2 + 9$ and so on. It seems so simple when you know how it is done, so go ahead and make some squares of your own. It does not matter what numbers you use for by proceeding as directed the ultimate number must always be equal to the sum of the initial generating sets.

Incidentally, another amusing trick you can perform is by making a magic square from a calendar. All you have to do is to draw a square round 16 numbers

	4	0	9	3	1
2	6	2	11	5	3
6	10	6	15	9	7
0	4	0	9	3	1
7	11	7	16	10	8
5	9	5	14	8	6

FIG 2

directing the operations he will no doubt say that you saw the numbers and had only to do a little mental arithmetic to know the answer. This is quite possible of course, but you may either invite him to make another selection on his own while you stand aside or initially show him the procedure and retire while he makes the selections. For effect it is always better to contemplate the squares with the pennies laid in position before 'forecasting' the total which, in the case of our diagram, will always be 37.

We will now analyse this particular square so that you may use any number you desire to make a magic square of the same kind. It may be as large as you like since the mathematical principles involved remain the same.

In Fig. 2 you will see that we have two sets of numbers, one at the side and one on top of the square. If you add these together you will find that they total 37 and the numbers in the individual squares are obtained by adding the corresponding sets together. For example,

(i.e. 4×4) on any calendar and if you proceed as originally directed the final number will be twice the sum of the numbers at either of the diagonally opposite corners. Try this for yourself.

Finally, you may use the same idea as the basis for a novel birthday card. Prepare a square so that the sum of the two generating sets is equal to the age of your friend. Write the instructions on the card and when your friends totals the selected numbers he will find his own age!

STRIKE UP THE BAND

Next week we shall start a series of articles showing how to make your own instruments for a junior band.

Make sure of your copy.



CHARMING MUSICAL BOXES



MUSICAL SWISS CHURCH
No. 3364. Holds about 30 cigarettes
10/11 (post 2/-)



ILLUMINATED MUSICAL SWISS CHURCH
No. 256 Special. Full kit contains materials, paint, glue, electrical fittings, etc.
26/6 (post 2/3)



TWO-STOREY MUSICAL SWISS CHALET
No. 255 Special
Kit contains materials, paint, glue, etc. (post 2/3) **21/-**



'GONDOLA' BOX
No. 3388. For trinkets or cigarettes.
14/8 (post 2/-)

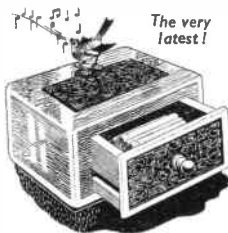

'WHISTLING BIRD' BOX
No. 261 Special. Bird rotates and whistles when drawer is opened for a cigarette. Kit for Box 14/11 (post 2/3), Mechanism (with bird) 24/9 (post 9d.) extra.



WILLOW PATTERN BOX
No. 3284
For cigarettes, trinkets, etc.
10/- (post 2/-)



OLD WOMAN WHO LIVED IN A SHOE MUSICAL BOX
No. 259 Special. For cigarettes or trinkets.
24/11 (post 2/3)



GRAND PIANO
No. 3250. Kit to make includes wood, hinges, printed keyboard, etc.
13/3 (post 2/-)



TREASURE CHEST MUSICAL TRINKET BOX
No. 3312
Charming reproduction of a pirate's treasure chest.
15/9 (post 2/-)

Kits and Musical Movements from all Hobbies branches or direct by post from

**HOBBIES LTD (Dept. 99),
DEREHAM, NORFOLK**

SWISS MUSICAL MOVEMENTS

Choice of 28 Tunes
(One Tune per Movement)
Westminster Chimes
Kiss Me Honey-Honey
The Knick-Knack Song
Anniversary Waltz
Jingle Bells
O My Papa
Blue Danube
Vienna, City of my Dreams
The Harry Lime Theme
from 'The Third Man'
Brahms' Lullaby
Parade of the Wooden Soldiers
Church Bells Air
The Bridge on the River Kwai
(Col. Bogey)

Ave Maria de Gounod
Silent Night
Limelight
Moulin Rouge
Greensleeves
Tales from the Vienna Woods
Home Sweet Home
Swedish Rhapsody
Bells of St. Mary's
Blue Bells of Scotland
Irish Eyes are Smiling
Auld Lang Syne
Teddy Bears' Picnic

Price 14/11
(post 6d.)

IMPORTANT — When ordering please give 2nd. & 3rd. choice

MODERN CABINETS FOR MODERN HOMES

Kit No.
3144
72/-
(carriage paid)



27 ins.
high
18 ins.
wide

IDEAL AS A BEDSIDE CABINET

Kit contains selected planed wood, dowel rod, handle, hinges, design sheet and instructions, etc.

Send for free copy of 'Profitable Leisure'

HOBBIES LTD. (Dept. 99) DEREHAM NORFOLK

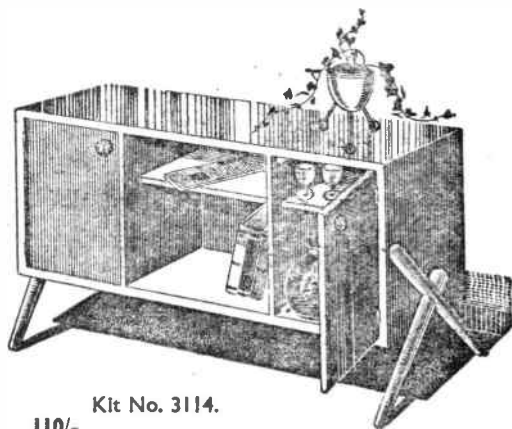

Kit No. 3114.
110/-
(carriage free)

FOR THE LOUNGE

This cabinet is a really outstanding piece of work. Size 3 ft. long, 27 ins. high. Kit contains selected planed wood, hinges, handles, design sheet with instructions.

WOOD BENCH VICE

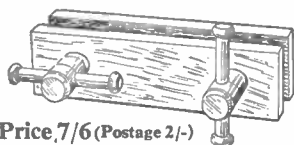

A strong hardwood vice which can be screwed to the work bench. A real serviceable tool, well made, and fitted with hardwood screws. 12 in. long.

From branches or:
HOBBIES LTD
Dereham, Norfolk

Price 7/6 (Postage 2/-)

HEAR ALL CONTINENTS With H.A.C. Short-Wave Receivers

Suppliers for over 18 years of radio S-W Receivers of quality.
One-Valve Kit, Price 25/- Two-Valve Kit, Price 50/-
Improved designs with Danco coils. All kits complete with all components, accessories and full instructions. Before ordering, call and inspect a demonstration receiver, or send stamped addressed envelope for descriptive catalogue.
H.A.C. Short-Wave Products (Dept. 22), 11 Old Bond Street, London, W.1

MAKING YOUR HOBBY MAKE MONEY

HOW, WHY any handicraft can make money for you — everything you should know.

40 pages of experience — 5/6 from

G. SEALE
Regent House, 26 Queen's Rd., Coventry

IT'S EXCITING. IT'S PROFITABLE.
Flower painting can bring extra income. Previous experience unnecessary. Waiting markets. Inexhaustible demand. Details free. Popular Art Services (HW), Clun, Salop.

PERSONAL COLUMN LTD., Falcon House, Burnley, Lancs. Pen Friend — all hobbies. Correspondents in almost every Country. All ages. S.A.E. for details.

HOMEWORKERS required to make up and machine simple household goods. Experience unnecessary. Good pay. Regular work. S.A.E. for details to Dept. 28, Arnold, 10 Shelley Road, Worthing, Sussex.

GLASGOW

DO YOU KNOW?

HOBBIES LTD have a branch at

328-330 ARGYLE STREET

where the manager and staff are always willing to give you the benefit of their experience with any of your handicraft problems.

LEARN

RADIO & T/V SERVICING
for your OWN BUSINESS/HOBBY

● by a new exciting no-maths system, using practical equipment recently introduced to this country
FREE Brochure from:—

RADIOSTRUCTOR

DEPT. G81, READING, BERKS. 10/1/62.

100 DIFFERENT stamps free! Request 4d. upwards discount approvals. — Bush, 53 Newlyn Way, Parkstone, Dorset.

ENJOY WRITING? Then write for Profit. Send for 'Writers' Handbook' (free) detailing countless opportunities for beginner or experienced. — Writers' Ring (HW) 5 Edmund Street, Birmingham.

50 STAMPS FREE to applicants for fine stamps on approval. Discounts and Post Paid. — McKendrick (H), 9 Nethercourt Farm Road, Ramsgate, Kent.

LEARN RADIO & ELECTRONICS the NEW Practical Way! Very latest system of experimenting with and building radio apparatus — 'as you learn'. FREE Brochure from: Dept. H.W. 10, Radiostructor, Reading.

'BRER RABBIT' PINCUSHION

CUT one each of pieces A, B and C from $\frac{1}{4}$ in. thick wood with a fret-saw. Glue A into piece C and glue piece C to the base B.

The pincushion is made from two pieces of white material sewn together as shown in the small detail. Stuff it with cotton wool and glue or pin it in position to the tail.

The rabbit should be painted brown and white. The base could be green flecked with brown and yellow. (M.p.)

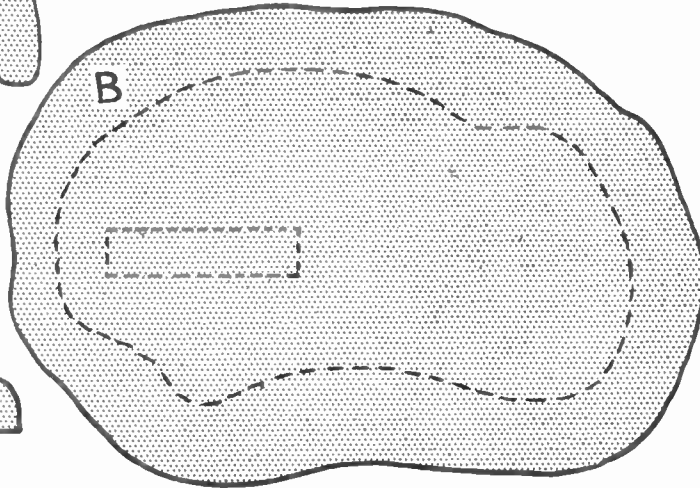
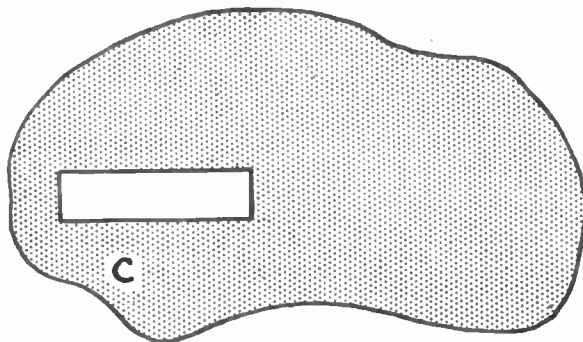
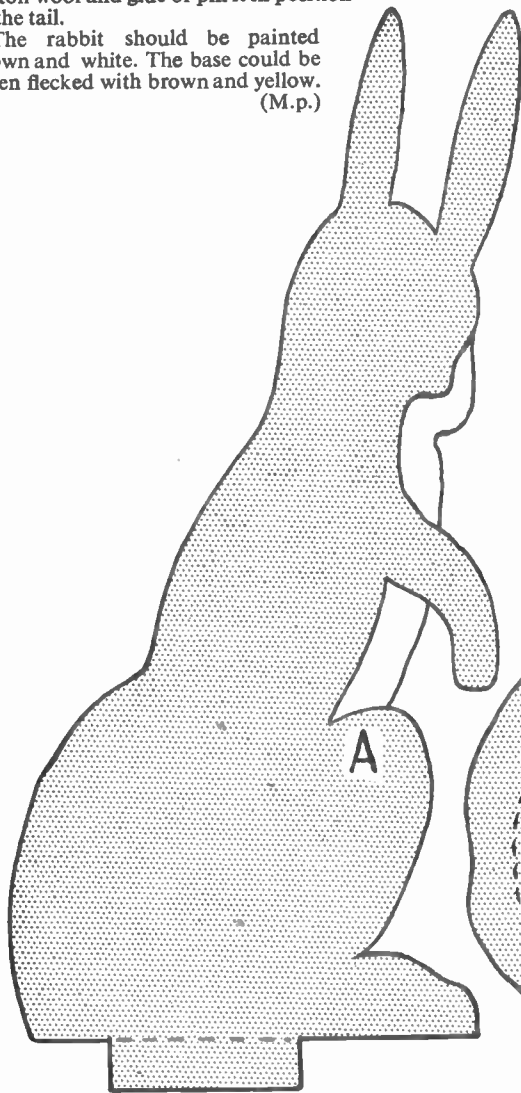
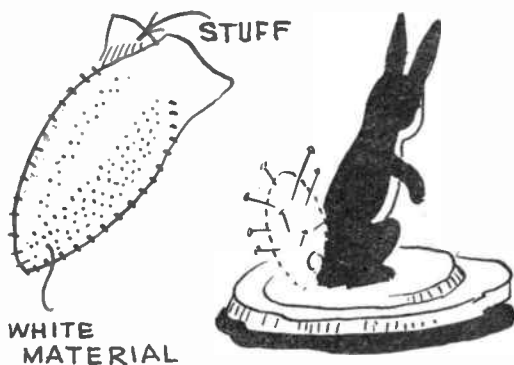

Single seat and two seat CANOES

COMPLETE AND READY
FOR THE WATER — OR
IN KIT FORM TO MAKE
YOURSELF

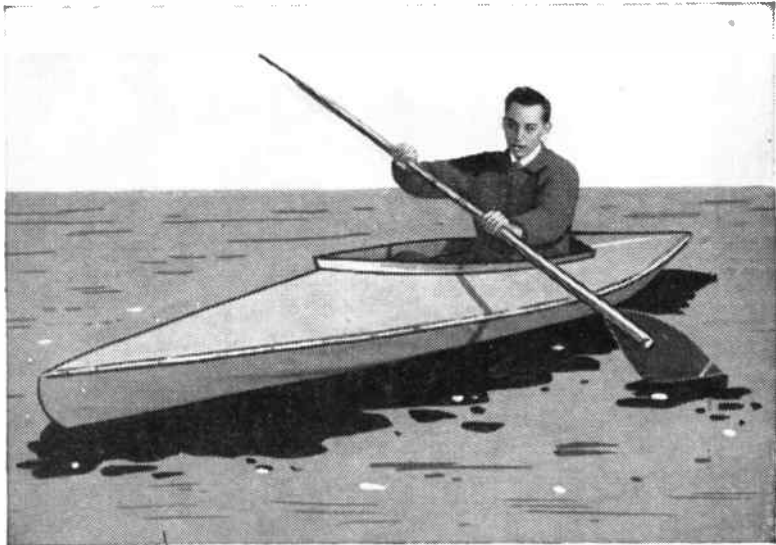

THE PBK 10 SINGLE SEATER

These popular craft are designed by that well-known authority, P. W. Blandford. With canvas skins, they are propelled by double-bladed paddles and are thoroughly at home on lake, river or canal — or even on the sea in experienced hands. They are offered as complete canoes, or as specially prepared kits, which include full building instructions. Easy terms are available, subject to the completion of a simple form of Agreement.

PBK 10 Single seat — 11 ft. long
28 in. beam — load 300 lb.

COMPLETE CANOE (without paddles)
CASH PRICE £24.5.0 (part p. & p. £2 extra),
or EASY PAYMENTS £6 DOWN (plus £2
part p. & p.) & 6 monthly payments of £3.4.8.

COMPLETE KIT (except paint and
varnish and without paddles)
CASH PRICE £15.10.0 (part p & p. 15/- extra)
or EASY PAYMENTS £4 DOWN (plus 15/-
part p. & p.) and 6 monthly payments of £2.0.9.

DOUBLE-BLADED PADDLES, 47/6 Complete (part p. & p. 2/6 extra)

PBK 20 Two seater — 15 ft. long
32 in. beam — load 700 lb.

COMPLETE CANOE (without paddles)
CASH PRICE £32.10.0 (part p. & p. £2.10.0
extra), or EASY PAYMENTS £8 DOWN
(plus £2.10.0 part p. & p.) & 6 monthly pay-
ments of £4.6.9.

COMPLETE KIT (except paint and
varnish and without paddles)
CASH PRICE £22.5.0 (part p. & p. 20/- extra)
or EASY PAYMENTS £5.10.0 DOWN
(plus 20/- part p. & p.) & 6 monthly payments
of £2.19.4.

(DEPT. 99)

DEREHAM



NORFOLK