

Look-in

Junior TVTimes No 31 Week Ending 7 August 1971 Every Thursday 5p



**INSIDE: RALEIGH
"CHOPPER" CYCLES &
JACO ROLLERSKATES
TO BE WON!**

It's here!
**On The
Buses**
in a new colour
picture story





A bit of bath bother for Leslie!



By arrangement with Leslie Crowther.



LIFT OFF

BY STEWART WALES

FIVE ... four ... three ... two ... one ... **LIFT OFF!** It's not the launching of a space rocket, but something just as exciting. For the countdown has already begun for Granada Television's third 'LIFT OFF' series which starts on Tuesday 10th August.

As in the previous two shows, pretty Ayshea Brough will introduce the programme and its selection of popular artists. Singer Wally Whyton and the young dancing quartet the 'Feet' are also part of the resident 'Lift Off' team, and the inimitable Ollie Beak is looking forward to being on television again.

To find out all about the new series, I visited Ayshea's mews flat in London with LOOK-IN photographer, Rod Shone.

After helping to carry armfuls of cameras and lighting equipment into the sitting room, I watched as Ayshea placed an Elton John L.P. on the turntable of her record player (Elton's one of her favourite singers). Then she began to talk about 'Lift Off.'

"The first five programmes will be reserved just for requests," she explained. "This is because of the fantastic response from viewers (many of whom read my weekly column in LOOK-IN). And, only records chosen by them will be played. In all, we'll be showing about fifty different names and addresses in the first show alone."

How? Well, the wonders of modern photography provide the answer. As the disc is being played, about fifty caption cards will be set up. The cameras will switch from one card to another and squeeze in as many names as possible. This particular spot is called 'the Bumper Play' and 'Knock Three Times' is the most-requested record on the first programme. But don't be disappointed if

Ayshea, hostess of Lift Off takes a turn at the microphone to introduce her guests Marc Bolan of T. Rex and Johnny Johnson and the Bandwagon



The tremendously popular group of artists who call themselves the 'New Seekers'.



One of Ayshea's favourite singers—Elton John.



The Tremeloes—they've made many smash hits.



Here's the fantastic Marmalade. You'll be able to see them on a future 'Lift Off' programme.

continued from page 3

LIFT OFF

you chose another song—there will be other Bumper Plays later on in the series.

"Who are the guests appearing on the first 'Lift Off'?" I asked Ayshea. "The Sweet and Miki Antony," she replied. "They're super artists."

There are many other big names lined up for the series. These include the Tremeloes, New World, Marmalade, the New Seekers, Pickettywitch and Mac and Katie Kissoon (currently enjoying great success with their disc Chirpy Chirpy Cheep Cheep).

The new 'Lift Off' will also reserve a spot for showing excerpts from many of your favourite films. "Hundreds of viewers have asked for this spot so we've done our best to please them," said Ayshea. At this stage of the interview, I asked Ayshea a few questions about herself.

"Someone once asked me why I didn't make a pop record," she said. "I thought about it for a while and shortly afterwards I *did* make a record," she recalled. "That's how I started my singing career."

But Ayshea is not only a singer. She is also a talented actress and has attended the Royal Academy of Dramatic Art. One of her acting roles included a regular part in the science fiction series, *U.F.O.*

Her hobbies? "I love riding, swimming and astrology," she smiled. Ayshea's a pet fan as well. And her four dogs—Bogweed, Guyreena (so named because of her arrival on Guy Fawkes night), Fred and Daisy May, certainly prove it. Just mention the word 'mice' to Ayshea and you might expect her to turn and run. In fact, this is not the case. Another interesting hobby of hers is to collect them—though, admittedly, they're model ones made of cloth!

"I have two ambitions," she said. "One is to have a hit record. The other is to have a film role with Paul Newman." Having heard her latest disc 'Master Jack', which she'll be singing on the first show, I'm sure she'll achieve one of those ambitions in the very near future.

So, prepare for 'Lift Off'! It's screened at 4.55 in all regions. That means wherever you live, you'll be in for a swinging time with Ayshea and her guests!



The one and only Ollie Beak.

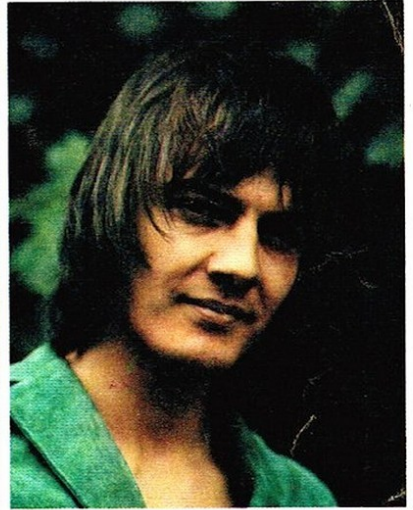

Left: Ayshea at home—with one of her toy mice. Top right: Miki Anthony—he's on the first Lift Off with the Sweet (above). Below: another Lift Off 'resident' — Wally Whyton.

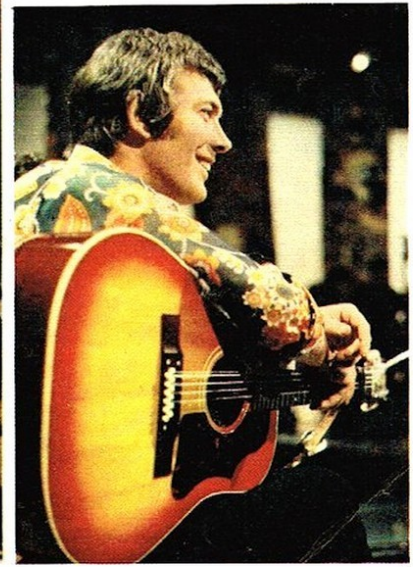

A critical crash-course for the time-travellers!

TIMESLIP

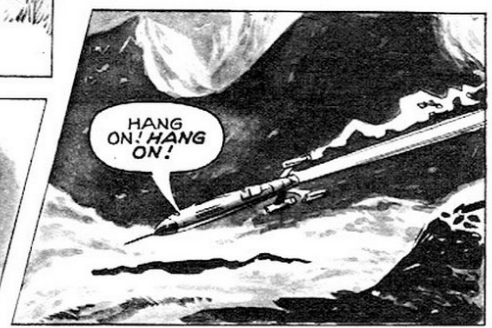

STRESSED FOR THE VIOLENCE OF LIFT-OFF AND RE-ENTRY, THE NOSE AND BODY OF THE MASSIVE SHIP REMAIN IN ONE PIECE...

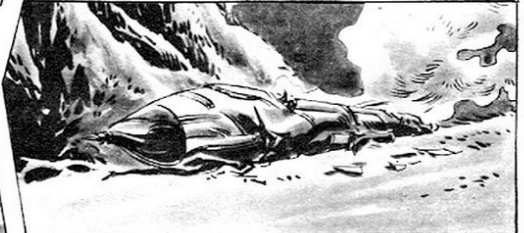



MEANWHILE, IN THE WRECKAGE, SIMON SLOWLY RECOVERS HIS SENSES...



Next week: A struggle for survival!

Magpie turns to some air aces of World War One

First Fighting Fliers!

AT three thousand feet, the pilot of the flimsy Fokker triplane adjusted his goggles. He took a deep breath and banked his aircraft sharply—nosing it into a screaming dive. To an observer, the sight would have appeared as a harsh act of nature. A bright red bird of prey swooping down towards its victim—a Sopwith Camel—a fighter aircraft of the Royal Flying Corps—Britain's airforce in 1916.

The pilot of the German plane was none other than Baron Manfred von Richthofen—better known as the legendary 'Red Baron'.

A mere five hundred yards above his unsuspecting victim, the Red Baron squeezed the 'fire' button in his cockpit. His Spandau machine gun, capable of firing five hundred rounds a minute, chattered into life. The little Fokker shuddered as the pulsating gun grew red hot. Seconds later, the Red Baron knew he had been successful. A trail of jet black smoke belched from the body of the English aircraft and, like a stricken bird, it spiralled earthwards. The Red Baron had justified again his reputation of being the most feared German flying ace of the war.

Such was the scene in the skies over Europe during World War One. The German pilots matched their skill against that of the English, Canadians and French. While their comrades lay hidden in the muddy trenches below, pilots from all countries fought their own lone war in the sky.

But strangely, the duels in the skies had not always been so deadly. When the war broke out, all aircraft had been unarmed. They had no possible means of attacking each other. Pilots began to carry rifles and take pot-shots at enemy aircraft that came within range. But it was soon found that rifles were too clumsy to handle. So revolvers and automatic pistols became popular weapons. But they, too, weren't much use and rival pilots often went on their way with a parting wave.

The French partly solved the problem of fire power. They mounted machine

guns on to their aircraft. Then, realising that some of the bullets would hit the propeller, they fitted steel deflector blades on to it. This method had its problems, though. The bullets hitting the blades caused shocks and vibrations that eventually weakened the engine.

It was the German aircraft designer, Anthony Fokker, who invented the ideal firing system. He realised that the solution was to fire *between* the blades by interrupting the firing of the gun whenever part of the propeller passed in front of the muzzle. So he fitted all German fighters with 'interrupter' gears which made this possible.

At this stage, a new era in sky-fighting began. Men like

Max Immelman came to the fore of the German airforce. He proved himself a superb pilot who devised a number of air manoeuvres, the best-known of which was the 'Immelmann Turn'. He was possibly the first pilot to realise the importance of tactical manoeuvres as a means of shooting down an enemy and avoiding being shot down. But, like most of the famous aces, Immelman's luck ran out. His aircraft broke up during a fight on 18th June, 1916.

He was succeeded by Oswald Boelcke who had his own team of pilots—among whom was Manfred von Richthofen, who later led the famous 'Flying Circus' with such distinction. This was the name given to a certain group of dedicated fighter pilots who were referred to as the 'Flying Circus' because their triplanes were painted gaudy colours.

The Red Baron's last dog-fight was on April 21st, 1917. His plane was seen to lose height and crash behind British lines. On April 22nd, he was buried with military honours by No. 3 Squadron of the Royal Australian Airforce. This last act in the career of the Red Baron was a tribute paid by an enemy to his great courage and flying skill.

There were, of course, many brave English aces, too. One of the most popular was 'Micky' Mannock who shot down over fifty enemy aircraft during his career. He had all the essentials of an air ace—coolness, self-mastery, and exceptional eyesight.

Billy Bishop was a Canadian ace. He was a careful pilot and a crack shot—destroying seventy-two German aircraft in the war. Unlike many of his brave colleagues, he lived to survive the war and later became an Air Marshal and Chief of the Canadian Air Staff.

But whether these resourceful fliers were French, German, English or Canadian, they all had one thing in common. Their unflinching courage and daring inspired affection in their comrades and respect in their enemies.

You'll be able to learn some facts about the air aces of the Second World War in *Magpie* next month, when special items will be devoted to the subject during 'Battle of Britain' week!



Above: A Fokker triplane—the efficient German fighter.

Right: Anthony Fokker, the German aircraft designer. He devised an interrupter gear which was fitted on to all fighter aircraft. This enabled a machine gun mounted on the front of the plane to fire between the blades of a rotating propeller. His ingenious invention led to a new era of serious air fighting that played an important role in the First World War.



Murgatroyd





Guynemer,
the Famous French flier



Oswald Boelcke,
a leading German ace.



Billy Bishop, who became
a Canadian Air Marshal.



Baron Manfred von Richthofen
the 'Red Baron'.



'Micky' Mannock destroyed
over fifty German aircraft.

Smithy's idea soon gets Fenn Street into the 'swim' of things!





LIFT OFF

Thank you all for your letters naming the writer of 'Here Comes My Baby'. As many of you said, it was Cat Stevens and the lucky winners will receive 'Lift Off' scarves shortly. The winners are Terry Buckle, of London, E.11, Susan Ellison of Sale, Cheshire, Eileen Proctor of Kendal, Westmorland, Nicholas Levy of Brighton, and Janet Free from London E.1. When I was a very young record fan, Perry Como was very popular — remember



'Catch a Falling Star'? Perry was the first of the very relaxed 'pop stars', and he set the trend for a certain kind of music which was followed in this country by that type provided by Val Doonican. And it's certainly good, too! Perry is now back in business in England after two big hit records and his album, 'It's Impossible' is really worth buying. The fabulous tracks include such great songs as 'Raindrops Keep Falling On My Head', 'Something', 'Close To You', 'Snowbird' and many others. I would advise anybody who wants a really relaxing and beautiful sounding L.P. to go and get this one straight away.

Agatha

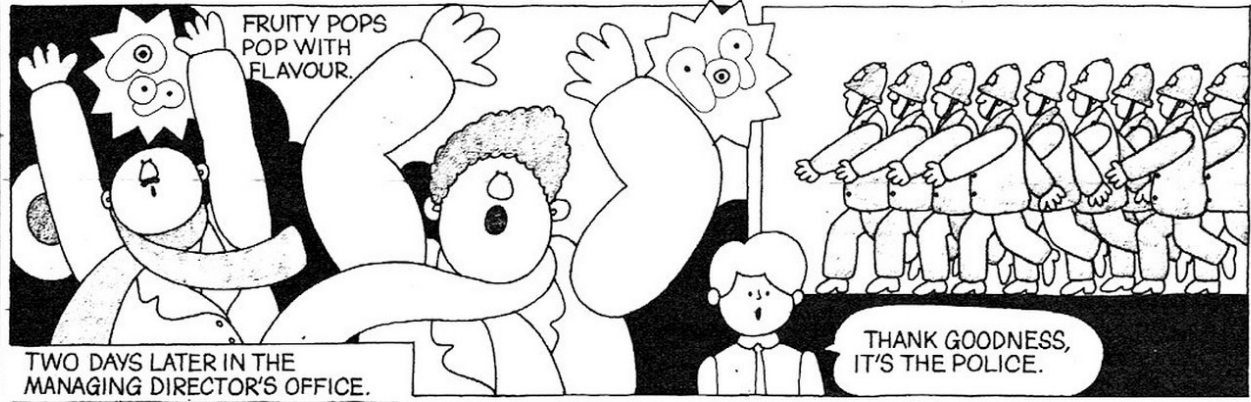

TWO DAYS LATER IN THE MANAGING DIRECTOR'S OFFICE.



AND AS A REWARD HE GAVE THEM A HUGE CASE OF..... FRUITY POPS. FRUITY POPS POP WITH FLAVOUR.

PROVE TO YOUR FRIENDS THAT FRUITY POPS POP WITH FLAVOUR.

EQUIPMENT: ONE DRY, EMPTY MILK BOTTLE. ONE BIG BALLOON. ONE PIN. ONE PACKET OF FRUITY POPS.

INSTRUCTIONS: TAKE A FEW FRUITY POPS AND PUT THEM INTO THE MILK BOTTLE. NOW STRETCH THE BALLOON OVER THE NECK OF THE BOTTLE AND TIP THE BOTTLE UPSIDE DOWN, SO THAT THE FRUITY POPS TIP INTO THE BALLOON. NOW BLOW UP THE BALLOON AND KNOT IT TIGHTLY. ANNOUNCE TO YOUR FRIENDS YOU CAN PROVE FRUITY POPS POP WITH FLAVOUR, THEN TAKE THE PIN AND BURST THE BALLOON. WATCH THEIR AMAZEMENT AS FRUITY POPS POP ON TO THE TABLE AS IF BY MAGIC!

FRUITY POPS POP WITH FLAVOUR.

YOUR VIEW

Popular TV personality Des O'Connor selects this week's entries from the LOOK-IN Post . . .



STAR LETTER

APPLE TURNOVERS

My Mum and Dad make their own wine, and one day we had a load of apples to use. My Dad couldn't be bothered straining the apples, so he decided to extract the juice by using Mum's spin-drier! Everything seemed to be fine until Dad thought he heard a knock on the door and left Mum in the kitchen with the dancing spin-drier. Suddenly the lid burst open, and covered the kitchen and Mum in apple pulp. When Dad came back he couldn't help laughing, but Mum felt more like crying. To relieve her feelings, she threw some of the pulp at Dad, but only succeeded in plastering the hall, too. So, no wine was made that day, just a whole lot of cleaning up!

Gary Tonge,
High Wycombe, Bucks.

★ Congratulations, Gary, you've won £2! I had an uncle who used to make wine . . . he used to tread on the grapes with bare feet. But he got the sack one day: he was caught sitting down on the job. He was getting a little behind in the work!

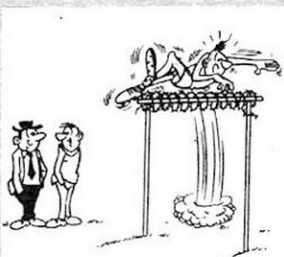

"Amazing how his jumping has improved."

Keith Waterhouse,
Lancashire.

COMIC HOLDER

Other readers as well as myself have probably heard their mothers threatening to throw their comics in the bin if they don't tidy them up. So I thought of this idea. Using a large, empty cornflakes box, cut off the

flaps at one end. Cover it with sticky-back plastic or wrapping paper and fasten it to your bedroom wall with a piece of ribbon and a picture hook. This makes a very pretty comic holder. Since I've made mine, I've had no more complaints!

Christine Collins,
Newton-le-Willows, Lancs.

★ A clever idea, Christine. Have you heard about the new cereal that's on the market? You get a whole box of plastic toys and if you search around inside you'll find a cornflake.



"See you tomorrow—
same time, same place."

John Tickle, Manchester, 22.

TIME SLIP

Every morning I get up at six o'clock to do a paper round, but one morning my Mum came rushing in to my bedroom saying I was late, it was quarter past seven. I quickly got my clothes on and dashed out, but when I got to the paper shop it was closed. I was just going to knock on the door, when I saw my Mum rushing up the street waving her arms. When she got to me she said she'd made a mistake, and had woken me at quarter to three!

Bryan Evans,
Swinton, Lancs.

★ I can see I'd have to get up early in the morning to catch you, Bryan.



"Waiter, how long will
my spaghetti be?"
"Only about 10 to 12 inches sir!"

L. Quarmby,
Yorkshire.

OH, MR. O'CONNOR . . .

You are my favourite entertainer. I have an L.P. record of yours, and I play it at least once a day. I'm sad to say that I haven't many pictures of you and would love LOOK-IN to print one. Why haven't we seen you on television

for such a long time? Is there any news about when we can expect to see you again?

Barbara Shaw, Malvern, Worcs.

★ Thank you for your lovely letter, Barbara. You should be seeing my new series now . . . are you sure it's not on in your region?

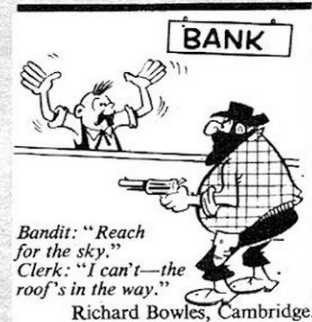

Bandit: "Reach
for the sky."

Clerk: "I can't—the
roof's in the way."

Richard Bowles, Cambridge.

READER'S REQUEST

I like the comedian Les Dawson. Could you please print a picture of him in LOOK-IN?

Richard Ailxill,
Derby.

★ The Editor is happy to oblige, Richard.



Win £2 for the Star Letter. £1 for any other letter or joke!

Plus: a special signed photograph of the Your View star will be posted to the sender of every item published!

Why not write now to Your View, LOOK-IN, 247 Tottenham Court Road, London W1P 0AU? But remember—when you write, also enclose a list of your favourite LOOK-IN features, plus the feature you don't like (if there is one).

More excitement with the farmyard friends...

Follyfoot

FRAMED BY THE WILY HAMMONDS OF PINCHCROFT HOTEL, STEVE IS AWAITING CHARGES FOR STERLING TANGO, A MARE IN FOAL. EVERYONE AT FOLLYFOOT KNOWS HE IS INNOCENT, HAVING FOUND TANGO ABANDONED AT THE FARM GATE... AND DORA DISCOVERS THAT HER OWNER IS EX-CIRCUS RINGO TED CHARLTON, WITH STEVE AND THE COLONEL, SHE GOES TO CHARLTON'S COTTAGE, ONLY TO FIND...

OH, NO! IT'S BEING DEMOLISHED TO MAKE ROOM FOR A MOTORWAY!

THERE'S NO CHANCE OF HELPING STEVE IF TED CHARLTON CAN'T BE FOUND...

YOU SAY YOU'VE SEEN HIM FROM TIME TO TIME, HANGING ABOUT NEAR FOLLYFOOT, DORA...?

EXCUSE ME! DO YOU KNOW WHERE THE MAN WHO LIVED HERE HAS MOVED?

BUT HE ALWAYS RUNS FOR IT. ANYWAY, WE CAN'T JUST ASSUME HE'LL TURN UP AGAIN - WE'VE GOT TO FIND HIM BEFORE I GO UP IN FRONT OF THE MAGISTRATES!

SEARCH ME! THE PLACE WAS EMPTY WHEN I ARRIVED!

GOT A MESSAGE FOR YOU, LAD. YOUR CASE COMES UP SATURDAY MORNING - BE AT THE COURT SHARP AT TEN!

BACK AT FOLLYFOOT, THEY MAKE THE MISTAKE OF DISCUSSING THE SITUATION WITHIN EARSIGHT OF RON STRYKER...

AND RON PASSES EVERYTHING ON WHEN HE MEETS HIS PAL LEWIS HAMMOND...
 A CIRCUS GROOM, EH? THINK THEY'VE GOT MUCH CHANCE OF FINDING HIM, RON?
 YOU WHAT? YOU DON'T KNOW THE MEANIN' OF THE WORD, MATE? YOU GET TIRED SLEEPIN'!
 COR! ALL RIGHT FOR THEM, PLAYIN' SHERLOCK HOLMES WHILE I DO ALL THE WORK!

DUNNO, DO I? BUT THAT DORA'S PRETTY SMART AT TIMES. I RECKON SHE'LL HAVE A RIGHT OLD GO!

I'D BETTER TELL DAD ABOUT THIS! CAN'T HAVE THINGS GOING WRONG - NOT NOW!

MEANWHILE, STEVE AND DORA ARE OUT ON THEIR HORSES...
 CAR COMING, DORA! HELLO, IT'S THE POLICE!

THERE'S A CALL FOR YOU ON THE LOBBY PHONE DOWNSTAIRS, MR. CHARLTON!

TWO DAYS! IT'S HOPLESS!
 I'M NOT SO SURE! LISTEN - IF CHARLTON'S COTTAGE WAS BOUGHT FOR A MOTORWAY, HE'D HAVE BEEN RE-HOUSED, RIGHT?
 EE, WELL, I DON'T KNOW... IS IT MONEY...?

COME ON! BACK TO FOLLYFOOT! WE'RE GOING TO PHONE THE COUNCIL AND SEE IF WE CAN FIND HIS NEW ADDRESS!

BUT AT THAT MOMENT, IN THE BLOCK OF FLATS WHERE TED CHARLTON LIVES...

OH, AYE? I'LL COME AT ONCE!

THIS IS DAWSON HERE, OF DAWSON AND SMYTH, SOLICITORS. WE HAVE CERTAIN NEWS THAT MIGHT BE TO YOUR ADVANTAGE, MR. CHARLTON. CAN YOU COME DOWN TO LONDON AND SEE US?

TED CHARLTON AGREES, AND THE CHECKER GIVES HIM AN ADDRESS IN MAYFAIR - A FALSE ADDRESS...
 WE - AH - MIGHT SAY THAT! WE'LL REFUND ALL YOUR EXPENSES, NATURALLY!

LOOK FORWARD TO SEEING YOU, MR. CHARLTON, TOMORROW AFTERNOON? GOOD BYE FOR NOW!

THERE, I DON'T THINK WE'VE ANYTHING TO WORRY ABOUT WITH CHARLTON SURELY OUT OF FOLLYFOOT'S REACH!
 SHREWD, DAD! REAL SHREWD!

BUT WHEN DORA MAKES HER CALL TO THE COUNCIL...

TAKE ME INTO TOWN, UNCLE! AND HURRY! I THINK TED CHARLTON'S ALREADY BEEN GOT AT!

14 Based on the Yorkshire Television series Follyfoot © 1971 Yorkshire Television Ltd. (The original story of Follyfoot, by Monica Dickens, is published by Heinemann at £1.25 and p.p.a. at 20s.)

Will Dora catch Charlton in time? See next week! 15

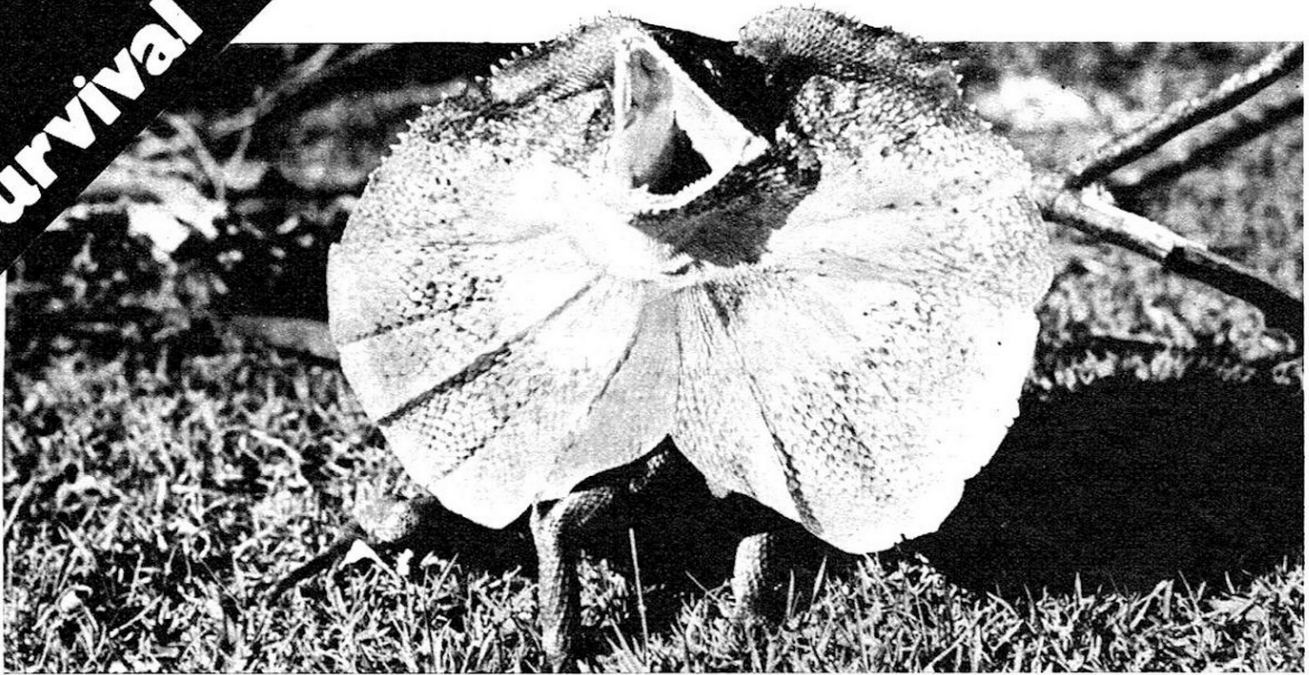

Completing his series on Australia, Colin Willock talks of some reptiles . . .

Lizards Larger than Life!

NO, YOU'RE NOT SEEING THINGS. It is a great big lizard running nearly as fast as a man could, and standing upright on its back legs. That yellow 'collar' puffed out like an Elizabethan ruff, is a sort of crest which seems to flop forward over the weird creature's face.

You needn't worry, though. The strange inhabitant has darted up a tree. Once again, it's just a case of Australia living up to form by producing something way-out in every class of animal.

This reptile, that runs on its back legs (the movement is known as 'bipedal' to scientists), is Australia's frilled lizard. It erects that yellow crest either when scared or when it wishes to frighten something else.

Then there are what the Aussie's call 'goannas'. These are giants compared to even the big frilled lizard. 'Goanna' is

the name given to them by early Australian settlers and is short for 'iguana'. But, of course, they didn't know that these lizards which sometimes grow to eight feet long, aren't iguanas at all. They belong to the family of predatory lizards called 'monitors'.

Watch a big goanna in action as it tackles an unwary marsupial and you'll get some idea of what it must have been like on earth when the dinosaurs were on the war-path. For the goannas have some physical features that suggest a distant relationship with the sea-monsters, called monosaurs, which lived 160 million years ago.

Did you know that a great deal of Australia's interior comprises burning desert? Many of the strange reptiles of this continent have adapted themselves very well to the harsh, desert conditions.

One lizard—the white salt dragon—has evolved sunken eyes protected by slitted eyelids, like visors, to guard it against the glare. This is very useful for the creature exists by hunting ants on the blinding white surface of Lake Eyre.

Now here is a fascinating case of 'convergent evolution'. This simply means two quite different species, living in different parts of the globe, evolving in much the same outward form to cope with similar living conditions.

I wrote previously of the lizard called the horned toad of Arizona, in south west America. Well, the Australian desert has produced a spiky little lizard which is almost identical to the horned toad. He's called the mountain devil and is a very spiky-looking customer indeed.

So far, we have not mentioned snakes. In fact, Australia has one-hundred-and-forty land species and twenty sea snakes. One of the land varieties is the most poisonous snake in the world. It's called the taipan and carries at least two-hundred doses of venom powerful enough to kill a man in minutes.

Occasionally, the taipan meets its match. The goanna can not only usually outfight this deadly customer but will even eat it, too! Goannas are immune to the taipan's venom, though no one quite knows why.

Goodbye to Australia's odd animals for a while. Next week, I'll see you in South America. I shall be describing some of the fantastic animal life that this great continent supports.

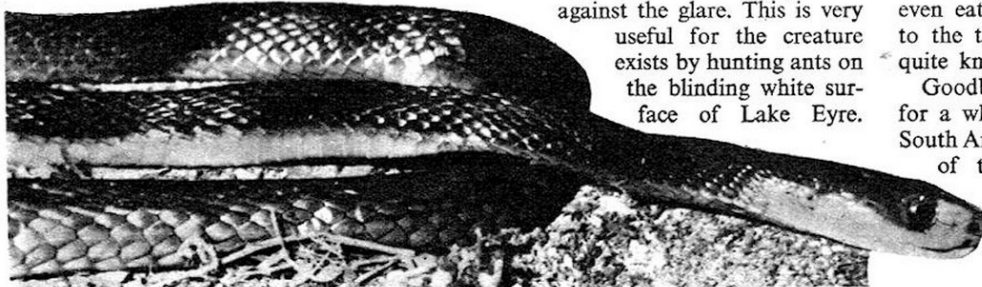

The deadly poisonous Taipán snake.

The Mountain Devil looks like a row of sharp thorns. Despite this little lizard's terrifying appearance, it is only deadly to ants—eating thousands at a time!

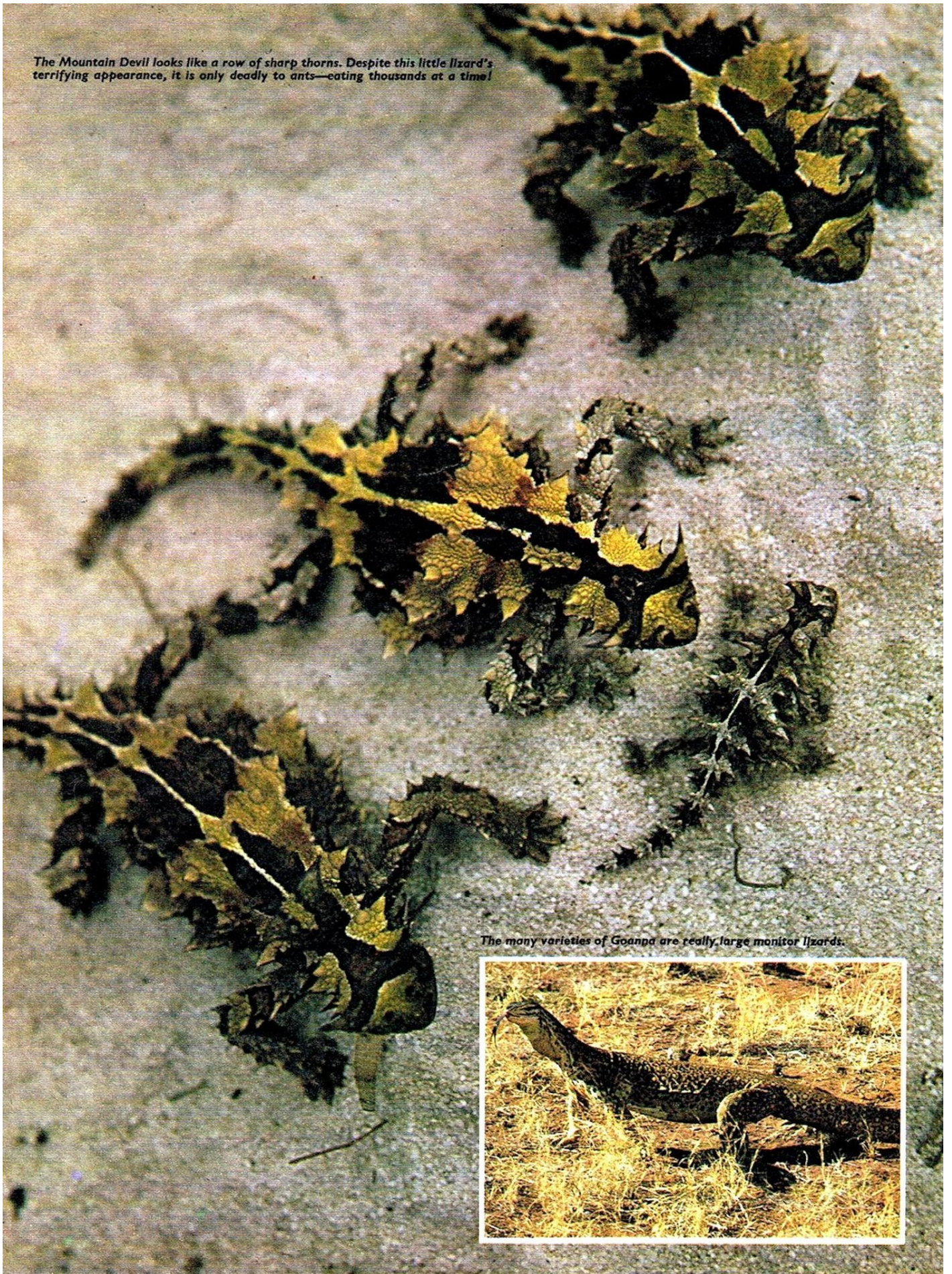

The many varieties of Goanpa are really large monitor lizards.



Look out for next week's Look-in



★ TV's popular *ON THE BUSES* has been made into a cinema film. Next week's *LOOK-IN* presents a special feature in full colour.

★ **ANOTHER GREAT COMPETITION.** More Raleigh 'Chopper' cycles to be won, plus 3 super Hotwheels Pit Stop displays, 150 Hotwheels cars and 50 posters.

Don't miss the excitement in next week's *LOOK-IN!* Order your copy NOW!



Challenge the Look-in secret agent and you could win £1

All around Britain's coastal holiday resorts, *LOOK-IN* Secret Agents will be appearing Monday to Friday during the next three weeks. The first reader to recognise the Secret Agent and challenge her with the correct statement will be given a crisp new £1 note.

How to make the challenge

First you must have a copy of *LOOK-IN* which is currently on sale the week the challenge is made. When you recognise the Secret Agent you must show her your copy of *LOOK-IN* and say: "LOOK OUT FOR LOOK-IN. YOU'RE THE SECRET AGENT!" The first *LOOK-IN* reader to make a successful challenge will be given the prize of £1.

How to recognise the Secret Agent

The *LOOK-IN* Secret Agent will wear a small badge, like the one shown enlarged on the bottom corner of the picture below. Once a successful challenge has been made, the badge will be removed.

Where the Secret Agents will appear

The *LOOK-IN* Secret Agents will appear at the resorts listed below on the days indicated. A.M. timing is between 11 a.m. to 12 noon. P.M. timing is between 3 p.m. and 4 p.m.

Kent/Sussex

MARGATE	Mon. a.m.	Wed. p.m.	Promenade, near Lido top entrance
BRIGHTON	Tues. a.m.	Fri. p.m.	Between West and Palace Piers.
FOLKESTONE	Wed. a.m.		Eastcliffe Sands.
HASTINGS	Thurs. a.m.		Seafront, near Fishmarket.
BOGNOR REGIS	Tues. p.m.	Fri. a.m.	Central Prom., between Rex Ballroom and Pier.
RAMSGATE	Mon. p.m.		East Foreshore, nr. Bathing Station.
EASTBOURNE	Thurs. p.m.		Promenade, near Bandstand.

Dorset/Devon

TORQUAY	Mon. a.m.	Wed. p.m.	Seafront, near Pier.
	Fri. a.m.		
LYME REGIS	Tues. a.m.	Thurs. p.m.	In vicinity of Cobb.
PAIGNTON	Mon. p.m.	Wed. a.m.	In vicinity of Festival Hall.
	Fri. p.m.		
EXMOUTH	Thurs. a.m.		Beach Gardens.
WEYMOUTH	Tues. p.m.		Prom., between Clock and Statue.

North Devon/Somerset/South Wales

ILFRACOMBE	Mon. a.m.	Wed. p.m.	Seafront, Wildesmouth Beach.
PENARTH	Tues. a.m.	Thurs. p.m.	Promenade, near Pier.
WESTON-S-MARE	Wed. a.m.	Fri. p.m.	Marine Lake.
BARRY	Tues. p.m.	Thurs. a.m.	Main Promenade.
MINEHEAD	Mon. p.m.	Fri. a.m.	Seafront, near the Avenue.

Lancashire

BLACKPOOL	Mon. a.m.	Tues. p.m.	Prom., between Central and North Piers.
	Thurs. a.m.	Fri. p.m.	
LYTHAM	Tues. a.m.	Wed. p.m.	Promenade, near Pier.
SOUTHPORT	Wed. a.m.	Thurs. p.m.	Promenade, near Pier.
MORECAMBE	Mon. p.m.	Fri. a.m.	Central Promenade.

Yorkshire

REDCAR	Mon. a.m.	Fri. p.m.	Prom. Between Beach Centre and Pier.
SCARBOROUGH	Tues. a.m.	Wed. p.m.	Northstead Manor Gdns.
BRIDLINGTON	Wed. a.m.	Thurs. p.m.	North Foreshore.
FILEY	Tues. p.m.	Thurs. a.m.	Central Foreshore.
WHITBY	Mon. p.m.	Fri. a.m.	Near Gardens and Boating Lake.

East Anglia

GREAT YARMOUTH	Mon. a.m.	Fri. p.m.	Between Marina and Wellington Pier
CLACTON	Tues. a.m.	Wed. p.m.	Central Seafront.
SOUTHEND	Tues. p.m.	Wed. a.m.	Central Foreshore.
	Thurs. p.m.		
WALTON ON NAZE	Thurs. a.m.		Central Beach area.
LOWESTOFT	Mon. p.m.	Fri. a.m.	Esplanade.

REMEMBER, YOU MUST HAVE A CURRENT ISSUE OF *LOOK-IN* WHEN MAKING THE CHALLENGE.



For readers in Northern Ireland

The *LOOK-IN* Secret Agent will be visiting coastal resorts in Northern Ireland during August. Here, readers carrying current issue of *LOOK-IN* will be challenged and asked a simple question. If you can answer the question correctly you will be given some increased spending money for your holiday. So in Northern Ireland, too, make sure you have your copy of *LOOK-IN* with you.

5 Raleigh 'Chopper' cycles to be won plus 100 pairs of Jacoskates for runners-up!



The famous 'Chopper' has a 15½ inch frame which suits boys and girls from 8-14 years. Sturmey Archer 3-speed gears are fitted with stickshift control and speed indicator panel. Many other fabulous features are included in the 'Chopper' which retails at £34.95.

Jaco Rollerskates are sturdily constructed for long life, are rust-resistant and are adjustable for size. With lace-up fronts, they have double ball-bearing wheels with rubber tyres and self-guiding shock absorbers. The recommended retail price for Jacoskates is approximately £3.25 according to size.

1 Here are two famous football trophies. Can you name them?

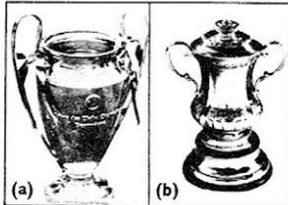

2 In which popular television series does this boy actor (centre) appear?



3 For which League club is well-known personality Jimmy Hill playing in this picture?



4 A world famous tower—what is it called?

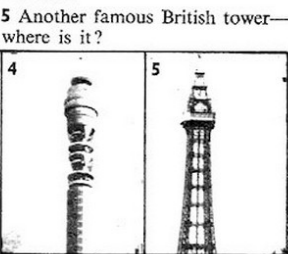

5 Another famous British tower—where is it?

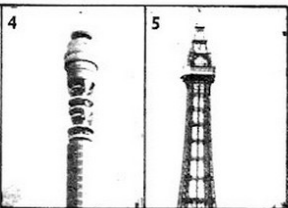

6 Here is Stonehenge—in which county is it?



7 What is the name of this famous ship moored at Victoria Embankment?



8 Which TV singer owns this dog?



9 This is Britain's large radio telescope. What is it called?

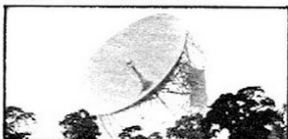

10 This is a close-up of an everyday object, magnified many times. What is it? (Clue: you'll find it close to the road).



HOW TO ENTER

On the left is a simple general knowledge quiz. All you have to do is answer the ten questions correctly, entering the answers in the coupon provided. Then, in as few words as possible, complete the sentence: 'I like LOOK-IN because.....'

Fill in the rest of the coupon by adding your name, address, age and shoe size and post your entry to the address shown, to arrive not later than Friday, August 20, 1971.

RULES: All entries will be examined and 5 Raleigh 'Chopper' Cycles will be awarded to the 5 best correct entries, and 100 pairs of Jacoskates will be awarded to the next best 100 entries. Neatness, age and ingenuity of sentence completion will be taken into account. The competition is open to all readers in the UK other than relatives or agents of employees of Independent Television Publications Ltd., Raleigh Industries Ltd., and Jacoskates Ltd.

Winners will be notified by post by September 11, 1971. A list of prize-winners will be available after September 11, 1971, on receipt of a stamped addressed envelope.

Send your entry to LOOK-IN Quiz Competition, P.O. Box 40 Kettering, Northants.

1a b 6
 2 7
 3 8
 4 9
 5 10

Name

Address

Age Shoe size

I like LOOK-IN because

Closing date, Friday, August 20, 1971

Dave's blunder gives away a penalty!

The Super-Save!

Part Three of this exciting football story, selected by ex-soccer star and TV sports personality, Jimmy Hill.



Soccer-mad Sally Grant discovers that Dave Bryant, the Carford City goalkeeper, has lost his confidence, following a minor injury. Knowing that Carford must beat Kingsbury Rovers in their last match, to gain promotion, Sally searches through her collection of football facts and figures, for something that might help Dave...

Dave's biggest danger will be Bert Lunnon, the Kingsbury striker. I'm sure I made a note about Lunnon having a... weakness!

Inside the ground, Dave Bryant's younger brother, Archie, and his 'East Mound' gang, are already in position...

Clear off, Goldilocks! You know the rules - no dozy girls allowed on the East Mound!

Keep your rotten old mound! Anyway, I can't help Dave from up here!

Sally is behind the Carford goal as city take the field...

Gosh! Dave looks even more on edge! If only I could remember that fact about Bert Lunnon!

Only desperate covering saves Carford from disaster...

An early Kingsbury attack - and the big, bustling striker races for a loose ball...

Lunnon means to hustle the goalie into making a mistake!

Don't worry! He won't bother our Dave!

But Dave Bryant's shattered nerves are his worst enemy...

Good grief! Young Bryant flinched away! He... he's lost the ball!

U-U-UUF!

What's the matter with our Dave? He's usually as safe as houses...

Then, as Archie's unhappy brother makes another ghastly blunder...

Penalty! Sam Bailey's pushed it off the line. It was the only way he could stop Kingsbury from scoring.



A HUSH FALLS OVER THE STADIUM AS BERT LUNNON STRIDES UP TO TAKE THE VITAL SPOT-KICK...

THE WAY BRYANT'S PLAYING, IT'S BOUND TO BE A GOAL!

... AND THAT MEANS THE END OF OUR PROMOTION HOPES!



THEN, SUDDENLY...

THAT'S IT—THE VERY THING I'VE BEEN TRYING TO REMEMBER! OH, I MUST TELL DAVE...



S-SALLY!

DAVE, LISTEN! IT MAY BE YOUR ONLY CHANCE OF SAVING THE PENALTY...

HO! GET THAT CRAZY KID OFF THE PITCH!



SALLY MANAGES TO GASP A FEW WORDS TO DAVE, BEFORE SHE IS BUNDLED OFF BEHIND THE BARRIER...

PEEP!

HERE IT COMES! YOUNG BRYANT WON'T EVEN SEE IT!



IN A BLUR OF LEATHER, THE BALL ROCKETS FROM LUNNON'S BOOT— BUT DAVE IS ALREADY JACKKNIFING SIDWAYS...

MY STARS! HE... HE'S DONE IT! DAVE GOT TO IT!

SAAAVED!

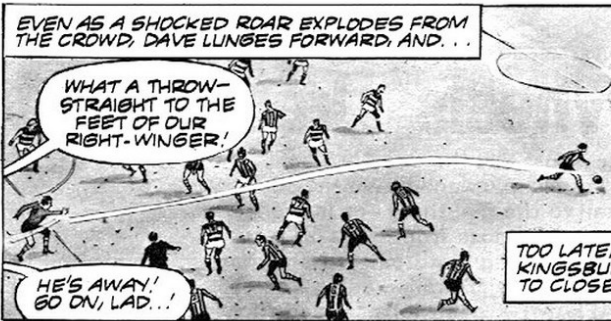

EVEN AS A SHOCKED ROAR EXPLODES FROM THE CROWD, DAVE LUNGES FORWARD, AND...

WHAT A THROW-STRAIGHT TO THE FEET OF OUR RIGHT-WINGER!

HE'S AWAY! GO ON, LAD...



IT'S IN— IT'S A GOAAAL!

THEY'LL NEVER CATCH US NOW! THAT MUST BE THE WINNER!

TOO LATE, THE STARTLED KINGSBURY DEFENCE TRIES TO CLOSE ITS RANKS...



ANOTHER GOAL FOR CARFORD, AND, AS FANS MOB DAVE AFTER THE GAME...

WE'RE IN THE 1ST DIVISION, DAVE— THANKS TO THAT SMASHING SAVE OF YOURS!

DON'T THANK ME, ARCHIE— THANK SALLY GRANT!



SHE REMEMBERED THAT WHEN BERT LUNNON WIPES HIS RIGHT BOOT ON HIS SOCK— AS HE DID BEFORE THE PENALTY— HE ALWAYS SHOOTS WITH HIS LEFT FOOT! SHE MANAGED TO TIP ME OFF, AND I WAS READY FOR IT!



SO WHAT D'YOU SAY, ARCHIE? I RECKON ANYONE WHO KNOWS AS MUCH ABOUT FOOTBALL AS THAT, DESERVES V.I.P. TREATMENT!

ER... W-WELCOME TO THE EAST MOUND, SALLY!

THANKS, ARCHIE BRYANT! I'LL... ER... THINK ABOUT IT!

Another super new star strip, next week!

Hey kids! win a free Hot Wheels™ AMX Drag racer!



Just like the real one in the Hot Wheels™ Drag Team!

The Hot Wheels AMX Drag racer is just like the one Shootin' Ed Shaver drives for the Hot Wheels Drag Team up and down the country.

Your AMX car is exact in every detail to the real thing—as is every Hot Wheels car. And there are over 50 to choose from! And *only* on Hot Wheels cars will you find these outstanding features: *Torsion bar suspension *Low friction wheel bearings *Detailed engines *Opening bonnets *Custom SPECTRAFLAME® paint jobs *Speed slicks with racing stripes *Mag wheels *Special heavy track-hugging body. You name it, the Hot Wheel cars have it . . . and *only* the Hot Wheels cars.

To make sure you get your FREE Hot Wheels AMX racing car, you have to enter the exciting competition on the next page.

Remember, you *cannot* buy this AMX car in the shops. So enter now and you could be one of the lucky winners!

And when it comes to racing track, it's *only* the Hot Wheels track that comes in orange 2' lengths. *You buy more and build as and when you want it. *It's the real true to life track that gives you the real race atmosphere *You can use Hot Wheels track indoors *or* outdoors. In a small space or a wide open space.

*And what a range of accessories:— dare-devil loops, jump-ramps, stunt loops, dual-lane curves, flyovers and many others . . . the combinations are endless. *Hot Wheels give you a larger range of these accessories than the imitators.

Go with Hot Wheels—the original and best.



Hot Wheels – the fastest set of treads on the track.

Here's all you have to do...

Just identify the 15 Hot Wheel cars below giving them their correct name. It's as simple as that. Look for this exciting new Hot Wheels pit-stop display in your local toyshop. There you'll find all 50 of the fabulous Hot Wheels cars on display. These 15 are among them.

After identifying the 15, complete the line below and cut out the page. Send it along with two Hot Wheels Collectors buttons—which come free with every Hot Wheels car—to the following address:
Mattel "Hot Wheels" Competition, PO Box No. 9, Faversham, Kent.

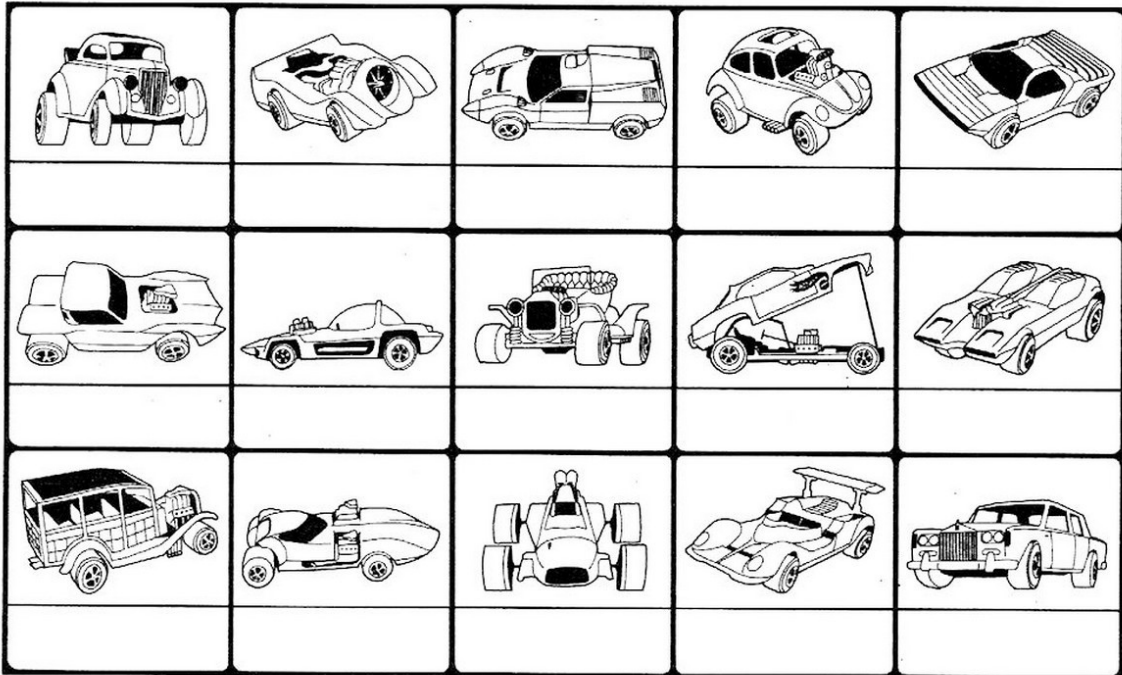
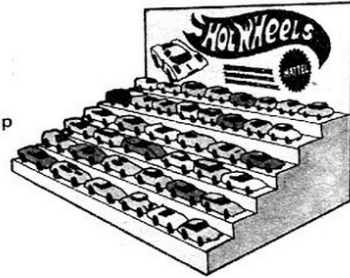

1 The Competition is open to all children resident in the United Kingdom, except to the families of the employees of Mattel Limited and their Advertising Agencies or anyone else connected with the running of the Competition.

2 All entries must be on official Entry Forms, in ink or ball point pen, and received at the official Competition Address by the Closing Date of 30th October, 1971.

3 The prizes will be awarded to those Competitors who have correctly identified the

most Hot Wheels Cars. In the event that there are more best entries than prizes available the Panel of Judges will award the prizes to those qualifying Competitors who have submitted the most appropriate Advertising Slogans.

4 All valid entries will be examined by the Panel of Judges—which will comprise the Advertisement Manager of the I.P.C. Juvenile Group a director of an Advertising Agency and the Sales Promotion Manager of Mattel—and they will award the prizes in accordance with Rule 3.

5 No responsibility can be accepted for entries which arrive late and proof of Posting cannot be accepted as proof of arrival. All altered, damaged and illegible entries will be disqualified.

6 Only one prize may be awarded per household.

7 Winners will be notified by post, in due course, and a copy of the Prize Winners List will be sent to anyone enclosing a stamped addressed envelope with their entry.

8 All other directions contained elsewhere in this Advertisement are to be considered part of the Competition Rules.

Complete the following advertising slogan in at least 8 or more words: "I think Hot Wheels are great because:-"

NAME _____

ADDRESS _____



So hurry! And you could soon have one of the 2000 Exclusive Hot Wheels Drag Racers. Absolutely FREE!

The start of a brand new picture story comedy ...

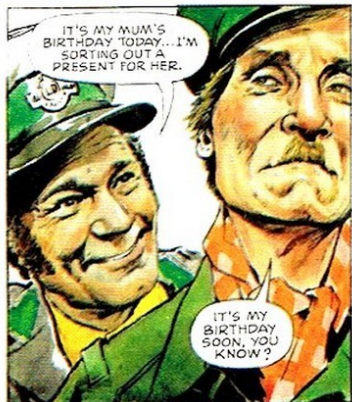

AS STAN DRIVES THE BUS FROM THE GARAGE, THREE FURTIVE MEN WATCH FROM A PARKED CAR...



GIFT WRAPPED, THE PRESENT IS CARRIED LOVINGLY FROM THE STORE...



Next Week: The search begins!

Once again, Buntly James, Jack Hargreaves, Jon Miller and Fred Dinenage, are all set to answer your questions. Congratulations to this week's winners. If you haven't already written in why not do so now? You can win a £1 Hamlyn book of your choice for any question you have published. Send your entry to: How! LOOK-IN, 247, Tottenham Court Road, London, W1P 0AU.

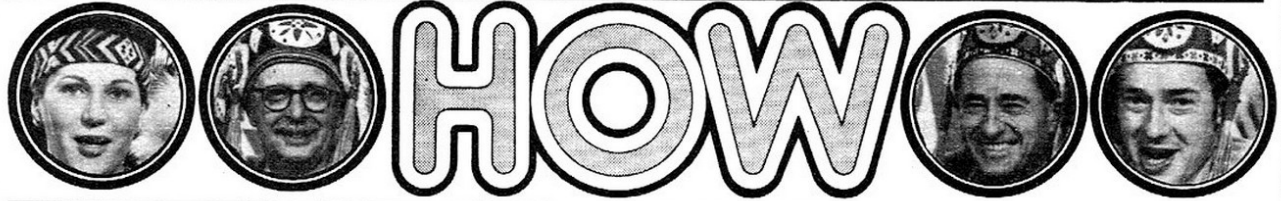

HOW does a camera work?
Wendy Lucking, Sunningdale, Berks.

A camera, big or small, expensive or cheap, is a darkened box with a glass lens at one end of it. At the other end is the place where the film, with its specially-treated surface facing the lens, is held. As light must not reach the surface except at the right moment, the lens is covered with a shutter.

When the camera operator presses the knob or lever, the shutter is opened for a split second by the shutter release, and light passes through the lens and sends an impression of the view or person photographed to the sensitive surface of the film. The light has an effect on the chemicals in the film, though these changes are only seen when the film is soaked in a chemical solution called a developer. The negative which is developed is used to make a print on special paper.

As to the all-important lens, this can be a very simple, small, crescent-shaped piece of glass, or a compound lens made of

several skilfully made lens parts. These let more light through so that pictures can be taken in bad light. The size of the lens can be altered by overlapping blades called an iris diaphragm, controlled by moving a lever. This is a feature of more expensive cameras.

Shutter speeds can be varied, too, altering 'exposure' time. The speeds may range between a second and a five-hundredth of a second. Most modern cameras contain a switch that allows the user to fire a flash bulb as the shutter opens for taking pictures in the dark. Cine cameras take many still pictures in swift succession. Run together, the pictures appear continuous.

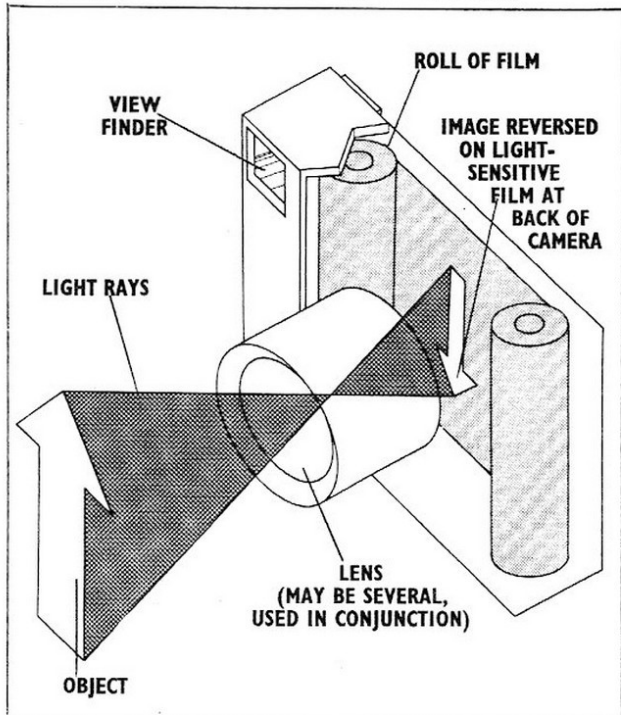

HOW was the first fire brigade started?
Kay Cullingford, Gilesgate, Durham.

No one knows for certain, but volunteer fire-fighting forces were going strong in Ancient Egypt and, possibly, even earlier. The trouble was to get enough water to the right spot. Probably, the first fire brigades used buckets and, as the men had no special clothes, could not get near the flames. A line of men passing buckets forward was a traditional way of coping, for many years.

Modern fire-fighting dates from after the appalling Great Fire of London of 1666. After it, laws were passed about how houses should be built, fire insurance schemes were started, and the first simple fire-engines appeared. In 1672, a hand-pumped fire-engine with a leather hose capable of spraying a jet of water at the flames was invented in Holland. It was quite an efficient appliance.



An engraving showing the first fire-engine, used in Holland about 1660.

HOW long ago was the Ice Age?
Kay Blackman, Chatham Kent.

Ice Ages would be nearer the mark, Kay, for there have been more than one. But the Ice Age started about a million years ago and ended around 8,000 B.C. No one knows why it happened. The great ice sheets reached as far south as the Thames, northern Germany and the northern United States.

The sheets were sometimes as much as two miles thick! Finally the ice retreated, only stopping when it reached such bleak spots as Antarctica and Greenland. Chillingly, there may be another Ice Age to torment our descendants.

HOW did the death watch beetle get its peculiar name?
Jane Williams, Clifton, Notts.

This beetle with the sinister name was so-called because of a tapping sound it makes. Superstitious folk used to believe that the sound was a warning of sudden death. Some people apparently still believe this. Actually, the tapping is a mating call the beetle makes by banging its head on wood.









The grubs of the death watch beetle love oak beams and do much damage to old buildings, like churches. Give these beetles rotten beams and they are very happy!





© 1971 Southern Television Ltd. Based on the Southern Television series.

[All details correct at time of going to press.]

FOR COMPLETE DETAILS OF ALL ITV PROGRAMMES SEE TVTIMES

Lookin on your ITV programmes this week: Aug 7-13

	Saturday	Sunday	Monday	Tuesday	Wednesday	Thursday	Friday
ANGLIA 	12.50 World of Sport 5.10 U.F.O. 7.15 Des O'Connor Show	2.15 Sunday Film 4.40 The Golden Shot 5.35 Jamie 6.30 The Lost Centuries 7.25 Doctor At Large	4.30 The Romper Room 4.55 Flipper 5.15 Follyfoot 6.40 Opportunity Knocks!	4.35 Paulus Room 4.50 Sooty 5.15 Ace of Wands 7.00 Survival Film	4.25 The Romper Room 4.50 Sooty 5.15 Ace of Wands 7.30 The Thursday Film	4.35 Mel-O-Toons 4.50 Captain Scarlet 5.15 How 7.00 Survival Film	4.25 The Romper Room 4.45 Voyage To The Bottom Of The Sea 7.00 The Sky's The Limit
MIDLANDS 	12.15 Joe 90 12.50 World of Sport 5.10 Lost in Space 6.45 Feature Film	2.15 Star Soccer 4.40 The Golden Shot 5.35 Jamie 6.30 The Lost Centuries 7.25 Doctor At Large	4.40 Origami 4.55 Bush Boy 5.15 Follyfoot 6.40 Opportunity Knocks!	4.35 Paulus 4.50 Sooty 5.15 Ace of Wands 8.00 The Saint	4.35 Enchanted House 4.50 Skippy 5.15 How 7.00 Thursday Movie	4.35 Enchanted House 4.50 Skippy 5.15 How 7.00 Thursday Movie	4.35 Zingalong 4.50 Thunderbirds 7.00 The Sky's The Limit
BORDER 	11.50 Forest Rangers 12.50 World of Sport 5.10 On the Buses 5.40 The Smith Family 6.15 Feature Film 8.00 Des O'Connor Show	3.15 Joe 90 4.45 The Golden Shot 5.35 Jamie 6.30 The Lost Centuries 7.25 Doctor At Large	4.40 Origami 4.55 Skippy 5.15 Follyfoot 6.15 Survival 6.45 Opportunity Knocks!	4.40 Paulus 4.55 Sooty 5.15 Ace of Wands 7.00 Feature Film	4.35 Stories of Tuktu 4.55 Rainbow Country 5.15 How 7.00 Feature Film	4.40 Zingalong 4.55 Cowboy In Africa 7.00 The Sky's The Limit	4.40 Zingalong 4.55 Cowboy In Africa 7.00 The Sky's The Limit
CHANNEL 	12.50 World of Sport 5.15 Man from U.N.C.L.E. 6.15 On the Buses 6.47 Saturday Film	2.15 Star Soccer 3.10 Feature Film 4.45 Golden Shot 5.35 Jamie 6.30 Lost Centuries 7.25 Doctor At Large	4.10 Puffin 4.50 Woobinda 5.15 Follyfoot 6.15 Flintstones 6.45 Opportunity Knocks!	3.56 Pingwings 4.05 Puffin 4.50 Sooty 5.15 Ace of Wands 7.00 Star Movie	3.56 Origami 4.05 Puffin 4.15 Survival 4.45 Joe 90 5.15 How 7.05 Thursday Film	3.56 Zingalong 4.05 Puffin 4.20 Gilligan's Island 4.50 Land of the Giants 8.00 Department S	3.56 Zingalong 4.05 Puffin 4.20 Gilligan's Island 4.50 Land of the Giants 8.00 Department S
GRAMPIAN 	12.30 Twizzle 12.50 World of Sport 5.15 U.F.O. 6.15 Whittaker's 7.00 Saturday Film	2.50 Sunday Matinee 4.40 The Golden Shot 5.35 Jamie 6.30 The Lost Centuries 7.25 Doctor At Large	4.25 Origami 4.40 Yak 4.55 Cowboy In Africa 6.40 Opportunity Knocks!	4.50 Sooty 5.15 Ace of Wands 6.10 Silver City Folk 7.00 Thursday Film	4.45 Rumble Jumble 5.15 How 6.10 Top Team 7.00 Thursday Film	4.45 Huck Finn 5.15 Follyfoot 6.05 The Smith Family 7.00 Sky's The Limit 8.00 The Avengers	4.45 Huck Finn 5.15 Follyfoot 6.05 The Smith Family 7.00 Sky's The Limit 8.00 The Avengers
GRANADA 	12.20 Spiderman 12.50 World of Sport 5.10 U.F.O. 6.15 Bugs Bunny 6.30 Sky's the Limit 7.30 Des O'Connor	2.55 The Great Stars 4.40 The Golden Shot 5.35 Jamie 6.30 The Lost Centuries 7.25 Doctor At Large	4.45 Once Upon a Time 4.55 Rocket Robin Hood 5.15 Follyfoot 6.15 Beverly Hillsbillies 6.40 Opportunity Knocks!	4.35 Zingalong 4.50 Sooty 5.15 Ace of Wands 6.30 Randall & Hopkirk	4.35 Origami 4.45 Woobinda 5.15 How 6.25 Carry On Laughing	4.35 Thunderbirds 6.25 Albert & Victoria 6.55 The Saint	4.35 Thunderbirds 6.25 Albert & Victoria 6.55 The Saint
WALES/WEST 	12.10 Bush Boy 12.50 World of Sport 5.10 Flintstones 6.15 Saturday Cinema	2.15 Star Soccer 3.15 Sunday Matinee 4.45 The Golden Shot 5.35 Jamie 6.30 Lost Centuries 7.25 Doctor At Large	4.55 Sky Hawks 5.19 Follyfoot 6.45 Opportunity Knocks!	4.40 Tinkertainment 4.55 Sooty 5.20 Ace of Wands 8.00 The Champions	4.40 Tinkertainment 4.50 Pippi 5.20 How 7.30 Mid-Week Movie	5.06 Zingalong 5.19 Robin Hood 7.00 Sky's the Limit 7.30 Friday Film	5.06 Zingalong 5.19 Robin Hood 7.00 Sky's the Limit 7.30 Friday Film
LONDON 	11.50 Thunderbirds 12.50 World of Sport 5.10 Catwazele 6.45 Des O'Connor Show	2.15 Forest Rangers 3.45 Strange Report 4.45 Golden Shot 5.35 Jamie 6.30 Lost Centuries 7.25 Doctor At Large	4.40 Yak 4.55 Lost in Space 6.40 Opportunity Knocks!	3.40 Paulus 4.55 Sooty 5.20 Ace of Wands 7.00 The Smith Family	3.40 Origami 4.55 Woobinda 5.20 How 6.55 It's Tarbuck 7.30 Thursday Film	3.45 Zingalong 4.25 Skippy 4.55 Secret Squirrel 5.20 Follyfoot 7.00 On the Buses 7.30 Sky's the Limit	3.45 Zingalong 4.25 Skippy 4.55 Secret Squirrel 5.20 Follyfoot 7.00 On the Buses 7.30 Sky's the Limit
SCOTTISH 	12.15 Phoenix Five 12.50 World of Sport 5.15 Cowboy In Africa 6.15 Smith Family 6.45 Saturday Movie 8.30 Des O'Connor	2.20 The Lost Centuries 2.45 Big Match 4.40 The Golden Shot 5.35 Jamie 7.25 Doctor At Large	4.55 Holiday Cavalcade 5.15 Follyfoot 6.15 Flintstones 6.40 Opportunity Knocks!	4.10 The Enchanted House 4.50 Holiday Cavalcade 5.15 Ace of Wands 6.15 Popeye	4.10 Paulus 4.50 Sky Hawks 5.15 How 7.05 Thursday Film	4.10 The Magic Elephant 4.50 Holiday Cavalcade 5.15 Skippy 6.10 Bonanza 7.30 The Saint	4.10 The Magic Elephant 4.50 Holiday Cavalcade 5.15 Skippy 6.10 Bonanza 7.30 The Saint

SOUTHERN	TYNE TEES	ULSTER	WESTWARD	YORKSHIRE
 12.50 World of Sport 5.15 Man from U.N.C.L.E. 6.15 The Golden Shot 7.05 Doctor At Large 8.05 Saturday Film	 12.15 H. R. Pufnstuf 12.50 World of Sport 5.10 Bonanza 6.15 Saturday Comedy 8.00 Das O'Connor Show	 12.15 Woobinda 12.50 World of Sport 5.10 Greatest Show on Earth 6.15 Saturday Picture	 12.50 World of Sport 5.15 Man from U.N.C.L.E. 6.15 On The Buses 6.45 Saturday Film	 12.15 H. R. Pufnstuf 12.50 World of Sport 5.10 Gunsmoke 6.35 Saturday Comedy 8.00 Das O'Connor Show
3.00 Mad Movies 5.35 Jamie 6.35 The Lost Centuries 7.25 On The Buses	4.15 Branded 4.40 The Golden Shot 5.35 Jamie 6.35 The Lost Centuries 7.25 Doctor At Large	3.45 Randall and Hopkirk 4.45 The Golden Shot 5.35 Jamie 6.30 Lost Centuries 7.25 Doctor At Large	2.15 Star Soccer 3.10 Feature Film 4.45 The Golden Shot 5.35 Jamie 6.30 Lost Centuries 7.25 Doctor At Large	3.15 Soccer 4.45 The Golden Shot 5.35 Jamie 6.30 The Lost Centuries 7.25 Doctor At Large
4.20 Mr. Piper 4.25 Best Of Lucy 4.55 Lost In Space 6.45 Opportunity Knocks!	4.40 Paulus 4.55 Skippy 5.20 Follyfoot 6.45 Opportunity Knocks!	4.30 Romper Room 4.55 Lone Ranger 5.20 Follyfoot 6.10 F Troop 6.45 Opportunity Knocks!	4.00 Once Upon A Time 4.10 Gus Honeybun 4.50 Woobinda 5.15 Follyfoot 6.45 Opportunity Knocks!	4.40 Once Upon A Time 4.55 Woobinda 5.20 Follyfoot 6.45 Opportunity Knocks!
4.19 Cartoon 4.50 Sooty 5.15 Ace of Wands 6.30 Survival 7.00 Hogan's Heroes	4.35 The Enchanted House 4.50 Sooty 5.15 Ace of Wands 6.30 Survival	4.25 Romper Room 4.50 Sooty 5.15 Ace of Wands 6.10 Best of Lucy	4.05 Gus Honeybun 4.50 Sooty 5.15 Ace of Wands 7.00 Nanny and the Professor	4.35 The Enchanted House 4.50 Sooty 5.15 Ace of Wands 6.33 Survival
4.19 Mr. Piper 4.50 Lone Ranger 5.15 How 7.35 The Saint 7.30 Friday Film	4.35 Origami 4.50 Forest Rangers 5.15 How 6.30 Nanny and the Professor 7.00 Thursday Film	4.25 Romper Room 4.50 Bush Boy 5.15 How 6.10 Nanny and the Professor 7.30 Thursday Film	3.56 Origami 4.05 Gus Honeybun 4.15 Survival 4.45 Joe 90 5.15 How 7.05 Thursday Film	4.35 Origami 4.50 Bush Boy 5.15 How 6.33 Randall and Hopkirk
4.19 Cartoon 4.50 Charlie Brown 5.15 Follyfoot 7.00 Sky's The Limit 7.30 Friday Film	4.10 Flintstones 4.35 Zingalong 4.50 Land of the Giants 6.30 On the Buses 7.00 Sky's The Limit	4.25 Romper Room 4.50 Land Of The Giants 7.00 The Sky's The Limit 7.30 Laredo	3.56 Zingalong 4.05 Gus Honeybun 4.20 Gilligan's Island 4.50 Land of the Giants 8.00 Department 5	4.35 Zingalong 4.50 Land Of The Giants 7.00 Sky's The Limit



Here is a very clever trick which will make everyone think that you have hidden eyes.

Hot Money

Show five 10p pieces on a metal tray. You have already selected one and marked it with a pen-knife or nail-file. The marked coin is handed round so that several specta-

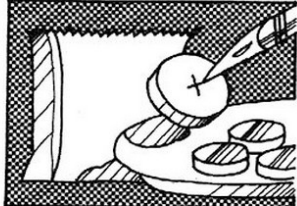

tors can examine it for themselves—then it is dropped into a paper bag, together with the other coins. After a quick shake to mix the coins, you put the bag behind your back, reach inside, and bring out a coin—THE MARKED ONE!

How could you possibly find the right coin without looking? Simply because it will be a little warmer than the others—having been handled by the audience—while the rest stay cool on the metal tray.

Contrary Candle

If you asked a friend to blow a candle gently to make the flame point towards himself—he would say it was impossible

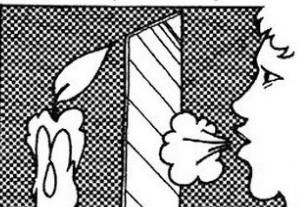

—the flame will always point in the direction you blow.

But if you hold a piece of cardboard, about three inches square, between you and the flame, and blow at that, the flame will flutter—towards you—surprising isn't it?

(Make sure you are very careful not to burn yourself.)

Matchbox Skyscraper

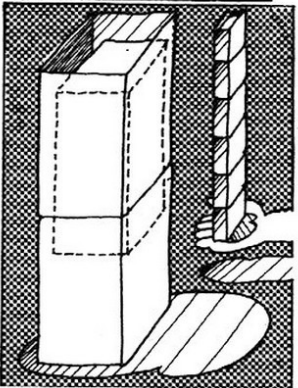

To balance one empty matchbox on the end of another is easy—three or four is a little more difficult—but if you know the secret you can balance a dozen without fear of them toppling.

All you have to do is remove the drawer from the first matchbox. Now put the next box on top, and secretly push its drawer down a little way into the first, as shown by the dotted lines in the illustration. This is repeated as many times as you wish.

GEASER TIME

Did you solve last week's conundrum—what would go up a pipe down but not down a pipe up... and so on? Well, to put you out of your misery the answer is—AN UMBRELLA.

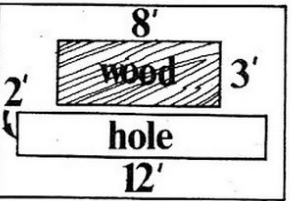

This week's teaser (above), is about a carpenter who has to fill a gap in the floorboards which is two feet wide by twelve feet long. But the only piece of wood he has is three feet by eight feet. How can he cut the wood into TWO pieces, which can be arranged to fill the hole exactly? Answer next week.

By arrangement with David Nixon. Based on the Thames TV programme. (Illustrations by David Jeffers)

Look-in

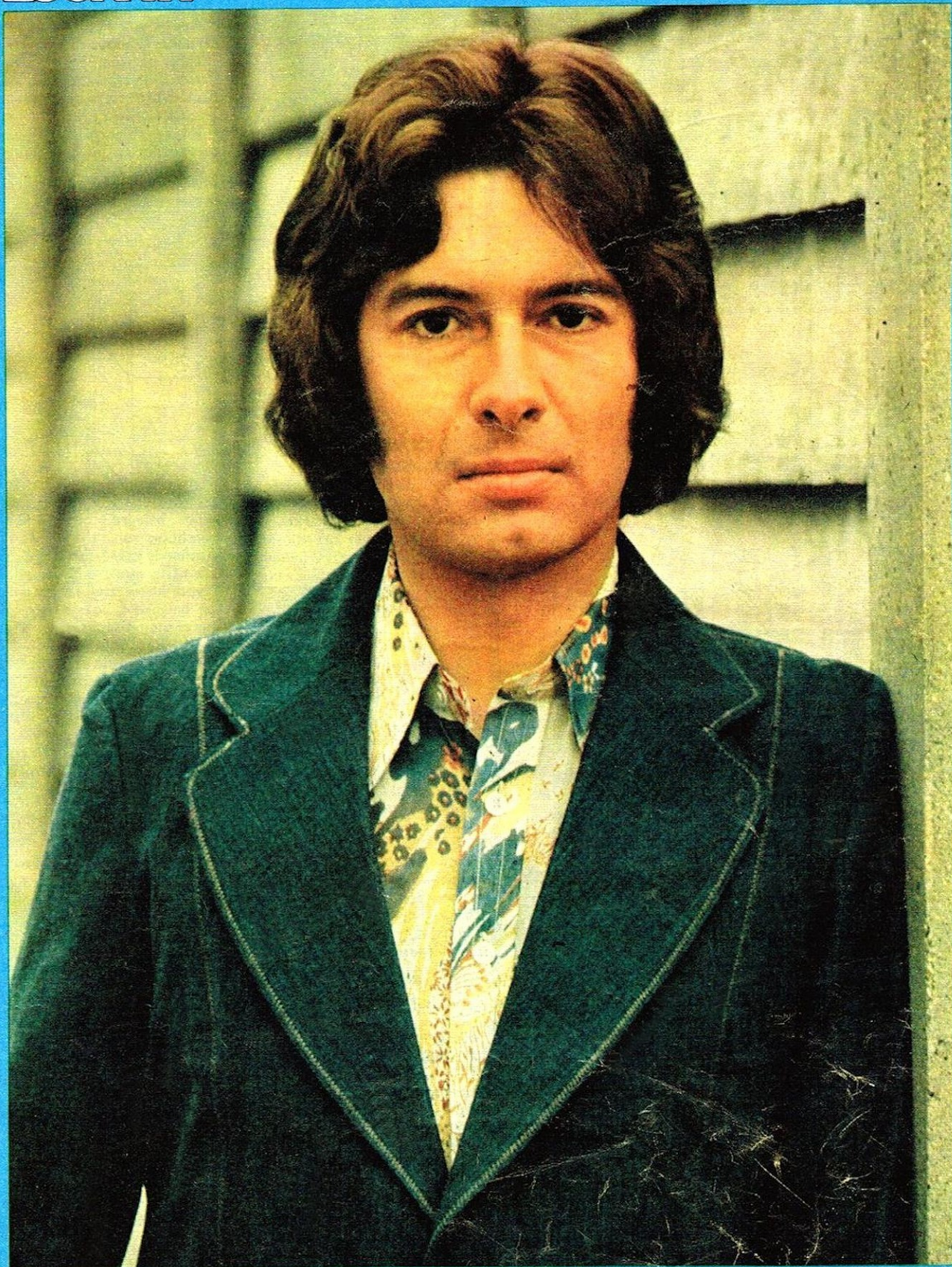

MICHAEL MACKENZIE

More excitement with the farmyard friends...

Follyfoot

FRAMED BY THE WILY HMMKONDS OF PINKEST HOTEL, STEVE IS AWAITING CHARGES FOR STEALING TANGO, A MARE IN FOAL. EVERYONE AT FOLLYFOOT KNOWS HE IS INNOCENT, HAVING FOUND TANGO ABANDONED AT THE FARM GATE... AND DORA DISCOVERS THAT HER OWNER IS EX-CIRCUS HAND TED CHARLTON. WITH STEVE AND THE COLONEL, SHE GOES TO CHARLTON'S COTTAGE... ONLY TO FIND...

OH, NO! IT'S BEING DEMOLISHED TO MAKE ROOM FOR A MOTORWAY!

THERE'S NO CHANCE OF HELPING STEVE IF TED CHARLTON CAN'T BE FOUND...

YOU SAY YOU'VE SEEN HIM FROM TIME TO TIME, HANGING ABOUT NEAR FOLLYFOOT, DORA...?

EXCUSE ME! DO YOU KNOW WHERE THE MAN WHO LIVED HERE HAS MOVED?

BUT HE ALWAYS RUNS FOR IT. ANYWAY, WE CAN'T JUST ASSUME HE'LL TURN UP AGAIN-- WE'VE GOT TO FIND HIM BEFORE I GO UP IN FRONT OF THE MAGISTRATES!

SEARCH ME! THE PLACE WAS EMPTY WHEN I ARRIVED!

GOT A MESSAGE FOR YOU, LAD. YOUR CASE COMES UP SATURDAY MORNING-- BE AT THE COURT SHARP AT TEN!

BACK AT FOLLYFOOT, THEY MAKE THE MISTAKE OF DISCUSSING THE SITUATION WITHIN EARSHOT OF RON STRYKER...

AND RON PASSES EVERYTHING ON WHEN HE MEETS HIS PAL LEWIS HAMMOND...

A CIRCUS GROOM, EH? THINK THEY'VE GOT MUCH CHANCE OF FINDING HIM, RON?

DUNNO, DO I? BUT THAT DORA'S PRETTY SMART AT TIMES. I RECKON SHE'LL HAVE A RIGHT OLD GO!

MEANWHILE, STEVE AND DORA ARE OUT ON THEIR HORSES...

COR! ALL RIGHT FOR THEM, PLAYIN' SHERLOCK HOLMES WHILE I DO ALL THE WORK!

YOU WHAT? YOU DON'T KNOW THE MEANIN' OF THE WORD, MATE? YOU GET TIRED SLEEPIN'?

I'D BETTER TELL DAD ABOUT THIS! CAN'T HAVE THINGS GOING WRONG-- NOT NOW!

CAR COMING: DORA! HELLO, IT'S THE POLICE!

TWO DAYS! IT'S HOPELESS!

THERE'S A CALL FOR YOU ON THE LOBBY PHONE DOWNSTAIRS, MR. CHARLTON!

BUT AT THAT MOMENT, IN THE BLOCK OF FLATS WHERE TED CHARLTON LIVES...

OH, AYE? I'LL COME AT ONCE!

THIS IS DAWSON HERE, OF DAWSON AND SWYTHE, SOLICITORS. WE HAVE CERTAIN NEWS THAT MIGHT BE TO YOUR ADVANTAGE, MR. CHARLTON. CAN YOU COME DOWN TO LONDON AND SEE US?

I'M NOT SO SURE! LISTEN-- IF CHARLTON'S COTTAGE WAS BOUGHT FOR A MOTORWAY, HE'D HAVE BEEN RE-HOUSED, RIGHT?

COME ON! BACK TO FOLLYFOOT! WE'RE GOING TO PHONE THE COUNCIL AND SEE IF WE CAN FIND HIS NEW ADDRESS!

EE, WELL, I DON'T KNOW... IS IT MONEY...?

TED CHARLTON AGREES, AND THE CALLER GIVES HIM AN ADDRESS IN MAYFAIR-- A FALSE ADDRESS...

WE-- AH-- MIGHT SAY THAT! WE'LL REFUND ALL YOUR EXPENSES, NATURALLY!

LOOK FORWARD TO SEEING YOU, MR. CHARLTON, TOMORROW AFTERNOON? GOOD BYE FOR NOW!

THERE, I DON'T THINK WE'VE ANYTHING TO WORRY ABOUT WITH CHARLTON SAFELY OUT OF FOLLYFOOT'S REACH!

SHREWD, DAD! REAL SHREWD!

BUT WHEN DORA MAKES HER CALL TO THE COUNCIL...

TAKE ME INTO TOWN, UNCLE! AND HURRY! I THINK TED CHARLTON'S ALREADY BEEN GOT AT!

YES, THANK YOU, I'VE GOT THE ADDRESS, BUT-- BUT YOU SAY SOMEONE ELSE HAS ASKED FOR IT? JUST AN HOUR AGO...? I SEE!

14 Based on the Yorkshire Television series Follyfoot © 1971 Yorkshire Television Ltd. (The original story of Follyfoot, by Monica Dickens, is published by Heinemann at £1.25 and 9P in at 20p.)

Will Dora catch Charlton in time? See next week! 15