

# Look-in

Junior TVTimes No 1 week ending 1 January 1972 Every Thursday 5p

## Your future by the stars!

A Look-in on 1972 featuring horoscopes for all readers!



**Ed Stewart—  
Taurus the bull, see page 3**





# Crowther in trouble

Leslie lends a hand—and puts his foot in it!



By arrangement with Leslie Crowther.



Maurice Woodruff and some of your favourite television personalities present...

# Look-in's look at '72!

Talking to Ed Stewart, LOOK-IN found that he was born under Taurus the Bull. Each star sign has its own lucky colours and numbers and as 1972 dawns, thoughts turn to predictions, horoscopes and resolutions.

To help you look-in on your future, we asked foremost clairvoyant Maurice Woodruff (pictured right) to compile some special horoscopes for all LOOK-IN readers.

Maurice also gave us some predictions about famous people and major interests for the coming year. To add to the fun, LOOK-IN invited twelve top TV personalities to say what they think about the new year.



## Capricorn ♄

Dec. 21-Jan. 19

You have a year ahead of you in which you must concentrate on your own individual efforts—because there are times when you are too concerned with the affairs of others. A friend who has a strong personality should prove to be of tremendous help to you. A hobby either at home or in the sporting field will be one of the highlights of your year. You strong-thinking Capricornians should make a lot of headway.

Lucky colours: Black, Brown and sometimes Red.

Lucky numbers: 5, 7 and 19.



**DAVID NIXON** ★ I can guarantee that next year there'll be a lot of weather! Personally I never read horoscopes and I never make resolutions these days, though I'm sure I did when I was younger.

## Aquarius ♒

Jan. 20-Feb. 18

The first part of your year may not be particularly exciting for you and will hold its ups and downs. But from April onward you should find yourselves here, there and everywhere. A test or examination which you will take during the year should come out well—as long as you have concentrated in advance and not allowed it to worry you. Older folk around you may be thinking of making moves which could effect you—but only for the better. You will also make a very firm and long-lasting friendship which brings you great happiness.

Lucky colours: Black or Blue.

Lucky numbers: 9, 10 and 21.



**LESLIE CROWTHER** ★ I like to think I'm not superstitious but I am really. My prediction for the New Year is that everything is going to cost more. I've decided I'll try not to worry this year.

## Pisces ♷

Feb. 19-Mar. 20

You will start your year off making resolutions but we all know what happens to most of those resolutions. You have got a very full year ahead which could involve the study of a fresh subject plus some travelling. A person around you who you have not thought to be quite 'with-it' should, by mid-year, prove you wrong. He or she will be an excellent chum. You will have to curb your Pisces stubbornness and compromise at times throughout the coming twelve months.

Lucky colours: Blue, Mauve or Purple.

Lucky numbers: 2 and 7.



**TOMMY COOPER** ★ By the early Spring of 1972 I believe that women will be wearing sequined blouses highlighted by open-toed football boots. Speaking as a fatty, I resolve to stick to a rigorous diet.

## Aries ♈

Mar. 21 to Apr. 20

All of you Arians have a much more settled year ahead of you—Saturn has been in your sign until recently making things not go quite as well as they should have done. But as it has now left your sign, most things should improve. Two characteristics you must try to curb during 1972—firstly, your impulsiveness and secondly, your temper. Although you are pioneers, this does not mean that you must dominate. Those of you who like to organise outings and events or be somewhere in the forefront will get the best from your year.

Lucky colours: Pillar-box Red, Royal Blue.

Lucky numbers: 3, 7 and 9.



**BOBBY BENNETT** ★ I predict that Glyn Poole will grow another two inches this coming year, and that Leeds United will win the F.A. Cup!



## Taurus

April 21-May 20

There will be opportunities for you to shine in your own particular field this year—and you should receive encouragement not only from those around you but from older folk as well. Where your everyday life is concerned you should take advantage of the fact that one particular person appears to think highly of your abilities and will therefore be of great help to you. You Taurian girls will become more fashion-conscious and may find yourselves doing a spare time chore to make yourself a little extra cash.

Lucky colours: Blues in any shade.  
Lucky numbers: 1, 5 and 8.

**ED STEWART** ★ Ed's not superstitious. He says: 'I don't mind walking under a ladder or anything—as long as a bucket of paint doesn't fall on my head'. I read my horoscope but I don't take it seriously. I usually make resolutions—but normally they only last for a few weeks. My prediction for 1972—Everton will win the F.A. Cup.



**Maurice Woodruff predicts for:**

■ **Pop:** We will see the music of the thirties coming right to the fore. Dancing will change and a new jazzy dance step, similar to the Charleston will appear. Two artists come to mind in the singing of new type ballad numbers are Libby Morris and Malcolm Roberts. Another young man who will make a very big impression on this particular scene will be David Essex.

■ **Space:** There will again be talk of orbiting Mars and by the year's end, an attempt will be made to land a craft on the planet. This will not be immediately successful but will bring forward a definite landing time on Mars by several years. A new type of rocket will be tried out successfully.

## Gemini

May 21-June 20

Just as long as you try to start your year in a determined manner, then all should go well for you. Your usual slight mixed up state of mind will disappear—remember you Geminis always have to make your mind up to choose between two things, not one. In other words, 'shall I go this way or that way?' There seems to be little doubt that you should be gaining more confidence in yourself as your year progresses. The fact that you are given a certain amount of responsibility should spur you on and make you optimistic. By the year's end you could well find yourself having made a move and therefore being in new surroundings.

Lucky colours: Yellow, Orange and all shades of Green.

Lucky numbers: 1 and 5.



**ANITA HARRIS** ★ I've got four resolutions for 1972. I will improve my golf. I will polish my Jumbleland Flying Nittybug once a week. I will find a wife for Albert, my Afghan hound. I will take a leaf out of the song and try to 'spread joy up to the maximum'. Horoscopes? I do read them. My prediction for 1972 is that Maurice Woodruff will make several predictions for the new year!

■ **Fashion:** The mini skirt will remain extremely popular but the flared skirt will also come to the forefront. Materials will change and pout, which is very heavy taffeta, will be used for both dresses and skirts. Hair styles will follow the trend of the page boy as opposed to the now layered, feathery look. It will be a pretty year for the girls.

Where the boys are concerned, their hair styles will become shorter. Colour will be of importance to the boys and those pencil slim slacks will return in a more stylised way than before.

## Cancer

June 21-July 21

Some of you could well find yourself changing school or job at the beginning of your year—this of course will bring you in touch with new things and new faces. Generally, Cancer people are sensitive—therefore try your best not to be unduly upset by people's thoughtless remarks. You may not see eye to eye with a relative but I can assure you that they will be thinking only on your behalf and you would do well not to oppose them. With little doubt, you have an interesting year.

Lucky colours: Green or Grey.

Lucky numbers: 2, 3 and 9.

**REG VARNEY** ★ Who doesn't look at their horoscopes? I do, I can't resist them. Resolutions? Two years ago I decided to stop smoking, but it wasn't until I was ill that I managed to give up. This year I've promised myself that I'll do more oil painting. I've done five, landscapes and seascapes, but it's so interesting and relaxing that I swear I'll do more. 1972 will see West Ham at the top of the league and I predict the double for them. See if I'm right!



■ **for George Best**

Born May 22, George is a Gemini, a sign that belongs to people who are usually very intelligent. Within two years, George will be asked to take over as manager of a team and by October of 1972 he will either announce his intention to become engaged or married.



## Leo

July 22-Aug. 21

You have an interesting year and it is absolutely essential that you make a firm resolution to have strength of purpose for your future success. You like to help others and be popular and of course there will be times throughout the year when you will make decisions which might upset friends around you. Health appears to be good, but you should not take any undue risks sportswise. By the year's end you will be surprised at the progress you have made and just how many of your ideas have been taken notice of. On the whole, 1972 will be a year of many achievements for you.

Lucky colours: Yellow or Gold.

Lucky numbers: 5 and 9.



**JIMMY HILL** ★ Reg Varney's got a nerve. I've got a hunch that Manchester City will win. See if I'm right! Once in a while I look at my horoscope. Usually I have a choice between Leo the Lion or Cancer the Crab, depending on who is writing the Zodiac. I resolved to give up sugar last year because my horse was finding me a bit heavy—it's always easier to make and keep a resolution if it's out of consideration for someone. This year I'm going to play more tennis and do more horseriding.

■ **for Jimmy Tarbuck**

(Born Feb. 6). Jimmy was born under the sign of Aquarius and although we can see him laughing and joking he is studious and deep-thinking by nature. 1972, should prove to be one of Jimmy's most outstanding years. He will slightly change his image and make a major film. Jimmy will have his own new television series which will be on a much grander scale than anything he has done to date. He will also change his house and can expect an addition to his family. When Jimmy wants to accomplish something he can be very self-willed and independent.



## Virgo

Aug. 22-Sept. 21

Just as long as you do not expect too much from your year ahead then all appears to go well for you. There will be patches of irritation, but at the same time, there will be great happiness by way of compensation. You can make plans but I cannot promise you that all of these will turn out okay. You may find yourself getting angry with a relative—but they will only be advising you from their own experience.

**Lucky colours:** All shades of Brown or Grey.

**Lucky numbers:** 1, 5 and 8.

**CHERYL BURFIELD** ★ I predict that 1972 will be a good year for me. I predicted that in 1970—and it turned out to be true, so I'll keep my fingers crossed! My resolution is not to get fat, though when I was little I used to resolve not to answer my mum and dad back and to be angelic. Didn't keep them. I read horoscopes all the time. I had my palm read once and it was uncanny how much true information I was given.



### ■ For Jack Wild

(Born Sept. 30). Jack is born under the sign of Libra which makes him a harmonious and happy young man gifted with strong artistic ability. Jack will almost run away with a part he plays in a TV series and he will also be involved with music throughout the coming year.



## Libra

Sept. 22-Oct. 22

Your year starts off very well because you will find that you are thinking more clearly and more decisively. When you take stock half way through the year, you should find that your assessment of others is bang-on and just as long as you have one set purpose you should be in the position to go out after this. In my opinion, 1972 should be one of the strongest years that you have known so far. During the twelve months, a gift voucher should put you in the position of being able to acquire something you have long wanted.

**Lucky colours:** Green, Blue and Brown.

**Lucky numbers:** 7, 12 and 25.

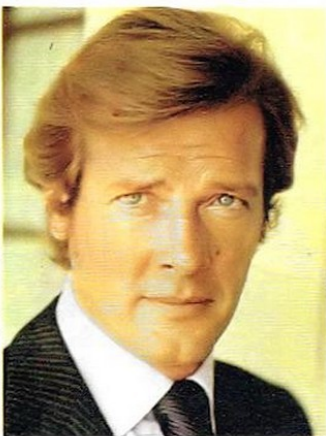

**ROGER MOORE** ★ I only want to read my horoscope if it's good, though I tend to do the opposite. If it says I'm going to win money, I'm sure to lose at cards. My New Year's resolution is this year I shall not make a New Year's resolution. That's the only resolution I can keep. I was born on the 14th July, 1937, so 7 is a lucky number for me. My favourite colour is blue anyway, so I'm glad it's my lucky colour as well.

### ■ For Muhammad Ali

(born Jan. 17) Muhammad Ali is born under the sign of Capricorn which should make him ambitious and idealistic. Like most Capricornians, when he states his point of view he will be extremely profound. During 1972 Muhammad Ali will meet up with irritations but not bad luck. Financially he should do extremely well—he will not get a stab at getting his world title back—but could do so at a later date. Muhammad Ali will be involved in writing and will also appear either on the television screen or the cinema screen in an acting role before the end of the coming year. We shall also see more of him in England. He is a very determined man.



## Scorpio

Oct. 23-Nov. 21

1972, whilst being a very good year, will be a hard working one for you at times. But as compensation for this you should certainly meet a good measure of success. You will be in the position to use your incentive and in this way you could achieve things that you want. Many of you will be taking on a new interest which you will regard as a challenge. There will be some irritations and frustrations, but nothing to really worry you.

**Lucky colours:** Dark Red and Crimson.

**Lucky numbers:** 1, 8 and 12.

**AYSHEA** ★ I'm very superstitious. My grandmother was a medium, and I go regularly to the Belgrave Spiritualist Institute. The trouble is that I read ten different horoscopes and so tend to get rather confused! I've resolved that in the coming year, I won't put off doing anything I should do until tomorrow—I'll do it here and now. I'm positive that the Americans will land on Mars in 1972.



### ■ For Rolf Harris

(Born Mar. 30) Rolf is born under the sign of Aries which is the strongest of them all. During the coming year Rolf will have his finger in more than one pie. He will enter into the writing field and will share a new television series with a lady star. He will travel a lot in 1972.



## Sagittarius

Nov. 22-Dec. 20

It is the more serious-minded Sagittarians who reap the greatest benefits from 1972. One thing you have got to keep in mind and that is tolerance and patience because we cannot expect to get things at once or expect others to think as quickly as most Sagittarians do. There will be a great deal going on around you in your own home and amongst your friends. Those of you whose interests lay either in the music or sporting fields should do extremely well. In the latter part of the year a close friend or relative will suggest an idea which should spark off your interest.

**Lucky colours:** Purple, Lilac, Mauve and Deep Blue.

**Lucky numbers:** 2, 6 and 8.



**SUSAN STRANKS** ★ My life is paved with good intentions, but I resolve to be tidier, to finish the things I start, to write my appointments in my diary and then not lose my diary! I predict that some form of life will be found on Mars and I hope so—then they'll spend more money on the space project. I do believe in horoscopes and I'm sure people fall into their Zodiacal categories—I know I'm very typical of my sign.

### ■ For Carol Hawkins

(born Jan. 31) Carol, who plays Sharon in TV's Fenn Street Gang, is born under the sign of Aquarius which immediately tells me that she is highly intelligent. The year ahead for Carol is interesting in as much as she will do a television play apart from her present series, but it will be a more serious role that she will create. She will also be offered a film part but will have to be very careful to avoid being stereotyped. Carol will also purchase a property which she may not necessarily live in for a while but could use as an investment.

★ Note: Turn to page twenty-five and the 'How' team will give you some more information on the signs of the Zodiac.



A crashed car—and fight for freedom!

# FREEWHEELERS

PROFESSOR STINESKY HAS BEEN IMPRISONED IN A HOSTILE COUNTRY FOR YEARS. THE FREEWHEELERS ATTEMPT TO RESCUE HIM FROM A CASTLE TOWER BUT FIND THE OPPOSITION HAS HOOOWINKED THEM INTO TAKING A DECOY AGENT. NOT TO BE BEATEN, COLONEL BUCHAN ARRANGES AN AMBUSH WHEN THE PROFESSOR IS BEING TRANSFERRED TO ANOTHER PRISON. THE PLAN GOES WELL UNTIL A SOLDIER MANAGES TO SHATTER THE TYRE OF THEIR ESCAPE VEHICLE...



© 1977 Southern Television Ltd. Based on the Southern TV series.



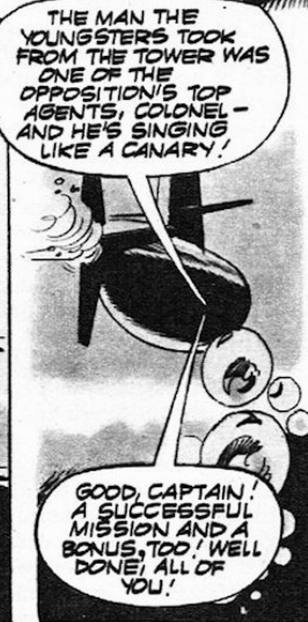



# The prints that cannot lie

*A thief with dirty hands... a whitewashed wall... and Magpie investigates a great step forward in the fight against crime.*

**T**HE doctor's house had been burgled—but the Japanese police could not understand why Henry Faulds, a medical missionary in Tokyo in the 1870s, was so excited by the sooty finger-marks on his whitewashed wall.

They were amazed when the 'mad foreigner' insisted that the man they had arrested should make marks on paper with his inky fingers; and when, after comparing these marks with those on the wall, Faulds declared their captive was innocent, they shrugged in disbelief.

When the real thief confessed a few days later, and Faulds showed the police that the marks left by his fingers were exactly like those on the wall, they credited the doctor with magical powers.

## TELL-TALE LINES

For some years, inspired by the Japanese custom of signing documents with thumb or finger prints, Faulds had been studying the patterns made by the 'capillary lines', the ridges of skin on the finger tips which, we now know, do not change from birth to death. Now he had shown that this pattern could be used to identify a thief, he wrote to the British magazine *Nature*: 'When finger marks on clay, glass etc., exist, they may lead to the scientific identification of criminals.'

But although Faulds offered his discovery to Scotland Yard and even offered to test it at his own expense, the British police were not interested. They were more concerned with 'anthropometry', an identification system based on the measurements of different parts of the body, invented by the Frenchman Alphonse Bertillon.

Bertillon's system, although more accurate than early fingerprinting methods, was clumsy. It called for a dozen or more absolutely accurate measurements, as well as a series of photographs. However, in 1892, an English scientist named Francis Galton proved that the odds against any two fingerprints being the same were as high as 64,000,000,000 to one—and that if 16 points of identification between two prints were the

same, those prints were certainly similar in all respects. So fingerprinting replaced anthropometry as the most important factor in 'forensic science', or scientific crime detection. Sir Edward Henry, who became Assistant Commissioner at Scotland Yard in 1901, was responsible for its acceptance by the British police.

Since about 1914, the fingerprinting of suspects (whose prints are destroyed if they are found to be innocent) and convicted criminals has been a matter of police routine. Some years ago, when the police of Blackburn



**An identical fingerprint—sufficient proof for the suspect's conviction.**

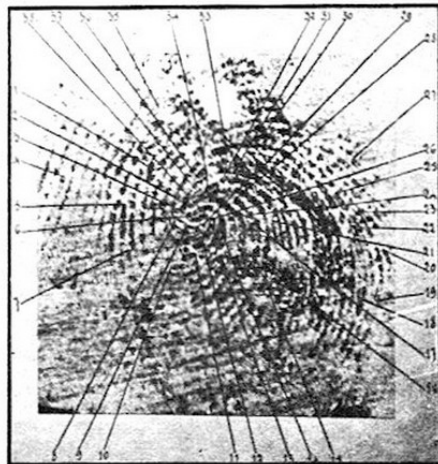

## Murgalroyd



were hunting a dangerous criminal, the fingerprints of every male over 17 in the city of around 120,000 people were taken. The police got their man!

## FINGERS ON FILE

The Fingerprints Registry is the most important department of the Criminal Record Office (CRO) at New Scotland Yard. It is believed to contain near 2,000,000 sets of prints. As well as the fingerprints of both hands, the CRO's file on every convicted criminal contains his real name and 'aliases' (false names, of which one criminal had 400!); his detailed description, with photographs; and a list of his crimes and his methods of committing them.

It is the proud boast of the CRO that the one thing no criminal can escape is—his past!

To bring out recently-made 'latent' fingerprints (prints invisible to the naked eye) on a shiny surface, dust the surface lightly with fine talcum powder. After a few moments, gently blow the powder away: the grains that remain sticking to the surface, should show up the outline of the prints.

★ Watch out for a new look Magpie, next week!



FEDERAL BUREAU OF INVESTIGATION  
 UNITED STATES DEPARTMENT OF JUSTICE  
 J. Edgar Hoover, Director

# History of the "West Brothers" Identification..

Bertillon Measurements are not always a Reliable Means of Identification



In 1903, one WILL WEST was committed to the U. S. Penitentiary at Leavenworth, Kansas, a few days thereafter being brought to the office of the record clerk to be measured and photographed. He denied having been in the penitentiary before, but the clerk doubting the statement, ran his measuring instruments over him, and from the Bertillon measurements obtained went to his files, returning with the card the measurements called for properly filled out, accompanied with the photograph and bearing the name WILLIAM WEST. Will West, the new prisoner, continued to deny that the card was his, whereupon the record clerk turned it over and read that William West was already a prisoner in that institution, having been committed to a life sentence on September 9, 1901, for murder.



The Bertillon measurements of these, given below, are nearly identical whereas the fingerprint classifications given are decidedly different.

The case is particularly interesting as indicating the fallacies in the Bertillon system, which necessitated the adoption of the fingerprint system as a medium of identification. It is not even definitely known that these two Wests were related despite their remarkable resemblance.

Their Bertillon measurements and fingerprint classifications are set out separately below:



177.5; 188.0; 91.3; 19.8; 15.9; 14.8; 6.5; 27.5; 12.2; 9.6; 50.3  
 15- 30 W OM 13 Ref: 30 W OM 13  
 28 W I 26 U OO

178.5; 187.0; 91.2; 19.7; 15.8; 14.8; 6.6; 28.2; 12.3; 9.7; 50.2  
 10- 13 U O O Ref: 13 U O 17  
 32 W I 18 28 W I 18

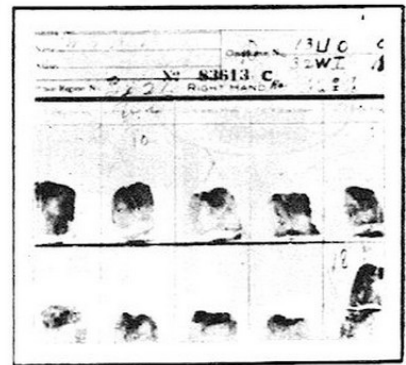

The case above indicates the greater degree of accuracy from fingerprints compared to Bertillon's system.

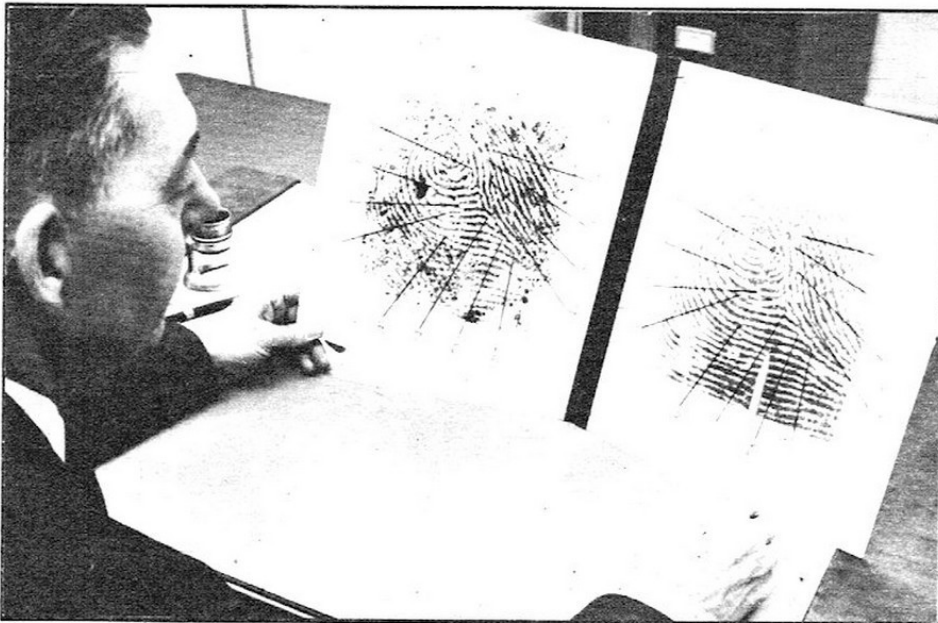

An FBI fingerprint expert compares latent and inked fingerprints before testifying.

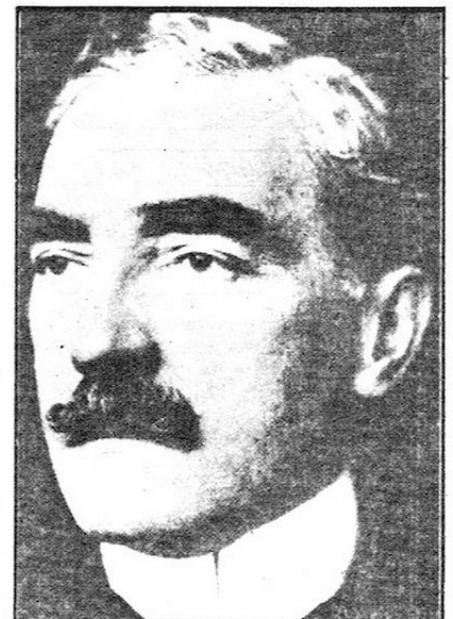

Sir Edward Henry chose fingerprinting.



New Year resolutions cause a riotous revolution . . .

# PLEASE SIR!

IT IS THE FIRST DAY OF THE NEW YEAR TERM...



OOOPS! SORRY, NORM! THE WIND CAUGHT IT...

YEEEEK!

NOW YOU'LL 'CATCH' IT! OL' POTTY'S KICKED THE BUCKET WITH SHOCK!

BUT FOUR 'C' ARE IN FOR A SHOCK...

HERE IT IS—DON'T BE FRIGHTENED, LAD! I'M NOT ONE TO FROWN ON A LITTLE 'IGH-SPIRITED FUN.



COR', I THOUGHT HE'D DO HIS CONKERS!

AS THEY ENTER SCHOOL...



YOU DON'T THINK HE'S ILL—SORT OF SICKENING?

NO, POTTY ALWAYS LOOKS A BIT FUNNY!

LIVEN UP! LET'S BE HARLEM GLOBE-TROTTERS!



'S FUNNY, BUT I PREFER NORMAN STROPPY...

YEAH, IT'S NOT NATURAL!

LOOK OUT, YOU TWO!

MR. PRICE AND DORIS EWELL EMERGE...

PHEEW! THAT'S DONE IT!



UGH! GREAT SLOPES OF SNOWDON!

REALLY! THE HEADMASTER'S TEA!

FOUR 'C'S' NEXT SHOCK IS EVEN MORE STAGGERING...

STEADY, MISTER PRICE! I REFUSE TO HAVE HOT WORDS OVER A LITTLE SPILLED MILK!



PEACE AND GOODWILL IT IS! I SHALL REFRAIN FROM CLOUTING A FEW HEADS!

THEN THE HEADMASTER EXPLAINS...

NOBLY SAID, PRICEY! OUR NEW YEAR'S RESOLUTION—HELPFULNESS, KINDNESS AND TOLERANCE. AWAY WITH HARSHNESS!



I KNOW. LET'S MAKE OUR NEW YEAR'S RESOLUTION THE SAME! JUST TO BE NICE ...

GOOD IDEA! WE'LL SHOW THE STAFF WE CAN BE AS GOOD!



NEXT MORNING...

WE'LL START NOW! LET'S CARRY OLD DORIS'S CASES.



Based on the London Weekend Television series created and written by John Esmonde and Bob Larbey © 1972 Esmonde Larbey Ltd.



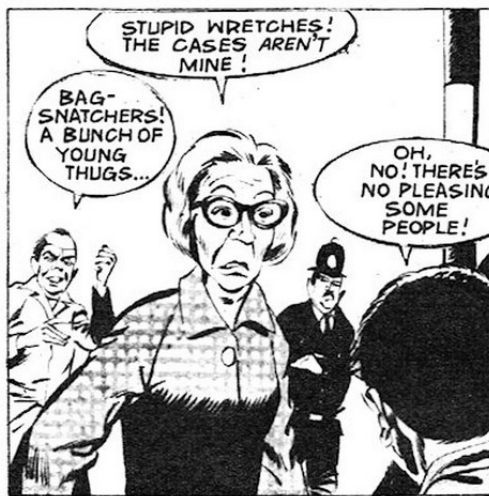

# LIFT OFF

If any of you are looking for some good records to spend your Christmas money on, there are certainly lots around at the moment. The first is a new album by the Sweet, called 'Funny How Sweet Coco Can Be', which is on R.C.A. No. SP.8238. It's a great album. 'Jackie's Junior Choice'—including 'Octopus's Garden' and 'Chirpy-Chirpy-Cheep-Cheep' is another L.P. which I'd recommend. It's recorded by Dublin-born Jackie Lee who started her career singing regularly on an Irish radio children's programme when she was only twelve years old. So who better to make an album aimed especially at younger listeners?



The Sweet's four star line-up

Pye have also released 'A Golden Hour Of Best Loved Fairy Stories' told by Max Bygraves and Roger Moore, in addition to several other well-known personalities. By the way, I'm tipping 'Soley Soley' by the Middle Of The Road as a definite top ten hit. But in my opinion, the pick of the New Year bag is Elvis Presley with 'I Just Can't Help Believing'. It must put the 'King' back at number one. To finish, M.C.A. Records have issued a maxi single of four numbers—from the show 'Jesus Christ Superstar'—featuring Yvonne Elliman who originally played Mary Magdelene. On the 'maxi' she sings 'I Don't Know How To Love Him' and 'Everything's All Right', as well as two other superb songs. Well, there are a few thoughts for you. Happy New Year!

*Agnes*

Next week: a hilarious history lesson!



# Look-in is proud to announce a fantastic new competition

**Win a space holiday in Miami U.S.A.—  
and watch the launch of Apollo 16!**



A BOAC 707 jetliner to carry you in skyhigh comfort. Right: Disney World opens with a bang



★ During the next four weeks, LOOK-IN will publish four parts of a super new competition. The winner, with a parent, will be flown to America by BOAC 707 jetliner to spend 7 days in sunny Miami.

★ Included in the holiday will be an outing to Patrick Air Force base to look at the famous space museum, a day's visit to the fabulous new Disney World and the never-to-be-forgotten experience of actually watching Apollo 16 lift off from Cape Kennedy on its way to the Moon.

★ The first part of this super competition and details of the fabulous list of prizes will appear in next week's LOOK-IN.

★ Don't miss this great opportunity. Order your copies of LOOK-IN Now!

COMPLETE THIS COUPON AND HAND IT TO YOUR NEWSAGENT TODAY

Please reserve/deliver ..... copies of the next 4 issues of LOOK-IN (Numbers 2, 3, 4 and 5).

NAME .....

ADDRESS .....

SIGNATURE OF PARENT OR GUARDIAN .....

## Look out for next week's Look-in



Also next week, Ed 'Stewpot' Stewart introduces a new feature-spread entitled STEWPOT'S LOOK-OUT. Ed will be looking out for items of special interest to LOOK-IN readers which will keep you up to date with the TV scene. PLUS—CATWEAZLE COMES TO LOOK-IN. The first of a new strip cartoon featuring TV's ancient magician. The demand for next week's LOOK-IN will be tremendous—so don't delay . . .





# YOUR VIEW



This week, Wendy Craig—star of 'And Mother Makes Three'—selects these entries from the LOOK-IN Postbag, including the special £2 Star Letter...

## STAR LETTER

I'd like to tell you how I became a Royal Marine for a day. It all happened when I visited 'H.M.S. Victory' whilst on a school trip. We were shown round by a fat and jolly round-faced Marine. Because I'm so little he kept picking me up, saying that I had an impish face. Then he, took off his hat and coat and put them on me. 'There,' he said, saluting, 'welcome aboard, new recruit Gould.' I felt very proud. I told him my dad is a Royal Marine, too, but I had never had his hat on. It was very interesting.

We saw the spot where Nelson fell and died. When we were setting off, I remembered that I was still wearing the hat and coat. I had to run back to the ship and there he was at the door. I gave him his things and he said: 'Ooh, presents—I love them.' Then he said that I should have kept them as souvenirs. I laughed and said goodbye. I'll never forget the day I became a Royal Marine on 'H.M.S. Victory'.

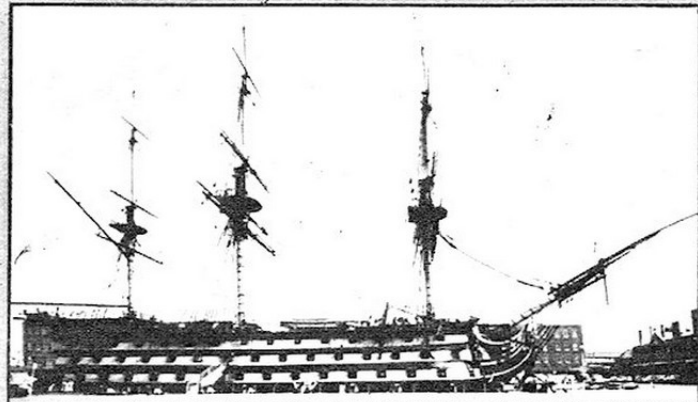

Adele Gould, Grimsby, Lincs.

★ Sounds as though you had a really good time, Adele—and not even sea-sick, like poor old Horatio used to be. Above, is a picture of 'H.M.S. Victory'.

### BELLY FULL

I live near the sea and one day, on the way home from fishing, I found I had lost all my pocket money. I had only

caught one fish and when I arrived home, I cut it open to clean it. There in its stomach was a fifty-pence piece. This really did happen. I had heard

of people finding all sorts of things in fishes, but I didn't think it would happen to me.

A. Reader, Rhyl, North Wales.

★ I shall have a good search next time I sit down to my sardines on toast!

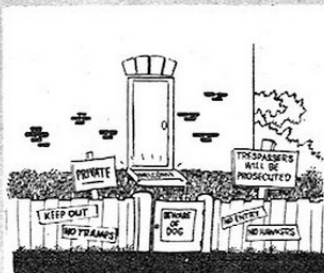

A. Milkowski, Ealing.

### AEROPLANES

A silver flash in the summer sky  
An aeroplane is passing by  
Over the streets and over the town  
On through the night when the sun's gone down  
Over the land and over the sea  
A few more days and where will it be?  
Through the sky where the clouds are curled  
The aeroplane will cross the world.

Nighat Siddiqui, London E.17.

★ Thank you, Nighat, for your very vivid poem.



"It's okay, officer—I'm nine!"  
LOOK-IN reader

### SACHA AND CHIPS

The other day my two friends and I were having our dinner at school. Karen and I were talking about the singer Sacha Distel. Ruth (my other friend) seemed to be in a dreamy mood so to get her talking I said: 'Do you like Sacha Distel?' In a dreamy voice she said: 'I don't know—I've never tasted it before.'

Julie Young, Gosport, Hants.

★ Well, she's thinking on the right lines—he certainly is 'dishy'.



### FOOTBALLING FIREMEN

During the summer holidays, I went to stay with my aunt. Across the street from her house is a fire station. On the first morning there I went to watch the firemen in the station. I asked how much water was in the tank of the engine and one of the firemen said there were three-hundred gallons of it. I said I thought that was a lot. When my aunt called me in to have my lunch, one of the firemen squirted water on to my dress. I was soaked to the skin. After I had eaten and was dried out, he asked me to come over and have a game of football. I laughed. He said: 'No one will laugh at you.' I went and played football. I had a good time.

Veronica Vaughan, Glasgow, Scotland.

★ Football is fun, and why shouldn't girls play it? It would be interesting to hear what other readers think about that.

continued on page 18



# Follyfoot

CONCERN FOR THE TREATMENT OF HORSES PROMPTS DORA TO KEEP A WATCHFUL EYE ON THE WILD WEST-STYLE HOLIDAY RANCH RUN BY MAJOR HOLLIS. THE HORSES ARE OKAY BUT GLEN CALHOUN AND HIS TWO SIDEKICKS, AMERICANS HIRED BY THE MAJOR, ARE NOT! DORA OVERHEARS THEM PLANNING TO ROB WEALTHY GUESTS INVITED TO A SPECIAL RODEO. BUT THEN SHE IS CAUGHT...



SO LONG, KID! IF WE MAKE A GOOD HAUL TOMORROW, WE MAY TELL SOMEONE YOU'RE HERE...

NNNFF! MMMFF!

AS HOURS PASS, DORA'S FRIENDS AT FOLLYFOOT FARM BEGIN TO GET ANXIOUS...



I'M GOING OVER TO MAJOR HOLLIS'S RANCH TO SEE WHAT'S HAPPENED TO HER!

BET SHE'S HAVIN' A BARNEY WITH HIS PERISHIN' STALLIONS!

FOLLYFOOT

BUT WHEN STEVE ARRIVES AT THE BAR-Y...

CAN'T SAY I'VE SEEN ANYTHING OF HER, MY BOY. HAVE YOU, CALHOUN?

NO, SIR! NOT A SIGHT.



TAIL HIM, JED. IF HE GOES ANYPLACE NEAR THE OLD BARN, DEAL WITH HIM!

SURE THING!

BUT STEVE, BAFLED, GOES STRAIGHT BACK TO FOLLYFOOT...

I JUST DON'T GET IT...



I'LL LAY ODDS SHE'S HIDING UP SOMEWHERE UNTIL DARKNESS, MATE - SO'S SHE CAN SNEAK IN AND GET A CLOSE LOOK AT THE MAJOR'S HORSES!

WELL, MAYBE YOU'RE RIGHT - IT'S THE SORT OF DAFT THING SHE MIGHT DO...



NEXT MORNING - SATURDAY - THE MAJOR'S RICH VISITORS BEGIN TO TURN UP FOR THE RODEO...

WHAT - HO, ALGY OLD BOY! LIKE YOUR OUTFIT, BUT WHERE'S THE HORSE?

DIDN'T FANCY RIDING IT ALL THE WAY FROM OXFORD, OLD FRUIT!



AH! STEVEN AND RONALD! SO GLAD YOU COULD COME. BUT NO DORA?

SHE STILL ISN'T BACK, MAJOR. SLUGGER'S HAD TO 'PHONE THE POLICE!

Based on the Yorkshire Television series Follyfoot. © 1972 Yorkshire Television Ltd. (The original story of Follyfoot by Monica Dickens, is published by Heinemann at £1.25 and Pan at 20p.)



THE GRAND WILD-WEST SHOW BEGINS...

I STILL THINK WE OUGHT TO BE OUT SEARCHING...



COME OFF IT, MATE. WE KNOW SHE WAS HANGIN' ABOUT THIS PLACE. CHANCES ARE WE'LL PICK UP A CLUE SOONER OR LATER...

MEANWHILE, IN THE OLD BARN, DORA IS EXHAUSTED. NOT SO GOBBY, HER HORSE. HE HAS KEPT UP AN INCESSANT KICKING AND WHINNYING...



AND IN THE WOODS OUTSIDE...



HULLO! WHAT THE DICKENS IS THAT NOISE COMING FROM THE OLD BARN?



GOOD GRIEF!

RINGS, WATCHES, WALLETS—TURN 'EM OVER. AN' MAKE NO MISTAKES—WE'RE GOOD WITH THESE GUNS!



STRENGTH! I DON'T BELIEVE IT! IT'S GOT TO BE SOME KIND OF JOKE!

THEN, IN A MOMENT OF PARALYSED SILENCE...



DON'T MOVE! THERE ARE TWO BARRELS OF TWELVE-BORE SHOT RIGHT BEHIND YOU, SO DROP THOSE GUNS!

DOWN AT THE BAR-Y, CALHOUN MAKES HIS PLAY...

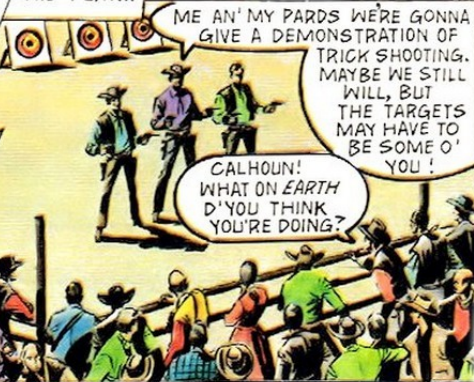

ME AN' MY PARDS WE'RE GONNA GIVE A DEMONSTRATION OF TRICK SHOOTING. MAYBE WE STILL WILL, BUT THE TARGETS MAY HAVE TO BE SOME O' YOU!

CALHOUN! WHAT ON EARTH D'YOU THINK YOU'RE DOING?

FROZEN WITH SHOCK, THE CROOKS ARE OFF GUARD FOR ONE VITAL MOMENT...



GET 'EM!

TARNATION! THE GIRL!!

THE TREACHEROUS DEVILS! AND TO THINK I TRUSTED THEM!

I OVERHEARD THEM PLOTTING, MAJOR! THEY HAD ME TIED UP IN A BARN ALL NIGHT!

MERE WORDS CAN'T EXPRESS MY GRATITUDE TO YOU, YOUNG LADY—NOR TO YOU, SIR!



COME ON, MAJOR! YOU WANTED A WILD WEST SHOW, NOW YOU'VE 'AD ONE!

Join the farm-friends

in a new adventure, next week!





A Monitor Lizard—similar to those used in films to appear as prehistoric monsters.

*Colin Willock completes his swampland safari by meeting ...*

## The 'Dummy' Dinosaur

**The other morning I was drowsing in the sun outside our tent in the Okavango Swamps in Botswana. Suddenly I awoke to find myself looking at what, in my sleepy state, I took to be a dinosaur. A huge lizard was staring at me from the reeds.**

It was a Nile monitor, fully six feet long and a very nasty customer if you happen to get him cornered. Actually, I wasn't so far out with my 'dinosaur' guess. Monitor lizards have been going strong for one-hundred-and-thirty-million years. The biggest of them, the komodo dragon of Indonesia, grows to over ten feet. Film companies often use monitors as 'stand-ins' for dinosaurs. With the aid

of a little trick photography they look very much the part, with their long snout and neck flashing, forked tongue, sinuous shape and big beady eye.

The Nile monitor isn't confined to the Nile at all. You find this big lizard all the way from south of the Sahara to the Cape of Good Hope. Unlike many of the land-based monitor lizards, such as the goannas of Australia, the Nile species spends most of its time in or around water. That's why the long, powerful tail is flattened at the sides, to act as an oar blade which drives the great brute through the water.

My six-foot monster obviously regarded me as a dangerous specimen. He launched himself into the swamp and took off at a rate of knots. I thought this to be rather a compliment since monitors

aren't afraid of many things, including crocodiles!

A few days before, with 'Survival' cameraman Dieter Plage, I'd watched a couple of these lizards busily digging crocodile eggs out of a sand bank while the parents were off having a swim. Dieter told me he'd even seen a monitor lizard unearth the eggs from under a mother croc' which was guarding them.

Even the name 'monitor' is interesting. The Arab word for lizard is *waran*. The German colonists confused this with their word *warnen* which means 'warning'.

So the lizards became 'monitors', those which warn others about their behaviour. My view is that the monitors, with their taste for young birds and eggs, could start worrying about their own conduct a little!



# The Fenn Street Gang



Based on the London Weekend Television series created and written by John Esmonde and Bob Larbey © 1977 Esmonde Larbey Ltd.





Join William Mervyn for the final road-race in the . . .

# Crazy Car!

THERE IS OBVIOUSLY SOMETHING VERY STRANGE ABOUT 'ARCHIE'—A HOT-ROD WHICH A CAR MART SUPPLIES TO DAVE AND SUE BARRY. ARCHIE INSISTS ON CHASING A MERCEDES WHOSE OCCUPANTS HAVE COLLECTED PACKAGES DROPPED FROM A PLANE. ENGINE BELLOWING, ARCHIE ROARS FOR THE STREAM...



DON'T BLAME ME FOR THIS—I'M ONLY HOLDING THE STEERING-WHEEL! HOLD TIGHT!

YOU CAN OPEN YOUR EYES NOW—WE'RE OVER! I'VE GREAT FAITH IN ARCHIE...



I WISH I HAD! I'M SHAKING LIKE A LEAF!

ARCHIE JUMPED THE STREAM AS A SHORT-CUT. LOOK, IT'S THE CROOKS' CAR!



ALL I WANT TO DO IS STOP!

WE'VE NO BRAKES AND THE ACCELERATOR'S JAMMED!

DON'T WORRY—REMEMBER, ARCHIE THINKS FOR HIMSELF!



IT'S THOSE YOUNGSTERS IN A SPORTS CAR. WE'RE STILL BEING TAILED!



PERHAPS WE CAN LOSE THEM WHEN WE REACH THE MAIN ROAD.

TWO CARS NOW TRAVEL LIKE ROCKETS...

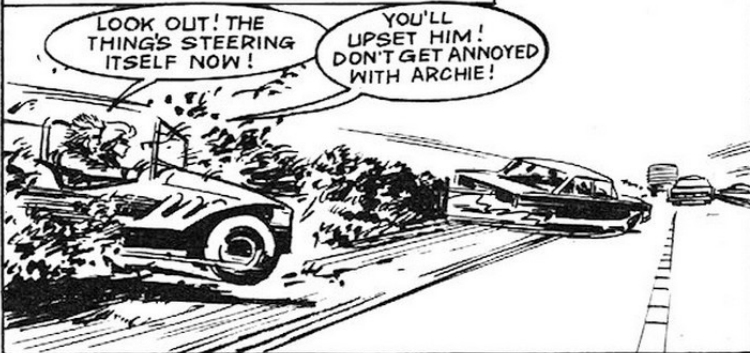

LOOK OUT! THE THING'S STEERING ITSELF NOW!

YOU'LL UPSET HIM! DON'T GET ANNOYED WITH ARCHIE!



HOOT! HOOT!

SORRY, ARCHIE, I'M TOO SCARED TO THINK WHAT I'M SAYING. JUST TAKE IT EASY!

## YOUR VIEW

### FOLLYFOOT FAILURE

I am very disappointed with your recent artwork with Follyfoot. I enjoy LOOK-IN very much indeed—it is my favourite magazine. But why was Follyfoot drawn differently in issue forty-seven? Up until then it was great. The story is still good; it is only the artwork. Dora and

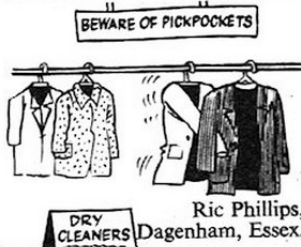

Ric Phillips, Dagenham, Essex.

Steve both look different.

Beryl Lee, Halesowen, Worcs.

★ Our artist, Mike Noble, who usually illustrates Follyfoot, has been chained to his drawing board for ages, muttering about never having a holiday (sob, sob). We couldn't bear his pathetic moans any longer, so off he went whilst another illustrator kindly filled in while he was away. I'm sure you will agree that we were right—anyway, he was nearing nervous exhaustion! Now, normal service has been resumed, so we hope you're enjoying Follyfoot as much as ever!



"I'm afraid we had woodworm in the organ!"

Barry Gardner, Brentwood, Essex.



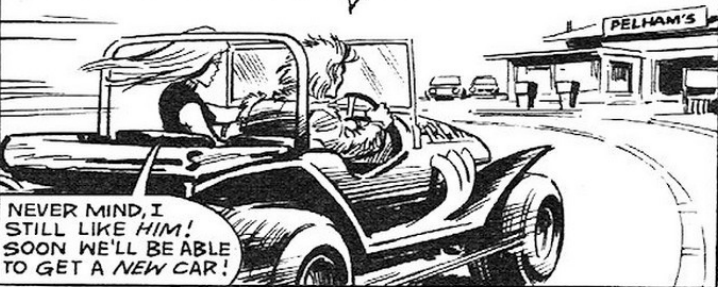
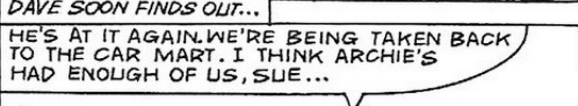
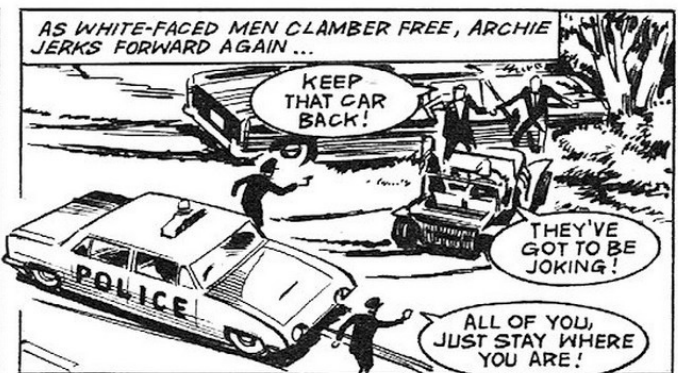
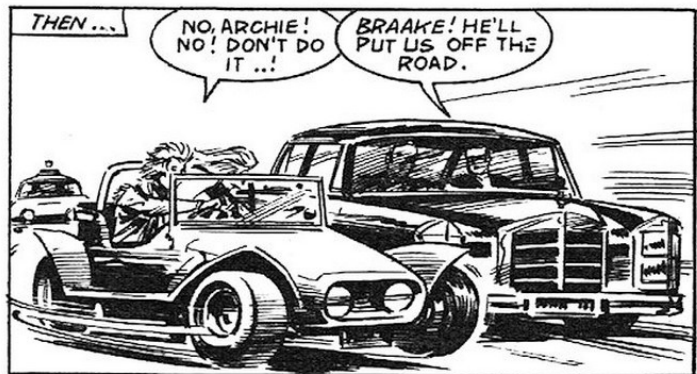

**LOCKER DECORATION**

At school we have lockers to keep our things in and my friends stick pictures of their favourite pop stars on the doors. My favourite is Rod Stewart but I cannot find a picture of him. Please could you do this, so that I can put him on my door?

Maria Wile, Littlehampton, Sussex.

★ Sorry it's so small, Maria, but there isn't a lot of room on this page and a mini Rod Stewart is better than none, I would think.



**BEWARE! DOCTOR AT LARGE!**

My Dad and I went to the doctor's surgery the other night. It's a group practice with five doctors working from the same place. The receptionist opened

the little hatch and said: 'Which doctor?' 'No thanks,' said my dad, 'the ordinary one will do.'

A. James, Leeds, Yorks.

★ At least you have a choice!



Win £2 for the Star Letter and £1 for any other letter or joke! Plus, a special signed photograph of the Your View star will be posted to the sender of every item published! Why not write now to Your View, LOOK-IN, 247 Tottenham Court Road, London W1P 0AU? Remember when you write—enclose a list of your six favourite features in order of preference.



# STEWSPOT'S CHOICE



## MOR-NING!

Lovely to be with you once again—especially as it's New Year's week, 'cos we can all make our New Year's resolutions. What are yours? To be nice to your brother? Finish writing those Christmas thank-you letters, won't you? Good for you.

It's very easy to make resolutions that you know you're going to break—we all do that. But this year why not promise yourself that you're really going to help somebody else who is ill or unhappy or too old to help themselves? Do it five, five-hundred, five million

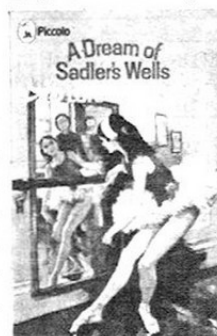

**Brand-new ballet book!**

I received a letter from Julie Mullender in Sawson, Cambs. She told me that she and her friend held a bazaar for the NSPCC, collecting things and selling raffle tickets, books, crayons, toys and sweets and raised over three pounds (terrific, Julie!). That's not all you can do—there's shopping and cleaning for old people who can't do their own, or just being helpful to mum by looking after your brothers and sisters. But that's the sort of New Year's resolution to make—one that's helping others. I'll want to hear

what ideas you've had, so write around at the moment, by the way. Perhaps one you can take your dad to see is 'The Mickey Mouse Anniversary Show'. (Actually, you can take granddad, as well!)

Mickey Mouse is over forty years old now and the film goes right back to when Walt Disney was drawing Mickey in a garage (cars

can read about in History, of course?)

**AIRFIX - 600 SCALE  
GRAF SPEE**



weren't as dangerous then as they are now). This film's so interesting that I think it should be shown in schools as a lesson in drawing and animation!

Just in case you're wondering what to do with all that lovely money you received for Christmas, how about an Airfix model of the famous German battleship 'The Admiral Graf Spee' (which you



Then for the girls—especially those who like ballet—there's a brand new paperback series about Veronica who has a 'Dream Of Sadler's Wells'. That's the first book (20p) which is followed by 'Veronica At The Wells' and two more after that. So keep on your toes (ha! ha!) and look out for those. I'm a poet and don't know it!

'The Admiral Graf Spee' battleship for all model-makers.

**AIRFIX - 600 SCALE  
GRAF SPEE**

Well, that's about it for this week, when you've read the quizzical verse sent in to me (it's clever, too) and the joke from Jane Ward, of Bradford Yorks.

Oh, by the way—I almost forgot. How do you like me in the picture this week? Do you have any old dolls or cuddly toys that you don't really want (now you've had loads for Christmas)? If so, why not send them to me at the address below and they—like the toys shown—will be given to hospitals. Here's where to write: Ed Stewart Fan Club, 24 New Bond Street, London W.1.

**BYE-EEE!**

Mickey's still the mostest—even after forty years!

\*\*\*\*\*

My first is in skate,  
But not in ice.  
My second is in great,  
But not in nice.  
My third is in sale,  
But not in sold.  
My fourth is in new,  
But not in old.  
My fifth is in cap,  
But not in hat.  
My sixth is in dog,  
But not in cat.  
My seventh is in little,  
But not in big.  
My all is a 'DJ',  
Which I really dig.

Answer: Stewpot

\*\*\*\*\*

LOOK OUT for LOOK-IN next week—and Stewpot with a difference!





Robert Harbin introduces . . .

# DO-IT-YOURSELF ORIGAMI



Hello, again! Alison Reynolds, aged fourteen, wins a £1 postal order for her fine cathedral which she has based on the traditional church. See how you get on with this excellent model.

## CONSTRUCT A CATHEDRAL

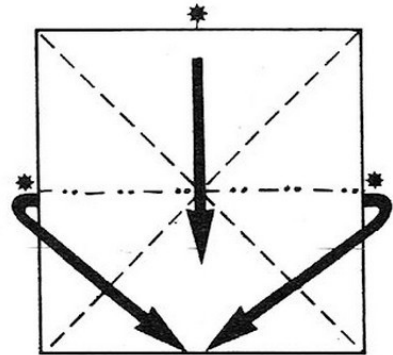

1. Crease then fold 'water-bomb' base

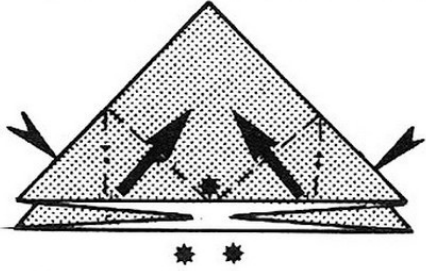

2. Lift 2 corners and squash

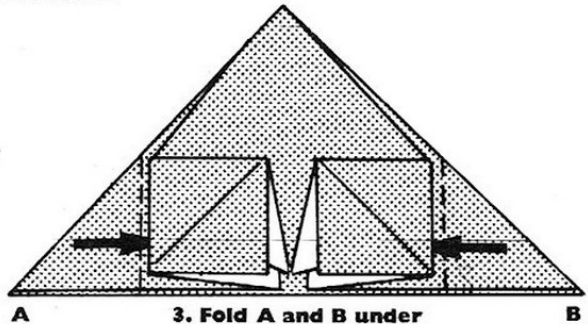

3. Fold A and B under

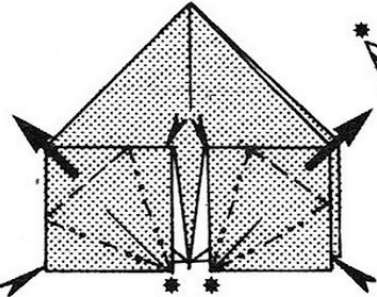

4. Lift flaps and make "petal" folds

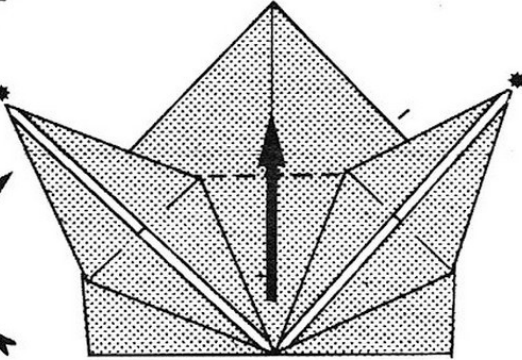

5. Fold flap up

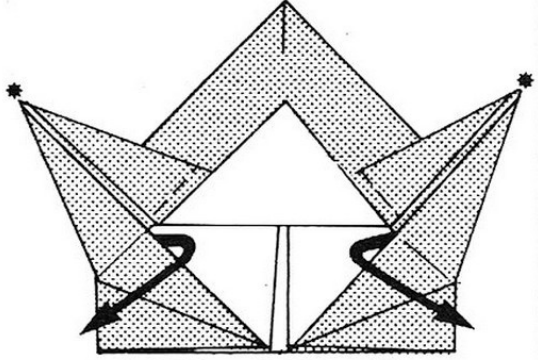

6. Pull sides out. Fold points down

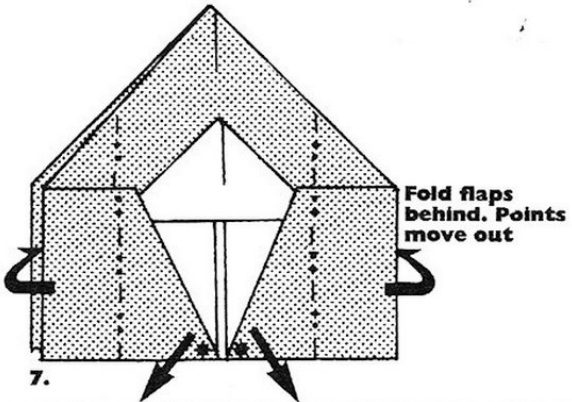

Fold flaps behind. Points move out

7.

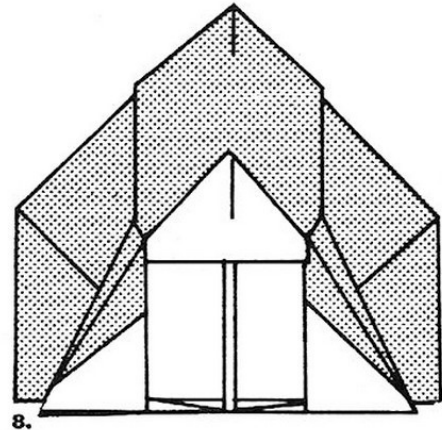

8.

Valley fold	Mountain fold
Cut	
Creases	
Fold in front	→
Fold behind	→
Push in, sink or squash	➤
Hold here	○ Watch this spot ★

You can win £1! ★ If you feel you can invent a new Origami model, write down the details (together with your own name and address) and send them to Do-It-Yourself Origami, LOOK-IN, Junior TVTimes, 247 Tottenham Court Road, London W1P 0AU. I will send a £1 postal order for any item I select to publish. So, hurry and get your paper thinking-cap on now!



# TIMESLIP

ABLE TO TRAVEL THROUGH THE INVISIBLE TIME-BARRIER, LIZ SKINNER AND SIMON RANDALL ARE BACK IN THE YEAR 1314. SINCE SPORT IS BANNED BY ROYAL DECREE OF KING EDWARD THE SECOND, AND BECAUSE HE HAS A FOOTBALL WITH HIM, SIMON IS PUT IN THE STOCKS OF A NORTHUMBRIAN VILLAGE, AND LIZ BESIDE HIM. THEY GET FREE UNDER COVER OF DARKNESS. BUT THEN...

THERE IS NO CHOICE...

THE SCOTS ARE COMING! MAN THE RAMPARTS! EVERYONE TO ARMS!

WE CAN'T GET BACK TO THE TIME-BARRIER IN THE SQUARE! THEY'LL HAVE CONSTABLES THERE TO MAKE SURE NOBODY RUNS FROM THESE DEFENCES!



SIMON'S REPLY IS LOST IN THE ROAR OF THE CHARGING SCOTS...

SIMON! WHAT WILL WE DO?

BUT SIMON—WE MIGHT BE KILLED!

WITH ME, MEN! FOR THE GLORY OF SCOTLAND! FOLLOW THE MACINNIS!



DEATH OR VICTORY!

ALL FOR KING EDWARD!



AS THE SCOTS' ATTACK DRIVES INTO THE VILLAGE...

WE MIGHT BE ABLE TO MAKE IT! WHEN I SAY RUN—RUN!

FOR PETE'S SAKE BE CAREFUL! IF ONLY YOUR STUPID FOOTBALL HADN'T GOT US INTO ALL THIS!

IN THE THICK OF THE FIGHTING, LIZ AND SIMON CROUCH AGAINST THE EARTHWORKS...

IT'S MADNESS, SIMON! WE'VE GOT TO GET AWAY FROM HERE!



DON'T PANIC, LIZ! IF WE SEE AN OPENING, WE RUSH THROUGH AND GET TO THE BARRIER! STAY DOWN AND KEEP YOUR EYES OPEN!







I DIDN'T MEAN TO KICK THROUGH THE TIME-BARRIER IN THE FIRST PLACE, DID I?

WE'LL NEVER DO IT!



WITHIN FEET OF THE TIME-BARRIER, DISASTER STRIKES...

PRISONERS AND PLUNDER! COME, LADS - WE HAVE THEM ON THE RUN!



GATHER TO ME! MACINNIS THE EAGLE!

SIMON! HELP! HELPPP!



UNARMED, SIMON IS HELPLESS! BUT SHEER DESPERATION COMES TO HIS AID...

MUSTN'T MISS! MUSTN'T!



LIKE A BULLET, THE BALL STREAKS FROM SIMON'S FOOT...

GNUHHH!

THWANN!



SIMON! OH, SIMON...

IT'S ALL RIGHT, LIZ. WE'LL MAKE IT YET!



AMIDST CLASHING SWORDS AND DARTING SPEARS, THE TWO FRIENDS SCRAMBLE THROUGH THE CROWD...

OCHONE! THOSE SASSENACHS SEEK TO FLEE THE BATTLE! CUT THEM DOWN!



GLITTERING BLADES SLASH AT THEIR TARGETS - BUT BITE THIN AIR!

AAAAGH! THEY VANISHED!

THRANNNGGG! KA-DANGG!

DISAPPEARED! RIGHT BEFORE OUR EYES!



AND IN THE WHIRLING MIST OF THE TIME-BARRIER...

SUDDENLY, ALL IS SILENT...

WE...WE'RE BACK... IN OUR OWN TIME!



IT'S NEVER BEEN CLOSER, LIZ. NEVER!

PROMISE ME SOMETHING, SIMON! NEVER PLAY FOOTBALL HERE. NOT EVER AGAIN.



I CAN'T, CAN I? NOT UNTIL I GET ANOTHER BALL! I SUPPOSE MY OLD ONE'S GOING TO BE THE PROPERTY OF EDWARD THE SECOND OR ROBERT THE BRUCE. BUT I'M NOT GOING BACK TO FIND OUT!

...THAT THEY HAD FOUND IN THE VERY NICK OF TIME...



# ON THE BUSES

ARTHUR DECIDES THAT STAN'S BUS ENGINE CAN BE HOTTED-UP TO RACING CAR PERFORMANCE. READY FOR WORK, STAN EXPLAINS THINGS TO JACK...



IF WE HAD THAT SORT OF POWER WE COULD TAKE THINGS EASY WHEN WE WANTED TO...

YEAH! AND THEN MAKE UP THE TIME BETWEEN. OLD BLAKEY WOULD...



TALK OF THE DEVIL...

COME ON, YOU TWO! HAVEN'T YOU GOT THAT BUS OUT YET? YOU'RE LATE AGAIN! REMEMBER WHAT I TOLD YOU ABOUT RELIEF DRIVER JONES...

OKAY, BLAKEY—KEEP YOUR HAIR ON!

COR! JUST LOOK AT JONSEY—RARING TO GO!



STAN DRIVES ALONG HIS ROUTE — AND A MILE FROM THE DEPOT...

THIS IS IT! NOW JUST MAKE A FEW ADJUSTMENTS TO THE ENGINE...



THERE YOU ARE, MATE! HOLD ON TO YOUR TICKET MACHINE — THERE'LL BE NO STOPPING US NOW!

JUST AS WELL, STAN! WE'RE LATER THAN EVER!



IN FACT JONES HAS CAUGHT UP WITH US! WE'RE RUNNING TO HIS SCHEDULE — NOT OURS!

DON'T WORRY, JACK! WE'LL SOON FIX THAT!



TO STAN'S AMAZEMENT, RELIEF DRIVER JONES OVERTAKES...

STONE ME! HE'S A MANIAC! HE NEARLY MADE ME CRASH THEN!

WITH HIS NEW-FOUND POWER, STAN PRODUCES A FEW SURPRISES...



HA! THAT'LL TEACH HIM!



WANTS TO MAKE A RACE OF IT, EH? RIGHT!



IN THE EXCITEMENT, BOTH DRIVERS GET CARRIED AWAY...

COME BACK! YOU'RE SUPPOSED TO STOP!

BUS STOP

PERISHING BUSES! IT'S QUICKER TO WALK!



THEY COMPLETE THEIR JOURNEYS...



WHAT HAPPENED, BUTLER? ARE YOU ILL? YOU'RE ON TIME!

I KNOW, BLAKEY—THOUGHT WE'D TRY IT YOUR WAY FOR A CHANGE!

HE'S CRAZY! I WANT TO REPORT HIM FOR DANGEROUS DRIVING!



AH, YES! DRIVER JONES! I'VE HAD A DOZEN COMPLAINTS FROM PASSENGERS—WHY DIDN'T YOU STOP FOR THEM? WHAT ARE YOU PLAYING AT? YOU'RE HALF AN HOUR EARLY!



IF THERE'S ONE THING THAT'S WORSE THAN BEING LATE—IT'S BEING EARLY! WATCH IT, JONES, OR YOU'LL BE CLEANING THE BUSES, NOT DRIVING THEM!

DON'T WORRY, MATE—WHEN YOU'VE BEEN HERE AS LONG AS WE HAVE YOU'LL FIND OUT YOU JUST CAN'T PLEASE OLD BLAKEY!

© Based on the London Weekend TV series written by Ronald Wolfe and Ronald Chesney.



Once again, Bunty James, Jack Hargreaves, Jon Miller and Fred Dinenage are all set to answer your questions. Congratulations to this week's winners. If you haven't already written in why not do so now? For any question published, winners can choose from 20 Hamlyn books, each to the value of £1. Send your entry to: How! LOOK-IN, 247, Tottenham Court Road, London, W1P 0AU.



**Spectacle Frame Deaf-Aid**

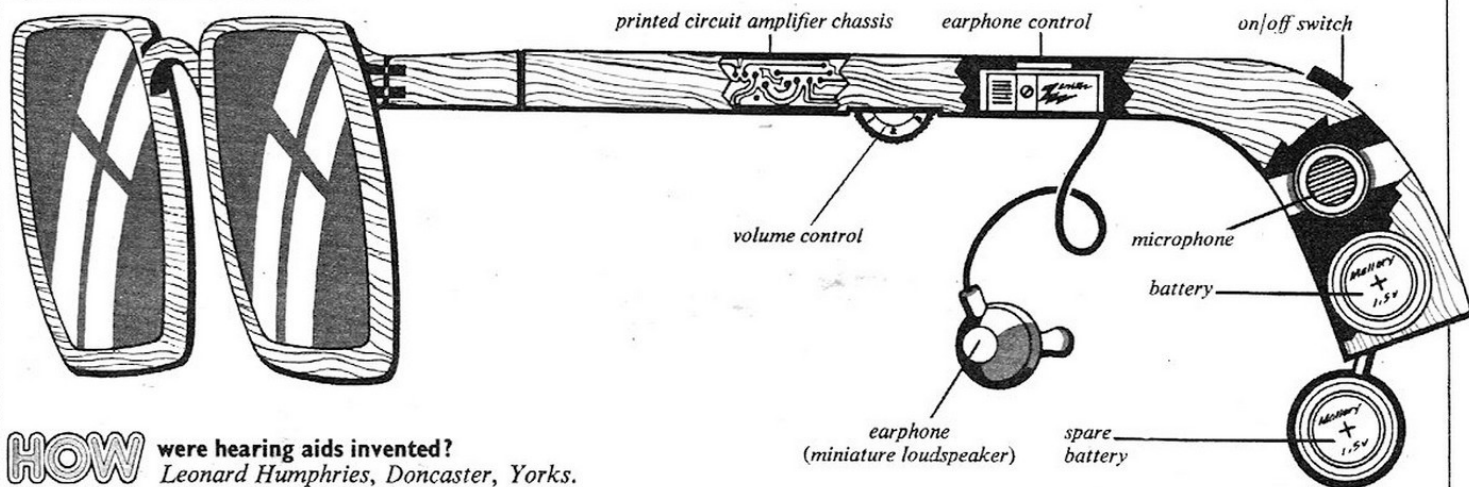

**HOW** were hearing aids invented?  
*Leonard Humphries, Doncaster, Yorks.*

There are basically two sorts of aid. 'Air-conduction' aids simply make sounds louder. But some people cannot transmit sound through both their inner and outer ear so they use 'bone-conduction' aids. These carry sound to the bony part of the deaf person's head, normally just behind the ear. The bone

carries sound vibrations to the hearing nerves of part of the inner ear called the 'cochlea' and, when these nerves are active, hearing follows.

Bone-conduction aids have been used since the 17th century, before which ear trumpets were used. Around 1800 came the 'audiphone' or 'dentiphone',

whose edge a deaf person held between his teeth. The sound vibrations were carried from there to the hearer's nerves via the jawbones and skull.

Electric hearing aids, rather like small telephones in operation, came in around 1900, but they were rather big and clumsy at first. Next came the 'vacuum

tube' aid, smaller and using a crystal mike, two batteries and a vacuum-tube amplifier. In 1953 came another breakthrough, the electronic transistor hearing aid. These tiny objects can even be built into spectacle frames or worn in the hair. We have come a long way from ear trumpets!

**HOW** long the is longest pier in Britain?  
*Douglas Tye, Middlesbrough.*



We think you mean the longest pleasure pier, Douglas. That is the one at Southend-on-Sea in Essex, which is 1.33 miles long. It dates from 1889 and was extended to its present length in 1929. It is the longest pier of its kind in the world. Southend's famous pier (pictured above) offers ten-pin bowling and is an ideal focal point for the many sponsored walks which are held along its 1.33 miles.

**HOW** did the Zodiac originate and why?  
*Ray Butterworth, Preston, Lancs.*

The Zodiac is a quite narrow, imaginary band in the sky through the middle of which the sun seems to travel on its annual journey through the heavens. The band is wide enough to hold the paths of the planets and moon and twelve constellations (groups) of stars and the imaginary band is divided into twelve equal parts, which are called 'signs'.

The ancients thought the sun, the moon and the stars and planets were gods and goddesses, so were naturally very interested in them. By studying the stars of the Zodiac they thought, like modern astrologers, that they could tell the future. The Babylonians were among the first to study the Zodiac. The twelve constellations are Aries (*the Ram*), Taurus (*the Bull*), Gemini (*the Twins*), Cancer (*the Crab*), Leo (*the Lion*), Virgo (*the Virgin*), Libra (*the Scales*), Scorpio (*the Scorpion*), Sagittarius (*the*

*Archer*), Capricornus (*the Goat*), Aquarius (*the Water Carrier*), and Pisces (*the Fishes*). Notice that more than half are animals? That explains the word Zodiac, which comes from an ancient Greek word meaning 'to do with animals'.

Each of the constellations is said to lie in the sign next to the one which has its name. So the constellation *Taurus* lies in the sign of *Gemini* and so on. This is due to the fact that the signs move round the heavens with what is called 'the precession of the Equinoxes'—the movement of the earth round the sun which determines our seasons and lengths of days.

**Turn to page three for the 'stars' on the stars!**

**HOW** many bones are there in the human body?  
*A. Lever, Seacombe, Wallasey, Cheshire.*

In all, there are two hundred and six.

**HOW** long is the longest railway tunnel and where is it?  
*Timothy Price, Surrey.*

It is the Simplon II Tunnel, linking Switzerland and Italy under the Alps and it is twelve miles five-hundred-and-fifty-nine yards long.













© 1971 Southern Television Ltd. Based on the Southern Television series. (Illustration by David Jefferts)

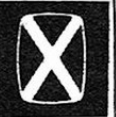

[All details correct at time of going to press.]

FOR COMPLETE DETAILS OF ALL ITV PROGRAMMES SEE *TVTIMES*

# look4in on your ITV programmes this week: Jan 1 - Jan 7

	Saturday	Sunday	Monday	Tuesday	Wednesday	Thursday	Friday
<b>ANGLIA</b> 	12.50 World of Sport 5.00 Rovers 5.30 The Flintstones 6.00 Please Sir! 7.00 Saturday Film	2.45 Film 3.55 Match of the Week 4.45 The Golden Shot 5.35 The Intruder 7.25 On the Buses	4.00 Romper Room 4.55 Flipper 5.20 Bright's Boffins 6.45 Opportunity Knocks!	4.10 Enchanted House 4.55 Sooty Show 5.20 Magpie 7.00 Movie of the Week	4.00 The Romper Room 4.55 Lift Off 5.20 Tottering Towers 7.30 The Thursday Film	4.10 Rupert Bear 4.55 Bush Boy 7.00 Dick Van Dyke 7.30 The Thursday Film	4.00 Romper Room 4.50 Voyage To The Bottom Of The Sea 7.00 Sky's the Limit 7.30 Persuaders! 8.30 Who Do You Do?
<b>MIDLANDS</b> 	12.15 Joe 90 12.50 World of Sport 5.00 It Takes a Thief 6.00 Dick Van Dyke 6.30 Please Sir! 7.00 Saturday Film	2.15 Star Soccer 3.15 Film 4.45 The Golden Shot 5.35 Flaxton Boys 7.25 On the Buses	4.10 Nanny & the Prof. 4.40 Origami 4.55 Forest Rangers 5.20 Bright's Boffins 6.45 Opportunity Knocks!	4.40 Once Upon A Time 4.55 Sooty 5.20 Magpie 7.00 Star Movie	4.10 Ghost, Mrs. Mulr 4.40 Enchanted House 4.55 Skippy 5.20 Tottering Towers 8.00 Jason King	4.40 Rupert Bear 4.55 Lift Off 5.20 Magpie 7.00 Thursday Movie	4.55 Lost in Space 7.00 Fenn St. Gang 7.30 Persuaders! 8.30 Sky's the Limit
<b>BORDER</b> 	12.50 World of Sport 5.00 U.F.O. 6.00 Please Sir! 6.33 Saturday Film 8.00 The F.B.I.	1.55 Football 2.55 Sunday Matinee 4.45 The Golden Shot 7.25 On the Buses 7.55 The Big Film	4.40 Origami 4.55 H. R. Pufnstuf 5.20 Bright's Boffins 6.45 Opportunity Knocks!	4.40 Once Upon A Time 4.55 Sooty 5.20 Magpie 7.00 Tuesday Western	4.40 Enchanted House 4.55 Lift Off 5.20 Tottering Towers	4.40 Rupert Bear 4.55 Rainbow Country 7.40 Feature Film	4.10 Ghost and Mrs. Mulr 7.00 Sky's the Limit 7.30 Persuaders! 8.30 Who Do You Do?
<b>CHANNEL</b> 	12.50 World of Sport 5.00 U.F.O. 6.00 Please Sir! 6.30 Saturday Film	2.00 Big Match 3.00 Feature Film 4.45 Golden Shot 5.35 The Intruder 7.25 On the Buses 7.55 Film	4.05 Once Upon A Time 4.50 Rovers 5.20 Bright's Boffins 6.45 Opp. Knocks!	4.10 Pingwings 4.55 Sooty 5.20 Magpie 7.00 Star Movie	4.05 Lancelot Link 4.55 Lift Off 5.20 Tottering Towers 8.00 Hawaii Five-O	4.05 Origami 4.22 Nanny & the Prof. 4.50 Joe 90 5.20 Magpie 7.00 Thursday Film	4.05 Pinky and Perky 4.25 Smith Family 4.55 Mayerlick 7.00 Sky's the Limit 7.30 Persuaders!
<b>GRAMPIAN</b> 	12.15 The Bugaloos 12.50 World of Sport 5.00 Batman 6.00 Tommy Cooper 6.30 Please Sir!	2.50 Sunday Matinee 4.45 The Golden Shot 5.35 The Intruder 7.25 On the Buses	12.00 Holiday Film 4.40 Rupert Bear 5.20 Bright's Boffins 6.00 Cartoon Time 6.45 Opportunity Knocks!	3.40 Nanny and the Professor 4.40 Once Upon A Time 5.20 Magpie 7.00 Tuesday Western	3.40 Smith Family 4.40 Stories of Tuktu 4.55 Lift Off 5.20 Tottering Towers 7.00 This is Your Life 8.00 Department S	3.40 Dick Van Dyke 4.40 Origami 4.55 Rainbow Country 5.20 Magpie 7.00 Thursday Film	3.40 Jimmy Stewart 4.55 Flintstones 5.20 Tom Grattan 7.00 Sky's the Limit 7.30 The Persuaders! 8.30 Who Do You Do?
<b>GRANADA</b> 	12.15 Supercar 12.50 World of Sport 5.00 Greatest Show On Earth 8.00 The Comedians 8.30 Please Sir!	1.55 Football 2.50 Sylvester 4.40 The Golden Shot 5.35 The Intruder 7.25 On the Buses	4.35 Hatty Town 4.50 Spiderman 5.20 Bright's Boffins 6.40 Opportunity Knocks!	4.40 Origami 4.55 Sooty 5.15 Magpie 7.00 Film 8.20 Sylvester	4.35 Rupert 4.55 Lift Off 5.15 Tottering Towers	4.35 Once Upon A Time 4.50 Arthur 5.15 Magpie	4.35 Magic Bowl 4.50 Captain Scarlet 5.20 Rainbow Country 7.00 Sky's the Limit 7.30 Persuaders! 8.30 On the Buses
<b>WALES/WEST</b> 	12.15 Captain Scarlet 12.50 World of Sport 5.00 Randall and Hopkirk 6.00 Please Sir! 7.00 Saturday Cinema	2.15 Big Match 3.15 Sunday Matinee 4.45 Golden Shot 5.30 The Intruder 7.25 On the Buses	4.15 Tinkertainment 4.30 Superman 4.50 Robin Hood 5.20 Bright's Boffins 6.45 Opportunity Knocks!	4.15 Tinkertainment 4.55 Sooty 5.20 Magpie 6.35 Doctor At Large 8.30 Mike & Bernie	4.15 Tinkertainment 4.55 Lift Off 5.20 Tottering Towers 6.30 Smith Family	4.15 Tinkertainment 4.55 Huckleberry Finn 5.20 Magpie	4.15 Tinkertainment 4.55 Cowboy in Africa 6.35 Bonanza 7.30 The Persuaders!
<b>LONDON</b> 	12.15 Stingray 12.50 World of Sport 5.00 U.F.O. 6.00 Please Sir! 8.00 Hawaii Five-O	1.15 Captain Scarlet 2.15 The Big Match 4.45 Golden Shot 5.35 The Intruder 7.25 On the Buses	3.45 Dangerman 4.40 Rupert 6.40 Opportunity Knocks!	4.10 Simon Locke 4.40 Once Upon A Time 5.20 Magpie 7.25 Tuesday Film	4.40 Paulus 4.55 Lift Off 5.20 Tottering Towers 8.00 The Saint	4.40 Origami 4.55 Acom Ant 6.55 Thursday Film	4.40 Pinky and Perky 4.55 Arthur 5.20 Bright's Boffins 6.30 F Troop 7.30 The Persuaders! 8.30 Who Do You Do?
<b>SCOTTISH</b> 	12.20 H. R. Pufnstuf 12.50 World of Sport 5.00 Alice in Wonderland 6.00 Please Sir! 6.30 Saturday Feature	2.55 Feature Film 4.45 The Golden Shot 7.25 On the Buses	3.30 Origami 4.55 Batman 5.20 Bright's Boffins 6.20 Simon Locke 6.40 Opportunity Knocks!	4.55 Sooty 5.15 Magpie 6.20 Hogan's Heroes 6.50 The Tuesday Film	4.55 Lift Off 5.15 Tottering Towers 8.00 Department S	4.55 Bush Boy 5.15 Magpie 7.00 Thursday Film	3.30 Kiri 4.55 Fireball XLS 6.20 Mr. Magoo 6.30 Jimmy Stewart 7.00 Sky's the Limit 7.30 The Persuaders!
<b>SOUTHERN</b> 	12.50 World of Sport 5.05 Randall & Hopkirk 6.00 Tommy Cooper 6.30 Please Sir! 7.00 Saturday Film	2.00 Big Match 4.40 Golden Shot 7.25 On the Buses 7.55 The Big Picture	4.30 Best of Lucy 4.55 Richard the Lionheart 6.45 Opportunity Knocks!	4.55 Sooty 5.20 Magpie 6.30 Fenn Street Gang 7.00 Tuesday Film 8.30 Mike & Bernie's Show	4.55 Lift Off 5.20 Tottering Towers 8.00 Jason King	4.55 Joe 90 6.30 Junkin 7.00 Thursday Film	4.55 Voyage To The Bottom Of The Sea 7.00 Sky's the Limit 7.30 The Persuaders!



**TYNE TEES**

12.15 The Bugaloos  
12.50 World of Sport  
5.00 U.F.O.  
7.30 Please Sir!

2.10 Shoot  
3.10 Sunday Matinee  
4.45 The Golden Shot  
5.35 The Intruder  
7.25 On the Buses

4.40 Grasshopper Is.  
4.55 Lift Off  
5.20 Tottering Towers  
8.00 Jason King

4.40 Origami  
4.55 Captain Scarlet  
7.00 Film

4.40 Pinky and Perky  
4.55 Flintstones  
7.00 Sky's the Limit  
7.30 Persuaders!

**ULSTER**

12.15 Skippy  
12.50 World of Sport  
5.00 Best of Lucy  
6.00 Please Sir!  
6.30 Saturday Picture  
8.00 The Persuaders

2.15 Big Match  
3.15 Sunday Matinee  
4.45 The Golden Shot  
7.26 Star Movie

4.30 Romper Room  
4.55 Lift Off  
5.20 Tottering Towers  
7.00 Dr. Simon Locke  
8.20 Cartoon Time

4.30 Romper Room  
4.55 Forest Rangers  
7.00 Dr. Simon Locke

4.30 Romper Room  
4.55 Lift Off  
5.20 Tottering Towers  
7.00 Dr. Simon Locke  
8.30 Mike and Bernie

**WESTWARD**

12.50 World of Sport  
5.00 U.F.O.  
6.00 Please Sir!  
6.30 The Saturday Film

2.00 The Big Match  
3.00 Feature Film  
4.45 The Golden Shot  
5.35 The Intruder  
7.25 On the Buses  
7.55 Film

3.55 Gus Honeybun  
4.05 Origami  
4.22 Smith Family  
4.55 Flintstones  
7.00 Sky's The Limit  
7.30 Persuaders!

3.55 Gus Honeybun  
4.05 Origami  
4.55 Joe 90  
7.00 Thursday Film

3.55 Gus Honeybun  
4.05 Lancelot Link  
4.55 Lift Off  
5.20 Tottering Towers  
8.00 Hawaii Five-O

**YORKSHIRE**

12.15 The Bugaloos  
12.50 World of Sport  
5.00 Randall & Hopkirk  
6.00 Voyage To The Bottom Of The Sea

2.15 Soccer  
3.10 Sunday Cinema  
4.45 The Golden Shot  
5.35 The Intruder  
7.25 On the Buses  
7.55 Film

4.40 Rupert  
4.55 Lone Ranger  
6.30 The Smith Family  
7.00 Film

4.40 Rupert  
4.55 Lift Off  
5.20 Tottering Towers  
8.00 Jason King

4.40 Enchanted House  
4.55 Sooty  
5.20 Magpie  
6.30 Dr. Simon Locke  
6.55 Tuesday Western

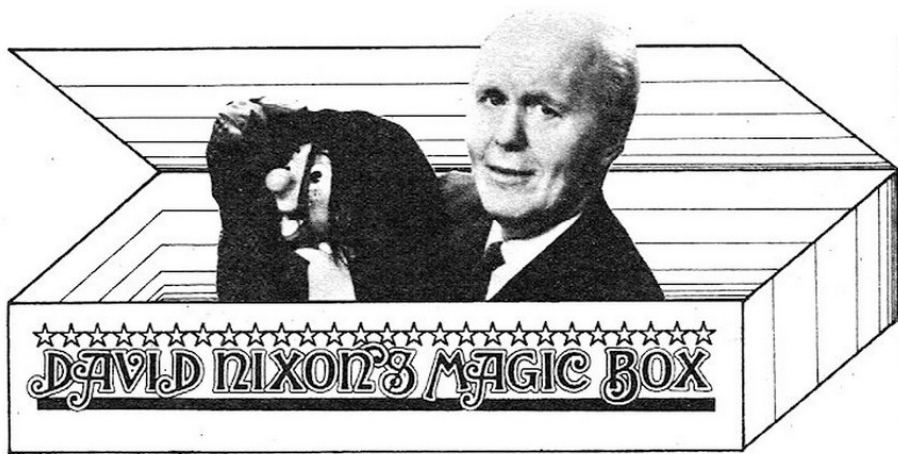

**DAVID NIXON'S MAGIC BOX**

**Jumping Crosses**

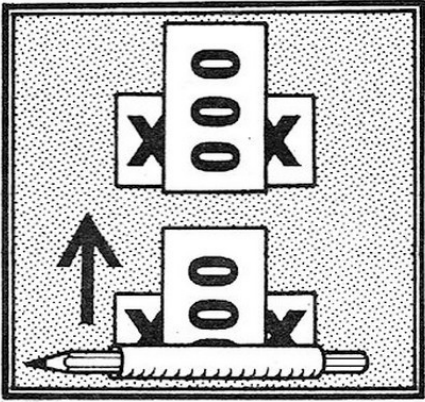

Take two pieces of paper, each about the same size as a £1 note and draw three crosses on one and three noughts on the other. Arrange them as shown in the picture with the noughts on top. Place a pencil along the bottom edges of the papers together with it. Now unroll the papers—still keeping everything flat on the table—and you will find that the crosses are now on top. Amazing, eh? Try it for yourselves and see!

**Cash Balance**

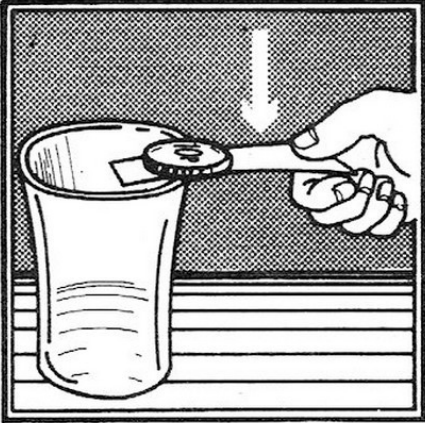

Place a narrow strip of paper about six inches long over the edge of a tumbler and balance a ten-penny piece flat on it. The problem you put to your friends is to remove the strip without upsetting the coin. The correct pro-

cedure is as follows. Hold the strip out straight with one hand, while you bring the forefinger of the other hand sharply down on the centre of the strip. It's a good idea to practise this one in private beforehand.

**The Big Book Blow**

For this challenge stunt you need a big fat book—like a dictionary. Stand the book upright on the table and ask your friends if they can blow it over. When they have run out of puff, show them how it can be done. Stand the book on an empty paper bag near the edge of the table. Now inflate the bag and over the book will go—toppled merely by your breath power!

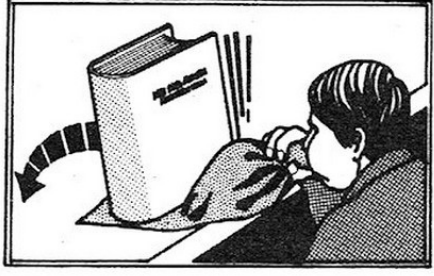

**TEASER TIME**

For last week's puzzle you had to divide the shape illustrated into four pieces exactly the same size and shape. The dotted lines show you how it's done.

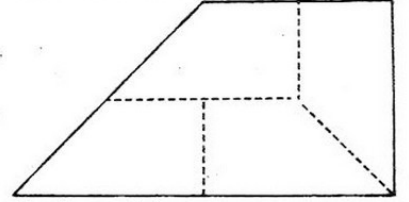

Here's a quick teaser to try out on your friends. Ask them to write down a four figure number which, when divided by two, will leave absolutely nothing. When they give up, just write 8888. Divide it in two by drawing a line right across the middle—and that will leave nothing but a row of noughts.



By arrangement with David Nixon. Based on the Thames TV programme. Illustrations by Hardy Escamery



# LIFT OFF FOR THE APOLLO SET!

9 BEAUTIFUL REPLICAS OF APOLLO MISSION BADGES WILL BE EXCLUSIVELY OFFERED IN LOOK-IN DURING THE NEXT 5 WEEKS!

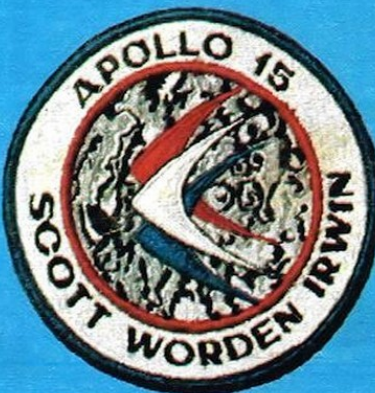

Designed by the U.S. astronauts, the Apollo mission badges are embroidered with thousands of coloured stitches and will be offered at a specially attractive price.

**Don't miss next week's Look-in for the first exciting offer!**