

Look-in

Junior TVTimes No 15

w/e 8 April 1972 Every Thursday 5p



GREAT OFFER!
REPLICA OF
APOLLO 16
MISSION BADGE
SEE BACK COVER



Doctor in Charge

NEW SERIES BEGINS SUNDAY ★ READ ABOUT IT INSIDE, PAGE 5

Crowther in trouble

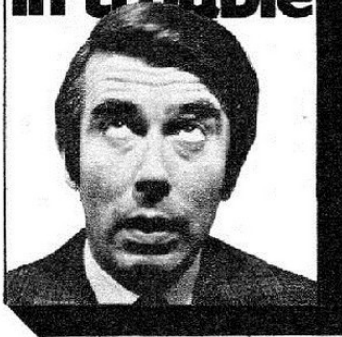

Sun-bathing makes Leslie really 'browned off'!

THE CROWTHERS ARE STILL ON HOLIDAY, AND VERY EARLY, ONE DAY...



AND SO...



... TO THE GARDENS ATTACHED TO LESLIE'S HOLIDAY APARTMENT...



Look-in

Number 15
(Cover Illustration by Arnaldo Putzu)

SPACE LAUNCH COMPETITION PRIZEWINNER

Judging has now been completed on the recent LOOK-IN Space Launch Competition published during the January issues.

The winner, who will soon be travelling to Miami Beach, is **Jeremy Goodwin, of Hockley, Essex.**

Following is the complete list of runners-up and details of the prizes they will be receiving.

50 AIRFIX APOLLO SATURN V KITS

- have been won by:
- Jonathan Smalley, Knadhill, Surrey.
 - Paul Daniels, St Peter's, Kent.
 - Elin James, Crymch, Pembrokeshire.
 - D. R. Smith, Maidstone, Kent.
 - Jonathan Daniel, Preston, Lancs.
 - Adrian Tyrrell, Haywards Heath, Sussex.
 - Martin Smith, New Earswick, Yorkshire.
 - Raymond Martin, East Ham, London.
 - Christopher Cessford, Lutterworth, Leics.
 - Simon Clatworthy, Holmrook, Cumberland.
 - Roger Wills, Rainham, Essex.
 - Ian Rowley, Eastwood, Notts.
 - Keith Mitchell, Sittingbourne, Kent.
 - Russell Chandler, Greenock, Scotland.
 - Alan Bagnall, Wallsend-on-Tyne.
 - M. O'Dowd, Basford, Notts.
 - Jamie Cabbett, Brighton, Sussex.
 - Terry Francis, Portsmouth, Hants.
 - Jeffrey Hackett, Batemoor, Sheffield.
 - Michael Cooke, Bournemouth, Hants.
 - T. C. Stokes, Bricket Wood, Herts.
 - Mark Coleman, Dulwich, London.
 - Anthony Wood, Blaydon-on-Tyne, Durham.
 - T. Spracklen, Marlow, Bucks.
 - Clive Fisher, Fazeley, Staffs.
 - Kevin Fisher, Fazeley, Staffs.
 - Terry Carter, Southcourt, Bucks.
 - Anthony Smith, Bushey, Herts.
 - David Ferrisey, Liverpool.
 - Kevin Smith, Milton, Hampshire.
 - Darren Pye, Hull.
 - Robert Terry, South Chingford.
 - Anthony Taylor, Kidlington, Oxon.
 - Stephen Pearce, Pimpton, Devon.
 - Duncan Clearing, Haughton Green, Lancs.
 - Derek Hayes, Sirewsbury, Shropshire.
 - Julie Garton, Todwick, Sheffield.
 - David Kay, Rosyth, Scotland.
 - Andrew Parker, Gorseley Leys, Staffs.
 - Andrew Lister, Prestwich, Lancs.
 - Andrew Korah, Withington, Lancs.
 - Sunil Patel, Wellingborough, Northants.
 - Ivor Hobson, Shenfield, Essex.
 - David Evans, Peasley, Notts.
 - John Hooper, Scarborough, Yorkshire.
 - Simon Furness, Amersham, Bucks.
 - Nicholas Cooper, Wimbledon, London.
 - Malcolm Gorham, Edgware, Middlesex.
 - William Bum, Barmulloch, Glasgow.
 - Richard Taylor, Kidlington, Oxon.

50 AIRFIX SATURN 1B KITS

- will be despatched to:
- Arthur Plews, Grangetown, Teesside.
 - Paul Rodgers, Garston, Herts.
 - Anthony Nelson, Leeds, Yorkshire.
 - Gary-Paul Khan, London, SW11.
 - Richard Tubman, Corlissand, N. Ireland.
 - Alan Walker, Newlands, Glasgow.
 - Jennifer Thompson, Monk Bretton, Yorks.
 - Stephen Brewer, Leitchworth, Herts.
 - Dawn Anderson, St. Albans, Herts.
 - Frank Butler, Copnor, Hants.
 - Fiona Love, Welwyn Garden City, Herts.
 - Lynn Fisher, London, E3.
 - Fiona Bennett, London, SE4.
 - Colin Gilbert, Drigs, Cumberland.
 - Graham Hall, Headington, Oxon.
 - Christopher Dixon, Caterham, Surrey.
 - Phillip Cowell, Crown Hill, Devon.
 - James Gamer, Bognor Regis, Sussex.
 - Alan Tyrer, Bitterne, Southampton.
 - Anna Leaves, Aldershot, Hants.
 - Alastair Stewart, Felmersham, Beds.
 - Alan Janes, Abingdon, Berks.
 - Eric Hamilton, Musselburgh, Scotland.
 - Andrew McCarthy, Falkestone, Kent.
 - David Stock, Irlam, Lancs.
 - Trevor Prew, Ramsgate, Kent.
 - Adam Clark, Lincoln.

Continued on Page 20

By arrangement with Leslie Crowther.

A shock for Stan on Cup Final day!



CONDUCTOR, ALF GLOVER, HAS MANAGED TO GET STAN A TICKET FOR THE CUP FINAL, AND IN ORDER TO GET OFF WORK, STAN FAKES A FALL AND PRETENDS HE HAS HURT HIS LEG...

YOU FOOLED BLAKEY, ALL RIGHT MATE, BUT I'M SUPPOSED TO BE TAKING YOU TO THE HOSPITAL! WHAT HAPPENS NOW?

SIMPLE! WE 'AVE A QUIET CUPPA FOR 'ALF AN HOUR THEN GO BACK AN' TELL OLD MISERY-CHOPS THAT I WASN'T ADMITTED!



SO, BACK AT THE DEPOT...

WELL, BUTLER, WHAT DID THE DOCTOR SAY? IS IT BAD?



TERRIBLE! LIGAMENTS STRETCHED AN' STRAINED ALL OVER THE PLACE! I WON'T BE CLIMBIN' INTO A DRIVING CAB UNTIL MONDAY, AT LEAST!

HARRY NORTH.



I FEEL SO GUILTY ABOUT IT, SATURDAY BEIN' OUR BUSY DAY, AN' ALL! IF ONLY I HADN'T BEEN SO CLUMSY!

THERE, THERE, BUTLER! DON'T BLAME YOURSELF. YOU GET OFF HOME AND REST. WE'LL FIND A REPLACEMENT SOMEHOW!

MINUTES LATER...

HA, HA, HA, WHAT A GIGGLE! DID YOU SEE HIS FACE, JACK? 'IT'S NO USE BLAMIN' YOURSELF, BUTLER! GO HOME AND REST.' YAA, HAA, HAA!



YOU'LL BE LAUGHIN' ON THE OTHER SIDE OF YOUR FACE IF HE FINDS OUT, MATE!



NOT A CHANCE! JUST THINK OF ME AT THE MATCH TOMORROW!

GAH! LUCKY DEVIL!

NEXT DAY STAN IS READY WITH PLENTY OF TIME TO SPARE...

WAA-AAY! PLAY UP UNITED! COME ON, THE RED AND WHITES!

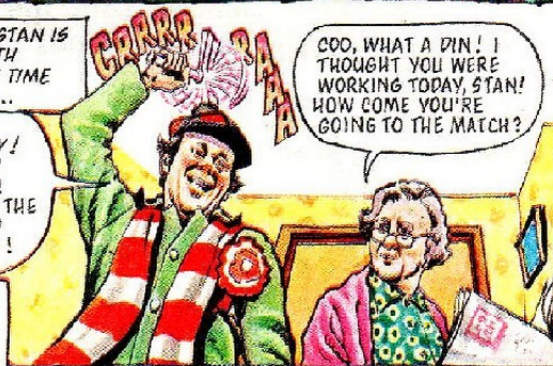

COO, WHAT A PIN! I THOUGHT YOU WERE WORKING TODAY, STAN! HOW COME YOU'RE GOING TO THE MATCH?



LET'S JUST SAY I NEARLY HAD A NAGTY ACCIDENT! BYE, MUM - SEE YOU AT TEA-TIME WHEN WE'VE WON THE CUP!

WEMBLEY STADIUM ON CUP FINAL DAY! A FANTASTIC SIGHT...

LET'S SEE NOW, MY TICKET'S FOR ROW Y, SEAT 42...

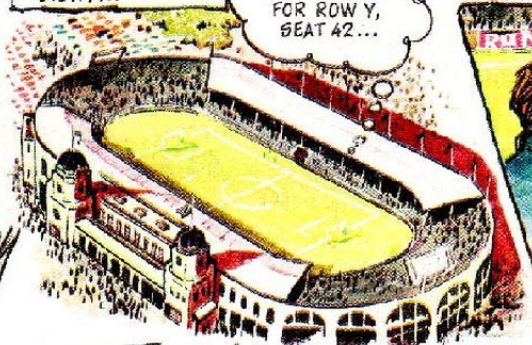

'ERE WE ARE, PERFECT! A SMAGHIN' VIEW! WON'T BE LONG NOW!



TIME WEARS ON UNTIL SUDDENLY, FIVE MINUTES BEFORE THE KICK-OFF...

ROW Y, SEAT 43, MATE! CAN YOU TELL ME WHERE IT IS?

YES, SIR, ON YOUR LEFT. HALFWAY ALONG!

...STONE THE CROWS, THAT VOICE! IT CAN'T BE!

BUT IT IS...



BLAKEY! H...WE MUST 'AVE BOUGHT A TICKET OFF ALF GLOVER 'N ALL!



THE PERISHER'S GOT THE FLAMIN' SEAT NEXT TO MINE!

Based on the London Weekend Television series written by Ronald Wolfe and Ronald Chesney

STEWSPOT'S LOOK-OUT

DIDDLEY-DUM, DIDDLEY-DEE, DIDDLEY-DUM, DIDDLEY-DEE... That, as you probably spotted immediately, is the sound of train wheels running over the track.

I love going places by train—especially when it's nosh-time and I can eat while I'm travelling.

Recently, I took a train to Sheffield where I was to visit the Children's Hospital. They were going to meet the great Doctor Stewpot. But it was *me* who needed a doctor by the time I arrived. What for? To calm me down!

The waiter (or steward as he's called on a train) was a real Surly Sam. He spilt the soup, didn't serve me *nearly* enough spuds (I love em!) and then overcharged me on the bill. To make matters worse, he complained when I asked for another cup of coffee.

'Right,' I thought, 'that's the last time I go by rail. Stick to your bike in future, Stewpot,' I said to myself.

On the way back from Sheffield, however, it was entirely different. When the steward arrived, I decided to start afresh and not be influenced by the incident on the upward journey.

Guess what? The steward turned out to be the 'double' of Frankie Howerd and I couldn't stop giggling every time we spoke.

He was so polite and so charming, that I forgot about my arguments with the other chap.

So, in future, I *will* stick to trains and leave my bike in the shed after all.

The point of all this—is always try and put on a happy face and be polite. It makes other people nicer to you.

* Talking of trains, take a look at Magpie on page 21.

Black Beauty Rides Again!

Remember the horse made famous by novelist Anna Sewell? It was, of course, *Black Beauty*. London Weekend Television has just started filming a new series based on the book, and the leading role—the horse

itself—was recently cast.

It goes to Black Jet, the seven-year-old in the picture, who came to England four years ago, winning several races on the northern courses. And, as his near namesake, it's odds-on he'll be equally as successful on the screen, too!

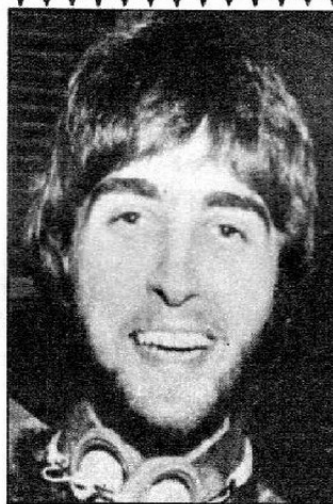

Fan Club News!

Two more 'must' addresses for pop-pickers: fans of *Johnnie Walker*, write to c/o Jill & Chrissie, 20 Little Underbank, Stockport, Cheshire; and all admirers of *Georgie Fame* to c/o Jackie, 67 Brook Street, London W.1.



The world of medicine is always looking for fresh discoveries. In the case below, it enjoys a new name to a well-proven fun-filled formula . . .



DOCTOR IN CHARGE

Feeling depressed? Run down? In need of a tonic? Take some good advice, and pay regular visits to the hospital for the next twenty-seven weeks! Not *any* old hospital, of course. Where the prescription is strictly for laughs, the place in question must be Saint Swithin's! Based on the brilliantly successful books by Richard Gordon, the 'Doctor' series on television began with 'Doctor In The House', continuing with 'Doctor At Large'. And now the favourite characters are back on the screen for a third run in 'Doctor In Charge'. The new stories are set in and around Saint Swithin's Hospital, and this time the central figure is to be Dr. Duncan Waring, played by Robin Nedwell, whom older fans will remember seeing as a medical student in the first series. Supposedly coming back to Britain after a two-year stint in the United States, 

PRETENDERS See episode seven, this week! ★ Recognise the man under-guard at the rear of the column, in the picture? It is Joachim—once again in the hands of the king's dragoons. But Elam is planning his rescue—with the help of Fast Jack and his rebels, who want the powder-wagon the soldiers are escorting. An ambush awaits them in Cheddar Gorge.



DOCTOR IN CHARGE

← Dr. Waring takes up an appointment as Senior House Surgeon to Loftus, the irascible Professor of Surgery, played by Ernest Clark. Needless to say, Waring isn't back five minutes before the unfortunate professor is reaching for his nerve tonic.

The happy-go-lucky Waring is assisted, hindered, involved and misguided by that suave man-of-the-world, the anaesthetist Dr. Dick Stuart-Clark, portrayed by Geoffrey Davies. Then there's Dr. Paul Collier, Stuart-Clark's companion in hearty drinking and hare-brained thinking—played as before by George Layton, and a distracting newcomer to the scene in the delightful shape of Sammie Winmill, who plays Nurse Sandra Crumpton.

Just add Bingham—whom we know to be the greatest medical brain of the century, because he told us himself—Dr. Laurence Bingham, made satisfyingly hate-worthy by actor Richard O'Sullivan—and you have all the main ingredients for a sure-fire anti-gloom medicine.

Off-set, the actors who play these parts are much the same as we see them on the screen. With two exceptions. Richard O'Sullivan is neither brash nor pompous, and Ernest Clark is anything but fiery and irascible. Broadly, though—and this is perhaps some of the charm of

the series—they portray real people. People whom viewers can believe in. It raises a frightening train of thought. Suppose real doctors could be found who were as zany as this lot!

The mind boggles, for example, to think of a surgeon having the hobby of the real-life Robin Nedwell. He collects those terrifying, keen-bladed Japanese swords! And Richard O'Sullivan, sharing with some of the others a passion for a



Dr. Duncan Waring and nurse Crumpton.

game of darts . . . it would be a brave patient who submitted to his attentions with a hypodermic needle!

Oddly, one of the cast could have entered the medical profession. George Layton comes from a doctor's family, and his grandfather was City Pathologist of his home town, Bradford.

'Doctor In Charge', which is presented by London Weekend Television, promises to be one of the top comedy series of 1972. Its predecessor, 'Doctor At Large', made TV history by being the first British comedy programme to be screened in America.

Dr. Waring with his colleague Dr. Laurence Bingham, (Richard O'Sullivan).

Roundabout Runabout!

Let's imagine you've just had a birthday or that Aunt Clara has made her yearly visit and given you some extra pocket-money.

Right! You've got 75 new pence in your pocket and you're going round in circles wondering what to spend it on . . .

Well, talking of circles, Dougal from the *Magic Roundabout* has decided—in roundabout terms—to get mobile. That's why he can be found, together with friends Dylan and Brian Snail, in a really great car from Corgi.

It is colourfully painted and on the bonnet is a transfer of the *Magic Roundabout* and the wheels are fast-running red Whizz-wheels.

What's more, it's available in the shops now! So why not hurry round and get something really worthwhile for that 75p?



THE LOOK-IN CROSSWORD



Across:

- Bringing back the colour, like on an old painting.
- David, pictured, is featured in *Tightrope*.
- Basically an indoor sport played with rackets and a high net.
- There is a different one for each television network; it also separates England and France.
- A small weight.
- Helps you to hear.
- Doris of *Coronation Street*: m.p.h. is used to calculate it.
- American singer Miss Horne.
- What the masters are supposed

to do at Fenn Street School.
16. Most modern Moon shot; we offer you the badge this week. (6,7).

Down:

- Island famous for sugar.
- Pictured actor—one of the *Doctors In Charge*. (5,7).
- They are hit by the rackets in 7 across.
- This week's pin-up.
- Like 2 down this pictured actor also stars in *Doctor In Charge*. (6,6).
- Defenders in hockey or soccer.
- Comedian Charlie.
- Our show-jumping Princess.

Across: (2) Restoring; (6) Munro; (7) Badminton; (10) Channel; (11) Ounce; (12) Ear; (13) Speed; (14) Lena; (15) Teach; (16) Apollo Sixteen. Down: (1) Cuba; (2) Robin Nedwell; (3) Shuttlecocks; (4) O'Connor; (5) George Layton; (7) Backs; (8) Drake; (9) Anne. :sawnsu



SMILE WITH STEWPOT

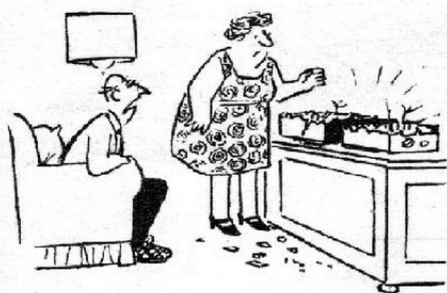

"I said try giving it a tap—not a karate chop."



"Can I have a . . . ?"



"I told you not to talk politties with the dustmen!"

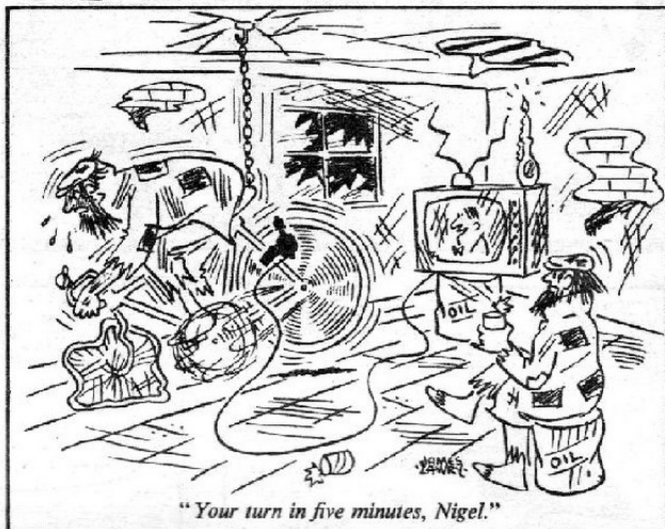

"Your turn in five minutes, Nigel."

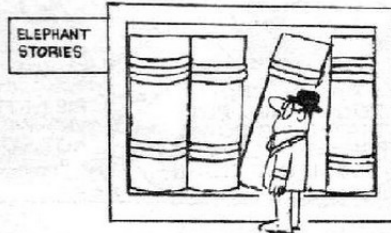

EXCITING NEWS! A FREE GIFT IN NEXT WEEK'S LOOK-IN

★ Much interest has been created by the LOOK-IN offers of replicas of Apollo Mission badges. ★ Now these badges have been reproduced in self-adhesive vinyl form at a reduced scale. Next week, LOOK-IN will contain one of the nine badges pictured here—and it will be absolutely FREE. ★ Also in next week's LOOK-IN, 'Stewpot's Look-Out' welcomes Ken Goodwin!

**Don't miss out—
order your copy of
LOOK-IN now!**

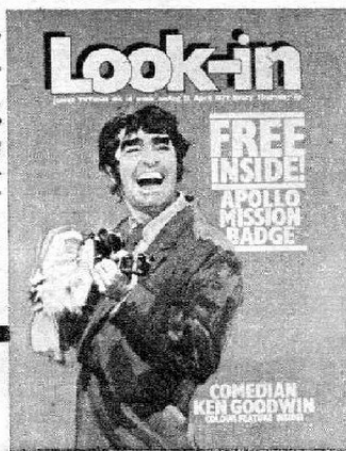

For once the ancient sorcerer is 'speechless'!

CATWEAZLE



WHEN CATWEAZLE LANDS UP IN THE TWENTIETH CENTURY HE MAKES FRIENDS WITH JOE BOND, WHOSE FATHER IS A STAGE-MAGICIAN - THE GREAT BONDINI. AN ANCIENT BOOK OF BONDINI'S GIVES CATWEAZLE A FAR-FETCHED RECIPE FOR A SPELL THAT WILL TAKE HIM BACK TO HIS OWN TIME. ONE OF THE INGREDIENTS IS 'HOOT OF OWL' - BUT CATWEAZLE RECKONS HE'S FOUND THE SECRET OF COLLECTING IT...

IT'S A TAPE-RECORDER - BELONGING TO THE THEATRICAL BIRD-CALL IMITATOR, EAGLE EVANS...



GAHHH! IT'S YOU AGAIN! PUT THAT THING DOWN BEFORE YOU BREAK IT, YOU OLD CLOWN!

FIE! FTTT! WHY WILL IT NOT HOOT?



I COME ALL THE WAY OUT HERE TO RECORD THE SONG OF A TREE-CREEPER, AND YOU BARGE IN AND RUIN EVERYTHING!



HOOT! THOU ART MINE NOW, TRICKERY-BOX! HOOT, HOOT! I COMMAND THEE!

I MEANT NO HARM, MASTER. ALL I CRAVE IS THE HOOT OF AN OWL!

IRRITABLY, EVANS WINDS BACK AND PRESSES THE RE-PLAY BUTTON...



I DON'T KNOW WHAT YOU'RE BABBLING ABOUT! SEE HOW MUCH TAPE YOU'VE SPOILED!

HOOT! THOU ART MINE NOW, TRICKERY-BOX! HOOT, HOOT! I COMMAND THEE!

HEARING HIS OWN VOICE HAS AN ASTONISHING EFFECT ON CATWEAZLE...



EEEEK! GURRRK!

BACK AT THE THEATRE WHERE BONDINI IS PLAYING, CATWEAZLE SEEKS OUT JOE...



MMMP! URRRKK! CROAKLE!

PARDON? IS THERE ANYTHING WRONG?

CATWEAZLE SEEKS PEN AND PAPER. THEN...

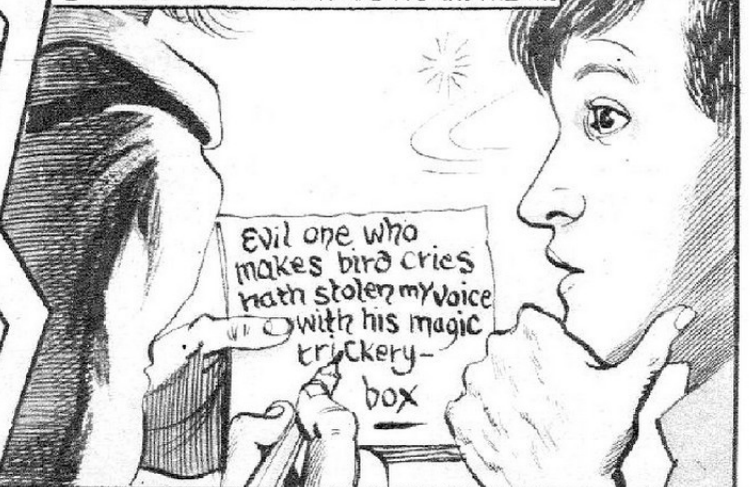

Evil one who makes bird cries hath stolen my voice with his magic trickery-box

SEVERAL SHEETS LATER, JOE HAS MANAGED TO WORK OUT WHAT HAS HAPPENED...



IT WAS ONLY A TAPE-RECORDER! IT HASN'T PINCHED YOUR VOICE, YOU CHUMP! TRY AND SPEAK - GO ON...

MMMM...



HERE GOES - I HOPE HE REALISES IT'S FOR HIS OWN GOOD!

THOU LIZARD-FACED, RAT-TAILED...

... NOW, NOW, CATWEAZLE! SHOUTING LIKE THAT WILL MAKE YOU LOSE YOUR VOICE!



SO LATER...

RIGHT. NOW I'LL TELL YOU WHAT I'LL DO. I'LL RECORD AN OWL-HOOT FOR YOU - AND GIVE YOU THE PIECE OF TAPE TOMORROW. OKAY?

I FEAR THEE NO LONGER, TRICKERY-BOX! AIEEE! THAT YOU CAN CAPTURE ANY SOUND AND REPEAT IT, TIME AFTER TIME!



WOE IS ME! I SHALL NEVER SPEAK AGAIN!

THERE'S ONLY ONE WAY TO SNAP HIM OUT OF THIS!

YAAAGGH!

THWARKKKK!

WHY - 'TIS A WONDER! I CAN SPEAK! MAYHAP THE SHOCK DROVE OUT THE WICKED DEMON OF POSSESSION!

THINK WHAT YOU LIKE. AND NOW, IF YOU'RE QUITE READY, I HAVE A TAPE-RECORDER, AND I'LL SHOW YOU, STEP BY STEP HOW IT WORKS!



AND THAT NIGHT...

HOO-HOOOOO! HOO-HOOOO!

I MUST BE AS CRAZY AS CATWEAZLE, DOING THIS! I HOPE THE NEXT INGREDIENT FOR HIS ROTTEN SPELL'S A BIT EASIER TO FIND!

Potter's hilarious new hobby poses a problem!

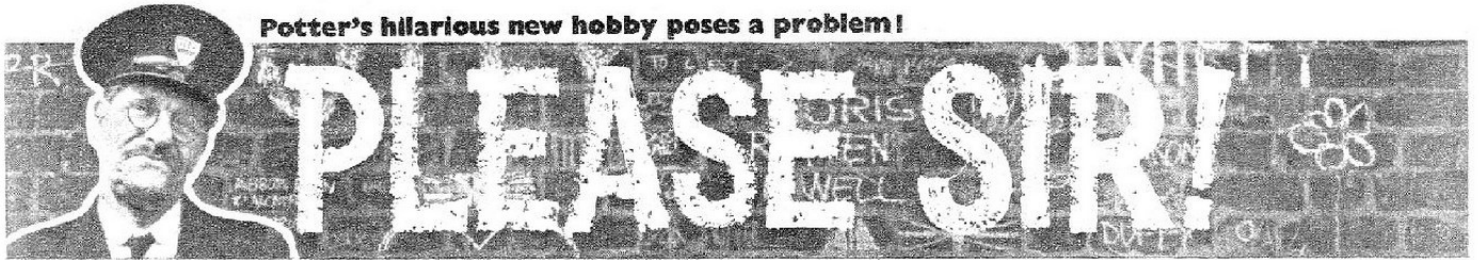

ONE MORNING...



RELAX - YOU ARE GETTING SLEEPY, 'EADMAS-TER! YOU FEEL YOU'D LIKE TO GIVE NORMAN POTTER AN 'ALF DAY OFF...

EH?



I FEEL NOTHING OF THE SORT! PULL YOURSELF TOGETHER, NORMAN, AND KINDLY STOP SWINGING THAT WATCH!

OWWW! ER, SORRY, SAH! JUST MY LITTLE JOKE. NO 'ARM MEANT...

MR. PRICE GETS THE NEXT SHOCK...



DROWSY - DROWSY - GAZE INTO MY EYES...

'ERE, WHAT'S UP WITH OL' NORM'?

HE'S HAVING A FUNNY TURN.



FROM HERE ON YOU WILL CLEAN OUT YOUR LABORATORY! I SHALL NOT BE NEEDED...

HE'S GONE CRAZY!

NO! POTTYS ALWAYS LIKE THAT...



BUT...

GIVE OVER! HAVE YOU LOST YOUR CONKERS, BOYO? YOU'LL DO YOURSELF A MISCHIEF STARING LIKE THAT...

EH...?AAGH! WATCH IT!



NOW, WHY HASN'T IT WORKED? MOST PECULIAR - I FOLLOWED THE INSTRUCTIONS...

LET'S SEE WHAT THE OLD CLOWN'S UP TO! ... COR-LUMME - HYPNOTISM!



LATER, BETWEEN LESSONS...

'ERE, LET'S HAVE A GIGGLE. IT'S A PITY TO DISAPPOINT OL' NUTTY NORM'...

YEAH! WHAT D'YOU WANT US TO DO, TERRY?



MAKE AS MUCH ROW AS YOU CAN. GO ON!

THIS AIN'T A ROW - MINE'S MUSIC!

POTTER'S COMIN' NOW!

Based on the London Weekend Television series created and written by John Esmonde and Bob Larbey © 1972 Esmonde Larbey Ltd.

THE NOISE DRAWS SWIFT ATTENTION...



I'LL TRY ME 'FLUENCING ON THEM YOUNG THUGS. MY BIG CHANCE!

BOOM!
THUD!

POTTER, MAKE THEM HUSH! TELL THEM I'LL PUT THEIR NAMES IN THE 'NAUGHTY BOOK' WHEN I GET THERE...

POTTER FIXES FOUR 'C' WITH AN EAGLE EYE...



... WATCH THE WATCH! YOU FEEL DROWSY - QUIET! SSSSH!

IT'S WORKING! IT'S MY WILL-POWER...

YOU'RE IN A TRANCE! OH, MY GOODNESS, YES! START TO CLEAN UP THE ROOM. HEE-HEE!



WE WILL CLEAN UP THE ROOOOOM!

NO... OWWW! THEY'VE GONE BARMY! COME ROUND - DE-HYPNOTISE, YOU ORRIBLE SHOWER!

HOWEVER, THINGS GO WRONG - AS USUAL...



CLEAN... IT... UP!

THROW EVERYTHING OUT!

OH, NO! THEY'VE GOT IT WRONG! WAKE UP! THOSE TEXT BOOKS - STOP!

WHAT THE OLD HARRY...?

HEEELP! I'VE HYPNOTISED THEM! I CAN'T BRING 'EM OUT! THEY'RE UNDER THE 'FLUENCE!



YEEEEEK, MY EAR! OKAY, OKAY - I'VE RECOVERED!

WE WERE ONLY PULLING OLD POTTY'S LEG!

RIDICULOUS MAN!



RUBBISH, NORMAN!



POOR NORMAN! YOU LOOK SHAKEN - TAKE THE REST OF THE DAY OFF!

EH? THANK YOU, SAH! WITH A GENTLEMAN LIKE YOU, 'EADMASER, WHO NEEDS HYPNOTISM?

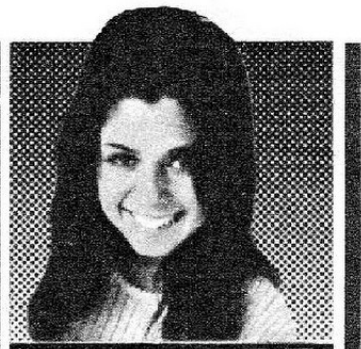

LIFT OFF

'Everybody's Talking' was the title of the song that made Harry Nilsson an international singing star. But he has since justified the enthusiasm of his reception by the public with three fine albums and his last hit single—'Without You'. But although Nilsson has been so successful on record—and last January actually had two TV shows screened on the same channel on the same day!—believe it or not, he has never done a live show or concert. I found this so hard to understand that I even telephoned the very hard-working Press Officer of R.C.A.

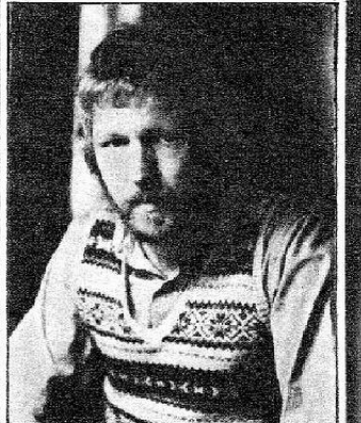

Everybody's talking about Harry Nilsson—a talented recording artist.

Records to check—and he assured me that it was so. Nilsson has always been described as 'a record person' and at one time there was an almost standard reply if anyone mentioned his name. You would answer: 'Harry who?!' A good deal of this myth has been created by Harry himself but I think it's a shame that his fans can only get a very occasional glimpse of him on television or listen to him on record. I for one would love to go and see him.

Well, who knows—if he reads this he might do a concert for us all! Bye for now.

Next week: Cromwell the 'peacemaker'!

THE MARKED MAN

The final instalment of Look-IN's exciting 'whodunnit' story!

AN EYE-SHAPED TATTOO CONVINCES P.C. TOD MANNION THAT MARTY LEWIS IS BEHIND A £50,000 ROBBERY, EVEN THOUGH LEWIS IS REPORTED TO BE SERVING A TWO-YEAR SENTENCE IN PARKWAYS PRISON. DESPITE WARNINGS FROM DETECTIVE-SERGEANT TRAGG, TOD PURSUES HIS HUNCH, AND WHEN HE LEARNS THAT LEWIS WAS INVOLVED IN A FRUITLESS ESCAPE-ATTEMPT, THE YOUNG CONSTABLE 'BORROWS' A PATROL-CAR, AND HURTLIES OFF...

... REPORT FROM CAR ABLE SEVEN, SARGE! MANNION HAS JUST BEEN SPOTTED HEADING WEST, ALONG VENNER STREET!

THEN GET AFTER HIM. I WANT THAT IDIOT ROUNDED UP BEFORE HE LANDS US IN COURT FOR WRONGFUL ARREST!

MEANWHILE, TOD MANNION HAS ARRIVED AT HIS MYSTERIOUS DESTINATION ...

THE 'SILVER PALACE' AMUSEMENT ARCADE—MARTY LEWIS'S OLD HANG-OUT! THE LADS HAVEN'T EVEN BOTHERED TO CHECK IT OUT, BECAUSE THEY THINK HE'S IN PRISON!

... BUT I THINK HE HELPED TO STEAL FIFTY-THOUSAND QUID—AND I MEAN TO PROVE IT!

HEY, COPPER! WHERE DO YOU THINK YOU'RE GOING...?

THE LITTLE ATTENDANT LEAPS TOWARDS A ONE-ARM BANDIT...

HE MUST BE ON TO SOMETHING! I'D BETTER WARN THE BOYS...

AND, NEXT MOMENT...

NICE OF YOU TO DROP IN TO THE ARCADE, COPPER—BUT YOU WON'T FIND IT VERY AMUSING!

HECK! THAT ATTENDANT MUST HAVE ALERTED THE GANG!

A PICKAXE-HANDLE WHISTLES PAST TOD'S HEAD...

YOU'D BETTER GET OUT OF HERE, LADS! I NEED THESE!

YOU'RE WELCOME, MATE!

TWO DOWN! ONE TO GO!

NNNFF!

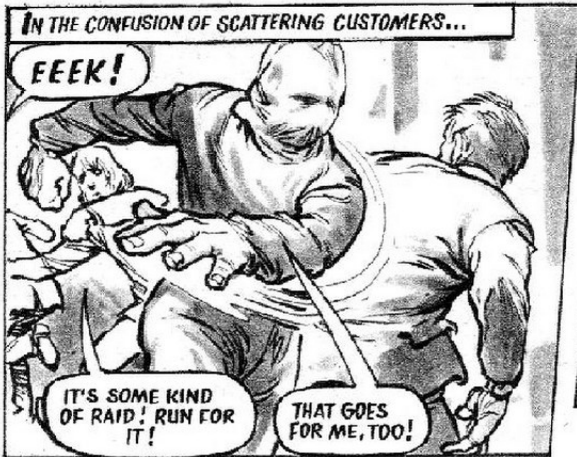

IN THE CONFUSION OF SCATTERING CUSTOMERS...

EEK!

IT'S SOME KIND OF RAID! RUN FOR IT!

THAT GOES FOR ME, TOO!



BUT TOD'S PURSUERS ARE CLOSE-BY...

HELLO! I'LL BET HE ISN'T WEARING THAT MASK FOR A FANCY-DRESS PARTY! GRAB HIM, MEN!



THEN...

... I'VE GOT THE OTHER TWO, SARGE! IF YOU WHIP OFF HIS MASK, I THINK YOU'LL FIND THAT YOU'VE COLLARED MARTY LEWIS!

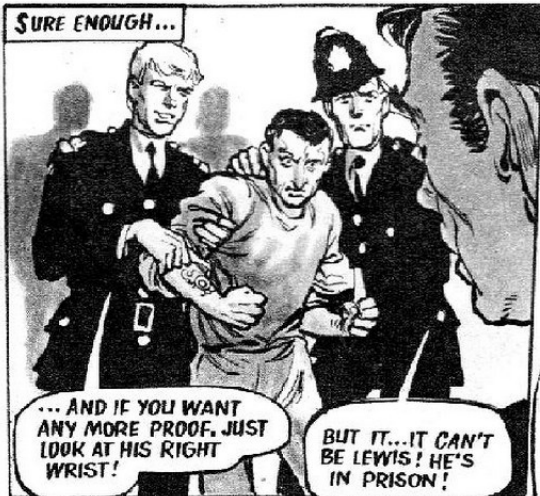

SURE ENOUGH...

... AND IF YOU WANT ANY MORE PROOF, JUST LOOK AT HIS RIGHT WRIST!

BUT IT...IT CAN'T BE LEWIS! HE'S IN PRISON!



IT'S MARTY'S DOUBLE WHO IS IN PARKWAYS—OR AT LEAST SOMEONE WHO LOOKS VERY MUCH LIKE HIM, WITH THE HELP OF A LITTLE PLASTIC SURGERY! THEY MADE THE SWITCH DURING THAT PHONEY ESCAPE-BID!



"AS YOU SAID, MARTY WAS ONLY AT LARGE FOR A FEW HOURS, BUT THAT WAS LONG ENOUGH FOR HIM TO CHANGE PLACES WITH HIS DOUBLE, BEFORE THE SEARCH-PARTIES FOUND THE BOGUS MARTY HIDING IN THAT BARN..."

IT TAKES ONLY A FEW HOURS TO CONFIRM TOD'S STARTLING THEORY...



HERE'S THE LOOT, SARGE — EVERY LAST PENNY! IT MUST HAVE BEEN HIDDEN IN THE ARCADE, ALL THE TIME!

AND WE DIDN'T EVEN BOTHER TO SEARCH IT!



B... BUT WHAT ABOUT THE BLOKE IN PARKWAYS?

PROBABLY PROMISED A FAT CUT OF THE PROCEEDS, IN RETURN FOR FINISHING MARTY'S SENTENCE! THE WAGES-SNATCH COULD HAVE BEEN THE FIRST IN A SERIES OF PLANNED ROBBERIES!

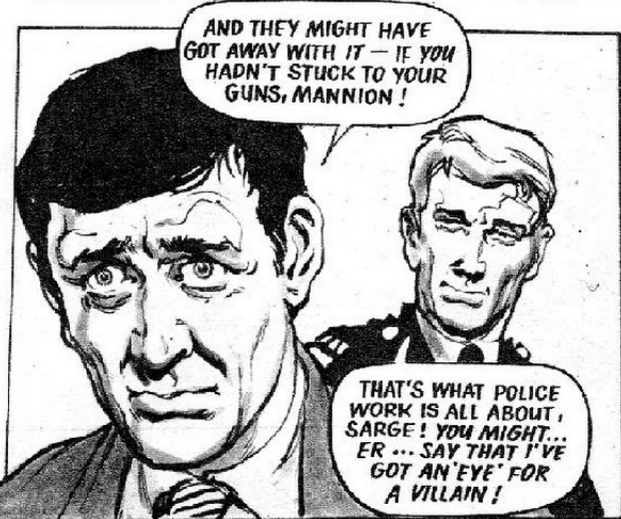

AND THEY MIGHT HAVE GOT AWAY WITH IT — IF YOU HADN'T STUCK TO YOUR GUNS, MANNION!

THAT'S WHAT POLICE WORK IS ALL ABOUT, SARGE! YOU MIGHT... ER... SAY THAT I'VE GOT AN 'EYE' FOR A VILLAIN!

Snowy the pit pony provides a problem!

Follyfoot

DORA HAS TAKEN SNOWY, AN EX-PIT PONY, TO FOLLYFOOT FARM. BUT SNOWY, THANKS TO YEARS SPENT IN UNDERGROUND DARKNESS, IS PRACTICALLY BLIND - AND IT LOOKS AS THOUGH THE OTHER FOLLYFOOT HORSES ARE TRYING TO TAKE ADVANTAGE OF HIM...

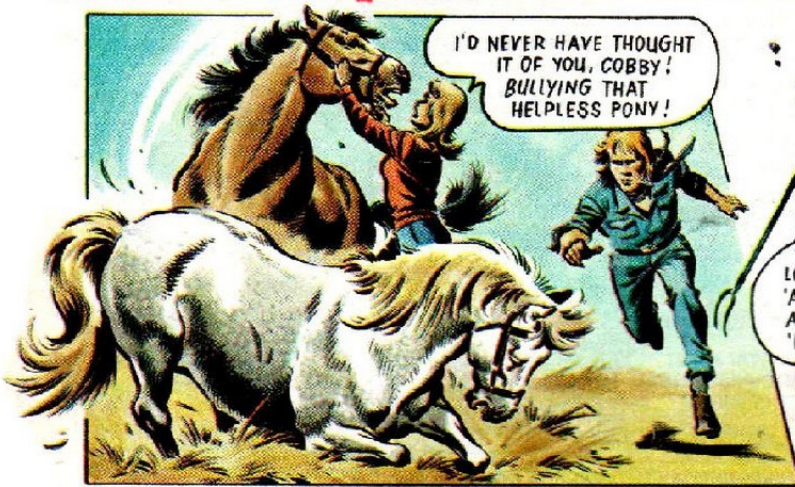

I'D NEVER HAVE THOUGHT IT OF YOU, COBBY! BULLYING THAT HELPLESS PONY!

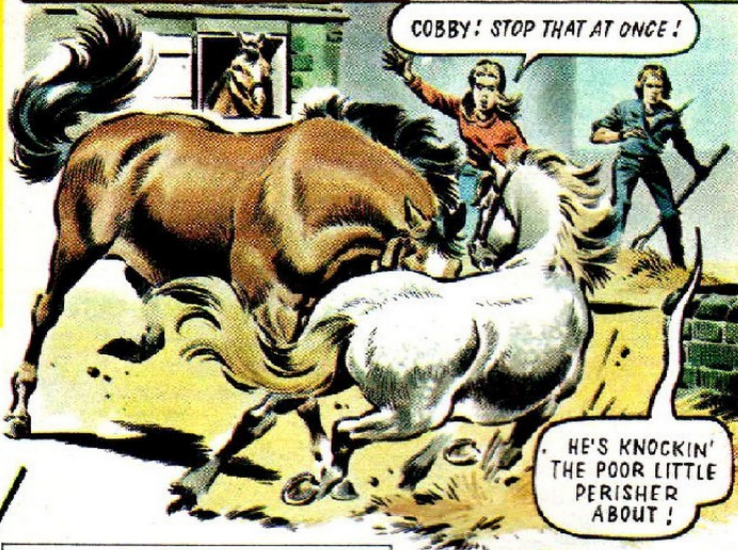

COBBY! STOP THAT AT ONCE!

HE'S KNOCKIN' THE POOR LITTLE PERISHER ABOUT!

WITH COBBY SAFELY STALLED...

LOOKS LIKE WE'LL AVE TO GIVE SNOWY A STABLE TO 'IMSELF, DORA!



THAT'S EASIER SAID THAN DONE! WE JUST HAVEN'T GOT ROOM!

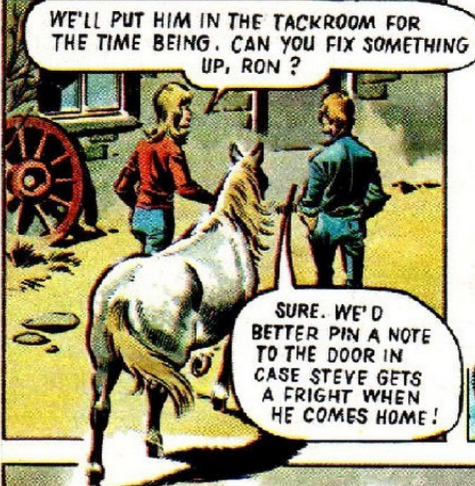

WE'LL PUT HIM IN THE TACKROOM FOR THE TIME BEING. CAN YOU FIX SOMETHING UP, RON?



STEVE? WHY. WHERE'S HE GONE?

SURE. WE'D BETTER PIN A NOTE TO THE DOOR IN CASE STEVE GETS A FRIGHT WHEN HE COMES HOME!

UP ON THE MOORS WITH A BUNCH OF PONY-TREKKERS. ONE OF HIS OLD MATES IS IN CHARGE OF A PARTY OF SCHOOLKIDS OR SOMETHIN'!



STEVE IS ENJOYING HIMSELF...

THIS MUST BE QUITE A CHANGE FOR YOU, DAVE - BEING A TEACHER!

IT CERTAINLY IS. BUT I'M KILLING TWO BIRDS WITH ONE STONE, SO TO SPEAK!

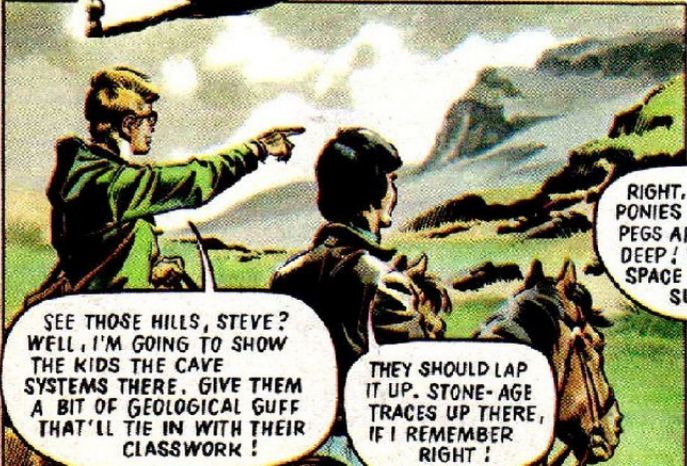

SEE THOSE HILLS, STEVE? WELL, I'M GOING TO SHOW THE KIDS THE CAVE SYSTEMS THERE. GIVE THEM A BIT OF GEOLOGICAL GUFF THAT'LL TIE IN WITH THEIR CLASSWORK!

THEY SHOULD LAP IT UP. STONE-AGE TRACES UP THERE, IF I REMEMBER RIGHT!



AT LAST THEY REACH A LONELY, DESERTED SHEPHERD'S HUT...

RIGHT, YOU LOT! PICKET THE PONIES - AND MAKE SURE THE PEGS ARE DRIVEN NICE AND DEEP! THEN FIND YOURSELVES SPACE IN THE HUT FOR YOUR SLEEPING BAGS!

Based on the Yorkshire Television series Follyfoot © 1972 Yorkshire Television Ltd.

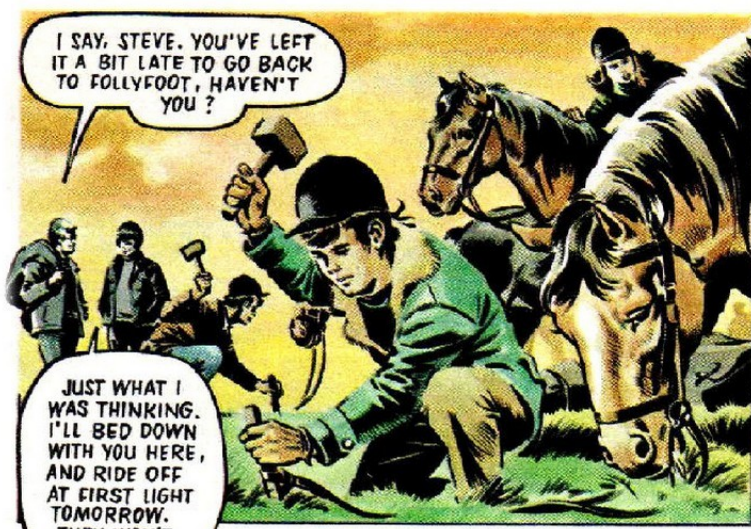

I SAY, STEVE. YOU'VE LEFT IT A BIT LATE TO GO BACK TO FOLLYFOOT, HAVEN'T YOU?

JUST WHAT I WAS THINKING. I'LL BED DOWN WITH YOU HERE, AND RIDE OFF AT FIRST LIGHT TOMORROW. THEY WON'T MISS ME!



AS THE MOON RISES OVER THE MOORS...

PSST! MARK! ARE YOU AWAKE?

UHH? WHAT IS IT, JOHNNY?

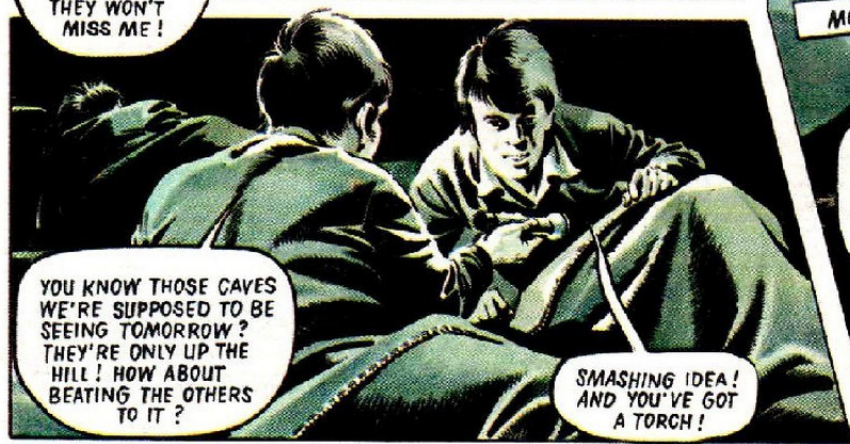

YOU KNOW THOSE CAVES WE'RE SUPPOSED TO BE SEEING TOMORROW? THEY'RE ONLY UP THE HILL! HOW ABOUT BEATING THE OTHERS TO IT?

SMASHING IDEA! AND YOU'VE GOT A TORCH!



MOMENTS LATER...

WE CAN BE BACK AGAIN BEFORE ANYONE ELSE IS AWAKE! AND WE CAN LEAVE SOMETHING UP IN THE CAVES TO PROVE WE WERE THERE FIRST!

WE'LL PROBABLY GET A RIGHT TELLING OFF—BUT IT'LL BE WORTH IT!

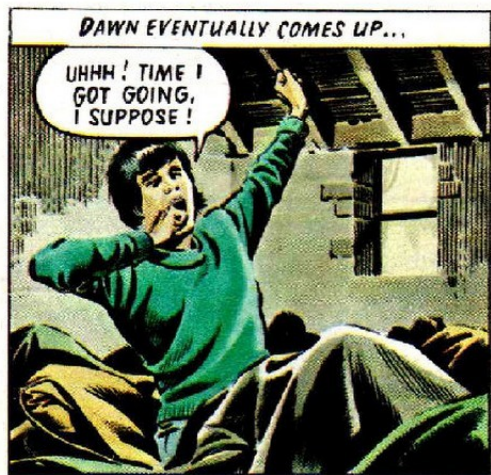

DAWN EVENTUALLY COMES UP...

UHHH! TIME I GOT GOING, I SUPPOSE!



HELLO! TWO OF THE YOUNGSTERS UP BEFORE ME? THAT'S ODD...



A LOOK OUTSIDE REVEALS NOTHING, AND IT'S IN STEVE'S NATURE TO WORRY...

EH? WHAAAT...?

DAVE! DAVE—WAKE UP! I THINK TWO OF YOUR LITTLE TERRORS HAVE DONE A BUNK!



JOHNNY AND MARK! BUT THEIR PONIES ARE STILL HERE!

IT DOESN'T MAKE SENSE! WHERE THE DICKENS COULD THEY HAVE GOT TO?

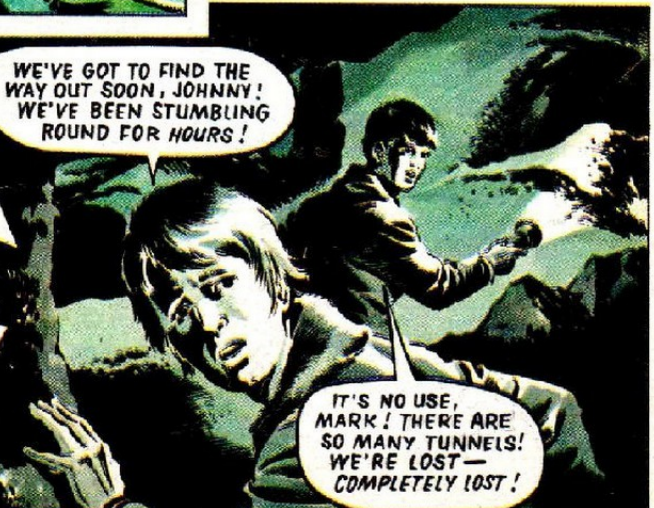

WE'VE GOT TO FIND THE WAY OUT SOON, JOHNNY! WE'VE BEEN STUMBLING ROUND FOR HOURS!

IT'S NO USE, MARK! THERE ARE SO MANY TUNNELS! WE'RE LOST—COMPLETELY LOST!

YOUR VIEW



Elizabeth Robillard, 'Perfect' of Harlech Television's historical serial 'Pretenders', makes this week's selection of letters, jokes and pictures from the LOOK-IN Postbag, including the £2 Star Letter...

STAR LETTER

During a recent power-cut, when it was too dark even to read LOOK-IN, I decided to try to make a silhouette portrait of my sister. I put a torch in position so that its beam shone on to a large sheet of paper pinned to a flat wall. My sister stood in front of the paper. With a pencil I followed the lines cast by her shadow and then, after unpinning the paper, painted the area inside the pencilled outline black. The result: an attractive silhouette portrait.

Lesley Sheppard,
Shoreham-by-Sea, Sussex.

★ I'm told that this was a favourite pastime in Queen Victoria's days, Lesley. But it's a splendid idea—and there's no need to wait for a powercut to try it.

MIGHTY MONSTER

In 'The Marc Bolan Story' (LOOK-IN, 12th February), it states that *Tyrannosaurus Rex* was the largest creature that ever walked the earth. But I think that *Brachiosaurus* was larger.

Noel Blandon,
Orpington, Kent.

★ And the Natural History Museum, London, says that you are quite right, Noel. Although *Tyrannosaurus* was taller, the remains of an immature *Brachiosaurus* show that it had a total length of over 74 feet and weighed around 40 tons. A full-grown specimen might be ten feet longer and weigh at least 45-50 tons—with a brain weighing only seven ounces! Right: a scale drawing comparing man and monster.

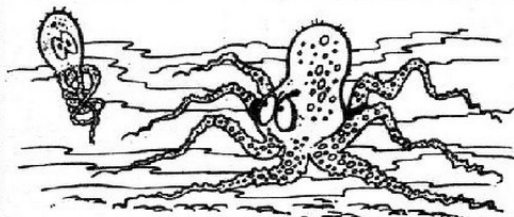
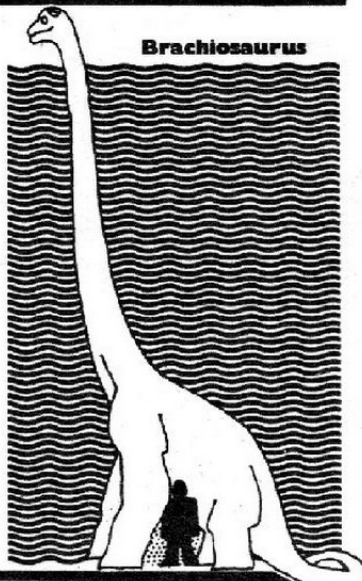

"There—that should keep you out of mischief for a while!"

Julie Lilleywhite,
Charlwood,
Surrey.

MYSTERY MAMMAL

Please would you print a picture of an Australian animal? I know about kangaroos and koala bears—so could you show a more unusual creature?

Michele Green,
Redditch, Worcs.

★ They don't come much more unusual than this one: it swims like a fish, lays eggs, has webbed feet and a bill like a duck. None other than the mysterious duck-billed platypus.



DEAF AID

I am deaf, and need to wear a special hearing aid all the time. My aid helps me to hear, and I can also read people's lips if they speak slowly and carefully. It doesn't worry me that I'm deaf—but I would like it if everyone could remember to speak clearly and perhaps a little slower than usual when speaking to a deaf person.

Stephen Iles,
Loughton, Essex.

★ I'll remember that, Stephen—and I hope all LOOK-IN readers will do the same.

FRIENDLY 'FLUFF!'

Here is my cat, 'Fluff', playing with the budgie from next door. They're good pals! My cat has mothered two litters of kittens.

Margaret Beswick,
Manchester 10.



★ A £1 prize for a prize 'Mum'!



More smiling faces from among the photographs sent in by LOOK-IN readers.

Carol Young,
Cheetham,
Manchester 8



Hammad
Sindhu,
Selly Park,
Birmingham.

Win £2 for the Star Letter and £1 for any other letter or joke! Plus, a special signed photograph of the Your View Star to the sender of every item published! Why not write now to Your View, LOOK-IN, 247 Tottenham Court Road, London W1P 0AU? Remember when you write—enclose a list of your six favourite features in order of preference.

If you'd like to see your photograph in LOOK-IN, please send in one when you write, and we'll try to print it. However we regret that photographs cannot be returned.

Maureen's idea has an 'upsetting' effect on the gang!

The Fenn Street Gang

FRANK ABBOTT AGREES TO MEET HIS BOSS'S NEPHEW AT THE BUS STATION AND LOOK AFTER HIM FOR THE DAY, BECAUSE THERE'S A FIVER-PLUS EXPENSES-IN IT. FRANK'S FENN STREET PALS ARE ONLY TOO GLAD TO JOIN IN! AT A LOCAL FUNFAIR, HOWEVER, THEIR ENTHUSIASM BEGINS TO WANE...

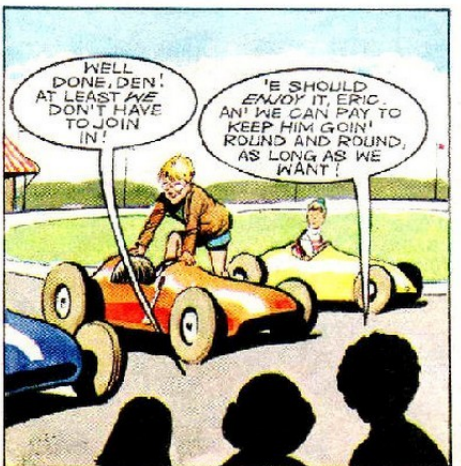
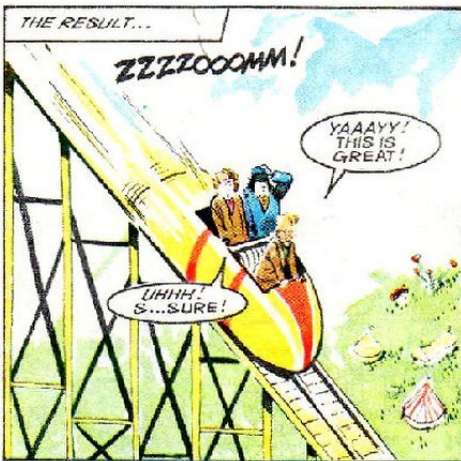

Next week: Frankie's biggest blunder! 17

Based on the London Weekend Television series created and written by John Esmonde and Bob Larbey © 1972 Esmonde Larbey Ltd.

Simon and Liz run a gauntlet of danger—because of a torch!

TIMESLIP

LIZ SKINNER AND SIMON RANDALL PASS THROUGH THE INVISIBLE TIME-BARRIER TO THE DAYS OF ROBIN HOOD. SIMON USES HIS ELECTRIC TORCH TO SAVE AN OUTLAW FROM CAPTURE BY THE SHERIFF OF NOTTINGHAM'S MEN. A FEW MINUTES LATER...

SIMON, THEY'RE OUTLAWS! MEN IN LINCOLN GREEN!

THEY DON'T SEEM TOO FRIENDLY, EITHER — EVEN THOUGH WE HELPED ONE OF THEM. PHEW! THAT ARROW DIDN'T MISS ME BY MUCH!

HOLD! MAKE NO MOVE, WORKERS OF WITCHCRAFT!

HE MEANS THE TORCH! THEY'RE SCARED OF IT. I WARNED YOU IT WOULD GET US INTO A MESS!

GRIMLY, A GREAT FIGURE STEPS FORWARD ...

TELL THE STRIPLING TO CAST DOWN THE SILVER LIGHT OF WITCHCRAFT HE CARRIES.

YOU HEARD HIM, STRANGER! OBEY — IF YOU VALUE YOUR LIFE.

QUICK, SIMON, DO WHAT THEY SAY!

I SUPPOSE IT'S NO GOOD TRYING TO EXPLAIN ABOUT ELECTRICITY!

THE OUTLAWS SCATTER IN PANIC ...

SIMON THROWS THE UNBREAKABLE TORCH ...

WE'RE FRIENDS. WE MEAN YOU NO HARM! LOOK — THERE IT IS!

NOW WHAT WILL HAPPEN TO US? I DON'T THINK THEY'RE VERY CONVINCED!

AS THE TORCH HITS THE GROUND ...

AARGH! BEWARE! THE DEMON LIGHT!

DOWN, LIZ!

THE STRANGERS SEEK TO DESTROY US!

WE'RE SAFER WITH THE TORCH! COME ON, RUN — THIS IS OUR CHANCE!

WE'VE GOT TO FIND OUR WAY BACK THROUGH THE TIME-BARRIER!

© 1972 ATV Network Ltd. Based on the ATV programme.

MEANWHILE, FROM NOTTINGHAM CASTLE...



LEAD ME TO WHERE YOU SAY THE WITCHES WERE SEEN. I HAVE SORE NEED OF A SORCERER!

MY LORD SHERIFF, I SPOKE BUT THE TRUTH. THE YOUTH CARRIED A SMALL MACE THAT GLOWED LIKE THE SUN!



WITH SUCH A MACE I COULD DEFEAT THE ACCURSED OUTLAWS PLAGUING OUR FOREST. COME—LET US HUNT THE SORCERERS DOWN!



THE OUTLAWS ALSO RECOVER FROM THEIR FEAR...

WE RAN LIKE SCARED RABBITS, YET NONE OF US SUFFERED HURT FROM THE STRANGERS. THE AMAZING MAGIC THEY WIELD MIGHT WELL HELP US IN OVERCOMING OUR FOES!

AYE! AYE!



SIMON AND LIZ STILL RUN ON...

WE'RE LOST, SIMON— I TELL YOU WE'VE COME THE WRONG WAY!

IT'S DAYLIGHT, TOO! THE TORCH WON'T SHOW UP ENOUGH TO SCARE ANYONE ELSE!



NEXT MOMENT...

THERE THEY ARE!

LOOK!

TAKE THEM ALIVE IF YOU CAN! I WANT THE MACE! RIDE!



HALT! SURRENDER— OR DIE!

OH, NO! WE DON'T STAND A CHANCE!



CONCEALED ARCHERS SEE THE DANGER...

FLIGHT YOUR SHAFTS!

AN AMBUSH!

KEEP GOING THROUGH HERE! EITHER WAY, WE'RE LOSERS IF WE GET CAUGHT!

AS LIZ AND SIMON CHANGE DIRECTIONS...

LOOK! WE'VE FOUND THE TIME-BARRIER— THANKS TO THEM!

THE NEXT THEY KNOW...

AT LEAST IT PROVED ROBIN HOOD AND HIS MERRY MEN EXISTED!

OH, NO, IT DIDN'T— IT ONLY PROVED THERE WERE OUTLAWS— AND THAT AN ELECTRIC TORCH WASN'T SAFE TO HAVE IN THOSE DAYS!



NOT A MOMENT TOO SOON, EITHER! WHAT LUCK!



Continued from Page 2

Keith Witham, London, SE16.
 M. Fessey, Wilford, Notts.
 David Barke, Wallasey, Cheshire.
 Terry Smith, Blurton, Staffs.
 Jason Williams, Walthamstow, E17.
 Paul Levy, Pinner, Middlesex.
 David Large, Bourne End, Bucks.
 Jonathan Cainan, Sidcup, Kent.
 Trevor Howls, Kitts Green, Birmingham.
 Paul Mendison, Agar Grove, London.
 Ian McGowan, Chilton, Co. Durham.
 John Pritchett, Bradway, Sheffield.
 S. P. Downs, Stockport, Cheshire.
 G. E. Buckley, Preston, Lancs.
 Kevin Simpson, Eastbourne, Sussex.
 Neil Cole, Leicester.
 Paul McNulty, Stevenage, Herts.
 Simon Woods, Arncliffe, Notts.
 Giordano Salvi, Kettering, Northants.
 Malcolm Jackson, Hull, E. Yorks.
 Christopher Coggrave, Stavely Road, Hull.
 James Laisley, Crownhill, Devon.
 Nigel Jarvis, Sittingbourne, Kent.

50 AIRFIX SEAKING HELICOPTER KITS are on their way to:

Garry Rowe, Rutherglen, Glasgow.
 P. Gilbert, Driggs, Cumberland.
 Stephen Warkin, Portchester, Hants.
 David Spicer, St. Leonards-on-Sea, Sussex.
 Christopher Smith, Cleave Hill, Glos.
 John Maguire, Mottingham, London.
 Antonio Centurion, Great Barr, Birmingham.
 John Twinning, Camock Wood, Staffs.
 Caroline Kayner, Chipstead, Kent.
 D. Copley, Leyton, London.
 Aidan Potts, Kingham Hill, Oxon.
 Christopher Toop, Dorchester, Dorset.
 Christine Hooper, Brighton, Sussex.
 Karen Stevenson, Stratford-upon-Avon.
 John Hodges, Walsall, Staffs.
 Sean Verrigan, Coventry, Warks.
 Matthew Spence, Southsea, Hants.
 Roger Smith, Saltney Ferry, Cheshire.
 Joanne Bailey, Stanbridge, Beds.
 Clive Mallard, Alveyn Park, London.
 Peter Kelly, Coventry, Warks.
 Michael Waters, West Leigh, Hants.
 Eowin Hadden, Yardley, Birmingham.
 Michael O'Hagan, Farlington, Portsmouth.
 Keith Lloyd, Ewell, Surrey.
 J. Smith, Braunstone, Leicester.
 J. Bulsing, Welwyn Garden City, Herts.
 David Shreeve, Thornton-Cleveleys, Lancs.
 C. Edmonds, Coventry, Warks.
 Martin Lloyd, Ewell, Surrey.
 Lawrence Hopkins, Cippenham, Bucks.
 Graham Farley, Iford, Essex.
 Andrew Dennis, Redhill, Notts.

Gary Salmon, Knotty Ash, Liverpool.
 Robert Poyell, Worthing, Sussex.
 William Francomb, Liverpool 11.
 Paul Stevenson, Stratford-upon-Avon, Warks.
 S. Hale, Wickford, Essex.
 Karl Bock, Argoed, Mon.
 Stanley Gallow, Anlaby, Yorkshire.
 Owen Williams, Whitmore Park, Coventry.
 Richard Bickley, Scunthorpe, Lancs.
 Andrew Haddleston, Middlesbrough.
 Andrew Hourd, Melton, Leics.
 Judy Johnson, Gatley, Cheshire.
 Paula Cotterill, Biddulph, Staffs.
 Treena Aspinall, Little London, Hants.
 Diane Hayes, New Mill, Herts.
 Paul Pridgen, Dunstable, Beds.
 Gary Galbraith, Edinburgh.

50 AIRFIX LUNAR MODULE KITS have been won by:

Peter Britten, Hutton, Lancs.
 Richard Phelan, Kettering, Northants.
 Clive Roberts, Cricklewood, London.
 Alan Haggerty, Paisley, Renfrewshire.
 Steven Bird, Morden, Surrey.
 Ian Campbell, Wootton Manor, Oxon.
 Nigel Lyons, Aylesbury, Bucks.
 Lester Lee, Salford, Lancs.
 Stephen Rose, Great Harwood, Lancs.
 Robin Ives, Guildford Road, Surrey.
 Melody Kimble, Worthy Down, Hants.
 Graeme Sheldon, Lintorpe, Teesside.
 Colin Prestidge, Shoreham-by-Sea, Sussex.
 David Llewellyn, Bridgend, Glamorgan.
 A. Benton, Chelmsley Wood, Birmingham.
 Anthony Webb, Swinton, Lancs.
 Melvin Mrowiec, Ipswich, Suffolk.
 Conor White, Co. Antrim, N. Ireland.
 Stephen Pritchard, Castle Bromwich.
 P. Browning, Llantwit Major, Glamorgan.
 Paul Lawrence, Letchworth, Herts.
 Kenneth Findlay, Thundersley, Essex.
 Ian Duncan, Clydebank, Dunbartonshire.
 Paul Watson, Chester-le-Street, Durham.
 Kim Topley, Port, S. Wales.
 Christopher Taggart, Macclesfield.
 Colin Malons, Belfast, Ireland.
 Karen Wood, Newby, Yorkshire.
 Peter McMahon, Nile Street, London.
 Mark Campkin, Tolworth, Surrey.
 David Bodey, Ellesmere Port, Cheshire.
 Martin Sharrock, Shirley, Surrey.
 G. Steele, Chemsley Wood, Birmingham.
 Michael Page, Welwyn Garden City, Herts.
 Neal Wood, West Bromwich.
 Andrew Judd, Romsey, Hampshire.
 Shaun Ahearne, Clifton Estate, Notts.
 William McDermott, Sutton, Lancs.
 Alan Taylor, Hampstead, London.
 Gavin Cope, Hilltop, Notts.

Vincent Finlayson, Alloa, Scotland.
 Stephen Evans, Cowslip Estate, Glamorgan.
 John Pugalis, Park, Middlesbrough.
 Philip Forster, E. Tilbury, Essex.
 Kenneth Palfrey, Houghton Regis, Beds.
 Colin Vickers, Alford, Lincs.
 George Ritchie, Weymouth, Dorset.
 Steve Clewley, Hednesford, Staffs.
 S. Smith, St. Johns, Worcester.
 Simon Hyslop, Roichell Park, Dumfries.

100 AIRFIX ASTRONAUTS SETS will go to:

Andrew Packman, Upton, Hants.
 A. Adams, Cottesmore, Rutland.
 Peter Conkerton, Holderness Rd., Hull.
 Kevin Brooks, Wimbledon, London.
 Marc Hope, Doonfoot, Ayr.
 Stephen Murray, Appleton, Lancs.
 Mark Harrison, Wakefield.
 Russell McNee, Partick, Glasgow.
 Christopher Dawes, Hurst Green, Worcs.
 George Bailey, Madeley, Nr. Crewe.
 Jeremy Newman, South Street, Kent.
 S. Brunton, Rochester, Kent.
 Paul Twiname, Liverpool 5.
 Christopher Willmott, Fattlee Park, I.O.W.
 Stephen Wallace, Southport, Lancs.
 Derek Potter, Lochgally, Scotland.
 Stephen Elliott, Ash, Hants.
 Mark Maberley, Furnace Green, Sussex.
 Robin Miller, Yew Tree Estate, Walsall.
 Julie Fenby, Cleckheaton, Yorkshire.
 Andrew Emmerson, Disley, Cheshire.
 Alan Ball, South Normanton, Derbyshire.
 Ian Nicholson, The Knap, Glamorgan.
 Steven Lalyk, Balderton, Notts.
 Alan Kinroy, Dunblane, Perthshire.
 Kevin Alban, Teignmouth, S. Devon.
 David Ellis, Paignton, Devon.
 Kemp Anderson, Hamilton, Scotland.
 N. Risdale, Northampton.
 Adrian Hall, Richmond, Cumberland.
 Peter Strachan, Longacre, Kirckcudbright.
 Timothy Price, East Molesey, Surrey.
 Michael Greener, Dunnington, Yorkshire.
 Clive Pratt, Homel Hempstead, Herts.
 Michael Skinner, Boreham Wood, Herts.
 Paul Woods, South Harrow, Middlesex.
 Gary Thomas, Chilwell, Notts.
 David Swinburne, Scarborough, Yorks.
 R. Jones, Crewe, Cheshire.
 Christopher Kings, Poole, Dorset.
 John Tohill, Luton, Beds.
 Martin Dalby, Crumpsall, Manchester.
 Kevin Kay, Arnold, Notts.
 Martin Critchley, Nottingham.
 Paul Thompson, Worthing, Sussex.
 Peter Hobbs, Tottenham, London.
 Stephen Daitrey, Eastbourne, Sussex.

Charles Randall, Devauden, Mon.
 John Lawton, Glasgow, Scotland.
 Simon Pownall, Norwich, Norfolk.
 John Fielder, Newcastle, Staffs.
 Roger Moore, Ramsey, Isle of Man.
 Ian Seymour, Harrow, Middlesex.
 Richard Spicer, St Leonards-on-Sea.
 Wayne Baillie, Selstide, Westmorland.
 Dene Parington, Llanfairfechan, Caerns.
 Simon Morris, Brighton, Sussex.
 B. Hassan, North Shields, Northumberland.
 Malcolm Ellery, Portland, Dorset.
 David Baldock, Langley, Kent.
 Ian Calvert, Maidstone, Kent.
 Alan Answorth, Allenton, Derbys.
 David Strike, Sidcup, Kent.
 John Dawson, Hull.
 D. Allen, Wellng, Kent.
 Ian McBain, Liverpool, Lancs.
 James Haughey, Twechar, Glasgow.
 Martin Hill, Wakefield, Yorkshire.
 Christine Bunting, Wallasey, Cheshire.
 Valerie Rowder, Bursledon, Southampton.
 Keith Bailey, Calford School, Suffolk.
 Gerald Wigmore, Hayes, Middlesex.
 Mark Kingdom, Paignton, Devon.
 Stewart Rollason, Etingshall, W'hampton.
 Peter Sandbrook, Hayling Island, Hants.
 Stephen Porter, Southport, Lancs.
 D. Cooper, Salisbury, Wilts.
 T. Marsh, Hereford.
 Peter O'Dowd, Currie, Scotland.
 David St Pier, Camvee Island, Essex.
 Marilyn Zanelli, Sheffield.
 David Law, Black Notley, Essex.
 Neil Stearles, Gravesend, Kent.
 David Beechey, Rochester, Staffs.
 Neal Liggins, Kettering, Northampton.
 Mark Godfrey, Oldfield Park, Bath.
 James Stewart, Drunchapel, Glasgow.
 Stephen Locke, Kings Lynn, Norfolk.
 Ian White, Nelson, Lancs.
 Stephen Crick, Sittingbourne, Kent.
 Ian Peter, Ennsforth, Hampshire.
 Paul Srivalson, Hillingdon, Middlesex.
 Michael Way, Darlington, Co Durham.
 Michael Langer, Chalfont-St-Peter, Bucks.
 Andrew Ashley, Westwimble, Surrey.
 J. Dawson, Washington, Co Durham.
 Graham Tapp, Maidstone, Kent.
 Tony Cameron, Hebburn, Co. Durham.
 Joe Bennett, West Hampstead, London.
 Matthew Williams, Blackheath, London.

☆☆☆☆☆☆☆☆☆☆☆☆☆☆☆☆

Congratulations to all the Look-in winners. Look out for more exciting competitions in Look-in soon!

"Zoomy balloonies?"

"By 'Matchbox', eh? ...looks fun..."

30 mind-bending seconds later..

THURP!!

FE-E-OW!!

RAA-SPI!!

MATCHBOX
ZOOMY
balloonies
 ONLY 25p

MATCHBOX
 'MATCHBOX' is the registered trade mark of Lesney Products & Co. Ltd. London E9 5PA.

MAGPIE

CYRIL LITTLEWOOD'S

NATURE NOTES



COWSLIP

There is so much bird activity taking place that you could spend every day carrying out observations. The birds that you see or hear will depend largely upon whereabouts you live. But even in the heart of the city, you may be able to see some of the new arrivals if you keep an eye on the parks. Nest-building and egg-laying will be going on all around you as April continues,

Last week, I talked about the activity of the animal world during this month. But also in April, most of our migrant birds choose to return for the summer. So keep your ears pinned for an exciting chorus of new bird songs.

Among the early arrivals is the willow warbler. Later on the blackcap, sedge warbler, wood warbler, white-throat, turtle dove, garden warbler and nightingale will join the migrant masses.

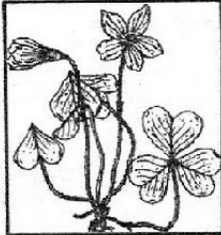

WOOD SORREL

and in the cases of several species the young will already be hatched.

Plant life

April is also the great month for botanists. Among the more familiar wild flowers to be seen should be the celandine, stitchwort, strawberry, hyacinth, purple orchis, arum, herb Robert and Cowslip. Wood sorrel, crowfoot, toothwort and wood spurge may all be found in our woodlands.



GREATER STITCHWORT

Magpie Music Makers



This week, Will Yeomans introduces us to an instrument which is important to any symphony orchestra and is especially favoured by composers of chamber music.



THE CLARINET is a single beating reed instrument and was known to Ancient Egypt. A primitive form is the Pibcorn or Hornpipe, having the sounding tube of wood or bone holding the reed attached to pieces of horn. Denner of Nurnberg is said to have been the creator of the modern clarinet pattern in the early 18th century. The top illustration shows a sketch of the Pibcorn or Hornpipe, while the lower one shows an early 19th century clarinet.

Farewell, Beautiful Belle

This month all railway enthusiasts must say a sad goodbye to the world-famous 'Brighton Belle' Pullman train that will run for the last time on April 30th—making eight trips between London and Brighton.

Then she will go up for sale to the highest bidder. So unless you're considering adding her to your private collection, here is your final chance to witness her in motion — travelling between Brighton and

London's Victoria Station, during the course of the day.

Magpie are paying homage to this 'queen of trains' by giving the 'Brighton Belle' a spot on the programme on April 27th, when Susan Stranks will be looking at the train's most interesting feature.

LOOK-IN, too, will be investigating her legend in an exciting feature coming soon!

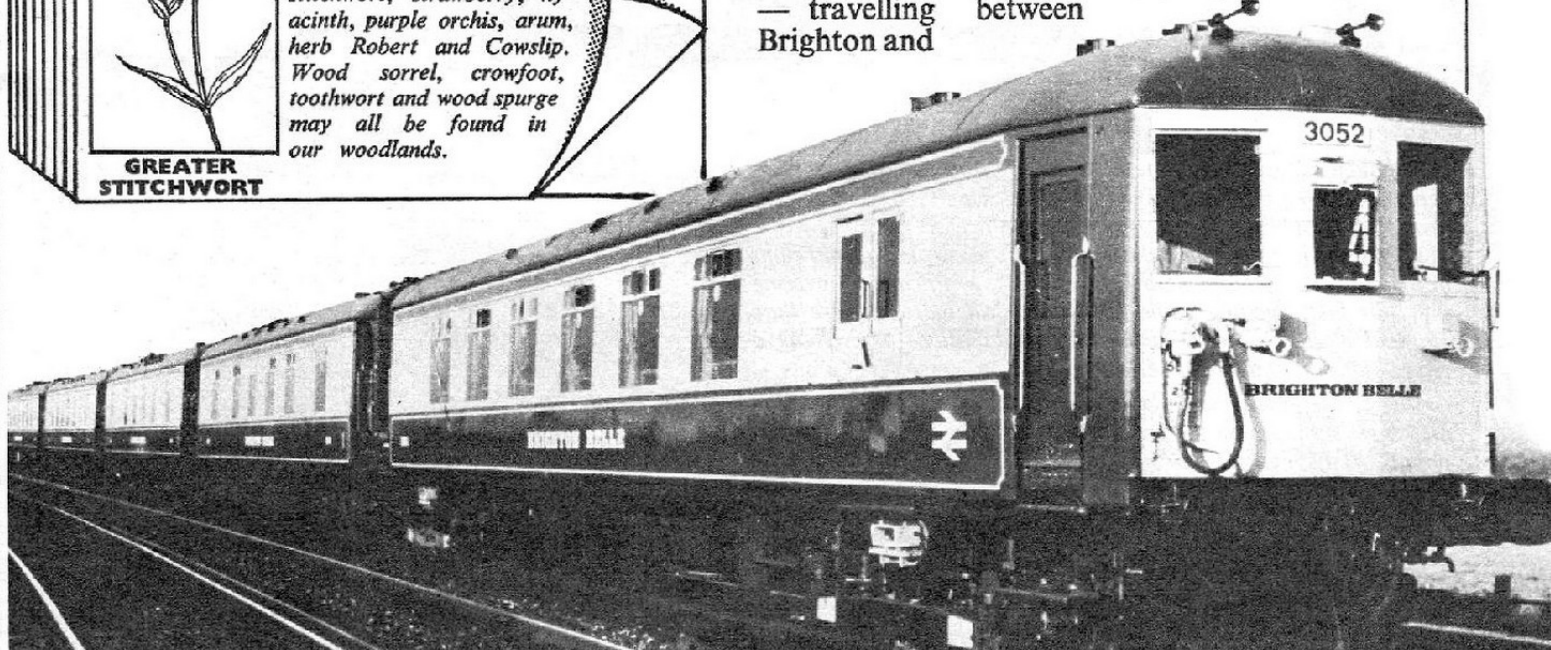

HEY-UP AND OVER!



"It's like no other race: any jockey is proud just to finish the course. To win it—that would be fantastic!" That's former Champion National Hunt jockey Josh Gifford's opinion of the Grand National, the world's greatest steeplechase.

Run over a four-and-a-half mile course at Aintree, Liverpool (you can watch it for yourself, on Saturday, April 8th), the National is the longest event in the British horse-racing calendar. And it is certainly the toughest. In a double circuit of the course, the riders and their mounts must navigate the fifteen fences twice each; fences like the formidable 'Chair'—a six-foot-wide ditch with a fence of layered spruce as high as a man beyond it.

THE RACE BEGINS

In 1837, the name 'Grand National' was given to a steeplechase run either at Aintree or nearby Maghull. But the National as we know it really came into being in 1839, when a group of gentlemen headed by Lord Stanley decided to organise an annual 'four-mile race across country for gentlemen riders'. That year the race, watched by around 50,000 spectators, was won by a horse called Lottery—but it is best remembered for the fall of Captain Becher from his mount, Conrad, at the obstacle which has been called Becher's Brook ever since.

One of the most attractive features of the National is that amateur riders are still able to enter their own mounts to compete with the professional jockeys and the best horses that the big commercial stables can produce. And the National is such an 'open' race that no horse can really be said to be 'without a chance'. Remember 1967, when a single horse, falling at the twenty-third fence, brought down most of the strongest contestants, leaving a 'no-hoper'—far enough back until then—to take evasive action

Becher's Brook has been nearly a century since Captain Becher took his famous fall there in 1839.

Anyone For Squash?

Although squash is a game with aristocratic ancestry—it probably developed around 1850 at Harrow School—it is no longer restricted to public schoolboys and army officers.

Within the last ten years, the number of squash players and clubs in Britain has doubled. People from all walks of life are discovering that this fast, exciting game—in which skill matters more than physical strength—provides first-class relaxation, as well as a ready-made slimming course.

One of the new squash players is Magpie's Douglas Rae. You may have seen him on the programme recently, learning the basic points of the game from Jonah Barrington, the thirty-year-old Cornishman who has won every major squash event in the world. Points are scored by striking the ball against the front wall of the squash court in such a way that your opponent is unable to return it. Douglas managed to take several points, although playing against a champion—proving that even a complete beginner can put up a good showing and enjoy the game.



Douglas learns how to hold the racket.



**Above: Golden Miller on his way to a win in record time—1934.
Below: The first Grand National run at Aintree in 1839.**

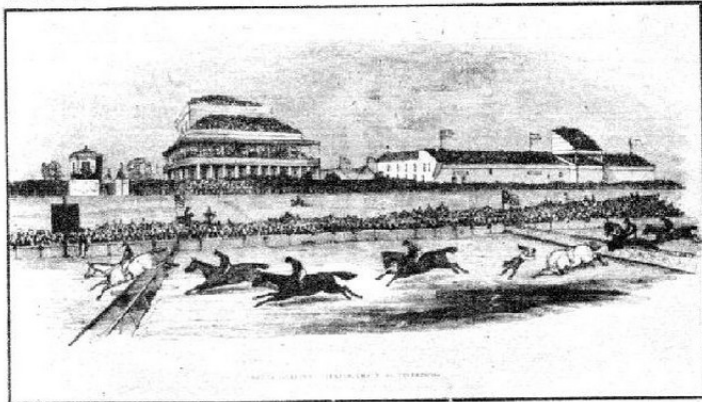

Disaster! Devon Loch sprawls — and loses.

and go on to win?

MEMORABLE MOMENTS

Even that pile-up couldn't compare with that of 1928, when forty-one of the forty-two horses fell! But the National is rich in drama: in 1902 it was run in a snowstorm and the winner, Grudon, had its hooves packed with butter to prevent slippery snow 'balling' on them. In 1934, Golden Miller, perhaps the greatest ever horse 'over the sticks', was ridden to victory in the record time of nine minutes, twenty-four seconds.

TRAGIC ENDING

In 1956, Devon Loch, owned by the Queen Mother, came over the last fence well clear of the rest, only to fall on level ground—fifty yards from victory!

As early as the first National

in 1839, the Society for the Prevention of Cruelty to Animals (founded in 1824, 'Royal' since 1840) was protesting about the severity of the Aintree fences. In recent years, the obstacles have been modified, but they still remain the toughest of all tests for horse and rider — and provide one of the most exciting spectacles that British sport has to offer.

☆ If you would like to know more details about playing squash, there is plenty of information in the Squash Rackets Association's handbook (price 50p) available from: 26, Park Crescent, London WIN 4ED

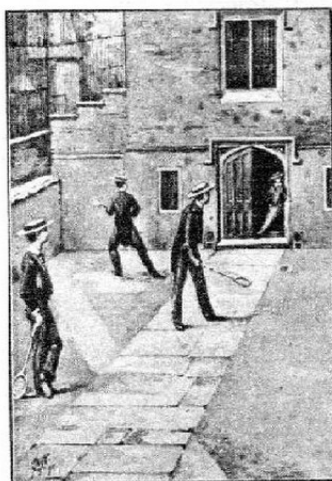

Early squash rackets at Harrow School.

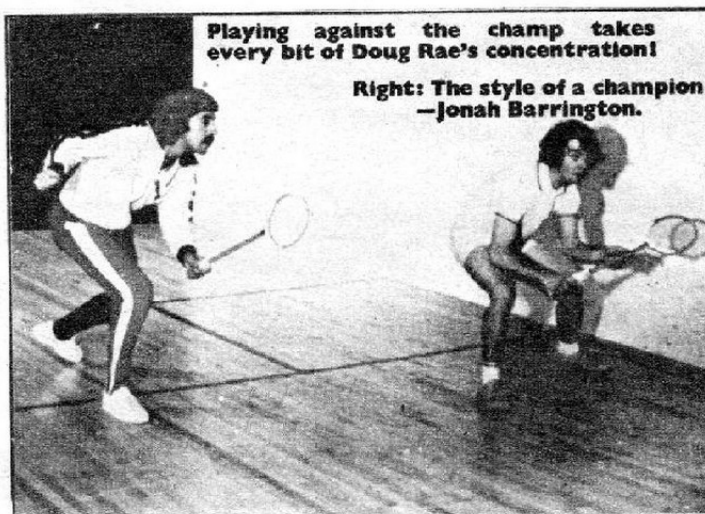

Playing against the champ takes every bit of Doug Rae's concentration!

Right: The style of a champion —Jonah Barrington.



Look-in

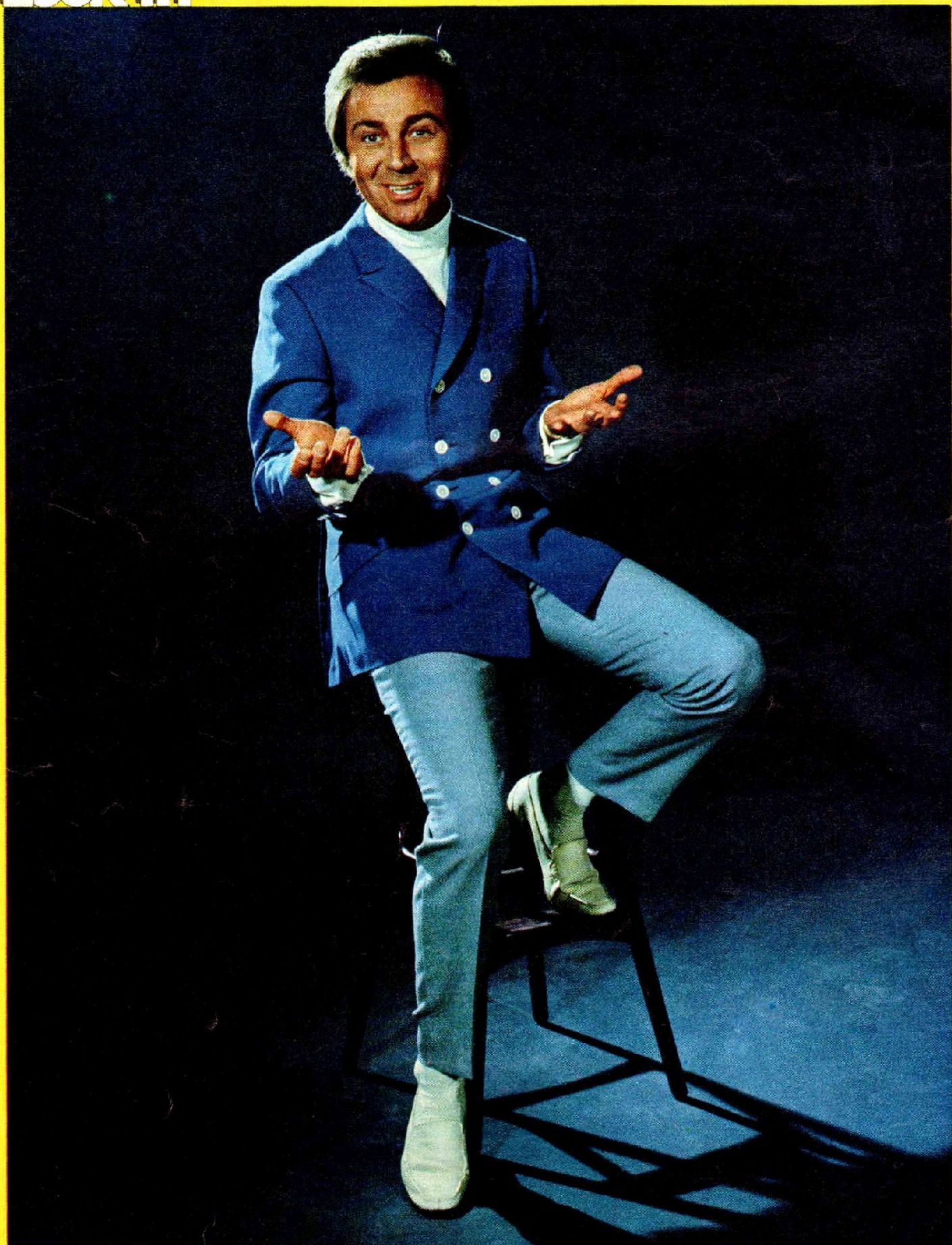

DES O'CONNOR

Once again, Bunty James, Jack Hargreaves, Jon Miller and Fred Dinenage are all set to answer your questions. Congratulations to this week's letter-writers. Why not send in a How! question? For any question published, readers can choose from 20 Hamlyn Books, each to the value of £1. Send your entry to: HOW! LOOK-IN, 247, Tottenham Court Road, London, W1P 0AU.



HOW



HOW does blushing come about?

Patricia M. Eves, Guisborough, Yorkshire.

Blushing happens when the skin's tiny blood vessels swell with blood all of a sudden. These vessels are called 'capillaries' and the swelling is caused by 'vasodilator' nerves which, as those who blush know (even if they don't know that very scientific word), are set off by something which suddenly embarrasses them or, perhaps, makes them very happy. It's nothing to worry about, though people who blush *do* worry about it. Usually, once you grow up, this seemingly uncontrollable happening only occurs occasionally. And, let's face it, if you blush it is said to mean that you have a warm heart!

HOW and when were the first locks and keys made?

Peter Thomas, Sydmor, Jersey.

The first locks and keys date back to Egyptian times, some 4,000 years ago, Peter. They were big wooden bolts operated by wooden keys which looked not unlike modern toothbrushes, but bigger. These were attached to gates. The principle on which the Egyptian lock worked was a simple one: pegs fell into holes in the bolt and could only be pushed up by the toothbrush-key, which was slipped into a special hole in the bolt. The pegs of the key had to match the pins of the lock or the pegs could not be pushed up.

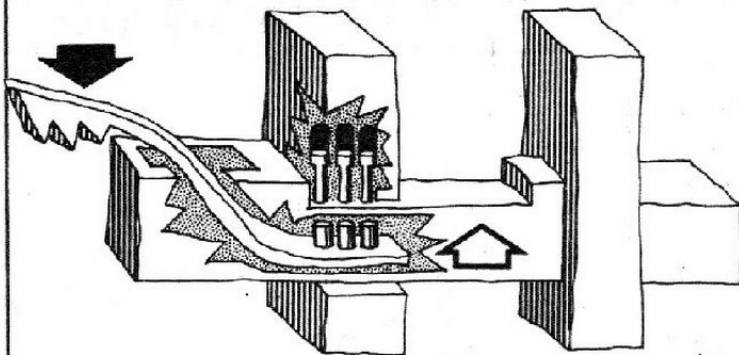

HOW did the saying 'double Dutch' originate?

Suzanne Freed, Harrow, Middlesex.

'Dutch' was quite often used in the past as another word for foreign. This was taken one step further in the last century, when people began saying 'double Dutch' when they meant gibberish, or something quite beyond their understanding.

HOW many different breeds of horses are there approximately in the world?

Pat Joslyn, Rumney, Cardiff.

There are roughly sixty breeds of domesticated horses, Pat, and one wild breed—the tarpan of



A Przewalski's wild horse and foal at Whipsnade Zoo.

Central Asia. There are other wild horses in the world, but the point to remember is that they are descended from domestic ones run wild. The other name of the tarpan is Przewalski's horse, after a Russian explorer.

Sanctorius's thermometer of 1611.

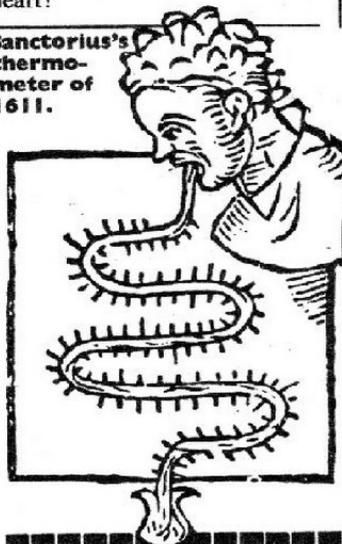

HOW does a thermometer work and who invented it?

Julie Purslow, Cheshire.

Water and other substances swell when they are heated and shrink when they are cooled. Thus, it is on this fact that most thermometers depend. The ancient Greeks knew that air expands when it is heated, and a Greek named Philo made a 'thermoscope' some 2,000 years ago. This probably resembled the first air thermometer, made by the great Italian scientist Galileo in 1592. He put a scale

beside his tube so that he could tell the difference between temperature and heat. And they are different! A burning ember is far hotter than a hot drink, but the drink contains more heat, because there is more of it.

A friend of Galileo's called Sanctorius improved on his thermometer by making one in which a coloured liquid was forced down by the air expanding. This had a glass bulb which the patient held in his mouth: the higher his temperature, the lower went the water level.

RUBBIEH WORKSHOP

With spring already here and summer on the way, you'll soon be heading down to the coast for some swimming and sun-bathing. And what more likely to see on any beach than a Punch and Judy show? In this last article of our series, you are invited to present your own...

PUNCH AND JUDY.
YOU WILL NEED:

- 1 SAFETY MATCHBOX.
- 2 MATCHES.
- 1 6" x 6" WHITE CARTRIDGE PAPER.
- BALSA GEMENT.
- RED AND BLUE FELT-TIP PENS.

PIERCE HOLES THROUGH MATCHBOX AND TRAY LARGE ENOUGH TO TAKE A MATCH.

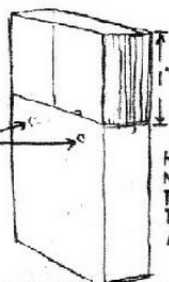

HOLES SHOULD NOT BE MORE THAN 1/4" FROM THE TOP OF THE MATCHBOX.

STAGE 1. PARTLY OPEN MATCHBOX. SO THAT THE TRAY IS EXPOSED 1".

STAGE 2. DRAW TWO HEADS, ONE OF PUNCH AND ONE OF JUDY.

WHEN CUTTING OUT THE HEADS LEAVE ENOUGH PAPER ON THE BASE SO THAT THE MATCHSTICK CAN BE FITTED ON.











HOLE DIAMETER OF MATCHSTICK.

MATCHSTICK.

[All details correct at time of going to press.]

FOR COMPLETE DETAILS OF ALL ITV PROGRAMMES SEE TVTIMES

Lookin on your ITV programmes this week: April 8-14

	Saturday	Sunday	Monday	Tuesday	Wednesday	Thursday	Friday
ANGLIA 	11.50 Cowboy in Africa 12.50 World of Sport 5.10 Flintstones 5.45 Sale of the Century 6.15 Ken Dodd 6.45 Saturday Film	3.25 Dick Van Dyke 3.55 Match of the Week 4.40 The Golden Shot 5.35 Pretenders 7.25 Doctor In Charge 7.55 Star Movie	4.25 Romper Room 4.55 Clapper Board 5.20 Pardon My Genie 6.00 About Anglia 6.45 Opportunity Knocks!	4.40 Enchanted House 4.55 Junior Showtime 5.20 Magpie 7.00 About Anglia 7.00 Mystery Movie	4.30 Romper Room 4.55 Lift Off 5.20 Tightrope 7.00 This Is Your Life 8.00 Cade's County	4.40 Rupert Bear 4.55 Captain Scarlet 6.00 Magpie 7.00 About Anglia 7.00 Thursday Film 7.30 Jason King	4.25 Romper Room 4.50 Voyage To The Bottom of Sea 6.00 About Anglia 7.00 Sky's The Limit 7.30 Jason King
MIDLANDS 	12.15 Captain Scarlet 12.50 World of Sport 5.10 Sale of the Century 5.45 Ken Dodd 6.15 The Comedians 6.45 Feature Film	3.15 Star Soccer 3.15 Film 4.40 The Golden Shot 5.35 Forest Rangers 7.25 Doctor In Charge 7.55 Film	4.10 Nanny & the Prof. 4.40 Nuts & Bones 4.55 Skippy 5.20 Pardon My Genie 6.40 Opportunity Knocks!	4.10 Simon Locke 4.40 Once Upon A Time 4.55 Junior Showtime 5.20 Magpie 7.00 Tuesday Western	4.10 Ghost & Mrs. Muir 4.40 Grasshopper Is. 4.55 Lift Off 5.20 Magpie 7.00 Sky's The Limit 7.30 Thursday Movie 8.50 Popeye	4.40 Rupert Bear 4.55 Get This 7.00 Magpie 7.30 Jason King 8.30 Shirley's World	4.10 Julia 4.40 Zingalong 4.55 Lost in Space 7.30 Jason King 8.30 Shirley's World
BORDER 	12.50 World of Sport 5.45 Ken Dodd 6.30 Saturday Film 8.30 Saturday Variety	2.15 Big Match 3.15 Sunday Matinee 4.40 The Golden Shot 5.35 Pretenders 7.25 Doctor In Charge 7.55 Film	4.10 Julia 4.40 Nuts & Bones 4.55 Clapper Board 5.20 Pardon My Genie 6.45 Opportunity Knocks!	4.10 Arthur 4.40 Once Upon A Time 4.55 Junior Showtime 5.20 Magpie 7.00 Tuesday Western	4.40 Grasshopper Is. 4.55 Lift Off 5.20 Tightrope 7.00 This Is Your Life 8.00 Cade's County	4.35 Cartoon 4.40 The Enchanted House 4.55 Woobinda 5.20 Magpie 7.15 Thursday Film	4.10 Smith Family 4.40 Zingalong 4.55 Flaxton Boys 7.00 Sky's The Limit 7.30 His & Hers
CHANNEL 	12.50 World of Sport 5.10 Tommy Cooper 5.45 Sale of the Century 6.15 Saturday Film	3.00 Feature Film 4.40 Golden Shot 5.35 Pretenders 7.25 Doctor In Charge 7.55 Feature Film	4.05 Once Upon A Time 4.50 Rovers 5.20 Pardon My Genie 6.45 Opp. Knocks!	4.10 Nanny & the Prof. 4.40 Once Upon A Time 4.55 Junior Showtime 5.20 Magpie 7.00 Star Movie	4.05 Paulus 4.55 Lift Off 5.20 Tightrope 7.00 Treasure Hunt 8.00 Cade's County	4.05 Nuts & Bones 4.22 Funny Face 4.50 Skippy 5.20 Magpie 7.00 Thursday Film	4.05 Zingalong 4.22 Dick Van Dyke 4.50 Land of the Giants 7.00 Sky's the Limit
GRAMPIAN 	12.15 Batman 12.50 World of Sport 5.45 Ken Dodd 6.15 Big Movie 8.30 Saturday Variety	3.10 Film 4.40 The Golden Shot 5.35 Pretenders 6.30 Adam Smith 7.25 Doctor In Charge	4.10 Junkin 4.40 Rupert Bear 5.20 Pardon My Genie 6.35 Cartoon Time 6.45 Opportunity Knocks!	4.10 Nanny & the Prof. 4.40 Once Upon A Time 4.55 Junior Showtime 5.20 Magpie 6.10 Royal Clansmen 7.00 Tuesday Film	4.10 Jimmy Stewart 4.40 Enchanted House 4.55 Lift Off 5.20 Tightrope 7.00 This Is Your Life 8.00 Cade's County	4.10 Julia 4.40 Nuts and Bones 4.55 Rumble Jumble 5.20 Magpie 6.10 Win a Word 7.30 Thursday Film	4.10 Smith Family 4.40 Zingalong 4.55 Flaxton Boys 5.20 Ivanhoe 7.00 Sky's The Limit 7.30 It Takes a Thief
GRANADA 	11.50 Play the Game 12.15 Secret Service 12.50 World of Sport 5.10 On the Buses 5.40 Ken Dodd 6.20 Film	1.55 Football 2.50 The Great Stars 4.40 The Golden Shot 5.35 Pretenders 7.25 Doctor In Charge 7.55 Film	4.40 Once Upon A Time 4.55 Clapper Board 5.15 Pardon My Genie 6.40 Opportunity Knocks!	4.45 Junior Showtime 5.15 Magpie 6.25 Jimmy Stewart 7.00 Film	4.55 Lift Off 5.15 Tightrope 7.00 This Is Your Life 8.00 Cade's County	4.50 Make A Wish 5.15 Magpie 7.25 Film	4.50 Land of the Giants 6.15 Lift Off 6.20 Kick Off 6.35 Mysterious Island
WALES/WEST 	11.15 Sesame Street 12.50 World of Sport 5.10 Sale of the Century 5.45 Ken Dodd 6.15 Saturday Cinema	2.15 The Big Match 3.15 Sunday Matinee 4.40 Golden Shot 5.35 Pretenders 7.25 On The Buses 7.55 Film	4.15 Tinkertainment 4.30 Superman 4.50 Tom Grattan 5.20 Pardon My Genie 6.45 Opportunity Knocks!	1.20 Phoenix Five 4.15 Tinkertainment 4.55 Junior Showtime 5.20 Magpie 6.35 Western	4.15 Tinkertainment 4.55 Lift Off 5.20 Tightrope 7.00 This Is Your Life 8.00 Cade's County	3.50 Simon Locke 4.15 Tinkertainment 4.55 Huckleberry Finn 5.20 Magpie 6.35 Sky's The Limit 7.10 Midweek Movie	3.20 Grasshopper Is. 3.35 Enchanted House 4.15 Tinkertainment 4.55 Voyage To The Bottom Of The Sea 6.35 Bonanza
LONDON 	11.15 Sesame Street 12.50 World of Sport 5.10 Sale of the Century 5.45 Ken Dodd 6.15 Feature Film	1.15 Stingray 2.15 The Big Match 3.15 Jason King 4.40 Golden Shot 5.35 Pretenders 7.25 Doctor In Charge	4.40 Rupert 4.55 Lassie 5.20 Pardon My Genie 6.40 Opportunity Knocks!	3.45 Danger Man 4.40 Once Upon A Time 4.55 Junior Showtime 5.20 Magpie 7.25 Action Film	4.40 Hatty Town 4.55 Lift Off 5.20 Tightrope 7.00 This Is Your Life 8.00 Cade's County	4.40 Nuts and Bones 4.55 Secret Squirrel 5.20 Magpie 7.00 Thursday Film	11.00 Bugs Bunny 4.15 Clapper Board 4.40 Zingalong 4.55 Land of the Giants 6.15 F Troop
SCOTTISH 	11.50 Bushboy 12.15 T. Grattan's War 12.50 World of Sport 5.10 Road Runner 5.45 Ken Dodd 6.15 Saturday Feature	2.15 Feature Film 4.40 The Golden Shot 5.35 Pretenders 7.25 Doctor In Charge 7.55 Sunday Feature	3.30 Origami 3.45 Simon Locke 4.55 Arthur 5.20 Pardon My Genie 6.15 Smith Family 6.30 Best of Lucy 4.25 Junkin 4.55 Clapper Board 5.20 Pardon My Genie 6.45 Opportunity Knocks!	3.30 Foo Foo 4.55 Junior Showtime 5.20 Magpie 6.20 Cartoon 6.30 Hogan's Heroes 7.00 The Tuesday Film	3.30 Pinky & Perky 4.55 Lift Off 5.20 Tightrope 6.30 On The Buses 7.00 This Is Your Life 8.00 Cade's County	3.30 Once Upon a Time 4.55 Fireball XLS 5.20 Magpie 6.20 Cartoon 6.55 Thursday Film	3.30 Kiri 4.55 Lost in Space 6.20 Cartoon 6.30 Jimmy Stewart 7.00 Sky's The Limit 7.30 Strange Report
SOUTHERN 	11.45 Thunderbirds 12.50 World of Sport 5.10 Primus 5.45 Ken Dodd 6.15 On the Buses 6.45 Saturday Film	1.30 Stingray 2.00 Big Match 3.00 Film 4.40 Golden Shot 5.35 Pretenders 7.25 Doctor In Charge	3.30 Best of Lucy 4.25 Junkin 4.55 Clapper Board 5.20 Pardon My Genie 6.45 Opportunity Knocks!	4.15 Ping Wings 4.55 Junior Showtime 5.20 Magpie 6.30 Sale of the Century 7.00 Tuesday Film	4.15 Enchanted House 4.55 Lift Off 5.20 Tightrope 7.00 This Is Your Life 8.00 Cade's County	4.15 Sean The Leprechaun 4.55 Rich'd the Lionh't 5.20 Magpie 6.45 Simon Locke 7.15 Thursday Film	3.00 Kate 4.15 Paulus 4.55 Voyage To The Bottom Of The Sea 7.00 Sky's The Limit 7.30 The Saint

Robert Harbin introduces . . .

DO-IT-YOURSELF ORIGAMI



The Cicada

The cicada or 'singing beetle' is most abundant in the tropics but it is also a traditional Japanese Origami fold, made from a square of paper. Why not try it?

1. Fold in half

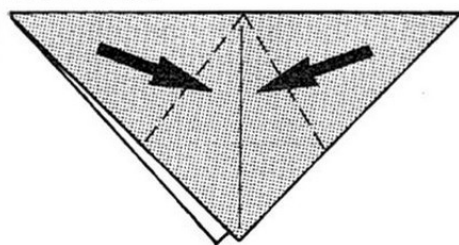

2.

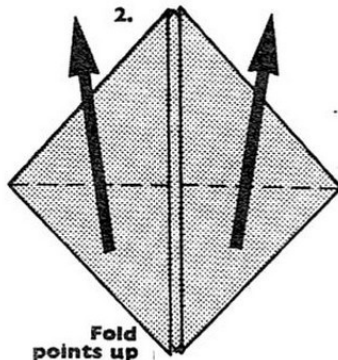

Fold points up

3.

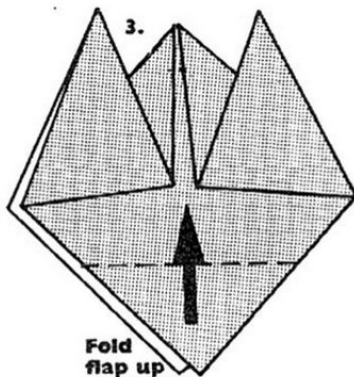

Fold flap up

4.

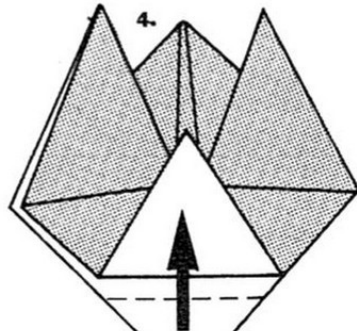

Fold again

5.

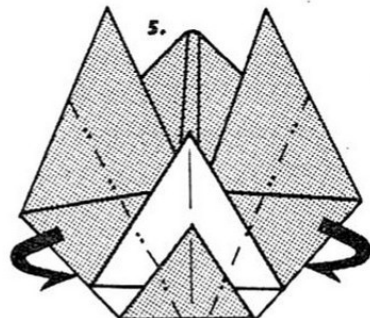

Fold sides under, then fold eyes

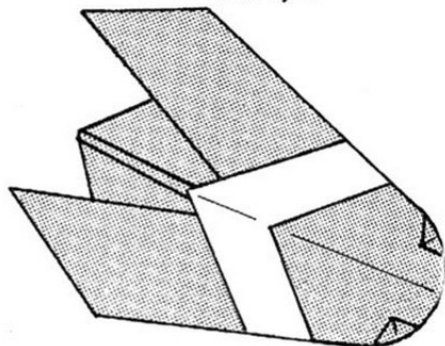

You can win £1 for your new model!

If you feel you can invent a new Origami model, write down the details (together with your own name and address) and send them to Do-It-Yourself Origami, LOOK-IN, Junior TVTimes, 247 Tottenham Court Road, London W1P 0AU. I will send a £1 postal order for any item I select to publish. So, hurry and get your paper thinking-cap on now!

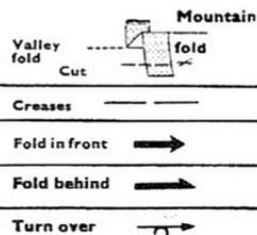

TYNE TEES

4.40 Make A Wish
4.55 Flaxton Boys
5.20 Flintstones
6.30 The Partners
7.00 Sky's The Limit
7.30 His & Hers

3.40 Simon Locke
4.40 Make A Wish
4.55 Lift Off
5.20 Tightrope
7.00 This Is Your Life
8.00 Cade's County

4.50 Sean The Leprechaun
4.55 Junior Showtime
5.20 Magpie
6.30 Hogan's Heroes
7.00 Tuesday Western

4.40 Once Upon A Time
4.55 Rainbow Country
5.20 Pardon My Genie
6.45 Opportunity Knocks!

2.20 Soccer
3.15 Champions
4.15 Charlie Brown
4.40 The Golden Shot
5.35 Pretenders
7.25 Doctor In Charge

11.50 Arthur
12.15 Lidsville
12.50 World of Sport
5.10 Primus
5.45 Ken Dodd
6.15 Saturday Film



ULSTER

4.30 Romper Room
4.55 Thunderbirds
7.00 Sky's The Limit
7.30 Jason King
8.30 His & Hers

4.30 Romper Room
4.55 Forest Rangers
5.20 Magpie
7.00 Dr. Simon Locke
7.30 Feature Film

4.30 Romper Room
4.55 Lift Off
5.20 Tightrope
7.00 This Is Your Life
8.00 Cade's County

4.30 Romper Room
4.55 Junior Showtime
5.20 Magpie
7.00 Midweek Movie

4.30 Romper Room
4.55 Clapper Board
5.20 Pardon My Genie
6.15 Funnny Face
6.45 Opportunity Knocks!

2.00 The Big Match
3.15 Sunday Matinee
4.40 The Golden Shot
5.35 Pretenders
7.25 Doctor In Charge
7.55 Star Movie

11.35 Gus Honeybun
11.45 Rupert
11.55 Lone Ranger
5.10 Tommy Cooper
5.45 Sale of the Century
6.15 The Saturday Film



WESTWARD

3.55 Gus Honeybun
4.05 Zingalong
4.20 Dick Van Dyke
4.50 Land of the Giants
7.00 Sky's The Limit
7.30 I Spy

3.55 Gus Honeybun
4.05 Nuts & Bones
4.20 Funnny Face
4.50 Skippy
5.20 Magpie
7.00 Thursday Film

3.55 Gus Honeybun
4.05 Paulus
4.55 Lift Off
5.20 Tightrope
7.00 Treasure Hunt
8.00 Cade's County

3.55 Gus Honeybun
4.10 Enchanted House
4.22 Dr. Simon Locke
4.55 Junior Showtime
5.20 Magpie
7.00 Star Movie

3.55 Gus Honeybun
4.05 Once Upon A Time
4.50 The Rovers
5.20 Pardon My Genie
6.45 Opp. Knocks!

2.00 Soccer
3.15 Department S
4.40 The Golden Shot
5.35 Pretenders
7.25 Doctor In Charge
7.55 Feature Film

11.50 Skippy
12.50 World of Sport
5.10 Primus
5.45 Ken Dodd
6.15 Saturday Film
8.30 Saturday Variety



YORKSHIRE

4.40 Zingalong
5.20 Flintstones
7.00 Sky's The Limit
7.30 His & Hers
8.00 Hawaii Five-O

4.40 Nuts and Bones
4.55 Lone Ranger
5.20 Magpie
6.30 Smith Family
7.00 Cartoon
7.15 Thursday Film

4.40 Hatty Town
4.55 Lift Off
5.20 Tightrope
7.00 This Is Your Life
8.00 Cade's County

4.40 Enchanted House
4.55 Junior Showtime
5.20 Magpie
6.30 Hogan's Heroes
7.00 Tuesday Western

4.40 Once Upon A Time
4.55 H. R. Pufnstuf
5.20 Pardon My Genie
6.45 Opportunity Knocks!

2.20 Soccer
3.15 Department S
4.40 The Golden Shot
5.35 Pretenders
7.25 Doctor In Charge
7.55 Film

11.50 Skippy
12.50 World of Sport
5.10 Primus
5.45 Ken Dodd
6.15 Saturday Film
8.30 Saturday Variety



Exclusive Look-in offer!

APOLLO 16 MOON MISSION BADGE THIS FABULOUS REPLICIA FOR 65p

ON APRIL 20, when John Young and Charlie Duke manoeuvre the Apollo 16 Moonship ready for final touchdown as Ken Mattingly circles above, their landing will be the most tricky yet. Their target—an area just north of the crater Descartes in the Southern half of the Moon—is known as 'the lunar Himalayas', with mountains as tall as Everest. Photographs suggest it was where some huge volcano spewed out lava millions of years ago—which is why the men are going there.

★ The badge tells the story of their mission to the Descartes region of the Moon, and bears their names, embroidered round the rim, together with silver stars—16 for Apollo 16. Across the badge is a gold, winged symbol of flight, put there at the request of Charlie Duke, who is an Air Force Colonel. The remainder of the badge is a broken-up U.S. flag (red, white and blue stripes, with the stars around the rim and an eagle on top) which was the choice of the other two pilots—both Navy men. The emblem is set against a background of their mountainous target, Descartes.



(Actual size)

To commemorate the historic launch of Apollo 16, LOOK-IN is offering, at a special price, a brilliant replica of the mission badge the astronauts helped to design. Approximately 4 inches in diameter, it is embroidered in six colours with nearly 10,000 stitches. Send off now for this fabulous offer and you could receive your own Apollo 16 badge in time for the lift off which takes place Sunday, April 16.

Send to: LOOK-IN Apollo 16 Badge Offer
P.O. Box 50, Kettering, Northants.

16

Name: _____

Address: _____

I enclose cheque/PO value _____

for _____ badges. ★ Allow 28 days for delivery.

★ ALL YOU HAVE TO DO to own this magnificent badge is complete the form on the left stating your name and address, and send it together with a postal order or cheque to the address shown. Order without delay. Cheques/POs should be made payable to Independent Television Publications Limited.