

Look-in

Junior TVTimes No 30 week ending 22 July 1972 Every Thursday 5p

The TV speed car

Special feature inside, page 5



SPECIAL OFFER! SPACE CHARM BRACELET

Crowther in trouble

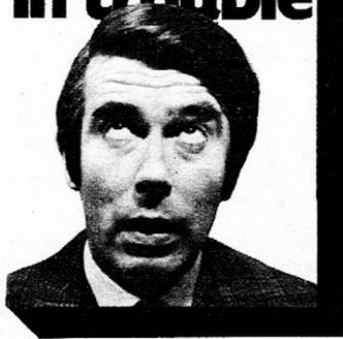

Leslie keeps the family cool!

ONE SUNNY SATURDAY MORNING...

THE LAWN'S MORE YELLOW THAN GREEN. I'D BETTER GIVE IT A GOOD WATERING WITH THE HOSE... HELLO! WHOSE PULLING THE OTHER END?

SLUDDENLY...

DONK!

YEEKES! SOMEONE DID THAT ON PURPOSE! WHAT'S HAPPENING..?

A GOOD GUESS...

AND SO...

THERE'S NO NEED TO SULK, LESLIE - YOU DID PROMISE...

HUH? I WAS THINKING I'LL BET THE BEACH IS PACKED OUT!

THERE! WHAT DID I TELL YOU?

ALL RIGHT! BUT WE NEEDN'T GIVE UP SO EASILY. THERE'S STILL THE SWIMMING POOL...

... AND MORE CROWDS...

Poolad

PHEW! DON'T TELL ME WE'RE ALL GOING TO STAND ON THE END OF THAT!

NOT ALL OF US, LESLIE - JUST YOU, YOU CAN PARK OVER THERE!

AND SO...

YOU CAN KEEP OUR PLACE, WHILE I GET SOME ICE-CREAMS FOR THE KIDS...

SOON...

NOT LONG NOW - I'LL NEED TO COOL DOWN AFTER THIS WAIT...

HEY! AIN'T THAT LESLIE CROWTHER?

YEAH - BAGS HIS AUTOGRAPH! COME ON!

LESLIE IS RIGHT AGAIN...

YOU'RE DETERMINED TO WATER YOUR GARDEN AT ALL COST, AREN'T YOU?

OH, NO! I'M REALLY IN HOT WATER NOW! JEAN'LL BE FURIOUS! SHE'LL THINK I DID IT ON PURPOSE!

THAT'S YOUR LOT! WE'RE FULL UP!

... WHICH KEEPS EVERYONE HAPPY!

THERE! THIS WAY EVERYTHING GETS WET!

HOORAY! CLEVER OL' DAD! I KNEW HE WOULDN'T LET US DOWN!

WAIT A MINUTE! I'VE AN IDEA...

LESLIE, YOU'RE NOT JUST CLEVER - YOU'RE CRAFTY!

Look-in

Number 30
[Cover illustration by Angus McBride]

Some Seasonal Questions

What has Reg Varney to do with the island of Malta? Where is Wendy Padbury's hideaway? Why does Edward Woodward, TV's Callan, go to Cyprus each year?

The answers to these questions about where the stars go on holiday can be found in an intriguing feature included in the LOOK-IN HOLIDAY SPECIAL.



Also there is an article on where the stars are appearing in their summer shows this year. And Jon Miller of How! fame tells you some interesting things to look for on the seashore.

Strip cartoons, stories, jokes, puzzles, games and a host of other activities, featuring all the regular LOOK-IN favourites, add to the package of 64 packed pages with 20 in full colour.

LOOK-IN Holiday Special is on sale now! Price 15p Don't miss it!

A lock-out for Leslie next week!

Starts today! A great new story...



ONE SATURDAY MORNING, STAN IS BRIEFED ON A SPECIAL JOB...

IT'S A PRIVATE CHARTER, BUTLER! YOU'LL BE DRIVING A PARTY OF GIRLS TO THE LUXTON CHURCH FÊTE.

GIRLS? DID YOU SAY GIRLS, BLAKEY?



STONE ME, MATE, THAT'S RIGHT UP MY STREET!

I THOUGHT YOU MIGHT SAY THAT, BUTLER. HERE THEY COME!



HOORAY! THERE'S THE BUS!

ALL ABOARD! BAGS ME THE FRONT SEAT!

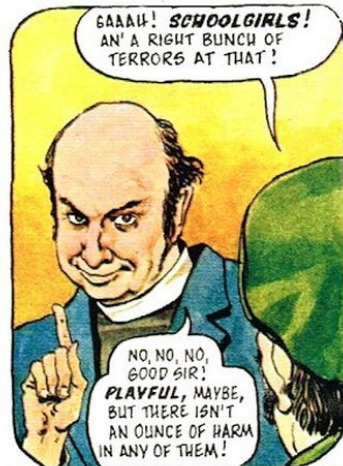

GAAAH! SCHOOLGIRLS! AN' A RIGHT BUNCH OF TERRORS AT THAT!

NO, NO, NO, GOOD SIR! PLAYFUL, MAYBE, BUT THERE ISN'T AN OUNCE OF HARM IN ANY OF THEM!



THIS, BUTLER, IS THE REV. SOPWITH! HE'S IN CHARGE OF THE PARTY!

BETTER 'IM THAN ME, THAT'S ALL I CAN SAY!



OFF THEY SET...

YOPPEEE! Ding, Ding, Ding!

'one man went to mow...

STONE THE CROWS! THEY'RE GOIN' BEPBERK - THIS AIN'T A BUS, IT'S A MOBILE MONKEY-HOUSE!



AT LAST THE FÊTE IS REACHED...

FÊTE

OKAY, YOU LOT, ALL OFF! AND ONE AT A TIME, IF YOU DON'T MIND!

GAH, DON'T BE SUCH A MISERY! WE'RE ON A DAY OUT...



... SO CHEER UP AND STOP MOANING!



FAN ME! WHAT A LIFE! OKAY, VICAR, THEY'RE ALL YOURS, AND THE BEST OF BRITISH...

HEY, VICAR, WHAT IS IT?

UUUUH!

HARRY NORTH

Next week: Stan's fate rests in the fair! 3

© Based on the London Weekend Television series written by Ronald Wolfe and Ronald Chesney.

STEW POT'S LOOK-OUT

Niagara Falls—I could hardly believe it, but there I was standing at one of the most beautiful (if not noisy) sights I'd ever seen—and all thanks to my recent trip to Canada. At school, a favourite subject of mine was geography. But, not surprisingly, Niagara Falls didn't seem quite so wonderful from within a text book! What my school books *did* tell me, though, was that the Falls are in two principal sections separated by Goat Island, and serve as part of the boundary between Canada and the States.

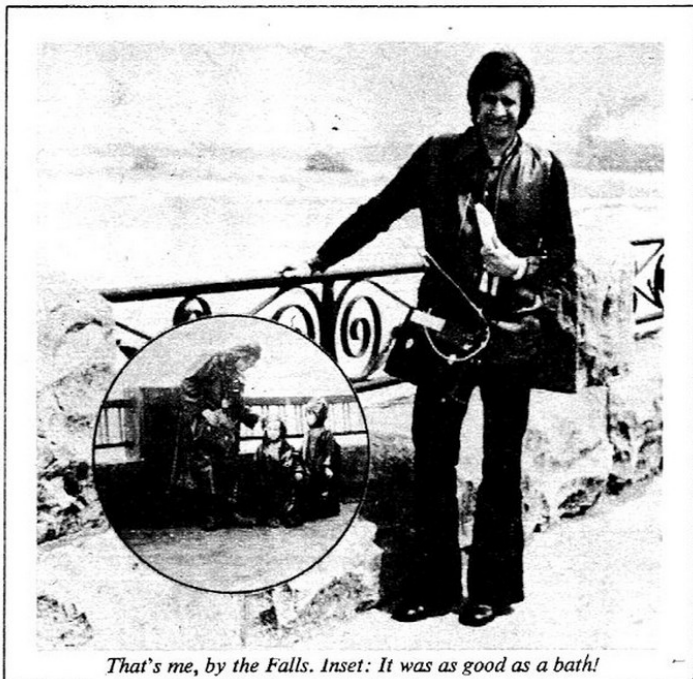

That's me, by the Falls. Inset: It was as good as a bath!

The Canadian division is the greater, and called the Horseshoe Fall. It's 158 feet high and the length of its curving crest line is about 2,600 feet. In addition, 114 million gallons of water pass down it every minute!

When I took a 'look-see' for myself, I pulled on some rubber boots and a mackintosh. You *have* to wear them, for behind the falling water, cut into the rock, are tunnels which take you very close to the water.

There's a lift to take you down 125 feet, and the elderly man who operated it told me he'd had 150 schoolchildren that morning who said that standing near the Falls was worse than taking a bath! (Not that I'm complaining, myself, 'cos I enjoy a good ol' splash-about!)

MODEL MAKER

Any model-maker who wants to get stuck into a new kit, won't come unstuck with either of these two from Airfix.

For aircraft-enthusiasts, the Corsair II has 79 finely-detailed parts and measures 7½ in. long with a wingspan of 6½ in., when completed. Full painting instructions and a display stand are also included in the pack.

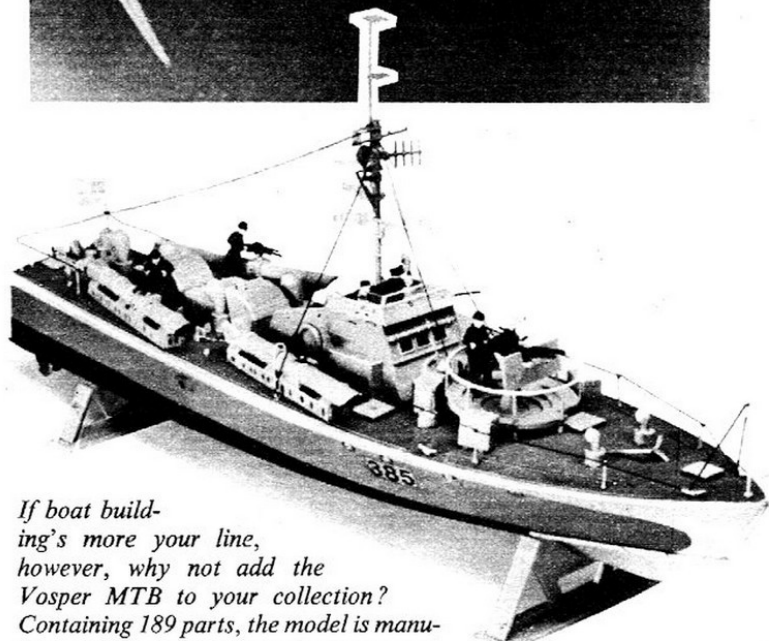

If boat building's more your line, however, why not add the Vosper MTB to your collection? Containing 189 parts, the model is manufactured in light grey polystyrene and measures over 12 in. long, when finished. Each kit costs 35p.



Motor sport is already a screen spectacular, but now new excitement is offered by TV's own super-speed saloon...

the Thames Flier!

NEXT TIME YOU'RE OUT WITH DAD IN THE CAR, tighten your seat-belt (always wear it, remember!), close your eyes, and try to imagine the same sedate family saloon in which you're riding being hurled around a racing circuit at speeds well over the 'ton'. Feel its tyres fighting for a hold as it jockeys for position on a tight corner; hear the full-throated roar of its engine building up to full power along the straight.

If you've a good imagination, it may give you some idea of what it would be like to ride beside Gerry Marshall as he drives Thames Television's Vauxhall Firenza to victory in saloon car races all over the British Isles. When cars with

only minor mechanical differences from the vehicles that pack our busy roads every day battle for supremacy over miles of tricky track, Gerry Marshall in the Firenza is usually up there at the front as the chequered flag signals the winner over the line.

Since Thames decided to race a Vauxhall Firenza in their colours, in September last year, Gerry Marshall has taken the car to thirteen wins out of eighteen starts, setting three new track records in the process. In May this year, in a 

the Thames Flier!

Saloon Car Championship of the British Automobile Racing Club (BARC)—an event in which the Firenza is currently leading overall—Gerry covered the tough Croft Autodrome circuit in Yorkshire in a new lap record time of 1 minute 15.6 seconds at an average speed of 83.5 miles per hour. Since then, he has also scored wins at Oulton Park, at Ireland's Mondello Park circuit and Thruxton.

Winning is nothing new to Gerry Marshall, a bluff, colourful character whose eighteen-stone frame must find the seat of the Firenza a tight squeeze. He won his first saloon car race—in a

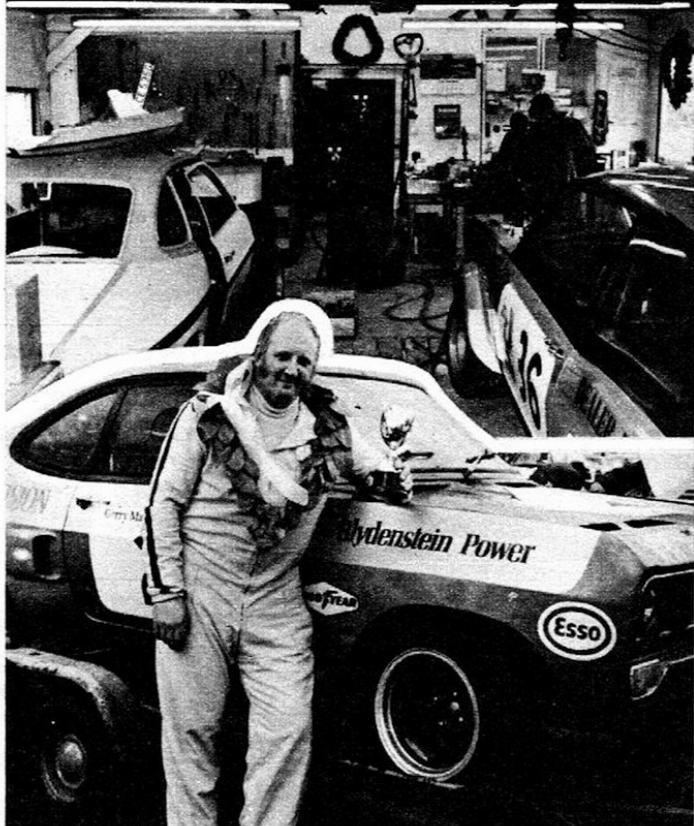

Foreground: Gerry Marshall wins the main saloon car race at Oulton Park, 1972. To background: the converted railway station at Shepreth, which serves as the Firenza workshop.

Mini—in 1964, and later broke the lap record at Brands Hatch, Britain's premier 'production car' circuit, on his first appearance there. In more than 200 races, he has never seriously damaged a car; since saloon car racing is an expensive business, this—together with his winning ways—makes him a real top-notch.

Backroom-boy

"Gerry's incredible skill and fighting spirit make him one of the best saloon car drivers in the world," says Bill Blydenstein. And Bill is an authority: it is at his workshop in a disused railway station at Shepreth, Hertfordshire, that the Thames Firenza—and the Vauxhall Vivas raced by Dealer Team Vauxhall—are prepared. An ex-racing driver, who won the BARC Saloon Car Championship in 1960, Bill Blydenstein is acknowledged to be the top 'backroom-boy' in the sport. It is his engineering 'know-how' that coaxes the extra power from the Firenza's 2.5 litre engine, giving it a maximum speed of over 140 miles per hour and enabling it to compete with—and beat—larger-engined competitors. Since Bill and Gerry joined forces in 1967, they have become a well-nigh invincible team.



BOOKSHELF

For all animal-lovers, this week's 'Spotlights' are on cats and dogs. With the help of colour drawings, both books tell you about all the main breeds, and in 'Spotlight on Dogs', there's a special feature on dog health.

Generally, people tend to know more about the different breeds of dogs than they do those of cats. But in 'Spotlight on Cats', many less-common types are illustrated. There's also a chapter on kittens, and another on the wild members of the cat family.

☆ All good stuff at only 40p each, at your local bookshop. (Published by Hamlyn's.)

FAN CLUB NEWS!

Not so much a fan club—more an Appreciation Society as far as American singer Johnny Cash is concerned.

If you want to write to him, send your letter to the following address, and it will be forwarded to Johnny's home in America.

We can't guarantee a reply, but we're told that Johnny does his best to answer all his fans—wherever they are!

Good enough? Then post your letter to: The Johnny Cash Appreciation Society, c/o Barry Rowden, 56 Warwick Gardens, London Rd., Thornton Heath, Surrey Cr4 7ND.





**Look in
Special
Offer**

**SPACE
CHARM
BRACELET
FOR 50p**

This attractive gilt bracelet bearing six charms commemorates landmarks of the Space Age. The gilt charms show **Vostok** — the Russian spaceship which carried Yuri Gagarin; **Neil Armstrong** taking the first walk on the Moon; **Telstar**, the first Transatlantic TV satellite; **the Moon Car** — with two seated astronauts; **Apollo Spaceship** — Command and Service Modules; **Nimbus**, the weather satellite which sends back cloud pictures to help forecasters.

☆ **All you have to do** to own this magnificent charm bracelet is to complete and send the coupon below to the address shown. Enclose a cheque or postal order for 50p per bracelet, which includes postage and packing. Make your cheques and P.O.'s payable to Independent Television Publications Ltd. and allow 28 days for delivery.

Please send me..... *Space Charm Bracelets.*
 I enclose cheque/P.O. to the value of

Name

Address

.....

.....

Allow 28 days for delivery.

The trio are saved by a returned ticket!

Doctor in Charge!



WHEN THEY PAWN PROFESSOR LOFTUS'S DRESS SUIT AND THE PAWN TICKET IS ACCIDENTALLY SNATCHED BY MARTINSIDE HOSPITAL STUDENTS DURING A RAG-DAY STUNT, DUNCAN, PAUL AND DIK HAVE TO GET IT BACK! DISGUISED, THEY RAID THE MARTINSIDE NURSES' HOSTEL, BUT WHEN A LOCAL TRAIN IS DERAILED THEY'RE CAUGHT UP IN THE GENERAL FLAP! A SHORT-SIGHTED NURSE, MISTAKING THEM FOR COLLEAGUES, INSISTS ON GIVING THEM A LIFT...



LOOK, DUNCAN - WE'LL JUST HAVE TO HI-JACK THE CAR!

ARE YOU CRAZY? THE POOR GIRL MIGHT THROW A FIT!



BESIDES - WE COULD BE NEEDED. I'M AFRAID THERE'S ONLY ONE DECENT THING TO DO...



ER... EXCUSE ME, MISS. WE'VE... ER... GOT A CONFESSION TO MAKE!

EEEEK!



DUNCAN TELLS ALL, THROWING HIMSELF AT THE NURSE'S MERCY...

YOU OUGHT TO BE ASHAMED! BUT I SHAN'T REPORT YOU. WHEN THIS IS ALL OVER, I MIGHT EVEN GET THAT PAWN TICKET BACK FOR YOU...

YOU'RE A REAL SPORT!



THEY ARRIVE AT THE SCENE OF THE CRASH...

DOESN'T LOOK TOO BAD, THANK GOODNESS!

A FEW MINOR JOBS FOR US CHAPS...

...PROBABLY - WE'LL SEE YOU LATER, NURSE!



MINOR INDEED. THE WORST INJURIES ARE A FEW SCRATCHES AND BRUISES...

...PUT MY BEST SUIT ON FOR THE JOURNEY, TOO.

AT LEAST THAT'S THE ONLY THING THAT'LL NEED STITCHES!



MEANWHILE...

CAN YOU HELP MY TEDDY? I THINK HE'S SPRAINED HIS ANKLE!

SURE! I'M GLAD TO SAY HE'S BARELY TOUCHED!



SUDDENLY...

HULLO - HERE'S A CHAP IN A STATE I DON'T WORRY FRIEND, I'LL GIVE YOU A HAND OUT!

MMMFFF - GNNFF...



GET AWAY YOU IDIOT! I'M TRYING TO REACH MY CASE! IT'S FALLEN DOWN INSIDE!

I... I KNOW THAT VOICE...

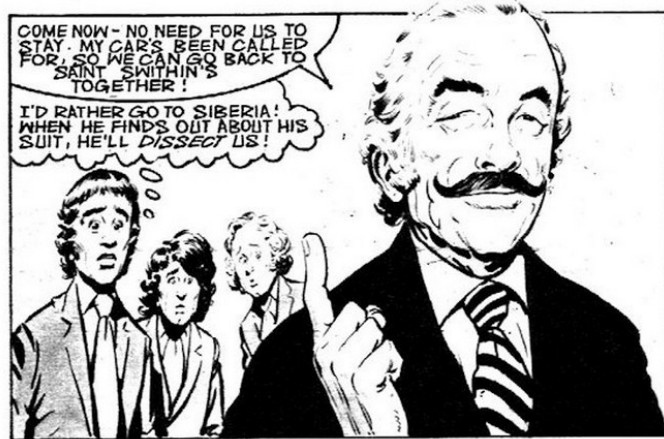

Some 'shock treatment' turns the tables!



PLEASE SIR!

AT MORNING BREAK IN THE STAFF-ROOM...

BOYO, A RAID ON DORIS'S STORE CUPBOARD IS INDICATED. LET'S BORROW THE ODD CAKE OR BISCUIT!



AN EXCELLENT IDEA, PRICE! WHAT THE EYE DOESN'T SEE WON'T BE GRIEVED FOR, AS THEY SAY.



GREAT CRAGS OF CAERNARVON - IT'S 'BUGGED'!

RINGING BELLS... ASTOUNDING!

SURPRISE! SURPRISE! THE LONG HAND OF SCIENCE CATCHES THEM RED-HANDED, DORIS!



RED-FACED, TOO, HEADMASTER! REALLY, ONE HARDLY KNOWS WHOM TO TRUST!

PERMIT ME TO PRESENT OUR MASTER OF SCHOOL SECURITY - NOBLE NORMAN! I AM INDEBTED TO HIM FOR WIRING UP THE ALARMS!

IT WOULD BE POTTER! I'D LIKE TO SEE HIM WIRED UP!



ALLOW ME, SAH! SEE? MASTER-SWITCH ON! EVERY APERTURE IS CONNECTED - LET EVIL-DOERS EVERYWHERE TREMBLE!



THANK YOU, NORMAN. I AM INDEED A MAN OF POWER! 'SWITCHED ON', IN FACT!

MEANWHILE, FOUR'C ARE BUSY...

IT'S ALL CLEAR! I'LL JUST TAKE BACK OUR CATAPULTS OL' POTTER CONFISCATED. AFTER ALL, THEY ARE OUR PROPERTY!



YEAH! PICK THE LOCK, TERRY! USE CELIA'S HAIRPIN!

BRAAANNN TRRRRIING!



YEEARGH! IT'S WIRED UP...

YEEOW! LOOK OUT! MY GUITAR - YOU'VE UNWIRED IT! ALL THE STRINGS 'AVE SNAPPED!

BREAKING AND ENTERING, EH, STRINGER? ER, WATCH IT, LAD - NO VIOLENCE!

I'LL PUT THEIR NAMES DOWN IN MY 'NAUGHTY' BOOK!

STOP SHOVIN', POTTY - OR ELSE!



Based on the London Weekend Television series created and written by John Esmonde and Bob Larbey © 1972 Esmonde Larbey Ltd.

LATER, IN THE PHYSICS LAB...

SIR, I 'EARD ABOUT THE BISCUIT CUPBOARD. ER... WE WAS WONDERING IF WE MIGHT DO A DEAL?

CERTAINLY NOT, BOY... ER... KEEP TALKING— IF POTTER'S SECURITY'S ON YOUR MIND, WE SHARE UNPLEASANT THOUGHTS!

AS SCHOOL FINISHES...

MASTER-SWITCH ON, NORMAN! I CAN LEAVE WITH A CLEAR CONSCIENCE...

GOODNIGHT, SAH! I'LL MAKE MY LAST SECURITY CHECK ON ALL DOORS AND WINDOWS! ANY INTRUDER WOULDN'T STAND A CHANCE OF ESCAPE!

SURPRISINGLY, A BOX-ROOM DOOR IS OPEN, AND...

HELLO! I'LL INVESTIGATE— COULD BE SOMEONE INSIDE... DOPS!

DEAD RIGHT, MATE— YOU! OPERATION 'PULVERISE PERISHIN' POTTY' BEGINS!

THAT'S IT— WIRE ON OL' PRICEY'S 'SHOCKING COIL' FROM THE LAB'. IT'S HARMLESS BUT IT SURE GIVES A TINGLE!

NOW WE SCARPER!

INSIDE...

I'LL SOON... YEEIIHES! I'M ELECTRIFIED! GAAH!

BRAAANNNG!
TRRRRRRIIINNNG!

I'LL OPEN A WINDOW AND— OH, NO! THERE GOES THE MAIN BURGLAR-ALARM!

I... ER... I... SAH, I'VE BEEN DONE!

RRRRIIINNNG!

SOMEONE'S INSIDE ALL RIGHT! I'EAR'D 'EM YELLING! PROBABLY A PETTY THIEF!

WELL DONE, STRINGER— I CONGRATULATE YOU ON FETCHING THE POLICE!

SO DO I!

YOU WILL BE, POTTER, IF THE SYSTEM ISN'T DISMANTLED TOMORROW. YOU'VE CAUSED ENOUGH TROUBLE!



LIFT OFF

I've often been singing on my own and thought to myself: "Thank goodness no one else is here to listen to that!" No doubt, it's an experience we've all had at one time or another, but sometimes it's lack of courage that is the difference between a fantastic performance and dismal failure!

For example, MELANIE has an unusual voice and style of singing that isn't to everybody's taste.

However, she has the ability and confidence to get hold of a song and sing it in a way that no one else would ever think of—listen to her version of the oldie 'Somebody Loves Me' on her 'Garden In The City' album and you'll know what I mean.



Melanie—a versatile artist.

Apart from singing, Melanie is also a marvellous song-writer. Perhaps her most successful number was 'Look What They've Done To My Song Ma'—an American hit for her—and a huge hit for the New Seekers throughout the World, making No. 1 in England.

Her other records such as 'Lay Down' with the Edwin Hawkins singers and 'Brand New Key' show a rare variety of style, and from her huge world-wide following I can see that her talent is rightly appreciated!

Just as a matter of interest, Melanie was discovered by accident in true show business tradition. She was going for an audition, entered the wrong room, and found herself in the presence of Peter Sherek—a famous producer. He suggested that as she had a guitar, she might as well play it for him.

That's what I call lucky—both for Melanie and her fans!

Bye for now!

A flight flop puts the ancient sorcerer down in the dumps!

CATWEAZLE



CATWEAZLE, THE SORCERER FROM NORMAN ENGLAND, ARRIVES IN THE TWENTIETH CENTURY AND TEAMS UP WITH JOE BOND AND HIS STAGE MAGICIAN FATHER. CATWEAZLE GATHERS A LOAD OF RUBBISH IN THE BELIEF THAT HE HAS THE INGREDIENTS FOR A SPELL TO TAKE HIM BACK TO HIS OWN TIME. BEFORE JOE CAN STOP HIM, THE OLD MAN DECIDES TO PUT THE SPELL TO THE TEST...



I HAVE THE POWER! TO FLY THROUGH THE AGES!

GUHHH! STOP, CATWEAZLE! WE'RE ON THE SECOND FLOOR!



TOO LATE...

YOWOOO!

OH, MY GOSH!

FLY! I GOMMAND MYSELF! TCHAH, WILL NOTHING WORK?



By MIRACULOUS CHANCE...

YEEAGH!

THUMM!



SPROINGG!



THANK GOODNESS!

GOODNESS HAS NOUGHT TO DO WITH THE ODOUR OF THIS TRAVELLING PIGSTY, HUFF-SNUFF! COME DOWN AND EXTRACT ME!



LATER, WHILE CATWEAZLE IS TAKING AN UNACCUSTOMED BUT VERY NECESSARY BATH, JOE'S FATHER COMES BACK TO THE LODGINGS WITH A VISITOR...

THIS IS SILAS CREECH, JOE. BE A GOOD LAD AND FIX US A CUPPA!

LUMME! HE GIVES ME THE CREEPS JUST TO LOOK AT HIM!



MISTER CREECH IS INTERESTED IN MAGIC, JOE. REAL MAGIC, AND THE SUPERNATURAL.

INDEED I AM. I EXPLORE THE DARKEST REGIONS OF HIDDEN POWER — WHERE DEMONS REIGN AND FEAR IS THE COMMONPLACE!

ER... JOLLY INTERESTING!

© L.W.I. Productions Ltd. 1972.

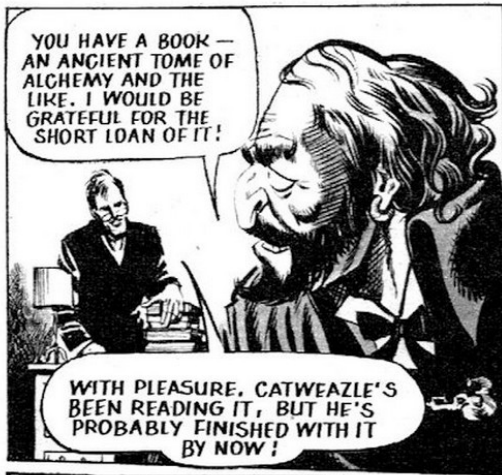

CATWEAZLE'S EYE FALLS ON THE OLD BOOK...



ALMOST CASUALLY, THE SINISTER CREECH EXTENDS ONE POINTED FINGER...



Dora makes a startling discovery!

Follyfoot

A CONVICT NAMED MULVANEY BREAKS JAIL AND STEALS STEVE'S HORSE TO MAKE HIS GETAWAY. HIS LEFT ARM BROKEN, MULVANEY HAS A ROUGH TIME ON THE OPEN MOOR BUT THE HORSE INSTINCTIVELY PULLS HIM THROUGH. HE REACHES A LONELY HOMESTEAD, WHERE HE FINDS...

A DOCTOR! LOOKS LIKE MY LUCK'S CHANGED AFTER ALL!



SEEMS I HAVE NO CHOICE. AND YOU CAN RELAX. I'M FAR TOO LONG IN THE TOOTH FOR VIOLENCE.



PUT THAT THING DOWN BEFORE IT GOES OFF. AND I'M NOT A DOCTOR. I'M A VET!

IS THAT SO? YOU CAN STILL DO A JOB ON MY BUSTED ARM, CAN'T YOU? YOU'D BETTER!

MEANWHILE, AT FOLLYFOOT FARM...



COME ON, SULTAN! TRY SOME OF THIS. IT'LL MAKE YOU FEEL BETTER!

IT'S NO GOOD, SLUGGER. I WONDER IF DORA'S GOT TO THE VET YET...?



WHAT DID SHE HAVE TO RIDE OVER FOR? COULDN'T SHE HAVE PHONED?

NO, MATE. SULLIVAN'S PHONE'S OUT OF ORDER. YOU FEELIN' OKAY NOW?



SURE. THAT CONVICT DIDN'T CLOUT ME THAT HARD. BUT HE'S STILL GOT MY HORSE, RON. THAT'S WHAT WORRIES ME!

AS SULTAN'S FEVER GETS WORSE AND WORSE, HIS ONE HOPE OF HELP - DORA - IS RIDING OVER THE HIGH MOORS...

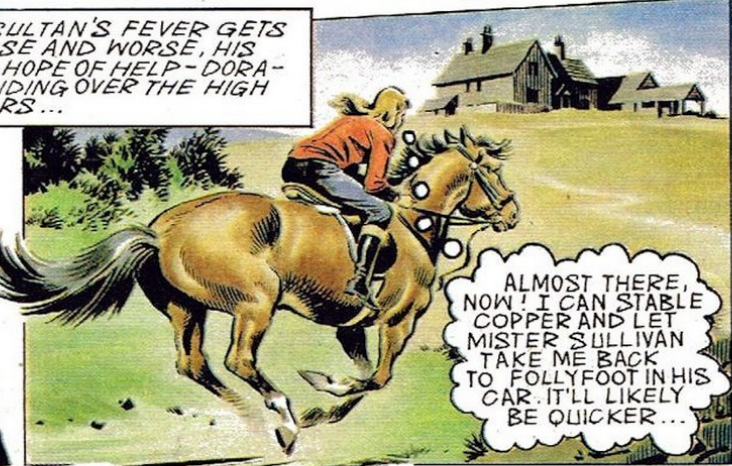

ALMOST THERE, NOW! I CAN STABLE COPPER AND LET MISTER SULLIVAN TAKE ME BACK TO FOLLYFOOT IN HIS CAR. IT'LL LIKELY BE QUICKER...



HULLO! MISTER SULLIVAN!



THAT'S ODD!
HE'S NOT HERE!
MAYBE HE'S IN THE
OUTBUILDINGS...



MISTER SULLIVAN!
WHERE ON EARTH IS HE?
HIS CAR'S STILL
HERE...



THEN...

AHHH!
WHAT THE...?

M. NOBLE



GOSH!
YOU CERTAINLY
GAVE ME A
SHOCK...

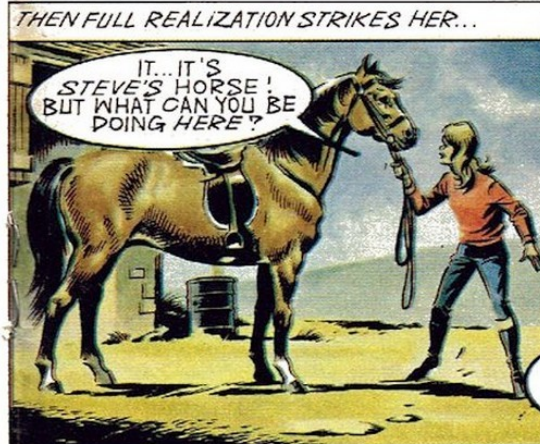

IT... IT'S
STEVE'S HORSE!
BUT WHAT CAN YOU BE
DOING HERE?

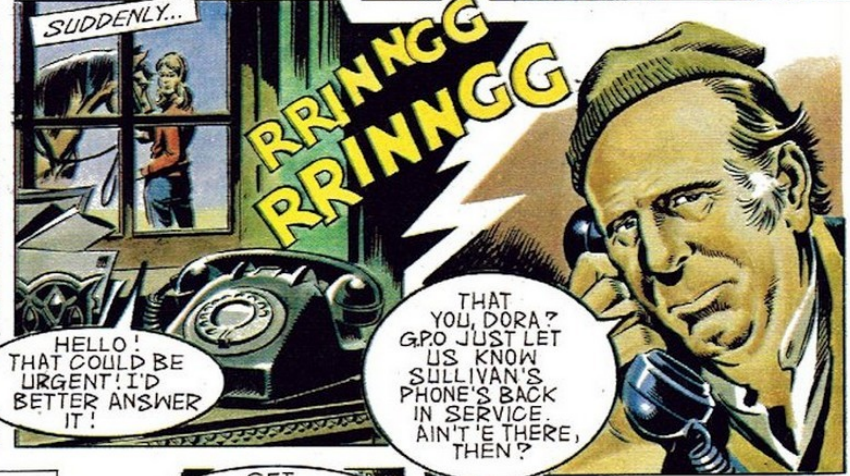

SUDDENLY...

RRINGG
RRINGG

HELLO!
THAT COULD BE
URGENT! I'D
BETTER ANSWER
IT!

THAT
YOU, DORA?
GPO JUST LET
US KNOW
SULLIVAN'S
PHONE'S BACK
IN SERVICE.
AIN'T 'E THERE,
THEN?

GRADUALLY, THE STORY IS PIECED TOGETHER...



IT'S OBVIOUS WHAT'S HAPPENED!
MULVANEY - THE CONVICT. HE'S BEEN
AT SULLIVAN'S - AND FOR SOME
REASON, HE'S TAKEN THE VET
AWAY WITH HIM!

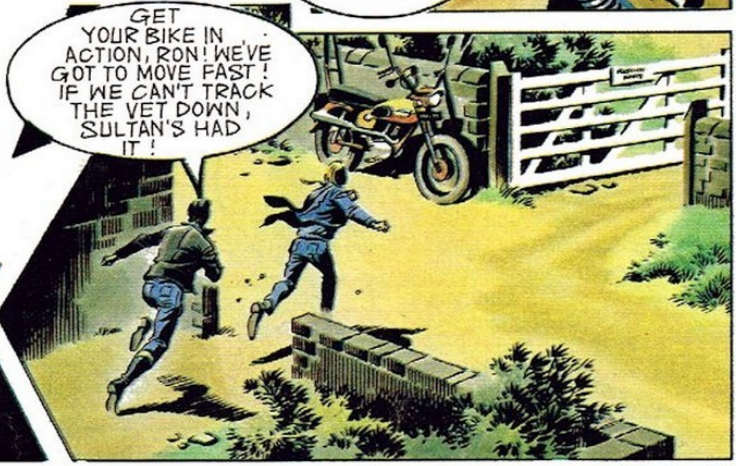

GET
YOUR BIKE IN
ACTION, RON!
WE'VE GOT TO
MOVE FAST!
IF WE CAN'T
TRACK THE VET
DOWN,
SULTAN'S HAD
IT!

YOUR VIEW



This week, Petra Markham, 'Mikki' of Thames Television's new 'Ace of Wands' serial, makes the selection of letters, jokes and pictures from the LOOK-IN Postbag, including the £2 Star Letter...

STAR LETTER

I thought readers might be interested in these calculations on what the average human being does in a seventy-year life span. He spends six years eating, and his intake includes twenty tons of bread, eighteen tons of potatoes, twenty-four tons of fruit and vegetables and 30,000 eggs. He spends about twenty-three years sleeping, eight years watching television or just doing nothing, four-and-a-half years chatting, and one year talking on the telephone. And he spends eighty days looking into mirrors!

Leslie Newman,
West Dulwich, London S.E.21.

★ Twenty tons of bread—and all those spuds! If I don't go on a diet, I'll not dare to look in a mirror for one second, let alone eighty days!



DISCORD

Last year, when my auntie asked me what I would like for a birthday present I said I would like a Gilbert O'Sullivan record, as I am one of his greatest fans. One week later, the postman delivered a lovely L.P.—of Gilbert and Sullivan, the 19th-century composers of comic operas!

Marie Gerrard, Glasson Dock.

★ Just to clear it up here are all three. (Bottom, left, Sullivan).

TOUCHWOOD'S PAL

I have a toad for a pet. He is quite small, about one-and-a-half inches long and one inch wide, and has a shiny green skin with brown spots. When he is hungry, he squeaks—and I feed him some insects. He can jump about five inches in one bound, and when I race him against my friends' toads he usually wins.

Billy Neal,
Orpington, Kent.

★ I suppose you'd get along well with Catweazle, Billy—but I'll stick to nice fluffy kittens.



Mine's at the cleaner's."

Nicholas Hugo,
Cardiff.

READERS PHOTOGRAPHS

Here is another selection from among the photographs sent in by LOOK-IN readers.



Fiona Randall,
Bristol 5.

Susan Hoyle,
Bristol 4.

Colin Ireland,
Neath, Glamorgan.

John McElwee,
Angus, Scotland.

SAFETY FIRST

While we were travelling in a car with my young niece, my mum fastened her seat-belt. The little girl looked at her inquisitively for while and then asked: "What have you got your life-belt on for?"

Margaret Jordan
Hedworth Estate, Jarrow

★ Funny—but true, too. Seat-belts save lives; always wear them, even on the shortest journeys.

PICTURE REQUEST

I am very interested in space, particularly the Lunar Rover which was used on the Moon. Please could you print a picture of it?

M. Morgan, Macclesfield.

★ For all space-fans, here is the Lunar Rover at the Descartes landing site.



★ Win £2 for the Star Letter and £1 for any other letter or joke, plus, a special signed photograph of the Your View Star. Why not write now to Your View, LOOK-IN, 247 Tottenham Court Road, London W1P 0AU? Remember when you write—enclose list of your six favourite features in order of preference.

If you'd like to see your photograph in LOOK-IN, please send in one when you write, and we'll try to print it. However, we regret that photographs cannot be returned.

The Fenn Street Gang

Frankie makes a flying fall!

WHEN OLD GRAMMARIANS CHALLENGE ERIC DUFFY AND HIS PAIS TO REPRESENT FENN STREET FORMER PUPILS IN A CRICKET MATCH, ALL THEY'RE OUT FOR IS A LAUGH AT THE LADS' EXPENSE. THAT'S WHY, WHEN FRANK ABBOTT'S DEMON BOWLING LOOKS POTENTIALLY DANGEROUS, THE GRAMMARIANS KIDNAP HIM AND LOCK HIM IN A LONELY ALLOTMENT SHED ...

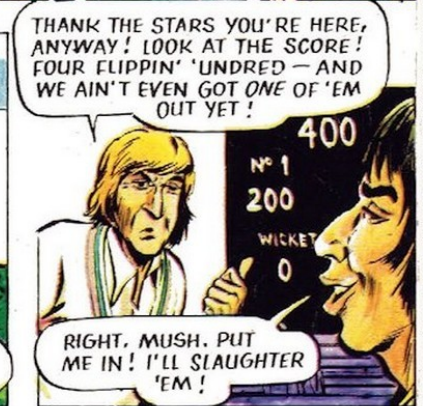
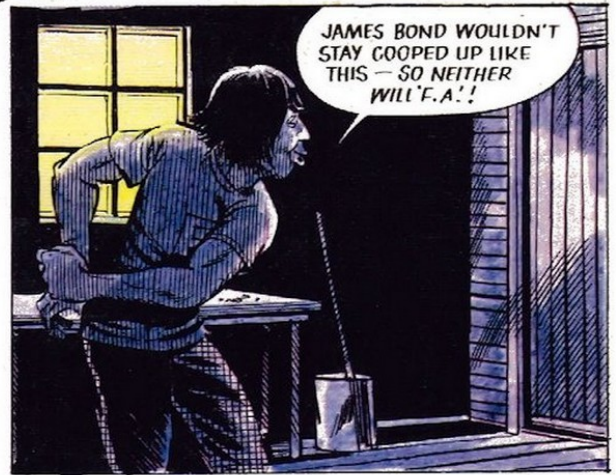

Based on the London Weekend Television series created and written by John Esmonde and Bob Larbey © 1972 Esmonde Larbey Ltd.

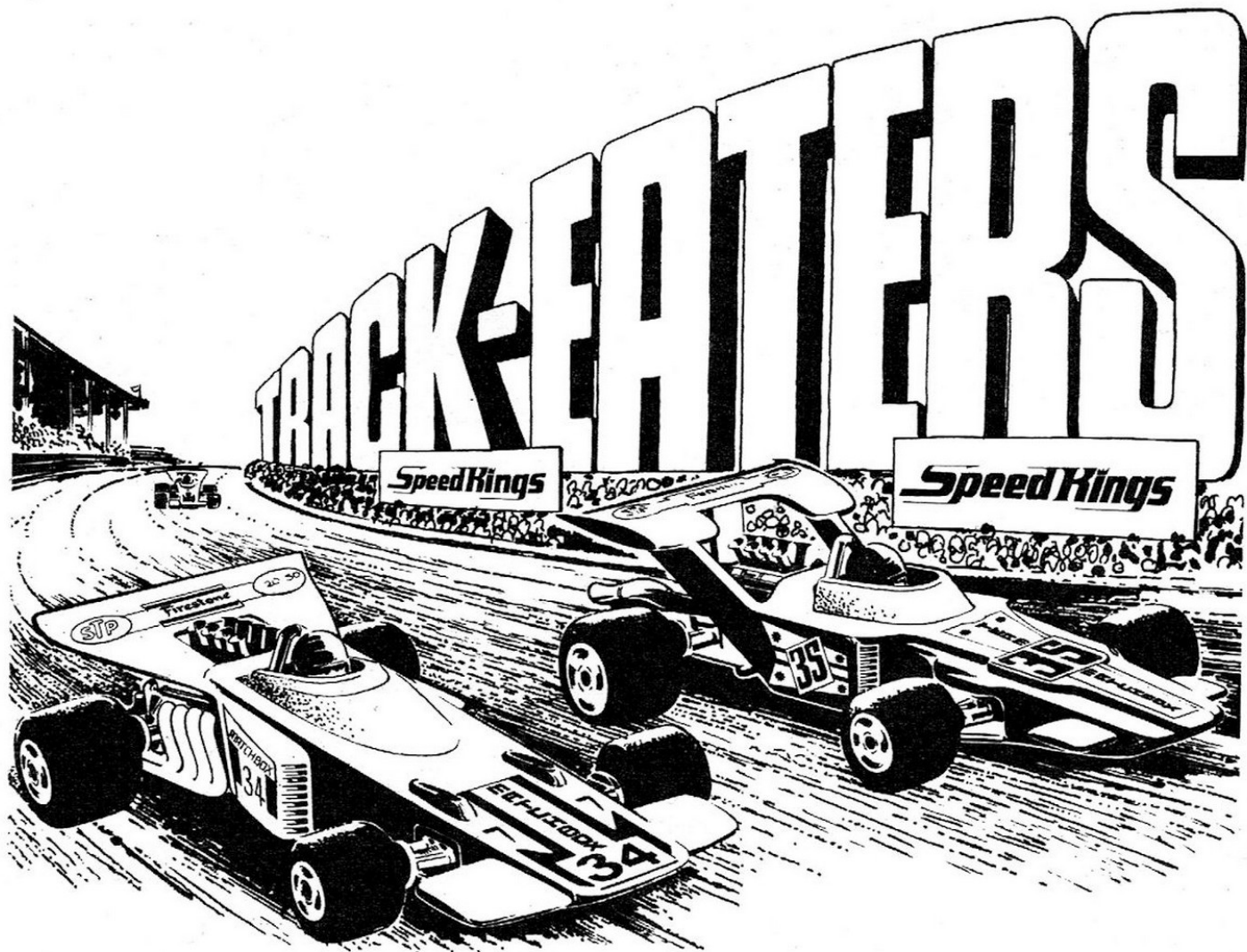

K-34 Thunderclap

Here's a bright yellow Grand Prix racer just as hot as the "MATCHBOX" Team Surtees cars being raced by Mike Hailwood in the 1972 European Formula 2 Championships. It's got a bossy V8 engine, branched megaphone exhausts, rear aerofoil, racing suspension and fat, slick, racing wheels.

K-35 Lightning

This Formula 1 model is flame red with yellow racing stickers. It's slimmer than the K-34, with a higher rear aerofoil. But there's the same chrome finished V8 engine and megaphone exhausts. The same racing suspension and wide no-tread slicks. Both models are just like the real thing. Boy you should see them go!

Recommended retail price 49p each.

NEW FROM

"MATCHBOX"

"MATCHBOX" is the registered trade mark of
Lesney Products & Co. Ltd., London E9 5PA.



Get a load of this!

**K-7 Racing car transporter plus
"MATCHBOX" 34 Formula 1 racing car.**

Fab new Super King design for your "MATCHBOX" 1-75 racers. Flip-up side doors. Flap-down rear. Sliding, pull-out ramp for loading. Superfast wheels that rip along. A load of fun.

DAVID NIXON'S MAGIC BOX



Jacob's Ladder

Paper-tearing tricks can be great fun to do. Here is an easy one. You need several sheets of newspaper which you paste together to make a long strip. Then roll it into a fairly loose roll, and flatten it out, as shown in fig 1. Tear or cut along

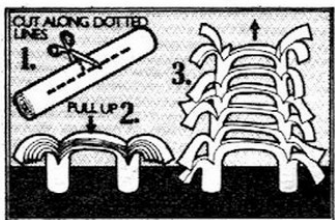

the dotted lines and open out, as in figure 2. Now gently pull up the top 'rung' of the ladder, and you should end up with something like figure 3. Of course, the longer the roll of

paper you use, the higher the ladder will be. Why not see how large a ladder you can make this way?

The Vanishing Square

You'll need a big piece of paper for this remarkable bit of geometrical magic. Ready? Then draw the rectangle shown in figure 1—only much larger—making all the little squares $\frac{1}{2}'' \times \frac{1}{2}''$. Note that the rectangle is 13 squares long by 5 wide—making 65 squares in all.

Cut out the shape, and then cut it up into 4 pieces, as indicated by the heavy black lines.

Now re-assemble the pieces into the form of a square, as shown in figure 2, and count the squares again. There are 64! So where did that extra square go? See what I mean by magic?

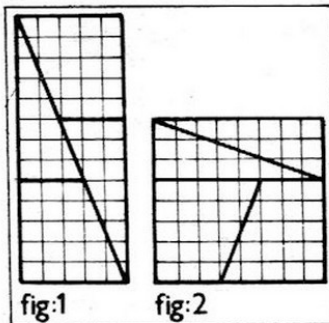

TEASER TIME

How to write the figures 1803 without taking your pencil from the paper—that was last week's teaser. The diagram shows you how it's done. Just fold the edge of the paper over, and write in one continuous line, as shown. When you unfold the paper, there will be your number.

Here is another number puzzle of quite a different kind. The digits written below are in a very special kind of order.

8.5.4.9.1

The question is—what is that special order, and what are the next two digits? Answer next week.

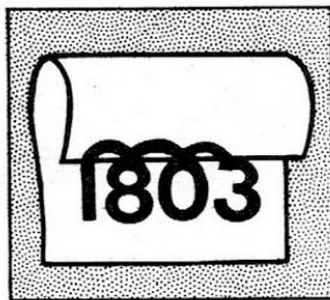

SMILE WITH STEWPOT



"Fred's more interested in the technical side of television."



"Remember—stick to the script. No funny stuff!"

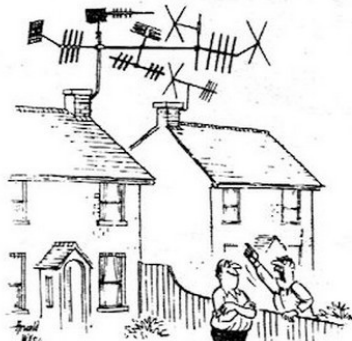

"... and furthermore you're violating my air space!"



"Have you been fiddling about with the contrast again?"



BE LIKE THE CHAMPIONS USE A GARCIA fishing reel

Mitchell and Galion models
from £1.12 to £11.08
at any good tackle shop.

Send 3p stamp for free catalogues.
Garcia Tackle Ltd., Cannon Street
Southampton SO9 2RB

garcia

The finest reel in the world

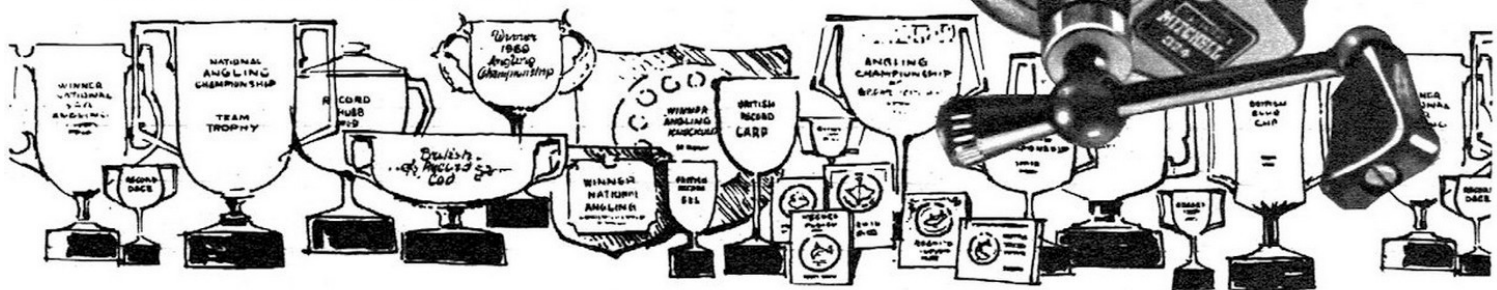

Chessington Zoo has got the lot!

It's Surrey's more to see 'n do zoo!

Over 1,000 animals. Funfair.
Free slides, swings, roundabouts
and model village. Super circus
(dates & times on request).
Miniature train rides. Pets' corner.
Lovely gardens. Open every day.
Only 30p (children 15p). Bring a
party—it's even cheaper for 30 or more!

On the A243
between Hook
and Leatherhead

Epsom 27227 Sorry—dogs not admitted

JUNIOR CINEMA

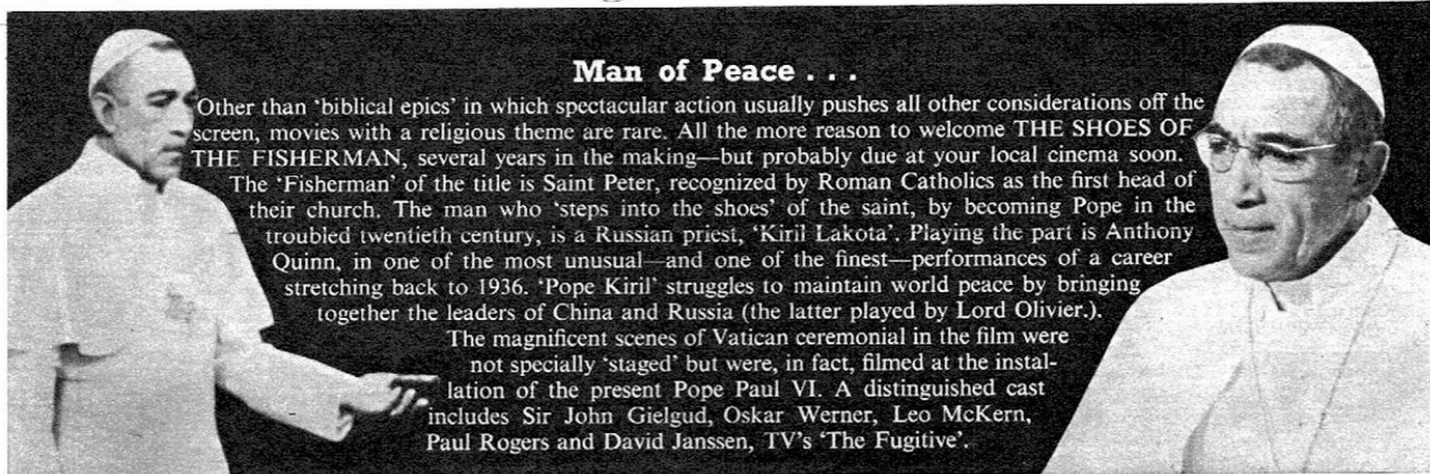

Man of Peace . . .

Other than 'biblical epics' in which spectacular action usually pushes all other considerations off the screen, movies with a religious theme are rare. All the more reason to welcome **THE SHOES OF THE FISHERMAN**, several years in the making—but probably due at your local cinema soon.

The 'Fisherman' of the title is Saint Peter, recognized by Roman Catholics as the first head of their church. The man who 'steps into the shoes' of the saint, by becoming Pope in the troubled twentieth century, is a Russian priest, 'Kiril Lakota'. Playing the part is Anthony Quinn, in one of the most unusual—and one of the finest—performances of a career stretching back to 1936. 'Pope Kiril' struggles to maintain world peace by bringing together the leaders of China and Russia (the latter played by Lord Olivier).

The magnificent scenes of Vatican ceremonial in the film were not specially 'staged' but were, in fact, filmed at the installation of the present Pope Paul VI. A distinguished cast includes Sir John Gielgud, Oskar Werner, Leo McKern, Paul Rogers and David Janssen, TV's 'The Fugitive'.

. . . And Man of Science

In the mid-nineteenth century, Charles Darwin's book *The Origin of the Species* created a sensation with its revelation that the world was not 'created' in a moment but had evolved slowly over millions of years. Those of you who remember last year's LOOK-IN 'Survival' feature 'Discovering the Galapagos', will know that Darwin's 'theory of evolution' was formed on a voyage to the Galapagos Islands and South America in 1831—and now film director Jack Couffer (who made such great 'wild-life' movies as **LIVING FREE** and **RING OF BRIGHT WATER**) has followed in Darwin's tracks to make **THE DARWIN ADVENTURE**. This dramatization of the great scientist's life and work, packed with film-of-creatures ranging from soldier-ants to sea-elephants, will be on release very shortly. Shown here is actor Nicholas Clay, as Charles Darwin.



All Right, Jacques!

Although French actor-director Jacques Tati has been making movies since 1931, he has only been famous throughout Europe for his brand of comedy since the huge success of **JOUR DE FETE** in around 1950. In his films, Tati plays 'Monsieur Hulot', a bumbling character who is the most accident-prone man in the world. In his latest movie, **TRAFFIC**, now on release, 'Hulot's' misfortunes centre around motor-cars. In fact, the cars are the real 'stars' of the film. They get up to the most amazing tricks—like the Citroen seen here.

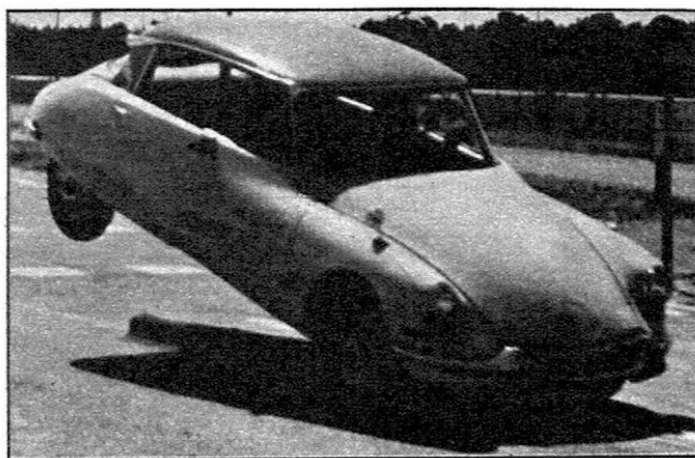

***** XI: Spectacular!

The credit for the first 'long' movie made in America must go to Jesse Lasky and Cecil B. De Mille (the latter a top producer-director until his death in 1959) for **THE SQUAW MAN**, a four-reeler made in 1913. But it was D. W. Griffith who really marked the 'coming of age' of the movies with **THE BIRTH OF A NATION** (1914). Into this three-hour-long masterpiece, Griffith packed everything he had learned of the cinematic craft in years of turning out one-reelers. It had a thrilling, fast-moving plot with lots of action and a strong current of sentiment. Although its story, set in the American South immediately after the Civil War, is marred by Griffith's violent anti-Negro prejudice, **THE BIRTH OF A NATION** is perhaps the most important single movie ever made, because of its immense influence on all other movie-makers. The American President Woodrow Wilson described Griffith's work as 'writing history with lightning'.



Here are some of the feature films you will be able to watch on television this week. (Note: all details correct at time of going to press.)

- Thursday, July 20
- 7.00 p.m. (Border) **THE FIRST MEN IN THE MOON**—science-fiction
- 7.10 p.m. (Scottish) **A PATCH OF BLUE**
- 7.15 p.m. (Southern) **HOUSE OF NUMBERS**—crime thriller
- 7.25 p.m. (Yorkshire) **APARTMENT FOR PEGGY**
- Saturday, July 22
- 7.00 p.m. (Granada) **THE GLASS WEB**—crime thriller
- Sunday July 23
- 2.55 p.m. (Granada) **WHO DONE IT?**—Abbott & Costello
- 7.55 p.m. (Granada) **DROP DEAD DARLING**—Tony Curtis
- Tuesday, July 25
- 6.55 p.m. (Granada) **PLEASE TURN OVER**—comedy

TIMESLIP

PASSING THROUGH THE INVISIBLE TIME-BARRIER, LIZ SKINNER AND SIMON RANDALL FIND THEMSELVES ON A TROPICAL ISLAND INHABITED BY DINOSAURS. THEY MANAGE TO FLY A JET-PROPELLED HELICOPTER WHOSE ORIGINAL OWNERS ARE IN SOME KIND OF DANGER...



THERE'S THE SKULL-SHAPED ROCK WE SAW ON THE VIDEO SCREEN!

WE'LL HEAD TOWARDS IT!

WE MUST FIND OUT WHAT HAPPENED TO THE REAL OWNERS OF THIS MACHINE.

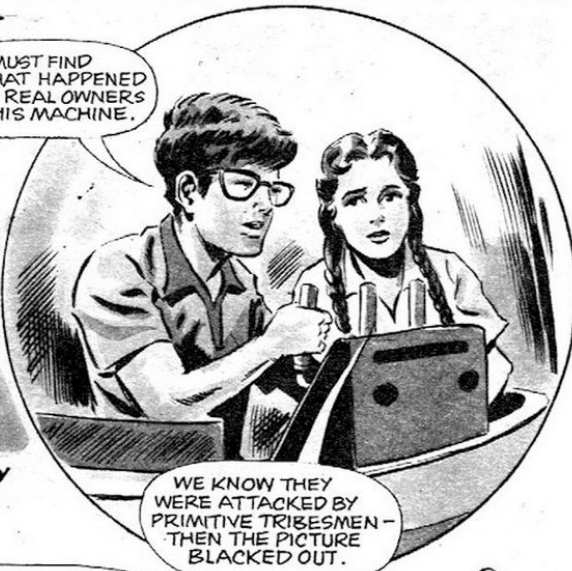

WE KNOW THEY WERE ATTACKED BY PRIMITIVE TRIBESMEN - THEN THE PICTURE BLACKED OUT.

HOW CAN WE EXPLAIN THAT WE ARRIVED FROM THE TWENTY-FIRST CENTURY IN A TIME-MACHINE?

MEANWHILE...

SACRIFICE THEM TO THE GOD OF THE SKULL! THEY ARE EVIL - IN LEAGUE WITH DEMONS!



YOU'RE WRONG - WE'RE FROM A DIFFERENT AGE. YOU DON'T UNDERSTAND!



IT WON'T DO US MUCH GOOD. OUR MACHINE MUST HAVE BEEN DISCOVERED BY SOMEBODY ELSE AND REMOVED.

DOWN THERE, LIZ - I THINK WE'VE FOUND THEM! TWO PRISONERS - THEY'RE BEING SHOVED ALONG BY THOSE WARRIORS...



BUT HOW DO WE SAVE THEM, SIMON? IF ANYTHING HAPPENS TO THEM IT'S OUR FAULT!

A WAVE OF HEAT MEETS THE CAPTIVES...

I CAN SMELL SULPHUR! WE MUST BE NEAR A VOLCANO...



THE GLOW'S FROM MOLTEN LAVA! SEE THE FIRE WELLING UP FROM THAT PIT?

FORWARD! THE GODS AWAIT YOU!



THEY MEAN TO THROW US IN! IT'S THEIR WAY OF SACRIFICE...

THE HELICAR SWOOPS...



WE'RE GOING IN, TOO! I'LL THINK OF SOMETHING - I HOPE!

YOU MUST - AND IT HAD BETTER BE FAST!



LOOK! IT'S THE HELICAR - OUR TIME-MACHINE.

HELP US! HELP US! THEY'RE GOING TO HURL US INTO THE PIT!

LIZ AND SIMON RECALL...

SUDDENLY...



DOWN! WE ARE VISITED BY OUR FRIENDS FROM THE SKY!

THEY ARE THE MIGHTY ONES WHO SAVED US FROM THE DEMON MONSTER.

SIMON, WHAT DO THEY MEAN? THEY'RE ALL BOWING - WHY?



IT IS SAFE TO LAND...



THIS IS YOUR CHANCE - I'D GET GOING BEFORE THE TRIBESMEN CHANGE THEIR MINDS.

SIMON, ASK THEM WHATAGE THEY'RE FROM - AND WHATAGE THIS IS?

DON'T YOU REMEMBER THE GIANT DINOSAUR? HOW WE LURED IT AWAY FROM A GROUP OF PEOPLE BY 'BUZZING' IT WITH THE HELICAR?

THEY'RE NOT HANGING AROUND LONG ENOUGH TO ANSWER, I CAN'T SAY I BLAME THEM.



WE'VE DONE IT! WE'RE ON OUR WAY, TOO!

TRUST YOU NOT TO BE INTERESTED IN ANYTHING SCIENTIFIC!

THE NEXT THEY KNOW...



HERE'S HOW WE STARTED - A WET DAY ON OUR SUMMER HOLIDAYS. OH, WELL! IT'S BACK TO NORMAL ALL RIGHT.

IT NEVER LOOKED BETTER. I PREFER RAIN TO DINOSAURS ANY TIME.

Look-in

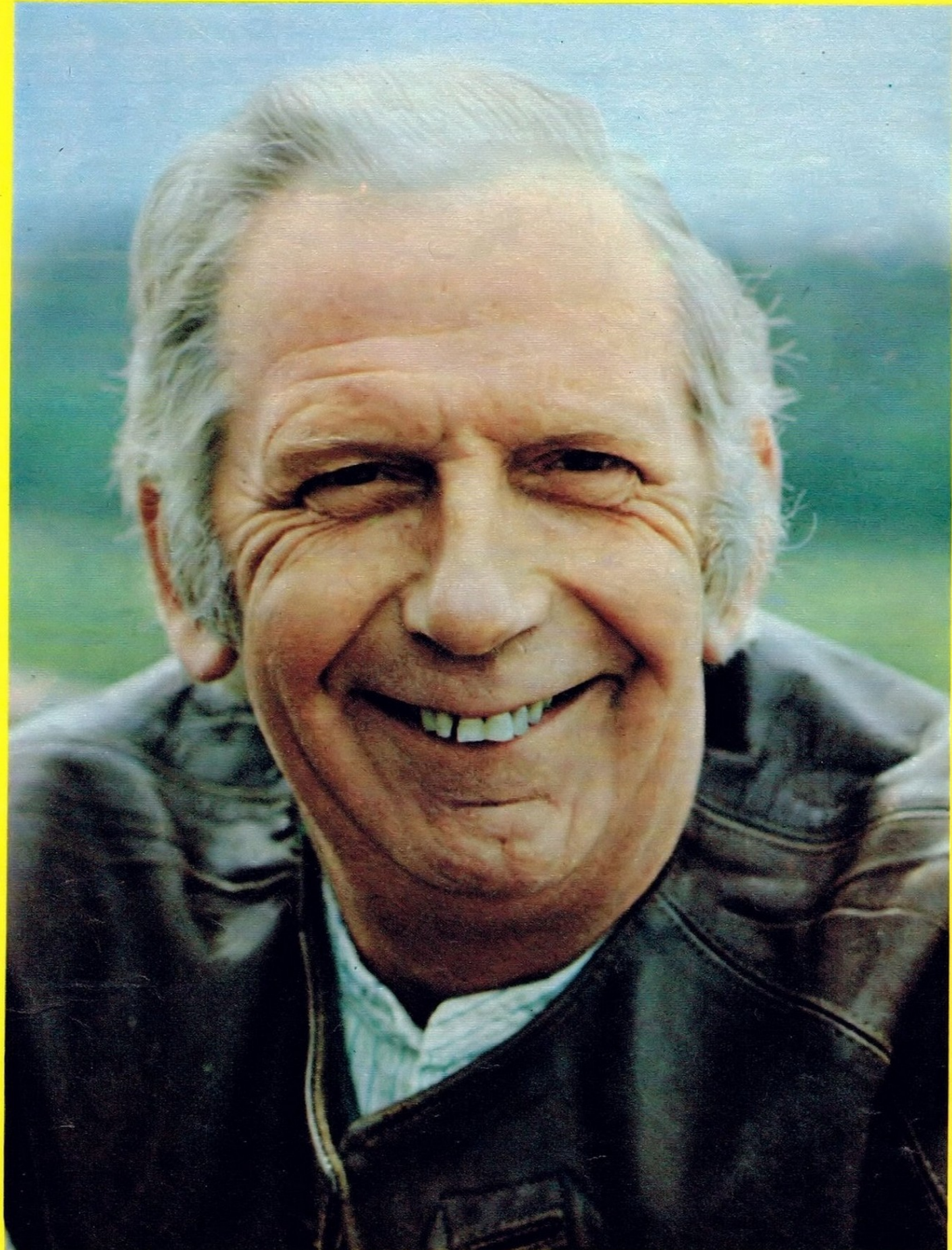

ARTHUR ENGLISH

Once again, Bunty James, Jack Hargreaves, Jon Miller and Fred Dinenage, are all set to answer your questions. Congratulations to this week's winners. If you haven't already written in why not do so now? For any question published, winners can choose from 20 Hamlyn Books, each to the value of £1. Send your entry to: HOW! LOOK-IN, 247 Tottenham Court Road, London, W1P 0AU.

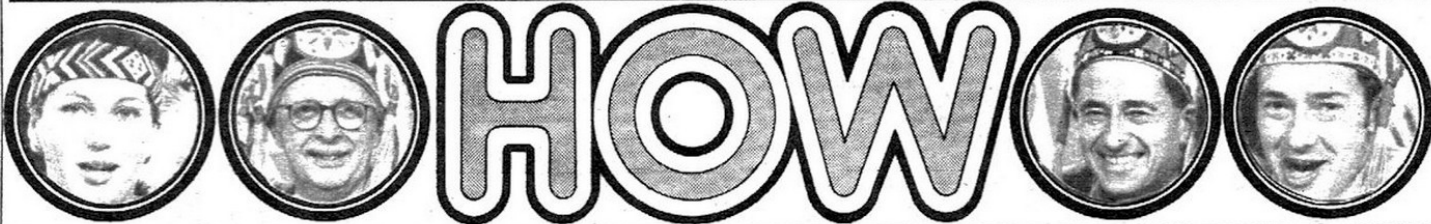

HOW were the first puppets made, and what of?

Jayne Nicholls, Lowestoft, Suffolk.

The word puppet is usually taken to include all types of puppets, including marionettes, which are worked by strings. The other most common type is the glove puppet. The first puppets were probably being played with in prehistoric times, but the first we know about for certain were used in China, many centuries ago. These were shadow puppets, made of fish or animal skin, which was beaten to become thin, then dyed and shaped and given joints, and mounted on rods or canes. Next came the performance, with the shadows thrown on to a screen lit by the sun. Puppets have been popular, as far as is known, all over the world for as long as records have been kept.



A complex stringed puppet — or marionette.

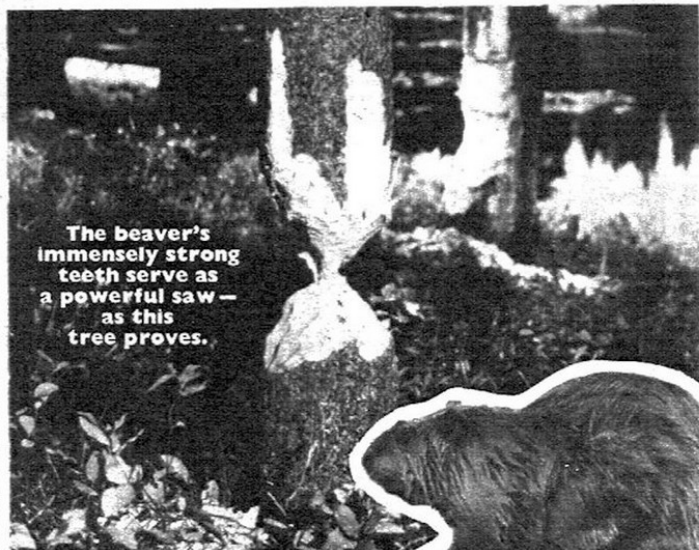

The beaver's immensely strong teeth serve as a powerful saw — as this tree proves.

HOW does a beaver make a dam?

Tracey Salter, Smethwick, Worcs.

First, perhaps, we should tell you *why* a beaver (right) builds a dam. It is to make a pool of deep, still water to cover the entrance to its lodge and so keep it safe from enemies, and it builds the lodge as well. It also uses the pool to store the branches whose bark is its winter food.

To construct a dam, beavers first cut down suitable trees near the water's edge with their sharp teeth, then cut the wood to convenient sizes. Whole beaver families next combine to make the dam, which consists of the cut wood, branches, mud and stones. These dams are marvellous feats of engineering, which sometimes take years to finish. As well as helping the beavers, the dams are often popular with farmers, for the gathered water can make dry areas fertile.

HOW did algebra start?

Antoinette Lever, Wallasey, Cheshire.

As you no doubt have discovered, Antoinette, algebra is a branch of mathematics which makes use of symbols instead of numbers. The actual word is Arabic and, back in the 9th century A.D., an Arab mathematician named al-Khowarizmi brought the system to Europe. It was already old then, for the

ancient Egyptians, Greeks and Chinese knew how to use algebra. So no one knows who invented it in the first place. The famous quadratic equation was solved more than 2,000 years ago! The first algebra book published in Europe dates back to 1494.

Look out for next week's Look-in

... when you can discover 'The Secrets Behind Mark Strong' — in an exciting FREE, four-page supplement, containing a great competition with 400 prizes to be won! ★ Plus: A new dose of laughter with another story of 'Doctor in Charge'! ★ Plus: Meet 'The Old Man Of The Sea' — in a special Survival feature!











It's all in next week's **Look-in** order your copy now!



[All details correct at time of going to press.]

FOR COMPLETE DETAILS OF ALL ITV PROGRAMMES SEE TYTIMES

Look-in on your ITV programmes this week: July 22-28

	Saturday	Sunday	Monday	Tuesday	Wednesday	Thursday	Friday
ANGLIA	 11.30 Sat. Morning Pic. 1.15 World of Sport 5.10 Who Do You Do? 5.40 Primus 6.15 Charlie Williams 7.00 Saturday Movie	2.30 Film 4.10 Simon Locke 4.40 Golden Shot 5.35 Follyfoot 7.25 Dr. In Charge 7.55 Star. Movie	4.15 Cartoons 4.25 Romper Room 4.55 Clapperboard 5.20 Treasure Island 6.45 David Nixon	4.15 Felix the Cat 4.40 Enchanted House 4.55 Junior Showtime 5.20 Full House 7.00 Mystery Movie	4.15 Cartoons 4.30 The Romper Room 4.55 Little Big Time 5.20 Ace of Wands 7.00 Shirley's World 8.00 Cade's County	4.15 Jimmy Stewart 4.40 Paulus 4.55 Skippy 5.20 How! 7.00 Sale of the Century 7.30 Thursday Film	4.15 Cartoons 4.25 The Romper Room 4.55 Land of the Giants 7.35 Comedians 8.00 Combat
MIDLANDS	 12.25 Captain Scarlet 1.15 World of Sport 5.10 It Takes a Thief 6.15 Charlie Williams Show 7.00 Film	2.15 Sport 3.15 Film 4.40 Golden Shot 5.35 Follyfoot 7.25 Dr. In Charge 7.55 Film	4.10 Nanny & Prof. 4.40 Cliff's Kids 4.55 Forest Rangers 5.20 Treasure Island 6.45 David Nixon	4.10 Simon Locke 4.40 Rupert Bear 4.55 Junior Showtime 5.20 Full House 7.00 Tuesday Western	4.10 Ghost & Mrs. Muir 4.40 Magic Ball 4.55 Little Big Time 5.20 Ace of Wands 7.00 Who Do You Do? 8.00 Cade's County	4.35 Nuts & Bones 5.20 How! 7.00 Sale of the Century 7.30 Thursday Movie 8.25 Comedians	4.10 Julia 4.40 Happy House 4.55 Lost in Space 7.00 In For A Penny 7.30 Persuaders 8.25 Comedians
BORDER	 1.15 World of Sport 5.10 Please Sir! 5.40 Sale of the Century 6.15 Charlie Williams Show 7.00 Mystery Movie	2.15 Sportsworld 72 3.15 Sunday Matinee 4.40 Golden Shot 5.35 Follyfoot 7.25 Dr. In Charge 7.55 Big Film	4.10 Here's Lucy 4.40 Cliff's Kids 4.55 Clapperboard 5.20 Treasure Island 6.45 David Nixon	4.40 Pingwings 4.55 Junior Showtime 5.20 Full House 7.00 Tuesday Film	4.40 Ivor the Engine 4.55 Little Big Time 5.20 Ace of Wands 7.00 Jokers Wild 8.00 Cade's County	4.10 Simon Locke 4.40 Nuts and Bones 4.55 Funky Phantom 5.20 How! 7.00 Thursday Film	4.40 Happy House 4.55 Lidsville 5.20 Rovers 7.30 In For A Penny 8.00 Shirley's World 8.25 Comedians
CHANNEL	 1.15 World of Sport 5.10 Who Do You Do? 5.40 Sale of the Century 6.15 Charlie Williams 7.00 Mystery Movie	2.00 The Avengers 2.55 Feature Film 4.40 Golden Shot 5.35 Follyfoot 7.25 Dr. In Charge 7.55 Film	2.40 Cliff's Kids 2.55 Puffin 4.55 Clapperboard 5.20 Treasure Island 6.45 David Nixon	4.10 Enchanted House 4.20 Puffin 4.55 Junior Showtime 5.20 Full House 7.00 Star Movie	4.05 Paulus 4.20 Puffin 4.55 Little Big Time 5.20 Ace of Wands 6.10 F Troop 7.00 Best of Please Sir!	4.05 Nuts and Bones 4.18 Puffin 4.22 Dick Van Dyke 4.50 Skippy 5.20 Primus 7.00 The F.B.I.	4.05 Happy House 4.20 Puffin 4.22 Jimmy Stewart 4.50 Flintstones 5.20 Primus 7.30 The F.B.I.
GRAMPIAN	 1.15 World of Sport 5.10 Batman 5.40 Who Do You Do? 6.15 Charlie Williams Show 7.00 Mystery Movie	2.20 Sunday Matinee 4.40 Golden Shot 5.35 Follyfoot 7.25 Dr. In Charge 7.55 Film	4.40 Cliff's Kids 4.55 Rumble Jumble 5.20 Treasure Island 6.15 Lucy Show 6.45 David Nixon	4.40 Yak 4.55 Junior Showtime 5.20 Full House 6.10 Jim MacLeod 6.55 Tuesday Film	4.40 Enchanted House 4.55 Little Big Time 5.20 Ace of Wands 7.00 Jokers Wild 8.00 Department 'S'	4.40 Nuts and Bones 4.55 Pippil Longstocking 5.20 How! 6.10 Top Team 6.55 Thursday Film	4.40 Happy House 4.55 Rumble Jumble 5.20 Bushboy 7.00 Comedians 7.30 Jesse James 8.00 Benny Hill Show
GRANADA	 10.40 Sesame Street 12.15 Thunderbirds 5.10 Primus 5.40 Who Do You Do 6.15 Charlie Williams 7.00 Saturday Thriller	2.15 Sportsworld 72 3.15 Film Matinee 4.40 Golden Shot 5.35 Follyfoot 7.25 Dr. In Charge 7.55 Film	4.40 Cliff's Kids 4.55 Clapperboard 5.15 Treasure Island 6.40 David Nixon	4.40 Enchanted House 4.55 Junior Showtime 5.15 Full House 7.00 Father Dear Father 7.30 Film	4.40 Sean The Leprechaun 4.55 Little Big Time 5.15 Ace of Wands 6.30 Jimmy Stewart 8.00 Cade's County	4.40 Nuts and Bones 4.55 Lidsville 5.15 How! 6.25 U.F.O. 7.20 Film	4.40 Happy House 4.50 Skippy 5.15 Funky Phantom 6.30 Riptide 7.30 In For A Penny 8.00 Protectors
WALES/WEST	 1.15 World of Sport 5.10 Please Sir! 5.40 Sale of the Century 6.15 Charlie Williams Show 7.00 Mystery Movie	2.15 Sportsworld 72 3.15 Sunday Matinee 4.40 Golden Shot 5.35 Follyfoot 7.25 Dr. In Charge 7.55 Film	3.30 Enchanted House 4.15 Tinkertainment 4.30 Bugs Bunny 4.55 Clapperboard 5.20 Treasure Island 6.45 David Nixon	4.15 Tinkertainment 4.55 Junior Showtime 5.20 Full House 7.10 Tarzan	4.15 Tinkertainment 4.55 Little Big Time 5.20 Ace of Wands 6.30 Dave Cash 8.00 Hawaii Five-O	3.45 Simon Locke 4.15 Tinkertainment 4.55 Joe 90 5.20 How! 6.35 Dick Van Dyke 7.10 Mid-Week Movie	4.15 Tinkertainment 4.55 Woodbina 5.20 Flaxton Boys 6.30 Jimmy Stewart 7.30 Comedians 8.00 Cade's County
LONDON	 11.40 Sesame St. 1.15 World of Sport 5.10 Best of Please Sir! 5.40 Sale of the Century 6.15 Charlie Williams 7.00 Action Film	1.15 Stingray 2.15 Sportsworld 72 3.15 Jason King 4.40 Golden Shot 5.35 Follyfoot 7.30 Dr. In Charge	1.35 Skippy 3.15 Monday Movie 4.40 Cliff's Kids 4.55 Clapperboard 5.20 Treasure Island 6.40 David Nixon	3.45 Dangerman 4.40 Yak 4.55 Junior Showtime 5.20 Full House 7.35 Movie of the Week	1.35 Woodbina 4.40 Hatty Town 4.55 Little Big Time 5.20 Ace of Wands 6.25 Cartoon Time 7.00 Smith Family	3.45 Marcus Welby 4.40 Nuts and Bones 4.55 Atom Ant 5.20 How! 6.00 Wreckers at Work	1.40 Bushboy 4.40 Happy House 4.55 Land of the Giants 6.30 Dick Van Dyke 7.00 The Comedians 7.30 The F.B.I.
SCOTTISH	 12.40 Primus 1.15 World of Sport 5.10 Best of Please Sir! 5.40 Who Do You Do? 6.15 Charlie Williams 7.00 Action Movie	2.15 Sportsworld 72 3.15 Feature Film 4.40 Golden Shot 5.35 Follyfoot 7.25 Dr. In Charge 7.55 Sunday Feature	4.40 Cliff's Kids 4.55 Clapperboard 5.20 Treasure Island 6.15 Dick Van Dyke 6.45 David Nixon	4.10 Animal Land 4.40 Origami 4.55 Junior Showtime 5.20 Full House 6.15 Hogan's Heroes 6.45 Film	4.10 Animal Land 4.40 Hatty Town 4.55 Little Big Time 5.20 Ace of Wands 7.00 Jokers Wild 8.00 Cade's County	4.10 Animal Land 4.40 Nuts and Bones 4.55 Funky Phantom 5.20 How! 6.15 U.F.O. 7.10 Film	4.40 Happy House 4.55 Skippy 5.20 Cartoon Cav. 6.30 In For A Penny 7.00 The Comedians 7.30 The Saint
SOUTHERN	 12.10 Thunderbirds 1.15 World of Sport 5.10 Avengers 6.15 Please Sir 6.45 The Comedians 7.15 Mystery Movie	1.45 Bushboy 2.15 Sportsworld 72 4.40 The Golden Shot 5.35 Follyfoot 7.25 Dr. In Charge 7.55 Film	4.10 Twizzle 4.25 Junkin 4.55 Clapperboard 5.20 Treasure Island 6.45 David Nixon	4.15 Torchy 4.55 Junior Showtime 5.20 Full House 6.30 Smith Family 7.00 Tuesday Film	4.15 Enchanted House 4.55 Little Big Time 5.20 Ace of Wands 6.30 Get This 7.00 Jokers Wild 8.00 Cade's County	4.15 Send For Dithers 4.55 Stingray 5.20 How! 6.45 Simon Locke 7.15 Thursday Film	4.15 Paulus 4.55 Voyage To The Bottom of the Sea 6.30 Who Do You Do? 7.35 Sale of the Century 8.05 The F.B.I.

TYNE TEES

12.15 Joe 90
 1.15 World of Sport
 5.10 Primus
 6.40 Who Do You Do?
 6.15 Charlie Williams
 7.00 Mystery Movie
 3.15 Sunday Matinee
 4.40 Golden Shot
 5.35 Follyfoot
 7.25 Dr. In Charge
 7.55 Film
 1.15 World of Sport
 5.10 Primus
 5.40 Who Do You Do?
 6.15 Charlie Williams
 7.00 Saturday Film
 1.50 Lidsville
 1.15 World of Sport
 5.10 Who Do You Do?
 5.40 Sale of Century
 6.15 Charlie Williams
 7.00 Mystery Movie
 12.15 Woobinda
 12.40 Lidsville
 1.15 World of Sport
 5.10 Primus
 5.40 Who Do You Do?
 6.15 Charlie Williams

ULSTER

4.40 Nuts & Bones
 4.55 Rovers
 5.20 Howl
 7.25 Film
 3.40 Simon Locke
 4.40 Make a Wish
 4.55 Little Big Time
 5.20 Ace of Wands
 6.30 Shirley's World
 7.00 Jokers Wild
 4.30 Romper Room
 4.55 Rovers
 5.20 Howl
 7.00 Shirley's World
 7.30 Feature Film
 4.30 Romper Room
 4.55 Little Big Time
 5.20 Ace of Wands
 7.00 Sporting Challenge
 8.00 Cadé's County
 3.55 Gus Honeybun
 4.05 Nuts & Bones
 4.22 Dick Van Dyke
 4.50 Skippy
 5.20 Howl
 7.00 Thursday Film
 4.40 Nuts & Bones
 4.55 Funky Phantom
 5.20 Howl
 6.30 It Takes a Thief
 7.25 Thursday Film

WESTWARD

1.45 Bewitched
 3.00 Movie Matinee
 4.40 Cliff's Kids
 4.55 H.R. Pufnstuff
 5.20 Treasure Island
 6.45 David Nixon
 4.30 Romper Room
 4.55 Clapperboard
 5.20 Treasure Island
 6.10 Smith Family
 6.35 Cartoon Time
 6.45 David Nixon
 2.45 Gus Honeybun
 3.00 Cliff's Kids
 4.55 Clapperboard
 5.20 Treasure Island
 6.45 David Nixon
 4.40 Cliff's Kids
 4.55 The Rovers
 5.20 Treasure Island
 6.45 David Nixon

YORKSHIRE

3.40 Paulus
 4.55 Junior Showtime
 5.20 Full House
 6.30 Hogan's Heroes
 7.00 Western
 4.30 Romper Room
 4.55 Junior Showtime
 5.20 Full House
 6.10 Lidsville
 7.00 Mid-Week Movie
 3.55 Gus Honeybun
 4.10 Enchanted House
 4.22 Odd Couple
 4.55 Junior Showtime
 5.20 Full House
 7.00 Star Movie
 4.40 Once Upon a Time
 4.55 Junior Showtime
 5.20 Full House
 6.30 Hogan's Heroes
 7.00 Tuesday Western

Robert Harbin introduces ...

DO-IT-YOURSELF ORIGAMI



Clever Container

Try this clever box by John Richardson of Doncaster, who wins this week's prize pound. You will need to watch those 'repeat' signs.

1. Crease diagonals, fold corners

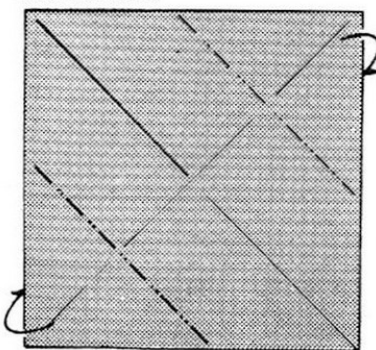

2. Fold over and over twice

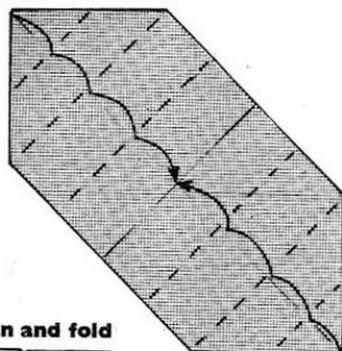

3.

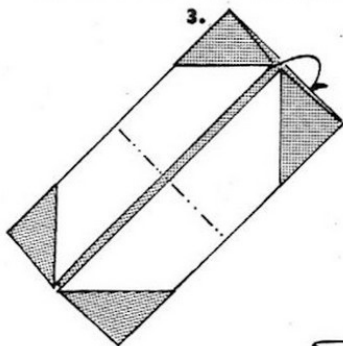

4. Open and fold

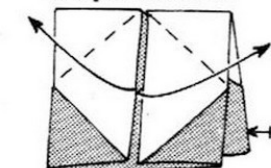

5. Four squash folds

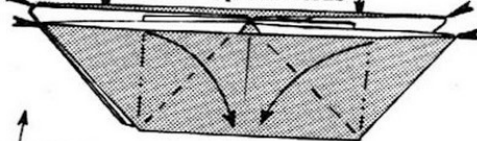

6. Tuck in 4 flaps

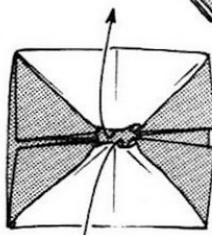
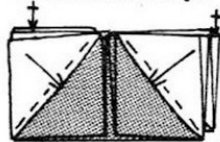

7.

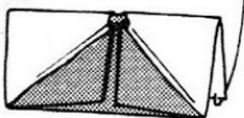

8. Open out, form box

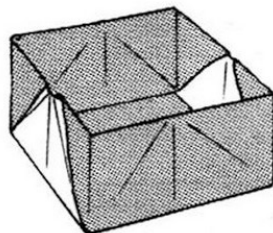

You can win £1 for your new model!

If you feel you can invent a new Origami model, write down the details (together with your own name and address) and send them to Do-It-Yourself Origami, LOOK-IN, Junior TVTimes, 247 Tottenham Court Road, London W1P 0AU. I will send a £1 postal order for any item I select to publish. So, hurry and get your paper thinking-cap on now!

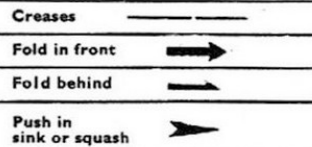
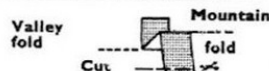

There's a famous Sea Adventurer like me, free in every special pack of John West.



And I want you to win a super Sea Adventure of your own, too.

How to get us

In every special pack of John West Skippers, Herrings, and Kippers you'll find a card of us. Besides me - I'm Sir Francis Drake - there's Christopher Columbus, Vasco da Gama, Captain Cook and lots of others.

Get our Full Colour Sea Chart too

Like the one I'm holding. Its a copy of a real 17th century Sea Chart and around the edges are places for you to stick in our cards. With six already there to give you a flying start.

How to win your Super Sea Adventure

With your Sea Chart you'll get an entry form. Altogether twelve thrilling Sea Adventures to

Norway, the home of the Vikings, must be won. So fill in the coupon below and send off for your chart and entry form now.

**JOHN WEST
Perfect food for growing Sea Adventurers**



Cut out this coupon and send with 10p (to include postage and packing).
To: John West Sea Adventurers Offer,
P.O. Box 57, Bebington, Wirral
XL62 4XW.

Name _____
Road _____
Town _____

Competition closes 28 Feb. 1973

Cut this out as a reminder for Mum