

Look-in

Junior TVTimes No 6 week ending 5 February 1972 Every Thursday 5p

MINISTRY
OF
DEFENCE
KEEP OUT



**EXCLUSIVE
SPACE BADGE OFFER
★ COMPLETE THE
APOLLO SET!
SEE BACK COVER**

**THROUGH THE
'TIMESLIP'
BARRIER TO
'TIGHTROPE'**

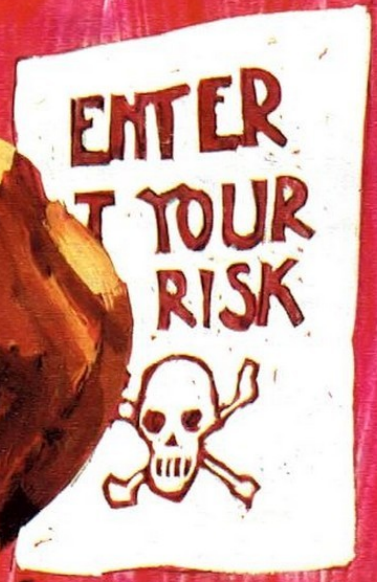

**SPENCER BANKS
TRIUMPHS AGAIN**
see special
feature inside



Crowther in trouble

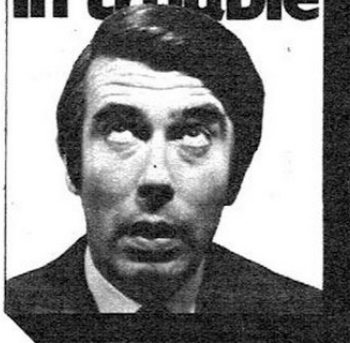

Holiday heartbreak for Leslie!



Look-in

Number 6

[Cover painting by Arnaldo Putzu]

Have you taken the opportunity to obtain the glorious replicas of the Apollo Mission badges which have been featured on recent back-covers of LOOK-IN? They really are magnificent collectors' items and make wonderful embellishments for anoraks and other clothes.

This week, LOOK-IN completes the Apollo set by offering replicas of the remaining badges which the astronauts helped to design. These are the emblems chosen for the missions that did not make moon landings

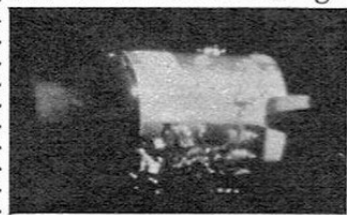

The damaged Apollo 13 spacecraft.

and of course include the famous Apollo 13 badge.

You will remember that Apollo 13 was intended to make a landing on the lunar surface but an explosion curtailed the flight and gave rise to high drama and tension when the world waited with baited breath to see if the three astronauts, James Lovell, Fred Haise and John Swigert could be returned to Earth.

Fortunately, the ill-fated mission had a happy ending.

A 'boob' for Blakey—but Butler loses out!



INSPECTOR BLAKE HAS WON SECOND PRIZE IN A COMPETITION— FIVE THOUSAND POUNDS PLUS A HOLIDAY IN BERMUDA! HE HAS DECIDED TO RESIGN AND THE DELIGHTED STAN HAS ORGANISED A FAREWELL 'DO'...

FAN ME! CHAMPAGNE, COLD BUFFET— YOU'VE LASHED OUT, EH, STAN.

STONE THE CROWS, YOU MUST BE OFF YOUR ROCKER!

NOT ME! FOUR HUNDRED WOULD BE A SMALL PRICE TO PAY TO SEE BLAKE'S BACK GOIN' THROUGH THAT DEPOT DOOR FOREVER! HEH! HEH!



S' RIGHT! INCLUDING THE GOING-AWAY PRESENTS I BOUGHT, THIS LITTLE LOT'S SET ME BACK FORTY QUID!



SUDDENLY...

AHEM!

CHASE ME UP A CONKER TREE—DON'T TELL ME THAT'S BLAKEY!



HO! HO! HO! YOU DON'T 'ALF LOOK FUNNY, MATE! WHAT ARE YOU SUPPOSED TO BE? A DECORATED MAYPOLE?

JEALOUSY WILL GET YOU NOWHERE, BUTLER! THIS IS WHAT ALL THE BEST PEOPLE ARE WEARING IN BERMUDA THESE DAYS!



OWEVER, I WOULDN'T EXPECT YOU TO APPRECIATE THE FINER POINTS OF LIFE!

COURSE NOT, BLAKEY! ANYWAY, ON THIS 'APPY OCCASION, I'D LIKE YOU TO ACCEPT THESE FAREWELL GIFTS...



BUTLER— WORDS FAIL ME!



THAT'S GOOD, COS' I AIN'T FINISHED YET! LADS —A TOAST! TO THE END OF BLAKEY!

ER... EXCUSE ME, GENTLEMEN! I'M LOOKING FOR INSPECTOR BLAKE! MY NAME IS PEABODY, OF THE 'DAILY GLOBE'!



EX- INSPECTOR IT IS NOW, MY OLD SON! I HAVE YOUR LETTER RIGHT HERE! ON THE STRENGTH OF ME WINNING SECOND PRIZE, I PACKED IN MY JOB!

OH, DEAR, THAT'S WHAT I CAME TO SEE YOU ABOUT! OUR TYPIST MADE AN UNFORTUNATE MISTAKE...



Dear Mr. Blake, We the proprietors of the Daily Globe have pleasure informing you that you have won 2nd prize in our recent competition.

SHE LEFT OUT A '2'! YOU HAVE ACTUALLY WON THE 22ND PRIZE WHICH I'M AFRAID IS ONLY A FREE MONTH'S SUPPLY OF CRUNCHY-WUNCHY DOG FOOD!

WHAT?



HAAH-HAAH-HAAH, FIVE THOUSAND QUID ONE MINUTE, DOG FOOD THE NEXT!

FROM BERMUDA TO BOW-WOWS! WHAT A LAUGH!

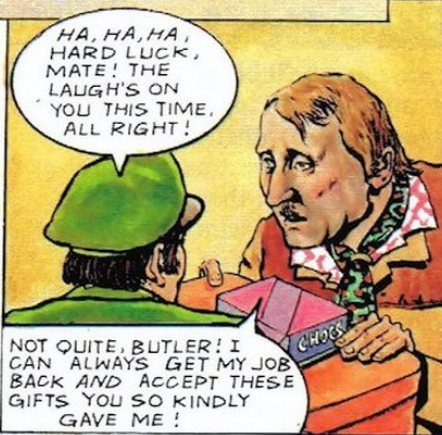

HA, HA, HA, HARD LUCK, MATE! THE LAUGH'S ON YOU THIS TIME, ALL RIGHT!

NOT QUITE, BUTLER! I CAN ALWAYS GET MY JOB BACK AND ACCEPT THESE GIFTS YOU SO KINDLY GAVE ME!



THEY'LL COME IN VERY USEFUL WHEN I TAKE MY ANNUAL 'OLIDAY THIS YEAR IN BLACKPOOL!

GAH, MY TROUBLE IS, I CAN NEVER WIN! JUST THINK, FORTY QUID DOWN THE DRAIN AND BLAKEY'S BACK IN BUSINESS!

© Based on the London Weekend TV series written by Ronald Wolfe and Ronald Chesney.

STEW POT'S LOOK-OUT

THE OTHER DAY, another big bag of mail arrived for Stewpot's LOOK-OUT and I must say you are the best letter-writers, joke-tellers and poets I've ever met. So the Editor said I could print a few whenever I liked in LOOK-IN, and their senders will each receive a small prize.

Coming up with the first, right now, from Corrinne Nock of Redditch, Worcs.

Now here's a joke from Soong Ken Ma, of Carmarthen.

Did you hear about the two potatoes who didn't see eye to eye?
When one took off his jacket, the other thought he'd had his chips!

Dream Horse

*On the beach by gentle seas,
Mane rippling in refreshing breeze,
Soft, silky eyes and gentle face,
Nose of velvet and mane of lace.
Beautiful tail swaying around,
Nodding his head without a sound,
Muscles so strong in every limb,
I couldn't resist a ride on him.*

*I jumped on his back and gripped with my knees,
And urged him onwards towards the trees,
As light as air we floated along,
We went so fast, he was so strong.
We galloped through a screen of fire,
But my horse would never tire,
We leapt a hedge, a fence, a stream,
What a pity 'twas a dream.*

Great, isn't it. What do you think of the picture? It's from 'Follyfoot', of course. I could just imagine *myself* riding!

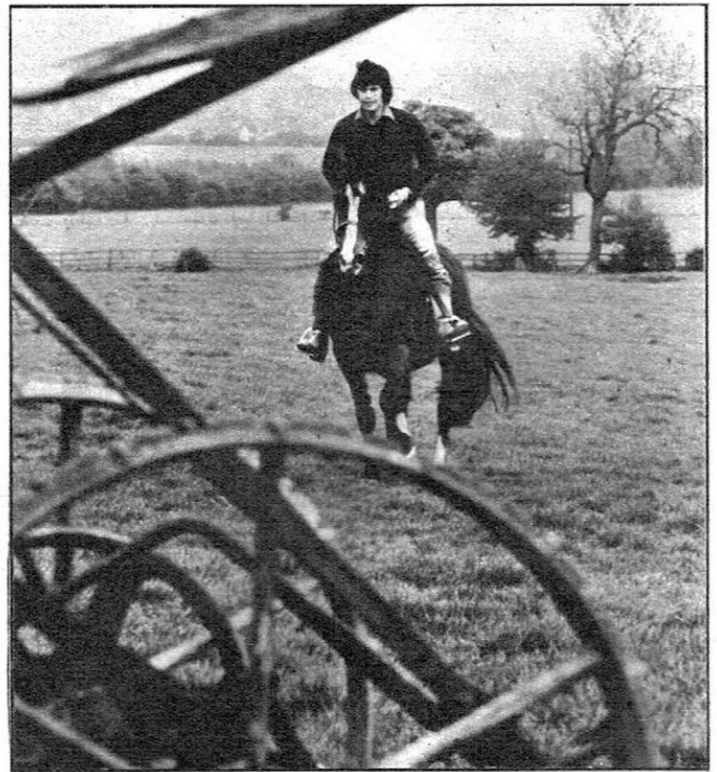

'On The Buses' Buddies!

ASK BOB GRANT how he is these days and he'll beam with that famous assortment of teeth and say: "Happy, happy and busy!" Remember Stephen Lewis (that's Blakey) and Bob (conductor Jack) have taken up the pen and are now not only acting in the 'On the Buses' programme but are conspiring to write four of the seven episodes of the new series (issue 3)?

Well, the other day, they revealed how they dream up the new episodes.

"We've been allotted the conference room at London Weekend Television centre. We face each other across

a shiny table and try to get inspired! Sometimes we get ideas from viewers who write in suggesting a plot—we have had a couple of good ideas from the LOOK-IN strip."

Stephen and Bob are old buddies. They worked as actors together many years ago in an experimental drama group in London's East End. They've also

just written two plays that will be on display in London's theatreland later this year.

Isn't it boring for an actor to appear in the same series for a long time? "Not at all. I drove a bus myself once when I couldn't get any theatre work. And I've worked in a frozen food factory. After that lot, working in a television



WIN A TIDDLEYWINK BADGE!

Here's your chance to win a Junior Showtime Tiddleywink Badge. All you have to do is think of an original joke and write it down. Then cut out and complete the coupon on the next page. Send your joke—together with the coupon—to: Junior Showtime Joke Time (J.S.J.T.), Junior Showtime, Yorkshire Television, The Television Centre, Leeds LS3 1JS.

If your joke is selected to be read out by compère Bobby Bennett on any one programme in the new series (starting on March 28 in all regions) you will receive a badge—FREE.

But although there are several weeks to go—get thinking right away. For the senders of the first two hundred jokes pulled out of the Joke Time Mailbag will each be sent a badge anyway, FREE of charge, as a special offer to LOOK-IN.



Meet a mole named Boris!

Calling all readers in the South-East of England. There's a rather unusual mole which recently broke the surface down south. His name's Boris and he's making brief appearances during Southern Television's news magazine programme: 'Scene South East' on Friday evenings at six o'clock.

Boris is a semi-animated cartoon character drawn by Ted Harrison, who also provides the voice. But Boris's future TV career depends upon the viewers' reactions. So, if you have any comments you want to make about him, just write them down and send them to: Mr. Hodgson, Dover Manager, Southern Television, Dover Studio, Russell St., Dover.

Who knows—it could depend on you whether or not this mole-in-the-hole returns underground again!



PANTO STAR From rags to riches! Attractive Irish singer Clodagh Rodgers has turned her attention to the pantomime scene for the first time. She is currently starring as Cinderella in the London Palladium's £110,000 production. Watch out for a personal interview in a future issue of LOOK-IN!



series could never be called boring." Bob Grant took another long pull at his champagne glass. "Steve's birthday," he said, nodding towards his colleague who sat blinking like an owl through thick-rimmed glasses. A stirring chorus of 'Happy Birthday, dear Stephen went up to mark the occasion.

★★★★★★★★★★★★★ Fan Club News!

For those readers who've written in pleading for the fan club addresses of both Rod Stewart and Sean Connery, your wish is granted. For Rod Stewart write to him at c/o 1st Floor, 30 Brown Street, Manchester 2. For Sean '007' Connery write to him at c/o Hatton and Bradley, 8 South Molton Street, London W1.

★★★★★★★★★★★★★

The Look-in Crossword

FROM 'TIME

Spencer Banks talks about his latest TV role

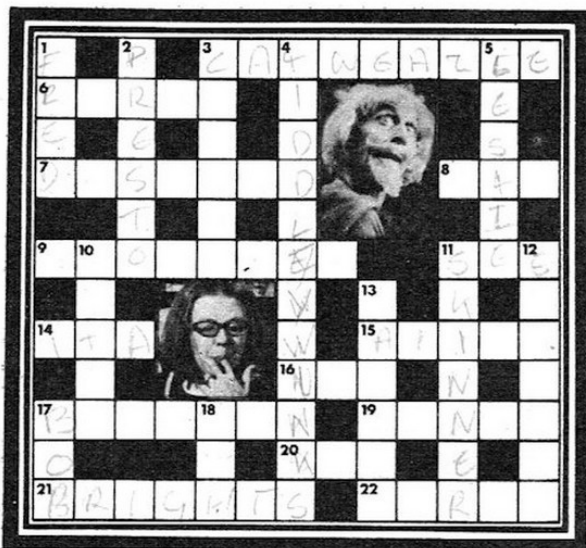

MARTIN CLIFFORD is no ordinary school-boy. He is studying for his 'A'-levels during his final year, like many another pupil. But once you know that Martin is actually young actor Spencer Banks, therein lies the first major difference.

The second point is that Martin's school is close to an American Airforce base involved in N.A.T.O. exercises.

The third—which sets the story rolling for ATV's spy-thriller series *Tightrope* — is that Forrester, from British Intelligence suspects there are spies in the nearby village who will attempt to sabotage the base. Needless to say, it is Martin whom Forrester calls upon to work with him against the enemy.

The thirteen-week programme started on January 19 — and for Spencer it offered the beginning of a new TV image, over and above his well-known part as Simon Randall in *Timeslip*.

Recently, Spencer spoke to LOOK-IN during a telephone interview, to discuss his rôle in *Tightrope*.

Q: How does the part of Martin Clifford compare to that of Simon Randall?

A: *It's completely different. You can't really compare the two. For a start the age of each character varies quite considerably.*



Martin Clifford tries to get some sense out of Forrester

Q: Which character did you prefer playing?

A: *I couldn't really say. I enjoyed each one as much as the other.*

Q: Do you feel that your present rôle requires more acting skill?

A: *Yes, it does. The character is older—in fact, about seven-*



Spencer Banks as Martin Clifford, studying for 'A' Levels.

teen to eighteen — and is rather more complicated.

Q: Is this your first major part since *Timeslip*?

A: *I played *Four Eyes in Alexander The Great* — a comedy rôle. But that was all.*

Q: Do you prefer serious parts?

A: *Yes, I do. I prefer drama to comedy. Good comedy is very difficult and exacting.*

Q: Do you find serious acting easier than comedy?

A: *No. They are a technique in themselves. It's just that I'd rather choose straight parts.*

Q: Cheryl Burfield starred as Liz Skinner with you in *Timeslip*. Do you hope to co-star with her again?

A: *I'd like to. It's a question of a suitable part coming up, such as a new series of *Timeslip* if ATV decided to do one.*

Q: Was there a particularly funny incident which you remember during the filming

Across:

- Our pictured pin-up is a magician from the past played by 9 and 17 across.
- Not as plentiful.
- Llewelyn, the colonel in *Follyfoot*.
- Travel through space.
- See 3 across.
- Viewers do this.
- Independent Television (initials).
- Pictured, from *On the Buses*.
- Unwell.
- See 3 across.
- Mrs. Walker from the *Rovers Return*.
- Goodwin the comedian.
- Boffins.
- Hare who plays Mum in *On the Buses*.

Down:

- How's Dinenage*.
- Hey, that is the magic phrase!
- Fail to put in an appearance.
- Flipping game and a *Junior Showtime* group whose badge you can get this week.
- Crowther.
- An actor in a non-speaking part or a run a batsman does not score.
- Liz from *Timeslip*.
- Football, cricket or hockey teams.
- European country, capital Warsaw.
- Monkhouse and Grant share this name.
- First and last tonic solfa note.

Answers: Across: 3. Catweazle; Anna Karen from *On the Buses*. Pictured: Catweazle; Anna Karen from *On the Buses*. Down: 1. Extra; 11. Skinner; 12. Eleens; 13. Poland; 17. Bob; 18. Doh; 19. Doh; 20. Doh; 21. Doh; 22. Doh; 23. Doh; 24. Doh; 25. Doh; 26. Doh; 27. Doh; 28. Doh; 29. Doh; 30. Doh; 31. Doh; 32. Doh; 33. Doh; 34. Doh; 35. Doh; 36. Doh; 37. Doh; 38. Doh; 39. Doh; 40. Doh; 41. Doh; 42. Doh; 43. Doh; 44. Doh; 45. Doh; 46. Doh; 47. Doh; 48. Doh; 49. Doh; 50. Doh; 51. Doh; 52. Doh; 53. Doh; 54. Doh; 55. Doh; 56. Doh; 57. Doh; 58. Doh; 59. Doh; 60. Doh; 61. Doh; 62. Doh; 63. Doh; 64. Doh; 65. Doh; 66. Doh; 67. Doh; 68. Doh; 69. Doh; 70. Doh; 71. Doh; 72. Doh; 73. Doh; 74. Doh; 75. Doh; 76. Doh; 77. Doh; 78. Doh; 79. Doh; 80. Doh; 81. Doh; 82. Doh; 83. Doh; 84. Doh; 85. Doh; 86. Doh; 87. Doh; 88. Doh; 89. Doh; 90. Doh; 91. Doh; 92. Doh; 93. Doh; 94. Doh; 95. Doh; 96. Doh; 97. Doh; 98. Doh; 99. Doh; 100. Doh; 101. Doh; 102. Doh; 103. Doh; 104. Doh; 105. Doh; 106. Doh; 107. Doh; 108. Doh; 109. Doh; 110. Doh; 111. Doh; 112. Doh; 113. Doh; 114. Doh; 115. Doh; 116. Doh; 117. Doh; 118. Doh; 119. Doh; 120. Doh; 121. Doh; 122. Doh; 123. Doh; 124. Doh; 125. Doh; 126. Doh; 127. Doh; 128. Doh; 129. Doh; 130. Doh; 131. Doh; 132. Doh; 133. Doh; 134. Doh; 135. Doh; 136. Doh; 137. Doh; 138. Doh; 139. Doh; 140. Doh; 141. Doh; 142. Doh; 143. Doh; 144. Doh; 145. Doh; 146. Doh; 147. Doh; 148. Doh; 149. Doh; 150. Doh; 151. Doh; 152. Doh; 153. Doh; 154. Doh; 155. Doh; 156. Doh; 157. Doh; 158. Doh; 159. Doh; 160. Doh; 161. Doh; 162. Doh; 163. Doh; 164. Doh; 165. Doh; 166. Doh; 167. Doh; 168. Doh; 169. Doh; 170. Doh; 171. Doh; 172. Doh; 173. Doh; 174. Doh; 175. Doh; 176. Doh; 177. Doh; 178. Doh; 179. Doh; 180. Doh; 181. Doh; 182. Doh; 183. Doh; 184. Doh; 185. Doh; 186. Doh; 187. Doh; 188. Doh; 189. Doh; 190. Doh; 191. Doh; 192. Doh; 193. Doh; 194. Doh; 195. Doh; 196. Doh; 197. Doh; 198. Doh; 199. Doh; 200. Doh; 201. Doh; 202. Doh; 203. Doh; 204. Doh; 205. Doh; 206. Doh; 207. Doh; 208. Doh; 209. Doh; 210. Doh; 211. Doh; 212. Doh; 213. Doh; 214. Doh; 215. Doh; 216. Doh; 217. Doh; 218. Doh; 219. Doh; 220. Doh; 221. Doh; 222. Doh; 223. Doh; 224. Doh; 225. Doh; 226. Doh; 227. Doh; 228. Doh; 229. Doh; 230. Doh; 231. Doh; 232. Doh; 233. Doh; 234. Doh; 235. Doh; 236. Doh; 237. Doh; 238. Doh; 239. Doh; 240. Doh; 241. Doh; 242. Doh; 243. Doh; 244. Doh; 245. Doh; 246. Doh; 247. Doh; 248. Doh; 249. Doh; 250. Doh; 251. Doh; 252. Doh; 253. Doh; 254. Doh; 255. Doh; 256. Doh; 257. Doh; 258. Doh; 259. Doh; 260. Doh; 261. Doh; 262. Doh; 263. Doh; 264. Doh; 265. Doh; 266. Doh; 267. Doh; 268. Doh; 269. Doh; 270. Doh; 271. Doh; 272. Doh; 273. Doh; 274. Doh; 275. Doh; 276. Doh; 277. Doh; 278. Doh; 279. Doh; 280. Doh; 281. Doh; 282. Doh; 283. Doh; 284. Doh; 285. Doh; 286. Doh; 287. Doh; 288. Doh; 289. Doh; 290. Doh; 291. Doh; 292. Doh; 293. Doh; 294. Doh; 295. Doh; 296. Doh; 297. Doh; 298. Doh; 299. Doh; 300. Doh; 301. Doh; 302. Doh; 303. Doh; 304. Doh; 305. Doh; 306. Doh; 307. Doh; 308. Doh; 309. Doh; 310. Doh; 311. Doh; 312. Doh; 313. Doh; 314. Doh; 315. Doh; 316. Doh; 317. Doh; 318. Doh; 319. Doh; 320. Doh; 321. Doh; 322. Doh; 323. Doh; 324. Doh; 325. Doh; 326. Doh; 327. Doh; 328. Doh; 329. Doh; 330. Doh; 331. Doh; 332. Doh; 333. Doh; 334. Doh; 335. Doh; 336. Doh; 337. Doh; 338. Doh; 339. Doh; 340. Doh; 341. Doh; 342. Doh; 343. Doh; 344. Doh; 345. Doh; 346. Doh; 347. Doh; 348. Doh; 349. Doh; 350. Doh; 351. Doh; 352. Doh; 353. Doh; 354. Doh; 355. Doh; 356. Doh; 357. Doh; 358. Doh; 359. Doh; 360. Doh; 361. Doh; 362. Doh; 363. Doh; 364. Doh; 365. Doh; 366. Doh; 367. Doh; 368. Doh; 369. Doh; 370. Doh; 371. Doh; 372. Doh; 373. Doh; 374. Doh; 375. Doh; 376. Doh; 377. Doh; 378. Doh; 379. Doh; 380. Doh; 381. Doh; 382. Doh; 383. Doh; 384. Doh; 385. Doh; 386. Doh; 387. Doh; 388. Doh; 389. Doh; 390. Doh; 391. Doh; 392. Doh; 393. Doh; 394. Doh; 395. Doh; 396. Doh; 397. Doh; 398. Doh; 399. Doh; 400. Doh; 401. Doh; 402. Doh; 403. Doh; 404. Doh; 405. Doh; 406. Doh; 407. Doh; 408. Doh; 409. Doh; 410. Doh; 411. Doh; 412. Doh; 413. Doh; 414. Doh; 415. Doh; 416. Doh; 417. Doh; 418. Doh; 419. Doh; 420. Doh; 421. Doh; 422. Doh; 423. Doh; 424. Doh; 425. Doh; 426. Doh; 427. Doh; 428. Doh; 429. Doh; 430. Doh; 431. Doh; 432. Doh; 433. Doh; 434. Doh; 435. Doh; 436. Doh; 437. Doh; 438. Doh; 439. Doh; 440. Doh; 441. Doh; 442. Doh; 443. Doh; 444. Doh; 445. Doh; 446. Doh; 447. Doh; 448. Doh; 449. Doh; 450. Doh; 451. Doh; 452. Doh; 453. Doh; 454. Doh; 455. Doh; 456. Doh; 457. Doh; 458. Doh; 459. Doh; 460. Doh; 461. Doh; 462. Doh; 463. Doh; 464. Doh; 465. Doh; 466. Doh; 467. Doh; 468. Doh; 469. Doh; 470. Doh; 471. Doh; 472. Doh; 473. Doh; 474. Doh; 475. Doh; 476. Doh; 477. Doh; 478. Doh; 479. Doh; 480. Doh; 481. Doh; 482. Doh; 483. Doh; 484. Doh; 485. Doh; 486. Doh; 487. Doh; 488. Doh; 489. Doh; 490. Doh; 491. Doh; 492. Doh; 493. Doh; 494. Doh; 495. Doh; 496. Doh; 497. Doh; 498. Doh; 499. Doh; 500. Doh; 501. Doh; 502. Doh; 503. Doh; 504. Doh; 505. Doh; 506. Doh; 507. Doh; 508. Doh; 509. Doh; 510. Doh; 511. Doh; 512. Doh; 513. Doh; 514. Doh; 515. Doh; 516. Doh; 517. Doh; 518. Doh; 519. Doh; 520. Doh; 521. Doh; 522. Doh; 523. Doh; 524. Doh; 525. Doh; 526. Doh; 527. Doh; 528. Doh; 529. Doh; 530. Doh; 531. Doh; 532. Doh; 533. Doh; 534. Doh; 535. Doh; 536. Doh; 537. Doh; 538. Doh; 539. Doh; 540. Doh; 541. Doh; 542. Doh; 543. Doh; 544. Doh; 545. Doh; 546. Doh; 547. Doh; 548. Doh; 549. Doh; 550. Doh; 551. Doh; 552. Doh; 553. Doh; 554. Doh; 555. Doh; 556. Doh; 557. Doh; 558. Doh; 559. Doh; 560. Doh; 561. Doh; 562. Doh; 563. Doh; 564. Doh; 565. Doh; 566. Doh; 567. Doh; 568. Doh; 569. Doh; 570. Doh; 571. Doh; 572. Doh; 573. Doh; 574. Doh; 575. Doh; 576. Doh; 577. Doh; 578. Doh; 579. Doh; 580. Doh; 581. Doh; 582. Doh; 583. Doh; 584. Doh; 585. Doh; 586. Doh; 587. Doh; 588. Doh; 589. Doh; 590. Doh; 591. Doh; 592. Doh; 593. Doh; 594. Doh; 595. Doh; 596. Doh; 597. Doh; 598. Doh; 599. Doh; 600. Doh; 601. Doh; 602. Doh; 603. Doh; 604. Doh; 605. Doh; 606. Doh; 607. Doh; 608. Doh; 609. Doh; 610. Doh; 611. Doh; 612. Doh; 613. Doh; 614. Doh; 615. Doh; 616. Doh; 617. Doh; 618. Doh; 619. Doh; 620. Doh; 621. Doh; 622. Doh; 623. Doh; 624. Doh; 625. Doh; 626. Doh; 627. Doh; 628. Doh; 629. Doh; 630. Doh; 631. Doh; 632. Doh; 633. Doh; 634. Doh; 635. Doh; 636. Doh; 637. Doh; 638. Doh; 639. Doh; 640. Doh; 641. Doh; 642. Doh; 643. Doh; 644. Doh; 645. Doh; 646. Doh; 647. Doh; 648. Doh; 649. Doh; 650. Doh; 651. Doh; 652. Doh; 653. Doh; 654. Doh; 655. Doh; 656. Doh; 657. Doh; 658. Doh; 659. Doh; 660. Doh; 661. Doh; 662. Doh; 663. Doh; 664. Doh; 665. Doh; 666. Doh; 667. Doh; 668. Doh; 669. Doh; 670. Doh; 671. Doh; 672. Doh; 673. Doh; 674. Doh; 675. Doh; 676. Doh; 677. Doh; 678. Doh; 679. Doh; 680. Doh; 681. Doh; 682. Doh; 683. Doh; 684. Doh; 685. Doh; 686. Doh; 687. Doh; 688. Doh; 689. Doh; 690. Doh; 691. Doh; 692. Doh; 693. Doh; 694. Doh; 695. Doh; 696. Doh; 697. Doh; 698. Doh; 699. Doh; 700. Doh; 701. Doh; 702. Doh; 703. Doh; 704. Doh; 705. Doh; 706. Doh; 707. Doh; 708. Doh; 709. Doh; 710. Doh; 711. Doh; 712. Doh; 713. Doh; 714. Doh; 715. Doh; 716. Doh; 717. Doh; 718. Doh; 719. Doh; 720. Doh; 721. Doh; 722. Doh; 723. Doh; 724. Doh; 725. Doh; 726. Doh; 727. Doh; 728. Doh; 729. Doh; 730. Doh; 731. Doh; 732. Doh; 733. Doh; 734. Doh; 735. Doh; 736. Doh; 737. Doh; 738. Doh; 739. Doh; 740. Doh; 741. Doh; 742. Doh; 743. Doh; 744. Doh; 745. Doh; 746. Doh; 747. Doh; 748. Doh; 749. Doh; 750. Doh; 751. Doh; 752. Doh; 753. Doh; 754. Doh; 755. Doh; 756. Doh; 757. Doh; 758. Doh; 759. Doh; 760. Doh; 761. Doh; 762. Doh; 763. Doh; 764. Doh; 765. Doh; 766. Doh; 767. Doh; 768. Doh; 769. Doh; 770. Doh; 771. Doh; 772. Doh; 773. Doh; 774. Doh; 775. Doh; 776. Doh; 777. Doh; 778. Doh; 779. Doh; 780. Doh; 781. Doh; 782. Doh; 783. Doh; 784. Doh; 785. Doh; 786. Doh; 787. Doh; 788. Doh; 789. Doh; 790. Doh; 791. Doh; 792. Doh; 793. Doh; 794. Doh; 795. Doh; 796. Doh; 797. Doh; 798. Doh; 799. Doh; 800. Doh; 801. Doh; 802. Doh; 803. Doh; 804. Doh; 805. Doh; 806. Doh; 807. Doh; 808. Doh; 809. Doh; 810. Doh; 811. Doh; 812. Doh; 813. Doh; 814. Doh; 815. Doh; 816. Doh; 817. Doh; 818. Doh; 819. Doh; 820. Doh; 821. Doh; 822. Doh; 823. Doh; 824. Doh; 825. Doh; 826. Doh; 827. Doh; 828. Doh; 829. Doh; 830. Doh; 831. Doh; 832. Doh; 833. Doh; 834. Doh; 835. Doh; 836. Doh; 837. Doh; 838. Doh; 839. Doh; 840. Doh; 841. Doh; 842. Doh; 843. Doh; 844. Doh; 845. Doh; 846. Doh; 847. Doh; 848. Doh; 849. Doh; 850. Doh; 851. Doh; 852. Doh; 853. Doh; 854. Doh; 855. Doh; 856. Doh; 857. Doh; 858. Doh; 859. Doh; 860. Doh; 861. Doh; 862. Doh; 863. Doh; 864. Doh; 865. Doh; 866. Doh; 867. Doh; 868. Doh; 869. Doh; 870. Doh; 871. Doh; 872. Doh; 873. Doh; 874. Doh; 875. Doh; 876. Doh; 877. Doh; 878. Doh; 879. Doh; 880. Doh; 881. Doh; 882. Doh; 883. Doh; 884. Doh; 885. Doh; 886. Doh; 887. Doh; 888. Doh; 889. Doh; 890. Doh; 891. Doh; 892. Doh; 893. Doh; 894. Doh; 895. Doh; 896. Doh; 897. Doh; 898. Doh; 899. Doh; 900. Doh; 901. Doh; 902. Doh; 903. Doh; 904. Doh; 905. Doh; 906. Doh; 907. Doh; 908. Doh; 909. Doh; 910. Doh; 911. Doh; 912. Doh; 913. Doh; 914. Doh; 915. Doh; 916. Doh; 917. Doh; 918. Doh; 919. Doh; 920. Doh; 921. Doh; 922. Doh; 923. Doh; 924. Doh; 925. Doh; 926. Doh; 927. Doh; 928. Doh; 929. Doh; 930. Doh; 931. Doh; 932. Doh; 933. Doh; 934. Doh; 935. Doh; 936. Doh; 937. Doh; 938. Doh; 939. Doh; 940. Doh; 941. Doh; 942. Doh; 943. Doh; 944. Doh; 945. Doh; 946. Doh; 947. Doh; 948. Doh; 949. Doh; 950. Doh; 951. Doh; 952. Doh; 953. Doh; 954. Doh; 955. Doh; 956. Doh; 957. Doh; 958. Doh; 959. Doh; 960. Doh; 961. Doh; 962. Doh; 963. Doh; 964. Doh; 965. Doh; 966. Doh; 967. Doh; 968. Doh; 969. Doh; 970. Doh; 971. Doh; 972. Doh; 973. Doh; 974. Doh; 975. Doh; 976. Doh; 977. Doh; 978. Doh; 979. Doh; 980. Doh; 981. Doh; 982. Doh; 983. Doh; 984. Doh; 985. Doh; 986. Doh; 987. Doh; 988. Doh; 989. Doh; 990. Doh; 991. Doh; 992. Doh; 993. Doh; 994. Doh; 995. Doh; 996. Doh; 997. Doh; 998. Doh; 999. Doh; 1000. Doh; 1001. Doh; 1002. Doh; 1003. Doh; 1004. Doh; 1005. Doh; 1006. Doh; 1007. Doh; 1008. Doh; 1009. Doh; 1010. Doh; 1011. Doh; 1012. Doh; 1013. Doh; 1014. Doh; 1015. Doh; 1016. Doh; 1017. Doh; 1018. Doh; 1019. Doh; 1020. Doh; 1021. Doh; 1022. Doh; 1023. Doh; 1024. Doh; 1025. Doh; 1026. Doh; 1027. Doh; 1028. Doh; 1029. Doh; 1030. Doh; 1031. Doh; 1032. Doh; 1033. Doh; 1034. Doh; 1035. Doh; 1036. Doh; 1037. Doh; 1038. Doh; 1039. Doh; 1040. Doh; 1041. Doh; 1042. Doh; 1043. Doh; 1044. Doh; 1045. Doh; 1046. Doh; 1047. Doh; 1048. Doh; 1049. Doh; 1050. Doh; 1051. Doh; 1052. Doh; 1053. Doh; 1054. Doh; 1055. Doh; 1056. Doh; 1057. Doh; 1058. Doh; 1059. Doh; 1060. Doh; 1061. Doh; 1062. Doh; 1063. Doh; 1064. Doh; 1065. Doh; 1066. Doh; 1067. Doh; 1068. Doh; 1069. Doh; 1070. Doh; 1071. Doh; 1072. Doh; 1073. Doh; 1074. Doh; 1075. Doh; 1076. Doh; 1077. Doh; 1078. Doh; 1079. Doh; 1080. Doh; 1081. Doh; 1082. Doh; 1083. Doh; 1084. Doh; 1085. Doh; 1086. Doh; 1087. Doh; 1088. Doh; 1089. Doh; 1090. Doh; 1091. Doh; 1092. Doh; 1093. Doh; 1094. Doh; 1095. Doh; 1096. Doh; 1097. Doh; 1098. Doh; 1099. Doh; 1100. Doh; 1101. Doh; 1102. Doh; 1103. Doh; 1104. Doh; 1105. Doh; 1106. Doh; 1107. Doh; 1108. Doh; 1109. Doh; 1110. Doh; 1111. Doh; 1112. Doh; 1113. Doh; 1114. Doh; 1115. Doh; 1116. Doh; 1117. Doh; 1118. Doh; 1119. Doh; 1120. Doh; 1121. Doh; 1122. Doh; 1123. Doh; 1124. Doh; 1125. Doh; 1126. Doh; 1127. Doh; 1128. Doh; 1129. Doh; 1130. Doh; 1131. Doh; 1132. Doh; 1133. Doh; 1134. Doh; 1135. Doh; 1136. Doh; 1137. Doh; 1138. Doh; 1139. Doh; 1140. Doh; 1141. Doh; 1142. Doh; 1143. Doh; 1144. Doh; 1145. Doh; 1146. Doh; 1147. Doh; 1148. Doh; 1149. Doh; 1150. Doh; 1151. Doh; 1152. Doh; 1153. Doh; 1154. Doh; 1155. Doh; 1156. Doh; 1157. Doh; 1158. Doh; 1159. Doh; 1160. Doh; 1161. Doh; 1162. Doh; 1163. Doh; 1164. Doh; 1165. Doh; 1166. Doh; 1167. Doh; 1168. Doh; 1169. Doh; 1170. Doh; 1171. Doh; 1172. Doh; 1173. Doh; 1174. Doh; 1175. Doh; 1176. Doh; 1177. Doh; 1178. Doh; 1179. Doh; 1180. Doh; 1181. Doh; 1182. Doh; 1183. Doh; 1184. Doh; 1185. Doh; 1186. Doh; 1187. Doh; 1188. Doh; 1189. Doh; 1190. Doh; 1191. Doh; 1192. Doh; 1193. Doh; 1194. Doh; 1195. Doh; 1196. Doh; 1197. Doh; 1198. Doh; 1199. Doh; 1200. Doh; 1201. Doh; 1202. Doh; 1203. Doh; 1204. Doh; 1205. Doh; 1206. Doh; 1207. Doh; 1208. Doh; 1209. Doh; 1210. Doh; 1211. Doh; 1212. Doh; 1213. Doh; 1214. Doh; 1215. Doh; 1216. Doh; 1217. Doh; 1218. Doh; 1219. Doh; 1220. Doh; 1221. Doh; 1222. Doh; 1223. Doh; 1224. Doh; 1225. Doh; 1226. Doh; 1227. Doh; 1228. Doh; 1229. Doh; 1230. Doh; 1231. Doh; 1232. Doh; 1233. Doh; 1234. Doh; 1235. Doh; 1236. Doh; 123

'ESLIP' TO 'TIGHTROPE'



The role of Clifford is a hard one—as the bruise proves.

of *Tightrope*?

A: *Not that I can think of. It was a lot of hard work, though I generally found the filming, fun.*

Q: **What was the most exciting part of filming?**

A: *I did a fight sequence which was a bit of a giggle. I get knocked about by two thugs until Forrester arrives to help me. But, come to think of it, I rather get knocked about a bit throughout the whole series!*

Q: **Have you any plans for the future?**

A: *Now I'd like to do theatre*

—but it's a question of work being available.

Q: **Have you any final comments about *Tightrope*?**

A: *Just that I hope viewers find it as exciting as I did!*

... And, that, only you can answer. But if you haven't yet tuned in, don't forget to do so this week. Full details are given in the programme pages of LOOK-IN.

Here are the Moon landing badges offered in the previous four issues of LOOK-IN. (See back cover.)



Colonel Buchan finds a vital clue!

FREEWHEELERS

A SINISTER MESSAGE IS SENT TO BRITISH INDUSTRIAL CORPORATIONS. THE AUTHOR OF THE RANSOM DEMAND IS A COMPUTER EXPERT AND DOUBLE AGENT NAMED RUDY SCRIBNER WHO HAS BUILT HIMSELF A SECRET HIDEOUT BENEATH THE SEA...



DETAILS OF THE MESSAGE REACH COLONEL BUCHAN AND THE FREE-WHEELERS AT DOVER...



DR. JO BELL APPROACHES...



THE SUBMARINE IS A SPECIAL UNDERWATER RESEARCH VESSEL...



JO EXPLAINS THE SYSTEMS...

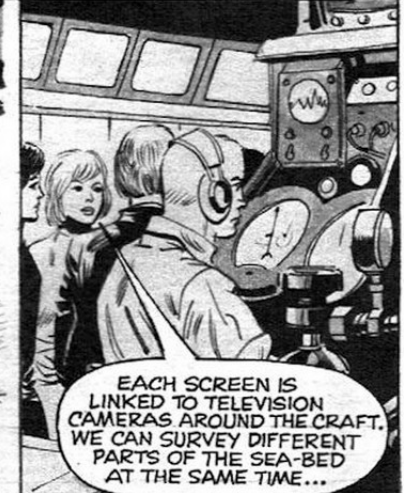

© 1977 Southern Television Ltd., Based on the Southern TV series.



A RADIO VOICE SOUNDS OUT...





PLEASE SIR!

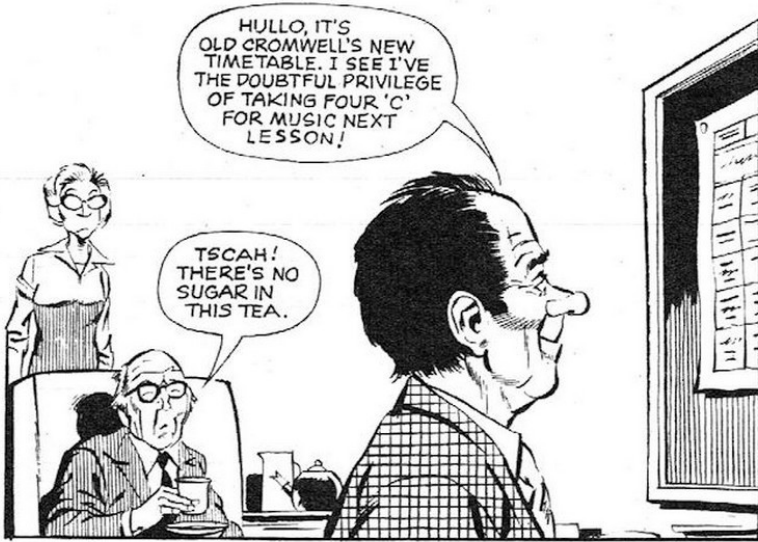

Based on the London Weekend Television series created and written by John Esmonde and Bob Larbey © 1972 Esmonde Larbey Ltd.



THE CHAIR WEDGES MORE FIRMLY...



POTTER DROPS...



LEFT OFF

In response to the many requests that followed our last series, here is another picture of 'Middle of The Road'. Apart from anything else, they really do



'Middle Of The Road'.

deserve a mention for having recently been one of the very few acts to have three records in the Top Thirty—all at the same time!

I am now going to get on to my hobby horse and no doubt some of you will say, 'a bit late'—because the album I'm going to talk about has been out since Christmas. But in this case, a late review is better than no review. It's called 'Stones' by Neil Diamond who, as I've said before, is one of my idols.



Neil Diamond.

But, to get back to the L.P., it's on the UNI label No. UNLS 121 and includes 'I am... I said', 'Chelsea Morning' (written by Joni Mitchell) and a tear-jerking version of 'If you Go Away' the song written by Jacques Brel and Rod McKuen which has turned into a standard over the past year.

The L.P. is so beautifully-made and Neil sings with such feeling that all I can say is buy it!

Bye for now.

P.S. If you'd like to know more about Neil, here's his fan club address: Neil Diamond, c/o 7, Apposum Way, Beaver Estate, Hounslow, Middlesex.

More frolics at Fenn Street School next week!

Catweazle's confusion causes a car crash!

CATWEAZLE



CATWEAZLE, THE SORCERER FROM NORMAN TIMES, LANDS UP IN THE TWENTIETH CENTURY, WHERE HE GETS INVOLVED WITH YOUNG JOE BOND AND HIS FATHER, A STAGE MAGICIAN KNOWN AS 'THE GREAT BONDINI'. BELIEVING CATWEAZLE TO BE NO MORE THAN SOME KIND OF MADMAN, BONDINI CHUCKS HIM OUT BUT THE OLD MAN HIDES IN THE BACK OF A HIRE-CAR TAKING THE BONDS TO A THEATRE ENGAGEMENT...

HE SPURNS ME BECAUSE HE FEARS I WILL GAIN THE SECRETS OF HIS MAGIC! BUT I MUST HAVE HIS POWERS, IF I AM TO RETURN TO MY OWN TIME!

CATWEAZLE HAS HEARD BONDINI SPEAK OF THE MAGIC CIRCLE...

THAT MUST BE IT! VERILY, IT HATH THE POWER TO SPEED THIS CARRIAGE WITHOUT THE AID OF HORSES!

NEXT MOMENT—CHAOS!

'TIS MINE!

WHAT THE DICKENS?

YEEAAAGH!

IT'S THAT CRAZY OLD LUNATIC! STOP HIM! HE'LL KILL US ALL!

THE KEYS! SNATCH OUT THE KEYS!

URRRGH! GOT 'EM!

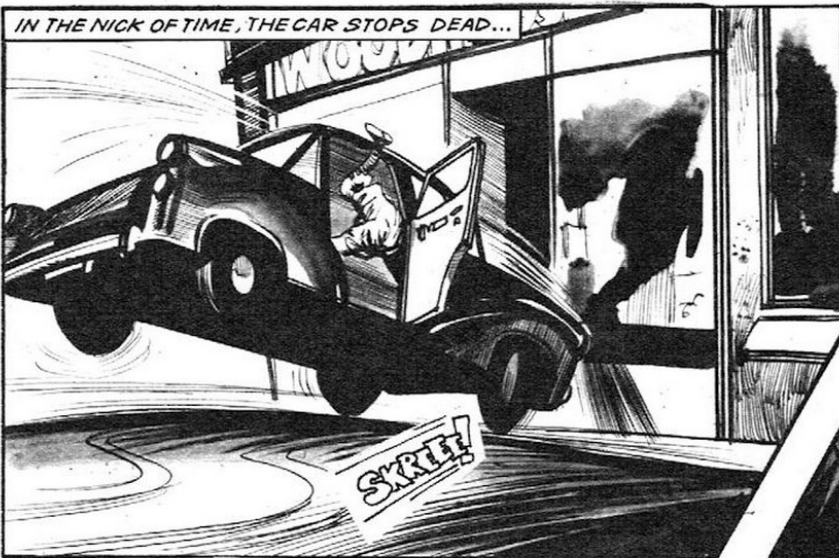

IN THE NICK OF TIME, THE CAR STOPS DEAD...



TERRIFIED BEYOND MEASURE, CATWEAZLE LEAPS OUT AND SCUTTLES OFF...

THE CIRCLE RESISTED MY POWER! NOTHING WORKS!



AMAZINGLY, THERE ARE NO POLICE ON THE SCENE AND AFTER APOLOGIES TO WHITE-FACED BYSTANDERS...

MORE CAUTION! THAT IS WHAT'S NEEDED, TOUCHWOOD MY HEART! I KNOW WHERE THEY ARE GOING AND WE SHALL FOLLOW— NEVER FEAR!



WHAT...WHAT WAS IT? A NIGHTMARE?

DAD! ARE YOU ALL RIGHT?

BASHED MY HEAD. IT'S OKAY— DON'T WORRY!



DELAYED CONCUSSION, I'M AFRAID. HE'LL HAVE TO SPEND THE NIGHT IN HOSPITAL.

POOR OLD DAD! THAT MEANS HIS ACT'S GOING TO BE CANCELLED! HE CAN'T AFFORD TO LOSE JOBS LIKE THIS!

AND LATER, BACKSTAGE AT THE ADELPHI, MAULFORD...



GET A DOCTOR, SOMEONE! DAD'S PASSED OUT!



TCHAH! WILL I NOT MAKE AMENDS? 'TIS EASY, MASTER! IF THY FATHER CANNOT SHOW HIS MAGIC TO THE CROWD, THEN I SHALL TAKE HIS PLACE!

OH, DO WHAT YOU LIKE! I DON'T CARE ANY MORE!



WHAT HAVE I SAID? IF THAT HALF-WIT GETS OUT ON THE STAGE, ANYTHING CAN HAPPEN!



PSSST! MASTER! 'TIS I!

YOU...? YOU'VE GOT A NERVE COMING HERE! THIS IS ALL YOUR BLINKING FAULT, YOU OLD IDIOT!

Daisy doesn't take kindly to strangers—especially Steve!

Follyfoot

THANKS TO LEWIS HAMMOND AND HIS RECKLESS MOTOR-CYCLING, JOE BASSETT, THE LOCAL RAG-AND-BONE MAN, ENDS UP IN HOSPITAL WHILE HIS MARE, DAISY, COMES TO FOLLYFOOT TO BE LOOKED AFTER. BUT RIGHT FROM THE START, IT'S CLEAR THAT DORA, STEVE AND RON ARE GOING TO HAVE TROUBLE WITH HER...



I DON'T KNOW WHAT WE'RE GOING TO DO! SHE JUST WON'T EAT!

LET ME HAVE A GO, DORA. I'VE A WAY WITH THE LADIES!



NOW THEN, OLD GIRL! PERK UP FOR STEVE!



YOWWW!

HA! HA! A WAY WITH THE LADIES, 'E SAYS!



IT'S NO LAUGHING MATTER, RON. SHE'S PINING, THAT'S WHAT IT IS!

LEAVE HER TILL SHE GETS REALLY HUNGRY, THEN, WE'LL SEE!

MEANWHILE, OVER AT PINECREST HOTEL, RUN BY THE HAMMONDS...

LEWIS, YOU'RE A STUPID YOUNG IDIOT! I SUPPOSE YOU REALISE THIS RAG-AND-BONE CHARACTER COULD SUE? FINE PUBLICITY THAT'LL BE!



I'M... I'M SORRY, DAD.



YOU WILL BE, MY LAD—IF I CAN'T PERSUADE BASSETT TO SETTLE OUT OF COURT!

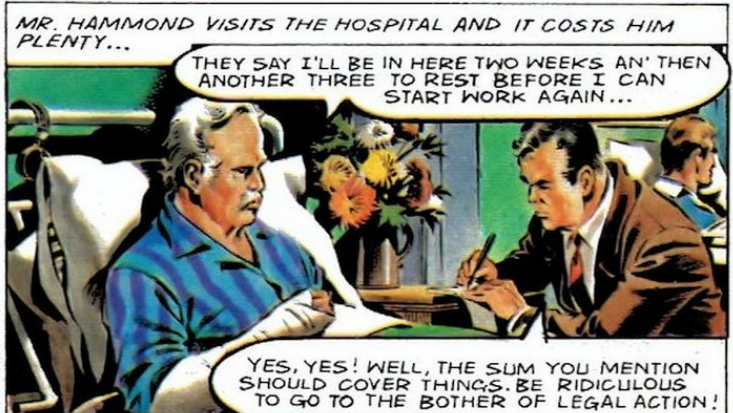

MR. HAMMOND VISITS THE HOSPITAL AND IT COSTS HIM PLENTY...

THEY SAY I'LL BE IN HERE TWO WEEKS AN' THEN ANOTHER THREE TO REST BEFORE I CAN START WORK AGAIN...

YES, YES! WELL, THE SUM YOU MENTION SHOULD COVER THINGS. BE RIDICULOUS TO GO TO THE BOTHER OF LEGAL ACTION!

Based on the Yorkshire Television series Follyfoot © 1972 Yorkshire Television Ltd.

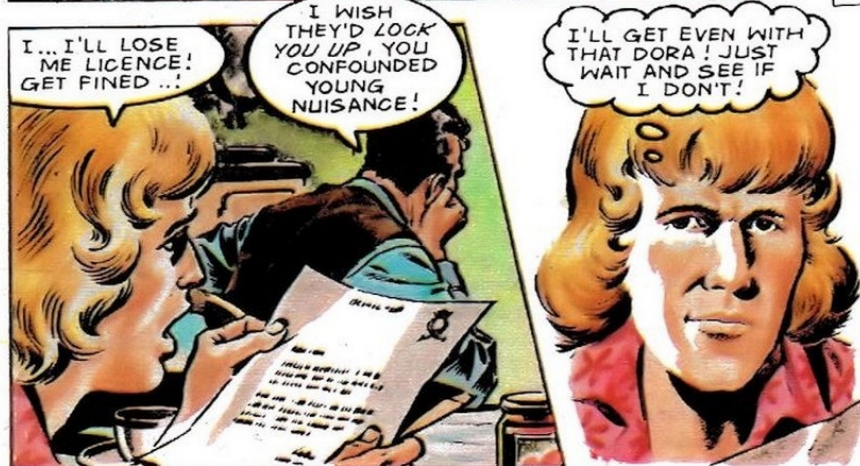
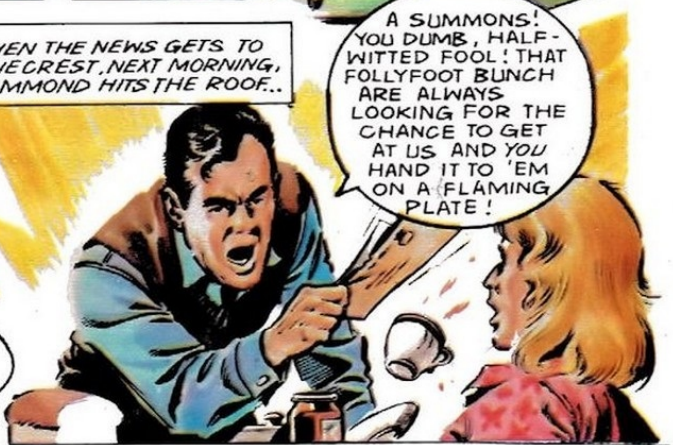

YOUR VIEW

Tom Owen, who plays Dick in Thames Television's 'Tottering Towers', selects these entries from the LOOK-IN Postbag, including the £2 Star Letter...



STAR LETTER

My friend has two dogs called Dusty and Mush. Dusty is Mush's mother. About two o'clock one morning Mush gave birth to some puppies and one of them crawled away and got its head stuck in a radiator, which fortunately was switched off. Dusty saw the pup and started to bark like mad. My friend Lynne came downstairs to see what all the fuss was about. She thought that Dusty wanted to draw attention to the new puppies and, after looking at them, turned to go back upstairs, without seeing the little one with its head in the radiator. Dusty started barking again. Lynne told her to be quiet and lie down but Dusty started crying and whining, and walked over to the radiator. Then Lynne saw the pup, picked it up and carried it back to its mother.

Susan Canning,
Tring, Herts.

★ What an intelligent and loving grandmother those little pups have got.



POP'S SONG

When my brother Keith was younger, daddy was doing some crazy-paving. He loves singing and he started to sing a song as he mixed the cement. Keith, who was watching him, was listening. In the song is a

line about 'I'm getting sentimental over you'. Keith then started crying and said: 'You're not getting cement all over me!'

Allison Reilly,
Bottisham, Cambs.

COVER-LOVER

I get LOOK-IN every week and I like the paintings on the cover. Please could you tell me who paints them, because I think they're super?

Richard Sherman,
Norwich, Norfolk.

★ The artist this week is Arnaldo Putzu, but if you want to check every week, we mention the name of the artist on page 2. Glad you like the covers. If any readers have comments or suggestions to make about LOOK-IN, please write and let us know.

GIRLS AND FOOTBALL

I am a keen football fan and go to many matches which I enjoy very much. I don't know why everyone thinks it's only for boys—I'm sure girls would do just as well if they got the chance. Most boys say it's too rough for girls but I think it is a game of skill, not rough tactics. Come on, girls—have a go!

Jayne Humphries, Worcs.

★ I agree, Jayne. Sock it to 'em!

★★★★★★★★★★★★

Please, please could you print a picture of Chelsea's Peter Osgood? Although I am a girl, I'm mad about football. Can we have more information about football in LOOK-IN?

Kristina Ashby, Kent.

★ Turn to page 21 for part 2 of 'ABC of Football'—and watch out for next week's issue!



TURNING SCARLET

When we were on our holidays in Spain in the summer, my brother and I were playing Captain Scarlet on our bed. I was Captain Scarlet and he was a Mysteron. When I knocked him off the bed (which was supposed to be a boat), he said that he'd been swallowed by a shark and was living inside it. Then he said it was all right, he'd lit a match and the shark had coughed him out.

Colin Davies,
Glamorgan, S. Wales.

★ Sounds like a modern story of 'Jonah and the Whale'!

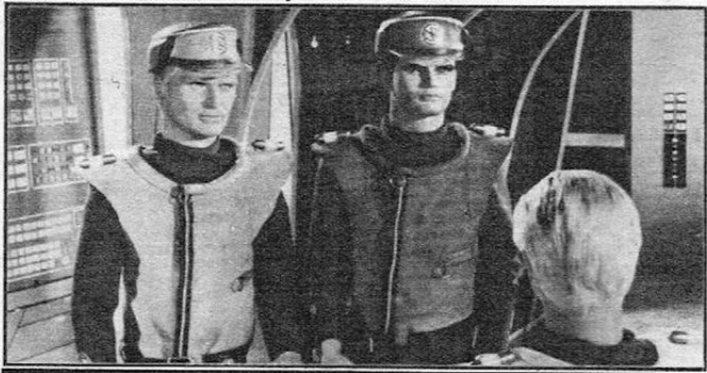

Win £2 for the Star Letter and £1 for any other letter or joke! Plus a special signed photograph of the Your View star will be posted to the sender of every item published! Why not write now to Your View, 247 Tottenham Court Road, London W1P 0AU? Remember when you write to enclose a list of your six favourite features, in order of preference.

The gang make their stage debut!

The Fenn Street Gang

WHEN FRANKIE ABBOTT SAYS HE'S GOING TO JOIN THE LOCAL THEATRE, HIS FRIENDS IN FENN STREET CAN ONLY GASP. THEN, AMAZINGLY, THEY SEE HIS NAME ON THE ROYAL THEATRE! THEY ALL PILE DOWN FOR THE OPENING NIGHT - BUT THERE ARE STICKERS OVER ABBOTT'S NAME, AND THE MANAGER TELLS THEM HE'S LEFT FOR A SUDDEN WEST END ENGAGEMENT...

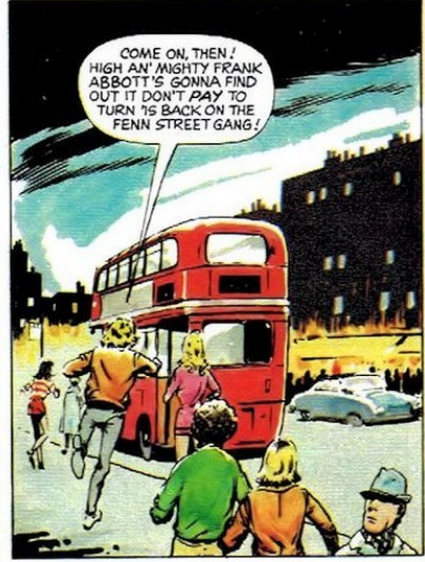

Based on the London Weekend Television series created and written by John Esmonde and Bob Larbey © 1972 Esmonde Larbey Ltd.

Next week: Mistaken Identity! 17

A strange new adventure begins today!

TIMESLIP

LIZ SKINNER AND SIMON RANDALL HAVE THE INCREDIBLE ABILITY TO PASS THROUGH THE INVISIBLE BARRIER TO THE DIMENSION OF TIME. THEY ARE LAUGHING AND ARGUING AS THEY EMERGE FROM A CINEMA...

THE MENACE OF THE GREEN PLANET



OF ALL THE OLD NONSENSE! I THOUGHT IT WAS VERY FUNNY!

TRUST YOU! I THOUGHT IT WAS EXCITING - AND CREEPY. I HEARD YOU GASP MORE THAN ONCE.



A PLANET ON WHICH INANIMATE OBJECTS CAME TO LIFE! I DIDN'T GASP, I WAS YAWNING!

DON'T START GETTING HEROIC, I KNOW YOU, SIMON RANDALL!

INCREDIBLY, NEXT MOMENT, EVERYTHING IS WHIRLING ABOUT THEM...



L...LIZ! WH...WHAT HAPPENED? WE ARE PASSING THROUGH THE TIME-BARRIER.

I... I THINK WE'RE GOING THROUGH SPACE AS WELL!

THE NEXT THING THEY KNOW...

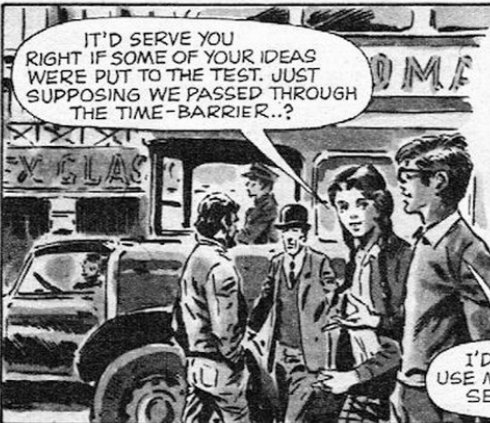

IT'D SERVE YOU RIGHT IF SOME OF YOUR IDEAS WERE PUT TO THE TEST. JUST SUPPOSING WE PASSED THROUGH THE TIME-BARRIER...?

I'D JUST USE MY COMMON-SENSE!

WHERE ARE WE? IT STILL LOOKS LIKE EARTH?

THE STREET SEEMS DESERTED! EVERYTHING'S IN RUINS!



LOOK - TROPICAL VEGETATION! YET I COULD SWEAR THIS IS BRITAIN.

THERE ARE MONKEYS AND PARROTS! IT'S IMPOSSIBLE... AT LEAST, IT SHOULD BE!

UNEASILY, PULSES TINGLING, THEY WALK ON. THEN...



IT'S LIKE THE THAMES EMBANKMENT IN LONDON! THE TIME MUST STILL BE THE TWENTIETH CENTURY!

UGH, SIMON - THAT SNAKE! LOOK OUT!

© 1972 ATV Network Ltd. Based on the ATV programme.



SIMON SPEAKS NERVOUSLY...

WARILY, THEY MOVE ON...



TOGETHER THEY BREAK INTO A RUN...



THE GROUND IS VIBRATING BEHIND THEM...



SUDDENLY, THE HUGE PURSUER STOPS DEAD...



A DOORWAY HAS OPENED...

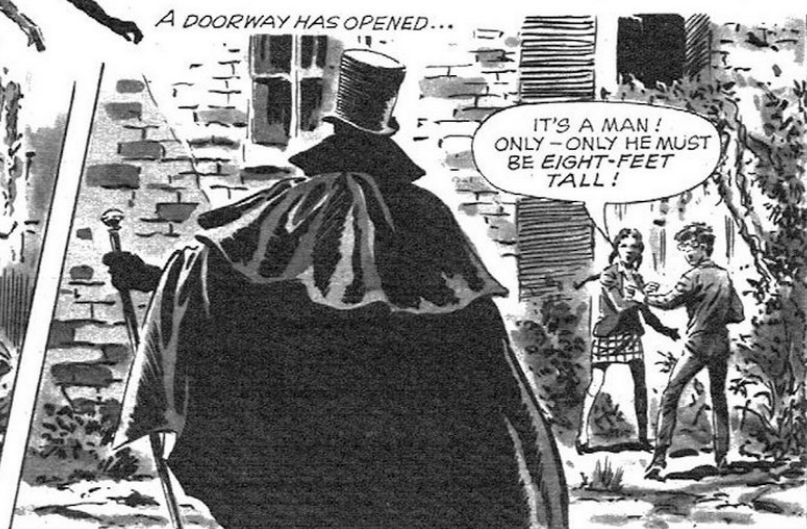

MAGPIE



SPACE SPOT

Magpie's Peter Fairley now comes to LOOK-IN with more details on what's happening in the space race.

American scientists are now preparing to launch the first spacecraft to Jupiter. It should blast off later this month.

The 550-pound robot — called 'Pioneer F'—will take nearly two years to reach the planet, which is the largest in our Solar System (more than 300 times bigger than the Earth).

To get to Jupiter, the little, insect-like craft will have to travel through the Asteroid Belt—a trail of broken-up rocks which circle around the Solar System between 180,000,000 and 350,000,000 miles out. Scientists calculate that there could be as many as 50,000 asteroids ranging in size from one mile to 480 miles across. They are believed to be the debris from a planet which broke up.

To reach Jupiter, 'Pioneer F' has to journey about 500 million miles. So the Atlas-Centaur rocket that will launch it from Cape Kennedy has been

fitted with an extra, third stage. This rocket motor will boost it away from Earth at 32,400 m.p.h.

On reaching Jupiter, 'Pioneer F' will swing around behind the planet, coming to within 100,000 miles of its surface. It will take pictures—pictures that should be far better than any taken through telescopes from Earth—and also perform 12 other experiments, including several to find out what sort of an atmosphere the planet has.

Jupiter is always hidden by a dense layer of clouds which form pale, grey-blue and salmon pink bands around the planet. Scientists are not yet sure whether it is solid—like the Earth—liquid or just a mass of gas. 'Pioneer F' should find out, as it goes past.

After passing by Jupiter, the spacecraft will streak on out into space to become the first object to leave our Solar System.

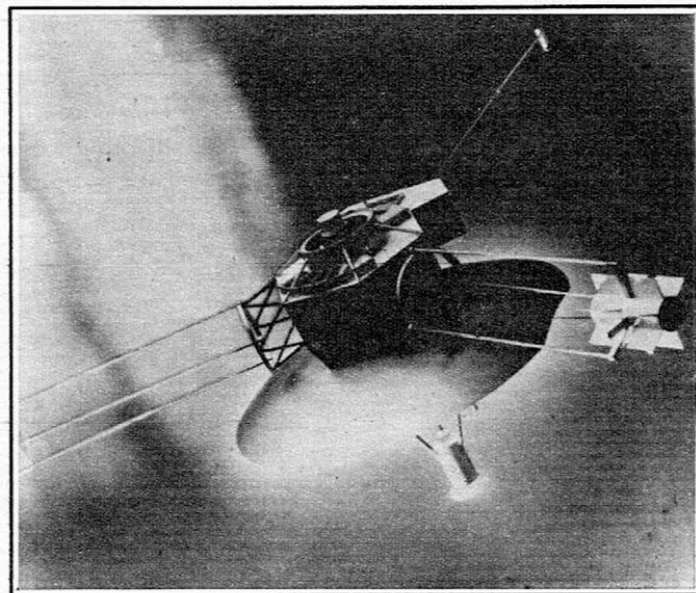

An artist's impression of 'Pioneer F' passing Jupiter.



—Here are two more letters from the Magpie Mailbag. If you've written in to the programme, remember to keep your eyes open. Your letter may well appear in this column in the near future.

Bad Budgie

Dear Magpie,
I would like to tell you about my daft budgie whose name is 'Jackie'. I call her daft because when she sits on my finger, she tries to rest her head against my face and fall asleep. She loves lettuce, apples and oranges, but her

favourite is fizzy pop. Whenever I am drinking pop, she flies towards me, settles on my finger and drinks the liquid from my glass when I tip it up towards my own mouth.

Diane Graves, Middlesex.

Puppy Predator

Dear Magpie,
This letter is about our dog, 'Smokey'. He has a beautiful black coat but his paws are white and there is a little white triangle on his chest. One day, when my mum tried to put him inside the house, he didn't want to go. Then she noticed something. Beside his dinner plate was a dead rat. We all thought 'Smokey' was very clever to kill a rat because he is only three months old.

Geraldine McGuirk, Eire.

Magpie Music Makers

Once again, music expert Will Yeomans talks about another instrument and its history. This week, he looks at the violin.



The ancestor of the violin family was known in Norman times as the Lyra. It sometimes had three strings which were tightened by pegs on the underneath side of the instrument. This drawing taken from a medieval carving shows the Devil tightening the bow-hair with right-hand forefinger.



Continuing LOOK-IN's alphabet of soccer, based on the programme, this week we look at: **B for Ball**

The Chinese were pushing a leather ball about their lawns as long ago as two hundred years B.C. But there is a tradition that the first football ever used in Britain was the head of a Danish brigand. Certainly, the football was established here during the Roman occupation, and there are records of annual festival matches between the shoemakers and drapers of Chester, who fell upon an inflated pig's bladder encased in leather, which they then violently kicked to each other in the name of sport. Nowadays, footballs are tubeless.



© 1972 Thames Television Ltd. 'Magpie' is published by arrangement with Thames Television Ltd.

TELL ME...

Jack Wild appeared on Magpie's 'Tell me' spot to answer viewers' questions. Here are some of those which there was not time for him to answer 'on air'.

What was it like in America when you were doing your TV shows?

I've been to the States quite a number of times and travelled to most of the major cities. I was mainly doing record promotion and appearing on talk and variety shows. It was very interesting going to places like New York, Houston and Philadelphia; oddly enough, I really felt as though I was in England most of the time, except that the pace of life was much faster.

Which comedians and singers do you admire most?

I think Peter Sellers is hilarious. Then I also admire Marty Feldman, Terry Scott and Elton John. But it's best, if possible, not to base your style on people you admire—and to be original.

Was it very difficult for you when your voice broke?

Well, it wasn't really, at all, because whereas most people's voices break over a fairly short period, mine broke very gradually. So I hardly noticed it happening. And, anyway, my voice has always been a bit husky, so it didn't make that much difference. After playing in Oliver on the stage my voice wasn't normal for about two years and even now after a recording session, I can't speak!

What is your next film?

The Pied Piper of Hamelin, which is opening in London at Easter. Donovan plays the piper and I am the crippled boy. It was fun making the film—we went to a little village in Germany which looks the same now as it did in the fifteenth century, and all the rats had to be imported from England.

WE'RE JUST WILD ABOUT...

ONCE UPON A TIME (seven years ago, actually) Jack Wild lay in a heap at the side of the road trying to catch his breath. He had been playing football with his friends and was exhausted. There happened to be passing by a theatrical agent who was on the look-out for chorus boys to appear in the stage version of 'Oliver'. When she asked the boy if he would like a job, he said: "No, thanks. I've got one helping the milkman."

Nevertheless, Jack was persuaded to leave his yoghurts. He stepped into a fairy tale of fame and fortune that became a reality, and made Jack Wild one of the most popular young entertainers of the 70s.

Jack was born in Royton near Manchester, but moved to Hounslow with his family when he was eight. His school friends teased him about his strange Northern accent, so Jack gradually changed his speech into a cross breed of Mancunian and Cockney.

After the stage production of 'Oliver' came the film version where he met and made friends with Mark Lester. They appeared together in a later film 'S.W.A.L.K.'. Jack had his own television show (Junior Show-

time) and later the fantastically popular 'H. R. Pufnstuf'. He's made tours of America and done guest appearances on numerous shows both here and across the Atlantic. He's also made seven records (including the sound track of 'Oliver'). All in all, it's a far cry from his work on the milkround!

★ Watch out for a colour pin-up of Jack Wild in next week's LOOK-IN.

WILD FACTS

Born . . . 30th Sept., 1952

Height . . . 5ft. 4in.

Colour of hair . . . Brown

Colour of eyes . . . Brown

Hobbies . . . Football, motor-racing and tropical fish

Likes . . . People with a good sense of humour

Dislikes . . . Two-faced people and cricket

Favourite food . . . Fillet steak

Girls . . . 'Mod' in dress, with long hair



Jack Wild in 'S.W.A.L.K.'—the



Another shot from 'S.W.A.L.K.'. This time the friends are sabotaging someone's lunch.



story of three kids from the tough London area of Lambeth



Here's Jack again—sharing a bite with Mark Lester.

Mine in a Million

TAKING A TRIP TO ALL SORTS OF FASCINATING PLACES is just part of the job as far as *Magpie* is concerned. Whether it is Switzerland or Somerset, doesn't really matter—provided the researchers come up, with something new to present to the viewers.

A few weeks ago, if you remember, it was Switzerland and *LOOK-IN's* Editor, Alan Fennell, went along to tell you about the Lost Valley. This time, we turn with Tony Bastable to Somerset—and for him, his second journey to the famous city of Bath.

Many of you may recall that last time he went there, he actually took a bath—Georgian style—in the naturally warm waters of their spa.

On his latest trip, he 'went under' again—one-hundred-foot down, to be precise. The reason? He was investigating a 'mine in a million'—Monks Park Mine—which is probably

the only one of its kind still working in England. It provides 'dressed' Bath Stone for buildings.

If you watch the programme next week, you'll find that Tony discovered many other intriguing facts about the mine.

Until the beginning of the last war, up to 1,000 men were employed in a complex of mines at Monks Park. Now, just one remains and there are only two teams of three men working it.

Up to 1952, horses were used to excavate the stone. They have now been replaced by machinery. When the stone is cut underground it is tested



Tony Bastable (right) chats with some workers—one-hundred-feet down at Monks Park Mine near Bath, Somerset.

for faults and squared off. It is finally sent to merchants and used mainly for facing buildings. The tragedy is that the mining of this stone is a dying trade. Though far less attractive, concrete, being cheaper and easier to use, is the modern replacement.

And what did Tony have to

say about it all? "I found it extremely cold and damp down there—but very interesting." To end on a note of humour, Tony said: "the Bath Stone was beautiful and it resembled huge blocks of Wensleydale cheese. You never know—perhaps they'll find the Moon is made of Bath Stone one day!"

Look-in



Much Magic
all to Readers!
Geoffrey Bayldon
— Catweazle —

GEOFFREY BAYLDON AS CATWEAZLE

Once again, Bunty James, Jack Hargreaves, Jon Miller and Fred Dinenage, are all set to answer your questions. Congratulations to this week's winners. If you haven't already written in why not do so now? For any question published, winners can choose from 20 Hamlyn books each to the value of £1. Send your entry to: How! LOOK-IN, 247, Tottenham Court Road, London, W1P 0AU.



HOW



HOW do roadway 'cat's eyes' work?

M. P. Harmon, Worcs.

They are simply small glass reflectors set in rubber. They do not light up themselves but catch the light of car headlights and reflect it back. Being set in the middle of the road, they are ideal safety devices to keep traffic on the correct side. They were given that name because cats' eyes, too, shine at night when a light is reflected on them.

HOW were mountains formed?

Ivan Brooks, Herts.

There are several ways, Ivan. First there are fold or folded mountains, like the Himalayas and Alps. They have been thrown up into huge 'folds' or ridges by movements of the Earth's crust. In the same category are block mountains, masses formed by land subsiding or by rocks breaking and tilting. Mountains are also formed by erosion, the tougher rocks being left while the softer rocks alongside are worn away, often by rivers.

The third category comprises those formed by volcanic explosions, with the lava and ash piling up round an opening in the Earth's crust. These can be very high: typical examples can be found in the mighty Rockies of North America and the Andes of South America.

HOW does a Venus Fly Trap eat flies and how does it give off an odour?

Sheryl Ellerington, Yorkshire.

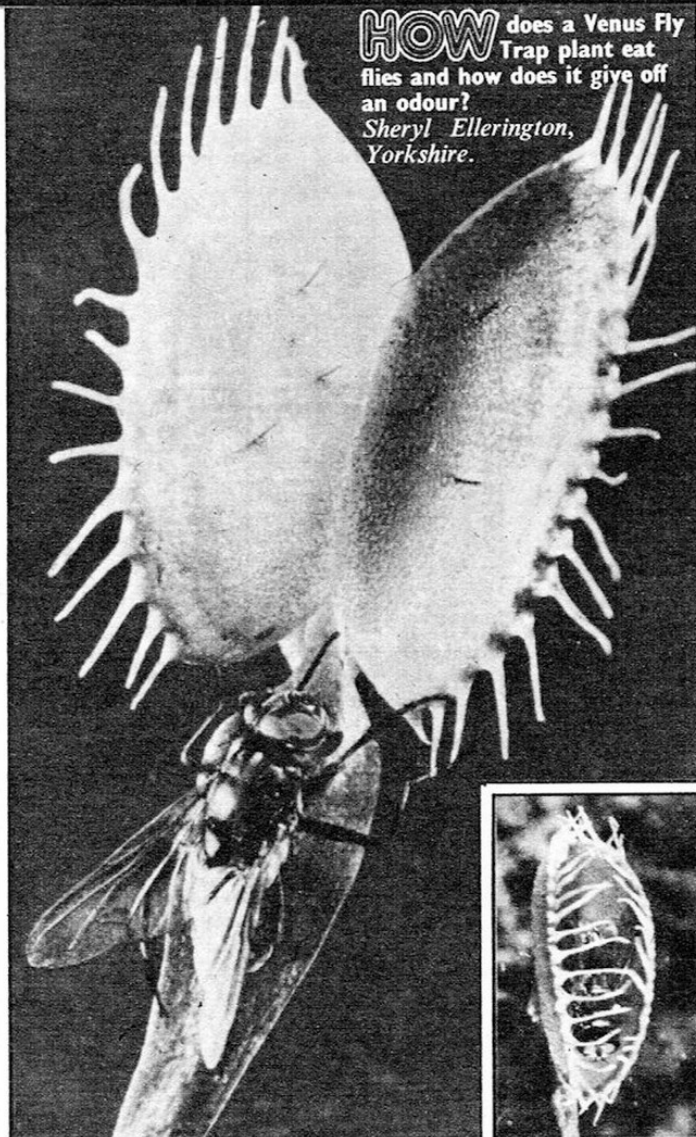

This amazing plant is a native of swampy parts of North and South Carolina and Florida in the United States. Each of its leaves has two halves which are hinged together and have bristles on their edges. On the inner surfaces of the leaves are very sensitive hairs which, even if they are touched lightly, make the two halves of the leaf snap firmly together. The victim is usually a fly. It takes about ten days as a rule for the plant to digest the fly which it does by special digestive juices. The Venus Fly Trap gives off no special smell. Insect-eating plants usually grow on boggy soil which does not give them all the nourishment they need, especially nitrogen. This is why they make up for the lack in such an extraordinary way.

Left and below: A sequence of photographs showing the Venus Fly Trap in action. The spikes stop an insect from escaping.

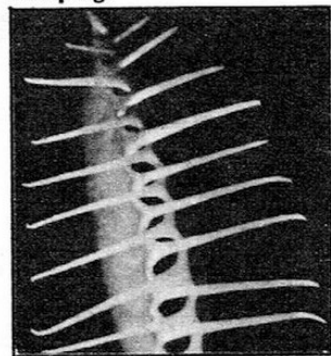

RUBBISH WORKSHOP

This week completes the four-part series on how to make the Rubbish Workshop Tug Boat. The last stage concerns you with the details to add the finishing touch. Watch out for another model to make, starting next week!

STAGE 9. CABIN DECORATION. USING WHITE PAPER, COVER THE EXPOSED PART OF THE WHEEL-HOUSE. WINDOWS, DOORS, LIFE-BELTS ETC., CAN BE DRAWN BEFORE GLUING ON WHILE PAPER IS FLAT.

SUGGESTED DECORATION

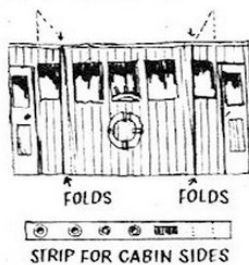

GLUE PAPER ON THE FRONT AND SIDES

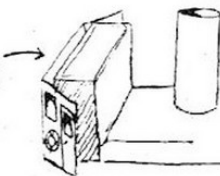

FLAP FOR GLUING

2 VENTILATORS 1/2 INCH HIGH CUT OUT OF PAPER. GLUE IN POSITION NEXT TO THE DECK HATCH.

A COLLAR STUD MAKES A PERFECT SIREN TO SIT ATOP OF THE WHEEL-HOUSE.



Lookin' on your ITV programmes this week: Feb 5 - Feb 11

	Saturday	Sunday	Monday	Tuesday	Wednesday	Thursday	Friday
ANGLIA	11.50 Cowboy in Africa 12.50 World of Sport 5.10 Rovers 5.40 Flintstones 6.35 Film 8.00 Who Do You Do?	3.25 Ghost & Mrs Muir 3.55 Match of the Week 4.45 Golden Shot 5.35 The Intruder 7.25 Please Sir!	4.25 Romper Room 4.55 Flipper 5.20 Bright's Boffins 6.45 Opport. Knocks!	4.40 Enchanted House 4.55 Sooty 5.20 Magpie 7.00 Film	4.30 The Romper Room 4.55 Get This 5.20 Tightrope 7.00 This Is Your Life	4.40 Rupert Bear 4.55 Bush Boy 5.20 Magpie 7.00 Dick Van Dyke 7.30 Thursday Film	4.25 The Romper Room 4.50 Voyage To The Bottom Of The Sea 7.00 Sky's the Limit 7.30 The Persuaders! 8.30 Fenn St. Gang
MIDLANDS	12.15 Captain Scarlet 12.50 World of Sport 5.10 It Takes A Thief 6.05 Who Do You Do? 7.00 Film	2.15 Star Soccer 4.45 Golden Shot 5.35 The Intruder 7.25 Please Sir! 7.55 Film	4.10 Nanny And The Professor 4.40 Origami 4.55 Forest Rangers 5.20 Bright's Boffins 6.45 Opport. Knocks!	4.40 Once Upon A Time 4.55 Sooty 5.20 Magpie 7.00 Star Movie	4.40 Enchanted House 4.55 Skippy 5.20 Tightrope 8.00 Jason King	4.40 Rupert Bear 4.55 Get This 5.20 Magpie 7.00 Sky's The Limit 7.30 Thursday Movie	4.40 Hatty Town 4.55 Lost In Space 7.00 Fenn St. Gang 7.30 The Persuaders! 8.30 Jimmy Stewart
BORDER	12.50 World of Sport 5.10 Primus 5.35 Tommy Cooper 6.05 Who Do You Do? 6.40 Film 8.30 Saturday Variety	1.55 Football 2.55 Feature Film 4.45 Golden Shot 5.35 The Intruder 7.25 Please Sir! 7.55 Big Film	3.42 Junkin 4.10 Nanny And The Professor 4.40 Origami 4.55 H.R. Pufnstuf 5.20 Bright's Boffins	4.40 Once Upon A Time 4.55 Sooty 5.20 Magpie 7.00 Star Movie	4.40 Enchanted House 4.55 Get This 5.20 Tightrope 7.00 This Is Your Life 8.00 Cade's County	4.40 Rupert Bear 4.55 Woobinda 5.20 Magpie 7.40 Feature Film	4.40 Hatty Town 4.55 Bush Boy 5.20 Tom Grattan 7.00 Sky's The Limit 7.30 The Persuaders! 8.30 Fenn St. Gang
CHANNEL	12.50 World of Sport 5.10 U.F.O. 6.05 Who Do You Do? 7.00 Film	3.00 Feature Film 4.45 Golden Shot 5.35 The Intruder 7.25 Please Sir!	4.05 Once Upon A Time 4.50 Rovers 5.20 Bright's Boffins 6.45 Opport. Knocks!	4.10 Enchanted House 4.25 Simon Locke 4.55 Sooty 5.20 Magpie 7.00 Star Movie	4.05 Paulus 4.55 Get This 5.20 Tightrope 7.00 Treasure Hunt	4.05 Origami 4.20 Nanny and the Professor 4.50 Bushboy 5.20 Magpie 7.00 Thursday Film	4.05 Pinky & Perky 4.25 Dick Van Dyke 4.55 Flintstones 7.30 The Persuaders! 8.30 Fenn St. Gang
GRAMPIAN	11.50 The Bugaloos 12.50 World of Sport 5.10 Batman 5.40 Film 8.30 Saturday Variety	2.50 Sunday Matinee 4.45 Golden Shot 5.35 The Intruder 7.25 Sunday Film	3.40 Junkin 4.40 Rupert 4.55 Rovers 5.20 Bright's Boffins 6.35 Cartoon Time 6.45 Opport. Knocks!	3.40 Nanny and the Professor 4.40 Once Upon a Time 4.55 Sooty 5.20 Magpie 7.00 Film	3.40 Smith Family 4.40 Stories of Tuktuk 4.55 Get This 5.20 Tightrope 8.00 Department S	3.40 Dick Van Dyke 4.40 Origami 4.55 Adventures In Rainbow Country 5.20 Magpie 7.00 Thursday Film	3.40 Simon Locke 4.40 Pinky & Perky 4.55 Flintstones 5.20 Tom Grattan 7.00 Sky's the Limit 7.30 The Persuaders!
GRANADA	12.20 H.R. Pufnstuf 12.50 World of Sport 5.10 Primus 5.40 Fenn St. Gang 6.10 Men of Action	1.55 Football 2.50 Sylvester 4.40 Golden Shot 5.35 The Intruder 7.25 Please Sir! 7.55 Big Picture	4.35 Hatty Town 4.50 Spiderman 5.20 Bright's Boffins 6.40 Opport. Knocks!	4.40 Origami 4.55 Sooty Show 5.15 Magpie 7.00 Film	4.35 Rupert 4.55 Get This 5.15 Tightrope	4.35 Once Upon A Time 4.50 Arthur 5.15 Magpie 7.00 The Villains	4.35 The Magic Ball 4.50 Captain Scarlet 5.15 Rainbow Country 7.00 Sky's the Limit 7.30 The Persuaders!
WALES/WEST	11.25 H.R. Pufnstuf 11.50 Captain Scarlet 12.15 Seaspray 12.50 World of Sport 5.10 Randall and Hopkirk	2.15 Big Match 3.15 Sunday Matinee 4.45 Golden Shot 5.35 The Intruder 7.25 Please Sir!	4.15 Tinkertainment 4.30 Superman 4.50 Robin Hood 5.20 Bright's Boffins 6.45 Opport. Knocks!	4.15 Tinkertainment 4.55 Sooty 5.20 Magpie 6.35 Dr. At Large 7.05 Tuesday Western	4.15 Tinkertainment 4.55 Get This 5.20 Tightrope	4.15 Tinkertainment 4.55 Huckleberry Finn 5.20 Magpie 6.35 Sky's The Limit 7.00 Mid-Week Movie	4.15 Tinkertainment 4.55 Cowboy In Africa 6.35 Bonanza 7.30 The Persuaders! 8.30 Fenn St. Gang
LONDON	12.00 Grasshopper Is. 12.15 Joe 90 12.50 World of Sport 5.10 U.F.O. 6.05 Who Do You Do? 6.35 Feature Film	1.15 Stingray 2.15 Big Match 3.15 Feature Film 4.45 Golden Shot 5.35 The Intruder 7.25 Please Sir!	3.45 Dangerman 4.40 Rupert 4.50 Land of The Giants 6.40 Opport. Knocks!	4.10 Simon Locke 4.40 Once Upon A Time 4.55 Sooty 5.20 Magpie 7.05 Movie of the Week	4.40 Paulus 4.55 Get This 5.20 Tightrope	4.40 Origami 4.55 Atom Ant 5.20 Magpie 7.10 Thursday Film	4.40 Pinky & Perky 4.55 Arthur 5.20 Bright's Boffins 6.30 F Troop 7.00 Sky's The Limit 7.30 The Persuaders!
SCOTTISH	12.50 World of Sport 5.10 U.F.O. 6.05 Dr. At Large 6.35 Smith Family 7.00 Western	5.35 The Intruder 7.25 Please Sir!	3.30 Origami 3.45 Castle Haven 4.55 Batman 5.20 Bright's Boffins 6.15 Simon Locke 6.45 Opport. Knocks!	3.30 Foo Foo 4.55 Sooty 5.20 Magpie 6.20 Hogan's Heroes 6.50 Tuesday Feature	3.30 Winter of Enchantment 4.55 Get This 5.20 Tightrope 6.20 Popeye 8.00 Department S	3.30 Once Upon A Time 4.55 Fireball XLS 5.20 Magpie 6.15 Cartoon 7.00 Thursday Film	3.30 Kiri 4.55 Lost In Space 6.20 Mr. Magoo 6.30 Jimmy Stewart 7.30 The Persuaders! 8.30 Fenn St. Gang
SOUTHERN	11.45 Thunderbirds 12.50 World of Sport 5.10 Randall and Hopkirk 6.05 Who Do You Do? 7.00 Saturday Film	1.30 Stingray 2.00 Big Match 4.45 The Golden Shot 5.35 The Intruder 7.25 Please Sir! 7.55 Big Picture	4.30 Best of Lucy 4.55 Richard The Lionheart 5.20 Bright's Boffins 6.45 Opport. Knocks!	4.55 Sooty 5.20 Magpie 6.30 Fenn St. Gang 7.00 Tuesday Film	4.23 Teddy Bear 4.55 Get This 5.20 Tightrope 8.00 Jason King	4.23 Heckle and Jeckle 4.55 Superman 5.20 Magpie 6.45 Junkin 7.15 Thursday Film	4.55 Voyage To The Bottom of the Sea 7.00 Sky's the Limit 7.30 The Persuaders! 8.30 Dr. At Large

ANGLIA

MIDLANDS

BORDER

CHANNEL

GRAMPIAN

GRANADA

WALES/WEST

LONDON

SCOTTISH

SOUTHERN

4.40 Pinky and Perky
4.55 Flintstones
5.20 Tom Grattan
7.00 Sky's The Limit
7.30 The Persuaders!
8.30 Fenn St. Gang

4.40 Origami
4.55 Captain Scarlet
5.20 Magpie
7.00 Popeye
7.05 Thursday Film

4.40 Grasshopper Is.
4.55 Get This
5.20 Tightrope
8.00 Jason King

4.40 Enchanted House
4.55 Sooty
5.20 Magpie
6.30 Simon Locke
7.00 Tuesday Western

4.40 Once Upon A
Time
4.55 Rainbow Country
5.20 Bright's Boffins
6.45 Opport. Knocks!

4.40 Sunday Matinee
4.45 Golden Shot
5.35 The Intruder
7.25 The Big Film

11.50 The Bugaloos
12.15 World of Sport
5.10 Bonanza
6.00 Who Do You Do?
7.00 Action 90

4.30 Romper Room
4.55 Thunderbirds
7.00 Sky's the Limit
7.30 The Persuaders!
8.30 Fenn St. Gang

4.30 Romper Room
4.55 Forest Rangers
5.20 Magpie
7.00 Simon Locke
7.30 Film

4.30 Romper Room
4.55 Get This
5.20 Tightrope
7.00 This Is Your Life
8.00 Cade's County

4.30 Romper Room
4.55 Sooty
5.20 Magpie
7.00 Bonanza

4.30 Romper Room
4.55 Joe 90
5.20 Bright's Boffins
6.15 Best of Lucy
6.45 Opport. Knocks!

2.15 Big Match
4.15 Survival
4.45 Golden Shot
5.35 The Intruder
7.25 Please Sir!

12.30 Grasshopper
Island
12.50 World of Sport
5.10 Dick Van Dyke
6.05 Who Do You Do?
6.35 Saturday Western

3.55 Gus Honeybun
4.05 Pinky and Perky
4.22 Dick Van Dyke
4.55 Flintstones
5.20 Ask Westward
7.30 The Persuaders!

3.55 Gus Honeybun
4.05 Origami
4.20 Nanny and the
Professor
4.50 Bushboy
5.20 Magpie

3.55 Gus Honeybun
4.05 Paulus
4.55 Get This
5.20 Tightrope
7.00 Treasure Hunt

3.55 Gus Honeybun
4.10 Enchanted House
4.22 Simon Locke
4.55 Sooty
5.20 Magpie
7.00 Star Movie

3.55 Gus Honeybun
4.05 Once Upon A
Time
4.50 The Rovers
5.20 Bright's Boffins
6.45 Opport. Knocks!

2.00 Big Match
3.00 Feature Film
4.45 Golden Shot
5.35 The Intruder
7.25 Please Sir!

11.45 Rupert
12.50 World of Sport
5.10 U.F.O.
6.05 Who Do You Do?
7.00 Saturday Film

4.40 Pinky and Perky
4.55 Flintstones
5.20 Tom Grattan
7.00 Sky's The Limit
7.30 The Persuaders!
8.30 Fenn St. Gang

4.40 Origami
4.55 Lone Ranger
5.20 Magpie
6.30 The Smith Family
7.00 Thursday Film

4.40 Rupert Bear
4.55 Get This
5.20 Tightrope
8.00 Jason King

4.40 Enchanted House
4.55 Sooty
5.20 Magpie
6.30 Simon Locke
7.00 Western

4.15 Dick Van Dyke
4.40 Once Upon A
Time
4.55 H.R. Pufnstuf
5.20 Bright's Boffins
6.45 Opport. Knocks!

2.15 Soccer
3.10 Sunday Cinema
4.45 Golden Shot
5.35 The Intruder
7.25 Big Film

11.50 Phoenix Five
12.15 The Bugaloos
12.50 World of Sport
5.10 Randall and
Hopkirk
6.00 Who Do You Do?

Robert Harbin introduces ...

DO-IT-YOURSELF ORIGAMI



Dutch Bonnet

If you're interested in clothes from other lands, you'll like this week's model of a Dutch Bonnet. And congratulations to the designer, Martin Griffett—you'll be receiving your one pound prize shortly.

1. Crease a rectangle

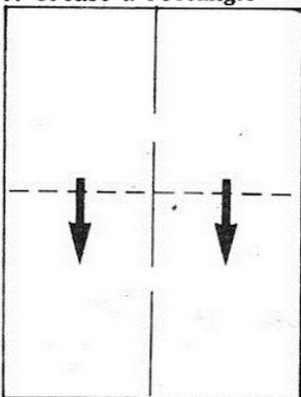

Fold in half

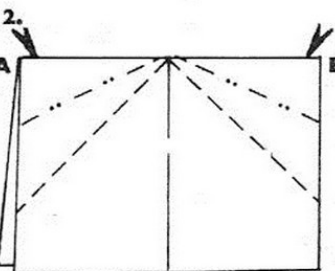

Fold A and B and squash

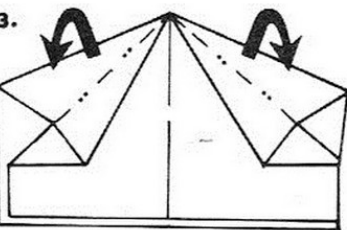

Fold flaps behind

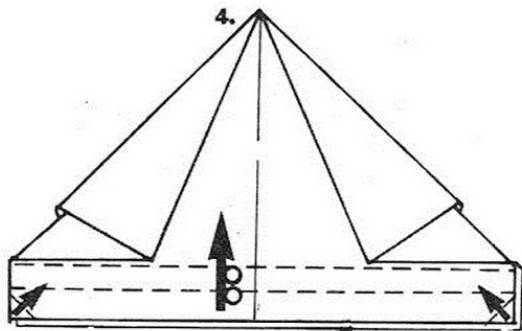

Fold little corners and then fold over and over. Repeat behind

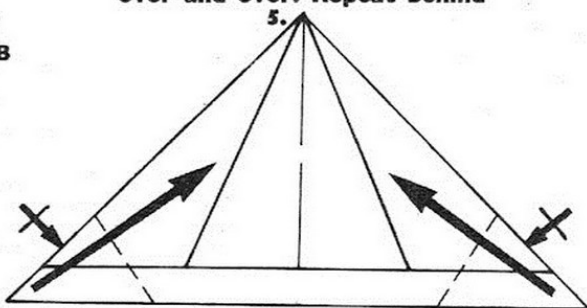

Fold points up front and behind

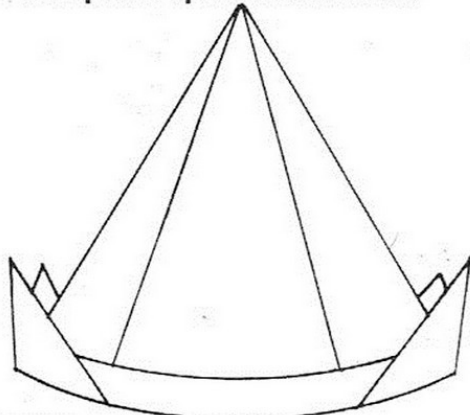

You can win £1 for your new model!

If you feel you can invent a new Origami model, write down the details (together with your own name and address) and post them to Do-It-Yourself Origami, LOOK-IN, Junior TVTimes, 247 Tottenham Court Road, London, W1P 0AU. I will send a £1 prize for each item I publish.

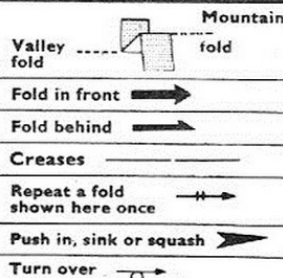

COMPLETE THE APOLLO BADGES SET! Exclusive Look-in offer!

THESE FIVE REPLICAS OF MOON MISSION BADGES YOURS FOR £3

During the past four weeks, LOOK-IN has exclusively offered replicas of the four Moon Landing badges. Now, to complete the set of Apollo Mission emblems these superb replicas, embroidered in many coloured silks, are offered at the inclusive price of £3.00



TO GET THESE WONDERFUL SOUVENIRS which can be sewn to blazers, anoraks or made into an attractive wall decoration, fill in the coupon printed below and send it, together with your cheque or postal order, to the address shown on the coupon. Allow 28 days for delivery. ★ If you missed the Moon Landing badges, illustrated on page 7, these are still available at the individual price of 65p each. Prices include postage and packing.

Please send me the badges I have indicated by placing the number required in the appropriate box below.

I enclose cheque/postal order to the value of £..... to cover the cost of badges.

Apollo 7 badge
 Apollo 8 badge
 Apollo 9 badge
 Apollo 10 badge
 Apollo 11 badge

Apollo 12 badge
 Apollo 13 badge
 Apollo 14 badge
 Apollo 15 badge

Send to: Apollo Badges, P.O. Box 51, Kettering, Northants.
 Individual badges are 65p each.

The set of badges Apollo 7, 8, 9, 10 and 13 inclusive cost £3.00.

Name _____
 Address _____

Allow 28 days for delivery.