

PHOTOTELEGRAPHY.

E. S. RITTER, M.I.E.E.

IN the October, 1928, number of this Journal a brief description was given of the "Belin," "Bell," and "Siemens-Karolus" systems. Since then a number of British newspapers have brought into use one or other of the three systems. The Siemens-Karolus system is in use in Japan by two newspaper companies, and the Australian Post Office has also a service between Melbourne and Sydney. The Belin system is in use between Peking and Mukden in China. In the United States, the Bell system has a service between New York, Boston, Atlanta, Cleveland, Chicago, St. Louis, San Francisco and Los Angeles. On the continent of Europe a public service is available between Berlin, Frankfort-on-Main, Copenhagen, Vienna and Stockholm, using the Siemens-Karolus apparatus. The rates, charged per 100 square centimetres, which is the minimum charge, are approximately as follows; the charge for larger sizes per square centimetre up to a maximum of 18 by 25 centimetres being one hundredth of the minimum charged for one hundred square centimetres. Triple rates are charged for urgent messages and a slight reduction for messages sent after 7 p.m.

The British newspapers using phototelegraphy transmit to and from London and their provincial offices, using "Four-Wire" telephone circuits rented from the Post Office as private wires, either for 24-hour service or in other cases for 12-hour service from 6 p.m. to 6 a.m. Where the paper has more than one provincial office it is usual to transmit simultaneously from London to the other offices. The newspapers also link up with associated offices on the Continent, using the same system over the public trunk lines; for example, those using the Belin system link up with Paris. Those using Siemens system connect with Milan, Hamburg, Paris, Berlin, Copenhagen, Frankfort, Stockholm (the last three stations being also open for public service), whilst in the case of Berlin there are two private installations, as well as that at the German Head Telegraph Office.

The Post Office has installed a Siemens-Karolus set in G.P.O. (West) for public service between London and Berlin. The service has since been extended to Frankfort and Copenhagen and may also be extended to Vienna and Stockholm should the demand arise. The apparatus is also used for a private service to a news agency in Paris fitted with similar apparatus. Since the opening of the service, the amount of traffic has been relatively small, but there are signs that it is on the increase. So far, it has been almost exclusively used for news pictures, but there are possibilities that it may

	Min. Size. 100 cm ²	Full Size. 450 cm ²
Berlin-Frankfort	4/-	18/-
Berlin-Copenhagen	10/-	45/-
Berlin-Stockholm	12/-	54/-
Berlin-Vienna	10/-	45/-
Frankfort-Copenhagen	12/-	54/-
Frankfort-Stockholm	14/-	63/-
Frankfort-Vienna	10/-	45/-

be used for sending written messages, code and cypher where accuracy is of importance, diagrams and plans, and also financial statements which are difficult to telegraph in the ordinary way. The charges to Berlin and Frankfort are for a minimum of 96 square centimetres £1, and for each square centimetre above, 2½d.; making a charge of £4 13s. 9d. for the maximum size of 18 by 25 centimetres contain-

the latter case being due to the small number of trunk lines available for the service.

A brief description of the apparatus installed may be of interest. The installation (see Fig. 1) consists of a sender, a receiver and a two-bay control rack supplied by Siemens and Halske; a Power Switchboard constructed by the Central Telegraph Office Engineering Section, London District, to plans prepared by the Engineer-in-



FIG. 1.—POWER SWITCHBOARD, SENDING MACHINE, CONTROL RACK, RECEIVING MACHINE.

ing an area of 450 square centimetres. To Copenhagen the charge is £1 4s. 0d. for 96 square centimetres and 3d. per square centimetre additional for larger sizes. The Berlin and Frankfort services are open from 7 a.m. to 11 p.m. weekdays and 3 p.m. to 11 p.m. Sundays, whilst that to Copenhagen is open 7 a.m. to 9 a.m. and 6 p.m. to 11 p.m. weekdays and 6 p.m. to 11 p.m. Sundays, the restricted hours in

Chief's Research Section, and also the necessary batteries of secondary cells (see Fig. 2) laid out and installed in a like manner in an adjacent room. The switchboard provides charging facilities for anode batteries of 220-240 volts, filament or heating batteries of 12-14 volts, and photo-cell and grid bias batteries of various voltages contained in a lead-lined earth screened cupboard. The 12-volt filament battery is



FIG. 2.—FILAMENT AND ANODE BATTERIES.

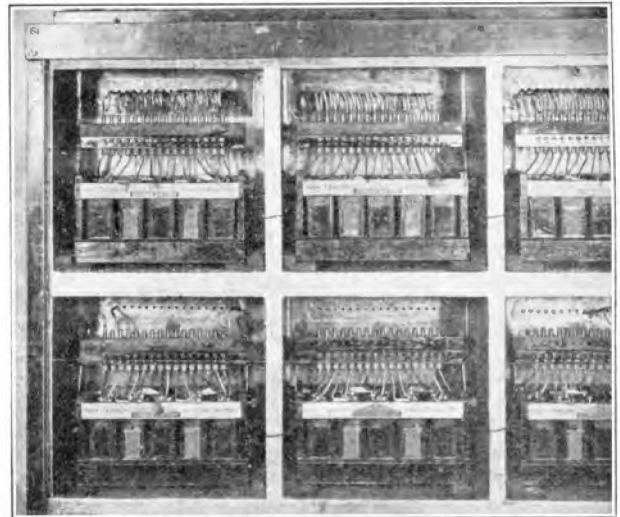

FIG. 3.—PHOTO-CELL AND GRID BIAS BATTERIES.

charged from a motor-generator, and is in duplicate, one battery being charged when the other is in use. There is an end cell switch fitted on each battery. The 220-volt anode battery is also in duplicate, and each battery is split into two halves to enable the charging to be done direct off the 220-volt D.C. mains. The mains also supply current for the tuning fork

thermostat and heater, as well as the driving motors of the picture sender and receiver. The photo-cell batteries (see Fig. 3) are in 30-volt units tapped at every cell; each unit of 30-volts is interchangeable with every other unit and is taken out for charging purposes. In order to avoid a multiplicity of loose wires, an ebonite

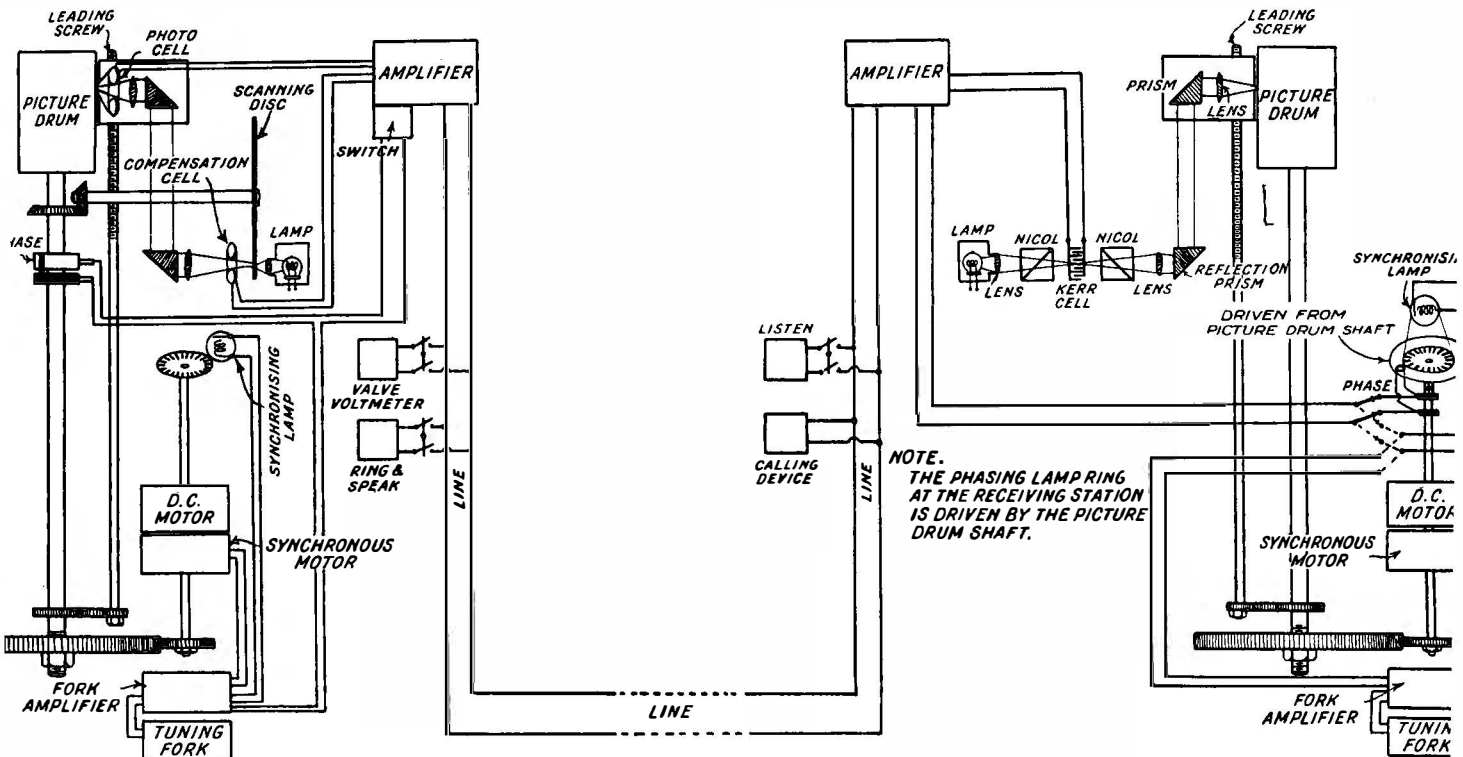

FIG. 4.—SCHEMATIC DIAGRAM.

strip on top of each unit has been fitted with 16 brass connecting sockets with brass locking screws, each connecting socket going to the junction of two cells by a soldered connection. Pins mounted on another ebonite strip fit into the sockets; the pins are soldered to the wires going to the switchboard. To replace a unit it is only necessary to loosen the screws, withdraw the top strip with the pins, take out the accumulator unit, replace with another unit, press in the top strip and tighten the screws. The ebonite strips have been accurately drilled and all are interchangeable; all exposed parts are carefully covered with vaseline. With the exception of the photo-cell battery, all the cells are topped with a mineral oil which prevents acid spraying during charging.

THE PICTURE APPARATUS.

A tuning fork of 1020 cycles per second, kept at a constant temperature by an electric heater controlled by a thermostat, is driven by a valve and its tone amplified and supplied to the stator of an inductor alternator, of which there is one in the sender and one in the receiver; in addition, fork tone is supplied to light a "neon" lamp above a stroboscopic disc in both sender and receiver. A D.C. motor drives the sender and is kept in synchronism by the alternator on the same shaft. The picture drum is driven by a gear from the motor shaft. Light from a gas-filled lamp similar to that used for automobile headlights is interrupted by a revolving disc with holes or teeth on its periphery and a light spot is focussed on the rotating picture drum, whence it is reflected back into a photo-cell, Fig. 5. As the drum rotates, the light spot and photo-cell are moved either up or down parallel to the axis of the picture drum by a lead screw at the rate of a fifth of a millimetre per revolution. By means of a gear-changing lever, this traverse may be changed to either a quarter of a millimetre or a third of a millimetre per revolution of the picture drum. The photo-cell originates an electric current proportional to the light falling on it; this current when amplified is sent over the telephone line. The light being interrupted, the current is an alternating one, having a frequency corresponding to the light interruptions and an amplitude proportional to the light and shade of the picture.

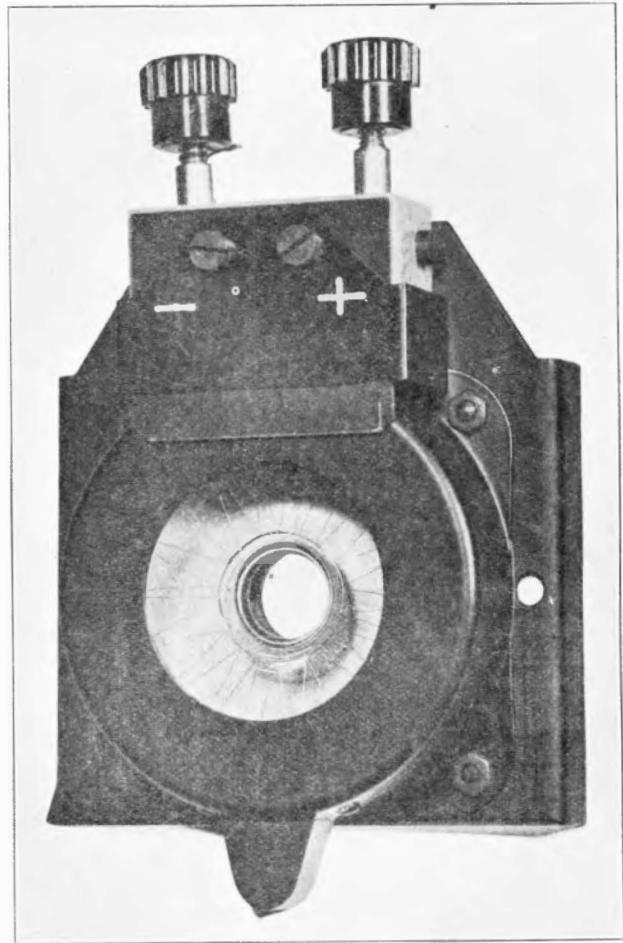

FIG. 5.—PHOTO CELL.

To compensate for the characteristics of the receiving equipment, it is desirable when sending a tone picture such as a photograph, to send, say, one volt to line for white and about one fourth of a volt for black, instead of one volt for white and nothing for black as would be the case if the arrangement was exactly as described above. In order to do this, a second photo-cell is placed in the path of a portion of the interrupted light beam so that it receives a constant amount of interrupted light. The amount of this light is so adjusted that the "compensation" photo-cell produces a quarter of a volt of amplified current. The two photo-cells act on the same amplifier in such a way that their outputs add and this accomplishes the desired result. In addition, a further facility is provided, should a positive picture be required at the receiving end instead of a negative, by arranging the com-

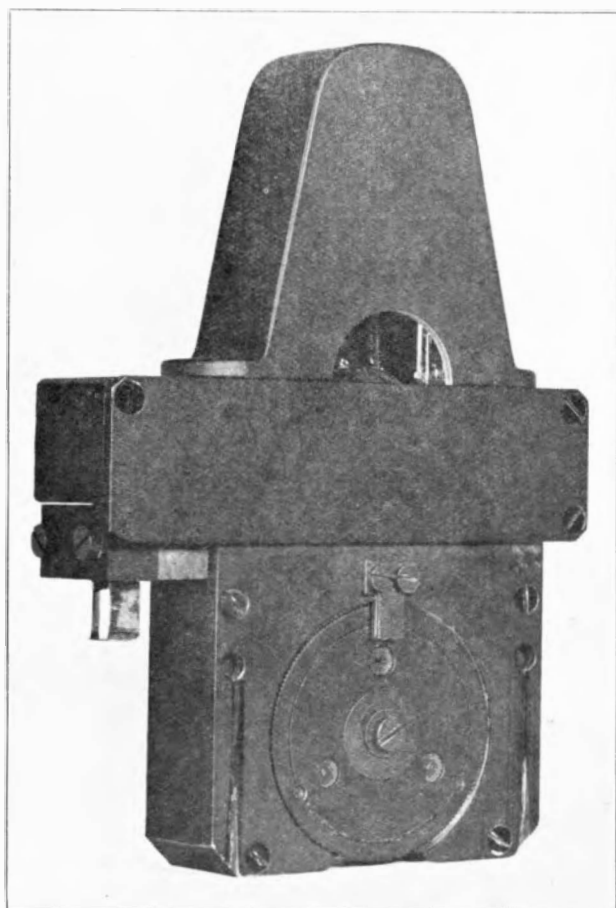

FIG. 6.—KERR CELL. BACK VIEW SHOWING APERTURE.

pensation cell to give an output of one volt of amplified current and connecting the picture cell so that its output subtracts from the output of the compensation cell the required result is obtained, namely, one volt for "black" on the picture and a quarter of a volt for "white."

The interruptor or carrier frequency is about 1100 cycles per second, but by changing the discs and using others with different numbers of holes other frequencies may be produced.

At the receiving end a drum driven in the same manner as the picture drum at the sending end has a photographic film clipped to its circumference. A light spot is focussed on the film and traverses it at the rate of a fifth of a millimetre per revolution (or a quarter or a third of a millimetre by gear change to correspond with the sender if required). The light spot, produced by a similar lamp to that at the sending end, is controlled in intensity electrically by the

amplified current received from the line. The light from the lamp is passed through an optical system, which includes a nicol prism to polarise the light, then between the plates of a "Kerr" or "Karolus" cell (see Fig. 6), which is a small electrical condenser immersed in nitrobenzol and sealed in a glass vessel, then through a second nicol prism and thence to the film in the form of a light spot. The amplified carrier current from the line is applied to the terminals of the condenser as an alternating current at a pressure of a maximum (for white sent) of about 700 volts.

The nicols are adjusted so that no light is passed with no voltage on the Kerr Cell; with a small increase of voltage very little light passes; for a further increase in voltage the light passed is proportional to the increase in voltage. Thus, when white or the maximum current is being sent, the maximum light falls on the film which, when developed, shows a black mark, producing a white mark on the printing paper. When black or minimum current is being sent, the compensation cell at the sending end is so adjusted that the voltage received is sufficient to operate on the Kerr Cell at the point where the light response is beginning to be proportional to the voltage received, and so one condition for correct tone reproduction is achieved. When no tone reproduction is desired, such as with diagrams or print, no compensation is sent, thus resulting in a sharper reproduction.

ADJUSTMENT OF SYNCHRONISATION AND PHASE.

In order to get the two machines to run at exactly the same speed, fork tone is sent over the line from the sender to the receiver. At the receiving end, it is connected to light the stroboscope lamp in place of the home fork tone, and the stroboscope is observed to see if the home fork is gaining or losing in comparison with that at the sending end. The home fork is adjusted by increasing or reducing the condenser reaction on the driving valve. Increasing the reaction has the effect of increasing the amplitude of the fork and slightly slowing it down, whilst decreasing the reaction has the reverse effect. The accuracy obtained is as follows: a gain of one sector in 50 seconds corresponds to a gain of one cycle in 100 seconds, a sector corresponding to half a cycle, or one hundredth of a cycle per

SPECIMENS OF PICTURES RECEIVED.

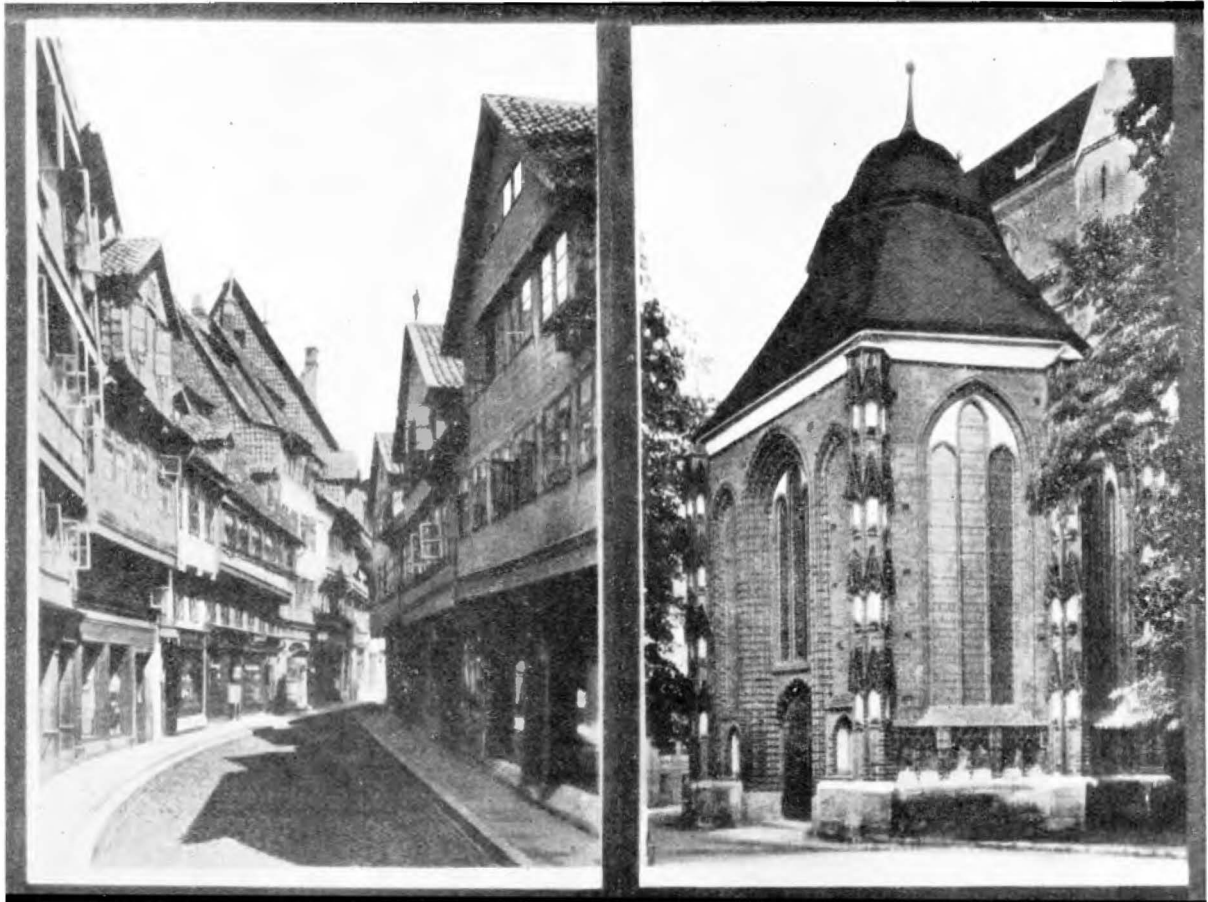

RECEIVED FROM BERLIN.

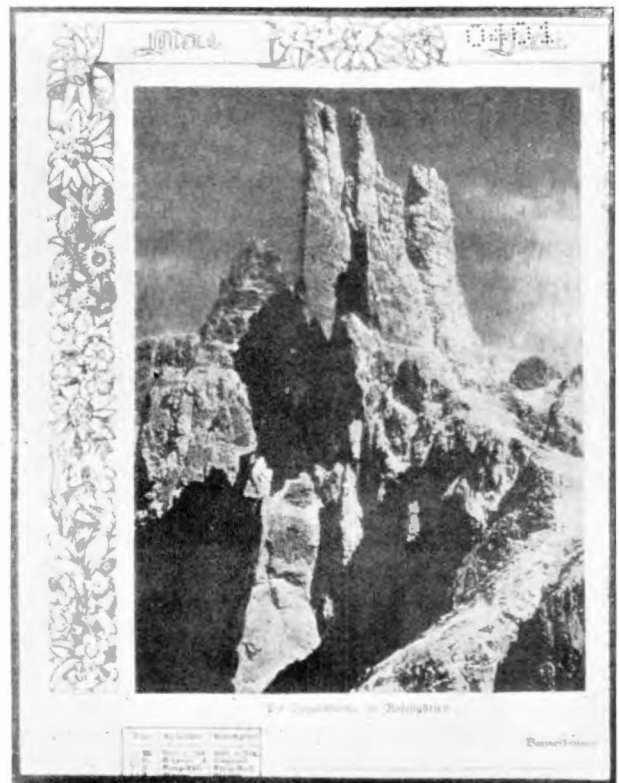

RECEIVED FROM VIENNA.



RECEIVED FROM COPENHAGEN.

second. Calling the fork frequency 1000 cycles per second (actually it is 1020 cycles) this corresponds to an accuracy of one cycle in 100,000 cycles; in practice an accuracy of one in 250,000 is worked to. Looked at another way, the length of the spiral scan of the picture is 813 feet approximately; at the receiving end a gain or loss of 0.04 of an inch is allowable.

In order to phase or set the sending and receiving drums in the correct relative position, a signal consisting of fork tone is sent over the line by a commutator once per revolution of the sending drum; at the receiving end this tone is used to light a neon lamp rotating at the same speed as the film drum. The receiving machine is adjusted so that this lamp lights opposite a given mark, indicating that the two drums are in the same relative position, taking into account automatically the propagation time of the line, which may amount to an appreciable portion of the drum circumference.

On the panels are mounted control voltmeters, etc., a telephone for speaking and a 500-cycle modulated by 20-cycle tone ringer and ringer receiver; space is left for fitting a second ringing receiver so that two lines may be operated simultaneously. The keys are interlocked to minimise as far as possible operating errors. Various fuses are provided in the circuits, as well as visible and audible alarm circuits. The machines can be set so as to run a full picture or a part as required. When the picture is finished an alarm lamp lights on the machine as an indication to the operator.

The setting up of the line sending fork tone, phasing and white should take not more than five minutes; running a full picture with a five line screen about 20 minutes, but if four line screen be used this could be done in 16 minutes. At the termination of the last picture, about four minutes is required so that the distant station may develop it far enough to see that it is O.K.

When a series of pictures have to be sent, the setting-up time between pictures need not exceed one or two minutes. The times given above are for expert operators at both ends; with inefficient

operators at one or both ends these times will be largely exceeded. Under normal operation a picture handed in at Berlin should be delivered to the addressee in London within two hours.

**TELEGRAPH AND TELEPHONE PLANT IN THE UNITED KINGDOM.
TELEPHONES AND WIRE MILEAGES, THE PROPERTY OF AND MAINTAINED BY
THE POST OFFICE IN EACH ENGINEERING DISTRICT AS AT 31ST DEC., 1929.**

No. of Telephones owned and maintained by the Post Office.	Overhead Wire Mileages.				Engineering District.	Underground Wire Mileages.			
	Telegraph.	Trunk.	Exchange.	Spare.		Telegraph.	Trunk.	Exchange.	Spare.
660,770	529	3,965	53,231	120	London	24,908	95,086	2,512,268	99,513
86,888	2,190	21,264	69,001	2,414	S. East	4,004	58,149	241,959	38,902
90,327	4,456	31,850	93,462	3,641	S. West	21,685	14,847	174,148	65,770
72,346	6,282	39,012	65,968	6,492	Eastern	24,446	40,321	153,059	64,310
104,801	8,450	45,205	62,947	4,666	N. Mid.	33,109	59,079	261,541	107,662
89,071	4,922	31,002	77,562	4,165	S. Mid.	12,219	29,305	210,126	83,273
61,624	4,744	50,018	56,601	3,422	S. Wales	6,682	28,942	137,586	70,157
113,869	7,978	26,575	53,789	4,507	N. Wales	13,794	42,939	304,708	61,078
168,553	1,469	15,695	44,903	3,269	S. Lancs.	14,645	83,273	533,280	51,027
98,809	6,212	30,302	48,741	3,528	N. East	13,342	46,929	264,208	74,036
68,289	3,891	23,961	40,132	2,775	N. West	8,477	36,323	177,119	29,465
50,922	2,556	16,049	26,739	2,862	Northern	7,326	20,073	142,429	40,615
23,034	4,493	8,904	13,652	584	Ireland N.	136	2,920	51,163	2,642
93,714	5,396	27,096	40,411	1,226	Scot. East	6,167	15,388	163,093	42,793
71,006	7,211	24,568	44,890	1,685	Scot. West	11,864	26,774	232,181	34,844
1,854,083	70,779	375,457	762,329	44,696	Total	202,804	606,348	5,558,868	866,093
1,822,328	71,058	374,341	748,532	41,975	Figures as at 30 Sept., 1929	202,006	588,075	5,441,522	873,241



AUTOMATIC EXCHANGES.

NEW STANDARD APPARATUS RACKS AND SHELF MOUNTING.

G. BROWN, A.M.I.E.E.

THE introduction of the Department's standard rack scheme will be responsible for some important changes in the disposition and appearance of Automatic Exchange equipment. The familiar Line Switch Unit with Preselectors on one side and Final Selectors on the other and the Selector Board, consisting of two 9' 3½" racks back to back with a terminal assembly closing one end, will no longer be called for in new exchanges.

Arrangements are being made to adopt as standard, channel-shaped shelves of pressed steel for mounting apparatus and a racking scheme which will give greater flexibility of layout and better floor load distribution, at the same time making the fullest possible use of available building accommodation.

The adoption of a standard type shelf is important and has far-reaching effects. A feature of the shelf is that each complete selector or relay set is assembled as a separate unit on its own base; connection is made to the cabling through jack points on the shelf. The jack points will be rigidly standard and will result in various Contractors' apparatus being interchangeable as far as unit selectors and relay sets are concerned. Therefore, all apparatus will be on the units and detachable from the shelves. Only jacks and wiring will be permanently attached to the shelf.

Construction and Dimensions.—The design of the new standard has followed the lines of

what is generally referred to as the "single-sided" rack scheme, similar to the racking arrangements which have been used for many years in P.O. Exchanges of Messrs. Siemens No. 16 type. The apparatus will be mounted on one side only, with wiring accessible from the rear.

British Standard Mild Steel Angle Sections will be used in the construction of the racks, the dimensions and details of which are shown in Fig. 1. An important change from present

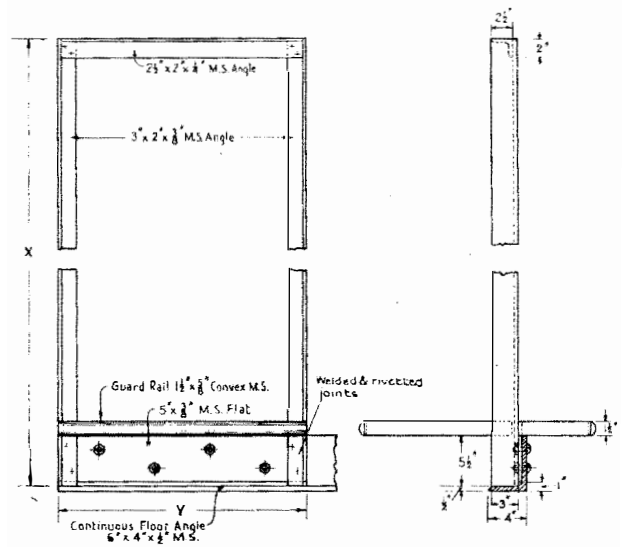

Dimension X	Main Exchange	10' 6"	10' 6"	10' 6"
	Satellites	8' 6"	8' 6"	8' 6"
Dimension Y	Ab Exchanges	4' 6"	3' 4"	2' 6 1/2"

FIG. 1.—CONSTRUCTIONAL DETAILS OF RACK.

practice is the $6'' \times 4'' \times \frac{1}{2}''$ angle laid on the floor surface as a continuous footing under each suite of racks, for floor load distribution. The racks will be securely bolted to the floor angle and braced at the top by means of cable runways. Lengths of floor angle, sufficient for initial requirements only, will be laid at the outset and joints in the angle should not occur under the junction of two racks. As the weight of $6'' \times 4''$

$12'$ is obtainable in the apparatus rooms. In exchanges where $12'$ is not obtainable, the racks will be $8' 6''$ high. For subscribers' preselectors, all ranks of selectors, directors, coders, senders and relay sets, a $4' 6''$ wide rack will be used. Keysender "B" position apparatus requires a $3' 4''$ rack and alarm equipment apparatus $2' 6\frac{1}{4}''$. It will be seen that the bulk of the apparatus will be on the same width of rack ($4' 6''$) which should

Number of Racks per Suite	Initial Arrangements	Ultimate Arrangements
1 Initially & Ultimately		
1 Initially & 2 Ultimately		
1 Initially & 3 Ultimately		
1 Initially & 4 Ultimately		
2 Initially & Ultimately		
2 Initially & 3 Ultimately		
2 Initially & 4 Ultimately		
2 Initially & 5 Ultimately		
3 Initially & Ultimately		
3 Initially & 4 Ultimately		
3 Initially & 5 Ultimately		
4 Initially & Ultimately		
4 Initially & 5 Ultimately		
5 Initially & Ultimately		

FIG. 2.—CONTINUOUS FLOOR ANGLES FOR $4' 6''$ RACKS.

$\times \frac{1}{2}''$ angle is a little over 16 lbs. per foot, it will be necessary to restrict the lengths for handling. A convenient arrangement for meeting these conditions, using five stock lengths, is shown in Fig. 2. Convex steel guard rails will be fitted at the front and rear of every rack as protection against damage to apparatus and wiring by portable equipment.

The racks will have a uniform height of $10' 6''$ in exchanges where a minimum clear height of

facilitate to some extent the preparation of floor plan drawings.

Shelves.—The pressed steel channel type shelf has been developed by the Automatic Telephone Manufacturing Co., Ltd., Liverpool, and will be used with the standard racks for mounting all apparatus except preselectors. Fig. 3 shows a portion of a channel type shelf, looking at the front.

Three lengths of channel shelf will be used as follows:—

Length of Shelf.	No. of Switches per Shelf.	Width of Rack.
4' 4 $\frac{7}{8}$ "	10	4' 6"
3' 2 $\frac{3}{8}$ "	7	3' 4"
2' 5 $\frac{1}{8}$ "	5	2' 6 $\frac{1}{4}$ "

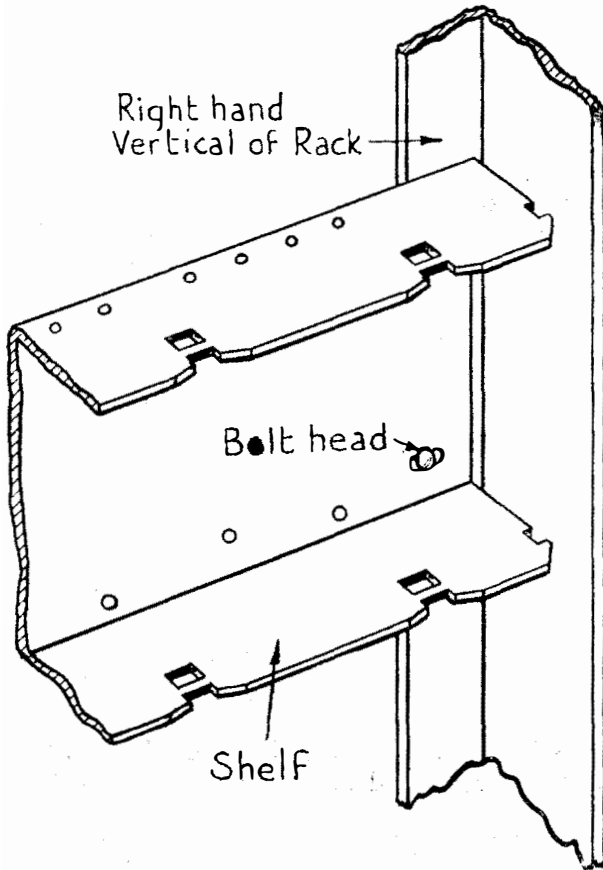

FIG. 3.—SECTION OF CHANNEL TYPE SHELF.

A typical arrangement of a 20 outlet group selector "jacked-in" on a channel type shelf is seen in Fig. 4, which also shows the method of terminating cables at the rear of the shelves.

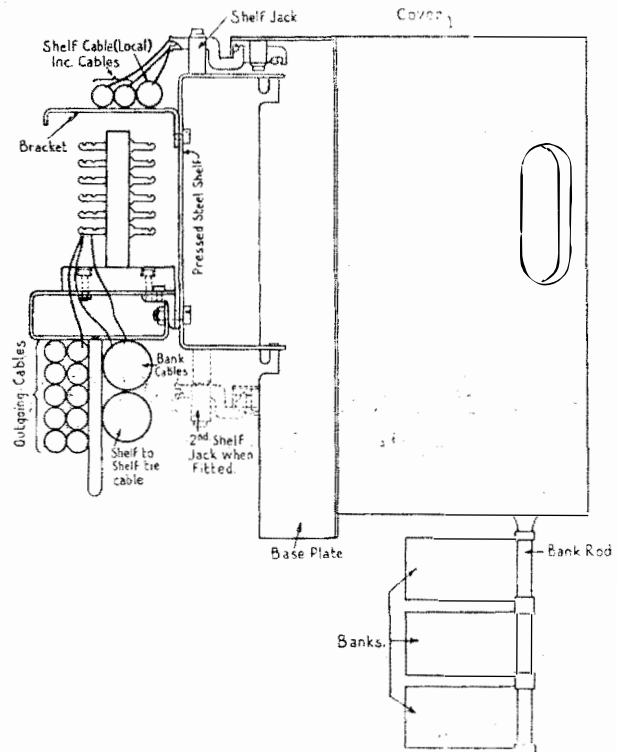

FIG. 4.—SECTIONAL VIEW OF SELECTOR SHELF AND CABLE CONNECTIONS.

Subscribers' preselectors will be mounted 20 per shelf on 4' 6" racks as in Fig. 5. Each shelf is a self-contained detachable unit of 20 preselectors, with associated line and cut-off relays and spark quench condensers. If required, an access switch for connecting routine test apparatus may be mounted in the first position on each shelf. Each preselector is carried on two anti-vibration springs as shown in Fig. 6.

A 5 x 20 connection strip is mounted on the left of the shelf for incoming cables. For outgoing cables there is another connection strip fitted on the right. The outgoing connection

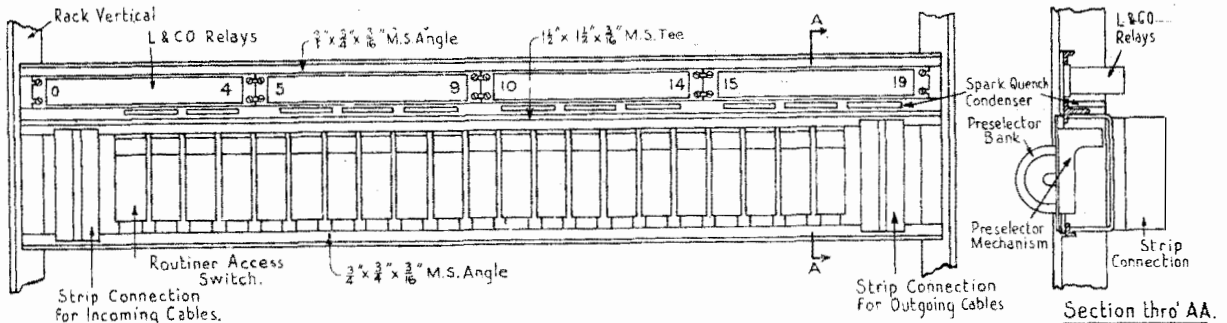
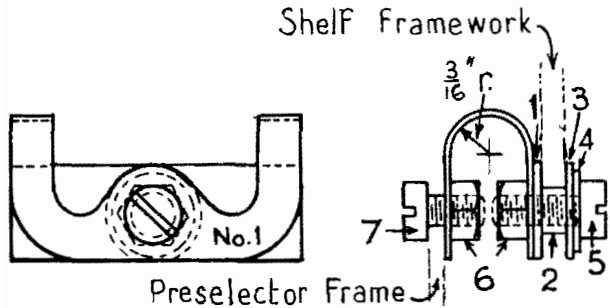

FIG. 5.—UNIT SHELF OF SUBSCRIBERS' PRESELECTORS.

strip will be 4 × 25 for Booster Battery and 5 × 25 for 4th wire metering systems. This arrangement allows in each shelf, on the outgoing side, a row of 20 tags for miscellaneous connections.



- 1.. Insulation.
- 2.. Ebonite Bush
- 3.. " Washer
- 4.. Washer
- 5.. 3 B.A. x $\frac{7}{16}$ " Conn Hd. Screw brass
- 6.. 3 B.A Hex. Nuts. (large) brass.
- 7.. 3 B.A x $\frac{9}{32}$ " Conn. Hd. Screw brass

FIG. 6.—ANTI-VIBRATION SPRING FOR PRESELECTORS.

Cabling.—A schematic diagram of the cabling for a single subscribers' line circuit is seen in Fig. 7. Between the M.D.F. and I.D.F., two wires per circuit will be provided for ordinary lines. In the case of P.B.X. lines, three wires are required as the "P" wire is extended to the main frame for "busyng." Five wires per circuit are required from the local side of the I.D.F. to the preselector racks. The outlets

from all ranks of selectors will be terminated on Trunk Distribution Frames. These frames are very similar in design to the I.D.F. with connection strips, 6 × 20 type, mounted vertically on the incoming side and 3, 4, or 5 × 20 type mounted horizontally on the outgoing side. Grading is carried out on the vertical connection strips, and the graded groups cross-connected to the outgoing cables which are terminated on the horizontal strips.

Disposition of Apparatus on Racks.—In the arrangement of the apparatus, consideration has been given to the possibility of damage to the bottom row of banks by men stepping on the guard rails. Reference to Fig. 8 shows the method of attaching the guard rails to the rack verticals. A clear 15" has been allowed normally between the floor and the bottom of the lowest piece of apparatus. In certain cases the clearance from the floor may be reduced to 12" to allow an additional shelf being fitted, but never less than 12". The bottom of the guard rail will be 6" from the floor so that there should be sufficient clearance to safeguard the bottom banks.

The fixing centres of the channel type shelves have been arranged to give a minimum clearance of 1 $\frac{1}{2}$ " between the top of the apparatus on one shelf and the bottom of the apparatus on the shelf above, wherever possible. This clearance is considered sufficient for the safe withdrawal of switch covers, and allows wiper cords to hang free.

Shelf designations are alphabetically arranged from the bottom upwards.

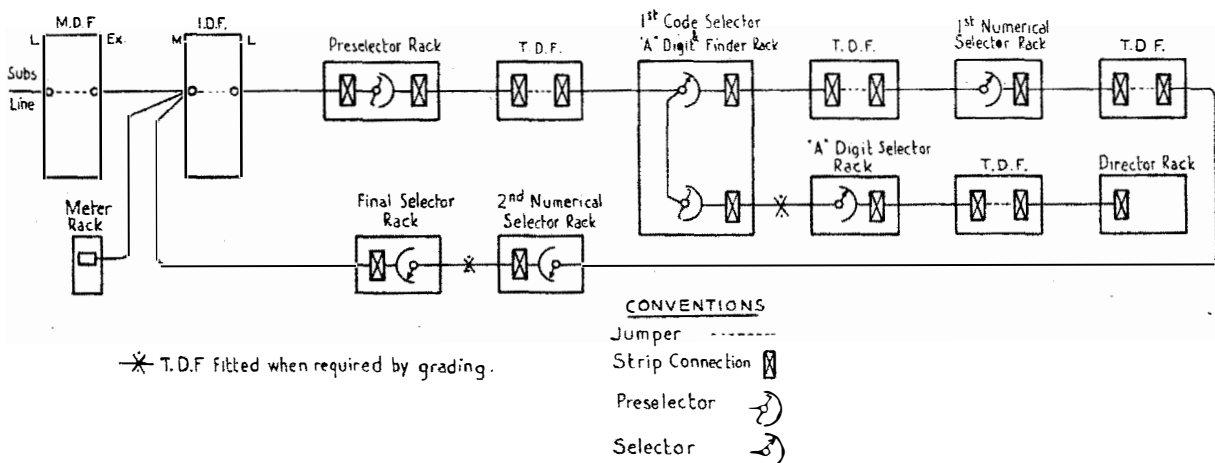

FIG. 7.—SCHEMATIC CABLING OF SUBSCRIBER'S LINE CIRCUIT.

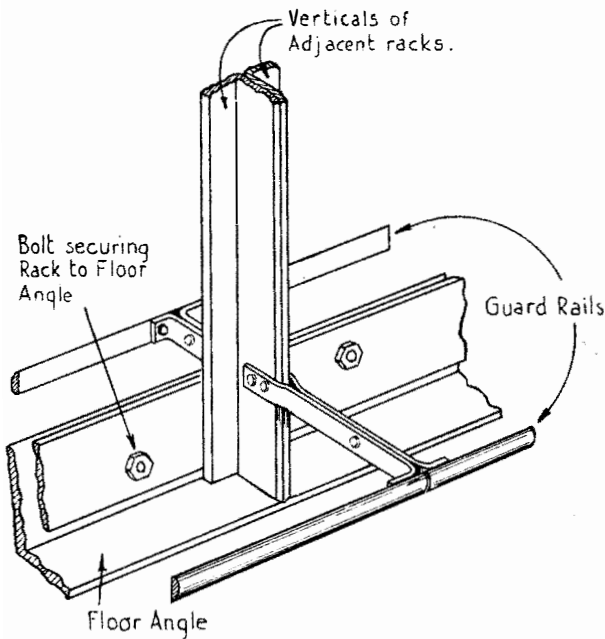

FIG. 8.—METHOD OF ATTACHING GUARD RAILS TO RACK VERTICALS.

Subscribers' Preselectors.—A fully equipped preselector rack is shown in Fig. 9. Each shelf has its preselectors numbered 0 to 19 in addition to the number of the subscriber's line concerned. To locate a given subscriber's preselector, a reference to records will give the rack number, shelf letter and numerical position of the preselector, *e.g.*, 2468/PS—2/B5, indicating that the preselector of Subscriber No. 2468 is the 5th switch on shelf B of rack No. 2.

The outlets from this rack may be arranged in any grouping desired, in multiples of 20.

Group Selectors.—Fig. 10 shows a typical Selector Rack equipped with 6 shelves of 200 outlet selectors. Where 100 outlet selectors are used, 7 shelves may be mounted on a 10' 6" rack, as in this case the Selector has 2 banks, whereas the 200 Outlet Selector has 3 banks.

Referring again to Fig. 4, an end view of a typical connection strip is seen, five of which are mounted at the rear of alternate selector shelves. Easy access to the soldering tags is provided by connecting the bank tails, outgoing cables and shelf tie cables to the same side of the connection strip. A general view of the cabling of a shelf of selectors equipped with connection strips is shown in Fig. 11. The tie cables would, of course, only be provided if more than 20

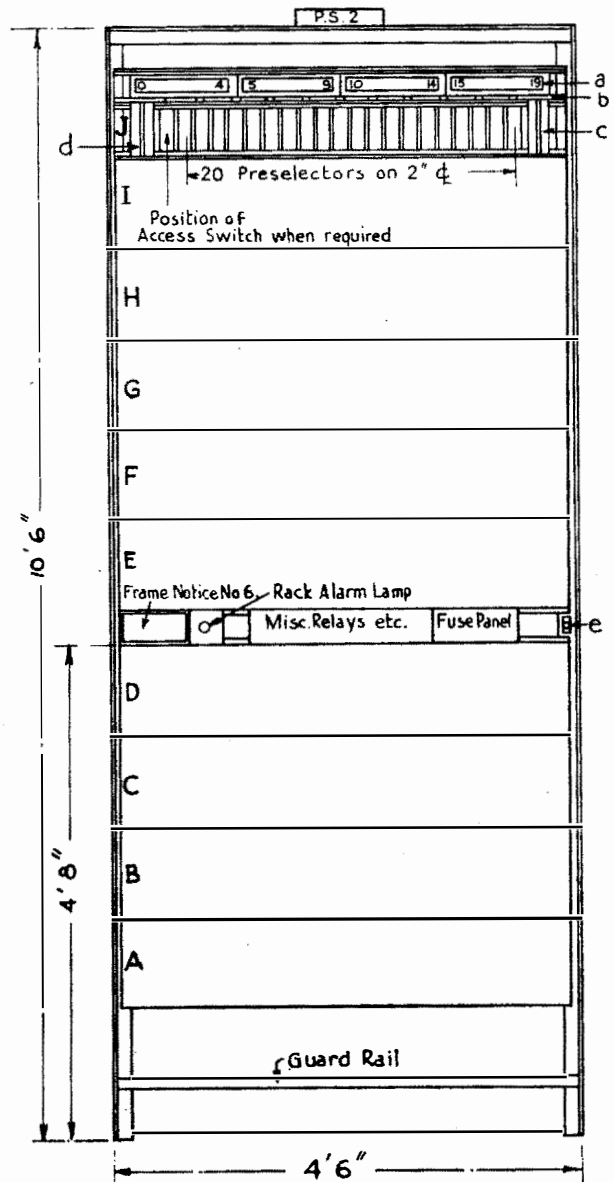

Note:— Shelves A to I equipped similar to Shelf J

- a ... L&CO Relays for 20 Subs. Lines
- b ... Spark Quench Condensers
- c ... Strip Connection for O/G Cables
- d ... " " Incoming Cables
- e ... Battery Jack

FIG. 9.—PRESELECTOR RACK.

selectors were grouped, or in the case of the 100 outlet selectors where the 7th shelf was grouped with a shelf in another rack. The outgoing cables are led away to the Trunk Distribution Frame. On the top of Fig. 4 will be seen the

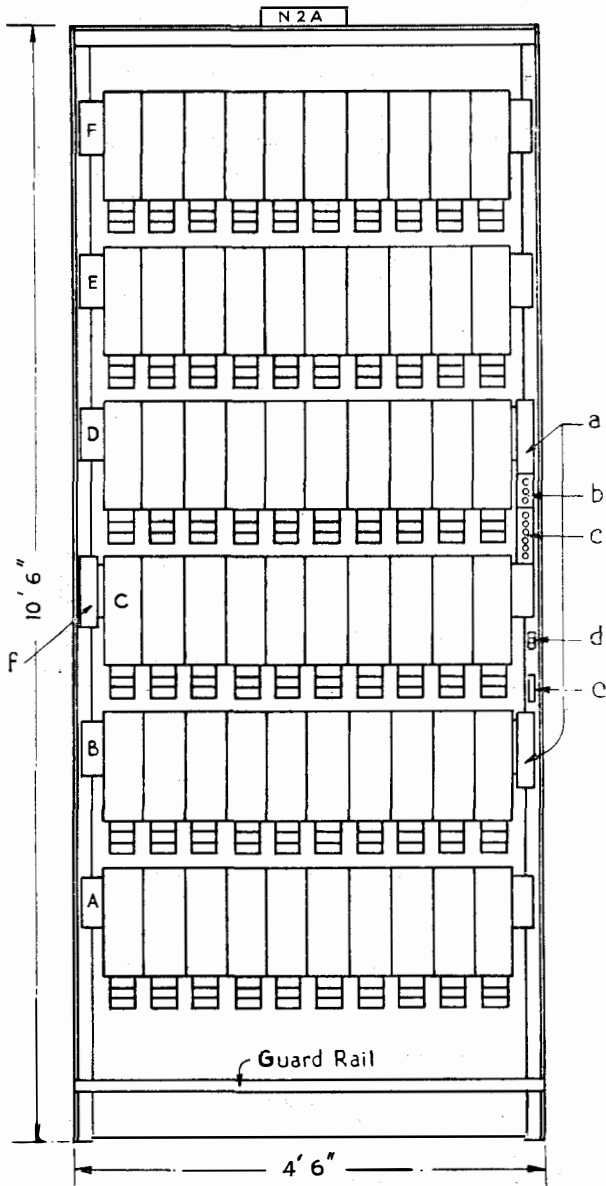

- a ... Misc. Relays
- b ... Rack Alarm Lamps
- c ... Shelf " "
- d ... Battery Jack
- e ... Jack for Traffic Meters
- f ... Fuse Panel

FIG. 10.—RACK FOR GROUP SELECTORS (200 OUTPUT).

relatively small set of incoming cables connected to the shelf jacks.

1st Code Selectors.—Due to the circuit conditions involved, the base of a 1st Code Selector is $7\frac{1}{2}$ " longer than that of an ordinary group selector, with the result that only 30 of the former and the associated "A" digit finders, can be accommodated on a 10' 6" rack. See Fig. 12. Connection strips are fitted at the rear of each shelf so that groups of 10 selectors may be cabled out to the T.D.F., otherwise the arrangement of the bank tails and outgoing cables is similar to that of the group selectors.

The "A" digit finder banks are terminated on connection strips mounted alongside the finders.

Final Selectors.—Three types of final selectors are equipped on the 4' 6" rack. These are:— (a) 200 line and 2/10 P.B.X. finals, (b) 11/20 and over 20 P.B.X. finals, and (c) 100 line finals. The first two mentioned are mounted 50 per rack in five shelves of 10 and the 100 line finals are mounted 60 per rack in six shelves of 10, for 12' rooms.

Each final selector shelf, whether fully equipped or otherwise, will have its full complement of 32 point jacks fitted. Test and Trunk Offering final selectors may be mounted in any desired position.

A typical 200 line and 2/10 P.B.X. final selector rack is shown in Fig. 13.

The shelves are equipped at the rear with five connection strips to each group and the method of connecting the bank tails and outgoing cables is similar to that described for the group selectors. The disposition of the 200 3-wire connections is shown in Fig. 14. It will be seen that the 7th row of tags is commoned. This provides a means of connecting a 1300 ohm spool or relay to the "private" of any spare or unallotted line joined to "N.U. Tone." A 3 x 20 connection strip is fitted (1 per rack) to provide auxiliary connections when the number of lines

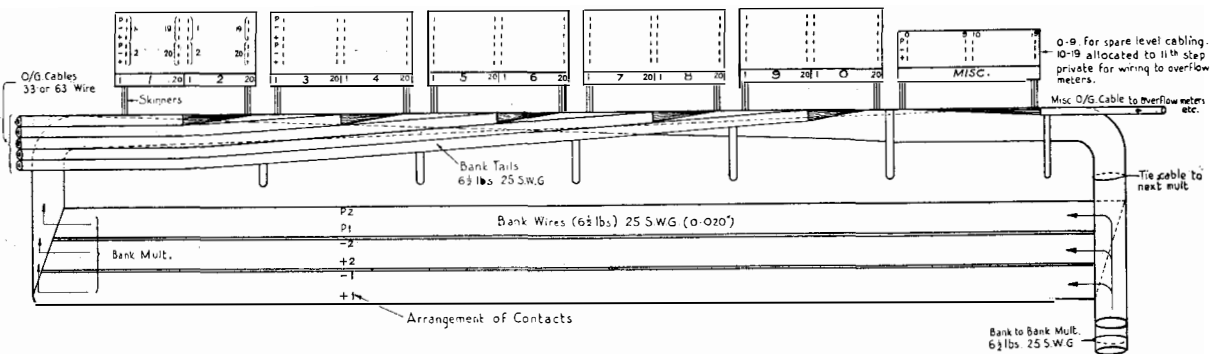
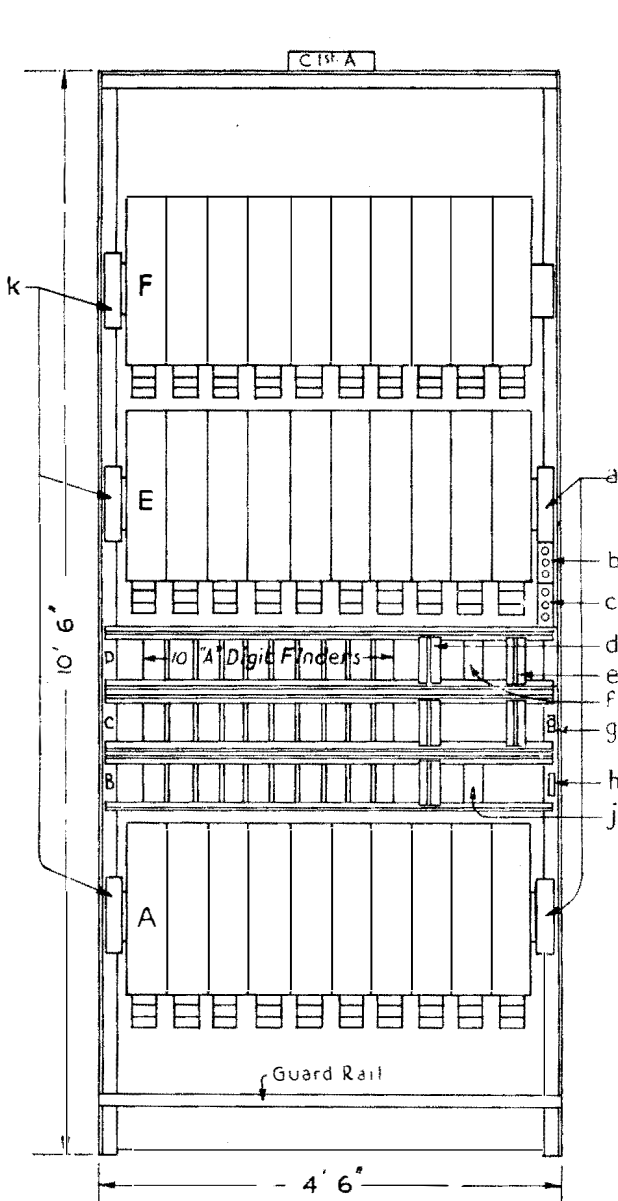
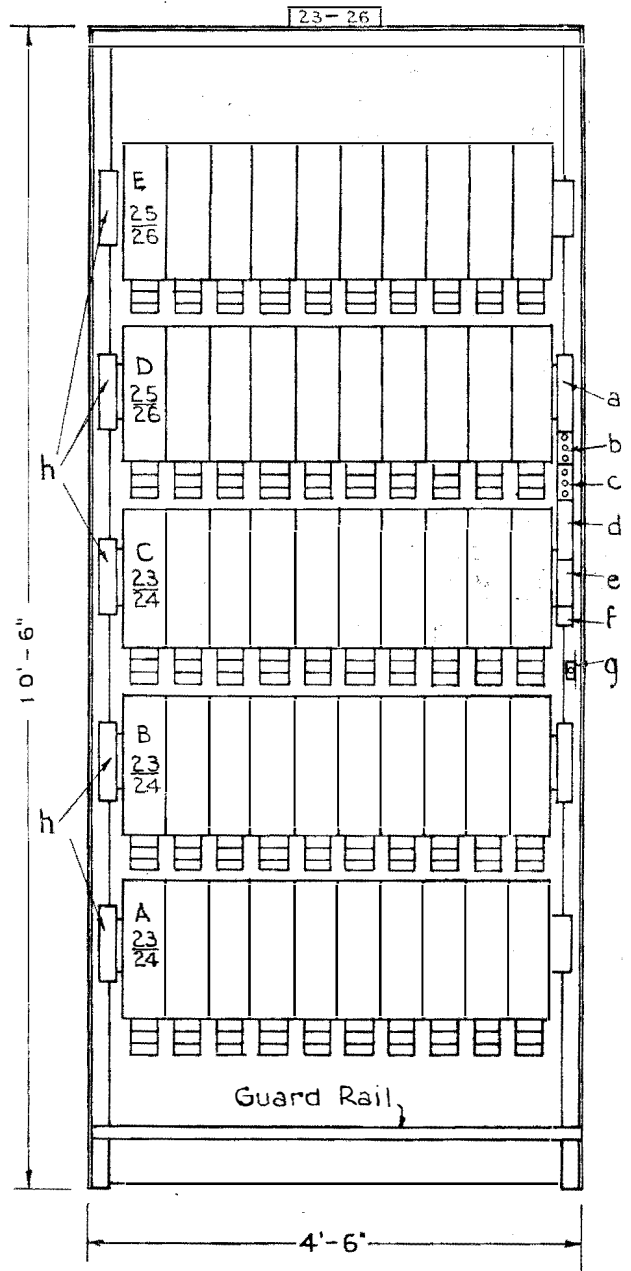

FIG. 11.—GENERAL VIEW OF SELECTOR SHELF CABLING.



- a... Misc Relays
- b... Rack Alarm Lamps
- c... Shelf Alarm Lamps
- d... Strip Conn. for "A" Digit Finder Outlets
- e... " " " Access Switches
- f... Routiner Access Switch for Shelves E & F
- g... Battery Jack
- h... Jack for Traffic Meters
- j... Routiner Access Switch for Shelf A
- k... Fuse Panels.

FIG. 12.—FIRST CODE SELECTOR RACK.



- a... Misc. Relays.
- b... Rack Alarm Lamps.
- c... Release Alarm Lamps.
- d... Test Jacks.
- e... Links for Busy etc.
- f... Screw Terminals.
- g... Battery Jack.
- h... Shelf Fuse Panels.

FIG. 13.—RACK FOR FINAL SELECTORS (200 LINE).

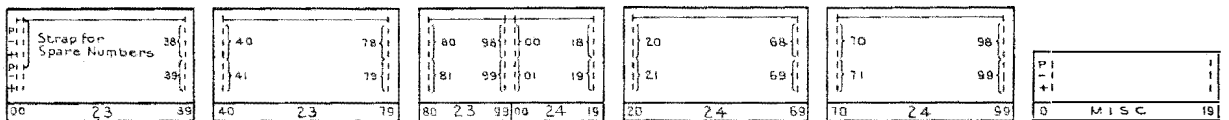
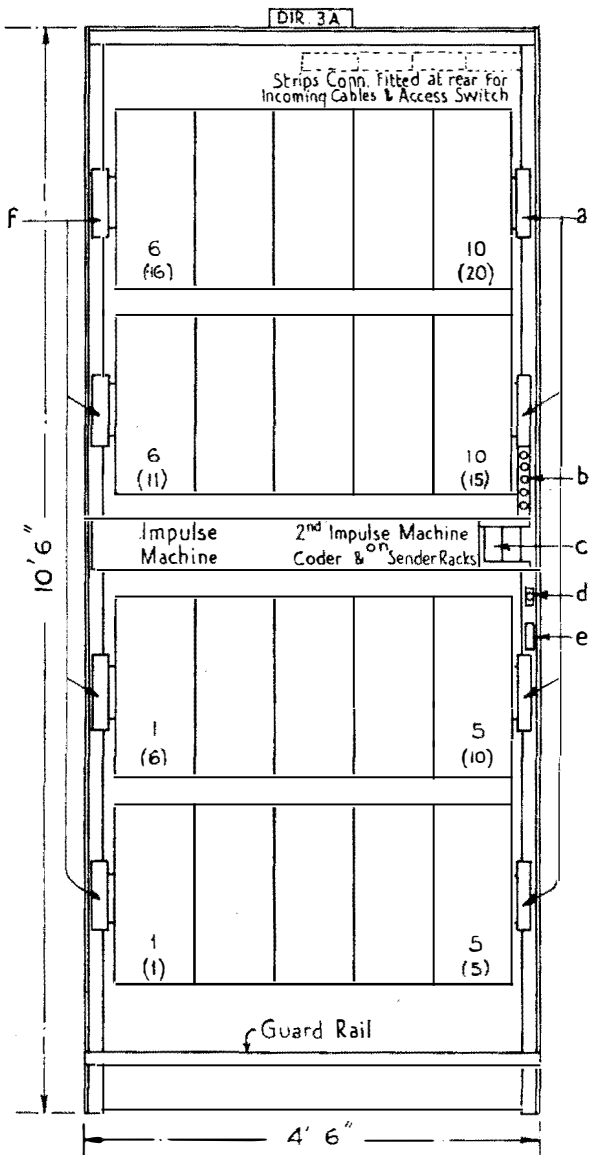

FIG. 14.—FINAL SELECTOR MULTIPLE TERMINATION.



Note: Rack accommodates 10 Directors, 20 Coders or 20 Senders. Marking without brackets indicates Directors. " " in " " Coders or Senders.

Typical Rack Designation for Senders SENDERS BAY!
 " " " " Coders CODERS BAY!

- a... Misc Relay
- b... Rack Alarm Lamps
- c... Routiner Access Switch
- d... Battery Jack
- e... Jack for Traffic Meter
- f... Fuse Panels

FIG. 15.—RACK FOR DIRECTORS, CODERS OR SENDERS.

on a P.B.X. exceeds 10. There is also a miscellaneous power connection strip at the top rear of each rack.

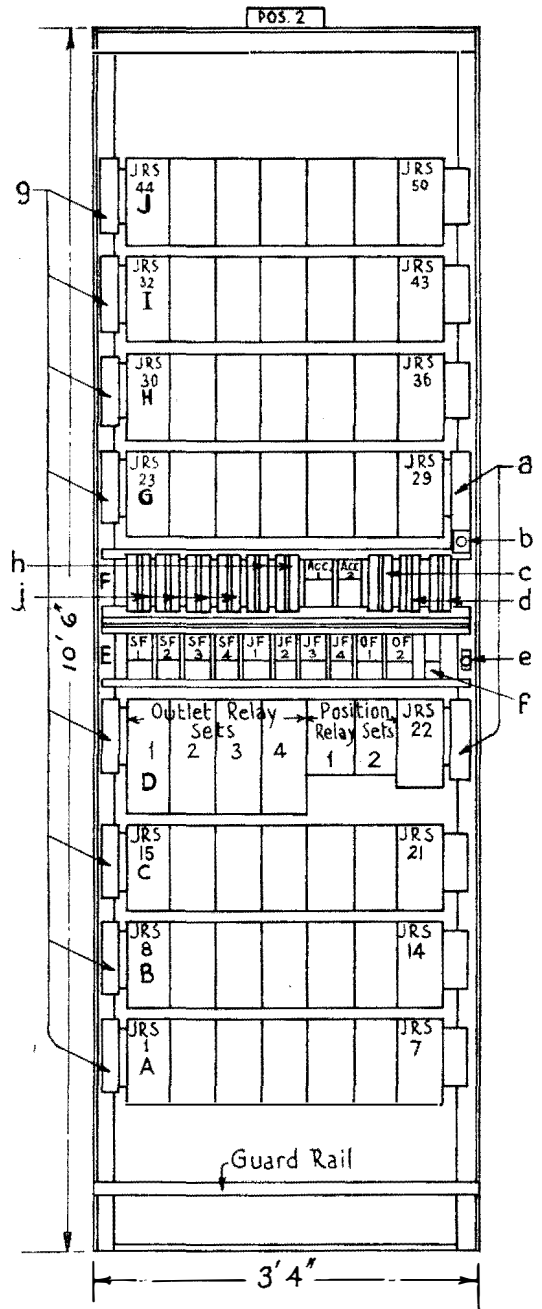

- a... Misc. Relays
- b... Rack Alarm Lamp
- c... Strip Conn. for Access Switch
- d... " " " Misc
- e... Battery Jack
- f... O.W. Tone Preselector
- g... Fuse Panels
- h... Strips Conn. for Junction Finder Outlets
- j... " " " Sender " "

FIG. 16.—KEYSENDER " B " POSITION APPARATUS RACK.

Directors, Coders or Senders.—A 4' 6" rack mounts 10 Directors (Fig. 15). The components of the Director are assembled in two parts, each on its own base. Part 1, consisting of the "B.C." switch and the translation field, is mounted above the digit registers forming Part 2. 20 coders or 20 senders may be mounted, five per shelf, on the 4' 6" rack.

Keysender "B" Position Apparatus.—The relay sets, junction finders and sender finders required for the junction circuits connected to a Keysender "B" position will be mounted on a 3' 4" rack, as in Fig. 16. One rack is, therefore, required for each equipped junction position of this type.

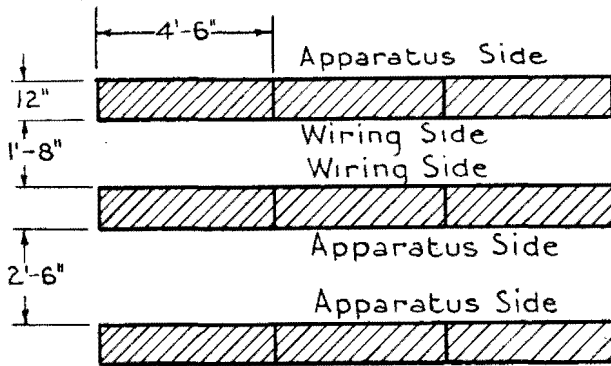

FIG. 17.—RACK LAYOUT SHOWING GANGWAY.

General.—The racks described in the preceding paragraphs are typical and will perhaps suffice to give a general idea of the scheme.

Power will be served to the apparatus from vertical bus bars fixed on the left of every rack. Small fuse panels, fitted with alarm fuses and varying in number according to the battery connections required, will be associated with the bus bars. Each rack will be provided with fuse alarm lamps fitted on the right hand vertical. Miscellaneous relays, battery jacks, test jacks, etc., will also be mounted on the right hand verticals, space being provided at the end of the channel type shelves for mounting this apparatus.

No mention has been made of racks for meters, routiners, special apparatus or test jack frames, as the present construction of these will not be affected, except for changes of minor consequence necessary to make them fit in with the cabling arrangements.

The following schedule gives the capacities of the principal racks to be used :—

Type of Rack.	No. of sets per Rack.	
	12' Rooms.	10' & 11' Rooms.
Preselectors	200	160
Selectors. Group 200 outlet ...	50	50
" " 100 " 	70	50
" Final 200 line	50	40
" " 100 line	60	40
" " P.B.X. 11/20	50	40
" " " over 20	50	40
" 1st Code single metering with "A" digit finders	30	20
" 1st Code excess fee metering with "A" digit finders	30	20
" "A" Digit	70	50
" Discriminating	40	30
" Discriminating and Group Selectors	—	20 + 20
Directors	10	—
Coders	20	—
Senders	20	—
Relay Sets. 10 relays per base	120	100
" " 12 " " 	110	90
" " 14 " " 	100	70
" " C.C.I. & " Coders finders	120	—
" " C.C.I. & Coder finders (Tandem)	70	—
Keysender B. 50 Junc. R.S. & Appt. for 1 position	1	—

The new racks will be installed in suites with apparatus sides face to face so that alternate apparatus and wiring gangways are formed, as in Fig. 17. The minimum permissible width for an apparatus gangway is 2' 6" clear and 1' 8" clear for a wiring gangway.

As the racks in 12' rooms will be 10' 6" high, ladders will be required to provide access to the upper shelves for maintenance. Several proposals are now being investigated with a view to determining the most suitable design of ladder for the purpose.

It will be appreciated from the following table of weights that considerable floor-loads are carried by modern Automatic Exchange buildings. In some recent cases the floors have been designed to carry a load of 2 cwt. per square foot, but as the limits of weight will be known for the standard racks it may be possible in future to reduce that to a lower figure, say 1½ cwt. per

square foot, with safety and consequent percentage reduction in the cost of building steelwork.

Estimated weights of typical fully equipped Standard Racks :—

10' 6" Racks for :	Weight in lbs.				Totals.
	Framework including Guard Rails.	Apparatus	Cabling and Wiring.	Floor Angle.	
Subscribers Preselectors ...	202	858	150	73	1283
Group Selectors (200 Outlet) ...	"	1275	"	"	1700
Group Selectors (100 Outlet) ...	"	1175	"	"	1600
1st Code Selectors ...	"	825	"	"	1250
" A " Digit Selectors ...	"	1175	"	"	1600
Final Selectors (100 Line) ...	"	1315	"	"	1740
Final Selectors (200 Line) ...	"	1175	"	"	1600
Directors ...	"	575	"	"	1000
Relay Sets (General) ...	"	1325	"	"	1750
Relay Sets (C.C.I.) ...	"	1175	"	"	1600
Keysender " B " Apparatus ...	185.5	608	"	56.5	1000

In conclusion, it is anticipated that as direct results from the use of the racks described, there will be greater flexibility of layout and economy of floor space due to the increased height of the racks and the fact that effective use is made of their full capacity for mounting apparatus. There is also the possibility of lighter floor construction due to better distribution of floor loads.

As the racks will be of uniform design, extensions of exchange equipment may be carried out with greater facility and installation time may ultimately be reduced due to the number of standard units that can be assembled, wired and tested in the factories.

The first contracts to be carried out with Channel Type Shelves will be for the Bristol Area and Acorn (London), although in the former case a different type of Preselector Rack

assembly has been agreed for manufacturing reasons.

Many useful discussions with mutual advantage have taken place between Contractors' representatives and members of the Engineer-in-Chief's Staff while the scheme was developing. Appreciation is due to the Engineers of the undermentioned firms for their helpful co-operation and generously contributed data :—

Automatic Telephone Manufacturing Co. Ltd.

Standard Telephones & Cables, Ltd.

Siemens Bros., Ltd.

The General Electric Co., Ltd.

Ericsson Telephones, Ltd.

The writer is also indebted to Mr. S. A. Waters, of the Engineer-in-Chief's Office, for valuable assistance in preparing the diagrams and sketches for this article.

SOUTHEND-ON-SEA MULTI-EXCHANGE AREA.

C. A. MITCHELL and S. G. LAST.

THIS rapidly growing area embraces ten exchanges and it was the intention that seven of these should be changed over to Automatic working simultaneously. Owing to accommodation difficulties, however, one of them, namely Great Wakering, had to be left in abeyance. The other three exchanges in the area are to remain manual, on a dialling-in and dialling-out basis, until economic considerations warrant conversion. The dialling-out codes consist of the first two digits of the five figure numbers allotted to the exchanges in the trunking scheme. Thirteen other exchanges, outside the multi-exchange area, dial-in to Southend.

The cut-over took place at midnight on 27th April, 1929. The operations, from the commencement of the disconnection of the old exchanges to the completion of the cut-in of the six new exchanges, occupied six minutes. Apart

from the fact that certain P.B.X. night extension arrangements had been left incorrectly connected by a subscriber, thus giving rise to permanent loops on the exchange lines concerned, no trouble was encountered.

The following exchanges were closed down :—

Name.	System.	No. of Positions.
Southend Main and 1st Relief ...	Magneto Multiple ...	19
Southend 2nd Relief...	C.B. No. 10 ...	12
Leigh-on-Sea ...	Magneto multiple ...	9
Thorpe Bay ...	C.B.S. No. 2 ...	3
Rochford ...	Magneto ...	2
Hadleigh, Essex ...	Village Auto ...	—
		45

Brief particulars of the new conditions are shown in the accompanying schedule.

Name.	Multiple		Trunk Ends.	Junction Ends					Numbering Scheme.	Subs. cut over	
	Equipped	Capacity		Auto to Auto	Auto to M. Bd.	M. Bd. to Auto.	Signal ling	D/I & D/O		Exch. Lines	Stations
Southend-on-Sea	3,200	6,000	59	312	86	37	—	56	{ 2000-4899 49000-49299 }	1983	2789
Leigh-on-Sea ...	2,100	4,500	—	110	32	14	—	—	{ 7100-7499 75000-76699 }	1045	1252
Marine ...	1,500	3,200	—	95	29	11	—	—	{ 6100-6699 67000-67899 }	704	979
Thorpe Bay ...	800	1,800	—	49	13	5	—	—	{ 8100-8799 88000-88099 }	366	382
Hadleigh ...	500	1,200	—	32	10	4	—	—	58100-58599	105	117
Rochford ...	200	300	—	26	2	3	—	—	56100-56299	92	112
Gt. Wakering ...	100	300	—	—	—	—	2	—	53100-53199	Not yet	ready
Fastwood ...	} Remaining	} Manual	} at present.						D/O Code 51		
Hockley ...									" " 54		
Shoeburyness									" " 52		
	8,400	17,300	59	624	172	74	2	56		4296	5631

The Auto-manual board is at Southend-on-Sea Exchange. It consists of twenty positions, two of which are equipped for key-sender working.

The old manual exchanges were housed in converted private houses or temporary wooden structures, while the displaced village automatic exchange of 150 lines was contained in a small building designed for a 50-line equipment. All

these premises were entirely unsuitable for the accommodation of the new automatic plants and six new buildings were erected. That at Southend, which, in addition to containing the main exchange, houses the Sectional Engineer and his Headquarters Staff, is shown in Fig. 1.

This building is so closely surrounded by other properties that it was necessary to take the



FIG. 1.—SOUTHEND EXCHANGE.

photograph from the top of a near-by pole, hence the obstructed foreground.

A typical satellite exchange of medium size is shown in Fig. 2, while a smaller one appears in Fig. 3.

The superseded exchange at Hadleigh, which was opened in February, 1924, was the first automatic exchange to be installed by the Department's Staff. It was also the first village automatic exchange in this country, where individual line switches were dispensed with by the use of line finders. On this system the standard rural automatic exchange has been developed and in view of the present activity in the provision of small units, the picture of the Hadleigh building shown in Fig. 4 will be of interest.

The plant at the six new exchanges was provided and installed by the Standard Telephones

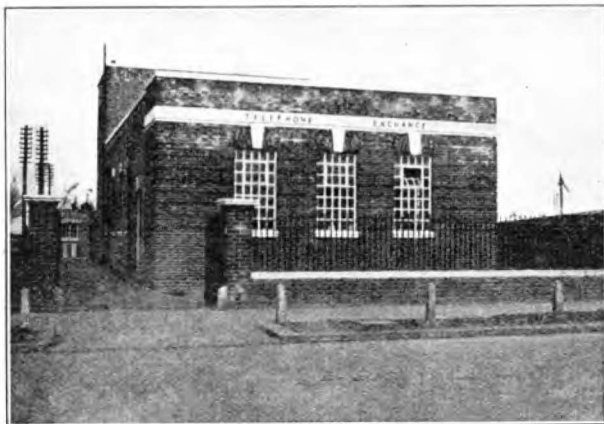

FIG. 2.—MARINE EXCHANGE.

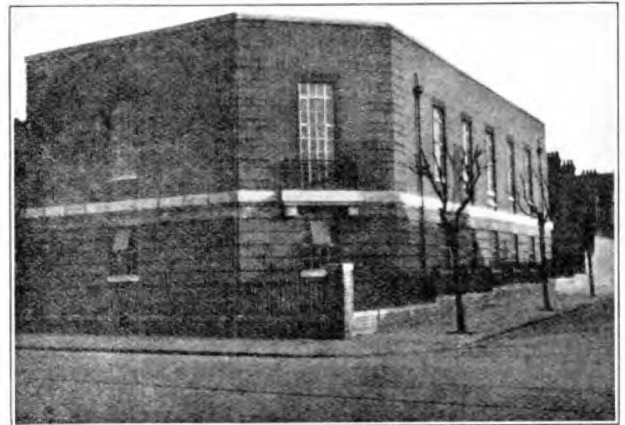

FIG. 3.—THORPE BAY EXCHANGE.

& Cables, Ltd. The power plant at the three larger exchanges was supplied by the same company, while in the three other cases it was fitted by the Engineering Department's own staff, stock items being used. At Hadleigh and Rochford, there being no public electricity supply, the charging machines are driven by gas engines. In these cases the electric light installations and the ventilating fans are run from the exchange batteries.

At the Southend Exchange a Plenum system of ventilation has been installed. The filter is of the oiled baffle type, the plant being supplied by the Visco Engineering Company.



FIG. 4.—HADLEIGH VILLAGE AUTO EXCHANGE.

Particulars of the groups of junctions involved are shown in Fig. 5.

Discriminating Selector Repeaters of the P.O. type were used for the first time at satellite exchanges in the Southend Multi-exchange Area. For local calls they act as group selectors after absorbing one or more digits. The D.S.R's at Hadleigh absorb two digits, while those at Leigh-on-Sea, Marine and Thorpe Bay absorb one digit. For junction calls they function as repeaters.

The D.S.R's call forth comment from visitors on account of their unusual length. This is to enable them to accommodate the discriminating relays on the selector base plate. A near view of one of the new switches appears in Fig. 7.

The following is an illustration of the functioning of a D.S.R. which absorbs two digits:—

A Hadleigh subscriber calls another Hadleigh subscriber. All Hadleigh numbers have the figures 58 for their first two digits. When the calling subscriber removes his receiver, his line

Exchange	TYPE & GAUGE	NO OF CTS	DESCRIPTION	Exchange	TYPE & GAUGE	NO OF CTS	DESCRIPTION		
Hadleigh	DSR O/G SECYS	13	→ 1ST SELRS	Rochford	G 40LB	11	1ST SELRS ← RLS VIA REPTRS		
	" O' LEVELS	8	→ MANL BD		G 40LB	2	" ← CCB REPTRS		
	CCB REPTRS	3	→ 1ST SELRS		G 40LB	11	2ND SELRS LEVELS ← 3RD SELRS		
	3RD SELRS	16	← 2ND SELRS 5BL		Z 40LB	2	MANL BD		
	" "	3	← MANL BD		D 10LB	1	" → TRUNK OFFERING		
	TRUNK OFFERING	1	" "		D 10LB	1	" → INTERCEPTION		
	INTERCEPTION	1	" "		D 10LB	1	" → RURAL PLY LINE		
	RURAL PLY LINE	1	" "		D 10LB	2	TEST DESK → TEST DISTRIBUTOR		
	4.040M				3.611M 40LBS			3.617M 10LBS	
	Leigh on Sea	DSR O/G SECYS	49		→ 1ST SELECTORS	Thorpe Bay	INF G 10LB	21	1ST SELRS ← DSR O/G SECYS
" O' LEVELS		30	→ MANL BD	G 40LB	11		MANL BD ← " O' LEVELS		
CCB REPTRS		9	→ 1ST SELECTORS	G 40LB	4		1ST SELRS ← CCB REPTRS		
2ND SELRS		31	← SUBS 1ST SELECTORS	INF G 10LB	14		SUB 1ST SELRS → 2ND SELRS		
" "		21	← D/I P KSB	G 40LB	10		D/I P KSB → " "		
2ND SELRS LEVEL		3	← MANL BD	Z 40LB	4		MANL BD → " "		
3RD " 75		3	" "	D 10LB	1		" → TRUNK OFFERING		
" " 76		4	" "	D 10LB	1		" → INTERCEPTION		
TRUNK OFFERING		1	" "	3.493M					
MANL BD INTERCEPTION & METER OBSERVATION		2	" "	Marine	INF G 10LB		37	1ST SELRS ← DSR O/G SECYS	
2.430M & 2.434M 40LBS			G 40LB		27	MANL BD ← " O' LEVEL			
2.435M 10LBS			G 40LB		8	1ST SELRS ← CCB REPTRS			
			INF G 10LB		32	SUB 1ST SELRS → 2ND SELRS			
			G 40LB		18	D/I P KSB → " "			
			Z 40LB		4	MANL BD → 2ND SELRS LEVEL G			
			Z 40LB		6	" → 3RD " 67			
			D 10LB		1	" → TRUNK OFFERING			
			D 10LB		2	MANL BD INTERCEPTION & METER OBSERVATION			
			1.000M						

FIG. 5.—JUNCTION GROUPS.

A rack of D.S.R's at Thorpe Bay exchange is shown in Fig. 6. An outgoing secondary switch of the rotary line switch type is associated with each Discriminating Selector Repeater. These secondary switches, which can be seen mounted in two rows at the top of the rack, find junction outlets for use when a call to another exchange is required.

"O" level calls are not routed in this way, however, but via a separate group of junctions connected to the "O" level of the D.S.R. banks.

switch hunts and seizes a D.S.R., the outgoing secondary (O.G.S.) of which seizes a first selector at Southend which gives the calling subscriber "dialling tone." When the first digit "5" is dialled, the shaft of the D.S.R. rises to level 5, cuts in and tests the first contact, causing the release to operate and drop out the shaft. Meanwhile the first selector wipers in the main exchange have risen to level 5, cut in and seized a second selector. When the second digit 8 is dialled, the D.S.R. shaft rises to the eighth level, cuts in and is again released. The shaft of the

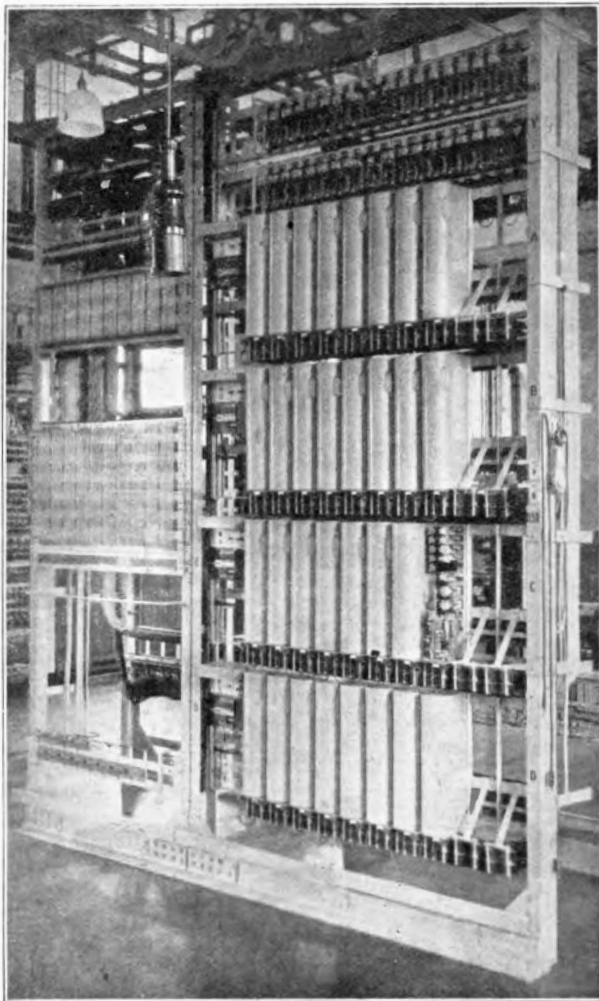

FIG. 6.—RACK OF DISCRIMINATING SELECTOR REPEATER, THORPE BAY.

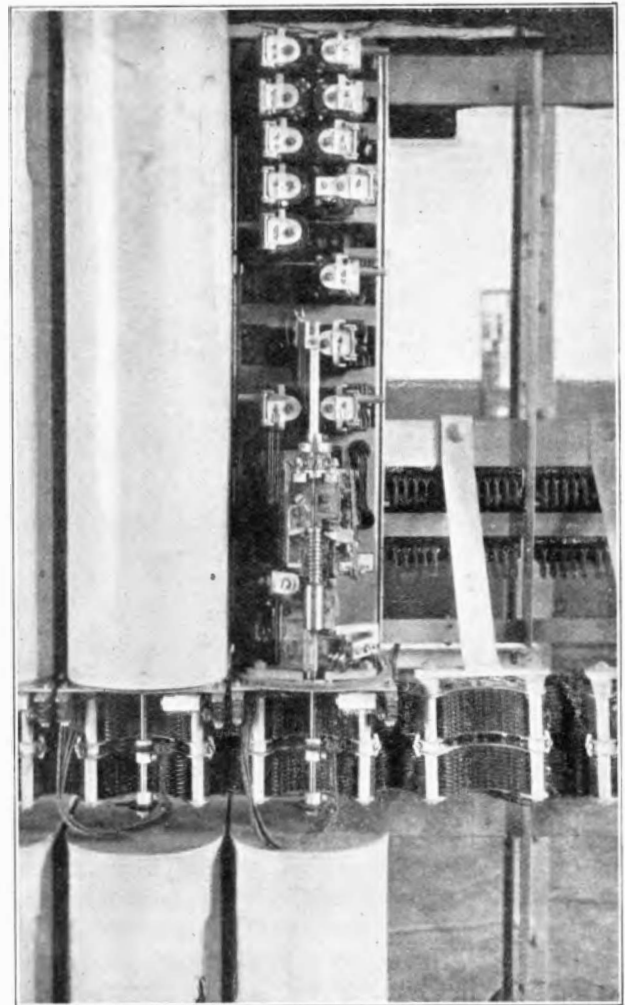

FIG. 7.—D.S.R.'s WITH RELAYS.

second selector in the main exchange rises and cuts in momentarily, but the junction is released at once by the D.S.R. at Hadleigh, thus freeing the first and second selectors at the main exchange. When the third digit is dialled, the D.S.R. raises its shaft to the appropriate level and acting as a 3rd selector cuts in and obtains an idle final selector. The two last digits operate the final selector and the call proceeds in the usual manner.

When a Hadleigh subscriber dials "O," the D.S.R. shaft rises to "O" level and, rotating over it, finds an idle outlet to the Manual Board.

When a Hadleigh subscriber dials, as first digit, any figure but 0 or 5 or, having dialled 5 as first digit, uses as second digit a figure other than 8, the D.S.R. shaft rises and remains

operated. The call proceeds, *via* the outgoing secondary and junction, to the main exchange where it is dealt with by the selectors and routed according to the number dialled.

Fig. 8 is a diagram of the conditions.

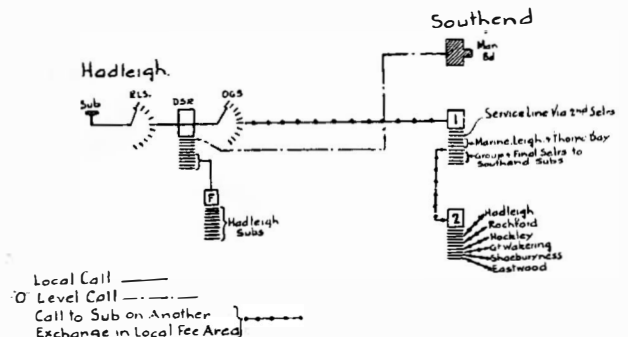

FIG. 8.—HADLEIGH-SOUTHEND CIRCUIT.

At Leigh-on-Sea, Marine and Thorpe Bay Satellite Exchanges, where only one digit is absorbed, the D.S.R's drop out when the first digit dialled is 7, 6 or 8 respectively. The D.S.R's then act as second selectors, third selectors being necessary for five figure local numbers.

In the case of Rochford, the number of local calls being relatively small, the subscribers' Rotary Line Switches seize First Selectors located at Southend. Only Third and Final Selectors are required at Rochford, apart from the subscribers' line equipments, junction repeaters, etc. All calls are routed *via* Southend and in the case of a call from one Rochford subscriber to another, two Southend junctions are used. This "in-and-out" arrangement is known to circuit and switch men as "Trombone" working.

The Key-sending "B" positions at Southend are not of the sloping panel type used in Director areas, but are made to mount "en suite" with the Auto-manual board. In Fig. 9, it will be seen that the junction lamps and assignment keys are mounted in the space usually occupied by cord circuit keys, while the Dis and Busy keys are in the panels.

A view of the group selectors and special apparatus racks in the main apparatus room at Southend appears in Fig. 10. The first selectors are on the four boards on the right. They are of the 200 outlet type, hunting over two levels of 10 simultaneously and therefore having 600 point banks.

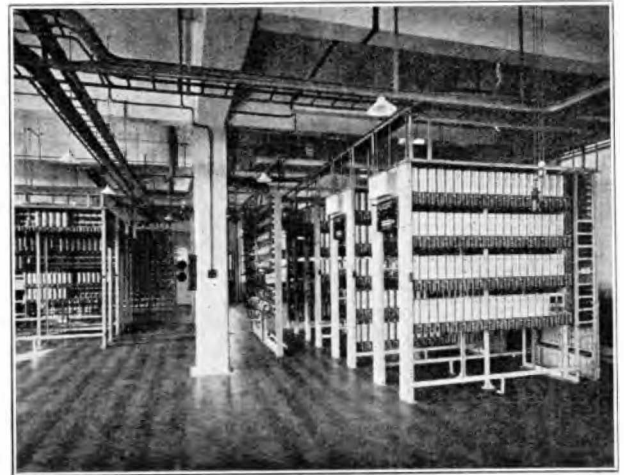

FIG. 10.—GROUP SELECTORS AND SPECIAL APPARATUS RACKS, SOUTHEND.

Figs. 9 and 10 are from photographs kindly supplied by Messrs. Standard Telephones & Cables, Ltd.

The work in connection with the external plant was of considerable magnitude, a very large development scheme having to be carried out simultaneously with the transfer arrangements. To prevent disturbance of circuits after the change-over, it was necessary that the re-distribution covered by this scheme should, as far as it was possible, be completed beforehand. The work which was due for completion by April 27th, 1929, was commenced on June 4th, 1928. Apart from a considerable amount of renewal work, mainly on D.P's and subscribers' terminals, the following is approximately what was achieved in connection with transfer arrangements, junction requirements, new development plant and rearrangements :—

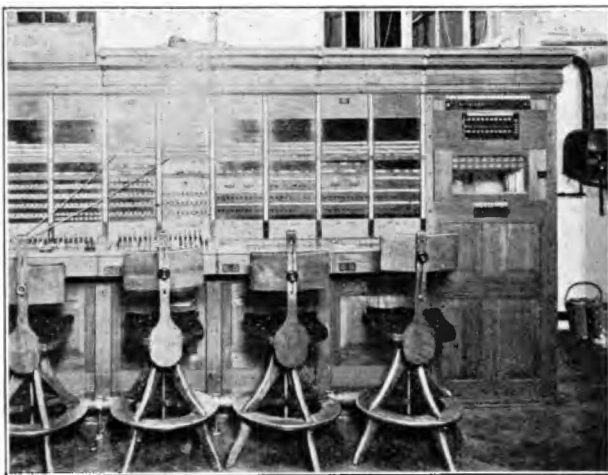

FIG. 9.—SOUTHEND MANUAL ROOM. C.T. SECTION AND METER PANEL. KEY-SENDING B POSITIONS (1 AND 2). COMBINED A AND B POSITIONS (3 AND 4).

	Main Ex- change Area.	Main Ex- change Auto.	Junctions. Auto.
Duct Work Completed	9.5 mls.	8.5 mls.	6.5 mls.
Cabling Completed ...	21.6 "	17.0 "	13.6 "
(1) Additional D.P's. and Distribution Points	290 =	216 new D.P's erected 74 existing poles converted.	
(2) Total Number of new D.P's brought into use and exist- ing D.P's re- arranged	492		
(3) New wire erected in connection with (2)	59 mls.		
(4) Overhead wire re- covered in con- nection with (2)	540 "		

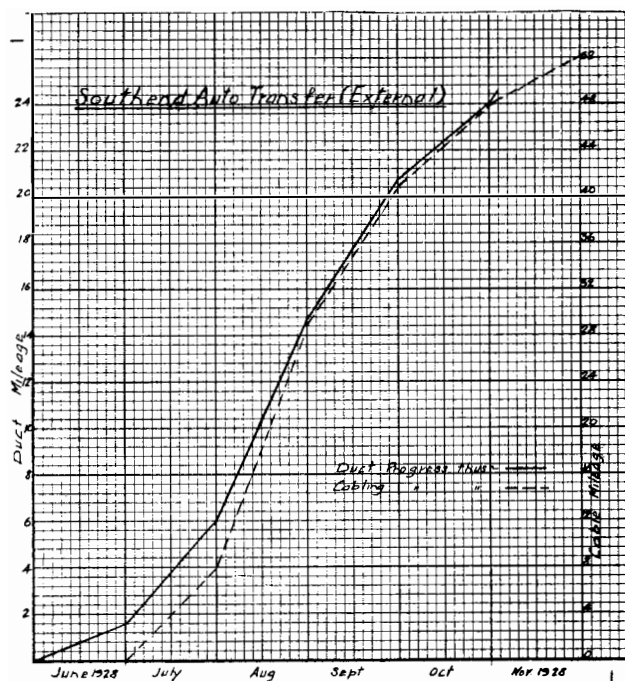

FIG. 11.

Figs. 11 and 12 shows the duct and cabling progress. In connection with the duct work four E.O's were issued (1) for an advance portion covering busy thoroughfares which had to be completed before the commencement of the summer season; (2) Junction scheme; (3) Main Exchange Area; (4) Marine Exchange Area.

A steady progress of approximately 2000 yards per week was maintained on duct work, employing five to seven Contractors' gangs.

Cabling work was carried out at high pressure. At the busiest periods as many as five gangs were employed on rodding and cabling. It will be

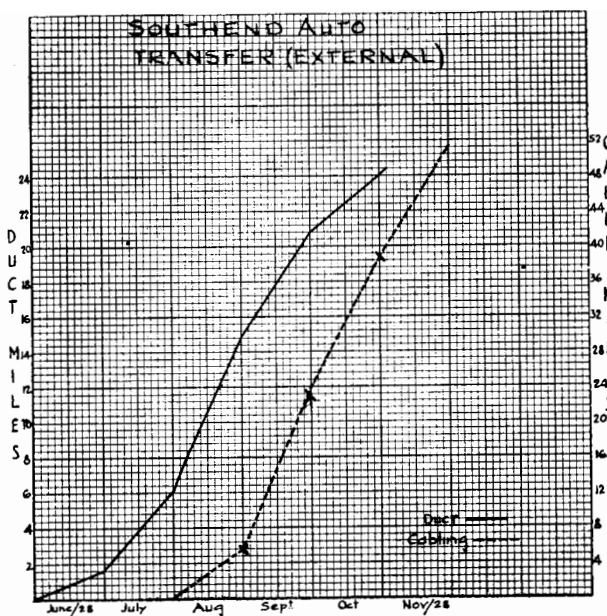

FIG. 12.

gathered that the supply of cable was given priority to enable such progress as is indicated by the graph, to be maintained.

In the various areas, Southend, Leigh-on-Sea, Hadleigh, Thorpe Bay, and Rochford, 49 cable jointers were employed. A large proportion of the overhead rearrangement work was put in hand prior to the completion of the underground sections and D.P. branches. Work at D.P's was advanced by running new leads and spurs to subscribers' premises, in readiness, so that on completion of the underground cables, only change-over and recovery work remained to be done on the open lines.

THE ACCURATE MEASUREMENT OF ARTICULATION.

JOHN COLLARD, B.Sc.(Eng)., A.M.I.E.E.

1.0. *Introduction.*

THE value of articulation measured on a given telephone circuit is so obviously a logical measure of the performance of the circuit from the speech point of view, and the carrying out of an articulation test is, at first sight, such an easy operation, that many people must have wondered why articulation does not occupy a more prominent position among the different quantities used in telephone measurements. The reason that it does not do so is that, while the equipment required to carry out an articulation test is comparatively simple, the results depend so essentially on the human element that serious errors are liable to occur unless special precautions are taken in making the test. The results of articulation tests, when carried out carefully under proper conditions, are so valuable, however, that during the last few years a comprehensive study of the whole subject has been undertaken, first by the International Standard Electric Corporation and lately by the International Telephone and Telegraph Laboratories, Incorporated, with a view to determining how an articulation test can most accurately be carried out. This study embraces both the theoretical and practical aspects of the problem, and, since the results are of considerable interest to telephone engineers, it is proposed to give here a brief description of what has been done. Two previous papers* † by the author have dealt in considerable detail with the theoretical side of this work, and it is, therefore, proposed in the present paper to deal chiefly with the practical application of this work to the development of a technique for the accurate measurement of articulation.

* "A Theoretical Study of the Articulation and Intelligibility of a Telephone Circuit," *Electrical Communication*, Jan., 1929.

† "The Calculation of the Articulation of a Telephone Circuit from the Circuit Constants," *Electrical Communication*, Jan., 1930.

2.0. *Articulation and Intelligibility.*

Before going further into this subject, it may be as well to describe the different quantities that have been used in the past as a measure of the articulation of a telephone circuit.

Since the telephone circuit is designed primarily to transmit conversations from one subscriber to another, it appears reasonable, at first sight, to make the articulation test approximate as nearly as possible to an ordinary conversation. With this end in view, a series of sentences are prepared and are called over the circuit to be tested. For the sake of simplicity these sentences are usually arranged so that each conveys a single intelligible idea, such as "The engineers quickly repaired the car." The percentage number of these sentences that are correctly received by the listener is then defined as the intelligibility or sentence articulation of the circuit.

A test of this nature takes a considerable time to carry out and the results are liable to be inaccurate, owing to the fact that they depend so essentially on the number and length of the words used in the test sentences. To overcome these difficulties it is usual to employ a rather simpler form of articulation test in which either separate words or just meaningless syllables are called over the circuit. If actual words are used, ordinary spelling can be used so that the testers do not have to learn a special phonetic script, but there is the disadvantage that errors may occur due to the possibility of the listener being able to guess a word even when he has not heard all the component sounds correctly. When words are used, the percentage number correctly received by the listener is called the word articulation.

To avoid any guesswork on the part of the listener, meaningless syllables are most commonly employed. The disadvantage is that, since the syllables are not actual words, some doubt may arise in the caller's mind as to how they are to be pronounced; and when the listener's form is being corrected, ambiguous spelling may make it difficult to decide whether he correctly received a

syllable. The best way of avoiding this trouble is to adopt a form of special phonetic script in which a given sound is always represented by the same symbol. It has been found that callers and listeners very quickly learn a phonetic script of this nature and that no additional errors are caused by its adoption. Each syllable called over the circuit will, of course, consist of several individual speech sounds; a speech sound being either a consonant or vowel. If the percentage number of syllables correctly received over the circuit is determined, this is called the syllable articulation. If the percentage number of individual speech sounds is determined, this is called the sound articulation.

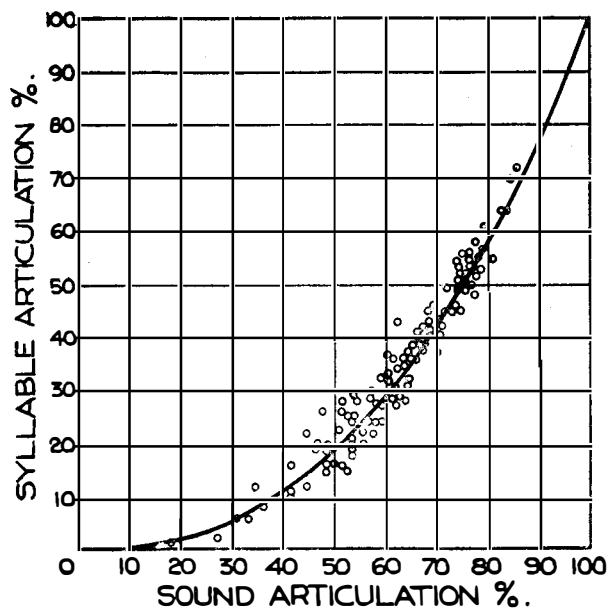

FIG. 1.

3.0. Theoretical Relationships.

In one of the papers* referred to above it was shown that, in spite of the fact that the different values of articulation depend essentially on certain characteristics of the testers, and in spite of the fact that word articulation and intelligibility introduce what is apparently guesswork on the part of the listener, there is a perfectly definite theoretical relation between the average values of these different quantities. By making certain reasonable assumptions as to the psychological processes taking place in the mind of the listener and by the use of the ordinary laws of probability, definite algebraic formulæ were established giving the theoretical relationships

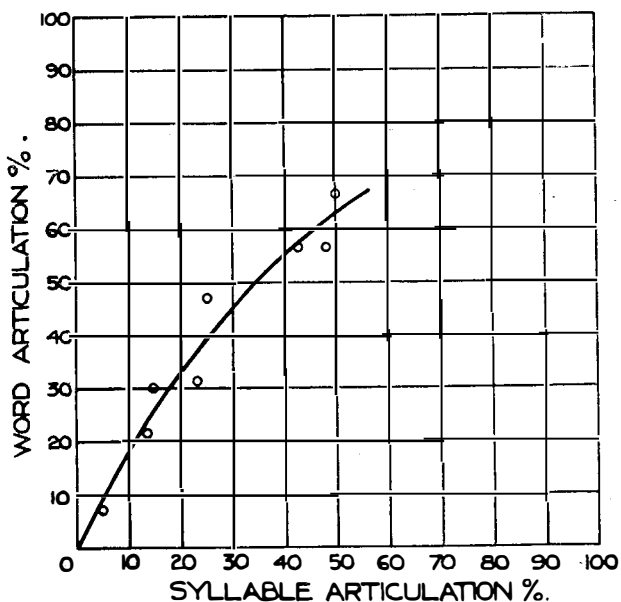

FIG. 2.

between the different quantities. In order to determine whether these theoretical relations agreed with practical results, a number of experiments have been carried out in which the different quantities were measured by means of actual articulation and intelligibility tests. Since the very close agreement between the theoretical and practical values is one of the most interesting results of this work, a number of examples have been given in this present paper. These examples are shown in Figs. 1, 2, 3, and 4. In

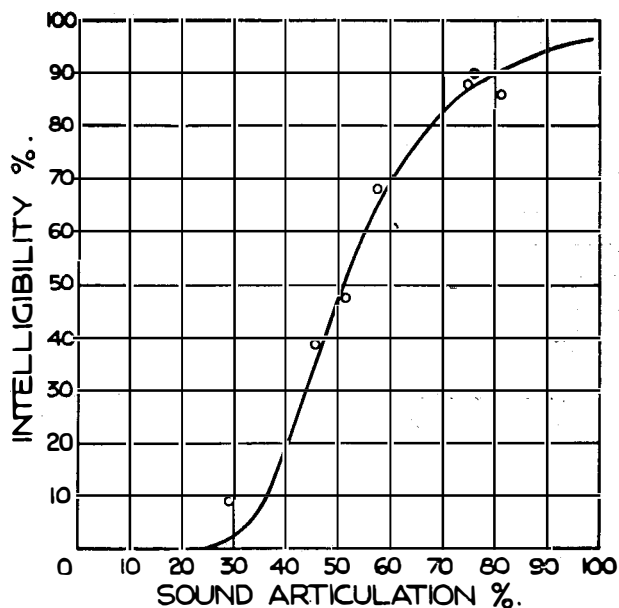

FIG. 3.

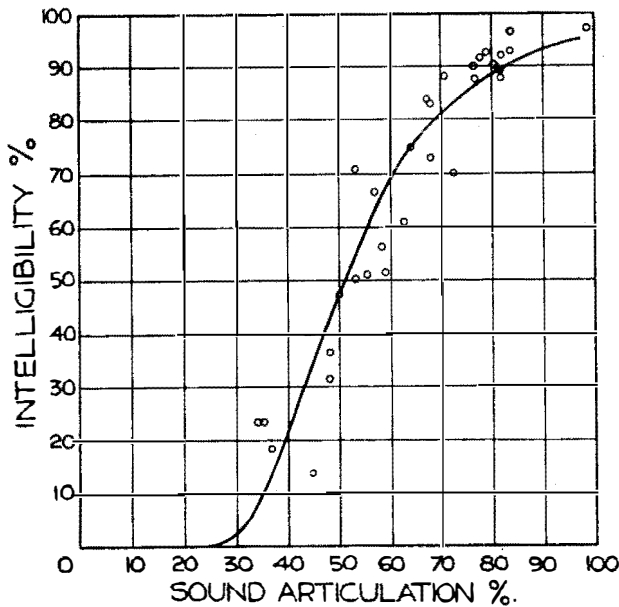

FIG. 4.

each example the curve is calculated from the theoretical formula, while the small circles are the actual measured values. It will be seen that in every case the theoretical curve passes closely through the centre of the experimental points, showing that the agreement between theory and practice is very good.

The formulæ are given below, for the full meaning of the different constants and the methods of evaluating these, reference should be made to the previous paper.*

$$S = 100 \left(\frac{D}{100} \right)^n$$

$$W_n = \frac{100}{1 + k_n \left| \left(\frac{100}{D} \right)^n - 1 \right|}$$

$$I = \frac{100}{1 + h \left| \left(\frac{100}{V} \right)^m - 1 \right|}$$

$$V = \frac{I}{100} \sum p_n W_n$$

where D = average percentage sound articulation.

S = average percentage syllable articulation.

W_n = average percentage word articulation for words of n sounds.

I = average percentage intelligibility.

$h, m, p,$ and k_n are constants depending on the language for which the results are obtained.

In the second paper† referred to above, these theoretical relations were carried a step further and it was shown that, just as intelligibility could be calculated in terms of word articulation and word articulation in terms of sound articulation, sound articulation could itself be expressed as a function of a new quantity called the band articulation. This new quantity was introduced chiefly because it enables the articulation of a telephone circuit to be calculated merely from a knowledge of the constants of the circuit. It is mentioned here, however, because its use has enabled a very simple method of calibrating an articulation crew to be developed. This method has the double advantage of having a sound theoretical basis and of giving satisfactory results in practice. A description of the practical application of the method is given in section 6.0, so that the remarks here are confined to a short discussion of the reasoning on which the theory is based.

It was shown that, while each speech sound contained frequency components throughout most of the audible range, the large components by which the sound is recognised are all grouped together into one or more little frequency bands. The number of these bands in a sound varies from one to five according to the sound. Since it is by noting at what frequency these bands occur that a listener distinguishes one sound from another, they have been called the characteristic band of speech. We can imagine the listener as receiving the different characteristic bands of a sound, considering each one in turn, recognising at what frequency it occurs and so deciding on what sound was called. The probability that the listener will receive a sound correctly is therefore closely related to the probability that he will receive the individual bands correctly. This latter probability is called the band articulation since it is analogous to sound articulation. It will be realised that since each sound consists of one or more characteristic bands, just as each word consists of one or more

sounds, the formula relating sound articulation and band articulation will be of exactly the same form as that relating word articulation and sound articulation.

The expression giving the relation between the average sound articulation and the average band articulation is:—

$$D = \sum \frac{100 k_l}{1 + c_l \left(\frac{1}{b^l} - 1 \right)}$$

where b = average percentage band articulation.

l = number of characteristic bands in a sound.

and c_l and k_l = constants.

The curve obtained from the above expression is shown in Fig. 5.

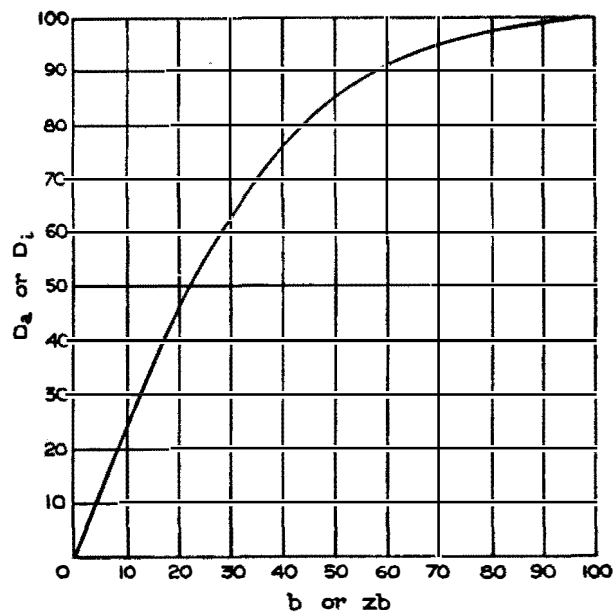

FIG. 5.

4.0. Choice of a Quantity to be used as a Criterion of Circuit Performance.

Each of the quantities mentioned above has been used in the past as a measure of the performance of a telephone circuit from the speech point of view. This leads to considerable confusion and it is consequently very desirable that some one quantity should be standardised for future use. Some consideration is therefore given in this section to the relative advantages and disadvantages of the different quantities,

from the point of view of their value as a criterion of circuit performance and also from the point of view of their application to practical measurements.

Intelligibility tests have several disadvantages from the practical point of view, the chief among which are the lengths of time required for the test and the difficulty of obtaining accurate results, owing to the large number of factors which may cause random errors. Intelligibility, however, is probably the best criterion of circuit performance, since the telephone circuit is usually required to transmit ideas from one subscriber to another.

Word articulation requires less time for a test than intelligibility and is somewhat less subject to the effect of chance factors. Apart from this, however, it has little to recommend it.

Syllable and sound articulation are both measured by calling syllables over the circuit. The use of test syllables, of course, has the great advantage that it eliminates the guesswork that occurs when words or sentences are used, and requires only a comparatively short time to make the test. These two quantities are, therefore, much to be preferred to the others and it only remains to decide whether syllable or sound articulation should be used. Some difference of opinion exists on this question, but the results of this study have led to the adoption of sound articulation as the most suitable quantity from all points of view. Syllable articulation depends essentially on the number of sounds in the test syllables. A circuit which gave a sound articulation of 70%, for instance, would give a syllable articulation of 49% if 2-sound syllables were used and 34% if 3-sound syllables were used. Where syllable lists are used in which syllables containing different numbers of sounds are included, the result will depend, of course, on the percentage number of each type of syllable. If, therefore, an experimenter states that he has obtained a value of syllable articulation of, say, 50%, on a certain circuit, this statement gives no idea of the performance of that circuit unless he tells us at the same time exactly what type and proportion of syllables he is using. In other words, the standardisation of syllable articulation is really no standardisation at all. Sound articulation, on the other hand, is practically independent of the number of sounds used in the

test syllables, provided syllables of only two or three sounds are used. In consequence, if a value of sound articulation is quoted, it is not important to know what type of test syllables were used. The probable error is less for sound articulation than it is for syllable articulation for most practical cases. This is an important advantage of the use of sound articulation.

When a change of some sort is made in a given telephone circuit, the change in intelligibility is more nearly equal to the change in sound articulation than it is to the change in syllable articulation. This is a further reason for preferring sound articulation to syllable articulation.

For these reasons, and as a result of several years of practical testing of articulation, it has been decided to standardise sound articulation as a measure of the performance, from the speech point of view, of telephone circuits and apparatus.

When an articulation crew is used to measure articulation on a given telephone circuit, the value they obtain will depend, to a certain extent, on the amount of previous training they have had. The value obtained will also depend on the mental development of the members of the crew. For this reason, it is very difficult, if not quite impossible, to compare articulation results taken by different crews or even results taken by the same crew at different periods. To overcome this difficulty it is proposed to use a quantity called the Ideal Sound Articulation. This quantity is defined as the value of articulation that would be obtained on a given circuit by an ideal crew. It is obviously independent of crew factors and depends solely on the circuit. In the section dealing with the calibration of a crew it will be shown that it is possible to calculate the ideal sound articulation from a given measured value.

Out of all these quantities the only one that seems to satisfy all the required conditions is the Ideal Sound Articulation and, since it is proposed to standardise this quantity for all articulation work, a summary of its advantages is given below.

- (1) It is independent of the articulation crew used to obtain it.
- (2) It is of all the possible quantities the one least affected by the construction of the test lists.

- (3) It has the smallest average error for practical circuits.
- (4) The change in it, brought about by some change in the circuit, is most nearly equal to the corresponding change in intelligibility.
- (5) It is the quantity from which the others can most easily be calculated.

5.0. *Chance Factors.*

The next step in the development of an accurate technique is a study of all the different factors which can influence the value of sound articulation measured on a given circuit. Below is given a list of the most important of these factors, together with a discussion of their effect on articulation and how it can be either eliminated or controlled.

- (1) The pronunciation of the caller and any other peculiarity in his speech.
- (2) The degree of hearing of the listener.
- (3) The mental development of the testers.
- (4) The fatigue of the testers.
- (5) External conditions, such as room noise.
- (6) The degree of training in articulation testing of the testers.
- (7) The number of sounds used to form the test syllables.
- (8) The frequency of occurrence of the individual speech sounds in the test syllables.

Factors (1), (2) and (3) have a very considerable effect on the value of articulation measured on a given circuit, but their effect can, of course, be controlled to a certain extent by suitably choosing the testers. It is obviously desirable to avoid including anyone with some abnormal pronunciation, some defect in the speech organs or some defect in hearing. Some callers give very variable results due to their not being able to keep their calling volume constant. Other callers fail, due either to over-emphasis of the test syllables or to the adoption of a monotonous tone of voice when calling. These defects can be discovered by simple speech and audiometric tests. It is necessary, of course, in selecting a crew to avoid carrying this elimination of abnormalities too far. Ordinary subscribers vary considerably both in their calling volume and in the degree of hearing, and, consequently, if the results of an articulation test are to be really

representative of actual conditions, a normal amount of variation from one tester to another is to be desired. Also, women as well as men should be included in the crew if really representative results are to be obtained. The mental development of the crew is less easy to determine, but it exerts, nevertheless, an important effect on the results obtained. Some testers, for example, seem quite unable to concentrate upon an articulation test and are useless for the work. Others, while giving good results for the first few tests, soon tire and become quite useless. These defects are difficult to detect by any preliminary tests and probably the only way of avoiding them is to select the testers from a reasonably intelligent class and then to reject, subsequently, any that prove unsatisfactory in this respect.

Factors (4) and (5) are very closely allied, since the external conditions such as the existence of room noise, bad lighting, and uncomfortable seats, very quickly bring about a state of fatigue. A striking example of this is shown in Fig. 6. A series of articulation tests was being carried out and these tests extended over a period of several weeks. Tests were being made on a number of different circuit conditions and each day a control test was carried out on a standard calibration circuit. Sometimes this control test was made early in the day and sometimes towards the end of the day. The listeners were enclosed in silence cabinets, but these cabinets were far from perfect and, as there was a considerable amount of room noise outside the cabinets, the listeners were subjected to a certain amount of noise which was very tiring. In Fig. 6 the values of articula-

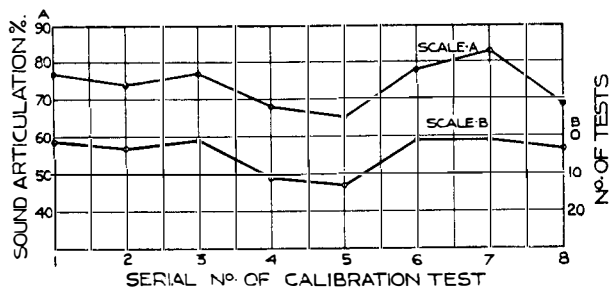

FIG. 6.

tion obtained on the calibration circuit on the different days are plotted in the upper curve and in the lower curve are shown the number of tests which had been carried out each day before the

control test was made. It will be seen that there is quite a close agreement between the two curves, the value of articulation obtained in the control test being very much less when it was carried out at the end of the day than when it was carried out at the beginning of the day when the testers were fresh. This shows very clearly that every effort should be made to eliminate as far as is possible the effect of external conditions on the testers. With this end in view, proper silence cabinets should be employed to avoid the effect of external sounds and, where possible, it is desirable to use separate cabinets for each listener so as to avoid one listener disturbing another. Careful attention to the lighting and ventilation conditions is necessary and the seating accommodation should be arranged so that the testers do not have to sit in an uncomfortable position. These points may appear unimportant, but it is only by paying attention to small details of this nature that reliable and consistent articulation results can be obtained.

As an articulation crew becomes trained to a certain technique, the value of articulation that they obtain on a given circuit gradually increases. This effect is shown in Figs. 7 and 8 where re-

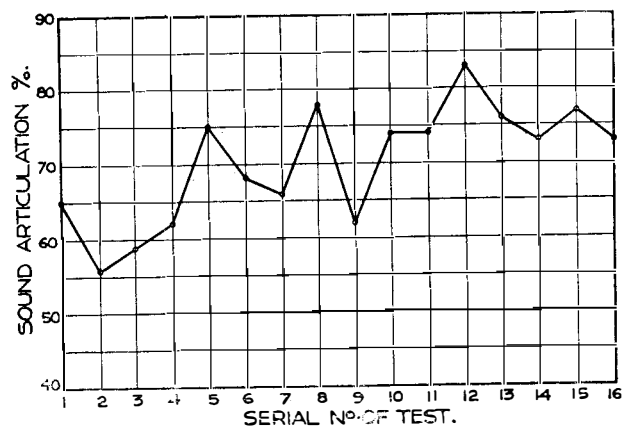

FIG. 7.

sults are given for two different cases. Fig. 7 gives the results for a single caller-listener combination, while Fig. 8 is for the average of two such combinations. It will be seen that the average value of articulation varies from about 60% at the beginning to about 70% at the end of the series of tests. The period of time over which this gradual improvement occurs varies for different testers. In some cases it has been

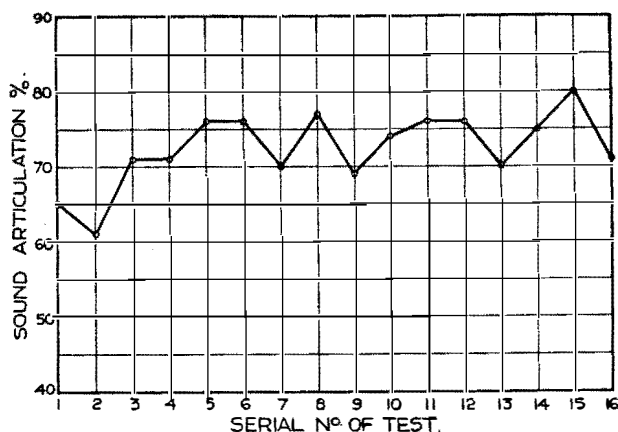

FIG. 8.

found that a tester reaches his steady state value in about a week, while in other cases the average curve still rises after two or three months. Even when two articulation crews are fully trained and have reached their steady state value, they will not necessarily obtain the same value of articulation for a given circuit, even if the average of a number of tests is taken. This is due, of course, to inherent differences in the testers composing the two crews. Measured values of articulation are, therefore, only relative and not absolute. To overcome this trouble and to avoid as far as is possible errors due to the fatigue and training effects, a method of calibrating an articulation crew has been devised. This method is discussed fully in the next section.

The number of sounds used in the test syllables and the frequency of occurrence of the individual sounds will both affect the articulation obtained, and their choice depends on whether or not the results are to approximate as closely as possible to speech conditions. There appears to be some difference of opinion on this point. Some writers have advocated a technique in which both the frequency of occurrence of the individual sounds and the arrangement of the test syllables approximated very closely to speech conditions, in order that the results shall represent a true criterion of speech. Other writers have argued that for practical testing it is better to simplify the technique as far as possible by using only one type of syllable and a uniform frequency of occurrence for the individual sounds. In the technique which was developed as a result of this study, lists are used in which the advantage of

simplicity and a close approximation to speech conditions are combined. These lists consist each of 200 sounds formed into 80 syllables, of which 40 are of the form consonant-vowel or vowel-consonant while 40 are of the form consonant-vowel-consonant. The frequency of occurrence of the individual sounds is arranged to be the same as in ordinary English speech. In making the analysis from which these frequencies of occurrence were obtained, only the key words in the sentences were analysed and actual spoken English was used. A key word in a sentence is defined as any word which carries an appreciable proportion of the sense of the sentence, so that its omission from the sentence would make the meaning obscure or ambiguous. The syllables are formed from the sounds entirely at random.

It will be obvious that these syllable lists are simple in form; the only further simplification that could have been made would be the use of only one type of syllable instead of two types. It was thought, however, that the very slight sacrifice in simplicity due to the use of two types of syllable was more than offset by the better approximation to speech conditions. It only remains to show, therefore, that these lists do approximate very closely to speech conditions and that further complications in the types of syllable employed are not actually necessary. In the course of this work it has been found that double consonants of the type pl, st, br, nt, etc., are received by the listener almost as though they were single sounds, so that syllables of the form consonant-consonant-vowel-consonant give the same articulation as syllables of the form consonant-vowel-consonant and syllables of the form vowel-consonant-consonant give the same articulation as syllables of the form vowel-consonant. It is therefore possible in an articulation test list to substitute more simple syllables for the more complicated forms without affecting the value of articulation obtained. If this is done it is found that approximately half the syllables employed in ordinary speech can be represented by the form consonant-vowel-consonant and half by the form vowel-consonant or consonant-vowel. It is of interest to note that Fletcher in a recent publication[‡] arrives at the same result. As a final demonstration of the accuracy with which syllable lists of the form described here approxi-

mate to actual speech conditions, the results of Figs. 2, 3 and 4 can be used. The theoretical value of word articulation and intelligibility in these figures was calculated using values of sound articulation obtained with the syllable lists just described. Since the calculated results do agree very closely with the measured values of word articulation and intelligibility, and since actual speech tests were used to obtain the measured results, it follows that these syllable lists do give results which are a good criterion of actual speech. Tests made with lists including more complicated syllable forms gave results which, as might be expected, varied more widely about the mean than do results obtained with the simpler forms. It is therefore desirable to omit all complicated forms from the syllable lists. On the whole, therefore, it seems reasonable to assume that the syllable lists suggested here form a satisfactory practical compromise between extreme simplicity and an absolute imitation of speech forms. The lists described here have, of course, been arranged for the English language, but similar arguments apply to any other language.

6.0. Calibration of Articulation Crew.

From the previous section it will be obvious that, while the effect of some factors on articulation results can be eliminated or reduced within permissible limits, there are certain quite important factors which cannot be removed. Examples of the latter are the effects of training and fatigue. While factors of this nature still exist it is obviously very difficult, if not quite impossible, to compare results taken at one time with results taken at some other time, or to compare results taken by different crews. To overcome this difficulty, a method has been developed by means of which it is possible to calibrate an articulation crew.

In a previous section it was shown that sound articulation could be expressed as a function of the band articulation. When a sound is transmitted to the listener, there are two factors which determine whether or not he will recognise a given characteristic band. The first of these

factors depends on the characteristics of the circuit over which the sound has been transmitted; if the circuit introduces a large amount of distortion, the listener will find it difficult to recognise the characteristic band. The second of these factors depends on the characteristics of the listener; if he thinks slowly or if he is unable to keep his attention from wandering, he will find it difficult to recognise a characteristic band. It is this second factor which changes as the listener becomes properly trained or as he becomes fatigued. Suppose that we take an ideal listener, *i.e.*, one for whom the second factor is unity, and determine the average probability that he will receive a characteristic band correctly over a given circuit, let this probability be b . Now suppose we take a given listener who is not ideal and determine the probability that he will receive a characteristic band correctly over an ideal circuit, *i.e.*, a circuit for which the first factor is unity, let this probability be z . Then, if we use the given listener on the given circuit, the probability that he will receive a characteristic band correctly will be the product of the previous two probabilities, in other words it will be equal to zb . This assumes, of course, that the value of z really is a constant for the listener and is not affected by the kind of circuit on which he measures. The extent to which this assumption holds good in practice will be discussed later, for the moment it will be assumed that it does so.

In the second paper† referred to above it was shown how b could be calculated for a circuit. If, therefore, we take a circuit for which we know b and measure a value of sound articulation on it with a crew whose calibration is to be determined, then from Fig. 5 we can find the corresponding value of zb and knowing b we thus determine z for the crew in question.

Suppose now that it is required to determine the ideal sound articulation for a given telephone circuit using the crew which has just been calibrated. We obtain a value of sound articulation with this crew on the given circuit and from Fig. 5 determine the corresponding value of zb . Since we know z for the crew, we can immediately calculate b and then from Fig. 5 again we can find the value of sound articulation corresponding to b . This value will be the ideal sound articulation, since it is the value corresponding to zb when z is unity.

† "Articulation Testing Methods." H. Fletcher and J. C. Steinberg. *Bell System Technical Journal*, October, 1929.

The success of this method of calibration depends on the correctness of the assumption that z is a true constant for a given crew and does not vary according to the circuit conditions under which it is measured. It does not seem immediately obvious from any theoretical reasoning that this should be so. Indeed, one might be justified on theoretical grounds in assuming that when a listener is using a bad circuit he exerts a greater effort and, since z is a measure of his mental effort, we might expect z to change. As a matter of fact when the author first attempted to calculate intelligibility from sound articulation exactly the same objection was raised; it being

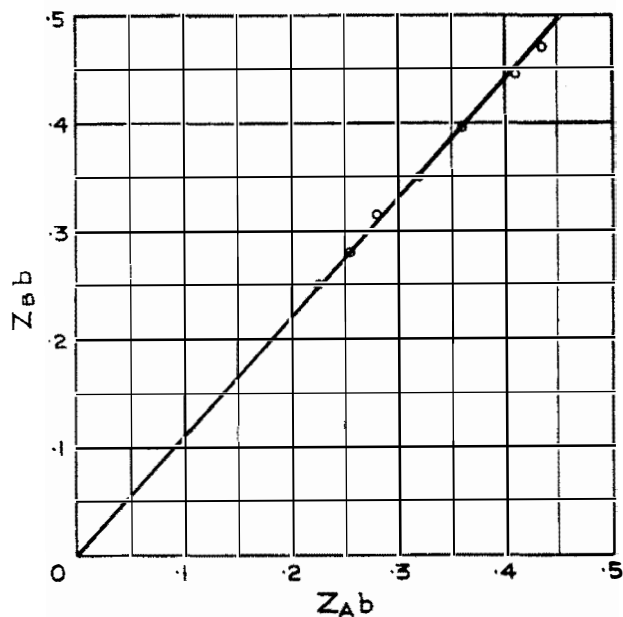

FIG. 9.

said that the practical results would never agree with the theoretical results because, when the listener was using a bad circuit, there was a variable factor depending on the amount of effort exerted by him. Actually, as will be seen from the curves given in this paper, the practical results do agree with the theoretical results, so that, apparently, this variable factor does not exist. In exactly the same way it has been found that z really is a constant for a given crew. This will be obvious from Figs. 9, 10, 11 and 12. Fig. 9 was obtained in the following way. A series of articulation results were measured on a circuit whose attenuation could be varied. Results were

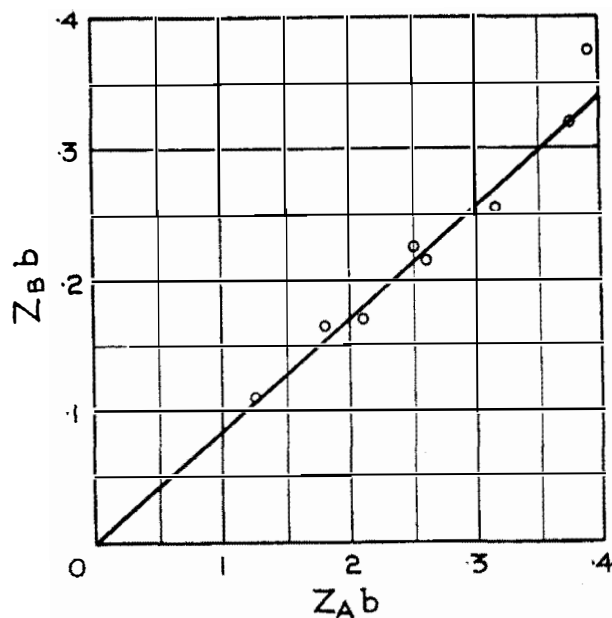

FIG. 10.

obtained for different values of attenuation and for each value of attenuation two values of articulation were obtained, one with a crew A and one with another crew B. Corresponding values of sound articulation D_A and D_B were converted to values of zb using Fig. 5. A series of pairs of values $z_{Ab_1}, z_{Bb_1}, z_{Ab_2}, z_{Bb_2}$, etc., were thus obtained. If we now divide one value of a pair by the other we get a ratio z_A/z_B and, if z_A and z_B

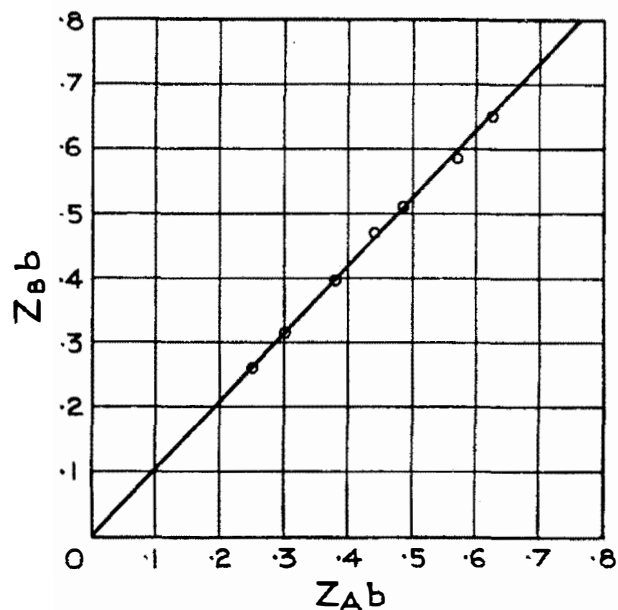

FIG. 11.

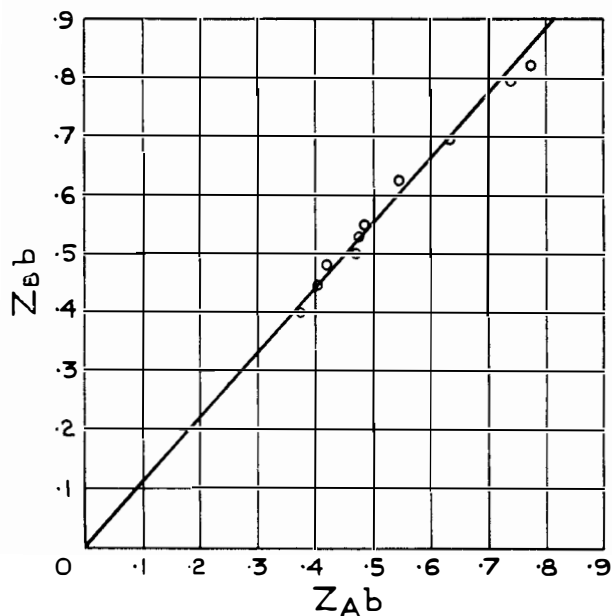

FIG. 12.

really are independent of the circuit condition this ratio should be constant. In Fig. 9 corresponding values of $z_A b$ and $z_B b$ have been plotted one against the other so that, if z_A/z_B is constant, all the points should lie on a straight line through the origin. Fig. 10 was obtained in a similar way except that the circuit condition which was changed was the amount of line noise in the circuit. It will be seen that the points do fall close to a straight line in each case and that this line does pass through the origin. The points do not fall so close to the line in the second case because the testing crew was smaller and the average error was consequently larger. For the first case the average error of the measurements was less than $\pm 1\%$ and for the second case about $\pm 2\%$. In order to give a more general demonstration of the accuracy with this calibration method two further sets of results are given in Figs. 11 and 12. The points for these two cases were obtained in exactly the same way as for Figs. 9 and 10 except that the values were obtained from some articulation results published recently by Fletcher.† It will be noticed that here again the points all lie very close to a straight line through the origin. It is clear from these examples that the assumption of a constant z for a given crew is correct in practice within the limits of experimental error.

It will be as well here to point out under what conditions this method, or indeed any other method of calibration, cannot be expected to give good results. When an articulation crew first starts testing, the values they obtain are low, but gradually increase as the crew becomes more expert. This has been referred to before and is illustrated in Figs. 7 and 8. If, after the crew has reached a steady state on a certain type of circuit, they are transferred to a different type of circuit, they go through the same process of improvement on the new circuit. This is in spite of the fact that they may be considered fully trained as regards the first type of circuit. The second time, however, the period of training is very much shorter, and the greater and more varied the experience of the crew, the more rapidly do they reach a steady state on a new circuit. If, now, a crew has reached a steady state on the calibrating circuit and is used to obtain results on some new circuit, the values they obtain on the calibrating circuit will be no indication of what variations they may get on the new circuit until after the first few tests on the new circuit have been completed and the steady state on this circuit has been reached. Since, however, the first few tests on a new circuit are never very reliable, they should not be used in any case, so that this does not constitute a disadvantage of the proposed method of calibration.

As an example of the use of this method of calibration, the following case is given. A set of tests was made on four different occasions on a circuit into which a large amount of line noise was introduced. During each of the four tests a calibration reference test was made on a circuit for which the value of b was known. The values obtained are given below together with the corresponding values of ideal sound articulation calculated by means of the calibration method given above.

Measured Sound Calibration Circuit.	Articulation. Test Circuit.	Ideal Sound Articulation.
71.0	51.5	61.5
75.0	58.0	63.5
73.0	51.5	60.0
73.0	53.0	61.5

The average error in the measured values of articulation for the test circuit is $\pm 4.5\%$ and for

the values of ideal sound articulation $\pm 1.4\%$. The average error for the ideal sound articulation is within the limits of experimental error for the individual measurements which in this case were $\pm 2\%$.

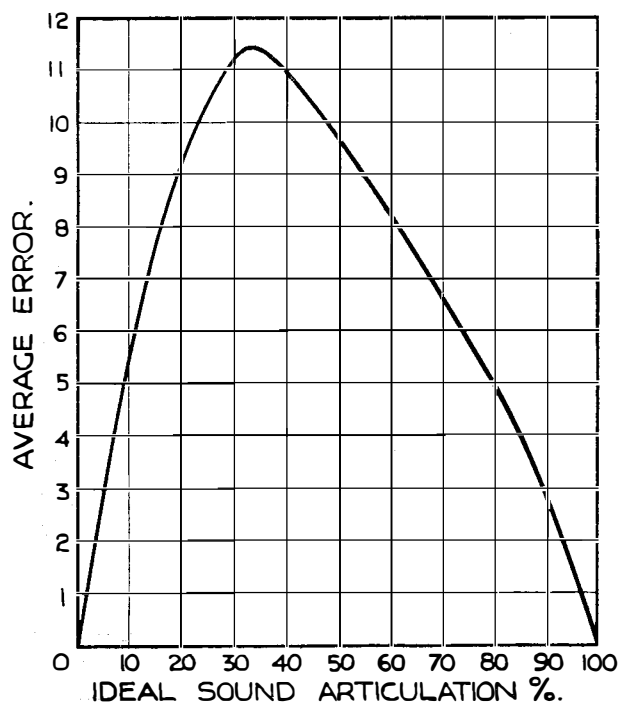

FIG. 13.

7.0. Accuracy obtainable in Articulation Tests.

It is of interest to consider what degree of accuracy can be obtained in an articulation test when all the precautions suggested in this paper are taken, and when the method of calibration described here has been used. The accuracy of the measurements will depend, of course, on the value of articulation, but for a circuit giving an ideal sound articulation of 70—80% such as would be obtained for the average circuit between two subscribers, the average error for a caller-listener combination has been found to be

about $\pm 6\%$. In this work a crew of nine testers is used, each tester calling in turn to the remaining eight. The average of these 72 results is known as the crew average and the average error for this will be about $\pm 0.7\%$.

The average error for other values of articulation is given in Fig. 13.

8.0. Conclusions.

Everyone will doubtless agree as to the desirability of adopting a standardised technique for articulation testing, so that results obtained by different experimenters may be directly comparable. Unfortunately, there is no such uniformity of opinion on the question as to what particular technique should be adopted as standard. However, the technique suggested here includes the advantages of simplicity and a reasonably close approximation to actual speech conditions. In addition it is founded on a sound theoretical basis and confirmed by a long series of practical tests. In particular the novel method of calibrating the articulation crew combined with the use of Ideal Sound Articulation removes one of the chief objections to articulation testing, that is to say, that results obtained at different times or by different crews are not comparable. The accuracy obtainable is such that the average error does not exceed $\pm 1.5\%$ for the worst case and for normal circuits is less than $\pm 1\%$. It is hoped, therefore, that the particulars given here of the new articulation technique may prove of material assistance to all those telephone engineers who have articulation tests to carry out and that it may eventually lead to the adoption of a universal standard technique for articulation testing.

In conclusion, the author would like to thank the International Standard Electric Corporation and the International Telephone and Telegraph Laboratories, Incorporated, for permission to publish the results given in this paper.

AN IMPROVED FORM OF MAXWELL D.C. INDUCTANCE BRIDGE AND A METHOD OF MEASURING THE TIME CONSTANT OF THE CORE OF A MAGNET.

L. H. HARRIS, M.Sc., and H. WILLIAMS, A.C.G.I.

IN the following paper in which various types of D.C. Inductance Bridge are considered the term "current balance" refers to the case where zero deflection of the galvo results from the current in it being zero at every instant, while the term "quantity balance" refers to the case where zero deflection of the galvo results from the aggregate quantity of current through it being zero.

In that form of Maxwell Bridge, shown in Fig. 1, the conditions of balance under A.C. conditions are obtained by equating the products of the impedances of opposite arms of the bridge, that is,

$$QS = (R + j\omega L) \left(\frac{P}{1 + j\omega CP} \right)$$

which, on separating the real and imaginary parts, gives for balance

$$\frac{L}{C} = QS = PR.$$

The conditions are independent of frequency and it follows that they hold for a source containing any combination of frequencies such as the make or break of a battery or any irregular wave shape.

The Rimington-Maxwell Bridge, shown in Fig. 2, is also commonly used for D.C. Inductance measurements, the conditions of balance evolved from equating the products of opposite arms of the bridge being as follows:—

$$QS = (R + j\omega L) \left(P - T + \frac{T}{1 + j\omega CT} \right)$$

$$\therefore QS + j\omega CTQS = (R + j\omega L)(P + j\omega CPT - j\omega CT^2).$$

Separating real and imaginary terms

$$\left. \begin{aligned} QS &= PR - \omega^2 LCT(P - T) \\ CQST &= RCPT - RCT^2 + PL. \end{aligned} \right\}$$

Substituting the essential initial condition for steady balance of $PR = QS$, two conditions are obtained for balance

$$\frac{L}{C} = \frac{RT^2}{P}$$

$$\text{and } \omega^2 LCT(P - T) = 0,$$

that is, either T must equal P (giving the simple Maxwell Bridge) or else $\omega = 0$, indicating that current balance would only be obtained with very slow sine wave alternations.

It follows from this that if current balance were essential for the balance of this bridge on make or break of the battery, that it could not be used for the measurement of D.C. inductance. Rimington has pointed out, however, that zero deflection of the galvo can be obtained if the conditions are such that the aggregate quantity of electricity through the galvo is zero, in which case current balance can be dispensed with. Mathematical consideration of the simple case where the resistance of the galvo is large follows. Taking first the current balance of the Maxwell Bridge: Consider the "make" of the battery current. The growth of current in P from 0 to

$$\frac{E}{P+Q} \text{ is given by } \frac{E}{P+Q} \left(1 - e^{-\frac{t}{\tau}} \right) \text{ where } \tau \text{ is } \frac{PQ}{P+Q},$$

$$\text{while the growth of current in } S \text{ is given by } \frac{E}{R+S} \left(1 - e^{-\left(\frac{R+S}{L}\right)t} \right)$$

The voltages across P and S are therefore

$$\frac{EP}{P+Q} \left(1 - e^{-\frac{t}{\tau}} \right) \text{ and } \frac{ES}{R+S} \left(1 - e^{-\left(\frac{R+S}{L}\right)t} \right)$$

and these must be equal at every instant for current balance. For this to be true, the initial and final voltages must be equal and also the time constants must be equal.

$$\text{That is, } \frac{P}{P+Q} = \frac{S}{R+S}, \text{ or } PR = QS.$$

$$\text{and } \frac{R+S}{L} = \frac{P+Q}{CPQ} \text{ i.e., } \frac{L}{C} = \frac{PQ(R+S)}{P+Q} = SQ.$$

FIG. 1 MAXWELL

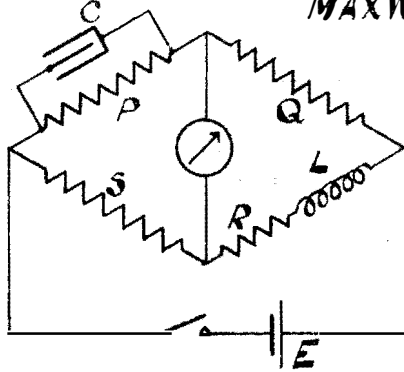

FIG. 2 RIMINGTON-MAXWELL

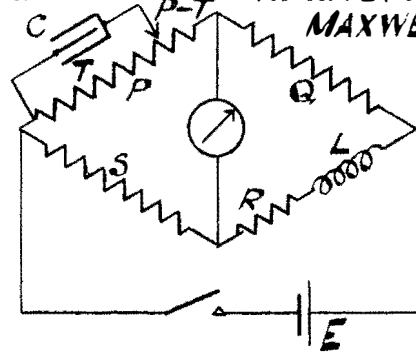

FIG. 3

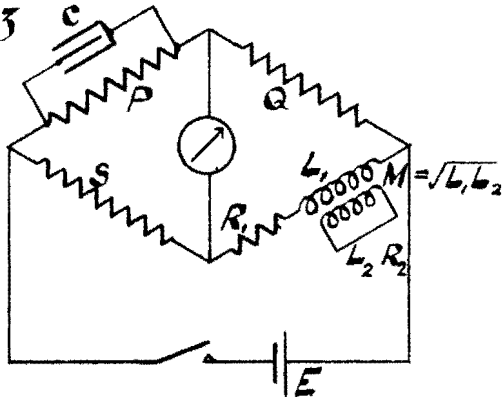

FIG. 4

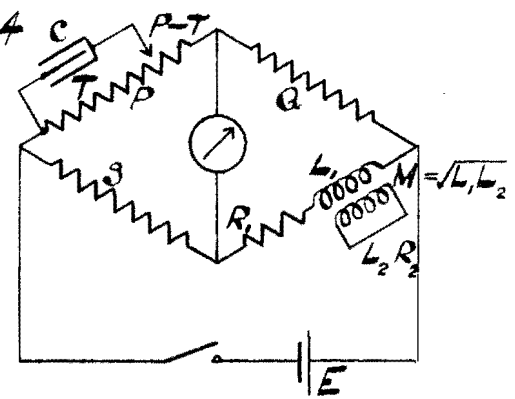

FIG. 5

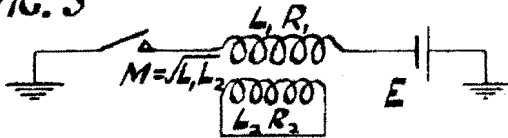

FIG. 6

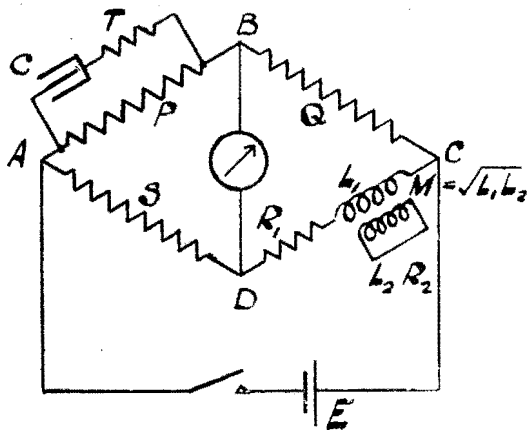
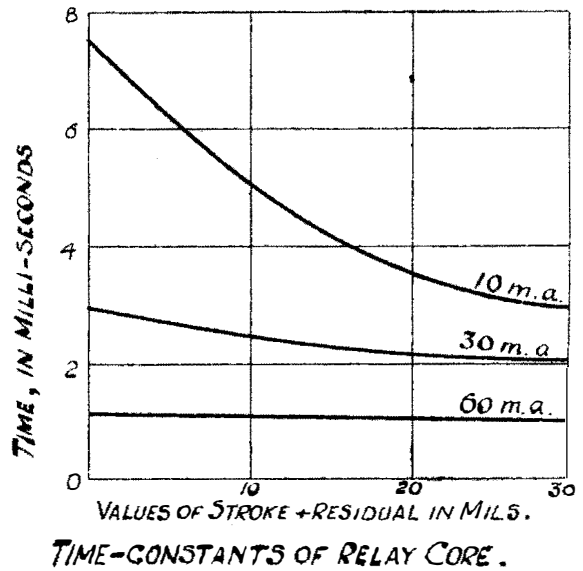

FIG. 7



These conditions are those obtained in the first instance for the general case.

In the case of the Rimington-Maxwell Bridge (Fig. 2), the current in the arm Q, on switching on the battery decays logarithmically from

$$\frac{E}{P+Q-T} \text{ to } \frac{E}{P+Q} \text{ according to the law}$$

$$i_q = \frac{E}{P+Q} + \left(\frac{E}{P+Q-T} - \frac{E}{P+Q} \right) e^{-\frac{t}{Cr}}$$

$$\text{where } r = \frac{T(P+Q-T)}{P+Q}$$

while in the arms S and R the current grows from zero to $\frac{E}{R+S}$ according to the law

$$i_s = \frac{E}{R+S} \left(1 - e^{-\left(\frac{R+S}{L}\right)t} \right)$$

as in the simple Maxwell Bridge.

It is obvious from the nature of these currents, one jumping immediately to a finite value, and the other growing logarithmically from zero, that the voltage across the galvanometer cannot be zero at every instant and therefore a current balance is impossible. If the voltage across the galvanometer is found and the conditions for making the integral of this voltage zero are calculated, this condition will also be the condition for zero aggregate quantity of electricity in the galvanometer.

From the above, the voltage across Q will be

$$\frac{EQ}{P+Q} + \frac{ETQ}{(P+Q)(P+Q-T)} e^{-\frac{t}{Cr}}$$

$$\text{and across R is } E - \frac{ES}{R+S} \left(1 - e^{-\left(\frac{R+S}{L}\right)t} \right)$$

$$= \frac{ER}{R+S} + \frac{ES}{R+S} e^{-\frac{R+S}{L}t}$$

The difference between these voltages gives the P.D. across the galvanometer, and since

$$\frac{Q}{P+Q} = \frac{R}{R+S}, \text{ this will be:}$$

$$\text{P.D. across galvo.} = \frac{ETQ}{(P+Q)(P+Q-T)} e^{-\frac{t}{Cr}} - \frac{ES}{R+S} e^{-\left(\frac{R+S}{L}\right)t}$$

Integrating this expression between the limits $t = 0$ to $t = \infty$ gives

$$- \frac{ET^2QC}{(P+Q)^2} + \frac{ESL}{(R+S)^2}$$

$$= \frac{EQ^2}{(P+Q)^2} \left(-\frac{T^2C}{Q} + \frac{LS}{R^2} \right), \text{ which is zero}$$

$$\text{if } \frac{L}{C} = \frac{T^2R^2}{SQ} = \frac{T^2R}{P} \text{ since } PR = QS.$$

It will be seen, therefore, with this type of bridge that, although current balance is impossible, a quantity balance may be obtained. It is usual to use a long period galvo for these measurements, but, nevertheless, a double kick is usually visible, which detracts from the accuracy of the result.

The Effect of the presence of a Closed Secondary Winding.

In most inductances in practice, there is present some semblance of a closed secondary circuit, e.g., the iron core of the inductance or in the case of relays, slugs and sleeves for slowing down the rate of flux change. The presence of this secondary circuit renders the above theory invalid due to the fact that the current in the primary of a coil can jump instantaneously to a finite value providing there is present a closely coupled closed secondary circuit. For example, in the circuit of Fig. 5, on closing the switch the current in the primary circuit can easily be shown

$$\text{to be } \frac{E}{R_1} \left(1 - \frac{T_1}{T_1+T_2} e^{-\frac{t}{T_1+T_2}} \right) \text{ where } T_1 \text{ and}$$

T_2 are the time constants $\frac{L_1}{R_1}$ and $\frac{L_2}{R_2}$ of the primary and secondary respectively. This means that the current jumps at $t=0$ to $\frac{T_2}{T_1+T_2}$ of its final value.

If the simple Maxwell Inductance Bridge of Fig. 1 be used for the measurement of a coil having a closed secondary circuit, as shown in Fig. 3, it follows that current balance is impossible, but quantity balance can still be obtained, the conditions being the same as those previously required for current balance. Referring to Fig. 3, the current in Q on switching

$$\text{on} = \frac{E}{P+Q} + \left(\frac{E}{Q} - \frac{E}{P+Q} \right) e^{-\frac{t}{Cr}}$$

$$\text{where } r = \frac{PQ}{P+Q}$$

$$\text{Current in } S = \frac{E}{R_1+S} \left(1 - \frac{T_1}{T_1+T_2} e^{-\frac{t}{T_1+T_2}} \right)$$

$$\text{Volts across } Q = \frac{EQ}{P+Q} + \frac{EP}{P+Q} e^{-\frac{t}{Cr}}$$

$$\text{Volts across } R_1 = E - \frac{ES}{R_1+S} \left(1 - \frac{T_1}{T_1+T_2} e^{-\frac{t}{T_1+T_2}} \right)$$

Difference = P.D. across the galvanometer

$$= \frac{EP}{P+Q} e^{-\frac{t}{Cr}} - \frac{EST_1}{(R_1+S)(T_1+T_2)} e^{-\frac{t}{T_1+T_2}}$$

$$\int_0^{\infty} \text{P.D.} = \frac{EP^2CQ}{(P+Q)^2} - \frac{EST_1}{(R_1+S)}$$

$$= \frac{EP^2CQ}{(P+Q)^2} - \frac{ESL_1}{(R_1+S)^2}$$

$$= \frac{EP^2}{(P+Q)^2} \left(CQ - \frac{L_1}{S} \right), \text{ which is}$$

zero, giving a quantity balance if $\frac{L_1}{C} = QS$.

Similar reasoning shows that with a secondary circuit the Rimington-Maxwell Bridge gives a quantity balance independently of the presence of the secondary circuit, the conditions of balance being as before

$$PR_1 = QS \text{ and } \frac{L_1}{C} = \frac{R_1 T^2}{P}$$

This was demonstrated recently by Dr. Turney in J.I.E.E., Vol, 66, p. 382.

The chief advantage of the Rimington-Maxwell Bridge is that a fixed condenser can be used instead of an expensive variable standard, and quantity balance obtained by moving the tapping along the resistance P. A further property of this bridge can, however, be made use of if both the tapping point along P and the condenser are variable. This property is demonstrated below. Referring to Fig. 4, on switching on, the current in the branch Q decays logarithmically as before according to the law

$$i_q = \frac{E}{P+Q} + \left(\frac{E}{P+Q-T} - \frac{E}{P+Q} \right) e^{-\frac{t}{Cr}}$$

$$\text{where } r = \frac{T(P+Q-T)}{P+Q}$$

while the current in S obeys the law

$$i_s = \frac{E}{R_1+S} \left(1 - \frac{T_1}{T_1+T_2} e^{-\frac{t}{T_1+T_2}} \right)$$

where $T_1 = \frac{L_1}{R_1+S}$ and $T_2 = \frac{L_2}{R_2}$ are the time

constants of the primary and secondary circuits respectively. The voltage across Q is therefore

$$V_q = \frac{EQ}{P+Q} + \frac{ETQ}{(P+Q)(P+Q-T)} e^{-\frac{t}{Cr}}$$

and across R_1

$$V_R = E - \frac{ES}{R_1+S} \left(1 - \frac{T_1}{T_1+T_2} e^{-\frac{t}{T_1+T_2}} \right) = \frac{ER_1}{R_1+S} + \frac{ES}{R_1+S} \left(\frac{T_1}{T_1+T_2} \right) e^{-\frac{t}{T_1+T_2}}$$

These must be equal for a current balance, the three conditions necessary being therefore

$$\left. \begin{aligned} \frac{EQ}{P+Q} &= \frac{ER_1}{R_1+S} \\ \frac{ETQ}{(P+Q)(P+Q-T)} &= \frac{ES}{R_1+S} \left(\frac{T_1}{T_1+T_2} \right) \\ \frac{1}{Cr} &= \frac{1}{T_1+T_2} \end{aligned} \right\}$$

The first condition is simply the D.C. balance condition that $SQ = PR_1$ while the second and third conditions simplify by substitution to

$$\frac{L_1}{C} = \frac{R_1 T^2}{P}$$

$$\text{and } \frac{L_2}{R_2} = \left(\frac{P-T}{T} \right) \frac{L_1}{R_1}$$

The first two conditions are those for quantity balance, while the third condition gives a potential method of measuring the time constant of a secondary circuit for cases where direct measurement is impossible, *e.g.*, the core of a relay.

As quantity balance can be obtained with the first two conditions only, it is necessary to be able to distinguish between quantity and current balance in order to obtain the third condition.

Two methods were found workable. The first was to make use of the "double kick" present with a quantity balance (particularly when using a quick-moving instrument) and to adjust the value of C and the tapping point in P until the movement of the needle was a minimum. The second method made use of a rectifier and reversing switch in series with the galvanometer to cut off half the oscillations in the instrument, and so preventing the bridge being balanced unless all the three conditions for current balance were present.

The use of the Rimington-Maxwell Bridge in this way is extremely tedious, for in obtaining current balance every alteration in the condenser value necessitates a readjustment of the tapping point on P , and many such adjustments are necessary. To avoid the interdependence of adjustment the modified bridge shown in Fig. 6 was devised. In this case steady balance is first obtained; then by adjusting C quantity balance is secured and, finally by adjusting the resistance T in series with the condenser the bridge is balanced for current, no further adjustment of the capacity being necessary.

The conditions for current balance on making or breaking the battery in this bridge can be simply shown by finding the condition which will make the balance independent of frequency as follows:

For current balance

$$QS = \left(\frac{I}{P} + \frac{I}{T + \frac{I}{j\omega C}} \right) \left(R_1 + j\omega L_1 + \frac{\omega^2 M^2}{R_2 + j\omega L_2} \right)$$

the expressions in brackets being the impedances of the arms AB and CD respectively. Working this out and putting in the steady state balance condition of $PR_1 = QS$ shows that for the bridge to be independent of frequency the conditions

$$\frac{L_1}{C} = PR_1 = QS \text{ and } \frac{L_2}{R_2} = CT \text{ must hold.}$$

These conditions are independent of one another and therefore facilitate the use of the bridge. The following shows for the simple case how the introduction of T enables current balance to be obtained without affecting the conditions for quantity balance in any way.

On closing the battery switch the current in

Q decays logarithmically from $\frac{E}{Q + \frac{PT}{P+T}}$ to

$\frac{E}{P+Q}$ according to the law

$$i_Q = \frac{E}{P+Q} + \left(\frac{E}{Q + \frac{PT}{P+T}} - \frac{E}{P+Q} \right) e^{-\frac{t}{\tau}}$$

$$\text{where } \tau = T + \frac{PQ}{P+Q}$$

while in S the current obeys the law

$$i_S = \frac{E}{R_1+S} \left(1 - \frac{T_1}{T_1+T_2} e^{-\frac{t}{T_1+T_2}} \right) \text{ where } T_1 =$$

$$\frac{L_1}{R_1+S} \text{ and } T_2 = \frac{L_2}{R_2}$$

The voltage across Q is therefore

$$\frac{EQ}{P+Q} + \frac{EP^2Q}{(QP+QT+PT)(P+Q)} e^{-\frac{t}{\tau}}$$

$$\text{and across } R_1 \text{ is } E - \left(\frac{ES}{R_1+S} - \frac{ES}{R_1+S} \frac{T_1}{T_1+T_2} e^{-\frac{t}{T_1+T_2}} \right) \\ = \frac{ER_1}{R_1+S} + \frac{EST_1}{(R_1+S)(T_1+T_2)} e^{-\frac{t}{T_1+T_2}}$$

For current-balance the conditions are therefore

$$\left. \begin{aligned} \frac{Q}{P+Q} &= \frac{R_1}{R_1+S} \\ \frac{P^2Q}{(QP+QT+PT)(P+Q)} &= \frac{EST_1}{(R_1+S)(T_1+T_2)} \\ \text{and } \frac{I}{T_1+T_2} &= \frac{I}{C \left(T + \frac{PQ}{P+Q} \right)} \end{aligned} \right\}$$

Simplifying these conditions $QS = PR_1$, $\frac{L_1}{C} = QS$, and $\frac{L_2}{R_2} = CT$ as obtained previously.

Now considering quantity balance: — The P.D. across the galvanometer is

$$\frac{EQ}{P+Q} + \frac{EP^2Q}{(QP+QT+PT)(P+Q)} e^{-\frac{t}{\tau}} - \\ \frac{ER_1}{R_1+S} + \frac{EST_1}{(R_1+S)(T_1+T_2)} e^{-\frac{t}{T_1+T_2}}$$

which with the steady condition of $PR_1 = QS$ is

$$\frac{EP^2Q}{(QP + QT + PT)(P + Q)} e^{-\frac{t}{T}} - \frac{EST_1}{(R_1 + S)(T_1 + T_2)} e^{-\frac{t}{T_1 + T_2}}$$

For zero aggregate quantity in the galvo the integral of the P.D. from $t=0$ to $t=\infty$ must be zero.

$$\therefore \frac{PQC}{P + Q} = T_1 = \frac{L_1}{R_1 + S}$$

from which $\frac{L_1}{C} = SQ$ independent of the value of T .

In practice the accuracy of measurement of L_1 and R_1 is good, but the accuracy of the result for the secondary circuit is limited to about 10%, by the incomplete coupling usually present between the core and winding and probably by the self-capacity. Further, the assumption that the core of a relay can be represented mathematically as a simple secondary winding is only approximate with the result that instead of zero deflection sometimes a minimum has to be taken.

It is of course the time constant of the core which largely determines the release lag of a quick-release relay, while its operation is dependent both on the time constants of the winding and of the core. For the application of the time constants of a relay to the calculation of operate and release time lags, reference may be made to the paper on "The Principles of Relay Timing,"

by Dr. Turney, loc. cit. Fig. 7 shows the time constant of the core of a typical telephone relay as measured by this method. It will be noticed that it varies with the degree of saturation of the iron and also with the armature air gap. Tests on a relay fitted with a copper sleeve showed that the time constant of the sleeve could be measured fairly accurately, but in the case of a relay fitted with a copper slug at the armature end of the core the incomplete coupling was found to interfere with the balance to a large extent.

As the eddy current losses in an inductance supplied with A.C. are dependent on the time constant of the eddy current paths in the core the above modification may have an application to A.C. Bridges. It was noticed that the time constant of the core of a Repeating Coil 4006A was about 0.3 milliseconds.

Other types of bridge can be used such as Illovcis' modification of the Maxwell Bridge in a similar manner, but that of Fig. 6 is most convenient in practice as the balance conditions are independent of one another.

Apart from the application of this bridge to the measurement of time constants of the cores, etc., of inductances, the modification enables more exact measurements of the primary inductance to be obtained as the "double kick" effect generally present due to the necessity for quantity balance can be reduced by adjustment of the resistance T to give current balance.

The following table shows the current and quantity balance conditions for the particular types of bridge discussed in this paper:—

Conditions of Balance.				
	Inductance without secondary circuit.		Inductance with secondary circuit.	
	Quantity Balance.	Current Balance.	Quantity Balance.	Current Balance.
Maxwell Bridge ...	$\frac{L}{C} = QS = PR$		$\frac{L_1}{C} = QS = PR_1$	Not possible
Rimington-Maxwell Bridge ...	$\frac{L}{C} = \frac{T^2R}{P}$ and $PR = QS$	Not possible	$\frac{L_1}{C} = \frac{T^2R_1}{P}$ $PR_1 = QS.$	$\frac{L_1}{C} = \frac{T^2R_1}{P}$ $PR_1 = QS.$ $\frac{L_2}{R_2} = \left(\frac{P - T}{T} \right) \frac{L_1}{R_1}$
Modified Maxwell Bridge of Fig. 6 ...	$\frac{L}{C} = QS = PR$	$\frac{L}{C} = QS = PR$ and $T = 0$	$\frac{L_1}{C} = QS = PR_1$	$\frac{L_1}{C} = QS = PR_1$ $CT = \frac{L_2}{R_1}$

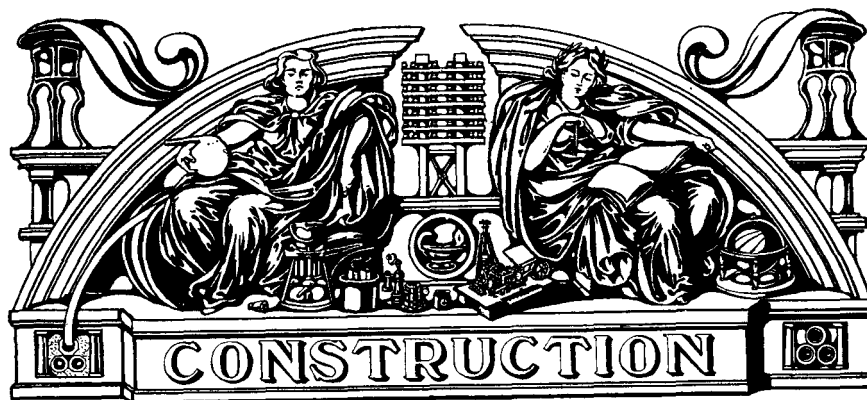

A.C. METHODS OF FAULT LOCALISATION IN TELEPHONE CABLES.

W. T. PALMER, A.M.I.E.E., and M. E. TUFNAIL, Student, I.E.E.

SUMMARY. — *Theoretical and practical details are given of the application of audio-frequency alternating current measurements for the purpose of localising faults in paper-core cables, with special reference to the continuously-loaded type of such cables. Methods are given for dealing with the case of a complete breakdown of the insulation of all circuits and for the case of a high resistance fault in one conductor of a pair. It will be seen that when so applied the A.C. methods have many advantages over the D.C. methods and, unlike the latter, the former give absolutely reliable results with errors of less than 1%, from SIMPLE ARITHMETICAL CALCULATIONS.*

Introduction.—(1) With the increasing use of lead-sheathed paper-core submarine cables for telephonic links between this country, neighbouring islands and the Continent, there is an ever-increasing risk of the complete breakdown of all circuits of some important route due to the failure of its submarine link. When the lead sheath of such a link is fractured (by anchors, trawls, rocky sea-bed, etc.) the penetration of sea-water and the consequent earthing of every wire is only a matter of hours, or perhaps minutes. Fault localisation by direct current methods then becomes unsatisfactory for several reasons, chief among which ranks the polarisation at the fault. Sometimes a “ Varley Loop ”

test is possible by arranging for a “ good ” wire *via* another route, but this involves the expenditure of much valuable time, whilst frequently the “ good ” wire so obtained is unsatisfactory, due to induced currents which adversely affect the galvanometer deflection, and the localisation can only be stated within wide limits. In such cases, when all circuits are badly affected, the A.C. method used as described in Section I. gives results with a much greater degree of reliability than any of the D.C. tests which can be applied.

(2) Another type of fault, difficult to localise and encountered in underground cables more frequently than in submarine cables, is that of a high resistance concentrated at some point in one conductor of a pair. Examples of the likely causes of such faults are badly soldered connections at loading points and at the cable joints. Usually the fault resistance varies rapidly throughout the localisation test and renders the use of D.C. methods difficult and often unreliable, whereas the A.C. method described in Section II. may be applied without loss of accuracy in such cases.

SECTION I.—COMPLETE BREAKDOWN OF ALL CABLE CIRCUITS.

Theoretical Considerations. — Consider the case of a contact fault of resistance F ohms at a distance l nauts from the sending-end of a cable

having otherwise uniformly distributed electrical constants and closed by its characteristic impedance Z_0 . See Fig. 1.

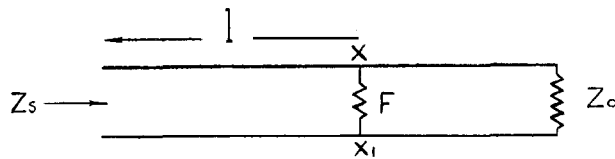

FIG. 1.

The resulting terminating impedance, Z_r , of this arrangement at XX_1 is given by

$$Z_r = \frac{FZ_0}{F + Z_0} \dots\dots\dots(1)$$

and the sending-end impedance, Z_s , by

$$Z_s = \frac{Z_0 Z_r \cosh \gamma l + Z_0^2 \sinh \gamma l}{Z_0 \cosh \gamma l + Z_r \sinh \gamma l} \dots\dots\dots(2)$$

where Z_0 is the characteristic impedance of the cable,

γ is the propagation constant of the cable
 $= \beta + j\alpha$ and

β is the attenuation constant,
 α is the wave-length constant.

This equation (2) can be evaluated from a knowledge of the value of F and of the primary constants $R, L, G,$ and C . (See Table I.). In the case of a short-circuit, $F=0$, then equation (2) becomes

$$Z_s = Z_0 \tanh \gamma l \dots\dots\dots(3)$$

From (3) Z_0 is considered to be constant and to have zero angle (a condition which is approximately true in the case of a continuously-loaded cable for frequencies within the audio-range considered) it can be shown that the sending-end impedance, Z_s , will pass through maximum points when

$$2\alpha l = \pi, 3\pi, 5\pi \dots \text{etc.} \dots\dots\dots(4)$$

Hence the frequency f_1 at which the first maximum point occurs in the ideal case can be found from the expression

$$2\alpha_1 l = 2l \sqrt{\frac{1}{2} \{ \sqrt{(R^2 + \omega_1^2 L^2)} \omega_1^2 C^2 + \omega_1^2 LC \}} = \pi \dots\dots(5)$$

where $\alpha_1 =$ wave-length constant at a pulsance
 $\omega_1 = 2\pi f_1$,

- $R =$ resistance per unit length,
- $L =$ inductance per unit length and
- $C =$ capacity per unit length.

From equation (5) it can be readily shown that the value of f_1 is given by the expression

$$f_1 = \frac{\pi}{4l \sqrt{l^2 R^2 C^2 + \pi^2 LC}} \dots\dots\dots(6)$$

Thus knowing the value of f_1 by measurement, it is possible to use equation (6) or the more approximate and convenient equation (7) following, to calculate the distance to the fault F .

Approximations to Equation (6).

(a) *The Loaded Cable.* — If $l^2 R^2 C^2$ be neglected as a first approximation, the expression becomes

$$f_1 = \frac{1}{4l \sqrt{LC}} \approx \frac{K}{2l} \dots\dots\dots(6A)$$

where K is a constant.

Again from equation (4) it is seen that the theoretical second maximum point occurs at a frequency $f_2 = 3f_1$ and hence $f_2 - f_1 = 2f_1$. If, therefore, we write f as the frequency interval between successive maximum points we obtain

$$f = 2f_1 \approx \frac{1}{2l \sqrt{CL}} \approx \frac{K}{l} \dots\dots\dots(7)$$

It is important to notice that the first maximum point may be considered to occur at a frequency $\frac{1}{2}f$ from zero, *i.e.*, at half the mean frequency interval.

Equation (7) is essentially true for all values of F small enough to cause pronounced periodic maximum points to occur in the Z_s/f curve, and can be obtained in another way as follows:—

*Electrical energy will be partly reflected at the fault F and part will travel to the distant end. The phase of the reflected portion at any given frequency, when it reaches the sending-end, will have changed by an angle $(2\alpha_1 l + \phi_1)$ radians, where $\phi_1 =$ change in phase produced at the fault

F ,

$\alpha_1 =$ wave-length constant at the frequency f_1 considered

and $l =$ distance to the discontinuity F .

Then if two successive maximum points, which are found in the value of the sending-end

* See *I.P.O.E.E. Paper No. 76 (1919)* by *C. Robinson and R. M. Chamney.*

impedance as it changes with frequency, occur at frequencies f_1 and f_2 cycles per second respectively, we have

$$(2\alpha_2 l + \phi_2) - (2\alpha_1 l + \phi_1) = 2\pi$$

and $\therefore l = \frac{\pi + \frac{1}{2}(\phi_1 - \phi_2)}{\alpha_2 - \alpha_1}$ (8)

If we assume $\phi_1 = \phi_2$, and in the case of the continuously loaded cable with contact fault this is very nearly true (See Table I.), we get

$$l = \frac{\pi}{\alpha_2 - \alpha_1}$$

or, in the case of the loaded cable, writing $f = f_2 - f_1$ and $\alpha_1 = 2\pi f_1 \sqrt{LC}$ we have

$$l = \frac{l}{2f\sqrt{CL}}$$
(9)

which is the same as equation (7).

(b) *Unloaded Cable.*—In this case, putting $L=0$ in equation (6) we get

$$f_1 = \frac{\pi}{4l^2 RC}$$

and $\therefore l = \sqrt{\frac{\pi}{2RCf}}$

Practical Considerations.—A convenient form of bridge for measuring the sending-end impedance is shown in Fig. 2(a). With this form

of bridge the actual bridge resistance readings can be used in place of the calculated impedance for the purpose of fault localisation. [See Pp. 45/6 B(I) on Experiments made at Dover]. Equation (7) is best used in the form—

$$l = K \div f$$
(10)

where K is an empirical constant determined by introducing at a known distance l along the cable circuit (generally the distant end of the cable) a contact resistance across a selected pair. The sending - end impedance curve is then measured over a range of frequency, and from this curve a value for f is computed. Hence from equation (10) we get K . When a breakdown occurs a sending-end impedance-frequency curve is taken on the same pair and the new mean frequency interval f between successive maxima of impedance is computed. By the use of equation (10) again the distance to the fault can be found. The advantages of using equation (10) are that any lack of uniformity in the normal cable constants and any difference between the values of ϕ_1 and ϕ_2 in equation (8) above, are taken into account to some extent when the value of K is found from experiment.

In obtaining the value of f it is not necessary in any case, when obtaining the requisite impedance-frequency curve, that all the test frequency intervals be very small, since they are only required to determine the *number* of maximum points occurring in the frequency range considered. Then, if n such maximum points are found, the n th maximum only need be carefully explored at very small test frequency intervals, in order to obtain as accurately as possible the value f_n at which it occurs. The value of the mean interval, f , is then found from the expression

$$f = f_n \div (n - \frac{1}{2})$$
(10A)

since the first maximum occurs at half an interval, f , from zero.

In this expression the value of f_n should be as high as is consistent with its accurate determination. The following test results will illustrate the application of the method and show the degree of accuracy to be expected in localisation. They also indicate those cases where some precaution, and slight modification to the simple procedure outlined, may be necessary to obtain the most accurate results.

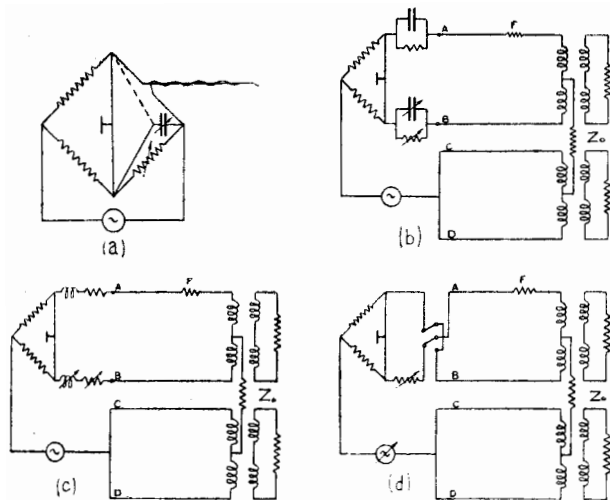

FIG. 2.

- (a) Sending end Impedance Bridge.
- (b) Impedance unbalance Bridge, using capacity and resistance.
- (c) Impedance unbalance Bridge, using inductance and resistance.
- (d) Zero Reactance Bridge.

EXAMPLES OF TEST RESULTS.

(A). *Anglo - French (1926), Continuously - Loaded, Submarine Telephone Cable.*

This cable has a total length of 50.5 nauts between Canterbury and Boulogne. The value of K was obtained by tests from Canterbury on a selected side circuit, in the following manner :

The selected pair was looped at Boulogne to another pair, the circuit so formed being terminated at Canterbury with 400 ohms (the approximate characteristic impedance of the line). A contact resistance of 50 ohms was connected across the circuit at Boulogne, *i.e.*, at 50.5 nauts, and the resulting sending-end impedance then measured over a range of frequencies. The bridge-resistance readings so obtained are shown in Fig. 3 plotted against frequency. This figure

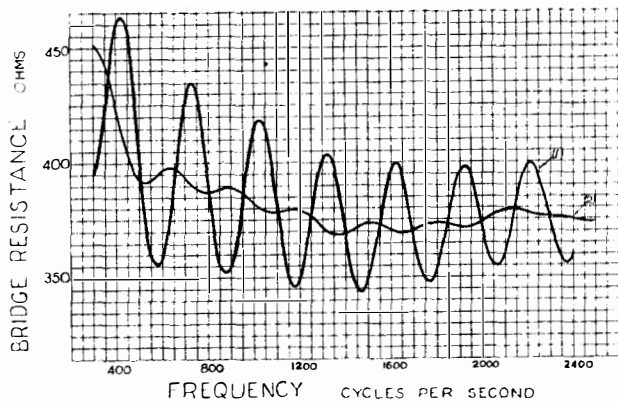

FIG. 3.—ANGLO-FRENCH (1926) CABLE.

Results for side Circuit with (1) 50 ohms contact fault at $l = 50.5$ nauts and (2) terminated by 400 ohms at Boulogne.

also gives the Z_0/f curve for the same pair terminated by 400 ohms at Boulogne. The 8th maximum occurring after zero frequency was carefully explored at very small frequency intervals and from these resistance readings were subtracted the corresponding readings obtained when the 50 ohms was removed, *i.e.*, from the faulty impedance characteristic subtract the normal impedance characteristic over the frequency range considered. (See also Pp. 47/8 C). The value of the frequency at which the 8th maximum value of the differences occurs is

2208 c.p.s. (f_s), from which $f = 294$ c.p.s. and $K = 14870$.

NOTE.—The principle of subtraction of the normal impedance curve of a circuit from the corresponding impedance curve of that circuit when faulty is essential in certain cases (and in general leads to greater accuracy of localisation) and is discussed in paragraph C. It is therefore desirable to have recorded an exact impedance frequency curve of a pair, prior to breakdown, if this method of localisation is to be applied with the greatest possible accuracy. Some interesting results are given in Section III., of the seasonal change of characteristic impedance, measured over a period of a year, for cables of the type under consideration.

Two examples of complete breakdowns occurring in this cable are, one on 17th November, 1928, and another on 9th December, 1929. In the former case an A.C. test gave 6 maximum points between zero and 2000 c.p.s., the 6th maximum being carefully explored and occurring, after subtraction of the normal ordinates, at 1696 c.p.s. From equation (10A) $f = 1696 \div 5\frac{1}{2} = 308.2$ c.p.s. and from equation (10) the A.C. localisation gives 48.2 nauts from Canterbury. The actual distance to the fault was 48.34 nauts from Canterbury, *i.e.*, an error of 0.3%.

In the second case, more than twelve months after the first, the same value of K was used and the A.C. localisation gave 41.7 nauts to the fault from Canterbury. The actual distance was within 0.5 naut of that figure.

In both the above cases there was a varying E.M.F. in the fault of about 0.2 volt and with D.C. tests considerable polarisation took place, causing the fault resistance to vary considerably from a mean value of about 300 ohms. The effect of these and other variations on the accuracy of the A.C. test was studied at Dover Submarine Cable Depot, on some spare lengths of continuously-loaded cable, and the results are given in Pp. 45/6 B following :—

(B). *Experiments Made at Dover.*

(1) *Use of Bridge Resistance Readings for the Determination of K .*—It was found that the results obtained for K by plotting the bridge resistance readings against frequency gave essentially the same results as those obtained

by plotting Z_0 . The difference between the value by plotting Z_0 in no case exceeded 0.5%. This is principally due to the fact that in the neighbourhood of all maximum impedance points the reactance part of the impedance is practically zero. Further, the effect of this difference is decreased by using the bridge resistance readings when localising faults and employing the value of K obtained from a bridge-resistance-frequency curve.

(2) *Tests made with Different Values of F.*—A family of several of the curves obtained with different values of F at 10.2 nauts is shown in Fig. 4. It will be noticed that the mean interval

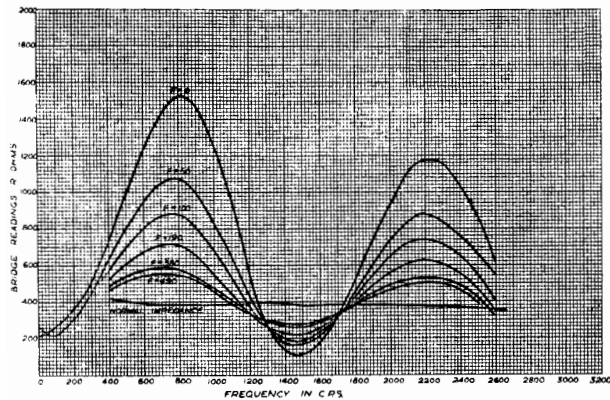

FIG. 4.—RESULTS OBTAINED WITH CONTACT FAULTS OF VARIOUS VALUES AT THE SAME DISTANCE FROM THE TESTING END.

slightly increases as F increases and this indicates that the exact value of K (for the higher values of fault resistance) will be slightly greater than that for the lower values of F . The mean value of K , however (14,000), is not as much as 1% different from the extreme values likely to occur in practice. The amplitudes (A) of the first maximum points of these curves, after subtraction of the normal impedance bridge readings, are shown plotted against values of F in Curve 1, Fig. 5. Curve 2 in that figure is a similar example in which $l=20.95$ nauts.

As the distance l to the fault increases the slope of the A/F curve everywhere decreases until, in

the limit, when l has such an attenuation length as to give the infinite line condition, $A=0$ at all frequencies and the curve coincides with the axis of F .

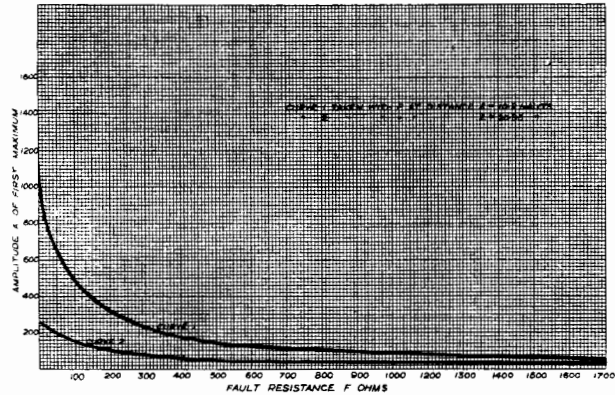

FIG. 5.—VARIATIONS OF AMPLITUDE OF FIRST IMPEDANCE MAXIMUM (A) WITH FAULT RESISTANCE (F).

(3) *Tests made with Faults at Different Distances, l , from the Testing End.*—Fig. 6 shows the relation between the amplitude, A , and the distance, l , obtained with a fault resistance of 380 ohms introduced at various distances from the testing end.

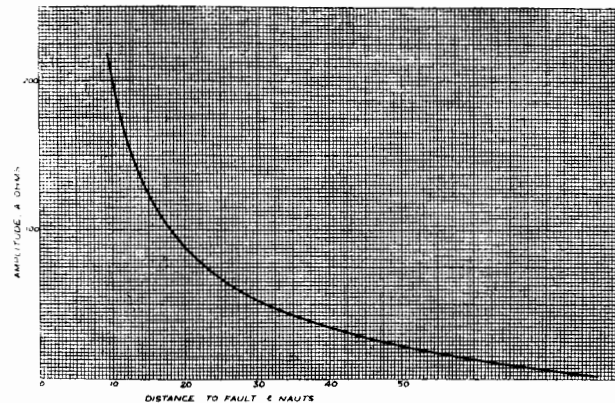

FIG. 6.—VARIATIONS OF FIRST MAXIMUM OF IMPEDANCE (A) WITH DISTANCE TO FAULT (l). Fault resistance constant and = 380 ohms.

TABLE I.

COMPARISON OF THEORETICAL AND MEASURED SENDING-END IMPEDANCE CHARACTERISTICS FOR CIRCUIT WITH CONTACT FAULT. ANGLO BELGIAN (1926) TYPE CABLE.

DISTANCE TO FAULT = 10.2 NAUTS.

Fault Resistance F ohms.	Frequency f c.p.s.	Calculated Sending-End Impedance Z_s Vector ohms.	Measured Sending-End Impedance Z_s Vector ohms.	Calculated Frequency at Maximum Points f_1 and f_2	Calculated Values of ϕ_1 and ϕ_2	Calculated Values of K.
0	637	1246/20° 15	1295/16° 30'	716	0° 17'	14,910
	716	1479/8° 48	1425/8° 20'			
	796	1242/39° 5	1195/38° 20'			
	851	983/51° 41	960/50° 40'			
	2108	1066/19° 21	1015/19° 30'	2177	0° 31'	
	2188	1173/6° 22	1165/0° 0'			
2267	1004/30° 28½	1035/29° 0'				
1000	637	470.5/6° 35½	470/8° 10'	670	5° 43'	15,260
	676	471.1/7° 50	470.5/8° 45'			
	716	470.1/11° 14	468.5/10° 10'			
	2108	445.8/2° 34½	438.3/1° 50'	2167	1° 50'	
	2148	446.9/3° 50½	441.5/3° 20'			
	2188	446.8/4° 53½	442.2/4° 55'			
	2211	445.6/5° 45	442.0/5° 40'			
	2267	439.3/7° 53½	439.7/7° 20'			

(4) *Effect of Variation of Fault Resistance during the Period of Testing.*—The effect of a large and rapid variation of the fault resistance on the interval f is best seen by reference to Fig. 7 and from those results it will be seen that

seriously affected. Further, the error could be decreased by repeating the tests over the selected maximum (a) with increasing test frequencies, (b) with decreasing test frequencies, and a mean value of f computed from the results.



FIG. 7.—BRIDGE RESISTANCE FREQUENCY CURVES OBTAINED WITH FAULTS VARYING IN VALUE THROUGHOUT THE TEST AS SHOWN BY LOWER CURVES.

the error in localisation would be relatively small since the interval of the maximum points is not

(5) *Effect of E.M.F. and Earth Faults.*—Tests made with wet faults by means of a small piece of damaged cable, immersed in sea-water, inserted at known distances l from the testing end, showed no appreciable effect on the accuracy of localisation. The E.M.F. at the fault varied from 0.1 to 0.3 volt and the resultant contact fault resistance from about 10 to 30 ohms. The insulation resistance of the circuit to earth was low and neither this feature nor the effect of E.M.F. and polarisation, affects the accuracy of localisation.

(C). *Isle of Wight (1928), Coil-loaded, Submarine Telephone Cable.*

This cable was tested for K through suitable building-out networks and K found to be 8570.

Fig. 8 (Curve A) shows the normal impedance curve of the selected circuit together with the impedance curve obtained after the introduction of a contact fault of 20,000 ohms at a distance of 22.4 nauts from the testing end (Curve B). The difference between these two curves (amplitudes A) is shown plotted in Fig. 8 (Curve C). The mean interval f is much easier to obtain from Curve C than from B and is 303 c.p.s. Thus the localisation is 22 nauts.

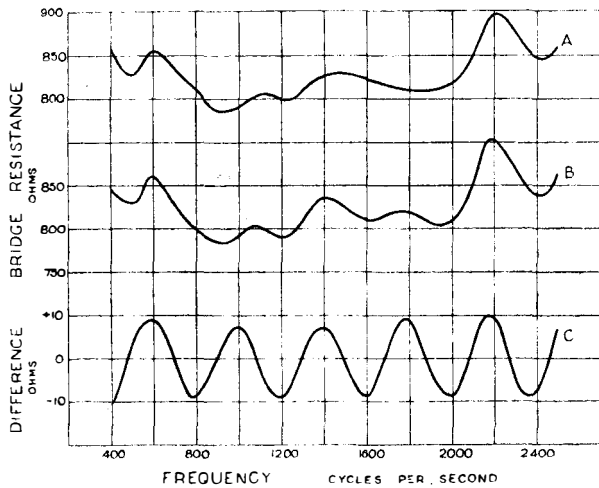

FIG. 8.—ISLE OF WIGHT (1928) COIL-LOADED SUBMARINE CABLE.

- (A). Normal Impedance (Bridge Resistance readings).
- (B). Impedance with 20,000 ohm fault at 22.4 nauts (do.).
- (C). Difference Curve B—A.

NOTE.—The Z_0/f curve obtained with a fault in the line actually represents the normal impedance vector of the line, plus a rotating vector due to reflection. If the effect of this latter vector is small compared with the variations occurring in the normal impedance curve, the shape of the resultant impedance curve will not be sufficiently definite to give an accurate value for the required interval f . In such a case it is necessary to subtract the ordinates of the normal curve from those of the faulty, or resultant, curve and the curve of difference so obtained will give a clearly defined value for f . The example just given and shown in Fig. 8 will illustrate this point.

(D). *Isle-of-Man (1929), Continuously-Loaded Cable—Underground Portion. Case of One Maximum only occurring within the Frequency Range considered.*

This is a case where only one impedance

maximum occurs within the audio-range and an approximate localisation can be obtained from the relation

$$2\alpha_1 l = \pi$$

i.e., $2f_1 l = K$
 or $l = K \div 2f_1$ (11)

Owing, however, to the relatively large shift of the frequency of the first maximum impedance with different values of fault resistance (see Fig. 4) unless some allowance is made for this effect an error of localisation of as much as 10% may be caused. Such errors, due to the variation of f_1 with F (and thus with A), can be considerably lessened by obtaining experimental data on shorter lengths of cable in the works or on spare lengths of cable, and Fig. 9 represents such data obtained for the Anglo-Belgian (1926) type cable, where values of f_1 are shown plotted against amplitude, A , for distances up to 10 nauts, beyond which equation (7) may be employed. In obtaining this data it is only necessary to draw a few of the curves from actual experiments on lengths available and interpolate for the intermediate curves.

An example of the use of Fig. 9 is supplied by the Isle of Man (1929) land cable which has approximately the same electrical constants as the Anglo-Belgian (1926) cable. This cable became faulty due to water penetration. In this case an impedance test showed that $f_1 = 1174$ c.p.s. and $A = 1485$ ohms. These values of f_1 and A are the co-ordinates of a point in Fig. 9 and the curve passing through this point is seen to be one corresponding to a distance of $l = 7.05$ nauts, an error of 0.5%, since the actual fault was found at a distance from the testing end of 7.01 nauts. If equation (11) be used, however, taking $K = 14940$, the localisation is $l = 6.37$ nauts which is an error of 9%.

SECTION II.—HIGH RESISTANCE IN ONE CONDUCTOR.

(a) *Sending-end Impedance Method.*—Fig. 10 represents a high resistance fault F , distant l

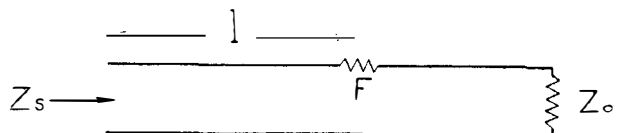

FIG. 10.

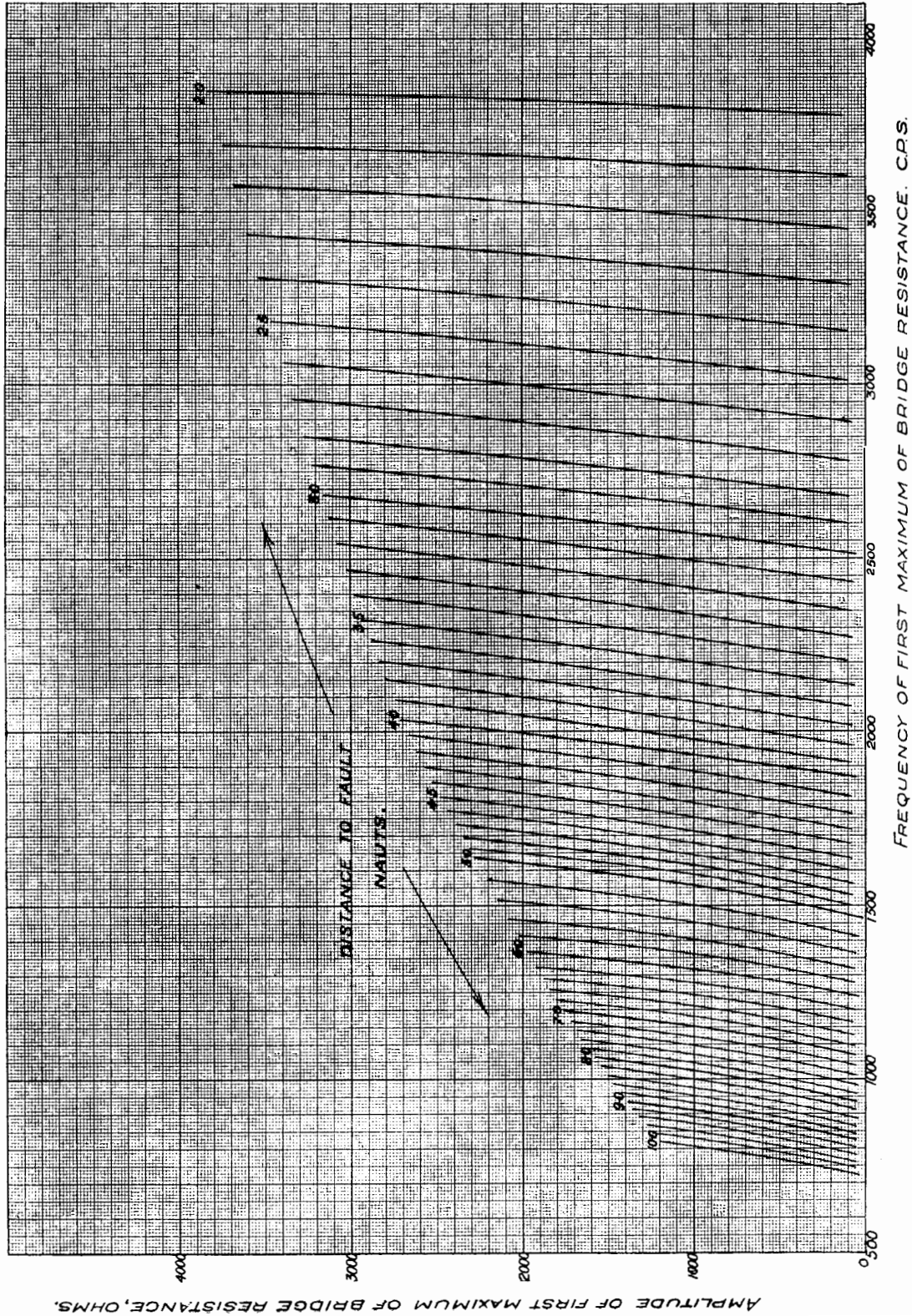

FIG. 9.

from the sending-end of a cable, having otherwise uniformly distributed constants and closed by its characteristic impedance Z_0 . Following the method adopted in Section I. it can be shown that sending-end impedance frequency curve will pass through successive maximum points when

$$2al = 2\pi, 4\pi, 6\pi \dots \text{etc.} \dots\dots\dots(12)$$

Hence a similar relationship holds between the distance l and the frequency interval f to that given in equation (7) and this equation is essentially true for all values of F large enough to cause pronounced maximum points to occur in the Z_s/f difference curve. To localise such a high resistance fault therefore by this method, the procedure is as follows:—

- (1) Use equation (10) in the form

$$l = K_1 \div f \dots\dots\dots(13)$$

where the value of K_1 is found by experiment for a selected pair as in Section I. (See note below). This may be done prior to the development of a fault or at the time of localisation by taking K for the neighbouring pair in the cable.

- (2) Obtain a value of f from bridge resistance readings of the Z_s/f curve of the faulty circuit and from equation (13), using the above value of K_1 , obtain the localisation l .

NOTE.—Whereas for the case of a contact fault the first maximum point f_1 occurring from zero frequency is given by a value equal to one-half the frequency interval, in the case of a high resistance fault the value f_1 is equal to a complete frequency interval. Hence in computing the value of f for any given Z_s/f curve, where n maximum points occur after zero frequency, it is necessary to use the expression

$$f = f_n \div n \dots\dots\dots(14)$$

Deformation.—If the conductor resistance fault occurs so near the sending-end that only one or two maximum points, due to the fault, occur, it will be noticed that subsidiary undulations are present in the Z_s/f curve which “deform” the curve from its theoretical shape. This effect is termed “deformation” and an illustration of the effect is given in Fig. 11. The deformation of the curve for the main reflection from the fault is due to secondary reflections influenced by:—

- (1) The value of the terminating impedance.
- (2) The length of cable between the fault and the distant termination.

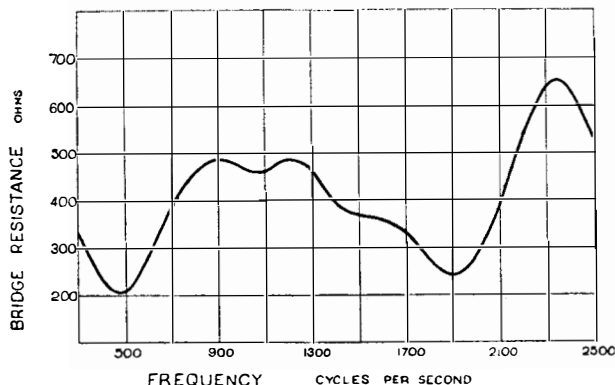

FIG. 11.—EXAMPLE OF DEFORMATION PRODUCED IN $Z_s - f$ CURVE WHEN F IS NEAR THE TESTING END.

The influence of (1) is felt principally upon the magnitude of the subsidiary reflections, whilst (2) chiefly effects their phase. It is not practicable to obtain a satisfactory rigorous mathematical treatment, or a complete experimental investigation of these effects, in order to make use of the first maximum part of the sending-end impedance curve for the localisation of near-up faults (as in the case of near-up contact faults—see Fig. 9). Moreover, the zero reactance method, described later, minimizes the necessity for such an investigation.

**(b) Impedance Unbalance Method.*—Fig. 2 (b) and (c) shows two possible arrangements of the impedance unbalance bridge required to localise a high conductor resistance fault, using the phantom circuit as a reference circuit. Resistance and reactance are inserted in the bridge to produce in the telephone circuit a current equal in magnitude, but opposite in phase, to that produced by the faulty circuit. A similar equation to that of (13) can be used, viz.,

$$l = K_2 \div f \dots\dots\dots(15)$$

where K_2 is a constant determined by introducing a high resistance at the distant end of the cable (or at some other known distance along the

* “Telephone Circuit Unbalances,” by C. P. Ferris and R. G. McCurdy. Bell Reprint No. B-134-1. July, 1925.

cable) in a similar circuit to that of the faulty circuit, plotting against frequency the real or imaginary component of the unbalance impedance required at the bridge and obtaining the mean frequency interval, f , of the maximum points. This experimental determination of K allows to some extent for different localised phase-angle changes at different frequencies and for slight variations of V_1 and V_2 produced by changes in the electrical constants with frequency —where V_1 and V_2 are the electric wave-velocities of the faulty and reference circuits respectively and, theoretically,

$$K_2 = \frac{V_1 V_2}{V_1 + V_2}$$

If $V_1 = V_2 = V$ we get $K_2 = \frac{V}{2}$ where V is the velocity of electric-wave propagation along the circuit tested and applies to the case considered in Section I. Thus these methods are only strictly accurate. (1) If V_1 and V_2 are absolutely constant over the range of frequencies considered. (2) If the localised phase-angle change, ϕ , produced at the fault itself is also constant over that frequency range.

The value of f with this impedance unbalance method is found by using equation (14), as for the sending-end impedance method and it will be realised that the former is essentially an adaptation of the latter method. It has about the same degree of accuracy when more than one maximum point is obtained in the audio-frequency range, but it suffers from the same disadvantage of deformation when applied to faults so near the testing end that only one or two maximum points are obtained.

The arrangement in Fig. 2(b) involves some calculation to obtain the real parts of the unbalance impedances and a more convenient arrangement is that using inductance and resistance, Fig. 2(c), since in that case the bridge resistance readings represent these real values and can be plotted directly without calculation. This will not give essentially different results from those obtained with capacity and resistance.

(c) *Zero Reactance Method.*—The necessary arrangement of apparatus is shown in Fig. 2(d) and, in addition to the equal ratio arms, consists simply of a resistance R , which can be placed in series with the good conductor or in series with

the faulty conductor by means of the reversing switch S . The value of R and the frequency of supply are adjusted simultaneously until silence is obtained in the telephone. The frequency is then increased or decreased and R readjusted until the next silent point is obtained. This operation is repeated throughout the audio-range and each successive frequency so obtained indicates that the wave propagated to and from the fault has passed through 2π radians (as indicated by successive maximum impedance points in Section I. and II.). By reversing the switch S , a second set of frequencies can be obtained having, theoretically, the same frequency interval as the first set but being of intermediate values. All the zero reactance frequencies can be represented by $2n\pi$ where $n = 1, 2, 3, 4 \dots$ etc., for one position of the switch and $n = \frac{1}{2}, 1\frac{1}{2}, 2\frac{1}{2}, 3\frac{1}{2}, \dots$ etc., for the other position of the switch and vice-versa.

Let the frequency of zero reactance points as they occur from zero frequency be $f_1, f_3, f_5 \dots$ for one position of S and $f_2, f_4, f_6 \dots$ for the other position.

Let f be the mean frequency interval for use in the equation

$$l = K_3 \div f \dots\dots\dots(16)$$

where K_3 can be obtained by experiment. It has been found that the best value of f to be used in equation (16) is obtained by neglecting altogether the value of f_1 (see Fig. 12) and computing the value of $f_{2n} \div n$ where $n = 1, 1\frac{1}{2}, 2, 2\frac{1}{2} \dots$ etc. The value of n is made as great as possible consistent with the accurate determination of f_{2n} .

Some experimental results are given here to illustrate the application of the method:—

TABLE II.
DISTANCE TO FAULT=20.95 NAUTS.
VALUE OF $K_3=13,780$ —OBTAINED WITH TEST
RESISTANCE OF 500 OHMS.

F ohms.	f c.p.s.	Localis- ation in nauts.	Error %
2	643	21.43	+2.3
5	646	21.33	+1.8
10	646	21.33	+1.8
50	645	21.36	+1.9
200	654	21.07	+0.57
500	654	21.07	+0.57
∞	661	20.85	-0.47

Reduced by taking K_1 with test resistance of 50 ohms. See Table III.

TABLE III.

DISTANCE TO FAULT=20.95 NAUTS.
 VALUE OF $K_3=13,510$ —OBTAINED WITH TEST
 RESISTANCE OF 50 OHMS.

F ohms	f c.p.s.	Localis- ation in nauts.	Error %
2	643	21.01	+0.29
5	646	20.91	-0.19
10	646	20.91	-0.19
50	645	20.95	nil
200	654	20.66	-1.4
500	654	20.66	-1.4
∞	661	20.44	-2.4

} Reduced by
taking K_3 with
test resistance
of 500 ohms.
See Table II.

Tests made at Dover Submarine Cable Depot on Spare Lengths of the Anglo-Belgian (1926) Cable. $K_3=13,780$, obtained with test resistance of 500 ohms.

(1) A summary of the results for a 500-ohm conductor resistance fault when introduced at various distances from the testing end, is contained in Fig. 12. The different circuit lengths

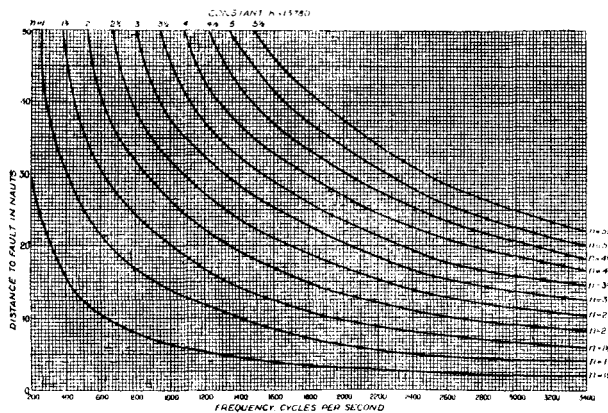

FIG. 12.—ZERO FREQUENCIES V. DISTANCE.

were obtained by looping back pairs and terminating the circuits by the characteristic impedance as for the tests given in Section I.

Two particular examples are as follows:—

(2) Distance to Fault=12.57 nauts, $F=500$ ohms.

In this case $f_{2n}=3276$ c.p.s. and $n=3$. Hence $f=1092$ and the localisation given is

$$l = \frac{13780}{1090} = 12.62 \text{ nauts, an error of } 0.4\%.$$

(3) Distance to Fault=4.19 nauts, $F=500$ ohms.

The value of $f_{2n}=3312$ c.p.s. and $n=1$. Hence $f=3312$ and the localisation given is

$$l = \frac{13780}{3312} = 4.17 \text{ nauts which is an error of } 0.5\%.$$

Effect of Fault Variation.—To illustrate the effect of the fault resistance on the accuracy of localisation some results are given in Table II. for a case in which the effect was most marked. It will be noticed that a fault of 2 ohms was easily localisable at a distance of about 21 nauts, but that in such a case of a low value fault the experimental value of K_3 should be taken with a lower test resistance than 500 ohms and the error of localisation decreased. See Table III.

The accuracy of the zero reactance method depends on the accuracy with which f_{2n} can be determined, and the smallest value of F which can be localised is limited by the magnitude of the reflected wave compared with resultant of the reflections received at the bridge from the existing distributed unbalances normally in the cable. Thus in any balanced cable a conductor resistance fault of sufficient magnitude to cause crosstalk which interferes with the working of a circuit can be localised by the zero-reactance method. Further, this method possesses the following advantages over the methods given in (a) and (b):—

- (1) It is simpler and quicker.
- (2) It can be used for faults near the testing end where the other two methods are less accurate due to deformation.
- (3) The zero-reactance frequencies can be quite definitely found, whereas the maximum points used in (a) or (b) are extremely difficult to obtain definitely, especially when the value of fault resistance is low.

SECTION III.—EFFECTS OF SEASONAL TEMPERATURE VARIATIONS ON THE ACCURACY OF FAULT LOCALISATION.

Temperature change produces a much greater percentage change on the D.C. resistance of a cable than upon the inductance or capacity. See Figs 13 and 14. It follows for the case of a telephone route over which the temperature is

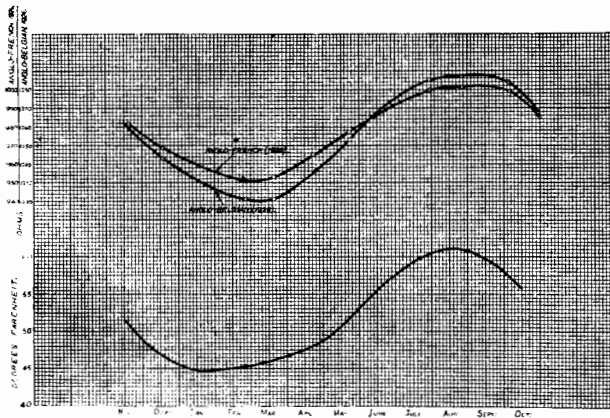

FIG. 13.—SEASONAL VARIATIONS OF D.C. RESISTANCE OF SUBMARINE CABLES AND MEAN SEA TEMPERATURE.

not uniform (such as a route which includes a submarine length in addition to subterranean lengths) that the resulting distribution of conductor resistance with length will have greater non-uniformity than either the distribution of inductance or capacity. Therefore when D.C. resistance tests are made, if the temperature difference between two parts of the same route be appreciable, the use of a mean resistance per unit length (calculated from the measured total resistance divided by the total cable length) for the purpose of converting ohmic distance to actual distance, may lead to considerable errors of localisation. On the other hand, when A.C. localisation tests are applied as described in the previous Sections, the constant K which is used depends for its magnitude principally upon the inductance and capacity of the cable. Since these constants show very little change with temperature (see lower curves in Fig. 14) it is

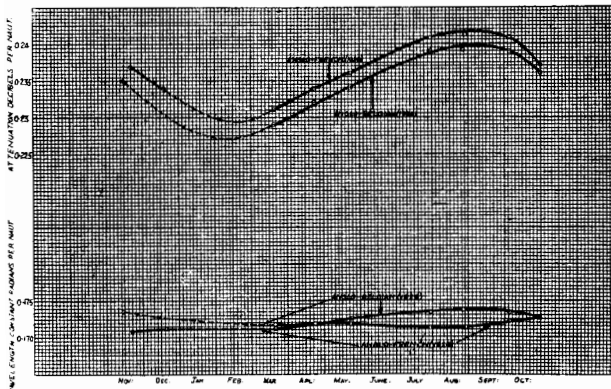

FIG. 14.—SEASONAL VARIATIONS OF ATTENUATION AND WAVE-LENGTH CONSTANTS OF SUBMARINE CABLES.

seen that the corresponding change in the value of K is extremely small and hence the temperature distribution over the route does not, as in the D.C. case, lead to serious errors of localisation.

An example of the possible error due to temperature difference is given here for the case of a D.C. localisation test.

Example. A cable consists of 10 nauts of land cable and 40 nauts sea cable. The mean temperature difference between land and sea is 8°C. During the existence of a fault a Varley loop test gives a steady Varley reading of 810.6 ohms, and the "good" loop resistance is 965.

From these figures the mean conductor resistance per naut loop is 19.3 ohms and this gives a localisation of 8.0 nauts. Taking a temperature coefficient for copper of 0.004 ohm per degree

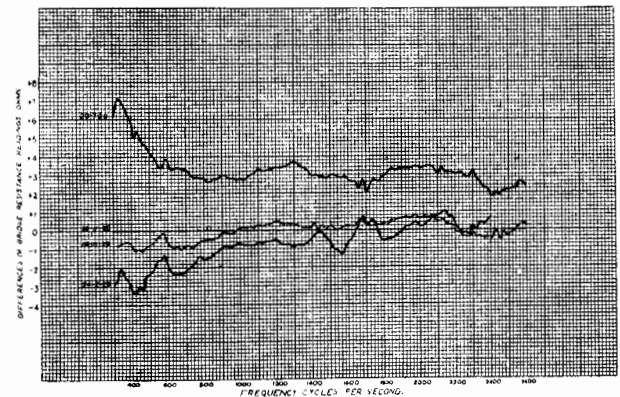

FIG. 15 REPRESENTS EXTREME CHANGES OF Z_0/f CHARACTERISTIC AS MEASURED ON ANGLO-BELGIAN (1926) CABLE FOR A PERIOD OF ONE YEAR.

Centigrade the corrected distance to the fault is 7.80 nauts, *i.e.*, an error of 2.6% when using a mean conductor resistance per unit length in the absence of information concerning the distribution of temperature over the route.

Seasonal Changes of D.C. Resistance, Wave-Length Constant, and Characteristic Impedance.

Some interesting data has been obtained for two Continental paper-core submarine telephone cables as a result of measurements taken each month for the period of a year. A brief summary is as follows:—

D.C. Resistance.—Fig. 13 shows the variation

of this feature plotted against time together with some mean sea-temperatures plotted to the same base. The maximum variation from a mean value of the resistance is 5%.

Wave-Length Constant.—See lower curves in Fig. 14. In this case the maximum variation from a mean value is 0.5%, *i.e.*, only one-tenth the corresponding figure for the D.C. resistance. In Fig. 14 is also shown the variation of the attenuation constant of the two cables throughout the year.

Characteristic Impedance.—See Fig. 15. This shows the case for the Anglo-Belgian (1926) cable. The change in the magnitude of the

impedance is shown in these curves as differences between the original bridge resistance readings obtained on 19-11-28 and those obtained in subsequent tests. The original test results are therefore represented by the straight line drawn through zero resistance. These tests show that the seasonal variation of the characteristic impedance is small enough to permit the use of the same Z_0/f curve for localisation purposes at any season throughout the interval between successive repairs. It is interesting to note that the impedance of the circuit considered was not different at any frequency, one year after the first test, by more than 0.3%.

EFFECTS OF EARTHQUAKE ON TELEGRAPH AND TELEPHONE COMMUNICATIONS.

A. D. BAGGS, A.M.I.E.E.

Telegraph Engineer, New Zealand.

ON the 17th June, 1929, at approximately 10.17 a.m., the whole of New Zealand was shaken by an earthquake of particularly severe intensity. During the month that followed, over 500 shakes of varying intensities were recorded in the most affected areas. Preliminary investigations indicated that the epicentre of the disturbance had its origin in the Murchison District, situated in the north-western portion of the South Island. In this area the earthquake was of the maximum intensity on the Rossi-Forel scale. Roadways, bridges, buildings and land suffered considerable damage, while the topography of the countryside was extensively altered.

It was fortunate that the maximum intensity of the earth movement occurred in a thinly populated area. Twelve lives were lost as a direct result of the disturbance. Had the earthquake occurred at night time or affected a city such as Auckland, with its quarter of a million people, the loss of life would have been appalling. The disaster was in no way identical with volcanic action, and the maximum intensity was confined to a clearly indicated area, 50 miles long by 30 miles broad, west of Murchison.

The north-western portion of the South Island

of New Zealand is mainly mountainous in character and not so adaptable to close settlement as other parts of the Dominion. The world-famed Buller River, which flows through this locality, was temporarily blocked by huge landslides from the mountain sides. The upper and lower gorge roads, so popular with tourists because of their scenic beauty, were similarly blocked by landslides. The lower road was cleared for traffic within a few days, but it will be many months before the upper road is restored to its original condition or even made reasonably passable.

Surveys in the Murchison area show that the upthrust of land reached a maximum of sixteen feet at some points, and that the decline in other places was nine feet. Geological experts describe the disturbance as one of the most extensive earth movements in modern history. A new area of land in the form of an island, sixty chains long and sixteen chains wide, was thrown up from the seabed near Mokihinui on the west coast to an average height of eighty feet.

The districts of Westport (population 8,000), Takaka (1,000), Karamea (600), Motueka (2,000), Nelson (17,000), and Greymouth (12,000) immediately surrounding Murchison were also

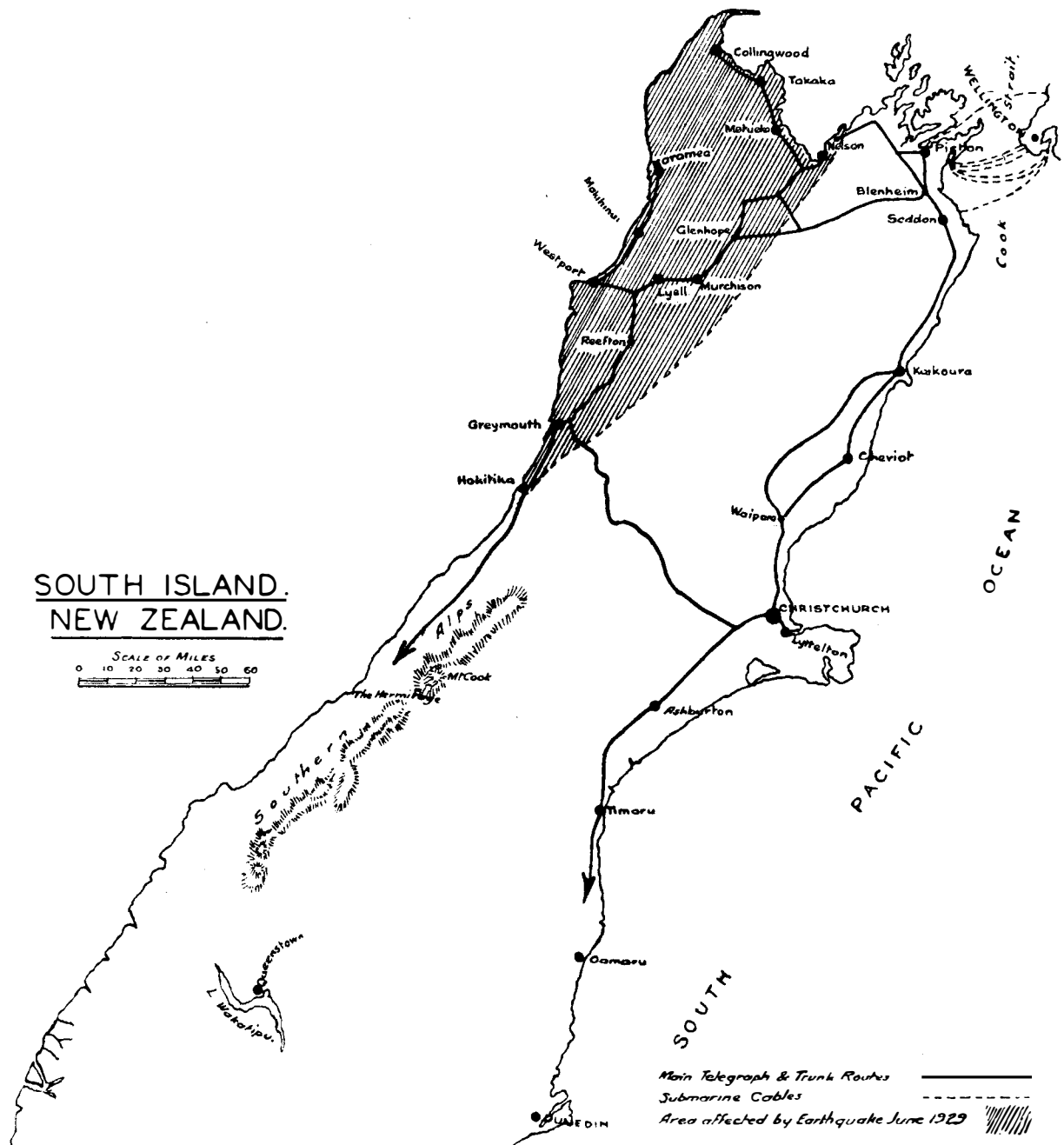

severely affected by the earthquake. Apart from these localities, no damage of any moment was suffered in other areas.

The Westport Post Office, a large and comparatively new brick building, containing the telephone exchange, was so extensively damaged as to necessitate its complete demolition at a later date. The Post Office tower, containing the town clock, fell into the main thoroughfare dur-

ing the shake. Fortunately, the internal equipment of the telegraph office and telephone exchange was not seriously damaged, but had to be removed under hazardous and extremely trying conditions and reinstalled in an adjoining wooden building.

No damage resulted to the internal equipment of other departmental buildings in the disturbed areas beyond the breaking of



FIG. 1.—MURCHISON. MATAKITAKI SLIP. A HUGE TREE REDUCED TO SPINTERS.

hundreds of primary battery jars. The electrolyte in the secondary battery cells at the Grey-mouth and Nelson B.M.S.B. telephone exchanges, the Blenheim W.E. rotary automatic telephone exchange, and the Seddon voice frequency and carrier current repeater station was observed to swing from side to side in the containers, but none of the liquid was lost. By far the greatest damage was suffered by telegraph and telephone outside plant, both underground and overhead. The Westport telephone exchange duct system was badly damaged by crushing. Several cases also occurred in other areas of damage to underground armoured telephone cables. A fissure which opened up across the roadway at Takaka broke the lead sheathing of one cable in half.

Overhead plant, however, was the most severely affected, and staffs, transport and material supplies were considerably taxed to meet the emergency. Telegraph and toll lines



FIG. 2.—MURCHISON. HODGSON'S GROCERY STORES.

were interrupted over practically the whole of the northern half of the South Island. Thousands of contacts occurred on telephone subscribers' lines in the more affected areas.

The greatest damage occurred immediately north and south of Murchison over an area of about 30 miles and between Mokihinui and Karamea. In these sections long lengths of pole line were carried away by gigantic landslides



FIG. 3.—MURCHISON. MATAKITAKI BRIDGE AND APPROACH.

accompanying the earthquake or caused by the incessant torrential rain which followed for twelve days. Road transport to Westport and Karamea was impossible and, to enable communication to be established until the overhead lines were restored, an aeroplane was utilised to carry radio operators and short-wave wireless plant from Christchurch to Westport and Karamea.



FIG. 4.—MATARITAKI SLIP. VALLEY FILLED TO DEPTH OF 80 FEET. ONE HOUSE BURIED AND 4 PERSONS PERISHED. HOUSE IN FOREGROUND IS TOP STOREY OF ANOTHER HOUSE AFTER MOVING $\frac{1}{2}$ MILE.

The trunk lines between Murchison and Inangahua Junction and between Westport and Karamea have not been restored at the time of writing owing to landslides carrying away the roads on both routes. It will be some considerable time before repairs can be effected, and it is quite possible that new road and telegraph routes will in some cases have to be surveyed.

Queer happenings to pole lines came under notice in several instances. North of Westport, a line of poles erected near the roadside was thrown over at an angle of 45 degrees, making it impossible for traffic to proceed along the road. South of Murchison, the roadway alongside the Buller River dropped bodily a number of feet, leaving the pole line standing. At Takaka a line of poles was turned round about 20 degrees, straining the wires to fiddle-string tightness on

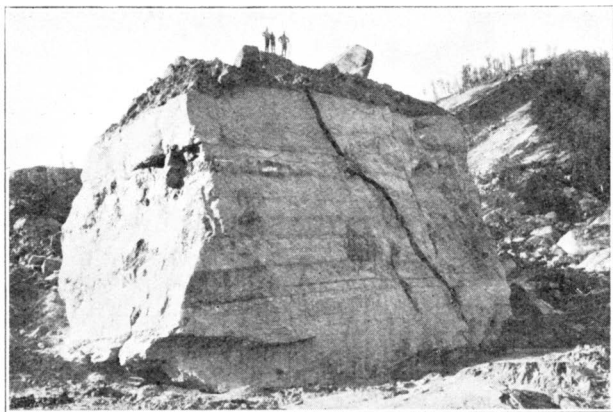

FIG. 5.—MURCHISON. BOULDER, 1000 TONS WEIGHT, COVERS HOUSE BELOW IT. THREE PERSONS PERISHED HERE. BOULDER CAME DOWN WITH MARIUS SLIP.

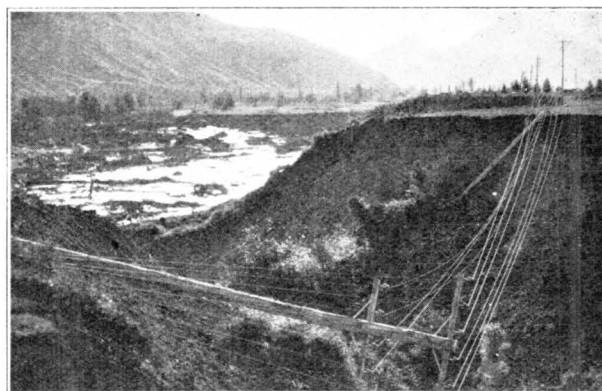

FIG. 6.—MURCHISON. POWER POLES AND LINES AFTER A FEW MINUTES DANCING.

one side of the arms, those on the other side resembling a clothes line. In the more severely affected area, poles were thrown out of alignment



FIG. 7.—NELSON. REMAINS OF TOWER, BOYS' COLLEGE.



FIG. 8.—WESTPORT. POST AND TELEGRAPH OFFICE.

to one side or the other. Numerous cases occurred of angle poles shifting on the surface block while the heel block held. A number of Kaiwhaka (cedar) poles used for the power reti-



FIG. 9.—WESTPORT. HARBOUR BOARD'S RAILWAY LINE.

culatation at Murchison were broken off at the ground line, completely wrecking the system. High tension and service lines fell across telegraph and telephone wires in all directions. Standard methods of protection and regulation crossings proved useless in such circumstances. Throughout the Murchison district, wires were found twisted together like messenger wire and had to be cut before they could be separated. In this area disconnections, due to the breaking of wires, were numerous. All drop leads on buildings at Murchison were broken.

During the week following the "big shake," communication between Nelson and Murchison was maintained with the utmost difficulty, owing to the recurring tremors, landslides and torrential rain. Linemen had a perilous and unenviable time restoring and maintaining communication, but their work greatly assisted in the arrangements for the evacuation of women and



FIG. 10.—REPAIRING BLENHEIM UG. CABLE.

children and the transport of food supplies, etc., for the township and district. The early restoration of these services had a fine moral effect on the spirits of the townspeople.

Some idea of the magnitude of the damage to the overhead plant may be gained from the fact that it will take approximately two months to make permanent repairs in the Murchison district alone.

The use of telephone lines in the Murchison district by members of the Scientific and Research Department in connection with their sound-ranging apparatus was also an interesting feature. Electrolytic microphones were placed at points north, south, east and west of Murchison where the apparatus was located, the object being to determine the epicentre of the disturb-



FIG. 11.—KARAMEA. RUINED ROAD WITH FISSURE FILLED WITH WATER.

ance by time calculation from the well-known laws regarding the rate of travel of the main wave of an earthquake.

Several lessons are to be learned in New Zealand from the West Coast disaster. In cases of overhead line work no extraordinary precautions can be taken. Routes are invariably defined beforehand and the plant is at the mercy of nature's vagaries.

Secondary cells, but particularly the containers and stands, should be made of the strongest material. The electrolyte is always in danger of running over in cases of excessive swaying and should not be unnecessarily close to the top of the jars. The breaking of glass containers causes serious delay in replacement, and the plates are liable to buckle and deteriorate as a result of exposure to the air.

Exchange buildings should preferably be built of steel and ferro-concrete. Brick and stone structures in the affected areas were dangerously

shaken by the earthquake. The placing of heavy automatic exchange switchgear above the ground floor needs careful consideration.

Where failure of the main water supplies are feared, an auxiliary tank or well should be made a part of the most important buildings. Fires are frequently known to complete the destructive work of an earthquake in congested areas. Fire-proof structures to resist such an occurrence are required.

It is not known whether earth tremors giving rise to a wave motion that would cause damage to an underground system by working along its length are as destructive as sudden shocks, but it is apparent that greater attention requires to be given to structures of this character.

Where bridges are used to support duct systems or cables, care needs to be exercised to prevent breakages at the approaches, as many cases arose where the structure was lifted above or receded below the road level. The choice of a bridge of fireproof construction should be considered if alternative routes are available.

The crushing or collapse of conduits cannot be avoided in all cases, but consideration should

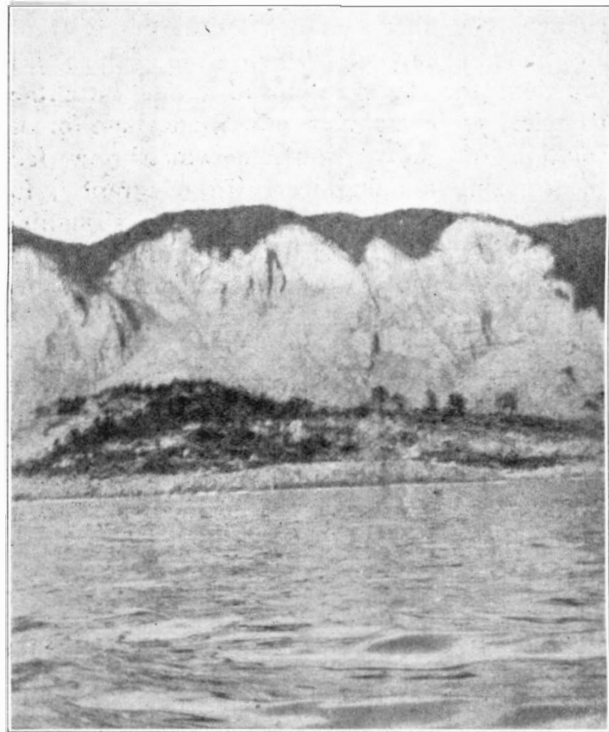

FIG. 12.—MOKIHIHI. SEA BOTTOM FORCED UP TO 80 FEET. DARK PATCHES ARE MARINE GROWTH AND SHELL FISH. LANDSLIDES EXPOSED WHITE CLIFFS.

Hence, we may write

$$i_n = \frac{e^{j\omega t}}{Z(j\omega)} + \phi(t)$$

From equation (3) we get,

$$\frac{e^{j\omega t}}{Z(j\omega)} + \phi(t) = \frac{d}{dt} \cdot e^{j\omega t} \int_0^t h(\tau) \cdot e^{-j\omega\tau} \cdot d\tau$$

Putting $\int_0^t = \int_0^\infty - \int_t^\infty$ and making the indicated transformations, we get the functional identity,

$$h = \frac{1}{Z(p)} [I] = p \int_0^\infty h(t) \cdot e^{-pt} \cdot dt \dots(5)$$

The above equation was first given by Heaviside in his "Electromagnetic Theory," Vol. III., where it is shown that the operational equation is the symbolic equivalent of infinite integral equation of the Laplace kind. Thus it can be seen that the problem of evaluating an operational equation has been reduced to the purely mathematical problem of solving the integral equation. The satisfactory solution of an infinite integral equation is, in the majority of cases, a very difficult matter. Fortunately, a large number of integrals of this type have been worked out and consequently the solution of operational equations can frequently be written down by inspection. When this is not the case, however, the procedure is to expand the operational equation in such a form that the individual terms can be made recognisable by transformation, as identical with known solutions. The integral theorem may be used to test the validity of a solution to an operational equation, and provides, through the work of mathematicians, the interpretation to certain operational equations which might not have been solved otherwise. Mr. J. R. Carson, of the American Telephone and Telegraph Company, makes the infinite integral theorem the central feature of his operational methods of analysis, and has, by its aid, ratified many of Heaviside's unestablished operational processes and deduced important criteria concerning the correct application of operational methods to transmission problems.

A simple example will illustrate the "go" of the integral theorem.

Let it be required to determine the current entering a smooth infinite line with distributed resistance R and capacity C per unit length. From the differential equations of the problem the operational equation is easily derived; we have,

$$I(t) = \sqrt{\frac{pC}{R}} \cdot [I]$$

Associating a known function in the integral theorem, we get,

$$\sqrt{\frac{C}{R}} \sqrt{p} \cdot [I] = \sqrt{\frac{C}{R}} \cdot p \cdot \int_0^\infty \frac{e^{-pt}}{\sqrt{\pi t}} \cdot dt \dots\dots(6)$$

Hence,

$$I(t) = \sqrt{\frac{C}{R}} \cdot \frac{1}{\sqrt{\pi t}}$$

The above expression gives the current at any time t entering a smooth non-inductive line. Suppose now, that in addition to the distributed resistance R and capacity C, the line has distributed leakance G per unit length. The operational equation of the problem is now,

$$I(t) = \sqrt{\frac{pC + G}{R}} \cdot [I]$$

In order to solve this operational equation, make use of equation (6), by increasing p by λ throughout, where $\lambda = \frac{G}{C}$

Hence, we have,

$$\sqrt{\frac{C}{R}} \cdot \sqrt{p+\lambda} \cdot [I] = \sqrt{\frac{C}{R}} \left(I + \frac{\lambda}{p} \right) \cdot p \cdot \int_0^\infty e^{-pt} \cdot \frac{e^{-\lambda t}}{\sqrt{\pi t}} \cdot dt$$

Thus,

$$I(t) = \sqrt{\frac{C}{R}} \left(I + \lambda \int_0^t dt \right) \frac{e^{-\lambda t}}{\sqrt{\pi t}}$$

From the above equation it can be seen that the effect of the leakance G per unit length, is to attenuate the wave by the factor $e^{-\lambda t}$, and add a progressive integral component of the attenuated wave.

Another example illustrating the flexibility of the integral theorem will be given.

Suppose that it is required to determine the loading coil values for the loading of double-phantom telegraph circuits. A double-phantom circuit has a distributed series resistance R and inductance L per unit length and a distributed shunt capacity C per unit length. The distributed leakage conductance G, which in actual U/G cables is very small, may always be neglected when only quasi-distortionless high speed telegraphic transmission is being considered. If *i* denotes the current at any point *l* on the line, the descriptive differential equation for the current wave is,

$$\frac{\partial^2 i}{\partial l^2} = LC \frac{\partial^2 i}{\partial t^2} + RC \frac{\partial i}{\partial t} \dots\dots\dots(7)$$

The presence of L in the above equation introduces the phenomenon of true propagation with finite velocity, instead of the diffusion phenomenon which results when L is considered to be zero, as in an unloaded line. In order to investigate the factors influencing the formation of telegraphic signals, it is best to start with the direct current wave first, assuming that the line is terminated by its characteristic impedance.

A simple operational transformation of equation (7) yields,

$$i_1 = \frac{pC}{\gamma} \cdot e^{-pl} \cdot [I]$$

where,

$$\gamma = \frac{1}{a} \sqrt{p^2 + 2p\phi}$$

$$a^2 = \frac{1}{LC}$$

$$\phi = \frac{R}{2L}$$

From the integral theorem, we get,

$$\sqrt{\frac{C}{L}} \cdot p \cdot \frac{e^{-\frac{l}{a} \sqrt{p^2 + 2p\phi}}}{\sqrt{p^2 + 2p\phi}} \cdot [I] = \sqrt{\frac{C}{L}} \cdot p \cdot \int_0^\infty e^{-pt} \cdot F(t) \cdot dt \dots\dots\dots(8)$$

The problem is thus reduced to the evaluation of the function F(*t*). In order to make equation (8) agree with a known Bessel function, put $\sigma = \frac{l}{a}$ and $2p\phi = 1$, then rewriting equation

(8), we get

$$\sqrt{\frac{C}{L}} \cdot \frac{e^{-\sigma \sqrt{p^2 + 1}}}{\sqrt{p^2 + 1}} \cdot [I] = \sqrt{\frac{C}{L}} \int_\sigma^\infty e^{-pt} \cdot J_0(\sqrt{t^2 - \sigma^2}) dt$$

where *J*₀ represents the Bessel function of order zero, which has zero value for *t* < σ and the value *J*₀($\sqrt{t^2 - \sigma^2}$) for *t* > σ . Now assume that *p* increases to *p* + *d*, and we get after transformation,

$$\sqrt{\frac{C}{L}} \cdot \frac{e^{-\frac{l}{a} \sqrt{(p+d_1)^2 + \sigma_1^2}}}{\sqrt{(p+d_1)^2 + \sigma_1^2}} \cdot [I] = \sqrt{\frac{C}{L}} \int_{l/a}^\infty e^{-p+d_1)t} \cdot J_0\left(\sigma_1 \sqrt{t_1^2 - \frac{l^2}{a^2}}\right) dt \dots\dots(9)$$

where the arbitrary parameters are $d_1 = \frac{a}{l} \cdot d$

and $\sigma_1 = \frac{a}{l} \cdot \sigma$. Making equation (9) identical with the operational equation of the problem by putting, $d_1 = \phi$ and $\sigma_1 = j\phi$, we obtain

$$i = V \sqrt{\frac{C}{L}} \cdot e^{-\phi t} \cdot I_0\left(\phi \sqrt{t^2 - \frac{l^2}{a^2}}\right) \dots\dots(10)$$

where *I*₀ is the Bessel function of imaginary argument and order zero. Also V represents the transmitting end voltage. Before equation (10) is applied to any particular case it is necessary to see that the number of loading coil sections *n* is great enough to make $\text{Cos} \left(\frac{\pi}{n}\right)$ practically equal to $\left(1 - \frac{\pi^2}{2n^2}\right)$. Also the right-hand side of equation (10) needs multiplying by the reflection coefficient K. Taking a particular case, we have, R = 11 ohms, C = 1.15 × 10⁻⁷ Farads, V = 50 volts, and *l* = 443 miles. The current that the receiving apparatus requires to work satisfactorily is 6 mA. From equation (10) the distributed inductance L per mile was found to be 0.2 Henry. This L value when multiplied by the distance in miles between the repeater stations gives the required loading coil inductance. In this particular case the calculated values were experimentally verified.

The chief feature of the above examples is the ease with which working formulae has been derived, unfortunately, this advantage does not attend all the applications of the integral theorem, especially when it is applied to certain lumped networks. In many problems, excluding difficult types of transmission problems, it is found that, from the point of view of directness and simplicity, the direct operational method is preferable to the integral theorem. An example will make this limitation of the integral theorem clear.

Suppose that it is required to obtain a formula to represent the building-up of the sinusoidal currents in high-pass wave filters. For simplicity it will be assumed that the filter is terminated by its characteristic impedance, and that the series and shunt elements are non-dissipative. Let Z_1 represent the lumped series impedance and Z_2 the lumped shunt impedance.

In operational notation, we have $Z_1 = \frac{1}{pc}$ where c is the series capacity, and $Z_2 = pL$ where L is the shunt inductance and p is the differential operator $\frac{d}{dt}$.

The operational equation for the direct wave h , in, say, the third section is easily obtained from an application of Kirchhoff's law. We have,

$$h = \sqrt{\frac{C}{L}} \cdot \frac{\left(\sqrt{1 + \left(\frac{\omega_c}{p}\right)^2} - \frac{\omega_c}{p} \right)^6 \cdot [1]}{\sqrt{1 + \left(\frac{\omega_c}{p}\right)^2}} \quad [1]$$

where

$$\omega_c = \frac{1}{2\sqrt{LC}}$$

Transforming the operational equation into a form in which Bessel series may be used and then expanding and identifying term by term by means of the integral theorem, we obtain the series,

$$h(t) = \sqrt{\frac{C}{L}} \left\{ J_0(x) - 6 \int_0^x [J_0(x) - J_1(x)] dx + 15 \int_0^x \int_0^x [J_0(x) - 2J_1(x) + J_2(x)] dx^2 - 20 \int_0^x \int_0^x \int_0^x [J_0(x) - 3J_1(x) + 3J_2(x)] dx^3 + \dots \right\}$$

where $J_n(x)$ denotes the Bessel function of order n and argument $x = \omega t$. Now the e.m.f. $\hat{e} \sin \omega t$ is applied to the terminals at time $t = 0$, and consequently the required expression to give the building-up of the sinusoidal currents in the third section is obtained by an application of equation (3). It will be found that calculations made from the resulting series, whilst not actually impossible, are extremely difficult owing to the complicated nature of the mathematics involved. By means of Heaviside's expansion theorem or power series solutions, the transient oscillations in both high and low pass filters may be obtained with remarkable directness, even when the operational equation of the problem is complicated by dissipation and reflection. For the particular problem discussed above the expansion theorem yields the best form of solution because the characteristics of the dependent variable may be immediately determined by inspection.

These remarks are not intended to show that integral equation methods are not of great value. There can be little doubt that this method is one of the best for dealing with the very difficult problems of wire transmission theory. But there are certain problems, however, like the one discussed above, that can be solved more conveniently by other methods.

The integral theorem may be derived from the study of electrical networks in terms of the Fourier integral, and is, in fact, a general relationship resulting from Fourier analysis. This introduces the important fact that operational methods are the working tools of the classical Fourier method. This, however, was not the view of Heaviside, who appeared to have an even greater contempt for analytic functions than for other conventional mathematics. In the Fourier method of analysis everything is made to depend upon a known steady-state solution, a fact which seems to be the origin of considerable confusion and misinterpretation. Because the various schemes for solving the transient type of problem can be shown mathematically to depend upon a known steady-state solution, it must not be inferred that the one type of solution may be derived from the other merely by processes of ordinary A.C. mathematics. This, of course, is obvious from the mathematical consideration of the canonical equations (1). It will be interest-

ing, however, to illustrate the fallacy of this idea and to approach the operational method through the Fourier integral.

Consider the general case of an electrical network, originally in a state of equilibrium, to which an e.m.f. $E(t)$, is applied at time $t = 0$.

Let this applied e.m.f. be represented by the real part of the function $\mathbb{E} [I] e^{j\omega t}$.

Hence,

$$F(t) = \mathbb{E} [I] e^{j\omega t}$$

In order to make an analysis of the building-up phenomena in the system we may commence with a study of the differential equation,

$$I(t) = \frac{\mathbb{E} [I] e^{j\omega t}}{Z(p)} \dots\dots\dots(11)$$

where

$I(t)$ = generated time function which represents the instantaneous value of the current in any section.

$Z(p)$ = generating impedance function.

Rewriting equation (11) in terms of a Fourier integral we get,

$$I(t) = \frac{\mathbb{E} e^{j\omega t}}{2Z(p)} \left(1 + \frac{2}{\pi} \int_0^\infty \frac{\sin \omega t}{\omega} \cdot d\omega \right) \dots\dots(12)$$

The function $Z(p)$ may be obtained from the auxiliary equations (2) and it can be seen that it is the points of discontinuity of this function which determine what process may be employed to evaluate equation (12). To evaluate this equation it is necessary to transform it into a contour integral. Making this transformation, we get,

$$I(t) = \frac{\mathbb{E}}{2\pi j} \oint \frac{e^{(p+j\omega)t}}{p \cdot Z(p + j\omega)} \cdot dp \dots\dots\dots(13)$$

For $t < 0$ the contour will enclose no poles and consequently the value of $I(t)$ will be zero as it should be. For $t > 0$, however, the contour will enclose all the poles of the generating impedance function, which includes a steady-state pole at the origin which is included in the contour by surrounding the origin by a small semicircle. The path of integration may now, in accordance with the theory of residues, be deformed into small circles about each of the poles, and the sum of these residues will give the transient response of the network. The general problem is thus reduced to the evaluation of a contour

integral. Now, for network problems, the function $Z(p)$ has only a finite number of poles, all different from each other and from zero. Also all these poles are of the first order and lie on the left-hand side of the axis of imaginaries. In this case we have,

$$Z(p) = \frac{D(p)}{M(p)}$$

where $D(p)$ and $M(p)$ are polynomials in p ; $D(p)$ being of a higher order than $M(p)$. A direct algebraic transformation of $Z(p)$ gives,

$$Z(p) = \sum_{n=1}^{n=m} \frac{M(p_n)}{(p - p_n)D'(p_n)}$$

This enables us to evaluate the residues at the poles of the functional equation (13), and we get

$$I(t) = \frac{\mathbb{E} e^{j\omega t}}{Z(p)} + \mathbb{E} \sum_{n=1}^{n=m} \frac{e^{p_n t}}{(p_n - j\omega) \frac{\partial Z(p)}{\partial p} \Big|_{p=p_n}} \dots\dots(14)$$

where $p_1, p_2 \dots p_n$ are the roots of the equation $Z(p) = 0$.

The first right-hand term of equation (14), is the steady-state A.C. component, whilst the summation term gives the transient oscillations.

Now, in general,

$$Z(p)_{p=j\omega} = R + jX$$

where R is the resistance component and X the reaction component of the impedance. Taking the real part of equation (14), we get,

$$I(t) = \frac{\mathbb{E}}{\sqrt{R^2 + X^2}} \text{Cos}(\omega t - \phi) + \mathbb{E} \sum_{n=1}^{n=m} \frac{p_n e^{p_n t}}{(p_n^2 + \omega^2) \frac{\partial Z(p)}{\partial p} \Big|_{p=p_n}} \dots\dots\dots(15)$$

If now the mathematics of ordinary A.C. theory are to be sufficient to solve the transient type of circuit problem, the following conditions must be fulfilled, namely: (a) the steady-state term must be zero at time $t = 0$, and (b) the steady state term must be equal to

$$-\mathbb{E} \sum_1^m \frac{p_n}{(p_n^2 + \omega^2) Z'(p)_{p=p_n}}$$

It can be seen at once, from equation (15), that both the necessary conditions are not fulfilled and consequently the mathematics of steady-state A.C. theory is insufficient for the solution of the transient type of circuit problem. It should be noted that the so called "Transient method" of circuit analysis is really a "Steady-state summation method." This fact may be readily verified by putting $\omega = 0$ and $\hat{E} = 1$, in the general equation (14), when we get,

$$h(t) = \frac{I}{Z(0)} + \sum_{n=1}^{n=m} \frac{e^{p_n t}}{p_n \frac{\partial Z(p)}{\partial p} \Big|_{p=p_n}} \dots\dots\dots(16)$$

which is the famous Heaviside expansion theorem derived from standard steady-state equations through the Fourier integral. From an expansion theorem solution it is generally possible to deduce by inspection the characteristics of the dependent variable without numerical calculation, an advantage not possessed by a series solution. The chief disadvantage of the expansion theorem solution lies in the fact that the location of the roots of $Z(p) = 0$ may be very difficult, and in some cases, even impossible. When dealing with transmission lines it is found that the roots of $Z(p)$ are infinite in number and consequently the difficulty involving in calculating from the expansion theorem would not justify its use. These remarks, however, do not apply to the non-inductive telegraph cable. For this case the expansion theorem solution is probably the simplest and most easily computed form of solution, and is, in fact, much easier to use than the A.C. steady-state method that has been developed for dealing with the telegraph cable. This A.C. method will now be briefly discussed.

In equation (12) put

$$\frac{I}{Z(p)} = \frac{I}{Z(j\omega)} = a(\omega) + jb(\omega)$$

and obtain

$$I(t) = \frac{Ea(0)}{2} + \frac{E}{\pi} \int_0^{\infty} \frac{a(\omega)}{\omega} \sin \omega t \cdot d\omega + \frac{E}{\pi} \int_0^{\infty} \frac{b(\omega)}{\omega} \cos \omega t \cdot d\omega \dots\dots\dots(17)$$

which is Milnor's A.C. method. In equation

(17) the first term is of zero frequency and the integral terms contain components of all frequencies.

A very simple example will illustrate the limitations of the A.C. method.

Let it be required to derive an expression to represent the building-up of the current in a coil of inductance L and resistance R in response to a direct voltage E .

We have

$$\frac{E}{Z(j\omega)} = E \cdot \frac{R - j\omega L}{R^2 + \omega^2 L^2}$$

and

$$I(t) = \frac{E}{2R} + \frac{E}{\pi} \int_0^{\infty} \frac{R \sin \omega t}{\omega R^2 + \omega^3 L^2} \cdot d\omega - \frac{E}{\pi} \int_0^{\infty} \frac{L \cos \omega t}{R^2 + \omega^2 L^2} \cdot d\omega \dots\dots\dots(18)$$

The evaluation of infinite integrals of this type presents formidable mathematical difficulties, even in relatively simple cases. The infinite integrals of equation (18), have been evaluated by Bierens de Haan, and are given in "Nouvelles Tables D'Integrales D'efinies," page 252. From these solutions we get the well-known equation

$$I(t) = \frac{E}{R} \left(1 - e^{-Rt/L} \right) \dots\dots\dots(19)$$

For dealing with the problems of telegraphy and telephony, with the exception of the long telegraph cable in which the frequency range varies from zero to about 1.6 times the operating frequency, the A.C. method outlined above is practically useless, and will remain useless, until some device is invented for rapidly evaluating infinite integrals of the required type. It is interesting to note the remarkable ease with which the expansion theorem yields the above result.

We have $Z(p) = R + pL$

$$\therefore Z'(p) = L$$

and
$$p_1 = -\frac{R}{L}$$

Substituting in equation (16) we immediately obtain equation (19). Equation (17) illustrates a fact pointed out by Heaviside many years ago,

namely, that the transient behaviour of a network may be expressed mathematically in terms of its A.C. steady-state performance and is completely determined by the behaviour of the generating impedance function along the axis of imaginaries. This fact, however, must not lead to underestimating the complexity involved in actually constructing solutions for particular problems. Thus, A.C. methods lead us back to the consideration of the auxiliary equations (2) and the Heaviside operational equation (4). One of Heaviside's most difficult problems was the finding of practical ways of interpreting operational equations and he devoted the first two volumes of his "Electromagnetic Theory" to their solution. In his researches Heaviside made no pretence to rigorous formulation and only allowed physical and vectorial ideas to guide his mathematics to important results. One of his methods was to obtain the explicit solution of a number of problems by classical methods and then compare them directly with their operational equations. Thus he was led to attach a definite meaning to his operators which significance he would apply to those problems in which the classical methods failed him.

Heaviside usually evaluated his operational equations by expanding them in series and applying them term by term to the unit function [1]. Heaviside found that if the right-hand side of the operational equation be expanded in inverse powers of p , thus,

$$h = \left(C_0 + \frac{C_1}{p} + \frac{C_2}{p^2} + \dots + \frac{C_n}{p^n} \right) [1] \dots\dots(20)$$

then the operational expansion is converted into an explicit convergent power series solution by replacing $\frac{C_n}{p^n} [1]$ by $\frac{C_n t^n}{[n]}$ throughout.

obtaining

$$h(t) = C_0 + C_1 t + \frac{C_2 t^2}{[2]} + \dots + \frac{C_n t^n}{[n]} \dots\dots(21)$$

where the C's are constants.

It should be noted that the above method does not involve the determination of the roots of an equation and is particularly useful in discussions in which a knowledge of the first current surge is sufficient. In many practical problems it is found that the evaluation of the coefficients $C_1, C_2 \dots C_n$ may be very laborious and that the

slow convergence of the series makes the numerical evaluation rather tedious. In technical problems the best form of solution is one which enables us to infer the characteristics of the dependent variable without detailed calculation, and in this respect the Heaviside expansions leave much to be desired. When a power series solution of a problem exists it will be found to be far superior in its simplicity to any other form of solution. This method of expansion in power series is applicable to practically all problems which involve only lumped constants. There are, however, an important class of problems arising in connection with wire transmission theory where a direct power series solution does not exist. As an example of the use of the Heaviside power series expansion, consider the simple case of the first current surge in, say, the third section of a low pass filter. The operational equation of the problem, neglecting the disturbing effects of dissipation and reflection, is readily obtained.

We have

$$h = \sqrt{\frac{C}{L}} \cdot \left(\frac{\omega_c}{p} \right)^2 \cdot F_1(p) \cdot F_2(p) \cdot [1]$$

where the factors

$$F_1(p) = \frac{1}{\sqrt{1 + \left(\frac{\omega_c}{p} \right)^2}}$$

$$F_2(p) = \left(1 + \sqrt{1 - \left(\frac{\omega_c}{p} \right)^2} \right)^{-6}$$

and ω_c denotes $\frac{2}{\sqrt{LC}}$

Each factor must now be expanded by the binomial theorem. After this, the two resulting series must be multiplied together, from which the required power series solution can be immediately obtained. A very serious inherent disadvantage which is attached to power series expansions is that unless the series can be recognised and summed its slow convergence makes the numerical work very laborious.

For the class of problems where a power series solution does not exist Heaviside found that if the operational equation can be transformed into

$$h = F(p) \cdot \sqrt{p} \cdot [1]$$

where $F(p)$ is some function of p which admits of a power series expansion in p , so that the operational equation may be written as

$$h = (C_0 + C_1p + C_2p^2 + \dots + C_np^n) \sqrt{p} [I]$$

where the C 's are constants and n is integral, then a divergent and asymptotic series is obtained

by replacing $\sqrt{p} [I]$ by $\frac{1}{\sqrt{\pi t}}$ and p^n by $\frac{d^n}{dt^n}$.

Heaviside also found that if the operational equation of a problem can be transformed into the form

$$h = (C_0 + C_1p + C_2p^2 + \dots + C_np^n) [I] \\ + \sqrt{p}(d_0 + d_1p + d_2p^2 + \dots + d_np^n) [I]$$

then, in general, a solution divergent and asymptotic may be obtained by discarding the first expansion entirely, except for the first constant term C_0 , and making the same substitutions as before.

Heaviside in his "Electromagnetic Theory," Vol. II., gave no information or criteria for the correct application of his divergent expansion methods. Consequently he left the theory of the divergent solution of operational equations in a rather unsatisfactory condition. It should be noted, however, that when an asymptotic expansion of a transmission problem exists, the Heaviside method will find the solution with incomparable ease and directness. A simple example will make this clear. Let it be required to derive a formula for the current entering a loaded line. The operational equation of the problem, neglecting the distributed leakance G , is obtained from

the differential equations and may be written in the form

$$h = \sqrt{\frac{C}{L}} \cdot \sqrt{\frac{p}{2\phi}} \cdot \frac{1}{\sqrt{1 + \frac{p}{2\phi}}} \cdot [I]$$

where $\phi = \frac{R}{2L}$

Expanding the denominator by the binomial theorem and replacing $\sqrt{p} [I]$ by $\frac{1}{\sqrt{\pi t}}$ and p^n by $\frac{d^n}{dt^n}$, we obtain the asymptotic expansion of the function,

$$h(t) = \sqrt{\frac{C}{L}} \cdot e^{-\phi t} \cdot I_0(\phi t)$$

The asymptotic expansion of this function is usually derived by very difficult and intricate processes, a fact which may be verified by consulting Watson's "Theory of Bessel Functions." The supreme ease and simplicity of the Heaviside method is remarkable.

It may seem strange that wire transmission analysis that deals entirely with real variables finds it necessary to use the theory of the complex variable to rigidly establish some of its fundamental laws. This is, however, due to the fact that the analysis of transmission networks is really the study of their behaviour when subjected to discontinuities and the introduction of the theory of discontinuous functions into wire transmission theory is not merely a matter of elegance but one of practical necessity.



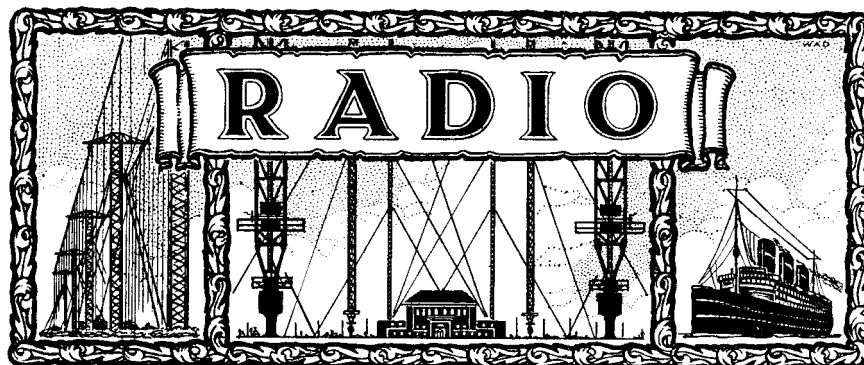

PORTISHEAD SHORT WAVE TRANSMITTER.

A. J. GILL, B.Sc., M.I.E.E., M.I.R.E., and A. G. McDONALD, A.C.G.I., B.Sc., A.M.I.C.E.

GENERAL.—In order to give facilities for handling ship and shore traffic on short wave-lengths, an experimental short wave transmitter was brought into operation at Devizes in 1927. Prior to the use of wave-lengths of the order of 17-40 meters, long range communication was effected through the medium wave transmitters at Devizes, which were afterwards transferred to Portishead. These transmitters had a working range of approximately 2000 miles. Telegrams for ships outside this range are transmitted from Rugby, but in this case under normal circumstances no reply from the ship to the effect that the telegram had been received is possible. In the case of ships fitted with short wave transmitters acknowledgment is possible and it was found that during some part of the 24 hours, usually between the hours of 1500 to 0400, communication could be effected over very long ranges.

On closing down Devizes Radio Station and transferring its services to Portishead opportunity was taken to rebuild the short wave transmitter and change the aerial system.

Power Supply.—The power supply of the transmitter installed at Portishead consists of a synchronous motor-generator set driven from an outside three-phase A.C. supply, 416 volts, 50 cycles; the D.C. output of the motor-generator drives a motor-alternator and a motor-generator. The output of the motor-alternator, 400 volts, 300

cycles, single-phase, supplies through the transformer the main H.T. feed, and the output of the motor-generator, 20-30 volts, is used for heating the filament of the oscillator valve.

The main power for the Devizes transmitter was obtained from a 30 B.H.P. crude oil engine coupled to a D.C. generator. The A.C. and D.C. supplies for the transmitter were obtained from a D.C.-driven motor-alternator and motor-generator. The power supply at Portishead is A.C. and in the design of the new equipment for Portishead two alternative power supplies were possible:—

- (1) New A.C. motor-driven D.C. generator for the filament supply and a new high tension transformer using the 50 cycle mains.
- (2) Provision of new motor-generator set, the output from which would be suitable for driving the existing motor-alternators and motor-generators and using the existing high tension transformer.

The latter course was chosen, as the frequency of the existing alternators was 300 cycles per second, which would therefore give a better note with less smoothing equipment than a 50 cycle supply; also it was considered that the rotating armatures of the main motor-generator and the motor-alternator driven from it would tend to act as buffers and damp out any fluctuation of the

mains voltage due to the keying load of the long wave transmitters. This proved in practice to be the case and no trace of variation of the alternator voltage on a steady load could be observed at times when considerable variation of the mains voltage was evident.

The alternators were wound with an extra field winding designed to give constant output voltage under load and thus compensate for the fall in voltage due to the regulation of the alternator. The current supplied for the extra field winding was obtained by leading the negative high tension return of the oscillator from the centre tap of the main high tension transformer to the alternator and then back to the earthing point on the oscillator filament. This necessitated a switching system so that the central rectifier could be connected to either of the alternators and then to either of the oscillators in use.

The compensation due to the keying load is thus automatic and since a diverter is fitted the current in the extra field can be adjusted so that the alternator voltage remains sensibly constant under varying loads.

Normal working figures for the installation are:—

	Alternator. Voltage.	Plate Voltage.		
Alternator level compounded	{	400	8700	Off load.
		400	6550	On load.
		360	5440	On load with extra winding not in use.
Alternator over- compounded	}	400	8700	Off load.
		425	7000	On load.

The difference between the on and off load plate voltages when level compounded is, of course, the difference between the peak voltage and working voltage of the rectifier.

Although a smaller variation of the plate voltage is possible by over-compounding, it is not used because under certain conditions—mainly when the transmitter is being retuned—a reaction effect is experienced. The increase in alternator volts increases the high tension volts and feed current and this in turn increases still further the alternator volts, so that on a long "mark" the supplies build up continuously until the overload trips.

The subsidiary switchboard handling the supplies to the transmitter is shown in Fig. 1. The board is of the dead-front type and consists

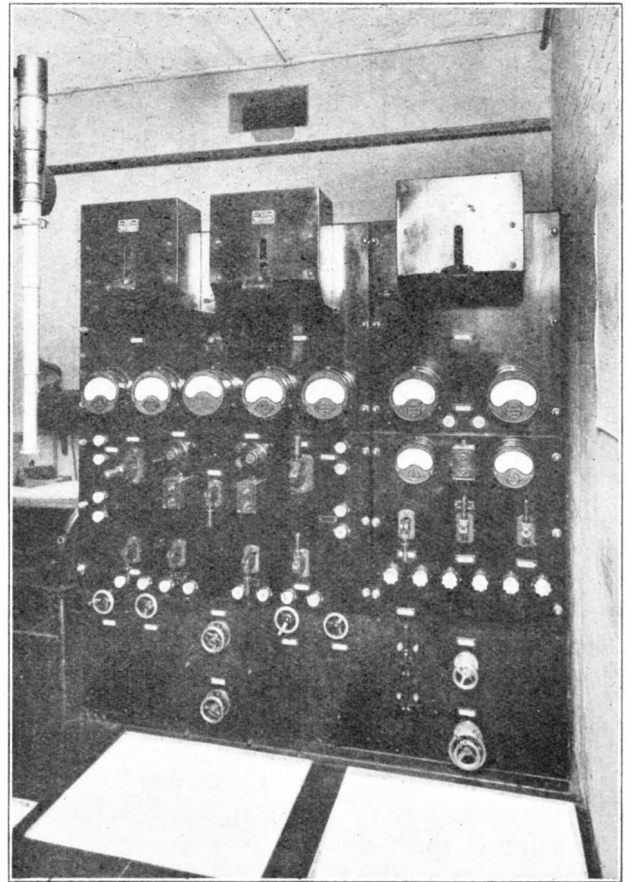

FIG. 1.—SUBSIDIARY SWITCHBOARD.

of an A.C. panel on the left and a D.C. panel for filament supplies in the right. Means are provided for synchronising and paralleling both the 300 \sim alternators if desired.

Transmitter.—The transmitter, Fig. 2, con-

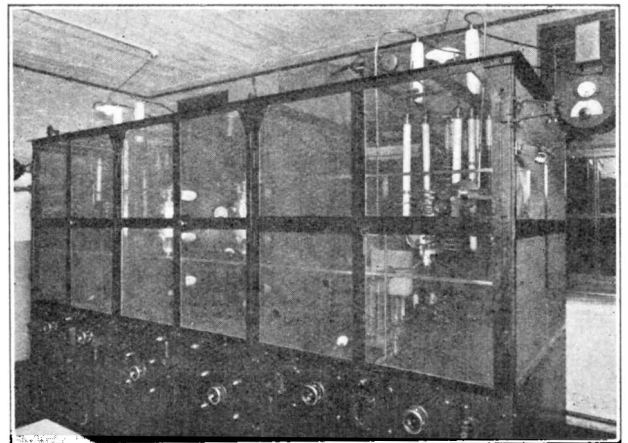

FIG. 2.—THE TRANSMITTER.

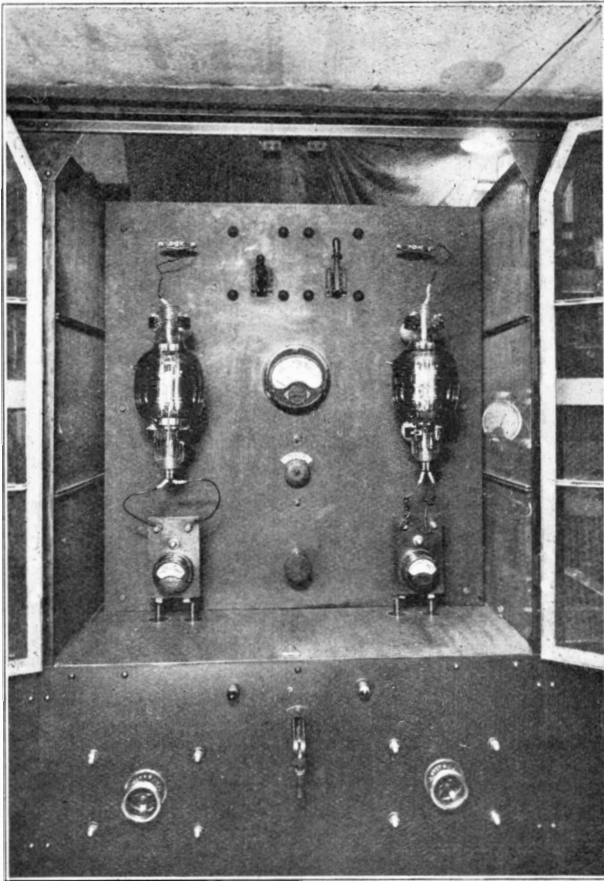

FIG. 3.—BI-PHASE THERMIONIC RECTIFIER.

sists of a brass framework divided into three screened compartments. The middle compartment contains the rectifier, that on the left the 26.59 metre transmitter and that on the right the 36.54 metre transmitter. The high tension supply for the transmitter is obtained from a bi-phase thermionic rectifier (Fig. 3) fed from a motor-alternator set. The normal high tension voltage is 7000. Two glass rectifier valves, each capable of dissipating 1500 watts, are used and, under the present conditions of running, lives of 7000 hours have been obtained. Power is switched on and off from the transmitter by a contactor system and interlocked with it are overload releases, safety switches on all enclosures in which high voltage equipment is situated and an alarm and shut-down circuit should the air blast cooling the oscillator valves fail.

Two complete and separate oscillators are used for the two wave-lengths of the transmitter and

these are fed from one central rectifier. Switching arrangements permit the earthing of one of the oscillator enclosures while the other is in use so that maintenance duties may be carried out. The filaments of the rectifier valves are heated from the main 50 cycle A.C. supply, and since they are not working up to saturation the voltage variations of the mains have no effect on the high tension supply. The rectifier panel is sheet steel, porcelain and paxolin insulators being used where necessary.

Oscillator System.—Two separate oscillator units, one tuned to 36.54 meters (8210 Kc/s) and the other tuned to 26.59 meters (11280 Kc/s) are used. All the condenser settings, coupling between coils, etc., remain untouched and the change in wave-length can therefore be made in 20 seconds. Fig. 4 shows the details of the 26.59 meter oscillator and Fig. 5 shows a general circuit diagram. The type of oscillating circuit used is one which has been developed by the

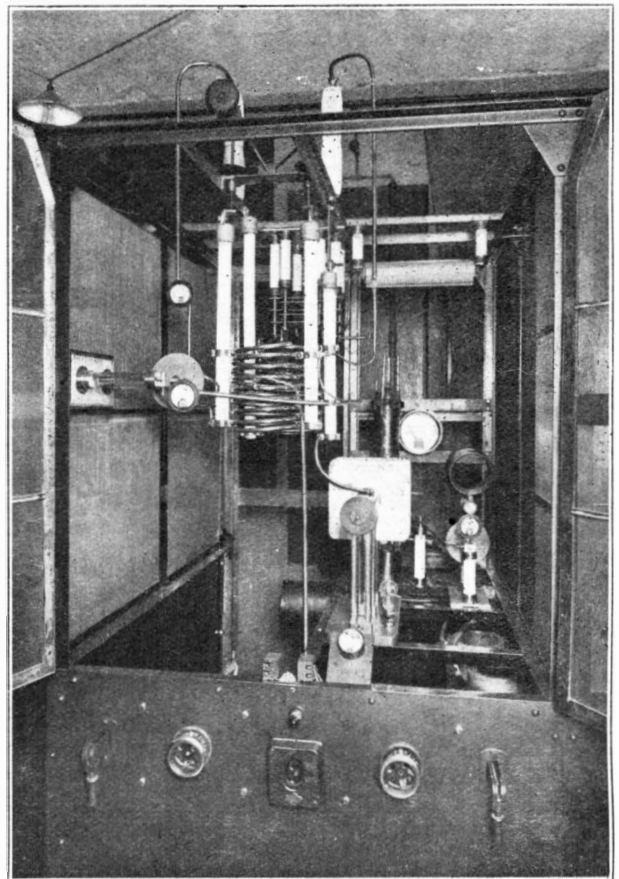

FIG. 4.—26.59 METER OSCILLATOR.

Post Office and has been found to be very stable and suitable for single valve transmitters.

A single silica valve having a maximum dissipation of $3\frac{1}{2}$ kilo-watts is used as the oscillator valve and has proved satisfactory, lives of over 5000 hours being obtained.

The high tension supply after rectification has two 0.25 microfarad smoothing condensers connected across it. The supply is therefore only

that for a service of this character the operators had a strong preference for I.C.W. transmissions. The oscillator valve filaments are heated by direct current from a motor-generator set, across the terminals of which is floated a secondary battery, but for emergency use A.C. can readily be brought into operation. All tuning controls of the transmitter are external to the enclosure so that there is no danger of the opera-

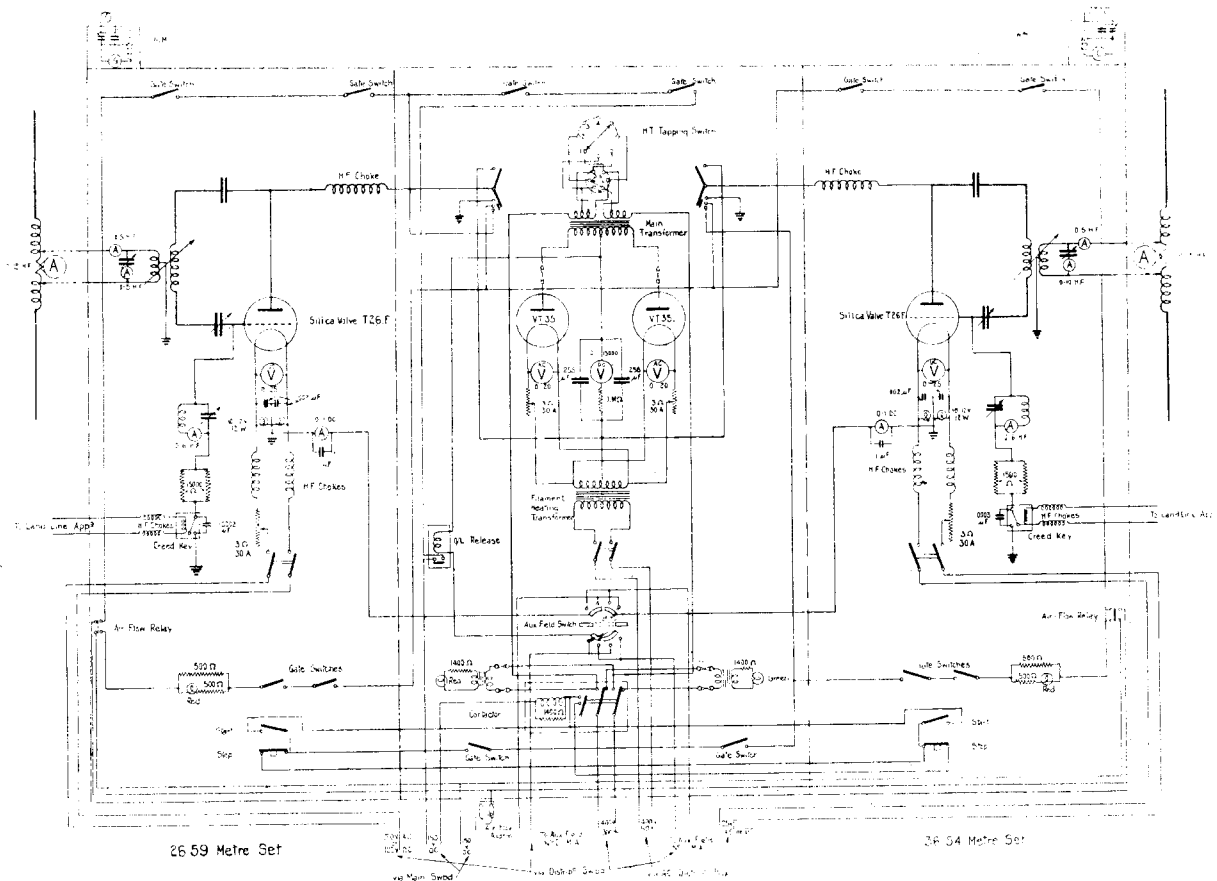

FIG. 5.—CIRCUIT DIAGRAM.

partially smoothed and the resulting emission is interrupted continuous waves. It has a characteristic note due to the remaining ripple which serves to help to identify the station, but can of course readily be heterodyned. A pure C.W. transmission was employed for a short time at Devizes and more smoothing was used initially at Portishead, but in tests with ships it was found

tors incurring risks during tuning operations.

All the insulators are of porcelain and pyrex. No wooden frameworks or fittings are used. The transmitter is keyed by interrupting the grid circuit. There is thus no radiation on "space." The adjustment of the tuned grid circuit is such that no sparking at the key can be observed. During erection, tests were con-

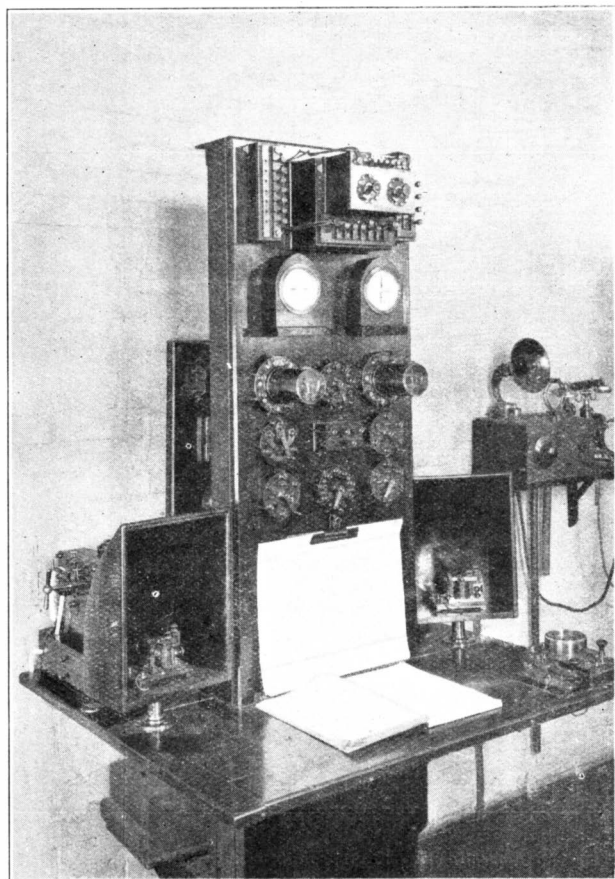

FIG. 6.—TELEGRAPH CIRCUIT APPARATUS.

ducted to ascertain whether or not the use of sheet steel round the bottom of the framework had any detrimental effect on the aerial current. With the coils in their present position no variation in aerial current with sheathing on or off was noted. The grid, anode and filament seals and the envelope of the silica valve are cooled by an air blast. Failure of the air supply is protected against by a relay trip circuit. Wave meters are permanently fitted to the top of each oscillator framework so that the wave length can be checked at frequent intervals.

Control.—Reception of ship's transmissions is carried out at Burnham Radio Station and control of Portishead transmitter is therefore effected from this station. Simplex telegraph working is used for this as a telephone circuit is available as a speaker between the two stations (Fig. 6). Control from the Central Radio Office, London, was also required and in this case the line is

worked duplex. Switching arrangements are also provided so that the transmitter can be keyed locally. The transmitter is controlled by a Creed key operated by the telegraph signals. The machines for the power supplies, etc., are switched on in advance of the regular times of working so that all coils, resistances, etc., are warmed up to their normal working temperature, thus minimising possible slight changes in wave length.

Aerial System.—Separate aerial systems (Fig. 7) are used for each of the wave-lengths. In each case a half wave dipole consisting of a copper tube mounted on porcelain insulators and supported on a 70ft. wooden pole is used as an aerial. The aerial is fed at the centre by a transmission line. The impedance of the aerial and its coil was matched up to the surge impedance of the transmission line by varying the taps at which the transmission line joined the aerial coil. The transmission lines in each case consist of two 400-

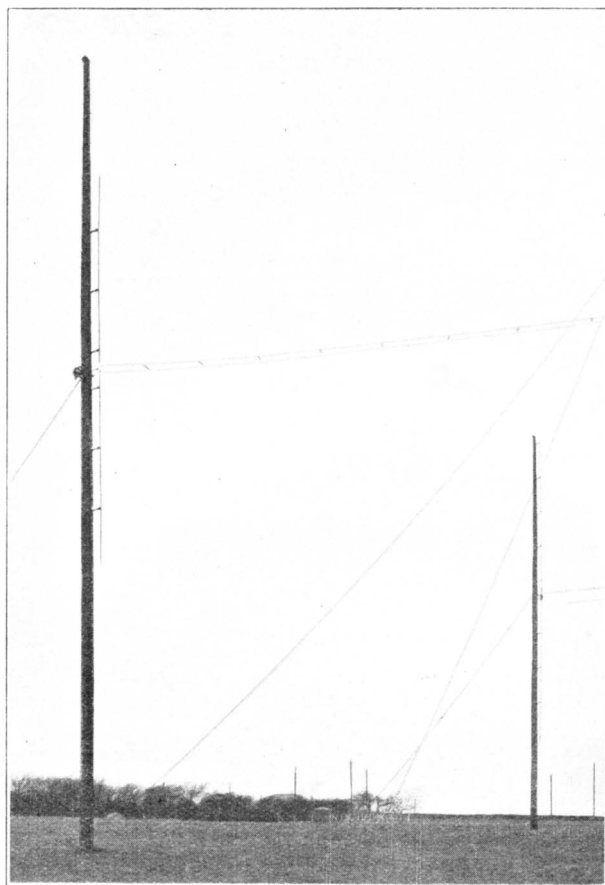

FIG. 7.—AERIAL SYSTEMS.

PORTISHEAD SHORT WAVE TRANSMITTER.

lb. copper wires, spaced 9" apart and supported on line insulators on 36ft. poles. In the course of tests it was found that the sway of the transmission lines during stormy weather had a marked effect on the oscillator output, and accordingly the transmission lines were laced together with pyrex insulators. Slight flexibility at the point where the lead in enters the building is allowed, to avoid breaking the glass window.

The aerial ammeters are mounted on the poles and can be read by means of a telescope from the transmitting room.

Tests.—Normal working powers for the transmitter, using a Mullard silica valve T.26.F as oscillator are:—

	<i>Wavelength.</i>	36.54 <i>metres.</i>	26.59 <i>metres.</i>
Main D.C. supply—volts		140	140
current—amps		62	64
A.C. Alternator Output—			
volts		416	400
amps		11.3	11.5
Plate Volts		7000	6800
Plate current—milliamps		500	500
Aerial current—amps ...		8.8	7.6
Transmission line current—			
amps		3	2½

The working range of the transmitter covers practically the whole of the world and ships are regularly worked at very long distances. A normal log of Burnham is as follows:—

RECORD OF SHORT WAVE SHIPS WORKED BY PORTISHEAD S.W. TRANSMITTER, CALL-SIGN GKT.

JAN. 11TH, 1930.

	<i>Ships</i>	<i>Position.</i>
	<i>Wave.</i>	
0010 Saragossa VPNJ	35.5	Near South Pole.
0100 Guilioesare IBWO	36	Pernambuco for Rio.
0112 Orania PGOB	36	Santos for M. Video.
0832 Southern Princess ZMGK	36	Ross Sea, 12,500 South.
1507 Aorangi GDVB	36	807 Miles S. Sydney.
1540 Vegoe LDHN	36	500 West Lands End.
1610 Yorkshire GDKC	36	Due Suez 0600/12th.
1645 Oxfordshire GLZF	36	Due Port Sudan 12th.
1817 Narkunda	36	Mediterranean.
1820 Arundel Castle GCZL	36	Due Durban 12th.
1855 Egero LDIQ	36	About 800 South.
1940 Kenilworth Castle GLVT	36	2,000 Miles South.
2130 Coronda VPNL	36	3,000 Miles South.
2136 Mazzini IBYO	36	At Port Sudan.
2204 Bremen DDAS	36	New York.
2216 Olympic GLSQ	36	New York.
2247 Duchess of York GSYN	36	St. John's N.B.
2254 Saragossa VPNJ	36	In Pack Ice S. Pole.
2319 Kenilworth Castle GLVT	36	See Above.
2022 Duchess of Richmond	36	St. John's N.B.
2035 Orontes GBXM	36	Red Sea.

JAN. 12TH, 1930.

<i>Time.</i>	<i>Ship and Call Sign.</i>	<i>Ships</i>	<i>Position.</i>
		<i>Wave.</i>	
0011	Kenilworth Castle GLVT	36	2400 South.
0032	Carnarvon Castle GJSL	36	2200 South.
0034	Narkunda GCVB	36	Port Said.
0049	Thorshammer LCTJ	36	South Antarctic.
0105	Caronia GLRY	36	Havana.
0325	Saragossa VPNJ	36	Near South Pole.
0824	Southern Princess ZMGK	36	12,000 Miles South
0852	Caronia GLRY	36	Havana.
1103	Bremen DDAS	24.5	2,600 West.
1513	Aorangi GDVB	36	Off Auckland.
1535	Oronites GBXM	36	Red Sea.
1800	Oxfordshire GLZF	36	Leaving Port Sudan.
2147	Coronda VPNL	36	3,000 South.
2231	Southern King GJZT	36	3,200 South.
2250	Yorkshire GDKC	36	Suez.
2300	Olympic GLSQ	36	Near New York.

At the present time the "Discovery" in the South Polar Regions is communicated with every day. No skip distance has been observed on the 36 meter transmissions and ships quite close in can readily be communicated with. The 36 meter transmitter is used during darkness and partial darkness periods and is much more effective than the 26 meter. This latter wave is used for daylight transmissions and is not entirely satisfactory. Previously a wave-length of 17.81 meters was used, but many of the ships' receivers would not readily oscillate on this wave-length. The comparatively recent growth of ship traffic on short waves can be judged from the following

totals of words transmitted and received through the Portishead transmitter and the Burnham receiving station. The totals are expressed as a percentage of the total traffic.

From Ships.		To Ships.	
Messages.	Words.	Messages.	Words.
1927.			
0.6%	0.6%	1.3%	1.2%
1928.			
12.2%	11%	15.5%	17%
1929.			
87.2%	88.4%	83.2%	81.8%

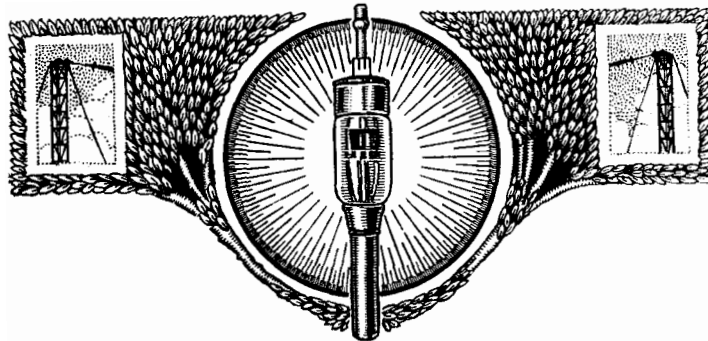



NOTES & COMMENTS

THE Lord President of the Council of the Department of Scientific and Industrial Research has had under consideration the appointment of a Chairman of the Radio Research Board of this Department in succession to Admiral of the Fleet the late Sir Henry Jackson, G.C.B., K.C.V.O., F.R.S.; and, on the recommendation of his Advisory Council, he has appointed Lieutenant Colonel A. G. Lee, O.B.E., M.C., Assistant Engineer-in-Chief, G.P.O., to be Chairman of this Board, of which he has been a member since August, 1928. Our heartiest congratulations are extended to Col. Lee on this important appointment which has been conferred upon a P.O. official for the first time. Col. Lee has also been appointed a Vice-President of the American Institution of Radio Engineers.

A fusion of manufacturing interests has been arranged between The Relay Automatic Telephone Company, Limited, and The Sterling Telephone & Electric Company, Limited.

The manufacturing facilities at Relay House, Streatham Hill, will be considerably augmented to deal with the dual output of these two Companies, which will manufacture Automatic Telephone apparatus and Manual Telephone apparatus respectively.

All enquiries in connection with the Sterling Company's products should now be addressed to:—

RELAY HOUSE,
STREATHAM HILL,
LONDON, S.W.2.

TELEPHONE DEVELOPMENT IN CANADA.

The Dominion Bureau of Statistics at Ottawa has forwarded to the High Commissioner of Canada in London its Report for 1928 on Telephone Statistics, from which it appears that the number of instruments in use increased by 6 per cent. during that year. The total number of telephones installed was 1,334,534, an average of 13.82 per hundred of the population. Canada comes second among the nations of the world in the utilisation of the telephone, her average being exceeded by that of the United States, which was 15.8 per hundred in 1927.

British Columbia led the Provinces of Canada with an average of 20.8 telephones per hundred of population, Ontario coming second with an average of 18.3 and Saskatchewan third with an average of 13.2, the other Provinces in order being Alberta with 12.3, Manitoba with 11.8, Quebec with 10.4, New Brunswick with 7.9, Nova Scotia with 7.8, and Prince Edward Island with 5.7 per hundred. The estimated number of telephone conversations during the year was 2,292,000,000 local calls and 36,177,000 long-distance calls.

Telephones in Canada are not operated by the Dominion Government, and there are no less than 2,447 telephone systems. Of these, five are owned by the Provincial Governments of Alberta, Saskatchewan, Manitoba and Ontario; 137 are municipal and 1,557 are co-operative; these being mostly in the Province of Saskatchewan. Private telephone systems numbered 161, many of these being transcontinental private

lines; and 93 telephone systems are operated by partnerships.

Telephone wire mileage is 3,982,867, pole line mileage totalling 207,566, including 4,546 miles of underground conduits.

One Company to spend \$160,000,000 in five years.

The Bell Telephone Company of Canada proposes to spend \$31,500,000 this year in the Provinces of Quebec and Ontario as part of its five-year programme comprising the installation of 250,000 new telephones, involving a gross outlay of \$160,000,000.

INDUSTRIAL RESEARCH IN CANADA.

The High Commissioner of Canada in London has received from the Canadian Manufacturers' Association at Toronto a copy of the January, 1930, issue of its monthly journal "Industrial Canada" which is largely devoted to the question of research in Canada.

The journal in question contains articles by officials of the National Research Council at Ottawa, as well as one by the Chairman of the Ontario Research Foundation, and others describing industrial research in Alberta, Nova Scotia, New Brunswick, British Columbia, Prince Edward Island and Saskatchewan. It can be consulted at the Canadian Building, Trafalgar Square, London, S.W.1.

"WIRED WIRELESS" DEVELOPMENT IN NORTHERN ONTARIO.

The Bell Telephone Company of Canada is constructing in Ontario, at a cost of \$1,500,000, a new line from Oshawa to Sudbury, *via* North Bay. The line, about 300 miles long, will be operated on the "wired wireless" principle, making it possible for eight persons to converse at one time over the same pair of wires, or for two people to talk and 40 people to be in communication on teletype or telegraph simultaneously.

Construction will be completed in a year from the beginning of operations, and the line will handle not only the increasing telephone busi-

ness between Toronto and the northern Ontario mining districts, but will be a link in the Atlantic-Pacific system. On the completion of this transcontinental project, being brought into existence by co-operation between the Bell Telephone Company and the various telephone systems in the Maritime Provinces and western Canada, persons in Halifax will be able to talk to Vancouver over an all-Canadian route with perfect audibility.

FROM "THE TELEGRAPH AND TELEPHONE AGE" OF FEB. 1, 1930.

Harold Vivian, chief control operator of the Columbia Broadcasting Company, formed part of the circuit which enabled the radio audiences of fifty-nine stations in the United States and Canada to hear the speech of King George V. at 6 o'clock in the morning on January 21, at the opening of the Naval Conference in London. A few minutes before the King was to speak, a member of the control room staff of the Columbia Company tripped over a wire leading to the generator which energizes the Columbia network. Vivian examined the breakage. It would take at least twenty minutes, he realized, to make repairs. Meanwhile the King's speech would be over and thousands of radio listeners who had sat up late or arisen early to hear him would be disappointed. Vivian grasped the ends of the broken wires, one in either hand, to restore the circuit. The shocks of the 250-volt charge and the leakage of the current through his body to the floor shook his arms with spasms, but he held on until new wires could be connected. By that time his hands had been slightly burned and he was feeling the effects of the ordeal. As soon as the broadcast was finished he was sent home to bed. He had been through a tremendous nerve-racking experience, but the doctors said that he was not seriously hurt. The King's speech lasted six minutes. It was not preceded by any announcement. His voice was heard clearly, but none of the thousands of the Columbia's listeners was aware that save for Vivian's presence of mind and his pluck in clinging to the frayed ends of the broken wires their wait to hear the King would have been in vain.

EXTRACT FROM "THE ENGINEER,"

DATED 3RD JANUARY, 1930.

*From their Tokyo Correspondent.**The World Engineering Congress in Japan.*

"The telephone in its practical application is one of first-rate interest to every business man in Japan, where the price of the telephone placed in your house or offices is Yen 1200, say, £120 sterling. This price is fixed by the Government. The telephone situation here is so outrageous that foreign newcomers refuse to believe it, and quite naturally imagine that the old stagers are engaged in some regulation joke. The matter as it affects foreigners assumed a serious aspect quite recently when the Japan agent of a firm in Europe sent to headquarters a statement of establishment expenditure, which included the item Yen 2000 for telephone. He was threatened with legal proceedings, and it took quite a lot of explaining. In the boom years, 1917-21, the price of a telephone rose as high as Yen 4000. This extraordinary situation is created by that condition that causes all high prices—scarcity of the article in demand. It could be remedied within a year, but the interest of the "telephone broker," behind whom are banks who finance the broker, is of greater concern to the Government than the interest of the public. When some years ago, it appeared that an effort was to be made to end the situation and provide telephones for all who required them, the brokers rose in protest at the threat to their 'interests,' and had their way.

There are several ways of obtaining a telephone. One may be rented at a charge of from Yen 20 to Yen 30 per month, according to number and condition of the market. It is installed at a charge of about Yen 25—payable by renter—who must also pay the quarterly Government fee for use, amounting to Yen 16.50, and the sum of 3 Yen per call. To those in a hurry there is what is called 'quick installation,' whereby one who has deposited Yen 15 with the official telephone bureau and been promised an instrument within seven years, may obtain installation within six months by payment down of Yen 500 or thereabouts. Hundreds of thousands of ratepayers are on the books of the telephone bureaux in the different towns of the empire, each having paid a deposit of Yen 15—

on which he receives no interest—who are patiently waiting, waiting. It has been said that a people has the Government it deserves!"

DR. M. MERKER.

We regret to record the death in Paris on June 28th last, of Dr. M. Merker.

Dr. Merker, who was born in Warsaw in 1886, joined the Bell Telephone Manufacturing Co. of Antwerp in November 1921, and remained there until December, 1928, when he was transferred to the Paris Laboratories.

Dr. Merker will be chiefly remembered in this country for his work on the application of the Theory of Probabilities to problems of Telephone Traffic. An article on this subject appeared in this Journal for April, 1924. But like others of his nationality, Dr. Merker was an accomplished linguist and other articles on the same subject will be found in the Technical Journals of both France and Germany.

Dr. Merker's death, at the early age of 43, is a serious blow to the technical side of Automatic Telephony.

POST OFFICE COMMERCIAL
ACCOUNTS 1928-9.

Statement of Balances shown in the Telegraph and Telephone Income and Expenditure Accounts since 31st March, 1912.

Year.	Surplus or Deficit (after charging interest on Capital).	
	Telegraph.	Telephone.
	£	£
1912-13	-1,175,347	303,343
1913-14	-1,211,742	239,111
1914-15	-1,232,955	- 111,018
1915-16	- 520,047	- 118,177
1916-17	- 529,639	201,729
1917-18	- 556,330	355,468
1918-19	- 685,139	- 36,261
1919-20	-2,636,183	-1,961,710
1920-21	-3,728,779	-4,721,970
1921-22	-3,032,246	- 559,132
1922-23	-1,696,836	939,009
1923-24	-1,270,925	1,596,917
1924-25	-1,645,525	463,006
1925-26	-1,299,214	550,830
1926-27	-1,349,112	283,375
1927-28	-1,380,829	107,391
1928-29	- 757,237	524,695

In commenting on the previous year's accounts we stated that the year now covered by these accounts would probably show better results, and this is borne out by the above figures.

As from 1st April, 1928, the Imperial Cable and Beam Wireless Telegraph Services were transferred to Imperial and International Communications Ltd. The Imperial Cable Service Account does not now appear and the Wireless Telegraph Service Account loses much of its importance. The cash receipts from Broadcasting licences amounted to £1,358,187, of which sum the B.B.C. received £887,616.

In the Telephone Service Income and Expenditure Account, the income for the year from rentals, call fees, etc., amounted to £20,348,722, an increase of 1½ millions over the previous year. The expenditure expanded by £1,036,975, the chief increases being £528,639 for depreciation and £341,040 in interest on capital, as would be expected from the larger plant, etc.

The total capital raised amounts to £120,239,166, but of this £35,137,337 has

been redeemed. The Engineer-in-Chief and Controller of Stores certify for the proper condition of the plant and the engineering stores in stock respectively. The assets in the General Account Balance Sheet, including land and buildings, plant, engineering stores, sundry debtors for revenue and cash in hand amount to £133,025,748.

Holborn Gas Explosion.

As the result of negotiations between the P.O. and the Gas Light and Coke Co., it was agreed that each party should bear the cost of restoring its own damaged plant and share equally compensation to third parties. For the purposes of the Commercial Accounts, the cost of repair to the P.O. may reach £48,000, of which one-third has been allocated to renewals and two-thirds to maintenance, apportioned between telegraph and telephones on a mileage basis. A sum of £30,000 has been placed in reserve against compensation to third parties.

HEADQUARTERS NOTES.

The resignation of Mr. S. A. Pollock, Staff Engineer in charge of the Research Section, has led to two changes in the administration at Headquarters. Captain B. S. Cohen, who was formerly at Dollis Hill and who had been in charge of the N.T. Coy's laboratories before the transfer, has returned to the Research Section, changing over from the Test Section to Research. Mr. C. Robinson has been promoted to take Captain Cohen's place in charge of the Test Section. Mr. Robinson is well known to the staff generally by his contributions to the literature of the I.P.O.E.E. on the subject of Tele-

phone Repeaters and it is not too much to say that the successful operation of the underground network is largely due to his work on repeaters and their associated transformers and balances. His services in this direction are widely recognised throughout the world, as he has read several papers before the C.C.I. meetings on the continent. As head of the Test Section, Mr. Robinson will still be closely associated with cable testing and it is understood he will hold a watching brief on the subjects of which he is an acknowledged authority.

EXCHANGE EQUIPMENT.

The following works have been completed :—

Exchange.	Type.	No. of Lines.
Brierley Hill	New Auto.	500
Davidson's Mains	"	620
Dudley	"	1220
Hillside, London	"	2400
Mitcham	"	1500
Stourbridge	"	1020
Summertown	"	600
Edinburgh Central	Auto Extn.	1460
Harrogate	"	1700
Morningside, Edinburgh	"	870
Murrayfield, Edinburgh	"	650
Newington, Edinburgh	"	660
Southampton	"	410
Swansea	"	1000
Bexhill	New Manual	1460
Farnborough (Kent)	"	800
Herne Bay	"	1250
Redhill	"	600
Hitcham	"	1270
Skegness	"	620
Theydon Bois	"	300
East Grinstead	Manual Extn	250
Ramsgate	"	450
Sydenham	"	2050
Airworks, Ltd.	P.A.B.X.	20
Bond Worth & Son	"	30
Cheltenham Corporation	"	30
Decca Gramophone	"	30
Geo. Clark & Son	"	30
Geo. Shaw & Co.	"	30
Horlicks Malted Milk	"	30
Mickley Coal	"	20
Royal Sussex Hospital	"	30
Wellsteads, Ltd.	"	30

Orders have been placed for the following works :—

Exchange.	Type.	No. of Lines
Acorn, London	New Auto.	4400
Bristol Central	"	5050
" North	"	2000
" South	"	1000
" West	"	3300
" Bedminster	"	875
" Easton	"	1500
" Kingswood	"	570
" Stoke Bishop	"	520
" Westbury	"	1100
" Whitchurch	"	100
Cheriton	"	320
Folkstone	"	2200
Hythe	"	800
Kings Langley	"	500
Lyminge	"	160
Radlett	"	760
Sandgate	"	400
Watford	"	3450
Bath	Auto Extn.	Obsn. Equip.
Maida Vale	"	Switching Plant.
Worthing	New Manual	3460
Altrincham	Manual Extn	960
Chester	"	520
Guildford	"	940
Perth	"	360
Wembley	"	1340
Bradbury Agnew	P.A.B.X.	40
Colgate Palmolive	"	30
French & Sons	"	30
Hollins & Co.	"	30
Lewis Berger	"	30
Royal Sussex Hospital	"	30
Shell Mex (Plymouth)	"	30

DISTRICT NOTES.

LONDON.

EXCHANGE LINES AND EXTENSIONS.

In December 31st, 1929, there were 383,356 direct exchange lines and 645,939 telephone stations in the London area. The increase during the quarter was 7,456 exchange lines and 12,456 stations.

The total number of private wire telephones in the London area is 16,640. An addition of 16,500 loop miles was made to the local line mileage, the total of which is now 1,283,150 loop miles.

NEW AUTO. EXCHANGE.

The " Primrose " Exchange, situated in the North West District of London, close to Regent's

Park, was opened on the 15th February, 1930. The exchange equipment, which is of the " director " type, was manufactured and installed by the Automatic Telephone Manufacturing Company, Limited. Its installation occupied a period of about eleven months. At the transfer 4,026 subscribers' lines were cut in from the Primrose Manual Exchange and 700 new junctions were brought into use. The latter exchange has ceased to function temporarily, but will be re-conditioned and opened again in May, 1930, as " Cunningham," a manual exchange which will take the growth in the Abercorn area until the second unit of the new automatic Abercorn Exchange is built in 1934.

The new Primrose Automatic Exchange is

equipped for 6,900 lines. There are 57 ordinary units of 100 rotary line switches and final selectors, 52 "A" digit switches, 93 directors, 614 1st and 403 2nd numerical switches. The manual switching plant consists of 15 "A" positions and 6 "B" positions. The transfer operations, comprising the removal of heat coils at the closing exchange, the withdrawal of wooden wedges on the main frame at the new exchange and the simultaneous change over from coder call indicator to Strowger working at the automatic exchanges in the London network having direct junctions to the new Exchange, was effected in 120 seconds. A test of all circuits (subscribers' and junctions) was completed within three hours. Only 18 faults were discovered as a result of this test, representing 0.44% of the circuits transferred; there were no junction faults. The speed with which the transfer was carried out, the clean cut and orderly arrangements, the absence of any single adverse incident, together with the entirely satisfactory results obtained at the post transfer test, is very creditable to those who organised the arrangements.

AUTOMATIC EXCHANGES UNDER CONSTRUCTION.

The equipment at the following automatic exchanges is well advanced:—

Amherst, Fairfield, Addiscombe, Livingstone, Macaulay, Shepherds Bush, Gladstone and Gulliver.

C.C.I. POSITIONS AT MANUAL EXCHANGES.

The growth of automatic telephone traffic has necessitated the provision of additional C.C.I. positions at Finchley, Park, Clissold, Marylebone, East Hounslow, Paddington, Croydon and Putney.

NEW MANUAL EXCHANGES.

The following Manual Exchanges were opened on the dates mentioned:—

Springpark. Opened on January 1st on equipment previously used for Beckenham.

Redhill, No. 1 C.B. type equipped with 1400 lines. Opened on January 15th.

Theydon Bois, No. 10 C.B. type equipped with 300 lines. Opened on January 22nd.

New exchanges at Ingrebourne and Loughton are being equipped.

CORROSION OF CABLE SHEATHS.

Cases of corrosion of cable sheaths are unfortunately not rare, but it is unusual to have faults of this type reported on adjacent cables while the ground is opened to clear specific trouble in one cable. The little demon who watches these matters usually arranges for the second trouble to occur after the repairs to the first cable have been completed and the job left. A case has recently occurred in the London District where trouble on three trunk cables were cleared at one point, although only one fault had been reported when the repairs were commenced.

When a partial breakdown on the Guildford cable was brought to notice, the position of the fault was located from Toll Test and the first opening of the cable was made at a point which proved to be 1.75 ohms from the seat of the trouble. Measurement of the distance from the first cut indicated that the fault was likely to be in a particular manhole in which the cable was very inaccessibly placed. It was desired, if possible, to avoid opening the joint at this point (A). A narrow slit was, therefore, made in the sleeve to enable access to be obtained to a pair for testing purposes. This pair was picked up at the next manhole (B) 51 yards distant and Varley and Murray tests were made to obtain a precise location of the fault.

The location of the fault as shown by the Varley test made from B was 3.75 yards from A, the location according to two Murray tests made from B was (1) at 2.28 yards from A, and (2) 0.2 yards from A. A further Murray test was then made from A by which the location of the fault was shown as 1.26 yards from A. The ground was excavated immediately outside the manhole and the conduits cut. No sign of damage to the cables was, however, found and the manhole wall was therefore broken into. At this point the cable was found to be very severely corroded and punctured in two places. Similar damage was also found to have been caused to the sheath of the Southampton cable. A breakdown on this cable was reported and localised by Toll Test and punctured in two places. Similar damage to the same neighbourhood during the time that the road-side localisation test was being made on the Guildford cable. The cable sheath of the Woking cable was also found to be badly corroded but not punctured. The faults on the

Guildford and Southampton cables were removed by the application of heat and carbon dioxide gas and the sheaths of the three cables were made good by patches.

KIOSKS.

There are over 1,700 kiosks in the London District and the decoration of these receives close attention so that these conspicuous structures in the London streets may present a pleasing appearance. Arrangements are at present being made to carry out the work of re-decoration of 600 of the above number. The opportunity will be taken in the case of Kiosks No. 1 to introduce the new colour scheme, viz., Clipsham stone colour and Post Office red.

TELEPHONE ARRANGEMENTS FOR NAVAL CONFERENCE.

A brief reference was made in the last issue to the telephone arrangements for the Naval Conference and it might be well to state in more detail what these arrangements are, so that it may be seen what an important part the telephone plays in national and international matters to-day.

As is well known, the conference is being held in St. James' Palace. Over 90 telephones have been specially installed. In addition, it was necessary for the District staff to construct and fit 52 special cabinets for the use of Press representatives of various nations.

In these 52 cabinets are fitted 23 Private Wires to the various newspaper offices in the City and West End; 14 Multi Coin Boxes working on Regent for local and Toll calls; and 15 Telephones controlled by attendants for Trunk, Continental and Trans-Atlantic calls. Each Private Wire Cabinet is marked with the name of the newspaper to which it has been allotted, and the instruction cards and notices in the Multi Coin Box Cabinets are printed in English, French and German.

Two attendants' switchboards, controlling the 15 telephones mentioned above, with 15 Exchange lines on Gerrard and two direct lines to Trunk Records, are situated in the Guard Room behind a special counter provided for the Post Office. In this room there are also two Post Office Teleprinters working direct to the Central Telegraph Office and five Tele-printers owned by the chief

Cable Companies. A Baudot telegraph set is also installed. Twenty-three extensions connected to a special Private Branch Exchange position in Gerrard Exchange have been installed in the various State Rooms used by the delegates, including three special cabinets in the Matted Hall for use by delegates who desire to make private calls. Two Private Wires to the Foreign Office also exist. The wiring of these extensions proved a matter of some difficulty owing to the necessity of carrying out all wiring and fixing without touching any of the valuable woodwork in the State Rooms. The problem of bringing the external leads in at each window was solved by raising the lower part and inserting a batten through which the leads were taken.

At the Ritz Hotel, two special $\frac{10 + 50}{65}$ switchboards were installed for the American Delegation, with 10 exchange lines and 75 extensions which were diverted from the main board. This necessitated the provision of a 100-pair cable from the basement to the fifth floor.

Similar arrangements were made at the Carlton Hotel for the French Delegation, where two $\frac{10 + 50}{65}$ boards with eight exchange lines and eighty extensions were fitted.

At Claridges Hotel a special $\frac{10 + 50}{65}$ board accommodating 8 exchange lines, and 30 extensions (24 of which were diverted from the hotel board) was installed for the Italian Delegation, while at 46, Grosvenor Square, an empty house which has been taken over by the Japanese Delegation, two $\frac{10 + 50}{65}$ switchboards with 10 exchange lines and 45 extensions were provided.

EXCHANGE TRANSFERS.

G. J. GAWTHORNE.

In connection with the transfer of Primrose Hill Exchange to the new automatic equipment, the external cabling scheme is such as to involve the diversion of about 75% of the subscribers' circuits *via* the new Main Distribution Frame so that tees to the new automatic equipment can be made on this frame and not externally. Similar procedure was adopted at the transfer

of Maida Vale and in that case it was found that the M.D.F. became very congested with jumper wires, which had to be cut away and recovered after the transfer. Some of these

change. The switchboard cabling has been run on the under side of each shelf and is therefore quite clear of the jumper field. Odd lengths of old cable have been used, this being possible

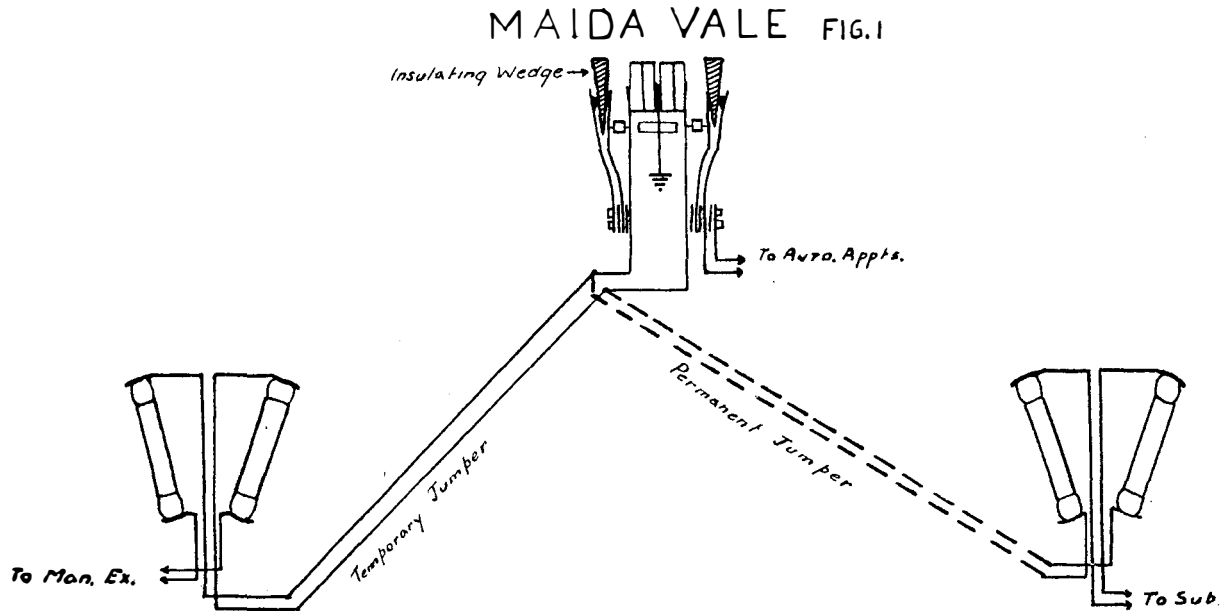

were very long and as there is a certain amount of risk in pulling out long jumpers, due to chafing, great care was necessary to prevent damage to the permanent jumpers.

The method adopted at Maida Vale is shown in Fig. 1, from which it will be seen that it was necessary to insert insulating wedges in the arresters on the automatic exchange side of the frame. As the diversions must take place some months prior to the actual transfer, these wedges become a continuous source of trouble to working circuits, owing to their being displaced accidentally by men working on the frame. It is also necessary to keep records of the temporary jumper and cable pairs and as the number of circuits concerned at Maida Vale was about 2000, this work occupied much time.

At Primrose Hill the number of circuits is about 3000, and in view of the experience at Maida Vale it was decided to adopt the method shown in Fig. 2. By arrangement with the External Engineer, incoming cables from the subscribers have been connected by means of switchboard cable to the corresponding pair number in the outgoing external cable to the Manual Ex-

owing to a large quantity from old Edgware Exchange being available, but, even with new cable, switchboard cable is cheaper than 1 pair/12½ Flameproof. By strapping the two external cables through in this manner the diversion of the circuit is entirely in the hands of the External Engineer and diversions to the new cables can be made without the assistance of internal staff.

Running and terminating switchboard cables of 20 pairs is much faster than running 20 jumper wires; the internal men are therefore able to keep well ahead of the external, and the necessity for keeping a record is obviated. It will be noted in Fig. 2 that the switchboard cable is connected to a tag end which was not cut off when the main cable was terminated. The joint is insulated by means of a paper sleeve, and the main cable soldered connection is not interfered with in any way. The line fuses are also left out, which enables the permanent jumper to be run without interference with the working circuit after the diversion work is completed.

It is also unnecessary to insert insulating

PRIMROSE HILL FIG.2

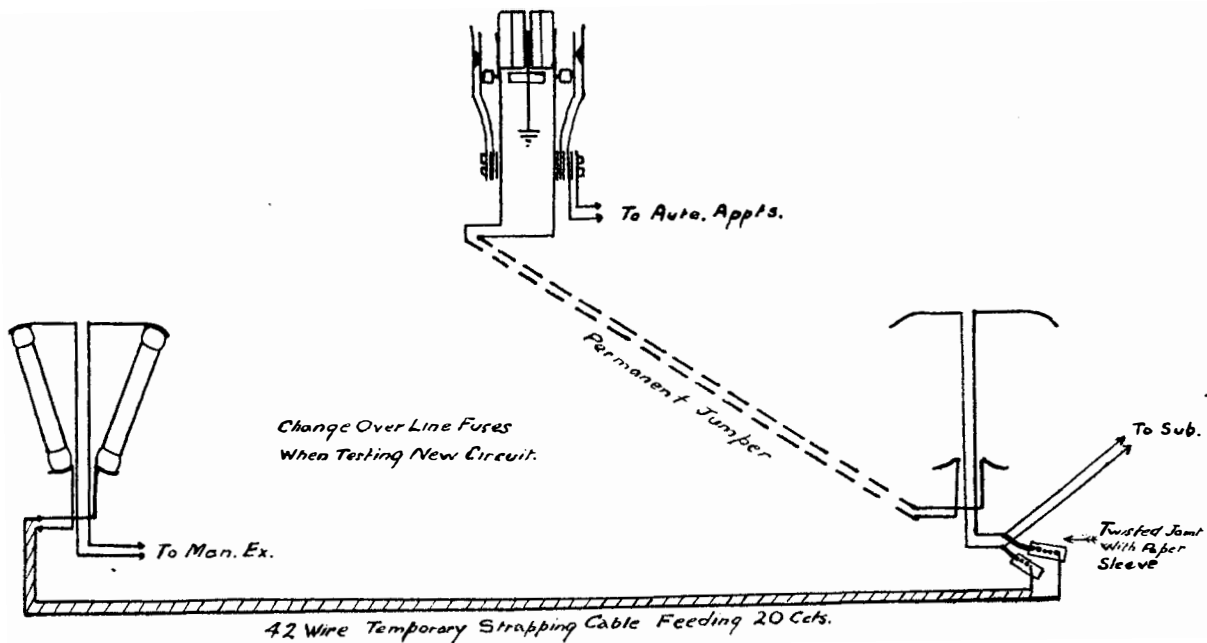

wedges until all work on the M.D.F. is finished and everything ready for the dial speed and final testing to commence, when of course the subscribers' line fuses must be inserted. After the transfer the strap cables can be more easily cut away, and there is no risk of chafing permanent jumper wires when recovering.

The difference in the cost per 1000 circuits of the two schemes described, taking the average length of 10 yards per jumper, is as follows:—

Maida Vale	Labour	700 manhours
	Material	£41 13s. 4d.
Primrose Hill	Labour	300 manhours
	Material	£25 10s. 5d.
Saving on Primrose Hill:—		
	Labour	57%
	Material	38%

In addition to the advantages described above, the method adopted at Primrose Hill has the further advantage that the work of diversion is accelerated and the period during which circuits are liable to interruption by external operations is therefore reduced.

SCOTLAND WEST DISTRICT.

UNDERGROUND CABLING WORK BY THE AID OF MECHANICAL MEANS AND IMPROVED APPLIANCES.

J. D. MACLEOD.

The article by Mr. J. R. M. Elliott in the October, 1929, issue of the Journal has no doubt been read with a great deal of interest by all officers carrying out cabling work. Probably by this time the method used, or a modified form of it, has been tried in other Districts and it would be interesting to know the results obtained.

Shortly before the article appeared, a main cabling work of approximately 10 miles long was undertaken by the staff in Scotland West District. In this and subsequent cabling cases, mechanical aids of a simple nature were used for drawing in the cables and perhaps the following particulars of these aids and the results obtained will be of some interest.

As a motor winch was not available for drawing in the cable, consideration was given to the use of the best available local means and after tests and trials it was decided that the 3-ton

Albion motor lorry in use in the district was quite suitable for the purpose. Another special appliance used was a Grease-box designed by Mr. Aitken, Superintending Engineer, and constructed locally under the supervision of the Mechanic Shop Inspector. By this contrivance

Drum Jacks. The former type was found to possess a decided advantage as compared with the latter type.

Fig. 3 shows the draw-rope hitched to the 3-ton motor vehicle with a rope guiding arrangement, made up of two 8-way arms fitted with two re-

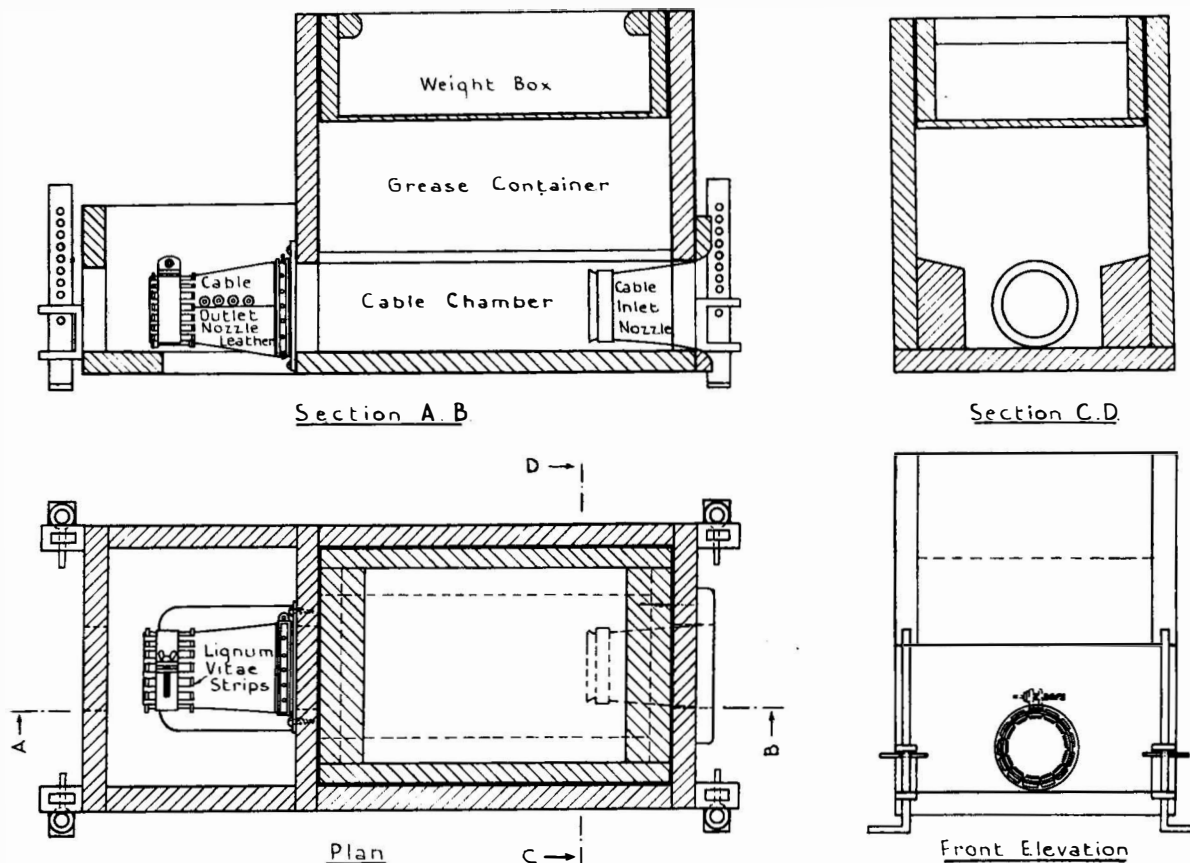

FIG. 1.—GREASE BOX DETAILS.

the cable is lubricated with the desired quantity of petroleum jelly in passing from the cable drum to the duct. The supply of grease is regulated by the weight 56 to 112 lb. in the weight box. The arrangement is simple and effective.

Particulars of the design of the Grease-box are shown in the foregoing Fig. 1. Outlet nozzles varying from one inch diameter upwards as required can be easily fitted to suit any particular size of cable. Fig. 2 shows the grease-box in position with the cable passing through the bed of petroleum jelly to the duct mouth. It may be mentioned that "Cable Reel Drum Jacks" were used instead of the old type of

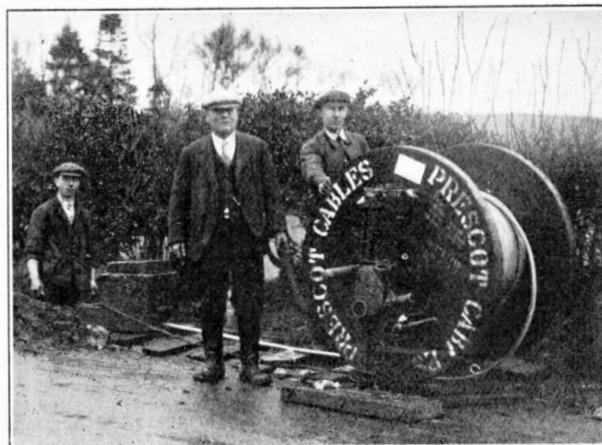

FIG. 2.—GREASE BOX IN POSITION.



FIG. 3.—DRAW-ROPE HITCHED TO LORRY.

volving pulleys, fixed in the jointing chamber. Two adjustable iron brackets are fitted at the lower pulley to permit the pulley being placed in line with the duct mouth. The arrangement is quite simple and effective and can be readily fixed in position.

The speeding up rendered by the aid of these appliances and the motor vehicle necessitate a definite organisation of the men employed in order to avoid overlapping and in order to make full use of the improvement derived from the mechanical aids. The organisation programme was given to the Inspector in charge of the work and also to the two Foremen, in schedule form (one Foreman was in charge of the cabling group and another Foreman was in charge of the men rodding duct, drawing in draw-ropes and opening joint holes in advance and also of the men filling in joint holes behind the cabling group). Without any previous instruction on the organisation arrangements it was interesting to watch the progress made with the work as the men benefited from each day's experience.

These brief notes will not permit full particulars of the organisation arrangement being stated, but the writer will be pleased to furnish full particulars to any officer desiring information on the point. The schedule arrangement should be altered to suit local requirements.

The following tabulated particulars show briefly the actual costs and the calculated savings by the foregoing arrangements, as compared with Provincial average costs, on the Greenock-Wemyss Bay Main Cable early in 1920, and within the last four months on the Coatbridge-Bathgate and the Wisham-Carlukel-Lanark Main Cables:—

CASE I.—GREENOCK-WEMYSS BAY CABLE.

18,251 yards. Gp. III.

74 pr/70 P.C. 54 pr/70 M.T. 24 pr/70.

	Actual Manhours.	P.A. Rates.
Effective Manhours ... (Drawing in Cable).	1426	3650
Ineffective Manhours	627	1241
Total Manhours	2053	4891
Cost at Average Rate	£137 18 9	£328 12 3
Cost of 3-Ton Lorry	19 16 0	—
Estimated Cartage	—	34 13 0
Total	£157 14 9	£363 5 3
Nett Saving	£205 10 6	

CASE II.—COATBRIDGE-BATHGATE CABLE.

26719 yards. 54 pair/40 P.C. Quad.

	Actual Manhours.	P.A. Rates.
Effective Manhours ... (Drawing in Cable).	1247	5343
Ineffective Manhours	658	1817
Total Manhours	1905	7160
Cost at Average Rate	£128 19 8	£484 15 10
Cost of 3-Ton Lorry	24 0 0	—
Estimated Cartage	—	42 0 0
Total	£152 19 8	£526 15 10
Nett Saving	£373 16 2	

CASE III.—WISHAM-CARLUKEL-LANARK CABLE.

17766 yards. P.C. Quad 40 lb. Gp. II.

	Actual Manhours.	P.A. Rates.
Effective Manhours ... (Drawing in Cable).	951½	2008
Ineffective Manhours	350	686
Total Manhours	1301½	2694
Cost at Average Rate	£88 2 9	£182 8 1
Cost of 3-Ton Lorry	13 0 0	—
Estimated Cartage	—	22 15 0
Total	£101 2 9	£205 3 1
Nett Saving	£103 0 4	

In Case I. approximately two miles of the route was in a busy industrial town and the remainder along a rural highway. The road is narrow at several points and has many bends.

In Case II. approximately $4\frac{1}{2}$ miles of the route was through industrial towns and the remainder along a busy highway, but with very little cross traffic. It may be mentioned that in one short day—19th December to be correct—over three miles of cable was drawn in towards the end of the work and as the men benefited by previous days' experience.

In Case III. approximately $2\frac{1}{2}$ miles of the route are in rural townships and 3 miles along a disused road. The remainder of the route is along a busy highway.

These hurried notes are put forward only as showing what can be done to speed up cabling work by the use of available local mechanical aids. The methods used in these cases are worthy of pursuit and the question of fitting suitable gear, for drawing in cables, on certain motor vehicles in use throughout the districts is thought worthy of consideration.

NORTH WALES DISTRICT.

Cases of damage to telephone poles caused by road vehicles are fairly common at the present time, but perhaps a rather unusual instance which occurred in the Stoke-on-Trent Section a few weeks ago may be of interest.

In this particular case, a Main Line pole (a 40-ft. Stout) carrying 21 important Trunk Circuits, was smashed clean in two by a motor-lorry without causing any interruption of service and no faults were reported as a result of the accident. The lorry, which was loaded with eight tons of rice in bags, was proceeding down a hill in the neighbourhood of Knypersley, North Staffordshire, at a speed obviously excessive having regard to the heavy load, the hill and the wet condition of the road at the time, when the application of the brakes caused it to skid sideways and crash broadside into the pole. Fortunately, the lorry came to rest over the place where the pole previously stood and the upper portion of the pole, with wires and arms undisturbed, was left firmly planted among the bags of rice on the lorry, practically over its original position.

The accompanying photograph shows the

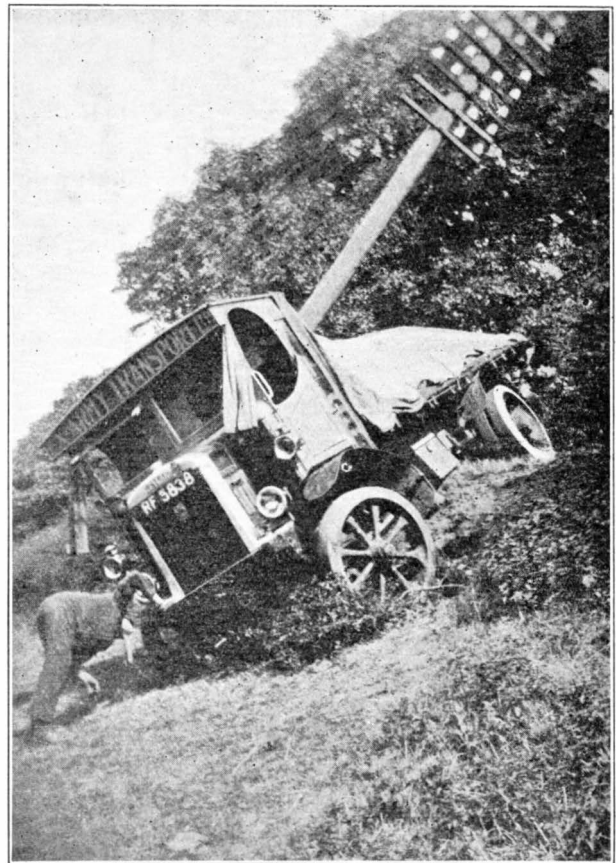

state of affairs immediately after the accident and luckily no one was hurt. The curious character of the accident also facilitated repair work, as it was simply necessary to support the wires on extension arms and ladders while the broken pole was being taken down, and after the lorry had been pulled back on to the road, a new pole was erected in the original position without difficulty.

Dudley, together with Stourbridge, Brierley Hill and Cradley Heath Exchanges were changed over successfully at 2 p.m. on Saturday, the 8th February, 1930, to the new Strowger Auto Exchange equipment installed by Messrs. Siemens Brothers & Co., Limited. A total of 380 Junctions and Trunks and 2210 subscribers' lines were transferred.

The junction transfer arrangements were very complicated, necessitating the use of change-over strips at several points and included the diversion or ceasing of 123 direct junctions to sub-exchanges.

A large number of Trunk and Junction circuits

had to be diverted to Dudley, where the Manual Board for the area is situated.

Dudley was formerly an Automatic Exchange of the Standard Telephones & Cables Rotary Machine Switching type installed in 1916. The other three exchanges changed over were of the Magneto type.

At the invitation of Lieut.-Col. Brain (Postmaster-Surveyor, Birmingham) nearly three hundred representative people attended an interesting inauguration ceremony in Dudley on

Friday, the 11th instant, when the Mayor of Dudley dialled the first call from the Town Hall. The Mayor of Stourbridge also dialled the first call from the Town Hall to Stourbridge. The Mayors, Col. Brain and Mr. R. A. Weaver (Superintending Engineer) made appropriate speeches, and afterwards the guests were entertained to tea in the Town Hall. The visitors then made a tour of inspection of the new Dudley Automatic Exchange accompanied by members of the Engineering Staff as guides.

THE INSTITUTION OF P.O. ELECTRICAL ENGINEERS: CENTRE NOTES.

LONDON CENTRE.

The third meeting was held on December 10th, when Mr. J. C. Dallow read a paper on "Rural Automatic Exchanges." Lantern slides, and the demonstration of a working Rural Automatic Exchange Unit helped the audience to appreciate one more stage in the development of the Telephone Service. An interesting discussion followed to which Mr. Dallow ably replied.

At the fourth meeting on January 14th, Mr. J. N. Hill read a paper entitled "Critical Methods of Investigation as applied to the study of Telephone Areas and Plant Layout." Lantern slides helped to elucidate many of the problems, and the subsequent discussion and Mr. Hill's masterly reply to the many critical questions, held the interest of the audience. The paper is undoubtedly a valuable addition to the literature of Plant Layout.

The fifth meeting was held before a large gathering on February 11th, when Capt. A. C. Timmis, B.Sc., A.M.I.E.E., read a paper entitled "Carrier Current Telephony." The paper dealt exhaustively with the present state of the art, and the discussion and subsequent demonstration of apparatus designed by Capt. Timmis brought an interesting and instructive meeting to a close.

INFORMAL MEETINGS.

On the 28th January, Mr. W. C. Burbridge, A.M.I.E.E., read a thought provoking paper entitled "Some Development Heresies." The

subsequent discussion was prolonged and animated and the variety of opinions expressed amply justified the name of the subject. Mr. Burbridge fearlessly replied, and the meeting closed with a hearty vote of thanks to the author.

At the meeting on February 25th, Mr. A. Miller, A.M.I.E.E., read a paper entitled "London Building Acts." The attendance was disappointing in view of the care that had obviously been taken in preparing the paper. In the subsequent discussion many questions were asked and ably replied to by Mr. Miller.

NORTH WESTERN CENTRE.

A visit of inspection was paid to the Works of the Automatic Telephone Manufacturing Co., Ltd., Liverpool, on the 20th January, 1930. The firm very kindly afforded facilities for an inspection of the Tool Room, Machine Shops, Switch Assembly, Woodworking, Rack Assembly, Switchboard Wiring and Coil Winding Departments, also the Circuit Laboratory, etc. The visit proved most interesting and instructive and the thanks of the Centre are specially due to the Works Manager (J. Nixon, Esq.) for the general arrangements and to Messrs. Bell, Flenley, Maitland and Owen for conducting the members round the Works and for their lucid explanations of the various items and processes.

A meeting of the Centre was held at Preston on the 24th February, 1930, when a joint paper entitled "Blackpool Telephone Repeater

Station" was read by Mr. A. S. Carr, B.A. (Cantab.), A.M.I.E.E., and Mr. E. Hopper, A.M.I.E.E.

The Chairman of the Centre, Mr. J. M. Shackleton, M.I.E.E., presided.

The paper opened with a general survey of the subject of telephone transmission and the conditions which have to be satisfied in order to secure efficient results and comply with modern requirements. An outline of the equipment at Blackpool was then sketched with special reference to those features which are unique or of unusual interest, and the laying of the new Anglo-Irish cable was also touched upon.

The lecture was illustrated by lantern slides and specially prepared diagrams and was followed by a discussion. D. B.

NORTH EASTERN CENTRE.

Our Session was opened by the Chairman, Mr. J. W. Atkinson, M.I.E.E., who reviewed the activities of the Institution during the last 24 years and consequent upon his close association with the General Council and the I.P.O.E.E. Journal was in a position to furnish the members present with accurate information regarding the growth of the Institution. After dealing with the Institution, he spoke of the advance made in the Telephone Service during the last 50 years; the wonderful progress of Radio Communications, and the present position of Telegraphs, finishing his address with a look into the future, which even with the present "depression from Iceland" was hopeful.

Mr. Ritter's lecture on "Picture Telegraphy" furnished the majority of the members with information quite new to them, and the manner in which Mr. Ritter handled his subject was indicative of the keen interest he takes in it, which enabled him to speak as an authority.

Mr. R. T. Robinson's lecture on "Motor Transport"—fully illustrated by lantern slides—brought the members into close contact with an every day subject, and the discussion which followed showed that as yet the transport question is far from being solved. It is clear that within the next few years considerable advance in the use of Mechanical Appliances and Motor Transport by the Engineering Department will be made.

In December a large number of the members paid a visit to Messrs. Greenwood and Batleys Works at Armley, Leeds. This firm manufactures turbines, heavy testing machinery, torpedoes, cartridges, electrical machinery, electric lorries, etc., and the thorough manner in which the gentlemen who took charge of the parties explained the different spheres of the firm's activities caused the visit to be highly educative.

The second half of the Session was opened by Mr. A. Morris, of the Engineer-in-Chief's Office, on "Telephone Cable Interference."

The paper was circulated before the meeting, and Mr. Morris dealt with the more important points. The discussion proved of the utmost value to the members present, who raised questions of practical difficulties experienced, and Mr. Morris went to some trouble in explaining the causes of the difficulties, and the remedies to be applied.

The February meeting was taken in hand by one of our youngest members—Mr. H. E. Francis—"Rural Automatic Exchanges," who dealt with the subject in such a way as called forth the highest praise of all present. Rural Automatic Exchanges are practically new, and the details furnished as regards locality, site, building, lay-out, apparatus and maintenance, were very acceptable. A lengthy discussion followed which added materially to the value of the paper, as Mr. Francis cleared away many misunderstandings and difficulties, and the opinion was expressed that it is by the giving of such papers the value of the Institution's work is enhanced.

SOUTH LANCASHIRE CENTRE.

The third meeting of the Session was held on Monday, December 16th, 1929, when Major H. Yorke Starkey, of the Engineer-in-Chief's Office, read a paper on "The Maintenance Efficiency of Exchange and Subscribers' Apparatus." The paper gave suggestions for dealing with the comparison of maintenance costs on an equated unit basis, and also certain standards to be used as a basis for workmen's loads. Comparison was made between the effective work carried out in this country and in similar areas in America, and the author endeavoured to show that this

country could be reasonably expected to effect savings comparable with those which have already been effected in America. The paper, which included the results of experimental trials of the scheme in Liverpool and in Manchester, aroused a very fruitful discussion.

At the fourth meeting of the Session, held on January 13th, 1930, a paper entitled "Further Notes on Motor Transport in the Post Office Engineering Department and Mechanical Aids to Construction Work" was presented by Mr. R. T. Robinson, of the Engineer-in-Chief's Office.

On account of its length the paper was not read in full, but the author dealt with the salient points as each of the numerous lantern slides was displayed on the screen. In the discussion which followed many interesting points were raised, to which the author ably replied.

The fifth meeting of the Session was held at 7 p.m., on Tuesday, February 11th, 1930, when the members of the North Western Centre of the Institution of Electrical Engineers were present by invitation.

For this joint meeting the Institution was fortunate in arranging a lecture on "Talking Films" by Mr. S. S. A. Watkins, Recording Manager of the Western Electric Co. There were over 650 people present, including representatives of firms interested in cinema production.

Mr. Watkins opened his remarks by saying that in the short time at his disposal it was impossible to give more than a superficial description of the subject. From his account, however, of the methods of recording, synchronisation and reproducing the sound pictures, members of the audience were able to obtain an excellent idea of the scientific principles applied to the problem and the manner in which the various difficulties had been overcome in achieving commercial success. The lecture was illustrated by a large number of excellent lantern slides.

Following the lecture Mr. Watkins ably dealt with a large number of interesting questions raised by members of his audience, and this gave added enjoyment to a very successful meeting.

MR. ALFRED JAMES EAMES.

Mr. A. J. Eames, Assistant Superintending Engineer in the South Lancashire District, retired on February 15th after nearly 45 years'

service. After four years in the Central Telegraph Office, he transferred to the Clerical Staff of the Engineering Department. Eight years later he was appointed Sectional Engineer at Uxbridge and subsequently he moved to Shrewsbury and Liverpool. In 1923 he was appointed to the position of Assistant Superintending Engineer.

During his earlier engineering service, Mr. Eames was responsible for the re-building of some of the heaviest open trunk lines in the Home Counties. Whilst in Liverpool he served in both the Internal and External Sections and after the War carried through schemes of local development of considerable magnitude. During the war he rendered valuable service in connection with Coast Communications.

Farewell gatherings were held in Manchester and Liverpool. Mr. W. J. Medlyn, Superintending Engineer, Mr. T. E. Herbert, Assistant Superintending Engineer, and many other speakers, gave expression to the cordial relations which have always existed between Mr. Eames and all sections of the staff, and full tribute was paid to his high personal qualities.

A handsome piece of furniture was presented to Mr. Eames as a token of the regard and esteem in which he is held in the District.

NORTH WALES CENTRE.

The third meeting of the Session was held on 11th December, when Major G. A. Blackwell read a very interesting paper on "Fault Procedure," in which the procedure now in force was fully described and the uses of the various forms and records explained and commented upon. Members had previously been supplied with copies of the printed forms referred to by the lecturer and a discussion of considerable length ensued, during which some criticisms of the procedure were made, and pleas for simplification were entered. It is interesting to note that summaries of the opinions expressed by the speakers have been collected and an opportunity given to the Headquarters section most interested of perusing them, an opportunity, it should be mentioned, which has been welcomed and appreciated.

The fourth meeting was held on 8th January, 1930, when Captain N. F. Cave-Browne-Cave,

B.Sc., M.I.E.E., read a non-mathematical paper entitled "Sound" in which some of the most recent literature on this subject was explored and commented upon, with special reference to its bearing on telephony. The mechanism of hearing was described and illustrated, and the important effects of phantom sounds and other subjective phenomena were explained. Captain Cave had gone to considerable trouble in preparing slides, photographs and other exhibits, and his paper was listened to with rapt attention. At the conclusion of the discussion a very hearty vote of thanks was passed, with complimentary references to his ability to make a scientific subject highly interesting and entertaining.

The fifth meeting was held on 12th February, on which occasion we had the pleasure of a visit from a Headquarters Officer, who read a paper on his special subject. This was Mr. A. Morris, A.R.C.Sc., M.I.E.E., of the Research Section, Engineer-in-Chief's Office, whose paper was on "Telephone Cable Circuit Interference." The written paper was a somewhat technical one, but Mr. Morris, instead of keeping close to his copy, launched out into a more digestible extempore explanation of many of the forms of interference and of the means of overcoming them. The ensuing discussion was of such length that it had to be closed on the approach of train time.

I.E.E. : WESTERN CENTRE.

The annual dinner was held at the Royal Hotel, Cardiff, on 13th January, when there was a large attendance of members and guests, the latter including many ladies. Mr. Sidney B. Haslam, Chairman of the Centre, presided and the company included Col. Sir Thomas Purves (President of the Institution), Sir Felix J. C. Pole, Alderman William Walker, Principal George Knox, Mr. C. G. Morley New, Mr. J. W. Beauchamp, etc., etc. The South Wales District staff of the Post Office was represented by Mr. J. S. Terras, Superintending Engineer.

In replying to the toast of the Institution, proposed by Alderman Walker, Sir Thomas Purves said he desired to acknowledge the great work which was being done by the Western

Centre. The success of the Centre showed very pointedly that London was not the sole fountain of wisdom in the Institution.

The toast of "Kindred Societies and Guests," proposed by Mr. Morley New, was responded to by Principal Knox and Sir Felix Pole. Other speakers were Mr. Beauchamp, Mrs. D. Watts-Morgan, Mrs. Morley New, Brig.-Gen. C. G. Bruce and Mr. Walter Bache.

THE INSTITUTION OF P.O. ELECTRICAL ENGINEERS.

Officers of Colonial and Foreign Telegraph Administrations who are engaged in Electrical Engineering Works may be admitted as Colonial and Foreign Corresponding Members respectively, after application.

Subscription payable annually in advance on 1st April in each year :

Colonial Members	£1 0 0
Foreign	£1 10 0

These sums include Annual Subscription to the Journal of P.O. Electrical Engineers and the supply of all Professional Papers issued during the period covered by subscription.

Forms of application for Colonial and Foreign Membership can be obtained on application to

The Secretary,
Institution of P.O.E. Engineers,
G.P.O. (Alder House), E.C.1.

or the undermentioned gentlemen who have kindly agreed to act as representatives of the Institution in their respective countries :—

R. Badenach, Esq., B.Sc. (Melb.),
Chief Engineer's Office,
Postmaster-General's Department,
Treasury Gardens,
Melbourne, C2,
Australia.

H. C. Brent, Esq.,
District Telegraph Engineer's Office,
Wellington, N.Z.

N. N. Banerjee, Esq., A.M.I.E.E. (Ind.),
Divisional Engineer, Telegraphs,
Calcutta West Division,
8, Wellesley Place,
Calcutta,
India.

A. T. Kingston, Esq., M.B.E., A.M.I.E.E.,
Office of the Chief Engineer,
Telegraphs & Telephones,
C.T.O.,
Colombo,
Ceylon.

A. J. Kellaway, Esq.,
Department of Posts and Telegraphs,
P.O. Box 366,
Pietermaritzburg,
South Africa

CURRENT LITERATURE.

The Journal of the Institution of Electrical Engineers, Vol. 68, No. 396, Dec., 1929.

Inaugural address. Col. Sir T. F. Purves, President. A summary of the address has already been published. See January issue of this Journal.

Chairman's address from the following subsections are given: Wireless, Meter and Instrument, Western, South Midland, Irish, North-Eastern, North-Western, Mersey and Wales, North Midland, Scottish, East Midland, Dundee, Sheffield and Hampshire.

Vol. 68, No. 397, January, 1930.

The Analysis and Measurement of Noise emitted by Machinery. A. G. Churcher and A. J. King.

Progress Reviews: Electro Physics, Electrical Plant and Machinery including Marine, Domestic Applications of Electricity, Supply Tariffs and Methods of Change, The Electrical Equipment of Automobiles, and Electric Traction.

Some Measurements in Cornwall of the Signal Strength from 5 XX. J. H. Reyner, B.Sc.

Vol. 68, No. 398, February, 1930.

Low Temperature Carbonization of Fuel: American, German and English practice. S. McEwen, Prof. P. Rosin, E. H. Smythe and E. G. Weeks.

Naval Wireless Telegraph Communications. G. Shearing, B.Sc., and Capt. J. W. S. Dorling. The Valve Maintained Quartz Oscillator. J. E. P. Vigoureux, M.Sc.

High Frequency Resistance Measurement by the use of a Variable Mutual Inductance. W. Jackson, M.Sc.

Journal of the American Institution of Electrical Engineers.

Vol. XLVII., No. 12, December, 1929.

Series Synchronous Condensers for Generation of Voltage consumed by Line Inductance. Theodore H. Morgan.

Annual Reports of Committees on Electro Chemistry and Electrometallurgy, on Transportation, Marine Work and General Power.

Current Transformer Excitation under Transit Conditions. D. E. Marshall and P. O. Longguth.

Spray and Fog Tests on 220-Kv Insulation. R. J. C. Wood.

Audio Frequency Transformers. Voltage-Ratio Characteristics determined by the Low Voltage Cathode Ray Oscillograph. Paul Klev, Jr., and D. W. Shirley, Jr.

Vol. XLIX., No. 1, January, 1930.

The Chicago Long Distance Toll Board. E. O. Neubauer and G. A. Rutgers. The Chicago Toll Office, serving 1,200,000 stations, has recently been supplied with new equipment. The new plant and lines are described and compared with former methods.

Magnetic Circuit Units. A. E. Kennelly. A discussion of the historical developments of magnetic circuit units and proposals *re* standardisation.

Theory of a New Valve Type Lightning Arrester. J. Slepian, R. Tanberg and C. E. Kaause.

Ionization Currents and the Breakdown of Insulation. J. J. Torok and F. D. Fielder.

Air Transport Communication. R. L. Jones and F. M. Ryan. Successful operation of transport service requires rapid and dependable communication between plane and ground. Two-way telephony provides this.

Vol. XLIX., No. 2, February, 1930.

Transoceanic Telephone Service: General Aspects. T. G. Miller. Extent and growth of service since 1927 are outlined. At present 85% of world's telephones are included in area served and 50 calls are made per business day. Plans for future are outlined.

Three Regions of Dielectric Breakdown. P. H. Moon and A. S. Norcross.

Experience with Carrier-Current Communication on a H.T. Inter-connected Transmission System. Philip Sporn and Ray H. Wolford.

Descriptive of system on 132 Kv network, 2500 miles long, is given.

Journal of the Franklin Institute. Vol. 209, No. 1, January, 1930.

Unbraced Cables. Jacob Feld, C.E., Ph.D.

Usual methods of design for long spans are inaccurate, because they omit elastic stretch. Equations are derived to cover all possible cases, loaded and unloaded, allowing for variations of temperature and movement of supports. Bibliography included.

BOOK REVIEWS.

"High Voltage Cables." By L. Emanuelli, M.I.E.E., M.Amer.E.E. 107 pp. Published by Messrs. Chapman & Hall. Price 8/6 net.

This book, based on a course of lectures prepared for the Engineering Faculty of the University of London by Mr. Emanuelli, deals, as would be expected in an informative manner with modern high voltage cables, and like Mr. Dunsheath's book,* recently reviewed, can be thoroughly recommended to engineers and students, the two books being to a certain extent complementary.

The first part is introductory and gives a short outline of the manufacture of a paper insulated cable and then deals with the materials used, first the paper and then the impregnating compound, and the effects of varying the proportions of oil and resin. Tests on the materials and methods of preparation are described.

The electrostatic field set up in the cable is dealt with at length, this being of course of great importance as directly the field ceases to be uniform the voltage gradient through the insulation is affected and the risk of breakdown increased. After dealing with dielectric losses the author passes on to the actual impregnation of the cable and the means employed to obtain uniform saturation without the formation of gas bubbles, the presence of which entirely alters the designed stresses and leads to breakdown of the cable.

The final chapter deals with the mechanical and electrical properties of the finished cable and finally with the oil filled cable now being used successfully for very high voltages. The book is well illustrated throughout.

J. MCG.

* "High Voltage Cables," by P. Dunsheath, O.B.E., M.A., B.Sc., M.I.E.E.

"Le Système de Télégraphie Baudot et ses Applications." Par P. Wercy. Pp. viii. + 640: 4th edition. Paper covers 56 francs: Bound 66 francs.

This standard book on the Baudot multiplex system was written primarily as a course of instruction for French dirigeants. The first section contains a complete description of the apparatus, methods of synchronism, and wiring of the system. Detailed descriptions of the adjustments, electrical and mechanical, are given in the second section.

The third section deals with the flexibility of the system to traffic requirements and describes fully the method of extending channels by the system échelonée and by retransmitters. Chapters are also included on the application of duplex to the system and the Picard method of correction from signals.

It is interesting to note that the extensive use of three and four station working in France is apparently confined to simplex circuits. No description of a duplex three station circuit is given.

Modern developments are dealt with in the last section which has been brought up to date by the inclusion of descriptions of the Doignon-Wendonça - d'Oliveira Governor, automatic working on the Murray system, the Verdán method of eliminating the effect of atmospherics on Baudot reception when used on radio communications, and methods of Voice frequency working.

The book is well illustrated with over 260 figures and the price compares very favourably with similar types of British technical works.

STAFF CHANGES.

STAFF CHANGES.

POST OFFICE ENGINEERING DEPARTMENT.

PROMOTIONS.

Name.	Grade.	Promoted to	Date.
Robinson, C.	Assistant Staff Engineer, Research Section, E.-in-C.O.	Staff Engineer, Test Section, E.-in-C.O.	31-1-30
Horner, F. H.	Executive Engineer, Shrewsbury Section, N. Wales District.	Assistant Staff Engineer, E.-in-C.O.	19-12-29
Gill, A. J.	Executive Engineer, Radio Section, E.-in-C.O.	Asst. Staff Engineer, Radio Section, E.-in-C.O.	19-12-29
Morris, A.	Assistant Engineer, Research Section, E.-in-C.O.	Executive Engineer, Radio Section, E.-in-C.O.	19-12-29
Bell, R. W. S.	Assistant Engineer, Technical Section, S. Lancs. District.	Executive Engineer, Shrewsbury Section, N. Wales District.	5-1-30
Prentice, D. B.	Skilled Workmen Cl. I., Scot. West District.	Inspector, Scot. West District.	23-1-29
Milton, G. F. A.	} Skilled Workmen, Cl. I., E.-in-C.O.	} Inspectors, E.-in-C.O.	23-10-28
Cook, A. C.			23-10-28
Evans, A. F. E.			23-10-28
King, E. F. H.			11-11-28
Blackhall, W. A. C.			11-11-28
Denyer, W. C.			4-11-28
Stewart, A. D.			18-11-28
Osborne, W. V.			30-9-28
Corkett, H.			4-11-28
Lidstone, F. J. W.			4-11-28
Dennison, R. F. A.			2-12-28
Siems, C. V.			4-11-28
Tilly, C. N.			23-1-29
Jeynes, E. H.			20-7-29
Lush, A.	Skilled Workmen, Cl. II., E.-in-C.O.	Inspector, E.-in-C.O.	2-3-29
Sharpe, G. E.	Skilled Workmen, Cl. I., S. East District.	Inspector, S.E. District.	2-3-29
Sharpe, G. E.	Skilled Workmen, Cl. I., N. Mid. District.	Inspector, N. Mid. District.	To be fixed later.
Ostins, P. C.	} Skilled Workmen, Cl. I., N. Wales District.	} Inspectors, N. Wales District.	15-2-30
Grigg, C. E.			1-1-30
Ovenall, E. W.			7-2-29
Davis, A. T.			17-4-29
Whittingham, L.			21-11-29
Beattie, M.			To be fixed later.
Finney, C. W. Mc. S.	Skilled Workmen, Cl. I., Scot. West District.	Inspector, Scot. West District.	To be fixed later.
Finney, C. W. Mc. S.	Skilled Workmen, Cl. I., S. Lancs. District.	Inspector, S. Lancs. District.	"

APPOINTMENTS.

Name.	From	To	Date.
Legg, G. E.	} Probationary Inspectors.	} Inspectors.	1-11-29
Barker, H.			1-1-30
Hall, L. L.			"
Stanton, E. P.			"
Purvis, C.			"
Clarke, C. W.			"
Ward, W. C.			"
Calveley, C. E.			"
Sheppard, J. A.			"
Jackson, G.			"
Morley, J. E.			"
Hawkins, C. F. W.			"
Farren, P. E.			"
Jago, W. G.	"		

STAFF CHANGES.

PROMOTIONS—continued.

Name.	From	To	Date.
Brett, S. I.	Limited Competition.	Probationary Assistant Engineers.	28-1-30
Richards, C. E.			9-2-30
Affleck, D. B.			9-2-30
Penney, A. E.			26-1-30
Stanesby, H.			9-2-30
Flowers, T. H.			9-2-30
Scantlebury, L. F.			10-2-30
Pearson, A. W. C.			10-2-30
Harrison, G. B. W.			10-2-30
Hibbs, A.			10-2-30
Harmston, A. T.	Open Competition.	Probationary Assistant Engineers.	19-1-30
Warren, F.			20-2-30
Charles, F. N.			23-2-30
Duff, J. B.			"
Smith, J.			"
Hodges, P. G. L.			"
Hunt, A. M.			"
Gerrard, J.			"
Gray, R. E.			"
How, S. F.			"
Smith, C. N.	Limited Competition.	Probationary Inspectors.	"
Atherton, W. S.			"
Pratt, F. A. N.			2-3-30
Davis, S.			23-2-30
Druett, L. W.			"
Donovan, J. G.			"
Gill, E. S. A.			"
Cottenden, S. E.			"
Wooding, W. T.			"
Green, R. G.			9-3-30
Amos, A. J.	Open Competition.	Probationary Inspectors.	24-2-30
Seaman, E. C. H.			3-3-30
Franklin, G.			23-2-30

RETIREMENTS.

Name.	Rank.	Districts.	Date.
Eames, A. J.	Assistant Suptg. Engineer.	S. Lancs.	15-2-30
Burton, G. M.	Executive Engineer.	N. East.	22-2-30
Ryall, J. B.	" "	S. Wales.	20-3-30
Stone, H. C.	" "	London.	31-3-30
Horton, F. D.	" "	S. Mid.	31-3-30
Billingham, G. W.	" "	N. Wales.	15-1-30
Wyatt, J.	Assistant Engineer.	N. Mid.	31-3-30
Hammond, E. J.	" "	E.	23-1-30
Cooper, J. O.	" "	S. Lancs.	31-12-29
Kay, C. P.	" "	N.	31-12-29
McAllan, J.	Chief Inspector.	Scot. East.	28-2-30
Burnett, A. T.	" "	S. Wales.	1-2-30
Chambers, C.	" "	S. Lancs.	31-12-29
Laney, J. W.	Inspector.	London.	6-2-30
Hollis, T.	"	N. Wales.	2-2-30
O'Leary, A. J.	"	S. West.	7-1-30
Price, A. W.	"	S. Wales.	1-12-29
Bavliiss, A. E. H. V.	"	N. Wales.	31-12-29
Forrester, J.	"	Scot. West.	5-1-30
Dvkes, E. H.	"	London.	31-12-29
Quilter, H. J.	Draughtsman Class I.	E.-in-C.O.	31-1-30

STAFF CHANGES.

RESIGNATIONS.

Name.	Rank.	District.	Date.
Pollock, S. A.	Staff Engineer.	Research Section, E.-in-C.O.	31-12-29

DEATHS.

Name.	Rank.	District.	Date.
Sly, R. C.	Inspector.	London.	27-12-29

CLERICAL ESTABLISHMENT.

RETIREMENTS.

Name.	Grade.	District.	Date.
Loney, H. J.	Executive Officer.	Engineer-in-Chief's Office.	31-12-29
Cowley, P. J.	Higher " Clerical " Officer.	" N. Midland. "	25-1-30
Morris, G. L.	" "	London District.	10-3-30
Atkinson, E. W.	" "	" "	28-3-30
Griffiths, E. F.	Principal Clerk.	Engineer-in-Chief's Office.	31-3-30
Mountain, W. S.	" "	" "	31-3-30

BOARD OF EDITORS.

B. O. ANSON, M.I.E.E., Chairman.

P. J. RIDD, M.I.E.E.

H. KITCHEN, M.I.E.E.

A. J. GILL, B.Sc., M.I.E.E., M.I.R.E.

J. PRESCOTT.

E. H. M. SLATTERY.

W. CRUICKSHANK, M.I.E.E., Managing Editor.

J. J. MCKICHAN, O.B.E., A.M.I.E.E., Assistant Editor.

COMMUNICATIONS.

All Remittances and Communications should be addressed to the MANAGING EDITOR, P.O.E.E. JOURNAL, Engineer-in-Chief's Office, Alder House, London, E.C.1.

Binding covers and copies of the Contents for Vol. 3 to 22 are available, and may be obtained from the local agents for 1s. 6d. and 3d. respectively. Subscribers can have their copies of Vol. 22 bound, with index included, at a cost of 3s. by sending the JOURNALS to the local agents. Orders for bindings, Vols. 1—19, should indicate whether the original binding with black lettering, or the later pattern in gold, is required. Covers with gold lettering will be the only type stocked from Vol. 20 onwards.

The price of the JOURNAL is 1s. 3d. (1s. 6d. post free) per copy, or 6s. per annum, post free. All back numbers 2s. each.