

# THE POST OFFICE ELECTRICAL ENGINEERS' JOURNAL

**VOL. 43**

**JULY 1950**

**PART 2**

## CONTENTS

	PAGE
INTRODUCTION TO ELECTRONIC AUTOMATIC TELEPHONE EXCHANGES: SPEECH PATH SWITCHES AND LINE SIGNALLING—T. H. Flowers, M.B.E., B.Sc., M.I.E.E. . . . .	61
LOCAL LINE PLANT: PAIR APPROPRIATION RECORDS—A. Morris, A.R.C.Sc., D.I.C., Wh.Ex., M.I.E.E., and W. H. Dolan, B.Sc.(Eng.), A.M.I.E.E. . . . .	69
DESIGN OF SQUARE-LAW RECTIFIER CIRCUITS FOR MEASURING INSTRUMENTS—D. C. Walker, B.Sc.(Eng.), A.M.I.E.E., D. L. Richards, B.Sc.(Eng.), A.M.I.E.E., and G. P. Horton, B.Sc.(Eng.) . . . . .	74
A SURVEY OF MODERN RADIO VALVES—Part 5—Valves for Use in the Range 30-3,000 Mc/s (Bands 8 and 9)—R. W. White, B.Sc., F.Inst.P., A.M.I.E.E. . . . .	78
A POLARISED RELAY OF IMPROVED PERFORMANCE—H. A. Turner, B.Sc.(Eng.), A.M.I.E.E., and B. Scott, M.B.E., M.B.A., B.Sc.(Eng.), A.C.G.I., A.M.I.E.E. . . . .	85
THE LONDON-CASTLETON EXPERIMENTAL RADIO-RELAY SYSTEM—A. H. Mumford, O.B.E., B.Sc.(Eng.), M.I.E.E., Capt. C. F. Booth, O.B.E., M.I.E.E., R. W. White, B.Sc., F.Inst.P., A.M.I.E.E. . . . .	93
OLIVER HEAVISIDE—An Appreciation—Sir George Lee, O.B.E., M.C., B.Sc., Past President I.E.E. . . . .	100
Notes on the Centenary Meeting, 18 May, 1950—W. G. Radley, C.B.E., Ph.D., M.I.E.E. . . . .	101
THE ELECTRICAL POWER SYSTEM FOR HANDLING CABLE IN H.M.T.S. MONARCH—A. J. Thomson . . . . .	102
NOTES AND COMMENTS . . . . .	106
INSTITUTION OF POST OFFICE ELECTRICAL ENGINEERS . . . . .	107
REGIONAL NOTES . . . . .	108
JUNIOR SECTION NOTES . . . . .	112
STAFF CHANGES . . . . .	114
BOOK REVIEWS . . . . .	68, 84, 99

Price 1/6 net

**THE INSTITUTION OF POST OFFICE ELECTRICAL ENGINEERS**

**STUDY AT HOME**      **You Can Have a College Training For a Few Shillings Monthly**      **IN YOUR SPARE TIME**

## CITY and GUILDS (Telecommunication) EXAMINATIONS

To every student we send a written Guarantee of Tuition until the examination is actually passed

Our tuition is so graded that each stage is reached without difficulty.

Personal attention is given to every student.

**FULL PARTICULARS AND  
ADVICE SUPPLIED FREE.**  
**WE TEACH BY POST IN ALL  
PARTS OF THE WORLD.**

*The most progressive and most successful  
Correspondence College in the world*

*The Bennett College Limited*



**Dept. 24, THE BENNETT COLLEGE, SHEFFIELD**

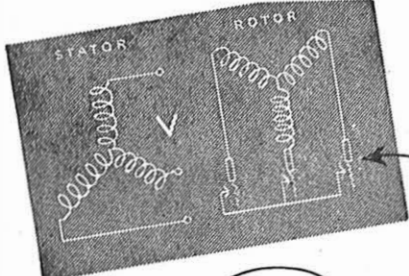

A.C. Polyphase Wound  
Rotor-Rotor Rheostat.

**FOR EVERY PHASE OF ELECTRICAL WORK**

The British Electric Resistance Co. Ltd. can answer the multitude of resistance problems that beset the electrical circuit designer. For twenty years Berco resistances have been giving reliable and steadfast service, and the Berco range is designed to meet every requirement.

Berco engineers are specialists in resistance design and their knowledge is at your disposal.



**RESISTANCES**

**THE BRITISH ELECTRIC RESISTANCE CO. LTD.**  
Queensway, Ponders End, Middlesex  
Telephone: Howard 1492      Telegrams: Vitrohm, Enfield  
BR2033-AQ

# "ANACOS"

REGD.



## TELEPHONE & TELEGRAPH WIRES

IN COPPER, CADMIUM-COPPER & BRONZE

*"the right connection"*



**FREDERICK SMITH & COMPANY**  
*(Incorporated in The London Electric Wire Company and Smiths, Limited)*  
**ANACONDA WORKS, SALFORD 3, LANCs.**  
Phone: Blackfriars 8701 (9 lines)      Grams: "Anaconda," Manchester

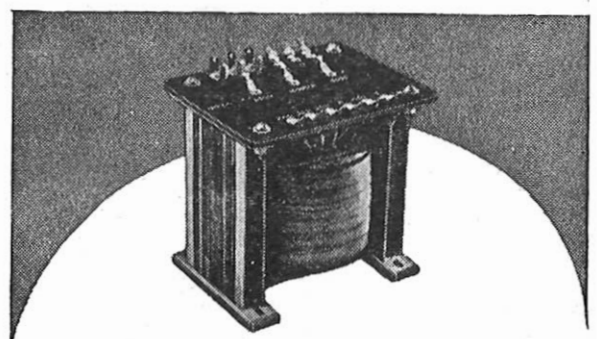

**When an unusual  
Specification  
is required.**

We can give you the benefit of 20 years' experience in transformer construction and design. We manufacture quantities but we do NOT mass produce. Every Instrument is built to suit your most exacting individual specification.

Send your enquiries for the personal attention of our Mr. W. Bryan Savage.



SAVAGE TRANSFORMERS LTD.      NURSTBED ROAD, DEVIZES, WILTS.

# THE POST OFFICE ELECTRICAL ENGINEERS' JOURNAL

Vol. 43

July, 1950

Part 2

## Introduction to Electronic Automatic Telephone Exchanges: Speech Path Switches and Line Signalling

T. H. FLOWERS†, M.B.E., B.Sc., M.I.E.E.

U.D.C. 621.395.4 : 621.318.572

Recent advances in the application of electronic devices to switching have turned the attention of telephone engineers to the possibilities of electronic exchanges. Systems with electronic control of mechanical switches are already in existence, but the future of fully electronic exchanges is more obscure. This article introduces the problem of the fully electronic exchange by discussing the electronic switching of speech circuits. It shows how simple electronic elements may be built into switches by multiplying, and how the same result can be achieved by multiplex telephony. It also indicates the primary means of controlling such switches by signals passed through them. Further aspects of the subject will be introduced in later articles, the next of which will deal with translating registers, one form of which is the familiar director.

### Introduction.

**E**LECTRONIC is a term applied to a variety of devices the action of which has to be explained in terms of the behaviour of electrons. These devices include as their most important members hot-cathode vacuum and gas-filled valves, cold-cathode gas-filled valves, rectifiers and cathode-ray tubes. Electronic apparatus and the techniques of using them have become basic to telephone speech transmission over all but the shortest distances. In the switching field, although the basic techniques of using electronic devices have been known for many years, practical application is not so advanced as in the transmission field. Nevertheless, even before the recent war, there was a movement in the direction of replacing heavily worked mechanical switches by electronic switches in order to increase the reliability of the switching, and during the war this process was accelerated, notably in the direction of fully electronic computers which reached giant proportions. This work greatly advanced the knowledge and practical experience of electronic switching devices, one of the results of which was an increased confidence in the ability of electronic switching apparatus to compete with electro-mechanical apparatus in cost and reliability.

Since the war, attention has been given by telephone engineers to the possibilities of partially or fully electronic automatic telephone exchanges, and it is not inconceivable that the systems of the future will be fully electronic. There are already in operation systems in which electronic devices are incorporated to control electromagnetic switches which carry the speech; the use of electronic devices as controlling elements in automatic exchanges is fairly well known and understood. The switching of speech circuits by the same means is known and practised in relatively simple applications, such as echo-suppressors, but the

knowledge needed to switch and control speech circuits on the scale essential to a fully electronic exchange is only just beginning to emerge. This article discusses possible means of solving these problems.

### TELEPHONE EXCHANGE SWITCH

A telephone system is built up of exchanges which are interconnected by groups of transmission lines, and to which the subscribers' lines are connected. Manual board and other non-subscriber lines will be treated as subscribers' lines for the present purpose. A number of connections can simultaneously exist in the system, each connection comprising a bothway communication path from a subscriber's station over a line to an exchange, then either over another line on the same exchange to another station or over any number of junctions in series to another exchange, thence over a line connecting that exchange to another station. The establishment of a connection is a complex problem of switching and transmission.

For the present, we will consider only that part of the problem which is concerned with bothway speech transmission from one station in the system to any other. This can be reduced to the problem of a single exchange, as shown in Fig. 1. The rectangle

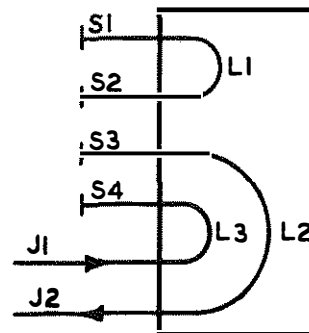

FIG. 1.—THE TYPES OF CONNECTION WHICH CAN BE MADE IN A SINGLE EXCHANGE.

†Assistant Staff Engineer, Research Station.

represents an exchange to which stations S1, S2 . . . are connected by lines and to which groups of junctions to other exchanges, represented by J1 and J2, are similarly connected. The problem of connection of any station to any other is solved if (1) any station exchange line can be connected to any other station exchange line terminated on the same exchange as the first, (2) any station exchange line can be connected to at least some of the junctions in every group of junction lines, and (3) sufficient junctions and means of connecting lines together are provided to enable as many connections to be made simultaneously as may be desirable. In Fig. 1 the loops L1, L2 and L3 represent the connections which may be made within the exchange. In a manually switched system the loops are plugs and cords; in an automatic system the loops are provided by switches.

Obviously one large switch, capable of accommodating all the subscribers' lines and the junctions and making all the necessary connections between them, would suffice, but is not practicable. It is well known to use smaller switches multiplied in ranks, with the ranks in series, to produce the effect of one large switch. The size of the smaller switches determines the numbers required in each rank and the number of ranks. This question is important to the economics of any system. Its influence is indicated in the following discussion, which refers only to the talking paths through switches.

#### Element Switches.

An "element switch" may be defined as a switch not capable of division into smaller parts and having the following properties:—

- (1) Two distinct sides.
- (2) On one side,  $N$  sets of terminals to which speech circuits may be connected, one to each set of terminals.
- (3) On the other side,  $M$  sets of terminals to which speech circuits may be connected, one to each set of terminals.
- (4) When suitably controlled, the switch will connect any set of terminals on the  $N$  side to any set of terminals on the  $M$  side, and many such connections may be made simultaneously up to the limit of  $N$  or  $M$  whichever is the less.

To be sure that the idea of an element switch is clear, consider a number of examples from existing practice. A single 100-point Strowger switch with its bank has a wiper side and a bank side. The wipers provide one set of terminals, i.e.  $N = 1$ , which can be connected to any of the 100 sets of bank terminals, i.e.  $M = 100$ , and the limit to the number of such connections which may be made simultaneously is set by  $N = 1$ . Similarly for a 25-point uniselector,

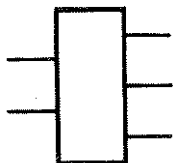

FIG. 2.—SYMBOL FOR AN ELEMENT SWITCH.

$N = 1$  and  $M = 25$ . For a relay, having make contacts, one set of terminals is provided by the make springs and one by the lever springs;  $N = 1$ ,  $M = 1$ , and only one connection can be made.

Fig. 2 is the symbol which will be used for an element switch having  $N$  sets of contacts on one side

and  $M$  the other, and which will be called an  $N.M$  element switch.

Element switches may be formed into switches of larger capacity by the well-known process of multiplying. In Fig. 3, two element switches having  $N = 2$

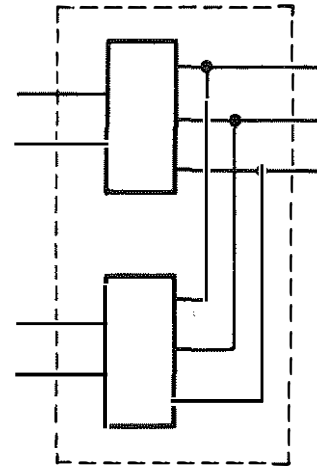

FIG. 3.—TWO ELEMENT SWITCHES MULTIPLIED TO MAKE ONE 4.3 SWITCH.

and  $M = 3$  are shown with the  $M$ -side terminals multiplied together. The resultant switch, which is indicated by the dashed-line rectangle, is a 4.3 switch made up of two element switches. With  $x$  element switches all multiplied together on the  $M$  side, the resultant would be a  $xN.M$  switch. If  $y$  of the  $xN.M$  switches are multiplied on the  $xN$  side, making a total of  $xy$  element switches, then the resultant would be an  $xN.yM$  switch. Clearly, switches may be made as large as we please from any device which is capable of being adapted to make and break an electrical speech circuit.

Again illustrating the point from current practice, ten 100-point Strowger (1.100 element) switches are commonly multiplied on their bank sides to form a 10.100 switch, and then into a larger switch by further multiplying on the bank side. One 200-point Strowger switch is formed by taking two 1.100 switches (two 100-point banks and two sets of wipers) and multiplying the wipers. The fact that in practice the wipers are multiplied and not obviously multiplied is due to the mechanical construction of the switch, which compels both sets of wipers to move together. If the wipers could be moved independently, multiplying of the wipers would suffice. A cross-bar switch is built up of relay 1.1 element switches, the relays being multiplied first into 1.10 switches and then into 10.10 or 20.10 switches.

These two examples illustrate an important point. To provide a 100.100 switch from Strowger element switches requires 100 element switches. To provide a 100.100 switch from relays requires 10,000 relays, which is much more expensive. Hence 1.1 element switches are at a grave disadvantage unless they are extremely cheap. Small element switches are commonly multiplied into smaller units than the bigger element switches, with the result that a greater number of ranks of switches is necessary for a given size of exchange. 10,000-line Strowger exchanges can be



provided by line finders and three ranks of switches; the same size of cross-bar exchange may have ten stages of switching. Even with the advantage that more than one connection can be set up through one switch, it is difficult for cross-bar systems to compete economically with systems based on larger element switches.

#### ELECTRONIC EXCHANGE SWITCHES USING MULTIPLIED ELEMENT SWITCHES

A convenient starting point in the quest for an electronic exchange switch is the examination of all electronic devices which can be made to make and break an electrical speech circuit; an exchange may be built using any such device, although other questions, particularly economics, will enter into the final choice. Chief among the stated devices are valves, gas-discharge tubes, cathode-ray tubes and rectifiers. Examples of the use of these devices are the following.

Fig. 4 shows an element switch using a vacuum

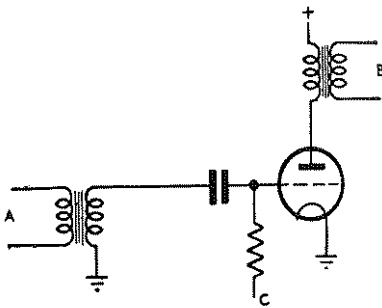

FIG. 4.—ELEMENT SWITCH USING A VACUUM VALVE.

valve. A and B are the input and output terminals respectively, and C is a control lead. When the potential of C is a suitable negative value, A is electrically connected to B, and when its potential is more negative, A is electrically disconnected from B.

Fig. 5 shows a 2.2 switch built up of four element switches, in which inputs A1, A2 can be connected to B1, B2 by controlling voltages on the leads C11, C12, C21, C22. These switches have to be duplicated to provide transmission in both directions; transmission can be made very satisfactory by negative feed-back. The disadvantage of the switch is that it is composed of 1.1 elements which are not cheap.

Fig. 6 shows an element switch in which A is normally disconnected from B, but can be connected by causing a discharge to take place through the gas discharge tube GT. The discharge can be started and stopped by a suitable control voltage applied to C, the discharge once started being maintained by the battery E, and the current controlled by the resistor R. The capacitor, K, provides a low impedance loop circuit for the speech currents. Means of multiplying the element switches can readily be seen. There are no hot cathodes to absorb power continuously, and the elements are relatively cheap. Transmission, which can take place in either direction, has to take account of the noisy and non-linear nature of the conduction through the gas.

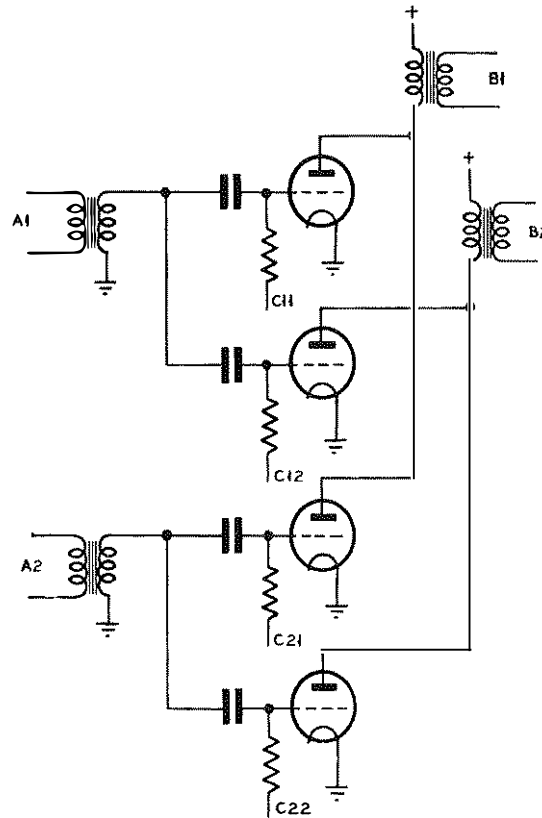

FIG. 5.—A 2.2 SWITCH, USING VACUUM VALVES, BUILT UP FROM 4 ELEMENT SWITCHES.

Fig. 7 shows a circuit similar to Fig. 6, but with a rectifier, QA, instead of the gas discharge tube. A is disconnected from, or connected to, B in dependence on the potential of C being above or below earth potential. Again transmission can take place in either

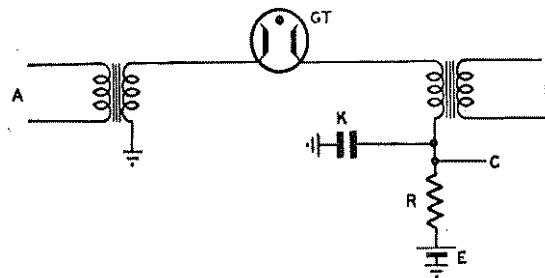

FIG. 6.—ELEMENT SWITCH USING A GAS DISCHARGE TUBE.

direction; the rectifier is not noisy, but it is non-linear in its conduction and care is needed to prevent distortion of the speech currents.

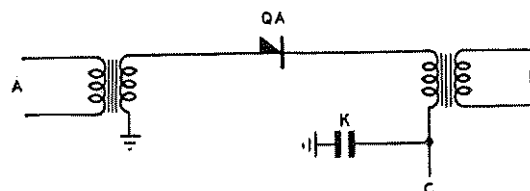

FIG. 7.—ELEMENT SWITCH USING A RECTIFIER.

Fig. 8 shows a cathode-ray tube having an input circuit, A, to modulate the beam current, a number of contacts at the screen end of the tube, each contact being brought out to an output, B, and a set of

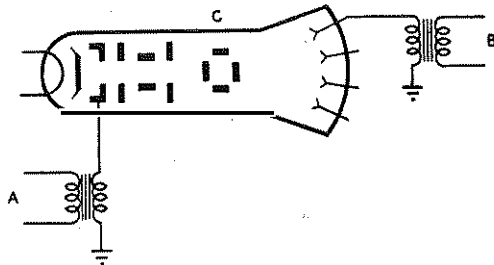

FIG. 8.—ELEMENT SWITCH USING A CATHODE-RAY TUBE.

deflector plates, C, the potential on which can be controlled to direct the beam to any desired output. The number of outputs can be as many as a hundred, and there are forms of construction, some involving secondary emission, by which both-way transmission can be provided by a single tube.

Cathode-ray tubes are expensive, but the fact that 1.100 element switches can be made is a compensatory advantage to a large extent. Their chief drawbacks are that the beam current is limited, so that the power which can be transmitted is small and considerable amplification individual to each channel B is necessary; and the cathode life is at present too short to be economical for a telephone exchange.

The element switches so far discussed may find application in small exchanges, but for larger exchanges the multiplex switches, described in the next section, may be more economical.

#### ELECTRONIC SWITCHES USING MULTIPLEX ELEMENT SWITCHES

Multiplex transmission can be regarded as a form of multiplexing. Consider the element switch in Fig. 9.

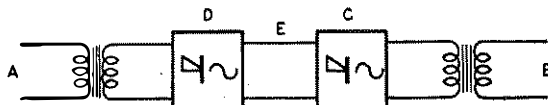

FIG. 9.—MULTIPLEX ELEMENT SWITCH.

An input, A, is connected through a modulator, D, to a common channel, E. A second modulator, C, may be controlled either to modulate or not to modulate the transmission from A back to audio frequency, whence A is either electrically connected or not connected to B. The modulation can be either by a carrier frequency (frequency-division multiplex), as in the familiar 12-channel and coaxial systems, or pulse modulation (time-division multiplex) as used, for example, in many radio links. The control applied to C may be the selection and switching on and off of the carrier frequency which will modulate back to audio frequency the transmission from D if it is there the modulation of a carrier frequency; or the selection and switching on and off of a pulse which will select the pulse applied by modulator D if the input from A is pulse modulated by D. In both cases other apparatus not shown in the diagram is needed,

for example, a filter, after the modulator C, to select the wanted audio frequency from the modulation products, and an amplifier after the filter to restore the level of the output at B to that of the input at A. If, now, a number of terminals B are provided, each with a modulator C (which can be controlled as previously described for C) and all terminals are connected to the common channel, E, then channel A can be connected to any channel B. If, further, a number of channels A with their modulators, D, are connected to the common channel, E, (the modulators, D, using different carrier frequencies or timed pulses to modulate the inputs at A) and if the modulators C can be controlled individually to select the transmission from any of the modulators D, then any A channel can be connected to any B. Two sets of equipment must be provided, one for transmission in each direction.

The terminals of a multiplex switch are expensive by comparison with other forms of element switch. The advantage of the method lies in this, that to produce an  $xN.yM$  switch, needs  $x + y$  terminals instead of  $x \times y$  element switches multiplied in the usual way, and for large switches this is economically a very great advantage.

It will be appreciated that multiplex transmission introduced solely for the purpose of switching is different in several respects from similar transmission over long distances. In particular, the negligible length of the common transmission path means that greater band-width is available with less phase distortion and noise. Hence the terminals can be simplified; frequency-division multiplexes can use wider channel spacings with, if desired, transmitted carrier and both sidebands, and time division can use amplitude modulation which is generally unsuitable for long-distance transmission. Frequency-division multiplex is familiar enough not to need detailed description. Time division is not so familiar and is described in the next section.

#### Pulse Modulation and Multiplex System.

An impulse is a single brief change of current and a pulse is a rhythmic train of impulses, as shown in Fig. 10 (a). Fig. 10 (b) shows a modulating voltage. In

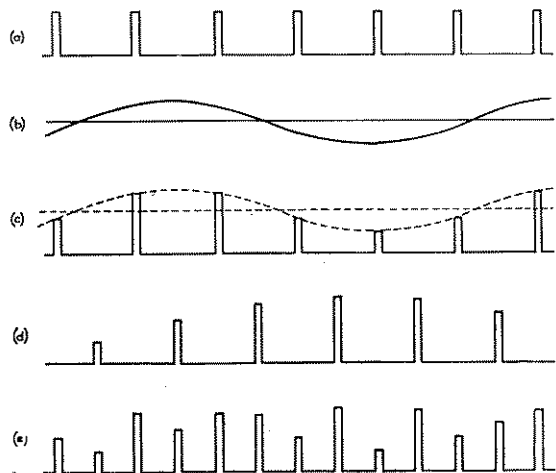

FIG. 10.—GRAPHS ILLUSTRATING THE PRINCIPLE OF TIME-DIVISION-MULTIPLEX TRANSMISSION.

(c) the wave of (b) is shown dotted and with its X-axis on the mean height, also shown dotted, of the impulses of (a). The full line shows the impulses which result when the impulses of (a) are modulated in amplitude by the wave (b). Provided that the frequency of the modulating source does not exceed in theory one-half, and in practice rather less than one-half, the impulse repetition frequency of the pulse, then the pulse can be demodulated back to the original wave (except that it is attenuated) by a low-pass filter. A second similarly modulated pulse, such as (d), the impulses of which are time-spaced so that they fall between the impulses of the first pulse, may be transmitted along with the first pulse over a common medium and without mutual interference, (e) showing the two pulses of (c) and (d) as a common transmission. For an electronic exchange switch, 100 equally time-spaced pulses may be desirable. The impulses, instead of being modulated in amplitude, may be modulated in a variety of other ways, for example, width or position relative to a mean width or position, but amplitude modulation is likely to be preferred for an electronic exchange switch because of its simplicity.

Fig. 11 shows in elementary detail an element switch

so far above earth potential that V1 is cut-off. A negative impulse applied to the grid of V2 cuts off all anode current from that valve and causes V1 to conduct and thus to produce an impulse across the resistor R1. It is not difficult to see that if a pulse is applied to the grid of V2, with no input to A, there will be across resistor R1 a pulse similar to Fig. 10 (a), except that it is negative-going instead of positive, and that this pulse will be amplitude modulated by any input to A. The pulse across R1 has its polarity inverted by valve V3 and applied to a modulator including valves V4 and V5, and operating similarly to the valves V1 and V2. It is to be noted, however, that the input to the grid of V4 is a pulse and that only if the impulses of the pulse applied to the grid of valve V5 coincide with the impulses of the pulse applied to the grid of V4, is the pulse from V1 communicated to the anode of V4, where it is demodulated by the low-pass filter, LPF, and then amplified to deliver to B a replica of the input to A. Assuming the pulse connected to the grid of valve V2 is continuously maintained, channel A is connected to B only if there is connected to the grid of V5 a pulse coincident with that at V2; to use the apparatus as an automatic telephone switch means that the pulse applied to V5 must be controlled by the switch.

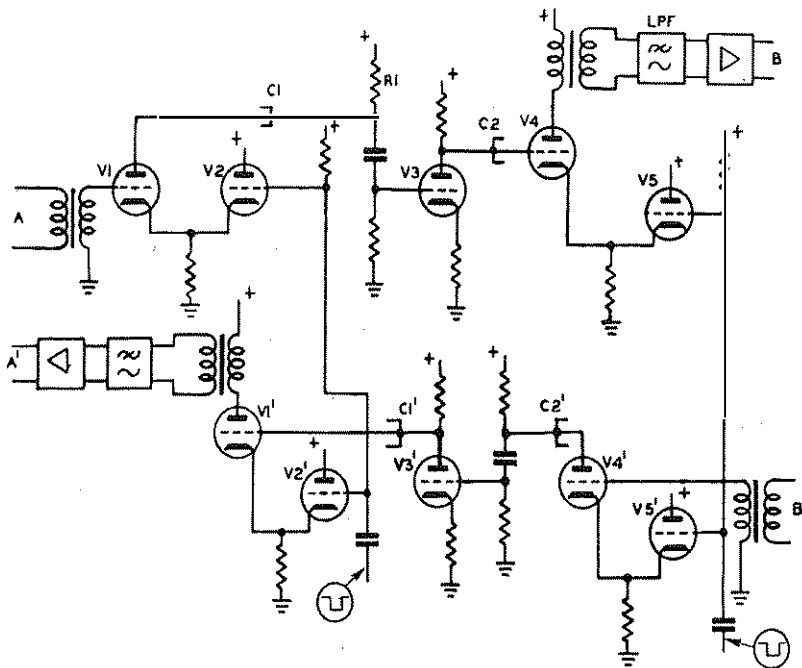

FIG. 11.—SIMPLIFIED CIRCUIT OF AN ELEMENT SWITCH USING PULSE MODULATION TO PROVIDE TWO-WAY COMMUNICATION.

using pulse modulation to provide two-way communication by 4-wire circuit between the channels A, A' and the channels B, B'. Channel A, which receives speech current from a trunk, is connected through a transformer to the grid of the valve V1 which, together with valve V2, forms a pulse amplitude modulator. The anode of V1 is connected to the anode positive voltage supply via resistor R1, and the cathode via a resistor to earth. Valve V2 has its cathode connected to the cathode of V1, and its grid via a resistor to a positive voltage such that normally the valve V2 conducts and raises the cathode potential

A transmission path from B' to A' similar to that from A to B can be traced, the pulses connected to the grids of the valves V2' and V5' being the same as those connected to V2 and V5 respectively. In this way a two-way-transmission element switch is produced. If now, further channels similar to A, A' have their modulators commoned to the commons C1 and C1', and the pulses to their valves V2 suitably time-spaced, and if further channels similar to B, B' have their modulators commoned to the commons C2 and C2', and the pulses to their valves V5 suitably controlled, any circuit having channels A, A' can be connected to any circuit B, B'.

Fig. 11 and the accompanying description is only one way in which a time-division multiplex switch may be constructed. There are many others. For example,

rotating beam tubes, in which a pencil or ribbon beam of electrons sweeps cyclically over a series of electrodes, are known to produce the same result. It will also be understood, without detailed description, that an arrangement equivalent to Fig. 11 exists for frequency-division multiplex. For example, the channels A, A' may be connected to modulators working with fixed carrier frequencies and the channels B, B' to modulators operated with carrier frequencies selected and connected according to the connections to be made through the switch.

## GENERAL PROPERTIES OF ELECTRONIC EXCHANGE SPEECH PATH SWITCHES

The very brief outline review given of the possible forms which electronic exchange speech path switches may take is by no means exhaustive, but is sufficient to indicate the general properties which may be expected of such switches. It is also useful to compare electronic with electro-mechanical switches with metallic contacts. An electronic switch is unlikely to provide the facilities of a metallic contact switch that any amount of power from D.C. to a frequency of many kilocycles per second may be transmitted without attenuation, or gain, or distortion. It is probable that an electronic switch cannot be economically constructed to carry much more A.C. power than is needed for the speech itself. Most forms of switch will not transmit D.C. at all. Multiplex switches are specially limited in respect of frequency bandwidth and are unlikely to transmit a bandwidth much in excess of that needed for speech transmission. They have an advantage, however, in that by controlling the modulating carrier frequency or pulse, transmission through the switch of a signal equivalent to a D.C. signal can be achieved, but the power so transmitted is severely limited. It is, therefore, to be expected that, although speech transmission through an electronic exchange will nominally suffer neither attenuation nor gain, this result will be the sum of a series of losses due to attenuating elements and gains due to amplifiers, with all the attendant variations and non-linearities of such devices. It is also to be expected that, because in an electro-mechanical exchange system the capacities of the system in excess of the power and bandwidth capacity needed for speech transmission are used for controlling functions such as line signalling, ringing the subscriber's bell, and operating his meter, the controlling signals in an electronic exchange will be very different from those in the corresponding electro-mechanical exchanges.

Many of the possible forms of electronic switch provide only unidirectional channels so that 4-wire circuits through the switches are unavoidable. In effect, 4-wire switching even in local exchanges is, therefore, very likely; in some systems it may prove essential in order to counteract the effect of the variation in loss or gain through the switches.

### SIGNALLING THROUGH ELECTRONIC SWITCHES

All electronic exchange switches must, of necessity, provide, through the switches, channels or circuits capable of transmitting A.C. at speech frequencies and powers; at some cost in money the transmitted frequency band can always be extended in one or both directions, that is, to sub-audio and/or super-audio frequencies, and the transmitted power handling capacity increased to perhaps two or three times that needed to carry speech currents. Although some electronic exchange switches provide D.C. signalling channels as well as A.C. channels through the switches, the D.C. channels will not in general carry all the required signals. The most general problem which is presented is that of signalling with A.C. with a minimum of frequency bandwidth and power handling capacity over that needed for speech transmission.

It will be understood that in a fully electronic exchange system the signals will for the most part be required to operate, for example, valves where voltage into a high impedance, i.e. small power, is sufficient. The limited power handling capacity of the switches is, therefore, no handicap except for ringing over a subscriber's line or operating his meter. This problem is considered separately later. For all other purposes, A.C. signals at low power can suffice; the problem is to find the channels for the signals and economical means of controlling and detecting them. Clearly one solution to the channel space problem is to provide separate speech and signalling channels through the switches, the exact analogy in electro-mechanical systems of speech and private wires through the switches. Secondly, if the channel which carries the speech currents transmits a band of frequencies wider than the speech currents need, signals can be transmitted over the channel and separated from the speech by filters.

Several means are known of electronically controlling alternating currents in the manner required for signalling. One is shown in Fig. 12. An A.C.

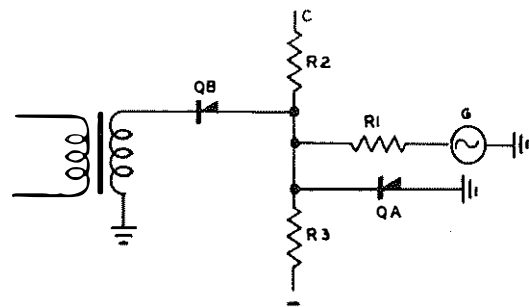

FIG. 12.—A METHOD OF CONTROLLING A.C. FOR  
SIGNALLING PURPOSES.

generator, G, usually common to a number of switches and having one side earthed, is connected through a resistor, R1, to a network of resistors, R2, R3, and rectifiers, QA, QB, the lead, C, being the control lead and resistor, R3, being connected to a negative potential. Rectifier QB is connected to a transformer, the primary of which is earthed on one side and the secondary connected to the signal circuit. If lead C supplies no current to the circuit, rectifier QA has current through it in its low resistance direction; the rectifier, QB, is biased to its high resistance condition. The attenuation between the generator and the signal channel is thus high, commonly 60 db. or more. If now the potential of lead C becomes sufficiently positive with respect to earth, rectifier QA becomes biased to its high resistance condition, and QB to low resistance. The attenuation between the generator and the signal channel is thus low, a few decibels perhaps. This element requires a D.C. controlling signal to control an A.C. transmitted signal. If the controlling signal is itself derived from an A.C. received signal from some other part of the system, rectification, possibly after amplification, of the received A.C. signal, will produce the required D.C. controlling signal.

Detection of signals is a matter of recognising the signals and producing from them the currents or

voltages required. Recognition of an A.C. signal may need tuned circuits or filters if more than one signal can be received over a channel. The received A.C. signal may be usable as such, or it may need to be transformed into D.C. by rectification; if it is required to be transformed into a signal at a different frequency, transformation into D.C. to control an A.C. source at the new frequency is the usual procedure. Amplification may be necessary to obtain sufficient power in the signal. Amplification of A.C. signals is simple with hot-cathode valves. Amplification of D.C. signals may be performed directly by hot-cathode valves used as cathode followers, or sometimes by cold-cathode tubes, and indirectly by converting the D.C. to A.C., amplifying and reconverting to D.C.

The purpose of the illustrations which have been given is not to discuss all the possible ways of signalling through electronic switches but to indicate that, because A.C. can be readily converted to D.C., D.C. to A.C., and either amplified, it is almost a matter of indifference whether the switches will transmit A.C. or D.C. at low or high power. It would be a matter of indifference if cost and complication did not enter into the question, and the practical problem is to keep these factors within acceptable limits. As an example of the sort of problem presented, and a possible solution, a circuit arrangement for subscriber's equipment is shown in Fig. 13, this circuit being based on the assumption of 4-wire switches capable of transmitting only low power A.C. but with a frequency bandwidth greater than that needed for speech transmission.

In Fig. 13, A and B are the two wires of a subscriber's line. A speech path exists from these two wires, through the hybrid transformer T1 and capacitor C1, and low-pass filter FT1 to the transmit channel of the 4-wire circuit through the switches. A

speech path also exists from the receive channel of the 4-wire circuit, through the low-pass filter FR1 and the hybrid T1 to the subscriber's line. A.C. signal paths independent of the speech path are provided through the high-pass filters FT2 and FR2 for the transmit and receive directions. Feeding current for the station transmitter, and controlling signals depending on the cradle switch, are derived from the battery which supplies current through the resistors R1 and R2, the secondary windings of a transformer, T2, and the 2-wire windings of the hybrid T1. The battery is tapped so that it produces both positive and negative potentials relative to earth. The positive terminal produces current which, when the A and B wires are not looped, flows through rectifier QA, rectifier QB thus being high resistance, and inserts a high attenuation path between the super-audio A.C. signal source S1 and the filter FT2, as described in connection with Fig. 12. When the subscriber's line is looped, the current flow through resistor R1 causes rectifier QB to conduct and rectifier QA to become high resistance, and hence to cause signal current to be transmitted on the transmit channel. In this way call, dial and clear signals on originated calls and answer and clear on terminating calls are signalled into the switches.

For ringing the subscriber's bell and operating his meter, two different super-audio signal frequencies are used. The filter FR2 is terminated in two series-tuned circuits, each tuned to one of the signal frequencies and producing a voltage magnification sufficient to control a cold-cathode gas discharge tube from the low-voltage received signal. The subscriber's bell is rung by a signal frequency to which TC1 is tuned and produces on the primer of the cold-cathode tube GT1 an A.C. voltage the maximum positive value of which is sufficient to fire the tube. Tube GT1 has in its anode the primary winding of the transformer T2 and is supplied with current from a 17 c/s source, on the positive half-waves of which the tube GT1 will fire if the primer is sufficiently positive, and on the negative half-waves of which the tube GT1 will extinguish. Hence, on receipt of a ringing signal, the tube GT1 will conduct during the greater part of each cycle from the 17 c/s source; the fact that the tube will be extinguished for part of the cycle means that the ringing will cease when the ringing signal operating on the primer ceases. The secondary windings of the transformer T2 communicate 17 c/s ringing to the subscriber's line. The capacitors C1 and C2 may resonate with the transformer inductance to the ringing frequency to increase the efficiency of the arrangement. The subscriber's meter is similarly controlled and operated by an A.C. meter signal of different frequency from the ringing signal and which operates gas tube GT2, the anode circuit of which contains the meter and is fed from a 50 c/s supply. In this manner the subscriber's bell can be rung and his meter operated by equipment, within the exchange, which sends out A.C. signals at low power, operation by voice currents from the line AB being prevented by the filters.

The example given in Fig. 13 is a relatively complicated and expensive solution to the problem of the subscriber's equipment. It can be simplified if the

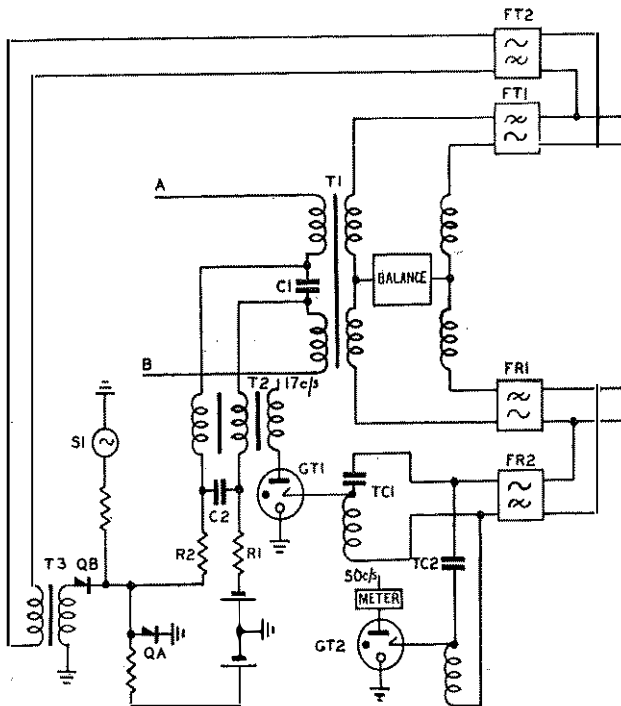

FIG. 13.—A CIRCUIT ARRANGEMENT FOR A SUBSCRIBER'S EQUIPMENT.



selectors can transmit a D.C. signal, or if separate signalling and speech paths through the switches are provided. The important point is to show that subscriber action signals can be transmitted through the switches as well as speech currents. It is not then difficult to imagine a complete system consisting of subscribers' lines, and ranks of switches in series, over which connections can be set up and controlled, and speech paths provided from subscriber to subscriber, or from subscriber to operator. The way in which the controlling signals may cause the required connections to be made is a separate study.

### *Conclusion.*

It has been shown that automatic exchange speech path switches can be provided by element switches using any means of making and breaking a speech channel, together with either multiplying or multiplexing the element switches, and that controlling signals can be generated, transmitted through the switches and caused to perform required controlling functions at a receiving point. These features are essential to any fully electronic system; the future of fully electronic systems depends very largely on the cost, complexity and reliability of the means adopted to provide these features.

---

## Book Reviews

"Electronic Circuits and Tubes," by the War Training Staff of the Cruft Laboratory, Harvard University. McGraw-Hill Publishing Co., Ltd., London. 948 pp. 45s.

This book has been prepared from the lecture notes of a special wartime training course given in the Graduate School of Engineering, Harvard University. It was originally intended to publish the entire lecture material in a single volume, but because the single volume would have been inconveniently large, and also because a portion of the manuscript was completed early, that part has been published in a separate volume entitled "Transmission Lines, Antennas and Wave Guides." The present volume is intended as an introduction to the volume published earlier. Eleven of the original twelve members of the wartime lecturing staff are authors of the present work.

There are in all twenty-four chapters and four appendices. The first nine chapters deal with A.C. theory, impedance matching, coupled circuits, filters and Fourier analysis. The next eight deal with valves, amplifiers, oscillators and power supplies, all using valves of the normal type and not those associated with radar and wave guide techniques. Six chapters deal with modulation, detection and radio receivers; here again the frequency range of the equipment discussed is limited and is concerned almost entirely with receivers of conventional types. The final chapter deals very thoroughly with timing circuits such as those used in radar. The appendices review Mathematics and Electricity and Magnetism.

One would have expected a volume dealing with electronic circuits and tubes to have dealt with the circuits and tubes normally associated with radar and wave guides, but it does not. There is only one brief reference to a magnetron and apparently no reference whatsoever to the other types of valve which are used at frequencies suitable for wave guides.

Although much is left out and the book suffers from different styles due to the numerous authors, the work is very thorough. There are several typographical errors, the most noticeable being the repetition of Fig. 4.1 of Chapter I as Fig. 4.1 of Chapter II.

The book is stated to be for juniors and seniors of colleges and engineering schools, but it is considered to be of more use as a book of reference for those parts of the subject which are dealt with so thoroughly.

H. T. M.

"An Introduction to the Theory and Design of Electric Wave Filters." Second Edition. F. Scowen, B.Sc., A.Inst.P. Chapman & Hall, London. 188 pp. 70 ill. 18s.

The design of electric wave filters is a very complex subject, and it is impracticable to incorporate, in a book of modest dimensions, all the more advanced techniques and finer points of design; these, indeed, are hardly likely to become working tools of any but the specialist. Yet there is much that the non-specialist communication engineer can do in preparing his own filter designs, and it is for this purpose that the present book was written. The author has had considerable design experience at the Post Office Research Station, and his book, which is concise and clearly written, should be at the elbow of all engineers who wish to produce workmanlike designs for themselves.

Despite the more recent contributions of workers such as Cauer, Bode and Darlington and the high degree of precision which they have made possible, it is a fact that most practical designs are even now based on the work of Zobel, published in 1923. The underlying principles of Zobel's methods and many practical hints in their application form the main subject matter of the present book. There is no need for flights into the realm of advanced mathematics to absorb all that is necessary for "bread and butter" designs, and the necessary introduction to complex numbers and hyperbolic functions is amply covered in the first chapter; this is followed by an introduction to the necessary basic electrical theory. A chapter is devoted to practical hints on construction and includes much useful information on the properties of component reactors as well as on the methods of measurement and adjustment of both components and complete filters.

The main additional feature of the new edition is an introduction to the design of filters on an insertion-loss basis, to which Darlington has made major contributions. Although the author has done much to present the problem and some of the means of solution in a simplified form, this, in the reviewer's opinion, must be regarded as a contribution to the general education of the student rather than as extending the design facilities available to the non-specialist engineer. At the present stage of the art, at least, design on an insertion-loss basis is a job for the specialist.

R. J. H.

# Local Line Plant : Pair Appropriation Records

A. MORRIS, A.R.C.Sc., D.I.C., Wh.Ex.,  
M.I.E.E., and  
W. H. DOLAN, B.Sc.(Eng.), A.M.I.E.E.†

U.D.C. 621.395.743.003.3

The basic purpose of engineering records of cable pair terminations is to facilitate circuit routing and maintenance. Such records, nowadays, display much additional information in the form of code markings, which is necessary for the operation of an elaborate provision-of-service procedure as followed in the Post Office system. Accuracy and adequacy are of extreme importance, and since waste of effort would result from omissions and errors, field tests are being made of a number of different record procedures to determine the sources of potential errors.

## Introduction.

WHILST post-war years have seen an exceptional increase in the number of telephone subscribers, the demand for service continues at a very high level. Restrictions on capital expenditure have limited the local line plant expansion necessary to meet such a demand satisfactorily, and the large addition to the number of working lines has been achieved only by depleting the spare plant. Whereas the number of distribution points increased approximately from 343,000 at December 1939 to 434,000 at September 1949, the percentage closed to service-extension rose from 17 to 31 per cent. over this period. The development of two-party shared service and the cabinet and pillar system of local line layout have served, to some extent, to offset the unsatisfactory spare plant position, but the present demand is so high in relation to the current supply of additional exchange-to-D.P. pairs that there would seem to be no prospect of short-term improvement of the position.

Line plant cable pair appropriation cards are an essential engineering record for the purpose of noting the identity of cable pairs at their terminals. They are used for circuit routing and maintenance purposes; they also give information as to the addresses and telephone numbers of subscribers. In order to overcome the difficulties of providing telephone service at the present time, and to ensure that priority and shared service requirements are met, extensive sales machinery has been developed. Its operation is based upon an elaboration of the line plant records, which are required additionally to display considerable information in the form of code markings, relating solely to the detailed business of giving service.

The extent to which all the line plant provided in a telephone system can, in fact, be made use of and the speed with which it can be brought into service depend upon the accuracy and completeness of the spare plant records. At the same time, efficient maintenance necessitates clear and correct details of working circuits. Much attention is given to this subject in other countries and it is of interest to note that a booklet issued by an American telephone company so far back as 1927 stressed, in no uncertain terms, the great value of adequate and accurate records.

So far as the trunk plant is concerned, the importance of record work is well recognised. This is

reflected in the considerable country-wide organisation, centralised at Headquarters and operated in the Regions and Areas by engineering, clerical and drawing-office staffs, which has been built up to deal with the provision of trunk circuits. In regard to local line plant, however, the equal importance of record work may not at first be apparent; particularly as such work is, of necessity, devolved to an extreme degree and is, in the main, carried out by minor staff. Furthermore, the plant cost per circuit is very much lower than that for trunk circuits. Nevertheless, the total value of the local line plant amounts to the enormous figure of £130 millions—some 50 per cent. greater than that of the trunk and junction line plant—and the routing processes in the two cases differ little in intricacy, except that whereas trunk lines in general are simple exchange-to-exchange links, local cable pairs are exchange-to-D.P. links, the latter terminals being widely dispersed territorially.

It is the object of this article to direct attention to the extreme importance of accuracy in the recording of local line plant, to emphasise the impairment and even waste of effort which would result from errors and omissions, and to stimulate an even greater interest in the work of compilation and upkeep of these records. Whilst the staff actually originating and using these records are given special training for the work, yet in present-day circumstances and in view of its importance, a statement of the problems involved will, it is thought, be of general interest.

## BRIEF DESCRIPTION OF RECORDS AND ROUTING PROCEDURE

The following brief description of the system of records employed in the appropriation of local cable pairs in this country will be helpful in the later discussion of the general subject. Particulars of the terminations of working pairs in subscribers' cables and of the availability of spares constitute the essential basic information for the provision and maintenance of telephone service. A simple, direct and complete record system is desirable. A standard method of card recording is employed throughout the country, and considerable study has been given post-war to the development of records for the cabinet and pillar system of plant layout. The cards are held at Installation Controls and are used there by Routing Officers in the general day-to-day business of circuit routing and provision of service. A typical Installation Control is shown in Fig. 1.

For a D.P. connected direct to the exchange, the exchange and D.P. terminations of all cable pairs from the D.P. are given on one card designated the

† Mr. Morris is Staff Engineer, Local Lines and Wire Broadcasting Branch, Engineer-in-Chief's Office and Mr. Dolan, Executive Engineer in that Branch.



FIG. 1.—A TYPICAL INSTALLATION CONTROL.

addition, the choice is made so as not to impair the chances of being able to use pins for the subsequent connection of the remaining pairs. These objects are best achieved by examination of all three cards jointly. The cards when laid out side by side (with the D.P. card on the left) present a clear picture of the various possible ways of making the selection.

The sequence of use of cards for all routing purposes is from D.P. to the exchange and a number of examples of the use of the cards for various layouts of plant are shown in Fig. 3.

Particulars of the principal cards employed in connection with cabinet and pillar layouts are as follows:—

Card Description	P.O. Code	Size
D.P. card	A2555	8 in. x 5 in.
Branch Cable card	A2550	Demi-Quarto
Main Cable card	A2549	Demi-Quarto

“D.P. card.” This card also exhibits information relating to shared service connections as well as elaborate markings required in connection with the present-day joint sales and engineering organisation for provision of service. The card is shown in Fig. 2.

The appropriation of pairs in subscribers' cable networks involving cabinets and pillars is normally made on three cards which show the relationship between the terminals of the distribution, branch and main cables, and are known as “D.P.,” “Branch Cable” and “Main Cable” cards respectively. Additional cards are employed for indexing and for the recording of multiple-teed cable pairs and link-cable pairs.

The procedure for allocating pairs for circuit provision will depend on whether pairs have been pre-pinned or pre-jumpered at cabinets and pillars. It is envisaged that ultimately the bulk of cable pairs will have been so arranged, and in that event allocation is a relatively simple process; a spare pair is traced through from the D.P. card via the Branch and Main Cable cards to the M.D.F., the circuit number or reservation symbol R then being entered on all three cards. Where circuit provision is dependent on the selection and connecting together of pairs in the distribution, branch and main cable networks, the pairs are selected so that bridging-pins rather than jumpers can be used for setting up the circuit; this applies particularly to cabinets where jumpering capacity is limited. In

D.P. CARD		Pillar No. <u>4/2</u>	Exch. <u>BLANKTOWN</u>	D.P. No. <u>101</u>	A2555 (LINES, Dis., AMB)			
S. Ref. No. <u>5</u>		D.P. Address <u>1, NEW STREET</u>						
Type of U.P.	Open Wire, Line, Arrived, Lead, Intentional Block, Warning, Intentional	Survey required not necessarily necessary	No. & Type of Terminations	D.P. Cable	Pairs	Minimum Spares	Distribution Cable Re-Ohms	
		*Delete as necessary	<u>15</u> B.T. No. 9		<u>15</u> Weight <u>62</u>	<u>3</u> 1.4.50	<u>46</u>	
D.P. Pair No.	Pillar 'D' Side	Term. No. 'E' Side	Ex.	Circuit No.	Name	Address	X Conn' to B.P. No.	Subs. Agrmt. No.
<u>1</u>	<u>51</u>	<u>51</u>		<u>3222 Y</u>	<u>SMITH H.</u>	<u>B, NEW STREET</u>		<u>PP</u>
<u>2</u>	<u>52</u>	<u>52</u>		<u>3567 X</u>	<u>ROBINSON F.</u>	<u>2B, NEW STREET</u>		<u>PP</u>
<u>3</u>	<u>53</u>	<u>53</u>		<u>A 17-4 30</u>		<u>2 36, HIGH STREET</u>		
<u>4</u>	<u>54</u>	<u>54</u>		<u>96 91</u>	<u>JOHNSON C.</u>	<u>HED LION HOTEL, HIGH STREET</u>		
<u>5</u>	<u>55</u>	<u>15</u>		<u>3322</u>	<u>M<sup>c</sup> DOUGALL &amp; Co</u>	<u>240, HIGH STREET</u>		
<u>6</u>	<u>56</u>	<u>16</u>		<u>5412 X</u>	<u>DONOVAN J</u>	<u>21A, NEW STREET</u>		<u>PP</u>
<u>7</u>	<u>57</u>	<u>29</u>	<u>R</u>		<u>FLOWERS T.</u>	<u>242, HIGH STREET</u>		
<u>8</u>	<u>58</u>	<u>6</u>		<u>3863 X</u>	<u>BLACK G.</u>	<u>1, NEW STREET</u>		<u>PP</u>
<u>9</u>	<u>59</u>	<u>31</u>		<u>9602</u>	<u>JOHNSON C.</u>	<u>RED LION HOTEL, HIGH STREET</u>		
<u>10</u>	<u>60</u>	<u>69</u>		<u>3322 EXTN 1</u>	<u>M<sup>c</sup> DOUGALL &amp; Co.</u>	<u>240, HIGH STREET</u>	<u>01</u>	<u>4/1</u>
<u>11</u>	<u>61</u>	<u>14</u>		<u>8305</u>	<u>SCOTT P.</u>	<u>5, NEW STREET</u>		
<u>12</u>	<u>62</u>							
<u>13</u>	<u>63</u>							
<u>14</u>	<u>64</u>							
<u>15</u>	<u>65</u>							

EXCHANGE..... <u>BLANKTOWN</u>		D.P. No. <u>101</u>		Other D.P.s on same PILLAR		
PILLAR No. .... Address.....		CABINET No. .... Address.....		D.P. No.		
PARTY LINES TEED TO CIRCUITS IN COL. 1						
Subs. No. * of Line to which Teed (from other side)	Subs. No. *	Name	Address	D.P. No.	Location of Tee	Subs. Agrmt. No.
<u>5412 X</u>	<u>2475 Y</u>	<u>BROWN, C.</u>	<u>21, NEW STREET</u>	<u>101</u>	<u>Subs lead in</u>	<u>PP</u>
<u>3567 X</u>	<u>2967 Y</u>	<u>GREEN, F.</u>	<u>16, NEW STREET</u>	<u>101</u>	<u>Pole 1</u>	<u>PP</u>
<u>3863 X</u>	<u>3520 Y</u>	<u>JACKSON H.</u>	<u>100, HIGH STREET</u>	<u>101</u>	<u>DP</u>	<u>PP</u>
<u>3222 Y</u>	<u>2481 X</u>	<u>COPLLEY L.</u>	<u>3, NEW STREET</u>	<u>101</u>	<u>DP</u>	<u>PP</u>

FIG. 2.—D.P. CARD, FRONT AND BACK.



Secondly, speed in the assignment of available facilities is essential for the smooth running of the provision-of-service organisation. In so far as long-term utilisation efficiency is concerned, the matter resolves itself into economic considerations of a similar nature to those employed when the plant was originally provided.

The pernicious effects of errors in D.P. cards and other records, in so far as day-to-day provision of service is concerned, cannot be over-estimated. In the present circumstances of plant shortage and pressure of demand for service, it is imperative that the information passing between Sales and Engineering organisations should be correct. If a spare service facility were shown as available on the records, when in actual fact it did not exist, the subsequent furnishing of incorrect advice to the applicant might result in a commitment to provide service at considerable expense. The interchange of information between Sales and Engineering Divisions in relation to the provision of shared service is considered subsequently.

#### *Planning.*

Whilst care has been taken to ensure as simple a system as possible, the records required for cabinet and pillar layouts are necessarily more detailed and extensive than those hitherto employed. In addition, the multiple-teeing of cable pairs in main and branch cable networks has necessitated the introduction of special records. As a consequence, more attention and effort is involved in maintaining a high standard of accuracy.

The planning of new development schemes is based upon card records relating to the working and spare components of the existing plant. It is obvious that the field staffs would experience difficulty in the execution of the planned work if errors were carried forward into the cable pair jointing and diversion schedules. A severe restriction would be imposed upon local line development planning if little or no reliance could be placed upon cable pair appropriation records; detailed jointing and diversion schedules could not then be made. Errors in the records would give rise to differences between the number of cable wires actually changed over and the number estimated. In such circumstances, planning could only be carried out on a broad basis; departures from estimate upset the planned stores-to-labour ratio, and close budgetary control would become impossible.

#### *Shared Service.*

The procedure for the provision of two-party shared service is largely based upon and necessitates an extension of scope of the engineering record machinery. The various code markings which, in this connection, are entered on D.P. cards have already been listed. In order to meet the circumstances brought about by the acute shortage of plant an involved provision-of-service procedure is necessary to ensure the interchange of all necessary information between Sales and Engineering Divisions. The omission of a marking from the D.P. card may result

in Routing Officers being unable to advise Sales staff of the facilities for providing telephone service. For example, if one subscriber only at a particular D.P. with no spares is marked P.P., an enquiry as to whether service can be provided at the same D.P. can be dealt with as—"Spare Sharing Facility Available." Unless a special survey was undertaken, absence of the P.P. marking would result in incorrect information being given as to the actual service facilities available.

#### *Spare Plant Return.*

A revision of the procedure for recording spare pairs in subscribers' cables has been necessitated by the introduction of flexibility based on cabinets and pillars. These have the effect of sub-dividing local cable systems into three sections, namely the main, branch and distribution networks. The old return provided complete information respecting spare pairs through from D.P. to exchange M.D.F. on one record, whereas the revised return which will make its first appearance in September, 1950, will provide information as to the spare position in each section of the network. The return will be derived from the cable pair appropriation records, and its primary object will be to provide a check on the adequacy of plant in the various sections of the network. As a secondary function the return will provide data for Regional control purposes and for statistical requirements at Headquarters.

Because of present-day restrictions on capital expenditure, the spare plant position, which is a major factor in deciding the question of augmentation, has to be carefully assessed. This will be assured only if the fundamental information provided on the cable pair appropriation cards is complete and accurate.

#### SOURCES OF ERROR

There are many paths by which errors can be conveyed to records and it is necessary to consider them in some detail. Firstly, errors may be introduced in the initial preparation of records due to clerical error or due to errors in the cable pair jointing schedules from which the records are compiled. During its life the information contained on a card record is continually changing due to the addition of new subscribers, recoveries, codings for provision of service conditions, etc. Errors may arise from an inadequacy of information or from a failure to record the details supplied.

The interchange of information between Sales and Engineering Divisions during the day-to-day business of providing telephone service makes it necessary that the information incoming for record purposes should be complete and accurate. Furthermore, the efficient team-working of field and record office staffs has to be promoted by a mutual understanding of the difficulties caused if, for example, a cable pair other than the one assigned were taken to give service to a new subscriber.

Duplication of records is most undesirable as any differences in the details recorded increase with time up to a stage when neither can be relied upon



as accurate. Indifferent attention to neatness and legibility when entering information on cards will lead to errors, as also will failure to ensure that cards are kept in good condition in suitable accommodation.

War damage to local line plant and improvisation of plant to meet war conditions have of themselves led to unavoidable errors in records in this country, and estimates of the accuracy and completeness of post-war records varies widely between Telephone Areas. War repairs to cables have led to not inconsiderable errors despite the steps taken at the time to locate and identify cable pairs in the field; active steps have also been taken in post-war years to find "lost" pairs. It will be appreciated that where there is doubt as to the accuracy of the records, numerous checks, by way of survey work in the field, may be necessary.

#### FIELD TRIALS

The detailed methods employed in the preparation and maintenance of records in any Area will depend to some extent on the organisation existing in that Area for local line plant planning, provision and maintenance. In order to assess the relative merits of differing organisations in so far as final record accuracy is concerned, and to identify the major sources of record errors, experiments are being undertaken in the Glasgow, Peterborough, and Reading Telephone Areas. An investigation will be made in each Area to check the accuracy and completeness of information forwarded to Installation Controls for entry on local cable pair appropriation records, i.e. sample checks of recorded information shown on Advice Notes, Diversion Schedules, and Jumper Connections at M.D.F.s will be made against the actual conditions in the field as shown by physical inspection of the plant. Sample checks of records after the replacement of faulty lengths of cable will also be included.

At the end of the experimental period, a return for each Area will be prepared which will show the numbers and percentage of errors and where these errors were located, i.e. in Advice Notes, Diversion Schedules, etc. It is hoped that this information will assist in the determination of any remedial measures considered necessary.

#### Conclusion.

Engineering cable pair records are nowadays augmented by extensive information in the form of code markings which are necessary to the present Sales procedure for providing telephone service (including shared service). In addition, the form of the record has been modified to suit the modern plant layouts resulting from post-war developments in local line planning methods. It is essential, therefore, that in the present circumstances of acute shortage of line plant, all staff concerned with records should have a clear appreciation of the part records play in the present-day business of providing telephone service and of the importance to be attached to the need for adequate and accurate records. It is obviously in the interests of the officer holding the record or supplying record information not to make clerical errors; likewise, it is in the best interests of an engineering officer in the field that he should never appropriate a spare pair on his own initiative, when a call to the record officer would secure a pair which would be marked as assigned.

Adequacy and accuracy in local line records can only be achieved by consideration being given to all aspects of the matter of routing pairs for telephone provision and maintenance purposes. Accommodation for staff, type of staff, training of field staff in a knowledge of, and appreciation of, the importance of records are but a few items which necessitate the continued active interest of the staff concerned with the telephone service.

### TELEGRAPH AND TELEPHONE STATISTICS—SINGLE WIRE MILEAGES AS AT 31 DECEMBER, 1949. POST OFFICE MAINTENANCE—EXCLUDING SUBMARINE CABLE.

REGION	OVERHEAD			UNDERGROUND		
	Trunks and Telegraphs	Junctions	Subscribers*	Trunks and Telegraphs†	Junctions‡	Subscribers¶
Northern Ireland .. ..	6,158	6,500	38,412	114,621	47,336	147,421
Scotland .. .. .	11,852	27,190	218,552	819,671	341,624	932,135
Home Counties .. ..	366	11,715	388,379	2,030,801	600,277	1,568,324
Midland .. .. .	1,652	19,269	242,510	1,145,773	364,371	1,125,416
North Eastern .. ..	2,395	12,174	208,536	926,712	360,792	1,109,428
North Western .. ..	830	5,785	124,379	733,912	420,978	1,318,039
South Western .. ..	1,257	21,179	299,878	1,054,511	224,382	867,994
Welsh and Border Counties	2,742	16,097	168,471	529,753	142,342	361,777
Provinces .. .. .	27,252	119,909	1,689,117	7,355,754	2,502,102	7,430,534
London .. .. .	—	416	88,329	1,077,955	2,286,926	4,130,129
United Kingdom .. ..	27,252	120,325	1,777,446	8,433,709	4,789,028	11,560,663

\* Includes all spare wires.

† All wires (including spares) in M.U. Cables.

‡ All wires (including spares) in wholly Junction Cables.

¶ All wires (including spares) in Subscribers' and mixed Junction and Subscribers' Cables.

# Design of Square-Law Rectifier Circuits for Measuring Instruments

D. C. WALKER, B.Sc.(Eng.), A.M.I.E.E.,  
D. L. RICHARDS, B.Sc.(Eng.), A.M.I.E.E.,  
G. P. HORTON, B.Sc.(Eng.).†

U.D.C. 621.314.6 : 621.317.7

The peak/root-mean-square ratio of speech waveforms may be as great as 11 db. or even more, so that a meter which is required to give accurate r.m.s. indications must be capable of handling an instantaneous input level well above that of a steady sine wave giving the same meter reading. A range of at least 16 db. is required over which the meter must conform to a square law. This can be achieved using a rectifier circuit connected to a D.C. moving-coil instrument by the novel principle of using rectifier discs in combination with series and shunt resistors. Three rectifier circuits are described which have been used in equipment for measuring noise or speech levels. An accuracy of about  $\pm 0.3$  db. has been achieved in measurements where practical waveforms are concerned.

## Introduction.

MANY measurements of alternating quantities require the use of an instrument which will give a true r.m.s. indication. If attention can be confined to sinusoidal waveforms almost any form of meter can be used provided it is suitably calibrated. For example, peak-reading or linear-rectifying thermionic voltmeters are commonly calibrated so that correct r.m.s. indications are given for a sinusoidal input. If a complex waveform such as noise or speech is to be measured it is often desirable to express the results of measurements as r.m.s. quantities and an accurate square-law meter is then necessary.

When the highest frequency of a component having appreciable magnitude is not greater than a few hundred cycles per second, moving-iron or electrodynamic instruments are suitable. Moving-iron meters are being developed for use at audio frequencies up to a few thousand cycles per second but none is yet available. Accurate measurements of complex waveforms may be made at almost any frequency by means of a thermo-couple meter. Such a meter is stable and reliable provided it is used carefully, but suffers from liability to damage by accidental overload. This is a particularly troublesome feature if the r.m.s. value does not remain constant over a period, say, of ten seconds, sufficient to take a reading.

Where speech or variable types of noise are concerned the r.m.s. value of the waveform is a function of time and also of the interval over which the waveform is integrated (integration period). The integration period of a thermal meter is controlled mainly by the thermal capacity of the couple element and cannot be reduced below a value of a few seconds. The integration period may be defined as that duration for which a steady input must be applied to ensure that the meter gives a maximum indication 2 db. lower than the indication which would result were the same steady input applied indefinitely.

The measurement of speech or noise levels (either acoustical or circuit noise) requires the use of meters having integration periods of the order of a few hundred milliseconds. This excludes the thermal type of meter. Thermionic valve circuits are available<sup>1,2</sup>

which enable an adequate range of square-law characteristic to be obtained but these all suffer from the necessity of setting the zero of the indicating instrument. If  $i$  is the instantaneous current through the D.C. milliammeter and  $v$  is the applied input voltage, the characteristic of a valve circuit could be  $i = A + Bv^2$  over a sufficient range of  $v$ , where  $A$  and  $B$  are constants. The zero setting is necessary to balance out  $A$ . A rectifier-type meter (i.e. a metal rectifier network followed by a D.C. moving-coil milliammeter) offers very many advantages and rectifier networks can be designed to have the characteristic  $i = Bv^2$  over a limited but sufficient range of  $v$ .

The waveform of speech and of many common types of varying noise is such that the peak instantaneous values of a speech or noise voltage are 4 to 6 db. higher than the voltage corresponding to the r.m.s. reading given by a meter having an integration period of 0.1 second (e.g. speech voltmeter). If the comparison is made with a r.m.s. meter having an integration period of more than about two seconds the peak/r.m.s. ratio may be as much as 11 db. These ratios are even greater when the speech circuit uses a carbon granule transmitter. This wide range of instantaneous values relative to the r.m.s. indication makes it necessary that the square-law characteristic of the rectifier network holds accurately over a correspondingly wide range. With 0.1 second integration period, a range from 5 db. below the normal r.m.s. reading to 11 db. above it is desirable. Over this range the instantaneous current should not depart from its correct value by more than 10 per cent. For a long-integration-period meter a total range of some 40 db. is necessary if r.m.s. indications of speech waveforms are to be obtained accurately.

## BASIC SQUARE-LAW CIRCUIT WITH METAL RECTIFIERS

The basic circuit for square-law rectifier networks is shown in Fig. 1, where  $R_1$  represents the source and meter load resistance and  $R_2$  a rectifier-shunting resistance. For practical applications, however, the circuit used would be of the full-wave type, probably employing a bridge network. Only the forward direction of the rectifiers will be considered and for this direction the current/voltage characteristic of a typical cuprous oxide metal rectifier (actually the Post Office C-type,  $\frac{1}{4}$  in. diameter disc) is shown plotted to logarithmic scales as curve (3) in Fig. 2. It will be seen that the slope is steeper than that corresponding to a square-law over most of its range, and only

† Engineers, Research Station.

<sup>1</sup> Harbottle, H. R. "The Circuit Noise-meter (Psophometer) and its Applications," *J.I.E.E.*, Vol. 83, p. 261 (1938).

<sup>2</sup> Ross, H. McG., and Shuffrey, A. L. "An Electronic Square-Law Circuit," *J.Sc. Inst.*, Vol. 25, p. 200.

approximates to that of a square-law over small ranges around 10  $\mu$ A and 10 mA. Increasing the diameter of the discs has the effect of moving the

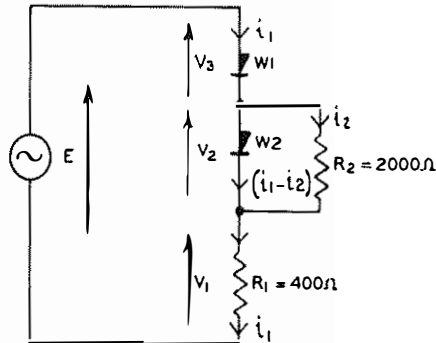

FIG. 1.—BASIC CIRCUIT OF SQUARE-LAW RECTIFIER NETWORK.

characteristic curve bodily upwards along the current axis, while connecting several discs in series shifts it to the right. The slope of the curve can only be reduced by combination with resistive elements—for instance, series resistance (including source and load impedances) modifies the characteristic at high currents. Changes can also be effected at lower currents by the novel principle of using several rectifier ele-

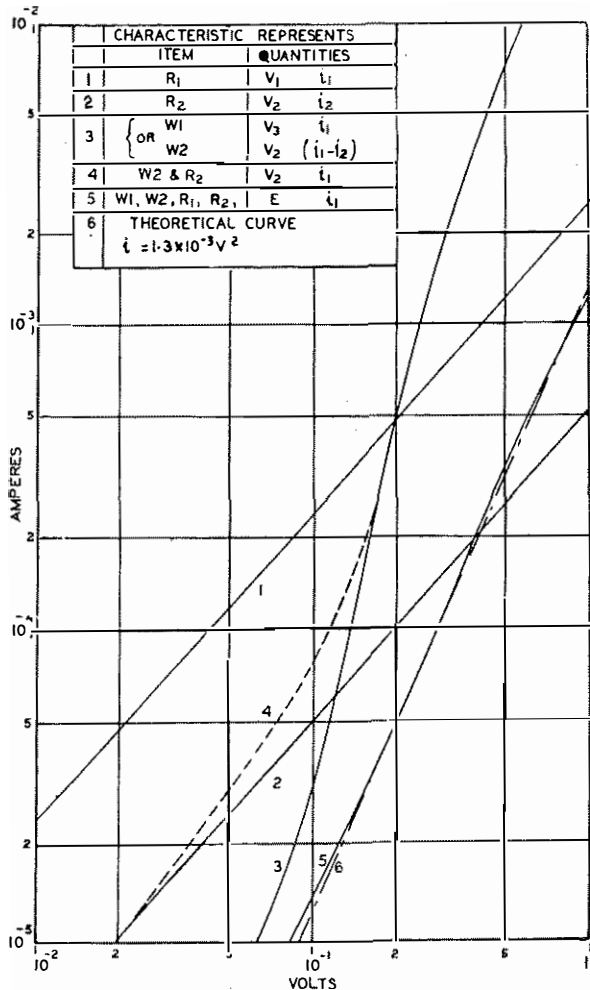

FIG. 2.—GRAPHICAL SYNTHESIS OF BASIC SQUARE-LAW RECTIFIER NETWORK.

ments in series and shunting some by resistors. Such a scheme was first developed in 1942 for use in a psophometer.

The function of each component of the circuit shown in Fig. 1 will be made clearer by a graphical synthesis of the characteristic for this simple case. Thus, in Fig. 2 curves (1), (2) and (3) represent, respectively, the current/voltage characteristics of  $R_1$ ,  $R_2$  and  $W_1$  or  $W_2$ . By adding the current ordinates of curves (2) and (3) curve (4) is obtained which represents the characteristic of  $W_2$  and  $R_2$  in parallel. Thence by adding the voltage abscissæ of curves (1), (3) and (4) the current/E.M.F. curve (5) is arrived at; this coincides reasonably well with the true square-law characteristic of curve (6).

The above example illustrates how  $R_1$  and  $R_2$  control the shape at opposite ends of the characteristic and this fact facilitates their choice in trial designs. In practice they may require slight adjustment after assembly to achieve the characteristic desired.

### TYPICAL CIRCUITS

#### Psophometer Detector.

One example of this rectifier network is shown in the psophometer detector circuit in Fig. 3. The output valve is triode-connected and voltage feedback is applied over the two amplifier stages to obtain a low output impedance—the transformed impedance presented to the rectifier being about 200 ohms. The meter has a full-scale deflection of 100  $\mu$ A but it is calibrated with a square-law scale. For convenience the rectifier bridge is type MBH 4-3-1 (P.O. C-type,  $\frac{1}{4}$  in. diameter discs in a moulded bakelite case which permits extra tags at the junction of each pair of rectifier elements).

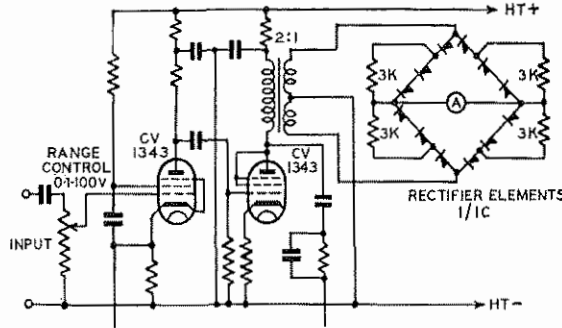

Fig. 3.—AMPLIFIER AND RECTIFIER CIRCUIT OF PSOPHOMETER.

The waveforms of noise which a psophometer is required to measure necessitate a reading accuracy of  $\pm 5$  per cent. for a sinusoidal input voltage from 0.4 to 2.5 times that required for full-scale deflection. Thus the direct current/r.m.s. A.C. input voltage (sinusoidal waveform) characteristic must be measured over an extended range, i.e. at least 1/6 to 6 times full-scale current—to check its deviation from a square-law. This entails using a special D.C. meter circuit with variable sensitivity but constant resistance.

#### Speech Voltmeter.

It is not necessary that the rectifier circuit should be arranged in bridge formation. If a double winding

(or a centre tap) is provided on the transformer feeding the circuit, an increase in efficiency is possible by using a bi-phase arrangement. Such an arrangement is used in the P.O. Speech Voltmeter Type 3 and the essential elements are shown in Fig. 4. Although

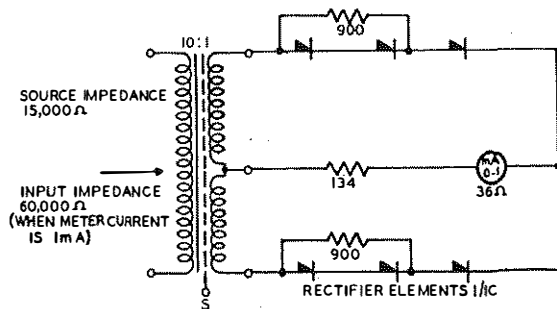

FIG. 4.—RECTIFIER CIRCUIT OF SPEECH VOLTMETER.

the type of rectifier discs is the same as in the psophometer, the use of a 1 mA indicating instrument necessitates different values of series and shunt resistors.

The speech voltmeter circuit enables the true r.m.s. voltage of a wave having the level distribution of speech<sup>3</sup> to be measured with an accuracy not worse than  $\pm 0.3$  db. provided that readings are made at a deflection between  $-3$  db. and the upper limit of the scale ( $+3$  db.). This assumes that the speech voltmeter has been correctly calibrated using a sinusoidal input at, say, 1,000 c/s.

#### Speech Analyser.

A speech analyser recently constructed by one of the authors<sup>4</sup> employed an integration period of 15 seconds, which may be increased to 60 seconds if required. The square-law circuit developed for this analyser is similar in principle to that employed in the psophometer and speech voltmeter and is shown in Fig. 5. To achieve the range of 40 db. it was necessary

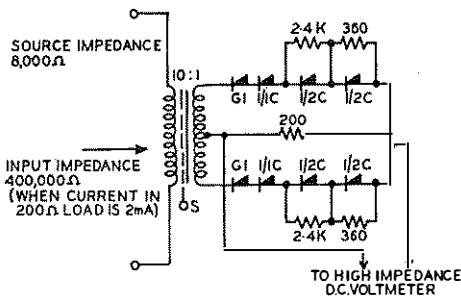

FIG. 5.—RECTIFIER CIRCUIT OF SPEECH ANALYSER.

to use more elements, as well as two different sizes of cuprous oxide disc. Fig. 6 shows the current/voltage characteristic, indicating that, over a range of 40db., the current is within  $\pm 20$  per cent. of the correct value. (This corresponds to an accuracy for instantaneous inputs of better than  $\pm 1$ db.)

Calculation of the error introduced by this circuit

under working conditions shows that, over a range of r.m.s. speech input level of 10 db., the error does not amount to more than  $\pm 0.25$  db. If the equipment is calibrated using a sinusoidal input at a level differing

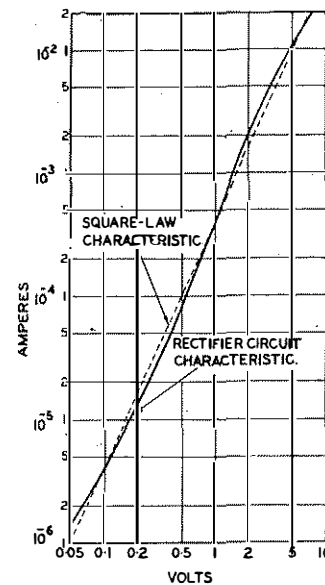

FIG. 6.—CURRENT/E.M.F. CHARACTERISTIC OF RECTIFIER CIRCUIT OF SPEECH ANALYSER.

considerably from the r.m.s. speech level, an additional error of not more than  $\pm 0.25$  db. is introduced.

In general, however, it can be arranged that calibration is carried out at a level within  $\pm 5$  db. of the r.m.s. speech level so that the total error is unlikely to exceed  $\pm 0.3$  db.

#### PERFORMANCE OF SQUARE-LAW RECTIFIER CIRCUITS

The usefulness of a square-law rectifier circuit depends, in practice, upon further factors than the possible accuracy of the static characteristic (instantaneous current/voltage relationship). It is important that the characteristic should be realisable without extreme care being necessary in the selection of rectifier discs and that the characteristic, once obtained, should remain constant under practical conditions. These features, together with the upper frequency limit, are discussed below. These effects apply almost equally to the three types of square-law rectifier circuit described above.

#### Selection of Discs.

Current/voltage characteristics measured on a sample of C-type discs show a fairly wide variation. The resistance limits (measured at 1 mA) to include 90 per cent. of individuals in one particular sample were 220 to 245 ohms at 20°C. The shapes of the several characteristics, however, are almost identical and can be superimposed, when plotted to logarithmic scales, by a linear change along the current axis. Typical curves are given in Fig. 7. This property of the characteristics enables matched sets of discs to be selected at a single value of current. Assembly of rectifier circuits is also simplified because, over the range of variation of individual characteristics which occur, circuits composed of matched sets of discs

<sup>3</sup> Dunn, H. K., and White, S. D. "Statistical Measurements on Conversational Speech," *Journal of the Acoustical Society of America*, Vol. 11, p. 278 (1940).

<sup>4</sup> "A Speech-Spectrum Analyser," *P.O.E.E.J.*, Vol. 41, p. 188 (1949).

differ very little in the accuracy with which they conform with a square-law. Some variation (amounting to about 1 db.) in absolute sensitivity occurs but this can easily be compensated by adjustment of the gain of the preceding amplifier. This conclusion is not quite true of the more complicated speech analyser circuit where some selection of the G-type disc is always necessary.

#### Effect of Temperature.

Temperature change affects the individual current/voltage characteristic of rectifier discs in such a manner that the whole characteristic is moved along the current axis with little change in shape, as shown in Fig. 8. The effect of temperature on the overall

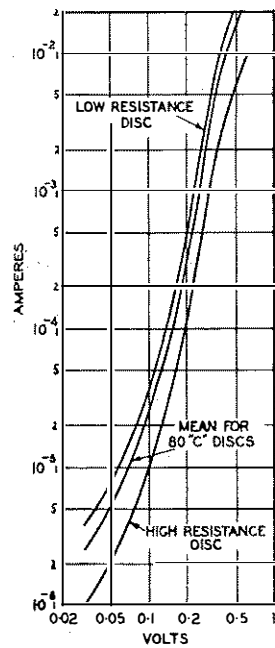

FIG. 7.—TYPICAL RANGE OF CURRENT/VOLTAGE CHARACTERISTICS OF "C" TYPE DISCS.

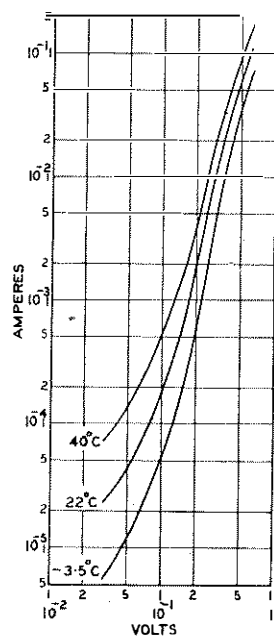

FIG. 8.—EFFECT OF TEMPERATURE VARIATION ON CURRENT/VOLTAGE CHARACTERISTICS OF "C" TYPE DISCS.

characteristic of the complete square-law circuit, furthermore, consists mainly of a change in absolute sensitivity with little change in the range of conformity with the quadratic law. Fig. 9 shows the effect on the complete circuit of the speech voltmeter (Fig. 4). The temperature coefficient of the complete circuit is as follows.

$\frac{1}{4}$	full-scale current,	+ 0.050 db. per °C.
$\frac{1}{2}$	" " "	+ 0.028 " " "
	full-scale	+ 0.017 " " "
2x	" " "	+ 0.0083 " " "

This effect, although rather large, does not seriously impair the use of these circuits provided that the calibration is adjusted before use.

#### Effect of Reassembling Sets of Discs.

The C-type discs used are assembled in a plastic holder with pressure applied by means of a coil spring. The resistance of discs is unaffected by being dismantled and reassembled, or by a change in pressure,

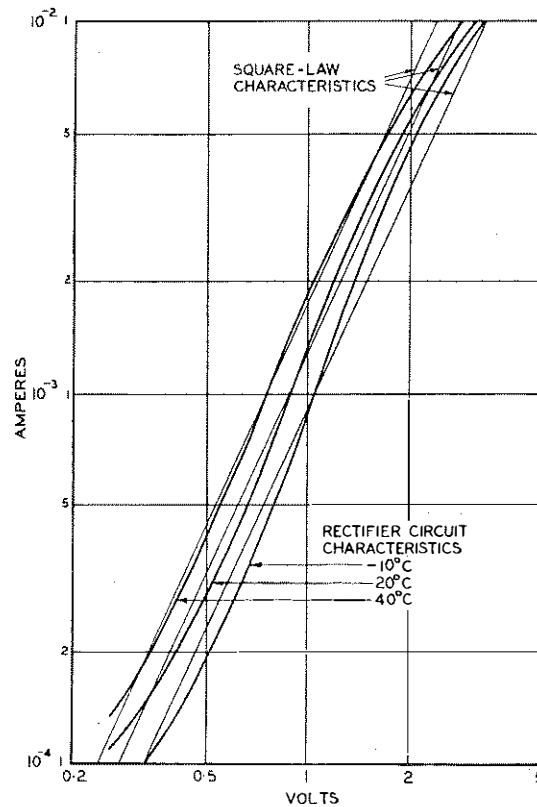

FIG. 9.—EFFECT OF TEMPERATURE VARIATIONS ON CURRENT/E.M.F. CHARACTERISTICS OF RECTIFIER CIRCUIT OF SPEECH VOLTMETER.

except for a temporary change of resistance amounting to about 5 percent, which disappears five minutes after reassembly, if the normal pressure is applied. If double the normal pressure is applied, a period of 10 minutes is required for stability to be reached.

#### Upper Frequency Limit.

The presence of the comparatively large self-capacitance of rectifier discs limits the use of the square-law circuits described here to frequencies not greater than about 12 kc/s. This, however, is ample for speech measurement or for measuring audio frequency noise.

The self-capacitance of a single C-type disc is of the order 2,000 pF. In the speech voltmeter where a bi-phase circuit is used the capacitance of three discs in series is shunted across the idle half of the transformer winding. This imposes a limit on the maximum leakage inductance of the transformer and some special attention is necessary in the design of the transformer. When a transformer having too great a leakage inductance is used the frequency characteristic rises to a maximum in the high frequency region. The magnitude of this effect varies with the level of voltage applied to the rectifier circuit. The leakage inductance must therefore be reduced to such a value that this rise in sensitivity occurs at frequencies beyond the range required. Similar, but slightly more complicated, effects occur in the psophometer and speech analyser circuits but the limitation of frequency range remains about the same.



# A Survey of Modern Radio Valves

R. W. WHITE†, B.Sc., F.Inst.P., A.M.I.E.E.

## Part 5—Valves for Use in the Range 30-3,000 Mc/s (Bands 8 and 9)

U.D.C. 621.385.1

The deterioration in the performance of normal valves at the higher frequencies is discussed, and the more important contributory factors are indicated. Desirable design features are tabulated, and some examples of the more important classes of Band 8 and 9 valves are briefly described.

### Introduction.

**B**AND 8 of the radio frequency spectrum (i.e. 30-300 Mc/s) accommodates such diverse services as high fidelity broadcasting, television, radar, navigational aid systems, and a wide range of civil and military communications. Since triode and pentode valves operating satisfactorily over part or all of this band are now readily available, use of it has become widespread, and in the more highly developed areas of the world frequency allocation problems are already acute.

Band 9 (i.e. 300-3,000 Mc/s) offers ten times the available frequency spectrum of Band 8, but is at present relatively little used in comparison with Band 8. Usage of Band 9 has increased to a marked extent in the last decade; but it may still be regarded as a transitional region so far as both valve and circuit technique are concerned. Few pentode valves will operate at all even at its lower limit of 300 Mc/s, but a limited number of the most advanced types of modern triodes can be used up to, or a little beyond, its upper limit of 3,000 Mc/s. In the region beyond 3,000 Mc/s, which will be covered in Part 6 of this survey, waveguide circuits are predominant, and the valves in common use are dependent on electron inertia effects for their normal operation; but it should be mentioned here that the types of valves used for Band 10 are also made for use in Band 9. To minimise duplication, however, the present article will be concerned primarily with the development of triode, tetrode, and pentode valves for operation between 30 Mc/s and the upper limits of frequency at present realisable.

The Post Office Engineering Department uses allocations in Bands 8 and 9 for communications between fixed or mobile stations, and for repeated relay systems. The modulation frequency band involved may range from a single telephony channel (say 300 to 3,400 c/s) through multi-channel telephony services to television systems involving frequencies up to 3 Mc/s. For Post Office applications, the main emphasis must be on valves suitable for use as stable amplifiers rather than as self-oscillators, and on continuous ratings rather than pulse conditions, while reliability and long life of the valves are of primary importance.

### Electron Transit-Time.

The electron possesses a ratio of charge to mass far greater than that for any atomic or molecular particle. Thus, when an electron is placed in an electric field it experiences a force of enormous proportions relative

to its mass, and by the normal Laws of Motion its acceleration is extremely rapid. Since electrons possess this extreme mobility, the operation of a valve at low frequencies may normally be regarded as instantaneous. At 100 Mc/s, however, we are dealing with signals which complete one cycle in a hundredth of a microsecond, and the time taken by electrons to traverse the inter-electrode spaces of a valve can no longer be neglected.

When a valve is operating under normal conditions of space-charge current limitation, the time of transit ( $t$ ) of an electron from cathode to grid is given approximately by the relation<sup>1</sup> :—

$$t = 6.6 \times 10^{-10} \left( \frac{d}{i} \right)^{\frac{1}{2}} \text{ seconds} \dots \dots \dots (1)$$

where  $d$  is the grid-cathode spacing in centimetres, and  $i$  is the current density in amperes per square centimetre. Thus for short transit-times, small electrode spacings and high current density are required. The latter requirement necessitates high voltages and high cathode emission.

In V.H.F. valves, finite electron transit-time leads to three main disadvantages. Firstly, the mutual conductance is decreased in magnitude and is made a complex quantity by the introduction of a phase angle varying with frequency and with changes in the applied voltages. Secondly, an input shunt resistance is introduced which varies approximately as the inverse square of the frequency, and as the inverse square of the cathode-grid transit time. Thirdly, increasing transit-time reduces the anode efficiency realisable in a power amplifier or oscillator. These effects lead to reduced operating efficiency as the frequency is increased, and degrade the performance of the thermionic valve as a converter of D.C. energy to R.F. energy. Even in the absence of other deleterious factors, they will eventually reduce the stage gain of an amplifier to unity, or stop the operation of a normal negative grid oscillator. Electron transit-time must therefore be regarded as a major limiting factor in the design of V.H.F. valves.

An additional effect of excessive transit-time which is not so well known is the introduction of unwanted phase modulation in an amplitude-modulated transmitter, even when the carrier is crystal controlled. It arises from variations of effective phase shift in the modulation stage (or in linear amplifiers following it) between peaks and troughs of modulation, is most marked in the troughs, and increases rapidly in magnitude as 100 per cent. amplitude modulation is approached. This phase modulation gives rise to

† Executive Engineer, Radio Experimental and Development Branch, E.-in-C.'s Office.

<sup>1</sup> Bell, Gavin, James, and Warren, "Triodes for Very Short Waves—Oscillators," *J.I.E.E.*, Vol. 93, Part IIIA, No. 5, pp. 833-46.

additional side frequencies which may cause interference to other services and which can cause distortion of the wanted modulation when the receiver bandwidth is too narrow to accommodate them. The phenomenon is relatively unimportant in transmitters handling a single audio channel; but it can be of importance in multi-channel systems where distortion limits are more stringent, and may be a limiting factor in V.H.F. single-sideband operation where filter pass-bands are closely fitted to the wanted frequency spectrum.

*Valve Capacitances and Lead Inductances.*

At low frequencies a valve may often be regarded as a small item added to, or tied across, an external tuned circuit; but in V.H.F. amplifiers the unavoidable capacitances and inductances within the valve envelope may form major portions of the tuned circuits, thus introducing serious problems in the design of inter-stage couplings. In the limiting case the circuit tends to vanish inside the valve. The internal capacitances and self-inductances of a triode are illustrated in Fig. 1, while Fig. 2 indicates the self-

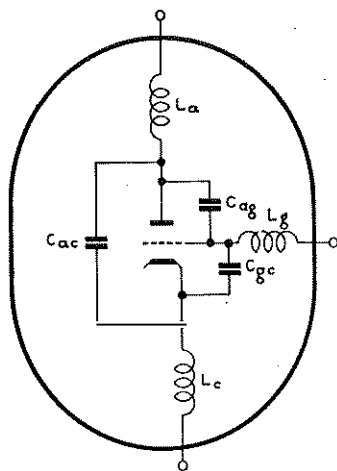

FIG. 1.—SELF-INDUCTANCES AND INTERNAL CAPACITANCES OF A TRIODE VALVE.

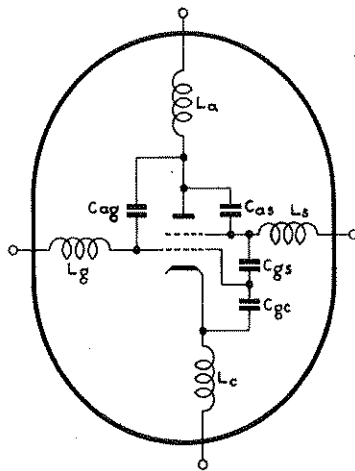

FIG. 2.—SELF-INDUCTANCES AND SOME OF THE MORE IMPORTANT CAPACITANCES OF A TETRODE VALVE.

inductances and some of the more important capacitances of a tetrode valve. Mutual inductances between leads have also to be considered in a full analysis of the operation of many V.H.F. valves.

Low input and output capacitances in a valve are of importance not only in ensuring reasonable circuit size at very high frequencies, but also on account of their influence on the maximum stage gain and bandwidth realisable, since to a first approximation the product of gain and bandwidth for any specified form of interstage coupling network is inversely proportional to the shunt capacitance. Because of transit-time limitations it is impossible to reduce capacitances in V.H.F. valves by increasing inter-electrode spacings, and capacitance between the active sections of adjacent electrodes can be reduced only by decreasing their areas. Stray capacitances between leads and supports make no useful contribution to the operation of the valve, and it is particularly important that they should be as small as possible.

Since a V.H.F. valve often forms the main tuning capacitance, reasonably close tolerances on input and output capacitances are most desirable if interchangeability is to be ensured.

In addition to the effect of lead inductances on circuit size, individual leads may be of special importance in particular circuits. For example, in the case of an amplifier valve with the cathode as the "earthy" electrode, self-inductance in the cathode lead may seriously reduce the shunt input resistance of the valve. If the cathode lead inductance is  $L_c$  and the grid-cathode capacitance is  $C_{gc}$ , then the input resistance resulting from the inductance of the cathode lead is given by:—

$$R_i = \frac{1}{\omega^2 g_m L_c C_{gc}} \dots\dots\dots(2)$$

where  $\omega$  is the angular frequency, and  $g_m$  is the mutual conductance of the valve. For fixed frequency operation  $L_c$  can be eliminated by series tuning, and in many cases a correct choice of the cathode resistor by-pass capacitance is all that is required. Lead inductance can be minimised by using short connections of large surface area, and on account of the large circulating currents which may occur, especially in narrow-band transmitters, low surface resistivity is desirable.

When the external circuit becomes very small it is often convenient to use a short section of transmission line instead of a coil as the external inductance. A coaxial line less than  $\frac{1}{4}$ -wavelength long and short-circuited at the far end has an inductive input reactance and can be used as a self-shielding inductance of relatively low loss. A line of low characteristic impedance will give the maximum external circuit size, but high characteristic impedance and short length are preferable in wide-band V.H.F. amplifiers.

*Unwanted Feedback.*

The phenomenon of unwanted feedback of energy from anode to grid in normal radio-frequency amplifiers is well known and requires little comment.

In early triode amplifiers it was countered by "neutralisation," and it led to the development of tetrode and pentode valves. By the use of a close-mesh screen electrode, reasonably wide spacings, and adequate external shielding, the anode-to-grid capacitance can be reduced sufficiently to allow very satisfactory results at broadcast frequencies. At very high frequencies, however, wide spacings are barred by transit-time troubles, a close-mesh screen leads to high screen current, and the inductance of the screen lead prevents proper earthing of the screen electrode so that the efficiency of the screening is reduced.

On account of the difficulty of producing satisfactory V.H.F. transmitting tetrodes or pentodes, neutralised triodes have been extensively used in power amplifiers. Satisfactory neutralisation is not, however, easy to achieve. Although the well-known capacitive bridge arrangement shown in Fig. 3 is satisfactory at, say, 5 Mc/s, a more complex arrangement, such as that shown in Fig. 4, is generally necessary at, say, 200

Mc/s. Unless the inductances of the grid and cathode leads are small, they will have to be series-tuned by capacitances  $C_g$  and  $C_c$ , in addition to adjustment of

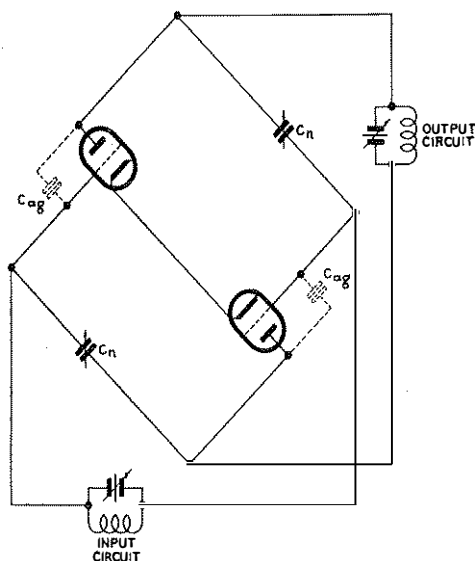

FIG. 3.—TYPICAL NEUTRALISING ARRANGEMENT FOR PUSH-PULL TRIODE AMPLIFIER OPERATING IN BAND 6 OR 7.

the normal bridge balancing capacitances  $C_n$ . As these adjustments are to some extent inter-dependent, correct neutralisation can be quite difficult.

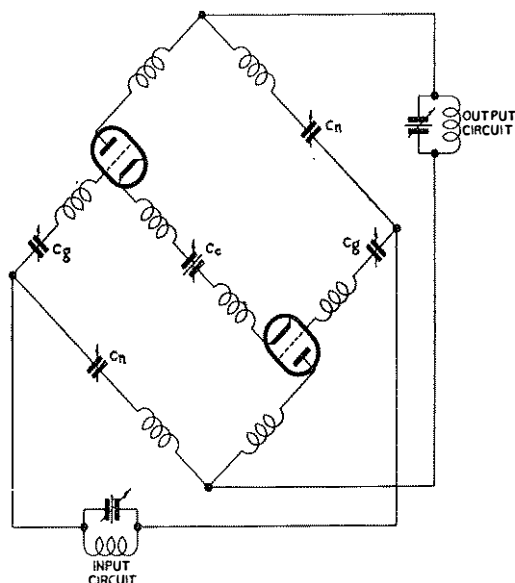
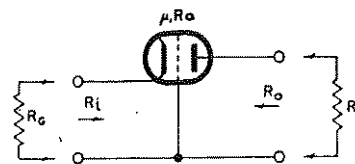

FIG. 4.—TYPICAL NEUTRALISING ARRANGEMENT FOR A PUSH-PULL TRIODE AMPLIFIER OPERATING NEAR TOP OF BAND 8.

The grounded-grid amplifier, shown in schematic form in Fig. 5, is a convenient alternative which also employs triode valves. In this case the cathode is used as the high potential input electrode, the anode is the high potential output electrode, and the grid which is common to the input and output circuits forms an electrostatic shield between them. The arrangement has the advantage of simplicity, and avoids the need

for neutralising capacitances. It is extensively used both for V.H.F. transmitters and as an input stage in V.H.F. receivers. In a grounded-grid amplifier the



$$\begin{aligned} \text{Input Resistance} &= R_i = \frac{R_a + R_L}{\mu + 1} \\ \text{Output Resistance} &= R_o = R_a + (\mu + 1) R_g \\ \text{Power Gain} &= \frac{R_L}{R_i} = (\mu + 1) \frac{R_L}{R_a + R_L} \end{aligned}$$

FIG. 5.—SCHEMATIC DIAGRAM OF GROUNDED-GRID AMPLIFIER, AND BASIC LOW FREQUENCY FORMULÆ.

anode current returns to the cathode through an external circuit which includes the impedance between the grid and cathode. The feedback introduced in this way has the effect of making the output resistance of a grounded-grid stage high, and the input resistance very low. In multi-stage grounded-grid amplifiers, an impedance transformation is therefore necessary at each inter-stage coupling network. The input resistance of a grounded-grid stage depends on its anode load, and the output resistance depends on the impedance between cathode and ground. Thus input and output circuits are not independent and tuning a multi-stage amplifier of this type is a relatively difficult process. In valves for grounded-grid operation, low grid lead inductance is generally very desirable, although for some fixed frequency applications a suitable value of grid inductance can be used to minimise unwanted feedback through the anode-to-cathode capacitance.

Noise.

At low frequencies, thermal agitation voltages due to random motion of electrons in external circuits generally set a limit to the smallest voltage which can usefully be amplified. The magnitude of the thermal agitation voltage across a resistance of  $R$  ohms, measured in an effective frequency bandwidth of  $B$  c/s, is given by:—

$$\text{R.M.S. voltage} = \sqrt{4kT BR} \dots \dots \dots (3)$$

where  $k$  is Boltzmann's constant (approximately  $1.37 \times 10^{-23}$ ) and  $T$  is the absolute temperature ( $273 + ^\circ\text{C}$ ). For example, the thermal agitation voltage across a resistance of 100,000 ohms at room temperature is approximately 2.2 microvolts R.M.S. for a bandwidth of 3,000 c/s.

At very high frequencies, however, circuit impedances and the thermal agitation voltages associated with them are less than at lower frequencies, and noise due to the random nature of the electron stream within the valves is generally predominant. As has been indicated in Part 3, valve noise is dependent on the construction and operating characteristics of the valve concerned, and is appreciably greater for multi-electrode than for triode valves. High slope at a low current is always desirable when low levels of valve noise are desired, and minimum possible

screen current is of great importance in the design of low-noise pentode or tetrode valves.

Although cathode lead inductance has such a marked effect on input admittance of a valve at very high frequencies, its effect on noise performance is relatively small, since degenerative effects on noise and signal are approximately equal. Electron transit-time, on the other hand, has a major effect on the noise performance of a valve, the noise level increasing appreciably whenever the transit-time exceeds a small fraction of one cycle. Low transit-time is therefore essential in the design of low-noise V.H.F. valves.

The overall noise performance, or noise factor<sup>2</sup>, of an amplifier is a function not only of the valves employed in its early stages, but also of the circuit arrangements with which they are associated. A triode used as a grounded-cathode amplifier generally gives a slightly lower noise factor than when used in a grounded-grid arrangement, but neutralising may be required. Considerable attention has recently been devoted to the design of input circuits giving the optimum noise factor for a given valve, and one of the most successful developments is the combination of a grounded-cathode triode feeding a grounded-grid triode as illustrated schematically in Fig. 6, and

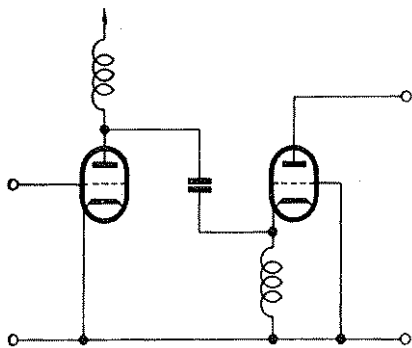

FIG. 6.—SCHEMATIC DIAGRAM OF A "CASCODE" AMPLIFIER.

generally known as a "cascode" amplifier<sup>3</sup>. This makes use of the low noise factor of a grounded-cathode arrangement of the first valve, and avoids instability by providing it with a very low impedance load—the input resistance of the grounded-grid stage.

#### Summary of Desirable Features in V.H.F. Valve Design.

Before discussing typical V.H.F. valve designs, it may be of value to summarise some of the more desirable features:

- (1) Low transit-time; i.e., small inter-electrode spacings and large current densities.
- (2) Low capacitances with close tolerances; i.e., small active electrodes, minimum stray capacitances in supporting structures, and precision methods of assembly.
- (3) Electrode leads of low inductance and low surface resistivity.

- (4) High slope.
- (5) High reliability; i.e., long and uniform life.
- (6) Ease of connection to suitable external circuits; i.e., valve and circuit should merge into one composite structure, but valve replacement should not be difficult.
- (7) Good internal shielding.
- (8) Efficient cooling of anode, grid, and screen in transmitting valves.
- (9) Low fluctuation noise in small signal valves; i.e. high slope at a low cathode current, and in pentode or tetrode valves minimum possible screen current.
- (10) High cathode emission, especially in transmitting valves; but low heater or filament consumption.
- (11) Rugged mechanical design, and freedom from microphony.
- (12) Ease of manufacture, and low cost.

#### Progress in Conventional Receiving Valves.

One of the first successful lines of progress in the development of V.H.F. receiving valves was the scaling down of the dimensions of normal valves and a rearrangement of the connections to produce the well-known "acorn" range of valves. These valves use small electrodes at close spacings, and minimise unwanted capacitance due to supports by relatively wide spacing of the connections to the electrodes, and elimination of the normal valve-base. The leads are short and of low inductance, and the input resistance of acorn valves in the V.H.F. band is roughly ten times that of corresponding receiving valves of normal design; but the manufacturing difficulties are considerable.

The CV1136 (Mullard RL7) is an interesting example of an alternative approach to the problem of making a satisfactory V.H.F. amplifier valve. This valve has an electrode structure of normal size supported by very short leads from a glass base, and cathode lead inductance is reduced to the absolute minimum by using four pins of the 9-pin base for the cathode connection. Separate cathode pins can be used for individual by-pass returns.

As examples of modern British practice in mass-produced V.H.F. receiving valves we may take the CV138 and CV139 which were developed under the auspices of the Services Coordination Valve Development Committee. These are miniature valves on B7G bases, and are illustrated in Fig. 7. Their low frequency characteristics are summarised in Table I. The CV138 is a general purpose high-slope pentode valve with a limiting frequency for satisfactory operation determined partly by transit-time and partly by the self-inductance of the single cathode lead. For fixed frequency applications above about 150 Mc/s it is advantageous to series-tune the cathode lead (e.g., by suitable choice of the cathode resistor by-pass capacitance), and a useful stage gain can then be obtained up to frequencies of the order of 200 Mc/s. The CV139 is a high-slope triode for use as a low-noise R.F. stage in V.H.F. receivers: it was designed

<sup>2</sup> Moxon, "The Noise Characteristics of Radar Receivers," *J.I.E.E.*, Vol. 93, Part IIIA, No. 6, pp. 1130-42.

<sup>3</sup> Wallman, Macree, and Gadsden, "A Low-Noise Amplifier," *Proc.I.R.E.*, 1948, pp. 700-8.

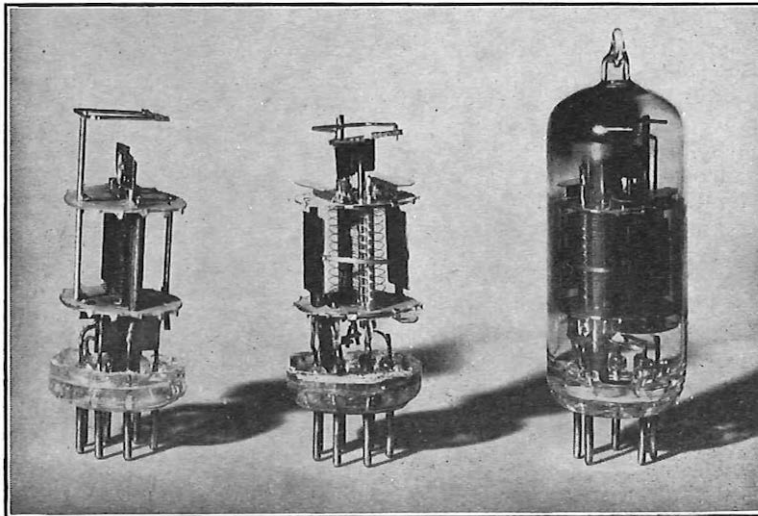

FIG. 7.—MODERN MINIATURE RECEIVING VALVES. (LEFT) INTERNAL STRUCTURE OF CV139 TRIODE; (CENTRE) INTERNAL STRUCTURE OF CV138 PENTODE; (RIGHT) CV138.

primarily for grounded-grid operation, and twin grid leads are provided.

TABLE I  
Characteristics of V.H.F. Receiving Valves

		CV138	CV139
Heater voltage	(volts)	6.3	6.3
Heater current	(amps)	0.3	0.3
Max. anode dissipation	(watts)	2.5	2.5
Max. screen dissipation	(watts)	0.8	—
Input capacitance, cold	( $\mu\text{F}$ )	7.6	5.1
Output capacitance	( $\mu\text{F}$ )	3.2	3.6
Output-to-input electrode capacitance	( $\mu\text{F}$ )	0.008	0.1
Normal operating conditions	$V_a$ (volts)	250	250
	$V_s$ (volts)	250	—
	$V_g$ (volts)	-2	-1.5
	$I_a$ (mA)	10	10
Input resistance at 45 Mc/s	$I_s$ (mA)	2.6	—
	$g_m$ (mA/V)	7.5	9
	(ohms)	8,200	—

Post-war progress in the field of mains-operated V.H.F. receiving valves has included two major developments. The first of these is the introduction of high-slope pentodes in the "sub-miniature" range of valves designed for direct soldering into circuits. Since the very small electrode assemblies of these valves, the short internal leads, and the absence of a valveholder result in low capacitances, low transit-time, and low lead inductances, they have a very good performance as Band 8 amplifier valves. The second line of progress has been the development, to at least a pre-production stage, of miniature triode valves having much lower transit-time, lower noise and lower capacitances than the CV139, and capable of operating efficiently in the lower part of Band 9. Such valves are of great value in low-level wide-band amplifiers, and a promising line of further development might be the combination of two of these triodes in one envelope for operation as a "cascode" amplifier stage.

The development of battery valves for operation above 30 Mc/s lags considerably behind that of mains operated valves. A range of battery acorn valves was introduced in America some years ago, but manu-

facture is difficult and the cost is high. For operation up to about 100 Mc/s, British 1.4 volt battery valves on B7G bases are now readily available; but there is a marked need for low consumption B7G-based valves which will give satisfactory stage gain and low noise at frequencies well above 100 Mc/s, without sacrifice of other essential features such as uniformity and long life. Sub-miniature battery valves of the soldered-in type have recently been introduced, and although not designed specifically for operation at very high frequencies, their very small electrodes, close spacings and relatively short internal leads result in quite good performance over a considerable part of Band 8.

#### Progress in Conventional Transmitting Valves.

When the process of improving V.H.F. performance by scaling down dimensions is applied to transmitting valves, one of the first problems encountered is that of cooling the small electrodes involved. The choice of anode material for radiation-cooled V.H.F. valves is a matter of compromise between such requirements as high melting point, high thermal emissivity, ease of fabrication, good mechanical strength, freedom from distortion or evaporation at high temperatures, ease of degassing during processing, and low cost. The materials most commonly used are molybdenum, tantalum, and carbon, and various surface treatments may be applied to improve performance. Carbon is an excellent radiator of heat, but is difficult to degas in thick sections and mechanically weak when thin. Tantalum is capable of operating at higher temperatures than carbon or molybdenum, and though an expensive material, it has the additional advantages of easy degassing during manufacture and a certain amount of "getter" action during normal operation. The grid in a V.H.F. power amplifier valve normally has to dissipate appreciable power, and as the grid structure must operate in close proximity to an incandescent cathode and a hot anode, efficient grid cooling is often a major problem.

Some widely used V.H.F. triodes of pre-war design are illustrated in Fig. 8. Recent progress in radiation-cooled valves of this class has been confined primarily to the reduction of lead inductance, especially of filament leads, and a number of improved designs have been produced.

The V.H.F. performance of conventional tetrode and pentode transmitting valves is limited to a large extent by long cathode and screen leads. Some progress can be made by shortening or duplicating these leads, but an alternative approach to the problem is the assembly of two tetrodes in the same envelope. These valves are designed for push-pull operation, and because of the proximity of the two electrode structures, low inductance interconnections can be provided between the two cathodes and the two screens. In some cases an internal by-pass



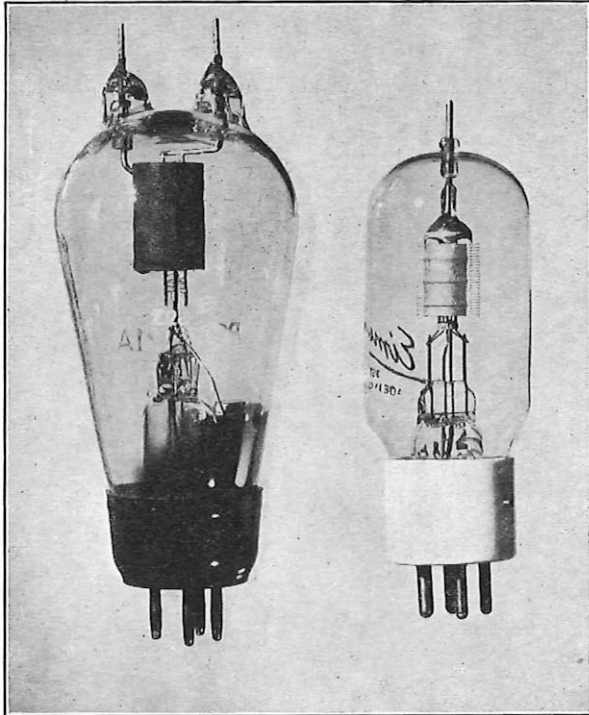

FIG. 8.—PRE-WAR RADIATION-COOLED TRANSMITTING TRIODES. (LEFT) CV1288; (RIGHT) 35T.

capacitor between cathodes and screens is also built into the valve envelope. The CV2666 and CV222 valves illustrated in Fig. 9 are examples of the twin-tetrode technique. The former has two 20-watt tetrodes in a double-ended envelope, and with suitable external circuits can be used up to a little over 200 Mc/s. The CV222 is a single-ended valve on a B9G base, and each anode is rated at 7.5 watts.

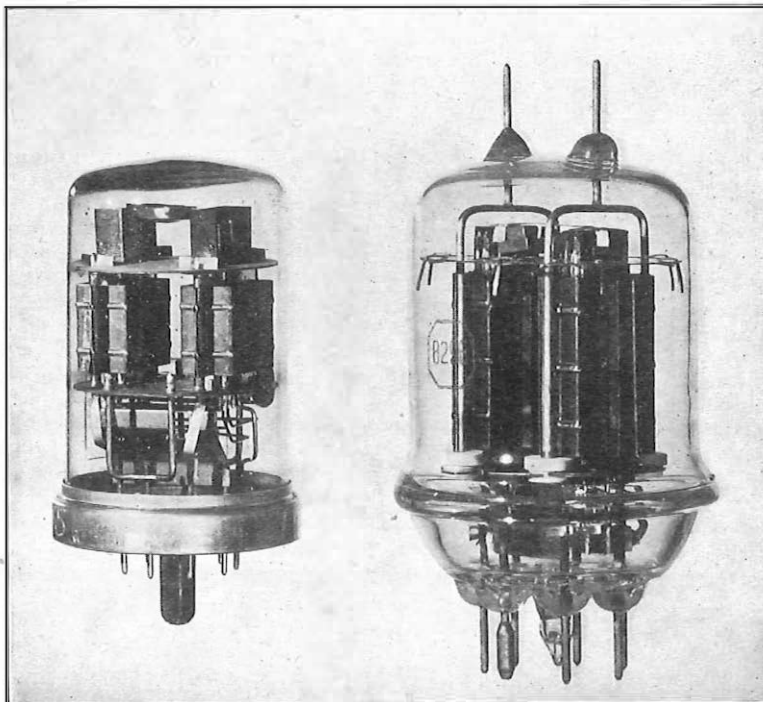

FIG. 9.—TWIN TETRODES. (LEFT) CV222; (RIGHT) CV2666 (829B).

Towards the upper limits of power and frequency, recent British development work on negative grid valves suitable for large-scale production has been concentrated primarily on external-anode triodes for forced-air or conduction cooling, and progress in this field has been considerable—especially among valves intended for pulse operation. Space does not permit a consideration of the many intermediate phases in the development of glass-metal V.H.F. valves, and descriptions will therefore be restricted to some of the more advanced designs suitable for use in C.W. amplifiers.

#### Ring-Seal Valves.

The most outstanding progress of the last decade in V.H.F. valves has been the exploitation of metal-to-glass sealing technique to give electrode connections in the form of discs or tubes of extremely low inductance and resistance. This technique has been applied particularly to triode valves, and has resulted in a readily available range of valves designed to operate as an integral part of coaxial line circuits<sup>1</sup>. Some examples of ring-seal transmitting triodes are illustrated in Fig. 10\*, and their main electrical characteristics are outlined in Table II.

TABLE II  
Characteristics of Ring-Seal Valves

	CV288	CV257	CV397	CV273
Heater voltage (volts)	13.5	6.3	6.3	6.3
Heater current (amps)	2.9	4	1.0	0.4
Max. anode voltage (volts)	1,000	600	400	350
Max. anode dissipation (watts)	250	75	20	10
Amplification factor*	40	22	35	30
Mutual conductance* (mA/V)	30	20	12	6
* at anode voltage (volts)	1,000	500	250	250
and anode current (mA)	250	100	40	20
Anode-grid capacitance (μμF)	16.5	6.5	2.0	1.1
Grid-cathode capacitance (μμF)	22	13.5	4.5	2.3
Anode-cathode capacitance (μμF)	0.4	0.3	0.04	0.02

The CV273 and CV397 are intended for conduction plus radiation cooling, while the CV257 and CV288 use forced-air-cooled anodes. All have indirectly heated oxide-coated cathodes, close-mesh grids of very fine wire, and extremely small inter-electrode clearances. The CV288 has its active electrodes in the form of short cylinders, but the three other valves employ planar electrodes. These triodes can be used as grounded-grid amplifiers up to frequencies ranging from approximately 1,000 Mc/s for the CV288 to approximately 3,000 Mc/s for the CV273.

Although progress has not been so rapid in the large-scale commercial development of pentode or tetrode valves using ring-seal technique, various pre-production types have been produced. This technique allows the realisation of a very low screen lead inductance, and the screen assembly forms a continuation of the external

\* The valves shown in Fig. 10 were developed in the Research Laboratories of the General Electric Co. Ltd., Wembley, England.

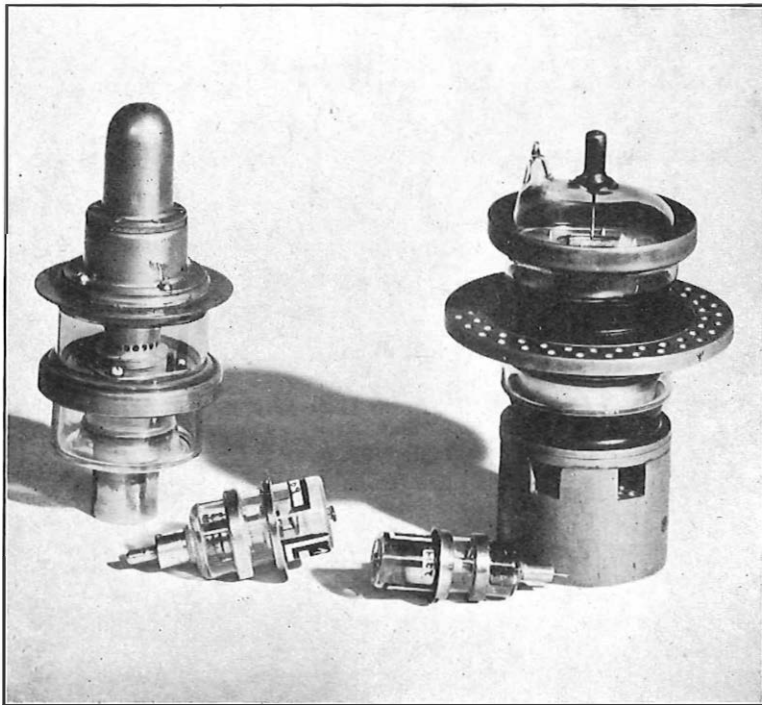

FIG. 10.—MODERN RING-SEAL TRIODES. (LEFT TO RIGHT) CV257, CV397, CV273, CV288.

shielding between output and input circuits. Further work seems to be desirable on ring-seal triodes or pentodes with built-in by-pass capacitors of negligible inductance between screen and cathode

—possibly using a ring of high dielectric constant ceramic. Such valves would have important applications in multi-stage wide-band V.H.F. amplifiers, and the better isolation of input and output circuits of each stage would make alignment considerably simpler than in multi-stage grounded-grid amplifiers.

#### Conclusions.

The design requirements of valves for Bands 8 and 9 are fairly well established, and their further development is largely a matter of ingenuity on the part of the designer plus steady improvements in manufacturing technique.

Progress in recent years has been rapid, though perhaps somewhat uneven. In the receiving valve field, miniature triode and pentode valves are readily available in mains-operated types having a useful gain up to at least 200 Mc/s; but further progress is desirable in the development of small pentode valves for still higher frequencies. Economical battery valves which will operate efficiently at frequencies well above 100 Mc/s are also

required. In the transmitting valve field, ring-seal triodes for grounded-grid operation have outstripped other types, but the development of comparable tetrode or pentode valves will be of great value.

## Book Review

"Crystals and X-Rays." Dr. K. Lonsdale, F.R.S.  
G. Bell & Sons, Ltd. 199 pp. 138 ill. 21s.

Dr. Kathleen Lonsdale needs no introduction to physicists throughout the world. Engineers may be less well acquainted with personalities in X-ray crystallography, a science in which British physicists have played an outstanding role. Sir William Bragg and his son, Sir Lawrence, respectively past and present Cavendish Professors of Physics at Cambridge, have each done pioneer work in the subject. Dr. Lonsdale was fortunate in working as a student under Sir William Bragg, to whom she readily acknowledges indebtedness and gratitude. One may say that she has also acquired some of Bragg's power of lucid expression, a necessary quality of the complete scientist.

The book is based on a course of public lectures delivered in 1946, and the author states as her object the stimulation of interest among those who do not, but might well, use X-ray crystallography in their own work and the instruction of those others who do use it without fully understanding the power of the tool they employ. As a result, the book is a broad survey of present-day knowledge and techniques and there can be no doubt that few concerned with the subject will fail to profit by reading it. With her object in mind, however, Dr. Lonsdale has been compelled to take short cuts in order to cover the ground so that a layman may be excused if he does not grasp at first reading, for example, the Fourier synthesis, the reciprocal lattice and the space groups.

From the point of view of our membership, parts of the book will be found both easy to follow and instructive, and can be recommended without reservation. In particular, the first two chapters giving an historical introduction to the subject and a most useful and practical discussion on the generation and properties of X-rays are noteworthy and it is here where the lucidity already referred to is most evident. The last two chapters also, on extra structural studies and the importance of the study of crystals, will give the layman more than a glimpse of the power of X-ray methods in determining not only atomic structure, but how the data have added to chemical, electronic and metallurgical knowledge and are now making advances in biology.

The book is singularly free from errors, only the definition of the Angstrom unit on page 3 and printing  $T^3$  as  $T_3$  on page 150 being noticed. It is abundantly illustrated with diagrams and plates which include some beautiful examples of diffraction and absorption photographs. Dr. Lonsdale has given a comprehensive list of text books for more detailed and incisive study, although a few words outlining the scope and special features of each book would have helped the serious student. A welcome feature, now becoming more general, is the printing in heavy type of the main pages of reference to subjects in the index.

As an introduction, parts of the book will be difficult to follow, but to a student of the subject it is unique in the breadth, conciseness and authority of its survey.

J. D. H.

# A Polarised Relay of Improved Performance

H. A. TURNER, B.Sc.(Eng.), A.M.I.E.E., and  
B. SCOTT, M.B.E., M.B.A., B.Sc.(Eng.), A.C.G.I.,  
A.M.I.E.E.†

U.D.C. 621.318.522

A polarised relay in which the magnetic circuit and contact system differ from those of previous relays has been standardised for Post Office use. Tests have shown that the relay offers improved performance over existing relays as regards sensitivity and contact pressure while low transit time, symmetrical operation and absence of contact bounce result in very little distortion to signals. Ease of adjustment has not been sacrificed in obtaining these results.

## Introduction.

AMONGST the apparatus requirements of modern telecommunications equipment is a relay which is more sensitive than the 3,000-type relay and which will also repeat impulses more accurately. The first important example of such a requirement was in System, Signalling D.C. No. 1 (the Long-Distance D.C. Impulsing scheme) where a polarised relay of S.T. & C. manufacture was used. This system is in service on a wide scale and reports indicate that a reliable service is being given.

With the development of the valveless System, Signalling D.C. No. 2 (the Single Commutation System) it became apparent that a relay of improved sensitivity would be advantageous. Attention was,

adoption as a standard Post Office item, it being decided in the early stages to limit the physical requirement to a single changeover contact action.

The availability of the relay has simplified the work involved in designing both the Teleprinter Automatic Switching System and an improved 2 V.F. receiver, and as these two developments were being undertaken concurrently with the standardisation of the relay the requirements of both telephone and telegraph engineers were considered.

The relays have been coded in the Post Office range of relays as Relay, Polarised 2B, 3B, and 4B, depending upon mounting facilities. Individual designs of the relays will be differentiated by three-figure numbers following the initial code.

Figs. 1 and 2 are photographs of the relays with

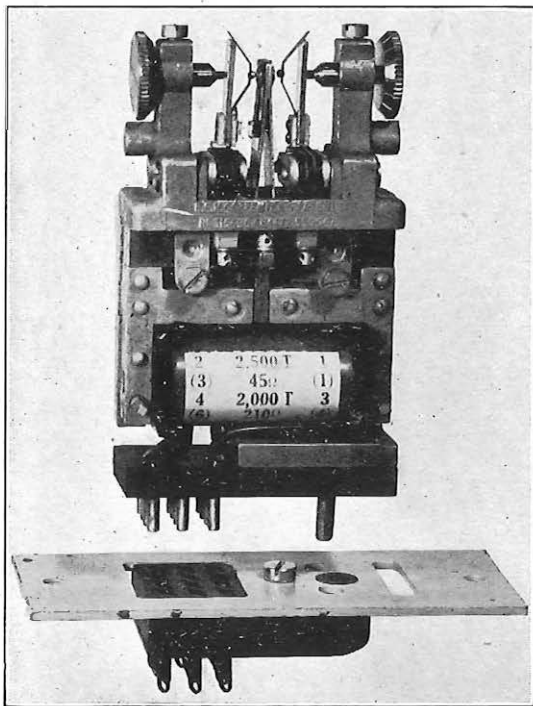

FIG. 1.—RELAY, POLARISED 2B WITH MAGNETIC SHIELD AND COVER REMOVED.

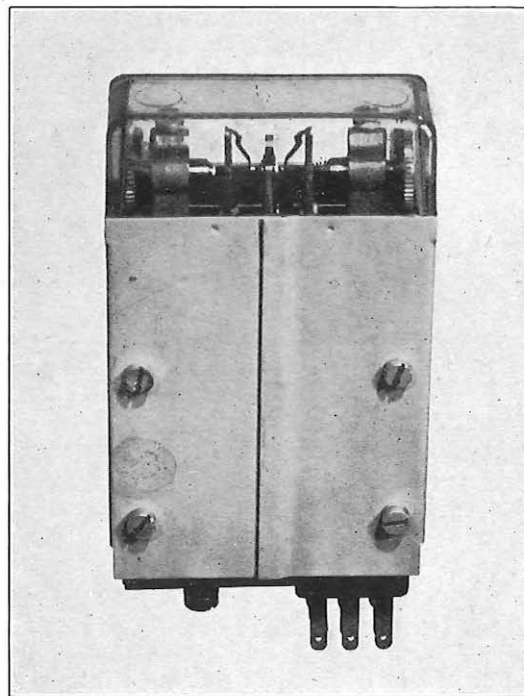

FIG. 2.—REAR VIEW OF RELAY, POLARISED 3B.

therefore, directed to the Carpenter relay (type 4)<sup>1</sup> manufactured by the Telephone Manufacturing Co. which was of a size suitable for mounting on standard 3,000-type relay plates. Tests on the relay led to its

single changeover contacts, showing two different mounting arrangements.

## The Magnetic Circuit.

The components of the magnetic circuit can be seen in Fig. 1, the circuit being represented schematically in Fig. 3.

The controlling coil is wound on a former on a core completing a magnetic circuit between the two pole

† Mr. Turner, now Chief Engineer, Postal Dept., Sierra Leone, was formerly Executive Engineer, Telephone Development and Maintenance Branch. Mr. Scott is Engineer, Telephone Development and Maintenance Branch.

<sup>1</sup> R. E. H. Carpenter; Patents 315496, etc.

pieces. Placed symmetrically on the pole pieces are two magnets, polarity as indicated. An armature is suspended at a point between the permanent magnets and movement of the armature is limited by the fixed contacts.

In Fig. 3 (a) let  $\Phi_{m1}$  and  $\Phi_{m2}$  be the fluxes in

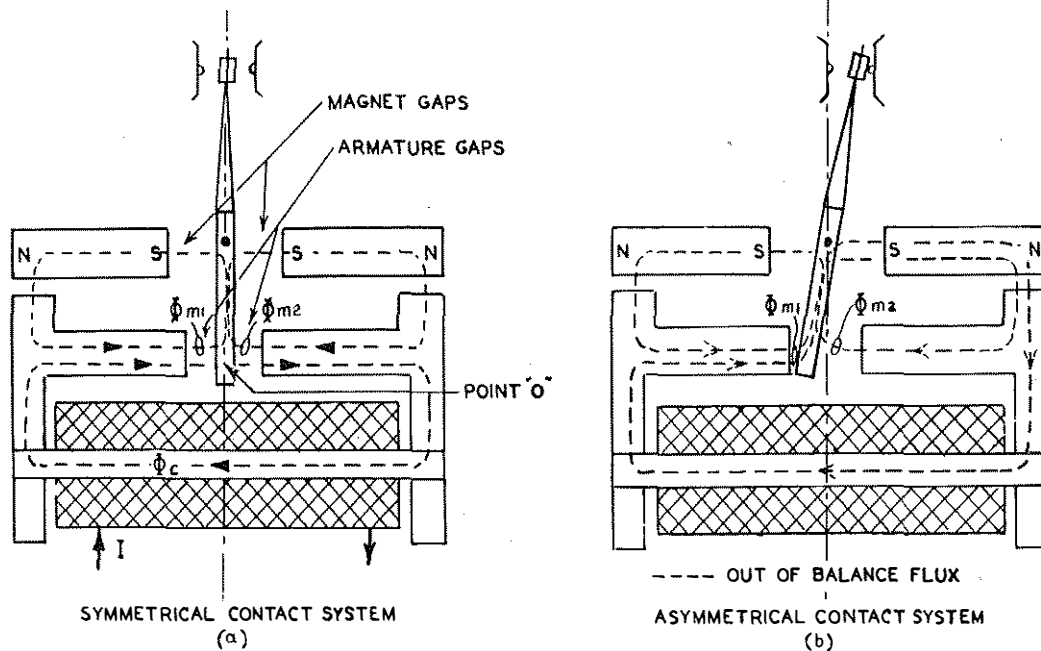

FIG. 3.—THE MAGNETIC CIRCUIT.

maxwells in the armature gaps due to the two magnets which are of equal pole strength and  $\Phi_c$  that due to the current  $I$  in the coil. Then the general expression for the force,  $F$ , on the armature at the point  $O$  is:—

$$F = \frac{1}{8\pi A} \left\{ (\Phi_{m1} + \Phi_c)^2 - (\Phi_{m2} - \Phi_c)^2 \right\} \text{ dynes.} \dots (1)$$

where  $A$  = effective cross-sectional area of armature gap in sq. cms.

Now, if the armature is held in the central position, as shown, the magnet gaps will be equal so that:—

$$\Phi_{m1} = \Phi_{m2} = \Phi_m \text{ (say)}$$

and it is possible to simplify expression (1) to:—

$$F = \frac{1}{2\pi A} \cdot \Phi_m \cdot \Phi_c \text{ dynes.} \dots (2)$$

Under free conditions the armature will move to the left and the force  $F$  is given by the general expression (1) and will increase with travel because  $\Phi_{m1}$  increases and  $\Phi_{m2}$  decreases as the air gaps change with the movement of the armature, the resultant out-of-balance flux passing through the core.

If there is no current in the coil,  $\Phi_c = 0$ , and in the central position  $F = 0$ , but this is an unstable condition and if the armature is deflected slightly off centre in either direction it will move over and take up a "side-stable" position where the force on the armature is given by:—

$$F = \frac{1}{8\pi A} (\Phi_{m1}^2 - \Phi_{m2}^2) \dots (3)$$

The foregoing refers to the normal side-stable balanced relay and variations as follows may be considered.

If, as in practice, the pivot is a suspension spring this exerts a restoring torque; if the spring is sufficiently thick it is possible for the armature to be held

centrally in the no-current condition or, if a force has been applied to move the armature to one side, for it to be returned to the central position after the force has been removed. This condition gives a "centre-stable" relay, in which the armature contact touches one or other side contact only when there is a current in the coil. The only advantage of a centre-stable relay is that it can respond to three conditions instead of two, since the armature contact remains disconnected in the centre-stable position with no current and can switch to either side according to the direction of current flow. For all practical purposes, where a finite contact pressure is specified a centre-stable relay requires more ampere-turns from the controlling coil than a side-stable relay.

If one of the fixed contacts is offset from its symmetrical position, as in Fig. 3(b), the relay becomes one-side-stable. The operate ampere-turns figure is increased, but the armature will move on a disconnection of current instead of needing a reversal. The relay under this arrangement has a permanent bias.

A second winding permits an electrical bias to be applied as required, enabling the operate ampere-turns figure to be increased or decreased to detect different circuit conditions.

Three windings may be required in some cases in order to present balanced conditions to line together with bias facilities, making possible differentiation between balanced, unbalanced, and reversed line currents.

The relay can be used in the anode circuit of a

valve, a bias winding being used to neutralise the effect of the standing anode current and enable the relay to operate on the steepest part of the mutual characteristic.

*Physical Description.*

The major components of a Relay, Polarised 3B are shown in Fig. 4.

hysteresis which is very much larger than the magnetic hysteresis introduced by the pole pieces.

*Core.*—Owing to the shunt magnetic circuit the core carries none of the permanent magnet flux in the centre-stable position and only a small amount in the side-stable position; consequently it can be of very small cross-sectional area without causing the relay to saturate in the normal operating range. On the

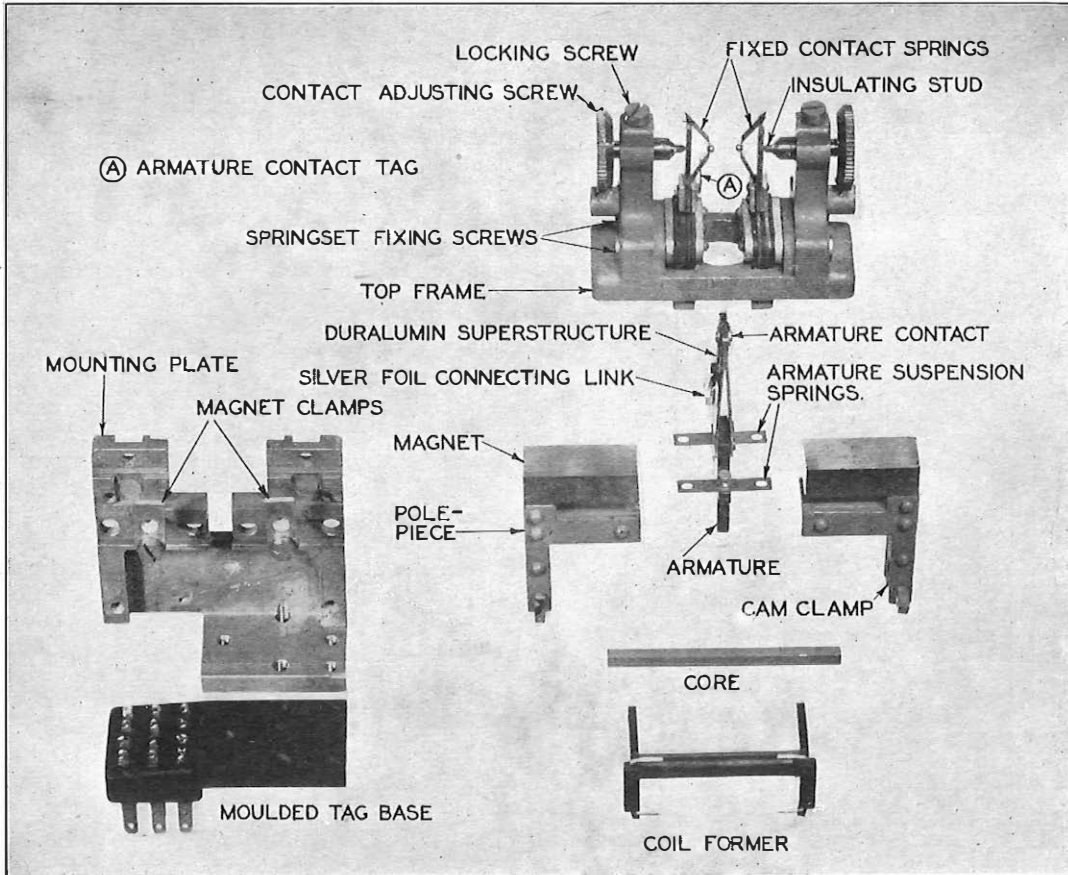

FIG. 4.—MAJOR COMPONENTS OF RELAY, POLARISED 3B.

*Frame.*—The mounting frame and top frame are die-cast in a non-ferrous alloy so that they will not affect the magnetic circuit whose elements they hold in place.

*Magnets.*—The magnets consist of bars of Alnico and are held in position with their North poles outwards by means of clamps and screws. These clamps hook under the top frame; therefore the top frame cannot be moved while the magnets are in position.

*Pole pieces.*—The pole pieces are laminated in order to keep eddy current losses to a minimum and are bolted to the mounting frame of the relay. The pole pieces for side-stable relays are made of radiometal which has a high permeability. If centre-stable or one-side-stable relays are introduced the pole pieces will be made of mumetal which has a lower magnetic hysteresis; this is of no benefit in a side-stable relay because the magnetic circuit, in providing side stability, leads to a mechanical equivalent of

other hand the fact that it does saturate with excessive energisation protects the relay from magnetic and mechanical damage. The core is a solid bar made of mumetal to minimise the magnetic hysteresis due to the high energising flux density in the core which would otherwise appreciably affect the performance, even of a side-stable relay.

*Coil Assembly.*—The coils are wound on bakelite formers through which the core can be passed and clamped by the cams fitted in the pole pieces. The small size of core results in a lower resistance for coils than would otherwise be possible, the limits of coil capacity being as follows:—

Turns	Resistance (ohms)	Gauge (S.W.G.)
360	0.7	23
26,000	5,000	46



Up to four windings can be provided on a coil assembly; they are normally wound in enamelled copper wire with turns exact and resistance  $\pm 20$  per cent., sandwich winding being used for balanced windings. The inductance,  $L$ , of the windings, measured at 50 c/s, is given roughly by:—

$$L = 2.5 \cdot 10^{-7} \cdot n^2 \text{ henries}$$

where  $n$  = number of turns.

The total heat dissipation from the coil assembly must be limited to a maximum of 2W; under these conditions the coil-to-coil and coil-to-relay insulation will withstand test voltages of 250V.

**Contact Materials.**—Copper-palladium, which has given an excellent performance in life tests, will be used as a standard contact material. Platinum contacts will also be available but the amount of metal required for the armature contact makes this expensive and the use of platinum will, therefore, be restricted to the more important types of telephone signalling apparatus.

**Fixed-Contact System.**—The fixed contacts are dome-shaped and mounted, as shown in Fig. 5, on

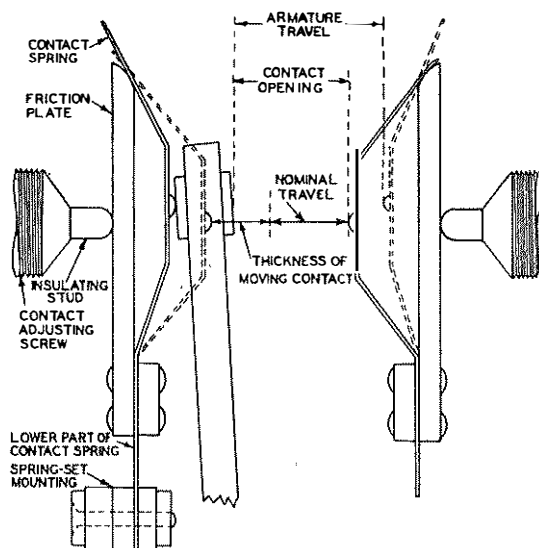

FIG. 5.—THE CONTACT ACTION.

beryllium-copper springs 10 mils. thick which are fixed at the lower ends and flex when contact is made, adequate damping being provided by the friction between the upper end of the spring and the plate against which it is tensioned. This form of contact mounting provides the bounce-free operation which is such an attractive point in the performance of the relay.

The contact spring extends beyond the point at which it is fixed to the plate down to the springset mounting, the lower part forming the flexible mounting that enables the plate and contact to be moved inwards by means of a contact adjusting screw with an insulated tip. This screw can be locked in position by a fibre pad inserted under a locking screw (Fig. 4).

**Armature Assembly.**—The solid, radiometal armature is extended upwards to carry a moving contact between the fixed contacts, by means of a super-

structure which is made of duralumin in order to keep the inertia to a minimum while providing mechanical stability.

In such a sensitive relay, firm mounting of the armature is essential as even a small relative movement between the armature and the magnetic circuit results in a change of sensitivity. Spring suspension strips, made of copper-beryllium, are used, thus avoiding the slackness that would result from worn pivots.

The armature assembly is mounted on these suspension springs so that it pivots about its centre of gravity to ensure that operation is unaffected by the position of the relay and to minimise the effect of vibration. The pivot line lies in a position between the magnet faces chosen so that redistribution of flux at the magnet gaps is kept to a minimum.

The armature contacts are of plate form to give satisfactory operation while the side contact springs flex and the contacts are sliding relative to one another. The contacts are riveted into an insulating bush in the duralumin superstructure and linked to a tag on the left-hand springset assembly by means of a loop of silver foil  $\frac{1}{8}$  in. wide and 2 mils. thick which causes negligible bias.

**Magnetic Shielding.**—The magnetic circuit of the relay has a reasonable freedom from leakage, but in practice a magnetic shield is necessary to prevent crossfire effects to and from adjacent relays and to prevent the presence of adjacent iron masses affecting the performance of the relay.

For the 2B and 3B models the magnetic shield is of mild steel and not only serves as a guard to the magnetic system but also forms part of the cover which is completed by a transparent plastic moulding.

This arrangement allows the relay to be adjusted for sensitivity, neutrality, and timing, with the magnetic shield in position.

The earlier 4B model uses a mild steel cover as a magnetic screen but suffers from the disadvantage that the bias tends to change when the cover is replaced after adjustment for neutrality.

#### Relay Mounting.

The methods of mounting the relay are as follows:—

**Relay, Polarised 2B.**—This model plugs into a 12-way Jack No. 72 and was developed for use in telephone or telegraph equipment employing strip mounting plates. The Jack No. 72 is designed to fit the standard 3,000-type relay mounting and enables the relay to be withdrawn for adjustment or contact cleaning. The relay and jack can also be mounted on relay-set plates where it is difficult to obtain access to the relay for testing purposes, and this method is being adopted for the Teleprinter Automatic Switching System.

For most uses it is anticipated that the contact pins and the thick locating pin will be sufficient to hold the relay in position, but where abnormal vibration is experienced two locking screws can be passed from the back of the Jack No. 72 through the mounting plate and plug base and screwed into the mounting frame of the relay.

**Relay, Polarised 3B.**—This is a wired-in model which can be mounted in the standard 3,000-type relay

mounting and is intended for use in jack-in relay sets which can be taken to a bench for adjustment of the relay. The Mark 2 version of the tag assembly, which is shown in Figs. 2 and 4, has been designed to be more rugged and to have better clearances than the earlier version.

*Relay, Polarised 4B.*—This model is used on certain telegraph switching equipment. The Jack No. 71 is of the Jones socket type and being rather larger than the Jack No. 72 requires a special drilling. The relay is retained in position by means of a clip which passes over the top of the cover.

*General Factors Affecting Relay Performance.*

*Armature Travel.*—The armature travel is adjusted by means of the side-contact adjusting screws, which are designed to give approximately 1 mil. travel of the screw for each division on the periphery of the screw head (16 divisions per revolution). Owing to the flexing of the contact springs the travel of the screws is not directly related to the armature travel (Fig. 5). In practice, the travel is set by bunching the contacts with the armature in its neutral position and turning each screw back an equal number of divisions, the total of the two being known as the "nominal travel."

The actual armature travel is larger than the nominal travel owing to the flexing of the contact springs, actual figures being of the following order on a standard relay :—

	mils.	mils.	mils.
Nominal travel	2	3	5
Armature travel, unenergised	2½	3½	6
Armature travel, energised 15 amp.-turns	5½	7	9½

The contact opening measured at rest on a side-stable relay will lie between the nominal travel and the unenergised armature travel. For adjustment purposes reference to the "travel" will refer to the nominal travel unless otherwise stated.

The manner in which the travel influences the sensitivity, contact pressure, and transit time of the relay is described later.

*Armature Suspension Spring.*—With a spring thickness of less than 10 mils. (approx.) the armature is side-stable and remains held to the side on which it is placed, under the influence of the flux from the permanent magnets; when the thickness is increased above 10 mils. (approx.) the spring exerts sufficient torque on the armature to retain it in a centre-stable position under unenergised conditions.

The relationship between suspension spring thickness and sensitivity, in terms of the ampere-turns required to operate the relay, is of the form shown by the solid lines in Fig. 6, which show that maximum sensitivity is obtained with a 10 mils. spring. The contact pressure at the operate ampere-turns is, however, related to both the spring thickness and the travel as shown by the dotted lines. In practice it is necessary to ensure adequate contact pressure for reliable performance, but once the minimum pressure

is specified the range of spring thickness and travel is limited to those parts of the curves above the pressure specified.

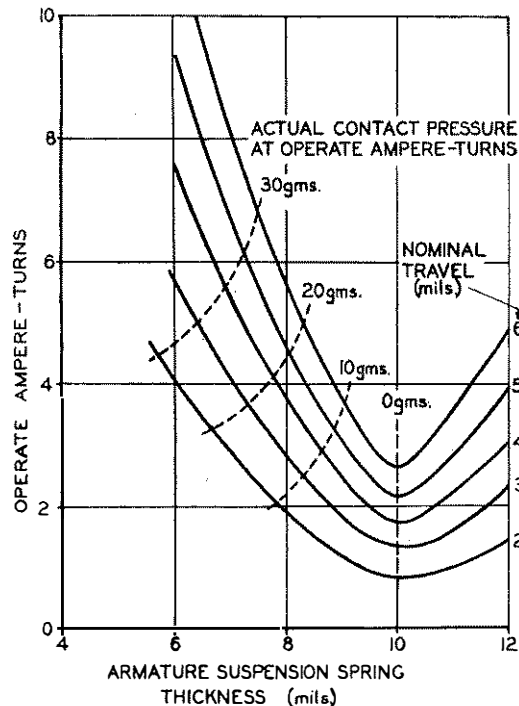

FIG. 6.—RELATION BETWEEN ARMATURE SUSPENSION SPRING THICKNESS AND SENSITIVITY; SHOWING CONTACT PRESSURES AT OPERATE AMPERE-TURNS.

On Post Office standard models a spring thickness of 7.5 mils. has been adopted; this ensures that the actual contact pressure does not fall below 12 gms. when the relay just operates at its maximum sensitivity, assuming a minimum nominal travel of 2 mils. With a 3 mil. nominal travel the minimum actual contact pressure rises to 18 gms.

*Magnet and Armature Gaps.*—The pole pieces are bolted to the frame with armature gaps of 8 mils. and located with great care to obtain mechanical symmetry. To enable the magnetic circuit to be balanced the magnets are sorted into pairs of equal strength before assembly, the magnet gaps being 30 mils. This sorting is necessary because the low incremental permeability of the magnet material makes it impracticable to adjust the permanent magnet fluxes by varying the air gaps.

If the relay is to remain unbiased over a wide range of energisation it is necessary for it to be mechanically and magnetically neutral. If mechanical bias is used to counteract magnetic bias due to the permanent magnets, neutrality can only occur at one value of energisation because the travel, and thus the effect of magnetic unbalance in the permanent magnet circuits, varies with energisation. Magnetic neutrality is arranged during assembly, as explained above, and mechanical neutrality by the use of equal contact spring pressures and by correct location of the pole pieces and fixed contacts relative to the armature.

If this balance is to remain satisfactory during service, neither the magnets nor the pole pieces should be loosened and moved. This makes the cleaning of



the magnet and armature gaps more difficult but since the magnetic shield on the 2B and 3B models normally remains fixed in place very little dust enters.

**Tolerances.**—Manufacturing limitations at present result in a variation in sensitivity between samples of  $\pm 30$  per cent. if they are all adjusted to the same travel; alternatively if a current test is used relays can be adjusted to a given sensitivity so long as a corresponding range is allowed in travel. The main causes of this variation in performance are firstly, the variation in stiffness of armature suspension springs and secondly, the fact that very small changes in the dimensions and materials of the magnetic circuit have appreciable effect on the performance. It is an important fact, however, that once assembled the relay remains stable.

On commencing production it was found possible to obtain an operate sensitivity of 4.7 ampere-turns on relays with a nominal travel of 3.5 mils., and since this was acceptable to the Post Office for many applications it has become a general specification standard.

**Performance.**

Some details of the performance of the single changeover contact side-stable model with 7.5-mils. armature mounting springs and contact spring pressures of 20 gms. are given below.

**Sensitivity.**—As already explained the sensitivity varies with armature mounting spring thickness but for a given spring thickness the sensitivity increases as the nominal travel is reduced. For Post Office use a minimum travel of 2 mils. has been adopted in order to provide reasonable contact clearance (which will be rather larger under dynamic conditions) and to avoid the necessity for frequent adjustment of travel to take up contact wear. A smaller travel also accentuates any mechanical instability that is present.

The relation between sensitivity and the nominal travel is shown in Fig. 7 which also shows the limits

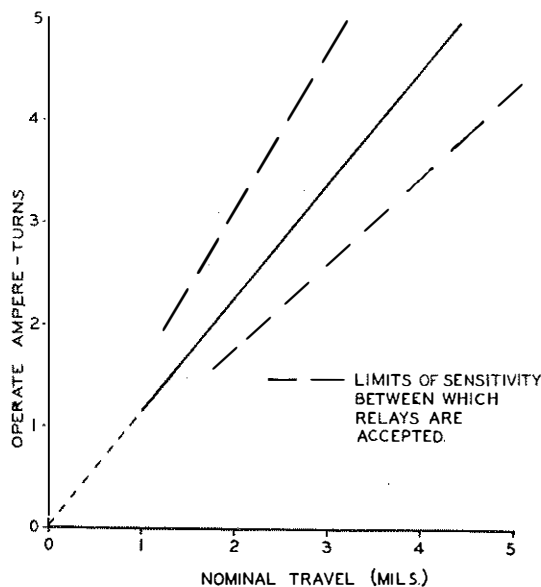

FIG. 7.—RELATION BETWEEN SENSITIVITY AND TRAVEL FOR 7.5 MILS. ARMATURE SUSPENSION SPRING.

of sample-to-sample sensitivity which may be experienced.

**Transit Time.**—The transit time varies with the nominal travel, the energisation, and the constants of the operating circuit.

The relation between transit time (break-to-make) and nominal travel is of the form shown in Fig. 8.

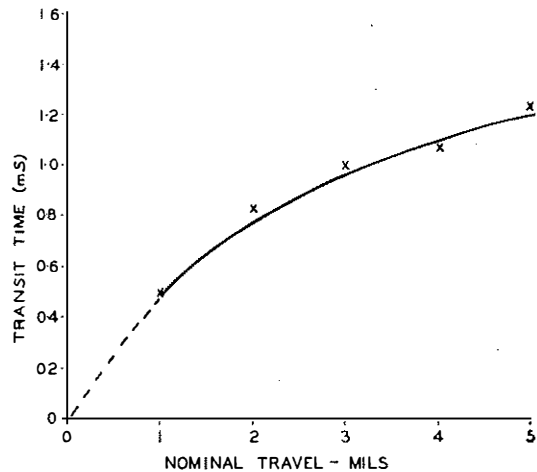

FIG. 8.—RELATION BETWEEN TRANSIT TIME AND TRAVEL WITH ENERGISATION OF 40 AMPERE-TURNS.

Specification of a minimum travel of 2 mils. sets the minimum time at about 0.8 mS. with energisation of the order of 40 ampere-turns with  $n^2/R = 1.1 \times 10^5$ .

Considerable work remains to be done on the variation of transit time with energisation, but with an energisation of only 10 ampere-turns in the example above, the minimum transit time increases to 1.5 mS. A bias winding or short-circuited coil increases the transit time. As an example, a short-circuited 4,000-turn, 750-ohm coil increased the transit time by 1.5 mS.

**Contact Pressure.**—For a side-stable relay the actual contact pressure is greater than the pressure necessary to separate the contacts as normally measured by a Post Office tension gauge. This is a result of the side contact following the armature contact for some distance, so that the force exerted by the armature at the point of separation is less than it was at the full deflection.

This is illustrated in Fig. 9 in which *a* represents half the nominal travel, and (*a* + *b*) represents half the total armature travel, the contacts being closed during part *b* of the travel. The force, *F*, exerted at the contact by the armature increases with travel along the line ABC, but at B the contact spring begins to flex and exerts an opposite force, *R*, which increases along DC with the deflection of the spring; thus, summing these two, the force, *T*, measured by a tension gauge follows the heavy line, starting from zero at E and increasing to a maximum at the point B where the contacts just break. Using 6-mils. contact springs and 7.7-mils. armature suspension springs on the single changeover model, the actual contact pressure is about 1.4 times the pressure measured by a tension gauge. The term "contact pressure" will refer in practice to the measured pressure, and the term "actual contact pressure" will be reserved for

the full pressure which is of interest in considering contact wear but is difficult to measure in practice.

For a centre-stable relay with 10-mils. armature suspension springs the actual contact pressure is normally within 10 per cent. of the measured contact pressure, while for 12-mils. suspension springs the

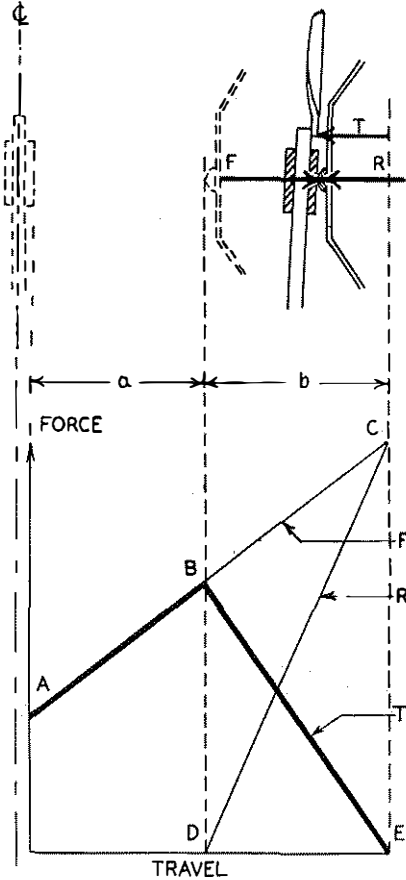

FIG. 9.—MEASUREMENT OF CONTACT PRESSURE WITH A TENSION GAUGE.

actual contact pressure is about 0.8 times the measured contact pressure.

For a given armature suspension spring thickness and contact spring thickness the contact pressure varies with both nominal travel and energisation.

The contact pressure increases linearly with nominal travel from zero at zero travel to 9.5 gms. (actual) at 5 mils. travel. With energisation up to 20 ampere-turns the contact pressure also increases on a linear basis (Fig. 10) but at this point saturation

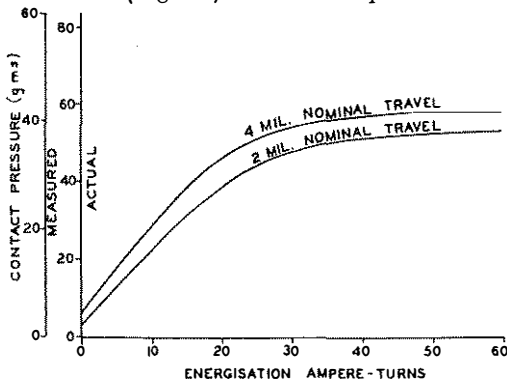

FIG. 10.—RELATION BETWEEN CONTACT PRESSURE AND ENERGISATION.

commences and becomes complete with an energisation of 60 ampere-turns.

#### Adjustment.

Laboratory work on the development of methods of adjustment indicates that the relay can be quickly and easily adjusted to meet a specified performance as to neutrality and sensitivity.

There are two approaches to the adjustment of the relay; the first is suitable for applications in which the sensitivity is not critical because the circuit conditions provide for an energisation of at least 11 ampere turns. The method consists of just bunching the contacts by screwing in the contact-adjusting screws with the armature in an approximately central position and setting the nominal travel by screwing back each adjusting screw by half the travel required; the relay is then energised with about 8 ampere-turns (R.M.S.) from a source with a symmetrical waveform and the bias measured on a D.C. bridge. The bias is then reduced to zero by screwing both screws an equal distance to one side or the other, thus maintaining the same nominal travel. An electrical test is desirable to detect the exact bunching point so that the contact springs are not flexed since this would result in an error in setting the travel. The 50 c/s A.C. power supply is normally suitable for energisation since the even harmonics, which introduce errors, are of very small amplitude in most Post Office stations.

Following this neutralising operation a D.C. test is made in each direction to check that the relay passes its test current figures; in order to obtain consistent results it is necessary first to apply the saturate current in the reverse direction and next to check that the non-operate and operate currents are met.

The second approach is used when it is necessary to adjust the relay to a sensitivity within much narrower limits than can be obtained by the first method owing to the sample-to-sample variation in performance (Fig. 7). In such cases the D.C. test is carried out first, readjust figures being specified for non-operate and operate currents for one coil, test figures for the remaining coils and a range allowed for the contact opening. Following the D.C. test the relay is neutralised by the A.C. method, the same travel being retained in order to avoid changing the sensitivity. Finally, the D.C. sensitivity is rechecked and the contact opening checked by means of a feeler gauge.

When a low transit time is required the normal procedure is to adjust the nominal travel to a specified figure designed to give a satisfactory performance, and to rely on the sensitivity tests to show up any deterioration in the performance of the relay that will increase the transit time. Alternatively the performance can be checked on a telegraph distortion measuring set or an impulse distortion tester.

There will be some applications, however, for which a manual method of adjustment will be sufficiently accurate. This method depends on the fact that with a very small nominal travel a slight mechanical bias makes the armature one-side stable. The armature is stroked from side to side by the finger while the contacts are moved inwards; if the armature re-

mains side-stable on one contact the opposite one is moved back slightly and the process of closing the contacts continued until bunching occurs. The use of lamps in series with the fixed contacts facilitates the procedure and ensures greater accuracy in determining the point of bunching ; the travel is then set by withdrawing each contact-adjusting screw by half the nominal travel required.

#### *Applications.*

The main advantages offered over previous relays are, improved sensitivity and contact pressure, absence of contact bounce, and low transit time, while the 2B and 3B models are also sufficiently small to be mounted in standard 3,000-type relay drillings. The fact that the relay is stable and simple to adjust is also of considerable importance.

The applications of the relay are growing in number ; the low transit time and absence of contact bounce together with the symmetrical action mean that the relay introduces very little distortion. This factor has led to its adoption in the System, Signalling S.C.D.C. No. 2, where the sensitivity of the relay facilitates the design of a circuit without valves that will pass impulses for distances up to 100 miles of cable.

The good impulsing performance has also led to the adoption of the relay in the 2 V.F. receiver and other impulsing circuits. In the Teleprinter Automatic Switching Scheme absence of contact bounce also makes it practicable to use the changeover contact action for operating the selector magnets, while the sensitivity of the relay makes it possible to leave the relay connected to line to await the clearing signal, because the total leak can be made of the order of 10,000 ohms and introduces little distortion to through signals.

In the System, Signalling S.C.D.C. No. 2 the relay is also used to respond to balanced, unbalanced, and reversed line conditions, the only advantage over other polarised relays being the saving in space.

#### *Two-Changeover-Contact Model.*

This model of the relay (Fig. 11) is in an advanced stage of development and is expected to prove useful in circuits where one of the changeover actions is used to pass impulsing signals forward while the other changeover action can be used for local control.

In order to equalise the contact pressures without complicated adjustment of the fixed contacts, a pair of self-aligning contacts is mounted on each side of the armature, the plates on which each pair of side contacts is fixed being mounted between pivots about which they can swivel. The plates tend to retain the position in which they are left owing to the friction in

the pivots, but there is nothing to prevent bunching if one plate is displaced manually ; however, this is rectified immediately the armature is moved to the other side and contact pressures become equalised after a few strokes. It is, however, necessary to consider the possibility of bunching as a fault con-

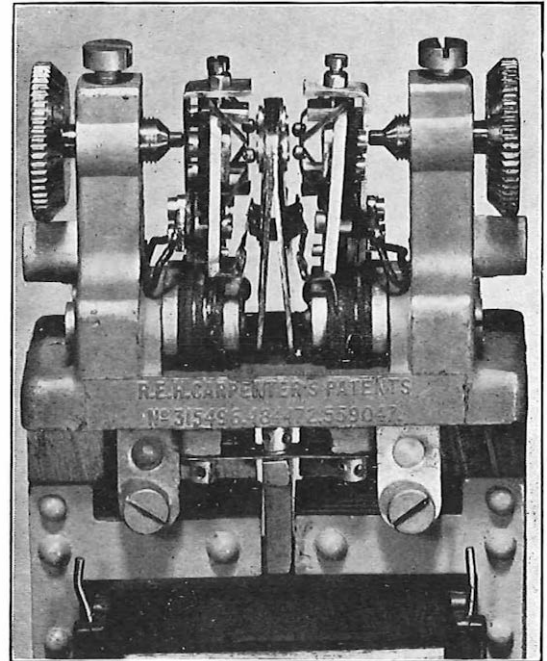

FIG. 11.—CONTACT SYSTEM ON TWO-CHANGEOVER-CONTACT RELAY.

dition should one pair of contacts become welded, but so far all efforts to cause bunching during tests of the relay have failed.

The relay is the same as the single-changeover model except for the armature superstructure and springset assemblies which carry the additional contacts ; the same mounting facilities will be available.

#### *Acknowledgments.*

The authors acknowledge the assistance given by the members of the Relay Group and the Circuit Laboratory of the Telephone Branch. Acknowledgment is also due to Mr. R. N. Hansford of the Research Branch for the basic work on variation of sensitivity with suspension spring thickness and on the measurement of contact pressure. In addition, thanks are due to the Telephone Manufacturing Co. for continued co-operation in the development of the standardised relay.

# The London-Castleton Experimental Radio-Relay System

A. H. MUMFORD, O.B.E., B.Sc.(Eng.), M.I.E.E.  
 Capt. C. F. BOOTH, O.B.E., M.I.E.E.  
 R. W. WHITE, B.Sc., F.Inst.P., A.M.I.E.E.\*

U.D.C. 621.397.743

The experimental wideband channel described in this article is a "single-frequency" relay system using frequency modulation with a maximum frequency deviation of  $\pm 3$  Mc/s, about a mean carrier frequency of 195 Mc/s. Attention is first drawn to the advantages and disadvantages of such a system as compared with the more usual arrangements involving frequency changing at each relay point; an outline follows of the equipment fitted at intermediate and terminal stations, and the article concludes with some details of the overall performance obtained to date.

## Introduction.

IN the article on Television Radio-Relay Links, published in the last issue of this Journal, brief mention was made of an experimental relay system set up by the Post Office Engineering Department. The transmitting terminal of this system is located at Rowley Lodge (near Barnet) and the receiving terminal is at the Post Office Radio Laboratory at Castleton (near Cardiff), with four intermediate repeater stations located at Green Hailey (near Princes Risborough), Widley (near Burford), Hook (near Swindon), and Wotton-under-Edge. The layout of the route is shown in Fig. 1.

is 195 Mc/s, and the transmitted waveform is shown in Fig. 2.

Single-frequency operation of a radio-relay link has the merits of economy in frequency allocations, uniformity and comparative simplicity of equipment at intermediate stations, and the avoidance of spurious products resulting from frequency-changing processes. In such a system, however, unwanted signals differing only in time delay from the wanted signal, and thus capable of passing freely through the amplifying equipment, can be a major source of distortion. The avoidance of pick-up of signals arriving by different paths is the primary problem of a single-frequency

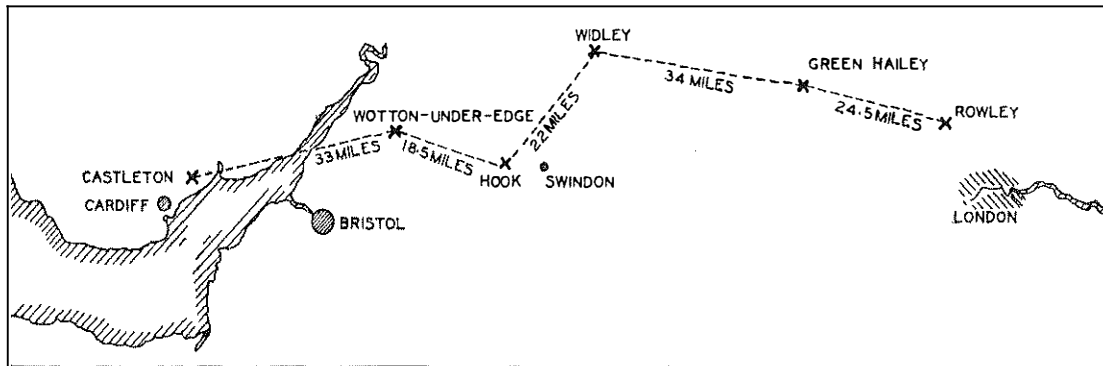

FIG. 1.—ROUTE OF THE LONDON-CASTLETON SYSTEM.

The link forms an experimental wide-band transmission channel and, although primarily designed to handle 405-line television signals, can also be used for preliminary investigation of radio-relay systems handling numbers of telephony channels. Since experience was required primarily on the radio system itself, and as it was not envisaged that it would be required to carry signals other than for experimental purposes, a control and supervisory system has not been provided.

It is normal practice in radio relaying to frequency-change at intermediate stations, but an unusual feature of this link is that the same frequency is transmitted throughout the chain, each repeater acting merely as a "straight" amplifier. Frequency modulation is used, with a total frequency excursion of 6 Mc/s from full white to the tip of the sync-pulse when transmitting television signals. The mean carrier frequency

system, and, in particular, very high attenuation (exceeding 120 db.) is necessary between the transmitting aerial and receiving aerial at an intermediate repeater station to avoid the production of "echo"

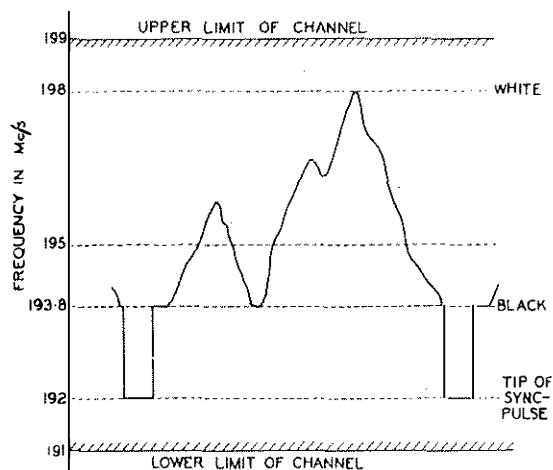

FIG. 2.—THE TRANSMITTED WAVE FORM.

\* In order as listed above the authors are respectively, Staff Engineer, Radio Planning and Provision Branch; Staff Engineer, and Executive Engineer, Radio Experimental and Development Branch, E.-in-C.'s Office.

signals by feedback from the transmitting aerial to the local receiving aerial. The high attenuation is obtained partly by the normal directivity characteristics of the aerials, but largely by spacing them up to 0.5 mile apart and locating them on opposite sides of hill-tops, as shown pictorially in Fig. 3. Two sites, a receiving

frequency-modulate a transmitter. The modulated signals are amplified at each of the four intermediate repeaters. At each of these the incoming signal is received on a rhombic aerial, amplified and fed over a coaxial cable to the nearby transmitting site where it is again amplified to give an output of 10W which

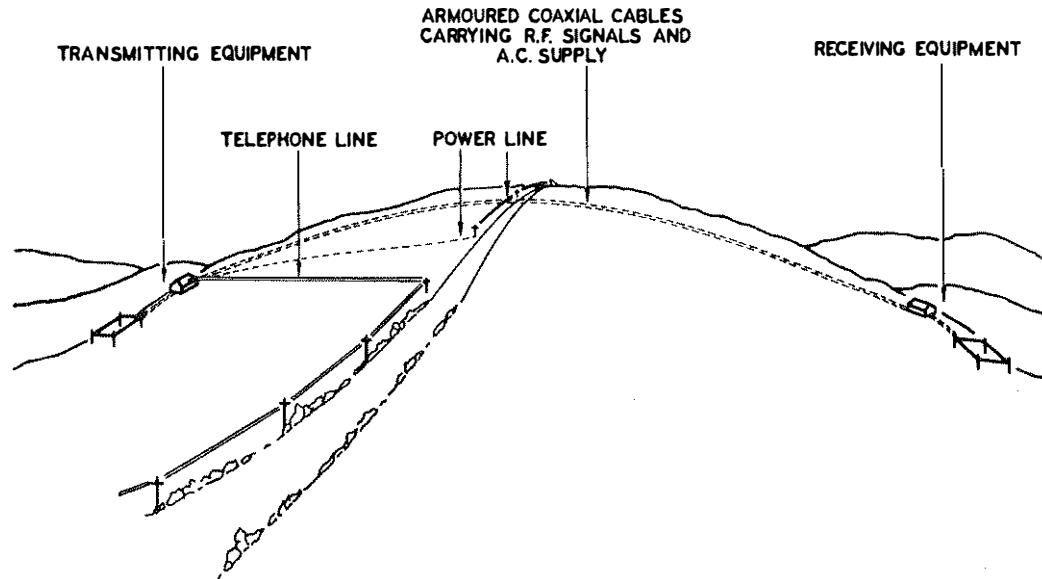

FIG. 3.—LAYOUT OF AN INTERMEDIATE RELAY STATION.

and a transmitting site, are required at each intermediate repeater, the two being linked by buried coaxial cable for the transmission of the radio frequency signal. It will be appreciated that the selection of sites for a system of this type is very difficult. It is not just a question of obtaining a series of sites on the tops of hills, but of obtaining pairs of sites each below the brow of the hill, but on opposite sides, and each site being optically visible with respect to the next station. However, this difficulty must be balanced against the relative simplicity of the system. As was expected, considerable trouble was experienced not so much in finding suitable sites, but in getting permission to use them for the purpose in mind.

The five hops forming the complete link vary in length from 18.5 to 34 miles, the paths being optical in all cases. For the sake of the experiment, signals are received at Rowley direct from the B.B.C. television transmitter at Alexandra Palace (Fig. 4), and, after demodulation, the video signals are caused to

be fed to the transmitting rhombic. At Castleton the received signal is amplified and demodulated to give a video signal which is applied to a picture monitor.

#### EQUIPMENT AT INTERMEDIATE STATIONS

The equipment at each intermediate station is divided between the receiving and transmitting sites as indicated in Fig. 5. Internal equipment included in the main chain occupies three 6 ft. 6 in. racks of normal 19 in. Post Office pattern, two of these racks being classified as "Low-Level Amplifier Bays" and the third as a "High-Level Amplifier Bay." One low-level amplifier bay is used at the receiving site between the receiving aerial and the inter-site coaxial cable, and the other precedes the high-level amplifier bay at the transmitting site. Working and reserve equipment is provided at all intermediate stations, the reserve system at each repeater normally being arranged as a complete parallel chain. Rack-

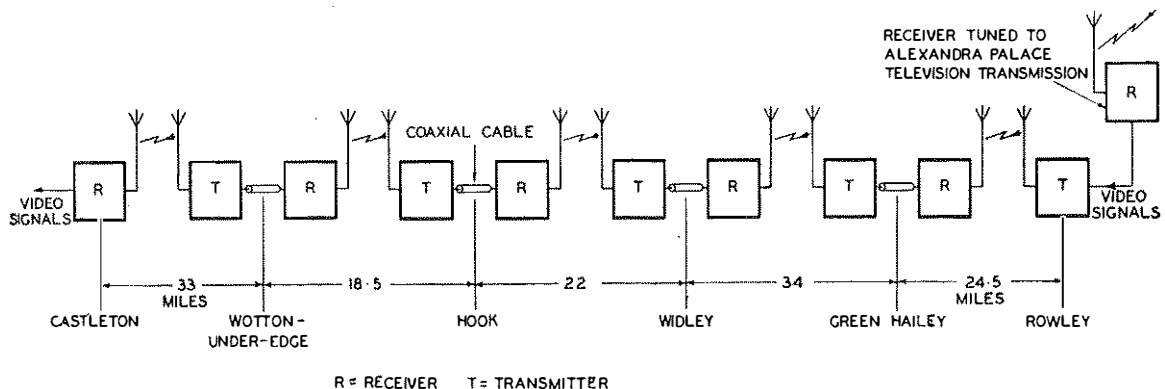

FIG. 4.—SCHEMATIC DIAGRAM OF THE SYSTEM.

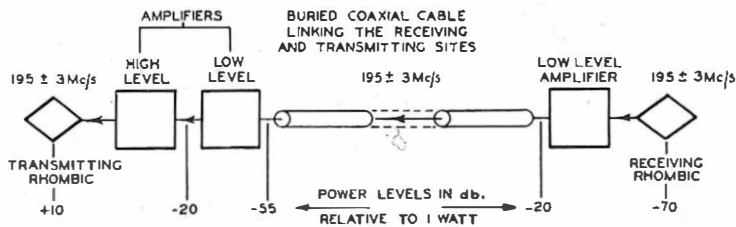

FIG. 5.—SCHEMATIC DIAGRAM OF INTERMEDIATE RELAY STATION.

mounted and portable test equipment is also provided.

#### Low-Level Amplifier Bays.

The low-level amplifier bays at receiving and transmitting sites differ slightly because of power feeding and control requirements, but the actual radio frequency amplifier units used in them are identical. Fan-assisted ventilation is employed on these bays to ensure low operating temperatures with a view to obtaining maximum possible valve and component life. In addition to accommodation for items essential to the main radio-frequency chain, and for power feeding, metering or control arrangements, space and power supplies are provided on each low-level amplifier bay to allow a demodulator of the type used at the receiving terminal to be jacked in for monitoring or test purposes.

The standard low-level radio frequency amplifier is a 14-valve unit on a vertical chassis and has been fitted with plug and jack connections to allow rapid replacement or interchange of units. The input stage uses a low-noise triode in a grounded-grid circuit, and this is followed by a main amplifier section comprising seven stages of CV138 pentodes with common-inductance-coupled double-tuned circuits as intervalve couplings. Stages 9 and 10 are limiters to remove amplitude variations, stage 11 is an output amplifier, stage 12 is a cathode-follower impedance-transforming output stage, and the remaining two valves are for monitoring and alarm purposes. Compre-

hensive metering facilities are provided. The amplifier is designed for 75 ohm input and output impedances, and provides a gain in the non-limiting condition of some 67 db. The input signal required for satisfactory limiting is of the order of -70 db. relative to 1W, and the output level under limiting conditions is -20 db. relative to 1W, i.e. 10 mW. The amplifier is illustrated in Fig. 6.

#### High-Level Amplifier Bay.

The high-level amplifier bay is designed to operate between 75 ohm coaxial input and output cables, with a normal input signal level of 10 mW and an output level of 10W. It contains three amplifier units arranged in series, a five-stage input amplifier being followed by two single-stage amplifier units. Ring-seal triode valves in grounded-grid circuits are used throughout. Power units for forced-air cooling are mounted on the same 6 ft. 6 in. rack as the amplifier units.

The five-stage amplifier uses CV273 triode valves operating at about 6W anode dissipation, and raises the power level from 10 mW to approximately 1W. The intervalve coupling networks take the form of top-inductance-coupled double-tuned circuits, arranged as impedance-transforming band-pass filters on account of the low input impedance which is a well-known characteristic of valves in grounded-grid circuits. The valves in this amplifier are arranged in a zig-zag manner through holes in a central screen, and lumped reactance circuits are used throughout. The general arrangement, with the stage screening covers removed, is shown in Fig. 7.

The single-stage amplifier unit uses a CV257 forced-air-cooled triode, operating with anode voltage of about 400 and an anode current of some 100 mA, i.e. appreciably under its maximum rating. The power output from the pair of single-stage units in series is at least 10W, for an input power level of 1W. Lumped reactances are used for most of the circuit elements,

but an adjustable coaxial line of 4 in. diameter is employed as a variable inductor in the primary of the output coupling network. The forced-air supply to the anode of the CV257 is fed through the hollow tube inner conductor of this coaxial line circuit. A single-stage amplifier is illustrated in Fig. 8.

#### Cables and Aerials.

Working and reserve cables of an armoured air-spaced coaxial type are laid at a depth of 2 ft. between receiving and transmitting sites at each of the intermediate stations. Details of the cable are as follows:—

- Inner conductor, copper .. 0.128 in. dia.
- Outer conductor, lead .. 0.75 in. inside dia.

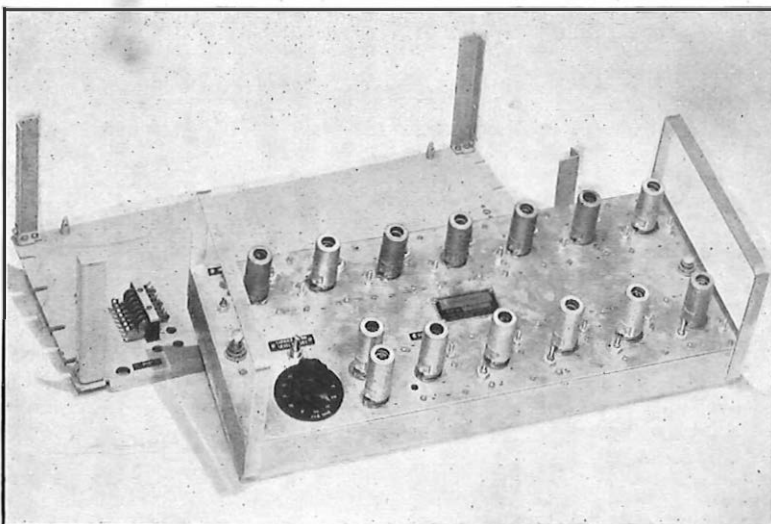

FIG. 6.—LOW-LEVEL AMPLIFIER UNIT.

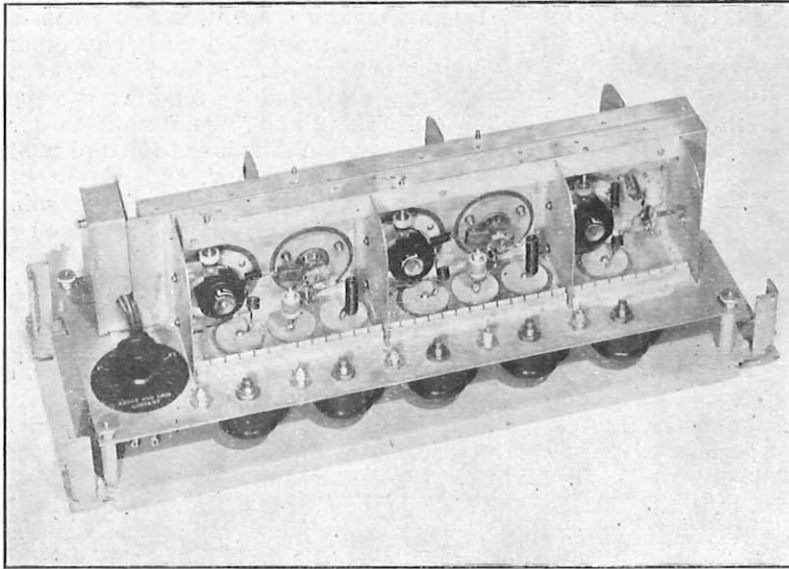

FIG. 7.—FIVE-STAGE GROUNDED-GRID TRIODE AMPLIFIER UNIT, WITH SCREENING COVERS REMOVED.

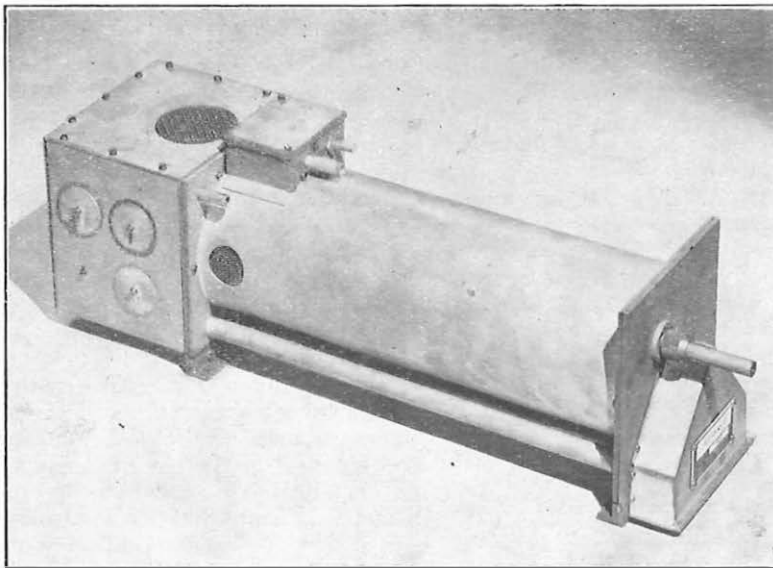

FIG. 8.—SINGLE-STAGE GROUNDED-GRID TRIODE AMPLIFIER UNIT.

Distrene spacers	..	..	3 in. interval
Overall diameter including steel tape armouring	..	..	1.39 in. dia.
Attenuation at 195 Mc/s	..	..	44 db. per mile
Characteristic impedance	..	..	102 ohms

The longest length of cable between sites is approximately two-thirds of a mile, giving an attenuation of just under 30 db. at a frequency of 195 Mc/s. To facilitate line-up of the system, however, the inter-site cable loss at all the intermediate stations is brought up to a standard value of 35 db. by external attenuators. Besides the radio frequency signals, each coaxial inter-site cable carries A.C. power from the

transmitting to the associated receiving equipment, suitable filters being provided to separate the two sets of signals ( $195 \pm 3$  Mc/s and 50 c/s respectively), and the cable terminations include networks for transforming from 75 to 102 ohms. In addition to the coaxial cables, two twelve-core cables are laid between the two sites for control purposes.

Because of their mechanical and electrical simplicity and of their broadband frequency characteristics, rhombic aerials were chosen. Each rhombic (Fig. 9) has a length of some 100 ft., breadth of about 35 ft., and a height between 15 and 30 ft. depending on the slope of the ground in front of the aerial. The width of the major lobe in the horizontal plane is some  $8^\circ$  and in the vertical plane about  $10^\circ$ . The front-to-back ratio is about 25 db., and the forward gain is some 15 db. relative to that of a half-wave dipole.

#### Test Equipment.

Fairly comprehensive monitoring and test facilities are desirable on an experimental link such as this, and equipment provided at each intermediate station includes the following:—

- (a) Demodulators (working and reserve) to allow extraction of the modulation from the signals passing through the repeater.
- (b) An oscilloscope with a Y-amplifier having a satisfactory amplitude and phase response up to 5 Mc/s, for examination of demodulated video, pulse, or square waveforms.

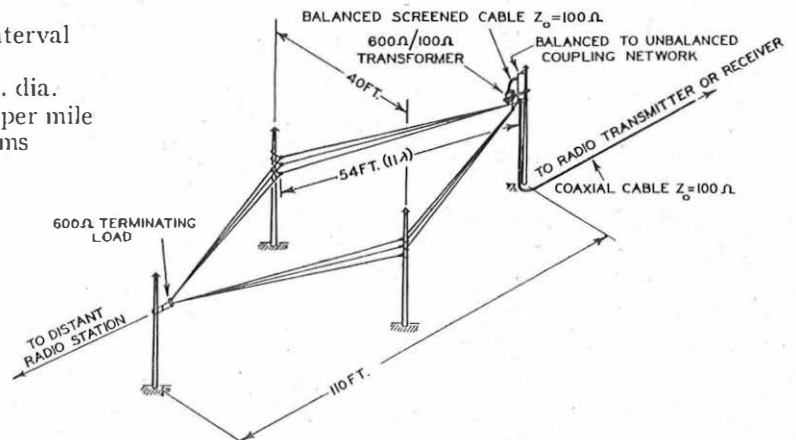

FIG. 9.—TYPICAL ARRANGEMENT OF RHOMBIC AERIAL.



- (c) A simple narrow-band receiver covering some 180-210 Mc/s for examination of the radiated radio frequency spectrum, measurement of relative levels of carrier and side frequencies, and investigation of any spurious signals in or near the operating band.
- (d) A scanning oscillator with crystal-controlled frequency "markers" to facilitate alignment of amplifiers on site, and to simplify any changes of bandwidth required.
- (e) Reflection coefficient display and measuring equipment (associated with the scanning oscillator) which greatly facilitates aerial and feeder adjustments, and can be used to check input impedance of equipment over the band.
- (f) A radio frequency level indicator, artificial loads, a valve tester, meters, and various minor items of test equipment.

The demodulator units are duplicates of those used at the terminal receiver. They are normally accommodated on the working and reserve low-level amplifier bays at the transmitting site, and arranged to monitor the outgoing signal from the station; but they can be jacked into the low-level bays at the receiving site if required, and used to check the signal being applied to the inter-site cable.

Items such as picture monitors and standard signal generators are not provided on a permanent basis at each repeater, but are taken to specific stations as and when required. A transmitter drive in transportable form is also available, and signals can be initiated at any intermediate station if required.

#### EQUIPMENT AT TRANSMITTING TERMINAL

The Rowley Lodge transmitter occupies two 6 ft. 6 in. racks, a "Transmitter Drive Bay" and a "High-Level Amplifier Bay" respectively, as shown in Fig. 10. As the system is an experimental one, equipment design—especially for the terminal

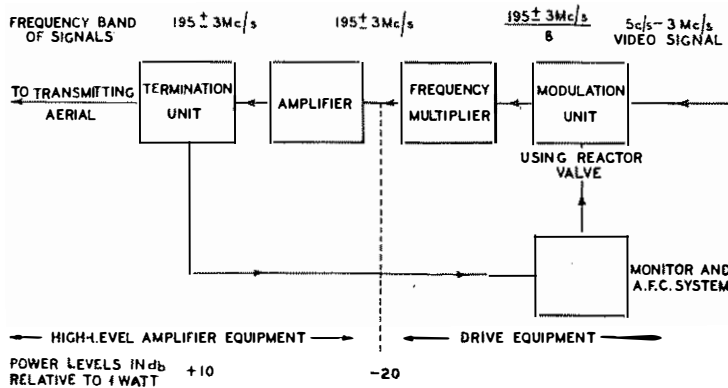

FIG. 10.—SCHEMATIC DIAGRAM OF TERMINAL TRANSMITTER.

stations—is not static, and various forms of drive equipment have been and are being used. In general, however, the video signal incoming to the drive equipment is applied to some form of reactance valve, and is caused to frequency-modulate an oscillator running at a sub-multiple of the desired carrier output frequency. The oscillator output is then frequency-multiplied, and amplified if necessary, to provide the desired carrier

frequency of  $195 \text{ Mc/s} \pm 3 \text{ Mc/s}$  at a standard power of 10 mW. The output signal from the transmitter drive bay passes through a high-level amplifier bay to raise the power level to 10W, and is then applied to a rhombic aerial. The high-level amplifier bay and aerial system are similar to those already described for use at intermediate stations.

#### Transmitter Drive.

In the modulator unit used for most of the earlier work on this link, the frequency-modulated oscillator operates at one-eighth of the final carrier frequency, as indicated in Fig. 10. The oscillator is of the Hartley type, and two reactance valves are connected in parallel with its tuned circuit, one being used for video modulation and the other for automatic frequency control purposes. The frequency-multiplier stages are conventional, except for the use throughout of wide-band interstage coupling networks having a flat response over at least  $\pm 3 \text{ Mc/s}$ .

The automatic frequency control system is arranged to stabilise the frequency corresponding to the tip of the sync-pulse (Fig. 2), and in the absence of an applied video signal the transmitter radiates 192 Mc/s, i.e. the D.C. component of a video signal is transmitted. A peak voltmeter across the video input to the modulator reactance valve is calibrated for use as a deviation meter, and an over-deviation alarm is associated with this. In addition, an independent over-deviation alarm based on instantaneous radiated frequency is included in the monitoring system.

#### Signal Sources and Test Equipment.

For experimental purposes various forms of modulating signal have to be applied to the link. Video signals are normally obtained by direct reception of Alexandra Palace transmission on a high-grade television receiver, but static test card patterns are also available, when required, from mobile monoscope equipment. Sine-wave signals from 10 c/s to 5 Mc/s are produced by a wide-range beat-frequency oscillator, and square wave sources cover 10 c/s to 200 kc/s. A pulse generator provides pulses adjustable in duration from over one line period down to one-third of a microsecond, with rise and decay times of just over 0.1 microsecond, and linear-phase-shift low-pass filters can be used to reduce the build-up times when required.

The radiated signal can be demodulated locally, and the monitoring equipment provided for checking it includes a picture monitor, and an oscilloscope having a Y-amplifier designed for operation up to 5 Mc/s.

#### EQUIPMENT AT RECEIVING TERMINAL

The signal from the receiving aerial at Castleton is amplified by a standard low-level amplifier, as indicated in Fig. 11, and is then applied to a demodulator unit which incorporates limiter stages, a dis-

criminator, and a video section. The receiver occupies a 6 ft. 6 in. rack, and is virtually a low-level amplifier bay of the type used at intermediate stations, but with

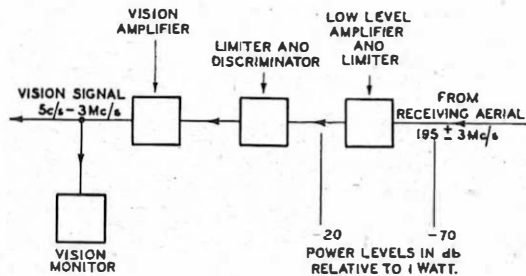

FIG. 11.—SCHEMATIC DIAGRAM OF TERMINAL RECEIVER.

the demodulator arranged as an integral part of it instead of just for monitoring purposes.

#### Demodulator.

The first valve in this unit is a CV139 triode operating as a grounded-grid amplifier, and the input impedance is adjusted to 75 ohms. The input stage is followed by a CV138 voltage amplifier, and this in turn feeds a primary limiter stage. A pair of secondary limiters which follow have their grids in parallel, but each anode feeds one half of a discriminator consisting of circuits resonant at approximately 189 and 201 Mc/s respectively. The outputs from the diodes in the two halves of the discriminator are amplified in separate single-stage video amplifiers before being combined and applied to a cathode-follower video output valve. Low internal impedance of the H.T. source is necessary for the video amplifier stages, and a series-valve H.T. stabilising system is included as an integral part of the demodulator unit.

The demodulator is designed to operate with a normal radio frequency input level of 10 mW, but it will operate satisfactorily on levels down to 5 mW. A frequency swing of  $\pm 3$  Mc/s in the applied signal provides a video output level of 1V peak-to-peak into a 75-ohm coaxial cable, and the demodulator is designed to handle satisfactorily modulation frequencies from 10 c/s to 5 Mc/s. In size and mechanical construction it closely resembles the low-level amplifier unit already illustrated in Fig. 6.

#### Monitoring and Test Equipment.

Testing facilities at the receiving terminal include almost all those available at intermediate repeaters, but a number of additional items of test equipment are also provided. In particular, a wide-band noise measuring amplifier and a range of low-pass filters are available for signal-to-noise ratio measurements, and video equalisers can be used to modify the overall frequency response of the link. Picture monitors are, of course, essential items, and two, of differing design, are normally associated with the receiver. In addition, the location of the receiving terminal makes available to it the normal measuring and test equipment resources of the Castleton Radio Laboratory. Before considering the results obtained to date it must be

emphasised again that the link is only an experimental one and that it has not been engineered to the standard necessary for a system operating on a commercial basis.

#### PERFORMANCE

Pictures were first sent over the complete system on 24th March, 1949, and Fig. 12 shows a recent example photographed from one of the picture monitors at Castleton.

Since the tests commenced a considerable amount of experimental data on the radio-relaying of television signals has been accumulated. It was expected that the avoidance of pick-up of signals arriving by different paths would be the primary problem of a single-frequency link, and this has been confirmed by the results so far obtained.

#### Initial Results.

The first overall tests showed fairly noticeable distortion due to signals displaced in time from the wanted signal. These unwanted signals were of three distinct types—one advanced with respect to the main signal by approximately 1.5 microseconds, the second type delayed by from 5 to 7 microseconds, and the third delayed by a small fraction of a microsecond. The first was due to pick-up at Widley of signals direct from Rowley (i.e. by-passing Green Hailey), while the second type arose from pick-up on receiving aerials at repeater stations of signals from the local transmitting aerials. The third type of echo was due to irregularities in aerials and cables, mis-termination of aerials, feeders, and input cables to equipment, and probably to some extent to short period propagation echoes due to external reflections.

In the original relay link layout, successive hops were zig-zagged slightly to minimise direct pick-up of the "next-but-one" station; but loss of a site near White Horse Hill necessitated acceptance of a site at Widley such that the first two hops are almost in line, and also the introduction of an additional station at Hook. Aerial directivity is thus of little assistance

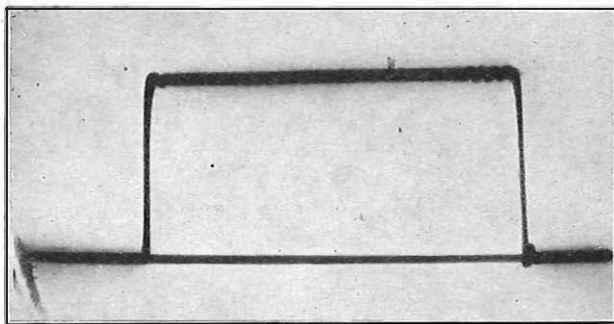

FIG. 12.—PICTURE RECEIVED ON MONITOR AT CASTLETON.

in minimising pick-up at Widley of direct signals from Rowley, and reduction of power at Rowley relative to the power radiated from Green Hailey has been necessary to reduce the advanced spurious signal to a reasonably satisfactory level. This can be done, of course, only at the cost of degraded signal-to-noise ratio on the Rowley-to-Green Hailey section, and increase in the relative level of the local "back-to-back" echo at Green Hailey.

#### *Present Performance.*

The overall characteristics required for transmission of 405-line video signals have been discussed in the article "Television Radio-Relay Links" already referred to, and the majority of the performance requirements specified therein are met by this link. Echo signals of the 5 to 7 microsecond group are a



10  $\mu$ S. Pulse, 50 kc/s P.R.F., 3 Mc/s Frequency Shift.

limiting factor, and have levels somewhat outside the specification figures. Considerable improvement has been effected, however, by increase of the front-to-back radiation ratios of aerials at repeater stations, and further work on aerial systems is in hand. There is a reasonable margin at present on signal-to-noise ratio, but some of this may have to be sacrificed in the reduction of echo signals. The pulse response of the link (Fig. 13) shows that the build-up and overshoot requirements can be met.

#### *Acknowledgments.*

The authors desire to thank their many colleagues in the Radio Branches who have contributed so much to this experiment, and to express their appreciation of most helpful co-operation from the staffs of the Regions in which the stations are situated.

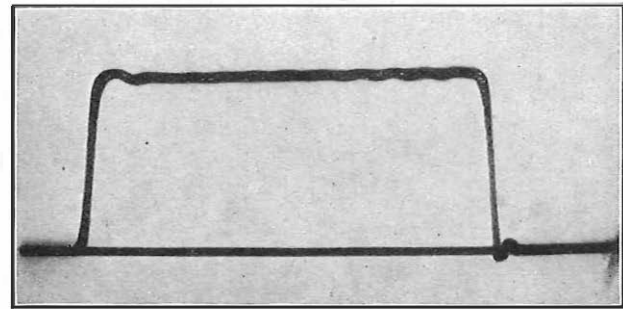

4  $\mu$ S. Pulse, 120 kc/s P.R.F., 3 Mc/s Frequency Shift. Build-up and Decay (10 per cent. to 90 per cent.) better than 0.15  $\mu$ S.

FIG. 13.—LONDON-TO-CASTLETON PULSE TESTS, 16TH AUGUST, 1949.

## Book Review

"Terrestrial Radio Waves." H. Bremmer. Elsevier Publishing Co. Inc., New York. 344 pp., 91 ill. \$6.75.

This book contains a rigorous mathematical treatment of the theory of the propagation of electromagnetic waves around a spherical earth with (a) a homogeneous atmosphere and (b) an atmosphere consisting of a troposphere and an ionosphere.

In part (a) the field intensity of the ground wave is first derived in the form of a series of zonal harmonics, which by Watson's transformation are later expressed as a series of residues in order to facilitate numerical computation. The conditions under which the various geometrical-optical methods may be used to calculate approximate values for the ground-wave intensity are then discussed. This part of the book concludes with a most useful chapter containing the results of many numerical calculations in the form of graphs of the field intensity plotted against distance for various frequencies, ground of various conductivities and dielectric constants and for a range of heights of the transmitter and receiver above the ground.

Part (b) deals first with the effect on the ground-wave intensity of refraction in an idealised, spherically symmetrical troposphere and later extends this to include the effects of super-refraction and duct formation in the troposphere. This part of the book also includes the theory of sky-wave propagation via the ionosphere, and

the effect of the earth's magnetic field on waves reflected from the ionosphere.

Because of the rigorous mathematical treatment of the subject this book will be primarily of value to the wave-physicist; nevertheless, since the theory is well illustrated by many numerical examples, it will also be of value to radio engineers concerned with the more practical problems of wave propagation. For the latter the main limitation of the book will probably be the absence of comparisons between the results of numerical calculations based on highly idealised conditions and the results of measurements of field intensity under conditions as they exist in practice. It is necessary, for example, to be very cautious in applying the results of calculations of field intensities on wavelengths shorter than about 1 metre, since the shadow effects of irregular terrain may lead to discrepancies of 10 or even 100 to 1 between the calculated and measured values of the field intensity. Other subjects which might be expected to come within the scope of a book on "Terrestrial Radio Waves" but which are not dealt with in the present volume include propagation over mixed terrain, e.g. land-sea boundaries, non-linear effects in the ionosphere, and the attenuation of centimetric waves by the atmospheric gases and by rain, hail and fog.

However, the treatment of wave propagation around a spherical earth under the highly idealised conditions assumed, is exceptionally thorough and rigorous, and the author is to be congratulated on the success he has achieved in extending and unifying existing theories on this subject.

W. J. B.

# OLIVER HEAVISIDE—An Appreciation

by

Sir George Lee, O.B.E., M.C., B.Sc., Past President I.E.E.

(*ex-Engineer-in-Chief of the Post Office*)

FROM time to time a genius springs up among us, and the world moves onward in some direction at a more rapid rate. Such a genius was Oliver Heaviside, and the particular direction in which the world moved was the improvement in telecommunications.

Heaviside, the centenary of whose birth was commemorated on 18 May, was a self-taught mathematical genius without any advanced mathematical education. He reached the age of 18 at a time when telegraphy was in its infancy, when duplex and quadruplex (which were subsequently invented by Heaviside) were not in existence. His uncle, on his mother's side, was the famous inventor and telegraph pioneer, Sir Charles Wheatstone, and it is probable that the influence of his uncle led Oliver into the telegraph field. The famous scientists, Faraday and Maxwell, had done their work on the fundamentals of electrical science and the telecommunications stage was thus well set for a man like Oliver Heaviside to enter, and his mathematics produced the fundamental sciences of telegraphy and telephony. Engineering does not advance by guesswork, it must have the science of a particular subject laid down mathematically, so that calculations can be made, and the effect of altering this or that component of the problem evaluated. The mathematics also points the way to further advances.

Heaviside commenced work as an operator with the Anglo-Danish Cable Co., and gained his practical experience in fault testing on this cable, and in experimenting with coils, condensers, batteries, telephones, etc.

From the age of 24, however, he worked entirely on mathematics. In telegraphy, Kelvin's KR law was the only transmission formula available, and in telephony there was none. Oliver set to work and put the transmission science on a very sound and practical basis. This is a very good example of the advantage of mathematics; Heaviside's transmission formulæ showed at once that if you increase the inductance of a line you can reduce the attenuation, and in consequence telephone to a longer distance. He suggested the addition of coils at intervals in the telephone lines and also what we now know as continuous loading.

Professor Pupin, in America, experimented by adding inductances in the telephone line and the

loading coil system was then born. The Post Office, in this country, commenced experimental work on loading coils in 1901, under Mr. Tremain, and the enormous network of loaded cables which we have at present was gradually built up. The valve amplifier came just before the 1914-18 war, and by inserting telephone repeaters in the lines at suitable intervals, the limit of talking distance was set by the time delay between question and answer when the time of travel of the speech along the line became too great.

Carrier working is now gradually superseding loading, though the latter is still necessary on shorter lines, where carrier working is not economical.

Heaviside's transmission formula also brought out another possibility, the distortionless circuit. This, however, though extremely interesting scientifically, has not been adopted practically, as it would be too expensive in repeaters. Also, carrier working is a better alternative from the standpoint of distortion.

Oliver Heaviside next turned his attention to wireless and he worked out many radiation problems. The most striking suggestion of his was that there was possibly a conducting layer in the upper atmosphere and that wireless waves might go round the world with their heads hitched on to the upper layer and their feet on to the ground or sea. This upper layer of ionised air was subsequently discovered by Appleton in 1925, at a height of 100 km. above the earth. Heaviside did not develop the idea any further and we do not know what led him to it. The value of this discovery is very great, as the seasonal changes in this and other higher layers, which were discovered by Appleton subsequently, have been mapped out, and the forecasting of the best short wave to use at a particular time in the future, for a specified route, is now carried out.

Heaviside lived as a recluse, in relative poverty. His mathematics were at first unacceptable to the orthodox mathematicians of this country, but by middle age he had been recognised, and before he died he was satisfied that his work was appreciated. We can now say that but for Heaviside, telecommunications would not have been developed to anything near their present extent at this present time. We are accustomed to thinking of telephones in terms of numbers of subscribers, but it must not be overlooked that without the possibility of talking to some distant subscribers, many people would not have a telephone at all.

# Notes on the Centenary Meeting, 18 May, 1950

by

W. G. Radley, C.B.E., Ph.D., M.I.E.E.

*(Deputy Engineer-in-Chief of the Post Office)*

Oliver Heaviside was for a time a member of the Society of Telegraph Engineers, as the Institution of Electrical Engineers was called in its early days. It was, therefore, fitting that the Institution should hold a commemorative meeting on the centenary of his birth.

The centenary meeting was in two sessions. During the afternoon, the President of the Institution, Professor E. B. Moullin, was supported by Sir Robert Robinson, President of the Royal Society, and both paid tribute to Heaviside. Sir George Lee then described the kind of man Oliver Heaviside was; Sir George Lee's paper was based on personal accounts by Heaviside's friends and quotations from his own letters and books. We gained a picture of a man who lived alone and whom very few people knew. This man was outspoken in his criticisms and at loggerheads with many of his contemporaries, but had many likeable characteristics.

Following Sir George Lee, Sir Edward Appleton, Principal and Vice-Chancellor, University of Edinburgh, who was to broadcast on Oliver Heaviside later in the evening, spoke chiefly of the reflecting layers in the upper atmosphere which were suggested by Heaviside in an article written in 1902. The selection of this speaker was a happy one as he has contributed so much to our present knowledge of these layers which are of great importance to long-distance radio communication.

The present Engineer-in-Chief, Sir Archibald Gill, referred to Heaviside's contributions to long-distance line telephony and telegraphy and while regretting that his suggestions for the inductive loading of lines had not been more quickly taken up, emphasised the value loading had been to the development of long-distance telephony in the years immediately following the first World War.

Contributions followed from Dr. M. J. H. Ponte, President of the Société Française des Electriciens and Past-President of the Société des Radioélectriciens, who attended in person to represent French engineers, and from Dr. O. E. Buckley, President of the Bell Telephone Laboratories, U.S.A., who sent a recorded message.

Professor E. B. Moullin then read a message from Professor Harold Jeffreys, Plumian Professor of Astronomy and Experimental Philosophy, University of Cambridge, which had particular regard to the value of Heaviside's physical mathematics, and Sir Edmund Whittaker, Emeritus Professor of Mathematics, Edinburgh University, paid a nice tribute to Heaviside's work on behalf of mathematicians generally. The afternoon session closed with a racy account of some of the more personal aspects of Heaviside's life from Dr. G. F. C. Searle, who is one of the few living scientists who knew Heaviside personally.

The President opened the evening session by referring to the work which Mr. H. J. Josephs, a member of the Research Branch at Dollis Hill, had done in studying the Heaviside manuscripts in the possession of the Institution. These manuscripts include a large number of loose sheets of paper and notebooks, containing the mathematics upon which Heaviside worked during the latter years of his life. Mr. Josephs found that they contained many new and significant theorems which Heaviside had probably intended to publish in his Fourth Volume on "Electro-magnetic Theory." In a short talk which Mr. Josephs gave later, he pointed out that these theorems contained the formulation of a unified theory in which electro-magnetism is correlated with atomic structure, mass-properties and gravitation.

Professor Willis Jackson of the University of London, presented a paper reviewing various aspects of Heaviside's published work. He showed how Maxwell's Theory of Electro-magnetic Wave Propagation had been used in Heaviside's successful endeavour to develop a comprehensive theory of telegraph and telephone line transmission. He gave a selection of extracts from Heaviside's writings which illustrated the spontaneity of his style and his power of deductive reasoning. Professor Balh van der Pol, Director-General of the C.C.I.R., followed with an historical survey of Heaviside's achievements with his operational calculus.

The last paper of the evening was presented by the author of these notes, and consisted of a review of 50 years' development in telephone and telegraph transmission as related to the work of Heaviside. The audience was given a demonstration of the benefits to be obtained by loading cables, from speech reproduced over loaded and unloaded circuits in a Post Office cable. Reflection of pulses of high-frequency current travelling along coaxial cables by irregularities in the cable were shown on cathode ray oscilloscopes and Sir Edward Appleton's first experimental determination of the height of the Heaviside layer was shown in a miniature form within the Lecture Theatre.

The vote of thanks to all who had taken part was proposed to a well-filled Lecture Theatre, including many of Heaviside's relatives, by Sir Stanley Angwin, the last Engineer-in-Chief.

The papers presented, and the tributes paid to Heaviside at the meeting, will be published in a special issue of the proceedings of the Institution of Electrical Engineers. The paper by Mr. Josephs, presenting Heaviside's hitherto unpublished theorems, will constitute a permanent contribution to scientific and mathematical thought.

# The Electrical Power System for Handling Cable in H.M.T.S. Monarch

A. J. THOMSON\*

U.D.C. 621.315.284

Electrically-driven cable engines are employed in the *Monarch*, giving important advantages over steam-driven machinery. The author details the equipment concerned, explains its operation, and gives particulars of typical cable-laying operations carried out recently.

## Introduction.

A SHORT description of the electrical power installation in H.M.T.S. *Monarch* was given in the general article on the vessel in the January, 1947, issue of the Journal. The system used is sufficiently novel, however, to justify a more detailed description, particularly, since it has now been in successful operation for three years. During this period *Monarch* has completed a sufficient number of repair and laying operations in the North and South Atlantic and the Mediterranean Seas, to compare performances with the more normal steam-driven cable machinery in use in other cable ships.

The essential requirements of cable-handling machinery at sea are flexibility, ability to stall on load for long periods and to pull away the cable slowly and steadily on the easing of the tension. Until the advent of the *Monarch*, the only drive considered suitable for these requirements was the triple-crank steam engine, which was eminently suitable for this class of work and appeared likely to hold this field indefinitely. The use of the constant current system, however, enables an electric motor to duplicate all the characteristics of steam engine performance and, in fact, to improve on them.

One disadvantage of the steam engine is the liability of the cylinders to become waterlogged when under prolonged stalled condition, with the consequent danger of cracked cylinder covers should the load take charge and rotate the engine. Under these same circumstances, the steam engine is sometimes difficult to start slowly and smoothly and, until cleared of condensate, is liable to jerk the cable. In addition, heat loss, by radiation from long steam pipe connections, can add considerably to the fuel bill. These disadvantages are eliminated in the motor drive whilst the desirable features of the steam engine are retained.

## THE GENERATOR ROOM EQUIPMENT

The electrical generating plant is installed in a space 45 ft. × 35 ft. abaft the main engine room and comprises the following items: Two 200-kW geared steam turbine sets 8,000/1,200 r.p.m., each with self-contained condensing plant. Each turbine drives two 100-kW, 220-V D.C. generators in tandem. Two six-cylinder diesel engines, rated speed 1,000 r.p.m., each driving a 100-kW, 220-V D.C. generator. Two amplidyne exciter sets, each driven by a compound-wound D.C. motor of  $4\frac{1}{2}$  h.p. at 1,500 r.p.m.

As one 200-kW steam set can normally supply all the light and power required, this arrangement gives a large reserve of plant readily available and com-

plete flexibility of generating equipment for any emergency which could arise during steaming, laying, or repairing cables. All six generators are available for parallel operation at constant voltage, and in this condition are normal compound-wound D.C. generators.

Three of these, however, one on each turbine-driven set and the one on the starboard diesel-engine-driven set, are available for use, in any combination, for supplying power to the 300-A constant current circuit which runs the full length of the ship. One turbine-driven set, with one generator on constant voltage and the other on constant current operation, is normally sufficient at sea for cable work. The diesel-driven sets are mainly for use in port when the main boilers are shut down. One set is sufficient for normal lighting, etc., but if power is required in the constant-current circuit both are run, the port machine on constant voltage operation and the starboard on constant current. Being quick starting and economical they are also very useful when the ship is on cable work and one steam set only in use for all purposes, to parallel-in with the machine in constant voltage condition and assist over peak load periods. One only, of the amplidyne exciter sets is used to supply the fields of the generators when on constant current operation, the other being kept in reserve.

Constant current distribution is arranged from a six-panel board (Fig. 1) which, with the exception of the excitation panel, is of the "dead front" type in view of the total voltage, which may reach a figure of 650V maximum. The inboard section is the excitation panel carrying the controls for the two amplidynes, the volt and ampere meters. The following three are the generating panels which are equipped with hand-wheels for changing over the appropriate generators from constant voltage to constant current, by means of switches at the back of the panels. The remaining two, on the outboard end, are the outgoing panels, one controlling the forward section of the series circuit, the other controlling the after-section. The forward section consists of two 160-h.p. motor-driven picking-up and paying-out cable machines and a 100-h.p. motor-driven combined capstan and anchor windlass, while the aft section comprises an 80-h.p. motor-driven paying-out machine and two 45-h.p. motor-driven mooring capstans. The board is provided with a mimic diagram running along the top, which shows clearly the condition under which the generators are operating and the distribution position at the outgoing panels.

The constant current mains and the constant voltage feeders are Pyrotenax cable, which has a mineral insulation and is sheathed in copper. This type of

\*Chief Engineer, H.M.T.S. *Monarch*.



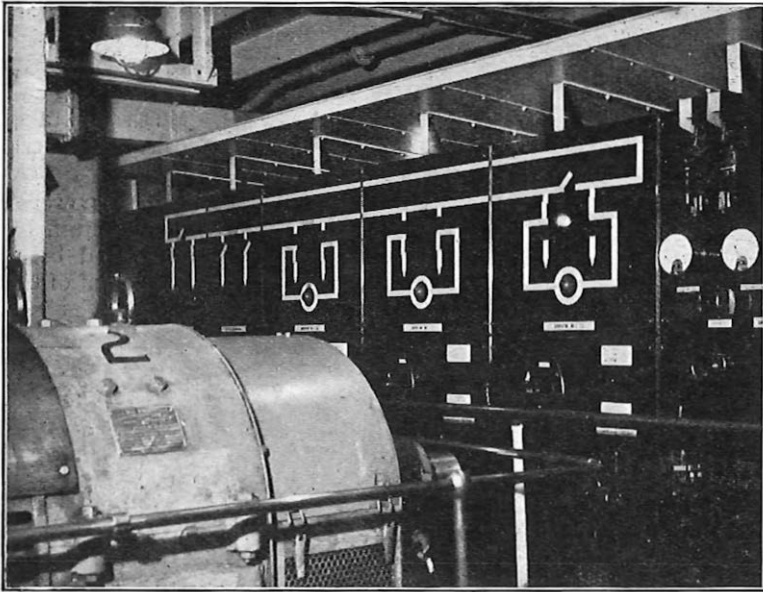

FIG. 1.—THE CONSTANT CURRENT POWER BOARD. MIMIC DIAGRAM SHOWS GENERATOR NO. 3 ON CONSTANT CURRENT OPERATION AND FORWARD DISTRIBUTION IN CIRCUIT.

cable is fireproof, mechanically strong and lends itself to neat and compact layout. The one disadvantage is that the insulating material is slightly hygroscopic and the ends require careful sealing; no trouble has been experienced, however, in practice, from this cause in *Monarch*.

Fig. 2 is a simplified diagram of the power circuit in the ship, showing the amplidyne in use as a constant-current regulator. The amplidyne is a D.C. generator

through these special cross, or quadrature brushes; the quadrature current is circulated in this short-circuit by inducing a small voltage in the armature between these brushes.

A primary or control field is provided to induce this small voltage but, since only a very low exciting current is required for this field, the control power is only a fraction of the power required by the field winding of an ordinary D.C. generator. The control field is on the same axis as the armature reaction field caused by the main load current and, since the control field is small, it is essential to neutralise this armature reaction field. To do this, a compensating winding which carries the main load current is provided on the stator. By this arrangement of the fields a very high amplification factor is obtained and, because of the laminated construction of the stator, rapid transient response. The reference field and control field of the amplidyne exciter oppose

each other and it is only their difference which is effective.

#### MOTOR CONTROL AND CHARACTERISTICS

The torque of each motor on the constant current circuit is controlled by adjustment of its separately excited field by the rheostat shown, and the self-excited field stabilises the speed. Contactors, C, allow for cutting each motor in or out of the series

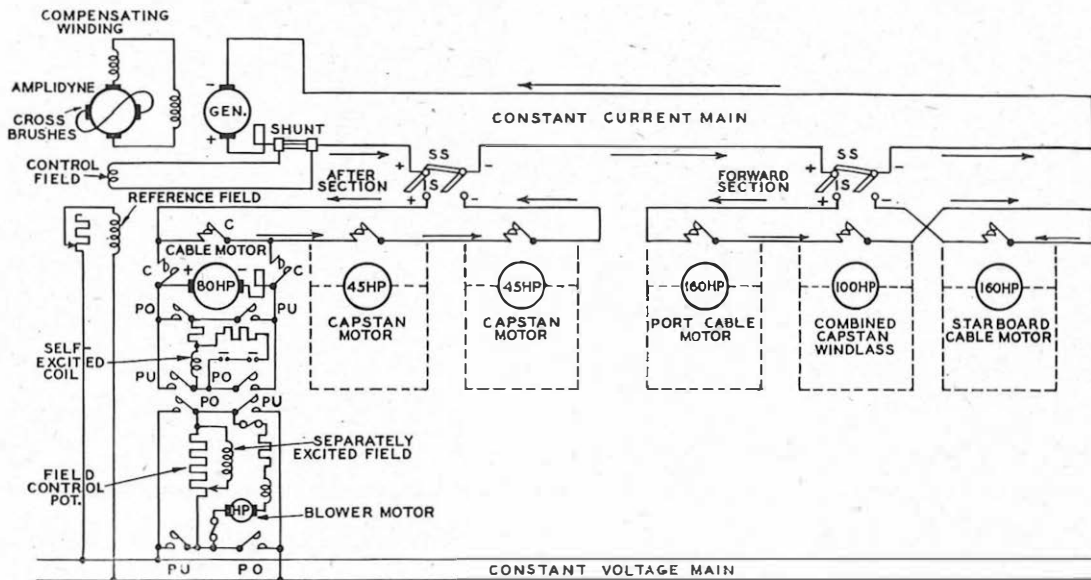

FIG. 2.—SIMPLIFIED CIRCUIT DIAGRAM OF POWER SYSTEM.

having two poles and two pairs of brushes at right-angles to each other, one pair of which is short-circuited. Unlike the ordinary D.C. generator the main field, instead of being induced by the normal field winding, is set up by currents flowing in the armature

circuit, and are interlocked in such a way that the series circuit is never broken. Contactors PU and PO determine the direction of rotation of the motor for picking up or paying out cable. The switches marked SS and IS are respectively the shorting and



isolating switches which control the two sections of the constant-current mains. To prevent accidental open-circuit, SS and IS are mechanically interlocked so that IS must be made before SS can be broken and conversely, when isolating a section, SS must be made before IS can be broken.

The control of the motors as fitted to *Monarch's* cable gear is simple; two mechanically interlocked handles are carried on a ship's telegraph-type pedestal, one handle controlling the direction of rotation and the other torque (and speed). A weatherproof electrical speed indicator panel with pilot lights is mounted close to each controller. With this simple arrangement, a very fine control over the tension in the cable is obtained when picking up with the forward machines. With the armature current held constant at 300A, the motor torque is controlled by varying the field excitation current and can be so adjusted by movement of the torque control handle that the motor will stall at any predetermined weight on the cable. On the load decreasing, as it does in practice, the motor will immediately commence to rotate in the picking-up direction until the load increases to the stalling weight as previously determined.

The following are the mean values of a number of readings taken with a weight of 6.5 tons over the bowsheaves, and the high gear ratio of 57/1 between motor and cable drum speeds:—

Current in armature circuit ..	300A
Minimum field current required to start armature rotating in pick-up direction .. .. .	4.7A
Equivalent turning effort developed by motor armature .. ..	880 lb./ft.

The slightest movement of the control handle to weaken the excitation current below 4.7A when picking up caused the motor to stop. This weight (6.5 tons) is the maximum which can be lifted at this ratio, but a low-speed gear ratio of 227:1 is provided, at which 26 tons can be lifted. With this weight over the bow sheaves the mean values of the readings are—

Current in armature circuit ..	300A
Minimum field current required to start armature rotating in pick-up direction .. .. .	8A
Equivalent turning effort developed by motor armature .. .. .	1,200 lb./ft.

The cable drum diameter is 5 ft. 8 in., and with a 2-in. diameter cable the respective cable speeds are 3 knots and 0.75 knot with a motor speed of 940 r.p.m. At these speeds and weights the crane-hook horse power is 134 in both cases.

In earlier cable ships it was common practice not to provide a power drive to the aft paying-out machine. It was often necessary, therefore, to improvise some form of drive, usually from the nearest winch, when starting to lay and before there was sufficient drag on

the cable to operate the machine. Wood-lined, water-cooled band brakes acting on cast iron drums were used to regulate the speed of the cable leaving the ship. This type of brake is not smooth in action and is difficult to regulate. An additional air or fan brake, driven by gearing from the drum shaft, was introduced later to improve performance.

*Monarch's* paying-out gear (Fig. 3) is powered by an 80-h.p. motor coupled to the cable drum by gearing, the ratio of motor to drum speed being 19.8:1. The use of electrical drive in the form of the

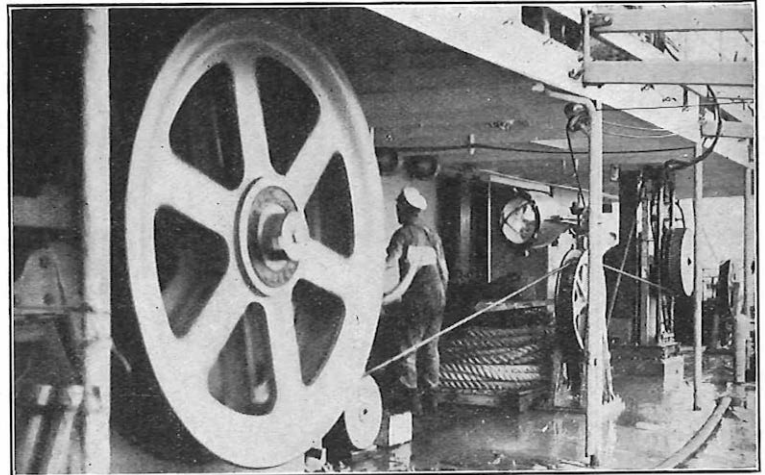

FIG. 3.—AFT PAYING-OUT MACHINE LAYING CABLE. VIEW LOOKING AFT.

constant-current system enables this motor to be used in cable laying as a powerful regenerative brake for controlling the cable speed in relation to the ship's speed. By using one of the 100-kW generators for constant current supply and the other for constant voltage, the regenerated power is usefully employed in supplying other electrically operated apparatus in the ship. The motor drive enables the aft paying-out machine to be used, to a certain extent, for picking up cable in addition to its use for paying out before the ship has gathered way and can exert sufficient drag on the cable to move the machine. Electrical braking was originally intended to be alternative, or supplementary, to the older type brakes, which are also fitted, but operating experience has reversed this intention and the latter are now considered supplementary.

#### TYPICAL LAYING OPERATIONS

In August, 1948, *Monarch* successfully laid 1,120 miles of deep-sea cable between Pernambuco and St. Vincent, 50 miles of which was paid out at the St. Vincent end over the bows in a depth of approximately two miles; the paying-out speed was six knots and the restraint on the cable three tons. The remaining 1,070 miles were paid out over the stern from Pernambuco, commencing at 5 p.m. on the 23rd August and finishing at 2 p.m. on the 30th August, when connection was made with the 50 miles previously laid.

Laying commenced in a depth of 13 fathoms; this

depth increased to over two miles after 50 miles had been paid out and, thereafter, remained reasonably constant between 2 and 2½ miles. The tension/depth graph (Fig. 4) for this particular job shows the ground

Tension graphs for a particular slackness are worked out before commencing to lay a cable, on a basis of 1,000 fathoms depth, and for a range of speeds, usually 4 to 7 knots. Corrections are made for

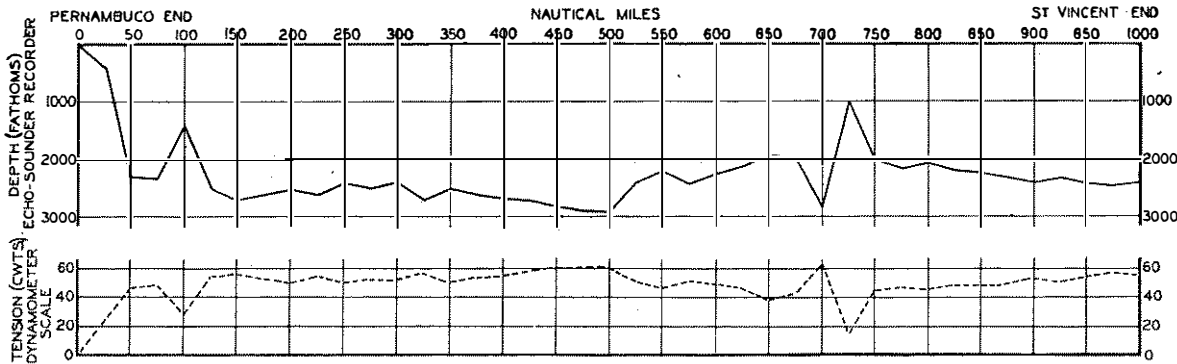

FIG. 4.—GRAPH OF TENSION AND DEPTH FOR ST. VINCENT-PERNAMBUCO RENEWAL IN AUGUST, 1948.

on which the cable was laid. The speed of the ship was kept between 6 and 7 knots, and the cable paid out with an average slack of 7.25 per cent.; the necessary tension in the cable for this was mainly about 2½ tons. The motor speed averaged 700 r.p.m., and the power regenerated at this speed was 42 kW.

At the speed and depth at which the cable was laid, the electrical brake alone was insufficient to regulate the cable speed and the fan brake was used to supplement it, an additional 25/30 h.p. absorption by this means being required to impose the necessary restraint on the cable. The friction brakes were not used except for holding purposes when the ship was stopped to change from one cable tank emptied of cable to a full one. Owing to the liberal rating of the motor of the paying-out machine, it will be possible in the future, by connecting the field coils in series-parallel and modifying the field control potentiometer resistances, to increase the maximum regenerative braking load by about 60 per cent. This will enable all braking to be made electrically, and the use of the fan brake can be dispensed with under normal conditions.

Referring to the depth/tension graph of the Pernambuco-St. Vincent renewal, it will be seen that, because of the difference in scales of depth and distance, a somewhat exaggerated picture of irregularities of the sea bottom is obtained. It shows more clearly, however, the relationship between the depth of the water and the tension applied to the cable to maintain the required amount of slack.

variations above or below this depth and for alteration in speed during the laying operation. Readings of depth, ship's speed and cable speed are taken at half-hourly intervals.

As a matter of interest to readers another typical tension/depth graph is shown in Fig. 5. This was taken from the paying-out log of the Malaga-Las Palmas diversion in July, 1949. As the sea bottom

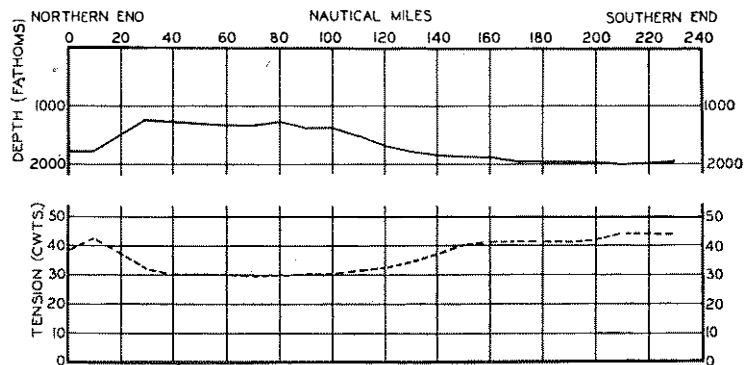

FIG. 5.—GRAPH OF TENSION AND DEPTH FOR MALAGA-LAS PALMAS DIVERSION IN JULY, 1949.

here is comparatively flat with no abrupt peaks or valleys, the cable was laid with a slack of 6.5 per cent. The cable used was recovered in the South Atlantic by the *Monarch* in 1948 and reconditioned by Pirelli at La Spezia; because of difficulty in handling in the cable tanks, it was paid out at the comparatively low speed of 5½ knots. In spite of the reduced speed the electrical braking was quite effective, and a regeneration of about 30 kW was obtained.

# Notes and Comments

## Recent Award

The Board of Editors has learnt with great pleasure of the honour recently conferred upon the following member of the Engineering Department :—

Swansea Telephone Area... de Jong, N.C.C... Area Engineer... Major, Royal Signals... The Order of Orange Nassau

### Mr. C. E. Moffatt, A.C.G.I., Wh.Ex., A.M.I.E.E.

Congratulations to Mr. C. E. Moffatt, Deputy Chief Regional Engineer, London Telecommunications Region, on his promotion to Staff Engineer, External Plant and Protection Branch, in succession to Mr. P. B. Frost.

Mr. Moffatt entered H.M. Dockyard, as a fitter and turner apprentice, in 1917, and after completing his apprenticeship course, he gained a Whitworth Exhibition and spent a further three years at the City and Guilds Engineering College, London, gaining the Diploma of A.C.G.I.



He entered the Post Office as Probationary Assistant Engineer in 1925. After a short period in the Testing Branch, he was posted to Southampton, remaining there until 1932, when he was transferred to the Technical Section of the old South Midland District at Reading. Two years later he was appointed Sectional Engineer at Reading, and took an active part in the drive for the expansion of the telephone service that resulted from the rate reductions introduced by Sir Kingsley Wood.

In 1938, he was appointed Assistant Superintending Engineer at Bristol and devoted increasing attention to the defence measures then being developed. The war period brought to the South-West Region, as it had then become, a full measure of bombing and he was concerned with the restoration of communications

after air attacks on Southampton, Bristol, Plymouth, Exeter, Bath, and many other places. In 1944, followed the urgent tasks of great magnitude that were a prelude to the D-day operations.

In 1946, he was transferred to London as Deputy C.R.E., and was concerned with the arrangements for the reorganisation of the engineering staff of the L.T.R. Since 1947, he has been Chairman of the L.T.R. Amateur Sports Association.

Possessed of a genial personality, an equable disposition, and a sense of humour, Moffatt brings to his new task a sound engineering knowledge and a wide experience. These qualities will ensure his success and all his many friends throughout the L.T.R. and elsewhere wish him well in his new sphere.

W. S. P.

### Retirement of Mr. P. B. Frost, B.Sc., M.I.E.E.

On 30th June, the Engineer-in-Chief's Office lost by retirement the services of Mr. P. B. Frost, Staff Engineer in charge of the External Plant and Protection Branch since 1937.

After completing his educational course in Electrical Engineering at the City and Guilds Technical College, Finsbury, and after having spent three years on Workshop Training and one year with the London County Council Tramway Department, Mr. Frost joined the Engineer-in-Chief's Office in 1909.



Experience in the Testing Branch and in the Power and Equipment Branches was followed by five years' service in the first World War as an Officer in what was then the Royal Engineers Signals Service. After a further period of duty in the Equipment Branch, Mr. Frost joined the External Plant and Protection Branch (then the Construction Section) in 1933, and specialised in problems arising from power circuit interference and corrosion. He was made an Assistant Staff Engineer in 1934. His work in this specialised field led to his representing the Post Office at a number of International Conferences (C.C.I.F. and C.M.I.) and to his acting as Chairman of two C.M.I. Investigating Committees. In these capacities he made important contributions to the work of the bodies concerned. His wide knowledge of different branches of Electrical Engineering led also to his representing the Post Office on a number of Technical Committees of the E.R.A. and B.S.I. and on Committees of the Institution of Electrical Engineers.

A modest and charming man, a sympathetic and helpful Chief and colleague, Mr. Frost will be missed as well by the many friends he has made in the office as by those whose contacts have been confined to official matters. It is the earnest wish of all that he may enjoy a long and happy period of retirement. J. L.

### The Cable and Wireless Ltd. Transfer

As part of a wide scheme for the reorganisation of Commonwealth communications, the operation of Cable & Wireless, Ltd., services in the United Kingdom was taken over by the Post Office on 1st April, 1950. This has involved the transfer to the Post Office of the Company's main operating station at Electra House, London, their branch offices throughout the country, and the five radio stations at Dorchester, Ongar, Bodmin, Brentwood and Somerton, respectively.

The Post Office now operates the above radio stations direct with points overseas, but cable traffic still passes on to the Company's system at Porthcurno cable station, Cornwall, and the Company continues to operate telecommunication services in all parts of the world, maintaining stations and offices overseas for this purpose.

Of approximately 4,400 of the Company's staff transferred to the Post Office, some 550 have been welcomed into the Engineering Department. We feel sure that our new colleagues will quickly settle down now that the transfer has been successfully concluded, and they may be assured of the hearty co-operation of all engineering staff with whom they come in contact during their official duties.

## Institution of Post Office Electrical Engineers

### Annual Awards for Junior Section Papers— Session 1948/49

The Judging Committee has selected the following from the papers submitted by the Local Centre Committees, and awards of £3 3s. 0d. and Institution certificates have been made accordingly.

Author	Junior Centre	Title of Paper
R. T. Ross	Aberdeen	"Aberdeen Trunk Test Rack"
D. G. Elliott	London	"The All-Relay Director"
A. Entwistle R. A. Gill	Bradford	"Flexibility in Cable Networks, the evolution of, and observations on the Cabinet and Pillar."

Normally five awards are made, but in view of the comparatively small number of papers submitted on this occasion the Council decided to limit the awards to three.

The Council is indebted to Messrs. W. S. Procter, H. F. Epps and G. S. Berkeley for kindly undertaking the adjudication of the papers forwarded for consideration.

### Essay Competition, 1949/50, Results

Prizes of £3 3s. 0d. each and Institution certificates have been awarded to the following three competitors: E. F. Taunton, Technical Officer, Inverness, "The Practical Training of Youths in the Post Office Engineering Department"; J. A. Nash, Technician Cl.II (A), Colchester, "Combined Construction: High Voltage, Low Voltage, and the G.P.O."; L. Gardner, Technical Officer, Prescot, "Some Special Faults Investigations and Clears."

Institution Certificates of Merit have been awarded to: W. H. Elliott, Technician Cl.II (A), Rugby Radio Station, "The methods evolved and difficulties encountered in performing the Acceptance Tests on a W12 Mk. IV Transmitter at Rugby Radio Station"; W. T. Webb, Technician Cl.II (B), Southsea, "Regional Training School"; H. B. Coulthard, Technician Cl.II (A), Carlisle, "Publicity."

J. READING,  
Secretary.

*N.B.*—Particulars of the next competition, entry for which closes on the 31st December, 1950, will be published later.

# Regional Notes

## North-Eastern Region

### FLOODING OF PATELEY BRIDGE EXCHANGE

On 15th February, 1950, a spell of heavy rain, followed by a rapid thaw of the snow on surrounding hills, caused the flooding of Pateley Bridge exchange to a depth of 13½ inches. Water entered the main and local underground cables via the M.D.F. and reached the lower L and K relays and junction relay sets, causing Pateley Bridge U.A.X. 13 and its dependent U.A.X. 12, Ramsgill, to be isolated at about 6.30 p.m.

A mobile U.A.X. 12 from York was taken to the site and connected to the underground cables at a convenient point on higher ground near the exchange. This enabled a temporary service to be restored to 74 of the 137 Pateley Bridge subscribers from 6.30 p.m. on 16th February, 1950. At the same time service was restored to Ramsgill U.A.X. 12 by connecting its three B/W junctions direct to Harrogate N.D. auto exchange. Restoration on a temporary basis was hampered by the fact that a distribution cabinet had also been flooded, and subscribers in the affected cabinet area could not be connected until the cabinet assemblies had been changed.

Fortunately the batteries were only slightly affected, and after recharging by means of the mobile generator they were soon restored to service. It was necessary, however, to renew all the underground cables from the M.D.F. to a nearby joint as the water had run back down the cables for a distance of six or seven yards. For the permanent restoration, it was decided to replace all individual items damaged by water and to dry out the internal wiring by using a concentration of heat, vacuum-cleaner attachments, fans and hairdriers. By working day and night shifts, and with concentrated effort, it was possible to complete the work and restore a full service on the original exchange by 2.30 p.m. on Sunday, 19th February, 1950.

Although a flooded-area type building had been erected, and the floods were the highest in the district for about 25 years, it was thought that precautions should be taken to minimise the risk of future flooding. The method adopted was to raise the whole of the U.A.X. equipment (four A, five B and one C Units) by 12 in., i.e. the maximum distance above the Units to the roof cross-members. U-shaped lifting brackets were made from 3 in. x 1 in. mild steel and passed under each Unit in the row. The brackets were then each bolted to two 4 in. x 4 in. H-iron girders, one at each side of the row of Units. Eight car-type lifting jacks were used, four at each side under the H-iron girders, and the Units lifted 6 in. The Units were then supported on sleepers and the lifting tackle transferred to the other row of Units.

It was necessary to complete the lift in stages of 6 in. because of the limit imposed by the cables connecting the C Units to the B Units. The play of 6 in. was obtained by unbolting the cable trough and breaking the gasket between the trough and the B Unit. The Units were finally supported on 12 in. x 6 in. H-Section iron girders, a short length of which was placed under the feet of each pair of Units. The lower row of secondary cells, the charging rectifier and the Power Company's meter and fuses were also moved to positions well clear of any further probable flood level.

T. J.

### EXPERIMENT IN KIOSK ERECTION

In order to reduce ineffective costs in travelling to decorate kiosks erected on site, especially in rural areas, it was decided to assemble and decorate kiosks at a central point. A suitable building where this work could

be done under cover was chosen, since this eliminates any loss of time due to bad weather.

As the weight of an assembled kiosk is about one ton, it was obvious that a three-man kiosk party could not load and unload the kiosk without either additional assistance or some mechanical aid. The use of additional manpower would have reduced the overall saving and, therefore, it was necessary to produce a mechanical aid. Various methods were considered and in the final arrangement the method of operation is as follows:—

- (1) kiosk, derrick, vehicle and lifting tackle in position ready to start loading.
- (2) kiosk lowered on to a roller fitted at rear end of the vehicle floor.
- (3) kiosk raised to a horizontal position, as shown in the illustration. Weight taken on rear roller.



KIOSK LOADING OPERATION.

- (4) derrick and kiosk moved forward. Kiosk weight now taken on rear and forward rollers.
- (5) kiosk in final carrying position, derrick loaded and operation complete.

Unloading is the reverse of the above procedure and, if necessary, the kiosk can be unloaded on to a flat trolley which has been made for the purpose of moving the kiosk in awkward places. In the majority of cases, the vehicle can be backed to the actual site.

The general procedure is for three men to assemble a number of kiosks. Two of the men then travel to the sites and prepare bases whilst the third man decorates the assembled kiosks. When bases and kiosks are ready the three-man party erects the kiosks. In using this method in the Middlesbrough area, the average saving has been 15 manhours per kiosk.

The derrick was constructed from angle and channel iron in the local workshop; it has already proved of use in handling U.A.X. Units and could also be of use in lowering loading coils into manholes, etc. E. R. T.



## Scotland

### CABLE-LAYING ON A GOLF COURSE

Occasion arose in April to lay a cable across two fairways of the Old Course of the Royal and Ancient Golf Club, St. Andrews, and the standard mole drainer equipped for feeding in cable behind the blade was used. As the course had been closed for a month to get it into perfect condition for the Amateur Championship, it was with some trepidation that the job was tackled, as a scar across that sacred turf on such an occasion would have caused much heartburning. However, the job was done, and the almost complete absence of any mark afterwards is the excuse for mentioning the matter here, as it was not realised that such a perfect reinstatement could be effected on cultivated grass. While the main closing of the slit was carried out by a heavy roller, it was found desirable to close it partially by foot pressure before putting the roller over it to avoid a slight turning of the sod and distortion of the edges. The job was completed by brushing the track with a stiff brush.

## Home Counties Region

### ROMAN REMAINS AT COLCHESTER TELEPHONE EXCHANGE

Colchester (Camulodunum) is one of the oldest, if not the oldest, recorded town in Britain; and the decision to enlarge the telephone exchange building by an extension in the rear, and at the same time to construct a deep basement, was of immediate interest to the archaeological world. The approximate design of the Roman town of Camulodunum, with its chequerboard layout of parallel streets running North to South and East to West, was known, and it was anticipated, that one of the streets would run through the portion of land which would have to be excavated.

Arrangements were made by the Ministry of Works, who were in charge of the building work, for the soil to be very carefully removed and hand-sorted so that nothing of archaeological interest which had a bearing on life at the time of the Roman occupation of Britain should be lost. The excavations commenced in January, and the expected Roman street was early in evidence with layers of shingle down to a depth of eight feet, along with plentiful supplies of the well-known Roman bricks.



ROMAN REMAINS

About six feet from the surface was the layer of burnt earth, a significant reminder of the troubles of the town in the year A.D. 61, when Queen Boadicea and her tribesmen of the Iceni stormed the town, exterminated

the garrison, burned everything to the ground and swept on to the South. From that level to a depth of about ten feet were the remains of the walls of buildings on both sides of the street, with the pediments of gateposts which must have been connected with buildings of considerable size. Portions of marble facings were also found along with quadrant-shaped tiles which were used, when placed in fours, to form sections of round pillars. Deep down in one corner of the excavation, side by side and embedded in the soil, were found two amphoræ or wine jars of the type used to convey wine from Italy to Britain. These, as illustrated, were almost perfect, and were considered by the authorities to be very fine specimens; they are now on show in the museum at Colchester Castle.

Many portions of pottery—from the fine decorated Samian ware to the crude locally-made varieties—were found, dating from the first Roman occupation, but only a few coins, although among them was one of Antonia, the wife of the Emperor Claudius, who captured Colchester in the year A.D. 43. Very deep in the excavations was found the skull of a wild boar in such a state of completeness that it will enable experts to build up a very good idea of the creature which roamed around the area in the very early days. H. C.

### PROTECTIVE MEASURES ON MAGDALEN BRIDGE, OXFORD

Magdalen Bridge is the principal means of approach to the centre of Oxford from the east, and this, with its historical and sentimental values, has made the preservation of the bridge a matter of more than local importance.

Concern has been felt for many years over the steady deterioration of the original stonework and the gradual disintegration of the mortar from the keystones. When it was discovered in the summer of 1949 that subsidences had occurred under the numerous service pipes passing over the bridge, the Borough Surveyor arranged for the water-proofing of the bridge as a matter of urgency, and it was decided to use a high-pressure cementation process whereby the bridge would be water-proofed and strengthened simultaneously. This process is intended to fill all voids and cavities in the arches and columns with cement and entails drilling holes of approximately 1 in. diameter at yard intervals in the road surface through which water is injected to wash out loose material including any disintegrated mortar. This is followed by a thin grout which is thickened up as the pressure increases until penetration through the immediate area of the bridge is secured.

It was felt that unless protective measures were undertaken the various service pipes would inevitably become blocked by the entry of the grout, and it was ascertained by piloting that no space for additional pipes was available. Ten Post Office steel and cast-iron pipes of various sizes and ages pass over the bridge together with one S.A.D., and a number of important trunk and junction cables as well as local cables are carried in them. Ten of these are situated under the north footway together with an 18-in. water main, two gas mains and electricity cables, all being confined within a depth of 19 in. over the main arches. Although the number of Post Office pipes was considered adequate for future requirements, it was known that certain old types of coupling existed at various places on the bridge and it was thought that vibration would inevitably have affected a number of joints, and that various cracks and defects might exist. At such points the liquid grout would penetrate and result in blockage of the pipes and

corrosion of the cables and prevent the essential recovery of a number of older cables, even if it did not penetrate to the manholes at the ends of the bridge.

It was decided therefore to expose all pipes over each of the arches and carry out protective measures at points where danger existed. Each joint was covered with two wrappings of hessian tape and a cement collar placed around the taped joints. These joints can be seen

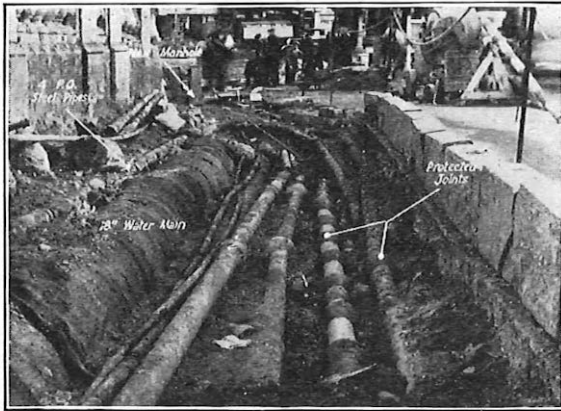

EXPOSED PLANT, INDICATING PROTECTION.

in the close-up view of the protective measures. In all, approximately 270 joints were concerned and the work spread over two months.

The work naturally presented certain difficulties from a contractual viewpoint. As each of the other Services concerned—water, gas and electricity—had also decided upon protective measures, proposals were made for one contractor to carry out the whole of the work and amicable arrangements made for the apportionment of the costs between the various authorities. By the co-operation of all parties, the contractor was enabled to commence work sufficiently in advance of the cementation process to ensure that the bridge work was not delayed. At the time of writing, the protective measures on the north footway are completed and the cementation process is proceeding steadily. No evidence of grout penetration exists, but the success of the measures will not be finally known until the process of recovery and renewal of the cables is completed later in the year.

The operations on the bridge have been complicated by the coincident construction of a roundabout in place of an old burial ground at the east end of the bridge. It has been necessary to carry out certain advance ductwork in conjunction with these operations and to abandon two old pipes passing through the centre of the roundabout. It has been found possible to divert these pipes into a new manhole and commence a programme of cable renewal, which it is hoped, will ensure a sufficient number of spare ways being available over the bridge for future requirements and will simplify some of the cable maintenance problems at this point in the Oxford network.

K. W. H.

#### SEVERE STORM DAMAGE

The wintry spell in the latter part of April culminated during the night of the 25th/26th in a sudden, short but heavy fall of snow which caused widespread havoc to open wires and poles in an area extending from Maidstone to beyond the border of the South-West Region, and from Ascot to Petersfield, Horsham and East Grinstead. There was also damage over much of the southern territory of the London Telecommunications Region.

The snow was of a heavy wet variety and there was sufficient frost in the air to cause the snow to stick to the wires and build up "ropes" of 1 in. to 2 in. diameter within two or three hours. Railway routes also suffered seriously and overhead power supplies to a number of exchanges and carrier stations were interrupted for a day or so.

Some 24,000 subscribers' lines were put out of order, the whole of the Guildford Telephone Area being seriously affected to the extent of 14,200 lines out of a total of 36,000. This varied from 50 per cent. out of order in the Basingstoke Maintenance Control territory to 25 per cent. in that of the Dorking Control. The damage was similarly severe in the Sevenoaks Maintenance Control of the Tunbridge Wells Telephone Area, with some 45 per cent. of the lines affected; in fact the impression gained in and around Sevenoaks was that hardly a span remained where the wires were intact and in good regulation, and relatively few poles were not pulled down upright. One of the photos shows typical damage to subscribers' lines. Parts of the

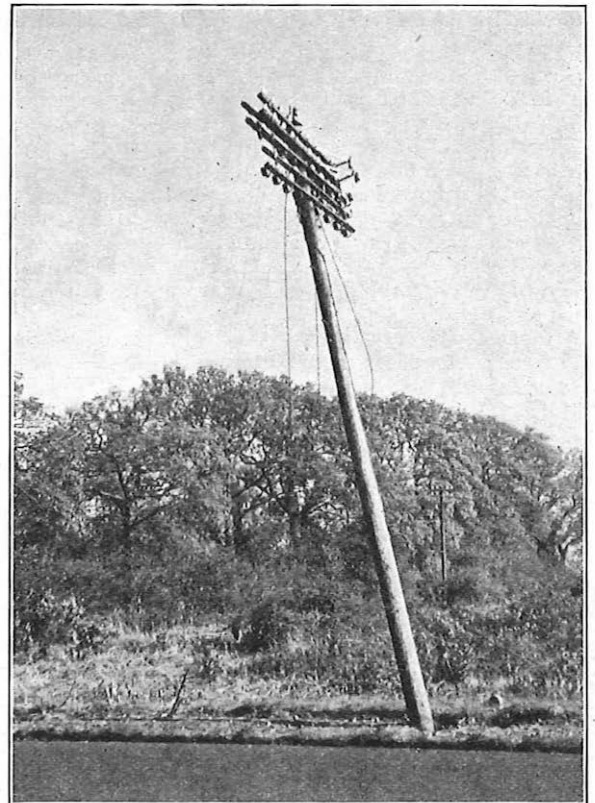

TYPICAL DAMAGE TO D.P. AND SUBSCRIBERS' LINES.

Canterbury, Reading, Portsmouth and Brighton Telephone Areas were also involved, but to a less widespread extent and by heavy concentration of effort were cleared within 10 days.

Pole breakages to a total of some 580 occurred, practically all falling in line with the route rather than at right angles since there was very little wind. The most spectacular breakages occurred on an "H" pole route between Sevenoaks and Tonbridge, as illustrated. Twenty-five such poles broke, but where no strut existed the breakage was generally at ground level. Similarly a heavy route between Basingstoke and Aldershot, containing wires up to 400 lbs., was down over much of



the distance, with poles and wires lying on the grass verge. Most of the wires were due for recovery, but the residual junction and subscribers' circuits necessitated the use of interruption cable pending underground or

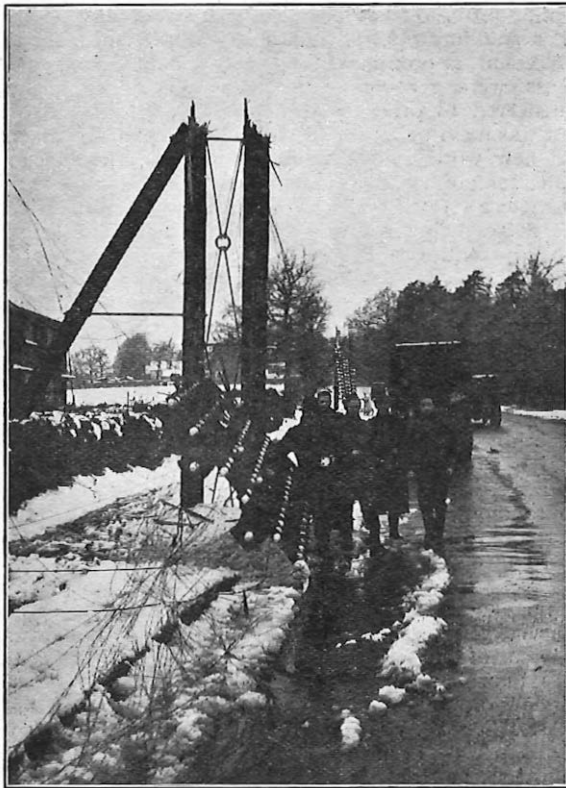

Reproduced by courtesy of "Tonbridge Wells Advertiser"

BROKEN H-POLE BETWEEN SEVENOAKS AND TONBRIDGE.

aerial cabling and opening new D.P.s. The great majority of broken poles showed no sign of decay.

Where D.P.s were broken, especially where forming part of an old heavy route, opportunity was taken in suitable cases to restore service by an increased number of D.P.s, mainly of the ring type. In general, where 10 or more wires were down for more than a few spans, interruption cable was laid, and in the great majority of cases was replaced by aerial cable as quickly as stores came to hand. About 60 miles of interruption cable was used. For the smaller routes and subscribers' drops the aim was to reset the poles and re-regulate the wires from the outset, temporary work being reduced to a minimum. Much work still remained, however, even after service had been restored, on routes where wires were slack but not damaged enough to put the subscribers out of service. In most cases stretched wires were pulled up rather than renewed, though renewal was involved later in some instances where the fault incidence showed this to be necessary.

The effect of this freak fall of snow was greater than can be recollected from any previous storms in the particular localities, and with 40 per cent. of the subscribers affected in the Guildford Area, and a similar proportion in the northern part of the Tunbridge Wells Area, it will be appreciated that restoration of even temporary service was bound to take a considerable time, even with a large influx of additional gangs. Fifty-seven gangs were loaned to these two Areas, including 31 on

a daily travelling basis from nearby centres in the surrounding Areas of the H.C. and L.T. Regions. The acute difficulty of finding lodgings for gangs was a limiting factor, and some were accommodated in P.O. staff rooms and a military camp. Military assistance on a small scale was also obtained and in the Guildford Area it is notable to record the voluntary assistance of clerical, draughtsmen and sales staff at week-ends for clearing and coiling tangled wire from farm entrances, etc.

After three weeks the number of subscribers out of service was reduced from 24,000 to 1,300 and restoration to all subscribers, including those in the most isolated localities, followed within a further week. All the staff concerned were, of course, working very long hours and they responded with that extra keenness and enterprise which they always show at such times of emergency.

R. O. B.  
H. M. W.

### Welsh and Border Counties Region

#### SWANSEA EXCHANGE—MAJOR EXTENSION

The Swansea zone centre exchange (Siemens No. 16 equipment) was installed in 1924, and is believed to be the oldest of its type in the country. Due to the increase in trunk traffic and the subscribers' waiting list it was necessary to provide relief prior to the new building programme; this involved a general shift of the telephone exchange and repeater equipment and power plant to provide sufficient accommodation to meet the needs of a fairly large extension.

The major portion of the accommodation to be made available was on the second floor of the Head Post Office, which already housed the Swansea repeater station, two 60-volt 2,200 ampere-hour batteries, and welfare room. It was necessary to provide a new repeater station, located two miles from the main exchange. The question of the long 2-wire ends on trunk circuits had already been taken into account by providing 4-wire terminations in the basement of the Head Post Office. In addition to this, all the M.U. cables were intercepted in the cable chamber and terminated on test tablets, the back ends being used as ties for the purpose of carrying the short two-wire ends to the trunk equipment. The interception of the Carmarthen-Swansea cables, etc., and the provision of a 494 + 4/40 screened cable between the new repeater station (SX/B) and the basement repeater station (SX/A), provided for sufficient 4-wire circuits to Swansea.

The shift of the main auto battery was carried out by the contractor with no interference to the service. Each box had to be emptied of acid and lead plates and transported separately by using a separate container secured in a suitably designed cradle for lowering externally by the use of jib and tackle. In the course of removal, it was found that the lead linings of 10 boxes were prone to leaks. The contractor was unable to provide new boxes immediately but, as a temporary measure, 10 submarine-type cells of equivalent capacity were supplied as substitutes.

The removal of 2 motor generators, associated bed-plates and filter, weighing approximately 5 tons, from the third floor to the basement, was carried out by contract. Careful organising and manipulative skill ensured the successful operation of the work without interference to the service. The space made available has been used to accommodate two suites of 60-volt sleeve-control switchboards of 21 and 14 positions dealing with demand and incoming traffic, respectively. The vacated bridge control trunk suite is being re-arranged to provide 13 additional toll positions.

It is envisaged that the additional trunk and toll positions will meet the traffic demands for several years. Since approximately 80 per cent. of the circuits are jointly accessible to both suites, bridge- and sleeve-control relay sets are used in conjunction with joint access equipment, and free line signalling on the new trunk suite works jointly with the existing visual engaged signal on the bridge-control toll suite. These facilities, plus the fact that two separate I.D.F.s (viz. trunk and toll) have to be taken into account, make jumpering of circuits and fault location work a complicated process. Staff concerned were, therefore, instructed during execution of the contract.

The provision of a 7-position test desk and associated test jack frames has eased the maintenance control congestion considerably and greater efficiency can now be attained.

To meet the subscribers' development and, at the same time relieve the load on the main exchange switching equipment, an additional satellite exchange,

using 2,000-type discriminator equipment, is in course of installation. The introduction of 2,000-type equipment necessitated provision of additional switching equipment and relay sets at Swansea exchange in order that conversion of battery and loop dialling between Siemens 16 and 2,000-type exchanges could be effected. Similar provision has been made for the conversion of other satellites to 2,000-type, and to obtain space for this equipment, approximately 500 subscribers' calling equipments were recovered and the subscribers affected transferred to other equipment.

It was inevitable that the considerable rearrangements and new work, and building alterations, should cause some temporary deterioration of service and throw much extra work on to the maintenance staff. Great efforts are being made by all concerned to restore to normal conditions and the contractor is to be congratulated on the successful organisation of an involved series of operations which are now approaching completion.

T. J. D.

## Junior Section Notes

### Birmingham Centre

The Annual General Meeting was held on 4th April, 1950. A brief review of the 1949-50 programme was read and the strength of the Centre was reported as 139. An interesting programme formed on the members' desires was carried out, and again visits were very popular.

The Centre's library has been gradually reformed, after total loss by enemy action during the war, and it contains a good selection of reference papers, correspondence courses, Journals, etc., and a healthy circulation of technical periodicals has been set up by the librarian. It was decided to strengthen this by purchase of further periodicals out of the Centre funds, as well as using those passed in to us by the Senior Section.

The Centre is still without a room for use by members as a library or reading room, due to accommodation difficulties in the Area, but it is hoped that we shall eventually secure a suitable room.

It is hoped that a larger number of members will take a more active part in the Centre's activities in the new session.

Officers and committee elected for 1950-51 at the Annual General Meeting:—

*Chairman*: K. G. S. Adams; *Hon. Secretary*: E. H. Cinderey; *Hon. Assistant Secretary and Librarian*: E. Bird; *Treasurer*: J. Cockhill; *Committee*: F. Carpenter, B. Headley, F. Windsor, H. Harper, R. Morris, L. Oliver, W. Johnson; *Auditors*: G. Crockett, A. Whitlock. E. H. C.

### Bournemouth Centre

The 1949-1950 session commenced in October after a lull in our activities. Some doubts existed as to whether or not our colleagues would support us, but we are pleased to say our fears were soon dispelled. The first lecture was given by Lt.-Col. F. A. Hough, M.B.E., M.Sc., A.M.I.E.E., on the subject of "Area Power Plant," during which the design principles of various types of motors were demonstrated by ingenious models of his own design. The following month one of our members, Mr. R. J. Matterface, gave a lecture entitled: "The Introduction of Automatic Telephones in the Bournemouth Area." Considerable interest was shown in this subject, because of the recent conversion of manual exchanges in the Bournemouth multi-office area.

In the new year our Area Engineer, Mr. E. S. Rusbridge, gave a talk summarising future national and local engineering developments. The questions which followed displayed keen interest in plans for the new Bournemouth main automatic exchange, and the effect on the local engineering programme of the reduction in Post Office expenditure. We then adjourned to inspect an exhibition of hobbies. The exhibits ranged from steam engines and chiming clocks to lampshades and embroidered table cloths, which shows the wide variety of talent of our colleagues.

In February we had a lecture and demonstration on "Television" by a member of the Field Research Unit of Messrs. Scophony Baird, for which we had a record attendance. The interesting discussion which followed indicated the deep interest taken in this topic and the many problems met by our television experimenters. The March meeting took the form of a Technical Challenge Quiz with our Bristol colleagues; the proceedings were conducted over land lines, resulting in a win for Bournemouth by two points. The answers emphasised the high technical standard of the teams, both of whom were skilfully handled by their respective Quiz Masters. Our Telephone Manager, Mr. W. R. Tyson, occupied this position at Bournemouth and produced much amusement with his witty remarks on how a Post Office cat is provided and maintained, a question submitted in lighter vein.

The lectures for this session have now been completed, and we are commencing a series of visits. The first took place on 15th April when we visited the Pirelli General cable works. This visit proved most instructive, and we were impressed by the complex machinery and efficient organisation which exists for providing power and telecommunication cables.

Our membership has now risen to 100, and we expect to improve on this. The past year has proved very encouraging and we hope has stimulated sufficient interest to bring forth more papers and new items for our 1950-51 session.

F. T. G.

### Darlington Centre

On the 16th February several members journeyed to Middlesbrough for the President's meeting, and participated in the discussion which followed Mr. Harbottle's talk. All voted the meeting most enjoyable.

The Centre completed the 1949-50 programme on 28th March with a talk—"The North-Eastern Electricity

Board"—brought forward from 7th March, due to the speaker's inability to attend. The speaker was Mr. T. E. Daniels, M.Eng., M.I.E.E., M.I.Mech.E. (Chairman of the N.E. Electricity Board), and his talk proved to be worth waiting for. The meeting attracted a good attendance of members and visitors, amongst whom were the Chief Regional Engineer (Mr. W. F. Smith), the Area Engineer (Mr. A. C. Pitcairn) and the Head Postmaster (Mr. C. O. Thomas). Mr. Daniels described, in a most illuminating manner, the generation of electricity, the grid system and the Board's administration. A most enthusiastic discussion followed, in which members and visitors took part—a salvo of 23 questions was fired at the speaker, who answered them in a most able manner. The vote of thanks by Mr. R. W. Cowen was endorsed by the C.R.E. and applauded by all present.

At the General Meeting on 18th April the Secretary reported there had been a membership of 70 for the session, with an average attendance of 31 at the meetings. The Committee were pleased that the programme had met with general approval. The Central Library had not been so well patronised, but there had been numerous requests for the Courses held by the Centre.

As no members had submitted written papers prior to their talks, they could not qualify for the National Competition or the C.R.E.'s prize.

A suggestion received from the Council of the Institution that a "Forum" should be set up in the Junior Section notes of the Journal was commended by the Centre Committee as it was likely to lead to an exchange of views with other Centres.

The offer of a prize by the Telephone Manager (Colonel J. R. Sutcliffe) for the best talk given by a member of the Darlington and Middlesbrough Centres was acknowledged as a fine gesture.

The statement of accounts, read by Mr. B. Midcalf, proved most interesting.

Officers elected for the Session 1950-51 are:—

*Chairman* : E. Pinkney ; *Vice-Chairman* : B. V. Northall ; *Secretary* : C. N. Hutchinson ; *Treasurer* : B. Midcalf ; *Committee* : N. V. Allinson, G. C. Beggs, R. W. Cowen, J. Cochrane, P. Dodd, G. A. Garry, T. L. M. Hebron, H. G. Midcalf, A. F. Millar, A. Snowden. *Auditors* : D. E. Dodds and J. D. Benhamin.

The Membership fee was fixed at 1s. 6d. for the 1950-51 session. C. N. H.

### Dundee Centre

The 1949-50 session was brought to a close on the 18th April, when Mr. Paterson, of the Scottish Information Office, presented the following films:—

"Electrical Generation," "Electro-Magnetic Induction," "Precisely Yours," "Wonders of the Deep," and "In all Weathers."

The meetings have been well attended, and the final membership reached a total of 81.

The committee thank all members for their support and hope to see them again in the 1950-51 session.

D. M.

### London Centre

This session, 1949-50, can be recorded as the most outstanding in the history of the Centre. The membership is now 2,500, an increase of 500 over last year's figures, and there is no doubt that deductions from pay have assisted in this matter, for which thanks must be extended to the old members of the London Centre Committee who have throughout the years advocated this principle.

The Programme for 1949-50 has been extremely interesting. The Lectures given and papers read have

been very instructive, and it is a pity that so many members fail to avail themselves of these advantages. It is hoped that two papers will be presented to the Senior Section's Competitions, for their annual awards. All Area Representatives and local committees have excelled themselves in the way they have presented and arranged their lectures, debates and visits. They have carried out their responsibilities well.

The use of the Senior Section Library has been very beneficial to all members, and their Periodicals, augmented by those purchased by the London Centre, have had a wide circulation.

An innovation in three Areas, West, North and Long Distance, has been the introduction of Radio Sections. These Sections deal primarily with the construction and maintenance of home-built Television and Radio sets. Members can also purchase component parts at reduced rates. Praise for the original idea should be extended to Mr. L. W. Evans, West Area.

Many Areas are taking advantage of the method whereby a percentage of their Members' Yearly Subscription is returned to them to help with local activities.

Owing to the late delivery of the 1950 Diaries, a financial loss has been incurred. However, for the 1951 Diaries, we have an assurance from the publishers of an earlier delivery.

A Committee, presided over by the General Secretary, Mr. A. W. Lee, has for the past six months been compiling an I.P.O.E.E. Junior Section Handbook containing data relative to Telecommunications. A novel feature of this Handbook will be its simplified index. It is hoped to present this book to the Committee during the 1950-51 session. In this respect, thanks must be extended to Mr. A. E. Penney, our Liaison Officer, for his offer to submit the material contained in the Handbook, to the various experts within the Engineering Department, for verification of its accuracy.

The Centre Committee wishes to record its thanks to our Senior Section Liaison Officer, Mr. A. E. Penney, for his steadfast help during the Season. The Committee also wish to take this opportunity of expressing their high appreciation of the energetic assistance given at all times by our Secretary, Mr. A. W. Lee. On account of the transfer to another position within the Department, of Mr. E. L. Tickner, the Centre lost one of its most valued members. During his twelve years of service as Member, Secretary and Chairman, of the Committee, he always set a very high standard of duty, and has left behind him a great tradition which it will be hard to maintain.

Finally, I am pleased to record a sound financial position of the London Centre of the Junior Section, and this is a very good augury for the future.

On behalf of the London Centre Committee, may I, as Chairman, express our deep appreciation to all the lecturers, the Senior Section, and the Department, for their valuable assistance, and to all others who have in any way helped in the smooth running of the Centre.

A. G. W.

### Middlesbrough Centre

The Annual General Meeting of the Middlesbrough Centre took place on Thursday, 20th April. The following officers were elected for the 1950-51 session:—

*Chairman* : D. Paterson ; *Vice-Chairman* : C. Allison ; *Secretary* : J. Brown ; *Vice-Secretary* : R. R. Johnson ; *Treasurer* : K. Lynas ; *Auditors* : N. F. N. Bennett, A. Bonnier ; *Committee* : J. C. Hall ; G. A. Buckle, H. D. Sloan, J. Mansfield, E. E. Sparkes, D. B. Sawyer, W. Burke.

The 1949-50 session proved to be a great success—figures showed a marked increase in attendances. The

(Continued on page 116)

# Staff Changes

## Promotions

Name	Region	Date	Name	Region	Date
<i>Engr. to Exec. Engr.</i>			<i>Prob. Engr. to Engr.—continued</i>		
Wooding, W. T.	L.T. Reg.	1.3.50	Holden, R.	E.-in-C.O.	10.5.50
Winterborn, E. E. L.	E.-in-C.O.	26.2.50	Benton, G. C.	E.-in-C.O.	31.5.50
Stone, M. C.	S.W. Reg. to E.-in-C.O.	19.3.50	Irwin, A.	E.-in-C.O.	1.5.50
Alston, G. J.	N.W. Reg. to W.B.C. Reg.	1.4.50	Burley, N.	N.E. Reg.	18.5.50
Hopkinson, E.	N.E. Reg.	26.2.50	Boxall, T. R.	E.-in-C.O.	1.5.50
Todkill, H.	E.-in-C.O. to Mid. Reg.	1.3.50	<i>Asst. Engr. to Engr.</i>		
Pooley, E. H.	H.C. Reg. to Mid. Reg.	5.3.50	May, R. H.	N.W. Reg.	1.4.50
Mitchell, C. W. A.	E.-in-C.O.	1.3.50	Bryant, J. W.	N.E. Reg.	23.4.50
Walker, D. C.	E.-in-C.O.	14.2.50	Waterhouse, L. R.	N.W. Reg.	1.4.50
Bampton, J. F.	E.-in-C.O.	14.2.50	Hunter, W. J.	N.E. Reg.	1.4.50
Truslove, E. H.	E.-in-C.O.	14.2.50	Waterman, L. R.	L.T. Reg.	11.4.50
<i>Engr. to Reg. Tng. Off.</i>			Jones, C. W.	N.W. Reg.	1.5.50
Hood, J. B.	Mid. Reg.	12.4.50	Rayns, F. H.	E.-in-C.O.	1.4.50
<i>Prob. Engr. to Engr.</i>			Dawson, C. F. O.	L.T. Reg.	1.4.50
Gauntlett, R. D.	E.-in-C.O.	2.2.50	Richards, P. W.	Mid. Reg.	1.4.50
Ridlington, A. D. V.	E.-in-C.O.	16.3.50	Cullen, W. E.	L.T. Reg.	1.4.50
Aspinall, C.	E.-in-C.O.	1.5.50	Wright, H. C.	E.-in-C.O. to L.T. Reg.	26.4.50
Bellew, T. K.	E.-in-C.O.	5.5.50	Winkley, W. J. F.	H.C. Reg. to E.-in-C.O.	23.4.50
Billinghurst, F. M.	E.-in-C.O.	31.5.50	Morgan, J. L. W.	E.-in-C.O.	1.4.50
Chick, P. G. S.	E.-in-C.O.	24.5.50	Dorner, D. J.	E.-in-C.O.	1.4.50
Hamer, R.	E.-in-C.O.	1.5.50	<i>Tech. Off. to Asst. Engr.</i>		
Hesketh, J. F.	E.-in-C.O.	1.5.50	Slade, W.	E.-in-C.O.	1.4.50
Kyme, R. C.	E.-in-C.O.	1.5.50	Bullen, W. L.	E.-in-C.O.	1.4.50
Manning, D. J.	E.-in-C.O.	31.5.50	Barker, W. V.	E.-in-C.O.	1.4.50
Orchard, H. J.	E.-in-C.O.	1.5.50	Pearson, P. R.	E.-in-C.O.	1.4.50
Williams, J.	E.-in-C.O.	24.5.50	<i>S. Sc. O. to P. Sc. O.</i>		
Williams, M. B.	E.-in-C.O.	1.5.50	Lynch, A. C.	E.-in-C.O.	22.4.50
Faulkner, E. B.	E.-in-C.O.	1.5.50	Shotton, D. C.	E.-in-C.O.	28.10.49
Parker, P. N.	E.-in-C.O.	1.5.50			

## Transfers

Name	Region	Date	Name	Region	Date
<i>Exec. Engr.</i>			<i>Asst. Engr.</i>		
Hawking, W.	W.B.C. Reg. to N.E. Reg.	1.4.50	Goymer, E. G.	E.-in-C.O. to Australian P.O.	2.3.50
Hoare, E.	N.E. Reg. to H.C. Reg.	1.4.50	Bennett, F. G.	L.T. Reg. to E.-in-C.O.	6.3.50
Jones, C. E. P.	E.-in-C.O. to L.T. Reg.	1.5.50	James, N. S.	E.-in-C.O. to W.B.C. Reg.	24.4.50
Tucker, D. G.	E.-in-C.O. to Admiralty	1.4.50	Kelly, F.	E.-in-C.O. to N.W. Reg.	30.5.50
<i>Engr.</i>			<i>Sen. Sc. Off.</i>		
Conn, C. A.	E.-in-C.O. to S.W. Reg.	12.3.50	Hansford, R. N.	E.-in-C.O. to Admiralty	1.5.50
James, L. R.	S.W. Reg. to L.T. Reg.	19.3.50			
Horton, G. P.	E.-in-C.O. to Admiralty	5.3.50			

## Retirements

Name	Region	Date	Name	Region	Date
<i>Asst. Staff Engr.</i>			<i>Engineer—continued</i>		
Ellson, F. A.	E.-in-C.O.	30.4.50	Howarth, H.	N.W. Reg.	30.4.50
<i>Area Engr.</i>			Delahunty, T. P. J.	L.P. Reg.	3.8.49
Robinson, R. P.	H.C. Reg.	31.5.50	Batch, E. B.	H.C. Reg.	28.2.50
Langford, L. C.	L.T. Reg.	28.2.50	Sparrow, V. J.	E.-in-C.O. (Resigned)	31.5.50
White, J. A.	H.C. Reg.	31.3.50	<i>Asst. Engr.</i>		
Arnold, W. H.	Scot.	30.4.50	Holt, H. L.	N.W. Reg.	31.3.50
<i>Engineer</i>			Carrothers, J. K.	N. Ire. Reg.	31.1.50
Blewitt, E.	S.W. Reg.	31.3.50	Hemington, H.	Mid. Reg.	24.4.50
McDougald, F. M.	N.W. Reg.	31.3.50	Skea, J.	Scot.	11.4.50
Brown, A. H.	Mid. Reg.	10.3.50	Appleford, L. E.	L.T. Reg.	30.4.50
Brock, W. P.	L.T. Reg.	31.3.50	West, V. A.	N.E. Reg.	30.4.50
			Vick, E. H.	N.W. Reg.	29.5.50

**Retirements—continued**

Name	Region	Date	Name	Region	Date
<i>Asst. Engr.—continued</i>			<i>Inspr.—continued</i>		
Rowlands, W. .. ..	Mid. Reg. (Health grounds)	17.5.50	Eager, J. .. ..	H.C. Reg. .. ..	19.9.49
			Petite, V. D. .. ..	H.C. Reg. .. ..	6.8.49
			Ware, F. .. ..	H.C. Reg. .. ..	31.7.49
<i>Inspector.</i>			Lewis, H. V. .. ..	H.C. Reg. .. ..	17.11.49
Closney, P. A. .. ..	L.T. Reg. .. ..	18.3.50	Rubidge, H. G. .. ..	H.C. Reg. .. ..	1.12.49
Lee, S. H. .. ..	N.W. Reg. .. ..	31.3.50	Power, E. M. .. ..	H.C. Reg. .. ..	19.11.49
Hastings, A. W. .. ..	L.T. Reg. .. ..	31.3.50			
Maltby, W. A. .. ..	L.T. Reg. .. ..	25.5.50	<i>Asst. (Scientific).</i>		
Mead, J. .. ..	Mid. Reg. .. ..	26.5.50	Harrison, M. A. (Miss) ..	E.-in-C.●. (Resigned)	25.5.50

**Deaths**

Name	Region	Date	Name	Region	Date
<i>Exec. Engr.</i>			<i>Asst. Engr.—continued</i>		
Walton, W. R. .. ..	L.T. Reg. .. ..	19.5.50	Webster, G. J. .. ..	E.-in-C.●. .. ..	26.3.50
<i>Asst. Engr.</i>			<i>Inspector.</i>		
White, O. .. ..	N.W. Reg. .. ..	7.3.50	Smart, C. .. ..	L.T. Reg. .. ..	30.4.50

**CLERICAL GRADES**

**Promotions**

Name	Region	Date	Name	Region	Date
<i>S. Ex. Off. to Staff Controller.</i>			<i>Ex. Off. to H. Ex. Off.—continued</i>		
Dunster, H. L. .. ..	E.-in-C.●. .. ..	1.4.50	Rooke, D. M. (Miss) .. ..	E.-in-C.●. .. ..	29.4.50
<i>H. Ex. Off. to S. Ex. Off.</i>			<i>Cl. Off. to Ex. Off.</i>		
Daly, G. .. ..	E.-in-C.O. .. ..	1.4.50	Rees, I. M. (Miss) .. ..	E.-in-C.O. .. ..	1.4.50
<i>Ex. Off. to H. Ex. Off.</i>			Curley, J. .. ..	E.-in-C.●. .. ..	27.2.50
Harmon, D. M. (Miss)	E.-in-C.●. .. ..	1.4.50	Peacock, C. O. G. G. .. ..	E.-in-C.●. .. ..	1.3.50
Burrows, W. H. .. ..	E.-in-C.●. .. ..	1.3.50	Tucker, F. Y. .. ..	E.-in-C.O. .. ..	26.4.50
Sheppard, A. M. (Miss)	E.-in-C.O. .. ..	1.5.50	Maskell, S. G. .. ..	E.-in-C.●. .. ..	1.5.50
			Green, B. .. ..	E.-in-C.O. .. ..	12.5.50
			Farr, B. .. ..	E.-in-C.O. .. ..	9.2.50

**Retirements**

Name	Region	Date
<i>Staff Controller.</i>		
Ford, F. C. .. ..	E.-in-C.O. .. ..	31.3.50
<i>H. Ex. Off.</i>		
Child, A. J. .. ..	E.-in-C.●. .. ..	28.2.50
French, F. S. .. ..	E.-in-C.●. .. ..	28.2.50
Batey, T. W. .. ..	E.-in-C.●. .. ..	31.3.50

**Transfer**

Name	Region	Date
<i>H. Ex. Off.</i>		
Granville, H. G. .. ..	E.-in-C.●. to Factories Dept.	20.2.50

**DRAUGHTSMEN**

**Promotions**

Name	Region	Date	Name	Region	Date
<i>D'man. Cl. I to Sen. D'man.</i>			<i>D'man. Cl. I to Senr. D'man.—continued</i>		
Downes, F. G. .. ..	E.-in-C.●. .. ..	5.2.50	Todd, J. C. H. .. ..	N.W. Reg. .. ..	25.1.50
Waldegrave, R. F. .. ..	E.-in-C.●. .. ..	5.2.50	Brown, J. F. .. ..	Scot. to W.B.C. Reg.	5.2.50
●wles, F. H. .. ..	H.C. Reg. .. ..	15.1.50	Howard, G. .. ..	Scot. .. ..	19.2.50

**Transfer**

Name	Region	Date
<i>Sen. D'man.</i>		
Ivory, B. .. ..	W.B.C. Reg. to N.W. Reg.	5.2.50

## JUNIOR SECTION NOTES—

(continued from page 113)

many suggestions put forward at the Annual General Meeting indicate another successful programme for our next session.

On 16th February we were honoured with a visit by the President, Mr. H. R. Harbottle, O.B.E., B.Sc., (Eng.), D.F.H., M.I.E.E. Eighty persons attended this meeting, and visitors included members from the Darlington Centre. Mr. Harbottle's paper entitled, "The Main Phenomena of Hearing and their Bearing on the Design of Telephone Communication Systems" was illustrated with slides and was received with great enthusiasm by all present.

On 4th March an interesting visit was made to Smith's Dock Co., Shipbuilding Yard, South Bank. Met by an official, we were shown an array of models of ships constructed by the firm, and had the details of each fully explained. This proved to be of great assistance when going over an actual ship. The Radar equipment had special appeal and was actually seen in operation.

A talk on "Radio Interference Suppression," given by one of our members, Mr. P. L. Hall, on the 16th March, was greatly appreciated—a lively discussion took place.

It is hoped that this support will be maintained.

J. B.

### Scarborough Centre

On Thursday evening, 30th March, the final paper for our 1949-50 session was duly presented. It took the form of a Five-Minute Essay Competition, and seven papers were read. The papers ranged from "The Introduction of Auto Switching on the Internal Telegraph Network" to "Basic Principles of Rocket Pro-

pulsion," and so close were the markings that the panel of Judges found it very difficult to select the winners.

We are indebted to the Senior Section for their presence and support, particularly to Messrs. Jordan, Sturdy and Murray, who were our Judges. Owing to prior engagements, the Telephone Manager and Area Engineer were unable to be present, and apologies were read on their behalf. Refreshments were served and so ended a most enjoyable evening, and the conclusion of another year's working.

A. B. C.

### Sheffield Centre

Thanks to very successful co-operation with the Sheffield Students' Section of the Institution of Electrical Engineers a joint dance was held in January. This was a great success, and all enjoyed the evening. The committee were relieved to find a very small profit showing on the balance sheet, and encouraged by this it is hoped to make the joint dance an annual social event.

The result of a general invitation to the Staff gave us a record attendance one evening in January, when Mr. Clarkstone gave a lecture on, and demonstration of, Television. The company of over 100 included members of the Sheffield Students' Section of the I.E.E. and members of the P.O. Engineering Department from Doncaster. After Mr. Clarkstone had given us a very clear and concise description of what happens in the transmitter and receiver, we sat and watched the results. The only difficulty was in deciding when to close the meeting! However, a fortunate interval in the transmission of a play just gave time to switch off quickly and say "That's all for to-night." We are pleased to record that after the meeting there was an appreciable increase in membership.

T. C. R. H.

### BOARD OF EDITORS

H. FAULKNER, C.M.G., B.Sc., M.I.E.E., Chairman,

F. E. NANCARROW, O.B.E., A.R.C.Sc., M.I.E.E.

P. B. FROST, B.Sc., M.I.E.E.

A. H. MUMFORD, O.B.E., B.Sc.(ENG.), M.I.E.E.

W. T. GEMMELL, A.C.G.I., B.Sc., M.I.MECH.E., A.M.I.E.E.

W. WEST, B.A., M.I.E.E.

D. A. BARRON, M.Sc., A.M.I.E.E.

A. F. STOLLARD.

G. E. STYLES, A.M.I.E.E., Managing Editor.

W. A. HUMPHRIES, A.M.I.E.E.

J. P. HARDING, B.Sc.(ENG.), } Assistant Editors.

A.M.INST.C.E., A.M.I.E.E. }

A. J. HUTCHISON, Secretary-Treasurer.

### Copyright

The entire contents of this JOURNAL are covered by general copyright, and special permission is necessary for reprinting long extracts, but Editors are welcome to use not more than one-third of any article, provided credit is given at the beginning or end thus: "From the *Post Office Electrical Engineers' Journal*."

The Board of Editors is not responsible for the statements made or the opinions expressed in any of the articles in this JOURNAL, unless such statement is made specifically by the Board.

### Communications

All communications should be addressed to the Managing Editor, *P.O.E.E. Journal*, Engineer-in-Chief's Office, Alder House, Aldersgate Street, London, E.C.1. Telephone: HEADquarters 1234. Remittances should be made payable to "The *P.O.E.E. Journal*" and should be crossed "& Co."

### Binding Cases

Cases for binding are available, and may be obtained from the Local Agents for 2s. Subscribers can have their copies of Volumes bound, at a cost of 7s. 6d., by sending the complete set of parts to the Local Agents or to the *P.O.E.E. Journal*, Engineer-in-Chief's Office, Alder House, Aldersgate Street, London, E.C.1. Orders for binding for Vols. 1-19 should indicate whether the original binding case with black lettering, or the later pattern with gold, is required. Cases with gold lettering are the only type stocked from Vol. 20 onwards.

### Back Numbers

The price of the JOURNAL, which is published quarterly, is 1s. 6d. (1s. 9d. post free) per copy, or 7s. per annum post free. Back numbers can be supplied, subject to availability of stocks, at 1s. 6d. each (1s. 9d. post free). Orders for back numbers may be sent to the Local Agents or to the Publishers.

### Advertisements

All communications relating to space reservations should be addressed to the Advertisement Editor, *P.O.E.E. Journal*, Alder House, Aldersgate Street, London, E.C.1. Communications regarding advertisement copy, proofs, etc., should be addressed to the Publishers, Messrs. Birch & Whittington (Prop. Dorling & Co. [Epsom], Ltd.), 49 Upper High Street, Epsom, Surrey.



## INDEX TO ADVERTISERS

	<i>Page</i>		<i>Page</i>
Alton Battery Co., Ltd., The .. .. .	vi	Muirhead & Co., Ltd. .. .. .	iii
Automatic Coil Winder & Electrical Equipment Co., Ltd. .. .. .	xiii	Neill, James, & Co., Ltd. .. .. .	vii
Automatic Telephone & Electric Co., Ltd. ..	x, xi	Painton .. .. .	xx
Bennett College, The .. .. .	ii	Pirelli-General Cable Works, Ltd. .. .. .	xx
British Electric Resistance Co., Ltd. .. .. .	ii	Pitman, Sir Isaac, & Sons, Ltd. .. .. .	xix
British Institute of Engineering Technology ..	vii	Savage Transformers, Ltd. .. .. .	ii
Creed & Co., Ltd. .. .. .	xii	Savage, W. Bryan, Ltd. .. .. .	xviii
Ericsson Telephones, Ltd. .. .. .	xv	Siemens Brothers & Co., Ltd. .. .. .	viii
Evershed & Vignoles, Ltd. .. .. .	v	Smith, Frederick, & Co. .. .. .	ii
General Electric Co., Ltd., The .. .. .	xvi, xvii	Standard Telephones & Cables, Ltd. .. .. .	xiv
Great Northern Telegraph Co., Ltd., The ..	xviii	Sullivan, H. W., Ltd. .. .. .	ix
Hall Telephone Accessories, Ltd. .. .. .	ix	Telephone Manufacturing Co., Ltd. .. .. .	xiii
International Correspondence Schools, Ltd. ..	xix	Tungstone Products, Ltd. .. .. .	iv
Macdonald & Co. (Publishers) Ltd. .. .. .	xix	Westinghouse Brake & Signal Co., Ltd. .. ..	vii
		Winn & Coales, Ltd. .. .. .	xix

# REMOTE POSITION INDICATION SERVO CONTROL

### MAGSLIPS

**SIZES:** 1½", 2" and 3"

### VOLTAGES:

50V to 150V  
according to type

### FREQUENCIES:

50c/s to 1100c/s  
according to type

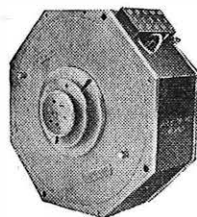
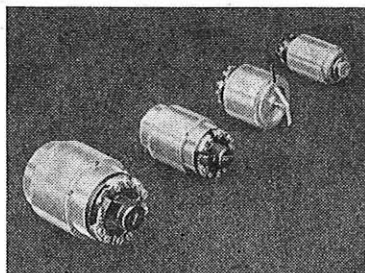

### INDUCTIVE POTENTIOMETER (IPOT)

**DIMENSIONS:** 6½" x 6½" x 3½"

**SUPPLY:** 50V 50c/s

# COMPUTATION

## POST THIS COUPON

### FOR DESCRIPTIVE LITERATURE

MUIRHEAD & CO., LTD.  
BECKENHAM · KENT · ENGLAND

*Please send me Bulletins B-580 and B-604 fully  
describing the Magslips and Ipots advertised in the  
"Post Office Electrical Engineers' Journal"*

NAME \_\_\_\_\_

ADDRESS \_\_\_\_\_

**MUIRHEAD & Co., Ltd.**  
PRECISION ELECTRICAL INSTRUMENT MAKERS  
**BECKENHAM · KENT · ENGLAND**

Phone: BECKenham 0041

Telegrams & Cables: MUIRHEADS ELMERS-END

PRECISION  
**MUIRHEAD**  
ELECTRICAL INSTRUMENTS

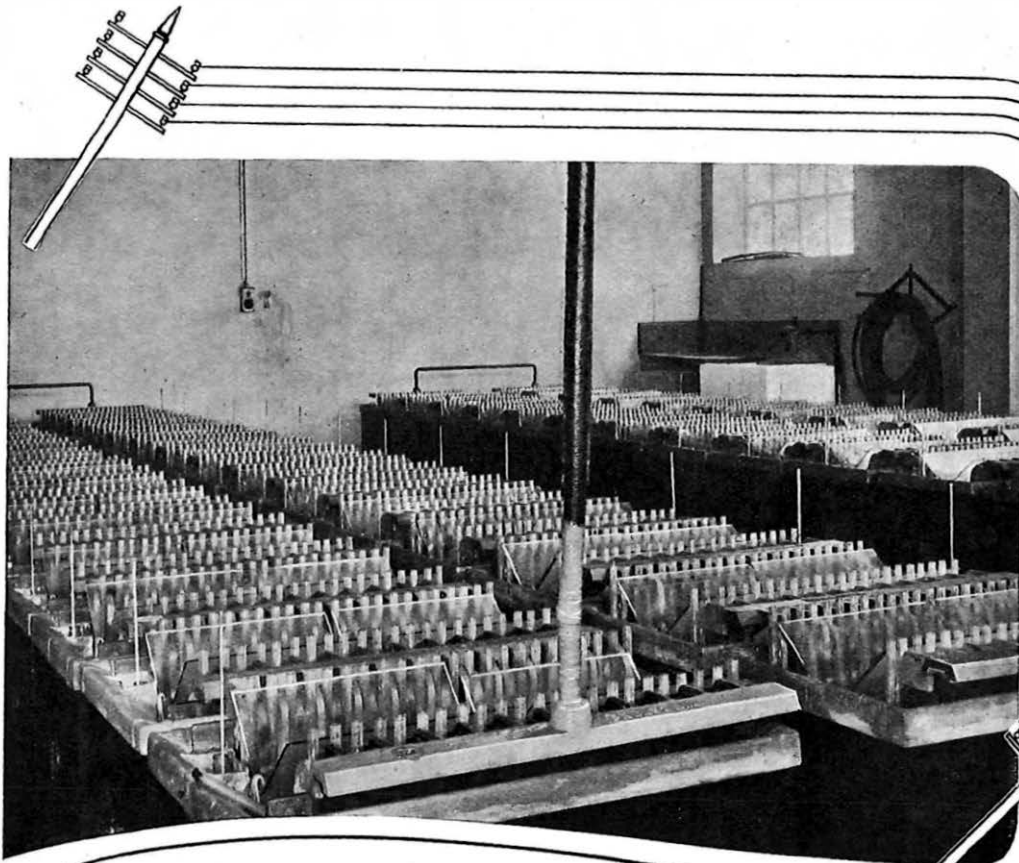

## POWER BEHIND THE LINES

**TUNGSTONE PLANTÉ CELLS** are being supplied to the British Post Office and Post and Telegraph Departments in many countries overseas. They conform fully to G.P.O. and British Standard specifications.

### OPEN TYPE CELLS

Similar to the illustration above, these are available in glass and/or lead lined wooden boxes in capacities from 100 a.h. to 500 a.h.

### REPLATALS

We are in a position to supply plates for the replating of any existing Planté Battery.

*Overseas customers are invited to cable or write their enquiries for batteries or parts. Visitors to London are welcome at our offices.*

### ENCLOSED TYPE CELLS

As illustrated on the right, these are in moulded glass boxes with sealed-in lids. Capacity range from 10 a.h. to 200 a.h.

### HIGH VOLTAGE TELEPHONE BATTERIES

Portable Type. Standard layout for 50 volts, in waxed hard wood crates, exactly to the requirements of the G.P.O.



# TUNGSTONE Batteries

For further particulars write : **TUNGSTONE PRODUCTS LIMITED**  
10 SALISBURY SQUARE · LONDON · E.C.4 · ENGLAND. Cables: "Dilutum" London.

# EVERSHED SPECIAL DUTY F.H.P. MOTORS

## TYPICAL D.C. SERVO MOTORS FOR ELECTRONIC CONTROL

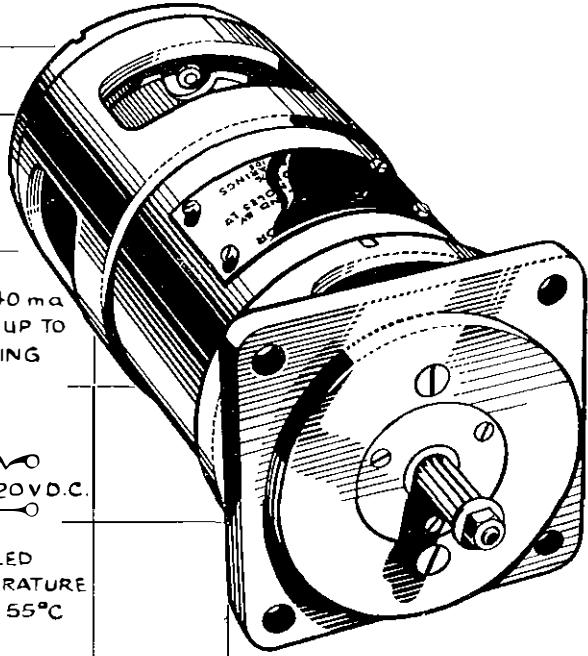
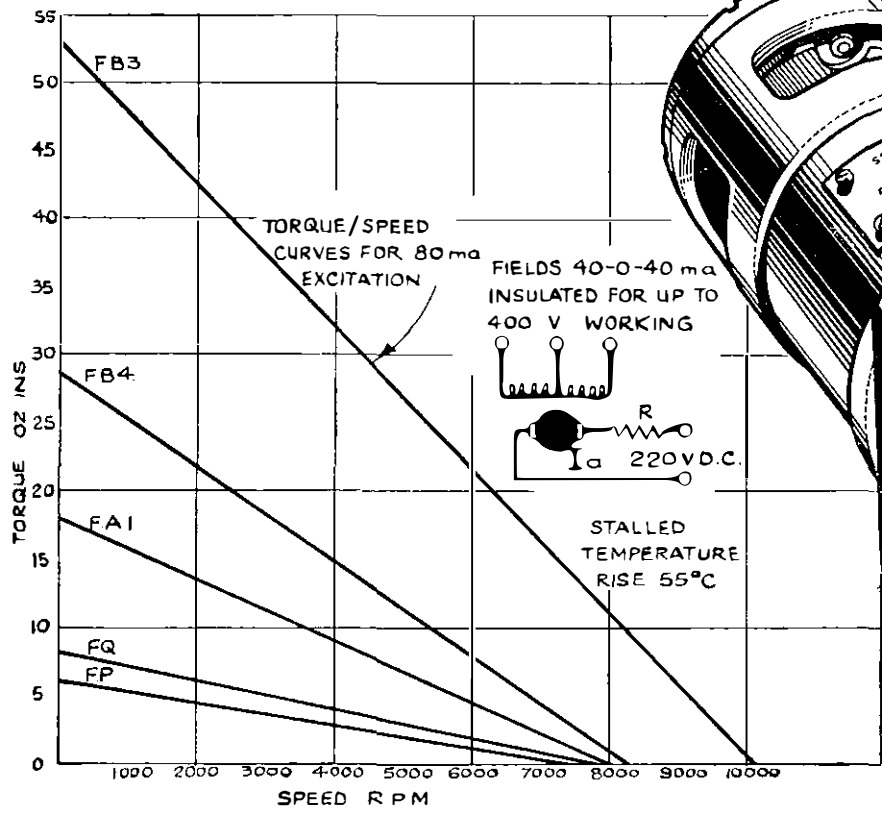

Motors may be supplied with a limited range of alternative Armature and Field Windings.

F.B.3 and F.B.4 Motors, fitted with Integral Field Surge Suppressors.

Shafts Plain or D.P. Spline.

All Motors rated for a stalled temperature rise of 55°C.

*Send for the Evershed Small Motors' Data Book, X22.*

FRAME SIZE	MOMENT OF INERTIA OZ. INS <sup>2</sup>	BRUSH & BEARING FRICTION OZ. INS.	I <sub>a</sub> AMPS
F.P.	0.5	0.5	0.25
F.Q.	0.75	0.5	0.33
F.A.1	1.8	0.5	0.75
F.B.4	2.2	1.0	1.5
F.B.3	2.2	1.0	3.0

# EVERSHED AND VIGNOLES LIMITED

ACTON LANE WORKS · CHISWICK · LONDON · W4

Telephone : Chiswick 3670

Telegrams : Megger, Chisk, London

Cables : Megger, London

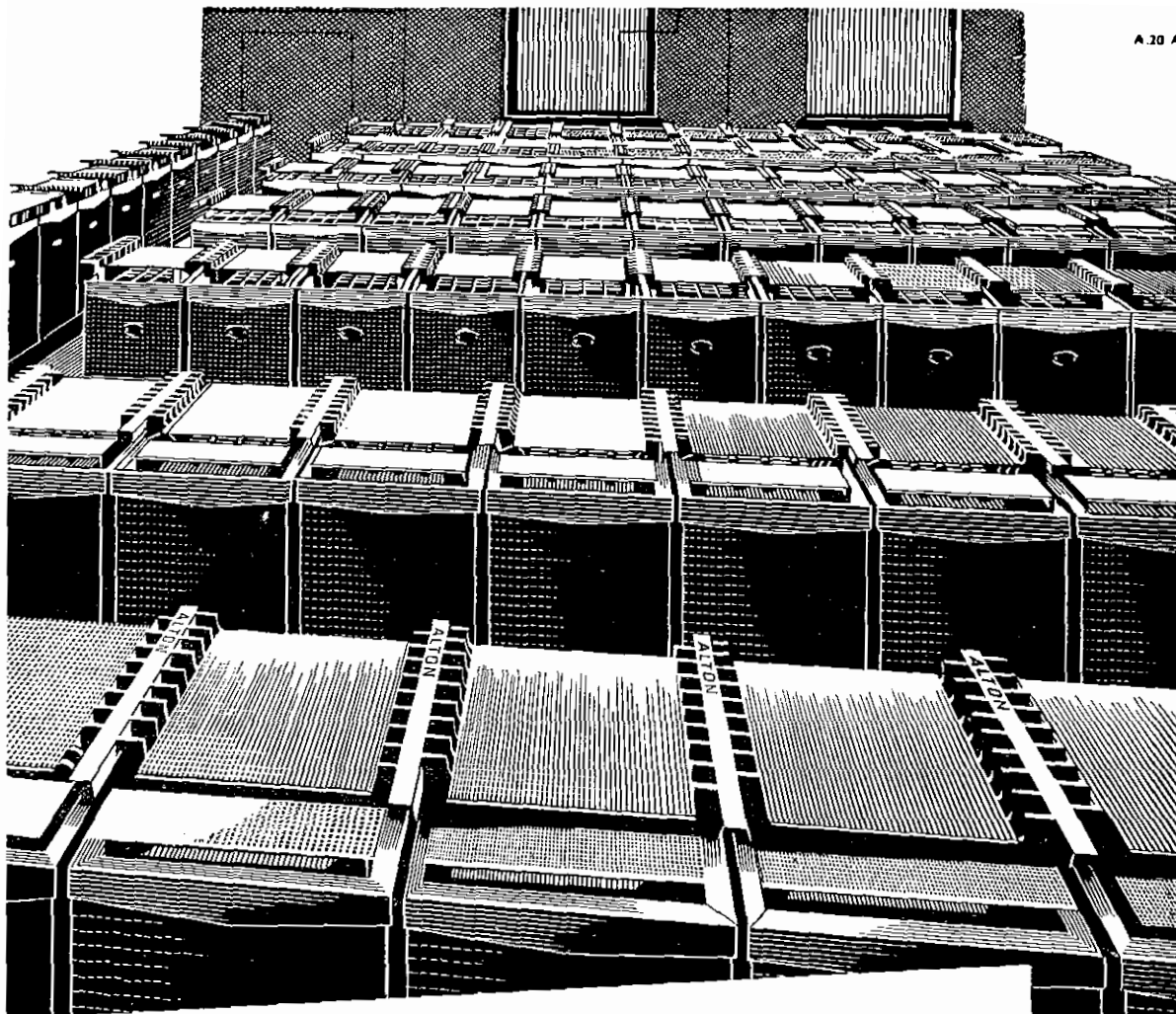

Alton has been exporting batteries for thirty years. In installations in sixty-five countries Alton Batteries, in capacities from 10 to 15,000 ampere-hours, are giving the service only good batteries can give. Alton, in any language, means good batteries and firm delivery dates.

# ALTON

## BATTERIES OF MERIT

THE ALTON BATTERY COMPANY LIMITED

Alton, Hants. Telephone: Alton 2267 and 2268

Telegrams: Battery, Alton

*Alton can also supply renewal plates for all makes of battery, British & Continental*

## VALUABLE FREE BOOK

Tells You How to Pass Your C. & G. or Promotion Exam. at First Attempt!

All Post Office Engineering personnel who are anxious to obtain early promotion should at once send for a copy of our handbook "ENGINEERING OPPORTUNITIES," which, among other intensely interesting matter, describes our unique methods of preparation for **TECHNICAL APPOINTMENTS IN THE POST OFFICE** (Assistant Engineer—New Style and Assistant Traffic Superintendent), **CITY AND GUILDS EXAMINATIONS** in Principles of Telecommunications (1-5), Radio (1-4), Telephone Exchange Systems (1-3), Telegraphy (1 and 2), Line Transmission (1 and 2), Lines Plant Practice (1 and 2), Mathematics for Telecommunications (1-5), Electrical Engineering Practice (Prelim. Inter. and Final), and outlines a wide range of non-examination courses in all branches of Electrical, Mechanical, Civil, Automobile, Aeronautical and Radio Engineering.

Assistant Engineer and Assistant Traffic Superintendent. Open competitions now resumed. Age extensions for established Civil Servants. Ask us for full details

We definitely guarantee  
"NO PASS—NO FEE"

If you intend to make the most of to-day's opportunities, you cannot afford to miss reading "ENGINEERING OPPORTUNITIES." It tells you everything you want to know to secure advancement, and describes many opportunities you may now be missing through lack of information. Send for your copy to-day—FREE and without obligation.

BRITISH INSTITUTE  
OF ENGINEERING TECHNOLOGY  
369 SHAKESPEARE HOUSE,  
17-19 STRATFORD PLACE, LONDON, W.1

# BIET

for the best focus on  
**ECLIPSE**

for  
**PERMANENT MAGNETS**  
for television  
radio and  
telecommunications  
specify **Eclipse**

EM16

JAMES NEILL & CO. (Sheffield) Ltd., SHEFFIELD

## The "WESTAT"

system of  
constant potential  
rectification

is extensively used for battery charging, and can be designed as a charger with a high degree of taper, or as a cyclic charger, with the great advantage that it is practically independent of mains fluctuations.

**WESTINGHOUSE**  
**WESTALITE**  
**RECTIFIERS**

Write for Data Sheet No. 62 to Dept. P.O.E.E.J. 3

**WESTINGHOUSE BRAKE & SIGNAL CO., LTD.**  
82 York Way, King's Cross, London, N.1

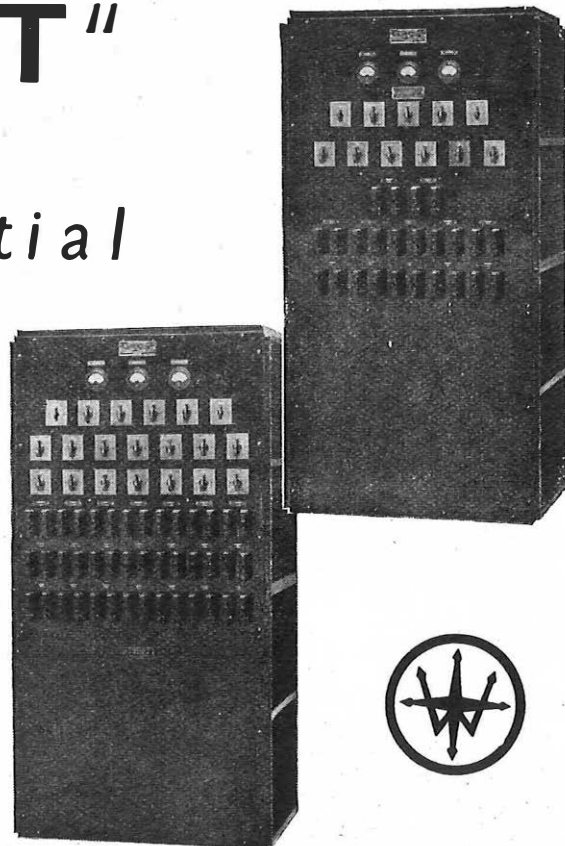

# SIEMENS

*High-Speed*

## MOTOR UNISELECTOR

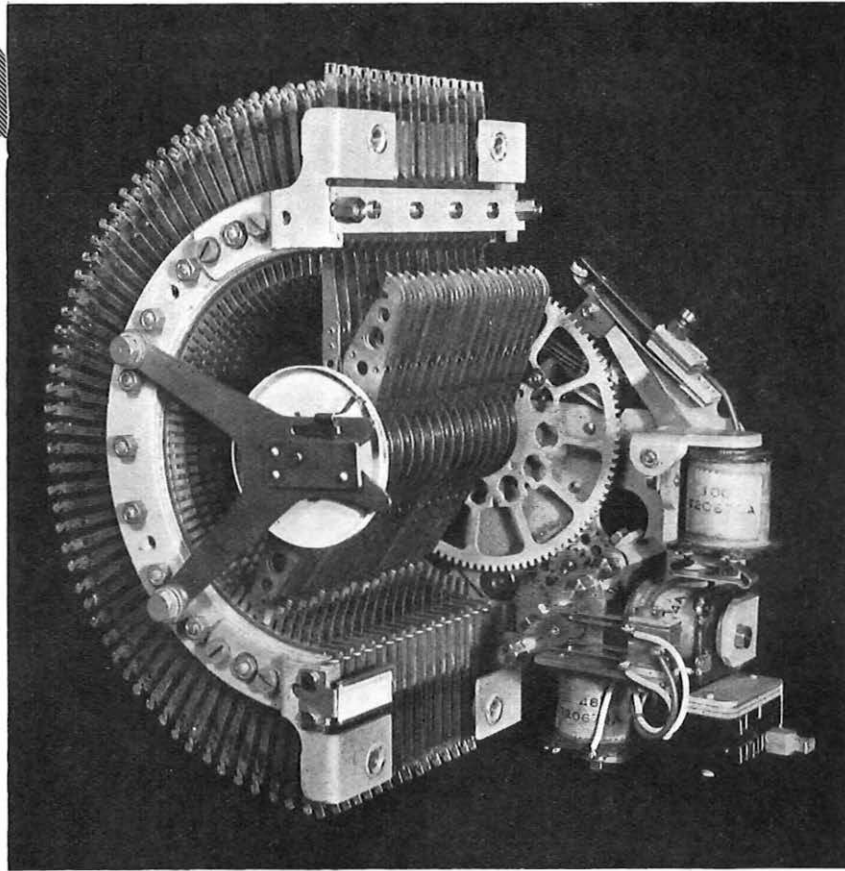

For their Trunk Mechanization Scheme the British Post Office has adopted the High-Speed Motor Uniselector illustrated above.

This Automatic switch has a searching speed of 200 outlets per second. This high speed together with its thorough reliability in operation render it the ideal switch for automatic trunk working.

The original type of Motor Uniselector has been in use for Line Finders at North Exchange, London, since June 1935

**SIEMENS BROTHERS & CO., LIMITED**  
WOOLWICH • LONDON • S. E. 18.



## MICRO-HARDNESS TESTER

DEVELOPED BY THE GUEST, KEEN, NETTLEFOLD LABORATORIES

This new instrument is suitable for use with a standard metallurgical bench type microscope.

It is designed to give a range of loads from 1 to 100 grams with a high degree of accuracy. The associated mechanical stage is provided with micrometer adjustments which permit very accurate movement of the specimen which is necessary for some Micro-hardness investigations. Some applications of this instrument are the measurements of:—

- ★ Hardness of phases of a micro structure.
- ★ Hardness of plated surfaces.
- ★ Case hardening and nitriding.
- ★ Hardness of thin wires, foils and soft metals.
- ★ Hardness variation in cold worked specimens.

*Descriptive folder, operating instructions, prices and specialised technical details from sole manufacturers:*

## AN H.T.A. PRODUCT

**HALL TELEPHONE ACCESSORIES LTD.**

*Precision Engineers and Instrument Makers*

70 DUDDEN HILL LANE, LONDON, N.W.10.

Tel.: Willesden 5141 (8 lines). Grams: Halltelacc, Harles, London.

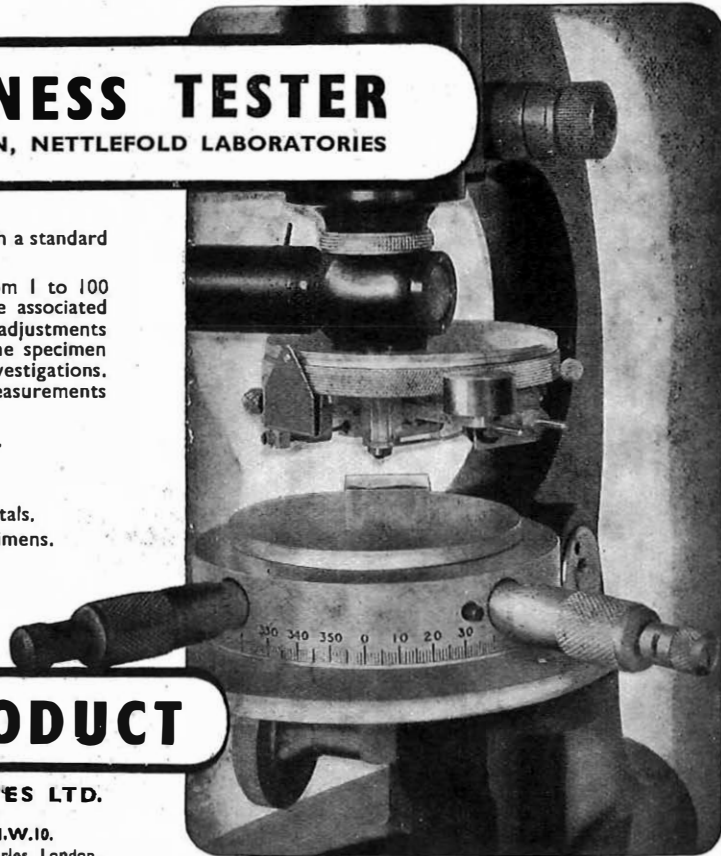

*We shall be pleased to select for any prospective purchaser a galvanometer suited to any particular industrial application or measurement problem.*

## A NEW SULLIVAN SUSPENDED COIL PORTABLE GALVANOMETER UNIT

... which may be supplied alone or boxed complete with scale, illumination (with mains transformer) and novel scale magnification.

The unit is exceptionally well constructed and reliable in performance and is completely enclosed within a draught and dust-tight bakelite case measuring only 8 cm. by 4 cm. by 12 cm. high. When boxed as a complete measuring system it measures only 26 cm. by 17 cm. by 15 cm.

A complete series of these portable galvanometer units is available, mounted or unmounted, with many scale arrangements and for any Sensitivity, time period or resistance.

**H. W. SULLIVAN  
LIMITED**

LONDON, S.E.15

Telephone: New Cross 3225 (P.B.X.)



**PRODUCTS OF THE COMPANY INCLUDE:** DIRECTOR AND NON-DIRECTOR AUTOMATIC TELEPHONE EXCHANGE EQUIPMENT, AUTOMATIC TRUNK EXCHANGES, RURAL AUTOMATIC EXCHANGES, PRIVATE AUTOMATIC EXCHANGES, PRIVATE AUTOMATIC BRANCH EXCHANGES, SINGLE AND MULTI-CHANNEL (CARRIER) TRANSMISSION EQUIPMENT; INTERCOM KEY-CONTROLLED TELEPHONE EQUIPMENT, CENTRALISED SUPERVISORY REMOTE INDICATION AND CONTROL EQUIPMENT; "RYTHMATIC" RIPPLE CONTROL EQUIPMENT; "ELECTRO-MATIC" VEHICLE-ACTUATED TRAFFIC SIGNALS; MINE TELEPHONES AND COLLIERY SIGNALLING EQUIPMENT.



*A stage in the production of crystals used to control frequency stabilisation in carrier oscillators. The crystal, held in a jig, is being fitted with phosphor-bronze wires .008 in. diameter which are soldered to both sides of the prepared crystal simultaneously by means of two hot air jets.*

## **From First Principles to Finished Product**

The behaviour of quartz crystal under physical and electrical stress—piezo

electricity—was discovered by Pierre and Jacques Curie as long ago as 1881.

Since then this phenomenon has been the subject of intensive research.

Engineers of A.T.M. organisation have applied it frequently in the solution

of problems in the field of telecommunications. One application which

involves the production of the quartz plates to exceptionally fine limits is the

stabilisation of carrier frequencies in A.T.M. multi-channel carrier systems.



**AUTOMATIC TELEPHONE & ELECTRIC CO. LTD.**

Export Department: Strowger House, Arundel Street, London, W.C.2 Telephone: TEMple Bar 9262.

Cablegrams: Strowgerex, London. Strowger Works, Liverpool, England.

# Creed

## TELEPRINTERS

*Built by specialists  
in machine telegraphy~*



N° 47 TAPE MODEL

*Write for  
Bulletin N° 21*

**Creed & Company Limited**

TELEGRAPH HOUSE  
CROYDON, ENGLAND

# CARPENTER Polarized RELAY TYPE 4

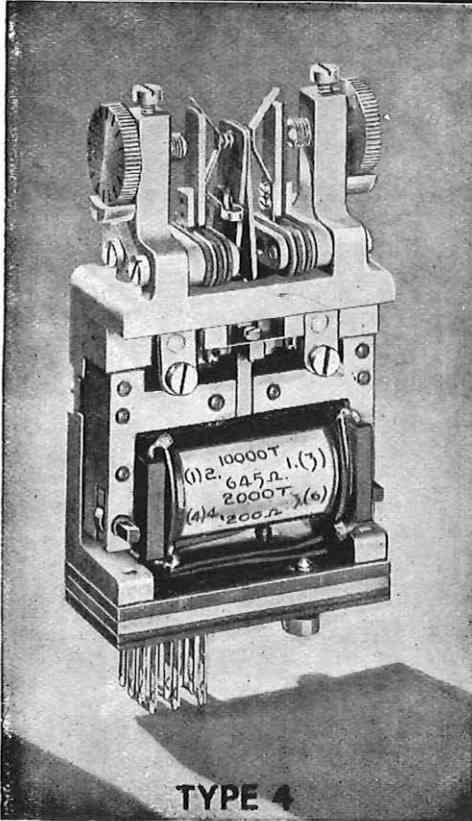

This is a medium speed, sensitive relay with long contact travel designed primarily as a telephone impulsing relay (D.C. dialling up to 100 miles and V.F. dialling on trunk circuits). It has also been successfully adopted for use in Telex systems.

Its sensitivity is such that when the gap is adjusted to .004 in. the relay will just operate at 50 cycles with 4 ampere-turns (corresponding to approximately 1 mVA) or on  $2\frac{1}{2}$  D.C. ampere-turns at low speeds. In service, however, the relay is normally operated at currents substantially larger than the minimum operating current.

Contact chatter is absent if the contact gap does not exceed .004 in. The contact gap is adjustable by means of fine pitch screws with knurled heads marked with .001 in. divisions.

Contacts on the armature tongue are insulated from it and thereby from the frame.

Terminals for soldered connections are fitted as standard.

The relay is supplied with a magnetic screening cover with transparent removable top to facilitate contact adjustment.

Dimensionally the relay is interchangeable with the type "3000" relay and can be supplied to fit directly to the drilling normally provided for the "3000" relay.

**Dimensions of the Type 4 Carpenter Relay are :—(With cover. Excluding wiring tags)**  
 $3\frac{3}{8}$  ins. high  $\times$   $2\frac{3}{16}$  ins. wide  $\times$  1 in. deep. Weight: 13 ozs.

Complete details available on request.

Manufactured by the Sole Licensees :—

## TELEPHONE MANUFACTURING CO. LTD.

Contractors to the British Commonwealth and Foreign Governments

HOLLINGSWORTH WORKS DULWICH LONDON, S.E.21

Telephone: GIPsy Hill 2211 (10 lines)



The AvoMeter is one of a useful range of "Avo" electrical testing instruments which are maintaining the "Avo" reputation for an unexcelled standard of accuracy and dependability—in fact, a standard by which other instruments are judged.

### ONE INSTRUMENT measures :—

Current, A.C. and D.C. (0 to 10 amps.)  
 Voltage, A.C. and D.C. (0 to 1,000 v.)  
 Resistance (up to 40 megohms)  
 Capacity (.01 to 20 mfd.)  
 Audio-frequency Power Output (0 to 2 watts)  
 Decibels (— 25 Db. to + 16 Db.)

Write for fully descriptive pamphlet.

**'AVO'**  
 Meters that Matter

**THE Model 7 Universal AvoMeter** is the world's most widely used combination electrical measuring instrument. It provides 50 ranges of readings on a 5-inch hand-calibrated scale, and is guaranteed accurate to B.S. first grade limits on D.C. and A.C. from 25 c/s to 2 kc/s. It is self-contained, compact and portable, simple to operate and almost impossible to damage electrically. It is protected by an automatic cut-out against damage through severe overload.

Sole Proprietors and Manufacturers :—

THE AUTOMATIC COIL WINDER & ELECTRICAL EQUIPMENT Co. Ltd.  
 Winder House, Douglas Street, London, S.W.1. Phone: VICToria 3404.9

# Telephone cables

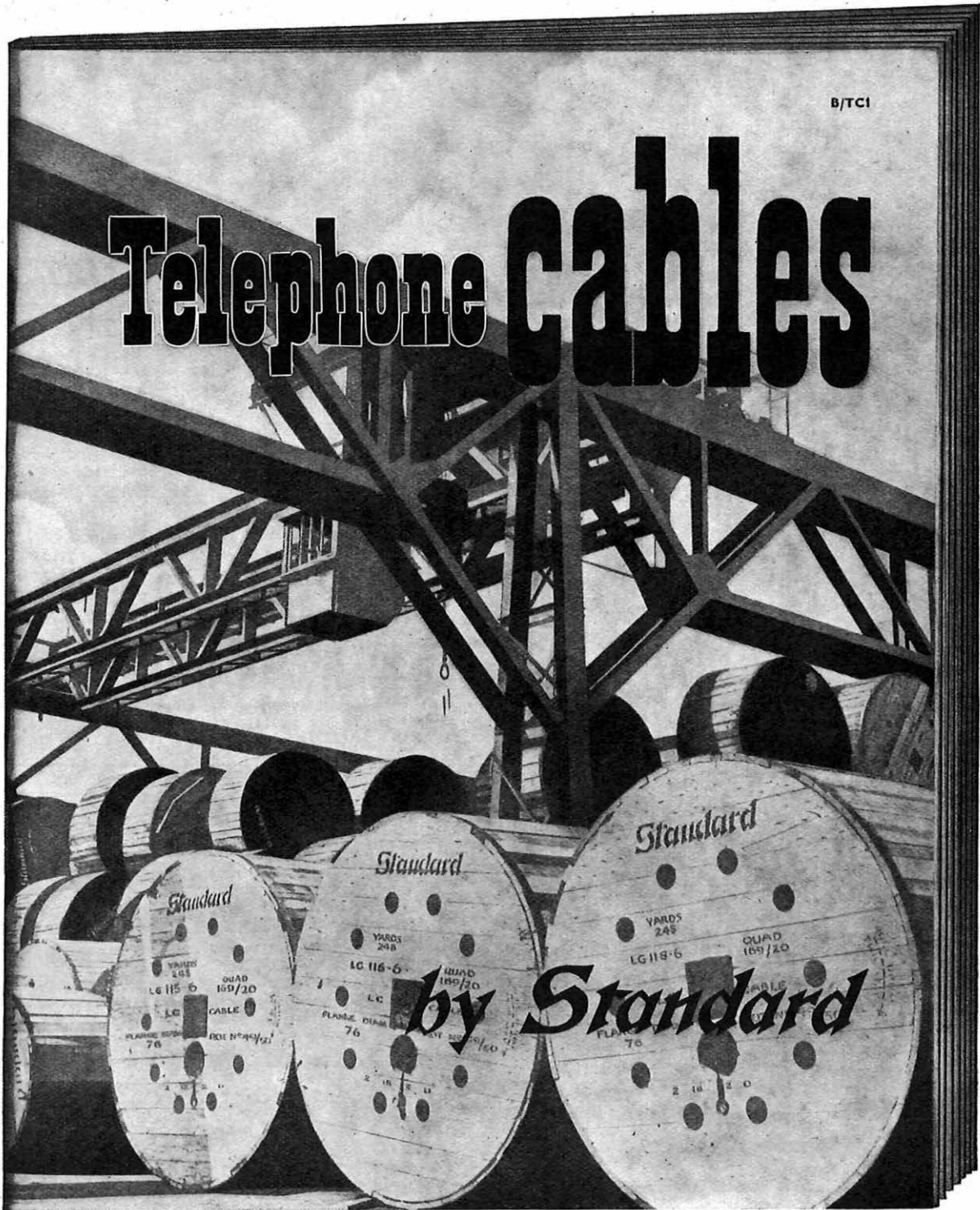

THIS catalogue, No. B/TC 1, contains the latest information on a wide range of telecommunication cables manufactured by "STANDARD."

***Standard Telephones and Cables Limited***

(Registered Office: Connaught House, Aldwych, London, W.C.2)

**TELEPHONE LINE DIVISION.**

**NORTH WOOLWICH, LONDON, E.16**



# MIGHTY midget . . .

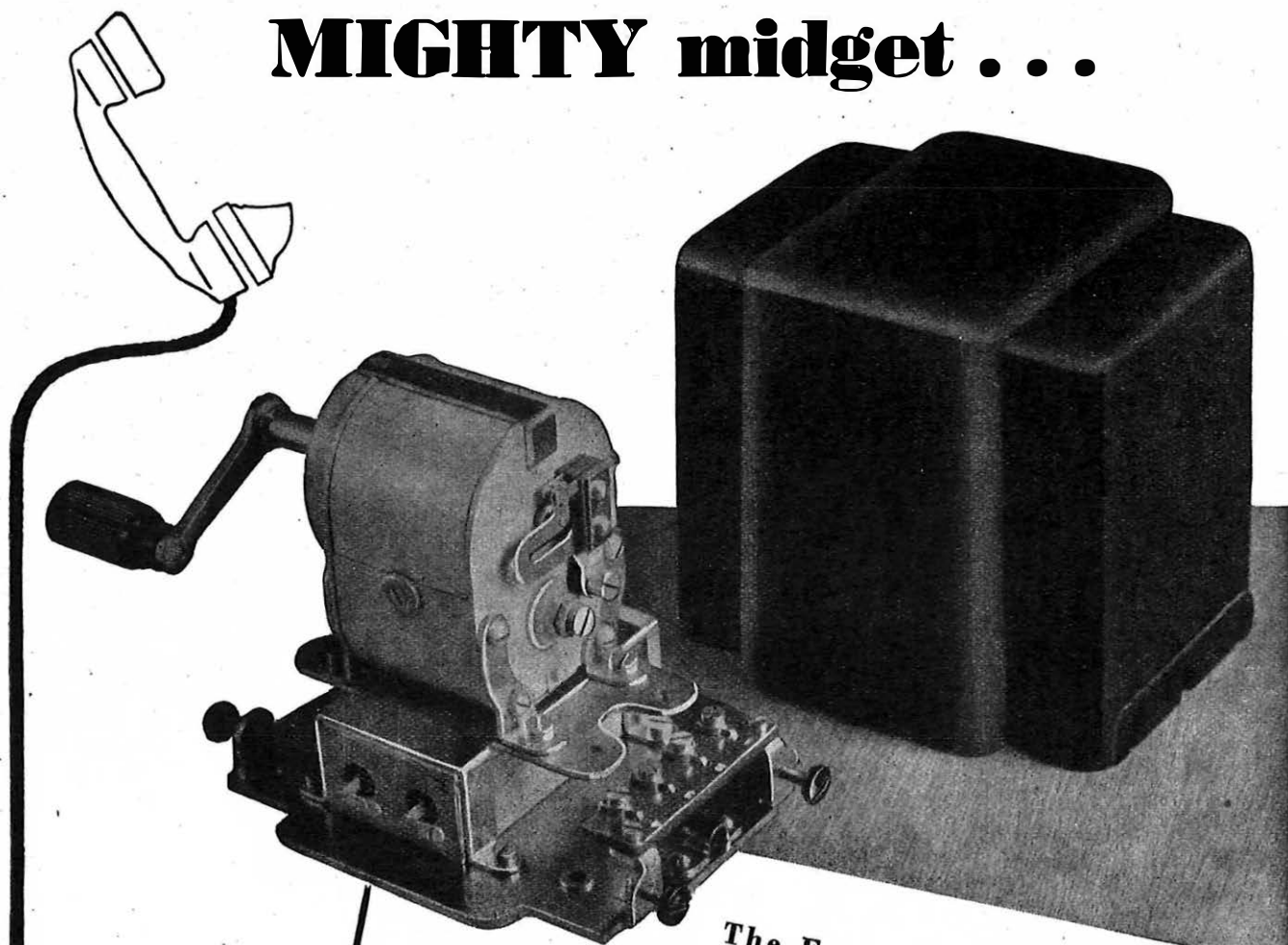

The Ericsson **ALNICO GENERATOR** illustrated is a robust yet elegant example of Ericsson practice. Has an output equivalent to the old 4-Bar unit but is less than half its size and weight. Certified safe for use in mines, and can be supplied unmounted or without the moulded bakelite case. Our heavy duty **ALNICO** generator is slightly larger but uses the same case.

THE

# Ericsson

## ALNICO GENERATOR

ERICSSON TELEPHONES LTD. • Head Office: 22 LINCOLN'S INN FIELDS, LONDON, W.C.2. • Tel: HOL. 69.36  
Works: BEESTON, NOTTS.



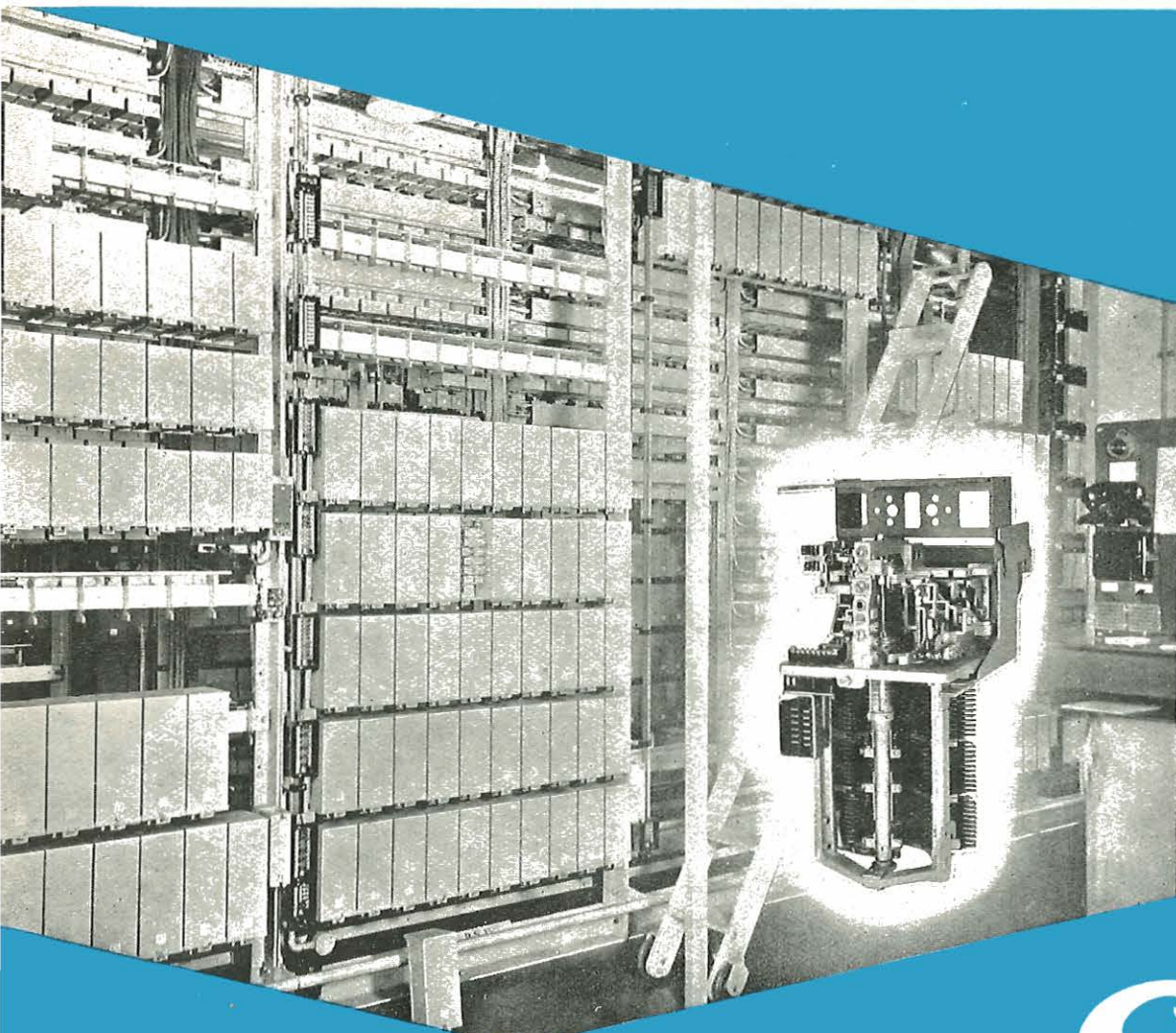

# G.E.C.

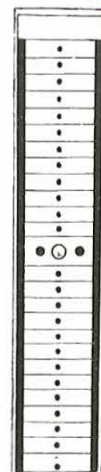

LINE AND  
RADIO  
SYSTEMS



**TELEPHONE  
EXCHANGES &  
INSTRUMENTS**



#### MAJOR PRODUCTS

Automatic and manual exchanges of any capacity.

Telephone transmission systems for coaxial tubes, underground cables, open-wire lines and radio links.

H.F., V.H.F., and U.H.F. radio systems, (including wide-band television links).

Telephone instruments for all purposes.

Cables and testing equipment, (by associated Companies).

Special systems for the control of electric power distribution networks, railways, water undertakings, etc.



# THE COMPLETE SERVICE

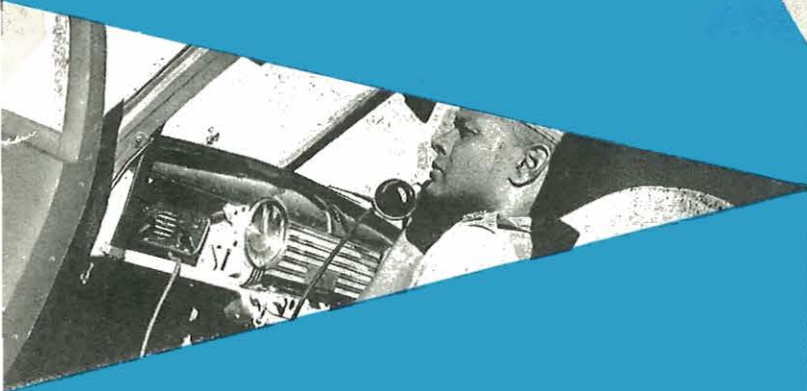

**WORLD-WIDE  
REPUTATION**

**THE GENERAL ELECTRIC COMPANY LIMITED OF ENGLAND**

TELEPHONE, RADIO & TELEVISION WORKS, COVENTRY, ENGLAND. Phones Coventry 4111 (10 lines) Telegrams and Cables: "Springjack Coventry."  
HEAD OFFICE: MAGNET HOUSE, KINGSWAY, LONDON, W.C.2. Phone: Temple Bar 8000 (90 lines). "Electricity, Westceit, London." Cables "Polyphase, London."

## UNIVERSALLY ADOPTED

### G.N.T.Co. TRANSMITTER MODEL II2

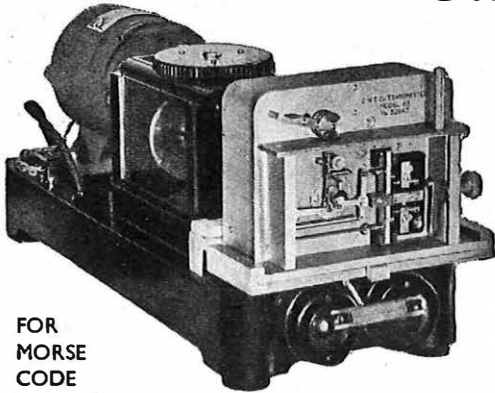

FOR  
MORSE  
CODE

13-250 words per minute without gear changes  
or readjustments.

Absolutely constant speed at all settings not-  
withstanding large voltage variations.

Noted for its easy maintenance.

Supplied with A.C. or D.C. motors as required.

**THE GREAT NORTHERN TELEGRAPH CO. LTD.**  
OF DENMARK

KONGENS NYTORV 28  
COPENHAGEN K. - DENMARK

AND

5, ST. HELEN'S PLACE,  
LONDON, E.C.3

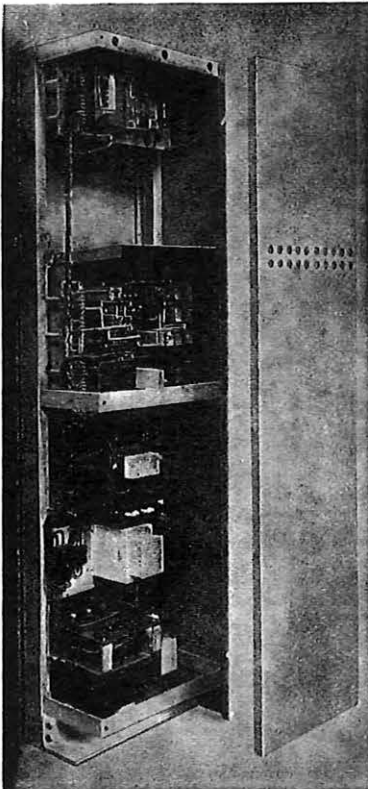

*The Mark II series of*

## SAVAGE AMPLIFIERS

*for Broadcast Relay*

● These Amplifiers are examples of what careful design can achieve. A lift-off back panel affords immediate access for maintenance purposes and the removal of six screws releases the side covers of the rack and exposes all the interpanel wiring. Even when the rack is sandwiched between others the side covers can be removed just as easily.

All valves are accessible from the front of the rack, and are protected by quick release grilles. The rack is completely flat fronted. The general appearance is further enhanced by the absence of a projecting front foot, and the masking of all panel fixing bolts. Similar racks carrying auxiliary apparatus can be placed side by side with amplifiers so that the whole installation is uniform in appearance.

*Complete specifications  
available on request.*

WESTMORELAND ROAD  
LONDON N.W.9  
TELEPHONE: COLINDALE 7131

**W. BRYAN SAVAGE  
LIMITED**





Regd. Products

**has your Corrosion Problems**

**TAPED**



Denso Tape protects mains, services and all metalwork, below or above ground, against the menace of chemical and electrolytical corrosion. Ideal for water- and gas-proofing and an aid to frost-proofing. Emergency repairs to gas mains and services. Water-proofing temporary cable openings. Specifications and Price Lists of "Denso" Anti-corrosive and Sealing Products without obligation from:—

**WINN & COALES LTD.**

TERMINAL HOUSE, GROSVENOR GARDENS, LONDON, S.W.1  
Telephone: SLOane 6146/7. Telegrams: DENSELTE, SOWEST, LONDON

**THE THEORY AND DESIGN OF INDUCTANCE COILS**

By **V. G. WELSBY, Ph.D., A.M.I.E.E.,**  
*Post Office Research Station*

This book is intended to assist the circuit designer in selecting the coil design most suitable for a given purpose, and to enable him to predict the changes which must be made in a given design in order to obtain any desired performance of the resulting coil. It will also appeal to students who must obtain a clear understanding of the applications and design of inductance coils.

60 illustrations 18/- net

**MACDONALD & CO.**  
(Publishers) LTD.  
43, LUDGATE HILL, LONDON, E.C.4

**SOUND INSTRUCTION by Postal Method**

The I.C.S., largest school in the world devoted to spare-time training by the postal method, offers you highly specialised Courses for the following examinations:

- P.M.G. Certificates for Wireless Operators.**
- C. & G. Illumination Engineering (Inter.)**
- C. & G. Electrical Engineering Practice, Installation and Telecommunications.**
- Graduateship of the B.I.R.E.**

*I.C.S. Examination students are coached till successful.*

Other Courses meet the requirements of all who desire to qualify for responsible positions in Electric Power, Illumination, Heating and Traction Systems. Equally successful is our instruction for Telegraph and Radio Engineers, Radio Servicemen, and in Elementary Radar and Electronics, Advanced Short-Wave Radio and Television Technology.

Instruction is by correspondence from textbooks specially prepared by many experts.

*WRITE FOR OUR SPECIAL BOOKLET* and state the particular subject or Examination in which you are interested.

**YOU MAY USE THIS COUPON**

**International Correspondence Schools Ltd.**  
Dept. 108, International Buildings, Kingsway, London, W.C.2

Please send me, free of charge, your special booklet on.....

Name..... Age.....

(BLOCK LETTERS, PLEASE)

Address .....



**PITMAN BOOKS**



**Antenna Theory and Design**  
(2 Vols.)

By H. Paul Williams, Ph.D., A.M.I.E.E., Sen.M.I.R.E. Profusely illustrated. Vol. I (Foundations of Antenna Theory) 21/- net. Vol. II (The Electrical Design of Antennæ) 63/- net. Just published.

**Electric Cables**

By Francis W. Main, M.I.E.E. A practical guide to the properties, construction, installation and maintenance of electric cables, with information on super-tension cables and other modern developments. 52 illustrations. Third Edition. 12/6 net.

**Power System Interconnection**

By H. Rissik. An important work, invaluable for the practising electrical engineer and a reliable textbook for the advanced student. Second Edition. 25/- net.

**Telephony—Vol. I**

By J. Atkinson, A.M.I.E.E. The first volume of a completely revised edition of Herbert and Procter's great work, recognized as the standard guide to telephony. This volume deals with general principles and manual exchange systems. 694 illustrations. 35/- net.

**PITMAN, Parker Street, Kingsway, London, W.C.2**

# TELEPHONE CABLES

OUR BROCHURE No. 9E (1949),  
GIVING INFORMATION AND SPECI-  
FICATIONS FOR A WIDE RANGE  
OF TELECOMMUNICATION CABLES  
MANUFACTURED BY US, IS  
AVAILABLE UPON REQUEST.

TELEPHONE:  
SOUTHAMPTON  
2141 (5 lines)

**IRELLI-GENERAL**  
CABLE WORKS, Ltd., SOUTHAMPTON.

TELEGRAMS  
"PIGEKAYBEL"  
SOUTHAMPTON

## MINIATURE VITREOUS ENAMELLED RESISTOR

TYPE M.V.1

**RATING** 3 watts for 250°C. rise.

**RESISTANCE RANGE** - 1-4700 ohms.

Full rated watts over the whole resistance range.

**DIMENSIONS** -  $15/32'' \times 13/64''$ .

Agents in Switzerland: Arnold Kleiner, Zug



Actual size of resistor

TYPE  
APPROVED

**PAINTON**  
*of*  
**NORTHAMPTON**

KINGSTHORPE, NORTHAMPTON.