

# THE POST OFFICE ELECTRICAL ENGINEERS' JOURNAL



Vol. 59 Part 4

JANUARY 1967

## CONTENTS

	Page
ELECTRONIC TELEPHONE EXCHANGES: COMPONENT SELECTION AND MODE OF OPERATION—J. A. T. French, B.Sc.(Eng.), C.Eng., M.I.E.E., and W. T. Lowe, C.Eng., M.I.E.E.	233
PRACTICAL ASPECTS OF PROVIDING TELEPHONE PLANT ON NEW HOUSING ESTATES—S. L. F. Fagg and F. G. Mead .....	241
A PROTOTYPE CONFERENCE REPEATER USING A NEW VOICE-SWITCHING TECHNIQUE—R. A. Jones, B.Sc.(Eng.) .....	246
PERFORMANCE OF THE DATEL MODEM No. 1A—N. G. Smith and R. H. Tridgcll, B.Sc., C.Eng., M.I.E.E. ....	250
THE LEIGHTON BUZZARD ELECTRONIC TELEPHONE EXCHANGE—S. H. Sheppard .....	255
TEST EQUIPMENT FOR THE DATEL SERVICE—DATEL TESTERS No. 1A, 2A AND 2B—G. D. Skingle, Graduate I.E.R.E., and J. C. Spanton, Graduate I.E.R.E. ....	262
THE NEW LEAFIELD RADIO STATION, Part 4—The H.F. Transmitters—A. E. N. Wase, C.Eng., M.I.E.E., and B. S. Jackson, B.Sc. ....	267
THE 5005-CROSSBAR TELEPHONE-EXCHANGE SWITCHING SYSTEM, Part 2—Application and Maintenance—H. Banham, B.Sc.(Eng.), C.Eng., M.I.E.E. ....	271
I.T.U. SEMINAR ON "THE TELEPHONE SERVICE," LONDON, SEPTEMBER 1966 .....	282
THE NEW LEAFIELD RADIO STATION, Part 5—The External and Switching Plant—M. Hart, C.Eng., A.M.I.Mech.E. ....	283
OPENING OF THE FIRST PRODUCTION ELECTRONIC TELEPHONE EXCHANGE AT AMBERGATE—J. A. Lawrence, T.D., Hon.C.G.I.A., C.Eng., F.I.E.E. ....	287
NOTES AND COMMENTS .....	290
INSTITUTION OF POST OFFICE ELECTRICAL ENGINEERS .....	297
REGIONAL NOTES .....	299
ASSOCIATION SECTION NOTES .....	301
STAFF CHANGES .....	304
INDEX TO VOLUME 59 .....	308
BOARD OF EDITORS .....	310
BOOK REVIEWS .....	254, 266, 298

Price 3s. (Post Paid 4s.)

Published in April, July, October and January by *The Post Office Electrical Engineers' Journal*,  
G.P.O., 2-12 Gresham Street, London, E.C.2.

Annual Subscription (post paid): Home, 16s.; Overseas, 17s. (Canada and U.S.A., 2 dollars 75 cents).

# THE POST OFFICE ELECTRICAL ENGINEERS' JOURNAL

Vol. 59 Part 4

JANUARY 1967

## Electronic Telephone Exchanges: Component Selection and Mode of Operation

J. A. T. FRENCH, B.Sc.(Eng.), M.I.E.E., and W. T. LOWE, M.I.E.E.†

U.D.C. 621.395.722:621.395.345

This article describes the types of components selected for use in electronic telephone-exchange systems and how they are used to ensure maximum reliability.

### INTRODUCTION

THE British Post Office, in conjunction with the five principal manufacturers of telephone exchange equipment in the United Kingdom, has devoted considerable time and effort to the development of new electronic switching systems. At the present time two major system developments are going into production. This article describes the types of components to be used in the present production systems. It also discusses the reasons for their selection, and outlines the codes of practice adopted to secure a long trouble-free life.

### SELECTION OF COMPONENTS

At a fairly early design stage during the development of the electronic switching systems, the types of components available were examined under the following headings.

- (a) Reliability.
- (b) Cost.
- (c) Availability.
- (d) Compatibility with mounting arrangements for other electronic components.
- (e) The need to limit the number of different types of a component to be used.

Component selection for any system, and in particular for electronic systems, is a compromise between first costs, maintenance liability and service performance; ideally, components should be cheap and have a very small failure rate over a 30-year life.

In practice, these requirements are not easy to satisfy. Some components are liable to fail by a slow wear-out process, and this leads to a rapid deterioration of service after a period of relatively fault-free operation. The use of such devices must be avoided. For components not exhibiting any noticeable wear-out characteristic it is difficult to determine by testing, or inspection, the probable life expectancy. The most that can be said about such components is that, if they show a very small

failure rate when operated under test conditions which are considerably more stringent than those expected in service, it is probable that the failure rate under much relaxed conditions will be correspondingly lower over a very much extended period of time.

For resistors, there is a fairly large accumulation of field data over many years that can be used with confidence to formulate codes of practice, especially where past failures have led to improved designs. With semiconductors, field experience frequently shows failure rates one or two orders smaller than for the same components under laboratory life-test conditions at maximum ratings. Moreover, many of the more common failure mechanisms of semiconductors are known and can be controlled in production. These factors can be used to establish codes of practice to achieve low failure rates over a 30-year life.

By such means, supplemented by laboratory tests and field trials, components may be selected with considerable confidence to give a highly reliable performance over an economically acceptable life, provided that circuits and operating environments are also properly selected.

### RELIABILITY AND MODE OF USE

In electronic systems, reliability is closely related to the mode of use of each component; it depends on such factors as power loading, voltage stress and working temperature. Rules have, therefore, been formulated to govern the use of each device: taking the transistor as a typical example, the maximum permissible junction temperature under working conditions in a circuit has been specified, and de-rating factors have been stipulated for all important parameters. The choice of a de-rating factor is a compromise between the efficient use of a component and achieving maximum reliability with life. Table 1 shows typical de-rating factors applied to the characteristics of transistors to allow for deterioration with life.

The following example illustrates the application of these de-rating factors. A transistor with a breakdown voltage  $V_{UBO} = 20$  volts was specified for use in logic circuits. The supply voltage for the logic circuits was fixed at 12 volts nominal, with a working range from 11.4 to 14.3 volts. Applying the de-rating factor of  $\times 0.8$  to  $V_{UBO}$  gives a design maximum of 16 volts, which,

†Telephone Electronic Exchange Systems Development Branch, E.-in-C.'s Office.

therefore, allows ample margin for surges on the voltage supply.

TABLE 1  
Typical Transistor De-rating Factors

Parameter	De-rating Factor	Function
$I_{EB0}; I_{CB0}$	$\times 2$	Leakage currents
$h_{FE}; h_{fc}$	$\left\{ \begin{array}{l} \times 1.15 \text{ on upper limit} \\ \times 0.85 \text{ on lower limit} \end{array} \right.$	Current gain $I_c/I_b$
$V_{BE(SAT)}$	$\times 1.1$	Saturation voltage, base to emitter
$V_{(BR)CEO}$	$\times 0.8$	Breakdown voltage, collector to emitter

Components tend to fail more easily at high temperatures, and it is, therefore, desirable to limit the ambient temperature for electronic equipment. The maximum ambient room temperature for an exchange is taken as  $+35^{\circ}\text{C}$ . Higher temperatures can occur within a rack, but silicon devices are able to operate reliably at an ambient temperature of  $+70^{\circ}\text{C}$ , so there is ample margin for local variations in temperature. The minimum ambient room temperature for design purposes has been taken as  $+5^{\circ}\text{C}$ .

To illustrate the effect of temperature: a possible mode of failure of a transistor is due to unwanted diffusion of metals, such as gold, used in the construction of the device. Such diffusion cannot be suppressed entirely but it is very much reduced at low junction temperatures. Consequently, if the circuit design limits the junction temperature, the life of the component will be increased.

A typical manufacturing technique for transistors is to lay down a thin layer of aluminium over the emitter and base regions where connexions are to be made. This is shown in Fig. 1. At high temperatures the aluminium

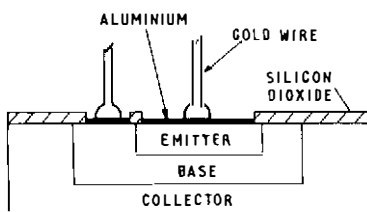

FIG. 1—GOLD-WIRE TERMINATION ON THE ACTIVE REGION OF A TRANSISTOR

combines with the gold connexion wires, forming a gold aluminium alloy which is brittle and non-conductive. The lead-out wire is, therefore, liable to either break or become high resistance at this point. The formation of the alloy, which is sometimes called "purple plague" because of its characteristic colour, can be avoided by using an all-aluminium construction, i.e. using aluminium connecting wires instead of gold ones or by oxidizing the aluminium before bonding. Yet another method is to increase greatly the area of gold wire in contact with the aluminium so that the time taken for all the aluminium and gold at the bond to become alloyed is increased beyond the wanted life of the component. The additional area is achieved by melting the end of the gold wire to form a globule, which is then welded in the usual way.

These problems all indicate the need for a low working temperature for the silicon slice. In the electronic-exchange designs all semiconductor devices have been restricted to a maximum junction temperature of  $100^{\circ}\text{C}$ , which is a compromise between obtaining sufficient power-handling capacity and reliable life.

#### RESISTORS

Three types of resistor were available:

- (i) Carbon composition, Grade 2.
- (ii) High-stability carbon, Grade 1.
- (iii) Metal-oxide film.

The Grade 1 carbon types were discarded because of a tendency to go open-circuit under certain conditions of light loading in humid atmospheres. Although at the time they were cheaper than the metal-oxide types (which were considerably more reliable) it was expected that the large quantities required for electronic systems would bring about reductions in the cost of the metal-oxide types. The Grade 2 carbon resistors available were reliable enough but were subject, in general, to a design tolerance of  $\pm 15$  per cent, which was inconveniently large for many purposes. Their cost was, however, considerably lower than the equivalent metal-oxide types, and it was decided that Grade 2 carbon resistors could be used whenever the available tolerances were acceptable. Elsewhere, metal-oxide resistors would be specified. Moreover, only metal-oxide types would be stocked for maintenance replacements.

A typical metal-oxide-film resistor assembly is shown in Fig. 2; it consists of a rod of optical-quality glass,

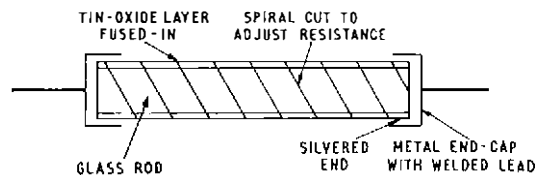

FIG. 2—METAL-OXIDE-FILM RESISTOR

the surface of which is coated with a layer of tin oxide. The tin-oxide layer is deposited on the glass rod at a high temperature to form a molecular bond with the glass. The reliability of this type of resistor is due partly to the similar thermal coefficients of expansion of the oxide film and the glass substrate, which eliminate mechanical stresses on the film during temperature cycling, and partly to the hardness of the film, which reduces its liability to mechanical damage. The homogeneous nature of the oxide film also results in very low electrical noise. An oxide-film resistor is, therefore, stable and reliable, and will remain within its specified tolerance under all the recommended operating conditions. If the resistor is rated conservatively it should have a mean lifetime well in excess of 30 years. An additional advantage of metal-oxide resistors is that each resistor has a "triple rating," which permits a considerable reduction in the number of resistors which must be stocked to cover a given tolerance range. For example, a resistor is specified as having a life stability of  $\pm 3$  per cent if used as a  $\frac{1}{2}$ -watt resistor, a life stability of  $\pm 2$  per cent if used as a  $\frac{1}{4}$ -watt resistor, or a life stability of  $\pm 1$  per cent at  $\frac{1}{8}$  watt.

Wire-wound resistors are not considered reliable

enough for widespread use on electronic systems, and their use has, therefore, been limited.

#### CAPACITORS

The types of capacitor available included those with dielectrics of paper, mica, ceramic, polythene, polystyrene or glass, and various types of electrolytic capacitor. Paper-dielectric types were discarded; these are rapidly being superseded for telecommunication and similar equipment by plastic types, which are more reliable in comparable situations. Mica and ceramic types offered little advantage over those with plastic dielectrics and were excluded in the interests of rationalization. Electrolytic types are not highly reliable over a long lifetime, and designs have excluded them wherever a failure would affect service.

British Post Office specifications for capacitors call for high standards of construction and sealing. Typically, for plastic-film capacitors, 2-point welding of lead-out ribbons is specified, and samples are subjected to climatic tests to ensure that sealing is adequate.

#### TRANSISTORS AND DIODES

An early decision was made to use silicon transistors and diodes in preference to germanium types, even though at the time the silicon versions were more expensive; the costs have since fallen to acceptable levels. The advantages of using silicon instead of germanium devices are:

- (a) the higher temperature at which the component can be operated without deterioration in performance,
- (b) lower leakage currents,
- (c) high reliability with stability of characteristics, and
- (d) the planar and epitaxial processes used in the production of these devices are very suitable for bulk manufacture with close control of the processes.

The number of types of diode and transistor has been limited for the following reasons.

- (a) To achieve low costs by bulk buying.
- (b) To simplify maintenance, and to obtain lower maintenance costs, by reducing the number of types stocked.
- (c) To increase the reliability of the components. This is achieved because of the closer control that can be obtained when manufacturing large quantities on a continuous-production line.
- (d) To ensure continuity of supply in future years because of a continual economic demand.

At the initial design stage, three basic types of transistor were required: a logic transistor, capable of switching at the desired operating frequency of the system, with enough gain to obtain a good fan-out drive to other logic circuits, a transistor for operating relays, using the 50-volt negative supply, and a medium-power high-speed transistor for driving ferrite cores or pulse highways.

For circuit flexibility it was desirable to have complementary types (i.e. n-p-n and p-n-p) of each of these devices. This resulted in a requirement for six basic types for common use; a few additional types for limited use were found to be desirable. Details of the types used are given in the Appendix.

The types of diode selected were: a medium-speed logic diode, rated at a peak inverse voltage of 20 volts, a general-purpose diode for d.c. blocking and surge suppression, rated at a peak inverse voltage of 150 volts,

an avalanche diode, which can carry high reverse currents at a nearly constant reverse voltage and is used mainly for surge suppression, a high-speed high-current diode for core drive, and a power diode for power-supply units.

The specifications written for the selected semiconductor devices contained the minimum number of test requirements consistent with ensuring the production, at low cost, of reliable components with the desired performance and quality. The specifications were written so that they provided sufficient information for a wide range of circuit applications. This required the specification of certain parameters, such as the gain of the transistors, to be given at several points within the working range of the component. In practice, this has proved to be a valuable feature of the specifications, and has contributed to a reduction in the number of types required.

#### Voltage Rating of Transistors

The maximum permissible collector-emitter voltage for any of the low-power logic transistors may be limited by either the de-rated  $V_{CE0}$  limit or the de-rated  $V_{CB0}$  limit, bearing in mind that the latter must include the reverse voltage applied to the base of the transistor to cut it off.

For the medium-power fast-switching transistor CV 7726,  $V_{CB0}$  (= 60 volts) is not a limiting factor, but  $V_{CE0}$  is limited to 30 volts maximum at collector currents above 1 mA. This limit is imposed by the fact that a negative-resistance region exists in the collector-current/collector-emitter-voltage characteristic with the base open-circuited, as shown in Fig. 3, if these limiting figures are exceeded. If the device is used with an inductive collector load it is possible for it to continue to conduct at a point on this characteristic after the base current has been turned off, unless suitable precautions are taken in the design of the circuit to hold  $V_{CE}$  below the limit. Such precautions are necessary to prevent excessive dissipation in the transistor and possible breakdown.

The lower limiting voltage and characteristic shown in Fig. 3 are functions of the variation of current gain of the

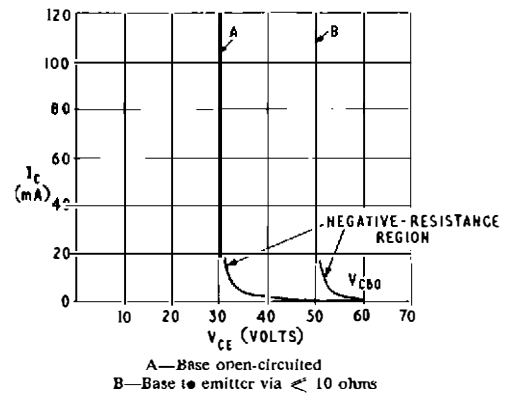

FIG. 3.—COLLECTOR-CURRENT/COLLECTOR-VOLTAGE CURVES SHOWING NEGATIVE-RESISTANCE REGION

device with collector voltage and current, and is a property of the material of which the device is manufactured and is not subject to degradation with life. It is possible to raise this  $V_{CE}$  limit towards the  $V_{CB0}$  limit by providing reverse base current when the transistor is turned off, and also by the additional use of external emitter resistance. By thus raising the  $V_{CE}$  limit above 30 volts, a sound practical design, which makes the best use of the voltage ratings of the device, has been achieved

with the CV 7726. It permits an absolute maximum peak  $V_{CE}$  of 30 volts under worst-case circuit conditions with a large factor of safety, which can exceed the desired derating factor of 0.8.

#### Dissipation Rating of Transistors

Silicon planar transistors are generally rated by the manufacturers to give a maximum junction temperature (e.g. 175°C) in an ambient temperature of 25°C, with a de-rating for higher ambient temperatures. For example, transistor CV 8615 has a manufacturer's rating of 300 mW for a rise in junction temperature above ambient of 175 - 25°C, i.e. 150°C. However, if allowance is made for a maximum ambient temperature of 55°C and a junction temperature of 100°C, the design must cater for a rise of only 100 - 55°C, i.e. 45°C. The power rating must, therefore, be reduced by a factor of 45/150, i.e. 0.3, giving only 90 mW for the device rating without a heat sink. For a transistor CV 7726 (maximum junction temperature 200°C for 800 mW dissipation) the continuous rating is reduced to (45/175)800 mW, i.e. 205 mW, for the device without a heat sink.

By using a heat sink (i.e. means of increasing the area of the device surface so that heat is removed from it more rapidly) the continuous rating of a device can be somewhat increased (Fig. 4). This increase is limited, even with

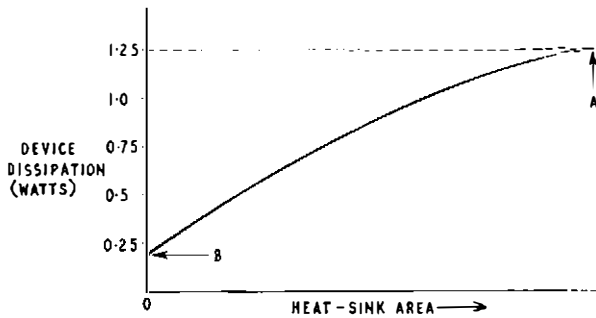

A—Thermal resistance from junction to air is same as junction to case  
 B—Thermal resistance junction to air = 220°C/W (= thermal resistance junction to case plus case to air)

FIG. 4—EFFECT OF HEAT SINK AREA ON MAXIMUM DEVICE DISSIPATION

an infinite heat sink, by the finite thermal conductivity within the component between the collector junction and the case, which allows the junction temperature to become increasingly higher than the case temperature of the component as the power dissipation is increased. There is little point, therefore, in using a bigger heat sink than one for which the thermal conductivity to the surrounding air is, say, 5 times that of the thermal conductivity within the device itself, between junction and case.

The internal thermal conductivity (measured in watts/°C), for which the corresponding thermal resistance from the junction to the case is often quoted (measured in °C/watt), also puts a severe restriction on the pulse dissipation rating for a transistor although its average dissipation may be quite permissible. In rating transistor CV 7726 for pulse operation the instantaneous peak dissipation is not permitted to exceed 2.8 watts, a figure which would limit the peak junction temperature at the end of each pulse to the manufacturer's rating; in addition, the average dissipation without a heat sink is limited to 200 mW. In practice, because the pulse duration is only a few microseconds, the thermal capacity of the collector of the transistor is sufficient to prevent the col-

lector junction temperature rising very much during each pulse: it would, therefore, vary only a little about its average value. Longer pulses, of course, would produce a bigger variation and a higher peak temperature, but the peak would always be below the manufacturer's limit. At least one manufacturer takes account of the thermal capacity of the collector junction by specifying a reduced "transient thermal resistance" (from the junction to the case) for short-duration pulses of low duty ratio. In this instance it is possible to take account of this property in assessing the device performance.

In all applications of the medium-power fast-switching device nearly all the dissipation occurs in or near to the bottomed condition (i.e. very low  $V_{CE}$ ), and a device with a very low bottoming voltage is essential for efficient usage.

#### MAGNETIC FERRITE CORES

Magnetic ferrite cores are used in electronic exchange systems for transformer or inductor cores and, in a core matrix, for information storage. Ferrites are chemical compounds of the general form  $MFe_2O_4$ , where M represents a divalent metal which can be copper, magnesium, manganese, nickel, iron, lithium or zinc. They form crystals having a cubic "spinal structure." The high-permeability linear ferrite cores used for transformers and inductors consist of mixed crystals of two ferrites, manganese and zinc. On the other hand, the square-hysteresis-loop type ferrite cores used for storage purposes consist of magnesium, manganese and copper-manganese ferrites; the new lithium-nickel ferrites are used where operation over a wide temperature range is required.

During manufacture the proportions of the powder mix are closely controlled, as these affect the characteristics of the core. A binding agent is added to the mix, and the cores are formed by compression. They are then baked at a high temperature, again under close control, and, after annealing, the completed cores are fed into an automatic testing machine. Although large numbers of cores are used in the systems, they are extremely reliable devices, with no detectable deterioration with life; it is expected that they will give virtually trouble-free service for the full life of the equipment.

#### Ferrite Cores for Linear Pulse Transformers

Pulse transformers are required in conjunction with balanced highways for pulse distribution and transmission between racks in order to obtain the best possible immunity from faults and interference. They are also required as the basic circuit element in the two types of threaded-core permanent store used in the TXE3-type of telephone exchange: these are the cyclically-addressed store for exchange terminal-equipment data, and the randomly-addressed program store of the main control unit. Pulses with durations of up to 4  $\mu$ s and with rise times of the order of 0.1  $\mu$ s are used, and for these pulses the use of linear ferrite cores of high permeability is ideal. Such cores have smaller losses, and are cheaper and easier to assemble, than metal tape or laminations, whilst their lower saturation flux density is no disadvantage.

For the transformers which supply power to the highways ( $Z_s = 100$  ohms) small ferrite pot-core assemblies were chosen. These, using a bobbin, are easy to wind,

and provide a compact efficient magnetic circuit which is easily accommodated in the mounting height available on a printed-circuit board. Interleaved or bifilar windings are used where necessary to reduce the leakage inductance. Cores having external diameters of 14 mm and 18 mm are used, and require, respectively, about 25 turns and 20 turns to produce 1 mH of shunt inductance. Pot cores are also used for some of the transformers which tap off the highways; for other transformers, where low leakage inductance is not so necessary but very low capacitance is required between the windings, these are well separated on a 0.3-inch outside-diameter toroidal linear ferrite core. A high shunt inductance is necessary for the tap-off transformers because up to 10 may be connected in parallel across each highway.

For the threaded-core stores, one row of 10 linear ferrite transformer cores is provided for each decimal digit to be generated. Information is stored by threading insulated wires once through one core in each row, and is extracted from the store by passing a  $2 \mu\text{s}$  100 mA pulse of current through one of these wires. For each core threaded, this wire forms a primary winding of a current transformer which produces a current of 2.5 mA in two 20-turn secondary windings. For this application a large toroidal (or rectangular) linear ferrite core is needed, having about  $1 \text{ in}^2$  of aperture, sufficient to accommodate up to 300 threading wires, and a cross-section sufficient to provide about  $2.5 \mu\text{H/turn}$ .

#### Pulse Transformer Design Considerations

In order to design a pulse transformer the following parameters must be known.

- (a) Pulse voltages, currents and terminating impedances to be used and permissible loss in the transformer.
- (b) Pulse width and duty ratio.
- (c) Pulse rise and fall times, and the permissible limits of these which may be introduced by the transformer.
- (d) Any d.c. component of current in any winding. In relation to these parameters the following properties of the transformer must be considered.
  - (a) Resistance of each winding.
  - (b) Losses in the core.
  - (c) Shunt inductance.
  - (d) Leakage inductance.
  - (e) Capacitance across each winding and between windings.
  - (f) Maximum flux density in the core in relation to the saturation flux density of the material of the core.

The maximum resistance of each winding is limited by the permissible transformer loss. For the small ferrite cores used, the core losses can be neglected provided that the maximum flux density used is kept low. The core chosen must be large enough to accommodate windings of a low enough resistance and a sufficient number of turns to provide the required shunt inductance. This has to be determined by considering the pulse voltage, width, and duty ratio, and the resulting maximum magnetizing current. This current adds to the primary current of the transformer and determines the maximum flux density in its core in conjunction with any d.c. component of current present in any winding. The magnetizing current must, therefore, be low enough to keep the flux density low, and it must be capable of being supplied by the circuit which drives the transformer primary. Calculation of the magnetizing current is discussed in more detail in a later paragraph.

The rise and fall times of the pulses may be increased if the transformer windings have too much leakage inductance or capacitance. The values of both of these parameters tend to increase with the number of turns, and there is a maximum obtainable ratio of shunt inductance to leakage inductance for a given core. This ratio lies typically in the range 100 : 1 to 1,000 : 1. A low leakage inductance requires the primary and secondary windings to be close together; better results are obtained by interleaving the windings, or by winding a number of wires on together and connecting them to give a turns ratio of 1 : 1 or 2 : 1, etc., as required. A low capacitance between windings is obtained by spacing the windings well apart. A low capacitance across each winding is achieved by spacing the layers of each winding with interleaved insulation.

Because of the conflicting requirements, a compromise has to be reached to obtain a high shunt inductance, low leakage inductance and low capacitances. This is not difficult if the impedances between which the transformer has to work are fairly low (i.e. of the order of 50 to 200 ohms), and for the pulse width and rise time being considered here of  $4 \mu\text{s}$  and  $0.1 \mu\text{s}$ , respectively.

As an example, a 1 : 1 transformer to drive a load of 50 ohms would require a leakage inductance referred to its secondary winding of  $L_1$  such that the time constant  $L_1/50$  was less than about 40 ns,\* giving a value of  $L_1 < 2 \mu\text{H}$ . The maximum effective shunt capacitance (to give a time constant of  $CR < 40 \text{ ns}$ ) must be less than 800 pF. A suitable shunt inductance  $L$  might be such as to give a time constant  $L/50$  of, say, five times  $4 \mu\text{s}$ , giving a value for  $L$  of 1 mH. The value of capacitance would not be reached even by a design to obtain minimum possible leakage inductance so that the best ratio of  $L/L_1$  for the core would be achievable. However, it is possible that capacitance between the windings would be limited, by interference considerations with highway-drive and tap-off transformers, to some value less than the limit imposed by rise time. The capacitance between windings which are not interleaved can be reduced considerably by inserting a metal screen between them.

If pulses occur singly, and the duty ratio is small, the above considerations will be sufficient to determine a trial design. In other instances the effect of the pulse pattern on the magnetizing current must be considered in more detail.

Fig. 5 shows the simplified equivalent circuit of a

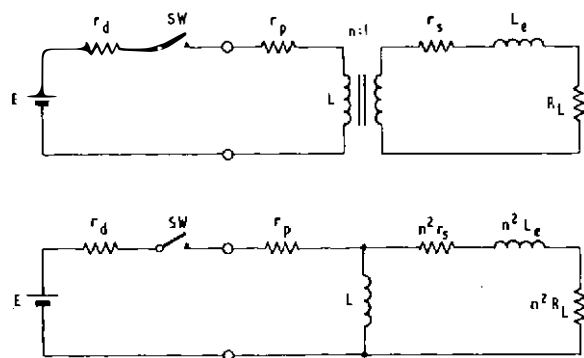

FIG. 5—SIMPLIFIED EQUIVALENT CIRCUITS OF  $n : 1$  PULSE TRANSFORMER DRIVING A LOAD  $R_L$

\*1 ns = 1 nanosecond =  $1 \times 10^{-9}$  seconds.

switching-transistor driver stage coupled to a resistive load by a transformer of ratio  $n : 1$ . Fig. 6 shows the waveforms appropriate to this circuit.

If the source resistance of the driver stage,  $r_s$ , is small enough to be neglected, it may be assumed that a constant voltage  $E$  is applied to the primary winding of the transformer for the duration of each pulse,  $t_p$ . If the transformer primary-winding and secondary-winding resistances,  $r_p$  and  $r_s$ , respectively, are also neglected at this stage, the voltage  $E$  will produce a current  $E/n^2R_L$  in the reflected load resistance  $n^2R_L$ , and a linearly rising current in the primary shunt inductance  $L$  to satisfy the relationship  $E = L di/dt$ . The current in inductance  $L$  after time  $t$  is, therefore,  $i = tE/L$ .

The current in inductance  $L$  magnetizes the core, and produces a flux  $\phi$  which is proportional to  $i$ . This linearly increasing flux is necessary in order to maintain an e.m.f. across the primary winding equal to the applied voltage  $E$  in accordance with the relationship  $E = n(d\phi/dt) \times 10^8$ , which gives flux  $\phi = t(E/n) \times 10^8$ . In terms of the current,  $\phi = i(L/n) \times 10^8$ .

The flux cannot be permitted to go on increasing indefinitely because the core would eventually saturate and the primary current would become excessive. The flux and current must, therefore, be permitted to decay sufficiently in the interval between pulses to produce acceptable maximum values of flux and current at the end of each sequence of pulses.

During the first pulse (Fig. 6(a)) the magnetizing

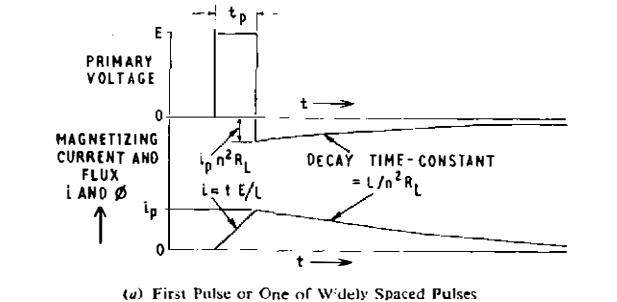

(a) First Pulse or One of Widely Spaced Pulses

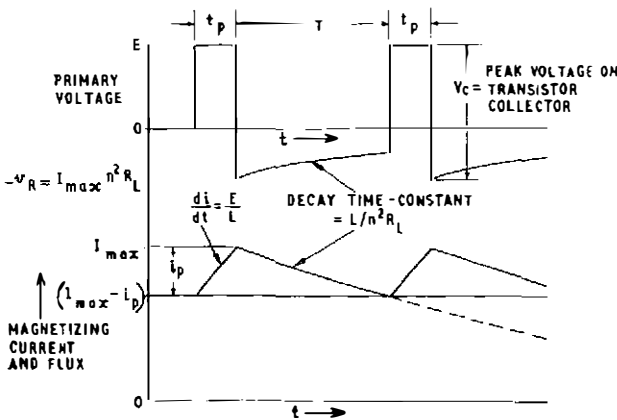

(b) Steady State in Sequence of Pulses

FIG. 6.—TRANSFORMER PRIMARY-VOLTAGE, MAGNETIZING-CURRENT, AND FLUX WAVEFORMS

current builds up by an increment  $i_p = t_p E/L$ . At the end of the pulse the voltage  $E$  is removed by switching-off the transistor, but the magnetizing current cannot change suddenly and continues to flow in the load resistance  $R_L$  after the normal load current has ceased. It produces an

initial reverse voltage across resistance  $R_L$  of  $i_p n R_L$ , and across the primary winding of the transformer of  $i_p n^2 R_L$ ; the current and voltage then decay exponentially with a time constant of  $L/n^2 R_L$ . If the time interval between pulses is at least several times this time constant, the current will return practically to zero in each interval. If not, the current will tend to build up during successive pulses until the decay of current in the interval between pulses,  $T$ , is equal to the rise in current,  $i_p$ , during each pulse. The magnetizing current then varies between the two limits  $I_{MAX}$  and  $I_{MAX} - i_p = I_{MAX} e^{-LT/n^2R_L}$ , as in Fig. 6(b).

$$\text{Hence, } I_{MAX} = \frac{i_p}{1 - e^{-LT/n^2R_L}}$$

The maximum reverse voltage swing is  $I_{MAX} n^2 R_L$ .

When the transformer has to work with a sequence of a few pulses at intervals  $T$  followed by a long gap, the magnetizing current gradually builds up on successive pulses to a maximum value  $I'_{MAX}$ , which is between  $i_p$  and  $I_{MAX}$ , and increases with the number of pulses in the sequence; it decays again during the long gap.

The maximum magnetizing current  $I_{MAX}$  or  $I'_{MAX}$  must be allowed for in designing the driving circuit for the transformer. It must be supplied by the transistor, and will cause the top of the pulse to droop if it produces a significant drop in the source resistance  $r_s$  or primary resistance  $r_p$ . Both the driving transistor and the load must tolerate the reverse voltage swing which occurs at the end of each pulse. If necessary, this reverse voltage may be limited, using a diode circuit, to protect the collector of the transistor against breakdown, either due to normal operation or due to the possibility of the load on the transformer secondary being disconnected. In some circumstances this may result in an increase in  $I_{MAX}$  because, if the reverse voltage is limited to  $V_R$ , the rate of fall of the magnetizing current is controlled by

$$e^{-L(di/dt)} \ll V_R.$$

Consideration of all the above factors will enable a satisfactory size of core for the transformer to be chosen.

### Ferrite Cores for Storage

A large number of ferrite cores are used in the electronic exchange systems as memory devices. These cores are made from a mixture of powdered manganese and iron oxides compressed to form a toroid. Plotting the magnetizing force,  $H$ , against flux density,  $B$ , gives a typical "rectangular" hysteresis loop such as that shown in Fig. 7. The core has two stable magnetic states, and

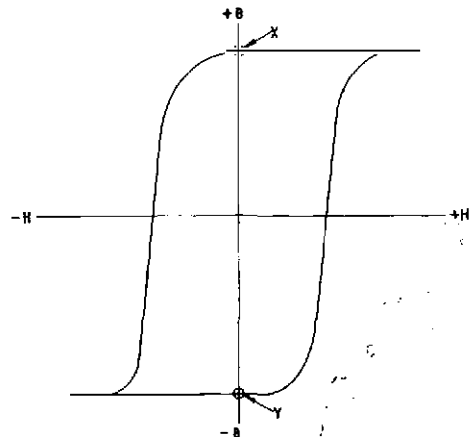

FIG. 7.—HYSTERESIS LOOP FOR FERRITE CORE



in the absence of any magnetizing force, it will remain magnetized in one direction or the other as shown by points X and Y. If a sufficiently large pulse of current is passed through a wire which is passed once through the centre of the core, or wound around the core several times, the core can be switched from one magnetic state to the other, switching taking place on each reversal of the driving current. During switching a second winding on the core will have a voltage pulse induced into it each time the magnetic state changes; the polarity of this voltage pulse denotes whether the core is changing from an X to a Y state or from a Y to an X state. If the X and Y states are chosen arbitrarily to represent logic 1 and logic 0, respectively, logic information can be written into the core, stored indefinitely, and read out at a future time. During the reading operation, the information previously stored is, however, erased.

#### OTHER COMPONENTS

Reed inserts and plugs and sockets will be dealt with in future articles and will not, therefore, be discussed here. For other components, such as inductors, keys and lamps, advantage has been taken of the high standard maintained through existing Post Office specifications and of development work done for other applications.

#### COMBINATION OF COMPONENTS

The components described are the basic building bricks for the electronic circuits. Fig. 8 shows the

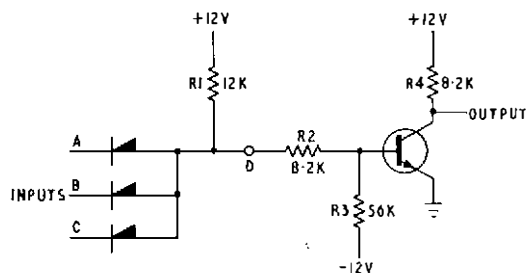

FIG. 8.—NAND GATE

combination of such components in a typical electronic circuit: a NAND gating element used widely in logic circuits. Its function is to give an indication when, and only when, a specified number of input signals (e.g. three) are present simultaneously. The circuit can be regarded as a switch which can be either in the "on" state or the "off" state. If +12 volts is applied to all three inputs, A, B and C, simultaneously, the input diodes become non-conducting and point D becomes positive. Base current flows from the +12-volt pole of the supply via resistors R1 and R2, and the transistor turns on. This provides a conducting path from the positive pole of the supply, via the collector load-resistor R4, to earth. In this condition, the potential at the output lies between 0.1 to 0.4 volts positive to earth. This state is regarded as the on condition of the gate, but in descriptions of circuit operation it is assumed that the output is at earth potential. If an earth is applied to any one, or all of the input leads, the diode or diodes concerned conduct, and the potential at point D falls to about 0.5 volts above earth. When this occurs, the transistor-base potential becomes negative, because the base is connected to the potentiometer formed by resistors R2 and R3 to the negative supply. This reverse

voltage biases the base-emitter junction and turns the transistor off: the potential at the output lead rises to +12 volts. In practice, a very small leakage current flows but this is ignored. The input/output conditions can be tabulated as shown in Table 2, which lists all combinations of possible input conditions; for three inputs there are  $2^3$  or 8 combinations. Usually, +12 volts is regarded as a logic "1" condition, and earth as a logic "0" condition. Only when a logic 1 is present on inputs A and B and C together, is there an earth condition on the output lead.

TABLE 2  
Truth Table for NAND gate of Fig. 8

Inputs			Output	Output Voltage
A	B	C		
1	1	1	0	zero
0	1	1	1	+12
0	0	1	1	+12
0	0	0	1	+12
0	1	0	1	+12
1	0	1	1	+12
1	0	0	1	+12
1	1	0	1	+12

Table 2 also shows that for any combination of 1s and 0s at the inputs, other than 111, the output lead is at +12 volts, representing a logic 1 condition.

When used to obtain a logical AND function, there is only one input condition that can be recognized uniquely at the output, namely 111. This output condition is logic 0 and is an inversion of the 1s present at the inputs; for this reason the circuit element in Fig. 8 is known as a NAND element, meaning AND with inversion. When used with any input conditions other than 111 the output is always logic 1. This means, in effect, that a logic 0 (earthing) condition at any input will cause the output to assume the logic 1 state. Another way of expressing this is to say that  $\bar{A}$  or  $\bar{B}$  or  $\bar{C}$  separately or together will give a logic 1 output, the bar sign under the letter indicating that the input represented is logic 0, whilst absence of the bar represents logic 1.

An alternative way of regarding the circuit element shown in Fig. 8 is to divide it into the two following parts.

(i) A simple AND element, consisting of the three diodes and resistor R1, which causes point D (the output of the AND function) to become positive when all three inputs are positive.

(ii) An amplifier, consisting of the transistor and resistors R2, R3 and R4. The amplifier is, however, an inverting device, i.e. when its input (the base) is positive its output (the collector) is earthing.

By combining (i) and (ii) the same logic result is obtained as that explained previously.

One NAND gate can be used to control a succeeding gate, or several in parallel. In this way, a chain of logic circuits can be built up to perform a series of logical manipulations.

From the point of view of component specification an apparently simple element such as that shown in Fig. 8 can become very complicated when tolerances are taken into account. The number of possible combinations of tolerances is very large—so large, in fact, that even computer studies of all possible variations become too costly to contemplate. The work involved in element

design can, however, be reduced by assuming the so-called worst-worst state, meaning that, with judgement, calculations of performance are based on tolerances taken to be simultaneously adverse. The main variables that need to be determined are the maximum permitted fan-in, which specifies the number of inputs that may be connected, the maximum permitted fan-out, which determines how many similar following elements may have their inputs connected in parallel to the output terminal, and the delay times for input and output signals.

#### CONCLUSIONS

Components used in electronic exchange systems must

have a low failure rate during a 30-year period to ensure a high quality of service to subscribers and to achieve the maximum possible savings in maintenance costs. It is confidently expected that the measures taken to specify components and to control their use will achieve these aims.

#### ACKNOWLEDGEMENTS

Acknowledgements are due to the five principal British manufacturers of telephone switching equipment who, in co-operation with the British Post Office, developed the electronic telephone-exchange systems under the auspices of the Joint Electronic Research Committee.

#### APPENDIX

##### Summary of Transistor and Diode Characteristics

TABLE 3  
Characteristics of n-p-n Transistors

CV Code	$V_{OB}$ (V)	$V_{CB}$ (V)	$V_{KW}$ (V)	$I_o$ (average) (mA)	P (mW)	$h_{FE}$	$f_t$ (Mc/s)	$C_{ob}$ (pF)	$t_r$ (ns)	Ambient Thermal Resist- ance (°C/mW)	Relative Cost
8615	20	20	5	50	300	35	50	10	300	0.5	1.0
8616	20	20	5	50	300	35	50	10	50	0.5	1.2
7644	65	65	5	100	300	50	50	20	—	0.42	2.0
7726	60	30	6	1,000	800	40	50	12	350	0.22	2.5
7495	60	40	5	500	800	20	40	25	—	0.25	2.5

TABLE 4  
Characteristics of p-n-p Transistors

CV Code	$V_{CB}$ (V)	$V_{OB}$ (V)	$V_{FB}$ (V)	$I_o$ (average) (mA)	P (mW)	$h_{FE}$	$f_t$ (Mc/s)	$C_{ob}$ (pF)	$t_r$ (ns)	Ambient Thermal Resist- ance (°C/mW)	Relative Cost
8841	20	20	5	50	250	15	0.4	80	—	0.5	1.5
9543	20	20	5	50	300	35	100	10	200	0.5	3.0
8842	65	65	5	50	250	15	0.2	80	—	0.5	2.0
9507	65	65	5	600	600	35	100	12	—	0.3	3.0
7085	80	32	40	8,000	1,300	30	—	—	—	0.047	3.0

TABLE 5  
Characteristics of Diodes

CV Code	Peak Inverse Voltage (V)	Forward Current ( $I_o$ ) (mA)	Capacitance (pF)	Stored Charge ( $Q_s$ ) (pC)	Reverse Recovery Time ( $t_{rr}$ ) (ns)	Relative Cost
8617	20	75	6	100	—	1.0
8790	150	150	—	—	—	1.0
8805	190	250	—	—	—	2.0
9637	75	75	2.8	75	5	3.0
8992	800	200	—	—	—	2.5
7311	100	2,600	—	—	—	2.0
9638	40	200	15	—	50	3.0

# Practical Aspects of Providing Telephone Plant on New Housing Estates

S. L. F. FAGG and F. G. MEAD†

U.D.C. 621.395.721.1:621.395.743

New housing estates impose heavy demands for telephones, and methods of reducing the number of manhours and the amount of money required to provide the necessary plant to a good engineering standard are of considerable importance. This article highlights some of the special problems involved in providing underground plant on housing estates, and methods of overcoming some of these problems are discussed.

## INTRODUCTION

THE provision of telephone service to the occupiers of new dwellings often sets the Post Office many problems. Residential estates vary greatly, from a few houses sited in a close, to very large sites that will ultimately contain many hundreds of houses. Each estate has its own individual characteristics both in house design and estate layout, and it is, therefore, very difficult to lay down any hard and fast rules for providing Post Office plant.

The sequence of construction of houses or bungalows on some estates is not orderly; such an estate thus becomes a number of disjointed units, making it extremely difficult, and sometimes impossible, to provide buried cable in the unmade public footpath when required, because of the miscellaneous building material usually found stacked on the site and in line with the proposed cable route. Closer co-operation between the Post Office, the builder, and all other service undertakers who are involved in the laying of their respective plants on an estate is, consequently, of great importance.

Except where the ultimate telephone density is very low, the cheapest method of providing telephones to houses on new estates is to use directly-buried polythene cable to serve ring-type distribution poles, with light-weight drop wires serving the houses, and this is the method that is normally adopted. If there is an objection to overhead plant then a wholly-underground system can be provided, subject to the objector agreeing to make a contribution toward the increased cost to the Post Office of providing this type of plant. The contribution may be made either in cash or by providing the equivalent value in labour, the latter being preferred by the Post Office.<sup>1</sup>

## UNDERGROUND LEAD-IN CABLES

In the past, where underground service has been provided to every house initially, it has been common practice to provide a cable from the footpath to the house, terminating the cable in a small external terminal block (Block, Terminal, No. 18) fixed to the outside wall of the house. The cable between this terminal block and the footpath was either buried direct in the ground with 18 in. depth of cover (12 in. if protected with 3 in. wide

wire mesh), or drawn into a previously-laid polythene or metal pipe.

On the other hand, leaving the provision of the lead-in cable until service is required has the disadvantage that cultivated gardens and paved surfaces are disturbed, involving much extra work and additional expense for reinstatement.

As a result of successful trials, the future method of providing an underground lead-in will be to pre-determine the position of the telephone, and then extend the external cable direct to this position inside the house during the house construction. The telephone position for each type of house is agreed at early meetings between the Post Office and the estate developers; it has been found that the most popular place for the telephone is either in the hall or the lounge.

When the builder has agreed to carry out work for the Post Office as his contribution to an underground system, the minimum amount of work required will be the provision of the complete lead-in, including the wire for the earth connexion, all necessary stores being provided free-of-charge to the builder by the Post Office.

As near as possible to the agreed telephone position the builder will fit a flush-fitting electrical conduit box (see Fig. 1), with a length of  $\frac{3}{4}$  in. polythene pipe attached

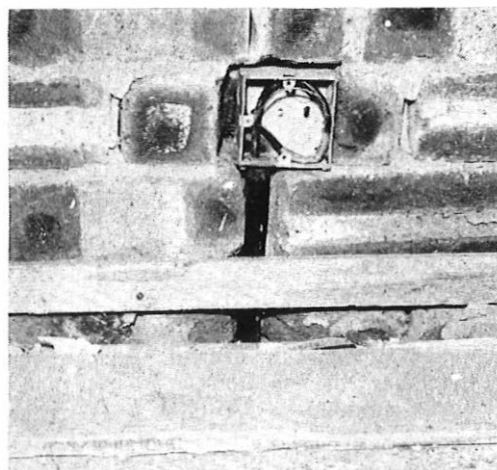

FIG. 1—POST OFFICE CONDUIT BOX IN CHASE IN WALL WITH CABLE AND EARTH WIRE COILED IN BOX

and leading outside the house. The external lead-in cable and earth wire are then passed into the house through the  $\frac{3}{4}$  in. polythene pipe to the conduit box, where a small surplus of cable and wire is left. After the wires have been prepared by the Post Office liaison officer for termination, they are recessed into the conduit box and a Post Office plastic cover is fitted. The subsequent provision of a telephone near this position merely requires the connexion to be made via a connex-

†Mr. Mead is in the External Plant and Protection Branch, E.-in-C.'s Office, and Mr. Fagg, now retired, was formerly in that Branch.

<sup>1</sup>REID, H. A. Planning Telephone Plant for New Housing Estates. *P.O.E.E.J.*, Vol. 58, p. 234, Jan. 1966.

ion strip in the conduit box, and the pleasing finished result is shown in Fig. 2. This method of directly joining the telephone cord to the external cable near the



FIG. 2—TELEPHONE TERMINATION INSIDE HOUSE

telephone position greatly facilitates fitting the telephone. If, eventually, the telephone is not required near this conduit box and the builder has not provided a pipe from the conduit box to an alternative position, an internal cable will have to be run, probably on the surface, from the conduit box to the desired position.

The builder will lay the lead-in cable in the water-pipe service trench from the house to the boundary of the footpath and garden, but if this is not possible the cable will be laid with an 18 in. depth of cover in a separate trench. The footpath end of the cable is either coiled and temporarily left attached to a wooden stake on the boundary of the footpath and garden (see Fig. 3), or is buried approximately 24 in. deep in the trench; subsequently, the Post Office jointers can locate the buried coils by using tone-testing equipment. The lead-in cable coils, which must be of sufficient length to allow the cable to be jointed to the Post Office footpath cable, are not jointed to this cable until all the other services are connected.

#### *Earth Connexion*

It is necessary to provide an earth connexion for signalling purposes if shared service is required. The form of earth provided in the past has been a connexion to a water pipe in the house or to an earth spike driven into the ground in the garden. Recently, the method of earth provision at dwellings was reviewed because of the increasing use of non-metallic water pipes. It has now been agreed that, when an underground lead-in cable is

provided, an earth wire, also terminated in the conduit box, should be provided at the same time as the cable. The earth will consist of a length of 3-strand 20 lb/mile

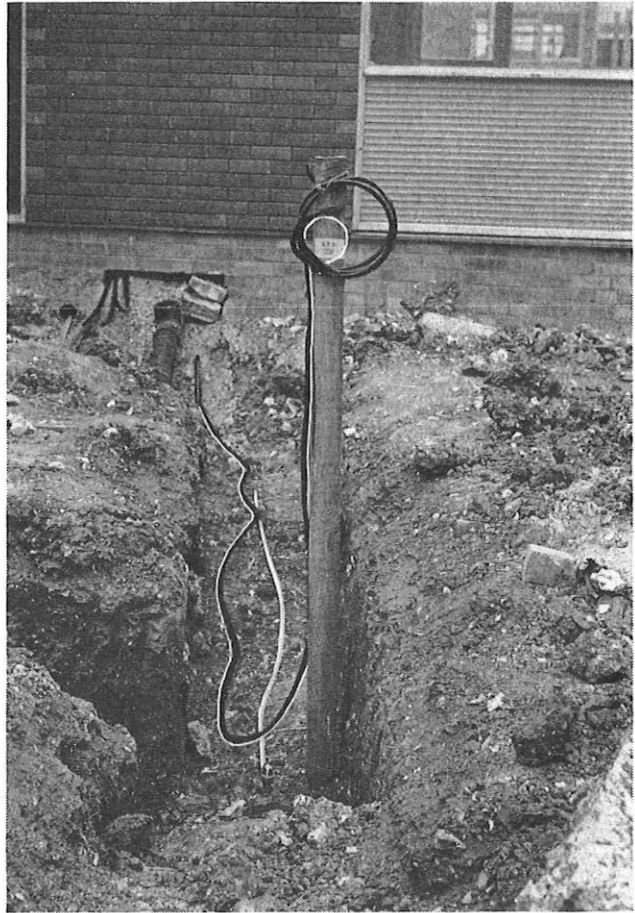

FIG. 3—LEAD-IN CABLE AND EARTH WIRE LAID BY BUILDER IN WATER-PIPE SERVICE TRENCH

copper wire laid in the ground with the lead-in cable, the wire having a minimum length of not less than 10 ft. actually in the soil beyond the house walls.

#### *Lead-in Cable*

Trials carried out using unprotected cable for the lead-in were not successful, and in future all lead-in cables will be armoured. The manufacturers reported that 1-pair 6½ lb/mile cable was too fragile to armour; an armoured 2-pair 6½ lb/mile cable was, therefore, chosen for the lead-in cable as it was found that the cost would be the same as for an armoured 1-pair 20 lb/mile cable. Advantage is taken of the second pair in the lead-in cable by jointing it to the "back end" of the distribution pair required for service. It is possible to provide a second telephone to any house by opening the distribution cable at the end remote from the exchange, and jointing the required back end to a spare distribution pair, as shown in Fig. 4. Where required the second pair could be used for connexion of an earth. The advantages of this back-end jointing is that it is only necessary to open at one point to provide a second telephone to one or more of a group of houses. The number of additional telephones that can be provided without extra cabling will, of course,

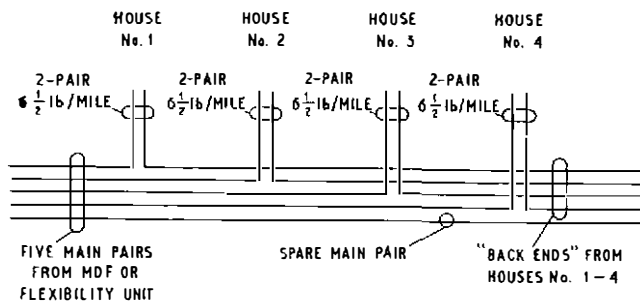

FIG. 4—USE OF SECOND PAIR IN 2-PAIR LEAD-IN

always depend on the number of spare through-pairs available at the end of the distribution cable.

#### BURIED CABLES IN FOOTPATHS

As a result of extensive field trials, solutions have been found to most of the underground lead-in problems on new housing estates. The greatest remaining difficulty, however, is the damage caused to Post Office polythene cables in footpaths by other service undertakers and builders. The faults so caused are costly to locate and repair, because, quite often, the faults are not detected until after the pavings are laid; this means breaking up new, and often expensive, pavings, causing much annoyance to builders, local authorities and residents.

Various depths of laying unprotected polythene cables under the footpaths have been tried, but 14 in. appears to be the best compromise: to go deeper is expensive and has not been found to offer a great deal more protection. Other service mains are normally buried with between 2 ft and 3 ft of cover. To attempt, therefore, to avoid completely the risk of damage the telephone cable would have to be buried at a greater depth than these mains, but burying cables to this depth would make it very difficult for the jointers who have to dig down to the cables to make their joints.

The standard position for Post Office plant under a footpath is 1 ft 5 in. from the face of the kerb of a 6 ft footpath; for 10 ft 6 in. footpaths the distance is 3 ft 5 in. Every effort is made to establish this position by agreement with the undertakers concerned, for investigations indicate that damage to a large number of footpath cables might have been avoided if the Post Office cables had been laid on the kerb side of the other service undertakers' mains. If Post Office cables are laid on the house side of other mains, the cables can easily be damaged by other undertakers' workmen digging across them when they are laying, jointing, or repairing their services into the house.

The laying of unprotected cables should be left very late—if possible until after all the other undertakers' mains have been laid and their services connected: even then, there is no guarantee that damage will not occur. The actual construction of the footpath—rolling in flints or hardcore, or driving spikes in the ground to support shuttering—often causes damage to the Post Office cables. However, the late laying of cable requires careful watching to ensure that paving is not laid before Post Office plant. When plant is provided late, ducts often have to be provided under drive-ins constructed before the footpaths are made. These ducts add to the cost of the work, are often found damaged when the time comes to use them, and threading the cables through the duct causes delay during cable laying.

#### PROTECTION FOR BURIED CABLES

Because of the damage to unprotected cable on housing estates many types of protection are currently used in Telephone Areas, including all types of duct and associated jointing boxes. The use of ducts is the most expensive method of protection and the joint boxes, often provided outside each house or pair of houses, add to the cost. Another form of protection commonly used is  $\frac{1}{4}$  in. expanded metal mesh, in 8 ft lengths and 3 in. wide, placed 2 in. above the cable, the 2 in. of soil between the cable and mesh being free from stones. This type of mesh does not, unfortunately, give the expected protection. It is easily displaced from above the cable during subsequent excavation, leaving the cable without protection. The mesh is sometimes regarded as builders' rubbish by other workmen who are excavating, and is discarded by them. Treated hard-wood boards wired together, and tiles similar to those used by Electricity Boards, have been tried but have not been found very satisfactory, mainly because they also get moved during excavation. These types of protection require a trench and cannot be used where moleploughing is being undertaken.

An investigation into plant provision on housing estates revealed that there was not going to be any easy solution to the problem of damage to Post Office unprotected cables. The best means of avoiding the damage appeared to be to use some form of protection within the cable itself, and it was considered that armouring the actual cable with mild-steel wires would probably be the most successful and economic method. The advantage of armouring is that the protection is part of the cable and cannot be displaced. The provision of a thicker cable sheath has been considered, but it was thought that it would not give the protection of armouring and would be only slightly cheaper.

Trials were, therefore, carried out on new housing estates throughout the country, using armoured cable. These cables were ordinary polythene types with galvanized mild-steel wires applied directly over the polythene sheath with an oversheath of extruded black PVC (PVC is less inflammable than polythene, and this allows the cable to be used for oil-depot installations, etc.). To enable a fair comparison to be made, Telephone Areas were asked to select estates where one section could be cabled with armoured cable and another with unprotected cable. On these estates approximately 3.5 miles of armoured cable and 2.5 miles of unprotected cable were laid under housing estate footpaths. On the armoured-cable trial sections no faults were recorded on the footpath cables, but on the unprotected sections there were 26 instances of damage during a period of 12 months. The estimated cost, including overheads, of clearing the faults on the trial unprotected cables was approximately £418. It would have cost approximately £368 to have armoured the cables; the indications are, therefore, that money and valuable manpower could have been saved if the unprotected cables had been armoured initially.

#### USE OF MECHANICAL AIDS ON HOUSING ESTATES

It has been very rare in the past for Telephone Areas to use mechanical aids to lay unprotected cables under the footpaths on housing estates for the following reasons.

(a) Because of past experience of footpath cables damaged by other undertakers and builders unprotected cables are laid as late as possible; this often means laying

the cables in short sections. Furthermore, the presence of building materials often prevents long lengths being laid. The use of mechanical aids for such short sections would usually be uneconomical.

(b) Delaying the laying of the cables until a late stage means that all the other services have been laid, and fear of damaging other services often discourages the use of mechanical aids.

(c) At a late stage of laying, the footpaths are often covered with waste building materials, such as broken bricks, bags of cement, timber, etc., which prevent the use of mechanical aids.

It was considered that the only way to overcome these objections, and to obtain the quite considerable savings thought possible with mechanization, would be to lay armoured cables mechanically under the footpath at a very early stage, before building materials arrive. Long lengths of cable could then be laid very quickly and cheaply. Trials were carried out on several housing estates to see if this early-laying technique was practical.

During the trials, attempts were made to lay the armoured cables as soon as the roads were completed or the kerbs or kerb bases had been laid, often before any other mains undertaker had arrived on site. Approximately 1½ miles of armoured cable were laid mechanically in the ground during these trials (see Fig. 5), and in all



FIG. 5—POST OFFICE FOOTPATH CABLES BEING LAID BY MOLEPLOUGH BEFORE BUILDING MATERIALS ARE DEPOSITED ON THE FOOTPATH

instances savings were made. In the most successful trial, in which a modified moleplough was used, cables were laid for an inclusive cost of 2.8 shillings/yard, against an estimated inclusive cost of 7.3 shillings/yard if Post Office staff had laid the cable in hand-dug trenches, or 7 shillings/yard if a contractor had carried out the work. No faults have been recorded on these trial installations, for which taped joints with grease-filled sleeves were used.

#### *Method of Mechanized Cable Laying*

The above-mentioned trials very quickly showed that

the Post Office types of mechanical aids had several limitations when used on housing estates. When laying cable in the Post Office standard position it was found that, with a chain-type excavator, one wheel or track had often to run on top of new kerbs. This practice is not favoured by the site contractors, and is not practicable when there is a difference in level between road and footpath. When using the standard Post Office small moleplough it was found that the plough blade would not keep its depth in the ground; consequently, instead of laying cables at 14 in. depth they often were found to have less than 9 in. of cover. Several new designs of small moleplough have now been approved.

A miniature light-weight moleplough has been developed that can be pulled by a winch on a Land Rover. This plough adopts the same principle as used for duct-ploughing; the cable is attached to the bottom of the moleplough blade, behind an enlarging head, and is then drawn through the ground in the hole left by the enlarging head. This method of drawing cables through the ground is only practicable when using armoured cable. The laying of ducts by moleplough, a great help on housing estates where duct is used to cater for an unspecified estate extension, has been described in a separate article in this Journal.<sup>2</sup>

The possibility of making a chain excavator that would run in the road alongside the kerb, with an offset boom that could dig a small trench in the footpath, is being examined.

#### *Advantages of Early Mechanized Cable Laying*

The techniques of early mechanized cable laying, only practicable with armoured cable, are favoured for the following reasons.

(a) Using armoured cable, laid early, service can become available, and plant is revenue earning, as soon as required, the costly provision and recovery of temporary overhead plant being avoided.

(b) In the past, sharing of other undertakers' trenches has often failed, or not been attempted, because of the vulnerability of unprotected Post Office polythene-sheathed cables. The armouring of the Post Office cables will encourage Telephone Areas to take advantage of this method of provision more often.

(c) On estates where concrete drive-ins cross the foot-path it is the present practice to lay some type of duct under all these footpath crossings to facilitate cabling later. The direct cost of the type of duct commonly used is 2 shillings/yard with, possibly, a further 6 shillings/yard for laying. In addition to this, finding and threading the cables through these short lengths of duct when the cables are laid is a very time-consuming process. Using armoured cables the cables would be laid before the

<sup>2</sup>FAGG, S. L. F., and WILSON, W. T. Laying Plastic Ducts by Moleplough. *P.O.E.E.J.*, Vol. 59, p. 104, July 1966.

drive-ins are constructed, and there would, therefore, be no need for any ducts.

(d) If cables have to be renewed under the footpaths or drive-ins, armoured cable can be drawn out of the ground in long lengths, with a new length of cable attached to the rear of the faulty cable. This method saves a considerable amount of time, and, perhaps more important, costly reinstatement.

#### CO-ORDINATION BETWEEN BUILDER AND LIAISON OFFICER

Many well-thought-out schemes have not obtained maximum economy in the past through lack of co-ordination between the Post Office and the estate builder. To overcome this problem, housing-estate liaison officers have now been appointed by the Post Office. The liaison officer will visit each housing estate for which he is responsible as frequently as necessary to ensure that he is kept fully informed of the progress of building operations and the laying of services, that the best time is chosen for the installation of Post Office plant, and that any work being carried out for the Post Office by the builder is executed correctly.

#### PRESENT EXPERIMENTAL WORK

##### *Jointing Posts and Boxes*

Trials are taking place of above-ground jointing posts. In the trials, up to 20 house-service leads are taken back in a common trench to a jointing post where they are jointed to the distribution cable, the joint being made inside the post above ground, thus eliminating a buried cable-joint outside each house (see Fig. 6). The leads are jointed to the distribution cable in the normal way, using grease-filled sleeves.

Small boxes to fulfil the same purpose, but which can be installed flush with the footpath, are being developed for places where above-ground posts are objected to by council surveyors.

##### *Shared-Trench Trials*

Trials are being carried out on new housing estates of sharing footpath trenches with the local Water Authority and with the Electricity Board. In the latter trials, the Electricity Board are provided with drums and coils of Post Office armoured cables, and carry out all the operations necessary for laying the cables under the guidance of the Post Office housing-estate liaison officer.

Other undertakers' trenches could be used with advantage on estates where kerb or road foundations are not laid early enough to allow mechanized laying to take place. This method could also be adopted on estates where all the roads are separated from the houses and there are no clearly-defined levels.

The economics of sharing trenches is being studied.



FIG. 6--ABOVE-GROUND JOINTING POST

#### CONCLUSIONS

The additional cost of armouring the buried cables used in combined overhead and underground distribution systems may be justified by the savings on maintenance, by the use of shared trenches and by mechanized cable laying. When comparing ordinary polythene cable with armoured cable, it must be borne in mind that quite a large proportion of ordinary polythene-cable schemes include some form of protection: with armoured cable no additional protection is necessary. Further stocks of armoured cable have been ordered for further trial work.

In the future, it is hoped that specialist housing-estate parties will be formed, equipped with all the necessary mechanical aids, stores and tools, possibly in one vehicle with a trailer. These parties will become specialists in providing plant on new housing estates and will work closely with the housing-estate liaison officers. Between them, they will carry out all the work connected with estates after the schemes have left the planning office.

Housing estates are a special challenge to telephone planning and construction staff, and many problems presented are being attacked vigorously. The employment of housing-estate liaison officers should ensure that the most economical methods are employed effectively.

# A Prototype Conference Repeater Using a New Voice-Switching Technique

R. A. JONES, B.Sc.(Eng.)†

U.D.C. 621.395.664.1:621.395.646:21.395.348.4

Audio-frequency signals, when unilateralized, may be treated as varying d. c. This considerably simplifies the design of voice-switched devices. As an example, the application of the technique to a voice-switched conference repeater is described.

## INTRODUCTION

A CONFERENCE repeater is a device used at a telephone exchange to give multi-way amplification between the circuits of a number of telephone subscribers requiring telephone-conference facilities. Such a repeater is necessary to avoid the appreciable mismatch losses which would occur if these circuits were simply connected together in parallel.

The device is, therefore, required to give something approaching unity voltage amplification between each and every other of the lines connected to it. All designs of conference repeater used to date by the British Post Office have provided this amplification as simultaneous bothway amplification by the use of hybrid and bridge circuits. In repeaters of this type, gain and stability are somewhat dependent upon line impedances, and this gives rise to two serious disadvantages. Firstly, the setting-up of a conference call may require adjustment of the amplifier gain, and, secondly, if one subscriber hangs up during a conference this may upset the hybrid balances sufficiently to cause howling. These difficulties have resulted in a certain unpopularity of existing conference repeaters and have led, recently, to the decision to attempt to produce a voice-switched system. In such a system, any party speaking would automatically gain access to the input terminal of the amplifier and simultaneously switch all other lines to the low-impedance output of the amplifier. Advantage would be taken of the fluctuating nature of the levels of speech signals to give break-in facilities.

Such equipment is available, but it is of American design\* and functions satisfactorily only with correctly terminated lines. Thus, a completely new circuit was required for use in the British network.

## PRIOR SWITCHING METHODS

Devices exist which employ electronic switching of signal channels, and typical of the gates by means of which switching is done is that shown in Fig. 1. Here the switching is by diodes, MR, which are amply forward or reverse biased according to whether the gate is required open to allow the signal to pass or closed to block the signal. The balanced arrangement and the resistors, R, swamping possible differences between the forward resistances of the diodes, are all necessary to avoid

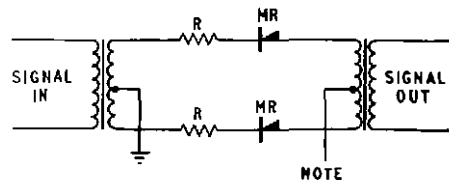

Note: Negative voltage closes gate, positive voltage opens gate.  
FIG. 1—TYPICAL SPEECH GATE

introducing switching noises into the signal path. The supply of the positive and negative voltages for switching purposes requires provision of a suitable control circuit.

Application of these principles to a voice-switched conference repeater would involve conversion of each line or circuit to 4-wire working, the insertion of gates in each direction of each circuit and provision of an elaborate control circuit to compare incoming levels in all channels and to switch the gates in favour of the channel having the largest signal. The total number of components which this would entail was thought to be prohibitive, so a totally new system of voice-switching was sought and was eventually devised.

## FUNDAMENTALS OF THE NEW SWITCHING TECHNIQUE

The new method of voice-switching makes use of the principle used in variable-area sound-on-film recording, and is demonstrated in Fig. 2. This principle is that, if

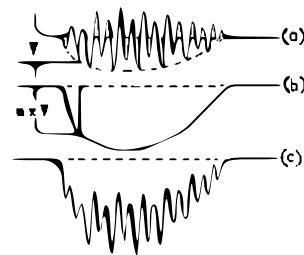

(a) Original Waveform  
(b) Envelope Component  
(c) Unilateralized Signal

FIG. 2—UNILATERALIZATION OF SOUND

Fig. 2 (a) represents the waveform of a sound, which may be speech, music or noise, then a change of form to that of Fig. 2 (c) will not audibly alter the sound. Advantage can be taken of this by electrically converting sound signals from alternating quantities of the type of Fig. 2 (a) to unidirectional ones of the type of Fig. 2 (c), which retain their same audio content but which may be switched with diodes in just the same way as d. c.

As this is a new technique it is perhaps necessary to define here some terms which will be used later. At the same time it is not suggested that they cannot be bettered. The "unilateralized" signal is the signal converted to the form of Fig. 2 (c) and lying wholly on, or to one side of,

†Mr. Jones is in the Telephone Exchange Standards and Maintenance Branch, E.-in-C.'s Office, but was formerly at the Post Office Research Station.

\*GRANDSTAFF, G. D. New Dynamic Impedance-Matching Circuit as Applied to a Conference Repeater. *Automatic Electrical Technical Journal*, Vol. 7, No. 1, p. 10, Feb. 1960.





points B and C. Thus, diodes MR4, MR2 and MR3, connected as in Fig. 4 (a), will all be reverse-biased and inoperative while line 1 is in control.

It is apparent, therefore, that each line has access to the amplifier input terminal via its fan-in diode. Once a line claims control it sees only the high input impedance of the amplifier, the other lines being fed from the low output impedance of the amplifier. Thus, the required switching is achieved. There remains the question of what happens when one subscriber tries to break in on another.

Break-in facilities are desirable, and in practice a signal on another line will manage to break through during the intersyllabic lulls of the signal in control. Break-through in the presence of an existing signal is prevented because any line not already in control sees the low impedance of the amplifier output, and this limits the voltage that can be built up by a fresh signal incoming on this line.

Because the semiconductor devices used for detecting and switching do not have the ideal abrupt transition from reverse to forward states at the origin, there is a lower limit to the levels of signals that they can handle. Similarly, the emitter-follower action of the common amplifier is not effectively maintained at very-low signal levels. It is essential, therefore, that the line transformers should give a reasonable step-up in voltage of the order of at least four times from primary to secondary. This in turn makes it necessary to work the transistors from an adequate supply voltage somewhere in the 20–50-volt range in order to handle the largest signals likely to be met.

#### Shortcomings of the Basic Circuit

A number of shortcomings make the simple circuit of Fig. 4 (a) unsuitable in practice. To enumerate them it is convenient to consider, firstly, signals incoming on line 1 and passing to a common point, e.g. point F, and then to consider other signals outgoing on line 1 from the same point.

#### Incoming Signals

(i) Despite its reflex nature, the detector circuit loads the line on negative-going peaks.

(ii) To ensure that the composite signal does not go positive on initial peaks at the onset of a signal, rapid charging of capacitor C1 by transistor VT1 is arranged. This results in an envelope component that exhibits steep negative-going leading edges which change the audio-frequency (a.f.) content of the composite signal.

(iii) The simple common amplifier circuit of Fig. 4 (a) has the weakness that if the value of resistor R2 is high enough to avoid loading an incoming line then it is too high to hold the base of transistor VT2 near earth potential with zero signal. This is particularly so at elevated temperatures.

#### Outgoing Signals

(iv) The detector in the unilateralizer functions not only on incoming but also on outgoing signals. This causes a unidirectional voltage to be developed nearly equal to, but in opposition to, the envelope component of the unilateralized outgoing signal. The unilateralization is thereby largely neutralized, and the fan-in and fan-out diodes become wrongly biased at some instants.

(v) The capacitor C1 is in series with the load presented by the transformer secondary on outgoing signals. It has already been pointed out, with reference to Fig. 3, that this is a load configuration which must be avoided with unilateralized signals. Incidentally, the situation is unaffected by emitter-follower VT1, which ideally is not conducting for outgoing signals.

Effects (iv) and (v) act together to cut off the fan-out diodes, especially with reactive lines. All five effects cause distortion in one way or another. The following description is of a more highly developed circuit which avoids these troubles.

#### Practical Circuit

Fig. 5 shows the circuit of a prototype 8-way conference repeater that works satisfactorily with a wide range of practical line conditions.

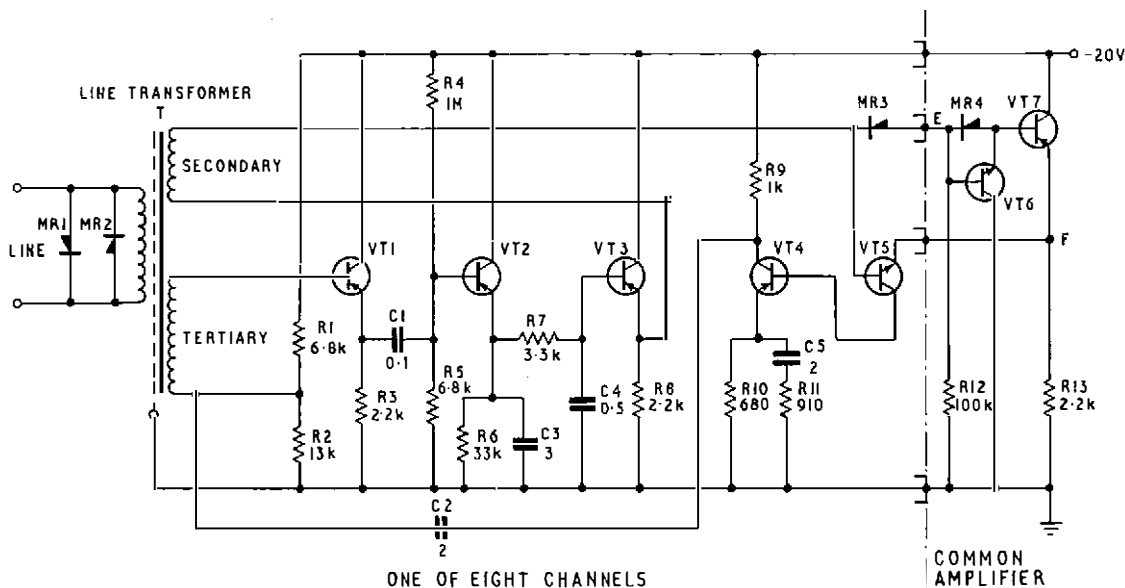

FIG. 5—PRACTICAL 8-WAY SWITCHED CONFERENCE REPEATER

Line transformer T has primary/secondary/tertiary ratios of 1 : 4.5 : 9. With these ratios and the 20-volt negative supply a maximum peak-to-peak line voltage of about 1.2 volts can be handled. Higher line voltages tend to upset the functioning of some of the stages, so use is made of the delayed forward characteristic of silicon diodes MR1 and MR2 to limit line voltages to approximately this value.

The detector VT2 is fed via a buffer stage, transistor VT1, which effectively prevents transistor VT2 from loading the line. Disregarding, for the present, the connexion of capacitor C2 to the lower end of the tertiary winding of transformer T, the additional stage is seen to be an emitter-follower.

To overcome effect (ii) described above an RC filter (R7, C4) has been added. An LC filter would be more efficient, but the further improvement would not in the present application justify the extra cost.

The filtered detector-output is not fed direct to the lower end of the transformer secondary but via another emitter-follower, VT3. This is incorporated to obviate the effect (v), previously mentioned. It does this as described below, and does not affect operation on incoming signals.

The unilateralized incoming signals pass to the common amplifier via the fan-in diode MR3. The circuit of the common amplifier is more elaborate than in the basic circuit of Fig. 4 (a) in order to achieve better thermal stability. As stated (effect (iii)), the weakness in the common amplifier of Fig. 4 (a) is that the value of resistor R2 is too high to stop the base of transistor VT2 from drifting negatively out of the control of an incoming signal. In the new circuit of Fig. 5, if the base of transistor VT7 tries to drift negatively with respect to point E, it sees the low resistance to earth at the emitter of another emitter-follower, n-p-n transistor VT6, and its drift is drastically reduced. On signals incoming to the common amplifier, however, diode MR4 conducts and the small voltage drop across it back-biases the emitter-base junction of transistor VT6, thereby cutting this transistor off. At the same time, the signal is fed to transistor VT7, and the common-amplifier circuit returns to that of a straight-forward emitter-follower.

In addition to going to the fan-in diode, incoming signals pass to the base of transistor VT5 but get no further, because they back-bias the base-emitter junction and switch off this transistor.

Considering now signals outgoing from point F, the output terminal of the common amplifier: these go to the fan-out, where the diodes of Fig. 4 (a) have been replaced by the emitter-base junctions of n-p-n transistors of which VT5 is the one in the channel shown. As has been described, transistor VT5 is switched off to incoming signals, but when the channel is outgoing, the function of transistor VT5 is twofold. Firstly, the emitter-base junction conducts, passing the signal to the secondary of transformer T. On these outgoing signals the lower end of this winding finds a return path via resistor R8 and, because capacitors C3 and C4 are now no longer part of the load, effect (v) is removed. Secondly, the conducting of the emitter-base junction of transistor VT5 switches this transistor on. This permits the signal to reach the base of transistor VT4, a grounded-emitter amplifier giving a phase reversal and a two-times voltage amplification to

the signal passed via capacitor C2 to the lower end of the transformer tertiary. The a.f. voltage applied to the base of transistor VT1 by the tertiary of transformer T on outgoing signals is thereby neutralized and effect (iv) is disposed of.

With the neutralizing a.f. voltage fed to the lower end of the transformer tertiary is a certain amount of envelope component voltage. This is minimized by keeping the values of capacitors C5 and C2 as small as possible consistent with their being effective at the lowest audio frequencies encountered. Additionally, the envelope component remaining is effectively prevented from reaching transistor VT2 and succeeding stages by the low value of capacitor C1. Here again a compromise is needed, as capacitor C1 must be large enough to maintain the low charging-resistance offered by the detector to capacitor C3. The effect of the low value of capacitor C5 in reducing the amplification of the envelope component by transistor VT4 also permits this stage to give a greater maximum a.f. output. This is necessary in order to achieve neutralization at the highest levels of signal encountered.

Diodes MR3 and MR4 are gold-bonded germanium diodes so as to minimize forward voltage-drop at low currents, thus ensuring that as low a level of signals as possible can be handled. For the same reason the transistors, particularly VT2-VT7, are germanium devices. Also, to the same end, every attempt has been made in the circuit design to employ the least possible number of semiconductor junctions (diodes and base-emitter junctions) in positions in the circuit where they are capable of adversely affecting the lower limit of signals that can be handled. An example is the choice of an a.c.-coupled emitter-follower circuit for transistor VT1 to present a high impedance to line instead of achieving a similar effect by compounding the first transistor with the emitter-follower-type detector VT2.

Also assisting in the handling of low-level signals is resistor R4, which applies a slight forward bias to the detector. This bias is communicated to all the semiconductor devices in the path of the incoming signals up to and including transistor VT7. The chosen value of resistor R4 is such as to strike a balance, at low levels, between the reduction in detector efficiency which it causes and the improvement produced in the performance of the other semiconductor devices mentioned. As it stands, the circuit has a dynamic range better than 30 db.

There is no indication that difficulties will be encountered in increasing the channel capacity of the repeater beyond the eight lines of the version described.

#### FURTHER APPLICATIONS OF UNILATERALIZATION

In addition to the conference repeater described, the method has been applied successfully to a switched loudspeaking-telephone.

Apart from these two devices the new method might find application in 2-wire repeaters, echo suppressors, long-line telephones, telephones for the hard-of-hearing, telephones for noisy situations and, perhaps, in other equipment in which speech channels have to be switched. The idea of being able to treat speech, music, or any other sound as a unidirectional quantity seems to open up many possibilities in the telephone and, perhaps, the radio fields.

# Performance of the Datel Modem No. 1A

N. G. SMITH and R. H. TRIDGELL, B.Sc., C.Eng., M.I.E.E.†

U.D.C. 621.376.3:621.394.4:681.142

The Datel Modem No. 1A has been tested under laboratory conditions and also on working circuits as found in the public switched telephone network. These tests are described and a summary of the results is given.

## INTRODUCTION

THE Datel Modem No. 1A, which is used for the Datel 600 Service,<sup>1</sup> was described in an earlier issue of this Journal,<sup>2</sup> but no details of the performance of the equipment were given. The modem has been subjected to controlled tests under laboratory conditions and has also been tested over working circuits as found in the public switched telephone network. These tests are described below, and a summary of the results obtained is included.

## PERFORMANCE CRITERIA

The Datel Modem No. 1A provides a voice-frequency (v.f.) telegraph channel capable of operating at modulation rates up to 1,200 bauds. The characteristic distortion produced by modems operating at such transmission rates is considerably influenced by the characteristics of the transmission medium, i.e. the telephone line, which connects the modulator and demodulator. Telephone-line characteristics, notably group-delay/frequency, which are unimportant so far as speech is concerned, have a serious, adverse, effect on the performance of modems such as the Datel Modem No. 1A. In addition, noise occurring on the telephone line, particularly impulsive noise, will cause fortuitous distortion in the data channel; such distortion will occasionally approach and sometimes exceed 50 per cent. Whenever the degree of distortion exceeds the margin of the receiving data-terminal equipment an error will occur in the receiver output. It follows that the margin of receiving apparatus for use with modems such as the Datel Modem No. 1A needs to be as large as possible. Good engineering design requires that manufacturers of data terminal equipment should aim for as large a margin as possible, since a small margin, say of  $\pm 30$  per cent, will seriously degrade the error-rate performance, or, if error-control equipment is used, considerably reduce the effective data-transfer rate.

From the above it will be realized that the important performance criteria of a modem are:

(a) the degree of distortion, particularly the maximum degree of individual distortion,\* and

(b) the proportion of transmitted elements that are incorrectly received, i.e. in error at the receiver output.

Both these criteria may conveniently be measured by the use of a Datel Tester No. 1A, which has a margin of about 49 per cent and is described elsewhere in this Journal.<sup>3</sup>

†Telegraph and Data Systems Branch, E.-in-C.'s Office.

\*The degree of individual distortion is the ratio of the time ( $t$ ) that a significant instant (transition) is displaced from an ideal instant to the duration ( $T$ ) of a unit interval (signal element). The ratio is normally expressed as a percentage, i.e.  $t/T \times 100$  per cent, and is considered positive when the significant instant occurs later than the ideal instant.

One method of evaluating data-transmission modems would be to measure the error rate when the modulator and demodulator were connected via a normal telephone line. Alternatively, for controlled tests the error rate may be determined when the v.f. line signal has been impaired by transmission through networks simulating various types of telephone line, and by uniform-spectrum random noise of predetermined bandwidth added at the input to the receiver. This latter method has been adopted to specify the performance of the Datel Modem No. 1A, and is, therefore, used to test modems after manufacture.

## TESTS APPLIED TO DATTEL MODEM NO. 1A

The tests to which the Datel Modem No. 1A have been subjected fall broadly into three classes. The first class of tests includes those mentioned above, which are applied to every modem before it leaves the manufacturer's works; such tests may be termed laboratory-type tests. The test conditions are carefully controlled, and close limits are specified for the performance of acceptable equipment.

The second class of tests comprises those necessary to enable the performance of the modem over the public switched telephone network to be assessed.

Thirdly, tests have been made to determine the limiting line characteristics over which the Datel Modem No. 1A will operate satisfactorily.

## Laboratory-Type Tests

In the laboratory-type tests, in addition to measuring the static conditions of the modem such as d.c. power-supply voltages, characteristic frequencies, discriminator characteristics, bias adjustment of the demodulator, etc., dynamic tests are applied which are designed to test the modem under reasonably severe conditions.

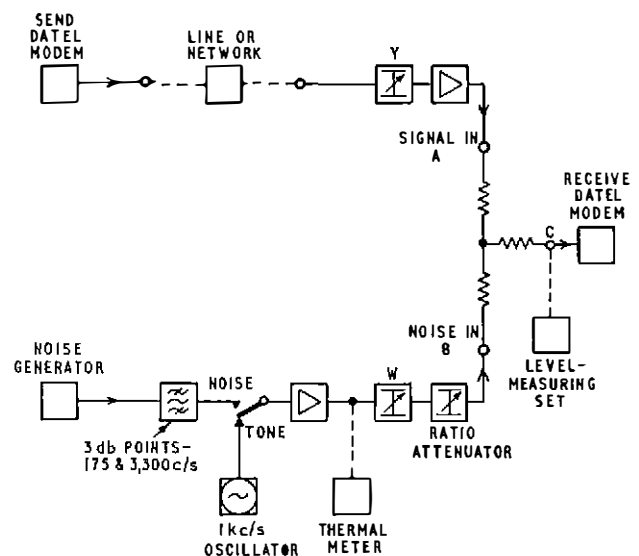

FIG. 1.—LABORATORY-TEST ARRANGEMENT

The technique used for these latter tests is to count the binary-digit (bit) errors occurring in the received data when the v.f. line signal is impaired by known factors, e.g. group-delay/frequency distortion, attenuation/frequency distortion, and uniform-spectrum random noise—often referred to as white noise. The method of testing is illustrated in Fig. 1, where the output of the modulator under test is shown connected to a line-simulating network. The output of the artificial line is combined with uniform-spectrum random noise before being connected to the demodulator under test.

The levels of the v.f. line signal and noise need to be carefully set, since 1 db difference in signal-to-noise ratio gives a large change in the error rate. The method of setting up the test is as follows. With the line network bypassed, the noise disconnected, and point B terminated with 600 ohms, attenuator Y is adjusted to give a reading of -6 dbm on the level-measuring set at point C when the send modem is transmitting a reversal signal, i.e. alternate 0 and 1 binary digits. The level with the network connected is then measured with the same transmitted signal and noted. The output power from the 1 kc/s oscillator is adjusted to be the same as that of the uniform-spectrum random-noise generator by comparison of the two on the thermal meter. With the v.f. signal from

the modem disconnected, the SIGNAL IN point (A), closed with 600 ohms, the ratio attenuator set to 0 db, and the 1 kc/s signal re-connected to point B in place of the 600-ohm termination, attenuator W is adjusted until the reading on the level measuring set is the same, to within 0.1 db, as that obtained with the signal from the test modulator connected. When the noise and modulator output signal are reconnected to the combining network, the signal-to-noise ratio will be indicated directly by the setting of the ratio attenuator.

Having set up the test as above, pseudo-random data signals are connected to the modulator under test, and the bit errors occurring in the output from the received-data set determined. It has been found that, using the technique outlined and making measurements of the order of 15 minutes duration, reproduceable results can be obtained.

Tests are carried out using three networks which simulate the static characteristics of different types of telephone line, and, also, with no network at all, this being referred to as the "back-to-back" condition. The first network (N1) represents three telephone carrier channels in tandem, the second network (N2) represents 100 miles of standard loaded cable (i.e. 20 lb/mile cable loaded with 88 mH at intervals of 1.136 miles), and the third network (N3) represents the nominal characteristics of an extreme connexion involving long junction and trunk circuits on the public switched telephone network, as described in an article in a previous issue of this Journal.<sup>4</sup> The characteristics of the N3 network are so severe that the maximum rate at which the Datel Modem No. 1A will receive successfully is 600 bits/second in mode A1.<sup>2</sup>

Some typical results of the tests are shown in Fig. 2. Referring to the curves obtained at 1,200 bits/second, it can be seen that, at the error rate of one error in  $10^3$  bits, there is almost a 3 db difference in signal-to-noise ratio between the extreme cases. This is mainly due to the differing group-delay/frequency characteristics of the networks. A further interesting point is that the back-to-back performance is poorer than that through network N2, this being due to the group-delay/frequency characteristic resulting from the filters in the Datel Modem No. 1A. Referring to the curves obtained using network N3 at 600 bits/second, it will be noticed that the performance is approximately the same as that obtained using network N1 at 1,200 bits/second, and requires a signal-to-noise ratio almost 3 db greater than that required for the same performance at 600 bits/second through network N2.

#### Public Switched Telephone Network Tests

The opportunity was taken when the first Datel Modems No. 1A were installed to make error-rate measurements following completion of the installation tests. Tests were made over several connexions and, if possible, to at least two different distant locations. Equipment to determine the distribution of errors on a block basis was available at the Datel Test Centre in London, and this formed one of the distant test locations. The maximum rate at which the equipment used for error-distribution assessment could be operated was 1,000 bits/second. Thus, the number of results at 1,200 bits/second is less than at 600 bits/second, but results are available at 1,000 bits/second. The error rate at 75 bits/second was also measured.

The duration of each test was limited to approxi-

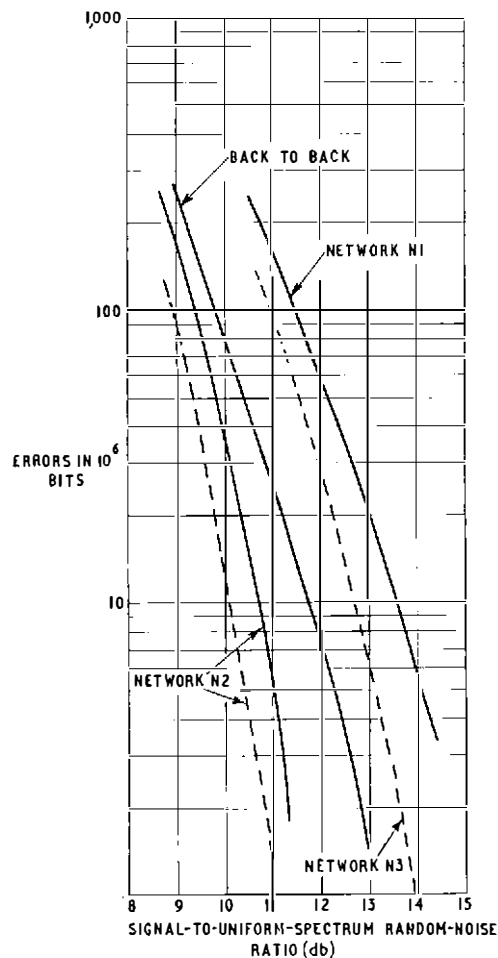

— 1,200 bits/second mixed signals, mode A2

- - - 600 bits/second mixed signals, mode A1

Note: The noise bandwidth was limited to 175-3,300 c/s (3 db points)

FIG. 2.—RESULTS OF TESTS VIA LINE-SIMULATING NETWORKS

mately a quarter of an hour: at 1,200 and 1,000 bits/second each test covered  $10^6$  bits, at 600 bits/second half a million bits were assessed, and at 75 bits/second each test embraced 58,500 bits. The results of these tests are summarized in Table 1.

TABLE 1

Summary of Results of Bit Error-Rate Tests on Circuits Routed via the Public Switched Telephone Network

Transmission Rate (bits/second)		75	600 Note 1	1,000	1,200 Note 1
Number of Connexions Tested		49	66	28	31
Number of Tests		117	97	48	31
Mean Bit Error-Rate 1 bit in		$1.8 \times 10^4$	$2.2 \times 10^4$	$3.0 \times 10^4$	$1.3 \times 10^4$
Percentage of Connexions with Bit Error-Rate Equal to or Less Than Value Stated	1 bit in $10^4$	83	90	87	63
	1 bit in $10^5$	Note 2	54	56	35
	1 bit in $10^6$	Note 2	Note 2	30	10
Percentage of Connexions with Bit Errors Equal to or Less Than Value Stated	50 per 1,000 seconds	98	88	76	52
	10 per 1,000 seconds	88	61	55	32
	2 per 1,000 seconds	75	42	38	12

Notes: 1. Two connexions would not work at 1,200 bits/second, and one connexion would not work at 1,200 or 600 bits/second.

2. The duration of each test was insufficient to provide these performance figures.

Information about error distribution was obtained during approximately half the 75 and 600 bits/second tests and all the 1,000 bits/second tests, but, for lack of equipment, during none of the 1,200 bits/second tests. This information is summarized in Table 2.

of one error in  $10^4$ - $10^6$  hits transmitted, if centre-point sampling is used.

The two tables cannot be directly compared, since the tests quoted in Table 2 happen to have, fortuitously, a lower mean error-rate than that quoted in Table 1. From Table 2 it can be inferred that about 70 per cent of errors are single-element errors widely separated from any other error, whilst the remainder of the errors occur in "bursts," i.e. they are grouped because they are caused by a common incident; a significant proportion of these bursts contain more than three errors. This error distribution is of importance to anyone designing an error-correcting system for use with the Datel 600 Service.

In the Datel Modem 1A the pass bandwidth of the receiving filter for the 75-bits/second channel is only about one tenth of that for the 600-bits/second or the 1,200-bits/second channel. Thus, for given power levels of signal and uniform-spectrum random noise in the audio-frequency band, the signal-to-noise ratio is 10 db greater in the low-speed channel than in the high-speed channel. This results in a dramatically-better error-rate performance in the low-speed channel. However, as the results show, there is little noticeable difference between the error-rates of the two channels on public switched telephone network connexions, and this is due to line noise having a higher energy at low frequencies than at high frequencies.

#### Limiting-Line-Condition Tests

The tests over limiting line conditions were designed to establish the maximum lengths of the various types of line plant over which the Datel Modem No. 1A would operate satisfactorily. In each of the tests the transmitted signal power was kept as high as possible without the risk of overloading line amplifiers, etc., in order to give

TABLE 2

Summary of Results for Block Error-Rate Tests on Circuits Routed via the Public Switched Telephone Network

Transmission Rate (bits/second)		75		600		1,000	
Block Size (bits)		100	1,000	100	1,000	100	1,000
Mean Bit Error-Rate 1 bit in		$2.7 \times 10^4$	$2.5 \times 10^4$	$6.5 \times 10^4$	$6.5 \times 10^4$	$5.3 \times 10^4$	$2.1 \times 10^4$
Number of Blocks Transmitted		$1.65 \times 10^4$	$1.6 \times 10^3$	$1.75 \times 10^6$	$1.75 \times 10^4$	$1.7 \times 10^6$	$2.23 \times 10^4$
Number of Blocks in Error		44	41	161	154	223	549
Mean Block Error-Rate 1 block in		375	39	1,087	114	762	42
Mean Number of Blocks Transmitted for Each Received Block Containing Bit Errors Stated	1 bit error	470	55	1,900	197	1,000	72
	2 bit errors	5,500	300	3,600	490	7,700	210
	3 bit errors	5,500	400	18,000	1,300	9,400	680
	4 or more bit errors	8,000	500	16,000	1,200	12,000	230
Percentage of Tests with Block Errors Equal to or Less Than Value Stated	50 per 1,000 seconds	100	100	100	100	99	97
	10 per 1,000 seconds	94	92	82	80	74	67
	2 per 1,000 seconds	81	83	56	48	35	34

In examining the above tables it should be noted that the samples are very small and, hence, cannot be used to predict accurately the performance to be expected when using these modems on the public switched telephone network. However, they do show that for any transmission rate the mean bit error-rate lies in the range

the maximum signal-to-noise ratio and, thus, ensure that the results were reasonably independent of noise. This meant that the technique of assessing performance by error-rate measurements could not be used, and the degree of individual distortion as measured by the Datel Tester No. 1A was used as the criterion of performance.

The tests were subdivided into three series in order to assess the effects of the different line characteristics described previously in this Journal.<sup>4</sup>

The first series covered the transmission of data at 600 and 1,200 bits/second over unidirectional telephone circuits routed on standard loaded cable. The results of these tests are shown graphically in Fig. 3, and it is

distortion on the modem are such that the telegraph distortion is increased by any signal-to-echo ratio less (worse) than 20 db, as shown in Fig. 6.

#### CONCLUSIONS

The tests which have been carried out with the Datel Modem No. 1A indicate that it is capable of transmitting

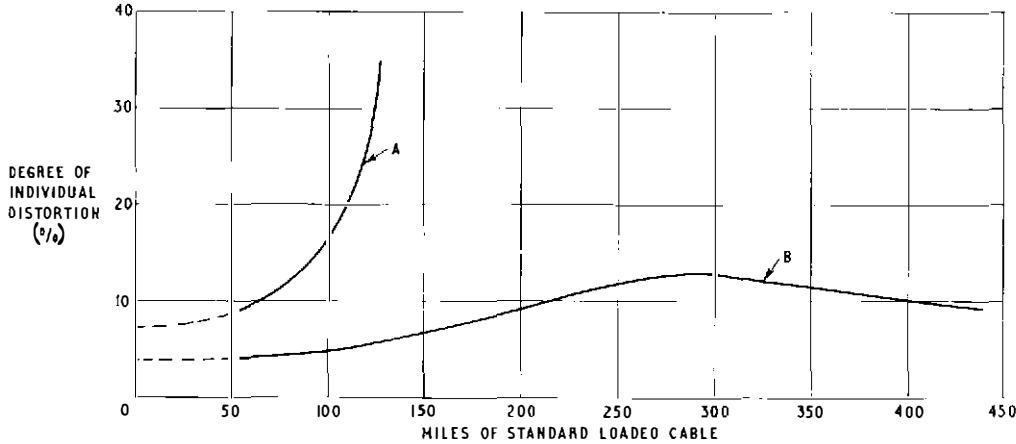

FIG. 3—DEGREE OF INDIVIDUAL DISTORTION RELATIVE TO LENGTH OF CIRCUIT

noteworthy that at 600 bits/second successful transmission can take place over several hundred miles.

The second series of tests was concerned with the transmission of data at 600 and 1,200 bits/second over telephone carrier channels connected in tandem. Again unidirectional connxions were used. The results of these tests are shown in Fig. 4.

binary data signals with low error-rate, typically 1 error per 20,000 bits transmitted, over a high percentage of the connexions found in the public switched telephone network. These tests were time-consuming, and, incvitably, the number of connexions tested were only a small number of the total possible. However, it is believed that the sample was reprcsentative, and that the results give

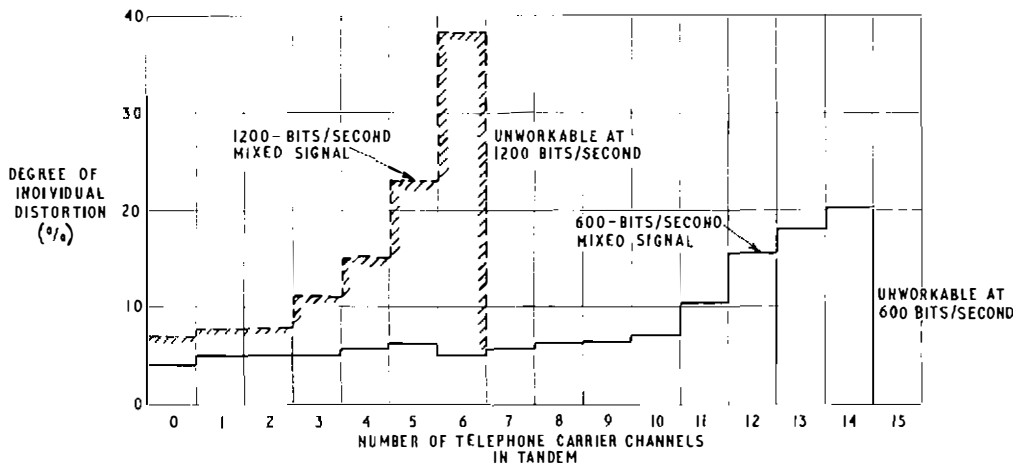

FIG. 4—DEGREE OF INDIVIDUAL DISTORTION RELATIVE TO THE NUMBER OF TELEPHONE CARRIER CHANNELS IN TANDEM

The third series of tests were designed to assess the effect of echoes which occur on telephone circuits due to mis-match at the 2-wire/4-wire termination between the 2-wire line extension and the termination unit. The circuit configuration used for these tests is shown in Fig. 5. The effect of an echo is to impose a ripple upon the group-delay/frequency characteristic of the line, the ripple, for a given data-signal strength, increasing rapidly with the echo-signal strength until it becomes the dominant feature. The effects of this group-delay/frequency

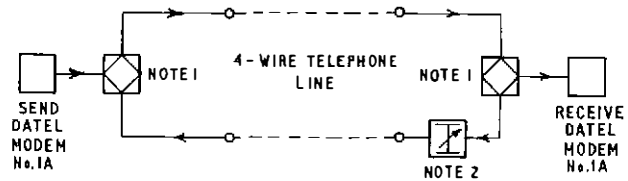

FIG. 5—TEST ARRANGEMENT FOR ASSESSING EFFECT OF SIGNAL ECHO

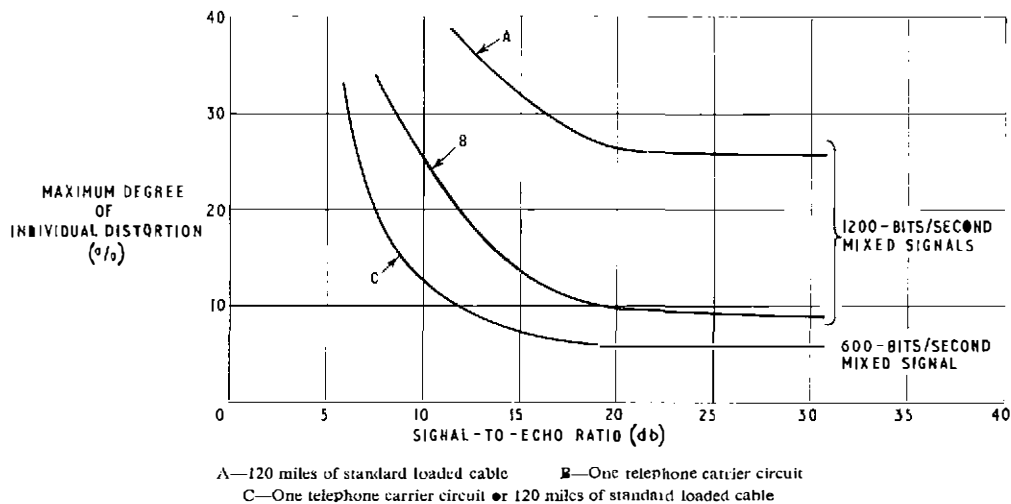

FIG. 6—EFFECT OF LISTENER ECHO ON PERFORMANCE OF DATAL MODEM No. 1A DEMODULATOR

a good indication of the standard of service which may be expected with present telephone line and exchange plant. They also show the wide variations existing between different connexions and, thus, the difficulty in predicting data-transmission performance in terms of error-rate between any two locations within the United Kingdom. A further important conclusion is that approximately 30 per cent of the errors occur in bursts and that this affects the design of an error-correcting system.

#### ACKNOWLEDGEMENTS

The work entailed in carrying out the tests reported involved many people, and the authors wish to thank all those who contributed to the tests, particularly the staff

of the Engineering Department's Telegraph and Data Systems Branch Laboratory, for the help given in obtaining the information on which this article is based.

#### References

- <sup>1</sup>SMITH, N. G. An Introduction to the Post Office Datal Services. *P.O.E.E.J.*, Vol. 59, p. 1, Apr. 1966.
- <sup>2</sup>ROBERTS, L. W., and SMITH, N. G. A Modem for the Datal 600 Service—Datal Modem No. 1A. *P.O.E.E.J.*, Vol. 59, p. 108, July 1966.
- <sup>3</sup>SKINGLE, G. D., and SPANFON, J. C. Test Equipment for the Datal Services—Datal Testers No. 1A, 2A and 2B. (In this issue of the *P.O.E.E.J.*)
- <sup>4</sup>WILLIAMS, M. B. The Characteristics of Telephone Circuits in Relation to Data Transmission. *P.O.E.E.J.*, Vol. 59, p. 150, Oct. 1966.

## Book Review

“Design Theory and Data for Electrical Filters,” J. K. Skwirzynski, M.I.E.E., D. Van Nostrand Company, Ltd. 730 pp. 186 ill. £8 10s.

There is no shortage of books dealing with electrical networks, many of them written with profound knowledge of the theoretical aspects. And yet, it is very difficult to find a book from which a non-specialist can learn how to design a network, such as a filter, by modern methods without danger of being overwhelmed by generalizations and subtleties for which an engineer's harassed existence allows little time.

Skwirzynski's valuable book remedies the situation in certain important respects. It deals mainly, if not exclusively, with reactance ladder filters whose loss characteristics between resistive terminations are of the so-called Chebyshev type, i.e. having equal ripples of permissible amplitude in the pass-band(s) and equal minima of required value in the stop-band(s). Although design methods for such “insertion-loss filters” have been available for a quarter of a century, the necessary calculations are of discouraging complexity even now. Fortunately, the advent of electronic computation has made it possible to compile tables which ease considerably the design procedure in many practical cases.

The larger part of the book consists of such tables covering, in the first instance, low-pass filters of degree 3 to 7, i.e. of one to three sections, with prescribed pass-band ripple, minimum stop-band loss and permissible gap between pass- and stop-bands. By applying simple transformations the tables can also be used for high-pass filters as well as for

band-pass and band-stop filters with frequency-symmetrical behaviour. The tabulated element values are normalized with respect to impedance and frequency. For filters of even degree, i.e. containing half-sections, element values are given for two different terminating conditions. Also contained in the tables are element values for the limiting terminating conditions of open-circuit and short-circuit on one side, and additional data are provided for taking dissipation into account in these cases. Further aids are tabulated for the computation of the poles of the transfer functions which are required when envelope delay or waveform response are of interest. The tables are accompanied by explicit instructions about their use and by well-chosen examples.

Preceding the tables and their explanations, the book gives an extensive introduction to the underlying principles, providing a high degree of penetration into the subject without confusing generalizations. A valuable addition to this theoretical part is a chapter on envelope delay, with particular attention to the delay characteristics encountered in filters of the type mainly considered, together with design methods for delay equalizers and even hints on their alignment.

The deliberate limitation of the scope of the book must surely be considered as a virtue. While one may have reservations on certain details of presentation, such as the choice of normalization, and may greedily wish that even more material was offered in the tables, no seriously adverse comment can be made about this book which should find general acclaim amongst a wide circle of communication engineers and designers.

J.M.L.



# The Leighton Buzzard Electronic Telephone Exchange

S. H. SHEPPARD†

U.D.C. 621.395.722:621.395.345

The telephone exchange system installed at Leighton Buzzard was developed under the auspices of the Joint Electronic Research Committee comprising the British Post Office and the five principal British Manufacturers of telephone-switching equipment. The general features of the design and the facilities provided are briefly described, and the mode of operation is explained.

## INTRODUCTION

**L**EIGHTON BUZZARD is a prototype installation of a design for an electronic telephone exchange capable of serving 10,000 or more subscribers. Equipment is provided initially for 3,000 subscribers and 300 junctions. The system exploits the advantage of the sealed reed-relay contact unit as a metallic cross-point allied to an electronic control which, by virtue of its extremely high speed of operation, can process calls on a one-at-a-time basis for the whole exchange and can, consequently, select a discrete connecting path which is the optimum for each call that is established.

The concept of sectionalization is applied to the switching equipment, and this, together with self-

†Telephone Electronic Exchange Systems Development Branch, E.-in-C.'s Office.

checking and repeat-attempt features, ensures that the system continues to provide an acceptable service in the presence of major faults.

A view of the equipment racks and the test console is shown in Fig. 1.

## THE SWITCHING UNIT

Fig. 2 illustrates the basic concept of switching stages obtained by interconnecting groups of relays assembled into co-ordinate matrices. From any C-inlet terminal a path can be set to select a particular subscriber from the 1,500 connected to A-switch outlets. For a local call a connexion would be established from each side of a link, through the switching array CBA to the respective calling and called subscribers.

The matrices are built up from strips of 10 reed relays and interconnected to provide the requisite trunking. Subscribers' lines, in groups of 100, are served by an A-switch, having 40 trunks, connecting to the B-switch stage. Each pair of trunks serves 10 subscribers, and the individual trunks are distributed so that the two pairs to which a subscriber has access are shared



FIG. 1—EQUIPMENT RACKS AND TEST CONSOLE

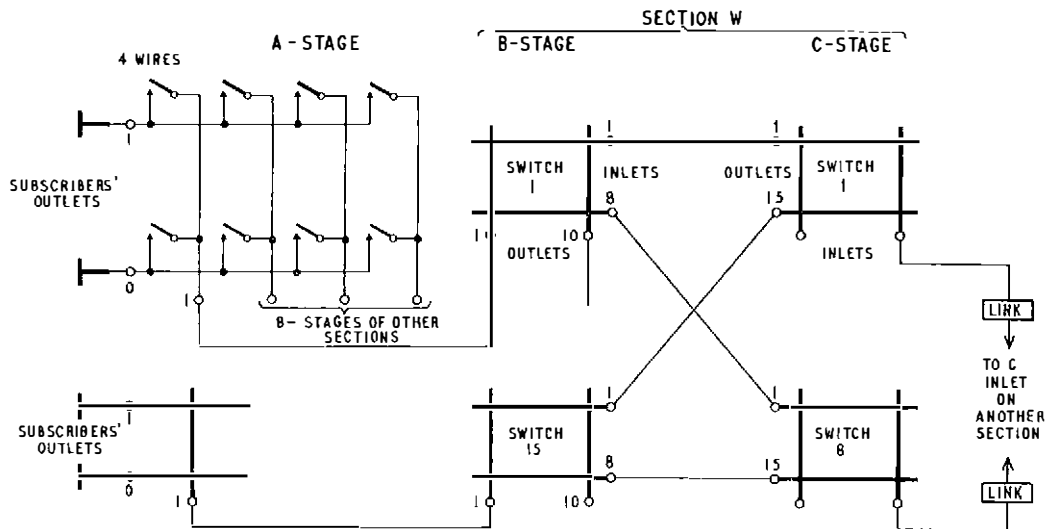

FIG. 2—BASIC SWITCHING CONCEPT

with 18 other subscribers. The B and C switching stages are fully interconnected, and are arranged in four sections which are connected to the 40 A-switch trunks in such a manner that each subscriber has access to the four sections of the B and C switching stages.

A group of 15 A-switches forms the first switching stage for a local unit serving 1,500 subscribers, and there

are two such units provided initially. The trunks from the A-switches to the B-switches are interconnected between the two units in order to improve the distribution of traffic, as illustrated in Fig. 3.

The outgoing-junction and incoming-junction switching units are similarly sectionalized, and there is, in addition, an auxiliary unit which provides a variety of

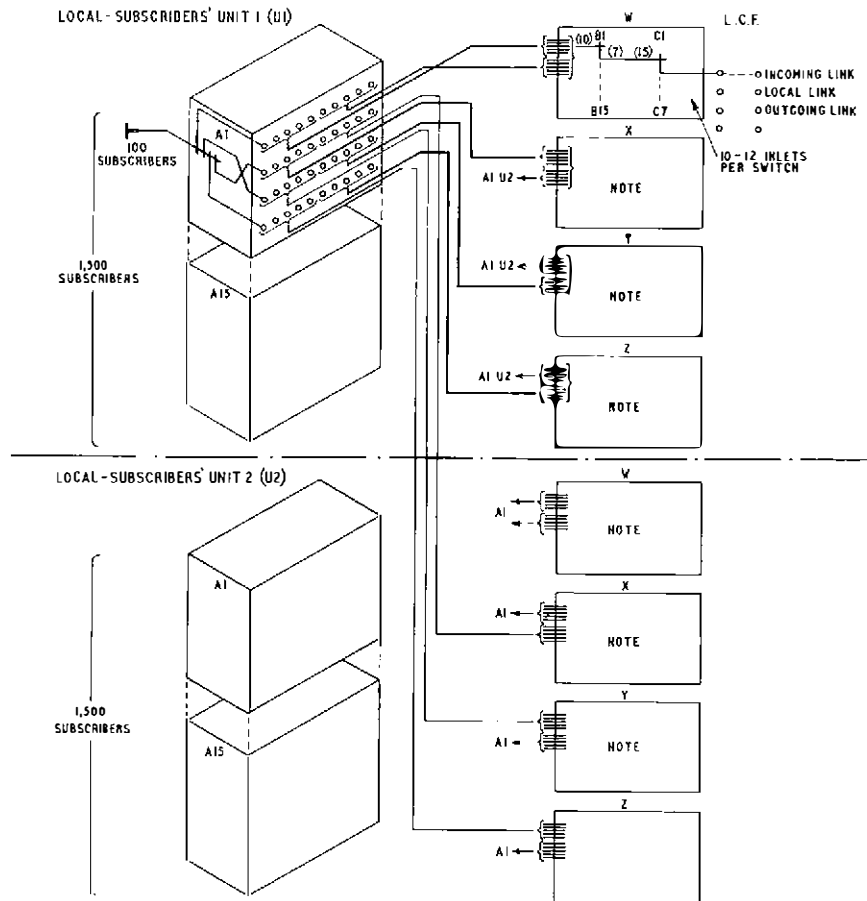

L.C.F.—Link-connecting frame  
 Note: The interconnections within the B and C switching stages X, Y and Z of local unit 1 and the B and C switching stages W, X, Y and Z of local unit 2 are the same as for the B and C switching stages W in local unit 1.

FIG. 3—LOCAL-SUBSCRIBERS' UNIT TRUNKING

coupling functions and which has duplicate sections only, as illustrated in Fig. 4.

In addition to the switching equipment the sectionalization includes route-choice (interrogators) and control apparatus (markers), and the system is arranged so that failure of one or even two sections does not prevent the remaining sections from providing service to all sub-

unit identity and outlet numbers for C-switches, B-switches and A-switches. The centralized route-choice equipment has a comparator which evaluates the data supplied by the sectionalized route-choice equipment and determines which of the exchange sections is best able to deal with each call in turn. This effectively combines the activities of the sections and produces an efficiency of traffic handling equivalent to a single large unit.

### Junction Units

The trunking arrangements for the junction units provide the availability necessary for these high-occupancy circuits. For the outgoing junctions the A-stage switching is omitted and the junctions are commoned on the B-switches. For large routes a form of grading is adopted whereby early-choice circuits are commoned to pairs of sections and the later choices have full commons to all four sections. For small routes all choices are connected as full commons.

Incoming junctions are connected to A-switches, and pairs of junctions share four trunks to the B-switch stage. The difference between arrangements adopted for incoming and outgoing junctions is due, in part, to the location of the transmission-bridge and supervisory-function circuit elements. For outgoing junctions these are located in the outgoing-junction relay-set, and the outgoing links are consequently simple and inexpensive, whereas for incoming junctions the incoming link is the point of supervision as for local links, and efficient traffic loading must be achieved.

### Cross-Linking Between Units

The completion of a call always requires the use of a link of the appropriate type, namely, local, outgoing, incoming or transit, between C-switch inlets of the units concerned. Each section of a unit, termed a sub-unit, has links of each type connected to its C-switch inlets, and the overall pattern of interconnexions is arranged to provide links from each sub-unit to each sub-unit of the adjacent sections (above and below). Thus, a completed call always requires the use of two sections, one being used for the connexion to the calling subscriber or junction and the other for the connexion on the called side.

In order to increase the availability and thereby promote efficient use of the more expensive supervisory links (local and incoming-junction links) a proportion of these are connected to C-switch inlets of more than one section, and these are known as overlying links.

### Trunking of Registers

Local registers are connected to C-switch inlets, and their availability is similarly increased by overlying connexions. Incoming registers have no connexions to switch inlets because a time-shared electronic dial-path is used to transfer pulsing information from the incoming-junction termination to a free register. This feature is necessary because the residual time of the inter-digital pause after selector search at a previous exchange may be insufficient to allow a connexion to a register to be established before the next digit is received.

### LOCAL-CALL PROCEDURE

The local-call procedure is described below and should be considered in conjunction with Fig. 5, which is an explanatory diagram of the Leighton Buzzard system.

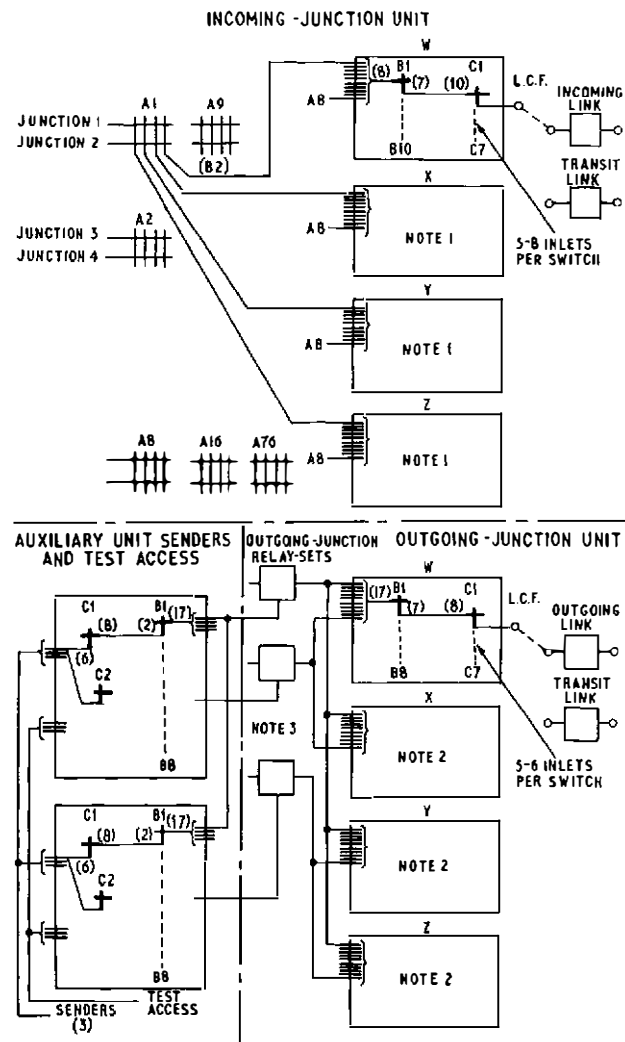

- L.C.F.—Link-connecting frame
1. The interconnexions within the B and C switching stages X, Y and Z are the same as those for the B and C switching stage W of the incoming-junction unit.
  2. The interconnexions within the B and C switching stages X, Y and Z are the same as those for the B and C switching stage W of the outgoing-junction unit.
  3. Some junction relay-sets are connected to pairs of sections and others are full commons.

FIG. 4—JUNCTION-UNIT TRUNKING

scribers. In addition to its intrinsic security advantages, the philosophy of sectionalization enables equipment quantities appropriate to high or low calling-rates to be provided by adjustment of the number of standardized sections, and is convenient for maintenance and extension purposes.

Division of the switching network in this way, together with full interconnexion between the B and C switching stages, allows each section to provide a routing from any input to each output (subscriber or junction) and to define this routing by an "equipment number" comprising

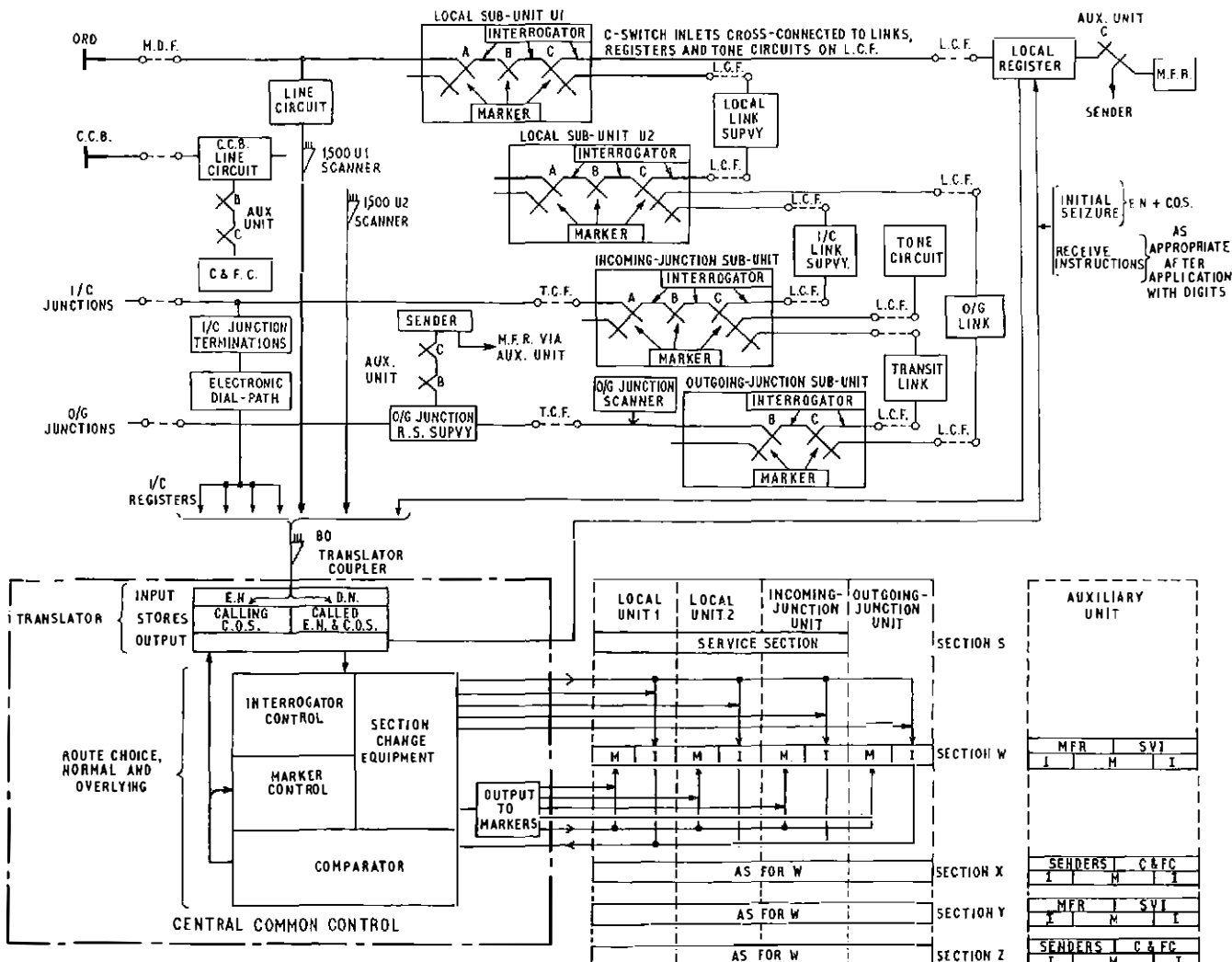

ORD—Ordinary exclusive and shared-service lines. C.C.B.—Coin box. L.C.F.—Link-connecting frame. C. & F.C.—Coin-and-fee-checking circuit. I/C—Incoming. O/G—Outgoing. M.F.R.—Multi-frequency receiver. E.N.—Equipment number. C.O.S.—Class of service. D.N.—Directory number. M—Marker. I—Interrogator. R.S.—Relay-set. SUPVY—Supervisory.

FIG. 5—EXPLANATORY DIAGRAM OF LEIGHTON BUZZARD SYSTEM

Each local unit incorporates a duplicated electronic scanner, driven from a 7 kc/s oscillator. A loop calling condition on a subscriber's line causes one of the scanners concerned to stop at that equipment-number position and to apply an "ask" signal to the translator coupler. Meanwhile, the partner line scanner is set to the indicated equipment number, and comparison between the outputs of the two scanners provides a cross-check that both are associated with the same calling line. After each complete scan (1,500 lines) the partner scanner becomes the working scanner and starts its search from the last position at which it has been set during its checking function.

The translator coupler (two are provided and normally used alternately) interrogates each circuit (registers and line scanners) for 70 ms per scanning cycle, and, when stopped by the line-scanner ask signal, seizes the translator and causes the line scanner to connect its signals to the translator common highways.

The translator receives from the line scanner an equipment number which identifies the calling line, and,

by application to its calling (A) store, determines the "class of service" for the line.

The calling-equipment number and a request for a register connexion are signalled from the translator to the route-choice unit, and the latter sends a start signal to all the interrogators of the local unit concerned, provided that their associated markers are free.

Each interrogator responds with a free or a busy indication for all C-switch inlets and for C-switch and B-switch outlets, and these data are evaluated by the comparator to select the section with the lowest numbered C-switch that is free and which has at least two other C-switches with free outlets. This method of choice "packs" calls towards the lowest-numbered C-switch. Under conditions of light traffic an immediate choice can often be made without application of the full comparator cycle. A chain-start arrangement varies the order of comparison of sections, and thus ensures that a fault on a particular routing within a section is unlikely to affect a repeat-attempt consecutive call.

The comparator sends a "success" (route-chosen)

signal to the translator and to the marker controls, and indicates the section and C-switch number.

The marker of the chosen section receives the equipment number via the section change equipment, the function of which is to convert the true equipment number to a variant applicable within the particular section, namely, to modify the equipment number to take account of the transposed interconnexions between A-switches and B-switches introduced for traffic reasons. In addition to an equipment number, the marker receives coded signals indicating the particular C-switch inlet on which the allocated register is connected, and the marker couples itself thereto. A positive marking potential is applied to the hold wire of the C-inlet by the marker and then, in turn, marking earth signals are applied to the marker wires for the C-stage, B-stage and A-stage cross-point matrices. The three cross-point relays that are operated remain held in series from an earth applied to the hold wire at the register.

The route-choice unit also signals the register number to the translator, and the latter identifies the register and sends an initial seizure signal to it, accompanied by the equipment number of the calling line and the class of service where applicable. Connexion of the marker to the selected register brings about "primary seizure" of the register, and, on completion of the cross-point operation, the conditions on the P-wire cause "secondary seizure" of the register. The loop-detecting element is then connected to the positive and negative wires in the register, and, on receipt of a loop signal, dialling tone is returned to the caller.

The completion of the P-wire circuit operates the subscriber's cut-off relay and disconnects the loop calling condition from the line-scanner gates. This allows the scanner to restart and, thereby, provides an indication that coupling to a register has been successfully achieved. Should a line scanner fail to complete its scan of 1,500 lines within  $1-1\frac{1}{2}$  seconds a fault detector causes a diagnostic routine to be started by the automatic fault-locator (see the later section on Maintenance and Security Features).

The register stores the digits dialled by the subscriber, and, after the first digit has been received, it applies to the translator and presents thereto the identity, i.e. the equipment number, of the caller and the digit dialled. For a local call the translator returns a signal to the register: "Come again with three more digits." The register subsequently reapplies and presents the identity of the caller and the four digits which he has dialled.

The directory number dialled is applied to stores on the called side of the translator, and the equivalent equipment number and the class of service of the called line are obtained. The full data for the calling line (from the register) and the called line are then applied to the route-choice unit with an indication that the call is local. Four local-unit interrogators will be sent a start signal, two in the calling and two in the called mode, and an initial comparison will be made to select the best of four possible routes (two up and two down between the pairs of sections). The four interrogators will then be sent a further start signal but with their functions transposed, i.e. those formerly used in the calling mode will be used for the called mode, and vice versa. Further comparison follows between the route chosen for the first interrogation and the four available from the second interrogation, and a best-best is selected based upon the call-packing features

already described. The comparator sends a success signal to the translator and to the marker controls, and indicates, to the pair of markers concerned, the section and C-switch number, and which marker is controlling the calling side and which the called side of the connexion, respectively. The markers receive the equipment number and class-of-service information from the translator, and are now able to set the connexions from the called line to the selected local link and from the link to the calling line.

The local links are reversible, and receive indications from the markers which side of the connexion is calling and called, respectively. Meanwhile a "finish" signal from the common-control basic timer will have caused the translator coupler to "scan on," releasing the common control from the register. Connexion of the local link to the calling line will be detected on the P-wire of the register and will cause the register to release. The local link now rings the called line, and provides supervision and local-call timing of the connexion.

If the called line is busy this condition is detected by the called-side marker and signalled to the link. The cross-points are released on the called side, and busy tone is returned from the link to the caller.

Unless the register is released within a predetermined period by the arrival of the link connexion, it re-applies to the common control, and a fresh attempt is made to set up the connexion. This facility is made use of to allow a further search on a call to a private branch-exchange (P.B.X.) group of lines if the selected line becomes engaged on an outgoing call during the mark-setting period.

In the event of a cable breakdown or other faults causing a permanent loop (PG) on a subscriber's line, the register is forcibly released after a pre-determined interval, and, in releasing, causes a "subscriber parked" signal to be applied to the line circuit concerned. This facility is provided by the use of a double-armature 2-step relay for the cut-off relay. To apply "park" conditions, the relay is left in the low-current step condition with one armature held in conjunction with its own make-contact unit. The line scanner incorporates both line and PG scanning arrangements and is arranged to ignore the park-plus-loop condition, but it will stop whenever it detects a park condition without a calling loop or vice versa. In either instance, a connexion is set to a register, and the appropriate action follows, namely, reset of park condition or return of dial tone to the caller.

#### JUNCTION CALLS

When the calling subscriber dials a junction code, the route-choice unit tests for a free circuit in the required group and causes a connexion to be set-up from the selected junction, via an outgoing link, to the calling subscriber. This connexion is normally made during the inter-digital pause, and the outgoing-junction relay-set then serves as an auto-to-auto repeater for the subsequent digits dialled by the caller.

If the required connexion cannot be established during the inter-digital pause, due to blocking or other causes, or if the caller is an m.f.-signalling subscriber, or is barred trunk calls, then a sender is associated with the selected outgoing-junction relay-set via the auxiliary unit.

Digits stored by the register in excess of those absorbed for local routing at Leighton Buzzard are transferred via the common control to the sender store, together with

any additional routing digits that may be required, e.g. on subscriber transfer to a remote exchange. These digits are pulsed out from the sender and are followed by any subsequent dialled digits, which are received directly by the sender and retransmitted.

Reference has already been made to the use of a time-shared electronic dial-path to convey seizing and pulsing information to incoming registers from incoming junctions. The incoming register also stores the identity (equipment number) of the calling junction. Application is made to the common control, as already described for the local-call register. The junction equipment number, applied to a translator store, provides class-of-service information for the particular junction, and use is made of this feature to apply route restriction to prevent unauthorized tandem routings.

If the incoming call is to a Leighton Buzzard subscriber then an incoming link forms the point of supervision and control, whereas permitted transit calls are connected via a bridgeless transit link and supervision is provided by the outgoing-junction relay-set.

A number of tone circuits are provided, connected to C-switch inlets, and these are used, when required, to apply equipment-engaged or number-unobtainable tone to a calling junction.

In the event of a PG condition on an incoming junction a tone circuit can apply a park condition to the junction concerned in a similar manner to that adopted for subscribers' lines. Normal conditions are restored as soon as the PG condition is removed.

Although incoming links could have been used to fulfil the functions of the tone circuits this would have entailed uneconomic provision of these links.

#### ADDITIONAL FACILITIES

##### *Subscribers' Facilities*

Any number of lines may be used to serve a P.B.X., and the equipment numbers allocated need not necessarily be consecutive. Each P.B.X. group requires only a single directory number unless night service or other special facilities are required. Provision is made for night-service busy or night-service interception, or both, to be provided if required, and for switching to be controlled by codes dialled by the P.B.X. operator concerned.

A single equipment number may be allocated to two directory numbers to provide for two subscribers sharing service. The system incorporates provision for selective ringing (X and Y subscribers), and for selective metering by phased pulses to a pair of meters connected to the common P-wire.

Coin-box lines are connected to special line circuits which provide facilities for the introduction of coin-and-fee-checking relay-sets on both incoming and outgoing calls. For the former connexions the coin-and-fee-checking circuit provides a pulse of identification tone when the call is answered, and then is normally released except for reversed-charge calls to the coin-box line from the Luton exchange manual board. On all outgoing calls from the coin-box line the coin-and-fee-checking relay-set remains in circuit throughout the call.

Provision is made for a limited number of subscribers' lines to be provided with instruments having keysets in place of dials, in addition to the normal telephone. When a calling loop is received from such lines they will be identified by a "maybe v.f." class-of-service from the

translator A-store, and will be connected to special late-choice registers; the register in turn will be connected to a multi-frequency (m.f.) receiver via the auxiliary unit. With such a connexion, the line polarity to the caller will be reversed and, if the keysending telephone is in use, this will activate oscillators in the telephone and cause tones to be received at the m.f. receiver. These tones, which represent a class-of-service signal indicating whether the line is normal or is barred from making trunk calls will also be heard by the caller and provide a signal to commence keysending. Digits received in two-out-of-five code will be converted to serial pulsing and transferred to the register stores. Application to the common control proceeds in the normal manner, but the m.f. receiver incorporates a buffer store to accommodate digits that may be received whilst the register is coupled to the common-control equipment.

##### *Service Facilities*

The junction class-of-service also serves to identify the service junctions (test and trunk-offering) which require special switching arrangements in order to provide a bridgeless connexion between the test or trunk-offering relay-set and the called line. These types of connexion are set up as for an outgoing-junction call from the subscriber's line concerned, and the test and trunk-offering relay-sets are connected within the outgoing-junction unit.

The high-speed common control and fast-switching features of the electronic exchange are of particular advantage for service observation since they permit observation to be made directly on a subscriber's line or a junction and yet enable a high level of observation traffic to be maintained to the operator.

Selection of the type of observation required (subscribers' lines or junctions) is made by dialling control codes over the trunk-offering junction.

To ensure that the normal grade of service is not impaired by service observation, and, consequently, to ensure that a true indication of the grade of service is given to the observation operator, a separate cross-point in the service section is used for the observation connexion.

When the centralized-service-observation junction is seized by the observation operator a demand signal is applied to the common control, and, for the next call of the requisite type that is initiated, a connexion is made immediately from the centralized-service-observation relay-set via the service section to the calling subscriber or junction. For a calling subscriber, the connexion of a register follows, but for a calling incoming junction the centralized-service-observation connexion is the only one made at this stage as the time-shared dial-path is used for signalling information to the incoming register. Release of the observation connexion is under control of the observation operator, and facilities are provided whereby she may either reset the displayed digits and observe follow-on calls from the same line or effect full release and be connected to the next originated call of the selected type.

The occupancy of the service-section cross-points by centralized-service-observation traffic is extremely low, and, therefore, the service section is also used to complete test or trunk-offering connexions which would otherwise fail due to blocking in the normal sections.

### *Special Facilities*

Electronic common-control systems of the Leighton Buzzard type have intrinsic features which may be exploited to provide new facilities. For example, the provision of subscriber control of facilities such as transfer is simplified by the identification of calling lines and their individual class-of-service store.

Subscribers with the optional-transfer facility can, by dialling a common control code (832), cause subsequent incoming calls for their line to be routed to a predetermined alternative Leighton Buzzard number. Alternatively, the calls can be transferred to the Post Office operator at Luton or to a number on an adjacent exchange. Whilst transfer is in operation the line concerned can be used in the usual manner for outgoing calls, and, on making such calls, the caller receives interrupted dial tone as a reminder that transfer is in operation. Normal conditions are restored by dialling a reset code (833).

Subscribers wishing to avoid disturbance by incoming calls during certain periods can be provided with the facility of transferring at will their incoming calls to a common verbal announcement: "This subscriber does not wish to receive calls at present." Unless reset by the subscriber, normal conditions are restored on all such lines at a predetermined time each day.

When a batch of subscribers' lines are made temporarily out of service it often becomes necessary to make repeated engineering visits to an exchange to restore service, on a piecemeal basis. This difficulty is avoided at Leighton Buzzard by providing a facility for remotely switching predetermined subscribers' lines by control codes dialled over the trunk-offering junction. Any subscriber's line can be allocated a discrete control code for as long as the control function is required.

Provision is made for a graduated howler to be applied to a subscriber's line by the application of an extended ring-key signal over the trunk-offering junction. To avoid misoperation, this feature is restricted to monitoring positions at Luton, and the signal is ineffective unless the line concerned is in the parked condition.

### MAINTENANCE AND SECURITY FEATURES

A 2-position cordless test-console (see Fig. 1) is provided as the main control of the security-switching and testing arrangements. One position is used for testing subscribers' lines, and the features normally provided on an exchange test desk are available. Line-test registers are used to gain access to any subscriber's line or outgoing junction for test purposes, and these can also be controlled remotely from the maintenance-control centre at Luton. Test links are provided on the test console to couple the line or junction under test to a variety of testing panels, including a dial-speed-and-ratio tester, a voltmeter, and a transmission-measuring set.

The other console position centralizes the exchange-testing arrangements. For all duplicated and sectionalized equipment a lamp display indicates the items in service and records any that are faulty. Keys are provided to over-ride the normal automatic change-over arrangements and to select either one or the other unit to remain in service.

An exchange test-register provides facilities for setting any type of call through the exchange equipment, and allows the routing to be specified so that particular items of equipment can be proved. The exchange test-register can be programmed to routine test registers, links of all

types, and tone circuits. Facilities are provided to trace calls on any exchange connexion, and to display the details of the switch outlets in use and the section, etc., on a common display panel.

A teleprinter on the test console provides a local record of fault and alarm conditions, and is also used to record details of highway signals that are present when a fault occurs on common equipment. The teleprinter is also used to tabulate details of all subscribers' lines that are permanently looped, and to provide a printed record of the output from the traffic-recorder equipment. In addition to the local record, there is a remote print-out of the information at the maintenance-control centre at Luton.

Associated with the test console is an automatic fault-locator which, whenever a faulty condition is encountered, performs a diagnostic routine by setting up test calls in a predetermined manner. High-speed or low-speed programs are available depending upon the nature of the fault indication, and the equipment is able to change-over the various duplicated items and, from the proportion of successes and failures obtained for the test calls, can determine the combination giving optimum serviceability. Items of duplicated equipment found faulty are switched out of service, and a full record of the test routines and results is printed out by the teleprinter to assist in the location of faults.

### POWER SUPPLIES

The exchange operates on three distributed supplies: 50 volts, +50 volts and -18 volts, with the earth return of the -50-volt and +50-volt supplies connected to the rack frameworks and the return of the -18-volt supply insulated from racking and used as a "quiet" (electronic) earth. The common control requires other voltages for bias and clamp supplies, etc., and these are derived from the 18-volt supply.

### CONCLUSIONS

Although adequate for a field-trial exchange the Leighton Buzzard design has certain disadvantages which make it unsuitable for a production system, and continuing development has resulted in an improved version which is undergoing model tests in the Post Office Circuit Laboratory.

Features of the new design (which will form the subject of later articles) include the use of a general-purpose switching unit with a method of trunking that provides the necessary flexibility for multi-path connexions, and the application in the common-control area of greater sectionalization and of computer-like features so that the requirements for growth and provision of new facilities can be readily met. The use of a reed contact having smaller dimensions for the new design has resulted in substantial space savings and power economy.

Despite these design differences, operating experience with the Leighton Buzzard prototype unit will provide valuable data concerning traffic-handling capability, maintenance techniques, and subscriber reaction to the new facilities provided.

### ACKNOWLEDGEMENT

The Leighton Buzzard exchange was a joint development by Associated Electrical Industries, Ltd., the Automatic Telephone and Electric Co., Ltd., and Standard Telephones & Cables, Ltd., in conjunction with the British Post Office.

# Test Equipment for the Datel Services—Datel Testers No. 1A, 2A and 2B

G. D. SKINGLE, Graduate I.E.R.E., and J. C. SPANTON, Graduate I.E.R.E.†

U.D.C. 621.394.4:681.142:621.317.799

The advent of the Datel Services has necessitated the development of specialized test equipment for installation, maintenance and performance testing of these systems. This article describes some testers for serial-type Datel modems. The first tester described is a comprehensive laboratory instrument, and the other types are simple field instruments.

## INTRODUCTION

THE advent of the Datel Services<sup>1,2,3</sup> has necessitated the development of specialized test equipment for installation, maintenance and performance testing of these systems.

A requirement of a Datel tester is that it should be interchangeable with a customer's data terminal equipment. The tester must, therefore, simulate the customer's equipment, providing a data source or a data sink (i.e. a receiver of data signals), or both, together with the control functions required between the data terminal equipment and the Datel modem. The basic requirements of a tester can be summarized as follows.

(a) It should provide a source of data signals of various patterns and data-signalling rates.

(b) It should act as a data sink.

(c) It should provide the necessary control and supervisory functions for the Datel modem.

The interconnexion between the tester (or the customer's equipment) and the Datel modem is called the interface, and the various circuits comprising the interface are called interchange circuits. C.C.I.T.T. Recommendation V24<sup>4</sup> specifies the interchange circuits, and both the tester and customer's equipments are required to comply with this recommendation.

In addition to the above requirements the tester should provide some or all of the following facilities.

(a) A means of measuring the bias distortion in nominal 1:1 ratio signals, thus enabling setting-up procedures to be carried out on the Datel modem.

(b) A means of detecting and indicating errors in the received data signals (an error in the received data is said to occur when, at the sampling point, the polarities of an incoming signal and of a signal generated by the tester differ).

(c) A means of measuring the degree of individual distortion<sup>5</sup> of a particular significant instant of the received data signals and expressing this as the peak distortion occurring within a given period. This individual distortion is normally expressed as a percentage, and is the ratio of the displacement ( $t$ ) of the significant instant from an ideal instant to the unit interval ( $T$ ). It may be expressed algebraically, thus:

degree of individual distortion =  $t/T \times 100$  per cent.  
The time  $t$  is considered positive when the significant instant occurs after the ideal instant. To enable this measurement to be carried out it is necessary to generate an ideal-instant signal locally and for it to be synchron-

ized with the incoming signal. To enable accurate measurement to be achieved, the synchronizing circuit must have sufficient flywheel action to be unaffected by the instantaneous displacement of the significant instant of the incoming signal from its nominal position in time.

(d) Since most data modems at present in use are asynchronous the tester should provide a continuous data flow to the modems and not employ a clocked method of operation. If the equipment is synchronous the tester must be capable of being driven from the clock pulses provided by the equipment.

The Datel Tester No. 1A fulfils all the above requirements and is intended for use in laboratories, Datel Test Centres, and for special fault investigations. The requirements for a general installation and maintenance tester are less stringent; for such applications the measurement of errors and peak distortions is not necessary. Datel Testers No. 2A and No. 2B fulfil the requirements for such testers; the Datel Tester No. 2B differs from the Datel Tester No. 2A in having interchange circuits similar to those provided on the Datel Tester No. 1A, enabling it to check the various Datel modem-control functions.

## DATEL-MODEM INTERCHANGE CIRCUITS

The Datel Tester No. 1A and the Datel Tester No. 2B will normally be connected to the Datel modem by means of an interface cable which can be plugged into a 25-way socket located on the Datel modem. As already stated, the various interchange circuits which comprise the interface are in accordance with C.C.I.T.T. Recommendation V24. The state of any interchange circuit is specified by a nominal +6 volts, indicating an "ON" or binary-0 condition and by a nominal -6 volts indicating an "OFF" or binary-1 condition.

These voltages impressed upon the interchange circuits serve to provide the control, supervisory and data-transfer functions between the tester (or the customer's equipment) and the Datel modem.

Push-buttons on the front panels of the Datel Testers No. 1A and 2B enable the required interchange conditions to be applied. Operation of a control button applies an ON condition on the selected interchange circuit to the Datel modem, the applied control function being marked on the top edge of the button. For most commands the Datel modem responds by returning an ON condition on another interchange circuit, causing an indicator lamp to light in the operated control button. The markings on the bottom edge of the button indicate the circuit which has responded to the command.

The operational sequence of the interchange circuits acting between a tester and a Datel modem is shown in Fig. 1. The sequence starts at the data-signalling-rate instruction and continues as shown; ON conditions are implied unless otherwise stated. A customer's equipment would automatically follow a similar oper-

†Telegraph and Data Systems Branch, E.-in-C.'s office.



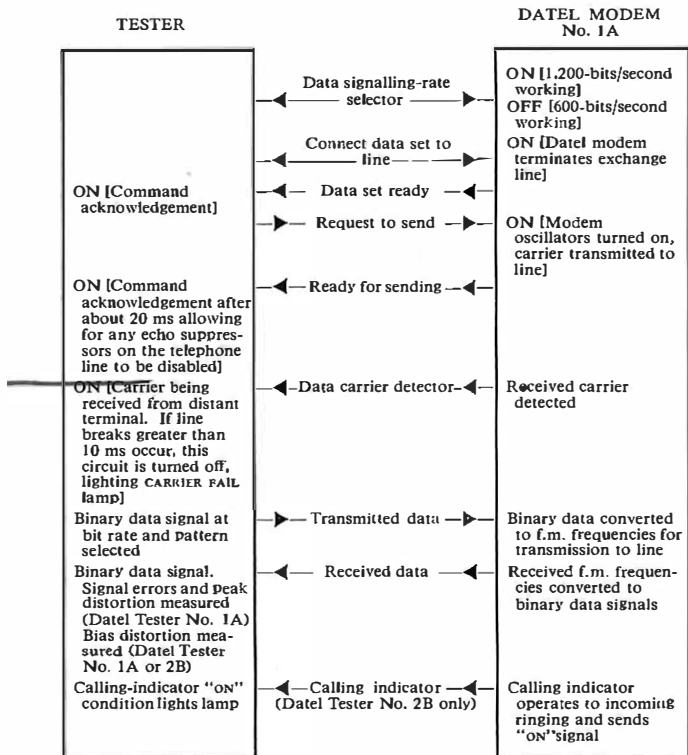

FIG. 1—DIAGRAM SHOWING INTERFACE BETWEEN THE DATTEL TESTER No. 1A OR DATTEL TESTER No. 2B AND DATTEL MODEM No. 1A

ational sequence after the connect-data-set-to-line condition, which is usually operator-initiated, has been applied.

#### DATTEL TESTER No. 1A

The Datel Tester No. 1A is intended for use in specialized locations such as Datel Test Centres and laboratories. The tester is portable, and the front-panel layout is shown in Fig. 2. A sliding cover protects the front panel while it is being transported, and a recess in the rear panel houses the mains and interface cables. The tester is driven from an a.c. mains supply in the range 180-260

volts. The power unit apart, the tester circuits are mounted on 12 printed-wiring boards, extensively using well-known basic logic circuit elements. The tester can simultaneously transmit and receive data signals having different data-signalling rates but having the same signal pattern.

#### Transmitter

Fig. 3 is a simplified block schematic diagram of the transmitter, which is driven by a 36 kc/s crystal-controlled oscillator, stable to  $\pm 0.01$  per cent. The oscillator output

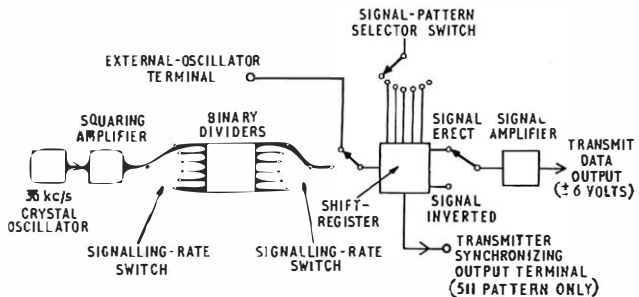

FIG. 3—SIMPLIFIED BLOCK SCHEMATIC DIAGRAM OF DATTEL TESTER No. 1A TRANSMITTER

is squared and fed into a binary-divider chain from which clock pulses are selected to drive a 9-element shift-register at the required data-signalling rate. The output from the shift-register provides either a steady-state binary-1 signal, 1 : 1, 1 : 3, 1 : 7 ratio binary-1 to binary-0 signal patterns, or 511-element pseudo-random patterns, at fixed data-signalling rates of 50, 75, 200, 600, 1,200, 1,800, 2,000, 2,400 or 3,000 bits/second, as selected by the switches. The pseudo-random patterns are also known as maximum-length sequences or chain codes, and in this instance their use has been limited to random sequence patterns repeated at 511-element intervals.

A facility for other transmitted rates up to 5,000 bits/second from an external oscillator is also provided. The output may be inverted to give the complementary patterns.

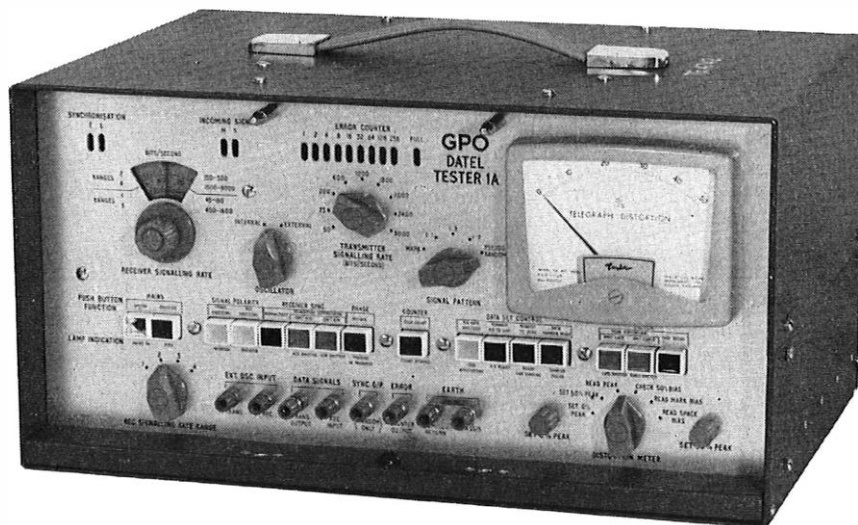

FIG. 2—DATTEL TESTER No. 1A

Fig. 4 shows the logic diagram for the transmitter shift-register when generating the 511-element pseudo-random pattern. Pulses derived from the 36 kc/s oscillator are used to step a 9-element shift-register. Outputs from the fifth and ninth bistable elements are fed-back,

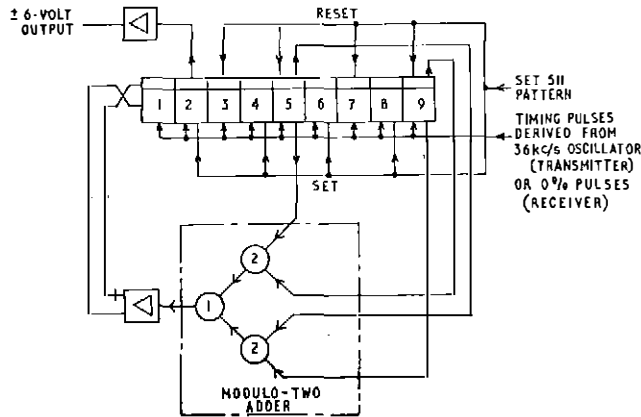

FIG. 4.—LOGIC DIAGRAM SHOWING METHOD OF GENERATING 511-ELEMENT PSEUDO-RANDOM PATTERN BY DATEL TESTER No. 1A

via a “modulo-two” adder, to generate the 511-element pseudo-random pattern. Modulo-two is the name given to an additive binary arithmetic operation whose only difference to normal binary addition is that totals are not carried over from one column to the next. The circuit element used to perform the function is an EXCLUSIVE OR gate, with input-output characteristics which may be stated in table form, thus:

$$\begin{aligned} 0 + 0 &= 0 \\ 0 + 1 &= 1 \\ 1 + 0 &= 1 \\ 1 + 1 &= 0 \end{aligned}$$

#### Receiver

A simplified block schematic diagram of the receiver is shown in Fig. 5. In operation the receiver is set up to generate a signal having the same data-signalling rate and pattern as that transmitted. The signals generated by the receiver are then compared with the incoming test signals, and the peak individual distortion of the incoming-signal transitions is indicated on a meter to a  $\pm 3$  per cent accuracy. Any element errors occurring in the received-signal pattern are counted.

The description of the receiver which follows deals only with the general principles of the operation, and Fig. 6 shows some of the receiver waveforms.

In order to compare the incoming and receiver-generated test signals, the receiver must generate a signal having both the same data-signalling rate and signal pattern as that originally transmitted. These two signals must then be maintained in phase lock (frame lock) at the receiver. This is achieved by detecting the transitions of the received signal elements and comparing them with the relative timing of local-signal transitions, derived from the receiver saw-tooth oscillator. A d.c. correction depends upon whether the local-signal transitions, integrated over a period, are early or late relative to the incoming-signal transitions. This d.c. potential is then used to increase or reduce the oscillator frequency until it is running at exactly twice the data-signalling rate of the incoming signals, at which point it is synchronized with

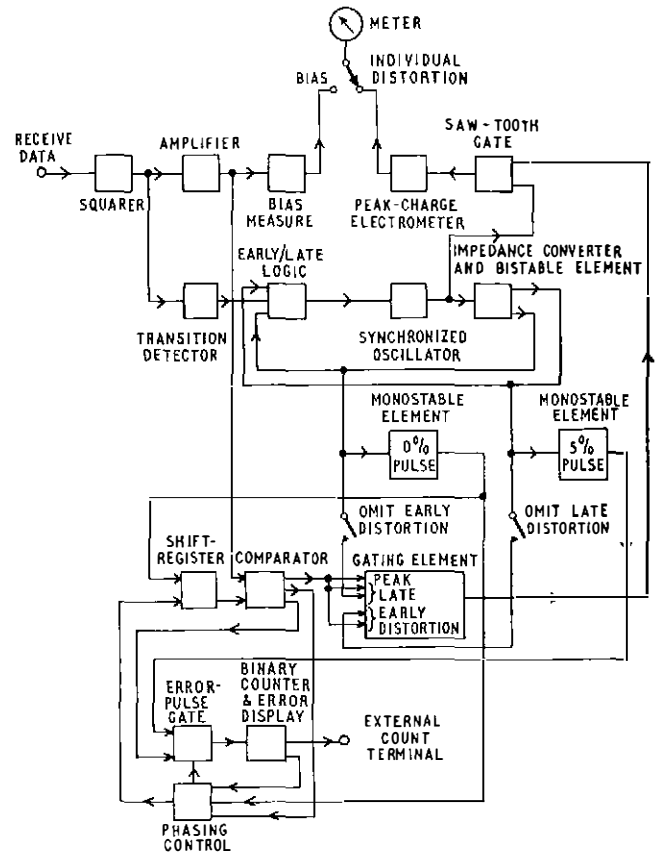
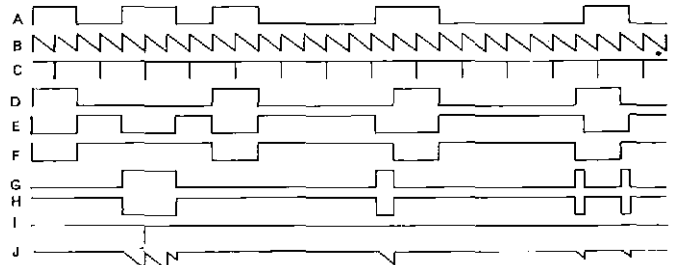

FIG. 5.—BLOCK SCHEMATIC DIAGRAM OF DATEL TESTER No. 1A RECEIVER

the incoming-data signals. The saw-tooth oscillator output, which now has a frequency twice that of the signalling rate, is divided and squared, so that one positive transition occurs at the start of, and one exactly half-way through, every nominal element. These transitions are used to trigger monostable elements which provide a 0 per cent pulse and a 50 per cent pulse.

The 0 per cent pulses derived from the receiver oscillator are used to provide clock pulses to drive a 9-element shift-register, similar to that used in the transmitter, and a local signal pattern is, thus, generated.



A—Received data signal  
B—Synchronized saw-tooth-waveform oscillator  
C—50 per cent pulses derived from oscillator output  
D—Erect output from shift-register  
E—Inverted received-data signal  
F—Inverted output from shift-register  
G—Erect output from generator  
H—Inverted output from comparator  
I—Error pulse, gating 50 per cent pulse and inverted output from comparator  
J—Input to measure-peak-distortion circuit, gating the saw-tooth waveform with the erect output from the comparator

FIG. 6 RECEIVER WAVEFORMS SHOWING PEAK-INDIVIDUAL-DISTORTION AND ERROR-INCIDENT MEASUREMENT

Before any comparison can be made between the locally-generated and the received signal patterns, the two signal patterns must be in phase with each other. The phasing action is initiated by the operator, and each error pulse resulting from the comparison of the incoming and local patterns is used to advance the local signal pattern one element with respect to the received signal. While the two patterns are out of phase, the receiver shift-register is stepped automatically for each error, thus advancing the local pattern until 16 consecutive elements are found to be in phase. It is then assumed that the correct phase relationship has been achieved. The error counter is reset to zero and then counts any errors in the incoming signals as they occur.

The locally-generated and the received signal patterns can now be compared. They are gated together, and any time displacement between the signal elements results in an output pulse whose width represents the distortion present in the received signal element.

Errors in the incoming signals are detected by a mid-point sampling technique using the 50 per cent pulses. An inverted output resulting from the comparison between the locally-generated and the received signal patterns is gated with the 50 per cent sampling pulse (Fig. 6, waveforms C, H and I). If the instantaneous voltages of the two pulses are the same then an error, as defined, has occurred. The output pulse from the error gate is used to step a binary counter having a total capacity of 511 error incidents. Indicator lamps display the error count, a COUNTER FULL lamp glowing when the count exceeds 511. The output from the error gate is also brought out to a terminal on the front panel, enabling an external counter to be used, if required.

The time displacement between the incoming and locally-generated signal elements is a measure of the distortion existing in the received signal element. An erect pulse resulting from the comparison is gated with the saw-tooth oscillator output, so that the negative-going slope of the saw-tooth waveform is applied to a voltage-measuring circuit for the duration of each erect comparator-output pulse. The saw-tooth waveform gated by the distortion pulse charges a capacitor so that

the voltage developed across the capacitor is proportional to peak distortion. This voltage is then applied to the grid of an electrometer valve\* used as a high-input-impedance cathode-follower, so having little effect on the capacitor discharge. The meter is situated in the cathode circuit of the electrometer valve and has a long delay time, thus allowing peak-distortion readings of up to 50 per cent to be made to a  $\pm 3$  per cent accuracy, the reading accuracy being limited to distortion peaks occurring more frequently than one every 2 seconds. Depressing the PEAK DISTORTION, OMIT LATE or OMIT EARLY buttons on the front panel of the tester enables either the peak-early or the peak-late distortion to be measured to the same accuracy limits. Bias-distortion measurements on incoming 1 : 1 ratio signals may also be made and displayed on the meter to a  $\pm 1$  per cent accuracy. Fig. 7 shows the logic diagram of the method used to detect element errors and to measure distortion.

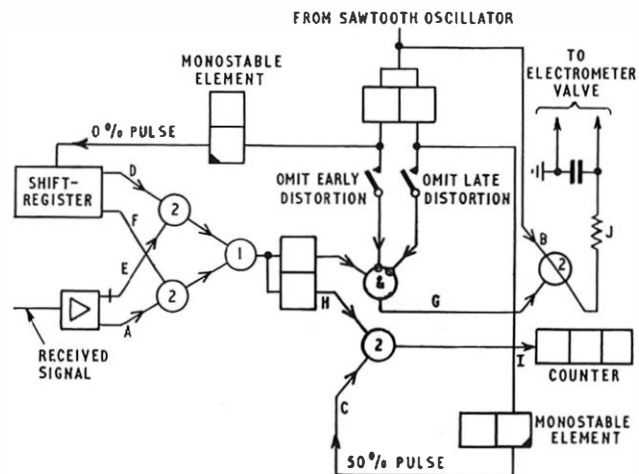

The letters A-J refer to the waveforms shown in Fig. 6. The analogue saw-tooth waveform B is gated by the digital waveform G: this is indicated by the linear-gate symbol.  
FIG. 7—LOGIC DIAGRAM SHOWING METHOD OF ERROR DETECTION AND DISTORTION MEASUREMENT



FIG 8—DATEL TESTER No. 2B

#### DATEL TESTERS No. 2A AND 2B

The Dattel Tester No. 2A was developed by the Post Office in an effort to provide a cheap and relatively simple tester for installation and general maintenance of equipment for the Dattel Service. The tester utilizes electronic circuits and is battery driven. Unlike Dattel Testers, No. 1A and No. 2B it does not have modem-control functions as these would require a large battery to light the acknowledgement lamps for the signalling conditions returned from the modem. It generates a steady binary-1 signal, a steady binary-0 signal, or 1 : 1, 1 : 7 and 7 : 1 ratio binary-1 to binary-0 signal patterns at signalling rates of 75, 200, 600 and 1,200 bits/second, and measures bias distortion of a nominal 1 : 1 ratio signal to an accuracy of  $\pm 3$  per cent on a centre-zero meter, after reconstituting the logic levels, i.e. after the incoming voltages have been converted to the

\*Electrometer valve—a valve having a much lower than usual grid current when worked under normal conditions.

voltages used in the binary logic circuits within the tester.

The Datel Tester No. 2B (Fig. 8) is commercially produced to a Post Office specification based on that of the Datel Tester No. 2A. The Datel Tester No. 2B is an a.c. mains-driven unit, operating over the range of 190–250 volts, and can, therefore, incorporate the modem-control functions. It generates a steady binary-1 signal, a steady binary-0 signal, or 1 : 1, 1 : 3, and 3 : 1 ratio signal patterns at rates of 50, 75, 200, 600, and 1,200 bits/second. The use of 1 : 3 and 3 : 1 patterns is to examine characteristic distortions on a centre-zero meter. With a 3 : 1 ratio binary-1 to binary-0 input signal the meter should read 50 per cent bias distortion; any deviation from this denotes the presence of characteristic distortion, assuming there is no bias distortion in the system. The tester measures the bias distortion of a nominal 1 : 1 received signal on a centre-zero meter to an accuracy of  $\pm 3$  per cent after reconstituting the logic levels. When in the transmit mode the outgoing signal from the tester is monitored on its own meter. The meter is also available for external use as a 10–0–10-volt centre-zero voltmeter.

## CONCLUSIONS

The test equipments described in this article have enabled the efficient installation and maintenance of Datel modems to be carried out. They have also enabled a preliminary evaluation of the error rate of the data transmissions routed over the switched telephone network to be made.

## ACKNOWLEDGEMENTS

The Datel Tester No. 1A and the Datel Tester No. 2B were developed to British Post Office specifications by The M.E.L. Equipment Company, Ltd., and Trend Electronics, Ltd., respectively.

## References

- <sup>1</sup>ALLERY, G. D. Some Aspects of Data Transmission. *P.O.E.E.J.*, Vol. 57, p. 264, Jan. 1965.
- <sup>2</sup>SMITH, N. G. An Introduction to the Post Office Datel Services. *P.O.E.E.J.*, Vol. 59, p. 1, Apr. 1966.
- <sup>3</sup>ROBERTS, L. W., and SMITH, N. G. A Modem for the Datel 600 Service—Datel Modem No. 1A. *P.O.E.E.J.*, Vol. 59, p. 108, July 1966.
- <sup>4</sup>C.C.I.T.T. Blue Book, Vol. VIII, Recommendation V24.
- <sup>5</sup>C.C.I.T.T. List of Definitions of Essential Telecommunication Terms (second impression) 1961. Definition 33.06.

## Book Review

“Reliability of Electronic Components.” C. E. Jowett. Iliffe Books, Ltd. 165 pp. 28 ill. 42s.

This book by the Senior Reliability Engineer of the British Aircraft Corporation sets out to “present the relevant facts describing the properties and stabilities of various classes of components and materials, with the object of indicating their proper application” which, it is hoped, “will help to eliminate the all too frequent failure of expensive equipment through the misapplication of small components, or inadequate consideration of electrical stability.”

The chapter headings give a fair idea of the scope, viz. Environmental Conditions and Atmospheric Corrosion; Soldering and Crimping; Resistors; Capacitors; Thermionic Valves; Transistors and Diodes; Metal Rectifiers (Selenium); Transformers and Inductors; Relays; Radio Frequency Cables; Electrical Contacts; Printed Circuits and Wiring; Potted Components and Encapsulation.

Along with the better known aspects of soldering there are useful discussions of silver-ion migration and whisker growth.

The standard types of fixed resistors and capacitors are fairly well covered, but information on variable resistors and potentiometers, and also on variable capacitors, is meagre. Some of the statements about oxide-film and metal-film resistors are inaccurate, but there is a good section on random pulses and discharges in capacitors. On page 45 it seems unnecessarily elementary to explain to readers of the standard who will use this book what  $10^6$  means and what a microfarad is.

The chapter on valves only occupies two pages, but transistors and diodes are dealt with more fully (12 pages), as are the majority of the other components.

On the whole this is a useful book for designers and students who need specific information on the multiplicity of points which can make or mar the reliability of components. It deals only with the conventional discrete components, but these types will almost certainly be with us for another decade. A future edition could usefully include information

about meters, reed switches, reed relays, and very highly reliable components, e.g. for submerged repeaters, satellites, and perhaps microminiature circuits.

The subdivision headings in some chapters could be improved, and there are some typographical errors, e.g. p.4 line 21 “set” for wet; p.15 line 28 “trichlorethlene”; p.19 line 19 “point” is omitted, p. 20 line 17 “con” is repeated; p. 36 line 8 “To” for Too; p. 39 line 20 “contant”; p. 117 line 32 “conjunction” p. 148 line 30 “stearo” for stereo. In chapter 12 the use of “glassfibre” as one word is a little unusual.

A.A.N.

## Book Received

“Signals, Systems and Communication.” B. P. Lathi. John Wiley and Sons, Ltd. xix+607 pp. 281 ill. 115s.

In this textbook, which is primarily written for those undergraduates who have already completed an elementary course in circuits or systems analysis, the author has presented a unified treatment of two subjects that have conventionally been treated independently: the analysis of the linear systems, and basic communication principles.

On the one hand, the study of signals leads into the analysis of linear systems and frequency transform methods, while on the other hand, it leads directly into communication theory. Thus, for an integrated approach, it is necessary to have a deeper appreciation of signal analysis than is customarily given in introductory treatments. The bilateral Laplace transform is developed as an extension of the Fourier transform, and the unilateral Laplace transform is then derived as a special case of the bilateral Laplace transform, the unit and relationship between the three transforms being emphasized throughout the book. They are developed, not as arbitrary mathematical operators, but as tools for representing a signal as a continuous sum of everlasting or eternal exponential signals.

The author has attempted, not only to develop mathematically the significant results in signal analysis, but also to present intuitive and qualitative interpretations of such results, emphasizing the physical appreciation of concepts rather than mathematical manipulation.

# The New Leafield Radio Station

## Part 4—The H.F. Transmitters

A. E. N. WASE, C.Eng., M.I.E.E., and B. S. JACKSON, B.Sc.†

U.D.C. 621.396.7:621.396.61.029.55

The 30 kW and 75 kW p.e.p. transmitters at the new Leafield radio station are designed for fully automatic operation over the frequency range 4–27.5 Mc/s. The two types of transmitter are similar except for their output stages, a pair of valves being used at slightly higher anode voltage in the larger version in place of a single valve. The 30 kW transmitter is described and the differences in the 75 kW version noted.

### INTRODUCTION

**T**RAFFIC signals from the telegraph terminals in London (Electra House or Fleet Building) are assembled by frequency-division multiplex equipment into 3 kc/s bandwidth aggregate signals, which are then applied to independent-sideband drive units. These units can provide two separate sidebands of up to 6 kc/s bandwidth on either side of a 100 kc/s reduced-level carrier. Alternatively, single-channel and two-channel telegraph circuits may employ a frequency-shift keying drive unit to produce a frequency-modulated signal also at 100 kc/s. Either type of drive unit can be connected to any transmitter through the switching matrix.<sup>1</sup> A frequency-changer associated with each transmitter transposes the 100 kc/s signal to 3.1 Mc/s at a level of 100 mW, as is the general practice in many h.f. transmitting stations.<sup>2</sup> A stable frequency in the range 4–8 Mc/s, supplied by a synthesizer<sup>3</sup> associated with the transmitter, is multiplied in the transmitter frequency-multiplier one, two or four times to produce a conversion frequency in the range 7.1–30.6 Mc/s. This signal is then mixed in a frequency converter with the 3.1 Mc/s drive

†Mr. Wase is in the Overseas Radio Planning and Provision Branch, E.-in-C.'s Office, and Mr. Jackson is in the Radio Division, Standard Telephones & Cables, Ltd.

signal. The lower sideband is selected as the required signal and is raised to full output power in the transmitter<sup>4</sup> amplifiers.

In the transmitter, the tuning of the amplifier stages is automatically adjusted by motor-driven variable inductors or capacitors, or both, under the control of phase discriminators. The phase of a sample voltage obtained from the tuned circuit is compared with the phase of a reference voltage, usually the stage input signal, and the motor-drive is energized until the two signals have the correct phase relationship: this will occur when the tuned circuit is in resonance. Output-impedance matching and overall gain are also automatically adjusted under the control of sampling circuits which compare the power-amplifier anode swing with the transmitter output level and with the transmitter input-signal level.

### GENERAL DESCRIPTION

The frequency range (4–27.5 Mc/s) covered by the transmitter is divided into nine bands, and the frequency from the synthesizer is accompanied by band-marking information which is used for coarse preliminary tuning of the amplifier stages, thus considerably reducing the range of search to be covered by the fine-tuning elements. The various stages of the transmitter are shown in the block schematic diagram in Fig. 1 and are described below.

#### Frequency Converter, Multiplier and Low-Power Amplifier Stages

The drive signal at 3.1 Mc/s is connected to input B and, thence, via a gain control and a buffer amplifier to

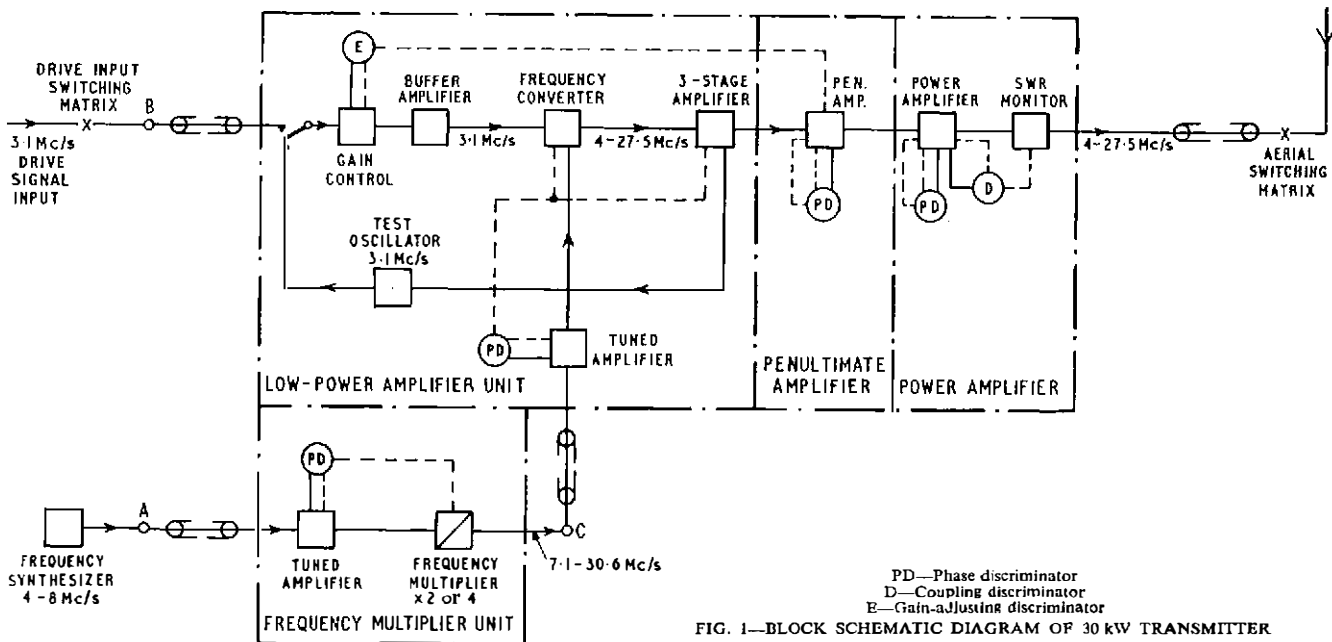

FIG. 1—BLOCK SCHEMATIC DIAGRAM OF 30 kW TRANSMITTER

the input of a frequency converter. The synthesizer output is connected to input A, and after multiplication is connected via a tuned amplifier to the final-frequency converter. This converter employs a balanced mixer arranged so that the amplitude of the output signal, and hence the output power of the transmitter, is directly proportional to the amplitude of the 3.1 Mc/s signal. The output circuit is tuned to the difference frequency, and the unwanted sum, signal and conversion frequencies, together with other unwanted products, are adequately suppressed to very low level at the grid of the following three-stage low-power amplifier, which uses air-cooled tetrode valves to provide an output of about 300 volts. The low-power amplifier unit is shown in Fig. 2.

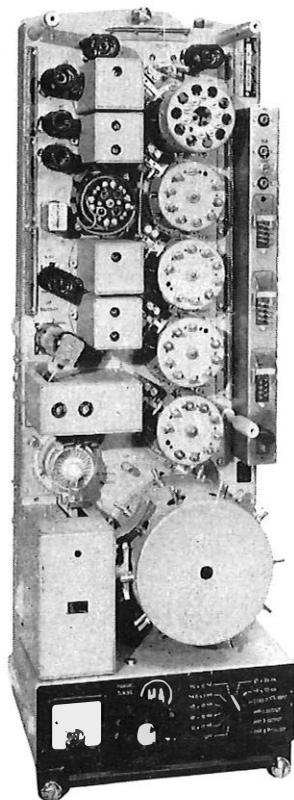

FIG. 2—LOW-POWER AMPLIFIER UNIT

Tuning of the frequency-multiplier, frequency-converter and low-power amplifier stages is achieved by switched fixed-value inductors, in conjunction with variable capacitors. The inductor coils are mounted in ganged nine-position turrets which are motor-driven in response to the band-tuning information.

Fine tuning of the low-power stages is achieved as follows. The amplifier preceding the multiplier stages is tuned to the synthesizer frequency by a motor-driven variable capacitor under the control of a phase discriminator. The variable capacitors in the multiplier stages are also ganged to this motor drive and are tuned simultaneously with the input amplifier.

The conversion frequency from the multiplier is amplified in a tuned stage before connexion to the frequency converter. This amplifier stage is tuned by a motor-driven variable capacitor under the control of a phase discriminator. The variable capacitors in the converter and the three-stage low-power amplifier are ganged

to the same motor drive, so that all stages of the complete unit are tuned simultaneously.

#### Penultimate Amplifier

A ceramic-envelope forced-air-cooled tetrode valve of 5 kW anode dissipation is used in the penultimate amplifier, which can develop an output power of over 8 kW without producing grid-current and is particularly suitable for use in linear amplifiers. It also has adequate power to drive the pair of output valves in the 75 kW version of this transmitter, and can be used as the output stage in a lower-powered version.

The anode circuit of this stage, shown in Fig. 3, comprises a  $\pi$ -connected arrangement of two variable vacuum-capacitors and a variable inductor, ganged together to a

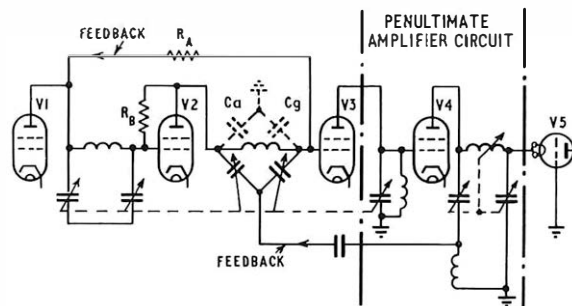

FIG. 3—PENULTIMATE-AMPLIFIER ANODE CIRCUIT AND NEGATIVE FEEDBACK CIRCUITS

common motor-drive to give continuous tuning over the 4-27.5 Mc/s band without range switching. Tuning is controlled by a phase discriminator which compares the phases of the anode and grid voltages.

#### Power Amplifier

Vapour cooling is employed for the triode valve in the power amplifier, as greater anode dissipation is possible with this method compared with air or water cooling. This is important in class-B linear amplifiers which operate at comparatively moderate efficiency, as only one vapour-cooled valve of 25 kW anode dissipation need be used where two would otherwise be required; the amplifier design is thus simplified and fewer components are used.

The power-amplifier anode-tuning compartment is shown in Fig. 4; the output is matched to a 50-ohm coaxial aerial feeder. A grounded-grid circuit arrangement is used for the triode valve with a  $\pi$ -connected anode circuit (Fig. 5), formed by two variable vacuum-capacitors, C1 and C2, and the variable inductor, L1. These components are ganged to a common motor-drive and give continuous tuning over the 4-27.5 Mc/s band without range switching. A series-resonant circuit comprising a variable vacuum-capacitor, C3, and a variable inductor, L3, are also ganged to the same motor-drive and tuned to suppress second-harmonic frequencies. The amplifier tuning is controlled by a phase discriminator which compares the phases of the anode-circuit and grid-circuit voltages. The output coupling inductor L2 is motor-driven under the control of an assessor which compares rectified signals proportional to the anode-voltage swing and the output power. The coupling inductor is adjusted until optimum loading is achieved. The transmitter output-power indication is obtained from a voltage standing-

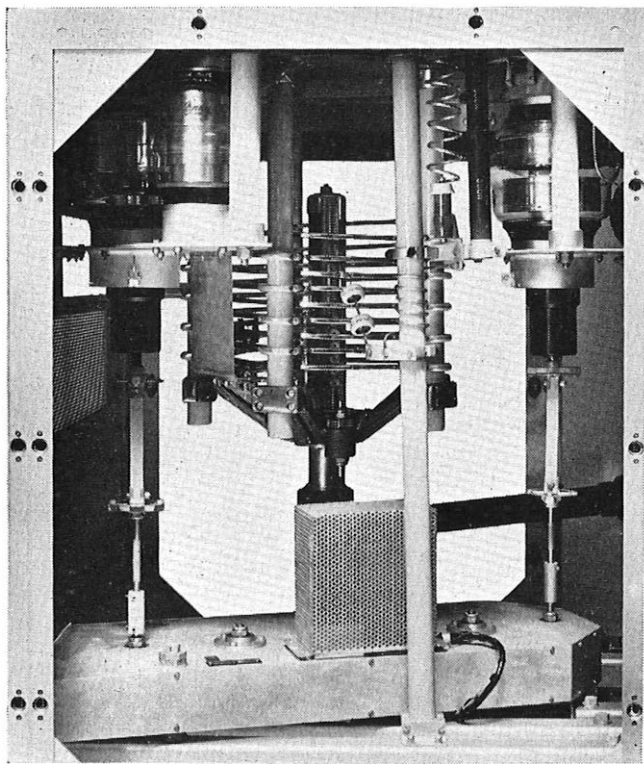

FIG. 4—POWER-AMPLIFIER ANODE-TUNING COMPARTMENT

wave ratio (v.s.w.r.) monitor<sup>5,6</sup> fitted in the output feeder, which continuously indicates the v.s.w.r. presented to the transmitter and provides protection against overload when the ratio exceeds a pre-determined value.

The anode inductor L1 comprises a fixed helix of rectangular-section copper, which is first silver-plated and then finished with rhodium plate. A pair of moving

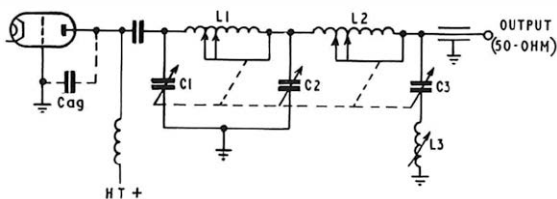

FIG. 5—POWER-AMPLIFIER ANODE AND OUTPUT CIRCUIT

contacts of silver-carbon composition grip the coil turns and are mounted on a pair of rotating wiper arms driven from a central spindle. The inductor is air-cooled, and additional cooling of the contacts is provided by a separate air supply fed via the hollow drive shaft and wiper arms. Each of the variable inductors has an additional wiper arm to short-circuit unused turns which might resonate at harmonic frequencies.

#### Negative Feedback

Negative feedback permits fuller exploitation of the power capabilities of power-amplifier valves while maintaining low distortion, and the overall feedback arrangements employed for the three-stage amplifier and the penultimate amplifier are shown in Fig. 3. The negative feedback applied around valve V2 is indepen-

dent of feedback applied to the following stages due to the use of a balanced bridge circuit, which prevents the feedback voltage applied to valve V3 from appearing at the grid of valve V2. Not more than two tuned circuits are included in any feedback loop, and the fixed feedback circuits can be left connected during tuning with no danger of self-oscillation. Approximately 6 db gain reduction is obtained by feedback around valve V2 and a further 6 db by overall feedback around valves V3 and V4. The high-power stage has 4 db feedback, inherent in grounded-grid amplifiers.

#### Automatic Tuning Sequence

Setting up a service frequency on a synthesizer initiates a tuning cycle and causes the band selector to re-position coils in the frequency multiplier and low-power amplifier units. A 3.1 Mc/s tuning signal is connected in place of input signal B and, while tuning of the frequency multiplier proceeds, coarse positioning of the tuning elements is in progress in other stages. When the frequency multiplier has completed tuning, the low-power amplifier commences fine tuning, but the output is suppressed to protect against overload until coarse tuning has been completed in both the penultimate and power-amplifier stages. The r.f. signal then increases to a controlled level at the grid of the penultimate amplifier, which self-tunes, and, as the stage comes into tune, it drives the power amplifier, which self-tunes and simultaneously adjusts coupling until correct loading conditions are achieved.

The input tuning signal-level is then compared with the level of a signal derived from the transmitter output, and the gain control E (Fig. 1) is adjusted under the control of a level discriminator to set the transmitter overall gain. The test signal is then replaced by a traffic signal which gives full output power. The discriminators controlling tuning and loading of the power amplifier and tuning of the penultimate amplifier remain in operation after the tuning cycle has been completed, to correct for variations in the impedance of the transmission line and aerial which may arise from changes in the weather conditions whilst the transmitter is in use.

The average time required to tune the transmitter on a change in service is usually about 30 seconds but the maximum time required is less than 2 minutes for an extreme change in frequency.

#### D.C. SUPPLIES

Silicon-diode rectifiers are used in all d.c. supplies except the e.h.t. supply to the high-power amplifier stage. Grid-controlled mercury-arc rectifiers are employed for both the 10 kV e.h.t. supply for the 30 kW transmitter and the 12 kV e.h.t. supply for the 75 kW transmitter. The silicon-diode rectifiers are protected against excessive transient voltages which may be developed and against excessive surge currents resulting from faults. It is necessary to control and limit all surges in the complete rectifier circuit, and to provide sufficient redundancy to ensure that failure of a single cell in a rectifier unit will not significantly degrade the safety margin.

#### TRANSMITTER COOLING

In the evaporative cooling systems<sup>7</sup> as used for the power-amplifier stage, the valve anode dissipates heat by converting water to steam in a valve boiler. The

major portion of the valve anode is immersed in water and the steam produced from the boiling water rises up a vertical Pyrex pipe, thence passing to an air-cooled heat-exchanger to condense with the water returning by gravity feed to the boiler. The system operates at low pressure, having a vent pipe from the heat-exchanger which is open to atmosphere, and in normal operation the steam pressure in the pipe above the valve is equivalent to about 1 in., water gauge. About 5 gallons of water are contained in the boiler and the associated header-tank, and as, over a period of service, there is a small loss of water due to evaporation, it is automatically topped up from a reservoir by a mechanically-operated water-level control valve in the header tank. The 30 kW transmitter has only a single valve boiler in the power amplifier, but in the 75 kW transmitter two valve boilers are connected in parallel between a larger heat-exchanger and the header tank. The total quantity of water contained in the latter system is about 6 gallons.

Two fans driven from a single motor are provided in the forced-air cooling system for the complete transmitter. The fans are located in the basement below each transmitter, and special attention given to the design has achieved a system that is comfortably quiet in operation. One fan is used as a blower to supply air at moderate pressure (about 4 in. water gauge) for cooling the penultimate amplifier-valve anode and auxiliary items. The other fan is used as an extractor, which draws in air from the transmitter hall for general cooling, including the heat-exchanger, and then either expels the heated air to the outside atmosphere or re-circulates it to the transmitter hall to provide building heating. Thermostatic controls govern the proportion of air re-circulated, which is mixed with fresh air to make up for the volume of warmed air displaced from the building. To avoid erratic performance, which could be caused by wind pressure on the outlet louvres, the cooling system is operated on the leeward side of the building by means of one-way valves in the inlet and outlet ducts, which have access to opposite sides of each transmitter wing.

#### PERFORMANCE

The transmitter equipment achieves an overall performance at full output power which complies with current C.C.I.R. recommendations. The level of suppression of harmonic and other spurious radiation adopted by the C.C.I.R. is not sufficient in all cases to remove the risk of interference with television and mobile receivers close to the transmitting station, and additional protection is provided by a low-pass filter<sup>8</sup> fitted in the transmitter output.

Fig. 6 shows a typical low-pass filter giving over 35 db attenuation at frequencies above 40 Mc/s, which is fitted in each transmitter output as standard practice in all new

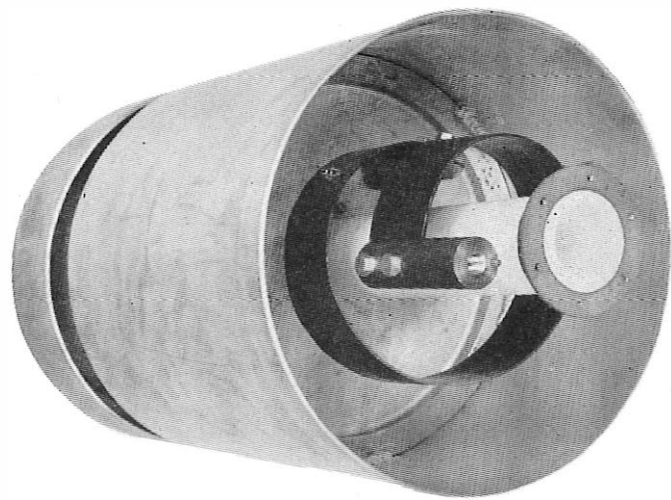

FIG. 6.—TWO-SECTION LOW-PASS FILTER FOR 30 kW TRANSMITTER WITH END CAPACITOR PLATE REMOVED

British Post Office transmitters.

#### CONCLUSIONS

The development of the modern self-tuned h.f. transmitter has been a major factor in realizing the design of the new automatic transmitting station at Leafield. The ability to tune automatically and rapidly to any desired operational frequency enables a common group of transmitters to be used for carrying a group of traffic services, and this increased availability of transmitters permits more intensive usage of high-power amplifier plant compared with previous installations, where the transmitters can operate on only a limited number of frequencies. An important additional operational advantage of the self-tuned transmitter is the automatic loading compensation provided which maintains full output power under changing external conditions during service.

(Part 5 appears on page 283)

#### References

- <sup>1</sup>CHAMBERS, J. A. The New Leafield Radio Station, Part 2—The Control System. *P.O.E.E.J.*, Vol. 59, p. 178, Oct. 1966.
- <sup>2</sup>BOOTH, C. F., and MACLARTY, B. N. M. H.F. Transmitting Station at Rugby. *Proceedings I.E.E.*, Vol. 103, p. 332, May 1956.
- <sup>3</sup>HUTTON-PENMAN, P. R., and BILLINGHURST, F. M. The New Leafield Radio Station, Part 3—Carrier Generation. *P.O.E.E.J.*, Vol. 59, p. 196, Oct. 1966.
- <sup>4</sup>HEATON-ARMSTRONG, L. J., and JACKSON, B. S. Modern Trends in H. F. Transmitter Design.
- <sup>5</sup>WATT-CARTER, D. E. Reflectometers. *P.O.E.E.J.*, Vol. 51, p. 37, Apr. 1961.
- <sup>6</sup>HEATON-ARMSTRONG, L. J. Patent No. 31041/59.
- <sup>7</sup>WASE, A. E. N. A Cooling System for High-Power Radio Transmitters. *P.O.E.E.J.*, Vol. 55, p. 40, Apr. 1962.
- <sup>8</sup>BROAD, E. R., and MAY, E. J. P. A 10 kW Low-Pass Filter. *P.O.E.E.J.*, Vol. 48, p. 94, July 1955.



# The 5005-Crossbar Telephone-Exchange Switching System

## Part 2—Application and Maintenance

H. BANHAM, B.Sc.(Eng.), C.Eng., M.I.E.E.†

U.D.C. 621.395.344:621.395.722

Part 1 of this article described the principles of a telephone exchange using 5005-crossbar switches. Part 2 describes the first application of these principles to a public telephone exchange in Great Britain, gives some details of how the exchange has performed, and outlines the maintenance procedures—both the present and those proposed for the future.

### INTRODUCTION

**A**MONG the first installations of the 5005-crossbar system were the Intercontinental exchange in Sydney and a private automatic exchange (P.A.X.) in the Plessey Company factory at Liverpool. These two widely different applications proved that the new system was adaptable, and their subsequent high reliability of

† Telephone Exchange Standards and Maintenance Branch, E.-in-C.'s Office.

operation showed that very good performance in public service could be expected. Accordingly, it was decided to install similar equipment (now designated TXCI) in an exchange in Great Britain where the complete system could be demonstrated and its possibilities thoroughly investigated. The site chosen was Broughton, Lancashire, which was within easy reach of the Liverpool factory of the Plessey Telecommunications Group, and whose existing manual exchange was programmed to be replaced by a local non-director exchange in about the right period.

The Post Office set a very stringent specification for the installation to ensure that the public service would be at least as good as that expected with the previously-planned Strowger exchange, and also instituted a close watch on the performance of the complete installation. Moreover,

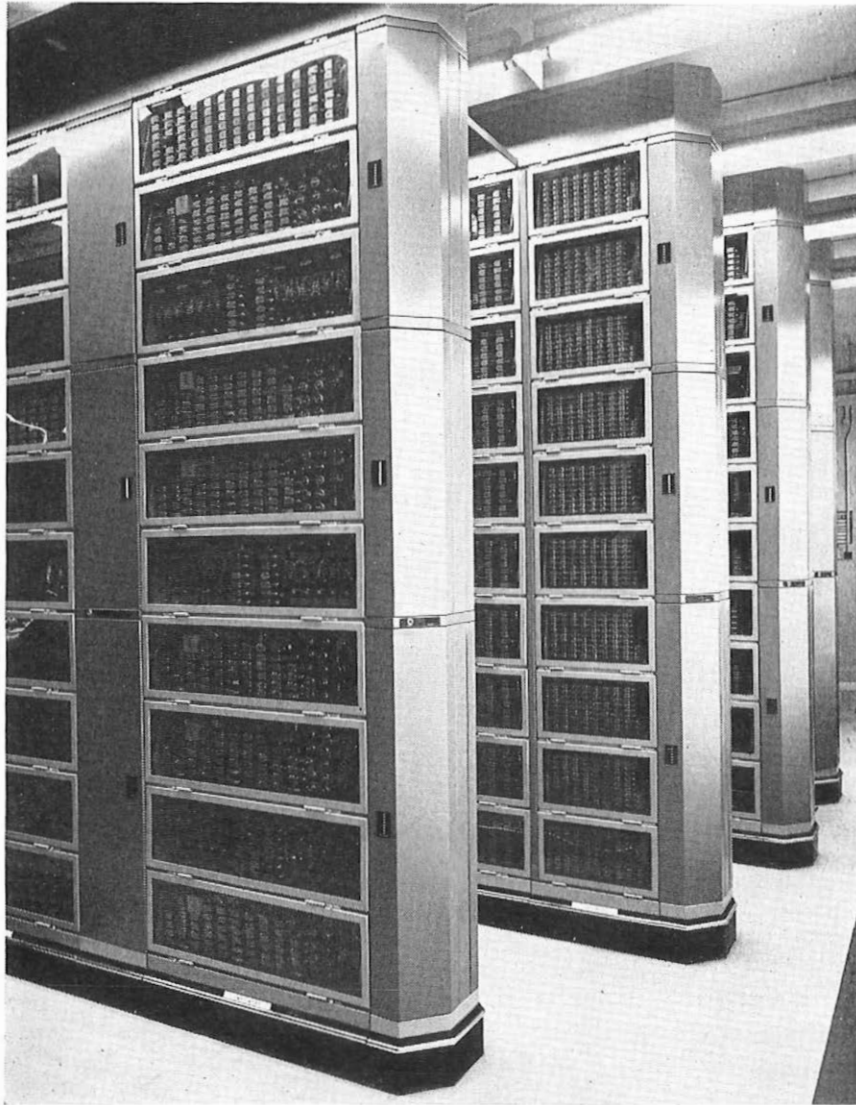

FIG. 9—GENERAL VIEW OF BROUGHTON EXCHANGE

the performance of a Strowger exchange, opened slightly earlier and having roughly similar capabilities, was recorded for comparison purposes. As shown later, Broughton exchange has met the specification easily, and, in fact, has proved even better in many respects, for instance in the maintenance effort required. The exchange has been a very popular attraction to foreign administrations, and its visitors' book is an index to practically the whole world.

The success of the system, allied to the general need for ever-increasing supplies of equipment to meet the growing demand for telephone services, has led to orders being placed for more, similar, exchanges: further developments of the system are in hand for the Intercontinental exchange in London and some group switching centres. These innovations will have considerable impact upon the present maintenance organization, and this article indicates some of the ideas which are put forward to meet the challenge.

#### BROUGHTON EXCHANGE

Broughton telephone exchange (Fig. 9) was opened in November 1964 in order to serve a mainly residential area, the majority of whose traffic passes through the neighbouring Preston telephone exchange. The local numbering scheme required subscribers numbers in the range 2,000-3,199; the exchange capacity was, therefore, for 1,200 lines, including 50 coin-boxes, and so required two fully-equipped 500-line distributors plus a partially-equipped distributor catering for 200 lines. The third

distributor has now been filled, and plans have been made for the eventual addition of two more distributors to bring the total capacity to  $5 \times 500$ , i.e. 2,500, lines. The principles of operation are those described in Part 1 of this article, with some modifications to suit the local circumstances and to fit the exchange into the existing network. Fig. 10 is a simplified diagram of the trunking scheme and illustrates some of the features discussed below. Tables 1 and 2 give, respectively, the busy-hour

TABLE 1  
Traffic Handled by Broughton Exchange

Type of Traffic	Busy-Hour Traffic Flow (erlangs)
Outgoing S.T.D. (ordinary)	1.8
Outgoing S.T.D. (coin-box)	0.57
Outgoing code-9	18
Outgoing code-1	1.3
Own exchange	1.3
Incoming	20

TABLE 2  
Broughton Exchange Numbering Scheme

Distributor	Number Range
1	2,000-2,499
2	2,500-2,999
3	3,000-3,499

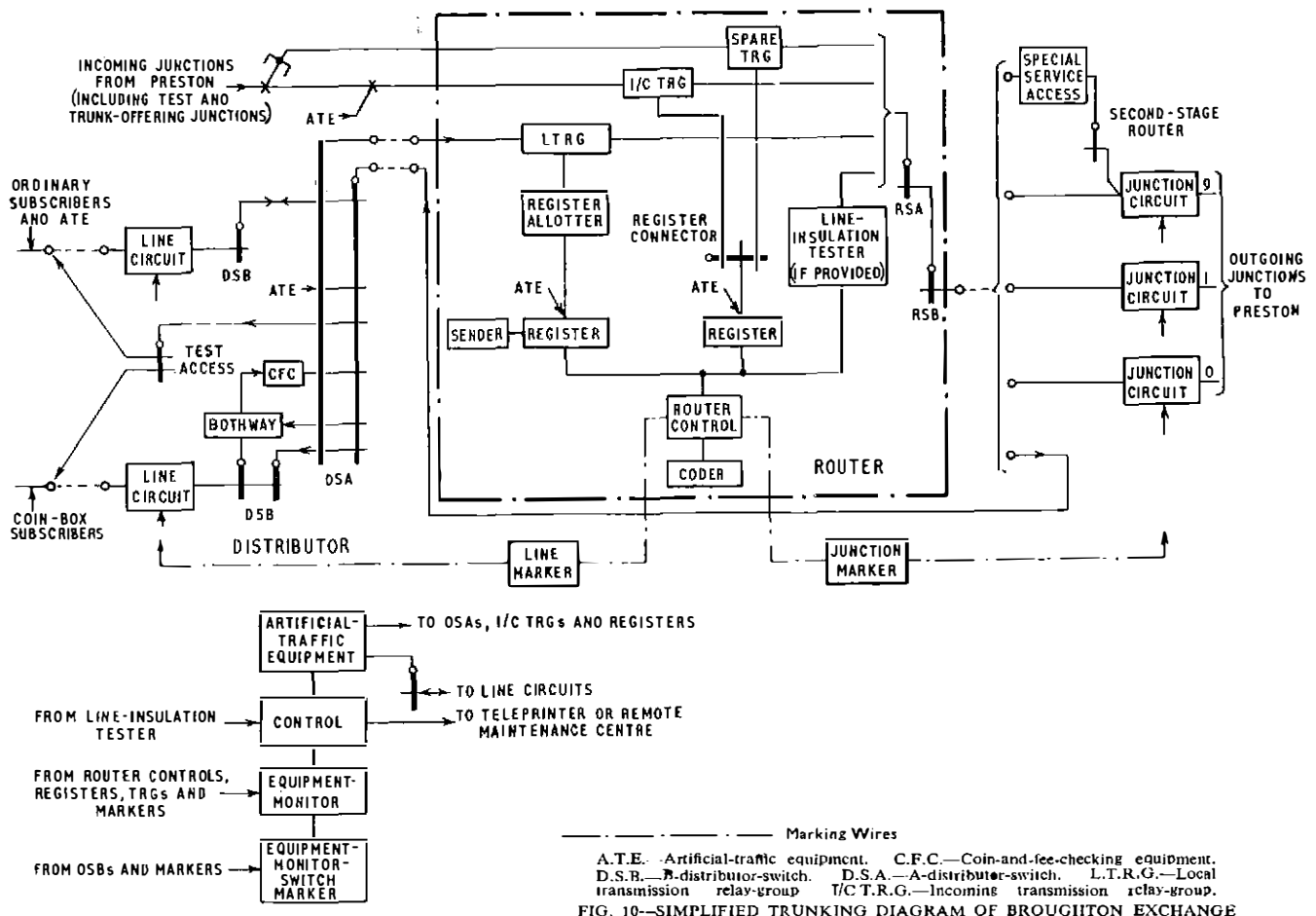

traffic for different types of call and the exchange numbering scheme.

#### *Modifications to Suit Traffic Flow*

The exchange area contains several important P.B.X.s, and these are connected in the numbering range 2,500–2,999 associated with distributor No. 2. In order to handle the high calling rate of these lines an additional A-distributor-switch was originally provided in this group, but, subsequently, all groups have been brought up to the same size.

However, the exchange has a low average calling rate, and, whereas a busy exchange would probably need separate routers, it is possible to use a common router to handle both local and incoming traffic. Nevertheless, some of the internal units of the routers, e.g. registers, still maintain their individual associations with local or incoming traffic.

The total busy-hour traffic of about 43 erlangs is well within the capabilities of a single router stage, so the outgoing junctions and local terminations are all connected direct from the router.

#### *Outgoing Junctions*

All outgoing traffic is routed to Preston on one of four junction groups: code 1 for manual and some other services, code 9 for adjacent exchanges and special services, and code 0 (separate groups for ordinary and coin-box lines) for subscriber trunk dialling (S.T.D.). At present all inter-exchange communication is by loop-disconnect signalling with 10 pulses/second pulsing. Each local transmission relay-group is equipped to deal with the varying requirements of these groups, either by itself or in conjunction with the outgoing-junction relay-sets.

For code-9 (except 999) calls the outgoing-junction relay-set merely performs a marking function, and all the loop calling, loop-disconnect pulsing, and supervision of line-reversal functions are carried out by the transmission relay-group.

For code-1 calls to the auto-manual board it is necessary to provide for manual hold and coin-and-fee-checking signal repetition. These extra facilities are embodied in the outgoing-junction relay-sets, of which there are 12, rather than in the local transmission relay-groups of which there are 64, because of the expense of the necessary transmission bridge. During the establishment of a call, this transmission bridge is not in circuit so that the loop-disconnect pulses from the sender are transmitted directly to line. As soon as sending is complete, the transmission bridge in the outgoing-junction relay-set is switched into circuit and that in the local transmission relay-group is switched out of circuit. Thus, the connexion is held and controlled from the outgoing-junction relay-set.

Code-0 calls are treated in a similar manner to code-1 calls except that the metering-over-junction facility replaces manual hold and coin-and-fee-checking signal repetition. Coin-box and ordinary calls are carried over separate junction groups.

Code-9 calls are connected from the router to the outgoing junctions via a grading field, so that any particular route switch has access to only a portion of the junctions available. This might cause a 999 call routed in such a way to be unable to find a free junction although one was actually available in another part of the grading. To prevent this, and so give full availability to all code-9

junctions, 999 calls are connected from the router to special service-access circuits, thence via a second-stage route-switch having access to the full route. After the final digits 99 have been sent to Preston, the special service-access circuit switches in a transmission bridge to supervise the connexion and provide manual hold, while the local transmission relay-group transmission bridge is removed.

#### *Coin-Box Lines*

Coin-box lines are included in the numbering range 3,000–3,499 associated with distributor No. 3 and are accommodated on two B-distributor-switches. They are fitted with standard Telephones No. 705, and so require full coin-and-fee-checking facilities at the exchange. These are provided by the standard electromechanical coin-and-fee-checking circuits modified to suit the TXC1 exchange input and output signals, as follows.

(a) Public or rented coin-boxes are identified in the coin-and-fee-checking circuits by class-of-service signals extended from the line circuit, so that the appropriate conditions can be applied to the incoming P-wire and, thence, to the subscriber's meter. The coin-and-fee-checking circuit itself extends a general "coin-box" class-of-service signal to the register, so that code-0 calls are routed via the coin-box junctions.

(b) Determination by a coin-and-fee-checking circuit as to whether a call is trunk or local is achieved, on a local call, by receipt of a meter pulse and a line reversal when the call is answered, and, on a trunk call, by receipt of a meter pulse only.

Callers gain access to an A-distributor-switch, and so to a register, via one of eight coin-and-fee-checking circuits, each of which is shared by two inlets, one on each B-distributor-switch.

Incoming calls to coin-box lines are arranged to use the spare inlets on the B-distributor-switches, i.e. those not connected to the coin-and-fee-checking circuits. If, however, all these inlets are engaged, the call will use one of the coin-and-fee-checking inlets, via a bothway-access circuit.

#### *Miscellaneous Facilities*

Centralized service observations (C.S.●) operate in a very similar manner to those on the Strowger system. The input side of the local transmission relay-group forms a suitable access point, and 35 of the transmission relay-groups are wired via connecting circuits to a relay-set giving standard C.S.O. facilities over a junction to Preston.

Service interception is similar to that on Strowger equipment except that a crossbar switch replaces the uniselector used to connect incoming calls to the manual-board junction.

The simplicity of the provision of changed-number interception (C.N.I.) illustrates one of the advantages of a common-control system. The jumper-wire from the M-tag of a subscriber's line requiring C.N.I. is removed from its normal position and is reconnected to a common CN-tag. Whenever the line marker connects earth to the M-lead in the process of setting up an incoming call, this earth is extended back by the line marker to the router control. The latter then cancels its first attempt and connects the incoming call to a junction giving access to the manual-board C.N.I. position.

All other facilities, e.g. local-call timing, are achieved by standard Strowger methods suitably adapted both physically and electrically. Where such services require to be jumpered to subscribers' line circuits, they are cabled to connexion strips adjacent to the line I.D.F. connexion strips on the line-circuit racks (see Fig. 11).

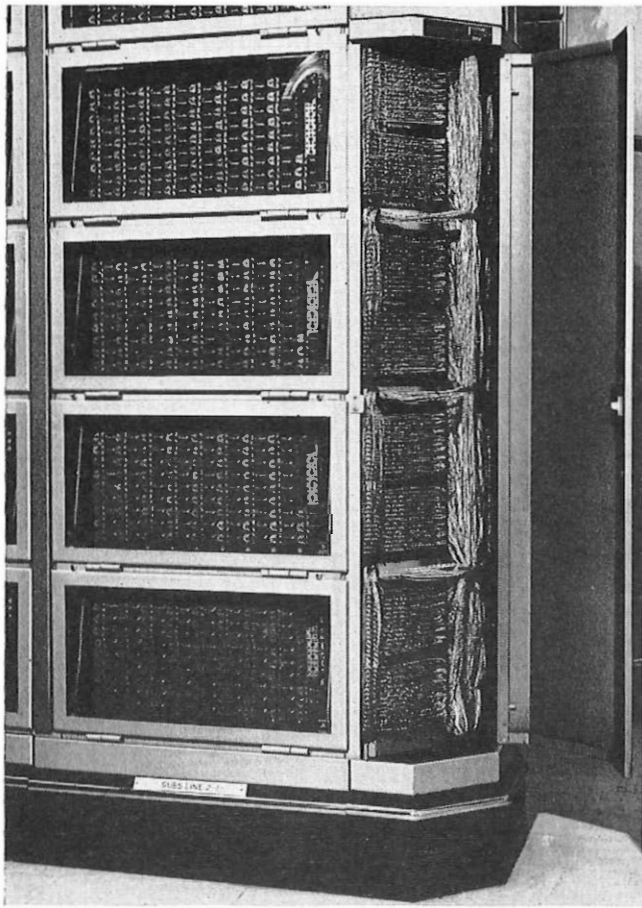

FIG. 11—SUBSCRIBERS' LINE-CIRCUIT RACK AND LINE I.D.F.

### Equipment Practice

As already explained, the exchange is based on crossbar switches, relays and other small components together with a number of larger items, e.g. ringing machines. Mounting arrangements are made flexible by the use of only two types of shelf for the switching network: one shelf holds a crossbar switch and 21 relays, while the other carries 11 rows of the manufacturer's type of relay or 13 rows of Post Office 3,000-type relays or various combinations of both, together with connexion strips and capacitor boxes at the rear. The two shelves have the same basic framework and so are physically interchangeable, both being hinged to permit access to the wiring (Fig. 12) and having provision for cabling to connexion strips that are pre-wired in the factory. Ten shelves, plus a fuse panel at the bottom, may be mounted on a single rack-side, two such rack-sides being combined back-to-back to form a complete rack 10 ft 10½ in. high, 3 ft 1 in. wide and 1 ft 5 in. deep. The height of the rack includes a cable trough for carrying the inter-rack cables; this trough is supplemented at Broughton exchange for some of the longer runs by over-ceiling cabling. Similar

arrangements apply to the large unit mountings, the connexion-frame mountings, and the subscriber's line-circuit mountings, except that the latter are only 1 ft 5 in. wide and fit on a combined line-circuit and B-distributor-switch rack.

The crossbar switches have a dustproof transparent cover, all access to the connexions being via the connexion strips under the metal side-covers. As all connexions on these strips are made using solderless wire-wrapped terminations, the tags are clean and smooth, and links for busying or test purposes can be slid on or off without difficulty. The installation has an unusual and attractive appearance as the crossbar racks are in hammer grey and green finish, which blends well with the light-grey finish of the few 2,000-type miscellaneous racks. Future installations will, however, have the standard light-straw-colour finish.

On panels at the end of the suites are mounted the supervisory equipment, such as alarm lamps and permanent-call (P.G.) indicators (Fig. 13).

The general success of this practice is shown by the installation of a 2,500-line exchange in a H-type building intended originally for an exchange of only 2,000 lines.

### MAINTENANCE

#### *Maintenance Policy*

It is a fact that each step forward towards making telephone exchanges more efficient and reliable also tends to render their maintenance more difficult. This is particularly true of common-control systems, and only by the adoption of completely new concepts is it possible to solve the problems. However, experience shows that these new concepts can so revolutionize the whole maintenance procedure that the new organization becomes more effective and efficient than ever before.

The Strowger system has many advantages from the maintenance point of view: the selectors can be seen to operate, they can be heard, they can be easily identified as small self-contained units, and their speed of operation is such that it can be observed. Thus, a trained maintenance man uses several of his natural senses to detect trouble and to isolate it. Crossbar equipment is silent, except perhaps for a reassuring but uninformative clicking sound, and although the operation of the magnet assemblies is certainly visible it takes place far too quickly for a visual check. Moreover, the completion of a single switching operation can entail the simultaneous co-operation of many units scattered throughout the exchange. The principle of common control, with its efficient use of setting-up equipment, implies that there are sensitive parts of the exchange where a single fault may cause a large deterioration in service. On the other hand, the Strowger selector is essentially mechanical and so needs regular lubrication, inspection and overhaul. This last fact has tended to dominate maintenance policy in the past, and the organization has been based on a procedure intended to locate and cure mechanical faults as soon as (or, preferably, just before) they appeared. Thus, all selectors are subjected to regular testing, and the frequency of checking has been based upon the rate of fault detection, e.g. some selectors are tested at such a rate that one fault is found on average for every 50 tests.

Such methods are not appropriate to a system that is composed almost entirely of crossbar switches and relays, both of which perform many millions of operations before

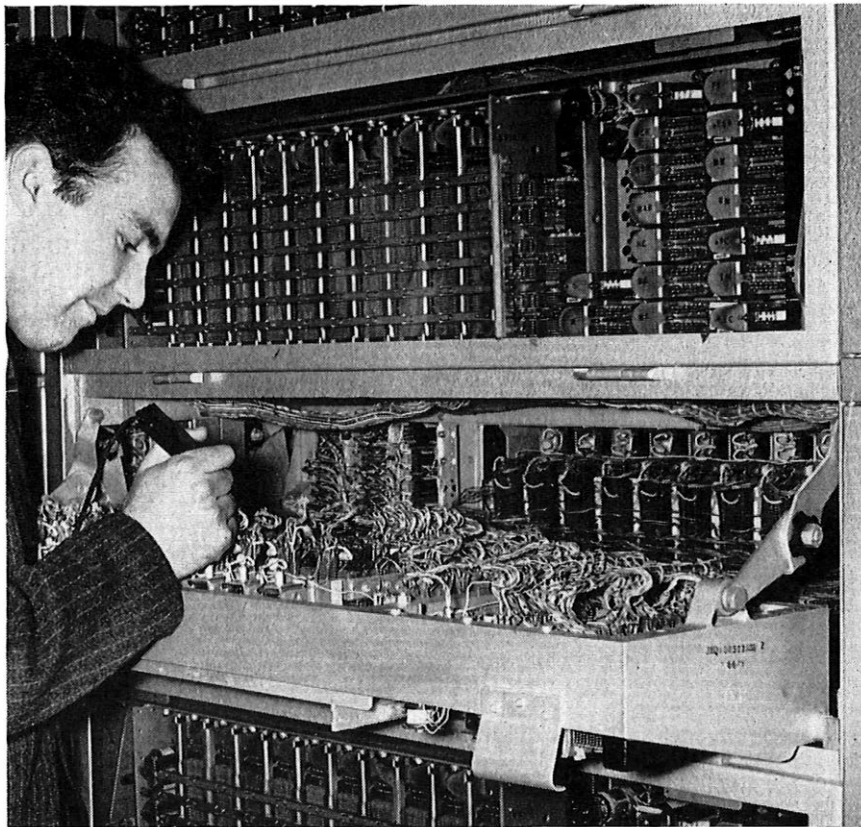

FIG. 12—CHECKING THE WIRING ON A B-DISTRIBUTOR-SWITCH

a fault is likely and which do not need regular lubrication or adjustment. There is now available a combination of devices built into the exchange to monitor and protect its

performance, and a maintenance organization designed to deal with faults only when they have been indicated by the exchange as likely to interfere with service. The provision of common control has made these ideas possible since most of the necessary test equipment can be provided on an exchange basis, whereas it would have been completely uneconomic to build similar protective devices into every selector in a Strowger exchange.

#### *Built-in Maintenance*

Some of the maintenance devices incorporated into the exchange are described in the following paragraphs.

(a) The several switching stages are each divided into two groups, designated X and Y. If a register tries to set up a call through one particular group and fails to do so within a preset time, or receives an indication that the path is faulty, then it releases its first attempt and tries again through another combination of groups. Thus, faults can exist in the exchange without affecting the subscriber, who does not even know that a second attempt is being made on his behalf.

(b) Vital equipment is monitored continuously. If a fault develops, appropriate action is taken, such as isolating the faulty section and giving an alarm.

(c) Failure of certain apparatus, such as crossbar switches, is self-detected and causes the apparatus to be taken out of service.

(d) After each call, the internal allocations are changed so that successive calls do not use the same paths.

#### *External Indicators*

Although faults may exist inside the exchange they will cause the relevant circuit to be either busied to traffic or

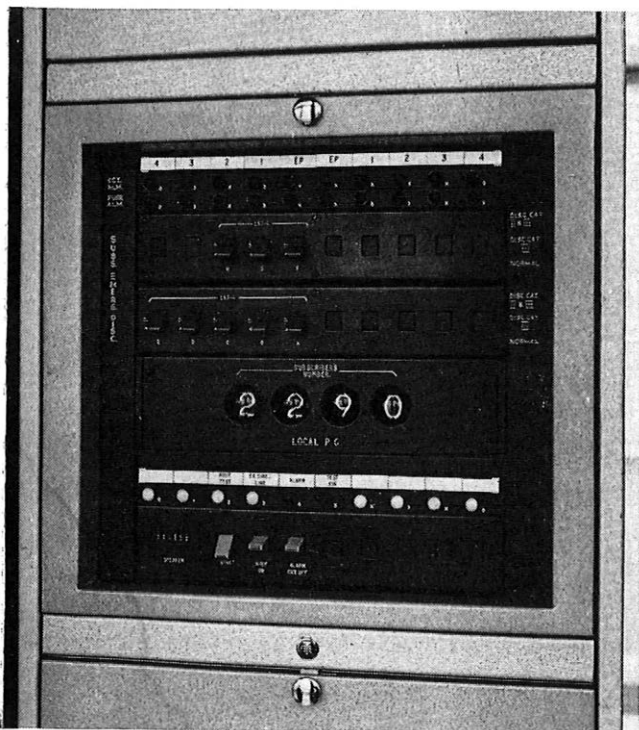

FIG. 13—ALARM LAMPS AND PERMANENT-CALL INDICATORS

bypassed by the second-attempt feature. Thus, their existence would not become apparent until they became so numerous that insufficient circuits were left in service to carry the traffic, especially as routine testing of all equipment is no longer practised. It thus becomes necessary to provide external indicators of what is happening inside the exchange and so give the maintenance staff "clues" as to the need for attention. The word clues is used deliberately, since it is not desirable, nor even practicable, for every fault indication to be pursued on its own account. It is much better for a complete set of information to be amassed before any investigation is started, as explained further below. The indicators provided fall into the following categories.

(i) *Meters.* The number of calls handled by each of the main items of common equipment is recorded on meters. The purpose of this is to allow the maintenance staff to detect any item that is not carrying its proper share of the load, perhaps because it has busied itself out of service or is being bypassed because of a fault. Comparison of readings from different sections of the same X or Y group, or of successive readings from the same section, can yield information about points of discontinuity in the switching network.

Other meters record the number of irregularities, as individual totals of marking failures, as number of failures at first or second attempt, and as number of calls meeting blocking (congestion within the exchange). All categories are divided into the various stages of setting up, i.e. line markers 1-2, routers 1X-2Y, etc.

(ii) *Equipment Monitor.* The crossbar switches carry up to 10 calls at the same time, and it would be very difficult to provide continuous external indication of the combinations of switch inlets and outlets used for all calls. However, there is a brief moment during the switching of each call when that call has individual attention, and this time is used to transfer identification of the switching stages to a temporary store, known as the equipment-monitor switch marker. At Broughton this contains a bank of cold-cathode tubes so mounted on a wall panel that their operation can be seen, but this visual facility appears to have little value and may not be perpetuated.

The router control checks the required connexions through the common-control equipments and speech-path switches each time it is called into use. When a failure is detected, the router control is released and the calling register is allowed to make a second attempt to establish the connexion, using completely different common-control equipments and switching paths. During the release time of the router control, the equipment monitor is seized, if previously free, and is then caused to store the identity of the calling transmission relay-group, the register and marker if employed, and further details of the switching-stage identities provided by the switch marker. Other information is added by the router control and equipment-monitor control to indicate the nature of the fault. Having stored the presented information, the equipment monitor calls on the maintenance teleprinter to print the fault details. The equipment monitor then releases and is available for further use.

(iii) *Alarms.* Fuse, power, ringing and tone-failure alarms are provided, together with individual alarms, e.g. for common-control access failures. This section of the exchange gives rise to practically the whole of the routine-testing needs, since the safety of the whole exchange may depend in the final resort upon the alarms.

## MAINTENANCE AIDS

Certain devices, either portable or built-in, are provided solely to allow the maintenance staff to check performance or to locate faults. Five such maintenance aids are described below.

### *Maintenance Console*

Although centralized service observations maintain a continuous watch on the overall service given to subscribers, it is also necessary to check in detail the performance of the exchange itself at regular intervals and to verify that all register stores are working correctly. This latter requirement would arise if, for instance, it was suspected that wrong numbers were being produced by the exchange—a malfunction which cannot be checked by the inbuilt equipment since it would be uneconomic to monitor separately what every subscriber actually dials.

A very versatile instrument has been provided for this and other purposes, comprising, basically, an artificial traffic generator and a call-progress monitor. The access equipment is situated in the exchange concerned, but the control console can be either in the same exchange or at a remote maintenance centre; in the latter instance it can be used to supervise up to 10 exchanges.

Since the same device may be used for printing out both fault reports and general service information, the maintenance console is also designed to accommodate



FIG. 14—MAINTENANCE CONSOLE

the common apparatus for the equipment monitor and the teleprinter-signal conversion circuits, as well as the teleprinter itself (Fig. 14). The maintenance console has three main functions, identified on the print-out as systems 01 to 03.

*System 01—Automatic Line-Insulation Tester.* System 01 is not an exchange maintenance aid, but its provision illustrates how devices built into the exchange can help solve the overall maintenance problem. The automatic line-insulation tester replaces a register and transmission relay-group in one of the routers and is connected to a bridge of the A-route-switch, via which it can obtain access to any line with the co-operation of the router control. The automatic line-insulation tester is programmed to test a block of lines in sequence and to print out the identity, and nature of the fault, of any lines which fall outside preset insulation limits. The equipment has not actually been fitted at Broughton since the local-line insulation routiner already provided at Preston can cater for the neighbouring exchanges as well.

*System 02—Artificial-Traffic Equipment.* The system has several programs which can be chosen from the maintenance console, and which can be checked by a special print-out. The three main programs are as follows.

(i) Quality-of-service measurements. The console is connected via a crossbar switch to 30 spare subscribers' line circuits which can be used either for originating or for terminating calls, so that  $30 \times 29$ , i.e. 870, different local combinations can be used. Furthermore, 10 different test numbers in other exchanges can be dialled from each line, giving  $30 \times 10$ , i.e. 300, outgoing combinations.

Access can also be obtained to incoming-junction circuits by switching the actual junction to a spare transmission relay-group and using its regular transmission relay-group for test calls. Thus, the working equipment is tested without interference with normal service. Ten transmission relay-groups chosen in a quasi-random fashion may be used in each test cycle to connect to the 30 subscribers' line circuits, giving  $10 \times 30$ , i.e. 300, incoming combinations. Similarly, tandem connexions may be tested by using the 10 incoming transmission relay-groups and the 10 outgoing codes, giving  $10 \times 10$ , i.e. 100, combinations.

The traffic offered by the artificial-traffic equipment can be varied to suit local circumstances, and the results of the tests are recorded on meters which show total calls, calls with no dial tone within a preset time, calls not completed, and calls with no metering. Thus, the quality of service over a given period is easily calculated.

(ii) For fault location the program is similar to (i) except that the artificial-traffic equipment stops, holds the call, and gives an alarm whenever it encounters an irregularity during the following tests: exchange-line conditions, ringing, called-subscriber answer, metering, release, called-subscriber busy, and correct routing to distant test number. As it would be impossible for a call to be held by the common control in the normal way, the artificial-traffic equipment is given, for this test, access via spare outlets of the A-distributor-switches, and special marking conditions are passed forward to inhibit time-out and the second-attempt feature.

If required, the artificial-traffic equipment can be set to repeat continuously any desired call instead of passing through all the possible calls in turn.

(iii) Register store check. The register store receives

digits direct from the subscriber and so cannot be checked for correct storage during its normal operation. The artificial-traffic equipment has direct access to all registers in turn, and is programmed to pulse in the digits 0-9 to all stores under adverse line conditions and in such a way that all possible combinations are tested. The outputs from the register stores are fed back, via the usual sender, into the artificial-traffic equipment and checked, any failure causing the teleprinter to print-out all details of the test (see Appendix). As for the quality-of-service tests, the artificial-traffic equipment can be set to stop on a fault or to routine continuously a particular register, either with the full test cycle or with preset digits. The controls for this purpose are mounted in the middle of a convenient main-equipment rack.

*System 03—Equipment Monitor.* The print-out may appear in two forms: single line for general failures, and double line for coder faults so that the two-out-of-five and one-out-of-four codes passed can also be shown (see Appendix). One element of the print-out indicates whether the call was originated by the artificial-traffic equipment whilst programmed to stop on a fault.

#### *Traffic Recorder*

Although not normally regarded as a maintenance aid, the traffic recorder performs a useful function in locating areas of blocking in complex switching systems, and so helps in the maintenance of the grade of service. Access is provided to both long-holding-time and short-holding-time equipment via a crossbar matrix, and the readings are produced on meters directly in erlangs.

#### *Universal Test-Set*

Despite its rather imposing title the universal test-set (Fig. 15) is basically a simple device which allows calls to be injected into line circuits or transmission relay-

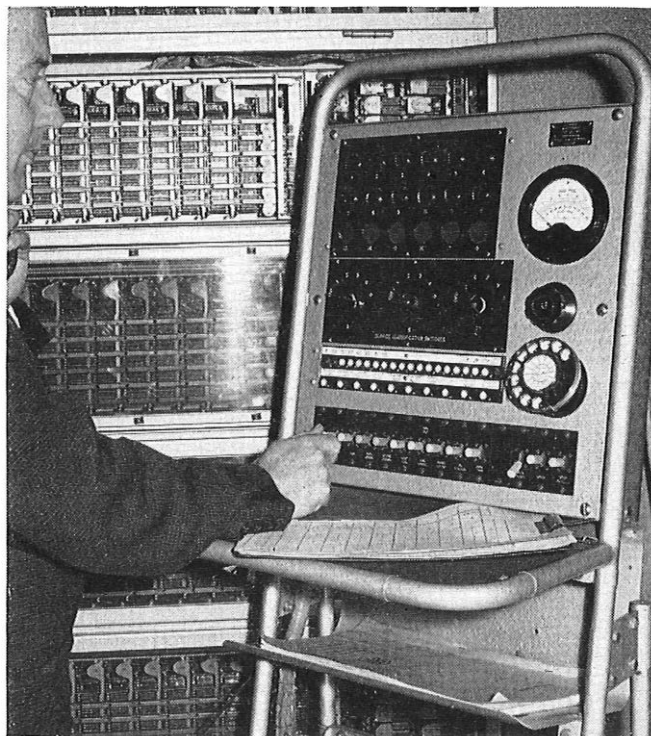

FIG 15—UNIVERSAL TEST-SET BEING USED ON DISTRIBUTOR RACK





- (b) Print-out of marking and path failures.
- (c) Recordings of traffic flow.
- (d) Subscribers' complaints.
- (e) Observation results.
- (f) Artificial-traffic equipment results, from this and other exchanges.
- (g) Reports of incoming difficulties, from local or S.T.D. reference centres.

Some of this information will lead to an immediate identification of the responsible item, and so to its cure. But many of the facts will be much more vague, since the faulty item concerned might be one of many thousand cross-points or there might be several such faults simultaneously or even intermittently. Provided that the quality of service is not deteriorating below previously-fixed standards then it is desirable to wait until sufficient statistics have been gathered to give a clear lead. Any attempt to trace each report will be very wasteful of maintenance effort and may even lead to more faults being caused than cured. Experience so far shows that "real" faults are rare, but, when they do occur, their presence is almost immediately obvious because of a rapid succession of failure reports. In these instances, the maintenance officer can quickly diagnose the trouble without any complex aids.

Future intentions are that all common-control exchanges will be normally unattended for maintenance purposes, and maintenance attention will be given only when actually required. The point at which this will be needed will be determined by analysis of the information printed-out at a maintenance centre. One scheme suggested is for the statistics received in bulk to be transferred to charts, individual to various items of equipment, e.g. routers and distributors (see Fig. 16(a) and (b), respectively), so that any build-up at a particular point is immediately obvious. The charts shown were plotted from the print-out used as an example in the Appendix, to illustrate the method. Normally, only individual call failures with no identified cause need be plotted. Charts could be prepared manually for moderately-sized installations, say, up to 10,000 lines, but for a maintenance centre controlling many exchanges a straightforward pigeon-holing data-handling machine would be more economical. With further progress, the data produced by the local exchanges could be fed direct to a computer which would produce the necessary day-to-day and long-term statistics, and would also have built-in alarms to direct immediate attention to dangerous situations, e.g. if the percentage of calls failing were to rise above a certain limit.

Until there is a sufficient concentration of common-control exchanges within a suitable radius to form a coherent group, they will be maintained individually, and the scheme outlined in the preceding paragraphs is being operated manually. A single chart is being used to collate the various results for overall management purposes. Many details of procedure are being tested, such as the two following.

(i) The optimum interval between meter readings. At Broughton exchange these were carried out daily at first, but the period has been gradually lengthened to observe the effect.

(ii) The optimum interval between examinations of the print-outs. With full-time attention, the maintenance officer can hear the teleprinter and can see immediately

whether or not further action is needed. An alternative method is for the maintenance console to be fitted with a device which measures the rate of call failure and signals the maintenance centre immediately the limit is exceeded. Various schemes for achieving this are being investigated.

#### SERVICE EXPERIENCE

Broughton exchange has given very satisfactory service during its 2 years' operation, and has proved that it gives many advantages in quality-of-service and maintenance requirements. Fig. 17 and 18 show some of the results, and from them it will be seen that the initial good performance has become even better as the maintenance staff has become more familiar with the system, and as the initial faults have been cleared. The centralized service observations have not revealed a single failure in Broughton exchange, despite the unusually large sample of calls checked. The effort required to maintain the

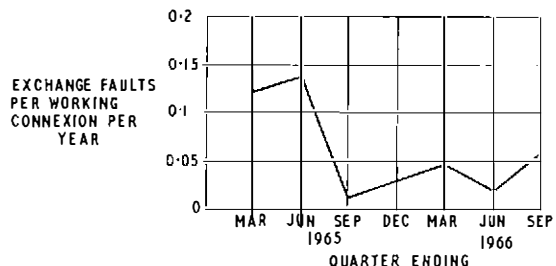

(a) Faults Reported by Subscribers

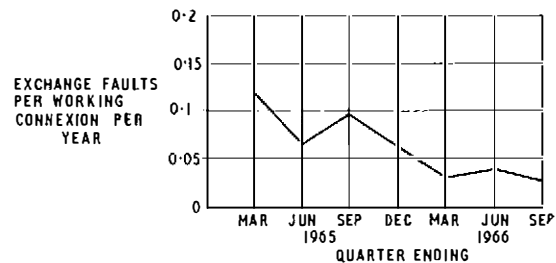

(b) Faults Detected by Exchange Staff

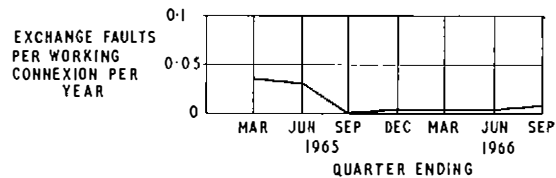

(c) Faults not Found

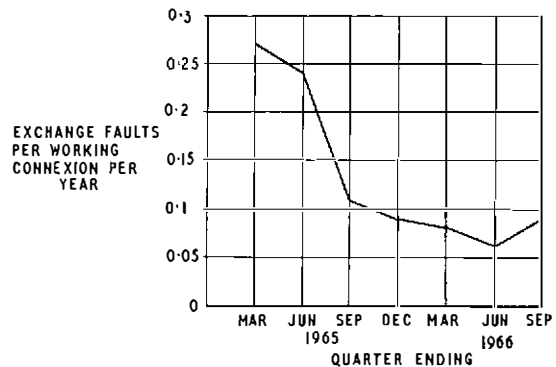

(d) Total Faults

FIG. 17—EXCHANGE FAULTS

exchange has varied between about 0.4 and 0.5 manhours/line/year, and it is expected that this value will fall as the exchange is extended, since much of the equipment is common and was provided initially.

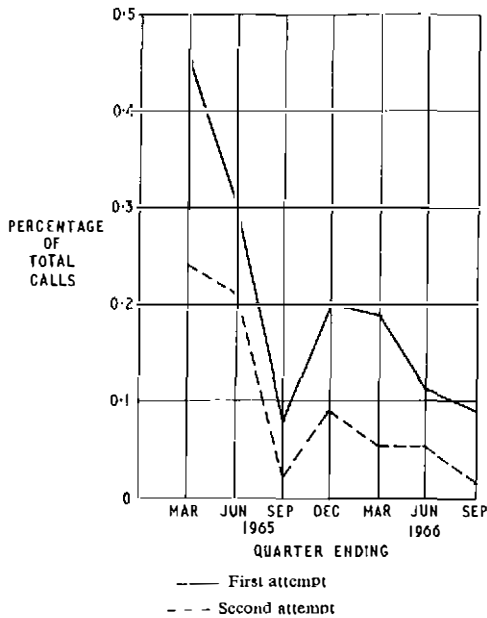

FIG. 18—CALL-ATTEMPT FAILURES

The maintenance technique has changed slightly from the original conception of analysis of bulk failure reports. About five reports a day are printed out: from these, perhaps 1 fault/week is found in the exchange; the other reports result from line faults. Thus, the maintenance man is quite able to check the results for individual faults or signs of a common fault, and a formal analysis is

unnecessary. Nevertheless, the statistics have been summarized and preserved for future information.

Some modification of the artificial-traffic equipment has proved desirable so that the whole program, lasting  $1,570 \times 30$  seconds, i.e. approximately 13 hours, can be divided into manageable sections. Experiments are continuing to determine the best method of running the artificial-traffic equipment.

The wisdom of switching the transmission relay-group on working junctions has also been questioned, and alternative schemes, such as seizing the junction itself, are being studied, especially for future exchanges where small groups of incoming junctions might be involved.

The maintenance console is to be redesigned so that the bulk of the apparatus will be fitted on the main equipment racks and only the teleprinter and controls will need to be separate. The latter may be mounted on a teleprinter table in the exchange-maintenance room or at the remote maintenance centre.

It takes the equipment monitor about 10 seconds to complete printing-out the details of a first-attempt failure, and long before the end of this time the second attempt should be completed. It is not possible to store the details of this second attempt in the switch marker while the latter is engaged in identifying the first attempt, so any further failure will be unrecorded. This could be a serious disadvantage, and consideration is being given to means of printing second-attempt failures, as well as first-attempt failures, for example, by the provision of a second store.

#### ACKNOWLEDGEMENTS

Much of the information for this part of the article has been obtained from the series of *A.T.E. Journals* listed in the bibliography at the end of Part 1. Thanks are due to the Editor of the *A.T.E. Journal* for permission to use this information, and to the staff of the Post Office North Western Region for their help in providing the statistics.

#### APPENDIX

##### Examples of Equipment-Monitor Print-Outs from Broughton Exchange

##### GENERAL PRINT-OUT

Time	Day	Month	Calling Exchange		Fault System	Router Control	Attempt Register		T.R.G.	R.S.B.		2nd R.S.		D.S.B.		Subscribers' or Junction Group		A.T.E.	Fault Reference Number				
			System	System			Register	Register		R.S.A.	R.S.C.	D.S.A.	Marker	Units									
0915	21	10	01	03	03	02	01	06	03	02	01	+	+	+	+	06	20	02	47	+	+	1	
0945	21	10	01	03	07	02	01	02	04	++	++	++	-	-	-	+	+	+	+	+	+	2	
1145	24	10	01	03	08	01	01	16			0	3										3	
1455	24	10	01	03	03	01	01	03	07	06	03	++	++	03	08	03	18	+	+	+	+	4	
1455	24	10	01	03	03	01	01	03	07	06	03	++	++	03	08	03	18	+	+	+	+	5	
1455	24	10	01	03	03	02	01	02	07	02	04	+-	++	03	08	03	18	+	+	+	+	6	
1455	24	10	01	03	03	02	01	07	02	06	03	++	++	02	08	03	18	+	+	+	+	7	
1500	24	10	01	03	03	02	01	04	04	07	05	++	++	01	08	03	18	+	+	+	+	8	
1500	24	10	01	03	03	01	01	01	05	01	01	++	++	01	08	03	17	+	+	+	+	9	
1500	24	10	01	03	03	01	01	03	10	06	01	++	++	01	08	03	03	+	+	+	+	10	
1510	24	10	01	03	03	01	01	02	05	02	01	++	+	01	08	03	18	+	+	+	+	11	
1025	25	10	01	03	07	02	02	17	-	+	+	+	+	+	+	+	+	+	+	+	+	12	
1050	25	10	01	03	03	02	01	03	03	06	03	-	+	+	+	+	+	52	02	+	+	+	13
1140	25	10	01	03	03	01	01	01	10	01	01	-	+	+	03	11	01	33	+	+	+	+	14
1140	25	10	01	03	03	01	01	07	01	06	05	-	+	-	01	04	02	33	-	+	+	+	15

(a) General

### CODER FAULT PRINT-OUT

Time	Day	Month	Calling Exchange	System	Fault (Coder)	Router Control	Attempt	Register	T.R.G.
1455	14	09	01	03	09	01	01	04	01
+0++0	0	00+0+	00+++	+++++	++++	+	++		0
2/5 No. of Digits	Mixed Digits	2/5 Route	2/5 Marker	2/5 Route	2/5 Marker	None	1/4	1/4	None
Direct Junction			Alternative Junction (not applicable at Broughton)			Tariff			

Note the extra element on the direct-junction route.

(b) Coder Failure

### REGISTER-STORE CHECK PRINT-OUT

Time	Day	Month	Calling Exchange	System	Register Busy	Router	Register	Store	Digit Sent	Digit Received	Pulse Speed
1035	28	10	01	02	1	01	02	2	9	2	2
1035	28	10	01	02	1	01	03	2	0	1	2
1040	28	10	01	02	1	01	04	7	4	3	2

(c) Register-Store Check

FIG. 19—EQUIPMENT MONITOR PRINT-OUT

#### Explanation of Print-Out Columns (Fig. 19(a)).

Some columns are self-explanatory, but others are coded as follows:

**Calling Exchange**—The exchange reporting the fault (01 = Broughton).

**System**—The device reporting the fault (03 = the equipment monitor).

**Fault**—Possible faults are numbered from 01 to 10.

**Router Control**—01 = router 1, control X; 02 = router 1, control Y; 03 = router 2, control X.

**Register**—Numbered 01 to 30 within each router. At the time of the above print-out, registers 11–17 were used for incoming junctions.

**T.R.G. (transmission relay-group)**—Numbered 01–10 within each R.S.A. (A-route-switch) group. Thus the individual transmission relay-group can be deduced from this number in conjunction with the R.S.A. number.

**R.S.A.**—Numbered 01–16 within each router.

**R.S.B. (B-route-switch)**—Numbered 01–10 within each router. Whether the X or Y section is concerned can be determined from the router-control column.

**R.S.C.**—As R.S.B. Not applicable at Broughton.

**2nd R.S.**—As R.S.B.

**D.S.A. (A-distributor-switch)**—Numbered 01–08 within each distributor.

**D.S.B. (B-distributor-switch)**—Numbered 01–20 within each distributor.

**Marker**—Numbered 01–20 for line markers. This also indicates the distributor number, and hence the particular group of 500 lines containing the called subscriber. Junction markers are numbered 51–99.

**Subscribers' group**—The called-subscribers' line groups are numbered 00–49, the significance of the numbers being as follows: first digit, the particular group of 100 lines within each 500-line distributor; second digit, the tens digit of the directory number.

**Junction group**—Numbered 01–20 within each junction marker.

**Units**—Numbered 01–09 for the units digit of the called subscriber's directory number (not applicable at Broughton).

**A.T.E.**—00 in this column indicates that the call was originated by the artificial-traffic equipment.

#### Individual Faults (see also the analysis in Fig. 16).

**Fault No. 1**—The connexion was set by marker 02 to a subscriber's line in the group 2,970–2,979 but the d.c. conditions encountered on the path were not correct (fault 03 — line-continuity fail). No more print-outs occurred, so the circumstances were noted but no further action taken.

**Fault No. 2**—Only the initial stages of the connexion were set up, and fault 07 indicated that a register-access-seizure failure had occurred.

**Fault No. 3**—Fault 08 — A-route-switch seizure fail. Register 16 identified an incoming-junction call, and the peculiar print-out may have been due to incorrect conditions received from the junction.

**Faults No. 4 to 11**—Eight print-outs in a short time indicated a common fault. Despite the variety of the other stages used, the same B-distributor-switch and marker always appeared, indicating a distributor failure. This evidence was reinforced by the near-unanimity of the subscribers' group numbers (not necessarily the same order as the equipment numbers), so B-distributor-switch 08 of distributor 03 was examined. The fuse serving the line relays associated with this switch was found to be loose; correction of this cured the trouble and no more print-outs occurred.

**Fault No. 12**—It seemed as if a second attempt was failing, although no first-attempt failure was recorded. This fault appeared again subsequently and was analysed. It was found that a register was passing incorrect information into a router control.

**Fault No. 13**—Referred to a call passed by junction marker 52 (1Y) to junction group 02 (code 9) but with a line-continuity fail. There was insufficient information to proceed with fault location.

**Faults No. 14 and 15**—Individual faults which were recorded but not pursued.

# I.T.U. Seminar on "The Telephone Service," London, September 1966

U.D.C. 061.3:621.395:654.15

THE International Telecommunications Union (I.T.U.) has in recent years suggested that the more-developed member countries should arrange seminars for the interchange of information with representatives from the rapidly developing countries of the world, and a number of such seminars have been held dealing with specific technical or general subjects. The British Post Office accordingly agreed to organize an engineering seminar of a general nature in London in September 1966. This Seminar was held at Hampstead in the residential accommodation of Westfield College, University of London, and was attended by 44 representatives of 30 different countries. It was opened by the Engineer-in-Chief on the afternoon of Sunday, 18 September, and for the succeeding 2 weeks an intensive program of lectures, demonstrations, discussions, visits and social activities was undertaken by the participants in co-operation with Post Office Headquarters, Regional and Telephone Area staff.

It had been decided that the subject of "The Telephone Service" should be taken for the Seminar as it was thought that the maximum benefit would be derived from a syllabus concerned with the practical aspects of the planning, construction and maintenance of a telephone network, rather than a fuller treatment of any one specific technical subject. The syllabus, drawn up in consultation with British Post Office Headquarters administrative and engineering Branches and members of the Engineering Department who have served with overseas administrations, attempted to meet the needs of "middle-range" engineering management.

Papers on the following subjects, describing present-day practices and discussing the problems involved in providing a telephone service, were presented:

- Development forecasting.
- Economics of engineering line-plant provision.
- Planning of subscribers' line plant.
- External works practices.
- Traffic theory and practice in telephone exchanges.
- Telephone-exchange systems.
- Planning of multi-exchange areas.
- National network planning.
- Telephone-exchange equipment planning.
- Planning of microwave links and trunk cables.
- Utilization of trunk circuits.
- Subscribers' apparatus and P.B.X.s.
- Sales and service organization.
- Systems of maintenance and the maintenance of exchange equipment, subscribers' apparatus, external lines, and line transmission and radio equipment.
- Future developments in the telephone service.

The program was interspersed with visits to the Post Office Research Station at Dollis Hill, Stokenchurch Radio Station, London Post Office Tower, installations in the Oxford and Reading Telephone Areas, and to the Circuit Laboratory, the visits being intended to supplement the lectures by giving a practical insight into the operation of Telephone Area installations and Headquarters departments. Social activities were not neglected, and these assisted in producing the very happy

atmosphere in which the proceedings were conducted; the Assistant Postmaster General gave a reception for the participants and the lecturers at Lancaster House, the telecommunication industry provided a most enjoyable evening party at the Café Royal, and Mr. A. W. Ryland, C.B., Deputy Director General of the British Post Office, gave a farewell party at the Waldorf Hotel.

Mr. Lloyd Mason represented the I.T.U. at the final proceedings of the Seminar, which was closed with a recorded message from Mr. J. Balcombe, Chairman of the Organizing Committee, who was, unfortunately, incapacitated for the duration of the Seminar.

On the last day of the Seminar an international telephone call was made to link the Seminar with a similar I.T.U. Seminar organized by the Australian Post Office and held in Melbourne, and the following recorded message from Dr. Sarwate, Secretary General of the I.T.U., was broadcast simultaneously to the two Seminars.

"It gives me great pleasure to have this opportunity of conveying greetings from the Union simultaneously to two Seminars almost on opposite sides of the world, which have been, during these last two weeks, discussing matters of primary importance in the field of telecommunications, a field which we all have chosen as our avocation in the cause of service to the public of the world.

"Here, in London, 44 representatives of 28 Telecommunication Administrations, have for the last 2 weeks been discussing the theme 'The Telephone Service,' while there in Melbourne comparable numbers of you are approaching the end of your discussions of the means of providing that service, under the title 'Development of the Telephone Network.'

"The officials at the Headquarters of the Union are pleased and are proud to have been able to form a link between the members of our Union, and so to have assisted in bringing together these two communities of people who are dedicated to the concept of linking together the peoples of the world, and so promoting not only national development but also international understanding and co-operation. I trust that such Seminars as these may be repeated from time to time in various other I.T.U. member countries, and that all those who are privileged to participate in them will, as a result, be better able to provide their respective countries with those telecommunication services which are so essential to their economic and social development.

"May I, in concluding this brief message from the International Telecommunications Union, say how much pleasure it gives me to be able to speak to you through the medium of an international link, the existence of which owes itself to that international co-operation in the telecommunications field which this great Union of ours has been promoting during the 101 years of its existence.

"I congratulate this Seminar here in London on reaching a very successful conclusion, and I have no doubt that when the Melbourne Seminar comes to an end, on Tuesday next, you will all feel that it has been a most rewarding experience."

K.W.H.

# The New Leaffield Radio Station

## Part 5—The External and Switching Plant

M. HART, C.Eng., A.M.I.Mech.E.†

U.D.C. 621.396.7 : 621.396.67 : 627.316.54

The new Leaffield radio station has to cater for two widely differing types of service: point-to-point services operating from 30 kW transmitters and press broadcast services operating from 75 kW transmitters. The aerials and switching equipment provided for the two services are described below.

### INTRODUCTION

THE new Leaffield radio station has to cater for two widely differing types of service: point-to-point services operating from 30 kW transmitters and press broadcast services operating from 75 kW transmitters. This article describes the aerials and switching equipment provided for the two services.

### POINT-TO-POINT SERVICES

A block schematic diagram of the aerial switching arrangement used for the point-to-point services is shown in Fig. 1. Each transmitter output is connected to a coaxial switching-matrix via a 50-ohm

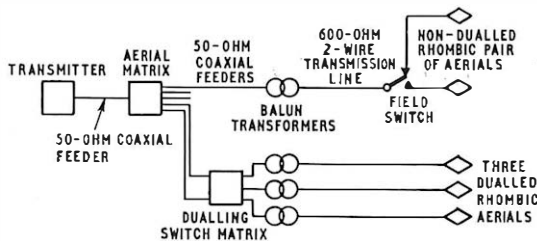

FIG. 1—AERIAL SWITCHING ARRANGEMENTS FOR THE 30 kW SYSTEM

†Overseas Radio Planning and Provision Branch, E.-in-C.'s Office.

coaxial feeder; in systems where dualling is not required the output of this matrix is connected via a similar feeder to a 50/600-ohm unbalanced-to-balanced transformer (balun). The transformer output is then connected by means of a 600-ohm open-wire transmission line to a field switch, for selecting one of two rhombic aerials according to the frequency of the transmission.

For those services where dualled operation is required, three aerials have to be allocated to each service and a slightly different arrangement is used. The output of the aerial matrix is connected to a second smaller, but similarly-constructed, dualling matrix (one for each dualled service) to give a first-choice or second-choice selection from the three aerials.

### Coaxial Feeders

The coaxial feeders have a nominal impedance of 50 ohms, and are constructed of high-conductivity copper tubes, the outer being  $2\frac{1}{8}$  in. diameter and the inner  $\frac{7}{8}$  in. diameter; polytetrafluoroethylene (p.t.f.e.) spacing insulators are used. The outer-tube joints are standard brass water-pipe fittings of the nut and cone type; the inner tubes are soldered together on ferrules. Each straight section contains a plug and socket running on a crimped beryllium-copper spring to allow for the differential expansion between the outer and inner tubes.

### Aerial Matrix

Two aerial matrices have been provided to give the required flexibility between transmitters and aerials. Each matrix has been built up from standard coaxial switch units (Fig. 2), and is arranged to provide for the interconnexion of six transmitters and 14 aerials. The switch unit has been designed to maintain close uniformity of feeder impedance and to handle a peak envelope power (p.e.p.) of 30 kW with a voltage standing-wave ratio (v.s.w.r.) not exceeding 2 : 1.

During the operation of a switch unit a solid p.t.f.e. drum, which contains the inner conductor of the coaxial tube, is rotated within a metal housing that forms the outer conductor of the coaxial tube. A common driving mechanism, controlled by a reversible motor, is used for each level of the matrix, the switches being coupled to it as required by means of solenoid-operated clutches. A cam assembly mounted on each switch unit operates micro-switches to give the necessary electrical interlock and supervisory signals. These interlocks ensure that not more than one transmitter at a time is connected to any one aerial, and that r.f. power is disconnected whilst a switch is moving; they also provide for the safe withdrawal of switches for maintenance purposes.

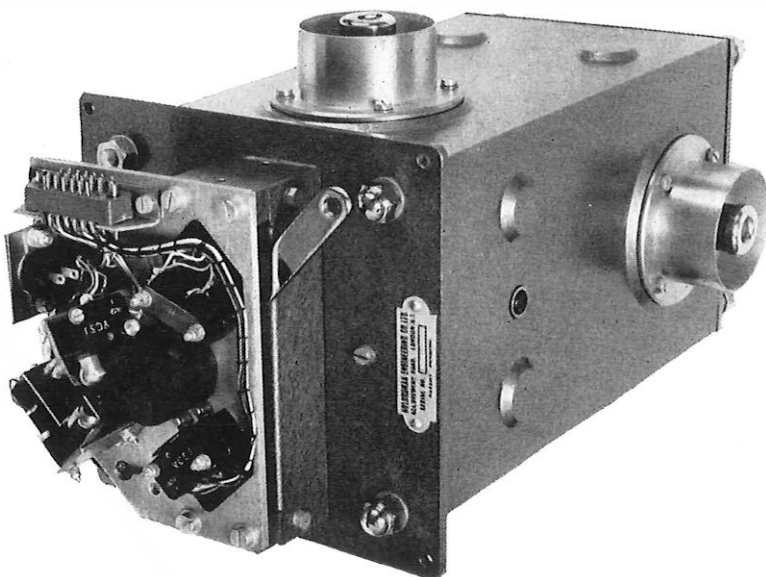

FIG. 2—30 kW COAXIAL SWITCH UNIT

### Balun Transformers

The 30 kW baluns are similar to those used at Rugby A radio station.<sup>1</sup> As a result of experience, however, it has been found necessary to add additional protection against lightning surges and static voltage build-up on the transmission lines; this has been achieved in the Leaffield installation by a combination of spark gaps and non-linear resistive elements.

The baluns are erected vertically on an external gantry close to the transmitter building. The gantry is 180 ft in length and accommodates 30 baluns; it is of welded-steel construction, and guarded cat-walks have been provided to facilitate safe access for maintenance. Fig. 3 shows the arrangement used.

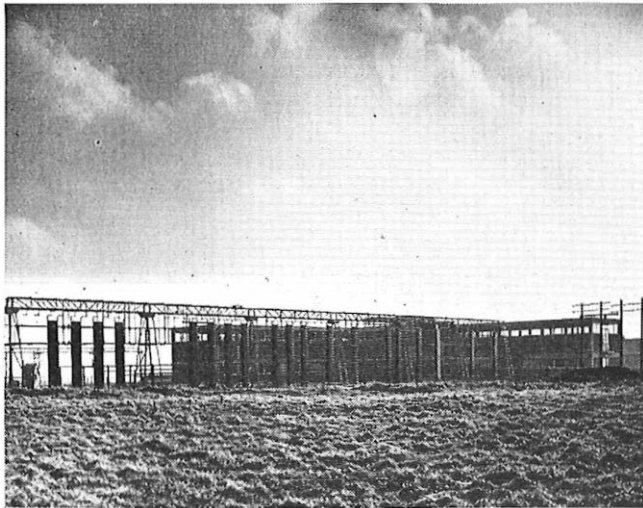

FIG. 3—THE GANTRY FOR 30 kW BALUNS

### Field Switches

On those routes which only require two aerials, selection is made by means of a Field Switch No. 1A mounted at the end of the transmission line near the base of the aerials (Fig. 4). The switch uses mercury-filled glass tubes for the contacts, and for safety reasons is operated by means of a small low-voltage remotely-controlled a.c. motor. Care has been taken, in the design of the switch, to maintain both the balance to earth and the impedance characteristic of the feeder system; measurements have shown that a v.s.w.r. of better than 1.2 : 1 is maintained over the frequency band of 4–28 Mc/s. Supervisory facilities are provided by means of auxiliary switch contacts.

### Transmission Lines

The open-wire transmission lines of 600-ohm impedance use 400 lb/mile hard-drawn copper wires spaced approximately 9 in. apart in the vertical plane. Wooden poles are used throughout to support the lines at an average height of 18 ft. The wires are falsely terminated, by means of tension-type insulators and straining screws, to every fifth pole, pass-through stand-off insulators being used at intermediate poles. The insulator design ensures that capacitance disturbance is kept to a minimum.<sup>2</sup>

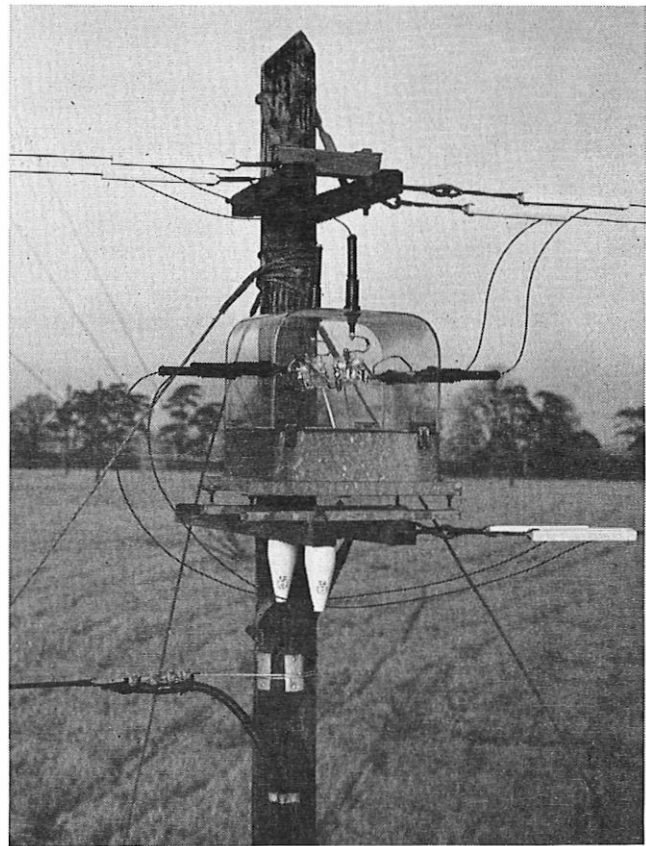

FIG. 4—FIELD SWITCH FOR NON-DUALLED POINT-TO-POINT AERIALS  
—FIELD SWITCH NO. 1A

### Aerials

The aerials are three-wire rhombics, constructed of 7 strand/22 s.w.g. cadmium-copper wire and supported at nominal heights of 75, 150 and 300 ft, from standard Post Office steel lattice masts. Much has been written on the design of rhombic aerials<sup>2</sup> and it is not proposed to deal with the design in detail here. The chief characteristics of the aerials are given in the table.

Dimensions of the Rhombic Aerials

Service	Aerial	Side Length (ft)	Semi-Side Angle (degrees)	Mean Height (ft)
Non-Dualled	1	450	65	150
	2	400	72.5	75
Dualled	1	500	63	300
	2	440	69.5	150
	3	415	72	75

All rhombics have a nominal characteristic impedance of 600 ohms, and are designed to keep the v.s.w.r. below 1.4 : 1 over the operating frequency range. The terminating impedance is a 1,000 ft long stainless magnetic-iron wire absorber line, giving a return loss of the order of 30 db.

Fig. 5 (a) shows the estimated performance of the two-rhombic non-dualled arrangement normally used, and Fig. 5 (b) shows that of the three-rhombic arrangement. In the latter, some compromise in the design has

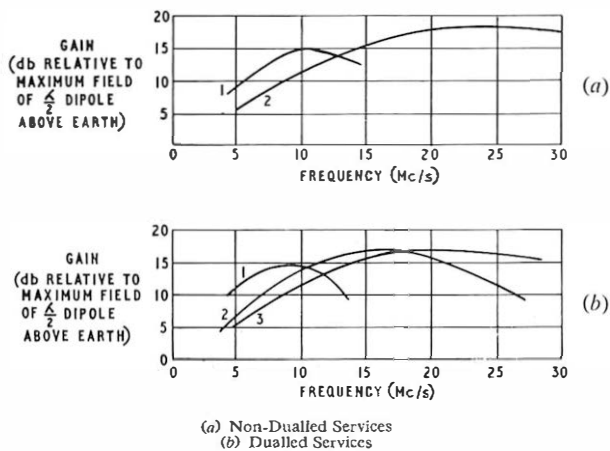

FIG. 5—GAIN CURVES OF THE RHOMBIC AERIALS

been necessary so that each frequency used can be accommodated on two aerials. The control arrangement ensures that the best aerial for a particular frequency is automatically selected if available; if in use, the second choice is selected.

#### PRESS BROADCAST SERVICES

Fig. 6 is a block schematic diagram of the aerial connexions used for the press broadcast services. The

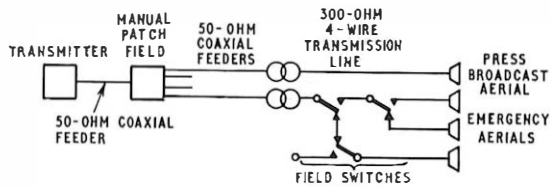

FIG. 6—AERIAL SWITCHING ARRANGEMENTS FOR THE 75 kW SYSTEM

transmitter output is connected via a 50-ohm coaxial feeder to a manual patch field, which allows some measure of flexibility between transmitter and aerial, and thence to a 50/300-ohm balun. The output of the balun is connected via a 300-ohm 4-wire transmission line to the aerial. One aerial outlet of the patch field has been specially arranged to give access, by means of remotely-controlled field switches, to any one of the three spare aerials provided.

#### Coaxial Feeders

The coaxial feeders used with the 75 kW transmitters (Fig. 7) are larger than those used for the point-to-point services because of the higher power. The outer tube is of  $3\frac{7}{8}$  in. diameter and the inner of  $1\frac{9}{16}$  in. diameter. The outer-tube joints are effected by means of a pair of shouldered brass flanges registering one to the other via a copper sleeve and held together by an encircling clamp; in other respects the fittings are scaled-up versions of those used for the 30 kW system.

#### Balun Transformers

The 75 kW baluns (Fig. 8) are similar in principle to those used for the point-to-point circuits, but, because of the higher voltages and currents involved, there are a number of electrical and mechanical differences. Each balun consists of three separate interconnected devices:

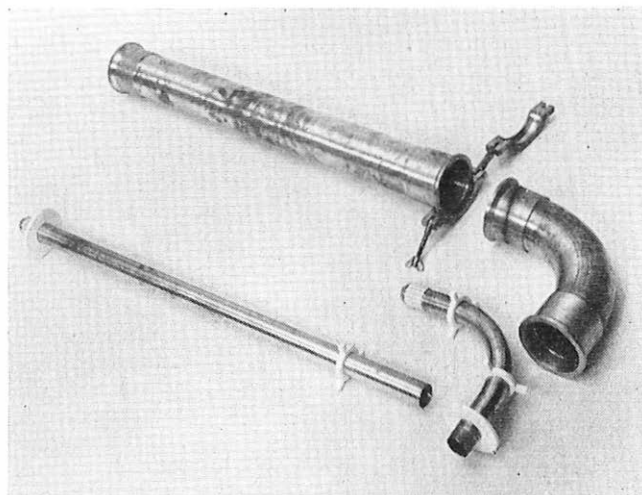

FIG. 7—75 kW COAXIAL-FEEDER COMPONENTS

a 1 : 1 balanced-to-unbalanced transformer, a 4 : 1 stub-compensated balanced-impedance transformer, and a triple-compensated transmission-line transformer, the element lengths being  $\lambda/4$  at the arithmetic mean frequency of the band to be covered (4-28 Mc/s). High-conductivity copper has been used in their construction, and the insulators and spacers are made of p.t.f.e. or polypropylene. As in the smaller baluns, protection against the effects of lightning surges and static build-up on the transmission lines has been provided. A target maximum v.s.w.r. of 1.25 : 1 over the band 4-28 Mc/s has been achieved.

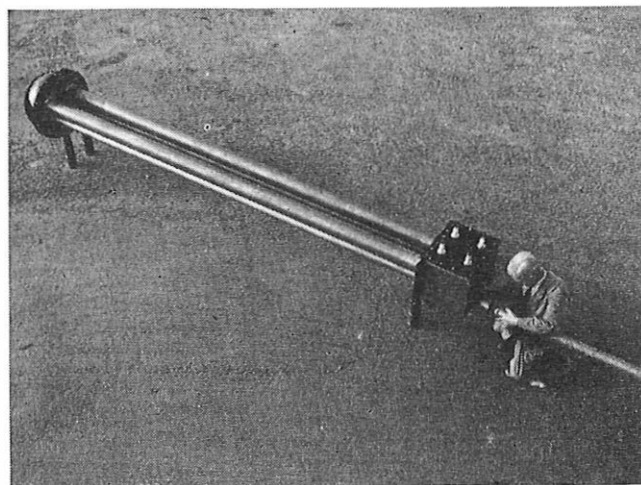

FIG. 8—A 75 kW BALUN

Because both low-impedance and high-impedance connexions are at one end, the baluns are horizontally mounted below a steel gantry but otherwise are similar to that used for the point-to-point services. For safety reasons the gantry is in a fenced compound.

#### Transmission Lines

At the higher power used (75 kW) for the press broadcast services it has been shown<sup>2</sup> to be more economical to use a 4-wire transmission line between the balun and the aerial. The arrangement used at Leafield consists of

four conductors, each of 400 lb/mile hard-drawn copper in approximately a 9 in. square format, resulting in a line having a characteristic impedance of approximately 300 ohms.

### Field Switches

Remotely-operated field switches (Fig. 9) are used to select the wanted one of the three emergency aerials; the power-handling capacity of the Field Switch No. 1A is

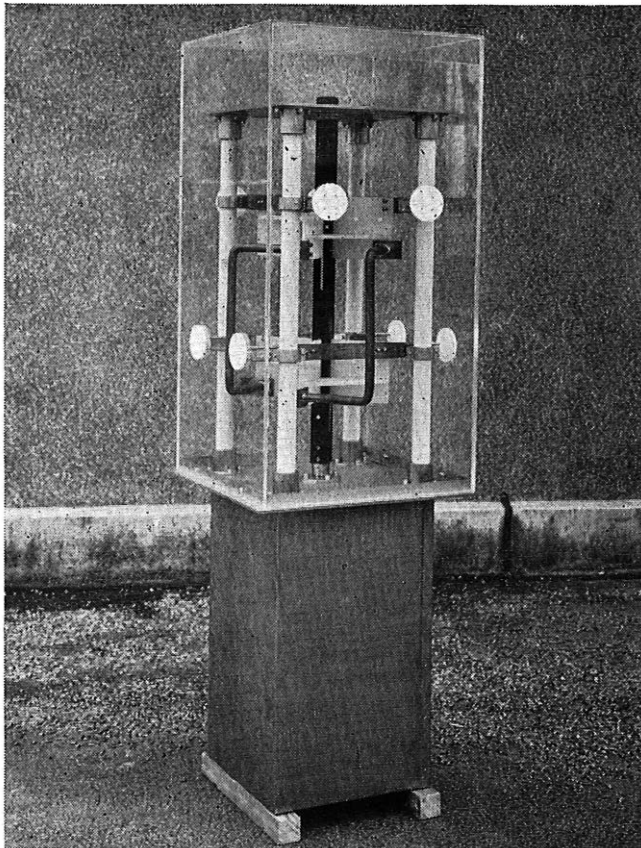

FIG. 9—FIELD SWITCH FOR THE 75 kW PRESS-BROADCAST EMERGENCY AERIALS

inadequate and a new switch was developed. Basically, the switch consists of a contact assembly supported on ceramic-rod frame members and operated to either of two positions by an axially-driven central shaft. In one position the transmission lines pass mutually at right angles to each other; in the other, the transmitter side of one line is cross-connected to the aerial side of the other.

### Aerials

The broadcast services require an aerial having a horizontal beamwidth of approximately  $60^\circ$  so that a large geographical area can be covered by each transmission. At the old Leafield station, tuned-element arrays of the Koomans type were used for these services, one such aerial being needed for each transmitted frequency; this is costly and if used at the new station would have resulted in more complex switching.

A new type of aerial, the log-periodic, has recently been developed<sup>3-7</sup> which is almost ideal for this type of service, as it has a wide azimuthal beamwidth, an

acceptable gain, and an arbitrarily large frequency range. The aerial consists of a number of half-wave dipoles connected across a transmission line, the lengths of the dipole elements and the distances between them being in a geometric progression with a common ratio, usually designated  $\tau$ .

The determination of the value of  $\tau$  is the first and most important step in design, since this largely decides the gain and number of elements. It is found in practice that not more than five adjacent elements can be effectively excited at any frequency, even in a non-tapered aerial ( $\tau = 1$ ), and that a sufficiently close approach to this condition is reached with  $\tau = 0.94$ . The number of elements in the aerial,  $n$ , then depends upon the bandwidth required according to the relation:

$$\tau^n \approx a \frac{f_{min}}{f_{max}}$$

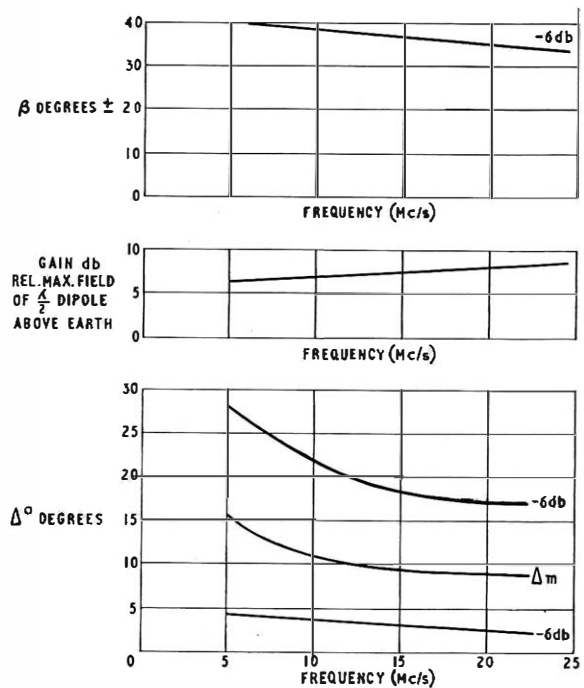

FIG. 10—PERFORMANCE CHARACTERISTICS OF THE LOG-PERIODIC AERIALS

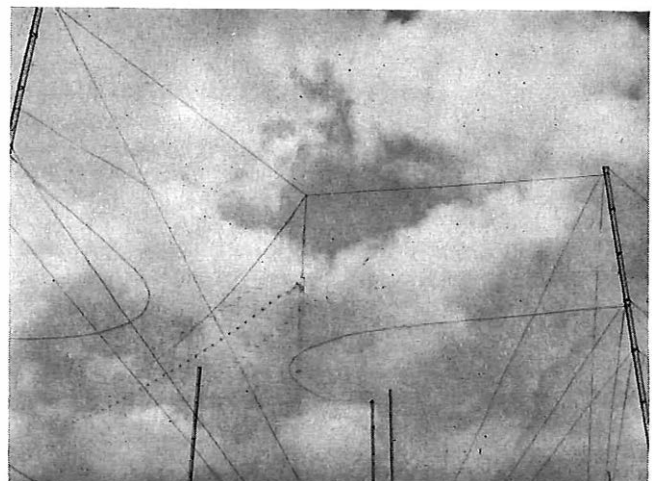

FIG. 11—CONFIGURATION OF THE LOG-PERIODIC AERIAL



where  $a = 3.25 \tau - 2.42$  for values of  $\tau$  between 0.88 and 0.95.

The remaining dimension, designated as  $\sigma$ , is the spacing between adjacent elements to give optimum phasing conditions, the spacing being expressed as a fraction of the length of the larger of any pair of elements.

As the result of model tests at both u.h.f. and v.h.f. the values of  $\tau$  and  $\sigma$  chosen for the aerials erected at Leafield are 0.94 and 0.17, respectively; this results in an aerial consisting of 31 elements to cover the bandwidth of 6–25.0 Mc/s. The gain and radiation characteristics and configuration are shown in Fig. 10 and 11, respectively.

#### CONCLUSIONS

To satisfy the operational requirements of the new Leafield transmitting station, techniques not previously employed at Post Office radio stations have been used: in particular, an aerial-switching matrix of new design and a version of the log-periodic aerial for the press broadcast services.

Experience so far indicates that the operational

requirements have been satisfactorily met and that the reliability of the equipment will measure up to the needs of a station which, it is hoped, will ultimately be operated unattended.

#### References

- <sup>1</sup>BROAD, E. R. High-Power Radio-Frequency Broad-Band Transformers. *P.O.E.E.J.*, Vol. 51, p. 8, Apr. 1958.
- <sup>2</sup>WATT-CARTER, D. E., and YOUNG, S. G. A Survey of Aerials and Aerial Distribution Techniques in the H.F. Fixed Services. *Proceedings I.E.E.*, Vol. 110, p. 1,529, Apr. 1963.
- <sup>3</sup>CARREL, R. C. The Design of Log-Periodic Antennas. *I.R.E. National Convention Record*, 1961.
- <sup>4</sup>DU HAMEL, R. H., and ISBELL, D. E. Broad-band Logarithmically Periodic Antenna Structures. *I.R.E. National Convention Record*, 1957.
- <sup>5</sup>DU HAMEL, R. H., and BERRY, D. G. A New Concept in High-Frequency Antenna Design. *I.R.E. National Convention Record*, Part 1, 1959.
- <sup>6</sup>ISBELL, D. E. Log-Periodic Dipole Arrays. *I.R.E. Transactions on Antennas and Propagation*, May 1960.
- <sup>7</sup>VEZBICKE, P. P. Measured Performance of an H.F. Log-Periodic Antenna. *U.S.A. National Bureau of Standards Report No. 6705*, June 1960.

## Opening of the First Production Electronic Telephone Exchange at Ambergate

J. A. LAWRENCE, T.D., Hon.C.G.I.A., C.Eng., F.I.E.E. †

U.D.C. 621.395.345:621.395.722

The new Ambergate telephone exchange, opened on 15 December 1966, is the first production electronic telephone exchange of the TXE2 type to go into service. This article describes briefly the system concepts and its introduction into the United Kingdom telephone network.

#### INTRODUCTION

THE 15 December 1966 may well turn out to be a milestone in the continued development of the United Kingdom telephone system. It marked the opening of the Ambergate electronic telephone exchange at a ceremony presided over by the Postmaster General, the Right Honourable Edward Short, M.P. (Fig. 1).



FIG. 1.—THE POSTMASTER GENERAL MAKING THE INAUGURAL CALL AT THE OPENING CEREMONY

This exchange is of special importance in that it is the first production unit of the British Post Office TXE2 electronic telephone-exchange system<sup>1</sup> to go into service. It is also the first production electronic system of its kind in Europe, and the first in the world in its particular field of use.

The Ambergate equipment was manufactured by Ericsson Telephones, Ltd., of Beeston, Nottingham, to designs developed jointly by the Post Office and Ericssons under the Joint Electronic Research Agreement.\* It is the forerunner of at least 24 other TXE2 exchanges to the same design from Ericsson Telephones, Ltd., planned to come into service during 1967–68. These will be supplemented by a similar quantity to be supplied by The General Electric Co., Ltd., of Coventry, during the same period.

In placing these orders the British Post Office has taken the first positive step towards the up-dating of the United Kingdom network with electronic equipment,<sup>2</sup> and, from now on, the TXE2 system will be the preferred system for all exchanges in the range of 200 to 2,000 lines. Orders for TXE2 exchanges may, therefore, be expected to continue at an increasing level for some long time to come.

The TXE2 system has already been proved in public service in a field-trial equipment brought into service on 10 June 1965 at Peterborough.<sup>3</sup> This installation has

†Telephone Electronic Exchange Systems Development Branch, E.-in-C.'s Office.

\*Joint Electronic Research Agreement (J.E.R.A.)—an agreement to co-operate in the research and development of electronic telephone-exchange equipment, between the Post Office and the five principal manufacturers of telephone-switching equipment: Associated Electrical Industries, Ltd., Automatic Telephone & Electric Co., Ltd., Ericsson Telephones, Ltd., The General Electric Co., Ltd., and Standard Telephones and Cables, Ltd.

given extremely satisfactory results, which have contributed largely to the Post Office decision to adopt TXE2 for general service.

#### SYSTEM CONCEPTS

##### *Cross-Points and Components*

The system is based on the use of the reed relay<sup>4</sup> as the basic switching element. The same type of relay is also used in the supervisory, register and control circuits, in conjunction with electronic elements using resistors, silicon transistors and silicon diodes.<sup>5</sup>

The use of the reed relay confers several important advantages. It is very fast in operation, it has fully-sealed contacts, and requires no adjustment—indeed, it cannot be adjusted. It also provides a highly-reliable noise-free contact through the use of gold-plated contacts. Being essentially a relay-type contact it offers no problems of compatibility with existing telephones and lines, both local and junction.

Its speed of operation enables the switches to be controlled by common equipment, which operates on a one-at-a-time basis: in effect, the whole exchange is momentarily stopped while a call is being set-up—but the stoppage is brief, being only a few tens of milliseconds.

##### *Use of Common Control*

The use of common-control equipment greatly improves the flexibility of the system to provide new services and facilities, and to make changes in the future. It does, however, involve a risk of exchange failure due to a fault in the common control. To avoid this the controls are duplicated, permitting maintenance work to be carried out on a faulty control without shutting down the exchange. Each control is also brought into use every few minutes to ensure that neither control can remain for very long with an internal fault.

Moreover, the controls are arranged to check that each call is properly set-up before dealing with other calls. When a faulty set-up is detected the control first attempts to again set up the call, without the subscriber's knowledge, over a different path; usually this is sufficient, and less than one in 1,000 calls, as seen by the subscriber, fail due to plant faults. If the second attempt fails, or there is a clear indication that the control currently in use is faulty, the other control is brought into use immediately and kept in use continuously until the trouble is cleared. Whenever a second attempt is made an automatic record of the conditions ruling at the time is made for later inspection by the maintenance officer. This has proved to be an extremely valuable aid to fault diagnosis.

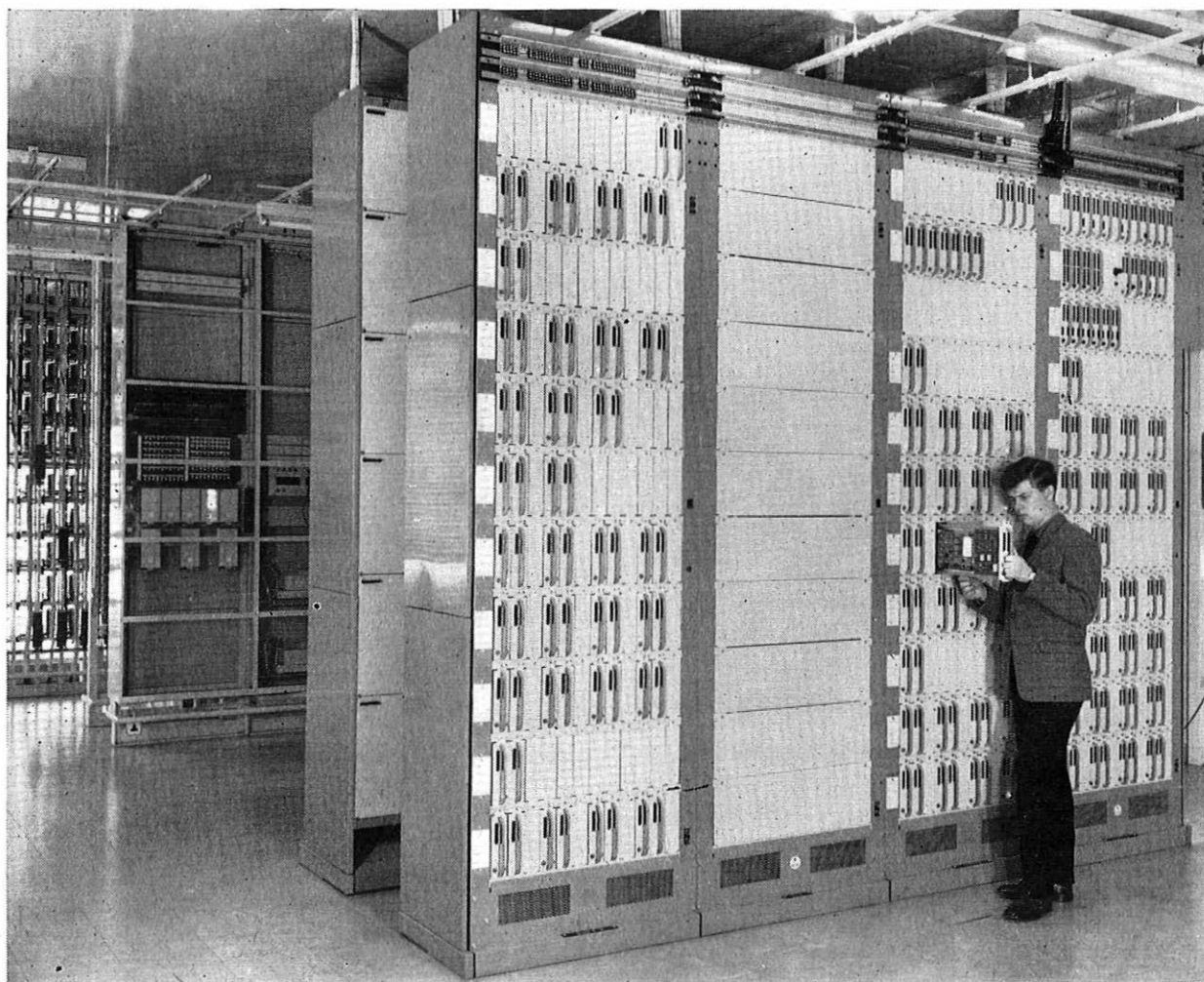

FIG. 2—AMBERGATE ELECTRONIC TELEPHONE EXCHANGE

### Switching Network

The basic switching network consists of several stages of reed-relay switches. Each stage is made up from multiples of a basic  $5 \times 5$  switching matrix (25 cross-points). Subscribers are connected to A switches and, thence, via B switches to outgoing supervisory circuits on C switches. Incoming calls are connected to D switches, which give each terminating supervisory circuit access to several C switches and, thence, via B and A switches to subscribers' lines. Thus, outgoing calls pass via three stages to reach an outgoing junction, incoming calls pass via four stages to reach subscribers' lines, and own-exchange calls pass via seven stages from subscriber to subscriber. The A, B and C switches carry traffic in both directions.

### Register Control

The TXE2 system is a register-controlled system, which means that calls originating or terminating must be connected to a register before any switching operations on the system can be effected.

The register behaves in some ways as would an operator on a manual exchange: when it is connected to a calling line it returns dial tone, inviting the caller to dial the wanted number. Numbers are detected and stored in the register until enough have been received to begin switching operations. Similarly, an incoming call also requires a register to process the numbers received over a junction. The inclusion of a register represents a basic departure from Strowger practice in non-director areas; it offers many advantages both in facilities, reliability and speed of operation. Its existence opens the way for the introduction of subscriber press-button telephones (kcyphones).

When a register has received enough information about a call it applies to the exchange control system for permission to operate on the network. When permission is given the register "talks" to the controls which carry out the necessary testing, switching and checking operations, and which finally release the register.

### Novel Features

The system has many novel features; among these the most interesting is perhaps the method by which new calls are detected and signalled to the control system for connexion. When a caller loops his line, his line relay operates and delivers a single brief pulse of current to a calling-number generator which is common to all lines. The generator produces the calling-line number in coded form and routes this to a free register via a by-path, i.e. the switching network is not yet involved in the call. The register responds by finding a free supervisory circuit, and, when this is found, signals are applied via the supervisory circuit to the associated C-switch terminals and, simultaneously, via a terminating marker to the calling subscriber's line. This marks the two end points on the system that have to be connected before dial tone can be given. The two end marks are caused to work their way through the switching stages concerned (C, B and A), and to indicate coincidence of free paths to a common switch-selector circuit, which chooses a free C, B, A path, if available, and connects the two marked points together. A somewhat similar sequence is followed for terminating calls.

Another novel feature of considerable operational value is the ability of the system to drop and re-connect calls during a pause between successive dialled digits.

This provides a discriminating facility: typically, it may be assumed that a new call will go to the parent exchange and the initial connexion will be to an outgoing parent supervisory circuit with access to the already allotted register. If, after one or, say, two digits, the assumption of a parent call is confirmed the register releases and the call continues as for an ordinary automatic-exchange to automatic-exchange call. If the call proves to be an own-exchange call the register is retained but the original set-up via the A, B and C switches is released, and the call re-set via a different path to pick-up a free own-exchange supervisory circuit with access to the same register. All this occurs between two successive dialled digits, and the subscriber is completely unaware of the operation. A similar re-set facility is available for calls routed direct to nearby exchanges.

The TXE2 system provides all of the standard facilities, and several new facilities both for subscribers' and operational purposes. These will be described in a later article in the series being published under the generic title "Electronic Telephone Exchanges."

### Space and Power Savings

The equipment (Fig. 2) itself occupies considerably less space than the corresponding Strowger equipment, but this saving is offset to some extent by other factors such as frames, power and common services which are similar to those used with the Strowger system. However, in the case of Ambergate the building, which is a standard H-type building and would normally contain Strowger equipment for 1,800 lines when fully occupied, could accommodate TXE2 equipment for 3,500 lines.

The power requirements are virtually standard, and the demand is the same as for equivalent Strowger equipment—if anything, the power demand is slightly smaller.

### CONCLUSIONS

The opening of Ambergate telephone exchange marks a significant step in the introduction of electronic techniques into the United Kingdom network. Post Office Regions may expect to receive TXE2 exchanges in increasing numbers over the next few years, and the increasing use of these exchanges will make a useful contribution to productivity in this field. Furthermore, several export orders have already been won, and the manufacturers regard the system as having valuable export potential.

### ACKNOWLEDGEMENTS

The efforts of the Joint Electronic Research Committee and, in particular, those engineers directly concerned in bringing the TXE2 system to its present stage of development are gratefully acknowledged.

### References

- <sup>1</sup>MATTHEWS, G. A., and HILLEN, C. F. J. A Small Electronic Exchange (PENTEX) for the British Post Office. Proceedings of the International Conference on Electronic Switching, Paris, 1966.
- <sup>2</sup>Developments in Exchange Equipment: Post Office Introduces Electronic and Crossbar Exchanges. *P.O.E.E.J.*, Vol. 59, p. 33, Apr. 1966.
- <sup>3</sup>HILLEN, C. F. J., LONG, R. C., and PORRITT, W. R. A. The Field Trial of Two Small Electronic Exchanges at Leamington and Peterborough. *P.O.E.E.J.*, Vol. 58, p. 1, Apr. 1965.
- <sup>4</sup>Reed Relays in the Small Electronic Exchange Systems at Leamington and Peterborough. *P.O.E.E.J.*, Vol. 58, p. 52, Apr. 1965.
- <sup>5</sup>FRENCH, J. A. T., and LOWE, W. T. Electronic Telephone Exchanges: Component Selection and Mode of Operation. (In this issue of the *P.O.E.E.J.*)

## Notes and Comments

**N. C. C. de Jong, B.Sc.(Eng.), C.Eng., A.M.I.C.E., M.I.E.E.**

Mr. N. C. C. de Jong was appointed Deputy Engineer-in-Chief on 12 September 1966. His new post arises from the creation of a second deputy to the Engineer-in-Chief and marks the greatly increased responsibilities of the Engineering Department in recent years in engineering management as well as technology. His appointment follows fairly soon after his promotion to Assistant Engineer-in-Chief, noted in this Journal in the January 1965 issue (Vol. 57, p. 277).



N. C. C. has packed a wide experience of people, jobs and places into the career which has taken him so far. After realizing a boyhood ambition to be a civil engineer and build bridges he was attracted by the traditions and wide range of interests of the Post Office Engineering Department, which he joined in 1934 as a Probationary Inspector. The range of jobs he has had since, both at home and overseas, and the variety of problems encountered have, he admits, more than satisfied even his restless nature.

He found increasing interest in field operations and the human problems associated with them, and left the Engineering Department in mid-career to seek managerial experience outside the sphere of engineering. He returned in two steps, first as a Regional Engineer and Telecommunications Controller, Northern Ireland, and in 1961 as Staff Engineer of the newly created Organization and Complements Branch of the Engineering Department. His responsibilities there included engineering organization and efficiency, and the engineering aspects of the use of computers. He lost no time in applying his field experience, which had convinced him that the need for improved management techniques and greater productivity was urgent. His energetic pursuit of these objectives led to the introduction of engineering Productivity Indices and was a major factor in the outstanding improvement so far achieved in engineering productivity.

In the last 2 years as Assistant Engineer-in-Chief his

responsibilities were widened to include the span of Cn, LLB, I, M, P and PE Branches of the Engineering Department. His chief interest continued to be in engineering organization, efficiency and service, particularly in installation and external work, but he has found time for several major reviews such as the motor-transport servicing organization, manufacturing policy in the Post Office factories, and the control of quality and reliability in equipment production. A special task has been the building-up of the postal-engineering effort needed to fully mechanize the 75 major sorting offices in this country by 1976.

He now moves to another sphere of duty which almost inevitably includes responsibility for engineering management services, engineering programs, performance, and service and postal engineering.

Finally a note on the man himself. His total lack of flamboyance and pretentiousness; his careful approach to problems and dislike of snap decisions; his even temperament and avoidance of oratory: these may disguise from those who do not know him well his continual search for better methods, the quality of his judgment, and the relentless persistence with which he pursues his goal. His many friends know he will serve us all well in the exciting years ahead and wish him success.

A.E.J.

**Retirement of Dr. G. H. Metson, M.C., D.Sc., Ph.D., M.Sc., B.Sc.(Eng.), C.Eng., F.I.E.E.**

In August 1966 Dr. G. H. Metson retired on health grounds from his position as Director of Research in the Post Office, following a distinguished and many-sided career as scientist, engineer, administrator and soldier.

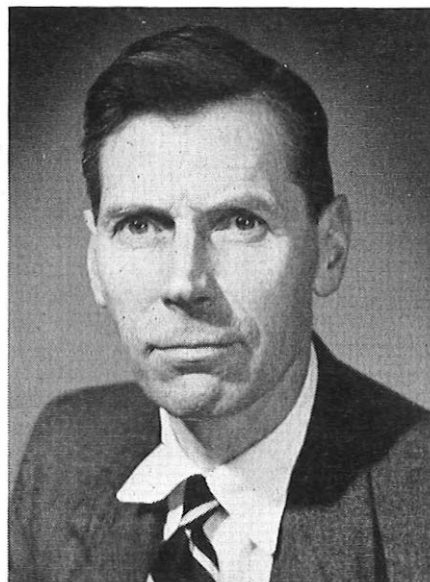

He joined the Research Station as a Youth-in-Training in 1925 and, whilst still a Skilled Workman, obtained a B.Sc.(Eng.) external degree and passed, in 1933, the examination for Probationary Assistant Engineer (old style). He was then posted to Northern Ireland, where

he continued his part-time studies at Queen's University, obtaining an M.Sc., and later a Ph.D., degree for research on magnetrons.

On the outbreak of war in 1939 he went to France as a Territorial with the Royal Corps of Signals, completing the first draft of his Ph.D. thesis during the "phoney" war, only to lose it at the evacuation from Dunkirk.

It is an indication of his outstanding personal qualities and especially of his courage and leadership that he was awarded in 1940 the Military Cross for gallantry. He later served with distinction in North Africa, Italy and India, attaining the rank of Lieutenant Colonel, after which he returned to the War Office as a General Staff Officer, Class 1.

After the end of the war his deep interest in science re-asserted itself, and he returned to Dollis Hill to work on thermionic valves of extremely high reliability for use in submarine-cable systems. His work in this field, and notably on the oxide-coated cathode, first as a Principal Scientific Officer and later as Senior Principal Scientific Officer, has been the subject of many Institution of Electrical Engineers papers—including the monumental 16-part study on "The Conductivity of Oxide Cathodes" which won him the Kelvin and Institution Premiums of that Institution. But his contributions have not only been on the scientific plane; they include also responsibility for the organization and operation of long-life valve production, and for overcoming the many practical and staffing problems that this entailed.

His work on long-life valves has had a marked effect on the practicability, reliability and economics of submarine-cable systems, and has been an invaluable contribution to inter-continental cable schemes such as TAT, CANTAT, SEACOM and COMPAC.

In 1956 he received "Special Merit" promotion to Deputy Chief Scientific Officer, and in 1958 was awarded a D.Sc. by Queen's University for his work on oxide-coated cathodes. He became Deputy Director of Research at Dollis Hill in 1962, and then Director in January 1965 on the retirement of Mr. R. J. Halsey.

His appointment as Director was warmly welcomed by his colleagues who knew they had as leader not only a man of sound technical judgment but one whose understanding of the human factors involved in staff management was profound and was coupled with wisdom and probity. Unhappily his tenure of office was curtailed by illness, which he bore with courage and fortitude. This circumstance has only to some extent been mitigated by the fact that he has accepted a part-time post as Consultant to the Research Branch. His sage advice will be valued in a wide range of topics, from reliability studies to the move of the Research Station to Martlesham. But even more, his colleagues welcome the return of a well-loved and deeply-respected member of the Dollis Hill team.

W.J.B.

**W. J. Bray, M.Sc.(Eng.), A.C.G.I., D.I.C., C.Eng., F.I.E.E.**

It is tradition and proven practice that the Director of Research is both a specialist in a particular field of communications science or engineering, an able administrator of a large complex of men and material, and a man with a firm grasp of the relevance of science or engineering to the services that the Post Office exists to provide.

John Bray, promoted to Director in September 1966

following the premature retirement of Gilbert Metson, is just such a man. His promotion gives great pleasure and satisfaction to those who, knowing him well over three decades or more, have seen these characteristics develop to the full with increasing seniority and responsibility.



His firm grasp of the "necessary," as opposed to the "possible" or the "nice to have," doubtless owes much to the hard school of H. M. Dockyard endeavour which was his starting point in electrical engineering. That inventiveness that has resulted in much of immense worth to the Department in the field of transmission, and radio transmission in particular, springs doubtless from the inspiration that he traces to the gifted teaching and leadership of Prof. Fortescue of Imperial College, where he graduated and did his first research as a post-graduate. And to his early task-masters in the Department, Gill, Radley, Mumford and Booth, he will doubtless attribute much of his—now—natural inclination to see all Research endeavour in the light of Departmental need and service. But to so attribute these qualities to others is to overlook the range and depth of John Bray's own personal contribution to Post Office engineering, and the resultant repute in which he is held at home and abroad.

On the relatively recent occasion of his promotion to Deputy Director of Research a close colleague spelt out his career at some length (*P.O.E.E.J.*, Vol. 58, p. 134, July 1965) and this need not be repeated here. Suffice to add that he assumes control of Research in the Post Office at a time when the challenges to, and opportunities for, invention can hardly ever have been greater. His colleagues have great confidence in his ability to meet the coming days, and wish him every success and happiness in their fulfilment.

J.H.H.M.

**H. B. Law, B.Sc.(Tech.), C.Eng., M.I.E.E.**

Mr. H. B. Law, who becomes the new Deputy Director of Research with responsibility for systems, brings to the post a wide experience of telecommunications engineering, a critical mind, and mature judgment. His appointment is generally recognized as an excellent choice: it is a

guarantee that the work of Research Branch will be pursued in a vigorous and progressive manner, and, above all, that it will be purposefully directed.



Mr. Law was born in Lancashire and received his professional education in Manchester. He joined the Department as Assistant Engineer (old style) by open competition in 1937, and was posted to the old Radio Branch at Dollis Hill. Here his name was associated with the development of stable crystal oscillators for applications ranging from frequency standards and carrier supplies to war-time navigational aids such as Gee and Oboe. Later, he represented this country at C.C.I.R. meetings on frequency standards, and was concerned with the establishment of the MSF standard-frequency service from Rugby radio station. His next foray, into the field of radio telegraphy, led to a number of papers before the Institution of Electrical Engineers and the award of the Kelvin Premium. His work showed how suitable techniques of reception and decoding could dramatically improve the performance of circuits disturbed by noise and fading.

Promoted to Assistant Staff Engineer in 1955, Mr. Law moved to RC Division of the Research Branch and carrier telephony. Here he sponsored a system with close-channel spacing for bandwidth conservation on submarine cables, and the use of companders to combat noise and crosstalk. On appointment to Staff Engineer in 1963 he returned to the radio fold for a short time in charge of RWS Division, before taking over the reorganization and expansion of RF Division to study "integrated" p.c.m. switching and transmission. After 3 years' preoccupation with the problems of electronic switching and digital logic, he leaves this field with an ambitious p.c.m. tandem-exchange experiment rapidly gathering momentum. His new post gives him the opportunity to gather up the many threads which have run through his professional career and weave them into the overall picture of an efficient and modern communication system.

Long residence in the South has not completely undermined Mr. Law's rugged constitution. When holiday times come round he spurns the *dolce far niente* of lesser breeds. For him it is likely to be camping, with his wife

and the remnants of a dispersing family, among the mountains and fjords of Norway. The absence of his mobile home-on-wheels from the Dollis Hill car park affords temporary relief to certain low-slung sports cars afflicted with persecution mania.

E.W.A.

**W. A. Humphries, T.D., C.Eng., M.I.E.E.**

It is with great pleasure that his many friends and colleagues learned of Mr. Humphries's appointment as Assistant Engineer-in-Chief.

Apart from an early period as a Youth-in-Training and Unestablished Skilled Workman in London his official career has been spent in the Engineer-in-Chief's office, where he has had a wide experience in the telephone-exchange field, covering development, planning and provision. Recently, as Staff Engineer of the Exchange Equipment and Accommodation Branch, much of his time and energy has been occupied both in stimulating the manufacturers to produce more exchange equipment, and in devising methods of channelling what was available to those areas which were feeling the greatest pressure from the upsurge in telephone traffic and demand. In this connexion he visited the U.S.A. to study the methods used in that country for equipment planning and provision.



Mr. Humphries's flair for concise expression and accuracy of detail was displayed during his years as Assistant Editor, and later Managing Editor, of this Journal, and few authors were permitted to depart from the high standards he set. During his period of office he was responsible for two special issues: those covering the Jubilee of the Institution of Post Office Electrical Engineers, and the laying of the first transatlantic telephone cable (TAT-1). He has also served on a joint C.C.I./I.E.C. Working Party of Graphical Symbols as representative of the C.C.I.T.T.

As a Territorial officer Mr. Humphries was called up for military service immediately before the outbreak of the last war. He served in various capacities and was Lines

Officer to the Chief Signals Officer, Lines of Communication, in Europe before returning to the Post Office.

In his younger days he was a keen footballer and represented the Civil Service in various athletic events, gaining a number of successes. Nowadays, like many of us, he has fallen for the attractions of motoring and other less energetic forms of recreation.

Mr. Humphries's courteous manner is backed by a strong personality and judgment based on a wide experience. His friends and colleagues offer him sincere congratulations and wish him well in his new appointment.

H.E.F.

#### **Retirement of Mr. H. Williams, A.C.G.I., C.Eng., F.I.E.E.**

Mr. H. Williams, Assistant Engineer-in-Chief, has retired after a long, varied and highly successful career in the Post Office Engineering Department.

He received his early training as an electrical engineer in H. M. Dockyard, Portsmouth, and in 1923 gained a Royal Scholarship to City and Guilds Engineering College, London University. He entered the Post Office as an Assistant Engineer (old style) in January 1926 and joined the Research Station at Dollis Hill. This early



work was on contact materials, spring-sets and magnetic-circuit design, leading to the design of the 3,000-type relay, which is still a Post Office standard. He was also concerned with studies of 2 v.f. signalling, and helped to lay the foundation for the introduction of this technique.

On promotion to Assistant Staff Engineer in 1938 he joined Lines Branch and began what was to become his life's work in the transmission field, including the development of carrier and coaxial-cable systems. By 1947 he had become Staff Engineer in charge of Lines Branch, and began that association with the work of the 3rd Study Group of the C.C.I.F., and later the 1st Study Group of the C.C.I.T.T., that has remained an important theme in his later career.

Then, after 15 years' absence, he returned to Research Branch in 1953 to take charge of RC Division in succession to Mr. R. J. Halsey, a post that involved the develop-

ment of negative-impedance repeaters, fundamental noise investigations and the development of short-distance carrier systems.

His promotion to Assistant Engineer-in-Chief in 1958 widened his field of responsibility to include LMD, LMP, Tg and Submarine Branches. Amongst his many duties was membership of the Editorial Board of the *Post Office Telecommunications Journal*, Chairmanship of the Joint C.C.I.R.-C.C.I.T.T. Study Group Special C on Circuit Noise, and Chairmanship of the Assistant Executive Engineer to Executive Engineer Promotion Board. His work for the Joint C.C.I.R.-C.C.I.T.T. Study Group is especially worthy of mention since, under his guidance, it prepared the way for internationally-agreed performance standards on a unified basis for coaxial-cable and radio-relay systems.

His quiet exterior conceals a very real ability to get to the heart of a problem and a certain determination to see it through to a successful conclusion. He has successfully commanded a "happy ship" and can look back with a sense of real fulfilment on the years he has spent in, and his achievements with, the Engineering Department.

Although he has retired from the Department, it is certain that Harold Williams's interest in telecommunications development remains undiminished, and it would not be surprising if he finds a further outlet for his energies in the near future.

W.J.B.

#### **H. Barker, B.Sc.(Eng.), C.Eng., M.I.E.E.**

Mr. H. Barker, who has succeeded Mr. H. Williams as Assistant Engineer-in-Chief, entered the Engineering Department in 1928 as Probationary Inspector in the Testing Branch.

After a period in the London Engineering District, the forerunner of the London Telecommunications Region, he was successful in the Probationary Assistant Engineer's



(old style) examination and was appointed to the Lines Section of the Engineer-in-Chief's Office where among other duties he was responsible for commissioning of early carrier systems. This was the period when the

cheap night trunk call was introduced and the demand for circuits almost doubled overnight.

In 1938 he was seconded to the Air Ministry to assist in the planning of a new communications system for the administration and operational control of the Royal Air Force. At the outbreak of war he was mobilized with the Royal Air Force Volunteer Reserve, and after a variety of duties at the Air Ministry he was appointed, in 1943, to the post of Deputy Chief Signals Officer, Second Tactical Air Force, and served in France and Germany until late in 1945.

Following demobilization, he returned to the Engineering Department, in the Subscribers' Apparatus and Miscellaneous Services Branch, until 1951 when he was seconded to the R.A.F. Fighter Command on special duties.

He returned to the Main Lines Branch in 1954, at a time of rapid expansion of the television network as a result of the setting up of the Independent Television Authority, which was followed later by an unprecedented upsurge in demand for trunk services. Thus, for the second time in his career he was faced with the problem of providing circuits faster than they had been provided in the past. That this was done is a matter of history. His appointment as Staff Engineer of the Main Lines Planning and Provision (LMP) Branch followed the decision to end the "Agreement" method of obtaining main-line plant, and, in its place, to introduce competitive purchasing arrangements. The ease with which this transition was made was due in no small measure to the far-sighted planning he initiated.

More recently he has been actively concerned with the extension of multi-channel working to shorter distances. He has been a proponent of small-tube coaxial-line systems, and in particular has played a notable part in introducing pulse-code modulation systems on junction routes.

He brings to his new appointment the energy and drive which he used to such good effect in LMP Branch. His wide experience, his energy and his resources will stand him in good stead, and his many friends both within and outside the Post Office will wish him well.

R.H.F.

**F. H. Reynolds, Ph.D., B.Sc.(Eng.), C.Eng., F.I.E.E., A.Inst.P.**

Dr. F. H. Reynolds was appointed Senior Principal Scientific Officer in the Active Devices Division of Research Branch in September, 1966. He entered the Post Office in 1940 as a Youth-in-Training and by 1946 had risen to Temporary Assistant Engineer (old style). During this early period of his career he studied at London University and obtained an honours degree in Electrical Engineering.

In 1946 he joined the Thermionics Group and so became one of the founder members of that organization. Shortly afterwards he transferred from the engineering to the scientific side of Research Branch with the rank of Scientific Officer. For the next 16 years the development of long-life valves for use in submerged repeaters became his main task. He played the major part in the design of the 10P-type valve now used in the Commonwealth submarine-cable system which stretches half-way round the world. The latest and most advanced type of submerged-repeater valve to be used in deep water also owes a great deal to design techniques he investigated on a prototype

at Dollis Hill in 1960 and 1961.

In addition to these vital development projects, Dr. Reynolds found scope for his scientific abilities by undertaking a program of research in thermionics, which culminated in the valuable exercise which gained him his Ph.D. in 1965. This work, on the influence of thin grid films on the characteristics of thermionic valves, proved to be of great importance in understanding some aspects of the physics of failure of these devices.

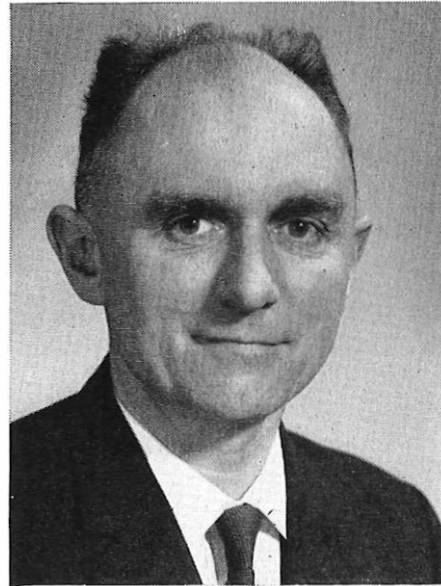

In the early years of the present decade it became clear that the transistor was going to take the place of the thermionic valve in submerged repeaters, and solid-state devices in general were going to be used in ever increasing numbers by the Post Office. For these reasons Dr. Reynolds transferred his interest to this new field of activity and was put in charge of a group engaged on the deposition of semiconducting films. This project could well lead to thin-film integrated circuits where the active device is produced by a technology compatible with the production of the passive components. The experience he gained here and in his earlier work will be of great value in Research Branch as increased emphasis is laid on the use of microcircuits in engineering applications.

His many friends will wish him every success in his new appointment.

M.F.H.

**C. A. May, M.A., C.Eng., M.I.E.E.**

Charles May, who was recently promoted Staff Engineer in charge of the Organization and Efficiency (Maintenance and Computers) Branch of the Engineering Department, entered the Post Office in January 1948 by Open Competition and was assigned to the Apparatus Group of Telephone Branch as a Probationary Engineer.

Prior to entering the Post Office he studied at Christ's College, Cambridge, receiving an honours degree in the Mechanical Sciences Tripos in 1944. During his Army career, Mr. May rose to the rank of Captain in the R.E.M.E. and saw service in India between 1944 and 1947.

He assimilated a valuable competence in many aspects of automatic telephony under Harold Corkett, and was



promoted to Senior Executive Engineer in Telephone Branch in January 1957. During the ensuing 4 years he was Post Office Liaison Officer for the original Highgate Wood electronic-exchange experiments, and was also an active member on the Subscribers' Apparatus Panel of the Joint Electronic Research Committee (J.E.R.C.). He assisted in the development of magnetic-drum register-translators, and was responsible for development work leading to the application of magnetic drums to metering subscribers' calls.



Upon the formation of the Telephone Electronic Exchange Systems Development Branch in October 1961, Mr. May was allotted one of the three prototype electronic-exchange projects—that for Leighton Buzzard, itself the prototype of TXE3—and put in charge of the electronics laboratory in Armour House. This experience fully qualified him for promotion in May 1963 to Assistant Staff Engineer in the developing computers section of the Organization (Efficiency) Branch.

Mr. May played a leading part in the successful installation of the Engineering Department computer (Elliott 503) in Gresham Street, with its attendant accommodation difficulties, staff recruitment and training; this computer provides the necessary services for other Branches. His responsibilities have included provision of consultancy services to other Post Office computer users, and the acceptance of LEO III and LEO 326 computers and their associated hardware and software. Neither the problems of simultaneous liaison with numerous manufacturers, the development of character-recognition, nor the loss, at one stage, of a large proportion of his best-qualified staff, deterred his zealous approach to work nor disturbed his equable nature.

Many readers of this and other technical journals will be familiar with published articles by Mr. May on electronic magnetic-drum metering and on the Highgate Wood exchange, and as many more will remember hearing his polished lectures on the functioning of data-processing equipment and of computer applications.

Charles May attended the Administrative Staff College

at Henley in the Spring of 1966, and, at 42, becomes the third youngest Staff Engineer in the history of the Engineering Department.

As well as continuing his involvement in staff-association matters since his early days in the Department, Mr. May has found opportunity for developing his interest in photography and music, when not absorbed with family pursuits in Surrey or in nomadic forays along the Côte d'Azur. His many friends in all Departments of the Post Office and in industry will join in wishing him well in his new appointment.

E.V.P.

#### **A. J. Barnard, C.Eng., M.I.E.E.**

Mr. A. J. Barnard, recently promoted Staff Engineer of the Exchange Equipment and Accommodation Branch, began his Post Office career in the Reading Telephone Area in 1937. After training in the provision and maintenance aspects of telephone exchanges, telegraphs and subscribers' apparatus, he spent some years on general maintenance duties. During this time he was loaned for a period to the Admiralty for work on radiographic examination of welded joints in ship construction.



Promotion to the rank of Inspector (old style) in 1945 brought him to London and started a long association with Telephone Branch, where he was employed, first, on work associated with d.c. pulsing systems and then on circuit design for automatic routers.

In 1948 he was successful in the limited competition for Executive Engineer and was promoted within Telephone Branch. He was still concerned with circuit design and his range included new service-observation equipment, 4-wire switching equipment associated with TAT-1 and for the inland trunk network, and register-translators and switching equipment for the Continental semi-automatic switching scheme.

In 1955 Mr. Barnard was promoted to Senior Executive Engineer and was responsible for much of the design and development of electronic and electromechanical controlling register-translators for S.T.D.

Further promotion took him to Dollis Hill in 1963,

and offered a brief association with electronic-exchange development. Links with the City were, however, strong and he returned the following year to the Exchange Equipment and Accommodation Branch, where, until his promotion to Staff Engineer in October of this year, he looked after planning, equipment standards and acceptance testing of telephone exchange systems.

For some years he has been an examiner in Telephony for the City and Guilds of London Institute, and several articles by him have appeared in this Journal. In his few leisure moments he is a keen exponent of the do-it-yourself crafts, whilst for complete relaxation he enjoys motoring on the Continent.

Quite imperturbable, Jim Barnard's methods are those of steady persistence and of winning his battles by good tactics rather than by spectacular charges. The many friends and colleagues whom he has quietly influenced during his Post Office career are glad to hear of his latest advancement and sincerely wish him continued success in the future.

J.S.

#### **W. T. Duerdoth, B.Sc.(Eng.), C.Eng., F.I.E.E.**

Mr. W. T. Duerdoth, who was recently the recipient of a Special Merit Award promotion to Staff Engineer, shares with one of his colleagues the distinction of being among the first engineers to benefit from the extension of these awards, previously confined to the scientific classes.

He was trained as an electrical power engineer at Faraday House, winning a Gold Medal and a London External B.Sc. degree. On joining the Department as Assistant Engineer (old style) in 1938 he started work in



Research Branch on voice-frequency signalling, but soon turned his attention to the design of submerged repeaters. During the design, building and installation of the first submerged repeater, laid in the Irish Sea in 1943, he learned a lot about the unreliability of capacitors. Another of his "babies" in the Lowestoft-Borkum cable has only recently been replaced. He went on to make a series of major contributions to the theory of negative-feedback

amplifiers, especially on the subject of multiple-feedback loops. Among other things, this work led to wideband high-power amplifiers, and an I.E.E. paper and the award of a Premium.

After producing repeaters for the first combined telephony and television coaxial-cable links to Holme Moss and Wenvoe, he turned to the new field of electronic switching, playing a large part in the Highgate Wood experimental electronic exchange. Something of a rebel in the then current atmosphere of analogue pulse-modulation techniques, he started thinking about digital systems. He put forward proposals for the combination of pulse-code-modulation transmission systems with digital electronic exchanges, which are now being energetically studied and are likely to be the cornerstone of future communication networks for the country. It is fortunate that his recent award enables his unrivalled experience, insight and skill to be retained in the service of this tremendous development, instead of being submerged in management problems (alias paper-pushing) which are so often the reward for promotion. He is the major architect of the experimental p.c.m. tandem exchange which is due to open with live traffic for a feasibility trial in West London at the beginning of 1968. His confidence in the future of digital systems is already being vindicated by the almost feverish plans now being put into operation for point-to-point p.c.m. transmission systems on junction cables, and by the developments in microelectronics technology which are making them economically attractive.

On the social side, Mr. Duerdoth has been Chairman of the Dollis Hill Branch of the Society of Post Office Engineers, and of the Research Branch Social Club. In the latter connexion he actually performed in one of the Christmas Pantomimes, but comments of this episode, very firmly, "never again." He used to do a lot of work for the Scout movement, but nowadays his leisure time is mainly taken up by family interests—and motor cars.  
E.W.A.

#### **D. L. Richards, B.Sc.(Eng.), F.S.S., C.Eng., M.I.E.E.**

When the Special Merit Award scheme for promotion of senior officers, which has been in operation for some time in the scientific Civil Service, was first extended to engineers, Mr. D. L. Richards was one of the two candidates from the Post Office, both of whom were successful. His promotion to Staff Engineer under this scheme recognizes his achievements and his international reputation in the field of telephone-transmission assessment, without side-tracking his energies on to tasks and duties which do not exploit his expert abilities and knowledge.

He entered the Department in 1935 as an open-competition Probationary Inspector with a sound professional training and a 1st Class Honours B.Sc.(Eng.) degree behind him. Posted to Research Branch, which he has made his home ever since, he worked on problems of noise on repeater-station and telephone-exchange power plant. This resulted in a number of published papers (fore-runners of an almost continuous stream from his prolific pen) and award of the Mather Premium.

Mr. Richards became a Probationary Engineer by Open Selection in 1942, and spent the next few years on work for the Services. In 1946 he started on the path which he was to make his speciality—telephone-transmission performance, subjective test methods and assess-

ment, and overall transmission planning of networks. Starting by assembling and appraising earlier work he laid the foundations for the "transmission performance" method of local planning. The subject grew with his career as he was promoted to Senior Executive Engineer in 1950, and to Assistant Staff Engineer in 1957, taking on an increasing international flavour. His work with the



C.C.I.F. (now C.C.I.T.T.) has been so extensive that "try Geneva" (or any of a range of major European cities) has become a very sensible suggestion when his own telephone remains unanswered. He played a very large part in the setting up of the C.C.I.F. Laboratory, initially in Paris and later in Geneva, and has been continuously active in helping to unravel the difficult problems, political as well as technical, of setting and maintaining standards which have made world-wide telephony practicable.

As standards of performance have advanced, mere loudness (or, more often faintness) as a measure of the

quality of a telephone connexion has been replaced by more and more sophisticated approaches involving the use of trained speech test crews (whose monotonous chanting of nonsense syllables fascinated a recent B.B.C. television producer), and the collection and analysis of opinions from ordinary telephone users. Experiments with live talkers consume very large amounts of time and money, and tend to produce results which are highly variable. All the resources of the science of statistics are needed to extract the last ounce of information, and Mr. Richards, with a long interest in the subject and a Fellowship of the Royal Statistical Society, is well able to exploit them.

For one with such an impeccable scientific approach to problems Mr. Richards has a blind spot: when the recent addition of a Triumph Spitfire to his fleet was mooted, the writer's suggestion that it should be a left-hand drive model so that he could pilot two at once was treated with undeserved contempt.

E.W.A.

#### Correction

It is regretted that an error occurred in the title of the article describing the Lincompex system which was published in the October 1966 issue of this Journal (Vol. 59, p. 163, Oct. 1966). The title should have been "The Lincompex System for the Improvement of H.F. Radio-Telephone Circuits."

#### Model Answer Books

Book of model answers are available for some subjects of the City and Guilds of London Institute examinations set for the Telecommunication Technicians' Course, and details of these books are given at the end of each Supplement to the Journal. These books include new model answer books for Radio and Line Transmission A and for Telephony and Telegraphy A.

#### Journal Binding

This issue completes Vol. 59, and readers wishing to have this volume bound should refer to page 310 for details. Readers should note, however, that, due to shortage of bookbinders in the London area who will undertake Journal work, there may be considerable delay before bound volumes are returned.

## Institution of Post Office Electrical Engineers

### Annual Awards for Associate Section Papers—Session 1965-66

The Judging Committee having adjudicated on the papers submitted by the Local Centre Committees, prizes and Institution certificates have been awarded to the following in respect of the papers named:

#### First Prize of £7 7s.

D. A. Spicer, Technical Officer, Tunbridge Wells Centre—  
"The Pressurization of the MU and CJ Cable Network."

#### Prizes of £4 4s. each.

H. F. Wood, Technical Officer, Lincoln Centre—  
"Modern Techniques of and Scientific Aids to Archaeological Research."

A. Webster, Technical Officer, Aberdeen Centre—  
"Carrier on Deloaded Audio Cable."

J. Fisher, Technical Officer, Colchester Centre—"A History of Mechanical Flight."

E. W. Scott, Technical Officer, Darlington Centre—  
"The Photo-Electric Cell."

The Council of the Institution is indebted to Messrs. A. J. Thompson, S. M. E. Rousell and W. G. Roberts of the London Telecommunications Region for kindly undertaking the adjudication of the papers. Brief reports on the prize-winning papers are as follows.

"The Pressurization of the MU and CJ Cable Network."  
By D. A. Spicer.

The paper indicates the personal association of the author with the subject. It deals with a topical subject and adequately covers the principles of the practical application of cable pressurization to cables in the author's area. It is a clear and logical exposition, and is well illustrated with diagrams. The subject was such as to maintain the interest of an audience, and this was aided by a demonstration of contactor operation under pressure-failure conditions.

*"Modern Techniques of and Scientific Aids to Archaeological Research."* By H. F. Wood.

Although outside the normal range of direct Post Office experience, this paper is extremely well written and includes information on the electrical and magnetic theories for locating and dating archaeological remains. The author maintained interest by dealing with local antiquities. The paper is comprehensive, and 52 slides were included when presented. This, coupled with the personal enthusiasm of the writer for his subject, no doubt maintained a very high degree of interest from audiences.

*"Carrier on Loaded Audio Cable."* By A. Webster.

This paper is on a topical subject and would interest a wide audience. It deals specifically with the application of "CODA" on a particular route and covers the ground satisfactorily. The paper could have been improved by a short historical approach, with references to other systems and to the relative performance and economics of these systems. The merit of the paper is in the interest it would arouse and the scope for discussion.

*"A History of Mechanical Flight."* By J. Fisher.

This paper has no telecommunication content but would obviously interest a wide audience from the members. The author is connected with a number of flying organizations, and, clearly, has a close personal knowledge of his subject. The presentation was in the form of an historical survey, and the treatment is such as to maintain the interest of a non-specialist audience.

*"The Photo-Electric Cell."* By E. W. Scott.

The author attempted a rather technical coverage of a good technical choice of paper. The merit of the paper would depend on the manner of presentation. There is evidence that a great deal of work has been involved in the collection of information, and the author includes a helpful bibliography, which is rather unusual in Associate Section

papers. The paper would have been enhanced by illustrations of the practical applications of photo-electric cells mentioned in the introduction to the paper.

S. WELCH,  
General Secretary.

#### Additions to the Library

Library requisition forms are available from Honorary Local Secretaries, from Associate Section Centre Secretaries and representatives, and from the Librarian, I.P.●.E.E., G.P.●., 2-12 Gresham Street, London, E.C.2.

2893 *Everyday Electronics*. T. Roddam (Brit. 1966).

An account of the electronic devices already playing a part in our lives—how they work rather than what wonderful things they do.

2894 *The Physics of Musical Sounds*. C. A. Taylor (Brit. 1965).

Intended for anyone who is fascinated by the relationship between physics and music—can be read by the less-mathematically-minded by omitting marked sections.

2895 *Colour TV Servicing Handbook, Vol. 1: Fundamental Principles*. W. Hartwick (Dutch 1965).

Describes the fundamental principles of colour-television techniques sufficiently for the subsequent understanding of receiver circuits.

2896 *U.H.F. Propagation*. H. R. Reed and C. M. Russell (Amer. 1966).

Presents current information on u.h.f. radio-wave propagation, and necessarily includes a review of all other related parameters of a u.h.f. communications system. It also shows how to determine operational ranges when using u.h.f. communications systems.

W. D. FLORENCE,  
Librarian.

## Book Review

"Electronics—A Bibliographical Guide, Vol. 2." C. R. Moore, B.Sc., and K. J. Spencer, F.L.A. Macdonald, Ltd. xvi + 369 pp. 85s.

The first volume of this work, which was reviewed on p. 112 of the July 1962 issue of this Journal, covered the period 1945 to June 1959. The present volume surveys the succeeding years 1959 to December 1964. The arrangement of this second volume follows broadly that of the original work and like the first volume has two main purposes. First it lists directly the major works in electronics literature: the authoritative text books, the survey articles, the reports on the main conventions and conferences, and a wealth of papers in which have been presented significant advances in the subject. Secondly, the aim has been to provide a means by which any paper in the vast field of electronics literature may be located.

The guide is divided into 70 sections. The first section is devoted to a list of reference works not included in the first volume. The remaining 69 sections are arranged in order of class number according to the U.D.C. and contain between them nearly 3,300 entries. Each section is devoted to a specialist field and comprises a list of all relevant bibliographies together with a selection of books and papers. Each entry gives the bibliographical details of the work cited, the total number of references cited in the work, and a brief annotation portraying its scope or, where the entry is one included for its bibliographical data, specifying the subject matter of the literature surveyed.

The guide provides an excellent starting point for those

who need to search the literature or prepare bibliographies in the field of electronics, and is worthy of a place on the shelves of every library covering this field.

The reception to the first volume of this work was so favourable that the publishers have felt justified in launching a series of similar guides in a variety of subjects.

D.C.G.

## Book Received

"Electrical Engineering Circuits." 2nd Edition. H. H. Skilling, Ph. D. John Wiley and Sons, Ltd. xv + 783 pp. 369 ill. 81s.

The first edition of "Electrical Engineering Circuits" appeared in 1957. In his preface to the second edition Professor Skilling says that, over the years, the publishers have forwarded to him suggestions and comments from users of that first edition, and these he has acted upon in preparing this new edition. In addition, he has considered it appropriate to expand two main areas: firstly, new material in the early chapters now introduces steady-state analysis of circuits to give greater generality, while, secondly, much of the latter part of the book has been rewritten to strengthen the treatment of Laplace analysis, including related theorems and proofs, convolution, and the impulse function.

Each chapter ends with a useful summary, which is immediately followed by a wide selection of problems, with associated section numbers to indicate how far the text should have been studied before any particular problem is tackled. There are 696 problems in all, and for a selection of these problems there are numerical answers at the end of the book.

## Regional Notes

### London Telecommunications Region

#### THE INTERNATIONAL SWITCHING CENTRE WOOD STREET

A large building to house the International Switching Centre is being erected for the External Telecommunications Executive on a site adjoining the Metropolitan/Monarch telephone exchange in Wood Street in the City of London. The building is being erected over part of Silver Street which has been closed as a public highway.

The main duct entry to Metropolitan/Monarch telephone exchange consisting of approximately 50 yards of a 30-way octagonal duct line fully occupied by cables, together with a large manhole in which the cables are turned, is situated under Silver Street (see the photograph).

It was found impossible to reconcile the building program with a program for new duct construction and a full-scale diversion of cables. The building was therefore erected over and around the duct line.

The total weight of cables, ducts and concrete surround is approximately 80 tons, and this has been supported on



a substantial timber structure carried on a pattern of 10 bored piles, each 30 ft in length and 2 ft in diameter, as shown in the photograph.

The building has been designed with an 8 ft wide by 10 ft high cable subway in the basement, and when construction reaches ground-floor level the ducts will be broken up and the cables transferred to wall bearers in the subway.

S. I. B.

### North Eastern Region

#### OPENING OF SHEFFIELD "CUTLER"

An account in the *P.O.E.E. Journal* of July 1927 records that at midnight on 5 March 1927 the Sheffield multi-exchange area was converted from manual to automatic working. Eleven manual exchanges were closed and nine automatic exchanges were brought into service. The total number of exchange lines transferred was 9,915 and the total multiple of the nine exchanges was 14,400 lines.

The heart of this Siemens No. 16 system was Sheffield Central Exchange in Telephone Buildings, West Street,

which continued to serve the area until 8.30 p.m. on 23 September, 1966, when a new local exchange, with a 12,400-line multiple and 9,628 working lines with subscriber trunk dialling (S.T.D.) facilities, was brought into service. The exchange building is shown in the photograph. Simultaneously a new junction tandem exchange and a new trunk automatic exchange were opened. There are 920 outgoing, 1,227 incoming, and 147 bothway trunk circuits connected

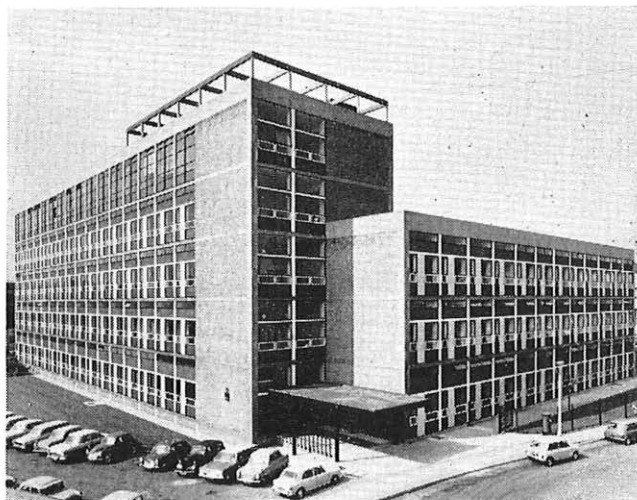

to the trunk exchange, and, in addition, 2,160 outgoing and 2,700 incoming junction circuits serve the junction tandem and the linked-numbering scheme. The S.T.D. equipment comprises three translators and 72 registers.

A new repeater station has also been installed, having four 16 supergroup terminal coaxial systems, two 60-circuit carrier systems, translation equipment, and transistor-type audio equipment.

The whole transfer was one of the largest undertaken in the provinces in recent years, the occasion being marked by a dinner given at a hotel nearby. This gathering included local dignitaries, the Director of the North Eastern Region, representatives of Associated Electrical Industries, the main equipment contractors, and the Telephone Manager's staff.

The Lord Mayor of Sheffield, Alderman Lionel Farris, gave the signal for the transfer to proceed by operating a stainless-steel change-over switch which had been specially made for the occasion. The Master Cutler, Sir Eric Mensforth, on completion of the transfer, made the inaugural call.

The engineering operations connected with the change-over were impressively displayed to the guests, and also to a gathering of staff in the Telephone Manager's Office, by closed-circuit television.

J. B.

### South Western Region

#### REMOVAL OF A WORKING MOBILE NON-DIRECTOR EXCHANGE AT FALMOUTH

Relief to Falmouth C.B. exchange became urgent in 1964, and, as the subscribers' line multiple could not be extended owing to the physical limitations of the manual positions, a mobile non-director exchange was provided to allow growth.

A site had been purchased for the future exchange, and the mobile non-director exchange was placed on this site in such a position that it would not interfere with the construction of the planned future building. On 8 April 1964

the mobile exchange was opened with a numbering range of 4,100-4,499. Fourteen junctions were provided to the Falmouth C.B. exchange and four to Truro non-director exchange to allow dialling access to the local automatic exchange network.

As amendments were made to the plans of the new building it became apparent that the mobile non-director exchange would have to be moved to allow the building to proceed. The move was to a new site 15 yards away but on made-up ground about 7 ft higher - a formidable task for the 8-ton top-heavy vehicle. Arrangements were made with the on-site building contractor to build a ramp of about 1 in 10 so that the mobile exchange could be drawn forwards for about 20 yards and then backwards up the ramp to its new position.

Before the move a footway box had to be built and four 100-pair polythene cables of sufficient length to allow the move were jointed in. The batteries inside the exchange were very securely fixed with battens. The vehicle has a rather high centre of gravity, and as the ramp could not be made perfectly, the fan was removed from one end of the exchange and the window from the other. Then, with the use of heavy battens inside the exchange and a rope held at each end by a 5-man gang, the top of the vehicle could be steadied during the move.

The emergency subscribers were diverted at the manual exchange via change-over keys so that in the event of an accident they could be switched to the manual exchange switchroom, thus safeguarding service.

The removal was planned for Sunday, 11 September 1966, at 7.30 a.m. As many relay-sets and switches as could be spared were removed to lighten the load and to lower the vehicle's centre of gravity. The electricity supply was then disconnected and the move was completed in about an hour with little trouble. A long wooden shaft was bolted to the tow bar to allow easy hand steering.

During the move retying of ropes was necessary, and an opportunity was taken to enter the exchange while canted at an extreme angle. Calls were proceeding quite satisfactorily, and it was surprising the number of calls being made at this early hour.

As soon as the vehicle was in its permanent position the removed switches and relay-sets were jacked in, restoring a full grade of service by about 10 a.m. The window and fan were then replaced, and as the morning was very damp and grey with mist, a temporary electricity supply connected so that the exchange could be dried out.

All subscribers were warned during the previous week of possible interruption to service, but in the event there were no faults, no interruption to service and no complaint from any customer.

G. A. T. L.

#### Scotland

#### ORKNEY CABLE RECOVERIES

External construction staff in the Orkneys recently pressed a veterinary instrument known as a "cattle dishorner" into the service of the Post Office. Mounted on a small bogie it was used to cut-up some 200 tons of lead-covered cable of diameters varying from 1½ in. to 2 in. The cable was first passed through the jaws of the instrument, the two lever handles brought together and the rack-operated guillotine cut through the cable like butter. The bogie was then

pulled along the cable a distance of 6 ft and the operation repeated. The device simplified and speeded-up the whole operation tremendously. The cable in question, which was part of the vast network laid down during the war linking up the multitude of defence points surrounding the naval anchorage at Scapa Flow, had become spare and was a maintenance liability. Many who worked in Orkney during the war will remember, perhaps with nostalgia, the famous Eastabout and Westabout ring cables.

Although a standard pneumatic cable guillotine is available, it is only possible to get it on loan for very short periods as there is a heavy demand for the only one available in the Region. The alternative, until the advent of the dishorner, was the extreme drudgery of chopping-up the cable with an axe. Furthermore, the apparatus associated with the pneumatic cable guillotine is heavy and clumsy to use, particularly when the cable route leaves the roadway. The dishorner, costing about £14 against approximately £200 for the guillotine, also is less tiring for the operator.

D. McD.

#### Northern Ireland

#### RECORDING OF INEFFECTIVE CALLS MADE TO ENGAGED LINES

Ineffective calls to engaged lines have been estimated to provide 15 per cent of the total traffic in a telephone exchange. In an effort to reduce this wasteful use of line plant and exchange equipment, an investigation of the method of identifying potentially busy lines and counting the ineffective calls made to them whilst they are engaged, is in progress in this Directorate. It is intended that the results obtained will be used to provide busy customers with tangible evidence of the need for an increase in their total exchange lines, where this is considered appropriate.

The apparatus employed is the transportable route-calls recorder with minor modifications. It can be used to explore for potentially busy lines in a 100-line or 200-line final-selector group, either ordinary or 2/10 P.B.X. lines, or to count the ineffective calls made to up to 10 lines in each final-selector group. When exploring for busy lines, normally 50 lines at a time can be checked in each group, but this total can be increased to 100 or 200 lines with the proviso that a further selection will be required to obtain results for individual lines, since only 50 meters are available, unless local knowledge of the lines involved makes this unnecessary. During this phase, both effective and ineffective calls made to the lines are registered. Lines showing totals above average can then be connected to count only the ineffective calls made to them. P.B.X. groups with up to 10 lines can also be connected to register ineffective calls only when all the lines to the P.B.X. group are engaged. The recorder is associated with the final selectors by means of plugs and cords, and up to 20 final selectors in a group can be associated.

The recorder, which has 20 tapping circuits, can deal with only one call at a time. However, in practice it has been found that this gives a satisfactory sample as the last two digits only of the customer's number are received before registration and release of the equipment. In addition, when used for counting ineffective calls it has been arranged that the recorder operates only when one or more of the observed lines becomes engaged.

E. H. McD. and R. E. B.

## Associate Section Notes

### Bath Centre

On 20 July, a party of 30 visited the Royal Armoured Corps Museum at Bovington Camp, Dorset. Members spent an interesting hour or two looking over tanks and armoured cars of various nationalities and ages.

On 14 September, a lecture was given by two of our members, Mr. R. E. Woolford and Mr. R. M. Cohe on "Cacti and other Succulents." This was beautifully illustrated by coloured transparencies of plants which they had reared. The meeting was poorly attended but thoroughly enjoyed by those who did come.

On 12 October, a lecture on "Deer and Other Wild Life," in particular, at the Cranbourne Chase, was given by Mr. Richard Prior, game warden. Mr. Prior is employed by the Forestry Commission to study deer and to reconcile as far as possible the need to allow the existence of deer with the damage done to young, planted trees.

Members were interested to hear of the large numbers of deer of different species living in the wild state and the widespread area covered throughout the United Kingdom.

W. J. R.

### Bournemouth Centre

Twenty-seven members of the Bournemouth Associate Section visited Vauxhall Motors recently. We were very cordially received by Vauxhall's, given refreshments before and after our tour and a very good lunch between visits to different factory buildings. On a conducted tour we saw the car engines being built; after lunch we saw the engines and all the other parts put together to make a car. We were greatly impressed by the computer system which ensured that, as the car being built passed along the production line, the various parts for it arrived at the right place and time to be built into it. This was the more impressive as very seldom were two cars of the same type following one another along the line.

The workers at no time seemed to be in a hurry yet production went on smoothly. At the end of the line some 2½ hours later we were told we had walked about 4½ miles, all of it of great interest to us.

After tea and biscuits we were returned to our coach, having enjoyed a most instructive tour of the works—for which our many thanks go to Vauxhall Motors.

T. G.

### Barnstaple Centre

The winter program of the Barnstaple Centre started, on 25 October, with a visit to the Central Electricity Authority Power Station at Yelland and was followed on 15 November with a film show by I.C.T. called the "Computer Challenge." The program continues as follows: 10 January: "Search and Rescue by Helicopter," by Master-Sergeant Gibson, R.A.F., Chivenor; 2 February: "The Introduction of Cross-Bar Exchanges into the Post Office Network"; 15 February: "Let's Take Up Colour," by Kodak.

The last two papers will be heard at Exeter at the invitation of the Exeter Centre.

F. D. C.

### Salisbury Centre

The main interest during the past 6 months has been centred on two tours.

On 11 August a party of 30 members of this centre were guests of Vauxhall Motors at Luton for a whole day's tour of the main car plant. During the tour we were shown all the different departments including the assembly line from start to finish, where a gallon of petrol was put into the tank and the car was driven off the assembly line. We were entertained to an excellent lunch and tea in the visitors'

restaurant. The members were unanimous in voting this trip a very worthwhile day's leave.

Two parties were shown over a local weekly newspaper works, and saw and had explained all the various departments needed before a newspaper can be "put to bed." A very interesting evening.

R. H.

### London Centre

Our third annual conference was held on 25 May at the Institution of Electrical Engineers. It was presided over by the Associate Section President, Mr. E. Hoare, with Mr. A. G. Welling in the Chair.

Mr. Hoare presented the inter-area Quiz Trophy to the winning team from South-West Area and the runners-up shield to West Area. Mr. Hoare then presented the C. W. Brown Award to Mr. N. V. Clark of North-West Area together with a cheque for 2 guineas. Special C. W. Brown Awards were also presented to Mr. H. A. Horwood and Mr. B. C. Hatch, two of our oldest members who were shortly to retire. In addition, each was presented with a small gift from the Committee for their past work in London Centre.

Membership continues to fluctuate due to promotions and new entrants, but at present we have just over 6,000 members. After a break during the summer months the 1966-67 session opened on 27 September with a talk on "Telecommunications in the U.S.S.R.," by Mr. S. C. Rosser of the Post Office Engineering Union. During his talk Mr. Rosser showed some very good colour slides of his trip.

Visits have been made to Shell Haven and Plessey Electronics at Havant. Both proved very interesting to our members and the hospitality was first class. Future visits have been arranged to Dimplex at Southampton and the Rank factory at Welwyn Garden City.

Our October lecture on "The Marconi Radio Telegraph" was given by Mr. B. W. Bardwell of Marconi Co., Ltd., Radio Division, assisted by Mr. Farley. Mr. Bardwell outlined the range of Marconi self-tuning h.f. equipment, commenting on the basic features, efficiency and economics of the system. After the talk we were shown a film of the Marconi range of transmitters, receivers, and telephone and telegraph terminal equipments operating as a system. The questions afterwards showed how interesting the evening had been to the small number of members present. After a lapse of 2 years or so we have at last managed to find an Editor (Mr. B. E. Bolton), and October saw the re-birth of the London Centre Quarterly Journal. This is a much needed item of publicity for the Associate Section as well as giving information on matters of general interest to members. Whilst there are teething troubles first impressions have, in general, been satisfactory. Articles for publication will always be welcomed by the Editor, as there is nothing like variety to keep a project of this sort going.

The annual quiz between London Telecommunications Region and Home Counties Region took place on 15 November. This year London were the hosts, and during the afternoon the visiting team and their supporters were divided into three parties and taken on visits to the Post Office Tower, Fleet Building (Telex) and the Circuit Laboratory. After these visits the teams and supporters, along with the quiz officials, had tea in Fleet Building dining club. Our thanks to the club manager for an excellent meal. The evening proved very interesting and despite the severity of some of the questions Canterbury were worthy winners by 46 points to 35½.

The Canterbury team was Messrs. H. N. Sturt (Capt.), K. Hounsell, J. Schuman, E. Ralph, C. Sheather and M. Butcher. The London Centre team was Messrs. R. Hammond (Capt.), S. V. Cook, K. Monahan, M. A.

Everett, J. T. Featherstone and J. Green. At the end of "Question Time" the Captain of the Canterbury team was presented with the trophy by the Associate Section President, Mr. E. Hoare.

We wish to thank our question master, Mr. E. Hoare, the adjudicators, Mr. F. C. G. Greening and Mr. A. Bluring, the scorer, Mr. F. Wilson, and the timekeeper, Mr. G. Hitchman, for giving up their time for this event. We would also like to thank the other members of the Senior Section who were present for their support.

Although we did not do so well this year the new session has started and by the time these notes are read the first round of the inter-area quiz will be well under way. Who will represent London next year?

R. M. H.

#### Exeter Centre

At the annual general meeting held in April the following officers and committee were elected: *President*: Mr. E. H. K. Brown; *Chairman*: Mr. R. Powlesland; *Vice Chairman*: Mr. P. C. James; *Hon. Treasurer*: Mr. C. A. E. Chandler; *Hon. Secretary*: Mr. T. F. Kinnaird; *Hon. Assist. Secretary*: Mr. M. J. Saunders; *Librarians*: Messrs. J. Curwood and N. H. B. West; *Auditors*: Messrs. G. E. Hall and D. J. Hitchcock. *Committee*: Messrs. O. N. Elliott, B. J. Rolston, G. A. B. Sealey, J. L. Summers and A. G. Williams.

The election of the new librarians was caused by the promotion of Mr. W. R. Coles to A.E.E. We are all very grateful for the work he has done as librarian in organizing and maintaining magazine circulation since the re-formation of the Centre, and we wish him every success for the future.

The summer session started with a visit to Wiggins Teape Paper Mills at Hele on 17 May. With the exception of the laboratories the tour included the whole of the factory and afforded us the opportunity of seeing how the use of a one-manpower "Paper Engine" made the difference between an £8,000 batch of perfect paper and a comparatively worthless pile of waste. At the other end of the production line the nimble fingers of the quality checkers and the ability of the semi-automatic guillotines was quite fascinating.

On the 13 June we visited the Tiverton factory of John Heathcoate (Textiles), Ltd. The factory is on the site of a disused wool factory which became vacant in the late 19th century when John Heathcoate "emigrated" to the south after his battle in the north with the Luddites. In the weaving sheds the noise from the machines makes lip reading an essential part of the job; it was obvious that the temporary deafness of the weavers did not prevent them from holding normal conversation. Without doubt the most fascinating part of the visit was the opportunity to see the very fine silk lace (net) which was being made on machines identical in design to the original John Heathcoate patent. This factory is the only one in the Heathcoate group which makes the silk lace. Doubtless we shall be making another visit to this factory in the future.

The final event was a visit to Fry's of Sommerdale. Some 30 members and their ladies made an early start to reach Sommerdale by 10.30 a.m. However, the tour was interesting and well worth the trip.

The party split up after the visit; some spent the afternoon visiting the Severn Bridge which (being mid-week) was comparatively deserted.

The winter program started as follows: 18 October: "Tombs and Pyramids of Ancient Egypt," by Mr. G. F. Cload; 9 December: "Quiz," return match between Exeter and Torquay.

The rest of the program is as follows: 10 January: "Grid Developments in the South West," by Mr. C. L. Chalk; 2 February: "The Introduction of Crossbar Exchanges into the Post Office Network"; 15 February: "Let's Take Up Colour," by Kodak, Ltd.

The Centre continues to flourish with events well attended. It is disappointing, however, that the Centre has not in-

creased its membership of late. Perhaps members could make an effort to rectify this; it should be easy to raise the present figure of 250 to 300.

T. F. K.

#### Bedford Centre

During the 1965-66 session we lost several of our members due to promotion to A.E.E. Among them was Mr. D. A. Crampton, who worked very hard for the Centre for almost two years as Chairman. Our membership now stands at 146.

The third annual general meeting was held on Tuesday, 4 October, and the following officers and committee were elected: *Chairman*: Mr. H. A. Fletcher; *Secretary*: Mr. E. W. H. Philcox; *Assistant Secretary and Librarian*: Mr. D. Green; *Treasurer*: Mr. L. W. Dodd; *Committee*: Messrs. R. G. Prignore, A. T. Mills, E. G. Pilgrim, C. T. Barnard, I. Harris and D. J. Ellis.

Although no set program has been drawn up as yet for the coming session, it is hoped to include some lectures designed to attract a larger proportion of our membership. Attendances have declined considerably of late.

Bedford Centre extends its best wishes to all Centres for 1966-67.

E. W. H. P.

#### Ipswich Centre

Our summer program got off to a good start in May with a visit to the Suffolk and Ipswich fire service where, after a film and talk, we were able to see the latest equipment used in fire-fighting.

In July a party of our members visited the motor works of Vauxhall Motors, Ltd., at Luton. The visit was of about 5 hours' duration, most of which was spent on the production line seeing the manufacture of the present range of Vauxhall cars.

Our next visit was to the Nuclear Power Station at Sizewell, where we saw one of the most modern power stations of its type in the country. It is the first time we have visited an operational nuclear power station, and great interest was stimulated.

The August outing took the form of a treasure hunt which was held in the evening, over a route lasting approximately 2½ hours. This has always proved popular with our Centre and, thus, we received good support, although darkness caught up with many of the competitors before completion of the course!

In September, we were guests of the Brooke Marine Shipyards, Lowestoft, for an afternoon, where we saw a small but very compact industry which sells its products to all countries of the world. We were able to see the construction of ships, large and small, and were surprised to find that in addition to this the firm completely fitted out each ship from wardrobe to radio directional aids.

Our summer program concluded in October with a visit to the B.B.C. Centre, Shepherds Bush, by a small party of our members. We have made several visits to the B.B.C. in the past years, and their popularity seems to increase every year.

R. L. B.

#### Bradford Centre

At the annual general meeting, held on 24 May, the following officers and committee members were elected: *Chairman*: Mr. E. Dennison; *Secretary*: Mr. G. Harrison; *Assistant Secretary*: Mr. V. J. Jocelyn; *Treasurer*: Mr. D. P. Killeen; *Librarian*: Mr. D. Relton; *Committee*: Messrs. G. Brown, S. Bulman, M. Firth, M. Galloway, H. Lancaster and J. Wharton.

On 22 September a party of 26 members visited the Swinton Works of Messrs. Chloride Batteries, Ltd., where a variety of secondary cells are manufactured. During the current session visits will also be made to Websters Brewery,



Halifax; Butterfield Ltd., engineers, Shipley; Mackintosh, Ltd., toffee works, Halifax; Wharfedale Wireless Co.; and the Ford Motor Co., at Hailwood.

Mr. R. C. Siddle has offered to tell us about his recent visit to Sweden, and Mr. A. Lemm will talk about "Mountaineering."

Our congratulations are extended to Mr. Siddle and to Mr. Grunwell upon their recent promotion, along with our thanks for their valued services as Secretary and Assistant Secretary, respectively, of the Bradford Centre.

G. H.

#### Aberdeen Centre

The opening meeting of our 1966-67 session was held on the 29 September. The evening was devoted to a quiz with the Inverness Centre. Broadcast lines connected Aberdeen, Huntly, Inverness, Wick and Kirkwall together for a very exciting contest which was won by the Inverness Centre, reversing the result of 2 years ago. The questions, which were prepared by the Regional Training School, Edinburgh, were a "mixed bag" and extremely suitable for this type of meeting.

On Wednesday, 5 October, a party of 18 members visited two factories in Dundee. In the morning the party were conducted through Ferranti, Ltd., where they were shown the manufacturing process of high-temperature valves, T.R. cells, microwave filters and circulators, plug and socket connexions, and the uses of ceramic material in microwaves. In the afternoon the party toured the machining factory of National Cash Register Co., Ltd. This factory produces 8 million parts a month for the other four N.C.R. factories in Dundee. Parts produced varied from small nuts  $\frac{1}{8}$  in. square, key levers and shafts to cash register casings. As is usual on such occasions, time was all too short.

At the second meeting of our program a talk was given by one of our members on "Network Analysis." The speaker explained the techniques of network analysis and concentrated on those aspects met with in our day-to-day work. The talk was broadcast to Huntly and Inverness.

R. M.

#### Ayr Centre

In April a group of our members attended a lecture organized by the Institute of Electrical and Electronics Technician Engineers which was held in the University of Strathclyde. The lecture, "The Future of Telecommunications," was given by Mr. D. A. Barron, our Engineer-in-Chief, and was very well received by the large audience present. In May a visit was made to Hunterston nuclear power generating station. Each of the two reactors in the station provide the motive power for three 60 megawatt turbine sets giving a total station output of 360 megawatts. It was noted with interest that it had not yet been necessary to replace the uranium rods originally installed in the reactors at the opening of the station in 1964.

At the annual meeting in June Mr. R. Clanahan was elected to the Committee to replace Mr. J. Scott who was recently promoted. The opportunity is taken to thank Mr. Scott for his past services and to wish him every success in his new post. A very full program has been arranged for the 1966-67 session and it is hoped that it will be found acceptable by our members.

A. B.

#### Dundee Centre

The start to our season's activities was somewhat saddened by the death of one of our most staunch members, Mr. J. H. Marshall. Howard had been a Committee member off and on for many years and was a regular attender at meetings—he will be sadly missed.

So far the program for the 1966-67 session has been as follows. 4 October: "Miscellany: S.A.L.T., L.L.I.R., 2-Wire Amplifiers, and Trunk Traffic Analysis," by Messrs. I. M. F. Smith, E. Ruse and G. Deuchars; 7 November:

Visit to Carolina Port Power Station; 13 December: film show "Forth Road Bridge" and "Heather Honey" by Mr. M. Williamson.

The rest of the program is as follows: 17 January: "The Computer," by Dr. J. M. Rushforth; 15 February: Visit to Seafeld Colliery, Kirkcaldy; 7 March: "Postal Mechanization," by Mr. W. Muir, Edinburgh; 7 April: Visit to S. T. & C. (Crossbar Switching Division), East Kilbride; April: annual general meeting.

The remainder should prove as interesting as the completed part, and it is hoped members will give it their support. The first item in the program "Miscellany" was included in order to encourage the younger members of the Centre to give talks. The result was very successful and did not appear to put any strain on the members concerned.

R. T. L.

#### Edinburgh Centre

The 1966-67 session commenced in October with a visit to Calton Hill Observatory. Unfortunately, due to bad weather it was not possible to observe the heavens. In spite of this a very interesting evening was had by the 18 members who braved the elements. Mr. Mathews, the director of the observatory, gave an enlightening talk on the results of the space programs of both America and Russia in the exploration of the surfaces of the Moon and Mars. He spoke about, and gave his personal views on, many recent theories.

We were sorry to lose the services of our Chairman, Mr. R. P. Donaldson, who was recently promoted Assistant Executive Engineer at the Regional Training School, Edinburgh. We would like to record our thanks for his past work in the Edinburgh Centre and wish him all the best for the future.

There has been a considerable increase in membership this year and the committee hopes that new members will join with the regulars in giving their support to what should prove to be a very interesting program.

J. A. C.

#### Inverness Centre

The Centre completed a most successful year with the annual general meeting on 28 April. Office bearers were elected as follows: *President*: Mr. J. J. Loughlin; *Chairman*: Mr. J. W. Innes; *Vice-Chairman*: Mr. B. W. Fieldsend; *Secretary*: Mr. W. Catto; *Treasurer*: Mr. D. Neave; *Committee*: Messrs. J. Eddie, A. R. Hutcheson, E. J. MacLay, F. MacInnes, R. R. Russell and R. I. Thompson.

Many suggestions were put forward for the 1966-67 program, which included an evening visit to the new gas installation in Inverness and a day visit to the new pulp-mill project at Fort William: both visits have since been arranged. After the business of the meeting was concluded, members sat down to an enjoyable meal in the canteen. This was followed by several short films of both local and technical interest.

In August we lost the services of our most efficient Secretary, Mr. W. Catto, when he was promoted to A.E.E. Mr. Catto had held the post of Secretary since the Centre was formed 3 years ago and had put in many hours of work to establish the Centre on its now firm foundation. We wish him every success in the future. Mr. A. R. Hutcheson agreed to act as Secretary for the rest of the session.

The new session opened on the 29 September in the games room, Friars Lane. A quiz was arranged with our neighbouring Centre, Aberdeen, on a friendly basis. The quizmasters for the evening were Mr. M. W. J. Allan in Inverness and Mr. J. H. W. Sharp in Aberdeen who kept a sharp though often jocular control on the proceedings. Inverness gained a narrow victory with a final score of 27½ points to Aberdeen's 26 which reversed the result of 2 years ago. The questions were set by the Regional Training School in Edinburgh to whom we would like to extend our thanks.

A. R. H.

# Staff Changes

## Promotions

Name	Region, etc	Date	Name	Region, etc.	Date
<i>Assistant Engineer-in-Chief to Deputy Engineer-in-Chief</i>			<i>Executive Engineer to Senior Executive Engineer—continued</i>		
de Jong, N. C. C.	E.-in-C.O.	23.8.66	Bishop, K. G. T.	E.-in-C.O.	20.9.66
<i>Deputy Director of Research to Director of Research</i>			Smith, N. G.	E.-in-C.O.	20.9.66
Bray, W. J.	E.-in-C.O.	23.8.66	Jefferis, A. K.	E.-in-C.O.	20.9.66
<i>Staff Engineer to Assistant Engineer-in-Chief</i>			Brown, R. J.	E.-in-C.O.	20.9.66
Humphries, W. A.	E.-in-C.O.	26.9.66	Whittington, K. W. H.	E.-in-C.O.	9.9.66
Barker, H.	E.-in-C.O.	28.10.66	Hogben, C. W.	E.-in-C.O.	26.9.66
<i>Staff Engineer to Deputy Director of Research</i>			Hunt, D. C.	E.-in-C.O.	20.9.66
Law, H. B.	E.-in-C.O.	12.9.66	Taylor, F. J. W.	E.-in-C.O. to N.E. Reg.	10.10.66
<i>Regional Engineer to Chief Regional Engineer</i>			Wood, R. A.	E.-in-C.O.	3.10.66
Rees, T. J.	L.T. Reg.	18.7.66	Godfrey, S. W.	L.P. Reg. to Mid. Reg.	3.10.66
<i>Assistant Staff Engineer to Staff Engineer</i>			Dell, F. R. E.	C.E.S.D.	3.10.66
Ducrdoth, W. T.	E.-in-C.O.	1.7.66	Sheldon, W.	Scot.	31.10.66
Richards, D. L.	E.-in-C.O.	1.7.66	Preston, A. G.	E.-in-C.O.	17.10.66
Barnard, A. J.	E.-in-C.O.	7.10.66	Fidler, R. G.	E.-in-C.O.	17.10.66
May, C. A.	E.-in-C.O.	17.10.66	Thomas, E. A.	E.-in-C.O.	28.10.66
<i>Senior Executive Engineer to Assistant Staff Engineer</i>			Redhouse, A. R.	E.-in-C.O.	28.10.66
Chilver, L. W. J.	E.-in-C.O.	1.7.66	Miller, C. B.	E.-in-C.O.	28.10.66
<i>Area Engineer to Regional Engineer</i>			<i>Executive Engineer (Open Competition)</i>		
Kent, S. T. E.	H.C. Reg.	5.10.66	Brookfield, J. J.	E.-in-C.O.	4.7.66
<i>Area Engineer to Deputy Telephone Manager</i>			Gargan, J.	E.-in-C.O.	22.8.66
McMillan, F. N.	Scot. to Mid. Reg.	11.7.66	Knowles, D.	E.-in-C.O. to N.W. Reg.	1.8.66
<i>Executive Engineer to Area Engineer</i>			Johnson, P. L.	E.-in-C.O.	10.8.66
Roach, J. D.	W.B.C. to Mid. Reg.	18.7.66	Taylor, M. G. C.	E.-in-C.O.	26.8.66
Woods, A. S.	N.W. Reg. to W.B.C.	11.7.66	Thomas, J. R.	E.-in-C.O.	1.9.66
Pikett, C. C.	Mid. Reg.	4.7.66	Cleaver, M. R.	E.-in-C.O.	1.9.66
Price, A. H.	L.T. Reg.	19.7.66	Rowlands, C. E.	E.-in-C.O.	1.9.66
Moffatt, J. J.	L.T. Reg.	24.8.66	Daniel, R.	E.-in-C.O.	5.9.66
Smith, D. J.	L.T. Reg.	24.8.66	Benton, R. H.	E.-in-C.O.	8.9.66
Hands, D. C.	Mid. Reg.	20.9.66	Powell, R. W.	E.-in-C.O.	29.3.66
Leask, D. R.	Scot.	20.9.66	Goodman, J. V.	E.-in-C.O.	7.9.66
Horrocks, P.	N.W. Reg. to W.B.C.	22.9.66	Kendall, J. P.	E.-in-C.O.	26.9.66
Porter, D. W.	S.W. Reg.	9.9.66	Waldie, D.	E.-in-C.O.	7.9.66
Clark, R.	N.E. Reg.	22.9.66	Ball, J. R.	E.-in-C.O.	26.9.66
Sanders, F. V.	E.-in-C.O. to L.T. Reg.	20.9.66	Gregory, M. D.	S.W. Reg. to E.-in-C.O.	19.9.66
Bird, J.	H.C. Reg.	10.10.66	Pine, R.	E.-in-C.O.	24.10.66
Heaton, N.	N.E. Reg.	26.9.66	Hurley, A. W.	E.-in-C.O. to N.W. Reg.	31.10.66
<i>Executive Engineer to Senior Executive Engineer</i>			<i>Executive Engineer (Limited Competition)</i>		
Kynaston, J. A. C.	W.B.C. to Mid. Reg.	6.7.66	Lough, J.	N.W. Reg.	4.7.66
Haigh, B.	N.E. Reg. to N.W. Reg.	4.7.66	Nicoll, T. R.	L.T. Reg.	4.7.66
Stenson, D. W.	E.-in-C.O.	12.7.66	Dudley, D. K.	E.-in-C.O.	11.7.66
Ball, P. W.	C.F.S.D. to E.-in-C.O.	8.8.66	Couls, S. P.	Mid. Reg.	4.7.66
Crosby, E. I.	E.-in-C.O. to L.T. Reg.	15.8.66	Croft, F. W.	N.W. Reg.	18.7.66
Walter, A. C.	L.T. Reg.	15.8.66	Skues, R. T.	H.C. Reg. to E.-in-C.O.	4.7.66
Eltringham, C. C.	E.-in-C.O.	24.8.66	Thorpe, C. A.	L.T. Reg. to E.-in-C.O.	5.7.66
Brookes, G. P.	E.-in-C.O.	19.9.66	King, P. G.	E.-in-C.O.	4.7.66
Burrows, J. G.	L.T. Reg.	20.9.66	Gorton, R. K.	N.W. Reg.	27.7.66
Newman, W. L.	L.T. Reg.	20.9.66	Andrew, G. I.	T.S.U.	4.7.66
Henty, G. A.	L.T. Reg.	20.9.66	Fowler, E.	Mid. Reg. to E.-in-C.O.	4.7.66
Lamont, P. A.	Mid. Reg.	20.9.66	Hawkins, A. G.	E.-in-C.O.	11.7.66
Weatherall, R. J.	L.T. Reg.	20.9.66	Toussaint, G. C. C.	E.-in-C.O.	1.8.66
Chide, D. P.	N.W. Reg.	9.9.66	<i>Assistant Executive Engineer to Executive Engineer</i>		
Iles, S. H.	T.S.U.	12.9.66	Pringle, R. G.	H.C. Reg.	7.7.66
Farrow, L. A.	E.-in-C.O.	22.9.66	Tolliday, E.	H.C. Reg.	7.7.66
Heward F. C.	E.-in-C.O.	22.9.66	Berry, A. F.	S.W. Reg.	7.7.66
McCarthy, C. R. S.	E.-in-C.O.	27.9.66	Doe, E. S.	E.-in-C.O.	3.8.66
Lines, P. W.	E.-in-C.O.	22.9.66	Linney, P. J.	E.-in-C.O.	3.8.66
Munro, D. C.	E.-in-C.O.	22.9.66	Day, J. E.	E.-in-C.O.	3.8.66
MacMahon, P. J.	L.T. Reg. to E.-in-C.O.	20.9.66	Eaton, R. J.	E.-in-C.O.	3.8.66
Goldsmith, J. R.	E.-in-C.O.	20.9.66	Mahoney, A. E.	E.-in-C.O.	3.8.66
			Crowther, J. L.	E.T.E.	3.8.66
			Green, H. J.	L.T. Reg.	3.8.66
			Kearney, W. T.	E.-in-C.O. to L.P. Reg.	3.8.66
			Wotten, P. L. G.	L.T. Reg.	3.8.66
			Stroud, R. E.	L.T. Reg.	3.8.66
			Courage, D. R.	L.T. Reg.	3.8.66
			Paul, N. A.	L.T. Reg.	3.8.66
			Rush, R. T. G.	L.T. Reg.	3.8.66
			Draper, G. T.	L.T. Reg.	3.8.66

Promotions—continued

Name	Region, etc.	Date	Name	Region, etc.	Date
<i>Assistant Executive Engineer to Executive Engineer—continued</i>			<i>Assistant Executive Engineer (Limited Competition) continued</i>		
Taylor, C. A.	L.T. Reg.	3.8.66	Alexander, W. R.	Mid. Reg.	9.5.66
Green, J.	N.I.	3.8.66	Downes, A. N.	S.W. Reg. to E-in-C.O.	31.5.66
Field, R. P. ( <i>In absentia</i> )	E-in-C.O. to E.T.E.	3.8.66	Manchee, D. J.	S.W. Reg. to E-in-C.O.	31.5.66
Strachan, D.	Scot.	10.8.66	Grunwell, K. H.	N.E. Reg. to E-in-C.O.	31.5.66
Dowsing, D. R. F.	H.C. Reg.	18.8.66	Barton, G. P.	S.W. Reg. to E-in-C.●	31.5.66
Bufton, C. W.	S.W. Reg. to H.C. Reg.	18.8.66	Tew, A. J.	F-in-C.O.	25.4.66
Best, R. J.	S.W. Reg.	18.8.66	Norris, F. A.	L.T. Reg. to E-in-C.O.	9.5.66
Vass, A. W.	S.W. Reg.	18.8.66	Barrow, B. S.	L.T. Reg. to E-in-C.O.	25.4.66
Thomas, M. G.	W.B.C.	18.8.66	Baxter, J. R.	L.T. Reg. to E-in-C.O.	31.5.66
Hodge, I. O.	S.W. Reg.	18.8.66	Oldfield, A. W.	N.W. Reg. to E-in-C.O.	9.5.66
Jenkins, T. W.	W.B.C.	18.8.66	Routhorn, G. A.	L.T. Reg. to E-in-C.O.	28.3.66
Blake, J. R.	W.B.C.	18.8.66	Edgson, R. L.	Mid. Reg.	9.5.66
Martin, R. K.	S.W. Reg.	18.8.66	Hart, M.	L.T. Reg. to E-in-C.O.	28.3.66
Masters, H.	W.B.C.	18.8.66	Hobson, I. J.	E-in-C.O.	28.3.66
Leach, N.	N.W. Reg.	30.8.66	Guest, H. H. J.	L.T. Reg. to E-in-C.O.	14.3.66
Doyle, D. G.	N.W. Reg.	30.8.66	Harris, D. E.	W.B.C. to F-in-C.O.	31.5.66
Bee, W.	N.W. Reg.	30.8.66	Irvine, N. J.	E-in-C.O.	28.3.66
Donnelly, H.	N.W. Reg.	30.8.66	Ault, R. A.	Scot. to E-in-C.O.	25.4.66
Davies, A. J.	N.W. Reg.	31.8.66	Jackson, J. B.	Mid. Reg.	9.5.66
Davies, W. G.	N.W. Reg.	31.8.66	Baker, V. C.	L.T. Reg. to E-in-C.O.	28.3.66
Atherton, H.	N.W. Reg.	31.8.66	Cranmer, B. J.	E-in-C.O.	31.5.66
Craigie, F. R.	H.C. Reg. to N.W. Reg.	31.8.66	Allen, M. C.	L.T. Reg. to E-in-C.O.	28.3.66
Wright, D. K. G. D.	Mid. Reg. to N.W. Reg.	31.8.66	Harris, A. N.	E-in-C.O.	31.5.66
Halford, J. M.	Mid. Reg.	30.9.66	Ing, P. J.	E-in-C.O.	31.5.66
Moore, A. J.	Mid. Reg.	15.9.66	Hicks, J. B.	L.T. Reg. to E-in-C.O.	28.3.66
Bullock, J. G.	Mid. Reg.	15.9.66	Egan, A. J.	L.T. Reg. to E-in-C.O.	28.3.66
Bradbury, B. W.	Mid. Reg.	15.9.66	Peacock, A. R.	J.T. Reg. to E-in-C.●	4.4.66
Cursley, J. J.	Mid. Reg.	11.10.66	Monk, C. L.	E-in-C.O.	25.4.66
Eacock, D. R. N.	Mid. Reg.	15.9.66	Woodroffe, J. M.	E-in-C.O.	31.5.66
Barry, A. P.	N.W. Reg.	20.9.66	Geeves, G. W.	L.T. Reg. to E-in-C.O.	28.3.66
Connolly, C. F.	N.W. Reg.	20.9.66	Gooderham, A. C.	E-in-C.O.	13.6.66
Atherton, F.	N.W. Reg.	20.9.66	Matthews, T. H.	E-in-C.O.	2.7.66
Smith, S. P.	N.E. Reg.	27.9.66	Hinks, M. T.	Mid. Reg.	1.6.66
Smith, G. H.	N.E. Reg.	27.9.66	Wilkinson, C. F.	H.C. Reg. to E-in-C.O.	28.3.66
Bucknall, E. B.	N.E. Reg.	27.9.66	Lindsay, P. E.	L.T. Reg. to E-in-C.O.	31.5.66
Barker, T. A.	N.E. Reg.	27.9.66	Beadle, J. G.	H.C. Reg. to E-in-C.O.	28.3.66
Lancaster, S.	N.E. Reg.	27.9.66	Whittaker, E.	N.W. Reg. to E-in-C.O.	9.5.66
Hardy, B.	N.E. Reg.	27.9.66	Alexander, J. S.	E-in-C.O.	2.7.66
Bayes, R. A.	N.E. Reg.	27.9.66	O'Neill, D. R.	L.T. Reg. to E-in-C.O.	9.5.66
Gough, G. J.	Mid. Reg.	30.9.66	Proudfoot, N. W. B.	Scot. to E-in-C.●	25.4.66
Tye, L. E.	E-in-C.O. to Mid. Reg.	30.9.66	Kane, A.	N.I. to E-in-C.●	4.10.66
Jones, H.	Mid. Reg.	30.9.66	Whitehouse, K. G.	Mid. Reg.	9.5.66
Snape, W. M.	Mid. Reg.	30.9.66			
Powell, R.	Mid. Reg.	30.9.66			
Richards, F. D.	Mid. Reg.	10.10.66			
Link, H. C.	W.B.C.	31.10.66			
Wilkinson, C. D.	N.E. Reg.	19.10.66			
<i>Assistant Executive Engineer (Limited Competition)</i>			<i>Inspector to Assistant Executive Engineer</i>		
Grant, A.	E-in-C.●	28.3.66	Beasley, W. W.	Mid. Reg.	1.6.66
Hammer, D. G.	E-in-C.O.	28.3.66	Russell, D. J. M.	H.C. Reg.	2.6.66
Thomas, A. F.	E-in-C.O.	14.3.66	Kettlewell, K.	H.C. Reg.	21.6.66
Lorentz, P. J.	N.E. Reg. to E-in-C.O.	25.4.66	Baugh, E. E.	S.W. Reg.	15.6.66
Allport, D. J.	Mid. Reg.	9.5.66	Waldon, D. E.	S.W. Reg.	15.6.66
Heath, J. W.	H.C. Reg. to E-in-C.O.	28.3.66	Ellis, S.	L.T. Reg.	28.6.66
Gilbert, M. A. E.	H.C. Reg. to E-in-C.O.	28.3.66	Devereux, L. E.	Mid. Reg.	8.7.66
Holmes, R. H. E.	Mid. Reg.	9.5.66	Hardy, W.	Mid. Reg.	8.7.66
Morris, K. J.	S.W. Reg. to E-in-C.O.	9.5.66	Lane, H. J.	Mid. Reg.	29.7.66
Roy, I. S.	Scot. to E-in-C.O.	25.4.66	Astley, D. J.	Mid. Reg.	29.7.66
Steele, D. G.	E-in-C.O.	25.4.66	Hague, C. A.	L.P. Reg.	29.7.66
Dolphin, H. W.	Factories Dept. to Mid. Reg.	25.4.66	Rushton, J.	Mid. Reg.	22.8.66
Sylvester, B. E.	L.T. Reg. to E-in-C.O.	28.3.66	Robinson, F. D.	Mid. Reg.	22.8.66
Bull, P. G.	Mid. Reg.	9.5.66	Ashton, R. H.	Mid. Reg.	22.8.66
Smith, C. R.	L.T. Reg. to E-in-C.O.	28.3.66	Harrison, H.	N.W. Reg.	26.8.66
Dickens, J. L.	L.T. Reg. to E-in-C.O.	28.3.66	Price, P. R.	N.W. Reg.	26.8.66
Willington, D. J.	E-in-C.O.	25.4.66	Marshall, R. A.	L.T. Reg.	5.9.66
Young, D. J.	Mid. Reg.	6.6.66	Wheeler, N. W.	L.T. Reg.	5.9.66
Church, R. G.	H.C. Reg. to F-in-C.O.	31.5.66	King, G. A.	L.T. Reg.	5.9.66
Coleman, A. E.	E-in-C.O.	28.3.66	Litchfield, A.	L.T. Reg.	5.9.66
Looime, S. R.	H.C. Reg. to E-in-C.O.	25.4.66	Mack, H. J.	L.T. Reg.	5.9.66
Mauder, J. W.	L.T. Reg. to E-in-C.●	28.3.66	Steele, F. J.	L.T. Reg.	5.9.66
Russell, P. A.	W.B.C. to E-in-C.O.	9.5.66	Rae, J. B.	L.T. Reg.	5.9.66
Stone, P. M.	E.T.E.	23.5.66	Moyce, W. J.	L.T. Reg.	5.9.66
Phipps, E. W. T.	S.W. Reg. to E-in-C.O.	31.5.66	Baker, R.	L.T. Reg.	5.9.66
Jackson, R.	Mid. Reg.	9.5.66	Roberts, F.	W.B.C.	7.9.66
			Henaghan, M.	Mid. Reg.	15.9.66
			<i>Technical Officer to Assistant Executive Engineer</i>		
			Owen, R.	H.C. Reg.	6.6.66
			Thomas, R. H.	W.B.C.	27.6.66

Promotions—continued

Name	Region, etc.	Date	Name	Region, etc.	Date
<i>Technical Officer to Assistant Executive Engineer—continued</i>			<i>Technical Officer to Assistant Executive Engineer—continued</i>		
Edwards, G. A.	H.C. Reg.	31.5.66	Wilson, B.	N.W. Reg.	26.8.66
Hutchins, A. R.	H.C. Reg.	27.6.66	Bradbury, T. R.	N.W. Reg.	26.8.66
Evans, J. W. G.	H.C. Reg.	7.6.66	Roberts, J. L.	N.W. Reg.	26.8.66
Kynaston, G. A.	W.B.C.	18.6.66	Evans, F.	W.B.C.	26.9.66
Grange, T. J.	H.C. Reg.	2.6.66	Greenwood, A. D.	N.W. Reg.	23.9.66
Medhurst, E. D.	H.C. Reg.	2.6.66	Larkin, J.	N.W. Reg.	26.9.66
Easen, P. W.	I.I.C. Reg.	2.6.66	Turner, R. O.	L.T. Reg.	5.9.66
Evans, G. A.	I.I.C. Reg.	2.6.66	Nevell, L. A.	L.T. Reg.	5.9.66
Hamilton, J.	Scot.	6.6.66	Melville, A. O.	L.T. Reg.	5.9.66
Maltby, R. C.	H.C. Reg.	2.6.66	Risley, D. A.	L.T. Reg.	5.9.66
Pickles, J.	N.E. Reg.	13.6.66	Watts, G. H.	L.T. Reg.	5.9.66
Butcher, T.	N.E. Reg.	13.6.66	Jarratt, P. J.	L.T. Reg.	5.9.66
Gray, H.	E.-in-C.O.	20.6.66	Alexander, F. J.	L.T. Reg.	5.9.66
Spain, J. I. E.	H.C. Reg.	21.6.66	Wilson, B. D.	L.T. Reg.	5.9.66
Mountstephen, I. J.	H.C. Reg.	21.6.66	Noakes, F. J.	L.T. Reg.	5.9.66
Price, F. G.	Mid. Reg.	21.6.66	Jordan, J. D.	L.T. Reg.	5.9.66
Haynes, A. C.	Mid. Reg.	21.6.66	Dipper, R. G.	L.T. Reg.	5.9.66
Moorc, D. R.	Mid. Reg.	21.6.66	Rowe, J. E.	L.T. Reg.	5.9.66
Collings, J. L.	Mid. Reg.	21.6.66	Starling, H. A.	L.T. Reg.	5.9.66
Graham, J. C.	Scot.	31.5.66	Southcott, L.	L.T. Reg.	5.9.66
Scemple, A. M.	Scot.	31.5.66	Pattner, R. E.	L.T. Reg.	5.9.66
Hart, J.	Mid. Reg.	21.6.66	Wadeson, C. J.	L.T. Reg.	5.9.66
Blackmore, A. M.	W.B.C.	18.6.66	Quartermaine, A. A.	L.T. Reg.	5.9.66
Fullwood, E. J.	W.B.C.	18.6.66	Bushell, P. L.	W.B.C.	27.9.66
Stoner, R. H.	H.C. Reg.	28.6.66	Huxtable, M. D.	W.B.C.	7.9.66
Lush, J.	H.C. Reg.	28.6.66	Miller, J. M.	N.I.	8.8.66
Dean, R. C.	H.C. Reg.	28.6.66	Rivis, D. A.	N.E. Reg.	10.10.66
James, J. A.	I.I.C. Reg.	28.6.66	Gowing, H. R.	E.T.E.	12.9.66
Green, A. F.	I.I.C. Reg.	28.6.66	Lowe, D.	Mid. Reg.	15.9.66
Hare, R.	S.W. Reg.	24.6.66	Durham, B. T.	Mid. Reg.	15.9.66
Dorward, J. A.	H.C. Reg.	30.6.66	Waddy, J. T.	Mid. Reg.	15.9.66
Rawlinson, K. A.	H.C. Reg.	30.6.66	Potts, E. H.	Mid. Reg.	15.9.66
Noble, J. F.	H.C. Reg.	21.6.66	Barlow, D.	Mid. Reg.	15.9.66
Saunders, D. C. W.	N.W. Reg.	20.6.66	Craddock, R. F.	Mid. Reg.	15.9.66
Rogan, A.	Scot.	20.6.66	Catto, W.	Scot.	19.9.66
Tuffin, D. J.	S.W. Reg.	20.6.66	Ronaldson, J.	N.E. Reg.	12.9.66
Corner, G.	N.F. Reg.	13.7.66	Dix, R. R.	S.W. Reg.	19.9.66
Massie, H. R.	W.B.C.	11.7.66	Stubbings, E. G.	S.W. Reg.	25.8.66
Jones, S. T.	W.B.C.	11.7.66	Brock, A. W.	S.W. Reg.	25.8.66
Davies, J. M.	W.B.C.	11.7.66	Byrne, B. H.	S.W. Reg.	25.8.66
Burch, D. H.	H.C. Reg.	2.7.66	Hoare, I. W.	S.W. Reg.	30.8.66
Hyde, J. W.	H.C. Reg.	13.7.66	Tarrant, S. F.	Mid. Reg.	15.9.66
Coleman, W. E.	S.W. Reg.	6.7.66	McIntosh, A. F.	Scot.	2.9.66
Pearson, R. C.	S.W. Reg.	6.7.66	Duddy, R. M.	Mid. Reg.	15.9.66
Stacey, J. A.	S.W. Reg.	6.7.66	Curtin, J.	Mid. Reg.	15.9.66
Hensley, H. A.	Mid. Reg.	8.7.66	Anderson, R. J. P.	Mid. Reg.	15.9.66
Rhead, C.	Mid. Reg.	8.7.66	Westlake, E. J.	S.W. Reg.	30.8.66
Hughes, F.	Mid. Reg.	8.7.66	Etherington, S. J.	Mid. Reg.	15.9.66
Ellis, R. J.	Mid. Reg.	29.7.66	Atkins, A. E.	Mid. Reg.	15.9.66
Cahill, D. E.	Mid. Reg.	29.7.66	Plummer, E.	Mid. Reg.	15.9.66
Cotton, R.	Mid. Reg.	29.7.66	Nicholson, P. K.	W.B.C.	7.9.66
Smith, J. H.	Mid. Reg.	29.7.66	Horton, J.	Mid. Reg.	15.9.66
Hotchkiss, E. S. M.	W.B.C.	28.7.66	Davey, R.	Mid. Reg.	15.9.66
Huke, J. A.	H.C. Reg.	13.7.66	Scott, G. W.	Mid. Reg.	15.9.66
Emmerson, G. H.	H.C. Reg.	1.8.66	James, R. A.	Mid. Reg.	15.9.66
Hoar, J. L.	Scot.	11.7.66	Hillyer, J. W. G.	Mid. Reg.	15.9.66
Moat, L. G.	S.W. Reg.	30.8.66			
Jacobs, K. W.	S.W. Reg.	6.7.66	<i>Draughtsman to Assistant Executive Engineer</i>		
Wells, R.	H.C. Reg.	2.8.66	Davies, W.	W.B.C.	11.7.66
Wilton, A. J.	E.-in-C.O.	9.8.66	Keenan, W. J.	N.W. Reg.	12.9.66
Burgess, L.	E.-in-C.O.	9.8.66	Heaton, R. V.	N.W. Reg.	19.9.66
Dickinson, J. P.	N.E. Reg.	10.8.66	Maguire, F. J.	N.I.	8.8.66
Howard, A. B. G.	Mid. Reg.	22.8.66	Dennif, P. S.	N.E. Reg.	12.9.66
Ashman, K. E.	Mid. Reg.	22.8.66			
Butler, A. H.	Mid. Reg.	22.8.66	<i>Technical Officer to Inspector</i>		
Dewson, R. F.	Mid. Reg.	22.8.66	Aldridge, F. M.	H.C. Reg.	11.7.66
Smith, H. H.	Mid. Reg.	22.8.66	Warnes, S. H.	H.C. Reg.	13.7.66
Walters, J. S.	Mid. Reg.	22.8.66	Stephens, R. C.	S.W. Reg.	6.7.66
Goodman, T. A.	N.I.	18.7.66	Weston, A.	H.C. Reg.	25.7.66
Nash, J. A.	E.-in-C.O.	31.8.66	Nicholls, T. N.	S.W. Reg.	1.8.66
Abbs, M. J.	H.C. Reg.	25.8.66	Lock, W. S.	S.W. Reg.	24.4.65
Moselcy, G. T.	N.W. Reg.	26.8.66	Shorrocks, J. A.	S.W. Reg.	6.9.66
Ward, W. H.	N.W. Reg.	26.8.66			
Winder, N.	N.W. Reg.	26.8.66			
Kenny, J.	N.W. Reg.	26.8.66			
Watt, J. A.	N.W. Reg.	26.8.66			

Promotions—continued

Name	Region, etc.	Date	Name	Region, etc.	Date
<u>Senior Technician to Inspector</u>			<u>Assistant (Scientific) (Open Competition)</u>		
Bridge, H. G. . . . .	S.W. Reg. . . . .	15.6.66	Ani, I. N. . . . .	E.-in-C.O. . . . .	14.7.66
Kern, W. G. . . . .	W.B.C. . . . .	4.7.66	de Borde, C. M. . . . .	E.-in-C.O. . . . .	25.8.66
Muirhead, R. . . . .	Scot. . . . .	5.7.66	Bedale, J. E. (Miss) . . . . .	E.-in-C.O. . . . .	17.10.66
Swapp, D. W. . . . .	Scot. . . . .	25.7.66			
McGowan, D. J. . . . .	Scot. . . . .	8.8.66	<u>Motor Transport Officer III to Motor Transport Officer II</u>		
Dawson, J. . . . .	N.E. Reg. . . . .	12.9.66	Edwards, W. T. A. . . . .	E.-in-C.O. . . . .	1.9.66
Failes, A. B. . . . .	Scot. . . . .	2.9.66	<u>Technical Assistant to Assistant Regional Motor Transport Officer</u>		
Irvine, L. B. . . . .	Scot. . . . .	5.9.66	Yaxley, A. E. . . . .	S.E. Reg. . . . .	17.10.66
Jackson, T. . . . .	Mid. Reg. . . . .	15.9.66	<u>Technical Assistant to Motor Transport Officer III</u>		
Britton-Jones, M. . . . .	W.B.C. . . . .	2.9.66	Morgan, E. G. . . . .	E.-in-C.O. . . . .	26.8.66
Wright, L. J. . . . .	Mid. Reg. . . . .	15.9.66	Leach, F. J. . . . .	E.-in-C.O. . . . .	13.9.66
Adams, G. W. . . . .	Mid. Reg. . . . .	15.9.66	<u>Workshop Supervisor I to Technical Assistant</u>		
Home, J. . . . .	N.E. Reg. . . . .	10.10.66	Whittle, R. . . . .	N.W. Reg. . . . .	21.9.66
<u>Technician I to Inspector</u>			Chadwick, W. E. . . . .	Scot. to E. Reg. . . . .	21.9.66
King, B. G. . . . .	H.C. Reg. . . . .	28.6.66	Thorogood, C. J. F. . . . .	London Reg. to E.-in-C.O. . . . .	21.9.66
Fry, D. J. . . . .	H.C. Reg. . . . .	7.6.66	Russell, S. G. . . . .	S.E. Reg. . . . .	21.9.66
Nye, A. B. . . . .	H.C. Reg. . . . .	28.6.66	Chater, R. W. . . . .	Mid. Reg. . . . .	21.9.66
Wallis, R. C. . . . .	H.C. Reg. . . . .	28.6.66	<u>Workshop Supervisor II to Technical Assistant</u>		
Field, E. T. . . . .	H.C. Reg. . . . .	28.6.66	Peat, G. B. . . . .	Scot. to E. Reg. . . . .	21.9.66
Standing, R. C. . . . .	H.C. Reg. . . . .	28.6.66	Gardiner, W. A. . . . .	N.W. Reg. . . . .	21.9.66
Phillips, H. J. . . . .	H.C. Reg. . . . .	28.6.66	<u>Leading Draughtsman to Senior Draughtsman</u>		
Whitbread, M. R. W. . . . .	H.C. Reg. . . . .	28.6.66	Holmes, D. G. . . . .	E.-in-C.O. . . . .	19.8.66
Davey, C. J. . . . .	H.C. Reg. . . . .	28.6.66	<u>Draughtsman to Leading Draughtsman</u>		
Lovelock, P. B. . . . .	H.C. Reg. . . . .	28.6.66	Thomas, R. F. . . . .	S.W. Reg. . . . .	17.6.66
Leonard, A. . . . .	W.B.C. . . . .	20.6.66	Green, R. . . . .	Mid. Reg. . . . .	17.6.66
Guy, R. G. . . . .	H.C. Reg. . . . .	28.6.66	Walker, A. E. . . . .	E.-in-C.O. . . . .	17.6.66
Fowler, A. G. . . . .	H.C. Reg. . . . .	28.6.66	Summerfield, E. R. . . . .	E.-in-C.O. . . . .	17.6.66
Newman, W. B. J. . . . .	H.C. Reg. . . . .	11.7.66	Jones, I. T. . . . .	N.W. Reg. . . . .	29.7.66
Whitehead, N. . . . .	N.W. Reg. . . . .	10.8.66	Bond, T. W. . . . .	Scot. . . . .	29.7.66
Holden, R. . . . .	N.W. Reg. . . . .	10.8.66	Ford, J. . . . .	L.T. Reg. to E.-in-C.O. . . . .	1.8.66
Davison, E. W. . . . .	N.W. Reg. . . . .	10.8.66	Leach, W. J. . . . .	E.-in-C.O. . . . .	6.10.66
Campbell, W. J. . . . .	H.C. Reg. . . . .	15.8.66	Chalklen, T. E. . . . .	E.-in-C.O. . . . .	17.10.66
Robertson, A. S. . . . .	Scot. . . . .	22.8.66	Kateley, H. D. . . . .	E.-in-C.O. . . . .	10.10.66
Ames, V. . . . .	H.C. Reg. . . . .	8.8.66	<u>Draughtsman (Open Competition)</u>		
Hannay, A. E. . . . .	W.B.C. . . . .	8.8.66	Armstrong, A. M. . . . .	E.-in-C.O. . . . .	19.10.66
Gullick, R. . . . .	W.B.C. . . . .	8.8.66	<u>Clerical Officer to Executive Officer</u>		
Copeland, W. A. . . . .	Mid. Reg. . . . .	8.8.66	Parker, R. (Mrs.) . . . . .	E.-in-C.O. . . . .	8.7.66
Lewis, L. R. . . . .	S.W. Reg. . . . .	2.8.66	Thyer, G. H. G. . . . .	E.-in-C.O. to Solicitors Dept. . . . .	1.8.66
Wallace, H. . . . .	N.W. Reg. . . . .	10.8.66	Ferrett, A. J. . . . .	E.-in-C.O. . . . .	5.8.66
Harrison, T. . . . .	N.W. Reg. . . . .	10.8.66	Tyler, T. E. . . . .	C.E.S.D. . . . .	15.8.66
Parker, G. . . . .	N.W. Reg. . . . .	26.8.66	Beechy, A. F. . . . .	E.-in-C.O. . . . .	22.8.66
Silvey, K. R. . . . .	W.B.C. . . . .	12.9.66	Taylor, J. A. . . . .	E.-in-C.O. . . . .	30.8.66
<u>Principal Scientific Officer to Senior Principal Scientific Officer</u>			Purdic, D. . . . .	E.-in-C.O. . . . .	12.10.66
Reynolds, F. H. . . . .	E.-in-C.O. . . . .	19.9.66	Brett, D. A. . . . .	E.-in-C.O. . . . .	31.10.66
<u>Senior Scientific Officer (Open Competition)</u>			Stanley, P. R. . . . .	E.-in-C.O. . . . .	31.10.66
Heckingbottom, R. . . . .	E.-in-C.O. . . . .	3.10.66	<u>Assistant Experimental Officer (Open Competition)</u>		
Andreas, A. . . . .	E.-in-C.O. . . . .	3.10.66	Godsmark, D. . . . .	E.-in-C.O. . . . .	16.8.66
Beales, K. J. . . . .	E.-in-C.O. . . . .	3.10.66	Abbott, J. M. (Mrs.) . . . . .	C.E.S.D. . . . .	8.9.66
<u>Scientific Officer (Open Competition)</u>					
Papadakis, A. C. . . . .	E.-in-C.O. . . . .	25.7.66			
Sinnadurai, F. N. . . . .	E.-in-C.O. . . . .	13.9.66			

Retirements and Resignations

Name	Region, etc.	Date	Name	Region, etc.	Date
<u>Director of Research</u>			<u>Assistant Staff Engineer</u>		
Metson, G. H. . . . .	E.-in-C.O. . . . .	22.8.66	Renton, R. N. . . . .	E.-in-C.O. . . . .	31.8.66
<u>Assistant Engineer-in-Chief</u>			Welch, S. (Resigned) . . . . .	E.-in-C.O. . . . .	31.10.66
Williams, H. . . . .	E.-in-C.O. . . . .	27.10.66	<u>Area Engineer</u>		
			Sharpe, H. T. A. . . . .	L.T. Reg. . . . .	22.7.66

# The Post Office Electrical Engineers' Journal

Volume 59, April 1966–January 1967

## INDEX

A	PAGE NO.	PAGE NO.
All-Figure Telephone Numbers .. .. .	40	
Aluminium Conductors for Telephone Cables .. .. .	106	
Associate Section Notes .. .. .	64, 142, 226, 301	
<b>B</b>		
BANHAM, H. The 5005-Crossbar Telephone-Exchange Switching System (Part 2) .. .. .	271	
Batteries, Operation and Maintenance of Secondary-Cell .. .. .	43	
BIGG, R. W. A Precision Magnetic Tape-Recorder .. .. .	55	
BILLINGHURST, F. M., and HUTTON-PENMAN, P. R. The New Leafield Radio Station (Part 3) .. .. .	196	
BREARY, D., and THOMSON, W. E. Planning London's Future Telephone Network by Computer .. .. .	167	
British Joint Computer Conference, 1966 .. .. .	91	
<b>C</b>		
Cables, Aluminium Conductors for Telephone .. .. .	106	
CHAMBERS, J. A. The New Leafield Radio Station (Part 2) .. .. .	178	
Characteristics of Telephone Circuits in Relation to Data Transmission .. .. .	151	
Clean Room for the Production of Silicon Planar Transistors, A .. .. .	34	
COLYER, J. O., THARBY, R., and SENIOR, R. C. Gases in Underground Plant and Their Detection .. .. .	80	
Commonwealth Telecommunications Conference, 1965–1966 .. .. .	116	
Component Selection and Mode of Operation, Electronic Telephone Exchanges: .. .. .	233	
Computer Conference, 1966, British Joint .. .. .	91	
Computer, Developing Relationship Between the Man and the .. .. .	85	
Computer, Planning London's Future Telephone Network by .. .. .	167	
Conference Repeater Using a New Voice-Switching Technique, A Prototype .. .. .	246	
CORKE, R. L., and SEARLS, A. W. A Clean Room for the Production of Silicon Planar Transistors .. .. .	34	
CORNER, A. C. The 5005-Crossbar Telephone-Exchange Switching System (Part 1) .. .. .	170	
Crossbar Exchanges, Developments in Exchange Equipment: Post Office Introduces Electronic and .. .. .	33	
Crossbar Telephone-Exchange Switching System, The 5005- (Parts 1 and 2) .. .. .	170, 271	
<b>D</b>		
Data Transmission, The Characteristics of Telephone Circuits in Relation to .. .. .	151	
Datel Modem No. 1A, A Modem for the Datel 600 Service— .. .. .	108	
Datel Modem No. 1A, Performance of the .. .. .	250	
Datel Services, An Introduction to the Post Office .. .. .	1	
Datel 600 Service—Datel Modem No. 1A, A Modem for the .. .. .	108	
Datel Testers No. 1A, 2A and 2B, Test Equipment for the Datel Services— .. .. .	262	
DAVEY, D. V., DENNING, S. F., and HEWARD, F. C. British Joint Computer Conference, 1966 .. .. .	91	
DAVIS, E., and FRANCIS, H. E. Decentralization of London's Trunk and Tandem Telephone Exchanges .. .. .	75	
Decentralization of London's Trunk and Tandem Telephone Exchanges .. .. .	75	
DENNING, S. F., HEWARD, F. C., and DAVEY, D. V. British Joint Computer Conference, 1966 .. .. .	91	
Developing Relationship Between the Man and the Computer .. .. .	85	
Development of Pulse-Code Modulation Systems .. .. .	10	
Developments in Exchange Equipment: Post Office Introduces Electronic and Crossbar Exchanges .. .. .	33	
Device to Replace Conventional Polarized Relays, A .. .. .	181	
Ducts by Moleplough, Laying Plastic .. .. .	104	
<b>E</b>		
Electronic and Crossbar Exchanges. Developments in Exchange Equipment: Post Office Introduces .. .. .	33	
Electronic Telephone Exchange at Ambergate, Opening of the First Production .. .. .	287	
Electronic Telephone Exchange, The Leighton Buzzard .. .. .	255	
Electronic Telephone Exchanges: An Introductory Review of Developments .. .. .	211	
Electronic Telephone Exchanges: Component Selection and Mode of Operation .. .. .	233	
ELKINS, A. H. Subscriber Push-Button Telephones Market-Research Trial .. .. .	200	
Engineering Aspects of Staff Comfort .. .. .	26	
<b>F</b>		
FAGG, S. L. F., and MEAD, F. G. Practical Aspects of Providing Telephone Plant on New Housing Estates .. .. .	241	
FAGG, S. L. F., and WILSON, W. T. Laying Plastic Ducts by Moleplough .. .. .	104	
Fire Hazards and Materials .. .. .	16	
5005-Crossbar Telephone-Exchange Switching System, The .. .. .	170	
Part 1—Trunking and Facilities .. .. .	271	
Part 2—Application and Maintenance .. .. .	75	
FRANCIS, H. E., and DAVIS, E. Decentralization of London's Trunk and Tandem Telephone Exchanges .. .. .	75	
FRENCH, J. A. T., and LOWE, W. T. Electronic Telephone Exchanges: Component Selection and Mode of Operation .. .. .	233	
<b>G</b>		
Gases in Underground Plant and Their Detection .. .. .	80	
<b>H</b>		
HALLIWELL, MARY A., and HENDERSON, J. C. The Use of X-Ray Diffraction to Study Defects Occurring During Silicon-Device Manufacture .. .. .	94	
HARRIS, L. R. F. Electronic Telephone Exchanges: An Introductory Review of Developments .. .. .	211	
HART, M. The New Leafield Radio Station (Part 5) .. .. .	283	
HAYES, H. C. S. Aluminium Conductors for Telephone Cables .. .. .	106	
HAYTON, F. New Jointers' Tents—Tents, Jointers', No. 3 and 4 .. .. .	52	
HENDERSON, J. C., and HALLIWELL, MARY A. The Use of X-Ray Diffraction to Study Defects Occurring During Silicon-Device Manufacture .. .. .	94	
HEWARD, F. C., DAVEY, D. V., and DENNING, S. F. British Joint Computer Conference, 1966 .. .. .	91	
HOLMES, M. F. Semiconductor Device Developments: General Introduction .. .. .	202	
HOPWOOD, R. W. Engineering Aspects of Staff Comfort Housing Estates, Practical Aspects of Providing Telephone Plant on New .. .. .	26	
HOYLE, J. H. The Introduction of Subscriber Trunk Dialing at Unit Automatic Exchanges .. .. .	20	
HUTTON-PENMAN, P. R., and BILLINGHURST, F. M. The New Leafield Radio Station (Part 3) .. .. .	196	
HYATT, J. L. The London Radiophone Service .. .. .	98	

	PAGE NO.
<b>I</b>	
I.T.U. Seminar on "The Telephone Service," London, September 1966 (S) .. .. .	282
Incoming Core-Type Register-Translator for Director Arcas	
Part 1—Principles of Design .. .. .	119
Part 2—The Functional Design .. .. .	183
Institution of Post Office Electrical Engineers	60, 138, 222, 297
Introduction of Subscriber Trunk Dialling at Unit Automatic Exchanges .. .. .	20
Introduction to the Post Office Datel Services, An .. .. .	1
IRELAND, W. A., and PRICE, C. K. Incoming Core-Type Register-Translator for Director Areas (Parts 1 and 2) .. .. .	119, 183
<b>J</b>	
JACKSON, B. S., and WASE, A. E. N. The New Leaffield Radio Station (Part 4) .. .. .	267
JONES, R. A. A Prototype Conference Repeater Using a New Voice-Switching Technique .. .. .	246
<b>K</b>	
KING, R. E., and WOOLLEY, F. The Repair of Faulty Loading Pots .. .. .	5
<b>L</b>	
LATIMER, E. D., and ROBINSON, H. F. Sheath Jointing of Plastic-Sheathed Cables .. .. .	206
LAWRENCE, J. A. Opening of the First Production Electronic Telephone Exchange at Ambergate .. .. .	287
Laying Plastic Ducts by Moleplough .. .. .	104
Leaffield Radio Station, The New (Parts 1-5) .. 130, 178, 196, 267, 283	
Leighton Buzzard Electronic Telephone Exchange, The ..	255
Lincompex System for the Improvement of H.F. Radio-Telephone Circuits, The .. .. .	163
Loading Pots, The Repair of Faulty .. .. .	5
London Radiophone Service, The .. .. .	98
LOWE, W. T., and FRENCH, J. A. T. Electronic Telephone Exchanges: Component Selection and Mode of Operation .. .. .	233
LUND, A. E. Stay Anchorages .. .. .	53
<b>M</b>	
MACKAY, A. C. The New Post Office Railway Station at the New Western District Office .. .. .	12
MAHONEY, A. E. Operation and Maintenance of Secondary-Cell Batteries .. .. .	43
Maintenance of Secondary-Cell Batteries, Operation and Materials and Fire Hazards .. .. .	43
MAY, C. A. The Developing Relationship Between the Man and the Computer .. .. .	85
MEAD, F. G., and FAGG, S. L. F. Practical Aspects of Providing Telephone Plant on New Housing Estates .. .. .	241
Modem for the Datel 600 Service—Datel Modem No. 1A, A .. .. .	108
Moleplough, Laying Plastic Ducts by .. .. .	104
<b>N</b>	
New Joiners' Tents—Tents, Joiners', No. 3 and 4 .. .. .	52
New Leaffield Radio Station, The	
Part 1—General Principles .. .. .	130
Part 2—The Control System .. .. .	178
Part 3—Carrier Generation .. .. .	196
Part 4—The H.F. Transmitters .. .. .	267
Part 5—The External and Switching Plant .. .. .	283
New Post Office Railway Station at the New Western District Office, The .. .. .	12
New Status of the Technical Support Unit .. .. .	18
Notes and Comments .. .. .	60, 135, 220, 290
<b>O</b>	
Opening of the First Production Electronic Telephone Exchange at Ambergate .. .. .	287
Operation and Maintenance of Secondary-Cell Batteries .. .. .	43

	PAGE NO.
<b>P</b>	
Papers and Articles on Telecommunications and Other Scientific Subjects .. .. .	71
Performance of the Datel Modem No. 1A .. .. .	250
Planning London's Future Telephone Network by Computer .. .. .	167
Practical Aspects of Providing Telephone Plant on New Housing Estates .. .. .	241
Precision Magnetic Tape-Recorder, A .. .. .	55
PRICE, C. K., and IRELAND, W. A. Incoming Core-Type Register-Translator for Director Areas (Parts 1 and 2) .. .. .	119, 183
Prototype Conference Repeater Using a New Voice-Switching Technique .. .. .	246
Pulse-Code Modulation Systems, Development of .. .. .	10
Push-Button Telephones Market-Research Trial, Subscriber .. .. .	200
<b>R</b>	
Radio Station, The New Leaffield (Parts 1-5) .. 130, 178, 196, 267, 283	
Radio-Telephone Circuits, The Lincompex System for the Improvement of .. .. .	163
Radiophone Service, The London .. .. .	98
Railway Station at the New Western District Office, The New Post Office .. .. .	12
Regional Notes .. .. .	61, 140, 225, 299
Register-Translator for Director Arcas, Incoming Core-Type (Parts 1 and 2) .. .. .	119, 183
Relays, A Device to Replace Conventional Polarized .. .. .	181
Repair of Faulty Loading Pots, The .. .. .	5
ROBERTS, L. W., and SMITH, N. G. A Modem for the Datel 600 Service—Datel Modem No. 1A .. .. .	108
ROBINSON, H. E., and LATIMER, E. D. Sheath Jointing of Plastic-Sheathed Cables .. .. .	206
<b>S</b>	
SALLIS, R. T. G. A Device to Replace Conventional Polarized Relays .. .. .	181
SEARLS, A. W., and CORKE, R. L. A Clean Room for the Production of Silicon Planar Transistors .. .. .	34
Semiconductor Device Developments: General Introduction .. .. .	202
SENIOR, R. C., COLYER, J. O., and THARBY, R. Gases in Underground Plant and Their Detection .. .. .	80
Sheath Jointing of Plastic-Sheathed Cables .. .. .	206
SHEPPARD, S. H. The Leighton Buzzard Electronic Telephone Exchange .. .. .	255
Silicon-Device Manufacture, The Use of X-Ray Diffraction to Study Defects Occurring in .. .. .	94
SKINGLE, G. D., and SPANTON, J. C. Test Equipment for the Datel Services—Datel Testers No. 1A, 2A and 2B .. .. .	262
SMITH, N. G. An Introduction to the Post Office Datel Services .. .. .	1
SMITH, N. G., and ROBERTS, L. W. A Modem for the Datel 600 Service—Datel Modem No. 1A .. .. .	108
SMITH, N. G., and TRIDGELL, R. N. Performance of the Datel Modem No. 1A .. .. .	250
SPANTON, J. C., and SKINGLE, G. D. Test Equipment for the Datel Services—Datel Testers No. 1A, 2A and 2B .. .. .	262
Staff Changes .. .. .	66, 146, 228, 304
Stay Anchorages .. .. .	53
Submerged Repeater System, A 12 Mc/s .. .. .	199
Subscriber Push-Button Telephones Market-Research Trial .. .. .	200
Subscriber Trunk Dialling at Unit Automatic Exchanges, The Introduction of .. .. .	20
<b>T</b>	
Tandem Telephone Exchanges, Decentralization of London's Trunk and .. .. .	75
Tape-Recorder, A Precision Magnetic .. .. .	55
TAYLOR, P. Materials and Fire Hazards .. .. .	16
Technical Support Unit, New Status of the .. .. .	18
Tents, Joiners', No. 3 and 4, New Joiners' Tents— .. .. .	52
Test Equipment for the Datel Services—Datel Testers No. 1A, 2A and 2B .. .. .	262
THARBY, R., SENIOR, R. C., and COLYER, J. C. Gases in Underground Plant and Their Detection .. .. .	80

	PAGE NO.
THOMSON, W. E., and BREARY, D. Planning London's Future Telephone Network by Computer .. .. .	167
Transistors, A Clean Room for the Production of Silicon Planar .. .. .	34
TRIDGELL, R. H., and SMITH, N. G. Performance of the Data Modem No. 1A .. .. .	250
Trunk and Tandem Telephone Exchanges, Decentralization of London's .. .. .	75
12 Mc/s Submerged-Repeater System, A .. .. .	199
<b>U</b>	
Unit Automatic Exchanges, The Introduction of Subscriber Trunk Dialling at .. .. .	20
Use of X-Ray Diffraction to Study Defects Occurring During Silicon-Device Manufacture, The .. .. .	94
<b>W</b>	
WASE, A. E. N., and JACKSON, B. S. The New Leaffield Radio Station (Part 4) .. .. .	267
WATT-CARTER, D. E. The New Leaffield Radio Station (Part 1) .. .. .	130

	PAGE NO.
WATT-CARTER, D. E., and WHEELER, L. K. The Lincompex System for the Improvement of H.F. Radio-Telephone Circuits .. .. .	163
Western District Office, The New Post Office Railway Station at the New .. .. .	12
WHEELER, L. K., and WATT-CARTER, D. E. The Lincompex System for the Improvement of H.F. Radio-Telephone Circuits .. .. .	163
WILLIAMS, H. The Commonwealth Telecommunications Conference, 1965-1966 .. .. .	116
WILLIAMS, M. B. The Characteristics of Telephone Circuits in Relation to Data Transmission .. .. .	151
WILSON, W. T., and FAGG, S. L. F. Laying Plastic Ducts by Molcplough .. .. .	104
WOOLLEY, F., and KING, R. E. The Repair of Faulty Loading Pots .. .. .	5
<b>X</b>	
X-Ray Diffraction to Study Defects Occurring During Silicon-Device Manufacture, The Use of .. .. .	94

#### BOARD OF EDITORS

J. H. H. MERRIMAN, O.B.E., M.Sc., A.Inst.P., F.I.E.E., Chairman.  
 L. F. SCANTLEBURY, O.B.E., Whit.Sch., A.C.G.I., D.I.C., F.I.E.E.  
 W. J. E. TOBIN, O.B.E., B.Sc.(Eng.), A.C.G.I., D.I.C., F.I.E.E.  
 E. W. AYERS, B.Sc.(Eng.), M.I.E.E.  
 E. J. MARKBY, M.I.E.E.  
 E. HOARE, B.Sc., F.I.E.E.  
 A. G. LEIGHTON, B.Sc.(Eng.), M.I.E.E., Managing Editor.  
 J. MARTIN, B.Sc.(Eng.), M.I.E.E., Deputy Managing Editor.  
 N. J. H. NINIM, B.Eng., } Assistant Editors.  
 R. A. SUDELL, }  
 B. FARR, A.B.I., Secretary-Treasurer.  
 R. P. MYHILL, Advertisement Manager.

#### Copyright

The entire contents of this Journal are covered by general copyright, and special permission is necessary for reprinting long extracts, but editors are welcome to use not more than one-third of any article, provided that credit is given at the beginning or end thus: "From *The Post Office Electrical Engineers' Journal*."

The Board of Editors is not responsible for the statements made or the opinions expressed in any of the articles in this Journal, unless such statement is made specifically by the Board.

#### Subscriptions and Back Numbers

The Journal is published quarterly, in April, July, October and January, at 3s. per copy; the post-paid price is 4s. per copy (16s. per year) via inland mail, and 4s. 3d. (17s., or 2 dollars 75 cents Canada and U.S.A., per year) via overseas mail. Back numbers will be supplied, if available, price 3s. (4s. inland mail, 4s. 3d. overseas mail) per copy. With the exception of April and

July 1964 and July 1965 Journals, copies of the October 1965 and all earlier Journals are no longer available. Orders should be sent to *The Post Office Electrical Engineers' Journal*, G.P.O., 2-12 Gresham Street, London, E.C.2.

Employees of the British Post Office can obtain the Journal through local agents.

#### Binding

Readers can have their copies of volumes bound at a cost of 15s. by sending the complete set of parts to the local Post Office distribution agent or to *The Post Office Electrical Engineers' Journal*, G.P.O., 2-12 Gresham Street, London, E.C.2.

#### Remittances

Remittances should be made payable to "*The P.O.E.E. Journal*" and should be crossed "& Co."

#### Advertisements

All correspondence relating to advertisement space reservations, copy, proofs, etc., should be addressed to the Advertisement Manager, *The Post Office Electrical Engineers' Journal*, G.P.O., 2-12 Gresham Street, London, E.C.2.

#### Communications

With the exceptions indicated above, all communications should be addressed to the Managing Editor, *The Post Office Electrical Engineers' Journal*, G.P.O., 2-12 Gresham Street, London, E.C.2. Telephone: HEADquarters 1234.

#### Model Answer Books

Books of model answers to certain of the City and Guilds of London Institute examinations in telecommunications are published by the Board of Editors. Details of the books available are given at the end of the Supplement to the Journal.





# Marconi is advanced space communication

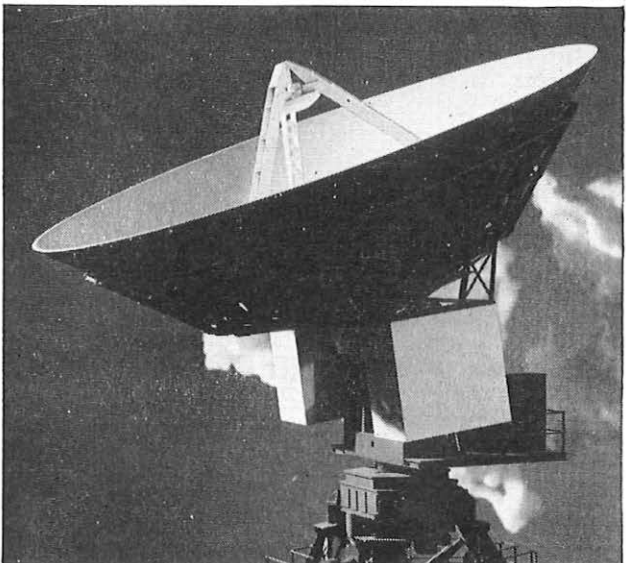
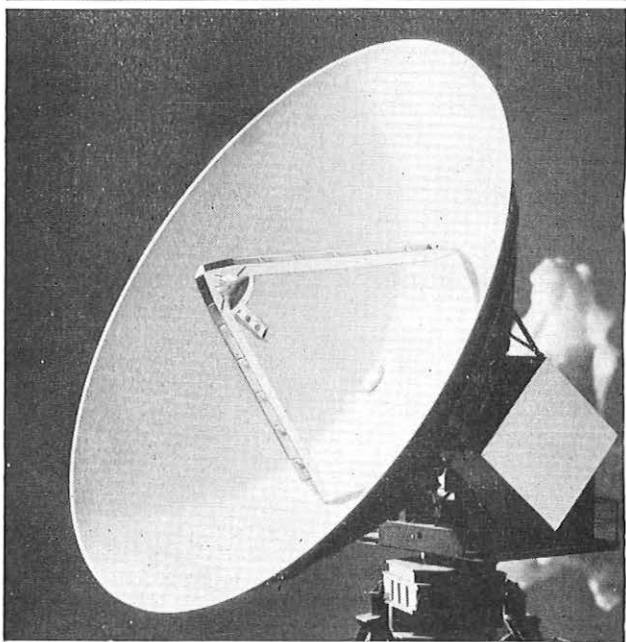
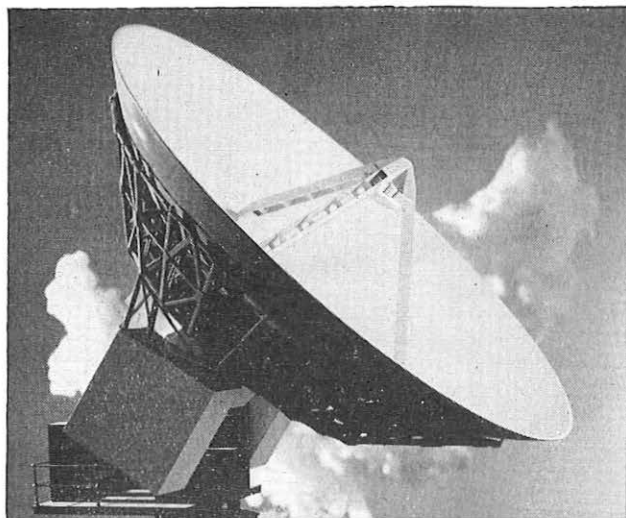

Britain's first overseas civil satellite communication ground station has been built by Marconi on Ascension Island for Cable and Wireless Limited. Marconi has also supplied Britain's first three military space communication stations.

Marconi space capability is based on long experience in all the elements required by communication systems via synchronous and random orbit satellites—computers for traffic handling and aerial direction, highly accurate aerial and servo control systems, ultra high frequency transmitters and extremely sensitive receivers. Marconi has a lifelong experience in planning, designing, manufacturing, installing and commissioning complete operational systems anywhere in the world.

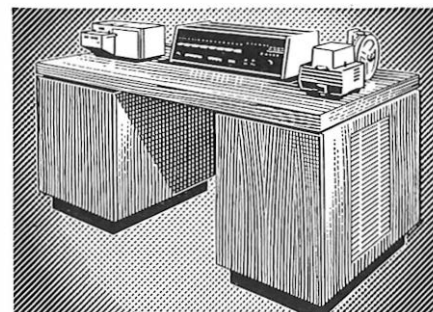

Marconi Myriad computer—a vital part of many Marconi space communication systems.

## Marconi space communication systems

AN 'ENGLISH ELECTRIC' COMPANY

The Marconi Company Limited, Space Communication Division, Chelmsford, Essex, England

LTD/PSI

# TCL *cables speak all languages...*



*TCL cables being laid in the main business centre of Hong-Kong*

TCL is very much in the export business. TCL serves the British Post Office and organisations throughout the world. Current overseas orders exceed £7 million. TCL produces all types of dry core and plastic cables, supplies Coaxial cables capable of handling some 2 million high frequency channels and over 3 million conductor miles annually. TCL has, in fact, the largest telephone cable plant in Europe. Why are TCL cables in such demand? Because they are reliable and always meet specification. A complete technical advisory service is readily available.

# TCL

Telephone Cables Limited, Dagenham, England  
 Telephone: DOMinion 6611 Cables: Drycore Dagenham  
 THE ORGANISATION WITH 130 YEARS' EXPERIENCE

# SILICON PLANAR n-p-n TRANSISTORS ZT190 SERIES

GENERAL PURPOSE TRANSISTORS  
COMBINING LOW COST AND VERSATILE  
PERFORMANCE

ZT191 has Qualification Approval to Specification CV8615



ACTUAL SIZE  
BS3934  
SO-12A/SB3-6B  
JEDEC TO-18

**FERRANTI**  
*First into the Future*

RATINGS AND CHARACTERISTICS	ZT190	ZT191	ZT192	ZT193	Unit	Test Conditions
Max. Collector-Base Voltage	20	20	40	40	V	
Max. Collector-Emitter Voltage	15	20	20	20	V	
Max. Dissipation	300	300	300	300	mW	at 25°C
Max. Collector-Base Leakage Current	200	50	50	50	nA	at 25°C $V_{CB}=20V$ $I_E=0$
Max. Collector-Emitter Saturation Voltage	350	200	200	200	mV	$I_C=10mA$
D.C. Current Gain	50-190	35 min.	38-120	75-200		$I_C=10mA$ $V_{CE}=0.4V$
Min. Transition Frequency	200	300	300	300	Mc/s	$I_C=10mA$ , $V_{CE}=10V$ , $f=100$ Mc/s
Max. Storage Time	156	300	200	200	nS	$I_C=1B_1=1B_2=10mA$

Write now for full details to: FERRANTI LTD · GEM MILL · CHADDERTON · OLDHAM · LANCS. Telephone (061) MAIN 6661

FE272

# NOW-the PLESSEY 700 radio telephone with 19" rack mounting

(and it's even easier to install and maintain)

A radio telephone link is cheaper and easier to install than a good quality copper wire circuit at 3 miles. For emergency uses or over difficult terrain line systems may be impossible or too costly to install. In any situation Plessey can provide fully line integrated radio telephone systems with these benefits—

## low installation costs, less maintenance, greater reliability

And now a rack mounted version with even greater access—the front panel hinges down for routine maintenance checks. Full subscriber and exchange integration facilities are provided by plug-in circuit cards which can easily be changed to meet different requirements. 5 watt amplifier, party line operation, subscriber check metering and coin box operation can also be incorporated. The 700R operates in the frequency bands up to 470 Mc/s, is fully transistorised and can be powered by batteries, ac/dc converter, thermoelectric or solar converters. Plessey offers a comprehensive system planning, surveying and installation service. For further information contact: AT & E (Bridgnorth) Division, The Plessey Company Limited, Bridgnorth, Shropshire, England. Telex: 33373.

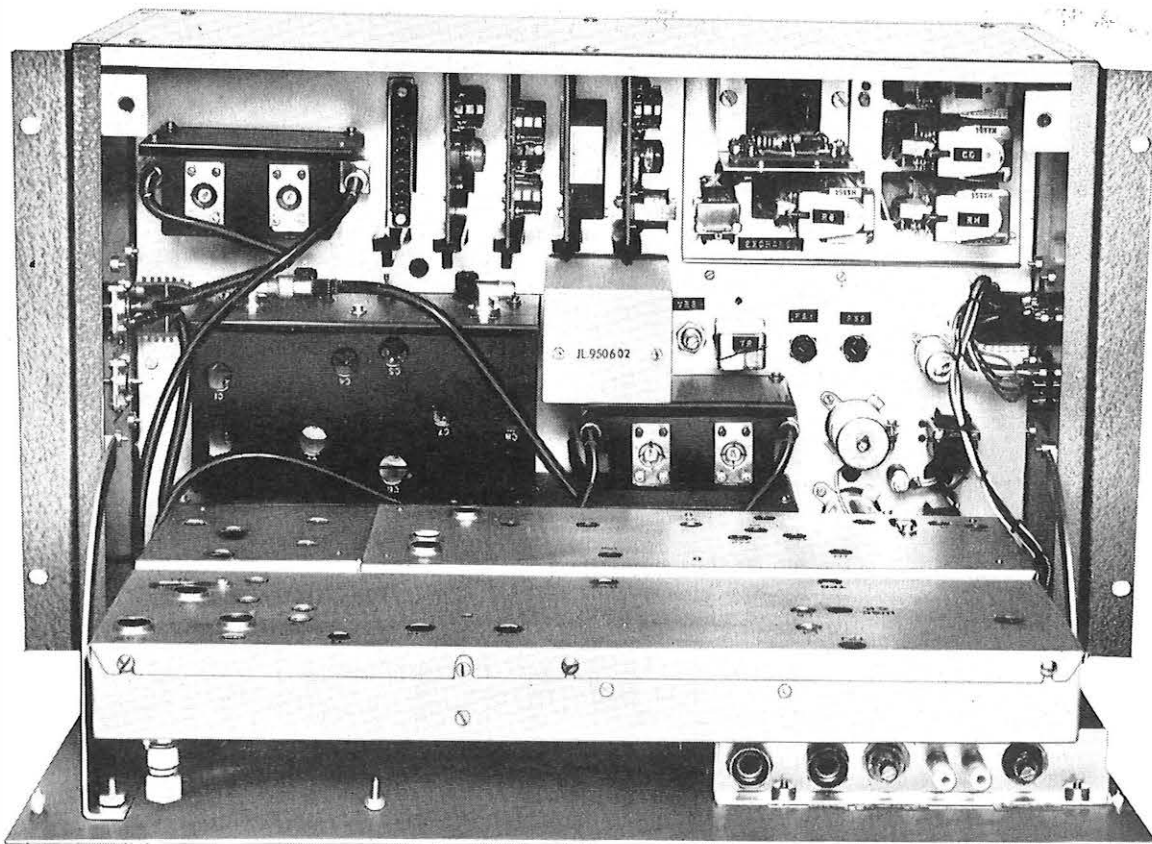

**PLESSEY Electronics** 

## Facts speak for themselves

The installed cost per circuit-mile of submarine telephone cable systems has fallen from nearly \$600 in 1956 to less than \$25 today. Cable systems have an expected life of at least twenty years and annual maintenance costs are very low.

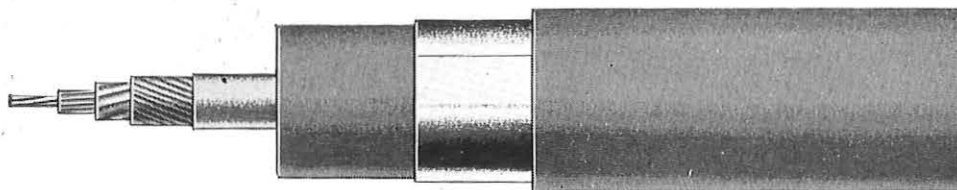

## Submarine Cables Limited

(An AEI Company) GREENWICH, LONDON S.E.10

We plan, supply and install complete transocean systems, fully transistorised and capable of handling 640 simultaneous conversations.

# MST SUCCESS

**SALES NOW  
EXCEED  
£8,000,000**

**More and more  
countries are buying  
Marconi Self-Tuning  
systems . . .**

and one good reason is:

## **GREATLY INCREASED TRAFFIC- CARRYING EFFICIENCY**

- Great reduction in 'outage' time.
- Earlier generation equipment in use today can take up to 30 minutes to complete a routine frequency change.
- **MST takes less than 1 minute for the same operation.**
- Increased revenue results from this very significant improvement.
- A.F.C. can be entirely dispensed with when operating with other systems of comparable stability.



**and other good reasons include:**

### **Reduced capital outlay**

MST designs reduce demands for space, and need for standby equipment. Installation costs are decreased.

### **Increased reliability**

Maximum use of solid state techniques plus the use of wideband amplifiers reduces number of moving parts, gives higher reliability and longer equipment life.

### **Economy of manpower**

High equipment reliability together with full remote control facilities permit unmanned station working. Complete h.f. systems can be controlled by one man.

### **World-wide acceptance**

30 countries throughout the world have ordered more than £8,000,000 worth of MST equipment to improve their communications services.

# **Marconi** telecommunications systems

AN 'ENGLISH ELECTRIC' COMPANY

The Marconi Company Limited, Radio Communications Division, Chelmsford, Essex, England

LTD/H77

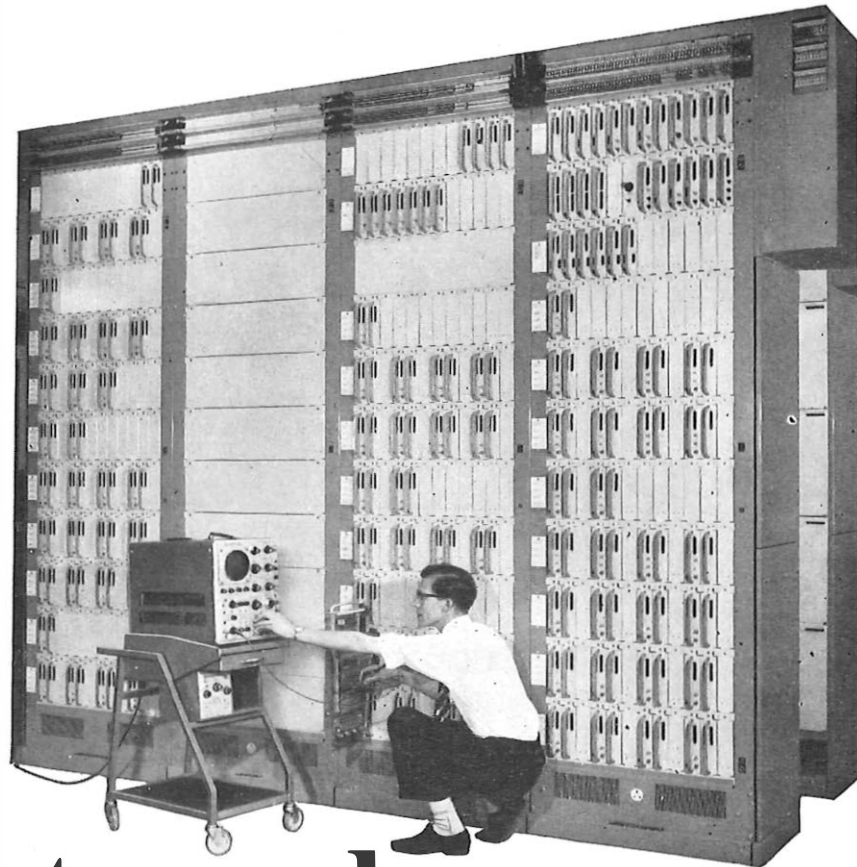

# In 1966 Ambergate made history as Europe's first production electronic exchange in service.

In formally opening the new TXE2 electronic exchange at Ambergate, Derbyshire, England in December 1966 the British Post Office made history.

It was the first electronic exchange in Europe to come off a quantity production line.

TXE2 (marketed overseas by Plessey Telecommunications as PENTEX\*) was developed in collaboration with the BPO and British Telecommunications Manufacturers who are parties to the Joint Electronic Research agreement. The system was adopted in February 1966 for future exchanges in the U.K. of up to about 2,000 lines, with a total traffic of 230 erlangs, and is now in full

production by Plessey in order to meet the substantial orders placed by British and other P and T authorities.

Designed for unattended operation, Pentex is based on the space division principle, with reed relay components for path switching. Occupying half the floor space of a corresponding electro-mechanical exchange, the system allows for easy changes, extensions and the introduction of a large number of additional services.

Automatic fault checking and indication and a minimum of moving parts make Pentex an inherently reliable system.

For further details please write for the Pentex brochure to:—

The Plessey Company Limited  
Telecommunications Group  
Electronic Switching Division  
Edge Lane, Liverpool 7, England  
Tel: Stoneycroft 4830 Telex: 62267

Incorporating Automatic Telephone and Electric Company Limited, Ericsson Telephones Limited (Etelco Limited) and Communication Systems Limited.

\* Registered Trade Mark.



## PLESSEY Telecommunications

# Adamin

## MICRO SOLDERING INSTRUMENTS

13 models

5 WATTS TO 24 WATTS

- **HIGH PERFORMANCE**  
360/375°C. Some models 450°C and 500°C.
- **MINIATURE**  
Overall lengths  $6\frac{1}{4}$  in. to  $7\frac{3}{8}$  in.  
Bits down to 0.040 in. diam.
- **LIGHT**  
Weights from  $\frac{1}{4}$  oz. to 1 oz. without flex.
- **RAPID HEATING**  
30 seconds to 2 minutes.
- **ABSOLUTELY SAFE**  
A & B types low voltage.  
C types fully earthed and flash tested.

*Literature on request*

## LIGHT SOLDERING DEVELOPMENTS LTD

28 Sydenham Road, Croydon, Surrey  
Telephone: CRO 8589 and 4559



## PITMAN BOOKS

### Silicon and Germanium Power Rectifier Technology

R. Wells

This work covers the production testing of diodes, the electrical design of rectifier equipment, protection and cooling and testing of complete equipment. 47s 6d net.

### The Silicon Gate-controlled Switch

Edited by G. J. Pridham

Aimed at HNC and higher level electronics students, this short monograph was originally presented as a symposium by experts from four major electronics companies. The device is a transistor-type mechanism, recently developed, which has found wide application in computer and other electronic circuitry. 12s 6d net.

### Radio and Electronics

Edited by J. H. Reyner

The steadily increasing use of electronic techniques creates a serious problem for the young engineer or craftsman who wishes to extend his knowledge. This work provides information of a highly practical nature, avoiding highly theoretical considerations and concerning itself mainly with fundamental principles. Volume 2 is mainly devoted to practical applications.

January 31st

Two-volume set 6 gns net.

39 Parker Street London WC2

## VALUABLE FREE BOOK

Tells You How to Pass Your C. & G. Examination at First Attempt!

All Post Office personnel who are anxious to obtain early promotion should at once send for a copy of our handbook "ENGINEERING OPPORTUNITIES" which, among other intensely interesting matter, describes our unique methods of preparation for the CITY AND GUILDS EXAMINATIONS for the Telecommunication Technicians' Certificate and for individual subjects: Mathematics, Engineering Science, Engineering Drawing, Elementary Telecommunication Practice, Telecommunication Principles, Radio and Line Transmission, Telegraphy and Telephony, Line Plant Practice. It also contains details of our courses covering the G.C.E. subjects required for promotion to Assistant Engineer, Telecommunication Traffic Superintendent and other grades; and the City and Guilds examinations in Electrical Engineering Practice, the A.M.I.E.R.E. and A.M.S.E. Examinations, in addition to a wide range of non-examination courses in all branches of engineering—Radio and Electronics, Electrical, Mechanical, etc.

We also provide tuition for the Radio Amateurs' Examination and the P.M.C. Certificates for Radio Operators, with or without Morse training. Details are given in the handbook.

On "SATISFACTION OR REFUND OF FEE" terms

If you intend to make the most of your opportunities, you cannot afford to miss reading "ENGINEERING OPPORTUNITIES." It tells you everything you want to know to secure advancement, and describes many opportunities you may now be missing through lack of information. Send for your copy today—FREE and without obligation.

BRITISH INSTITUTE  
OF ENGINEERING TECHNOLOGY  
727D ALDERMASTON COURT,  
ALDERMASTON, BERKSHIRE

# BIET





**If the features you want can't be found  
in ordinary motors and generators,  
you're reading the right page**

**because E.D.C. make specials only**

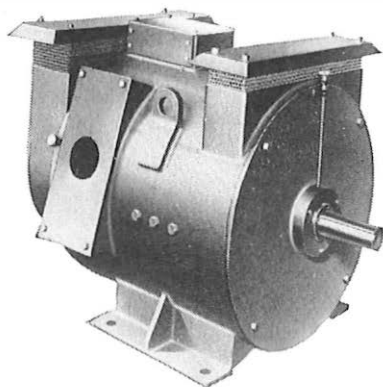

FOR EXAMPLE: D.C. motors up to 200 h.p. for particular voltages and specific speeds, which can be so watertight as to be submersible, or completely flameproof. They can be even made entirely in aluminium for light weight.

These same properties can also be specified for D.C. generators. We make these with outputs up to 150 k.w. and 600 volts. In other words, E.D.C. design and build *exactly* to your needs—in any quantity.

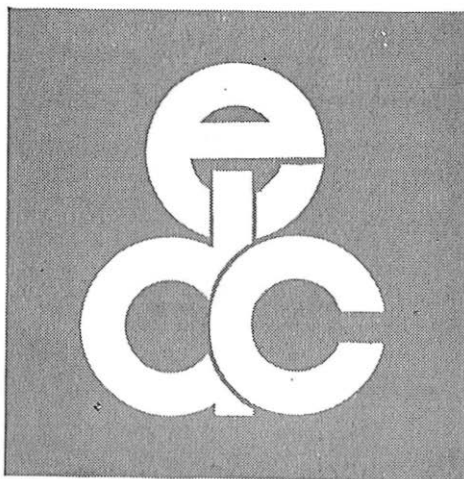
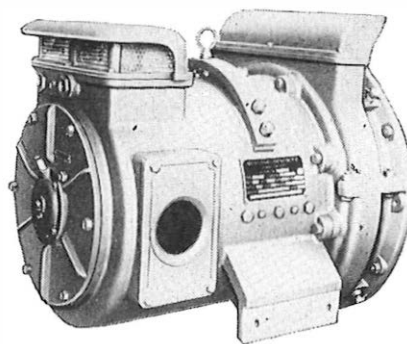

**ELECTRO-DYNAMIC CONSTRUCTION CO. LTD.**

ST. MARY CRAY, ORPINGTON, KENT.

Please send me more details of your purpose-made D.C. motors and generators.

NAME \_\_\_\_\_

COMPANY \_\_\_\_\_

ADDRESS \_\_\_\_\_

\_\_\_\_\_

# LITERATURE

## to help in your fight against corrosion

Building, Steelwork,  
Electrical, Maintenance  
and Plumbing.

The DENSO Anti-Corrosion Service offers a wide range of materials—tapes, cords and compounds—to cope with most anti-corrosion, waterproofing and sealing problems. To illustrate how DENSO can help in *your* particular industry, we offer a number of booklets each dealing with specific subjects. Complete and mail the coupon below for any that you require.

#### WINN & COALES LTD.

Denso House, Chapel Rd., London, S.E.27. Tel: GIP 7511  
Also at Manchester, Belfast and Dublin.  
Denso Agents throughout the World.

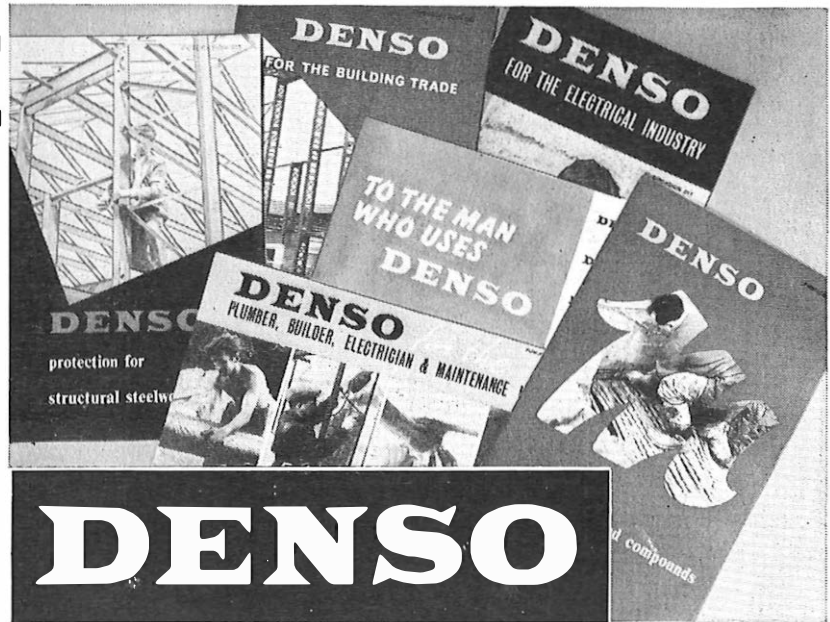

Please send me without obligation the following literature:

- Denso Mastics and Compounds  Denso for the Electrical Industry   
Denso for the Building Trade  Denso protection for structural steelwork   
Denso for the Plumber, Builder, Electrician & Maintenance Engineer

(tick where required)

NAME \_\_\_\_\_

ADDRESS \_\_\_\_\_

P.O.4.

## Eddystone

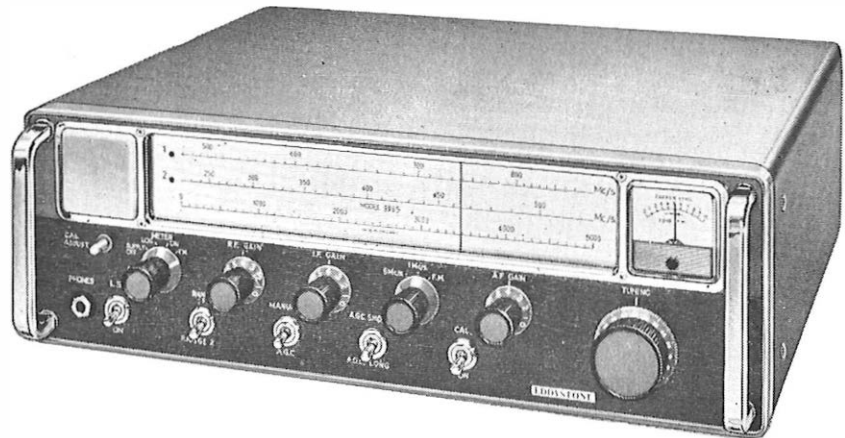

### 990S vhf/uhf communications receiver

The Eddystone model '990S' is a fully transistorized single conversion receiver for reception of a.m. and f.m. signals over the range 230 Mc/s to 870 Mc/s. Two separate r.f. heads are used incorporating trough-line circuits, the range switch energizing one or other unit according to the range selected.

The use of a high intermediate frequency (36.5 Mc/s) ensures good image protection and the alternative bandwidths provided permit reception of signals carrying amplitude, video or frequency modulation. A low impedance output at the intermediate frequency is available for driving ancillary equipment.

The audio frequency response is excellent, and a built-in monitor speaker is fitted, together with outputs for external speaker, telephone headset, and remote lines.

Operation is from standard a.c. mains 100/125 or 200/250 volts (40 to 60 c/s), which is transformed and rectified to 12 volts d.c. A socket is provided for direct input at 12 volts d.c., the current consumption being 0.3 to 0.5 amperes.

Other noteworthy features include the standard Eddystone precision gear-driven slow-motion tuning assembly; clear tuning scales; crystal calibrator; panel tuning meter; independent r.f. and i.f. gain controls; compact size; and light weight.



## Eddystone Radio Limited

Eddystone Works, Alvechurch Road, Birmingham 31  
Telephone: Priory 2231 Cables: Eddystone Birmingham Telex: 33708

LTD/ED13



## See the point ?

Cables less than half as thick as this pencil can be used to carry nearly 1,000 simultaneous conversations, *three times* the previous maximum, in a system developed by G.E.C. (Telecommunications) Limited.

This new fully semiconductored small-diameter coaxial-cable system, which has been under development for the past two years and has undergone extensive trials, has been ordered by the G.P.O. for use initially on about 40 links in Britain's trunk network. The installation of the first of these links, between Bournemouth and Salisbury in Southern England, was completed in record time, making the system the first of its kind to go into public service in Britain. The performance is well within the CCITT limits for this type of circuit. Since up to 960 conversations can be held over two cables each only 0.174in (4.4mm) in diameter, the system is particularly valuable in overcoming trunk call congestion.



**G.E.C.**

**Takes telecommunications  
into tomorrow**

G.E.C. (Telecommunications) Ltd.  
Telephone Works, Coventry, England

## EXISTING LINES **ONLY 2** CONVERSATIONS

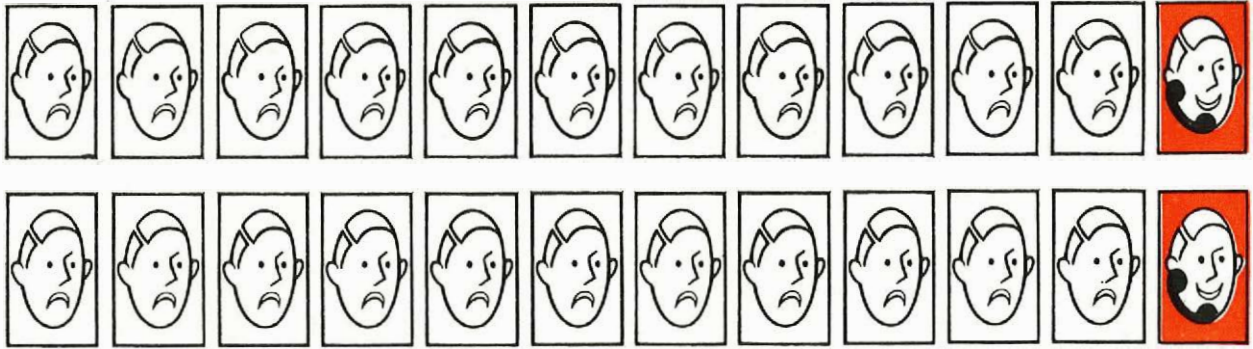

## SAME LINES **NOW 24** CONVERSATIONS



The number of conversations that can be carried over existing telephone cables can now be dramatically increased using the Pulse Code Modulation System developed by G.E.C. (Telecommunications) Limited.

G.E.C. have been working on the new system for about three years, and following extensive field trials in public service carried out by the G.P.O., P.C.M. systems are to be installed initially on about 70 links in Britain's telephone network.

The system enables cable circuits at present carrying only two conversations to carry 24 conversations, power-fed repeaters being installed at 2000-yard (1800-m) intervals to amplify the signal. The system is particularly suitable for towns and cities where it is more economical to expand the capacity of existing cables using P.C.M. equipment than to undertake the costly operation of laying additional cables.

High-quality speech circuits are provided even in areas subject to high noise conditions.



**Takes telecommunications  
into tomorrow**

G.E.C. (Telecommunications) Ltd.  
Telephone Works, Coventry, England

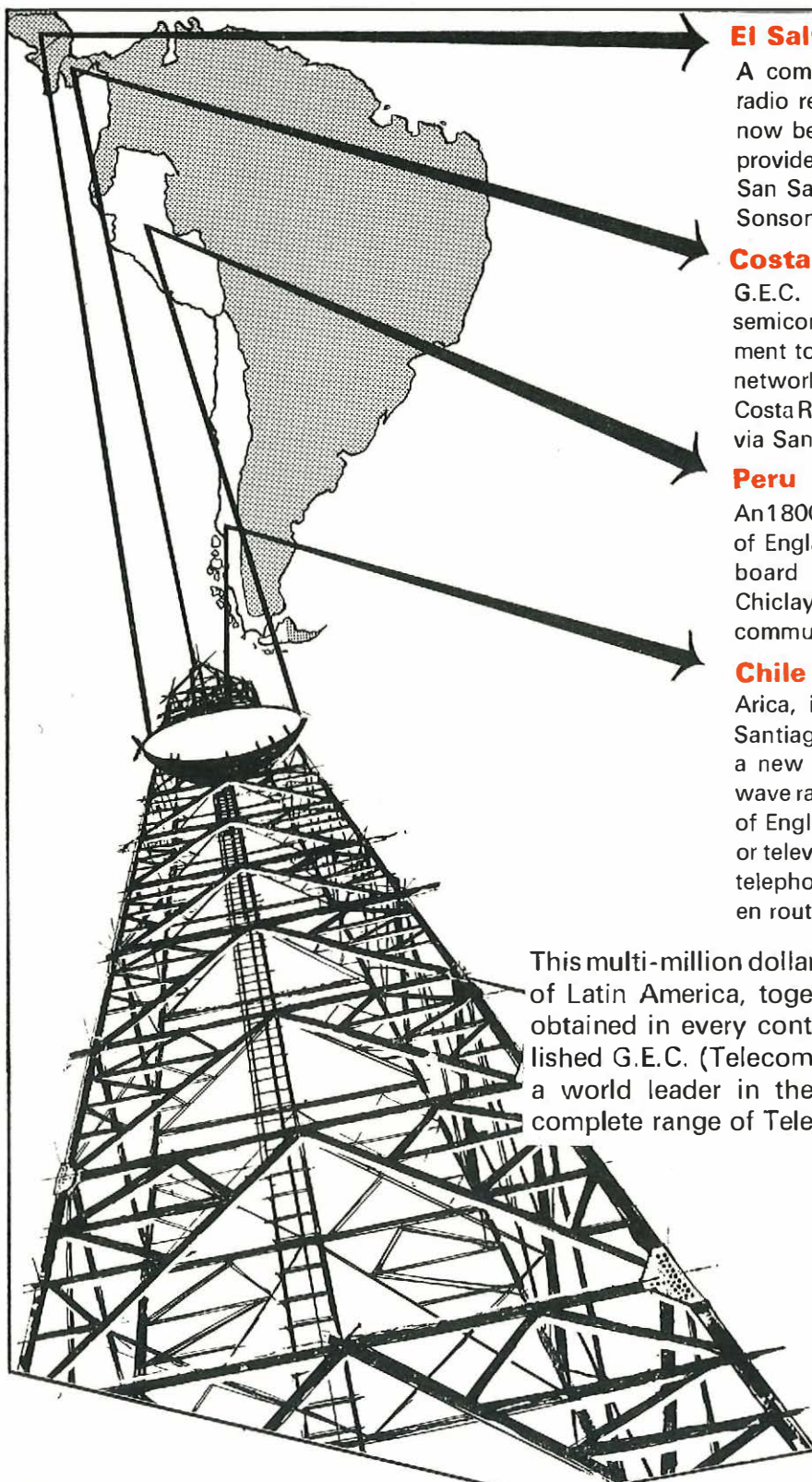

**El Salvador**

A completely semiconductored microwave radio relay system by G.E.C. of England is now being installed to span the country and provide telephone communication between San Salvador and San Miguel, Santa Ana, Sonsonate and Usulután.

**Costa Rica**

G.E.C. of England is supplying completely semiconductored microwave radio equipment to provide a telephone communication network linking all the principal towns of Costa Rica. The network extends from Liberia, via San José, down to Panama.

**Peru**

An 1800 km microwave radio system by G.E.C. of England, stretches along the Pacific seaboard linking Arequipa, Lima, Trujillo, Chiclayo and Piura in a nationwide telephone communication network.

**Chile**

Arica, in the northern zone of Chile, and Santiago, the capital, will soon be linked by a new completely semiconductored microwave radio network being supplied by G.E.C. of England. The network conveys telephone or television signals and in addition provides telephone communication for 21 other towns en route.

This multi-million dollar contribution to the development of Latin America, together with many other contracts obtained in every continent of the world, have established G.E.C. (Telecommunications) Ltd., of England as a world leader in the design and manufacture of a complete range of Telecommunications equipment.

**G.E.C. of England serves the progress of Central and South America**



**G.E.C. (Telecommunications) Ltd**  
Telephone Works, Coventry, England



The expedition, under the command of John McDouall Stuart, leaving Chambers Creek on 8th January 1862.

From originals held in the Archives  
Department of the Public Library of  
South Australia.



Point Stuart, where the coast was first reached on 24th July 1862.

# £2,000 REWARD

Over 100 years ago, the South Australian government offered £2,000 to the first person to cross to the Northern part of the continent. One of the main reasons for doing so was to bring about the proposed link with the cable and telegraph line to Europe.

The reward was eventually won by John McDouall Stuart, who succeeded in finding a route across the centre of Australia on his sixth and final expedition.

More than a century later, a new £3,200,000 transcontinental microwave communications system, linking eastern and western Australia, is to be supplied by G.E.C. (Telecommunications) Ltd., of Coventry, England. The system, one of the longest civil microwave links in the world, will be in service in 1969. By this date, telephone traffic over the 1500 mile route linking Perth and Adelaide—as far apart

as London and Moscow—will amount to about one million calls a year.

Initially, the system will provide two bothway radio bearer circuits, one main and one standby, with a capacity of 600 telephone circuits. The standby circuit may also be used to provide a television link giving a nationwide T.V. network. In addition a separate T.V. link will be provided between Northam, near Perth, and Kalgoorlie.

Completely semiconductor equipment, operating in the 2000 Mc/s frequency band, will ensure maximum reliability and minimum maintenance of the equipment throughout the mainly virgin country which it will traverse. Over a hundred years after John McDouall Stuart's achievement, G.E.C. (Telecommunications) Ltd. will forge new links across the continent.

## Takes telecommunications into tomorrow

G.E.C. (Telecommunications) Ltd.  
Telephone Works, Coventry, England

# TELEGRAPH Type T24P

**Compact 24 channel VF  
telegraph terminal equipment  
sets new standards of  
system flexibility, low first  
cost and reliability**

TMC Type T24P equipment embodies the latest design and construction techniques and is suitable for the provision of data or telegraph circuits. The use of 62 Type equipment practice and the direct modulation of each channel allows the system to be readily extended by plug-in units from 1-24 channels, thus offering great flexibility of operation. Write now for full details of TMC Type T24P equipment. It can be installed with confident expectation of years of trouble free service and increasing utilisation.

- All channels directly modulated
- Up to 96 bauds low distortion working
- Fully transistorised
- Compact (five 24-channel terminals can be mounted on a 9 foot rack)
- Optional pilot control and rack mounted test equipment
- Simplified installation and maintenance

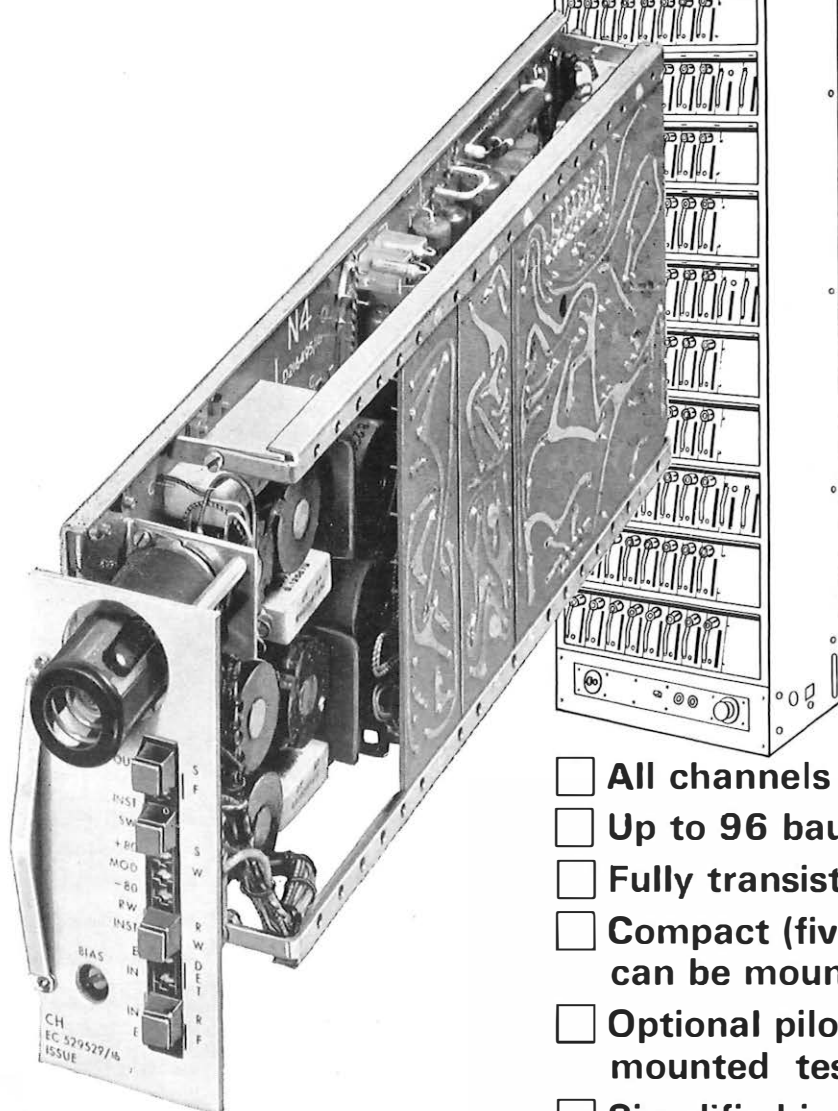

## TMC

### TELEPHONE MANUFACTURING COMPANY LIMITED

TRANSMISSION DIVISION

Sevenoaks Way St Mary Cray Orpington Kent Telephone: Orpington 27020

Cables: Bubastis London Telex: 28115

TMC is a registered trade mark

A member of the  group of companies

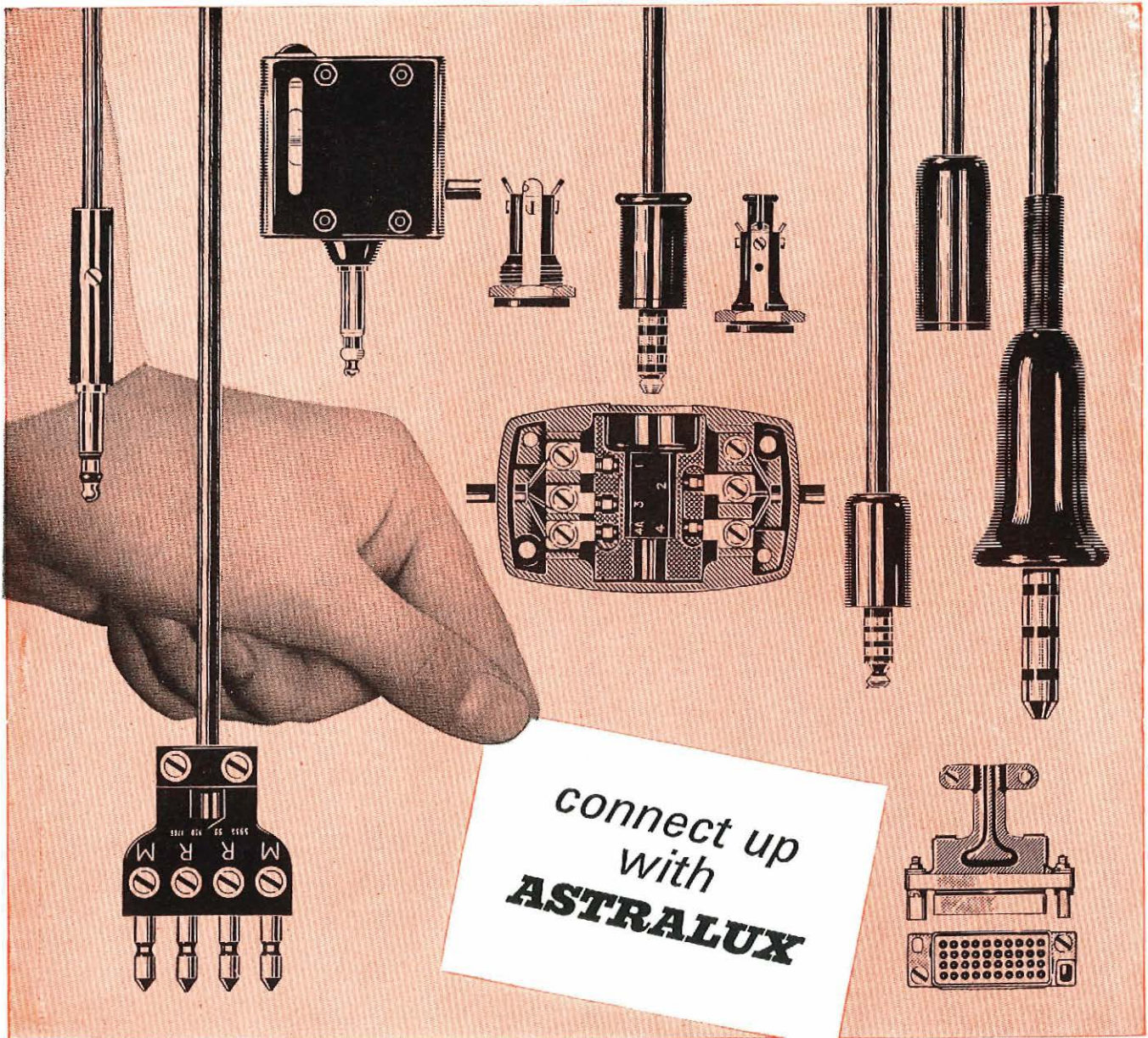

PLUGS, SOCKETS, JACKS – in all sizes and for every purpose – are made by the Special Products Division of Astralux Dynamics Ltd. They're chosen by the British Government and approved by the Post Office and Aircraft Industry. The special Astralux design service for prototype models is used by these organisations and by private industry. You can rely on Astralux efficiency and technical accuracy to produce equipment strictly to specification – and quickly. Plugs, Sockets and Jacks are just some of the products of a company streamlined to serve world-wide industry today. Learn more about what Astralux can offer *you*. Write to us for descriptive literature.

**Illustrated from left to right**

- 1** Plug 316    **2** Plug 406
- 3** Plug 235    **4** Jack 84A
- 5** Plug 420    **6** Jack 95A
- 7** Socket 626 with Hex. Nut
- 8** Plug 671    **9** Socket 626
- 10** Plug Electrical 119
- 11** 40-way Connector  
male and female

***ASTRALUX*** dynamics limited



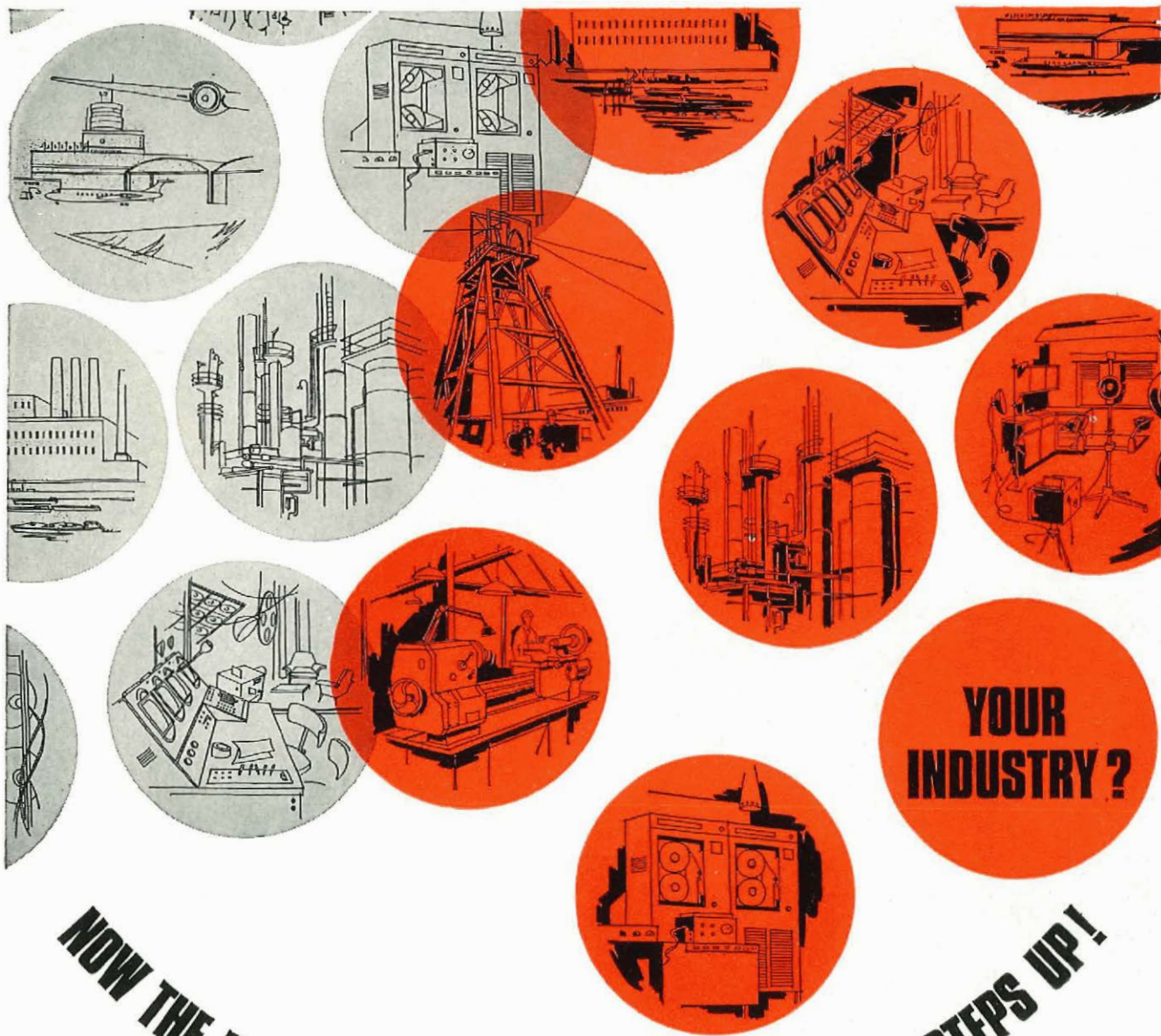

**YOUR  
INDUSTRY?**

**NOW THE BIG SWING TO ASTRALUX V.S.T. REALLY STEPS UP!**

**Everywhere Astralux Voltage Stabilising Transformers outperform and outdate conventional C.V.T. systems**

**HERE'S WHY ASTRALUX V.S.T. IS REPLACING C.V.T. IN INDUSTRY AFTER INDUSTRY:**

**Better Performance.** That means Improved Output Voltage Stability—output voltage maintained within  $\pm 0.5\%$  for input voltage changes of  $+10\%$ — $20\%$ . Even when the voltage fluctuation is as great as  $+10\%$  to  $-30\%$  the V.S.T. will maintain the output voltage to within  $\pm 1\%$ . ● **Latest Materials.** High temperature (Class F) materials give optimum reliability and increased safety margins on operating temperatures. ● **Low external field** The latest techniques in magnetic core design give improved performance, coupled with high efficiency, while still offering low external fields. ● **Stable Voltage—Stable Prices.**

ASTRALUX prices remain stable over long periods, so costing a job ahead is facilitated with this advanced system. ● **Over 10,000 models!** The ASTRALUX V.S.T. Standard Range consists of ten basic models with over a thousand variations on each. *No other manufacturer* offers such a choice, or can offer such economical prices. ● **Low Cost Specials.** You can order V.S.T. 'specials' at little more than the cost of standard units. Our design department will be happy to prepare prototypes to your specification, for incorporation into equipment under development. Free illustrated booklet giving full details of ASTRALUX V.S.T. from

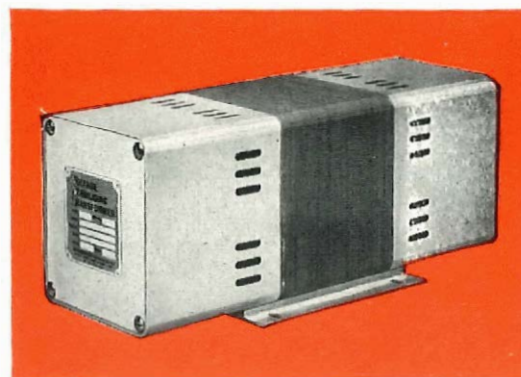

**ASTRALUX** dynamics limited TRANSFORMER DIVISION • BRIGHTLINGSEA • COLCHESTER • ESSEX • TEL. BRIGHTLINGSEA 2617/6.

# New Receiver

## *PLESSEY PR155*

### *MF/HF Communications Receiver gives*

#### *PRECISE TUNING*

Better than 100 c/s resolution

#### *EASE OF OPERATION*

Two tuning controls

#### *HIGH STABILITY*

5 c/s short term

#### *WIDE FREQUENCY RANGE*

60 kc/s — 30 Mc/s

#### *LOW RADIATION*

Less than 5 microvolts

#### *VERSATILE*

Multi-mode, including SSB

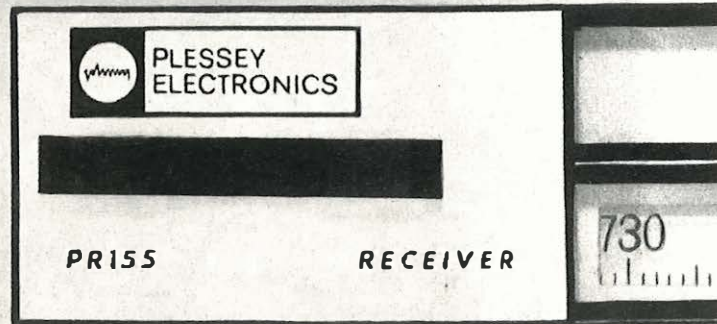
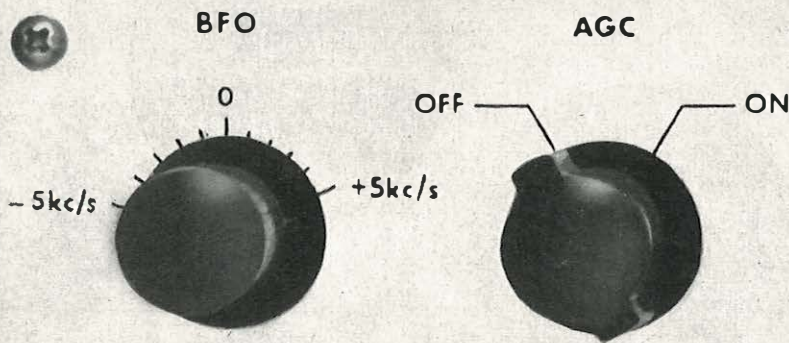

AUDIO GAIN



IF GAIN



MEGACYCLES



PHONES



BANDWIDTH

6 kc/s — 4  
300 c/s — 5 FILTER  
SSB — 6

SLOW —

# rom PLESSEY

## ook at a few of the PR155's outstanding features

parate controls for IF and AF gain. Fast, o-knob tuning covers the whole range 1 kc/s to 30 Mc/s.

vo-speed control of kilocycle tuning knob ows fast or slow-motion drive for positive, curate and vibration-proof tuning without ecklash.

witch selection of CW, AM, USB and LSB us two spare positions for other modes to it customer's special requirements.

andwidths of 300 c/s, 3 kc/s (SSB) and kc/s. Three spare positions for customer's ecial requirements.

- \* Easy-to-read illuminated tuning scales with effective total length of 175ft. (53m.) provide resolution of 100 c/s.
- \* Unique form of automatic gain control, with 20 m/sec rise time, 400 m/sec hang time and 100 m/sec decay.
- \* Variable BFO 5 kc/s above or below the carrier.
- \* Modular construction for rapid servicing.
- \* Panel meter monitors either RF level or audio output to line.

Write for a brochure, which gives details and full specification, to :

The Plessey Company Limited  
Radio Systems Division  
Ilford, Essex, England  
Telex: 23166

**PLESSEY**  
**Electronics**



PE(E)4K

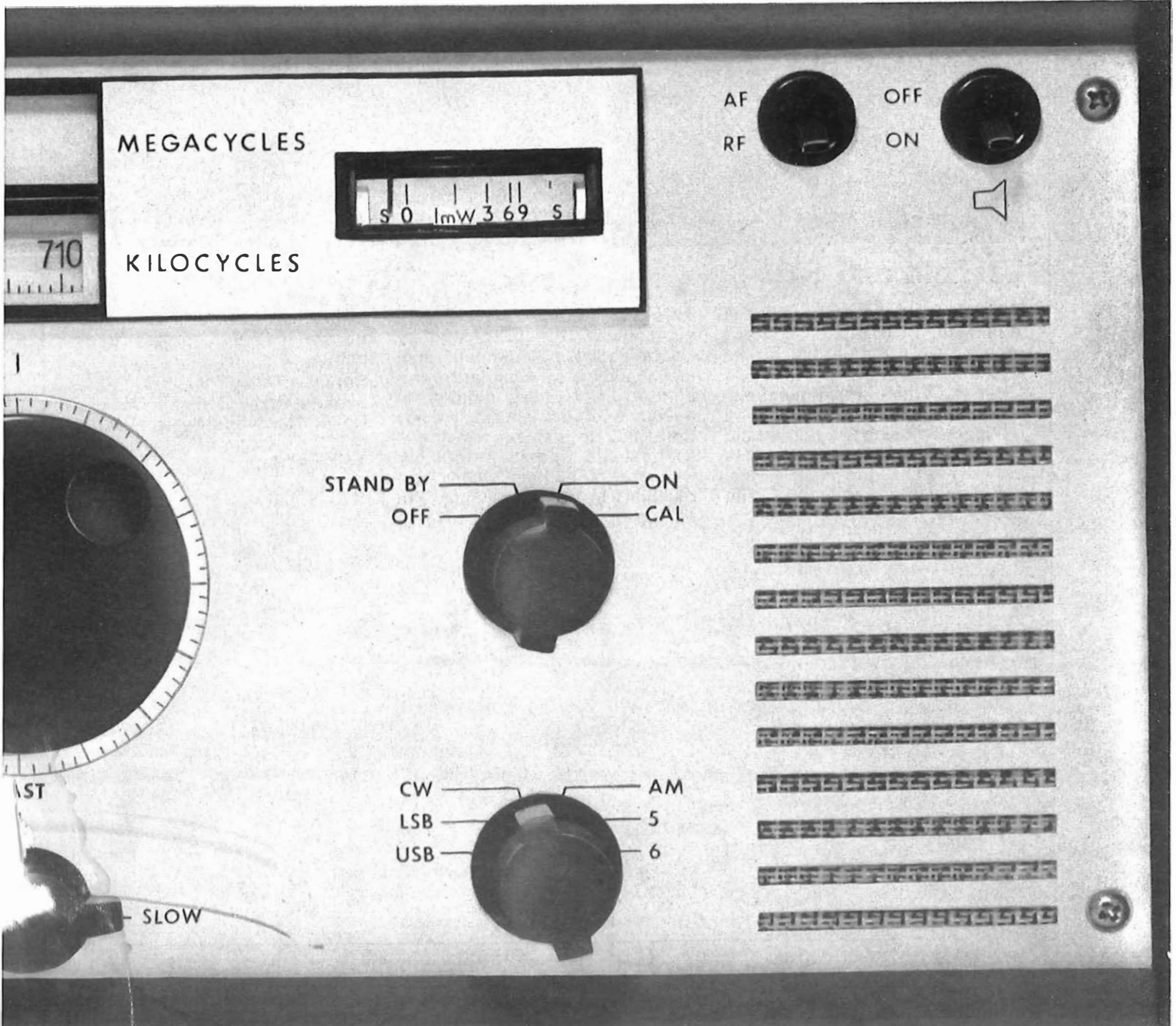

# STC Telecommunications Review



## Leaffield and STC

When Mr. Joseph Slater MP, the Assistant Postmaster General, pressed the button at the formal opening ceremony of the new GPO Radio Station at Leaffield, this simple, but significant action inaugurated comprehensive radio telegraph, telephone and press services to East and West Africa, the Middle East, India and South East Asia.

This new station, with its eighteen automatically tuned transmitters and associated equipment built and installed by Standard Telephones and Cables Limited, is designed to principles evolved by the GPO to achieve maximum economy in operation together with the highest efficiency and reliability in traffic handling. The station represents a major advance

toward the ideal of a completely unattended high power transmitting complex.

Standard Telephones and Cables Limited, Radio Division, Oakleigh Road, New Southgate, London N.11. Telephone: ENTerprise 1234. Telex: 261912.



## Bringing people together is our business

Through Step-by-Step, Crossbar and Electronic Switching Equipment

Nearly five million lines of STC 'Step-by-Step' equipment are already in world service. Today, over 10,000 skilled workers are employed in its production.

Complete development and manufacturing facilities are now being established for the world's most successful Crossbar system. At present, over 1½ million lines of this system are operating in 65 countries.

As an equal member of the Joint Electronic Research Committee, STC is well to the fore in the field of electronic switching—the system of the future.

Through these activities, STC is maintaining its world-wide lead in telephone engineering. Advice on the supply of equipment is available through STC consultancy services. And the installation of new exchanges is carried out by

expert teams of engineers. It's a world-wide service, too. STC have associate companies in 51 countries.

Standard Telephones and Cables Limited, Telephone Switching Group, Oakleigh Road, New Southgate, London N.11. Telephone: ENTERprise 1234. Telex: 21612.

world-wide telecommunications and electronics

# STC

**ADCOLA** SOLDERING  
PRODUCTS LIMITED  
(Regd Trade Mark) EQUIPMENT

FOR  
 TOTAL EFFICIENCY

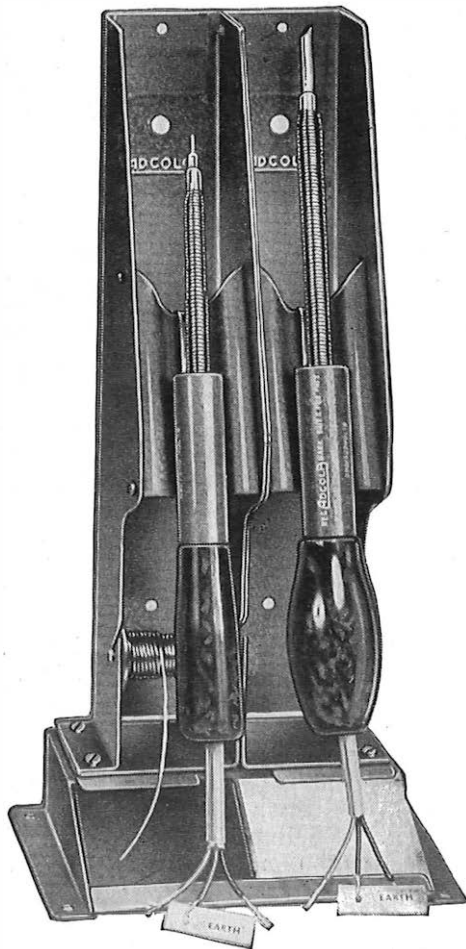

FOR CATALOGUES APPLY DIRECT TO SALES DEPT

**ADCOLA PRODUCTS LTD.**  
 ADCOLA HOUSE  
 GAUDEN ROAD  
 LONDON, S.W.4

Telephone: MACAULAY 0291/3

Telegrams: SOLJOINT, LONDON S.W.4

**MICROPHONES**  
**ACCESSORIES**  
**TRANSISTORISED "RADIOMIC"**  
**and other EQUIPMENT**

Top ranking quality  
 Top ranking performance

**LUSTRAPHONE**

St. George's Works  
 Regent's Park Road, London, N.W.1  
 Telephone: PRImrose 8844

**MODEL ANSWER BOOKS**

CITY AND GUILDS OF LONDON INSTITUTE  
 TELECOMMUNICATION TECHNICIANS' COURSE

Four model answer books are available, each covering one of the following subjects:

**TELECOMMUNICATION  
 PRINCIPLES A**

**TELECOMMUNICATION  
 PRINCIPLES B**

**ELEMENTARY  
 TELECOMMUNICATION  
 PRACTICE**

**RADIO AND LINE  
 TRANSMISSION A**

Price 7/6 each (Post Paid 8/-)

Orders may be sent to the Journal Local Agents or to:

The Post Office Electrical Engineers' Journal,  
 G.P.O., 2-12 Gresham Street, London, E.C.2

## Switch over to Reliable Relays

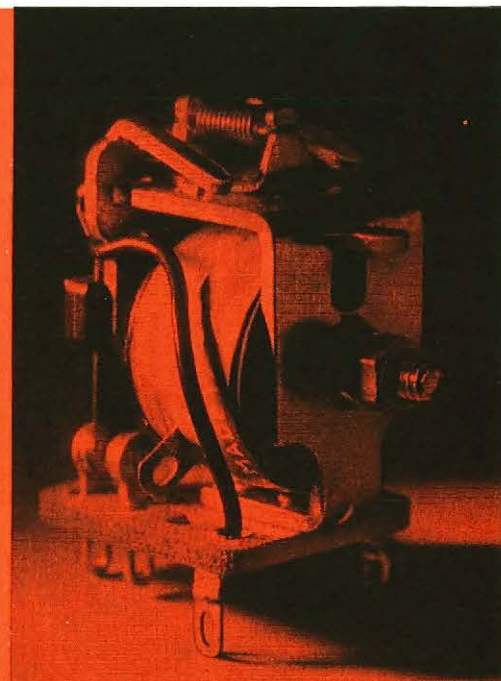
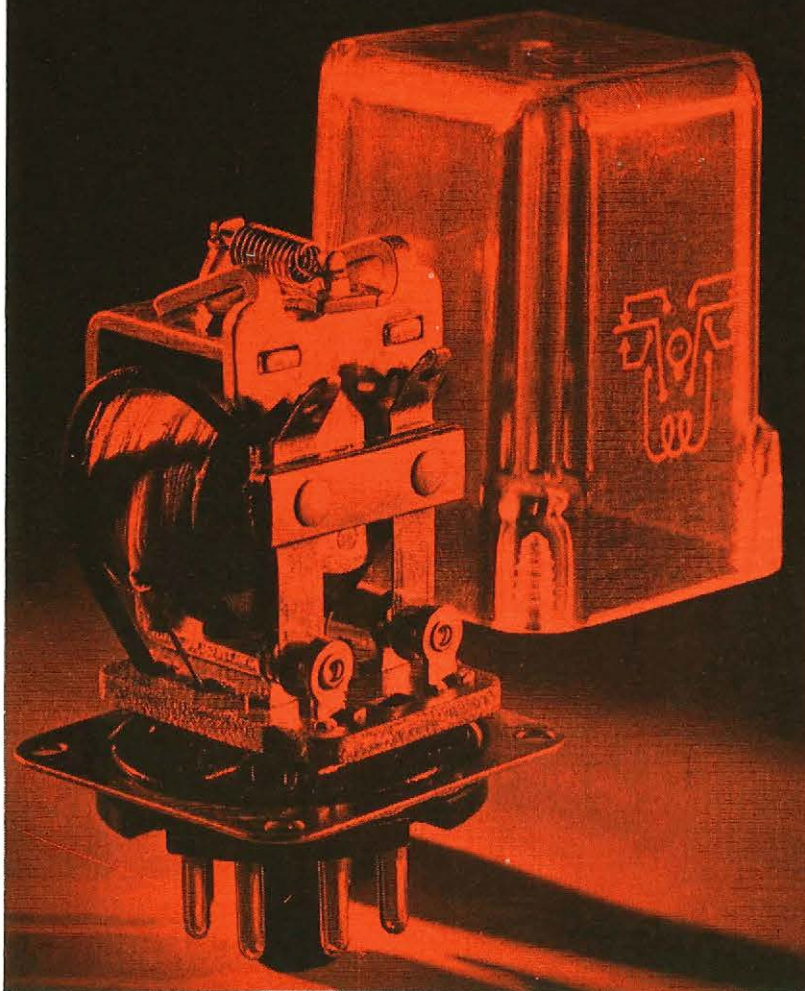

Radiospares for long-life relays! They're made to the highest standards of quality throughout and all types are available "by return of post".

Miniature plug-in relays—12V. or 24V. d.c. coils, 115V. a.c. coils.

4 P.C.O. contacts rated 3A. a.c.

Open series—12V. d.c. or 230V. a.c. coils 2 P.C.O. contacts rated 250V. 5A. a.c. Also 6V. d.c. coils with 115V. 2A. a.c. contacts.

Plug-in relays—d.c. and a.c. coils with 2 or 3 P.C.O. contacts rated at 2A. or 5A. or 10A. 250V. a.c.



### **Radiospares Ltd.**

4-8 Maple Street · London W.1 · England · Tel: EUSten 7232 (8 lines)  
Telegrams and Cables: Radesperes, London W.1

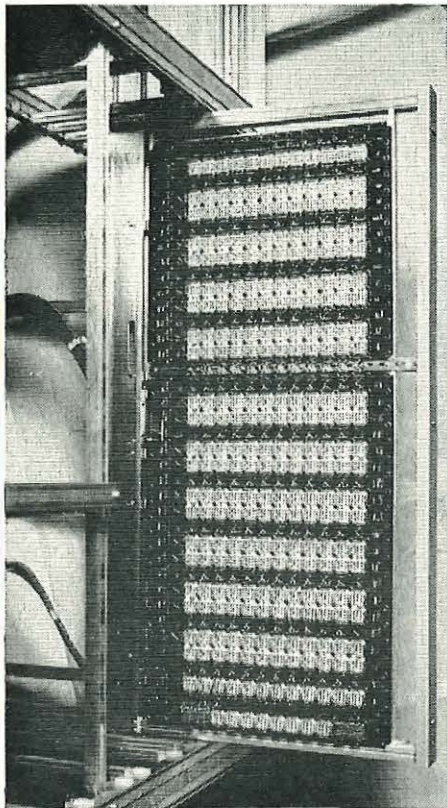

# REX<sup>®</sup>

THE REED ELECTRONIC EXCHANGE<sup>®</sup>  
No. 18 system

## packs more lines into less space— **AND LEAVES ROOM FOR UNLIMITED EXPANSION**

### REX in a nutshell

By providing electronic common control of reed relay spatial switching, the REX system offers an extremely compact and reliable solution to both the switching and control problems of modern exchange design. The REX exchange has been developed by AEI to integrate smoothly with existing automatic networks: its exceptional flexibility ensures full growth capacity for both services and traffic . . .

### Wider range— more accessibility

An entirely new Reed & Electronic Modular Apparatus practice (REMA) has been designed by AEI engineers to provide completely compatible mounting of reed relays and electronic circuit components. Combined with a new sliding-frame mounting system, the REMA practice allows more than 20,000 lines of REX switching equipment to be accommodated in the space normally required by a 10,000 line electro-mechanical exchange. In existing buildings this means more space for future expansion: in new exchanges it makes possible great savings in construction and installation costs. And because the REX subscriber's line circuit can tolerate substantially wider line conditions, a REX exchange will serve an area much larger than that of a conventional exchange, with significant reductions in line plant investment.

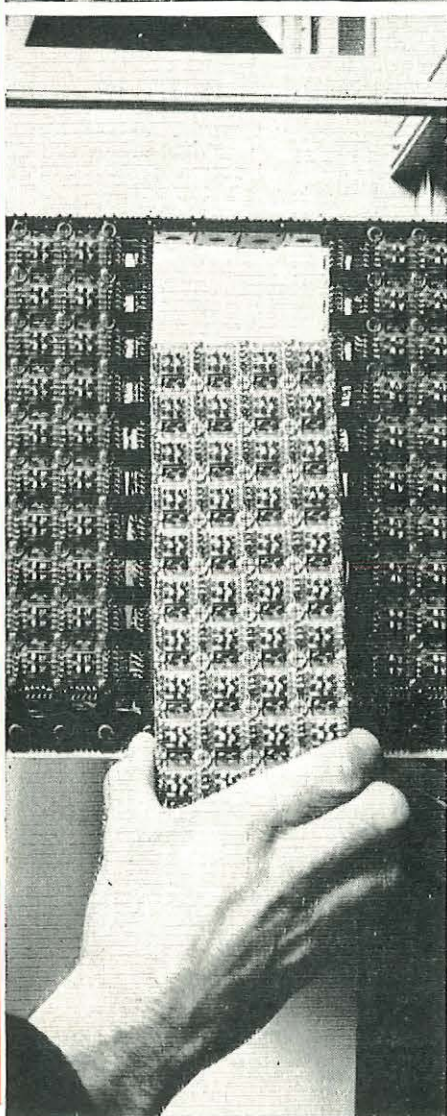

### Designed for expansion

The basic design allows for all future switching requirements, including abbreviated dialling and subscriber's automatic transfer, together with all current standard features such as data for automatic message accounting. A stored programme control is provided to expedite inclusion of these and any other special facilities that may be required during the life of the exchange with virtually no redundancy of initial apparatus.

### Minimum maintenance

The high-speed electronic control system is programmed to give complete automatic self-checking and self-reporting of fault conditions and at the same time, routes calls away from areas of faulty equipment. A 3,000 (ultimately 7,000) line prototype reed electronic exchange supplied to the BPO at Leighton Buzzard,\* has been designed for completely unattended operation and reports all servicing requirements to a remote maintenance control centre.

Maximum service security has been ensured by exhaustive circuit design and testing during the development period and by replication of important items of equipment. The control area is sub-divided into independently switched functional units thus ensuring continued operation in the face of faults. Thanks to the REMA system every part of the REX exchange is accessible for inspection or servicing.

\* Developed in conjunction with the BPO under the auspices of the Joint Electrical Research Committee.



## SOPHISTICATED ELECTRONICS— BUILDING BLOCK SIMPLICITY!

### The REX switching element

The basis of the REX system is the reed-relay switching element. It contains only nine different piece parts, compared with 200 in a bi-motional selector, and its very simplicity makes it uniquely reliable. There's nothing to wear out and it is sealed completely against dust and atmospheric pollution.

### The REX switching matrix

Switching matrices can be built up in any form simply by clipping reed-relay crosspoints together. Thus unlimited provision for the growth of lines and links is built into the REX system.

### The REX switching unit

Basic switching arrays are built up out of matrices and are arranged in parallel to form a REX switching unit. Typically, a 1,000-line four-section unit would serve a community with an average calling rate of 150 call seconds per line in the busy hour; other calling rates can be accommodated by varying the number of sections.

### The multi-unit REX exchange

Switching and linking arrangements are provided for all sections of each unit so that complete crosspoint path interconnection is made between all lines of the REX exchange. The special linking pattern adopted can cater for all traffic patterns whilst retaining simplicity of control.

### REX electronic control

The REX electronic control has three main areas of activity:

**Scanners and Registers:** To determine the source and final destination of a call.

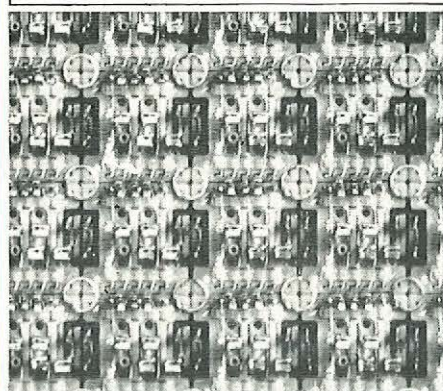
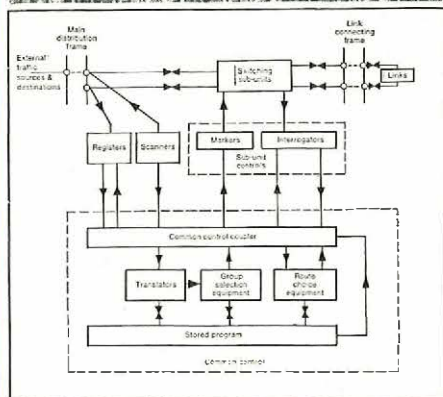

**Markers and Interrogators:** Concerned with interrogating the state of crosspoint paths and marking these paths through the switching sub-units.

**Common Control:** Processes the necessary call setting data in accordance with instruction from the stored programme control so that the calls are routed with maximum utilisation of the switching networks.

### Information for administrations

The AEI REX Information Service is one of the most comprehensive programmes ever offered. In addition to brochures and full technical data, AEI will gladly arrange for their lecture team to visit the engineering staff of interested administrations to provide an introductory course on basic REX principles. Later, key personnel would receive full training both at AEI's UK factories and on-site during installation. Training schools staffed and maintained by AEI are also under consideration for territories where reed electronic exchanges are proposed as standard.

### Please write for full details

Public Telephone Systems  
Department (Electronic)  
Telecommunications Group  
Associated Electrical Industries Limited  
Woolwich, London SE18.  
Tel: Woolwich 2020

*REX is a UK registered trade mark.*

# AEI

## TELECOMMUNICATIONS

## INDEX TO ADVERTISERS

---

	PAGE		PAGE
Adcola Products, Ltd. . . . .	22	Marconi Co., Ltd., The . . . . .	1, 6
Associated Electrical Industries, Ltd. . . . .	24, 25	Pirelli General Cable Works, Ltd. . . . .	28
Astralux Dynamics, Ltd. . . . .	16, 17	Pitman, Sir Isaac, & Sons, Ltd. . . . .	8
British Institute of Engineering Technology . . . . .	8	Plessey Co., Ltd., The . . . . .	4, 7, 18, 19
Connollys (Blackley), Ltd. . . . .	26	Pye Telecommunications, Ltd. . . . .	27
Eddystone Radio, Ltd. . . . .	10	Radiospares, Ltd. . . . .	23
Electro-Dynamic Construction Co., Ltd. . . . .	9	Standard Telephones & Cables, Ltd. . . . .	20, 21
Ferranti, Ltd. . . . .	3	Submarine Cables, Ltd. . . . .	5
G.E.C. (Telecommunications), Ltd. . . . .	11-14	Telephone Cables, Ltd. . . . .	2
Light Soldering Developments, Ltd. . . . .	8	Telephone Manufacturing Co., Ltd. . . . .	15
Lustraphone, Ltd. . . . .	22	Winn & Coales, Ltd. . . . .	10

# Reliability

A dependable telephone system is essential to modern society. Connollys cables, with built-in reliability, have played an important part in maintaining the efficient operation of the public telephone service in this country since 1890: and Connollys reliability has been further proved in telecommunication installation in the many countries overseas.

## CONNOLLYS

**Connollys (Blackley) Limited**  
Cable Division  
Blackley, Manchester 9  
Telephone: Cheetham Hill 1801

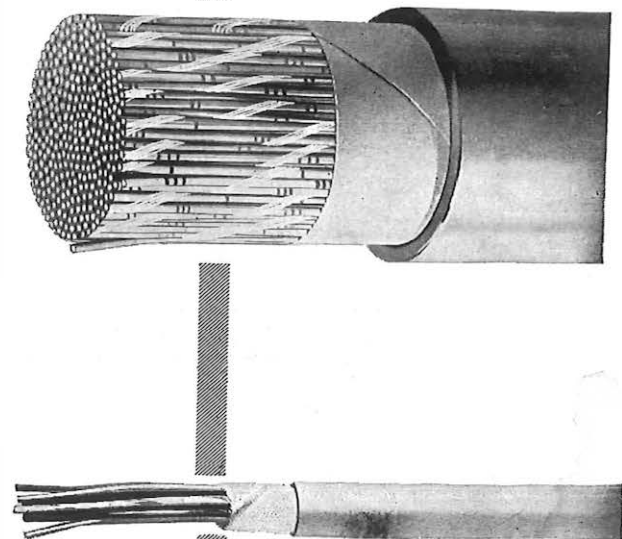

CL71

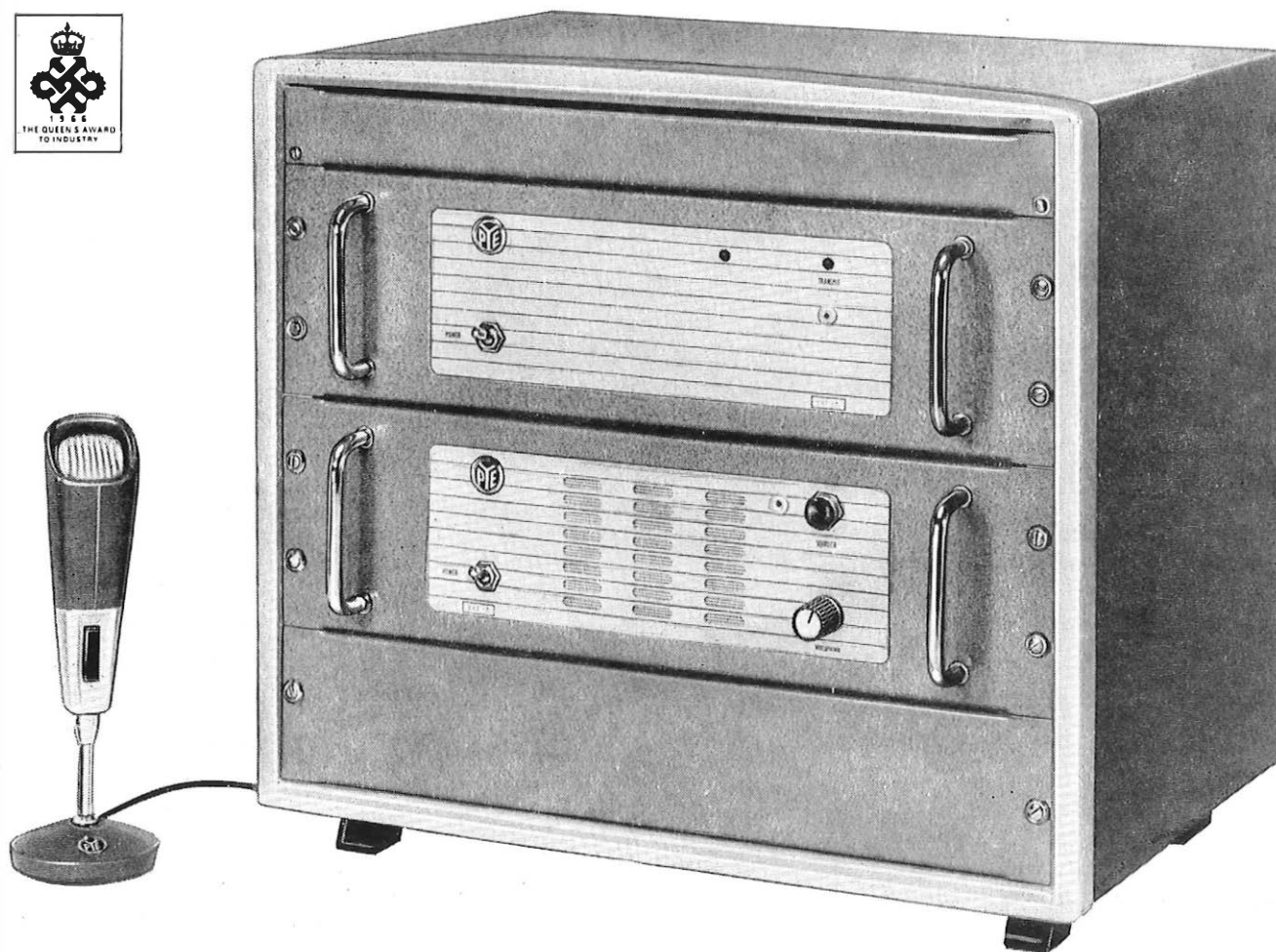

# New..... Solid State U.H.F. Fixed Station

## for 450 to 470 Mc/s

The new Pye F450T u.h.f. base station has a fully transistorised transmitter and receiver, for maximum reliability and minimum size. The equipment is frequency-modulated, operates from 450 to 470 Mc/s, with 40 to 60 kc/s channel spacing, and is suitable for use with mobile and Pocketfone radiotelephones.

**Pye Telecommunications Limited**  
Cambridge, England. Telephone: Cambridge 61222. Telex: 81166.

- \* Choice of control systems.
- \* Elimination of relays in transmitter with the exception of aerial changeover.
- \* Output stage protected against 'no-load' conditions.
- \* High-stability receiver squelch circuit eliminates background noise in the absence of a signal.
- \* 4W nominal r.f. output.
- \* Remote control facilities.



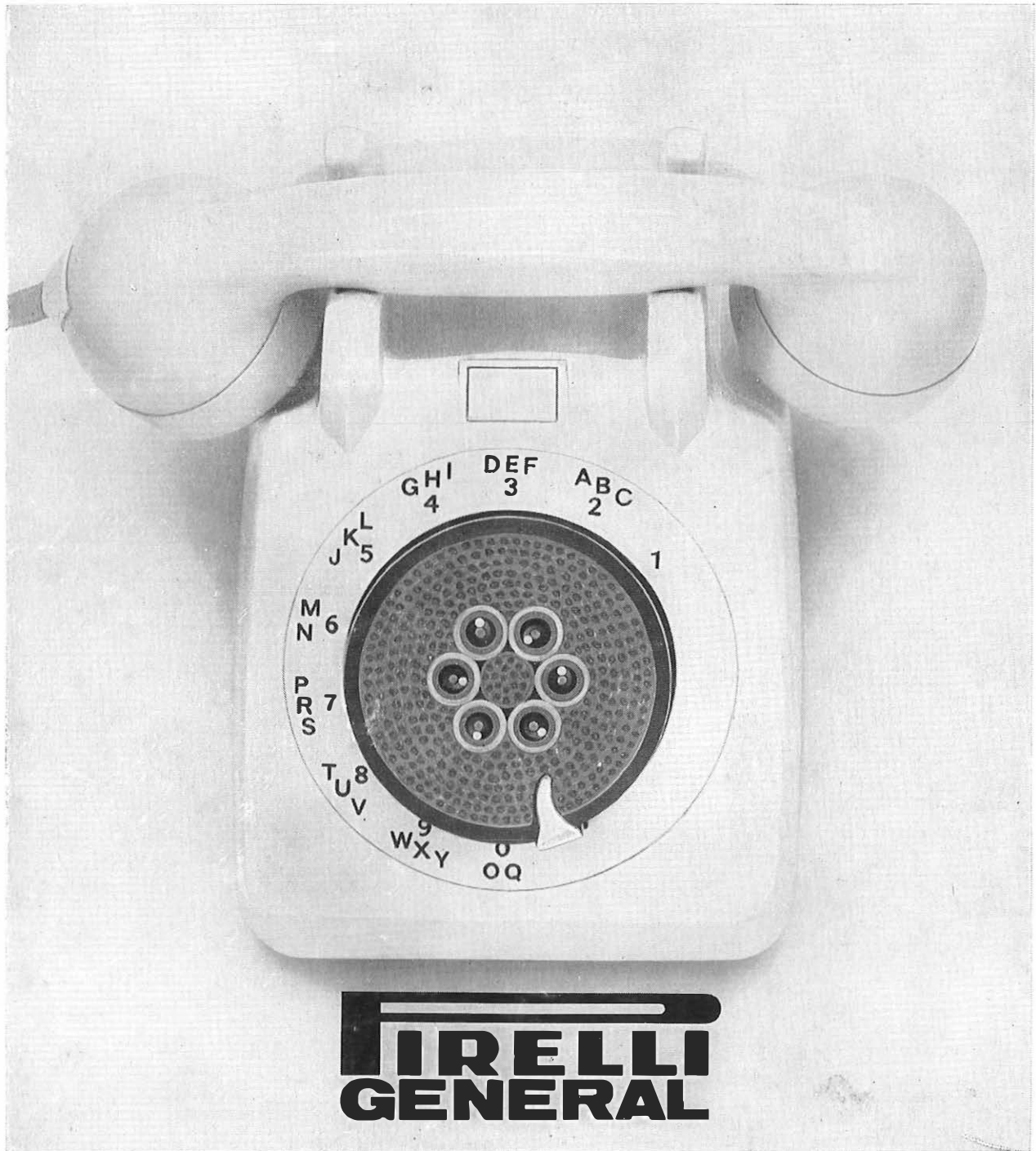

**PIRELLI  
GENERAL**

## TELECOMMUNICATIONS CABLES

Pirelli General are in a position to advise on complete Telecommunications schemes and are organised to manufacture and install cables for distribution and trunk services; also carrier and all types of coaxial cables.

Pirelli General also manufacture cables to meet special requirements of Public Utilities or of industry.