

# THE POST OFFICE ELECTRICAL ENGINEERS' JOURNAL



## CONTENTS

	Page
MEN, CIRCUITS AND SYSTEMS IN TELECOMMUNICATIONS—J. H. H. Merriman, O.B.E., M.Sc., A.Inst.P., C.Eng., F.I.E.E.....	241
A NEW MANHOLE-COVER LIFTER—LIFTER, MANHOLE COVER, No. 3—J. O. Colyer, B.Sc.(Eng.), C.Eng., M.I.E.E.....	251
PROGRAMMED LEARNING—A NEW DESIGN FOR TRAINING, Part 1—An Introduction to Pro- grammed Learning—A. C. Holmes, C.Eng., M.I.E.E., and K. R. Crooks, Graduate I.E.R.E.....	253
A VOICE-FREQUENCY SIGNALLING SYSTEM FOR OUT-OF-AREA EXCHANGE LINES—W. J. Murray .....	259
A NEW ANNOUNCING EQUIPMENT—EQUIPMENT, ANNOUNCER, No. 9A—K. E. Bailey.....	264
SWITCHING AND SIGNALLING TECHNIQUES FOR THE INTERCONTINENTAL TELEX SER- VICE, Part 2—London (Fleet) Intercontinental Telex Exchange—W. A. Ellis, C.Eng., M.I.E.E., and E. E. Daniels .....	266
A DIGITAL-DISPLAY DECIBELMETER FOR AUDIO FREQUENCIES—L. W. Ellen, C.Eng., M.I.E.E., and A. Coyte .....	274
X-RAY INSPECTION OF POLYTHENE-INSULATED SUBMARINE-CABLE JOINTS AND GLAND MOULDINGS—J. E. H. Cosier and R. W. Windle .....	280
A TEST INSTRUMENT WITH A DIRECT-READING FAULT BRIDGE—OHMMETER No. 18A— G. W. Crosby .....	285
A NEW ECHO SUPPRESSOR FOR LONG-DISTANCE COMMUNICATIONS—P. H. Shanks, M.Sc., C.Eng., M.I.E.E.....	288
ELECTRONIC TELEPHONE EXCHANGES: REED-SELECTOR SYSTEM FIELD TRIAL AT BELGRAVIA EXCHANGE, LONDON—E. Newell, B.Sc.(Eng.), C.Eng., M.I.E.E., and R. D. Peacock	293
A NEW DIAL-PULSE DETECTOR—M. J. E. Sands .....	300
TRANSIT SWITCHING CENTRES USING BXB1121 CROSSBAR EQUIPMENT, Part 1—Trunking, Facilities and General Operation—N. Walker, M.B.E., B.Sc.(Eng.), C.Eng., M.I.E.E., F. A. Stallworthy and R. F. McLusky, C.Eng., M.I.E.E.....	302
NOTES AND COMMENTS .....	308
INSTITUTION OF POST OFFICE ELECTRICAL ENGINEERS .....	308
REGIONAL NOTES .....	310
ASSOCIATE SECTION NOTES .....	312
STAFF CHANGES .....	314
BOARD OF EDITORS .....	317
BOOK REVIEWS .....	258, 273, 284, 299, 307

Price 3s. (Post Paid 4s.)

Published in April, July, October and January by *The Post Office Electrical Engineers' Journal*,  
2-12 Gresham Street, London, E.C.2.

Annual Subscription (post paid): Home, 16s.; Overseas, 17s. (Canada and U.S.A., 2 dollars 40 cents).

# THE POST OFFICE ELECTRICAL ENGINEERS' JOURNAL

Vol. 60 Part 4

JANUARY 1968

## Men, Circuits and Systems in Telecommunications\*

J. H. H. MERRIMAN, O.B.E., M.Sc., A.Inst.P., C.Eng., F.I.E.E.†

U.D.C. 621.39:658.5

This paper was delivered by Mr. J. H. H. Merriman on the occasion of his inaugural address as Chairman of the Electronics Division of The Institution of Electrical Engineers on Tuesday, 31 October 1967. Mr. Merriman, who is Senior Director of Engineering of the British Post Office, is President of The Institution of Post Office Electrical Engineers. The Board of Editors are, therefore, grateful to The Institution of Electrical Engineers for permission to reprint this paper, in which Mr. Merriman discusses the interplay that exists in telecommunications between engineer and society and between circuits and men, and gives examples of changes in organization and methods that have led to increased productivity. The Board of Editors intend to follow up this address with articles in later issues of this Journal on engineering management.

### GENERAL INTRODUCTION

#### General

MY aim in this address is to show that telecommunications is not only a dialogue between sender and receiver; it is a dialogue between user and provider. It is not only circuitry; it is man management. It is not only a social service; it is a vast, successful and profitable business. I.E.E. records contain many eminent discourses on the developing scenes of telecommunication technology, but there seems to have been no prior attempt to dwell on this fascinating interplay that exists in telecommunications, between engineer and society and between circuits and men. It would indeed be tempting to take the arguments further and deeper into a discussion of the moral responsibilities of the telecommunicator. This is not the place so to do, but as we veer away, we see how it is that we now state that the task of the engineer in telecommunications is not only to create the facility, but also to concern himself with the possible impact of that facility upon social structure and individual reaction. In macroscale there may be issues of balances of scarce resources; in microscale it may be the suitability of a design for a specific customer. These then are the seed thoughts out of which my address must spring. It must spring, obviously, out of experience and out of a career spent for the most part in the service of the Post Office. In that sense it will represent collective experience, and I shall do my best to maintain both the integrity of others' contributions and the standards of my predecessors.

\*Reproduced by permission of The Institution of Electrical Engineers.

†Senior Director of Engineering.

#### *Diversity of Telecommunications*

Post Office telecommunications are complex and diverse. Facilities include all types of public and private communication—telegraph, speech, television and data. The services cover Britain, and construction methods suited to each type of locality have to be used. In a sense, too, with our overseas services, our business is global. It certainly can never be merely local. Line communication is over open wires, covered wire, aerial and underground cable with lead, steel or polythene sheaths containing pairs or coaxial tubes. Speech-frequency channels are provided over metallic pairs, over amplified 4-wire or 2-wire circuits and by multiplexing, using frequency, time-division or p.c.m. techniques. They are also provided over v.h.f., s.h.f. and u.h.f. radio links; direct, via relay stations, and via satellite. Telegraph and data channels are provided direct or via speech channels using a.m. or f.m. multiplexing. Channels are switched by a variety of manual, Strowger, crossbar and electronic methods.

Looking along the time dimension, we see the history of telecommunications in the making. Research staff are exploring the possible new shapes of telecommunications in 5-20 years time. Development staff are specifying next-generation methods. Planning and works staff are providing circuits and switching equipment needed over the economic provision periods immediately ahead. Installation staff are providing for customers' demands as they are received, and maintenance staff, with plant provided over the last 30-40 years, aim to improve the service given to the customer. Each broad division operates over almost the full range of facilities, geography and techniques.

#### *The Men of Telecommunications*

As in many industries, perhaps our greatest problem is deployment, use and, in one sense, control, of manpower. This problem is in two parts: first, the growth of the staff needed to install and keep in repair our growing system; secondly, the problem of management and control in an industry that is almost doubling in size every half decade and yet has to cope with the technological explosion in innovation.

Fig. 1 illustrates the extent to which we had been increasing our share of the national manpower. The

working population of 1972 will be  $\frac{1}{2}$  per cent less than it is now. Obviously, if the country is to have more consumer goods and more services, industry as a whole, manufacturing and service, will have to produce these

vital to our success as a business that we not only make substantial reductions in staff/station ratio but also, by full exploitation of technology, reduce costs wherever practicable.

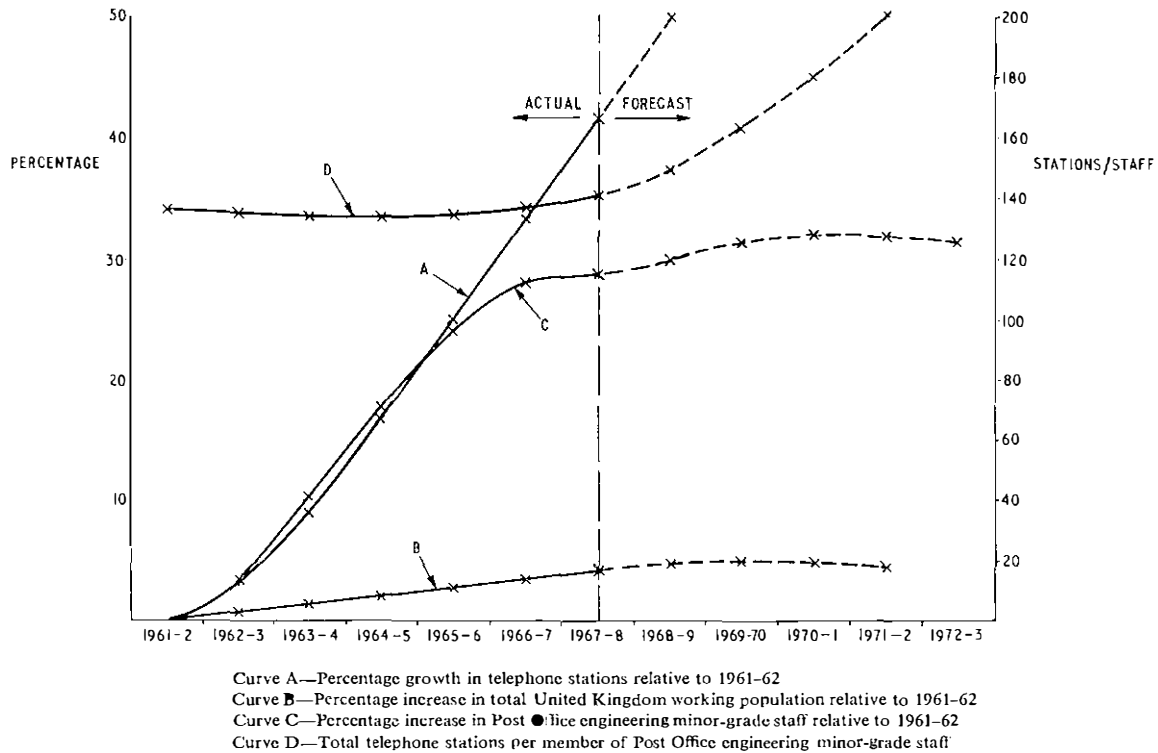

FIG. 1—POST OFFICE SHARE OF NATIONAL MANPOWER

with rather less than its present staff. In spite of the explosive growth of demand for telephones and even more for trunk circuits, we intend to play our full part in this and to expand the system with very little increase in our engineering manpower.

Throughout, it is a matter of fine judgment to balance the deployment of limited available skilled resources between managing the present and providing for the future.

### The Business of Telecommunications

The business aim of the Post Office in telecommunications is simply stated. It is to provide the best service at the lowest cost and to aim to secure at least an 8 per cent return on net assets. Currently our net assets run at about £1,500 million, and our annual capital expenditure at about £300 million. Most of this capital is spent on exchange and line plant, which, for economic and practical reasons, has to be provided from 2 to 20 years in advance and, once provided, can only in small degree be redeployed. This makes our business particularly susceptible to departures from forecast. Not only national forecasts of demand but even those for individual exchanges, streets and junction routes are critical. Therefore, unless adequate margins of spare plant are provided, demands above those forecast must mean delay in providing service. But any increase in rate of demand in turn increases the ratio of future size to present size and, therefore, of investment to income. It is therefore

### DEVELOPMENT OF INCREASING PRODUCTIVITY IN TELECOMMUNICATIONS

#### General

As a business enterprise, therefore, it may already be seen that increasing productivity is vital. Increasing productivity, in this sense, is taken to mean the harnessing of technological opportunity and scientific management to optimize the efficiency of the organization. The two factors are inseparable. But before we can go very far we must define the critical parameters. We measure productivity by the improvement in the ratio output/input in one or all of the three prime resources, capital, materials and labour, in management units. Our management unit is a telephone "area" geographically defined to include at present, say, 100,000 to 500,000 telephone "stations." There are 58 such areas in Britain and they employ some 100,000 engineering staff. In most areas, and in very broad terms, approximately 40 per cent of the engineering staff will be concerned in maintenance and repair, 20 per cent on installing new telephones and 40 per cent on constructing major extensions to the system. For broad managerial control, we use an "input" unit of 1,000 manhours. The number of telephone stations in a management unit is one obvious "output" unit. Examples of four productivity indices, using these units, are shown in Fig. 2 and indicate performance achieved and future prospects. As an example, it will be seen that we now provide new customers' service with only half the engineering man-

power effort of 4 years ago. This sort of improvement does not just happen—it is the result of an intensive and combined effort by the technical-development staff, the application of sound engineering and scientific principles

Given effective measurement of output, and given also realistic targets for most classes of work, efficient management of planning and works becomes possible. Fig. 3 is a simplified diagram of the managerial and

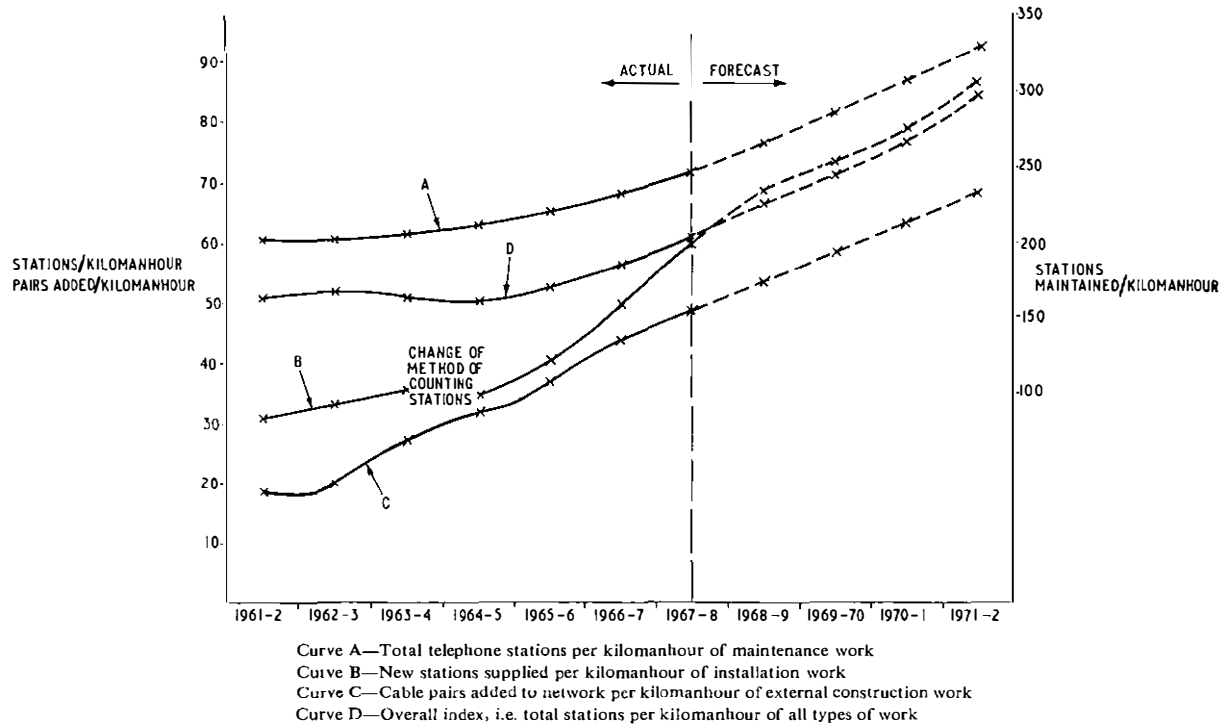

FIG. 2—UNITED KINGDOM PRODUCTIVITY INDICES

to management, and the enthusiastic co-operation of management and staff in the field. The means by which this was achieved are summarized in the next sections.

#### Organization for Productivity Development

Early in the development of this drive for increased efficiency and productivity, it was recognized that a separate management unit would have to be created, detached from line responsibility and free from every-day pressures, but given authority to take those steps necessary to see that local managers are given all information, techniques and equipment they needed to achieve these new targets.

#### Some Techniques used in Productivity Development

**Work Measurement.** Although work-measurement technique is most often associated with repetitive factory operations in controlled conditions where variations are small, it is equally valuable in field operations such as line-plant construction, or customers' installation work, where there are wide variations in conditions of work, time spent travelling, etc. From measurements taken on a random sample of field observations one can, with a degree of confidence calculated from the size of the sample and its variability, set national standards for work elements such as erecting a pole or installing an extension bell. These standard or basic hours can then be added to measure the standard work content of a complete job or series of jobs. Comparing the actual time taken with the standard time gives a measure of performance, or performance rating.

supervisory control of external (i.e. underground cabling and major overhead-route provision) works.

**Statistics.** With unavoidably wide variations in the performance of apparently similar work (e.g. erecting a pole) in different situations (e.g. in soft soil or rock, in a grass verge or concrete pavement), it becomes necessary to measure in statistical terms in order to make sound deductions.

Using these criteria and techniques, a system using 136 different standard rates is already replaced by a simpler one using only 93, which gives far greater accuracy of control. And, of course, the system is in a sense self improving, as the progressive refinement of field information against performance target is examined.

**Queueing Theory.** We wanted recently to assess the saving in staff time which would accrue from self service instead of storekeeper service for certain items of stores. We could measure everything except the saving in queueing time (because the operation could not be readily repeated). So we treated storekeepers as switches, the amount of time they were serving as traffic, and the average time at the counter as call duration. By reducing serving time and time at the counter in proportion to the transactions saved by self service, the saving in staff time was assessed. As a result of these studies, staff now serve themselves, without documentation, with a wide range of certain small, frequently used, items.

#### Examples of Productivity Improvement Already Achieved

**Telephone-Cable Jointing.** Work study was made in 1963 of cable jointers' work on construction projects.

For very many years it had been the practice for every jointer to be accompanied by a "mate." The conclusions of the study were, however, that, as a general practice, jointers should work without mates; only when safety required it should two men work together. This

underground-cable maintenance and of improved control procedures for underground-cable provision work. Both these are now in progress.

*Long-Length Cabling.* When the use of polythene-sheathed cables had been developed to the point where

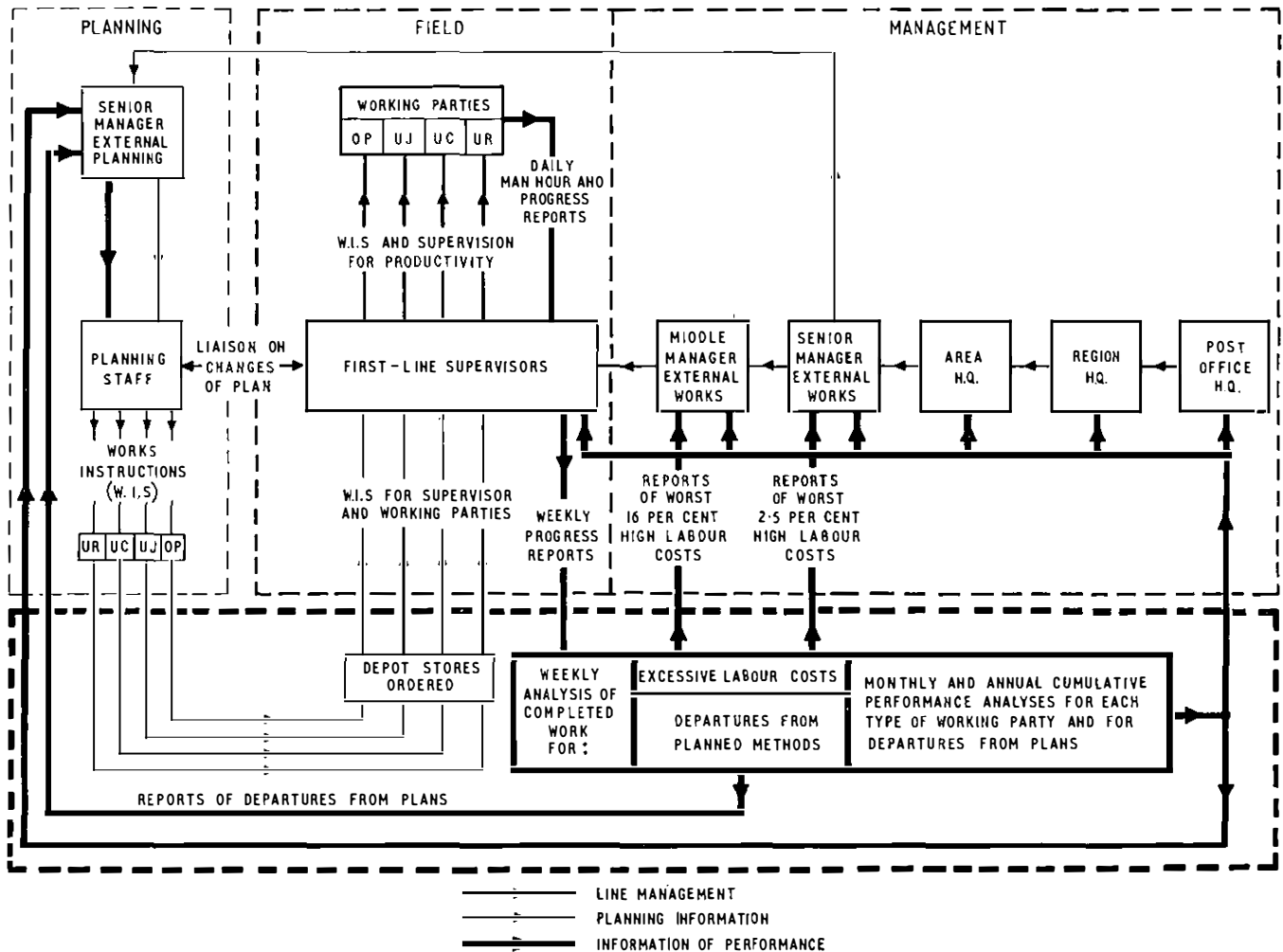

FIG. 3.—WORKS SERVICE ORGANIZATION

required the development of a revised tool kit and enabled a lighter vehicle to be used. With these, solo jointer working was demonstrated in various parts of the country, and in 1965 agreement was reached with the staff associations that, except where safety required it, this would be the normal method of working. To minimize the amount of time two men had to work together also required the development and production of new lighter tents and a device for lifting heavy joint-box covers, both of which could be used by one man.

As so often happens when a work study is made, there were bonus side products. We are now developing equipment to signal cable-pair identities to the jointer from the exchange, and so allow the exchange officer and jointer to work independently. We are also developing cable-jointing machines, which, on cable joints containing many hundreds of pairs, should produce really worthwhile improvements in productivity. The study also emphasized the desirability of further studies of

it was a sound engineering proposition, the work of pulling them into underground ducts was studied. The traditional method of pulling in, in 180 yd lengths or less, necessitated by the weight and length of the older lead cables, could now be discarded. The new polythene-sheathed cables, being lighter and having a lower coefficient of friction, could be pulled in in lengths of up to 1,000 yd. To exploit this advantage, new cabling techniques had to be developed, and all the staff concerned, both planning and works, had to be trained to use them. Again, further work was seen to be desirable, and we are now developing (a) improved equipment for threading through the duct the rope or flexible rod to be used for pulling in the cable, (b) more easily handled mechanical aids to clear obstructed ducts, and (c) better mechanical aids for pulling in the cable. As this development work progresses, we are improving the organization and work methods to make best use of the aids and to reduce further the idle time. Meanwhile we are reaping

the benefit of our earlier productivity measures of solo jointing and long-length cabling. Between them, these account for most of the 24 per cent improvement already shown in Fig. 2, from 38 added pairs per kilomanhour in 1965, to 50 added pairs per kilomanhour in 1967.

*Installation of Telephones.* In 1963 a study was started of overhead wiring work by gangs. It soon became clear that the greatest potential for improvement was in the work of providing the overhead wires from distribution poles to customers' premises. A simple form of insulated wire held at the pole and at the house in wedge clamps had already been developed as a cheaper form of connexion replacing the heavy galvanized spindles, porcelain insulators and open wire, which had been the previous standard. Method study of the work led to the conclusion that it could be most efficiently done by using some new techniques which were developed to allow one man to erect cable across a road while the other directed traffic, by providing the outside wiring on the same visit as the fitting of the telephone, and by employing two men trained to do both types of work. Besides giving greater productivity, this meant that customers received only one visit and were given service more quickly. This change was introduced in 1964, but study of the work continued, and with further developments it proved practicable for most of the simple jobs (those not involving a road or power-wire crossing) to be done by only one man. Plans were made to equip these men with vehicles, tools and stocks of stores, including some 30 telephones of various types and colours, and in mid 1966 "the 1-man installer" was introduced. The men in the 2-man parties and the 1-man installers are interchangeable, and between them do almost all the work for residential and some business customers. The results have been one of work study's biggest success stories: since the changes were introduced the productivity has in 3 years increased from 37 telephones provided per kilomanhour to 64—an improvement of 42 per cent, or 12.5 per cent per year, representing a saving of some 10,000 staff.

*Location of Engineering Depots.* Some 55,000 Post Office engineering staff travel daily from their official headquarters to their work in the field. New engineering depots must therefore be placed to minimize travelling costs. Sometimes this can be seen quite clearly from the road configuration and telephone densities. Where, however, the situation is complex and the ideal position is not self evident, the problem is an ideal one for computer assistance in its solution. A simple linear program calculates, for each road junction, the amount by which the 20-year travelling cost for a depot there would exceed the minimum. These cost figures are used first to guide the search for a site and later, when sites have been found, to assess the total site plus travelling cost, which, with practical considerations, will decide the "best buy."

*Maintenance.* Each new generation of equipment is designed with lower maintenance cost very much in mind. Technological development is, of course, essential if this is to be so. Already we can see the pattern developing in exchange equipment, where each new generation already in operation requires only half the maintenance work load of its predecessor. In very broad terms, using the index manhours/line/year, the figures for Strowger, crossbar, and electronics are 2, 1.0, and 0.5, respectively. The productivity results of this are self evident.

We still have, of course, the problem of maintaining

the very many old exchanges that exist and form the bulk of the system. To increase the effectiveness and reduce the cost of this maintenance, we are increasingly installing equipment which can be left to perform a surveillance routine over a complete telephone exchange and which will either signal when it has found a fault, so that it can be cleared with minimum delay, or will print out details for attention later. Many such devices are already in use, many more are being manufactured, and new and more sophisticated ones are being developed. In general, where such aids have relieved the staff of routine testing, we have achieved productivity gains of 5 per cent. Over the whole field of exchange maintenance, we have gained 40 per cent in productivity since 1959.

#### *Possible Future Improvements in Productivity*

Experience over the past half decade has shown that, given determined management, given staff free from day-to-day pressures who are able to examine critically every stage of routine operations, and to have full access to the wide expanding range of technologies available for new designs of tools and equipment, changes worth about £0.1 million p.a. per head of staff so employed can and do arise.

It may be thought that, at this rate, returns must diminish. However, two important facts suggest that this is not yet so. First, we have only just started to introduce the general technique of management by objective and control by exception. In these areas we shall be experiencing a new series of problems, not in telecommunications but in communications between field force, supervision and management. Secondly, we are only just beginning to touch the fringe of computer-aided management. It is true that, to a very high degree, computers already work out our payrolls, control stores provisioning and serve as aids in research, design and development. Very large returns await to be collected from computerization of the substantive engineering business of, for example, maintaining on a national basis records of line-plant usage (where even a 1 per cent increase in efficiency could yield an annual capital saving of £10 million). These, and other similar factors, give substance to the belief that substantial improvements in productivity remain to be developed in the decades ahead.

#### MATCHING TELECOMMUNICATIONS TO MEN

##### *General*

The development of increasing productivity, by itself, is a challenge to the native wit and inventiveness of engineers; when achieved it gives satisfaction to the economists, but of itself could give rise to offence in user and provider alike. For, in one extreme, no purpose is served if we achieve a highly productive telecommunications service that is not attractive to our customers. In the other extreme, a highly productive service will fail if the staff involved in it are not fully co-operative in the changes that productivity necessarily involves.

##### *Matching the System to the Staff*

Human aspects of productivity improvement are vital to successful change and are the most difficult to allow for. At a national level, it is relatively easy to convince people of the merit of greater productivity. At individual

level, changes may not be so obviously desirable and must be designed so that unavoidable alterations in the lives of the staff affected do not involve unacceptable disadvantages. At each impending change it is vital to consider changes in career prospects or of relativities with other groups of staff. Staff made surplus by productivity measures can often be absorbed rapidly enough by growth and wastage, but, if not, must be retrained and employed elsewhere. These aspects are discussed with staff representatives at the earliest possible stage in the development of the proposals. When, finally, the implementing instruction is written and published, there remains just one last major task—to get several hundred, perhaps thousands, of human beings to change their ways of working to obtain the full potential gain in the particular circumstances. In places the “n.i.h.” (not invented here) complex operates—“Why change?—we are doing fine as we are. It won’t suit conditions here; we’re not ready for it yet.” Such objections can rarely be overcome unless the originator is able, by direct contacts, to infect those responsible for local implementation with his own enthusiasm and expertise.

If change can be accompanied by other evidences of change, then there is a far greater prospect of an overall change of attitude. In some cases, at the same time as changes in technological and working practice, we have deliberately introduced changes in vehicles, safety procedures and protective clothing, as well as changes in instruction bulletins and booklets. For example, the latter are now heavily illustrated in strip-cartoon style to show the evils of wrong methods and the merits of right ones.

#### *Matching the System to the Customer*

Ideally, we would like to be able to provide a customer with a telephone when he wants one, be reasonably certain that he will like it when he has it, and hope that when it goes wrong (as all well designed systems will) we can repair it quickly. The telecommunications service has then to be matched to the customer under each of three main headings: provision, design and repair.

(There is an implied, and very real, fourth heading, cost, but for the purpose of this paper, this can be disregarded.)

*Telephones by Appointment.* Ever since the Second World War, our ability to supply telephone service has been limited by shortages of line plant and exchange equipment. Strenuous efforts are being made to overcome these shortages, both by increasing manufacturing capacity and also by reducing the time required to install extensions of plant.

Despite these problems, we decided in 1964 that we should speed up the provision of service for those cases not affected by plant shortage. The target, to meet 50 per cent of all orders where service could be given within 2 weeks of application, was, in fact, achieved by November 1966 in most areas, and in the same period productivity on installation work improved by 34 per cent. However, despite this improvement in speed, we were still not able to tell our customers at the time they placed an order for service just when the engineers would call to do the work. To be able to do this was very desirable; the problem was to find out how to achieve this without sacrificing productivity.

The method used to tackle the problem was to allow a small team of work-study engineers to experiment in

selected areas in co-operation with their colleagues responsible for sales procedures. Their basic problem was that demand for telephone services in any locality fluctuates according to all sorts of factors, some seasonal, some economic, some local and others just random. To maintain productivity with these fluctuations in demand, while at the same time giving a reasonably quick service by appointment, an organization has been developed in which the level of engineering staffing is adjusted to the expected level of demand, but, to maintain high productivity, a reserve is created of other less urgent work, which can be drawn upon as required when appointment work falls off. Experience with the scheme so far suggests that it will be both practicable and economic to operate an appointments system for straightforward installation work for the majority of our customers, most of whom live in urban areas, and this is now our plan.

*Human Factors and Design.* Telephones, data terminals, telex machines, like other domestic and office artifacts, are expected to be more than pieces of functional machinery. Increasing regard is being paid to appearance and the relation of function to style. No major item of equipment is developed without these factors being carefully introduced at an early stage.

Design and style are, however, subjective and transient. Of more permanent and objective character is the developing science of “human factors” in telecommunications.

This is an omnibus science that contains ergonomics and psychometry, as well as basic communication science. It is concerned with the interaction of human beings with their environment, especially the complex man-made environment of telecommunications. The telephone service, and indeed the many other services provided by the Post Office, are a part of this environment. If they are to be of maximum possible benefit to the community, human factors must be taken into account right from the earliest stages of research and planning, to daily operation and maintenance.

The design of equipment such as switchboard positions, control consoles, etc., at which people have to work, constitutes a class of problem involving ergonomics which recur again and again. They appear in relation to telephones, telegraphs and radio. They affect primarily the staff, but members of the public also operate P.B.X. switchboards and use Post Office counters and encounter similar problems when using a public call office.

An example of the difficulties to be resolved in call-office design is that of placing the dial in such a position that it can be used for emergency 999 calls by a child, without making its use impossible for a tall man wearing a bulky overcoat who has left his reading glasses at home.

*Fault-Repair Service.* A faultless service would be uneconomic and probably technically impracticable, but fault-repair services are notoriously difficult to organize and manage. Given an emergency, the traditions of telecommunications are such that impossible things are done in incredibly short times.

Records during the past year show, for example, main underground coaxial routes being restored to service after cable rupture by bulldozer in under an hour. The emergency line to a doctor or hospital is restored often in minutes. But the problem of reconciling reasonable service with productivity is, in this area, a difficult one. To try to resolve this we have resorted to computer simulation.



To produce a realistic flow of work which varies from day to day, yet over a long period conforms to the patterns of fault arrival and attention times, the Monte Carlo technique is used; i.e. random numbers are generated and used to select arrival and attention times from the known pattern. The clearance of these faults is then determined by setting rules for the faultsman (e.g. his hours of duty, conditions for working overtime, frequency of asking for work when he has no fault in hand). The outcome in terms of faultsman's time, average times from report to clearance of fault and percentage of faults which have to wait overnight is then computed. By changing the fault loads and the rules for the faultsman, the effects of these changes can be seen. The logical point of working is a broad optimum, on one side of which service falls very rapidly for little gain in efficiency, while in the other direction there is little return in improved service for lower efficiency. Possible staffing arrangements and procedures based on these analyses are being discussed with the staff representatives.

#### TOWARDS A BETTER SYSTEM

##### Introduction

Progress towards a better system cannot be separated from progress towards a bigger system, because the economic life of telecommunications plant is 20-40 years, and technical obsolescence rarely justifies the cost of premature replacement. Thus, the present period of great and rapid expansion is largely determining the general pattern of the services which will exist up to the end of the century. Table 1 indicates the current forecasts of expansion on which the current investment pattern is based.

The key to this dilemma is for the plant and systems to be flexible, i.e. capable of changing their purpose and function during life with the minimum of modification. So one may define a good system as one which has versatility and openness built in to permit it becoming a better system in future.

Obsolescence is inevitable in the rapidly changing technologies upon which telecommunications depends, but this is not compatible with stability of long production runs in which processes can become fully understood while quality control and cost reduction are allowed to work steadily and quietly, leading to the best product at the lowest price. It may be that both manufacturing and operating interests are best served by a kind of "relaxation oscillation," in which pressures for design change, both from user and maker, are deliberately resisted for periods long enough to ensure that change, when made, reflects a significant technical or economic advance, is based on adequate study, and fits into an overall strategic plan.

##### All-Digital System

The long-term possibility of developing a general-purpose digital network is engaging the minds of research workers in the Post Office and industry and in many other countries. The attractive feature is that, having put all classes of message into a digital form, the interface and conversion problems are minimized, and a single yet versatile network can freely handle all forms of communication. It must be firmly stated that these possibilities lie in the future.

At the present time, the application of digital-transmission techniques is wholly within the short-

TABLE 1  
Telecommunications Network Forecasts

	1967	1975	1980	2000
Exchange connexions: business .. .. .	$2.3 \times 10^6$	$3 \times 10^6$	$4 \times 10^6$	} $26 \times 10^6$
residential .. .. .	$4.5 \times 10^6$	$10 \times 10^6$	$13 \times 10^6$	
Number of trunk circuits .. .. .	58,000	200,000	320,000	$1.5 \times 10^6$
Capacity of trunk circuits (MHz miles) .. .. .	19,000	68,000	110,000	600,000
Number of junction circuits .. .. .	566,000	$1.2 \times 10^6$	$1.8 \times 10^6$	$5.6 \times 10^6$
Capacity of junction circuits (MHz miles) .. .. .	16,000	35,000	52,000	180,000
Local calls per year $\times 10^6$ .. .. .	6,450	13,000	19,000	40,000
Trunk calls per year $\times 10^6$ .. .. .	930	2,300	3,600	15,000
●verscas calls per year $\times 10^6$ .. .. .	9	32	60	430

Plant which is now being installed ought to meet the following five criteria.

- (a) Interwork with existing plant.
- (b) Give the best performance that we know how to achieve.
- (c) Be economically competitive.
- (d) Be able to continue to interwork with succeeding generations of equipment.
- (e) Not become technically obsolete in performance or facilities before the end of its economical life.

These requirements are not readily compatible, particularly if the technological change is fast compared with equipment life, as it is at present. It is fatally easy to reduce the conflict between (a), (c) and (d) by imposing rigid standardization on the system, which effectively precludes requirement (e) from being met in the long

distance field, where p.c.m. systems are being introduced at a rate of over  $\frac{1}{4}$  million channel miles per annum to provide junction telephone circuits of the order of 10 miles or so in length. An experimental time-division tandem exchange, compatible with the parameters of the junction p.c.m. system, has been designed by the Post Office and will be installed next year. The way seems to be open for the evolution of star-connected p.c.m. networks where difficult synchronization problems can be avoided in many town and city areas (Fig. 4).

Very big steps extending over many years have yet to be taken before the vision of a national digital network can be realized; long-distance, high-capacity digital links and multiplexers have to be developed to the point where they are technically and economically viable and subsequently installed on a scale which is extensive

enough to link up the major centres: problems of digital-exchange design and network synchronization must be solved before a complex digital network can be brought into existence. The need for an advance on a broad

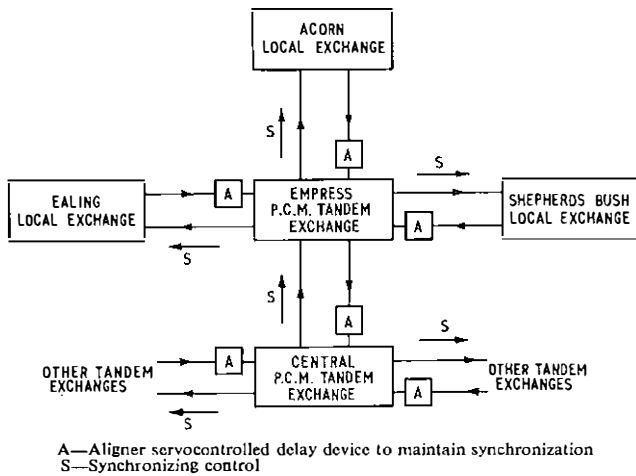

FIG. 4—TANDEM P.C.M. EXCHANGES: POSSIBLE BUILD-UP OF STAR NETWORK

front is recognized by those working in this field both nationally and internationally. The dilemma is that the attractiveness of p.c.m. transmission and switching in specific fields (notably at present in junction telephone networks and perhaps soon in multi-access communication satellites) can demand specific optimum solutions which may not best adapt to the long-term possibilities of a common network for carrying many types of signal besides telephony. There is considerable concern, and rightly so, at the possibility of a series of special-purpose networks evolving independently in the future.

The realization of such a general-purpose digital network linking main centres in future decades is only part of the story, possibly the most straightforward part. Subscribers, however, have to obtain access to this network by methods which can cater for varying requirements, which can be made available as and when needed, which do not involve vast outlays for special-purpose communication capacity of low utilization and which can be operated at tariffs which are profitable to the operator and acceptable to the user. At a rough estimate, the existing local-cable network connecting telephone subscribers to their local exchanges comprises some  $10^7$  pair miles and represents an investment of some £400 million. For the foreseeable future, replication of this network by others dedicated to specialized facilities cannot be envisaged; new services must exploit the existing network as far as practicable. Studies of such possibilities are now being pursued.

#### *Towards a Less Noisy System*

In conventional f.d.m. transmission systems, slowly varying Gaussian noise whose mean power is approximately proportional to the length of a circuit is a parameter which designers can deal with quantitatively. Within a small country such as Britain, this kind of noise is rarely important. Long-distance connexions, particularly intercontinental calls, inevitably experience a significant level of sustained noise, but the designs of the transmission systems used comply with stringent international recommendations, which seek to ensure that

only a very small proportion of calls encounter difficulty. These standards are achieved with adequate margins.

Noise generated within exchanges, however, comes from many sources, not all of which are amenable to quantitative treatment by the designer. Impulsive noise in existing automatic exchanges, using rotary or stepping selection, is known to be due to mechanical vibration caused by the stepping of adjacent mechanisms, and occurs at wiper-to-bank contacts, at shelf jacks and at relay spring-sets. Short-comings of switches using sliding contacts have been well known for many years. Telephone exchanges fitted with reed relays or crossbar switches are expected to be free from much of the impulsive noise which is encountered in our older exchanges.

Use of inherently quiet switching apparatus, although a major step, does not remove the need to adopt uniformly high standards of construction practice at other points in the telephone system where dry contacts occur. Modern electronic equipment is now using a card form of construction, which, for ease of manufacture, installation and replacement, is built up from small units which are plugged into mating sockets fixed to a rack framework; fortunately the contacts have to handle only small power, so that it is possible to have gold-plated contact surfaces giving reliable, noise-free contacts at an acceptable cost.

#### *Towards a Faster System*

The process of setting up a telephone connexion on an automatic system involves the man and the machine in complementary actions. Consider first the traditional means whereby the subscriber gives his instructions to the machine, the dial. This is cheap and highly reliable, but tedious and slow when many digits have to be dialled and frustrating to the user in that it operates at the machine's speed. More attractive to most subscribers is the "keyphone," which is fast, easy to use and operates at any speed the subscriber chooses, but requires more complicated equipment at the exchange and so is more costly. The relative overall efficiency of a subscriber using either of these devices is a topic for human research, and is receiving attention internationally.

It is therefore important to evaluate the economics of subscribers' calling devices with reference to the overall system. If the information necessary to set up a call can be obtained from the subscriber more quickly and more accurately, this reduces the holding time of common equipment and reduces traffic loading due to incorrectly set up or abandoned calls.

The requirement that the machine should set up calls quickly was easily met in non-director networks, where a subscriber's speed was limited by his dial, and where step-by-step switches followed the dial with no noticeable delay. However, current developments, such as the introduction of keyphones, the introduction of registers and the ability to set up very long chains of connexion with multi-link signalling and switching, could involve delays which subscribers would find intolerable. Present trends in the national network are towards an increase in the number of direct trunk routes, so that only a minority of calls have to negotiate an intermediate trunk-switching stage. Faster signalling and switching schemes for all calls are being studied. In addition, the transit network is being introduced, which will be controlled by

TABLE 2  
Typical Call Setting-up Times

Type of Call and Conditions	Dialling Time (seconds)	Waiting Time for Ring Tone (seconds)	Total Setting-up Time (seconds)
<i>Non-director area; 6-digit local call</i>			
Strowger network, telephone with dial .. .. .	9	1	10
Strowger network, keyphone .. .. .	2	7	9
Future electronic network with fast signalling, keyphone .. .. .	2	2	4
<i>Director area; 7-digit local call</i>			
Strowger network, telephone with dial .. .. .	11	3	14
Strowger network, keyphone .. .. .	2	8	10
Future electronic network with fast signalling, keyphone .. .. .	2	2	4
<i>Director exchange; s.t.d. call to another director exchange via a single trunk link</i>			
Strowger networks, telephone with dial .. .. .	14	9	23
Strowger local networks, multi-frequency signalling trunk link, telephone with dial .. .. .	14	5	19
Future electronic network with fast local and trunk signalling, keyphone .. .. .	3	2	5
<i>Non-director exchange; s.t.d. call to another non-director exchange via five trunk links</i>			
Strowger networks, telephone with dial .. .. .	Service operated manually at present		
Strowger local networks, multi-frequency signalling trunk links, telephone with dial .. .. .	14	10	24
Future electronic network with fast local and trunk signalling, keyphone .. .. .	3	12	15

fast signalling between registers and which in principle will handle all trunk calls which cannot be handled automatically at the moment, since they require more than one intermediate switching point. Twenty-four of these transit centres, which are 4-wire switched crossbar exchanges, will be in service by 1970. Table 2 compares the time taken to set up calls using various techniques, including those now being developed. The overall effect of all these time-saving processes is very considerable if they are introduced in harmony with one another. The savings in common equipment which could accrue from the phased introduction of keyphones, fast inter-register signalling and electronic exchanges could in theory be as high as £100 million by about 2000 AD. These savings could, in practice, only be partially realized, as the registers, etc., involved cannot be fully shared and have to be provided in discrete magnitudes. But, nevertheless, the worth of these techniques is considerable.

#### *Towards a Self-Governing, Self-Healing System*

With the growth in size and complexity of telecommunications networks, the extension of automatic working has gone a long way to minimize the need for human intervention under normal conditions. Automatic systems should have the power to detect errors and faults and to fall back on alternative courses of action to maintain service when normal outlets are unavailable or congested. In modern types of exchange, particularly electronic exchanges, extensive use is made of fault-checking facilities on live traffic and on test calls. Each connexion set up through an exchange is checked, and second attempts are made automatically (without the subscriber being aware that this is happening) in the event of failure. Common equipment is duplicated with automatic change-over facilities, and faulty units are automatically removed from service. Plans include facilities for setting up automatically from an unattended exchange a data-transmission connexion to a distant maintenance centre, where a printed record of the nature

and location of a fault can be given. Future exchange systems will have, as their basic maintenance tool, a teleprinter which records automatically the results of periodic routine checks and any abnormal situations which develop, and from which the maintenance man can deduce the state of the exchange and plan any remedial action which is necessary.

At present, automatic alternative routing in the trunk network is not a feature of s.t.d. in Britain, although an element of this will be introduced when the 4-wire switched transit network is opened. This network, connecting group, district and main switching centres, will have the technical possibility of providing alternative routing at each stage. Manually controlled routing changes to cope with emergency or breakdown conditions can be provided by the operation of keys or by making changes to the translations.

With the introduction of the transit network and the availability of more versatile exchange systems and more powerful signalling systems, it is appropriate to consider to what extent automatic alternative routing in the trunk system should be developed. To what extent the busy periods are staggered, how traffic fluctuates between one day and another and the existence, at any given instant, of spare capacity in the network which could be used to carry diverted traffic are topics which are now being studied. One approach to this problem is the broad concept of network management by a computer-like control system. Information on the flow of traffic and the state of the network over a considerable area is fed into a central processor, which determines the optimum route for each call as it arrives and instructs particular switching centres accordingly. Such a system appears to have the possibility of coping with abnormal demands on certain routes and of reacting to minor breakdowns by diverting traffic on to other routes, but it is not clear, because the basic traffic data are not yet available, to what extent these desirable objectives could be achieved without an all-round increase in the level of circuit provision. The key to these problems lies in the twin concepts of information and control; that is to say in

the continuous generation of traffic-flow data from all switching centres, their presentation at suitable control points by means of data-transmission links (which might be associated with a common-channel signalling system) and the continuous analysis of these data for the purpose of controlling the network. In principle, this control would be automatic, but it must have the possibility of human intervention under critical conditions. The Post Office is setting up, as a first stage, "network co-ordination centres" where manual control of the network would be exercised.

It seems unlikely, however, that any automatic re-routing scheme operating on a circuit-by-circuit basis can cope with a major breakdown involving the sudden loss of a very large block of circuits as, for example, when a main cable or radio route carrying many thousands of channels is put out of service. Fast acting broadband protection methods are necessary to deal with these breakdowns and are already a feature of microwave radio routes which are provided with main and protection channels (working through common aerials and feeders), beginning with 1 + 1 up to a maximum of 6 + 2 as the route is progressively equipped. The overall serviceability of microwave links with protection channels averages 99.95 per cent.

Cost considerations have hitherto precluded the adoption of a similar scheme for coaxial-cable systems (cable damage accounts for the bulk of the lost service time—the average serviceability is 99.5 per cent—and this is the most expensive part to duplicate), but the broadband cable network has now grown to such a size as to justify an independent standby co-ordinated radio and cable links network which will interconnect the more important nodes of the system. Plans are now being drawn up to provide an extensive network of spare channels and automatic switching facilities, to become available in the next few years.

The concepts of information and control are fundamental to any telecommunications system, and current trends are leading towards the use of much more powerful means of information transfer, which can be closely allied to exchange control systems. Accurate transmission of information is, of course, essential if an acceptable standard of service is to be obtained, and much work has gone into the development of speech-path signalling systems in which the characteristics of the signals used for the different functions of, for example, seizing a circuit, releasing a circuit, transmitting routing and numerical information are tailored to meet the specific requirements of each piece of information with an acceptable risk of error. The modern tendency is to exploit the possibilities of coding to permit detection of errors of transmission such as might be caused by a momentary disconnection or burst of noise. Possibilities of error detection are greatest in those situations where common equipment is used and cost can be related to usage. Four stages in the development of signalling systems can be recognized: first, systems in which the possibility of error is minimized by careful design; secondly, the introduction of compelled signalling systems in which the receipt of a plausible signal has to be acknowledged back to the sending end before the next signal is sent; thirdly, restricted *m*-out-of-*n* code in which the receiver, by the use of logical and sequencing criteria, can recognize incorrect or incomplete messages and request a retrans-

mission; and fourthly, the use of a common data channel to carry signalling information coded in binary form with, typically, a simple block error-detection code by which the undetected errors can be reduced to negligible proportions.

One type of common data-channel system now being studied for international and, possibly, national service (C.C.I.T.T. No. 6) uses a common path to carry the line signals, i.e. calling, clearing and answering, from one processing centre to another, as well as the register signals, i.e. those needed to route the call. The data channel and both registers are, of course, associated with common equipment at each exchange and are only in use for each call for the short time needed to transfer the information or establish the connexion.

#### CONCLUSION

The end product of a more efficient system is the ability to supply customers with more facilities and a higher standard of service at a lower overall cost. For several decades the cost of long-distance circuits has been reduced progressively by the use of multiplexing techniques in which the productivity of a transmission path is increased as more and more channels are derived from it at ever diminishing cost per MHz mile. We now envisage 60 MHz coaxial-cable systems in which 10,800 telephone circuits can be carried on a single pair of tubes. Even bigger capacities are promised when microwave techniques are applied to guided-wave transmission. This already results in the fact that, within our national network, only a very small number of circuits are long enough for line-bandwidth costs to dominate. The dominant cost in the provision of the average inland trunk circuit is in the switching, signalling and multiplexing equipment in the terminal stations.

Contemporary developments in switching techniques do not offer much prospect of dramatic savings in switching costs nor of increased productivity so long as circuits have to be switched individually. Indeed, the introduction of 4-wire transit switching to meet the transmission objective on multilink connexions could be regarded as a step away from that goal. The first major step towards increased switching productivity may have to await the switched-multichannel-highway principle applied to digital switching of p.c.m. signals. In addition to the large saving in cross-points there is the saving in multiplex terminals, but this has to be set against the greater complexity of the t.d.m. exchange, and severe problems of synchronization remain to be solved.

Provision of service "on demand" is inescapably related in engineering terms to the degree of flexibility and "expandability" built into the local distribution network. The pre-existence of the present network, an investment of some £400 million, is both an obstacle and a challenge. It is an obstacle because it has been planned largely on a demand or penetration of considerably lower than 100 per cent on an average. It is a challenge because it represents a bandwidth/noise resource that, even in its present condition, appears to offer means for providing added facilities and added stations. If this can be achieved it may not only offer hope of continuing productivity in this field, but may also serve to bridge the gap until the full exploitation of digital techniques in the local network becomes economically possible.

In the field of maintenance, a general tendency can be recognized of increasing the span of activity of each man.

Individual circuits and individual switches will need less human attention in future. This is an inevitable requirement, since the expansion of the system cannot be matched by a corresponding expansion of the maintenance force. So maintenance attention will increasingly be directed towards collective units, to assemblies of channels and wideband-transmission media and to common control and centralized processing systems. Deep understanding of the network and diagnostic ability may well become the most essential skills for the efficient operation of the future system. If we are brilliant in our preparation for the future we shall foresee every crisis, every failure possibility and either plan or program it out of the system. But we shall probably not be brilliant (or even if we were to be, the design might never

be commercially viable); we shall be sound practical engineers. And this will mean that, from time to time, faults will occur that disrupt business. As these occur, staff ingenuity and resource will rise to the occasion, and the experience gained will be built-in to later designs and procedures. In this sense, both men and systems become self optimizing.

My aim, in this address, has been to outline the vivid interplay that exists in telecommunications between men, circuits and systems. If I have succeeded, it is through the active support of many colleagues whose energetic development of productivity and whose technical inventiveness is recorded here; it is also through the foresight of former colleagues, upon whose foundation work we in Post Office engineering now build.

## A New Manhole-Cover Lifter—Lifter, Manhole Cover, No. 3

J. O. COLYER, B.Sc.(Eng.), C.Eng., M.I.E.E.†

U.D.C. 621.866.624.027:621.315.233

An attempt has been made to produce a manhole-cover lifter for everyday use by external staff. The device now on field trial is described, and its design features are discussed.

### INTRODUCTION

THE design of a new manhole-cover lifter was commenced with the object of reducing the incidence of injuries to staff. At about the same time it was pointed out that lifting carriageway covers was one of the few remaining operations performed by external staff that required two men. It seemed possible that the other problems connected with single-jointer working could be solved, and so it was specified that the new lifter should enable one man to lift and move away any cover.

Accident statistics show, not surprisingly, that the risk of back injury is greatest among people whose work involves frequent heavy lifting. There are many causes of lifting accidents—bad technique, excessive loads, faulty equipment, etc. It is obvious that the most effective way of preventing these accidents is to eliminate manual lifting. Existing lifters do not achieve this because they are used for special purposes only, and supplement, but do not replace, manual lifting. The new lifter has, therefore, been designed for regular, routine use by all external staff, replacing present manual lifting methods entirely. Prototypes which appear technically satisfactory have been produced, but only an extensive field trial will show whether they are fully acceptable to users.

### PRINCIPLES OF DESIGN

A cover lifter for everyday use must be acceptable both to the staff and to the administration when compared with ordinary manhole keys. This means it must be as convenient and light as possible, and, since very

large numbers will be required, it must not be unduly expensive nor require much maintenance.

As a first step in meeting these requirements the maximum lift was fixed arbitrarily at 2,000 lb. Little information was available on the actual force required, and it was recognized that this force might be insufficient to free badly-stuck covers. However, some limit on the force was essential if the size of lifter was to be kept within reason, and experience to date suggests that 2,000 lb is, in fact, ample. Special equipment (Lifter, Manhole Cover, No. 1) is already available for covers which are badly stuck.

The most promising mechanisms available for providing the lifting force are hydraulic jacks, screw jacks or levers. Hydraulic jacks were ruled out on grounds of maintenance and capital cost. A simple lever, such as is used for the Lifter, Manhole Cover, No. 2,\* needs to be very long to give the necessary mechanical advantage; this makes the lifter unwieldy. Various more elaborate arrangements of levers were considered, but, finally, screw jacks were chosen as best meeting the requirements. A screw jack is inefficient, but this is, in one respect, an advantage since it means it will not run-back under load, and no special devices are required to ensure that the cover stays suspended when the jack handle is released.

Fig. 1 shows the principle of a conventional mechanical lifter. A beam spans the cover and is supported at its

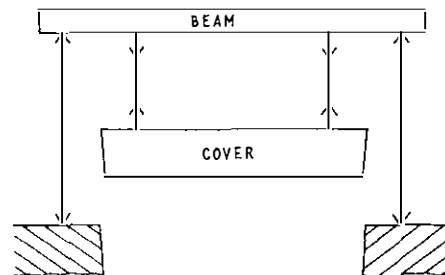

FIG. 1—PRINCIPLE OF COVER LIFTER WITH BEAM

†External Plant and Protection Branch, Engineering Department.  
\*Manhole-Cover Lifters. *P.O.E.E.J.*, Vol. 51, p. 70, Apr. 1958.

ends by the lifting jacks; the keys are attached to the beam and support the cover. Since the beam has to resist the bending moment produced by the upward thrust of the jacks and the load on the keys, it must be strong and, therefore, heavy. It is also inconvenient in use, since it must cater for a range of cover sizes and key positions. On the other hand, the cover itself spans most of the distance between the jacks and is extremely strong, so the idea arose to eliminate the beam entirely. It was realized that this could be achieved simply by scaling up the No. 2 Joint-Box Key, and so the new design came into being (Fig. 2). The lifter (Lifter,

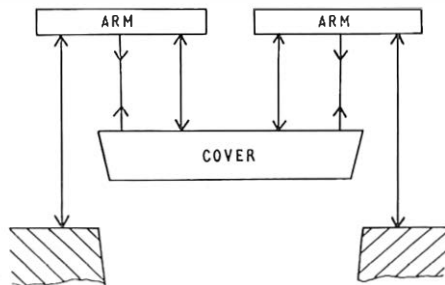

FIG. 2—PRINCIPLE OF NEW COVER LIFTER

Manhole Cover, No. 3) consists of two separate jacks, each with a short arm carrying a key in the centre and bearing downwards on the cover at the end farthest from the jack. It will be evident from simple mechanics that, if the key is supported at the mid-span of the arm, the downward force exerted by the arm on the cover is equal to the downward force exerted by the jack on the ground, say  $f$  lb, while the upward lift on the key is equal to the sum of these forces,  $2f$  lb. Hence, the net lift on the cover is  $2f - f = f$  lb, but the force tending to pull the key out of the cover is  $2f$ . Fortunately, keys and keyways have ample strength to resist this double force, and, as it is short, the jack arm may be made strong enough without becoming excessively heavy.

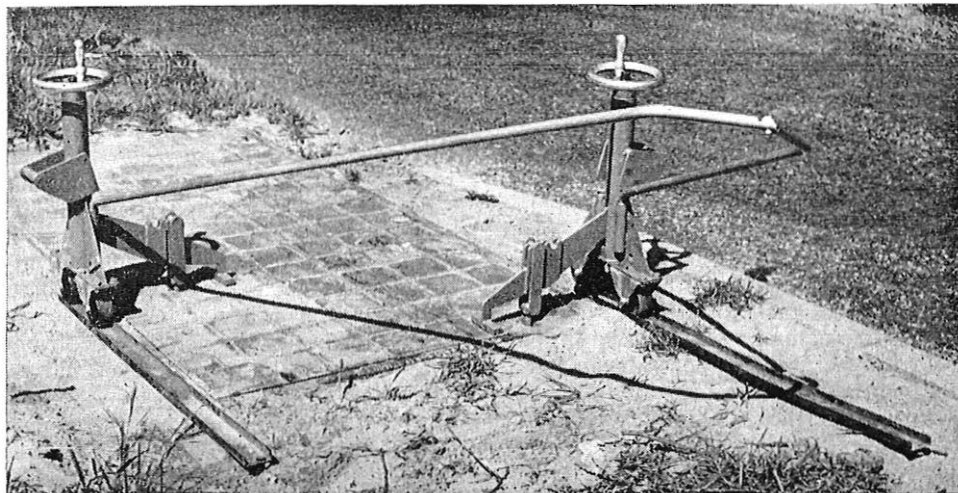

FIG. 3—MANHOLE-COVER LIFTER No. 3 WITH WHEEL-GUIDE CHANNELS

In the choice of material, cheapness and convenience for once coincide: for the large numbers and rather complicated shapes required, diecasting is cheaper than fabrication and this leads to the use of an aluminium alloy, which is light to handle.

Wheels were provided to enable the cover to be moved when raised; it was found that metal channels for these to run in were a great advantage, both for easy running on rough ground and as guides to ensure that a wheel could not fall down the opening when wheeling square covers (see Fig. 3). Handles have been provided to link the jacks and enable one man to wheel them; the use of handles is optional when two men are available. Unit-type covers have four key holes, but it is found that they can be lifted easily with the two jacks placed diagonally, and a special handle with arms of unequal length is supplied for this operation. Unit-type covers require different keys from those used for earlier covers.

#### FIELD TRIALS

The original prototype was issued to a jointing party in the London Telecommunications Region, and has been in use for many months. This set of equipment was fabricated in steel, and a number of similar lifters have been obtained by Regions. All have been very well received by the users; the equipment works well, and appears to have achieved the most difficult design aim—acceptability to the staff. The keys have given some trouble because, for the small quantities involved, it has not been practicable to get them forged, and various welded constructions have been used. Some jack screws have broken and stronger ones will be used in future.

A contract has been placed for 1,600 lifters in die-cast aluminium alloy to enable bulk production techniques to be tried out and to spread the field trial over a larger area.

#### FURTHER DEVELOPMENT

The new lifters need only two types of key, and with these any existing type of cover can be lifted. However, consideration is now being given to covers divided diagonally into two triangular parts, each with one key hole at its centre. These appear to have important advantages and a number are on trial, but, unlike all

previous covers, they do not provide a solid beam spanning the space between the keyholes. In order to lift these mechanically, a cross-beam will be needed and an additional part for association with the new lifters is being made for trial.

# Programmed Learning—A New Design For Training

## Part 1—An Introduction to Programmed Learning

A. C. HOLMES, C.Eng., M.I.E.E., and K. R. CROOKS, Graduate I.E.R.E.†

U.D.C. 371.33

Since 1954 there has been considerable re-thinking about the problems of education and training. Extensive research and development of established principles have created a new educational technology called programmed learning, which offers a fresh vision for our training system. Part 1 of this article will answer, in a wide sense, the question "What is programmed learning?" The second part will consider past, present and future uses of programmed learning, attempt to substantiate the claims made for it, and outline the fields of application for future development.

### INTRODUCTION

IN the 2,000 years before 1954 there had been little or no improvement in our teaching methods: our lecture and classroom techniques were still basically the same as those of the ancient Greeks. In 1954 Professor B. F. Skinner published a paper entitled "The Science of Learning and the Art of Teaching" in the *Harvard Educational Review*. Since that date "programmed learning," which was the main theme of his paper, has been gradually accepted by teaching circles.

In the old system, teaching consisted fundamentally of a teacher talking to a small group of people in a controlled environment. The system was obviously teacher orientated, there being a tendency for the audience to be dominated by the lecturer or teacher. To be a very good lecturer under these conditions was far from easy; to succeed he had to possess a set of particular characteristics. He had the task of guiding the student to the desired conclusions through the impressions gained from being in the controlled environment. Essentially the student should make judgments, based upon his own opinions and evaluations. For the teacher to be successful he should not dominate or obstruct the student's thinking process; basically he should be a catalyst. At all times the process he controls should be methodical, and at no time should chaos and the resulting confusion be allowed to occur. The general environment should be conducive to easy and interested learning.

In more leisurely times these methods were very satisfactory, but, with the rapid increase of our scientific and technological knowledge, desired levels of education have been very hard to attain. Education is finding it almost impossible to keep up with these rapid advances.

Since 1954 there has been considerable re-thinking upon the problems of education and training. Well-established principles have been carefully re-examined, and, as the result of extensive research and development, a new educational technology has been evolved based upon the original concepts of programmed learning. To overcome present training difficulties these new techniques must be applied as soon as possible, for the intelligent use of programmed learning as a training system will help management in the solution of labour and productivity problems.

† Mr. Holmes is in the South Central Telephone Area, London, but was formally in the Engineering Branch, London Telecommunications Region; Mr. Crooks is in the latter Branch.

### PRESENT PATTERN OF LEARNING

The relatively low effectiveness of the conventional classroom situation can be seen by considering that a lecturer gives out verbal information at approximately 100 words a minute whereas students can absorb information at a much higher rate. Only a small proportion of the classroom student's brain capacity is thus occupied at one time, leaving the rest idle. In the training-school classroom of 24 students the lecturer can only engage the specific attention of one or two at any given time. The others can "switch themselves off" if they wish, by looking out of the window, thinking of other things, notewriting, etc. This may be further aggravated by recent emotional disturbances such as a rushed journey or a meal. Another important consideration is that when a student receives the approval or criticism of the lecturer immediately after making a response to a question, he will learn more effectively than if he has to wait for a long period of time. A student in today's situation may wait between one and six weeks before his learning is tested and consequently reinforced.

The current pattern of training in the engineering field is that vocational courses are organized on the basis of training demands forecast some 6-9 months previously. It is unfortunate that the many other factors involved cause a large number of students to have a training course at a time more related to the availability of seats than to the time of their need for such training. Consequently, some students wait a long time before being given a course, whilst others have a course in which some of the material is not relevant to their training need, i.e. their job. In a well-organized training scheme the right amount of training is given to the right person at the right time.

### TOWARDS AN IDEAL LEARNING SITUATION

The problems of learning (though not necessarily the economics) tend to diminish with a tutorial system in which a tutor has only one or two students at a time. Here the tutor is able to give individual attention to the needs of his students and, hence, can give immediate approval or criticism of the student's progress. Furthermore, students are less able to "opt-out" of the learning situation for any length of time because it is possible for questions and answers to frequently pass to and fro throughout the tutorial. This system, with all its virtues, is also the most expensive.

### *Some Principles of Learning*

The following list gives some of the generally-accepted principles of learning upon which any learning-teaching situation should be based.

(a) The student must be motivated to learn, otherwise he may lose his new-found knowledge shortly after gaining it.

(b) The learning process is better served by intrinsic motivation, than that of an extrinsic nature.

(c) Learning by success or reward is preferable to learning by failure or punishment.

(d) The student must be guided to the learning goal by an organized sequence of small steps.

(e) Teaching must be adapted to the personal needs of the individual, i.e. speed and level of presentation.

(f) The immediate knowledge of results, i.e. of mistakes or success, aids learning.

(g) It is preferable for a learner to be an active participant than a passive reader or listener.

(h) The decision of what each person should learn depends closely on the capacity of the learner, and must be unambiguously stated.

(i) The student must be challenged to discover principles for himself.

(j) Long retention of material can be assisted by practice and by recalling it during the learning process.

The above principles underlie any good teaching method; for various reasons only some of them are evident in the classroom, whereas the majority are to be found in tutorial and also in programmed learning. Programmed learning is directed towards a practical realization of the tutorial system without incurring such high costs.

#### WHAT IS PROGRAMMED LEARNING?

Programmed learning provides a situation in which a student is led through a set of validated learning steps, dictated by the results of detailed analyses of the subject matter and the student, synthesized into a "program," thereby enabling the student to be actively involved in the achievement of a stated learning goal. Programmed learning is characterized by the following features.

#### *Active Engagement of Students in Learning Process*

The program from which the student learns is designed to confront him regularly with decisions, the consequence of which determines the rate of subject mastery. He becomes the student in a tutorial, with the program leading him on and expecting a demonstration of his understanding at every stage. Unlike the classroom, he cannot "switch himself off" at the expense of the argument being prepared: instead, the program will wait and only the student's concentration will have been lost.

#### *Rate of Learning to Suit Student*

Students have an optimum rate of intake of information, and programmed learning makes this information available in a form that enables such a rate to be realized. It is one of the responsibilities of a lecturer to determine the best rate of progress for his class, but, unfortunately, whatever rate is selected it will be unsuited to the learning rate of a large number of the students. Furthermore, the student is less likely to be anxious about his own ability to keep pace with a larger group if he can work at his own speed.

#### *Presentation of Material in Small Amounts*

The subject matter is divided into small units called "frames." Each frame must be assimilated easily by the student and will thereby mould his behaviour towards the learning goal. The frames usually vary in size from one sentence to several small paragraphs, but at least part of each small step will require a response from the student. This may be in the form of filling in a blank, answering a question, selecting an appropriate statement from a given

list of alternatives, or performing some other action. This activity must cause the student to demonstrate his level of understanding the material.

#### *Reinforcement of Learning Giving Immediate Knowledge of Results*

At each step in the program the response made by the student is judged before the commencement of the next step. In fact, the next step is normally governed by the correctness of the previous response. Thus, the learner is kept on the right path to his goal and deviates only for remedial material before returning to the main sequence. The immediate and continuous knowledge of his progress is part of the motivation to continue learning.

#### *Training Tailored for Specific Students and Leading Them to a Guaranteed Performance*

Whilst any type of training should ideally be aimed at achieving a guaranteed performance from specified students, the fact is that in the past it has not. Programmed learning places paramount emphasis upon the analytical breakdown of training needs. From such analyses it is possible to identify individual training tasks and the people in need of them. Hence, with particular trainees in mind, small packets of instruction can be combined on a modular basis to form a given training course. Because an integral part of program preparation is that of validation or testing, a program is regarded as acceptable only when students, for whom the program was written, have demonstrated a high standard of performance after taking the program. Few other forms of instruction are subjected to this degree of worthiness before being dispensed. The guarantee is made possible by programming for a specific section of trainees, referred to as the "target population."

#### *Incorporation of a Measure of Quality Control*

Teaching is an organized system for producing learning, and learning is a product which, like produce of industry, can be measured. With the introduction of programmed learning it is possible to collect reliable information about the student's progress. Thus, as the learning goal is precisely defined and the lessons exactly repeatable, modifications to the process can be made until the desired objective is attained.

#### THE STAGES INVOLVED IN PROGRAM PREPARATION

Programmed learning offers a new philosophy for training in which the development of a complete training system can be set forth. Originally, it was frequently regarded as only another form of presenting material, but, as the following stages show, the program seen by the student is backed by considerable research so that the guaranteed high standard of training is achieved. The stages in developing a training plan are shown diagrammatically in Fig. 1.

#### *Analysis of Job for which Training is Envisaged*

The particular job is studied in order to provide a description of the performance and output of an expert, and to determine the influence of various elements of the job and related jobs.

*Task Analysis.* The job is next divided into discrete parts called tasks. A critical examination is then made of each task in order to specify clearly the work performed, in what manner, with what aids, and why it is so per-



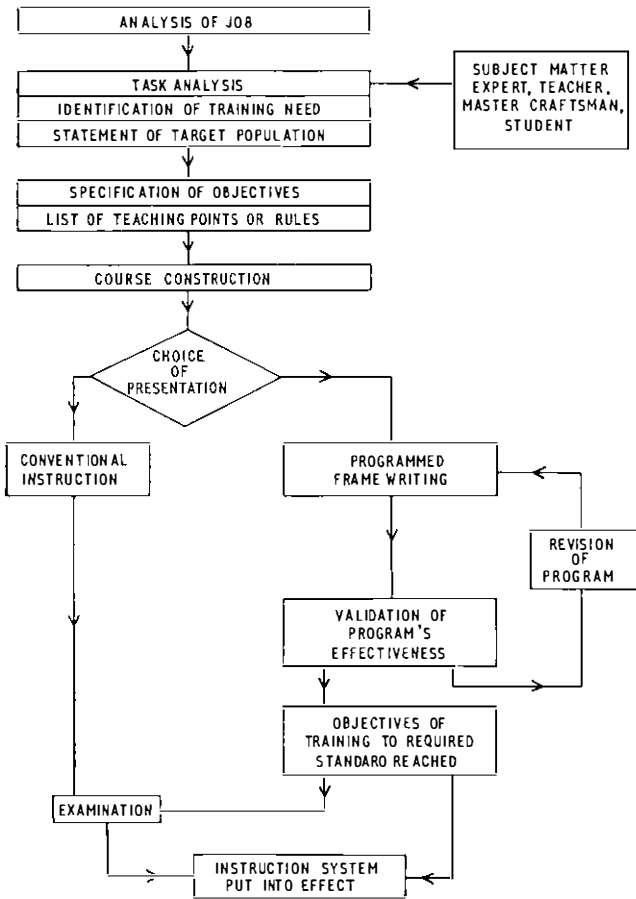

FIG. 1—A TRAINING PLAN

formed. An analysis of skills, training deficiency and environment will also be performed so that a training need, if any, can be stated. It is important at this stage to identify the cues used in decision making and any other information relevant to the student obtaining mastery of the subject. This analysis is a time-consuming process and involves consultation with all interested parties, i.e. the expert in the particular skill, teachers and potential students, etc.

*Identification of Training Need and Statement of Target Population.* Resulting from the task analysis, the presence or absence of a training need will then be stated. Savings can result where training is shown to be unnecessary or, alternatively, where a positive training need is established it will be stated in precise terms.

Whilst investigating these job aspects a clear picture is being built up of the students for whom the instruction is intended—the target population. The statement of the target population must identify the students in terms of their age range, sex, reading level, I.Q., etc., and should include the assumptions that can be made about their standard of knowledge or skill before they commence the instruction.

*Specification of Objectives and Formation of a List of Teaching Points or Rules*

Following the two previous stages, it is now possible to specify, again in precise, unambiguous terms, the objectives of the course in a manner capable of being measured and tested. It will be a statement of what the student can

do at the end of the instruction, under what conditions, and to what level of proficiency. This is often a lengthy exposition, and relates in principle to the syllabus for present-day courses, but in considerably more detail.

The precise degree of learning that the student is required to achieve is now known, and from the task analysis it is possible to determine the strategy for achieving it. From this follows the writing of a list of every teaching point or rule, organized into a sequence that will dictate the teaching order.

*Course Construction—Conventional Instruction or Programmed Frames*

It is important here to decide whether conventional instruction or programmed frames, etc., are the most effective means of presentation for maximum learning. Whatever medium is most efficient or most suited, and open to the programmer, bearing in mind economics, should be used. If it is decided to use programmed frames, for there is an exceedingly wide variety of situations in which they are applicable and indeed desirable, then consideration can be given to the use of the techniques at present employed in frame writing. These are illustrated below.

(a) *The Linear-Constructed Response.* The linear-constructed response technique requires the writing of small frames, averaging from one to two sentences, and at each frame enlisting a response from the student. This would take the form of completing a sentence, filling in a blank, or in other given ways, to construct his own response. The frames are presented in a linear manner so that the student can progress along one route only through the program. Fig. 2 shows a simple example of the linear method. The correct response is given in the box to the

(1) We know that water can be used as a source of power, e.g. water-wheel, hydro-turbine, etc. Similarly, electricity can be used as a source of p. ....	↓ Answer below
(2) Water can be transferred through a pipe from one place to another, where it can again be used as a source of .....	power
(3) When electricity is transmitted through a cable it can be used as a ..... of ..... at the distant end.	power
(4) The characteristics of this cable cause a certain opposition to the flow of electricity, so that a lesser amount of power reaches the distant end. Thus, the amount of electrical power available at the distant end is—.....	source of power
(5)	less

FIG. 2—SIMPLE EXAMPLE OF LINEAR TECHNIQUE

right of the following frame, but is hidden from view until the response has been made and the next frame therefore revealed.

(b) *Multiple Choice.* It is usual with the multiple-choice technique to write a larger frame of one or two small paragraphs and to terminate it with a question, pertinent

to the material just given. A group of alternative answers to the question will be provided, and the student chooses the one most appropriate to his understanding of the prior instruction. The alternative answers made available are carefully selected to cater for different areas of misunderstanding (except the right answer), thus providing a means of error diagnosis and feedback to the program. The next frame seen by the student will be determined by this choice and will provide any necessary remedial material, before proceeding with the main theme. Hence, different frames may be seen by different students according to their learning requirements. Fig. 3 shows an example of this method. The arrows indicate the next frame presented according to the answer selected.

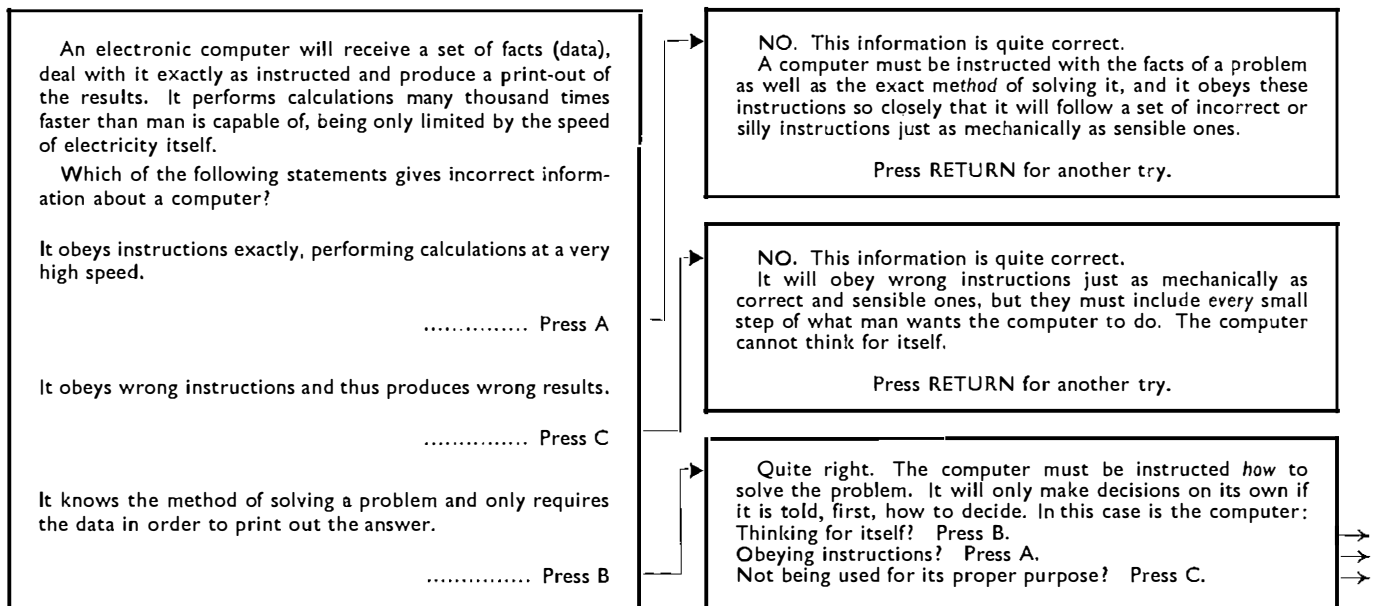

FIG. 3—A BRANCHING SEQUENCE

Programs are frequently prepared as a hybrid of techniques (a) and (b) if the subject matter, target population and other factors indicate that this is desirable.

(c) *Mathetical Exercises.* Although the principles of obtaining and reinforcing behaviour are still maintained, the mathematical\* type of program makes use of bold illustrations and appealing design features. Instead of presenting the information in small steps, whole-page spreads may be used to present as much material as the student can reasonably negotiate, thus allowing him to see the direction that his learning is taking. Such exercises are usually presented in three main sections, as in Fig. 4, thus:

- (i) a demonstration of the required learning,
- (ii) a page prompted with cues to assist a correct response, and
- (iii) an unprompted page requiring the correct response in full.

An adjunct to the mathematical techniques is to teach the subject retrogressively. This means that the learning goal will be reached each time the student completes a sequence

\*Mathetics—the term applied to a system of analyses used to achieve objectives in programmed learning. “Frames” in mathematical programs do not aim at uniformity, but are of varying lengths and contain words, diagrams and pictures, etc.

from a progressively-earlier starting point.

#### Validation and Revision

Before a program is offered with the guarantee that it will teach, it is subjected to testing under its operating conditions on a sample of students from within the target population. The standards set are high, for with a linear program it is required that 90 per cent of the students obtain a result of 90 per cent or more in a test set to measure their achievement. Variants of these figures are quoted for other programs depending upon the standard laid down in the objectives. The results of these try-out sessions are closely analysed, and the weak parts of the program are re-written until the required standards are

realized. If the student fails to reach this standard he is not considered dull, as the onus for learning achievement has now been removed from him and placed upon the programmer.

#### FORMS OF PRESENTATION—THE WORKING SITUATION

So far the term program has referred to the organized sequence of material from which the student learns. The vehicle by which this is conveyed to the student is the “hardware” of programmed learning. In its simplest and cheapest form, the program can be presented in loose-leaf or fast-bound textbooks, and as such is referred to as a “programmed text.” However, there are certain desirable elements of control over the learning process that are not possible with books, and commercial exploitation of this fact has resulted in the production of a wide range of machines for presenting programmed material. They are known as “teaching machines.” Although they have a number of advantages, their disadvantage lies in some instances in their high initial cost. A brief review of some of the teaching machines available at present will be given in Part 2 of this article. It is a plain fact, however, that whereas teaching machines need programmed learning, programmed learning does not depend upon teaching machines—a programmed text may well suffice. Other forms of presentation include: tape record/playback,

synchronized film and tape, inductive magnetic loops, closed-circuit television, and the use of overhead projectors.

The situation of a student on a programmed course is that, although under the watchful eye of a tutor, he will receive his instruction from a text or a teaching machine (when this medium is appropriate) and make what pertinent notes he is requested to as the program proceeds. He will be taught to perform or demonstrate learning the actual task or job that his work demands of him, resulting in a prescribed level of behavioural achievement rather than just an understanding of the necessary achievement. The rate of progress of one student will be independent of another, so that it is possible for the more able student to complete a course ahead of those requiring more time. This, however, does not necessarily reflect any greater intelligence upon the faster students.

**ADVANTAGES AND DISADVANTAGES OF PROGRAMMED LEARNING**

In common with other instructional systems, programmed learning has its advantages and disadvantages. The main advantages over conventional instruction are summarized below.

- (a) The analytical approach combined with the services of a competent expert ensures that the training is both pertinent and of the highest standard.
- (b) Programs prepared by one training school may be

used on a wide basis—regional, national and international—thus ensuring a uniform standard of instruction.

(c) Training can be provided at times convenient to the student and management, rather than waiting for the formation of a group.

(d) Instruction is paced at the learner's own learning speed.

(e) An immediate knowledge of learning achievement promotes more effective learning.

(f) A high degree of motivation is provided by students' repeated successes: this is, for many, a new experience.

(g) A measure of quality control is introduced.

(h) Each program forms a training module, a number of which can be compiled to form a modular training scheme.

(i) The tutor responsible for the students can give individual attention as and when difficulty arises.





(j) Tutors are able to concentrate their efforts on areas of difficulty, leaving routine instruction of rote facts to the program.

(k) Time saved by instructors can either be directed to

The Symbols used to represent Relay Contacts

---

We will next learn to identify the symbols used to represent the four types of relay contact unit in common use.

<p>1. </p> <p style="text-align: center;">MAKE (M)</p>	<p>2. </p> <p style="text-align: center;">BREAK (B)</p>
<p>3. </p> <p style="text-align: center;">CHANGE-OVER (C)</p>	<p>4. </p> <p style="text-align: center;">MAKE-BEFORE-BREAK (K)</p>

Note carefully that the lever spring  performs the action as indicated by the name of the unit (with abbreviation in brackets).

A.....(M) unit is shown at 1.  
 A.....(B) unit is shown at 2.  
 A.....(C) unit is shown at 3.  
 A.....(K) unit is shown at 4.

Complete the above statements and then turn over the page.

page d.







<p>1. </p> <p style="text-align: center;">(M)</p>	<p>2. </p> <p style="text-align: center;">(B)</p>
<p>3. </p> <p style="text-align: center;">(K)</p>	<p>4. </p> <p style="text-align: center;">(C)</p>

Diagram 1 shows a.....contact unit.  
 Diagram 2 shows a.....contact unit.  
 Diagram 3 shows a.....contact unit.  
 Diagram 4 shows a.....contact unit.

Complete the above statements and then turn over the page.

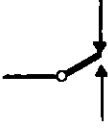
page e.

<p>1. </p>	<p>2. </p>
<p>3. </p>	<p>4. </p>

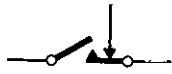
Name the contact units with the appropriate abbreviations in the space provided under each symbol.

page f.

FIG. 4—A SIMPLE MATHEMATICAL EXERCISE

the programming group for the preparation of further programs, or permit a more economical distribution of manpower.

The main disadvantages are as follows:

(a) The combined analyses, frame-writing and validation stages occupy a large amount of time. This results in the high initial cost of the programs, which only becomes economically justified when used by a large number of students.

(b) There is a reduction in the instructor-student relationship normally found in the classroom; such an environment is an accepted factor in learning.

(c) The less-efficient tutor may tend to regard the programs as entirely self-sufficient and not play his part in the difficult areas of learning.

(d) The administration of the programs requires careful attention to ensure that the right program is given to the student at the right time. The student has no redress against a program if it is too difficult for him.

(e) Program writers are required to exhibit a range of skills for which there is a strong competitive demand, hence there may be difficulty in recruiting the right staff for the duty.

#### RELATIVE COST FACTORS

When considering the costs of programmed learning it is appropriate to relate them to existing methods of training. In the first instance a large proportion of programming time is devoted to analysis, and, although attributed to programmed-learning costs, is equally appropriate to conventional instruction. It is possible to obtain a cost per student per week figure for conventional instruction, which will take into account all relevant factors from the bricks and mortar of a training establishment to the lecturer and student's manhour rate. However, this figure is basically linear over long periods of time. The cost of program writing and revision on the other hand, although initially high, decreases in inverse proportion to the number of students, as a recent cost analysis at a Regional Engineering Training School has shown. It is thus more economic to write programs on subjects that are likely to have a large audience.

The capital costs of machines or other devices may need to be considered, but again they become an economic proposition after only a few hundred students have used

them. The programs themselves have a variable life, dependent upon their type and amount of handling required. In most cases where their life is short, reproduction is cheap. Student time is not normally a factor in the comparison although, as a programmed course is likely to take less time than its conventional counterpart, the training time will be reduced. It may be feasible for programmed learning to take place in Telephone Areas, thus avoiding the need for the students to travel to a Regional Engineering Training School, whilst at the same time maintaining a uniform standard of learning. One relative factor for which costing is difficult concerns the improved performance resulting from more efficient training. The absence of a parameter for measuring this means that only qualitative consideration can be given.

#### CONCLUSIONS

Programmed learning as an educational technology has been hailed as the most significant development in communicating knowledge since the invention of printing, and as such is likely to become one of the major landmarks in our educational and training practice. It is clearly advantageous that its impact should make us look at our methods of training more critically.

Programmers find their work as challenging as that of any lecturer. They are obliged to state their objectives concretely and arrange the material so that the student achieves his goal, possibly seeing material as the student sees it—for the first time. This virtually compels them to recognize undeclared assumptions which often cause mental gymnastics within the student. Its significance to a lecturer is such that having prepared a programmed sequence he will gain a vast personal insight into the learning process that will always stand him in good stead.

By using the techniques described, Post Office engineering training today is placing much more emphasis on learning, rather than teaching—an approach too infrequently applied to other instructional techniques. However, it should be understood that programmed learning and teaching machines are not here to replace the training-school instructor or Area Training Officer but rather to improve their standards and increase their productivity.

*(To be continued)*

---

## Book Received

"The BEAMA Directory for British Electrical and Allied Equipment, 1967-68." Published for The British Electrical and Allied Manufacturers' Association by Pergamon Press, Ltd. 556 pp. 60s.

The BEAMA Directory provides an up-to-date source of reference to British electrical and allied manufacturers and their products, ranging from the largest power plants to the smallest household appliances. For ease of reference the

directory is divided into sections, the main ones being a Directory of Manufacturers, Trade Marks, Technical Information Section, Buyers' Guide and Foreign Languages. The last-named section provides a handy reference to the equivalent expressions in German, Spanish, French, Portuguese and Russian for the English headings found in the Buyers' Guide section, and should be useful in conjunction with that section to enable users to rapidly identify sources of supply when not fully conversant with English terminology.

# A Voice-Frequency Signalling System for Out-of-Area Exchange Lines

W. J. MURRAY†

U.D.C. 621.395.385.4

The replacement of audio cables by multi-circuit h.f. transmission systems is making it increasingly difficult to use d.c. signalling for out-of-area exchange lines. A v.f. signalling system has, therefore, been developed to permit out-of-area exchange lines to be provided over lines of any length and composition.

## INTRODUCTION

IN an earlier article<sup>1</sup> the application of d.c. signalling techniques in the design of out-of-area exchange-line equipment for use in conjunction with audio cable pairs was discussed. The rapid conversion of the main trunk network to multi-circuit transmission systems has made it increasingly difficult, with the limitation of d.c. signalling, to find suitable audio line plant to meet the continuing demand for out-of-area exchange lines. For the provision of out-of-area exchange-line service utilizing circuits routed on h.f. line plant, where no separate metallic signalling path is available, it has been necessary to develop a.c. signalling equipment capable of converting normal subscriber and exchange line signals into suitable voice-frequency (v.f.) signals for transmission over carrier-type circuits. The design of this equipment was considerably influenced by the standard national signalling system, S.S.A.C. No. 9,<sup>2</sup> and the principles of this system have been incorporated as far as they are compatible with the requirements of out-of-area exchange lines. The system is basically a 4-wire signalling system, using a single frequency of 2,280 Hz and with 2-wire connexion to the subscriber's line and to the exchange equipment. It has been designed to operate over a circuit of nominal 3 dB loss, in conjunction with subscribers' local lines of up to 1,000 ohms transmission equivalent resistance (t.e.r.).

## THE V.F. SIGNALLING EQUIPMENT

To enable a subscriber to have normal exchange service on a distant automatic exchange over a 4-wire transmission path provided on the h.f. network two signalling equipments have been designed: one is referred to as the main-exchange relay-set, and the other as the local-exchange relay-set. The main-exchange relay-set is for use at the exchange to which the subscriber desires connexion, and provides the 4-wire/2-wire termination of the circuit with access to the standard automatic-exchange subscriber's line equipment on the 2-wire side. The local-exchange relay-set is designed for installation at a 50-volt telephone exchange; exceptionally, it may be installed in the subscriber's premises, provided suitable power supplies are available. The design of the local-exchange relay-set is such that it is capable of operating over subscribers' lines of up to 1,000-ohm loop resistance with a ballast-type transmission feed on the 2-wire side of the 4-wire/2-wire line-terminating unit, which is located in the relay-set. The main-exchange and local-

exchange line-signalling relay-sets each comprise two parts: both parts use a standard 2,000-type relay-set base-plate, one providing accommodation for the 3,000-type relays, and the other for the signalling and transmission equipment. The 2,280 Hz signal-frequency oscillator and the v.f. receiver and buffer amplifier employ transistor circuits using power supplies derived from the normal 50-volt exchange battery. A block schematic diagram of the equipment is shown in Fig. 1.

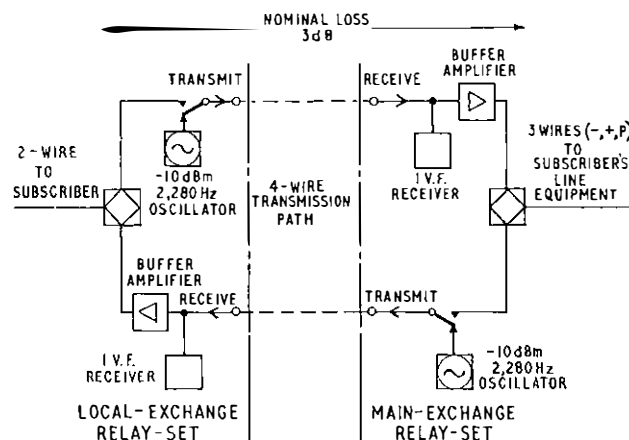

FIG. 1—OUT-OF-AREA SUBSCRIBER'S V.F. LINE EQUIPMENT

In addition to providing service from direct exchange lines, the out-of-area line-signalling equipment is suitable for operation with extension plans, and P.M.B.X. and P.A.B.X. installations, providing, in each case, unidirectional or bothway traffic as required. Access from P.A.B.X. selector levels to out-of-area exchange-line equipment is obtained via a P.A.B.X. exchange-line relay-set. For this application, the out-of-area local-exchange relay-set has been designed to accept either loop or earth calling signals, and to maintain a busy condition to a P.A.B.X. exchange-line relay-set until the exchange equipment at the main exchange has released.

## V.F. Line Signals

The signalling system has been designed to operate when interposed between a subscriber's apparatus and an automatic-exchange subscriber's line equipment, converting the signals normally passed between that subscriber's equipment and the local automatic exchange into v.f. signals for transmission over a 4-wire circuit.

All the v.f. signals are continuous or are timed pulses of the 2,280 Hz signal frequency, transmitted at a sending level of  $-6 \text{ dBm} \pm 1 \text{ dB}$  with reference to a point of zero relative level. As the signal sending circuit is associated with the 4-wire transmit path, a nominal  $-4 \text{ dB}$  point, the 2,280 Hz signals are transmitted at a nominal signal level of  $-10 \text{ dBm}$ .

†Telephone Exchange Systems Development Branch, Engineering Department.

The 2,280 Hz v.f. signals are transmitted over the 4-wire circuit within the limits quoted in the table, and are accepted within the limits of the recognition times shown.

Line Signals for Out-of-Area Subscriber's Line Signalling System

Direction of Transmission	Signal	Signal Duration	Recognition Time (ms)
Forward, from subscriber	Seizure	60–120 ms	20–40
	Digital pulses	44–102 ms	20–30
	Forward clear	{ 650 ms minimum }	350–525
Backward, to subscriber	Ringing	400 ms on†	70
		200 ms off†	—
		400 ms on†	70
	Release guard	{ 2 seconds off† Continuous }	—

† Approximate duration

### Check Signal

In addition to the signals listed in the table, a check signal is returned from the main-exchange relay-set on the receipt of any 2,280 Hz signal received subsequent to the seizure signal. The recognition of this check signal by the local-exchange relay-set causes the 4-wire transmission path to be split, and, hence, any false signals passing into the system from the 2-wire line are interrupted.

**Release-Guard Signal.** The check signal also functions as a release-guard signal on clear-down by maintaining a continuous backward v.f. signal till the main-exchange equipment has released. This release-guard signal is used on earth-calling P.A.B.X. lines to maintain a holding circuit to the P.A.B.X. exchange-line relay-set for the purpose of guarding the P.A.B.X. selector-level outlet.

**Line Splitting.** While a call is in progress the receipt of the signalling frequency in either direction is accompanied by the splitting of the 4-wire transmission path. This disconnection limits spill-over, and prevents signals in the forward direction causing interference to other signalling systems. The line splitting is controlled by the application of a d.c. earth signal to the buffer amplifier in the receive transmission path.

### Calls Outgoing from the Subscriber

**Seizure.** On calls originated by the subscriber the local-exchange relay-set responds to the calling signal by transmitting a v.f. seizure signal over the transmit path of the 4-wire circuit to the main exchange. At the distant end the 1 v.f. receiver, connected across the receive transmission path, responds to the v.f. tone, and, on recognition of the seizure signal, the main-exchange relay-set extends a loop seizure condition to the exchange equipment in preparation for dialling. Following the sending of the seizure signal, the transmission path is completed for the return of dial tone to the subscriber.

**Pulsing.** Loop-disconnect pulses received from the subscriber's dial are transmitted to line, as v.f. pulses corresponding to the dial-break pulses, under the control of a pulse corrector. At the main-exchange end the 1 v.f. receiver responds to the v.f. digital signals, whose make-to-break ratio is corrected by a pulse corrector before repetition to the exchange equipment as loop-disconnect

pulses. The 4-wire speech path is split during the transmission of each pulse train, and re-established during the inter-digital pause to permit the return of supervisory tones to the subscriber.

**Clear-Down.** When the calling subscriber clears down a forward-clear signal is transmitted by the local-exchange relay-set. On recognition of this forward-clear signal by the main-exchange relay-set, the holding loop is disconnected to release the forward-exchange equipment. During the release sequences, the check signal, which is returned from the main-exchange relay-set on receipt of the forward clear, is maintained to provide a release-guard signal to the local-exchange relay-set. With loop calling, re-seizure of the equipment before the release sequence has been completed is prevented by disconnecting the 2-wire-line side of the local-exchange relay-set for a minimum period of 600 ms.

With earth calling from P.A.B.X.s, a holding condition is extended to the P.A.B.X. line relay-set while the check signal is being received. This guards the P.A.B.X. selector-level outlet against follow-on calls until the distant main-exchange equipment has restored to normal.

### Calls Incoming to the Subscriber

**Ringing.** On calls incoming to the subscriber the ringing current applied from the main-exchange final selector causes the main-exchange relay-set to transmit, over the 4-wire circuit, v.f. signals in sequence with the interrupted ringing supply and of approximately the same duration, i.e. interrupted v.f. signals, 400 ms on, 200 ms off, 400 ms on, 2 seconds off, etc. This sequence continues until the subscriber answers or the caller clears. At the local-exchange relay-set the 1 v.f. receiver, connected across the receive transmission path, responds to these signals to operate the ringing-recognition circuit, which remains operated over the ringing cycle to extend locally-generated ringing current to the subscriber's line.

**Answering.** When the subscriber answers, the ringing from the local-exchange relay-set is tripped, and a v.f. signal is returned as an answer signal to the main-exchange relay-set. Recognition of this signal causes a loop condition to be applied to the 2-wire side of the main-exchange relay-set to trip the ringing from the final selector. Speech-transmission conditions are then established.

## SYSTEM DESIGN FEATURES

### V.F. Receiver and Buffer Amplifier

The out-of-area exchange-line system employs a transistor-type single-frequency (2,280 Hz) receiver with a buffer amplifier, assembled together on one mounting and operated from the normal —50-volt exchange supply. The receiver has an operating bandwidth of  $\pm 25$  Hz, centred on the nominal signalling frequency of 2,280 Hz, over the level range of  $-6$  dBm  $\pm 9$  dB. The receiver and buffer amplifier are based on the design developed for use in the national network.<sup>3</sup>

### 2,280 Hz Oscillator

A transistor-type 2,280 Hz signal oscillator is provided as an integral part of the local-exchange and main-exchange signalling relay-sets. The oscillator, which is based on the design of the Oscillator No. 96A, used for transmission-testing purposes, operates from the normal

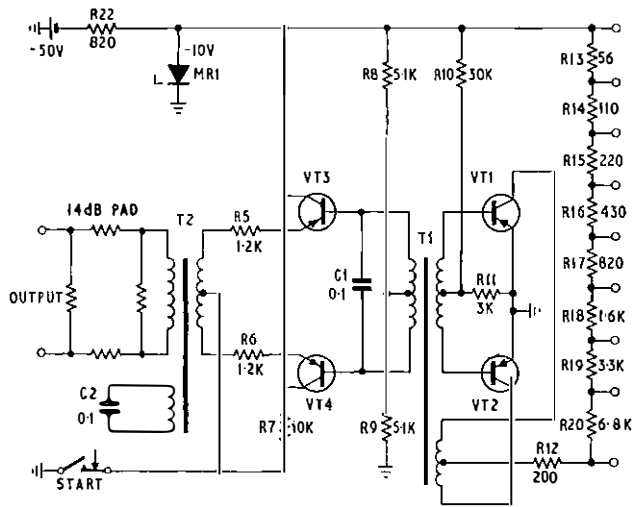

FIG. 2.—2,280 Hz OSCILLATOR

—50-volt exchange power supply. It has an output of  $2,280 \pm 6$  Hz at a level of  $-10$  dBm  $\pm 1$  dB. The oscillator is normally quiescent, and is energized by the application of earth potential to a start lead.

The oscillator comprises an oscillatory circuit followed by a buffer-amplifier stage giving a nominal 600-ohm output impedance (Fig. 2). The oscillatory circuit uses a common-emitter push-pull arrangement of transistors (VT1 and VT2) connected to a three-winding transformer, T1, the tuned secondary winding of which feeds an emitter-follower push-pull amplifier stage. Adjustment of the oscillator output is obtained by wiring straps across sections of the resistor chain R13–20. The output stage comprises transistors VT3 and VT4 and transformer T2. In this configuration the input of the amplifier offers a high impedance across the oscillator tuned circuit, and, with the bias provided by resistors R8 and R9, the output stage gives class-A amplification. The output transformer is tuned to reduce harmonics in the output, the tuned circuit consisting of capacitor C2 and the tertiary winding of transformer T2. The number of turns on the tertiary winding have been chosen to allow a practical value of capacitor C2 to be used. A 14 dB attenuator has been included in the output from the oscillator to ensure that the return loss remains within permissible limits.

The —50-volt exchange supply is reduced, by means of an 820-ohm resistor (R22), to the nominal —10-volt required by the oscillator. A Zener diode (MR1), in conjunction with the 820-ohm voltage-dropping resistor, ensures that the oscillator operating voltage is maintained within close limits with exchange supply-voltage variations between 46 and 52 volts.

#### Pulse Correction of Digital Signals

The pulse corrector used in the local-exchange and main-exchange relay-sets is based on a design of pulse corrector originated by the General Electric Company, Ltd.<sup>4</sup> The main circuit elements are as shown in Fig. 3. Pulse correction is provided by relay RC, in conjunction with relays XA, XB and the capacitor C1. The 600-ohm and 3,500-ohm windings of relay RC are differentially connected, which, together with capacitor C1, makes it slow to operate and slow to release. The operate time of

the relay results from the opposing flux set up in the 3,500-ohm winding by the charging current of capacitor C1 when contact XA2 operates. Under release conditions the differentially-connected 600-ohm and 3,500-ohm windings are series aiding, and the release time of the relay results from the flux set up in these windings by the discharge current of capacitor C1. Relay RC, which controls the duration of the repeated pulses, has a natural cyclic time of approximately 10 pulses/second with a 2:1 make-to-break ratio. At input speeds of 10 pulses/second the corrector gives output pulses of approximately 66 ms break and 34 ms make. The cyclic time is varied under the control of relays XA and XB with input pulses at speeds other than 10 pulses/second.

At input speeds below 10 pulses/second the corrector functions in a constant-length break-pulse output mode, with a pulse duration of approximately 66 ms, down to certain limiting values of input pulse speed and ratio. At slower input speeds a holding circuit is provided via contact RC1 operated and contact XB1 normal for relay RC after the normal release time of 66 ms has expired. As a result, the duration of the output break pulse is increased. At higher input speeds, relay RC is released before the normal release time of 66 ms has elapsed, due to the disconnection of the capacitor C1 discharge path through the series-aiding windings by the operation of contact XA2. As in these circumstances capacitor C1 will not have fully discharged by the time contact XA2 operates, the subsequent operate time of relay RC will be less than the normal operate time of 34 ms. Consequently, at input speeds above 10 pulses/second the corrector functions in a constant-length make-pulse output mode, the pulse duration depending on the speed of the input pulses.

#### OUTLINE OF OPERATION

The main circuit elements used in the setting-up of an outgoing and an incoming call are shown in Fig. 4.

#### Operation on Calls Originated by the Subscriber

*Seizure.* The sequence commences with relay A in the local-exchange relay-set operating to the subscriber's line loop, or, for an earth-calling P.A.B.X., to earth potential connected to the negative wire. Contact A1 operates relay B. Contact B1 starts the oscillator, and a 2,280 Hz tone is transmitted in the forward direction as a seizure signal, the duration of which is governed by the slow

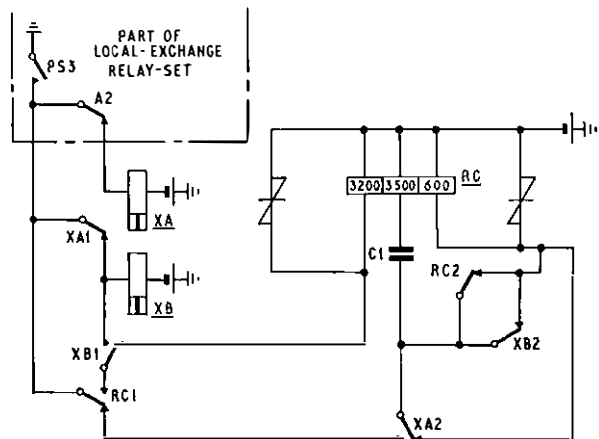
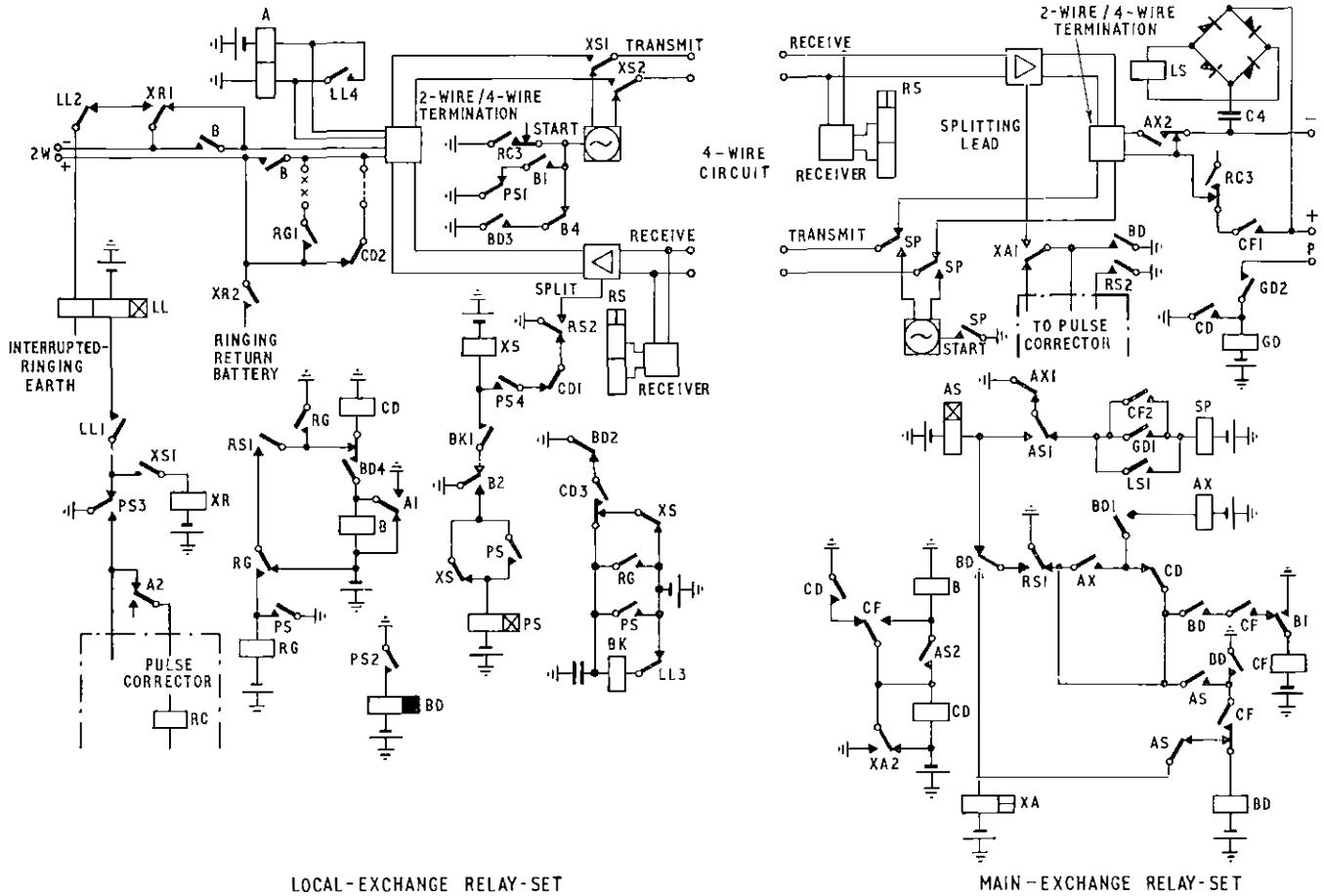

FIG. 3.—PULSE CORRECTOR



LOCAL-EXCHANGE RELAY-SET

MAIN-EXCHANGE RELAY-SET

Notes: 1. - - - indicates strap for loop-calling lines.  
 2. x x x indicates strap for earth-calling lines.

FIG. 4—MAIN CIRCUIT ELEMENTS FOR OUTGOING AND INCOMING CALLS

operation of relay PS, nominally 70 ms. Contact B2 operates relay PS; the oscillator start lead is disconnected at contact PS1, ceasing the transmission of the seizure signal. Contact PS4 operates relay XS, and the transmit path of the 4-wire line transmission circuit is connected through at contacts XS1 and XS2.

At the main exchange the receiver responds to the seizure signal and relay RS operates. Contact RS1 completes a circuit for slow-operate relay AS, the nominal 35 ms operate time of relay AS providing the seizure-signal recognition time. Contact AS2 operates relay B, contact B1 operating relay CF and contact CF1 looping the 2-wire line to the associated subscriber's line circuit. On the termination of the seizure signal, relay RS releases. Contact RS1 releasing, completes an operate path for relay BD. Contact BD1 operates relay AX, and the 2-wire transmission path is connected through for the return of dial tone to the subscriber.

**Digital Pulsing.** During the break period of each dialled pulse, relay A in the local-exchange relay-set releases. Contact A2 repeats the dialled pulses to the pulse corrector while contact A1 permits relay CD to operate. Contact CD1 releases relay XS, and contacts XS1 and XS2 connect the oscillator output to the transmit path. Contact RC3 of the pulse corrector applies a start

signal to the 2,280 Hz oscillator, and v.f. pulses corresponding to the break period of each dial pulse are transmitted in the forward direction.

At the main exchange the receiver-output relay, RS, responds to the v.f. digital signals, contact RS2 repeating the pulses to the corrector for pulse-ratio correction before they are repeated, under the control of contact RC3, as loop-disconnect pulses to the exchange equipment. Contact RS1 disconnects relay AX, and contact AX2 provides a zero-resistance pulsing loop. At the end of each pulse train, relay CD restores, operating relay AX which completes the transmission path.

**Clear-Down.** On clear-down by the calling subscriber, relay A releases in the local-exchange relay-set. Contact A1 operates relay CD and short-circuits relay B. Contact A2 extends an earth to the pulse corrector to operate relay RC. Contact CD1 releases relay XS, and the v.f.-signal sending circuit is prepared by contacts XS1 and XS2, which, in conjunction with the oscillator-start signal applied by contact RC3 on operation of the pulse-corrector relay RC, results in the sending of the forward-clear signal. Contact B2 releases relay PS, and contact B4 provides an alternative circuit for the control of the oscillator against the release of relay RC. Contact PS3 disconnects the pulse corrector, and contact PS2 releases



the slow-release relay BD which, at contact BD3, disconnects the oscillator-start circuit to terminate the sending of the forward-clear signal. The combined release times of relays B, PS and BD time the duration of the forward-clear signal. Contact BD4 releases relay CD, and, on loop-calling lines, contact CD2 restores the 2-wire line, which was disconnected on the release of relay B, to permit further outgoing calls by the subscriber.

On earth-calling P.A.B.X. lines, clear-down of the P.A.B.X. equipment is prevented until the v.f. check signal returned from the main-exchange relay-set is terminated by the release of the main-exchange equipment. The receipt of this signal operates relay RS in the local-exchange relay-set, and contact RS1 maintains the circuit of relay RG independently of the release of relay PS on clear-down. Contact RG1 maintains an earth on the positive line to the P.A.B.X. exchange-line relay-set. On cessation of the check signal, relay RS releases and contact RS1 disconnects relay RG. Contact RG1 disconnects the positive line to permit clear-down of the P.A.B.X. equipment.

At the main-exchange relay-set, relay RS operates to the forward-clear signal. Contact RS2 applies a signal to the pulse corrector to operate slow-operate relay RC, while contact RS1 disconnects relay AX and operates relay XA. Contact XA1 causes the buffer amplifier to split the line, and contact XA2 operates relay CD and short-circuits relay B. Contact AX1 operates relay SP, the contacts of which start the oscillator and connect the check signal to the transmit path. Operation of pulse-corrector relay RC disconnects the 2-wire holding loop at contact RC3. Relay CF is disconnected on release of relay B, and contact CF1 prevents re-seizure of the forward exchange equipment on release of relay RC. Contact CF2 disconnects relay SP, and the check signal is terminated. However, if the main-exchange equipment has not yet released, relay SP remains operated under the control of relay GD, which is connected to the P-wire, and the check signal continues to be transmitted as a release-guard signal. When the earth is removed from the P-wire, relay GD releases and contact GD1 disconnects relay SP to cease the transmission of the check signal.

#### *Operation on Incoming Calls to the Subscriber*

*Ringin*g. On calls incoming to the subscriber, rectified relay LS, connected in series with capacitor C4 across the 2-wire line, operates during each application of the ringing current from the final selector. Relay SP, operated by contact LS1, applies a start signal to the 2,280 Hz oscillator, permitting v.f. signals to be transmitted in the same sequence as the interrupted ringing from the final selector.

At the local-exchange relay-set, the receiver responds to the incoming v.f. signals, and the output relay RS

operates. Contact RS1 operates relay CD, contact CD3 completing the circuit for the capacitor-controlled ringing-detection relay BK. This relay has a nominal 70 ms operate time to provide a signal-recognition time, and a nominal 2.5 second release time which ensures the relay does not release during the no-tone periods of the ringing cycle. Relay BK operates relay XS at contact BK1. Contact XS1 operates relay XR, and contacts XR1 and XR2 complete the circuit for the application of a locally-generated ringing current to the subscribers' line. During the ringing cycle, relays RS and CD operate during each tone period.

*Answer*. When the subscriber answers, relay LL operates and holds itself via contact LL1. Contact LL2 disconnects the ringing from the subscriber's line, contact LL3 disconnects the operate circuit of relay BK, and contact LL4 operates relay A. The operation of relay A initiates the sending of a seizure signal, in this instance as an answer signal, as described in the previous section for an outgoing call. At the end of the seizure signal the hold circuit of relay LL is disconnected at contact PS3 on operation of relay PS, and relay A is left dependent on the subscriber's loop.

At the main-exchange relay-set, the receiver responds to the seizure signal and output relay RS operates. Contact RS1 completes a circuit for the slow-operate relay AS, which provides the signal-recognition time. Contact AS1 disconnects the relay SP, and contacts of relay SP disconnect the v.f. signal and connect the transmit path through. Contact AS2 operates relay B, and contact B1 operates relay CF. Contact CF1 completes a loop circuit on the 2-wire line to trip the ringing from the final selector. The subsequent operation is as described in the previous section for an outgoing call.

*Clear-Down*. Clear-down from an incoming call is similar to that described in the previous section for an outgoing call, and commences when the out-of-area exchange-line subscriber replaces his handset.

#### CONCLUSIONS

The development of the v.f. out-of-area exchange-line signalling system will permit the use of circuits routed on h.f. line plant for the provision of out-of-area exchange lines of any length, and will avoid the continuing commitment to retain audio cable pairs for this particular service.

#### References

- <sup>1</sup>HOWARD, R. F. The Impact of Recent Developments on Out-of-Area Service. *P.O.E.E.J.*, Vol. 46, p. 177, Jan. 1954.
- <sup>2</sup>MILES, J., and KELSON, D. Signalling System A.C. No. 9. *P.O.E.E.J.*, Vol. 55, p. 51, Apr. 1962.
- <sup>3</sup>WELCH, S. Signalling Systems for Dialling over Transoceanic Telephone Cables. *I.P.O.E.E.* Printed Paper No. 225, Apr. 1964.
- <sup>4</sup>*G.E.C. Telecommunications Journal*, Vol. 30, July 1960, and British Patent No. 816911.

# A New Announcing Equipment—Equipment, Announcer, No. 9A

K. E. BAILEY†

U.D.C. 681.842

This article describes a new playback unit based on the tape-loop cassette-storage technique which has been developed for changed-number announcements.

CHANGED-NUMBER announcements are catered for at present by a variety of commercial tape and disk recording machines; these machines are now obsolescent, and a standardized playback unit, Equipment, Announcer, No. 9A, has been developed to replace them. The new unit comprises a tape deck and amplifiers (Fig. 1), and measures  $14\frac{1}{2}$  in.  $\times$   $11\frac{1}{2}$  in.  $\times$   $7\frac{3}{4}$  in. It is a

announcer because the reliability of the centre-feed spool has not yet been proved equal to the cassette method: a prototype machine with a cassette has been run continuously for 1 year without any degradation of the quality of the announcement.

Recording facilities have been omitted from the new machine since, the announcements being changed relatively infrequently, it is more economic and simpler to make the recordings on a separate tape recorder which can serve any number of announcers. The recorded tape, carrying an announcement of up to

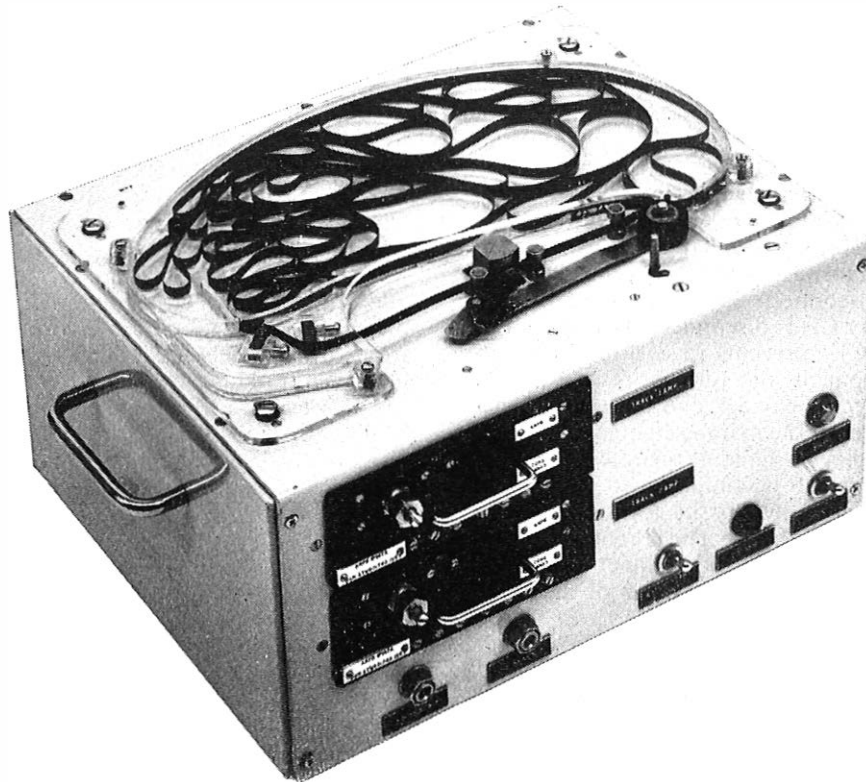

FIG. 1—EQUIPMENT, ANNOUNCER, No. 9A

relatively inexpensive machine, which should require a minimum of maintenance.

The main features of announcements such as changed-number announcements are that they vary in length, have to be played back repetitively, and are of a reasonably long-term nature, i.e. they remain unchanged for 2–3 weeks. These requirements have been provided for in the Equipment, Announcer, No. 9A by means of the continuous tape-loop technique.

There are two recognized methods of tape-loop storage: namely, by means of a cassette, or by a centre-feed tape spool. The former was chosen for this new

$3\frac{1}{2}$  minutes duration, is cut to length, looped and fed into the storage cassette on the new announcing equipment.

The design of the cassette has been evolved, by experiment, to provide a smooth tape movement at the  $3\frac{3}{4}$  in./second replay speed of the machine. The convolutions followed by the tape within the cassette are quite arbitrary. With this type of storage there is a tendency for the tape to snatch as it is drawn out of the cassette, and this can give rise to “flutter.” To combat this the tape is fed through a damping device, consisting of two carbon brushes (see Fig. 2), before reaching the replay head. To facilitate loading the cassette, the pinch wheel and pressure pad are lifted off the tape by means of a single control.

†Factories Department; formerly of the Telephone Exchange Standards and Maintenance Branch, Engineering Department.

To change an announcement the top of the cassette is removed and the old tape withdrawn. The new tape, which has already been spliced into a loop, is loaded by threading a portion through the cassette. The capstan motor is then run, the pinch-wheel control released, and

A synchronous hysteresis motor\* is used to drive the tape loop; this has the advantage that no separate flywheel and jockey are required. In this type of motor (Fig. 3) an external rotor is used, which also functions as a flywheel. Because of the small diameter of the

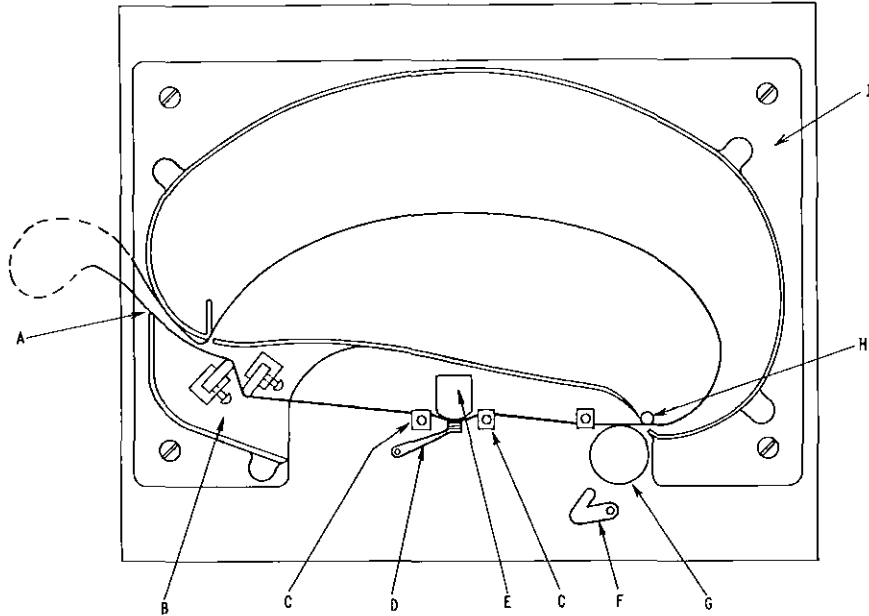

A—Tape-loading slot. B—Carbon brushes. C—Tape guides. D—Pressure pad. E—Replay head. F—Pinch-wheel control. G—Pinch wheel. H—Capstan. I—Cassette

FIG. 2—TAPE DECK

the remainder of the loop feeds itself into the cassette. The alternative method of fitting a pre-loaded cassette was examined, but the cost of the precision engineering required to ensure full interchangeability of the cassettes was not considered justified.

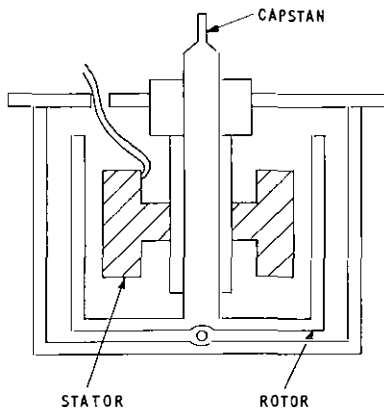

FIG. 3—CONSTRUCTION OF SYNCHRONOUS HYSTERESIS MOTOR

capstan (approximately  $\frac{1}{8}$  in.) the tape tends to stick to the pinch wheel. This is overcome by means of a special tape-guide, incorporated in the cassette, having a protruding tongue which fits into a groove cut into the periphery of the pinch wheel, thus ensuring that the tape is lifted off the pinch wheel.

The replay head is a twin-track type, which allows two separate announcements of approximately equal length to be played back simultaneously. If this facility is used a special tape recorder is required for recording the announcements: on normal twin-track tape recorders the tracks are recorded in opposite directions whereas for the tape used on an Equipment, Announcer, No. 9A the recording on each track has to be in the same direction.

The amplifiers, one for each track, are the standard Amplifier No. 147A already used on the congestion announcer, Equipment, Announcer, No. 8A. The output from these amplifiers may be taken from two jacks situated at the front part of the machine or, if required, from a tag strip inside the machine.

\*SKILLING, H. H. Electromagnetics. John Wiley and Sons, Inc.

# Switching and Signalling Techniques for the Intercontinental Telex Service

## Part 2—London (Fleet) Intercontinental Telex Exchange

E. E. DANIELS and W. A. ELLIS, C.Eng., M.I.E.E.†

U.D.C. 621.394.34(100)

Part 1 of this article described the Type C Signalling System, adopted by the C.C.I.T.T. for the intercontinental transit switching network. This part describes the equipment now being installed in London (Fleet Building) to provide fully-automatic intercontinental telex service.

### INTRODUCTION

THE equipment being provided in the London (Fleet) telex exchange to provide a fully-automatic intercontinental service can be considered in two parts: firstly, that carrying traffic originated by United Kingdom subscribers, which has associated with it automatic ticketing equipment to record the information necessary for assessing both subscribers' and international accounts; secondly, equipment primarily designed for switching intercontinental transit traffic. The latter, in addition to carrying transit traffic to and from the intercontinental network, also carries traffic received from the network to terminate in the United Kingdom.

As far as possible, common designs of equipment have been used for both groups of equipment. Marker switching techniques, using motor-uniselector group selectors have been adopted, in order to increase the speed of switching and to provide full-availability access to routes of up to 100 circuits. Within the intercontinental exchange, 5-unit teleprinter-keyboard signals only are used as selection signals, the choice being mainly governed by the following considerations.

(a) Greater reliability with the larger numbers of digits to be selected by subscribers. In the intercontinental exchange, up to 12 digits are required, including the destination code of the distant country.

(b) Subscribers' selection signals can be recorded directly on the ticketing machine as the destination of the call.

(c) Storage of the selection signals is simpler and can be effected more economically.

(d) Register holding times are shorter.

(e) End-of-selection and class-of-traffic signals can be more readily included.

(f) The majority of intercontinental routes will employ keyboard selection signals.

### TRUNKING PRINCIPLES

Fig. 5 shows the trunking arrangements of the intercontinental exchange.

Subscribers' obtain access to the intercontinental exchange by dialling the international access code 20 followed by the digit 7. Continental countries obtained via the same level-20 selectors have country codes with initial digits 2 to 6.

From level 207 an automatic-ticketing access relay-set is seized. A motor-uniselector group selector is permanently associated with this relay-set, which is held throughout the call and contains the mechanism for timing the call duration.

From the access relay-set one of a group of control relay-sets and its associated ticketing machine is seized and, following a preliminary exchange of identification information between the subscriber and the ticketing equipment, the connexion is extended to a register into which the subscriber teleprints the required number. The digits required to route the call are transferred from the register into a common translator, which marks the first group-selector stage directly and provides the register with the information for marking a second group-selector stage giving access to the required intercontinental route. Outgoing routes obtained in this way will either carry terminal traffic to systems using existing signalling standards, or they will give access to Type C centres. In the latter case they will carry either terminal traffic to the distant system or traffic requiring to be transit switched. Initially, the direct routes using existing signalling standards will predominate.

Both incoming terminal and transit traffic from the intercontinental transit network obtain access to the switching equipment via bothway Type C trunk relay-sets. Traffic reaching this country on routes using existing signalling standards is routed via incoming Strowger group selectors, from which the standardized code 00 gives access to the intercontinental switching equipment via incoming Type C access relay-sets. These relay-sets also carry miscellaneous traffic, principally that from the United Kingdom manual switchboard.

Both Type C trunk relay-sets and incoming Type C access relay-sets have permanently-associated motor-uniselector group selectors, which are marked by the translator in a similar manner to that adopted for the subscribers' traffic stream. Again, marking of the second group-selector stages is effected from the register—in this instance a different type of register (transit register) having incoming facilities suitable for Type C signalling.

For terminal traffic from the intercontinental transit network it is necessary to provide access to the United Kingdom domestic network and, as traffic for the United Kingdom forms the larger part of the total traffic incoming from the transit network, it is taken directly from the first group-selector stage. It is also necessary to provide access for transit traffic to European routes, and for this purpose joint access will be given to circuits carrying European traffic originated in the United Kingdom, which will continue to use existing signalling standards and incur charges based upon metering.

A number of items of equipment shown on the

†Telegraph and Data Systems Branch, Engineering Department.

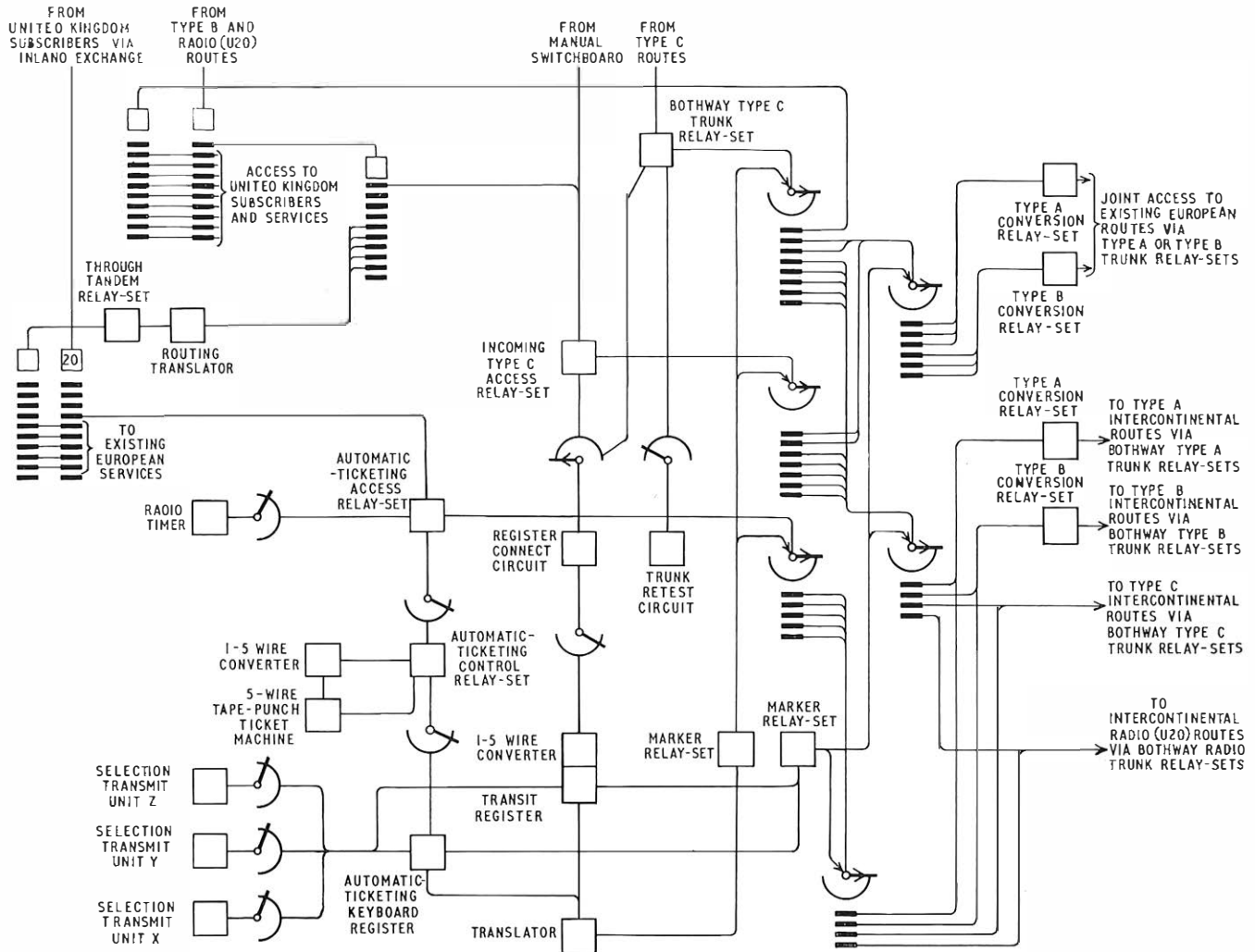

FIG. 5—TRUNKING ELEMENTS OF THE INTERCONTINENTAL EXCHANGE

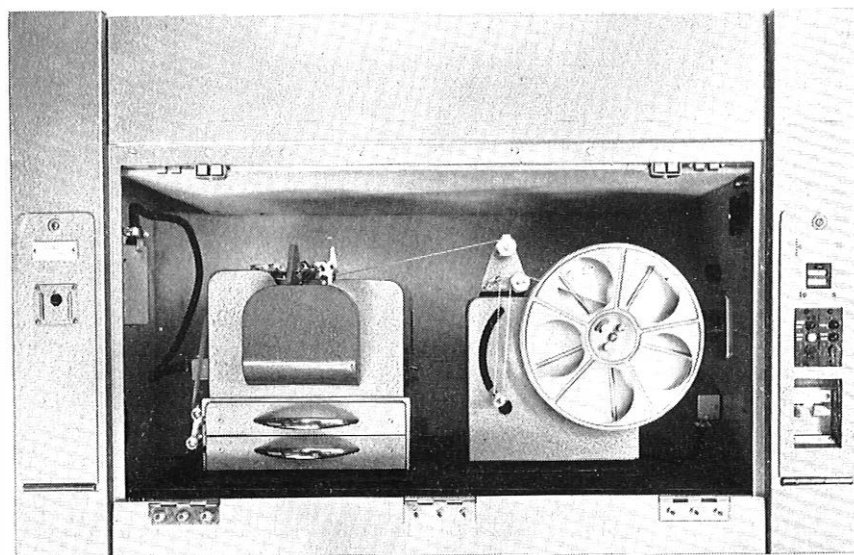

FIG. 6—AUTOMATIC-TICKETING UNIT

trunking diagram, but not mentioned in this general outline, will be referred to in later sections.

**AUTOMATIC TICKETING**

Call charges are recorded on paper tape using a Reperforator No. 5D, which accepts the input signals in 5-unit form with a separate wire for each code element. A tape winder is provided with each reperforator, both machines being mounted in cabinets as illustrated in Fig. 6. A key-and-lamp panel is associated with each reperforator for control purposes.

**Recorded Charging Information**

Fig. 7 shows the signals recorded on both the calling subscriber's teleprinter and the ticketing machine for assessment of the call charges. It will be seen that the ticketing machine makes two entries for each call: that recorded when the call is set up being termed the "head" entry, and that recorded when the call is released being termed the "tail."

When the automatic-ticketing control relay-set is seized, a group of entry-separation characters and a reference code for the call are transmitted automatically

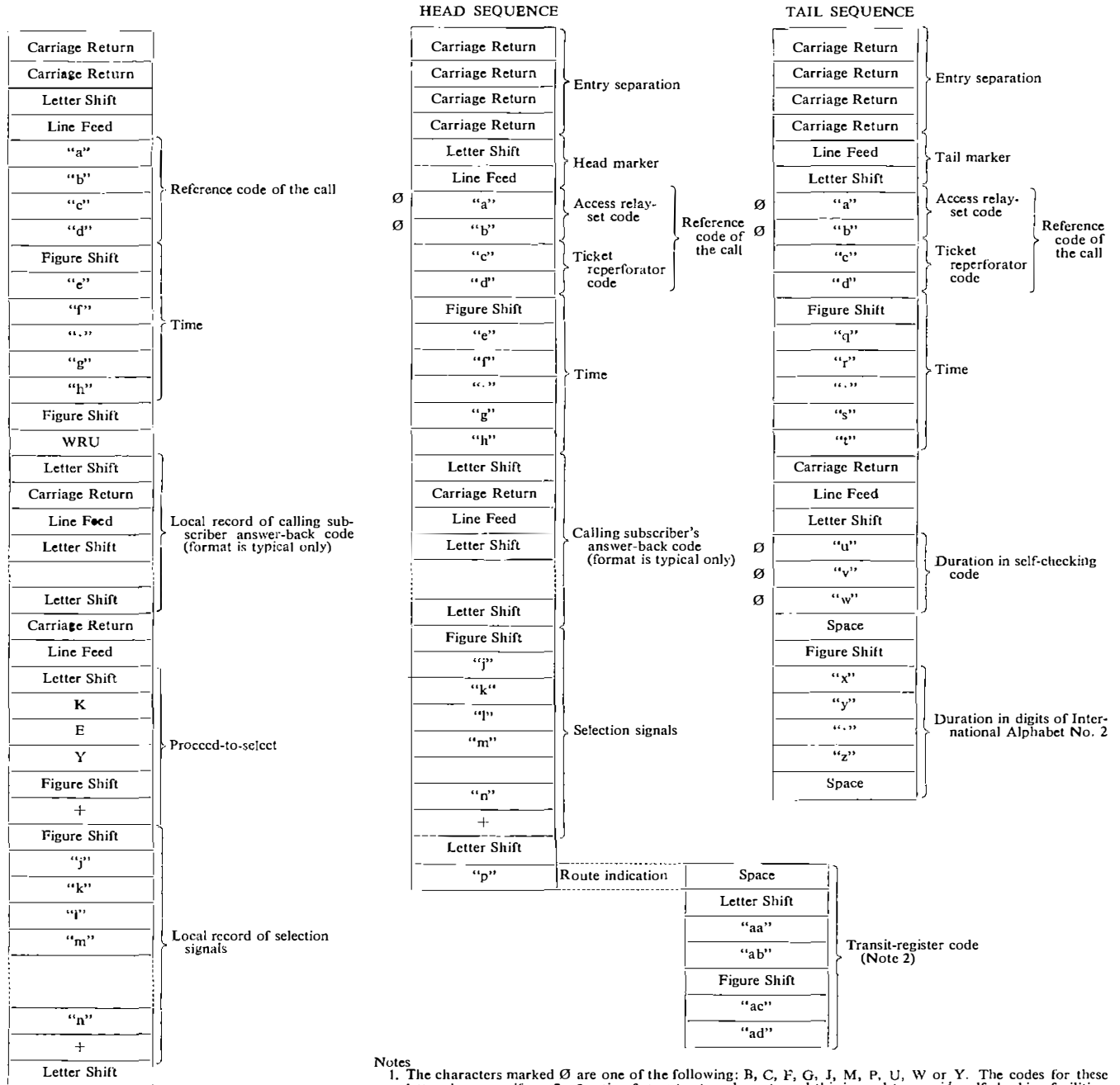

Notes  
 1. The characters marked Ø are one of the following: B, C, F, G, J, M, P, U, W or Y. The codes for these letters have a uniform 2 : 3 ratio of start to stop elements and this is used to provide self-checking facilities.  
 2. As an alternative to the route-indication character recorded on terminal calls, one or more transit-register codes may be recorded to identify the transit centres used for the connexion.

(a) Signals Recorded on the Calling Teleprinter

(b) Signals Recorded on the Ticket Reperforator

FIG. 7—RECORDED INFORMATION FOR AUTOMATIC TICKETING

to the ticketing machine. The principal function of the reference code is to enable corresponding head and tail entries to be associated during processing of the record, but it is also returned to the caller for use in the event of a call being disputed. As an aid to fault location, the reference code is so chosen that it enables the equipment used for the call to be identified. The code comprises two letters from the special group B, C, F, G, J, M, P, U, W, and Y indicating the access relay-set used for the call, a third letter indicating the group of ticketing machines, and a fourth indicating the machine within the group. A maximum of 20 groups of 20 machines can be identified.

Each of the characters in the special group B, C, F, G, J, M, P, U, W and Y has a 2-out-of-5 code format, and the entry-separation carriage-return characters have a 1-out-of-5 format. The element ratio of these characters is tested at appropriate points in the recording as a check of both the signal-distribution equipment and the 1-to-5-wire conversion equipment associated with each control relay-set.

To complete the identification of the call, the reference code is followed by a numerical group indicating the time in hours and minutes. The non-homing control-relay-set hunter is arranged to step on after each tail entry to minimize the possibility of successive calls seizing the same ticketing machine and, therefore, carrying the same identification.

Following transmission of the reference code, the answer-back code of the calling teleprinter is taken and recorded on the ticketing machine to identify the caller. It will also be printed as a local record on the calling teleprinter. The control relay-set then hunts for a free automatic-ticketing register. When this is found, a proceed-to-select signal consisting of the sequence "letter shift, KEY, figure shift, +" is transmitted to the caller, but not to the ticketing machine, as an invitation to use the teleprinter keyboard to select the required subscriber, using the format "figure shift, 2-digit or 3-digit destination code, the distant subscriber's number and the end-of-selection signal (+)." This information is recorded by the ticketing machine to identify the destination of the call and by the register for routing the call.

If the connexion is set up using a form of signalling other than Type C, the register, in releasing, indicates the route used for the call by causing one of the four characters B, C, F or G to be recorded on the ticketing machine, in order to cater for multiple routes to a country. A further use of this facility would be on a call to one of the United States domestic networks, the traffic to which is automatically shared between the three United States telegraph carriers: Radio Corporation of America, International Telephone and Telegraph Corporation, and Western Union. After recording this route-indicating character, the ticketing machine is released and is then available to accept further head and tail entries for other calls. The control relay-set remains marked, however, by the access relay-set and is re-seized for the tail entry, when the call is terminated.

For calls using Type C signalling, the ticketing machine remains in circuit until the call-connected signal is received, in order to record the register codes returned from Type C centres. These codes are required in the United Kingdom for the assessment of transit charges.

The access relay-set remains held throughout the call,

and records the chargeable duration in 6-second steps on a group of three miniature uniselectors (Post Office Type 4). In the event of a call being set up over an error-corrected radio circuit, character-release pulses are returned from the radio equipment, through the group-selector stages, to the access relay-set. On recognition of these pulses, one of a common group of radio-call timer relay-sets is called into the connexion to make any adjustment necessary for periods of error correction, during which no charge is made. This method of recognizing a radio circuit simplifies the use of mixed routes comprising both cable and radio circuits.

On termination of the call, the access relay-set waits for the marked control relay-set to become free and re-seizes it for the tail entry. The reference code for the head sequence is repeated, to enable both entries for the call to be associated during processing, and is again followed by the time.

The duration of the call is then transmitted to the ticketing machine, firstly, as three of the 10 characters of the self-checking group to be used for automatic processing and, secondly, in numerical form for ease of monitoring, if required for maintenance purposes. A recording is restricted to a maximum duration of 99.9 minutes, a call being forcibly released if this time is exceeded. For ineffective calls the record on the ticketing machine is the same as for effective calls, except that the duration reading is zero.

#### *Processing the Recorded Information*

The recorded information will be processed automatically by computer, and the first step in this process is to associate the head and tail sequences, which are identified by their having the same reference code.

As head and tail sequences may be separated by entries relating to other calls some simplification has been effected, and, at the same time, the effects of possible equipment failure minimized by restricting to four the number of head sequences which may be recorded on a machine and for which the tail sequences remain outstanding.

As a further aid to automatic processing, the following features have been incorporated:

- (a) consecutive entries are separated by four carriage-return combinations,
- (b) each head entry commences with letter shift, line feed,
- (c) each tail entry commences with line feed, letter shift, and
- (d) the next four characters in each entry form the reference code.

In addition to providing information for subscribers' and international accounts, it is proposed to obtain statistical traffic information from the record. As an example of this type of statistical information, not usually encountered, it will be seen that by comparing the duration recording of calls via radio circuits with the difference between the times of the head and tail entries, and applying a correction factor for the average recording delay, a record can be obtained of the efficiency of the radio circuit. When the automatic-ticketing equipment cannot provide all the information required, it will be supplemented by conventional traffic recorders and meters. In addition to the traffic statistical information,

any irregularities in recording will be returned to the exchange for maintenance attention.

#### *Accuracy of the Recorded Information*

In addition to the normal engineering safeguards included in the equipment, a number of self-checking features have been incorporated in order to maintain a reliable performance. These are listed below.

(i) The timing uniselectors must have restored to their normal positions before the access relay-set or radio-call timer can be seized.

(ii) A check is made of the ability of all the timing uniselectors to step before a new call can be set up.

(iii) A check is also made, upon clearing, that further stepping of the timer has occurred on effective calls.

(iv) A check is made that the second carriage-return of the head and tail sequence has a 1-out-of-5 format.

(v) A check is made that the access relay-set codes and chargeable-time record have a 2-out-of-5 format.

(vi) The caller's answer-back code must correspond to a continuous succession of characters of finite length.

(vii) The selection signals are checked for the required format, i.e. correct insertion of figure-shift and end-of-selection signals, a valid destination code, and that they do not exceed a specified number of digits.

(viii) The outputs to the register, and to the ratio-check element, are taken from spring-sets associated with the reperforator tape-punching mechanisms, so that in the event of failure of these mechanisms calls can no longer be set up.

(ix) Alarm contacts are provided on the machines to guard against tape exhaustion, tape breakage between the reperforator and tape winder, and failure of the tape to feed. Under the first two fault conditions the equipment is busied to further head entries only, because it is still possible to record outstanding tail entries. If tape-feed failure occurs the equipment is busied to all entries.

#### *Operational Facilities*

The key-and-lamp unit located on the ticketing cabinet, provides the following facilities in association with controls on the machines.

*Out-of-Service Key.* The operation of the locking OUT OF SERVICE key causes the ticketing machine to be busied against seizure for fresh calls. The ticketing machine, however, continues to record tail sequences of calls for which head sequences have already been recorded. An associated RECORD COMPLETE lamp is arranged to flash when the OUT OF SERVICE key is operated and one or more tail sequences remain outstanding, and to glow steadily when all outstanding entries have been recorded.

*Identification Key.* The operation of the non-locking IDENTIFICATION key causes the ticketing machine to record a dummy head and tail sequence. The format of this recording corresponds to that for a normal call, but the characters simulating the answer-back code contain the date, which completes the information needed to identify the perforated tape once it has been removed from the machine. The key is operated to provide the first and last entries on the tape at the time of its renewal. Non-operation of a fault lamp during this operation is taken as an indication that the equipment is functioning satisfactorily. The IDENTIFICATION key is only effective with the OUT OF SERVICE key thrown.

*Tape Run-Out.* A RUN-OUT button on the reperforator is provided to facilitate replenishment of the tape supply. Its operation causes combination No. 32 (unpunched tape) to be recorded. This, in combination with the identification entry, indicates to the computer the beginning and end of a valid tape.

*Fault Lamp.* The FAULT lamp lights to indicate that the exchange ticketing equipment associated with the ticketing machine has detected a fault by operation of one of the self-checking features of the system.

*Tape Alarm Lamp.* The TAPE ALARM lamp lights to indicate failure of the reperforator tape. It also indicates absence of the mains power supply to the cabinet, except when this occurs in conjunction with operation of the OUT OF SERVICE key during tape changing.

*Traffic Meter.* A meter is provided to allow periodic sampling of the number of calls recorded by each machine.

#### AUTOMATIC SWITCHING EQUIPMENT

In general, the switching equipment has been designed using similar electromechanical techniques to those adopted for the inland and continental telex service. Electronic elements have been introduced to a greater extent than in the earlier equipment, either to enhance the performance under repetitious operating conditions or to reduce the size of components. A typical example of the former development is the replacement of the mechanical service-signal-generation equipment used on earlier telex installations by an electronic version, and, as an example of the latter, the use of a high-impedance read-out has enabled the capacitances of the large group of storage capacitors for each register to be reduced from 1.0  $\mu$ F to 0.1  $\mu$ F, with a corresponding reduction in space.

While a detailed description of the equipment used is beyond the scope of this article, it is thought that the following points may be of interest.

#### *Register-Translator Facilities*

The automatic-ticketing keyboard register and the intercontinental transit register differ primarily in the incoming facilities that they provide. The former is required to accept manually-transmitted selection signals from subscribers, and does not call the common translator into service until the end-of-selection signal has been recognized, in order to avoid any delays in selection being reflected on to the intercontinental network. The transit register generally receives selection signals at automatic-transmission speed and, in order to provide the fastest switching time, completes the connexion to the translator as soon as sufficient information is available to identify the outgoing route.

The transit register requires to recognize a wider range of incoming forward-path signals, notably the Type C class-of-traffic signals, and take any appropriate action, such as preventing further alternative routing if this has already occurred at previous transit centres. It also has to return the Type C backward-path signals in response to the class-of-traffic and class-of-traffic check signals.

The following switching facilities are provided by both types of register, in conjunction with the translator, following examination of the destination code and the initial digit of the called number.



(a) Marking of the first and second group-selector stages using a 2-out-of-6 marking condition, which provides for  $15 \times 15$  possible routings.

(b) Alternatively routing the call with up to three alternatives. Routes using Type C signalling return a group-busy signal from the trunk relay-sets so that time is not wasted by offering the call to a route containing no free circuits.

(c) A 2-out-of-6 or 4-out-of-6 code signal is used to select one of 30 possible selection formats and causes a selection-transmit unit to be associated with the register according to the type of selection format required by the overseas system. The decoding arrangements provide for up to six groups of selection-transmit units, with variants within each group, but at present only the following three groups have been allocated: for keyboard selection, dial selection, and selection signals in Type C format.

(d) Sharing traffic to any destination code between a number of routes by offering calls to each in turn.

(e) For Type C signalling on a bothway circuit, recognizing a dual seizure (head-on collision) and re-offering the call to the same route.

If the Type C reception and transmission-confirmation signals are not received satisfactorily, a fail condition is passed to the outgoing-trunk relay-set, which calls into circuit one of a common group of relay-sets to re-test the circuit.

### Marker-Switching Principles

Fig. 8 shows the marker-switching principles adopted. The translator, when seized, extends earth potential via the test element in the register and over the forward-signalling path to confirm that the marker relay-set is associated with the group selector. Relays TM and HF operate, and a similar test is made to ascertain that the exchange marker multiple is free. If so, relay H operates and connects a -80-volt signal over the backward-signalling path to operate relay K in the group selector and then relay KO in the marker relay-set.

With all the necessary equipment interconnected, earth potential is returned to operate relay TO in the translator, which causes two of the six marker multiple wires to be earthed and two of the corresponding relays MA-MF in the marker relay-set to operate.

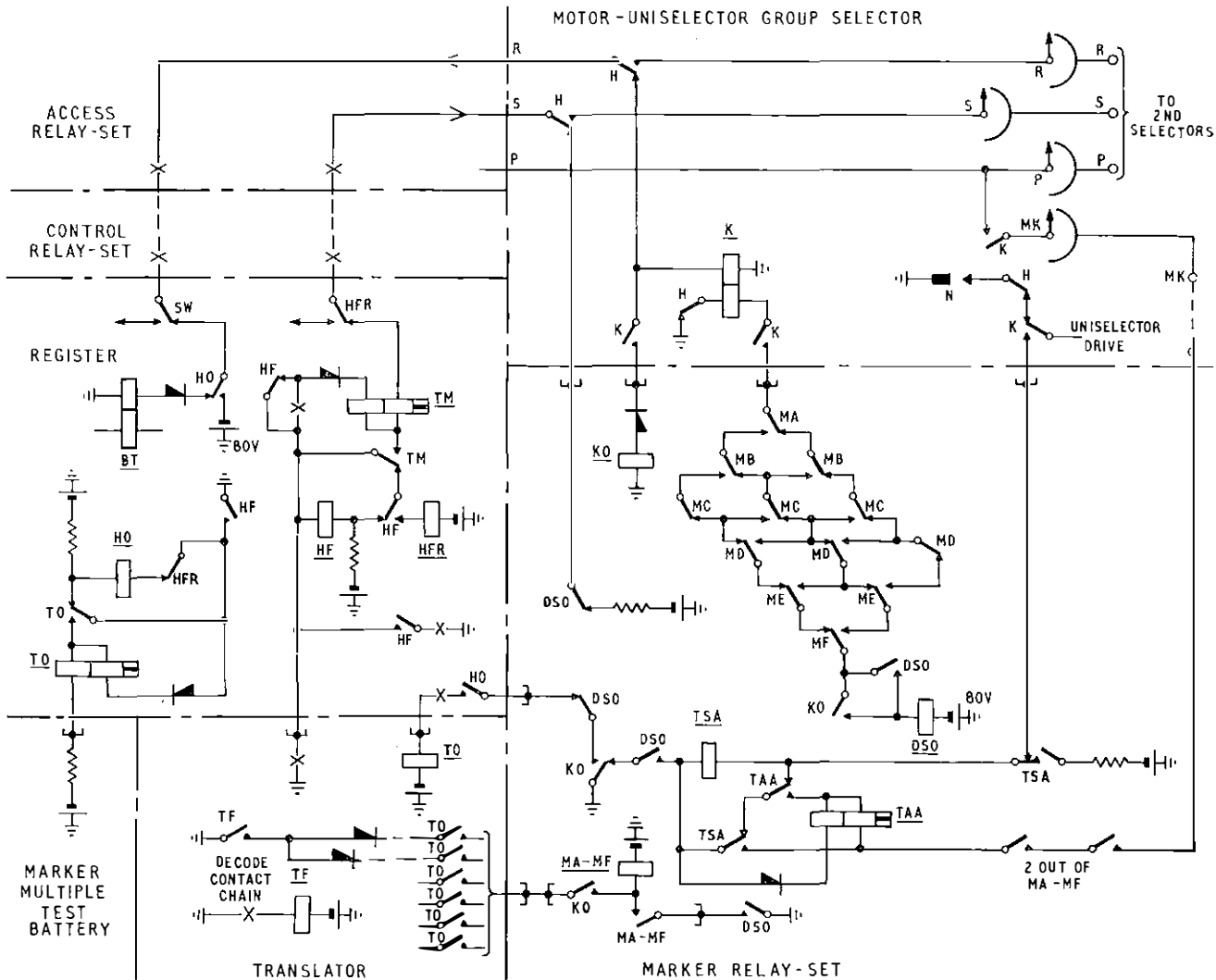

Battery potentials are 50 volts unless shown otherwise

FIG. 8—PRINCIPLES OF MARKER SWITCHING

A holding condition extended from the group selector operates relay DSO in the marker relay-set, following a check that only two out of the six code relays have operated. Relay DSO, in operating, causes test relay TM in the register to release and to operate relay HFR, as an indication that the marking condition has been accepted. Relay HO releases and in turn releases relay TO in the translator and relay KO in the marker relay-set to isolate the marker multiple. The holding time of the translator and the marker multiple is approximately 100 ms.

The release of relay KO causes the group selector to drive until relay TSA in the marker relay-set operates to the first outlet, within the group marked on the MK arc, having a free test potential on the P-wire to the succeeding equipment.

Relay TSA, operating, cuts the group-selector drive circuit and operates the switching relay, H.

With the group selector switched, the marker relay-set, one of which is provided for every 10 group selectors, is released and so is relay HFR, to permit the register to mark the second group-selector stage in similar fashion, the marking information for this having been stored in the register to avoid the need to re-engage the translator for this purpose.

When relay H in the group selector switches, earth potential is connected, via a resistance, to the backward signalling path. However, if all outlets in the marker group are engaged, the group selector switches to a separate busy outlet, which returns -50 volts on the backward path to operate relay BT in the register and initiate alternative routing if this is required.

In practice, although omitted from Fig. 8 in which, for simplicity, relays with suffix 'O' only are shown, odd and even translators are provided, with a reserve for maintenance purposes. The marker multiples arc also duplicated for each translator.

### Recognition of Backward-Path Signals

On transit calls through the exchange it is necessary to convert the Type A or Type B call-connected signals received from the terminal country into the Type C format of combination No. 32 (a 120 ms pulse of A polarity) followed by eight combinations No. 29 (a 20 ms pulse of A polarity) for transmission over the intercontinental transit network, and it is convenient to standardize on this format for automatic ticketing also. It will be seen from the trunking diagram that conversion relay-sets are included on outgoing routes to Type A or Type B systems. Their function is to provide the necessary discrimination between call-connected signals and printed service signals, inserting the appropriate Type C call-connected signal for the former and permitting the latter to pass unchanged. The principles of this discrimination are described in Part 1 of this article.

An element generally used for recognition of the various backward-path signals is illustrated in Fig. 9; this particular example is located in the automatic-ticketing access relay-set for the purpose of identifying the call-connected signal and then starting the call-duration measurement.

Stop polarity (-80 volts) is the idle backward-path signalling condition while a call is being set up. On receipt of any teleprinter signals relay PM operates to the +80 volts start element, and this in turn operates the self-pulsing relay RG. The timing characteristics of this relay are such that it operates to the minimum period of start polarity on the backward path, corresponding to a teleprinter character (20 ms), and is adjusted to have a combined operate and release lag of 135 ms, thus operating once for each character received. With relay RG operated, capacitor C1 is allowed to discharge, potentiometer RV2 being adjusted so that this capacitor reaches zero potential after start polarity has persisted

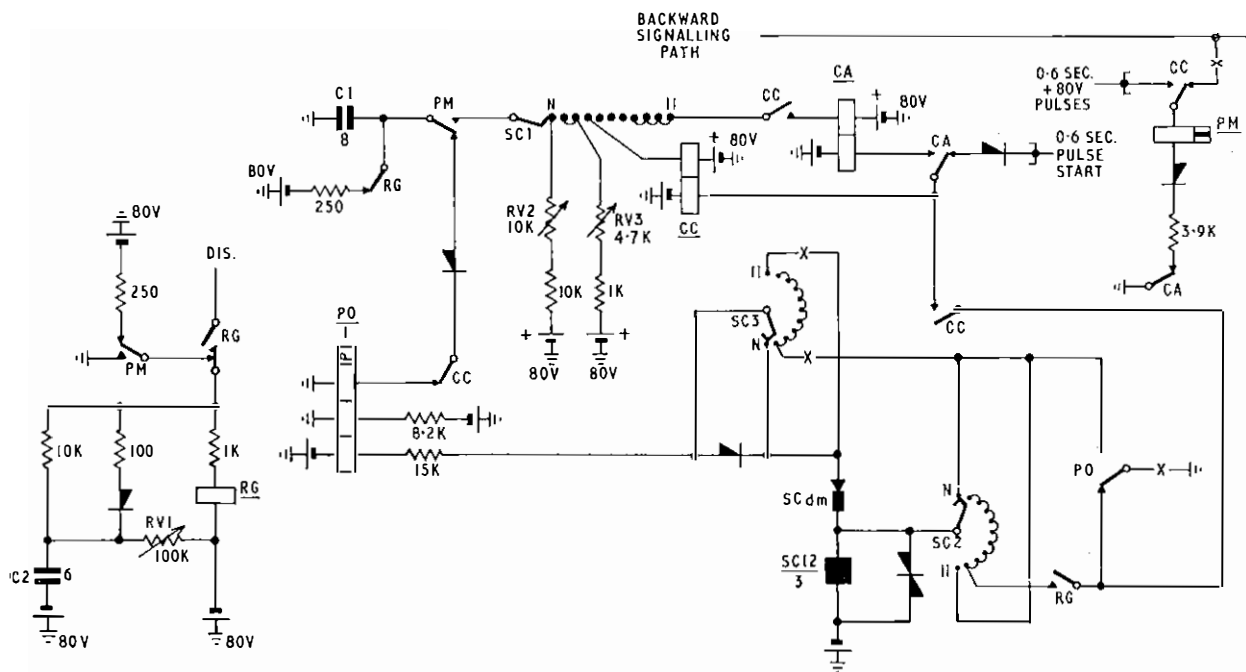

Battery potentials are 50 volts unless shown otherwise

FIG. 9—CIRCUIT ELEMENT FOR RECOGNITION OF THE CALL-CONNECTED SIGNAL

on the backward path for 100 ms. Restoration of relay PM has no effect, therefore, until combination No. 32 (120 ms pulse of A polarity) is received, when capacitor C1 is charged positively and operates relay PO. This energizes uniselector SC drive magnet via arc SC2 and also holds relay PO via SC interrupter springs and arc SC3. When the drive magnet is sufficiently energized to operate the interrupter springs, relay PO releases and the uniselector steps to outlet 1. On this outlet, and on the following outlet in the example shown, RV3 is adjusted for zero potential on capacitor C1 after start polarity has persisted on the backward path for 30 ms, so that, if combinations No. 29 (20 ms pulse of A polarity) are received, relay PO cannot operate and the uniselector merely steps under control of relay RG to any pre-determined outlet, where relay CC operates. Relay CC transfers relay PM from the backward-signalling path to a 0·6-second pulse supply and uniselector SC continues to step until relay CA operates to start the duration measurement. This delay to the start of charging can be pre-set in 0·6-second steps.

If signals other than combination No. 29 are received following the combination No. 32, relay PO operates to the positive charge on capacitor C1 when relay PM releases and completes a self-drive circuit for uniselector SC, via arc SC3. At the same time, relay PO holds to its own contact until outlet 11 is reached, when

it is again dependent on the drive-magnet interrupters, the release of relay PO stepping the uniselector to the normal position.

This illustrates the method adopted for recognizing backward-path signals comprising single pulses of start polarity by use of a simple CR timing element. The same element forms the basis of the circuit for determining whether the Type C backward-path signals are satisfactory or not, and, if satisfactory, distinguishes between a transit failure or head-on collision and initiates the appropriate action.

#### CONCLUSION

So rapid has been the growth of telex traffic, especially international traffic, that an adequate service can only be maintained by the early introduction of fully-automatic service for all relations having a significant amount of traffic. Within Europe this has already been achieved to a large extent, and new countries continue to be added as opportunity occurs. The adoption by the C.C.I.T.T. of the signalling and switching standards described in the first part of this article provides a firm basis on which to provide a similar fully-automatic intercontinental service. The extent of the British Post Office participation in the establishment of such a service is exemplified by the equipment described in the second part of the article.

---

## Books Received

“Technique of Microwave Measurements, Volumes I and II.”

Edited by C. G. Montgomery. Constable and Company, Ltd. Vol. I: xxxi+469 pp. 332 ill. 16s. Vol. II: x+467 pp. 296 ill. 16s.

“Microwave Receivers.” Edited by S. N. Van Voorhis. Constable and Company, Ltd. xviii+618 pp. 421 ill. 24s.

The above two books were originally published by McGraw-Hill Book Co., Inc., in the Massachusetts Institute of Technology Radiation Laboratory Series as Volume 11 (1947) and Volume 23 (1948), respectively. By the co-operation of McGraw-Hill with Dover Publications, Inc., the books, unabridged and unaltered, have now been reproduced in Dover paperback editions on a paper which, the publishers claim, gives minimum show-through and will not discolour or become brittle with age; the pages are sewn in signatures, and the books may be opened flat without fear of pages dropping out.

The early development and engineering of microwave radar equipment required considerable effort to be spent on improvements in the art of microwave measurements: new techniques had to be devised which were suitable for laboratory use, and these then had to be modified and adapted for use in the factory and in the field. In “Technique of Microwave Measurements” the authors endeavoured to select those techniques and apparatus which they considered most likely to prove useful to future workers in the microwave field.

The receivers and circuits described in “Microwave Receivers” sprang almost entirely from radar techniques. Microwave receivers used with radar systems are usually

characterised by two special properties: the ability to deal with the weakest possible signals, which may be comparable to or even weaker than the noise in the system, and with pulse signals covering an extremely wide dynamic range, which, therefore, require wide-band circuits and place very severe requirements on the transient behaviour of the whole receiving system. However, as it was considered that many of the features of such systems would be applicable in other fields, the authors endeavoured to reach a sufficiently fundamental standpoint in their presentation so as to permit such applications.

“Wireless World Diary, 1968,” T. J. & J. Smith, Ltd., in conjunction with Iliffe Electrical Publications, Ltd. 79 pages of reference material plus diary pages of one week to an opening. 6s. 6d.

The reference section of this diary contains the addresses of over 150 radio and allied organizations in this country and abroad, tabulated details of the world's television standards, information on the B.B.C. PAL colour television signal, a list of frequency allocations covering the United Kingdom, useful formulae, switching symbols, unit abbreviations, some transistor near equivalents, valve-base connexions, and a variety of other information.

# A Digital-Display Decibelmeter for Audio Frequencies

L. W. ELLEN, C.Eng., M.I.E.E., and A. COYTE†

U.D.C. 621.317.743

A fully-automatic wide-range digital-display decibelmeter for audio-frequency measurements is described. The instrument utilizes well-known circuit configurations employing semiconductors throughout and is mains-driven.

## INTRODUCTION

THE display of routine measurements in digital form makes a worth-while contribution to the problem of making accurate observations and records. The testing officer is relieved of the necessity of estimating the sub-divisions of a needle-type indicating instrument, and is presented with a clear and unmistakable reading in exactly the form required. It was, therefore, decided to investigate the possibility of designing a wide-range fully-automatic instrument for measuring signal levels over the audio-frequency range, giving readings directly in decibels relative to 1 mW in 600 ohms. The need to give readings in orthodox form, i.e. + or - relative to 0 dBm, gives rise to some complications, but this had to be accepted; the alternative of changing the standard level of 1 mW could not be entertained. An instrument has been produced giving the following facilities and characteristics.

- (a) Level range: -61 to +19.9 dBm.
- (b) Frequency range: 200 Hz to 15 kHz, with an optional modification to 50 Hz.
- (c) Accuracy:  $\pm 0.1$  dB, except at very low levels or extreme frequencies.
- (d) Display: neon numerical indicating tubes, with provision for three digits and + or - sign, and any number of remote displays used one at a time.
- (e) Circuits: all circuits use semiconductors, with no electromechanical parts and with fully-automatic range selection.
- (f) Reading delay: small variations are displayed within  $\frac{1}{4}$  second, while changes of range take a maximum of 6 seconds and average about 3 seconds.
- (g) Protection against false readings: the display is extinguished until a correct reading is reached, and an anti-jitter circuit prevents ambiguity on signals with slight random variations.
- (h) Input impedance: for a terminated-level measurement it is 600 ohms; for a through-level measurement it is over 30,000 ohms.
- (i) Power supply: power is supplied from the a.c. mains, and the instrument requires approximately 60 watts.
- (j) Overall dimensions:  $10\frac{1}{4}$  in.  $\times$  7 in.  $\times$   $7\frac{1}{4}$  in.

Most of the circuits consist of well-known configurations of components described in standard works, and only a few of the lesser-known circuit elements, together with the block schematic diagram of the complete decibelmeter, are described herein.

†Main Lines Development and Maintenance Branch, Engineering Department.

## PRINCIPLE OF OPERATION

A measurement in decibels requires the ratio between the signal voltage and a reference voltage to be expressed as a logarithm. This may conveniently be done by timing the discharge of a capacitor through a fixed resistance. Such a discharge follows an exponential law, and this gives a convenient method of comparing two levels in terms of natural, or napierian, logarithms: that is, to base  $e$ . The natural scale of such a measurement is therefore in nepers, but conversion to decibels is easily achieved by choosing component values that in effect multiply the result by 8.686.

Thus, if a capacitor, of capacitance  $C$ , is charged to a given voltage,  $V_0$ , and then allowed to discharge through a fixed-value resistor of resistance  $R$ , the voltage,  $V$ , after time  $t$ , falls according to the equation  $V = V_0 e^{-t/RC}$ ,

$$\text{i.e. } V/V_0 = e^{-t/RC}.$$

$$\text{Thus, } \log_e V_0/V = t/RC,$$

$$\log_{10} V_0/V = 0.4343t/RC, \text{ and}$$

$$20 \log_{10} V_0/V = 8.686t/RC.$$

$$\text{Therefore, } V_0/V \text{ decibels} = 8.686t/RC.$$

If  $RC$  is made equal to 10 ms, and  $t$  is measured by counting the number of cycles of an 8.7 kHz oscillator, the number counted is a direct measure of the relative levels of  $V$  and  $V_0$  in tenths of a decibel. The range of such a generator extends theoretically from 0 to  $-\infty$  dB, but practical considerations limit the upper voltage to which the capacitor may conveniently be charged and the lower voltage at which it may be accurately compared with the known signal. A ratio of 4:1 (= 12 dB) is possible, but in the interests of accuracy and stability the present instrument operates the logarithmic-law generator over a range of only about 2:1, i.e. 6 dB. The maximum count is thus about 60 tenths of a decibel, and a frequency stability of 1 per cent is adequate for the driving oscillator, which consists of two cross-coupled transistors connected in standard multivibrator form. A variable resistor permits calibration. The oscillator frequency is nominally 17.4 kHz and is halved in an anti-jitter circuit described later. The actual frequency of the oscillator is set to take up any tolerance in the components, giving an  $RC$  value of nominally 10 ms.

The capacitor is charged about four times per second, under the control of a Zener diode, to a voltage of 5.5 volts, this voltage being that at which such diodes have the least voltage variation with change of temperature. At the instant at which the charging voltage is removed the 17.4 kHz oscillator is switched on to drive a counting chain. During discharge of the capacitor its voltage is compared with a steady voltage obtained by amplifying and rectifying the signal to be measured. When the two voltages are equal the oscillator is stopped and the total count controls the display. The counters are reset immediately before the next measurement. During counting, the display on each display tube is a blur of all 10 figures, but each measurement takes, at most, about 8 ms and is followed by a display lasting about  $\frac{1}{4}$  second, and the blur is seen by the eye only as a

slight flicker four times a second. This has been described as a "visual tick" and is found to have the very desirable effect of reassuring the user that the instrument is not held on a fixed reading.

#### DESCRIPTION OF CIRCUIT ELEMENTS

##### Range Switching

As the practical range of the logarithmic generator is restricted to about 6 dB, range switching is necessary. This takes the form of four switched-gain amplifiers whose gain can be changed by 5, 10, 20, and 40 dB, respectively. The gain can thus be varied in 5 dB steps from 0 to 75 dB. A further amplifier of fixed gain, followed by a voltage-doubler full-wave rectifier, is arranged to give a d.c. output of 5.5 volts when a sinusoidal signal of +20 dBm is applied to the high-impedance input

added. This process continues until the signal is brought within range or maximum gain is reached. On the other hand, if the signal is too large the count from the 17.4 kHz oscillator will be zero, and a reset pulse is then delivered to the tens counter, setting all the amplifiers to minimum gain. Gain is then restored in 5 dB steps, as already described, until the appropriate range is reached.

During range-changing the display is extinguished. Great importance is attached to this feature, as random readings occur during this period, and if they are allowed to be displayed there is a serious risk of an incorrect reading being taken; furthermore, the display of a series of meaningless readings is psychologically unsound. If the input signal is beyond the range of the instrument in either direction the numerical display remains extinguished, but the display of a + or - sign indicates whether the signal level is too high or too low.

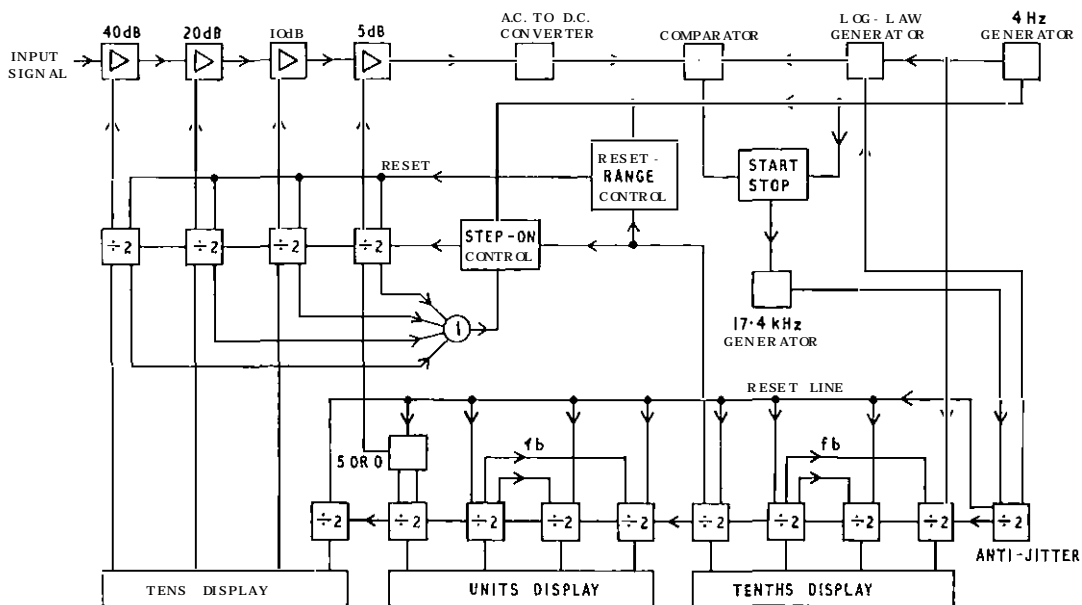

FIG. 1—BLOCK SCHEMATIC DIAGRAM OF DIGITAL DECIBELMETER

transformer with all switched-gain amplifiers at minimum gain. With the amplifiers at maximum gain the same d.c. output is obtained with a signal of -55 dBm, and the lower measurable limit of about 2.5 volts then corresponds to an input of about -61.4 dBm. Thus, 16 ranges are available in 5 dB steps, each range covering about 6 dB and giving a 1 dB overlap to avoid hunting on marginal signals.

The switched-gain amplifiers are controlled, respectively, by the four outputs of a 4-stage binary counter. This counter is conveniently referred to as the "tens" counter because it controls the tens display, but its first stage determines whether the units counter is reset to 0 or 5 at the beginning of each measuring cycle (see Fig. 1).

The tens counter is not reset at each measuring cycle, and remains in a steady state so long as the input signal is within a 6 dB range. If, however, an excessive count is recorded (i.e. beyond the 6 dB range) a single pulse is delivered to the tens counter, thus increasing the overall gain by 5 dB. If the gain is still inadequate an excessive count will again occur and a further 5 dB gain will be

At low frequencies there are conflicting requirements: maximum smoothing of the rectified signal to avoid fluctuations of the reading due to ripple, and minimum smoothing to permit rapid response to level changes when the range is changed. A key is, therefore, provided to stabilize low-frequency readings by adding extra smoothing after the correct range has been found. When a number of measurements, all at similar levels, are to be made, time may be saved by use of the LOCK ON RANGE key; this is operated manually after the automatic range selection has taken place on the first measurement. The applied signal may then be varied or disconnected without causing an automatic hunt to a new range, the display being extinguished if the signal is outside the selected range but reappearing quickly when a signal in the appropriate range is restored.

##### Discrimination Between Positive and Negative Levels

The digital count received by the tenths and units decade counters will always be greater for a lower level of signal within any one range. It is clear that for levels

below 0 dBm, i.e. negative levels, a lower level should give a greater reading, whereas for levels above 0 dBm, i.e. positive levels, the opposite is true. It follows that the decade counters are required to count forwards for negative levels and backwards for positive levels. It is possible to achieve this by duplication of the display matrix, but in the present instrument it has been arranged to reverse the counters themselves.

A simple binary counter counts forwards or backwards

reached on the tenths, units and tens counters simultaneously, and switches the reversing toggle so that the counters are reversed before the next counting pulse is received.

### Reversible Counters

Each decade counter consists of four binary stages (basically a scale-of-sixteen counter) with feedback arranged so that six of the possible combinations are

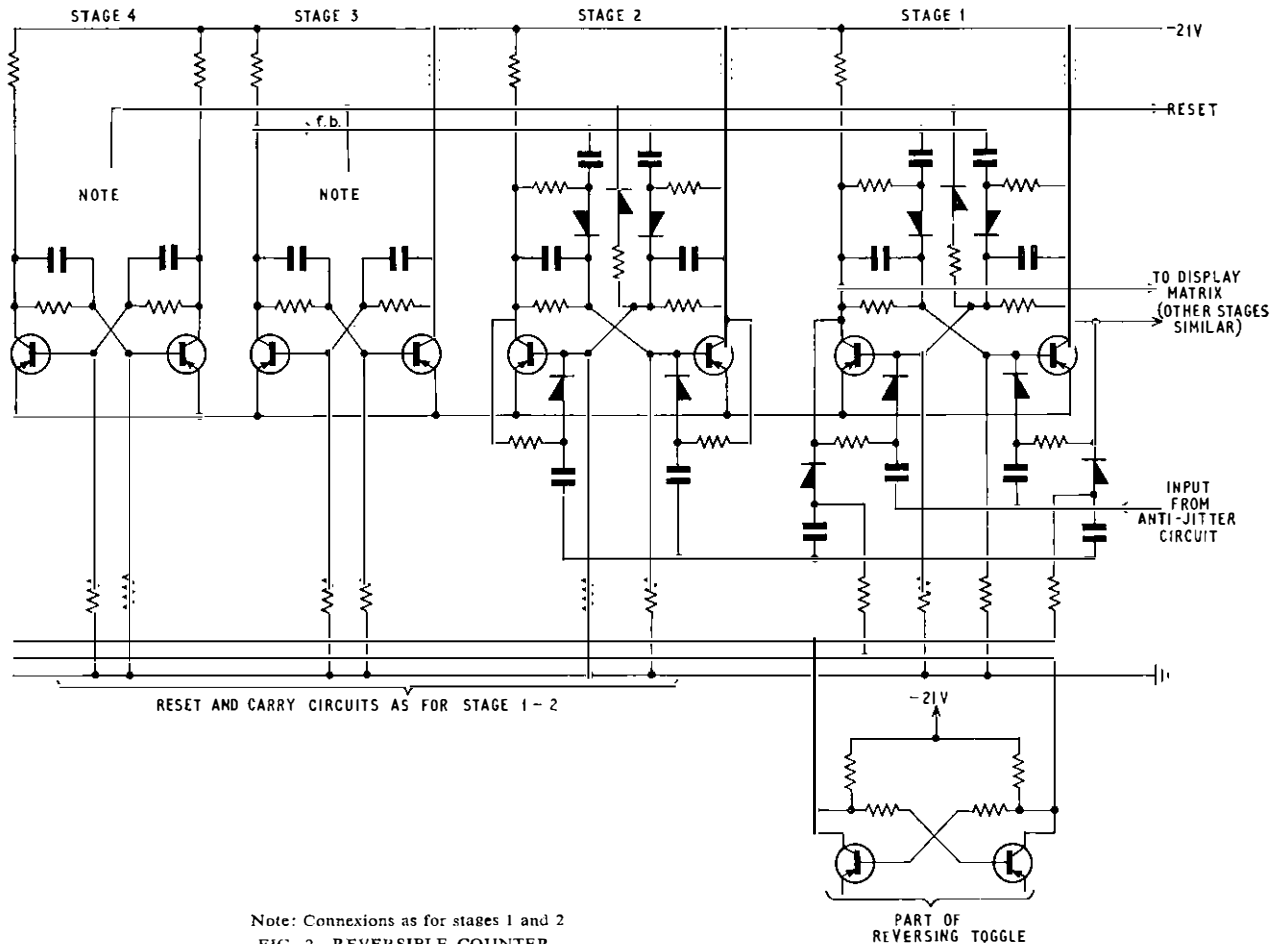

Note: Connexions as for stages 1 and 2  
FIG. 2—REVERSIBLE COUNTER

according to which of the two outputs of a stage is used to drive the next stage. In forward binary counting the carry signal to the next stage occurs when a stage changes from 1 to 0, whereas for backwards counting the carry signal occurs on the change from 0 to 1. The tenths and units counters are, therefore, arranged so that the carry signal may be obtained from either output of each stage under the control of potentials applied to two control wires by a reversing toggle; this is a bistable element which is set in one state or the other by the tens counter. The setting of the latter determines which range is in use and, therefore, determines the direction of counting required. One range straddles the zero, and for this range it is necessary to reverse the count as it passes through zero. The reversing circuit is, therefore, made sufficiently fast to operate well within one cycle of an 8.7 kHz signal. A multi-way gate detects the instant at which zero is

Sequence Table

Forwards		Binary Stages				Backwards	
Decimal	Jumps due to $f_b$	4th	3rd	2nd	1st	Jumps due to $f_b$	Decimal
0		0	0	0	0		0
1		0	0	0	1		1
2		0	0	1	0		2
3		0	0	1	1		3
4	↓	●	1	0	0	↑	4
5		●	1	1	1		5
6		1	0	0	0		6
7		1	0	1	0		7
8		1	0	1	1		8
9	↓	1	1	0	0	↑	9
0		1	1	1	1		0
		0	0	0	0		0

eliminated. For a counter which is to be reversible it is necessary to ensure that the feedback logic is true in both directions. The circuit adopted is shown in Fig. 2, while the binary and feedback sequence for both directions is shown in the table. It will be noted that the combinations for 4 and for 9 are different in the two directions. The display decoding matrix is arranged to ignore the first and second stages for these numbers, discrimination on the third and fourth stages being sufficient to establish the correct display.

The tens counter is similar to the tenths and units counters, but the reversing and feedback components are omitted, giving a straightforward scale-of-sixteen counter. All three counters have reset lines to enable them to be set to zero, and the fourth stage of the units counter has an additional connexion enabling it to be set to 5 when the range in use so requires.

### Control Circuit

The control circuit is shown in Fig. 3. A multivibrator running at about 4 Hz provides the basic control and

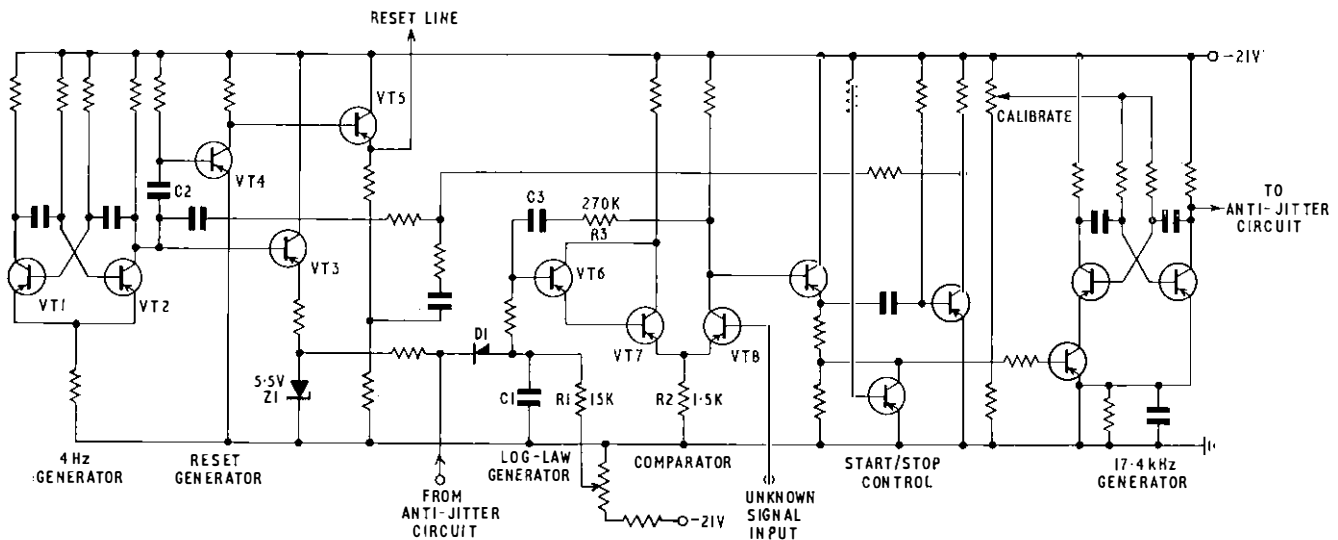

FIG. 3—CONTROL CIRCUIT

measuring sequence. During that part of the cycle for which transistor VT2 is switched off the negative potential applied to the emitter-follower transistor VT3 polarizes Zener diode Z1 and charges capacitor C1 to 5.5 volts. Ample time is available for the capacitor to charge fully via the diode D1. When transistor VT2 turns on, the emitter-follower transistor VT3 turns off, and the capacitor C1 starts to discharge logarithmically through resistor R1. At the same time a differentiated pulse via capacitor C2 turns off transistor VT4 and generates a short high-amplitude negative pulse at the emitter of transistor VT5 which resets the units and tenths counters. The 17.4 kHz oscillator is also switched on and starts to drive the counters as soon as the very short reset-pulse ceases.

The voltage on capacitor C1 is compared with the d.c. voltage derived by the long-tail transistor pair VT7 and VT8 from the signal of unknown level. To ensure that the logarithmic law is not distorted by the non-linear impedance of transistor VT7 a further stage, transistor VT6, is added to increase the input impedance to a value very high compared with the 15,000-ohm discharge

resistor. The potential across the 1,500-ohm common-emitter resistor, R2, follows the logarithmic voltage decay until it becomes very slightly less than the d.c. potential applied to the base of transistor VT8, which then turns on. Positive feedback via resistor R3 and capacitor C3 sharpens the edge of the pulse generated at the collector of transistor VT8, and this pulse is used to stop the 17.4 kHz oscillator. Provided that it is within range, the count is then shown on the units and tenths display. If the signal voltage is too high, transistor VT8 remains on throughout the measuring cycle and the 17.4 kHz oscillator does not start, giving zero count. Small variable resistors enable the exact potential of the earth returns on each side of the comparator to be adjusted slightly to trim the logarithmic-scale shape.

### Anti-Jitter Circuit

A signal which lies exactly, or lies very nearly, on the border between two digital values will in any digital measuring instrument show random variations between the two values, due to very small fluctuations or noise.

This is usually acceptable in laboratory work where the user can give close attention to every reading, but for routine use in the field it is very desirable that the user should be left in no doubt. Rapid alternation of 9.9 and

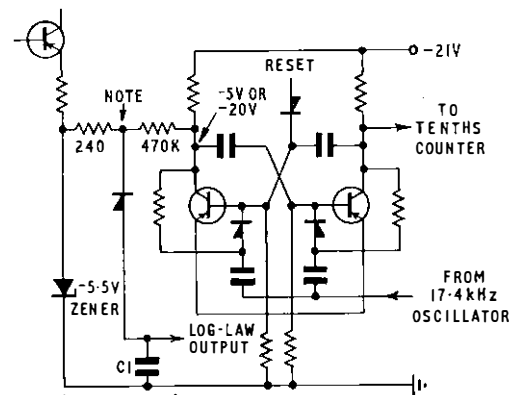

(PART OF FIG. 3)  
Note:  $5.0$  or  $5.0 \pm (15 \times 240) / 470,000 = 5.0$  volts  $\pm 0.12$  dB  
FIG. 4—ANTI-JITTER CIRCUIT

10.0, for example, could result in the reading being incorrectly recorded as 9.0, 10.9 or even 19.9.

Any such ambiguity is avoided in the present instrument by arranging that a marginal reading is deliberately biased one way or the other, thus giving a steady reading. This is done by a simple binary-counter stage (Fig. 4) interposed between the 17.4 kHz oscillator and the first stage of the tenths counter. This stage can be regarded as measuring half a tenth, i.e. 0.05 dB, and is used to change the voltage to which capacitor C1 (Fig. 3) is charged by about 0.01 dB, thus altering the next measurement by that amount. It is arranged that if a measurement results in the anti-jitter binary circuit stopping in the 0 position (say 10.00) the next measurement is biased towards an increased count, thus ensuring that the next count is 10.00 or 10.05. If, however, a measurement results in a 5 in this stage (say 9.95) the next measurement is biased towards a decreased count, thus ensuring that though the next count may be 9.90 it will not be 10.00. Thus, there is a greatly increased tendency for the readings to fluctuate between 9.90 and 9.95, but this has no effect on the display, as the second decimal is not shown, and, for example, the tendency to fluctuate between 9.9 and 10.0 is completely eliminated unless the signal varies by a significant amount. The changing of the apparent level by about 0.01 dB is equivalent to a deliberate error, but its magnitude is much less than the overall accuracy and is, therefore, insignificant.

#### Switched-Gain Amplifiers

Each switched-gain amplifier (Fig. 5) consists of two transistor stages: the first provides the voltage gain, while the second is an emitter-follower giving low output impedance without undue loading of the first stage. The connexion of capacitor C2 enables a high gain to be obtained, while negative feedback from the output emitter of transistor VT2 to the input base of transistor VT1 controls and stabilizes the overall gain and d.c. bias points. The input and output impedances are low and swamped by the coupling resistor R1: resistor R1 may be regarded as divided into two equal parts so that the input and output impedances are then finite and matched. The change of gain is obtained by the connexion of resistor R2 and diode D1 to the mid-point of the feedback resistors R3 and R4. Diode D1 may be either forward or backward biased by a control potential from a stage of the tens counter. When forward biased its impedance is low and the feedback signal is partially shunted to earth; the gain of the amplifier is then high. When the diode is backward biased its impedance is high and the feedback is fully effective; the gain of the amplifier is then low. Capacitor C1 isolates the d.c. control potential from the amplifier, and the value of resistor R2 controls the amount of gain variation. Diode D1 is not operated on the curved part of its characteristic, being either fully on or cut off, and non-linear distortion is thus avoided. The 5, 10 and 20 dB amplifiers (Fig. 5(a)) differ only in the value of the components in the feedback networks. The 40 dB amplifier consists of two 20 dB circuits in cascade, the control line being common to both.

The 20 dB circuits require a very low value for resistors R2 and R5, and the reactance of capacitor C1 then seriously degrades the performance at low frequencies unless its capacitance is made inconveniently large. The performance can be improved by using a modified circuit (Fig. 5(b)) in which transistor VT3 replaces control diode

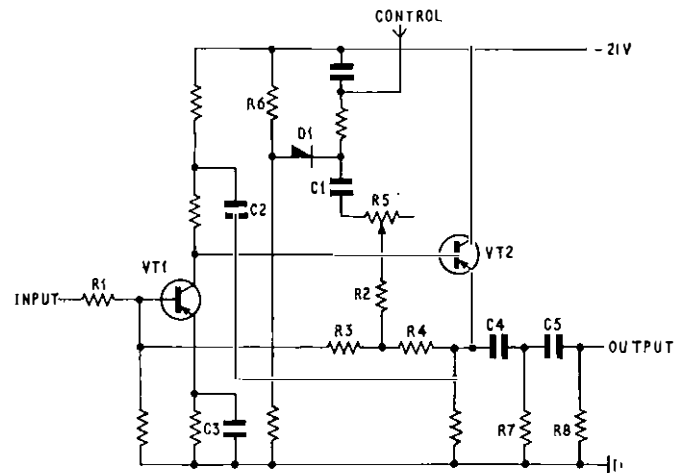

(a) Normal Switched-Gain Amplifier Circuit

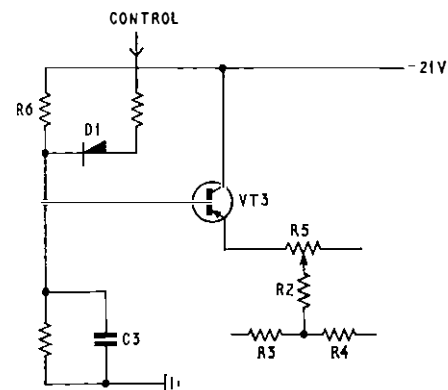

(b) Modified Circuit to give Improved L.F. Characteristics

FIG. 5—SWITCHED-GAIN AMPLIFIER CIRCUITS

D1. When this transistor is switched on, the capacitor C3 in its base circuit is seen at the emitter as if multiplied by the gain of the transistor; thus, a 25  $\mu\text{F}$  capacitor appears as upwards of 1,000  $\mu\text{F}$ , while the control line sees it only as 25  $\mu\text{F}$ , thus avoiding excessive load on the tens counter. When the transistor is switched off, its emitter presents virtually an open-circuit to the feedback signal.

The method of changing the gain inevitably gives rise to quite large surges during range changing. A simple high-pass network of capacitors and resistors, C4, R7, C5 and R8, between amplifiers materially reduces these surges, but, nevertheless, voltages exceeding the normal signal voltages reach the signal rectifiers and result in an apparently "high" signal while the overall gain is still too low for the real signal to be measured, thus preventing further gain being switched in until the surges have died away. This results in delay in finding the appropriate range, but it is necessary to arrange that the apparent signal due to a surge is not interpreted as a high signal requiring the tens counter to be reset to minimum gain, for this would cause continuous hunting and failure to find the correct range. It is, therefore, arranged that this reset condition cannot be generated until about  $\frac{1}{2}$  second after a range change, allowing ample time for switching surges to be dissipated.



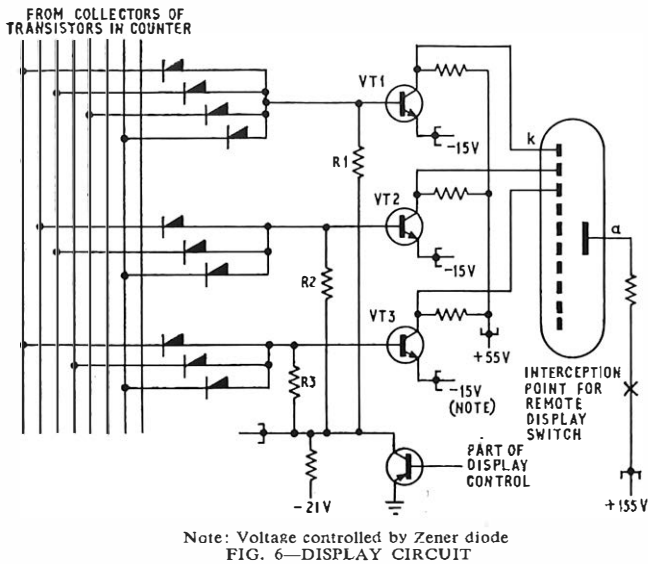

### Display

The three numerical digits and the + or - sign appear on neon display tubes. These tubes require 170 volts to strike, and extinguish at 100 volts. They can, therefore, be controlled by transistors capable of handling about 70 volts. The current required is 2 mA per digit for a small-size display and 4 mA for a large display.

Fig. 6 shows the gating and control arrangement for the display. The necessary 170 volts is obtained as a positive supply of 155 volts together with a 15-volt Zener-controlled tap from the -21-volt supply serving the amplifiers, counters, etc. Each numeral is controlled by a n-p-n transistor rated at 70 volts and 300 mW. So long as one or more of the counter binary stages controlling a given numeral are holding the corresponding control transistors VT1, VT2, VT3, etc., switched off, the display tube receives only 100 volts. When all the relevant binary stages for any one numeral are simultaneously in the appropriate state an earth is applied via one of the resistors R1, R2, R3, etc., to the base of the required

FIG. 7—DIGITAL-DISPLAY DECIBELMETER

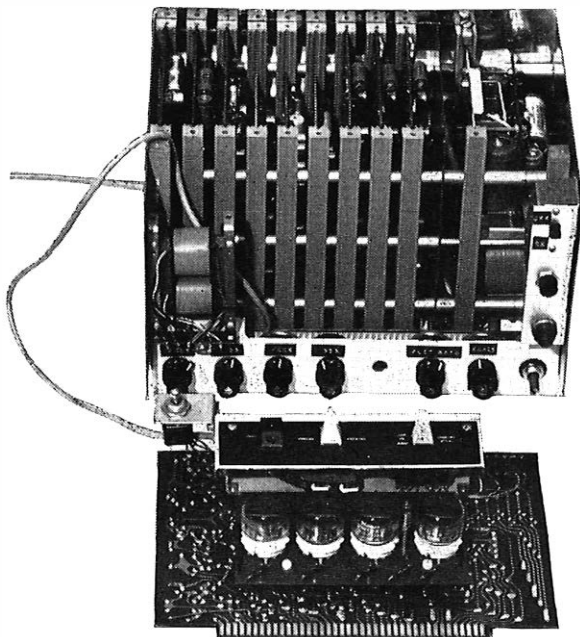
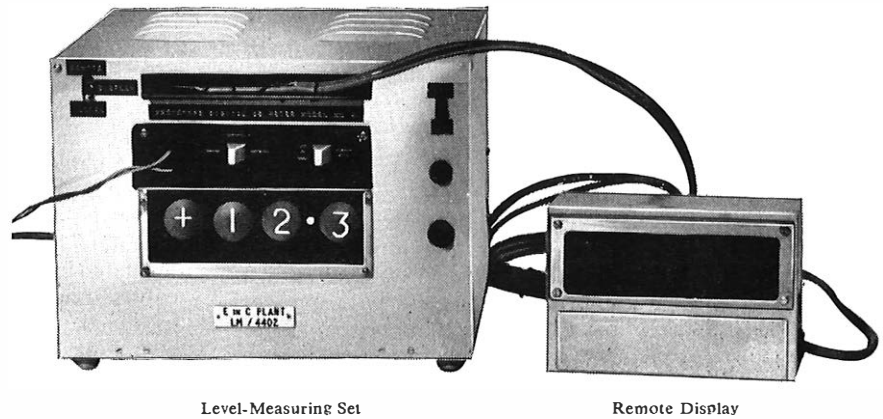

FIG. 8—DECIBELMETER OPENED TO SHOW CALIBRATION CONTROLS AND DISPLAY BOARD JACKED OUT

control transistor, which turns on and applies the full 170 volts to the appropriate cathode of the display tube.

In addition to the built-in display an extension unit can be provided to switch the display to a remote point. For this, 32 wires are required, and these may be multiplied to several display points. Only one point may be used at a time owing to limitations in the display-control circuit, and simple switching of the 155-volt supply avoids violation of this requirement. An attempt to use several displays simultaneously might result in damage to the display control transistors.

### Power Supplies

A very simple mains-driven power unit supplies  $\frac{1}{2}$  amp at 21 volts to the transistor circuits, stabilized by a simple regulator, and 20 mA at 155 volts to the display tubes.

### MECHANICAL CONSTRUCTION

A metal case  $10\frac{1}{4}$  in.  $\times$  7 in.  $\times$   $7\frac{1}{4}$  in. contains plug-in printed-circuits, the power unit, and the display tubes.

The external controls (Fig. 7) consist of an on-off switch and two lever-type keys: one lever-type key gives through-level and terminated-level conditions, and provides a CHECK 10 dB facility by switching in a 10 dB pad,

the second provides LOCK ON RANGE and STABILIZE AT L.F. facilities. A further 2-way switch is provided when a remote display is required.

Internally, calibration controls (Fig. 8) are provided for each amplifier, and the frequency of the 17.4 kHz oscillator can be adjusted. Also, the logarithmic-law scale shape can be trimmed.

#### PERFORMANCE

The prototype digit-display decibelmeter has given satisfactory service for several months, and several further models are ready for field trial. The prototype

performed satisfactorily under test in the temperature range 0–50°C. No serious drift has been observed in calibration, but it is recommended that, when the greatest possible accuracy is required, the calibration should be checked daily, half an hour after switching on.

#### ACKNOWLEDGEMENTS

The instrument was designed and developed in the Engineering Department Main Lines Development and Maintenance Branch Laboratory, and acknowledgements are due to past and present staff who worked on the project.

---

## X-Ray Inspection of Polythene-Insulated Submarine-Cable Joints and Gland Mouldings

J. E. H. COSIER and R. W. WINDLE†

U.D.C. 620.179.15:658.562:621.315.68

Submerged-repeater system cable joints and glands are inspected by means of X-rays. The equipment, processes and film assessment are described.

#### INTRODUCTION

THE advent of submerged-repeater systems has necessitated inspection and quality-control practices of much higher standards than previously required for land-based repeater systems. These systems earn a high revenue, and a fault will, of necessity, be of greater duration than on a comparable land coaxial system. Thus the revenue loss, together with the high cost of cable-ship operations for fault clearance, means that every effort must be made to keep the fault liability so low that the high capital-cost systems remain an economic proposition.

The general guiding principle has been that all components, cable joints and repeater glands shall be manufactured to standards of reliability to give a fault-free life of at least 20 years. This long-life requirement and the fact that submarine cables are now being stressed by the higher d.c. voltages used for power feeding repeaters, possibly up to 13 kV, resulted in the development of the radiographic examination of cable joints and of the glands that allow the cable to enter the repeater casing but prevent the ingress of sea water at high pressures. This radiographic examination of polythene should detect heavy inclusions of dirt or metal which are substantially denser than the polythene, and voids which are more transparent than it.

Both the cable joints and the glands are essentially cylindrical polythene mouldings around a central metal component, and the shadow cast by the latter can be used to check its concentricity. The X-ray method gives no information on the grade of polythene used or the presence of hard bake, i.e. oxidized polythene, nor will it give any direct indication of lack of fusion between the injected and the parent material. A photographic record is considered essential for critical assessment, and has the further advantage of producing a permanent record that is available for later consultation.

The earliest recorded examination of submerged-repeater components by radiographic means was that of the "pudding-type" gutta-percha glands used for the E-type repeaters installed in the Aldeburgh-Domberg No. 5 cable in August 1950. These repeaters were connected into the existing cables by means of the traditional hand-made joints. This method was also used for the repeater joints in the Holyhead-Dublin polythene-insulated cable in 1953. All subsequent joints in polythene cables and all repeater glands have been injection moulded, and it became the general policy that all mouldings should be subjected to a non-destructive examination by means of X-rays. Thus, the non-destructive test is designed to provide the following information.

- (a) Concentricity of cable conductor or gland stem with respect to the mouldings.
- (b) The presence of contraction voids or air bubbles in the mouldings.
- (c) The presence of inclusions of materials having a different density from that of the polythene.
- (d) Cracks or other inclusions in the moulding.

This article describes the equipment and processes currently used for these tests.

#### EQUIPMENT DESIGN

To fulfil the test requirements it is essential that the technique and equipment should be capable of detecting small changes in density in the polythene and of indicating these changes in the density of the photographic image. This change of density could be due to a small void or reduction in the thickness of the polythene, in which case the image on the film will appear darker; on the other hand, it could be due to the presence of an inclusion of higher density than the polythene, in which case the film image will appear lighter due to the attenuation of the X-ray beam. The standard which has been set for joints and gland mouldings is that the process should be capable of detecting discrete changes in density of the order of

---

†Post Office Research Station.

3 per cent of the thickness of the polythene being examined. In practice, changes of 1 per cent can often be detected. It should be noted that the centre conductor of a joint and the gland stem appear on the film as almost transparent images, equivalent to large metallic inclusions.

The optimum conditions for producing the required photographic record are governed by

- (a) the type of radiation and the equipment design,
- (b) the exposure conditions, and
- (c) the type of film and processing.

Unlike the larger X-ray tubes used for commercial and medical purposes, those used for these tests are not water-cooled. Electrons are emitted from a hot tungsten filament, and are attracted at great speed by the high potential of a heavy copper anode; the electrons are suddenly stopped by the collision with the copper atoms, and their impact produces a great deal of heat and some X-rays. The electrons are focussed upon a small spot about 0.3 mm diameter, from which the X-rays travel out in all directions in straight lines. X-rays are absorbed by materials in proportion to their density and thickness, and, in order to reduce the absorption by the glass envelope, a bubble is blown in the tube wall to thin the glass and reduce filtration. This bubble can be clearly seen in the photograph of an X-ray tube in Fig. 1.

Both the quality and intensity of X-rays vary with the anode voltage applied to the tube. The greatest fault discrimination is obtained at the lowest possible voltage, and the lowest practical voltage should always be used to examine a specimen. However, the soft radiation produced at very low voltages is so readily absorbed that it does not penetrate the tube wall, and it may also be so strongly absorbed by the specimen that impracticably-long exposure times are required. For the purpose of testing polythene mouldings, the equipment used is arranged to work in the range 10–20 kV and the exposure times are of the order of 1 minute. Polythene is a light material and absorbs X-rays only feebly, but the metal conductors and gland stems in the centre of the mouldings are, by comparison, opaque and these mask the areas of the mouldings in line with them. Hence, several views at different angles to the cable must be examined to check the polythene properly.

For this reason the Mark VI X-ray camera shown in Fig. 2, presently used for testing cable joints, is arranged so that the camera head, containing the X-ray tube, e.h.t. power supply and film carrier, rotates round the axis of the cable under test. The head may be rotated through 150° from the horizontal, and can be locked at any desired angle on the graduated quadrants. The angles normally used are 0°, 30°, 60°, 90°, 120° and 150°, and notches at these angles are provided on the quadrants to give positive locations at these orientations.

The cable remains stationary during the tests, being held in clamps which are

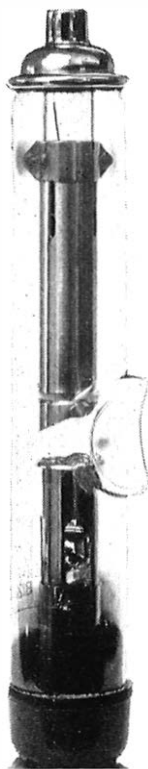

FIG. 1—X-RAY TUBE FOR MARK VI CAMERA

independently adjustable for varying sizes of cable up to 2 in. in diameter. Thus, joints between dissimilar cables can be accommodated. The jaws are of a toggle type which provide a positive location without leaving pressure marks on the cable and without bending the conductor. The camera head and cable clamps are attached to a baseboard. The lower part of the transit case forms a cover over the camera and is secured to the baseboard by toggle catches. The film holders consist of metal sliding trays which take envelope-packed films, either 10 in. × 8 in. or 12 in. × 10 in. in size. The film is held in position by hinged side-pieces, and can be located in four predetermined positions relative to the sample under test. These positions are arranged to provide a title space and three views at different sample orientations on each film, the necessary masking being provided by the aperture in the camera casing. The film-carrier transport is by manual operation, but consideration is being given to a design whereby the film is advanced to the next position as the camera head is rotated. An interlock is provided to prevent the energization of the X-ray tube if the film holder is not in position.

The title space is also used to expose a stepped monitor, and this is hinged in the camera head and can be folded out of the way when not required. A plug and socket connects the camera head to the control unit via a flexible lead. If the e.h.t. transformer were in the control unit, a flexible lead capable of carrying 20 kV with an associated plug and socket suitable for the same voltage would have been required; as a result of this requirement it was considered safer, particularly for shipboard use, to mount the e.h.t. transformer in the camera head.

The control panel is a standard 19 in. panel mounted in the top compartment of the transit case, which also has storage space for the connecting leads. The panel accommodates the meters, switches, lamps, timer, filament transformers and Variac. The filament current for the X-ray tube is taken from a mains transformer and is controlled by a variable resistance in the primary. The anode voltage for the tube is generated by the e.h.t. transformer inside the camera head, and is controlled by altering the voltage applied to the primary by the Variac; the tube acts as its own rectifier. The transformation ratio of the e.h.t. transformer is 100:1, and the kilovoltmeter on the control panel actually measures the 0–250 volt output of the Variac. Thus, the voltmeter does not automatically indicate that the e.h.t. transformer is applying a potential to the anode: this indication is given by a neon lamp which operates when the exposure switch is closed. The intensity of radiation is governed by the tube current, and this is indicated by the milliammeter. The timer, which is operated from a 50 Hz supply, has a graduated dial to indicate the time in seconds and is controlled by the exposure switch. The size of the focal spot of the X-ray beam is controlled by a focussing electrode. The potential applied to this electrode is derived from the voltage drop across a resistance in series with the anode circuit. This also supplies feedback to the tube, which enables a useful degree of stabilization of the set to be obtained by suitably adjusting the resistance.

#### FILMS AND FILM PROCESSING

The sensitivity of the X-ray test is governed by the contrast and grain size of the film. A high-contrast film will indicate a void more readily than a low-contrast

one, as the film blackening at the void will be increased with greater contrast. Unfortunately, the higher-contrast and finer-grain characteristics are normally obtained at the sacrifice of film speed, and, therefore, during early development work a number of different grades of film were investigated. The one finally chosen was a compro-

work a temperature of the order of 23°C is normally used. Although this is slightly higher than that used in normal commercial practice, the resultant development time of approximately 3 minutes (depending on the developer used) reduces the delay between the exposure and inspection of the film.

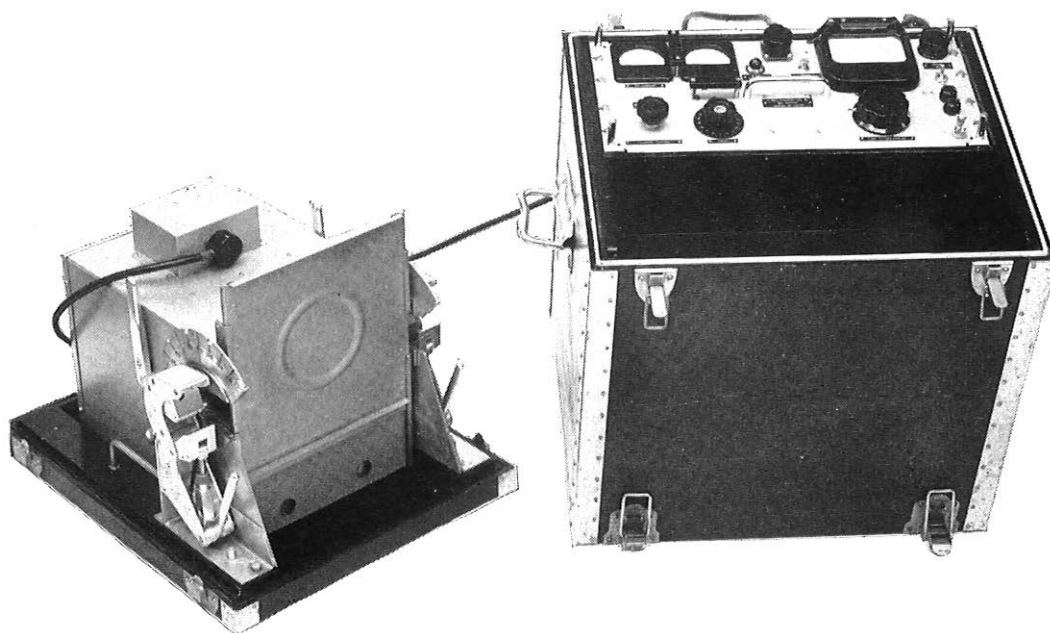

FIG. 2—MARK VI CAMERA

mise between high-contrast and fast exposure times. The film is dependent upon the quality of processing to maintain a constant degree of contrast and grain size. Over the years this film has been very satisfactory and has contributed a great deal to the high standard obtained with moulded joints and glands.

It is very important that the photographic processing is carried out systematically and carefully to avoid difficulties in film interpretation. The quality of processing should be such that it should be possible to assume that any unusual markings appearing on the film are not due to processing faults. The film at all times must be handled with care to avoid pressure marks and scratches. The emulsion should not be touched with the fingers, which may leave a greasy deposit that would affect development, and, in particular, it should not be splashed with processing solutions or water prior to development. The exposed film, which is envelope packed, should always be transferred to the developing frame on a clean dry bench. Handling of the film in the wet condition must be undertaken with great care as the emulsion is very easily damaged in this condition. It is difficult to make a satisfactory copy of a radiograph, so whenever a duplicate copy is required it is usual to expose a second film of the subject.

The dark-room arrangement will vary according to the accommodation available, but it will normally consist of a dry bench, developing tanks, and film washing and drying facilities. Illumination during processing is provided by a suitably designed safe light. The films are developed by the time-and-temperature method, and, thus, the measurement of the temperature is of the utmost importance for consistent results. For shipboard

The sequence of operations for the film processing is as follows.

- (i) Remove the film from the envelope and load into the processing frame.
- (ii) Place the film in the developing solution, agitating periodically for a time dependent upon the type of developer and its temperature.
- (iii) Remove the film from the developer, allow it to drain, and place it in a stop bath, consisting of a solution of glacial acetic acid, for approximately 1 minute.
- (iv) Remove the film from the stop bath, allow it to drain, and place it in the fixing solution for twice the time that it takes for the film to clear.
- (v) Remove the film from the fixing solution, and wash it in clean water for approximately 1 hour.
- (vi) Hang up the film in a dust-free atmosphere to dry.

All solutions should be at the same temperature. Where quick inspection of the film is required, the film can be viewed in the wet condition immediately after the film has cleared. The film must be returned to the fixing solution immediately after examination for completion of the processing.

#### FILM ASSESSMENT

Voids in the polythene insulant, which are shown on the film as darker areas, are not permitted although certain defined separation voids are allowed in the specification. The ability to detect a narrow void or crack is limited as its inclination to the X-ray beam will be very important (Fig. 3), and the change of density could be outside the limit of detectability. As a guide to the optimum exposure for a particular sample a stepped

monitor is provided. This monitor consists of varying thicknesses of polythene which contain artificial voids of 3 per cent of the mean sample thickness, and the exposure is selected so that the void and the step appropriate to the thickness of the sample to be X-rayed is clearly distinguishable.

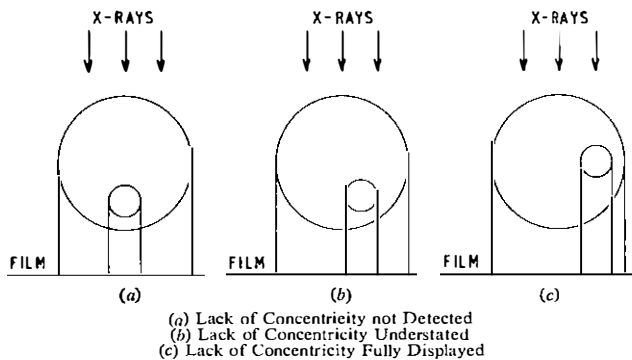
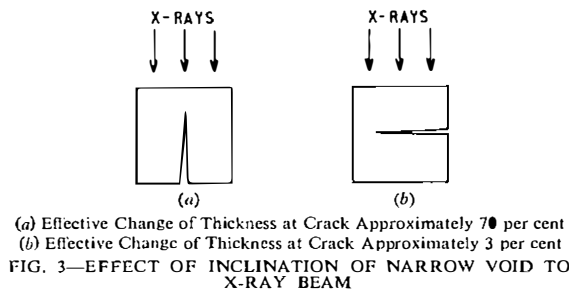

Concncentricity is defined in terms of the minimum allowable wall thickness, and, ideally, should be measured in the correct orientation (Fig. 4). The number of views taken is obviously limited by practical considerations and, therefore, the specified number of views for a particular moulding is a compromise. Reference to Fig. 5 will show that the apparent wall thickness  $x$ ,

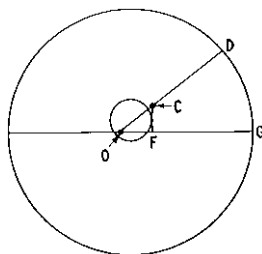

CD =  $a$  = possible minimum wall thickness  
 FG =  $x$  = apparent wall thickness

FIG. 5—RELATIONSHIP BETWEEN APPARENT WALL THICKNESS AND POSSIBLE MINIMUM THICKNESS

as shown on the film, is not necessarily the wall thickness in the plane OG through the centre of the cable and normal to the X-ray beam, but could be produced by a projection to point C from the centre conductor on the plane OD, resulting in a lesser wall thickness  $a$ . It can be shown that the relationship between the apparent wall thickness  $x$  and the possible minimum thickness  $a$  is

$$x = r - (r - a) \cos \pi/2n,$$

where  $r$  = radius of the core, and  
 $n$  = number of views.

The assessment of inclusions is a complicated procedure as not only their size but their proximity to each other and to the outer surface must be taken into account. These factors are assessed using a points scheme for evaluation. No attempt is made to distinguish the effects due to the nature of the different inclusions. All particles are considered equivalent without reference to the density with which they appear on a film, and the points

Dimensions of Inclusions Standard

Diameter of Sphere (in.)	Sieve Size B.S. No. 481: 1933	Point Value	Diameter of Circumscribing Circle to Represent Critical Spacing (in.)
0.035	20 mesh	25	not required
0.028	24 mesh	15	0.14 ± 0.015
0.022	30 mesh	10	0.11 ± 0.01
0.016	40 mesh	5	0.08 ± 0.008
0.010	60 mesh	2	0.05 ± 0.005
0.0065	90 mesh	1	0.033 ± 0.003
0.003	200 mesh	1	not required

value is first of all defined by size as shown in the table. To simplify the problem of dealing with the various shapes of particles the size of any inclusion is considered to be that of its circumcircle on the film. All views of a sample exposed in different orientations are considered together for the assessment of inclusions, so that a single inclusion appearing on more than one view will only be assessed once. The position of the particle is taken into account, it being accepted that particles lying completely on the surface are less objectionable than those contained wholly in the insulant; for example, a speck of copper on the surface of the moulding will ultimately make intimate contact with the return tape or braid and will not necessarily produce an abnormal condition. Similarly, the decrease in field strength away from the centre conductor suggests that particles are less serious near the outer surface. In a radiograph, surface inclusions will not necessarily be shown as such and this leads to some difficulty in assessment.

In a cable core checked in three positions, a particle on the surface but inclined at, say, 30° to the beam in one view may appear in a similar position to one just below the surface on a plane normal to the beam in another view. The extent of this ambiguity is accepted as the limit of the concession, and particles lying within a specified distance of the surface, depending on the wall thickness of the polythene, are counted at half their normal value. The distribution of particles must be considered as well as their position: a number of particles in a moulding may be quite acceptable if widely distributed, but, when closely grouped, may be a source of potential danger and would be quite unacceptable. Such close groups are defined as groups separated by less than the diameter of their largest component and are considered to be coherent. Open groups of particles are also found which do not qualify for the close-group rule but which may still represent a potential hazard. Here it is considered that interaction can take place between particles, and the maximum distance for interaction is arbitrarily taken to be five times the diameter of the largest particle. A penalty has, therefore, been devised by which particles within this qualifying distance

have the points value of the smaller particle doubled. This rule for groups can be applied to particle arrays of more than two particles by considering all qualifying pairs. Thus, if a particle of points value 10 has a particle of points value of 2 and one of points value  $\frac{1}{2}$  within the qualifying distance, the total score for the three particles would be  $10 + (\frac{1}{2} \times 2) + (2 \times 2) = 15$ . If the smallest particle ( $\frac{1}{2}$ ) lies within the qualifying distance

particles which contribute effectively to the score. Such particles are examined and compared to ensure that each is counted once only with proper allowances and penalties.

As a basis for determining the allowable degree of particle contamination, a standard of 25 points/in<sup>3</sup> of insulant has been used. To determine the size of the inclusion a magnifying lens fitted with a suitable graticule is used.

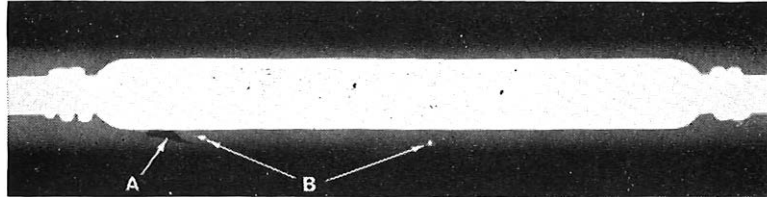

A—Void. B—Inclusions

FIG. 6—RADIOGRAPH OF REJECT LIGHTWEIGHT-CABLE CORE JOINT SHOWING VOID AND INCLUSIONS

of the next larger particle (2), an additional smallest particle ( $\frac{1}{2}$ ) would be added, bringing the total to  $15\frac{1}{2}$ . If more than four such pairs exist in a group or chain, the assembly is scored by doubling the value of all constituent particles.

Finally, the distribution of inclusions must be considered on a wider scale, and so the specification is applied to the worst section of the moulding. This assessment area need not be too small as the rules for groups of particles takes account of localized areas of contamination, and a length of 2 in. has been chosen. To obtain the best estimate of the total score of inclusions in the assessment area, it is necessary to examine all the views of the sample together. Therefore, for counting purposes each 2 in. length is examined in all views for

A radiograph of a 0.99 in. Lightweight-cable core joint is shown in Fig. 6. This shows the presence of both a void and inclusions.

#### CONCLUSION

The radiography of moulded polythene joints and glands has proved to be essential for the maintenance of the required high standard of quality for deep-sea sub-merged-repeater systems.

#### ACKNOWLEDGEMENT

The authors would like to acknowledge the previous work of Mr. D. C. Shotton, on which much of this article has been based.

## Books Received

“Theory of Servomechanisms.” Edited by H. M. James, N. B. Nichols and R. S. Phillips. Constable and Company, Ltd. xiv + 375 pp. 159 ill. 18s.

“Computing Mechanisms and Linkages.” A. Svoboda. Edited by H. M. James. Constable and Company, Ltd. xii + 359 pp. 177 ill. 18s.

The above two books were originally published by McGraw-Hill Book Co., Inc., in the Massachusetts Institute of Technology Radiation Laboratory Series as Volume 25 (1947) and Volume 27 (1948), respectively. By the co-operation of McGraw-Hill with Dover Publications, Inc., the books, unabridged and unaltered, have now been reproduced in Dover paperback editions on a paper which, the publishers claim, gives minimum show-through and will not discolour or become brittle with age; the pages are sewn in signatures, and the books may be opened flat without fear of pages dropping out.

“Theory of Servomechanisms” was prepared largely as an effective method of disclosing the work carried out in this

field at the Radiation Laboratory as applied to automatic-tracking radar systems. This problem is particularly difficult because the signal to be used in tracking may be seriously distorted by interference, fading and receiver noise, thus making it necessary to consider the servomechanism as a device intended to deal with an input of known statistical character in the presence of interference with known statistical character. The book falls into two parts: the first is devoted to the sinusoidal steady-state analysis familiar to engineers in its application to electrical systems; the second, to statistical methods of servomechanism design.

In the words of its author, ‘the work on linkage computers described in “Computing Mechanisms and Linkages” was carried out under the pressure of war. War gives little opportunity for the advancement of abstract knowledge; all efforts must be concentrated on meeting immediate needs. In developing techniques for the design of linkage computers, the author has therefore been forced to concentrate on finding practical methods for the design of computers rather than on developing a unified and systematic analysis of the subject. The war has thus given to this work a special character that it might not otherwise have had.’

# A Test Instrument with a Direct-Reading Fault Bridge— Ohmmeter No. 18A

G. W. CROSBY†

U.D.C. 621.317.733

A test instrument is described which includes a new bridge network, enabling the conductor resistance to an earth or contact fault to be measured directly without the use of the conventional Varley or Murray formulae. The test instrument can also be used to measure loop resistance and insulation resistance; it will also locate disconnection faults.

## INTRODUCTION

THE Ohmmeter No. 18A\* is a portable battery-operated test instrument designed for easier methods of testing. It caters for the measurement of insulation and loop resistance, and for the location, without the use of complicated formulae, of earth, contact, and disconnection faults on local lines. The conductor resistance to an earth or contact fault is read directly from the ohmmeter's variable resistance.



FIG. 1—OHMMETER No. 18A

The ohmmeter is powered by a 9-volt dry battery, which feeds the bridge direct for low-resistance measurements, but also feeds a transistor-type 1,000 Hz oscillator

†External Plant and Protection Branch, Engineering Department.

\*The Ohmmeter No. 18A is subject to Patent Application No. 6159/66.

for measuring disconnection faults, and a transistor-type 500-volt d.c. converter for high-resistance measurements.

Separate meters are used for insulation and bridge measurements: one meter has a full-scale deflexion of  $26 \mu\text{A}$  and is used to indicate the value of insulation resistance measured, the other acts as a galvanometer and has a deflexion of  $17.5\text{--}0\text{--}17.5 \mu\text{A}$  to indicate bridge balance. The galvanometer incorporates mechanical protection against overload and is also shunted by diodes, thus dispensing with the need for an adjustable galvanometer shunt. A low-impedance head-gear receiver is used as a detector on a.c. measurements. The weight of the ohmmeter including the battery is 9 lb, and the overall dimensions are  $7\frac{1}{2}$  in.  $\times$  10 in.  $\times$  8 in. The ohmmeter is illustrated in Fig. 1, and the circuit connexions are shown in Fig. 2.

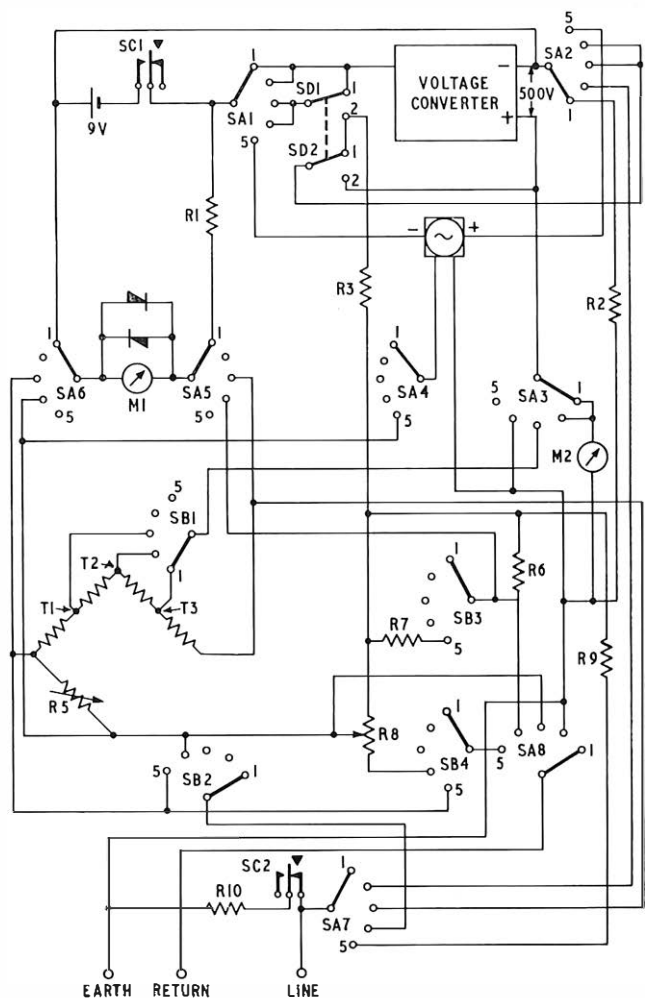

FIG. 2—CIRCUIT DIAGRAM OF OHMMETER No. 18A

## OPERATION

### Battery Test and Calibration

The d.c. voltage-converter circuit operates from the internal 9-volt battery, producing a nominal testing voltage of 500 volts at the output terminals, and the correct function of the ohmmeter is dependent upon the internal-battery voltage not falling below 6 volts. The condition of the battery is checked by setting rotary TEST FUNCTION switch, SA (Fig. 2), to position 1. This switches resistor R1 in series with meter M1 across the battery, and when the battery voltage is less than 6 volts the current flowing through the meter will not be sufficient to move the pointer beyond the CHANGE BATTERY marking on the meter scale. This switch position also enables a 1-megohm calibration check to be made. A 1-megohm resistor, R2, is switched in series with the insulation meter M2 across the converter output, and a diode stabilizing circuit enables the meter to be calibrated automatically to the 1-megohm scale position unless the internal battery voltage is less than 6 volts. The circuit for the battery test and 1-megohm calibration is shown in Fig. 3.

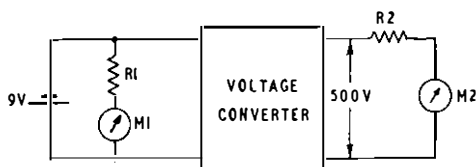

FIG. 3—BATTERY-TEST AND 1-MEGOHM CALIBRATION CIRCUIT

### Insulation Testing

The circuit for insulation testing is shown in Fig. 4. This is a conventional circuit, the 500-volt output from

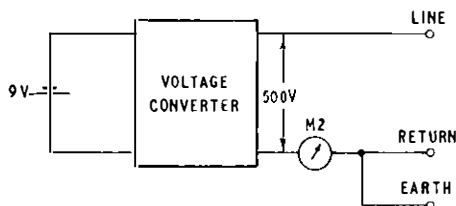

FIG. 4—INSULATION-TEST CIRCUIT

the converter being connected in series with the meter movement and the insulation to be tested. The value of the insulation resistance is indicated by meter M2 on a 2.5 in. single scale that is calibrated to read from 0.01 to 1,000 megohms. After the insulation has been measured, the line is automatically discharged by resistor R10 (Fig. 2), this resistor being switched across the output terminals when the non-locking on-off switch, SC (Fig. 2), is released.

### Loop-Resistance Measurement

Loop resistance is measured by a Wheatstone bridge circuit, as shown in Fig. 5. There is a 202-ohm and a 909-ohm resistor in each of the two ratio arms; this enables a  $\times 10$  or  $\div 10$  bridge ratio to be obtained. The third arm of the bridge is a four-decade adjustable resistor, the resistance of which is variable from 0.1 to 999.9 ohms.

Under short-circuit conditions the 500-volt d.c. converter delivers 3.5 mA, with a current drain of 200 mA from the internal battery; therefore, to conserve the battery power and to improve the bridge sensitivity, loop-resistance measurements should be made with the

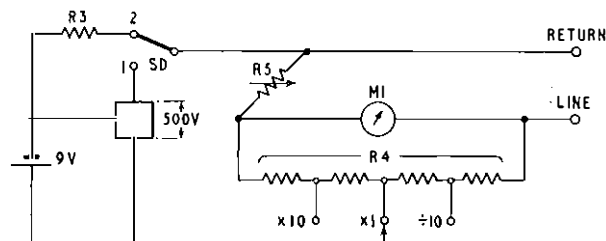

FIG. 5—WHEATSTONE BRIDGE CIRCUIT

BRIDGE VOLTAGE switch, SD, at the low-voltage setting (position 2). In this position the bridge is fed directly from the internal battery, and the current drain from the battery is equal to the current flowing into the bridge, this being greater than 3.5 mA but very much less than 200 mA. Another advantage of the alternative voltage provided by switch SD is that it is possible to check that a metallic-loop resistance is being measured and not a loop resistance through a low-insulation fault path. The variable resistance value required to balance the bridge when the correct loop resistance is being measured is stable with change of applied voltage, whereas the loop resistance through a low-insulation path will vary with a change of applied voltage.

### Earth-Fault and Contact-Fault Location

The conventional method of determining the conductor resistance to an earth or contact fault involves measurement of the closed-loop resistance and necessitates calculations which may lead to errors; it is also necessary to adjust the resistors in the two ratio arms of the bridge to obtain the correct ratio for full use of the bridge variable resistance. Previous ohmmeters in use by British Post Office engineering staff have a four-decade adjustable resistor with a resistance that is variable from 1 to 9,999 ohms in 1-ohm steps, and with these ohmmeters the conductor resistance to an earth fault or a contact fault is obtained as follows.

(a) When the closed-loop resistance value,  $L$ , is greater than 1,000 ohms, set the bridge ratio to  $\times 1$ , and measure the Varley bridge resistance  $R$ . At balance

$$\text{resistance to fault, } x = (L - R)/2.$$

(b) When the closed-loop resistance value,  $L$ , is less than 1,000 ohms, set the bridge ratio to  $\div 10$  and measure the Varley bridge resistance  $R$ . At balance

$$\text{resistance to fault, } x = (10L - R)/11.$$

(c) When the closed-loop resistance value,  $L$ , is less than 100 ohms, set the bridge ratio to  $\div 100$  and measure the Varley bridge resistance  $R$ . At balance

$$\text{resistance to fault, } x = (100L - R)/101.$$

The application of these formulae under field conditions can easily lead to errors, and their elimination by the use of a direct-reading bridge circuit is a considerable advantage.

The new method of measuring the resistance to an



earth fault or a contact fault with the Ohmmeter No. 18A uses a direct-reading bridge circuit consisting of a four-arm resistance network as shown in Fig. 6.

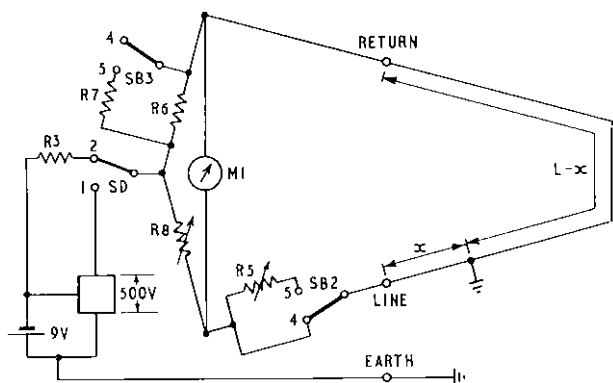

FIG. 6—DIRECT-READING BRIDGE CIRCUIT FOR EARTH-FAULT OR CONTACT-FAULT LOCATION

With no current flowing through the meter the balance equation is

$$R_6x = R_8(L - x) \quad \dots\dots (1)$$

Resistor R8 is in the form of a helical potentiometer, the resistance value of which at balance is not required to be known. When the rheostat switch, SB, is set to position 5, resistors R6 and R7 are in parallel, and the ohmmeter variable resistor, R5, is switched in series with the resistance to the fault  $x$ ; balance of the bridge is disturbed and is restored by adjustment of resistor R5. At rebalance, the bridge equation is

$$\left(\frac{1}{R_6} + \frac{1}{R_7}\right)^{-1} \cdot (R_5 + x) = R_8(L - x) \dots\dots (2)$$

From equations (1) and (2)

$$R_6x = \left(\frac{1}{R_6} + \frac{1}{R_7}\right)^{-1} \cdot (R_5 + x).$$

If  $R_6 = R_7$ , then

$$R_6x = (R_5 + x)R_6/2.$$

Therefore,

$$x = R_5.$$

Hence, the resistance of the ohmmeter variable resistor R5 at bridge rebalance is equal to the conductor resistance to the fault,  $x$ , to the nearest 0.1 ohm; fractions below 0.1 ohm can be estimated from the pointer movement about the centre-balance mark.

The BRIDGE VOLTAGE switch can again be used to advantage, i.e. if the fault resistance is such that the bridge cannot be balanced with the switch in the low-voltage position, a change to the high-voltage position will enable a balance to be achieved with fault resistances of the order of 1 to 2 megohms.

### Tests for Disconnexion

The components used in the bridge are incorporated in a different circuit to enable disconnexion faults to be located in unloaded cables, by comparing the capacitance of the faulty conductor up to the disconnexion with that of the remainder of the faulty wire to the far end plus the capacitance of a good wire completing the closed loop, assuming that the capacitance to earth per unit-length of the faulty wire is uniform and equal to that of the good wire. Fig. 7 shows the circuit of the disconnexion-fault bridge: the input to the bridge is obtained from the 1,000 Hz internal oscillator and balance is indicated by minimum tone in the head-gear receiver.

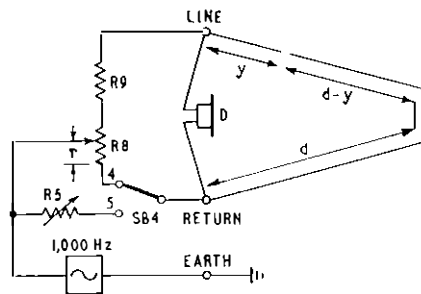

FIG. 7—DISCONNEXION-FAULT LOCATION BRIDGE

Using the notation of Fig. 7, in which

$d$  = length to far end,

$y$  = distance to the disconnexion from the testing end,

$C_y$  = capacitance to earth of the faulty wire up to the disconnexion, and

$C_{2d-y}$  = capacitance to earth of the remainder of the loop,

$$\text{then } (R_9 + R_8 - r) \cdot \frac{1}{\omega C_{2d-y}} = r \cdot \frac{1}{\omega C_y} \quad \dots\dots (3)$$

$$\text{and } (R_9 + R_8 - r)C_y = rC_{2d-y} \quad \dots\dots (4)$$

On switching the rheostat switch, SB, to position 5, the portion  $r$  of resistor R8 is replaced by the variable resistor R5, and, on rebalancing the bridge, the value of resistor R5 indicates directly the value of that portion of  $r$  of resistor R8.

If  $R_8 = R_9 = 100$  ohms, and assuming uniform capacitance per unit-length throughout the loop, then equation (4) becomes

$$(200 - r)y = r(2d - y).$$

$$\text{Therefore, } 100y = dr,$$

$$\text{and } y = \left(\frac{r}{100}\right)d.$$

Thus, the value of  $r$  gives the distance  $y$  to the disconnexion as a percentage of the distance  $d$  to the far end of the faulty wire.

# A New Echo Suppressor for Long-Distance Communications

P. H. SHANKS, M.Sc., C.Eng., M.I.E.E.,†

U.D.C. 621.395.664.12

A new echo suppressor has been designed specifically for use on circuits with long propagation times. This article outlines the basic requirements for satisfactory suppression and break-in. The final design was successfully tested on circuits routed over the HS-303 synchronous-orbit satellite.

## INTRODUCTION

PRIOR to the introduction of high-velocity transmission systems in the national network, long-distance telephone connexions were carried over 4-wire amplified circuits routed, for the most part, on loaded audio cable. Such circuits possessed round-trip propagation delays of the order of 15 ms per 100 miles, which, in conjunction with poor return losses of the 4-wire/2-wire terminations, could render the connexion subjectively unacceptable with certain conditions of echo amplitude and delay. Echo suppressors were, therefore, normally associated with such circuits.

With the introduction of carrier, coaxial and microwave systems, echo suppressors were no longer required on national circuits, but were re-introduced at a later stage for use on international submarine-cable circuits, e.g. the transatlantic telephone cables. In general, the types used were of the same, or similar, design to those originally developed for the national network.

The introduction into the international network of synchronous-orbit satellites, involving mean one-way propagation times of about 270 ms per hop, with the possibility of long submarine-cable extensions, has necessitated research into the problems encountered with delays of this magnitude. A prototype design, embodying a number of novel features, is described.

## ECHO-SUPPRESSOR LOCATION

Ideally, the most advantageous location for the echo suppressors would be as near as possible to the 4-wire termination, remote from the talker, where the echoes are returned. As is immediately obvious, this would require a prodigious quantity of such devices—one for every termination in the country.

The transmission plan for the United Kingdom requires all international circuits to pass through the international switching centre in London. This is considered to be the most suitable location for the echo suppressors as they can be directly associated with the circuits which require them. However, this introduces a secondary problem: the echo suppressors must be able to accept end-delays (twice the propagation time from the echo suppressor to the telephone set at the same end of the connexion) of up to 20–25 ms. Although end-delays are shorter than this within the United Kingdom, such delays are possible in, for example, the United States or when circuits are extended from London to certain European countries. The effects of end-delay are considered later.

Echo suppressors situated as shown in Fig. 1 are termed “half echo suppressors,” because two such

devices are required for one circuit. A single device situated at the mid-point of the circuit would be referred to as a “full echo suppressor.” Such devices are extensively used in the United States, but are not used for international circuits because the position of the mid-point of the connexion is generally indeterminate and could vary from call to call.

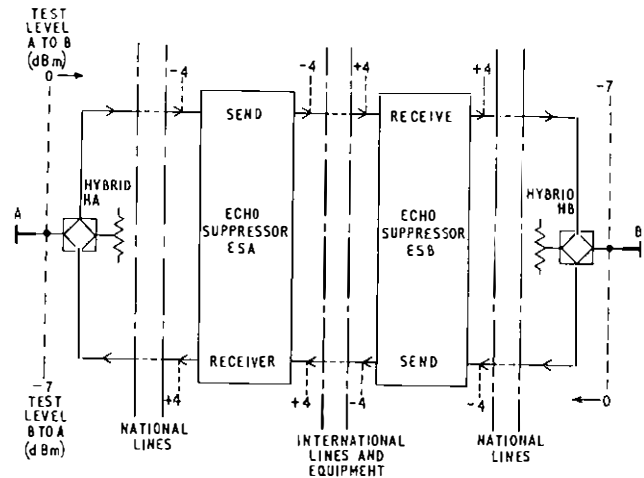

Note: Echo suppressor ESA serves to suppress echoes of speech from the talker at B. The main suppression occurs in the send path of the echo suppressor, but supplementary suppression during double talking is provided by inserting some loss in the receive path. Correspondingly, echo suppressor ESB serves to suppress echo from the talker at A.

FIG. 1.—POSITIONS OF ECHO SUPPRESSORS IN INTERNATIONAL TELEPHONE CONNEXION

## ECHO-SUPPRESSOR REQUIREMENTS

An echo suppressor must, like any other transmission element in a connexion, comply with general requirements such as transmission loss, noise, power-handling capacity, attenuation/frequency distortion, non-linear distortion, impedance, crosstalk, reliability and ease of maintenance, but such matters are not discussed here. No consideration has been given here to such features as disabling for signalling or data transmission, or indeed actual physical size, all of which are extremely important.

During about 60–70 per cent of the time that conversation is taking place, speech is present in one direction of transmission only; during such phases of conversation the suppressors are required to ensure absence of appreciable talker echo while either party is talking, and this is achieved by the introduction of a large loss in the return direction of transmission. It is only for a relatively small proportion of conversation time, perhaps only a few per cent of the duration of a call, that speech is present simultaneously in both directions at the points to which an echo suppressor is connected. These occurrences are termed “double-talks,” and the echo suppressor is required to recognize this condition and act in an appropriate manner so that, as far as possible, neither participant is prevented from being heard by the other.

† Post Office Research Station.

The term "break-in" is used to denote the desirable action of a suppressor while double-talk is present. Although efficient suppression of echo in the absence of any double-talking is perhaps the most important feature of any good design, this must not be achieved at the expense of undue mutilation of wanted speech during the much less frequent occurrences of double-talk.

The design requirements for suppression and break-in are, in some respects, mutually incompatible; compromises in respect of the values of certain parameters in the design must therefore be accepted. Taken individually, the subjective effects of various aspects of performance can be assessed fairly readily by suitable tests in the laboratory; choice of the best compromise between these parameters, however, requires tests involving very close approximations to real conversation. The requirements for suppression and break-in for ideal conditions are treated in detail below.

### Suppression

The basic function of the echo suppressor is to remove unwanted talker echo. Therefore, it must be able to detect speech present on the receive path (Fig. 2(a)), and, when appropriate, insert a large loss in the send path which will return the echo to the talker at the end remote from the echo suppressor. The following series of desirable characteristics can be laid down for the

suppression control path to obtain, under ideal conditions, the optimum performance.

(a) The speech detector, SD1, must distinguish between the presence or absence of speech, and not be confused by the inevitable presence of a certain amount of circuit noise. This may be achieved by setting a detector threshold level,  $T_N$ ,\* at which suppression takes place and which is sufficiently above the circuit-noise level  $N$ . The margin,  $T_N - N$ , should be only large enough to avoid false operation of the suppressor under the most unfavourable conditions of circuit noise. A value of  $T_N$  of between  $-35$  and  $-30$  dBm0 appears to be satisfactory in practice.

(b) The frequency characteristic of the suppression control path should be restricted to a bandwidth of 500 Hz to 3.4 kHz. Within the pass-band, the sensitivity should rise, by about 6 dB per octave, with increase in frequency. The low frequencies are cut off to avoid interference by inaudible signals of appreciable amplitude, e.g. mains-frequency inductions; the high-frequency sensitivity is augmented to assist in detection and suppression of sibilants, which tend to be weak but easily audible.

(c) The suppression operate time for high-level signals, for example at 0 dBm0, should not exceed 1.5 ms, as the full effect of the suppression is not obtained unless the operate time is short. A longer operate time leaves rather easily detectable "spikes" of residual echo; these are quite distinct in origin from any clicks that the operation of the suppressor gate itself may generate but which must, of course, also be reduced to negligible proportions. The operate time may be longer at signal levels only just above the threshold  $T_N$ .

(d) To ensure satisfactory suppression in the presence of end-delay, the suppression should not be released until a period of about 50 ms has elapsed after cessation of signal in the suppression control path. This is referred to as "suppression hangover," and allows for 20-25 ms end-delay and sufficient time for speech signals to die away.

(e) When suppression is present, a large loss (more than 50 dB) should be inserted in the send path by the operation of the speech gate.

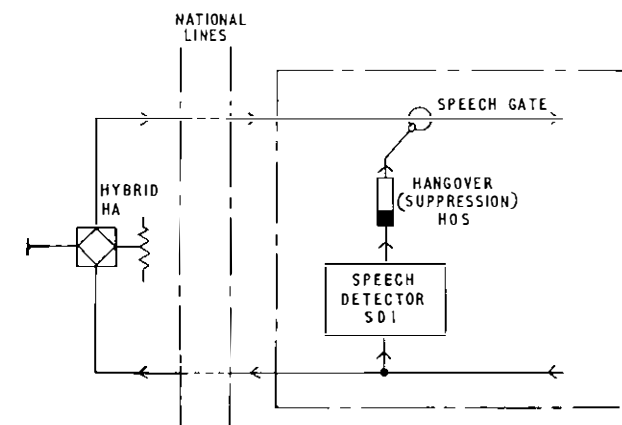

(a) Basic Suppression Facility

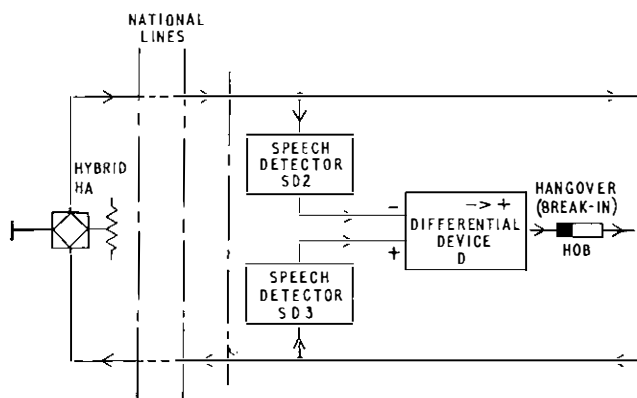

(b) Basic Break-In Detector

FIG. 2—BASIC ECHO-SUPPRESSOR ELEMENTS

### Break-In

Double-talks occur during only a small percentage of any conversation, and their incidence depends very much upon the nature of the conversation and the characteristic behaviour of the participants. Laboratory tests have shown<sup>1</sup> that, as the propagation time is increased, double-talks increase due to the occurrence of conversational confusion.

When a double-talk takes place, a difficult decision is faced by the echo-suppressor logic. If suppression is removed or inhibited the near-end speech can pass unimpeded, but it will be accompanied by echo signals that will be returned to the remote talker; if suppression is allowed to take place no echoes will be transmitted, but the wanted speech will be removed or, at least, mutilated. The relative importance of these two deleterious effects depends upon the conversational circumstances.

It is important that the remote talker should be able to hear any interjections such as "Yes," "Quite," "No,"

\* $T_N$  is defined as the minimum level of circuit noise that would cause false suppression.

etc.; the clarity is not very important, but it is important that the talker should realize quickly when the second party is attempting to interrupt with a possible question or disagreement.

The requirements for satisfactory break-in when double-talk is present may be summarized as follows.

(a) Suppression should be removed or inhibited as soon as possible after the interruption, to prevent undue mutilation. Steps taken to avoid false actuation of the break-in facility by echo, when end-delay is present and the return loss is small, conflict with this requirement and some compromise is necessary.

(b) Once break-in has been established, it must be maintained for the short periods of time within the spoken word when the signal on the send path has momentarily fallen below that on the receive path. These inter-syllabic intervals can be as long as 350 ms; longer periods would represent intervals between individual utterances. This is an extremely important requirement because, although several milliseconds operate time can be accepted at the beginning of words or utterances, interruptions even shorter than this are quite unacceptable within any utterance. The break-in condition can be maintained by providing a break-in hangover, or by a combination of this and loss switched into the receive control path, thus introducing some hysteresis whereby the threshold for releasing the break-in is lower than that for its operation.

(c) The absence of any suppression of the echo returned to the talker at the remote end of the connexion is not important if the echo signals coincide with the speech from the near-end talker, because the echo will be masked by the wanted speech. At the end of the near-end customer's utterance, however, the break-in conditions maintained by the break-in hangover will allow the echoes to return un-attenuated and there will be no speech to mask it. Therefore, it is desirable to introduce some form of attenuation into the echo path without affecting the send path. A suitable point in the circuit is in the transmission path of the receive channel (see Fig. 1). A reduction in the listening level is not important during periods of break-in as the near-end customer is speaking and probably ignoring what he hears. Various methods of introducing this loss are mentioned later.

(d) The break-in condition should not be falsely maintained due to the presence of speech on the receive path leaking to the send path through a poor return loss while the break-in hangover is still operative but after the near-end speech has ceased. This possibility can be prevented by careful choice of the receive transmission loss and the break-in hysteresis mentioned in (b) above. Prolonged bursts of echo after certain double-talks indicate the occurrence of this fault condition.

Subjects taking part in laboratory conversation tests appear not to notice mutilations because many of them are masked by their own speech. These degradations will only be noticed and become annoying when heard just after the listener has finished speaking.

#### LOGICAL OPERATIONS TO MEET REQUIREMENTS

To operate efficiently, an echo suppressor must combine successfully the two facilities, suppression and break-in, described above, in such a way that the logic can distinguish between these two conditions and act accordingly.

The actions of the two parts can be illustrated diagrammatically (as shown in Fig. 3), where possible combinations of speech voltage on the two paths of an echo suppressor are represented in two dimensions by a point in a plane. The area Y, Fig. 3(a), encloses those points that represent no suppression present, and area Z represents the area appropriate to the presence of suppression. The receive voltage that defines the boundary between areas Y and Z is the threshold voltage,  $T_N$ , of the speech detector. This diagram only illustrates the steady-state conditions; the operate times and hangovers can be imagined as time intervals that must elapse on crossing a boundary before the action appropriate to that area becomes effective.

The presence of a signal on the send path is no indication that it is desirable that the speech gate should be

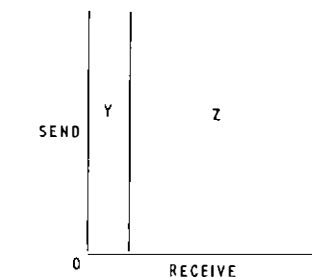

(a) Suppression Facility

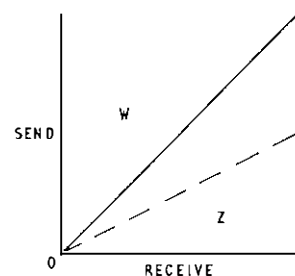

(b) Break-In Detection

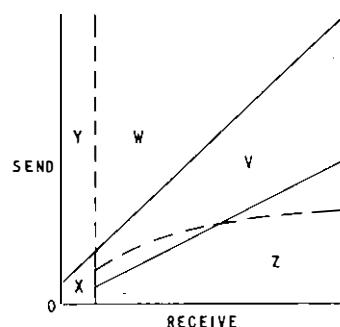

Notes:

1. Break-in inhibits suppression for 300 ms, but suppression does not inhibit break-in.
2. Area V is treated as W if entered from W, but as Z if entered from Z or X.

(c) New Echo Suppressor

- Area V—Neutral area
- Area W—Break in
- Area X—Quiescent—no speech present
- Area Y—No suppression
- Area Z—Suppression

Distances along the axes represent the envelope voltages on the respective signal paths

FIG. 3.—ECHO-SUPPRESSOR OPERATIONAL DIAGRAMS

open; the signal might be an echo transmitted round the return loss of the termination. Because of this, rules must be built into the echo-suppressor logic, and the various compromises required need careful consideration. The need for the break-in action must depend upon a particular relationship being reached between the signal amplitudes on the send and receive paths. Fig. 2(b) shows the arrangement normally employed. The differential detector, D, operates relay HOB when the input voltage on the send path exceeds that on the receive path and is above the threshold level for the operation of speech detector SD2. Under static conditions, a combination of signals falling in the area W (Fig. 3(b)) is interpreted as requiring break-in action, whereas one falling in area Z is interpreted as not requiring break-in action.

Speech consists of a complex waveform varying at syllabic rate over a range of levels exceeding 30 dB. Thus, speech detector SD1 (suppression) could operate directly from the instantaneous speech waveform, but, to avoid unnecessary operation from narrow spikes of interference, it is convenient to perform the speech detection within detector SD1 by rectification and smoothing. The time-constant of the smoothing network must not be excessive because it would then render the operate time too long; about 1 ms is found to be suitable. This smoothing, together with the hangover, ensures that the suppression is not removed too frequently during continuous speaking.

The effects of the amplitude variations upon the operation of the break-in detectors are very important. When two equivalent speech signals are present simultaneously on the send and receive paths, their difference in voltage would vary rapidly in sign in the absence of any smoothing; break-in hangover would ensure that the output from the differential logic remains constant for a period equal to the hangover. Speech detectors SD2 and SD3 incorporate rectification and smoothing, the values of the time-constants being of prime importance.

In the presence of appreciable end-delay (20–25 ms), speech detector SD3 must be able to maintain its output for a period at least equal to the end-delay, so as to prevent false operation due to an echo transmitted round the return-loss path. However, the echo-suppressor must also work efficiently when there is no end-delay, and, therefore, detector SD3 must function as quickly as detector SD2. The rise time-constant of detector SD3 must be short, whilst its decay time should be considerably longer. A further feature required of the differential speech detectors is that they must be matched over their complete dynamic working range (approximately 50 dB), otherwise one control path would be more sensitive than the other.

Once the break-in condition has been established it must produce various effects in the circuit. It must (a) immediately inhibit the closure of the speech gate to allow transmission of speech from the local customer, (b) increase the effective sensitivity (hysteresis) of speech detector SD2 by the introduction of a loss (ILa) in the receive control path prior to detector SD3, and (c) introduce a loss (ILb) into the receive transmission channel. Fig. 4 shows the logic diagram devised for the new echo suppressor designed at the Post Office Research Station. This design keeps separate the two basic facilities of suppression and break-in, and thereby minimizes the number of compromises required between them.

When there is no speech to require break-in, the normal suppression is operative, but, when the break-in detector has caused operation of relay HOB, the suppression is immediately removed by means of the logic AND gate; the suppression hangover can be quenched at the same time. The relatively long break-in hangover

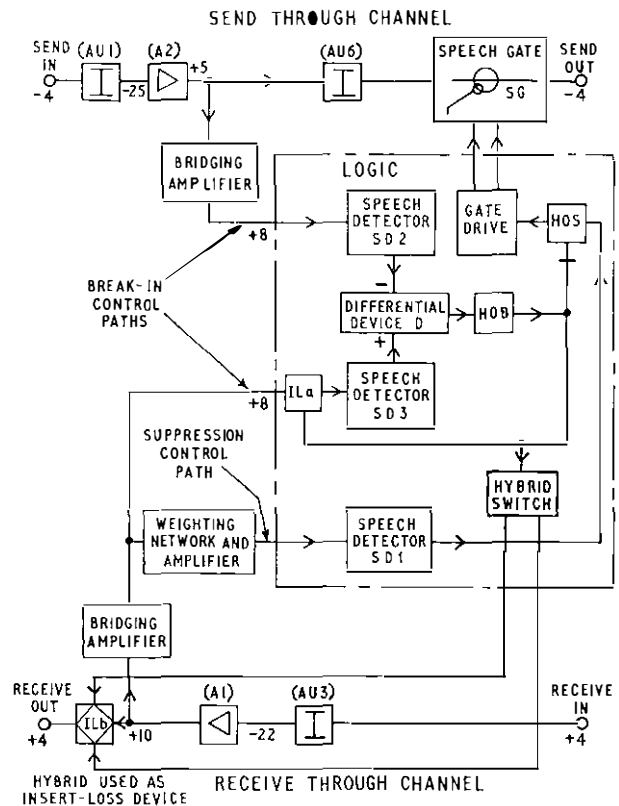

- Notes:
1. Relays HOB and HOS each operate when a pre-determined negative voltage is applied.
  2. Both bridging amplifiers and the suppression-path weighting network have gain adjustment and, thereby, adjustment of threshold sensitivity.

FIG. 4—FUNCTIONAL DIAGRAM OF NEW ECHO SUPPRESSOR

(300 ms) prevents premature release of the condition during the inter-syllabic pauses; this effect is also augmented by the hysteresis introduced by the insert-loss device ILa. Fig. 3(c) illustrates the operation of this design. A neutral (or bi-stable) area, V, considerably extends the area in which break-in is maintained. As explained earlier, under poor return-loss conditions, if loss is inserted in the receive control path and not in the signal path, it is possible for break-in to be falsely maintained. For this reason the loss ILb is inserted in the signal path, increasing the return loss and reducing the level of the echo returning to the remote end.

There are two methods by which these losses can be effected: either by fixed attenuators or by syllabic compressors. Each of these has its own particular merits and disadvantages. Attenuator arrangements can be switched in and out of circuit far quicker than a syllabic compressor can respond, and they are also considerably cheaper and more reliable. The dynamic range of the differential speech detectors can effectively be increased in proportion to the amount of compression introduced by a compressor; this device has little or no effect at low

signal levels and maximum effect at high levels. If the two losses ILa and ILb are made equal and are always switched together, it is clear that they could be replaced by a single device in the receive speech path on the international side of the point at which the receive control path is taken off. Hence, only one switched attenuator would be necessary as against two compressors.

Introduction of further logic could remove an undesirable effect associated with attenuators, namely, that the circuit noise changes in level with the operation of the break-in detector; it would be possible to provide means to inhibit operation of ILa and ILb when the receive speech level is below  $T_N$ .

#### PERFORMANCE

The new echo suppressor closely follows the requirements explained above. A number of prototypes based on them were produced, and these were carefully analysed both objectively and subjectively. The testing procedures involved are extremely complex and, hence, only the general procedure adopted will be explained.

For the purpose of objective testing, the echo suppressor can be treated as a "black-box" and pure tones can be used in the initial measurements. Checks are made first on the various aspects mentioned earlier, required of all transmission elements, and then on the particular functions pertaining to echo suppressors. These are basically the measurement of the threshold level of suppression,  $T_N$ , the accuracy of the matching of the speech detectors, SD2 and SD3, and the operation of break-in. Echo suppressors, unfortunately, do not work under such static conditions, so that dynamic testing is also essential.

To measure the suppression operate-time and hangover-time constants, an amplitude-modulated tone is applied to the receive transmission channel and a low-level constant tone to the transmit or send channel. The effects are displayed on an oscilloscope monitoring the output waveforms, and this gives a direct indication of what action the echo-suppressor takes as the input levels are varied. This procedure can be used in a slightly modified form for the measurement of the corresponding break-in time-constants.

Subjective testing may be carried out in the laboratory by talking over a simulated 4-wire circuit including two half echo suppressors and with added propagational delay. Comparisons are made between the various available designs of echo suppressors by answering such questions as: "Can I converse freely over this circuit?" "Does it effectively suppress all echoes?" and "Are portions of utterances mutilated or otherwise affected?" If the answers are favourable under fairly adverse conditions of return loss and propagation time, then more exacting tests can be carried out. The duration of this testing and its cost depend upon the accuracy required and the number of conditions involved. Further details are given in articles relating to subjective testing methods under laboratory conditions.<sup>2, 3</sup>

The most important factor still remains to be answered after the laboratory tests are complete—will the public accept it? The answer to this question must be based on customer reactions. These can be determined by questioning customers who have spoken over connexions which

had long propagation times. An efficient device must work so that the customer is not aware of its existence in the circuit; hence, in any questionnaire, careful phrasing must be used to avoid putting words into the customers' mouths to cause a biased answer.

With the inauguration of the Early Bird satellite link between Europe and the United States in 1965, one of the largest subjective tests ever carried out over the public telephone network began and lasted for approximately six months.<sup>4</sup> Planning of this test started early in 1964 and involved the cooperation of a number of different telephone administrations. This was very costly and time-consuming, and required a great deal of statistical analysis; such tests are, therefore, employed only after exhaustive laboratory testing, where results are obtained more rapidly and with less expense. Laboratory tests can also employ objective measurements, and these are clearly preferable to subjective ones.

#### CONCLUSIONS

The prototype echo suppressors based on the requirements explained in this article were successfully tested in the laboratory and in the public network over the HS-303 communications satellite. They were found to be a great improvement on echo suppressors currently in service, especially where long propagation times were involved. Furthermore, it was shown that they are compatible with, and at least as satisfactory in performance as, another echo suppressor (The Western Electric Co., Type 2A) designed for use under similar conditions. Two of the British Post Office Research Branch prototypes have been loaned to the C.C.I.T.T.\* laboratories in Geneva as part of a demonstration circuit exhibiting the effects of long propagation times.

A specification for the development and manufacture of a new echo suppressor (British Post Office, Type 7A) has been based on this work. The production models have many advantages over current devices: (a) each echo suppressor incorporates tone disablers for signalling or data transmission, or both, (b) each 62-type rack accommodates 36 channel equipments, whereas only 14 were possible previously, (c) the equipment uses transistors throughout and is laid out on printed-wiring cards, giving increased reliability, and (d) the adjustment facilities have been simplified and reduced to a minimum. The first 300 Type 7A echo suppressors were installed in the International Exchange, London, towards the end of 1967, and are giving the public improved international telephone connexions.

#### References

<sup>1</sup>RICHARDS, D. L. Conversation Performance of Speech Links Subject to Long Propagation Times. International Conference on Satellite Communication, *I.E.E.*, p. 247, November 1962.

<sup>2</sup>BRADY, P. T., and HELDER, G. K. Echo Suppressor Design in Telephone Communications. *Bell System Technical Journal*, Vol. 42, p. 2,893, 1963.

<sup>3</sup>RICHARDS, D. L. Theoretical Study of the Functioning of Echo-suppressors. *Teletechnik*, English edition, Vol. 7, No. 2, p. 71, 1963.

<sup>4</sup>HUTTER, J. Customer Response to Telephone Circuits Routed via a Synchronous-Orbit Satellite. *P.O.E.E.J.*, Vol. 60, p. 181, Oct. 1967.

\*C.C.I.T.T.—International Telegraph and Telephone Consultative Committee.

# Electronic Telephone Exchanges: Reed-Selector System Field Trial at Belgravia Exchange, London

E. NEWELL, B.Sc.(Eng.), C.Eng., M.I.E.E., and R. D. PEACOCK†

U.D.C. 621.318.56: 621.395.722

The first phase of a field trial of reed-selector system modules has recently been completed. This article outlines the arrangements and describes the system modules tested during phase one, and gives results of the trial to date. Mention is also made of those modules currently being installed and commissioned which will be involved in the second phase of the trial.

## INTRODUCTION

ON the 25 January 1967 the first reed-selector system modules to be developed and manufactured were connected into public service at Belgravia telephone exchange, South Centre Area, London Telecommunications Region. This article outlines the arrangements during the first phase of the trial, and briefly describes the system modules recently in service at Belgravia exchange. The results of the trial to date are given in some detail, and mention is also made of those modules, currently being installed and commissioned, which are involved in the second phase of the trial due to commence shortly.

The reed-selector system (TXE6) is being developed specifically to cater for extensions and partial replacements of existing electromechanical exchanges, and the extent to which this system might contribute to future needs can be appreciated from the fact that some two-thirds of exchange equipment currently being purchased is for this purpose. The system is built up of a number of functionally self-contained units, which take the form of system modules and of which there are two types; register modules and switch modules. This modular concept has led to the development of a system which, once introduced into the trunking of an electromechanical exchange, is capable of gradual expansion to replace the complete exchange in an economic manner as successive partial replacements result in the disappearance of the Strowger equipment. This gradual transformation can proceed without the need for extensive rearrangement or modification of existing equipment.

All signalling between the register and switch units is effected at high speed over the speech path in order to minimize the holding time of common equipment, and a fast d.c. signalling system has been developed for this purpose: the system is fully sequenced and uses discrete d.c. potentials on the positive and negative wires, not only for the forward digital information but also for the backward information, which indicates progress on the connexion being established.

The purpose of the field trial was to establish that when the first two TXE6 system modules, a register and a switch module, were introduced into the trunking of an electromechanical exchange they were capable of closely interworking with existing Strowger equipments in the same trunking and with equipments in distant electromechanical exchanges, and of performing satisfactorily

in public service. The trial has proved most successful in establishing these facts, and, during the first phase of the trial, the equipment carried over one million calls. Experience at Belgravia exchange has emphasized the greater value of a public service trial compared with the alternative of extensive laboratory tests, when dealing with this type of equipment.

The opportunity was also taken at Belgravia to interwork the two system modules with a prototype test-equipment (fault-printer) rack, and this maintenance aid proved invaluable in bringing to light minor circuit and system shortcomings, most of which became apparent during the first weeks of the trial, and in locating faults that occurred from time to time.

The two system modules used for the trial are a 10 pulses/second (p/s) auxiliary unit rack and an intermediate-switch unit rack. The 10 p/s auxiliary unit rack is the simplest form of register module; fully equipped the rack caters for 288 inlets shared between three controls, 96 to each, but in the Belgravia situation it was merely necessary to partially equip two controls by providing 48 working inlets to each. The 96-inlet control is referred to as a 10 p/s auxiliary unit (10 p/s a.u.). The intermediate-switch unit rack is the most commonly used, and, hence, the most important switch module of the TXE6 system; it is broadly equivalent to 192 Strowger group selectors, and the 192 inlets on the rack are divided into four 48-inlet groups, each group being associated with a 48-inlet/200-outlet trunking unit. Two controls are provided per rack, and each control serves two trunking units, i.e. 96 inlets, as in the case of the 10 p/s a.u. Again, it was only necessary at Belgravia exchange to equip two trunking units, one in each control. The 96-inlet control is referred to as an intermediate-switch unit (i.s.u.).

## FIELD-TRIAL ARRANGEMENTS

The 96 i.s.u. inlets, when introduced into the Belgravia numerical train via change-over keys, replace the Strowger N2nd selectors on level 3. The i.s.u. is preceded in the trunking by the 10 p/s a.u., and outlets from the latter are connected one-for-one with inlets of the i.s.u., via the equipment I.D.F. Hence, when in service the trial equipment takes over the level-3 N2nd-selector switching function normally performed by the 91 Strowger selectors existing at this point in the Belgravia exchange trunking, leaving five spare inlets for testing purposes. However, it must be pointed out that the 10 p/s a.u., in common with other register units, is capable of controlling a number of TXE6 switching stages and, in practice, this would invariably be the case. The change-over keys are cabled to the equipment I.D.F. and jumpered into the existing trunking between the Strowger N1st and N2nd selectors, and the 48 inlets to each 10 p/s a.u. are also associated with the change-over keys via equipment I.D.F. jumpering (Fig. 1).

The outlets of each 48-inlet/200-outlet trunking unit

†Telephone Electronic Exchange Systems Development Branch, Engineering Department.

are divided for the purposes of this trial into 10 levels with 20 outlets (availability) per level. On each level, the outlets of the two trunking units provided on the i.s.u. rack form two grading groups of a simple 2-group grading. These gradings, which are accommodated at the rear of the i.s.u. rack, are similar to, and in many instances identical with those of, the Strowger equipment being replaced. The outlets of each grading are cabled from the i.s.u. rack to the equipment I.D.F. and jumpered in parallel with the corresponding outlets of the associated Strowger grading. The three racks of trial equipment are shown in the photograph in Fig. 2: the test-equipment rack is on the left, the 10 p/s a.u. rack is in the middle, and the i.s.u. rack is on the right of the suite.

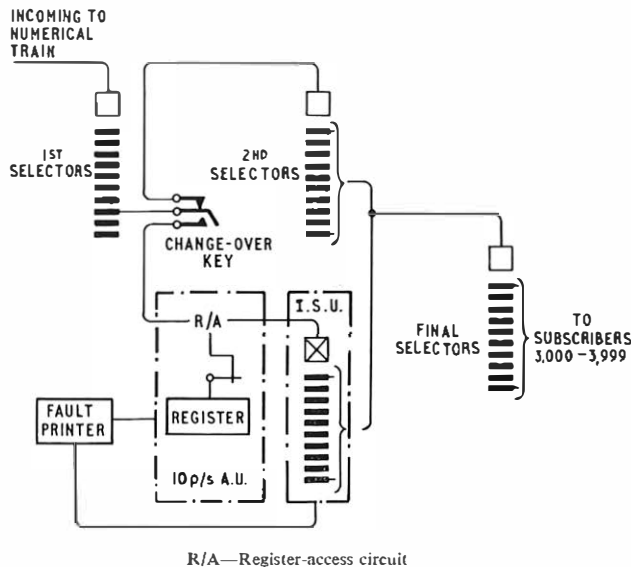

FIG. 1—TRUNKING ARRANGEMENTS FOR FIRST PHASE OF THE FIELD TRIAL

#### 10 P/S AUXILIARY UNIT

A 10 p/s a.u. (Fig. 3) serves 96 inlets, each of which is connected to a register-access circuit containing a register-access switch with five outlets to registers and switching access to a single d.c. sender provided for each 10 p/s a.u. A common group of registers (6-14) is graded over the outlets of the register-access switches, these outlets forming eight grading groups with 12 inlets per group, and each register has switching access (CT) to the d.c. sender under the control of a register isolator. Each register in turn may employ the d.c. sender as and when required; during fast d.c. signalling both the register and d.c. sender are associated with the same inlet, the register via the register-access switch and the d.c. sender via the sender-access switch.

On seizure, the access circuit applies to the call isolator for register association. The call isolator deals with overlapping demands on a one-at-a-time basis, and, in respect of a successful demanding inlet, passes a 1-out-of-8 indication to the register interrogator and selector in order that it might interrogate the five registers available to the grading group containing this inlet. A free register is selected by means of a cyclic test, and, accordingly, one of five register-access cross-point relays (RA-RE) associated with the successful demanding inlet

is operated. The incoming speech wires are then extended into the selected register, and the demand to the call isolator is removed. Loop-disconnect pulses of the first digit to be received are counted and stored, and on detection of the inter-digital pause the register applies to the register isolator for the services of the d.c. sender. Following a successful demand, the stored digit is passed into the d.c. sender, being stored in fast-d.c.-code form, and after a successful check of the coded digit the d.c. sender extends a delayed seizure signal to the associated i.s.u. inlet. This signal is also detected in the register-access circuit to operate relay SW and connect the d.c. sender to the forward speech wires. A proceed-to-send signal is then received from the stage register of the associated i.s.u. and, in response to this signal, the d.c. sender transmits the digit forward.

The stage register prepares to set up the connexion through the i.s.u. stage and returns one of the following signals.

- (i) Free path—Strowger.
- (ii) Free path—reed.
- (iii) No free path.

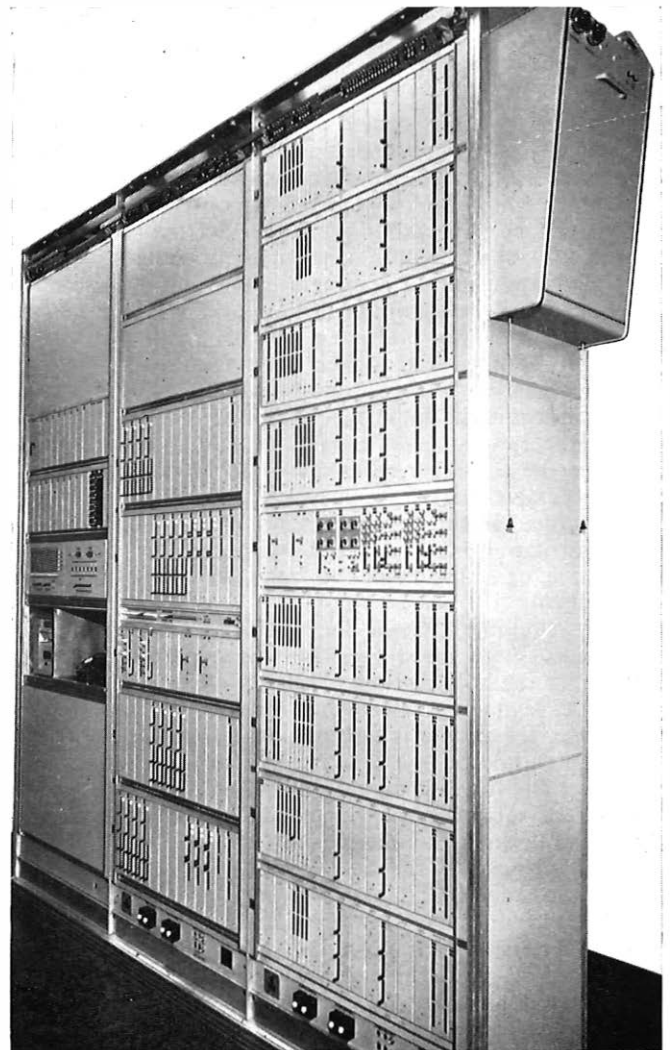

FIG. 2—THE SUITE OF TRIAL EQUIPMENT



When a free outlet exists on the required level giving access to Strowger equipment at the next stage, as is the situation at Belgravia, then, on receipt of a free-path—Strowger signal and following switch-through in the associated i.s.u., the d.c. sender will test for the correct line potentials from the Strowger final selector and, if successful, will extend a switch-through signal to the access circuit. The register and d.c. sender are then released, and the access circuit remains held to an earth potential either on the incoming P-wire or the outgoing S-wire; in this instance it is a backward-holding earth via the S-wire from the Strowger final-selector. On receipt of a free-path—reed signal when the succeeding stage is an i.s.u., the register counter is reset, the d.c. sender released, and the register then awaits the arrival of a further 10 p/s digit. If a no-free-path signal is received, then the register releases the register-access switch and the access circuit returns plant-busy tone to the caller.

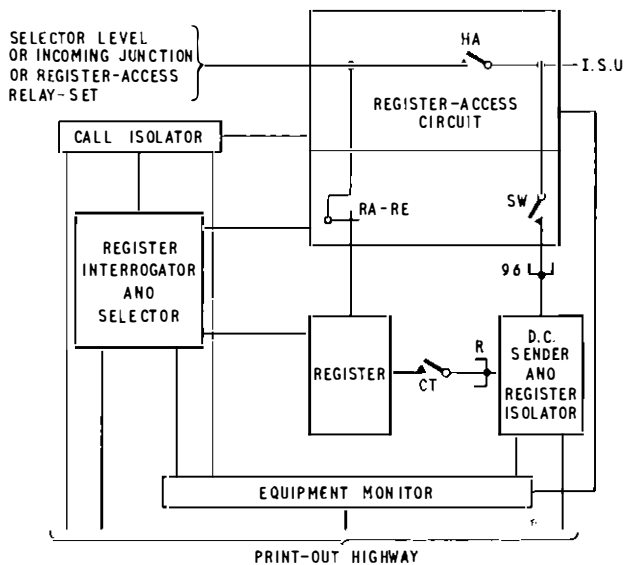

FIG. 3—BLOCK SCHEMATIC DIAGRAM OF 10 p/s AUXILIARY UNIT

INTERMEDIATE SWITCH UNIT

As already mentioned, the i.s.u. consists of two independent trunking units which share the same common control. Each trunking unit consists of a 2-stage network of A-switches and B-switches (Fig. 4). Each A-switch, of which there are four per trunking unit, has 12 inlets, and these have access to the same 20 links which are connected to 20 B-switches, one link to each. Each B-switch has four inlets, and these have

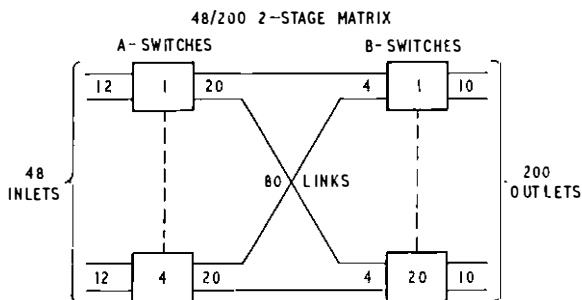

FIG. 4—BASIC TRUNKING UNIT OF INTERMEDIATE-SWITCH UNIT

access to 10 outlets. The matrix, therefore, provides full accessibility between 48 inlets and 200 outlets, and in certain applications, for example at Belgravia exchange, these 200 outlets can be arranged as 10 levels, with 20 outlets per level. The reed relays which form the A-switches and B-switches each have four make contact-units, switching the negative and positive speech wires, a signalling (S) wire which is used when working to an associated equipment, e.g. at Belgravia it provides, as already mentioned, a path for the backward-holding earth from the Strowger final-selector, and a hold (H) wire for seizure, interrogation, marking and holding purposes.

As shown in the simplified block schematic diagram (Fig. 5) each inlet has a simple access circuit. Once an inlet has been seized and requires to be switched the access circuit applies to the call isolator for the services of the stage register and associated interrogator and trunk marker, and path selector. As in the case of the 10 p/s a.u. the call isolator deals with overlapping demands on a one-at-a-time basis, and an output (1-out-of-8 plus 1-out-of-12) from the call isolator causes the successful demanding inlet to be associated with the stage register via the register-access switch, a single cross-point relay per inlet. The stage register then returns a fast d.c. proceed-to-send signal over the speech wires to the preceding register unit (in the Belgravia trial, the 10 p/s a.u.), and this prompts the forward sending of the routing digit in coded form. The stage

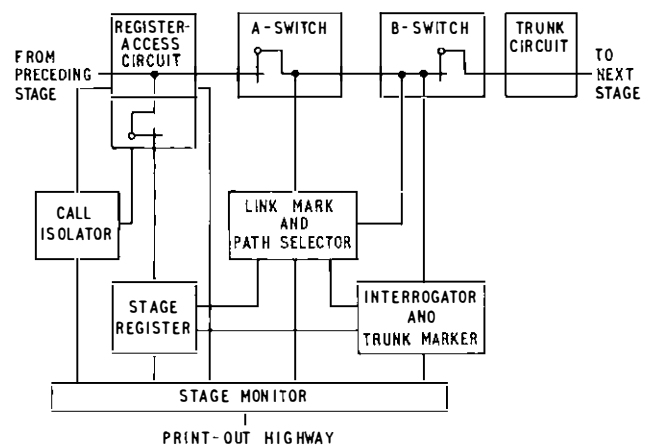

FIG. 5—BLOCK SCHEMATIC DIAGRAM OF INTERMEDIATE-SWITCH UNIT

register decodes this digit to decimal form and passes it to the interrogator and trunk marker. A 1-out-of-8 indication is also passed to the interrogator and trunk marker from the call isolator in order that the 20 links, associated with the A-switch serving the successful demanding inlet, might be interrogated. In addition, the interrogator and trunk marker examines the 20 outlets of the level indicated by the digit received. Connexions can only be set up when like-numbered links and outlets are free and the interrogator and trunk marker passes information to the path selector indicating all the free combinations of link and outlet; the path selector selects the first free choice in order to obtain an outlet traffic loading similar to that for Strowger equipment, and informs the stage register that a free path is available. The stage register then returns an acknowledgement

signal to the preceding register as an indication of the progress and state of the call. When interworking to a 10 p/s a.u. this fast d.c. acknowledgment signal may, as already mentioned, take one of three forms. If a no-free-path signal is returned the forward connexion is released and plant-busy tone returned to the caller. If a free-path—reed or free-path—Strowger signal is returned the d.c. sender associated with the 10 p/s a.u. removes the forward digit on receipt of this signal, and the stage register then applies a set-up mark to the inlet, which, in conjunction with marks from the path selector and the interrogator and trunk marker, operates the relevant A and B cross-point relays.

The connexion is then switched through, and, following a successful cross-point check, the stage register is released and becomes available for the setting up of a further connexion. The complete operation from seizure of the i.s.u. inlet to the release of the stage register takes some 50 ms, but switch-through is completed some 20 ms earlier.

#### TEST-EQUIPMENT RACK

Each TXE6 system unit includes a monitor circuit which checks for the correct functioning of the common control and detects any failures. In the TXE6 system a facility has also been provided for recording such failures on a printer. The fault printer and associated equipment, which includes a lamp-display read-out unit, are mounted on a test-equipment rack. The normal provision of this rack would be one per TXE6 installation, but there is the possibility that the printer itself might be located at some central point, an engineering maintenance centre, to serve a number of smaller installations.

The basic requirement for print-out is that this process should not unduly delay the natural working speed of a common control. In the TXE6 system, such controls have a holding time of between 30 and 50 ms, and even the present high-speed character printer in use on the prototype rack requires approximately 300 ms for a line of 11 characters. Therefore, to avoid holding common controls during this printing time, reed-relay stores are provided to accept the information from a control prior to print-out. The control can then be released, with the store holding the information for the print-out period. Two stores with mutual change-over are provided to ensure that, in the event of two near-simultaneous demands for the printer, both sets of information are in due course printed out.

Simple marking earths are used to convey the information to be printed from a common control over a print highway to the test-equipment rack, and a separate print highway is commoned to all system units of the same type.

The printer used on the prototype rack is a Venner TSA 65. This has 11 print wheels each having 12 positions: 10 positions are used for numerals 1-0, the eleventh position for a dash, and the twelfth position is blank. All 11 wheels print simultaneously.

One of the 12 positions is marked for each wheel, the blank being marked if no character is required and the dash being used when incorrect information, i.e. a more-than-one mark, is presented to a wheel. The print-out cycle takes approximately 300 ms, and, since each print-out consists of two lines, the total time taken for a complete print-out is of the order of 600 ms.

A typical i.s.u. fault print-out is shown in Fig. 6. In line 1, reading left to right, the first three characters give the rack and unit identity, the next seven give information about the fault and the last gives an indication of the nature of the fault. In line 2, the first four characters are used for further information when there is interworking with other register units and the reed-selector version of the final selector (the terminal-switch unit), and the remaining seven characters give the date and time of day.

Fig. 7 shows a block schematic diagram of the fault-printer equipment. The two stores are each capable of holding 150 bits of information arranged in 15 groups of 10, each group being associated with a print wheel for first-line or second-line print-outs. Each common highway has its own pattern of groups, and those groups with more than 10 wires require cross-connexion to two sections of the store for print-out of tens and units. Also, coded information is sometimes used involving two groups of wires, which need decoding before print-out of the corresponding numerical value. A highway conversion circuit is used for this purpose, and one is required for each common highway. These conversion

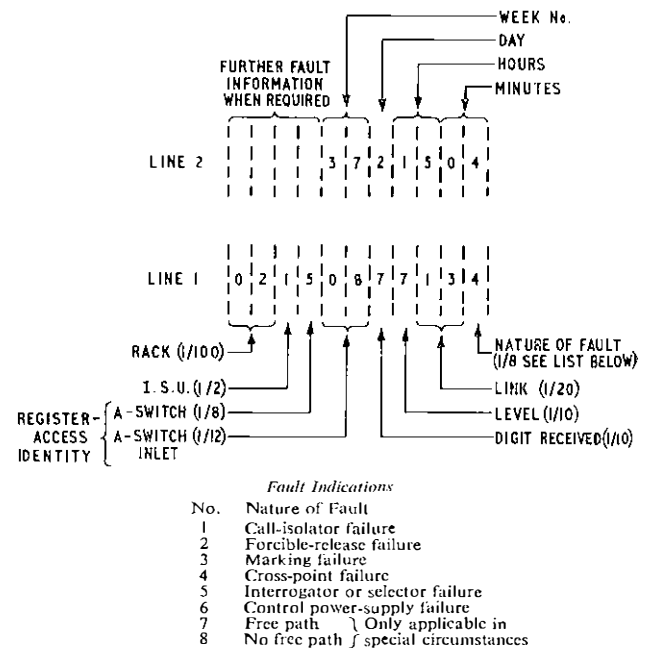

FIG. 6—TYPICAL INTERMEDIATE-SWITCH UNIT PRINT-OUT

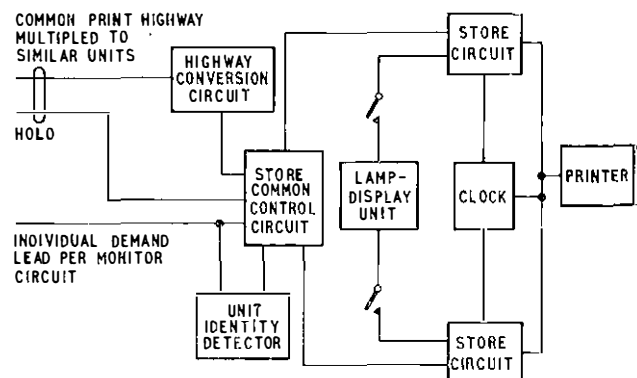

FIG. 7—BLOCK SCHEMATIC DIAGRAM OF FAULT PRINTER

circuits also provide flexibility between the common highways and the store sections, thus facilitating re-arrangement of the print-out information if and when required.

When the equipment is idle the common highways are extended to one of the stores by the store common control, and when that store has received information relating to a common-control failure it is disconnected from the highway and replaced by the free store. Before the fault information is passed to the store the demanding monitor circuit tests for a free condition on its printer demand lead. If a free condition exists, then the store is seized and association with the monitor circuit is maintained over the hold wire whilst the control information is connected to the print highway. The successful demanding monitor circuit identity is determined and, as soon as information has been stored, a 5 ms timing element is started. When this timing circuit matures, the store common control releases the hold condition to the monitor circuit. The control information is removed from the print-highway, and, after a check of the highway for any spurious signals, the store common control changes over to the free store. Following print-out of the stored information, the store is released.

A facility exists which can inhibit print-out, and the stored information can be used to operate the lamp-display read-out unit. This facility has been particularly useful whilst carrying out detailed investigations of some of the system and circuit shortcomings that came to light during the trial. Whereas the printer can only print a dash when a more-than-one mark is applied to a wheel, the more-than-one indication can be read directly from the lamp-display unit. The lamp unit can be associated with both stores.

Each print-out contains information regarding the day and time, and this is obtained from an electronic and reed-relay clock which is driven by a 30-second earth-pulse signal from the exchange master clock.

A "total-calls" meter is mounted on the rack, and can be associated with any system unit or units. At Belgravia exchange it has been used to record the number of calls switched to final selectors by the two 10 p/s a.u. common controls.

#### EQUIPMENT PRACTICE

The three trial racks are of standard size, i.e. 10 ft 6 in. high, 36 in. wide and 24 in. deep overall. With these dimensions, gangways wider than those to the present standard will be required, but these have been arranged so that six suites of electronic racks will use the same floor space as eight suites of 2,000-type racks, e.g. in a 45 ft wide apparatus room 72 electronic racks will occupy the same floor area as 64 2,000-type racks.

For the plug-in units a depth of approximately 18 in. is normally used, but this can be reduced if increased wiring and cabling space is needed at the rear of the rack. Units can be in any width from 0.8 in. for a single card to 6.0 in. for framed units mounting bulky items of equipment, in steps of 0.8 in. A commonly used unit width is 2.4 in., which allows reed relays to be mounted in matrix formation with all wiring accessible at the sides. Unit heights can be in multiples of 1.2 in. This variability is most important where reed-relay matrices are used since the system trunking must determine the

switch dimensions and the size of matrix. Fig. 8 and 9 show typical plug-in units.

The use of specially designed aluminium extrusions, some of which have quite elaborate cross-sections, gives the required variability without incurring high tooling costs for the wide range of piece-parts involved. The necessary complexity and accuracy can be built into the extrusion die at the outset at little cost, and, thereafter, rack manufacture comprises cutting off appropriate lengths of extrusion, drilling and fixing together, in the main with self-tapping screws. Similar facilities can be provided with folded sheet-steel construction, and a practice is being developed using this method. The basic dimensions will be the same as for the extruded-aluminium practice, and it is an essential requirement that plug-in units will be interchangeable between the two practices. The i.s.u., 10 p/s a.u. and director originating-register racks are being designed using the aluminium practice. The terminal-switch unit and other types of register rack will use the sheet-steel practice, particular to the developing manufacturer.

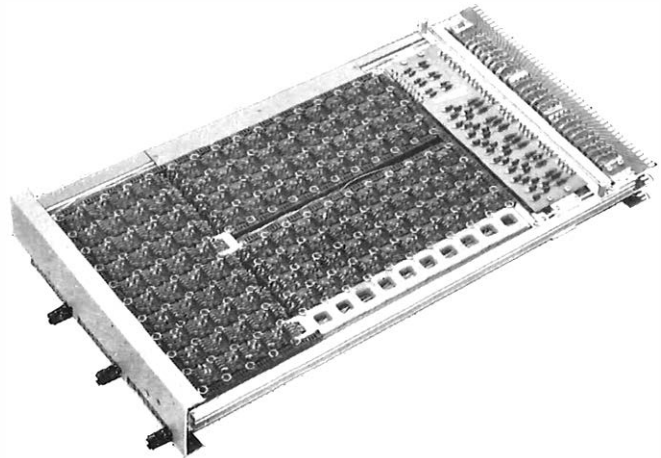

Three 4 × 10 B-switches are mounted on this unit  
FIG. 8—MATRIX SWITCH PLUG-IN UNIT

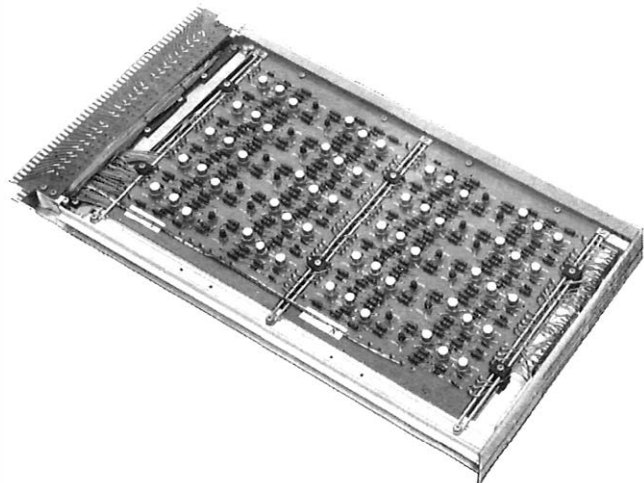

FIG. 9—ELECTRONIC CONTROL PLUG-IN UNIT: INTERROGATOR AND TRUNK MARKER OF INTERMEDIATE-SWITCH UNIT

Wrapped-wiring techniques are employed for the rack wiring, and cabling to and from the rack is terminated directly on to the appropriate plug-in connector tags instead of using rack connexion strips factory wired to the multiple or to shelf jacks as in the 2,000-type equipment practice. The cost and space penalty of grading tags and associated rack wiring is also avoided by grading directly on to the connector tags; such gradings are a feature of both the 10 p/s a.u. and i.s.u. racks at Belgravia exchange.

#### FIELD-TRIAL RESULTS

There were two in-service periods during 1967, the first from 25 January to 1 May, and the second from 25 July to 3 November. The equipment was taken out of service on 1 May to enable various minor modifications, particularly in the trunk interrogation area of the i.s.u., to be carried out at the factory in advance of the second phase of the trial.

The performance of the trial equipment can be measured against

- (a) detected call-failures recorded by print-out,
- (b) equipment failures found by routine tests,
- (c) operator complaints to special-fault control, and
- (d) subscribers' complaints to ENG.

During the first in-service period the equipment handled 530,000 calls with a detected call-failure rate of 1 call failure per 1,030 calls, and during the second period a further 476,000 calls were carried with a failure rate of 1 call failure per 19,000 calls. These figures are the results of an analysis of the print-outs occurring during the two periods. Although these failures resulted in unsuccessful calls, busy tone was returned to the caller on each occasion.

The inlets to the equipment were routine tested from time to time and three faults were found which would have caused call failures, the caller receiving busy tone on each occasion that the faulty access circuit was taken into use. Two of these failures were due to 3,000-type relay contact-units out of adjustment, and the other to a disconnected reed insert.

A small number of subscriber and operator complaints of mis-routing were received during the early part of the trial, and on investigation it was found that this was due to the insertion of a digit 1 as the 2nd numerical. A false dial pulse was being generated by early designs of equipment (tandem 1st selectors and auto-to-auto relays) in some of the London director area tandem exchanges. The fast response time of the TXE6 pulse-receiving element in the 10 p/s a.u. registers resulted in a momentary fall in line current, when the inductive supervisory relays were reconnected into the signalling loop at the end of each dial-pulse train, being wrongly interpreted as a dial pulse; more recent designs of tandem-exchange equipment incorporate a 2-stage drop-back circuit element to avoid this effect. Two contributory causes were found for operator complaints from the parent auto-manual centre. Firstly, due to the capacitive nature of the operator's position circuit, the line current build-up was such that the pulse-receiving element tended to release momentarily following register seizure, and this, coupled with a design error in the register itself, was sufficient to produce infrequent misroutings. In both of the above cases, once the cause of the trouble became clear, remedial action in the form

of a register modification was quickly taken and no further trouble has been experienced.

During the first in-service period 26 fault dockets were prepared following maintenance attention, and of these 17 were issued during the first 5 weeks; in the second period there were a further 11 dockets. An analysis of those dockets for which faults were cleared is shown in the table.

Analysis of Faults Cleared	25 Jan. to 1 Mar.	1 Mar. to 1 May	25 July to 3 Nov.	Total
<b>Reed-Relay Failures</b>				
(i) Reed Inserts				
(a) Open-circuit (non-operate)	1	0	3	4
(b) Short-circuit	1	2	0	3
(c) Disconnected on mounting tag	4	1	3	8
(ii) Relay Coils				
(a) Open-circuit	2	0	1	3
<b>3,000-type Relays</b>				
(a) Contact-units out of adjustment	2	0	0	2
<b>Transistors</b>				
(a) Open-circuit	0	1	0	1
(b) Short-circuit	1	0	0	1
<b>Diodes</b>	0	0	1	1
<b>Edge-Connector Trouble</b>				
(a) Unit not inserted correctly	1	0	0	1
(b) Intermittent high resistance	0	0	1	1
(c) Damaged	1	0	0	1
<b>Wiring Faults</b>				
(a) Open-circuit	1	2	0	3
(b) Short-circuit or earthing	1	1	0	2
(c) Dry joint	0	0	1	1

#### FUTURE OPERATIONS

The field trial is now being extended to include the terminal-switch and the incoming-register modules for director exchanges. The incoming-register rack has replaced the 10 p/s a.u. rack, which no longer has a part in the field trial, and the terminal-switch module will be used to replace some of the existing level-3 final-selectors. Fig. 10 shows the trunking arrangements for the second phase of the field trial.

#### CONCLUSIONS

The trial has proved most successful in establishing both the compatibility and technical viability of the TXE6-system 10 p/s a.u. and i.s.u. modules in an electromechanical environment, and experience at Belgravia has emphasized the greater value of a public-service trial compared with the alternative of extensive laboratory tests, when dealing with this type of equipment.

The equipment carried over one million calls, with an average failure rate of one call failure per 1,900 calls for the whole period of the trial; however, once the minor system and circuit shortcomings had been cleared, the call-failure rate for the latter part of the second

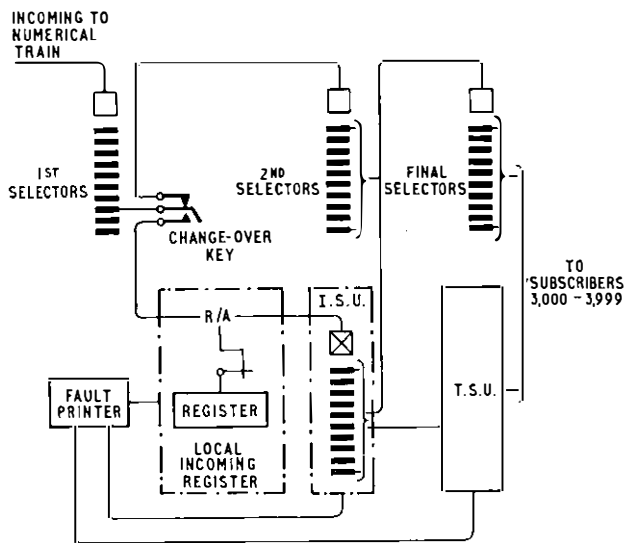

FIG. 10—TRUNKING ARRANGEMENTS FOR SECOND PHASE OF THE FIELD TRIAL

in-service period was better than one call failure per 27,000 calls. It is worth emphasizing that, in this context, a call failure is an event that causes a print-out; it does not result in "no-tone" to the caller. In many instances the event will give rise to a successful automatic repeat attempt.

Throughout the field trial the fault printer functioned very successfully and proved extremely valuable as an aid to the location of the small number of faults which occurred, and as a means of monitoring the performance of the equipment. Indeed, experience with the fault print-out arrangements has led to the conclusion that such arrangements should be regarded as an essential feature of any modern switching system.

Meanwhile, the Post Office and the associated manufacturers are collaborating to engineer standard production modules, the first of which are expected to be ready for production early in 1968.

#### ACKNOWLEDGEMENTS

The Belgravia exchange field-trial equipments constitute B.T.T.D.C. developments proceeding under the auspices of the Joint Electronic Research Committee comprising representatives of the British Post Office, Associated Electrical Industries, Ltd. (A.E.I.), Automatic Telephone & Electric Co., Ltd. (A.T.E.), Ericsson Telephones, Ltd. (E.T.L.), The General Electric Co., Ltd. (G.E.C.), and Standard Telephones and Cables, Ltd. (S.T.C.). The efforts of those engineers of the developing manufacturer (A.T.E.) and the Post Office who have been directly concerned with these developments are gratefully acknowledged. Thanks are also due to the London Telecommunications Region, and, in particular, to the maintenance staff at Belgravia exchange, for their co-operation during the trial.

## Book Review

"Understanding Graphs." S. A. Knight, B.Sc., F.R.S.A. Blackie and Son, Ltd. viii+231 pp. 135 ill. 18s.

As the title implies, "Understanding Graphs" deals solely with graphs and covers both their theory and practical applications. The stated intention of the book is to fill the gap between the extremes of coverage in standard texts; at one end of the scale, graphs and charts are sketchily confined to an odd chapter in books on arithmetic and elementary algebra, and at the other are included in books that cover co-ordinate geometry and require a knowledge of calculus and advanced algebra. The book rightly claims to present a full and general survey of elementary graphical mathematics.

There is no doubt that a student working conscientiously through the book will have obtained a good general knowledge of the subject by the time he reaches the end, as the material is presented in a very commendable simple style with plenty of worked examples. It follows a logical sequence from general introductory chapters on elementary ideas and drawing graphs from observations and equations, followed by chapters discussing straight lines, parabolas and cubic equations. Before continuing the sequence with chapters on growth laws, non-linear laws and graphs, and the representa-

tion of trigonometrical functions, there is a useful introduction to the ideas of imaginary numbers and asymptotes, and a treatment of rates of change and the estimation of areas. The book concludes with chapters on maxima and minima, and polar co-ordinates.

The only serious criticism that may be levelled concerns Chapter 1, which is specifically mentioned as covering important parts of the London G.C.E. Statistics papers. On page 8, among notes on drawing graphs, the statement is made that it is permissible to draw only that part of a graph which gives specific information. For statistics students, however, attention should have been drawn to the dangers of suppressing zeros on graphs illustrating general trends, and it would have been advisable for the author to have included warnings of the other ways in which graphs can lead to wrong conclusions being made.

The book can be recommended for students of G.C.E. O-level mathematics and similar examinations, but whether or not such students could afford or really need such a comprehensive text for just part of the syllabus must remain a matter for conjecture.

J.A.P.

# A New Dial-Pulse Detector

M. J. E. SANDS†

U.D.C. 621.395.361.1: 621.373.52

Since their introduction in 1960, which puts them among the first types of exchange equipment to use transistors, Monitoring Units No. 1A and No. 2A have been successfully used for the detection of dialling on subscribers' lines. A superseding item has now been designed and is described here. It takes advantage of the greater choice of transistors now available, which permitted a different approach to the design.

## INTRODUCTION

IN an earlier article in this Journal\* a line-signal monitoring unit using transistors was described. The circuit is typically used as a high-impedance dial-pulse detector on subscribers' lines, being used for this purpose in some centralized service-observation circuits, printer meter-check connecting circuits, and elsewhere. However, since its introduction as Monitoring Units No. 1A and No. 2A, several of the components used in its construction have become obsolete or are in danger of becoming so, and with no satisfactory alternatives to these components available it was decided to design a superseding item.

## CIRCUIT DESCRIPTION

To achieve a high-impedance input the original circuit uses an audio-frequency oscillator, energized by drawing a current of a few microamperes from the positive line during the make period of the dial pulsing contact unit. The output of the oscillator is amplified and rectified, and then used to operate the monitoring-unit output relay. This method of obtaining a high impedance was used because the characteristics of the most readily available transistors were at that time such as to make the design of a more conventional d.c.-coupled circuit difficult and expensive. In use as a dial-pulse detector this circuit has proved to be very satisfactory, and has the characteristic of not responding to small-duration inputs—a useful facility for rejecting voltage surges. However, difficulty has been experienced due to the sensitivity of the oscillator to small sample-to-sample variations in several of its components, resulting in many circuits failing the manufacturers' acceptance tests. A further difficulty is that below 40° F the circuit tends to misoperate and may cease to function altogether.

When considering the design of the superseding item it was decided that a sufficiently high input impedance could be obtained using a d.c.-coupled circuit because of the greater choice of transistors available, especially low-leakage silicon types which were not available at the time of the earlier design. An advantage envisaged with a d.c.-coupled circuit was that of greater freedom of choice of transistor types, especially if they were used only fully conducting or fully cut-off. Under these conditions practically any transistor of the correct voltage rating and with a certain minimum large current

gain should be suitable, considerably simplifying the provision of replacement transistors should the need arise.

It was found early on in the tests of the new circuit that, when used in certain equipment, the characteristic and rather complex distortion produced by the original circuit had to be reproduced quite closely in order that the equipment in question should continue to operate reliably. It was thought that to design the circuit with a pre-set complex output would unnecessarily limit its use and that it would be better to design the circuit to have no inherent distortion whatsoever while being, at the same time, capable of modification, by strapping tags on the base of the mounting, to produce the various types of distortion appropriate to its various applications. By extension of this idea the output could be modified further by components external to it, connected via the base tags.

An important requirement of the circuit is that it should not respond to short-duration inputs, an essential requirement if spurious operation to voltage surges is to be avoided. This characteristic is obtained by using a Schmitt trigger preceded by an integrating circuit, as shown schematically in Fig. 1(a). Waveforms showing the progress of a dial make-pulse through the circuit and its displacement in time are shown in Fig. 1(b). During the time that the dial pulsing contacts are closed the potential of the positive line drops from earth to a voltage between -2 volts and -25 volts, depending on whether the loop is of high or low resistance, but this amplitude is increased to 50 volts before the leading edge of the pulse is applied to the integrating circuit where the square leading and lagging edges are made exponential and applied to the Schmitt trigger. The Schmitt trigger is a 2-transistor d.c.-coupled bistable circuit which rapidly changes its state when its input reaches a pre-arranged potential. Application of the exponential leading edge of the input to the Schmitt trigger is ineffective until the pre-arranged triggering potential is reached, at which point the trigger rapidly changes its state to produce an output which operates the output relay. Obviously, if the duration of the input is less than the time taken to reach the triggering potential then that input will be ineffective. The exponential lagging edge, after a delay, switches the Schmitt trigger back again to its original state, so terminating the output.

The potential at which the trigger switches back to its original state is not equal to the potential required to switch it on in the first place. This difference, the backlash of the circuit, is used to ensure a minimum duration output, because having been switched to produce an output the Schmitt trigger will not switch back again to remove the output until the potential at its input has changed by an amount equal to this backlash voltage, and the time taken for this voltage change is dependent on the  $CR$  time of the preceding stage. Thus, the delay to the leading and lagging edges, and also the length of the minimum output pulse, are dependent on the  $CR$  time of the integrating circuit. In the circuit these times

†Telephone Exchange Systems Developments Branch, Engineering Department.

\*PRICE, C. K. A Line-Signal Monitoring Unit using Transistors. *P.O.E.E.J.*, Vol. 53, p. 121, July 1960.

may be varied from zero for distortionless operation to about 20 ms by strapping the tags on the base of the unit; they can be even longer if external components are used, as the CR time may then be adjusted to any practical value.

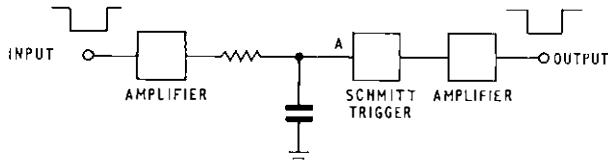

(a) Block Schematic Diagram of Dial-Pulse Detector

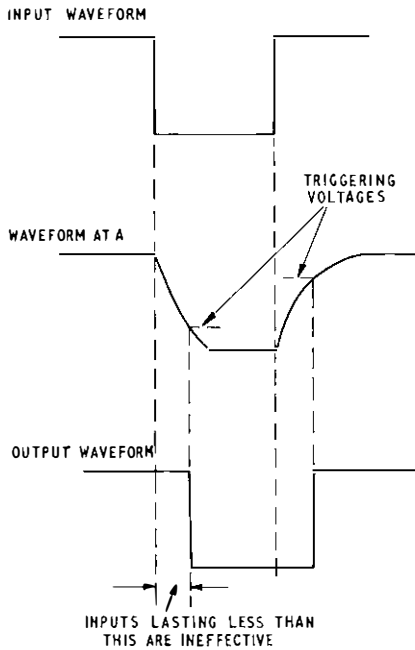

(b) Waveforms Showing Progress of Make Pulse through Dial-Pulse Detector

FIG. 1—ARRANGEMENT OF CIRCUIT TO AVOID SPURIOUS OPERATION TO VOLTAGE SURGES

Translation of the block schematic diagram into the actual circuit is shown in Fig. 2. Transistors VT1 and VT2 are connected in common-emitter configuration and are normally off, but are switched fully on by the

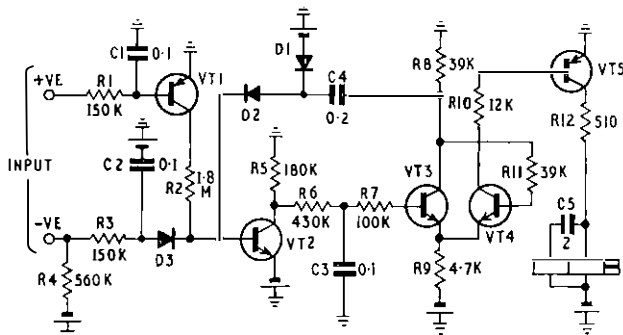

FIG. 2—CIRCUIT DIAGRAM OF DIAL-PULSE DETECTOR

input negative potential applied to the base of transistor VT1 via resistor R1. Transistors VT3 and VT4 comprise the Schmitt trigger, the normal state of which is transistor VT3 conducting and transistor VT4 cut off; an input cuts transistor VT3 off, allowing transistor VT4 to conduct. Transistor VT4, conducting, allows the final transistor, VT5, also connected in common-emitter configuration, to conduct and operate the output relay.

A further facility, which can be incorporated by connecting two tags on the base of the mounting, gives the circuit the useful characteristic of producing a constant output pulse of approximately 35 ms over a wide range of input-pulse durations, while input pulses lasting longer than 35 ms are reproduced without distortion. This facility is particularly useful in circuits where unselector magnets and similar magnetic circuits are energized during the make period of a fast dial being inadequate for this purpose. It is achieved by providing transient feedback from the output of the trigger to the input at the base of transistor VT2, via capacitor C4 and diode D2. When the trigger switches to produce an output, feedback provides base current for transistor VT2 independently of the normal input from the positive line via transistor VT1. This feedback lasts for approximately 35 ms, a time dependent on the CR time of the feedback path. Inputs lasting longer than this time will not be affected in any way.

When detecting dialling on subscribers' lines, by observing on the positive line, a guard is necessary against the effect of the disturbance to the steady line-looped conditions caused by each successive group selector switching. There are two practical conditions which, by removing the input to the circuit, give the false impression that the loop is broken. They are when the switching relay contact units (a) disconnect both wires simultaneously, and (b) disconnect the negative wire first, thus extending a high positive back-e.m.f. to line. The first difficulty is overcome in the same way as in the original circuit, namely, by connecting a negative potential to the negative line in order that the circuit shall be independent of the negative potential from the group selector. The second difficulty is overcome by using the positive back-e.m.f. on the negative line to hold the n-p-n transistor VT2 conducting during this transient period. One further guard is necessary on short lines because, when the dial spring-set contact units open a low-resistance loop, both lines are subject to one cycle of oscillation about the ultimate steady-state potential, which, in the case of the positive line, will be earth, and, for the negative line, -50 volts. The positive line swings first positively and then negatively before settling to the steady-state earth potential for the duration of the break. To prevent the negative swing from appearing as a closure of the dial contact unit, capacitor C1 charges to the initial positive swing via resistor R1, and commences to discharge via the same path, the CR time being chosen to make the following negative swing ineffective. This guard is described with the aid of line oscillograms in the description of the original circuit mentioned earlier.

# Transit Switching Centres Using BXB1121 Crossbar Equipment

## Part 1—Trunking, Facilities and General Operation

N. WALKER, M.B.E., B.Sc.(Eng.), C.Eng., M.I.E.E., F. A. STALLWORTHY  
and R. F. McLUSKY, C.Eng., M.I.E.E.†

U.D.C. 621.395.344.6:621.395.74

After a brief introduction to the trunk transit network, the basic crossbar-type group selection unit being used at transit switching centres is described. This is followed by details of the trunking and facilities provided, including a description of the equipment's general operation. Part 2 will describe the circuit principles and the equipment practice used.

### INTRODUCTION

TRANSIT switching centres (T.S.C.s) fall into two classes: main switching centres (M.S.C.s) and district switching centres (D.S.C.s). The M.S.C.s are fully interconnected with each other by direct routes, while each D.S.C. has a basic route connecting it with a suitable M.S.C. Each D.S.C. serves a number of group switching centres (G.S.C.s) in its vicinity, and is connected to them by direct routes. Collectively, the routes so far mentioned constitute the basic transit network<sup>1,2</sup> and are shown by the full lines in Fig. 1. These basic routes are engineered on a fully-provided basis.

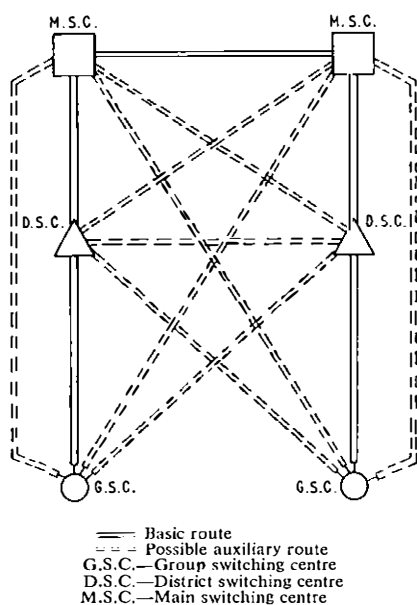

FIG. 1.—4-WIRE SWITCHED TRUNK TRANSIT NETWORK

The T.S.C.s can also have auxiliary routes such as those shown by dotted lines in Fig. 1. These routes may be engineered on a fully-provided or on a high-usage basis.

In addition to the arrangement shown, it is usual for a M.S.C. to have basic routes to G.S.C.s in its vicinity and, thus, to serve as a combined M.S.C./D.S.C. in respect of those G.S.C.s.

†Mr. Walker and Mr. McLusky are in the Telephone Exchange Systems Development Branch, Engineering Department. Mr. Stallworthy is with Standard Telephones and Cables, Ltd.

### TRANSIT SWITCHING CENTRES

All routes in the transit network are 4-wire terminated at the T.S.C.s, and it is the prime function of a T.S.C. to connect, as required, incoming circuits to outgoing circuits via suitable 4-wire switching equipment. To do this effectively provision must be made for go and return speech paths and a signalling path through the switches, together with arrangements for holding and guarding the connexion once it is established. The supervisory signals passing between incoming-line and outgoing-line terminations are repeated through the switches in d.c. form, and it is a requirement that the signalling path should be entirely separate from the speech paths to avoid the risk of interference between speech and signalling.

It is fundamental to the trunk transit-switching plan that the switching equipment at T.S.C.s should be register controlled. All T.S.C.s are, in principle, alike and perform their switching function on receipt of a three-digit code. This code is sufficient to identify the terminal centre to which the call is to be routed via the transit network, and it is used at each T.S.C. in the connexion to select an appropriate outgoing route. The codes used are allocated in accordance with the national numbering scheme and, in most cases, comprise the first three digits of the called subscriber's national number, excluding the trunk prefix-digit 0. Operation on the basis of a short code of uniform length, with the registers at T.S.C.s controlling only their own switching equipment, makes for simple design and economical provision of common equipment.

The basic functions of a T.S.C. can be realized by adapting the BXB1100 crossbar equipment to this particular use as described below. In this form it has been designated the BXB1121 switching system by the manufacturer. The exchange type has been designated by the British Post Office as TXK4.

### BASIC BXB1100 GROUP SELECTION UNIT

Several switching systems are already in existence which have the characteristics common to crossbar systems, but each is distinguished by some individual properties.<sup>3</sup>

The basic concept of a crossbar switching stage is an interlinked group of crossbar switches in a primary-secondary array. Such a switching stage can be used for line selection or group selection purposes. Common circuits are used to control the selection process and also to perform many other logical functions.

Crossbar systems differ in the size and type of crossbar switch used, the form of the interlinked array, and the method of control by the common circuits. The switch used in the BXB1121 system is the Pentaconta multi-selector, which is a large-capacity crossbar switch (see Fig. 2). It has up to 22 selectors (sometimes referred to



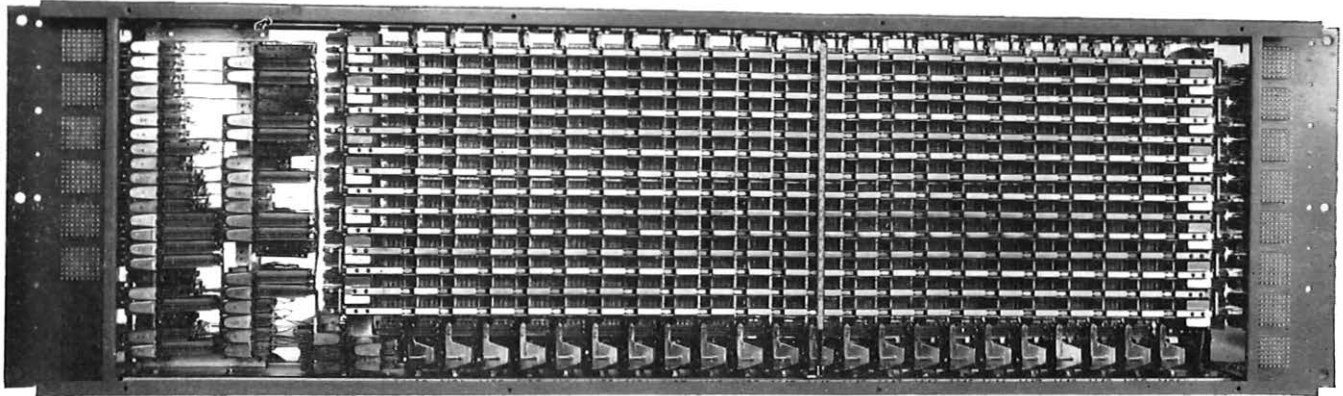

FIG. 2—PENTACONTA MULTI-SELECTOR

as bridges or verticals), and 14 horizontal bars allowing 28 outlets. By using the 14th horizontal bar, or the 14th and 13th horizontal bars, as change-over bars for outlet switching control, the outlets can be increased to 52 or 74, respectively, with a reduction in the number of wires per outlet. The switch has up to 10 make contact units at each cross-point, which allows the switching of up to 10 wires for 28 outlets, five wires for 52 outlets, and three wires for 74 outlets. T.S.C.s use multi-selectors capable of switching eight wires per cross-point, thus limiting their outlet capacity to 28.

This crossbar system is also characterized by the use of a feature called "interaid," which is a form of internal overflow routing. A typical group selection unit using the eight-wire multi-selector is shown in Fig. 3(a). In this example, nine primary sections and 20 secondary sections are equipped, making up a unit of 162 inlets and 560 outlets.

Each primary section has 22 selectors, 18 for terminating incoming trunk circuits and four for interaid traffic. All these selectors have access to 20 outlets, giving one link to each of the 20 secondary sections. The 18 incoming selectors also have access via eight outlets to eight interaid selectors, one in each of the other eight primary sections. The four interaid selectors in the primary sections also have access to eight outlets terminating on interaid selectors in the secondary sections.

Each secondary section has 11 selectors, nine being connected for direct traffic. The other two selectors of each secondary section are connected for interaid traffic. All 11 selectors have access to the same 28 outlets.

The essential difference between a normal direct connexion and an interaid connexion through a group selection unit is illustrated by Fig. 3(b). For a normal connexion, shown by the thick full line, a direct link is used to connect the calling primary selector to a secondary selector for access to the required outlet. Interaid is used when the primary selector has no free direct links to suitable secondary selectors. Under this condition the primary selector chooses an outlet to an interaid selector in another primary section in order to have access to other links. This path is shown in Fig. 3(b) by the thick broken line between the two primary sections. The interaid selector has access to both the special interaid links and the regular direct links proper to that section. These interaid selectors are arranged to select a special interaid link if available (shown by the thick broken line), and only to use a regular link (shown by the thin broken line) if the special links are busy.

The interconnexion of the primary and secondary sections follows various set patterns according to the traffic requirements.

The arrangement already described can be expanded for very large transit exchanges by doubling up each secondary section, as shown in Fig. 4, to give 56 outlets. This allows access to 40 secondary sections with a total of 1,120 outlets.

The connexion of an inlet to one of a group of suitable outlets via a group selection unit involves the selection of a link from the primary section concerned to a

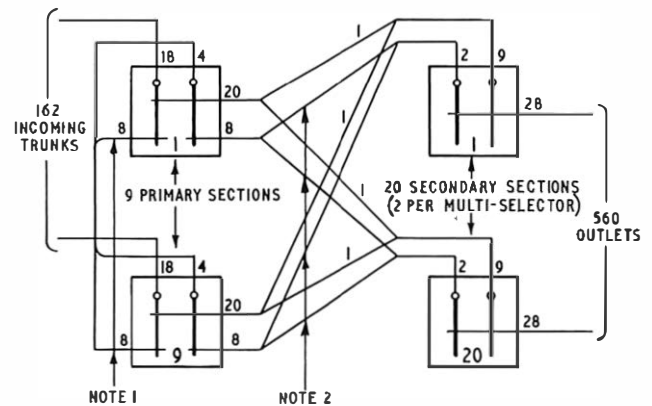

Notes: 1. Seventy-two interaid outlets to 36 interaid selectors  
2. Seventy-two primary outlets connected to 40 secondary selectors to form special interaid links

(a) Typical 162-Inlet/560-Outlet Unit

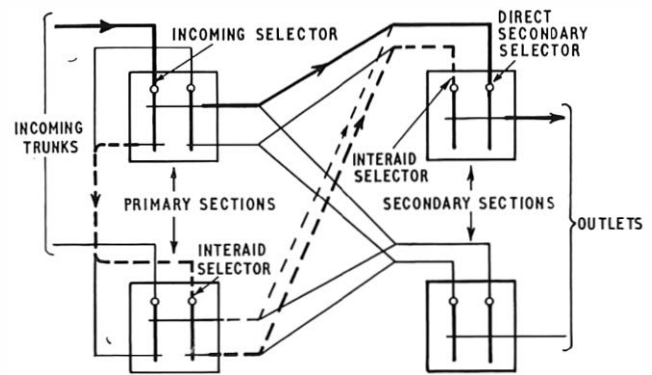

(b) Direct and Indirect Connexion

FIG. 3—INTERNAL TRUNKING OF A GROUP SELECTION UNIT

secondary section that has access to a free outlet in the required group. This function is performed by one of a pair of markers associated with the group selection unit, the markers being used alternately. To perform its function the marker is supplied with information identifying the primary section concerned, the group of outlets concerned, those that are free and the secondary sections containing them, and the free links between the primary section and the various secondary sections.

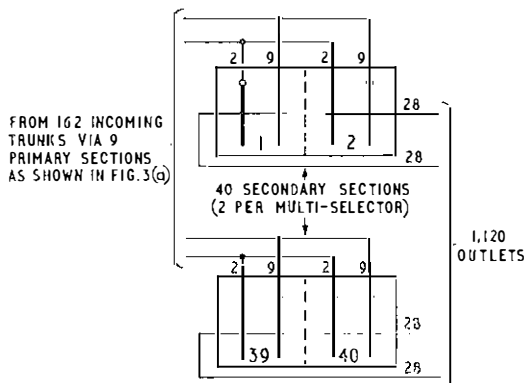

FIG. 4—INTERCONNECTION OF SECONDARY SECTIONS OF A 1,120-OUTLET GROUP SELECTION UNIT

TRUNKING ARRANGEMENTS OF TRANSIT SWITCHING CENTRES

The skeleton trunking of a T.S.C. using the crossbar group selection unit previously described is shown in Fig. 5. In one group selection unit there are nine primary sections and 20 secondary sections, giving 180 direct links between primary and secondary sections. Each primary section has 18 inlets for terminating incoming trunk circuits, and each secondary section has 28 outlets for access to outgoing trunk circuits, giving  $9 \times 18$ , i.e. 162, inlets to  $20 \times 28$ , i.e. 560, outlets. This trunking is suitable for small centres having less than 162 lines, but can be provided for centres having up to 324 lines or up to 486 lines by arranging, respectively, two or three of these group selection units multiplied to the same 560 outlets to form a block (see Fig. 6). For centres of still

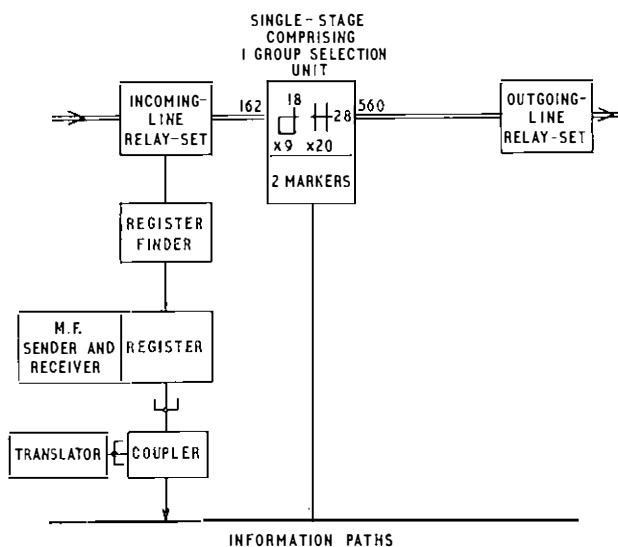

FIG. 5—TRUNKING SCHEME FOR A SMALL T.S.C. WITH SINGLE-STAGE SWITCHING

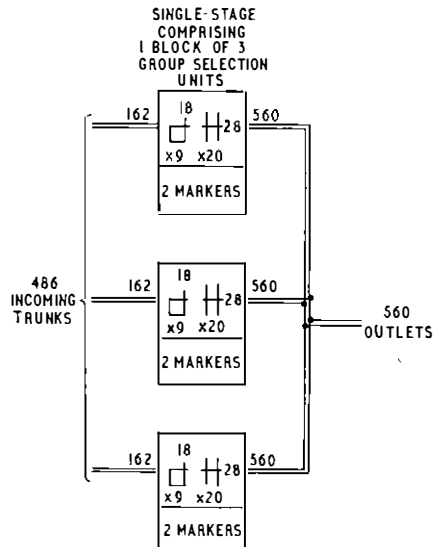
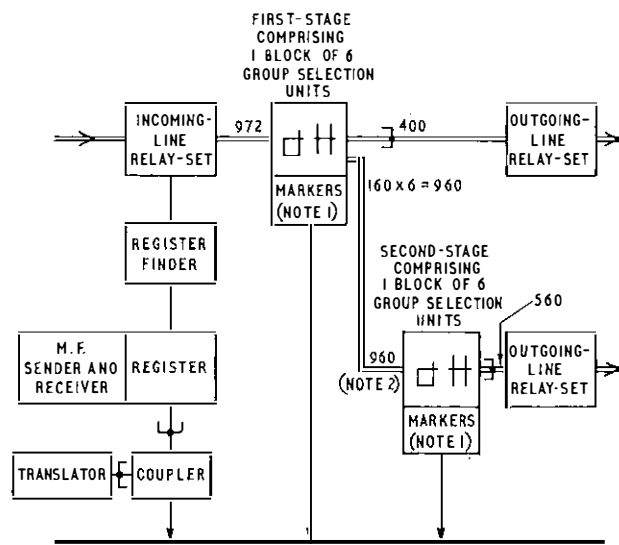

FIG. 6—FORMATION OF A BLOCK OF GROUP SELECTION UNITS

larger sizes, requiring more trunk circuits, second-stage group selection units are introduced as illustrated in Fig. 7, and the number of first-stage group selection units in a block can be augmented. In the example, six first-stage group selection units having 972 inlets are arranged to give access to 400 outlets directly from this first stage, and to  $6 \times 160$ , i.e. 960, links to second-stage group selection units having access to 560 outlets.

Fig. 5 and 7 show incoming and outgoing trunk circuits terminating on the inlets and outlets of the crossbar switches. At some centres there is a local G.S.C. in the same building as the T.S.C., or in a building so close to the T.S.C. that trunk circuits are not required between the two. In these circumstances there are no external trunk lines terminated by incoming-line and outgoing-line signalling relay-sets; the tie-circuits are cabled directly between the two centres and special relay-sets are used.



Notes: 1. Two markers per group selection unit are provided.  
2. In this example 972 second-stage inlets are available but only 960 of them are used.

FIG. 7—TRUNKING SCHEME FOR A LARGER T.S.C. WITH TWO-STAGE SWITCHING

### *Capacity of a T.S.C. and Extension Arrangements*

A T.S.C. must be designed so that economical trunking arrangements are possible for the number of incoming-line and outgoing-line relay-sets required initially, and so that, if necessary, extensions can be provided in very small steps. These small increments could be no more than the capacity of a single multi-selector. On the other hand, large-capacity exchanges of some thousands of line relay-sets should be possible without changing the basic principles of trunking or the methods of control.

For T.S.C.s it is reasonable to assume that the number of incoming-line relay-sets is approximately equal to the number of outgoing-line relay-sets, and, consequently, the number of switch inlets should be comparable with the number of switch outlets. This is achieved by forming blocks of group selection units with the outlets multiplied as shown, typically, in Fig. 6 and 7.

In forming a block, the number of secondary sections in each of the group selection units must be the same to give full availability to all outlets. However, the number of primary sections provided varies according to the number of inlets required, which can increase in steps of 18, and the capacity of each multi-selector used.

Two types of group selection unit have been mentioned, namely, the 560-outlet and the 1,120-outlet units, and the method of extension described below applies to both.

When a T.S.C. grows, the number of outgoing-line relay-sets may exceed the number of outlets available on a single block. The system can then be extended to comprise several blocks, some being first-stage blocks and some being second-stage blocks. Some outlets from the first stage provide the links between the two stages, the number of such links being a function of the traffic to be routed via the second-stage blocks and the grade of service required on the links.

The theoretical maximum capacity of a switching system comprising first-stage and second-stage blocks is reached when all the outlets of the first stage are used for links to second-stage blocks. This corresponds to 15,680 outlets from a system using 560-outlet group selection units, and double this number if 1,120-outlet group selection units are used. The number of inlets can be as many as required. The choice of the 560-outlet or 1,120-outlet type must be made at the design stage of the exchange since it is impracticable to modify one type to the other at a later date. If it is known initially that the outlets required are likely to exceed, say, 1,500 it is reasonable to consider the use of the 1,120-outlet arrangement.

### *Allocation of Circuits*

All circuits in an outgoing route appear on the outlets of group selection units in the same switching block, and the circuits are spread over the secondary sections of these units. For example, in a group selection unit having 20 secondary sections, a route of 20 circuits would have one circuit in each secondary section and would, therefore, be accessible over any direct link between the calling primary section and all the secondary sections. For routes having less than 20 circuits there would be a limited accessibility by direct links, but the accessibility is not allowed to drop in proportion to the number of circuits in a route. This is avoided by providing multiple appearances of circuits. Interaid arrangements provide additional access under all circumstances.

At small centres having a single switching stage, all outgoing routes have the advantage of single-stage switching and minimum switching time. At the centres having a mixture of direct single-stage switching and two-stage switching via secondary blocks, an order of priority has to be introduced for the allocation of routes to the single-switching stage. This is done with the overall transit network in mind so that calls connected over five transit links do not encounter double-stage switching, and, hence, longer switching time, at all four T.S.C.s in succession.

## FACILITIES AND OPERATION OF A TRANSIT SWITCHING CENTRE

### *Operation under Normal Conditions*

Consider first a call switched via one group selection unit having direct access to the required route, as in Fig. 5. The seizure of an incoming-line relay-set causes a register to be associated via the register-finder crossbar switches. When connected, this register and its multi-frequency (m.f.) sender and receiver return a m.f. transit-proceed-to-send signal; in response to this signal the controlling register at the originating centre sends the first three stored digits. The digits are received, stored and checked in the T.S.C. register. Meanwhile this register has seized a coupler, which in turn seizes a translator to which the three code digits are passed. At the same time, the coupler signals the primary section connected to the incoming-line relay-set to seize one of the two markers in that group selection unit, which then selects and seizes a free information path. The identity of this path is returned via the coupler via the primary section, incoming-line relay-set and register. The translator passes the translation to the coupler and is then released; the coupler connects itself to the information path concerned, which is used for passing the translation from the coupler to the marker. The information path is released as soon as the translation has been given to the marker, the marker proceeding to effect a connexion between the incoming circuit and a free circuit in the required route. This is achieved by selecting a secondary section having a free circuit in the outgoing route and to which there is a free link from the calling primary section.

The free circuit and the free link are selected at this stage by the operation of the magnets of the horizontal bars in both secondary and primary sections. The marker again chooses and seizes an information path, indicates the path to the coupler, and the coupler connects itself to it. A signal from the marker to the register, via the coupler, indicates that it is ready for completion of the connexion; the register does this by operating the primary-section and secondary-section selector magnets in turn. The information path, coupler and marker are released, and the register makes a d.c. continuity check over each wire switched at the cross-point before initiating its own release, thereby releasing the register finder and allowing the incoming-line relay-set to connect line to line.

Where the route required is accessible from the outlets of a second-stage group selection unit (Fig. 7) the marking and switching operations are carried out on a stage-by-stage basis. The first switching stage is completed as already described up to the point where both the information path and marker are released. The

coupler is not released, and, instead of finding a free circuit in an outgoing route, the connexion is made to a free internal circuit in a group of circuits to the inlets of a second-stage group selection unit. The register then causes the coupler to signal the primary section of the second-stage group selection unit, and the cycle of marking and switching operations is repeated via the second switching stage as described for the first stage, right through to the d.c. continuity check, release of the register, and completion of the transit path from incoming trunk line to outgoing trunk line.

The routes from a T.S.C. can be made up of wholly unidirectional, wholly bothway circuits, or a mixture of unidirectional and bothway circuits. Information is fed to the translators indicating the state of a whole route, and, when a translation is given, it is left to the marker to select an available free circuit in a route. For mixed routes, outgoing circuits are tested by the marker before bothway circuits.

#### Automatic Alternative Routing

Arrangements can be made for automatic alternative routing from one route to another in the event of the first-choice route being engaged. Fig. 8 shows an auxiliary route, X, from a D.S.C. to a "foreign" M.S.C. provided on a high-usage basis. When all circuits in this route are engaged, the translators at the D.S.C. will arrange for calls to be automatically diverted from route X to basic route Y and, hence, to reach the foreign M.S.C. via the "home" M.S.C. and basic route Z. This automatic-alternative-routing facility is available

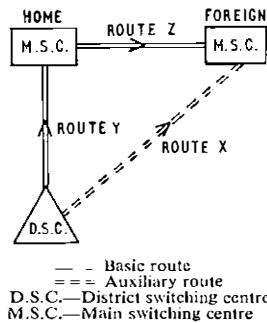

FIG. 8—ALTERNATIVE ROUTING

for use, as required, from one auxiliary route to another as well as from an auxiliary route to a basic route, but care must be taken to avoid the build-up of unacceptable routings. In the limit, at one centre the automatic-alternative-routing facility could make three diversions of a routing.

There are problems to be studied in deciding where and when to use this facility in the light of potential line-plant and equipment economies. Care is also necessary in arranging the sizes and make-up of routes to ensure that traffic overflowing from one route to another does not get an enhanced grade of service at the expense of other traffic normally using the second route.

#### Operation under Fault Conditions and Congestion

When failures occur it is undesirable that expensive trunk lines and trunk-exchange equipment should be held under the control of a caller, so provision is made for faults and failures to be detected by built-in checking

elements and, whenever possible, for the plant concerned to be released. For some failures an internal repeat attempt is made at the T.S.C. to establish the call, using different equipment wherever possible, without the caller being aware of the fact, and for this purpose the three code digits remain stored in the register and are immediately available if required.

*Internal Repeat Attempt.* Failure to complete particular functions in the control or switching equipment, or to gain access to items of common equipment, is detected either by design features which positively indicate the appropriate action or by the expiry of a short time-out cycle. In each instance, the same register takes steps to make one internal repeat attempt or to control the release of the call if a further failure occurs on the second attempt.

*External Repeat Attempt.* If valid code digits are not received in the register, or if a spare code is received, the register and any associated common-control equipment are released, and the controlling register at the originating centre is made to release the transit circuits and to make one more attempt to set up the call.

*Congestion.* Route congestion is determined by a route monitor. The information is immediately available to the translators so that translations appropriate to a congested route are withheld. Link congestion is recognized by the marker, and congestion of common equipment is detected by time-out processes. When any of these congestion conditions is detected (after a repeat attempt, if appropriate, has been made to establish the call), the register, in conjunction with the translator, substitutes a translation to route the call to a congestion announcement, and a signal is sent to the originating centre to indicate that this has happened. Congestion announcement at a T.S.C. is primarily for use on calls originated by operators.

#### Security

Precautions are taken in many ways to safeguard the service at a T.S.C. Built-in checking elements are provided to detect failures in the receipt and storage of the three-digit code and to check that two frequencies are received for each digit. When two consecutive failures occur in the same register it is artificially busied out and an alarm is given. On the other hand, steps are taken to prevent all registers being taken out of service by limiting the number artificially busied to a predetermined proportion of the total.

As far as possible, successive calls and repeat attempts of the same call should not seize the same common equipment, crossbar switches, or circuit in a route. The two markers in a group selection unit are, therefore, taken into use alternately, couplers, also in pairs, are seized alternately, and other built-in features are provided to cause the desired rotation of access.

Incoming traffic and routes are divided as equally as possible between all incoming sections by allocating individual circuits in a route to different primary sections. Similarly, outgoing routes are spread over the outlets of secondary sections on the basis of not more than one outlet per route per section until the number of outlets required exceeds the number of secondary sections; at this point there will be some multiple access to a route from a section, the amount depending upon the size of the route.

A step-on feature in all group selection units changes the starting point for selection of a free circuit in a route. While markers can test and select any one of the free circuits in a route, the order of testing rotates on successive calls; furthermore, the search and rotation are in opposite directions for each marker.

#### *Fault Recorder*

Registers, register finders and markers can detect failures of calls due to a fault or a delay, and are arranged to call in the fault recorder while the whole selection train is temporarily held. The equipment calling in the fault recorder, and all other major items of equipment concerned in the call, are coupled to the recorder's input stores to record the identity of each circuit, the state of its significant relays, the time and the date, all this information being registered simultaneously. When information storage has been completed, the recorder is released and the call proceeds to the next action—repeat attempt or forced release, as appropriate. The recorder transfers the stored information to a perforator.

The recorder can be switched off if an automatic record of failures is not required, but, whether it is on or off, individual meters associated with each register, register finder and marker record the number of occasions the recorder was, or would have been, called for.

#### *Records*

Provision is made for access to the main items of equipment and all routes to obtain records of calls and

traffic for the maintenance and management of the switching centre. In general, these are obtained from meters that count certain operations continuously, from analysis meters for occasional use, and from recording equipment enabling records of traffic flow to be made when required.

From meter readings, information can be obtained of the number of successful and unsuccessful calls, the number of repeat-attempt calls, the number of calls meeting congestion, and the forced releases of registers. In addition, there are meters associated with outgoing routes to count the calls offered to each route and those calls which overflow from a route.

The analysis meters are capable of counting the calls received at the centre in respect of one or more destinations identified by selected numbering-group codes. Traffic recording is possible on all incoming, outgoing and both-way line relay-sets, on the internal links provided between first-stage and second-stage group selection units, and on registers.

#### *References*

- <sup>1</sup>TOBIN, W. J. E., and STRATTON, J. A New Switching and Transmission Plan for the Inland Trunk Network. *P.O.E.E.J.*, Vol. 53, p. 75, July 1960.
- <sup>2</sup>TOBIN, W. J. E. The Signalling and Switching Aspects of the Trunk Transit Network. *P.O.E.E.J.*, Vol. 60, p. 165, Oct. 1967.
- <sup>3</sup>CORNER, A. C., and BANHAM, H. The 5005-Crossbar Telephonic-Exchange Switching System, Parts 1 and 2. *P.O.E.E.J.*, Vol. 59, pp. 170 and 271, Oct. 1966 and Jan. 1967.

*(To be continued)*

---

## **Book Review**

"Space Communications Systems." R. P. Filipowsky and E. I. Muehldorf. Prentice Hall Technology Series. xvi+575 pp. 194 ill. 96s.

This book covers the field of space-communications systems in a most extensive and commendable way, although most of the emphasis is on space-sector rather than ground-terminal aspects. The reader is first given a comprehensive statement of the fundamental design constraints, including spacecraft orbits, environment, reliability, payloads and power limitations, propagation, noise and transmission considerations. The second half of the book applies these fundamentals to four basic types of spacecraft: communication satellites, instrumental satellites, deep-space probes and manned spacecraft.

Readers specially qualified in any one of these applications will gain much from the discussion here of other applications. To other engineers newly studying the field of space communications, the book as a whole should prove invaluable. The rapidity with which developments are taking place is bound, of course, to call for the early up-dating of some sections of the book, which was first published in 1965. Thus, for example, the discussion of communication satellites virtually ends with the TELSTAR and RELAY experiments. Even since publication, remarkable advances have been made with the successful launching of INTELSAT I (EARLY BIRD) and INTELSAT II commercial satellites, and in the

vast preparation for a global system of satellite communications.

In view of the authors' grasp of their subject and the plentiful references to the technical literature, it is disappointing that so very few references are made to British work and published articles. Further, the recommendations of the C.C.I.R., which are quite crucial to some of the decisions of communication satellites and other spacecraft, receive inadequate mention. It may be hoped that these deficiencies will be remedied in future editions. The authors are evidently less conversant with this field than with others as, for example, is shown by the statement on page 130 that satellite communications must occasionally share frequencies with terrestrial systems. This is a massive understatement which our microwave radio-relay system colleagues will read with astonishment! The treatment of the transmission delay-time problem with synchronous orbit communication satellites is also far from complete, and a mention of entirely successful laboratory experiments made with a two-way delay time of as much as 1 second will scarcely be accepted in C.C.I.T.T. circles.

Nevertheless, the book as a whole is well planned and ably written and should prove a most worth-while addition to the bookshelf of the space-communication systems engineer.

J.K.S.J.

# Notes and Comments

## Supplement and Model Answer Books

Students studying for City and Guilds of London Institute examinations in telecommunications are reminded that the Supplement to the Journal includes model answers to examination questions set in all the subjects of the Telecommunication Technicians' Course. Back numbers of the Journal are available in limited quantities only, and students are urged to place a regular order for the Journal to ensure that they keep informed of current developments in telecommunications and receive all copies of the Supplement.

Books of model answers to certain of the City and Guilds of London Institute examinations in telecommunications are published by the Board of Editors. Details of the books available are always given at the end of the Supplement to the Journal. The books at present available include recently published editions of *Radio and Line Transmission A* (October 1966) and *Telephony and Telegraphy A* (February 1967).

## Syllabuses and Copies of Question Papers for the Telecommunication Technicians' Course

The syllabuses and copies of question papers set for examinations of the Telecommunication Technicians' Course of the City and Guilds of London Institute are not sold by *The Post Office Electrical Engineers' Journal*. They should be purchased from the Department of Technology, City and Guilds of London Institute, 76 Portland Place, London, W.1.

## Journal Binding

This issue completes Vol. 60, and readers wishing to have this volume bound should refer to page 317 for details. Readers should note, however, that, due to shortage of bookbinders in the London area who will undertake Journal work, there may be considerable delay before bound volumes are returned.

Some readers may prefer to make their own arrangements for their copies to be bound, and it is suggested that they find a bookbinder through a local trade directory or their local reference library. The attention

of the bookbinder should be called to the fact that Part 4, i.e. January 1968 issue, of Vol. 60 uses an unsewn binding.

## Notes for Authors

Authors are reminded that some notes are available to help them prepare the manuscripts of the Journal articles in a way that will assist in securing uniformity of presentation, simplify the work of the Journal's printer and draughtsmen, and help ensure that authors' wishes are easily interpreted. Any author preparing an article for the Journal who is not already in possession of the notes is asked to write to the Managing Editor to obtain a copy.

It is emphasized that all contributions to the Journal, including those for Regional Notes and Associate Section Notes, must be typed, with double spacing between lines, on one side of each sheet of paper.

Each circuit diagram or sketch should be drawn on a separate sheet of paper; neat sketches are all that are required. Photographs should be clear and sharply focused. Prints should preferably be glossy and should be unmounted, any notes or captions being written on a separate sheet of paper. Negatives or plates are not needed and should not be supplied.

## The Journal's Printers

*The Post Office Electrical Engineers' Journal* has been printed for the last 30 years at The Baynard Press by Sanders Phillips & Co., Ltd. However, this long association has now come to an end: The Baynard Press is moving to new premises in London, which will involve considerable changes in process and in the type of work undertaken, and Sanders Phillips, therefore, no longer wish to print the Journal.

The Board of Editors have placed the contract for printing the Journal with Unwin Brothers, Ltd., and this issue of the Journal is the first to come from The Gresham Press at Old Woking, Surrey.

The Board of Editors regrets any inconvenience to readers caused by the late distribution of the October 1967 issue of the Journal, printed during the change-over period.

---

## Institution of Post Office Electrical Engineers

### Annual Awards for Associate Section Papers—Session 1966-67

The Judging Committee having adjudicated on the papers submitted by the Local Centre Committees, prizes and Institution Certificates have been awarded to the following in respect of the papers named.

*First Prize of £7 7s.*

B. Smith, Technical Officer, Lincoln Centre—"The Pipe Organ."

*Prize of £4 4s.*

R. C. Siddle, Technical Officer, Bradford Centre—"Report of an Interchange with Sweden."

In addition, the following paper, which was considered worthy of submission to the Judging Committee for the main award, has been awarded a prize of one guinea.

D. Campbell, Technical Officer, Middlesbrough Centre—"Telex."

The Council of the Institution is indebted to Messrs. F. C. Haliburton, C. W. Bailey and L. B. Carson for kindly undertaking the adjudication of the papers submitted for consideration, and for the following report.

The Committee was disappointed to find that only three papers had been submitted for adjudication, but was impressed by their high standard. The paper by Mr. B. Smith on "The Pipe Organ" was adjudged to be the best, showing the author's great enthusiasm for his subject. He had obviously devoted a great deal of study outside his normal field, and had not only to do a lot of reading on organ building but, also, to make personal contacts with organ builders. The resulting paper is a nicely balanced, orderly

production with something of interest in it for most people, covering, as it does, organ construction, musical output and electrical circuits.

Mr. R. C. Siddle's paper, "Report of an Interchange with Sweden," shed refreshing light on the people and telephone practice of one of our European neighbours. After an interesting introduction giving his impressions of the country, the author presents a well-written description of the crossbar system of telephony. Some of the explanations may not be quite clear to the uninitiated reader, but this would leave scope for questions following the presentation of the paper at a meeting.

The third paper, "Telcex" by Mr. D. Campbell, showed clearly that he had devoted much effort to collecting the facts about his subject, and, in spite of being limited in scope, would be of interest and value to all concerned with the telex service.

A. B. WHERRY,  
General Secretary.

#### Additions to the Library

Library requisition forms are available from Honorary Local Secretaries, from Associate Section Centre Secretaries and representatives, and from the Librarian, I.P.O.E.E., G.P.O., 2-12 Gresham Street, London, E.C.2.

Members are reminded that Prize Essays, Associate Section Prize Papers, and various unpublished papers are held in the library for loan, and that a list will be sent on request. Field Medal award-winning papers are also held for loan and are listed in the Supplement to the Library Catalogue.

2923 *Basic Mathematics for Engineers*. D. J. Hancox (Amer. 1966).

A comprehensive study of the mathematics for the Ordinary National Certificate in engineering.

2924 *Electronics from Theory into Practice*. J. E. Fisher and H. B. Gatland (Brit. 1966).

Aims to formalize the design procedures covering a wide range of electronic circuits.

2925 *Lamps and Lighting*. Edited by H. Hewitt and A. S. Vause (Brit. 1966).

Should be of value to students of lighting and electrical engineering, applied physics, building technology and architecture, as well as to those concerned with the design of lamps and fittings and the installation of lighting systems.

2926 *Advanced Electrical Engineering*. A. H. Morton (Brit. 1966).

Aims to present in a clear manner some of the basic theoretical concepts which should be known to all professional and electronic engineers.

2927 *Radio and TV Servicing (1965-66 Models)*. J. C. Hawker and J. Reddihough (Brit. 1966).

Gives circuit diagrams, and setting-up and servicing details.

2928 *Computers for the Amateur Constructor*. R. H. Warring (Brit. 1966).

Provides a background knowledge of computers as a whole and their working principles, and is devoted mainly to practical descriptions of computer circuit elements well within the capabilities of anyone to build.

2929 *High Speed Diesel Engines*. A. W. Judge (Brit. 1967, 6th Edition).

Covers the development in this type of engine since 1957, particularly single engines from 2 b.h.p. to 12 or 16 cylinder engines with maximum outputs of up to 2,500 b.h.p., with speed ranges from about 1,500 to over 5,000 rev/min. Special consideration is given to

more recent developments, e.g. super-charged and turbo-charged engines, small-vehicle and marine engines, and standard power-rating methods.

2930 *Basic Electricity for Electronic Engineers*. A. W. N. Kerkhofs (Dutch 1967).

Intended to meet the need for a simple outline of the principles of electrical theory, and includes a sufficiency of material from d.c. to a.c. theory.

2931 *Elementary Electronics*. D. Hywel White (Amer. 1967).

Assumes the reader has an elementary knowledge of calculus, electricity and magnetism, but no previous experience in electronics—begins with first principles and proceeds to a level of reasonable skill in practical circuit and device design.

2932 *Laser Light—Fundamentals and Optical Communication*. C. C. Eaglesfield (Brit. 1967).

An introductory account of what a laser is, how it works, and how laser light compares with ordinary light and radio waves, with emphasis on the laser as a practical device.

2933 *Masers and Lasers*. H. A. Klein (Brit. 1967).

A well-illustrated and comprehensive book which will reward those studying science and will not be beyond those with little or none.

2934 *Integrated Electronics*. K. J. Dean (Brit. 1967).

Discusses their principles of operation with their limitations, and introduces the engineer to the wide variety of types which are now on the market.

2935 *Semiconductor Circuit Design*. J. Watson (Brit. 1966).

Will be of value to practising engineers who desire a knowledge of circuit design using semiconductor components. The author has restricted himself to considering the amplification and switching of audio-frequency and direct currents, and, therefore, gives a more detailed exposition than is found in more general electronic texts.

2936 *Automobile Fault Tracing*. S. A. Abbey (Brit. 1966, 3rd Edition).

Intended for the average owner as well as the experienced mechanic, this is a practical and well-illustrated handbook which stresses the importance of a logical and systematic method of fault tracing.

2937 *Electrical Technology*. E. Hughes (Brit. 1967, 3rd Edition).

For students of electrical engineering in the first year of degree courses and for the Ordinary National Certificate. Includes questions from recent O.1 and O.2 examination papers. In this, the latest edition, chapters on electronics have been greatly expanded.

2938 *A Guide to the Laser*. D. Fishlock (Brit. 1967).

A number of authoritative accounts concerning the invention of the laser, its several applications and the most promising lines of progress with its application.

2939 *Transistors for Audio Frequency*. G. Fontaine (French 1965).

An ideal text book, well illustrated, which gives a detailed study on audio-frequency applications, radio-frequency applications and switching applications of transistors.

2940 *Low-Noise Electronics*. W. P. Jolly (Brit. 1967).

A short, simple treatment suitable for those with the general scientific background of a first-year or second-year college student, who wish to have a working knowledge of this subject but have no time to study it at length.

2941 *Silicon Controlled Rectifiers*. A. Lytel (Amer. 1967).

Explains briefly the theory of operation of the s.c.r. and develops this theory into numerous control circuits for practical use. This book will be of benefit to everyone who wishes to keep abreast with current developments.

E. DOHERTY,  
Librarian.

# Regional Notes

## Scotland

### UNUSUAL CORROSION IN LEAD-IN CABLES AT GRANGEMOUTH EXCHANGE

Grangemouth, a small non-director exchange opened about 10 years ago, had not experienced any unusual cable-fault conditions. However, when cables were pressurized, a severe loss of air pressure occurred in seven out of eight unprotected lead-in cables. Tests on the affected cables confirmed that insulation resistance was within limits. An Arcton test on one of the cables proved that the leak was in the lead-in. The faulty lengths were found to be heavily corroded, and at the worst affected parts the corrosion had penetrated almost to the core. Tests of sheath potential and currents gave results which were within specified limits.

The corrosion material was identified as lead monoxide. Little information is available on this type of corrosion but it can occur in an alkaline environment as found in asbestos cement ducts or octagonal ducts bedded in concrete. The Grangemouth lead-in is octagonal duct in 4 × 3 formation, and some of the faulty cables showed light-grey patches of early corrosion at regular 18 in. to 24 in. intervals. The duct lead-in falls by some 18 in. towards the exchange manhole, which is normally flooded. A duct seal had been provided in the manhole and the water level normally covered the first two tiers of duct. The original unprotected cables had, however, been drawn into the top two tiers of duct. No other indications of lead monoxide corrosion have become apparent in this area and it appears to have been confined to the exchange lead-in. The only conclusion which can be drawn is that the lead-in construction was defective.

G. C. D.

## Midland Region

### TUNNELLING BY PIPE THRUSTING IN BIRMINGHAM

To meet the requirements for junction switching equipment, Telephone House is being extended by an additional eight-storey wing. The new cable chamber to serve this extension is at the opposite end of the building to the existing one. Access will be given via walk-through cable subways, connecting one end to the present cable chamber and the other, via the radio-tower basement, to the Snow Hill cable tunnel approximately 100 yards away.

The section under the tower and its extension under the adjacent Regional Director's Office were constructed as part of the building contracts for these projects and left stopped off at the footpath opposite Telephone House. It was now required to link this subway to the new cable chamber.

Concentrations of main undertaker's plant above the subway line and a main sewer below it and the need to avoid the main foundations and stanchions of Telephone House left only one possible route: directly under the main entrance. Open-cut construction would have meant closing this entrance and underpinning foundations.

In conjunction with the Ministry of Public Building and Works it was agreed that tunnelling by pipe thrusting should be used. This process involves cutting away the working face from within a tubular steel shield. As excavation proceeds along the line of the tunnel, the shield, followed by concrete lining rings, is continuously pushed forward by hydraulic rams. A small portable petrol engine driving a hydraulic pump supplies the motive power. The tunnel is thus continuously supported and no voids are left in the surrounding soil.

The work was carried out as a subcontract to the main building work, under the supervision of the Ministry of Public Building and Works. A single thrust pit was used for

both directions of tunnelling, under Telephone House and across Newhall Street. The only untoward incident occurred when the brakes failed on an articulated lorry delivering 7 ft diameter concrete tunnel rings to the site. In the resulting collision, the tunnel contractor's van and compressor were knocked into the thrust pit. Fortunately, the miners were working at the face and neither personal injuries nor damage to services resulted.

J. A. A.

### FIRE AT COLESHILL U.A.X. 14

At 5.45 a.m. on Saturday 8 September a prompt alarm from Coleshill U.A.X. 14 was received at Midland maintenance control, Birmingham. Just after this, operating staff reported an abnormal amount of difficulty on Coleshill Exchange. An emergency officer was despatched to the exchange and when he arrived there at 6.20 a.m. he found that the exchange was on fire and the fire brigade was in attendance. In the meantime the local police had advised that the exchange was on fire and steps were then taken to call out other emergency staff.

When the fire had been extinguished an examination of the exchange revealed that apart from fire damage to the wall lining and the ceiling in one corner of the apparatus room there was no other apparent damage to the building. The fire appeared to have originated in or about a wooden filing cabinet in the apparatus room. Because of lack of light it was difficult to make an assessment of the damage to the equipment. The most obvious damage was to the switchboard cabling, which was, in the main, cabled over the false ceiling. The cabling was severely damaged by heat between the ceiling and the upper part of the racks at each point where it emerged. The main battery fuses were blown, the busbars and their mountings were damaged, and there were heavy fumes from the battery. All the light fittings were damaged and the wall clocks had stopped at 6 o'clock. The cabling to the upper part of the combined M. and I.D.F. was damaged but the lower section, the M.D.F., did not appear to have been affected. There was no damage in the cable trench and the M.D.F. records were intact. An attempt was made to put a power supply back on to the least affected racks by isolating the busbars to the worst affected section. However, a further examination of the equipment revealed that selector mechanisms and relays had been so affected by smoke and heat that no useful purpose would be served by pursuing this course.

Communications were established from the exchange by using a telephone connected directly to a junction. By this means other officers in the Area and in Regional headquarters were advised of the position. Exchanges with junctions to Coleshill were asked to busy them. It was clear that exceptional steps would have to be taken to give some sort of service to the emergency subscribers and public call offices. There are 90 cable pairs between Coleshill and Castle Bromwich, a Birmingham director exchange, and these were used to connect the emergency subscribers to Castle Bromwich exchange. The public call offices, which could not be given any form of automatic service, were routed direct to Hill Street, Birmingham, as trunk subscribers. Because there was insufficient spare calling equipment at Castle Bromwich, outgoing facilities had to be withdrawn from about 30 subscribers in order to release equipment for the diverted circuits. This was arranged through the central enquiry point which had been set up by the Traffic Division. By late morning all public call offices were working as trunk subscribers and the more important emergency subscribers had service on Castle Bromwich. Work continued on the diversion of exchange lines until 10 p.m. when all emergency subscribers had service.



At this stage 70 subscribers' lines and public call offices had service.

During the Saturday morning a meeting on site of Area and Regional staff decided that the equipment, due to be replaced by a 5005-type crossbar unit in 1970, would have to be temporarily replaced. It was established that a mobile tandem unit could be made available from West Midland Area and three 400-line multiple units could be released from the Birmingham factory. These could be used to give temporary service to the majority of the subscribers.

Before mid-day, construction staff had started to dismantle the exchange and by working throughout the night they completed the work by the Sunday afternoon. Forty-one racks had been recovered and removed to storage in Birmingham. The M.D.F. and the power plant remained.

The only available space on which to stand the mobile units was on a 12 ft wide drive at the side of the building. This drive, which had been extended to the rear of the site during the building of the new exchange, sloped very steeply up from the road for about the first 30 ft of its length. Some degree of accessibility to the new building had to be retained for the builders who still had a great deal of internal work to do in the new building. Ashes and railway sleepers were obtained locally to stabilize the surface of the drive. A retaining wall at the lower end of the drive had been damaged during the building works and this was reinforced with pole sections driven in by the pole erection unit.

The first mobile unit was delivered at about 3.45 p.m. on Saturday and it was in position by 5.30 p.m. The tandem unit was on site at 7.15 p.m. Because of nightfall, delivery of the remaining two multiple units was deferred until the next day. By 4.0 p.m. on Sunday all four units were in position. As anticipated, there was considerable difficulty in getting the mobile units, each weighing about 7 tons, up the first steeply sloping section of the drive. This was finally done by means of a short-wheel-base vehicle assisted by a considerable number of men.

While the mobile units were being delivered, cable tails from the exchange side of the existing M.D.F. were prepared. As each mobile unit was positioned, these cables were connected direct to the assemblies. The use of the existing M.D.F. as a flexibility point allowed straight multiple jumpering in the mobile units. This proved to be a distinct advantage to those officers working in the restricted space, and the jumpering work proceeded rapidly.

Due to the fact that there was very little information available concerning the mobile units there were many problems relating to facilities and grading which had to be resolved on the spot as they were encountered. The mobile units had not sufficient capacity to replace the existing exchange completely. To meet the deficiencies in multiple, call-office calling equipments, first selectors and final selectors on one heavily-loaded group, additional equipment was installed in the existing building. The original power plant was used to supply this equipment.

The work of bringing the mobile units into service was continued on a 24-hour basis and late on Tuesday, 12 September, the first subscribers were connected. Restoration was continued at an increasing rate and by Friday, 15 September, 1,000 subscribers had service. The remainder were connected by Monday, 18 September. The diverted exchange lines were restored to Coleshill exchange as the appropriate sections of multiple became available. The junction pairs which were then freed were used to relieve the junction routes from the mobile equipment.

Throughout the period of restoration, the final acceptance testing of the mobile equipment was carried out by Test and Inspection Branch staff. To achieve complete restoration of service to all the subscribers in just over a week was in no small measure due to the ready co-operation and assistance of these officers and others of the Supplies Department and West Midland Telephone Area.

S. P., J. H. and H. J.

## South-Western Region

### BRIDGWATER HEAD POST OFFICE FOUNDATION STONE

The November issue of the Post Office monthly publication, *Courier*, contained a comprehensive and illustrative account of the arrangements made to prepare a casket containing tape recordings of the "Somerset Dialect" and other objects of interest which were deposited in the foundation stone at Bridgwater Head Post Office in November 1967. The December issue includes an account of the actual ceremony.

Readers of *Courier* and others may be interested in the measures taken to ensure that both the physical condition of the tapes and the technical merit of the recording will be preserved intact for posterity.

Two tapes, on which were recorded typical examples of the native "Somerset Dialect," were prepared by the orator. It was found on playing the tapes that both quality and background noise could be improved, and investigation and enquiries revealed that one tape had been prepared from a disk recorded in 1923 and taped on acetate-based tape and that the level of frequency response on both tapes was not linear.

As the physical life of acetate-based tape is limited it was decided to transcribe both tapes on to high-quality "Scotch" magnetic polyester-based tape No. 175, and the opportunity was taken to improve the quality of reproduction by filtering out mush and hiss and by careful operation of the volume control to level out peaks, while at the same time retaining the timbre, intonation and rhythm of the original dialogue.

To ensure that there would be no magnetic interaction, distortion or deterioration between tape layers, the tapes were rewound and interspaced with special leader tape.

The appropriate title, speed, subject, etc. were printed on the tape and each tape then enclosed and sealed in separate plastic containers. The plastic containers were then packed firmly in a commercial film-can lined with polystyrene and surrounded by silica-gel crystals enclosed in linen bags. Dry air was injected into the film can and the joints soldered. The can was then given two separate coats of paint and enclosed in a prepared lead pancake, previously lined with polystyrene, and the joints sealed.

A bronze title-plate, suitably engraved, was affixed to the outside of the lead container with epoxy resin and the whole given two coats of polyurethane lacquer.

As conditions under which the container will be lodged are difficult to determine, the measures taken will protect the tapes against:

- (i) magnetic interaction and deterioration between layers, and external magnetic effects from whatever source,
- (ii) physical vibration from traffic, which could set up magnetic fields and cause magnetic distortion or deterioration as well as physical damage,
- (iii) physical deterioration due to moisture, humidity, electrolytic action, acid, alkali or mineral-salt corrosion, and
- (iv) all expected temperature variations.

C. C. C.

## Eastern Region

### REMOVAL OF PELDON U.A.X. 13

During 1950, Peldon telephone exchange was converted from a U.A.X. 12 to U.A.X. 13 in a brick B-type building on the same site. Nine years later the floor of the new building cracked badly and a gap appeared between the foundations and the damp-proof course. These cracks were filled with cement in July 1959, and an investigation of the soil conditions revealed that the subsoil consisted of clay to an indeterminate depth. On Ministry of Works advice, underpinning of the downhill wall of the building was completed in October 1959.

No further subsidence occurred until October 1963 when the crack widened. The Ministry then advised that further

attempts to arrest subsidence would be of no avail. Early in 1964 vertical cracks appeared at each corner of the building.

At this time the exchange equipment consisted of 4 A units, 3 B units, 1 C unit, a 201 power plant and W.B. 400 equipment; sales forecasts indicated that additional equipment would be required in 1967 to cater for growth of the exchange. This new equipment could not be installed in the subsiding building.

Three main proposals were considered at this stage.

(a) To build and install a new exchange and, when this was ready for service, change over the existing subscribers to the new exchange.

(b) To erect a new building over the existing and demolish the old building from inside the new structure.

(c) To erect a new building adjacent to the subsiding one and move the exchange apparatus bodily into the new building prior to completion of the new building.

The third proposal was eventually adopted as being the cheapest by far in labour costs it being borne in mind that a U.A.X. 13 could be expected to serve this community until late in the 1980's.

In June 1966 land was purchased adjoining the western (uphill) boundary of the site and plans prepared for the erection of a timber B1-type building on a concrete raft to be supported by a ring beam on dwarf piles. The new concrete raft was planned to be surrounded with a concrete apron, necessary to prevent soil shrinkage from drying out, as well as providing a base on which to roll the exchange units. In order to move the exchange it was necessary to provide a platform on which the units could rest and which would

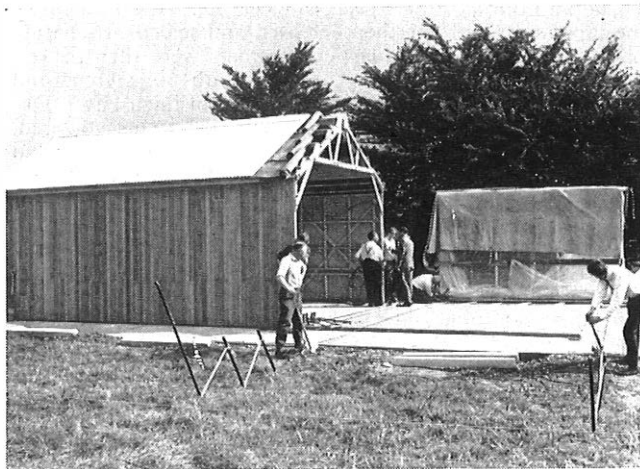

PULLING THE NEW APPARATUS ONTO THE RAFT

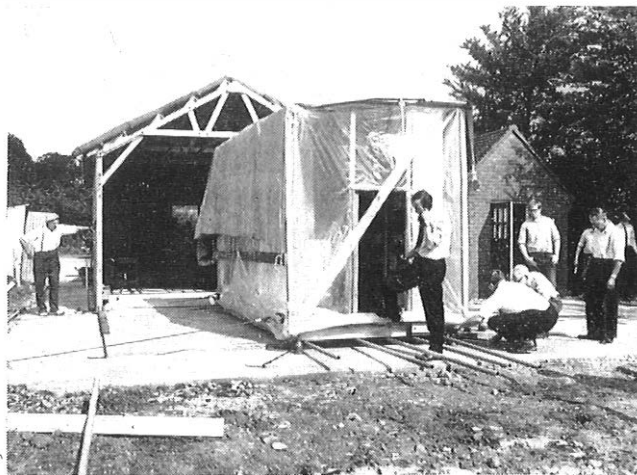

THE NEW APPARATUS ALMOST READY TO ROLL INTO THE NEW BUILDING

permit rolling in two directions mutually at right angles. This platform consisted of a raft made of 6 in. x 2 in. timber with noggins between the main members so as to present a flat bottom in each direction. A wooden superstructure on the raft carried a double skin of polythene to keep out dust and dampness and the top of the units was protected by a ceiling of 1 in. boards. Also, the underground cables had to be extended via the new-building cable trench, and a temporary power plant was installed in the old A-type building on the site and cabled via the new building to the equipment.

When one end of the new building was erected the roof of the old building was dismantled and it was planned to remove the one side wall through which the exchange would be rolled. In the event, when this wall was removed the other three walls were in such a dangerous condition that they also had to be removed. The raft was then jacked up using small hydraulic car jacks, and 2 in. scaffold tubes were placed under the raft. The exchange was pulled up the 9 in. rise on to the floor of the new building; at this point the raft was again jacked up and the scaffold tube rollers turned through 90°. The exchange was then pushed by 4 men into the erected end of the new wooden building. During this operation the power and underground cables were pulled back into the new building, where they were eventually shortened and a new power plant provided in the new building. The erection of the second half of the building then proceeded; special attention has been paid to site drainage to avoid a recurrence of the subsidence troubles. The operation is shown in the photographs.

N. A. P. and J. A. H.

## Associate Section Notes

### Aberdeen Centre

Our winter session commenced with a visit to Aberdeen central fire station on the evening of 13 September. The visit included a demonstration of the engines and tenders used in fire fighting, a mock rescue from the top of the hose-drying tower and a rescue from a smoke-filled room. On 3 October, Mr. C. Hatley gave a talk entitled "Transistor Battles." This talk, which described the difficulties encountered in designing cheap reliable transistors, proved interesting and informative and was well received by the members present.

R. M.

### Bath Centre

At the annual general meeting in April the following officers were elected: *President*: Mr. C. L. Burgess; *Chairman*: Mr. J. Moxam; *Vice-Chairman*: Mr. R. Hutchins; *Secretary*: Mr. W. J. Rossiter; *Assistant Secretary*: Mr. P. G. Martin; *Treasurer*: Mr. R. P. Bowers; *Social Secretary*: Mr. M. W. Bonning; *Magazine Secretary*: Mr. M. C. Willing.

In June a small party travelled to Southampton and an interesting evening was spent at the sorting office seeing the various items of postal-mechanization equipment. The arrival of outgoing mail was at its peak and we saw the segregation of letters and packages and the sorting of letters

into different lengths under ideal conditions. Particular interest was shown in "Alf," the Automatic Letter Facing equipment, and the variety of parcels which had passed through the parcel-sorting section and were awaiting shipment to Canada, U.S.A., and South Africa.

In July, the members of the Bath Post-Office Retired-Officers' Association were invited on a coach excursion across the new Severn Road Bridge to Tintern Abbey and Chepstow. Our guests included some old colleagues. The evening, a new venture for the Centre, was a great success, and one which will no doubt be repeated.

During the summer, our activities are mainly visits and on 1 September a party of 27 visited the Royal Worcester Porcelain Co. Those who travelled were most impressed by the craftsmanship involved in the production of some beautiful items of porcelain. The afternoon was spent in some rather unkind weather at Stratford on Avon.

On 5 October, we were fortunate in gaining permission for a party to visit the B.B.C. Television Centre, London. An absorbing afternoon was spent touring the studios, control rooms, tele-recording editing rooms, seeing conversion equipment for programs from European or American systems and many other items of interest. The party assembled in the evening at the Centre and saw the tele-recording of "The Illustrated Weekly Hudd" for subsequent transmission.

Also during October we attended a series of three weekly talks on "Better Driving" at the Police Driving School, Devizes, by kind permission of the Chief Constable of Wiltshire. This was followed by a Saturday afternoon demonstration by police drivers of the points covered, and of skidding control and correction on the school skid-pan.

W. J. R.

#### Southampton Centre

The 1967-68 session opened on 19 September when Mr. H. Pounds gave an informal talk on "The Control of Finance in Southampton Telephone Arca." The meeting was well attended, and Mr. Pounds was assisted by Mr. Smith during the discussion following the talk.

Similarly well-attended was the first visit of this session, to the Police Driving School at Devizes on 4 November.

Other items in the program for September-January period included a visit to Standard Telephones and Cables, Ltd., Submarine Cable Division at Southampton Docks and a talk by British Rail Signalling Division on "Electrified Signalling Techniques" coupled with a visit to a recently modernized signalling installation at Eastleigh.

During the first part of this session, membership has increased considerably to approximately 140 members.

D. J. B.

#### Plymouth Centre

At the annual general meeting of the Plymouth Centre held on 27 October the following officers were elected: *Chairman*: Mr. P. J. Mason; *Vice-Chairman*: Mr. N. H. Jeffery; *Secretary*: Mr. J. B. Lafford; *Treasurer*: Mr. G. Manley; *Librarian*: Mr. S. Newcombe; *Committee*: Messrs. V. Martin, N. Tolcher, H. Bayley, C. F. Hardisty and S. A. Currins.

Due to the promotion of both our chairman, Mr. Kingcombe, and treasurer, Mr. D. Grant, we have had to elect new officers and committee.

The winter program has been arranged and commenced with a visit in November to the New Breakwater Gas Plant at Oreston. We hope that the varied program ahead will be of interest to our members.

J. B. L.

#### Cambridge Centre

The 1966-67 session commenced in October with a talk on "Computers and Their Use in the Post Office" by Mr. C. A. May. Over 30 members attended this most interesting and informative talk.

This was followed later in the month by the first of three visits to the C.E.G.B. power station at Little Barford. These visits proved most popular and altogether over 50 members attended.

In December we saw films and were able to discuss many aspects of road safety with Mr. F. C. Garner of the Cambridge Accident Prevention Council. This was followed in January by two visits to R.A.F. Oakington to see night-flying operations and in February we enjoyed a talk on "Amateur Radio" by Mr. F. Porter of the Cambridge Amateur Radio Society.

The annual outing in March was to Telephone Cables, Ltd., Dagenham. Two visits were necessary in view of the large demand and altogether 42 members and 9 senior-section members attended. We were able to see the complete manufacture of many different types of underground telephone cables used by the British Post Office.

At the annual general meeting held on 6 April the following officers were elected for the 1967-68 session: *President*: Mr. A. E. Paterson; *Chairman*: Mr. L. Salmon; *Vice-Chairman*: Mr. R. F. Halls; *Treasurer*: Mr. C. F. Nunn; *Secretary*: Mr. R. J. Farrington; *Assistant Secretary*: Mr. R. J. Stewart; *Committee*: Messrs. C. Thorogood, J. Norman, T. Yates, L. Claydon, and I. Smith; *Auditors*: Messrs. J. Clark and P. Howlett.

We offer our congratulations to our previous vice-chairman, Mr. J. P. Wearn, on his promotion to Assistant Executive Engineer.

R. J. F.

#### London Centre

We are very pleased to welcome as the new President of the Associate Section, Dr. P. R. Bray, Principal of the Central Training School, Stone. Dr. Bray can be sure of a warm welcome should he be able to visit us when he is in London.

The 1967-68 session got off to a fine start with a talk on the work of the London Test Section by Mr. R. G. W. Nunn, of the Test and Inspection Branch, Engineering Department. This talk proved very interesting but was marred by an unusually small attendance.

"An Introduction to a Crossbar System" was the subject of a talk by Mr. P. H. Skinner, Exchange Equipment Branch, Engineering Department, at our October meeting. Many members of the Senior Section were present at what was a very informative lecture. Mr. Skinner brought along some colour slides and several pieces of equipment, including a working diagram of the testing and routing of a call. We have to thank the Automatic Telephone & Electric Co., Ltd., for the loan of the latter item.

Our January lecture "Organization and Procedure for Local Automatic Exchanges" was also most interesting.

It is with great regret that we have to report the recent death of our Registrar, Mr. J. W. Clayton, who had served London Centre well for several years.

R. W. H.

#### Edinburgh Centre

The 1967-68 session opened on 20 September with an excellent talk entitled "Cable Pressurization," given by one of our Area Engineers, Mr. D. R. Leask. This meeting was very well attended, 42 being present.

On 3 October, 30 members travelled to Alloa for a visit to Ind Coope, Ltd. We were conducted round the brewery and saw lager in various stages of preparation.

The committee are pleased to report that, after a very successful session last year, interest in the section seems to be growing stronger and we are hopeful of even better support throughout the present session.

M. K. F.

(Continued on page 317)

# Staff Changes

Name	Region, etc.	Date	Name	Region, etc.	Date	Name	Region, etc.	Date
<b>Promotions</b>			<b>Promotions—continued</b>			<b>Promotions—continued</b>		
<i>Deputy Director of Engineering to Director of Engineering</i>								
Barker, H.	Eng. Dept.	2.10.67	Watson, A. C.	L.T. Reg.	5.6.67	Davidson, P. D.	E. Reg.	5.6.67
<i>Area Engineer to Regional Engineer</i>								
Haworth, F.	Scot. to N.E. Reg.	10.7.67	Moon, G. N.	L.T. Reg.	5.6.67	Rogers, P. W.	E. Reg.	5.6.67
<i>Senior Executive Engineer to Assistant Staff Engineer</i>								
Collier, E. G.	Eng. Dept.	3.7.67	Balls, S. C. N.	L.T. Reg.	5.6.67	Castle, D. W.	E. Reg.	5.6.67
Turner, R. J.	Eng. Dept.	3.7.67	Bryan, W. R.	L.T. Reg.	5.6.67	Scott, C. J.	E. Reg.	5.6.67
Munday, S.	Eng. Dept.	10.8.67	Scott, S. B.	Eng. Dept. to L.P. Reg.	10.7.67	Pocock, M. J.	E. Reg.	5.6.67
Wilson, F. A.	Eng. Dept.	18.9.67	Goldie, W. P.	Eng. Dept. to Fact. Dept.	17.7.67	Miller, B. J.	E. Reg.	5.6.67
<i>Senior Executive Engineer to Regional Engineer</i>								
Marrriott, P. E.	Eng. Dept. to L.T. Reg.	3.7.67	Whitehead, R. A.	S.W. Reg.	11.8.67	Spanner, R. A.	E. Reg.	5.6.67
Collings, J. I.	W.B.C. to L.T. Reg.	15.6.67	Taylor, W. K.	Scot.	6.7.67	Rose, L.	Eng. Dept.	5.6.67
<i>Executive Engineer to Area Engineer</i>								
Burt, R. E.	S.W. Reg.	26.6.67	Keenan, R.	N.I.	26.7.67	Clarke, E. A.	Eng. Dept.	5.6.67
Stamp, J.	W.B.C.	29.6.67	Noble, A.	N.E. Reg. to Eng. Dept.	13.7.67	Fellows, E. W.	Eng. Dept.	5.6.67
Dearden, T. T.	N.I.	26.7.67	Beswick, W. S.	Mid. Reg.	28.7.67	Denham, J. R.	Eng. Dept.	5.6.67
<i>Executive Engineer to Senior Executive Engineer</i>								
Goodman, E. T. J.	Eng. Dept.	3.7.67	Fabian, D. F.	L.T. Reg.	24.7.67	Allen, E. R.	Eng. Dept.	5.6.67
<i>Executive Engineer (Open Competition)</i>								
Griffiths, J. M.	Eng. Dept.	19.6.67	Thornton, R. H.	E.T.E. to L.T. Reg.	21.8.67	Blackwell, G. A.	S.E. Reg. to Eng. Dept.	5.6.67
Cartwright, N. E.	Eng. Dept.	2.6.67	Jones, G. W.	W.B.C.	21.8.67	Goodall, G. S. D.	Eng. Dept.	5.6.67
Weller, J. A. H.	Eng. Dept.	24.7.67	Oakes, B. A.	Eng. Dept.	24.8.67	Haslop, A. W.	Eng. Dept.	5.6.67
Garrett, W. F.	Eng. Dept.	18.7.67	Trotter, T. M.	E.T.E.	13.7.67	Roberts, G. E.	Eng. Dept.	5.6.67
Christmas, T. M.	Eng. Dept.	17.7.67	Arnold, D. E. L.	Mid. Reg. to Eng. Dept.	29.8.67	Alhnutt, A. P.	Eng. Dept.	5.6.67
Hill, W. J.	Eng. Dept.	14.8.67	Hallett, K. L.	E.T.E.	13.7.67	Noe, R. P. J.	Eng. Dept.	5.6.67
Boulter, R. A.	Eng. Dept.	12.9.67	Lewis, M. F. J.	F.T.E.	13.7.67	Bryan, K. F.	Eng. Dept.	5.6.67
Tabor, K. J.	Eng. Dept.	18.9.67	Grainger, K.	N.E. Reg. to Eng. Dept.	4.9.67	Worman, A. M. A. F.	L.T. Reg. to Eng. Dept.	5.6.67
Cornforth, R. N.	Eng. Dept.	14.9.67	Hull, A. E.	Mid. Reg.	4.9.67	Rathbone, F. W.	Eng. Dept.	5.6.67
Ioannides, A.	Eng. Dept.	20.9.67	Davis, E. H.	S.W. Reg.	21.8.67	Callegari, C. R.	Eng. Dept.	5.6.67
Heath, C. R. M.	Eng. Dept.	25.9.67	Morse, C. E.	S.W. Reg.	21.8.67	Barrett, N. H.	N.E. Reg. to Eng. Dept.	3.7.67
Steele, P. G.	Eng. Dept.	27.9.67	Thomas, S. W.	S.W. Reg.	21.8.67	Heggie, V. S. J.	Eng. Dept.	5.6.67
Brown, R. A.	Eng. Dept.	2.10.67	Tame, C.	S.E. Reg. to S.W. Reg.	25.9.67	Corbin, P. J.	Eng. Dept.	5.6.67
Stockbridge, J. C.	L.T. Reg.	2.10.67	Gardner, B. W.	L.T. Reg.	29.8.67	Bailey, S. W.	Eng. Dept.	5.6.67
Schubert, R. A.	Eng. Dept.	2.10.67	Storey, J.	N.W. Reg.	25.9.67	Blackler, D. A.	Eng. Dept.	5.6.67
<i>Executive Engineer (Limited Competition)</i>								
Millington, D.	Eng. Dept.	19.6.67	Turner, H. W.	S.E. Reg.	5.9.67	Fraser, I. L.	Eng. Dept.	5.6.67
Bates, E. J.	Eng. Dept.	10.7.67	Mollar, E. L.	E. Reg. to S.E. Reg.	2.10.67	Trinder, D. A.	Eng. Dept.	5.6.67
Pullin, A. E.	T.S.U.	16.5.67	Ashman, D. E. C.	E. Reg.	25.9.67	Connolly, P.	Eng. Dept.	5.6.67
Swain, R. S.	Eng. Dept.	3.7.67	Hoare, T. H.	E.T.E. to Eng. Dept.	16.10.67	Hinkly, A. J.	Eng. Dept.	5.6.67
Phillips, K. H. C.	Eng. Dept.	19.6.67	Toye, L. E.	Eng. Dept.	25.9.67	Bowman, J. W. S.	S.W. Reg. to Eng. Dept.	5.6.67
Gurr, J. W.	Eng. Dept.	12.6.67	Darby, G. W.	Mid. Reg.	5.6.67	Banks, C. F. W.	Eng. Dept.	5.6.67
Smith, F. A.	Eng. Dept.	19.6.67	Farmer, P.	Scot.	31.7.67	Lillie, H. F.	Eng. Dept.	5.6.67
Penny, D. J.	Eng. Dept.	22.5.67	Herington, O. F.	Mid. Reg.	5.6.67	Shackleton, W. P.	N.W. Reg. to Eng. Dept.	5.6.67
Meikle, A. G.	Eng. Dept.	17.7.67	Viney, W.	N.W. Reg.	9.6.67	Sutton, R.	Mid. Reg. to Eng. Dept.	3.7.67
Wotherspoon, R. R.	Scot.	24.7.67	<i>Inspector to Assistant Executive Engineer</i>			Miram, J. A.	Eng. Dept.	5.6.67
Dunstan, P. C.	Eng. Dept.	7.6.67	Warman, D. A.	L.T. Reg. to Eng. Dept.	5.6.67	Bray, C. K.	Eng. Dept.	5.6.67
Pritchard, G. T.	Eng. Dept.	24.7.67	Lamper, J. A. M.	S.E. Reg.	7.6.67	Ryder, M. E.	E. Reg. to Eng. Dept.	5.6.67
Armstrong, E. S.	Eng. Dept.	12.6.67	Patching, W. J.	S.E. Reg.	7.6.67	Milne, C. S.	Eng. Dept.	5.6.67
Owen, W. J.	Eng. Dept.	26.6.67	Hoare, T. H.	E. Reg.	5.6.67	Middleton, A. E. H.	L.P. Reg. to Eng. Dept.	5.6.67
Sanders, M. V.	Eng. Dept.	26.6.67	Bihet, F. L. W.	E. Reg.	5.6.67	Fleet, A.	W.B.C. to Eng. Dept.	5.6.67
Lucas, D. R. H.	Eng. Dept.	12.6.67	Dalton, E.	N.E. Reg.	19.6.67	McDonald, P.	Eng. Dept.	5.6.67
Perkins, P. M.	Eng. Dept.	19.6.67	Grantham, N. H.	E. Reg.	5.6.67	Pratt, M. W.	Eng. Dept.	5.6.67
Buist, H. S.	Eng. Dept.	3.7.67	Cutter, S. W.	E. Reg.	5.6.67	Simkins, C.	Eng. Dept.	5.6.67
Webb, D.	Eng. Dept.	26.6.67	Polley, H. C.	E. Reg.	26.6.67	Stevens, A. E.	Eng. Dept.	5.6.67
Jackson, E.	N.W. Reg.	10.7.67	Snow, W. G.	E. Reg.	19.6.67	Biggs, S. L.	Eng. Dept.	5.6.67
Dawson, W.	Eng. Dept.	10.7.67	Clark, T. A. D.	E. Reg.	12.6.67	Sullivan, M.	L.T. Reg. to Eng. Dept.	5.6.67
Gillard, R. S.	Eng. Dept.	19.6.67	Hensy, E. N.	E. Reg.	5.6.67	Munson, K. H. T.	Eng. Dept.	5.6.67
Lovegrove, C. J.	Eng. Dept.	19.6.67	Musgrave, S.	W.B.C.	5.7.67	Bunyen, G.	Scot. to Eng. Dept.	5.6.67
Smith, J. R.	Eng. Dept.	19.6.67	Cook, J. H.	L.P. Reg.	15.6.67	Smith, J.	F. Reg. to Eng. Dept.	5.6.67
Domoney, R. P.	Mid. Reg.	24.7.67	Crichton, D. R.	Scot.	14.7.67	Kelly, A.	Eng. Dept.	5.6.67
Martin, D. G.	Eng. Dept.	3.7.67	Grubb, G.	W.B.C.	24.7.67	Cobb, J. B. G.	Eng. Dept.	5.6.67
Holmes, D. C.	Eng. Dept.	26.6.67	Jarrett, P. M.	L.T. Reg.	18.7.67	Wilcock, N. B.	Eng. Dept.	5.6.67
Hollands, D. W.	Eng. Dept.	19.6.67	Watson, A. C.	L.T. Reg.	18.7.67	Alger, J. W.	E. Reg. to Eng. Dept.	5.6.67
Fenton, W. A.	N.W. Reg.	24.7.67	Thorley, T. M.	Mid. Reg.	17.7.67	Havis, J. T.	L.T. Reg. to Eng. Dept.	5.6.67
Gubbay, D. M.	Eng. Dept.	19.6.67	Wyrill, J. J.	N.E. Reg.	8.8.67	Salway, J. B.	Eng. Dept.	5.6.67
Cook, R. E. E.	Eng. Dept.	3.7.67	Finall, W. T.	L.T. Reg.	21.8.67	Ambrose, J. E.	Eng. Dept.	5.6.67
Vickers, J. R.	E.T.E. to Eng. Dept.	3.7.67	Stittle, D. W.	L.T. Reg.	21.8.67	Berry, R. J.	Eng. Dept.	5.6.67
Hamer, D. G.	T.S.U.	26.6.67	Ward, T. A.	L.T. Reg.	21.8.67	Watson, J. R.	Eng. Dept.	5.6.67
James, P.	Eng. Dept.	3.7.67	Sutcliffe, H. C.	N.E. Reg.	8.8.67	Wilson, P. C.	S.E. Reg. to Eng. Dept.	5.6.67
Smith, R.	Eng. Dept.	12.6.67	<i>Technical Officer to Assistant Executive Engineer</i>			Boniface, R. R.	S.E. Reg. to Eng. Dept.	5.6.67
Rossiter, D. G.	Mid. Reg.	7.8.67	Williams, T. E. B.	N.W. Reg.	12.6.67	Marshall, F. L.	Scot. to Eng. Dept.	5.6.67
Cull, R. D.	N.E. Reg.	1.8.67	Brasher, F. S.	N.E. Reg.	5.5.67	Cutler, J.	Eng. Dept.	5.6.67
Smith, S. J.	Mid. Reg.	7.8.67	Bennett, H.	N.E. Reg.	5.5.67	Crampsey, D.	N.W. Reg. to Eng. Dept.	5.6.67
Bateson, F.	Mid. Reg.	21.8.67	Burlingham, J.	N.E. Reg.	5.5.67	Smith, C. J.	Eng. Dept.	5.6.67
Crooks, K. R.	L.T. Reg.	16.5.67	MacLeod, K. G. W.	Scot.	30.5.67	Bundy, R. C. H.	L.T. Reg. to Eng. Dept.	5.6.67
Walker, W.	Eng. Dept.	16.5.67	Callan, R. F. D.	S.E. Reg.	18.5.67	Patience, D. G.	Eng. Dept.	5.6.67
<i>Assistant Executive Engineer to Executive Engineer</i>								
Holroyd, K.	Eng. Dept. to N.W. Reg.	19.6.67	Masters, D. S.	S.E. Reg.	14.7.67	Hart, B. J.	Eng. Dept.	5.6.67
Moss, O. P.	S.W. Reg.	17.7.67	Prescott, D. B.	S.E. Reg.	5.6.67	Boxall, D.	Eng. Dept.	3.7.67
Tully, D.	Mid. Reg.	3.7.67	Hall, D. B.	S.E. Reg.	22.5.67	Page, T. J.	Eng. Dept.	5.6.67
Cartwright, A. D.	Eng. Dept.	3.7.67	Davis, E. A.	S.E. Reg.	5.6.67	Bailey, P. J.	Eng. Dept.	5.6.67
Reilly, W. J.	L.T. Reg.	5.6.67	Humphrey, S. G.	S.E. Reg.	19.6.67	Ritson, D. C.	L.T. Reg. to Eng. Dept.	5.6.67
Parsons, E. P.	L.T. Reg.	5.6.67	Stillman, H. R. F.	S.E. Reg.	1.7.67	Doig, D.	Eng. Dept.	5.6.67
Peters, D. G.	L.T. Reg.	5.6.67	Davies, K.	S.E. Reg.	26.6.67	Tuck, T. E. C.	L.T. Reg. to Eng. Dept.	5.6.67
Burnett, A. N.	Scot. to Eng. Dept.	10.7.67	Farquhar, G. E.	Scot.	30.5.67	Baxter, J.	N.E. Reg. to Eng. Dept.	3.7.67
Blackwell, D.	L.T. Reg.	5.6.67	Stevenson, D. L.	Scot.	15.5.67	Bush, P.	L.T. Reg. to Eng. Dept.	5.6.67
Tuerrena, V. H.	E.T.E. to Eng. Dept.	3.7.67	Marshall, R. G.	N.E. Reg.	19.6.67	Bryan, J.	L.T. Reg. to Eng. Dept.	5.6.67
<i>Assistant Executive Engineer to Executive Engineer</i>								
Holroyd, K.	Eng. Dept. to N.W. Reg.	19.6.67	Senior, J. R.	N.F. Reg.	19.6.67	Poulter, A. P.	Eng. Dept.	5.6.67
Moss, O. P.	S.W. Reg.	17.7.67	Campbell, A. C.	Scot.	22.5.67	Gladstone, D. J.	L.T. Reg. to Eng. Dept.	5.6.67
Tully, D.	Mid. Reg.	3.7.67	Robb, E. N.	Scot.	22.5.67	Talbot, D. R.	N.W. Reg. to Eng. Dept.	5.6.67
Cartwright, A. D.	Eng. Dept.	3.7.67	Mains, R.	N.E. Reg.	19.6.67	Smallridge, R.	S.W. Reg. to Eng. Dept.	5.6.67
Reilly, W. J.	L.T. Reg.	5.6.67	Streets, W. A. I.	N.E. Reg.	1.6.67	Ellis, H. A.	L.T. Reg. to Eng. Dept.	5.6.67
Parsons, E. P.	L.T. Reg.	5.6.67	Curry, J.	N.E. Reg.	19.6.67	Luckham, T. D. J.	E.T.E. to Eng. Dept.	5.6.67
Peters, D. G.	L.T. Reg.	5.6.67	Playle, R. E.	E. Reg.	5.6.67	Holmes, W. H.	Eng. Dept.	5.6.67
Burnett, A. N.	Scot. to Eng. Dept.	10.7.67	Hawkins, E. A.	E. Reg.	5.6.67	Roberts, J. W.	W.B.C. to Eng. Dept.	12.6.67
Blackwell, D.	L.T. Reg.	5.6.67	Tovey, J.	E. Reg.	5.6.67	Pepper, E. H. C.	L.T. Reg. to Eng. Dept.	5.6.67
Tuerrena, V. H.	E.T.E. to Eng. Dept.	3.7.67	White, D. H.	E. Reg.	5.6.67	Davis, R. J.	Eng. Dept.	5.6.67
<i>Assistant Executive Engineer to Executive Engineer</i>								
Holroyd, K.	Eng. Dept. to N.W. Reg.	19.6.67	Foster, E.	E. Reg.	5.6.67	Brittain, C. F.	Eng. Dept.	10.7.67
Moss, O. P.	S.W. Reg.	17.7.67	Peacock, D. J.	E. Reg.	5.6.67	Gasper, H. A.	L.T. Reg. to Eng. Dept.	5.6.67
Tully, D.	Mid. Reg.	3.7.67	Abel, F. A. D.	E. Reg.	5.6.67	Knightsong, K. G.	Eng. Dept.	5.6.67
Cartwright, A. D.	Eng. Dept.	3.7.67	Linford-Hazell, L. R.	E. Reg.	5.6.67	Summersgill, P.	Eng. Dept.	5.6.67
Reilly, W. J.	L.T. Reg.	5.6.67	Harper, J. E.	E. Reg.	26.6.67	Galley, S. J.	W.B.C. to Eng. Dept.	5.6.67
Parsons, E. P.	L.T. Reg.	5.6.67	Clare, M. C.	E. Reg.	5.6.67	Nixides, J. G.	L.T. Reg. to Eng. Dept.	5.6.67
Peters, D. G.	L.T. Reg.	5.6.67	Butler, R. S.	E. Reg.	28.6.67	Wren, R. J.	L.T. Reg. to Eng. Dept.	5.6.67
Burnett, A. N.	Scot. to Eng. Dept.	10.7.67				Wakefield, J. E.	Eng. Dept.	5.6.67
Blackwell, D.	L.T. Reg.	5.6.67				Perkins, A.	Mid. Reg. to Eng. Dept.	5.6.67
Tuerrena, V. H.	E.T.E. to Eng. Dept.	3.7.67				Rumens, L.	L.T. Reg. to Eng. Dept.	5.6.67

Name	Region, etc.	Date	Name	Region, etc.	Date	Name	Region, etc.	Date
<b>Promotions—continued</b>			<b>Promotions—continued</b>			<b>Promotions—continued</b>		
Phipps, T. J.	L.T. Reg. to Eng. Dept.	5.6.67	<i>Draftsman to Assistant Executive Engineer</i>			Davies, B. L.	S.E. Reg.	24.7.67
Coller, B. E.	L.T. Reg. to Eng. Dept.	5.6.67	Leggott, D. S.	E. Reg.	28.6.67	Hilder, G. C.	S.E. Reg.	24.7.67
Clarke, R.	L.T. Reg. to Eng. Dept.	5.6.67	Cramphorn, B. H.	L.P. Reg.	22.8.67	Bartlett, G. A.	S.E. Reg.	24.7.67
Jackson, D. A.	N.E. Reg. to Eng. Dept.	5.6.67	Adams, D. M.	L.P. Reg.	22.8.67	Evason, H.	L.T. Reg.	18.7.67
Russell, S. G.	L.T. Reg. to Eng. Dept.	5.6.67				Forster, R. M.	W.B.C.	24.6.67
Hall, G. R.	Mid. Reg. to Eng. Dept.	5.6.67				MacDonald, J. J.	Scot.	7.8.67
Dudley, L. J.	L.T. Reg. to Eng. Dept.	5.6.67	<i>Senior Technician to Inspector</i>			Connelly, R.	Scot.	27.7.67
Martin, R. W. G.	Eng. Dept.	5.6.67	Meredith, C. L.	S.W. Reg.	12.6.67	Warren, W.	Scot.	27.7.67
Bennett, D. N.	Eng. Dept.	5.6.67	Smith, D. W. J.	E. Reg.	26.6.67	Crocker, A. C.	Scot.	27.7.67
Jenkins, P. D.	Eng. Dept.	5.6.67	Watts, L. A.	E. Reg.	19.6.67	Godden, W. L.	L.P. Reg.	22.8.67
Stanbrook, V. W.	Eng. Dept.	5.6.67	Taylor, C. W. R.	L.T. Reg.	5.6.67	Roberts, R. B.	E. Reg.	7.8.67
Halligan, M. C.	Eng. Dept.	5.6.67	Lacey, W. L.	L.T. Reg.	5.6.67	Dutson, C. S.	L.T. Reg.	21.8.67
Goodridge, D. E.	L.T. Reg. to Eng. Dept.	5.6.67	Disspain, S. V.	L.T. Reg.	5.6.67			
Taylor, S. C.	Eng. Dept.	5.6.67	Francis, J. L.	L.T. Reg.	5.6.67	<i>Technician 1 to Inspector</i>		
Howard, M. H.	Eng. Dept.	5.6.67	Parker, F. S.	L.T. Reg.	5.6.67	Pearce, B.	S.E. Reg.	5.6.67
Barnard, G. T.	L.T. Reg.	21.6.67	Smith, J. H.	L.T. Reg.	5.6.67	Deamer, R.	N.E. Reg.	19.6.67
Dolley, P. J.	L.T. Reg.	21.6.67	Ross, A. F.	L.T. Reg.	5.6.67	Hartigan, J.	L.T. Reg.	5.6.67
Stone, C. M. S.	E. Reg.	5.6.67	Kingston, R.	L.T. Reg.	5.6.67	Trinder, T. A. J.	L.T. Reg.	5.6.67
Hooker, R. G.	E. Reg.	5.6.67	McGowan, J. E.	L.T. Reg.	5.6.67	Harding, H. C. C.	L.T. Reg.	5.6.67
Overend, R. K.	N.E. Reg.	19.6.67	Doubrowsky, F.	L.T. Reg.	5.6.67	Evans, R. I.	L.T. Reg.	5.6.67
Dewis, D. W.	S.E. Reg.	3.7.67	Sanders, G. R.	L.T. Reg.	5.6.67	Beale, G. H.	L.T. Reg.	5.6.67
Lacey, B.	N.E. Reg.	19.6.67	Mitchell, S. G.	L.T. Reg.	5.6.67	Kearley, R.	L.T. Reg.	5.6.67
Allen, W. F.	S.E. Reg.	3.7.67	Perrin, L. F. C.	L.T. Reg.	5.6.67	Harris, C. G.	L.T. Reg.	5.6.67
Gascoine, D.	S.E. Reg.	3.7.67	Smithson, E. J.	L.T. Reg.	5.6.67	Randey, P. H.	L.T. Reg.	5.6.67
Ansell, K. M.	S.E. Reg.	3.7.67	Vinton, L. J.	L.T. Reg.	5.6.67	Turnbull, S. E.	L.T. Reg.	5.6.67
Riley, D. L.	S.E. Reg.	3.7.67	Martindale, K. N.	L.T. Reg.	5.6.67	Campbell, E.	L.T. Reg.	5.6.67
Williams, F. E.	L.T. Reg.	21.6.67	Gilson, J. W.	L.T. Reg.	5.6.67	Collins, A. R.	L.T. Reg.	5.6.67
Underhay, D.	S.E. Reg.	3.7.67	Jackson, F. W. A.	L.T. Reg.	5.6.67	Sutton, A. A. F.	L.T. Reg.	5.6.67
Armitage, F.	N.W. Reg.	14.7.67	Harvey, S. H.	L.T. Reg.	5.6.67	Harvey, R. G.	L.T. Reg.	22.6.67
Moody, D. E.	N.W. Reg.	16.6.67	Brandeus, B. F.	L.T. Reg.	5.6.67	Kennedy, S.	L.T. Reg.	22.6.67
Galashan, C. T. E.	N.I.	24.5.67	Simpson, L. C.	L.T. Reg.	5.6.67	Gibbons, J. W.	L.T. Reg.	5.6.67
Jacobs, E. V.	W.B.C.	13.7.67	Isherwood, C. H.	L.T. Reg.	5.6.67	Hayward, P. D.	L.T. Reg.	5.6.67
Lea, B. T.	W.B.C.	13.7.67	Parker, S. L.	L.T. Reg.	5.6.67	Tiller, W. R.	L.T. Reg.	5.6.67
Bleackley, V.	N.I.	27.6.67	Lovering, L. R.	L.T. Reg.	5.6.67	Overington, B. H.	L.T. Reg.	5.6.67
Kerr, R. B.	N.I.	12.6.67	Woodgate, S. W.	L.T. Reg.	5.6.67	Barclay, A. C.	L.T. Reg.	5.6.67
Elworthy, A. A.	L.T. Reg.	18.7.67	Stratfull, W.	L.T. Reg.	5.6.67	Ironside, K. J. M.	L.T. Reg.	5.6.67
Clark, S. C.	L.T. Reg.	18.7.67	Lawrence, G.	L.T. Reg.	5.6.67	Hall, H. G.	L.T. Reg.	5.6.67
Askew, D. E.	L.T. Reg.	18.7.67	Hoath, A. R.	L.T. Reg.	5.6.67	Woodcock, V. R. D.	L.T. Reg.	5.6.67
Downes, A. J. K.	L.T. Reg.	18.7.67	Fuentes, R. A.	L.T. Reg.	5.6.67	Clements, J. T.	L.T. Reg.	5.6.67
Newton, R. G.	N.E. Reg.	24.4.67	Cater, M. A.	L.T. Reg.	5.6.67	O'Brien, B. J.	L.T. Reg.	5.6.67
Linbridge, K. B.	E.T.E.	20.6.67	Mills, J.	L.T. Reg.	5.6.67	Adams, T. E.	L.T. Reg.	22.6.67
Thurley, G. A. E.	E.T.E.	20.6.67	Lewing, R. A.	L.T. Reg.	5.6.67	Bamford, P. J.	L.T. Reg.	22.6.67
Viskin, K. P.	E.T.E.	20.6.67	Leeper, H. C.	L.T. Reg.	5.6.67	Robinson, K. E.	L.T. Reg.	5.6.67
Furse, D. W.	E.T.E.	20.6.67	Bellinger, R. W.	L.T. Reg.	5.6.67	Sparks, A. J.	L.T. Reg.	22.6.67
Hadjioannou, L. N.	E.T.E.	20.6.67	Mepham, R. F. J.	L.T. Reg.	5.6.67	Trinder, A. J.	L.T. Reg.	22.6.67
Bryant, A. J.	E.T.E.	20.6.67	Day, F. E.	L.T. Reg.	5.6.67	Stevens, J. A.	L.T. Reg.	5.6.67
Edwards, A. E.	S.W. Reg.	19.7.67	Phillips, F. J.	L.T. Reg.	5.6.67	Rainbow, S. R.	L.T. Reg.	5.6.67
Bark, L. J.	E.T.E.	20.6.67	Riddle, E. W. H.	L.T. Reg.	5.6.67	Dearmun, S. J. W.	L.T. Reg.	5.6.67
Johnstone, P. L.	E.T.E.	20.6.67	Newby, J.	L.T. Reg.	5.6.67	Shanahan, J. T.	L.T. Reg.	5.6.67
Downing, T. E.	E.T.E.	20.6.67	Cload, R. L.	L.T. Reg.	5.6.67	Taylor, K. H.	L.T. Reg.	5.6.67
Dorothy, T. E.	E.T.E.	20.6.67	White, S. V.	L.T. Reg.	5.6.67	Cockerton, T. C.	L.T. Reg.	5.6.67
Tyers, A. V. A.	Mid. Reg.	17.7.67	Smith, D. P. R.	L.T. Reg.	5.6.67	Butcher, D. P.	L.T. Reg.	5.6.67
Williams, W.	Mid. Reg.	17.7.67	Tetlow, H. S.	L.T. Reg.	5.6.67	Crowden, R. V.	L.T. Reg.	5.6.67
Ashmore, O. F.	Mid. Reg.	17.7.67	Williams, D. W. S.	L.T. Reg.	5.6.67	Maguire, B. C.	L.T. Reg.	5.6.67
Mills, P. C.	Mid. Reg.	25.7.67	Shepard, P. G.	L.T. Reg.	5.6.67	Stephen, R.	L.T. Reg.	5.6.67
Menisham, R. H.	Mid. Reg.	25.7.67	Sexton, D. E.	L.T. Reg.	5.6.67	Gregory, B. H. J.	L.T. Reg.	22.6.67
Lynch, B. A.	L.P. Reg.	22.8.67	Woods, T. S.	L.T. Reg.	5.6.67	Dobbins, W. H.	L.T. Reg.	5.6.67
Leather, W. F.	L.P. Reg.	22.8.67	Johnson, H. W.	L.T. Reg.	5.6.67	Jaynes, D.	L.T. Reg.	5.6.67
Sutton, W. H. J.	L.P. Reg.	22.8.67	Bunclark, A. G.	L.T. Reg.	5.6.67	Laker, C. A.	L.T. Reg.	5.6.67
Wigger, B. R.	L.P. Reg.	22.8.67	Fremaux, A. T.	L.T. Reg.	5.6.67	Ludlow, K. A.	L.T. Reg.	5.6.67
Morlay, W.	L.P. Reg.	22.8.67	Norris, D. F.	L.T. Reg.	14.6.67	Scott, R. T. S.	L.T. Reg.	5.6.67
Hill, W. C.	L.P. Reg.	22.8.67	Rose, F. G.	L.T. Reg.	5.6.67	Pinder, M. A.	S.E. Reg.	7.6.67
Bull, W. E.	L.P. Reg.	22.8.67	Jennings, J. H.	L.T. Reg.	5.6.67	Westpfel, D. R.	S.E. Reg.	5.6.67
Lording, J. D.	L.P. Reg.	22.8.67	Collyer, R. A.	L.T. Reg.	5.6.67	Moore, W. W.	N.E. Reg.	19.6.67
Roberts, A. P.	L.P. Reg.	22.8.67	Lawlor, D. D.	L.T. Reg.	5.6.67	Goddard, H.	N.E. Reg.	19.6.67
Frith, R. J.	L.P. Reg.	22.8.67	Norfolk, W.	L.T. Reg.	5.6.67	Senior, J.	N.E. Reg.	19.6.67
White, H. C.	L.P. Reg.	22.8.67	Nelson, T. E.	L.T. Reg.	5.6.67	France, G.	N.E. Reg.	19.6.67
McGrain, J. D.	Scot.	27.6.67	Entwhistle, M. J.	L.T. Reg.	5.6.67	Wardman, R.	N.E. Reg.	19.6.67
Cavell, G. E.	S.E. Reg.	17.7.67	Jessop, R. C.	L.T. Reg.	5.6.67	Ingram, G. R.	L.T. Reg.	21.6.67
Woodland, C. M.	Eng. Dept.	14.7.67	Warren, L. J.	L.T. Reg.	5.6.67	Senior, R. J. H.	N.E. Reg.	19.6.67
Bright, D. E.	L.T. Reg. to Eng. Dept.	14.7.67	Neatham, T. E.	L.T. Reg.	5.6.67	Soper, F. P.	N.E. Reg.	19.6.67
Cassidy, M. S.	L.T. Reg. to Eng. Dept.	14.7.67	Underhay, F. G.	L.T. Reg.	5.6.67	Grundy, M. R.	N.E. Reg.	10.7.67
Green, G.	N.W. Reg. to Eng. Dept.	14.7.67	Swonnell, F. B. F.	L.T. Reg.	5.6.67	Chapman, A.	N.E. Reg.	19.6.67
Nightingale, B. C.	L.T. Reg. to Eng. Dept.	14.7.67	Brook, J.	L.T. Reg.	5.6.67	Bankes, A. A.	N.E. Reg.	19.6.67
Jones, B.	L.T. Reg. to Eng. Dept.	14.7.67	Llewellyn, V.	L.T. Reg.	5.6.67	Long, A. A.	N.E. Reg.	19.6.67
Fishlock, A. F.	W.B.C.	3.8.67	Wright, J. F.	L.T. Reg.	5.6.67	Bagley, J. C.	N.E. Reg.	19.6.67
Jones, P. J. R.	W.B.C.	3.8.67	Wilkinson, C. E.	L.T. Reg.	5.6.67	Atkinson, G. E.	N.E. Reg.	19.6.67
Stead, R.	N.E. Reg.	8.8.67	Hanrahan, R. W.	L.T. Reg.	5.6.67	Hanley, W.	N.E. Reg.	19.6.67
Kilvington, R. I.	N.E. Reg.	8.8.67	Benstead, J. W.	L.T. Reg.	5.6.67	Bartholomew, J. B.	S.E. Reg.	3.7.67
Howell, M. H.	W.B.C.	10.8.67	Keeling, R. A.	L.T. Reg.	5.6.67	Summerscales, J.	N.E. Reg.	11.7.67
Dunsire, W. G.	N.E. Reg.	8.8.67	Smith, A. C.	L.T. Reg.	5.6.67	Singleton, N. G.	N.E. Reg.	11.7.67
Longden, B.	N.E. Reg.	8.8.67	Wood, R. W. N.	L.T. Reg.	5.6.67	Drake, K.	N.E. Reg.	11.7.67
Bower, G.	N.E. Reg.	8.8.67	Bull, J. B. J.	L.T. Reg.	5.6.67	Rushworth, G.	N.E. Reg.	11.7.67
Buckley, A.	N.E. Reg.	8.8.67	Pemberton, R. D.	L.T. Reg.	5.6.67	Geddes, R. B.	N.E. Reg.	11.7.67
Jones, H.	N.E. Reg.	8.8.67	Beacham, K. J.	L.T. Reg.	5.6.67	Rogers, N. E.	E. Reg.	4.7.67
Holmes, M. T.	L.T. Reg.	21.8.67	Harrnan, A. E.	L.T. Reg.	5.6.67	Wood, V. H.	N.E. Reg.	19.6.67
Pendegrass, J. J.	L.T. Reg.	21.8.67	Mansell, T.	L.T. Reg.	5.6.67	Burns, M. W.	N.E. Reg.	14.8.67
Finch, D. G.	S.E. Reg.	22.8.67	Barton, E. G. E.	L.T. Reg.	5.6.67	Thorpe, P.	N.E. Reg.	29.8.67
Fay, E. E.	S.E. Reg.	22.8.67	Chesterman, A.	L.T. Reg.	5.6.67	Leith, J.	Scot.	27.7.67
Davey, R.	S.E. Reg.	22.8.67	Barlow, W. A.	L.T. Reg.	22.6.67			
Levy, C. C.	S.E. Reg.	22.8.67	Cossey, F. C.	L.T. Reg.	5.6.67			
Barry, C. G.	W.B.C.	11.8.67	Rice, L.	L.T. Reg.	22.6.67			
Robinson, D. A.	N.W. Reg.	11.8.67	Cantell, F. H. J.	L.T. Reg.	3.7.67	<i>Principal Scientific Officer to Senior Principal Scientific Officer</i>		
Humphrey, R. A.	L.T. Reg.	21.8.67	Sander, R. D.	L.T. Reg.	3.7.67	Linke, J. M.	Eng. Dept.	1.7.67
Moss, S. A.	L.T. Reg.	21.8.67	Fagan, E. R.	L.T. Reg.	5.6.67			
Chick, H. F.	L.T. Reg.	21.8.67	Lawton, R. V.	L.T. Reg.	5.6.67	<i>Senior Experimental Officer to Principal Scientific Officer</i>		
Elliott, J. M.	W.B.C.	30.8.67	Stevens, M. G. C.	S.E. Reg.	5.6.67	Henderson, J. C.	Eng. Dept.	10.8.67
Germain, R.	N.E. Reg.	8.8.67	Millwater, J. R.	S.E. Reg.	22.6.67			
Fisher, A. E.	Mid. Reg.	17.8.67	Holmes, W.	L.T. Reg.	22.6.67	<i>Experimental Officer to Senior Experimental Officer</i>		
Lloyd, L. J.	Mid. Reg.	17.8.67	Holmes, R.	L.T. Reg.	3.7.67	Taylor, J. R.	Eng. Dept.	26.7.67
Edwards, P. D.	Mid. Reg.	17.8.67	Phillips, A. A.	S.E. Reg.	17.7.67			
Moreton, M. W.	Mid. Reg.	17.8.67	Turnbull, W. R.	S.E. Reg.	12.7.67			
Morris, L. E.	Mid. Reg.	24.8.67	Breeden, D. B.	N.W. Reg.				
Lovell, A.	Mid. Reg.	25.8.67						

Name	Region, etc.	Date	Name	Region, etc.	Date	Name	Region, etc.	Date
<b>Promotions—continued</b>			<b>Retirements and Resignations—continued</b>			<b>Transfers</b>		
<i>Experimental Officer (Open Competition)</i>			<i>Area Engineer</i>			<i>Area Engineer</i>		
Lemon, T. H.	Eng. Dept.	26.9.67	Munday, C. F.	S.W. Reg.	6.8.67	Baxter, F. C.	Hong Kong to L.T. Reg.	24.7.67
Gill, M. D.	Eng. Dept.	9.10.67	Pack, E.	S.E. Reg.	14.9.67	<i>Senior Executive Engineer</i>		
<i>Scientific Officer (Open Competition)</i>			Bridges, G. W. M.	Eng. Dept.	20.9.67	Millar, J. B.	Eng. Dept. to L.T. Reg.	17.7.67
Johnson, R. L.	Eng. Dept.	13.9.67	Miles, J. V.	Eng. Dept.	25.9.67	Harris, T.	Eng. Dept. to L.T. Reg.	17.7.67
Deutseh, E. S.	Eng. Dept.	27.9.67	Norris, H. E.	S.E. Reg.	30.9.67	Tufner, G.	Metropolitan Police to Eng. Dept.	31.7.67
Burslem, T. J.	Eng. Dept.	2.10.67	Barrett, C. J.	Eng. Dept.	29.9.67	<i>Executive Engineer</i>		
<i>Assistant (Scientific) to Senior Assistant (Scientific)</i>			<i>Assistant Executive Engineer</i>			<i>Executive Engineer</i>		
James, T. D.	Eng. Dept.	12.7.67	<i>(Resigned)</i>			Keen, D. S.	Eng. Dept. to Home Office	19.7.67
<i>(In absentia)</i>			Pedler, F. W.	N.E. Reg.	1.6.67	Sheldrake, R. J.	Fiji to S.W. Reg.	2.6.67
<i>Assistant Experimental Officer (Open Competition)</i>			Bentley, A. J.	L.T. Reg.	1.6.67	Gray, C. F.	L.T. Reg. to E. Reg.	21.8.67
Perkins, G. W.	Eng. Dept.	3.7.67	Marsh, W. G. J. E.	L.T. Reg.	3.6.67	Seamans, K. R.	Hong Kong to Eng. Dept.	4.8.67
Kalia, S.	Eng. Dept.	5.9.67	Mercer, P. T.	Eng. Dept.	3.6.67	Hyatt, F. L.	Eng. Dept. to RSD/WTS	9.8.67
Brewerton, G. A.	Eng. Dept.	2.10.67	Potts, A. E.	N.W. Reg.	5.6.67	Stoate, J. D.	Jamaica to Eng. Dept.	28.9.67
<i>Assistant (Scientific) (Open Competition)</i>			Pilgrim, W. R. O.	L.T. Reg.	10.6.67	<i>Assistant Executive Engineer</i>		
McDonald, R. D.	Eng. Dept.	21.7.67	Buchanan, R. C.	E.T.E.	18.6.67	Harman, F. H.	Eng. Dept. to L.T. Reg.	12.6.67
<i>Motor Transport Officer III to Motor Transport Officer II</i>			Hook, A. G.	L.T. Reg.	21.6.67	Smith, E. J. S.	L.T. Reg. to Home Office	24.7.67
Kirby, J. W.	Eng. Dept.	13.9.67	Cook, S. J.	Eng. Dept.	25.6.67	Thomas, J. D.	Eng. Dept. to N.E. Reg.	14.8.67
<i>Workshop Supervisor I to Technical Assistant</i>			Hodkinson, N.	N.W. Reg.	27.6.67	Warwick, F. L. S.	E.T.E. to Eng. Dept.	29.8.67
Pimm, R.	S.W. Reg. to Mid. Reg.	10.7.67	Greenwood, F. A.	N.W. Reg.	27.6.67	<i>Inspector</i>		
<i>Mechanic-in-Charge to Technical Assistant</i>			Hill, W. I.	S.E. Reg.	30.6.67	Dobson, T. R.	L.T. Reg. to Malawi	31.7.67
Wagg, G. H.	E. Reg. to Eng. Dept.	11.8.67	Wood, L. H.	L.T. Reg.	30.6.67	<i>Scientific Officer</i>		
MacDonald, J. W.	Scot. to Eng. Dept.	11.8.67	Nickson, A. L.	L.T. Reg.	30.6.67	Simmons, T. S.	Eng. Dept. to S.B.R.D.	4.10.67
<i>Mechanic A to Technical Assistant</i>			Day, W. J.	Eng. Dept.	8.7.67	<i>Assistant Experimental Officer</i>		
Welch, L.	N.E. Reg. to Eng. Dept.	25.5.67	Hogg, S. V.	L.T. Reg.	10.7.67	Ballingall, R. A.	Eng. Dept. to Ministry of Defence	25.8.67
McGinlay, J. P.	Scot. to N.E. Reg.	3.7.67	Sawyer, A. D.	N.W. Reg.	13.7.67	<i>Technical Assistant</i>		
Gordon, A.	Scot. to Eng. Dept.	11.8.67	Spencer, F. G.	S.W. Reg.	31.7.67	Pitcher, L.	Eng. Dept. to London Reg.	21.8.67
<i>Draughtsman (Open Competition)</i>			Hopkinson, R. R.	N.E. Reg.	31.7.67	<i>Draughtsman</i>		
Harmon, F.	Eng. Dept.	7.7.67	Brims, W.	L.T. Reg.	31.7.67	Hockey, R. N.	Eng. Dept. to M.P.B.W.	25.9.67
Williams, W. F.	Eng. Dept.	30.6.67	Wheeler, P. J.	Eng. Dept.	9.6.67	<i>Executive Officer</i>		
<i>Clerical Officer to Executive Officer</i>			<i>(Resigned)</i>			Wilson, W.	Eng. Dept. to P.O.S.D.	14.8.67
Perks, G. M. (Mrs.)	Eng. Dept.	1.8.67	Reed, D. C.	Eng. Dept.	9.6.67	Cusway, W. G. (Miss)	P.O.S.D. to Eng. Dept.	14.8.67
Hope, G. F. (Mrs.)	Eng. Dept.	1.8.67	<i>(Resigned)</i>			●Brien, M. E. (Miss)	Eng. Dept. to Ministry of Social Security	1.9.67
Lindfield, O. M. (Miss)	Eng. Dept.	1.8.67	George, F. A.	Eng. Dept.	30.6.67	<i>Deaths</i>		
Brecknell, A. F.	Eng. Dept.	1.8.67	<i>(Resigned)</i>			<i>Senior Executive Engineer</i>		
Bailey, P. A.	Eng. Dept.	1.8.67	Wilson, J. W.	Eng. Dept.	28.7.67	Lamb, A. H.	N.E. Reg.	22.7.67
Aydoire, R. J.	Eng. Dept.	1.8.67	<i>(Resigned)</i>			Mooney, B. K.	Eng. Dept.	21.9.67
Vining, S. A.	Eng. Dept.	1.8.67	Ing, P. J.	Eng. Dept.	31.7.67	<i>Executive Engineer</i>		
Watson, I. M. (Mrs.)	Eng. Dept.	7.8.67	<i>(Resigned)</i>			Connolly, C. F.	N.W. Reg.	8.7.67
Knights, G. A. (Miss)	Eng. Dept.	7.8.67	Carpenter, J.	L.P. Reg.	31.10.67	Gillard, C. H.	S.W. Reg.	9.7.67
Grange, F. G.	Eng. Dept.	14.8.67	<i>(Resigned)</i>			<i>Assistant Executive Engineer</i>		
Shayler, I. G. (Mrs.)	Eng. Dept.	14.8.67	Bannerman, C. L.	Scot.	19.7.67	Kelday, J.	Scot.	16.2.67
Langridge, R. G.	Eng. Dept.	18.8.67	Wilkinson, H. R.	N.E. Reg.	1.8.67	Hill, P.	N.W. Reg.	3.6.67
James, S. R.	Eng. Dept.	29.8.67	Ongley, W. A. J. L.	L.T. Reg.	5.8.67	Crampton, D. A.	E. Reg.	22.6.67
Bretherton, E.	Eng. Dept.	11.9.67	Soundy, W. H.	L.T. Reg.	8.8.67	McMullan, T. P.	N.I.	19.8.67
Andrew, H. G.	Eng. Dept.	4.9.67	Marshall, P. S. H.	L.T. Reg.	8.8.67	<i>Inspector</i>		
Smith, M. A. L. (Mrs.)	Eng. Dept.	18.9.67	Cooper, R. S.	S.W. Reg.	24.8.67	Parsons, J. H.	S.W. Reg.	4.7.67
<b>Retirements and Resignations</b>			Dinnen, T. S.	N.W. Reg.	27.8.67	Jones, J.	S.E. Reg.	21.7.67
<i>Regional Engineer</i>			Milton, W. J.	L.T. Reg.	29.8.67	Whittaker, W.	N.W. Reg.	12.6.67
Brock, P. R. W.	E. Reg.	30.9.67	Wallington, F. S.	S.W. Reg.	31.8.67	<i>Senior Executive Engineer</i>		
<i>Area Engineer</i>			Taylor, H.	N.W. Reg.	31.8.67	Lamb, A. H.	N.E. Reg.	22.7.67
Tinto, J. M.	S.W. Reg.	24.6.67	Calder, H.	N.W. Reg.	31.8.67	Mooney, B. K.	Eng. Dept.	21.9.67
McGachan, J.	N.I.	25.7.67	Russell, P. A.	Eng. Dept.	11.8.67	<i>Executive Engineer</i>		
Wooding, W. T.	L.T. Reg.	31.7.67	<i>(Resigned)</i>			Connolly, C. F.	N.W. Reg.	8.7.67
<i>Executive Engineer</i>			Filmer, A. J.	Eng. Dept.	31.8.67	Gillard, C. H.	S.W. Reg.	9.7.67
McLachan, D. W.	N.W. Reg.	14.7.67	<i>(Resigned)</i>			<i>Assistant Executive Engineer</i>		
<i>(Resigned)</i>			Geater, W.	L.T. Reg.	1.6.67	Kelday, J.	Scot.	16.2.67
Reynolds, N. J. E.	Eng. Dept.	18.8.67	Coles, C. W.	S.W. Reg.	30.6.67	Hill, P.	N.W. Reg.	3.6.67
<i>(Resigned)</i>			Coupland, F. C.	N.W. Reg.	8.7.67	Crampton, D. A.	E. Reg.	22.6.67
Rayner, R. C.	Eng. Dept.	31.8.67	Trigg, E.	L.T. Reg.	18.7.67	McMullan, T. P.	N.I.	19.8.67
<i>(Resigned)</i>			Larsen, T. F.	N.I.	22.7.67	<i>Inspector</i>		
Smith, G. T. C.	Eng. Dept.	31.8.67	Williams, G.	L.T. Reg.	27.7.67	Parsons, J. H.	S.W. Reg.	4.7.67
<i>(Resigned)</i>			Cheeseman, G. T.	S.E. Reg.	28.7.67	Jones, J.	S.E. Reg.	21.7.67
Johns, P. B.	Eng. Dept.	31.8.67	Sargent, W. T.	L.T. Reg.	31.7.67	Whittaker, W.	N.W. Reg.	12.6.67
<i>(Resigned)</i>			Tipping, J.	N.I.	31.8.67	<i>Senior Executive Engineer</i>		
Morse, M. J.	Eng. Dept.	30.8.67	<i>(Resigned)</i>			Lamb, A. H.	N.E. Reg.	22.7.67
<i>(Resigned)</i>			<i>Assistant (Scientific)</i>			Mooney, B. K.	Eng. Dept.	21.9.67
<i>Motor Transport Officer II</i>			Tovey, K. D. (Mrs.)	Eng. Dept.	1.9.67	<i>Executive Engineer</i>		
Mitchell, A. J.	Eng. Dept.	12.9.67	<i>(Resigned)</i>			Connolly, C. F.	N.W. Reg.	8.7.67
<i>Assistant Regional Motor Transport Officer</i>			Harridence, M. (Mrs.)	Eng. Dept.	1.9.67	Gillard, C. H.	S.W. Reg.	9.7.67
Williams, C. F. H.	Mid. Reg.	31.8.67	<i>(Resigned)</i>			<i>Assistant Executive Engineer</i>		
<i>Draughtsman</i>			<i>(Resigned)</i>			Kelday, J.	Scot.	16.2.67
Russell, W. G.	Eng. Dept.	31.8.67	<i>(Resigned)</i>			Hill, P.	N.W. Reg.	3.6.67
<i>(Resigned)</i>			<i>(Resigned)</i>			Crampton, D. A.	E. Reg.	22.6.67
<i>(Resigned)</i>			<i>(Resigned)</i>			McMullan, T. P.	N.I.	19.8.67

**Inverness Centre**

The last meeting of 1966-67, the annual general meeting, was held on 27 April under the chairmanship of Mr. J. W. Innes. Annual reports were presented by both secretary and treasurer, and showed that the committee had spared no effort to achieve a varied and interesting program during the year. Election of new office-bearers followed. The highlight of the evening was the showing of the film "The War Game." The aim was to provoke discussion amongst the members; this the film certainly achieved. The committee now hope that members will air their views at a debate during the session.

The new session opened on 14 September when Mr. P. Thunder, Standard Telephones and Cables, Ltd., East Kilbride, presented a talk "Crossbar Switching Techniques." His claim of reliability and low-maintenance costs, no more faulty wiper cords, messy oil-dag, or bank cleaning was welcome news to youths, Technical Officers and supervising officers alike.

On 12 October, Mr. I. Ramsay, Senior Meteorological Officer at Inverness airport, gave a talk on "Weather Forecasting." He began with showing those present how the five numeral blocks sent on the teleprinter circuits were decoded by the weather forecaster. From an actual message received that afternoon, he built up a weather chart on a map to show how a forecast is charted for a required area.

A. R. H.

**Exeter Centre**

The 1967-68 winter program has now been finalized:

- 9 November: "The Work of the Public Health Inspector," by Mr. F. G. Davies.
- 5 December: "Modern Rodding & Cabling Methods," by Mr. M. Doherty.
- 31 January: "Fault Location in Telephone Exchange Networks," by Messrs. K. W. Hix and C. E. A. Orridge.
- 28 February: "Banks and Banking," by Mr J. H. Brock, Lloyd's Bank, Exeter.

14 March: "The British Canal System," by Mr. G. F. Cload.

Members will doubtless appreciate that in future our winter meetings will be held in the more pleasant surroundings of Queens Building, University of Exeter. As directed at the last annual general meeting, Lecture Theatre Number 2 will be our future venue. It is hoped that members will take advantage and invite guests to our meetings.

The summer program for 1968 will be organized by the assistant secretary, Mr. J. J. Anning. Visits will be arranged as follows.

April: Second visit to B.M.C., Oxford. This visit is being arranged primarily to accommodate members who were unable to attend the first visit, held in 1967. The secretary will be contacting members about this.

May: Evening visit to Upton Pyne Water Works at Exeter.

September: British Aircraft Corporation at Bristol.

Please watch notice boards for news of these events.

The September visit will be held during mid-week and annual leave will be involved. Transport will be by coach.

This year's "Trainee Technician Apprentice" award will be presented at the January meeting.

T. F. K.

**Leeds Centre**

Membership of the centre continues to grow, and in the past year has increased from approximately 360 to over 400.

Visits to Tetley Brewery, Rolls Royce, English Electric and Leeds United football ground were well attended, and lectures, by Mr. J. V. Day, on the subject "Appraisal and Promotion," and Mr. M. F. D. Anderton on "Quality of Service and Reliability," were also enjoyed by members.

At our annual dinner and dance, which was the highlight of the year, 120 members and families enjoyed themselves at Ringways restaurant.

The program for the forthcoming session will include works visits, lectures, and film shows.

K. F.

**BOARD OF EDITORS**

- N. C. C. de JONG, B.Sc.(Eng.), M.I.E.E., A.M.I.C.E., Chairman.
- L. F. SCANTLEBURY, B.E., Whit.Sch., A.C.G.I., D.I.C., F.I.E.E.
- W. J. E. TOBIN, O.B.E., B.Sc.(Eng.), A.C.G.I., D.I.C., F.I.E.E.
- E. W. AYERS, B.Sc.(Eng.), M.I.E.E.
- G. E. BRETT, E.R.D., B.Sc.(Eng.), M.I.E.E.
- A. J. BARKER, F.I.E.E.
- A. G. LEIGHTON, B.Sc.(Eng.), M.I.E.E., Managing Editor.
- J. MARTIN, B.Sc.(Eng.), M.I.E.E., Deputy Managing Editor.
- N. J. H. NINNI, B.Eng., } Assistant Editors.
- R. A. SUDDELL, }
- B. FARR, A.B.I., Secretary-Treasurer.
- R. P. MYHILL, Advertisement Manager.

**Copyright**

The entire contents of this Journal are covered by general copyright, and special permission is necessary for reprinting long extracts, but editors are welcome to use not more than one-third of any article, provided that credit is given at the beginning or end thus: "From *The Post Office Electrical Engineers' Journal*."

The Board of Editors is not responsible for the statements made or the opinions expressed in any of the articles in this Journal, unless such statement is made specifically by the Board.

**Subscriptions and Back Numbers**

The Journal is published quarterly, in April, July, October and January, at 3s. per copy; the post-paid price is 4s. per copy (16s. per year) via inland mail, and 4s. 3d. (17s., or 2 dollars 40 cents Canada and U.S.A., per year) via overseas mail. Back numbers will be supplied, if available, price 3s. (4s. inland mail, 4s. 3d. overseas mail) per copy. With the exception of April and July 1964, July 1965, and January 1966 Journals, copies of the April 1966 and all earlier Journals are no longer available. Orders

should be sent to *The Post Office Electrical Engineers' Journal*, G.P.O., 2-12 Gresham Street, London, E.C.2.

Employees of the British Post Office can obtain the Journal through local agents.

**Binding**

Readers can have their copies of volumes bound at a cost of 25s. by sending the complete set of parts to the local Post Office distribution agent or to *The Post Office Electrical Engineers' Journal*, G.P.O., 2-12 Gresham Street, London, E.C.2.

**Remittances**

Remittances should be made payable to "*The P.O.E.E. Journal*" and should be crossed "& Co."

**Advertisements**

All correspondence relating to advertisement space reservations, copy, proofs, etc., should be addressed to the Advertisement Manager, *The Post Office Electrical Engineers' Journal*, G.P.O., 2-12 Gresham Street, London, E.C.2.

**Communications**

With the exceptions indicated above, all communications should be addressed to the Managing Editor, *The Post Office Electrical Engineers' Journal*, G.P.O., 2-12 Gresham Street, London, E.C.2. Telephone: 01-432 1234.

**Model Answer Books**

Books of model answers to certain of the City and Guilds of London Institute examinations in telecommunications are published by the Board of Editors. Details of the books available are given at the end of the Supplement to the Journal.



**-the first name in mobile radio**



# PYE 'CAMBRIDGE' mobile radio

for dependable, reliability-tested, peak-performance, **always**

- All-transistor receiver - 100 mA battery drain
- G.P.O. approved; meets U.S., Canadian and European specifications
- Sealed I.F. block fitters
- A.M. or F.M. versions
- Dust and splash proof
- Option of 12½ kc/s, 20/25/30 kc/s or 40/50/60 kc/s channel spacing
- 1 to 8 channels available

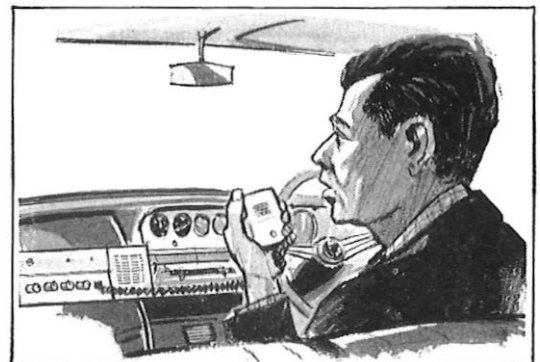

**Pye Telecommunications Limited, Cambridge, England.**  
Telephone Cambridge 61222. Telex 81166



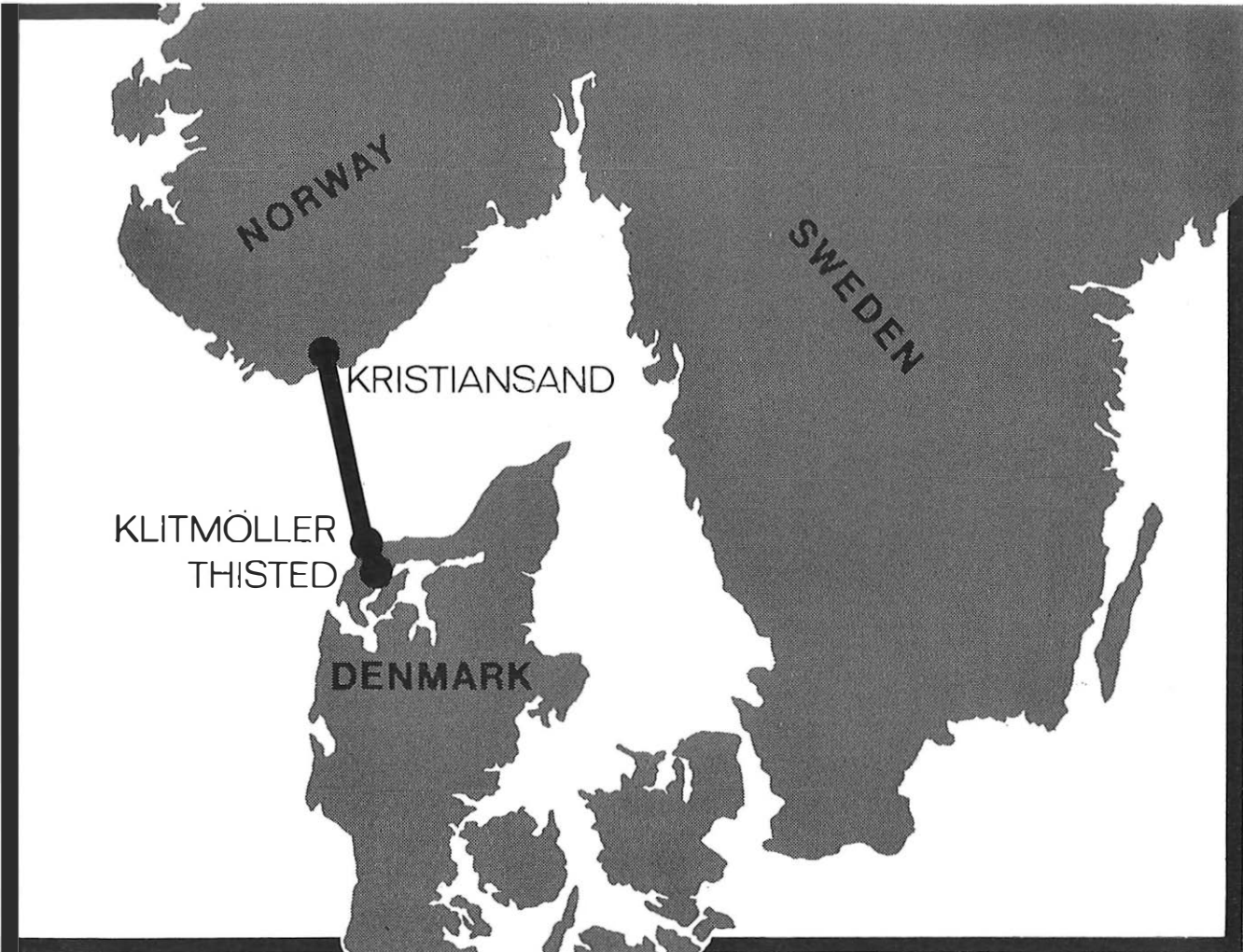

# The world's first 480 circuit Submarine Telephone System **Norway-Denmark**

The world's first 480 circuit submarine telephone cable system went into operation on October 9th, 1967 between Norway & Denmark. The contract was carried out by an all-British company, Submarine Cables Limited who manufactured the 80 nautical miles of cable and 10 transistorised repeaters. The special terminal equipment was manufactured by AEI Telecommunications Group. The cable was laid by the Post Office cables ship 'Monarch' under charter to Submarine Cables Limited. The successful completion of this contract is proof that all-British enterprise is still ahead in this important field of activity.

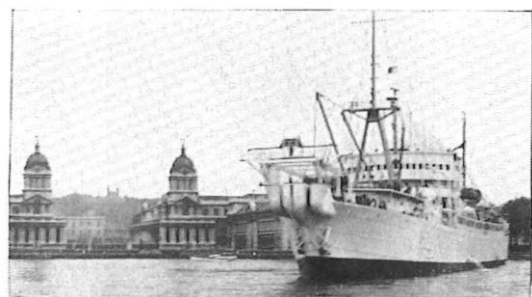

*The Post Office cables ship 'MONARCH' passes the Royal Naval College Greenwich on her way to lay the Norway-Denmark Cable.*



## **Submarine Cables Ltd**

(an AEI Company) GREENWICH, LONDON, S.E.10.  
Telephone: 01-858 3291 Telex: 23687 Cables: Moorings London S.E.10.

# Plessey equipment in telecommunications

The Plessey Telecommunications Group is the largest organisation in the Commonwealth developing and manufacturing equipment for public and private telephone systems. It is one of the five product groups of The Plessey Company Limited, a major force in the related fields of telecommunications, electronics, radar, radio, automation and avionics.

**Conventional and advanced systems**  
The Plessey Telecommunications Group, which employs 30,000 people at home and overseas, manufactures a complete range of exchanges and ancillaries used by P & T Authorities throughout the world. The Group's capability includes Strowger, crossbar and electronic systems.

**Four new factories**  
To keep pace with British Post Office and overseas demands for switching systems, the Group has acquired no less than *four* new factories in the past year.

**Strowger**  
Millions of lines throughout the world are served by Plessey's Strowger systems—and these exchanges are being built at an increasing rate in the Plessey factories in Liverpool, Nottingham and Sunderland.

**'5005' Crossbar**  
Plessey has invested many millions of pounds from its own resources in this system—and is the only British company to have developed a commercial crossbar system. Originally designed for overseas use, '5005' Crossbar is now being supplied to the British Post Office for large non-director exchanges, group switching centres and the international 'Gateway' telephone centre in London. At a time when telephone-operating authorities throughout the world are faced with rapid expansion of facilities '5005' Crossbar meets the needs because of its speed of operation, flexibility, versatility and built-in features which will provide STD and other facilities when required.

*Wiring a crossbar exchange during installation in Nigeria.*



*Conveyor-line wiring of racks for Strowger exchanges at Plessey's Chorley factory.*

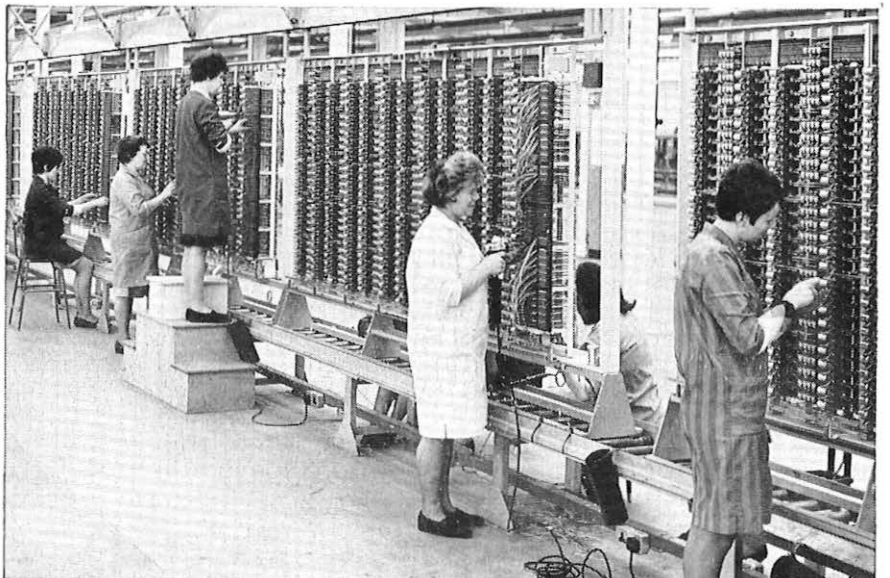

### Pentex

Designated Type TXE2 by the British Post Office and adopted by them in 1966 as standard for exchanges up to 2000 lines, this reed crosspoint system—Europe's first production electronic exchange—is made by the Plessey Telecommunications Group and is marketed overseas under the name 'Pentex'. The cut-over of the first installation was in December 1966, at Ambergate in Derbyshire. It caters for 700 lines, with ultimate expansion to 2000.

Pentex was developed by Plessey, in co-operation with the British Post Office, under the auspices of the Joint Electronic Research Committee. Manufacture is proceeding apace to meet orders from the British Post Office for 30 exchanges in 1967 and a further 30 in 1968, together with overseas orders.

Pentex exchanges take up less space, need less maintenance and offer higher switching speeds than conventional electro-mechanical equipment. Microphonic noise is virtually eliminated.

*The start of constructional work on a six-storey building at Wood Street in London, which will house the new London Gateway '5005' Crossbar telephone exchange to be manufactured by Plessey.*

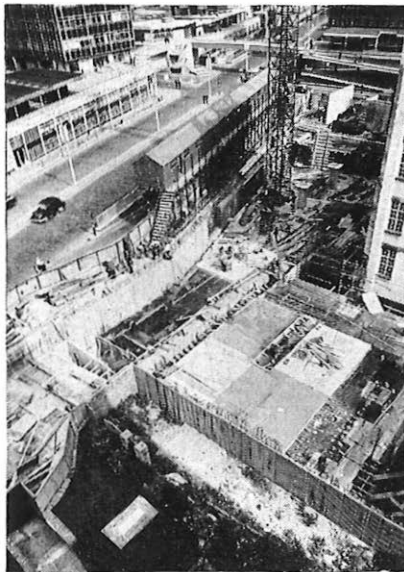

### Pex

The private automatic exchange (PAX) goes electronic and becomes PEX. Adapting the principles of the Pentex System, Plessey Telecommunications Group are completing the development of this private exchange which will accommodate both dial and press-button telephones.

The prototype is a 240-line system, which can be progressively enlarged to 480 lines. The design principle can also be used to build exchanges up to about 2000 lines.

Modifications are also possible to enable PEX to be adapted for private electronic branch exchanges (PEBX) connected to the public telephone network.

*The main distribution frame is part of the Plessey equipment in a 10,000 line exchange serving one of the main areas in the metropolitan zone of Caracas in Venezuela.*



### Reed Selector

Plessey in conjunction with the British Post Office, has developed the intermediate switching stage of the Reed Selector System. This system, designated TXE6 by the British Post Office, is to be used for extending and replacing Strowger exchanges.

The Telecommunications Group has carried out a field trial at the Belgravia exchange in London where intermediate switching equipment was trunked to replace 91 Strowger selectors. This trial proved that Plessey's design fulfilled all the requirements — minimum rearrangements of existing Strowger equipment, minimum provision of new Strowger equipment, convenience of maintenance, and other advantages connected with the introduction of reed-relay exchanges.

*Checking the ferrite core incoming register translator equipment at the Mercury Trunk Switching Centre.*

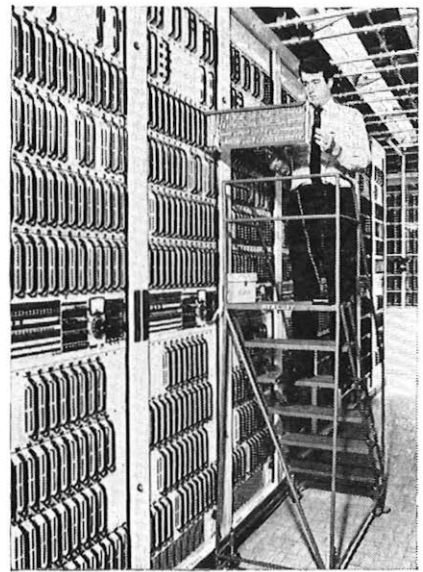

**PLESSEY TELECOMMUNICATIONS**

# Marconi Instruments

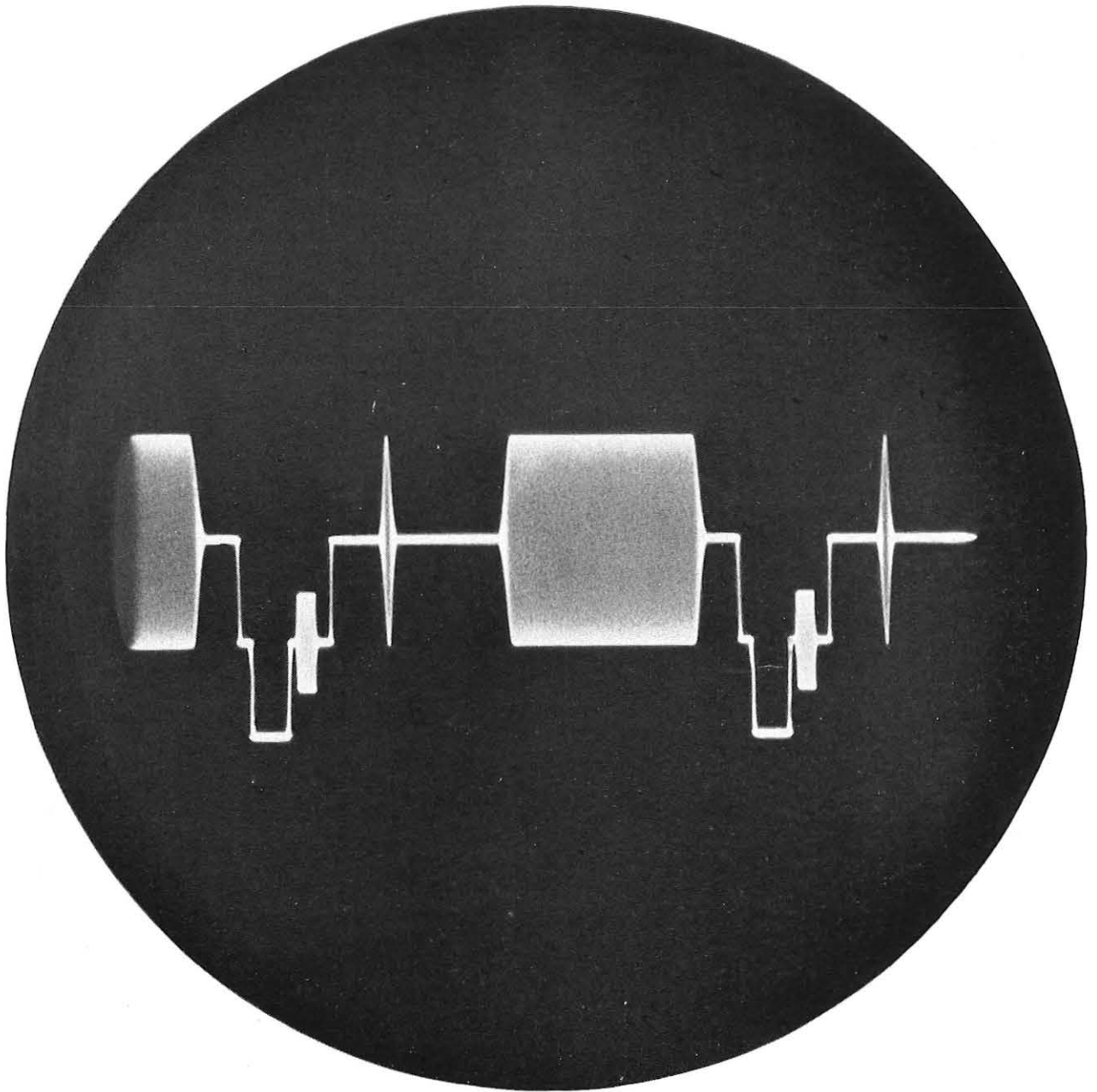

# announce the widest range of compatible, low-cost television transmission testgear *suitable for all standards*

The comprehensive new M.I. range of television transmission testgear is tailored to today's needs in broadcast engineering. The instruments are compatible for building into composite transmission test assemblies. Competitively priced, they are suitable for use on all systems. The range includes:

- \* sine-squared-pulse and bar generators for monochrome & colour
- \* test set for luminance/chrominance gain and delay inequality measurements on colour links
- \* blanking and sync mixers
- \* sweep generators
- \* transmitter sideband analysers

#### Sine-Squared-Pulse and Bar Generator TF2905

Fully transistorised. For 405 and 625 line television systems, monochrome and colour. Generates the standard test waveforms— $\sin^2$  pulse, bar, and staircase (sawtooth optional) or 50Hz square wave on line syncs—for evaluating the performance of television transmission systems. In addition to two types of waveform an oscilloscope trigger pulse is available from a separate outlet. The several versions available meet the requirements of all leading authorities.

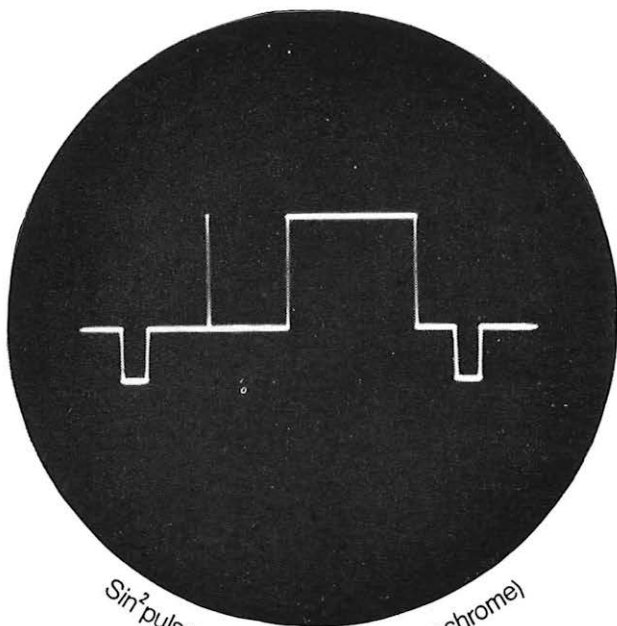

*Sin<sup>2</sup> pulse and bar on Sync. (monochrome)*



Send for full details now . . .

MARCONI INSTRUMENTS LIMITED

An English Electric Company

#### Colour Gain and Delay Test Set TF2904. Fully transistorised

For NTSC and PAL colour television systems. Measures the inequalities in gain and delay between chrominance and luminance channels. The instrument is based on an original design by the BBC.

#### Blanking and Sync Mixer TF2908. Fully transistorised

For 405, 525 and 625 line television systems. Enables sweep or video test waveforms to be superimposed on studio blanking and sync pulses. It is suitable for use with a sweep generator operating a field repetition rate or a test line waveform generator.

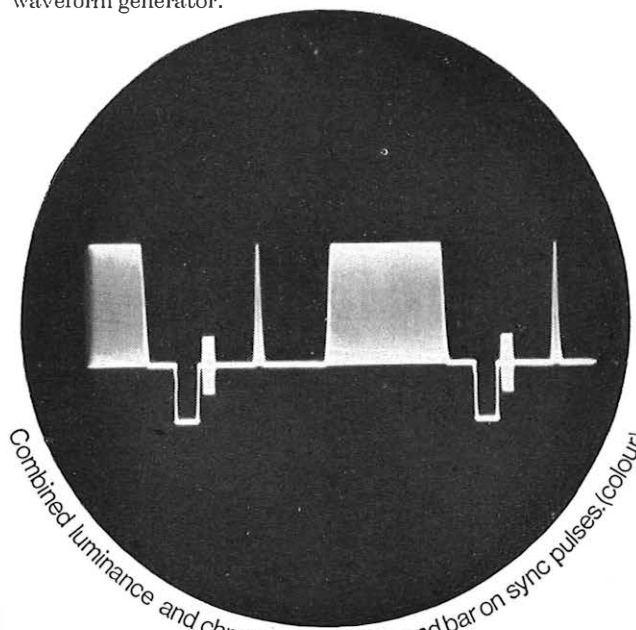

*Combined luminance and chrominance pulse and bar on sync pulses. (colour)*

St. Albans, Herts. Tel: St. Albans 59292 Telex 23350

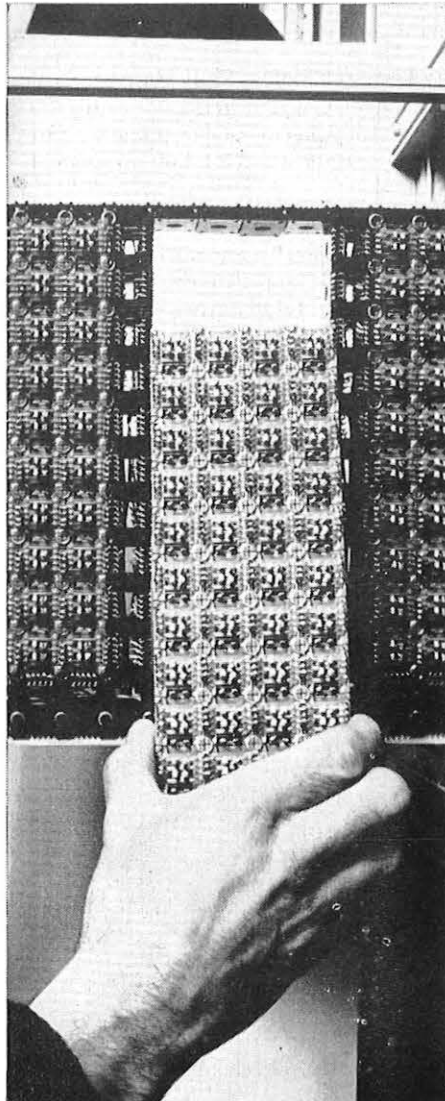
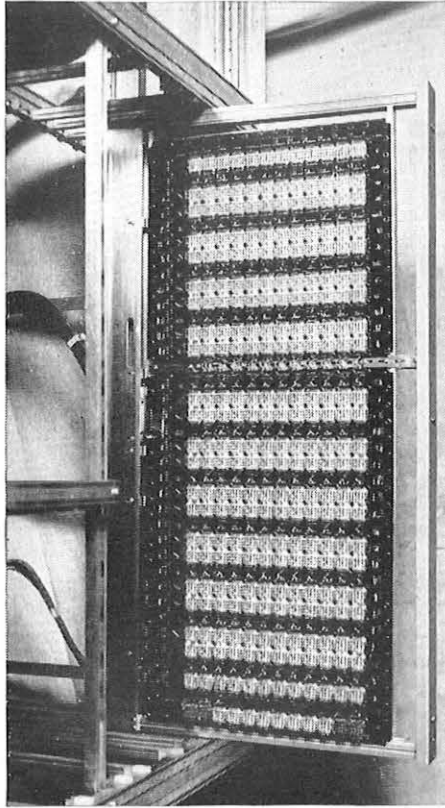

# REX

THE REED ELECTRONIC EXCHANGE

No. 18 system

## packs more lines into less space— AND LEAVES ROOM FOR UNLIMITED EXPANSION

### REX in a nutshell

By providing electronic common control of reed relay spatial switching, the REX system offers an extremely compact and reliable solution to both the switching and control problems of modern exchange design. The REX exchange has been developed by AEI to integrate smoothly with existing automatic networks: its exceptional flexibility ensures full growth capacity for both services and traffic . . .

### Wider range— more accessibility

An entirely new Reed & Electronic Modular Apparatus practice (REMA) has been designed by AEI engineers to provide completely compatible mounting of reed relays and electronic circuit components. Combined with a new sliding-frame mounting system, the REMA practice allows more than 20,000 lines of REX switching equipment to be accommodated in the space normally required by a 10,000 line electro-mechanical exchange. In existing buildings this means more space for future expansion: in new exchanges it makes possible great savings in construction and installation costs. And because the REX subscriber's line circuit can tolerate substantially wider line conditions, a REX exchange will serve an area much larger than that of a conventional exchange, with significant reductions in line plant investment.

### Designed for expansion

The basic design allows for all future switching requirements, including abbreviated dialling and subscriber's automatic transfer, together with all current standard features such as data for automatic message accounting. A stored programme control is provided to expedite inclusion of these and any other special facilities that may be required during the life of the exchange with virtually no redundancy of initial apparatus.

### Minimum maintenance

The high-speed electronic control system is programmed to give complete automatic self-checking and self-reporting of fault conditions and at the same time, routes calls away from areas of faulty equipment. A 3,000 (ultimately 7,000) line prototype reed electronic exchange supplied to the BPO at Leighton Buzzard,\* has been designed for completely unattended operation and reports all servicing requirements to a remote maintenance control centre.

Maximum service security has been ensured by exhaustive circuit design and testing during the development period and by replication of important items of equipment. The control area is sub-divided into independently switched functional units thus ensuring continued operation in the face of faults. Thanks to the REMA system every part of the REX exchange is accessible for inspection or servicing.

*\* Developed in conjunction with the BPO under the auspices of the Joint Electronic Research Committee.*

## SOPHISTICATED ELECTRONICS— BUILDING BLOCK SIMPLICITY!

### The REX switching element

The basis of the REX system is the reed-relay switching element. It contains only nine different piece parts, compared with 200 in a bi-motional selector, and its very simplicity makes it uniquely reliable. There's nothing to wear out and it is sealed completely against dust and atmospheric pollution.

### The REX switching matrix

Switching matrices can be built up in any form simply by clipping reed-relay crosspoints together. Thus unlimited provision for the growth of lines and links is built into the REX system.

### The REX switching unit

Basic switching arrays are built up out of matrices and are arranged in parallel to form a REX switching unit. Typically, a 1,000-line four-section unit would serve a community with an average calling rate of 150 call seconds per line in the busy hour; other calling rates can be accommodated by varying the number of sections.

### The multi-unit REX exchange

Switching and linking arrangements are provided for all sections of each unit so that complete crosspoint path interconnection is made between all lines of the REX exchange. The special linking pattern adopted can cater for all traffic patterns whilst retaining simplicity of control.

### REX electronic control

The REX electronic control has three main areas of activity:  
*Scanners and Registers*: To determine the source and final destination of a call.

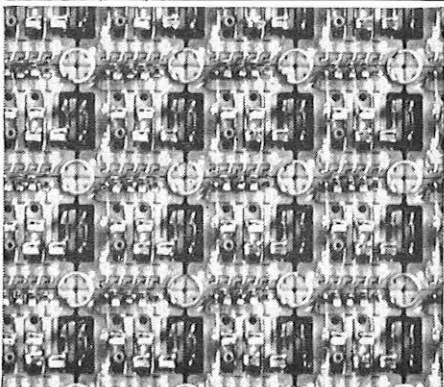
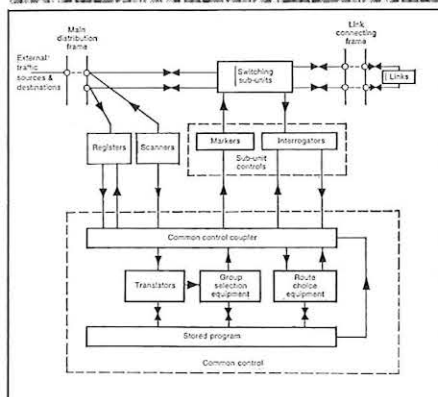
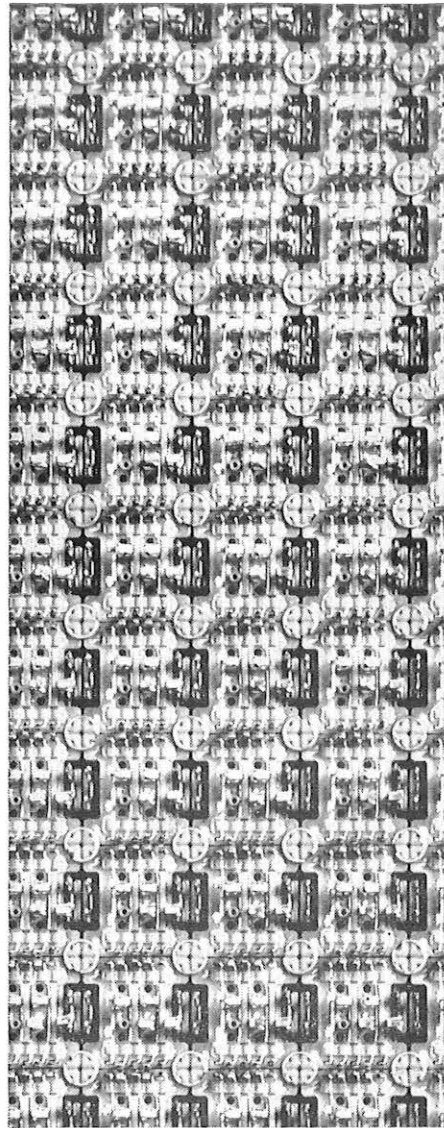

*Markers and Interrogators*: Concerned with interrogating the state of crosspoint paths and marking these paths through the switching sub-units.

*Common Control*: Processes the necessary call setting data in accordance with instruction from the stored programme control so that the calls are routed with maximum utilisation of the switching networks.

### Information for administrations

The AEI REX Information Service is one of the most comprehensive programmes ever offered. In addition to brochures and full technical data, AEI will gladly arrange for their lecture team to visit the engineering staff of interested administrations to provide an introductory course on basic REX principles. Later, key personnel would receive full training both at AEI's UK factories and on-site during installation. Training schools staffed and maintained by AEI are also under consideration for territories where reed electronic exchanges are proposed as standard.

### Please write for full details

Public Telephone Systems  
Department (Electronic)  
Telecommunications Group  
Associated Electrical Industries Limited  
Woolwich, London SE18.  
Tel: Woolwich 2020

*REX is a UK registered trade mark.*

# AEI

## TELECOMMUNICATIONS

# This coaxial cable has to be perfect for all locations

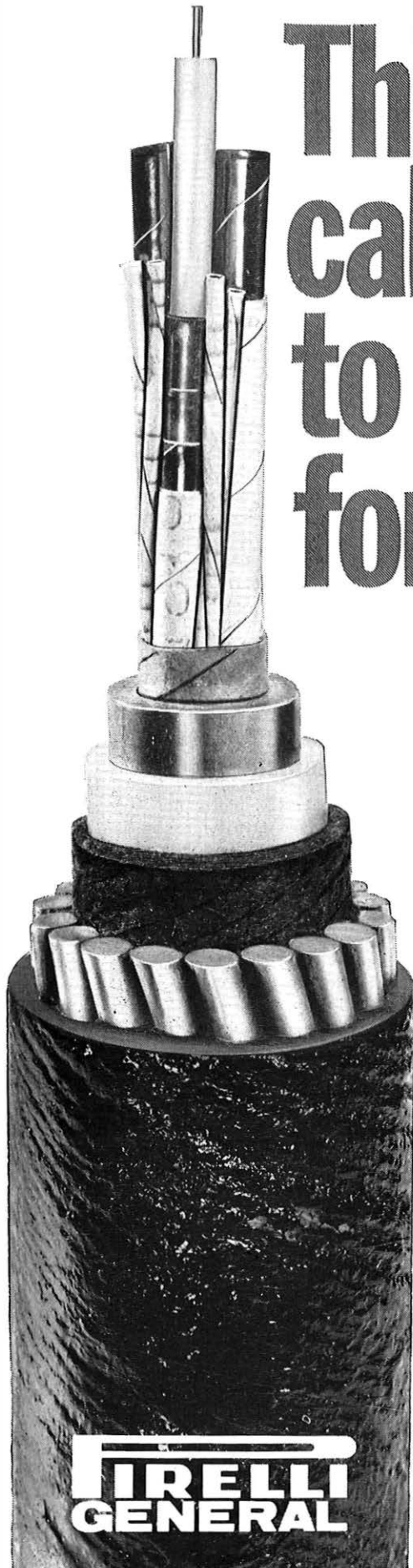

...even at the bottom of a river!

Manufactured by Pirelli General, the first armoured .174 miniature coaxial cable to be installed in Britain was recently laid on the bed of the River Tamar as part of the 80 mile telecommunications link between Plymouth-Truro-Penzance. Installation was by Pirelli Construction Company, except for the river crossing, carried out by the General Post Office.

Up to 960 conversations can be held simultaneously over each two tubes, of only .174 inch diameter with a performance well within CCITT limits for this type of circuit. This installation follows the first of these links (Salisbury-Bournemouth) which was completed in record time by the Pirelli Construction Company.

**PIRELLI GENERAL CABLE WORKS LTD · SOUTHAMPTON  
TELEPHONE : SOUTHAMPTON 20381**



**G.E.C.** of England

G.E.C. (Telecommunications) Ltd., of Coventry, England is a world leader in the field of telecommunications. This large industrial complex, backed by the vast resources of its parent, The General Electric Co. Ltd. of England including a virile research and development organisation, is fully capable of undertaking complete contracts, including the manufacture and installation of a comprehensive range of telecommunications equipment, surveying, planning, maintenance, and the training of personnel.

**International**

**capability in telecommunications**

G.E.C. can demonstrate the proven ability to undertake complete contracts on a 'turnkey' basis for the supply of completely integrated national telecommunication networks in many different parts of the world.

**Transmission** equipment with

**world - wide** acceptance

One of the major contributions made by G.E.C. to the advancement of the world's communications has been in the field of transmission equipment. In particular, the introduction of semiconductored microwave radio equipment is an advance of fundamental importance. This equipment, with its inherent advantages of greatly improved reliability, lower maintenance cost and substantially reduced power consumption, enables the many advantages of solid-state techniques to be fully exploited.

**Advanced design in**  
**6000 MHz** equipment

The G.E.C. UHF broadband radio relay equipment Type SPO 5504 exemplifies the advanced characteristics of this new transmission equipment. It is completely semiconductored and operates in the frequency bands 1700 MHz. to 1900 MHz and 1900 MHz. to 2300 MHz. The equipment conforms to the C.C.I.R. recommendations and can provide up to 960 high quality speech circuits or TV (monochrome) plus one sound channel, or TV (colour), 405, 525 or 625-line systems. It is suitable both for high-capacity long haul links and for more lightly loaded short haul links. One of the more recent examples of the application of the G.E.C. 2000 MHz equipment is described overleaf.

**G.E.C.**

**Takes telecommunications  
into tomorrow**

G.E.C. (Telecommunications) Ltd.,  
of Coventry, England.

# G.E.C. of England brings the to Transcontinental

Over £3,000,000

2000 MHz

1500 miles

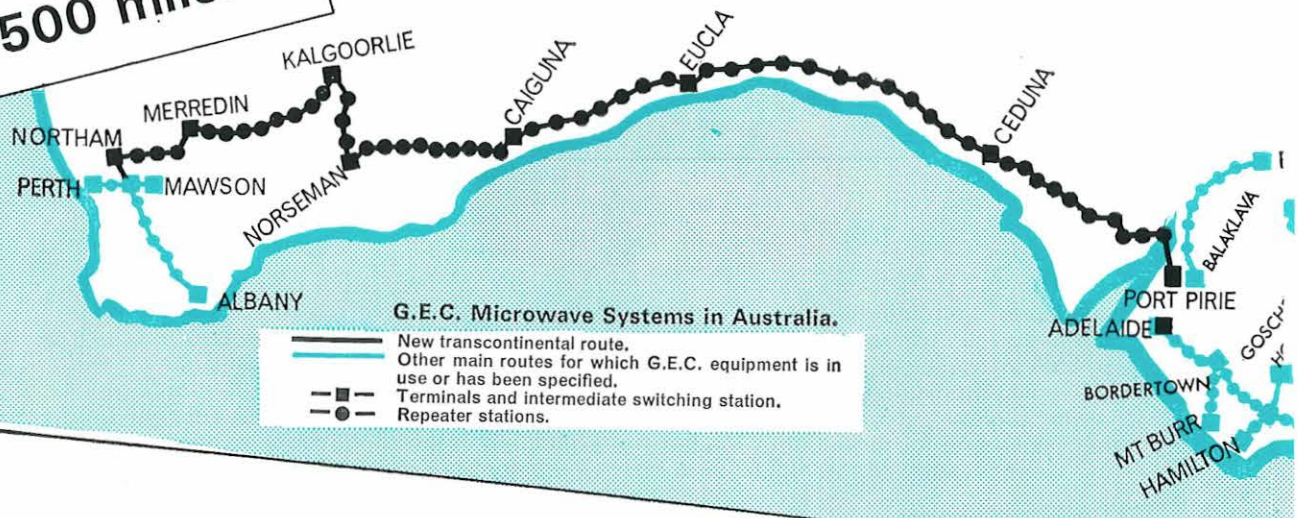

**G.E.C. Microwave Systems in Australia.**

- New transcontinental route.
- Other main routes for which G.E.C. equipment is in use or has been specified.
- Terminals and intermediate switching station.
- Repeater stations.



# latest techniques Telecommunications.



The new 2000 MHz transcontinental microwave communications system linking eastern and western Australia is to be supplied by G.E.C. (Telecommunications) Ltd., of Coventry, England. The contract, worth well over £3,000,000, was gained in the face of intense international competition. One of the longest civil microwave links in the world, it will be in service in 1969, by which time, telephone traffic over the 1500 mile route linking Perth and Adelaide — as far apart as London and Moscow — will amount to about one million calls a year. Initially, the system will provide two bothway radio bearer channels, one main and one standby, with a capacity of 600 telephone circuits. The standby channel may also be used to provide a television link giving a nationwide T.V. network. In addition a separate T.V. channel will be provided between Northam, near Perth, and Kalgoorlie.

The completely semi conductored 2000 MHz equipment will ensure maximum reliability and minimum maintenance of the equipment throughout the mainly virgin country which it will traverse.

For this contract, the standard equipment is being specially modified by G.E.C. to enable wind-driven generators to be used for the main source of power at isolated, unattended repeater stations. Standby diesel generators will be provided for use during windless periods. This special feature of the system is of cardinal importance as the repeaters can be as far as 400 miles from the nearest maintenance centre. The new link will be the biggest single contribution made by G.E.C. to Australia's telecommunications network. Similar links supplied by G.E.C. of England already connect centres in five states. When the Perth-Adelaide system is completed, G.E.C. communication links will span fully threequarters of the southern seaboard.

## Takes telecommunications into tomorrow

G.E.C. (Telecommunications) Ltd.,  
of Coventry, England.

# G.E.C. of England

brings latest techniques  
to 2000 MHz equipment

## Specification summary

U.H.F. Completely Semiconductored  
Broadband Radio Relay Equipment SPO.5504

### Broadband Characteristics

Operating Frequency Bands:  
1700 to 1900 MHz 1900 to 2300 MHz.

Transmitter Output:

1.6 watts nominal.

Transmitter Output Impedance:

50 ohms unbalanced.

Receiver Input Impedance:

50 ohms unbalanced.

Baseband Input/Output Impedances.

75 ohms unbalanced.

Transmitter Heterodyne:

Oscillator Crystal controlled.

Stability of transmitted frequency:

1 part in  $10^4$  including modulator.

Receiver Bandwidth:

Does not exceed  $\pm 20$  MHz (at  
-3 db points).

Receiver Noise Factor:

Nominally 5.5 db.

### Baseband Characteristics (i) Telephony

Capacity:

Up to 960 channels.

Baseband Input Level:

-45 dbr.

Baseband Output Level:

-20 dbr.

Mean Deviation:

200 kHz r.m.s. at channel test  
level.

Pre-emphasis:

As C.C.I.R. recommendations.

### (ii) Television

Capacity:

Colour or Monochrome signals with a  
maximum frequency of 6 MHz.

Input/Output Impedance:

75 ohms unbalanced.

Input Level:

Minimum 1 volt double amplitude peak  
(d.a.p.).

Output Level:

1 volt minimum d.a.p. monochrome and  
colour.

Pre-emphasis:

As C.C.I.R. recommendations.

Deviation:

8 MHz peak-to-peak without pre-emphasis

### General

Power Supplies:

24 volts d.c. In-built d.c. voltage regulators  
cater for supply variations of 21.8 volts to  
28.15 volts.

Power Consumption:

Each transmitter/receiver 5.5 amps. Each pair  
duplicated modulators 1.5 amps. Each pair  
duplicated demodulators 1.5 amps.

For full details  
write for  
Standard  
Specification  
SPO 5504

### ANTENNAS

		8 ft. diam.	12 ft. diam.	15 ft. diam.
Forward	1800 MHz	30.5 db	34 db	36 db
gain	2100 MHz.	31.0 db	34.5 db	36.5 db
Beam width to				
half power points		$\pm 2.5^\circ$	$\pm 1.5^\circ$	$\pm 1.25^\circ$

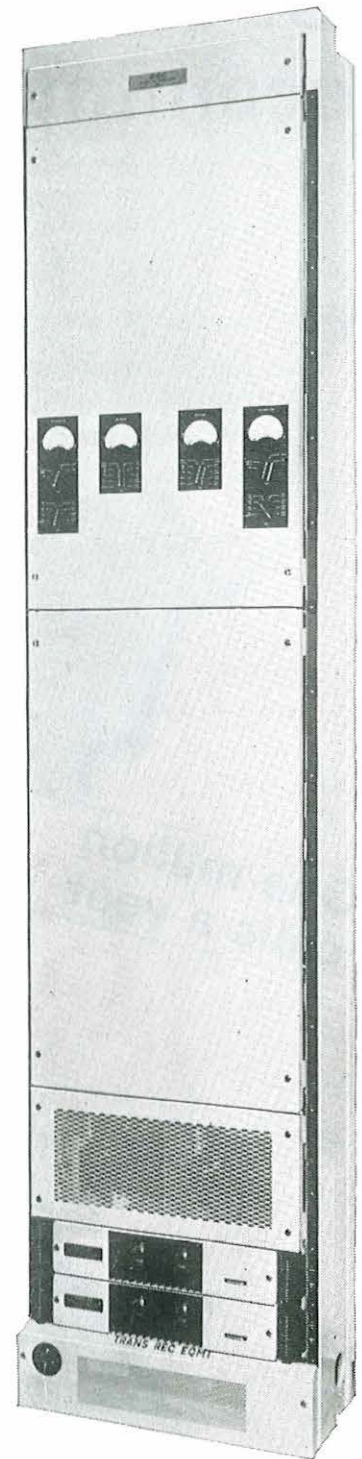

Two transmitters and receivers  
accommodated in one rack 7' 6"  
high x 20½" wide x 8½" deep.

Takes telecommunications  
into tomorrow

G.E.C. (Telecommunications) Ltd.,  
of Coventry, England.

# When is an Avo meter not an Avometer?

When it gives you (a)  $\pm 0.3\%$  accuracy, (b) (c) 100% solid state, (d) (e) (f) semiconductor characteristics data, (g) valve characteristics data, or (h) digital L/C/R measurements.

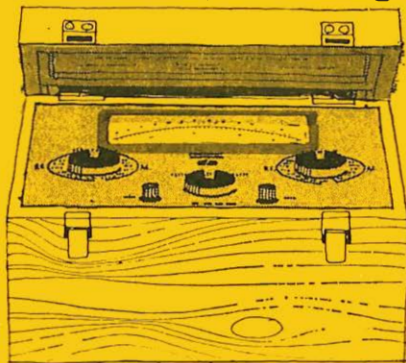

**a** **PRECISION AVOMETER** Measures d.c. voltage (1.5-1500V scales,  $\pm 0.3\%$  f.s.d.\*), d.c. current (1.5mA-15A scales,  $\pm 0.5\%$  f.s.d.\*), a.c. voltage (3V-1500V scales,  $\pm 0.75\%$  f.s.d.), a.c. current (3mA-15A,  $\pm 0.75\%$  f.s.d.). \*meets B.S.S. 89/1954 for precision-grade instruments.

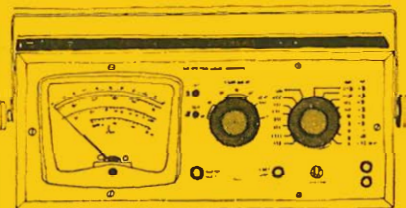

**b** **MULTIMETER HI108** Battery-operated fully-transistorised, measures a.c./d.c. voltage (100mV-1000V scales,  $\pm 4\% \pm 3\%$  f.s.d.), a.c./d.c. current (1 $\mu$ A-3A scales,  $\pm 4\% \pm 3\%$  f.s.d.), resistance (2k $\Omega$ -20M $\Omega$  scales), power (-20 to +60db, 9 scales), r.f. voltage (300mV-10V scales, up to 250MHz with external probe available separately).

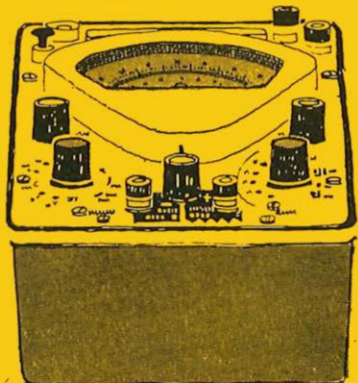

**c** **MULTIMETER CT471A** Battery-operated, fully-transistorised, sensitivity 100M $\Omega$ /V, measures a.c./d.c. voltage (12mV-1200V scales,  $\pm 3\% \pm 2\%$  f.s.d.), a.c./d.c. current (12 $\mu$ A-1.2A scales,  $\pm 3\% \pm 2\%$  f.s.d.), resistance (12 $\Omega$ -120M $\Omega$  scales,  $\pm 3\%$  m.s.d.), h.f./v.h.f./u.h.f. voltage with multiplier (4V-400V scales up to 50MHz; 40mV-4V up to 1000MHz).



**d** **IN-CIRCUIT TRANSISTOR TESTER TT164** Direct-reading, easy to operate, accurate measurements under static and dynamic conditions. Collector voltage: continuously variable, 0-10V. Collector current: continuously variable 0-10mA, 20mA, 30mA. Measures beta (150-300 scales,  $\pm 5\%$ ) and leakage current (300nA-1mA scales).



**e** **TRANSISTOR & DIODE TESTER TT537** Measures both transistor and diode characteristics. Collector voltage: continuously variable 0-12V, stabilised. Collector current: 1 $\mu$ A-1A. Base current: 0.1 $\mu$ A-50mA. Measures hfe (50-1500 scales,  $\pm 3\%$ ), leakage current (50 $\mu$ A-1.5A scales), diode forward voltage drop (1.5-5V scales, 0-500mA forward current) and breakdown voltage (100-1000V scales, 3mA & 200 $\mu$ A currents limited on short circuit to 13mA & 1.3mA).



**f** **TRANSISTOR ANALYSER MK2** Available in both mains-powered and battery-powered versions; provides accurate measurements in grounded-emitter configuration; accommodates high-power and switching types. Collector voltage: 0.05-12V (up to 150V external). Base current: 1-40mA scales. Collector current: to 1A in 5 ranges. Measures leakage current (from 2 $\mu$ A), bfe (25-250 scales), saturation voltage, turn-over voltage and noise factor.

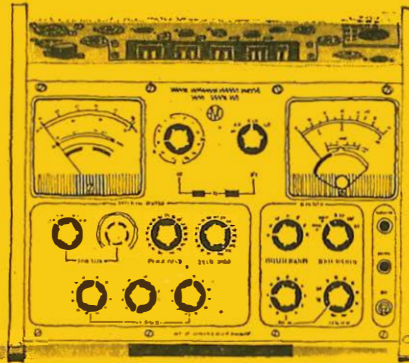

**g** **VALVE CHARACTERISTIC METER VCM163** The most comprehensive instrument of its kind ever offered by Avo. Provision for testing nuvistors, compactrons and other special types with up to 13 pin connections. No need to back off standing anode current before measuring mutual conductance, which is continuously monitored under all conditions. Heater voltage: 0-119.9V in 0.1V steps. Anode and screen voltages: 12.6V-400V. Grid voltage: 0-100V continuous. Measures gm: 6-60mA/V f.s.d. in 3 ranges.

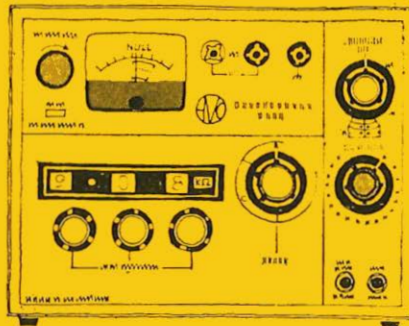

**h** **UNIVERSAL BRIDGE B150** A battery-operated general-purpose bridge with unique automatic digital display of measured component values. No multiplying factors required. Overall accuracy of inductance, capacitance and resistance measurements is  $\pm 1\% \pm 1$  digit. Residuals 0.2pF, 0.15 $\mu$ H and 2m $\Omega$ . Internal 1kHz oscillator & 9V battery, provision for external supplies.

Here are eight members of the Avo test equipment range that combine traditional Avo quality with some of the most advanced instrument technology available anywhere. Start your measurements with a standard Avometer, of course, but as your requirements develop and expand, remember the many other ways in which Avo can continue to help you. For full details, contact Avo Ltd, Avocet House, Dover, Kent. Telephone Dover 2626. Telex 96283.



AV $\Omega$  MEANS BASIC MEASUREMENTS ALL OVER THE WORLD

## VALUABLE FREE BOOK



### Tells You How to Pass Your C. & G. Examination at First Attempt!

All Post Office personnel who are anxious to obtain early promotion should at once send for a copy of our handbook "ENGINEERING OPPORTUNITIES" which, among other intensely interesting matter, describes our unique methods of preparation for the CITY AND GUILDS EXAMINATIONS for the Telecommunication Technicians' Certificate and for individual subjects—Mathematics, Engineering Science, Engineering Drawing, Elementary Telecommunication Practice, Telecommunication Principles, Radio and Line Transmission, Telegraphy and Telephony, Line Plant Practice. It also contains details of our courses covering the G.C.E. subjects required for promotion to Assistant Engineer, Telecommunication Traffic Superintendent and other grades; and the City and Guilds examinations in Electrical Engineering Practice, the A.M.I.E.R.E. and A.M.S.E. Examinations, in addition to a wide range of non-examination courses in all branches of engineering—Radio and Electronics, Electrical, Mechanical, etc.

We also provide tuition for the Radio Amateurs' Examination and the P.M.G. Certificates for Radio Operators, with or without Morse training. Details are given in the handbook.

#### On "SATISFACTION OR REFUND OF FEE" terms

If you intend to make the most of today's opportunities, you cannot afford to miss reading "ENGINEERING OPPORTUNITIES." It tells you everything you want to know to secure advancement, and describes many opportunities you may now be missing through lack of information. Send for your copy today—FREE and without obligation.

BRITISH INSTITUTE  
OF ENGINEERING TECHNOLOGY  
727D ALDERMASTON COURT,  
ALDERMASTON, BERKSHIRE

# BIET

## Elementary Telecommunication Principles

R. N. Renton

A balanced treatment of the first-year subject Engineering Science and the second year subject Telecommunication Principles of the City and Guilds Telecommunication Technicians' Course. Paperback 30s net. Hardback 40s net

## Principles of Electrical Technology

H. Cotton

For first-year electrical engineering students comes this book which replaces Electrical Technology. Fully up-to-date, it now uses M.K.S. units and is more concerned with electronics than its predecessor. 45s net

## Advanced Electrical Technology

H. Cotton

A comprehensive text for second and final-year students of electrical engineering. 75s net

PITMAN 39 Parker Street London WC2

# WHITELEY

ELECTRICAL RADIO CO., LTD.

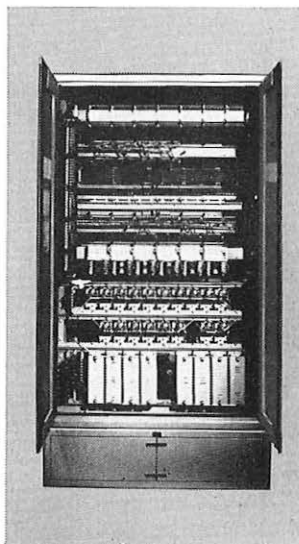
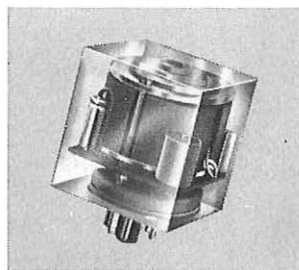

provide a  
comprehensive  
service for  
the design &  
manufacture  
of electronic  
equipment &  
components

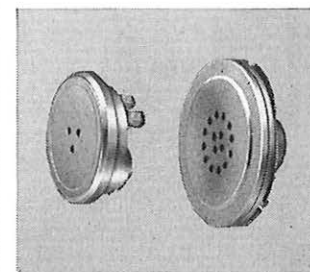

Whiteley Electronic Equipment & Components are designed and precision-built in the Company's own factories. Every operation is strictly controlled, every part is vigorously inspected and tested. Nothing is left to chance—hence Whiteley's enviable reputation.

### WHITELEY ELECTRICAL RADIO CO. LTD

MANSFIELD · NOTTS · ENGLAND  
London Office: 109 KINGSWAY, W.C.2

Tel: Mansfield 24762  
Tel: HOLborn 3074



# FERRANTI solid state microwave devices

Solid State Sources	VHF to J-Band
Frequency Multipliers	VHF to J-Band
Parametric Amplifiers	UHF to X-Band
Variable Capacitance Diodes	UHF to J-Band

*Write for copies of data sheets to:*

The reliability of these microwave devices has been proved by many years experience in various applications. They will operate over a wide range of ambient temperature and their extremely long life makes them ideal for installation in remote sites. Ferranti solid state sources and parametric amplifiers have been used in the Mark I and Mark II radio telescopes at Jodrell Bank for a number of years. The stability of their characteristics has been demonstrated during continuous observation programmes lasting several months. Our standard range consists of over fifty devices and a design team is available to develop units for special applications.

FERRANTI LTD · SOLID STATE MICROWAVE GROUP · ELECTRONICS DEPT.  
WYTHENSHAW, MANCHESTER, 22. Tel: (061) MERcury 5291

# Litesold



## 20 WATT SOLDERING INSTRUMENT

- **CONTROLLED TEMPERATURE**  
Design holds max. temp. of 380°C. within close limits.
- **EASY BIT REPLACEMENT**  
Simple, fast replacement of low-cost copper bits. Non-wearing PERMATIP bits cut servicing costs.
- **BEAUTIFULLY COMPACT**  
Length 7½ in. Weight 1¼ oz. Max. handle dia. 0.715 in.
- **UNEQUALLED PERFORMANCE**  
Ideal for fast production soldering on the majority of modern electronic equipment.
- **ALL VOLTAGES**
- **NEON INDICATOR**  
10, 18, 20 and 25 watt models supplied to special order with Neon Indicator.

The LITESOLD range includes six other models (10, 18, 25, 30, 35 and 55 watts), and many accessories. Please ask for colour catalogue L34.

### LIGHT SOLDERING DEVELOPMENTS LTD

28 Sydenham Road, Croydon, CR9 2LL  
Telephone 01-688 8589 and 4559



Oh, you're not like  
all the others...  
You're different  
somehow

When you're looking for motors and generators that don't come in conventional stock lines, you're looking for us.

E.D.C. specialise in specials. Squirrel cage motors, for instance, are built up to 200 HP with any form of mechanical fixing arrangement. AC motors and DC motors, supplied to suit any mounting, can be watertight or flameproof, shockproof and super-silent, just as you wish. Generators, too, are made in infinite variations to meet 'different' requirements in industrial, marine and telecommunications fields.

Please send me more details of your purpose-made motors and generators.

Name .....

Company .....

Address .....



ELECTRO-DYNAMIC CONSTRUCTION CO. LTD.  
ST. MARY CRAY, ORPINGTON, KENT. Tel: 27551



# FIXED CAPACITORS

A wide range, to suit practically every application, is listed in our Catalogue. Types included are:-

- Silvered Mica
- Ceramic (including Disc, Tubular and lead-through patterns)
- Foil and Paper
- Metallised Paper Polystyrene and Polyester
- Electrolytic (a great variety)

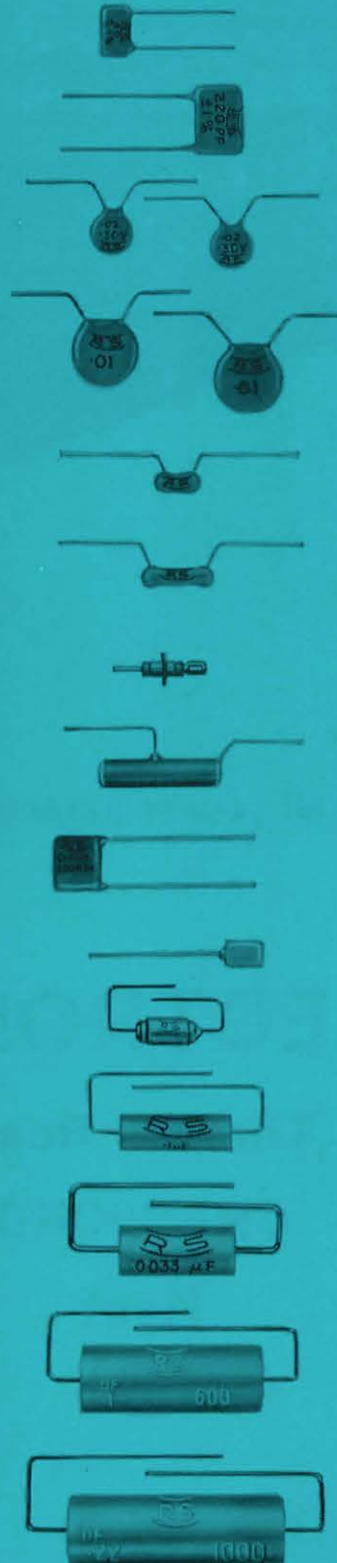

**Radiospares**

4/8 Maple Street, London, W.1.

Telephone: 01-387 7232 (8 lines)

Grams & Cables: Radiospares, London, W.1.



# **TYPE 62 EQUIPMENT**

..... all your requirements can be supplied by

# **CRAY ELECTRONICS LTD**

**Thames Road**

**CRAYFORD**

**Kent**

Sales and Technical  
Service

CRAYFORD 26526

G.P.O. approved

Complete range  
in stock

# STC Telecommunications Review



**Deep down there  
continents are talking**

**Just one fault—and  
they'd stop**

**STC has never lost a  
continent**

**... quite a record!**

Almost half the world's submerged telephone repeaters are ours; over 1,000, with a combined service record of 3,500 unblemished years. And, moreover, we've supplied enough cable to stretch right around the world.

Two-way repeater techniques — now the world standard — were pioneered by STC in co-operation with the British Post Office. Our position as the leading supplier of submarine cable systems and as an innovator of new repeater and cable techniques is now undisputed.

Current orders stand at over £32 million for systems linking South Africa to Portugal, Portugal to U.K., Italy to Spain, Italy to Sardinia, Germany to Sweden and Sicily to Tripoli. Three of these will incorporate our very latest development—transistorised repeaters and terminal equipment that permit up to 640 simultaneous two-way telephone conversations. STC has also provided systems for NATO use in the Mediterranean area.

Standard Telephones and Cables Limited, Submarine Cable Division, Southampton, Hampshire. Telephone: Southampton 74751.



**You can pick out the new Deltaphone with your eyes closed**

So compact and lightweight is the new Deltaphone, you can lift it with one hand. Easily.

At 4.3 inches (109 mm), the body is only slightly wider than the dial. And the handset is less than half the weight of the more conventional variety—just 4 ounces (120 gs)!

When a call comes through on the Deltaphone, listen. It doesn't ring. It warbles discreetly. At any volume level you choose.

When it's silent, the Deltaphone still attracts attention. By its looks.

And high technical specifications match its elegant appearance. With the added attraction of restrained colours to choose from and optional dial illumination, the Deltaphone makes the ideal choice—wherever functional elegance is essential.

Standard Telephones and Cables Limited, Telephone Switching Group, Oakleigh Road, New Southgate, London, N.11. Telephone: 01-368 1234. Telex: 21612.

**Colour TV link distortion**

**Differential phase and amplitude characteristic measurement**

Extensive field tests by the British Post Office have confirmed the performance claims for the STC 74252 Distortion Measuring Set.

Major features include meter readings which supersede the conventional c.r.o. display; solid-state construction throughout and portable or rack-mounted versions.

Measurements on the four range meter are unaffected by acceptable noise on the colour t.v. system. Thus tests no longer need c.r.o. display interpretation. Phase variations between  $0.2^\circ$  and  $15^\circ$  and amplitude variations between 0.25% and 5% can now be measured. For full technical details on the 74252-A & B 625- and 525-line Distortion Measuring Sets write to: Standard Telephones and Cables Limited, Testing Apparatus & Special Systems Division, Corporation Road, Newport, Monmouthshire. Telephone: ONE 3 72281. Telex: 49367.





## Researching ahead to stay ahead



**AHEAD IN STEP-BY-STEP SWITCHING.**  
Over five million lines are already in world service. The new St. Botolphs London Telex Exchange—an important International and Inter-continental transit centre—will be STC equipped. St. Botolphs will provide the most up-to-date switching and signalling systems for world-wide Telex service.

**AHEAD IN CROSSBAR SWITCHING.**  
Three more GPO orders for major transit switching centres. To date over 16 exchanges will be supplied with the STC Crossbar System.

**AHEAD IN ELECTRONIC SWITCHING.**  
STC has been in this technique from the very first, and as a member of the Joint Electronic Research Committee is the leading developer of the large TXE4 system.

Whatever the future, a massive £5 million a year research investment will ensure that STC maintains its world-wide lead in telephone engineering.

Standard Telephones and Cables Limited, Telephone Switching Group, Oakleigh Road, New Southgate, London, N.11. Telephone: 01-368 1234. Telex: 21612.

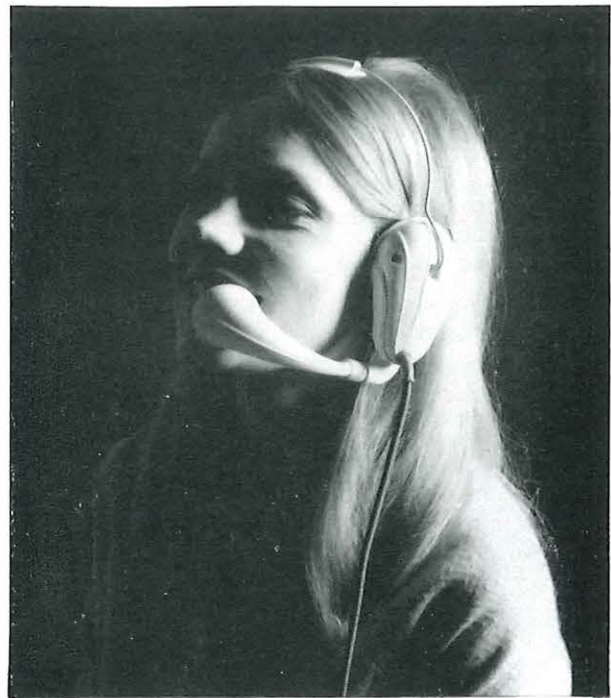

## STC makes telephonists light-headed

STC makes headsets that are so light and comfortable some telephonists forget they're wearing them. They can nod, shake, shrug or frug and the headset stays put.

The exclusive STC 'Rocking Armature' principle improves sensitivity and frequency response. So STC headsets work better (and so do telephonists). All told, STC headsets make telephonists happier, and more efficient.

Made of nylon plastic and virtually unbreakable, the headsets are available in black and grey (colours approved by the GPO) and ivory.

Write, phone or telex for leaflet D/104 to:  
Standard Telephones and Cables Limited, Telephone Switching Group, Oakleigh Road, New Southgate, London, N.11. Telephone: 01-368 1234. Telex: 21612.

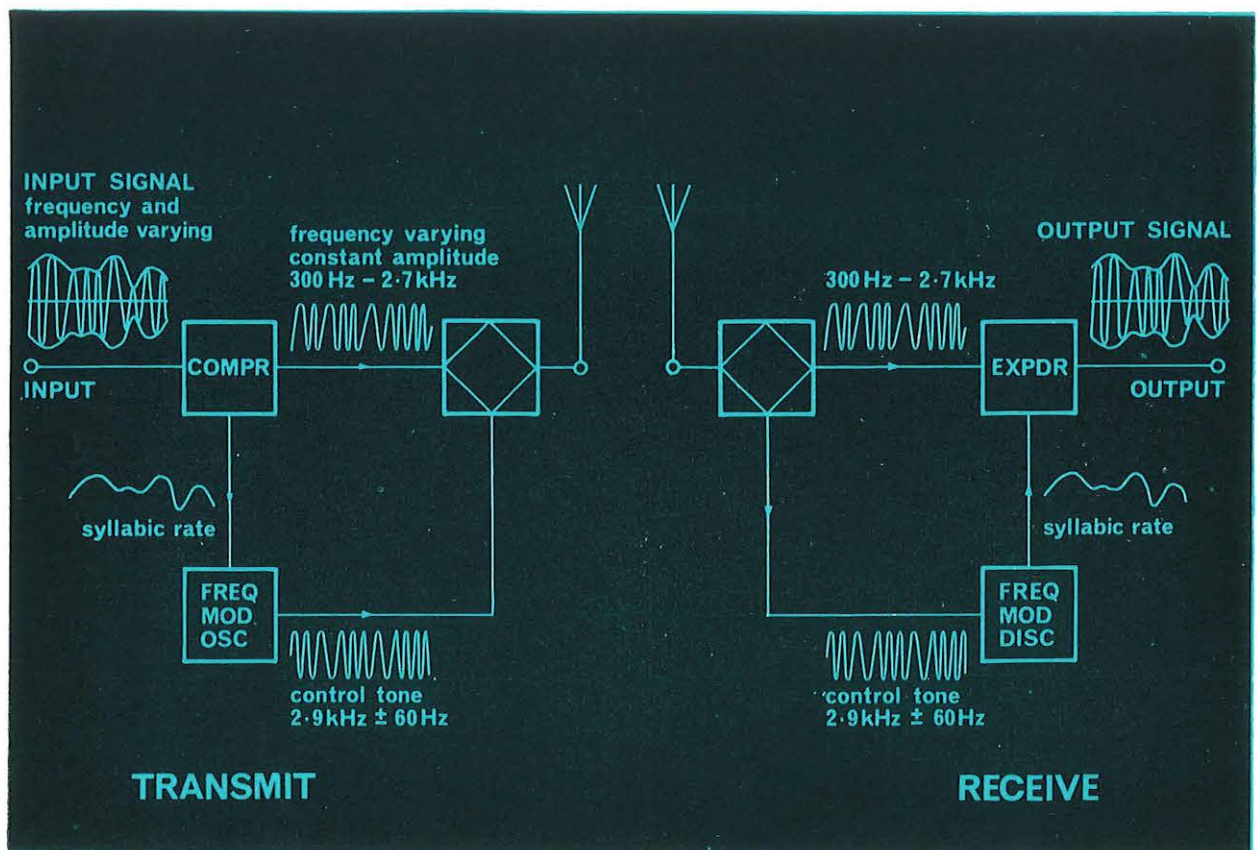

## Always on the air—ignoring the ionosphere

Long distance HF radio telephone links need speech-operated gates to prevent 'singing'. Result—interference, interruption or even complete shut-down when radio noise and fading are troublesome.

STC LINCOMPLEX enables almost any conventional four-wire radio telephone system to use Companding techniques, as it features a constant net loss system. Result—optimum transmitter loading, high signal-to-noise ratio, extended traffic handling capacity.

Voice frequencies are transmitted at constant amplitude between 300 Hz and 2.7 kHz. The voice amplitude variations are used to modulate a variable frequency oscillator, providing a constant amplitude control tone of  $2.9\text{ kHz} \pm 60\text{ Hz}$ . This is transmitted alongside the frequency signal and the two recon-

stituted at the receiver. Since the received signal is only frequency dependent an overall constant loss can be maintained.

A special feature of STC LINCOMPLEX is the remote switching of privacy systems with automatic delay compensation. All performance parameters are in accordance with BPO specifications.

LINCOMPLEX installation costs are rapidly recovered by the increased revenue resulting from greater usage time.

A brochure gives full technical details. Write, phone or telex to: Standard Telephones and Cables Limited, Testing Apparatus and Special Systems Division, Corporation Road, Newport, Monmouthshire. Telephone: ONE 3 72281. Telex: 49367.

# STC

# Why use bulky short-life relays?

when

## **ASTRALUX**

## **REED**

## **RELAYS**

are

# **Inexpensive Long-lasting Space-saving**



GB 91

GB91—MICRO MINIATURE SPST reed relay designed to military and space applications where space and weight are at a premium. Meets or exceeds requirements of MIL-B5757D-12. Contact material gold or rhodium. Contact rating 250 MA at 28 VDC. Operating voltages 6, 12 or 24 VDC, others special.

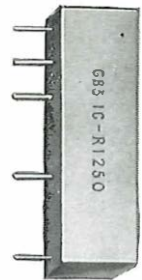

GB 31

GB31—MINIATURE size SPDT dry reed or SPST mercury wetted. Available in moulded epoxy housing or chrome plated steel case. Contact rating form C dry reed 250 MA at 28 VDC res, mercury wetted 3 AMPS at 28 VDC 50% duty cycle. Designed for printed wiring assembly.

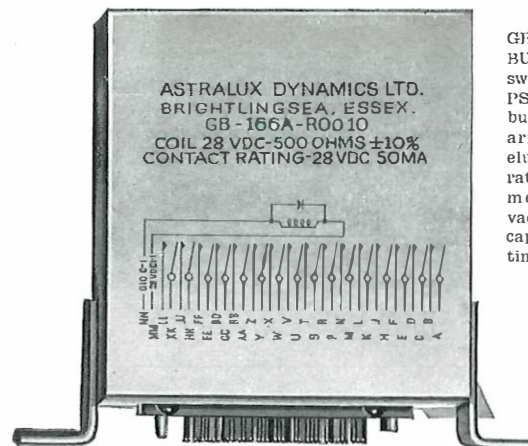

GB 166A

GB 166A—CUSTOM BUILT, multi reed switch reed relay 16 PST. Designed and built to meet military standards including shock, vibration and environmental. Unit is vacuum epoxy encapsulated in hot tinned steel housing.

ASTRALUX DYNAMICS LTD.  
BRIGHTLINGSEA, ESSEX.  
GB-166A-ROO 10  
COIL 28 VDC-500 OHMS  $\pm 10\%$   
CONTACT RATING-28 VDC 50MA

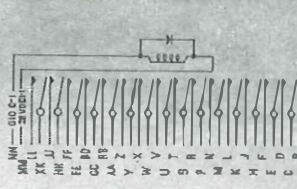

It is astonishing the large number of Relays that are taking up unnecessary space, when Astralux special custom built Relays, as our G.B. 166A, occupy approximately 1/20th the area of normal types. Compare also their full load life in the order of  $10 \times 10^6$  cycles, and it's not surprising why these little wonders are gaining rapid popularity. **Learn also of our new "Reedac" semi solid-state heavy duty Relays rated at 5 amps, 10 amps or 15 amps** with a switching speed of 1 millisecond, extremely low RFI and a life of 500 million cycles.

*Write now for catalogue illustrating the really wide range of circuit ready Reed Relays.*

## **ASTRALUX** *dynamics limited*

# Opportunity to blow!

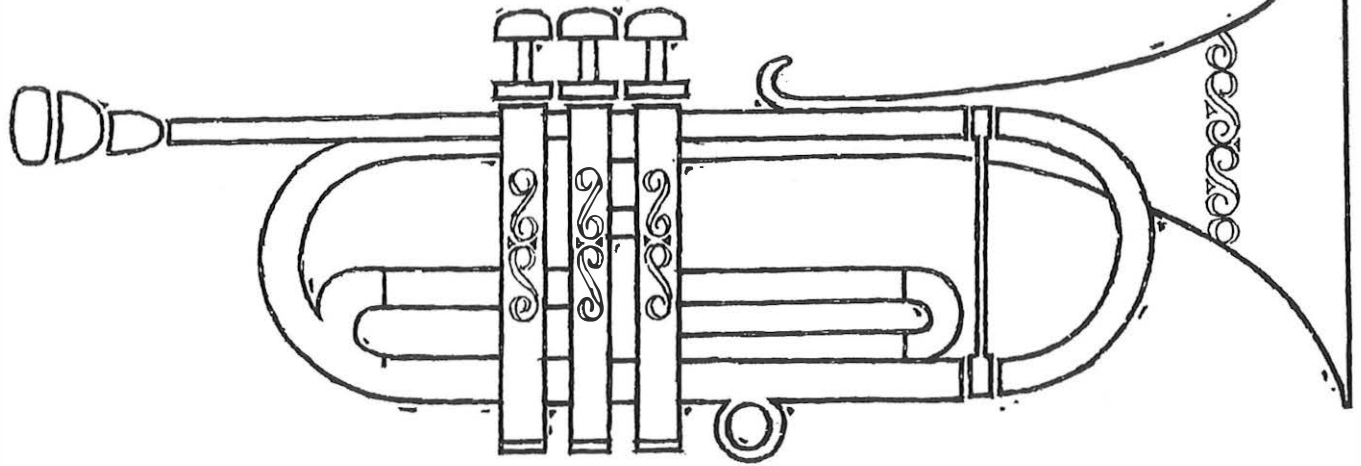

It's not unusual to sound off about extraordinary achievements. So we're taking time out to say that Connollys have continually supplied telephone cables to the British Post Office for over 58 years! We also supply cables to most countries abroad.

Want to make a hit? ... then swing to Connollys for *your* cable needs.

## CONNOLLYS

Connollys (Blackley) Limited Cable Division  
Blackley, Manchester 9. Tel: Cheetham Hill 1801

CL73



## Eddystone 830/7

### Wide range communications receiver

#### PRIMARY FEATURES:

- I.F. SELECTIVITY: Over-all bandwidth continuously variable within the limit of 1.3 kHz and 6 kHz and narrowed to 50 Hz when using the 100 kHz crystal filter.
- VERSATILE TUNING: Incremental control allows tuning to within one kHz with main tuning standardized against internal crystal calibrator.
- CRYSTAL CONTROL: Instant changeover to crystal-controlled operation with rapid selection of up to eight spot frequencies.
- HIGH STABILITY: First and second oscillator circuits can be crystal-controlled for high stability operation.
- SENSITIVITY: Better than 3 microvolts for a 15 dB signal-to-noise ratio.
- RECEPTION MODES: Accepts C.W., A.M and S.S.B modes.

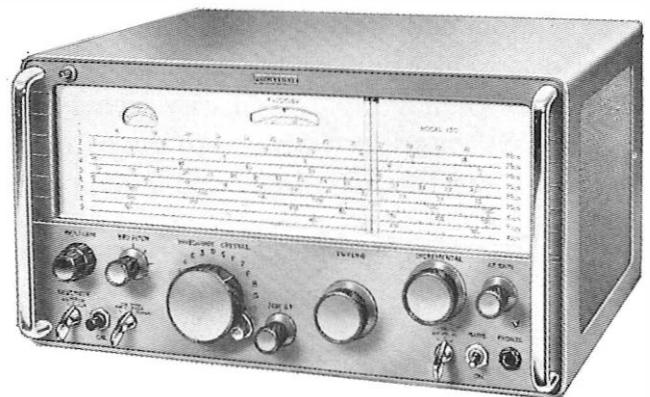

Comprehensive technical data available from:

Eddystone Radio Limited, Eddystone Works, Alvechurch Road, Birmingham 31. Telephone: Priory 2231. Telex 33708

A MARCONI COMPANY

LTD/ED32



# ECONOMY

**120 channels—  
single tube**

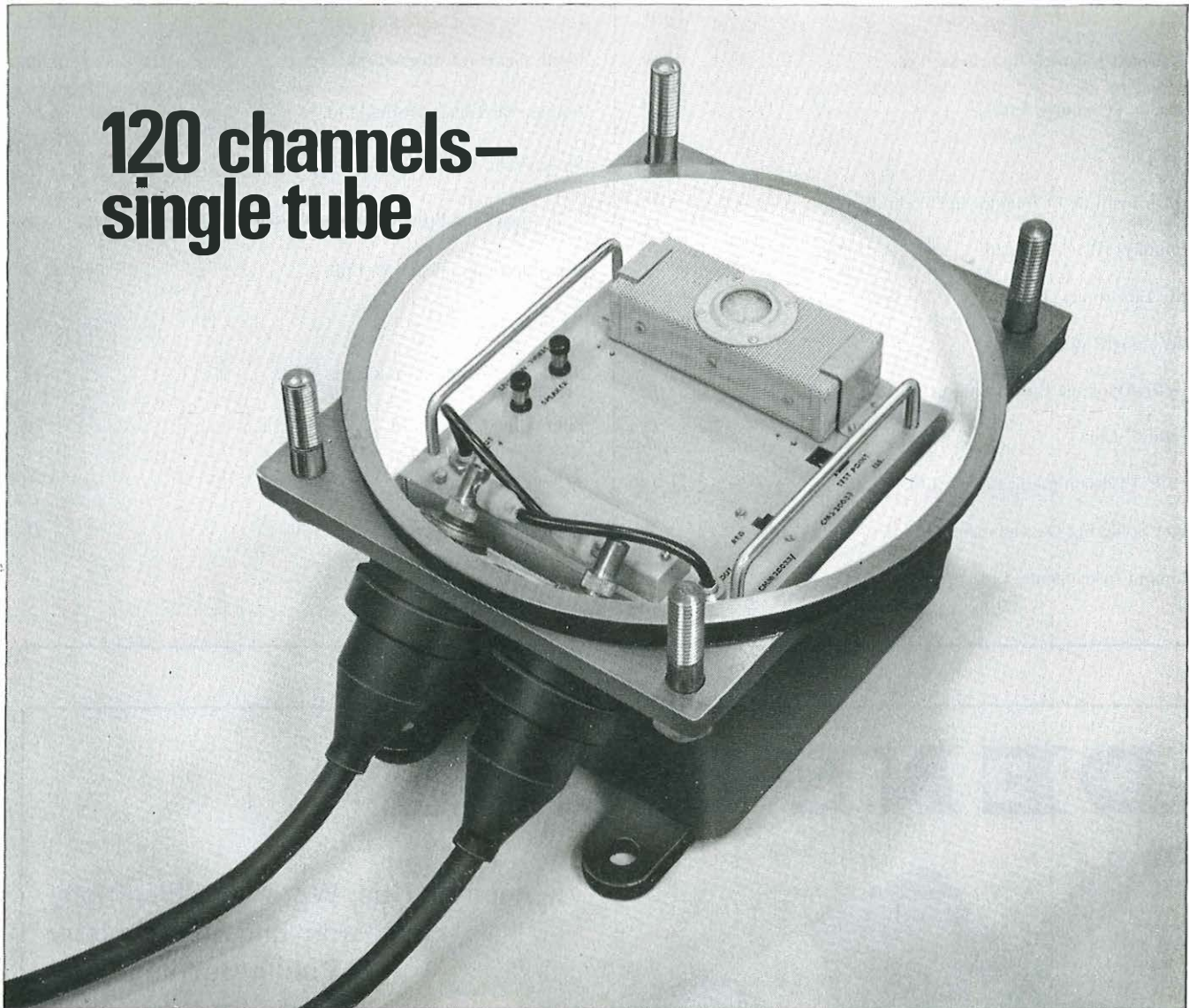

## **Plessey C120A** is the only British **120 channel** coaxial transmission system

The Plessey C120A has been specifically designed to bridge the awkward gap between open wire systems and large capacity coaxial systems. On a single coaxial tube it transmits 120 channels duplex *plus* power feeding *plus* supervisory circuits.

**Economical to install** The system will operate satisfactorily over any standard type of coaxial pair whether installed underground or along existing pole routes. If standard 0.375" coaxial tube is used, power feed is required only every 200 miles. Dependent repeaters are needed every seven miles—but they are enclosed in hermetically sealed cast-iron chambers which can be placed in

shallow manholes and thus avoid the need for costly repeater buildings.

**Economical to operate and maintain** The system is fully transistorised and inexpensive to operate. Installation and maintenance can easily be carried out by semi-skilled staff.

*Type of transmission:* 2-wire *Baseband frequency:* H F direction 812-1304 KHz; L F direction 60-552 KHz.

*Terminal and main repeaters:* Input from STE—45dbr (min)  
Output from STE—20dbr (max).

**PLESSEY**  
**Electronics**



*For full information contact:*

The Plessey Company Limited

AT&E (Bridgnorth) Division, Bridgnorth Shropshire England

Tel: Bridgnorth 2521 Telex: 33373

## INDEX TO ADVERTISERS

	PAGE		PAGE
Associated Electrical Industries, Ltd. . . . .	8, 9	Pirelli General Cable Works, Ltd. . . . .	10
Astralux Dynamics, Ltd. . . . .	25	Pitman, Sir Isaac, & Sons, Ltd. . . . .	16
Avo, Ltd. . . . .	15	Plessey Co., Ltd., The . . . . .	4, 5, 27
British Institute of Engineering Technology . . . . .	16	Preformed Line Products (Great Britain), Ltd. . . . .	29
Connollys (Blackley), Ltd. . . . .	26	Pye Telecommunications, Ltd. . . . .	2
Cray Electronics, Ltd. . . . .	20	Radiospares . . . . .	19
Eddystone Radio, Ltd. . . . .	26	Standard Telephones & Cables, Ltd. . . . .	21-24
Electro-Dynamic Construction Co., Ltd. . . . .	18	Submarine Cables, Ltd. . . . .	3
Ferranti, Ltd. . . . .	17	Telephone Cables, Ltd. . . . .	30
G.E.C. (Telecommunications), Ltd. . . . .	11-14	Whiteley Electrical Radio Co., Ltd. . . . .	16
Light Soldering Developments, Ltd. . . . .	18	Winn & Coales, Ltd. . . . .	28
Marconi Instruments, Ltd. . . . .	6, 7		

# DENSO *M*astic-

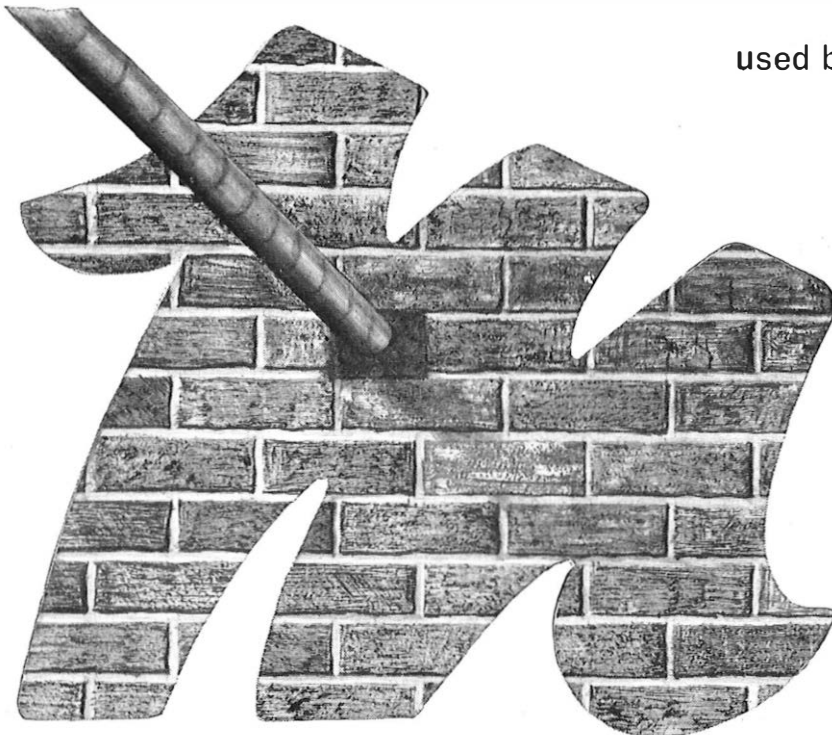

used by Gas, Water and Electricity Boards and the Ministry of Public Buildings and Works for the sealing of service entries.

*Write for a copy of Publication 019 describing the uses of DENSO Mastics and compounds to:—*

**WINN & COALES LTD**

Denso House, Chapel Road  
London S.E.27 Tel: 01-670 7511

Also at Manchester, Belfast and Dublin. Agents throughout the Commonwealth



**Ever done a  
make-off in  
30 seconds?**

With a **GUY GRIP DEAD END** — it's dead easy. Jobs that used to take 1½ to 2 hours—with the new **GUY GRIP DEAD ENDS** can now be completed in 10 minutes. No tedious make-offs, no tools are required, galvanising is undamaged, no stay rods to adjust, **GUY GRIP DEAD ENDS** are the simple and effective means of making-off stay strands and *cannot slip*. Big economies are effected by this method. Demonstrations arranged. Write or 'phone for comprehensive literature.



**Preformed**  
TRADE MARK

PREFORMED LINE PRODUCTS (GREAT BRITAIN) LIMITED  
ANDOVER · HAMPSHIRE · ENGLAND · TEL: ANDOVER 4044/5 · CABLES: PREFORMED ANDOVER  
AGENTS THROUGHOUT THE WORLD. MANUFACTURED UNDER LICENCE FROM PREFORMED LINE PRODUCTS CO. CLEVELAND · OHIO · U.S.A.  
COVERED BY PATENT AND PATENT APPLICATIONS NOS. 817535 · 817055 · 817531 · 805330 · 817644 · 789908.



TCL produces all types of dry core and plastic cables, serves the GPO and organisations in 75 countries throughout the world.

A complete technical advisory service is available.

**Telephone Cables Limited,**  
Dagenham, England. Tel: 01-592 6611  
Cables: Drycore Dagenham

The organisation with 130 years' experience.

**TCL**  
**IN SEVENTY FIVE**  
**COUNTRIES**