

# The Post Office Electrical Engineers' Journal

---

**VOL 62 PART 2 / JULY 1969**



# THE POST OFFICE ELECTRICAL ENGINEERS' JOURNAL

Vol. 62 PART 2 JULY 1969

## Contents

	<i>page</i>
<b>National Data-Processing Service—The Way Ahead—F. J. M. Laver</b>	71
<b>Dialling Problems in Telephone Kiosks—F. E. Williams</b>	73
<b>An Aerial Cabling Unit—D. W. Stenson, R. Hall and B. L. Nuttall</b>	75
<b>Microwave Radio-Relay Links: The Effects of Spurious Emissions from High-Powered Radars—D. E. Cridlan</b>	80
<b>The Accurate Length Measurement of Ferromagnetic Strands and Cables by Magnetic Marking—K. Wilkinson</b>	84
<b>International Telegraph Alphabet No. 5—D. A. Chesterman</b>	89
<b>A 9-Channel V.H.F. Coaxial-Cable Closed-Circuit Television Distribution System—P. W. Lines</b>	93
<b>Recognition of Speech by Machine—S. R. Hyde</b>	100
<b>Standardization of the Large Cordless-Type P.A.B.X.—P.A.B.X. No. 4—R. A. Notman</b>	105
<b>Electronic Acceptance Testers for Strowger-Type Telephone Exchanges—C. Wroe</b>	112
<b>Luminescent Materials Used in Postal Automation—C. F. Forster</b>	120
<b>Polyvinylchloride (P.V.C.) Rods—E. Sullivan</b>	124
<b>Press Notices</b>	126
<b>Notes and Comments</b>	130
<b>Institution of Post Office Electrical Engineers</b>	131
<b>Associate Section Notes</b>	132
<b>Regional Notes</b>	134
<b>Board of Editors</b>	136
<b>Book Reviews</b>	79, 83, 88, 104, 119

Published in April, July, October and January by *The Post Office Electrical Engineers, Journal*, 2-12 Gresham Street, London, E.C.2

Price 3s. 5s. (Including Postage and Packing). Orders by post only.

Annual Subscription (post paid): Home, 20s.; Overseas, 19s. (Canada and U.S.A., 2 dollars 50 cents).

# National Data-Processing Service—The Way Ahead

F. J. M. LAVER, B.SC., C.ENG., F.I.E.E.†

U.D.C. 681.3.001.6: 621.39

*Data-processing is playing an increasing part in the improvement of business efficiency. The Post Office were granted powers in 1967 to run a complete commercial computer service aimed at increasing the use of computers in industry and business.*

*A large number of projects are already being handled and future changes in technology and customer requirements are seen to have a big impact on the service.*

*The Post Office with its long experience in this complex field stands ready to play its part in these developments.*

## THE DEVELOPMENT OF THE NATIONAL DATA-PROCESSING SERVICE

It will be as well to start this article by saying something about how the National Data-Processing Service (NDPS) came into existence, that is, how the Post Office obtained the powers to run a separate commercial business for providing computer service for customers in the commercial world as well as for its own use.

In 1964 some consideration had been given to selling spare time on the Post Office's large computers to outside bodies, but Post Office powers did not at that time allow a complete computer service to be offered. Thus, although "raw" computer time could be sold, systems and programming effort, and the provision and operation of computer centres for outside users was not possible. The 1967 Post Office (Data Processing Service) Act, however, gave the Post Office full powers to run a complete commercial computer service, with assurances that information about its customers' business, derived by NDPS from its work on their behalf, would not be disclosed to third parties. The Post Office Bill now before the House of Commons contains similar provisions. In addition, during the debates leading up to the 1967 Act, the Postmaster General undertook that NDPS would show separate accounts in the annual Post Office Report and Accounts and make its charges comparable with those of outside computer concerns with whom it was competing. The Minister assured the House that NDPS would not use its position within the Post Office either to subsidize Post Office customers at the expense of outside users, or to overcharge them in order to compete unfairly with its commercial rivals.

The Government's objectives in setting up NDPS were to promote the increased use of computers in industry and business, and to use the advantages of scale to provide small computer users with services which otherwise they could not afford to provide for themselves. It was hoped also that the NDPS intervention in the commercial world would assist the rationalization of business methods, which is so vital to Britain's attempt to solve its economic and financial problems. In attempting to meet these objectives, NDPS is bringing to bear a large staff and equipment capability. The staff was built up in the former Computer and Office Services Department of the Post Office, numbers about 1,400, and includes one of the country's largest teams of programmers and systems analysts. The equipment includes former Post Office computers, except those used by GIRO and by Telecommunication Headquarters for scientific work, now taken over by NDPS, and consisting of:

- 6 English Electric LEO 326,
- 2 Elliot 405s (the first Post Office computers purchased in 1957 and used mainly on payroll work), and
- 3 ICL 4-70s on order.

NDPS computers are housed in centres in various parts of the country. There are three centres in London and one each in Edinburgh, Derby and Portsmouth. Further centres are planned in 1969-70 for London and Leeds. It is proposed to develop centres in the Midlands, Manchester, the North East, Glasgow, the South West and South Wales. These centres will be designed to serve the needs of NDPS customers generally, although, initially, some of them may be dedicated to one particular customer.

## NDPS AND THE COMPUTER BUREAUX

In its early stages NDPS services will be provided mainly for its Post Office customers, but plans are in hand to make a serious attempt to capture a significant share of the computer-bureau market. The bureau scene at this time is populated by young concerns full of vitality, and its statistics suggest that an annual growth rate as high as 30-50 per cent in the United Kingdom will not be unusual over the next five years or so. So fast a growth presents problems to all bureaux wishing to expand; it will also lead to very bracing competition and perhaps to some specialization of function amongst bureaux. There are three main suppliers to the bureau market:

- (a) computer manufacturers—as an adjunct of marketing, program testing, and so on.
- (b) commercial bureaux—some small in comparison with NDPS but having great flexibility in their approach.
- (c) individual users—selling spare time at marginal rates to occupy their underloaded machines.

NDPS will be providing a whole range of services from simple card-punching operations to the provision of a full-scale package deal covering systems development, programming, and operating at a NDPS computer centre. It therefore offers a service very similar to those of commercial bureaux.

In its role as a computer bureau NDPS is able to offer considerable advantages to customers. Thus, it has a large professional staff able to operate in the very specialized field of computer work. Again, it is used to dealing with large computer projects like GIRO and telephone-billing, and this experience should enable it to tackle its customers' problems with confidence. An example of the use which can be made of its size advantage is the invitation, which NDPS received a year or so ago, to undertake the preparation of a computer scheme for handling the documentation and clearance of

† Mr. Laver is the Director of the National Data-Processing Service.

cargo imports at London Airport. This scheme involves the provision and operation of on-line real-time computer facilities at the airport—available day and night seven days a week. The main access to the system will be by means of CRT sets situated in airlines', customs and agents' offices, and in transit sheds. The system will provide an inventory control of incoming cargo, calculation of customs duty and purchase tax, selection of goods or documents for examination and the preparation of agents' debit schedules.

## **PRESENT NDPS ACTIVITIES AND ACHIEVEMENTS**

Most of NDPS' work at the moment is for the Posts and Telecommunications businesses where more than 50 projects are in hand, some very large ones.

### **Telephone Billing**

Accounts for more than 4 million telephone subscribers are being handled on NDPS LEO 326 machines. Ultimately, 7 such machines in 4 regional centres will be fully occupied on three-shift working, in producing bills, ledgers, subsequent payment reminders and follow-up notes, in total involving the use of something like 70 different programs. Work is also going ahead on producing telephone directories by computer using an ICT 1904 machine and film-setting equipment.

### **Postal Order Records**

For the Postal business, NDPS has installed high-speed data-transmission equipment between Chesterfield and London to record on computer the details of something like 800,000 postal orders per day sent from the Postal Branch to the NDPS centre in Kensington. A total of 10 million characters per day are received from postal orders presented in random sequence, and the results are filed in serial-number order on magnetic tape. The information is stored in the computer and enables the Postal business to check whenever a postal order is lost.

### **Pilot Projects for the ICL Systems 4-70 Machine**

At its new Leeds centre, NDPS plans to implement some full-scale and some pilot projects on the new ICL System 4-70 machine. These will include directory compilation and Broadcast Receiving Licence records. NDPS has also produced timetables for the central London fleet of mail vans. This fleet has some 500 vehicles stationed at five garages, and performing about 30,000 time-critical trips and covering about 250,000 miles per week. Other projects handled by NDPS include the systems work for GIRO, involving the design of an electronic banking system; a comprehensive payroll system for 80,000 employees, which will extend to something like 300,000 employees over the next five years; a system of stores control involving the control of receipts, issues, provision and accounting for 40,000 stock items valued at £90 million mainly in the Telecommunications business. This system provides for automatic stock replacement, and the periodic re-calculation of stock levels.

### **Data-Capturing Service**

A major development project which has now reached the stage of prototype production is the "counter machine," which captures data at source on magnetic tape ready for transmission to the computer. The machine combines an accounting with a recording function, and is electronically programmed to provide check digit verification, account updating and field-selection facilities. The development of this machine and its attendant reader and central-processing system, opens up possibilities for a national data capture and transmission service serving both Post Office and commercial interests.

### **On-line Banking for the Trustee Savings Bank**

Outside the scope of Post Office work, NDPS is engaged in a study leading up to the provision of an on-line banking system. The system will serve nine Trustee Savings Banks and will be completely on-line, employing some 330 real-time terminals installed in 172 branches dealing with 2 million accounts and processing a total of 17 million transactions a year.

### **Management Information Service**

NDPS has also been commissioned to undertake a joint feasibility study with a local authority in the North East for the extension and integration of their existing computer services into the Management Information Service field. Centred in an NDPS computer installation, the new system could become the basis for a comprehensive and highly-selective management information service, giving chief officers press-button access to information stored in the computer.

## **THE FUTURE**

### **Microelectronics**

There can be little doubt that the computer industry is growing and advancing very rapidly indeed, or that the art will develop in a number of interesting and inter-related ways. Solid-state devices have completely transformed the reliability, cost, speed and size of central processors. The developments of microcircuits and of large-scale integration will allow increasingly complex systems to be designed. These systems will make for greater compatibility and transform the approach to such functions as data editing and code conversion.

### **Software**

A striking feature of the current scene is the rising importance of software. This has been long predicted, but it may be short-lived. The costs of complex software are growing, whereas the costs of complex hardware are falling. The economic balance may soon begin to tip towards hardware solutions of some software problems. Increasing use could be made of special-purpose hardware for standard routines and control operations.

### **Multi-Access Computing**

The introduction of multi-access and time-sharing computer techniques has had consequences which users are only just beginning to exploit. Multi-access computing needs data-links, but this is only one aspect of the growing convergence between computing and communicating. At the basic circuit level telecommunications is turning towards pulse techniques and to using the same kinds of microelectronic circuits as do computers. The messages that flow over data circuits into computers may one day do so without any transformation of signals or codes.

### **Computers and Communications**

As well as computers needing communications, the converse is emerging as computers are being developed for the control of switching either in electronic exchanges or in store-and-forward data message networks. The Post Office is already engaged in research in these matters. This convergence of data processing and data transmission will also lead towards the standardization—of messages, operating conventions and hardware interfaces.

All this growth and change presents a challenge to the computer bureau business, which is itself fast outrunning the growth of computing generally. The swing to using bureaux could, by their promotion of standard systems, accelerate the march towards the grand design of the "information utility"

or "cashless society" in which information is handled electronically and seldom appears outside the system. Conceiving a totally-integrated network or "grid" of computers and communications serving commerce, industry and Government is all too easy; actually implementing it will be a mammoth task involving many many thousands of man years.

It seems likely indeed that a national computer network will grow up rather gradually through the linking of separate schemes rather than as a single master project. Difficult problems of compatibility will arise and their solution will be complicated by continual technical advance. Any large

scheme, whose growth spans several innovation cycles of the equipment involved, has to be planned in an open-ended fashion.

## CONCLUSION

Exciting possibilities exist for the development of computer service in this country. The Post Office, with its long experience in this complex field, is well suited to participating in this development; and its new computer business, NDPS, stands ready to grasp the opportunity to play its part.

---

# Dialling Problems in Telephone Kiosks

F. E. WILLIAMS, M.SC.(ENG.), F.I.E.E.†

U.D.C. 621.395.663.6: 621.395.636.1.001.5.

*The restricted internal dimensions of telephone kiosks raise special problems in dialling. The variation in size of the human frame is such that a position of the dial which suits some users may be very inconvenient for others.*

*To obtain a set of parameters for future designs of coinbox, a human-factors laboratory experiment has been performed with volunteer subjects to find the best position for the dial. The results show that, on the basis both of least dialling-time and highest opinion-rating, there is a clearly-defined optimum height and angle.*

## INTRODUCTION

With the introduction of subscriber trunk dialling, the British Post Office produced a newly-designed pay-on-answer coinbox for use in public call-offices for which the designers received an award from the British Design Centre. This coinbox had many advanced features, but one feature which did not find universal favour was the position of the built-in dial mounting. To make the complete item more compact and of shallow depth from front to back, the dial was mounted in a more upright position than hitherto, at an angle of 30° to the vertical.

The coinbox is mounted to be accessible to older children and persons of short stature. The dimensions of the standard outdoor and indoor kiosks, however, are such that some men of large build encounter difficulty in dialling.

To obtain a set of parameters for future designs of coinbox, a human-factors experiment was made to find the best position, in height and angle, for the dial when mounted on the front of the existing coinbox and used in the standard kiosks. For comparison, a similar test was made without a kiosk with the coinbox simply mounted on a free-standing vertical board, with appreciably greater free floor area than that of the standard kiosk.

## EXPERIMENTAL PROCEDURE

Four standard call-office booths were set up in the laboratory (Fig. 1), two being of the outdoor type, and two of the indoor type as used inside railway stations and in Post Offices. The principal interior dimensions of the two types

are substantially the same. A fairly large number of volunteer subjects, drawn at random from the staff of the Research Department, were asked to dial series of telephone numbers in these booths, and their dialling performances, with various positions of the dial, were recorded.

In London the booths are normally fitted with a directory holder, which accommodates the four bulky London directories on pivoted carriers. This directory holder reduces the free space in the booth, but it also serves as a shelf and many users find it convenient to lean upon. Arrangements were



FIG. 1—Kiosks set up in laboratory for dialling experiment

† Research Department, Telecommunications Headquarters.



FIG. 2—Number to be dialled appears on an illuminated screen made for tests to be made both with and without the directory holders.

When first brought into service, the coinbox was fitted diagonally across one corner of the booth, but it was found that in this position it was more vulnerable to vandalism, and a straight fixing to the rear wall was subsequently standardized. In the experiments, both methods of mounting were included, and the dial height and angle could also be adjusted. Altogether a total of 64 subjects was used, of both sexes, and covering a wide range of sizes, ages and skills.

Previous experience of dialling studies has shown that, unless the subjects are subjected to some form of stress, very few dialling errors are made, and the essential differences between dials do not become apparent. The method of stressing adopted was to make the subject memorize each number before commencing to dial. In each booth a small translucent screen was mounted in the rear wall above the coinbox (in place of the usual mirror), and a seven-digit London telephone number of the form 01 234 5678 (of which the 01 code was not to be dialled) was rear-projected on to this screen (Fig. 2). The subject was allowed to study the number for as long as he (or she) liked, but, on commencement of dialling, the projected display vanished. After the seven digits had been dialled, the next number was automatically presented.

Each subject paid four separate visits to the laboratory on different days, dialling ten seven-digit numbers in each booth on each occasion. The dial heights and angles, for each group of ten numbers dialled, was altered.

As each number was dialled, the total time taken to dial the seven digits was recorded, as were the actual digits dialled, and hence the errors. At the completion of each test, the subject completed a form stating his opinion of the convenience (or otherwise) of the dial position he had just used, on a four-point scale ranging from very easy to use to very difficult.

The order of presentation of the sixteen dial positions was varied from subject to subject according to a designed plan, and the blocks of ten seven-digit numbers were also rotated so that each block appeared an equal number of times with each of the dial positions. To eliminate the effect of variations in daylight, all tests were carried out under artificial light, the only illumination in the booth being that normally provided at night.

### RESULTS OF THE EXPERIMENT

The preferences of the various subjects were judged by allocating points to the answers on the completed opinions forms. These points varied from four for very easy to use, to one for very difficult to use. The mean opinion score of all the subjects was plotted on two curves to give the best dial angle and height. (Figs. 3 and 4). Also plotted was the mean dialling time against the angle of the dial (Fig. 5).

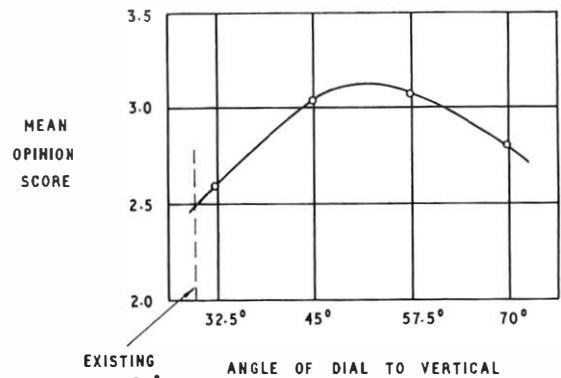

FIG. 3—Effect on opinion score of dial angle

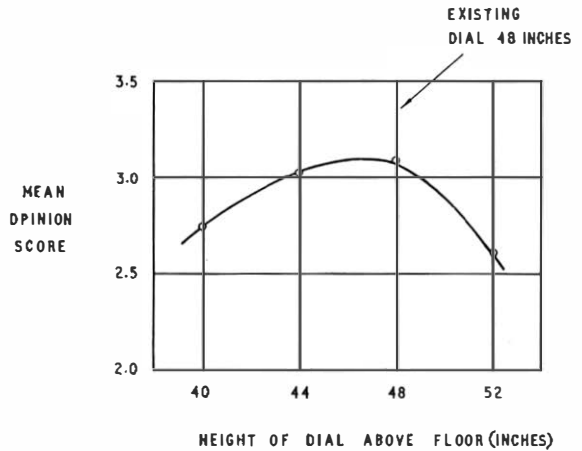

FIG. 4—Effect on opinion score of dial height

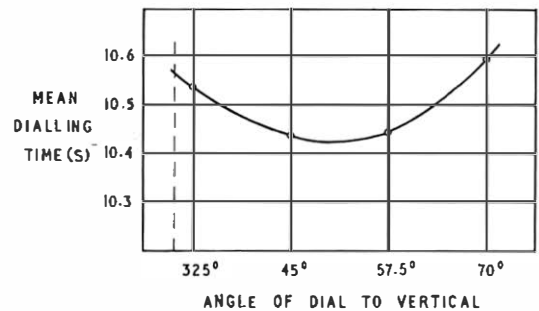

FIG. 5—Relation between dial angle and time, in seconds, taken to dial a seven-digit number

### CONCLUSIONS

This human-factors experiment demonstrates that a substantial improvement in customer satisfaction can be obtained by altering the angle of the slope of the dial on the pay-on-answer coinbox, from the present 30° to the vertical, to about 52° to the vertical. At the same time the fixing could with advantage be lowered by about two inches, so that the dial centre is at a height of 46 inches from the floor. The opinion scores show that the effect of this change is to reduce the percentage of users finding the dial very difficult to use from 20 per cent to 3 per cent.

A more detailed analysis of the results show that a preference is also evident for the diagonal corner-mounting of the coinbox, and it is unfortunate that this had to be discontinued because of its greater vulnerability to vandals. The bulky directory holder appears to be liked by many users, possibly because it provides a shelf which can be leant upon.

### ACKNOWLEDGEMENTS

Acknowledgement is made to Mr. R. B. Archbold and Mr. B. Copping for assistance in the preparation of this paper.

# An Aerial-Cabling Unit

†D. W. STENSON, B.SC.(ENG.) R. HALL, and B. L. NUTTALL, B.A.

U.D.C. 621.315:668.564

*The policy of mechanization of overhead construction methods has resulted in trials of an American aerial-cabling unit which consists of a turntable and extensible boom mounted on a vehicle chassis. The trials have shown the device to be capable of significant savings of both labour and time in the erection of the heavier aerial cables and the development of a cheaper, British-made machine, with a wider application, is now taking place.*

## INTRODUCTION

During the past few years there has been considerable change in the design of overhead plant, with the emphasis on the use of plastic-sheathed, self-supporting aerial cable, light-weight fittings, and wider use of light poles. The size and loading of aerial routes have been much reduced. Consequently, the physical effort required at the construction stage is less and the work is carried out under much safer conditions. The erection of poles is perhaps the heaviest and most hazardous part of the job, and the first effort at mechanizing overhead construction was made in this direction.

† Mechanical and Civil Engineering Branch, Telecommunications Development Department, Telecommunications Headquarters.

Some three years ago, the pole-erection unit was introduced and is now in wide use throughout the country.

Attention is now being given to improving methods and techniques of erecting and recovering aerial cable. A specially-designed machine for use on such work has been available in North America for a number of years. It consists of a vehicle-mounted, telescopic aerial-platform, equipped with power tools and pulling winch (Fig. 1), and is used mainly with lashed aerial-cable systems.

The general requirements of an aerial-cabling unit are that it should enable the speedy and safe erection of all forms of aerial cable with the minimum of manpower. It should be particularly efficient for the erection of self-supporting cable which has an integral suspension wire, and its use must lead



FIG. 1—Aerial-cable erection unit

to significant reductions in the overall cost of overhead construction work.

### GENERAL DESCRIPTION

The aerial-cabing unit consists of a turret-like base and boom mounted on a British-made chassis. The boom has a telescopic inner section with a work bucket attached to the end of it by means of a torque tube and steel fork-arms. The maximum outreach of the unit is 24 ft 7 in, and it has a maximum working height of 36 ft. The unit is stabilized against roll by a torsion bar on the rear axle and outriggers or stabilizing jacks are unnecessary at any time. All motions of the boom and turret are effected by electric motors, and the current for these motors is provided by an engine generator set. This set is mounted at the rear of the vehicle body and consists of a 10 h.p. 4-stroke, 2-cylinder engine running on propane gas.

All motions of the bucket can be controlled, either from the vehicle body, or from the bucket itself. A two-way loud-speaker system provides communication between the cab and the bucket.

### The Boom

The boom consists of two hollow, welded, rectangular sections. The outer-boom section, which is pivoted on the turret, has a reversible electric motor mounted at the end of it that extends and retracts the inner boom by means of a chain drive. Over extension or retraction is prevented by means of a double-acting limit switch mounted at the end of the main boom. Should either of these fail, additional mechanical stops are provided to prevent boom over-travel. A safety cam is also provided on the inner boom. This automatically engages the outer-boom section if the chain should fail, and locks the two boom sections together to prevent the inner boom from telescoping.

The boom is elevated by means of an electric motor mounted in the turret, which drives the end of the outer boom by means of a double chain. At maximum elevation a limit switch is operated which stops the motor, and another switch comes into operation if the elevation chain becomes slack. This will occur, for example, when the boom is seated in its carrying rest, or when the bucket rests on the ground. Should the elevation chain fail, a hydraulic safety cylinder located on the turret locks the boom in position. After manual release of the valve on the safety cylinder the boom will descend slowly to the ground.

The boom is equipped with a lifting yoke and fixed hook, which is rated to lift a maximum load of 2,000 lb at a radius of 6 ft.

### The Turret

The turret and boom are rotated by means of a second electric motor and gears. This motion is limited by means of a limit switch after the turret has rotated continuously for three complete revolutions from the centre position, i.e. the turret may be rotated for six complete revolutions from one extreme of its travel to the other. The motor is protected from continuous overload operation by a thermal overload switch. If this is actuated, the motor is switched off and cannot be re-operated until the switch cools. A friction brake is also fitted to provide accurate boom positioning.

Should there be an electrical failure of any motor, all motions of the boom can be performed manually, although it is necessary to disengage the friction brake before the boom can be rotated.

Control switches for the turret and boom are mounted on the side of the electrical panel. These consist of a set of three toggle switches controlling elevation, extension and rotation, and they may be operated individually or simultaneously. Also mounted on the panel is a meter for recording the running

hours of the generator set, a socket for the electric tow-line ground control, and sockets for a 110-volt supply.

### The Work Bucket and Controls

The bucket is fabricated from steel tubing and is of sufficient size to carry one person, his tools, and necessary fittings (see Fig. 2). The unit is rated at a safe working load of 500 lb, with the boom fully extended in any position.

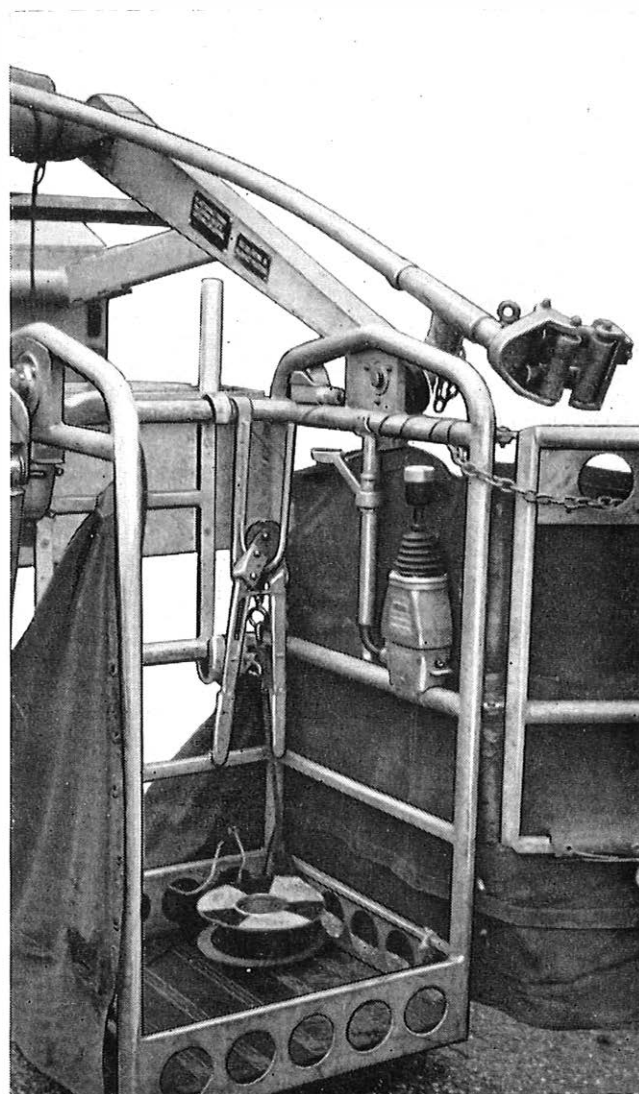

FIG. 2—Work bucket and joystick control

Free swinging of the bucket is prevented by means of a hydraulic damper between the bucket and the fork arms.

The main bucket control is a single-lever, joy-stick-type directional control with a thumb-operated, recessed safety-button which must be held down before any operations will take place. Moving the joy-stick in any direction causes corresponding motion of the bucket, and the three directions of motion may be employed individually or simultaneously. For example, pushing the joy-stick simultaneously downwards, forwards and to the right will lower, extend and rotate the bucket to the right. Movement of the control operates corresponding micro-switches mounted at the base of the control, and these in turn operate 110-volt solenoids in the electrical panel on the turret.

A stop-start switch for the electric generating set is also provided on the base of the bucket control switch, as well as a toggle switch for controlling the electric tow-line.



### The Electric Generating Set

The electric generating set consists of a 10 h.p., Onan, 4-stroke, 2-cylinder engine running on commercial propane. The engine drives a 220-volt, 3-phase, 60 hz generator with an output of 3.5 kVA. The three main motors are driven from the 3-phase supply, but associated control solenoids and switches are operated by the voltage between one phase and the chassis; a nominal 110-volt. The supply is approximately balanced by using different phases for operating the separate equipments.

A self-starter, which operates from the vehicle battery, is provided for the engine.

### The Chassis

The aerial-cabing unit is mounted on a British-made Dodge KP 900 chassis. This has a forward-control three-man cab, power-steering, and a short wheel-base, making it extremely manoeuvrable in restricted conditions. The vehicle has a four-speed gear box and a 2-speed rear axle. When being driven with an operator in the bucket, both the low-gear and low-ratio rear axle are engaged, and the unit then has a maximum speed of approximately 5 miles per hour. The stability of the unit, with the maximum load in the bucket, is achieved by means of a very large torsion bar linking the vehicle rear springs together.

To overcome wheelspin on muddy or snowbound roads, the vehicle is fitted with a Dennis extricator, which consists simply of rollers mounted on each end of a solid shaft. By operating two hand screws these rollers can be made to bear against the vehicle rear tyres, thus effectively locking out the differential and preventing wheelspin.

### Intercommunication

The aerial-cable unit is equipped with a transistor-type intercommunication system. The combined loudspeaker and microphone is mounted at the end of the inner boom, facing the bucket, so that controls are not necessary for the operator in the bucket. Normal direction of transmission is from the operator in the bucket to the vehicle driver. To transmit from the cab it is necessary to depress the talk switch.

### Electric Tow-Line

This is a small electric winch with a maximum pull of 600 lb that can be used for many cabling operations. It is mounted on the vehicle chassis and consists of a 110-volt motor driving a capstan through sheaves and a V-belt. If necessary, three speeds can be obtained by moving the V-belt. The capstan can either be used as a simple capstan winch, or wound with 90 ft of nylon rope so that it then acts as a conventional winch.

The electric tow-line, and the direction of rotation of the capstan, can be controlled either from the bucket, or from a separate ground control. The winch is self-braking in either direction by a worm-gear drive.

### Cable Storage

Cable drums of maximum diameter 5 ft 6 in are carried on hydraulically-controlled arms at the rear of the vehicle, and a load of up to 3,500 lb can be accommodated. Additional cable may be towed on a cable trailer. The hydraulic system is powered by a 1 h.p. electric motor which is located, with the pump, in a small cubicle on the near side of the vehicle.

The cable-drum spindle is equipped with a magnetic brake, and rheostat control from the cab enables the payout tension in the cable to be accurately controlled during cabling operations.

Facilities are also provided for the storage of suspension wire in the well situated behind the driving cab. Payout tension of suspension wire is controlled in a way similar to that of cable.

### ERECTION OF CABLE WITH THE AERIAL-CABLING UNIT

The unit was designed for the erection of lashed aerial-cabing systems, which are in more general use in North America. No difficulties have been experienced, however, in applying it to self-supporting combined systems, and trials in this country have been concerned mainly with this type of cable. Two basic methods of working have been developed, the choice of system being dependent upon site conditions.

#### Direct Placing of the Cable

In this method, the cable drum is carried on the rear drum spindle and paid out as the vehicle moves slowly along the route. The route must permit the cable to be attached on the road side of the poles. The direction of erection must be such that the cable will be paid out to the near side with the vehicle moving on the correct side of the road as far as possible. The starting point is preferably at a stayed terminal pole but, if an intermediate pole is selected, a temporary stay may be necessary. Where an obstruction occurs within two or three spans of a section end, it may be preferable to cable towards that end, or to position the vehicle beyond the obstruction and fleet the cable back to the terminal pole.

The vehicle is prepared by threading the cable from the underside of the drum, through the fairleads to the forward-mounted bullwheel on the vehicle, and out along the boom to the fairlead on the bucket (see Fig. 3). The towline is fitted

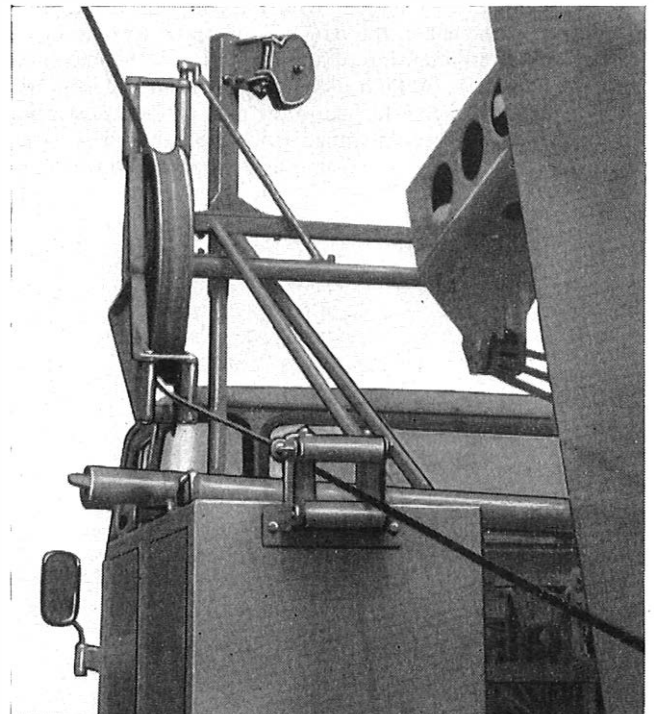

FIG. 3—Aerial cable threaded through fairlead and bullwheel, for the "direct placing" method of erection

with a cam-action grip and is fed along the boom to the bucket. The operator takes with him into the bucket all the tools and pole fittings necessary for the section. He then raises and positions the bucket conveniently close to the pole and terminates the cable suspension wire. On completion, he instructs the driver to proceed along the route. The cable-drum brake is adjusted to give sufficient clearance tension in the cable as it is paid out from the bucket fairlead. When travelling between poles, the boom is positioned as far as possible in line with the vehicle to avoid unnecessary strains on the machine and unnecessary extension of the boom. As the intermediate pole is approached, the operator instructs

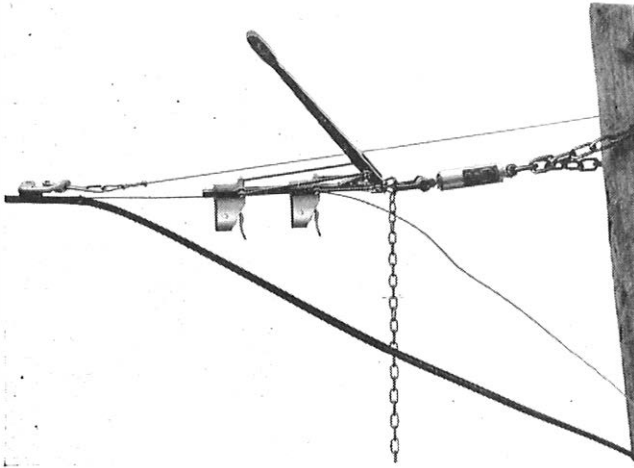

FIG. 4—Arrangement for final tensioning showing the towline and cam-type grip, the Tirfor tensioner and Piab dynamometer

the driver to stop and positions the bucket at working height alongside the pole. The pole is then drilled and the cable supports fitted using an electric impact wrench. The cable can now be transferred to rest loosely over the pole support, the driver instructed to move on, and the bucket again moved into its paying out position. Thus, cable is erected at reasonable clearance until the terminal pole is reached. Final tensioning is carried out in two stages. After attaching the winch tow-rope grip to the cable, the winch is operated to take in the cable slack up to a tension of about 600 lb, i.e. the maximum pull of the winch. A Piab dynamometer with a Tirfor tensioning device is then attached to the pole and the suspension strand which has been stripped from the cable. The Tirfor is used to apply the final tension and the strand terminated.

Fig. 4 illustrates the arrangement. During tensioning, the driver may need to check that the cable has not fouled branches, and, since up to 20 spans may have been erected, a bicycle together with a radio transmitter, has been found useful. On completion of tensioning the vehicle returns over the route inserting the “anti-galloping” twists, and clamping or binding in the cable at intermediate poles.

Variations in the sequence of events may be necessary depending on the route conditions, and some examples are given below.

At road crossings it is usual to attach a temporary clamp to the cable close to the pole fitting. This prevents the cable dropping across the road should tension be released inadvertently. If clearance is doubtful, a temporary suspension rope, with cable pulleys attached at intervals along its length, can also be erected to support the cable across the road.

Where the route is long enough to require more than one length of cable, a temporary stay is normally necessary at the jointing pole to ensure that successive cable lengths can be fully tensioned as they are erected. Alternatively, the first cable length may be made off temporarily at the jointing pole at “payout” tension. The next length can then be cabled back to the jointing pole, and both cables tensioned simultaneously, without erecting a temporary stay to stabilize the pole.

Where an obstruction occurs towards the end of a section, the cable can be temporarily clamped at the last pole before the obstruction, and the remaining cable taken off the drum and left at the pole. With the vehicle at the terminal pole a towline can be taken back over the route on foot to pick up the cable end. The winch can then be used to haul in the towline and the cable.

#### Drawing-in the Cable

The presence of open-wires, arms, trees, or the need to attach the cable to the pole on the field side, will prevent the



FIG. 5—Aerial-cabling unit erecting replacement cable for an open-wire route using the “drawing-in” method

erection of the cable as described. For these situations the following technique can be adopted.

The cable drum is parked on a trailer at a convenient position near the first pole with the drum-spindle braked to prevent over run and give some tension to the cable. The cable end is taken up the first pole and passed through a pulley block fitted to the pole. The towline passing through the bucket fairlead is then attached about 4 to 5 yards from the cable end, and the cable is drawn in as the vehicle moves along the road (see Fig. 5). Where the cable has to pass behind the pole, or through the arms, the vehicle is stopped and the cable is temporarily anchored using a separate line and grip. The towline may then be removed from the cable, passed round the pole, or through the arms and re-attached to the cable. After removing the temporary anchor, cabling can proceed as before.

After terminating at the final pole, the unit returns to the first pole to pull up, tension, and make-off. Since braking at the trailer is limited, payout tensions are necessarily lower in this method and sag is greater. It is essential, therefore, to use the temporary suspension line and cable rollers where clearance is important. Temporary suspensions are recovered during the final run over the route to insert twists and bind in the cable.

### Lashed Cable Systems

The unit has also been used to erect a suspension strand, and to lash polythene and lead-sheath cables to new and existing strands. Erection of the strand is a simple operation and follows a procedure similar to that described for the self-supporting cables. The ease with which the boom can be positioned, and the provision of the towline and winch, greatly facilitate the use of the lashing machine so that speedy erection is possible.

### CONCLUSIONS

The unit, which handles well in restricted conditions, has operated without difficulty on almost every type of road, and in most weather conditions. The problem of operating in narrow lanes has not proved a serious one as the vehicle is stationary for only a few minutes at each pole, and serious delays to other road users rarely arise.

The joystick control is simple and positive, and with very little experience the operator is able to place himself quickly and accurately in any desired working position. Training of crews for this machine has presented no problems, and there is no undue difficulty in using the unit safely and efficiently after a few hours instruction.

The trial has shown quite clearly that aerial-cabling work can be performed easily and safely by two men using the unit, with a saving of better than half the man hours. More important, perhaps, the crew experience far less fatigue than with normal manual methods of construction.

It is clear that the improvement in productivity is high, particularly on those routes carrying heavier cables of the trunk or junction type, or the longer local cables. The majority of cables erected today are, however, of the smaller local type, and the scope for this high-cost imported machine is limited. The experience gained has been invaluable, and work is already proceeding on the development of a cheaper, British-made machine. Although this will have rather fewer facilities, it is hoped to produce a unit which will handle the more common, smaller cables, and will have a wider application in the field of overhead wiring and cabling construction.

### ACKNOWLEDGMENTS

The authors would like to acknowledge the generous co-operation and assistance they have received during the trials of this unit from their colleagues in the Civil and Mechanical Engineering Branch and in the Wales and Border Counties.

---

## Book Review

"Filter Design Tables and Graphs." E. Christian and E. Eisenmann. John Wiley and Sons, Ltd, ix + 310 pp. 80s.

This book is, to some extent, a complement to Saal's now widely-known filter catalogue.\* It does not contain circuits and their elements, but tabulates in its main part the pole-zero patterns for certain important classes of filters. The tables are supplemented by well-designed charts from which one can read the properties of the attenuation characteristics available from the tabulated patterns. A wide range of low-pass attenuation characteristics is covered under the classifications of 'Butterworth' (maximally-flat), 'Chebyshev' (equal-ripple pass band), 'inverse Chebyshev' (equal minima in the stop band) and 'Cauer' (equal ripple in the pass band and equal minima in the stop band).

While for many purposes practical reactance-ladder realizations, such as those tabulated by Saal\* or Skwirzynski,†

\*R. Saal, "The design of filters by a catalogue of normalized low-pass filters." Telefunken (1963).

†J. K. Skwirzynski, "Design theory and data for electrical filters." Van Nostrand (1965).

will be all that an engineer requires, some applications make it essential to know beforehand the phase or envelope-delay characteristics which are to be expected from a filter. Such information can be obtained from the pole-zero pattern, and so can waveform responses. The patterns can also be used as starting points for realizations in forms other than by reactance ladder-networks, for instance by active circuits.

In contrast to the networks themselves, their pole-zero pattern can be extended in a more general manner than by reactance transformations to cover, for instance, reactance filters between unequal terminations or bandpass filters of a behaviour not entirely symmetrical about a point on a logarithmic frequency scale. A 28-page introduction gives brief advice on such matters and also includes well-chosen examples.

As Professor Van Valkenburg rightly points out in the foreword, there is nothing degrading about using charts, tables and curves in design work. The book will thus be not only a welcome source of information for the communications engineer in general, but also a valuable and time-saving aid for the expert.

A.J.L.

# Microwave Radio-Relay Links: The Effects of Spurious Emissions from High-Powered Radars

D. E. CRIDLAN, C.ENG., M.I.E.E.†

U.D.C. 621.394/5: 621.37.029.6 :621.396.96

*The rapid growth of both microwave radio-relay telecommunications links and of radar services for civil and military purposes, poses problems of co-existence for which there are no immediate solutions. Present trends in the use of solid-state equipment for radio-relay systems tend to intensify the difficulties. This article discusses the problem and describes the measurement of spurious radar emissions, quoting typical results.*

## INTRODUCTION

The past decade has embraced a period of considerable growth for all modern forms of communication. The network of microwave radio-relay links, which carries a considerable proportion of the trunk telephone, television and data traffic in the United Kingdom, has expanded steadily, and the introduction of that most modern addition to the field of long-distance communication, the communications satellite, has opened a new era in microwave history. At the same time, the development of air transport, both military and civil, with allied improvements in methods of air defence and air-traffic control, has resulted in a growing demand for new radar services throughout the country. The presence of these radars within the environs of the microwave radio-relay network presents a problem in co-existence to which there is no immediate solution. The problem is intensified by the present trend in microwave radio-relay equipment design, occasioned by the introduction of solid-state techniques, towards the use of transmitters of reduced output power, with a partially-compensating improvement in the noise performance of the accompanying receiver.

Before the problem of co-existence can be examined, a knowledge of the frequency and level of every unwanted component of the emission from each suspect radar is required. A method by which the unwanted components of a radar transmission can be measured and the equipment which is employed in the making of these measurements are described in this article; results, typical of many obtained in practice are compared with an assessment of the maximum tolerable level of interference in a terrestrial radio-relay system.

## THE RADAR SIGNAL

In broad terms, the present generation of radar equipments may be divided into two main categories: those powered by klystron oscillators, and those by magnetron oscillators. Until recently the output from the klystron oscillator was thought to be free from spurious components which were unrelated to the fundamental frequency, with only harmonics of that fundamental present at a significant level. Unfortunately, this view has proved to be unfounded, and, in one instance, evidence of the presence of substantial spurious components in the output of a klystron-driven radar has been found. The magnetron oscillator is a well-known offender in this field, for it generates, in addition to the wanted signal, a wealth of unwanted harmonic and unrelated spurious components, many of which fall in frequency bands allocated to other users.

The output from any particular microwave oscillator, magnetron or klystron, will contain unwanted components which differ both in frequency and amplitude from those of other oscillators of nominally identical pattern. The signature, or radiation characteristic, of a hypothetical radar is illustrated in Fig. 1; it is typical of several that were measured.

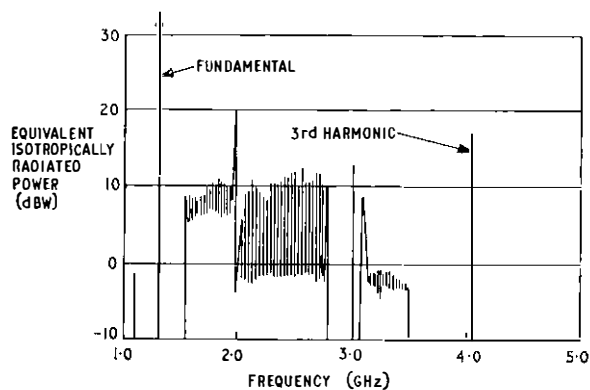

FIG. 1—Radiation characteristic of hypothetical radar

From this characteristic it may be deduced that an interfering signal from a radar source may consist of either a sharply-defined peak, occupying no more than a few kilohertz of bandwidth, or a broad band of noise spreading over several hundreds of megahertz. The term signature, which is often used by radar engineers to denote the radiation characteristic of a particular unit, suggests the existence of a stable condition, but, in practice, a unit that is found on test to be free from high-level spurious radiation may, after a maintenance overhaul, become a source of severe interference.

## TOLERABLE INTERFERING NOISE POWER

The general performance standards upon which the design of radio-relay links in the United Kingdom are founded are those agreed by the C.C.I.R.\* and published in the form of a series of recommendations.<sup>1</sup> These documents define a hypothetical reference circuit for telephony, consisting of nine homogeneous sections, each 278 km in length. One such section provides a convenient unit on which to base an interference study.

The noise level in any telephone channel that is one of a number carried on a radio-relay link is a variable quantity, and, for this reason, the C.C.I.R. recommended statistical limits of tolerable noise power. In making these recommenda-

† Line and Radio Systems Provision Branch, Network Planning and Programming Department, Telecommunications Headquarters.

\* C.C.I.R.—International Radio Consultative Committee.

tions the committee assumed that noise surges and clicks from power-supply systems or from switching apparatus would be reduced to negligible proportions, and these were not taken into account when the noise limits were fixed. It is reasonable to suppose that rhythmic noise-bursts of the type which would result from the reception of an interfering radar signal were also omitted from these studies and it is, therefore, necessary to assess the risk of interference from radar sources and, as an interim measure, to determine the degree of protection required for the United Kingdom terrestrial network. A general indication of this degree of protection can be determined from an examination of the noise performance of part of the hypothetical reference circuit.<sup>1</sup>

The psophometrically-weighted noise in the top telephone channel of one ninth of the hypothetical reference circuit should not exceed 83 pWOp,\* or approximately -60 dBmOp,† (3 pW/km), for more than 20 per cent of any month, and, of this, the total weighted noise from all sources of interference should not amount to more than, say, 50 pWOp, or -73 dBmOp. For the purpose of this study, a generous assumption that the whole of this allowance may be absorbed by the presence of an interfering radar signal has been made.

The interfering noise present in any radio-borne telephone channel will depend upon the frequency, amplitude and nature of the interfering signal. Recent unpublished work by Medhurst assesses the noise power which, in the worst channel, results from the simultaneous reception of wanted and unwanted signals. From this work it is possible to deduce the conditions under which the limit of 50 pWOp of noise may be reached. If the interfering carrier is modulated by a broadband or white-noise signal, this limit will be reached when, at the input to a receiver of a 960-channel telephony system, the wanted-to-unwanted carrier ratio is as high as 74 dB. This ratio increases to 83 dB when the interfering carrier is unmodulated. These figures relate to the worst conditions, when wanted and unwanted carrier frequencies are critically related. In this present study similarity between the broadband of noise emanating from some radars and the white-noise modulated broadband signal considered by Medhurst is assumed.

Wanted received signal levels are dependent upon transmitted powers, net path losses and aerial gains. These will differ for each radio station and for each system, but are unlikely to exceed -53 dBW for a thermionic-valve or hybrid system in which the transmitter output stage is a travelling-wave amplifier, or be less than -75 dBW for low-powered, all solid-state, systems. From these data the tentative limits of tolerable interfering signal to be measured at the input of a microwave radio-relay link receiver were calculated, and are listed in Table 1.

The effect of interference upon the quality of a television picture is not so readily expressed, since the subjective effects of noise on the picture are more than ever dependent upon the nature and frequency of the interfering signal. The objectionable effect of radar interference, as seen by the viewer, is more closely related to the peak power of the radar pulse than to the pulse duration or repetition rate and, therefore, an assessment of interference potential is at present related to the peak power of the suspect source.

Other writers have expressed their views as to the maximum level of interference that can be tolerated at the input of a microwave radio-relay link receiver, and all were based on the results of subjective tests. Microwave systems used for telephony as well as those used for television have been studied in this way. Kingan and Dennison<sup>2</sup> disclosed a wanted-to-unwanted carrier ratio of 16 dB on a pre-emphasized circuit, or 17 dB without pre-emphasis, for interference

\* pWOp—picowatts at a point of zero reference level, measured psophometrically.

† dBmOp—decibels relative to a milliwatt measured psophometrically at a point of zero relative level

**TABLE 1**  
**Level of Interfering Carrier Power Which Can Produce**  
**50 pWOp of Noise in the Worst Telephone Channel**  
**of a 960-Channel System Operating Under**  
**C.C.I.R. Conditions**

Interfering Carrier	Ratio of Wanted-to-Unwanted Carrier Level (dB)	Estimated Limits of Wanted Received Signal (dBW)	Limit of Interfering Received Signal Power (dBW)
Modulated	74	-53	-127
	74	-75	-149
Un-modulated	83	-53	-136
	83	-75	-158

that was classified as "just non-discernible on a television screen". Using an approximate figure of 15 dB, and allowing a fading margin of 30 dB, the authors specified a minimum tolerable wanted-to-unwanted signal level of 45 dB. In a quoted example, reference is made to a wanted received carrier power of -69 dBW, which would result in a minimum tolerable interfering signal power of -114 dBW. In an earlier publication, Campbell<sup>3</sup> carried this work a stage further and sought to define the maximum equivalent isotropically-radiated power (e.i.r.p.) from a radar source that might be located at any point along the boundaries of a strip one mile in width and centred on the microwave path. His subjective tests resulted in the following limits of e.i.r.p.: +10 dBW for telephony links, and -15 dBW for television links.

Assuming free-space line-of-sight propagation between the radar and the microwave-link aeriels, and making due allowance for aerial discrimination, these limits suggest that the maximum-tolerable level of interference, measured at the input of a radio-link receiver, should not exceed -120 dBW for telephony links and -145 dBW for television links.

The receiver noise powers associated with the present generation of microwave systems are rarely better than -123 dBW, and to set a limit to the maximum tolerable level of interference that is markedly below this figure would seem to be pointless.

No doubt a small number of low-power, all-solid-state systems will be installed during the next few years, but it is to be hoped that, with the improvement in solid-state devices, a return to conventional powers will soon be possible. Moreover, the designers and manufacturers of the next generation of radars will no doubt achieve a welcome reduction in the level of spurious radiation. It would seem, therefore, that a maximum interfering-signal limit of -120 dBW, measured at the input terminals of a microwave receiver, will provide a sufficient margin of protection for all but a small number of links in the United Kingdom. The proposed standard will afford sufficient protection for both telephony and television channels.

Subjective tests carried out on a Post Office radio-relay link indicate that this proposed limit will be adequate for the present generation of thermionic-valve systems, but it may be that a lower limit will be necessary in an area served by low-powered all-solid-state systems.

So far in this article, emphasis has been placed on the maximum level of unwanted signal that can be tolerated at the input of a microwave receiver, but it is necessary, eventually, to specify the maximum tolerable e.i.r.p. of unwanted components of a radar emission. Campbell attempted to find a partial solution to this aspect of the interference problem as long ago as 1958, and reference has already been made to his work in this article. Until an agreed limit of spurious and harmonic emission is contained within the design specification of every

new type of radar equipment, it will be necessary to assess the interference potential of each new unit with reference to its particular geographical location.

The profile of a typical path between a radar and a microwave radio-relay station is shown in Fig. 2. The profile is

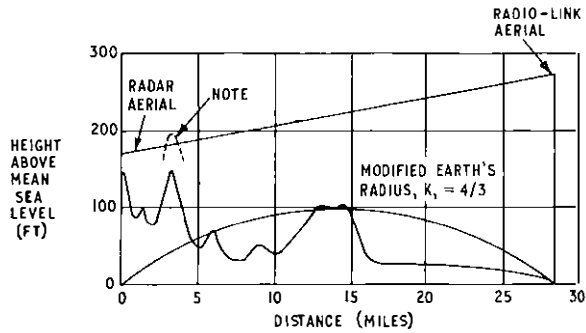

Note: Height of hill modified to allow for apparent curvature of earth

FIG 2—Typical path profile

drawn with reference to a flat earth, and the height of the most prominent obstacle has been modified to make allowance for the apparent curvature of the earth under normal conditions of propagation, that is, when the earth-radius factor,  $K$ , is equal to  $4/3$ . From the work of Bullington<sup>4</sup> it is possible to assess the shadow loss caused by the presence of the hill some 3 miles from the radar. With these parameters the maximum tolerable interfering-signal levels are calculated for the 2,000 and 6,000 MHz frequency bands, as shown in Table 2. An

TABLE 2

Maximum Tolerable Interfering-Signal Levels in a Typical Example

Parameters	Frequency Band (MHz)	
	2,000	6,000
Free-space path loss (28.3 miles) ..	-131 dB	-141 dB
Microwave-aerial gain .. ..	-36 dB	+44 dB
Microwave-aerial discrimination (12°) .. ..	-20 dB	-30 dB
Shadow loss .. ..	-10 dB	-12 dB
Net loss .. ..	-125 dB	-139 dB
Maximum tolerable interfering-signal power at the receiver ..	-120 dBW	-120 dBW
Maximum tolerable e.i.r.p. of the interfering signal .. ..	+5 dBW	+19 dBW

exercise of this kind must be carried out for every possible path between the new radar and the several radio-relay stations in the area. In this way the interference potential of each new radar installation is assessed. Mobile radar units, which are not entirely unknown, are particularly troublesome in that a hurried study must be completed for each proposed new site.

### MEASUREMENT TECHNIQUE

The method which is used to detect and measure the power of each unwanted component present in a radar signal is based on the use of the Polarad Model R Receiver which can, with the aid of a series of interchangeable tuning units, provide broad frequency coverage extending from 400 to 46,000 MHz. This receiver has a measured sensitivity of  $-120$  dBW, and selectivity which affords a bandwidth of 3 MHz between 3 dB points. The instrument can be used to indicate the power content in a pulse received from a pulse-modulated radar.

The peak power of the received signal is indicated on a signal-output meter, and its waveform may be displayed on an oscilloscope. The same screen may also be used to display the waveform derived from a calibrated pulse-modulated signal generator. The arrangement is illustrated in schematic form in Fig. 3. The output from the signal generator is adjusted in

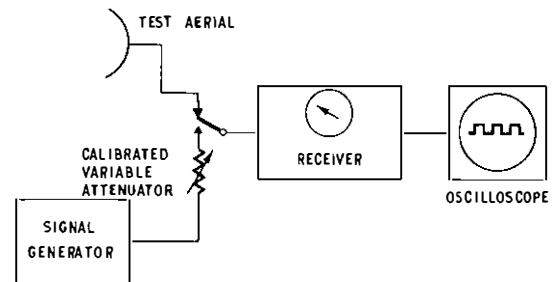

FIG. 3—Block schematic diagram of test equipment

frequency, pulse rate and pulse width to match the displayed radar waveform. With the aid of an external, calibrated, variable attenuator an accurate measure of the peak power of the received signal can then be made. For the purpose of a preliminary study, sufficient accuracy can be obtained without resort to the visual comparison of two signals, and the details contained in the radar manufacturer's specification concerning pulse width and rate may be used with confidence to provide an adequate match. Moreover, it has been found that, within the limits of pulse width and rate encountered in United Kingdom radars, mean settings may be used to obtain an accuracy which is better than  $\pm 1.0$  dB.

In a typical practical study a vehicle containing the test equipment is sited in the far field of the aerials, at a distance from the radar great enough to ensure that the Polarad receiver is protected from possible break-through of the fundamental signal. Normally, a minimum distance would be of the order of one quarter mile. An unobstructed path between the aerials is essential, and these are both aligned to give an indication of maximum signal level at the receiver. The exact level of the incoming signal is determined by comparison with the known output, of similar form, obtained from the signal generator. A careful search is then made over the appropriate frequency band, which usually extends from 1.4–7.7 GHz, for other components of the radar emission, and the level of each spurious signal is determined by comparison with the calibrated source.

### MEASURED CHARACTERISTICS OF RADAR SIGNALS

Two examples of the measured characteristics of typical radars, in which the spurious components of a radiated signal having an e.i.r.p. in excess of one watt, are plotted against the normalized relative frequency,  $f/f_r$ , and shown in Fig. 4. Those frequency bands allocated to the fixed-link services and which could be affected by the presence of out-of-band components of the radar signal are also shown on the same scale. Fig. 4(a) shows a number of apparently unrelated spurious radiations which, in the case of a C-band radar, were found to be present at frequencies below that of the radar fundamental. Fig. 4(b) illustrates the pattern of unwanted spurious and harmonic components that were found to be present in the output of an L-band radar at frequencies above that of the fundamental.

### A SPECIFIC INSTANCE OF RADAR INTERFERENCE

Few instances of interfering signals reaching Post Office radio-relay systems from radar sources have been reported, and when they have, a detailed examination of the signal and

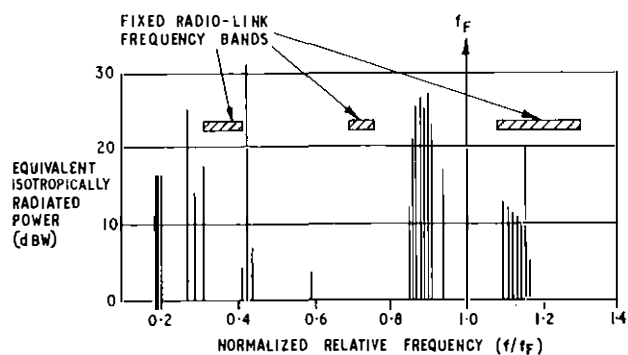

(a) Spurious radiations in output of C-band radar

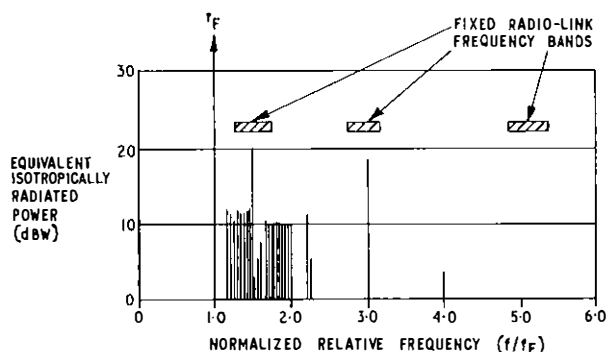

(b) Spurious and harmonic components in output of L-band radar at frequencies above fundamental

FIG. 4—Measured characteristics of typical radars

its effect has not been possible. Reference has been made in Table 1 to the maximum level of noise which is tolerable in a particular telephone channel. In the field, the white-noise test-set is used to check the telephony performance of a working radio link, but this equipment with its small number of pre-determined measuring channels is unsuited to the detailed determination of an interference pattern. The few results which are available confirm that the standard set by the British Post Office and described in this article provides the microwave radio-relay network with an adequate, but not unnecessarily stringent, degree of protection. For example, it was found that the interfering signal from a neighbouring radar caused a 1 dB degradation in the noise-power ratio measured in the top slot of a particular broadband radio

channel. The calculated level of the interfering signal which produced this degradation was  $-109$  dBW. On this same link, interference of the same order was found to be present also in the bottom measuring-slot, and the calculated level of this second interfering signal was  $-108$  dBW. In the absence of a detailed examination of the baseband spectrum, which would reveal the actual frequency and level of each unwanted component and its effect upon channels other than those in which measurements were made, the results of these and other similar observations provide reasonable support for the decision to adopt the present standard.

## CONCLUSIONS

The manner in which each case of potential radar interference is examined on its merits, with due consideration being given both to the geographical location of the source and to the likely signature of a particular type of radar unit, must, by virtue of the unstable nature of the interference, offer a limited degree of accuracy. A new approach is necessary, and those engineers who have, in recent years, been concerned with the study of interfering signals that emanate from the present generation of radars are convinced that the time has come when discussion must take place between radar designers and microwave radio-relay link planners.

Both radar and line-of-sight installations are increasing in number; satellite systems, with extremely sensitive low-noise receivers, are now firmly established in the communications field. With the increasing use of solid-state devices in microwave equipment, the use of lower radiated powers and low-noise receivers is becoming more common in line-of-sight systems. At the same time the signal output from certain new radar installations would appear to be greater than ever before. With these changes afoot, the risk of interference in the s.h.f. band increases, and the need for a negotiated agreement between users with such widely different objectives becomes essential.

## References

- 1 International Radio Consultative Committee (C.C.I.R.), Documents of XIth Plenary Assembly, Oslo, 1966, Recommendation 392 et seq.
- 2 KINGAN, A. J., and DENNISON, L. W. Siting of Microwave Systems in a Radar Environment. *Electronics and Communication* (Canada) June 1961.
- 3 CAMPBELL, R. D. Radar Interference to Microwave Communication Services. *Electrical Engineering*, Vol. 77, p.916, Oct. 1958.
- 4 BULLINGTON, K. Radio Propagation at Frequencies Above 30 Megacycles. *Proc. I.R.E. Waves and Electrons Section*, p. 1122, Oct. 1947.

## Book Review

“Magnetic Materials and their Applications.” I.E.E. Conference Publication No. 33. 246 pp. Numerous illustrations.

Conferences on magnetic materials are regular events in the U.S.A., less common in Britain. The I.E.E. conference from which the 53 papers are assembled in this book has gathered a representative collection of British work over a period of two or three years with a few good European contributions, but of course very little from America. The bias is mainly towards engineering applications, but in some of the papers materials are seen from the physicist's point of view. The scope of the conference did not include the fundamental theoretical aspects of magnetism.

It may come as a surprise that nearly half the papers are about silicon-iron, a material which might have been thought well understood by now. But the effect of orientation on domain structure, and of both on power losses, is not yet

fully explored; and the effect of magnetostriction on transformer noise remains a controversial topic. The measurement of loss in silicon-iron is the subject of six papers.

Thin films, used mainly for computer stores, attracted less attention than might have been expected—only six papers. The communications specialist will regret the fewness of the papers on ferrites—eight—and on nickel-iron alloys—five.

As a book to read, this has all the faults to be expected in a collection by diverse authors writing on highly specialized subjects. It has two virtues, however: it shows where the main effort of research on magnetic materials is being directed (and, by inference, where it is *not* being directed); and it gives the occasional glimpse of materials with new or enhanced properties, now being studied in somebody's laboratory but perhaps generally available in a few years' time.

A. C. L.

# The Accurate Length Measurement of Ferro-magnetic Strands and Cables by Magnetic Marking

K. WILKINSON†

U.D.C. 531.71: 621.318.1.

*An experimental equipment has been developed for accurately applying magnetic marks to any long thin ferro-magnetic article and for the subsequent detection of such marks.*

*When the marks are applied and detected in a reciprocating mode the technique affords an accurate method of length measurement. The equipment could find particular application in the accurate length measurement of those designs of submarine cable which are formed upon high-tensile steel core.*

## INTRODUCTION

To avoid undue waste in the manufacture of modern submarine cables it is necessary to measure their lengths accurately. Usual methods rely upon the use of friction wheels, but they inherently suffer from errors, for instance that produced by wheel slip. Magnetic methods of marking steel cables and strands to improve length measurement have already been developed<sup>1,2</sup>, but the methods of detection employed invariably depend for their operation on the moving magnetic mark cutting a pick-up coil, thereby producing a voltage signal with an amplitude proportional to cable speed. Elaborate variable-gain amplifiers operating from detection rate meters have to be employed if the system is to work over a wide range of cable speeds. To meet these requirements a novel method of measuring 0.99 in diameter submarine cable has been developed. This method applies a mark to a moving line of cable and subsequently detects it at unit distance ( $l$ ) from the point of application. Detection initiates the application of a further mark, which is therefore a distance ( $l$ ) along the cable from the originating mark. The process is continuous until such time as a mark goes undetected or the feedback link from the detector to marker is broken. Hence, the length of the cable may be measured by counting the number of marks that have passed the detector. Provided that the time taken to detect and re-apply a mark is short, the length-measuring accuracy will be reasonably independent of cable speed. Fig. 1 shows the basic layout of the system.

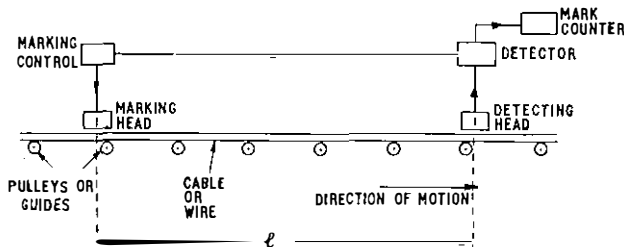

FIG. 1—Layout for measurement of cable length

Another application of the magnetic marking of submarine cables is in defining the locations of manufacturing defects immediately prior to the dielectric-extrusion process. By defining such defects at this stage, the affected areas can be subsequently examined by X-ray techniques without disrupting the extrusion process.

† Tests and Inspection Branch, Purchasing and Supply Department, Telecommunications Headquarters.

The techniques described are applicable to any long thin ferro-magnetic wire or strand, and also to the length measurement of taut wires as used in submarine cable-laying operations. When submarine cables are laid in deep water sufficient slack cable must be paid out to enable the cable to be subsequently drawn to the surface during repair operations. To control the amount of slack cable laid it is necessary to have an accurate measure of the distance covered over the seabed. For this purpose a taut steel-wire is paid out from the ship, the length paid out being a measure of the distance covered.

## THE MAGNETIC MARK

If a ferro-magnetic wire or strand is magnetized over a short length in relation to its thickness, the free poles set up by the magnetized area will tend to oppose further magnetic penetration resulting in a weak mark. Further, the mark will tend to spread out along the wire with a resultant reduction in external field-strength. For these effects to be negligible in high-tensile steel, the length of application of the magnetized area should be greater than 25 times the diameter of the wire.

If a steel wire is passed through a solenoid (Fig. 2(a)), and the coil energized with a current pulse, the wire will be magnetized and give rise to a standard field pattern (Fig. 2(b)). If now the horizontal and vertical components of field strength are monitored along the datum line, the field-strength patterns may be drawn (Figs. 2(c) and 2(d)). From these responses the field-strength gradient in regions (i) and (ii) is shown to be small. The locations of points (iii), (iv), (v) and (vi) will be dependent upon the position of the datum line, and also on the strength of the applied magnetic mark. Hence, there is no point in the horizontal and vertical responses which can accurately define a point along the strand.

If a second magnetized area is introduced adjacent to the first with like poles adjoining, the field-strength pattern is modified. This bi-polar mark produces a high field-strength gradient in the horizontal component of field strength at the interface of the two magnetized areas (i); the locational accuracy of this zero-field point will be independent of both field strength and location of the datum line with respect to the wire. Bi-polar marks can be used to define points along an 0.99 in diameter lightweight submarine cable with a locational accuracy better than  $\pm 0.05$  in at a distance of 1 in from the steel heart wire of the cable.

Bi-polar marks can be produced by either passing the cable through a solenoid arrangement or over a composite electro-magnet (Fig. 3). The marking current is supplied by control-



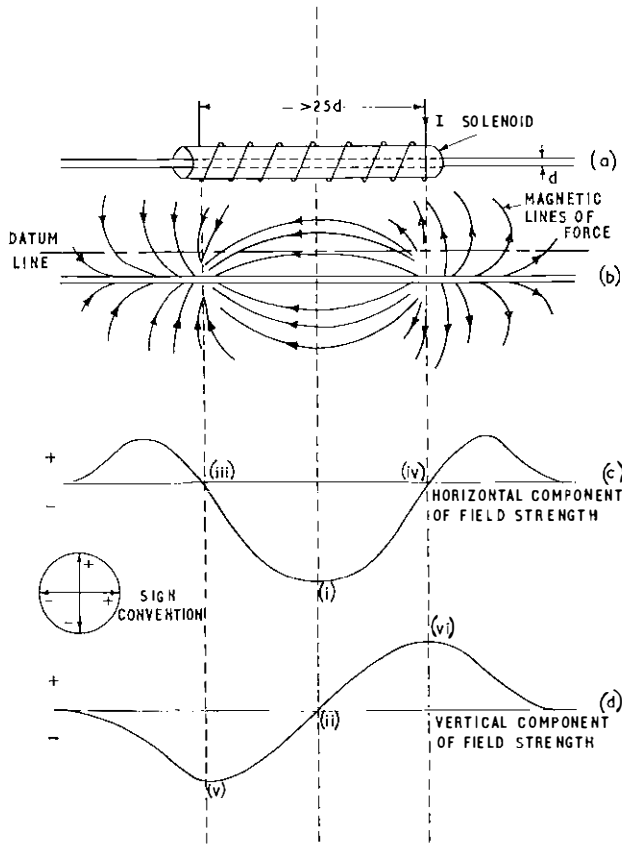

FIG. 2—Magnetic-field pattern produced by a single mark

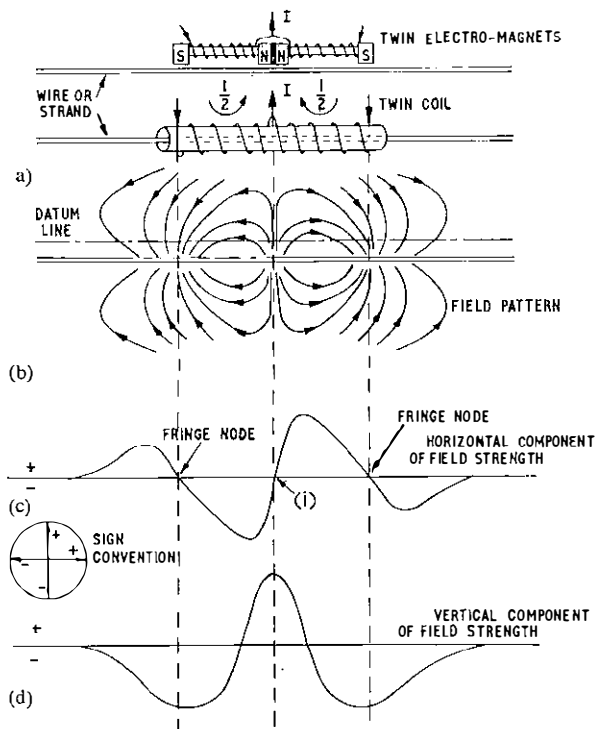

FIG. 3—Magnetic-field pattern produced by a bi-polar mark

ling the discharge of a capacitor through the marking coils by means of a silicon-controlled rectifier. In this way, a half sine-wave current-pulse of less than 1 ms duration can be used to magnetically saturate the wire. With a marking duration of this order the blurring effect of marking a cable moving at speed is negligible.

## THE SENSING ELEMENT

The element used to sense the magnetic field strength is called a magnetometer and must be sensitive, robust, and capable of rapid response to an applied field and sensing the direction of the field. The saturable reactor type of magnetometer was chosen for this application on account of its high sensitivity and commercial availability.

### Saturable Reactor Magnetometer

#### Construction

This magnetometer consists of two thin parallel mu-metal wires, each nominally wound with an equal number of turns of fine wire, which constitutes the drive or excitation circuit. The individual windings are connected in series and arranged so that their magnetic circuits are in opposition (Fig. 4(a)). A third winding envelopes both drive windings to form an output coil.

#### Operation

With no externally-applied axial component of magnetic field along the mu-metal, the instantaneous value of flux density present within the output coil is zero. This is due to the two drive coils being connected in series opposition.

With an external horizontal component of field present, ( $+\Delta H$ ), and assuming that the drive signal is sufficiently large to drive the negative excursions beyond  $-B_{sat}$  then the positive excursions of flux density are limited to a peak value of,

$$B_{sat} - \mu\Delta H, \text{ where } B_{sat} \text{ is the maximum flux density, and the negative excursions are allowed to reach a peak value of,}$$

$$B_{sat} + \mu\Delta H, \text{ see Fig. 4(b).}$$

Hence, the net change in flux density in the coils will be,

$$(B_{sat} - \mu\Delta H) - (B_{sat} + \mu\Delta H) = -2\mu\Delta H.$$

If the direction of the applied field is now changed from  $+\Delta H$  to  $-\Delta H$  then the net change in flux will now be,

$$(B_{sat} + \mu\Delta H) - (B_{sat} - \mu\Delta H) = +2\mu\Delta H.$$

Thus, the amplitude of the net flux density is proportional to the applied external field  $\Delta H$ , and the phase of the

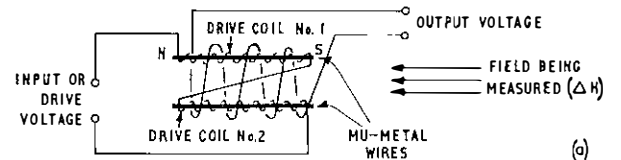

(a) Mechanical arrangement

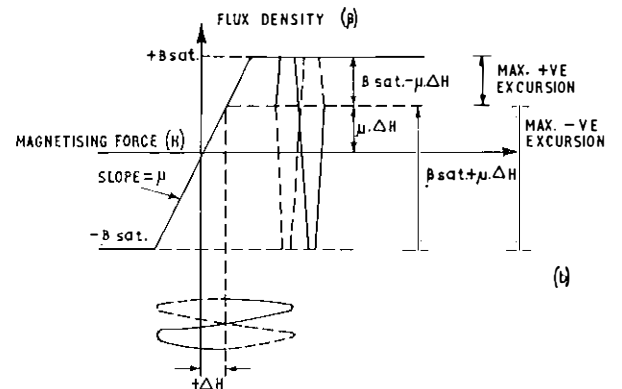

— H & B IN DRIVE COIL No. 1      - - - - H & B IN DRIVE COIL No. 2

(b) Idealized B-H curve for mu-metal

FIG. 4—Magnetometer element

flux-density waveform is changed by 180° when the applied field is reversed.

The net core flux will cut the output winding giving rise to an output voltage given by,

$$\text{output voltage} = N_s \frac{d\phi}{dt} = N_s a \frac{dB_c}{dt}$$

where,  $N_s$  = output-winding turns,  
 $a$  = cross-sectional area of wires,  
 $B_c$  = resultant flux density linking with the output winding,  
 $\phi$  = flux linking with the output winding,  
 $t$  = time in seconds.

This voltage will be rich in the second-harmonic component of the drive signal, this component being a reasonably linear function of the externally-applied field. The phase of this output will be governed by the direction of the axial component of field within the element.

### OPERATIONAL PRINCIPLES OF THE DETECTOR

#### General

If the magnetometer element is mounted parallel to the cable along the datum line (Fig. 3), the output from the element produced by a passing mark can be arranged to follow the horizontal field-strength pattern, so long as due regard is given to the phase of the output voltage, i.e. by using a phase-sensitive rectifier (p.s.r.). Similarly, if an element is mounted at 90° to the cable it is possible, by using p.s.r.s, to produce a voltage analogue of the vertical field-strength pattern.

The detector is required to detect the central node produced in the horizontal-field pattern (Fig. 3(c)), and ignore the two other fringe nodes at the extremities of the mark. If the vertical field is detected in addition to the horizontal field, the negative-going lobes (Fig. 3(d)) associated with the required node can inhibit the fringe nodes in the horizontal field.

An experimental node detector is shown in block schematic form in Fig. 5. Fig. 6 shows the waveforms at various points throughout the circuit.

#### Operation

Both the horizontal and vertical magnetometer elements are driven by the 2 kHz oscillator. In addition a third output is taken from the oscillator, rectified and the second-harmonic component filtered to form a 4 kHz reference signal.

the passage of a mark, the output from the vertical element will be as shown in Fig. 6(b). The second-harmonic component present after passing through the 4 kHz band-pass filter is shown in Fig. 6(b), and clearly shows the change in phase produced by the changing direction of the vertical component of field. This signal is amplified and passed on to p.s.r.2 where it is compared in phase with the reference signal. The output of p.s.r.2 (Fig. 6(c)) is a voltage analogue of the vertical field (Fig. 3). The central negative lobe is selected by rectification, and the 8 kHz pulses produced by p.s.r.2 are amplified, smoothed and used to operate the monostable element B (Fig. 6(e)). Hence, monostable B operates after the first fringe node in the horizontal component of field has passed and releases before the second fringe node reaches the detecting head. The negative-output of monostable B is therefore used to open the gate following the horizontal magnetometer element.

The second-harmonic component of the output from the horizontal element (Fig. 6(f)) is gated by the vertical channel to produce an input to p.s.r.1, as shown in Fig. 6(g). After phase-sensitive rectification (Fig. 6(h)), the negative-going 8 kHz pulses are selected by rectification (Fig. 6(i)), amplified, smoothed and the direct voltage produced is used to operate monostable element A (Fig. 6(k)) operates a counter, thereby indicating the number of marks which have passed the detector, and also generates a pulse which is fed back to the marker unit to initiate the application of a further mark. The detector output pulse occurs precisely at the central node (Fig. 6(l)).

#### ACCURACY

There are three sources of error which can produce inaccuracies in practice.

- (i) Static errors of mark-detection caused by extraneous large-volume fields, e.g. the earth's magnetic field.
- (ii) Tensional errors caused by varying pulling-tension altering the cable length between marker and detector.
- (iii) Errors due to the loop response time, which are directly proportional to cable drawing speed.

Any large-volume field will effectively displace the response of the detected horizontal field pattern (Fig. 7). If this field is steady it can be compensated for simply by the adjustment of the marker-detector separation. Where the extraneous field is varying, and where greater accuracy is required, a compensating circuit utilizing an additional magnetometer sensing element can reduce these errors to minimal dimensions.

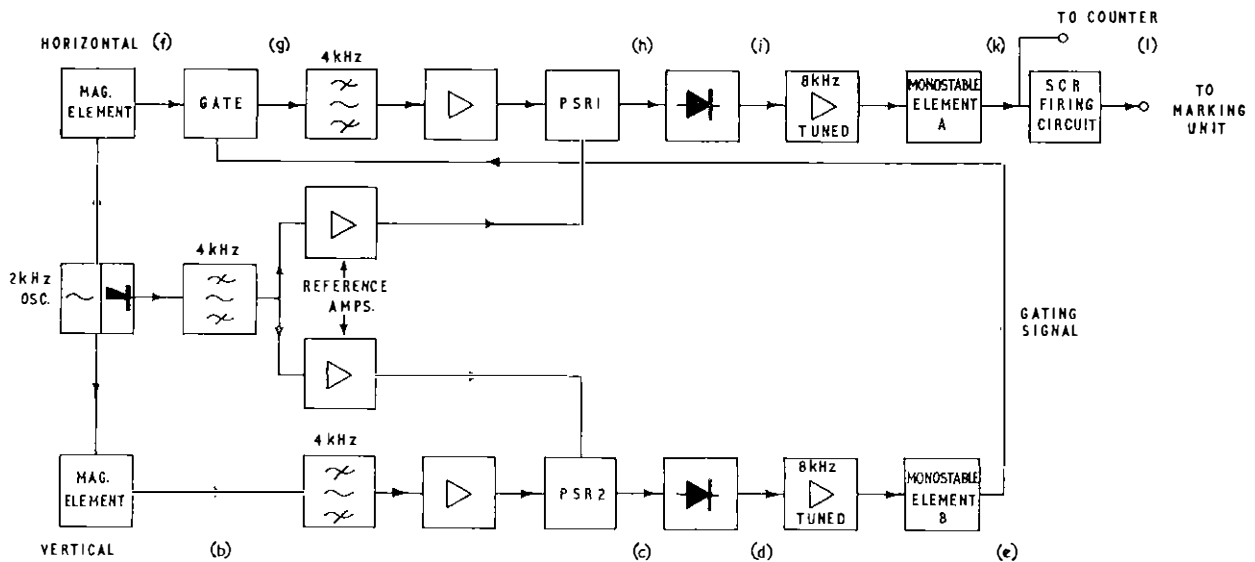

FIG. 5—Block schematic diagram of the experimental node detector

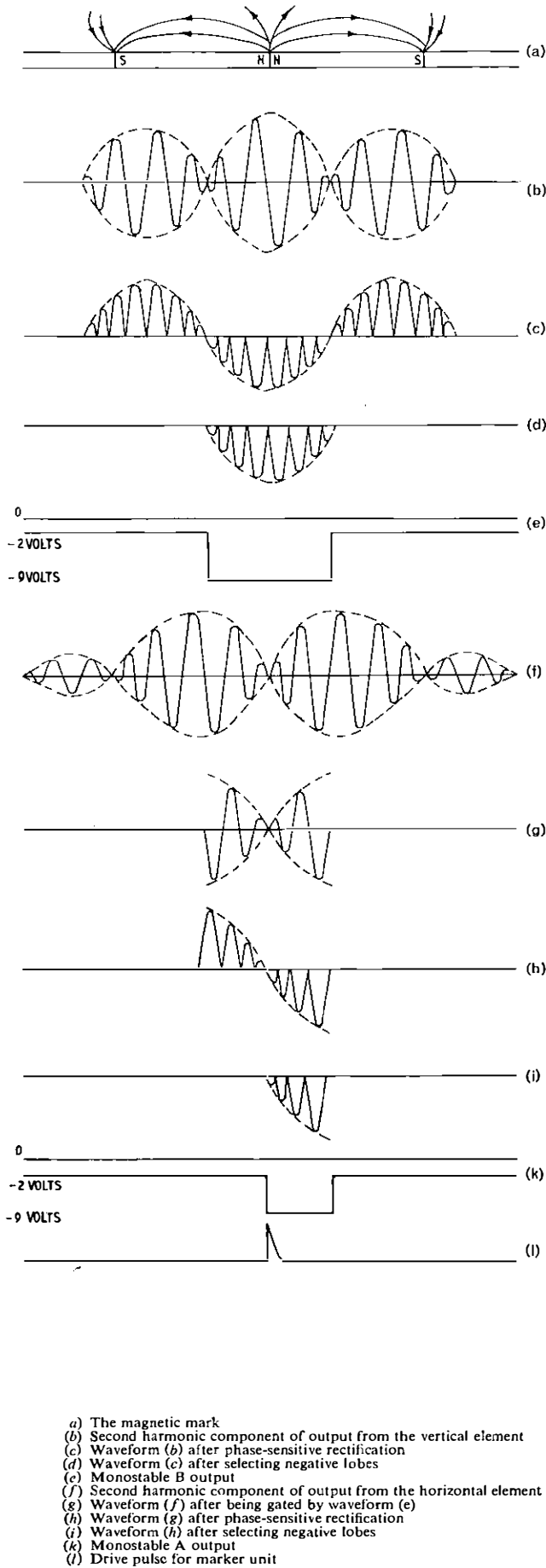
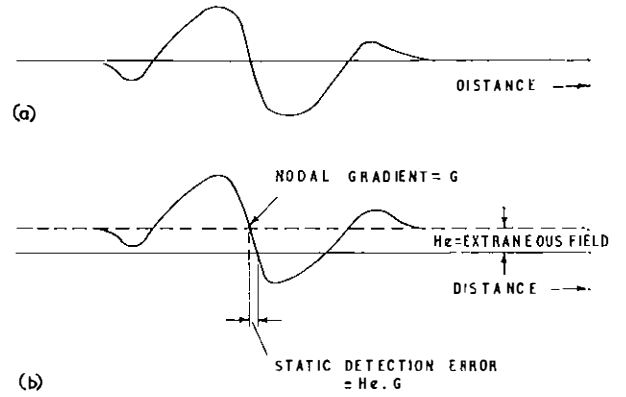
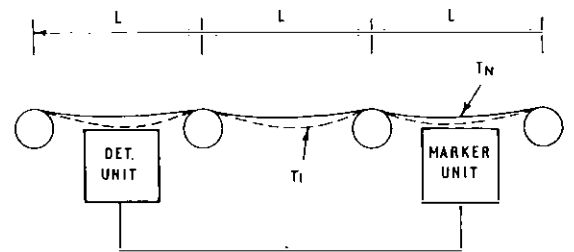

FIG. 6—Waveforms for the experimental node detector



(a) Horizontal component of magnetic field in the absence of any extraneous field  
 (b) Horizontal component of magnetic field in the presence of an extraneous field of magnitude  $H_e$

FIG. 7—Static detection error produced by an extraneous magnetic field



$$\Delta l \approx \frac{L^3 W^2 n}{12 T_n \Delta T}, \text{ where } \Delta T = T_N - T_I$$

$W$  = Weight of cable per unit length  
 $n$  = Number of spans

FIG. 8—Tensional errors in the measurement of cable length

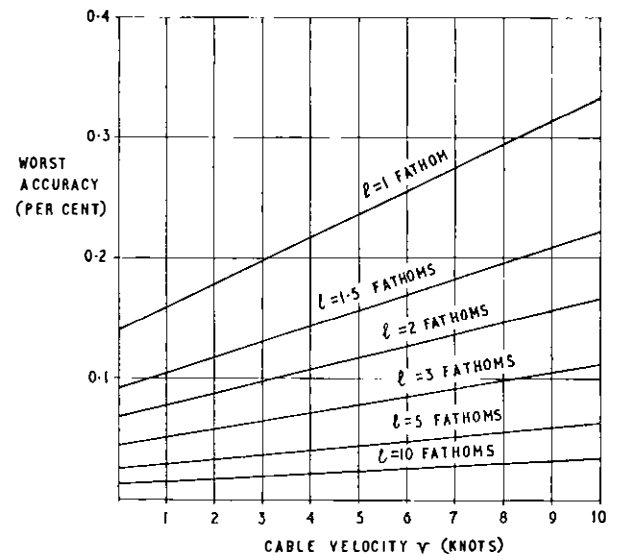

FIG. 9—Graph of predicted accuracy against cable velocity with marking length ( $l$ ) as a parameter

These errors affect the overall-length measuring accuracy in direct relationship to the marker-detector separation, i.e. 0.1 in error in 60 ft gives a higher accuracy than 0.1 in in say 10 ft.

The tensional errors will normally be due to cable stretches and the sag produced between cable supports or pulleys. Fig. 8 shows the variation in length due to varying sag caused by changes in tension. The catenary produced by a cable freely hanging between supports has been approximated to a parabola because of the minimal dip normally experienced.

In practice the only errors of any importance are those due to the loop response time, and the static errors due to large volume fields. The predicted accuracies of such a system are shown in Fig. 9.

## CONCLUSIONS

An experimental mark detector has been constructed and tested under laboratory conditions and found to operate both

accurately and reliably. It has been proved possible to use such a method of length measurement for both factory and shipboard use on 0.99 in lightweight submarine cable. The method is equally applicable to the accurate measurement of taut wire on board ship. Two parallel systems, one for taut wire the other for submarine cable, could be utilized for the automatic measurements or control of the slack cable paid out from the cable-laying ship.

## ACKNOWLEDGEMENTS

Acknowledgements are due to colleagues in the Research Department for their fundamental concept of the bi-polar mark.

## References

<sup>1</sup> FALK, C. J. Magnetic Wire Footage Meter. United States Patent 2,488,277. 1949.

<sup>2</sup> BOWERS, W. E. Methods and Apparatus for Measurement. United States Patent 3,066,253. 1962.

## Book Review

“Taschenbuch der Hochfrequenztechnik.” (Handbook of high-frequency engineering). V. H. Meinke und F. W. Gundlach. xxxii + 1667 pp. 2400 ill. \$24.65.

Literally translated, Taschenbuch means pocket-book, but its size (8 in by 5 in by 2 $\frac{3}{4}$  in) and weight (3 lb 5 oz) make it obvious that only giants could use it as such. It is, in fact, a radio engineers' reference book restricted to communication. Direction finding and navigation are therefore not dealt with. Nothing explicit is said about the problems of multi-channel telephony or high-speed data transmission, and very little about television. Even so, the amount of information offered is simply enormous.

The subject matter is divided into 25 main sections as follows.

- A Components (157 pages, 187 references),
- B Circuits with lumped components (87 pages, 113 references),
- C High-frequency transmission lines and cables (63 pages, 199 references),
- D Homogeneous, especially hollow, wave guides (48 pages, 141 references),
- E Transmission-line components and circuits (50 pages, 176 references),
- F Wave-guide components and circuits (51 pages, 217 references),
- G Transmission-line and cavity resonators (28 pages, 126 references),
- H Aerials (142 pages, 134 references),
- J Wave propagation (50 pages, 141 references),
- K Semiconductors (72 pages, 136 references),
- L Valves, construction and characteristics (73 pages, 161 references),
- M Microwave valves (65 pages, 104 references),
- N Pre-amplifiers and power amplifiers (140 pages, 157 references),
- O Transmitter amplifiers and neutralization (53 pages, 112 references),

- P Detection (31 pages, 40 references),
  - Q Mixing and frequency changing (36 pages, 35 references),
  - R Oscillators (51 pages, 114 references),
  - S Pulse techniques (36 pages, 112 references),
  - T Noise (55 pages, 190 references)
  - U Modulation (104 pages, 226 references),
  - V General principles of communication (37 pages, 118 references),
  - W Transmitters (47 pages, 145 references),
  - X Receivers (62 pages, 143 references),
  - Y Measurements at high frequencies (102 pages, 161 references),
  - Z Power supplies of small and medium sizes (14 pages, 18 references),
- Index (about 2,400 entries).

The work has been shared by 50 authors who are in industry, at universities, or with the post office; they are all acknowledged experts in their field. This ensures that the treatment is often excellent and never less than adequate. A multiplicity of authors makes unified representation difficult and overlapping almost unavoidable, but the editors have obviously dealt with the problem as well as can be expected.

This is the third edition of the book which first appeared in 1956. It is therefore obvious that it must have met with great approval at least in the German-speaking communities. Of special interest are the many references at the end of each main section which quote publications up to 1965, and occasionally up to 1967. The whole western hemisphere is represented, although there is naturally a certain emphasis on German contributions which is appropriate in a book mainly written for the German market. The list of references would be even more useful if the titles of the papers had been given.

Anybody with a working knowledge of German should find this book to be a very valuable source of information and a useful guide to the literature on the subject.

J. M. L.

# International Telegraph Alphabet No. 5

D. A. CHESTERMAN

U.D.C. 621.394.14

*In telegraphy Murray is remembered for his code, which is perpetuated in the International Telegraph Alphabet No. 2 (ITA 2). This alphabet was ratified by the International Telecommunication Union in 1932, and is now widely used on telex and private-circuit installations throughout the world. However, more sophisticated telegraphic communication is required today, particularly with the widespread use of computers, and the International Telegraph Alphabet No. 5 (ITA 5) has been developed to meet these needs. The introduction of this new telegraph alphabet for data and message interchange will provide many new facilities and possibilities. At the same time it introduces a variety of problems. The wide possibilities of the escape sequences require early international agreement on sequence allocations to ensure compatibility between different Administrations. Also, the introduction of layout control on receiving machines by tabulation and other characters, presents new and challenging mechanical problems.*

## INTRODUCTION

Communication over distances, other than by speech, has always been a problem for man. The conflicting requirements of speed and accuracy have led him through the phases of smoke and drum signals to the heliograph and the morse key up to more elaborate systems. Since electrical telegraphic communication began in 1837 there have been many ingenious machines using various codes and alphabets. Their complexity and speed of transmission, has usually, been dictated by the ability of the transmitting and receiving mechanisms to faithfully process these signals. Baudot, Hughes, Wheatstone and others have made their contribution to the art, but the work of Morkrum on the teleprinter has probably been the most enduring. Murray is remembered for his code, which is perpetuated in the International Telegraph Alphabet No. 2 (ITA2). This alphabet was ratified by the International Telecommunication Union in 1932, and is now widely used on telex and private-circuit installations throughout the world. However, more sophisticated telegraphic communication is required today, particularly with the widespread use of computers, and the International Telegraph Alphabet No. 5 (ITA5) has been developed to meet these needs. The use of the new alphabet is increasing rapidly, and in this article an attempt is made to highlight the new facilities and to discuss some of the problems involved in its introduction.

## Definition of Terms

*Telegraph Alphabet.* A table of correspondence between the printed characters and functions, e.g. space, line feed, and the telegraph signals which represent them. It is common practice in British Standards Institution (B.S.I.) and International Standards Organization (I.S.O.) publications to refer to the alphabet as the code table.

*Character.* A position, allocation or combination in the alphabet.

*Telegraph Code.* A system of rules and conventions according to which the telegraph signals corresponding to a message should be formed, transmitted, received and translated.

*Telegraph Signal Element.* Each of the parts constituting a telegraph signal according to the code, and distinguished from the others by its nature, magnitude, duration and relative position.

In the present context an element must be in one of two conditions:

- (i) positive, also referred to as start polarity, or A, or 0, or
- (ii) negative, also referred to as stop polarity, or Z, or 1.

† Telegraph and Data Systems Branch, Telecommunications Development Department, Telecommunications Headquarters.

An element in a binary code is now commonly referred to as a "bit."

*Functional Character.* A character to initiate the performance of a process, usually mechanical and non-printing: also known as a "control."

*Graphic Character.* A character to be, or capable of being, printed.

*Telegraph Signal.* The set of conventional elements established by the code to effect the transmission of a printed character or the control of a particular function: this set of elements is characterized by the variety, the duration and the relative position of the component elements.

In the present context of start-stop telegraphy using ITA5, a signal comprises one start element and seven code elements (i.e. the character), one parity element and one, or two, stop elements.

## INTERNATIONAL TELEGRAPH ALPHABET NO. 2

International Telegraph Alphabet No. 2 (ITA2) is the alphabet in current use on the telex service. It is a 5-unit code, and there are, therefore,  $2^5 = 32$  combinations, of which, normally, all but one are used. This alphabet is reproduced in Fig. 1. To allocate 26 combinations exclusively for the Roman alphabet, thus leaving only six combinations for other graphics and functions would impose a severe limitation on the usefulness of the alphabet. Each graphic combination has, therefore, been allocated two functions, and the receiving mechanism is put into the appropriate shift, or case, by the FIGURES or LETTERS combination. Hence, ITA2 offers 52 graphical, two shift, three functional and one unallocated, characters.

The introduction of ITA5 is unlikely to adversely affect the growth rate of the present international telex network, but the possibility of interworking between the two alphabets, albeit by complex equipment, may well stimulate its expansion.

## INTERNATIONAL TELEGRAPH ALPHABET NO. 5 Brief History

The new International Telegraph Alphabet No. 5 originated from a proposed American Standard Code for Information Interchange (ASCII) put forward by the American Standards Association in 1962. This was developed by the C.C.I.T.T.† and the I.S.O., and culminated in a joint meeting in Paris in April 1966, at which the present alphabet was agreed. This was ratified by the I.S.O. in June 1968, and at the C.C.I.T.T. IVth Plenary Assembly at Mar del Plata in October 1968.

‡ C.C.I.T.T.—International Telegraph and Telephone Consultative Committee.

Combination No.	Code Elements					British Teleprinter Keyboard
	1	2	3	4	5	
1	•	•				A —
2	•			•	•	B ?
3		•	•	•		C :
4	•			•		D WHO ARE YOU
5	•					E 3
6	•		•	•		F %
7		•		•	•	G @
8			•		•	H £
9		•	•			I 8
10	•	•		•		J BELL
11	•	•	•	•		K (
12		•			•	L )
13			•	•	•	M .
14			•	•		N ,
15				•	•	O 9
16		•	•		•	P 0
17	•	•	•		•	Q 1
18		•		•		R 4
19	•		•			S '
20					•	T 5
21	•	•	•			U 7
22		•	•	•	•	V —
23	•	•			•	W 2
24	•		•	•	•	X /
25	•		•		•	Y 6
26	•				•	Z +
27				•		CARRIAGE RETURN
28		•				LINE FEED
29	•	•	•	•	•	LETTERS
30	•	•		•	•	FIGURES
31			•			SPACE
32						NOT USED

• Indicates stop polarity

FIG. 1—International Telegraph Alphabet No. 2

### General

The alphabet uses a 7-unit code, and the original concept allowed for a 6-unit set to be derived from it. The present standard allows for this 6-unit set but, as this contraction provides only 64 characters, the resulting limitations will probably preclude its general use. The I.S.O. are discussing the expansion of ITA5 into an 8-unit environment, thus providing 128 combinations in addition to those of the standard alphabet, which would remain a part of this later

concept. However, the use of such an expansion is restricted, and it is not intended for general information interchange.

The bit pattern of each character is indicated in Fig. 2, e.g. that for M is 1011001. A more convenient reference is by column/row; M, would thus be shown as M (4/13). The control characters, which are all located in columns 0 and 1, are usually abbreviated in capitals, as shown in Fig. 2, e.g. ACKNOWLEDGE would be written ACK (0/6).

In this article, reference to characters is by column/row (Fig. 2) and this method is commonly used in C.C.I.T.T. and I.S.O. publications. A character can also be represented by its binary number, which is the same as the representation on punched tape with the convention 0 = no hole and 1 = hole. A further method is to represent each character by its decimal number, but this is not in general use.

The alphabet can be divided into four sub-sets:

- (i) control (columns 0 and 1),
- (ii) numeric (columns 2 and 3),
- (iii) alpha capitals (columns 4 and 5), and
- (iv) alpha lower case (columns 6 and 7).

These sub-sets are useful for a closer consideration of the alphabet.

### ALPHA GRAPHIC CHARACTERS

The Roman alphabet, in lower case and in capitals, is included here together with COMMERCIAL AT, UNDERLINE and UPWARDS ARROW. A number of diacritical signs are provided which, in conjunction with BACKSPACE (0/8), can be placed over the last character printed. In this way acute and grave accents, and other marks used in European languages, can be provided.

There are seven character positions which are national options. Scandinavian countries, for example, will use them for alphabetic extension. In the United Kingdom, the United States of America and in Western Germany there is a close agreement between the symbols allocated to these positions nationally, and the United Kingdom choices are shown in Fig. 2 at positions 4/0, 5/11, 5/12, 5/13, 7/11, 7/12 and 7/13. Due to the requirement by the Decimal Currency Board to show monetary sums in the form £42·67½, the British Post Office will probably opt for the fraction ½ to be allocated to position 5/12 instead of REVERSE SLASH. Suffix 10 is a further option that can be used in this position in the United Kingdom.

The DELETE character (7/15) is primarily to obliterate errors that may have appeared during the preparation of punched tape prior to transmission; this character is represented on tape by a hole in each of the seven information tracks; normally, it has no graphical representation.

### NUMERICAL GRAPHIC CHARACTERS

In addition to the 10 numerals, there is a miscellany of graphics, including two which, if used in conjunction with BACKSPACE, take on the meaning of diacritical signs. This device is used once also in the alpha-graphic sub-set and is a means of expanding the total number of graphics available without making further allocations, i.e. these three characters have a dual interpretation according to the mode of implementation.

### CONTROLS

The control characters are further sub-divided, and are considered in detail under the appropriate sub-headings.

#### Transmission Controls

The transmission controls (TC) are functional characters intended to control or facilitate transmission of information over telecommunication networks. There are 10 such characters as shown in Table 1.

Bits								Column							
b <sub>7</sub>	b <sub>6</sub>	b <sub>5</sub>	b <sub>4</sub>	b <sub>3</sub>	b <sub>2</sub>	b <sub>1</sub>	Row	0	0	0	0	1	1	1	1
								0	0	1	1	0	0	1	1
								0	1	0	1	0	1	0	1
								0	1	2	3	4	5	6	7
0	0	0	0	0	0	0	0	NUL	[TC <sub>7</sub> ] DLE	SP	0	@	P	,	p
0	0	0	0	1	1	1	1	[TC <sub>1</sub> ] SOH	[DC <sub>1</sub> ]	!	1	A	Q	a	q
0	0	1	0	0	0	0	2	[TC <sub>2</sub> ] STX	[DC <sub>2</sub> ]	"	2	B	R	b	r
0	0	1	1	1	1	1	3	[TC <sub>3</sub> ] ETX	[DC <sub>3</sub> ]	£	3	C	S	c	s
0	1	0	0	0	0	0	4	[TC <sub>4</sub> ] EOT	[DC <sub>4</sub> ]	§	4	D	T	d	t
0	1	0	1	1	1	1	5	[TC <sub>5</sub> ] ENQ	[TC <sub>8</sub> ] NAK	%	5	E	U	e	u
0	1	1	0	0	0	0	6	[TC <sub>6</sub> ] ACK	[TC <sub>9</sub> ] SYN	&	6	F	V	f	v
0	1	1	1	1	1	1	7	BEL	[TC <sub>10</sub> ] ETB	'	7	G	W	g	w
1	0	0	0	0	0	0	8	[FE <sub>0</sub> ] BS	CAN	(	8	H	X	h	x
1	0	0	1	1	1	1	9	[FE <sub>1</sub> ] HT	EM	)	9	I	Y	i	y
1	0	1	0	0	0	0	10	[FE <sub>2</sub> ] LF	SUB	*	:	J	Z	j	z
1	0	1	1	1	1	1	11	[FE <sub>3</sub> ] VT	ESC	+	;	K	[	k	{
1	1	0	0	0	0	0	12	[FE <sub>4</sub> ] FF	[IS <sub>4</sub> ] FS	,	<	L	\	l	
1	1	0	1	1	1	1	13	[FE <sub>5</sub> ] CR	[IS <sub>3</sub> ] GS	-	=	M	]	m	}
1	1	1	0	0	0	0	14	SO	[IS <sub>2</sub> ] RS	.	>	N	^	n	_
1	1	1	1	1	1	1	15	SI	[IS <sub>1</sub> ] US	/	?	0	—	o	DEL

Position 5/12 has suffix 10 or the fraction  $\frac{1}{2}$  as alternative allocations

FIG. 2—International Telegraph Alphabet No. 5

**TABLE 1**  
Transmission Control Characters

Character No.	Abbreviated Code	Purpose
TC <sub>1</sub>	SOH	Start of heading
TC <sub>2</sub>	STX	Start of text
TC <sub>3</sub>	ETX	End of text
TC <sub>4</sub>	EOT	End of transmission
TC <sub>5</sub>	ENQ	Enquiry—broadly equivalent to WHO ARE YOU in ITA2
TC <sub>6</sub>	ACK	Acknowledge—an affirmative in response to a sender
TC <sub>7</sub>	DLE	Data link escape. This character is used in conjunction with others exclusively to provide supplementary data-control functions
TC <sub>8</sub>	NAK	Negative acknowledgment—negative response to a sender
TC <sub>9</sub>	SYN	Synchronous idle—provided for use in synchronous transmission systems so that, in the absence of any other character, a signal is provided from which synchronism may be achieved or maintained between terminal equipments
TC <sub>10</sub>	ETB	End-of-transmission block

**TABLE 2**  
Format Effectors

Character No.	Abbreviated Code	Purpose
FE <sub>0</sub>	BS	Backspace—controls the printing position one printing space backwards on the same printing line; it does not backspace a tape-perforating mechanism.
FE <sub>1</sub>	HT	Horizontal tabulation—controls the movement of the printing position to the next of a series of predetermined positions along the printed line.
FE <sub>2</sub>	LF	Line feed—controls the movement of the printing position to the next printing line.
FE <sub>3</sub>	VT	Vertical tabulation—controls the movement of the printing position to the next in a series of predetermined printing lines.
FE <sub>4</sub>	FF	Form feed—controls the movement of the printing position to the first predetermined printing line on the next form.
FE <sub>5</sub>	CR	Carriage return—controls the movement of the printing position to the first printing position on the same printing line.

**Format Effectors**

Functional characters (Table 2) which control the layout or positioning of input or output information are referred to as format effectors.

**Device Controls**

Functional characters that can be used to control ancillary devices such as tape readers are shown in Table 3.

**TABLE 3**  
**Device Controls**

Character No.	Purpose
DC <sub>1</sub> -DC <sub>3</sub>	To switch on an ancillary device such as a tape reader or tape punch
DC <sub>4</sub>	To interrupt, or switch off, ancillary devices

#### Information Separators

Table 4 lists the characters used to separate and control information in a logical sense.

**TABLE 4**  
**Information Separators**

Character No.	Purpose (note)
IS <sub>1</sub>	Unit separator
IS <sub>2</sub>	Record separator
IS <sub>3</sub>	Group separator
IS <sub>4</sub>	File separator

Note: These characters are intended to be used in a hierarchical order.

#### Specific Controls

There are eight control characters, outside those shown in Tables 1-4, which control a miscellany of functions e.g. BELL, CANCEL, SUBSTITUTE. Three of these, together with DATA-LINK ESCAPE (DLE), have considerable importance in the context of the extension, or of the expansion, of the alphabet beyond that shown in Fig. 2.

#### Extension of Transmission Controls

The purpose of DLE, DATA LINK ESCAPE (1/0), is to provide supplementary data-transmission control functions. In a DLE sequence, only graphics and transmission-control characters can be used. The DLE character changes the meaning of a limited number of consecutive characters. For example, the sequence DLE, H, NAK might mean "Repeat all information from SOH." Clearly, the interpretation of such sequences has to be mutually agreed beforehand by all parties concerned.

#### Extension of Graphics

The character SO, SHIFT OUT (0/14), provides the capability of printing an alternative set of graphics, up to a maximum of 95, in place of those shown in columns 2-7 of Fig. 2, whilst retaining the ability to communicate in the standard alphabet. The 32 control characters and DELETE are not affected by SHIFT OUT. Reversion to the standard alphabet is by use of character SI, SHIFT IN (0/15).

#### Escape Sequences

An escape sequence consists of the character ESC, ESCAPE (1/11), followed by one or more characters. Such sequences are used primarily to obtain additional control functions which may provide, among other things, graphics or graphic sets outside the standard set. However, such control functions must not be used as additional transmission controls. The 10 TC characters together with DEL and NUL must not be used in ESCAPE sequences.

Escape sequences are very versatile, and may be of two, three or possibly four characters in length; there is therefore a considerable number of permitted combinations available.

Such a sequence is of the form ESC, INTERMEDIATE (0, 1 or 2), FINAL. To ensure that the FINAL is recognized as such, irrespective of the length of the sequence, all such sequences have to be mutually agreed. International agreement is required for the broad allocation of sequences to particular types of application, e.g. graphic extension, additional device-controls, national choices. The I.S.O. are currently studying code-extension procedures that involve ESCAPE sequences and SHIFT OUT and SHIFT IN.

#### APPLICATIONS OF THE ALPHABET

The ASCII alphabet is used widely in the United States of America and, as it was the forerunner of ITA5, the two alphabets are very similar. The use of ITA5 in the United Kingdom is expanding rapidly for use with multi-access computer bureaux. In such a system, customers have access to a common computer via the switched telephone network. The equipment for each customer comprises a telephone with suitable press-button keys, a modem for the Datel 200 service (Datel Modem No. 2)\* and a 7-unit teleprinter. Each customer is charged on a time-occupancy basis, plus a fixed rental.

There is likely to be a demand for private circuits for use with 7-unit teleprinters. The remote control of typesetting, and the transmission of meteorological information, such as weather maps, are possible uses in this field. There is also a potential demand for private networks for such concerns as transport groups and banks to operate with the alphabet.

A third, tentative, use could be for an improved telex service, possibly with access to the present 5-unit, 50-baud, network via suitable convertors.

#### SERIAL SIGNAL FOR TRANSMISSION TO LINE

Normally, signalling between teleprinters is on a start-stop basis. The complete start-stop signal embodying ITA5 comprises one start element, seven code elements, according to the particular character being transmitted, and one parity element to provide overall even parity with the seven elements of the character, followed by one or two stop elements, according to the particular terminal equipment in use.

The parity element enables odd-numbered elemental errors to be detected, in particular, single-element errors. When an error is detected, the receiving machine can respond in one or more of a variety of ways: the attention of the operator can be attracted by a bell; or the machine can print a particular symbol signifying an error. A more elaborate procedure is for the machine to cease printing and to return NAK NEGATIVE ACKNOWLEDGMENT (1/5), which causes the transmitter to send CR CARRIAGE RETURN (0/13) followed by a repetition of the last line. The line will be overprinted, and the space, created by the error, filled correctly.

The present character-clearance rate is 10/second, and this results in a line signalling speed of 100 or 110 bauds, according to the length of the stop element. To date, there is no international agreement upon the signalling speeds to be used.

#### FUTURE DEVELOPMENTS

ITA5 is now accepted, having been ratified by the C.C.I.T.T. and the I.S.O., and future development is in the expansion to an 8-unit alphabet and the exploitation of the escape sequences. It is essential that early international agreement be reached on the broad allocation of escape sequences to various applications, so that these can be developed nationally with the confidence that their international use will not be inhibited later.

\* SPANTON, J. C., and CONNELLAN, P. L. Datel Modems for the Datel 200 Service-Datel Modems No. 2. *P.O.E.E.J.* Vol. 62, p. 1 April 1969.



# A 9-Channel V.H.F. Coaxial-Cable Closed-Circuit Television Distribution System

P. W. LINES, C.ENG., M.I.E.E.†

U.D.C. 621.397.5: 621.315.212.1

*The background to schools television and a general description of the Post Office 9-channel v.h.f. distribution system were the subject of an article in the January 1969 issue. The present article gives a more detailed description of the items used in the distribution network, from the output of the channel-modulating equipment, situated at the studio, to apparatus at the schools using the service. A subsequent article will describe the modulating equipment, the frequency spectrum, and those aspects of television receivers that have to be considered in the overall system design.*

## OUTLINE OF SYSTEM

The demand for closed-circuit television facilities for schools is growing, and large distribution networks already exist in some cities. A general description of the type of network now being provided by the British Post Office has already been given;<sup>1</sup> this article describes in rather more detail the type of cable used and the associated transmission and monitoring equipment.

The maximum range of the coaxial-cable distribution system described in this article is 20 miles, using 0.62 in single-tube polythene-dielectric coaxial cable. A transmission band from 40 MHz to 140 MHz is employed; the lower frequency is determined by the frequency limitations of v.h.f. television receivers, and the upper frequency is fixed by the number of television channels to be transmitted and their performance over a distance of 20 miles. Each channel is suitable for 625-line colour transmission, and the system has a 140 MHz line pilot signal.

The whole of the line network is underground and uses the same duct routes as telephone cables. The main feeders are routed via telephone exchanges, and the 50-volt exchange batteries are used to supply power, via the coaxial cable, to the dependent repeaters. The dependent repeaters may be spaced at up to 800-yard intervals, the precise location of a repeater being decided by the position of a suitable footway box or manhole in which it can be mounted.

Apart from the send terminal, there are five major transmission-equipment items:

- (i) dependent repeater,
- (ii) power-feeding repeater,
- (iii) branching units,
- (iv) receive-terminal repeater, and
- (v) supervisory monitoring equipment

## CABLE PERFORMANCE

The initial system concept, based upon the performance of trial sections of 0.62 in diameter coaxial cable, was that repeaters with a gain of 24 dB would be spaced at 880-yard intervals. The early production cable had a higher attenuation than the trial cable, and it was decided to relax the specification limits in this respect and reduce the repeater spacing to 800 yards.

The reason for the higher-than-expected attenuation involves relatively-simple fundamental cable-design theory.

There are two major factors that influence the attenuation of the cable in the region of 100 MHz: the copper losses due to the surface resistance of the conductors, and the dielectric losses introduced by the polythene between the inner and outer conductors. The classical formula for cable attenuation is

$$\alpha = \frac{R}{2Z_0} + \frac{GZ_0}{2}, \quad \dots \dots (1)$$

where  $\alpha$  = attenuation in nepers per metre,  
 $R$  = effective loop resistance per metre,  
 $G$  = dielectric conductance per metre, and  
 $Z_0$  = characteristic impedance of the cable.

It is more convenient to express the second part of the formula in terms of the tangent of the dielectric loss angle ( $\tan \delta$ ), the velocity,  $v$ , of propagation of signals along the cable, and frequency,  $f$ , rather than in terms of the conductance of the dielectric, thus

$$\alpha = \frac{R}{2Z_0} + \frac{\pi f \tan \delta}{v} \text{ nepers per metre} \quad \dots \dots (2)$$

The characteristic impedance of a coaxial cable with a polythene dielectric is given by

$$Z_0 = \frac{60}{\epsilon_r} \cdot \log_e \frac{b}{a} \text{ ohms}, \quad \dots \dots (3)$$

where  $a$  = radius of the inner conductor ( $1.21 \times 10^{-3}$  m for 0.620 in cable)

and  $b$  = radius of the outer conductor ( $7.9 \times 10^{-3}$  m for 0.620 in cable).

The relative permittivity  $\epsilon_r$  of the solid-polythene dielectric lies in the range 2.29 to 2.35, and, if a value of 2.30 is assumed and the dimensions given above for 0.620 in cable are taken then the cable impedance is approximately 75 ohms.

The effective loop resistance of the cable is determined by the skin effect, i.e. by the current being constrained to flow near the surface of the conductors only. At high frequencies the effective resistance,  $R$ , per metre of cable can be expressed in terms of

$$R = \sqrt{[(f\mu_0\mu_r)/4\pi\sigma]} (1/a + 1/b) \text{ ohms} \quad \dots \dots (4)$$

where  $\mu_0 = 4\pi \times 10^{-7}$ ,

$\mu_r$  = relative permeability (1 for copper), and

$\sigma$  = conductivity (approximately  $5.8 \times 10^7$  mho/metre for copper).

From this last formula the effective loop-resistance of the cable, and hence the first part of the attenuation equation (2) is proportional to the square root of the frequency.

† Line and Radio Branch, Telecommunications Development Department, Telecommunications Headquarters.

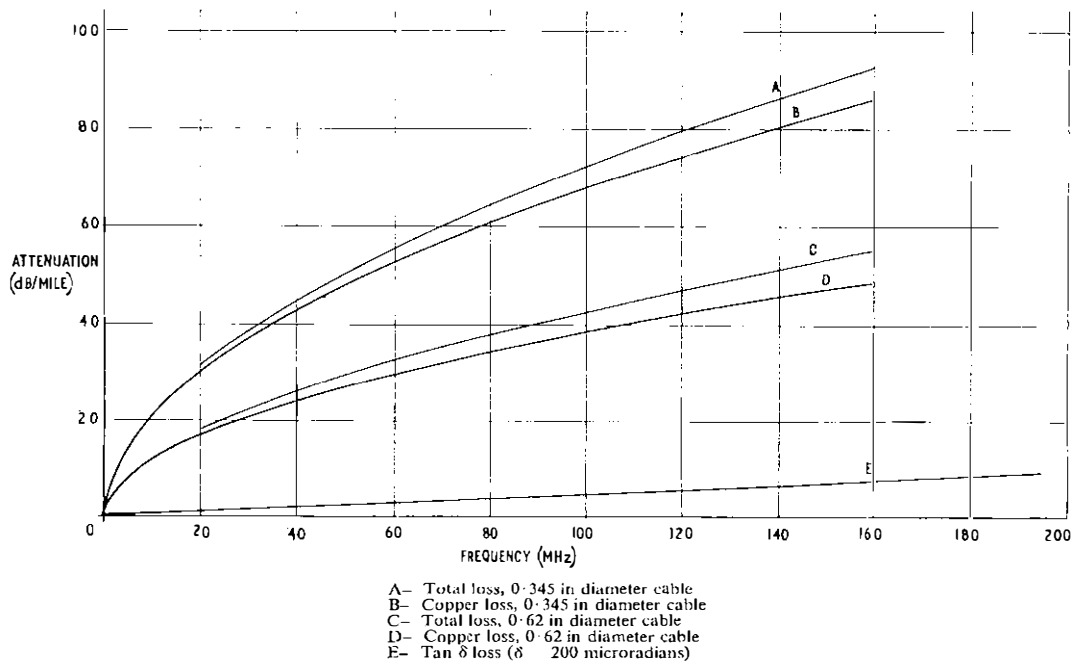

FIG. 1—Loss/frequency characteristics of 0.62 in and 0.345 in diameter coaxial cables at 10° C

The attenuation due to the second term of equation (2) is directly proportional to frequency, and, in practice, the loss angle also tends to increase slightly with frequency. The attenuation due to the loss angle is independent of the cable size. Fig. 1 shows the attenuation characteristics of the 0.620 in and the smaller 0.345 in coaxial cables used in this system. At low frequencies the dielectric loss is a small proportion of the total attenuation, but at 140 MHz it might typically be 12.5 per cent for 0.620 in cable incorporating polythene with a typical loss angle ( $\delta$ ) of 200 microradians.

Inconsistency of the loss angle of the polythene was largely responsible for the comparatively high variation in the attenuation of the early-production cable sections. Polythene with a closer tolerance on its tan  $\delta$  is now used in the manufacture of this cable, and a more consistent attenuation is achieved. Small variations of cable dimensions within the tolerance limits and the amount of work-hardening of the copper conductors, which reduces conductivity, can also affect the attenuation slightly.

Although the cable impedance has been made 75 ohms for reasons of standardization, with polythene dielectric an impedance of 50 ohms would produce a more economical cable design in terms of either at least 10 per cent lower attenuation for the same cable diameter or lower cost for the same attenuation and smaller overall diameter. These advantages are not, however, sufficient to offset the disadvantages of introducing another cable standard.

### DEPENDENT REPEATER

The heart of the repeater is the amplifier, which consists of three stages, each with a gain of about 8 dB. The first two

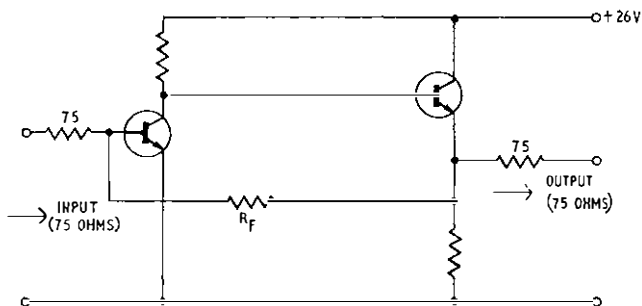

FIG. 2—V.H.F. amplifier input stage

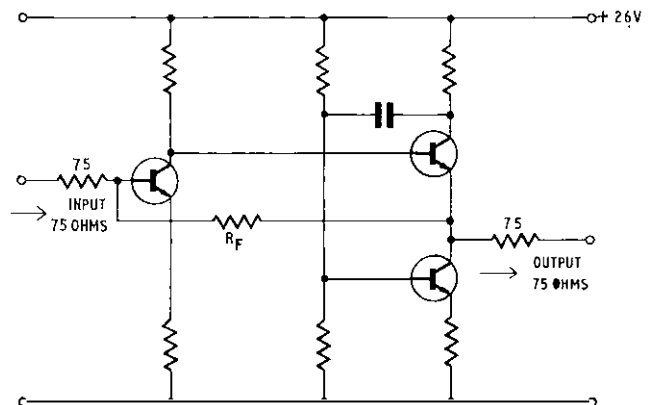

FIG. 3—V.H.F. amplifier output stage

stages are similar in design, using two transistors in each stage. The output stage is a single-ended push-pull circuit employing three transistors. The basic elements of these amplifiers are shown in Fig. 2 and 3, in which power-supply decoupling, bias and trimming components have been omitted. The gain  $G_F$ , is controlled by the feedback resistor,  $R_F$ , and is given approximately by the formula

$$G_F = 20 \log_{10} (R_F + 75) / 75 - 6 \text{ dB}$$

In a practical circuit  $R_F$  does not always exist as a single ideal resistor but is modified by associated circuit components. As up to nine television channels are to be carried on a single path, the linearity of the amplifiers must be sufficient to prevent interference between channels. The main intermodulation products that have to be considered are: second-order products caused by the vision carriers; and cross-modulation, which is a third-order product. The effect of second-order intermodulation would be to produce pattern-interference on some channels, while cross-modulation is the unwanted transfer of modulation signals from one vision channel to another; the visible effect is somewhat similar to video "crosstalk". The system design allows for 40 cascaded amplifiers, so that the performance of a single-amplifier must be proportionally better. The main long-term system performance objectives are as follows.

(a) Peak-to-peak picture-signal-to-r.m.s. weighted-noise ratio on the worst channel: 40 dB.

(b) Vision-carrier signal-to-r.m.s.-interference ratio, due to second-order distortion: 50 dB.

(c) Cross-modulation expressed as the ratio of the wanted picture to unwanted interference, with nine operating channels: 46 dB.

(d) *K*-rating\*: 6 per cent, including distortion due to a modulator and demodulator.

cable slope-correcting networks between the main-path amplifier stages and a 4-terminal attenuator at the input of the main amplifier. The 2-terminal network configuration is shown in Fig. 5; it consists of a 2-section RC ladder network and a resonant circuit tuned to approximately 140 MHz to give a minimum loss at that frequency. A selection of these networks is available in 2dB steps of cable-section attenuation

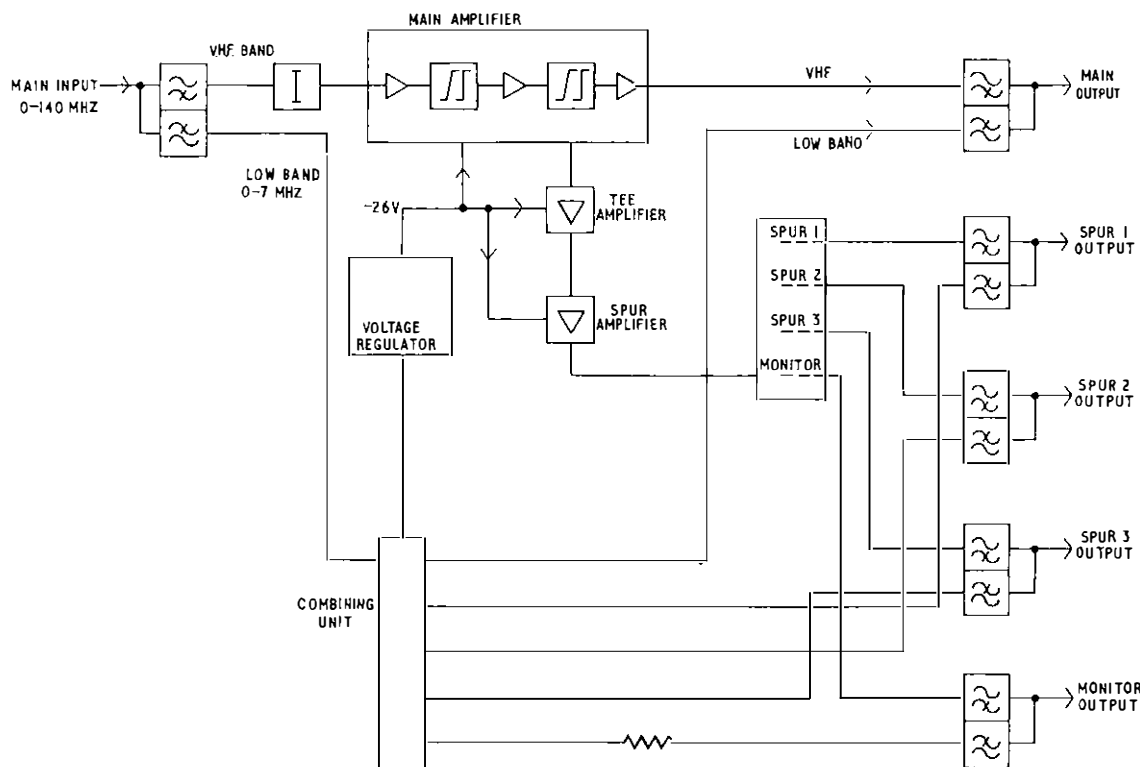

FIG. 4—Block schematic diagram of dependent repeater

Fig. 4 shows the block diagram of a dependent repeater; there is a main input, main output, three spurs and a local monitor point. The normal vision-carrier levels are 50 mV at the main output and 25 mV from the spur outputs. The power to operate each repeater is supplied from an exchange battery, the repeaters being parallel-connected. A series-feed arrangement is not feasible, because of the branching nature of the system. The regulator unit stabilizes the output voltage to 26 volts over an input-voltage range of 30–75 volts, at a current of 175 mA. The power-separating filters pass d.c. and frequencies up to 7 MHz through the low-pass section, and 40 MHz and above through the high-pass section. The spur and monitor outlets are fed via the high-impedance teeing amplifier, spur-path amplifier and hybrid-transformer splitting unit. The spur-path amplifier is of the same design as the main-amplifier output stage. The d.c. paths of the input and outputs are combined in the combining unit.

Up to three repeaters can be fed via a spur path of a line repeater and the main-path current should not exceed 2 amperes. It is usually the cable loop-resistance (8.2 ohms/mile for 0.62 in cable) that determines the power-feeding limit; for 800-yard spacings in 0.62 in cable, six repeaters can be fed in tandem with a minimum line-feeding voltage of 46 volts. Both-end power feeding is usually employed on routes between telephone exchanges. The monitor output gives access, in addition to the main 40–140 MHz transmission band, to the low-frequency band for h.f. speaker communication, and to the repeater power-supply voltage via a protective resistor.

Equalization is accomplished by fitting 2-terminal type

at 140 MHz; the network loss is the inverse of the cable attenuation/frequency characteristic.

The mechanical construction of the repeater is illustrated in Fig. 6; the case length is approximately 18 in and its diameter 4 in. The six cables enter the repeater via the brass gland-assembly, which is filled with an epoxy resin to prevent

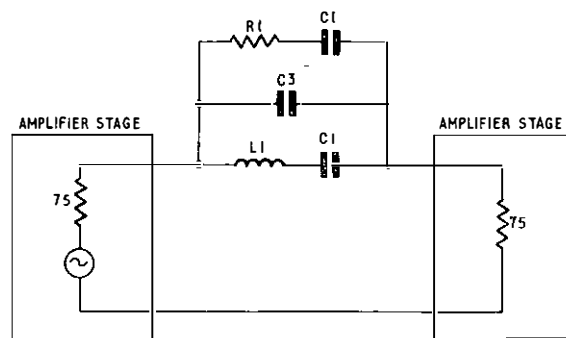

FIG. 5 Two-terminal equalizer used between amplifier stages

water from entering the repeater through the cables. The tail cables have a braided outer-conductor to make them more flexible. Ferrite sleeves, passed over the tail cables to form coaxial chokes, are embedded in the epoxy resin; this minimizes any unwanted electrical coupling effects caused by longitudinal currents flowing in the cable sheaths. The printed-circuit boards and the power-separating filters are mounted between three bars attached to the gland assembly.

The voltage-regulator unit has a heat-sink plate which is in contact through phosphor-bronze leaf-springs with the end of the brass case. The case itself is bolted to the flange of the gland assembly with an O-ring water-seal between the

\* *K*-rating—linear waveform-distortion assessment

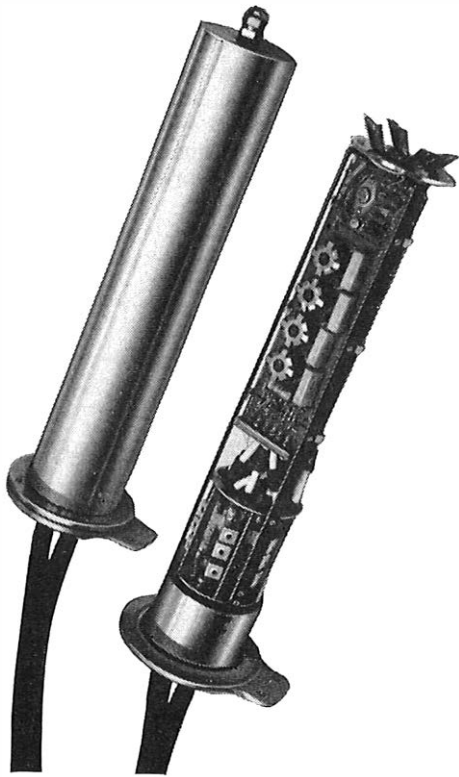

FIG. 6—Dependent repeater with and without cover

two parts. A valve is fitted on the closed end of the case for pressure testing, normally at 9 lb/in<sup>2</sup>. The brass case is an excellent electric screen; it is insulated from the cable conductors and internal structure of the repeater to prevent electrolytic corrosion which could otherwise result, in a damp or wet environment, because of the power-feeding voltage-drop along the cable.

The repeaters are supplied with 9 ft cable tails, which are jointed to the distribution cables by a compression-moulding

technique. It is expected that eventually plug-and-socket connexions suitable for an underground environment will be designed, and this will ease the task of changing a faulty repeater.

### POWER-FEEDING REPEATER

Power-feeding repeaters are usually mounted in telephone exchanges and, in addition to the function of applying a -50 volt power supply to each cable, they afford automatic gain control (a.g.c.) and residual-equalization facilities. The a.g.c. range is  $\pm 3$  dB, and this allows for correction due to temperature changes of  $\pm 10^\circ\text{C}$  over more than 3 miles of the 0.62 in cable. Exchanges are usually spaced, in urban areas at least, at distances of between about 1 mile to just over 3 miles.

The repeater is contained in a wall-mounted metal box<sup>1</sup> in a dry cable-chamber or other suitable accommodation. The main cables are connected at the top of the repeater via short flexible coaxial leads, and the engineering speaker and supervisory-monitoring equipment are connected via the sockets on the bottom. The equipment includes six ammeters; one records the local amplifier current and the other five record the line currents, which may be up to 2 amperes each. Fig. 7 is a block diagram of the repeater. The main and spur-path amplifiers and power-separating filters are similar to those used in the dependent repeater. Line-current overload-trip units are provided in the power panels. They are press-button-type units that can be easily re-set.

The most complex part of the repeater is the a.g.c. circuit. The control loop is actuated by the 140 MHz pilot signal as observed at the output of the main amplifier. A detected version of this signal is compared with a d.c. reference, and the difference signal is then amplified and used to control the loss of a variable Bode network<sup>2</sup> in the v.h.f. path in such a way that the pilot-signal level is held constant at 50 mV at

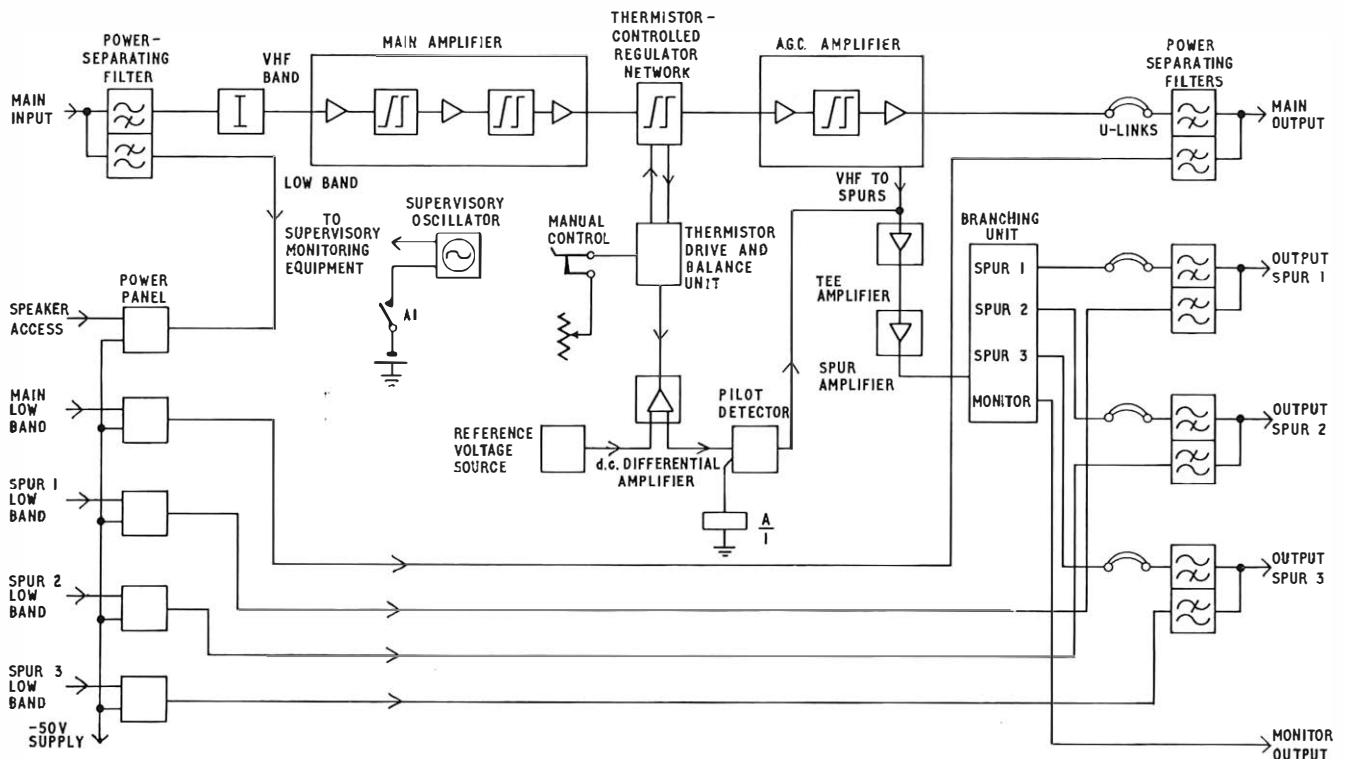

FIG. 7—Block schematic diagram of power-feeding repeater

<sup>1</sup> HAWORTH, J. E. The Schools Television Distribution Network *P.O.E.E.I.* Vol. 61, p. 250, Jan. 1968.

<sup>2</sup> BODE, H. W. Variable Equalizers. *Bell System Technical Journal*, Vol. 17, p. 229, April 1938.

the main output. The repeater may also be operated on a manual gain control basis when required. There are two thermistors, TH1 and TH2, in the variable-loss Bode network (Fig. 8), one in the shunt path and one in the series path, and the insertion loss can be changed by varying the thermistor resistances. However, it is necessary to maintain the relationship between the resistances of the two thermistors in such a way that the input and output impedances of the network

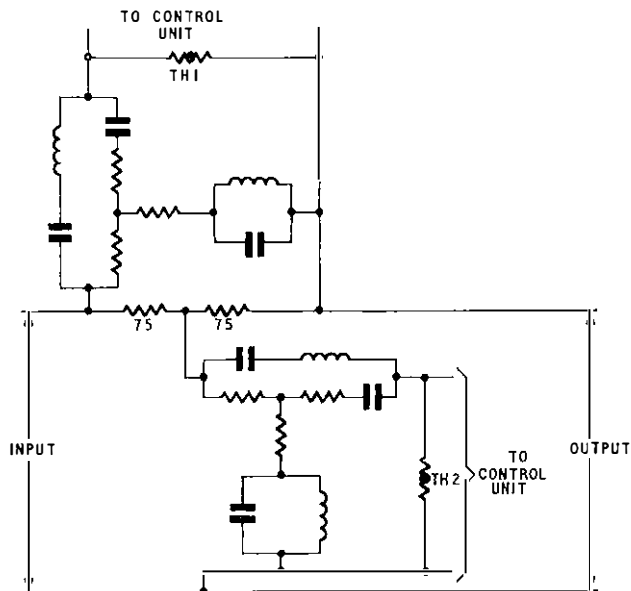

FIG. 8—Basic circuit of variable Bode equalizer

remain constant at 75 ohms for all values of insertion loss within the control limits of the network. This relationship is  $R_{TH1}/R_A = R_B/R_{TH2}$ , where  $R_A$  and  $R_B$  are determined by the circuit design. This is achieved by making the thermistors electrically form part of a bridge circuit that is driven by a separate 150kHz supply; any out-of-balance voltage is used to control the d.c. flowing through the thermistors to bring the bridge into balance. The network has a loss of 12 dB at the mid-point of its control range and variations from this follow a cable-shape characteristic, as shown in Fig. 9.

The system residual gain-misalignment is equalized at power-feeding repeaters, and 4 dB of extra gain has been provided for this purpose. The general limits adopted on gain misalignment are that, under the mean temperature con-

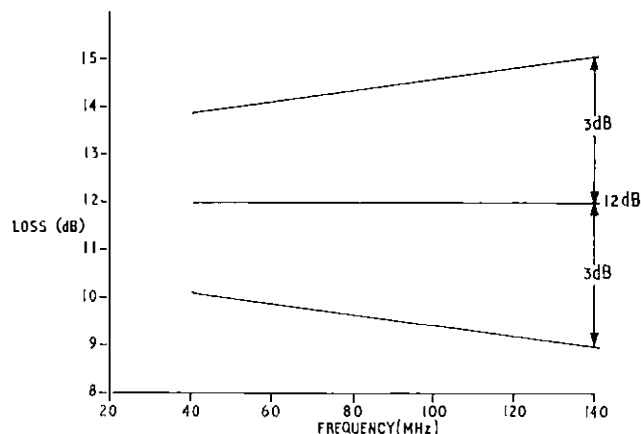

FIG. 9—Insertion loss of variable Bode equalizer

dition, the misalignment should be within  $\pm 4$  dB at the output of any dependent repeater and within  $\pm 1$  dB after residual equalization at the output of a power-feeding repeater. The local feeds from exchanges to schools have a mean temperature-misalignment allowance of  $\pm 3$  dB, thus

giving an allowance of  $\pm 4$  dB from the network input at the studio to the output of the receive-terminal repeater in a school. Additional level variations will occur on feeds to schools due to temperature changes for which there is no compensation in receive-terminal repeaters, but it is expected that the total misalignment, due to all causes, will not normally exceed  $\pm 6$  dB.

## BRANCHING UNITS

Branching units are installed in the underground network in the same way as dependent repeaters. Physically, they have a similar case construction to that of the dependent repeater, but the case is only 9 in long and only three tail cables are needed. The loss through the unit is nominally 3.5 dB in each path. There is a second unit available with a loss of about 1 dB on its main through path and 11 dB on its spur path. Power-feeding voltages can be fed via either path.

## RECEIVE-TERMINAL REPEATER

The signal level at the input point at each school will depend on the cable length from the preceding dependent repeater and the basic function of a receive-terminal repeater is to amplify these signals to give a standard channel-carrier level of 50 mV at its output. There is an internal cable distribution in each school that provides outlet sockets in classrooms in which television receivers are installed. The terminal repeaters are wall-mounted with the coaxial-cable connexions at the top.<sup>1</sup>

A mains supply is necessary at each repeater, and one of the two lamps on the front cover of the repeater is the MAINS-ON indicator lamp. The second lamp is a PILOT indicator, which glows while the 140 MHz line-pilot signal is being received. The engineering-speaker access point is on the right-hand side of the case and the v.h.f. monitor point is accessible after removing the outer cover. The two following facilities may be used as and when required.

(i) Selected schools, about 25 per cent of the total, return a supervisory tone in the 20-50 kHz band to the local telephone exchange all the while that the pilot is being received. The receive-terminal repeater power supply is then taken from the incoming coaxial cable to avoid alarms due to a local mains failure.

(ii) Where a school is situated beyond the normal power-feeding reach of an exchange battery, the terminal repeater can power-feed two line repeaters from its own internal power unit.

A block schematic diagram of a receive-terminal repeater is shown in Fig. 10, and it includes the appropriate connexions to be made when any of the optional units are fitted.

The four amplifier stages produce a total gain of 31 dB. This high gain, compared with that of a dependent repeater, is an economy measure in that it sometimes saves using an additional dependent repeater in the final section of cable. Cable equalizer networks and attenuators are fitted as for the dependent repeater, and although space for residual equalizers exists, in practice the cable equalizers and attenuators are usually adequate. The pilot is tapped off the amplifier output, and passes through a tuned amplifier to the detector, which in turn operates the relay and pilot lamp. A second pair of relay contacts apply power to the supervisory oscillator, if fitted. A "box-inside-a-box" construction was adopted to provide adequate screening and so minimize pick-up from mobile, broadcast radio and television sources. The outer box is connected to the local earth associated with the mains supply, but the inner box is connected to the outer conductor of the incoming coaxial cable.

## SUPERVISORY MONITORING EQUIPMENT

If a fault occurs on the system, it is desirable to locate it quickly. In order to provide a supervisory coverage over a

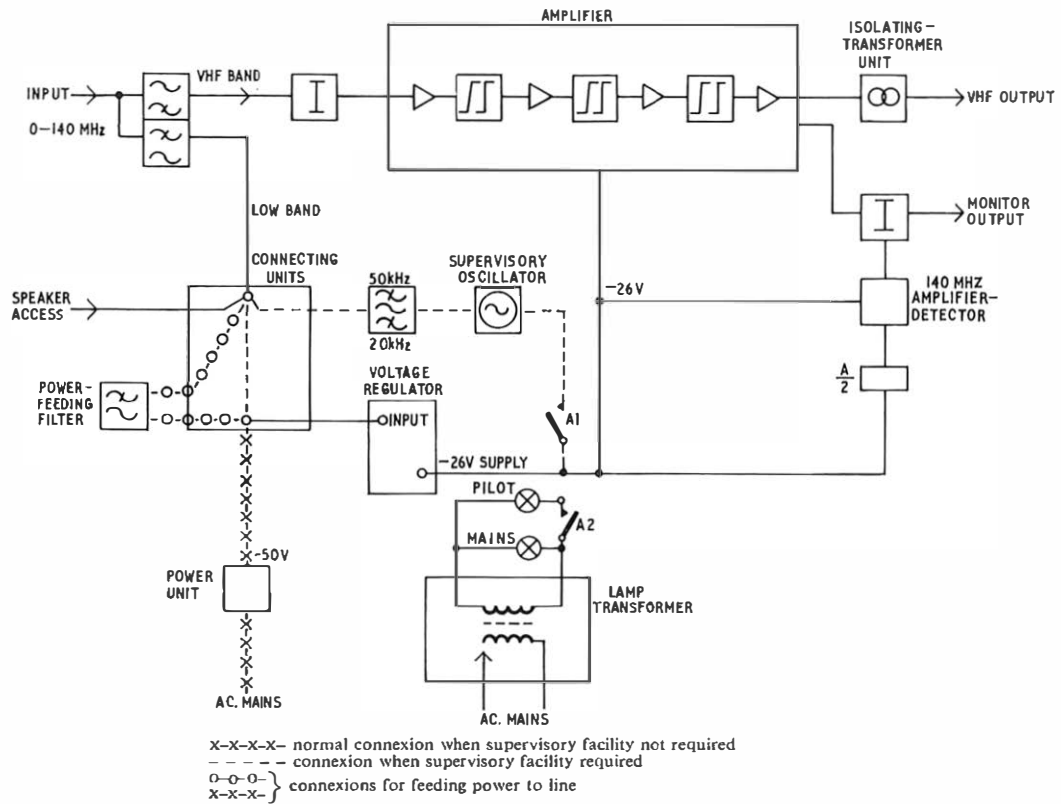

Fig. 10—Block schematic diagram of receive-terminal repeater

large part of the system, selected receive-terminal repeaters send back supervisory frequencies to the telephone exchanges from which they are power-fed. The system is fail-safe, in that all of the signals are on until a fault occurs, when one or more will fail. The supervisory oscillators are fitted in approximately one terminal repeater in four, and this is normally sufficient to cover more than 90 per cent of the cable network; a fault occurring in the remaining few per cent of the network could only affect one or two schools. It is particularly desirable to select supervisory terminal repeaters so that any potential faults in dependent repeaters can be located quickly. Supervisory facilities were not included in dependent repeaters, so that their size and complexity could be minimized.

The supervisory monitoring equipment is fitted in telephone exchanges, and consists of one 62-type equipment shelf (see Fig. 11). Up to 10 supervisory frequencies can be received by one equipment from receive-terminal repeaters and adjacent power-feeding repeaters plus one from the local power-feeding repeater. These frequencies are in the band

20–50 kHz, starting at 20.8 kHz and spaced at 3.2 kHz intervals.

A block schematic diagram of part of the equipment is shown in Fig. 12. The incoming signals are combined on a common path which feeds to all of the plug-in supervisory detector panels—one panel per frequency. The band-pass filter selects the appropriate supervisory frequency, and the output from the following detector operates a relay. If the supervisory signal fails the relay releases, the SUPY FAIL lamp glows and a loop alarm is extended. In a network where all of the supervisory alarms are to be concentrated, by providing separate alarm circuits from each exchange to a central maintenance-control point, this is all that is required. However, where alarms are not extended beyond the local exchange, in order to avoid the cost of the alarm-extension circuits, an alarm-inhibit facility is employed. This is necessary to prevent a system pilot-signal failure, perhaps at the send terminal, causing a prompt alarm at every exchange. A test key is provided on each supervisory detector panel and can be used to insert 10 dB of attenuation in the input

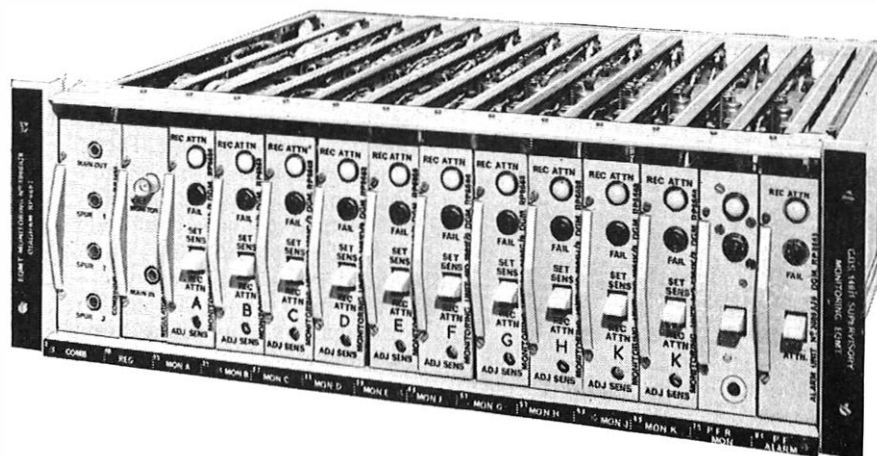
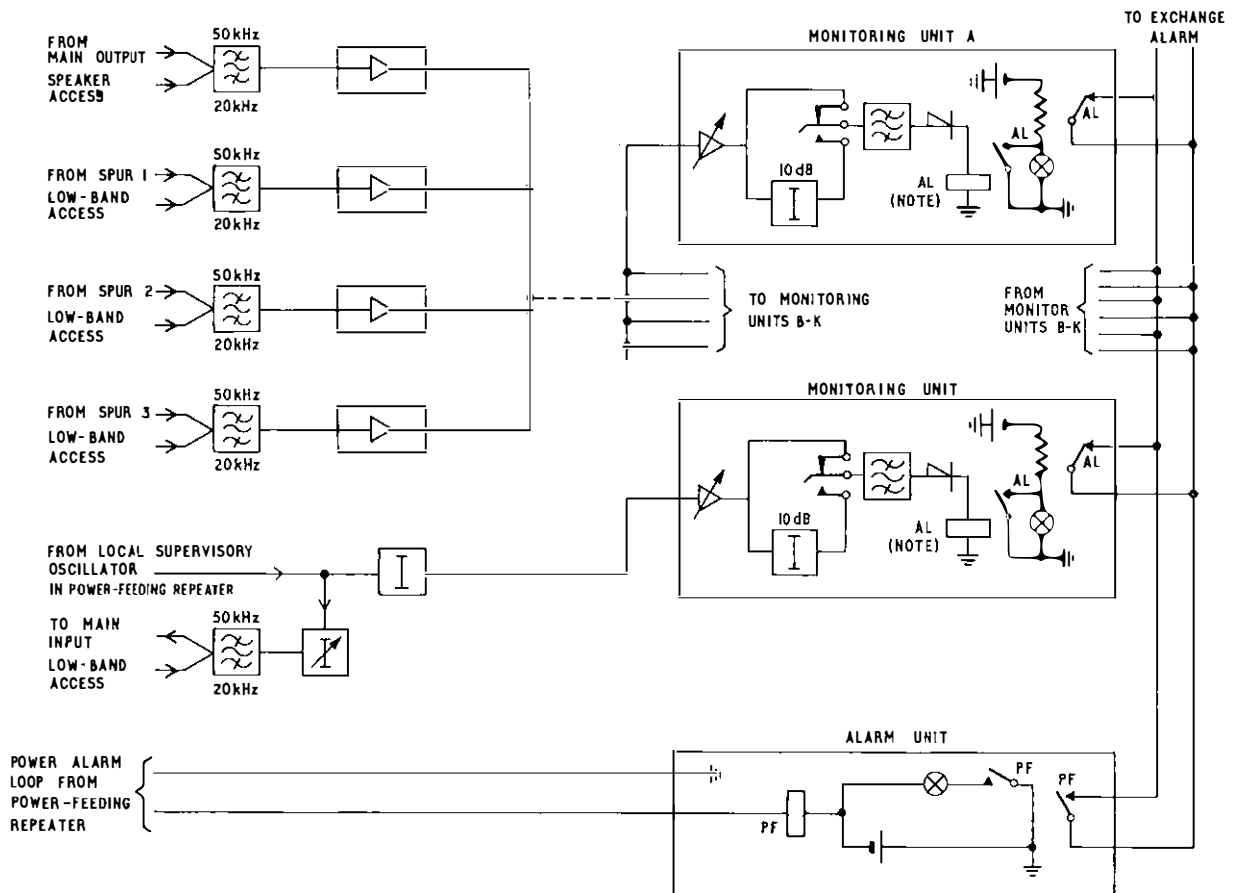

Fig. 11—Supervisory monitoring equipment



Note: Relay AL is normally operated

FIG. 12—Block schematic diagram of supervisory monitoring equipment

signal path to simulate a failure condition. A RECEIVE ATTENTION facility is included on the same key. The intention is that the monitoring equipment should be mounted at a point where maintenance staff have ready access to it; a power-feeding overload alarm, v.h.f. monitor point and speaker-access points are also provided on the equipment.

### MAINTENANCE FACILITIES

There is a high degree of inherent reliability built into the network by using a robust cable and equipment employing silicon planar epitaxial transistors and approved components. A transmission monitor point is provided at each repeater output to facilitate fault-location work. At a dependent repeater this monitor point, which for ready access is normally located just below the manhole cover, can also be used for making measurements of power-feeding voltage and for the connexion of an h.f. engineering speaker. If a fault occurs, the area of a network affected is deduced from the supervisory alarms and fault reports from the customer. Subsequent location then proceeds in logical steps by taking measurements of the power-feeding voltage and 140 MHz pilot signal at selected repeater outputs. For this purpose a simple battery-operated tester, enabling the pilot and power-feeding

voltage to be measured, has been produced. It has the advantage that it can be used by staff without specialized transmission training. More obscure types of faults need more complex test equipment as used for commissioning a system. Cable pulse-testing equipment has proved invaluable in several instances.

The clearance of equipment faults is carried out by replacing faulty units, which are then serviced at a repair centre. When rapid restoration of service is necessary due to a dependent-repeater fault, it is replaced by cutting each tail cable and fitting coaxial plugs to the cable stubs and a temporary maintenance replacement repeater already terminated with coaxial sockets is then connected. A permanent replacement repeater is installed later, when more time is available to carry out the more lengthy jointing operation.

No regular routine tests are necessary on the dependent repeaters, but level checks are made at the monitor points of power-feeding repeaters at regular intervals and the supervisory alarms are also checked periodically. Schools are not visited on a regular maintenance-routine basis, because of the time and effort involved, but sample checks are made from time to time to obtain information on general trends of any performance changes.

# Recognition of Speech by Machine

S. R. HYDE, B.SC., ASSOCIATE MEMBER I.E.E.†

U.D.C. 534.7/8:621.376.33:681.3

*A successful means of recognizing speech with a machine could have widespread repercussions in many fields by simplifying the complexities of machine control. The problems of recognizing speech by machine have led to some very modest achievements and have produced no recognizer with wide-scale commercial possibilities. This article reviews some of the methods which have been employed, the nature of the speech signal itself and some of the possible applications which await the eventual success of speech-recognition research.*

## INTRODUCTION

Automatic speech recognition could have a profound effect on the type of communication and data-processing facilities available to the general public in the future. A computer which could understand human speech directly would not need a keyboard or paper-tape reader for data input and so could be used by any telephone subscriber. Speech input would be unlikely to replace other forms of computer input in wide-scale commercial and industrial use, but it would be an ideal method for occasional use by unskilled operators and as such might help to bring about a low-cost computing service for domestic subscribers. Besides its value as a calculating machine, the computer's ability to store very large quantities of information would make possible a truly comprehensive telephone enquiry service supplying answers to questions on almost any subject. The computer would reply in natural speech also, since the problems involved in making computers talk are largely solved.<sup>1</sup>

Another application of automatic recognition is in speech transmission economy. The development of analysis-synthesis telephony has made possible already a reduction of the order of ten to one in the channel capacity needed to transmit speech.<sup>2</sup> Automatic recognition of the message in a speech signal and its transmission in terms of a code representing sound elements might lead to a saving approaching one thousand to one. The introduction of satellite and other wideband, long-haul communication links have reduced the necessity for such extreme transmission economy in our present time, but if man ventures far into space a very low-capacity channel is likely to be the only means of communication with earth.

There are a number of operations which would benefit from automatic speech recognition. Some applications which have been proposed are speech dialling of telephone numbers; postal sorting, where a human sorter reads the destination aloud while dropping the item into a chute, so saving the separate operation of pressing a key or choosing one bin out of many possible bins; air-traffic control, where a computer keeps track of the individual aircraft and is up-dated by information derived from the controller's voice; the control of mechanical aids by a paralysis victim who retains the ability to speak; the remote control of complex machinery by telephone, and the control of a "third hand" when working under difficult conditions or in situations where the hands must be kept free.

## Accuracy of the Speech Recognizer

Some of the suggested applications might be performed by machines with limited powers of recognition, say with restric-

tions on the size of the recognition vocabulary or in the number of possible users. There is, however, one respect in which there is very little room for compromise; the recognition operation must be accurate. An ambiguous response for no obvious reason would destroy the user's confidence in the machine. The performance must depend to some extent on the care with which the talker pronounces his words and some variation in pronunciation is normal in speech. Also, the user would not expect the machine's performance to be significantly worse than that of a human listener, and so would be unlikely to accept the need for excessive care in speaking or for unnatural forms of pronunciation. This means that the machine would have to perform well (make correct decisions) when the acoustic signal was highly ambiguous.

The construction of such a recognizer requires detailed knowledge of many different aspects of speech communication between human beings. Very little of this knowledge is available at present and the problems involved in obtaining such knowledge are exceedingly complex. Existing information does, however, permit the construction of recognizers achieving some degree of success.

## THE SPEECH SIGNAL

Most people think of speech as being conveyed in the form of words. Words are spoken by the talker and words are heard by the listener. Most listeners also have little difficulty in detecting that spoken words have a strong rhythmic structure which divides them naturally into syllables. The phonetician, who has been trained to listen more carefully, is able to divide the syllables up into smaller sound elements called phonemes. The phoneme is a unit of perceived sound quality which is closely analogous to the letter in the written language. To the communications engineer, speech is a rapid air-pressure fluctuation which can be transformed into an electrical analogue, by means of a microphone, and transmitted over an electrical circuit.

The mechanical speech-recognizer forms a link between these different viewpoints, accepting the electrical signal at its input, analysing the signal's characteristics in order to decide the sound element, word, or meaning intended by the talker and providing an indication of the recognition decision at its output.

A most meaningful description of the speech wave is that in terms of its short-term energy spectrum, the distribution of acoustic energy in frequency and the variation of this distribution with time. The shape of the spectrum and its time dependence is shown in the sound spectrogram (Fig. 1) which is effectively a three-dimensional graph displaying frequency (vertical axis), time (horizontal axis) and intensity (blackness of trace). The dark bands are due to intense local

† Research Department, Telecommunications Headquarters.



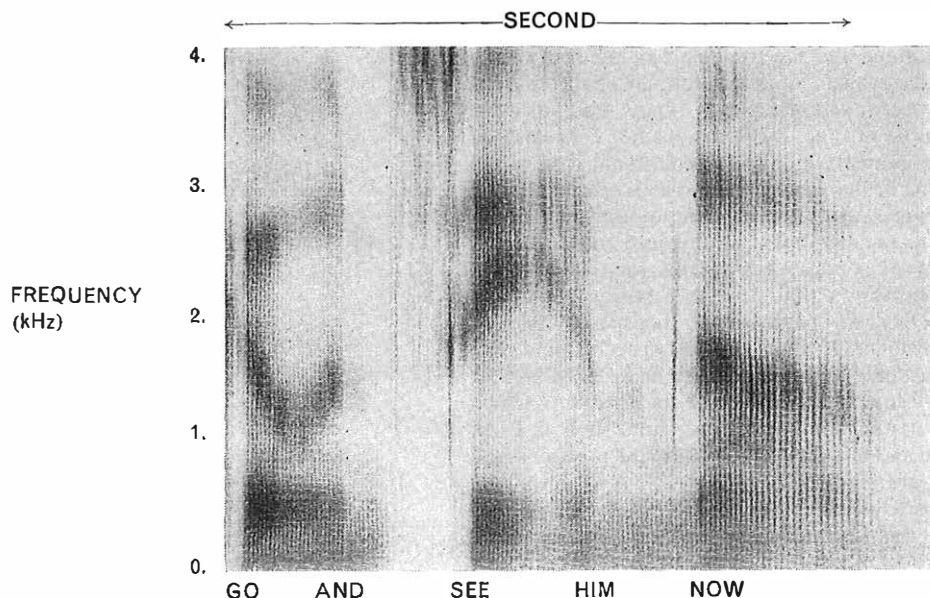

FIG. 1—Sound spectrogram of a short sentence.

peaks in the energy distribution. These peaks are called formants and are labelled  $f_1$ ,  $f_2$ ,  $f_3$ , in order of increasing frequency. Over the frequency range of greatest interest, 0–4 kHz, there are usually four or five such spectral peaks. The frequency positions of the formants have a major effect in determining sound quality and hence they convey much of the meaning in speech.

#### Formation of the Speech Signal

The sounds of speech may be thought of as the result of an acoustic-filter operating on the output of a sound generating source. The filter is formed by the vocal tract which is the tube, including the throat and mouth cavities, that extends from the larynx to the lips. The resonant frequencies of this filter result in the formant peaks of the energy spectrum. The response of the filter depends on the shape of the vocal tract. The shape is controlled by the positions of the tongue, lips, jaw and velum (rear part of the soft palate). Changes in the shape of the vocal tract during speech are thus reflected in variations in the formant frequencies.

#### Voiced Speech Sounds

There are two different types of sound source in speech, resulting in two different types of speech sound, voiced sounds and unvoiced sounds. In voiced sounds, the sound originates in vibration of the vocal cords. The vocal cords are two folds of fleshy tissue which are situated in the larynx and can be brought together to obstruct the flow of air from the lungs. The air pressure forces the inner edges of the vocal cords apart so allowing a small quantity of air to escape. The flow of air produces suction forces which, together with the tension of the larynx muscles, cause the vocal cords to snap shut again. This process repeats at a rate which depends on the air pressure, the muscle tension and the mass of the vocal cords.

The vocal-cord vibration breaks up the steady flow of air from the lungs into pulses of air current. It is the sound resulting from these pulses which elicits the sensation of pitch in the human listener. For normal speech by a man the pulses occur at about 70 to 160 Hz, depending on the pitch. For a woman, the rate will normally be about twice that for a man. The spectrum of this pulse waveform contains energy which is mainly concentrated at harmonics of the fundamental frequency of larynx vibration. These harmonic components have significant energy up to about 10 kHz. The sound from the larynx passes through the vocal tract before emerging from the mouth. The harmonics which lie near the formant frequencies are enhanced by the vocal-tract resonances, and hence emerge stronger than neighbouring harmonics (shown in Fig. 2).

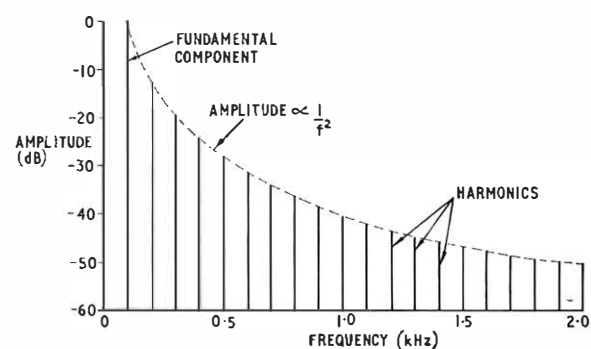

(a) Idealized spectrum of larynx waveform for a fundamental frequency of 100 Hz

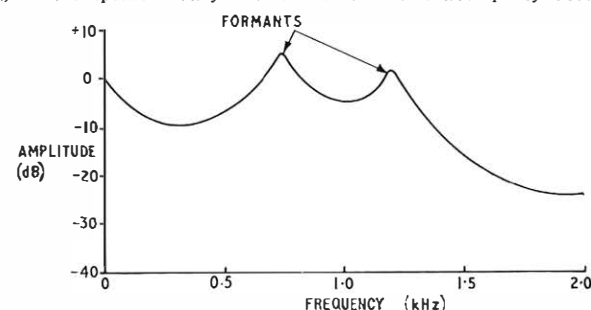

(b) Spectrum of vocal tract transfer function during the "A" sound in father.

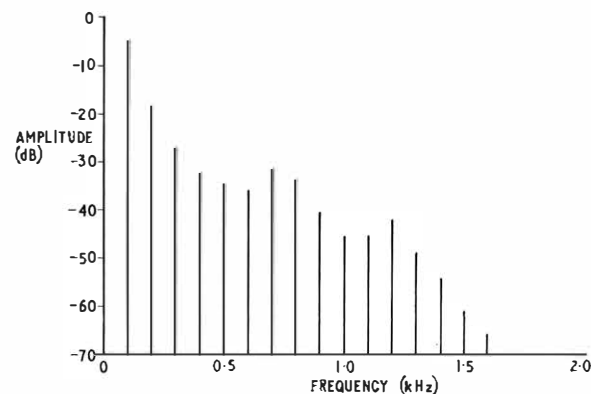

(c) Spectrum of combined signal (output from the lips).

FIG. 2—Voice-energy spectrum during a vowel sound

#### Unvoiced Speech Sounds

The source of energy in unvoiced speech sounds is air turbulence, due to a strong current of air being forced through a constriction within the vocal tract. This is heard as a hissing

sound in, for example, 'S', where the constriction is between the front of the tongue and the front part of the roof of the mouth. The source waveform is random in shape and its energy is spread over a wide frequency range; but, since the signal is not periodic in time, this energy is not concentrated into harmonic components as in the larynx signal. The sound passes through part of the vocal tract and so is affected by the vocal-tract resonances. In general though, only the high-frequency formants are significant in unvoiced sounds.

A careful study of sound spectrograms for a number of different utterances shows that there is a strong connexion between the spectrogram pattern and the speech element identified by the listener. In some types of speech sound, like the vowels and sustained consonants such as S, F, M and N, it is the relative frequency positions of the formants which are most characteristic. For other consonants such as P, B, T and K, it is the sudden variation in formant positions and intensities which are significant. The problem in automatic recognition is thus to observe the variation of the signal with time, and, from this information, to decide which sound elements and word were intended by the talker. This is a very much more difficult task than it appears at first sight.

### APPROACHES TO AUTOMATIC RECOGNITION

The most general view of a speech-recognition machine is probably that of a two-stage device performing the essential functions of signal analysis and pattern classification (Fig. 3).

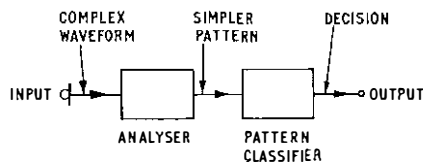

Fig. 3—General view of a speech recognizer

The speech signal is very complex, and direct recognition of the shape of the speech wave itself is quite impractical. The purpose of the signal analyser is to generate new patterns, on the basis of the input speech signal, which are simpler than the original signal but retain all the information which is important for recognition. The pattern classifier then observes these patterns and decides which member of the machine's recognition vocabulary was intended by the talker.

### Signal Analyser

The most common form of signal analyser extracts information about the short-term energy spectrum. The spectrum analyser most often employed is of a type developed for use in analysis-synthesis telephony and is generally referred to as the channel-vocoder spectrum-analyser,<sup>2</sup> (Fig. 4). In this analyser, a bank of band-pass filters (normally between 10 and 40 in number) is arranged to cover the important frequency range (300 Hz-4 kHz). The envelope of the signal from each filter is detected and smoothed, and the result is a set of slowly-varying voltages which, when taken together, represent the spectral distribution of signal energy. The output of the spectrum-analyser may directly form the input to the pattern classifier, or a set of pattern detectors may intervene.

It has already been noted that the frequency positions of the formants are a most important feature of speech signals. Formant measurement with the channel-vocoder type of spectrum-analyser simply requires an indication of the frequencies of the channels containing local energy maxima. Another method of formant measurement (Fig. 5) uses wideband filters to divide the frequency scale up into regions likely to contain a single formant only. The output of each channel is connected to a zero-crossing counter. This is a circuit which gives an output proportional to the average rate at which the input signal crosses the zero axis. For simple

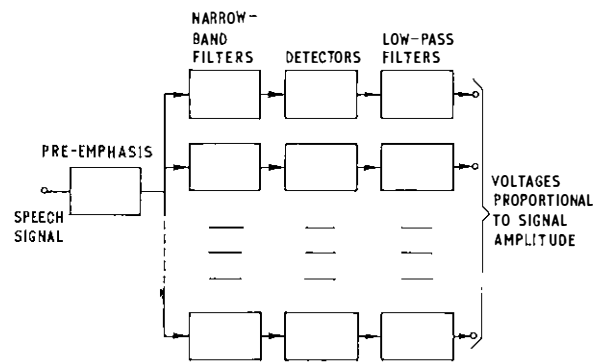

(a) Spectrum analyser.

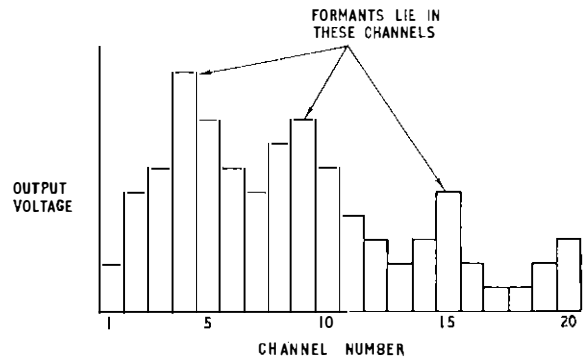

(b) Output signal obtained from the spectrum analyser.

Fig. 4—A typical channel-vocoder type of spectrum analyser

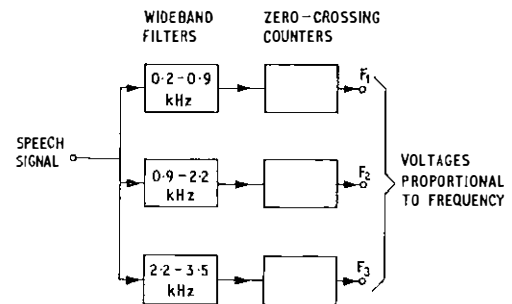

Fig. 5—Formant frequency measurement using zero-crossing counters

waveforms, zero-crossing counting can give an accurate measure of the dominant frequency component, but when two or more components have comparable amplitude serious errors can arise.

### Pattern-Classifiers

The pattern-classifier may take several different forms and may involve different degrees of complexity. It can contain several stages of error-correction and decision operations and is generally operated by a digital computer.

The simplest forms of pattern-classifier base their decisions on the measurable acoustic patterns alone. This is sometimes sufficient, but the human listener also makes use of a great deal of built-in information, such as knowledge of the grammatical rules under which sentences are generated in the language, or of the probability of certain speech sounds or words occurring at different points in the sentence. Other information that may be used is the sub-conscious knowledge about the physical limitations of the talker's speech organs, or personal knowledge about the vocal characteristics of the talker, or that each spoken sentence must make sense and ought to be relevant to the topic of conversation. More complex recognizers might store information about some of these factors and use it to improve on recognition decisions taken at the level of the acoustic signal.

Most of the recognizers built in the past can be assigned, at least on the basis of their recognition operations at the acoustic level, to one of two general forms of pattern classifier. These are the pattern-matching type and the feature-detecting type.

### Pattern-Matching Classifier

The pattern-matching classifier (Fig. 6), generally stores typical patterns of the type to be recognized, and classifies the incoming signals on the basis of a comparison with each

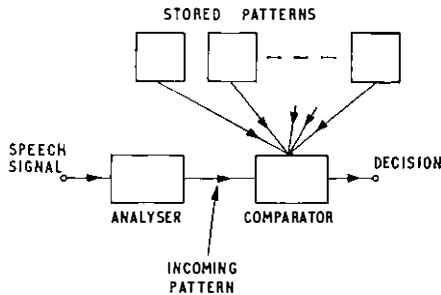

FIG. 6—Pattern-matching classifier

of the stored patterns. The advantages of the pattern-matching classifier are that, it is usually simpler in its overall design and that it can be easily re-trained to accept different talkers, vocabularies and languages.

### Feature-Detecting Classifier

The feature-detecting classifier (Fig. 7) consists of a set of individual circuits, each designed to detect the presence of a particular feature of the input pattern. The classification decision, is then based on the simultaneous or sequential

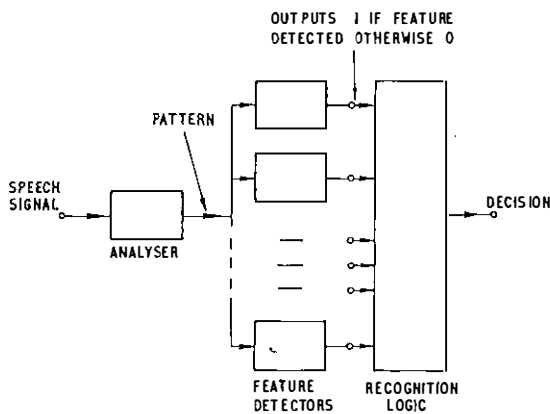

FIG. 7—Feature-detecting classifier

occurrence of the features normally found in the patterns of interest. The main advantage of the feature-detecting classifier is that, it is able to give greater emphasis to minor differences which distinguish between otherwise similar patterns.

The perceptual difference between two speech sounds is often greater than a view of their overall spectral patterns would suggest. Feature detection is therefore more likely to be successful in wide-scale speech recognition.

### Recognizer Vocabulary Size

Some speech recognizers have been built to recognize phoneme and syllable-sized elements. Others have based their decisions on the patterns of complete words. When the recognition vocabulary is small, it is more efficient to recognize complete word patterns. If the vocabulary is suitably chosen, recognition can be based on very simple considerations, such as the number of voiced and unvoiced sound elements detected. A very common ingredient of recognition vocabularies is the set of spoken numerals 0 to 9. This leads to some

difficulty as the set includes words which are often confused even by human listeners, such as five and nine.

When the recognition vocabulary is very large, as it must be for a general speech recognizer, it is necessary to recognize the words in terms of a smaller set of sound elements. This leads to some very severe difficulties. One of these difficulties results from the inertia of the vocal organs. A sound element which requires a particular tongue position affects, and is affected by, an adjoining element which requires a different tongue position. The tongue moves relatively slowly between the two positions and, often does not fully reach the second position before moving off towards its position in a third sound element. Another important effect is co-articulation. While one speech organ, say the tongue, is fixed in its position for the articulation of one speech sound, another organ not directly involved in the production of that sound, say the lips, will begin to move in anticipation of the following speech sound. These effects result in a dependence between neighbouring elements which makes the individual patterns difficult to interpret, and a smoothing out of the changes in sound patterns at the element boundaries so that it is often quite impossible to tell from simple acoustic measurements how many sound elements are actually present.

Speech sound patterns are further complicated by variations in a talker's voice due to changes in his physical and emotional state, or by the differences between talkers due to physical differences and variations in accent and speaking habits, or by the effects of room resonance and the addition of interfering noises.

The many difficulties encountered in the recognition of speech sound elements has prevented the long-expected development from the recognition of isolated words to the recognition of general connected speech. It has also shown the need for a much greater appreciation of the whole speech phenomenon. There are few signs to suggest that the situation will improve significantly in the very near future.

### FUTURE SPEECH RECOGNIZERS

A speech recognizer built at the Bell Telephone Laboratories in 1952,<sup>3</sup> could recognize the ten digits spoken by a single talker with an accuracy of 98 per cent. A recent review of speech recognition systems lists almost 30 different recognizers reported since that date. This list does not include the many different studies in general speech research not directly related to machine recognition. The more successful recognizers achieved recognition scores in the middle 90 per cents for vocabularies of about 30 words by populations of about 20 talkers, or slightly higher scores on smaller vocabularies by fewer talkers.

None of the reported systems could accept such conditions as normal continuous speech, large variations in talker characteristics, background noise or harmonic distortion, which have little effect on human listener performance.

No speech recognizer of the present time is likely to justify wide-scale commercial development. A machine which could recognize a large vocabulary of words by a large number of different talkers, for example most telephone users, is quite unrealistic at present. However, a device for machine control would be feasible, because a small vocabulary of suitably chosen words is adequate, and adjustment to suit a few familiar talkers is acceptable. Another possibility is a device which could pick out a few pre-selected words or phrases from normal speech by a larger population of talkers, although the reliability with which this could be done would vary greatly with the talker.

### CONCLUSION

The main reason for the modest level of achievement in this field is the lack of extensive, reliable information about any but the more superficial aspects of recognition by the human listener. Despite these somewhat pessimistic observations there is some reason to be more confident about the future.

Earlier studies have provided much valuable groundwork and some of the mistaken assumptions of previous workers can be seen and avoided. Powerful, convenient computing facilities are widely available and advances in electronic technology seem to promise economic realizations of even the most complex hardware devices.

Real advances are now possible; research tasks of the immediate future are probably those leading to a better understanding of human-speech perception.

The widescale application of automatic speech recognition is still some way off. However, a limited application of the more restricted forms of recognizer during the next five to ten years can be expected.

The main impact of automatic speech recognition will probably be in allowing voice communication with machines intended to serve human needs. Typical uses are mechanical housemaids, typists and gardeners; driverless taxis, unmanned

restaurants, self-adjusting teaching machines; intelligent dwellings which cater for the family's needs; designer's assistants which perform calculations, draw sketches, present data and evaluate techniques, leaving to the human the essential function of creative thought. These and other devices as yet unimagined may one day be commonplace, but most will rely on the ability of a machine to understand human speech.

## References

<sup>1</sup> HOLMES, J. N. Machines that Talk, *Science Journal*, Vol. 4, No. 10, p. 75, Oct. 1968.

<sup>2</sup> FLANAGAN, J. L. Speech Analysis, Synthesis and Perception, *Springer Verlag*, 1965.

<sup>3</sup> DAVIS, H. K., BIDDULPH, R., and BALASKEK, S., Automatic Recognition of Spoken Digits, *Journal of the Acoustical Society of America*, Vol. 24, No. 6, p. 637, Nov. 1952.

## Book Reviews

"Radio and Line Transmission (A)." D. C. Green, A.M.I.E.E., Pitman and Sons, Ltd, xi + 321 pp. 294 ill. 45s.

As the title suggests, this book has been written to cover the Radio and Line Transmission (A) syllabus of the City and Guilds Telecommunications Technician's Course. Three subjects are dealt with which are not in the current syllabus, namely, receiving aerials, power supplies and simple semiconductor theory. Most students will, however, find some, if not all, of the chapter on semiconductor theory quite helpful as an introduction to the chapter on transistors. Two omissions, as far as the syllabus is concerned, are load lines and the treatment of Class "A", Class "B" and Class "C"—operation of simple tuned-transistor and valve amplifiers. It is unfortunate, as the book has been written for a specific syllabus, that the author did not consult the City and Guilds regarding their latest syllabus.

This small criticism in no way affects the general excellence of the book. It is well written and fully illustrated with worked examples contained in each chapter plus a good selection of typical examination questions at the end of each chapter.

Each chapter deals fully, yet economically, with a specific section of the syllabus, there is little cross-reference from one chapter to another and the contents and order of each chapter have been chosen to provide a logical approach to the subject of Radio and Line Transmission. Theory and practice are nicely balanced and the final chapter gives a concise and up-to-date review of communication systems. The mathematics are adequate and well within the scope of second year Telecommunications Technician's Course Students.

This is an excellent text book, beautifully printed and bound, and it is fully recommended to any student taking the City and Guilds examination in Radio and Line Transmission A and any student wishing to gain an insight into the field of Radio and Line Transmission. The City and Guilds have been asked to add this book to their list of recommended text books.

P. N. P.

"Radio and Line Transmission." D. Roddy, M.Sc., C.Eng., M.I.E.E., A.M.I.E.R.E. Pergamon Press, xi + 251 pp. 160 ill. 35s. Hard, 25s. Soft.

This book is the first volume of a series of three, intended in particular to cover the City and Guilds Radio and Line Transmission subject and, more generally, to provide instruction for technicians specializing in radio communications, and senior technicians on National Certificate courses. The information contained in this volume, additional to that required for Radio and Line Transmission A, will be of benefit to City and Guilds students, since it ensures that the ground is prepared for more advanced study.

The requirements of the City and Guilds Course have been covered, but the treatment could have been more explicit in places. The subject matter is simply dealt with, and care has been taken that explanation is not given in terms of concepts proper to subsequent years' syllabuses. The book is mainly non-mathematical, and the explanations of phenomena and the descriptive treatment are in general good. However, exceptions occur. It is stated, for instance, that modulation is necessary because aerials are not efficient at audio frequencies. No mention of a number of other equally cogent reasons. The accuracy of the text is good, but information regarding frequencies for television distribution is misleading.

Chapter headings are Waves, Logarithmic Units, Speech and Music, Amplitude Modulation, Passive Components, Series and Parallel Tuned Circuits, Electro-Acoustic Devices, Semiconductor and Thermionic Devices, Rectifier and Demodulator (Detector) Circuits, Amplifiers, Tuned Circuit Oscillators, Radio Systems, Line Telephony and Line Telegraphy. Exercises are given at the end of each chapter, and brief numerical answers are included. The index is adequate.

The principal function of this book will be for use as a text-book for the examination student in elementary radio and line communication, and it would be of little value as a reference work. The printing is fairly well spread out and the total amount of information contained is not great. Since this would be only one of several books that would be required for study of the stated courses, it seems doubtful if the average student would consider the expense justified.

P. J. L.

# Standardization of the Large Cordless-Type P.A.B.X.—P.A.B.X. No.4

R. A. NOTMAN, C.ENG., M.I.E.E.†

U.D.C. 621.395.26:389.6

*Since 1958, all requirements for large cordless-type p.a.b.x.s were met by the telephone equipment manufacturers supplying their own designs which were approved by the Post Office. A standard p.a.b.x. has now been developed and some of the features of the new design are described in this article.*

*The p.a.b.x. should find its greatest application in the 300–1200 line range but some very large installations up to 7,000 lines, have been planned.*

## INTRODUCTION

A Post Office standard p.a.b.x. for large installations, i.e. over 50 extensions, was introduced into service as long ago as 1950 and made use of a cord-type manual switchboard. It is known as the P.A.B.X. No. 3<sup>1</sup> and is widely in use today. However, the advantages of a cordless switchboard, e.g. easier and speedier operator control and greater scope for a more functional and attractive design of manual position, made it worthwhile to standardize a cordless system as well. Five proprietary designs<sup>2</sup> by the principal manufacturers were in existence; each offered a variety of facilities and were approved by the Post Office for use by subscribers. These pre-standard versions were well received and confirmed public interest in the cordless system, but the inevitable differences between them, and the maintenance problems which arose in coping with the five variants made the development of a standard version more urgent.

The new design had to be capable of offering the facilities of the existing types of p.a.b.x., introduce a number of new features and eliminate the known weaknesses.

The project was undertaken jointly by the p.a.b.x. manufacturers and the Post Office as a British Telephone Technical Development Committee development with Standard Telephones and Cables, Ltd. as the liaison manufacturer. The standard P.A.B.X. No. 4 was introduced from June 1966. Concurrently with the design of the main p.a.b.x., a register-controlled satellite was designed to meet the growing requirements of large installations for fully-integrated private telephone networks.

Customers requiring a large-size p.a.b.x. negotiate with one of the equipment manufacturers and once installed, the Post Office carries out a program of acceptance testing similar to that used at public exchanges as a preliminary to the call-through test and opening of the exchange to traffic. The Post Office then maintains the exchange.

## EQUIPMENT PRACTICE

Well-proven techniques of public-exchange practice have been followed for the automatic equipment which consist of jack-in relay-sets, uniselectors, and two-motion switches of the 4000-type, mounted on open-type racks. Conventional equipment was used because the fairly complex facilities were required as quickly and cheaply as possible and development costs were minimized.

One of the difficulties encountered in standardizing p.a.b.x.

equipment is the varying accommodation offered by customers for housing the apparatus, and for this reason standardization has been limited to circuits and components only. The manufacturers retain freedom to adopt their own design of rack layout, and to some extent in the method of inter-connecting the equipment, provided that Post Office standards are met. Nevertheless, all manufacturers have found it expedient to aim at a more or less uniform grouping of equipment, based on a four-rack arrangement of line and final-selector equipment, group selectors, line-terminating relay-sets and position-equipment for the cordless switchboard. In addition, there is usually a miscellaneous equipment rack for the ringer and miscellaneous items of equipment.

The make up of position-equipment racks depends on the availability to be provided, but each rack will normally carry access equipment for one or two switchboard positions.

Standard ringing supplies and tones are derived from a Dynamotor No. 44A for all but the largest installations, at which a Dynamotor No. 41A may be necessary. Provision is made for a second machine and automatic change-over equipment where the size of the installation warrants it or where there is need for additional system security.

## TRUNKING

Two independent switching trains are used, one to route extension to extension and directly-dialled outgoing traffic and the other, the incoming train, to deal with operator-extended and directly-dialled incoming calls. The local switching train is similar in many ways to that designed for the P.A.B.X. No. 3 in that it employs 50-point uniselectors as line finders and 100-outlet group and final selectors. The final selectors incorporate a divided-feed transmission bridge.

The incoming switching train has several features not generally found in step-by-step switching practice, mainly because the transmission bridge and the ringing and supervisory elements are located in the line-terminating relay-sets rather than in the final selectors. This allows a relatively simple switch train with a straight-through transmission path from the relay-set to the called extension. Supervisory indications are signalled to the relay-sets on auxiliary wires making a total of six wires per outlet on the group-selector multiple.

The divided-feed transmission bridge in the line-terminating relay-set provides a focal point for the p.a.b.x. and a d.c. barrier between the public network and the internal switching operations. Transmission problems are eased in that feed current to extensions does not depend on exchange-line length and control of ringing from the relay-set simplifies supervision. The ring-when-free facility is also controlled from the relay-set. Part of a typical trunking diagram for a P.A.B.X. No. 4 is shown in Fig. 1.

† Mr. Notman is in Test and Inspection Branch, Purchasing and Supply Department, but was formerly in Exchange Facilities Division, Telecommunications Development Department, Telecommunications Headquarters.

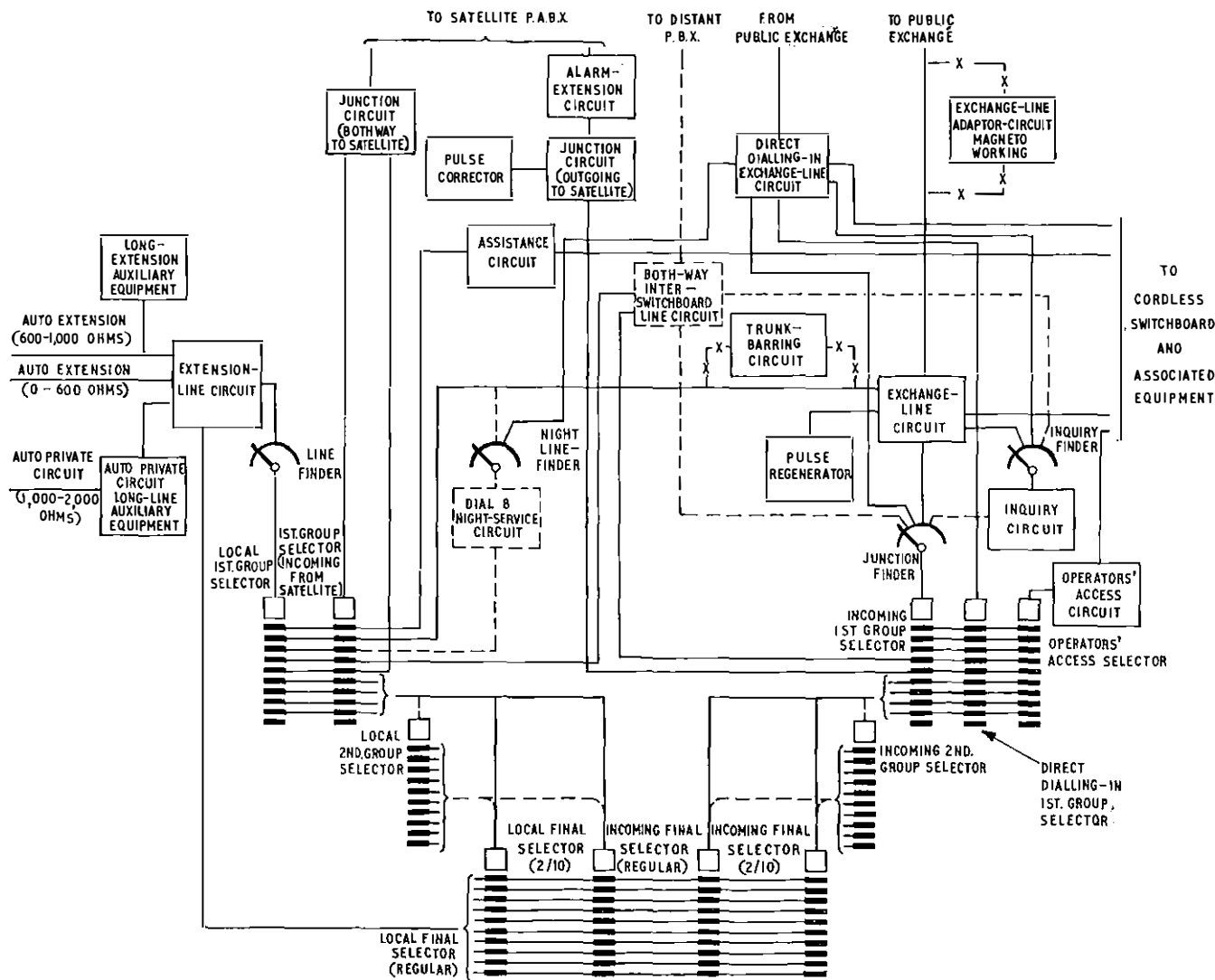

FIG. 1—Trunking diagram of the P.A.B.X. No. 4 with the D.D.I. facility

A 3-digit, 4-digit or mixed 3- and 4-digit numbering scheme can be employed. The linefinders are Type-2 uniselectors serving 50 lines per group.

The exchange lines and inter-p.b.x. lines, other than Signalling System A.C. No. 13 (S.S.A.C. No. 13) circuits, are arranged in 20-line groups with provision for a maximum of 4 inquiry circuits. Thus, each group can be accommodated on the banks of a 25-point junction finder. Generally, both-way circuits are used and 12-16 junction finders suffice for 20 circuits. The junction finders are directly connected to incoming first selectors and form the start of the incoming train. At larger installations, where exchange lines are provided on a unidirectional basis, incoming and outgoing circuits are mixed within a group.

Incoming traffic from satellites is passed via both-way-junction relay-sets to directly-connected first group selectors which have a common multiple with the local switching train.

The local switching train gives the extensions access to the public exchange from level 9 of the local first group selectors in the conventional manner, level 7 is generally allocated for inter-p.b.x. traffic and level 8 is used for one form of night service. The remaining levels serve the p.b.x. local-numbering scheme and provide satellite access. Level 0 routes assistance traffic to the cordless switchboard.

The position-circuit and connecting-circuit finders (Fig. 2)

are both 50-point finders, the former being a motor unisector. This provides for a maximum of 50 circuits which can be exchange lines, inter-p.b.x. lines or assistance circuits associated with a position for answering or originating calls. If position availability greater than 50 circuits is required, additional finders can be added, and a wiper-switching circuit used to select the required finder.

### Direct-Access Routings

An important advantage of the cordless system is that operator effort can be reduced to a minimum by designing the position equipment in such a way that calls are answered and manipulated in a few seconds, leaving subsequent supervisory operations to be looked-after automatically. Operator effort is further reduced in that all outgoing traffic may be directly dialled from the extensions, and, if the optional facility of direct dialling-in from the public exchange is added, all incoming calls may also be completed without operator intervention. A brief outline of the routings available to extensions by direct dialling is given below.

### Extension-to-Extension Calls

A conventional linefinder system gives access to the first selector. The linefinder start circuit, in common with all similar start circuits within the p.a.b.x., incorporates a start-dis-

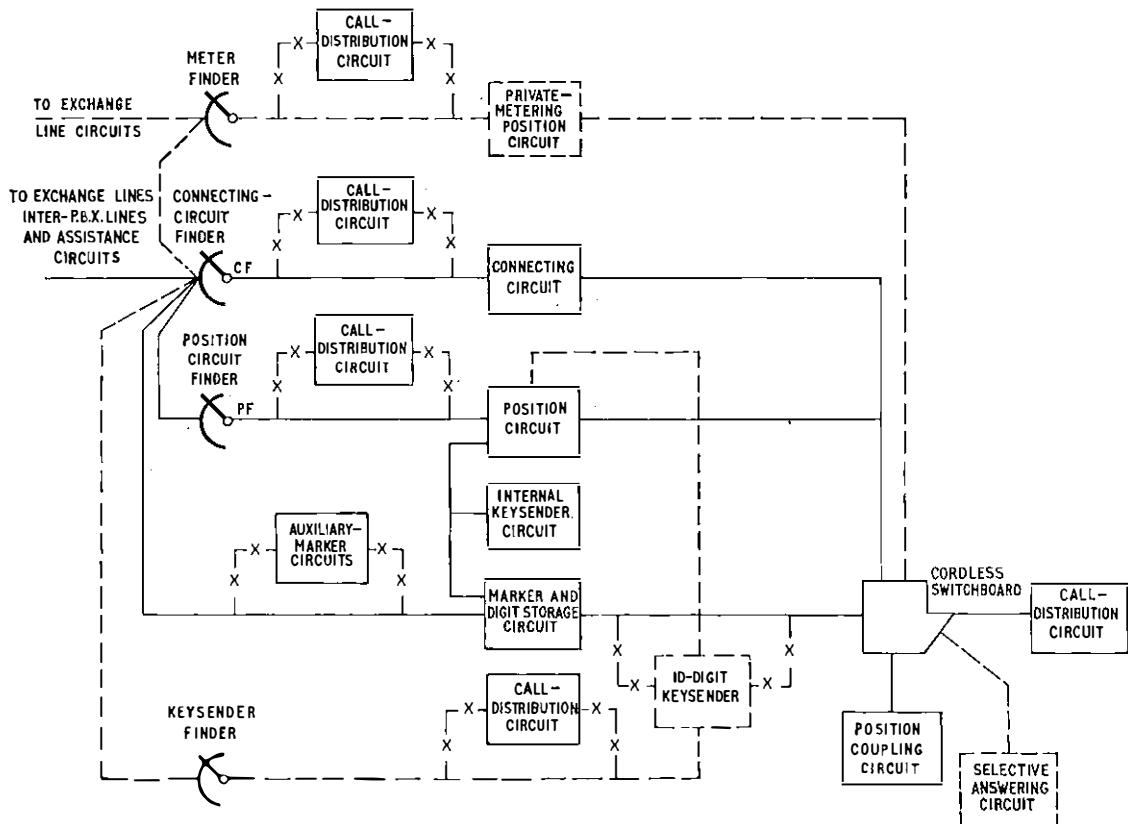

FIG. 2—Block schematic diagram of the cordless switchboard and associated equipment

tribution uniselector to ensure that a faulty first selector does not interrupt the start chain. Standard loop-disconnect pulses position the selectors. Control of ringing and ringing tone is located in the final-selector transmission bridge and first-party release is given.

### Extension-to-Exchange Calls

Calls to the public exchange are normally set up by direct access from level 9 of the local first group selectors, but can be completed if necessary via the switchboard. A variety of trunk-barring arrangements are available to restrict the dialling range on level 9 according to local requirements. This is predetermined for each extension by strappings on the line circuit. The trunk-barring relay-sets can be associated with the exchange-line relay-sets and these employ Type-4 uniselectors to count the initial digits dialled. If a barred code is received, the trunk-barring relay-set inhibits further dialling and causes number unobtainable (N.U.) tone to be returned to the caller. Non-selective barring of all outgoing calls can be arranged by omitting a strap in the line circuit. In this case the first selector switches to the eleventh step and returns N.U. tone. Provision is also made for key-controlled trunk-barring whereby operation of a Yale-type switch-lock on the telephone applies the barring.

Assuming that access is allowed, the selector hunts over level 9 for a free exchange-line relay-set which in turn seizes the line circuit at the public exchange and dial tone is returned. During the setting up and clearing down of calls, the exchange-line relay-set in any p.a.b.x. has an exacting role to play, in that it must function as an auto-auto relay-set terminating a bothway junction, and must interwork with a simple line circuit at the public exchange. In the P.A.B.X. No. 4, standard earth-calling principles are used to call the public exchange, i.e. earth is applied to the B-wire of the exchange line to operate the line relay in the line circuit. The public exchange returns battery on the B-wire and earth on the A-wire, when

a first selector has been seized. The exchange-line relay-set can discriminate between outgoing and incoming calls and does not depend on the maintenance of the conditions from the public exchange for holding. The element in the exchange-line relay-set which monitors the conditions at the public-exchange end of a connexion has been arranged to respond to signals of either polarity on both wires of the exchange line to suit all types of public exchange.

All extension telephones are of the 700-type fitted with a regulator, and provision has been made to limit the current flowing in the extension line to a value comparable with that received on an equivalent direct exchange line, otherwise the regulator tends to degrade transmission on short extension lines when connected to long exchange lines. At installations with exchange lines exceeding a specified transmission equivalent resistance (t.e.r.), resistors will be fitted in the transmission bridges of the p.a.b.x. to reduce the extension feed current to the optimum value.

### Extension-to-Inter-Switchboard Line Calls

Direct-access calls to distant p.b.x.s are routed via local first-selector levels to the inter-switchboard line circuit. If necessary, second-selector levels may be used. Sometimes it is necessary to provide a large number of routes each with only one or two circuits and, to prevent waste of outlets on the access levels, a 2-digit group selector has been developed to provide this facility economically.

This selector steps vertically in response to the first digit and horizontally to the second digit received. It can also function as a normal 100-outlet group selector by cutting-in and automatically hunting for a free circuit after the first digit. The choice of 1-digit or 2-digit working is a pre-set condition on the levels. In practice, routes with many circuits are allocated single-digit levels and routes with one or two circuits are given 2-digit codes. A type of group hunting is employed on the 2-digit levels to allow limited hunting for a free circuit

within a small group. Provision is made for through dialling to distant p.a.b.x.s over routes equipped for loop dialling, single commutation d.c. (S.C.D.C.) and 1 v.f. signalling (S.S.A.C. No. 13). The S.S.A.C. No. 13 system provides for pause-free dialling into distant p.a.b.x.s, i.e. extension users dial the routing digits to gain access to an S.S.A.C. No. 13 link and then dial the remaining digits without the usual pause to listen for second dial tone. Under pause-free dialling conditions, the hunting time of a junction finder could be an embarrassment and accordingly S.S.A.C. No. 13 links are always directly connected to first selectors at the incoming end. Auto-manual working is available using A-wire earth signalling and automatic generator signalling (a.g.s.). All the above mentioned systems are suitable for bothway working; a.g.s. is restricted to working between P.A.B.X.s No. 4.

The line-terminating relay-sets for the inter-switchboard circuits provide the hold-for-inquiry feature and calls can be transferred to distant p.b.x.s (if permitted). The inter-switchboard relay-sets follow the same circuit principles as the exchange-line relay-sets and incorporate a divided-feed transmission bridge along with ringing and supervisory elements.

### Tandem Connexions

Incoming calls from distant p.b.x.s may be routed through incoming first selectors to the appropriate level for access to an outgoing inter-switchboard route, thereby using the p.a.b.x. as a private tandem switching centre.

### Inquiry and Transfer

Operation of the telephone-instrument button on an established exchange or inter-p.b.x. line call, starts an inquiry finder (uniselector), shown in Fig. 1, hunting for the line-terminating relay-set involved. When an inquiry circuit has been associated, it in turn extends a start condition to a free incoming first selector. The associated junction finder then connects the selector to the inquiry circuit and dial tone is returned to the caller. The extension user may then dial the number of any extension or the code for any inter-p.b.x. circuit. The called party is rung from the inquiry circuit and, on answering, can speak to the caller without being overheard by the distant party. A hold condition is maintained on the external call from the time of pressing the button regardless of whether the distant caller clears or not.

If a call is to be transferred, the inquirer replaces his handset and the removal of the extension loop condition causes the junction finder to hunt for the exchange line or inter-p.b.x. relay-set. The inquiry circuit and the original selector train release leaving the external call connected to the new extension. Subsequent inquiries and transfers may be carried out as desired.

### CORDLESS SWITCHBOARD AND ASSOCIATED EQUIPMENT

Unless the direct-dialling-in facility is provided, all incoming calls are answered at the switchboard. As outlined earlier, up to 50 exchange lines, inter-p.b.x. lines or assistance circuits can be terminated on the banks of the connecting-circuit finders and also on the banks of the motor-uniselector position finder. Access for more than 50 circuits can be provided by adding further position finders and connecting-circuit finders and introducing the facility of call distribution. In effect this facility employs a wiper-switching circuit to select the switches serving the wanted circuit.

Three typical cordless switchboard designs are shown in Figs. 3, 4 and 5. Each manufacturer had complete freedom of design provided that the operational and maintenance requirements of the Post Office were met. That a great deal of effort was devoted to achieving elegant and well-integrated designs is borne out by the fact that all switchboards



FIG. 3—Cordless switchboard by Standard Telephones and Cables Ltd.



FIG. 4—Cordless switchboard by Ericsson Telephones Ltd.

submitted to the Council of Industrial Design received approval.

The display panels are generally of the secret type, i.e. the





FIG. 5—Cordless switchboard by GEC-AEI Telecommunications Ltd.

legends remain invisible or unobtrusive until the lamp concerned glows. This avoids clutter on the screen which could be distracting to operators, but poses problems of specular reflexion from the surface. Considerable ingenuity has been exercised in overcoming this problem. Each switchboard has a digit keyset to control its internal keysender and a KEYSEND key to switch the keyset to the external keysender (if provided). All switchboards are provided with a dial as security against keysender failure. Since its appearance does not harmonize well with the rectilinear lines of the switchboard, the dial is so mounted that it is out of sight when not in use. The general layout was specified by the Post Office for operational reasons, but some variations in detail will be found.

Taking for example Fig. 3, the keyshelf layout consists of two rows of push-button keys made up of illuminated selective ANSWER keys on the left, connecting-circuit SPEAK and HOLD keys in the centre and the digit keyset on the right. Also on the left (top row) are keys for LINE IDENTIFICATION, TRANSFER, SUPERVISOR and the line-splitting keys, SPEAK EXCHANGE and SPEAK EXTENSION. The DIAL RELEASE, and RECALL keys form a group on the extreme right. The KEYSEND and CANCEL keys are included in the keyset group.

The display lamps are located in cells behind a translucent panel. The supervisory group, RINGING, BUSY and WAITING occupy the area immediately above the connecting circuit keys in the lower centre of the display. The pilot group, i.e. LISTEN-IN, MONITOR, SUPERVISOR, EMERGENCY, PILOT, TRANSFER and POSITION FAIL occupy a central position. The upper centre of the display contains the tens and units lamps for the line-identification indication. These groups are flanked right and left by the calls-waiting indicator consisting of a thermometer-type illuminated column with a numeric indication. Up to 30 calling-group lamps occupy the left of the display. The corresponding busy-group lamps occupy the right of the panel. Also on the right, or alternatively with the pilot group in the centre, are lamps to indicate KEYSEND, SENDING, ROUTE ENGAGED, or DIAL.

## OPERATION OF THE CORDLESS SWITCHBOARD

### Operator-Answered Calls

Either common answering or selective answering may be provided. With common answering, a common pilot lamp, and/or an indication from the calls-waiting display, denotes that one or more calls are waiting to be answered. No indication of the type of call waiting is given at this stage. Operation of a SPEAK key on a free connecting circuit, followed by depression of the COMMON-ANSWER bar or key, causes the finder on the selected connecting circuit to hunt for a marking condition corresponding to a calling line. This finder then extends a marking condition via the finder multiple to the corresponding outlet on the position finder bank. The position finder then drives and connects the position to the calling line. An indication of the type of call, derived from the banks of the position finder, now appears in the group identification section of the lamp display.

If selective answering is used, the incoming traffic is divided into groups according to the class of traffic, e.g. both-way exchange line, assistance, and each group is allocated an illuminated plunger-type key. Thus the operator can exercise some choice in the type of call to be answered. The circuit operation is similar to that outlined for common answering except that an indication of the type of call is given before answer. The calls-waiting display operates with either type of answering. The lamps are switched into circuit by a chain of current-sensitive relays energized by a current proportional to the number of lines calling.

While a call is being handled on the position, the group-identification indication may be supplemented by identification of the actual line within the group. This is displayed by a group of tens and units display lamps in the centre of the panel and illuminated by operation of the LINE-IDENTIFICATION key.

### Extending Incoming Calls to Extensions

On receiving a request for an extension, the operator merely uses the keyset to key in the digits of the extension number and restores the SPEAK key to retire from the circuit. The digit-storage circuit associated with the internal keysender enables the digits to be keyed in rapidly and pulsed out to the incoming selector train at 10 p.p.s. via the keysender. As each successive switching stage is reached, a proceed-to-send signal in the form of an earth on the positive wire is returned to the keysender, thereby speeding up completion of calls and avoiding the need for an arbitrary inter-digital pause.

### Supervision

The main function of the connecting circuit is to provide supervision within the p.a.b.x. and because it is effectively in parallel with the circuit to be supervised, it is not used to connect the call in the generally understood sense. Certain public exchanges return a reversal to the p.a.b.x. when the called subscriber answers, but this is by no means universal and could not be relied upon for supervision. Thus, only tone supervision of the external side of a call can be given.

A high standard of internal supervision is provided using three lamps per connecting circuit to indicate primarily, ringing, busy and waiting. When an incoming call is being extended, the operator's telephone-set remains connected to the external side of the call. This means that while it is necessary to rely on lamp supervision to indicate the condition of the extension, it does ensure that p.a.b.x. tones are not heard by outside callers. This requirement is being relaxed to the extent that ring tone will in future be returned to outside callers.

Normally supervision of a call ceases when the called extension answers. The call releases automatically from the switchboard and the connecting circuit becomes free. If,

however, it is desired to retain supervision of the call beyond this stage, the connecting-circuit HOLD key is operated and the supervisory lamps then continue to indicate the condition of the call.

Further supervisory indications are given by a flashing waiting lamp (750 ms on, 750 ms off) to call in the operator and a similar flashing signal in conjunction with a steady glow on either the BUSY or WAITING lamp warns that the call has remained in the ringing-out or busy condition for 30 to 60 seconds.

### Outgoing Calls from the Switchboard

The majority of outgoing calls from the p.a.b.x. are completed automatically by extensions, but certain extensions may be barred from dialling beyond the p.a.b.x. numbering range or may wish to have their calls set up for them. They then dial the assistance code (normally 0) and ask the operator to complete the call. Fig. 1 shows that level 0 traffic is routed to the switchboard via the assistance circuits. Calls are signalled to the operator either on the common pilot lamp or on the lamp associated with the assistance answering key, according to the answering system employed. Such calls cannot be completed on demand and the operator sets up the outgoing call and reverts it to the caller as for an incoming call.

All outgoing routes are allocated a separate identification code which must be keyed in to the marker and digit-storage circuit to mark the group of circuits from which a free line will automatically be selected. Exchange lines are generally allocated the marking code-digit 9 to line up with the direct-access digit 9 dialled by extensions to obtain the same route.

The one-out-of-ten signals from the keyset are converted into n-out-of-four signals to operate the appropriate number of storage relays in the digit-storage circuit. Contacts of these relays extend a marking earth to all circuits in the wanted group on the banks of the connecting-circuit finders. The selected connecting-circuit finder drives to the first free outlet of the group and extends a marking condition via the CF uniselector bank to the corresponding outlet on the position-finder bank. The PF uniselector in turn associates the position with the marked outlet and dial tone is returned from the exchange line. At this stage, the operator must operate the KEYSEND key to switch the keyset from the marker and digit-storage circuit to the 10-digit keysender. The keyed-in digits required to route the call in the public network are initially stored on relays and subsequently pulsed out at 10 p.p.s. under the control of an interacting relay and capacitor circuit. Standard inter-digital pauses are introduced, timed by relays.

When all digits have been keyed-in, the keyset may be reconnected to the internal keysender by a second depression of the KEYSEND key. Pulsing out continues and, when the called number answers, the operator may complete the call to the extension by again using the digit keys to key-in the extension number. The digits required to route the call internally via the incoming train are stored in the digit-storage circuit as before and pulsed out at 10 p.p.s. to step the selectors. As described for incoming calls, the selectors signal to the keysender when they are seized, to avoid the need for an arbitrary inter-digital pause. The reverted call may now be completed and the connecting-circuit SPEAK key restored.

To further reduce operating time per call the 10-digit keysender, although provided one per switchboard, is not connected directly to the exchange lines via the position circuit. A separate keysender finder is used and this ensures that the keysender may be left pulsing out its digits while the operator deals with another call. A KEYSEND lamp on the display panel indicates that pulsing out is continuing. This facility assumes greater importance if the capacity of the keysender is increased to cope with international subscriber dialled (I.S.D.) calls of up to 17 digits.

Should the operator wish to call an extension when there is no outside call to be extended, she must use the operators' access circuit. This circuit is directly connected to a first group selector having a common multiple with the incoming first group selectors. Access is obtained by keying-in the appropriate code after selecting a free connecting circuit. The marker circuit will mark a free operators' access circuit on the banks of the connecting-circuit finder. Extension-to-extension calls cannot be completed by the operator.

Automatically-connected tandem calls have been referred to earlier, but the case of tandem inter-p.b.x. calls completed by the operator also arises. An incoming call from a distant p.b.x. will call on the switchboard in the normal way. If the call is to be extended to another p.a.b.x., the operator must key-in the digits required to step the incoming selectors to the level required and then operate the KEYSEND key to change-over to the external keysender. The necessary digits to set up the call in the distant p.a.b.x. can then be keyed. The 10-digit keysender generates inverted pulses to step the selectors in the incoming train, but conventional pulses are required to pass over inter-p.b.x. circuits to distant p.a.b.x.s, and, accordingly, as soon as an inter-p.b.x. circuit has been seized from a selector level, a signal is returned to the keysender to change it over to conventional pulsing. Supervision is given as always on the internal side of the connexion, the inter-p.b.x. line outgoing from the tandem p.a.b.x.

### OPTIONAL FACILITIES

A considerable number and variety of optional facilities were developed for the pre-standard P.A.B.X.s No. 4 and equivalent facilities will be called for on the standard version. The need to provide for the more popular of these was borne in mind at the design stage and, where possible, this was done provided it did not increase the basic cost. A few of the more common optional facilities are described briefly below.

#### Direct Dialling-In

This facility enables outside callers to set up calls to p.a.b.x. extensions without the assistance of the p.a.b.x. switchboard operator<sup>3</sup>. Its development required consideration of the main-exchange design so that the overall pulsing performance was maintained and appropriate methods of trunking at the public exchange and the p.a.b.x. were used. Care was taken not to introduce additional transmission losses compared with corresponding operator-completed calls to ensure that transmission would not impose a limitation on the scope of direct dialling-in (D.D.I.).

The D.D.I. exchange lines form a separate incoming group of lines and terminate on D.D.I. exchange-line circuits. These are directly connected to incoming first group selectors which have a common multiple with the indirectly-connected incoming first selectors. Thereafter, the D.D.I. traffic and the operator-extended traffic share common second final selectors. Full or partial D.D.I. may be provided subject to the availability of multiple at the public exchange. The D.D.I. exchange-line relay-set incorporates a transformer-type transmission bridge with a pulse-repeating element, so designed that calls may be dialled through to the final selector in the main p.a.b.x. without pulse regeneration. The pulsing problem has been eased because the ratios of make and break used for internal pulsing have been inverted within the p.a.b.x. on the incoming switch train. This technique was originally adopted for circuit reasons, but the inversion to 66 per cent make and 33 per cent break pulses for stepping the p.a.b.x. selectors opposes the characteristic trend of pulse distortion which builds up in the public network, thereby keeping the overall distortion within acceptable limits.

The trunking arrangement is shown in Fig. 1. Normal inquiry and transfer facilities are available, and it will be seen that the D.D.I. exchange-line circuits have outlets to the banks of inquiry finders, which in turn give access to inquiry

circuits and indirectly-connected first group selectors. If a D.D.I. call is to be transferred, the answering extension will first set up an inquiry call. The earth signal from the telephone press button is detected in the D.D.I. exchange-line circuits which then associates an indirectly-connected first selector via an inquiry finder, an inquiry circuit and a junction finder. Dial tone is returned from the selector and the inquiry number can be dialled. On transfer, the clear-down condition from the D.D.I. extension, causes the junction finder to switch to the bank position to which the D.D.I. circuit is connected, and the direct-access route clears down.

The D.D.I. exchange lines form a separate group from the normal bothway route to the switchboard. Thus, if the D.D.I. route is to have access to the switchboard, a special routing must be provided. For this the switchboard is given a number on the final-selector multiple. Calls dialled in to this number result in a signal being passed back over the incoming train to the D.D.I. circuit, to cause it to set up a calling condition on the switchboard, and release the selectors used to set up the call. Any number within the range may be allocated for the operator, but the final-selector group concerned must be of the 2-10 group-hunting type, as use is made of the group-hunting feature to self-drive the wipers to the 11th step for the return of the discriminating signal. One operator number is usually sufficient as the circuit is designed for simultaneous seizure from a number of final selectors, and the holding time is short.

The range of D.D.I. has been extended to include satellite exchanges, but dialling from the public network through a main p.a.b.x. to a satellite is liable to introduce excessive pulse distortion unless a pulsing aid is introduced to counteract it. A relatively simple pulse corrector has been found adequate based on a design developed by the Plessey Co., Ltd. The correctors are associated with the outgoing junction relay-sets, but mounted separately. Setting up and periodic checking of the corrector performance requires a 10 p.p.s. source derived from a rack-mounted relay and capacitor combination.

All D.D.I. lines must have access to the switchboard for operator call-in purposes, and this applies equally to outgoing-only exchange lines used for level 9 traffic. This means that each of these lines must be given an appearance on the banks of the connecting-circuit and position-circuit multiples. In view of the small amount of assistance traffic expected from these routings, it is uneconomic to give such lines exclusive appearance on the switchboard multiples (which may necessitate the use of costly call-distribution equipment) and a call-in concentrator has been developed to provide a more economic solution. The lines concerned are terminated on the banks of a uniselector, which will switch to a calling line, and extend it to a single appearance on the switchboard multiples. Individual line identification is lost with this method.

### Subsidiary Switchboards

These include supervisors' desks and inquiry desks in the switchroom, and executive units with keycalling and perhaps loud-speaking telephone facilities for selected extensions. Standard equipments are being developed to give these facilities.

### Night Service

A frequently-used arrangement allows any extension to answer an incoming call after hours by dialling 8. Access to the relay-sets providing this facility is gained from level 8 of

the local first selectors, and the relay-sets have an associated uniselector which hunts for and connects the calling line. D.C. bells, each common to a number of extensions, provide the calling signal. Another system allows one extension to answer any one of a group of exchange lines on receipt of a ring on the telephone bell, or using yet another system, an extension can be directly connected to a particular exchange line. The former arrangement allows a warning tone to be superimposed on the conversation if the extension is engaged when an exchange call arrives.

### Metering

Provision has been made for extension and position metering. Switchboards may have up to four cyclometer-type trip-meters and associated keys and supervisory lamps. Operation of the meter key, under a free meter, will cause the meter finder (Fig. 2) to connect the meter to the outgoing or both-way line selected for the call. A flashing meter-supervisory lamp indicates when the call is finished, so that the meter can be read and reset to zero.

Metering Units No. 3B can also be used with the bothway exchange-line circuit to detect subscriber trunk dialled (s.t.d.) metering pulses and extend d.c. signals to operate cyclometer-type extension meters. The facility can be made available to satellite extensions by extending meter pulses over the main-satellite junction to operate meters at the extension.

### Switchboard Availability Greater than 50 Lines

All finder circuits associated with the cordless switchboard can be connected via the call-distribution circuit as shown in Fig. 2. The uniselectors can accommodate up to 50 circuits. If a greater availability is required, additional uniselectors are provided and relay switching used to select the uniselector serving the wanted circuit. Alternatively, limited availability can be given to each switchboard in a multi-position suite.

### CONCLUSION

The P.A.B.X. No. 4 should find its greatest application in the medium size range, i.e. from 300-1,200 lines, or where a smaller but readily extensible installation is required. In this region, the cost of common equipment is spread over a reasonable number of lines so that the cost per line is moderate. Some very large installations have been planned up to about 7,000 lines. These tend to become the focal points for private networks with many inter-p.b.x. lines to other branches or out-stations. The introduction of 2-digit group-selectors should effect worth-while economies in trunking where there are a large number of inter-p.b.x. routes with few circuits per route.

### ACKNOWLEDGEMENTS

The photographs of the cordless switchboards are reproduced by permission of GEC-AEI Telecommunications, Ltd., Ericsson Telephones Ltd. of the Plessey Telecommunications Group and Standard Telephones and Cables Ltd.

### References

- <sup>1</sup> ROCHE, J. J., Post Office Standard P.A.B.X.s, Part 3—The P.A.B.X. No. 3. *P.O.E.E.J.*, Vol. 47, p. 133, Oct. 1954.
- <sup>2</sup> MARCHANT, P. A., An Introduction to Large Cordless P.A.B.X.s. *P.O.E.E.J.*, Vol. 53, p. 231, Jan. 1961.
- <sup>3</sup> TAYLOR, S. C., Direct Dialling-in to P.A.B.X. Extensions. *P.O.E.E.J.*, Vol. 61, p. 245, Jan. 1969.

# Electronic Acceptance Testers for Strowger-Type Telephone Exchanges

C. WROE†

U.D.C. 621.38.001.4: 621.395

*The acceptance of new telephone-exchange equipment from the manufacturers is made easier by the use of a series of specially-designed testers. Two recently-introduced testers that use electronic techniques to solve new problems in acceptance testing are described. The rapid testing achieved by the new techniques has permitted new procedures to be adopted that are not only more satisfactory to both the Post Office and the equipment contractor but enable a relatively-small quantity of testers to cope with the testing involved in a national installation program.*

## INTRODUCTION

The provision of new telephone exchanges and the extension or replacement of existing ones accounts for a large proportion of the annual capital expenditure on telecommunications plant by the Post Office. The efficient acceptance testing of the equipment involved is of great importance, and, for Strowger-type exchanges, functional testing of electromechanical selectors is a vital phase of the work. The development of electronic testers to facilitate these tests is described in this article.

Each exchange installation is purchased under the terms of a formal contract, and the manufacturer is responsible for the erection of the equipment on site to the satisfaction of the Post Office clerk of works. In order to achieve a standard of inspection that is uniform throughout the country, this officer is guided by testing specifications that set out the tests to be made and the action to be taken on the results. Much of this work is simple and repetitive, such as the point-to-point testing of selector-bank multiples, and, in the design of suitable test equipment, automatic stepping from one test to the next has been included wherever practicable. Automatic testers are now available for almost every phase of an installation, and their provision on loan from a central store allows them to be used economically on contract after contract.

On-site acceptance testing may be regarded as the final stage in a whole series of tests, which start on the manufacturers' production line, that have the object of removing defective items. This testing is a non-productive process, and the manufacturer is well aware that too much testing leads to excessive costs. On the other hand, too little testing permits the release of an unacceptable number of defective items from the factory; unacceptable, because these items incur proportionally greater costs in remedial treatment on site.

A middle of the road course exists, in which costs are minimized with a particular level of defects present in the products. For the Post Office, the seriousness of these defects is measured in terms of their potential effect on the telephone service. Each defect is an infringement of some part of the specification for the exchange, but the amount of deviation from the ideal, and, indeed, the importance of that particular detail, can only be assessed as a result of long experience. The same argument applies equally to acceptance testing carried out by the Post Office: there is an economic level of testing that will provide the necessary assurance of quality and at the same time minimize the cost to the Post Office. It is accepted that a small proportion of defective items will

exist at all stages, and the clerk of works is responsible for ensuring that this proportion is an economic minimum when the equipment goes into service.

## EXCHANGE ACCEPTANCE-TESTING SEQUENCE

The opening phase of a new exchange installation consists of the erection and inspection of apparatus racks and the installation of the exchange cabling. For Strowger-type exchanges, this is followed by a series of detailed checks of the adjustment of all electromechanical devices, overall assessment being deduced from random samples. Functional testing is the final phase of acceptance testing, and, naturally, takes place at a time when little remains of the period planned to cover the whole exchange installation. As each equipment is checked functionally, large groups of items, each previously assessed by sample checks, detail by detail, work together as a unit. Sampling no longer provides the necessary assurance, since no circuit should be put into service with a defect which would prevent its operation.

In acceptance testing the Strowger-type equipment much time is spent on functional tests of 2-motion selectors, with the prime object of proving their performance under a range of pulsing conditions, and to provide the necessary tolerance of subscriber's dial-pulse variations. Originally, tests were made using specially-calibrated test-dials connected to the selectors by means of a simple key-box, but, in order to relieve the testing engineer of the task of almost continuous dialling, the dials were soon replaced by sets of pulsing contacts driven by means of an electric motor (Fig. 1). By using the

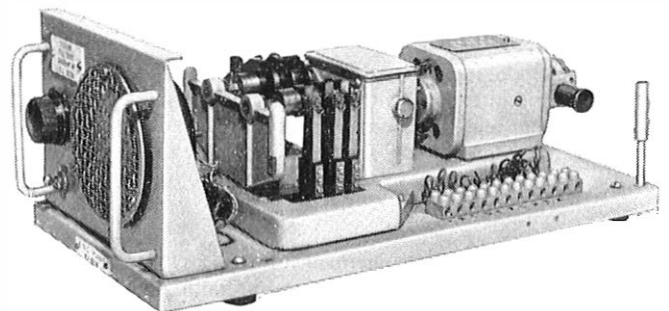

FIG. 1—Motor-driven pulse-generator

machine-generated pulses, together with a simple control circuit, each selector can readily be subjected to a range of tests. The pulse speeds and ratios used have, however, remained virtually unaltered since selectors of this type were introduced.

† Exchange Equipment Design and Installation Standards Branch, Telecommunications Development Department, Telecommunications Headquarters.

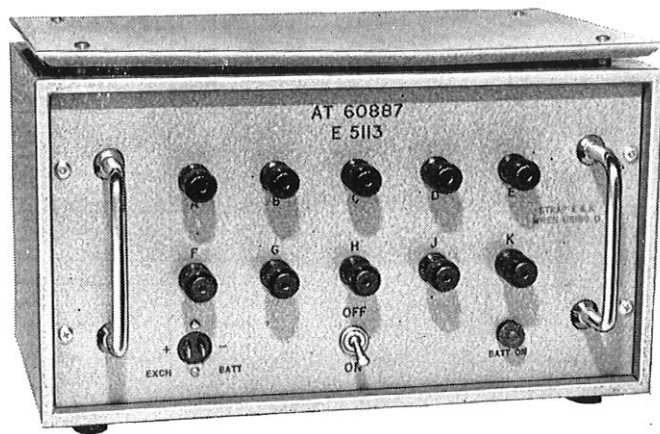

FIG. 2—Electronic pulse-generator

### ELECTRONIC PULSING UNIT

The rapid growth of the investment program and the need to replace test equipment nearing the end of its useful life prompted the design of a replacement unit for the pulsing machine, using transistor-controlled relays. A small batch of prototype pulse-generators proved satisfactory, and the electronic approach showed the particular advantage that readily-available components could be used. A new design, using encapsulated circuit-elements, has now been produced that is sufficiently stable to permit calibration to be dispensed with in normal use. Fig. 2 shows a production electronic pulsing unit, of which there are now 200 in service. Fig. 3 shows the simplicity of the internal layout. A glass-fibre printed-circuit card carries 21 encapsulated circuit-blocks, and an oscillator fine-speed-control potentiometer. The output relays are mounted in international-octal valve bases and are retained by rubber cushions mounted in metal cowls screwed to the chassis side-plates. The chassis itself is used to mount two simple voltage-stabilizer circuits, using Zener-diode control, which provide  $-12$ -volt and  $-24$ -volt supplies to the circuit blocks from the exchange  $-50$ -volt supply, the total demand being about 100 mA.

Fig. 4 shows the logic diagram of the basic counting circuits; the waveform family which it generates is also shown. The oscillator is of the relaxation type, in which one encapsulated Schmitt trigger circuit provides the feedback circuit for another in order to produce oscillation; the natural frequency is nominally 360 Hz. The output drives three frequency-dividing circuits in parallel, performing divide-by-

two, divide-by-three, and divide-by-five functions, respectively, on dividers A, B and C. Each waveform-diagram illustrates one of the possible ways of decoding the output from each divider, and the figures describe the identity of the inputs from the various stages of the dividers which it is necessary to gate together in order to produce a similar pulse in the position shown. For example, if binary 1 signals on outputs C2, C3 and C5 were gated together, an output pulse would occur immediately following that illustrated for outputs C1, C3 and C5. It will also be clear that since two, three and five are numbers that are prime to each other there are 30 ways in which an output can be taken from the six stages and AND gated together to produce a pulse that occurs only once in every 30 steps. Such a pulse is shown used in Fig. 4 to drive dividers D, E and F, which form a dividing system identical to A, B, and C. These pulses are used to mark the start and end of all dial pulses provided by the machine, and, in order to produce a family of output ratios, it is necessary to establish a relationship between them so that they can all be produced from a common source of signals. In this instance the ratios required are those which mark the agreed limits of dial performance, i.e.  $20 : 80$ ,  $33 : 67$  and  $50 : 50$ . When translated into the form  $6 : 24$ ,  $10 : 20$  and  $15 : 15$ , the development of the divide-by-30 factor is made obvious. It only remains to select one of the 30 pulses as a reference pulse, and the start and stop pulses for each required ratio can readily be fixed. In a similar manner, the dividers D, E and F can be used to identify any whole dial pulse within the complete cycle of 30. Pulsing can thus be started and stopped to provide any desired pulse-train.

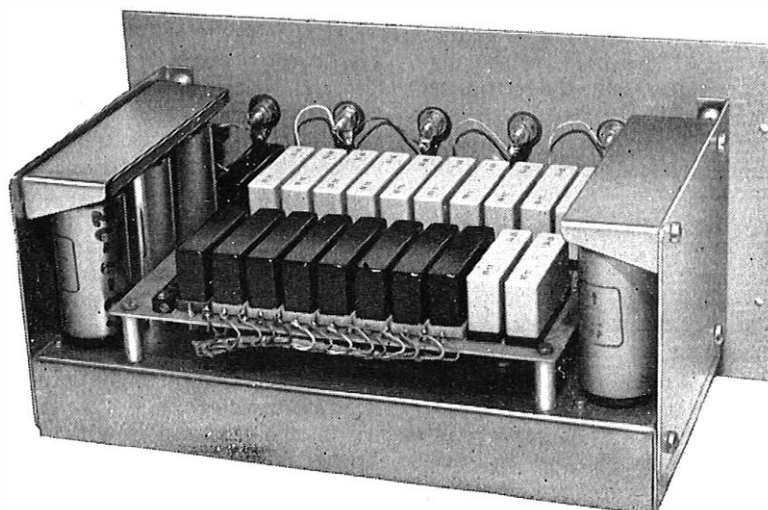

FIG. 3—Internal layout of electronic pulse-generator

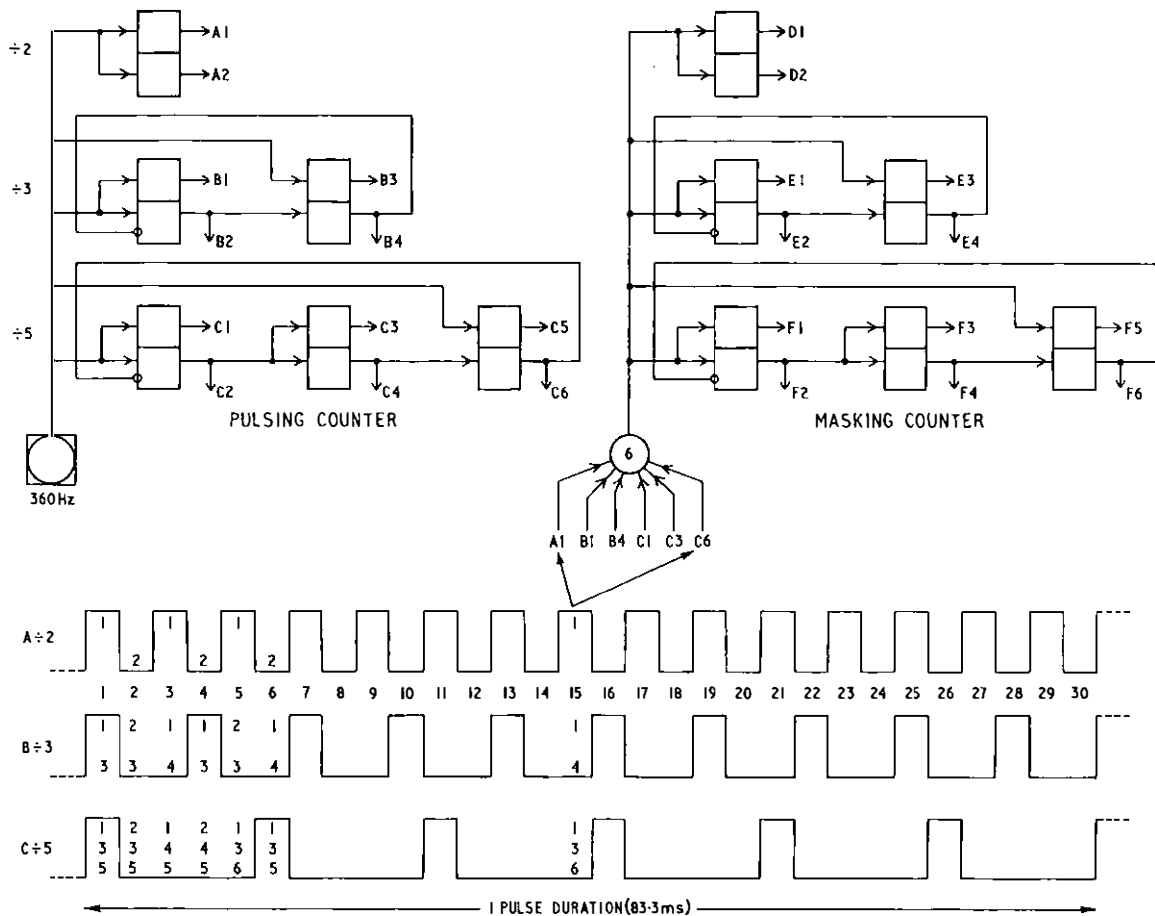

FIG. 4--Logic diagram of electronic pulse-generator

Fig. 5 shows the decoding circuits and the output relays, together with a diagram of the whole output-pulse scheme devised to meet acceptance-testing requirements. The relay contacts are wired to terminals on the front of the tester and provide test conditions completely isolated from the tester drive-circuits. It is necessary to arrange change-over of the masking conditions during the make period of the dial pulses. Since the drive pulse for the masking counter is derived from the reference-pulse position on the masking ratio-counter, it is, therefore, impossible for pulse-clipping to occur.

The use of start and stop pulses throughout the tester logic requires that the output relays are themselves bistable in order to provide the memory function of staying in the position ordered by the last pulse-drive instruction. Mercury-wetted contact bistable reed relays\* are used, principally because of their long-life expectancy and the complete absence of any need for maintenance. It is estimated that even the pulsing contacts will last for 30 years, each pulse being formed cleanly with the inherently bounce-free characteristics of the mercury-wetted reed.

#### AUTOMATICALLY-CONTROLLED GROUP-SELECTOR TESTER

The acceptance-testing procedure for group selectors requires the testing officer to divide his time between various physical operations. In sequence these are

- (i) making connexions to selectors to be tested,
- (ii) reading testing instructions,
- (iii) operating test keys, and
- (iv) judging tester and selector response.

\* ELEY, A. C., and LOWE, W. T. Electronic Telephone Exchanges: Reed Relays for Exchange Systems. *P.O.E.E.J.*, Vol. 60, p. 140, July 1967.

The introduction of the electronic pulsing unit did nothing to improve this practice, but, during work on prototypes using simpler logic and circuits employing discrete components, it was foreseen that real productivity improvements would occur if the whole series of tests on each selector were applied under automatic control. The testing engineer would then be relieved of the tedious task of repeatedly reading the test schedules, and of checking the results of each test; he could then concentrate purely on observing the selectors undergoing their test program.

A new tester (Fig. 6) was, therefore, developed that performs tests using conditions identical in every way to the original manual tests, but which reduces the actual testing time from about 5 minutes to 20-25 seconds for each selector. Lost time that would normally occur during change-over of test cords is eliminated with this tester by having two sets of access connexions. Uninterrupted testing can be achieved by moving one set of access cords to the next selector to be tested during the test of the previous one. When a test cord is connected to a selector the free condition is detected and used to start the test sequence. A loop is applied, and the resulting busy condition is checked before applying the first pulse-train. If the wipers enter the correct level and switch to the correct test-outlet, the loop is disconnected and the selector is released. Correct release conditions are checked before the selector is offered another test-cycle, and progress through the series of test-cycles which form a complete program is shown on the program-step indicator. When a fault is detected, the test sequence stops and the fault display is illuminated to indicate the nature of the defect. The test program at present used has eight test-cycles during which the test conditions are varied to cover all the required functional tests. Fig. 7 shows the internal construction; the main circuits are mounted on plug-in boards.

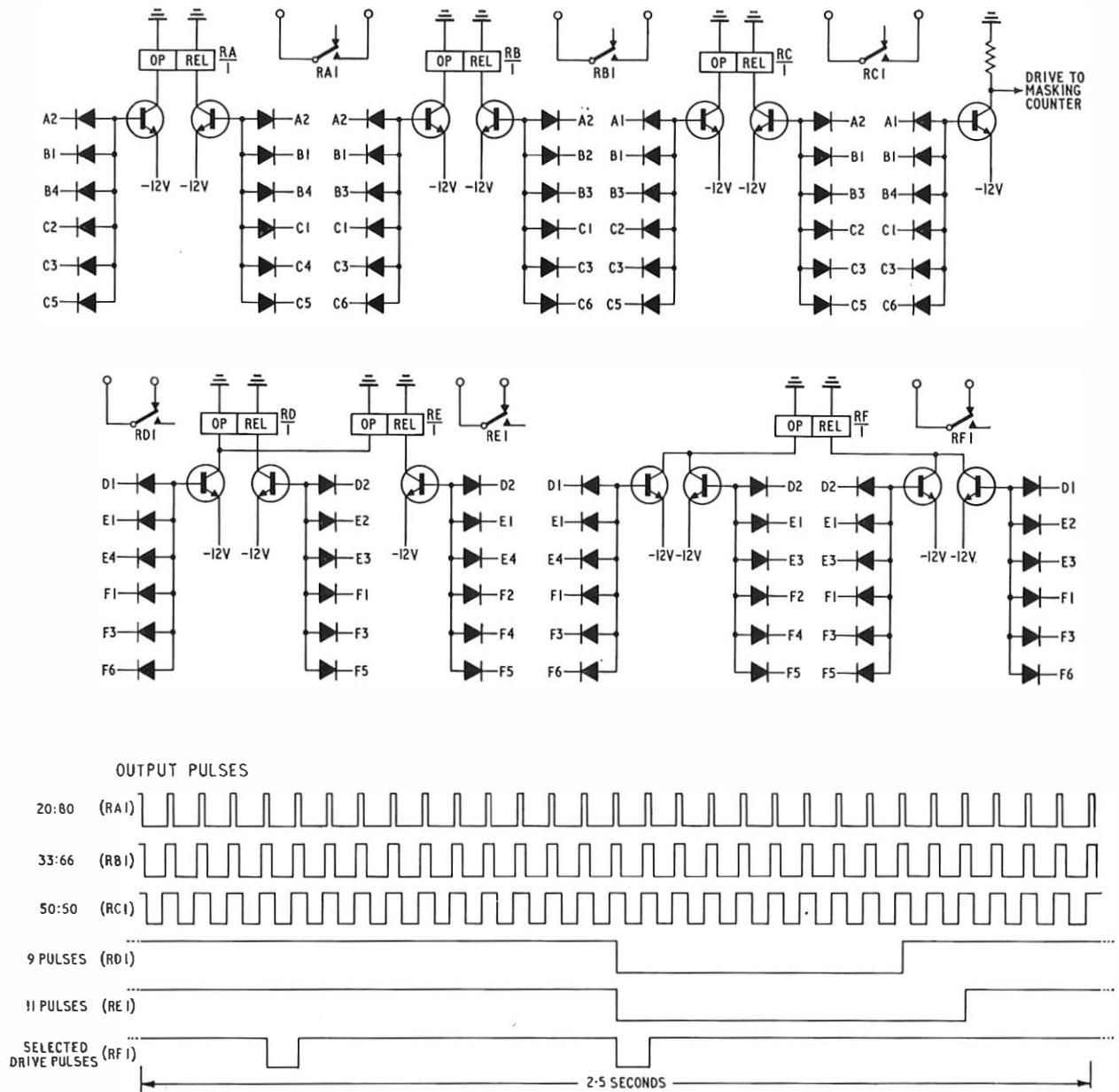

FIG. 5—Electronic pulse-generator output circuits



FIG. 6—Electronic group-selector tester

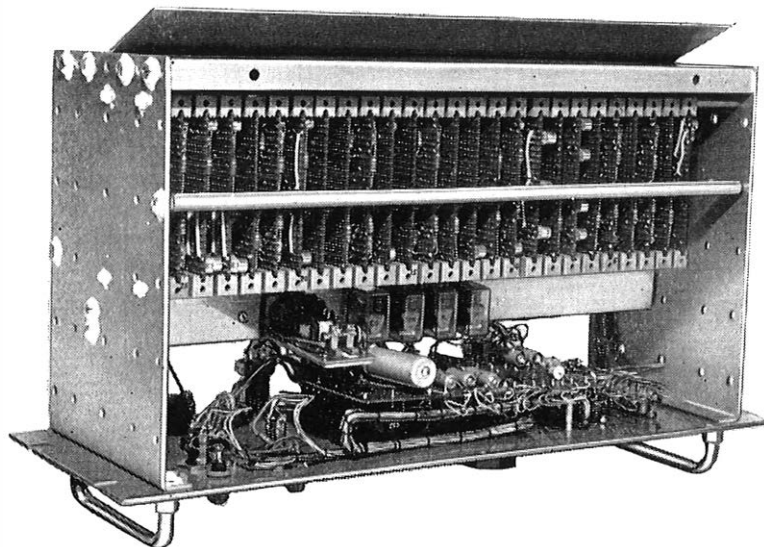
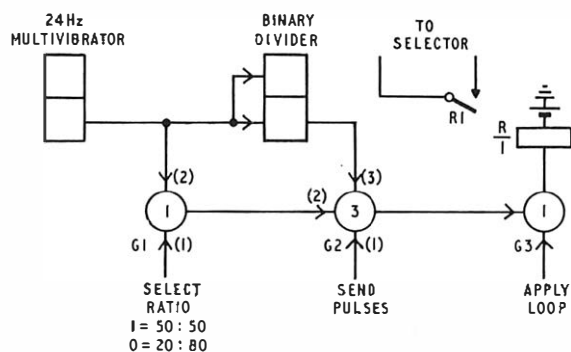
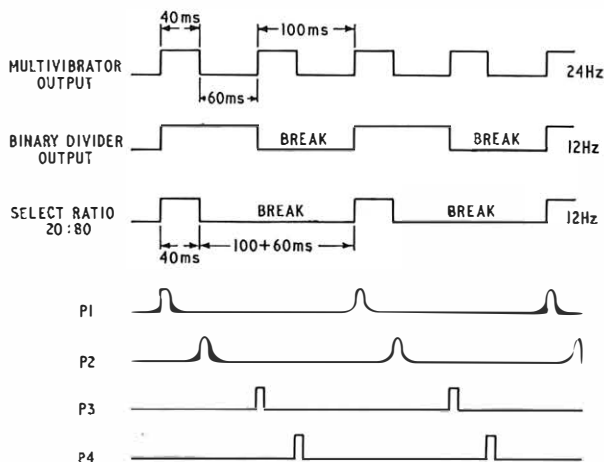

FIG. 7—Internal layout of electronic group-selector tester



(a) Logic diagram



(b) Waveform relationships

FIG. 8—Group-selector tester logic diagram

## CIRCUIT ELEMENTS

### Pulse Generator

Fig. 8(a) shows the logic of the pulse generator, and the waveform relationships of the various outputs are shown in Fig. 8(b). The main oscillator is a variable-speed multivibrator, normally operating at 24 Hz, that drives a binary dividing bistable circuit to produce a 50 : 50 ratio waveform at 12 Hz. The multivibrator is set to oscillate with a 40 : 60 ratio independently of the speed of oscillation. Output-pulsing relay R is operated from the pulse generator under the control of a d.c. instructional signal SEND PULSES to gate G2 input (1). If a 50 : 50 ratio is required this instruction is

present and a permanent output is fed to gate G2 input (2). The output from G2 is present when the binary divider (input (3)) is present and therefore contact R1 pulses out with a 50 : 50 make-to-break ratio. If the 20 : 80 ratio is required the select-ratio input is absent and the output only appears during the 40 per cent phase of the oscillator. When gated with the binary divider in gate G3 (inputs (2) and (3)) the output selects alternate 40 per cent phases of the oscillator waveform to produce a 20 : 80 ratio over a period of two cycles. Circuits not shown on the diagram employ the oscillator and binary-divider waveforms to produce a family of drive-pulses P1-P4 for use as timing pulses throughout the tester.

### Counter and Code System

The design of the bistable circuits used throughout the tester was dictated mainly by the need for simplicity, due to the use of discrete components. The basic form is used (Fig. 9), and setting and resetting are achieved by d.c. con-

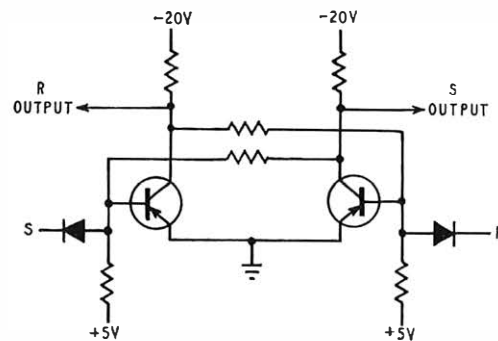

FIG. 9—Bistable toggle circuit

ditions applied via an isolating diode to the base of the appropriate transistor. For the counter, the need for pulse-steering circuits is avoided by employing the P pulses already generated as drive pulses, as well as at the same time providing the necessary synchronization between pulsing-out and counting logic.

The code used in the counter is such that only one change of state of a toggle occurs in each stage of the counting process. It will also be seen from the diagram that the count reverts to 6 if any attempt is made to count beyond 11. In the course of normal successful testing of selectors "count 11" is never reached, and it is therefore convenient to use it as the time-out marker for tests in which the expected event does not occur, due to a fault.



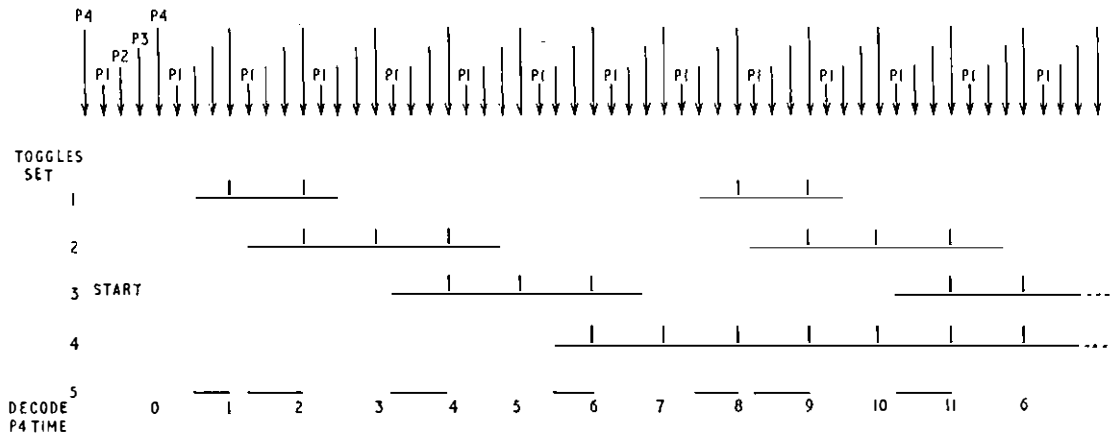

FIG. 10—Counter-toggle timing chart

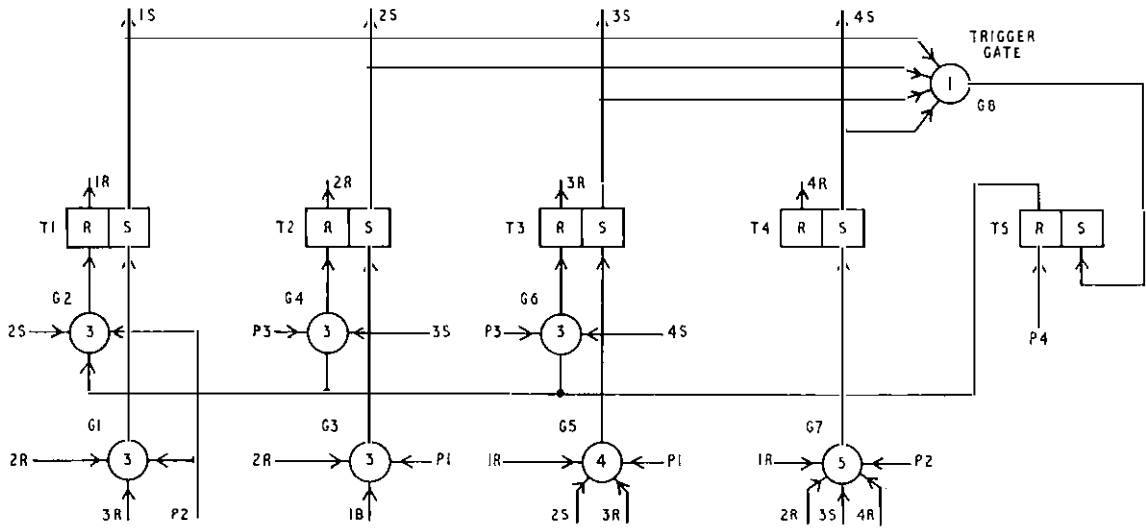

FIG. 11—Counter-logic diagram

**Counter Operation**

Fig. 11 shows a simplified logic diagram of the counter. When drive pulses are connected to start the counting-process, gate G1 responds to set toggle T1 at P2 time. The change of state of this toggle produces a trigger pulse at gate G8, which sets toggle T5. The toggle reset gates G2, G4 and G6 are inhibited by the absence of the T5R input until after P4 when toggle T5 resets. Since P4 is the time at which the state of the counter is observed, on this occasion with only toggle T1 set the output may be decoded as "count 1".

At P1 time, gate G3 sets toggle T2 which again inhibits reset due to the operation of gate G8 and toggle T5. The next P4 time sees toggles T1 and T2 set leading to a decode "count 2". During the next P1-P4 cycle no further toggles set at P1 or P2 times, and, therefore, toggle T5 remains reset. Reset gate G2 now operates at P3 time and resets toggle T1 to produce "count 3" at P4 time. This pattern of events continues in a similar manner until "count 11" is reached. The precise setting and resetting times for all toggles can be determined by inspection of Fig. 10 and 11.

**The Digit Memory and Comparison Gates**

During the process of pulsing-out the counter is stepping in synchronism with the dial pulses. When the state of the counter is examined at each P4 time, a break pulse is being transmitted which could be the last one in the pulse train. The signal to end the pulsing-out process must be derived from the state of the associated counter by comparing it with a program instruction marking the total number of dial pulses to be sent. This takes the form of four toggles preset with the

value of the digit to be sent, using the same code as that employed in the counter. Fig. 12 shows the logic diagram of

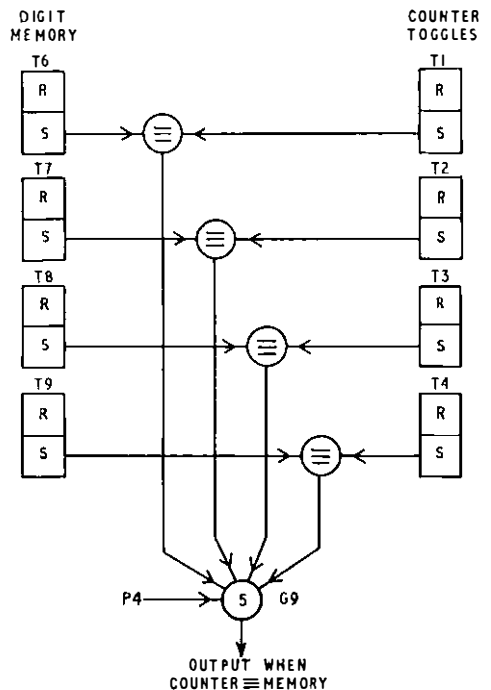

FIG. 12—Equivalence diagram

the comparison circuits, in which the main feature is that a comparison gate checks for equivalence between the digit memory and the current state of the counter.

The P4 input to gate G9 ensures that the comparison is only made when the counter state is stationary and valid. Fig. 13 shows the circuit diagram of the equivalence gate,

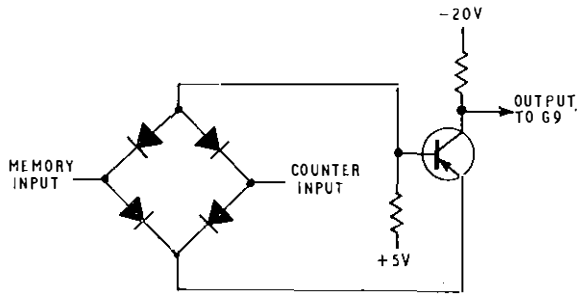

Fig. 13—Comparison-gate circuit

and its operation is easily understood if the input diodes are considered as a standard configuration full-wave rectifier circuit. In order to make the transistor conduct and therefore indicate by the presence of an earth, that a state of difference exists, the full-wave rectifier circuit must provide an earth to the emitter and a negative drive-voltage to the base. The bridge rectifier ensures that any arrangement of earth and -50-volt connexions will provide an earth, but should both inputs be the same, either -50-volts or earth, then one of the essential drive conditions to the transistor will be absent, the transistor will be turned off, and an enabling negative output will be applied to gate G9.

**PROGRAM LOGIC**

Fig. 14 shows the logic diagram of the tester as a whole, in which those elements already described have been included

as schematic blocks for the sake of simplicity. The test program commences with the connexion to a selector looking for the free condition of the P-wire. Toggle T10 sets in response to correct conditions and instructs the pulse-generator logic via gate G12, to apply a permanent loop to seize the selector. If a correct P-wire busy condition is then observed, the counter is started (by gate G10) without bringing into use the comparison logic. When the count reaches 6, gate G20 operates at P4 time to set toggle T11, followed by toggle T12 due to the retiming gates G13 and G14. Thus, half a second after the initial seizure, toggle T12 instructs the pulse generator to changeover from permanent loop to pulsing conditions. The time lag between the operation of toggles T11 and T12 is detected by gate G16, and its output is used in conjunction with the output from the first stage of the program-step register to determine the digit to be written into the memory toggles. For test cycle No. 1 this digit is nine and therefore toggles T6, T7 and T9 are set via diodes wired between their inputs and the gate G21 array output 1.

At this point a reset circuit sets the counter at its home position, and pulsing-out and counting continue together until nine break-pulses have been sent and gate G9 detects a complete state of equivalence between the counter and the digit memory. Toggles T11 and T12 now reset with a retiming interval between them so that the change-over from pulsing-out to a holding loop occurs during the make period following the ninth break. Gate G15 operates in a manner similar to that of G16, but, this time, at the end of pulsing, and this is used to step the program step register in readiness for writing-in the digit allocated for the second test-cycle.

Gate G15 output also sets toggle T13 to prime the first of the detector circuits monitoring the selector operation. The selector has at this time stepped to level 9 and now starts to hunt for a free outlet. So that this action can be tested, the early choices on the level arc made busy in the normal way,

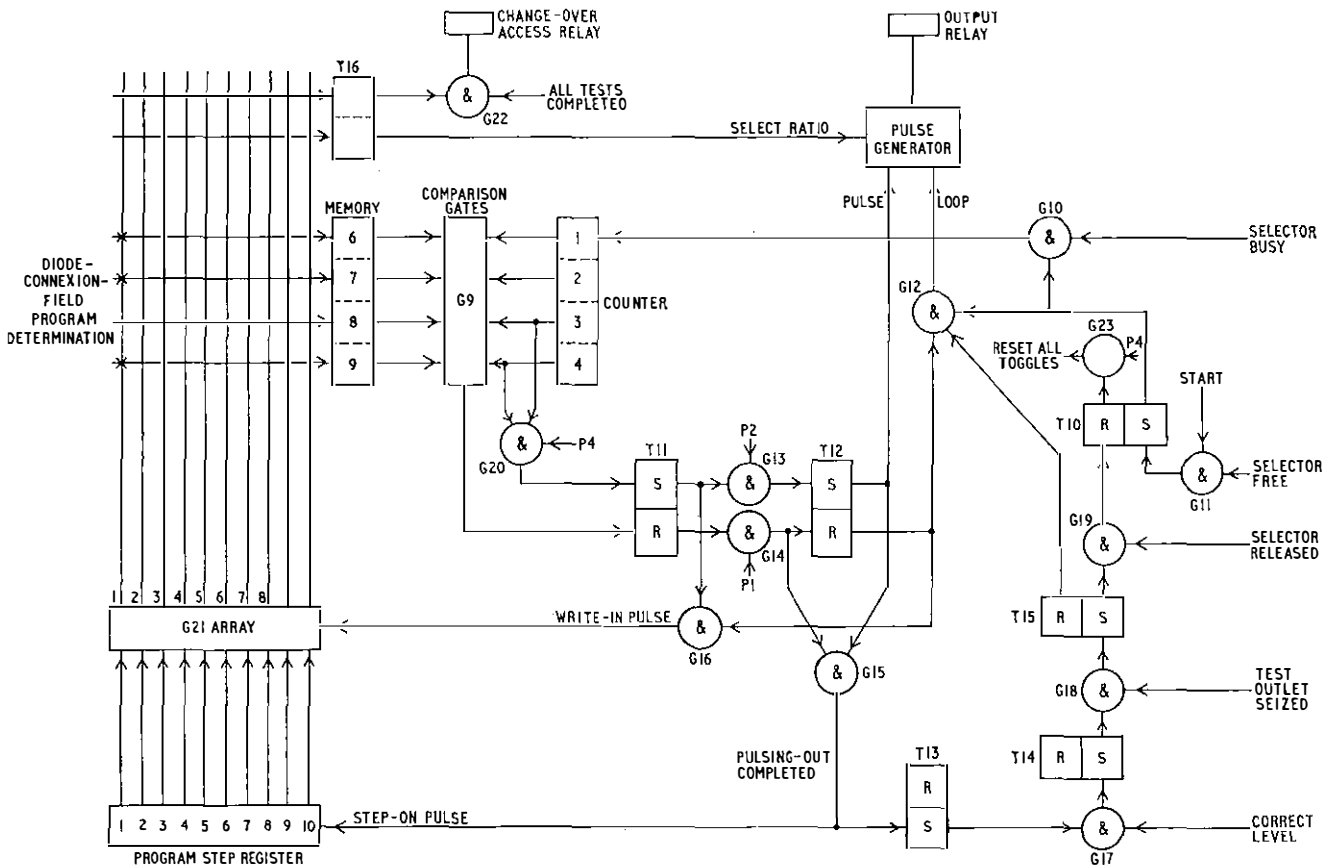

Fig. 14--Logic diagram of group-selector tester

except that the first outlet is earthed via a 150-ohm resistor. As this first choice is tested by the selector a small voltage is developed from its testing potential which is inspected by gate G17, and the output is used to set toggle T14. Since level 9 is the test level for nearly all test-cycles, this action can be interpreted as a correct-level signal. For other levels an alternative signal is used to set toggle T14.

A simple test-element connected to the test-outlet feeds back to the tester the information that the correct outlet has been seized, and gate G18 records the fact by setting toggle T15. The reset output, R, of the toggle is removed from gate G12, and the holding loop is disconnected to cause the release of the selector. The P-wire is observed at this time to ensure that the release-guard earth appears correctly before gate G19 is permitted to reset toggle T10 and thereby mark the end of a successful test-cycle, with all the logic reset by gate G23. The operation of succeeding test-cycles is substantially the same, with the program step register advancing one step on each cycle and thus changing the testing conditions as necessary to complete the desired test program. Toggle T16 is set during the last test-cycle on a particular selector, and on completion of all tests, causes the test access to change to the alternate cord before beginning the program again without a pause of any kind.

## CONCLUSIONS

A study of selector-testing times using the new automatically-controlled tester compared with the previous testing procedure show that the time saving alone has more than justified its development. Moreover, the initial provision of about 60 of these testers has proved sufficient to deal with the immense program of exchange equipment installation which has been necessary in recent years. The basic simplicity and speed of the new procedure has led to one particular improvement in acceptance-testing practice. Formerly, a contractor who offered equipment found to be below standard in the early stages of acceptance testing had the whole batch of selectors handed back for further attention. This was intended principally to minimize testing time on the part of the Post Office, and the contractor was obliged to recheck all items in the batch before reoffering them for acceptance. These difficulties are largely removed to the mutual advantage of both parties by using the speed of the tester to allow tests on all selectors regardless of the findings, and then to reject only those definitely found to be defective. While acceptance testing is obviously essential, speed is nowadays just as essential, and it is hoped that further developments along the lines described will make their contribution in the common aim of providing a satisfactory telephone service.

---

## Book Reviews

“Telecommunications.” W. Fraser, M.Sc.(Eng.), F.I.E.E. Macdonald & Co. Ltd, 803 pp. 450 ill. 84s.

This is the second edition of “Telecommunications” which was first published in 1957. It is a very comprehensive text-book, written mainly for students reading for an engineering degree but has been found to be extremely useful to those studying for the Higher National Certificate in Electrical Engineering, the examinations for membership of the I.E.E. and I.E.R.E. and for the higher grades in the City and Guilds Telecommunications Courses.

The book covers a very wide range of subjects including, for example, network theorems, circuit theory, modulation, telephony, telegraphy, UHF devices, aerials and radio transmission systems. The second edition contains a much improved section on semiconductor devices. The chapters dealing with amplifiers and oscillators have been amended to include transistor circuits as well as valve circuits. The treatment of noise has also been improved and given a separate chapter.

There are many worked examples given in the text and most chapters end with a good selection of questions, although questions involving the use of transistors are few. Answers to the numerical questions are given at the end of the book.

Due to the extremely large field covered by this book the author has necessarily dealt mainly with the basic principles of each topic and has written these in a clear and concise manner. The chapters on line transmission and filters are especially good, but because of the basic approach the chapters dealing with systems, i.e. telephony, telegraphy and radio, tend to be limited. However, for students wishing to read further into a subject, a list of references is given at the end of each chapter.

The book has a good index, and with the slightly improved layout, makes a very useful reference book.

B. R. L.

“Information Theory and its Engineering Applications.” (4th Ed.) D. A. Bell, M.A., Ph.D., F.I.E.E. Pitman and Sons, Ltd. 227 pp. 34 ill. 35s.

This is the fourth edition of a book originally written in 1951, very soon after the papers by Shannon were published and stimulated interest in this subject. The new edition differs from the third (1962\*) chiefly by the inclusion of a new chapter on error-correcting binary codes. Chapter 9 has been retitled “Theoretical Applications” and embraces Chapter 9 of the third edition (entitled “Electronic Computers and Data-processing”) and the information on linguistics and the morse code, previously found in appendixes 2 and 4, together with new material on optics and biology. Chapter 8 (“Practical Application of the Theory”) has been extended and now makes brief reference to pulse code modulation systems; the material on television in this chapter has been much amplified, especially in references to colour. The book is now 29 pages longer.

The first edition was early in the field and therefore much needed at the time, but the explanations which have since become available in more recent books dealing with the fundamental principles are much easier to understand than the lecture-notes style of Dr. Bell. The book can therefore be recommended now mainly as a link with the original papers which are quoted in rather copious footnote references.

D. L. R.

\* P.O.E.E.J., Vol. 56, p. 243, Jan. 1964.

# Luminescent Materials Used in Postal Automation

C. F. FORSTER, M.Sc., A.R.I.C.†

U.D.C. 681.187:535.37

*Development of machinery to enable mail to be handled automatically is necessary to reduce the labour content of this work. As part of this process, an effective means of identifying that letters have been stamped with stamps of the correct value is required. One method of achieving this is to print a luminescent material on the stamps. Luminescent materials are also used to print addresses on envelopes to enable subsequent sorting operations to be automatic.*

*A review of the materials and techniques used by postal administrations for automatic letter-facing is given. This is followed by a description of the properties and uses of the organic phosphors invented at Dollis Hill for facing and letter coding. A comparison of the effect of colour and density of background of postage stamps on the luminescent-intensity is also given.*

## INTRODUCTION

During 1961, a series of articles in this Journal reviewed the state of the art in postal-automation in Great Britain, covering facing and segregation,<sup>1</sup> coding-sorting<sup>2</sup> and the phosphors used for both types of process.<sup>3</sup>

Automatic letter-facing machines and letter-sorting equipment are now well past the experimental stage in many other countries besides Great Britain. The methods employed differ considerably in detail but the fundamental principles involved are common to all systems.

This present article reviews the way in which different physical phenomena have been exploited in the various countries as means of detection and/or segregation of different classes of mail. Changes in the British system since 1961 which have been made, or are in process of development, are also described.

## BASIC METHODS USED FOR AUTOMATIC LETTER-FACING

All systems in current use depend for their operation on making the postage stamp affixed in the top right-hand corner of the envelope uniquely identifiable from other features on the envelope. Various methods of achieving this have been investigated.

### Optical Detection by Colour Contrast

This depends on the recognition of the stamp as a colour, contrasting with the envelope. Only certain colours are completely suitable, for example pale greys and blues, are often not detected. Additionally, false detection of such things as advertisements and airmail-labels may interfere with stamp detection.

By using colour separation filters it is possible preferentially to separate letters bearing stamps representing different classes of mail. However, the number of suitable colours is limited and the strength of their signal is always reduced by the filter.

### Magnetic Detection

This works well on cheques and postal orders, but is not suitable for use on letters which are often bulky and lack flatness.

### Electrical Conduction

An extensive practical trial of conducting graphite lines printed on the reverse side of postage stamps was carried out in 1958-59.<sup>3</sup> Although technically successful the cost of printing was high and this method was abandoned, in favour of phosphorescent lines, in 1961.

### Fluorescence

This is a phenomenon whereby a substance absorbs ultra-violet (u.v.) radiations and emits the energy in the form of radiations of longer wavelength, usually in the visible region of the spectrum. The energy conversion processes involved in fluorescence are very rapid and cease abruptly when the irradiation is discontinued.

### Phosphorescence

The fundamental difference between phosphorescence and fluorescence is that the energy changes within the molecule during u.v. irradiation are more complex, and involve delays, so that when the irradiation is discontinued the emission process carries on for an appreciable time with diminishing intensity. The decay is generally exponential in character with a half-life varying from a few milliseconds to many seconds. Each phosphor has its own individual emission and decay characteristics.

## USE OF FLUORESCENT MATERIALS

The widespread use of blue-fluors in paper used for envelopes poses a problem in the attempt to make the stamps unmistakably recognizable by their fluorescence. The solution commonly adopted is to use a fluor with a yellow emission so that by using a blue absorbing filter only the emission from the stamp can reach the detector.

Since some of the u.v. light is reflected unchanged by the fluorescent object, an u.v. absorbing-filter must also be used to ensure that only yellow light from the stamp is detected. The use of filters reduces the strength of the ultimate signal to such a degree that very sensitive detectors are required. For this reason many postal administrations have preferred to use the more expensive phosphorescent materials.

The German Post Office adopted fluorescent detection for letter-facing in 1960. Originally they used a substance known as Lumogen UV impregnated into the paper. This gave it a faint yellowish-tinge in daylight and a bright-yellow fluorescence under u.v. excitation. Because of the high cost of Lumogen-treated paper they changed to a new fluor, salicyl-

† Research Department, Telecommunication Headquarters.

aldazine, which gives a white emission about four times as bright as Lumogen. The Danish Post Office uses similar equipment and fluorescent paper.

Italy and Sweden began using stamps printed on to yellow fluorescing paper for use with German letter-facing machines. Swedish stamps normally have very wide margins but the Italians revived an obsolete design and reduced the size so that the margins were wider than before.

The Belgian and Netherlands Post Offices issued a few low-value stamps in 1962 printed on German Lumogen-treated paper. The Belgian stamps can only be identified with a u.v. lamp, but those from the Netherlands are easily identified because they are on un-watermarked paper.<sup>5</sup> In 1965 both administrations abandoned the use of fluors in favour of the Swiss phosphor Teufen.

The Japanese Post Office has tried optical-scanning and phosphorescent-scanning for letter-facing, using a short-life phosphor printed in the shape of a hollow-rectangle covering all the white margins of each stamp. Currently they are using a paper treated with an overall blue-fluor.

## INORGANIC PHOSPHORS

### Short-Duration Inorganic Phosphors

These phosphors have sufficient afterglow to be just detectable after the u.v. light has been extinguished. However, delay times as short as 3 ms do not permit the physical transfer of the envelope bearing a phosphorescent stamp from the irradiating-point to the reading-point. Consequently the irradiating and reading points must coincide, with a fast-moving shutter simultaneously cutting off the irradiation beam and exposing the detector and vice versa in rapid alternation or using an electronically-pulsed source reading during the dark phases.

This method is employed by the U.S. and Australian Post Offices using a short-lived red-emitting phosphor to suit the particular detector used in their equipment. The Australians use only a red-emitting phosphor in their facing machines because so far they are not interested in segregating special classes of mail.

Two kinds of paper are used by the Australian stamp printers, a plain paper coated only with phosphorescent material for recess-printed stamps and a glossy paper coated with phosphor and kaolin for photogravure printed stamps.

The U.S. Post Office employs a red-emitting phosphor and a green-emitting phosphor to enable them to segregate two different categories of mail. These phosphors were primarily designed for use in coloured electric advertising-signs where a long persistence was not required. The values employed to defray air-mail postage rates are printed on paper impregnated with a red-emitting phosphor and other values used for surface-mail are printed on paper impregnated with a green-emitting phosphor. Filters are used to distinguish which colour is being emitted by a particular stamp and the machine sorts it accordingly.

### Medium Duration Inorganic-Phosphors

In these phosphors, the afterglow is sufficiently long to allow the physical transfer of the excited stamp from the irradiating-point to the detecting-point.

At present four countries, (Switzerland, Norway, Belgium and the Netherlands), are using a green-emitting phosphor of this type. The half-life is about 80ms which is just long enough to permit detection by a photo-electric detector placed adjacent to the irradiating-source but separated by an opaque screen.

The Swiss Post Office uses a phosphor-coated paper containing short violet-coloured fibres to make it distinguishable from non-phosphor paper.

Both Belgium and the Netherlands use phosphor-coated stamps. The Belgian stamps can only be identified by u.v. light but the Netherlands stamps, although on watermarked

paper, are identifiable by the high gloss of the phosphor coating.

## ORGANIC-RESIN PHOSPHORS

The objections to the use of inorganic phosphors for postal use are their high cost, high density and relatively large particle size which make them unsatisfactory for use in most printing inks.

A number of organic phosphors invented at Dollis Hill in 1957<sup>4</sup> are free from these drawbacks. They are less stable to u.v. light and moisture than inorganic phosphors, but no difficulties due to this have arisen to date. The effect of moisture is reversible and on drying the phosphorescence is largely restored. Hydrophobic ink media also act as a protection against brief accidental wetting.

The organic phosphors are polymers of urea-formaldehyde, melamine-formaldehyde, or cyanuric acid-formaldehyde, containing a third component known as the activator. These resins are not long-chain compounds like polythene, nylon, or polyvinyl chloride, but are rigid three-dimensional macromolecules formed from a number of cross-linked rings.

Given the necessary molecular structure, the size of the activator molecule has a bearing on the optical properties of the phosphor formed from it. A single ring such as terephthalic acid or sulphanilic acid makes a phosphor with an emission in the u.v.-violet region. By attaching a second ring the emission moves away from the u.v. region to the blue region. If the rings are fused together the emission changes further in the same direction to green or yellow, and with a triple fusion the emission is orange.

### Use of Organic-Phosphors

The optical properties of these resins can be varied by the selection of an appropriate activator so that phosphors with violet, blue, green, yellow, orange and red emissions are available. For postal purposes in Britain two distinct phosphors are required; firstly, for use on stamps for automatic facing and segregation of first and second class mail and secondly, for use in destination coding of envelopes. Instead of using phosphors with different coloured emissions like the U.S. Post Office, the British Post Office has found it more convenient to use phosphors with different energization requirements. While most of the organic resin phosphors can be energized by u.v. light of 3,650 Å there are some which are not excited at all by this wavelength and need u.v. light of shorter wavelength (2,537 Å) to excite them.

Originally a phosphor containing parahydroxydiphenyl (PHD) was used on postage stamps. This is inert to 3,650 Å u.v. light but glows greenish-blue when excited by 2,537 Å u.v. light. However, the brightness of this phosphor was much lower than that of the phosphor designated for destination coding containing carbazole sulphonic acid (CSA), and since the development of coding was then still some years away, CSA was also used on stamps as a interim measure.

In 1965, with the installation of both an automatic letter-facing machine (ALF) and code-printing and letter-sorting machines at Norwich, it became necessary to change phosphors on the postage stamps. Several new phosphors having the inertness of PHD to 3,650 Å u.v. light and the brightness of CSA to 2,537 Å u.v. light had by then been discovered, and terephthalic acid (TPA) was selected on its optical properties and is presently in use. Unfortunately it makes a very hard resin which is more difficult to grind than the other phosphors and a change to sulphanilic acid (SA) is contemplated.

In order to use ALF to separate first-class mail from second-class mail, the appropriate stamps representing each service must be easily distinguishable by the machine (and also visually for the many sorting offices still without ALF's). This is done by having only a single bar on the lower rate stamp instead of the usual two.

## FACTORS AFFECTING LUMINESCENT EFFICIENCY

### Printing Methods

The phosphor-bars are printed by whatever method the stamp printer finds convenient. Whenever possible, the bars are printed from a second photogravure cylinder on the machine printing the stamps. When all the printing cylinders of the machine are occupied in printing multi-colour stamps, then the bars may be printed as a separate operation on a sheet-fed press by the photogravure or letterpress process.

Since the decision was made to print phosphor bars on all stamps, the flexographic process has been adopted as an alternative method for printing bars on to stamps in the reel. In flexography the bars are printed from a rubber-covered cylinder which picks up the impression from an engraved or photo-etched inking cylinder. The screen pattern is usually blurred during transfer from the rubber cylinder but sometimes traces of it remain. This printing unit can be combined with the photogravure machine to add the phosphor bars to the reel of freshly printed stamps before cutting into individual sheets. Letterpress and flexographically printed bars are solid and completely fill the area allotted to them. Photogravure, on the other hand, prints a regular pattern of dots which leaves non-phosphorescent areas surrounding each dot. This reduces the total phosphorescent output by about 20 per cent as compared with other printing methods (Fig. 1).

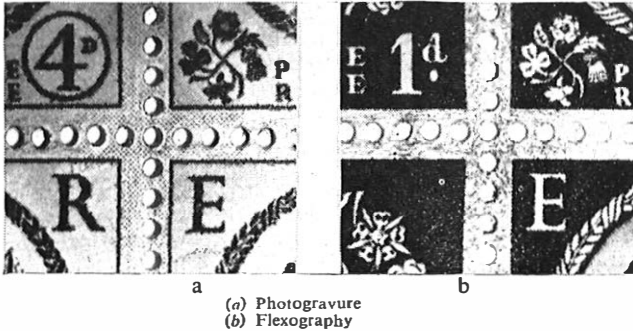

Note: The stamps have been lightly rubbed with a soft pencil to show the dotted pattern indicative of photogravure and the amorphous pattern typical of letterpress or flexography.

FIG. 1—Comparison of printing methods

### Background

On an all-white background the loss of 20 per cent output due to photogravure printing is not significant for successful detection by ALF. Other factors such as gross misplacement

of the perforations (which enlarges the area of one bar at the expense of the other) may exceed this. In an extreme case ALF may only detect the wider bar and sort the letter as second-class.

A further and bigger reduction of phosphorescent intensity occurs when the bars are printed on to a dense solid background as exists on most of the present definitive stamps and some of the Painting stamps (Fig. 2).

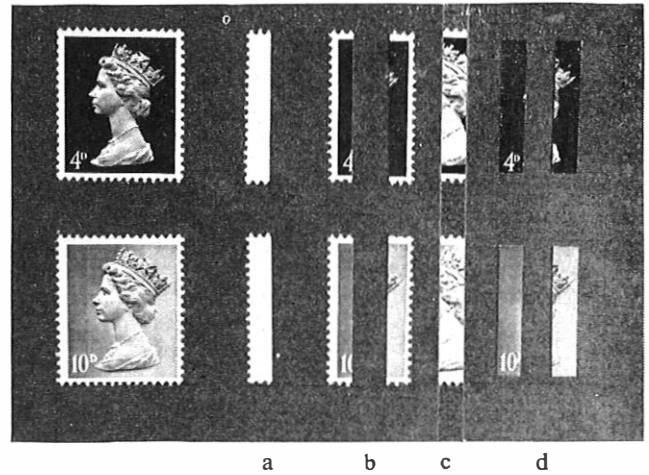

Phosphor test specimens

- (a) From sheet margin  
(b) From stamp with perforation gutters, one wide and one narrow.  
(c) From centre of stamp.  
(d) From dark background without perforation gutter.

FIG. 2—4d. and 10d. stamps printed in the same colour (sepia-black).

Table 1 shows the reduction in phosphorescent intensity caused by the different colours and background densities of the present series of postage stamps. The last column gives the reflectance of the various colours at 4,000 Å expressed as a percentage of the reflectance of a magnesium-oxide standard white.

The correlation between the reflectivity of the colour and the phosphor emission is quite general. The reduction effected by the dark colours represents a very high proportion of the possible emission from a white background. The 1s. value and the 3d. with one central bar are outstandingly good because of the violet colour and the light background. Of the stamps on a dark background the 3d. violet is the best and the 4d. sepia-black is one of the worst.

Table 1- Effect of Density and Colour of the Underlying Background on the Phosphorescent Emission

Value	Colour of stamp	Phosphorescence. Phos-tester readings			Percentage emission		Percentage reflectance (Spectro-photometer)
		Sheet margin (a)	Solid ground + perf. gutter (b)	Solid ground only (d)	$\frac{d}{a} \times 100$	$\frac{b}{a} \times 100$	
Blank	White sheet margin						55
4d.	Dull orange .. ..	345	113	62	18	33	4.5
1d.	Yellow-olive .. ..	350	109	49	14	30	5
2d.	Red-brown .. ..	318	96	41	13	30	6.3
3d.	Violet (2-bars) .. ..	296	135	85	29	45	13
	Violet (1-bar) .. ..	478	314*			65*	
4d.	Black (2-bars) .. ..	308	101	49	16	32	4
	Black (1-bar) .. ..	391	159*			40*	
5d.	Grey-blue .. ..	196	69	38	18	35	9
6d.	Magenta .. ..	202	62	27	14	31	10
7d.	Bright green .. ..	279	103	60	22	37	5
8d.	Vermillion .. ..	370	121	59	16	33	7
9d.	Bottle green .. ..	351	104	42	12	30	4
10d.	Black (light ground) .. ..	570	224	137	24	39	12
1s.	Violet (light ground) .. ..	573	330	270	47	58	35
1s. 6d.	Deep blue and green .. ..	613	170	60	10	28	7
1s. 9d.	Black and orange .. ..	326	97	40	12	30	2.5

\* Specimen (c). One bar of phosphor down the centre of the stamp over the Queen's portrait

The emission from the 4d. stamp with one phosphor bar down the centre is 40 per cent of the emission from the white sheet margin, and is comparable with the 39 per cent emission from the 10d. stamp. The emission from the 2-bar 4d. stamp with phosphorescent vertical gutters is only 32 per cent, and if the white gutter is removed and replaced by an all-dark background the response is reduced to 16 per cent. Although the white gutter in a correctly perforated stamp represents only a quarter of the phosphorescent area its removal or reduction in area by misplaced perforations has a considerable effect on the overall emission. In an extreme case the phosphorescent response on the reduced side may fall below the detectable level.

The poor response arising from unfavourable backgrounds can be improved by printing the phosphor bars more deeply. Column (a) in the Table shows the variations that are encountered in normal production, ranging from 196 to 613. The low values recorded in columns (b) and (d) for the 5d. and 6d. stamps are mainly due to inadequately inked phosphor bars.

The response of the 5d. greyish blue stamp is on the low side, partly due to the admixture of grey in the colour. A brighter colour such as the ultramarine used on the former 4d. stamp would give a better signal on ALF and would increase the visual distinction needed for manual sorting.

## ADDRESS CODING

Until a machine capable of reading all kinds of handwriting has been devised the address will have to be read initially by human eye and then transcribed into a series of printed marks arranged in a particular pattern capable of being scanned and acted upon by a machine.

This transcribed code address generally takes the form of a series of dots and spaces, up to 14 in number. Each address is then represented by one particular arrangement. In practice one series of 14 dots or spaces represents the name of one of the 2,000 or so post-towns in the United Kingdom and another series is used to denote the street and house number. The current practice is to print the post-town information horizontally about half an inch from the bottom of the envelope and the street particulars horizontally near the top of the envelope.

The code marks could be printed in a variety of materials, but for reasons already stated it is preferred to use phosphorescent marks as the least likely to be perturbed by the inclusion of dyes or fluors in the paper or by words or designs written or printed on the envelope.

Because the second line of phosphor dots may impinge on to the postage stamp it is essential to ensure that no interference is encountered from the phosphor marks printed on the stamps for facing purposes. The avoidance of such interference can be achieved in a variety of ways, the one chosen by the British Post Office being to preferentially excite the code marks by a wavelength of u.v. light which does not excite the stamp phosphor.

This method uses two of the selective organic cyanuric acid-formaldehyde phosphors developed at Dollis Hill. The two phosphors differ only with respect to the activator used. CSA is used in the coding-phosphor (which is excited by u.v. light of 3,650Å) while the stamp phosphor (which is unresponsive to u.v. light of this wavelength and requires the shorter wavelengths of the order of 2,537Å for excitation) uses TPA.

## APPLICATION OF PHOSPHOR CODE MARKS TO MAIL

Conventional printing techniques are unacceptable because the drying time is too long and because envelopes containing bulky contents offer a poor surface for printing and are easily ruptured by quite low pressures exerted by the type face. Also, if the envelope contains hard objects, such as coins,

some of the dots might fail to print altogether. It has been arranged that each code pattern contains an even number of dots, so that one dot failing to print would be detected by the checking apparatus placed immediately after the printer. Two missing dots would be acceptable to the checking apparatus but would of course indicate the wrong code, and the envelope would mis-sort.

For various reasons liquid printing inks are unacceptable and some form of solid ink having a reasonably low melting point must be used.

Two methods of using low melting point materials are currently available.

### Hot-Pot Method

This method consists of a bath of molten wax-phosphor mixture through which the printing rods operate. Molten material is continuously pouring over a weir on to the tips of the rods so that material cannot congeal on them. When required to print, the rods are pushed forward through the curtain of molten material and carry a small blob of phosphor into contact with the paper of the envelope where it adheres and congeals when the rod is withdrawn back into the hot cascade.

This method is generally very successful but has the one drawback that the phosphor dots on the envelope tend to be raised above the surface of the paper in the shape of a shallow dome. The dot can therefore be scraped by the reading head, causing some material to adhere and thus upsetting the reading of the signals. The reading head must make close contact with the envelope to ensure that it receives light only from one dot at a time with no interference from those adjacent.

This method is very economical and if the drawback mentioned can be overcome it could be successful, though the maintenance of molten wax bath at each printer might cause difficulties.

### Paper-Tape Method

This was the first practical method used for applying phosphor code-marks to envelopes. A proprietary blocking foil (as used for printing the gold lettering on book covers) was used, substituting the phosphor powder for the normal pigment. These foils are expensive to make, because the coating consists of three separate layers, and produce prints of unnecessarily high quality for code-marks. Attempts were made, therefore, to devise a simpler coating mixture which could be applied to the backing at one operation. A mixture similar to that used in the hot-pot method, but incorporating a release agent, was found to be suitable. This tape, like the three-layer tape, could only be used once, but it is cheaper to manufacture. Further experiments in this connexion are still in hand.

## CONCLUSIONS

After eight years of operational use the organic phosphors have proved their value and reliability on postage stamps for the facing and separation of mail into two categories. They have shown also that they can be used for destination coding without interference from the phosphor on the stamp.

Measurements of the phosphorescent emission from stamps of different colours show that the most favourable colours are those lying towards the violet end of the spectrum and the least favourable are the highly-absorptive colours such as brown and black.

A comparison of the 3d. and 1s. violet stamps and the 4d. and 10d. sepia-black show that the depth of the background is very significant and that in the worst cases it is chiefly the signal derived from the white margins of the stamp which is effective. When these are seriously reduced in area by misplacement of the perforation, malfunction of ALF is likely to occur.

From the measurements it is clear that an ideal stamp for ALF would resemble the obsolete 4d. pale blue and that the current 4d. sepia-black is the least effective. An improvement is effected when one bar is placed centrally over the royal image, and a further improvement can be expected now that the colour has been changed to red.

#### ACKNOWLEDGEMENT

Acknowledgement is due to Mr. A. D. Walker of Purchasing and Supplies Department in supplying data for Table 1 and in the preparation of the illustration.

#### References

- <sup>1</sup> PILLING, T. Automatic Letter Sorting—The Luton Experiment. *P.O.E.E.J.*, Vol. 54, p. 31, April 1951.
- <sup>2</sup> PILLING, T., and HORROCKS, P. Coding Desk and Code-Mark Reader for Use with Automatic Letter Sorting Machines. *P.O.E.E.J.* Vol. 54, p. 122, July 1961.
- <sup>3</sup> FORSTER, C. F. Use of Phosphorescent Code Marks in Automatic Letter-Facing and Sorting Machines. *P.O.E.E.J.*, Vol. 54, p. 180, October 1961.
- <sup>4</sup> FORSTER, C. F. British Patent No. 870504 (filed 1958).
- <sup>5</sup> BARNES, A. J. Automatic Letter Facing, *Stamp Collecting*, Vol. 110, p. 453-9 (1968).

---

## Polyvinylchloride (P.V.C.) Rods

E. SULLIVAN†

U.D.C. 621.422: 678.744.534

*For many years ducts have been rodded with cane rods similar to those used by chimney sweeps.  
The advent of improved materials has led to great improvements in design of ordinary and continuous rods which make them easier to use.*

#### INTRODUCTION

During the war, difficulties in the supply of rattan cane used in the manufacture of rods for the rodding of cable ducts gave impetus to the search for substitute materials. The possibility of replacing cane by a plastic material was first investigated in November 1943, but the plastics then available were unsuitable and attention was given to the production of steel rods. After the war, the supply of rattan cane improved and, although cane rods became standard issue again, the development of steel rods continued and a continuous-rod version was introduced in 1948.

Neither type of rod was entirely satisfactory, mainly because they tended to buckle under thrust exceeding 60 lb. This caused the leading end to spiral within the duct and to take an indirect course through existing cables, thus increasing friction which absorbed thrust and reduced the force available at the leading end.

For satisfactory operation, a rod has to meet two conflicting requirements; flexibility to give ease of handling, and rigidity to withstand a longitudinally-applied thrust without undue bending.

Developments in the plastics industry made a major contribution to a solution to this problem, and in 1965 a p.v.c. rod of  $\frac{7}{8}$  in diameter was produced for the Australian Post Office. Their experience was passed on to the British Post Office and a similar rod was put on field trial at the beginning of 1966. This trial was successful and production in quantity began early in the following year.

† Civil and Mechanical Engineering Branch, Telecommunications Development Department

#### SPECIFICATION

The new rods consist of unplasticized p.v.c. tubes 9 ft in length with a modifying agent to improve the impact strength. The outside diameter is  $0.937 \pm 0.005$  in with a wall thickness of 0.125 in. The rods are joined together by brass couplings identical to those fitted to cane rods, thus permitting the continued use of existing attachments. To satisfy the conflicting requirements mentioned in the introduction, it is specified that a plastic rod simply supported at the ends of a span of 5 ft, and subjected to a mid-span load of 6 lb, shall not be deflected more than 3 in at a temperature of 20°C. The hazard of cold shatter has been thoroughly investigated and the mode of failure of the present material under a bending load is by folding, rather than by shatter, at temperatures down to -15°C.

#### CHARACTERISTICS

The new rod is lighter, more flexible, has a lower friction coefficient and a better longitudinal rigidity than earlier rods. It also restores more fully to its original shape after bending. It is less susceptible to abrasive damage and has a long life. The lighter material enables rods longer than those manufactured from cane to be developed; cane rods are restricted to 5 ft lengths by their inherent characteristics. A length of 9 ft has been chosen to facilitate handling and transportation. The increase in length of rods also reduces the weight of a given set, as fewer couplings are needed and, less time is required for coupling.

Because the handling of these rods has been found to be well within the capabilities of two men over the standard



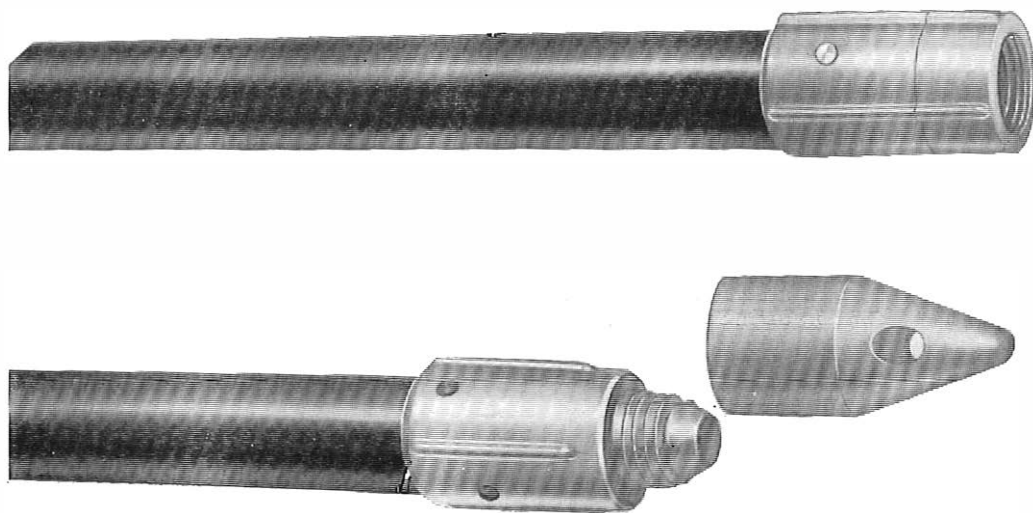

Fig. 1 Experimental Nylon Couplings

cablings distance, they have greatly facilitated the work of two-man rodding parties.

### FURTHER DEVELOPMENTS

#### Continuous p.v.c. Rod

Shortly after the production of the straight sectionalized rod, a continuous p.v.c. rod was developed. This is mounted on a transportable reel similar to that on which the standard, steel continuous rod is fitted.

It is supplied in 600 ft lengths, the leading end being fitted with a threaded nozzle for use with the various adapters required. This rod and reel have been produced to eliminate the need to couple short sections and to give ease in rodding where a vehicle can be suitably positioned.

A further advantage is that, because no couplings are required, the central bore can be used to provide water under pressure to clear obstructions caused by silt, the water being pumped into a connector at the centre of the reel.

#### Nylon Couplings

More recently, straight rods have been fitted experimentally with couplings manufactured from nylon 66 in natural colour (Fig. 1). These are considerably lighter than those of brass and are of simpler design as they depend on thread distortion for their locking facility instead of the spring-loaded catch fitted on the brass couplings. The screw thread used is  $\frac{3}{4}$  in Whitworth, 10 threads per inch, which withstands, when coupled, a pull of approximately 1,500 lb. The nylon couplings are attached to the rod by two  $\frac{3}{16}$  in diameter, brass cross-pins similar to those fitted to cane rods. The male part of the coupling is designed to have a register behind the thread, with a close fit to its counterpart. This gives greater rigidity to the assembly and relieves stress on the thread when the rods are bent whilst being handled. To enable a firm grip to be taken whilst they are being handled, the couplings are provided with four ribs parallel with their axis. Although these experimental couplings show promise, field experience has indicated that further work must be done on them. Pending a successful

outcome to this, brass couplings will continue to be employed on general issue rods.

Suitable rod attachments manufactured from nylon 66 are also in course of development. These will reduce considerably the range of items required. The leader for this type of rod is shown in Fig 1.

A straight rod with nylon couplings, Rods Duct No. 2, 6 ft in length has been produced for use by jointers. This length was chosen to enable the rods to be more easily carried on the vehicle used on this duty.

#### Test Results

In recent tests, 360 yards of standard duct route were successfully rodded by two men using 9 ft lengths of p.v.c. with nylon couplings. Using 5 ft lengths of cane rod, with brass couplings, only 145 yards could be rodded.

The route consisted of earthenware self-aligning duct  $3\frac{3}{8}$  in in diameter, in which was already a polythene sheathed cable of  $1\frac{3}{8}$  in diameter. The maximum thrust required to rod the lengths was 120 lb for p.v.c. and 130 lb for cane respectively.

The weight of 200 yards of the nylon rod (67 lengths) is 124 lb, and that of 200 yards of cane rods (120 lengths) is 180 lb.

#### CONCLUSION

Research into this aspect of external work is being actively pursued. Although the introduction of plastic materials has enabled considerable advances to be made in the rodding field, further work remains to be done. An important requirement on which development is continuing, is a satisfactory coupling for plastic rods and the use of recently-developed plastic materials could lead to the production of a rod having an integral coupling.

Although a power-driven rod of plastic material is expected to be available shortly, there will be a need for sectionalized rods for the foreseeable future.

# Press Notices

## Three Telephone Exchanges a Day PMG Announces New Group on Specifications

By the end of March the Post Office expected to take over telephone exchanges and extensions of exchanges from the manufacturers at the rate of three a day. This was stated by the Postmaster General, the Rt. Hon John Stonehouse, M.P., when he spoke on 4 February at the annual dinner in London of the Telecommunication Engineering and Manufacturing Association.

Last year, said Mr. Stonehouse, just under 300 exchange contracts were completed—rather less than one a day. By the end of last year the figure had risen to two a day for a seven-day week.

As a result, the delays which had been growing steadily for the past two years would start to reduce.

But despite this improvement, the Post Office was still being promised completion dates which slipped seriously at the last minute. This prevented the Post Office giving the public the service they were entitled to and led to criticism of the Post Office and of manufacturers. He would not be satisfied, and he knew that manufacturers would not be satisfied, until all promised dates were achieved.

Referring to the ending next October of the bulk supply agreement, the Postmaster General commented: "The fact that your share of the business will depend upon your success in quoting keen prices, meeting our required delivery dates and providing plant of the highest quality can only increase the efficiency of the industry. This will help you in your other home and overseas markets and, of course, it will enable us to give better service and to grow more rapidly."

Mr. Stonehouse revealed the setting up of an Advisory Group on Telecommunications Systems Definitions—with members invited from the Association "to join us in the work of this Group". This would help the Post Office to draw up specifications and create those definitions which are necessary to ensure compatibility and inter-working between the elements of the telecommunications services.

The Group would from time to time publish the results of its advice so that the world would know about the standards that were being set. The Post Office would be free to seek or receive advice, or have discussions with any supplier, or potential supplier, who might wish to be regarded as an established member of the Group or to make significant contributions to its work.

Within a few years the framework specifications of this Group would be of vital importance to this country and also to our telecommunications exports because the Group would take into account industry's view of its potential export opportunities.

The newly defined specifications would be quite unlike old specifications, which defined everything down to the last nut and bolt, said Mr. Stonehouse. Instead, they would prescribe overall performance requirements of the essential elements of the Post Office telecommunications system and the wider demands of the world telecommunications market, thus creating a new concept in specifications.

The P.M.G. ended by saying: "This, then, is our task, both at home and overseas. It is one we cannot complete unless you as suppliers play your part. This I know you can and will do."

## New Member of Post Office Board

The Postmaster General, the Rt. Hon. John Stonehouse, M.P., has appointed Mr. F. J. M. Laver to be a member of the Post Office Board. Mr. Laver, who is Director of the National Data Processing Service, will serve on the Board in a personal capacity.

Mr. F. J. M. Laver, B.Sc., C.Eng., F.I.E.E., was born in 1915 at Plymouth, Devon. Educated at Plymouth College and Medway Technical College, Gillingham, he later took a London external degree by private study in mathematics and logic. He entered the Post Office Engineering Department as a Probationary Inspector in 1935, and began at the Post Office Research Station, Dollis Hill, as an electronics engineer developing standards of frequency and time; later he worked on coaxial cable systems for speech and television. He moved

to Radio Planning Branch in 1951 to work on international radio questions. He began the engineering appraisal of commercial computer systems in 1956; trained Post Office engineers in programming, and helped to launch the use of computers in the Engineering Department. In 1963 he transferred to the Treasury as Assistant Secretary of the Organization and Methods Division responsible for advising on applications and purchases in all Departments. In 1965 he moved to the Ministry of Technology to set up its Computer Advisory Service and later became the head of the Computer Division of its Engineering Group, and in 1968 was appointed Director of the National Data Processing Service.

He has written numerous technical papers, also some books for young people on electronics and physics; and is the author of a layman's guide: *Introducing Computers*, published by H.M.S.O.

He is a member of the Council of the Institution of Electrical Engineers and of its Electronics Divisional Board.

He is married, and has three children. His spare time is occupied in writing and in reading.

## From Counter to Computer Decimal Point-of-Sale Machine

Business reactions to a low-cost data-capture machine for point-of-sale use in the decimal era are being collected by the GPO's National Data Processing Service (NDPS). No larger than an electric typewriter, the electronic counter machine records transactions on magnetic tape for input into computer systems, simultaneously printing details on bills, vouchers and account books in a form equally readable by man and machine.

The counter machine has been developed by English Numbering Machines Ltd. under contract to the NDPS, to record accounting information in a form that computers can use without further data conversion. It handles a wide range of point-of-sale business including cash payments, credit and rental accounting, and invoicing. Using a simplified keyboard, the counter assistant or stores clerk records details of each transaction on the magnetic-tape tally roll. All subsequent operations, including accounting and stock control, can then be carried out automatically, saving time and reducing costs by eliminating the lengthy process of punching and verifying cards or tape.

With less than two years to the introduction of Britain's decimal currency, the counter machine has been designed for decimal working. The first prototype is now being shown to prospective customers; the machine is expected to be in production in 1971; and it is hoped that it will be available to customers that year.

Pre-programmed for automatic selection of the appropriate process from a wide variety of transactions, the counter machine offers many other refinements. These include two individual check-digit verification systems. And all details keyed into the machine are displayed to the operator on an illuminated panel. Despite this high degree of automation a minimum of operator instruction is needed and accurate and reliable results can be achieved with only a few hours' training. The Post Office is studying the potentialities of machines of this type for its own counters.

## Post Office Overall Profit of £32M

Introducing the White Paper "Post Office Prospects 1969-70", published 13 March, the Rt. Hon. John Stonehouse, Postmaster General, said in London: "This year we have analysed the expected current year's results in some detail and we have also shown the uneconomic and social services the Post Office bears. The two-tier service has, despite a drop in traffic, made a good contribution to postal finances. Whilst continuing to make a success of two-tier, we must now direct attention to the loss-making services, particularly parcels, postal and money orders. I am considering what should be done about improving these particular results.

"In preparation for Corporation status I have this year allocated more overhead expenses to current account. This has the effect of reducing Post Office profitability by nearly £9 million in this year. Our overall profitability is thus reduced from £41 million to £32 million."

The telecommunications services of the Post Office are expected to make a profit in 1968-69 of £39 million (a return

on capital of 7.5 per cent) and in 1969-70 of £71 million (8.8 per cent return on capital).

The White Paper states that the two-tier post has resulted in an excellent and reliable service for 5d. letters—94 per cent are delivered on the day after posting. The proportion of 5d. letters has risen from 25 per cent at the start of the service to 32 per cent, which was the target figure.

The standard of the second-class service has also been improved, and now 94 per cent of 4d. letters are delivered within two days of posting.

The number of letters handled during the first six months of the year 1968-69 was 70 million (1½ per cent) above the general level for the previous year. However, as a result of the introduction of higher charges, traffic for the year is expected to be about 1 per cent below that for 1967-68.

#### *Postal Finances*

In the early part of the financial year 1968-69 the inland letter service produced a loss of £4 million. The introduction of the two-tier service and higher charges changed this situation, and in the latter part of the year a profit of £3½ million was made.

However, as a result of an increase in costs of £4 million above the level forecast by the National Board for Prices and Incomes, the fall in traffic due to the higher charges and the industrial action early in 1969, there is expected to be a loss in the postal services in 1968-69 of £7 million. The loss for 1969-70 is estimated at £5 million.

In 1968-69 inland parcels are expected to bring a loss of £3.5 million, postal and money orders together one of £3 million and National Giro a loss of £2 million. Other postal services expected to show losses are: redirection of mail (£600,000), registration service for parcels (£400,000), the newspaper post concession (£1.1 million), articles for the blind (£700,000). Expenditure on collections and deliveries in rural areas is estimated to exceed revenue by some £15 million a year.

The inland letter service is expected to make a profit this year of £3.5 million, and next year of £5 million, and the overseas services of £1 million.

#### *Telecommunications Finances*

The estimated income for the telecommunications services in the current year is £558 million, with an expenditure of £519 million. Estimated comparable figures for 1969-70 are £639 million and £568 million.

Capital investment for 1968-69 is estimated at £334 million and for 1969-70 at £357.7 million.

The number of inland trunk telephone calls forecast for 1968-69 is 1,177 million, a growth rate of 11.5 per cent, and for 1969-70 1,342 million, a growth rate of 14 per cent. The comparable figures for inland local calls are 6,870 million (7 per cent) and 7,420 million (8 per cent). The growth rate of inland telex calls in 1968-69 is estimated at 11 per cent (19 per cent for 1969-70), for international telex 22 per cent (26 per cent), for telephone calls to the Continent 15 per cent (15 per cent) and for intercontinental calls 25 per cent (25 per cent).

The improvement in the telephone service in 1967-68 was continued in 1968-69. Plant shortages still cause congestion, but more equipment will be available in the coming year which should reduce overloading and improve service.

It is planned to increase the trunk network in the coming year by about 12,000 circuits, representing a growth of 16 per cent. New exchanges or extensions to existing ones will be opened at the rate of almost three a day in 1969-70. Some 380 new telephone exchange buildings, including extensions, will be started, and about 750,000 lines added to the network which connects subscribers' premises with telephone exchanges.

It is expected that orders will be met during 1969-70 for about 1,350,000 connexions to the telephone system; 900,000 of these will be new connexions. The number of connexions at 1 April 1969 is estimated to be 7,690,000, and at 31 March 1970, 8,220,000.

At 31 December 1968 the waiting list was 101,000. This compares with 118,000 at the beginning of January 1968, and a peak on 1 April 1968 of 138,000. Further reductions in the waiting list are expected in 1969-70.

During the year the Post Office will convert to the dial system 70 of the 140 manual exchanges still in service at March 1969. By March 1970, 99 per cent of customers will have local dialling service, and 86 per cent will be able to dial their own trunk calls.

International subscriber dialling, already available to seven European countries, will, it is hoped, be extended in 1969-70 for London customers to parts of Canada and the United States, including New York.

During summer this year the first Indian Ocean satellite will be launched, and, working through the Post Office earth station at Goonhilly, there will be telephone, telegraph and television links with Australia, India, Japan, Malaysia and the Persian Gulf.

Within the next two years half the telephone traffic between Britain and countries outside Europe will be relayed by satellite. Some telecommunications services are running at a loss. The current loss on telephone kiosks, taken as a whole, is £2.8 million a year. In particular, many rural telephone boxes cannot be made profitable. The loss on inland telegrams is £2.6 million a year. A public duty willingly assumed by the Post Office is the free 999 emergency service, on which the loss is £500,000 a year.

#### *Postal Services*

Despite severe competition by nationalized and private carriers, the speed and reliability of the parcel post has enabled the Post Office to maintain its share of the market. Mainly as a result of the industrial action in January, a fall of 3 per cent in traffic is expected in 1968-69, but recovery of this is anticipated in 1969-70.

During the coming year five major mechanized sorting offices will be brought into service at Croydon, Huddersfield, Manchester Sorting Office, Sheffield and the London Overseas Mail Office.

At Croydon, Newport (Mon.), Southampton and London East Central District Office, machines will be installed for code marking and automatic sorting of letters.

During the year postal codes will be allocated to more London districts and 27 more major provincial towns. This will bring the number of addresses coded to over 10 million—well over half the number of addresses in Britain.

#### *National Giro*

By March 1969 the number of business and personal Giro accounts opened was 100,000. Account holders can already pay about 60 per cent of major household bills through Giro.

Over the next few months the volume of business transacted through Giro should increase substantially as more people use this cheap and easy method of money transfer to pay bills. It is expected that Giro will be increasingly used to replace postal and money orders.

#### *National Data Processing Service*

The National Data Processing Service has a London headquarters and six computer centres—three in London, and one each in Derby, Edinburgh and Portsmouth. Two more centres, in Leeds and London, will be opened in 1969-70. The computers at the new centres will be mainly used by the Post Office, but there will be some capacity available for commercial work.

The NDPS has been set as a financial target a net return of 8 per cent on net assets averaged for the period 1968-69 to 1971-72.

The profit in 1968-69 and in 1969-70 is estimated to be £100,000.

#### *Waiting List Down Again*

Britain's telephone waiting list at the end of March stood at just over 87,000—a reduction of 50,000 in a year.

This is the biggest drop since 1957-58, when it went down by 67,000 from 157,000. The year before that the waiting list was 228,000.

The number of new telephone exchange connexions supplied during the year ended 31 March was a record 821,000.

## More Telephones

Orders for telephone service met by the Post Office in the six months to 31 March totalled 663,108—37,251 more than in the same period a year earlier. Most uncomplicated orders now go through under the Appointments Plan. Over three-quarters of these are being completed, in accordance with customers' wishes, within a fortnight, and about half within a week.

## Time Calls Up

Calls to the Speaking Clock telephone service totalled 233·9 million in the year ended 31 March—an increase of 4·8 per cent on the previous year. Sixty-seven million calls were in the London area.

## February 'Phone Calls up 14½ Per Cent

Britain's telephone users made 739 million trunk and local calls during February—an increase of 14·5 per cent on February 1968.

## Helping the Hard of Hearing

An Australian development, adapted by the GPO, could make it easier for the hard of hearing to know when a telephone is ringing.

The device is a sweep tone caller. It can be used with an ordinary telephone, replacing the normal ring with a wail which rises and falls through a range of both high and low notes.

This enables a person who has difficulty in hearing the tone at one frequency to hear it at another pitch.

The Royal National Institute for the Deaf (RNID) are currently carrying out practical trials on this and three other calling devices at their Gower Street headquarters in London and will report their findings to the Post Office.

The other devices, which are already generally available, are the tone caller in the Trimphone, an electronic buzzer and a loud bell with four-inch gongs.

Hard-of-hearing visitors to the RNID are asked to indicate which of these four calling signals they can hear most readily. When full results of the tests are known the Post Office will decide whether or not to market the sweep tone caller.

A great deal of Post Office apparatus is designed to help the handicapped. This includes an amplifying telephone handset for the hard of hearing, a marked dial for the blind, a faint-speech amplifier for people with partial loss of voice and a sensitive button device enabling the disabled to contact the operator for assistance in making a call. The sweep tone caller was developed by the Australian Post Office.

## Commonwealth Telecommunications Board to End

The last formal meeting of the Commonwealth Telecommunications Board took place in London on 27 March. The Board has now ceased to function and its role as the forum for Commonwealth co-operation in telecommunications is assumed by the Commonwealth Telecommunications Council assisted by the Commonwealth Telecommunications Bureau, its permanent organ. The Council will be concerned with the co-ordination of the international telecommunications facilities serving the needs of 655 million people in 23 countries.

The Board was established in 1949 and Britain has been its permanent home. Its main concern has been with the implementation of the agreements reached in 1948 between the great majority of Commonwealth Governments for the mutual exploitation on a common user basis of the network of telegraph cables and radio facilities which link these countries together and to non-Commonwealth countries. Its work has ensured the most efficient use of the network and continuing benefits to users through charges for services substantially lower than those paid in other countries. The Post Office has always been the largest user of the system and has paid a share of the total costs proportionate to its use.

But the advent of more modern communication facilities, such as intercontinental submarine telephone cables and satellites has necessitated the reorganization of the arrangements for Commonwealth co-operation to cover the whole

field of telecommunications. Following a Conference in London in 1966 a Commonwealth Telecommunications Council was formed and first met in London on 17 April 1967. The Council comprises senior officials of the External Telecommunications Administrations of the Partner Governments; it meets at least once a year in different Commonwealth countries. While it will take over the work of the Board in administering the facilities covered by the 1948 agreements, it has a prime objective of devising and recommending to Governments, a unified system of accounting which would embrace all services carried by all media used in Commonwealth telecommunications.

The Council's fourth meeting was held in Marlborough House on 14-25 April and representatives of 20 member countries attended.

The British member of the Board, Mr. C. J. Gill, Director of External Telecommunications in the Post Office, is currently Chairman of the Council.

## Post Office Economic Development Council Advisory Group on Data Transmission

The Economic Development Committee for the Post Office has established an Advisory Group on Data Transmission (membership attached). Its terms of reference are:

"To review

- 1 developments in data transmission,
- 2 the implications for Post Office investment of such developments and thence, through the Economic Development Committee for the Post Office, to assist Post Office management in its task of optimizing Post Office investment programs."

The Advisory Group has been set up to help the Post Office assess the implications of the very rapidly growing demands for services to transmit data to and between computers. Post Office investment in data transmission represents a growing proportion of the total investment in the telecommunications system of the country.

Users (computer bureaux, scientific users, large firms, etc.) and the communication and computer industries will not be directly represented on the Group, but will be invited to give evidence to it. In this way the Group will have access to the widest possible spread of information. The Group will also maintain close liaison with the Electronics EDC.

### Members of the Advisory Group

#### Chairman

Professor A. W. McIntosh Professor of Marketing at the London Graduate School of Business Studies

#### Members

Mr. H. Barker	Director of Network Planning, Post Office
Lord Bowden of Chesterfield	Principal, University of Manchester Institute of Science and Technology
Lord Delacourt-Smith	General Secretary, Post Office Engineering Union
Lord Jackson of Burnley	Pro-rector, Imperial College of Science and Technology
Mr. F. Rock Carling	Head of Computer Division, Ministry of Technology
Mr. J. R. S. Homan	Assistant Industrial Director, National Economic Development Office

(Professor McIntosh, Mr. Barker and Lord Delacourt-Smith are members of the EDC.)

The Chairman of the EDC is Sir Andrew Crichton, Managing Director of P. & O. and Chairman of Overseas Containers Ltd., and its members comprise senior representatives of Post Office Management and trade unions, four independents and a representative of the National Economic Development Office.

In addition to its concern with the place of posts and telecommunications in the growth of the economy, the Post Office EDC is currently preparing to report on telecommunications productivity in Britain, the Netherlands and

Sweden, and on management development in the Post Office under corporation status (the Post Office becomes a public corporation in October).

### Cheaper Telephones

New telephones of the 700 series (known as the Modern Telephone) became cheaper from 18 April with the withdrawal of the £1 single-payment charge for instruments of this type. Abolition of the charge was announced in the House of Commons on that day by the Postmaster General, the Rt. Hon. John Stonehouse, M.P.

First introduced 10 years ago, the 700-series telephone now becomes the standard instrument for all normal new installations.

Trimphone, as part of the 700 series, will also cost £1 less to install but the extra 7s. 6d. a quarter rent for this de luxe instrument will still apply.

Older, pre-700 series telephones will now be installed only to replace instruments of the same type which have to be changed for maintenance reasons.

Subscribers who have pre-700 series instruments and wish to change them for the 700 type should consult the local Telephone Manager's office. The fee for a changeover will be the normal 30s. change-of-instrument charge.

### Britain in Forefront with Electronic Exchanges, says P.M.G.

By the end of this year, the Post Office expects to bring three new electronic telephone exchanges per week into service in various parts of the country, the Postmaster General, the Rt. Hon. John Stonehouse, M.P., said on 21 April. The P.M.G. was opening the International Conference on Switching Techniques for Telecommunications Networks at the Institution of Electrical Engineers.

Britain has a leading role in the advancement of electronic switching technology, he said.

Since the world's first production reed-electronic system had been installed at Ambergate, Derbyshire, in December 1966, ten more such exchanges have been brought into service. Many more are in advanced stages of installation.

Orders for these systems—called TXE2—are now being placed with British manufacturers at a rate of about £6 millions per annum.

The system is proving to be extremely reliable in operation, with very low running costs and a good return on capital, he continued. It not only provides all the basic customer and service facilities but opens up possibilities of a range of new customer services and equipment. Push-button telephones are one new development which will become possible as electronic systems spread.

Manufactured to Post Office specifications by Plessey (ET), GEC-AEI and S.T. & C., the TXE2 system is suitable, he said, for all local terminal and local tandem exchange applications, as well as for minor group switching centres. Although the basic single unit is designed to cater for up to 2,000 lines, growing smoothly from 200 lines upwards, two or more units can be coupled together to increase capacity.

TXE2, P.M.G. concluded, may justly be regarded as an electronic system advanced both in concept and technology. Firmly based on the know-how and resources of the British Post Office and British industry, it represents a foundation of technological experience upon which can be built a telephone system unsurpassed in the world.

### P.O. Wins Safety Trophy

For its work on accident prevention, the Post Office has won the Sir George Earle Trophy for 1969. The trophy is awarded annually by the Royal Society for the Prevention of Accidents. It was the first time the Post Office had entered for it.

The society's citation says the award was made in recognition of the Post Office's "outstanding achievement in establishing a fully co-ordinated accident prevention organisation embracing over 400,000 employees in diverse occupations working principally in relatively small groups and extending to the individual linesman and postman, which, in a period

of five years, has resulted in a reduction in accidents in this important public service."

Lord Beeching, RoSPA president, presented the trophy at the society's annual national industrial safety conference in Scarborough on Wednesday, 7 May.

The foundation-laying work which was the main basis of the Post Office's entry was carried out under the direction of its Chief Safety Officer, Mr. G. A. L. Everitt. The full co-operation of the Post Office Staff Associations has played an important part in the results achieved so far, as has also the growing attention which is being given to safety by all levels of Post Office management.

Post Office workers are involved in some 35,000 accidents a year resulting in injury. The most common are those that occur in handling objects, falls and stepping on or bumping against things. The dramatic, serious or fatal accident is rare, and there is not the obvious incentive to act safely which comes from major and well-known hazards faced in industries such as chemical engineering and mining. This makes it harder to persuade the individual worker to think safety and to realize that his safety is largely within his own control.

Since 1964, the Post Office has followed a phased plan of action on safety, beginning with the establishment of a small safety staff at national headquarters and the setting up of staff safety committees throughout the country. As a result, the Post Office has achieved for the first time a progressive reduction in the accident rate. In the three years to September 1968, the number of accidents resulting in lost time was reduced from 1.18 to 1.13 per 100,000 manhours worked. The money spent on safety has been more than offset by the saving in accident costs.

### "QE2" Communications

*"Only the Postman Missing"*

As the world's most luxurious ocean liner begins to earn her living, the Post Office, too, hopes to receive some reward from *QE2*, through her communications facilities, for the considerable effort which it has put into making those facilities the most sophisticated ever provided on board ship. Months of testing and development work have ensured a satisfactory communications channel for the direct printing of a daily newspaper on board. Problems of interference on radio channels caused by the ship's diverse electrical apparatus and problems created by new features in the liner's radio installation have been largely overcome. Post Office expertise was provided by operating and engineering personnel loaned to help staff and maintain radio circuits during the difficult first acceptance trial.

Passengers on this maiden voyage will know nothing of these things, however, and will be able to enjoy, through Post Office ship-shore services, almost every means of long-distance communication available ashore—only the postman will be missing. Never before has a ship and its passengers been in such intimate touch with friends and associates ashore.

The newspaper, which is being made available daily to the ship, containing the latest national and international news, and transmitted to the ship over Post Office circuits each night, will be delivered to passengers earlier than similar newspapers are delivered to many homes ashore. Thanks to Lincompex, a Post Office development which almost eliminates the effects of radio interference and makes maximum use of transmitter power, really high-quality radiotelephone circuits will be available with telephone subscribers on both sides of the Atlantic. The effect this improvement is likely to have on the use of radiotelephone facilities on board was shown during acceptance trials when the number of paid minutes handled with *QE2* by Post Office services exceeded 800 on each of two days, surpassing all previous records. For the businessman who requires speedy two-way communication with a written record, the ship will have access to all telex subscribers in the United Kingdom through the newly-opened ship-shore radioteleprinter service. This facility also proved its worth during *QE2*'s first acceptance trial when it was used to clear up to 20,000 words of press material a day with little delay—a feat that could never have been achieved using ordinary morse circuits. Radio-phototelegraph and facsimile transmission facilities are also available as well as all the normal safety and radiotelegraph services.

# Notes and Comments

## **W. A. Humphries, T.D., C.Eng., M.I.E.E.**

Mr. W. A. Humphries, who started his career in the Post Office as a youth in training, succeeds Mr. C. E. Calveley as Director of Development.



During his career Bill Humphries has accumulated a wide experience and expertise in the development, planning and provision of telephone exchanges. He became Staff Engineer of the old Equipment Branch in 1963 when the great increase in demand for telephone services was becoming apparent. This was a formidable challenge but his success can be judged by the fourfold increase in supplies of exchange equipment to the P.O. since then.

He became Assistant Engineer-in-Chief in 1966. His responsibilities for a while covered a wide range: external construction, local lines, motor transport, inspection and postal engineering but he subsequently returned to telephone exchange systems and apparatus development, provision and maintenance.

When the Control Division of the Purchasing and Supply Department was created in 1968 Bill Humphries, as Deputy Director of Engineering, became its first head. Once again the problems facing him were formidable: the ending of the Bulk Supply Agreement, the changing structure of Industry and the still accelerating demand for telephone services. The results of his efforts are already becoming apparent.

Mr. Humphries was Managing Editor of this Journal for several years and one of his greatest achievements was the Special Issue celebrating the Jubilee of the IPOEE—one of the most fascinating publications on telecommunications that has ever appeared.

Bill Humphries' many friends in the Post Office and Industry will be delighted by his new appointment. The combination of his strength of character and wide knowledge of communications will ensure that it is successful.

D.W.

## **J. K. S. Jowett, B.Sc.(Eng.), C.Eng., F.I.E.E.**

Mr. J. K. S. Jowett's promotion to Deputy Director of Engineering will give great pleasure to everyone who knows him. The post that he now fills in the Telecommunications Development Department puts him in charge of the technical development of satellite communications, a fascinating and rapidly expanding branch of telecommunications. He brings to the job qualifications, experience and personal characteristics that are admirably suited to it.

Mr. Jowett is a professional engineer in the best tradition. He has published a considerable number of papers and articles, mostly on radio-wave propagation, and more recently

on satellite communications. Although one suspects that his first inclinations might have been towards an academic career, he has most effectively adapted himself to more down-to-earth matters of business and action with technological



overtones which have been a large part of his life in recent years. His obvious competence, integrity and friendliness gain him the respect and affection of his associates wherever he may be.

He is no stranger to international conferences, having been a senior member of U.K. delegations to many Plenary Assemblies and International Study Group meetings of the CCIR, and Administrative Radio Conferences of the ITU, concerned with broadcasting and space. During the last few years he has regularly led the delegation that represents the United Kingdom and the Republic of Ireland at the bi-monthly meetings of the Intelsat Technical Sub-Committee in Washington. Thus he has become a commuter on the Transatlantic Ferry and an internationally recognized authority on satellite communications.

H.S.

## **E. Davis, C.Eng., M.I.E.E.**



News of the promotion and appointment of Mr. E. Davis as DDE, Control Division, Purchasing and Supply Department, to succeed Mr. W. A. Humphries, TD, was received by his many friends in LTR with a mixture of pleasure and regret. Pleasure that the worth to the Post Office of a comparatively

young man continued to be recognized and rewarded; regret at the loss of an agreeable colleague whose contribution to the affairs of the LTR has been both valuable and decisive.

A description of Mr. Davis' career appeared in the April 1968 issue of this Journal and it is unnecessary to repeat it here. Everybody who knows Eric will wish him well in his new sphere of activity. That he will bring a positive contribution to his new job and achieve his objectives are foregone conclusions about which there is no room for doubt.

E.W.W.

#### Notes for Authors

Authors are reminded that some notes are available to help them prepare the manuscripts of the Journal articles in a way that will assist in securing uniformity of presentation, simplify the work of the Journal's printer and draughtsmen, and help ensure that authors' wishes are easily interpreted. Any author preparing an article for the Journal who is not already in possession of the notes is asked to write to the Managing Editor to obtain a copy.

It is emphasized that all contributions to the Journal, including those for Regional Notes and Associate Section Notes, must be typed, with double spacing between lines, on one side only of each sheet of paper.

Each circuit diagram or sketch should be drawn on a separate sheet of paper; neat sketches are all that are required. Photographs should be clear and sharply focused. Prints should preferably be glossy and should be unmounted, any

notes or captions being written on a separate sheet of paper. Negatives or plates are not needed and should not be supplied.

#### Syllabuses and Copies of Question Papers for the Telecommunication Technicians' Course

The syllabuses and copies of question papers set for examinations of the Telecommunication Technicians' Course of the City and Guilds of London Institute are not sold by *The Post Office Electrical Engineers' Journal*. They should be purchased from the Department of Technology, City and Guilds of London Institute, 76 Portland Place, London, W.1.

#### Publication of Correspondence

The Board of Editors would like to publish correspondence on engineering or technical aspects of articles published in the *Journal*.

Letters of sufficient interest will be published under "Notes and Comments". The first appearance will be in the October 1969 issue. However, correspondents should note that, as it is necessary to send copy to the printer well before publication date, it will only be possible to consider letters for publication in the October issue if they are received before 15 August 1969.

Letters intended for publication should be sent to the Managing Editor, Room 563, Procter House, London, W.C.2. and must show the correspondent's name and address.

---

## Institution of Post Office Electrical Engineers

#### Institution Field Medal Awards, 1967-68 Session

In addition to the Institution Senior and Junior silver and bronze medals, the Field Medals are awarded annually for the best papers read at meetings of the Institution on field subjects primarily of Regional interest.

Field Medals were awarded to the following authors for papers read during the 1967-68 session:

- R. C. Morris, Colchester. "The Recruitment, Training and Education of Engineering Technician Apprentices."
- A. Scott, Glasgow. "Steps Towards Exchange Maintenance by Direction."
- J. R. Tipple and L. F. Williams, Birmingham. "Birmingham Radio Tower-Planning, Construction and Commissioning."

#### Result of Essay Competition, 1968-69

A prize of £6 6s. and an Institution Certificate have been awarded to the following competitor:

- D. E. G. Coles (Technical Officer), Birmingham. "The Valuable Effect of Work Study upon the Provision of Urgent Private Wires."

Prizes of £3 3s. each and Institution Certificates have been awarded to the following four competitors:

- J. Methuen (Technical Officer), Salford. "Circuit Chasing in Theory and Practice."

F. Eastham (Technical Officer), Blackburn. "A Jointer and his Mate."

G. S. Booth (Instructor), Stone. "Visual Aids to Training."

J. F. Crake (Technical Officer), Blackburn. "The Underground Duct Network."

Institution Certificates of Merit have been awarded to the following five competitors:

D. Watkins (Technical Officer), Middlesbrough. "A Simple Introduction to Gas Pressure and its Measurement."

D. C. Ferguson (Technical Officer), Oldmeldrum. "Plastics in Overhead Plant."

J. Morrison (Technical Officer), Dundee. "The Small Automatic Exchange."

J. A. Reeves (Instructor), Stone. "The Start of a P.B.X. Era."

J. D. Knight (Trainee Technician), Mt. Pleasant. "A Deeper look into Stores."

The Council of the Institution records its appreciation to Messrs. T. J. Morgan, T. Nicholson and R. Holden, who kindly undertook to adjudicate upon the essays entered for the competition.

*N.B.—Particulars of the next competition, entry for which closes on 15 January 1970, will be published later.*

A. B. WHERRY,  
General Secretary.

# Associate Section Notes

## Dundee Centre

At the annual general meeting, held on 8 April 1969, the following appointments were made *Chairman*: Mr. R. L. Topping; *Vice Chairman*: Mr. R. C. Smith; *Secretary*: Mr. R. T. Lumsden; *Treasurer*: Mr. D. L. Miller; *Committee*: Messrs. W. Bell, W. Hennesey, J. McNeill, I. M. F. Smith, G. Stephen, M. Williamson and W. Wilson.

The Chairman and Secretary reported, not without criticism, on the attendance at the meetings during the 1968/69 session. Lectures were excellent and varied and worthy of praise.

Mr. E. A. W. Page, our Liaison Officer, was present and reported on his visit to the Liaison Officers' Conference at Stone. Mr. Page commented on the high standard of the meetings and asked that all members try to encourage the younger members to attend.

Suggestions for next year's program were offered and we should have another interesting season ahead.

R. T. L.

## Aberdeen Centre

Forty-six members and guests attended a talk on "P.C.M. Developments" given by Mr. A. Sandison. This interesting talk was very well received mainly because of the interest aroused by the P.C.M. systems being installed in the Area. At the end of his talk Mr. Sandison answered numerous questions on the subject.

On the 12 March Mr. J. Davidson, one of our own members, gave a talk on "Field Hygiene and Sanitation as Applied to Civil Defence". This talk was humorously and interestingly delivered and all present enjoyed the evening very much.

R. M.

## Ayr Centre

The 1968-69 session opened in October with a visit to the Monsanto plant at Dundonald. This U.S. based firm receives its raw material, nylon salt, from associated factories and, after the various forming and spinning processes, the finished product is nylon yarn, which is produced in great quantity by means of a continuous process.

The November meeting was a talk entitled "Pulse Code Modulation" by Mr. A. Sandison, T.H.Q. Edinburgh. The attendance of 31 was above average and there were many questions both from external and internal members.

In January, a visit was made to Scottish Aviation Ltd, Prestwick. Engine and airframe overhauls were in progress in various departments and representative aircraft were on view.

A talk on architecture was given in February by Mr. F. W. Dunbar with slides showing architectural progress from ancient to modern times.

Our meeting in March was a talk entitled "People and Places" by Mr. F. J. de Courcy, Deputy T.M. Scotland West. With the aid of an excellent collection of slides our speaker gave a running commentary on various holidays abroad as well as nearer home and a very enjoyable and interesting evening resulted.

A. B.

## Inverness Associate Centre

As was expected, our March meeting was the most successful one during the current session. The speaker was Mr. W. Sheldon, S.E.E., T.H.Q. Scotland, and his subject was "Transit Switching." Mr. Sheldon is well known to many of our members and proved to be a most informative and entertaining speaker.

The installation of a transit switching centre in Inverness is due to start sometime in the near future and it was obvious that this factor of local interest and Mr. Sheldon's reputation as a lecturer had drawn the crowd. The audience numbered 49 and 9 further members listened at the outstations.

Our annual general meeting was held in the Tower Hotel on Thursday, 10 April 1969 at 7 p.m. A debate followed the

A.G.M. Four press-ganged speakers gave their views on "Means of Increasing Productivity." Subject and speakers were:

- (1) By organization: Mr. J. I. Murray, Executive Engineer (Maintenance)
- (2) By persuasion: Mr. J. C. Glennie, Assistant Executive Engineer (Internal Construction)
- (3) By attitudes: Mr. W. A. Allan, Technical Officer (Automatic Equipment Clerk of Works)
- (4) By incentives: Mr. I. Stewart, Technical Officer (Repeater Station Maintenance)

We had a lively debate and an entertaining evening to close what has been a successful session with ever-increasing participation of our younger members.

W. A. A.

## Edinburgh Centre

On Wednesday, 5 March our guest speaker was Squadron Leader H. McMaster, A.F.C., A.F.M., R.A.F. who is a member of the R.A.F. Aerospace Briefing Team.

The talk, entitled "Project Apollo," was a tremendous success. Squadron Leader McMaster showed film and slides of the Gemini and Apollo Space flights as well as of the assembly of a Saturn Rocket and its transport from the vehicle assembly building to the launching pad.

The various manoeuvres concerned with the Apollo 11 space flight and the manned landing on the moon was also shown. The Lunar Excursion Module was shown undergoing its tasks concerned with detaching from the command module, landing on the moon, take-off and rendezvous with the orbiting command module.

The talk ended with a discussion on the Apollo Nine Mission, which was in progress at the time of the lecture.

G. A. K. R.

## Bedford Centre

Membership in this Centre seems to remain steady around 180 with the usual small fluctuations due to promotions and new members.

During the 1968/69 winter session our lecturers have covered some very interesting and fashionable subjects. One of them, "Basic Principles of Electronic Exchanges," was a follow-up lecture to the one last session on the general policies and applications concerning the use of this type of exchange. In March the subject was "Basic Principles of Computers."

A lecture on the "Design and Manufacture of Transistors" was followed up by a visit to Texas Instruments of Bedford, where transistors and integrated circuits are produced.

A lecture on "Aeronautical Research" was given by a scientist from the R.A.E. Bedford and, subsequently, a group of our members visited Thurlough and toured the main workshop, where scale models of aircraft, including "Concorde" are made for testing in the wind tunnels. We also saw the high speed supersonic wind tunnel, where speeds of up to mach 2.2 are simulated, and visited the hangar which contains several experimental aircraft.

The remaining lectures for this session were "Principles of Pulse Code Modulation" on 15 April and "Lasers" on 28 May to which the lecturer brought and demonstrated a helium-neon laser.

E. W. H. P.

## Barnstaple Centre

The winter program of this Centre consisted of the following:

- 21 January, "Lundy, Isle of Granite." A talk and film show by Mr. John Dyke, Artist.
- 11 February, "Water Power." A talk and film show on water power past and present by Mr. B. Hughes, Lecturer from Bideford.
- 18 March, "Project '68." A talk by Mr. K. J. Trussler and



Mr. N. Tolcher on the provision of a closed circuit television network to Plymouth schools.

All these papers were well received but attendances were small. Would members try to attend as many meetings as possible and help to make them a success.

F. D. C.

### Gloucester Centre

The winter program commenced with the December meeting held at Cheltenham, when a talk given by Barrie Edgar (Senior Television Producer—B.B.C. Midland Region) was well attended. His subject was "Focus on Vision" and covered the aspects of producing television outside broadcasts, explaining the difficulties and humorous incidents he had experienced producing such programs such as "Songs of Praise" and "The Cheltenham Gold Cup."

In February, one of our Assistant Executive Engineers, Mr. G. J. Franklin, talked to our members at Gloucester on the principles of line transmission. This was a most interesting and informative lecture, well prepared and including numerous film slides dealing with the audio, coaxial and carrier equipment used in line transmission.

The combined meeting with the Swindon Associate Section was held at Cirencester in March. The subject was "P.C.M.—Past, Present and Future" and the paper was presented by Messrs. J. H. Bowen and R. C. Harvey, both members of the Gloucester Associate Section. This meeting was extremely popular, the attendance exceeding one hundred.

Our final meeting of this session was held in Gloucester during April and incorporated the annual general meeting and a talk on "Ciné Photography" by Mr. G. H. Adams also one of our own members. Mr. Adams covered the history of ciné photography and explained the advent of Super 8 and Single 8 with its advantages and disadvantages. He then gave advice on the size of films and equipment available to the amateur photographer. Finally he presented three amateur ciné films, including a recent prize-winning entry.

Our summer season of visits commenced in June with a tour of the B.O.A.C. headquarters at London Airport. Future visits will be to Harveys at Bristol for a wine tasting, the new signal box at Gloucester, and the B.B.C. studios at Shepherds Bush and Bristol.

P. G. W.

### Exeter Centre

The attendance at the Centre's January and February meetings continued to be good, with the almost annual presentation by Mr. G. F. Cload drawing a considerable audience. His talk this year was entitled "British Castles" and covered castles which were built during and after the Norman Conquest, the reason for their erection, the siting and the acquisition of labour and materials. It made a very enjoyable evening. Mr. J. J. Anning thanked the speaker on behalf of the Centre.

The February meeting consisted of a paper entitled "Steps Towards Exchange Maintenance by Direction" given by Mr. A. Scott, Executive Engineer, Glasgow Telephone Area. Mr. Scott explained the action taken in his area to arrest a general tendency towards a degrading of the service given by the automatic switching equipment. An interesting discussion followed the talk, which was closed by Mr. R. Fry who thanked the speaker.

Probably the most enjoyable of all evenings for many years was arranged in March when three members of the Centre presented the following papers: "Talking Books for Blind," by G. S. Steer, Esq., "The Work of the Volunteer St. John Ambulance Driver," by F. J. Brown, Esq., "Model Engineering," by N. H. B. West, Esq.

There was a definite atmosphere of pride created at this meeting, the speakers can be proud of their presentations for it was felt that the papers were given in a professional manner. Attendance at centre meetings, in general, continues to be good but the Officers and Committee feel particularly disappointed by the comparatively poor response to this event, which after all, was a very special one. It is hoped, that should we be fortunate enough to be able to arrange a similar event in the future, the membership will make an extra effort to repair the damage done. The speakers are nevertheless to be warmly congratulated for the preparation and presentation

of their papers. Perhaps they will gain satisfaction from their achievements in spite of the poor support.

At this last meeting we were also to have heard a paper by Mr. R. E. Allen entitled "The Growth of the Scout Movement." Mr. Allen has been a long standing volunteer over the years and had to bring his paper up to date in readiness for presentation, it was unfortunate that he was unavoidably indisposed at the last minute. The work he did is also appreciated by the Officers and Committee.

T. F. K.

### Plymouth Centre

We have enjoyed another successful winter session. This started with the annual general meeting in October at which the following officers and committee were elected: *Chairman*: P. J. Mason; *Secretary*: J. B. Lafford; *Treasurer*: G. Manley; *Committee*: N. Jeffery, S. Newcombe, V. Martin, C. F. Hardisty, S. A. Currins, S. Butcher and B. Penwill.

The November meeting was a paper entitled, "Project '68—The Provision of Closed Circuit Television for Plymouth Schools," read by K. J. Trussler and N. J. Tolcher. This meeting was extremely gratifying as it was presented for the first time by one of our own members.

In December, a lecture was given entitled "Petrol Injection and its Application to Everyday Motoring" given by Mr. E. R. Parker, a member of the staff of Petrol Inject Ltd., a subsidiary of Tecalemit Ltd. one of the pioneers in this form of engineering. These were followed by visits in January and February to the local Meteorological Office and H.M.S. Eagle, the largest aircraft carrier in service with the Royal Navy.

In February Mr. Long from THQ presented his paper "The TXE2 Electronic Switching System," which proved of great interest to our members as several of these exchanges are due to be commissioned in our Area. Interest continues to grow in our centre and it is hoped this will be maintained.

J. B. L.

### Southampton Centre

The 150 members of our section continue to support our monthly functions which have had a bias toward visits this year. A start was made with an informal talk on "Trunking and Grading" given by Mr. E. W. Ingram of Southampton Area. This was followed by the lecture "TXE2," given by Mr. R. C. Gorrings, in the absence of Mr. Long. This was very interesting, despite local electrical hazards.

Two Saturday morning visits found members at Plessey at Titchfield and the C.E.G.B. Generating Station which is now being built at Fawley. Plessey's Abbey Works construct wire-wound parts for relays, inductances and television components. During a pre-tour lecture, it was explained that the C.E.G.B. Generating Station is built on the Solent mud flats because the fuel supply from Esso Refinery is near, the land was inexpensive and water transport and water for cooling is at hand. High-voltage switching and transmission techniques are a unique feature of this station.

The British Aircraft Corporation at Hurn, Christchurch made us very welcome for a full view of the production line of a B.A. C. 1-11 during an evening in March.

R. G.

### Canterbury Centre

After a long absence from these pages the Canterbury Centre returns with a few words about its activities in the past few months.

On the 5 September 1968 we held our annual general meeting shortly after the much regretted death of the President, Mr. P. D. Gilbey, Telephone Manager of the Canterbury Area. This meeting saw the election of some new faces on to the Committee; which stands as follows: *Chairman*: Mr. P. L. Johnson; *Vice Chairman*: Mr. F. Muston; *Hon. Secretary*: Mr. R. A. Hedger; *Treasurer*: Mr. B. Fletcher; *Librarian*: Mr. B. Clapson; *Committee*: Messrs. E. Ralph, D. Greenhead, R. Elphick, P. Waller, M. Weller, J. Crundwell, W. Gretton and R. Pantrey.

In the week following the annual general meeting, thirty members visited the Kent County Police H.Q. at Maidstone, touring the Traffic Control and Operations Room.

October saw a visit to the Post Office Tower which included

a film show, the television switching centre, trunk test room and a trip to the observation galleries.

Towards the end of January we were visited by Mr. Mather of ● and M. Branch who gave a talk on "Work Study as an aid to Management," an enlightening talk but poorly attended.

Twenty members visited the Royal Observatory, Sussex, on 4 February 1969. A most interesting trip, thoroughly appreciated by those attending.

Later in the month the Centre embarked on a new venture, in inviting the membership to bring along wives and friends to a travel talk and filmshow given by Mr. Bielby, Manager of Pickfords Travel Agency, Canterbury. The ladies present expressed their thanks at being included on this occasion. The meeting would have been better attended but for bad weather.

R. A. H.

### Stoke-on-Trent Centre

In 1968-69 the formal meetings of the centre were "The Area Board," "Radio Stoke," "Life Aboard Cables," a quiz (Stoke versus Stoke), and "The Radiophonic Workshop of the B.B.C."

Attendances at these meetings ranged from 25 to 110, and the committee are grateful to those members who came along, and trust that the new program will attract even better attendances.

The committee are also grateful for the help and assistance they received during the session from the Telephone Manager, Mr. K. Gray, the area board, and the secretary and members

of the Stone/Stoke senior section. The committee are further obliged to Messrs. Bill Cawley, Don Robinson, Roy Parton, Ken Davies, and Cliff Winfield for being in such fine form in their contest with the Stone quiz team, and to Messrs. Bernard Colclough and Jack Yates for auditing the centre books.

At our meeting on 8 January 1969 we bade farewell to our chairman, Mr. J. A. Hart, on his retirement from the Post Office. During his nine years at Stoke Mr. Hart was a consistent source of strength to the centre, and we hope he enjoys a long retirement.

The annual general meeting took place with Mr. K. T. Bevington in the chair. In his review of the session Mr. Bevington referred to the imminent departure of the president to become Telephone Manager, Leicester, and said that Mr. Gray's interest in the centre became evident within days of his arrival at Stoke. He and his board not only opened each new session, but he himself also very kindly presented two papers to the centre: "Appraisements" and "Promotion Procedure." We are all very grateful to Mr. Gray and assure him that his impact here will remain and stimulate us for many sessions.

The following officers were elected to serve the centre for the 1969-70 session: *Chairman*: Mr. J. W. A. Attwood; *Vice-Chairman*: Mr. C. Winfield; *Secretary*: Mr. B. Alderson; *Assistant Secretary*: Mr. K. T. Bevington; *Treasurer*: Mr. E. A. Hudson; *Librarian*: Mr. H. Hawkins; *Committee*: Messrs. Parton, Yates and Shaw; *Auditors*: Messrs. B. Colclough and G. Hulme.

S. P. H

## Regional Notes

### Midland Region

#### *Trial of Heavy Moleplough Equipment*

The laying of 4-way duct on a section of the Stoke-Wolverhampton cable route has now been completed using Yates-Badger heavy moleplough equipment as a trial for Headquarters.

The existing London-Birmingham-Manchester radio network is expected to be exhausted by 1973, and THQ are engaged on planning of new inter-city high-capacity coaxial cable links. The present concept is that these new cables will be 18 tube 0.375 coaxial, equipped with 60 MHz line systems having a capacity of 90,000 circuits in the one cable sheath. With such high capacity cables the Post Office must reduce the risk of service interruptions to a minimum, and an examination is being made of the need to segregate, lay at extra depth and provide cross-country routes for high capacity cables.

Work is already proceeding on the provision of a new Stoke-Wolverhampton main-circuit cable which requires the provision of about 10 miles of new 4-way track between Stafford and Stoke. This section of duct was selected by THQ for the moleplough trial as being representative of average country duct-laying conditions but with, perhaps, above average grass-verge width. Early contact was established with Yates-Badger Pipelines Limited by THQ, and the contractor agreed to develop attachments to enable 4 pipes of 3½ in p.v.c. duct to be ploughed simultaneously. The decision to proceed with the scheme was taken in July 1968 and, after survey and production of duct estimate by Stoke Telephone Area, a contract for the provision of all duct work between Stafford and Stoke was let to Yates-Badger Pipelines Limited.

The Badger Minor, which was employed for the duct laying, is a track-driven vehicle capable of ploughing to a depth in excess of 5 ft; the plough blade being hydraulically controlled. To increase the drawbar pull and to obtain extreme smoothness, a Tugmaster was used to assist the Badger Minor Machine. The Tugmaster is held stationary by a ground anchor and the Tugmaster and Badger Minor machines are coupled by a steel hawser. A winch on the Tugmaster is then

used to draw the Badger Minor machine towards the Tugmaster, the Badger Minor diesel engine being engaged in drive to take the weight of the Badger Minor machine.

The route was surveyed for loading manholes at 2,000 yd, to cater for a proposed junction cable, with intermediate extra-depth joint boxes at 250 yd intervals. Consideration was given to the use of prefabricated manholes, but it was not possible to obtain supplies in time for this scheme.

P.V.C. ducts were stuck together to make up sections of the required length up to 250yd, using Post Office compound composed of adhesive and filler. The 4 ducts were attached, via expanding moles, to the plough blade, which was positioned in a prepared pit, and pulled through the ground. An operator walking beside the plough blade controlled the depth of lay through a remote control box.

Considerable difficulty was experienced in the initial stages of the scheme due to failure of the adhesive with consequential separation of ducts when under tension. This was thought to be at least partly attributable to the adverse weather conditions experienced at that time, particularly cold and moisture. The difficulty was largely overcome with the improvement in weather and the extra care employed in cleaning and jointing of duct, but the true reasons for the earlier failures are not known and further investigation is required. It is of interest to note that duct joint separations were easily found by blowing a missile through the duct which stopped at the point of non continuity. Duct was laid in horizontal, vertical and quad formation; although horizontal formation was abandoned early on, as it was considered that the design of plough blade/follower was not suitable for this formation. Techniques were improvised for passing duct under drains and other surfaces by disconnecting the plough blade and repositioning it on the other side of the obstructing pipe then reconnecting the duct to the plough blade by the use of a chain. Offset ploughing was satisfactorily undertaken with the machine on the carriageway when the grass verge was of insufficient width to accommodate the machine. Several lengths of duct were successfully laid at depths in excess of 4 ft.

Just over 3 miles of duct was laid by ploughing whereas at the planning stage it was estimated that 5 miles should be possible. Given suitable conditions it was expected that up to

1,000 yd per day could be ploughed but, in practice, the best achievement was 600 yd.

The cost of the ploughing operation was slightly less than duct laying by conventional means but it is worth noting that



Badger Minor machine showing method of connexion to p.v.c. pipes

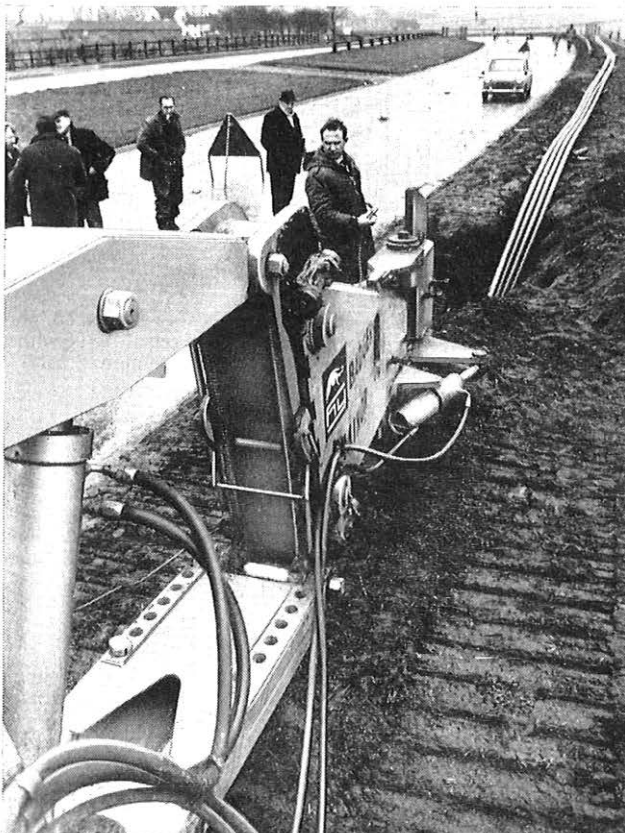

Badger Minor machine in operation

there is no change in cost when depth of cover is increased from 2 ft to 4 ft. It is confidently expected that future schemes, in the right conditions and properly surveyed, will achieve a laying performance of 1,000 yd per day at an economical price.

J. W. Young and E. H. Pooley

### South Eastern Region

#### *Worthing and Swanedan; Conversion to Automatic Working*

After a life of thirty-eight years in which it grew to be the largest manual exchange in Western Europe, the Worthing CB manual telephone exchange was replaced by a new 13,600-line automatic exchange on 26 March 1969 at 1330 hours. At the same time Swanedan CB manual exchange ended its long service, being replaced by a new automatic exchange of 7,000 lines accommodated in a new building erected next door to the old exchange. The new Swanedan centre also contains a telephone repeater station, subscriber-trunk-dialling group-switching equipment and an associated 34-position auto-manual board with directory and enquiry suites comprising an additional 16 positions. A maintenance control centre of 11 test positions is installed in a common m.d.f. and test room.

Advantage was taken of the conversion to adjust exchange area boundaries by means of a coincident area-correction transfer, which diverted about 900 subscribers from the old Worthing exchange to the new Worthing (Swanedan) exchange. The transfer at Worthing (Swanedan) was effected by a full break-jack scheme) whilst the Worthing (Central) and the area-correction transfer was performed by a mixture of break jacks and teed circuits. The s.t.d. equipment, maintenance control centre and auto-manual board had already been phased into service in a scheduled program over several weeks prior to transfer. This included providing s.t.d. facilities for Littlehampton, Rustington, Storrington and Lancing, and major junction rearrangements were necessary.

The eighth and final stage of transfer was initiated by the Mayor of Worthing, Alderman Mrs. D. E. Rudd, J.P., who, upon receipt of a "cut in" instruction from the engineer-in-charge of transfer, pulled the first wedges to introduce the new equipment. Because of the complexity of the operation, a complete closed-circuit television system was installed and operated by the Television Outside Broadcast Department of THQ Service Division. In addition to cameras, monitor receivers, sound and vision mixers and the associated equipment and circuits, microwave transmitters and receivers operating at 7 GHz and 12 GHz carried the video signals from the Head Post Office roof and the new Worthing (Central) exchange to the control centre at the new Swanedan building. Here, a moment-to-moment picture program was assembled together with a suitable explanatory commentary on the background and progress of the transfer. This was recorded on video-tape recording equipment. The continuous monitoring of the action at the transfer main stations proved an invaluable aid to the controlling engineer. The moment of transfer was delayed for about a minute whilst an emergency call was dealt with by the operating staff at each of the old exchanges.

A formal opening of the two new exchanges took place on Friday, 28 March 1969 at which ceremony the Mayor of Worthing presented the Telephone Manager, Mr. A. J. Barker, with two bronze plaques commemorating the opening of the automatic exchanges. At the ceremony, a video tape recording of the transfer operation was shown as a completed program and was well received by the assembled company.

Only two manual exchanges now remain in the Brighton Telephone Area, Newhaven and Hailsham. Newhaven is to be converted to automatic working during the coming summer and Hailsham is programmed to be replaced by a crossbar exchange during 1970.

L. P. Mealy and D. Tribe

### London Telecommunications Region

#### *Concrete "Stitching" for a Manhole Repair*

A report was received in 1967, of a severe crack in the floor and end-wall of a recently-constructed, non-standard manhole, in the Rodney telephone exchange area.

The London Regional Works Branch carried out an investigation into the cause of the failure of the unreinforced concrete floor-slab. Samples of concrete, taken from the manhole for analysis, indicated that the texture, physical content and compressive strength of the concrete were satisfactory and that corrosive chemicals were not present in sufficient quantity to account for the damage. Further investigation revealed that the 36-way p.v.c. duct nest had moved in relation to the inside face of the manhole wall and that this movement was attributable to differential settlement of the soil beneath the ducts. The concrete block containing the p.v.c. ducts had acted as a lever, placing abnormal stresses on the end wall and floor slab of the manhole.

The Road Research Laboratory had published a paper on the subject of concrete stitching techniques, as applied to the repair of concrete carriageway foundations, and it was decided to attempt the manhole repair, using a modified form of these methods. A period of one year was allowed to elapse, to ensure that no further movement had occurred. It was estimated that the cost of complete demolition and reconstruction of the manhole would be in excess of £1,000, making the repair a much more attractive proposition.

The remedial work was undertaken by the L.T.R. City Area Mechanical-Aids staff.

The floor screed was first removed and the structure dried out by means of a hot-air blower. Holes were drilled in the floor slab, to a depth of three inches, at twelve inch spacings on either side of the crack and six inches from it. A diamond-tipped drill was used for this purpose to minimize vibration and the attendant risk of breaking away the concrete adjacent to the crack. Channels, one inch deep, were then cut between pairs of holes, crossing the crack at right angles.

Stitches were manufactured from  $\frac{3}{4}$ -inch diameter, mild-steel bar, the ends being bent through 90 degrees to correspond with the holes and channels. The crack in the floor was widened and cleaned, polyester-resin mortar being trowelled in to act as a sealant. The holes and channels were then filled with polyester-resin mortar and the stitches inserted, any displaced surplus mortar being struck off with a trowel. The photograph shows the stitches *in situ*.

A three-inch floor screed was required to complete the repair, but it was feared that the adhesion between the existing floor concrete and the screed would be inadequate. This was avoided by the use of "Bondcrete", a proprietary bonding agent.

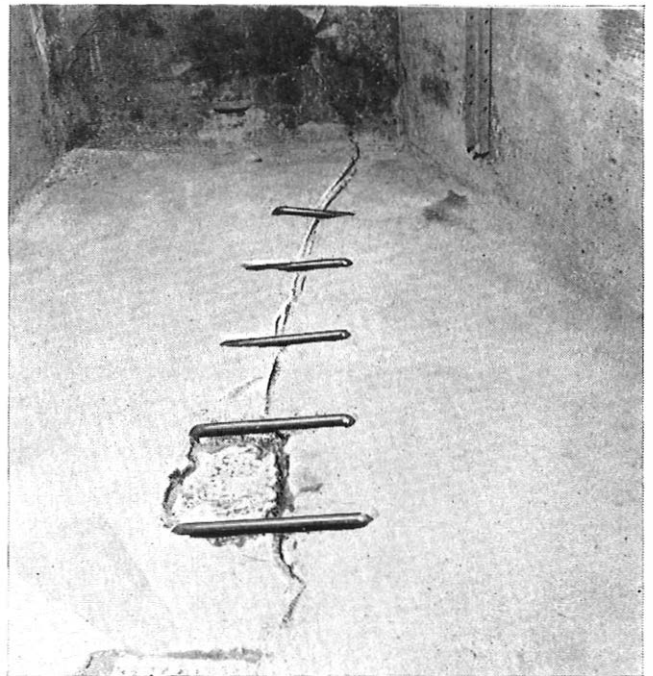

Concrete stitching method

Because of the increased thickness of the new screed, it was necessary to insert shuttering in the sump and round the floor-mounted anchor iron. The cracks in the end wall were first treated with the bonding agent and then made good with portland cement mortar, a further quantity of the bonding agent being added to the water to improve the ultimate tensile strength of the mortar. The normal reinforcement in the end wall is regarded as an adequate safeguard against further movement in this area.

The patient is as well as can be expected after the operation but will be kept under observation over a long period to ensure that there is no relapse. Only then can the job be regarded as completely "sewn up".

R. Harper

#### BOARD OF EDITORS

N. C. C. de JONG, B.Sc.(Eng.), C.Eng., M.I.C.E., F.I.Mech.E., F.I.E.E., Chairman  
 E. W. AYERS, B.Sc.(Eng.), C.Eng., F.I.E.E.  
 A. J. BARKER, C.Eng., F.I.E.E.  
 A. J. BARNARD, C.Eng., M.I.E.E.  
 G. E. BRETT, E.R.D., B.Sc.(Eng.), M.I.E.E.  
 A. C. CROISDALE, M.B.E., B.Sc.(Eng.), C.Eng., M.I.E.E.  
 J. MARTIN, B.Sc.(Eng.), C.Eng., M.I.E.E., Managing Editor  
 N. J. H. NINIM, M.Sc., B.Eng., Deputy Managing Editor  
 R. A. SUDELL  
 P. G. STEELE, B.Sc.(Eng.) } Assistant Editors  
 C. R. M. HEATH, M.A. }  
 B. FARR, A.B.I., Secretary-Treasurer  
 N. G. CRUMP, A.M.I.T.E., Advertisement Manager

#### Copyright

The entire contents of this Journal are covered by general copyright, and special permission is necessary for reprinting long extracts, but editors are welcome to use not more than one-third of any article, provided that credit is given at the beginning or end, thus: "From *The Post Office Electrical Engineers' Journal*."

The Board of Editors is not responsible for the statements made or the opinions expressed in any of the articles in this Journal, unless such statement is made specifically by the Board.

#### Subscriptions and Back Numbers

The Journal is published quarterly, in April, July, October and January, at 3s. per copy: 5s. per copy including post and packing (20s. per year) via inland mail, and 4s. 9d. (19s. or 2 dollars 50 cents Canada and U.S.A., per year) via overseas mail. Back numbers will be supplied, if available, price 3s. 6d. (5s. 6d. inland mail, 5s. 3d. overseas mail) per copy. With the exception of January and October

1966 Journals, copies of the January 1967 and all earlier Journals are no longer available. Orders, by post only, to *The Post Office Electrical Engineers' Journal*, 2-12 Gresham Street, London, E.C.2.

Employees of the British Post Office can obtain the Journal through local agents.

#### Binding

Readers can have their copies bound at a cost of £1 12s. 6d. plus 4s. 6d. return postage, by sending the complete set of parts, with a remittance to Press Binders Ltd., 4 Iliffe Yard, London, S.E.17.

#### Remittances

Remittances should be made payable to "*The P.O.E.E. Journal*" and should be crossed "& Co."

#### Advertisements

All correspondence relating to advertisement space reservations, copy, proofs, etc., should be addressed to the Advertisement Manager, *The Post Office Electrical Engineer's Journal*, 2-12 Gresham Street, London, E.C.2.

#### Communications

With the exceptions indicated above, all communications should be addressed to the Managing Editor, *The Post Office Electrical Engineers' Journal*, 2-12 Gresham Street, London, E.C.2.

#### Model Answer Books

Books of model answers to certain of the City and Guilds of London Institute examinations in telecommunications are published by the Board of Editors. Details of the books available are given at the end of the Supplement to the Journal.

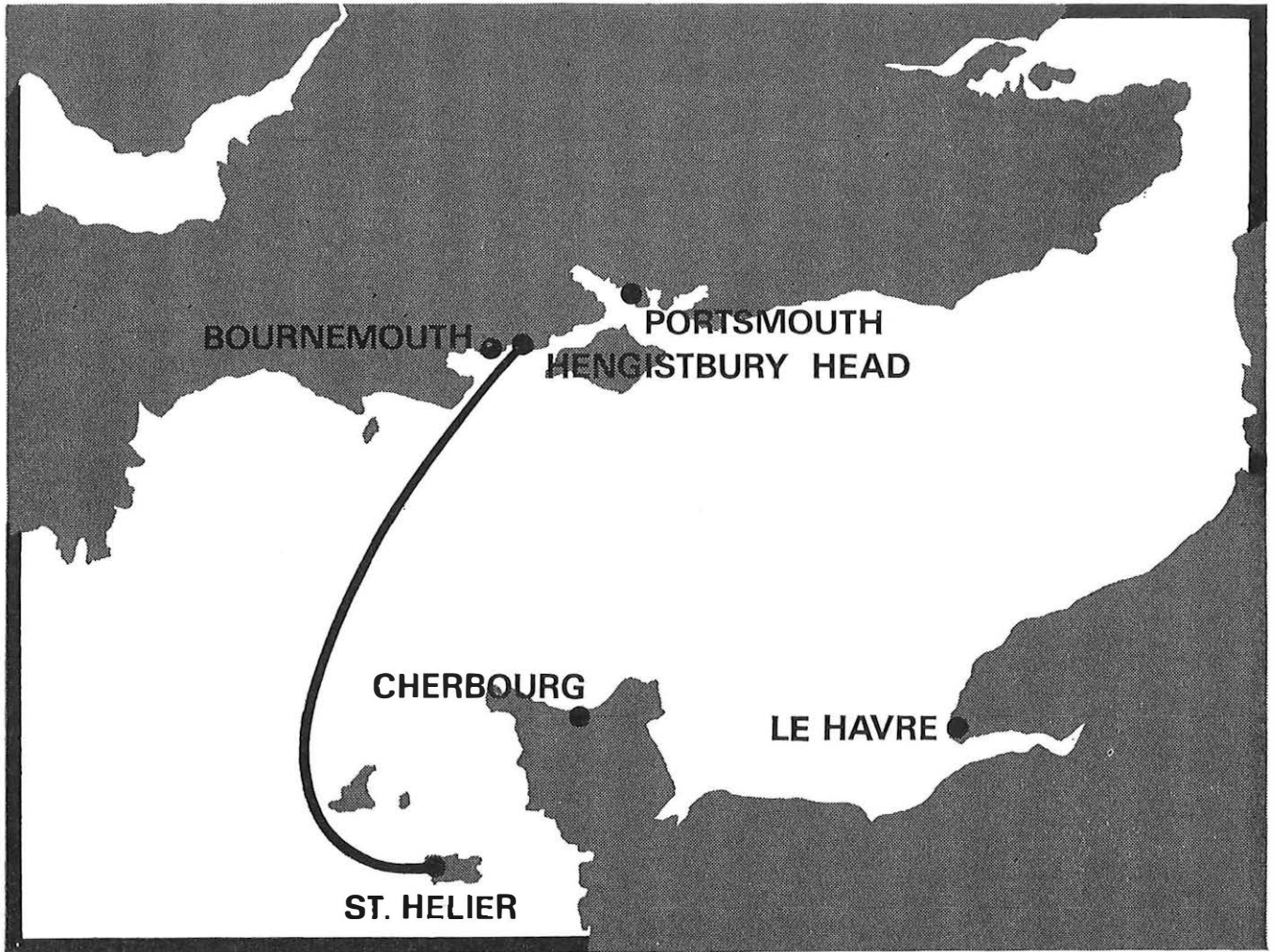

## The world's second 480 circuit Submarine Telephone System\* **England-Jersey**

The world's second 480 circuit submarine telephone cable system went into operation in February 1968 between England and Jersey. The contract was carried out by Submarine Cables Limited who manufactured the 137 nautical miles of cable and 21 transistorised repeaters. The special terminal equipment was manufactured by A.E.I. Telecommunications Group. The cable was laid by the Post Office Cables ship Monarch, and the shore ends by the Cables ship Poolster.

\* The world's first 480 circuit submarine telephone system was also manufactured by Submarine Cables Limited and went into operation between Norway and Denmark in October 1967.



*The Jersey end of the cable being taken ashore from the Cables ship Poolster.*



# Submarine Cables Ltd

A Member of the GEC Group of Companies, GREENWICH, LONDON, S.E.10

Telephone: 01-858 3291 Telex: 23687 Cables: Moorings London S.E.10.

COMPACT • LONG LIFE • RELIABLE • ECONOMIC

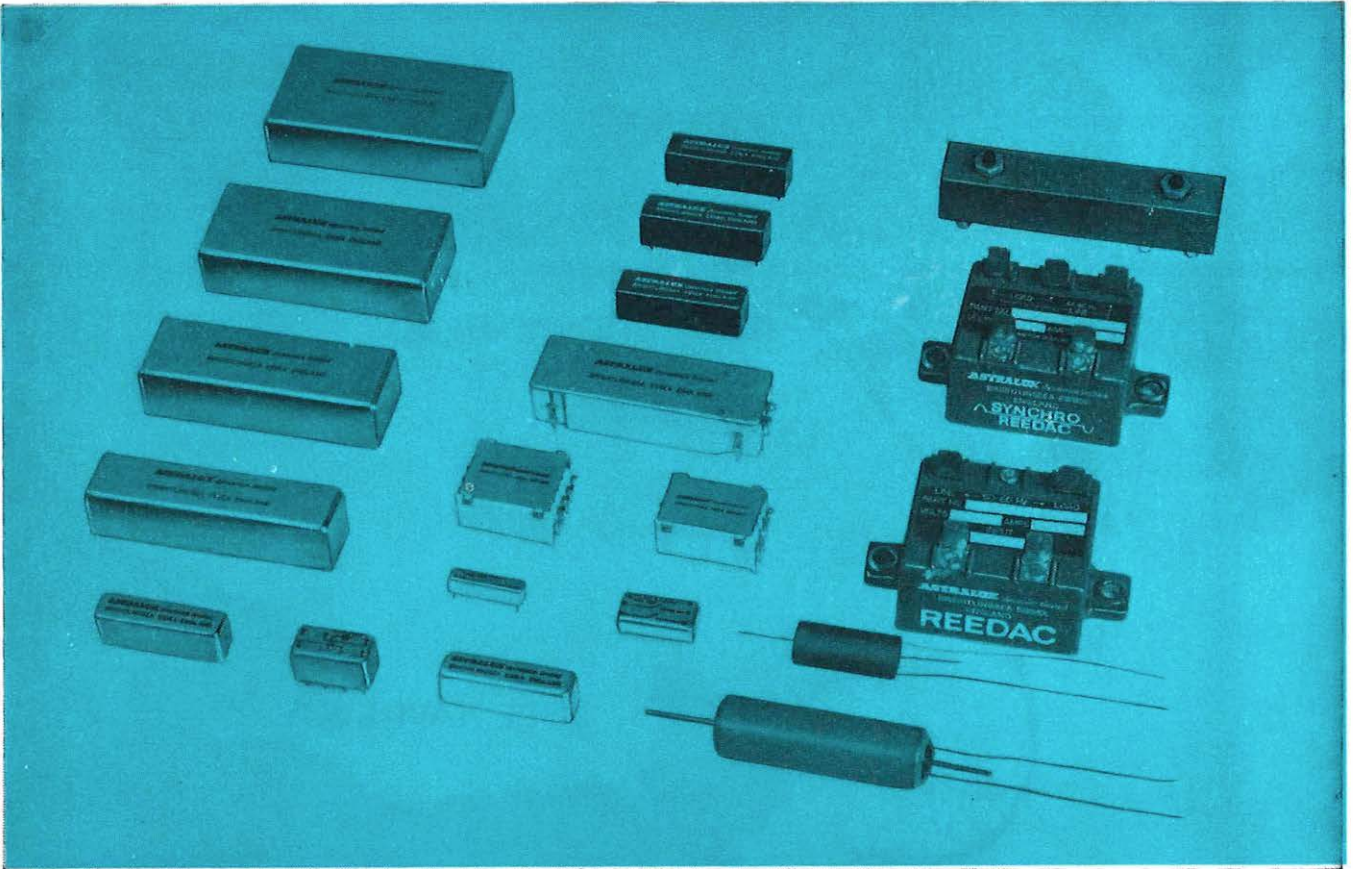

# Ask Astralux about Reed Relays.

**Because we offer:—**

- The widest range in the Country.  
Our illustration merely shows some of our more standard types.
- 'Economy' models when price is all important or models to meet stringent military specifications.
- A prototype design service to develop models for your special application.

Why not find out about the Astralux range of Reed Relays? If you haven't used Reed Relays before we would be pleased to advise on their applications. Or if you use them already why not ask Astralux to quote for your particular requirements.

With our comprehensive range coupled to our experience in Reed Relay technology we offer a service second to none in this field.

**Write for our Catalogue illustrating the wide range of circuit-ready Reed Relays.**

Are you interested in switching high A.C. Currents? Ask about our Reedac.

**ASTRALUX** *dynamics limited*

Relay Division, Brightlingsea, Colchester, Essex, England. Tel: Brightlingsea 2517/8

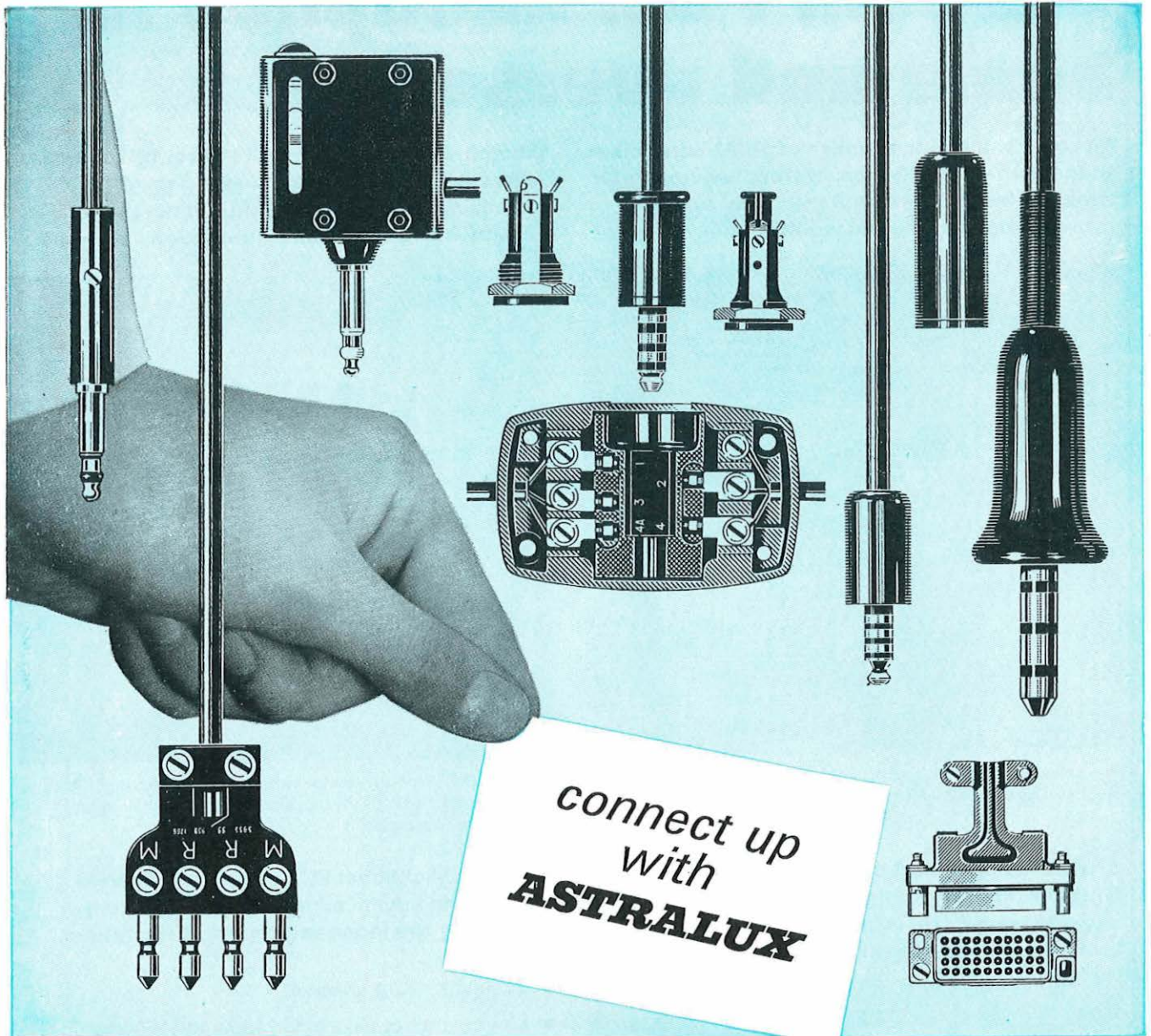

PLUGS, SOCKETS, JACKS — in all sizes and for every purpose — are made by the Special Products Division of Astralux Dynamics Ltd. They're chosen by the British Government and approved by the Post Office and Aircraft Industry. The special Astralux design service for prototype models is used by these organisations and by private industry. You can rely on Astralux efficiency and technical accuracy to produce equipment strictly to specification — and quickly. Plugs, Sockets and Jacks are just some of the products of a company streamlined to serve world-wide industry today. Learn more about what Astralux can offer you. Write to us for descriptive literature.

**Illustrated from left to right**

- 1** Plug 316    **2** Plug 406
- 3** Plug 235    **4** Jack 84A
- 5** Plug 420    **6** Jack 95A
- 7** Socket 626 with Hex. Nut
- 8** Plug 671    **9** Socket 626
- 10** Plug Electrical 119
- 11** 40-way Connector  
male and female

**ASTRALUX** *dynamics limited*

# Marconi PCM multiplies at home and overseas

Marconi is a major supplier of PCM equipment to the British Post Office. Marconi equipment is supplied for the London Region and many other Regions in the United Kingdom.

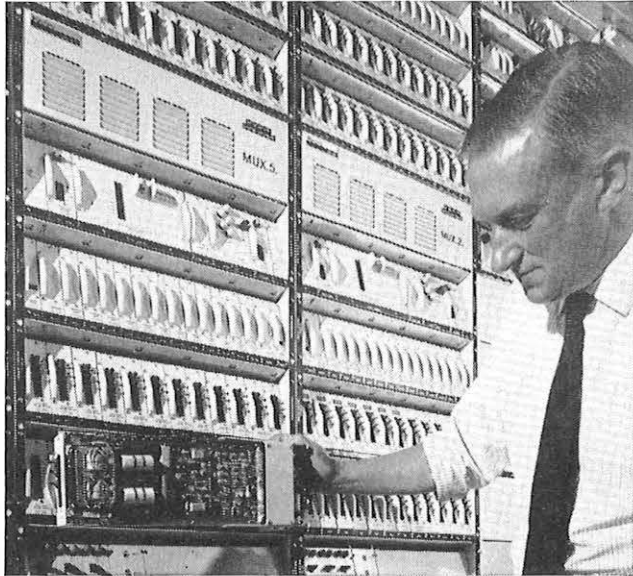

The Belfast-Bangor link, the first link installed by the GPO, employs Marconi PCM equipment.

British Rail, the first organization in the United Kingdom outside the GPO to take advantage of PCM, is using Marconi equipment to improve the efficiency of its communications.

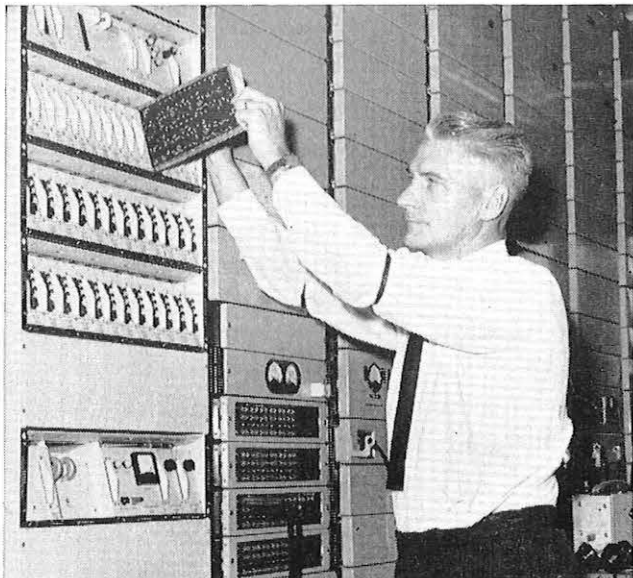

Marconi 24-channel PCM equipment at Euston Station on the Euston-Bletchley link.

Marconi PCM has been ordered for use overseas, where it will be playing a major part in increasing the capacity of public telephone networks and other communications systems.

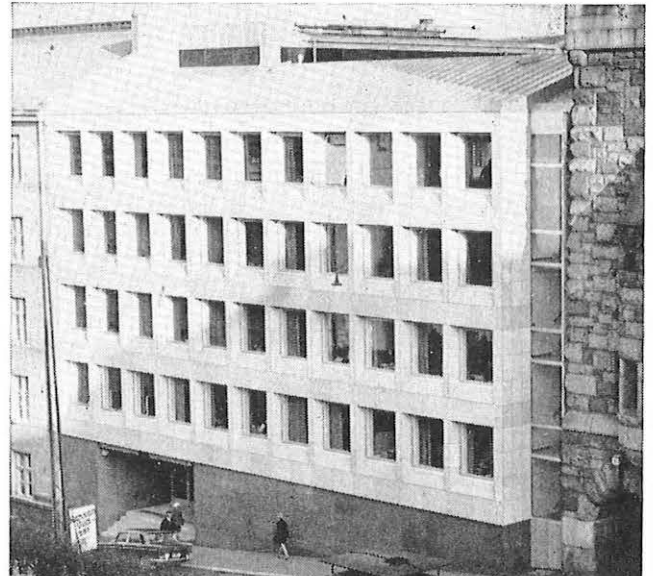

The Helsinki Telephone Company has ordered Marconi PCM to increase the circuit capacity between the main exchange and a number of city suburbs.

Marconi 24 channel PCM equipment Series U1310 is an advanced multiplexing system employing the latest microcircuit technique.

- 24 simultaneous channels.
- Low cost, since most of the apparatus is common to all 24 channels.
- Pulse system permits the use of regenerative repeaters to prevent noise and distortion build-up along the line.
- Deeper penetration of advanced micrologic circuits gives greater reliability.
- Advanced manufacturing processes and testing techniques increases equipment reliability.
- Suitable for future integrated switching system.
- A range of signalling sets for different exchange conditions.
- Suitable for data transmission, and teleprinter facility incorporated.
- Accurate fault location and comprehensive fault alarm facility.

## Marconi line communications

Specialists in digital transmission, including Marconidata, Pulse Code Modulation, and 'Autoplex' and 'Autospec' error-correcting equipment.



# Marconi

–pioneers  
of S.S.B and I.S.B  
–announce the  
newest in an  
extensive range  
of receivers



## The new **HYDRUS** high quality low-cost H.F receiver for international point-to-point services

FREQUENCY RANGE 1.5 TO 30 MHz  
I.S.B, S.S.B, D.S.B, F.S.K, C.W

### HYDRUS offers

- ★ Exceptional versatility
- ★ Very high reliability
- ★ All solid-state, incorporating the latest field effect transistors
- ★ High stability
- ★ Frequency synthesis tuning
- ★ Fast re-tune and change of operating mode
- ★ Panclimatic operation
- ★ Available for operation in many transmission modes



The Marconi Company Limited  
Radio Communications Division  
Chelmsford, Essex, England

Member of GEC-Marconi Electronics Limited

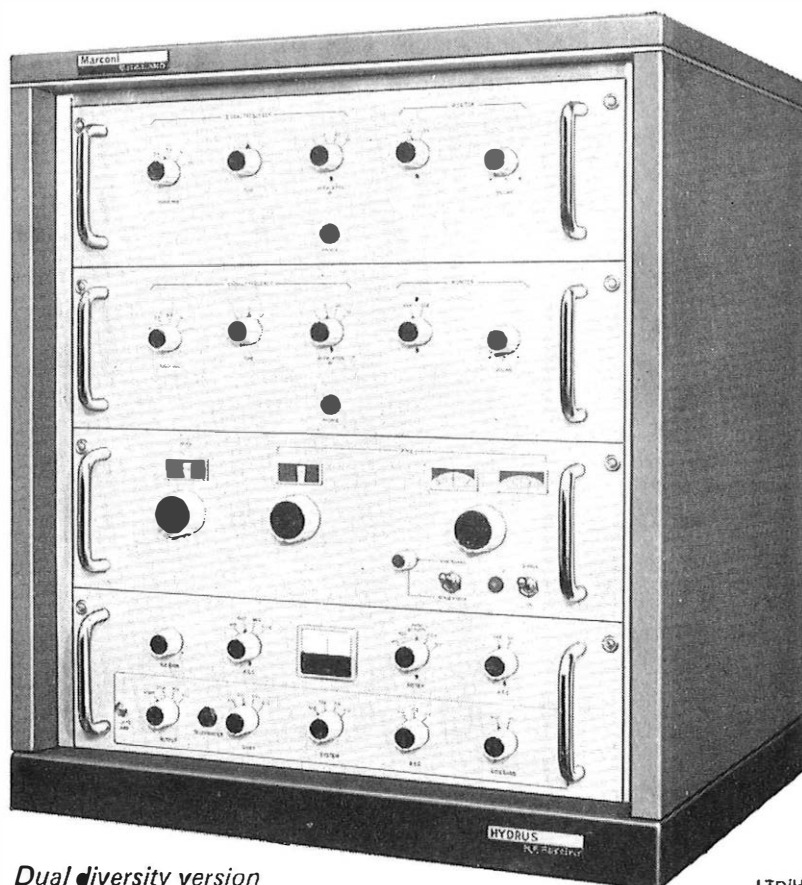

*Dual diversity version*

# logical family planning



## THE NEW 9000 TTL FAMILY AVAILABLE NOW

TODAY: FOR YOUR TTL DATAPACK  
RING WITHAM 3401  
EXTENSION 500 (TELEX 99293)

Eight more of the fast-growing 9000 family of TTL integrated circuits

9020 dual JKK flip-flop

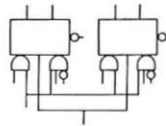

9000 clocked J-K flip-flop

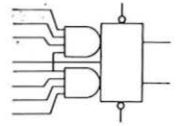

9002 quad 2-input NAND gate

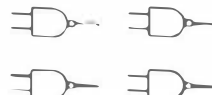

9601 retriggerable monostable multivibrator



9001 clocked J-K flip-flop with J & K inputs

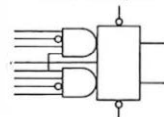

9016 TTL hex inverter

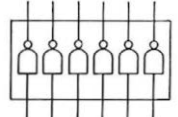

9022 dual JK flip-flop

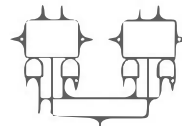

9008 single 4 AND/NOR gate

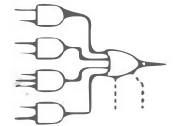

**Plan ahead—confidently—  
with Marconi-Elliott Microelectronics**

MARCONI-ELLIOTT MICROELECTRONICS LIMITED, WITHAM, ESSEX, ENGLAND, AND GLENROTHES, FIFE, SCOTLAND  
Member of GEC—Marconi Electronics Limited

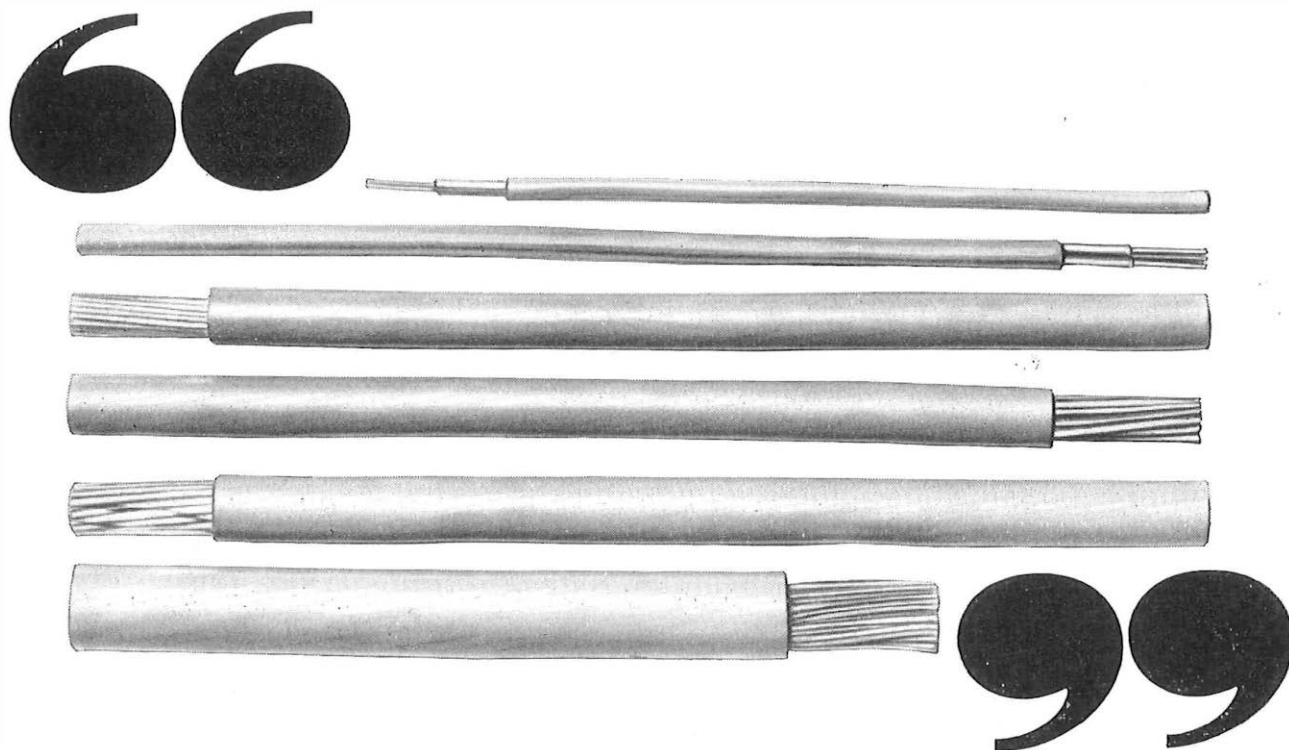

“**PIRELLI  
GENERAL**”  
and the power  
of speech

Internal telephone communication systems call for the same degree of reliability as for national networks. Pirelli General manufactures a range of multipair and multi-way internal telephone cables which are stocked for immediate delivery. To reduce cross-talk in the multipair construction the pairs are twisted and laid-up with varying lays. Each cable has a distinct colour identification scheme for the cores or pairs which facilitates quick termination, and a Terylene ripper cord assists in quick removal of the PVC sheath. For further details ask for Publication C3:1968.

PIRELLI GENERAL CABLE WORKS LIMITED · SOUTHAMPTON · TELEPHONE: SOUTHAMPTON 20381

# STC Telecommunications

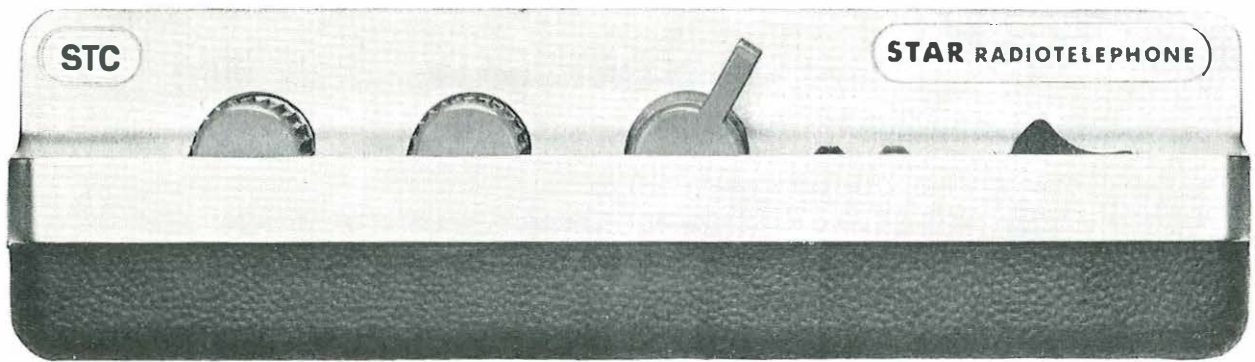

## STAR performer

### 20 good reasons why STAR UHF Mobile Radiotelephone is the best radiotelephone in the world

- ★ Elegantly styled.
- ★ Designed for safe use in vehicles.
- ★ Excellent range and penetration of built-up areas.
- ★ Crystal-clear speech quality.
- ★ Noise cancelling microphone.
- ★ No ignition noise.
- ★ Very low battery drain.
- ★ Simple installation and removal.
- ★ Anti-theft catch.
- ★ High reliability.
- ★ Meets world-wide specifications.
- ★ 25 kHz and 50 kHz channel spacing.
- ★ Printed UHF transmitter circuitry.
- ★ Transmission line coupling of power transistors.
- ★ Solid-state antenna change-over switching.
- ★ Helical tuning coils in receiver.
- ★ Quartz crystal filter.
- ★ Quartz crystal discriminator.
- ★ Integrated circuits.
- ★ Fully solid-state.

**STC Mobile Radiotelephones Ltd., New Southgate, London N.11.**  
**Telephone: 01-368 1200. Telex: 261912.**

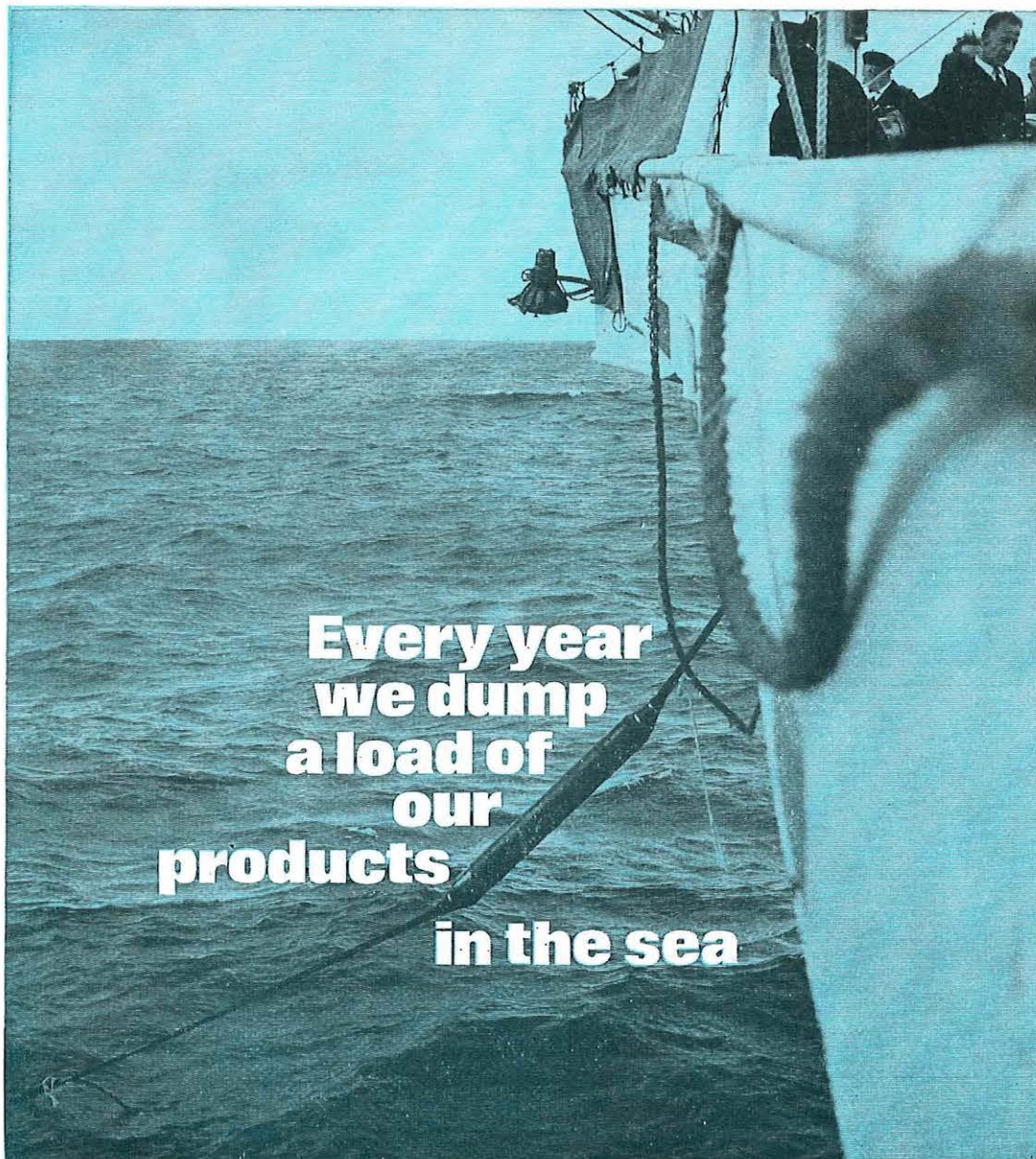

**Every year  
we dump  
a load of  
our  
products  
in the sea**

And that's the best place, of course, for submarine cables, repeaters and equalisers. We reckon they should stay down there for at least 25 years without attention. Which is why we make them to incredibly high standards of reliability, with nothing left to chance.

And the shore terminal equipment too, generally duplicated with automatic changeover to ensure utmost reliability, is made to compatibly high standards.

In collaboration with the British Post Office we've been in the forefront of submarine systems developments since the early 1950's. And have unsurpassed practical experience – STC engineers have participated in 34 major projects worth £137 million.

First with deep-water systems of 160 and 360 circuits, STC will also be first with a 640 circuit deep-water system.

STC innovations include the master-slave power feeding system,

and a special test lead which makes equaliser laying that much easier.

STC cable, too – simultaneously carrying intelligence and feeding power to the repeaters – is of optimum performance/cost design and cannot be bettered anywhere in the world. For the very first system to use the new 1½-inch diameter lightweight cable STC was selected to provide all of the cable.

We don't stop at manufacturing the equipment for submarine cable systems. Add an overall capability for systems planning, project management installation of complete systems including civil engineering works and services – and you have a unique organisation able to meet any requirement, anywhere – on time! All this, just to drop things in the sea.

Standard Telephones and Cables Limited,  
Submarine Systems Marketing, North Woolwich,  
London, E.16. Telephone: 01-476 1401. Telex: 21645.



world-wide telecommunications and electronics

# STC

## Some people get quite worked up when they have an STC Deltaphone

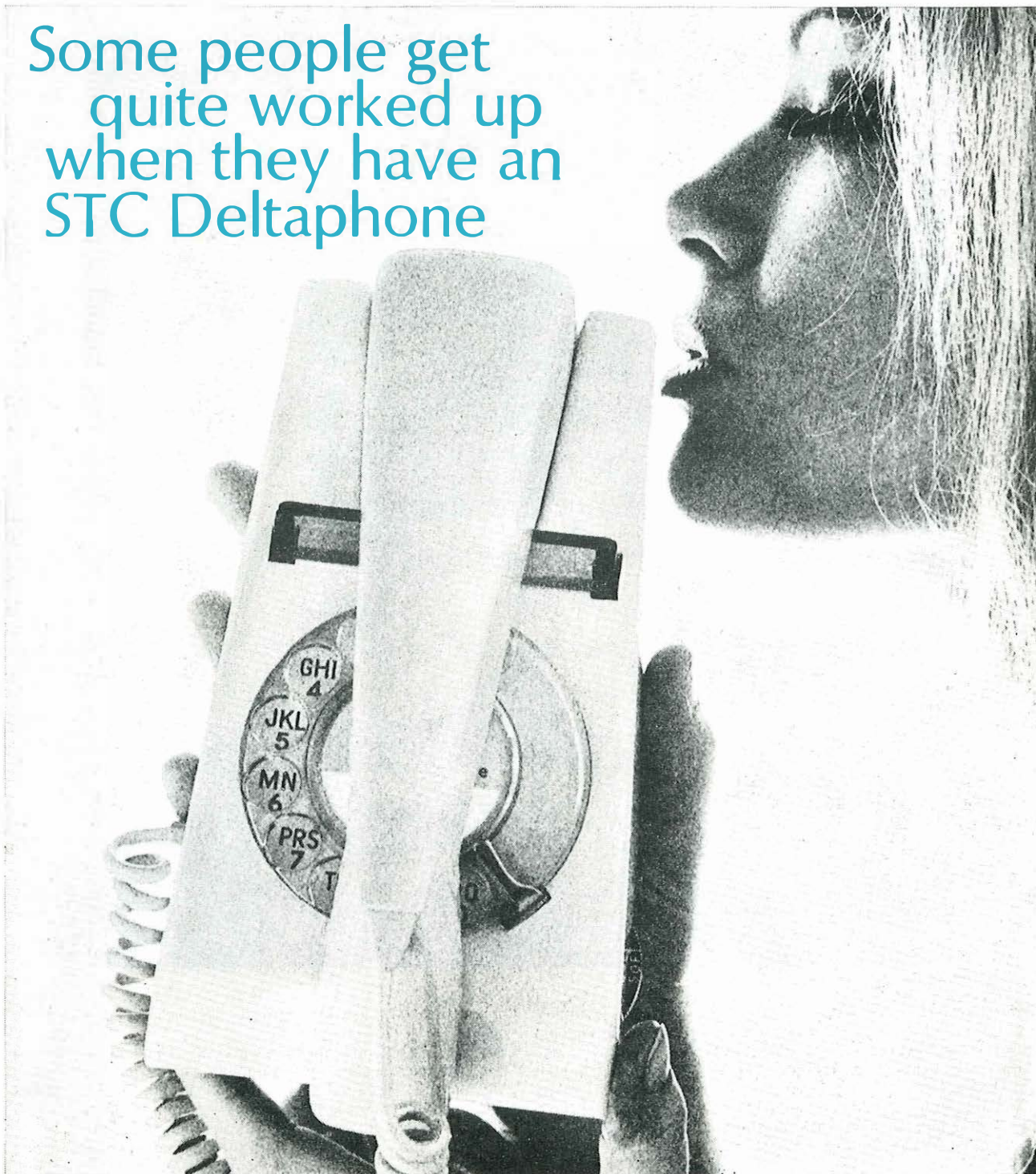

STC's Deltaphone is pretty exciting, after all. And it does things other telephones don't. For instance, it can glow in the dark. There's an optional luminescent dial which lets you dial without turning lights on. And nobody gets disturbed when the Deltaphone rings. Mainly

because it doesn't ring. It just *warbles* – at the volume you set. In fact, the Deltaphone is very sociable. People like it because it's slim – at 4.3 inches it's only a fraction wider than the dial. And the 4-ounce handset is only half the weight of a conventional one. So it's twice as nice to hold. Add the Deltaphone's restrained

colours, its elegant shape – and its exacting technical specification – and you have an irresistible telephone. Standard Telephones and Cables Limited, Telephone Switching Group, Oakleigh Road, New Southgate, London N.11, England. Telephone 01-368 1234. Telex: 21917

## Lincompex eliminates singing problems



### No, not you Brunnhilde, sit down.

STC LINCOMPLEX eliminates singing suppressors in long distance HF radio telephone links—plus all the problems that go with them.

By using a constant loss system and Companding techniques, STC LINCOMPLEX terminal equipment can be integrated into almost any 4-wire radio telephone system—and the benefits are enormous.

Optimum transmitter loading is made possible. A high signal to noise ratio brings even warbling Wagnerians over loud and clear (so help us). And the increased traffic handling capacity quickly repays the cost of installation.

A full range of ancillary items can be supplied, such as echo suppressors, band displacers, control shelves, etc.

Furthermore, a special feature allows remote switching of privacy systems with automatic delay compensation.

For brochure giving full technical details, write, phone or telex: Standard Telephones and Cables Limited, Testing Apparatus and Special Systems Division, Corporation Road, Newport, Monmouthshire.

Telephone: ONE 3 72281. Telex: 49367.

**Standard Telephones and Cables Limited**

Hello darling.  
Where in the world  
are you now?



And a voice answers. Loud and clear. From two or two thousand miles away – or more. STC helped to make it possible. However the call was transmitted. Over a land link. Through the air via satellite. Under the sea. Via cable, microwave or radio. Whether the call came through a simple village switchboard. Or a giant automatic exchange in a big city.

Across the world STC has installed over 5 million lines of Step by Step equipment, and is now producing the internationally accepted Pentaconta\* crossbar system.

As a member of the British Joint Electronic Research Committee STC is a leading developer of the revolutionary TXE4 electronic exchange. STC – backed by the international know-how of ITT.

Always researching new ways. Faster ways. To link peoples of the world.

Standard Telephones and Cables Limited,  
Telephone Switching Group, Oakleigh Road,  
New Southgate, London, N.11, England.  
Telephone: 01-368 1234 Telex: 21917

\*Registered trade mark of the ITT System

**Standard Telephones and Cables Limited**



air...  
the  
perfect  
insulant...

**the clever part is how you use it!**

Making co-axial cable calls for advance production and engineering techniques. In an automatic process, TCL takes copper wire, moulds plastic discs at critical distances along its length, wraps it with plastic foil, and applies a copper strip longitudinally to form a tube.

Two laps of steel tapes followed by two laps of paper tape – and the tube is made and protected with a speed and precision hitherto unobtainable. Each tube is then subjected to searching electrical and mechanical examinations.

**Telephone Cables Limited** Dagenham, Essex. Tel: 01-592 6611. Cables: Drycore Dagenham. Telex: 896216  
*The organisation with 135 years' experience.*

Air... plus care. These are the ingredients that give TCL co-axial cables their renowned performance standards.

TCL – the largest company in Europe exclusively concerned with the manufacture of telecommunications cable – makes *all* types of dry core and plastic cables and as well as being a major supplier to the British Post Office also exports to over 70 countries throughout the world. A world-wide technical advisory service is provided.

**TCL**  
put **more** into  
telephone cables



RR.. RR.. RR.. RR..



## and the telephone still rang

When the power cut plunged the place in darkness the 'phone was still dependably alive. Naturally, that's how it is always. So that we take it for granted. But behind that dependability often enough are the stand-by generators powered by Rolls-Royce diesels. That's where reliability starts, with the reputation of Rolls-Royce. As well as the many Rolls-Royce generating sets supplied to the G.P.O. for use on telephone networks, there are countless other applications in all fields of public service and industry—in hospitals, computer blocks, broadcasting, refrigeration—in fact wherever continuity of operation is essential.

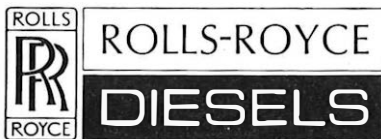

Rolls-Royce Ltd., Shrewsbury, England  
 Tel: 52265 Telex: 35171 Grams: Roycar Shrewsbury  
**DIESEL AND PETROL ENGINES · AERO ENGINES · MOTOR CARS  
 INDUSTRIAL GAS TURBINES · ROCKET MOTORS · NUCLEAR PROPULSION**

P9721

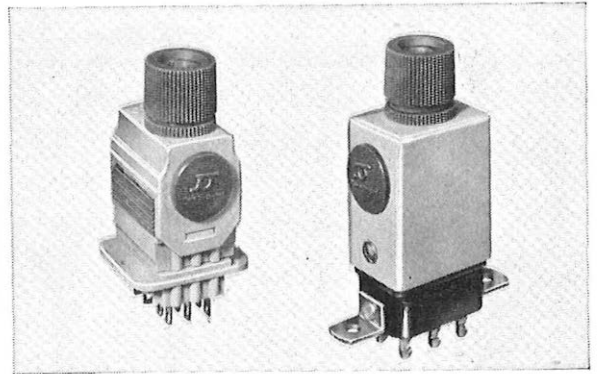

## JONES 300 and 400 SERIES Mk II

Announcing the new Cannon Jones Mk II 300 (miniature) and 400 (standard), basically similar and interchangeable with types produced by Cannon for the last 28 years with important design improvements.

**Cannon Electric  
 (Great Britain) Ltd.,  
 Lister Road,  
 Basingstoke, Hants.  
 Tel: Basingstoke 3171**



## VALUABLE FREE BOOK

**Tells You How to Pass Your C. & G. Examination at First Attempt!**



All Post Office personnel who are anxious to obtain early promotion should at once send for a copy of our handbook "ENGINEERING OPPORTUNITIES" which, among other intensely interesting matter, describes our unique methods of preparation for the CITY AND GUILDS EXAMINATIONS for the Telecommunication Technicians' Certificate and for individual subjects—Mathematics, Engineering Science, Engineering Drawing, Elementary Telecommunication Practice, Telecommunication Principles, Radio and Line Transmission, Telegraphy and Telegraph, Line Plant Practice. It also contains details of our courses covering the G.C.E. subjects required for promotion to Assistant Engineer, Telecommunication Traffic Superintendent and other grades; and the City and Guilds examinations in Electrical Engineering Practice, the A.M.I.E.R.E. and A.M.S.E. Examinations, in addition to a wide range of non-examination courses in all branches of engineering—Radio and Electronics, Electrical, Mechanical, etc.

**We also provide tuition for the Radio Amateurs' Examination and the P.M.G. Certificates for Radio Operators, with or without Morse training. Details are given in the handbook.**

**On "SATISFACTION OR REFUND OF FEE" terms**

If you intend to make the most of today's opportunities, you cannot afford to miss reading "ENGINEERING OPPORTUNITIES." It tells you everything you want to know to secure advancement, and describes many opportunities you may now be missing through lack of information. Send for your copy today—**FREE** and without obligation.

**BRITISH INSTITUTE  
 OF ENGINEERING TECHNOLOGY  
 677D ALDERMASTON COURT,  
 ALDERMASTON, BERKSHIRE**



# IOR the current slicers



International Rectifier  
semiconductors lead the world  
when it comes to slicing current  
waveforms—into just the right  
shape to solve your own  
particular problems.

Whatever the application—rely on **IOR**

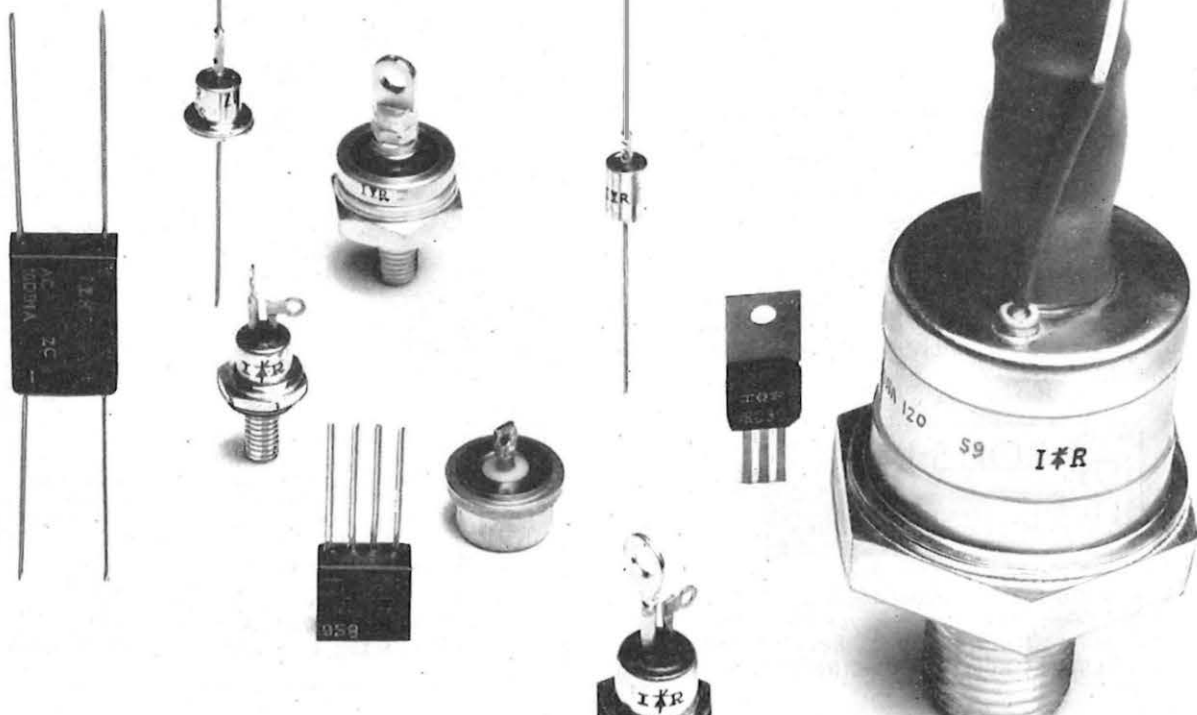

**Point to Point  
Broadcasting  
Radio Relay  
Ground to Air  
Navigational Aids  
Business Radio**

**Design**

Site layouts  
Aerial System Design

**Aerials**

LF 'T' and 'L' Aerials,  
Mast Radiators,  
HF Dipoles, Quadrants,  
Rhombics, Log Periodics,  
Vertical Incidence Arrays,  
Conicals, Biconicals  
VHF & UHF Yagis, Helices,  
Ground Planes, Colinears,  
Whips, Marine Aerials,  
Television Arrays to 100kW e.r.p  
MICROWAVE Passive Reflectors,  
Dishes 3" to 60 ft. dia.

**Supporting Structures**

Self-supporting Towers,  
Tubular and Lattice Masts,  
Telescopic Masts

**Accessories**

Coaxial and open wire Feeders,  
Filters, Aerial Switches,  
Lead-in panels, Earth Systems.  
Air-cooled Transmitter Loads.  
Termination Networks

**Installation**

World Wide Service

**C & S Antennas**  
provide  
a complete  
aerial service  
LF to Microwave



**C & S Antennas Ltd**

Wentworth House, Eastern Avenue, Ilford, Essex, England.  
Telephone: 01-554-0102 Telex: 25850 Cables: Antennas Ilford (England)

# TYPE 62

## FULL RANGE

7 TO 14 DAY DELIVERY

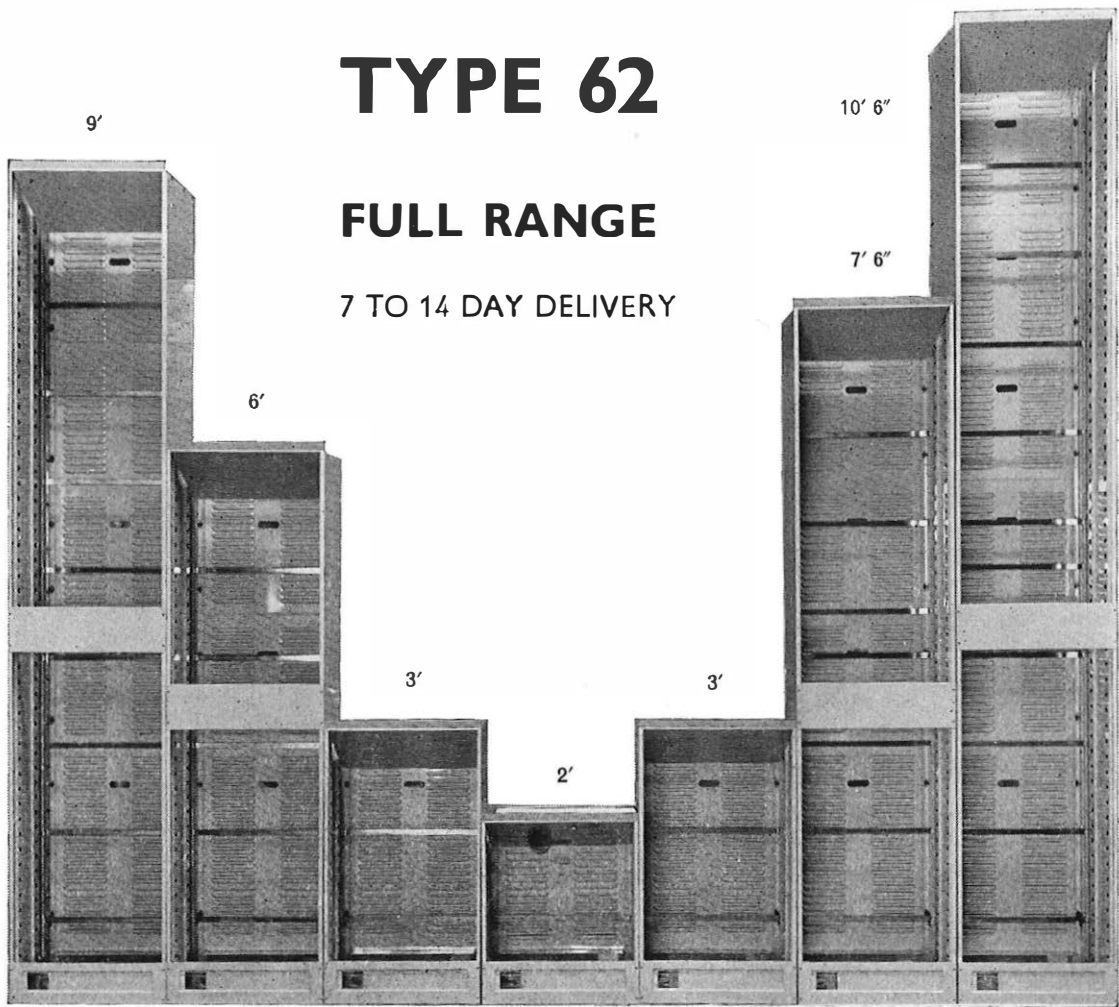

### HIGH PRECISION MECHANICS

FOR INSTRUMENT ELECTRONIC AND AUTOMATION INDUSTRIES

TELECOMMUNICATIONS  
MECHANICS

**G.P.O. APPROVED**

IMMEDIATE QUOTATIONS AND  
TECHNICAL SERVICE

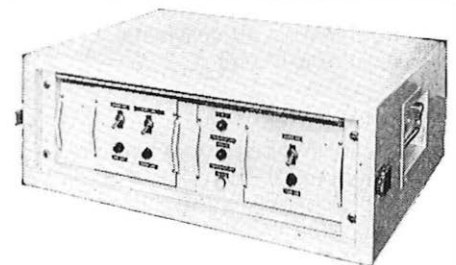

SHELF ASSEMBLIES

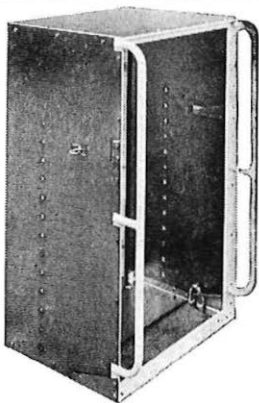

P.C.M. TRANSIT JIG



DATA MODEM

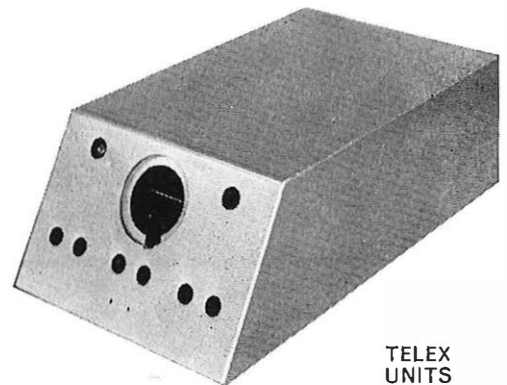

TELEX  
UNITS

# CRAY ELECTRONICS LTD

THAMES ROAD, CRAYFORD, KENT  
TELEPHONE: CRAYFORD 26526



From living animal to fossil takes  
nature many millenia. From receipt of your  
order for components to despatch  
takes us an average of some 40 minutes.  
One of the reasons why we have over  
40,000 happy customers on our books is  
because there are no old fossils in our  
organisation.



**Radiospares**

P. O. Box 427

13-17 Epworth Street, London, E.C.2.

Tel: 01-253 9561. Telex: 262341.

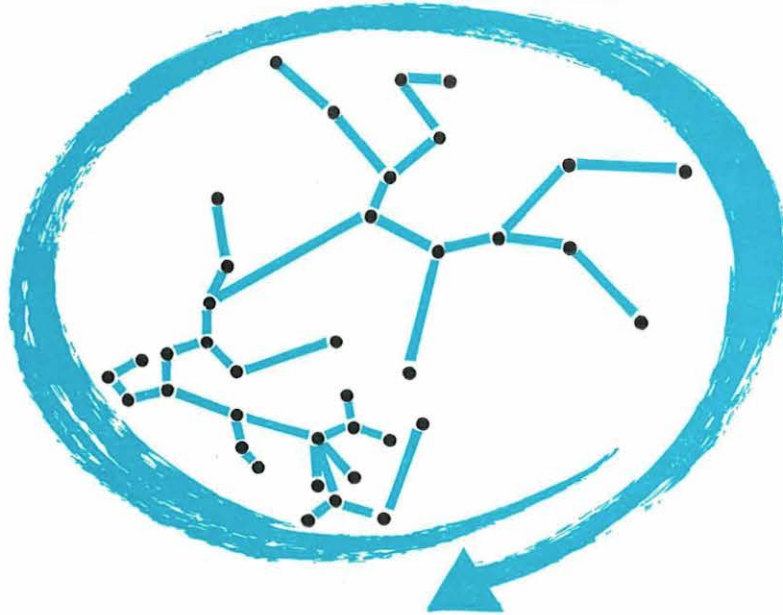

the new  
telecommunications  
network  
by G.E.C.  
of England

will fit  
Nigeria  
very well

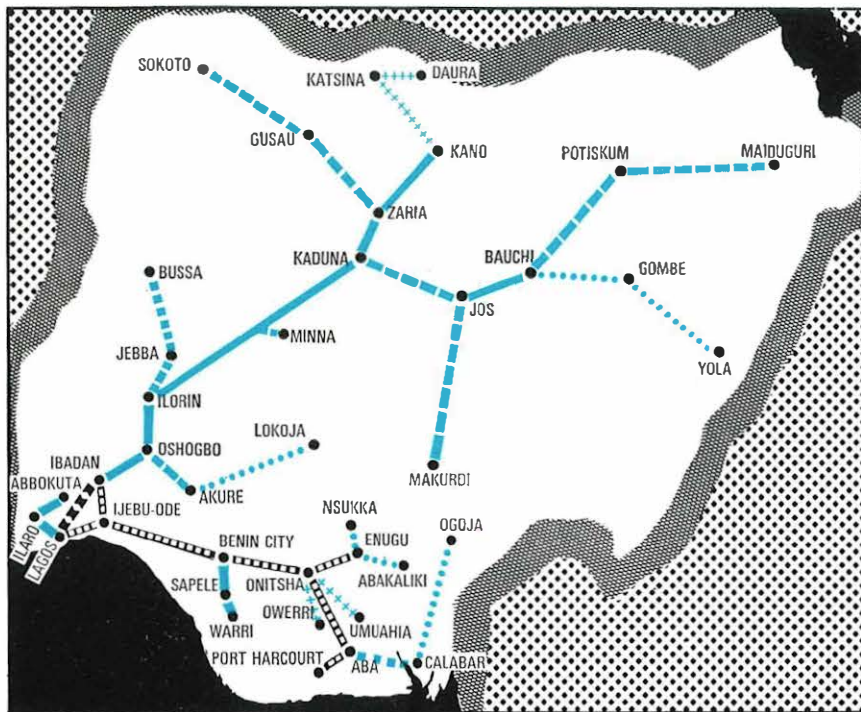

The facts are impressive . . . a £9.6 million contract placed by Nigeria's Ministry of Communications with GEC-AEI Telecommunications Limited . . . a 2500 mile microwave and VHF radio network linking all twelve state capitals and many smaller communities . . . with about 100 stations en route to carry telephone conversations over Nigeria's vastly varying terrain . . . GEC to undertake all aspects of the project from route surveys to commissioning, including a comprehensive training programme and the use of computer-controlled critical path analysis to ensure the smooth progress of the contract.

Behind the facts is a long and close association between GEC of England and the Nigerian Ministry of Communications culminating in this development which will give Nigeria an advanced telephone service, the equal of any in the world.

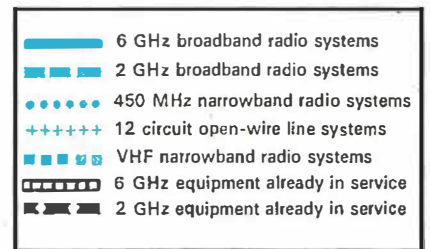

**Takes telecommunications into tomorrow**

GEC-AEI TELECOMMUNICATIONS LIMITED,  
OF COVENTRY, ENGLAND.  
A Management Company of The General Electric Co. Ltd. of England.

## If talking on the telephone involves you



... in this



...or this



...you need this

The LST4 loudspeaking telephone leaves the busy executive free to make notes and refer to documents as his telephone conversation proceeds. It also enables others present in the office to participate in a conference call, speaking to and hearing the distant party just as if he was in the same room. And when privacy is required, the executive can use the handset provided. Fully semiconductorized and tropicalized for operation under damp-heat conditions, the LST4 is made to a rigorous specification by G E C of England and attractively finished to provide a neat and functional aid to effective business communications.

**G.E.C.**

**Takes telecommunications into tomorrow**

GEC-AEI TELECOMMUNICATIONS LIMITED,  
OF COVENTRY, ENGLAND.

A Management Company of The General Electric Co. Ltd. of England.

**GEC**  
of England  
make  
**Multiplex** for  
a multiplicity  
of purposes

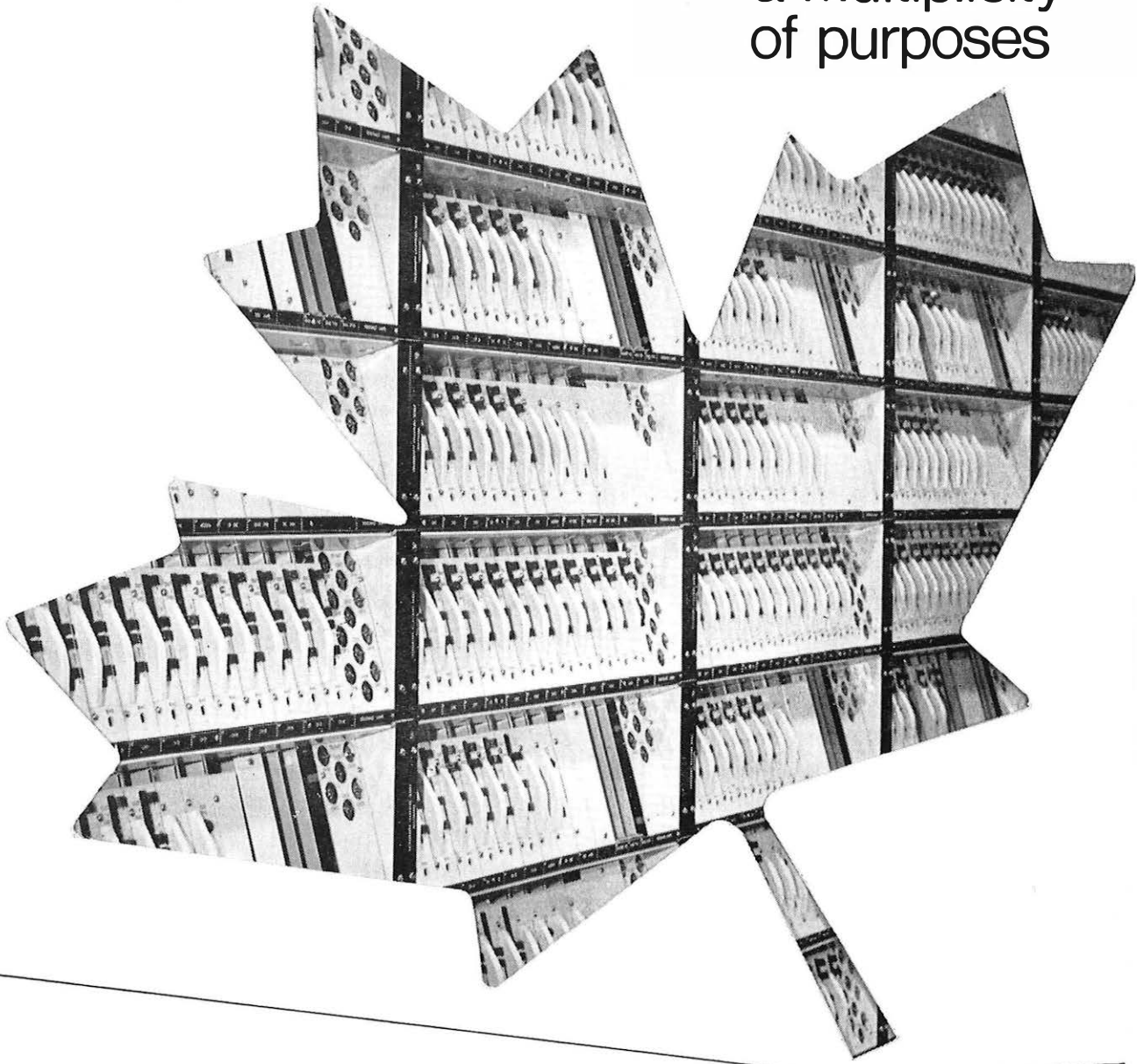



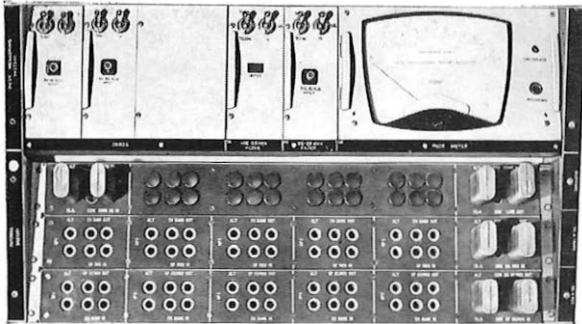

GEC Multiplex equipments are designed first and foremost to meet both CCITT and North American standards. Beyond that, GEC go out of their way to ensure that their Multiplex equipment incorporates the flexibility necessary to serve any administration.

For example, the patching unit illustrated above, with a specially built-in pilot meter, meets the specific requirements of the Canadian market. The 3,000-mile overland section of the Commonwealth Cable scheme between Montreal and Vancouver is equipped with GEC Multiplex. Similarly, GEC Multiplex equipment will meet your requirements.

With over 40 years' experience in the design and manufacture of Multiplex equipment to meet the needs of the world's markets, GEC continue to maintain their position in this field.

This is one facet of the total capability in telecommunications that is offered by GEC.

**Takes telecommunications  
into tomorrow**

**GEC-AEI TELECOMMUNICATIONS LIMITED, OF COVENTRY, ENGLAND.**

A Management Company of The General Electric Co. Ltd. of England.

## INDEX TO ADVERTISERS

	PAGE		PAGE
Astralux Dynamics, Ltd. . . . .	2, 3	Marconi-Elliott Microelectronics Ltd. . . . .	6
British Institute of Engineering Technology . . . . .	13	Pirelli General Cable Works, Ltd. . . . .	7
Cannon Electric (GB) Ltd. . . . .	13	Preformed Line Products (Great Britain) Ltd. . . . .	23
Cray Electronics Ltd. . . . .	16	Radiospares . . . . .	17
C & S Antennas Ltd. . . . .	15	Rolls-Royce, Ltd. . . . .	13
Davall Electronics Ltd. . . . .	22	Standard Telephones & Cables, Ltd. . . . .	8-11
GEC-AEI Telecommunications, Ltd. . . . .	18-21	Submarine Cables, Ltd. . . . .	1
International Rectifier Co. (GB) Ltd. . . . .	14	Telephone Cables, Ltd. . . . .	12
Marconi Co., Ltd., The . . . . .	4-5	Whiteley Electrical Radio Co., Ltd. . . . .	24

# Davall

## moulded track potentiometers



Developed for the specialists who require a reliable and long-life component operating at low noise levels and retaining a stable resistance curve. DAVALL potentiometers are suited to all telecommunication and metering applications, and feature a hot moulded carbon track element where the large cross-sectional area allows high voltages to be applied without fear of generating high current densities. Local high spots, overheating and premature failure are eliminated.

Tracks can be supplied with linear, logarithmic or other mathematical functions, and remain faithful throughout an operational life in excess of 100,000 operations. Noise level actually decreases with life. The integral moulding of track, base and element not only dispenses with unsatisfactory rivets, solders and crimps, but provides a basically dust-free and humidity-resistant component.

DAVALL type 81 dust-sealed miniature pre-set series is Post Office approved. Other ranges are to similar standards; DEF 5122 and BS 122 are the minimum parameters for all DAVALL pots. Available in all standard resistance values from 33 ohms to 2 megohms, switched, pre-set, spindle operated or edge operated; for printed circuit or chassis mounting. . . . Full details from

**Davall** Davall Electronics Limited  
Rothersthorpe Avenue, Northampton, NN4 9JL.  
Telephone: 0604 62761



**Ever done a  
make-off in  
30 seconds?**

**With a GUY GRIP DEAD END—it's dead easy.** Jobs that used to take 1½ to 2 hours—with the new GUY GRIP DEAD ENDS can now be completed in 10 minutes. No tedious make-offs, no tools are required, galvanising is undamaged, no stay rods to adjust, GUY GRIP DEAD ENDS are the simple and effective means of making-off stay strands and *cannot slip*. Big economies are effected by this method. Demonstrations arranged. Write or 'phone for comprehensive literature.



**Preformed**  
TRADE MARK

PREFORMED LINE PRODUCTS (GREAT BRITAIN) LIMITED  
ANDOVER, HAMPSHIRE, ENGLAND · TEL: ANDOVER 4044/5 · CABLES: PREFORMED ANDOVER  
AGENTS THROUGHOUT THE WORLD. MANUFACTURED UNDER LICENCE FROM PREFORMED LINE PRODUCTS CO. CLEVELAND · OHIO · USA  
COVERED BY PATENT AND PATENT APPLICATIONS NOS. 817535 · 817055 · 817534 · 805338 · 817644 · 768908.

**the GPO  
are proud to serve  
55 million people**

**WHITELEY  
are proud to serve  
the GPO**

The development and manufacture of telecommunications equipment requires forethought, research, technical expertise and a great deal of co-operation. Whiteley of Mansfield have been providing these services to the G.P.O. and industry for many years, producing anything from a control knob to complete electronic and telecommunications equipment.

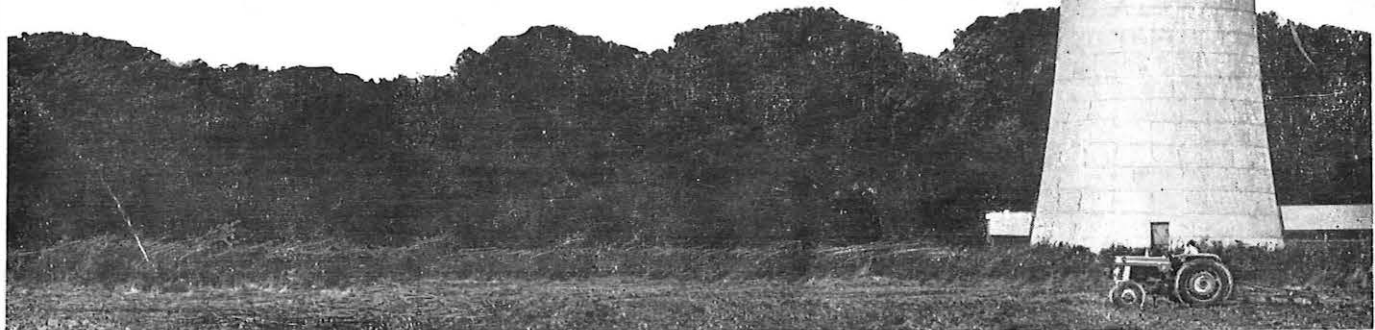

**WHITELEY ELECTRICAL RADIO CO. LTD.,** Mansfield, Notts, England. Tel. Mansfield 24762

London Office: 100 King Street W.C.2 Tel. 01 405 2074