

# The Post Office Electrical Engineers' Journal

---

VOL 74 PART 3 OCTOBER 1981



**1981**

**1906**

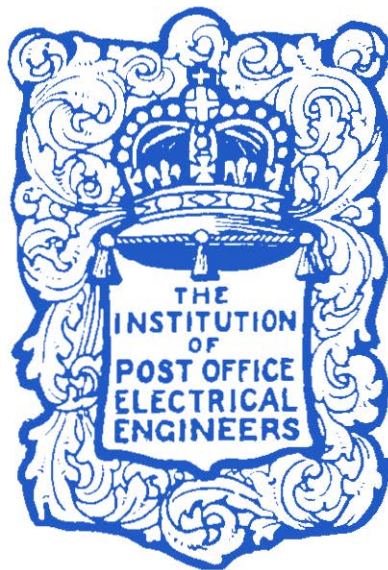

**IPOEE 75th ANNIVERSARY**

# THE POST OFFICE ELECTRICAL ENGINEERS' JOURNAL

VOL 74 PART 3 OCTOBER 1981

## Contents

<b>Foreword</b>	<b>147</b>
The President	
<b>The Institution of Post Office Electrical Engineers 1906-1981</b>	<b>148</b>
<b>Local Centre Chairmen and Honorary Local Secretaries 1981-82</b>	<b>149</b>
<b>Seventy-Five Years of the Institution of Post Office Electrical Engineers</b>	<b>150</b>
A. B. Wherry	
<b>TELECOMMUNICATIONS AND SOCIETY</b>	
<b>The Past Twenty-Five Years</b>	<b>156</b>
A. V. Knight and D. Wray	
<b>THE INLAND NETWORK</b>	
<b>The Evolution of the Inland Telecommunications Network</b>	<b>162</b>
K. E. Ward	
<b>INTERNATIONAL SERVICES</b>	
<b>A Review of the International Services</b>	<b>172</b>
C. J. Maurer	
<b>SWITCHING AND SIGNALLING</b>	
<b>The Evolution of Switching Systems Architecture</b>	<b>187</b>
L. R. F. Harris and J. Martin	
<b>Developments in Control Technology for Telephone Switching</b>	<b>194</b>
T. E. Longden and J. P. Kirtland	
<b>Developments in Signalling Systems Since 1956</b>	<b>199</b>
J. Tippler and J. Martin	
<b>Developments in Switching Systems Technology</b>	<b>203</b>
C. J. Hughes and T. E. Longden	
<b>Progress Towards Common-Channel Signalling</b>	<b>210</b>
B. W. Moore	
<b>Developments in Channel-Associated Signalling Technology</b>	<b>213</b>
P. B. Frame	
<b>Packet-Switched Data Communications Networks</b>	<b>216</b>
P. T. F. Kelly	
<b>Telex Switching and Signalling</b>	<b>219</b>
E. E. Daniels	
<b>MECHANICAL AND CIVIL ENGINEERING</b>	
<b>External Plant</b>	<b>223</b>
D. G. Clow and D. W. Stenson	

Published in April, July, October and January by *The Post Office Electrical Engineers' Journal*,  
2-12 Gresham Street, London EC2V 7AG.

Price: 80p (£1.30p including postage and packaging). Orders by post only.

Annual subscription (including postage and packaging): home and overseas £5.20.  
(Canada and the USA \$12.00.)

Price to British Telecom and British Post Office staff: 48p.

© 1981: The Institution of Post Office Electrical Engineers.

<b>CUSTOMER APPARATUS</b>	
<b>Telephone Instruments, Payphones and Private Branch Exchanges</b>	<b>235</b>
C. F. J. Hillen	
<b>TRANSMISSION</b>	
<b>An Historical Overview</b>	<b>249</b>
W. G. Simpson	
<b>Digitalization of the Junction and Main Networks</b>	<b>254</b>
M. J. Schickner	
<b>Microwave Radio-Relay Systems</b>	<b>257</b>
J. A. Chisholme	
<b>Frequency-Division Multiplex Line and Terminal Equipment</b>	<b>260</b>
M. J. Andrews	
<b>Audio Transmission</b>	<b>263</b>
J. L. Lonergan	
<b>Transmission Equipment Practice</b>	<b>265</b>
N. G. Crump	
<b>POSTAL ENGINEERING</b>	
<b>Foreword</b>	<b>267</b>
A. F. Beardmore	
<b>Letter-Post Mechanization : 75 Years of Progress</b>	<b>267</b>
K. H. C. Phillips	
<b>Parcel Sorting Systems and Ancillary Postal Equipment</b>	<b>271</b>
H. Goodison	
<b>Building Engineering Services in the Postal Business</b>	<b>277</b>
R. E. Finden	
<b>The Post Office Railway</b>	<b>280</b>
I. W. S. Berg	
<b>RESEARCH</b>	
<b>Research</b>	<b>282</b>
J. R. Tillman	
<b>THE FUTURE</b>	
<b>The Next Twenty-Five Years</b>	<b>298</b>
J. S. Whyte	
<b>Change and Development March 1931–March 1956–March 1981</b>	<b>234</b>
<b>Institution of Post Office Electrical Engineers</b>	<b>303</b>
<b>Notes and Comments</b>	<b>303</b>

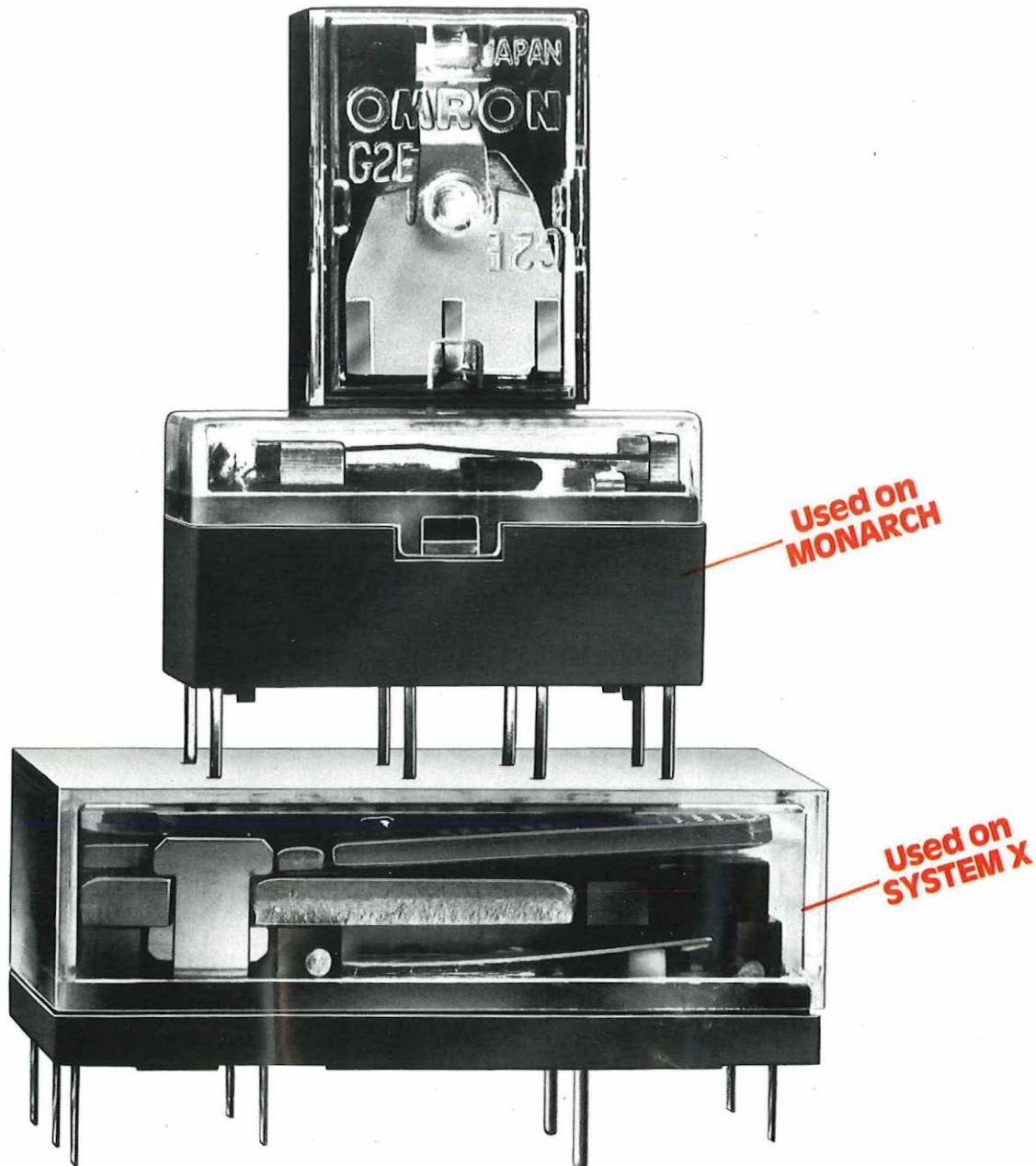

# WE CUT THE PRICE. WE CUT THE SIZE. WE LEFT THE OMRON QUALITY.

IMO can now offer you the high quality and reliability that you have come to expect in Omron relays, in their new series of low profile, printed circuit mounting subminiatures.

There's a tremendous range for every interface, communication and output application, suitable for mounting with sockets or directly onto printed circuit boards. There are low cost types like the LC1-NE, where price is a major consideration, and high reliability types like the LZN's with gold-clad, bifurcated crossbar contacts and card lift-off operation.

With contact ratings up to 10A and 240VAC and down to 10 $\mu$  A, all in a variety of housing styles and sizes, and up to four changeover contacts per relay, this range from IMO offers

you real design flexibility. All usual AC and DC coil voltages are available from stock.

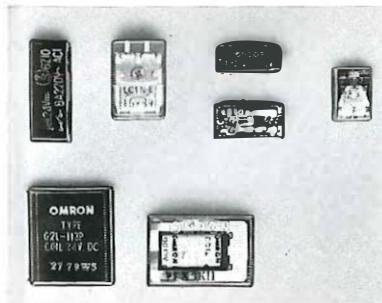

With the increased requirement for complete reliability in electronic circuitry, you'll need relays at the right price and the highest quality.

In a word, Omron—from IMO.

## IMO

**Much more  
than you may know**

IMO Precision Controls Ltd.,  
1000 North Circular Road,  
Staples Corner, London NW2 7JP.  
Tel: 01-452 6444. Telex: 28514.



# Everybody's talking about Ferranti ICs.

## Codecs

Ferranti ships more Codecs into U.K. telecommunications equipment than any other supplier. The ZNPCM1 and ZNPCM2 are in volume production now and provide an economic and compact solution for single channel Codec applications.

## ULA

Ferranti Uncommitted Logic Array (ULA) provides quickly the economic and performance benefits of custom LSI whatever your application sector.

We are the major supplier of ULA LSI circuits in telecoms equipment throughout Europe. The Ferranti ULA offers you the widest range of array products from linear to high speed digital and complexities from 100 to 2000 gates and above.

## Microphone Amplifier

The ZN470 has been selected for use in British Telecom telephones including the Ambassador. Designed to match the BT patented electret microphone the device provides improved speech quality and long term reliability. It is also thought to be the only IC capable of meeting BT's stringent lightning surge requirements.

It's Ferranti ICs for telecommunications—all the way. Send for further information to:

IC Marketing, Ferranti Electronics Limited,  
Fields New Road, Chadderton, Oldham OL9 8NP  
Telephone: 061-624 0515 Telex: 668038

# FERRANTI

## Semiconductors



5500 lines or more

# Thoroughbreds of 120 lines communication

...an elite family of advanced business telephone systems...microprocessor controlled.

20 lines

6 lines

3 lines



## GEC 13/24

1 exchange line + 3 extensions.  
2 exchange lines + 4 extensions.  
Intercom service.  
Call hold - Call divert.

For the small business, private house, or secretarial system working on a larger PBX line.

## GEC 16

1 + up to 6 extensions.  
Intercom Service.  
Selective call barring.  
Wide range of services.

## GEC 520

Up to 5 exchange lines.  
Up to 20 extensions.  
A wide range of advanced services built in. Comprehensive admin. control features and selected services programmed with small keypad.  
For the small business.

**GEC** GEC Telecommunications Limited, P.O. Box 53, Coventry, CV3 1HJ England.

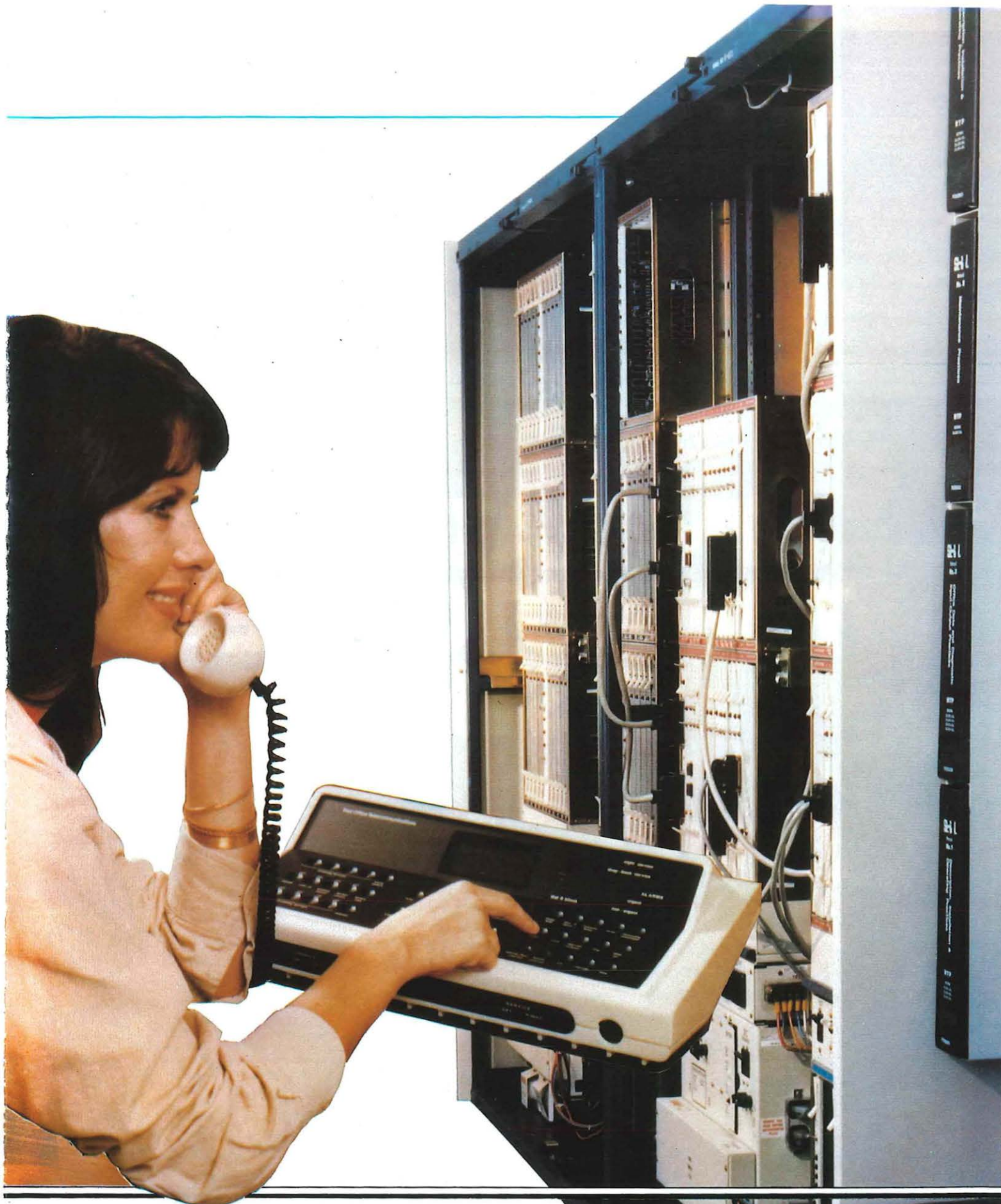

### **CDSS-1**

Up to 32 exchange lines.  
Up to 120 extensions.

Digital switching with stored-program control and wide range of new services. No preventive maintenance – self checking diagnostic programs and software test procedures. Software control easily reconfigured and updated to exploit very high traffic handling capability and system flexibility. Ideal for the future electronic office.

### **SL-1**

Up to 5500 lines, or more, in any mix of  
exchange and extension lines.

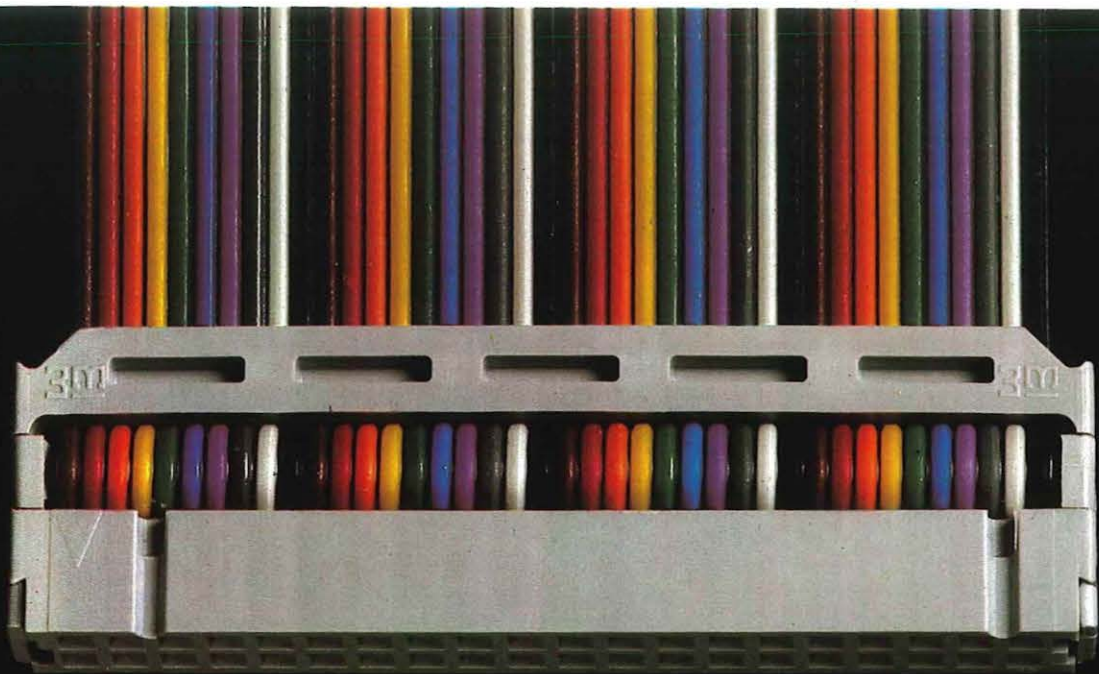

# UNBEATABLE: THE SCOTCHFLEX SYSTEM

## Here's what makes it unbeatable

- The original i.d.c. system
- Global endorsement by key specifying authorities, including British Telecom approval as P.O. connector 224.
- World-wide compatibility
- British manufacture
- Proven 40-year reliability from exclusive 'U-contact' design
- The fullest range of connectors, cable, accessories and tooling.

3M Scotchflex interconnection systems. Available from 3M direct or their distributors: ITT Electronic Services, Invader Components, M.D.L. Components, Vero Electronics and Verospeed.

For details write or phone Lynn Walters at:  
3M United Kingdom Limited,  
Freepost, Bracknell, Berks RG12 1BR.  
Telephone: Bracknell (0344) 58509.

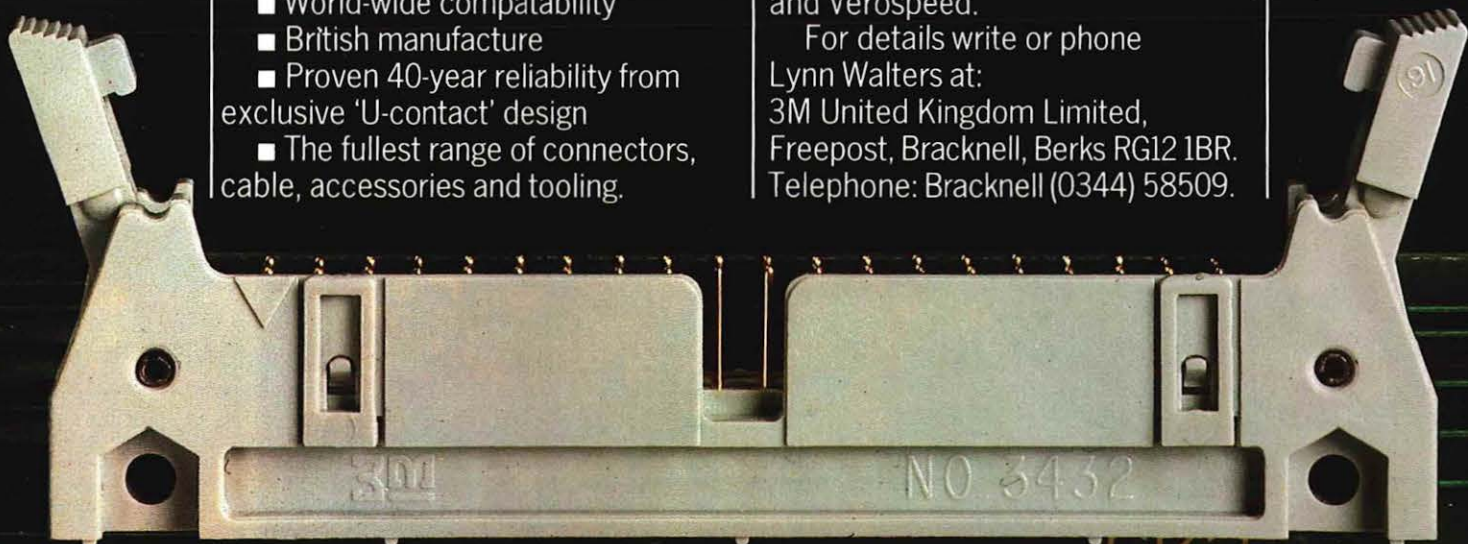

3M and Scotchflex are trade marks

**3M**

C1



# VMOS from Ferranti

VMOS—the Vertical MOSFET technology, for applications from microprocessors and display drivers to switching power supplies.

VMOS—the power transistor technology offering very fast switching performance, high input impedance and greater ruggedness.

Ferranti offer VMOS in the broadest range available. N-channel and P-channel. Voltages up to 650V. Currents up to 16A continuous, 32A pulsed.

You will get switching times as low as 5nSec, ON-resistances as low as 0.1 ohms and as wide a range of packages as you will need.

See how much power and versatility you've got with Ferranti VMOS.



Send for data to:

Ferranti Electronics Limited,  
Fields New Road,  
Chadderton, Oldham, OL9 8NP.  
Tel: 061-624 0515 Telex: 668038

Ferranti GmbH, Widenmayerstraße 5,  
D8000-Munich-22, West Germany.  
Tel: 089-293871 Telex: 523980

Ferranti Electric Inc.,  
87 Modular Avenue, Commack,  
N.Y. 11725, U.S.A.  
Tel: 516-543 0200 Telex: 510226 1490

## FERRANTI Semiconductors

# FAR AND AWAY, MORE VERSATILE

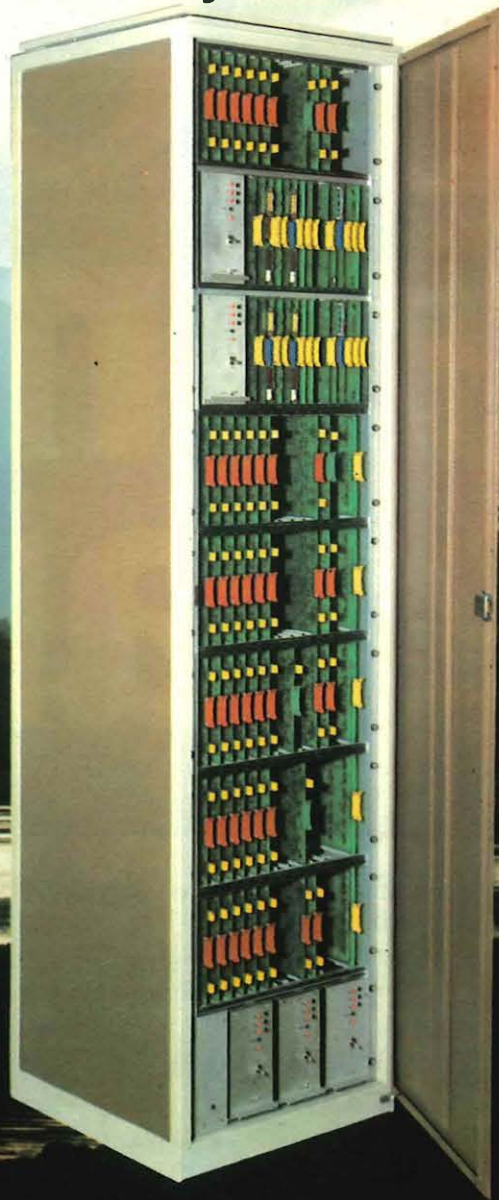

## THE PLESSEY RURAL DIGITAL EXCHANGE-UXD

The Plessey Rural Digital Exchange (UXD)\* is a digitally switched, software-based, microprocessor-controlled public telephone exchange. It's been designed for cost effective, reliable unattended operation where high-level subscriber service is required for up to 600 lines.

The latest techniques in solid-state electronics make the UXD particularly suited to rural applications as a free-standing, unattended exchange, or as part of a fully integrated rural network. It lets Telephone Administrations provide economical communications for small communities, and gives subscribers at these locations features usually obtained only from

larger, stored-program-controlled systems.

Write to Plessey Telecommunications International Marketing Department for a detailed brochure.

\*The UXD5 exchange has been developed jointly by British Telecom and Plessey Telecommunications Limited. The UXD5 has been adopted by British Telecom for use as a digital replacement for existing rural (UAX) exchanges.



**PLESSEY**  
**telecommunications**

Plessey Telecommunications Limited,  
Beeston, Nottingham,  
United Kingdom NG9 1LA  
Tel: Nottingham (0602) 254831  
Telex: 37201

# Quite impartially, we believe we offer the best advice.

British Telconsult is the consultancy service of British Telecom. And because we have no manufacturing interests, we are quite impartial when it comes to providing a consultancy service for the latest developments in telecommunications.

At present we are involved with 47 countries round the world covering every aspect of telecommunications business, from

## COMMUNICASIA '81

We hope to have the pleasure of meeting you in person on the British Telecom stand.

switching and transmission to administration.

If you want to know more about us, call 01-588 3013 (or if calling from outside the UK +441 588 3013). Telex: 887523.

Or you can write to us at British Telconsult, 55 Old Broad Street, London EC2M 1RX, UK.

British

## TELCONSULT

The Consultancy Service of British Telecom - part of the Post Office



SIR JOHN GAVEY, C.B., M.I.E.E.  
First President of the  
Institution of Post Office  
Electrical Engineers  
1906



MR. J. S. WHYTE,  
C.B.E., M.SC.(ENG.), F.ENG., F.I.E.E.  
President of the  
Institution of Post Office  
Electrical Engineers  
1981

# The Post Office Electrical Engineers' Journal

---

## BOARD OF EDITORS

D. Wray, B.SC., C.ENG., F.I.E.E., Chairman; D. F. Ashmore; E. Davis, C.ENG., M.I.E.E.; C. E. Rowlands, B.SC., C.ENG., M.I.E.E.; F. V. Spicer, B.A.; A. W. Welsh, C.ENG., M.I.E.E.; G. White, B.SC., PH.D., SEN.MEM.I.E.E.E.

**Managing Editor** V. L. Dunhill, B.SC., C.ENG., M.I.E.E. **Deputy Managing Editor** A. R. Lawrence, C.ENG., M.I.E.E.

**Secretary-Treasurer** B. Farr **Advertisement Manager** N. G. Crump

---

## FOREWORD by The President

On the occasion of its 75th Anniversary, I wish to congratulate the Institution of Post Office Electrical Engineers on the achievements of the last 75 years and to thank all who have contributed to its success.

This issue of the *Journal* reviews the changes that have taken place in telecommunications and postal services over the 25 years since the Golden Jubilee of the Institution, these changes being brought about by the application of the tremendous advances that have been made in science and technology.

Although the *Post Office Electrical Engineers' Journal* is primarily a technical journal, no current review of telecommunications in the UK would be complete without reference to the changing regulatory environment. In its 75 years history the Institution of Post Office Electrical Engineers has seen many changes, and its members have made many contributions to national objectives in war and peace. But the British Telecommunications Act 1981 will lead to changes that will be more deep-seated and fundamental than any that have been experienced before. The supply, installation and maintenance of practically all attachments to British Telecom's network will be open to competition. Safeguards for the consumer will exist through appropriate processes of specification and approval, although these functions will not be undertaken, as hitherto, by British Telecom.

The new Act also gives the Secretary of State for Industry the power to authorize direct competition within the network. How the telecommunications scene in Britain will look when the time comes to write the centenary issue of this *Journal* is therefore particularly difficult to foretell. However, one thing is certain: the national need is for more extensive, more diverse and more cost-effective telecommunications of every kind. Within British Telecom, the organizational structures, working practices, staff management and union attitudes will have to evolve and adjust to the new situation. Given flexibility of attitudes and positive purpose, British Telecom and the Institution can face the future with confidence and look forward to serving the Nation as well in the next 25 years as they have in the past 75 years. This will not happen by itself. Everybody is directly involved and has a part to play. With the challenge comes opportunity; I am sure that everybody will respond in a manner worthy of our long history.



# THE INSTITUTION OF POST OFFICE ELECTRICAL ENGINEERS 1906-1981

## PRESIDENT

1906-07	Sir John Gavey C.B., M.I.E.E.
1907-12	Major W. A. J. O'Meara C.M.G., M.INST.C.E., M.I.E.E.
1912-19	Sir William Slingo M.I.E.E.
1919-22	Sir William Noble M.I.E.E.
1922-32	Col. Sir Thomas Fortune Purves O.B.E., M.I.F.E.
1932-39	Sir George Lee O.B.E., M.C., B.SC., M.I.E.E.
1939-46	Col. Sir Stanley Angwin K.B.E., D.S.O., M.C., T.D., M.I.E.E.
1946-51	Sir Archibald J. Gill B.SC.(ENG.), M.I.E.E., F.I.R.E.
1951-54	Sir W. Gordon Radley K.C.B., C.B.E., PH.D.(ENG.), M.I.E.E.
1954-60	Brig. Sir Lionel H. Harris K.B.E., T.D., M.SC.(ENG.), F.C.G.I., M.I.E.E.
1960-65	Sir Albert Mumford K.B.E., B.SC.(ENG.), F.Q.M.C., M.I.E.E.
1965-67	D. A. Barron C.B.E., M.SC.(ENG.), C.ENG., F.I.E.E.
1967-77	Professor J. H. H. Merriman C.B., O.B.E., D.SC.(HON.), M.SC., A.INST.P., C.ENG., F.I.E.E., F.K.C.
1977-	J. S. Whyte C.B.E., M.SC.(ENG.), F.ENG., F.I.E.E.

## CHAIRMAN OF COUNCIL

1906-07	G. M. Carr M.I.E.E.
1907-08	J. W. Woods M.I.E.E.
1908-11	A. J. Stubbs M.INST.C.E., M.I.E.E.
1911-12	Sir William Slingo M.I.E.E.
1912-13	H. R. Kempe M.INST.C.E., M.I.E.E.
1913-15	Sir William Noble M.I.E.E.
1915-21	A. J. Stubbs M.INST.C.E., M.I.E.E.
1921-22	Col. Sir Thomas Fortune Purves O.B.E., M.I.E.E.
1922-29	A. L. DeLattre M.I.E.E.
1929-31	E. H. Shaughnessy O.B.E., M.I.E.E., M.I.R.E.
1931-32	Sir George Lee O.B.E., M.C., B.SC., M.I.E.E.
1932-35	Major H. Brown O.B.E., M.I.E.E.
1935-39	Col. Sir Stanley Angwin K.B.E., D.S.O., M.C., T.D., M.I.E.E.
1939-42	P. J. Ridd C.B.E., M.I.E.E.
1942-46	Sir Archibald J. Gill B.SC.(ENG.), M.I.E.E., F.I.R.E.
1946-54	H. Faulkner C.M.G., B.SC.(ENG.), M.I.E.E., F.I.R.E.
1954-55	Col. J. Reading M.B.E., E.R.D., B.SC.(ENG.), M.I.E.E.
1955-65	D. A. Barron C.B.E., M.SC.(ENG.), C.ENG., F.I.E.E.
1965-67	Professor J. H. H. Merriman C.B., O.B.E., D.SC.(HON.), M.SC., A.INST.P., C.ENG., F.I.E.E., F.K.C.
1967-73	N. C. C. de Jong B.SC.(ENG.), C.ENG., M.I.C.E., F.I.MECH.E., F.I.E.E.
1973-80	J. F. P. Thomas B.SC.(ENG.), C.ENG., M.I.E.E.
1980-	D. Wray B.SC.(ENG.), C.ENG., F.I.E.E.

## SECRETARY

1906-08	J. W. Atkinson I.S.O., M.I.E.E.
1908-10	J. M. Crawford
1910-11	J. H. Bell
1911-23	T. Smerdon A.M.I.E.E.
1923-29	R. V. Hansford D.SC., M.I.F.E.
1929-31	P. G. Hay M.I.E.E., F.S.I.
1931-35	J. Innes C.B., B.SC., M.I.E.E.
1935-51	Col. J. Reading M.B.E., E.R.D., B.SC.(ENG.), M.I.E.E.
1951-57	H. E. Wilcockson A.M.I.E.E.
1957-67	S. Welch M.ENG., A.M.I.E.E.
1967-78	A. B. Wherry B.SC.(ENG.), C.ENG., F.I.E.E.
1978-	R. E. Farr

## HONORARY TREASURER

1906-07	J. W. Woods M.I.E.E.
1907-09	D. H. Kennedy A.M.I.E.E.
1909-12	H. R. Kempe M.INST.C.E., M.I.E.E.
1912-19	J. W. Atkinson I.S.O., M.I.E.E.
1919-22	A. O. Gibbon M.I.E.E.
1922-25	E. H. Shaughnessy O.B.E., M.I.E.E., M.I.R.E.
1925-28	B. O. Anson O.B.E., M.I.E.E.
1928-31	C. J. Mercer M.I.E.E., M.I.R.E.
1931-34	B. O. Anson O.B.E., M.I.E.E.
1934-36	P. J. Ridd C.B.E., M.I.E.E.
1936-39	R. M. Chamney B.SC., A.M.INST.C.E., A.M.I.E.E.
1939-40	G. F. O'Dell B.SC., M.I.E.E.
1940-46	R. M. Chamney B.SC., A.M.INST.C.E., A.M.I.E.E.
1946-49	C. W. Brown M.I.E.E.
1949-51	W. T. Gemmell B.SC.(ENG.), A.C.G.I., M.I.MECH.E., A.M.I.E.E.
1951-55	D. A. Barron C.B.E., M.SC.(ENG.), C.ENG., F.I.E.E.
1955-58	R. E. Jones M.B.E., M.SC., D.I.C., A.C.G.I., M.I.E.E.
1958-61	J. J. Edwards B.SC.(ENG.), M.I.E.E., D.I.C., A.C.G.I.
1961-63	J. Stratton M.I.F.E., A.C.G.F.C.
1963-67	J. W. Freebody B.SC., WHIT.SCH., A.C.G.I., D.I.C., C.ENG., F.I.E.E.
1967-70	E. C. Swain B.SC.(ENG.), C.ENG., M.I.E.E.
1970-73	H. T. McGrath B.SC.
1973-76	R. T. Mayne B.SC., C.ENG., F.I.E.E.
1976-79	C. F. J. Hillen B.SC. TECH., C.ENG., M.I.E.E.
1979-	A. V. Knight B.SC., C.ENG., F.I.E.E., F.B.I.M.

# LOCAL CENTRE CHAIRMEN AND HONORARY LOCAL SECRETARIES 1981-1982

LONDON CENTRE	<i>Chairman</i> <i>Secretary</i>	N. J. H. Ninnim, M.SC., C.ENG., M.I.E.E. L. J. Hobson, T.ENG., M.I.T.E.
EASTERN (COLCHESTER) CENTRE	<i>Chairman</i> <i>Secretary</i>	R. A. Robinson, B.SC.(ENG.), C.ENG., M.I.E.E. P. M. Cholerton, T.ENG.
EASTERN (BLETCHLEY) CENTRE	<i>Chairman</i> <i>Secretary</i>	A. E. Hull D. R. Norman
BIRMINGHAM, COVENTRY AND WEST MIDLANDS CENTRE	<i>Chairman</i> <i>Secretary</i>	J. W. Rance, B.SC.(ENG.), C.ENG., F.I.E.E. D. F. Ashmore
EAST MIDLANDS CENTRE	<i>Chairman</i> <i>Secretary</i>	J. W. Young, B.SC.(ENG.) D. W. Sharman
NORTH-EASTERN CENTRE	<i>Chairman</i> <i>Secretary</i>	R. Kelsey R. S. Kirby, B.SC.
NORTHERN CENTRE	<i>Chairman</i> <i>Secretary</i>	D. Wardman L. G. P. Farmer
NORTHERN IRELAND CENTRE	<i>Chairman</i> <i>Secretary</i>	J. B. Millar, B.SC., C.ENG., F.I.E.E. W. H. Tolerton
NORTH-WESTERN (MANCHESTER AND LIVERPOOL) CENTRE	<i>Chairman</i> <i>Secretary</i>	E. Jackson, DIP.E.E., C.ENG., M.I.E.E. W. Edwards, M.SC.
LIVERPOOL SUB-CENTRE	<i>Chairman</i> <i>Secretary</i>	E. Fowler, C.ENG., M.I.E.E. J. Bennett
NORTH-WESTERN (PRESTON) CENTRE	<i>Chairman</i> <i>Secretary</i>	R. F. Howard, B.SC.(ENG.), C.ENG., F.I.E.E. R. L. Osborn
SCOTLAND EAST CENTRE	<i>Chairman</i> <i>Secretary</i>	P. M. Mansfield, B.SC.(ENG.), C.ENG., F.I.E.E. N. A. Braid
ABERDEEN SUB-CENTRE	<i>Chairman</i> <i>Secretary</i>	J. Lough, B.SC.(ENG.), C.ENG., F.I.E.E. T. M. Keldie
DUNDEE SUB-CENTRE	<i>Chairman</i> <i>Secretary</i>	E. J. Simpson, C.ENG., M.I.E.E. G. Duff
SCOTLAND WEST CENTRE	<i>Chairman</i> <i>Secretary</i>	A. S. Petrie, T.D. G. Dobbie
SOUTH-EASTERN CENTRE	<i>Chairman</i> <i>Secretary</i>	G. Bishop J. M. Smith, T.ENG., M.I.T.E.
SOUTH-WESTERN CENTRE	<i>Chairman</i> <i>Secretary</i>	R. E. Burt, C.ENG., M.I.E.E. D. P. Cosh
EXETER/PLYMOUTH SUB-CENTRE	<i>Chairman</i> <i>Secretary</i>	G. P. Barton, C.ENG., M.I.E.R.E. C. Gould
SOUTHAMPTON/BOURNEMOUTH SUB-CENTRE	<i>Chairman</i> <i>Secretary</i>	W. Luff, C.ENG., M.I.E.R.E. M. S. Blake
STONE/STOKE CENTRE	<i>Chairman</i> <i>Secretary</i>	N. Fox, C.ENG., M.I.E.E. J. Coulson, C.ENG., M.I.E.R.E.
WALES AND THE MARCHES CENTRE	<i>Chairman</i> <i>Secretary</i>	N. G. Smith D. A. Randles
CHESTER SUB-CENTRE	<i>Chairman</i> <i>Secretary</i>	C. G. Hughes L. F. Argyle
SHREWSBURY SUB-CENTRE	<i>Chairman</i> <i>Secretary</i>	B. L. Goffee, B.SC. J. C. Price
MARTLESHAM HEATH CENTRE	<i>Chairman</i> <i>Secretary</i>	J. D. Andrews, C.ENG., M.I.E.E. R. M. Brooks, M.SC.

# THE INSTITUTION OF POST OFFICE ELECTRICAL ENGINEERS

## Seventy-Five Years of the Institution of Post Office Electrical Engineers

A. B. WHERRY, B.SC.(ENG.), C.ENG., F.I.E.E.†

UDC 061.1 (091)

*The Institution of Post Office Electrical Engineers was founded in 1906 "to promote the general advancement of electrical and telegraphic science and its applications, and to facilitate the exchange of information and ideas on these subjects amongst the members of the Institution, and for this purpose: to hold meetings for reading and discussing communications; to print and circulate among the members such communications as the Council may deem worthy; and to form a Library of books, publications and manuscripts . . ."*

*The present rules contain some amplification of the terms used in 1906, but the essential principles have remained unchanged since then.*

### INTRODUCTION

The first formally constituted Council Meeting of the Institution was held on 6 June 1906. The first subject discussed was "Formal Inauguration of the Institution by the President". The first President was John Gavey, who was also the Engineer-in-Chief and who was subsequently knighted. He was aided by Mr. G. M. Carr who had been instrumental in organizing that first meeting and, indeed, became the first Chairman of Council of the Institution.

The background to the establishment of the Institution is summarized in a paragraph of the first annual report which

states, "In April 1905, the engineers, realizing that the time had come when individual studies should be assisted by a co-operative movement, formed the Society of Post Office Engineers . . .". A circular indicating the aims and objects of the Society was issued, and it was brought to the attention of the Headquarters Department with the result that a liberal grant-in-aid was secured from the Treasury. With an enlarged membership and a somewhat wider scope, the present Institution was formally established the following year. The initial Treasury grant of £500 was used to start a technical library.

At the end of the first session, the Institution had 775 members. The Central (Lending) Library came into effective operation, 16 reference libraries were established under the supervision of Local-Centre Secretaries, and the circulation of technical periodicals commenced. At the 14 Local Centres

† Chairman, North West Telecommunications Board, and Vice-Chairman and former Secretary of the Institution of Post Office Electrical Engineers



Standing: E. Marmion\*, C. G. Suett, M. E. Barnes, J. W. Turnbull, J. D. Overall, J. M. Avis, M. E. Webb, W. N. Lang, K. Coxey\*, L. W. F. Vbranch, D. F. Ashmore, R. D. Edwards, B. H. House, P. M. Annett, D. V. Gasson  
Seated: A. V. Knight (Honorary Treasurer), A. B. Wherry (Vice Chairman), D. Wray (Chairman), D. A. Davey (Vice Chairman), R. E. Farr (Secretary), M. J. Sutton (Assistant Secretary)  
Absentees: A. G. Leighton, N. Fox (President, Associate Section), N. R. Paul, F. V. Spicer, D. A. Spurgin\*, L. Thomas\*, P. Walling\*  
\*1981-82 new member

Officers and Members of Council 1980-81 and new members for 1981-82



(two of them in what is now the Republic of Eire), a total of 40 meetings were held, at which papers were read and discussed.

After the presentation of the first Annual Report, Sir John Gavey paid tribute to the great variety of papers that had been read. He pointed out that the Institution had achieved far more than the Society of Telegraph Engineers (later to become the Institution of Electrical Engineers) had done in its first year of 1871—a Society that was supported by all the leading electrical engineers of those days, and had the advantage of having all its members gathered in the Metropolis.

## ORGANIZATION

The affairs of the Institution are supervised by a Council, of which the Chairman and Vice-Chairmen are nominated by the President of the Institution. The members of Council, including the Honorary Treasurer, are nominated and elected by the members; representation is by British Post Office (BPO) grade. The Secretary, the Librarian and their assistants are appointed by Council. At its inception the Council numbered 14, including 10 elected members. The number has been increased from time to time to ensure adequate representation and is now 23, including the elected Honorary Treasurer and 16 elected members. The President and Vice-Presidents of the Institution are appointed by Council.

From the beginning, Local Centres have been established to conduct the field work of the Institution; responsibility is vested in the Local Committees for the working of each Centre, for all arrangements connected with the preparation of the annual programme of meetings, and for the observance of the rules of the Institution. The Local Committee consists of a Chairman nominated with the agreement of the Chairman of Council; a Vice-Chairman chosen by the Local Chairman (exceptionally, in London, both officers are nominated by the President); an Honorary Local Secretary; and elected members of the Committee.

In the inaugural session, 14 Local Centres were formed, organized on a Metropolitan and Provincial Engineering District basis. However, in 1935, BPO services were regionalized; as a consequence, it was necessary to reframe the rules, primarily to safeguard the membership rights of those



R. E. Farr—Secretary of the Institution



D. Wray, B.SC., C.ENG., F.I.E.E.—Chairman of Council

employed on the engineering side of the regional organization. The existing Local Centre organization was retained as far as practicable, with some Regions containing more than one Provincial Centre. This process of adjustment continued in the early war years, when regionalization was brought into full effect. The number of Local Centres has now risen to 17; the last Centre to be established, following the move of the BPO Research Laboratories from Dollis Hill in London, was at Martlesham Heath in 1977.

For many years, some Council meetings have been held at Local Centre venues, so that officers of the host centre can participate in discussion. The practice has been extended so that, now, 2 of the meetings each year take place at Provincial Centres; the remaining gathering is in London, with officers of the London Centre present.

Elections for Council, London Centre and Provincial Centre Committee members are held in 3-year cycles, sequenced to ensure continuity in each committee.

## MEMBERSHIP OF THE INSTITUTION

At the time of its foundation, the Institution was “open to all officers of the Engineering Department of the Post Office, from the Engineer-in-Chief to Sub-Engineers and Clerks”. Revision of the rules has been necessary from time to time to take account of expansion of the BPO, the creation of new engineering grades, regionalization of services and the establishment of the BPO as a public corporation. Corporate Members are now classed as Members (engineers) and Affiliated Members (others who are not engineers, but who do work associated with that of the engineers).

Local Committees are asked annually to determine whether, in their opinion, any of their members fulfil the requirements of honorary membership. The current rule (established in 1922, when there were 6 Honorary Members) states, “The Council may elect a limited number of Honorary Members from among persons whose services to the Institution have been of an exceptional character”. Recommendations, sup-

Fairlight,  
Bampton Wick.  
4. 12. 07.

J. W. Atkinson, Esq.,  
1, Colfe Road,  
Forest Hill,  
S.E.

Dear Mr. Atkinson,

It affords me very great gratification to note the resolution of the Council to elect me as an Honorary Member of the Institution of the Post Office Electrical Engineers. I feel much honoured and gratified by this action and I need scarcely say I shall continue to take a deep interest in all the work of the Institution.

With kind regards,

Yours very truly,



Sir John Gavey's letter of acceptance of Honorary Membership of the Institution

ported by as much detail as possible, are forwarded for Council's approval. In most cases, the award of honorary membership has been timed to coincide with a member's retirement from the BPO. However, this does not have to be the case where a member's service to the Institution has been outstanding.

In 1908, the rules were extended to allow "Officers of Colonial and Foreign Administrations engaged in electrical engineering work" to be admitted as non-corporate Corresponding Members. Today, corresponding membership is still permitted, and the rules specifically mention the Commonwealth and the European Economic Community. Former Corporate Members of the Institution, who have left the service of the BPO for work of a similar nature, may also retain their interest through this class of membership.

The acquisition of the National Telephone Company's (NTC's) system, and the consequent transfer of staff to the BPO Engineering Department in the autumn of 1912, was followed by an increase in membership. A still larger increase in the following year was attributable to the continuing enrolment of ex-NTC staff, and to the extension of membership. The outbreak of the First World War curbed the activities of the Institution and the growth in membership. Similarly, a further break occurred during the Second World War. At its formation, the membership represented 70% of those eligible, which is recorded as "exceeding the sanguine expectation of the Organizing Committee". The present membership still represents 70% of eligible engineering staff.

### INSTITUTION MEETINGS

The most important activity of the Institution is the holding of meetings, normally 7 in each session at each Local Centre. Papers are presented, mainly by members, on scientific, technical and allied matters associated with the activities of the BPO, and there are opportunities for discussion. Through

these meetings, the Institution is able to give its members interesting and valuable information on progress in the telecommunications field. Papers are presented during sessions that commence early in October and terminate in April or May each year.

From 40 meetings in the first year, there was a steady rise to 76 just prior to the commencement of the First World War. After a period of curtailment due to the war, meetings resumed almost to pre-war proportions, with a total of 70 meetings. In the last full session before the outbreak of the Second World War, the number of meetings at the 14 Local Centres had increased to 88. Once again the impact of war had its effect on the Institution's activities; nevertheless, during the war, 100 meetings were held on an Area basis, including 7 informal meetings of the London Centre. In the immediate post-war years, meetings were very soon re-established to reach a figure of 140 at the 14 Centres and 20 sub-Centres then functioning. The number of Centres now stands at 17, with 7 sub-Centres. In recent sessions, the number of meetings held has exceeded 150.

The era of continual change, from the straightforward manual telephones in use at the beginning of the century to the more complex present-day digital techniques of switching and transmission, is reflected by papers presented to the membership. Early titles such as *The Common Battery Telephone and Terminal Poles for small Post Offices and Telephone Exchanges* compare with recent papers such as *Generating Electricity from Solar Energy* and *Global Satellite Communications*. The number of meetings, and papers presented, are not the only criteria of the value of each session's proceedings, the range of subject matter (a matter for selection by Local-Centre Committees), and the standard of the contributions (recognized by Council in the selection of papers for printing and medal awards) are of equal, if not greater, importance.

The publication of papers selected from those read before the Centre has been an important function of the Institution. By this means, the more important contributions have been made available as works of reference not only to the entire membership, but also to all those interested in the design, provision and operation of telecommunications equipment and systems, including subscribers from the Commonwealth and Dependencies, Foreign Administrations and Industry. However, fewer members have been prepared to commit their presentations to paper in recent years and this, coupled with the rapid advance of technology that quickly makes information out-of-date, has meant the publication of very few papers in recent years; more emphasis has been placed upon the articles published in this *Journal*.

### LIBRARY FACILITIES

The Central (Lending) Library was formed in July 1906. The initial £500 Treasury grant was used to purchase a selection of books, and a catalogue was circulated to members. A separate Library Committee was formed and this important Committee has functioned continuously since then. From the outset, demand for issue of books was heavy and an additional post of Librarian was created. When the initial grant was exhausted, all subsequent books added to the library were purchased out of revenue. During the First World War, facilities remained available to members on active service and, as a result, it is recorded that "there is reason to fear that some books have been buried in the trenches and dug-outs in the French battlefields". To extend the range of books available to members, the scope of the Library was extended in the 1930s to include those in Messrs Lewis's Technical and Scientific Library. This method of meeting occasional demand shows considerable economies compared with increasing the number of books held in the Library.

The present Library contains over 1750 books and the Library Committee, as well as examining new works and

editions with a view to purchase, also keeps under continuous review the need for retaining the older books. Also under the control of the Library Committee is the selection of periodicals for circulation. Each member is entitled to select one periodical from a current range of 16 titles.

During the inaugural session, 16 reference libraries were set up in the offices of Superintending Engineers, under the supervision of the Local Secretaries. By the end of the 1907-08 session, a total of £140 from the Treasury Initial Grant had been spent on the equipping of these libraries, each of which comprised about 30 standard works of reference. Despite a small, but regular, expenditure on the maintenance of the reference libraries, it was noted by Council in 1919-20 that the existing volumes had become largely obsolete, and it was therefore proposed to re-equip the reference libraries with selected up-to-date works of reference. Completion of this task was reported in 1922-23. Over the following years, the Department adopted a more liberal policy in the provision of reference works of specific value to specialized duties; thus, the need for local reference libraries became progressively less, so that, by 1938, Council was able to authorize their closure.

### INSTITUTION AWARDS

From its inception, the Institution has offered 4 medal awards annually for the best papers read to meetings of Local Centres, subject always to sufficient papers reaching the requisite standard.

The design for the Institution Medal was produced in 1907 by a member of the Institution, Mr. O. P. Moller of the Engineer-in-Chief's Office, who received the prize offered by Council for the best design. The obverse side of the medal bears the very appropriate Latin inscription *Nil Sine Labore* (Nothing is achieved without toil). The same basic design has also been used since 1923 for the Institution's seal embossed on Institution Certificates, and in a slightly modified form on the front cover of the *Journal*.

The first medal awards for papers read during the inaugural session were notified at the second Annual General Meeting and were:

Senior Silver Medal—Mr. J. E. Taylor, for his paper entitled *Electric Wave Propagation*

Senior Bronze Medal—Mr. J. G. Hill, for his paper entitled *Telephone Transmission*

Junior Silver Medal—Mr. A. O. Gibbon, for his paper entitled *Underground Construction (Provinces)*

Junior Bronze Medal—Mr. J. S. Brown, for his paper entitled *Telephone Trunk Signalling Arrangements*

The records show that a similar high standard has always been observed in the allocation of medal awards; for instance, only once in the past 20 years have all 4 medals been awarded during one session. Likewise, for the same period, a total of only 18 papers qualified for a medal award. No papers were submitted for 1980. In 1950-51, the Council decided to broaden the scope of the medal awards by instituting a Field

Medal for the best paper read at a Local-Centre meeting on a subject primarily of Regional interest. This step was taken in recognition of the value of papers on field subjects, even though they were not regarded as being appropriate for printing. The present rules now permit 3 field medals to be awarded annually, subject to Council approval.

After the First World War, an Essay Competition was introduced by Council "to further interest in the performance of engineering duties, and to encourage the expression of thought given to day-to-day departmental activities". It was an immediate success, no fewer than 60 essays being submitted to the judging committee of the day. The competition was continued throughout the war and was well supported, but since the 1950s, there has been a steady decline. In an attempt to stimulate an interest in essay writing, the Council invited entries for a special 75th Anniversary Essay Competition. The best essay on a theme concerned with the future role of British Telecom was to be awarded a unique Anniversary Silver Medal and, in addition, prize money totalling £200 for the best 10 essays was on offer. However, the response, although improved, did not reach the desired standard in either the number or quality of entries. The special medal was not awarded and Council has now reluctantly decided not to organize any further essay competitions.

In 1933, the Council considered that the time was opportune "to encourage the work of the City and Guilds of London Institute in its efforts to promote technical education by awarding prizes in one of the examination subjects associated with the art of electrical communications". Arrangements were agreed, whereby the Institution would present annually a first prize of £3 and second prize of £2 10s to the candidates obtaining these places in the Intermediate Telephony examination. The last year for making awards for City and Guilds of London Institute examinations was 1970.

### THE POST OFFICE ELECTRICAL ENGINEERS' JOURNAL

The management of the *Journal* is vested in a committee consisting of a Chairman, who is the Chairman of Council, and 6 members. Up to 1973, the editing of the *Journal* was conducted on a part-time basis by volunteer staff. However, increased pressure of work led to difficulties in maintaining the standard of editing; consequently 2 full-time editorial posts were created, paid for by the BPO. The *Journal* is distributed to over 110 countries, and the present Editors, just like the previous Editors, strive to maintain a balance of content and technical level to meet the needs of all readers.

The first issue of the *Journal*, published in April 1908, was an immediate success, the whole issue being sold by the end of the year. A competition was held for the design of the cover, the successful entry being submitted by Mr. O. P. Moller, who had won, the previous year, the competition for the design of the Institution Medal. A small page size format was used and retained until 1927, when a change to demy-quarto size pages was made. The condition that the *Journal* should be self-supporting was met in the first year of operation. During the First World War, the size and circulation of the *Journal* decreased, and trading losses were incurred. The Council considered, however, that the *Journal* was such an important feature of the Institution's work, and was held in such high esteem by electrical engineers throughout the world, that every effort should be made to continue its publication despite the risk of further loss. As a feature of particular value, a *Supplement*, consisting of model answers to the latest City and Guilds of London Institute examinations in telecommunication subjects, was introduced in 1931. The Supplement has been issued free with each copy of the *Journal* ever since and now covers the examinations under the Technician Education Council scheme.

As in the First World War, publication of the *Journal* was



The Institution Medal

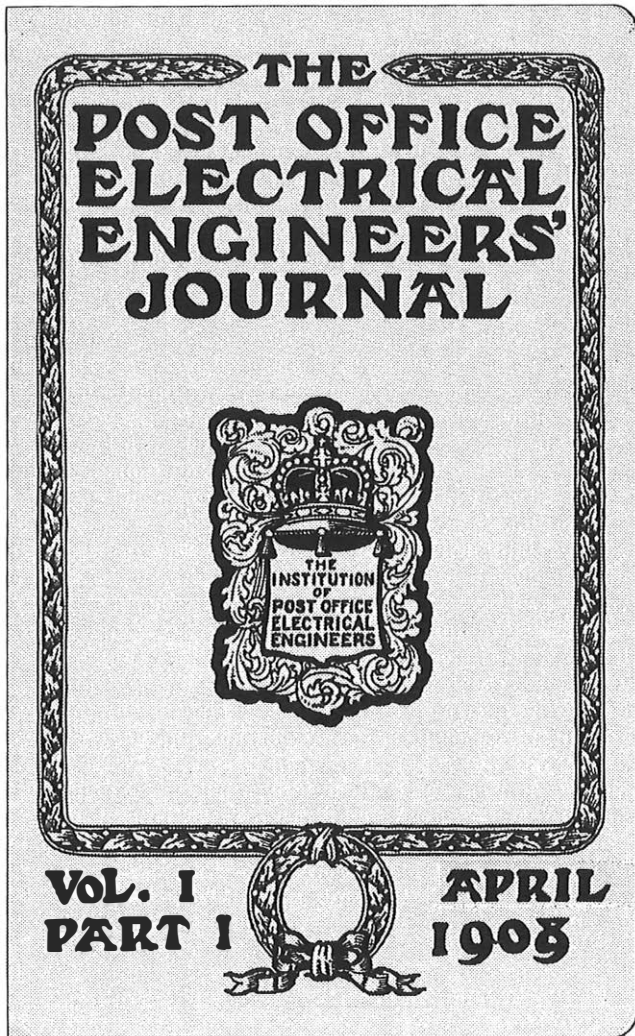

First Edition of the *Post Office Electrical Engineers' Journal*

maintained throughout the Second World War, but the size was drastically reduced because paper was rationed. Although circulation decreased, it did not fall below 75% of the pre-war figure. In April 1951, a new format was adopted for the *Journal* and *Supplement* which substantially increased the amount of material per page, but in spite of this economy, rising production costs still made it necessary to increase the price. The circulation then dropped suddenly, but slowly increased again.

To acknowledge the 50th anniversary of the Institution in 1956, Volume 49, Part 3 was devoted to the first 50 years of the Institution. Part 4 of the same Volume dealt exclusively with *The Transatlantic Telephone Cable* and cost so much to publish that an overall loss was incurred for the year, but the balance sheet for the next year showed a well deserved profit. One of the most popular issues was Volume 51, Part 4, published in January 1959. This was a specially enlarged issue devoted entirely to *Subscriber Trunk Dialling*. It was sold at normal prices, despite its increased size; demand could not be satisfied and a re-print was made.

Volume 61, 1968 appeared in a new style, with a new cover design and revised page layout, on A4 sized paper; the same general format is in use today.

The change in format coincided with a change of printer. From 1938, the *Journal* had been printed by the Baynard Press of Sanders Phillips & Co. Ltd. With a move to new premises and a change of printing process, Sanders Phillips indicated to the Board of Editors that they no longer wished

to print the *Journal*. After the announcement, a new printing contract was then signed with the present firm of Unwin Brothers Ltd., The Gresham Press at Old Woking, Surrey.

During the first 3 years of the 1970s, the cost of printing and publication rose 33% and, to restrict the price increases, economies were made. These included a slight reduction in size, a change to lithographic printing so that cheaper paper could be used and a cheaper method of distribution. The change to decimal coinage in February 1971 resulted in a rounding down of the *Journal* cost to members from 4s 3d to 21p. Since that time, steadily rising paper and printing costs have necessitated further price increases, and there is no sign of a change in this trend.

To commemorate the centenary of the first intelligible transmission of speech by telephone, made by Alexander Graham Bell to his assistant Thomas A. Watson in Bell's laboratory, at 5 Exeter Place, Boston, USA on 10 March 1876, several articles were published in Volume 69 in April 1976. In contrast, the remaining articles were devoted to the possibilities for the future development of communication services.

Finally, a quotation that appeared in the first-ever publication of the *Journal*: "It shall be our earnest endeavour to keep our pages open for the free and healthy discussion of all subjects relevant to our profession, and at the same time to secure that nothing unworthy shall sully them.", has certainly been maintained throughout the history of the *Journal*.

#### ASSOCIATE SECTION

The establishment of the Associate Section of the Institution, originally named the *Junior Section*, was sponsored by the Institution in 1931. Mr. C. W. Brown was appointed the first President of the Section, to act in an advisory capacity to the Council in matters relating to its welfare. The functioning of the Section suffered as a consequence of the Second World War, although all but a few of its Centres operated normally. In the post-war years, the Council was anxious for the Section to regain its pre-war position; a committee was therefore set up to consider and report on the steps desirable to arouse greater interest. As a result, Associate Section Liaison Officers were appointed in each Area, together with a Liaison Officer to each Senior Centre Committee, so that the Senior Section could guide and foster Associate Section activities.



C. W. Brown, M.I.E.E.—First President of the Associate Section, 1931-36



P. M. Bray, PH.D., M.SC., C.ENG., F.I.E.E., M.B.I.M.—President of the Associate Section, 1968-73



N. Fox, C.ENG., M.I.E.E.—President of the Associate Section

The personal interest of Senior Section members produced the required results.

In 1971, Dr. P. R. Bray formed an exploratory committee to examine the possibility of establishing a National Committee for the Associate Section. Although not all Local Associate Section Centres agreed to join, agreement was reached in principle and objectives were decided upon. The rules in use for the London Centre were used as a guide to establish a National Committee. As an incentive, the BPO gave an initial grant to the National Committee of £2000 and, to assist with general administration costs, all affiliated members contribute an annual fee of 10p. Present membership of the Centres affiliated through the National Committee stands at 22 000. The National Committee, on behalf of these Centres, pays an annual bulk fee of £50 to the Institution funds, while the few remaining independent Local Associate Section Centres pay an annual fee of 2p per member. In return, Associate Section members have the right to borrow books, manuscripts and periodicals held in the Institution Central Library.

One of the original objectives of the National Committee was to organize an annual National Technical Quiz Competition. This has proved to be very successful and the annual dinner, at which 3 prizes are awarded, provides a memorable occasion each year to mark the final of the competition. The National Committee has always been successful in finding a person of standing from within the BPO organization to make the presentation of prizes at the annual dinner. In 1974, the then BPO Chairman, Sir William Ryland, attended the dinner and made the presentations.

The prizes are:

(a) *E. W. Fudge Trophy* awarded to the Local Associate Section Centre that, in the opinion of the Committee, has completed the best project to further the success of the Associate Section during the previous year;

(b) *Dr. P. R. Bray Trophy* awarded to the Local Associate Section Centre that wins the National Technical Quiz Competition; and

(c) *Cotswold Trophy* donated by the Gloucester Centre in 1973 and awarded to the Local Associate Section Centre that, in the opinion of the National Committee, has furthered the aims of the Associate Section during the previous year more than any other Centre.

It was originally intended that a national journal should be published, but this proved too costly.

#### THE FEDERATION OF TELECOMMUNICATIONS ENGINEERS OF THE EUROPEAN COMMUNITY (FITCE)

During 1978, the Institution was invited by colleagues in Europe to join with them in the Federation of Telecommunications Engineers of the European Community (FITCE). Since then, discussions have taken place, mainly regarding the difficult question of conditions of membership against the background that entry into the corresponding European institutions is based almost exclusively on university qualifications.

At its meeting in early-1981, the Council decided to join the Federation, and an invitation to Institution members with the requisite qualifications to apply for membership of FITCE appears on p. 305 of this issue of the *Journal*.

#### CONCLUSION

In a message to the membership in Volume 72 of the *Journal*, published in July 1979, the present President of Council, Mr. J. S. Whyte, C.B.E., made the following statement:

"It is clear that the Institution of Post Office Electrical Engineers will continue to have as important a part to play in the future as it has in the past. For our Institution is at the same time an informal educational force, a forum where the research scientists can rub shoulders with experienced practical engineers, a channel of uninhibited comment and—not the least important—the justification for friendly sociable occasions. It will be an invaluable part of the mortar that binds together the elements of our enterprise.

I wish all of you all possible success in the exciting and challenging years that lie ahead."

The above passage seems the most appropriate way to conclude this brief synopsis of the past 75 years of the Institution.

#### ACKNOWLEDGEMENTS

The author wishes to thank Mr. J. H. Stephenson for researches into the early history of the Institution.

# TELECOMMUNICATIONS AND SOCIETY

## The Past Twenty-Five Years

A. V. KNIGHT, B.SC., C.ENG., F.I.E.E., F.B.I.M.†, and D. WRAY, B.SC.(ENG.), C.ENG., F.I.E.E.\*

UDC 621.39:301

*Many factors have influenced telecommunications development over the past 25 years. This article relates this progress not only to the technological advances that have taken place, but also to the changes in the social and economic environment.*

### INTRODUCTION

It was Buckminster Fuller who observed that change and growth had become so evident in all areas of human activity that all graphs having time as their horizontal axis should be turned on their side to indicate that change is now the normal state. In this article, however, graphs will still be shown in the old-fashioned conventional way; but it has certainly been a remarkable quarter of a century of change.

In less than a generation man has been seen—literally, seen—to venture into space and launch his artefacts into the midst of the solar system. Millions have taken their holidays in Majorca and Miami. Flower-power, the hippies and psychedelic fantasies have come and gone. Large multinational organizations have become larger and more powerful; but at the same time we have been assured that “Small is Beautiful” and have had the mini-car, the mini-skirt and the micro-electronic circuit—not always particularly beautiful. Housewives carry powerful computers and anti-rape whistles in their handbags. Two US Presidents and one Pope have been shot in public. The British, French and Belgian empires have virtually disappeared. Major powers have been unsuccessful in military ventures (Vietnam and Suez), and what were once minor protectorates in the Persian Gulf have become oil-rich states holding the world's economy in their grasp. Bras have been burnt in the name of women's lib; and the world now has 4 woman Prime Ministers. Accelerating technological progress has been countered by anti-technology lobbies: anti-nuclear, anti-microwave (“The Zapping of America”), anti-chip, anti-hydrocarbon fuel, and anti-airport.

Growth in some areas has been balanced by decay in others. The first supersonic aircraft to go into commercial service, the first vertical take-off fixed wing aircraft and the first hovercraft have appeared: but grass grows through branch-line railway tracks and rural bus services are curtailed and suspended. Hundreds of thousands attend pop concerts in the grounds of decaying stately mansions whilst cinemas stay dark or are converted to bingo halls. An uneasy peace has prevailed in Europe for 36 years but mob violence has erupted in the streets and on football pitches. Established churches have seen their congregations dwindle whilst exotic minor cults proliferate.

Above all, it has been the dawning of the silicon age. Although the transistor was invented nearly 35 years ago, it was not until the mid-1950s that silicon took over from germanium as the preferred material. This device has had a profound effect on society. Cheap transistor radios brought the call for Arab unity to every camp, caravan and camel, and were offered as rewards to Indians who would undergo sterilization. Artificial intelligence and memory have found their way into every corner of telecommunications, data processing, telemetry, production control, domestic appliances,

toys and games. It has led to the convergence of the technologies and thence to the applications of computing, telecommunications and home entertainment, and so to the revolution heralded by Prestel and the first appearance of telematics terminals (see Fig. 1). Silicon now emerges, in the form of the optical fibre, as a transmission medium in its own right—the first significant challenge to the copper conductor for over a century. Blake could not have guessed the practical manifestation of his spiritual insight when he saw infinity in a grain of sand.

But as the hardware shrinks so software grows. “Software”, a term used only by the esoteric minority 25 years ago, already accounts for more than 50% of the cost of products ranging from telephone exchanges to satellites. There is scarcely any branch of engineering development in which software has not become an essential ingredient; and the need for a grasp of software fundamentals has spread out from the design of the equipment through to its customer application and maintenance. At a time of mounting unemployment in the manufacturing and construction industries, there is a world-wide shortage of software specialists.

In nearly all the social changes mentioned above, telecommunications, particularly when joined with its promiscuous sister, broadcasting, has had an important role. It has not necessarily been the cause of these stirring events, but it has constituted the return half of the feedback loop, sometimes positive, sometimes negative. For instance, it is widely asserted that the reporting of street violence on television leads to a wave of copy-cat incidents, and that the ring-leaders use citizen's-band radio to organize their forces; on the other hand, the nightly portrayal of the Vietnam War to the homes of people whose husbands and sons were fighting there led the US government to withdraw its forces.



FIG. 1—Prestel terminal (1979)

† Business Planning and Strategy Department, British Telecom Headquarters, and Honorary Treasurer, IPOEE

\* Director Business Planning and Strategy, British Telecom Headquarters. Mr. Wray is also Chairman of Council, IPOEE and Chairman of the Board of Editors of this *Journal*

## EVENTS

On 4 November 1956, Budapest Radio broadcast to the world "Help Hungary! Help us . . . help us!" Communications were swift, but international political action was slow and the insurrection was crushed. News of Egypt's nationalization of the Suez Canal and other institutions was brought rapidly to the public; but, again, political and military reaction was cumbersome and the invasion of Egypt ended in ignominy.

In the UK, in 1956, there were 5 million telephones and 4 million exchange connexions; 23% of telephones were still connected to manual exchanges. A long-distance trunk call cost 2/6d for 3 minutes when connected by an operator. Today, an equivalent call, dialled by the customer in the cheap rate period, costs 14p, a reduction of 82% in real terms. The telephone network carried 4200 million inland calls and there were 2 million international calls, the inter-continental calls being mostly carried on high-frequency radio links. Since then, the number of inland calls has increased fivefold and international calls over a hundredfold.

The first transatlantic telephone cable, TAT1, was opened for service in September 1956. It had been expected that this new facility would be able to cope with the growth in North Atlantic traffic for many years, perhaps as long as the 20-year design life of the cable. But customers were attracted by the high quality and reliability of their connexions, and demand rocketed; more transatlantic cables followed in swift succession. (Unfortunately, this TAT1 phenomenon has since been quoted many times by people who argue that no new telecommunications service is risky; if it is provided, they say, the public will use it. There is a great deal of sad evidence to show this assertion is not true.)

Biology, for long a dormant science, was revived by the discovery of DNA. Radio telescopes detected signals from Venus and Jupiter. Experimental colour television signals were transmitted; then the famous transmitter at Alexandra Palace was closed down and the BBC television services were transferred to Crystal Palace.

The Jodrell Bank radio telescope was inaugurated in 1957 and was almost immediately diverted away from its primary purpose when the space age proper began with Sputnik bleeping its way around the world in October of that year. It was the International Geophysical Year and the British Association discussed continental drift and wondered whether Antarctica could be used as a giant cold store. Presumably there was no connexion with the opening of the British Post Office (BPO) Weather Information Service.

Dr. Vivian Fuchs crossed Antarctica in 1958, but omitted to set up a giant food store. The BBC experimented with some stereo radio broadcasts but doubted whether there was any possibility of the system being used regularly. A significant step in British telecommunications was the inauguration of subscriber trunk dialling (STD) in Bristol. (According to popular legend, the Queen, when making the inaugural call to the Lord Provost of Edinburgh, asked what would happen if she dialled the wrong number. "You will still get the Lord Provost of Edinburgh" she was assured.)

Castro came to power in Cuba in 1959 and has been there ever since. The first Mini (car, not skirt) appeared in the streets (see Fig. 2) and the first Hovercraft thundered and skidded over the waves. Russia pulled off another space spectacular by photographing the far side of the moon. Not quite so far afield, South Lancashire enjoyed the first car radiophone service and Bristol was first again with an STD Pay-On-Answer call box.

The whole of the inland Telex service had been converted to automatic working by 1960 and the first communications satellite, a passive reflecting balloon called *ECHO*, was launched. *ECHO* was a bold but false start; it became punctured by myriads of tiny meteorites and its smooth reflecting surface became as cratered as the moon.

And so into the "swinging sixties". It is difficult to recapture



FIG. 2—Morris Mini-Van (1960)

the heady euphoria of those days. Britain had the Beatles, Carnaby Street, a new wave of dramatists, the best whisky, ballet, novelists and music. It was Courreges, in Paris, who designed the costumes for a film called *Do You Like Women?* (that is, to eat) in which the heroine appeared in short skirts and long boots; but it was Mary Quant who exploited the idea and developed a world trade. Britain, it seemed, was on the crest of a creative wave. CANTAT, the British-designed submarine cable between the UK and Canada came into operation in 1961.

Then in 1962, the Highgate Wood electronic exchange opened, in advance of its time (see Fig. 3). TELSTAR, the first active communications satellite, was built by Bell and

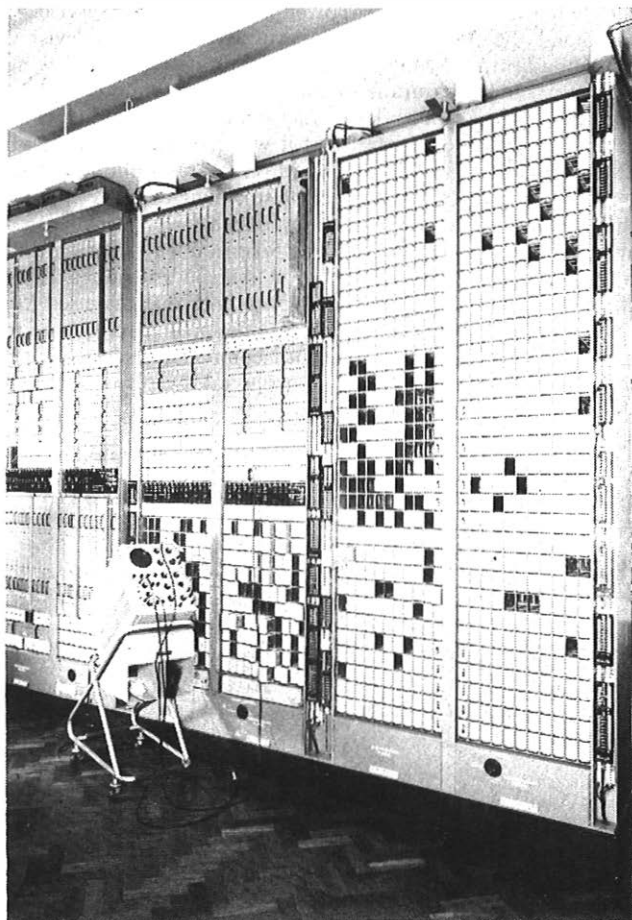

Note: Line units (right) and delay-line stores

FIG. 3—Highgate Wood electronic exchange (1962)

launched by NASA†, and Goonhilly, one of the first 3 satellite earth stations in the world, became the model for nearly all subsequent earth stations and is still going strong; its 1962 contemporaries have long since been put to subordinate uses. The Beatles recorded *Love Me, Do* and started their extraordinary careers of creativity, mysticism, mania and tragedy.

The TELSTAR and RELAY satellites travelled in low non-equatorial elliptical orbits and transatlantic transmissions were intermittent. Goonhilly was hurriedly activated from its stand-down status in 1963 when news came of President Kennedy's assassination. Within 3 hours of the event, television pictures of the tragedy were broadcast all over the world. (It had taken 3 days for the news of President Lincoln's assassination to travel across America). But satellites had not killed cables. TAT3 was opened between the USA and Britain, as was an operator-dialling service for telephone calls. International subscriber dialling (later to be re-named *international direct dialling*) was introduced between London and Paris.

There were 3 notable telecommunications innovations by the BPO in 1964: the first crossbar exchange opened at Broughton; trial pulse-code modulation (PCM) systems (see Fig. 4) were provided on junction cables; and the first datel service (Datel 100) was introduced. This first modest move into data transmission, heralded by Datel 100, was the start of the computer/communications era and was to have a profound effect on business organization and efficiency. (Coincidentally, junction PCM could be regarded as the first step towards digital transmission, a parallel and necessary component in the take off towards the telematics services of the future). But another era ended with the death of Sir Winston Churchill; his funeral was covered by the most elaborate television outside broadcast that had yet been staged.

A prominent feature of the London skyline appeared in 1965 when the Post Office Tower was opened for service. It combined the functions of a microwave tower, a television switching centre, a vital node in the main network, a viewing platform and a restaurant. It was featured in countless films, plays, novels and transatlantic races; and it was such a proud symbol of public enterprise that it was the object of a bomb attack by the Angry Brigade. The London radiophone service opened in the same year; it became so embarrassingly popular that 15 years later the frequency allocation was exhausted and no new subscribers could be taken on—a situation that was partially alleviated this year by the introduction of 12·5 kHz channel spacing and an automatic exchange service. INTELSAT I, the first communications satellite to operate in the geostationary orbit, came into commercial service, with the principal earth stations in Europe taking turns to act as the European space terminal.

† NASA—National Aeronautics and Space Administration



FIG. 4—Installation of a 24-channel PCM system

The first production TXE2 opened at Ambergate in 1966 and the change to all-figure telephone numbers commenced in the director areas. The second of these events generated the type of public outcry so familiar to those who wrestle with the complexities of a national service. Why had we lost FLAXman? Had FULham been wiped off the map? Would RIVERside be submerged?

The Earth seemed to punish those who carelessly exploited its resources. In 1966, Aberfan became the focus of national horror when an unstable coal waste tip engulfed the village school. Then, in 1967, another unforgettable name became news when the stricken *Torrey Canyon's* cargo of oil fouled miles of South Western beaches. There followed the first-rumblings of the anti-pollution movement, a movement that later spawned the Friends of the Earth, Greenpeace and many others. Anti-pollution led to anti-technology; engineers found they had to assert that their creations were intended to benefit society, not to debauch it. The Arab-Israeli six-day war was the first portent, unheeded at the time, that the world could not be fuelled for ever on cheap oil from the Middle East. INTELSAT II succeeded INTELSAT I and gave unbroken multiple access to all earth stations in the Atlantic Region.

Two more notable events in Britain's telecommunications history occurred in 1968. The first all-transistorized 12 MHz (2700 circuit) coaxial cable system was brought into use; and Empress, the first PCM telephone exchange, was inaugurated. The Postmaster General of the time said that the particular significance of Empress was that it was the first example of the use of switched PCM signals to carry live traffic anywhere in the world; fast micro-electronic circuits had played a major part in the design of an experiment which would lead to a system that would be fast, efficient and cheap and take any form of traffic—voice, vision or data—in its stride.

The main event of 1969 was one of the most outstanding achievements of the century, indeed, of all time. Neil Armstrong, uttering "One small step for man . . ." stepped out of his spacecraft on to the surface of the moon in full view of millions a quarter of a million miles away. The power of telecommunications and broadcasting could scarcely have been more dramatically demonstrated. But telecommunications was not merely the vehicle which enabled the event to be seen; it was an essential element, amongst so many other technological marvels, that had enabled the event to happen. The American people were naturally suffused with the pride of a spectacular achievement; but even this did not distract them from the horrors of Vietnam, whose malignant jungles alternated with the surface of the moon on their screens. Technology could capture the moon, but could not subjugate the relentless Vietcong. Somewhat overshadowed by these world events, but of great parochial importance, was the formation of the Post Office Corporation. The BPO was no longer a part of the Civil Service; there was no longer a Postmaster General.

The new Corporation did not celebrate its own birth in any particularly spectacular fashion. It introduced the Tape Callmaker, a repertory dialler device, in 1970 and issued its first alphabetical telephone directory to be compiled by computer. A rather more arresting innovation was the Con-division service which opened in 1971 but which has made slow, albeit positive, progress during the last 10 years (see Fig. 5).

By now the ebullience of the swinging sixties had subsided, engulfed in the gloomy seventies with its inflation, oil shortages and international terrorism. But in spite of this gradually deepening mood of despair, science and technology continued to march ever onwards. Radio astronomy, spurred and assisted by parallel developments in aerospace and computer techniques, opened up new fields of research; astronomical theories were hastily revised as Quasars and Pulsars were discovered. Optical astronomy was joined by infra-red and X-ray astronomy and sophisticated observatories were piggy-backed into space on satellites, to escape





FIG. 5—Confravision studio at the BPO Research Centre (1978)

the blurring cataract of the atmosphere.

Materials technology produced strong new substances in alloys, crystals and fibres. Carbon fibres found their way into aero-engines and tennis racquets; titanium was used in supersonic aircraft, nuclear reactors, and the skulls of accident victims. Biologists plunged into the secrets of cells, proteins and amino-acids, and caused uneasy excitement as they fabricated genetic material hovering at the edge of the sci-fi world of genetic engineering.

Satellite scrutiny of earth resources, in company with new drilling and earth-sounding techniques, and spurred by the oil crisis created by the Yom Kippur war of 1973, led to the discovery of new oil deposits and deeper understanding of the Earth's structure. Theories of continental drift have given way to plate tectonics. The Earth has responded to this unwelcome attention by erupting into a 25-year demonstration of unprecedented earthquake and volcanic activity.

Perhaps the most important development of all in its effect on human activity was the establishment in the early-1970s of a number of small companies in an area of California which later became known as *Silicon Valley*. The micro-processor had arrived. With quite extraordinary rapidity the size of the circuit elements diminished, the speed of logical operations accelerated and the cost per element of logical operation and storage fell (see Fig. 6). Powerful computers were deposited on a silicon chip and the potential for artificial intelligence was recognized and exploited in hundreds of

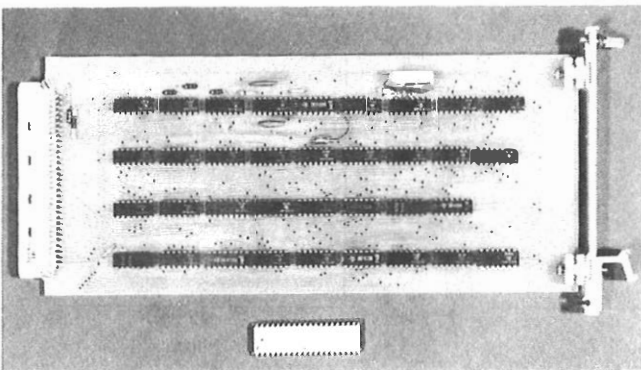

FIG. 6—Board-mounted integrated circuits with the equivalent large-scale integration version shown below

industries. Once again the public could see that technology could be both a boon and a bane. It was fine to have a computer in your washing machine, your camera or your car; but would the people made redundant because of automation in the manufacturing industries find employment in the rapidly expanding service sector?

Returning to the world of telecommunications, the main means of inter-continental communication (the satellite and the submarine cable) were each flourishing in spite of, or perhaps because of, the presence of the other. INTELSAT had, by now, well tried operational systems in all 3 ocean areas; and CANTAT 2, the second British-designed cable between Canada and Britain came into service in 1974. Apart from CANTAT 2, things were pretty grim in Britain which suffered an energy crisis, the 3-day week and finally the miners' strike which brought down the Government. There was a political crisis in America, too. The Watergate affair—sparked by an attempt to use communications technology for illegal ends—culminated in the resignation of President Nixon and the imprisonment of several of his aides. The proceedings were watched avidly all over America; coin-in-the-slot television sets were installed in airports so that travellers could keep abreast of developments while waiting for their planes.

The centenary of the telephone was celebrated in March 1976. In that hundred years, the international telephone service had become man's most costly and complex artefact. It had caused the creation of probably the first—and probably the most successful—of all international organizations, the International Telecommunications Union. In Britain, the BPO marked the centenary by closing its last manual exchange at Portree (see Fig. 7), by opening a tropospheric-scatter radio link to the oil and gas production platforms in the North Sea, and by cutting into service the first TXE4 exchange at Rectory, Birmingham.

One of the BPO's most successful and fast-growing services, radiopaging, was opened in 1977 after a trial in the Thames Valley area. Inflation was now at the lowest it had been for 5 years and there were hopes of having survived the worst of the recession and being on the road to recovery.

It was not to be. Within 2 years the Shah had been evicted from Iran and the return of the Ayatollah Khomeini had precipitated another Middle East crisis. Oil prices soared and consumption dropped. The world was looking for new sources of energy but the vociferous anti-nuclear lobby impeded the development of what is probably the most promising—and, to date, the safest—alternative to hydro-carbon fuels. At first sight, it was scarcely the most opportune time to launch some major telecommunications innovations.

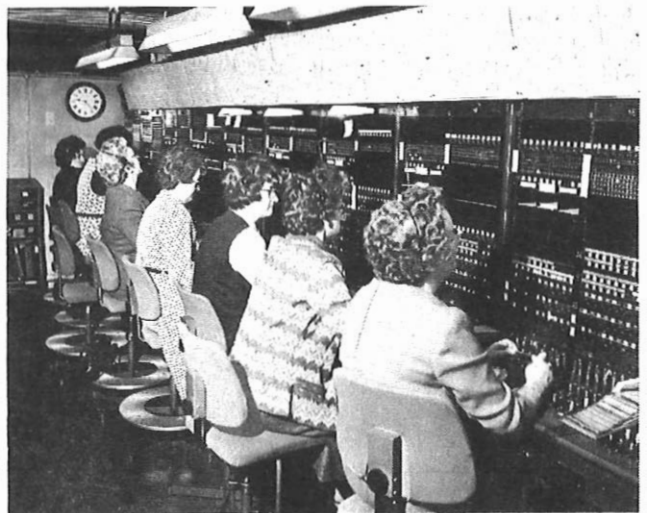

FIG. 7—Portree CBS2: the BPO's last manual exchange

(Photograph by Capital Press, Edinburgh)



FIG. 8—System X at Telecom 79, Geneva

But Prestel, the world's first public viewdata service, was opened in London and the BPO's first digital local exchange was put on trial in Glenkindie. The highlight of the year—and acknowledged as such by most of the world's telecommunications authorities—was the live demonstration of System X at Telecom '79, Geneva. Not only was the exchange shown working with a variety of terminal apparatus (including Monarch and Herald) and services (including slow-scan television), but, equally impressively, it demonstrated how the BPO and its suppliers could collaborate in producing a system of high sophistication (see Fig. 8).

The demonstration became a working reality when the first operational System X exchange opened at Baynard House in 1980. In the same year, crowning years of innovatory work in the BPO's Research Department and a number of field trials, the first optical fibre transmission systems were brought into commercial service in the public network. That summer, following a Government decision to separate the British Post Office operations, the telecommunications business had anticipated its new corporation status by trading under the name of *British Telecom*.

And now, in 1981, yet another technological triumph that will certainly have a significant effect on telecommunications—the space shuttle—has been seen; and the BPO has reached one of the most critical stages of its history. Not only has telecommunications separated from Posts and Giro and become a separate corporation (British Telecommunications); the

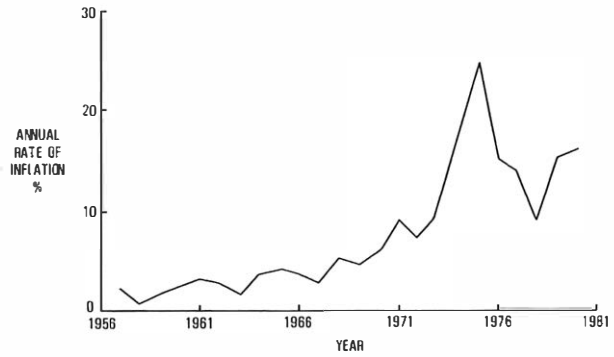

FIG. 9—Annual rate of inflation

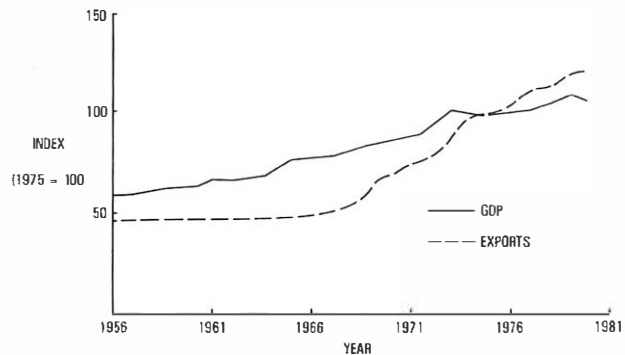

FIG. 10—Growth in GDP and exports

business finds itself in a highly competitive situation, certainly in the supply of most forms of terminal apparatus and perhaps in key parts of the network as well.

### TRENDS

In the midst of a world-wide recession, the relationship between the economic environment and the demand for telecommunications services becomes only too apparent. Cessations increase, the order book becomes slim and companies, in their drive for economies, closely monitor the necessity for telephone calls. But looking back over a period of 25 years shows that the growth in demand for telecommunications services has been remarkably consistent and robust.

The most obvious economic variable in recent years has been the rate of inflation. Fig. 9 shows how this has moved in

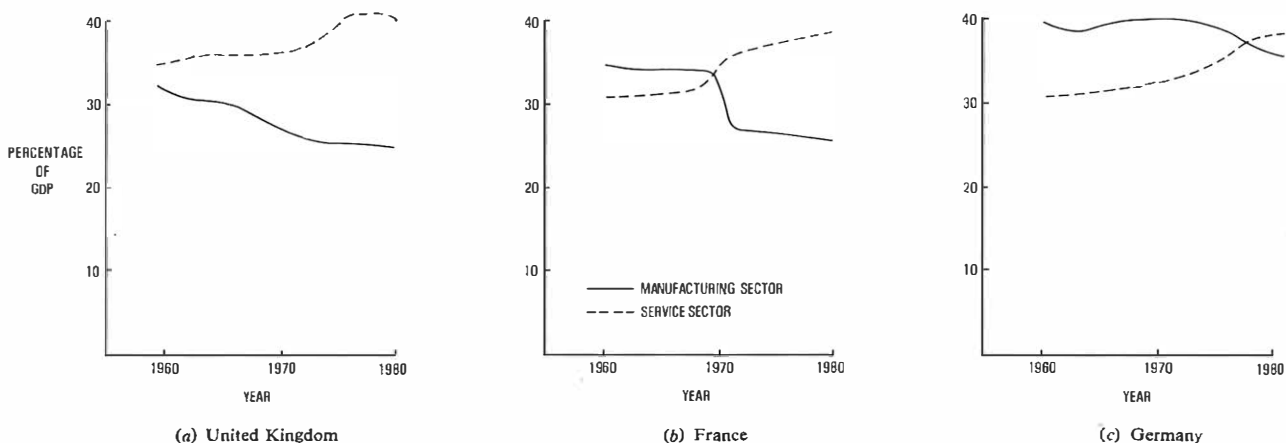

FIG. 11—Comparison of proportion of GDP arising from service and manufacturing industries

the past 25 years, soaring to an unprecedented 25% per annum in 1975, then falling, then rising again. Within the last few months, assurances have been given that the rate is dropping, but it seems most unlikely that it will return to the stability of 1956-60 when annual inflation rarely exceeded 2%. It was the sterling devaluation of 1967 that resulted in a rise to 9% per annum; then came the Yom Kippur war and a much sharper increase in the rate of inflation as a consequence of the oil price rise. So much of the economy of the developed nations (and, increasingly, of the lesser developed nations) depends on oil that the succession of price increases has a world-wide inflationary effect. The lesser developed nations now spend 30-40% of the revenue from their exports on imported fuel.

Prices alone, however, do not measure the standard of living; the gross domestic product (GDP: an index of the volume of goods and services produced), although an imperfect indicator, is a better guide. Fig. 10 shows that the UK GDP grew steadily through the late-1950s and 1960s, but the rate of growth declined after the 1973 crisis; within the last year it has actually fallen. However, the UK's volume of exports, apart from a set-back in 1973-74, has steadily grown over the 25-year period.

The economy is changing in nature as well as in size. Over 200 years ago, Adam Smith, with remarkable prescience, described 3 stages of a nation's economy: the primary agricultural and mining stage; the secondary industrial stage; and the tertiary stage of distribution and services, including financial services. This transition from the secondary to the tertiary stage can be seen in the economies of nearly all advanced countries by comparing the proportion of GDP attributable to the manufacturing and service sectors. In the UK, this transition occurred earlier than in most other European countries, perhaps because the UK was the first to experience an industrial revolution and to run down the agricultural labour force. This is illustrated in Fig. 11, which compares the transition from manufacturing to service sectors in UK, France and Germany. The curves displayed in Fig. 11 are of movements in GDP; had they been expressed in proportions of employment in the manufacturing and service sectors the divergence would be even more marked because service work is essentially labour-intensive and productivity improvement in the service sector has been only about one-third of that in manufacturing.

As the economy moves from the primary through to the secondary and tertiary stages, so do the products become more specialized and diverse. This is reflected in the demand for telecommunications services; for instance, in the UK, the proportion of the industry's output spent on telecommunications is only 0.6% for mining and quarrying; it is 1.3% for manufacturing; 1.8% for services excluding distribution; and 2.8% for distribution.

Thus, in the UK, there are 2 counteracting forces at work: the economy as a whole is in recession; but the nature of the economy is becoming increasingly service-oriented and so, because of the communications-intensive nature of the service sector, the demand for telecommunications services continues to grow. Fig. 12 shows that the number of telephone stations has more than quadrupled in the past 25 years whereas the increase in GDP is less than 80%. The increase in trunk calls (Fig. 13) and international calls (Fig. 14) over the same period is even more dramatic. In none of these curves can one detect any slackening in rate of growth, except perhaps in business stations where there are signs of impending saturation.

Figs. 12, 13 and 14 all refer to the telephone service. The past 25 years has also seen the significant appearance of non-voice services. In 1956, there were just over a million Telex calls; by 1980, this number had grown to 91 million inland calls and 77 million external calls. In 1956, there was no Datel service at all; in 1980 there were nearly 70 000 BPO modems attached to the network and probably as many privately-supplied items.

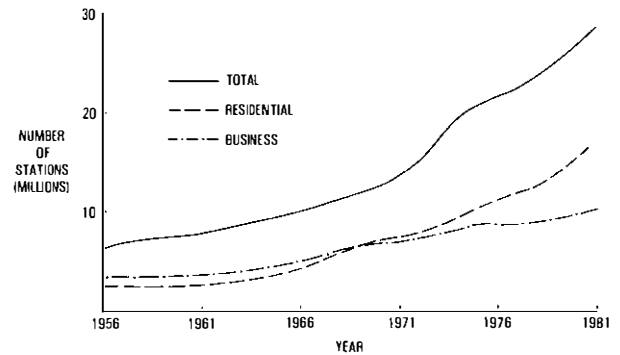

FIG. 12—Growth in the number of telephone stations

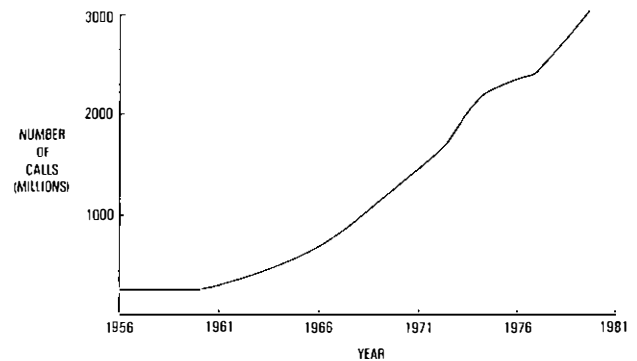

FIG. 13—Growth in trunk traffic

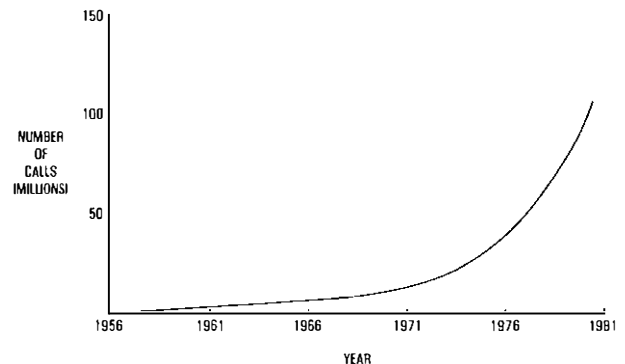

FIG. 14—Growth in international traffic

## CONCLUSIONS

The past 25 years has been a period of social, economic and technological ferment with each of these factors influencing the others and with telecommunications being effected by, and having an effect on, all three. The BPO has undergone 2 major changes in status and organization. New services have abounded and growth in demand—apart from a few transitory deflexions—has been healthy with no signs of abatement. The realization that information can be stored and manipulated cheaply in silicon; the achievement of transmitting information almost instantaneously to virtually any part of the world; the first groping concepts of information technology; all these lead us to conclude that we are probably present at the birth of a totally new, almost unimaginable, science—Knowledge Engineering.

# THE INLAND NETWORK

## The Evolution of the Inland Telecommunications Network

K. E. WARD, C.ENG., M.I.E.R.E.†

UDC 621.39

*The development of the inland switched telecommunications network over the past 25 years has been the story of unprecedented growth and technical innovation, which has allowed the establishment of a fully-automated service. This article reviews the historical development of the network and describes plans for its future evolution using digital switching (System X) and digital transmission techniques.*

### INTRODUCTION

A *White Paper*, published in 1957, outlining the British Post Office (BPO) plans to automate fully the telephone system heralded the start of an era of 25 years of fundamental change to the network that is described in this article. The *White Paper* concluded that the 2 steps, namely, simplified charging and automation, "together constitutes the most sweeping and radical reform since the Post Office took over the telephone service from the National Telephone Company in 1912".

The extent to which the needs of customers are met, in a cost effective manner, is largely conditioned by the capabilities of the network. It is the core of the Business and comprises the telephone exchanges and interconnecting transmission paths disposed so that customers can make satisfactory calls to all other users in an economic manner. The inland network can be considered as a number of discrete sub-networks connected to form the total network. Component networks comprise: the local network from customers' premises, to and including local exchanges; the junction network which includes junction tandem exchanges and the trunk junctions between local and trunk exchanges; and the trunk, or main

network of trunk exchanges (known as *main network switching centres* (MNSCs)) interconnected by trunk, or main network transmission links. Special-purpose networks such as the Telex and data networks are provided for services that cannot be handled by the telephony network because of technical or economic constraints.

### GROWTH OF THE NETWORK

There has been an ever-increasing growth in the network over the past 25 years as illustrated by Figs. 1, 2 and 3, which show the major network parameters of connexions, calls and capital assets. The increasingly sophisticated demands from customers, together with the reduction of price to customers (in real terms) arising from network management efficiency and technical innovation, has resulted in a large increase in originating traffic (see Fig. 2) and the introduction of a variety of new services. The network is characterized by massive investments in plant having economic lives of several decades; Fig. 3 shows the increase in such investments (at 1981 price levels) and how the balance of costs has swung towards exchanges owing to the greater impact of technological progress on trunk and junction transmission plant.

† Network Strategy Department, British Telecom Headquarters

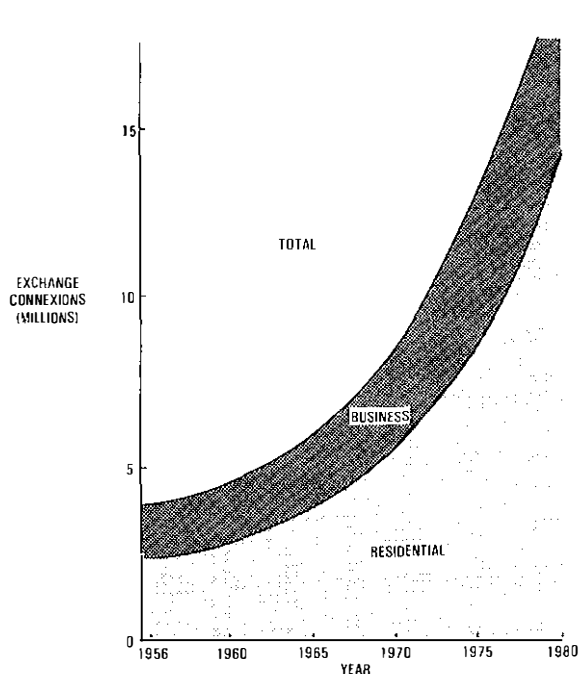

FIG. 1—Growth of exchange connexions

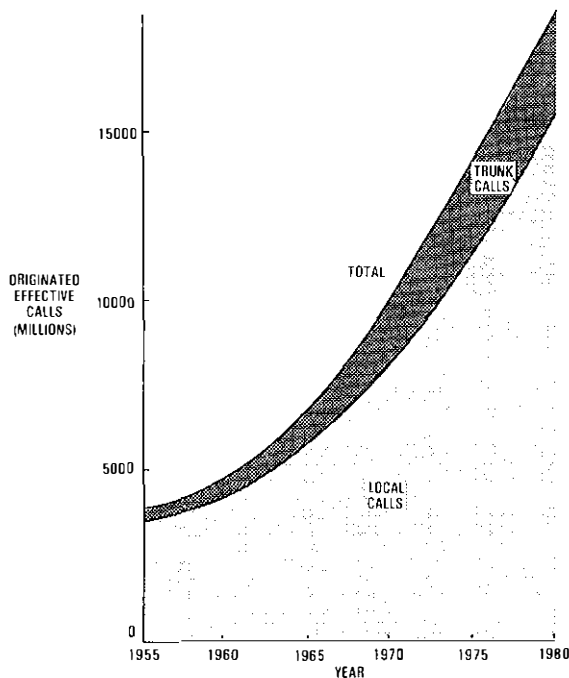

FIG. 2—Growth of originating effective calls

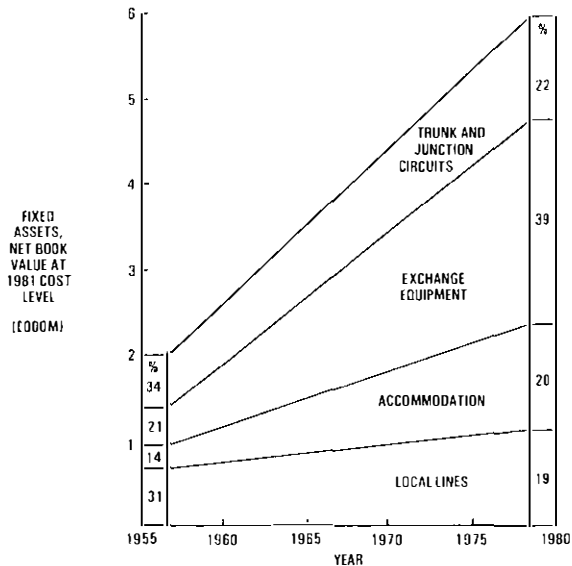

FIG. 3—Growth of network assets

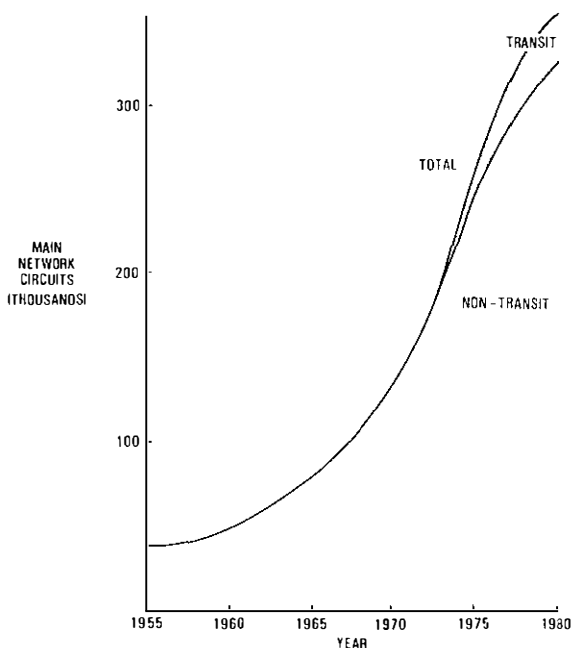

FIG. 4—Growth of main network circuits

## NETWORK DEVELOPMENT

### THE MAIN NETWORK

The most dramatic development during the past 25 years has occurred in the main network, which has grown tenfold (see Fig. 4), and changed from a largely manual system to full automation where all customers can dial their own trunk calls. Planning for the change from a manually-controlled trunk service to full automation commenced shortly after the end of the Second World War when, in 1946, the Post Office Trunk Mechanization Steering Committee was set-up to recommend the policy for the mechanization of the main network. The Committee recommended that single operator automatic control of the majority of trunk calls (that is, trunk mechanization) should be the first objective.

#### Trunk Mechanization

By the mid-1950s, the main network comprised 26 fully interconnected *zone centres* and about 250 *group centres*, many of which were mechanized, and interconnected to meet the "1933 Transmission (and Routeing) Plan" shown in Fig. 5.

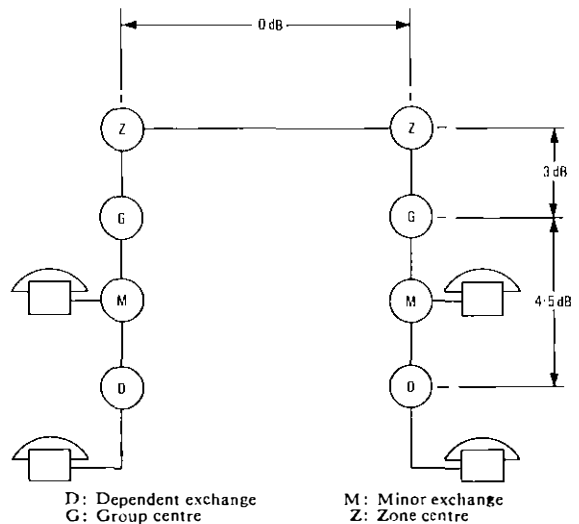

FIG. 5—1933 Transmission Plan

Semi-automatic routeing was carried out on a non-register basis, the single controlling operator dialling a routeing-dependent code of between 3 and 15 digits, obtained from a local set of routeing instructions contained in a visible index file (VIF).

#### Subscriber Trunk Dialling

The first step towards the introduction of full automation, known as *subscriber trunk dialling* (STD), was to introduce a fundamental tariff change to simplify call charging. Charges had been computed on the basis of call duration and radial distance between originating and terminating local exchanges. However, the need to determine the charges to about 6000 exchanges from any given exchange would have introduced considerable equipment complexity under full automation. Therefore, in 1958, a system of *group charging* was introduced in which the country was divided into 637 charging groups, each covering an average area of about 400 km<sup>2</sup>. This reduced by a factor of 10 the charge list for any given exchange. The relationship of charging to distance was obtained by measuring the distance between hypothetical charging points in each charging group. Care was taken in the formulation of charging groups to minimize charging anomalies arising from call charges not strictly relating to distance between exchanges. The most obvious anomaly relating to exchanges on opposite sides of a fee boundary was avoided by charging calls between exchanges in home and adjacent charging groups at the same (local) fee.

On the 5 December 1958, Her Majesty the Queen dialled the inaugural STD call at Bristol, and the UK network entered an era that was to reach full automation in 1979, the twenty-first anniversary of the introduction of STD. The STD scheme adopted was constrained to involve minimum cost and disturbance and was largely conditioned by the existing network, namely a 2-wire switched non-register controlled Strowger system. It consisted of the use of a single translation of dialled digits into routeing digits by a controlling register-translator (RT) located at parent automatic trunk exchanges, termed *group switching centres* (GSCs), usually located at existing group and zone centres. The routeing digits directly controlled the Strowger switches in up to 3 trunk exchanges (except in director areas where incoming RTs were provided) and this was analogous to the previous single operator control under trunk mechanization.

Until the advent of STD, each customer in the UK was identified by a name representing the exchange (or linked-number scheme) and a local number. The introduction of STD made it necessary to convert the exchange name into a unique code that could be dialled and recognized universally.

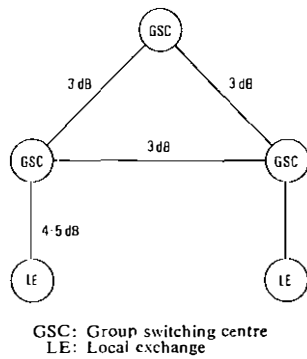

FIG. 6—1933 Transmission Plan modified for STD

The national number scheme adopted allocated some 700 national number group (NNG) codes to charging groups and GSC catchment areas. Each code consisted of 1, 2 or 3 digits; hence, the national number comprised the NNG code and a local number. The number length, including the trunk access prefix 0, was constrained to a maximum of 9 digits to conform to international recommendations. Following the use of letters to represent exchange names in director areas, it was decided to make the STD codes similarly recognizable, for example, Leicester had the code (0)LE3; thus trunk codes were allocated on a somewhat random basis. However, in preparation for the sectorization of London, the use of letters in both director areas and STD codes ceased in 1969 in favour of an all-figure number (AFN) scheme.

The 1933 Transmission Plan specified for trunk mechanization was modified for the introduction of STD (see Fig. 6) to connect local exchanges direct to their parent GSC and to limit STD connexions to a maximum of 2 trunk links (that is, 3 GSCs). This was necessary to minimize post-dialling delays and to provide a better tolerance to transmission loss. Full direct dialling required a traffic routing between every GSC and NNG, that is  $378 \text{ GSCs} \times 700 \text{ NNGs} = 264\,600$  routeings. The inevitable result of the limitation on traffic routing was that full STD could not be provided by the network. Even the provision of a large number of economically unjustified routes would not have significantly increased the access because of the limitations of the RTs on routing digits and translation capacity.

### The Transit Network

To overcome the limitations of the 2-wire GSC-GSC network to provide full customer-to-customer dialling, a separate basic transit network was established. It consists of 9 fully interconnected *main switching centres* (MSCs), and 28 *district switching centres* (DSCs), the transit exchanges collectively being known as *transit switching centres* (TSCs). The provision of *basic* traffic routes, that is, GSC-to-parent DSC, DSC-to-parent MSC, was mandatory to ensure that a basic or hierarchical routing was always available between all customers. However, *auxiliary* routes between all parts of the network were provided where economically justified. This required the definition of the 1960 Transmission Plan shown in Fig. 7, to which the present network conforms. The transit network which was established to carry traffic that could not justify routeings on the 2-wire (GSC) network, carries a small proportion, about 6%, of the total originating trunk traffic. However, about 60% of the traffic routeings, mainly between places with little or no community of interest, are carried on the transit network. To ensure that acceptable post-dialling delays are achieved, fast multi-frequency (MF) signalling is used with fast (crossbar) switching. Transmission performance standards are met by switching all calls on a 4-wire basis within the transit network. The TSCs are register controlled, with each register controlling its own switching equipment on receipt of the 3-digit NNG code, which is sufficient to identify the terminal GSC. Once the terminal GSC is reached, the

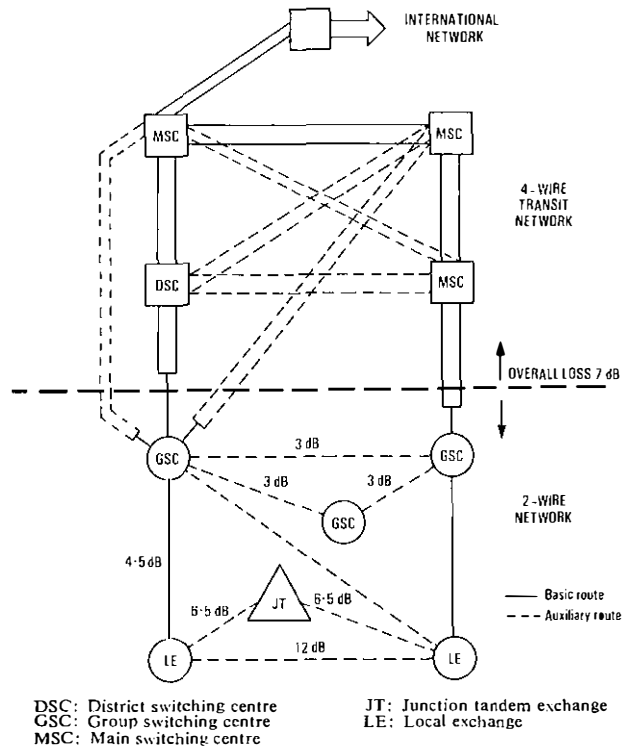

FIG. 7—1960 Transmission Plan

final digit of the NNG code is repeated followed by the rest of the dialled number. The gradual transfer of traffic from the operator-controlled trunk-mechanization network to the transit network commenced in 1971 with the connexion of Kingsbridge, Wolverhampton and Worcester, and was completed by 1979.

### Interim Modernization

In 1966, it was decided to order crossbar systems as an interim modernization measure to bridge the gap between the run-down of Strowger orders and the development of digital trunk exchanges. This resulted in the provision of Plessey 5005 Crossbar equipment, designated *TXK1*, at new GSCs, second unit GSCs, and sector switching centres (SSCs) in London. The first *TXK1* GSC, at Dover, was brought into service in 1973 and there are, at present, about 80 in service varying in size from 4000 E to several small GSCs in the Highlands of Scotland with an initial capacity of about 20 E.

The period under review has also seen progress in the signalling field, where a new standard one voice-frequency (1VF), 2280 Hz, signalling system designated *SSAC9* was introduced to supersede the old pre-war 2VF system (*SSAC1*).

### International Access from the Inland Network

Access from the inland to international network, on a manually-controlled basis, continued to grow from its modest beginnings in 1891 until, in 1973, a limited subscriber dialling access was given from the London director exchanges to Paris. This access was extended in the following year, enabling all director-area customers to gain international subscriber dialling (ISD)—now known as *international direct dialling* (IDD)—access to 5 of the principal continental countries. At present, IDD facilities are provided in about 90% of GSCs, allowing 99% of UK customers access to over 100 countries. The international network access prefix is 010. Access to the Irish Republic is obtained directly from the inland network by using STD codes.

### THE JUNCTION NETWORK

Over the past 25 years, the junction network has increased in

size from 200 000 circuits to about 1 million circuits. At the beginning of the era, access to customers on nearby exchanges over the junction network was obtained by dialling local codes followed by the customer's local number. In large towns and cities served by a number of exchanges, a range of customers' local numbers was usually shared between the exchanges to form a linked-numbering scheme area to give a uniform dialling procedure. Special dialling codes were used for access to exchanges outside the linked-numbering scheme area. In the 6 very large linked-numbering scheme areas (that is, London, Birmingham, Manchester, Liverpool, Glasgow and Edinburgh) letters had been introduced into local numbers to assist customers in dialling numbers of 7 digits; the first 3 letters identified the exchange, followed by 4 figures. The large number of exchanges in these 6 areas, combined with the use of letters, made it desirable to use an exchange system with a high degree of flexibility in respect of routeing. This was achieved by using the translating facilities of the *director* exchange system, the director being a particular form of register-translator. In a smaller link-numbering scheme area, a central main exchange was generally surrounded by a number of satellite exchanges and the system referred to as a *non-director* area.

The unprecedented expansion of the telecommunications service in the major cities, such as London, together with the shortage of accommodation in city centres and the need to improve transmission performance and provide for new facilities, forced a re-appraisal of the plans for switching trunk and junction traffic in cities.

### Sectorization

For London, a special team known as the *London Trunk and Junction Network Task Force*, was set-up to study how future developments should be achieved. They reported in 1965, concluding that a policy of sectorization should be adopted. This required that the 12 trunk, 3 toll and 7 junction tandem units serving over 350 local director exchanges should be relieved, for growth, by the establishment of 7 new telephone switching centres known as *sector switching centres* (SSCs) located about 13–14 km from the centre of London in the 7 outer Telephone Areas. The 4 central Telephone Areas, occupying a central circle of about 6 km radius, would be served from existing central switching units (CSUs), augmented as required. To allow incoming trunk and adjacent-charge-group calls to be routed direct to the SSCs, it was necessary as a prelude to sectorization, to re-allocate the 3-digit codes of individual director exchanges so that the appropriate sector (or central area) could be identified by the first 2 digits of the local numbers. Customer and administrative disruption was minimized by removing the 3-letter identification of local director areas and instituting all-figure numbering (AFN).

Plans were formulated for the efficient routeing of the 5 separate types of traffic; that is, incoming trunk calls, international calls, local adjacent-charging-group calls, within-charging-group calls and operator handled calls. The first SSC opened in 1974, and currently 6 of the 7 SSCs are operational with a total switching capacity of 24 000 E. Although the numbering schemes in the other director areas were re-arranged with the introduction of AFN, to facilitate the introduction of sectorization, studies established that there was no operational or economic justification for changing.

### The Junction Transmission Network

Paper core quad trunk (PCQT) cable, mainly laid in earthenware ducts or deep-level tunnels, has been used almost exclusively to provide junction circuits. Most cable pairs used for audio circuits are loaded with 88 mH coils spaced at 1.83 km intervals to provide an adequate frequency response

over the range 300–3 000 Hz. Where transmission limits are exceeded, amplification is used, mainly by 2-wire repeaters most of which are of the negative-impedance type. To meet growth, the capacity of existing cables has been increased by using selective pairs as bearers for transmission systems using pulse-code modulation (PCM) digital systems. Initially, 1.5 Mbit/s 24-channel systems were used, the first being introduced in 1964, and there are some 4000 systems now installed in junction networks throughout the country. These systems have now been superseded by the new European standard, 2 Mbit/s 30-channel systems, which are being installed in ever increasing numbers.

### LOCAL NETWORK

The local network of lines from local exchanges to customers has proved remarkably resistant to the impact of technological development. A reduction in costs has been achieved by using polyethylene sheathing for cables, automatic cable jointing machines, and the substitution of aluminium alloy for copper. There has been a progressive move to put plant underground for ecological reasons, and as a move towards direct pre-cabling to customers' premises. The reliability of the network has been greatly increased by the introduction of cable pressurization of local-main cables during the 1960s.

The major changes in the local network over the past 25 years have occurred in the exchange sector. At the start of the period, about 22% of exchanges (over 1300) were manual and the rest Strowger. Manual exchanges were rapidly replaced during the first decade (see Fig. 8) but the last manual exchange, at Portree on the Isle of Skye, was not closed until 1976. From the mid-1960s onwards, modern local exchange systems were progressively introduced in the local network, as shown in Fig. 8. These comprised 2 versions of crossbar exchanges; namely, the Plessey TXK1 (the first of which was opened in 1964 at Broughton) and the STC TXK3 versions, together with the TXE2 small reed-relay electronic exchange which was introduced in 1966. Large reed-relay electronic exchanges, designated *TXE4*, were introduced in 1976. Currently there are 514 crossbar exchanges, 1228 TXE2 exchanges and 134 TXE4 exchanges operational in the local

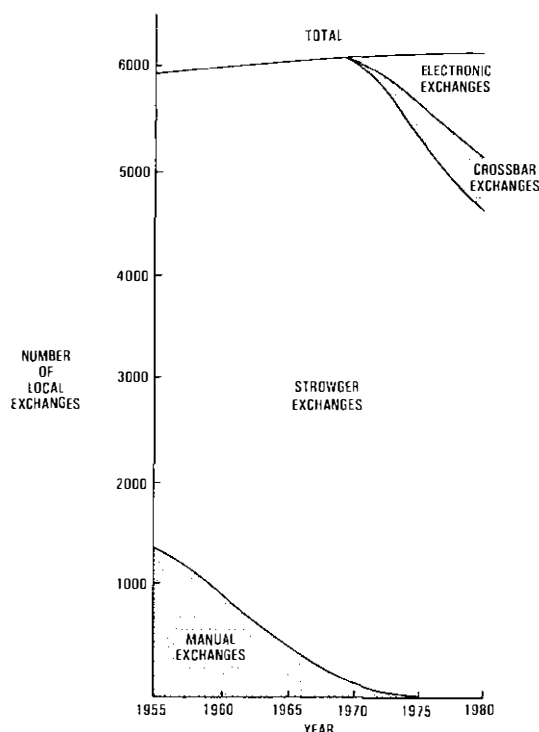

FIG. 8—Recovery of manual local exchanges and penetration of modern exchanges

network. There has also been some enhancement to Strowger director exchanges by the introduction of stored-program control (SPC) and electronic directors to replace their electro-mechanical counterparts.

The difficulty of meeting the high growth of exchange connexions led to the introduction of shared service which, in 1960, comprised nearly 25% of all connexions. Since then, there has been a progressive decline in the proportion of connexions that are shared service to about 10% at present, although the total number of shared-service connexions is higher than it was in 1960.

### OPERATOR SERVICES

The progressive automation of the network from trunk mechanization through to the current situation of full STD access has inevitably resulted in a run-down of the operator force (as shown in Fig. 9), the closure of small auto-manual centres (AMCs), and changes to the nature of the operator service. The AMC has assumed the role of an assistance point for customers requiring help from an operator in obtaining a call, together with specialized services such as directory enquiries (DQ) and credit-card calls. Modernization of bridge- and sleeve-control AMCs is being carried out by the use of cordless (CSS1) switchboards, which now constitute nearly 25% of all AMCs.

In the last decade or so, considerable advances have been made in operating procedures for recording operator controlled calls and bringing them to account, leading, for instance, to the introduction of microprocessor based automatic call-recording equipment (ACRE). Similarly, studies of DQ work have led to improved procedures and methods for presenting up-to-date DQ records for easy and rapid operator search. At present, microfiche records are under evaluation for general introduction, and the retrieval of information on to visual display terminals (VDTs) from computer files is under consideration.

### NON-VOICE NETWORKS

The past 25 years have seen a considerable growth in non-voice type services and the establishment of specialized networks to handle them. In particular, the widespread commercial use of computers has resulted in a growing need to provide facilities for the transmission of data over the network.

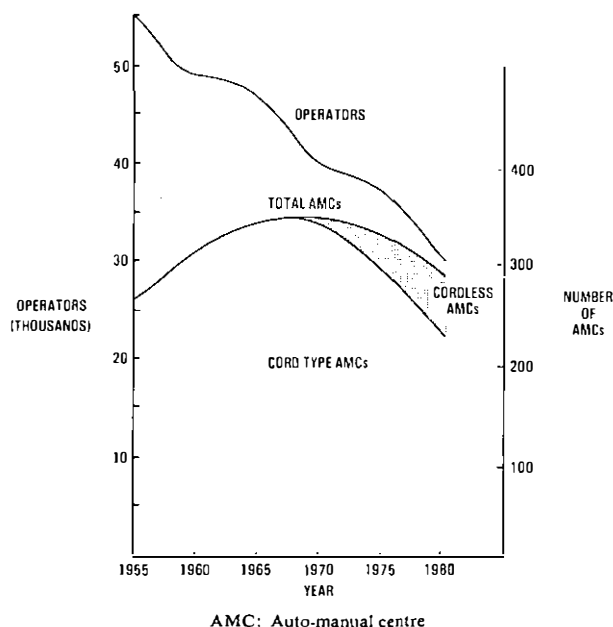

FIG. 9—Operator run-down and AMC modernization

### The Telex Network

Telex, one of the oldest examples of a digital service, was originally provided over the public switched telephone network (PSTN) using a carrier signal of 1500 Hz. It was eventually decided that the service could be provided more economically by a dedicated network, and so a manual service using switchboards located in London and major provincial centres was established in 1954.

In 1958, an automatic service was introduced, using Strowger equipment. The Telex network comprised 6 fully interconnected zone centres located at London, Birmingham, Bristol, Glasgow, Leeds and Manchester, with area exchanges established in charging areas where justified by the concentration of customers. The conversion of the inland Telex network to automatic working was completed in 1960. In order to provide facilities for the disposal of telegrams direct to Telex customers, access was provided from the inland teleprinter automatic switching system (TASS)—the switched network used for telegram transmission—to the Telex network. As public telegram traffic declined, it was transferred to the Telex network and the TASS network closed. Manual switchboards were used in London and main provincial centres for enquiry and assistance calls.

Economic transmission was provided using multi-channel voice-frequency (MCVF) telegraph systems which allowed 12 Telex circuits (and subsequently 24) to be provided over a single voice channel. The transmission performance plan for the network ensured that distortion between teleprinters was not worse than that of 5 normal MCVF circuits in tandem. The early MCVF systems, using amplitude modulation techniques, were succeeded by frequency-shift keying systems with their inherently greater voice immunity and insensitivity to level variations. In turn, these systems are now being superseded by time-division multiplexed systems which produce a composite digital signal at 64 kbit/s and have a capacity for 240 Telex circuits at 50 bauds; they interface to group-band modems (modulators/demodulators) or a 64 kbit/s channel of a primary PCM system. Initially, the private circuit digital data service will provide the 64 kbit/s bearers for such systems.

During the 25 years up to the present time, the Telex network has grown an astonishing fiftyfold (see Fig. 10). From the start, the proportion of external Telex calls has been high and today about 57% of all Telex calls are for overseas destinations. The number of exchanges increased from 11 to 51. However, apart from the introduction of a small number of SPC remote concentrators in London, to augment the multiple capacity of existing Telex exchanges, the technology has remained virtually unchanged. The Strowger equipment used in Telex exchanges is now obsolete, fault prone, inefficient and limited in its capability to provide advanced facilities for customers. It has therefore been

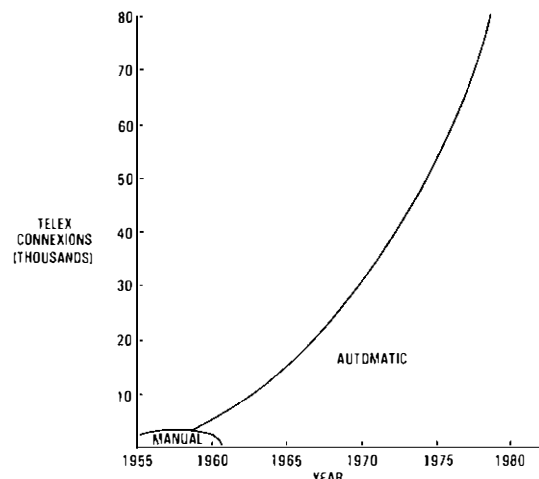

FIG. 10—Growth of Telex connexions



decided to progressively modernize the network by the use of an SPC digital switching system. This system has the capability of handling data at 110, 200, 300 and 600 bit/s with the possibility of extending the speed range up to 9.6 kbit/s. It also provides advanced facilities, such as store-and-forward, multiple address, delayed delivery, broadcast, speed and code inter-working and call re-direction. Current plans envisage the installation of 11 such exchanges by the mid-1980s, which will replace 22 Strowger Telex exchanges and serve about 35% of Telex customers.

In the longer-term, it can be expected that the future of the Telex service will be heavily influenced by other text communications services due to be introduced, such as fast facsimile and Teletex. The latter uses standardized intercommunicating wordprocessors that enable text to be prepared, edited and then transmitted at 2400 bit/s fully automatically between storage devices incorporated in the Teletex terminals. The British Telecommunications Teletex service will use the Telex network, the PSTN and the packet-switched network (PSN). A migration of Telex users to the Teletex service can be expected, but Telex, in its basic form, is likely to be required well into the 1990s. There will be a need to intercommunicate between the Telex and Teletex services and this will require interconnexion of the Telex network, PSN and PSTN.

### Data Transmission Services

#### Datel

During the early-1960s, the need to interconnect remotely sited computers and terminals began to arise and was met, using the readily available PSTN and also leased lines, by using modems to interface with customers' data terminal equipment; this converted digital signals to analogue form for transmission over a network designed for voice services. Up to the present time there has been a sustained high growth of data terminals as shown in Fig. 11 and the UK

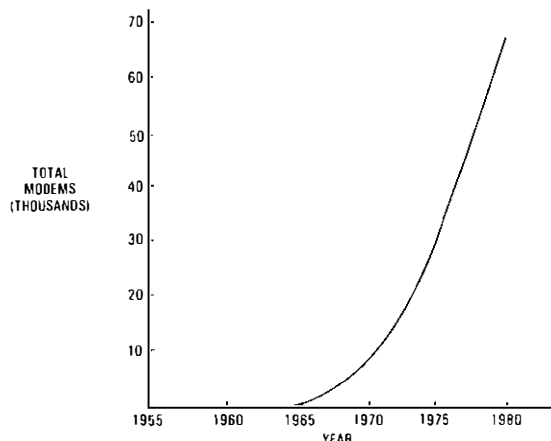

FIG. 11—Growth of Datel connexions

has considerably more terminals than any other European country. Developments in modem technology have progressively extended the data transmission rates that can be carried over the PSTN from the original Datel 100, introduced in 1964, to provide data transmission at 50 bit/s over the Telex network or 110 bit/s over private telegraph circuits, to the 9600 bit/s half duplex or the 1200 bit/s full duplex systems available today. It is expected that 2400 bit/s full duplex will become feasible in the near future with further technical development. A summary of the Datel Services is given in Table 1.

#### Switched Data Network

Although the ubiquitous PSTN provides cheap and reliable Datel services on a network wide basis on demand, it was designed for voice services and imposes severe technical limitations on data transmission owing to bandwidth, error rate and slow call set-up. Because of these limitations, and

TABLE 1  
Summary of Inland Datel Services

Service	Year	Signal Path	Transmission Speed (bit/s)	Mode	Remarks
Datel 100	1964	Telex PC	50 110	Asynchronous Asynchronous	Duplex or half duplex
Datel 200	1967	PSTN PC	200 200	Asynchronous Asynchronous	Speeds up to 300 bit/s possible over PSTN and PC
Datel 600	1965	PSTN PC	600 1200	Asynchronous Asynchronous	Speeds up to 1200 bit/s possible 4-wire PC required for duplex working
Datel 1200 Duplex Service	1980	PSTN	1200	Asynchronous Synchronous	
Datel 2400	1968	PC	2400	Synchronous	4-wire PC required
Datel 2400 Dial Up	1972	PSTN	2400	Synchronous	Can be switched to 600/1200 bit/s when 2400 bit/s not possible
Datel 2412	1977	PSTN PC	2400 2400	Synchronous Synchronous	May be necessary to switch to 1200 bit/s on some connexions 4-wire PC required
Datel 4800	1980	PSTN PC	4800 4800	Synchronous Synchronous	May be necessary to switch to 2400 bit/s 4-wire PC is required
Datel 4832	1978	PC PSTN (Stand-by)	4800 4800	Synchronous Synchronous	4-wire PC required May be necessary to switch to 3200 bit/s
Datel 48K	1970	Wideband Circuit	40.8 k 48 k 50 k	Synchronous	

PSTN: Public switched telephone network  
PC: Private circuit

the considerable user requirements for within-house systems, the majority of users systems (about 70% of Datel modems) operate over leased lines. The ability to equalize permanent leased lines and provide 4-wire transmission enables data rates of 9600 bit/s full duplex or higher to be achieved on voice-band circuits, or 48, 72 and 120 kbit/s over group-band circuits which are the equivalent of 12 voice circuits.

Although there will continue to be a need to provide in-house networks, it has been recognized that technological development and standardization are leading to new applications that could require interconnexion between private systems. Hence, there is a need for a better switched data service than can be provided over the PSTN. The earliest experimental high-speed switched data network was opened in 1970. It was a 48 kbit/s manually-switched network interconnecting London, Birmingham and Manchester, but customer reaction was disappointing and it was closed down. However, in the early-1970s, consideration was given to the establishment of an automatic switched data service. Of the 2 techniques, *circuit* and *packet* switching, the latter was considered most attractive because dynamic multiplexing was more suited to the predominant use of remote terminals accessing high-speed computing facilities. It also offered a number of attractive features to the user such as inter-working between terminals of different data rates, error-checking and correction on a link-by-link basis, alternative network routing, dynamic multiplexing on customers' local ends enabling a single physical link to support a number of simultaneous transactions to a variety of destinations, and so on. Additionally, the packet-switched network will support simple character-type terminals, either directly connected or accessing the packet-switched network via dial-up connexions over the PSTN.

To test the market for a packet-switched service and enable the BPO, users and the data processing industry to improve their understanding of the techniques and potential offered, it was decided to establish an experimental packet-switched service (EPSS). The experiment formally opened in 1977 with 3 packet switching exchanges (PSEs), based on the Ferranti Argus 700E processor, located in London, Manchester and Glasgow and interconnected by 48 kbit/s links. The network was equipped with 57 packet ports serving customers (in addition to those required for inter-PSE links) and 89 character terminal ports accessible via the PSTN. The experiment was most successful; a liaison group was established as a forum for the interchange of customer experience in adapting systems and applications to packet-network working and valuable work was also done in the area of high-level protocols.

To meet the increasing commercial market for a public packet-switched service to the international standards that emerged during the period of the EPSS, it was decided to establish a national packet-switched service (PSS), a view supported by the Government sponsored National Committee on Computer Networks (NCCN). The network, using Telenet TP4000 equipment supplied by Plessey Controls Ltd., was opened in 1981 as a 9-node network interconnected by 48 kbit/s links and capable of supporting 450 packet ports and 1250 character ports. Current plans envisage an expansion of the network to 20 nodes in 1982.

#### *Private Data Circuits*

To exploit the increasing availability of digital transmission plant to improve the leased line data services, a private circuit digital data service (PCDDS) is planned to be introduced in 1983. It will comprise a national 2048 kbit/s network from which individual circuits will be derived by means of dedicated PCDDS muldexes (multiplexer/demultiplexer) and extended digitally to customers' premises over the local network to give synchronous user rates of 2400, 4800, 9600 and 48 000 bit/s full duplex. A 6 + 2 bit envelope will be adopted to provide sophisticated in-service monitoring and maintenance aids with user rates reiterated to 64 kbit/s for transmission over

PCM systems. The muldex equipment will be located at exchanges, designated *multiplexing sites*, which will be located in areas of high data demand. At strategically placed multiplexing sites, known as *cross-connexion sites*, flexibility for interconnecting individual 64 kbit/s channels will be provided.

With the penetration of digital switching (System X) and transmission plant into the network, a circuit-switched data service will become more viable and it is proposed to provide such a service over the integrated services digital network (ISDN), which will provide 64 kbit/s channels for non-voice services into customers' premises. A pilot ISDN is scheduled to be available in London in 1983.

## NETWORK MODERNIZATION

Although today's network is fully automatic, enabling all customers to dial their own trunk calls, with about 90% of international traffic direct dialled to more than 100 countries, it suffers from a number of constraints. The main network, in particular, is controlled by electromechanical Strowger and crossbar switches and, apart from the transit network, routes its traffic entirely by Strowger pulses. This apparent lack of modern technological progress largely arises because of the widespread introduction of Strowger equipment and the extraordinary flexibility of such equipment to cater for changes in requirements by the *ad hoc* addition of register-control and specialized relay-sets. However, the decision to provide 95% of STD access via 2-wire switched step-by-step, in-band signalling routeings has imposed severe constraints on its further evolution. In addition, by today's standards, it is slow, noisy, fault prone, with large accommodation requirements and limited in its capability to provide the customer and administration facilities that can be seen as potential requirements for the future. It is also dependent on semi-precision mechanical production and adjustment to small tolerances, which make its manufacture and maintenance highly labour-intensive, expensive and sensitive to inflation. During the 1960s, it became apparent that with the continuing high growth in traffic, severe economic penalties could result from the continuing use of existing technology; therefore, a number of major network studies were undertaken.

## UNITED KINGDOM TRUNK TASK FORCE

In 1967, a special multi-disciplined team, the *United Kingdom Trunk Task Force* (UKTTF), was established to study the problems of the main network and to produce long-term strategic proposals for its modernization. Extensive computer-assisted studies were carried out taking account of forecast growth, future cost trends, technological development and potential new services. The results indicated that the most economic solution for the main network would be to provide SPC digital exchanges interconnected by digital transmission systems, with common-channel inter-processor signalling; that is, an integrated digital network (IDN) in CCITT† terminology. Indications were that the total network costs, in terms of annual charges, would be reduced by about 50% compared with a continuation of the existing space-switching/analogue transmission network. It was also apparent that significant economic advantages could be achieved by the introduction of digital transmission systems into a space-switching environment and this stimulated the development of high-capacity digital transmission systems which are now being introduced into the network.

## ADVISORY GROUP ON SYSTEMS DEFINITION

Also in the late-1960s, a joint BPO/Industry team called the *Advisory Group on Systems Definition* (AGSD), was studying

† CCITT — International Telegraph and Telephone Consultative Committee.

the fundamental criteria on which to base ongoing switching developments. These studies ranged over the whole development process, but took particular account of network implications. The work effectively laid the foundations for the System X family of digital exchanges using micro-electronic technology, integrated digital switching and transmission, SPC, and common-channel signalling. System X, the first exchanges of which are being currently introduced into the network, has therefore been developed in the context of an overall strategy for the evolution of the UK network.

### LOCAL EXCHANGE MODERNIZATION

Modernization of local exchanges also came under scrutiny in the late-1960s when an investigation into the economic and practical aspects of the accelerated replacement of Strowger local exchanges was carried out. A large number of renewal strategies were studied, which led to a policy for the accelerated replacement of all Strowger local exchanges by the mid-1990s, and a decision to introduce, as an interim modernization measure, the widespread use of reed-relay switching local exchanges (TXE2 and TXE4). In addition to improving service to the customer and reducing costs, this interim modernization step has proved particularly valuable in building-up manufacturing and operating experience of electronic switching systems, thus enabling the progression into the future digital era to be planned with some confidence.

### NETWORK MODERNIZATION STRATEGY

In the mid-1970s, as the development of digital transmission and switching (System X) systems matured, an extensive investigation was carried out to determine the policy for modernizing the network by the accelerated replacement of analogue plant with digital and to evaluate the options for converting the network to an IDN. The studies took account of practical circumstances, manpower aspects, financial constraints and manufacturing implications. Since they encompassed all sectors of the network, the evaluation was a particularly complex process which required extensive computer assistance. The results of the studies indicated that:

- (a) The difference in the economics of rapid and slow rates of network conversion was marginal.
- (b) Future customer needs would include an improved quality of service and a wider range of services. Judicious use of digital plant would enable a significant proportion of customers to be brought within the catchment area of digital plant in return for a relatively modest outlay.
- (c) The early modernization of the main network was essential to improve the quality of service given to the customer and to provide a nationwide foundation for the introduction of new facilities and services.
- (d) There was a need to enhance existing modern reed-relay electronic exchanges to provide supplementary telephony services comparable with those provided from System X digital exchanges.
- (e) The full potential of the digital network to carry an increasingly sophisticated range of new services would only be realized by extending digital working down to the customers' premises, together with enhanced customer-to-network signalling, to form an integrated services digital network (ISDN).

Resulting from the conclusions of the strategy studies, a network modernization policy is now being implemented. The main elements of the strategy are:

- (a) To deploy System X equipment in such a way as to maximize the service capabilities to those customers who will put the highest value on them. The target is to interconnect the major UK cities by a high-capability integrated digital network by the mid-1980s.
- (b) To replace all trunk and tandem exchanges with

System X by the early-1990s with complementary digital transmission modernization to give a total IDN.

(c) To provide complementary System X local switching capability coincident with the installation of trunk exchanges, taking account of the marketing potential for new services, so that the service capability can be brought to customers most likely to benefit from it.

(d) To eliminate large Strowger local exchanges from the network by the early-1990s, and all Strowger by the mid-1990s.

(e) To launch a trial of an ISDN as soon as possible.

(f) To replace the remaining crossbar and electronic local exchanges by the year 2015.

### THE INTEGRATED DIGITAL NETWORK

Maximum benefit from digital systems can be achieved only if switching and transmission are deployed in a coherent manner as a network of digital switching centres interconnected by digital transmission links to form an IDN; that is, speech signals are encoded and multiplexed into the PCM format as they enter the network at the originating local exchange, and then are transmitted and switched in digital form through the network until they reach the destination local exchange where they are demultiplexed and decoded back to their original form. This achieves significant network economies and permits unified treatment of a variety of services that can be encoded and multiplexed together into a common digital format for transmission over common digital paths, with sophisticated digital processing where necessary.

#### Network Structure

The IDN now being introduced represents a fundamental change in network structure. It comprises 5 separate but interdependent component networks (see Fig. 12); namely, the switched digital network, the signalling network, the digital transmission network, the synchronization network, and the administration network.

#### Switched Digital Network

The switched digital network comprises the digital exchanges and their interconnecting traffic routes. The introduction of the 30-circuit basic transmission module (instead of the presently used 12-circuit module), together with reduced switching costs, increases the level of traffic required to justify direct optional routes between switching centres. This, together with the use of both-way traffic routes, has the effect of reducing the number of traffic routes required in the 1990s from approximately 17 000 in an analogue network to about 5500 in the IDN. Automatic alternative routing (AAR) will be employed to allow for re-routing of traffic under congestion and breakdown conditions, with the consequent improvement in quality of service. The new network will be hierarchical, as at present, but will comprise 3 instead of 4 tiers.

#### Signalling Network

Inter-exchange signalling will be between exchange processors in the form of labelled messages over a common 64 kbit/s signalling channel conforming to the CCITT Signalling System No. 7 specification as described elsewhere in this issue. A separate signalling network, analogous to the switched telephony network, will be established as a common transport service for telecommunications and administration messages. The signalling network will comprise signal transfer points (STPs) whose processors receive signalling messages, recognize their destination and re-transmit them, interconnected by signalling links to form a hierarchical network.

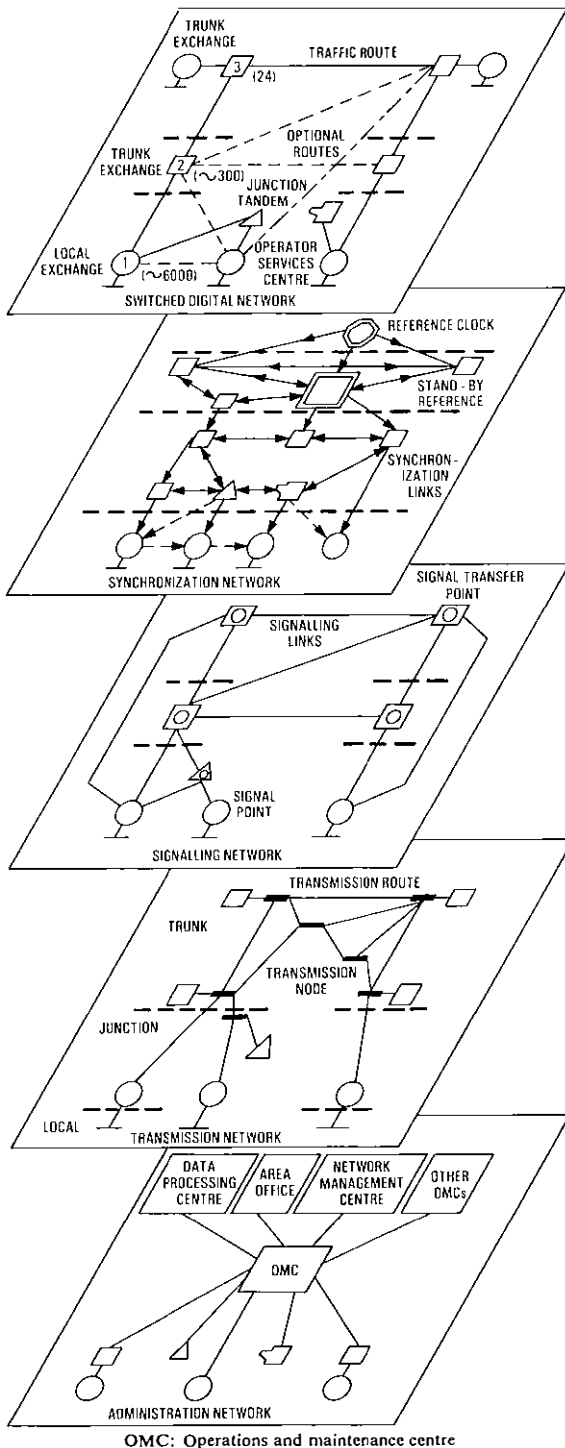

FIG. 12—Structure of the integrated digital network

Security will be provided by diversity of signalling links and automatic re-routing of signalling messages under plant breakdown conditions.

**Digital Transmission and Synchronization Networks**

When digital transmission links are used to interconnect digital exchanges, the exchange clocks and incoming bit streams must be at the same average frequency or information will arrive at exchanges at a different rate than it can be processed, with consequent errors known as *slip*. The IDN will be synchronized to a high-stability national reference clock by a hierarchical structure of synchronization links interconnecting the exchanges over which messages are

passed to keep all exchange clocks in step.

**Administration Network**

The administration and management of the network will be carried out from *operations and maintenance centres (OMCs)* and *network management centres (NMCs)*. The OMC is designed to be the focal point for a catchment area of exchanges. In addition to providing a concentration/control point for man-machine communication, with its exchanges, it carries out maintenance control, remote manipulation of exchange stored data and call-accounting functions. Network management is the dynamic surveillance of traffic flowing through the network, together with the re-routing of traffic to overcome network congestion and plant failure conditions. This function will be carried out at a number of NMCs. Interconnection of OMCs and NMCs to the various exchanges and data-processing centres will be by data links that constitute the administration network.

**THE FUTURE**

The past has seen the decline of the agricultural age and the emergence of the industrial era supported by powerful developments in physical transportation. Current trends suggest that, in future, service industries will dominate. The product of the service sector is information which requires to be collected, stored, manipulated, retrieved and communicated. The rapid growth of data services is evidence of this trend. The telecommunications network will therefore assume an even more important part of the infrastructure of society and be a key element in the economic health of the country.

The micro-electronic revolution that has provided the means for modernizing the network is now penetrating home and office. Text processing will assume growing importance in the emerging "electronic office". Such an office will utilize the convergence of office machinery, computing and communications (sometimes known as *Telematics*) to provide a single paperless integrated system for the capture and manipulation of information in electronic form. The need for such units to communicate with corresponding units will add to the scale and nature of the traffic to be provided for in the network. Powerful microprocessors can also be expected to penetrate the home, paving the way for a wide variety of applications such as shopping from home, automatic billing of utility services, new forms of interactive entertainment and education, electronic mail and newspapers, and information retrieval. The latter has already been introduced into the UK network, under the name of *Prestel*. Electronic funds transfer, already extensively used between banks, will also link shop and bank over the network, and widespread penetration of such a service is predicted.

It can therefore be seen that the balance of person-to-person communication will progressively shift from the traditional face-to-face and postal mail methods to telecommunications, and such a move will become intensified by the need for energy conservation for transportation. The era of the "information society" has arrived, and the future network will need to handle a wide variety of voice, data and visual services. It will deal with information communication, not just telephony, and the traditional functions of switching, transmission and signalling will need to be supplemented by information recognition, storage, processing and retrieval to create a single-service-providing active network. The complex effect on society, commerce and industry of an enhanced telecommunications service together with technological progress, can be expected to generate ever-increasing demands on the network, creating the need for flexibility to respond at short notice. The network will need to be resilient to the effect of over-loading and breakdown, and have a high survival capability, since society will rely on it more and more.

## The Integrated Services Digital Network

The provision of the IDN provides a firm basis to meet the demands of this future, providing a common network infrastructure for the conveyance of a wide variety of information in digital form. But, as long as the customer is connected by the conventional local line to a standard PCM codec, the service potential will be severely constrained. However, if the IDN is extended down to a customer's premises by digital transmission, with enhanced customer-to-network signalling and an appropriate customer/network interface, then the all-purpose network necessary to meet the demands of the future can be created. Such a network is known as the *integrated services digital network* (ISDN). The necessary interfaces, signal requirements and protocols are being determined and injected into international discussion as an input to the formulation of standards for an international ISDN. The most significant future network development will therefore occur in the local network with the widespread penetration of digital transmission down to the customer's premises. Currently, it is planned to interconnect customer's terminals with System X exchanges using an 80 kbit/s transmission system, providing for simultaneous transmission of 64 kbit/s (for speech or data) and an 8 kbit/s data channel together with 8 kbit/s to provide the necessary enhanced customer-to-network signalling. For digital PABX customers, a 2048 kbit/s digital line system will be used to access the ISDN in which thirty 64 kbit/s channels can carry either voice or data traffic, with common-channel signalling provided at 64 kbit/s. It is intended to establish a pilot network in London, in 1983, to evaluate in the field the implications of the ISDN and to test customer reaction to the wide spectrum of new services that can be provided. The ISDN will then rapidly penetrate the network in the latter half of the 1980s coincident with its modernization.

## Satellites

The future terrestrial network can be expected to be complemented by a satellite based overlay network offering advanced digital communications services. Such specialized satellite services (SSSs) will use cheap small-dish earth stations located at customer's premises and will allow greater flexibility in providing services, with the facility for multi-destination broadcasting of information. Agreement has already been reached with European Telecommunications Authorities in the European Space Management Authority (EUTELSAT) for capacity in 2 future satellite systems from the mid-1980s; namely, the European Communication Satellite (ECS), which is being constructed by a Consortium headed by British Aerospace, and Telecom 1, a French Government project which is planned to provide domestic services in France. The European Orbital Test Satellite (OTS) is currently being used to evaluate SSS applications and commercial trials of small dish satellite systems are scheduled to commence later this year.

In the more distant future, customers are likely to require a telecommunications service with far greater mobility where a telephone number will identify a person wherever he may be located. A universal pocket telephone accessible over a nationwide mobile-radio system can be envisaged where the businessman will carry a briefcase data terminal and display to receive electronic mail and messages.

## CONCLUSIONS

The past 25 years have seen a remarkable evolution of the inland network allowing full automation to be provided together with the introduction of data services. The future will see even more revolutionary changes necessary to meet the needs of an information-based society and to take advantage of technological developments in micro-electronics, fibre optics and satellites. Although the telephony service will continue to dominate, a wide variety of new services will

penetrate the network. The foundations of the future network are now being laid by the rapid introduction of digital switching and transmission to modernize the network. This approach to the digital era is made with some confidence since the decision to go digital has been backed by many years of research and development experience stemming from the invention of PCM, in the 1930s, by an Englishman, Alec Reeves. Experimental coders using thermionic valves were constructed in the early-1950s, followed in 1958 by the extensive introduction of practical PCM systems in the field. Similarly, digital switching systems have been researched since the 1950s, with experimental systems carrying live traffic in the late-1960s and early-1970s.

## Bibliography

- GIBSON, M. E., and MILLAR, D. R. An Experimental Manually-Switched 48 kbit/s Data Transmission Network. *POEEJ*, Vol. 64, p. 52, Apr. 1971.
- GIBBS, J. W., and JACKSON, F. G. Introduction to International Dialling from Non-Director areas. *POEEJ*, Vol. 64, p. 44, Apr. 1971.
- CROOKS, K. R. A New Generation of Auto-Manual Centres for London. *POEEJ*, Vol. 63, p. 212, Jan. 1971.
- BENSON, D. L. Local Exchange Renewal Strategy: Formulating a Strategy. *POEEJ*, Vol. 67, p. 130, Oct. 1974.
- WHERRY, A. B., and BIRT, T. F. The London Sector Plan: Background and General Principles. *POEEJ*, Vol. 67, p. 3, Apr. 1974.
- BREARY, D. A Long Term Study of the UK Trunk Network. *POEEJ*, Vol. 67, p. 37, Apr. 1974.
- MOON, R. J., BEALE, G. A., and TARRY, D. G. TXE2 Electronic Exchange System: The Evolution from Mark 1 to Mark 3. *POEEJ*, Vol. 69, p. 210, Jan. 1977.
- FRANCIS, H. E., and DAVIS, E. Decentralization of London's Trunk and Tandem Telephone Exchanges. *POEEJ*, Vol. 59, p. 75, July 1966.
- BELTON, R. C., and SMITH, M. A. Introduction to the British Post Office Experimental Packet-Switching Service (EPSS). *POEEJ*, Vol. 66, p. 216, Jan. 1974.
- HADLEY, D. E., and MEDCRAFT, D. W. F. Experimental Packet-Switched Data-Transmission Service: Network Design and Implementation. *POEEJ*, Vol. 67, p. 88, July 1974.
- HARE, A. G. Local Distribution—An Assessment for Future Systems Development, Parts 1 and 2. *POEEJ*, Vol. 68, p. 204, Jan. 1976, and Vol. 69, p. 27, Apr. 1976.
- SPRATT, C. J. A Review of Data Transmission in the UK. *POEEJ*, Vol. 69, p. 19, Apr. 1976.
- KYME, R. C. The Junction Network. *POEEJ*, Vol. 69, p. 175, Oct. 1976.
- HARRIS, L. R. F., and DAVIS, E. System X and the Evolving UK Telecommunications Network. *POEEJ*, Vol. 72, p. 2, Apr. 1979.
- BOULTER, R. A., and BUNN, W. Network Synchronization. *POEEJ*, Vol. 70, p. 21, Apr. 1977.
- TOBIN, W. J. E., and STRATTON, J. A New Switching and Transmission Plan for the Inland Trunk Network. *POEEJ*, Vol. 53, p. 75, July 1960.
- ORBELL, A. G. Preparations for Evolution Towards an Integrated Services Digital Network. International Communications Conference, Boston, June 1979.
- GRIFFITHS, J. M. Digital Local Networks. *POEEJ*, Vol. 72, p. 206, Jan. 1980.
- FRANCIS, H. E. The General Plan for Subscriber Trunk Dialling. *POEEJ*, Vol. 51, p. 258, Jan. 1959.
- WHYTE, J. S. Telecommunications—The Way Ahead. Conference on Communications Equipment and Systems, Birmingham, Apr. 1980.
- WARD, K. E. Planning the Evolution to an Integrated Digital Transmission and Switching Network for Telephony. IEE Conference on Telecommunications, Sept. 1975.
- WARD, K. E., and DUNMORE, G. The Modernization of the UK Switched Telecommunications Network. IEE Conference on Telecommunications Transmission—Into the Digital Era, Mar. 1981.
- WARD, K. E., and LONNEN, K. W. J. Integrated Digital Networks and Integration of Services—Facts and Ideas. International Communications Conference, Toronto, June 1978.
- Eurodata Foundation Yearbook, 1981—Data Communications Services in Europe.
- ADAM, A. R., and LEE, E. J. B. The British Post Offices Packet Switched Services. Conference on Communications Equipment and Systems, Birmingham, 1980.
- WHERRY, A. B. Planning Problems Associated with a Developing Trunk Switching System. *POEEJ*, Vol. 62, p. 38, Jan. 1970.
- LINFORD, N. S. The Evolution of the UK Telephone Service. *POEEJ*, Vol. 69, p. 12, Jan. 1970.
- MARKS, D. J. A Decade of Growth in the Trunk Telephone Network 1952–1962. *POEEJ*, Vol. 56, p. 177, Oct. 1963.

# INTERNATIONAL SERVICES

## A Review of the International Service

C. J. MAURER, C.G.I.A., B.SC.(ENG.), C.ENG., F.I.E.E.†

UDC 654:621.39

*This article briefly reviews the growth of the British Post Office international service over the past 25 years and goes on to describe the more significant developments that have contributed to the expansion of services over this period.*

### INTRODUCTION

Since the mid-1950s, the British Post Office (BPO) overseas or external services, now known as *British Telecom International* (BTI)\* services, have expanded at a remarkable rate. Growth on the telephony side in excess of 20% per annum has been recorded and it is likely that double figure rates will continue for a long period. Demands for higher standards, greater capacities and new services have been matched by spectacular technology development. Of these, the introduction of inter-continental submarine cables and communication satellites in geostationary orbits must rate as 2 of the more significant developments. The automatic Telex service, which opened with 1600 subscribers in 1954, has now developed into a fully automatic international service. The international telephone service changed in 1958 from a manually operated service to semi-automatic operation, and in 1963 international subscriber dialling (ISD), now known as *international direct dialling* (IDD), was introduced.

### GROWTH OF THE INTERNATIONAL NETWORK 1956-81

#### INTERNATIONAL TRANSMISSION NETWORK Submarine Cables and Microwave Links

The advent of the new submerged repeater in the mid-1950s was the real start of the submarine cable era. In 1956, a 36-channel cable between Oban and Newfoundland was laid (TAT 1), followed 3 years later by TAT 2 between Newfoundland and France. In addition, increased demand between the UK and the continent gave rise to the provision of additional cable capacity across the North Sea. In 1961, a milestone was reached in the Atlantic with the introduction of a 60-circuit cable to Canada (CANTAT 1). This system employed lightweight cable and 2-wire rigid repeaters and, together with its derivatives, subsequently became the world standard for deep-water cables. In the mid-1960s, transistorized repeaters became available to revolutionize submarine cable systems and in 1967, the UK-Jersey system was installed, employing transistors produced by the BPO Research Department. During the early-1970s, repeaters capable of operating at higher rates (14 MHz) were used in North Sea cable systems. The TAT systems by this time had reached the fifth generation with an 845-circuit system between the USA and Spain; similar techniques were used on CANTAT 2 (1974),



FIG. 1—The CS *Alert*, built 1961

which increased this route capacity by 1840 circuits. System capacities have subsequently increased to 4000 circuits on TAT 6 (1976) and on the UK-Belgium No. 4 cable (1977). At present, plans are in hand to provide optical-fibre submarine cables between the UK and Europe by the mid-1980s, followed by a similar cable across the Atlantic.

During the past 25 years the BPO's fleet of cable ships has been updated; *Alert 3* was sold for scrap in 1960, and *Monarch 4* was sold to Cable and Wireless Ltd. in 1970. The current fleet consists of 3 ships: the *Alert 4*, (see Fig. 1) *Iris 2* and *Monarch 5*.

Another important transmission link with Europe is provided by a 4 GHz microwave link between Tolsford Hill, Kent and Fiennes near Calais. The link was opened in 1960 to provide 10 supergroups for telephony and one television channel and has been progressively expanded up to its present capacity of 96 telephony supergroups and 2 television channels. These are used for circuits to France and 19 other European countries.

#### High-Frequency Radio and Communications Satellites

Until 1956, when the first transatlantic telephone cable was inaugurated, the heavy demand for long-distance inter-continental voice communications which followed the Second World War could be met only by radio (mostly high-frequency (HF) radio using the 4-30 MHz frequency band). Despite the availability of high-grade submarine cable circuits which quickly supplanted radio services on the dense North Atlantic routes, the major expansion of HF radio facilities, which

† Director International Network, British Telecom Headquarters  
\* British Telecom International is the trading name of the International Division of British Telecommunications

started in the early-1950s, continued well into the 1960s to meet the growing demands for service by the smaller and developing countries of the world.

In parallel with the submarine cable developments in the 1950s, new technology opened the way to satellite communications. On 14 February 1961, a Memorandum of Understanding was signed between the BPO and the National Aeronautics and Space Administration (NASA) confirming an intention to collaborate in developing the new medium (NASA had similar agreements with other administrations). By Spring 1962, an earth station had been designed, with a large involvement of the BPO Research Department, and built at Goonhilly in Cornwall (see Fig. 2)<sup>1</sup>. Other earth stations were built at Andover (Maine, USA) and Pleumeur Bodou (Brittany, France). The TELSTAR I satellite<sup>2</sup> (see Fig. 3), designed and built by Bell Laboratories and launched on 10 July 1962, was used by the 3 earth stations to demonstrate that 2-way transatlantic satellite communication was technically feasible for multi-channel frequency-division multiplex (FDM) telephony transmission. In the summer of 1962, television signals transmitted via this early satellite network were broadcast by the BBC and excited great public interest. They were the first-ever live inter-continental high-definition television signals. Further transatlantic experiments were carried out using the RELAY I satellite when it was launched on 13 December 1962. The TELSTAR and RELAY satellites had been launched into relatively-low elliptical orbits, with an orbital period of around 3 hours. Complex equipment was necessary for tracking the satellites which were seldom visible simultaneously from both sides of the Atlantic for as long as 30 minutes during each pass.

Arthur C. Clarke had envisaged the use of satellites in a geostationary orbit; that is, a circular equatorial orbit, 36 000 km high. Geostationary satellites appear to stand still in the sky and are therefore easier to use for communication systems, but the transmission path, and consequently the transmission time (typically 260 ms earth station-to-earth station), is very long by terrestrial standards and might impede the easy flow of a telephone conversation. The injection of satellites into this orbit also presented technical difficulties in the early-1960s. However, the 3-satellite SYNCOM programme of 1963-4 demonstrated a solution to the orbit-injection problem.

It was recognized that an international co-operative organization was required to provide the satellites and administer their use and, in 1964, eleven nations signed agreements that set up the *International Telecommunications Satellite Consortium* (INTELSAT). The EARLYBIRD satellite project was taken over by INTELSAT and the satellite was launched on 6 April 1965 into a low orbit and then moved out to a geostationary orbit. It was found acceptable in a programme of customer trials in the summer of 1965 and, under the name *INTELSAT I*, provided commercial transatlantic communication from August 1965. Soon additional satellites were introduced, providing virtual global coverage and, today, operational satellites carry about 5000 telephone circuits from the UK and some 106 countries belong to INTELSAT. The latest series of satellites now being launched, *INTELSAT V*, have a capacity of 12 000 telephone circuits plus 2 television channels.

INTELSAT was the first operational satellite system and it is still by far the most important. However, other systems have been established to provide domestic and special services. In 1984, satellites operating in digital mode will be used to communicate with Europe, and similar techniques will be used 6 months later across the Atlantic.

The introduction of commercial satellite communications in 1965 had little impact on HF radio services for a few years because the high cost tended to limit participation to the more affluent countries; indeed, HF radio was at an all-time peak—350 radio telegraphy circuits on 44 different routes and 87 radio telephony circuits on 41 routes—in 1969.

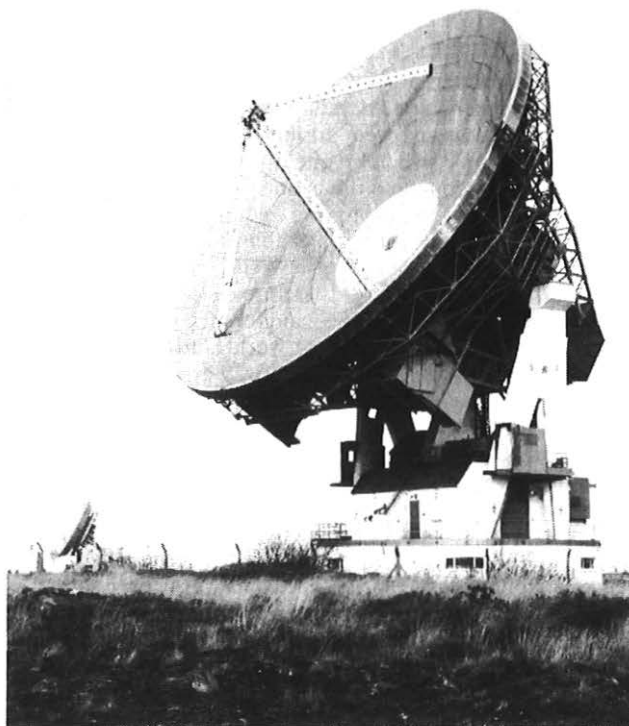

FIG. 2—The Goonhilly 1 aerial, Goonhilly Downs, Cornwall

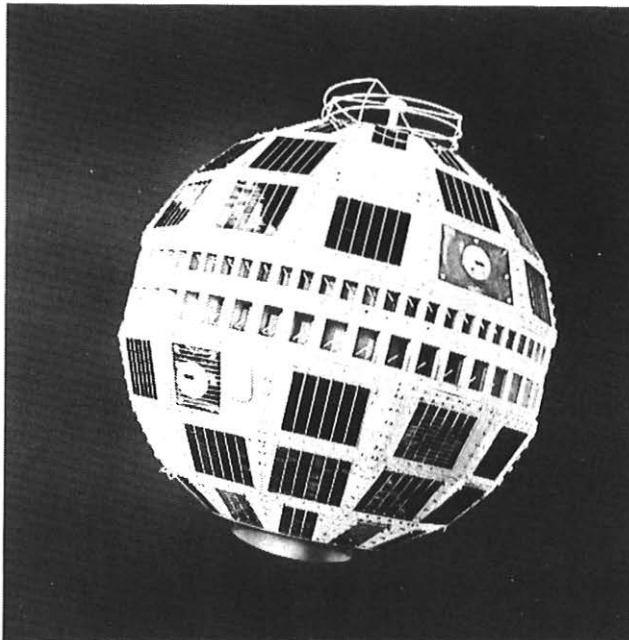

FIG. 3—The TELSTAR satellite

However, by the mid-1970s most of the BPO's larger correspondents had equipped themselves with satellite earth stations and the progressive reduction, year-by-year, of the cost of using the satellite medium, together with the advantage of being able to establish solid communications 24 hours a day, 365 days a year enticed more and more countries away from the HF medium. The high capital cost of establishing a standard INTELSAT earth station was still a considerable deterrent for the developing countries, but the introduction in the last few years of smaller antennae (known as *Standard B*) costing about 20% of the larger earth terminals has so

reduced costs that even the smallest of the developing countries has been able to participate, and the HF international services have been virtually eliminated. HF radio is still used extensively for long-range maritime services and for Press broadcast services.

### **INTERNATIONAL TELEPHONY**

In 1956, the international telephone service was served by 2 manual exchanges, Faraday and Wood Street, located in London. These evolved during the late-1950s to semi-automatic working, whereby one operator at the originating end was able to complete the connexion through the distant administration's network to the required subscriber. This degree of automation required signalling facilities and network standardization. Agreement between administrations on interworking aspects were therefore necessary to ensure network compatibility and the main fora for these discussions were the CCITT† for the whole world and the CEPT\* for Europe. Meanwhile, STD was underway in the UK and there was an obvious need for IDD facilities.

To provide this capacity, additional equipment was required at each inland trunk centre as well as at Faraday exchange. In the national network, the design of the magnetic-drum register-translator included adequate storage for international calls. This permitted an early introduction of IDD from director areas, and the first customer-dialled calls were made in 1963 between London and Paris. The IDD service was further extended to non-director areas from 1971 onwards and during 1971 a second international switching centre (ISC), Wood Street, was introduced. To meet further demand, Mollison and De Havilland ISCs located at Stag Lane in North London were introduced into service in 1974 and 1975 respectively. Growth continued through the 1970s and demand was met by 2 additional ISCs, Mondial and Thames, installed at Mondial House and brought into service in 1979 and 1980 respectively. Current plans envisage a digital ISC in service in 1984 at Keybridge House.

### **INTERNATIONAL TELEX**

International Telex has evolved in pace with, and in some cases, in advance of, the telephony service. Automatic Telex opened in 1958, and the network was developed around the London Fleet exchange which opened in 1960. Direct dialling in the national network increased demand for international Telex direct dialling (IXDD) and this service was opened in 1961. In 1973, a second Strowger international Telex exchange was opened in St Botolph's House, and, as a result of continuing demand, this was extended with stored-program control (SPC) equipment in 1978. A further Telex switching unit is at present being installed in Keybridge House. The international Telex service now has access to 87 000 UK customers and over 98% of all UK originated Telex calls are set up automatically by the customer.

### **INTERNATIONAL TELEGRAPHY**

The importance of the international telegraph service has declined since the 1950s; but, several significant improvements to the service have taken place. The public telegraph service has been largely converted to 5 unit code operation and an automatic international switched Gentex network introduced. An international push-button torn-tape relay system using perforated paper tape as the storage medium, introduced in 1964, was replaced in 1967 by an electromagnetic message relay system which used magnetic-tape and ferrite-core storage. The installation of a SPC telegram retransmission centre (TRC) in 1976 provided an automatic link between inland telegraph offices and international Gentex and Telex networks. It has recently been extended to cater for maritime telegrams.

† CCITT—International Telephone and Telegraph Consultative Committee

\* CEPT—Conference of European Postal and Telecommunications Administrations

### **MESSAGE AND DATA SERVICES**

International data services were inaugurated with the opening, in 1965, of international Datel, using the public switched telephone network to meet the need for low-speed data communications. Datel services have developed progressively and today offer a wide range of data rates to over 20 countries. The international leased-telegraph message-switching service (ILTMS) using SPC message-switching equipment, was developed during the 1970s, and this service has grown so that today it provides world-wide private networks for 55 major customers. Public data switching services were first offered internationally in 1977, when a database access service was opened to the USA. This pioneer service was followed, in 1978, by the world's first international packet-switched data service (IPSS). In parallel, the BPO participated in the establishment of EURONET; a European packet-switched network meeting data communication requirements within and between European Economic Community (EEC) countries. The IPSS is being progressively developed and will carry some of the new telematic services such as Teletex.

The last 25 years have seen a growth in international leased telephone circuits from single figures to around 2100 circuits today. The highest growth rate in this period was during the first half of the 1970s when the business community, looking for locations to set up their communications centres, decided the UK (London) met their needs. Since the mid-1970s, however, the growth rate has settled between 15–17% per annum. The number of international leased telegraph circuits is around 1700 today—with growth rates during the period of up to 25% per annum. This figure has now dropped, with the advent of competing services (for example, Telex) to around 7%.

### **MARITIME AND TRANSHORIZON RADIO SERVICES**

The 1950s saw the development of radio-telephony in the medium and very-high frequency (VHF) bands for maritime services, but it was not until the late-1960s that single-sideband transmission was introduced. The VHF service has continued to expand and today it is the major means of coastal communication. Although HF telephony services for long distance operation became commonplace in the 1970s, morse telegraphy still maintained its predominance. More recently, however, the introduction of error-corrected radio-teleprinter facilities has offered a more flexible alternative to morse, and the demand for this service is growing rapidly, although so far without much effect upon demand for the older service.

BTI also makes use of the Maritime Satellite (MARISAT) system, which has provided satellite communications to ships since 1976, and this involvement in maritime satellite service will increase greatly when the MARISAT services are taken over by the International Maritime Satellite (INMARSAT) system early in 1982. Nevertheless, the transfer of ships to it is unlikely to take place overnight and demand for the conventional services is likely to continue well into the 1990s. At short ranges, the long term demand will probably be met by means of automatic ultra-high frequency (UHF) facilities likely to be introduced in the late-1980s.

To date, most of the offshore production platforms operating in the North Sea communicate to shore by transhorizon tropospheric-scatter microwave radio systems. The first opened for service in 1975 and now many platforms 160–280 km from shore are in use.

### **SUMMARY**

The previous paragraphs have given an indication of the tremendous growth which international services have experienced and of the opportunities for further expansion. The remainder of this article is devoted to a more detailed examination of the international transmission network, international services and foreseen developments in the face of technological change.



# THE INTERNATIONAL TRANSMISSION NETWORK

## DEVELOPMENT OF SUBMARINE-CABLE AND MICROWAVE SYSTEMS

The 75 years from 1906 to 1981 have seen submarine cables come full circle from digital transmission in the form of telegraphy to the development of digital transmission on optical fibre<sup>3</sup>.

By 1950, cables with repeaters that would work in tandem had been developed, and 2 early UK-Netherlands cables had been upgraded to 60 circuits capacity in the first exploitation of this technique in the BPO's international network. October 1954 saw a new cable containing 7 tandem repeaters laid from the UK to Norway. The ideas formed on this system, including the new standard double-ended repeater, were to be the basis of the British contribution to TAT 1, the first transatlantic telephone cable. TAT 1, put into service in 1956<sup>4</sup>, marked the start of an era of progressive exploitation of FDM on submerged, repeatered, coaxial cable systems (see Fig. 4). TAT 1 comprised 2 sections; the longest from Clarenville, Newfoundland to Oban, Scotland was of an American design employing 4-wire working on 2 cables equipped with uni-directional flexible repeaters. The second section, a British design employing rigid bi-directional repeaters giving 4-wire working on a single cable through the use of 2 frequency bands, extended the circuits across the Cabot Straits from Clarenville to Sydney Mines in Nova Scotia. The initial capacity was 36 channels, but the rapid rise in international traffic made it necessary to introduce *ad hoc* measures to increase the cable

capacity. This was done firstly by using American supplied EB Channel Banks (top frequency 1500 Hz), later replaced by BPO designed 2 kHz channel equipment (top frequency 2200 Hz). Subsequently, 3 kHz channel spacing<sup>5</sup> and time assignment speech interpolation (TASI) equipment<sup>6</sup> were used. The latter technique for increasing capacity is now commonly in use across the Atlantic.

It was not long before the growth in the demand brought about the TAT 2 cable (France-Newfoundland 1959), of similar design. The increasing demand was also being felt in European waters, giving rise to the development of a 120-circuit system in 1958 to supplement the existing 60-circuit design. It also gave rise to the installation of a microwave link between Tolsford Hill and Fiennes, over which there are now 5 working radio channels, plus 3 protection channels, for telephony and 2 for television. The link was brought into operation in 1960 when one radio channel with a capacity of 600 telephony circuits and one television channel were provided in the 4 GHz band; additional channels in this band were added in 1965 (600 circuits) and 1971 (960 circuits). The capacity was further increased in 1974 by using the lower 6 GHz band (1800 circuits) and in 1975 (1800 circuits). Although the television channels have been modernized, the 4 GHz band telephony channels still use the original valve-operated radio equipment. However, it is planned to replace this in 1982 with modern equipment giving 3 working channels each of 1260 circuits capacity.

In 1960, the longest cable in the UK-Continental network was provided to Goteborg, Sweden<sup>7</sup>. This 60-circuit system was a trial run for the first cable to Canada, laid in 1961 (CANTAT 1)<sup>8</sup>. This British system was the first transatlantic system to use single-cable working and rigid repeaters (the TAT 1 extension apart), and it also introduced the BPO-designed lightweight cable for use in deep water. This type of cable, which has become a world standard, was unarmoured, the strength necessary for laying and recovery operations being obtained from a torsionally-balanced core of steel wires. Its centre conductor was a longitudinal copper tape formed over the steel core, and the outer conductor comprised helically-wound copper tapes covering the polyethylene dielectric of just under 25 mm diameter. Modern cables usually have a dielectric outer diameter in the region of 38-43 mm, the outer conductor being made up in a longitudinal-tape format. Aluminium has also replaced copper as the outer conductor in many cable designs. The modern armoured shallow-water cables are similar except that the core is of mild steel rather than high-tensile steel. CANTAT 1 was also the first leg of a scheme to link the Commonwealth, which during the years 1962-3 completed the link Canada-Hawaii-Fiji-New Zealand-Australia (COMPAC)<sup>9</sup>. This was supplemented later in the 1960s by SEACOM linking Australia with Hong Kong and South East Asia.

In 1961, the BPO acquired the first of its present fleet of cable ships; *Alert 4* replaced *Alert 3*, which had been obtained as war reparations and which had assisted in the post-war developments in communication with the mainland of Europe until sold for scrap in 1960. *Monarch 4*, which was, for a long time, the largest cable ship in the world, was sold to Cable and Wireless Ltd. in 1970 and renamed *Sentinel*, but not before doing her fair share in many projects including TAT 1, TAT 2, CANTAT 1, COMPAC and SEACOM.

In 1963, a large increase in transatlantic capacity with the introduction of TAT 3 (138 circuits between the UK and the USA)<sup>10</sup>, followed 2 years later by a carbon copy TAT 4 to France. In 1964, the BPO experimented with transistorized repeaters (commercial devices) in a UK-Belgium cable<sup>11</sup> and, by 1967, a new generation of submarine cable systems entered the network. The 480-circuit repeaters, employing devices of high reliability manufactured by the BPO Research Department, were first installed between the UK mainland and Jersey. All subsequent British repeaters have also used devices of BPO design<sup>12</sup>.

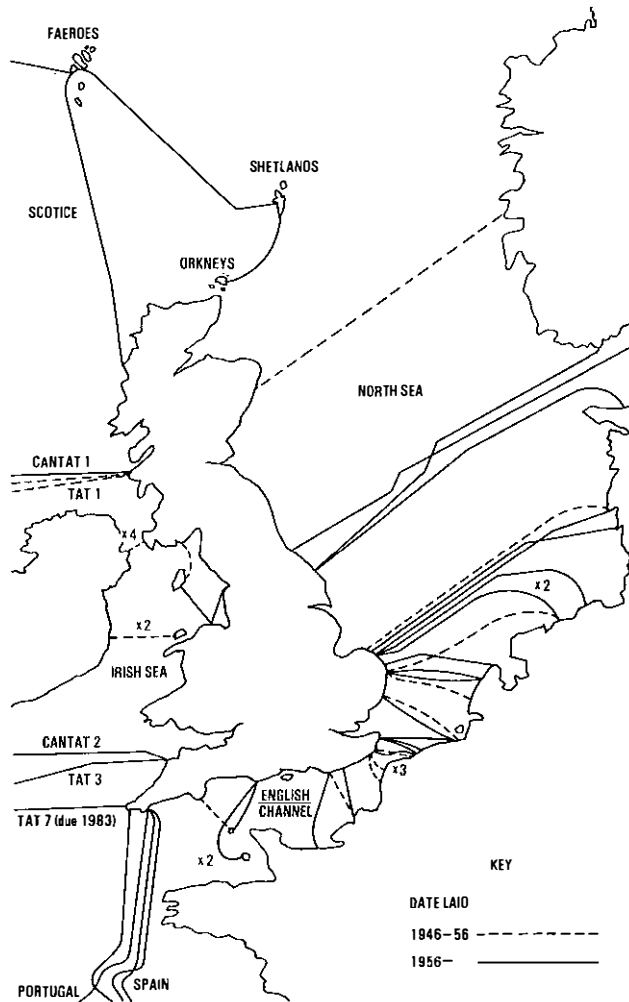

FIG. 4 Submarine cables terminating in the UK

## Cable Development in the 1970s

By the late-1960s, the race was on to keep system capacity ahead of circuit demand. During 1971–75, repeaters with a top frequency of 14 MHz, giving up to 1380 circuits, were used extensively in the North Sea and to the Iberian Peninsula. Meanwhile, in 1970, American technology had again spanned the Atlantic to Spain with TAT 5 providing 845 circuits. This period also saw the provision of perhaps the best known of the British 14 MHz systems, CANTAT 2 (1974)<sup>13</sup>. Its 1840 circuits from Widemouth to Beaver Harbour, Canada, demonstrated that British and American technology were very much on a par. It was during this period that the potential advantages of centralized marine facilities became evident, and in September 1974 the Central Marine Depot (CMD) at Southampton came into operation<sup>14</sup>. This site, along with a secondary base at Dalmuir, Scotland, now houses all the BTI marine staff, ships, spare cable and spare repeaters. The Southampton CMD introduced the revolutionary concept of pre-loaded *pans* for cable handling to reduce ship turn-around time and to avoid damage to cable that was inevitable if it had to be moved frequently. This *pan-loading* concept was carried through in the design of the BPO's 2 newest repair ships, *Monarch 5* (1975)<sup>15</sup> and *Iris 2* (1976), which replaced the scrapped *Ariel* and *Iris 1*. These ships have also set new standards of manoeuvrability by being equipped with an active rudder and a steerable bow thruster. Along with *Alert 4*, they complete the present fleet.

Currently, the world's 2 largest capacity commercially available submarine systems have top line-frequencies of 45 MHz (designated *NG*) and 30 MHz (designated *SG*). The *SG* system was a joint USA-UK-French development and was first used in TAT 6 (USA-France) giving 4000 circuits. It will be used again for TAT 7 (USA-UK) in 1983. The British *NG* system, designed and manufactured by STC Ltd. has many configurations, and can provide as many as 5520 circuits when equipped for 3 kHz working. The first system of this type used in the BPO's international network was the UK-Belgium No. 4 cable in 1977; it has since been provided on several other routes,

It is almost certain that the current submarine technology could make one more jump in capacity; to around 10 000 circuits<sup>3</sup>. However, this will probably never happen, as the techniques of utilizing optical fibres are rapidly being established. As well as reducing costs, providing potentially large capacity, and reducing operational problems by utilizing fewer repeaters and thinner cables, optical-fibre systems lend themselves ideally to operation in a digital network. All the world's submarine system manufacturers are known to be studying such systems, and it seems likely that they will become commercially available in the mid-1980s and will probably span the Atlantic, perhaps as TAT 8, by the end of the decade. British Industry (STC Ltd.) and British Telecom (BT) are well in the forefront of these developments, having already laid such a cable incorporating a prototype repeater in Loch Fyne, Scotland, during 1980<sup>16</sup>. Fig. 5 shows the comparison between samples of *SG* coaxial cable and Loch Fyne optical cable. These changes are once again putting submarine systems in the vanguard of new developments and are recreating the pioneering spirit that brought about, for example, the first transatlantic telegraph cables and TAT 1.

Despite the advances being made in the transmission aspects of submarine systems, the environment in which they are used at best remains the same. It is, in fact, probably becoming more hostile as the old enemy, the trawler, continually seeks to fish in deeper waters. Consequently, in the future, attention must also be given to seeking new and better survey techniques, improvements in armouring, and tools for burying cables. BT, in conjunction with other administrations, has already made some advance with these problems. Land simulation of trawler damage to cables, conducted by the BPO Research Department, led to the use of *Rock Armour*,

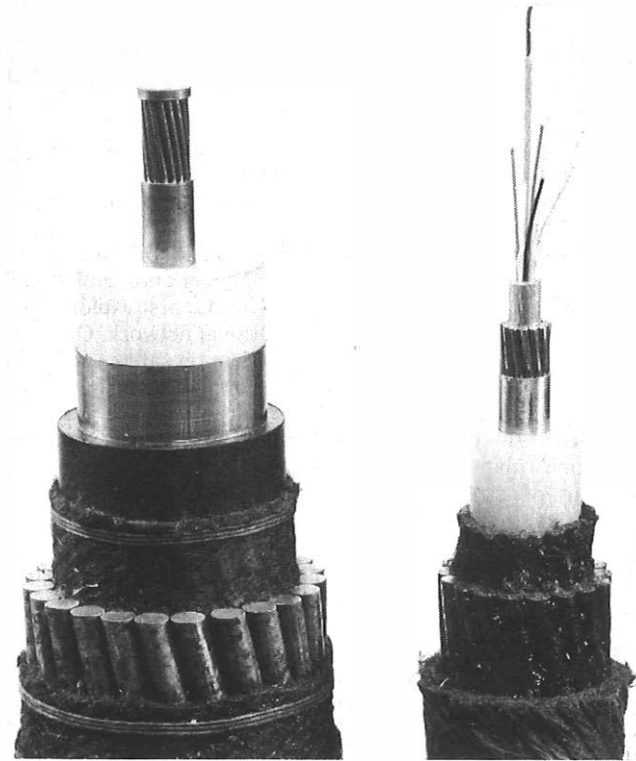

(a) *SG*-type coaxial cable (43 mm diameter) (b) Loch Fyne optical-fibre cable  
Note: The *SG*-type coaxial cable system has a capacity of 4000 circuits. Early optical-fibre cable systems have a capacity of 1920 circuits (140 Mbit/s) per fibre pair. The design shown allows a maximum of 5 pairs

FIG. 5—Comparison of submarine coaxial cable and optical-fibre cable

with its improved resistance to damage, on the recent UK-Netherlands No. 10 system. In addition, this resulted in recommendations being made on simple modifications to beam trawls that, if adopted, should reduce the incidence of faults. BT is also a partner in the development of SCARAB (submersible craft aiding recovery and burial), as well as developing a cable burial tool of its own, *SEA DOG*, for use in the North Sea and other areas adjacent to the UK.

## DEVELOPMENT OF SATELLITE COMMUNICATION

### The INTELSAT System

INTELSAT came into existence on 11 August 1964, an international organization constituted at 2 levels:

- (a) between governments, and
- (b) between designated telecommunications authorities.

Its function is to provide and manage satellites that are needed to interconnect the earth stations belonging to the telecommunications authorities. The organization has prospered; 106 countries now belong to it, its working capital is well in excess of one billion US dollars and the system carries most of the world's long-distance international circuits.

When INTELSAT was set up, the Communications Satellite Corporation (COMSAT), a private US corporation appointed by the US Government to provide satellite connections for the various US telecommunications companies with international services, had in progress a project for launching the EARLYBIRD satellite into a geostationary orbit, primarily to test the acceptability for commercial telephony of the long transmission delay (about 260 ms earth station-to-earth station) that arises with a high orbit<sup>17</sup>. INTELSAT took over the EARLYBIRD project and the satellite was launched on 6 April 1965. After preliminary tests of the spacecraft itself, earth stations which had been built in 1962 for the TELSTAR and RELAY tests were used to set up

a 240-circuit both-way FDM telephone link between USA and Europe. The only suitable station in North America was at Andover, Maine. There were 3 stations in Europe, at Goonhilly in Cornwall, at Pleumeur Bodou in France and at Raisting in the Federal German Republic. The European stations took turns, week-about, to operate the European end of the link, distributing circuits as required to all the participants.

Circuits were put into use commercially from July 1965 and user reactions to satellite and submarine-cable circuits were carefully compared over a 3-month period. The circuits were lined up to equivalent noise standards, the only significant difference between the media being transmission delay and the echo problem. The conclusion that emerged was that geostationary satellite circuits were acceptable for telephony, although submarine cable circuits were preferred<sup>18</sup>. These satellite facilities via EARLYBIRD, since renamed INTEL-SAT I, continued in use after the test period. INTELSAT decided in favour of the geostationary orbit for its subsequent satellites and indeed virtually all communication satellite systems developed since have made the same choice.

The EARLYBIRD satellite consisted essentially of a tunnel-diode amplifier (TDA) low-noise receiver input stage operating at 6 GHz, fed by an antenna that covered a large part of the Earth's northern hemisphere as seen from a geostationary satellite at about 20°W longitude. An intermediate amplifier, an amplitude limiter and filter assembly, a frequency changer and a 4 GHz travelling-wave-tube (TWT) amplifier completed the equipment. Two radio-frequency carriers, one east-going and the other west-going, could be amplified simultaneously; the output power per carrier was about 1 W. This receiver-frequency changer-transmitter combination, called a *transponder*, was powered by solar cells which covered part of the outer surface of the satellite. In order to drive adequately the satellite transponder and to receive a weak satellite signal with adequate carrier-to-noise ratio, the early earth stations had to use high-gain antennae, high-power transmitters, receiver input amplifier stages of exceptional low noise figure and special low-threshold demodulators. The original Goonhilly earth terminal, Goonhilly 1, with a 26 m diameter paraboloidal reflector, had a gain in the region of 60 dB. The low-noise amplifier was a travelling-wave maser, cooled by liquid helium and mounted in a cabin at the back of the antenna reflector structure so that short low-loss waveguides could be used to connect it to the feed at the focus of the reflector. The TWT transmitter power amplifier, rated at 10 kW, was located in a cabin on the antenna turntable. In most other respects the earth-terminal equipment was similar in principle to conventional microwave radio-relay equipment.

Only one INTELSAT I satellite was ever launched. Three second-generation satellites, INTELSAT II, were put into service in 1967. One joined INTELSAT I over the Atlantic and the other 2 were located over the Pacific Ocean. An INTELSAT II satellite, like INTELSAT I, carried 240 two-way circuits or the equivalent, but they could be divided between several or many different radio frequency carriers, thus providing for multiple access to the satellite. By the end of 1968, twenty earth terminals in 13 countries were in service in the Atlantic and Pacific Ocean regions and were connecting about 750 two-way telephony circuits plus occasional television links.

Growth and expansion have continued at a rapid rate ever since. INTELSAT II satellites were followed in 1968 by INTELSAT III. Satellite service was started in the Indian Ocean Region in 1969. The first INTELSAT IV (see Fig. 6) was launched in 1971 and the first INTELSAT IVA in 1975. Each type was bigger and each capable of carrying more traffic than its predecessor. INTELSAT IVA has 20 transponders and can carry about 6000 two-way telephone circuits plus 2 television channels. The technology has changed considerably in detail from INTELSAT I, but the principles of

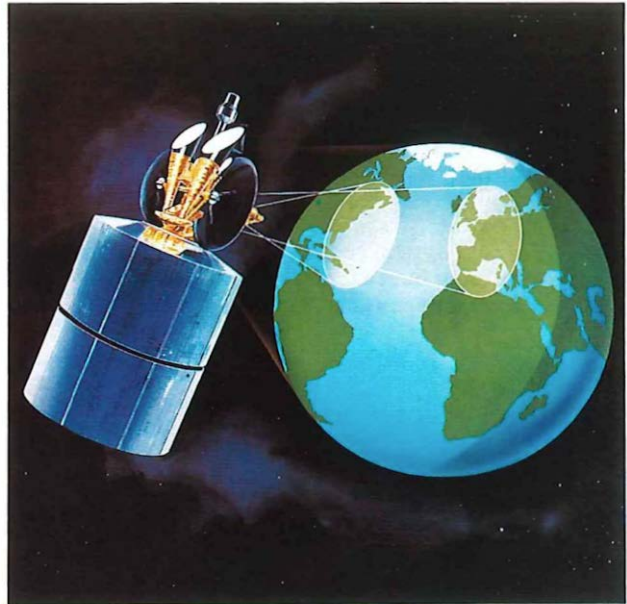

FIG. 6—An artist's impression of an INTELSAT IV satellite

operation have changed very little<sup>19</sup>. The system, however, has become more complex and comprehensive. It has been necessary to use 2 satellites in the Atlantic Ocean region for most of the time since 1967 and a third satellite has been used there since 1980. A second satellite is coming into use in the Indian Ocean region.

#### Earth Station Development

Satellite developments had to be matched at the BPO earth stations. A second terminal was built at Goonhilly in 1968 and it took over the Atlantic service from the original terminal, which was refitted extensively before it was put back into service with the Indian Ocean satellite. The third terminal at Goonhilly, completed in 1972, gave access to the second Atlantic Ocean satellite and permitted the massive UK-USA and UK-Canada routes to be split between 2 satellites<sup>20,21</sup>. A second earth station, at Madley, near Hereford, was opened in 1979 (see Fig. 7) and the first terminal to be built there took over the Indian Ocean service from Goonhilly 1, the original TELSTAR/EARLYBIRD terminal. Since then, Goonhilly 1 has been used to enable first one, then another of the other terminals to be released as necessary for modifications, so as to enable the earth terminals to keep pace with developments in the technology of the satellite system. The second terminal at Madley, completed in 1980, gives access to the third Atlantic Region satellite.

Earth terminals designed for international systems have been improved greatly in detail since 1965, but they have changed little in principle. Cassegrain antenna geometry is now general. The beam waveguide principle is often used to bring the antenna feed down to ground level, where apparatus like low-noise amplifiers and transmitters can be more conveniently housed. The use of bigger antennae, up to 32 m in diameter, has made it possible to replace maser low-noise amplifiers with wide-band parametric amplifiers, and has reduced the need for cryogenic cooling or eliminated it altogether. Otherwise, the main change over the years has been growth in the number of carriers and channels handled rather than any basic change of technique<sup>22,23</sup>.

#### INTELSAT—Present and Future

INTELSAT started service in 1965 when it had 19 members, 4 of them with operational earth stations, one satellite and a few dozen circuits working in a two-way 240-circuit system. At present, it has 106 members, about 200 operational earth terminals, 12 satellites (INTELSAT IVs and IVAs) and about 22 000 two-way international telephone circuits use the

system. Spare capacity in some of these satellites is leased to 15 countries for domestic satellite networks. Throughout the lifetime of the INTELSAT system, the UK has had a substantial share in its services, typically around 10–12% of the total. Thus, of the 22 000 circuits now flowing through the system, almost 5000 have one end in the UK and these include more than half of BT's circuits to the USA and Canada and all or most of the circuits to the rest of the American continent, Africa, Asia and Australasia.

The INTELSAT system continues to grow rapidly. A sixth terminal, also being built at Madley, will enable BT to gain access to a second operational satellite in the Indian Ocean

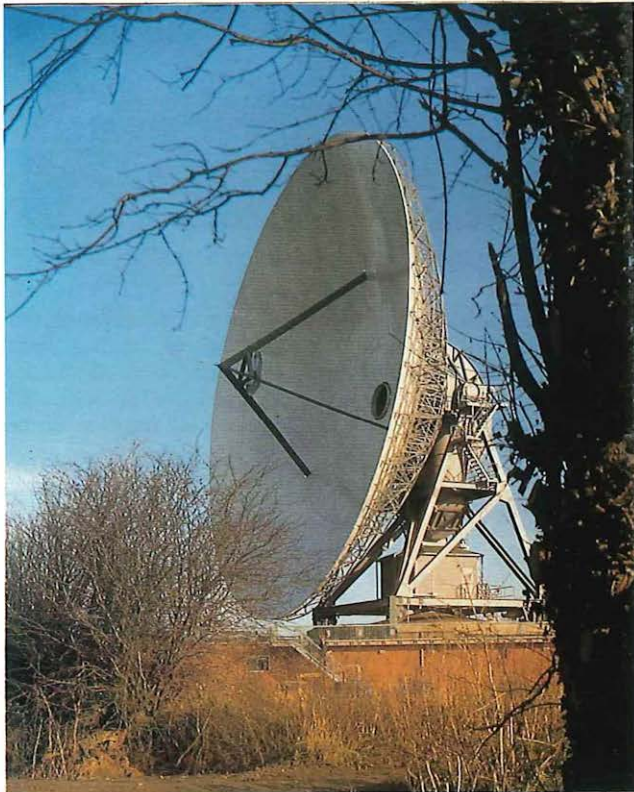

FIG. 7—Madley Earth Station, opened in 1979



FIG. 8—An artist's impression of an INTELSAT V satellite

region, thus permitting diversification of UK traffic to the principal countries operating in that region, such as Australia and Japan. The INTELSAT V generation of satellites (see Fig. 8) is now going into service<sup>24,25</sup>; the first launch was in December 1980, the second followed in May 1981 and 7 more await launch. These new satellites operate in new frequency bands at 14 GHz and 11 GHz, as well as in the 6 GHz and 4 GHz frequency bands that all the earlier INTELSAT satellites have used; this is one of the means by which the total capacity of the 27 transponders in each INTELSAT V satellite has been boosted to about 12 000 telephone circuits plus 2 television channels. Already, orders have been placed for 3 INTELSAT VA satellites, a stretched version of the INTELSAT V, and tenders have been invited for INTELSAT VI satellites of even greater capacity, which will take over the system in the second half of the 1980s. The first BT earth terminal operating in the new frequency bands is being fitted out at Goonhilly for access to one of the Atlantic region INTELSAT V satellites and it will be in service by mid-1982<sup>26</sup>. A second will be built at Madley in 1983.

So far, virtually all communication through INTELSAT has used analogue transmission. A new digital system, time-division multiple-access with digital speech interpolation (TDMA/DSI), is being developed. Conversion of part of the INTELSAT network to this mode of transmission will start in 1984–85 and progressive conversion of the remainder will follow. This technique increases the circuit capacity of the satellites and provides other economies as progress is made in converting the UK domestic terrestrial network to digital operation.

#### The European Communication Satellite System

At present virtually all international services within Europe are transmitted terrestrially. However, a regional satellite system is being developed to serve the western European countries and a new institution, known as *EUTELSAT*, has been established to manage it. The first of the regular satellites specially designed for this purpose, the European Communication Satellite (ECS), is to be launched in 1982 and regular service is to start about the end of 1983. The Orbital Test Satellite (OTS), an experimental precursor of ECS, was launched in 1978 and has provided valuable experience in the use of the 14 GHz and 11 GHz frequency bands in which the ECS will operate. The ECS system will be digital from the start, using TDMA/DSI, and it will provide a valuable digital overlay network between the European capitals. In addition, ECS is expected to carry extensive international television services for the European Broadcasting Union (EBU). The UK earth terminal for the ECS is to be built at Madley.

#### Small-Dish Satellite Services

International connexions between national communications networks were the first application of communication satellites and for BT this is likely to remain the most important application. However, another part of this article discusses the use of satellites for communication with ships at sea, and a third field of application is now coming into view. In this, low-cost earth terminals with small antennae, typically 4 m in diameter, located at or near the customers' premises, provide flexible and often unconventional facilities. This can be of particular value in the international field, since the customer can thereby get the novel services he needs without waiting for the terrestrial networks to be changed to provide these services.

Experimental, pre-operational services using the Orbital Test Satellite began this year. The operational service is to start at the end of 1983, using special facilities that have been added to the ECS satellites. Use for this purpose will also be made of capacity leased by EUTELSAT in the French TELECOM 1 satellite system.

## INTERNATIONAL TELEPHONY

International telephone services from the UK started in 1891 with service on 2 circuits from London to Paris. Growth was slow; by 1911 there were just 4 circuits to Paris and by 1920 only 15 in total between the UK and Europe. By 1939, almost 200 circuits were in use and service was available to the majority of European countries. On the inter-continental side, the telephone service only commenced in 1927, when HF radio links were opened between London and New York. The number of points served grew slowly so that, in 1956, there were just 70 inter-continental HF circuits, including 14 to the USA. Until 1949, all calls were manually handled in each country and booking was required, but from that year, commencing with Paris, demand service was progressively introduced to European countries. By 1956, calls to Europe were handled at the continental manual board in Faraday Building and international calls over HF radio links were handled at an international manual board in Wood Street, from where they were passed to the radio control centre at Brent Building in North London.

Growth in the international telephone service during the 1950s, and extension of automatic working within national networks, made it desirable to introduce facilities to enable operators to complete calls to customers in other countries without the assistance of operators in the distant country. This method of working was known as *semi-automatic operation*<sup>27</sup>, as distinct from manual operation. A problem to be overcome was the variation in technical arrangements, particularly those for signalling, in the various countries. The CCITT therefore designed and tested 2 types of signalling system for international use. The first of these, designated *CCITT Signalling System No. 4*, used 2 voice frequencies (VF) for control signalling and transmission of selection digits, the latter being forwarded in binary code. The other signalling system, *CCITT No. 3*, was based on 1 VF operation, with selection digits sent in a rhythmic code. The CCITT No. 4 signalling system used end-to-end signalling for the selection digits and this was considered to be an advantage for transit working. The 2 systems were extensively tested in the European field trial in the early-1950s, with the object of standardizing on one of them. In the event, agreement was not reached and it was left to the outgoing administration to choose the system that would be used; both systems were designed for unidirectional operation only.

Faraday continental exchange which was brought into service in 1958, was equipped with outgoing and incoming terminations for CCITT No. 4 signalling, but was equipped with only incoming terminations for CCITT No. 3 signalling to meet the French choice. The first circuits brought into service were to Amsterdam and Rotterdam. The ISC equipment in the inward direction included register-translators giving overseas operators a substantial degree of automatic access into the UK STD network, which was then being brought into service.

The extension of semi-automatic operation on North American circuits in 1963 involved a new signalling system designed to operate correctly via TASI trunks. It was also designed for bothway operation. Two frequencies (2400 Hz and 2600 Hz) were used for line-supervisory signalling purposes in the compelled mode. In addition, inter-register signals in a 2-out-of-6 form were used to transfer digital information in an *en-bloc* mode, thus avoiding the release of the TASI trunk. Semi-automatic operation to North America allowed over 90% of calls to be completed without assistance by an incoming operator, most of these being between the almost fully-automatic networks in London and New York. Similar arrangements were extended in 1965 and 1966 respectively, to Australia and New Zealand, following the opening of the first transpacific cable, COMPAC, which augmented, for the first time, the HF radio-telephone circuits to that part of the world.

With STD well underway by 1960, the scene was set for the introduction of direct dialling of international calls (IDD) by customers. In 1960, the CCITT allocated a unified system of 2-digit country codes for each country in Europe and the near and middle East. This plan was revised in 1964, when the world numbering plan of 1, 2 and 3-digit codes was approved. This numbering plan is still in use today. Under both plans, the UK code was 44. Provision of IDD required a UK customer to transmit up to 15 selection digits (including the prefix code 010) to his local exchange. The availability of IDD at different UK locations was thus dependent on the rate at which STD equipment of different types could be extended to accept the long digit trains. In London and provincial director areas, the magnetic-drum register-translators had the capacity from the outset, so it was with a London-Paris call in 1963<sup>28</sup> that IDD was opened, using a temporary expedient arrangement based on Signalling System AC9.

### FARADAY ISC

Meanwhile equipment provided at Faraday ISC for semi-automatic operation was extended to provide 4-wire switching for calls routed via the operator. Additional equipment, based on electromechanical principles, was designed and installed in Faraday ISC to provide automatic operation using the CCITT No. 3 and No. 4 signalling systems, allowing IDD to be extended to Belgium, the Federal Republic of Germany, additional parts of France, Holland and Switzerland from 1964. Subscribers at provincial director areas were also given IDD access via Faraday ISC in the same year.

IDD from non-director (ND) areas<sup>29</sup> required development of IDD register-translators and call-timers; this was completed during the late-1960s and led, during the 1970s, to the progressive introduction of IDD facilities to the remaining parts of the country. By 1981, this process is now almost complete and the remaining centres are planned for conversion in the next year or so. Traffic to ISCs from ND areas uses direct routes where justified, with the remaining traffic circulating through the transit network. The last phase of development of Faraday ISC was completed in 1969 with the opening of special equipment for automatic switching of international transit calls through London. Thereafter, Faraday ISC continued to provide yeoman service until it was closed at the end of 1980. A small part of the equipment will remain for another year or so to serve the needs of the Faraday international switchboards.

### MANUAL TRAFFIC

To meet growth during the mid-1960s, it became necessary to move some of the international switchboards from Faraday Building. This was achieved by providing equipment to allow for decentralized switchboards<sup>32</sup>, remote from the ISCs with which they were associated. The first remote centres were installed at Judd Street and Wren House, London in 1968 and 1969 respectively. Both used sleeve-control principles and the former was planned as an international control centre (ICC) for European traffic, while the latter handled inter-continental routes. Signalling arrangements were developed to provide 2-wire paths from London customers to the new ISCs, and 4-wire paths for access to provincial GSCs (for call reversion) and between the ICCs and ISCs. Although manual traffic declined in the 1970s, assistance and enquiry traffic grew in response to the development of IDD, and additional ICCs were opened at Brighton, Glasgow and Leicester to deal with assistance traffic originating outside London.

### WOOD STREET ISC

In 1970, about 58% of international calls from the UK were being dialled direct by customers and to meet growth, an additional ISC was opened at Wood Street, London in April

1971<sup>30</sup>. Wood Street ISC, based on the Plessey 5005T crossbar system, is coded *TXK2* by the BPO and, unlike the national *TXK1* system, is provided with 4-wire switching and a range of international signalling systems. Wood Street ISC is configured to maximize the utilization of the new building and it was planned to meet growth until about 1974. Incoming circuits to the ISC from the national network use either AC or DC line-signalling systems. IDD traffic from the London director area uses loop-disconnect, AC11 and DC3 line signalling, whereas that from outside London uses AC11 only. The inter-register signalling used in conjunction with AC11 and DC3 is the signalling system, Multi-frequency No. 2 (MF2). Operator-originated calls from remote manual boards use a modified MF2 inter-register signalling system, designated *MF3*, in conjunction with DC4 line signalling from London and AC11 (international) line signalling from provincial ICCs. Special DC signalling arrangements are used for calls from the associated international switchboards in Wood Street to provide a 4-wire by-pass to the 2-wire sleeve-control manual boards.

By the late-1960s, computer techniques were advancing rapidly and their application to the new concept of common-channel signalling was being studied. In 1968, the CCITT mounted an international field trial of a new signalling system designated *CCITT No. 6*<sup>31</sup>. *CCITT No. 6* uses a dedicated data link, normally operated at 2400 bit/s, to interlink control processors in international exchanges. All selection and circuit-control information is transmitted on the data link, leaving the speech-circuit terminations considerably simplified when compared with those required for earlier signalling systems such as *CCITT Nos. 4* and *5*. Each data link has the capacity for passing the total signalling information for approximately 2000 circuits. The UK trial equipment which included processors supplied by GEC Ltd., was operated in Wood Street in 1971-72. Although the field trial was successful, implementation of *CCITT No. 6* signalling was delayed for economic reasons until a processor controlled ISC was available.

#### STAG LANE

Shortly after the opening of Wood Street ISC, orders were placed for further *TXK2* equipment for installation in Mondial House, then under construction. By 1971, however, building delays at Mondial, coupled with phenomenal demand for international services required an urgent change of plan and a crash programme of work commenced to provide 2 additional ISCs at Stag Lane in North London. These were working in 1975, only 4 years after the decision to open the Stag Lane centre had been taken. One of these ISCs, De Havilland<sup>30</sup> uses the *TXK2* equipment diverted from Mondial House; the other, Mollison<sup>33</sup>, uses the LM Ericsson ARM20 crossbar system, new to the UK and coded *TXK5* by the BPO. The Mollison ISC introduced into the UK for the first time the *CCITT R2* signalling system<sup>34</sup>, newly standardized by the CCITT for regional use, being suitable for both national and short (non-TASI) international circuits. *CCITT R2* signalling was thereafter used on an increasing scale on circuits to Europe to supersede *CCITT No. 4*.

With 4 ISCs in service, it was no longer economic to provide the full range of international access and facilities at all ISCs. De Havilland is therefore designed to provide the full range of international facilities, transit access, operator and other facilities required by overseas countries. Mollison, however, is designed with separate incoming and outgoing units, the outgoing unit specializing in IDD traffic to the UK's 16 largest international routes.

#### MONDIAL HOUSE

Growth of the order of 20% per annum continued, and additional ISCs were ordered for Mondial House (see Fig. 9). The first, Mondial, is another *TXK2* and, during 1980, it progressively took over the full-facility function from



FIG. 9—Mondial House, London

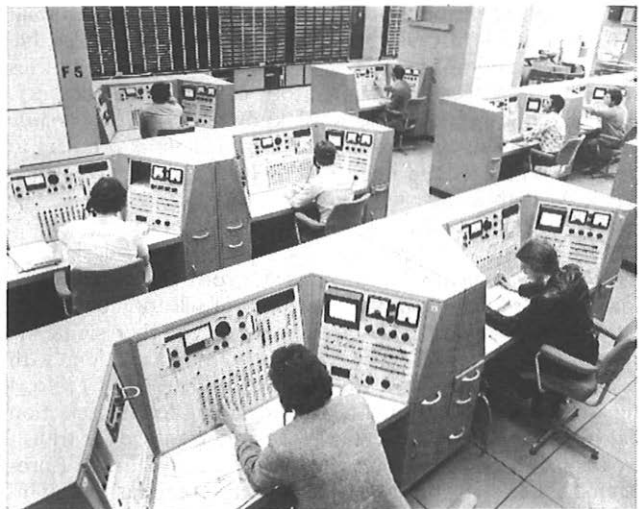

Note: The cordless consoles have a full range of instruments for exchange and transmission testing of the *TXK2* unit

FIG. 10—The international transmission maintenance centre, Mondial House

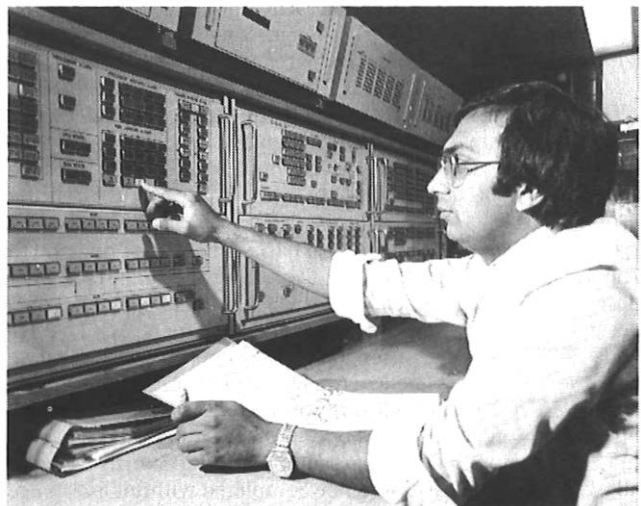

FIG. 11—The Thames ISC *TXK6* control room, Mondial House

De Havilland (see Fig. 10). The second, Thames, was ordered in 2 phases; the first phase comprises *TXK5* equipment, and the second phase an L. M. Ericsson SPC system, AKE13, designated *TXK6* by the BPO (see Fig. 11). The opening of

the TXK6 section of Thames allowed the CCITT No. 6 signalling system to be brought into full operational service for the first time, commencing with operation to the USA in March 1981. Mondial House has accommodation to cater for some 20 000 E of IDD traffic as well as an ICC of 80 positions.

### THE FUTURE

1981 thus sees BT with 5 ISCs in 3 locations (Wood Street, Stag Lane and Mondial House; Faraday having been closed) and a total switching capacity of about 27 000 E. An order for a further ISC, with digital switching, to be installed in the new Keybridge House building in London (Keybridge ISC), is planned for completion in 1984. In addition, a further extension to Thames ISC is in hand.

Current forecasts predict high growth for the next decade. To date the growth of IDD has been met by the provision of equipment in London. Whilst this policy has produced the most cost effective solution, some further diversity is now required and a provincial ISC is foreseen in the next decade.

## INTERNATIONAL TELEX

The conversion of the UK Telex service to automatic working commenced in 1958, and was completed at the end of 1960 with the opening of the largest exchange in the network at Fleet, London<sup>35</sup>. The full automation of the national network paved the way towards introduction of direct customer dialling of international Telex calls (known as *IXDD*). Further Strowger equipment added to Fleet exchange provided, from 1961, automatic customer access to the larger European routes which together handled some 90% of outgoing international traffic. Automation of the international service was complicated by the mixture of register and non-register Telex switching systems that had been set up in various countries after the Second World War. Individual choice in each country followed the predominant technology in use in each telephone network. The CCITT, therefore, found the need to standardize 2 basic international signalling systems, known as *Type A* and *Type B*. Fleet exchange was provided with a variety of outgoing terminations to enable interworking with other administrations who had jurisdiction over the type of incoming signalling to be used. Incoming terminations at Fleet, however, were standardized on *Type B* dialled signalling, since this was directly compatible with the Strowger-based UK national network.

In 1964, in anticipation of the need for world-wide automation of the Telex service, the CCITT standardized a world numbering plan for Telex (in which the UK destination code is *51*) and a new signalling system, *Type C*<sup>36</sup>, which was designed to be suitable for complex transit routing of calls via several countries, as well as direct point-to-point routes. The extension of *IXDD* from the UK with *Type C* operation to distant networks required the installation of special inter-continental switching equipment in Fleet exchange. This equipment included marker-switching techniques and used motor-uniselectors group selectors, the latter providing full availability on routes of up to 100 circuits. The equipment allowed the UK customer to use keyboard selection for the long digit trains that were required for some inter-continental calls. Hitherto, charging for international Telex calls had been provided by periodic operation of the meter in the local exchange; however, this procedure could not be extended to routes handled by the new inter-continental equipment and so, in 1968, automatic punched-paper-tape ticketing equipment was included in the international exchange. This allowed for detailed billing of inter-continental Telex calls, although pulse metering and bulk billing continued for calls to European destinations.

### ST. BOTOLPH'S HOUSE

Continued demand for international Telex led to the opening,

in 1973, of a second Strowger international Telex exchange at St. Botolph's House, London. This exchange adopted the same equipment and trunking principles as had been used at Fleet exchange, but was provided with about 3 times the capacity. With the development of SPC Telex exchanges, which improved reliability and at the same time provided scope for new facilities, an order was placed with Plessey Controls Ltd for a 5000-termination exchange, based on their 4660/70 SPC Telex system, to be installed in St. Botolph's House. In addition to the normal Telex capacity, facilities were included for an automatic Multitelex service. In this, a Telex message destined for several customers is placed in an electronic store, from which it is transmitted the required number of times without further action by the originating customer.

### MANUAL TELEX SERVICES

Until 1963, manual Telex service had been provided from the Central Telegraph Office (CTO) and, in that year, some 10% of calls still required operator control. These included calls on routes operated by HF radio or destined for non-automatic overseas Telex networks. In March 1963, the new outgoing only switchboards, supplied by Ericssons Telephones Ltd. and developed in conjunction with the BPO, were opened in Fleet Building to replace the remaining switchboards in the CTO. Separate radio- and cable-route positions were installed because of the differing service characteristics and operating procedures on the 2 types of route. Both types of position were based on the Teleprinter No. 12, which gave the most compact position layout achievable. The radio positions were linked to the automatic error-correcting (ARQ) equipment on the circuits selected, so that the viability of the radio channel was displayed to the operator.

With the further extension of *IXDD* during the following 2 decades, manually switched calls declined so that, by 1981, only a handful of routes are dealt with in this way. Assistance traffic on automatic routes declined more slowly and now forms the majority of the traffic handled on Telex switchboard positions. Plans are now in hand for a trial of modern switchboard consoles controlled by the processors in the new Keybridge international Telex exchange.

### INTERNATIONAL TELEX IN THE 1980s

Currently, orders are in hand for a further extension of the St. Botolph's SPC exchange and for provision of a second international SPC exchange, to be brought into service in Keybridge House in 1982. Keybridge international Telex exchange will include, as well as 10 500 Telex trunk terminations, provision for control of modern Telex switchboards and a large international Telex store-and-forward unit. This, in conjunction with corresponding facilities being installed in national exchanges, will allow the opening of a range of delayed and multiple-address international Telex message services, to supplement the traditional circuit-switched Telex service.

## INTERNATIONAL TELEGRAPHY

The importance today of the international telegraph service is much less than hitherto, but it has a history which reaches back to the first half of the nineteenth century. The first international telegraph circuit from the UK was laid from Dover to Calais in 1851, the year in which Louis Napoleon declared himself master of France, and the first transatlantic telegraph cable was laid in 1866. By 1891, the year in which the first cross-channel telephone cable was laid, the British Empire already had an inter-continental telecommunications network based on telegraph cables, albeit one requiring manual retransmission of messages at each intermediate cable station.

The first half of the twentieth century saw several major developments, including the introduction of regenerators, standardization on 50-baud operation for start-stop teleprinter apparatus for national circuits in 1929, establishment of manually-switched public Telex using VF transmission over telephone circuits in 1932 and its extension to the Continent using 1500 Hz VF transmission in 1936. After the war, international Telex was re-established exclusively on dedicated telegraph circuits using VF multiplexing.

In 1956, an international Telex switchboard was introduced in the CTO with some 70 positions giving service to Europe, USA and parts of Africa. In addition, the public telegraph service had been largely converted to allow transmission of telegrams using 5-unit code operation, and an automatic international switched Gentex network was being introduced to improve the efficiency of operations. In 1964, push-button torn-tape relay operation, based on a new system installed in Electra House, London, was introduced into the international telegram service. This system used perforated paper-tape as the message-storage medium and involved a substantial amount of manual processing. It was replaced in 1967 by a new electromagnetic message-relay system installed in Cardinal House, London which used magnetic-tape and ferrite-core storage for messages and 100-outlet motor uniselectors for switching. It was able to handle up to 3000 messages per hour and was connected to 50 international public telegraph circuits.

The next advance was in 1976, when SPC techniques were applied in the telegram service through the introduction of a telegram retransmission centre (TRC)<sup>37</sup>, based on the Philips DS714 processor (see Fig. 12). The new TRC replaced the combination of automatic, semi-automatic and manual systems used hitherto, and provided an automatic link between inland telegraph offices (ITO) and the international Gentex and Telex networks. The system design capacity was 12 500 messages per hour and 500 telegraph circuit terminations were available. Magnetic drums, discs and tape units were used for message storage in the system. Considerable attention was paid in the system design to the achievement of extremely high reliability.

To offset the rising financial losses and declining use of international and inland telegrams, both services have, since 1978, been managed jointly with the aim of covering their long-run avoidable costs; the 2 hitherto separately graded staffs have been integrated and a start has been made on switching all telegrams at the TRC. The number of main offices is being

reduced to 8, each dealing with inland and international telegrams. During 1982, these offices will be re-equipped with visual display units for receiving telegrams from customers by telephone or Telex. In rationalizing the telegram services in this way, the major problems are in the personnel rather than the technical field. The TRC is planned to remain in use throughout the 1980s

### PRIVATE TELEGRAPH SERVICES

Provision of private telegraph circuits on international radio routes began in 1953 and, by the late-1950s, demand was accelerating with many circuits required by the airline industry, who needed to transmit safety and operational-control messages and also flight reservations. Circuits were provided by adapting public telegraph facilities, using multiplexing techniques to derive half- or quarter-speed channels from basic (66 words/min) channels where this was adequate for the volume of messages. A substantial global network had been provided for BOAC in this way by 1957.

### AUTOMATIC ERROR-CORRECTING SYSTEMS

Performance on HF radio links could be poor at times, but fading was overcome by provision of ARQ facilities. By 1959, 40 electromechanical fully-automatic reformatting transmitter distributors (FRXD) in Electra House, using punched paper tape as the storage medium, were being used to connect Telex to international ARQ circuits. These devices suffered high maintenance costs and, in particularly poor radio conditions, the long tape loops could become tangled. In 1963, a magnetic-drum store ARQ equipment was introduced, providing up to 4000 characters of storage for each of 6 telegraph circuits. Ferrite-store systems, each providing a total of 24 000 characters of storage shared on a demand basis between 15 telegraph circuits, were purchased from Hasler Ltd. and installed from 1967. Use of the character store was regulated, to limit the number of characters that could be stored for any one circuit to 8000 (representing 20 minutes of message time). By 1970, some 700 telegraph and Telex channels from the UK were protected by ARQ facilities but, with the steady conversion of inter-continental routes to satellite operation, their use declined until, by 1981, only a handful of systems remained.

### MODERN DATA AND MESSAGE SERVICES

The steady reduction in demand for ARQ facilities in the 1970s led to a predicted surplus of the 15-line ferrite-store equipments and some of these were converted to provide message switching and store-and-forward facilities. These modified systems were connected to provide private message-switching networks for customers with several leased telegraph lines. During the 1970s, demand for this new international leased-telegraph message-switching service (ILTMS) grew steadily, and larger 64-line and subsequently 128-line purpose designed systems were installed. By 1981, ILTMS was being used by 55 major customers, whose networks in total involved some 900 telegraph circuit terminations. International data transmission, until the early-1970s, was based either on telegraph operation at speeds up to 100 bit/s or on use of modems on leased lines or the PSTN.

Modem developments, progressively raised the attainable transmission speed and work on international standardization in CCITT led to a progressive increase in the scope of the international Datel service. By the mid-1970s, data could be transmitted at up to 4800 bit/s on the international PSTN and 9600 bit/s on specially-conditioned leased lines to many countries. In addition, 48 kbit/s data could be transmitted using group-band modems over groups 2 or 4 in analogue supergroups to Europe, or at 50/56 kbit/s over single-channel-per-carrier (SCPC) satellite circuits to North America.

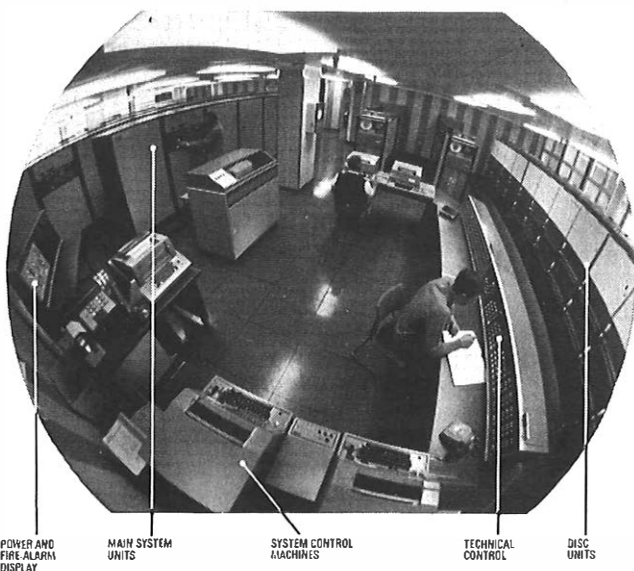

Fig. 12—The Telegram Retransmission Centre computer area



## PACKET SWITCHING

During the 1970s, studies concentrated on the problems of providing switched data services internationally on dedicated networks. This would improve transmission reliability and reduce the restrictions imposed on data transmission by the PSTN with its restricted bandwidth and slow (in computer terms) call establishment. Several private international experimental data networks were established with extensions in the UK, notably the European Informatics Network (EIN) and ARPANET. This work resulted, in 1977–78, in the installation of 2 international packet-switched data exchanges in Electra House.

The first of these opened in December 1978 and this marked the start of a new international packet-switching service (IPSS) by allowing a wide range of data terminal users in the UK to make data calls to database and other computer systems in the USA. Corresponding calls from the USA to computers in the UK could also be made. The second international packet exchange forms part of EURONET<sup>38</sup>, and opened in 1979 to interconnect computers and data terminal users in the member countries of the EEC (see Fig. 13).

## THE FUTURE OF NON-VOICE SERVICES

Currently, work is proceeding on a broad front embracing digital and analogue leased-line services, development of international packet switching and Datal, and interconnexion of the various public networks to provide a broad range of options for customers with international message and data traffic. These developments embrace the technological

opportunities provided by the microprocessor and digitalization generally, and lead inexorably towards a convergence of telephony, Telex, data, and message traffic into an integrated services digital network.

## MARITIME AND TRANSHORIZON RADIO SERVICES

### TERRESTRIAL RADIO SERVICES

The maritime service started with a medium-wave morse telegraphy service with an approximate range of 500 km operated from 6 coast radio stations. This was expanded in 1920 to include long-wave transmission from Devizes Radio (transferred to Burnham/Portishead Radio in 1925) with a range of approximately 3200 km. Telegraphy working on HF radio was introduced in 1926 followed by radio-telephony services for the handling of telegrams only in 1928. It was not until 1934 that the first radio-telephone link between ships and shore subscribers became available. The 1930s also saw the equipping of all coast stations with valve transmitters in place of rotary spark systems.

During the Second World War, the telephony service was discontinued and the telegraphy service came under the control of the Royal Navy. Naval and Commonwealth coast stations all over the world were linked to the UK by Admiralty point-to-point radio links, and British and Commonwealth ships could pass telegrams via the nearest coast station. This network was maintained for a while after the war as the *Commonwealth Area Scheme* and functioned extremely well, providing good service to ships in distant waters. However, as the commitments of the Royal Navy declined east of Suez, the justification for Admiralty involvement in a service which was becoming mainly used by the merchant fleet was eroded. In 1971, the scheme was discontinued, and ships had to depend once more mainly on direct links with the BPO coast stations, primarily Burnham (receiving) and Portishead (transmitting), for long-distance telegraph services.

In the post-war years, the medium-range services, provided now by 11 stations round the coast of the UK were greatly modernized. These stations provide both telegraphy and telephony services using radio frequencies at 500 kHz and between 1.6 MHz and 4.0 MHz. The development of remote receiving-aerial sites enabled coast stations to provide duplex telephony service.

Following work by the CCIR † Study Group VIII, an internationally agreed VHF short-range telephony system using frequency modulation was introduced in the UK in 1958, and has since been gradually extended around the coast. VHF gives an excellent performance within its service area and operation is simple, but its range is essentially line of sight (80 km). To provide continuous coastal coverage, therefore, the provision of a number of remotely-controlled stations operated from the manned coast stations is in progress. A total of some 30 remote stations will be provided when the programme is complete in 1984–85.

Public radio-teleprinter services were introduced in 1965, connecting UK Telex subscribers to ships for the first time. Demand has expanded significantly and this facility could ultimately displace morse telegraphy.

The early-1970s also saw the introduction of single-sideband operation for telephony requiring the re-equipping of all coast stations<sup>39</sup>.

Whereas the long-distance telegraphy service was operated from Burnham (see Fig. 14) and Portishead, the long-distance HF telephony service was provided, for many years, by transmitters at Rugby and receivers at Baldock, alongside many international point-to-point HF radio-telephony services. However, the decline in the latter, as submarine cables and satellites have taken over these services, accompanied by substantial growth in both long-distance telephony and telegraphy services to ships, has provided both the need and the

† CCIR—International Radio Consultative Committee

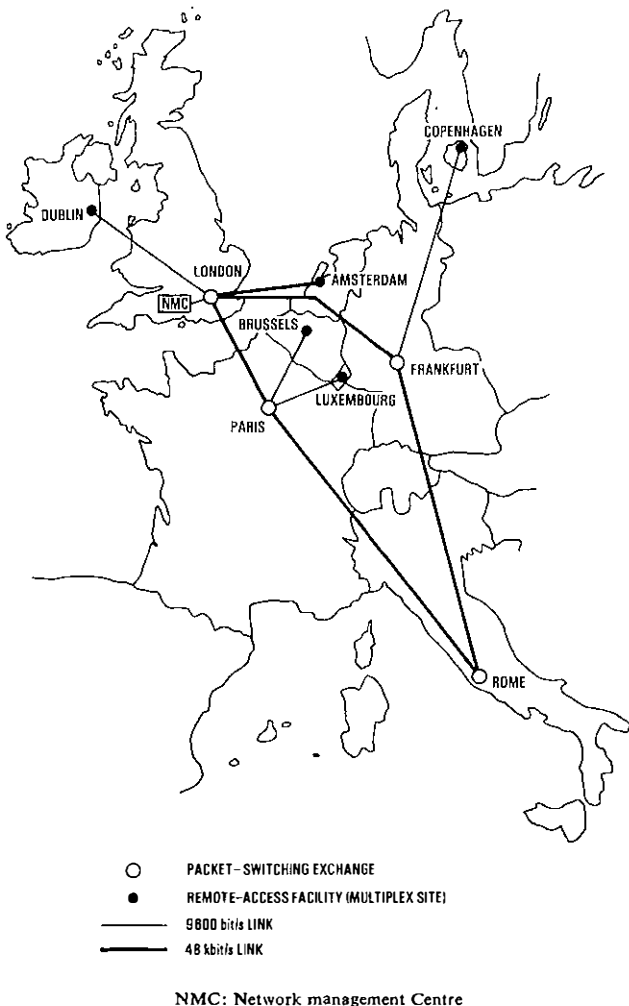

FIG. 13—The telecommunications network for EURONET at the opening date (end of 1979)

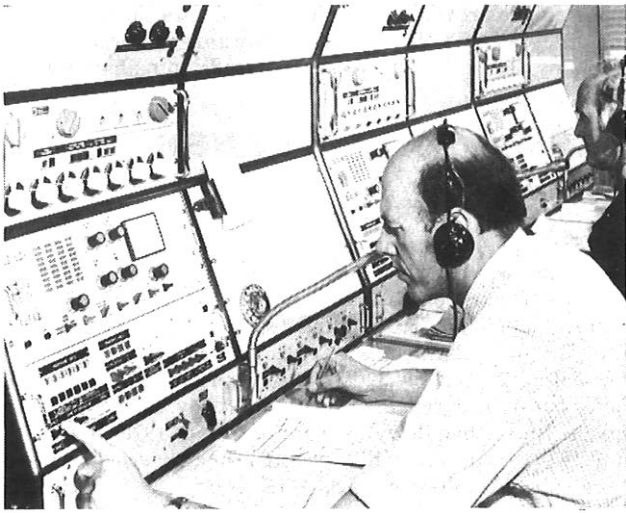

FIG. 14—Burnham Radio long-range ship-to-shore radio-telephone terminals, 1970–1981

opportunity for an extensive programme of development and rationalization. The transmitters for both of the maritime long-range services are now concentrated at Leafield, Rugby and Ongar. The receivers are located at Somerton, and a new operational control station is being built at Burnham. Portishead Radio was closed in 1979. A computerized message-handling system for telegrams will link radio operation positions directly to the telegram retransmitting centre for telegram disposal, an accounting tape being provided for off-line accounting.

During the mid-1960s, oil exploration in the North Sea required the extensive provision of new services to meet the demand. Systems providing radio-telephone and multi-channel radio-teleprinter services operating in the 2–4 MHz band in the independent-sideband mode were introduced at Humber and Stonehaven Radios. As the exploration area expanded, a new coast station called *Norwick*, remotely controlled from Wick Radio, was established in 1973 on the northernmost of the Shetland Isles. Recently, Lands End Radio has been fitted with a similar system for platforms operating in the South Western Approaches.

### MARITIME SATELLITE COMMUNICATION

During the early-1970s, sufficient interest emerged to encourage the Intergovernmental Maritime Consultative Organization (IMCO) to set up an international panel of experts (1972–1974) on maritime satellite communication to study the technical, operational, economic and institutional aspects of a maritime satellite system. The panel of experts produced a comprehensive report favourable to the establishment of a global system. This report was adopted by the International Conference which opened in London in April 1975 and, by 3 September 1976, the INMARSAT Convention and the associated Operating Agreement had been prepared, and were open for signature. The Conference also set up a Preparatory Committee to prepare the ground for the rapid establishment of the Organization when formed.

In 1973, the COMSAT Corporation had announced its intention to provide a maritime satellite service<sup>40</sup> which later developed into the MARISAT Consortium. In 1976–77, MARISAT launched 3 satellites, primarily for use by the US Navy, but having capacity available also for civil use. The first 2 satellites were located so as to serve the Atlantic and Pacific Ocean areas; the third was intended to act as an in-orbit spare. In time, however, sufficient confidence was established in the reliability of these satellites to enable the

third satellite to be relocated to serve the Indian Ocean area, and thus substantially complete world-wide coverage. Coast earth stations on the east and west coasts of the USA connect the Atlantic and Pacific Ocean satellites to the terrestrial network, and a Japanese station operates to the Indian Ocean satellite.

By May 1979, the INMARSAT Convention had received enough signatures and the Organization came into being on 16 July 1979. Preparations are being made for the new system to start operating with effect from 1 February 1982, taking over the services and some of the assets of MARISAT. The remainder of the satellite facilities needed for this initial operational period will be leased from INTELSAT and the European Space Agency (ESA).

INMARSAT is a two-tier international organization with headquarters in London. Its first tier is an Assembly of Parties in which all member countries are represented at governmental level. The Assembly acts as a watch-dog over the second tier, the Council, which has the job of running the system. The Council members represent the telecommunications administrations from each member country; by early-1981 there were 35 member countries. Each member's initial investment share is determined on the basis of its expected use of the service; the UK has the third largest share (at approximately 10%) after the USA and the USSR. Share allocations will be put on the basis of actual usage of the INMARSAT space segment when sufficient experience of operational use of the system has been obtained. Each member's voting power is weighted in proportion to his investment share.

Use of the MARISAT system was slow to build up in the early years. Shipowners tended to regard the system as pre-operational, being prepared to fit one ship in a fleet to evaluate the system but unwilling to go further without the assurance that there would be follow-on satellites when the first generation satellites had worn out. As the INMARSAT Organization came closer to operational existence, user interest has grown and the number of ship-equipment manufacturers (currently 13 world-wide) is also growing, creating competition in the quality of equipment and in particular the cost, which is falling in real terms. Furthermore, several telecommunications administrations, including BT, are building earth terminals, to eliminate the cost of relaying calls via the USA or Japanese stations. It is foreseen that INMARSAT tariffs will be lower than those of MARISAT, and this will also encourage ship fitting and use of the system.

By mid-1981, around 600 ships, including a number of British ships, have been equipped to use the system, access being gained to the system from this country via USA or Japan. Circuit quality and availability is much better than terrestrial HF radio can offer. Equipment on ships is in 2 parts. The above-decks element includes a 1.2 m parabolic aerial, which is gyro-stabilized to counter ships' movements at sea and has a satellite tracking facility to lock the aerial beam on to the satellite. The aerial is mounted in a radome as high as possible to avoid obstruction by the ship's superstructure. Some of the radio equipment, in particular the transmitter, is mounted in the radome. The below-decks equipment, which with new designs is becoming increasingly compact, comprises a rack of equipment, a Telex machine and a telephone handset as normal peripherals, but with the capability of handling facsimile and data up to 2400 bit/s. High-speed data (56 kbit/s) is being considered for some applications.

The UK coast earth station terminal is under construction at Goonhilly. The aerial and associated equipment, including a complex access, control and signalling system, are planned to be ready for service with the Atlantic Ocean satellite in May 1982. Terrestrial extensions to London into the international networks are well advanced, as are arrangements for telephone operators to handle outgoing telephone calls, for which current subscriber's metering equipment does not permit automatic operation. Arrangements are in hand for normal assistance from telephone operators and specialized maritime

assistance from radio staff at Burnham radio station. Apart from telephone calls in the shore-to-ship direction, the service will be automatic and will be an extension of the international network.

The UK coast earth station will operate to the Atlantic Ocean satellite covering an area enclosing 70° north and south latitudes and from the Gulf of Arabia to Panama. Access to the Indian Ocean, extending coverage as far east as Japan, will be gained through the collaborative provision by Denmark, Finland, Norway and Sweden, of a station in Norway (Eik). To extend service into the Pacific Ocean area, a memorandum of understanding has been signed with Singapore by both BT and the Nordic Group. The station at Eik will come into service during February 1982 and that at Singapore in Autumn 1982.

### TRANSHORIZON RADIO SERVICES

Some of the offshore production platforms built in the North Sea oil and gas fields are close in-shore. They communicate to shore typically by private line-of-sight microwave radio systems. In 1975, the first field far out to sea started production and many platforms are now in use 160–280 km from shore. For such distances, the choice of medium lies between submarine cable, satellite and transhorizon microwave radio by tropospheric scatter. Tropospheric scatter was chosen in 1975; in many circumstances, it would still be the best choice in 1981 although in the future the satellite medium will be an important alternative—certainly where much greater distances from shore are involved. BT has set up stations at Mormond Hill (near Aberdeen) and Scousburgh (near Lerwick) to provide the shore end of tropospheric-scatter links to platforms in the north-eastern part of the UK Continental Shelf. These stations now have links to serve the following pairs of North Sea platforms: Thistle and Cormorant, Beryl and Frigg, and Manifold and Piper. In addition, there are 2 links each serving a single platform complex in the Ninian and Fulmar fields. These links are, in general, paired, the 2 platforms being not too far apart. The shore station communicates with

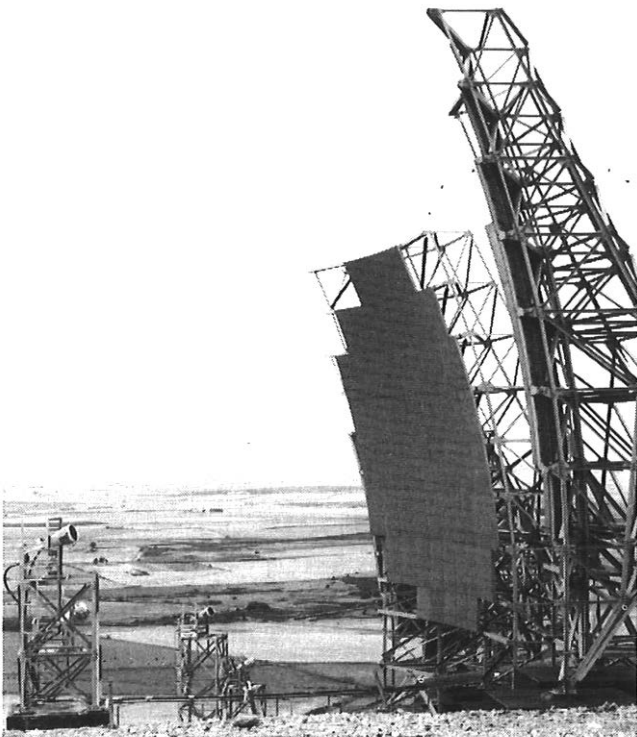

FIG. 15—Billboard antennae for tropospheric-scatter systems at Mormond Hill Radio Station

either platform of a pair and the other platform is served by an inter-platform line-of-sight link, thus providing high availability. Other nearby platforms are also connected into the tropospheric-scatter system by line-of-sight links. In this way, some 20 offshore production platforms are being served in 1981. In many respects, these tropospheric scatter systems are similar to multi-channel FDM microwave line-of-sight systems. They operate in the 1.9–2.65 GHz frequency band with a baseband capacity of 72 or 132 telephony channels. However, to overcome the high and fluctuating loss of the scatter mode of propagation, twin transmitters of 1 kW output power are used; low-noise parametric amplifiers provide the input stages of the receivers. Very large high-gain antennae, 12 m or 18 m billboard reflectors ashore (see Fig. 15) and 6 m or 9 m paraboloids offshore, are used in twofold diversity for transmission and fourfold diversity for reception. The circuits so provided are used for telephony and data and have direct access to the public network<sup>41</sup>.

### FUTURE DEVELOPMENTS

The long-range terrestrial radio-teleprinter system is currently operated manually at Burnham, but it will be converted to limited automatic operation during the next 2 to 3 years. This system will provide both ship and land based Telex subscribers with facilities for automatic direct access to each other or to a store-and-forward facility at Burnham.

The new digital selective-calling (DSC) system will be introduced at both long and medium-range terrestrial stations during the latter half of the 1980s and will provide improved facilities for coast stations when ships are called and vice versa. It should ultimately dispense with the need for ships' radio operators to keep a manual watch.

Expansion of the short-range terrestrial telephony services, now operating at VHF, will probably take place in the UHF bands and the service will ultimately be made fully automatic to allow direct dialling from a ship into the public telephone network and vice versa. The CCIR is currently formulating the operational specification of such a system for international adoption.

The satellite service is still very new; the most significant next stage of its development will be growth in the use made of the system by ships, and careful consideration is already being given to the form that the next generation of satellites, expected to be required about 1988, should take to meet these expanding commitments. However, it is already evident that a large number of small ocean-going ships are debarred, at present, from using satellite communication by the size, complexity and capital cost of the ship's equipment. Studies are in progress to identify system developments that would allow simpler, smaller ships' antennae to be used.

The future of the terrestrial maritime services is bound to be affected, to some degree, by the introduction of the INMARSAT system. Nevertheless, the terrestrial maritime service continues to be the scene of much innovation and rapid growth in traffic and it seems certain that there will be a continuing need for the service for many years to come.

### ACKNOWLEDGEMENTS

The author wishes to thank his colleagues in British Telecom International for their assistance in preparing this article; in particular, to David Withers for the sections on satellite communication and maritime services, to Dennis Gambier for the section on the submarine cable network, to John Goodman for the sections dealing with development of international services and to Michael Read for his work in co-ordinating the contributions.

### References

- 1 TAYLOR, F. J. D. Equipment and Testing Facilities at the Experimental Satellite Ground Station, Goonhilly Downs, Cornwall. *POEEJ*, Vol. 55, p. 105, July 1962.

- <sup>2</sup> TAYLOR, F. J. D., and BRAY, W. J. Preliminary Results of the Project TELSTAR Communication Satellite, Demonstrations and Tests: 10-27 July, 1962. *POEEJ*, Vol. 55, p. 147, Oct. 1962.
- <sup>3</sup> DAVIES, A. P. Submarine Cable Systems: A Review of their Evolution and Future. *POEEJ*, Vol. 72, p. 87, July 1979.
- <sup>4</sup> The Transatlantic Telephone Cable. *POEEJ*, Vol. 49, Jan. 1957.
- <sup>5</sup> Increasing the Traffic Capacity of Transatlantic and Other Submarine Telephone Cables. *POEEJ*, Vol. 52, p. 140, July 1959.
- <sup>6</sup> CLINCH, C. E. E. Time Assignment Speech Interpolation (T.A.S.I.). *POEEJ*, Vol. 53, p. 197, Oct. 1960.
- <sup>7</sup> The Anglo-Swedish Telephone Cable. *POEEJ*, Vol. 53, p. 165, Oct. 1960.
- <sup>8</sup> HALSEY, R. J. The Anglo-Canadian Transatlantic Telephone Cable System (CANTAT). *POEEJ*, Vol. 56, p. 73, July 1963.
- <sup>9</sup> Inauguration of the Commonwealth Pacific Cable (COMPAC). *POEEJ*, Vol. 57, p. 14, Apr. 1964.
- <sup>10</sup> A proposed New Cable System Direct to U.S.A.—TAT-3. *POEEJ*, Vol. 53, p. 169, Oct. 1960.
- <sup>11</sup> MYERSON, R. J. W. St Margaret's Bay-La Panne 420-Circuit Submarine-Cable System with Transistor-Type Submerged Repeaters. *POEEJ*, Vol. 60, p. 1, Apr. 1967.
- <sup>12</sup> HENDERSON, J. C., and WILSON, S. J. Design and Technology of Silicon Planar Transistors. *POEEJ*, Vol. 56, p. 239, Jan. 1964.
- <sup>13</sup> The CANTAT 2 Cable System. *POEEJ*, Vol. 67, pp. 142, 148 and 153, Oct. 1974.
- <sup>14</sup> EMERY, T. M. A New Concept in Submarine Cable Depots. *POEEJ*, Vol. 68, p. 149, Oct. 1975.
- <sup>15</sup> BACK, R. E. G. New Cable-Repair Ship—CS MONARCH. *POEEJ*, Vol. 68, p. 46, Apr. 1975.
- <sup>16</sup> SMITH, R. L. In a Scottish Loch. *BTJ*, Vol. 1, No. 1, p. 14, Spring 1980.
- <sup>17</sup> TAYLOR, F. J. D. The HS-303 Communications Satellite Project. *POEEJ*, Vol. 57, p. 221, Jan. 1965.
- <sup>18</sup> HUTTER, J. Customer Response to Telephone Circuits Routed Via a Synchronous-Orbit Satellite. *POEEJ*, Vol. 60, p. 181, Oct. 1967.
- <sup>19</sup> BACK, R. E. G., and WITHERS, D. J. The Development of the Intelsat Global Satellite Communication System, Part 1—The Early Years and the Intelsat III Satellite. *POEEJ*, Vol. 62, p. 207, Jan. 1970.
- <sup>20</sup> BACK, R. E. G., and WITHERS, D. J. The Development of the Intelsat Global Satellite Communication System, Part 2—Current Earth Station Practice and Future Systems. *POEEJ*, Vol. 63, p. 1, Apr. 1970.
- <sup>21</sup> MELLER, V. C., and DUFFY, P. S. J. The Large Steerable Aerials at Goonhilly Earth Station. *POEEJ*, Vol. 65, p. 2, Apr. 1972.
- <sup>22</sup> BEDFORD, R. A., and PURDY, J. E. Interference and Frequency Co-ordination at Earth Stations. *POEEJ*, Vol. 65, p. 85, July 1972.
- <sup>23</sup> FOULKES, S. A., and KEANE, A. J. Use of Single-Channel-Per-Carrier Terminal Equipment at Satellite System Earth Stations. *POEEJ*, Vol. 72, p. 54, Apr. 1979.
- <sup>24</sup> EATON, R. J., and KIRKBY, R. J. The Evolution of the INTEL-SAT V System and Satellite, Part 1—System Description. *POEEJ*, Vol. 70, p. 2, Apr. 1977.
- <sup>25</sup> EATON, R. J., and KIRKBY, R. J. The Evolution of the INTEL-SAT V System and Satellite, Part 2—Spacecraft Design. *POEEJ*, Vol. 70, p. 76, July 1977.
- <sup>26</sup> HALL, G. C., and MOSS, P. R. A Review of the Development of the INTEL-SAT System. *POEEJ*, Vol. 71, p. 155, Oct. 1978.
- <sup>27</sup> TURNBULL, M. G. Introduction of Semi-Automatic Operation of Continental Telephone Services. *POEEJ*, Vol. 52, p. 89, July 1959.
- <sup>28</sup> MILES, J. V. Introduction of International Subscriber Dialling from the London Director Area to Paris. *POEEJ*, Vol. 56, p. 33, Apr. 1963.
- <sup>29</sup> GIBBS, J. W., and JACKSON, F. G. Introduction of International Dialling from Non-Director Areas. *POEEJ*, Vol. 64, p. 44, Apr. 1971.
- <sup>30</sup> MODI, D. C., and YOUNG, K. W. The TXK2 Switching System at Wood Street and De Havilland International Gateway Exchanges. *POEEJ*, Vol. 70, p. 86, July 1977.
- <sup>31</sup> WALKER, P. J., and BALLINGER, D. R. The CCITT No. 6 Common-Channel Signalling System. *POEEJ*, Vol. 73, p. 235, Jan. 1981.
- <sup>32</sup> SMITH, G. E., and SOAMES, S. T. Decentralization of International Manual Boards. *POEEJ*, Vol. 62, p. 56, Apr. 1969.
- <sup>33</sup> WALKER, P. J., and BALLINGER, D. R. The TXK5 Switching System at Mollison and Thames International Gateway Exchanges. *POEEJ*, Vol. 70, p. 168, Oct. 1977.
- <sup>34</sup> IRELAND, W. A. An Introduction to the CCITT R2 Signalling System. *POEEJ*, Vol. 71, p. 37, Apr. 1978.
- <sup>35</sup> WILCOX, A., and BAXTER, E. C. Fleet (London) Automatic Telex Exchange. *POEEJ*, Vol. 54, p. 53, Apr. 1961.
- <sup>36</sup> DANIELS, E. E., and ELLIS, W. A. Switching and Signalling Techniques for the Intercontinental Automatic Telex Services, Part 1—Type C Signalling. *POEEJ*, Vol. 60, p. 210, Oct. 1967.
- <sup>37</sup> VEALE, A. A New International Telegram Retransmission Centre for the External Telecommunications Executive. *POEEJ*, Vol. 68, p. 226, Jan. 1976.
- <sup>38</sup> KELLY, P. T. F., and LEE, E. J. B. The Telecommunications Network for EURONET. *POEEJ*, Vol. 70, p. 208, Jan. 1978.
- <sup>39</sup> BRONSDON, E. G. Developments in Medium-Range Ship-to-Shore Radio Stations. *POEEJ*, Vol. 63, p. 71, July 1970.
- <sup>40</sup> BRANCH, P. N., and HOSKYNYS, R. F. Developments in Maritime Satellite Communications. *POEEJ*, Vol. 70, p. 154, Oct. 1977.
- <sup>41</sup> HILL, S. J. British Post Office Transhorizon Radio Links Serving Offshore Oil/Gas Production Platforms. *The Radio and Electronic Engineer*, Vol. 50, p. 397.

# SWITCHING AND SIGNALLING

## The Evolution of Switching Systems Architecture

L. R. F. HARRIS, M.A., F.ENG., F.I.E.E., and J. MARTIN, B.SC., C.ENG., F.I.E.E.†

UDC 621.395.345

*This article reviews the evolution of switching systems architecture over the past 25 years and shows how it has been influenced by advances in technology and the changing perception of the specific objectives of the system.*

### INTRODUCTION

It is sometimes said that there have been 2 revolutions in telephone switching: the move from manual to automatic and the move from electromechanical to electronic. Both are relevant to a review of the past 25 years, which has seen, in the UK, the completion of the former, and the latter well and truly launched.

But other, possibly even more significant changes have taken place in this period, affecting the very aims of switching systems development. These changes have been brought about by the emergence of new system concepts, by massive advances in technology and by the changing expectations for customer service for the future. Collectively these factors have had a profound effect on the architecture of switching systems, but the process has been gradual, through many projects, and the main purpose of this article is to give a view on the evolution that has taken place. Naturally, there are parallels in many countries and all have benefitted from the exchange of ideas between them: this review is set, however, in the context of developments in the UK, taking the year 1956 as the starting point.

### HISTORICAL PERSPECTIVE

In 1956, switching systems were mainly classified in terms of the switching technology used: manual, Strowger, crossbar and electronic.

#### Strowger

Most local exchanges were already automatic, based upon the step-by-step principles of the Strowger system (see Fig. 1), which had been brought to a high level of standardization through the endeavours of the joint Post Office-Industry British Telephone Technical Development Committee (BTTC).

Virtually all trunk and international calls required the services of an operator; but plans for subscriber trunk dialling (STD) were well advanced, and a range of electronic and electromechanical register-translator and supervisory equipments were in development for incorporation into the predominantly step-by-step environment.

† Mr. Harris is Director System Evolution and Standards and Mr. Martin is Director System X Development, both in British Telecom Headquarters

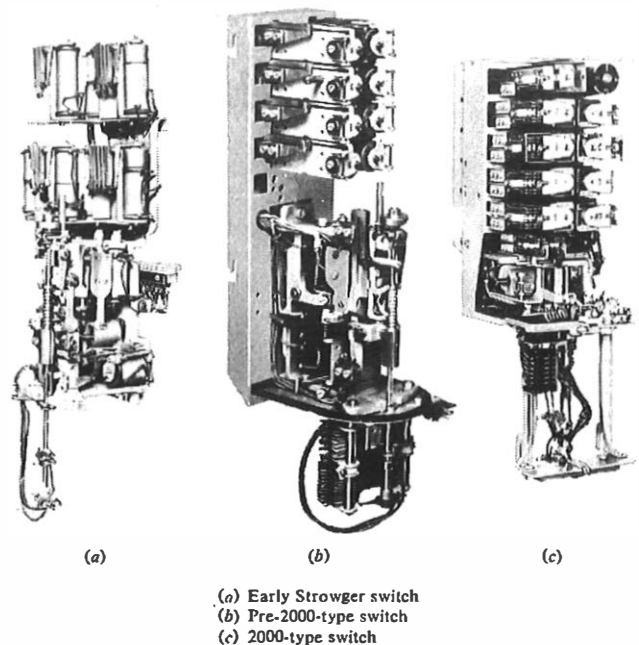

FIG. 1—Strowger 2-motion switches

#### Crossbar

Crossbar systems had already been adopted by various overseas administrations and, in 1956, a number of experimental systems were being independently considered by British firms. The TXK systems were introduced into the British Post Office (BPO) network in the early-1960s for STD in the main trunk centres and the 4-wire transit network, and in local exchanges to meet a somewhat unexpected increase in demand for telephone service without increasing Strowger production capacity<sup>1</sup>.

#### Electronic

Research on electronic switching had already been underway for some 9 years at the BPO Research Station at Dollis Hill and elsewhere, and 1956 saw the signing of the Joint Elec-

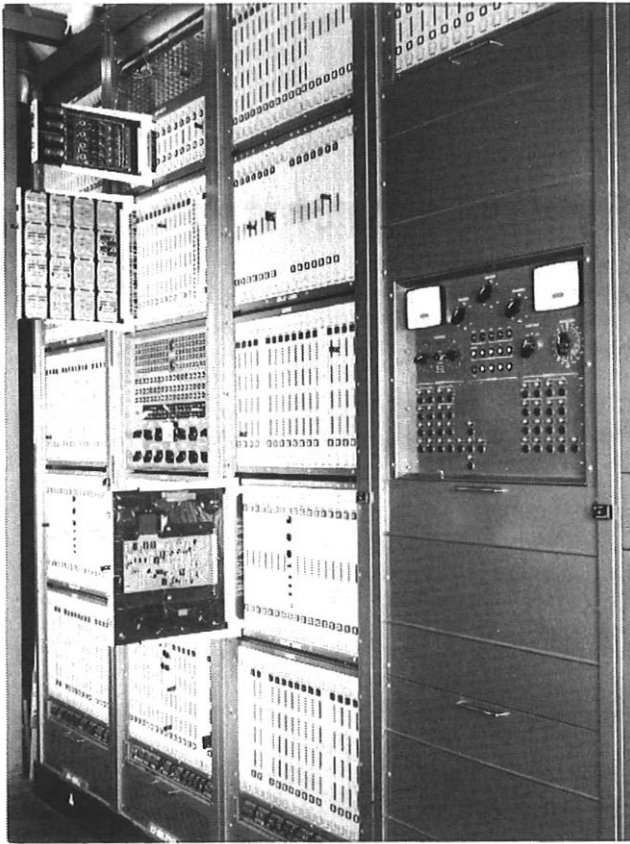

FIG. 2—Highgate Wood register racks (1962)

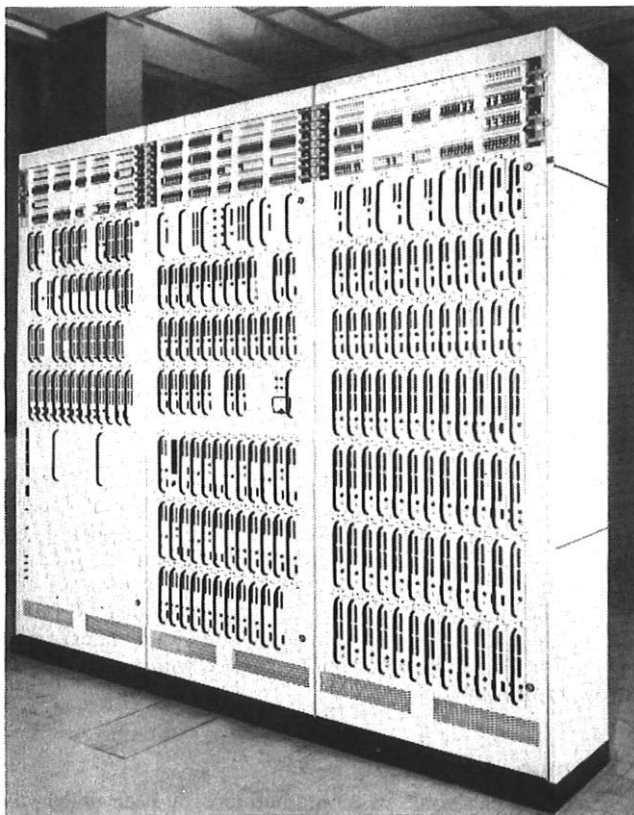

FIG. 3—Field trial installation of small electronic exchange (1965)

tronic Research Agreement (JERA) which enabled the combined resources of the BPO and its principal equipment suppliers to be pooled in a common programme. As a result of the JERA, a number of experimental pulse-amplitude modulation time-division multiplex (PAM-TDM) projects, of which Highgate Wood (see Fig. 2) is the best known<sup>2</sup>, were undertaken, but further exploratory development was carried out on the so-called high-speed and low-speed TDM systems in the early-1960s<sup>3,4</sup> before PAM-TDM was abandoned as a basis for public exchange switching in 1963. TDM research continued however, and the experimental digital exchanges at the Empress and Moorgate exchanges in London in the late-1960s built on the earlier PAM-TDM work, and pointed the way to the all-digital integrated systems of the future<sup>5,6,7</sup>.

Two areas of reed-electronic system development were also launched under the JERA:

(a) The large capacity systems which began with the trial TXE1 system used successfully for many years at Leighton-Buzzard<sup>8</sup>, progressed through TXE3<sup>9</sup>, and culminated in the adoption by the BPO in 1972 of the TXE4 system and its evolutionary successor TXE4A<sup>10</sup>. Some £1000M of TXE4/4A equipment will be in service by the mid-1980s.

(b) The TXE2 small capacity system which was introduced following field trials at Leamington and Peterborough in the mid-1960s (see Fig. 3), like the TXE4/4A, has been a major vehicle for equipment modernization and the transition, in production and operations, from electromechanical to electronic systems<sup>11</sup>. More than 1200 TXE2 exchanges are now in service.

## DEVELOPMENT OBJECTIVES

These various activities have all had the underlying objective of increasing cost-effectiveness to the end-user, the customer. But the specific objectives set—and the particular objectives of any development, and the resulting system architecture—must inevitably be a matter of judgment and compromise, dependent upon the capabilities of the technologies available and the current perception of need and acceptable risk; these perceptions themselves change with time, experience and circumstances. That, in a sense, is what this article is all about.

The evolution of objectives and architecture over the past 25 years inevitably culminates with System X and, in determining the bases of System X, advantage could be taken of the experience gained with all the earlier systems; for the first time, it was possible to envisage the use of system concepts and technologies that enabled comprehensive and almost idealized objectives to be set. The objectives are important in themselves, and they provide a framework for later discussion of the objectives and features of the earlier systems<sup>12,13,14</sup>.

## System X Objectives

The development of System X has the clear objective of meeting British Telecommunications' (BT) requirements with designs that are fully competitive on world markets. The basic aims include:

(a) low equipment, installation and cabling costs as specific and targetted objectives (component costs are an increasingly important factor);

(b) low accommodation and power-plant costs, made possible with micro-electronic devices of low power consumption;

(c) low running costs, with highly-reliable equipment and centralized management, maintenance and accounting facilities; and

(d) fully-effective service performance as perceived by the customer in terms of the range of services and facilities available, and their quality and convenience.

Considerable emphasis has also been placed on the objectives that go with such concepts as stored-program control (SPC), common-channel signalling and a modular approach to system organization:

(a) In-service flexibility for the day-to-day management of customer services and networks.

(b) Adaptability to meet diverse requirements (that is, service, network, inter-working and operational) in the BT network and overseas, with the same basic hardware.

(c) Potential for the progressive and cost-effective introduction of new customer and administrative services and facilities, by the addition of new hardware or software modules.

(d) The creation of effective network-planning options, particularly those that reduce the cost and increase the capabilities of the network as a whole; for example, in the provision of an integrated services digital network (ISDN).

(e) Evolutionary potential in terms of technology and practices, enabling the most effective technologies to be incorporated without changing the organization of the system as a whole.

Emphasis has also been placed upon the objectives that go with computer-aided design, automatic assembly and test methods, and a documentation database<sup>15, 16</sup>, namely:

(a) short procurement, installation and commissioning times, and

(b) short development time to generate, adapt and evolve designs and bring them into production to meet diverse or changing requirements or incorporate new technologies.

## EVOLUTION OF OBJECTIVES

Clearly, some of these objectives have been at the forefront of designers' minds throughout the past 25 years, notably those in the first group. Low equipment, accommodation and running costs have been prime aims of all developments, with specific objectives being determined largely by the technologies of the day. Similarly, clear criteria for the quality, grade and performance of the basic telephone service have been with us all along. And the most significant changes in the first group have been in the range of services and supplementary telephone facilities envisaged.

On the other hand, the impact of computer aids and automated test and assembly methods could hardly have been envisaged 25 years ago; therefore, it is perhaps in the middle group of objectives (concerned with the flexibility, adaptability and evolutionary potential of systems, and their impact on the network as a whole) that the most interesting changes have taken place.

It is convenient to discuss the architectural implications of these changes in relation to 3 categories of system: Strowger step-by-step, common-control and TDM respectively.

### Strowger

The main activity here has been the implementation of STD<sup>17</sup>. This, like the earlier move from local manual to automatic working, was aimed primarily at holding down running costs, which would have otherwise become prohibitively expensive with the number of operators required to cope with the increased demand. The fact that STD (and later international direct dialling (IDD)) could be introduced relatively easily into the Strowger system, by the addition of new register-translator and supervisory equipments at convenient flexibility points between switching stages, says much for the basic architecture of the system.

In the terminology of System X, Strowger is a highly modular system, having functional sub-systems with well defined interfaces between them. The use of relatively independent switches (see Fig. 4), each carrying one call only and each intimately associated with its own control, restricted the

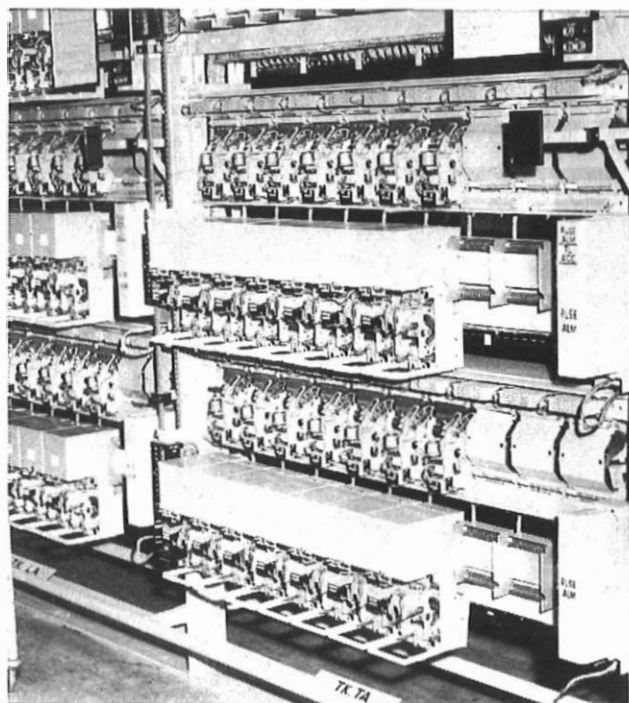

FIG. 4—Evesham trunk first selectors (1960)

effects of faults and enabled simple maintenance practices to be used. Also, the same robust and standard devices—switches and relays—could be adapted to meet a very wide range of requirements, including not only the basic non-director and director systems, but a number of unit automatic exchanges for smaller communities. A great deal of ingenuity went into minimizing the number of switches required, and the number of relay contacts required to perform a wide variety of signalling, timing and call supervisory functions. There can be no doubt about the adaptability of the devices used: but they were also highly inflexible in that their functions could not be changed readily in service, and this has proved to be a serious obstacle to further evolution.

### Common-Control Systems

First steps in the move towards common control were in the increasing use of register-translators for call routing; and this has been a feature of all subsequent systems. Their use both increases the convenience of the automatic service to the user in that the same codes may be used irrespective of the point of origin of calls, and costs are reduced in that calls can be optimally routed over transmission plant and through exchanges, with the option of using either tandem or direct routing.

An important aim behind the move from Strowger switches to crossbar (and later reed-relay) switches was the improvement of service performance in terms of transmission quality and reliability, while at the same time reducing labour costs incurred in the production and maintenance of equipment. However, because the cost of individual crossbar or reed-relay crosspoints was higher, new forms of trunking and control were used in order to keep their number down and to enable compensating savings in terms of, for example, the reduced amounts of cabling between ranks of switches<sup>18, 19</sup>. Measures taken to reduce the number of crosspoints included the use of concentrating switches common to both originating and terminating traffic, increasing independence between directory numbers and exchange terminations, and de-segregating customer's lines and other terminations according to their class-of-service or type.

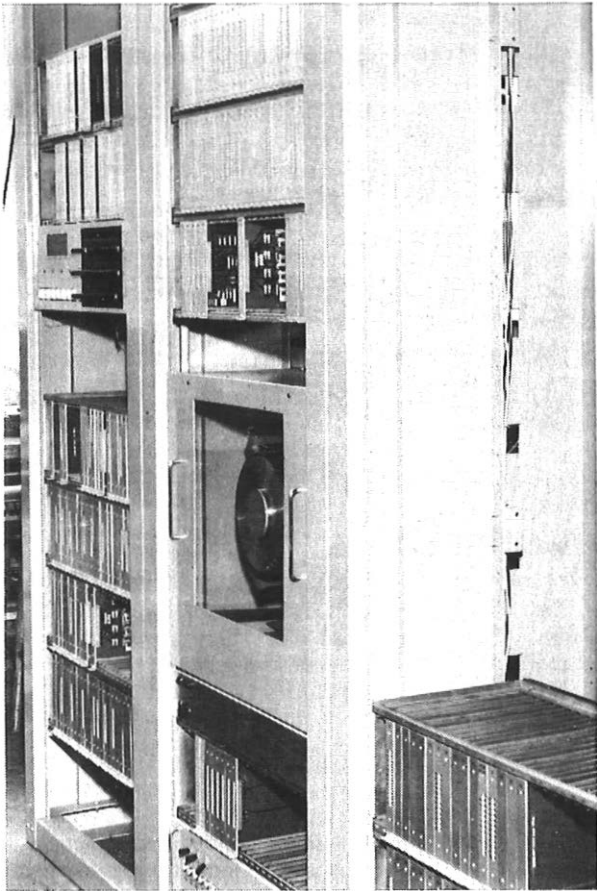

FIG. 5—Drum-metering equipment at Chatham (1961)  
(Photograph courtesy Standard Telephones and Cables Ltd.)

In their turn, these measures were consistent with the provision of common-control equipment to determine and set up appropriate paths through the switching network and to associate with that selected path the appropriate supervisory facilities. In many common-control systems, separate common equipments are clearly discernable; for example, register-translation functions, path selection using *end-marking* or *interrogation* techniques, the storage and manipulation of class-of-line, class-of-service and directory number information, and supervisory functions. Some of the early common-control systems had somewhat limited flexibility, particularly with regard to the number of classes of service, and in the relationship between equipment and directory numbers.

The degree of flexibility required was a major issue in the 1960s, and it was not until cheap and proven bulk storage was available that the issue was finally resolved in terms of complete flexibility. Much the same can be said of metering, which provides an interesting example of how the perception of risk has changed over the years. Although electronic metering using magnetic drums (see Fig. 5) has been under consideration for a great many years, its use was rejected in favour of traditional ratchet-type meters operated via cross-point contacts specifically provided for the purpose. This arrangement held down accounting costs and provided greater integrity of charge registration. Only comparatively recently have the costs of electronic storage and the pressures to offer the customer alternative forms of billing, such as itemized accounting, enabled fully-automatic accounting to be seriously contemplated.

## TDM Systems

The various experimental TDM systems have had a wide range of objectives, and clearly, greater risks could be taken in experimental projects than could be contemplated in substantive developments. In the very early PAM-TDM research, considerable emphasis was placed upon the greater reliability that would arise from the absence of moving parts and consequent wear, and on the search for electronic techniques that would replicate the performance of electromechanical equivalents<sup>20</sup>. Common-control *register-marker* principles were envisaged from the outset but, in the earliest experiments, PAM-TDM switches were used merely to replicate the performance of individual crosspoint matrices for inter-connexion by audio-circuits with *end-marking* and individual supervisory circuits.

The early programmes did much to clarify the basic requirements of switching systems in the UK, but were severely handicapped by the limited technologies available. The emergence of new technologies such as the germanium transistor, and magnetic drum and magnetostriction delay-line stores improved the situation and, with the invention of time-divided switching, supervision and control, appeared to offer prospects of an economic solution to all the basic functions required in a telephone exchange<sup>21</sup>. This promise led on to the JERA and the Highgate Wood experiment which, although conceptually in advance of the technologies available, demonstrated many of the common-control and switching principles exploited in later systems; for example, the use of electrically-alterable storage for directory number, state and class of line, code-translation and metering information, and, in rudimentary form, *time-space-time* trunking principles.

In the early-1960s, significant differences of view arose on the best way of securing common time-shared equipment against faults, and the *duplication of equipment*, *one-in-N sparing*, and *triplication with majority-decision* techniques were all used in the various PAM-TDM projects. There was also a great deal of discussion on the relative merits of permanently or variably assigning TDM channels to individual subscriber's lines; the former being favoured in the so-called *low-speed TDM system* which exploited complex limited-access switching arrays with traffic-mixing to economize in the number of time-divided crosspoints used.

These techniques had their parallels in some early reed-electronic systems, which is an indication that many problems and solutions in switching are more fundamental than the technology used. However, the PAM projects did highlight some problems unique to TDM systems, notably the problems of economically converting between audio and pulse signals at the periphery of the exchange, and between the high-speed low-power signals used within the exchange and the relatively low-speed high-power signals required, for example, for ringing and pulsing-out to other exchanges. No wholly satisfactory purely electronic solution to the latter has been found even for the interfaces of today's digital systems but, although other factors contributed, it was the fundamental problem associated with the former that finally led to the conclusion that PAM-TDM could not provide a viable basis for public exchange switching.

This conclusion was reached after studies were made in the early-1960s of the impact that the inherent gain of PAM exchanges would have on the transmission performance of the network as a whole. It was found that, although in the long term the inherent gain might lead to improved transmission performance and savings in line-plant, in the short term it would be difficult to provide even an acceptable overall performance without selecting appropriate line-balances and gains individually for each line terminating on the exchange<sup>22</sup>. These problems contributed significantly to the decision to concentrate development effort through the 1960s on reed switching with electronic control, and to refer TDM back to research, where overall network considerations



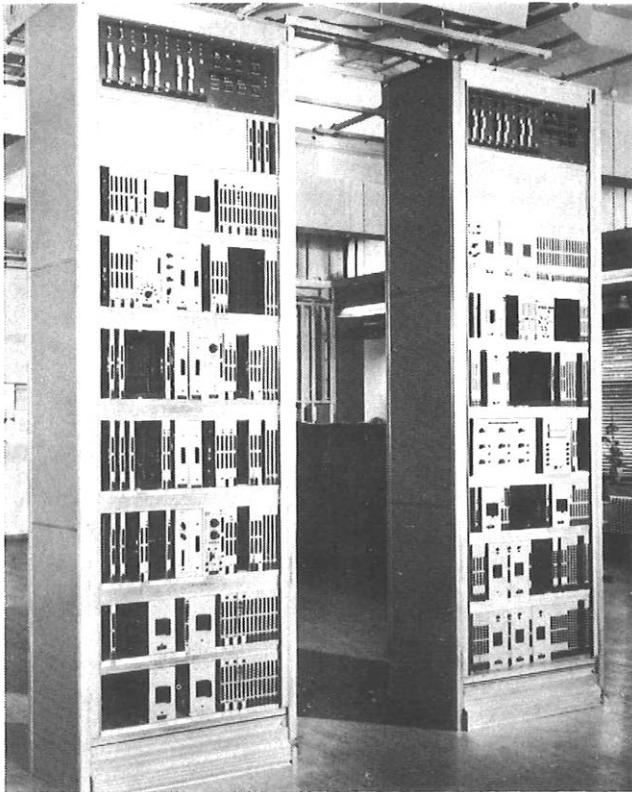

FIG. 6—Empress digital tandem exchange (1968)

were taken fully into account in the early thinking on integrated digital switching and transmission. From the outset, integration was seen as an important way of making the transmission performance independent of the number of exchanges involved in a connexion, and of reducing interface costs at the exchange periphery.

In the late-1960s, the Empress (see Fig. 6) and Moorgate tandem exchanges demonstrated the use of the early large-scale integrated (LSI) circuits in proving the practicability of digital switching and its compatibility with the digital transmission systems then coming into use.

### CHANGE AND COMPATIBILITY

Integrated digital switching and transmission is now, of course, a central feature of BT's current plans and developments. But the 1960s saw systems architects facing up to the fundamental problem of how best to reconcile 2 important characteristics of telecommunications systems: compatibility and change. For telecommunications to be possible at all, disciplined inter-working between all the elements of a network is essential; and new systems must work with the old. But by the mid-1960s, there was already talk of a massive explosion in the variety of services and facilities—voice, visual and data—that the telecommunications user would require in the future. The revolution in semiconductor technology was already underway, but the somewhat restrictive signalling and control techniques then in use made changes expensive and difficult to accommodate. It was at this time that increased emphasis was placed upon evolutionary potential and in-service flexibility as important criteria for systems development<sup>23, 24</sup>.

Small steps in this direction had been taken in, for example, the high-speed PAM-TDM system which employed manually-programmable logic for some of the control functions. Evol-

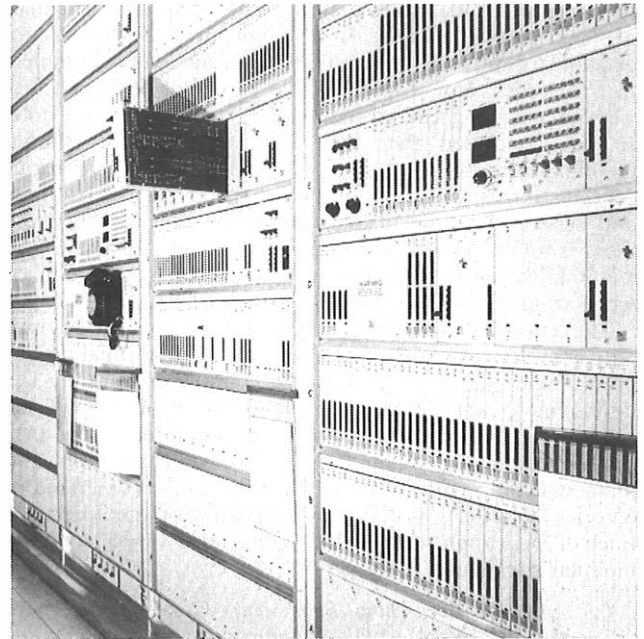

Note: Register card withdrawn

FIG. 7—Rectory TXE4 common-control equipment (1976)

utionary requirements were taken a great deal further in the TXE3 and, later, the TXE4 designs, which, for example, exploited modular general-purpose switches and serial-trunking techniques, facilitating the addition of new supervisory and register equipments required to provide additional facilities or to match new methods of signalling<sup>25, 26</sup> (see Fig. 7).

Similarly, a modular and flexible approach was made to control functions, by using manually-alterable (and later in TXE4A, electrically-alterable) programs governing the sequence of operations required to set up an increasing variety of types of connexion. These techniques have already been shown to provide useful degrees of in-service flexibility, and the evolutionary potential of the approach has been demonstrated by the moves into TXE4A which, through the replacement of some of the control sub-systems with more flexible designs, now has further potential for the introduction of new customer and administrative services and the exploitation of fast inter-register and common-channel signalling.

### THE EVOLUTIONARY SYSTEM X

However, by the late-1960s, it was recognized that emerging concepts such as SPC, common-channel signalling and integrated digital switching and transmission could, in culmination, provide an enduring solution to the problems of reconciling change and compatibility, and that the continuing development of semiconductor technologies would enable these to be implemented economically. It was also recognized that if the new system were introduced as an overlay on the existing network, calls completed within the overlay would be free of the existing inter-working constraints, and thus form the beginning of a high-capacity digital network providing an expanding range of services.

The joint BPO-Industry Advisory Group on System Definitions (AGSD) was set up in 1968 to carry these ideas further and define the developments required. The AGSD undertook a wide range of studies, both on the requirements and organization of networks and systems, and on the overall development process. Because of the enduring nature of telecommunications and the uncertainties involved in predicting service requirements, it concluded that the architecture of the new system should be defined more in terms of basic

functions and capabilities than in terms of specific schedules of facility requirements. It also sought to identify subdivisions of the total system that were functionally complete in themselves, and would be able to evolve independently without changing the structure of the system as a whole. It was concluded that the resulting subsystems should be multi-purpose so that they could be used in various combinations and configurations to meet diverse planning and service requirements, and that the interfaces between them should provide convenient points of growth and adaptability, enabling new subsystems to be introduced when required<sup>27,28</sup>.

These concepts have been followed through in the co-ordinated development of System X undertaken in a collaborative programme by the BPO, with GEC, Plessey and STC<sup>29</sup>. The development was substantively launched in 1976 and the programme has aimed to provide for a comprehensive range of applications including families of local exchanges and main switching centres, all of which have been described in a series of articles in the previous issues of the *Journal*<sup>30</sup>. Each of these applications is based on a repertoire of common modular subsystems, notably:

(a) *Subscriber Switching Subsystem* Concentrating subscribers traffic on to heavily-loaded common digital circuits. This sub-system may be used as a remote concentrator.

(b) *Digital Switching Subsystem* Interconnecting high-traffic digital circuits. An overall time-space-time configuration has been adopted.

(c) *Message Transmission Subsystem* Performing common-channel signalling functions.

(d) *Signalling Interworking Subsystem* Providing facilities for inter-working with existing exchanges using a diversity of channel-associated signalling systems.

(e) *Network Synchronization Subsystem* For operation in a synchronized total network.

(f) *Processor Subsystems* For call processing, call accounting, maintenance control, overload control and management statistics.

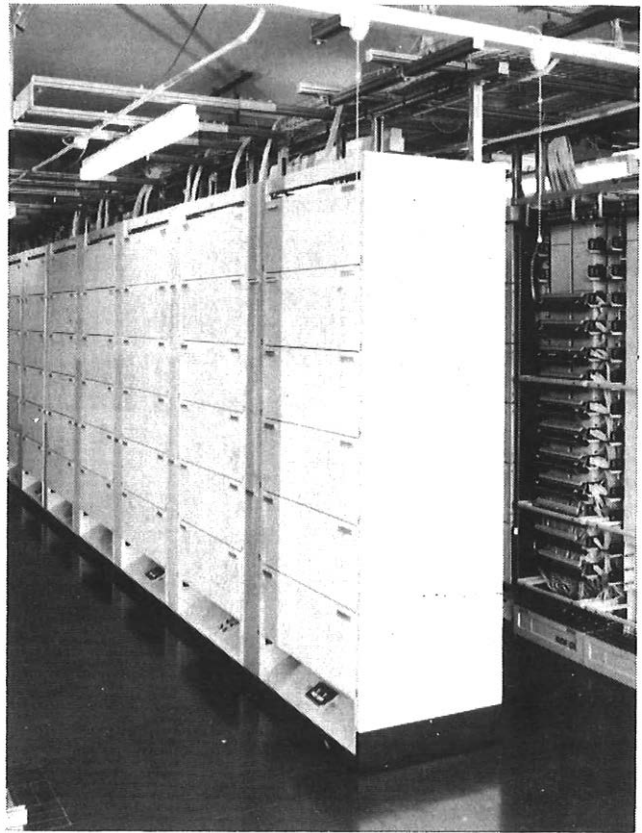

FIG. 9—Baynard House System X equipment (1980)

A *top-down* modular approach to software is used, in which considerable emphasis has been placed upon simplicity and maintainability. The resulting structure is based upon defined processes, with formally defined interfaces between them. Aids to the generation of software include a high-level programming language, and extensive support facilities for assembling the software required for specific installations.

Advantage has already been taken of the evolutionary potential of System X in introducing new technology, notably LSI technology (see Fig. 8), and in the provision of new supplementary telephone facilities. Various billing options will be available for the customer, and considerable interest is being shown in the automatic announcement facilities by which simulated speech is used to guide users through the procedures for new services. Such announcement facilities were demonstrated for the first time in the Pathfinder Exchange experiment at Martlesham, which also had a significant influence on the development of the Monarch all-digital PABX system and its rural public exchange derivative, UXD5 (now known as *TXD 05*), which exploits the digital speech path technologies of System X, using microprocessor control.

Currently, the first members of the System X family—a digital main exchange and a small local exchange—are giving excellent service at Baynard House in London (see Fig. 9), and at Woodbridge in Suffolk respectively. Significant quantities of System X equipment are now on order and volume production is planned to build up through the mid-1980s; this will provide the basis of a substantial export market, promoted through British Telecommunications Systems Ltd., which was formed in 1979.

## THE FUTURE

From this survey of the evolution of the architecture of switching systems in the UK, it will be realized that the process has been complex. If System X represents its culmin-

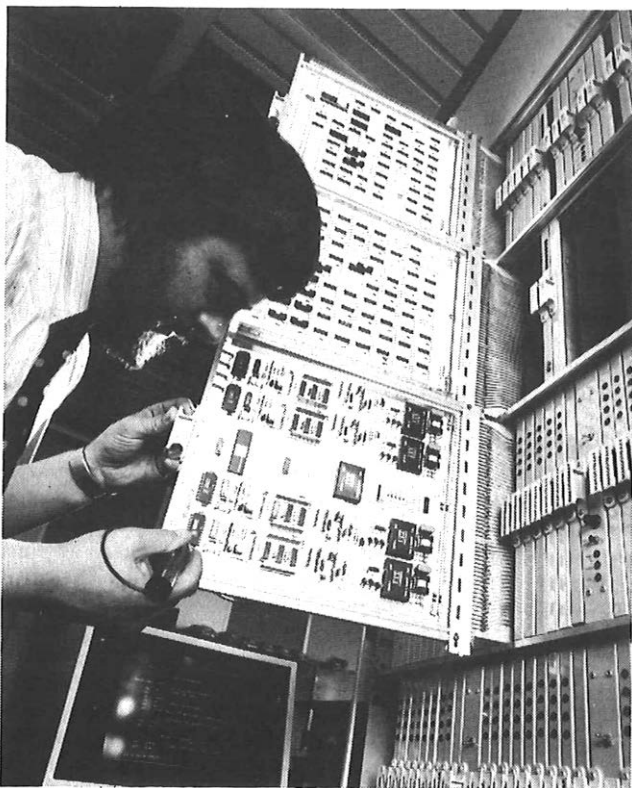

FIG. 8—System X prototype digital subscribers switching sub-system (1980)

ation, that development owes a great deal to the earlier developments, and reflects many of the architectural features of earlier systems—perhaps most notably the evolutionary aims of the TXE4/4A developments, the time-sharing principles of the early TDM systems, and the adaptability of the basic Strowger sub-systems to meet diverse requirements.

But System X has the greatest potential for evolution, and already further evolutions are envisaged; for example, in the further exploitation of automatic announcement services in the provision of integrated services digital networks and, eventually, in the evolutionary addition of switches for wide-band services. System X will be adaptable to new international standards as these are established. It is certain that the size of the equipment will continue to shrink as new and even more capable technologies become available, for example, for the performance of the basic line-unit functions of ringing, testing and signalling conversion.

In conclusion, it is natural to ask, what, if anything, will follow System X? Will there be some new set of system concepts, techniques or service requirements that will lead away from the bases of System X and require some new approach to systems architecture? The answers must lie with the future; but with the evolutionary potential of System X, deliberately created, it is far from clear what the incentive for further revolutionary change might be. No incentive is apparent of the magnitude that caused the move from manual to automatic, the introduction of STD, or the moves into common-control crossbar and reed-electronic systems, or the move to System X itself. But evolutionary changes in System X will surely arise, sometimes in dramatic form<sup>31</sup>.

## ACKNOWLEDGEMENT

In conclusion, acknowledgement must be made to the many contributions to the developments mentioned in this paper by many people in the BPO and in the Telecommunications Industry. Individually, each organization has contributed a great deal. But working together in BTDC, in JERA, in AGSD and in the collaborative forums of System X, they have achieved much more; particularly, as in the development of System X, when marketing, production and operational interests interact creatively in the overall development process, with comprehensive objectives in mind.

## References

- <sup>1</sup> CORNER, A. C., and BANHAM, H. The 5005 Crossbar Telephone Exchange Switching System; Parts 1 and 2. *POEEJ*, Vol. 59, pp. 170 and 271, Oct. 1966 and Jan. 1967.
- <sup>2</sup> HARRIS, L. R. F., MANN, V. E., and WARD, P. W. The High-gate Wood Experimental Electronic Telephone Exchange System: General Introduction. *Proc. IEE*, Vol. 107, Part B, Supplement No. 20, p. 70, Nov. 1960.
- <sup>3</sup> CAPLIN, J. S., and REGER, H. P. A Time-Division-Multiplex Exchange with Alternative Routeing. *Trans. IEEE*, Vol. 8, Com. 14, p. 221, June 1966.
- <sup>4</sup> FLOWERS, T. H. Trunking of a TDM Electronic Exchange with Subscriber's Lines having Permanently-Allocated Multiplex Channels. *Proc. IEE*, Vol. 112, p. 878, Oct. 1962.
- <sup>5</sup> DUERDOTH, W. The Possibility of an Integrated PCM Switching and Transmission Network. *Proc. of the International Switching Symposium*, Paris, 1966.
- <sup>6</sup> CHAPMAN, K. J., and HUGHES, C. J. A Field Trial of an Experimental Pulse-Code Modulation Tandem Exchange. *POEEJ*, Vol. 61, p. 186, Oct. 1968.
- <sup>7</sup> ROSE, D. J. Pulse-Code Modulation Field Trial Model. *Electrical Communication*, Vol. 46, p. 246, 1971.
- <sup>8</sup> SHEPPARD, A. S. H. The Leighton-Buzzard Electronic Telephone Exchange. *POEEJ*, Vol. 59, p. 225, Jan. 1967.
- <sup>9</sup> VOGAN, D. H., and PRICE, C. D. E. The TXE3 Experimental Exchange System. *POEEJ*, Vol. 62, p. 142, Oct. 1969.
- <sup>10</sup> MAY, C. A. Electronic Exchanges: The Steps Leading to TXE4. *POEEJ*, Vol. 65, p. 134, Oct. 1972.
- <sup>11</sup> LONG, R. C., and GORRINGE, G. E. Electronic Telephone Exchanges: TXE2—A Small Electronic Exchange System. *POEEJ*, Vol. 62, p. 12, Apr. 1969.
- <sup>12</sup> HARRIS, L. R. F. Strategic Systems Planning. Royal Soc. Symposium, Telecommunications in the 1980s, London, Mar. 1979.
- <sup>13</sup> MARTIN, J. Why System X? Special Features: System X and Communications. *Electronics and Power*, Vol. 26, p. 529, July 1980.
- <sup>14</sup> HARRIS, L. R. F. An Introduction to System X. International Switching Symposium, Paris, May 1979.
- <sup>15</sup> SIGRIST, P., and TEESDALE, R. R. System X—Basic Design and Make Principles. International Switching Symposium, Paris, May 1979.
- <sup>16</sup> PRICE, C. D. E., and ALLEN, D. System X Information Systems. International Switching Symposium, Paris, May 1979.
- <sup>17</sup> TOBIN, W. J. E., and STRATTON, J. A New Switching and Transmission Plan for the Inland Trunk Network. *POEEJ*, Vol. 53, p. 75, July 1960.
- <sup>18</sup> LONGDEN, T. E., and KIRTLAND, J. P. Developments in Control Technology for Telephone Switching. *POEEJ*, Vol. 74, p. 194, Oct. 1981.
- <sup>19</sup> HUGHES, C. J., and LONGDEN, T. E. Developments in Switching Systems Technology. *POEEJ*, Vol. 74, p. 203, Oct. 1981.
- <sup>20</sup> FLOWERS, T. H. Electronic Telephone Exchanges. *Proc. IEE*, Vol. 99, Part 1, p. 181, Mar. 1952.
- <sup>21</sup> HARRIS, L. R. F. Time-Sharing as a Basis for Electronic Telephone Switching. *Proc. IEE*, Vol. 103, Part B, p. 722, Mar. 1956.
- <sup>22</sup> FLOWERS, T. H. Transmission Network Planning with Electronic Exchanges. *Proc. IEE*, Vol. 107, Part B, p. 364, Nov. 1960.
- <sup>23</sup> WARMAN, J. B. *et al.* The Concept, Security and Checking of a Generalised REX System, and other papers. International Switching Symposium, Paris, Mar. 1966.
- <sup>24</sup> HARRIS, L. R. F. Electronic Telephone Exchanges: An Introductory Review of Developments. *POEEJ*, Vol. 59, p. 211, Oct. 1966.
- <sup>25</sup> WARMAN, J. B., and BEAR, D. The Trunking and Traffic Principles of a Sectionalized Exchange System. *Proc. IEE*, Vol. 113, p. 1331, Aug. 1966.
- <sup>26</sup> MARTIN, J. Electronic Telephone Exchanges: An Introduction to Switching Network Design. *POEEJ*, Vol. 60, p. 124, July 1967.
- <sup>27</sup> MARTIN, J. System X: Into the Digital Era. *Communications '78*, Apr. 1978.
- <sup>28</sup> TIPPLER, J. T., and KIRTLAND, J. P. System X: Architecture and Technology. International Switching Symposium, Paris, May 1979.
- <sup>29</sup> MORALEE, D. *et al.* Special Features: System X and Communications. *Electronics and Power*, Vol. 26, pp. 528–552, July 1980.
- <sup>30</sup> MARTIN, J. System X. *POEEJ*, Vol. 71, p. 221, Jan. 1979.
- <sup>31</sup> HARRIS, L. R. F. System X Evolution, Special Features: System X and Communications. *Electronics and Power*, Vol. 26, p. 552, July 1980.

# Developments in Control Technology for Telephone Switching

T. E. LONGDEN, C.ENG., M.I.E.R.E., and J. P. KIRTLAND, B.SC.(ENG.).†

UDC 621.395.345

*This article describes how control technology has developed over the past 25 years, firstly in the step-by-step switching environment, then through the common-control techniques, and ultimately to System X.*

## INTRODUCTION

The control processes of a switching system are concerned with the recognition of signals from a subscriber originating a call, and the establishment of appropriate switched connexions.

The facilities which a system is able to offer subscribers and the administration are determined to a large extent by the signalling capability and the ability of the control to respond to the signalling information.

It can be argued on these grounds that the earliest operator controlled exchanges met the requirements of a powerful switching system. They had a high-capacity signalling system (speech) between the customer and the control system (the operator). The control system was highly intelligent and could provide many facilities now regarded as advanced; such as alarm calls, call diversion, call waiting and alternative routing. Such systems were, however, slow and costly, and for today's network would be quite impracticable.

The inherent weaknesses of manual switching led to the introduction of automatic systems. Because of the limitations imposed by the technology of the time, early automatic switching systems were necessarily constrained to have control systems which could be implemented with relay circuits and electromechanical devices. Although many systems were devised, the step-by-step method in which the stages of a connexion are switched sequentially emerged as the most suitable for the technology available.

In 1956, the British Post Office (BPO) network<sup>1</sup> was firmly based on step-by-step switching techniques and the use of a subscriber dial which provided a very limited signalling repertoire.

In the non-director (ND) system employed over most of the UK, electromechanical selectors are controlled directly by subscribers' dials. The director system employed in the 6 main conurbations uses dial routing controlled by register-translators (RTs), or *directors*, from which the system's name was derived. The combination of A-digit selectors and directors enables the first 3 dialled digits (the ABC digits) to be examined. The director then provides appropriate routing information, generating pulse trains to control the subsequent switching operations. This element of common control provides the in-built flexibility in routing that permits very large linked-numbering schemes to be implemented in an economic way. The fact that the system is still in use unchanged in its fundamental concepts is a tribute to the system designers of the 1920s.

Over the past 25 years, the introduction of national, and subsequently, international direct dialling has required the development of controlling and incoming RTs to be integrated into the step-by-step network. Electromechanical directors have been replaced by new more reliable devices performing an

unchanged function, and completely new common-control exchange systems have been introduced.

These lines of development, which have all been made possible by continuous advances in technology, are described below.

## CONTROLLING REGISTER-TRANSLATORS

Controlling RTs<sup>2</sup> take over the functions previously performed by operators in setting up a trunk call. The equipment examines dialled digits, determines the charging rate for the call, and transmits call routing information.

Between 1958 and 1963, three types of controlling RT using different technologies were introduced. The first type, designed for use in ND areas, used cold-cathode circuitry, an electronic technology that was current at that time. The second type was a parallel development using conventional BPO electromechanical components. The third type of RT, designed for use in director areas, made use of magnetic-drum storage, a technique especially suitable for very large installations.

RTs of the electromechanical and magnetic drum-types are still in service, but the cold-cathode type has now been replaced. First-generation controlling RTs are now becoming obsolete and a processor-controlled RT in which the system logic is stored in software, and which is capable of replacing all existing types, is being introduced

### Cold-Cathode Electronic Register-Translators (Type 1)

This equipment, first used in Bristol in 1958, employs the voltage-transfer method of operation in which the output potential from one cold-cathode tube is used to strike another. Signals between tubes are controlled by rectifier gating. The cold-cathode tubes are used in counting chains for control purposes, digit counting and digit storage.

A central translator serves up to 40 registers which are scanned via a continuously operating allotter circuit.

### Electromechanical Relay-Controlled Register-Translators (Types 2, 3 and 5)

These are the electromechanical equivalent of the Type 1 RT and use uniselectors and relays for storage and control (see Fig. 1). The Type 2 has the capacity to serve only one charging group; the Type 3 serves up to 3 charging groups. The Type 5 was introduced to give multi-frequency (MF) inter-register signalling facilities (MF2) required by the introduction of the transit network. All 3 types have been modified to give the additional capability of handling international direct dialled traffic.

### Magnetic-Drum Register-Translators (Type 4)

For director areas with their heavy concentration of traffic, an RT was developed based on thermionic valves and the use of magnetic-drum storage. It has a large storage capacity

† Mr. Longden is in the Exchange Systems Department and Mr. Kirtland is in the System X Development Department, both in British Telecom Headquarters

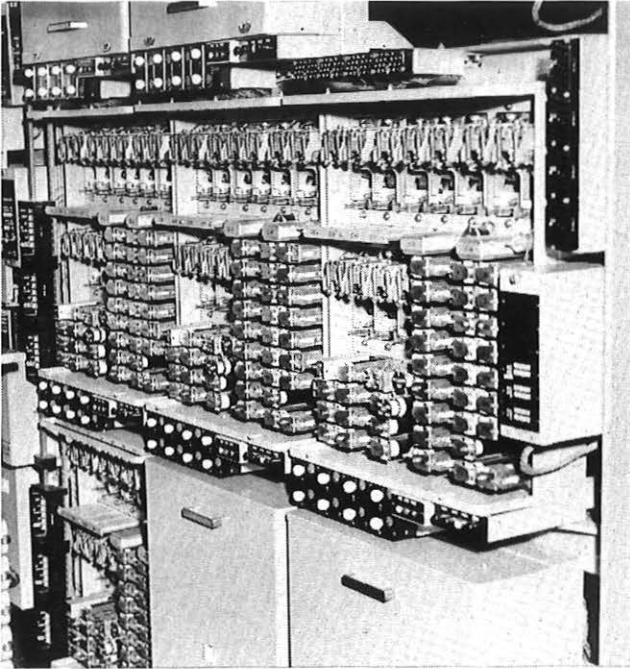

FIG. 1—Electromechanical registers (Evesham 1960)

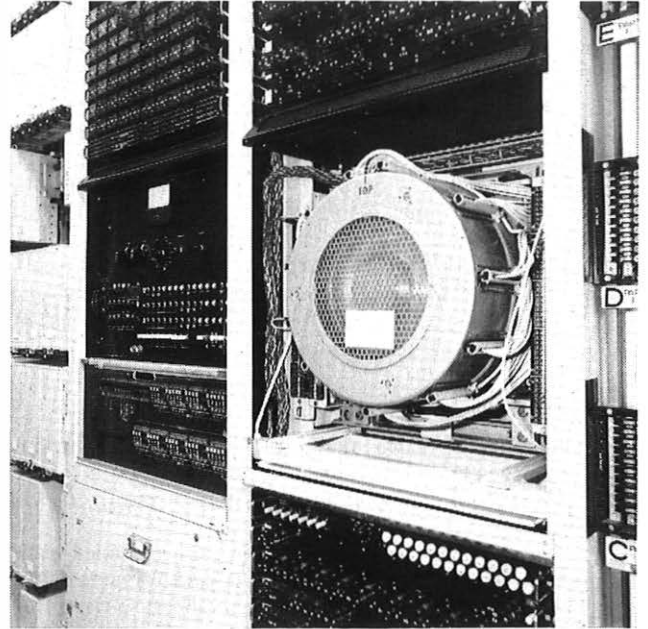

FIG. 3—Magnetic-drum of the Type 4 register-translator

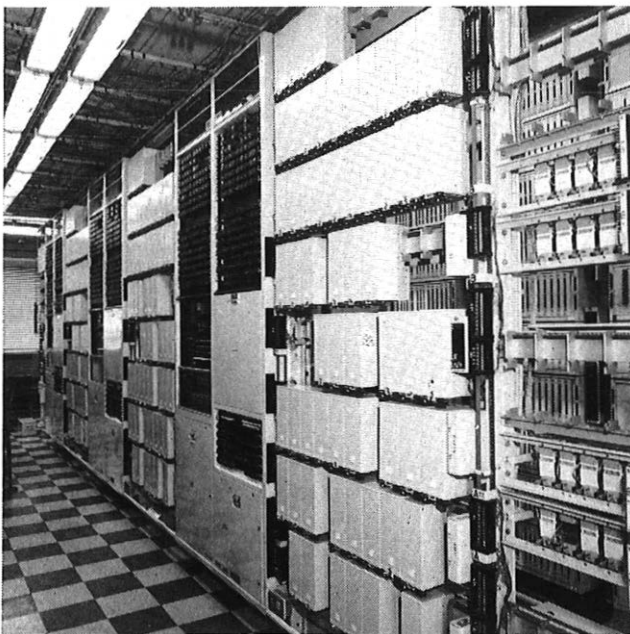

FIG. 2—Type 4 register-translator and associated equipment

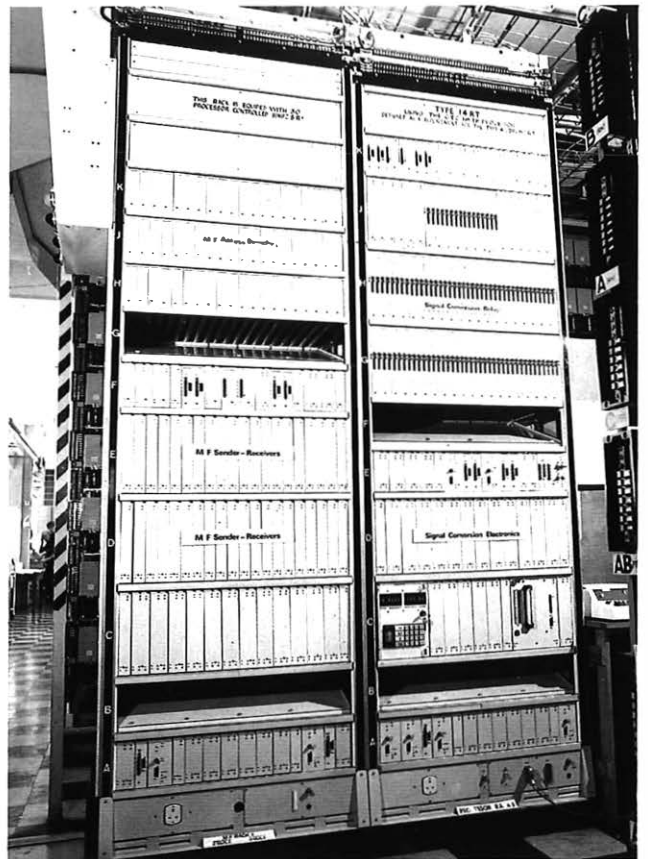

FIG. 4—Type 14 register-translator (1980)

and the equipment, although slow by present standards, is fast enough to control the functions of a large number of registers.

On a fully equipped rack, there are 47 register relay-sets, each associated with a register which is part of the surface of the magnetic drum. This drum is 230 mm in diameter and nearly 100 mm in width, with a nickel-plated surface on which information in the form of magnetic patterns may be recorded. Reading and writing heads are mounted around the circumference so that the information is written on tracks around the 100 mm surface. The drum can accommodate 68 tracks at 8 tracks/cm, each track being capable of holding nearly 300 pieces of information. (See Figs. 2 and 3.)

#### Processor-Controlled Register-Translator (Type 14)

The Type 14 RT, which uses the GEC MK1P processor, was

designed as a replacement for the Type 4 RT and its registers, stores and associated equipment. The Type 14 RT comprises:

(a) A processor rack, containing 96 signal conversion circuits (SCCs), a central processor unit (CPU) and associated equipment. The application program, translation data and temporary storage are contained in one common store; a metal-oxide semiconductor (MOS) volatile random-access memory (RAM) with a back-up cartridge unit is provided on the rack.

(b) An MF rack, containing 30 MF sender/receivers (S/Rs) with associated access and ancillary equipment. The S/Rs are processor controlled and each one is mounted on a single-card slide-in-unit.

A unique feature of this RT is the translation editor, which is a software module enabling translation changes to be input from a teletype up to 7 days in advance of implementation.

The Type 14 RT may also be used to replace the Types 2, 3 and 5 RT and all their associated equipment. New micro-processor controlled register access circuits (RACs) are provided to replace the existing register-access relay-sets; 128 RACs with their access and associated equipment are contained in a single rack. (See Fig 4)

### INCOMING REGISTER-TRANSLATORS

Incoming RTs<sup>3,4,5</sup> have fewer facilities than controlling RTs, the principal difference being that charge-rate determination is not required. Two types are now in use in the UK network.

The first type was introduced in 1965 and provided translation facilities on incoming routes to director areas. It is known as the *Type 6* RT and was the first to use transistors and ferrite cores (see Fig. 5). Each unit of common-processing equipment deals with 194 working registers; the remainder are used for special test purposes. The common equipment incorporates a translation field (Dimond ring) which produces up to 8 routing digits for each of the one thousand 3-digit codes. In-built monitoring of calls with fault reporting via a printer is one of the salient features of this equipment.

The second type is used in ND areas to accept inter-register signalling (MF2) from transit network routes. This is designated the *Type 10* and uses conventional electromechanical and relay technology, but transistors are used in the timing circuitry.

The technology of the existing types of incoming RT is now dated. Adaptation of RT Types 13 or 14 for this specialized application is technically feasible and will be implemented if required.

### ELECTRONIC DIRECTORS

As electronic techniques evolved in the 1950s, replacement of the heavily loaded electromechanical RTs used in director exchanges became an attractive proposition, and experimental installations were used as proving grounds for cold-cathode, magnetic-drum and ferrite-core technologies<sup>6,7,8</sup>. Eventually, 2 types of electronic director, both of which completely replace the short-holding-time equipment, were introduced.

#### Type 12 RT (SPC Director)

The Type 12 RT<sup>9</sup>, designed in the late-1960s, used the tech-

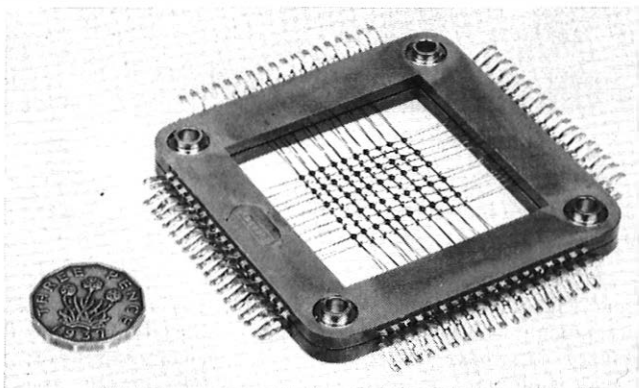

FIG. 5—Typical example of 10 × 10 matrix using 2 mm ferrite cores (1963)

nology available at that time; that is, discrete components, diode-transistor logic, Dimond-ring store, and core store. It has 60 traffic-handling signal conversion circuits (SCC) and 3 physically separate stores which provide the RT function:

(a) *Program Store* This holds the program for controlling the RT and consists of a field of large linear ferrite-cores (Dimond rings), through which a code wire is threaded, so that when a current is passed along the wire, a binary-coded octal instruction is generated.

(b) *Translation Store* This provides the normal translation function of routing, signalling and charging information in a

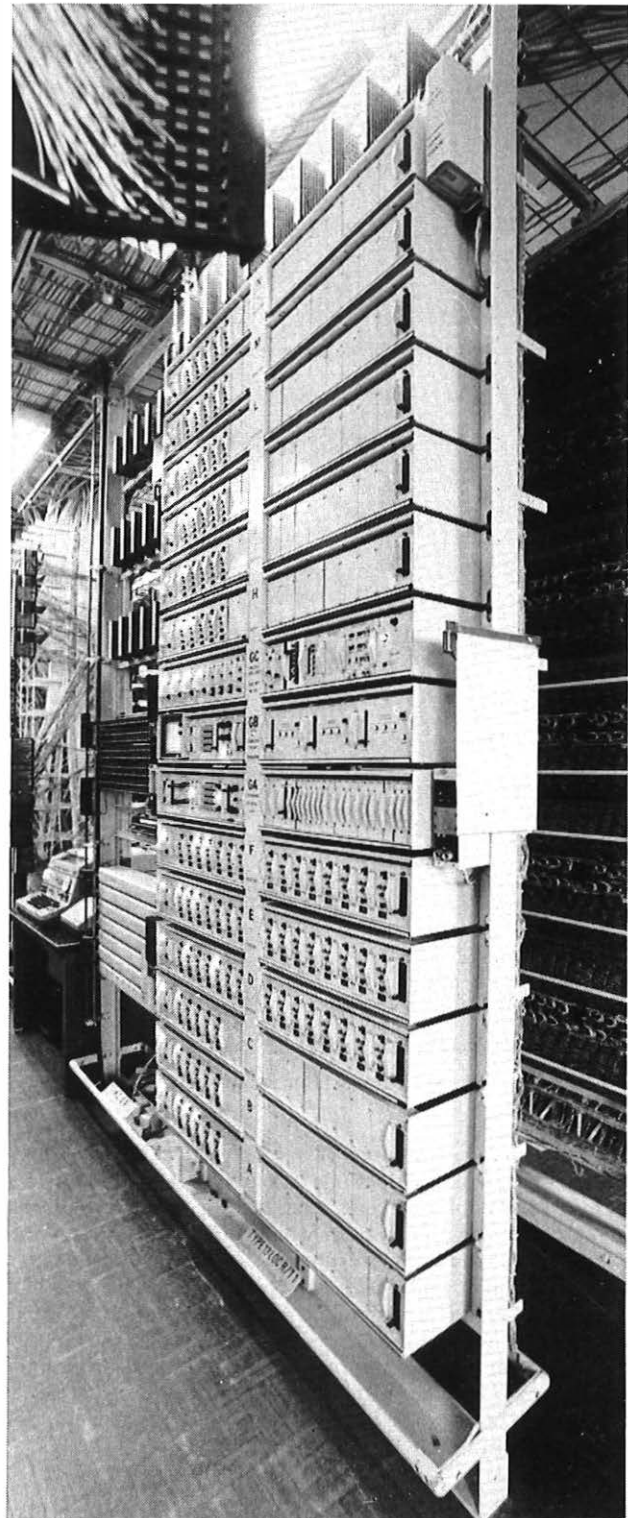

FIG. 6—Type 13 register-translator (MOST director) 1979

similar manner to the program store, though the physical layout is different.

(c) *Data Store* Each SCC has a total of  $16 \times 16$  bit word of standard read/write ferrite core-store allocated to it to provide temporary storage of incoming digits and general working space.

Associated with the stores is the CPU, which controls the operation of the stores and manipulates the information contained within them.

### Type 13 RT (MOST Director)

The Type 13 RT<sup>10</sup>, often referred to as the *MOST* director, was introduced in 1979 (see Fig. 6). It uses 4-phase metal-oxide-semiconductor-transistor (MOST) logic and provides facilities similar to the Type 12 RT but with a further increased saving in space (1 rack replaces about 12 racks of electro-mechanical equipment) and gives a further reduction in overall costs.

The reduction in size of the system has been achieved by extensive use of 24 different custom-designed integrated circuits (see Fig. 7).

The Type 13 RT is not a processor-controlled system. Call-routing digits are derived by means of discrete program codes held in a common translator store; this is an electrically alterable dynamic shift-register containing program codes to control the routing of calls. The control information is continuously cycled and applied to data highways which feed up to 180 registers on a standard 2000-type rack. The translator

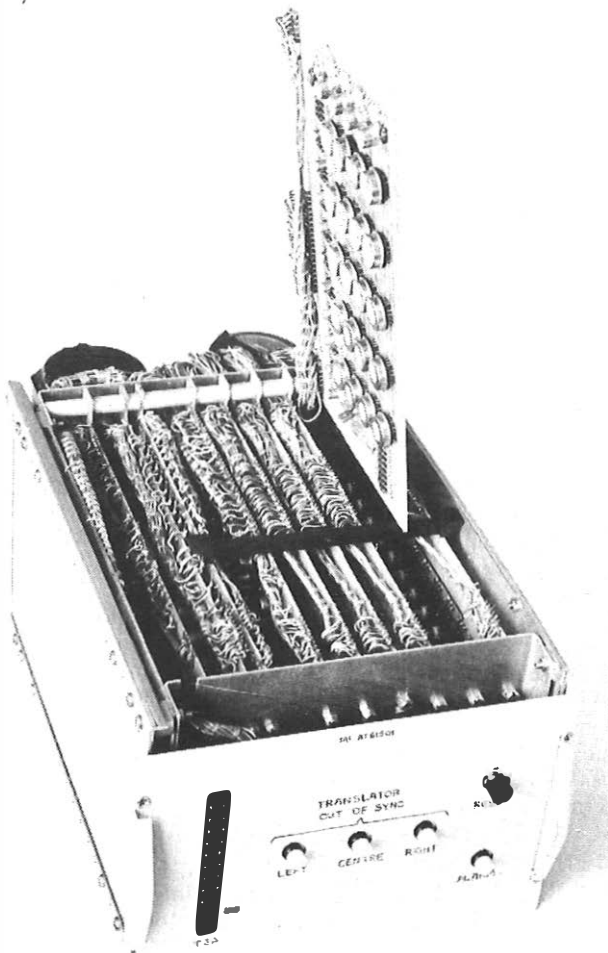

FIG. 7—Type 13 translator with a store card withdrawn

store consists of a matrix of two hundred 800 bit MOST shift-registers effectively forming one large shift-register with a single recirculating loop. The maximum length of the store is 2000 words (160 000 bit).

### COMMON-CONTROL EXCHANGES

Advance in technology has made it possible to bring together more control functions into a common-control unit which serves the whole exchange. The world trend has been away from step-by-step systems and towards a common control which takes over the register-translation function, call set-up and supervision, routining and diagnosis of faults as well as collection of traffic and performance data.

The design of the common-control unit and of computers has converged to the point where in the latest System X designs, the production of software programs and data represent a significant, if not the largest, share of the exchange development charges.

The reason for this trend is that common control in general, and stored-program control (SPC) in particular, make it very much easier to change the way in which the exchange responds to individual customers or to customers in general; for example, temporarily disconnection (TOS) of individual lines or introduction completely new facilities.

A brief review of the development of common-control systems in the UK network is now given.

### Crossbar Exchanges

The Plessey 5005 (TXK1 and TXK2)<sup>11</sup> system and the ITT BXB (TXK3 and TXK4)<sup>12</sup> systems adopted in the UK all use electromechanical registers, translators and markers, the principal differences being that the 5005 system uses end-to-end switching with self-steering, whereas the BXB system uses 20-wire parallel data highways that enable fast data-transfer between the control unit and switchblocks.

To improve the performance and reliability of the 5005 system to the point where it could be used in the London sector switching centres, the mechanical control unit was replaced by a GEC MK1C processor. This was superseded by the more powerful MK1P processor for use in ND group switching centres.

### Reed-Electronic Exchanges

The research activities leading to the introduction of reed-electronic systems are described in a companion article dealing with the developments in switching-system technology. The sealed reed-relay promised greater reliability and lower overall cost and was first used by the BPO in the TXE2 small local exchange which came into service in 1966. TXE2<sup>13,14</sup> broke new ground in that a customer's identity is completely independent of the position on the switch, being generated by a wire passing through a number of ferrite cores.

Class-of-service information is determined in a similar manner; this avoids the need to segregate lines such as coin-collecting boxes into separate groups, and has obvious advantages from the administration point of view.

The duplicated reed-transistor control unit is of relatively simple design, and offers no new facilities.

In operation, the calling-number generator passes the directory number to a free register. Under the supervision of the *call control*, which takes account of the class-of-service information, the register initiates the call set up between the customer and the selected route. Call control serves to process all calls on a one-at-a-time basis. The complete central control system is duplicated, the units being used for alternate 8 min periods.

Call set up is normally accomplished within 50 ms, well within a time-out of 120 ms. If the first attempt fails, initiation of a second attempt (another TXE2 innovation) by the control



FIG. 8—TXE4RD cyclic-store data-threading field (1976)

produces a print-out of the details of the first attempt.

The TXE4<sup>15</sup> large local exchanges, derived from the experimental TXE1 and TXE3 systems<sup>16,17</sup>, represent a further step forward in technology. The first TXE4RD systems installed in 1976 used threaded-wire stores for storing not only customer data but also the basic control programs (see Fig. 8). In the later TXE4A version, these stores were replaced by large-scale integration MOS shift-register and RAM/ROM (read-only memory) stores.

The control is split into 4 main functional blocks; cyclic store, main control unit (MCU), interrogator/marker, and the supervisory processing unit (SPU).

The cyclic store (MOS shift-register in TXE4A) holds customer and routing data. It is scanned continuously: incoming junction data at 12 ms; register and outgoing junction data at 36 ms; and subscriber data at 156 ms intervals. A bus system connects the output to all MCUs. To protect the system against data loss in the event of a power failure, a back-up magnetic cartridge system is provided.

The MCUs, which control the register and the call set-up functions, are provided on a traffic basis. The TXE4A version uses electrically programmable ROM (EPROM) and RAM stores for the program and work space respectively. An indication of the improvement in performance over the threaded-core TXE4RD can be obtained by the comparison of the register handling capacity of the 2 versions; that is, 96 and 36 respectively.

### System X Exchange

The next step on the technological road was the introduction of digital switching exchanges controlled by digital processors which are almost indistinguishable from commercial computers except for the fact that control systems are expected to operate to a much higher standard of reliability than commercial computers. Typically, a mean time between failure (MTBF) of 400 years is specified for the total failure of the control system for a large exchange.

The BPO, now known as *British Telecommunications*, in conjunction with British industry have developed a family of digital-switching telephone exchanges known as *System X*, the whole concept of which has been described in earlier issues of this *Journal*<sup>18</sup>.

For the small exchange, the control-function is performed by a processor unit which uses worker-stand-by techniques, whereas for the large exchanges exemplified by the Baynard House digital junction tandem exchange, known as *TXD 14*, which came into service in 1980, the central-control function is performed by a multiprocessor unit in which a number of CPUs share access to a common bank of RAM stores. Fig. 9 shows the Baynard House installation.



FIG. 9—System X large processor utility

Any of the CPUs can undertake any of the functions of the common-control unit; jobs are allocated by the next free CPU or by the CPU running the lowest priority task in the event that the new task has a sufficiently high priority. This processor (used with the Baynard House TXD 14) is of an early design which, when fully equipped on 13 racks, executes approximately 2 million instructions/s. Each instruction or data access has an error check to protect it against store errors. In the event of an error being detected, the system calls up a clean copy of the program or other data from the backing store.

The processor which will be used in most System X exchanges executes up to 4 million instructions/s, and uses magnetic-bubble storage technology for the backing store; the complete processing system occupying one rack.

The interface between the processor and the rest of the exchange is via a high-speed bus system which transmits task-based messages to and fro between the processor and the individual hardware module control units. In many cases these module control units are themselves commercial microprocessor units which are capable of performing repetitive or routine functions.

In the case of the local exchange concentration stages, the local microprocessor scans for new calls and sets up paths through the switch in accordance with instructions received from the main unit. However, in the event that the concentrator is remotely sited from the central processor and is isolated by cable breakdown, then the local microprocessor has sufficient intelligence to connect simple calls within the unit or to an operator.

The availability of low cost but powerful microprocessors, sometimes on a single chip, is perhaps the next most challenging problem for designers because they make possible a move back towards a more distributed form of control, which has certain attractions as far as growth and security are concerned.

### CONCLUSIONS

As can be seen from the foregoing, the introduction of new systems is conditioned by the availability of an appropriate technology.

Designers of control systems are continuously required to make judgements on when to introduce a new technology. On the one hand, to rely too heavily on recent but unproven technology involves a high degree of risk; on the other, a too



conservative approach produces an uncompetitive product. Clearly, research should be continuous, but the introduction of a new system must take account of the large investment involved and practical problems such as training.

With regard to the convergence of computers and exchange control systems, the experience of the computing industry suggests that the installed life of control systems will be shorter than in the past. This represents a challenge to both development and operational staff.

The long period of stability of the Strowger era is not likely to be repeated. The long-term future of the control of networks is not clear. It is possible to conceive a national network controlled by a few very powerful processors, the limitations being non-technical. At the other extreme, the increasing power of microprocessors could lead to the system's intelligence being distributed down to individual terminals.

## ACKNOWLEDGEMENTS

The authors wish to thank their colleagues in the System X Development and Exchange Systems Departments of British Telecom Headquarters for their assistance in preparing this article.

## References

- <sup>1</sup> The Inland Telephone Exchange System. *POEEJ*, Vol. 49, p. 185, Oct. 1956.
- <sup>2</sup> WALKER, N., BARNARD, A. J., BENSON, D. L., WOOD, R. A., and VOGAN, D. H. Controlling Register-Translators, Parts 1-4. *POEEJ*, Vol. 51, pp. 268, 272, 280 and 291, Jan. 1959.
- <sup>3</sup> WATERS, H. S., and SHEPPARD, S. H. Incoming Register-Translator for Director Areas, *POEEJ*, Vol. 51, p. 303, Jan. 1959.
- <sup>4</sup> BLANCHARD, D. T., and RYAN, W. A. Trunk Transit Network:

Incoming Register-Translators for Director and Non-Director Areas. *POEEJ*, Vol. 61, p. 176, Oct. 1968.

<sup>5</sup> PRICE, C. K., and IRELAND, W. A. Incoming Core-Type Register Translator for Director Areas, Parts 1 and 2. *POEEJ*, Vol. 59, p. 119 and 183, July and Oct. 1966.

<sup>6</sup> HERON, K. M., BAKER, H., and BENSON, D. L. An Experimental Electronic Director, Parts 1 and 2. *POEEJ*, Vol. 44, pp. 97 and 169, Oct. 1951 and Jan. 1952.

<sup>7</sup> MARWING, K. G. Design Features of the Lee Green Magnet Drum Register Translator. *POEEJ*, Vol. 51, p. 137, July 1958.

<sup>8</sup> LOUGHHEAD, W. A. E., and MATTHEWS, G. A. An Experimental 3-Digit Electronic Director using Magnetic-Core Circuits. *POEEJ*, Vol. 56, p. 255, Jan. 1964.

<sup>9</sup> HOOKER, D. S., and DUNN, R. T. A New Register-Translator using Stored-Program Control for Director Area-Local Exchanges. *POEEJ*, Vol. 67, p. 181, Oct. 1974.

<sup>10</sup> GRUNWELL, K. H., and WALTON, D. The MOST Director, Parts 1 and 2. *POEEJ*, Vol. 72, p. 266, Jan. 1980, and Vol. 73, p. 8, Apr. 1980.

<sup>11</sup> CORNER, A. C., and BANHAM, H. The 5005 Crossbar Telephone Exchange Switching System, Parts 1 and 2. *POEEJ*, Vol. 59, pp. 170 and 271, Oct. 1966, and Jan. 1967.

<sup>12</sup> BELL, R. L., BLOXHAM, G., and CALLAGHAN, B. F. TXK3 Director-Area Local Exchanges using BXB 1112 Crossbar Equipment, Parts 1 and 2. *POEEJ*, Vol. 67, pp. 66 and 169, July and Oct. 1974.

<sup>13</sup> LONG, R. C., GORRINGE, G. E. Electronic Telephone Exchanges: TXE2—A Small Electronic Exchange System. *POEEJ*, Vol. 62, p. 12, Apr. 1969.

<sup>14</sup> MOON, R. J., BEALE, G. A., and TARRY, D. G. TXE2 Electronic Exchange System: The Evolution from Mark 1 to Mark 3. *POEEJ*, Vol. 69, p. 210, Jan. 1977.

<sup>15</sup> GOODMAN, J. V., PHILLIPS, J. L., ROWE, M. T., HUGGINS, G., MILLS, W. B., and PATEL, C. TXE4 Electronic Exchange System, Parts 1-3. *POEEJ*, Vol. 68, p. 196, Jan. 1976, Vol. 69, p. 68, July 1976, and Vol. 70, p. 10, Apr. 1977.

<sup>16</sup> SHEPPARD, S. H. The Leighton-Buzzard Electronic Telephone Exchange. *POEEJ*, Vol. 59, p. 255, Jan. 1967.

<sup>17</sup> VOGAN, D. H., and PRICE, C. D. E. The TXE3 Experimental Electronic Exchange System. *POEEJ*, Vol. 62, p. 142, Oct. 1969.

<sup>18</sup> MARTIN, J. System X. *POEEJ*, Vol. 71, p. 221, Jan. 1979.

---

# Developments in Signalling Systems since 1956

J. TIPPLER, and J. MARTIN, B.SC., C.ENG., F.I.E.E.†

UDC 621.391

*Signalling is now developing towards advanced common-channel techniques, but large volumes of equipment in the network have required some further development of conventional techniques over the past 25 years.*

## INTRODUCTION

In 1956, at the time of the fiftieth anniversary of the Institution of Post Office Electrical Engineers, line plant was all analogue, with a large proportion of audio junction pairs; all trunk switching was operator controlled, albeit trunk mechanization and long-distance dialling by operators was spreading, with STD just around the corner; the transit network was well into the future; and all switching was 2-wire Strowger or Strowger-related. Electronic control methods had reached an advanced

state of development in the shape of cold-cathode and magnetic-drum register-translator designs, but high-capability central intelligence was not then a feature of the exchanges. Semiconductor technology was in its infancy.

Signalling systems available in the mid-1950s had been conceived to meet that environment. The 2 prime aims were to transmit dialled numbers at Strowger speed and to meet the relatively simple supervisory requirements of the ordinary telephone service. Simple control signals were added for metering, trunk offering, subscriber-group discrimination, manual hold, and a few more. The range of signal types, although small compared with that possible on common-channel signalling systems, had, nevertheless, made taxing

† Mr. Tippler is Director Exchange Systems and Mr. Martin is Director System X Development, both in British Telecom Headquarters

demands on the ingenuity of designers of relay logic in the use of the very restricted range of electrical and timing possibilities available on the lines.

In the past 25 years, the requirements have been transformed. Virtually all inland traffic is dialled by the customer as is more than 99% of international traffic. High-speed call set-up, essential for the transit network, is now rapidly finding application in the main, junction and local networks. The number of essential control signals has increased and is likely to expand very rapidly as the range of customer and administration services increases in line with the processing power of exchanges. Some of these needs now exceed the capability of conventional signalling systems; common-channel systems are therefore essential for the modernized main network and must be introduced as rapidly as possible in the junction network. Similar considerations call for an increased signalling capability on customers' lines.

This article indicates a few of the main steps in the evolution of conventional techniques in the UK since the 1950s. Common-channel signalling progress is described in a related article in this issue of the *Journal*<sup>1</sup>.

## MAIN NETWORK

In 1939, the 2 voice-frequency (2VF) dialling system had been introduced for use by operators on single-link calls, primarily on inter-zone-centre routes. By the early-1950s, most inter-zone-centre trunk traffic was handled by this system. With the advent of trunk dialling by operators, dialling over multi-link routes became essential, and timing and other problems made the original 2VF system inadequate for the purpose. Therefore, the Signalling System AC No. 1 (SSAC1)<sup>2</sup>, a prime feature of which was the use of mechanical pulse storage and regeneration techniques, was developed; this overcame the timing problems largely by inserting delays to accommodate the needs of Strowger switchgear and relay-sets. SSAC1 was essentially an expedient system. It met the initial needs of both operator dialling and STD, but it was slow, complex (because of the problems of handling bi-directional signals on a 2-wire line), bulky (because the complexity led to many relays and the equipment still used thermionic valves), and consumed considerable amounts of power.

In the early-1960s, the inadequacies of 2VF and SSAC1 led to the introduction of SSAC9<sup>3, 4</sup>, which is still the basic standard signalling system for the UK main network. The fundamental step with SSAC9 was the connexion of the signalling-set into the 4-wire part of the transmission path. This conceptually simple step required a breakthrough of the traditional boundary between the transmission and switching domains, but, in return, simplified the circuitry and enabled only one signalling frequency to be used. Even with the 2-wire-to-4-wire transmission termination included, the signalling set became smaller and more economical; this was of great significance in a period when the number of UK main network circuits over 40 km long had grown from 46 000 to 222 000, which represented an increase of about 350 000 signalling terminations. All circuits over 40 km long are now equipped with SSAC9, and this represents nearly half a million terminations. (See Fig. 1.)

The choice of signalling frequency stemmed from work carried out under the CCIF† (now CCITT\*), following the Second World War. During the 10 years from 1938 to 1948, there had been widespread development of transmission links having uniform attenuation/frequency characteristics, and it became possible to consider international standardization of signalling methods. To determine a signal frequency that offered the best compromise between signalling sensitivity and

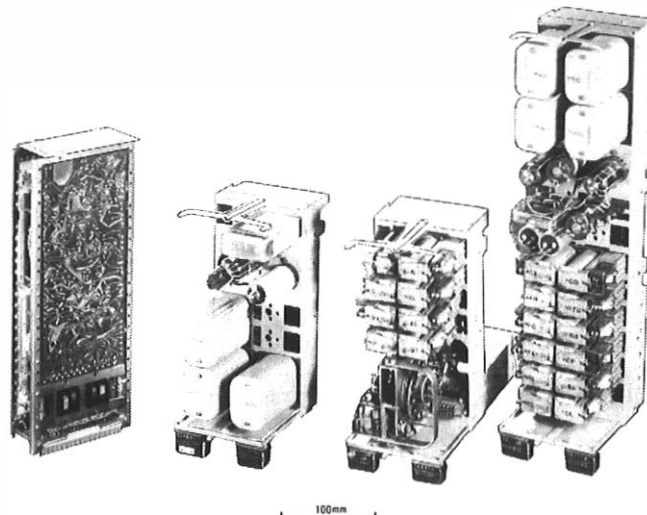

FIG. 1—Comparison of SSAC9M (left) and the three-unit SSAC1 outgoing signalling terminations

speech and noise immunity, extensive trials were carried out in London and Zurich on circuits carrying German, English, French, and Italian conversations, and with recordings of speech in other languages. The results showed that frequencies in the range 2000–2600 Hz should be used, and led to the adoption of a single-frequency system using 2280 Hz (as in SSAC9) and a two-frequency system using combinations of 2040 Hz and 2400 Hz. Although the two-frequency arrangement has some technical advantages, these were less important in UK inland use than the economy of the single-frequency system.

SSAC9 was a single-link line-signalling system, operating at speeds suited to Strowger switches. It was appropriate for a largely Strowger-based network, and it reflected the virtues and limitations of the Strowger system itself. However, another type of requirement emerged during the 1950s and 1960s—the need for fast multi-link signalling between the registers of common-control exchanges. In the UK, the need became pressing with the advent of the transit network, one of the reasons for which was to escape from the unacceptable delays imposed by Strowger systems when calls needed to use more than 2 trunk links. The answer was found in multi-frequency (MF) signalling, and SSMF2, was developed to provide it.

SSMF2 is now well established as the prime signalling medium of the transit network, but when development began it presented challenging and difficult problems. These arose from 3 main causes: the complexities of sender/receiver design for 2-out-of-5 and 2-out-of-6 code frequency-discrimination signalling; the strict limits on duration of signals necessary to meet the operating speed requirements and to avoid overloading of speech channels; and the impact of noise from exchange switches on multi-link calls. The last consideration was a factor in the decision to use the crossbar system for the transit network, rather than follow an earlier proposal to use motor-uniselectors.

The designers of SSMF2 foresaw the need, with the introduction of electronic exchanges, for an increased signalling capacity between exchanges for transferring such information as *class-of-service* to enable network-wide facilities to be developed. Accordingly, they provided for the later addition of an extra signalling frequency to increase the number of possible signals. Subsequent developments have meant that this latent capability has not been called into use.

In the early-1970s, as a complement to the exchange modernization programme based on TXE2 and TXE4 exchanges, introduction of an MF system, based on the CCITT R2 specification, was considered for use in the 2-wire main and junction networks to give an interim standard fast end-to-end

† CCIF—International Telephone (*Fernsprecher*) Consultative Committee

\* CCITT—International Telegraph and Telephone Consultative Committee

signalling capability to these networks. However, with the advent of the full digitalization and System X modernization programme, these proposals were discontinued. Instead, high-speed high-capacity signalling will be by the common-channel method, and this will be extended to earlier exchange types at appropriate stages of the programme.

## JUNCTION NETWORK

The junction network has continued to be served mainly by 2-wire signalling-sets, operating at Strowger signalling rates. Much of the development during the period has been concerned with adapting to a greater variety of exchange types and improving the technology to achieve greater economy.

However, the junction network has also had to provide for the special needs of STD. For example, the decision to base call charging on bulk metering at local exchanges, controlled by periodic signals from outgoing main network exchanges, introduced the need in the late-1950s for a new type of signalling that could deliver frequent pulses along a speech path during the conversational period, without noticeable interference with the speech. Although techniques using frequency separation were readily available for this function, they were not viable for the large number of circuits for which the facility was required.

A DC relay-controlled technique was devised<sup>6</sup> that signalled each pulse by successive stages of line-current reduction, reversal, and increase, to minimize the generated noise. This relatively complex method of signalling a simple pulse, although representing a practical solution within the network and switching system techniques available at that time, underlined the fact that the range of signals required had stretched to the limit the possibilities available with DC signals on 2-wire speech circuits.

A change of situation occurred on the junction network with the introduction of 24-channel pulse-code modulation (PCM) systems in the early-1970s, of which more than 7000 are now in use. The exploitation of DC signalling was immediately curtailed and, in its place, the greater potential available from the high-bit-rate capability of the digital channels was used. It had been determined that 7 bit encoding of speech signals would yield fully acceptable speech quality in the UK network environment for which the systems were intended. The simplest method of signalling was therefore to use the eighth bit available on each speech channel to carry the signalling information—a variant form of associated-channel signalling. (See Fig. 2.)

With a repetition rate of 8 kbit/s, the potential information capacity of the signalling channel is very high indeed. All that is required is appropriate logic or software at the ends of the link to interpret the ON/OFF sequences that can be applied to the signalling bit. This theoretically very large capacity can be exploited to whatever extent is demanded by the network functions it services, but at the cost of complexity in the terminals and a greater problem of detecting and correcting signalling errors. In the environment for which 24-channel PCM was adopted in the UK (that is, point-to-point working between conventional exchanges in the junction network), only a modest signalling capability was required. A relatively small range of forward and backward signals was adopted, using only the signalling bit combinations *all-mark*, *all-space*, and *alternate mark/space* (on alternate frames).

The combination of a dedicated signalling bit for each channel with the simple signalling repertoire has provided a very economical and robust system that has performed well as PCM has penetrated more and more routes. Signalling terminations have been developed to meet all the normal needs for the junction circuits and to interface with standard exchange systems; they also incorporate the logical functions required for applying the signalling-bit combinations to the functional needs of each circuit.

However, as network functions increased, and the cost of



FIG. 2—The first PCM switching exchange in the world (Empress, London) used eighth bit in-channel signalling in 1968

electronic techniques became increasingly less than that of relay equipment, it was evident that more use should be made of the potential capacity for coding of the bit-stream. The opportunity to do so arose with the evolution of the standard CCITT 30-channel PCM system specification. Since international standards now require full 8 bit coding of speech, and experience with early systems had developed confidence and competence to do so, the signalling was consigned to a time-slot separate from the speech channel<sup>7</sup>. It is, nevertheless, channel associated, but common logic based on the signalling channel (time-slot 16) can be used to provide economically for a larger variety of bit-coding patterns. Each speech channel is served by a 4 bit pattern appearing 500 times a second. The 4 bit pattern could yield 16 combinations, of which the *all-zeros* condition is not available because it is used for timing alignment purposes. In practice, in the UK, 8 combinations have so far proved sufficient for point-to-point working.

A further virtue of the separate signalling time-slot is that it can be used to provide for the common-channel data links if a route is to have common-channel signalling. Operated in this mode, the direct relationship of signalling and speech channels in the system no longer exists, but the signalling capacity of the channel is very much greater; typically, several hundred speech channels could be served by the capacity of one time-slot 16 channel, taking account of network performance requirements. Common-channel signalling pre-supposes some level of processor-control in the exchanges it serves. Without the processor, the necessary marshalling, sequencing, and validation of information for large numbers of calls would not be possible: without common-channel signalling, the processors would be rendered relatively inarticulate when communicating with other exchanges.

## LOCAL LINE SIGNALLING

With the exception of ringing current and standard tones, local line signalling between exchange and customer had

developed as a mainly DC 2-wire art, linked to the characteristics of calling equipments and supervisory bridges in Strowger and other electromechanical systems. Designers of customer equipment had reasonably come to take more-or-less for granted that these characteristics were definitive, and designs at all levels, from simple telephones to complex PABXs, exploited them.

With advancing complexity of facilities and the changing technology of electronic exchanges, the limitations of the conventional methods have restricted opportunities and led to increasing pressure for new methods. For example, the relatively high-voltage and high-current demands of conventional customer equipment are not directly compatible with the electronic technology most suited to exchange switching functions. Because the customer equipment base represents a very heavy investment that cannot practically be quickly replaced, electronic exchanges must include the necessary adaptation, with corresponding economic penalty.

This was a major factor in thwarting the attempts to develop fully electronic exchanges in the 1950s, and its effect can be seen elsewhere; for example, the customer line-circuit in TXE4 exchanges was originally conceived as having a resistance of 22 k $\Omega$ . However, the calling signal proved unreliable because the calling loop via a standard carbon microphone was of unstable and often too high a resistance at the low current values involved. This problem could be eliminated by adopting a 10 k $\Omega$  calling circuit resistance but, in certain stages of call set-up and clear-down, this resulted in misoperation of supervisory circuits on some types of PBX. It would have been possible to provide adaptors to be connected into selected lines only, but with unacceptable operational inconvenience. For these reasons the calling circuit finally emerged as a relatively low resistance circuit, but this caused problems in engineering the rack to safeguard against power overloading in the event of external cable breakdowns.

Various attempts have been made to replace conventional signalling elements to circumvent problems of compatibility between customer and exchange equipment. For example, considerable effort was applied to the development of a tone-call telephone, operated by a signalling tone from the exchange instead of ringing current, with the object of eliminating an expensive interface. However, the power level of the tone was limited by the crosstalk performance of local cables which, together with the problems of providing for plan-number working, made the resultant tone-calling arrangement uneconomic.

Another interesting development, aimed at eliminating DC discrimination calling signals on party lines, was a dial with an additional cam that could be set by the installation engineer. When set for the Y party, an extra short-duration pulse was added to pulse trains, and the pulse-amplitude modulation time-division multiplex exchange for which it was designed was able to discriminate.

Apart from the needs of electronic exchanges, the local network also experienced the impact of STD, and it was the metering requirement that added a new type of signal to the local-line family. This was the longitudinally-induced 50 Hz signal used to operate the subscriber private meter equipment offered to customers, on the introduction of STD, for the monitoring of their meter totals. This facility has not been as widely adopted by the market as was originally expected, but the signal developed for it is now receiving a new and more vigorous lease of life in its application to the new microprocessor-controlled payphones being introduced to replace the pay-on-answer coin-collecting boxes. Again, the solutions adopted were appropriate for the exchange environment of the day. They leave an unwelcome legacy for the electronic exchanges and line interface devices of today and tomorrow.

The foregoing discussion illustrates problems arising from the electrical constraints of conventional methods. The other constraints are signalling speed and signalling capacity. Signalling speed relates primarily to dialling or its equivalent.

Proposals for the introduction of MF keyphones emerged in the early-1960s, and the technical possibility was demonstrated at an early stage. A successful trial was carried out at Langham Exchange in the late-1960s. Particular technical problems were experienced in specifying sender and receiver parameters that could satisfy the widely varying conditions found on local lines, especially the need for immunity from dial-tone interference. More important though were the practical considerations of allying fast local-line signalling with the speed of Strowger exchanges. These considerations led to the alternative development of a keyphone that used micro-electronic techniques to store numbers and transmit them in Strowger form, with the additional benefit that the micro-electronics could incorporate permanent storage for frequently-used numbers.

However, with the advent of the later electronic exchanges and System X, and with a developing need for customers' telephones to be capable of addressing remote computer-based equipment (for example, Prestel) via the network, the MF keyphone's greater range of signals, higher speed, and ability to work directly through a voice channel are essential for many applications, as well as improving connexion speed. Provision for MF keyphones will automatically be made on the newer types of exchanges, and programmes to equip older types in accordance with marketing needs are already in hand. The use of MF keyphones on PABX extensions is already established.

With the restrictions caused by signalling limitations on local lines, it is plain that some form of enhanced signalling capability between exchange and customer is desirable. The use of common-channel signalling techniques would yield significant advantages between PABXs and public exchanges, and other forms of improved digital signalling will become available for less complex customer equipment.

Today, as consideration is being given to extending digital operation towards the customer to provide an even wider range of services and facilities, concerned with information technology in its widest sense, the ability for many signals to pass at high speed both to and from the customer is being built into the specifications for the next generation of equipment. There is again the urgent need for early CCITT standardization, but the pressure to service the customers is likely to make it necessary to adopt an early solution suitable for the UK, with the need for subsequent modification to CCITT standards.

## CONCLUSION

Signalling is moving into a new era of common-channel capability, consistent with the needs and technological capabilities of the new networks. Conventional technologies have, however, had to meet a great pressure for extended capabilities over the past 25 years, and have produced interesting problems and solutions.

## ACKNOWLEDGEMENT

The help of Mr. J. S. Gilroy in the preparation of this article, is gratefully acknowledged.

## References

- 1 MOORE, B. W. Progress Towards Common-Channel Signalling. *POEEJ*, Vol. 74, p. 210, Oct. 1981.
- 2 SMITH, D. C. Signalling System A.C. No. 1 (2 V.F.), Parts 1 and 2. *POEEJ*, Vol. 44, pp. 66 and 114, July and Oct. 1951.
- 3 MILES, J. V., and KELSON, D. Signalling System A.C. No. 9. *POEEJ*, Vol. 55, p. 51, Apr. 1962.
- 4 HILL, R. A., and GEE, J. H. Miniaturized Version of Signalling System A.C. No. 9. *POEEJ*, Vol. 65, p. 216, Jan. 1973.
- 5 HORSFIELD, B. R. Fast Signalling in the UK Telephone Network. *POEEJ*, Vol. 63, p. 242, Jan. 1971.
- 6 HEPTINSTALL, D. L., and RYAN, W. A. Metering over Junctions. *POEEJ*, Vol. 51, p. 335, Jan. 1959.
- 7 TURVEY, K. J. 30-Channel Pulse-Code Modulation System, Part 3—Signalling Units. *POEEJ*, Vol. 71, p. 225, Jan. 1979.

# Developments in Switching Systems Technology

C. J. HUGHES, B.SC., M.SC., C.ENG., F.I.E.E., and T. E. LONGDEN, C.ENG., M.I.E.R.E.†

UDC 621.395.345

*This article traces the developments in switching systems technology over the past 25 years, describing the progression from Strowger, through crossbar and reed-relay systems, to the current all-electronic stored-program-controlled System X exchanges.*

## INTRODUCTION

The basic requirement of a telephone exchange is very simple; namely, to connect any one of  $n$  inlets to any one of  $n - 1$  outlets economically, reliably and with acceptable transmission performance. Although the problem is deceptively simple, it has exercised the minds of generations of telecommunications engineers. Even with the technology available today, the ideal solution is not readily achieved. There is no doubt, however, that advances in technology over the past 25 years have made feasible more flexible and sophisticated switching systems.

The evolution of systems architecture and developments in controls over this period are described elsewhere in this issue of the *Journal*, whereas this article concentrates on the technology of switching.

## STROWGER SYSTEM PRINCIPLES

Twenty-five years ago, automatic exchanges in the British Post Office (BPO) network were all designed around step-by-step switching and the use of electromechanical devices. Such exchanges are now generally given the description *Strowger* (TXS). Exchanges of this type had by then been in use for some 40 years and, by 1956, had reached a high degree of standardization in the UK; the main building blocks were BPO 3000-type and 600-type relays, the 2-motion 2000-type selector mechanism and the types 2 and 3 unselector<sup>1</sup>.

There are two main variants of the TXS system, known as the *director* and the *non-director* (ND), both using the same basic switching principles. In the ND system, selection is directly under the control of a subscriber's dial, whereas the director system incorporates a form of electromechanical register-translator for determining call routings and generating pulse trains to control subsequent switching stages.

## STROWGER MECHANISMS

A detailed description of TXS mechanisms is beyond the scope of this article, but there are significant features that have influenced the design requirements of superseding systems; for example:

(a) unselector and 2-motion selector mechanisms are complicated mechanical assemblies, expensive to mass produce, and require skilled maintenance staff, and

(b) the electrical contact made between base-metal wipers and banks, although having the virtue of being cheap (which justifies inefficient use) is unreliable and can give rise to circuit noise, being susceptible to dirt, mechanical vibration and wear.

## STROWGER TRUNKING

In its simplest form, a TXS exchange consists of a subscriber-concentration stage, followed by a switching block that comprises ranks of 2-motion selectors; the detailed exchange

configuration is determined by the numbering scheme.

The 2000-type selector is a unidirectional expansion device that enables one input to gain access to any one of 200 outlets, but, by means of grading\*, a switching path on any particular level can be established to give whatever degree of concentration is required.

## COMMON-CONTROL SYSTEMS

The Strowger system is characterized by the lavish provision of contacts, and control of switch operation by means of pulse trains. The introduction of a central common-control unit, which need be used only during the setting-up phase of the call, overcomes many of the attendant disadvantages of the Strowger system. Firstly, the common-control unit can select more efficiently the path through the switched network. It follows that the number of contacts can be reduced considerably, with a consequent increase in reliability. Secondly, the operation of the switch can be simplified, albeit at the expense of complexity in the common-control unit.

The simplest form of common-control exchange uses a switch unit that consists of a matrix of crosspoints. The matrices are used to perform both the concentration and expansion functions at the periphery of the exchange, and the group selector function at the centre.

A simple crosspoint switching matrix is shown in Fig. 1.

\* Grading is the method of connecting level multiples together so that a group of selectors is given access to individual trunks on the early choices, but on later choices, shares access with other groups

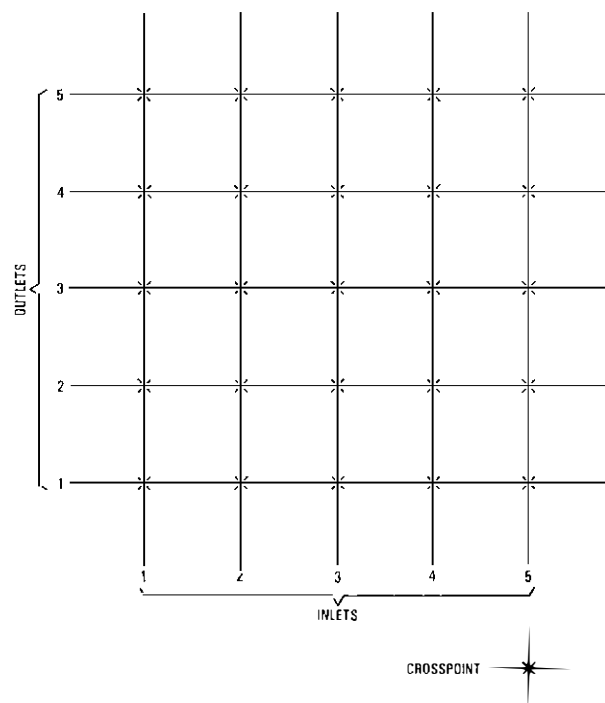

FIG. 1—Simple crosspoint switching matrix

† Mr. Hughes is in the System Evolution and Standards Department and Mr. Longden is in the Exchange Systems Department, both in British Telecom Headquarters

Any free outlet is available to any free inlet; therefore, the matrix has full availability. However, the simple matrix becomes impractical for all but the smallest exchanges. This difficulty is overcome by using multi-stage switching arrays, with link trunking.

A wide variety of switching devices have been used in common-control systems. Conventional relays were used in some early systems and one such exchange saw service in the UK network. It was, however, the availability of the crossbar switch that led to a general move away from step-by-step switching.

## THE CROSSBAR SWITCH

The crossbar switch is an electromechanical assembly, comprising a crosspoint matrix and control relays; Fig. 2 illustrates the principle of operation. The horizontal select bar operates first to prime the required outlet by moving the select finger in front of the lifting spring, followed by the operation of the vertical operating bar associated with the inlet, which traps the select finger causing the springset of the crosspoint to make. The horizontal bar is then released, leaving the spring-mounted select finger trapped in position and, thus, allows the second outlet associated with the horizontal bar to be used in conjunction with another inlet. The crosspoint contact, although open to the atmosphere, is established between precious metals and, because of its physical design, is more reliable than the TXS system.

The much simpler design of the crossbar switch generates little mechanical vibration. Its comparatively fast switching ability allows the established path to be tested, which enables repeat-attempt facilities to be provided.

## CROSSBAR SYSTEMS

Crossbar systems<sup>2,3,4,5</sup> were developed in various parts of the world from about 1930 onwards. Although the switch mechanism has many advantages, the trunking arrangements that result from the fixed matrix size lack the flexibility of the Strowger system. Because of this, and for other reasons, the development of a crossbar system in Britain was delayed until the post-war era. Then, the unexpectedly high demand for telephone service led to the adaptation of a number of proprietary systems.

Two systems were selected to form the basis of the BPO crossbar programme:

(a) The Plessey Telecommunications Ltd. 5005 system has been used in local non-director and group switching centre applications (termed *TXK1*) and in international switching centres (termed *TXK2*). This system uses a crossbar switch that has 10 vertical and 6 horizontal bars, with up to 10 con-

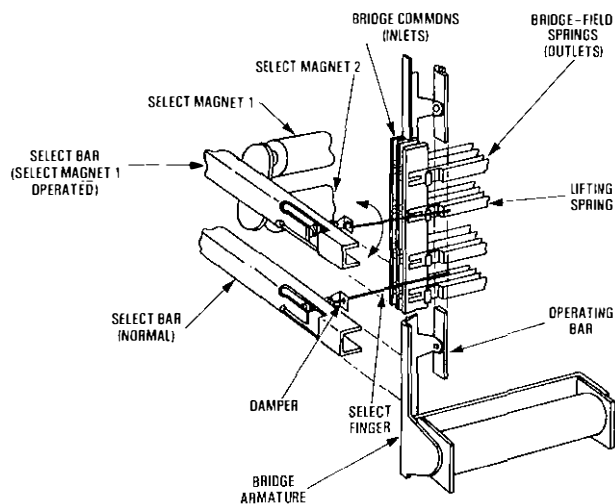

FIG. 2—Principle of operation of crossbar switch

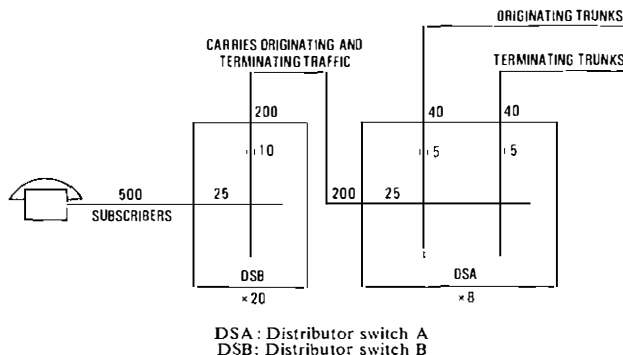

FIG. 3—TXK 1 local distributor stage

tacts per crosspoint. By using some of the horizontal bar positions as auxiliary or wiper switches, the 10 inlets of this switch can be given access to twelve 10-wire outlets, twenty 5-wire outlets or twenty-eight 3-wire outlets.

(b) The STC BXB 1100 system has been used in director and some local non-director applications (termed *TXK3*) and in transit switching centres (termed *TXK4*). The BXB multi-switch is larger than its 5005 counterpart, having 22 vertical and 14 horizontal bars, with up to 10 contacts per crosspoint. By allocating auxiliary positions, the inlets can be given 10-wire access to 28 outlets, 5-wire access to 52 outlets or 3-wire access to 74 outlets.

Although the basic inlet-to-outlet combination of a crossbar switch is fixed, various multi-stage arrays can be formed to provide the required switchblock functions. As an example, for the TXK1 local system, the concentration/expansion switchblock, called the *distributor*, is illustrated in Fig. 3. Twenty switches are used for distributor switch B, each having 10 inlets and 25 outlets. For distributor switch A, 5 inlets of each switch are used for originating traffic and 5 inlets for terminating traffic. A maximum of 60 distributors can be provided, allowing a maximum exchange connexion capacity of 30 000. The effect of link blocking is minimized by providing expansion at each rank of switches, which is achieved by arranging that each switch has more outlets than inlets.

## THE MOVE TO ELECTRONICS TECHNOLOGY

The major development in switching technology to take place during the last 25 years has been the transition from electromechanical to electronic techniques. Many of the advances in electronics date back to the Second World War. An example of equipment designed in this period is the COLOSSUS digital computer<sup>6,7</sup>, the details of which were only recently declassified. This equipment incorporated 1500 valves and executed parallel arithmetic at 5 kbit/s. The absence of mechanical wear in electronic modules, and the possibility of high-speed multiplexed and shared operation, suggested that these techniques could reduce the capital cost of switching systems by the extensive use of common equipment.

After the war, the BPO and the principal British manufacturers embarked upon research programmes aimed at the exploitation of electronics technology. At that time, virtually all automatic telephone switching equipment was of the TXS step-by-step type; therefore, it required a major change in system design to make best use of the high-speed common-control methods that were possible with the new electronics. For the speech path, some experiments were made using cold-cathode valves as electronic relays, but it was realized that the full potential of electronic systems could be achieved only with multiplexed operation. The choice of an electronic speech path was between space division, frequency-division multiplex (FDM) and time-division multiplex (TDM). In the period until 1955, when much of this early work was undertaken at the BPO Research Department at Dollis Hill, it was soon concluded that, with the electronic devices then available, TDM offered the most promising economic solution<sup>8</sup>.

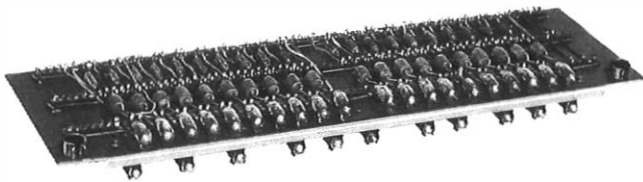

FIG. 4—Typical module of experimental PABX (1955) showing component mounting and interconnexion

Two pulse-amplitude modulation (PAM) TDM experiments were conducted at Dollis Hill: the first was on a simple electronic exchange<sup>9</sup> in the period 1949–52; the second was on a PABX<sup>10</sup> in the period 1953–55. Fig. 4 illustrates the components and interconnexion techniques that were then in use.

Another major activity in this early period was the development of electronic register-translators required for director systems, and for the development of the STD system<sup>11</sup>. This, in turn, led to the design of magnetic-drum translators, which have provided STD code translations in director areas since 1961.

### THE HIGHGATE WOOD PERIOD

In 1956, the BPO and the, then, 5 principal British telecommunications manufacturers agreed to pool research effort for further studies on electronic switching. The Joint Electronic Research Committee (JERC) was thus formed and, after an interchange of views and information gained from early research studies, decided to concentrate its combined efforts on the development and field trial of a TDM system. The electronic techniques available at the time (early transistors, diodes, valves, cold-cathode tubes) were more suited to large exchanges than to small ones, and so a field trial of an exchange design capable of serving 2000–20 000 lines was conducted at Highgate Wood<sup>12, 13</sup>.

The exchange was a 4-wire PAM-TDM system, with 2-wire-to-4-wire hybrid transformers in the line units. Each line could be switched to any of 100 amplitude-modulated pulse channels, on highways common to up to 800 lines and junctions; the channel repetition frequency was 10 kHz. The PAM switch operated by storing channel pulses in 100 ms magnetostrictive delay lines, and thermionic valves were used extensively throughout the design. Magnetic drums were used for exchange code translation, directory-number-equipment-number translations, class of service, and call and line-status information.

After a laboratory trial of the system at Dollis Hill in 1959, a 600-line field trial was commissioned at Highgate Wood in December 1962. As is now well known, the field trial was not a complete success. The system suffered from the diversity of techniques that it was designed to test; it was unnecessarily complex and the extensive use of thermionic valves, with power and reliability problems, could not be carried forward into a practical system. Nevertheless, for the maximum to be learnt from a research and development project, it is necessary to attempt designs that are near to the limits of the available technology. There is no doubt that all participants gained valuable experience from this project.

Although Highgate Wood was the first project undertaken by JERC, a whole range of time- and space-division systems were considered at this time, together with a wide diversity of crosspoints, trunking configurations and control principles. One such technique was the development of a 2-wire PAM-TDM design using the resonant transfer concept<sup>14</sup>, whereby the PAM signals from opposite sides of the exchange could be interchanged over the same signal pair. By 1960, JERC had studied preliminary designs of 7 promising electronic switching systems. There were 4 TDM systems, some of which incorporated some space switching; the designs incorporated magnetostrictive, magnetic-drum and ferrite-core

memories for time switching and control. The other 3 designs were basically space switches, based on solid-state crosspoints, cold-cathode tubes and reed relays.

By mid-1963, it was concluded that there was little prospect of producing a viable TDM system for the near future. The principle reasons were: the high component costs; the high power requirement, despite the elimination of valves in favour of transistors; maintenance problems; poor noise and crosstalk performance; and the incompatibility of the basic switching system with the existing signalling and ringing voltages of the network. The TDM field trials were therefore abandoned and TDM was referred back to research, later to resurface in the form of pulse-code modulation (PCM)-TDM systems. In contrast, the reed-relay prototype exchange showed great promise and laid the foundation for the TXE series of switching systems.

### THE REED RELAY

Compared with Strowger mechanisms and crossbar switches, the reed relay has many advantages: it is totally enclosed; the thin film of gold provides a reliable, noise-free contact at low cost; and it requires no adjustment. The non-latching type of reed relay has been favoured in Britain. This relies on the current in the coil to make and hold the contact, while the spring action of the relay tongue breaks the contact when the current is reduced nearly to zero.

### REED-RELAY SYSTEMS

#### TXE2 Exchange

By 1963, the combination of newly available *square-four* packaged 25 mm reed-relays and well-established transistor-transistor logic (TTL) devices had given system engineers the opportunity to design faster, more flexible and reliable systems, free from dependence on crosspoints that were open to the atmosphere and which, even in crossbar systems, were operated by comparatively complicated mechanical assemblies. The first production system of this type in the UK is known as the TXE2<sup>15</sup> (Fig. 5).

The switching network in the TXE2 exchange contains a number of similar units, each handling a fixed amount of traffic. It is a 4-stage network, in which most switches are multiples of a standard 5 × 5 reed-relay matrix switching module. The network is arranged so that all types of call are connected by using combinations of basic sequences. The switches are arranged so that traffic is initially concentrated through the A, B and C switches to a supervisory unit, which has access to a register via a separate register-access switch

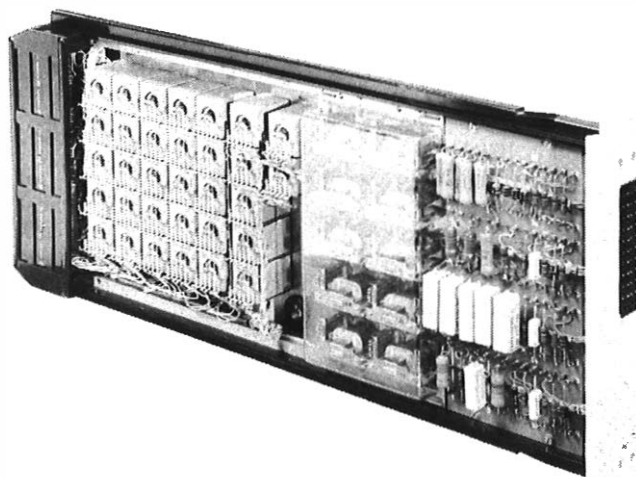

FIG. 5—Typical TXE2 slide-in unit (1967)

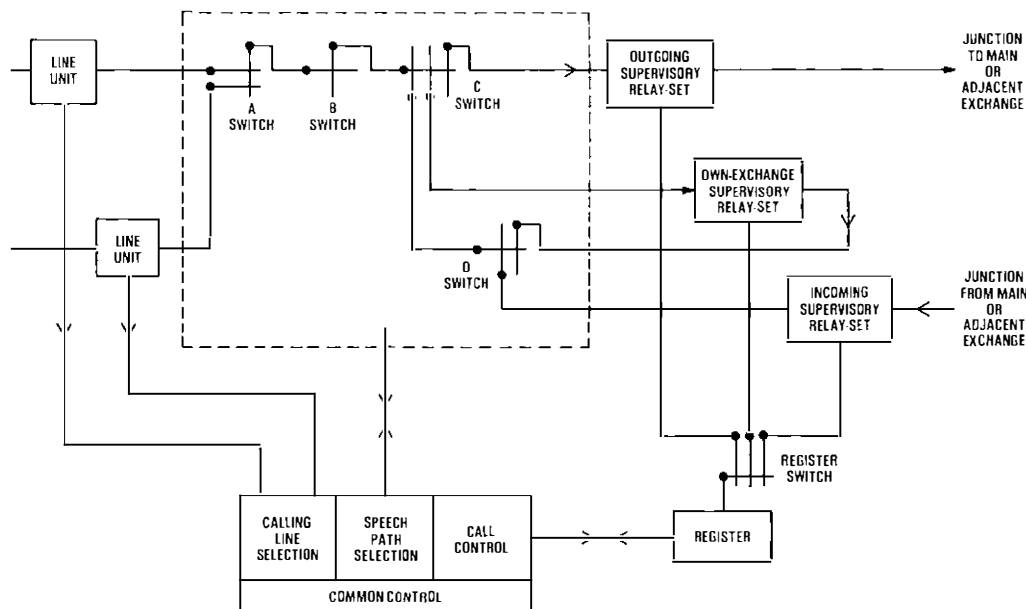

FIG. 6—Simplified block diagram of TXE2 switching network

(Fig. 6). Own-exchange calls are then extended through the D switch, and back through the C, B and A switches that give access to the called-customer's line.

Incoming junction calls are connected by incoming supervisory units, which have similar register-access facilities, to the D, C, B and A switch chain; these calls receive priority call processing. For outgoing calls, connexion to an outgoing supervisory unit is through only 3 crosspoints—the A, B and C switches.

To meet the increasing demands of operational requirements, the basic TXE2 switchblock has undergone 2 major developments. Less than 30 Mark 1 exchanges were installed before a linked-numbering-scheme capability was required, resulting in the Mark 2 design. Subsequently, a further redesign to produce the Mark 3 version increased the customers' connexions to a maximum of some 7000 (the total traffic handling increased from 225 E to 360 E), without the basic exchange trunking being changed<sup>16</sup>.

There are now more than 1200 TXE2 exchanges in service, and installation of new ones will continue for some years to come.

#### TXE4 Exchange

A larger version of the reed-relay exchange went through several stages of development. A TXE1 exchange was put into operation at Leighton Buzzard in 1969<sup>17</sup>, and the field trial of a model TXE3 exchange<sup>18</sup> took place in the BPO's circuit laboratory in London from 1968–70. The production engineered version—the TXE4 exchange—was brought into operation in 1976<sup>19,20</sup>.

In essence, the TXE4 system consists of an assembly of subsystems (functional building blocks) which, for the most part, work independently with a minimum of intercommunication. The exchange capacity can be extended by adding more subsystems; both switching and common-control equipment are added as required, subject to a minimum provision of common-control equipment for security. The system is designed for use as a local exchange handling from 2000 to 40 000 lines, with calling rates of between 0.02 E and 0.35 E.

As in the TXE2 system, a 4-stage switching network is used. Unlike the TXE2 system, however, the TXE4 network is arranged as a general-purpose switch, with the registers, junction relay-sets and tone circuits, as well as customers' lines, being connected to the switch block periphery (A switch).

The B and C switches are sectionalized to provide either 6 or 8 sub-units called *planes*; this arrangement enhances security because a fault affecting any one plane does not cause loss of service to customers or peripherals connected to a particular A switch since these switches have access across all planes in the unit. A unit comprising 6 planes can carry a customer's bothway traffic loading of approximately 170 E, while an 8-plane unit can carry approximately 230 E. All units in an exchange must carry the same number of planes and there is no provision to change this number during the life of an exchange.

Separate A switches are provided for customers and junctions/peripherals, and the traffic concentration can be varied to match calling rates by connecting between 40 and 400 customers to an A switch. The traffic within the unit is mixed at the C switches which are connected via link circuits to the D switch; this interconnects adjacent planes, both within the unit and with all other switching units in the exchange. All calls established through the general-purpose network thus involve 7-crosspoints and one link circuit. Intermediate paths are established during call set-up and typical serial trunking sequences are illustrated in Figs. 7 and 8.

TXE4 equipment is manufactured on plug-in units, which are mounted, as required, on standard wired racks (Fig. 9). Interconnexion between racks is by plug and socket. The modular design of TXE4 enables exchange extensions to be effected in economic units with the minimum of disturbance to in-service equipment.

The first production TXE4 exchange was brought into service at Birmingham Rectory in February 1976 and, to date, there are approximately 120 TXE4 RD (Rectory Design) exchanges in service. During the development of the TXE4 system it became obvious that, with changing technology, there were possibilities for cost reduction and system enhancement. After a feasibility study, the BPO placed a development contract in 1975 to produce a cost-reduced, updated system to be known as *TXE4A*. The TXE4A system is designed to be fully compatible with TXE4 RD exchanges, which can be extended with TXE4A equipment if required. No changes were made to the TXE4 RD switching network when developing the TXE4A system, although some switching equipment was re-distributed and new rack-codes generated. The first production TXE4A exchange went into public service at Leicester Belgrave in February 1981, and a further 3 exchanges are at an advanced stage of factory commissioning.



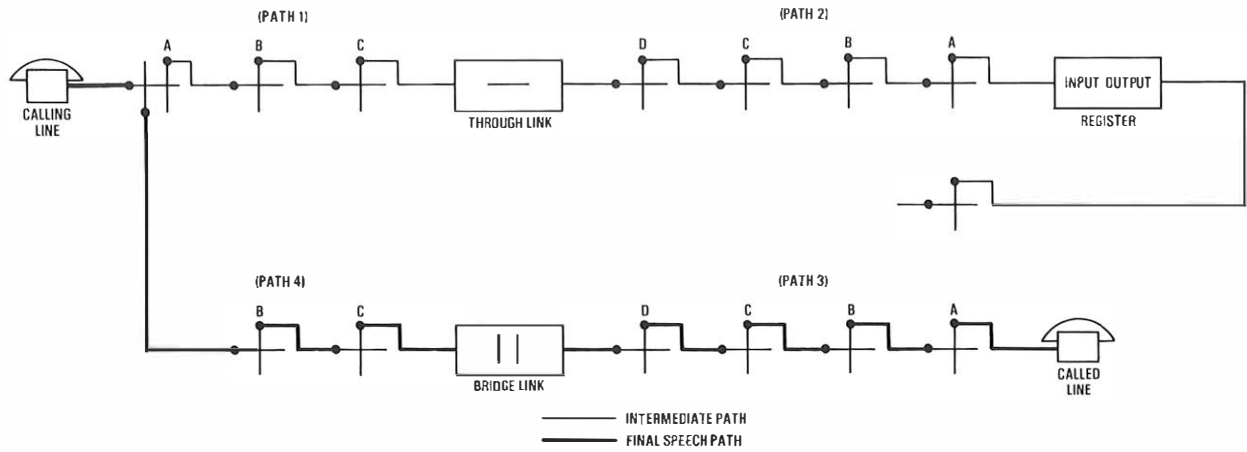
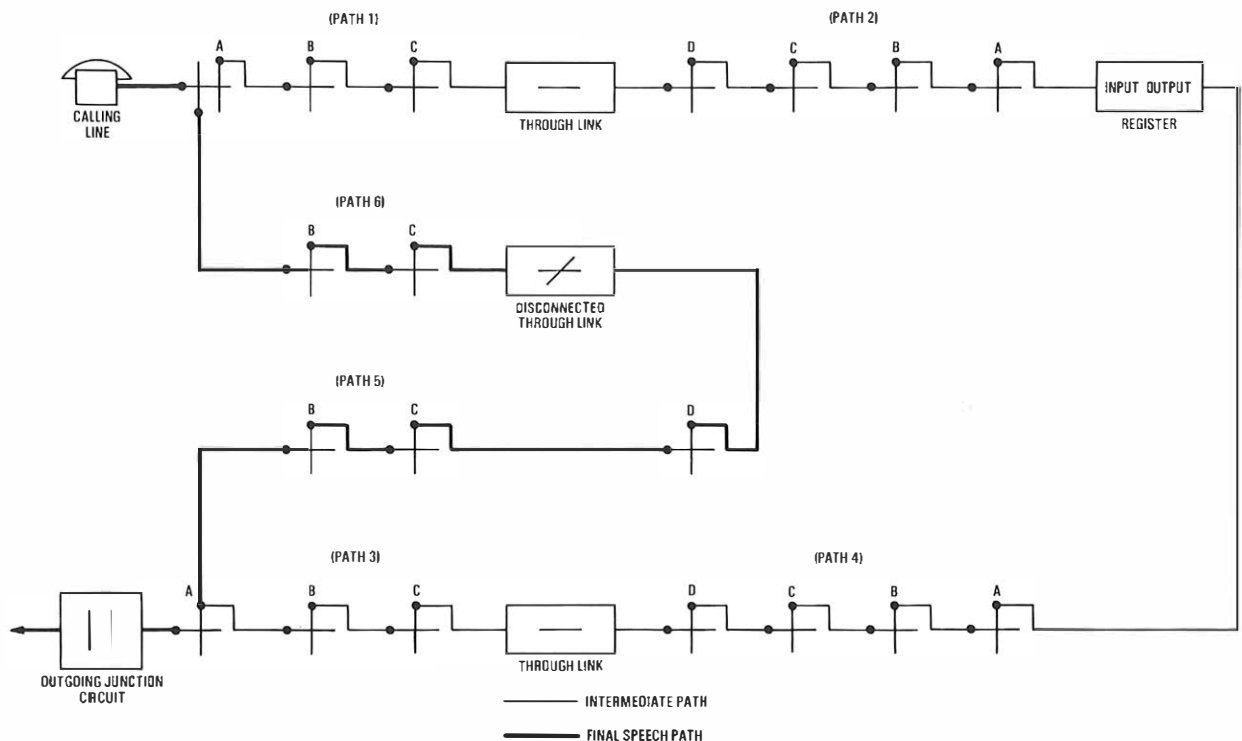

FIG. 7—TXE4 serial trunking sequence: own-exchange call



Note: The final speech path (5/6) is disconnected at the through link during call set-up to prevent mutual interference between customer signalling on path 1/2 and register signalling on path 3/4

FIG. 8—TXE4 serial trunking sequence: outgoing junction call

### PCM SWITCHING

At the same time as the TXE4/4A exchanges were being developed, exploratory work was being carried out in an attempt to eliminate the electromechanical reed switch and achieve a truly solid-state exchange. The problems with PAM-TDM systems were so great it was decided that they were unlikely to compete with the reed-relay systems described, except possibly for very small exchanges. On the other hand, a PCM exchange enabled the advantages of TDM to be exploited and avoided the transmission problems inherent in PAM exchanges. The high cost of the line units, including analogue-to-digital conversion, would be prohibitive for local exchanges, but this factor was less important for tandem and trunk exchanges<sup>21</sup>. Since PCM-TDM techniques were being used for transmission, the idea of switching without demultiplexing was very attractive.

Therefore, work on a feasibility trial of a PCM switch<sup>22</sup> began in 1965 at Dollis Hill and equipment was opened to live traffic at Empress exchange in West London in September 1968. This tandem switch was used to connect PCM traffic on six 24-channel PCM links between 3 neighbouring London exchanges.

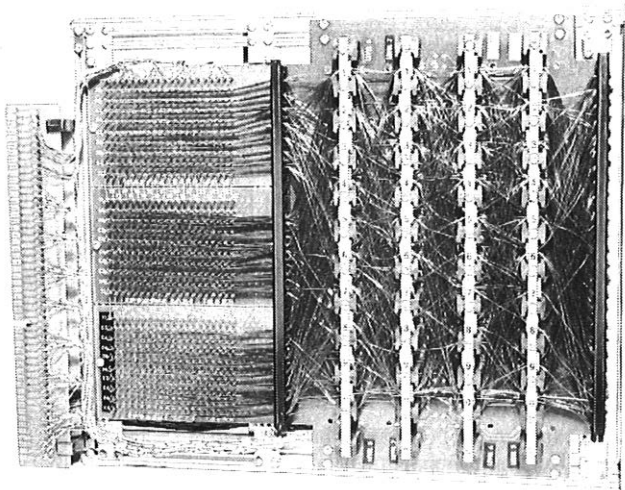

FIG. 9—TXE4 main control unit program store (1975)

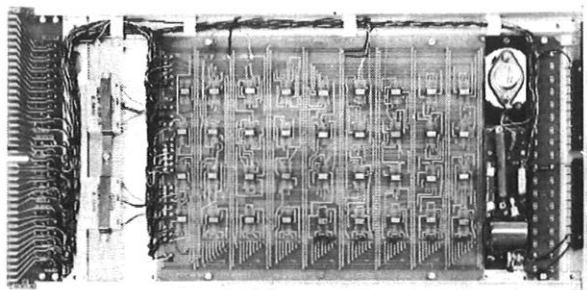

FIG. 10—Empress plug-in unit (1968)

A space-switching–time-switching–space-switching configuration was adopted, using diode-transistor-logic and some early TTL integrated circuits. The minimum digit pulse width was 325 ns and the spare switch paths were controlled by a cyclicly-addressed ferrite-core store, constructed from 0.75 mm ferrite cores. The time switch was a discrete component capacitor and diode store. Power supplies were distributed at  $\pm 12$  V and  $\pm 24$  V, with 5 V logic supplied by on-card regulation. The 3.072 MHz clock supplies and derived timing waveforms were triplicated and fed to the exchange racks. Fig. 10 shows an Empress plug-in unit, in which an array of integrated circuits mounted in flatpack packages can be seen. Recent thinking on interconnexion technology is towards small surface-mounted packages somewhat similar to these, and away from the dual-in-line packages that have mainly been used in the intervening period.

A second PCM-TDM trial switch<sup>23</sup> was built by STC and installed in 1971 to carry traffic at the Moorgate exchange in the City of London. This system was a small tandem switch, similar to Empress, except that the system was controlled by a duplicated processor system instead of the register control of Empress. Integrated circuit memories were used for control of time switching and space switching, but processor memory of 64 kbytes per processor was provided by ferrite core.

The success of these digital exchanges led to an extensive study of the main network by a Trunk Task Force. It was concluded that a main network based on integrated digital switching and transmission would offer significant economic advantages even on the component costs at that time<sup>24</sup>. Further cost reduction might be achieved by using large-scale integrated circuits. These conclusions, together with the flexible processor control experience of Moorgate and the evolutionary modular design of the TXE4 system, provided most of the basic concepts that led to the System X design philosophy.

### LARGE-SCALE INTEGRATED CIRCUITS

As the complexity of integrated circuits increased, complex custom circuit designs became increasingly expensive to develop and the specific designs did not allow the long production runs necessary to reduce costs. The concept of programmable logic<sup>25</sup> was one solution to this problem and it led to microprocessor development<sup>26</sup> by the BPO Research Department, which began in 1969. Another solution was the use of the uncommitted logic array (ULA), which allows a custom device to be designed with much lower development costs because only one stage of circuit fabrication, the aluminium interconnexion stage, is application dependent. The BPO Research Department microprocessor was based on a simple processor architecture, to be produced as 4 large-scale integration metal-gate metal-oxide semiconductor circuits; planned applications were simple logic replacement, or more complex tasks such as relay-set control. Unfortunately, this development was never completed because there were long delays in the production of some of the circuits and, at this

time, commercial microprocessors with a higher performance came on the market.

### STORED-PROGRAM CONTROL DESIGNS LEADING TO SYSTEM X

Although little has been said about overseas developments, many of the important advances in switching technology were first made by other countries. This is particularly true of the USA, which spearheaded the application of stored-program control (SPC); when the first BPO SPC exchange, Moorgate, was opened in 1971, there were already several Bell System SPC exchanges in public service. Nevertheless, much overseas development did not have direct application to the BPO network, and there was much to be learnt from field trials conducted by the BPO and UK manufacturers over the last decade.

### PATHFINDER EXPERIMENTAL EXCHANGE

The principles of SPC were applied to an experimental local exchange at Martlesham, code named *Pathfinder*<sup>27</sup>. It was opened in 1975 and was the first exchange in the BPO network to offer supplementary services. Although reed relays were used in the speech path, advanced techniques, such as electronic hold circuitry for the relays, and microprocessor control for peripheral functions were incorporated.

### DIGITAL LOCAL EXCHANGES

Once speech signals are in digital form, the range of digital micro-electronics components can be exploited very effectively to carry out the switching operations. Although the cost of conversion of the signals into the digital form is amply justified for trunk and junction exchanges, where the traffic has already been concentrated, it is much more difficult to carry out economically the conversion on every customer's line in a local exchange. Furthermore, the per-line cost must include not only the cost of analogue-to-digital conversion, but also the line-unit functions of battery feed, protection, ringing, loop supervision, 2-wire-to-4-wire hybrid unit and test access.

Nevertheless, the digital local exchange was seen as a desirable goal. It was realized that, if a digital exchange could be justified economically for voice service, it would open the door to a number of non-voice services based on 64 kbit/s digital channels. Early studies had shown that the line units could account for up to 80% of the total cost of the exchange. The research effort was, therefore, concentrated on the technologies that might lead to a reduction in the cost of the line unit.

The first item to be tackled was the codec<sup>28</sup>. The design shown in Fig. 11 uses a delta-sigma modulator operating at 2 MHz (a simple analogue circuit), with subsequent conversion to 8 bit companded samples at 8 kHz by the digital conversion circuit. Some discrete components are required for the delta-sigma modulator and for the anti-aliasing filter, but it is expected that the whole of the codec, together with the filters, will soon be developed in the form of a single integrated circuit.

The integration of the remaining line-unit functions on a subscriber's line interface chip (SLIC) has proved a difficult task because this part of the circuit must handle line power feeding, ringing current and high-voltage spikes from the line. In addition, the wound components (for example, the hybrid transformer) must be replaced by active circuits. Nevertheless, newer higher-voltage integrated circuit technologies are becoming available and some prototype SLIC circuits have been produced.

An experimental digital exchange (DX160) was constructed in the Research Department laboratories at Martlesham and this has served as a basis for 3 substantive digital switching developments, namely:

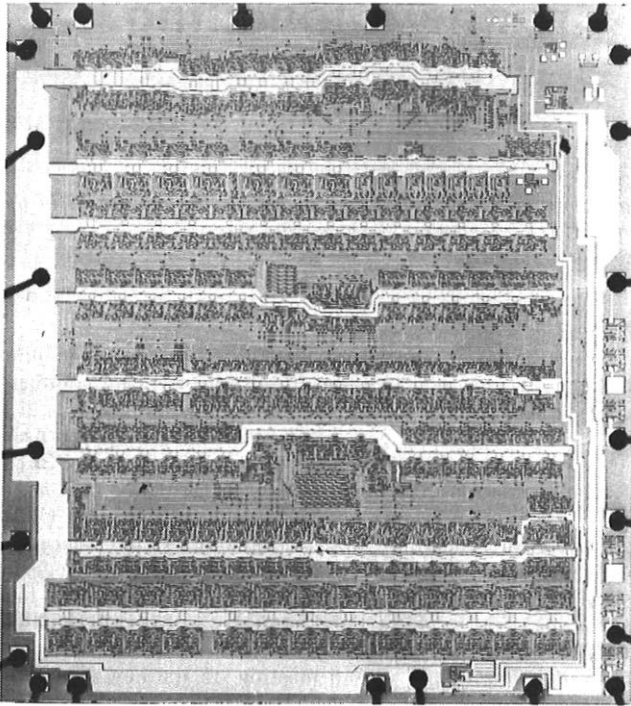

FIG. 11—Research Department code conversion circuit—part of line codec (1978)

- (a) Monarch PABX (120 line)<sup>29</sup>;
- (b) UXD5 very small local exchange<sup>30</sup>; and
- (c) System X digital subscriber switching subsystem.

## THE FUTURE

In the future, the system will become increasingly digital and development work has already been carried out on the feasibility of extending the 64 kbit/s digital voice equivalent (DVE) channels to the telephone instrument, which would then contain the codec and other analogue interfacing. This basic information rate will allow new customer services such as slow-scan television, high-speed facsimile and electronic newspapers to be carried. Much of the future effort on the introduction of new technology will concentrate on these new services because the switching problem will have been largely solved.

The BPO network will increasingly become a computer-like network, handling digital data of many types. The reducing cost of processing technology will allow new value-added services, such as text-to-voice conversion protocol adaptation and perhaps language translation, to be new areas of business for the BPO. The geometrically reducing costs of solid-state components will require a greater proportion of design effort to be expended on interconnexion technology, equipment practice, power supply and other peripheral system features, which would otherwise occupy an ever-increasing proportion of total system costs.

In the longer term, it would be unduly complacent to suppose that a fixed network based on 64 kbit/s DVE channels would meet all the needs of the future. Possible demands for increased mobile communications (in spite of radio spectrum limitations) and wideband (or high bit-rate) services have already been identified. Packet switching has been shown to be advantageous for certain types of data traffic, and the introduction of a packet-switched service has been justified, in part, by the changing economic balance between digital signal processing and transmission technologies.

If it is reasonably assumed that digital operation will continue to be the common factor in the future, then most of the fundamental technology for development is already available. However, the problems of providing the enhanced

capabilities on the network by economic evolution from, and interworking with, the System X network as at present conceived are likely to exercise the minds of research and development engineers for many years to come.

## ACKNOWLEDGEMENTS

The assistance of many colleagues in contributing to this article is acknowledged; the authors are particularly indebted to Messrs. F. Welsby and G. F. Cornwell, who collated much of the source material.

## References

- <sup>1</sup> The Inland Telephone Exchange System. *POEEJ*, Vol. 49, p. 185, Oct. 1956.
- <sup>2</sup> CORNER, A. C., and BANHAM, H. The 5005 Crossbar Telephone Exchange Switching System, Parts 1 and 2. *POEEJ*, Vol. 59, pp. 170 and 271, Oct. 1966 and Jan. 1967.
- <sup>3</sup> MODI, D. C., and YOUNG, K. W. The TXK2 Switching system at Wood Street and De Havilland International Gateway Exchanges. *POEEJ*, Vol. 70, p. 248, Jan. 1978.
- <sup>4</sup> BELL, R. L., BLOXHAM, G., and CALLAGHAN, B. F. TXK3 Director-Area Local Exchanges using BXB 1112 Crossbar Equipment, Parts 1 and 2. *POEEJ*, Vol. 67, pp. 66 and 169, July and Oct. 1974.
- <sup>5</sup> WALKER, N., STALLWORTHY, F. A., and MCLUSKY, R. F. Transit Switching Centres using BXB 1121 Crossbar Equipment, Parts 1 and 2. *POEEJ*, Vol. 60, p. 302, Jan. 1968, and Vol. 61, p. 20, Apr. 1968.
- <sup>6</sup> RANDELL, B. The First Electronic Computer. *New Scientist*, Vol. 73, No. 1038, 10 Feb. 1977.
- <sup>7</sup> COOMBES, A. W. M. COLOSSUS and the History of Computing: Dollis Hill's Important Contribution. *POEEJ*, Vol. 70, p. 108, July 1977.
- <sup>8</sup> FLOWERS, T. H. Electronic Telephone Exchanges. *Proc. IEE*, Vol. 99, Paper No. 1266, p. 181, Mar. 1952.
- <sup>9</sup> FLOWERS, T. H. Introduction to Electronic Automatic Telephone Exchanges. *POEEJ*, Vol. 43, p. 67, July 1950.
- <sup>10</sup> The Design of an Electronic PABX. BPO Research Report No. 13649, 1955.
- <sup>11</sup> BENSON, D. L., and VOGAN, D. H. Controlling Register-Translators, Parts 3 and 4. *POEEJ*, Vol. 51, pp. 280 and 291, Jan. 1959.
- <sup>12</sup> HARRIS, L. R. F. The Highgate Wood Experimental Telephone Exchange System. *Proc. IEE*, Vol. 107, Part B, Nov. 1960.
- <sup>13</sup> BROADHURST, S. W. The Highgate Wood Electronic Telephone Exchange. *POEEJ*, Vol. 55, p. 265, Jan. 1963.
- <sup>14</sup> FRENCH, J. A. T., and HARDING, D. J. An Efficient Electronic Switch, The Bothway Gate. *POEEJ*, Vol. 52, p. 37, Apr. 1959.
- <sup>15</sup> LONG, R. C., and GORRINGE, G. E. Electronic Telephone Exchanges: TXE2—A Small Electronic Exchange System. *POEEJ*, Vol. 62, p. 12, Apr. 1969.
- <sup>16</sup> MOON, R. J., BEALE, G. A., and TARRY, D. G. TXE2 Electronic Exchange System: The Evolution from Mark 1 to Mark 3. *POEEJ*, Vol. 69, p. 210, Jan. 1977.
- <sup>17</sup> SHEPPARD, S. H. The Leighton-Buzzard Electronic Telephone Exchange. *POEEJ*, Vol. 59, p. 255, Jan. 1967.
- <sup>18</sup> VOGAN D. H., and PRICE, C. D. E. The TXE3 Experimental Electronic Exchange System. *POEEJ*, Vol. 62, p. 142, Oct. 1972.
- <sup>19</sup> MAY, C. A. Electronic Exchanges: The Steps Leading to TXE4. *POEEJ*, Vol. 65, p. 134, Oct. 1972.
- <sup>20</sup> GOODMAN, J. V., and PHILLIPS, J. L. TXE4 Electronics Exchange System, Parts 1, 2 and 3. *POEEJ*, Vols. 68, 69 and 70, pp. 196, 68 and 10, Jan., July 1976 and Apr. 1977.
- <sup>21</sup> WALKER, E., and DUERDOTH, W. T. Trunking and Traffic Principles of a PCM Exchange. *Proc. IEE*, Vol. 111, Dec. 1964.
- <sup>22</sup> CHAPMAN, K. J., and HUGHES, C. J. A Field Trial of an Experimental Pulse-Code Modulation Tandem Exchange. *POEEJ*, Vol. 61, p. 186, Oct. 1968.
- <sup>23</sup> ROSE, D. J. Pulse-Code Modulation Tandem Field-Trial Model. *Electrical Communication*, Vol. 46, No. 4, p. 246, 1971.
- <sup>24</sup> UK Trunk Task Report. BPO Long Range Studies Division, Oct. 1971.
- <sup>25</sup> HUGHES, C. J., and JONES, W. G. T. Programmable Logic—A New Approach to Standardization. *POEEJ*, Vol. 63, p. 227, Jan. 1971.
- <sup>26</sup> HUGHES, C. J., and JONES, W. G. T. LSI in Telephone Exchange Peripheral Units. IEE Conference Publication, No. 54, p. 33, 1969.
- <sup>27</sup> SMITH, C. S. A., and PARK, I. D. C. Pathfinder: An Experimental Telephone Exchange using Stored-Program Control. *POEEJ*, Vol. 70, p. 68, July 1977.
- <sup>28</sup> EVERARD, J. D. A Single Channel PCM Codec. BPO Research Report No. 711, Feb. 1979.
- <sup>29</sup> POTTER, A. R. Monarch 120—A New Digital PABX. *POEEJ*, Vol. 73, p. 14, Apr. 1980.
- <sup>30</sup> AMES, J. R. et al. UXD5: A Small Digital-Switching Telephone Exchange for Rural Communities. *POEEJ*, Vol. 73, p. 241, Jan. 1981.

# Progress Towards Common-Channel Signalling

B. W. MOORE, B.SC., M.SC., C.ENG., M.I.E.E.†

UDC 621.395.34: 621.394.4

*This article reviews the progress made in common-channel signalling and highlights the milestones in the international specification activities which led to CCITT Signalling Systems Nos. 6 and 7.*

## INTRODUCTION

The study and development of common-channel signalling commenced in the early-1960s. For many years prior to this time, signalling system developments were based on channel-associated signalling principles. The control logic and control equipment associated with the earlier mechanical switching systems were provided on a per-circuit basis; for example, a signalling relay-set. Thus, it was appropriate to carry control signals within the speech circuit or within a channel dedicated to the speech circuit. Many variants of channel-associated signalling systems using AC, DC and multi-frequency (MF) techniques now exist. These developments are discussed elsewhere in this issue of the *Journal*<sup>1,2</sup>. As signal interchange is the key to the international interworking of telecommunications networks, much work has gone into the specification of internationally standardized signalling schemes in the CCITT\*.

A description of the signalling techniques discussed below is contained in the Appendix to this article.

## MOTIVATION FOR THE DEVELOPMENT OF COMMON-CHANNEL SIGNALLING SYSTEMS

During the 1960–1964 CCITT study period, the *Atlantic System* was adopted by the CCITT and standardized as the *CCITT Signalling System No. 5*<sup>3</sup>. The *Atlantic System* (using dual-frequency in-band line signalling and MF in-band forward inter-register signalling) had been defined to overcome the problems of CCITT Signalling Systems Nos. 3<sup>4</sup> and 4<sup>5</sup> (single and dual frequency respectively, combined line and inter-register signalling) which were incompatible with the time-assignment speech interpolation (TASI) system, used on inter-continental terrestrial routes, and with the existing North American signalling system.

However, views were expressed in the CCITT that the CCITT Signalling System No. 5 specifications could be improved upon. Areas of concern centred on the encumbrances included in the system as a result of the desire to optimize working on the TASI systems (for example, address information had to be sent in one block) and specific performance aspects such as:

- (a) post-dialling delay,
- (b) answer-signal delay,
- (c) the limited number of signals provided by the system, and
- (d) the availability of inter-register signalling only in the forward direction.

In the 1964–1968 CCITT study period, further study of the problems associated with signalling over the TASI system resulted in the specification of the *CCITT Signalling System No. 5bis*. This system worked in the overlap mode (that is, signalling could proceed without having to wait for the complete address), did not require a mandatory end-of-pulsing signal, and permitted both forward and backward inter-register signals.

However, trial experience with the CCITT Signalling System No. 5bis indicated that it did not provide a complete solution to the performance problems identified in the CCITT Signalling System No. 5 and because it has never been used in service, it has now been removed from the CCITT Recommendations. To resolve these performance aspects, a study question was formulated for the 1964–1968 CCITT study period, concerning a hybrid signalling system that used conventional channel-associated techniques for inter-register signalling, and a new common-channel technique for line signalling. The result of these studies was to be designated *CCITT Signalling System No. 6*.

By the time of the second meeting on the new signalling system, in autumn 1965, it had been recognized that a new signalling system that could cope with the requirements of a modern network was required; it had also become evident that the majority of opinion favoured the specification of a wholly common-channel signalling system. This was the form which the CCITT Signalling System No. 6 was to take. The arguments leading to this conclusion were twofold:

(a) The CCITT had recognized the significance of the problem in the international service caused by the necessity for signalling line splits in voice-frequency signalling systems, where a fast non-repeated verbal answer response could be clipped, or lost completely owing to the speech path being split on electrical-answer signal transmission. Common-channel signalling eased this problem.

(b) Processor controlled switching centres were being studied widely.

With the advent of stored-program control (SPC) switching centres it was recognized that the use of conventional analogue-signalling systems was inefficient. A method that presented information to the processor over one (or at most a very few) interface(s), rather than over a multitude of different interfaces, was considered desirable. This led to the consideration of bi-directional, high-speed data links between processors which could transfer digital signals by means of coded bit fields for a group of speech circuits in a very efficient manner.

Common-channel signalling offered a method of expanding the flexibility of SPC systems, and the signalling speed and signal capacity necessary to meet the requirements of the developing network.

The signalling system resulting from these studies was ratified in 1968. The initial Recommendations for the CCITT Signalling System No. 6<sup>6</sup> were for a system operating at 2.4 kbit/s over analogue bearers. Subsequently, a digital version which would allow the system to work over 4 kbit/s and 56 kbit/s digital bearers was added to the updated Recommendations; but this has not yet been implemented. The analogue version of the CCITT Signalling System No. 6 is in operation on some inter-continental routes and forms the basis of the common-channel signalling system used in the Bell network in the USA. It has been provided at the Thames International Switching Centre in London for service to the USA, Canada and Australia<sup>8</sup>. Further information on the background to these developments can be found in reference 9.

† System Evolution and Standards Department, British Telecom Headquarters

\* CCITT—International Telegraph and Telephone Consultative Committee

## THE EMERGENCE OF THE CCITT SIGNALLING SYSTEM NO. 7

During the late-1960s and early-1970s, much thought was being given to the signalling needs of integrated digital networks. In the UK, the Advisory Group on System Definition (AGSD) was studying the requirements of a digital common-channel signalling system for System X. At the same time, in the CCITT, a considerable body of opinion was building up among a number of European countries (including the UK) in favour of a new CCITT common-channel signalling system for digital networks.

The CCITT Signalling System No. 6 had been designed for use between analogue SPC telephone exchanges. Although a digital version was being specified, analysis of the requirements of future multi-service digital networks revealed a number of drawbacks. The principal ones were that, owing to the coding structure used, it was difficult to add the appropriate messages and signals to make the system applicable for other services (for example, for circuit-switched data networks), and that the error-correction technique had some limitations. The error-correction technique used in the CCITT Signalling System No. 6 can cause unnecessary retransmissions and subsequent disturbance to the sequence of signals. To avoid the consequence of this disturbance, *reasonableness checks* have to be performed on the received signalling information to resolve any ambiguities.

The following design objectives were agreed for a new common-channel signalling system which would be known as the *CCITT Signalling System No. 7*:

(a) It should be optimized for operation in digital telecommunications networks in conjunction with SPC digital exchanges.

(b) It should be optimized for operation over 64 kbit/s bearers, but should also be suitable for operation at lower speeds and over analogue bearers at, for example, 4·8 kbit/s.

(c) It should permit as much commonality as possible when used to carry signalling for different services, and it should be suitable for conveying administrative as well as call-control information.

(d) It should provide a reliable means for transfer of information in correct sequence without loss or duplication.

(e) It should incorporate features to meet very stringent security (availability) requirements.

## MILESTONES IN THE SPECIFICATION OF THE CCITT SIGNALLING SYSTEM NO. 7

It is interesting to review the stages in the study and specification of the new signalling system.

During the 1972–1976 CCITT study period, Study Group (SG) XI was entrusted with a question on 'Signalling arrangements for integrated digital telephone networks'.

*December 1973* During the first meeting of the SG XI, the design parameters, objectives and fields of application of a new system were considered. A questionnaire was produced on the requirements of the new system. (CCITT SG VII was, at the same time, studying common-channel signalling for data networks.)

*September 1974* The results of the questionnaire led to further system requirements. The principle of functional division of the new system into a common *message transfer part* and different *user parts* was identified (see Appendix). A fixed-length signal-unit format was agreed.

*February 1975* Proposed error-correction techniques were described and a comparative evaluation was initiated. Common trends were identified.

*September 1975* A preferred error-correction method was agreed after long and difficult debate. The length of the signal unit was agreed to be 80 bit. A joint group of experts of the interested study groups met and agreed a division of work

based on the functional division of the signalling system. A status report on the results of studies was produced.

*February 1976* Final meeting of SG XI of the study period. A variant error-correction method introduced by the Federal Republic of Germany was included in the questions for the new study period.

*March 1976* An inter-study-period meeting was held to evaluate the variant error-correction method, the signal-unit format and the error-check polynomial.

During the 1976–1980 CCITT study period, work continued in SG XI (and SG VII on data aspects).

*May 1977* The first SG XI meeting of the new study period was held. The possibility of changing to variable-length signal units was first introduced (by the Japanese). The meeting agreed to stay with fixed-length signal units, possibly longer than the 80 bits previously agreed. A drafting group was set up, under the co-ordination of the UK, to start drafting a specification text on the error-correction methods.

*December 1977* Canada, Japan and France made detailed proposals for change to variable-length signal units. After much debate, this change was agreed in principle.

The concept of *levels* within the system was introduced. An Experts Group was established, convened by the UK, to study further the new system and prepare a Recommendation text.

*March 1978* The CCITT Signalling System No. 7 Experts Group met. Progress was made on message-format principles.

*June 1978* The change to variable-length signal units was ratified. A combined receiver for both the *basic* and the variant *preventive cyclic retransmission* error-correction methods was agreed and their fields of application were defined. The first draft of the *telephone user part* was produced.

*January 1979* The 40 bit *standard* label was agreed for message routing.

The CCITT Signalling System No. 7 Experts Group met in January, June and September 1979.

*November 1979* All specification text was finalized.

*March 1980* The final meeting of the SG XI approved the draft Recommendations.

*November 1980* The VIIth CCITT Plenary Assembly ratified the CCITT Signalling System No. 7 Recommendations<sup>10</sup>.

A description of the functions of the CCITT Signalling System No. 7 may be found in references 11 and 12.

## DEVELOPMENT OF COMMON-CHANNEL SIGNALLING IN THE UK

For much of the period during which the above studies were in progress, the development of common-channel signalling for the British Post Office (BPO) network was in advance of the standardization activities. The process was thus iterative, in that the UK delegates from the BPO and Industry injected views and proposals based on national developments. In turn, the direction of the System X development of common-channel signalling was regularly reviewed and any necessary changes made. The result is that the CCITT Signalling System No. 7 is utilized in System X (the details can be found in other articles<sup>13,14</sup> and conference papers<sup>12</sup>).

## FURTHER WORK ON THE CCITT SIGNALLING SYSTEM NO. 7

Studies are continuing in the CCITT on the Signalling System No. 7. A number of areas (for example, signalling network aspects) need to be specified further and any problems experienced in interpreting or implementing the Recommendations need to be analysed.

Flexible, high-capability common-channel signalling is a key feature of integrated digital networks. Many countries have indicated their plans to use the CCITT Signalling System No. 7; and the majority of the main manufacturers intend to offer the system. In Europe it has been recommended that the CCITT Signalling System No. 7 should be used within, and between, the national digital networks. It is anticipated that the system will also be used on digital inter-continental routes between digital gateway exchanges.

Attention is now turning in many areas to the impact of the evolution towards integrated services digital networks (ISDN). The CCITT Signalling System No. 7 will have an important role to play in this exciting development. Call-control user parts already exist for application in networks dedicated to telephone and circuit-switched data services. Studies will be undertaken in the 1980-1984 CCITT study period to make necessary changes to the Recommendations, and the emergence of an *integrated services user part* for call control of many services in an ISDN is envisaged. In addition, a *standard operation and maintenance user part* for supervision of exchanges from remote centres is being considered.

## THE FUTURE

This article has briefly reviewed the emergence of common-channel signalling. The technique of common-channel signalling was originally conceived specifically for the conveyance of call-control information for circuit-switched calls across a telecommunications network. However, as the CCITT Signalling System No. 7 was being designed, it became clear that information transactions across a network, data services based on message transmission and conventional call control were all converging.

The present CCITT Signalling System No. 7 specifications allow a network message-transport capability to be developed. Although in the early applications this will predominantly be used for call control and operation and maintenance purposes, the extension of message-based signalling to customers over digital local lines, as proposed for the ISDN, will open up the possibility of much more extensive use of the common-channel signalling network as a message transport system. Will the result of such a trend be that one day all services will be provided by means of message switching?

## References

- 1 TIPPLER, J., and MARTIN, J. Developments in Signalling Systems Since 1956. *POEEJ*, Vol. 74, p. 199, Oct. 1981.
- 2 FRAME, P. B. Developments in Channel-Associated Signalling Technology. *POEEJ*, Vol. 74, p. 213, Oct. 1981.
- 3 CCITT Signalling System No. 5. CCITT Green Book, Vol. VI-2, Recommendations Q140-Q164.
- 4 CCITT Signalling System No. 3. CCITT Red Book, Vol. VI, Recommendations Q76-Q79.
- 5 CCITT Signalling System No. 4. CCITT Green Book, Vol. VI-2, Recommendations Q120-Q139.
- 6 CCITT Signalling System No. 6. CCITT Green Book, Vol. VI-3, Recommendations Q251-Q295.
- 7 CCITT Signalling System No. 6. CCITT Orange Book, Vol. VI-2, Recommendations Q251-Q295.
- 8 BALLINGER, D. R., and WALKER, P. J. The CCITT No. 6 Common-Channel Signalling System. *POEEJ*, Vol. 73, p. 235, Jan. 1981.
- 9 WELSH, S. Signalling in Telecommunications Networks. Peter Peregrinus Ltd. 1979.
- 10 CCITT Signalling System No. 7. CCITT Yellow Book, Vol. VI-6, Recommendations Q701-Q707, Q721-Q725 and Q741.
- 11 ROBERTS, S. Common-Channel Signalling for Digital Telecommunications Networks. IEE Conference Publication No. 184, Communication Equipment and Systems, p. 19, Apr. 1980.
- 12 DENMAN, D., and MOORE, B. W. The Use of CCITT Signalling System No. 7 in the British Post Office Signalling Network. Telecommunication Network Planning Conference, Paris, Sept. 1980.
- 13 JONES, W. G. T., KIRTLAND, J. P., and MOORE, B. W. Principles of System X. *POEEJ*, Vol. 72, p. 75, July 1979.
- 14 PRITCHARD, T. System X: Subsystems, Part 4—Common-Channel Signalling and the Message Transmission Subsystem. *POEEJ*, Vol. 73, p. 165, Oct. 1980.

## APPENDIX

### SIGNALLING PRINCIPLES

#### Channel-Associated Signalling

The channel-associated signalling technique is one in which the signalling information related to a traffic circuit is carried either

- (a) within the bandwidth of the circuit itself, or
- (b) on a separate signalling channel provided exclusively for that circuit.

In case (a), for telephony, the signalling information may be carried within, above or below the speech bandwidth. Signalling senders and receivers have to be provided on a per-circuit basis, either permanently dedicated to a particular circuit (for example, for line signalling) or connected from a pool of equipment when signalling is required over a particular circuit (for example, inter-register signalling).

Case (b) applies to signalling over pulse-code modulation (PCM) transmission systems. In a 30-channel system, time-slot 16 (TS16) provides a multiplex of 30 signalling channels, each permanently assigned to one of the traffic time-slots. Signalling logic is required for the TS16 signalling information, when the multiplex is terminated digitally and, on a per-traffic-circuit basis, at the analogue-to-digital conversion point.

#### Common-Channel Signalling

The common-channel signalling technique is one in which signalling information for a number of traffic circuits is carried over a separate, common-signalling channel. The signalling information carried in the common channel is label addressed; that is, each group of signalling information associated with a particular traffic circuit includes a reference to the identity of the traffic circuit to which it relates. Hence the number of traffic circuits which may share the use of one common-signalling channel may vary, and the number is limited only by such factors as security and labelling capacity. This is shown in Fig. 1.

Other key features of common-channel signalling are that the physical path taken by the signalling information may be different to that of the traffic circuits (this allows optimization of the signalling network), and that the common channel may be used to carry information that is not related to a specific traffic circuit (for example, for operational and maintenance purposes).

### FUNCTIONAL DIVISION OF THE CCITT SIGNALLING SYSTEM NO. 7

The fundamental principle of the structure of the signalling system is the division of functions into a common message transfer part and separate user parts for different users. This is illustrated in Fig. 2.

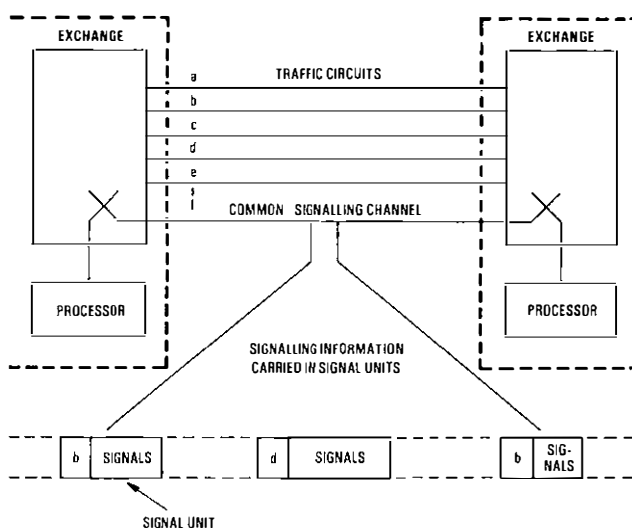

Note: Each signal unit carries a number of signals and the identity of the traffic circuit involved

FIG. 1—Common-channel signalling

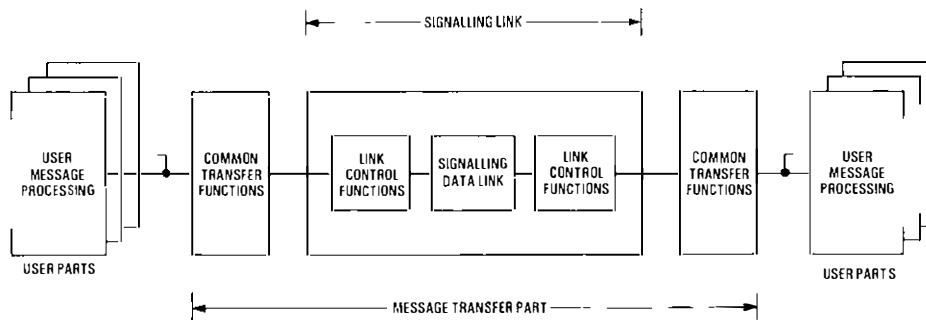

FIG. 2—Functional diagram of the CCITT Signalling System No. 7

The overall function of the message transfer part is to serve as a transport system providing reliable transfer of signalling messages between the locations of communicating user functions.

A user part defines the functions and procedures of the signalling system that are particular to a certain type of user of the system. The extent of the user part functions may differ significantly between different categories of users of the system such as:

(a) Users for which most communication functions are defined within the signalling system. Examples are telephone and data call

control functions with their corresponding telephone and data user parts.

(b) Users for which most user communication functions are defined outside the signalling system. An example is the use of the signalling system for transfer of information for some operation or maintenance purpose. For such an external user, the user part can be seen as a *mailbox* interface between the external user system and the message transfer function. The user part in this case would mainly contain message formatting functions.

## Developments in Channel-Associated Signalling Technology

P. B. FRAME, C.ENG., M.I.E.E.†

UDC 621.391

*This article describes the developments in technology that have occurred in equipment used in DC, AC, multi-frequency and pulse-code modulation signalling systems during the past 25 years.*

### INTRODUCTION

Twenty-five years ago, virtually all calls made in the UK telephone network were completed using channel-associated signalling systems. Today, this is still true for the vast majority of calls, which continue to use the conversation path for the dual purpose of routeing signalling or control information, and call supervision. Both DC and AC signalling systems are used and, although later designs of individual systems are functionally identical, the various realizations are a chronicle of the change in technology over the period. In general, the functional requirements and performance limits for signalling systems are constrained by the needs and capability of the equipment interworking in an established network; it is not surprising, therefore, to note that some of the first technologically advanced designs made their appearance in DC signalling systems.

### DC SIGNALLING SYSTEMS

Loop-disconnect pulsing has widespread use in the network, the most common source being the telephone dial and other customers' apparatus, but it also finds significant use in inter-exchange signalling. Notable examples of functionally related equipment designs that feature updated technology are: the pulse regenerator used on junction circuits in non-director

areas to extend the limits of dial-pulse control; the self-contained press-button telephone designed to work on existing exchanges without the need to modify, or provide additional exchange equipment; and various repertory diallers used by customers for automatic dialling.

The design of the pulse regenerator (Regenerator 5A)<sup>1</sup> exemplifies many of the advances in technology, and the problems inherent in using modern electronic devices in the hostile environment of a Strowger exchange. The earlier pulse regenerator (Regenerator 1A) used 3 magnets to control counting, storing and retransmission of the incoming pulses and a circle of 42 code-pins to act as a pulse store. In contrast, the micro-electronic version comprises, essentially, 2 metal-oxide semiconductor (MOS) large-scale integration (LSI) chips using 4-phase dynamic logic, together with a multivibrator or inductance-capacitance (LC) oscillator clock-pulse source, and peripheral interfaces made up from discrete semiconductor or resistive network components; the output pulses to the relay-set are repeated by a mercury-wetted reed relay. The design of the LSI chips is based on p-channel metal-gate MOS integrated circuit technology. Although these operate at a high voltage compared with bipolar devices, the  $-36\text{ V}$  and  $-25\text{ V}$  internal supplies must, nevertheless, be decoupled against induced electrical noise; a Zener diode is used to protect the design against excessive voltage rise on the  $-50\text{ V}$  battery supply. Later designs have a single internal power rail.

† Exchange Systems Department, British Telecom Headquarters

The design objectives for the micro-electronic regenerator included the need for superior performance and lower maintenance charges, compared with the electromechanical version. Improvement in functional performance is readily obtained by the use of sequential and/or combinational logic that provide means of checking and detecting errors. The closer control on pulse accuracies derived from stable timing sources provides better pulsing performance in speed and ratio, with consequent improvement in the quality of service to customers.

There are now approximately 250 000 micro-electronic Regenerators 5A installed in the network and therefore overall reliability, as measured by the mean time between failures (MTBF) of the device, is also crucially important, both to the quality of service and to the maintenance of the equipment. Indeed, if the electromechanical version had remained as the standard design, the quantity of regenerators now installed would have represented a considerable maintenance commitment to a device which, even with preventive maintenance, attained an MTBF of only about one year. In contrast, the micro-electronic regenerators now in service have an MTBF of 100 years; they are so reliable that they are not repaired but, as maintenance is by infrequent replacement, they are treated as throw-away items.

### CUSTOMER APPARATUS

The impact of modern technology on signalling applications in customers' apparatus has been no less important and striking, with innovation spurred on by both the competitiveness and volume of the potential market, setting a trend that, in future, will increase with greater liberalization in terminal equipment. For example, in terms of technology, the variety of repertory diallers available demonstrate markedly different methods of storing and retrieving line-signalling information. For DC signalling systems, the range includes optical, magnetic tape and semiconductor integrated circuits. Under emergency conditions, signalling and pulsing from the customer's terminal must operate independently of any power supply external to the telephone system. This requirement moved the designs through various stages of technology over a short period of time. In earlier versions of the self-contained press-button telephone, a local nickel-cadmium battery was used to provide the necessary power. The batteries were expensive and relied on a trickle charge from the line, which affected some line test equipment. Later designs of the self-contained press-button telephone use low-power integrated circuits, principally p- or n-channel MOS and low-power Schottky devices; these can be powered for the duration of the signal by the discharge of a capacitor which, in the inactive phase of operation, is charged from the line current.

Press-button telephones used on PABXs can employ DC Code-C signalling, which relies on the detection of various line conditions for each digit; these consist of combinations of disconnection, earth potential and various configurations of semiconductor diodes, and require the relays used as the detectors to be connected to various voltages. This simple signalling technology has been superseded by the use of multi-frequency No. 4 (MF4) signalling<sup>2</sup>, a system that is also used for press-button telephone service on public exchanges. MF4 is an analogue signalling system that uses 2 AC signals to represent each digit, the frequencies being chosen from 2 groups of 4 frequencies in the audio range.

In the MF4 keyphone telephone instrument, extensive development of the oscillators used to generate the frequencies has occurred. Early types used conventional LC-coupled oscillators which, because of the bulky components used, created severe problems in containing the design within the contour of the standard telephone; present designs rely on p- or n-channel MOS integrated circuits for their operation, with consequent benefits in the reduction of power and space requirements.

### VOICE-FREQUENCY RECEIVERS

All voice-frequency (VF) receivers are a compromise to optimize performance within the bounds of the conflicting conditions: on the one hand, to reduce signal simulations by speech, which will occur if the signal recognition time is too short; on the other hand, to minimize signal mutilation by noise. In addition to the receiver response time, a further important parameter in controlling voice immunity is the close frequency control and restricted bandwidth allowed for each signal frequency. Most receiver designs also include checks on the absolute and, for MF codes, the relative levels of the received signals, duration of signal and absence of noise.

The MF4 receivers situated at the exchange have also experienced technological innovation and update. The earliest designs were physically large, used discrete components throughout the design and were totally analogue in operation. In the analogue designs, modern technology has created scope for size reduction by the use of active filters, thick-film hybrid circuits in the limiter and detector stages and, for example, MOS p-channel LSI circuits for the logic functions in the timing and code-conversion stages of the receiver. However, because the signal must have a narrow bandwidth, an adjustable resistive component has to be provided in each signal channel to permit very close tolerancing of the designs and compensation of drifting due to ageing and variations in temperature.

Digital techniques give greater scope for further reductions in power and size, by allowing increased use of LSI circuits. Many modern MF4 receivers use a zero-crossing technique, in which the receiver detects when the signal waveforms pass through zero amplitude. The receiver measures the time between successive zero crossings, and counts the number of crossings in a given time window using a high-frequency reference signal derived from a crystal source. This system has the advantage that the bandwidth can be more closely controlled without the need for the filter characteristics to be adjusted, either during manufacture or while in service. Care is required in the design to provide adequate noise immunity and to avoid jitter because noise can displace the zero crossings, in a manner random enough to cause sampling errors.

### VOICE-FREQUENCY SIGNALLING SYSTEMS

Perhaps the most significant impact of technology on signalling systems since 1950 has occurred in the signalling systems used in the main network. This is particularly true of the AC line-signalling systems which, in the 1950s, were dominated by the use of the Signalling System (SS) AC No. 1<sup>3</sup>. The terminations of this 2VF signalling system are large, being based on the use of 3000-type relay logic, with the receiver employing 4 laminated-iron-core transformers, LC filters and 3 large thermionic valves. The initial characteristic curves of the thermionic valves are quite precise, but the effects of age causes them to change in a predictable manner. To overcome these effects, the design uses negative feedback and component derating to provide safe operating and performance margins against both failures and unacceptable error rates during the life of the equipment.

In the late-1950s, the 1VF SSAC9<sup>4</sup> was introduced, and is now the standard inland main-network signalling system. The system has been the subject of a number of technology updates, evolving from the original design using electromechanical components, LC filters and miniature thermionic valves, through a version using discrete transistors (SSAC9T) for the receiver, to the present standard (SSAC9M)<sup>5</sup>. In contrast to the 4646 cm<sup>3</sup> required for an SSAC1 receiver, an equivalent SSAC9M unit is accommodated in a volume of only 164 cm<sup>3</sup>. The discrete-transistor design initially followed relay mounting practice, the transistors being mounted on tag strips on the relay mounting plate. Later designs used printed-wiring boards for ease of production. The reduction in power and accommodation for the various technologies used in AC1,



**TABLE 1**  
Performance of AC Line Signalling Units

Parameter \ Signalling Unit Type	AC1	AC9 (valve)	AC9T	AC9M
Signalling Frequency (Hz) and Tolerance	600 ± 0.4% 750 ± 0.33%	2280 ± 0.25%	2280 ± 0.25%	2280 ± 0.25%
Receiver Sensitivity (dBm)	+10 to -20	+3 to -18	+3 to -18	+3 to -18
Receiver Bandwidth (as a percentage of signalling frequency)	2.5	2	2	1
Approximate Seizure and Cleardown Tone Times	seize 100 ms clear 6 s (worst case)	seize 65 ms clear 1.5 s	seize 65 ms clear 1.5 s	seize 65 ms clear 1.5 s
Reliability MTBF (years)	-	1	1	≈ 13

AC9T and AC9M signalling systems is shown in Fig 1. The impact of modern technology on design is most obvious in the present standard version, SSAC9M, which has no transformers in the receiver design, which uses operational amplifiers as a gyrator circuit to give simulated inductance in the filter circuits. Low-power transistor-transistor logic is used in the main for the logic elements. However, because these components operate from low-voltage supplies and cannot handle large power dissipation, an interface of discrete components and miniature relays is required to enable the electrically sensitive elements to interwork with electromechanical switching equipment, existing test equipment and the line. The logic, interface and receiver circuits forming the whole equipment are produced on separate printed-wiring boards, which are clamped together to form a single signalling unit. Table 1 shows the effect that the technology evolution has had on the performance of SSAC1 and SSAC9 signalling units; this indicates an ability to operate on a narrower bandwidth for the same overall performance, while the reliability has been improved to obtain an MTBF of approximately 13 years.

**PCM SIGNALLING**

The increasing use of pulse-code modulation (PCM) systems in the network has resulted in many more signalling facilities being required in different combinations to allow for various planning options in routing traffic. Apart from the basic supervisory signals, the need to provide for coin-and-fee-checking circuit control by operators, manual hold, metering over junctions and other signals results in additional logic and interface elements. Where discrete components were used, as

on some 24-channel PCM units, there was insufficient space on the standard plug-in-unit to contain all of the facility options. This resulted in the design of 17 different signalling units to cover the more usual signalling combinations, with the result that the designs did not provide full flexibility for planning purposes.

The use of more advanced technology has enabled some variety reduction to be achieved in the 30-channel PCM systems. The principal element in this variety reduction on the second generation 30-channel PCM systems is the use of uncommitted logic arrays, which has resulted in only 3 signalling terminations being required to cover all outgoing and incoming conditions, in association with a universal miscellaneous signalling unit. Although the circuits contain redundant logic when used for a particular route, the design gives overall advantages in the planning, purchasing, spares holding and maintenance for the system.

**CONCLUSION**

Evolution in technology has resulted in significant reductions in space and power requirements of signalling systems used in the network. This, together with the improved reliability given by modern semiconductor integrated circuits, has improved performance, while whole-life costs have been reduced. The advent of the information society and technological obsolescence seem to indicate a continuing need to exploit new technology. In this context, the increasing use of digital techniques in the network will ensure that call control and information transfer, whether by means of channel-associated signalling systems or otherwise, will exploit new technologies as they become established. In future, customers will expect more 2-way interaction between their terminal and the network; thus, increasing use will be made of devices such as microprocessors, where the flexibility to cope with change will to an extent be provided by changes in the stored program.

**ACKNOWLEDGEMENT**

The author gratefully acknowledges the discussions and information provided by Mr. R. J. Wood, Exchange Systems Department, during the preparation of this article.

**References**

- 1 LOCK, P. J., and SCOTT, W. L. The Regenerator 5A—A Micro-electronic Project for Strowger Exchanges, Part 1. *POEEJ*, Vol. 71, p. 110, July 1978.
- 2 BATTISTA, R. N., MORRISON, C. G., and NASH, D. H. Signalling System and Receiver for Touch Tone Calling. *IEEE Transactions, Communications and Electronics*, No. 65, Mar. 1963.
- 3 HORSFIELD, B. R., and SMITH, D. C. AC Signalling—A Review of Current Problems. IPOEE Printed Paper No. 204, Apr. 1952.
- 4 MILES, J. V., and KELSON, D. Signalling System AC No. 9. *POEEJ*, Vol. 55, p. 51, Apr. 1962.
- 5 HILL, R. A., and GEE, G. J. H. A Miniaturized Version of Signalling System AC No. 9. *POEEJ*, Vol. 65, p. 216, Jan. 1973.
- 6 TURVEY, K. J. 30-Channel Pulse-Code Modulation System, Part 3—Signalling Units. *POEEJ*, Vol. 71, p. 225, Jan. 1979.

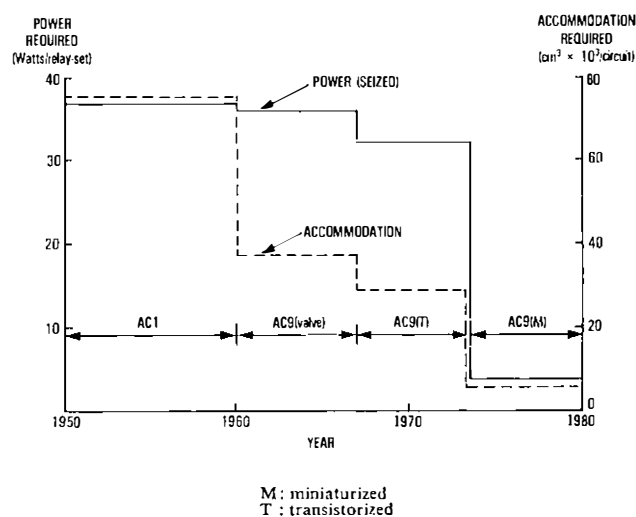

FIG. 1—Accommodation and power requirements of SSAC1 and SSAC9 signalling equipment since 1950

# Packet-Switched Data Communications Networks

P. T. F. KELLY, B.SC.(ENG.), C.ENG., M.I.E.E., M.B.C.S.†

UDC 621.394.4: 681.32

*This article reviews the history of the development of packet switching and the establishment of international standards. The present state of packet switching in the UK is also described.*

## INTRODUCTION

This article describes the present status of packet switching in the UK; in particular, the national public packet-switched service (PSS). It also reviews the history of packet-switching developments since the technique was conceived in the late-1960s until the present time, when, in most countries, public packet-switched networks are in operation or in the process of implementation. Of particular importance has been the establishment of CCITT\* Recommendations for packet-switching network protocols and customers' systems/network interfaces. This has enabled users and terminal suppliers to invest in packet switching with confidence, and telecommunications administrations to interconnect individually-developed national networks to form an international packet-switching infrastructure.

## THE BEGINNINGS OF PACKET SWITCHING

Information within computers is moved around from store location to location in the form of addressed blocks of characters. Blocks of information for different destinations are often dynamically multiplexed along common highways. Buffering and flow control is used to enable interworking between high-speed and low-speed processes. It was a natural extension of these principles to interconnect remotely located processors and terminals over external communication networks.

The first ideas on what was to become known as *packet switching* were presented in the USA during the early-1960s by Paul Baron in a series of Rand Corporation reports entitled *On Distributed Communications*. Pioneering work was done at the UK National Physical Laboratory (NPL), and Donald Davies of NPL is generally credited with introducing the term *Packet*. Larry Roberts of GTE Telenet, then working for the Advanced Research Projects Agency (ARPA) of the USA's Department of Defense, directed the development of ARPANET in the USA, the first large-scale country-wide network. The early-1970s saw the implementation of a number of experimental and research-oriented national and international networks, including the European Informatics Network (EIN) with its UK node located at the NPL.

For some time, administrations had recognized the limitations of the existing public switched telephone networks (PSTNs) for data transmission, and a special study group had been set up within the CCITT to produce recommendations for dedicated public data networks; eventually a set of Recommendations in the CCITT X series was issued.

During the 1970s, there had been much debate on the relative merits of circuit versus packet switching, but studies performed in the UK indicated that it would not be economically viable to introduce a dedicated circuit-switched data network in the then predominantly analogue-transmission telephone network infrastructure. Modernization of the tele-

phone network and the progressive introduction of digital transmission would provide a more suitable environment for a homogeneous circuit-switched system, and current plans are for the incorporation of circuit-switched data services in the integrated services digital network (ISDN). Recognizing that practical operating experience, with direct customer involvement, was the first necessary step in order to evaluate the advantages and disadvantages of packet switching, the British Post Office (BPO) launched its experimental packet-switched service (EPSS) as a research and development project.

## THE EXPERIMENTAL PACKET-SWITCHED SERVICE

For the EPSS, which was planned and implemented before the CCITT Recommendations were issued, the BPO developed its own protocols, designed to provide optimum network performance. It was then necessary to persuade customers to implement compatible interfaces in their terminal systems. The experiment formally opened in April 1977 with packet-switching exchanges (PSEs) at London, Manchester and Glasgow and has provided valuable information and experience in the implementation and day-to-day operation of a public data network on a national scale. Details of the development, implementation and operational experience of the EPSS are given in earlier issues of the *Journal*<sup>1-8</sup>. Before the EPSS could establish itself commercially, it was overtaken by the development of international standards for customer-terminal/packet-switching network interfaces, and developments in microprocessor technology. After the inception of EPSS, public packet networks were established in the USA, Canada, Spain, France and Japan; all adopted, or intended to adopt, the evolving CCITT standards. In addition, the implementation of EURONET for the EEC had acted as a catalyst for development of national packet-switching networks in Europe, and most countries were proceeding with plans to implement such networks.

These factors, together with the evidence of considerable commercial support for the UK international packet-switched service (IPSS) which had been opened to North America in 1978, and general recognition of the potential of public packet-switched networks in the environment of rapidly developing computer technology, influenced the BPO to proceed with plans for the PSS, the commercial service to follow the EPSS. This decision was also fully supported by the recommendations of the government sponsored National Committee on Computer Networks (NCCN) in a report that it published during 1978.

## CCITT RECOMMENDATIONS FOR PACKET-SWITCHING SERVICES

The first version of the CCITT Recommendation X25 was produced by Study Group VII of the CCITT in the 1972-1976 plenary period. A number of improvements and refinements were effected during the 1976-1980 plenary period. All administrations have agreed in principle to introduce the

† Exchange Systems Department, British Telecom Headquarters

\* CCITT—International Telegraph and Telephone Consultative Committee

latest version of Recommendations X25, X3, X28 and X29 into their respective networks during 1982.

### CCITT Recommendation X25

CCITT Recommendation X25 is the principal interface. It defines all procedures for packet terminals to transmit and receive packets in a full-duplex mode across the customer/network interface.

### CCITT Recommendations X3, X28, X29

All the evolving public packet-switched networks support simple unintelligent asynchronous-mode terminals as well as packet terminals. In order to do this, a packet assembly/disassembly (PAD) facility is incorporated at each PSE.

Asynchronous terminals are connected to ports providing access to the PAD facility, either via direct links or, more commonly for the low-usage terminal, via dial-up PSTN connexions to a group of PAD ports. Transmission to and from the asynchronous terminals to the PAD is in normal character mode, the data being assembled into packets by the PAD for onward transmission over the network to X25 packet terminals or other PADs.

Recommendations X3, X28 and X29 respectively define: the PAD functions and parameters for special facilities; the procedures and characters that are used by the asynchronous terminal operator when communicating with the PAD; and the additional procedures used by a normal X25 packet terminal when communicating over a packet network with an asynchronous terminal, via a PAD facility.

### CCITT Recommendation X75

A recent important recommendation, X75, defines the protocol to be used on interfaces linking separate public packet networks. Adopted within a national network, X75 enables enhancement and expansion with equipment of a different generation or from a different supplier.

### CCITT Recommendation X121

CCITT Recommendation X121 defines an international numbering scheme.

## THE UK NATIONAL PACKET-SWITCHED SERVICE

Based on a development by GTE Telenet, offered in the UK by Plessey Controls Ltd., and enhanced to be further ahead than other existing networks in terms of conforming to CCITT standards, the PSS was brought into a pre-operational state in 1980 and into full operation this year. PSS topology at opening date, and the extension planned for completion during 1981, are shown in Fig. 1.

The PSS exchanges comprise one or more switching units and an installation of modems that are used to provide links to customers' terminals and for inter-PSE trunks. The switching units are Telenet processors (TP4000s), the hardware in each unit being of modular multiprocessor architecture with built-in redundancy.

The network is controlled by main and stand-by network management centres (NMCs) in London, each comprising a mini-computer equipped with disc store, magnetic tape, visual display unit and printer. The NMC site is staffed 24 hours a day. The PSEs are designed for normally unattended operation with all test, maintenance and program loading being undertaken remotely; that is, from the NMC.

Each TP4000 has automatic fault diagnosis and will communicate automatically the existence of many types of hardware faults to the NMC. On-line diagnostics from an NMC or other maintenance control points (MCPs) can be achieved to a module level or in some cases to a function within a

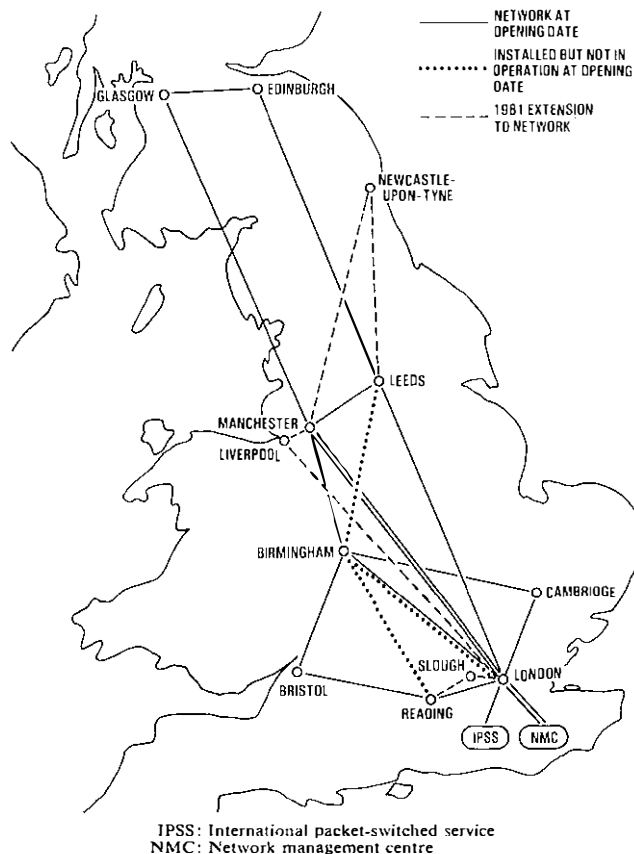

FIG. 1—The UK national packet-switched service

module. When a TP4000 is *cold started*, it has sufficient intelligence built in to enable it to set up a virtual call via a neighbouring switch and request initialization from the NMC. The NMC then sends back software and routing and look-up tables which are loaded by a program stored and executed in read-only memory (ROM). The NMC also deals with call-accounting information which is passed from individual PSEs on a call-by-call basis. The call-accounting information is written to disc stores at the NMC and is subsequently transferred to magnetic tape for off-line processing and the production of bills.

In setting standards for acceptable delay across the system, account has to be taken of future expansion whereby the introduction of more PSEs into the network could increase the number of links required to complete a connexion. As the PSS expands, a hierarchical topology will be introduced to ensure that no more than 5 within-network links in tandem will be necessary on a connexion between any 2 national PSEs. Over such a connexion involving 5 links it is estimated that 95% of all full-length data packets will be conveyed in significantly less than 500 ms, the average delay for such a connexion being less than 300 ms. The delay for the average connexion over the PSS will be much shorter than this—around 150–200 ms. For calls to an international gateway, no more than 2 links will be used nationally.

The initial market forecast, at the time authority was sought for proceeding with the PSS as a follow on to the EPSS, suggested the need for a fairly small network, with demand mainly coming from asynchronous terminals seeking facilities and access to databases on a relatively few X25 packet connected host computers. Since implementation of the PSS commenced, there has been a noticeable upsurge in market interest in packet switching, resulting from new emerging applications.

There are also indications that as a result there will be a greater demand than originally expected for packet-to-packet terminal working, particularly at 9600 bit/s. Consequently, plans are already being implemented to increase the capacity

of the PSS during 1981 to include new PSEs at Liverpool, Newcastle-upon-Tyne and Slough. A contract for a further enhancement of the service in 1982 has been placed. This will increase the network size to 19 PSEs (25 TP4000s).

### UK INTERNATIONAL PACKET-SWITCHED SERVICES

Recognition by the BPO of potential demand for database access to the USA led to the establishment of a trial service to the USA in conjunction with Tymnet and Western Union International (WUI) during 1977. Access was soon extended to the Telenet network, and customer reaction to the service was so favourable that the BPO decided to purchase proprietary equipment to set up an independent packet-switching service which would be, as far as possible at that time, in accordance with the CCITT recommended standards. The UK international packet-switched service (IPSS), opened in December 1978 with access to networks in the USA via individual links to each of the gateways provided by the 3 international record carriers ITT, WUI and RCA.

Growth has been considerable since the opening of the service, with links to Canada (accessing their DATAPAC and INFOSWITCH national networks via the Canadian TELEGLOBE international gateway), Spain, Hong Kong and Australia being added (see Fig. 2). During 1981, the PSS will be connected to the IPSS via links using the X75 internetwork protocol, and all national access to the IPSS will then be via the PSS. The PSS connexion to EURONET will be provided via X75 trunks from the IPSS gateway as soon as EURONET is modified to include X75 internetwork protocols (target date 1981).

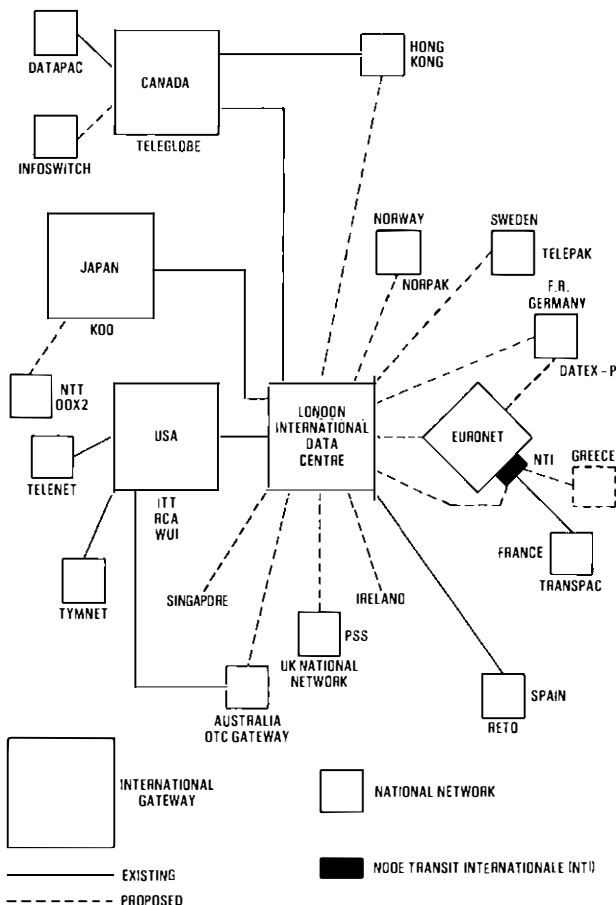

Note: The terms DATEX-P, TRANSPAC, TYMNET etc. refer to national packet-switched networks

FIG. 2—The planned UK international packet-switched service

### EURONET

EURONET<sup>9</sup>, the packet-switched network linking the 9 countries of the European Economic Community (EEC) and, more recently, Switzerland, has proved to be the catalyst for packet-switching developments in Western Europe. The idea for EURONET was conceived when the EEC became concerned at the proliferation of star-type networks being set up for information retrieval purposes. It was decided that a common approach would make better use of resources, and that a packet-switched network was the best solution for the telecommunications element. Early discussions took place between the Commission of the EEC and CEPT/CSTD† and it was agreed by both parties that the telecommunications network should be implemented collectively by the appropriate telecommunications administrations, leaving the standardization of databases and user procedures to the Commission. Recently, in order to identify the latter activity separately, the title *DIANE* (Direct Information Access Network—Europe) has been introduced for the EEC sponsored database access service that uses EURONET as the communication vehicle.

PSEs are located at London, Paris, Frankfurt, Rome and Zurich, with remote access via multiplexers in Amsterdam, Brussels, Copenhagen, Dublin and Luxemburg.

TRANSPAC, the French national packet-switched network, was connected to EURONET in the early part of 1980. Spain, Sweden, Norway, Greece, Austria and Yugoslavia also plan to gain access to and from EURONET in the near future, the first 3 via their national packet-switched services.

EURONET initially came into operation at the end of 1979 as a stand-alone network, primarily provided to carry the EEC database access traffic (*DIANE*), but able to carry other traffic as an embryonic European public data network. Progressively, as national packet networks open service and are interconnected either via EURONET or bilaterally, the function of EURONET as an independent network will disappear.

### FUTURE PACKET-SWITCHING DEVELOPMENTS

The co-ordinated efforts to establish an international packet-switching network infrastructure, the acceptance of international standards by terminal-equipment suppliers and by customers, and the appearance of more and more applications requiring interworking between different customer organization systems have caused a steady growth in the use of public packet-switched networks. The technique of packet switching provides considerable advantages in terms of economical transmission and interworking capability, and provides a basic network protocol upon which higher levels of terminal protocol can be developed for different applications. Hitherto, the relatively high cost of packet-switching equipment has been the major inhibiting factor that prevented packet switching developing on an even higher scale, but with the continuing fall in processing costs it is inevitable that packet switching will become more and more important as a facility within public telecommunications networks.

There is much speculation regarding the role for packet switching as ISDNs become established in the late-1980s. Much depends upon the economics and resultant tariffs of the ISDN services. The higher bit rates available in an ISDN environment (for example, 64 kbit/s and 2 Mbits/s) will cause a radical change in terminal developments and service applications, but certain interactive data transactions can always be transmitted more efficiently than voice over a given digital transmission system by means of multiplexing and packetizing. Packet-switching protocols also provide a homogeneous network facility which is independent of terminal data rates and which offers a sound foundation for future *open system* working.

† CEPT/CSTD—Conference of European Postal and Telecommunications Administrations/Special Committee for Data Transmission

## CONCLUSION

A review has been given of packet-switching developments in the international arena with special emphasis on the UK contribution during the last 10 years. The next 5 years or so will be important in terms of the maturing of international services on a commercial basis.

## References

- <sup>1</sup> BELTON, R. C., and SMITH, M. A. Introduction to the British Post Office Experimental Packet-Switching Service (EPSS). *POEEJ*, Vol. 66, p. 216, Jan. 1974.
- <sup>2</sup> HADLEY, D. E., and MEDCRAFT, D. W. F. Experimental Packet-Switched Data-Transmission Service: Network Design and Implementation. *POEEJ*, Vol. 67, p. 88, July 1974.
- <sup>3</sup> SPOONER, M. J., WILSON, E. J., and NEIL, W. Experimental Packet-Switched Service: Procedures and Protocols, Part 1—Packet

Formats, Facilities and Switching. *POEEJ*, Vol. 67, p. 232, Jan. 1975.

<sup>4</sup> SPOONER, M. J., WILSON, E. J., and NEIL, W. Experimental Packet-Switched Service: Procedures and Protocols, Part 2—Transmission Procedures. *POEEJ*, Vol. 68, p. 22, Apr. 1975.

<sup>5</sup> SPOONER, M. J., WILSON, E. J., and NEIL, W. Experimental Packet-Switched Service: Procedures and Protocols, Part 3—Operation of Asynchronous Terminals. *POEEJ*, Vol. 68, p. 110, July 1975.

<sup>6</sup> GARDNER, A. J., and SANDUM, K. N. Experimental Packet-Switched Service: Routing of Packets. *POEEJ*, Vol. 68, p. 235, Jan. 1976.

<sup>7</sup> BURGESS, M. J., and LOCKWOOD, J. A. Experimental Packet-Switched Service: The Customers and their Packet Terminals. *POEEJ*, Vol. 69, p. 122, July, 1976.

<sup>8</sup> MARLOW-MANN, P. D. G. Operational Experience and Evaluation of the British Post Office Experimental Packet-Switched Service. *POEEJ*, Vol. 72, p. 43, Apr. 1979.

<sup>9</sup> KELLY, P. T. F., and LEE, E. J. B. The Telecommunications Network for EURONET. *POEEJ*, Vol. 70, p. 208, Jan. 1978.

---

# Telex Switching and Signalling

E. E. DANIELS†

UDC 621.394.34

*Fully automatic Telex service celebrates its twenty-first anniversary this year, nationwide coverage being completed with the installation of the Strowger exchange in Fleet building in 1960. This article describes the equipment used for the automatic Telex service throughout this period and the progress so far towards modernization of the national network.*

## INTRODUCTION

The Telex service in the UK, and in several other countries, started as a subsidiary service on the telephone network. Calls were set up by using the telephone with subsequent transfer of the line to a teleprinter, associated with which was a unit for converting the DC teleprinter signals to AC line signals. A 1500 Hz signal, modulated to give TONE-ON for one DC condition and TONE-OFF for the other, was used in each direction. However, compared with a separate Telex network, this system had a number of disadvantages, and, after a few years service on a separate manual network during the 1950s, an electromechanical automatic Telex network was introduced; it was completed in 1960<sup>1</sup>.

## SOME CHARACTERISTICS OF TELEX SERVICE

Telex is exclusively a business service, with calls originated from a central point in each organization by private operators<sup>2</sup>; this reflects on the traffic pattern. It is not generally possible to attract a substantial proportion of originated traffic away from normal business hours by, say, the inducement of reduced off-peak tariffs.

Telex does not require attendance by the called party, and this makes the service extremely attractive internationally, especially between places with wide time differences; about

40% of calls are made to overseas destinations. In fact, until very recently, the number of outgoing Telex calls from the UK exceeded the number of outgoing telephone calls.

Most countries with developed Telex systems adopted a policy of using switching mechanisms and techniques similar to those used in their national telephone networks. This led to the adoption in various countries of widely different switching principles, and to subsequent problems of interworking. Some countries used step-by-step 2-motion selector systems; others used register-controlled marker systems, with rotary or crossbar switches as the matrix. Some used dial selection; others used the teleprinter keyboard to select the required number. Some used teleprinter signals to indicate ineffective call conditions to the caller; others used a simple functional signal such as starting and stopping the teleprinter motor.

In this country, it was decided to adopt a step-by-step system which used dial selection and was based on the 2000-type selector. This decision was partly determined by a forecast in the 1950s indicating that by 1980 there would be only 12 000 subscribers. Some measure of the success of Telex can be gained by the fact that there are currently some 90 000 subscribers.

## INLAND NETWORK

### Trunking and Charging

To facilitate routing and charging, a national numbering

† Exchange Systems Department, British Telecom Headquarters

scheme in which the UK has been divided into 50 charging areas, each with a single charging point, has been evolved. The first 2 digits of the subscriber's number identify the charging area (see Fig. 1). The tariff is based on the principle of proportionate time metering: the meter is stepped at intervals throughout the call, the frequency of stepping being determined by the chargeable distance<sup>3</sup>.

The layout of the system was originally based on 6 fully-interconnected zone exchanges, each with a star configuration of dependent area exchanges; this has now been expanded to include more zone exchanges in London.

Area exchanges are connected directly to parent zone exchanges and to other exchanges to which there is sufficient traffic. If a charging area has too few subscribers to justify the provision of a physical exchange, service is provided from a hypothetical exchange incorporated in the parent zone exchange, although few of these now remain. The trunking of an area exchange is shown in Fig. 2.

The time-zone metering equipment provides the facilities for examining the digits dialled to determine the tariff to be applied. The use of selectors to absorb digits in the local train is acceptable because of the low proportion (about 1%) of local traffic at most area centres. In fact, at small area centres 'tromboning' of local traffic is a useful simplification.

At the other extreme of exchange size is the London Fleet Inland Zone exchange opened in the 1960s<sup>4</sup>. The exchange makes use of a routing translator, which is a simple level-seized register inserted in the trunking of zone exchanges to route traffic via a distant tandem switching point, and so avoids the provision of an uneconomic direct route. Growth of the network has been such that their use is no longer justified on the inland network. A cordless manual switch-board is provided for assistance traffic<sup>5</sup>.

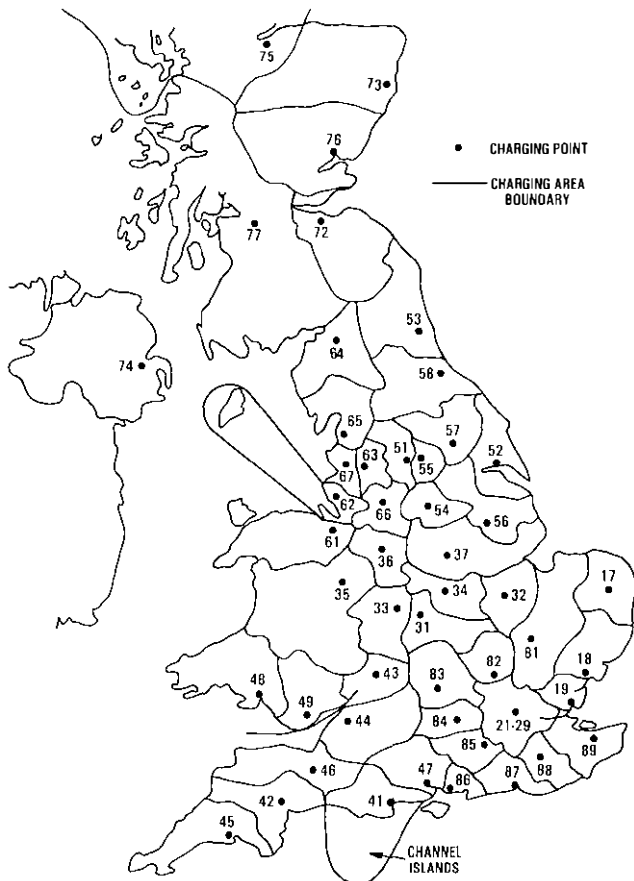

FIG. 1—Telex charging-area boundaries and associated 2-digit identifier

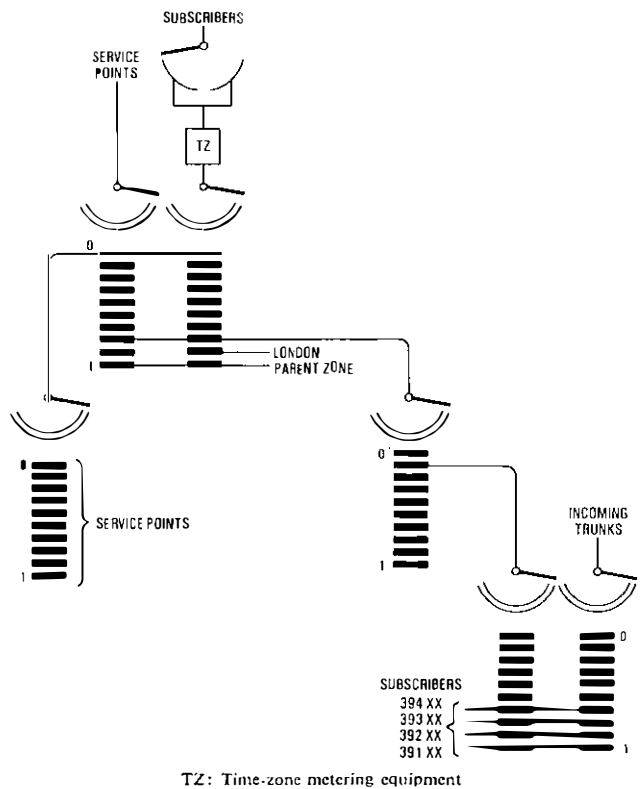

FIG. 2—Trunking principles of a Telex area exchange

## SIGNALLING

The signalling arrangements adopted for the inland system are based on signalling functions standardized by the CCITT\* for the international service. Establishment of an effective call is indicated to the caller by the automatic return of the called subscriber's *answer-back* code. On ineffective call attempts, the reason for failure is indicated by a letter sequence printed on the teleprinter page, followed by the automatic release of the connexion.

## Exchange Equipment

Switching circuits in the exchange use battery testing with backward holding. Clearing is controlled from the forward transmission path and, for this purpose, supervisory elements are located in the final selector and trunk relay-sets.

The subscriber's line circuit includes facilities for discriminating when the subscriber's power is switched off; when this happens it causes the *ABS* signal to be returned to a caller and indicates that the called subscriber is absent.

The time-zone metering equipment controls the setting up of the call, determines whether the call is to an inland or to an overseas destination and controls the charge for the call after an examination of the first 2 digits dialled. It checks the exchange for *answer-back* signals before it allows the charge to commence, and does any barring necessary to prevent irregular routing.

## INTERNATIONAL TRAFFIC

### Signalling

For signalling on international circuits, the CCITT originally recognized 2 different ranges of signals, referred to as *Type A* and *Type B*<sup>6</sup>.

These 2 groups of signals correspond to the basic types

\*CCITT—International Telegraph and Telephone Consultative Committee

used by administrations for their internal networks. It has been agreed that where 2 countries using systems of different types are to be interconnected, the calling country is normally required to adapt its outgoing circuits to conform to the requirements of the incoming country. Both types of signalling provide the same functional signals, the differences between the two being in the detailed signals used for a given function. In general, Type B has generally been used for dial-selection systems, but other combinations are possible and have been used in some systems.

The extension of fully-automatic Telex service into the inter-continental field led to the establishment of a number of new international standards. The cost of transoceanic cable or satellite circuits justified a high usage of direct circuits in conjunction with automatic alternative routing and subsequent transit switching of overflowed traffic. This required adoption of a world-wide numbering plan, and the identification of transit centres for international accounting purposes. There were many advantages in adopting a new obligatory signalling standard, known as *Type C*<sup>7</sup>, instead of continuing to use the many variants of the existing Type A and Type B signalling.

To increase the speed of signalling and to facilitate the use of any transmission medium, keyboard selection signals are used; acknowledgement signals, such as *proceed-to-select*, are dispensed with as far as possible, to avoid the effects of long propagation delays, and overlapping of the forward-path selection signals is permitted.

These new standards required the development of transit-switching equipment using different techniques from the Strowger principles previously used. In addition to their use for transit switching, it was convenient also to adopt these techniques for the equipment carrying traffic outgoing from UK subscribers and requiring new centralized accounting principles<sup>8</sup>.

Fig. 3 shows the trunking principles of one of the electromechanical inter-continental gateways. It is a common-control marker system using motor uniselectors as the switching matrix.

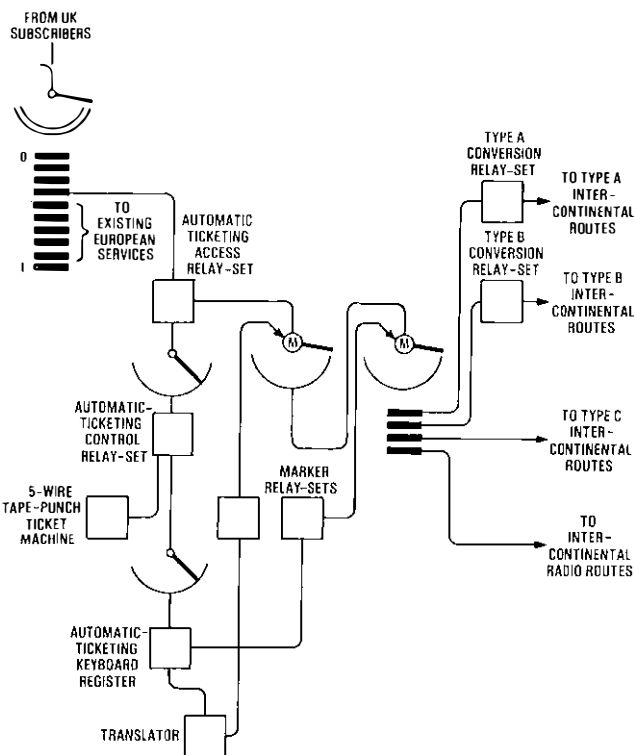

Fig. 3—Trunking principles of inter-continental Telex gateway exchange

## NEW DEVELOPMENTS

Most major administrations are now providing modern types of Telex exchange that facilitate new services such as:

(a) Message services equivalent to Telex but using higher transmission rates. New signalling standards for these services have been adopted already by the CCITT.

(b) Store-and-forward message services. For example, acceptance of a message for delivery, if possible, to a number of addresses. The caller would be given a report of delivery or failure to deliver.

(c) Message storage for subsequent delivery if the called line is engaged—a significant cause of failure of Telex calls. Alternatively, the caller can be made to wait until the line becomes free or he can be recalled when this occurs.

(d) Automatic testing of subscriber's lines and trunk lines.

(e) Management statistics, equivalent to central service observations, given automatically.

Virtually all of the modern exchanges use stored-program control (SPC) techniques associated with either a space-division or a time-division switch.

### International SPC Gateway Exchanges

In 1977, a new Telex gateway exchange, the Plessey 4660/70 exchange, was introduced into service in St. Botolph's House, London. This exchange is a time-division exchange using character-transfer techniques for traffic up to 300 bauds having pre-determined speed and code characteristics. Lines can be on physical pairs, or they can use voice-frequency division or time-division transmission systems<sup>9</sup>. The exchange interface is standardized at +80 V DC, the existing predominant line condition at that time.

In the St. Botolph's exchange, 3 processor-controlled subsystems are interconnected by a high-speed bus system; each subsystem can handle over 1000 E. For comparison, the original Fleet electromechanical gateway handled about 400 E of outgoing continental traffic and 250 E of outgoing inter-continental traffic.

A second gateway exchange is being installed at Keybridge House, London. This is the 4660/90 version using a later processor. The exchange interface in this case has been changed to 12 V DC, in keeping with the lower voltage standards required for modern transmission systems.

### Inland SPC Telex Exchanges

A contract has been placed with GEC Ltd. for a programme of 11 SPC exchanges for the inland network, to be manufactured by a subsidiary firm, the Canadian Marconi Company (CMC), and to be brought into service between 1982 and 1984. These will have capacity for some 50 000 lines and will represent modernization of about one third of the network.

Fig. 4 shows a block diagram of the CMC 755 exchange, which for Telex is a bit-transfer, as distinct from a character-transfer, switch, which gives a much faster information transfer through the exchange. The exchange is based on distributed microprocessors, rather than multiple units, each with main and stand-by processors. The triplicated time-division multiple-access (TDMA) bus switch provides a central switching point and gives each processor a time slot in which to communicate with any other processor.

Also connected to the TDMA switch is one or more routing and billing centres. These take the form of mini-computers and serve several functions:

- (a) to keep call routing records,
- (b) to control call set-up procedure, and
- (c) to keep a record of calls made for billing purposes.

To subscribers on the new exchanges, the most obvious change will be that from dial selection to keyboard selection

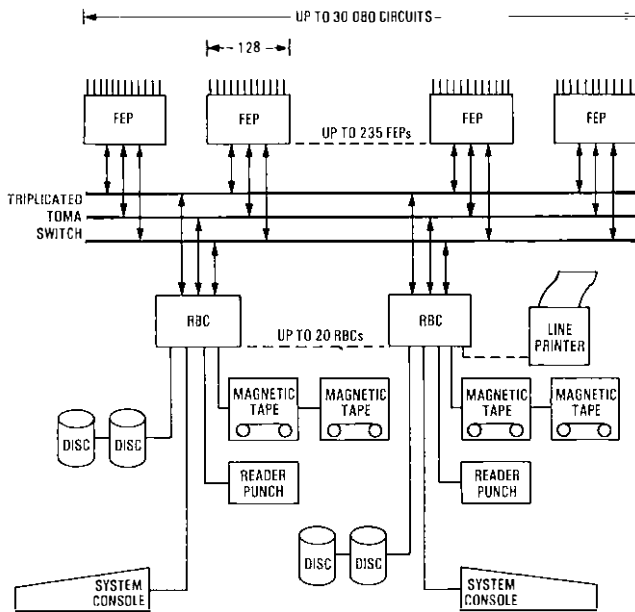

FEP: Front-end processor  
 RBC: Routing and billing centre

Note: 128 Telex circuits per processor—up to 30 080 circuits at 50 baud

FIG. 4—CMC755 Telex exchange

using a standard protocol for all calls, whether national, continental or inter-continental. The recording of charging and accounting information in local exchanges will avoid the need to exchange answer-backs, or an equivalent, with gateway exchanges and will save 5 s on all inter-continental call attempts.

Other improvements will accrue from the adoption of a new, faster international signalling standard Type D for use in the national network. This incorporates the signalling requirements for the many new facilities, such as the auto-

matic redirection of calls to destinations nominated by the called customer, included in the new exchanges.

### Inland Telex Line Concentrators

A miniaturized version of the Plessey gateway exchange, using microprocessor control, has been purchased in up to 1000-line units to augment the Strowger equipment, particularly in the London area, pending implementation of the SPC exchange programme. A variant of this equipment is being provided as an interface unit to give Telex subscribers early access to host computers on the packet-switched data network.

### CONCLUSION

This article has described the progressive modernization of the automatic Telex network from its inception until the mid-1980s. Further modernization beyond 1984 will depend, to some extent, on the availability of alternative systems and the extent to which new message retransmission systems, such as Teletex, penetrate the modern office scene, with the possible erosion of the more traditional Telex service.

### References

- 1 FORSTER, A. E. T. Automatic Switching for the Telex Service. *POEEJ*, Vol. 51, p. 193, Oct. 1958.
- 2 GARRETT, W. F. Teleprinter No. 23: A New Teleprinter for the Telex Service. *POEEJ*, Vol. 73, p. 54, Apr. 1980.
- 3 COLLINS, J. H. Generation of Meter Pulses for the Automatic Telex Service. *POEEJ*, Vol. 52, p. 196, Oct. 1959.
- 4 WILCOX, A., and BAXTER, E. C. Fleet (London) Automatic Telex Exchange. *POEEJ*, Vol. 54, p. 53, Apr. 1961.
- 5 HOWARD, R. F. A Cordless Telex Switchboard. *POEEJ*, Vol. 57, p. 110, July 1964.
- 6 DANIELS, E. F., and FORSTER, A. E. T. Subscriber Dialling of International Telex Calls. *POEEJ*, Vol. 54, p. 103, July 1961.
- 7 DANIELS, E. E., and ELLIS, W. A. Switching and Signalling Techniques for the International Automatic Telex Service, Part 1—Type C Signalling. *POEEJ*, Vol. 60, p. 210, Oct. 1967.
- 8 DANIELS, E. E., and ELLIS, W. A. Switching and Signalling Techniques for the Intercontinental Automatic Telex Service, Part 2—London (Fleet) Intercontinental Telex Exchange. *POEEJ*, Vol. 60, p. 266, Jan. 1968.
- 9 SKINGLE, G. D. Time-Division Multiplex for Telex-Customers' Lines. *POEEJ*, Vol. 68, p. 84, July 1975.



## External Plant

D. G. CLOW, C.ENG., F.I.MECH.E., F.R.MET.S., and D. W. STENSON, B.SC.(ENG.)†

UDC 621.39.005

*This article reviews the developments in external plant and practices that have taken place over the past 25 years.*

### INTRODUCTION

External plant, that part of the land-based network not housed in buildings, is a major component of the capital asset and running expenditure of the UK telecommunications system. For example, the local-line network alone accounts for about 19% of the total fixed assets of telecommunications plant and the trunk and junction network another 17% (the latter includes repeater stations in the costings). Of the workforce in the Telephone Areas, some 25% are engaged full-time on external work and another 30% have a substantial external component in their duties.

External plant tends to remain in service for long periods; items such as duct, jointing chambers, radio towers and poles are likely to survive many changes of transmission or switching system. The sheer quantity and wide distribution of the network leads to relatively slow but progressive change and reference to the fiftieth anniversary issue of this *Journal*<sup>1</sup> will show that most of the now widely implemented practices were foreshadowed then; the principal exceptions being communication by satellite and by optical fibres. The changes in plant design have been coupled with dramatic improvements in productivity, in which mechanical aids and revised working-party organization have played an important part.

The past 25 years have seen more than a 4-fold increase in the number of pairs in the local-main cable network and a 9-fold increase in speech channels in the trunk network. The rapid growth in demand for service has necessitated extensive installation of external plant, achieved with only a very small increase in the numbers of staff engaged on external work. New systems requirements are placing increasingly stringent performance and reliability standards on the external plant, both in the upgrading of existing plant and for new installations.

Two factors dominate external plant design:

(a) the demanding environment, because the plant has to withstand wind, rain, ice, sunshine or immersion in water, as well as human interference, and

(b) human safety considerations, because external work involves potential hazards ranging from falls from heights to risks from explosive or asphyxiating gas.

This article reviews firstly those parts of plant associated with signal transmission (namely, the cable system), then the structural containers or supports ranging from duct to radio towers and, finally, the working practices aspect. Space limitation requires a somewhat briefer treatment of some topics adequately covered in earlier issues of the *Journal* and given in the list of references at the end of the article.

† External Plant and Development Division, British Telecom Headquarters

### EXTERNAL-PLANT DESIGN

#### PAIR AND QUAD-TYPE CABLE DEVELOPMENT

Major changes have been seen in external pair-type cable in the past 25 years; these have resulted from both use of new materials and changing system requirements. Rationalization has also helped to reduce procurement costs and the number of standard cables is now only about a fifth of that which existed at the beginning of the period. The fiftieth-anniversary article pointed to the then future developments in the use of aluminium for conductors, polyethylene sheaths, and thinner plastic insulation, all of which have since been adopted.

#### Use of Plastics<sup>2</sup>

By the mid-1950s plastics had begun to make a major contribution in the development of cable design. By 1956 polyethylene was already established both for conductor insulation and for sheathing cable in sizes up to 50 pairs. The flammability problem restricts its application in buildings, but this does not inhibit its use for external cables, where its superior electrical properties make it an excellent conductor insulation. For cable sheaths, use of polyethylene was economic and had advantages over alternatives such as the early polyvinyl chlorides, which were prone to low temperature embrittlement. Polyvinyl chloride also has a higher water-vapour permeability than polyethylene. This problem of long-term water-vapour permeability of plastic cable sheaths was resolved by the development of a moisture barrier<sup>3</sup>. This consists of an aluminium foil applied longitudinally (originally helically) around the cable core, with overlap. The foil has a polyethylene coating on its outer surface, which becomes bonded to the polyethylene sheath when the latter is extruded over the foil-wrapped core. The early polyethylene-insulated-and-sheathed cable, used in the local-distribution network, allowed water entering at a point of sheath damage to flow freely along the inside of the cable with obvious results. With traditional paper insulation under similar conditions, the water is absorbed and the paper swells, thus restricting the damage. An attempt was made to restrict water flow in polyethylene cables by inserting a compound into the cable core during manufacture at about 20 m intervals. This was not entirely satisfactory since water entering a damaged sheath between water blocks still caused conductor corrosion if the wire insulation was not perfect. In the mid-1960s development of insulation extrusion techniques enabled polyethylene to be given a cellular structure which made attractive the development of a cable filled with petroleum jelly; the capacitance increase due to the petroleum jelly being offset by cellular insulation. Thus, the overall dimensions of the cable were virtually unchanged. The fully-filled

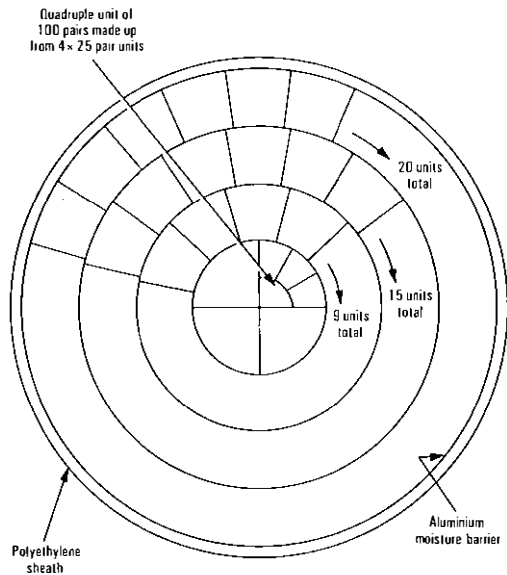

FIG. 1—Cable Polyethylene Unit Twin (PEUT), 4800 pr/0.32 mm

cable has significantly improved the reliability of installed plastic cable systems by a factor of 4 or 5, and many other telephone administrations have followed this UK lead.

In the local-main network the plastic unit twin cables (Cable PEUT) first used solid polyethylene insulation, but by 1968 trial lengths with cellular insulation were being installed. Fig. 1 shows Cable PEUT in cross-section. The improved dielectric properties of the cellular insulation allowed a reduction in overall cable diameter and thus the development of very high pair-density cables, up to 4800 pairs with 0.32 mm (formerly called 2½ lb/mile) conductors. This cable used 25-pair units, each pair within a unit being uniquely identified by a colour-code combination. Each unit is bunch-stranded, in contrast to the paper-insulated unit twin (Cable PCUT) type in which the units are assembled in a traditional manner with concentric layers of pairs. Initially, polyethylene-insulated cable tended to be used as a terminating cable for Cable PCUT, replacing the earlier and costly enamelled silk-and-wool core cable, until 1978 when Cable PEUT was used for whole routes. A cellular polyethylene-insulated trunk cable using quad construction (Cable PEQ No. 6 (see Fig. 2)) has also largely replaced the paper-insulated version (PCQT) and may also be terminated directly. In the earlier version (PEQ No. 5), a 0.5 mm conductor was used to keep within maximum allowable cable diameters, but cellular polyethy-

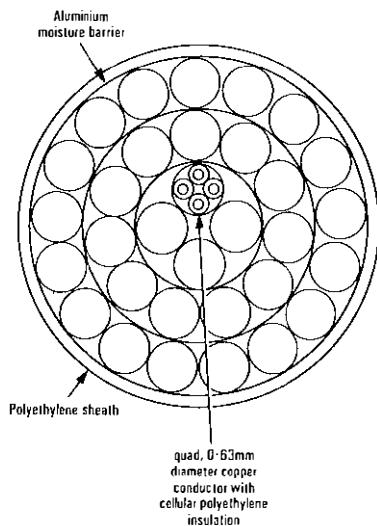

FIG. 2—Cable Polyethylene Quad (PEQ) No. 6, 60 pr/0.63 mm

lene permitted a return to 0.63 mm conductors in the PEQ No. 6.

For the local-distribution network, where cable is frequently used in situations exposed to sunlight, the cable sheaths contain carbon black. This greatly reduces the risk of cracking and embrittlement of the polyethylene caused by the action of ultra-violet radiation in sunlight. However, the larger cables, used exclusively underground, had natural unpigmented polyethylene sheaths. For two decades this seemed satisfactory, but the exceptionally sunny summer of 1976 showed that our margins were perhaps smaller than had been thought. Losses due to sheath cracking occurred on cable that had been stored for long periods in the open without protection prior to installation. Black polyethylene is now used for the outer sheath of all cables.

#### Use of Aluminium<sup>4</sup>

The fiftieth anniversary article indicated the possible application of aluminium both as a sheathing material and as the conductor material. As a sheathing material it has not been used except for some limited production in the mid-1950s, mainly because of the successful use of polyethylene.

The change to aluminium conductors because of the high and fluctuating costs of copper has been well-documented. The difficulties experienced with the ¼-hard aluminium used initially, led to a change to an aluminium alloy with its improved mechanical handling characteristics.

Aluminium was first introduced into the distribution part of the local network in fully-filled cables, since the filling gave protection against corrosion, and the increased-diameter penalty was not important. There were also trials of fully-filled cable in the main part of the local network during the early-1970s. However, there were objections to the more severe problems of handling and jointing these rather messy large cables. Furthermore, since this part of the network had been pressurized with dry air since the days of lead-sheathed paper-insulated cables, the circumstances existed to provide adequate protection. In addition, the use of jelly-filled cables in such a network would have required special measures to maintain the pressure protection standards for existing cables. On balance, the benefits of fully filling these large cables was marginal, and no further large fully-filled cables have been used.

#### Aerial Cable

Prior to the past 25 years, various designs of cable with an integral suspension strand were tried in order to avoid the

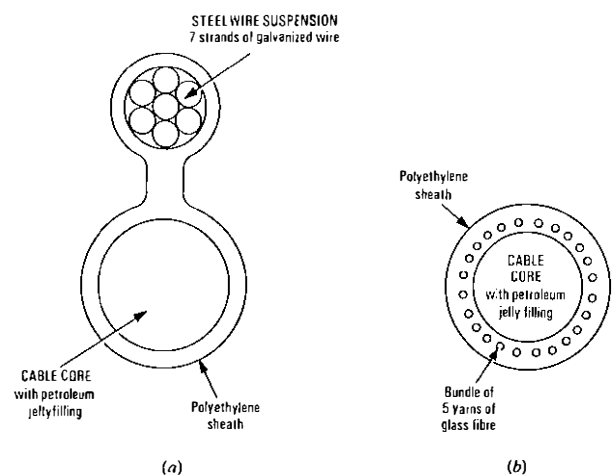

(a) Cable Polyethylene Twin (PET) Aerial, 20 pr/0.6 mm  
(b) Cable Polyethylene Twin (PET) Aerial, Glass Reinforced, 20 pr/0.6 mm

FIG. 3—Aerial cables

separate operation of lashing a cable to an already installed suspension wire. The design finally adopted and used for most of the period under review has a steel suspension strand laid up parallel to the cable core and then the whole sheathed with polyethylene to give a figure-of-eight cross-section (see Fig. 3(a)). However, because of this cross-section, it tends to be unstable aerodynamically and in particularly exposed locations a severe form of span vibration, known as *galloping*, occurs which can lead to fatigue failures at suspension points. A new cable design now on trial uses glass fibres embedded within the circular sheath as the strength members, as shown in Fig. 3(b). The stability in wind is much improved and the cable being lighter in weight and more flexible is more easily handled.

**Changes in Cable Design**

Changes in exchange design and in customers' equipment have had an impact on cable design and have led to a reduction of conductor sizes. In the local-main network 0.5 mm aluminium predominates; 0.32 mm copper is used for high pair-density shorter circuits and main-distribution-frame terminations; 0.5 mm copper has been retained for the 2-pair subscribers' lead-in cables pending a more general solution to 0.5 mm aluminium termination problems, and it is also used for the longer routes in the local-distribution network. A new design using 0.6 mm copper conductors which has a low capacitance and a better impedance match to the telephone has been introduced to replace the 0.63 mm and 0.9 mm diameter copper conductors. The smaller distribution cables have retained concentric layer construction until quite recently, but a change to a 10-pair unit construction is now nearly complete (see Fig. 4). These developments have given scope for greater efficiency in manufacture, and hence cost advantages, as well as an improvement in the general electrical characteristics.

**HIGH-FREQUENCY CABLES**

The past 25 years have seen an increasing interest in cables for higher-frequency use. In the mid-1960s, a single quad cable with 1.27 mm conductors, Cable Polyethylene Quad (PEQ) No. 4 (Fig. 5(a)), was introduced to provide for high-frequency

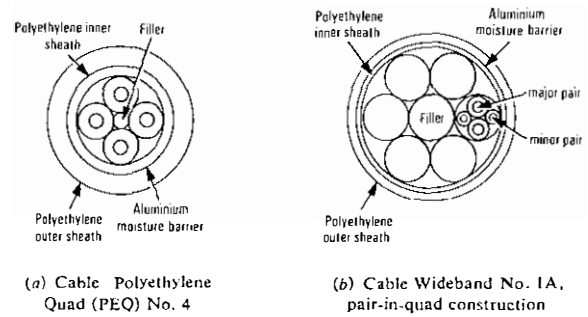

FIG. 5—Special-purpose cables

(HF) local network connexions for carrier, data, and video systems. More appropriate for television distribution is Cable Wideband No. 1A (Fig. 5(b)) introduced during the 1970s, which is either a 4 + 4 or a 6 + 6 pair cable in what is known as pair-in-quad formation. Each video pair is associated with an audio pair as a quad using 0.9 mm and 0.5 mm conductors respectively, the audio pairs giving a partial screening effect for the video pairs.

In the junction network, the use of pulse-code modulated (PCM) systems has progressed from the exploitation of the existing audio quad cables to the provision of new cable designs for exclusive PCM use. These cables are available in 10-pair unit construction in 20, 40, 60 and 80 pair sizes. They have a transverse screen of aluminium foil diametrically across the cable, thus reducing the near-end crosstalk which tends to be a limiting factor for bothway transmission within a single cable. In the transverse-screen cable, pairs in one half are reserved for the *send* direction of transmission, and the pairs in the other half for the *receive* direction (see Fig. 6).

**COAXIAL CABLES**

The British Telecom (BT) cable network includes approximately 200 000 pair (that is, a coaxial tube) kilometres of coaxial cable of which 79% is of the 1.2/4.4 mm type and the remainder is 2.6/9.5 mm. A number of cable designs are also used for communal-aerial television schemes, where the manufacturer is given some design latitude to meet a specified performance standard.

Development of coaxial cable has been limited to the introduction of the 1.2/4.4 mm type and improvements in production methods aimed at exploiting the potential of the designs. Lead sheaths with bitumen-hessian, and later polyethylene protection, have been used until recently. Polyethylene sheathing with a moisture barrier has become standard since the introduction of injection-welding sheath-closure techniques.

As the network has evolved, the main coaxial cables have carried frequency-division multiplex (FDM) systems of

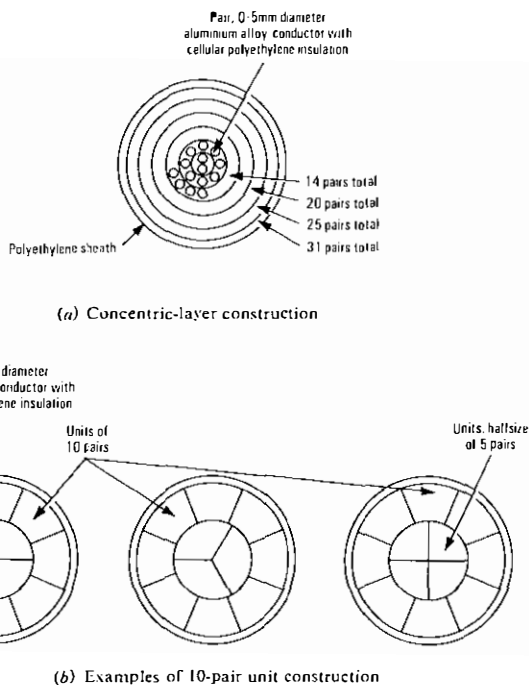

FIG. 4 Cable Polyethylene Twin Aluminium (PETAL)

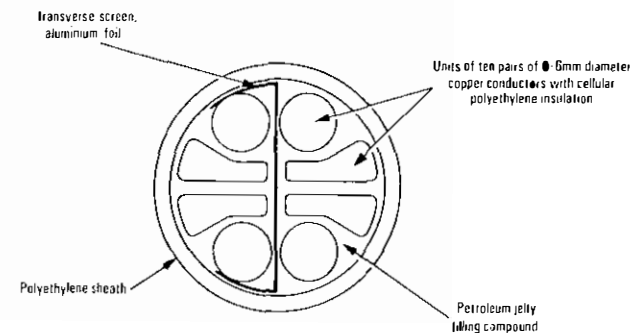

FIG. 6 - Cable Polyethylene Unit Twin, Transverse Screen, Fully Filled (PEUT TS FF), 80 pr/0.6 mm

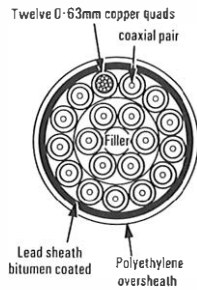

FIG. 7—Cable Coaxial, 18 pr/2·6/9·5 mm + 24 pr/0·63 mm

increasing bandwidth from 1·3 MHz initially, up to 12 MHz, and finally to 60 MHz. The same cables in the ground are now being exploited for the perhaps more demanding 140 Mbit/s digital line systems.

### 2·6/9·5 mm Coaxial Cable

Since the 2·6/9·5 mm coaxial cable design was introduced in 1938, coaxial pair construction has been progressively improved as new materials have become available and new manufacturing techniques have been developed. The most notable development occurred in 1973 when high-capacity routes between London and Birmingham and Birmingham and Manchester were being planned. The decision was made to install 18-pair 2·6/9·5 mm cables (shown in Fig. 7) with 60 MHz FDM systems<sup>5</sup>. Although the then current production of cable could have satisfied the performance requirements, it was intended that the new cables should also be able to support future high-bit-rate digital line systems (for example, 565 Mbit/s). The detection and elimination of reflexions at particular frequencies between 60 MHz and 500 MHz having sufficiently high magnitude to impair high-speed digital working has been well documented elsewhere; suffice to note here that these cables have a potential for high-bit-rate systems.

### 1·2/4·4 mm Coaxial Cable<sup>6</sup>

Cables using small-bore 1·2/4·4 mm coaxial pairs were introduced during the early-1960s. Initially these carried 4 MHz FDM systems, later upgraded to 12 MHz FDM. Although designed for use up to 12 MHz, the high-frequency performance of the coaxial pairs up to 100 MHz was adequate to support digital line systems up to 140 Mbit/s. However, tests on existing laid cable revealed that some of the joints and jointing techniques were unsatisfactory for the new high-rate digital line systems; many joints needed to be re-made to improved standards to allow satisfactory digital working.

To date, some 12 routes have been commissioned with 120 Mbit/s digital line systems and more routes are planned towards meeting the long-term all-digital network target.

## OPTICAL-FIBRE CABLES

At the time of writing, the first series of optical-fibre cables are being installed. A variety of cable constructions are being used initially, and the experience gained in handling these cables will facilitate the decisions to be made on future types and exploitation. Clearly this new transmission medium presents a whole range of new and challenging problems and possibilities for external cable and plant design. However, the reader is referred to the Research article in this issue for more details of systems<sup>7</sup>.

## JOINTING OF CABLES

Jointing of underground cables can be considered in two parts: firstly, connecting the transmission path, namely the

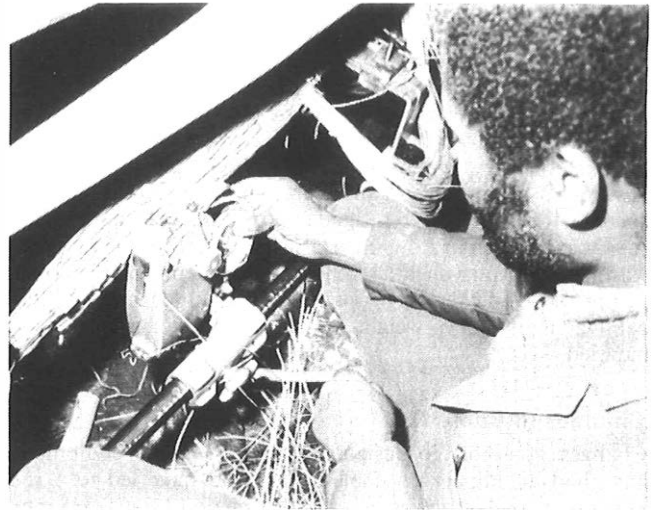

FIG. 8—Jointing Machine No. 4

metallic conductors and, more recently, optical fibres; secondly, sealing the sheath to protect the joints against mechanical damage and the ingress of moisture.

### Wire Connexions

The design of the cable can influence the conductor-jointing method. The lapped paper-insulated copper conductors being installed 25 years ago were joined by twisting the bare conductors together tightly and reinsulating the joint with a paper sleeve. This helped to trap the paper-tape insulation in place and gave a reasonably strong mechanical joint. For the majority of joints in the local network the joint was 'wetted' by the DC current required for signalling and for the carbon microphone, and this gave an acceptable electrical connexion. Where a better electrical connexion was required for trunk and junction circuits the twisted wires were also soldered. The rapid expansion of the local network and the use of larger cables stimulated consideration of mechanical methods of joining wires. A number of methods that involved twisting, welding and crimping techniques were evaluated before the development of the connector and semi-automatic crimping machine was started. This was to become the Jointing Machine No. 4 system<sup>8</sup>, shown in Fig. 8.

The strong economic pressure to adopt aluminium conductors, initially for distribution cables, gave impetus to the evaluation and adoption of the Bell Telephone 'B' Wire Connector in 1969. Although originally designed for copper conductors, it was found possible to modify this connector to give acceptable joints on  $\frac{3}{4}$ -hard aluminium and, later, aluminium-alloy wires. This method was adopted after trials had shown that it was impracticable to either weld or solder aluminium on a large scale under field conditions. With the later extension of aluminium into the local-main network the connector designed for use with jointing machines was also modified to enable aluminium wires to be jointed.

### Sheath Closures<sup>9,10</sup>

So long as lead-sheathed cables continued to be used, until the late-1950s, the centuries-old plumbing techniques were used to reseal the sheath at cable joints. The properties of polyethylene (for example, tough, resistant to chemical attack etc.) that made it a good sheath material also made it difficult to achieve a reliable sheath closure. There were no known adhesives with long-term reliability, and a welding or fusion technique comparable with plumbing lead was not then practicable. Methods used included filling of joint casings with wax or resin, expanding plugs, and tape systems. The use of self-amalgamating tape with sleeves for the small distri-

bution cables and epoxy-putty plumbing for pressurized cables was standard by the end of the 1960s and was to remain so until recently. None of these methods were considered sufficiently reliable and development continued.

During the 1970s, three new methods of closure were introduced. In the underground distribution network, the number of joints was reduced by adopting a radial system based on an above-ground jointing pillar and the Sleeve No. 31A (see Fig. 9). The Sleeve No. 31A type of closure relies on a long resin seal at the cable entries and yet provides an easily closed and re-openable joint which can function both as an underground distribution point and for test access. The Sleeve No. 31A was part of an overall design of jointing system for distribution cables which had the underlying philosophy of bringing the work to the jointer rather than having him work in a possibly very restricted and difficult situation below ground. A jig which enabled the jointer to sit with the joint at a comfortable height in front of him was designed. Slack cable is provided to enable this to be done; a further benefit was that the joint box becomes merely a place for the storage of cable and joint as it is not necessary to enter the box to carry out the jointing, and disturbance to other plant is thus minimized.

Another major development in distribution cable closures has been the introduction of heat-shrinkable materials with heat-sensitive adhesives which are now replacing the tape-and-collar methods. Heat-shrinkable materials improved greatly during the 1970s and trial results have shown that heat-shrinkable closures can be made more successfully under field conditions than the earlier taped closures. An example is shown in Fig. 10.

Lastly, extensive field trials have also demonstrated that a fusion method employing injection welding can give very much better results than the earlier methods used to close polyethylene-sheathed pressurized cables. A method of injection welding which is able to accommodate the wide range of sizes and types of cables used in the telephone network is now being introduced nationally. The initial



FIG. 9—Sleeve No. 31A with a jointing jig

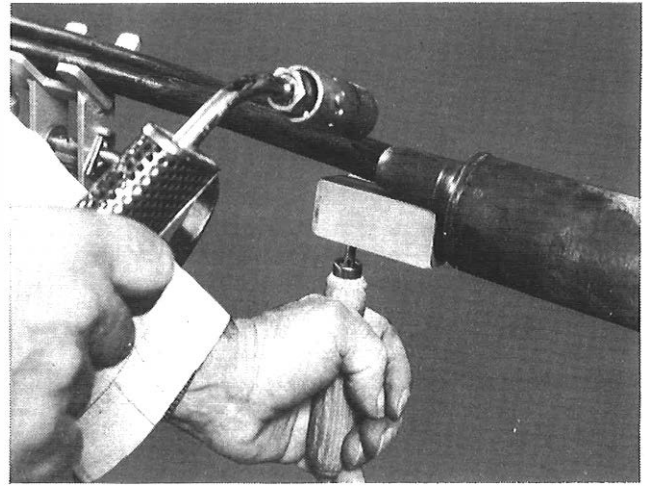

FIG. 10—A multi-entry heat-shrinkable sheath closure

results continue to support the optimism in the reliability of the method generated by the field trial. Injection welding in progress is shown in Fig. 11.

### CABLE PRESSURIZATION<sup>11</sup>

Twenty-five years ago all new coaxial cables were being pressurized on installation, and in 1957 the first trials of pressurizing cables in the local network were undertaken. The success of pressurization was demonstrated by a dramatic fall in circuit fault rates; this led to its rapid implementation on all trunk, junction and local-main cables in the following decade. Two different systems were used. The trunk and junction cables used a static dry-air pressurization system with pressure monitoring contactors at regular intervals along the cable. The nature of the local-main cable network made a static system difficult to achieve because of the presence of many spurs and joints, and a flow system in which dry air is supplied continuously was adopted. Even so, it was not practicable or economic to extend pressurization into the smaller cables generally beyond the primary cross-connexion point (that is, the cabinet) and these cables had no protection until fully filling with jelly was devised.

The benefits of pressurization were threefold:

- (a) the pressure monitoring system gave early warning of sheath damage,
- (b) ingress of moisture into the cable was eliminated except when substantial sheath damage occurred, and



FIG. 11—Injection welding of sheath closure in progress



FIG. 12—A modern wood distribution pole

(c) leaks could be located and cleared without the urgency necessary to prevent the serious damage by water and loss of service common with unpressurized cables.

## OVERHEAD CONSTRUCTION

### Poles

The wood pole (see Fig. 12) is still very much a feature of external plant. There are very few open-wire routes left in the UK and these are usually in remote areas. In the main, poles are used in the local network for distribution points (DPs) and for supporting small aerial cables. The typical DP serving up to 20 subscribers with individual overhead drop-wires is fed by an underground cable, although a few have aerial cable feeds. Thus the need for very large and strong poles has ceased, and a much restricted range of light and medium-duty poles is now used. Currently some 100 000 poles are purchased annually for new work and renewals.

The main problem with wooden poles is that of decay, with the ensuing risk of failure and hazard to people. The routine inspection of poles has been refined over the years as better statistical data have become available but, in spite of considerable experimental work, the hammer and probe tests for detecting decay have not been superseded. Alternative methods of preservation to increase the life of a pole have been tried, but creosoting by the Ruping process is still unchallenged.

The major development has been the recent introduction of a fabricated hollow pole as a distribution point<sup>12</sup> (see Fig. 13). The hollow pole is made of either glass-reinforced polyester resin or steel, and completely removes the need for personnel to climb the pole, because the suspension of dropwires can be carried out entirely from ground level. The benefits of such a system include more efficient and safer works practices and a better appearance. The first large production contracts for hollow poles have been placed in 1981.

Joint use of poles by both the electricity supply authorities and BT<sup>13</sup> has continued, and in some localities constitute a very significant proportion of the poles supporting subscribers' lines. The procedure of sharing has not been without problems largely because of ill-considered construction methods. The system is likely to be continued although significant changes in standards and practices are now taking place.



FIG. 13—Pole-Erection Unit erecting a hollow pole

### Drop Wiring

Twenty-five years ago, the standard method of feeding subscribers from distribution poles was by means of open-wires radiating from ring-type pole heads with insulators. As long ago as 1932, insulated 2-wire cadmium-copper drop-wires had been used as an alternative to open wires, but these were unsightly because of the necessary thickness of the rubber insulation and braided textile covering. The availability of plastics over the past 25 years, coupled with the use of high strength conductors, has permitted a size reduction so that the visual intrusion is minimal. All three current drop-wires use copper-coated steel conductors with polyvinyl-chloride (PVC) insulation. The 2-wire Cable Drop-Wiring No. 6 caters for most customer feeds, but a 3-wire version is available for situations where an earth needs to be extended to the subscriber's premises. A more heavily-insulated 2-wire cable is used in locations where there is the possibility of contact with overhead electrical distribution wires.

The steel-cored copper conductors have proved to have more than adequate mechanical strength, but are prone to corrosion if the insulation and the copper layer are damaged. Trials of a cable which re-explore the use of cadmium-copper conductors are now under way.

## UNDERGROUND CONSTRUCTION

### The Duct System

Although cables can be buried directly in the ground provided they are suitably protected, the majority of telephone cables are pulled into ducts. It is the practice to provide duct space against long-term needs, thus restricting the excavation and reinstatement of public thoroughfares to a minimum.

Twenty-five years ago  $3\frac{5}{8}$  inch internal diameter earthenware ducts were used almost exclusively. Single, 2, 4, 6 and 9-way multiple ducts using the self aligning (SA) duct design of spigot and socket were standard<sup>14</sup> until the introduction of

the single-way Duct No. 15 in 1967. The SA ducts were fired in coke-fired beehive kilns, but these became obsolete as a result of legislation restricting emissions into the atmosphere, and were replaced by gas-fired tunnel kilns. Some 300 Ducts No. 15, each 3 feet in length (latterly 1 m) could be close stacked on their ends on refractory trolleys which moved slowly through the tunnel heated with gas jets at floor level of the tunnel. The polyethylene socket and bituminous coating to the spigot were applied after cooling. Multi-way ducts were not suitable for this method of manufacture, and production of these ceased in 1968.

The first large-scale trials of a new generation of earthenware duct fired by a new method were undertaken in 1980. These kilns allow each duct to be carried separately on a horizontal conveyor through a closely-controlled and temperature-graded heat zone. The dramatic reduction in fuel costs helps to keep earthenware duct competitive with alternative materials. A reduction of wall thickness, and therefore weight, permits the use of 1.5 m lengths.

### Use of Plastics

Plastics have been used increasingly for the manufacture of duct.

A widely-available general-purpose polyethylene tubing of 25 mm external diameter and 2.6 mm maximum wall thickness, is used for underground feeds to customers premises. Known as *Duct No. 100* it replaced galvanized wrought-iron pipe in the early-1960s.

PVC duct was used experimentally in 1963 to replace pitch fibre and octagonal earthenware for larger duct nests for leads into exchanges. At this time PVC pipe was relatively expensive, so a thin-walled 89 mm diameter pipe was used, supported longitudinally by concrete spacers at 1.5 m intervals. Small-aggregate concrete was placed between the ducts and around the outside of the nest. It was necessary to pressurize the PVC duct to maintain its circular cross-section during the concreting operations. In 1968, PVC Duct No. 55 with a wall thickness of 2.3 mm was introduced which obviated the need for pressurizing during encasement. In 1970, a 3.8 mm wall duct permitted use without concrete in formations up to 9 ways. In larger formations concrete is used as a haunching along the sides and above the duct<sup>15</sup>.

The oil crisis later led to the wall thickness being reduced by 14% to reduce polymer costs. Known as *Duct No. 54D*, it is currently supplied in both 6 m and 1.5 m lengths with a 90 mm bore. A tapered socket on each length gives a tight joint which may be sealed with a solvent adhesive cement if necessary.

An intermediate size of duct (Duct No. 56) was introduced in 1968. It has a nominal 50 mm internal diameter and is supplied in 3 m lengths with a tapered socket formed on one end. Its main application is for low-density housing-estate development schemes.

Other duct materials such as asbestos-cement and pitch fibre have been used from time-to-time, but with the exception of steel for special strength applications, plastics (PVC and polyethylene) and earthenware have emerged as the most practical and economic materials. The competition from plastics has not gone unchallenged by the earthenware industry, and their innovative attitude towards their product may ensure the use of both PVC and earthenware for the 90 mm duct requirements.

### Cable Tunnels

The first deep-level tunnel solely for BPO cables was constructed in London in 1925. Further construction has continued right through to the present period<sup>16</sup>. Although most of the tunnels are in the London area, where tunnelling conditions are favourable and the need greatest, several provincial cities now have tunnel systems. Often in the

provinces the tunnelling conditions were adverse with difficult rock-strata problems to be overcome, unlike the more predictable and consistent conditions met in London clay.

Up to 1969, the London tunnels were mined by traditional manual methods and lined with cast-iron segments. In 1969 a tunnel was mined by mechanical means and lined with precast concrete segments, a method which was substantially cheaper than earlier techniques. In the provinces, poor ground conditions often necessitated the introduction of shield tunnelling to protect the miners from rock falls. Compressed-air working was generally used during construction of the tunnels to minimize the influx of water into the workings. The most recent tunnel constructed, in Cardiff<sup>17</sup>, in very difficult ground conditions, employed all the most advanced techniques, including compressed-air working and soil consolidation to control the ground water. It was the first tunnel in the UK to use fully-automated tunnel excavation machinery in a compressed-air tunnel and with guidance by a laser beam.

At the time of writing, no further deep-level cable tunnels are being built and future work is likely to be extensions to existing systems rather than new tunnels. The benefits of deep-level tunnels have often been difficult to quantify, but there have been significant benefits such as avoidance of disturbance to road traffic during construction or cabling operations.

Tunnels at a shallow depth combine many of the advantages of deep-level tunnels but at less cost, and will no doubt continue to be constructed. A technique used for many years has been to hand dig a tunnel with a small cross-section having a temporary timber lining. The tunnel is then filled with PVC duct and all remaining spaces packed with concrete so that the end result is very similar to a conventional multi-way duct route. More recently 'mini-tunnelling' has been developed; this produces a small-diameter tunnel by mechanized techniques, which can be used for similar applications. An example of such a tunnel being filled with duct is shown in Fig. 14.

### Jointing Chambers

Twenty-five years ago, virtually all manholes then being constructed were of the standard R series and utilized conventional bent-bar steel reinforcement. With the growth of the network and demand for duct space, larger chambers were needed and often these had to be constructed in ground that was already congested with other services. This led to

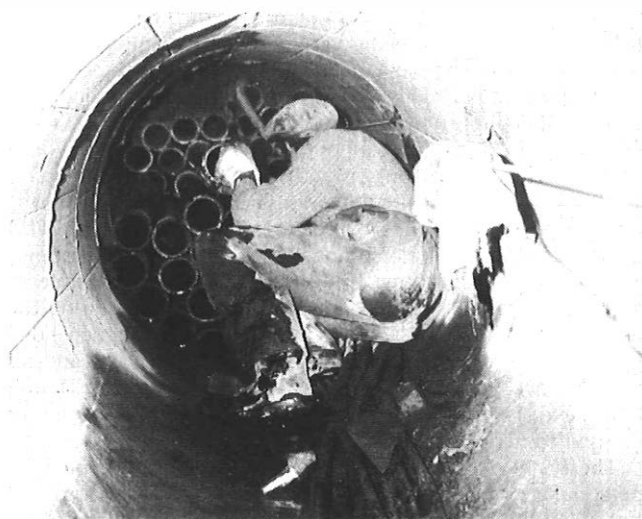

FIG. 14—Ducts being inserted into a mini-tunnel

an increase of non-standard structures. In the early-1960s, there was a return to the more simple, and therefore cheaper, straight-bar-reinforcement construction technique which had been used extensively in the 1920s and 1930s. This led to the introduction of the MR series of standard manholes and similar non-standard manholes. Since then, the increasing interest in the ergonomic aspects of jointing-chamber design has significantly increased the variety of standard manholes and, in particular, of larger structures. The concept of a column duct entry, first tried in the 1960s, permitted an improved cable layout to be achieved, but at some cost penalty because of the requirement for more excavation and more complex shuttering.

With the growth of high-capacity long-distance cable routes utilizing comparatively small duct routes (2-4 ways) came the need for a large joint box which was significantly cheaper than the small manhole which had been used previously. These boxes were introduced in the mid-1950s and very quickly displaced the small-capacity manhole. Associated with the major change in chamber configuration came the need for large box covers<sup>18,19</sup>, the carriageway type of which has continued to pose problems to the designer up to the present time. The increasing vehicle speeds and higher axle loads of lorries, combined with the present quality of road surfaces, have required better covers. Development work is being concentrated on the use of spheroidal graphite iron as an alternative to the previous standard, but weaker and more brittle, flake cast iron.

Prefabrication of manholes and joint boxes was studied between 1968 and 1976, including extensive trials of footway joint boxes. Asbestos-cement boxes were supplied from 1972 to 1977, but these did not prove to be cost-effective and were ultimately discontinued. A comprehensive study of prefabrication of larger (manhole) structures came to the same conclusion, although some were used on 2 trial duct routes. However, a prefabricated glass-reinforced plastic Joint Box No. 23 has been introduced to meet the need for an underground radial distribution system using the Sleeve No. 31A to provide flexibility and maintenance access. The box was designed within a tight financial limit in order to make radial distribution cost-effective.

### Gas in Underground Plant<sup>20</sup>

The dangers of the ingress of gas into underground plant has long been recognized, and gas-detection equipment for the use of BPO staff was developed over 40 years ago. The problem has worsened as the gas distribution network has aged and leakage into the soil has increased. The more serious development was the change to natural gas as a replacement for coal and town gas by the gas supply industry throughout most of the UK. Natural gas, being very dry, absorbs moisture and, in consequence, has the capability of drying out the old type of gas-pipe joints. This has presented the supply industry with a difficult problem of increased leakage. When leaks take place, a considerable amount of gas can find its way into cable ducts, with obvious risks to both staff and equipment.

A new gas detector, the Indicator Gas No. 5 (IG No. 5), was introduced in the 1960s to detect flammable gases. This instrument uses catalytic combustion on a platinum resistance element in a Wheatstone bridge circuit and thus is able to detect any combustible gas. The earlier testers, based on the use of sodium chlorpalladite or palladium chloride, depended upon the presence of carbon monoxide in town gas and, in consequence, were ineffective with natural gas. The Lamp Safety No. 1A, based on the miner's safety lamp, continues to be used to detect asphyxiating gases.

The IG No. 5 and Lamp Safety No. 1A were designed for personal use by all staff who are required to work underground but, in addition, some particularly vulnerable installations are fitted with fixed gas monitors which automatically sample the

atmosphere for flammable gas and give remote alarms long before gas concentration reaches a dangerous level.

The cable lead-in ducts to exchanges have long been recognized as the most likely point for ingress of gas into the building; as a result special duct seals are provided<sup>21</sup>. However, it was found that it was difficult in some circumstances to guarantee a gas-tight seal and so, in 1975, standards were introduced to ensure that the lead-in duct formation into buildings is sealed at both ends and, where it is impracticable to ensure the effectiveness of the seal, the first manhole or jointing chamber is ventilated. In new construction, ventilation is provided as a matter of course by means of a vent pipe and the system relies on a *chimney* effect. The need for these measures has unfortunately been demonstrated by gas explosions which have demolished some small exchanges in the period under review.

### HOUSING ESTATES

The provision of telephone service on housing estates is constrained by the need for strict economy. The standard method is to provide underground cable to distribution points on poles with the final link to subscribers' premises by overhead wiring. However, there is often pressure from developers and local authorities for a fully-underground system. This is undertaken when the estate developer is prepared either to make a financial contribution or to assist by carrying out part of the necessary work. A major problem with an underground system has been the risk of damage while the estate is still under construction and a variety of expedients have been used to overcome this.

Up to the early-1950s when the telephone penetration was low, lead-sheathed cable in a wrought-iron service pipe was provided from the house, and a brick or concrete joint box provided where the service cable was teed into the distribution cable. When polyethylene cable became available it appeared sufficiently robust to permit direct burial of the cable. However, the incidence of damage forced a change in the 1960s to steel-wire armoured cable, with the builder normally laying the service cable back to the footway. The BPO jointer later excavated to pick up the service cable and to make the joint into the distribution cable. The joint was housed in a special buried coupling. Damage still proved to be a problem; since 1977 the builder has provided a small-diameter polyethylene duct from the house to the footway enabling the cabling work to be undertaken when building work had ceased. The feed cables are taken either to a Sleeve No. 31A housed in a Joint Box No. 23 or to an above-ground jointing post. Although more cable is used than with the teed cable approach, the number of joints is significantly reduced, with the consequent improvement in reliability. Plant is now provided on the basis of 100% service penetration.

### STRUCTURAL ENGINEERING<sup>22</sup>

The supporting structures for radio aerial systems have changed greatly with developments in radio communication over the past 25 years. In 1956, most of the activity was concentrated on the reconstruction of ageing equipment at high-frequency (HF) radio transmitting and receiving stations. The structures were required to support wire aerial arrays and a new lightweight mast, the BP●-designed Mast No. 1, was then coming into service. Originally designed for a maximum height of 45 m, it has since been used up to 60 m. Many hundreds of masts to this design have been manufactured throughout the past quarter-century. In the early-1960s, another type, the Mast No. 2A was produced for heights up to 90 m. These designs incorporated 2 new features: all steelwork was galvanized to provide a method of corrosion protection aimed at eliminating or minimizing the need for costly maintenance painting; and the extensive use of prefabrication which minimized the amount of work to be done aloft.



The 1950s and early-1960s were the heyday of HF radio, but the introduction of long-haul submarine cable telephony systems, the rapid growth of the inland microwave network and then the advent of satellite communication, altered the emphasis of structural design. The characteristic of structures for microwave systems is the need for great rigidity in order to maintain the pointing accuracy of the radio beam.

Twenty-five years ago, the first BPO microwave radio systems were coming into service. The early systems used a few small dish aerials and the fairly large guyed masts used were able to provide the required height and rigidity of support structure. As aerial numbers and sizes grew, the self-supporting tower was used almost universally. A variety of designs have been used, the one-off designs being carried out by contractors and the BPO producing 3 tower designs conceived on a modular basis, the Towers No. 4A, No. 5A and No. 7A. Fig. 15 shows a Tower No. 5A. Each of these types utilized a restricted range of standard components from which towers of a wide variety of shapes and sizes could be assembled to suit the requirements of a particular site.

The BPO entered the field of computing for structural analysis work in the late-1960s. Prior to the use of computers, the determination of loads in structural members was done either by graphical methods or by analysis, both of which, for reasons of computational necessity, were based on simplified representations of the structure. The use of computers enabled a much more detailed analysis of structures to be undertaken; consequently, a much more efficient use of steel and concrete became possible.

Use has also been made of wind tunnels. Towers or tower components present a complex shape to the wind, and standard methods of calculation of wind-imposed loads often give a very conservative result. Testing of models in wind tunnels (see Fig. 16) has proved to be very cost-effective and has, for example, enabled existing structures to take more aerials without the strengthening which would have been otherwise indicated.

The advent of large steerable aerials at satellite earth stations has posed similar problems of stress analysis and wind-force determination to the fixed aerial systems and again computers and wind tunnels have been valuable tools in effecting their maximum utilization.

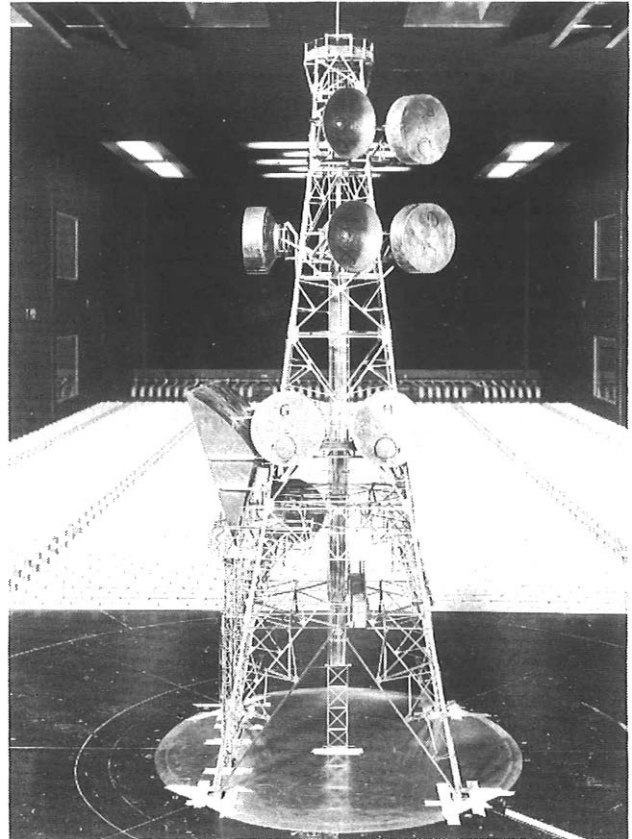

FIG. 16—Model tower undergoing wind-tunnel tests

## WORKING METHODS AND MECHANIZATION

### WORKING PARTY ORGANIZATION

From 1956 until 1965, working parties in the external field employed on installing plant and equipment were still using basically the same methods and techniques as those employed in the first quarter of the century. These labour-intensive techniques were based on large working parties of up to 10 in number with the use of hand tools and a few basic mechanical aids such as trailer winches and jacks.

In 1962 the Government's National Plan was launched. This asked all major businesses to critically examine their organization and methods with a view to improving overall output. The intention was to increase the gross national product by 25 % in 5 years; thus the plan was launched in what was called *National Productivity Year*. The BPO actually nearly doubled on the target figure, and the extensive mechanization of the external work figured strongly in this achievement.

### Overhead Construction

In the overhead sector of the external plant field, 2 items which were introduced were the pole erection unit (PEU) and the elevating platform. The size of an overhead working party was dictated mainly by the number of men necessary to safely erect and recover poles manually. Thus, the basic requirement of a PEU was to carry out the poling work safely and efficiently with 2 men. Included in the requirements were the mechanical installation of stay-wire screw anchors and the ability of the unit to carry all the stores required to do the job, including a day's supply of poles. In the period 1964-65 a completely self-contained mechanized vehicle, based on the line construction units used in North America, was introduced for carrying out poling operations. Each unit<sup>23</sup> consisted of a hydraulically-operated derrick with a telescopic boom mounted at the rear of the vehicle on the left-hand side of the



FIG. 15—Tower No. 5A

chassis. On the extendable portion of the boom were mounted a pole-hole borer and a winch, both hydraulically-operated. Auxiliary equipment consisted of a hydraulically-operated pole jack and back-fill rammer. A PEU is capable of erecting and recovering poles up to 15 m in length as well as installing screw-type ground anchors for stay wires. Its average performance is about 4–6 poles/d and it is operated by a 2-man party.

Various vehicle-mounted elevating platforms were being introduced by the BPO in the early-1960s, mainly for the maintenance of open-wire routes. With the continuing change-over to aerial cables, a mechanized system was required based on a mobile elevating platform which could erect cables effectively and safely with a reduced manning level<sup>24</sup>. The original manual method of aerial cabling had been to erect a suspension wire, and then the cable was either manually lifted and clipped to the supporting wire or lashed using a wire-lashing machine. This method of aerial-cable erection was time-consuming and labour-intensive. When self-supporting aerial cable was introduced, manual cable erection became more difficult, and a mechanized system of erecting aerial cable was developed. The first machines purchased to perform mechanized aerial cabling were based on the units used by the Bell Telephone Company of Canada, called the *Telsta Aerial Cabling Unit*. The unit consisted of a turret base which could rotate through 360°, and a main boom which had a telescopic inner section. A bucket was supported on steel arms at the end of the telescopic section of the boom. This basic unit, although satisfactory in its operation, proved to be too expensive and over-engineered for the smaller aerial-cable routes in the UK. A smaller and cheaper unit, known as the *Platform Elevating No. 3*, was thus developed. This was basically an 8 m articulated boom platform with an out-reach of 4 m and mounted on a forward-control Land Rover chassis. The only sizes of the aerial cable that the 2-man-operated unit could not tackle were the 50-pair 0.9 mm conductor twin cable and the 60 and 104-pair 0.9 mm conductor quad cable; the limitation being the cable's weight. Later units fitted to a Leyland Terrier 650 chassis had increased capability and could handle the 60-pair 0.9 mm conductor quad cable.

### Underground Construction

A reduction in the number of men in the working group was also achieved in construction and maintenance of joint-boxes and manholes. Most jointing chambers are constructed on site using reinforced concrete for the base and manhole roofs and brickwork or reinforced concrete for the walls. It was therefore necessary to design a self-contained vehicle which was required to carry all the tools and material needed for the construction and maintenance of joint-boxes, the erection of cabinets, maintenance of frames and covers, and the occasional construction of manholes. The first box-building vehicle was introduced in 1964<sup>25</sup>. It had a 7 t chassis on which was mounted a half-box body to the rear of the cab and at the rear a platform with drop sides. Facilities included a concrete mixer, road breaker, water pump, hammer drill and a concrete vibrator, all electrically driven from a portable propane-driven generator which was housed in the half-box body. A hydraulically-operated lorry loader having a capacity of 2 t and skips for fine and coarse aggregate were provided. This unit was replaced in the mid-1970s by the Type III unit, an uprated version based on a Leyland Boxer 1200 chassis, which had a greater carrying capacity and a 4 t crane mounted at the rear of the chassis. A hydraulic transmission system, driven from the vehicle's engine via a power take-off, operated the crane, an electric generator and a hydraulic road breaker. A box-building vehicle is operated by a 2-man party.

### CABLING IN DUCT

The installation of cables in duct has always been heavy work

in relation to most BT activities, and developments over the past 25 years have had the dual aim of making this area of operations more efficient and safer. Changing materials, mechanization and new practices have all played their part in the continuing evolution of cabling.

### Rodding

One of the most arduous tasks was pushing a set of rods through some 200 m of underground duct to install a draw-line. The standard items for this job were rattan cane rods which were never straight and had variable stiffness properties. In an effort to produce the required characteristics of straightness and flexibility, small-diameter continuous steel rods were tried, but these were difficult to handle and never popular. The problem of combining strength, lightness and straightness was overcome by a change to an extruded PVC tube which made an increased standard-length rod feasible. Many attempts were made in the 1960s to mechanize the pushing of the continuous steel rods. Pneumatic, electric and internal-combustion-engine motive systems were tried but none would reliably drive the rod for more than about 150 m up a duct. The successful introduction of the plastic hand rods led to experiments with a PVC continuous rod, although it was known that continuous-type rods tended to spiral round the inside of a duct and require more effort than could be applied manually for any useful length to be achieved. Various types of machine were tried and it was found that a thrust of 5 kN in either direction would enable at least 200 m to be machine rodded and have sufficient power on retraction to draw in small sizes of cable. The present type of machine which meets these parameters now has many years of successful service in the field.

As an alternative approach, several walking, crawling or wheeled devices had been tried at various times with the aim of pulling a line through the duct, but these were only effective in empty dry ducts. A successful pneumatically powered walking machine, the Duct Motor No. 1 was developed and introduced in 1965<sup>26</sup>. An improved version was introduced in 1980 and this version will crawl through 500 m of partly-occupied wet deviating track in 30 min.

### Rodding and Light-Cabling Vehicle

The successful development of the rod-pushing machine and the duct motor led naturally to the concept of a rodding-and-cabling package. It was felt that if a significant percentage of the hard physical work was mechanized, then much of the distribution network could be cabled with much smaller working parties and more safely. The aim was to incorporate all the necessary mechanical aids required into one vehicle to enable 2 men to install light cables. The final result was the very successful rodding and light-cabling vehicle<sup>27</sup>. This vehicle (see Fig. 17) uses a power take-off to hydraulically power a rodding-and-cabling machine, capstan winch, reeling mechanism, a low-pressure compressor for powering road breakers and submersible pumps, and a high-pressure compressor for the duct motor. It contains all the equipment necessary for a 2-man team to install cable up to 45 mm in diameter and has played a major role in improving productivity.

### Cabling in Longer Lengths

Lead-sheathed copper-conductor cable was never installed in lengths much greater than 160 m. These cables were heavy and had a high coefficient of friction with the duct. Plastic-sheathed cables changed these conditions significantly and, with modern equipment, cabling in long lengths became possible, eliminating many joints. It is now feasible in some instances to cable up to 1000 m in a single length. A programme of continuous development and improvement in the field of mechanical aids, such as winches and ropes to handle

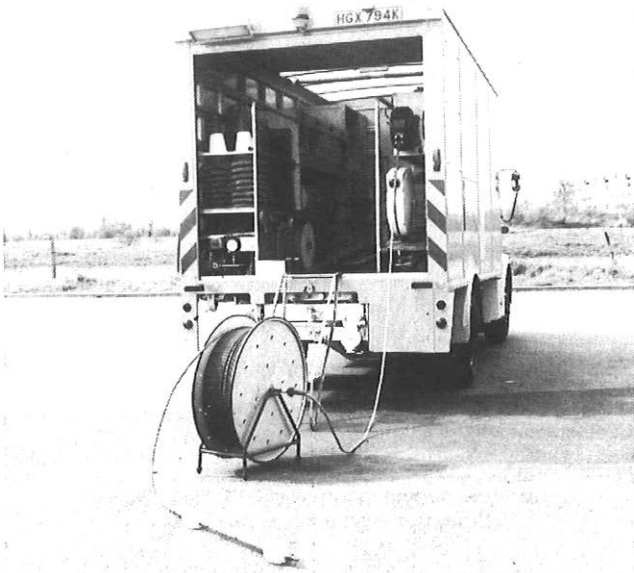

FIG. 17—Rodding and Light-Cabling Vehicle with duct motor in foreground

longer lengths, and turning wheels to enable cabling through points where joints would otherwise have been made, has made it possible to install much longer lengths. Recently further reductions in the coefficient of friction between the cable and the duct have been achieved with the introduction of a device for lubricating cables during installation.

#### Other Aids

In addition to those already described, a wide variety of mechanized equipment is available for other aspects of external work; these include gully emptiers for cleaning jointing chambers, trench excavators, thrust borers, cable recovery equipment and moleploughs.

#### INDUSTRIAL RELATIONS ASPECTS OF CHANGE

The BPO has a long history of consultation and co-operation with trade unions in the introduction of changes, and the Experimental Changes of Practice Committees (ECOPC1 and ECOPC2)<sup>28,29</sup>, with joint management and union membership, cover external working practices and safety. These committees have played a major role in the implementation of the productivity improvements. In most cases, proposals for changes in established practices are formulated after work-study techniques have been used to examine the way that work is carried out in the field and so point the way to improvements in tools, equipment and machinery which will enable the existing work force to more easily undertake the vast increase in work needed to expand the external network. The viability of new techniques is proved by field trials, with the trade unions fully consulted at all stages, so that the feedback of knowledge and experience of the field staff can be reflected in the new practices as they are introduced. Detailed negotiations with trade unions are undertaken where changes of grading or staffing ratios are involved. In general, the mechanization of external practices has been achieved with the minimum of staffing problems and enabled the BPO in the 10 years 1965–75 to more than double the overall size of the external network with only a very small increase in staff<sup>30</sup>. In some areas of work, the changes have been even more dramatic; for example, the external works productivity as measured in added local-main cable pairs per man year has risen by a factor of 6 between 1956 and 1980 as shown in Fig. 18.



FIG. 18—Local-line-construction productivity, 1956–80

#### EXTERNAL SAFETY

While the need for improvements in productivity was the driving force behind the early changes to long-standing works practices, the need to reduce the number of accidents that often result from laborious manual methods of construction also gave further impetus to the introduction of mechanical aids. In recent years, legal requirements placed on both employers and employees by the Health and Safety at Work legislation have resulted in increasing emphasis on safety in all aspects of external work. Greater awareness of safety considerations at all levels has contributed to improvements in accident rates, but there is little doubt that improved working practices, plant design and the mechanization of many external activities have been major factors in the reduction of the accident frequency rate (accidents per 100 000 manhours) from 2.08 to 1.27 over the past 25 years. In the last decade increasing attention has been given to materials or processes which give rise to health hazards. Areas of particular concern have been fumes or dust which could be inhaled, or fluids in contact with the skin. Thus asbestos has been replaced in any circumstance which could give rise to air-borne asbestos fibres, and resins or cleaning fluids are subjected to careful examination by the BT Occupational Health Service prior to their adoption.

In the context of industry as a whole, telecommunications is a low-risk business. The average fatality rate over the past ten years has been 2 per year; when low rates are achieved it is very difficult to maintain improvement. The potentially hazardous areas have already been closely studied and action taken, but continuous review is essential.

#### CONCLUSION

Compared to the previous 50 years the speed and extent of change in the 25 years under review has been much greater. The latter period has seen very significant reductions in unit cost, and comparable improvements in plant reliability and in safety throughout the external field. At the same time both the size and complexity of the transmission systems has markedly increased.

During the next quarter century the rate of development is likely to be similarly high since new systems tend to be more demanding in performance of external plant.

#### ACKNOWLEDGEMENTS

The authors wish to thank their many colleagues in the Transmission Department of BTHQ who provided material to facilitate the writing of this article.

**References**

<sup>1</sup> External Construction. *POEEJ*, Vol. 49, p. 173, Oct. 1956.  
<sup>2</sup> PRITCHETT, J. Development of Cables for the Changing Network. *POEEJ*, Vol. 64, 208, Jan. 1972.  
<sup>3</sup> GLOVER, D. W., and HOOKER, E. J. A Moisture Barrier for Polythene-Sheathed Cables. *POEEJ*, Vol. 53, p. 253, Jan. 1961.  
<sup>4</sup> PRITCHETT, J., and STENSON, D. W. Aluminium Alloy as a Conductor for Local-Network Cables. *POEEJ*, Vol. 68, p. 132, Oct. 1975.  
<sup>5</sup> PRITCHETT, J., and BARTLETT, G. A. The 60 MHz FDM Transmission System: Cable Design and Manufacture. *POEEJ*, Vol. 66, p. 158, Oct. 1973.  
<sup>6</sup> ALLAN, A. F. G. Small-Diameter Coaxial-Cable Developments. *POEEJ*, Vol. 57, p. 1, Apr. 1964.  
<sup>7</sup> TILLMAN, J. R. Research. *POEEJ*, Vol. 74, p. 282, Oct. 1981.  
<sup>8</sup> HARDING, J. P. A Wire-Jointing Machine for Subscribers' Cables. *POEEJ*, Vol. 62, p. 31, Apr. 1969.  
<sup>9</sup> LATIMER, E. D., and ROBINSON, H. E. Sheath Jointing of Plastic-Sheathed Cables. *POEEJ*, Vol. 59, p. 206, Oct. 1966.  
<sup>10</sup> STENSON, D. W. The Jointing of Polyethylene Cable Sheaths (Including Injection Welding). *Plastics & Polymers*, p. 217. Dec. 1975.  
<sup>11</sup> MYNOTT, C. R., and HARCOURT, E. N. A Review of Cable Pressurization in the British Post Office Network. *POEEJ*, Vol. 69, p. 169, Oct. 1976.  
<sup>12</sup> CLARK, D. The Hollow Pole. *POEEJ*, Vol. 73, p. 254, Jan. 1981.  
<sup>13</sup> LITTLE, S. J. The Joint Use of Poles for Telecommunications and Power Lines. *POEEJ*, Vol. 55, p. 31, Apr. 1962.  
<sup>14</sup> STENSON, D. W. The Manufacture of Earthenware Ducts. *POEEJ*, Vol. 56, p. 231, Jan. 1964.  
<sup>15</sup> HEARN, A. F., ROBERTS, J. C., and BIBBINGS, P. E. The Development of Polyvinyl chloride (PVC) Duct. *POEEJ*, Vol. 62, p. 249, Jan. 1970.  
<sup>16</sup> LAMB, W. H. The London Cable-Tube System. *POEEJ*, Vol.

63, p. 14, Apr. 1970.  
<sup>17</sup> JAMES, N. A. Cardiff Cable Tunnel. *POEEJ*, Vol. 73, p. 177, Oct. 1980.  
<sup>18</sup> JENNINGS, S. W., and HEARN, A. F. L. A New Frame and Cover for Carriageway Manholes and Joint-Boxes. *POEEJ*, Vol. 54, p. 164, Oct. 1961.  
<sup>19</sup> THORNTON, T. C., and MATTHEWS, R. E. A Double-Triangular Type Frame and Cover for Carriageway Jointing Chambers. *POEEJ*, Vol. 61, p. 82, July 1968.  
<sup>20</sup> COLYER, J. O., THARBY, R., and SENIOR, R. C. Gases in Underground Plant and Their Detection. *POEEJ*, Vol. 59, p. 80, July 1966.  
<sup>21</sup> ADAMS, R. H., and THARBY, R. The Protection of Operational Buildings against Gas Entry. *POEEJ*, Vol. 69, p. 110, July 1976.  
<sup>22</sup> CLOW, D. G. Steel Masts and Towers in the British Post Office, Parts 1, 2 and 3. *POEEJ*, Vol. 66, p. 231, Jan. 1974; and Vol. 67, pp. 49 and 102, Apr. and July 1974.  
<sup>23</sup> HUNT, R. J. The Pole-Erection Unit. *POEEJ*, Vol. 60, p. 93, July 1967.  
<sup>24</sup> STENSON, D. W., HALL, R., and NUTFALL, B. L. An Aerial Cabling Unit. *POEEJ*, Vol. 62, p. 75, July 1969.  
<sup>25</sup> TYRRELL, W. The Development of a Box-Building Vehicle. *POEEJ*, Vol. 60, p. 131, July 1967.  
<sup>26</sup> DEADMAN, D. J., and SLIGHT, J. R. A New Approach to the Duct-Rodding Problem—Ductmotor No. 1. *POEEJ*, Vol. 56, p. 91, July 1965.  
<sup>27</sup> MARTIN, R. W. A Rodding and Light-Cabling Vehicle. *POEEJ*, Vol. 64, p. 22, Apr. 1971.  
<sup>28</sup> CLINCH, C. E., WILLITT, A. H., and MARKWELL, T. E. The Experimental Changes of Practice Committees: ECOPCI. *POEEJ*, Vol. 68, p. 144, Oct. 1975.  
<sup>29</sup> HORNE, F. A., BACK, R. E. G., CROFT, E., DAVEY, K., and COLLETT, R. E. S. The Experimental Changes of Practice Committees ECOPCs 2 and 3. *POEEJ*, Vol. 69, p. 87, July 1976.  
<sup>30</sup> TURNER, G. E. Manpower Productivity in Telecommunications. *POEEJ*, Vol. 64, p. 138, Oct. 1971.

# Change and Development—March 1931—March 1956— March 1981

The last 50 years have been chosen because some services were not operating when the Institution was formed in 1906, and for others suitably related statistics were not available.

	1931	1956	1981		1931	1956	1981
<b>ENGINEERING STAFF</b>	28 430	76 080	114 827	<b>PUBLIC TRUNK CIRCUITS</b>	3900	21 550	233 815
<b>MANUAL TELEPHONES</b>	1 485 000	1 612 000	0	<b>LOCAL TELEPHONE CALLS</b>	1248 Million	3865 Million	16 840 Million
<b>AUTOMATIC TELEPHONES</b>	511 000	5 275 000	27 870 000	<b>TRUNK TELEPHONE CALLS</b>	122 Million	333 Million	3335 Million
<b>TOTAL TELEPHONES PER 100 POPULATION</b>	4.3	13.4	49.8	<b>CONTINENTAL TELEPHONE CALLS</b>	541 000	1 954 000	79 503 000
<b>MANUAL TELEPHONE EXCHANGES</b>	4287	1282	0	<b>INTERCONTINENTAL TELEPHONE CALLS</b>	4460	107 300	37 001 000
<b>AUTOMATIC TELEPHONE EXCHANGES</b>	580	4662	6315	<b>INLAND TELEGRAMS</b>	39 849 000	20 547 000	2 963 000
<b>PUBLIC CALL OFFICES</b>	34 580	68 200	76 985	<b>ENGINEERING MOTOR VEHICLES</b>	2560	18 590	50 470

# CUSTOMER APPARATUS

## Telephone Instruments, Payphones and Private Branch Exchanges

C. F. J. HILLEN, B.SC.TECH., C.ENG., F.I.E.E.†

UDC 621.395.6: 621.395.722

*The major changes and additions which have occurred in customer apparatus and equipment in the UK over the 25-year period 1956–1981 are reviewed. The scene is one of steady evolution, mainly spurred by advances in semiconductor technology. The most significant changes have been in the introduction of electronic PABXs, but towards the end of the period micro-electronics were beginning to have an impact on the design of telephone instruments and payphones. Now, in 1981, market and technology forces are primed for the introduction of change across the whole field of customer apparatus.*

### INTRODUCTION

In this omnibus article, a review is made of the many changes and additions to the customer apparatus field over the past quarter century. In this period, the UK telephone station population has grown from 7 million stations in 1956 to some 28 million in 1981. This growth has been achieved while the economic health of the country has fluctuated and, for the most part, resources have been focussed on meeting demand by the provision of basic telephone apparatus.

Advances in technology have injected change into the scene. In 1956, quantity production of the simple transistor had just begun, and this factor made feasible some new customer apparatus products; for example, loudspeaking telephones and callmakers. In the early-1970s, medium-scale and large-scale integration semiconductor devices, including the first microprocessors, were appearing; from about 1975 onwards these applications started to have an impact on customer apparatus as confidence in micro-electronic reliability and fitness of use became established.

The UK General Post Office (GPO) became a State Corporation in 1969; this change of status affected relationships with the UK Telecommunications Industry where, hitherto, development and production of new products for the UK market had been largely carried out on a co-ordinated basis. Hindsight shows that, in the immediate years following 1969, a lull or false stability occurred while fresh commercial attitudes were being formulated. Subsequently, matters changed with the introduction of such items as proprietary PABX equipments and proprietary press-button telephone variants. Now, in 1981, attitudes have received further stimulation by the creation of British Telecommunications (BT) and by Government deregulatory measures which have been enacted by Parliament and which, predictably, are injecting new dimensions into the market forces pertaining to customer equipment.

Some of the mainstream customer equipment has appeared to change very little: the ubiquitous 1981 dial telephone strongly resembles the 1959 item, though with subtle value engineering changes; similarly, the current coin-collecting box (CCB), now known as the *payphone*, resembles the 1956 product, albeit in a more rugged form and with a decimal coinage capability. However, each of these products are now moving to the natural end of their life cycle, and there are replacement products currently on trial, or at advanced

development stages. The PBX field though has seen more significant movement as the trend towards electronic solutions gained sway in the 1970s.

Some of the changes to telephone instruments and supporting apparatus, payphones, and PBXs that have occurred between 1956 and 1981 in the UK are now reviewed.

### TELEPHONE INSTRUMENTS

#### STANDARD DIAL TELEPHONES

Twenty-five years ago saw the introduction of the 700-type telephone to the UK telephone network. Prior to 1956, the 300-type telephone had been standard throughout the 1939–1945 war and the immediate post-war period.

Whereas the 300-type instrument was available in a variety of versions to serve specific situations and extension plans, the 700-type instrument was designed to be more omnipurpose and could be modified by field staff (for example, by the use of extra spring sets and buttons) to cater for the extension-plan variations.

The introduction of a rocking-armature receiver<sup>1</sup> (Receiver Inset No. 4T) to the 700-type instrument gave a transmission efficiency improvement which permitted longer subscriber lines to be used. However, the resulting high-sensitivity telephone was too loud on short lines and a regulator<sup>2</sup> was introduced.

The regulator chosen was an automatic current-sensing device consisting of a multi-element selenium rectifier, a resistance lamp and 2 resistors designed to introduce on the shortest lines approximately 6 dB loss in the send direction of transmission and 4 dB loss in the receive direction.

The 700-type first appeared in the guise of the 300-type instrument mouldings (see Fig. 1(a)) and used the Transmitter Inset No. 13 carbon microphone. In 1959, however, a new handset and complementing body shape (see Fig. 1(b)) was introduced and the 706-family of telephone instruments<sup>3</sup> was born. The regulator was made a plug-in replaceable item and a new carbon transmitter (Inset No. 16<sup>4</sup>) was developed.

The 706 telephone has provision for the addition of a single press-button, which permits shared service, PBX operator recall and simple extension plans to be catered for as well as the normal direct exchange line (DEL). A variant, the 710 telephone, was produced for more sophisticated arrangements requiring up to 4 press-buttons and 2 indicator lamps. A wall-

† Product Development Unit, British Telecom Headquarters

mounted version, Telephone No. 711, was also produced (see Fig. 1(c)). Secretarial facilities (Plan No. 107/105) of a switched main station with one or 2 extensions were achieved by development of a plinth unit (No. N625<sup>5</sup>) that is associated with the main 700-type instrument and a 12 V mains power unit.

In 1967, the 746-type telephones (Fig. 1(d)) were introduced; these are improved versions of the 706 range of telephones and offer similar facilities. The case styling and method of fixing is different from the range of 706 telephones in that the regulator components are permanently wired to the telephone circuit printed-wiring board, and the design of the induction coil has been changed. The wall-mounted version of the 746-type telephone is the Telephone No. 741.

More recently, selected improvements in the microphone, regulator and ringer have been instituted in the quest for improved performance and reliability; in particular, the microphone has received much attention, and various alternative solutions to the carbon microphone have been explored. Three transducer technologies—electret<sup>6</sup>, moving coil and piezo-electric film—are being placed on field trial in substantial quantities. The field-trial microphones (Microphone Inset No. 21A) have been designed as drop-in replacements for the Inset No. 16. If the new replacement transducers prove viable, then a phased replacement of the carbon microphone is likely to take place during the 1980s. This action should give improved transmission benefits to the instruments already invested in the system and bridge the way for interworking with a new generation of electronic instruments.

In the current population of some 28 million telephone stations, the 700-type family of dial instruments represents the largest single proportion by type and is still the current standard. With various refinements it has been the standard for some 20 years, but its days are now numbered as evolving technology permits capability enhancement and customer demand for purpose-built press-button telephones increases.

## PREMIUM INSTRUMENTS

Customers in the UK telephone network were not given any choice of telephone instrument prior to 1965, except for instrument colour (at extra cost) and wall-mounted variants. However, in 1965, an alternative-shape telephone, known as the *Trimphone*, was introduced as a premium option; this instrument was followed much later in the mid-to-late-1970s by *press-button* telephones, the *Compact* dial-telephone, and an expanding range of *special-range* telephones that had distinctive shapes.

### Trimphone

The original Trimphone (Telephone No. 712<sup>7</sup>) was introduced in 1965; this model was followed in 1971 by an improved version, the Telephone No. 722 (see Fig. 1(e)). The transmission circuit is similar to the 746 telephone but, to cater for the unique styling of the miniaturized handset, the microphone is mounted behind the earpiece; sound from a talker's voice is conducted to the microphone via an acoustic tube in the hollow handset moulding.

The Trimphone was the first British Post Office (BPO) telephone in which the handset is kept over the dial when not in use. The handset-rest doubles as a carrying handle.

The Trimphone incorporates a tone caller instead of a bell, and the dial numbers are illuminated from behind by a tube containing radioactive tritium gas: the Trimphone derives its name from these two features—*Tone-Ringing Illuminated Model*.

### Compact Dial-Telephone

After field trials in the mid-1970s, the Compact telephone<sup>8</sup> (Telephone No. 776) was first introduced in 1977 as a limited edition in the colour 'Balmoral Blue' to mark the occasion of the Queen's Silver Jubilee. More recently, the Compact tele-

phone has been made available in a choice of 2 colours: stone or brown. The Compact telephone is shown in Fig. 1(f).

The main distinguishing feature of the Compact instrument is its compact fore and aft dimensions, which permit it to be accommodated on a narrow shelf. The small instrument-size is achieved by mounting the bell unit in a separate housing. A special shelf-bracket has been devised to enable the Compact instrument to be wall-mounted; the bell unit may be housed within this bracket.

The Compact telephone uses the standard 746 telephone circuit, but opportunity was taken to introduce a new ringer unit, the Uni-Coil Bell No. 79. This ringer is now a component option with the 746 telephone.

## PRESS-BUTTON TELEPHONE INSTRUMENTS

The advantages offered by a keypad compared to a dial were recognized from the very earliest years of telephony, and a variety of electromechanical-based systems were developed. However, none of these could compete with the low-cost dial, and keypad instruments were not produced in significant numbers. Press-button telephones<sup>9</sup> started to be viable only after the invention of the transistor. Two basic types dominate the world's output today: in the UK these are called *multi-frequency* (MF4) and *self-contained* (SC) keypads.

MF4 telephones were developed by the Bell Laboratories in the USA in the late-1950s. At that time, transistors were becoming commercially viable but they were expensive, and therefore the cost of each telephone could justify only one transistor. Bell Laboratories developed a system using voice-band frequencies and demonstrated that 2 tones per digit had advantages over a single-tone per digit. They developed a system that has stood the test of time and is now a CCITT<sup>†</sup> recommended standard. The two-tone-per-digit system was realized by oscillating a single transistor at 2 frequencies when loaded with a combination of capacitors and coils that are selected by a complex keypad, which has contacts for each button and common contacts that are closed when any button is depressed. With the MF4 system, specialized receivers are required at the exchange to decode the tones.

In the late-1960s, an alternative press-button system, known as *Code A* or *Code C* (depending on coding arrangements), was designed for PABX application. A combination of full earth or rectified earth signals were applied to each leg of the line from the instrument and detected by an electromechanical relay-set at the PABX. At the time, this system was cheaper than the MF solution, but cost trends of electronic devices have since reversed the position and Code A/Code C signalling has now been superseded.

In the same way that MF4 telephones required the invention of the transistor, so a true dial-replacement keypad telephone required the invention of the integrated circuit (IC). Designs of SC telephones are so called because, unlike MF4, they require no specialized exchange receiving equipment other than that provided to accept dial-type pulsing signals. The SC telephone requires IC technology because the signalling speed is identical to the dial at around 1 digit/s, whereas the user can key in digits at a rate that can reach up to 8 digits/s over short periods. Therefore, an SC telephone requires an in-built memory to remember digits keyed, as well as control and timing circuitry to transmit the digits at the slow dial-rate.

### 700-Type MF4 Telephones

The BPO was slow to adopt MF4 signalling since no receiving capability existed in the predominantly Strowger exchanges. With the introduction into the UK, in the late-1960s, of the first PABXs equipped with MF4, impetus was given to the introduction of an MF4 telephone. This was housed in a 700-type chassis and was provided with a keypad with a

<sup>†</sup> CCITT—International Telegraph and Telephone Consultative Committee



(a) Telephone No. 760 (using 300-type case moulding)—1956



(b) Telephone No. 706—1959



(c) Telephone No. 711 (wall-mounted type)—1962



(d) Telephone No. 746—1967



(e) Trimphone (Telephone No. 722)—1971



(f) Compact (Telephone No. 776)—1977



(g) Telephone No. 724 (experimental press-button configuration—2 x 5)—1966



(h) Telephone No. 756 (self-contained press-button—3 x 3 + 1 configuration)—1975



(i) XPress callmaker (Telephone No. 772)—1978



(j) Telephone No. 786 (MF press-button Trimphone)—1979



(k) Ambassador (dial-type, Telephone No. 8100)—1981



(l) Ambassador (MF press-button type, Telephone No. 8300)—1981

FIG. 1—Standard and premium telephone instruments 1956–1981



(a) Astrofon (Thorn Ericsson)



(b) Contempra (GEC)



(c) Dawn (Northern Telecom)



(d) Ericofon 600 (Thorn Ericsson)



(e) Classic (STC)



(f) Rhapsody (GTE)



(g) Ericofon 700 (Thorn Ericsson)



(h) Deltaphone (STC)



(i) Deltaphone-deluxe (STC)



(j) Eiger (Webb and Wells Ltd.—Gfeller)



(k) Candlestick (STC)



(l) Mickey Mouse (Plessey)

FIG. 2—Special-range telephones (1981)





(a) LST1



(b) LST2 (GEC Paymaster)



(c) LST3



(d) LST4D



(e) LST4E



(f) A and LS No. 11A  
(Doric-Northern Telecom)



(g) A and LS No. 12A (Harmony)



(h) LST8 (Accord)

FIG. 3—Loudspeaking telephones

2 × 5 button configuration (see Fig. 1(g)). However, a 3 × 4 format was rapidly adopted and buttons marked \* and # were included. This format is now the CCITT recommended layout.

The early models used the bulky coil-capacitor circuitry originally developed by Bell, but later versions, introduced in 1979, used integrated circuit MF4 tone generators.

#### 700-Type Self-Contained Telephones

The first designs of SC telephones were housed in a 700-type chassis (see Fig. 1(h)). After a brief courtship with a 2 × 5 keypad, a 3 × 3 + 1 configuration was adopted; large-scale production of this design commenced in 1975. Although the external appearance remained largely unaltered, the internal design progressed steadily through 10 versions.

The earliest versions had extensive packaging problems since a battery was needed to keep the memory circuit active during line breaks, and relays (to provide off-normal and line-pulsing functions) had to be housed inside the telephone. In due course, the batteries were replaced by capacitors, and the relays by transistors. From 1980, all SC production models used capacitors and transistors and are a direct wire-for-wire replacement for their equivalent dial telephone on all extension plan arrangements.

#### Xpress Telephone

Integrated circuit technology used to provide the press-button facility readily permits the very useful additional facility of storing and sending telephone numbers. This facility

was introduced in the Xpress telephone in 1978. The Xpress instrument (see Fig. 1(i)) is an SC press-button telephone which stores up to 10 telephone numbers and which has the capability of repeating the last number dialed. A battery is required in the telephone to power the memory circuit during the ON-HOOK condition but, in due course, advances in semiconductor technology should eliminate the need for the battery.

#### SC and MF4 Trimphones

Although the first dial Trimphone appeared in 1965, it was 1977 before the first keypad version was in production. The delay was caused primarily by the problem of packaging the signalling electronics into the small volume of the Trimphone case. This problem was alleviated by marginally increasing the height of the case in keypad versions compared to the dial version.

The first design of Trimphone to achieve large-scale production was the SC version; this design incorporates relays, but no batteries are needed. Subsequent designs have eased the packaging problem further by eliminating the relays and introducing transistor pulsing.

An MF4 design (see Fig. 1(j)) had to await the development in 1979 of an integrated circuit to replace the bulky coils and capacitors.

#### The Ambassador Telephone

The Ambassador telephone range<sup>10</sup>, first shown at the Telecom '79 exhibition, Geneva, in 1979, is being introduced



(a) Tape callmaker  
(Autodial No. 201A)



(b) Card callmaker  
(Autodial No. 302A)



(c) XL callmaker  
(Autodial No. 104A/105A)



(d) Mono callmaker  
(Autodial No. 401A)

FIG. 4—Callmakers

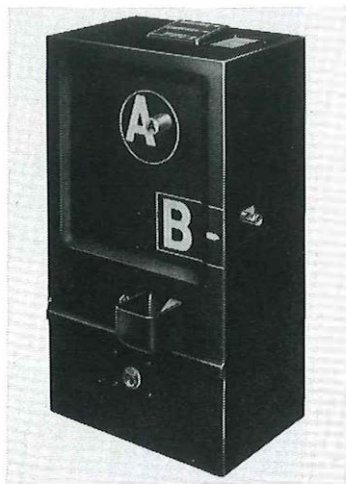

(a) Pre-payment payphone



(b) Pay-on-answer payphone



(c) Pay-on-answer payphone (strengthened version)

FIG. 5—Public payphones

during 1981. The design has been styled for press-button applications, but dial options are possible (see Figs. 1(k) and 1(l)). The Ambassador telephone is conceptually different to the 700-type family of instruments in that it has been designed as a plug-and-socket install-as-issued telephone for most of its applications.

The range of instruments consists of three series, known as the *basic*, *plan* and *facility*, though at the present time only the basic and plan versions are being produced.

The basic series, which caters for single telephone installations and simple extension-plan applications, can have dial or press-button (MF or loop-disconnect) signalling, a bell or tone caller, and can be wall-mounted or table-mounted. The press-button versions incorporate the 10-address store facility or an on-hook dialling (OHD) facility, or both can be provided if required.

The plan series caters for the more complex multi-line/secretarial requirements; each plan instrument contains a microprocessor and additional lamps and buttons for signalling purposes. The instruments are connected via 4-wire cable to a central control unit (CCU), which is also microprocessor based. A CCU with plan terminals constitutes an electronic plan system (EPS). Three sizes of EPS have been developed:

- (a) a custom-built, one exchange line and 3 stations (1 + 3),
- (b) a custom-built 2 + 4, and
- (c) a system which grows up to 5 + 10.

Each system provides incoming and outgoing exchange-line service, intercommunication, hold, transfer and divert

facilities. Each instrument is programmable by a customer, both for selective exchange-line ringing and for diversion to any nominated station.

The basic and plan series have been designed to interconnect mechanically with a range of add-on-modules, which includes subscribers' private meters, Amplifier and Loudspeaker (A and LS) No. 12A, autodials and answering sets.

The facility series was conceived to incorporate modules within one wider-bodied package rather than to provide a number of external units; at present, the latter option has been left open. The realization of the facility service will depend very much on market demand arising from the basic and plan combinations.

The Ambassador telephone is the forerunner of a new range of telephones for the 1980s. The instruments can be regarded as a stepping stone between the modern telephonic, which has evolved with conventional components from the 1930s, and the electronic telephone age. The electronic telephone with an electronic transmission circuit has been an attractive concept since the invention of the transistor. The economic arguments have hitherto been in favour of retaining the conventional induction-coil circuitry, but the position is now changing with modern electronic production technology.

The Ambassador telephone has been developed with both the conventional and electronic solutions in mind, but predictably it will be upstaged in due course by dedicated electronic solutions. Advanced electronic telephones are already at the prototype stage, and field trials of production quantities are expected during 1982 alongside the Ambassador telephone.



(a) Pay-on-answer wall-mounted payphone (CCB No. 700)—1959



(b) Compact pay-on-answer payphone (CCB No. 725)—1978



(a) Blue payphone (self-contained)—1979



(b) Self-contained table-top payphone—1981

FIG. 6—Renters' payphones

FIG. 7—New electronic range payphones

**TABLE 1**  
**Special-Range Telephone Instruments as at 1981**

Instrument Type	Country of Origin	Comments
Astrofon	Sweden	Press-button instrument with electronic transmission circuit
Contempra	Canada	Mini-dial mounted in handset. Instrument can be wall-mounted
Dawn	Canada	Futuristic 'flying saucer' shaped dial-instrument
Ericofon 600 and 700	Sweden	One-piece dial and press-button telephone
Classic	UK	Antique style dial-phone
Rhapsody	Belgium	Optional table or wall-mounted press-button instrument
Deltaphone	UK	Leather-covered Trimphone. Dial and press-button versions available
Eiger	Switzerland	One-piece press-button instrument with repeat-last-number facility
Candlestick	USA	Similar style to the Telephone No. 150, but of plastic construction
Mickey Mouse	USA	Modelled after the image of the famous Walt Disney character

### SPECIAL-RANGE TELEPHONES

To provide customers with a further choice of instrument types beyond the standard and premium range, an additional range of instruments termed *special-range* telephones was promoted in 1978. In general, this range of instruments embraces products with a shorter market life, variously following fashion, novelty and the latest technically innovative concepts. British Telecom† intends that the range will be changed systematically, with new products added and other products deleted as dictated by economic and market forces. This faster changing product line has required different measures to be instituted in stores-handling procedures compared to mainstream products. The 1981 range comprises telephone instruments from many different countries as well as those manufactured in the UK, as shown in Fig. 2 and indicated in Table 1. Most of the overseas instruments have needed modifications to provide the correct interface with the UK network and to meet BT planned transmission and signalling standards.

### LOUDSPEAKING TELEPHONES

In the 1930s, the BPO carried out some work on loudspeaking telephones<sup>11</sup> (LSTs), but the Second World War intervened and it was not until the mid-1950s that a fresh approach was made to the subject. The fundamental problem of LSTs was to obtain an acceptable level of received speech comparable with the speaking voice without encountering instability and echo effects caused by part of the received speech re-entering the near-end microphone.

The LST 1<sup>12</sup> (see Fig. 3(a)), which was a line-powered item, was the first attempt at solving the problem and, by careful juxtaposition of the separate loudspeaker and microphone units, an acceptable speech connexion with a distant telephone instrument was possible. However, instability was very likely when the distant instrument was also a loudspeaking tele-

† British Telecom is the trading name of British Telecommunications

phone, and the mains-powered LST 2, (see Fig. 3(b)) which incorporated a voice-controlled switch, was introduced to remedy the defect. Both the LST 1 and LST 2 became available to customers in 1960.

A waterproof cased version of the LST 1, the LST 3<sup>13</sup> (see Fig. 3(c)), was introduced in 1963 for use in a "hands-free" situation where washing down and disinfecting was necessary; for example, for use in hospitals. The LST 1 also formed the basis of the LST 5B and LST 7, which were specially devised to assist the handicapped.

A more versatile voice-switched LST, the LST 4<sup>14</sup> (see Fig. 3(d) and 3(e)), was introduced in 1966. The LST 4 has been the mainstay LST product throughout the 1970s, appearing in various press-button variant forms using DC Codes A or C, loop disconnect or MF4 signalling.

In the mid-1970s it was decided to seek an improved form of voice-switched LST that avoided the abrupt and near total switching of the LST 4. This led to the selection of a proprietary add-on loudspeaking unit, the A and LS No. 11A (also known as *Doric*); this design (see Fig. 3(f)) incorporates a soft switching technique, which is less intrusive to the two-way speech connexion. More recently the circuit elements of the A and LS No. 11A have been repackaged in the style of the Ambassador telephone, both as an add-on unit, the A and LS No. 12A (known as *Harmony*, see Fig. 3(g)), and an integral unit, the LST 8 (known as *Accord* see Fig. 3(h)). The A and LS No. 12A and LST 8 instruments will become available during the latter part of 1981.

Although further performance improvements are possible, the present state of the art is that this can only be achieved by much more sophisticated circuitry. The economies of large-scale integrated circuits will undoubtedly make this happen during the 1980s.

### AUXILIARY APPARATUS

The use of semiconductor devices has permitted the creation of a number of auxiliary items to complement the basic telephone; for example, callmakers and answering machines.

#### Callmakers

Callmakers are devices that can store a selection of telephone numbers. In the 1930s, a mechanical contrivance of cams and levers was developed to achieve this function, but the first significant commercial item was the Autodial No. 201A<sup>15</sup> (see Fig. 4(a)), which was marketed in the UK in 1970; this device uses a metal-oxide tape to store up to 400 numbers. The Autodial No. 302A (see Fig. 4(b)) was introduced in 1971; this device is a card callmaker in which the telephone number is stored as punched holes on a plastic card, one card is used for each telephone number.

The callmaker range was enhanced in 1979 with 3 additional models all using integrated solid-state devices: the Autodial No. 104A (known as the *XL callmaker*, see Fig. 4(c)), which stores up to 46 telephone numbers, and has a repeat last-number facility and a loudspeaker to monitor call progress; the Autodial No. 106A, which has the capability of storing 31 numbers; and the Autodial 401A<sup>16</sup> (see Fig. 4(d)), which stores a single number only. The latter unit was designed to aid disabled users and to provide service at unattended premises; for example, to provide a calling facility from an airport foyer to a car hire service, or to arrange a hotel booking.

Callmakers, either in their own right or as an integral part of the modern telephone, are likely to become increasingly popular during the ensuing years.

#### Answering Machines

The Answering Machine No. 1A was introduced in 1958. This device permits a telephone call to be answered automatically with a pre-recorded message of up to 20 s duration sent to the caller. A continuous loop of tape is used for recording the message.

TABLE 2

## Auxiliary Apparatus Introduced During the Period 1956-1981

Date	Apparatus
1956	Faultsman's Handset No. 280
1959	Subscriber's private meter (stimulated by the need to provide additional metering information on the introduction of subscriber trunk dialling)
1961	Flameproof telephone
1963	Pendant telephone
1968	Linesman's Telephone No. 704A
1969	Weatherphone
1973	Linesman's Telephone No. 704B
1979	Faultsman's Handset No. 281
1981	Subscriber's private meter (an electronic update of the 1959 product in the style of the Ambassador telephone and exploiting microelectronics coupled to a liquid-crystal display)

In 1963, the Answering Machine No. 1A was followed in production by the Answering Machine No. 2A. This machine is similar to the earlier model but has a message-length facility of between 30 s and 4 min. The Answering Machine No. 3A, which uses a tape cartridge as the storage medium, was introduced in 1979.

The Answering and Recording Set No. 101A was introduced in 1981. As well as providing a pre-recorded message facility, this equipment also permits the caller to record a message. A caller's message is recorded on a modified C60 compact cassette.

Some of the other auxiliary apparatus introduced in the period is given in Table 2.

## AIDS FOR THE HANDICAPPED

In this historical survey of telephone apparatus over the past 25 years, reference must be made to the various aids for the handicapped. This year, 1981, has been designated the *International Year of Disabled People*, but the significance of the telephone service to handicapped people has been recognized for many years and, since 1960, the range of aids available has been expanding almost continuously. For a severely handicapped person, modifications and supplements to the standard equipment may be tailored to suit individual need. However, for those handicapped to a lesser degree, selected arrangements from a standard range of accessories are often highly satisfactory. Thus, the loudspeaking telephone enables hands-free operation; the callmaker range permits the convenient setting up of pre-selected telephone numbers; press-button telephones require less dexterity than a dial; strategically placed extension bells or a trimphone with its distinctive tone caller can assist the selectively-deaf person to more readily identify an incoming call; and watch receivers or headsets can be added to help overcome various disabilities.

A supporting range of purpose-built items to assist the handicapped have been produced in the period, as given in Table 3.

The transition since 1956 from cord switchboards to a prominence of the cordless type has stimulated work to assist blind operators. This work has principally involved the substitution of lamp indicators by tactile indicators; a number of switchboards have been approved for this adaptation. For the future, there is prospect that high technology can assist by the application of voice-synthesis units to give a blind operator audible prompts that will indicate the changing status of the switchboard.

High technology is also expected to benefit other categories of disabled users. The so-called *intelligent telephone* terminal, perhaps fitted with simple touch controls, could well evolve to

TABLE 3

## Telephone Aids for the Handicapped

Date	Instrument
1960	Handset No. 4 (amplified handset)
1960	Sender No. 1 (for operator-assisted calls)
1961	Amplifier No. 143A (faint-speech amplifier)
1969	Loudspeaking Telephone No. 5B, latterly known as the <i>Servophone</i> , for use with equipment supplied by the Department of Health and Social Security
1975	Label No. 479C (enlarged dial-ring)
1978	Loudspeaking Telephone No. 7A (superseding the LST 5B)
1979	Coin-insertion guide for coin-collecting boxes (payphones)
1980	Receiver Inset No. 1/3T (inductive coupler for use with hearing aids)
1981	Press-button finger guide (to facilitate location of the required press button)
1981	Auxiliary Handset No. 1A (a hands-free handset)

meet the needs of particular users. Visual-display terminals should certainly assist the totally deaf; a visual facility for communication with the deaf, the *conversation page*, has already been devised for the Prestel service.

## PAYPHONES

Although payphones have been available almost since the advent of telephony, new generic designs of payphone have been introduced in the UK relatively infrequently. Not surprisingly, each new generation of payphones has differed significantly from its predecessors and has marked a major step forward either in policy, design philosophy, network capability or technology.

## PAY-ON-ANSWER PAYPHONES

Towards the end of the 1950s, the then familiar black *Button A and B* pre-payment payphone (see Fig. 5(a)) began to be superseded by the first versions of what has become known as the *pay-on-answer* (POA) payphone system<sup>17, 18</sup> (see Fig. 5(b)). The POA design was made necessary by the introduction of subscriber trunk dialling (STD), and its introduction to service was phased to coincide with STD access. To offer a fully automatic service to payphone users, the POA system has to work in conjunction with local-call timing and multi-metering equipment, and has to enable subscribers to extend calls by inserting additional coins during the progress of a call. The other significant difference between the POA system and its predecessor was the change from pre-payment to post-payment. This was considered the most pragmatic approach with the technology available, and was aimed at minimizing fraud and enabling simple operation.

It was not practicable to house the control logic within the POA payphone, and thus a two-part system was adopted: the payphone with its coin-validation mechanism is linked to a controlling relay-set situated in the local exchange. The exchange relay-set, designated the *coin-and-fee check* (C and FC) equipment, carries out the control functions on receipt of the coin-value signals from the payphone and the signal pulses from the network which convey the appropriate tariff information. The two-part approach in design allows economies in that the C and FC equipment can be provided in a traffic-sharing group on a grade-of-service basis.

The POA payphone is essentially a mechanical device and the C and FC unit is an electromechanical relay-set, although experimental electronic C and FCs were put on field trial in the late 1970s with a view to their introduction into electronic public exchanges. Many detailed design changes have been

made to the payphone to combat vandalism and theft, including the introduction of various strengthened casings, over the period 1966–1973. The model shown in Fig. 5(c) is now almost in universal use where an armoured version is necessary.

The introduction of decimal coinage in 1970 resulted in some fundamental changes to the design of the payphone mechanism, which had been built in the early-1950s to take up to 3 different duodecimal coins in the value ratio 1:2:4. However, to use decimal coinage, a 1:2:5 value ratio was required and, to achieve this, modification to both the payphone and the C and FC circuitry was necessary. When decimal coinage was introduced, the unit fee of the payphone was changed from 6d to 2p, and a considerable amount of anticipatory design and piece-part manufacture was necessary prior to the availability of the new coins. In the event, the challenge of 'D' (decimal) day, 15 February 1971, was met by the combined efforts of the BPO and Industry with a near total change of the whole payphone system in the space of 3 weeks.

Whereas the number of public call-offices has grown only slowly in the last 25 years, the number of rented payphones in private premises has increased substantially. A number of variants have been introduced for this market to supplement the original renters version, (see Fig. 6(a)). The latest variant (see Fig. 6(b)), which was introduced in 1978, is a compact version that can be wall-mounted, fitted to a trolley or used in a portable mode. In addition to changes in the coin values accepted to keep pace with inflation, new techniques are still being applied where beneficial; for example, a new paint finish has recently been adopted as a standard to improve appearance and durability and to allow easier removal of graffiti.

The bulk of payphones in service in 1981 are still of the POA type, but it became apparent during the 1970s that the viable life of the system was limited. Inflation had exposed a need to provide for greater flexibility in design to cope with tariff adjustment and to obtain the unit fee charge from a given combination of coins. As metering rates have increased (particularly with the widespread availability of International Direct Dialling (IDD)), the enforced breaks in transmission while additional coins are inserted have become more obtrusive. Furthermore, as the system has aged, the two-part concept has not assisted the quick localization of faults between the payphone and the exchange-based equipment.

### NEW ELECTRONIC PAYPHONE RANGE

Plans were made in 1978 to update the whole system by exploiting the advantages of electronic technology. In planning the change, note was taken of the need to harmonize the operating characteristics with the majority of other European countries. The BPO has decided that the new system will be based on a pre-payment approach, with refund of unused coins where appropriate: it was also decided to dispense with the two-part concept of POA and to opt instead for an integral design with logic control vested in the payphone itself.

A replacement program was instituted aimed at the introduction of 3 different designs of payphone to cover specific market sectors. The 3 designs are as follows:

(a) A payphone for high revenue-earning applications; this design offers maximum customer facilities and will be introduced into the service as quickly as possible.

(b) A mainstream or medium revenue-earning design for general application; this design will be as cost effective as is possible. Two variants of this design are envisaged: the first to be heavily armoured for call-office use; the second to be less heavily armoured, as required for most rented applications.

(c) A small portable design, exclusively for renters application where some supervision of usage is possible.

As the first step in the implementation of this programme, a

trial commenced in 1979 of a high-revenue-earning payphone (see Fig. 7(a)). This payphone, an adaptation of a Swiss design, is known as the *blue payphone* and is now being introduced in significant quantities throughout the UK.

Trials of a UK-designed renters' portable payphone (see Fig. 7(b)) will take place in late 1981, preparatory to general introduction to the UK network in 1982. Prototypes of the replacement medium-revenue-earning payphones are undergoing evaluation and are scheduled for introduction in early 1983.

During the 1980s, it is intended to make a significant penetration into the payphone market using these 3 designs. The instruments are expected to give customers easier usage and improved facilities. British Telecom should also benefit from improved operating features and reliability.

### KIOSKS

During the past 25 years, call offices (kiosks) have changed very little in design. They have always been rugged and long lasting, and the Kiosk No. 6 has remained the most used item. This design (see Fig. 8(a)), originally introduced in 1936, was constructed mainly of iron castings with wooden doors.

In the early-1960s, the BPO, recognizing that the styling of this kiosk was becoming dated, commissioned a number of design studies. An evaluation was also made of aluminium castings in lieu of iron, but this idea proved uneconomic at that time. The design finally adopted, the Kiosk No. 8<sup>19</sup> (see Fig. 8(b)), is of a more modern style; the use of cast iron has been continued, apart from the door which is constructed of cast aluminium. Large panes of toughened glass replace the small windows of the earlier design. Overall, the kiosk is extremely robust. It was introduced into service in 1969, but its penetration has been slow because the longevity of its predecessors and the relatively small growth factor of call offices.

More recently, further design studies have been commissioned that embrace a range of payphone housings for both outdoor and indoor use. The range includes a full kiosk, an open booth and a stand-alone pedestal. In addition, a design with special consideration for wheel-chair users has been commissioned. First experimental prototypes of these items (see Figs. 9(a), (b) and (c)) became available in 1981, but decisions to order them in significant quantities have not yet been made.

The standard kiosks have in some ways become an integral part of the landscape, and there is considerable depth of public opinion on their appearance. At present, there is public



(a) Kiosk No. 6

(b) Kiosk No. 8

FIG. 8—Public call offices



(a) Pedestal-type kiosk



(b) Weather-proof kiosk



(c) Disabled persons kiosk

FIG. 9—Experimental call-office prototype kiosks

debate as to whether the kiosks should be reidentified with British Telecom on its split from the Postal Business, by using a colour different from the traditional colour red. Limited trials of yellow coloured kiosks are being carried out, but any final decision will be influenced by the consensus of public opinion.

## PRIVATE BRANCH EXCHANGES

In 1956, the private manual branch exchange (PMBX) provided the dominant private switching-system. In 1981, the number of PMBX installations is still greater than the automatic types (PABX). However, as technology reduces both the cost differential between the 2 methods and provides the opportunity for greater sophistication, the wind of change towards the PABX method of operation predominates.

The PMBX provides the more personal supervision and service, and currently has a capital cost advantage over the PABX (particularly at small-size installations) and, because of this aspect, is unlikely to be completely eclipsed by the PABX in the foreseeable future. The evolving story of the PMBX and PABX equipment is now described, together with the associated and complementary switching equipments known as the *house exchange systems*, and *key-and-lamp units*.

### PRIVATE MANUAL BRANCH EXCHANGES

Twenty-five years ago, key-and-indicator switchboards and cord-and-indicator switchboards predominated, with size ranging from 1 + 3 to 15 + 60. The first major change was the supersession of the indicators (mechanical dolls-eyes) by

lamps, and this change led to the present range of lamp-signalling switchboards. Requirements for large multiple switchboards were met by the PMBX 1A (a development of the PMBX 1 cord-and-lamp-signalling switchboard), which catered for up to 1200 extensions.

The 2/xxx series PMBX<sup>20</sup>, introduced in the late-1950s, caters for a range of small-size installations. These units are key-and-lamp-signalling switchboards; 2 + 6, 3 + 12 and 4 + 18 versions are available; Fig. 10(a) shows the 2 + 6 unit. Each extension is wired with 4 wires: 2 wires are used for speech and 2 are used for signalling to the switchboard. These PMBXs have proved to be highly successful, and large numbers are still in use. They are rather basic but extremely cheap, and remain cost effective and hence difficult to replace, even with the latest technology. A 3/xxx series panel-version having a capacity of 5 + 25 was also introduced; these designs are used for mounting in custom-built desks and consoles.

The PMBX 4/1A cord-and-lamp-signalling switchboard<sup>21</sup> was introduced in 1967-68 to cater for the market sector requiring 20-100 extensions. This design, which is shown in Fig. 10(b), can be used as a multiple switchboard, but such application is difficult to achieve because of the amount of equipment needed inside the rear casing. Hence a variant, designated the *PMBX 11*, was designed for the multiple situation. This design gives a capability of up to 800 extensions and effectively supersedes the PMBX 4/1A for all but the largest installations.

The latest addition to the PMBX range, introduced in 1978, is the PMBX 12, a cordless switchboard with a 10 + 48 capacity. It is essentially an operator-controlled reed-relay matrix and offers improved performance over earlier PMBXs



(a) PMBX 2/2A (2 + 6)



(b) PMBX 4

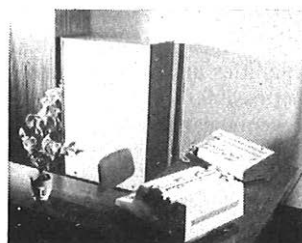

(c) PMBX 12 (Premier)



(d) HES 4

FIG. 10—Manual switching systems

in that it provides automatic clearing and direct outward dialling from extensions. This PMBX is, in some ways, the first (and probably the last) of a new generation of PMBXs in that it moves close to the PABX concept of operation by using automatic switching, albeit under manual (operator) control. In addition to easier operating procedures, maintenance is much reduced and the product is aesthetically attractive in an office environment (see Fig. 10(c)).

### House Exchange Systems

House exchange systems (HESs) are multi-wired press-button key systems; they equate to a small distributed PBX with the switching function resident in each terminal, providing named button-calling for internal communication and conference calls. In 1956, the systems available were the HES 1<sup>22</sup> (1 + 6) and HES 2 (2 + 11), packaged in a variant form of the 300-type telephone. In the early-1960s the range was superseded by the HES 3<sup>23</sup> and the HES 4, which were based on 700-type circuitry and case styling; the HES 4 is shown in Fig. 10(d).

### Key-and-Lamp Unit

A key-and-lamp unit (K and LU) is a multi-way line terminating unit that provides a means of connecting a number of telephones to a selection of exchange lines, PBX extensions or private circuits. In 1956, a pre-1940 design of K and LU was in use; it comprised a polished mahogany cased assembly of lever keys. In 1964, a new K and LU<sup>24</sup> in the style of the PMBX 2 series cordless switchboard was introduced. Like the HES, the K and LU is still in current use, but many of their applications are being displaced by alternative electronic equipment solutions, notably the Ambassador electronic plan-system and the Herald switching system.

### PRIVATE AUTOMATIC BRANCH EXCHANGES

Twenty-five years ago, the BPO and the UK telecommunications industry were operating under joint agreements for the development and supply of equipment, and PABX designs naturally followed the techniques used in main-exchange switching because this arrangement gave economies in piecemeal production, stores holding and staff training. Most of the PABXs in service therefore were of the Strowger type. At this time, smaller PABXs of less than 50 extensions (PABX Nos. 1 and 2) were produced in packaged form, installed by the BPO and rented to the customer. However, larger sized PABXs (PABX Nos. 3 and 4) that had uniquely tailored hardware solutions were, for investment reasons, permitted to be supplied direct to the customer by approved suppliers.

With the cessation of the joint development activity with industry in 1969, and the changing switching technology taking place in the public exchange domain, the BPO decided to introduce a PABX liberalization policy allowing proprietary offerings. The aim of this liberalization policy was to increase customer choice of PABX types and to permit alternative technologies. This led in the early-1970s to an increase in the number of approved PABX suppliers and to the emergence of a variety of large PABXs that used common-control techniques with crossbar, rotary and reed-relay switching systems. The techniques used were not directly translatable to small PABXs of less than 50 extensions without incurring a high cost overhead for the common equipment; thus the BPO's rental range PABXs continued to employ Strowger techniques.

As the costs of producing electronic equipment were reduced and the cost for producing corresponding mechanical items increased, the mid-1970s saw a move towards electronic solutions for large and small switching systems alike. The microprocessor era had arrived. Reduced cost of the common-control overheads, in conjunction with rapidly improving integrated circuit techniques, enabled greater sophistication to be achieved.

The BPO's standard range of electromechanical PABXs, the range of common-control proprietary systems, and the newly emerging range of rental electronic PABXs are now described. Reference is also made to the unfolding inter-PBX signalling scene.

### Standard Electromechanical PABXs

In 1957 there were 3 standard PABXs (designated *PABX Nos. 1, 2 and 3*), and they are still in current use. The first 2 are of unit-type construction with capacities of 10 exchange lines and 49 extensions; they differ in design mainly in the type of manual switchboard used. The PABX 1<sup>25</sup> uses a cordless board, and the PABX 2<sup>26</sup> uses a cord board with the option of an additional 30 manual extensions. The cordless board for the PABX 1 was modernized in 1966 to bring it into line with the then new range of cordless PMBXs. The PABX 3<sup>27</sup> is a large step-by-step open-rack exchange with a cord manual-board which limits the extension capacity normally to 1200, but which can be extended by using specially designed positions.

About 1958, the demand for facilities more sophisticated than those offered by the PABX 3 led to the introduction of large cordless PABXs<sup>28</sup>. Initially, these were equipments designed by the PABX manufacturers for the export market, but a standard version, the PABX 4<sup>29</sup>, became available in 1965; the PABX 4 is shown in Fig. 11(a).

The first small unattended PABX (PABX 5) was introduced in 1963 and this was followed in 1966 by the PABX 6<sup>30</sup>. Both of these PABXs have capacities of 5 exchange lines and 20 extensions; they differ mainly in the design of the equipment cabinet. Incoming exchange calls are answered by designated extensions and connected as required by using a transfer facility. The PABX 6 is shown in Fig. 11(b).

The last electromechanical PABX in the standard range is the PABX 7, which was introduced in 1969; it is similar in operation to the PABX 1, has a capacity of 20 exchange lines and 100 extensions and uses a cordless manual board. Its introduction marked an upwards change from 50 to 100 extensions in the demarcation size between the BPO rental range and the privately-supplied proprietary PABX.

### Proprietary Common-Control PABXs

Around 1970, two new suppliers entered the proprietary PABX field with alternative electromechanical systems: Swedish Ericsson, who supplied the L. M. Ericsson Crossbar (ARD 561), and Pye Business Communications who supplied the Philips common-control rotary (UH 200/900) (see Figs. 12(a) and (c)). These proprietary offerings were quickly followed by a range of PABXs from Plessey based on the 5005 crossbar switch, and Pentomat PABXs from STC based on the Pentconta Switch from ITT (see Figs. 12(b) and (d)). Mini-crossbar designs in the shape of the Ericsson *code switch* also arrived on the scene to improve space saving for the larger sized AKD 791 electromechanical PABX.

A third new supplier, IBM, appeared on the scene in 1970 offering a computer-based solid-state switching electronic

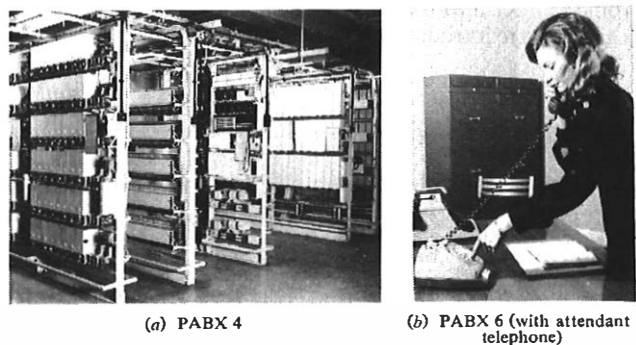
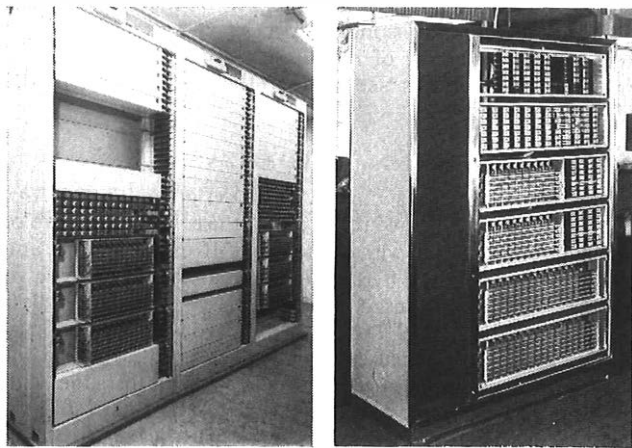
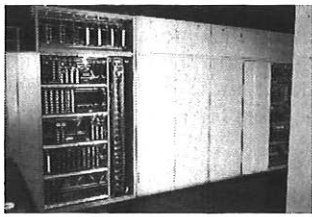

FIG. 11—Strowger-type PABXs



(a) ARD 561 (LME)

(b) PB 480 (Plessey)



(c) UH 200 (Phillips)

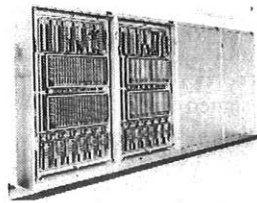

(d) P 200 (ITT)

FIG. 12—Common-control electromechanical PABXs introduced in the early 1970s

PABX 2750. This PABX, see Fig. 13(a), offered the market place the first stored-program-control (SPC) PABX—it was highly featured, and its capability could be modified or updated by software programming. The sophistication of the PABX 2750 posed radically new areas of experience for the field maintenance staff to cover. Operational experience with the PABX 2750 led to a uniquely packaged variant, the PABX 27SS, being produced to test the possibilities of dual maintenance; that is, IBM engineers serving the central processor control and BPO staff servicing the remainder of the PABX equipment.

The PABX 27SS was superseded in 1973 by the PABX 3750; this system more clearly addressed the problems of dual maintenance and was compliant with the evolving BPO requirements for SPC PABXs. The first PABX 3750s were jointly maintained in the same way as the PABX 27SS, but in 1976 the BPO took over first-line maintenance of the complete PABX.

By the mid-1970s, 2 other electronic PABXs had appeared on the scene: the REX80 from GEC, and the EPB2000 from Plessey. Both of these electronic PABXs employ reed-relay crosspoint switches in a similar fashion to the TXE2 public exchange.

Electronic technology was also being grafted into the other suppliers' PABXs: Ericsson introduced a programmable electronic marker into their AKD code-switch systems, and MF registers were introduced into many of the electromechanical



(a) IBM 2750  
(first UK SPC PABX)



(b) Plessey PDX  
(first UK digital PABX)

FIG. 13—Proprietary electronic SPC PABXs

TABLE 4  
Large PABXs

Manufacturer	System	Extension Capacity	Switching Technology
Electromechanical Systems			
UK Industry Standard	PABX 3	1500	Strowger
UK Industry Standard	PABX 4	1500	Strowger
Thorn Ericsson	ARD 561/2	270/540	Crossbar
Thorn Ericsson	AKD 791/2/3	9000	Code switch
ITT	P200	200	Crossbar (Pentaconta)
ITT	P1000 CT	1000	Crossbar
ITT	P1000 T2	9000	Crossbar
Pye/TMC	UH 200/900	200/800	Common-control rotary
Plessey	PB 480	480	Crossbar (5005)
Plessey	PB 1000/8000	1000/8000	Crossbar
Electronic Systems			
ITT	4080	2400 plus	SFC solid-state space
GEC	REX80	600	Common-control reed switch
GEC	SL1 LE	1000 plus	SPC digital
IBM	3750/1750	2516/760	SPC solid-state space
Plessey	EPB2000	2000	Common-control reed switch
Plessey	PDX800	800	SPC digital
Pye/TMC	EBX8000	8000	SPC reed switch

systems to permit press-button MF4 working.

Towards the end of the 1970s more electronic PABXs were introduced: the Plessey PDX (see Fig. 13(b)) and the GEC SL1 digital switching systems; Philips introduced a large SPC space system (the EBX8000<sup>31</sup>) that uses reed-relays in the speech path; IBM offered the PABX 1750, a SPC space-switched PABX similar to the PABX 3750, but with different central control and catering for a smaller number of extensions.

In the late-1970s, STC also introduced an electronic SPC PABX, the Unimat 4080: this PABX uses distributed micro-processor control of a semiconductor space switch.

By 1981, all the approved UK suppliers were offering SPC electronic PABXs in the above-100 extension size range, thus offering the UK business customer a considerable choice of supplier and system.

The main large PABX systems that have been approved for connexion to the network over the last 25 years are listed in Table 4. This list is not exhaustive; there were also a number of special-purpose PABXs and experimental prototypes installed in the period. Some of the PABXs have been superseded, but all of the PABX types listed are currently connected to the UK public switched telephone network (PSTN).

#### Rental-Range Electronic PABXs

In 1976 the BPO decided to initiate development of a modern range of electronic PABXs† to complement and eventually supersede the standard Strowger series. The complete size range of 6–100 extensions could not be covered economically by one system design, and so 2 development projects were started: one catering for the lower end of the range now covered by the PABX Nos. 5 and 6 and the HES series; the second to displace the larger-size PABX Nos. 1 and 7. The 2 resulting systems, known as *Herald* and *Monarch 120* respectively, have been in quantity production since 1980 and formal marketing on a national basis commenced in 1981. A third system, the *Regent*, was also introduced in 1981 to increase customer choice of product and features. These SPC call-connect systems are shown in Fig. 14.

† For marketing purposes, the term *call connect system* is now being used by British Telecom for this class of switching equipment.



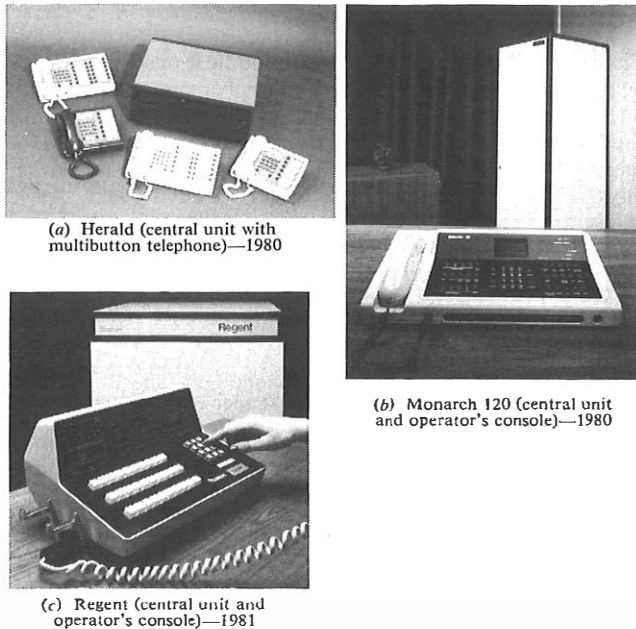

FIG. 14—SPC call-connect systems

### Herald

The Herald electronic PABX system was developed for British Telecom by TMC; the system is a flexible multi-mode system that can be configured to function as a key system, a PABX system, or as a hybrid. The system was designed primarily to serve up to 50 extensions, although its flexibility allows larger sizes (70 to 80 extensions) to be served.

The central control is microprocessor based, and linked into custom LSI interfacing logic; custom LSI is also used for the analogue transmission crosspoint arrays. The central switching unit is modular and, depending on size, can be assembled from one, 2 or 3 shelves.

Ordinary 2-wire telephones may be associated for the PABX mode and 4-wire Herald featurephones for the key-system mode. The Herald featurephone also gives users single-button operation for a variety of system features, such as abbreviated dialling, diversion, conference, and named extensions.

### Monarch 120

The Monarch system was derived from the Customer Switching System No. 1 (CDSS1), which was produced jointly by the BPO's Telecommunications Headquarters (THQ) Development and Research Departments in 1976; the design was engineered subsequently by GEC and Plessey Telecommunications. The Monarch system is a digital system that uses PCM coding and SPC.

The basic system<sup>32</sup> is targetted to provide a 120 extension capacity, but its digital trunking is inherently capable of dealing with larger system sizes. A fundamental design feature is the provision of the analogue-to-digital coding and decoding (CODEC) function at the extension line port, a feature which anticipates future interfacing with digital terminals and digital line plant.

The system is microprocessor controlled and backed by a substantial memory capability that permits an extensive range of PABX facilities previously associated only with much larger PABXs.

A separate microprocessor is also dedicated to the operator's console unit<sup>33</sup>, which is provided with touch-sensitive keys and a dot matrix electroluminescent display.

After trials within the BPO, the first CDSS1, since named *Monarch*, was demonstrated at the Geneva Telecom Exhibition in September 1979, where it provided PABX facilities for the British stand.

### Regent

The Regent electronic system was developed by the MITEL Corporation of Canada, where it is known as the *SX200*. An evaluation of the system and the changes needed to ensure compatibility of operation was carried out by Eastern Region staff on behalf of British Telecom Headquarters (BTHQ) and the resultant version, now titled *Regent*, is scheduled to be marketed in the UK during the second half of 1981.

The system uses space-division switching by means of solid-state crosspoints. The Regent system uses microprocessor SPC and provides a wide range of customer facilities. The capacity of the system is 120 extensions at typical UK business traffic-calling rates, but its extension capacity can be increased for low-traffic situations.

### Inter-PBX Circuit Signalling

The increase in the number of PBXs in service since 1956 has naturally led to an increased community of interest between PBXs by means of private circuits. The periodic commercial take-overs and formation of conglomerates has also led to the establishment of significant private networks in the period.

In the early days of telephony, inter-PBX signalling (manual AC) closely followed the magneto method used for signalling between telephone and exchange. This was later complemented by manual DC signalling to avoid the use of ringing current on trunk circuits. It soon became apparent that automatic signalling had advantages over the manual method and, as DC line plant and PBXs evolved, contemporary automatic systems were developed.

Because DC signalling could not be used on frequency-division multiplex (FDM) line plant, an inband voice frequency (VF) 1VF signalling system, SSAC13, was introduced in 1968 for long-distance automatic dialling.

The 1960s and early-1970s saw a plethora of signalling systems in existence, each PBX needing its own signalling equipment version to match a particular signalling system. In 1973, a rationalization plan was produced by the BPO which stipulated that, for new work,

- (a) DC signalling between PMBXs would be automatic balanced battery,
- (b) DC signalling between PABXs, and between PABX and PMBX would be single commutated DC (SCDC), and
- (c) AC signalling would be SSAC13.

In 1975, *E and M* signalling was introduced to exploit the outband signalling of groups of 12 speech circuits derived from 48 kHz wideband private circuits.

The increasing penetration of register-controlled PABXs in the mid-1970s created the need for an inter-register signalling system to exploit fast call set-up. This was achieved with the SSMF 5, a system which is similar to SSMF 2 used on the public network, but which has signal meanings appropriate to private network operation.

Another 1VF signalling system, the SSAC15, was introduced in the late-1970s, to supersede the SSAC13. The SSAC15 system uses the tone-on-idle signalling format, which is common in North America. The introduction of this system coincided with the creation of a "preferred signalling scheme" to provide a better match between PBX and line plant. The preferred line-signalling systems are

- (a) SSDC10 (SCDC) for DC circuits,
- (b) SSDC5 (E & M) for wideband private groups, and
- (c) SSAC15 (1 VF) for use where a DC path is indeterminate.

Each of the above line supervisory signalling systems can support the SSMF5 inter-register system in addition to 10 pulses/s signalling.

All the present-day signalling systems have been devised for analogue-system operation, but they can be used on PCM transmission and switching systems and are expected to play

their part well into the digital era.

## CONCLUDING REMARKS

This historical survey of the past 25 years shows that the repertoire of customer apparatus has steadily been extended. For the most part, progress, spurred on by technology, has been evolutionary rather than revolutionary. Some new concepts, however, were starting to be exploited towards the end of the period, one of the most significant being SPC. Initially applied to large processor-controlled switching systems, the SPC concept has blossomed with the appearance of the microprocessor, and has permitted mass produced hardware to be individualized to meet specific customer requirements.

Reference has been made to the intelligent terminal for which our transatlantic colleagues already have a name, the *Smartphone*. The Xpress telephone with its 10-address repertory memory and repeat-last-number feature is perhaps the first UK Smartphone. The emerging family of microprocessor-controlled payphones might also be considered in this category. At present, a microprocessor-controlled telephone, known as *Microtel*, designed by the British Telecom Research Laboratories, is being developed to a production stage, and no doubt such instruments will appear increasingly during the 1980s. Predictably, the future Smartphone with the association of voice-response and voice-interpretation modules can, with the correct schooling of a high density memory, lead to a very smart terminal indeed—effectively becoming a robot terminal.

The press-button terminal can be expected to play an increasing role in the cashless society, permitting the transfer of credit and verification numbers to a computer terminal with voice response.

In the payphone area, a debit-card payphone trial is now being conducted. The system under trial is based on a card with holographic coding that represents a quantity of meter units that are erased or debited from the card as the payphone call proceeds. Customer reactions are being sought during the trial, but it remains to be seen whether the cashless payphone of the future will ultimately be based on debit or credit methods.

Faster installation methods using both insulation displacement quick-connect wiring and plug-and-socket techniques have been adopted for the new range of PBX call-connect systems. The introduction of high-impedance ringers into the new range of Ambassador telephones, enabling the parallel connexion of plan instruments, has also allowed a simple plug-and-socket scheme to be introduced. The course has thus been set in 1981 to move generally towards plug-and-socket connected customer apparatus, thus permitting the apparatus to be marketed and installed in a way analogous to, say, an electric toaster or a television set.

Digital switching is another concept made feasible by micro-electronics, and has been pioneered in such PABXs as PDX, SLI and Monarch. The next steps awaited are the digital linking of the digital PABX, both to the PSTN and to the extension telephones: implementation depends on economic issues only, for the feasibility has been established. When digital telephones are available, the communication path will have been laid for the merging of data and telephony terminals. Motivation for such merging already exists, as demonstrated by the trend towards the automated business office, local-area networks, electronic mail and the multiple-network access planned for System X.

The events of the immediate past suggest that, in 1981, only the tip of the technological iceberg is visible, and further stimulus will surely come. The UK Government's deregulatory measures in 1981 concerning customer apparatus can also be expected to stimulate change, hopefully to serve the best interests of customers and not to hinder progress. The author covering this subject in the prospective centenary issue of the *Journal* in the year 2006 can be expected to have some exciting changes to write about.

## ACKNOWLEDGEMENTS

Thanks are due to the UK Telecommunications Industry for help in providing photographs of their proprietary equipment. Special thanks must also be made to the many colleagues of the Marketing Product Development Unit of BTHQ who have searched their memory banks for information from the earlier days at THQ of S Branch, TD2 and TD7 Divisions.

## References

- 1 ROBERTSON, J. S. P. The Rocking-Armature Receiver. *POEEJ*, Vol. 49, p. 40, Apr. 1956.
- 2 WILLIAMS, F. E., and WILSON, F. A. Design of an Automatic Control for a New Subscribers Telephone Set—The British Post Office 700-Type Telephone. *Proc. IEE*, Paper No. 2867E.
- 3 SPENCER, H. J. C., and WILSON, F. A. The New 700-Type Table Telephone—Telephone No. 706. *POEEJ*, Vol. 52, p. 1, Apr. 1959.
- 4 BEADLE, A. C., and HARVEY, F. J. A New Carbon-Transmitter—Transmitter Inset No. 16. *POEEJ*, Vol. 58, p. 102, July 1965.
- 5 AKESTER, K. M. A Switching Unit for Use with 700-Type Telephones—Plan Set N625. *POEEJ*, Vol. 53, p. 242, Jan. 1961.
- 6 WALKER, R. R., and MORGAN, A. J. The Electret: A Possible Replacement for the Carbon Microphone. *POEEJ*, Vol. 72, p. 15, Apr. 1979.
- 7 TROKE, F. E. Field Trial of the Trimphone—Telephone No. 712. *POEEJ*, Vol. 58, p. 8, Apr. 1965.
- 8 PALMER, G. B., and LANGHAM, P. C. A New-Style Telephone Instrument. *POEEJ*, Vol. 68, p. 118, July 1975.
- 9 CARO, S. C., and LITTLEMORE, D. T. Push-Button Telephones. *POEEJ*, Vol. 67, p. 224, Jan. 1975.
- 10 PRITCHARD, D. A., and BURTON, P. A. The Development of the Ambassador Range of Telephone. *POEEJ*, Vol. 74, p. 70, July 1981.
- 11 RYALL, L. E. A New Subscriber's Loudspeaking Telephone. *POEEJ*, Vol. 29, p. 6, Apr. 1936.
- 12 LOWE, W. T., and WILSON, F. A. A Loudspeaking Telephone without Voice Switching—Loudspeaking Telephone No. 1. *POEEJ*, Vol. 54, p. 1, Apr. 1961.
- 13 LOWE, W. T. A Waterproof Loudspeaking Telephone—Loudspeaking Telephone No. 3. *POEEJ*, Vol. 55, p. 6, Apr. 1962.
- 14 COPPING, B., and FIDDLER, R. G. Designing a Voice-Switched Loudspeaking Telephone—Loudspeaking Telephone No. 4. *POEEJ*, Vol. 60, p. 65, Apr. 1967.
- 15 SIMMONDS, T. G., and BURTON, P. A. Repertory Diallers. *POEEJ*, Vol. 62, p. 188, Oct. 1969.
- 16 BURTON, P. A. Mono Callmaker. *POEEJ*, Vol. 70, p. 10, Apr. 1977.
- 17 BASTOW, F. J., COLLINGWOOD, J. D., NEWELL, E., and PRICE, C. K. The Pay-on-Answer Coin-Box System. *POEEJ*, Vol. 51, p. 343, Jan. 1959.
- 18 SEYMOUR, E. H. A Pay-on-Answer Coinbox for Subscribers' Installations. *POEEJ*, Vol. 54, p. 176, Oct. 1961.
- 19 MOORE, M. B., MAILE, J. L., and MARTIN, B. A New Telephone Kiosk—Kiosk No. 8. *POEEJ*, Vol. 62, p. 54, Apr. 1969.
- 20 HALLIDAY, C. M., and LIDBETTER, E. J. New Cordless PMBXs No. 2/3A and 2/4A. *POEEJ*, Vol. 55, p. 244, Jan. 1963.
- 21 JONES, D. C., and CROUDACE, V. B. A New Lamp-Signalling Cord PMBX—Switchboard, PMBX No. 4/1A. *POEEJ*, Vol. 61, p. 84, July 1968.
- 22 LOWNE, W., and MORRIS, T. G. The House Exchange System. *POEEJ*, Vol. 28, p. 135, July 1935.
- 23 RANDALL, F. L., and WARD, S. A. L. A Simplified House Exchange System—House Exchange System No. 3. *POEEJ*, Vol. 56, p. 15, Apr. 1963.
- 24 DAVEY, L. R. New Key-and-Lamp Desk Unit. *POEEJ*, Vol. 56, p. 156, Oct. 1963.
- 25 ROCHE, J. J. Post Office Standard PABXs, Part 1—General Review of New Types and Details of PABX No. 1. *POEEJ*, Vol. 46, p. 159, Jan. 1954.
- 26 ROCHE, J. J. Post Office Standard PABXs, Part 2—The PABX No. 2. *POEEJ*, Vol. 47, p. 41, Apr. 1954.
- 27 ROCHE, J. J. Post Office Standard PABXs, Part 3—PABX No. 3. *POEEJ*, Vol. 47, p. 133, Oct. 1954.
- 28 MARCHANT, P. A. An Introduction to Large Cordless PABXs. *POEEJ*, Vol. 53, p. 231, Jan. 1961.
- 29 NOTMAN, R. A. Standardization of the Large Cordless-Type PABX—PABX No. 4. *POEEJ*, Vol. 62, p. 105, July 1969.
- 30 HEARNDEN, A. H. A Standard Unattended PABX—PABX No. 6. *POEEJ*, Vol. 58, p. 238, Jan. 1966.
- 31 FOUNTAIN, V. A. EBX8000 Stored-Program Control PABX. *POEEJ*, Vol. 74, p. 134, July 1981.
- 32 POTTER, A. R. Monarch 120.—A New Digital PABX. *POEEJ*, Vol. 73, p. 14, Apr. 1980.
- 33 WILLET, G. The Operator's Console for the Monarch 120 Digital PABX. *POEEJ*, Vol. 73, p. 138, Oct. 1980.

# TRANSMISSION

## An Historical Overview

W. G. SIMPSON, B.Sc., C.ENG., M.I.E.E.†

UDC 621.391

*This article broadly reviews the developments in transmission techniques during the past 25 years, which are reviewed in greater detail in the articles which follow.*

### INTRODUCTION

The telephone service has dominated the communications business for many years and much effort has been devoted to the design of transmission systems in keeping with the continual advances in technology to improve performance and reduce overall circuit costs. These systems have been fully exploited over the years to provide the extensive nationwide transmission network (shown in Fig. 1) using audio plant, carrier and coaxial cable systems, together with microwave radio-relay links, to interconnect the network nodes and provide the traffic routes between about 370 group switching centres (GSCs).

Although 2-wire and 4-wire amplified audio circuits have

† Director Transmission, British Telecom Headquarters

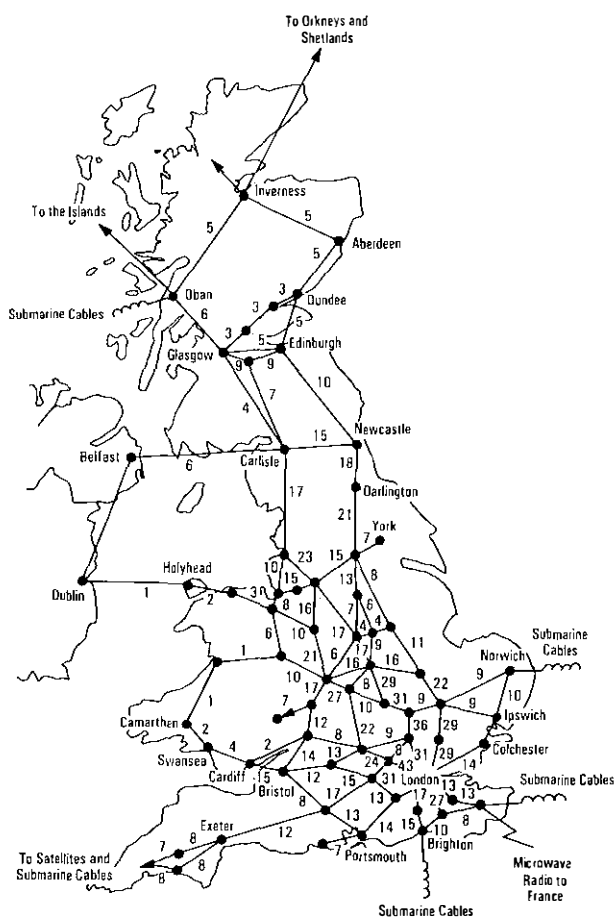

Note: Numbers indicate circuit quantities in thousands

FIG. 1—Major trunk traffic links

been used to provide both trunk and junction circuits, the main role of audio plant at present lies in the junction network to interconnect local exchanges to their parent GSCs, and in the local network to connect customers to their local serving exchanges.

The past 25 years has seen a very large growth in demand for trunk traffic stimulated during the 1960s, firstly by the penetration of subscribers trunk dialling<sup>1</sup> and maintained by the ever growing requirements of the many other services listed in Fig. 2, which also includes the various types of new services predicted to be required by the end of the century.

These new emerging customer services—on-line interactive visual information services, visual conferencing services, surveillance, etc.—call for a general-purpose network that has the capacity and flexibility to respond to rapidly changing customer requirements. This is leading to a convergence of voice, data, message and facsimile services where boundaries between the different users are merging and becoming less distinct. Studies have shown that an integrated services digital network (ISDN) offers the required characteristics to provide effectively and economically the range of new facilities. Consequently, the British Telecom (BT) network is to be modernized by replacing existing analogue plant with digital switching-and-transmission systems, thus forming an all-purpose integrated digital network which will provide the flexibility to meet the ever changing needs of the future.

In reviewing the progress that has been made in the development of analogue transmission systems over the past 25 years,

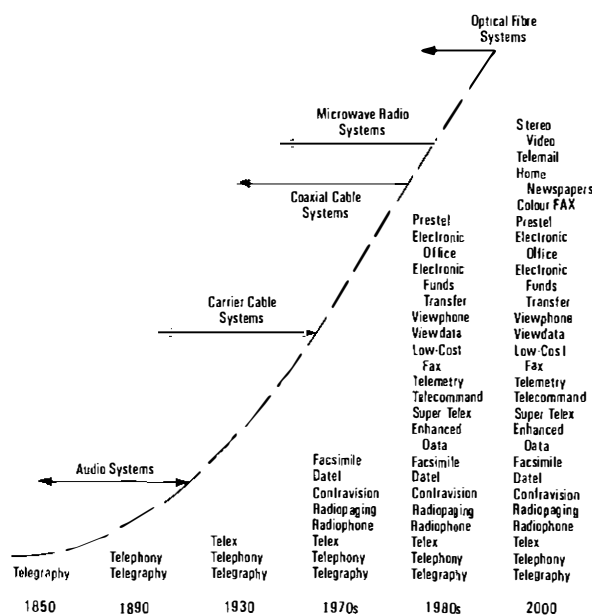

FIG. 2—Growth of services

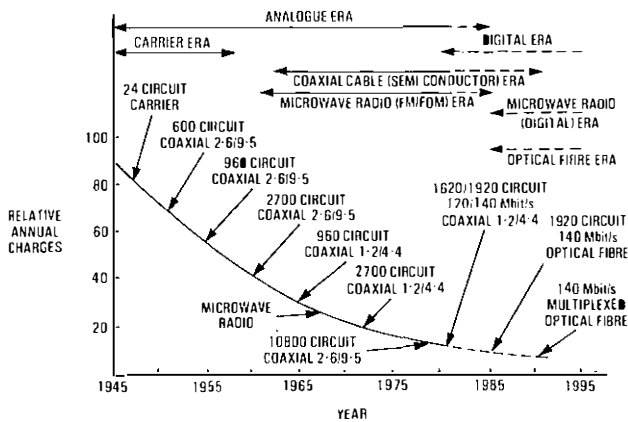

FIG. 3—Transmission plant relative annual charges for a 100 km circuit

it also seems appropriate to make mention of the range of digital transmission systems in course of development and production, from the low-capacity pulse-code modulation (PCM) systems on pair-type cables to the high-capacity high bit-rate systems for use on coaxial cable, optical-fibre cable and microwave radio. All these systems will be extensively used in the network modernization plans and to extend digital transmission into the local network to provide completely digital customer-to-customer links.

### THE USE OF FDM SYSTEMS IN THE NETWORK

The past 25 years have seen major technological advancements in the design of transmission equipment for use on both cable and microwave radio media to provide the very-high-capacity analogue frequency-division multiplex (FDM) transmission systems required to match the high growth rate in public telephony trunk traffic and customers' private-circuit networks for speech, data transmission and television purposes. Fig. 3 illustrates the large reduction in cost of the line element achievable by the aggregation to the extent of 2700 speech channels per transmission system.

The extent of the growth of FDM systems is illustrated in Table 1, which gives a comparison of the size of various elements of the trunk network at 1956 and that planned for 1981.

### Carrier Cable Systems

FDM techniques have been exploited extensively to provide a national network since the development of the 12-circuit carrier systems. These systems, operating in the band 12–60 kHz, were installed in the late-1930s and early-1940s on 24-pair balanced-pair cables, where one cable was used for each direction of transmission. The system was later expanded and

TABLE 1  
Trunk Network Plant

Network Capacity Planned for Year	1956	1981
Carrier Cable Network (pair-km in use)	352 000	0
Coaxial Cable Network		
(a) Large-Bore Cables (tube-km)	32 000	43 000
(b) Small-Bore Cables (tube-km)	0	158 000
(c) 15/16 Supergroup (hypergroup-km)	0	125 000
Microwave Radio Network		
(a) Television (channel-km)	1200	16 200
(b) Telephony (channel-km)	0	47 000
(c) Number of Stations	15	180

used during the period 1945–55 to provide 24 circuits per 2 pairs in the band 12–108 kHz, giving a total route capacity of 576 circuits. The carrier cables have given exceptional service over many years providing a national carrier network interconnecting the major cities in the UK. The phantoms of the carrier cables were fully utilized to provide high quality sound-programme circuits. The systems are now to be recovered and replaced by 8 Mbit/s digital line systems on the same cables.

### Coaxial Cable Systems

During the 1950s and 1960s coaxial cable systems became the dominant medium for the provision of trunk circuits. Improvements in valve technology and amplifier design allowed greater bandwidths until, by the early-1960s, a 12 MHz system with a capacity for 2700 circuits was possible. About this time transistors operating at higher frequencies became available, and design effort was concentrated on achieving high-capacity systems on both 1.2/4.4 mm and 2.6/9.5 mm coaxial cables, using buried repeaters and intrinsically safe lower power-feeding voltages. Table 2 shows the development of analogue systems culminating in the 60 MHz system which involved a new design of cable, power-feeding system and new installation practices.

### FDM Multiplexing

The exploitation of the wideband systems required equipment which enabled a large number of channels to be multiplexed. This equipment was developed using FDM techniques following the CCIF\* recommendations for coaxial line systems that the basic 12-circuit group should be in the range 60–108 kHz with channels assembled as lower sidebands of the carriers 64, 68... 108 kHz. The formation of larger multichannel assemblies to form the FDM hierarchical structure of super-

\* CCIF - International Telephone Consultative Committee

TABLE 2  
Development of Analogue Cable Systems

System	Coaxial Cable Systems		Nominal Repeater Spacing		Power Supply Voltage	Date in Service
	Traffic Band (kHz)	Circuit Capacity	1.2/4.4 mm cable (km)	2.6/9.5 mm cable (km)		
L-BM (0.45 in)	500–2 100	320	—	9.6–12.8	350 AC	1938
CEL 1, 2 and 2B	60–2 540	600	—	9.6	500–0–500 AC	1945
CEL 4	60–4 028	960	—	9.6	500–0–500 AC	1951
CEL 6	60–4 028	960	—	9.6	500–0–500 AC	1956
CEL 8	312–12 336	2 700	—	4.8	1000–0–1000 AC	1961
CEL 1000	60–1 300	300	5.7	—	250–0–250 DC	1962
CEL 1006	60–4 028	960	4.0	9.3	250–0–250 DC	1965
CEL 1007	312–12 388	2 700	—	4.5	250–0–250 DC	1965
CEL 4000	312–12 388	2 700	2.0	4.5	250–0–250 DC	1971
CEL 1020	4 404–59 580	10 800	—	1.5	500–0–500 DC	1980

groups and hypergroups used in the UK and their connexion to the various line and radio systems are shown in the figure on p. 262.

### Reduction in Size and Power Consumption

The need to meet FDM channel equipment requirements economically has invariably been the primary reason for the development of new forms of construction to complement advances in electrical component technology and availability of new materials. Twenty-five years ago, improvements in equipment practice allowed 4 groups of channel translating equipment to be mounted on a Type-51, 2743 mm (9 foot) high rack where each group consumed 42 W. In comparison, present Type 62 equipment practice on 2743 mm high racks can house up to 30 groups, each consuming only 10 W; equivalent to a size reduction of about 8 and a power consumption reduction of about 4 over the earlier equipment practices. A new equipment practice (TEPIE) is being introduced for digital transmission equipment which will provide improved packing densities and flexibility in use.

### MICROWAVE RADIO-RELAY SYSTEMS

The development of analogue microwave radio links in the British Post Office (BPO) network owes much to the need to provide domestic broadband television services. The first system went into service in 1949, carrying 405-line television in a single channel operating at 900 MHz between London and Birmingham. The current frequency allocations available to BT are detailed in Table 3.

**TABLE 3**  
**Analogue Microwave Radio-Relay System Frequency Allocations**

Frequency Band (MHz)	Number of Radio Channels	Traffic per Channel	Normal Usage Working Channels	Protection Channels
1 700-1 900	2	960	1	1
1 900-2 300	6	960	5	1
3 790-4 200	6	1 800	5	1
5 925-6 425	8	1 800	7	1
6 425-7 110	16	960	14	2
10 700-11 700	12	960	10	2

The 4 GHz and lower-6 GHz bands are used mainly for general trunk telephony traffic, with the television networks being carried mainly on the upper-6 GHz band. The first true microwave system using the 4 GHz band carried BBC television signals from Manchester to Kirk O' Shotts from 1952. A 240-circuit telephony capability was introduced in 1956, followed by maximum channel capacities of 960 circuits in 1959 and 1800 circuits in 1965. By 1980, microwave radio-relay systems carried 12% of all main-network telephony circuits and all long-distance television (equivalent to a further 7% of main-network telephony capacity).

### TELEVISION SYSTEMS

The first transmission networks provided by the BPO to distribute BBC and ITV<sup>2</sup> television programmes consisted of adapted telephony coaxial-cable line systems, together with early forms of microwave radio links.

By 1960, microwave systems were becoming standard for new provision on long routes, with a video system using coaxial cables for links up to 40 km<sup>3</sup>. With improved equipment, this arrangement continues today. The ITV network was completed in 1962.

Government allocation of the third television channel to the BBC was accompanied by the decision to change from 405-line monochrome to 625-line definition with colour. This channel required the provision of a full national network,

which spread steadily over the country during the 1960s, being overlapped by the re-provision of the other networks with a 625-line colour capability by the end of the decade. During the 1970s there was a large amount of re-equipping and rearrangement of existing services and the addition of a partial network of television links carrying BBC stereo sound on a 6 Mbit/s digital stream borne in analogue form.

The new television broadcasting network for the second ITV channel, unlike its predecessors, is due to open on a single date scheduled for the autumn of 1982.

In addition to broadcast networking, the use of closed-circuit television for commercial and public service purposes has increased substantially in the past 25 years. Further expansion of all visual teleconferencing services is expected in the years ahead, with increasing use of digital transmission.

### REVIEW OF DIGITAL DEVELOPMENTS

#### Programme for Digital Transmission

The limitations of the existing analogue transmission network were foreseen about 10 years ago when wide-ranging studies were conducted of the UK main network to determine the likely communications needs of society up to the end of the century.

The early studies gave the essential degree of confidence to include digital transmission in the plans for augmenting the BPO main transmission network for growth using, initially, 30-channel pulse-code modulation (PCM) systems followed by 120 Mbit/s digital line systems leading progressively to high bit-rate systems as development permitted.

More recent strategy studies have considered the best way to meet the Business Objectives to speed the creation of a general-purpose integrated services digital network. These studies have resulted in recommendations for the modernization of the network and the updating of the entire network as rapidly as possible with System X exchanges interconnected by digital transmission systems. This will involve the complete replacement of the existing FDM main transmission network with a digital one by the year 1992 to interconnect all primary switching centres; and the rapid penetration of the junction network with 2 Mbit/s systems to serve the digital local exchanges as they are brought into service during the next 20 years.

In moving to an all-digital network, a major objective is to have systems offering comparable circuit capacities maximizing the use of existing assets in terms of cable, underground equipment housings, power-feeding systems, surface intermediate stations and radio towers. These aspects have been given full consideration in the design and development of digital systems, to meet the requirements for speech and data transmission.

#### Introduction of Digital Transmission Systems

Digital transmission has been included in plans for augmenting the BPO transmission network for the last decade, when the first digital line systems introduced in 1968 were 24-channel PCM 1.536 Mbit/s systems using existing deloaded audio cable pairs in which 2 pairs were used, one for each direction of transmission. They were used in both the main and junction networks. A total of about 7000 systems have been installed in the UK network, but these will not form part of the modernization programme. These systems are now being superseded by the first-generation 30-channel PCM systems operating at 2.048 Mbit/s, which is fully compatible with the System X exchanges.

To provide the foundations of an integrated digital transmission and switching network, a range of digital transmission systems has been designed and plans made to bring them into service when production systems become available. The various systems, circuit capacity and proposed ready-for-service dates are shown in Table 4.

The standard multiplexing hierarchical structure is detailed in Table 5.

**TABLE 4**  
**Digital Development Programme**

Equipment or System Title	Circuit Capacity	Target Service Dates
2 Mbit/s Digital Line System	30	March 1979
120 Mbit/s Digital Line System	1 680	May 1979
Multiplex Equipment (2-8 Mbit/s and 8-120 Mbit/s)	—	May 1979
(8-34 Mbit/s and 34-140 Mbit/s)	—	July 1982
8 Mbit/s Digital Line System	120	March 1982
140 Mbit/s Digital Line System	1 920	April 1982
11 GHz Digital Radio-Relay System (5+1 bothway channels of 140 Mbit/s)	9 600	August 1982
Codec Equipment Supergroup	60	January 1984
Hypergroup	900	November 1983
4 and 1.6 GHz Digital Radio- Relay Systems	Up to 13 400	July 1985
140 Mbit/s Proprietary Optical- Fibre Systems	1 920	July 1985
140 Mbit/s Standard Optical- Fibre Systems	1920	August 1981
		July 1985

**TABLE 5**  
**Standard Digital Multiplexing Hierarchy**

Multiplex	Input	Output	Circuit Capacity
Primary	30 Speech Channels (0.3-3.4 kHz)	2 Mbit/s	30
Secondary or Second Order	4 by 2 Mbit/s	8 Mbit/s	120
Third Order	4 by 8 Mbit/s	34 Mbit/s	480
Fourth Order	4 by 34 Mbit/s	140 Mbit/s	1920

**Programme for Digital Radio in the Main Network**

Currently, BT is engaged in a programme of introducing digital radio into the microwave bands. This process is most advanced in the 11 GHz band, for which production equipment should be available for service from about the latter part of 1982 onwards. Each 11 GHz system can include up to 6 both-way 140 Mbit/s channels, including one protection channel. Development work is also in hand for the 4 GHz and lower-6 GHz bands where each band is expected to realize a capacity of 8 channels using reduced-bandwidth quadrature phase-shift keying (RBQPSK) modulation techniques. This equipment is expected to be in service by mid-1985 onwards.

**Optical-Fibre Systems**

The digital transmission systems described so far are primarily designed to fit existing networks and to establish a digital hierarchical structure. Optical-fibre systems, however, bring a completely new dimension to transmission in that it is a system specifically required for the digital age. Following the success of a number of experimental and trial systems<sup>4</sup>, BT decided in 1978 to invite tenders for a package of essentially proprietary systems. Orders were placed for 34 systems on 15 routes representing 3600 fibre-km. These systems are being brought into service in 1980-82. Orders for further systems have been placed to cover the period between 1983-85, when the penetration of optical fibres in the UK main network will be typically as shown in Fig. 4. This comprises some eighty 140 Mbit/s systems. Subsequent purchases will aim at the procurement of standard systems to meet all future main-network requirements, so allowing the purchase of coaxial cables to be phased out over the next few years.

**THE JUNCTION NETWORK**

In recent years there have been many developments influencing the junction network which have improved its performance

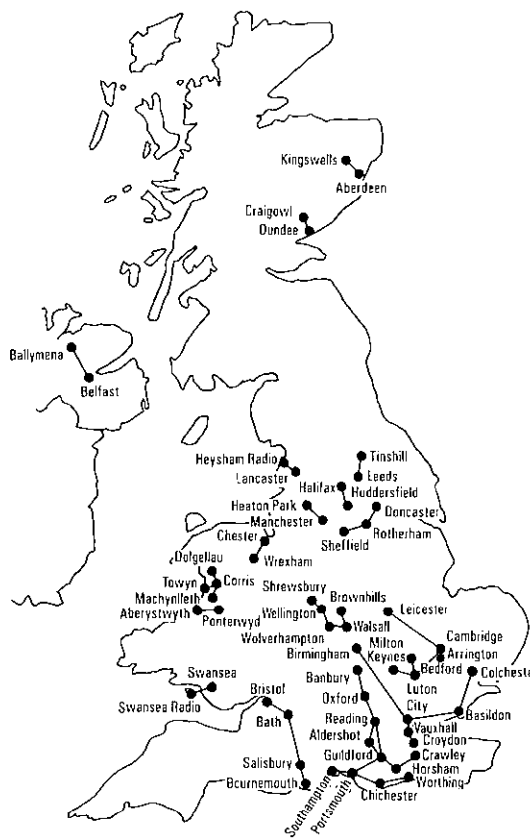

FIG. 4 ● optical-fibre systems 1980-85

and helped to reduce the cost per circuit. Since 1965 the 0.63 mm copper conductor has increasingly taken over from the 0.9 mm conductor as the preferred size for all junction cables and, at present, the network contains about equal quantities of cables of these gauges.

Most cables used for audio-frequency junction circuits are loaded with 88 mH loading coils spaced at 1.83 km intervals. Audio circuits, greater than 10 km in length are generally amplified to reduce the overall circuit loss to 3 dB. The introduction of the 2-wire negative-impedance amplifier from 1964 onwards allowed junction cables to be more effectively exploited in the provision of circuits; for the longer mixed-gauge-conductor circuits the 2-wire hybrid repeater offers a higher gain and the essential balance requirements. Four-wire circuits are now mainly used in the provision of private circuits routed wholly or partially on audio-type cables.

**Digitalization of the Junction network**

*PCM on Existing Cables*

The introduction of digital transmission into the BPO junction network began over 10 years ago as indicated previously, with the installation of 24-channel PCM systems. These systems were used principally in urban areas where they offered economic advantages, generally on the longer higher-growth routes, by increasing the circuit capacity of existing cables, thereby deferring the need for new cable and duct routes.

Following the decision to adopt the CCITT† recommended 30-channel format, the 2.048 Mbit/s system has superseded the 24-channel system. The planning rules adopted for 30-channel PCM systems were based on the assumption that they could follow the practice used in the provision of the 24-channel systems. However, new planning rules have had to be formulated to reduce problems arising from crosstalk<sup>5</sup>.

† CCITT — International Telegraph and Telephone Consultative Committee

As an alternative to using existing small cables, a  $2 \times 10$  pair system using a new design of 0.6 mm low-mutual-capacity local cable has been developed. When installed specifically for PCM this cable requires regenerators to be provided only every 2.5 km. The system uses a new housing, which it should normally be possible to locate in existing joint boxes, holding 8 regenerator-pairs.

A range of transverse-screen cables, based on the 0.6 mm low-mutual-capacity local cable, is being introduced for circumstances where new cables are to be preferred to intercepting existing cables. Similar regenerator section lengths to the twin-cable system are possible. However the next generation of 2.048 Mbit/s digital line system will use a ternary line code MS43. It is expected that this will allow satisfactory operation of 30-channel systems on existing cables with regenerators at the standard loading-coil spacing. On the twin-cable and the transverse-screen cable systems it should allow regenerator section lengths in excess of 3 km.

#### PCM on Optical-Fibre Cables

Low-capacity systems operating at 2, 8 and 34 Mbit/s on optical-fibre cables are being used on a small scale at present. They offer the advantage of not requiring intermediate regenerators in much of the junction network. A large-scale application of these systems can be foreseen as the cost decreases in the future.

### THE LOCAL DISTRIBUTION NETWORK

Over the past 25 years paper-cored lead-sheathed cables with copper conductors have gradually been superseded by aluminium-alloy conductors<sup>6</sup> with cellular polyethylene insulation and polyethylene sheaths which are pressurized in the local main network and jelly-filled on the distribution side<sup>7</sup> towards the customers' premises. Despite the considerable advances in electronic devices over this period, there is still no clear alternative to the technique of providing services in the local network using individual pairs of wires. About 19% of BT total capital assets, consisting of cable, duct, manholes, joint boxes and flexibility cabinets used to serve customer locations, are used in the provision of the present local network. With this scale of investment and because it is unlikely that a superior method to a simple metallic pair of wires will be devised before the BT network is substantially digital, there is a great need to produce methods of exploiting it to the fullest possible extent in terms of circuit time and frequency spectrum. The useable bandwidth is limited only by attenuation and crosstalk: the local network has the advantage over both the trunk and junction networks in that it is not bandwidth limited by loading coils or other constraints.

Despite being provided for audio-frequency use, the local cable network has already been exploited by many services at frequencies ranging up to 1 MHz. A limited use is made of a simple carrier system for providing 2 completely independent telephone circuits on one pair of wires. This has proved very useful as an expedient to provide service at short notice where there is a shortage of cable pairs.

There has been a history of increasing local-line transmission limits as telephones have been made more sensitive, culminating in the design of the 700-type telephone<sup>8</sup> about 20 years ago. Further increases in the telephone sensitivity are unlikely because of the limit set by overhearing through cable crosstalk. However, to improve the economics of provision higher line-resistance limits are desirable, permitting the use of fine gauge conductors in the cable network. As an interim measure loop extenders for both transmission and signalling have been used where the lines exceed the various local-line resistance limits.

Other devices such as line concentrators, where 96 customers are served over 16 lines to the local exchange, are being studied for network applications.

### EXTENDING DIGITAL TRANSMISSION INTO THE LOCAL NETWORK

The digital transmission network offers customers data channels at 64 kbit/s for low-to-medium speed applications and at 2 Mbit/s and above for high-speed uses. These different digit rates will cater for customers' requirements ranging from slow-scan surveillance systems to visual conferencing and visual interactive information services. These data channels will be carried on the same highways as the trunk digital telephony channels and access will be provided over local private network systems offering a number of digit rates. Later the ISDN will be available, offering customer access to the digital exchange at rates up to 80 kbit/s to provide a 64 kbit/s speech or data primary channel, with an 8 kbit/s data secondary channel and a further 8 kbit/s service channel for signalling and housekeeping. Various forms of systems suitable for connexion to customer premises are being considered. Some examples are:

(a) *Using Existing Telephone Cable Pairs* Methods of utilizing customers' telephone cable pairs to carry digital channels in addition to existing telephone calls are being assessed at BT's local-network test facility at Martlesham. Techniques for adding bothway digital paths on the 2-wire telephone pair without causing disturbance to the existing telephone service are being investigated and include burst-mode operation, echo-cancellation methods and frequency division methods. Such systems provide additional capacity of at least one bothway 64 kbit/s channel with the economic advantage of maximizing the utilization of existing assets.

(b) *Using Radio Systems* Digital radio systems operating in the 19 GHz band can provide a number of bothway channels and could be used for high-capacity customer connexions. Feeds to a number of lower-capacity customer distribution systems operating in the 29 GHz band at rates between 2 and 34 Mbit/s could also be provided. BT's assessments of both 19 GHz and 29 GHz experimental digital radio systems have indicated that they could provide satisfactory service quickly and economically, because the small size of aerials and equipment permits relatively easy mounting on buildings or poles and most applications would not need intermediate repeaters. Such systems are therefore considered ideal for high-capacity customer connexions that are required quickly, particularly where the connexion is required for only a limited duration.

(c) *Using Standard Cable Systems* Short-distance versions of the system used in the junction network are also available to provide high-capacity digital links to customers.

### CONCLUSIONS

During the past twenty-five years there has been a continuing high growth in the main network which has called for higher-capacity systems to meet the circuit requirements in an effective and economic manner. FDM techniques have been fully exploited in conjunction with technological advances in semiconductor devices to produce improved designs of coaxial line systems providing up to 2700-circuit capacities on standard 1.2/4.4 mm and 2.6/9.5 mm coaxial cables. The 60 MHz coaxial system demonstrates the ultimate achievement in high-capacity analogue system techniques which has any relevant practical application at the present time.

Advances in technologies have also enabled more compact designs of equipment with considerably less power consumption to be achieved in new equipment housing practices which economize in accommodation.

The economic and technical advantages of an all-digital transmission network have long been recognized, and a programme for the gradual introduction of digital systems into the network was put in hand to meet the growth requirements. However, it became clear that the new emerging customer services can more fully exploit the capability of the digital network and plans have been made to accelerate the rate of

conversion so that the existing FDM main transmission network is replaced with a digital one by 1992. Although this decision sets the seal on any future developments in the FDM field, it will be many years before the well established analogue network is fully replaced by a digital equivalent.

**References**

<sup>1</sup> Subscribers Trunk Dialling. *POEEJ*, Vol. 51, Jan. 1959.  
<sup>2</sup> GRANGER, S. H. The New Independent-Television Network. *POEEJ*, Vol. 48, p. 191, Jan. 1956.  
<sup>3</sup> SEWTER, J. B., and EDWARDS, P. J. The British Post Office Television Networks Present and Future. IPOEE Printed Paper

No. 224, 1963.

<sup>4</sup> BERRY, R. W., and RAVENSCROFT, I. A. Optical-Fibre Transmission Systems: The 140 Mbit/s Feasibility Trial. *POEEJ*, Vol. 70, p. 261, Jan. 1978.  
<sup>5</sup> DUFOUR, I. G. Provision of Digital Transmission in the Junction Network. *POEEJ*, Vol. 74, p. 92, July 1981.  
<sup>6</sup> WINTERBORN, E. E. L. Aluminium-Conductor Cables in the Telephone Distribution Network. *POEEJ*, Vol. 64, p. 146, Oct. 1971.  
<sup>7</sup> PRITCHETT, J. Development of Cables for the Changing Network. *POEEJ*, Vol. 64, p. 208, Jan. 1972.  
<sup>8</sup> SPENCER, H. J. C., and WILSON, F. A. The New 700-Type Telephone. *POEEJ*, Vol. 49, p. 69, July 1956.  
<sup>9</sup> GRIFFITHS, J. M. Digital Local Network. *POEEJ*, Vol. 72, p. 206, Jan. 1980.

# Digitalization of the Junction and Main Networks

M. J. SCHICKNER, DIP.E.E., C.ENG., M.I.E.E.†

UDC 621.395.74:621.394.4:681.327.8

**INTRODUCTION**

Digital transmission of telephony signals was not feasible over cable networks until the principle of pulse-code modulation (PCM)<sup>1</sup> was invented and patented in 1939 as a result of work by A. H. Reeves. The techniques evolved were, however, not realizable in an economic form until suitable semiconductor devices became available in the 1960s.

**PCM IN THE JUNCTION NETWORK**

The first application of PCM was in the short-haul junction network where traffic growth was predicted to be well in excess of that which could be reasonably catered for by audio circuits on balanced-pair cables, particularly as, in many cases, spare bores in cable ducts were not available for additional cables. The high cost of civil engineering work and, even more important, the difficulty of accommodating further duct-ways in the streets of our major cities made it imperative to consider methods of increasing the traffic-carrying capacity of the existing cables.

Temporary relief was achieved by converting 4-wire amplified circuits to 2-wire amplified working, thus potentially doubling the capacity of an existing cable, but once this process had exhausted the capacity it was necessary to consider other steps.

Consideration was given to using frequency-division multiplexing (FDM) in the form of carrier on deloaded audio cable<sup>2, 3</sup>, but this was dismissed in favour of PCM systems, because the former was expensive, and crosstalk in the cables designed for audio frequencies limited its use to one system in each balancing group.

Several UK telecommunications equipment manufacturing companies had shown an interest in the digital transmission of PCM signals as a solution to the problem. Therefore, the British Post Office (BPO) conducted field trials of 3 proprietary systems which were installed in 1966 on the Guildford-Haslemere, Reading-Marlow and Coventry-Rugby routes<sup>4</sup>. After evaluating these systems, the BPO introduced a standard 24-channel system which used 7-bit A-law encoding and had a transmission rate of 1536 kbit/s<sup>5, 6, 7</sup>. The frame structure is shown in Fig. 1(a).

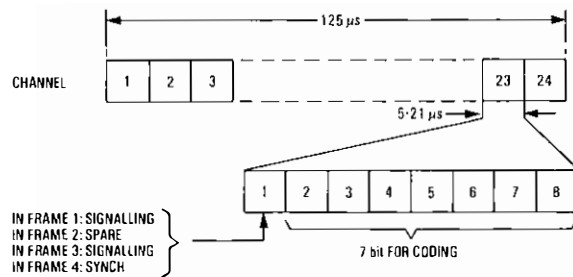

(a) 24-channel

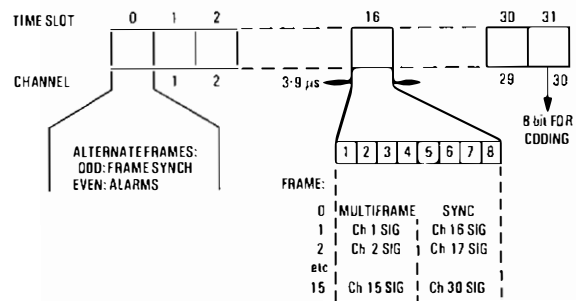

(b) 30-channel

Fig. 1—Frame structure of PCM multiplex signals

**THE 24-CHANNEL PCM SYSTEM**

As 24 channels is a large number in terms of the growth rate of individual junction routes, it was foreseen that on many routes the systems would be installed one at a time and that it would be more convenient and economical if the equipment for such systems was held in regional stores and installed by BPO engineers as and when required. To achieve this specifications had to be issued for each individual item of equipment instead of one specification for the complete system.

Studies had indicated that it was important to minimize the cost of per-channel items, and so it was decided that the signalling units which interfaced the Strowger-type switching

† Transmission Department, British Telecom Headquarters



equipment with the line system should be incorporated into the PCM multiplexing equipment as individual cards. Previously, signalling facilities had been provided as independent, and relatively costly, relay sets.

Because of the variety of signalling facilities required in the UK, 24 different types of signalling unit were developed and, when taken into account with all the other items such as regenerators, equalizers and alarm units, resulted in over 50 different items being specified. As a number of independent contractors decided to develop the full range of items and compete for BPO business, a considerable effort was expended by the BPO on type-approval testing and in ensuring compatibility between the 50 or so items produced to black-box specifications by 5 contractors.

Many technical problems were encountered in introducing the then novel technology of low-voltage (5 V) and high-speed (1536 kbit/s) digital circuitry into the hostile electro-mechanical environment of a Strowger telephone exchange, which can produce transients on the interfaces in excess of 1000 V.

Much effort was spent evaluating the number of PCM systems that could acceptably be carried by each type and size of cable in the junction network, bearing in mind that these balanced-pair cables were designed for use at audio frequencies. This problem was first tackled by the laborious method of measuring pair-to-pair crosstalk of a limited number of cables and then formulating empirical planning rules. Further complications were foreseen with the introduction of 30-channel systems operating at 2048 kbit/s, and so the general problem was more successfully tackled by using microprocessor-controlled crosstalk test sets that flood tested up to 36 cable pairs at a time and recorded the results on magnetic tape for analysis later by computer.

In spite of the immensity of the project, the many technical problems encountered and, not least, the retraining of many technicians versed in Strowger and analogue transmission techniques in the techniques of digital transmission, the BPO installed over 7000 systems operating at 1536 kbit/s during the period 1968–1980. These systems are providing the high-quality transmission expected of regenerative digital systems and have provided the necessary capacity required for the growth of the junction network.

### THE 30-CHANNEL PCM SYSTEM

In the late-1960s, several European administrations evolved a plan for a 30-channel PCM system using 8-bit A-law encoding, a transmission rate of 2048 kbit/s and a frame structure as shown in Fig. 1(b). As 8-bit encoding was considered necessary for national trunk and international circuits and as this system offered more flexibility in signalling, the BPO supported the proposal. However, the CCITT† failed to agree on a unique solution for international use, and there are now 2 world standards: one based on the North American 24-channel system which uses 8-bit  $\mu$ -law encoding and a transmission rate of 1544 kbit/s, and the other based on the European 30-channel system.

Agreement on the European standard initiated development of a BPO 30-channel PCM multiplex, its associated signalling units and the 2048 kbit/s line system<sup>8,9,10,11</sup>. Development effort and compatibility problems were significantly reduced by having one contractor design the whole range of signalling units, the range being reduced to 6 units by providing optional facilities on the cards. These units were designed under a development contract for the BPO so that all contractors could manufacture to the one design.

Field evaluation of the 30-channel system was carried out in 1976 and orders were placed for the first service systems in December of that year. These systems are now being successfully installed for both junction network use and, in association with higher-order systems, the main network.

† CCITT—International Telegraph and Telephone Consultative Committee

## DIGITAL TRANSMISSION IN THE MAIN NETWORK

Until recently, the main-network requirement of the BPO has been satisfied by high-capacity systems on cable and radio by using analogue techniques. The introduction of digital systems into the main network represents a change of policy which owes its origins to the work done by the UK Trunk Task Force (UKTTF), which studied the long-term telecommunications requirements of the society of the future, the technologies likely to be available and the cost of meeting these requirements with the available technology. The UKTTF concluded that service, operational and economic benefits would be derived from the adoption of digital transmission irrespective of the switching system employed, provided that a satisfactory range of transmission systems was made available, but that once a digital transmission network had been established, substantially greater savings could be achieved with the adoption of digital switching at group switching centres. Fig. 2 shows the relative annual charges of these network configurations. Digital switching units are being developed as part of a family of switching units under the generic description of *System X*. Recognizing that the key to the economic advantages of digital switching lay in having a digital transmission network, the BPO Board, in 1973, approved the development of a range of digital transmission systems, to be carried out in 3 phases<sup>12,13</sup>.

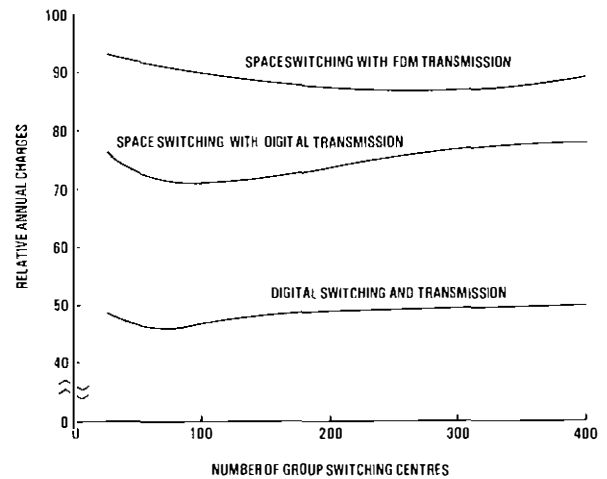

FIG. 2—Main-network annual charges for various network configurations

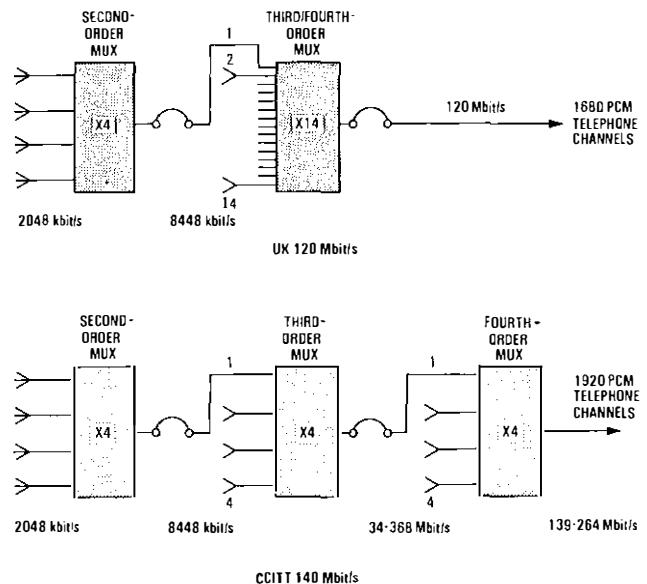

FIG. 3—Alternative digital hierarchies

## Phase 1

The BPO carried out studies during 1971–72 to maximize the digital capacity of the extensive cable network then being used for FDM systems. These studies concluded that, for coaxial cables, 120 Mbit/s was the highest bit-rate system feasible at that time and that it would be compatible with the existing 12 MHz FDM systems in respect of repeater spacing and power feeding.

The experimental systems installed on the Guildford–Portsmouth–Southampton cable routes demonstrated the feasibility and reliability of the proposed 120 Mbit/s system<sup>14</sup>, and this led to the ordering of over 100 systems in the period 1975–79.

Digital multiplexing equipments<sup>15</sup> were developed and produced in association with the line system to multiplex 4 tributaries of the CCITT 2048 kbit/s rate up to 8448 kbit/s, and then 14 tributaries at this rate up to 120 Mbit/s to give a total capacity of 1680 channels (see Fig. 3).

## Phase 2

The purpose of this phase was to increase the digital capacity of coaxial cables, to diversify resources by making use of other transmission media and to provide codecs to ease the transition from analogue to digital working. Fig. 4 shows the digital multiplexing and codecs necessary to provide the various services, and the telephone-circuit capacity of each hierarchical level.

### 140 Mbit/s Line System

By the time the BPO was committed to the production of

120 Mbit/s line systems, further developments had shown that it was feasible to achieve an even higher rate of 140 Mbit/s over the same cable lengths. This bit rate was recognized internationally, and the CCITT recommended a digital hierarchy which used a common factor of 4 to multiplex the European 2048 kbit/s rate up to 139 264 kbit/s, as shown in Fig. 3.

Following the BPO field trial of 120 Mbit/s systems, a further trial successfully showed that, by changing the line code from 4B3T to 6B4T, a capacity of 140 Mbit/s could be achieved with only minimal changes to the regenerators in order to accommodate the small change in symbol rate. While re-engineering the system to use the new code, the opportunity was taken to improve the supervisory system to one that uses a microprocessor for control purposes. This automatically analyses fault symptoms and then displays the major fault and its location. The re-engineered system<sup>16</sup> was put on field trial in 1979, and the first production systems were ordered early in 1980.

### 565 Mbit/s Line System

Studies were carried out and laboratory models built to prove the feasibility of a coaxial-cable system operating at 565 Mbit/s<sup>17</sup>. However, owing to the rapidity with which optical-fibre systems were being developed, it was decided that the cable system was not economic for general use and the development stopped. The cost difference between these systems was mainly due to the necessity of providing regenerators approximately every kilometre on 1.2/4.4 mm coaxial pairs compared to a 30 km spacing expected on optical-fibre systems. The number of regenerators would also have significantly effected the system's reliability.

### 8 Mbit/s Line System

Studies indicated that the 24-channel carrier FDM systems, used on the network of balanced-pair carrier cables, could be replaced by 8 Mbit/s digital systems. As these cables were still in a good condition, an 8 Mbit/s line system using a 4B3T line code was developed and successfully demonstrated on the Salisbury–Yeovil cable route<sup>18</sup>. This resulted in systems being ordered for service in 1982.

### Waveguide System

A 50 mm helix waveguide system<sup>19,20,21</sup> was developed by the BPO but, because of its very high capacity and high initial cost, it could be used economically only on a few routes in the UK. As with the 565 Mbit/s cable system, the development of optical fibres was the deciding factor in the decision to discontinue the waveguide development.

### Microwave Radio Systems

A separate article in this issue of the *Journal* describes the development of digital radio systems.

### FDM Codecs

During the next decade, when the main network will comprise both analogue and digital forms of switching and transmission, there will still be a need to provide additional capacity for growth on certain routes between analogue switching points. This will be best provided by installing digital transmission systems and using coders and decoders (codecs) to enable the FDM signals to be conveyed on digital transmission paths. For this purpose, supergroup<sup>22</sup> and hypergroup<sup>23</sup> codecs are being developed to provide service on 8 Mbit/s and 68 Mbit/s paths respectively from 1983 onwards.

### Television Codecs

For as long as the broadcasting authorities and the BPO's confravision services continue to use analogue forms of television signals for transmission over the BPO network, it will be necessary to provide television codecs to convey these signals over digital paths in that network. A number of codecs

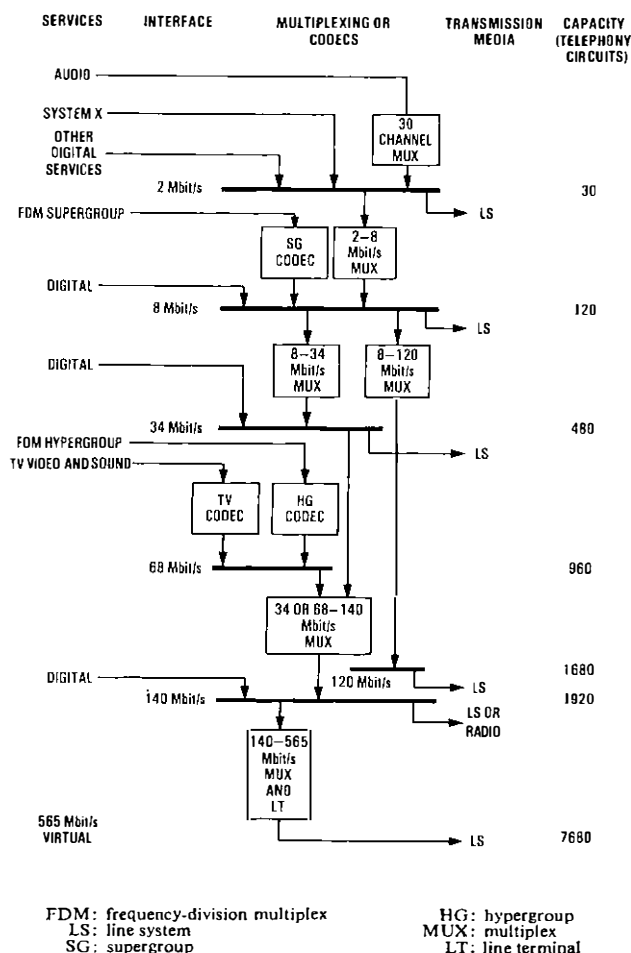

FIG. 4—Services provided by the digital transmission network

has been developed<sup>24</sup> and these use various rate reduction methods to provide broadcast quality signals over 68 Mbit/s digital paths.

#### Digital Multiplexing

Multiplexing equipments conforming to the CCITT's recommended hierarchy of 2–8–34–140 Mbit/s are under development<sup>16</sup> by the BPO for service in 1982. The 34–140 Mbit/s multiplex provides access for hypergroup and television codec signals simply by removing two 34 Mbit/s tributary cards and replacing them by one 68 Mbit/s tributary card.

### PHASE 3—OPTICAL-FIBRE SYSTEMS

Developments using high-grade optical fibres are now well under way and some proprietary systems are already in service. However, as this is such a topical subject which will be well covered in other issues of the *Journal*, it is not considered relevant to a historic review article such as this.

### CONCLUSION

It is too early in the history of digital systems to reach a conclusion; it would be better to say that the initial introduction of such systems into the junction and main network has been achieved and that they promise to provide higher-quality transmission at an ever reducing cost. The cost-reduction exercise will be continued into the future by greater use of large-scale integration and possibly by using digital-speech-interpolation methods to increase capacity. With the introduction of System X and the integrated digital services network, digital transmission will offer a much wider range of facilities for both telephony and data customers.

### References

- 1 WHYTE, J. S. Pulse-Code Modulation, Part 1. *POEEJ*, Vol. 54, p. 86, July 1961.
- 2 REYNOLDS, J., and JEYNES, E. The Design and Field Trial of a 12-Circuit Carrier Telephone System for use on Unloaded Audio Cables, Part 1. *POEEJ*, Vol. 50, p. 173, Oct. 1957.
- 3 TURNER, D., THOMSON, C. D., and CROSSLEY, J. The Design and Field Trial of a 12-Circuit Carrier Telephone System for use on Unloaded Audio Cables, Part 2. *POEEJ*, Vol. 50, p. 252, Jan. 1958.

- 4 Development of Pulse-Code-Modulation Systems. *POEEJ*, Vol. 59, p. 10, Apr. 1966.
- 5 JEYNES, E. Planning and Works Aspects of 24-Circuit Pulse-Code-Modulation Systems. *POEEJ*, Vol. 60, p. 33, Apr. 1967.
- 6 Installation Plans for Pulse-Code-Modulation Systems up to December 1969. *POEEJ*, Vol. 61, p. 44, Apr. 1968.
- 7 BOLTON, L. J., and BENNETT, G. H. Design Features and Application of the British Post Office 24-Channel Pulse-Code-Modulation System. *POEEJ*, Vol. 61, p. 95, July 1968.
- 8 BOAG, J. F. The End of the First Pulse-Code-Modulation Era in the UK. *POEEJ*, Vol. 71, p. 2, Apr. 1978.
- 9 VOGEL, E. C., and MCLINTOCK, R. W. 30-Channel Pulse-Code-Modulation System, Part 1—Multiplexing Equipment. *POEEJ*, Vol. 71, p. 5, Apr. 1978.
- 10 WHETTER, J., and RICHMAN, N. J. 30-Channel Pulse-Code-Modulation System, Part 2—2.048 Mbit/s Digital Line System. *POEEJ*, Vol. 71, p. 82, July 1978.
- 11 TURVEY, K. J. 30-Channel Pulse-Code-Modulation System, Part 3—Signalling Units. *POEEJ*, Vol. 71, p. 225, Jan. 1979.
- 12 BENNETT, G. H. Developments in Digital Transmission. *POEEJ*, Vol. 68, p. 243, Jan. 1976.
- 13 BECKLEY, D. J. Main Transmission Network: Planning of Digital Transmission Systems. *POEEJ*, Vol. 72, p. 27, Apr. 1979.
- 14 SCHICKNER, M. J., and ZICK, L. C. Development of a 120 Mbit/s Digital Line System, Parts 1 and 2. *POEEJ*, Vol. 69, p. 154, Oct. 1976, and p. 217, Jan. 1977.
- 15 BRIGHAM, E. R., SNAITH, M. J., and WILCOX, D. M. Multiplexing for a Digital Main Network. *POEEJ*, Vol. 69, p. 93, July 1976.
- 16 SCHICKNER, M. J. 140 Mbit/s Line System for British Telecom. *ITU Telecommunications Journal*, Vol. 47, p. 746, Dec. 1980.
- 17 POPPLE, G. W. A Demonstration 565 Mbit/s Digital Line System over Coaxial Cable. IEE Conference Publication No. 193, p. 146, Mar. 1981.
- 18 ALTMANN, W., HILL, B. M. E., LARNER, D. S., and MUMFORD, H. An 8 Mbit/s Digital Line System for Paper-Cored Quad Cables. IEE Conference Publication No. 193, p. 173, Mar. 1981.
- 19 MERLO, D. The Millimetric Waveguide System: The Current Situation. *POEEJ*, Vol. 69, p. 34, Apr. 1976.
- 20 RITCHIE, W. K., and ROWLANDS, C. E. The Millimetric Waveguide System: The Design, Production and Installation of the Waveguide. *POEEJ*, Vol. 69, p. 79, July 1976.
- 21 RAVENS CROFT, I. A. The Millimetric Waveguide System: Terminal and Repeater Equipment. *POEEJ*, Vol. 69, p. 250, Jan. 1977.
- 22 CORLETT, D. A Supergroup Codec. IEE Conference Publication No. 193, p. 132, Mar. 1981.
- 23 PEARCE, T. H. An FDM Hypergroup Codec for 140 Mbit/s Digital Systems. IEE Conference Publication No. 193, p. 128, Mar. 1981.
- 24 SEXTON, M. A Codec for Television Programme Distribution in a Digital Transmission Network. IEE Conference Publication No. 193, p. 124, Mar. 1981.

## Microwave Radio-Relay Systems

J. A. CHISHOLM, M.Sc., D.J.C., C.Eng., M.I.E.E.†

UDC 621.396.65.029.63

### INTRODUCTION

The first public demonstration of microwave radio telephony communication took place 50 years ago, on 31 March 1931, across the English Channel between Dover and Calais. The success of this experiment indicated that the band of frequencies from 1000–10 000 MHz offered considerable potential for providing wideband communication channels.

Since that first demonstration, an extensive network of microwave radio-relay links has been installed in the UK, amounting to some 35 million telephone-circuit kilometres, with 190 repeater and terminal stations. This network provides a method of transmission which is complementary to, but fundamentally different from, coaxial line systems, thus

maintaining a basic security in the overall network. Furthermore, radio-relay links have proved to be particularly valuable for connecting the main transmission network to those places which are remote or geographically difficult to reach by cable; for example, the Highlands and Islands of Scotland<sup>1</sup> and off-shore North Sea oil and gas installations<sup>2</sup>.

### ANALOGUE SYSTEMS

With the rapid development of radar during the Second World War came the development of associated microwave devices such as magnetrons, klystrons, mixer diodes, parabolic-dish aerials and broadband intermediate-frequency (IF) amplifiers. Post-war microwave radio development activities in the UK received great impetus from the Government's decision to extend domestic television coverage from the London area

† Transmission Department, British Telecom Headquarters

progressively to include the rest of the country.

In 1946, the British Post Office (BPO) set up its first experimental microwave radio link. This operated in the 4 GHz band between London and Castleton, near Cardiff. Three years later followed the first commercial link from London to the British Broadcasting Corporation (BBC) regional transmitter at Sutton Coldfield<sup>3</sup>. This link operated at 900 MHz, used earthed-grid triode valves for radio-frequency amplification and employed 4 repeaters to cover a distance of approximately 185 km. Next followed the Manchester-Kirk O'Shotts link in 1952, operating at 4 GHz and using the travelling-wave-tube (TWT) amplifier for the first time.

Other links were soon included to form a nationwide network for the BBC and later for the Independent Television Authority (now the Independent Broadcasting Authority (IBA)). Having created a microwave network, it was natural and economic to deploy it further to provide for growth of trunk telephony. The transmission linearity requirements for frequency-division multiplex (FDM) telephony are more stringent than for monochrome television, and it was not until 1956 that development work carried out by both the BPO and Industry resulted in the provision of a 4 GHz link with a capacity of 240 telephone circuits.

Radio stations generally use lattice steel towers or ferro-concrete structures sited on hilltops to facilitate line-of-sight transmission. Hop lengths average about 40 km, but may occasionally be as long as 65 km. The radio equipment is usually housed in a single-storey building at the foot of the tower and is connected to the aerial by elliptical bendable waveguide. Until very recently, the modulation method universally adopted has been frequency modulation (FM) for reasons which are well documented. Modern equipment is capable of transmitting up to 1800 channels of FDM telephony or one 625-line PAL television signal (CCIR† System I) per carrier. More recently, technology has advanced to the state where single-sideband (SSB) amplitude modulation could usefully replace FM, and so increase system capacity to 2700 channels per carrier, while still retaining the high transmission standards recommended by the CCIR. However, because of the decision to install digital main-line transmission systems in accordance with recommendations made in 1967 by the United Kingdom Trunk Task Force, development of SSB equipment will not now be pursued.

Over the years a number of articles have been published describing various aspects of microwave radio-relay systems. Several are listed for further reading in the bibliography at the end of this article. One, *Review of the BPO Microwave Radio-Relay Network* by R. D. Martin-Royle, L. W. Dudley and R. J. Fevin, is particularly recommended for its comprehensive coverage of planning and performance aspects, together with a review of the various technological developments which have most influenced equipment design.

## DIGITAL SYSTEMS

Now is a time of radical change. The main impetus is the need to convert the microwave network to digital transmission in accordance with the general strategic plan to change the entire UK network to digital operation. Other factors also forcing change are the advent of new semiconductor devices, new circuit techniques and the exploitation of new frequency bands.

In the early-1970s, an experimental microwave digital radio link was installed between Fairseat and Tolsford Hill<sup>4</sup>. This equipment provided 6 bothway channels in the band 5850–5925 MHz, 4 with a transmission capacity of 6336 kbit/s, and 2 with 2048 kbit/s capacity. The modulation method adopted was binary phase-shift keying (BPSK), and differential coherent detection was employed in the demodulator.

Following this successful trial, effort was concentrated on

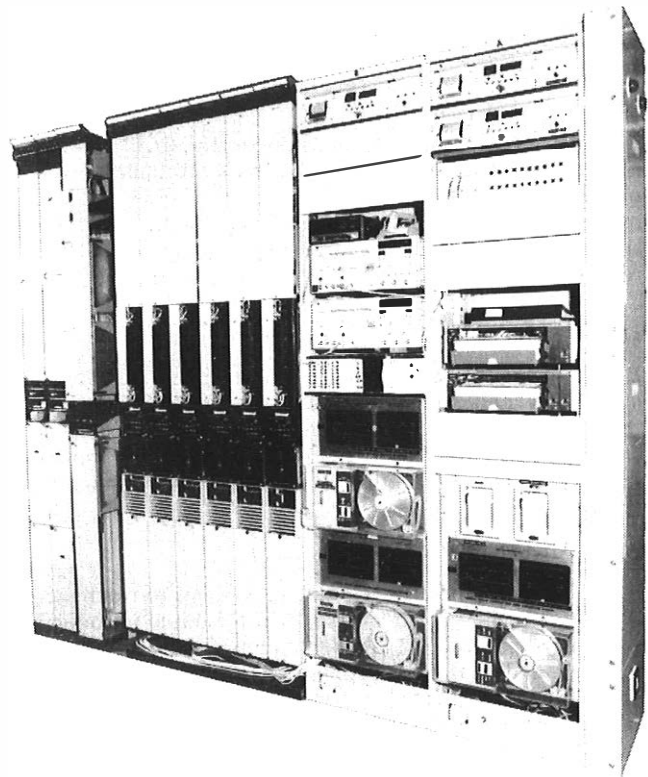

FIG. 1—11 GHz, 140 Mbit/s QPSK field evaluation equipment

developing a high-capacity trunk digital radio-relay system (DRRS) for operation in the 10.7–11.7 GHz band, which had previously been little exploited in the UK<sup>5</sup>. To make maximum use of existing assets, the equipment was designed to operate over the same network of stations and towers as exists for analogue systems, in the 4 GHz, lower-6 GHz and upper-6 GHz bands. The relatively long hop lengths (up to 65 km) and higher path loss at 11 GHz dictate that a simple and robust modulation technique must be used. A prototype system using quaternary phase-shift keying (QPSK) and coherent demodulation has reached an advanced state of development and is currently undergoing field evaluation over a 55 km hop between Birmingham and Charwelton<sup>6</sup>. Fig. 1 shows the 6 receivers installed at Charwelton, each receiver

TABLE 1  
Summary of Data of the 11 GHz Digital Radio-Relay System

System	Operating frequency Bit rate Number of RF channels	10.7–11.7 GHz 139 264 kbit/s 6 bothway
Transmitter	Modulation Symbol rate Output power	QPSK, direct RF modulation 73 728 kbaud, including 5.6% redundancy 10 W
Receiver	Nominal RF input level Input level for bit error ratio of 1 in 10 <sup>3</sup> Noise factor Intermediate frequency	–55 dBW –102 dBW 8 dB maximum 140 MHz
Protection Switching	Protection criteria Changeover	1 for 5 with dedicated stand-by; automatic changeover based on in-service error-rate assessment No break, slipless changeover occurs within 1 bit period
Service band		4 audio channels (1.2–16 kHz)

† CCIR—International Radio Consultative Committee

occupying one 150 mm wide rack. On the right of the figure can be seen 2 Type-62 racks containing an assembly of test equipment installed to monitor the performance of the radio channels throughout the trials. The results of this exercise are most encouraging and it is anticipated that 11 GHz DRRS equipment will be introduced into service in 1982. A brief system description is given in Table 1.

A dual-band aerial for operation in the upper-6 GHz and 11 GHz bands has also been developed to alleviate potential problems of aerial congestion and excessive wind loading on towers, a problem made more acute by the fact that a height-diversity† aerial must be added on approximately 50% of the hops to achieve the required system performance. The dual-band aerial functions as a cassegrain arrangement at 11 GHz with the subreflector comprising a complex pattern of near-resonant dipoles. At 6 GHz, however, the subreflector is essentially transparent, allowing the aerial to function at these frequencies as a focus-fed device. Fig. 2 illustrates the principle of operation in schematic form.

What of the future? From 1985 onwards, analogue radio-relay systems in both the 4 GHz and lower-6 GHz bands will be withdrawn from routes in the UK whenever the present equipment is deemed to have exceeded its useful life. This has prompted an investigation regarding possible digital exploitation of these frequency bands. The basic criteria applied to this latest work are fundamentally different to those which preceded the 11 GHz programme. For example, propagation conditions are expected to be less severe at 4 GHz and 6 GHz, and more efficient use must be made of the available spectrum<sup>7</sup>. It is highly desirable that digital systems operating in these bands be capable ultimately of providing a traffic-bearing capacity comparable with existing FDM/FM systems.

The equivalent net capacity of the principal frequency bands used by the British Telecom (BT) is shown in Table 2. It will

† At 11 GHz, most hops greater than approximately 40 km experience variations in received signal level arising from multipath propagation effects. Because the air is not a stable homogenous medium, the radio beam can be considered as a summation of several different rays each of which arrives at the receive aerial via a slightly different path. Cancellations and enhancements occur, and the resultant effect can cause sudden deep fading of the received signal. To combat this, height-diversity reception is employed, whereby the signals from 2 aerials, vertically spaced by approximately 200 wavelengths, are phased and combined before being fed to a single receiver. This significantly improves the percentage of time the receiver is presented with an acceptable signal.

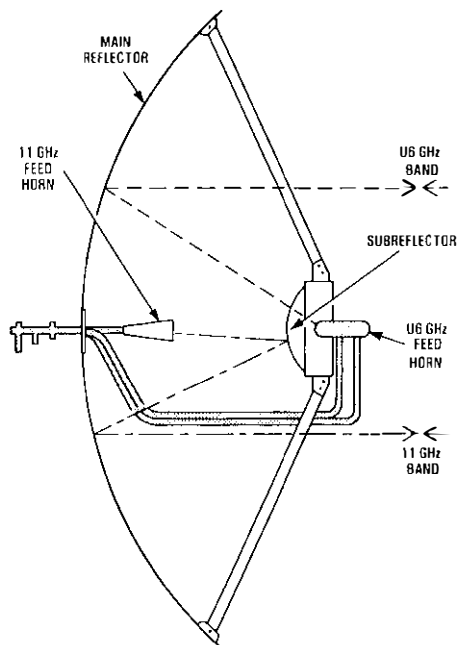

FIG. 2—Essential features of a dual-band aerial

TABLE 2  
Principle Frequency Bands; Comparison of Net Channel Capacities as Used by the BPO

Frequency band (MHz)	Total capacity* (2-way telephony channels)	Net telephony channels per MHz	Equivalent** net bit/s/Hz
Analogue systems:			
1900-2300	6 × 960 = 5 760	28.8	1.84
3790-4200	6 × 1800 = 10 800	52.7	3.37
5925-6425	8 × 1800 = 14 400	57.6	3.69
6425-7110	16 × 960 = 15 360 (8 × 2700 = 21 600)	44.9 (63.1)	2.87 (4.03)
Digital system			
10700-11700	6 × 1920 = 11 520	23.0	1.47

\*including protection radio channel

\*\*assuming one telephony channel equivalent to 64 kbit/s

be seen that the design objective for future digital radio-relay systems should be a net capacity approaching 4 bit/s/Hz. This calls for an improvement in spectral efficiency of about 270% compared with present 11 GHz DRRS equipment. A technique known as *reduced-bandwidth quaternary phase-shift keying* (RBQPSK) is one method of achieving such efficient spectrum utilization. Conventional QPSK modulation is employed, but the channel bandwidth is then severely restricted by filtering. The narrow-bandwidth filters distort the transmitted signal, but in a deterministic fashion which can readily be compensated in the receiver. A decision feedback equalizer is used, and this continually adapts to remove the inherent distortion, together with any additional distortion which may arise during multi-path propagation conditions<sup>8</sup>. By employing a second transmitter using the same frequency but with orthogonal polarization, the traffic capacity can be doubled to a total of 280 Mbit/s, occupying a radio-frequency bandwidth of approximately 65 MHz. Such a system is currently being evaluated on a link between Swaffham and Mendlesham in East Anglia.

## CONCLUSION

The role of microwaves in the terrestrial network is seen as an active and continuing one, with progression towards the use of advanced digital modulation methods to improve performance, and solid-state devices to provide high reliability. Although the BT's first steps into digital microwave systems have been at 140 Mbit/s and related to the main transmission network, it is apparent that the advantages to be gained from digital technology can also usefully be applied to systems with lower bit rates operating in the junction and local networks.

## References

- 1 HOWE, F. Modernizing the Highlands and Islands, *POTJ*, Vol. 27, p. 12, Winter 1975-76.
- 2 HILL, S. J. British Post Office Trans-Horizon Radio Links Servicing Off-Shore Oil/Gas Production Platforms, *The Radio and Electronic Engineer*, Vol. 50, p. 397, Aug. 1980.
- 3 CLAYTON, R. J., ESLEY, D. C., GRIFFITH, G. W. S., and PINKHAM, J. M. C. The London-Birmingham Television Radio-Relay Link, *Proc IEE*, Vol. 98, p. 204, July 1951.
- 4 DOE, E. S. A Digital Radio-Relay System, *POEEJ*, Vol. 65, p. 160, Oct. 1972.
- 5 JARVIS, E. G., and SCOTT, R. P. I. Development of an 11 GHz Digital Radio-Relay System, Parts 1 and 2, *POEEJ*, Vol. 72, pp. 102 and 153, July 1979 and Oct. 1979.
- 6 MUIR, A. W., and DE BELIN, M. J. The Field Evaluation of a 140 Mbit/s Digital Radio-Relay System in the 11 GHz Band, IEE Conference Publication No. 193, March 1981.
- 7 DAVIES, M. C., and CHISHOLM, J. A. Spectrum-Conserving Digital Transmission Systems for the 4 and 16 GHz Bands, IEE Conference Publications No. 188, July 1980.
- 8 DUDEK, M. T., and ROBINSON, J. M. A New Adaptive Circuit for Spectrally Efficient Digital Microwave-Radio-Relay Systems, *Electronics and Power*, Vol. 27, p. 397, May 1981.

## Bibliography

MARTIN-ROYLE, R. D., DUDLEY, L. W., and FEVIN, R. J. A Review of the British Post Office Microwave Radio-Relay Network, Parts 1, 2 and 3, *POEEJ*, Vol. 69, pp. 162 and 225, Oct. 1976 and Jan. 1977, and Vol. 70, p. 45, Apr. 1977.

BRAY, W. J. The Standardization of International Microwave Radio-Relay Systems, *Proc. IEE*, Vol. 108, p. 180, Mar. 1961.

JONES, D. G., and EDWARDS, P. J. The Post Office Network of Radio-Relay Stations, Parts 1 and 2, *POEEJ*, Vol. 57, pp. 147 and 283, Oct. 1964 and Jan. 1965.

BAKER, A. E., and BRICE, P. J. Radio-Wave Propagation as a Factor in the Design of Microwave Relay Links, *POEEJ*, Vol. 62, p. 239, Jan. 1970.

MOORE, R. A. The Testing of Broadband Radio-Relay Links, *POEEJ*, Vol. 63, p. 220, Jan. 1971.

ELKINS, N. A. The Reliability of Microwave Radio-Relay Systems, *POEEJ*, Vol. 61, p. 143, Oct. 1968.

MARTIN-ROYLE, R. D. Intermediate-Frequency Switching Systems for Microwave Radio-Relay Links, *POEEJ*, Vol. 61, p. 110, July 1968.

GRIFFITH, G. W. S. Twenty-five Years of Microwave Radio, *GEC Telecommunications*, No. 40, p. 2, 1975.

GAUNTLETT, R. D. Dual-Frequency-Band Horn-Aerial Systems, *POEEJ*, Vol. 60, p. 217, Oct. 1967.

CLOW, D. G. Steel Masts and Towers in the British Post Office, Parts 1, 2 and 3, *POEEJ*, Vol. 66, p. 231, Jan. 1974 and Vol. 67, pp. 49 and 102, Apr. and July 1974.

MARTIN-ROYLE, R. D. and HEATHER, J. M. Remote Control and Supervisory Systems for Microwave Radio-Relay Links, *POEEJ*, Vol. 63, p. 169, Oct. 1970.

# Frequency-Division Multiplex Line and Terminal Equipment

M. J. ANDREWS, B.Sc.†

UDC 621.395.46: 621.315.212

## INTRODUCTION (1930-1956)

In the early days of telephony<sup>1</sup>, trunk routes were provided by audio circuits carried either on overhead open wires or on underground pair-type cables. The techniques of inductive loading and cable balancing and the use of amplifiers improved the performance of these circuits to a certain extent, but it was the need to increase the capacity of routes, without recourse to additional cable installations, which led to the introduction of the first frequency-division multiplex (FDM) telephony equipment employed in the UK.

The earliest systems, known for a time as *wired wireless*, but more commonly later as *carrier systems*, were provided as expedients with no general standardization of operation or performance. The first systems, Carrier Systems No. 1, were installed in the period 1932-33 and provided a single carrier channel above the audio band on overhead routes. Over the next few years a number of different designs were introduced, giving an increasing number of circuits until the first 12-channel equipments became operational in 1936. Also during this period, valve amplifiers with negative feedback appeared, thus allowing intermediate repeaters, installed in surface buildings, to be provided along a route.

By 1938, international agreement had been reached on a set of common system standards (for example, 300-3400 Hz channels and 4 kHz channel spacing) and Carrier System No. 7, introduced in 1940-41, was the first equipment specifically designed to these parameters. Using single-stage modulation and crystal channel filters, Carrier System No. 7 formed its 12-channel group in the frequency band 60-108 kHz, the basic group band by then agreed for use on coaxial cable systems, and translated it into the 12-60 kHz 12-circuit line frequency band via a 120 kHz carrier. By using this equipment in both direct and translated modes, and by halving the spacing of repeaters, 12-circuit routes could be upgraded to 24-circuit working using the 12-60 kHz and 60-108 kHz bands, and by the mid-1950s most routes were used in this manner.

The first experimental coaxial-cable system was also in service by 1938, using surface-building-housed repeaters fed with power over the coaxial pairs. A number of systems to the general design of Unit Bay No. 1, devised by the British Post Office (BPO) Research Department at Dollis Hill, were installed from the early-1940s onwards followed by the first truly standardized systems (Coaxial Equipments, Line (CEL) No. 1A) in 1950. A line frequency range of 60-2540 kHz was employed, with signals assembled in the standard FDM hierarchical format of 60-108 kHz groups, and 312-552 kHz supergroups, 10 supergroups (600 circuits) being accommodated within the line spectrum. Repeater were spaced at 9.6 km intervals on 2.6/9.5 mm coaxial cable pairs, and automatic repeater changeover was initiated by failure of a 300 kHz line pilot. The line power-feed voltage was 350 V AC, capable of powering 2 repeaters, and manual temperature equalization was provided.

In 1951, the first 4 MHz coaxial line systems, designated *CEL No. 4*, were introduced, allowing 16 supergroups (960 circuits) to be transmitted in the band 60-4028 kHz, with main and stand-by repeaters at 9.6 km intervals, switched as a result of a 308 kHz pilot failure. This was followed in 1954 by *CEL No. 6A*, which had basically the same performance, but with automatic temperature equalization controlled by a 4092 kHz line pilot. On the latter, up to 6 dependant repeaters could be powered on each side of a power-feeding station using a 1000 V AC power-feed voltage, and terminal equipment was, for the first time, housed in the Type-51 equipment practice<sup>2</sup>.

By 1953, a new range of translating equipments, Carrier Systems No. 9, was being installed; these employed a high-stability crystal-controlled master oscillator for the carrier-generation function, replacing earlier equipments which relied on a high-accuracy reference signal being available from the line. Advances were still being made on pair-type carrier systems and plans had been laid by 1956 to transmit 60-channel assemblies, derived from translation of a basic 312-552 kHz supergroup, over low-capacity cables using the frequency range 12-252 kHz, with repeaters spaced at 19 km intervals.

† Transmission Department, British Telecom Headquarters

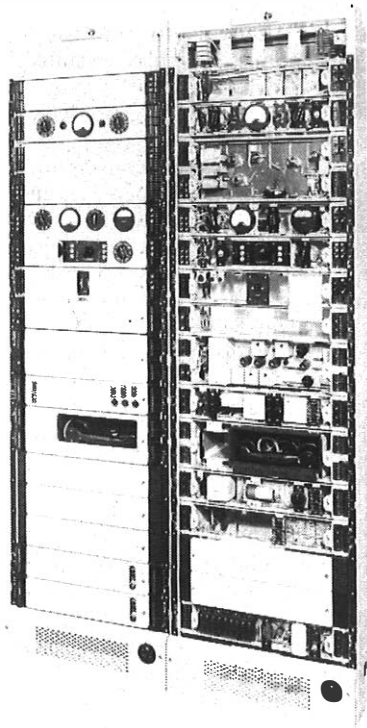

FIG. 1—Coaxial Equipment, Line No. 8A

## LINE SYSTEMS

### Coaxial-Cable Systems

In 1961, the first 12 MHz coaxial-line system, CEL No. 8<sup>3</sup> (see Fig. 1), was in use, with a capacity of 2700 circuits. This system operated over 2·6/9·5 mm coaxial pairs, as had previous 4 MHz systems, but the wider bandwidth employed, telephony traffic occupying the band 312–12 336 kHz, led to greater cable attenuation at the higher frequencies and, to offset this, the repeater spacing was reduced to approximately 5 km. The high power requirement of the valve repeaters, approximately 350 VA compared to 250 VA for a 4 MHz repeater, demanded power-feeding voltages of 2000 V AC. The system bandwidth was occupied by three 15-supergroup assemblies (each in the band 312–4028 kHz) together with pilots at 308 kHz, 4287 kHz and 12 435 kHz, the 4287 kHz pilot being used to provide automatic temperature equalization. Comprehensive supervisory facilities were provided and, in view of the large amounts of AC power fed to line, power-factor correction was applied.

By the late-1950s, reliable high-frequency transistors had become available and the benefits which these could bring to line systems were immediately grasped. In particular, the low power requirements and small size offered significant simplification of power-feeding facilities and associated safety features, and made possible for the first time the ability to install repeaters in manholes and footway boxes, rather than in expensive surface repeater stations.

Accordingly, in 1960, the first transistorized coaxial line system<sup>4</sup> was installed, between Hastings and Eastbourne. Providing 300 circuits in the line frequency range 60–1300 kHz, the system incorporated automatic level regulation via a 1054 kHz line pilot and operated over a coaxial cable having an inner diameter of 4·14 mm. Repeaters were mounted underground in manholes at 3·6 km spacings and were powered by a 49 mA constant-current power-feeding arrangement. A maximum of 12 repeaters could be powered within the overall safety limit of  $\pm 250$  V DC imposed on the power-feed voltage.

Experience with this system quickly established confidence in transistor line equipment and while 1300 kHz systems were

installed using 1·2/4·4 mm coaxial cable, attention was given to the design of a wider-bandwidth system. Performance of available transistors and the desire for compatibility with the existing systems led to the design of a 4 MHz (60–4028 kHz) equipment (CEL No. 1006) capable of working over either 2·6/9·5 mm or the, by then, standard 1·2/4·4 mm small-bore coaxial cables<sup>5</sup>, and with underground repeaters at approximately 9 km and 4 km intervals respectively. The repeaters were located in a new design of underground housing, Case Repeater Equipment No. 1 (CRE No. 1)<sup>6</sup>, housed in a footway box. The terminal equipment was installed in the Type-62 equipment construction practice<sup>2</sup>. Initial systems were installed in 1967. A 4092 kHz pilot provided automatic regulation by controlling the gain of, nominally, every third repeater; up to 8 dependant repeaters could be power fed from a terminal station.

Soon after the 4 MHz systems went into production, improvements in transistor technology permitted even greater-bandwidth line systems to be considered, and a 12 MHz system, CEL No. 1007, was developed to work on 2·6/9·5 mm coaxial pairs. The basic design parameters were broadly those fixed a decade earlier for the 12 MHz valve system (CEL No. 8A), although system regulation was controlled by the 12 435 kHz pilot. Repeater spacing was half that of CEL No. 1006 to facilitate later upgrading of such routes to 12 MHz working, and 10 repeaters in each direction could be powered from a terminal station, a nominal 50 mA line current being employed.

The advantages of having a standard 12 MHz transistorized system capable of working on both 1·2/4·4 mm and 2·9/9·5 mm coaxial cables were soon realized. However, while CEL No. 1007 was successful, its repeaters could not produce the noise performance necessary for working on the smaller diameter cable, the greater attenuation of which necessitated a closer spacing and, thus, a greater number of repeaters. Also, until that time each manufacturer had supplied complete systems which met the overall performance requirements, but whose component units were not necessarily compatible. The new system, CEL No. 4000<sup>7</sup>, offered both compatibility between units from different manufacturers and the ability to work on both cable types, and was first used in 1971.

CEL No. 4000 provides a traffic band of 312–12 388 kHz, the upper limit catering for a 3-supermastergroup assembly<sup>8</sup>, with line pilots at 308 kHz and 12 435 kHz, the latter controlling the line regulation. Repeaters are spaced at nominally 2 km and 4 km intervals respectively for small and large-bore coaxial pairs, thus allowing 4 MHz routes to be upgraded without resiting existing repeater points. Alternate repeaters were provided with the regulating facility and 7 dependant repeaters were powered using a maximum voltage of 250 V DC at 50 mA constant current.

The last significant development in analogue coaxial line systems used in the UK was the 60 MHz system<sup>9</sup>. With a traffic bandwidth of 4332–59 684 kHz, this system offered a fourfold increase in capacity compared with the 12 MHz systems, to 10 800 telephony circuits. To achieve this, a number of original features were employed: repeaters, spaced at 1·5 km intervals on an improved 2·6/9·5 mm coaxial cable, employed film techniques for the amplifiers, components being mounted direct on a ceramic substrate, the whole then being encapsulated in a hermetically sealed package. Power feeding requirements were increased to 110 mA at 1000 V DC, necessitating comprehensive safety features and, to optimize noise performance over the operating temperature range, both pre and post regulation was employed, controlled via 61·16 MHz and 2·9 MHz pilots. In view of the large number of circuits carried on a single cable system, security was enhanced by the provision of automatic changeover facilities, and a sophisticated supervisory system continuously monitored performance. The line spectra of the various systems is shown in Fig. 2.

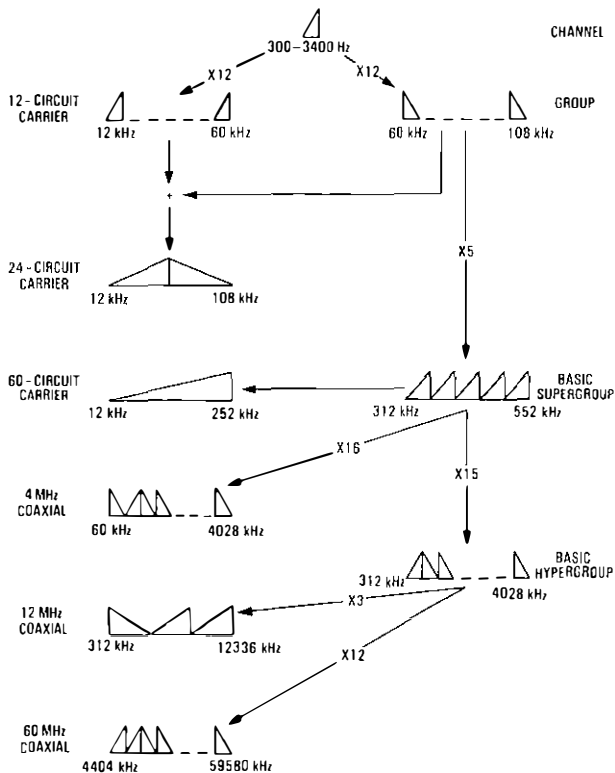

FIG. 2—Frequency spectra of carrier and coaxial-line systems

### Balanced-Pair Cable Systems

With the widespread use of coaxial-cable line systems for trunk circuits, further significant developments in carrier systems on balanced-pair cables after the mid-1950s were somewhat limited. The installation of 60-circuit equipments, using the line frequency range of 12–252 kHz, continued, and transistorized versions were developed and installed during the 1960s. Apart from this, and some transistorized 12-circuit equipment developed for specific Scottish routes, development of systems for balanced-pair cables for use in the UK network had effectively come to an end.

### FDM TRANSLATING EQUIPMENT

Equipments developed under the generic title of Carrier Systems No. 9 were valve operated and mounted on the Type-51 equipment practice. Each channel translating equipment (CTE) occupied one half of a 2743 mm (9 foot) high rackside and consumed approximately 50 VA, and each group translating equipment (GTE) occupied a complete 2743 mm rackside and consumed approximately 135 VA.

As has already been mentioned in the references to coaxial line systems, by the late-1950s advances in transistor technology had been such that their application to transmission equipment could be seriously considered and, by 1957–58, the first transistorized frequency-translating equipments were being installed. Mounted on the Type-56 equipment practice, their most significant feature was the tremendous reduction in physical size and power consumption compared with their valve predecessors. For example, an Equipment, Frequency Translating (EFT) No. 80A CTE occupied one sixth of a 2743 mm Type-56 rackside per group and consumed approximately 6 W, while an EFT No. 70A GTE could accommodate translating equipment for 4 supergroups on one 2743 mm rackside, each equipment consuming only 15 W. Thus, the introduction of transistorized translating equipment immediately reduced equipment size by between one third and one quarter and power consumption by up to one ninth of the valve equivalents.

With the introduction of Type-62 equipment construction practice, developed specifically for transistor-operated equipment, further economies of space resulted, and the new equipment designs (for example, EFT No. 1000A CTE and EFT No. 1001A GTE), offered respectively the translating equipment for one group and one supergroup on a single shelf of the new practice. Power consumption also reduced, this time to approximately 2.6 W per CTE and 5 W per GTE.

In the mid-1950s it had become standard to introduce a group reference pilot (GRP)<sup>10</sup> signal into every group path to enable transmission loss of the group to be accurately controlled manually and to assist in fault location. The GRP, a high-stability signal at 84.08 kHz, was combined with the traffic at the output of the transmit CTE and monitored at the receive CTE, thus being subjected to the same path conditions as the traffic. By 1968, equipment had been designed which allowed the received level of the GRP to automatically control the overall transmission loss of a group<sup>11</sup>. This group automatic-gain-control (AGC) equipment was installed prior to the group input of the CTE and enabled transmission loss to be continuously controlled without manual intervention, and also provided alarm outputs when the GRP level deviated outside preset limits. A facility was also provided to signal a fault state to the associated exchange to indicate that the appropriate circuits should be made busy. With this system, however, no means existed to automatically indicate the fault condition to the far end of the route.

As channel translating equipment forms by far the greatest proportion of equipment in the FDM transmission network, the incentive to take advantage of redevelopment to reduce costs has always been strong and, over the years, this has been the prime reason for most CTE redesign work. In late-1974 a new CTE was introduced<sup>12</sup> which not only followed the previous trend of cost reduction, but which also incorporated a range of new facilities designed to improve the quality of service and to reduce circuit maintenance and effort required when lining up circuits. Known as *new generation channelling*, the EFT No. 1035 incorporated the group AGC facility within the translating apparatus and, by use of modern miniature components including thick-film networks and active modulators, enabled a complete group end to be accommodated in half a Type-62 shelf. In addition to the basic AGC arrangement, facilities were also provided to initiate circuit busying at both ends of the route, known as *backward busying*, when one direction of transmission failed and, by means of a memory circuit, maintained the overall path gain constant when a GRP failure occurred. To make full use of the backward busying feature in the network, existing separate group AGC equipments are being retrospectively modified to provide similar facilities.

### CONCLUSION

The history of FDM line and terminal equipment spans approximately 50 years. In the first 25 years the majority of the parameters now considered as standard were defined and the basic techniques demonstrated and equipments progressed from being expedients to being provided as part of an overall network strategy. The past 25 years has seen the results of technological advancement applied to these systems with the resulting increase in system bandwidth and improvements in operational facilities coupled with drastic reductions in size and power consumption.

With the decision made to digitalize the UK national network, the need for further FDM developments has largely ended and one can but speculate about how the most recent advances in signal processing and large-scale integration (for example, switched-capacitor filtration and synthesized carrier-supply generators) may have affected a further generation of FDM equipment. However, it is interesting to note that, even now, the carrier cables installed so long ago still provide the means for conveying most sound-programme circuits, via



their phantoms, and will continue to give service for many years to come when they provide the transmission medium for future 8 Mbit/s digital line systems.

## References

- <sup>1</sup> Transmission and the Trunk Network. *POEEJ*, Vol. 49, p. 216, Oct. 1956.
- <sup>2</sup> N. J. CRUMP. Transmission Equipment Practice. *POEEJ*, Vol. 74, p. 265, Oct. 1981.
- <sup>3</sup> BORDISS, H. J. K., and DAVIES, A. P. A 12 Mc/s Coaxial Line Equipment—CEL No. 8A. *POEEJ*, Vol. 54, p. 73, July 1961.
- <sup>4</sup> ENDERSBY, J. C., and SIXSMITH, J. Coaxial Line Equipment for Small-Diameter Cables. *POEEJ*, Vol. 55, p. 44, Apr. 1962.
- <sup>5</sup> ALLAN, A. F. G. Small-Diameter Coaxial-Cable Developments. *POEEJ*, Vol. 57, p. 1, Apr. 1964.
- <sup>6</sup> CLINCH, C. E. E., and STENSON, D. W. Housing of Repeater Equipment Underground. *POEEJ*, Vol. 56, p. 158, Oct. 1963.
- <sup>7</sup> MILLER, J. R., and GIPP, J. A. L. Recent Developments in FDM Transistor Line Systems. *POEEJ*, Vol. 63, p. 234, Jan. 1971.
- <sup>8</sup> BLACKHALL, R. W. E. Frequency-Division-Multiplex Equipment. *POEEJ*, Vol. 66, p. 38, Apr. 1973.
- <sup>9</sup> The 60 MHz F. D. M. Transmission System. *POEEJ*, Vol. 66, Oct. 1973.
- <sup>10</sup> NAULIS, R. W. The Group Reference-Pilot Signal. *POEEJ*, Vol. 55, p. 237, Jan. 1963.
- <sup>11</sup> ELLIOTT, J. L. C. Group Automatic Gain-Control Equipment. *POEEJ*, Vol. 61, p. 3, Apr. 1968.
- <sup>12</sup> MCKAY, N. P., and PATEL, A. C. New Generation Channel-Translating Equipment. *POEEJ*, Vol. 66, p. 103, July 1973.

# Audio Transmission

J. L. LONERGAN, B.SC., C.ENG., M.I.E.E., DIP.A.F.†

UDC 621.396

## INTRODUCTION

The demise of telegraph circuits as the primary means of long-distance communications after 1900 began with the introduction of the telephone in the late-1870s. Initially, audio transmission posed few problems because of the short distances involved. However, a trunk system<sup>1</sup> based on overhead copper wires with a gauge of 800 lb/mile for main routes and 400 lb/mile for shorter routes had been introduced by 1896. Inevitably, this suffered from the ravages of bad weather. The solution to the problem: to use underground cable as a standard item in the trunk network, was eventually adopted, but not before the problems of resistance and capacitance values that were higher than in overhead cables were resolved. This was largely achieved by the techniques of loading, balancing, amplification and equalization; and the history of audio transmission is closely linked to the development and refinement of these techniques.

The development work carried out in the early-1920s on loading and balancing underground cables enabled them to supplant overhead wires economically and to enhance their performance by reducing, in particular, crosstalk.

The invention of the thermionic valve led to the development of repeaters. As early as 1913, experiments using gas-filled valves were taking place, and these led to the introduction of the 2-wire repeater. The development of vacuum valves resulted in their being used for all later designs of repeaters.

In the 1920s, 4-wire repeated circuits<sup>2</sup> superseded 2-wire circuits because of the former's inherent stability. The major innovation of the 1940s was the introduction of the Amplifier No. 32, a single-stage amplifier incorporating negative feedback and having a gain of 27 dB. The thermionic-valve era closed as the provision of audio trunk circuits waned. However, sufficient demand for audio equipment, largely on junction circuits, remained for the range of equipment to be redesigned in Type-51 equipment practice.

## THE AGE OF THE TRANSISTOR

Twenty-five years ago saw the dawning of the age of the transistor which revolutionized the design of all amplifiers, includ-

ing line amplifiers. As these new devices gained ascendancy, so the role of audio amplifiers in the trunk network declined, being used only for specialist purposes on private circuits and low-growth routes. The need grew, however, for new amplifiers of lower gain for use in the junction network. Such circuits, if of any appreciable length, required amplification to meet the transmission plan, yet it was necessary to provide such amplification economically. The pendulum swung fully when 2 versions of a 2-wire repeater were introduced, both utilizing transistors, namely:

- (a) the *negative-impedance repeater*<sup>3</sup> (using both series and shunt elements), and
- (b) the *hybrid repeater*<sup>4</sup>.

The negative-impedance repeater, being the cheaper, is widely used to provide gains of up to 13 dB on 88 mH/1·83 km loaded plant. Stability depends critically on both the terminating impedances and those of the repeater. Designed as a mid-line device, it has in fact been used considerably in a line-terminal role, with suitable modifications being applied.

The hybrid repeater is less sensitive to poor line matching and is used in the more difficult cases. The additional gain and wider range of adjustments available permit the amplifier to satisfy a range of line losses not possible with the negative-impedance repeater. Both devices were first introduced in Type-51 equipment practice, but are now manufactured in Type-62 equipment practice.

The 4-wire repeater was not neglected, however, and designs of more compact size and which were economically more viable to produce and utilize, were developed. The present standard is the Amplifier Unit No. 3/. . . which not only houses the basic amplifier but also associated equalizers, transformers, attenuators and balancing networks, all within part of a Type-62 shelf. Comparison with previous equipment with its separate racks of amplifiers indicates how dramatic has been the change in audio equipment design.

Additionally, a new range of branching and combining amplifiers has been introduced for distributing audio signals in specialized situations. More recently the conference amplifier facility has been redesigned and will be coming into service soon.

The period of the 1960s saw the introduction of the last major change in cable type; namely, the use of 0.63 mm (10

† Transmission Department, British Telecom Headquarters

lb/mile) copper conductors as the standard junction cable<sup>5</sup>. The increased attenuation of such cable accentuated the need for 2-wire repeaters, stimulating demand well into the late-1970s.

During the 1970s, a new approach to providing conditioned audio lines was investigated using negative-impedance boosters (NIBs)<sup>6</sup>. Such an approach was novel since it approached the solution to the distortionless condition ( $LG=CR$ )<sup>7</sup> from a different direction; in the case of NIBs, negative resistance and capacitance were introduced to the line to satisfy the equation. Thus, reduction of the distributed elements by use of negative elements at loading-point intervals produced wide-bandwidth circuits. The implementation of this technique on any wide scale, however, was frustrated by it arriving too late to satisfy the needs of a junction network moving rapidly into the digital era.

## SIGNALLING ON AUDIO CIRCUITS

Signalling on circuits was initially accomplished using DC or 17 Hz signalling relays at each repeater. Clearly, advantages exist if in-band frequencies are used. This was accomplished by the adoption of a 500 Hz signal modulated at 20 Hz. Today, audio amplifiers use by-pass circuits to provide DC, 17 Hz or 25 Hz signalling paths using the phantom circuits. The use of 500/20 Hz signalling has been superseded by the choice of 2280 Hz as the signalling frequency, in line with other signalling systems; for example, SSAC9, SSAC13 and SSAC15.

## INTERNATIONAL REQUIREMENTS

During the 1950s, the growth in international traffic led to the introduction of the TAT, CANTAT and COMPAC submarine cable systems. This was followed by satellite communications in the next decade. New attention was paid to 2 further audio items linked with long-distance international circuits: compandors and echo suppressors.

Compandors<sup>8</sup> are designed as 2-stage elements, the COMPRESSOR and the EXPANDOR. Circuits of thousands of kilometres in length were thought to have inherent high noise levels which would impair the transmission of speech. At the send end, compressors were used to compress speech levels above -30 dBm using a 2:1 law, placing the speech signals advantageously with respect to the noise. The improved signal-to-noise ratio is maintained until the inverse law is applied by the expander at the receive terminal. Thus, over the submarine cable link, an improved signal-to-noise ratio was maintained.

Echo suppressors<sup>9</sup> are necessary on circuits having propagation delays of 50 ms or more and which do not have high loop losses. Modern transmission plant and techniques ensure stable low-loss circuits, allowing speech echoes to confuse the two talkers and prevent normal speech. This is particularly so for satellite circuits where echo delays of the order of 500 ms are encountered.

The current echo suppressor, the Echo Suppressor No. 8A, was designed to CCITT† recommendation G161, as was its predecessor. Such a device requires a counterpart at the distant end of the circuit to identify jointly the presence of single-speech, double-speech or no-speech conditions. Under each of these conditions, appropriate attenuation is placed in circuit to permit speech to take place with the minimum of impairment.

## THE PRESENT AND THE FUTURE

The audio equipment described in this article largely provided trunk and junction amplified circuits, the bulk of which were used within the public switched telephone network. This will be less so in the future for the reasons given. The same equipment has been used to provide the more specialized requirements of private circuits. Such circuits, with their individual requirements and unusual routings, will continue to be provided economically and with flexibility. The growing importance of private circuits to the business community is reflected in the new work now being undertaken to improve audio equipment to be made available for their provision. Factors to be considered in designing such equipment are:

- (a) private circuits have special maintenance problems because of the individuality of their routing and circuit performance,
- (b) circuits are often used for data transmission as well as speech, and
- (c) the need to respond rapidly to customer circuit provision and service needs.

In response to this, British Telecom (BT) is devising improved circuit-accessing equipment which can be remotely controlled. At strategic points in such circuits, access switches will be provided; these, when opened from a central control, can be used to test the circuit performance. Rapid fault location should be possible, thereby improving BT's response to its customers. Additionally, the equipment to be found in customers' premises is to be enhanced with an automatic looping device, for identifying whether it is BT's plant or the customer's equipment which is at fault.

Currently, items identified as crucial to private-circuit provision are being developed, probably within the TEPIE equipment practice. The use of modern techniques, operational amplifiers, thick-film circuits, microprocessors, etc. will be incorporated into these new designs. These, and other new techniques, will enable BT to successfully provide audio circuits into the twenty-first century.

† CCITT—International Telegraph and Telephone Consultative Committee

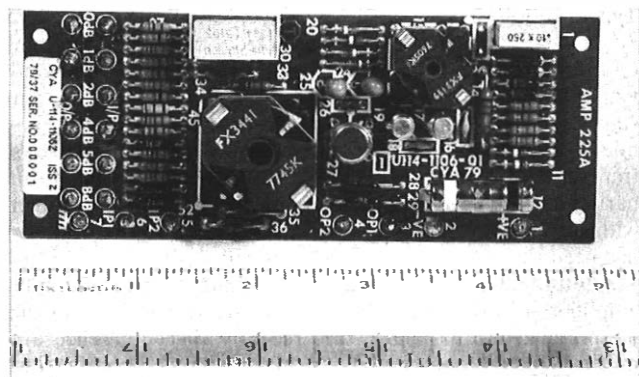

FIG. 1—Line-powered amplifier used in customers' premises

## References

- 1 Transmission and the Trunk Network. *POEEJ*, Vol. 49, p. 216, Oct. 1956.
- 2 ROBINSON, C., and CHAMNEY, R. M. Four-Wire Telephonic Repeater Systems. IPOEE Printed Paper No. 83, Jan. 1921.
- 3 NEILL, T. B. M., and TURNER, D. The Principles of Negative-Impedance Convertors and the Development of a Negative-Impedance 2-Wire Repeater. *POEEJ*, Vol. 51, p. 206, Oct. 1958.
- 4 JONES, I. O. An Improved Design for a 2-Wire Hybrid Repeater. *POEEJ*, Vol. 65, p. 21, Apr. 1972.
- 5 LAWRENCE, A. J., and DUFUR, I. G. Audio Junction Cables. *POEEJ*, Vol. 69, p. 239, Jan. 1977.
- 6 Lonergan, J. L. Negative-Impedance Boosters. *POEEJ*, Vol. 65, p. 103, July 1972.
- 7 Royal Signals Handbook of Line Communication. Vol.1.
- 8 THOMPSON, D. A Speech Compandor Using Junction Transistors. *POEEJ*, Vol. 55, p. 14, Apr. 1962.
- 9 HODSOLL, A. G. The Echo Suppressor. *POEEJ*, Vol. 63, p. 86, July 1970.

# Transmission Equipment Practice

N. G. CRUMP†

UDC 621.395.461

## INTRODUCTION

During its evolution, transmission equipment has been produced in various forms of construction. Early equipment was generally mounted on flat panels which were screwed to racks incorporating substantial steel uprights but, by the 1950s, this had given way to the first formally-adopted equipment practice—Type 51.

This article reviews the practices used since the first type was introduced.

## TYPE-51 AND TYPE-56 EQUIPMENT

Twenty-five years ago, transmission equipment was just beginning to incorporate transistors. This resulted in a degree of miniaturization which necessitated modification to the well-established Type-51 equipment practice<sup>1</sup> which had been used to accommodate valved equipment for the previous 5 years. In this practice (see Fig. 1), equipment was housed in shelves of open-frame construction which were fitted in single-sided racks and connected by U-links which joined shelf-end connectors with corresponding rack-mounted connectors on which the side-positioned rack cables were terminated. Shelf fronts were fitted with removeable covers which were perforated as required to give access to controls, indicators and test points. The equipment was cooled by natural convection currents flowing through the rack from bottom to top. Standardized alarm facilities were provided on a centrally-mounted shelf.

The modifications made to enable small equipment to be mounted were based on modular subdivision of the shelf. Each module was connected via U-links to the rack wiring. The modified practice was known as *Type-56* and is shown in Fig. 2.

## TYPE-62 EQUIPMENT

Further miniaturization and the acceptance of the printed-wiring board (PWB) as a good technical and economic solution to component interconnexion made necessary the consideration of a new form of equipment practice. A number of design concepts were studied and, in 1962, the practice subsequently known as *Type-62*<sup>2</sup> was chosen as the basis of future transmission equipment construction practice.

The basic format differed radically from all previous forms

of transmission equipment practice in being single sided, one rack having the same depth as 2 of the previous racks placed back-to-back. The rack housed equipment shelves, inclined at 15° to the horizontal, which accommodated plug-in units of various widths. The shelves were provided with connectors at the rear which complemented those mounted on the plug-in units; cables were situated in a cabling area at the rear of the shelves and connected directly to the shelf connectors. The latter were also directly interconnected where equipments consisted of more than one plug-in unit.

The plug-in unit consisted mainly of a vertically-mounted PWB in a metal frame fitted with a front panel, although chassis-type units were also used for some applications. The front panels carried any necessary controls, indicators and test points, and effectively formed the front face of the equipment (see Fig. 3).

The cooling strategy also departed significantly from that used previously. Natural convection was still employed, but the air flowed through louvres in the rear covers, between the plug-in units and exhausted via gaps above the plug-in-unit front plates. Air flow was aided by the 15° inclination of the shelves. Since each shelf had a solid top and bottom, air flow was exclusive to each shelf, and this gave a high degree of thermal isolation between shelves.

Shelf plug-in-unit connectors consisted of 2-part plastic mouldings carrying various combinations of unscreened and screened gold-plated contacts. Alarm facilities were provided on a per-equipment basis or by means of a common plug-in alarm unit.

For over a decade, this equipment practice proved to be a very practicable and cost-effective method of meeting transmission equipment construction requirements but, inevitably, changes in technology necessitated modification. These were incorporated at various times over the last 10 years or so to meet the needs of emerging new systems and production methods. The metal frame of the plug-in unit was not needed where only light-weight components were mounted on the PWB, and the frame was dispensed with where appropriate, the edges of the PWB forming the mechanical contact with the shelf. Plug-in-unit-to-shelf connectors were partly re-designed to give a better contact, and true coaxial contacts were made available to meet the needs of high-frequency and high-bit-rate systems. Connexions to the rear-of-shelf connector tags were originally soldered but satisfactory means of wire-wrapping were developed and became extensively used. The heat generated by high-speed digital systems was greater than the original cooling strategy could cater for, and provision was made for groups of shelves to be fitted with

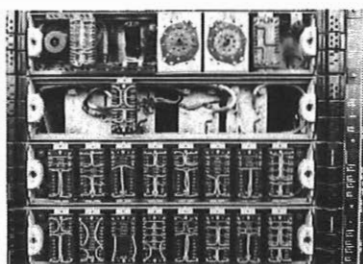

FIG. 1—Type-51 practice

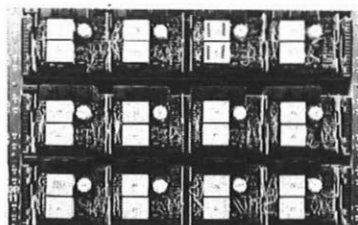

FIG. 2—Type-56 practice



FIG. 3—Type-62 practice

† Transmission Division, British Telecom Headquarters

auxiliary air intakes and exhausts. Complex digital equipment evolved which consisted of more than one shelf. This required considerable inter-shelf wiring which would have been very inconvenient to provide on-site. A means was devised of assembling the groups of shelves in a temporary framework to enable the wiring to be carried out in the factory. The completed equipment was then transported in the frame, which was removed as the shelves were slid into the rack.

Variants of the basic format appeared from time to time. These included a horizontal-shelf version for use with certain non-transmission applications, one of which had a different type of connector fitted. A cabinet was designed to enable the rack to be used in customers' premises.

This equipment practice was designed in the heyday of the analogue era. Nevertheless, it proved capable of accommodating the early digital systems with reasonable efficiency. However, as the systems grew in complexity some inherent characteristics of the design began to limit the equipment designer's scope to produce cost-effective systems. This was caused mainly by the introduction of integrated circuits; the associated increase in packing density and PWB tracking requirements, and the limited connector capacity, severely restricted equipment layouts. Technical problems also arose when high-bit-rate systems were designed, because of the distances involved in interconnecting circuit elements.

Manufacturing problems also began to emerge. The rear-of-shelf connectors were designed to be wired manually, and it proved impossible to modify this area to allow modern automatic production methods to be used. Factory testing was made difficult because the basic format did not lend itself to easy equipment connexion and disconnexion.

Installation requirements, too, began to indicate some shortcomings in the practice. All equipment had to be hard-wired and, as labour rates rose, on-site work became very expensive, as did on-site testing and fault clearance.

The somewhat unusual format (by worldwide standards) of the practice limited the scope for exports. In overseas stations back-to-back rack installation became established as the basis for station layouts and Type-62 equipment did not fit in well with racks from other suppliers. Overseas administrations were often reluctant to accept the standard BPO rack colour, and colour change of all the metal and plastic parts involved caused many difficulties. The relatively high cost of equipment, due mainly to the extent of manual production processes involved, also made export orders difficult to obtain.

## TEP1E EQUIPMENT

Thus, about 1975, a strong case for a new equipment practice began to build up, and consideration was given by both the BPO and Industry to the requirements of such a practice. Subsequently, a contract was placed with Industry for the development of a practice called TEP1E<sup>3</sup>, to meet these requirements. An early decision was made to re-adopt the half-depth format. This was dictated by the export and technical needs as indicated above and, also, by the desire to conform to the CEPT† harmonization recommendations for equipment construction standards which had begun to emerge about this period. Fundamentally, the practice was designed with digital equipment in mind.

The basic format of TEP1E remained PWB plug-in units mounted vertically within a shelf (see Fig. 4). The plug-in units were unframed and connected to the shelf via high-density connectors which also offered coaxial, high-current and optical-fibre connexion facilities. The rear-of-shelf inter-connexion area, generally known as the *backplane*, was designed to allow the use of both traditional and automatic wiring methods, including wire-wrapping and flow-soldered PWBs. Both balanced and coaxial connexions to the equip-

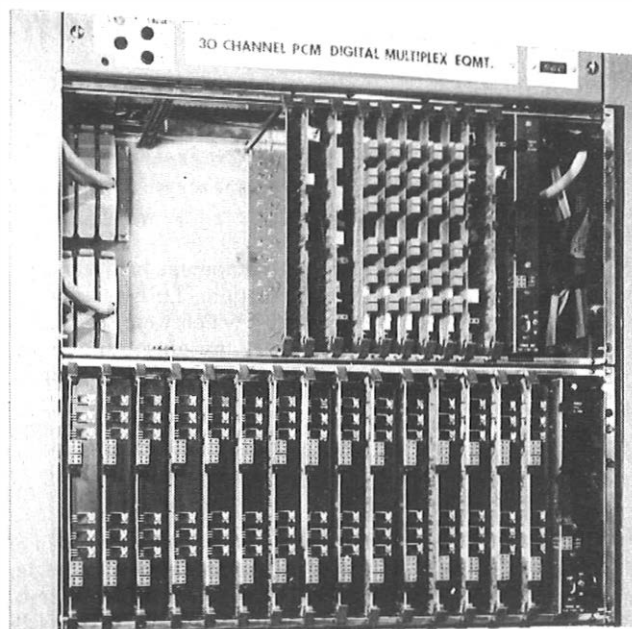

FIG. 4—TEP1E practice

ment ports were made via appropriate connectors mounted on the front of the shelf backplane. These connectors facilitated factory testing and reduced installation time. The close spacing of the plug-in units, typically about 30 mm, effectively prevented the use of plug-in-unit front plates, and overall shelf covers were re-introduced, as was the use of side-positioned rack cables and bottom-to-top cooling employing natural convection.

All previous practices used mild steel, but here a significant departure was made and stainless steel was chosen for the strength-providing members together with plastic-coated aluminium for the cladding. Both these materials were self-finished and allowed a further reduction in the amount of manual work required to fabricate equipment.

With the introduction of digital equipment and an increase in awareness of maintenance costs, a demand arose for a more comprehensive alarm system. This was provided by means of an alarm-display unit fitted to the end of equipment shelves and coupled to a rack-alarm unit situated at the top of the rack.

Currently, TEP1E is also being used for optical-fibre systems, and the deployment of fibres within the rack and equipment is being studied to enable the best layouts to be achieved having regard to technical, economic and safety considerations.

## CONCLUSIONS

For the future, there can be little doubt that further miniaturization will demand adaptation of the practice, and subdivision of the shelf can be envisaged. Nevertheless, TEP1E practice is expected to remain in use for at least a decade.

TEP1E could well be the last of the dedicated transmission equipment practices. As the integrated services digital network grows, the increasing number of co-sited transmission and switching installations will probably justify the use of a universal practice.

## References

- <sup>1</sup> HARRIS, E. T. C., and SPRATT, C. J. An Improved Form of Mechanical Construction for Transmission Equipment—51-Type Construction. *POEEJ*, Vol. 51, p. 197, Oct. 1958.
- <sup>2</sup> WALKDEN, M. R. Construction Practice for Transmission Equipment. *POEEJ*, Vol. 66, p. 25, Apr. 1973.
- <sup>3</sup> CRUMP, N. G. A New Equipment Practice for Transmission and Other Applications: TEP-1(E). *POEEJ*, Vol. 72, p. 160, Oct. 1979.

† CEPT—Conference of European Postal and Telecommunication Administrations

# POSTAL ENGINEERING

## FOREWORD

Over the past 25 years there has been a considerable growth in Postal Engineering activity. A number of factors are responsible for this including: the need to hold down the cost of the services; the need to remove as much heavy manual work as possible; and the need to improve the working environment of the staff. The result has been a considerable increase in the amount and complexity of mechanization that has been, and is still being, installed in offices. In addition, the ever present demand for greater reliability in machine performance and the need to provide up-to-date complementary services has meant that advantage has had to be taken of the latest advances in technology. Some examples of the developments that have taken place over this period, and an indication of the range of activities involved are given in the following articles.

Postal Engineering originated in the old Engineering Department of the British Post Office and has grown from there. As this *Journal* goes to print, Postal Engineering enters into a new phase in that it remains as part of the new Post Office created after the separation of the Postal and Telecommunications Businesses of the British Post Office.

At this stage, one can only guess at the progress that will occur over the next 25 years, but what is more certain is that the new Post Office will be making ever increasing use of technology in all its services, and hence the role and range of activities of Postal Engineering will continue to grow.

A. F. BEARDMORE,  
*Chief Postal Engineer*

---

## Letter-Post Mechanization: 75 Years of Progress

K. H. C. PHILLIPS, C.ENG., M.I.E.R.E.†

UDC 681.187: 656.851

*This article briefly reviews the historical and present-day developments in the mechanization of the letter-handling processes in the postal service.*

### INTRODUCTION

The history of postal communication can be traced back to biblical times, but it was not until 1837 that Rowland Hill made the postal reform proposals that resulted in the introduction of a universal postal rate for handling letter mail throughout the UK.

The first postal process to be mechanized was stamp cancelling. A steam-driven stamp-cancelling machine was patented in 1857, and a number of hand-operated machines which inked the stamp die automatically, were put into service in 1859.

Machines of a more-advanced design were soon introduced and provided stamp cancelling rates of up to 130 letters/min; these machines were in common use in the larger sorting offices before the end of the nineteenth century.

Between 1900 and 1925, belt-driven conveyor systems were introduced for carrying letters and packets around sorting offices. In 1933, at the Mount Pleasant sorting office in London, selective tray conveyor systems were introduced to permit semi-automatic routing of coded letter-baskets to selected unloading points throughout the letter-sorting area. Routing was effected by the position of code pegs inserted into the basket by the operator at the loading point. Since the beginning of the twentieth century, the worldwide growth in industry and commerce has had its effects on the British Post Office's (BPO's) mail business; traffic volumes have increased and have become progressively more expensive to process in

a labour-intensive industry. The need to contain costs by improved mail-handling methods, renewed interest in studies of mechanizing the letter-handling processes in sorting offices from the mid-1930s onwards.

### LETTER-HANDLING PROCESSES

The problems associated with the mechanization of letter handling are easier to explain when related to the basic processes of the manual system in a sorting office. The processes known as *segregation*, *letter facing* and *sorting* are described below.

#### Segregation

The first task in the mail-handling process is to segregate mail; that is, to separate mail pieces from an agglomeration comprising short, long, thick or thin letters, postcards, packets and periodicals into those items that are amenable to machine processing and those that are not.

A number of segregating techniques, including vibrating surfaces, thickness-gauging by rotating brushes, and the use of air jets, have been tried throughout the postal world. The most effective and efficient technique was conceived and developed by the BPO in the form of a drum segregator.

The unsegregated mail is fed into a 1.3 m diameter longitudinally-slatted drum that rotates, on its side, at 8 rev/min. The mail gently tumbles as the drum turns on an axis of 6°-7° to the horizontal, and letters less than 6 mm thick pass through the gauging slits between successive drum slats. The

---

† Postal Mechanization Division, Post Office Headquarters

remaining items traverse the length of the drum. Mail pieces that pass through the gauging slits pass over a key trap to remove keys and other small articles; the mail is then passed through a wide-letter extractor, which removes letters more than 140 mm wide from the mail stream. The letters that are finally stacked in the segregator represent 80% of the total input of letter mail. The BPO has 30 drum segregators in use; many of these have a potential capacity of 40 000 items/h.

### Letter Facing

Letter facing is the action of arranging letters to face the same way so that the addresses can be read, the stamps cancelled and the first- and second-class tiers identified. The 1930s saw the first unsuccessful attempts to automate letter facing and stamp cancelling, but it was not until the 1960s, when phosphor coating of adhesive stamps was introduced, that a workable design was produced. There are 2 designs of automatic letter-facing (ALF) machines now in use that can recognize the class and orientation of a letter by detecting the presence of phosphor bars, which are part of the stamp printing process. The phosphor bars are invisible in normal light, but they glow under ultra-violet irradiation within an ALF, and they can be identified without background interference. Business-reply letters can also be detected through optical detectors which measure the visible bar markings. The ALFs can process about 20 000 items/h.

For smaller offices where the installation of a segregator and automatic letter facing systems is not justified, a facer-canceller table (FCT) has been developed. An FCT is a type of mechanical aid that enables up to 10 postmen to separate machinable letters from packets and put first- or second-class letter post on appropriate belts, faced the right way. There are no stamp detectors in an FCT; the machine merely aggregates, cancels and stacks the machinable letters, a process which is faster than the equivalent manual processing. At present, the BPO has 70 ALFs and 53 FCTs in service.

### Letter Sorting

Attempts to mechanize the sorting process were begun soon after 1910. The first letter-sorting machine to be used operationally in the UK was known as the *Transorma*, and was commissioned at the Brighton Sorting Office in 1935. Based on a Dutch design, which was introduced in Rotterdam in 1931, the *Transorma* required each of its 5 operators to key a memorized code, and physically to place each letter into a carrier in strict synchronism with the machine. The 2 machines installed at Brighton each had 250 sorting boxes and a designed operating rate of 15 000 letters/h. Both machines gave reliable service and were withdrawn in 1969 after 34 years of use.

In 1946, work started on a design for a machine incorporating 120 boxes, but controlled by 6 operators (see Fig. 1); each operator was intended to work independently of other operators and at his own speed, using a *preview* facility, which is described later. The concept was attractive, but the control system was complex and required a synchronous mechanical and electronic interleaving of letters from operators into a common letter-transport system within the machine. After trials at Bath in 1955, the design was abandoned in favour of a simpler machine controlled by one operator.

The single-position letter-sorting machine (see Fig. 2) developed during the early-1950s had 144 sorting boxes and a designed sorting rate of 7200 letters/h. The previewing principle used in the 6-position machine was adapted to permit on-demand feeding of individual letters into each of 2 viewing positions, one above the other, in front of the operator. This arrangement allowed the operator to preview the next letter to be sorted in the upper position while he keyed the sorting code associated with the letter in the lower position. Significant improvements in operating speeds were achieved by

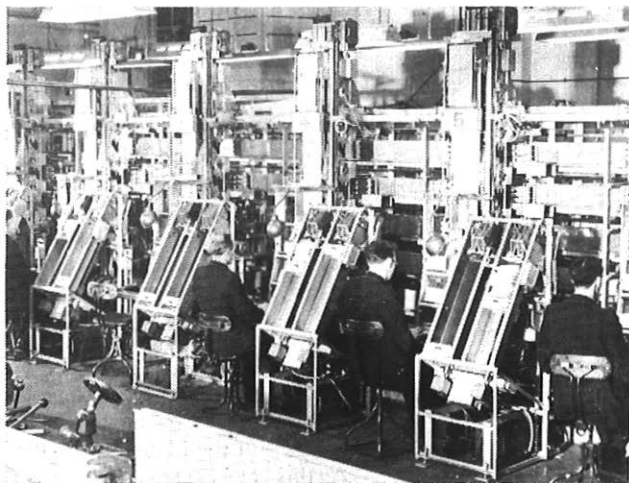

FIG. 1—The 6-position letter-sorting machine

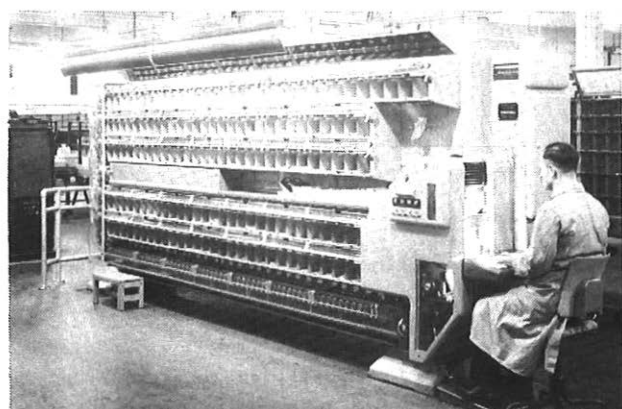

FIG. 2—Single-position letter-sorting machine

using this technique, which was adopted on a worldwide basis by other postal administrations active in the mechanization field. The prototype machine was put into service in 1955.

Early generations of the single-position letter-sorting machine were controlled from a 12 × 12 keyboard. Operators were expected to memorize the keyboard combinations associated with every sorting box; thus the sorting machine could be considered only as a mechanical aid. Changeable pre-wired plugs were used to alter the keyboard-code-to-selection-box routing arrangement, thereby providing the sorting flexibility necessary to meet the sorting requirements of different offices.

Alphanumeric keyboards were introduced on later versions of the machine, and operators were asked to key an alphabetic code extracted from predefined sections of the delivery address. This approach eliminated the need for the operator to memorize codes, simplified the training requirements, and reduced the operator's error rate. The alphabetic keyboard codes were converted into letter-routing signals within the machine by an electronic translator, which used ferrite-core memory technology.

### LETTER CODE MARKING

Although the single-position sorting machines could operate at sorting speeds in excess of 7000 letters/h, operator speeds rarely exceeded 2500 letters/h into 144 selections; this was, approximately, only 2.5 times the manual sorting rate on 48 selections, and was not really cost effective.

Also, this method of sorting had a major shortcoming in that the operator was required to read the address at every sorting stage; thus a letter might be read 6 times before

delivery. The solution was to code the letter at first reading so that, subsequently, the address could be machine read. Machine-readable code marks were printed on individual letters at coding desks, and a *reader* was provided in place of the operator on the sorting machines. The concept of converting the address information to machine-readable codes on each envelope was researched in the mid-1950s, and the first practical coding desk introduced in 1959 at Luton.

General code-marking techniques, including passive printing ink, magnetic inks, fluorescent inks, and phosphorescent inks, were considered. After these studies, phosphorescent ink was selected as being most suited to meet the postal service objectives of achieving a reliable, cheap, non-toxic code mark, and of ensuring maximum immunity from interference during the code-mark-reading process from printing on the envelope and chemical agents used in paper manufacture.

A number of code-marking formats were tried; the standard adopted has 2 rows of 14 binary marks at 16 mm and 64 mm from, and parallel to, the lower long edge of a letter. The lower row of marks is used for distribution and the upper row for local-delivery sorting.

Two types of sorting machine were developed in the early-1960s. The first was a high-speed machine capable of sorting 20 000 letters/h. It had only 20 sorting boxes and was designed to control the flow of mail through the sorting office by primary sorting of both the mail output from the coding desks, and that arriving in the office, into priority groups convenient for subsequent sorting.

The second machine, a 150-box sorting machine with an operating speed of 8000 letters/h, was based on established principles and incorporated ultra-violet irradiation and code-mark readers; it has become the main sorting machine in use by the BPO. The high-speed primary sorting machine proved to be too expensive for the facilities it provided.

## LETTER-POST PLAN

As a result of the successful trials of coding and sorting equipment at Luton in the early-1960s, it became feasible to plan the introduction of letter mechanization nationwide. The strategy that was developed required the concentration of mechanized sorting into 120 offices, later reduced to 83. Each mechanized letter office would interchange mail directly, and thereby simplify mail routing. The remaining 1600 sorting offices in the UK would provide the local collection, delivery and distribution function. Implementation of the plan also required changes to the traditions and practices of staff at all levels of the postal business.

It was recognized that the provision of an efficient mechanized letter system required that each letter must carry a specific address identification that was consistent with a national machine-coding and sorting system. The postal district concept had been introduced in London in 1856, and other major cities had followed suit. The proposal for a national system of post-codes specifically for mechanization purposes was a new concept. A trial code system was tested at Norwich in 1965 and today's post-code system is a modification to that experiment. Machine coding and sorting requires a high level of public usage to secure really efficient mail processing. A total of 1.5 million post-codes were allocated between 1969 and 1972; the codes covered most of the 22.5 million delivery addresses in the UK. Other countries have now developed similar post-code systems.

## CODING DESKS

The first generation of coding desks was put into operational use at Norwich in 1966; the installation comprised 12 desks. These were followed in other postal regions by a similar design of upright, high-level-loaded desks. All the coding desks used *preview* and *presentation* vertical viewing of letters

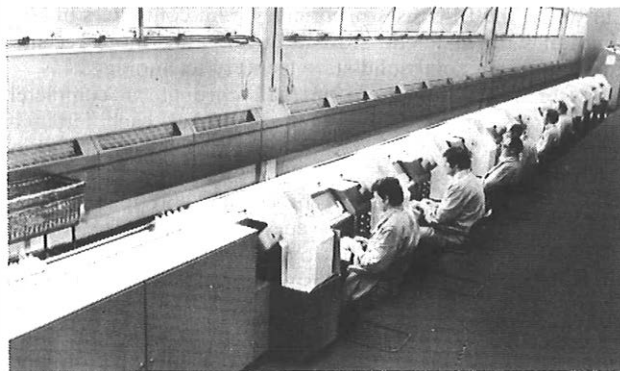

FIG. 3—Easyview coding desks

and an alpha-numeric keyboard; 3 designs of heated-pin printers were used, one of which predominated after trials. The first code tape used was made of glassine; later in the trials, a mylar-base tape coated with phosphor and thermo-setting resin was used, and the heat of the printer pins melted the resin into the envelope surface to secure the code dots. The code printed on an envelope was a translation of the keyed post-code; the translation into a unique binary code was achieved via a wired ferrite-core matrix. If an envelope had no post-code, an extract code based on the post town name was used to generate the code mark.

Although the first generation of coding desks was effective, they were large and had to be loaded from platforms, a feature that restricted efficient use of floorspace. In 1973, a second generation of coding desks, known as the *easyview* coding desk, was introduced. This design uses a novel presentation in that envelopes are moved on an easel belt from right to left. The speed of the easel belt is regulated by the position of the letter being coded, which is referenced to the end of the easel; this feature reduces an operator's eye movement while he reads an address as it passes into vision. Previewing still occurs and coding rates of over 3000 letters/h are possible. The initial 12 prototype desks were replenished automatically from a single loading point, and microprocessor-based control was used for the first time; the mail was despatched to desks in batches on a priority allocation. Automatic replenishment was not a success operationally, and dedicated logic control has been used subsequently to cut capital costs. A view of the *easyview* coding desks installed at the Redhill letter office is shown in Fig. 3.

The concept of presorting was re-introduced at the Redhill mechanized letter office in 1975. The presorter was designed to presort the coded mail output of the 12 linked *easyview* desks into 4 selections at rates of up to 35 000 items/h. This machine is capable of accommodating the fluctuations in coded mail from the 12-desk suite to which it is connected, and of regulating the flow of mail into streams suited to the later sorting stages on the 150-box sorting machines.

## PRESENT-GENERATION MACHINES

The present generation of sorting machines has been the result of evolutionary development since their introduction in 1966. The designs have proved to be very adaptable, and sorting rates have been increased from 8000 to 16 000 letters/h. Electromechanical analogue control systems have been replaced by micro-electronic systems to secure overall improvements in performance and reliability. Although limited to 150 sorting boxes, the machine is probably the most accurate letter-sorting machine available in the world at present.

The translation equipment used for keyboard-to-code-mark and code-mark-to-sorting-machine control instructions has also evolved to take advantage of technological developments that secure cost reductions and performance improvements.

Currently, the BPO uses proprietary mini-computers in combination with magnetic storage drums and, more recently, microprocessors and solid-state memory technology.

Successful transmission of mail through a completely mechanized sorting network requires that each letter be correctly handled by segregation, facing and code-marking equipment, together with reliable sorting by up to 3 separate sorting machines. Erroneous processing and misorting of mail reduces the overall effectiveness of a mechanized system.

Experience has shown that machines will always mistreat (that is, mis-sort or reject) a small proportion of the mail because of the wide variety of the physical characteristics of the mail. In 1971, an on-line computer-based machine-monitoring system which recorded trends in machine performance in normal operation, was introduced at Croydon. The later introduction of enhanced versions of this equipment at all mechanized sorting offices has significantly improved the overall performance achieved by the machinery, and simplified maintenance procedures. The maintenance monitoring system will, in future, also be used for operational performance monitoring.

### PRESENT-DAY LETTER MECHANIZATION IN THE UK

A total of 44 mechanized letter offices have already been commissioned, and another 39 offices will be brought into service within the next 5 years. Although significant productivity gains have been achieved in sorting offices, it will not be until most of the mechanized office network is complete that the UK postal service will secure maximum benefit from mechanization.

### ELECTRONIC MAIL

A trial public facsimile service, known as *Postfax*, was introduced in 1974; this service enabled the public to send messages between 22 Post Offices throughout the UK. Both special collection and delivery services were provided at all Postfax centres to ensure rapid transmission between sender and recipient. However, owing to a lack of public response, the service was discontinued in 1976.

In 1979, the BPO joined with 6 other postal administrations in the establishment of an international public facsimile service to provide express collection and delivery facilities at each network terminal. In 1980, this service, known as *Intel-post*, was extended to 20 centres throughout the UK to provide both domestic and international facsimile connexions.

A total of 51 Intelpost centres had been established by September 1981, and provision for interworking between the postal service and private facsimile users had been introduced experimentally. High-resolution facsimile (modified Group-III) machines having scanning and print times of less than 20 s are used in the international network: and conventional Group III and Group II machines are used in the UK network.

### FUTURE DEVELOPMENTS

Optical character-recognition techniques, as applied to letter mail, have been the subject of research for some years. The task is complicated by the fact that a recognition system must deal with more than 200 different type fonts included in address information on envelopes having a wide variety of format, physical characteristics, and colour. Current development work is aimed at introducing a prototype machine into service by September 1982. The machine, which will have an operating speed of up to 40 000 letters/h, will read the lower 3 lines of address information and have facilities for correlation between the various address components, including the post-code. Phosphorescent code marks will be printed on each

envelope by using ink-jet printing technology, and will be compatible with existing machinery.

The design concepts for a new generation of sorting machine are under review to achieve the development of machines capable of meeting the future needs of the postal service, including accommodation of the changing physical characteristics of letter mail.

Computer systems in combination with laser-printing technology will be introduced to enable large-quantity mailers to send computer magnetic tapes directly to the sorting office for electronic transmission to remote sorting offices for high-speed printing, automatic enveloping, and normal delivery to customers.

Developments in word processing, text communication, and related electronic message-handling systems will be reviewed to ensure that suitable interfaces with the growing information and message technology fields are available for interfacing with the existing postal-service network.

### ACKNOWLEDGEMENT

The development of the BPO's letter-mechanization capability for the 1980s owes much to years of co-operation between the operational and engineering branches of the UK postal service.

The development of postal engineering in the UK is in no small part due to the innovative ability of the engineering design teams involved; in particular, Messrs. J. Piggott, G. P. Copping and E. G. Hills who were leaders in their respective fields and contributed greatly to the results achieved over the last half century.

### Bibliography

- GEMMELL, W. T. The Transorma Letter-Sorting Machine. *POEEJ*, Vol. 29, p. 16, Apr. 1929.
- COPPING, G. P., and BEAK, K. L. A Single-Operator Letter-Sorting Machine, Parts 1 and 2. *POEEJ*, Vol. 51, pp. 104 and 188, July and Oct. 1958.
- COPPING, G. P., and LANGTON, H. J. Sorting Letters by Machine. IPOEE Printed Paper No. 216, 1959.
- WYLIE, G. A. Equipment for Training Letter-Sorting-Machine Operators. *POEEJ*, Vol. 52, p. 55, Apr. 1959.
- COPPING, G. P., and MYERS, T. R. Mechanization of the Initial Stages of Processing Mail, Parts 1 and 2. *POEEJ*, Vol. 52, p. 286, and Vol. 53, p. 12, Jan. and Apr. 1960.
- PILLING, T., and GERARD, P. S. Automatic Letter Sorting—The Luton Experiment. *POEEJ*, Vol. 54, p. 31, Apr. 1961.
- PILLING, T., and HORROCKS, P. Coding Desk and Code-Mark Reader for Use with Automatic Letter-Sorting Machines. *POEEJ*, Vol. 54, p. 122, July 1961.
- FORSTER, C. F. Use of Phosphorescent Code Marks in Automatic Letter-Facing and Sorting Machines. *POEEJ*, Vol. 54, p. 180, Oct. 1961.
- ANDREWS, J. D., and BELCHER, P. L. Time-Shared Code Translators for Letter-Sorting Equipment. *POEEJ*, Vol. 55, p. 173, Oct. 1962.
- PHILLIPS, R. S., and DAVISON, G. N. Mechanizing the Postal Service. *Proc. I. Mech. E.*, Vol. 177, No. 8, p. 205, 1963.
- DEUTSCH, E. S. Computer Simulation of a Character-Recognition Machine, Parts 1 and 2. *POEEJ*, Vol. 60, pp. 34 and 104, Apr. and July 1967.
- FORSTER, C. F. Luminescent Materials Used in Postal Automation. *POEEJ*, Vol. 62, p. 120, July 1969.
- British Postal Engineering Conference 1970. *Proc. I. Mech. E.* Vol. 184, Part 3H, 1969-70.
- DE JONG, N. C. C. Progress in Postal Engineering, Parts 1, 2 and 3. *POEEJ*, Vol. 63, pp. 65, 131 and 203, July and Oct. 1970 and Jan. 1971.
- COPPING, G. P., WHITTINGTON, K. W. H., and MUCKETT, R. G. Prototype Coding Desks for Letter Mail. *POEEJ*, Vol. 64, p. 98, July 1971.
- ANDREWS, J. D., BENNETT, H. A. J., and PRATT, A. D. Letter Office Computerized Monitor—LOCUM. *POEEJ*, Vol. 65, p. 172, Oct. 1972.
- ANDREWS, J. D. A New Code Translator for the Letter Sorting System. *POEEJ*, Vol. 65, p. 198, and Vol. 66, pp. 2 and 64, Jan., Apr. and July 1973.
- EVANS, D., HILLS, E. G., and WICKEN, C. S. An Easy-View Letter Coding Desk. *POEEJ*, Vol. 71, p. 70, July 1978.
- Progress in Postal Engineering Conference, Institute of Mechanical Engineers, 1979.



# Parcel Sorting Systems and Ancillary Postal Equipment

H. GOODISON, C.ENG., M.I.E.E.†

UDC 656.851: 681.187

*This article reviews developments in parcel sorting systems, including bulk-mail conveyors and chutes, over the past 25 years; together with a range of ancillary equipment such as stamp-vending machines and pillar boxes.*

## INTRODUCTION

During the past 25 years, there have been significant developments in parcel sorting equipment and ancillary postal equipment. Within postal buildings, there has been a steady increase in the mechanization of sorting parcels and conveying mail, with a recent acceleration in sophistication of control facilities through the introduction of electronics. Efficiency improvements have also been gained through the adoption of containerization. Even the design of the ubiquitous pillar box has seen changes, and inflation has created problems for the administration of stamp-vending machines. The main developments are reviewed below.

## PARCEL SORTING SYSTEMS

### PARCEL SORTING MACHINES

Prior to 1956, the only parcel sorting machines (PSMs) in use in the British Post Office (BPO) were the Sovex bucket or hopper machines which had been installed at Leeds and London Western District Office (WDO). An experimental machine, using trays and called *TOPSI*, was developed and installed in Bristol in 1962. This machine was built to tight tolerances that could not be maintained, and was subsequently withdrawn from service.

A tilted-belt machine, developed by the Australian Post Office in 1950, was installed in Melbourne in 1954<sup>1</sup>. It consisted of a belt carrying the parcels tilted at an angle of 37° to the horizontal and, at right angles to the lower edge of the belt, a side wall containing a number of discharge doors. The belt initially runs horizontally to form an induction section, and is turned to the required angle of tilt as it rides over a twisted section of the bed plate. Parcels loaded on the induction section slide across the belt at the tilt section and then proceed in contact with the side wall. The destinations are distributed along the length of the machine and, at each destination, there is a gap in the side wall, which is filled by a discharge door; this door can be opened to allow the parcel to slide off the belt, or closed to allow the parcel to continue on the belt past that destination. After reading the address on the parcel, the operator presses the keyboard button associated with the required destination of the parcel. He then places the parcel on the belt, and the control unit times its movement along the belt and causes the appropriate discharge door to open as the parcel reaches it. The parcel slides off the belt into a storage receptacle or onto a cross-conveyor. In this way, a parcel can be routed to any one of the destinations.

### Use of Tilted-Belt Parcel Sorting Machines in the UK

In 1962, the BPO installed 3 tilted-belt PSMs: one at Preston and two at Worcester (see Fig. 1). Changes were made to the

† Postal Mechanization and Building Department, Post Office Headquarters

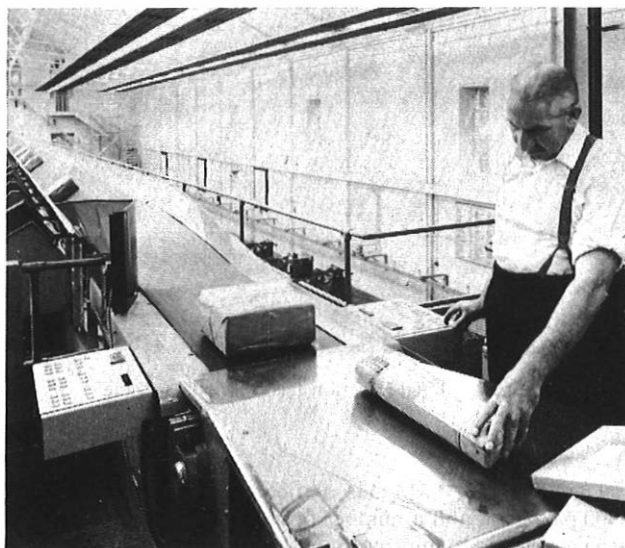

FIG. 1—Tilted-belt parcel sorting machine

Australian design; the electromagnetic controller was replaced by a mechanical (pin-wheel) type and the discharge doors were operated hydraulically instead of pneumatically. Following the success of the first machines, the BPO decided to adopt the tilted-belt PSM as the standard machine and, to date, over 100 machines are currently in operation at 26 sorting offices. The number of destinations provided varies between 20 and 50 according to the type of office. A typical sorting rate obtained with this machine is 700 parcels/h with a single operator, and can be increased to about 1000 parcels/h with a sorter-and-facer team. Since the introduction of the first machine at Preston in 1962, both the machine and its associated control equipment have undergone continuous development.

The mechanical pin-wheel controller has been succeeded by a variety of electronic controllers: magnetostriction delay line, core matrix, discrete-component transistor logic, and integrated circuit. Finally, a microprocessor controller has been developed, which is now on trial at Sheffield. This will not only improve the reliability of the system, but will also provide for the collection of the traffic information that the management of a modern sorting installation demands.

The main mechanical developments have been

- (a) the replacement of the hydraulic door actuators by pneumatic versions,
- (b) the use of triple doors to allow close spacing of parcels and aggregating conveyors,
- (c) the application of a low-friction compound to side walls to prevent loss of station by plastic-wrapped parcels, and
- (d) the use of glass-reinforced-plastic doors instead of steel to reduce the weight and noise level.

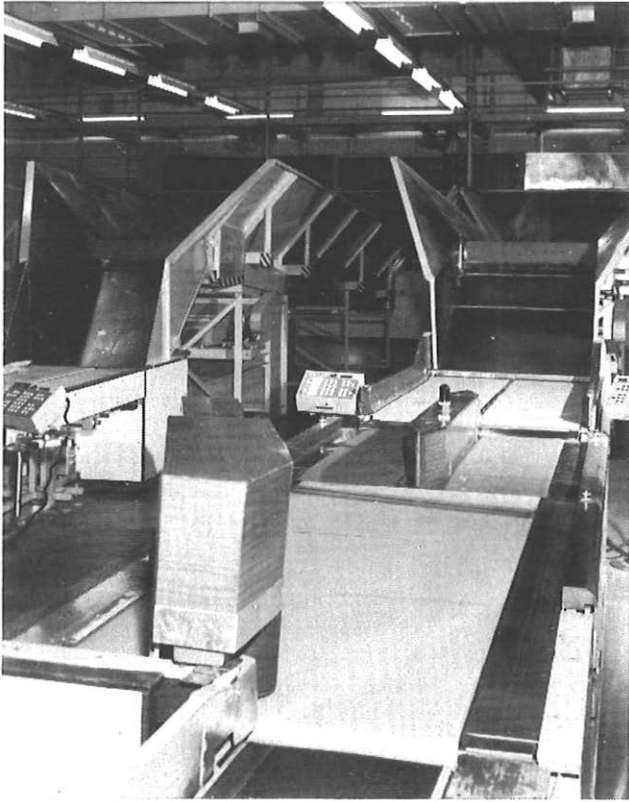

FIG. 2—Dual injection feed mark 1 machine

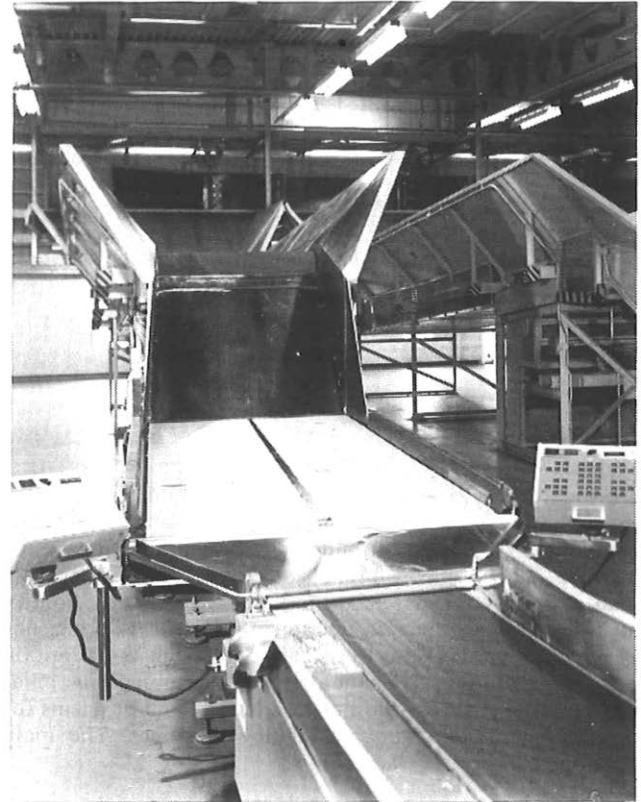

FIG. 3—Dual injection feed mark 2 machine

The tilted-belt PSM has a theoretical capacity of about 3000 parcels/h, and a number of multiple-input systems have been developed to improve the utilization of the machine. The first development was a triple injection feed unit, but problems were encountered in making a production machine. This was succeeded by a dual injection feed version (DIF1), which was installed in Liverpool in 1972 (see Fig. 2). This equipment enabled the output of 2 operators to be merged into a single stream and then fed on to a tilted-belt sorting machine<sup>2</sup>. Sorting rates in excess of 2000 parcels/h have been achieved with this machine.

However, in 1973, ergonomic studies of the sorting task were undertaken to seek alternative solutions<sup>3</sup>, culminating in the design of a second dual injection feed machine (DIF2) of a simpler, smaller and less costly design<sup>4</sup>. The operating principle of this machine required 2 operators to interleave their efforts, each having access to the common PSM sorting belt (see Fig. 3). The key features of the design were the trapezoidal sorting table and a start-stop roller. The trapezoidal sorting table enabled the 2 operators to work opposite each other and to be positioned in a more suitable position with relation to the parcel flow and the keyboard. The start-stop roller provided a means of controlling the flow of parcels on to the PSM; ensured a minimum gap between successive parcels; and, in conjunction with indicator lamps on the keyboards, minimized the frustration caused when both operators competed for the same sorting opportunity.

Two prototype DIF2 machines were installed at Peterborough Parcel Concentration Office (PCO) in 1974, and subsequently, 2 production machines were installed at Newcastle PCO. A production version of the earlier DIF1 machine was also installed at Newcastle; this has enabled the 2 designs to be compared. Although the DIF1 version is capable of a higher throughput than the DIF2 machine, its complexity results in higher capital cost and a lower reliability. The simpler design of the DIF2 machine is capable of producing sorting rates of around 1800 parcels/h.

#### Recent Developments in Parcel Sorting Machines

Although the tilted-belt PSM has served the BPO well during the past 19 years, the need has arisen for faster more flexible machines which can handle larger and heavier parcels. Consequently, a tilting-slat machine was installed in 1980, at Redhill PCO, for operational and engineering assessment (see Fig. 4). This machine comprises a driving chain, drawing along a line of slats, each 175 mm broad; any number of these can be tilted to discharge a parcel carried on them at the required discharge point. The slats can be tilted towards either side of the machine to discharge parcels. The tilting-slat machine can handle up to 5000 small parcels/h and can cope with large and heavy parcels. Machine utilization is high because it can be fed by 4 in-line induction stations.

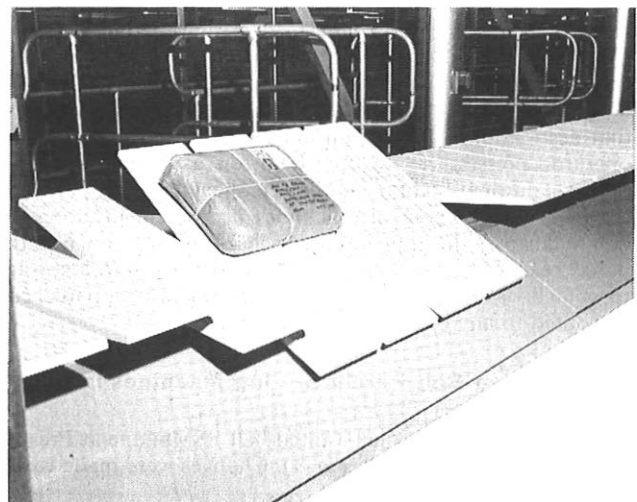

FIG. 4—Tilting-slat parcel sorting machine

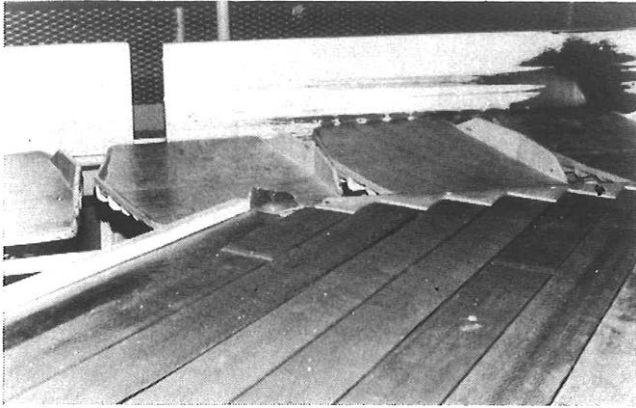

FIG. 5—Tilting-tray parcel sorting machine

Another high-speed machine is the tilting-tray PSM (see Fig. 5), which is being installed at the Glasgow PCO; this can process up to 10 000 small parcels/h and sort them to as many as 500 destinations. The trays, of an appropriate size for the average size parcel, are attached to a driving chain. Parcels are injected on to the tray from induction stations that are inclined at either 30° or 45° to the chain. Many induction stations can be sited at several points on the continuous-loop chain and, hence, a high machine utilization can be achieved. Flexibility is achieved by using a biplanar chain, which allows selections to be located anywhere on the office floor, and even distributed on several floors. On tilted-belt and tilting-slat machines, selections have to be arranged in a straight line.

The earlier ergonomic studies of the sorting task revealed that operating the keyboard takes a significant part of the time to sort a parcel. Unlike letter sorting, the current state of technology does not permit a code to be applied to the parcel at the first sorting stage to enable subsequent stages to be carried out automatically. Consequently, parcels have to be manually processed at each sorting stage. Various alternatives to the present PSM keyboard are being considered; for example, bar-coding, optical character recognition using light-pens, magnetic tagging and automatic voice recognition. A laboratory trial is being organized to determine the optimum coding method.

Existing designs of parcel-sorting installations have been equipped with meters for recording traffic flow and reports have been produced manually. This has been fraught with errors arising from various causes. A traffic recording system called *TRIPOS*—traffic recording in parcel office systems—is currently under development and due to be installed at Leeds PCO in September 1981<sup>5</sup>. This is based upon a mini-computer, which will monitor the parcel flow at up to 2000 points (depending on the size of the PCO), and will automatically prepare both daily and weekly summary reports on the total traffic handled and the flow to individual destinations. It will also have facilities to permit operational staff to interrogate the computer to determine the flow of traffic in specific parts of the system in real time.

### BULK MAIL CONVEYORS AND ELEVATORS

Flat-band conveyors have changed little since they were first used in the BPO in 1902, except for the belt materials where there is an accelerating move away from traditional woven cotton to synthetic materials. Modern materials provide more predictable characteristics against modern wrappings, and many are very hard wearing. Conveyors are now available with curved belts, which can provide turns without loss of height. These have been used experimentally in the BPO but have not yet been used operationally. Some manufacturers are also supplying conveyors in which the belt is made from a series of hinged moulded plastic slats or segments, and these

may well find application in the BPO, particularly for powered turns.

### Mail Uplift Systems

The desirability of conveying mail up rises elevated at angles greater than 30° prompted the development of the twin-band riser, which was patented by Messrs. Sovex Ltd. in 1932<sup>6</sup>. The smaller versions of these machines have given good reliable service. However, in the late-1960s, several scaled up machines were installed to provide uplifts of up to 20 m, but serious problems were experienced with excessive parcel damage, avalanches of mail causing jams at the bottom of the rise, and trapped and broken belts. This led to a series of experiments with gripfaced belts, different weighting arrangements for the cover belt, and the application of external pressure by means of minicar wheels running on the backs of the cover belt. Some improvements in operational performance have been achieved. A computerized mathematical model of the operation of a twin-band riser has been developed; this has shown that the forces exerted on parcels increase as they near the top of the machine, and the forces are very dependent on the weight of coverbelt and geometry of the discharge mouth. These aspects must be examined closely if any new twin-band risers are installed.

Mail uplift systems are most needed in multi-storey buildings in city centres, where floor space is most expensive. While the twin-band riser gave useful savings in floor space over slow-rise conveyors, the obvious need for a vertical uplift system led to the development of the airbag riser by Messrs. Sovex Ltd.<sup>7</sup>, and the Langton riser<sup>8,9</sup> by the BPO (see Fig. 6). The airbag riser was a logical development from the

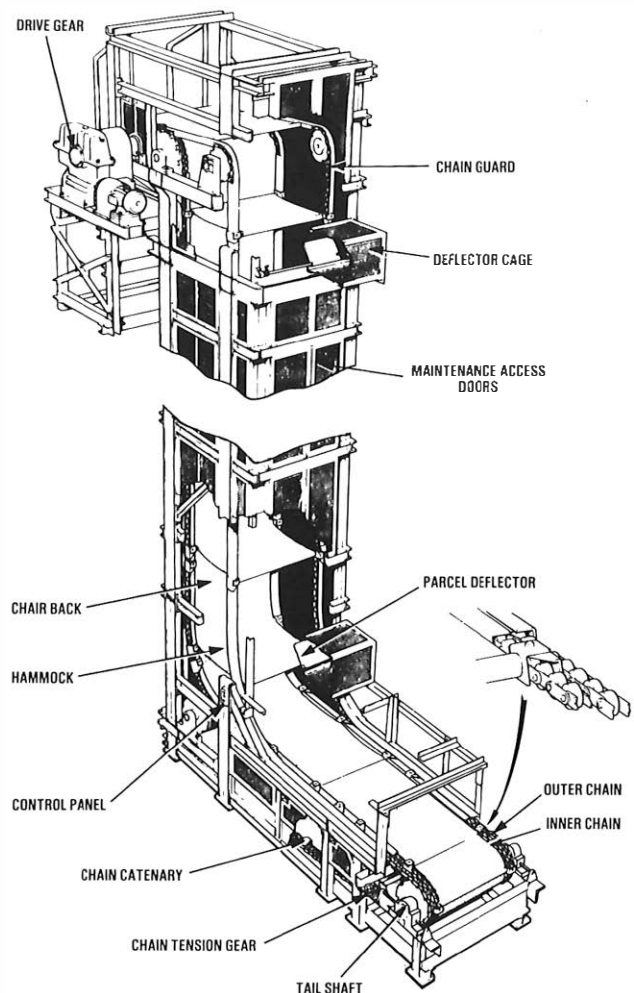

FIG. 6—Langton elevator conveyor

twin-band riser, with the weighted belt being replaced by a plain belt and pressure externally applied by a static low-pressure airbag pressing against the cover belt. These machines were installed at Southampton and Leeds parcel offices in 1959, but never found favour because of high parcel damage; they were withdrawn after about 12-years of service.

The prototype Langton vertical riser was installed at Paddington District Office, after which operational machines were installed at WDO, Liverpool and Southampton in 1966. By 1972, some 26 machines had been installed, but since then, only 2 have been installed at the new Liverpool Head Post Office. The operation of this machine depends on a series of short lengths of canvas belting carried on 4 chains so that they lie on top of each other like roofing tiles, to form a flat infeed conveyor. At the rising section, these short lengths of belt form hammocks which carry the mail vertically and then re-tilt just before the discharge point. The hammocks are carried on bars attached to the chains which pass through the sidewalls of the conveyor shaft. Many difficulties were experienced with early versions of the machine, and the sidewall slots have always caused jamming hazards. Much effort has been expended in trying to seal the sidewall slots, but a satisfactory solution still has not been found. Parcel damage has been a problem with this machine because of the large drop from the head roller to the take-off chute at the discharge. Some machines also suffered from excessive wear of the chain guides, but this was cured by the introduction of hardened track inserts. The Langton riser is still the only system that can provide uplifts of around 30 m, but its installation is now considered to be a last-resort measure. Slow-rise conveyors are finding favour once again, where space permits.

With the advent of containerization, vertical container elevators, usually known as *Goss elevators*<sup>10</sup>, were installed. Three entered service at Birmingham in 1971, followed by a further 4 at Manchester PCO in 1972. These quickly lost favour through badly designed drives, and have given way to goods lifts, and container lift-and-tip machines. One Goss elevator, with a BPO designed drive unit, was installed at Belfast and is still giving good service.

The transport and uplift of bagged mail is largely achieved by using overhead chain conveyors, particularly in mechanized letter offices. Since 1955, when the first chain conveyor was installed at Leamington Spa, close to 30 km of chain conveyor has been installed in sorting offices throughout the country<sup>11, 12, 13</sup>. Severe wear and failure problems have been experienced with extremely long multi-drive systems. Consequently, comprehensive theoretical studies have been undertaken and computer models have been produced. These have shown that conveyors can easily be overloaded under part-load conditions, and that careful consideration of drive characteristics, drive locations and idler sprocket positions is required for reliable operations. Fig. 7 shows the drive unit of a chain conveyor. Chain conveyors have been the subject of continuous development since their first introduction; if coupled with electronic control systems where necessary, they can provide a versatile transportation and sorting system.

## CONTAINERIZATION

The container traditionally used by the BPO for transporting bulk mail is the mail bag; thus, sorting offices have been designed to handle mail bags using chain conveyors. The BPO has also used rigid containers for many years, but these have been confined to assisting specific tasks within sorting offices or within a sorting area. Often containers have been associated with one machine or piece of equipment.

The use of rigid containers for inter-office working was first considered in 1962. Several wheeled containers for transporting loose parcels were tried in the mid-1960s, culminating in the Post Office Universal Trailer (POTU) Mk III in use in 1968<sup>14</sup>. Parcels could be loaded into road and rail

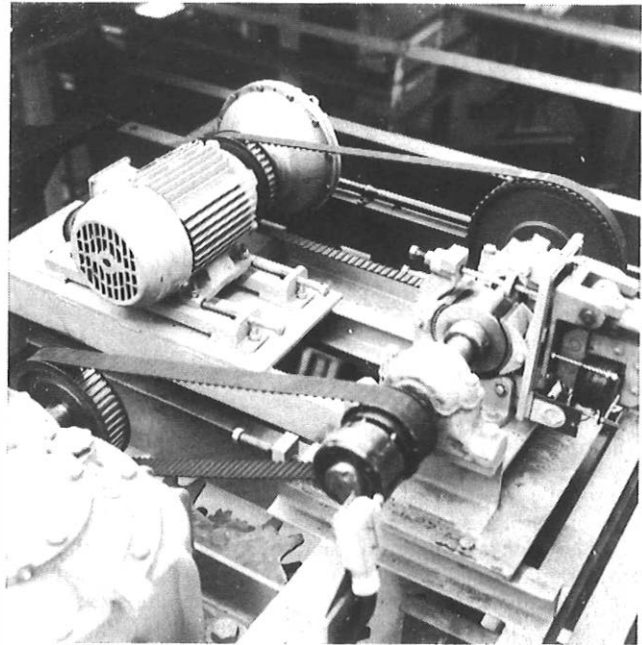

FIG. 7—Drive unit of a chain conveyor

vehicles, with much more speed and less manual effort, when the parcels were pre-packed in wheeled containers rather than in mail bags.

Extensive system studies resulted in the design of the Mail All-Purpose Trailer Equipment (MATE) Mk II being introduced in 1973 (see Fig. 8). This is a wheeled container, compatible with British Rail towing facilities; it is equipped with an overrun brake and a parking brake, which can be released by a deadman's handle. With the introduction of the MATE, containerization became an integral part of the Parcel Post Plan

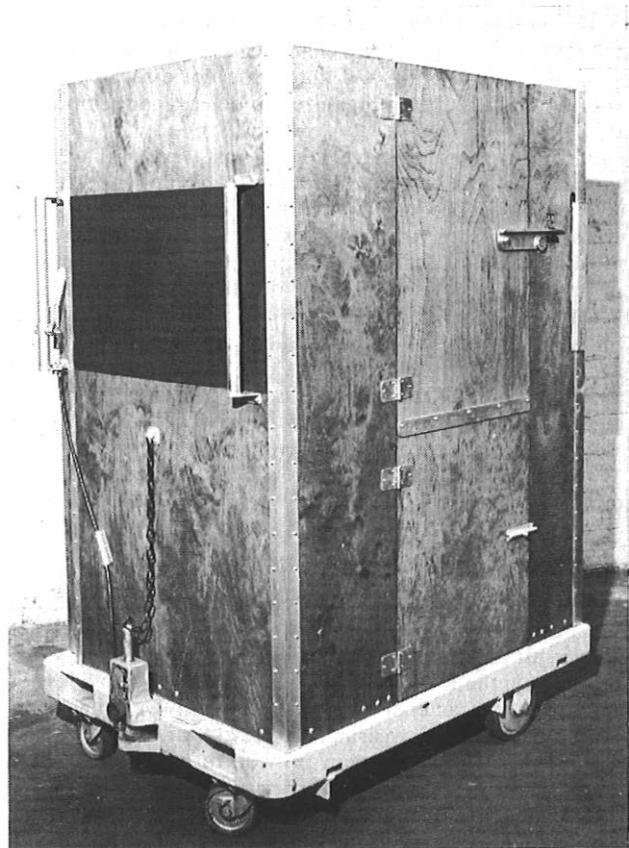

FIG. 8—MATE container

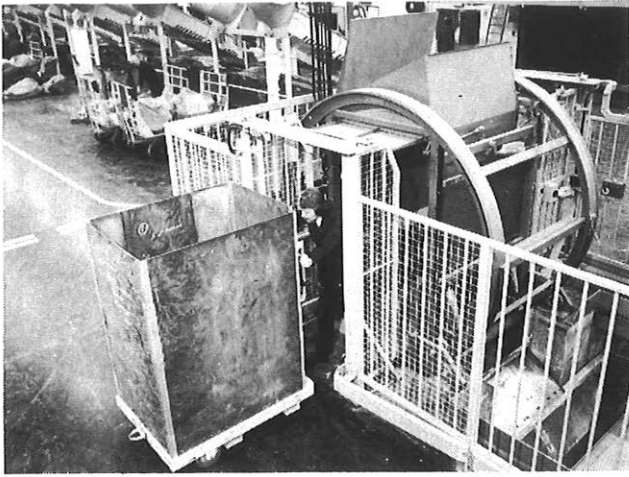

FIG. 9—Rotary tipper

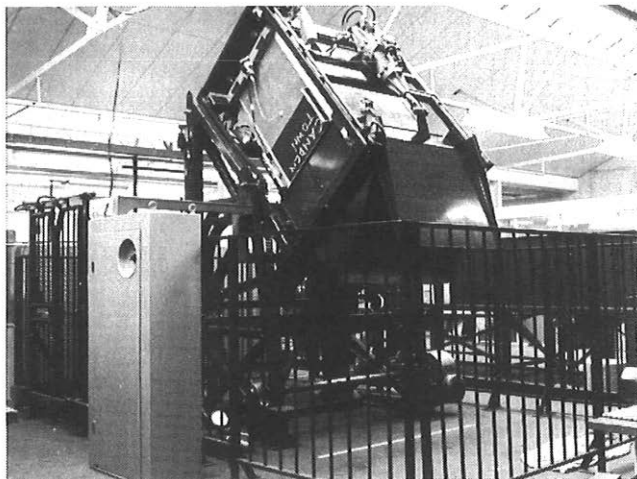

FIG. 10—Lift-and-tip machine

which concentrates the sorting of parcels into 27 main PCOs, between which mail is transported in containers on the busiest routes. Containers are also used for intra-PCO parcel traffic, where the volume of this traffic is large enough.

Rotary tippers have been designed to empty containers, and 8 PCOs are equipped with these machines (see Fig. 9). A further development is the high-speed lift-and-tip machine (Fig. 10), which elevates containers to a high level, discharges parcels from these containers and then returns the emptied containers to ground level<sup>15</sup>. Thus, containers are used to provide a damage-free uplift system and 2 such machines are installed in the newest PCO at Redhill. A considerable saving in capital costs, arising from the elimination of underfloor conveyors, basements and conventional uplift systems, can be expected in new offices handling containerized mail.

## CHUTES

In sorting offices, gravity chutes are used to transport mail from upper to lower levels. Unlike other aspects of mechanization, chutes are relatively cheap to manufacture and install, and require no motive power and little maintenance. The main types in use in the BPO are made of mild steel, and their angles of declination generally lie in the range 26°–30°. The various parcel wrapping materials used have a wide range of static and dynamic coefficients of friction against mild steel, and this range becomes wider as the atmospheric conditions change. This variation in coefficient of friction (0.2 to 0.8) results in wide ranging performance,

from refusal to slip to parcels attaining undesirable high speeds.

Until recently, the range of designs of chutes in use has been developed largely by empirical methods and, consequently, their performance has been somewhat unpredictable. In 1977, a prototype spiral chute, having a profile designed using a computer, was installed in Stockport Head Post Office<sup>13</sup>; this new profile chute was the result of fundamental work done at Queen Mary College, London. The object of the design was to control the position of any parcel at a fixed radius and limit the speed to less than 3 m/s. This should result in minimal parcel damage and no hazard to personnel. Although handling only mail bags, the Stockport chute behaved as predicted. In addition, the design permitted storage without spilling and prevented jamming under dynamic or static conditions.

A second prototype, exploring the lower limit of the profile range, was manufactured in glass-reinforced plastic during 1978, and was installed at the BPO's Camden Town Laboratory. Fig. 11 shows a new profile chute installed in the Nottingham Mechanized Letter Office. Chutes constructed in glass-reinforced plastic are much quieter and cheaper than those in mild steel. To reduce friction and increase the wear resistance of the chute, its surface is made of PPA54 compound, which was developed by the BPO for application on PSMs. The maximum dynamic coefficient of friction of this compound under varying environmental conditions remains below 0.4 against most of the common parcel wrapping materials—this enables the performance of the glass-reinforced plastic/PPA54 chute to be predicted more accurately.

Because the new profile chute is designed on the basis of particle behaviour, the resulting designs have a universal application for such items as parcels, packets, mail bags, sacks, grain and sand, both within postal administrations and the wider mechanical handling field. The new profile chute

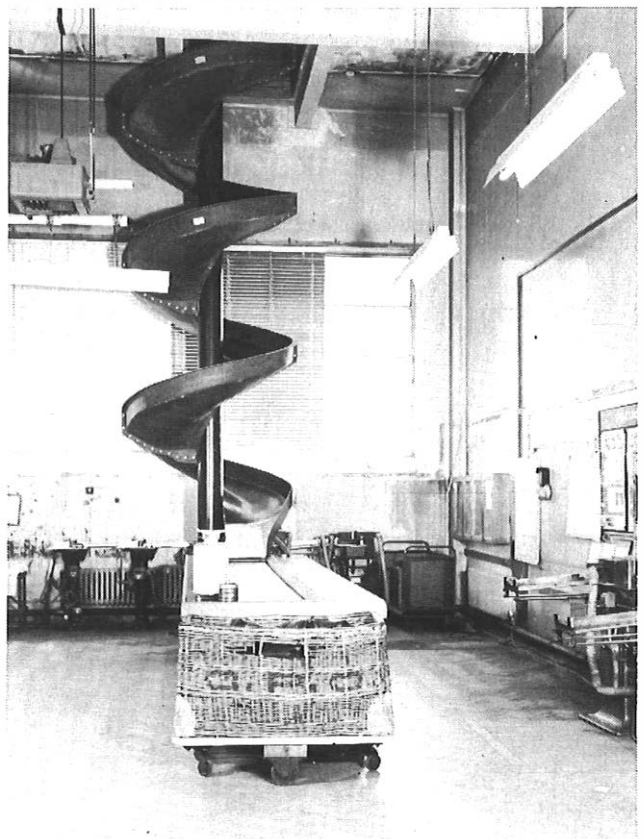

FIG. 11—New profile chute in the Nottingham Mechanized Letter Office

has now completed field trials and has been installed in new PCOs at Redhill (1980), Leeds (1981) and Hong Kong (1980). It is now proposed as the standard for the new-generation PCOs.

## ANCILLARY POSTAL EQUIPMENT

### STAMP-VENDING MACHINES

Stamp-vending machines should allow customers to obtain the stamps necessary to send one or more letters; also, to maintain the service, the value of the vend must rise as postage rates increase.

In 1957, a booklet machine (F1), taking 2/- coins, was introduced; 2500 of these machines were eventually purchased. Before decimalization of the currency in 1971, there were also about 20 000 stamp-roll machines, taking ½d, 1d or 3d coins. Of these, 2000 were converted to take the new 1p coin, the remainder being replaced during 1970-71 with 10 800 machines of a new design (G)<sup>16</sup>, which vended a strip of 5 mixed-value stamps for a 5p (1/-) coin.

With the rapid inflation experienced during the last decade, 6000 of the G machines were converted in 1975 to accept 10p coins, but this was only a stop-gap measure until a replacement could be developed. Stamp machines vending booklets are now preferred because they allow greater flexibility of contents to meet tariff changes than those vending strips of stamps. The replacement machines accept 50p coins and vend booklets for 50p (see Fig. 12), but the value of the vend can be increased to £1, £1.50 or £2 by simple adjustment. In 1980-81, 6700 of these machines were purchased. In addition to developing new machines, the BPO has extended the life of the existing F1 booklet machines by converting them to take

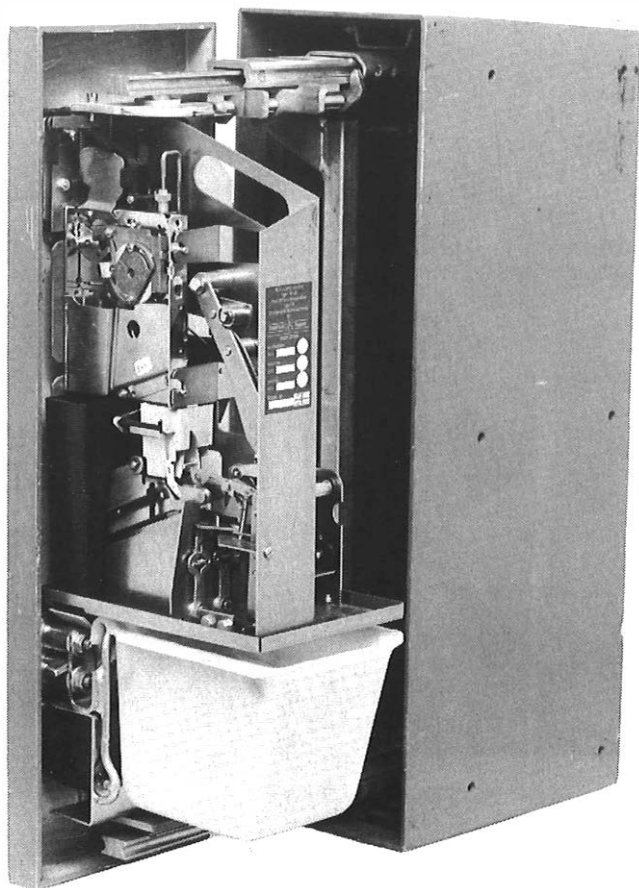

FIG. 12—H-type stamp-vending machine



FIG. 13—K-type pillar box

50p coins. Work is in hand to develop a microprocessor-controlled franked-label vending machine.

### PILLAR BOXES

Two hundred square-section pillar boxes<sup>17</sup> were put on trial in 1968-69. The changed shape was necessary to house an internal clearance mechanism, which halved the time taken to transfer the contents to the postman's collection bag. The box was constructed of sheet-steel panels, bolted to an angle-iron frame, mounted on a concrete plinth. The object was to facilitate both the erection and the repair of traffic damage, but the sheet-steel panels tended to rust. In place of the external vitreous-enamel plates and number tablets, the boxes were fitted with a new collection notice-plate, viewed through a window, and incorporating a rotary indicator to show the next collection number.

Another square-section box, which retained the clearance mechanism and new notice plate, but reverted to the use of cast iron for its construction, was introduced in 1975. This box, which had a lockable compartment in the bottom to take a postman's delivery pouch, enabled a postman to collect a second pouch without having to return to the sorting office. The box was costly, and did not achieve the expected savings from the clearance mechanism and second-pouch facility.

A new cylindrical cast-iron box, of modern appearance, was introduced last year; again, this has the new notice plate (see Fig. 13).

### ACKNOWLEDGEMENTS

The author wishes to thank his colleagues in the Bulk Mail Development Section for their assistance in the preparation of this article; also to thank Kosan Crisplant a/s and Logan Company for permission to publish Fig. 4 and Fig. 5, respectively.

## References

- <sup>1</sup> CASTELLANO, E. S. Tilted-Belt Parcel Sorting Machine. British Postal Engineering Conference. *Proc. I. Mech. E.*, Vol. 184, Part 3H, 1969-70.
- <sup>2</sup> HEARN, E., and BRIGHT, D. The Development of a Dual-Position Parcel Injection Feed Machine. Post Office PMB8 Divisional Report No. 79.
- <sup>3</sup> GREATHEAD, T., GALEA, S., and MILBURN, N. Ergonomic Investigation of Sorting Using a Twin Sorting Table. Post Office PMB8 Divisional Report No. 78.
- <sup>4</sup> WHITCHURCH, H., HENLY, H. R., WHITER, D., NAIR, M. R. V., and CUNNINGHAM, T. G. The Development of a Dual Injection Feed Mark 2. Post Office PMB8 Divisional Report No. 95.
- <sup>5</sup> HENLY, H. R. A System for Collection and Presentation of Management Data in Parcel Sorting Offices. Paper C237, International Conference on Progress in Postal Engineering, 6-8 Nov. 1979. Institution of Mechanical Engineers.
- <sup>6</sup> WILKINSON, A. J. Twin-Band Rising Conveyor. British Postal Engineering Conference. *Proc. I. Mech. E.*, Vol. 184, Part 3H, 1969-70.
- <sup>7</sup> SAUVEE, R. L. Airbag Vertical Rising Conveyor. British Postal Engineering Conference. *Proc. I. Mech. E.*, Vol. 184, Part 3H, 1969-70.
- <sup>8</sup> LANGTON, H. J. The Vertical Conveyance of Mail. *POEEJ*, Vol. 51, p. 112, July 1958.
- <sup>9</sup> WHITTINGTON, K. W. H. The Langton Riser. British Postal Engineering Conference. *Proc. I. Mech. E.*, Vol. 184, Part 3H, 1969-70.
- <sup>10</sup> EMSLEY, R. M. The Goss Vertiflow Elevator Drive. Post Office PMB8 Divisional Report No. 93.
- <sup>11</sup> SMITH, W. J., and ROGERS, J. D. Chain Conveyors in Postal Engineering. *POEEJ*, Vol. 51, p. 53, Apr. 1958.
- <sup>12</sup> SMITH, W. J. Chain Conveyors for the Transport of Mail in Bags. British Postal Engineering Conference. *Proc. I. Mech. E.*, Vol. 184, Part 3H, 1969-70.
- <sup>13</sup> GOODISON, H. Recent Developments in Chain Conveyors, Container Handling and Chutes. Paper C243, International Conference on Progress in Postal Engineering, 6-8 Nov. 1979. Institution of Mechanical Engineers.
- <sup>14</sup> SLATFORD, J. M. Containerization for Parcels and Bulk Mails in the Post Office. British Postal Engineering Conference. *Proc. I. Mech. E.*, Vol. 184, Part 3H, 1969-70.
- <sup>15</sup> SLATFORD, J. M., MACMILLAN, C. G., and SLAUGHTER, T. M. Development of Mail All-Purpose Trailer Equipment (MATE) Mark II. Post Office PMB8 Divisional Report No. 56.
- <sup>16</sup> BATH, R. J., and TAYLOR, M. G-Type Stamp Vending Machine. British Postal Engineering Conference. *Proc. I. Mech. E.*, Vol. 184, Part 3H, 1969-70.
- <sup>17</sup> CUTMORE, N. Development of the Pillar Letter Box 1852-1969. British Postal Engineering Conference. *Proc. I. Mech. E.*, Vol. 184, Part 3H, 1969-70.

---

# Building Engineering Services in the Postal Business

R. E. FINDEN, C.ENG., M.I.E.E.†

UDC 656.8:69.00

*This article outlines the work of Building Engineering Services in the Postal Business, reviews the developments in these work areas over the past 25 years and indicates the likely future trends.*

## INTRODUCTION

Building Engineering Services in the Postal Business covers the design, provision, installation and maintenance of a wide range of services; these include heating and ventilation (and air conditioning, where appropriate), electric lighting and power supplies, lifts and hoists, power doors, kitchen equipment and a number of associated items. The building service engineer's concern is to provide these services to good design standards. Good design and installation of engineering services depends greatly on communication and co-operation between architects, consultants, builders and British Post Office (BPO) engineers. Account has to be taken of the design and structure of buildings to ensure that the capacity of the plant installed is sufficient, with some provision for growth in load. It is also necessary to ensure that plant rooms are large enough and conveniently positioned, and that, where applicable, suitable structural ducts are provided.

Without satisfactory services, letter and parcel offices would function inadequately, or not at all. The building services engineer therefore performs a vital function in the Business, and this has increased with management and staff awareness of rising standards outside the BPO.

## HEATING AND VENTILATION

By the mid- to late-1930s, pumped low-pressure hot-water systems, with cast-iron or steel radiators, were the standard

form of heating system in most buildings. A few complexes, however, were heated by steam or pressurized systems. Ventilation was by openable windows and roof lights; mechanical ventilation systems were installed on only a very limited scale, mostly in basement or sub-ground accommodation, or to serve kitchens and toilets. Buildings constructed at that time were substantial, with thick outer walls, and limited glazing except where large areas of roof lights were used. This meant that, except for the latter case, heat losses and solar gain were containable.

Over the past 25 years, several factors have influenced the design and installation of heating and ventilation systems, including

- (a) changes in building design which, during the 1950-70 period, resulted in the erection of some buildings with large areas of glazing and reduced thickness of outer walls,
- (b) the Clean Air Act,
- (c) the Offices, Shops and Railway Premises Act, and
- (d) increasing awareness by the staff of working conditions.

These factors were accompanied by advances in technology and an economic requirement to reduce labour costs. The combination of these influences had a significant impact on the design of installations.

There has been a progressive increase in the use of mechanical ventilation incorporating filters, and either a means of tempering the air provided, or heating it within defined limits. In the final resort, this would become full air conditioning, but this is not provided in Postal operational buildings. Mechanical ventilation requirements have also been affected

---

† Engineering Division, London Postal Region

by other changes, such as the advent of basement parking, necessitating the provision of air extraction systems and, in certain motor transport workshops, the installation of direct exhaust coupled systems.

During the same period changes from solid fuel to light-grade oil have been made; this eased delivery and storage and produced savings in labour costs, because (apart from steam or pressurized plant) medium/large installations can be provided with automatic controls and alarms, and left unattended. Another significant reason for this change was the Clean Air Act. Controls have become much more sophisticated. Modern boilers have to start up automatically and function without skilled attendance. Controls could be programmed to achieve a satisfactory temperature at the commencement of daily occupation, and to reduce heating at a suitable time before close of business; they must also close down the boiler in the event of flame failure.

Multi-boiler installations operate sequentially on demand, to meet varying heating loads. Large buildings can be zoned, each zone being considered in relation to occupancy and aspect. Provision is made in the control system to compensate for major upward or downward variations in outside temperature. Recently, these controls have assumed increasing importance because of the campaign to save energy, and the more sophisticated optimizer control, which varies the start-up time according to the outside temperature, is yet a further development.

In addition to the dramatic advances made in the control systems, there have been improvements in boiler design. Modern packaged and economic fire-tube boilers can provide a much greater output for a given physical size than the older sectional type of boiler. Where a number of buildings have to be served by one boiler plant, there are advantages in using steam or pressurized boilers. The main flow and return systems operate at higher temperatures and the excessive temperature drops that would occur with low-pressure systems are avoided. Steam systems also have a fairly rapid response, but increased supervision is needed; in particular, blowing down boilers, sight gauges, and special devices (steam traps) are necessary to deal with condensation. Fig. 1 shows a large modern steam-raising plant.

Quite apart from design changes resulting from changes in the technology of heating and ventilation equipment itself, other changes have occurred in offices that have had repercussions on building engineering services design. Mechanized letter offices house coding desks and sorting machines which dissipate heat. Systems have been devised to control the environmental temperature within specified limits, the opportunity being taken to filter the air supplied and warm it in winter.

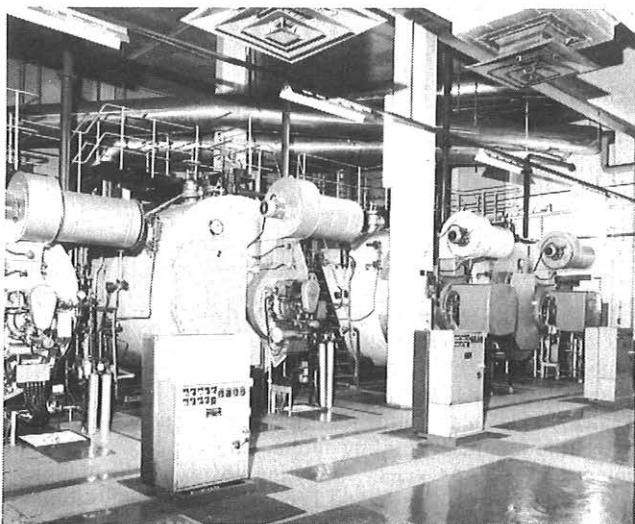

FIG. 1—Large modern steam-raising heating plant

The provision of counter screens in Branch Post Offices has led to tempered and filtered air-supply systems being installed on the staff side of counters in many offices.

## LIGHTING

During the past 25 years, there has been a change from installations using, in the main, either filament lamps and fittings, or the early fluorescent fittings which had 4 ft 40 W or 5 ft 80 W tubes and switch-start. Fig. 2 shows totally-enclosed filament fittings. Early fluorescent fittings used in sorting offices had translucent plastic shades above the lamps; static charges attracted dust which, because of the nature of the shade, soon gave a poor appearance despite frequent cleaning. These first tubes were either *daylight* or *warm white*, and neither gave the desirable colour rendering properties for use in restaurants.

Standards have been improved progressively to conform with general practice and fluorescent lighting is now used almost exclusively, except where display or special-effect lighting is required. Single or twin-tube fluorescent luminaires, with dispersive metal reflectors, are now used in sorting offices (see Fig. 3), and these give good downward lighting effect on the working plane, a pleasing appearance, and satisfactory maintenance and cleaning standards. In certain administrative buildings, continuous grid fluorescent lighting is provided. This gives good downward light, with adequate cut-off, to limit glare. Modern fluorescent tubes are much



FIG. 2—Totally-enclosed filament lighting in use several years ago



FIG. 3—Modern fluorescent lighting



more efficient than the early types and a range is available to give the most suitable colour rendering, although the current range of *warm white* tubes are satisfactory for almost all Postal Business purposes. Most tubes in use now are 5 ft 65 W and these give a light output of 4600–4750 lumens after 2000 h of use.

A further development that has occurred in the last few years has been the introduction of emergency lighting. Luminaires, incorporating rechargeable cells, are provided to meet safety requirements by ensuring that exit routes are illuminated if the mains supply fails. When mains failure occurs, a small fluorescent tube is switched on automatically and supplied from a rechargeable unit. The fitting reverts to normal operation upon restoration of mains supply.

### POWER SUPPLIES

Most buildings have 415 V 50 Hz 3-phase power supplies. Larger buildings usually accommodate Electricity Board sub-stations, housing one or more 11 kV–415 V 500kVA transformers. A few large complexes have 11 kV supplies; in these situations, the BPO provides high-voltage switchgear and transformers, as well as medium-voltage switchgear and distribution equipment. Distribution in most of the larger buildings uses rising bus-bar systems; these permit easy connexion of main and sub-main distribution boards and assist with the problem of balancing single-phase loads.

An example of the way that installations have changed over the years is illustrated by the Mount Pleasant sub-station which, originally, consisted of rotary converter sets fed from 6.6 kV feeders. The present plant uses smaller switchgear and occupies about a quarter of the space, with the 11 kV 3-phase 3-wire electricity supply being taken from a London Electricity Board ring main unit situated in the basement intake room. From there, a pair of polyvinyl-chloride steel-wire armoured cables feed the 2 halves of the high-voltage switch panel via their own oil circuit breakers (OCBs). This panel houses the OCBs and their associated protection devices—over-current, earth-leakage and reverse-power relays—together with instantaneous metering of phase voltages and currents. A supply is then taken via an OCB to each of the four 11 kV–415 V delta-star transformers. Each transformer is air cooled and rated at 1000 kVA, giving a maximum supply capability of 1600 A. An air-insulated circuit breaker, with overload and no-voltage coils, is fitted between the transformer and the medium-voltage bus bars which, in turn, feed a bank of six 400 A triple-pole and neutral switches. The complete assembly of transformer, air circuit breaker and switches is housed in a steel cubicle to form a packaged sub-station, two of which are shown in Fig. 4. From the 400 A switches, feeder cables are routed to the bottoms of the

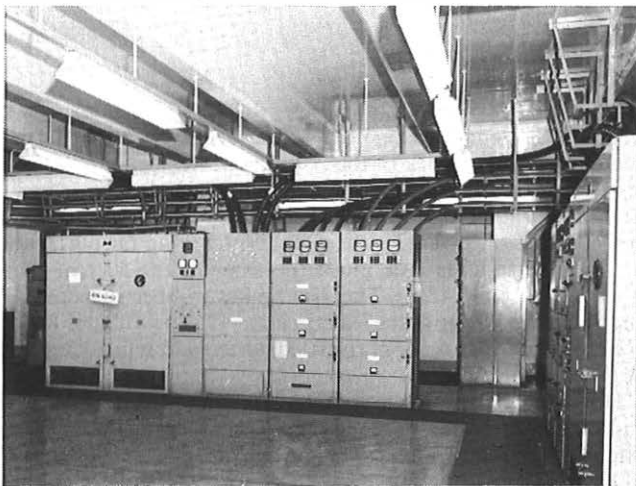

FIG. 4—Packaged sub-station units

vertical risers situated in various parts of the building. Main distribution boards are connected to the risers at different floors to supply the power and lighting requirements of the building.

Many of the conveyor systems in Mount Pleasant are DC powered and, to cater for this, the sub-station contains a pair of solid-state transformer-rectifier units, using banks of silicon diodes to provide a 220–0–220 V DC supply. This arrangement allows 440 V DC motors to be connected and provides 220 V DC for the control circuitry.

### STAND-BY GENERATORS

Because of the industrial unrest in the mining and electricity supply industries which was particularly prevalent in the early- to mid-1970s, the Postal Business began to provide an inexpensive and limited form of emergency power generation. This took the form of a number of fixed 3-phase sets of 25/50 kVA capacity and upwards. These sets provide a measure of lighting for manual sorting and access. They are self-contained, mounted on skid bases and are electrically started by means of manual controls. A longer-term programme has since been initiated, and larger sets are now being installed or provided in mobile form. These sets will provide power for heating pumps and controls, and supplies to kitchen equipment; also for a minimum of mail uplift equipment and lighting for operational areas. The largest sets are capable of accepting the starting surges imposed by one or two modern high-speed lifts, in addition to the other requirements. Fig. 5 shows a 250 kVA set mounted on a trailer. The unit is totally enclosed, providing weatherproofing and a high degree of silencing.

### LIFTS

Changes in lift design over the period have been obvious to passengers, not only in the physical construction, but also in the facilities provided. Perhaps the most noticeable feature of the change in construction has been the introduction of solid power-operated doors on both cars and landings, which resulted from safety considerations in the event of fire.

The improvement in the facilities provided for the user has resulted from the introduction of more sophisticated control equipment. Collective control has been widely introduced for passenger lifts. This has the advantage of being capable of storing information about calls and of differentiating between up and down calls, so that it is possible to answer all calls to ascend before reversing to answer all calls to descend. However, despite many improvements, a single collective lift may not be capable of satisfactorily accommodating peaks in



FIG. 5—Stand-by 250 kVA generator set mounted on a trailer

service. In such cases, it is often advantageous to use a second lift, so that the lifts act as a pair with one lift parked at a given floor, normally the ground or the main entrance of the building. This parked lift remains in this position until certain demand criteria are met, whereupon it is released to answer calls. Once the calls have been answered, the first free lift then returns to the parked position. This can be extended further because, when 3 or more lifts are provided, either zoned or programmed control can be provided, enabling the most economical use to be made of the lifts.

Improvements have also been effected in the motor control system, making it possible to achieve smooth acceleration. This is achieved by arranging to have a continuously-variable control of the armature voltage and current. For this system, DC power is provided to the lift traction motor from a mains-driven motor-generator set.

### POWER DOORS AND GATES

In many postal sorting offices, where yards and loading platforms are enclosed, the doors are so large that the manual effort necessary to open and close them is excessive. As a result, power-operated doors have been used increasingly, and their adoption aids operations because they can be closed readily when necessary for security purposes; furthermore, the ability to close the doors easily has uses in preventing draughts. The doors are normally of the folding shutter variety, hinged concertina fashion and strengthened by steel picket bars. The doors are supported and run in a top track that is securely fixed to the building structure. A lower floor level channel is fitted, but is used only as a guide track. The upper-track runners engage with a continuous chain arrangement, which is normally driven by a 3-phase electric motor, through a gear box. Control is by push-button starter, with a self-contained isolating switch. Other facilities include an electromechanical brake and limit switches, and inhibition of the *doors open* command when the doors are locked. Leading-edge obstruction sensors are fitted as a standard

safety feature; recess safety plates or floor pressure switches are also provided, where necessary. Emergency facilities must be provided so that the doors can be mechanically disconnected and operated manually.

### THE FUTURE

Reference has been made in this article to the importance of Building Engineering Services to the Postal Business and to the need for sound design and provision. Necessarily, this must be backed by an ongoing maintenance commitment to ensure that maintenance staff, who must be competent to deal with postal handling equipment of all types, can also provide a good service with the sophisticated heating and lift control circuits; indeed, this applies to all other aspects of Building Engineering Services maintenance, which includes skilled electrical and mechanical fitting.

Developments in Building Engineering Services in the future will be strongly related to the need for economic use of energy. To this end, high standards of building insulation, coupled with careful positioning of windows to avoid excessive solar gain, will be a high priority. Controls will become sophisticated, and will probably incorporate micro-chip technology with remote read-out of temperature, humidity and lighting levels. For large heating installations, there may be a return to the use of solid fuel, burnt on the fluidized-bed principle. Integrated environmental design/total energy systems, using recovery of all forms of waste heat, including that from lighting and extracted air, will become more predominant. The use of waste heat, and the heat available from outside air, by means of heat pumps has possibilities for use in administrative and counter accommodation.

Whatever the future holds, it is clear that, irrespective of whether accommodation is used for men or machines, the specification of the environment will become increasingly more stringent, and Building Engineering Services will be required not only to meet the challenge, but to meet it with increasing reliability.

---

## The Post Office Railway

I. W. S. BERG †

UDC 656.86: 656.2

*This article reviews some major developments in the Post Office Railway over the past 25 years. It also gives an indication of future trends.*

### INTRODUCTION

The Post Office Railway (POR) has been a vital link in the Royal Mail's transport network in London for well over 50 years and, such is the nature of railways, that the reader might be forgiven for assuming it continues moving mails over its 10 km route between Paddington and Whitechapel very much as it did when it opened in 1927. The 1927 POR "Mail Porter" would today, however, notice quite a few changes, many of which have taken place in the past 25 years.

### ROLLING STOCK

The most recent development is the delivery of the third-generation rolling stock (if the 2 special prototypes purchased in 1962 are excluded). So far, about half of the fleet of 34 new trains (see Fig. 1), costing in excess of £1M, has been delivered and commissioned. Under their modern-looking fairings, the powered bogie units look much the same as the 50-year old stock they are replacing. The disc brakes, rubber suspension and increased power of the experimental 1962 prototypes have been discarded in favour of the tried, tested and refined design of the 1931 units.

However, the use of up-to-date manufacturing techniques and the incorporation of modern materials have facilitated the extension of the routine servicing interval from 4800 km to 6400 km, and the period between major overhauls is confidently expected to be better than 160 000 km as compared with

---

† Post Office Railway, Engineering Division, London Postal Region.



FIG. 1—Two of the new trains in the maintenance depot. In the background is a restored car from a 1927 train

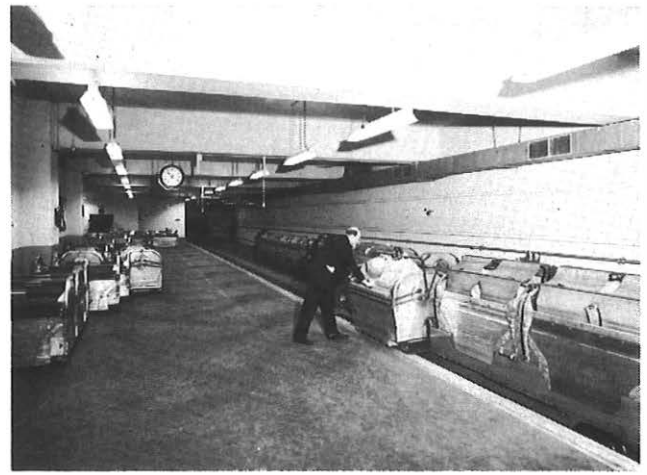

FIG. 2—The west-bound platform of the new WDO station

the previous 120 000 km. The new trains have been designed so that the DC traction motors are interchangeable with those of the old trains, thus facilitating the retention of a few of the better examples of the old stock for use as stand-by trains.

From the operations point of view, the new stock heralds an easier working life as waist-level container-loading-ramp release arms have been incorporated in the design, to eliminate the strenuous physical effort required to release the old-style low-level loading-ramp catch. Another innovation of direct benefit to the operator has been the complete replacement of all the old steel-framed plywood-panelled mail containers, weighing 675 kg, by containers of identical capacity, but constructed of duralumin alloy and weighing only 538 kg.

#### POWER SUPPLY

The traction power supply technology has undergone several changes in the last quarter of a century. The original 3 pairs of 400 kW rotary converters installed at the Western Parcels Office (WPO), Mount Pleasant, and at Liverpool Street, which were fed by a central 6.6 kV supply, were replaced in the late-1950s by a number of specially-designed locally-situated mercury-arc rectifiers, each with its own 11 kV supply from the public network. At present, these mercury-arc rectifiers, together with their associated transformers, are being replaced by more efficient silicon-diode stack rectifier units and air-cooled transformers designed to give the 440 V and 150 V DC outputs required for traction power.

#### NEW STATION

The year 1957 saw the commencement of what turned out to be nearly a 10-year operation to transfer parcel and letter sorting from the POR-served WPO at Bird Street and the Western District Office at Wimpole Street, to a large new fully-mechanized parcel and letter office situated in Rathbone Place just off Tottenham Court Road.

An essential feature of the new purpose-built office, which serves the commercially important W1 postal district of London commonly known as the *West End*, was the construction of a new access point to the POR, which at that time ran across the corner of the site of the sorting office. To ensure that the new station (Fig. 2) was reasonably accessible to the proposed new sorting office, it was necessary, before any construction work was commenced on the building above, to re-route the POR tunnels to enable the new station to be built centrally on the site. The engineering problems involved in excavating an area 22.6 m by 55 m to a depth well below the finished platform level some 18.3 m below ground, and

in preventing the collapse or movement of the surrounding buildings, were immense.

Before the required 24.4 m long steel piles could be driven into the ground, the existing tunnel had to be located exactly beneath the site. This involved surveys being made from the site up to the West Central District Office, 0.8 km away over-ground, then down to the POR station via the lift shafts, and then back along the tunnel to the area below the site. The accuracy with which the survey had been carried out was confirmed after the excavations were completed when the positions of one king pile 152 mm above the tunnel, and a soldier pile about 229 mm from the side of the tunnel were found to be exactly as calculated.

After completion of the excavation work, tunnel headings were driven to the east and west to connect up with the existing tunnel at step-plate junctions constructed from bolted-up cast-iron tunnel segment rings of increasing/decreasing diameters. Linking the new tunnel with the existing one was carried out during 5 consecutive weekends when the then normal POR closedown of 08.00 hours Sunday until 10.00 hours Monday was extended by 9 h to include the Saturday night. Thus the whole of this massive tunnel re-routing (and the ensuing reinforced-concrete station construction work) was achieved with a total of only 45 h lost service time.

#### FUTURE DEVELOPMENTS

A study is being carried out into the technical and economic feasibility of utilizing modern micro-chip technology to provide a centralized operating facility to replace the several hundred manually-operated levers situated in varying numbers at each of the POR's stations. The intention is to centralize as much as possible of the control apparatus; provide suitable interface equipment for the remaining local apparatus; and after that, to concentrate train operation into a centrally situated operating console spanning the entire network. This development would represent a giant step forward when compared with the previous change from the old exposed butterfly-type control relays to the miniature encapsulated plug-in relays that are now in use. This advance will certainly have passed into history when the next 25 years of the POR's operation and developments are reported.

#### Bibliography

- MACKAY, A. C. The New Post Office Railway Station at the New Western District Office. *POEEJ*, Vol. 59, p.12, Apr. 1966.  
 BAYLISS, D. A. The Post Office Railway, London. Turntable Publications, Sheffield, 1978.  
 MEW, G. M. The Post Office Railway. Convention on Automatic Railways, *Proc. I. Mech. E.*, Vol. 179, Part 3A, p. 39, 23-25 Sept. 1964.

# RESEARCH

J. R. TILLMAN D.SC., F.INST.P., C.ENG., F.I.E.E. †

UDC 62.001.007

*This article describes some of the major activities of the British Post Office Research Department over the past 25 years, including many that have led the world.*

## INTRODUCTION

The decade following 1945 saw the British Post Office (BPO) Research Station at Dollis Hill return fully to its pre-war role. Some projects left unfinished in 1939, such as coaxial cable systems and voice-frequency signalling, had been resumed while many new ones, such as electronic telephone exchanges, microwave radio-relay systems and submarine telephony were initiated. Then, as now, the terms of reference<sup>1</sup> were broad; they allowed a wide spectrum of innovative and experimental activities, calling on many disciplines directed towards both new, improved and cheaper services for customers, and greater productivity.

By 1956 a broad post-war programme was in full swing and has continued so. Inevitably it has been influenced by, and derived benefit from, progress in many other branches of science and engineering, perhaps most from that branch broadly known as *electronics*. Thus by the early-1960s the silicon transistor had already become capable of handling signals in the very-high-frequency band, cheaply, with little power dissipation and much space saving. It then became the basis of integrated circuits of steadily increasing flexibility in use, easing the task of equipment designers, the more so with the later development of the large-scale metal-oxide semiconductor (MOS) families of integrated circuits and memories. The designers of electronic digital computers had led the way in showing the power of all these devices in processing digital signals, an aspect quickly taken up in applications of the pulse-code modulation of speech and in digital transmission and switching.

Two early post-war projects had had major materials-processing content—the design and fabrication of quartz resonators for filters and frequency standards, and of reliable thermionic valves. Their success was followed by others.

The practices of research showed changes during the period 1956–81 in some important ways. In 1956, as earlier, many new ideas had primarily to be tested with physical models; full paper studies were often too complex for calculation by slide rule. The ready availability of digital computers is making computer-aided analysis, design, simulation and testing much more attractive as the first steps. When physical models have to be tested for their responses to electric signals, the increasing range of high-quality measuring instruments, widely applicable to telecommunications research, lessens the tedium of earlier measurement techniques.

Research on materials began to involve much more synthesis, often of successive, very thin, layers of only slightly differing compositions. Progress of such work could rarely be gauged solely by observations of the electrical or

other required properties; very powerful electronic, X-ray and electrochemical analytical techniques had frequently to be used.

No research laboratory can be an island in a world of ever increasing research activities with its attendant information explosion. Alleviation is afforded by BPO research staff increasing their contacts with those of the laboratories of UK Industry and of several government and many university departments; through CCITT\*/CCIR†† activities; by attendance at research conferences; and by using such information services as INSPEC provided by the Institution of Electrical Engineers.

This article cannot do justice to the wide range of research projects undertaken during the past twenty-five years. Those to be briefly described have been chosen primarily for their importance, real or potential, to BPO services, but also for their novelty, engineering and scientific content and variety of subject. Others could have been included by the same criteria but only by increasing the risk of over-much brevity in stating objectives, describing the means of reaching them and indicating their applications. Some projects, notably many relating to switching technologies, to digital transmission and to international networks find more suitable places in other articles of this issue.

Before turning to these chosen topics however, the move of the Research Department from Dollis Hill to Martlesham deserves attention, for it was a particularly noteworthy event.

## THE MOVE TO MARTLESHAM

The BPO first occupied the site at Dollis Hill, to set up the Post Office Research Station, in 1921. When new permanent buildings were opened there in 1933, the site must have seemed large enough for decades to come. But demands for additional buildings increased from 1950 onwards, both to sustain growth and occasionally for special purposes. The BPO was unable to purchase neighbouring land and planning permission for multi-storeyed building was largely withheld. Thus the questions, “when and to where should a move be made?” assumed more immediate importance, heightened by the increasing recognition of the disadvantages of the existing station, such as the inflexibility of the buildings and the grossly inadequate space for car parking. After one false start, the official search for a new site began in 1964 against a set of general requirements; for example, fully adequate size, not more than two hours travelling time from London, no environmental restrictions affecting likely research activities, and socially acceptable to staff.

† Until his retirement, Dr. Tillman was with the Research Department, British Telecom Headquarters

\* CCITT—International Telegraph and Telephone Consultative Committee

†† CCIR—International Radio Consultative Committee

The disused airfield at Martlesham Heath (10 km east of Ipswich) was the final choice, of which the BPO acquired a long lease on 0.4 km<sup>2</sup> (nearly 10 times the size of the Dollis Hill site) as well as purchasing a tract of adjacent farmland which is currently leased back for farming. The site is flat, as is the surrounding countryside for many miles, and its soil is light. It has good access to the A12 trunk road, which is less than 2 km away. There is a good variety of housing in Ipswich, two small towns and many neighbouring villages, including that of Martlesham Heath, much of which has now been built. The University of Essex, with whose Department of Electrical Engineering Science there is a close relationship, is about 40 km distant.

A schedule of the very diverse requirements was prepared by the BPO to meet the foreseeable needs for research, and presented to the Ministry of Public Works and Buildings (later the Department of the Environment) in 1966<sup>2,3</sup>. Some compromise was clearly called for between one very large building of extreme flexibility and several with different special features. While plans were being prepared it became desirable, if not essential, to phase the move over several years. To this purpose, rooms in some small permanent buildings on the site were converted to laboratories, accommodation in Ipswich and Felixstowe was rented, and some prefabricated single-storeyed buildings, well interconnected, were erected on site; all were occupied as soon as possible. The final plans, accepted by the BPO, formed the basis of a contract placed in 1969. The buildings were to include one for administration, a large laboratory block adjoined by two towers, and a services complex. Most of the working areas were to be air-conditioned. Construction began in 1969 but was seriously interrupted in 1972, soon after which the contractor went into liquidation; it resumed in 1973 and was finished in 1975.

Fig. 1 is an aerial photograph of the site, from the south-east, with the main buildings in the foreground. Fig. 2 shows another aspect of the administration building (right), the radio tower (centre) and the laboratory block (left). The administration building includes the following important facilities: there are two well-equipped lecture theatres, one seating 450, with a raked floor and a good stage, and the other, octagonal in shape, seating 60; the library is on three levels, a central well with square-shaped galleries at mezzanine level in turn surmounted by a large reading and journal-reference area; the uppermost floor of the building contains the restaurant and kitchens able to provide 1000 lunches daily.

The laboratory block has seven floors at 5 m spacing. Each, except the lowest which accommodates the air-conditioning plant, has a useful working area of nearly 3000 m<sup>2</sup> with



FIG. 1—Aerial view of the British Telecom Research Laboratories



FIG. 2—View of the main buildings from the north-west

another 1000 m<sup>2</sup> for equipment not requiring continuous attendance. The internal layout allows flexibility of room area based on a sub-module dimension of 1 m. There are few permanent dividing walls, the rooms being made from demountable steel-framed partitions that slot into fixed ceiling grids on a 2-sub-module pattern. The partitions rest on metal strips attached to the floor. The panels forming the opposite surfaces of the partitions are of plastic-coated steel, with the space between them filled with glass wool. Many services are available; for example, electrical and pipework from the floor ducts up to laboratory benches supplying water, compressed air, and drainage. Ring-main supplies of oxygen and nitrogen are similarly routed, as are other gases from cylinders housed on the balconies of each floor.

The service area is mostly single storeyed. The large workshops are airy, with very easy access. The water tower provides accommodation for drawing offices, some divisional offices and, at its top, a 200 m<sup>3</sup> water tank. The radio tower is much taller (73 m); it supports a prominent two-storeyed laboratory set at 45° to the faces of the main tower, and above that carries two circular aerial galleries. There are stairways in the main laboratory block, but lifts are housed only in the towers immediately adjacent.

There are many other buildings on the site, besides the original and the prefabricated. One contains equipments for the mechanical testing of submarine cables and the subjection of repeater housings to hydrostatic pressure appropriate to ocean beds. Another, just completed, has full facilities for the fabrication of integrated circuits, while a companion building houses electron beam microfabrication facilities for generating patterns for such circuits, of dimensions beyond the lower limit possible with optical techniques. Two more have extensive test facilities for examining switching systems.

## SPEECH COMMUNICATIONS

Telephone instruments have long been a subject for research. The 700 series of instruments, developed in the early-1950s, proved a notable success. Only one major modification proved necessary, to counter excess loudness noted by some customers with short exchange lines. A regulator<sup>4</sup> was fitted (as shown in the box in Fig. 3), consisting of a chain of rectifier elements and four resistors to form a variable-loss network under the control of the line current. For short lines, the transmitter sensitivity is reduced by up to 6 dB, the receive sensitivity by up to 4 dB and the side-tone by about 10 dB. On long lines (currents below 40 mA), the small loss incurred has been made up by changes elsewhere in the instrument.

The carbon-granule microphone was retained for its cheapness and high sensitivity, despite its non-linearity and variability; competing types required amplifiers which were comparatively expensive until cheap suitable integrated circuits were produced. An electret microphone (see Fig. 4) is

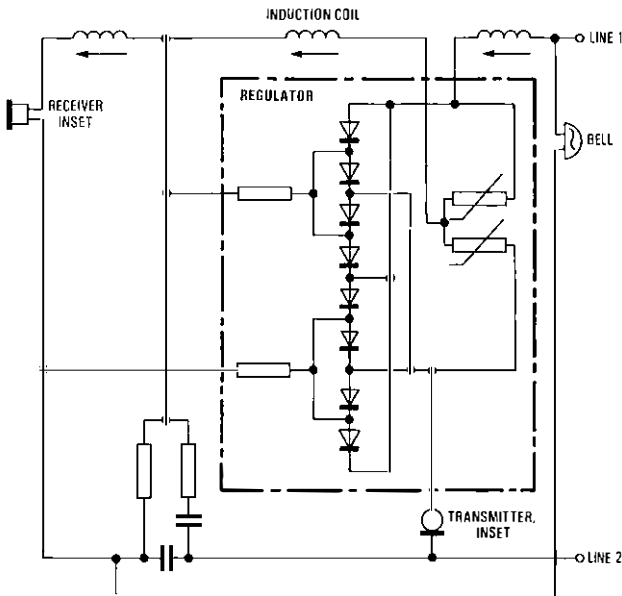

FIG. 3—The transmission circuit of the Telephone No. 706

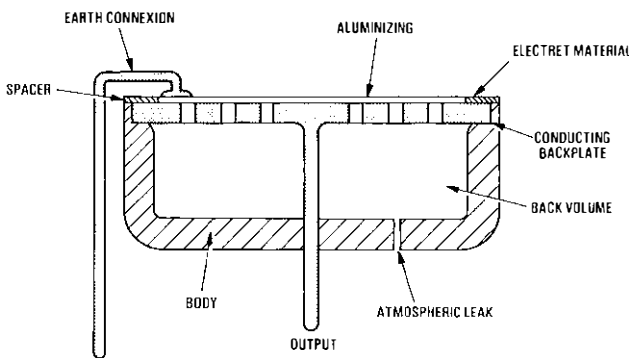

FIG. 4—Simplified cross-section of the electret microphone

now proposed<sup>5</sup>. An electret is the electrostatic equivalent of a permanent magnet. The material chosen, FEP Teflon, is in film form (13  $\mu\text{m}$  thick), metallized on one side. The other side is charged by passage over a knife edge maintained at a potential of about 700 V with respect to the earthed metallization. Some surface charge is deliberately leaked away, but the electret charge beneath the surface remains for many years when protected by a moisture barrier. Microphone action is akin to that of the condenser type. The only special features of the associated amplifier are a high input impedance ( $\sim 10\text{ M}\Omega$ ) and the ability to accept supply currents from 10–110 mA. Linearity and consistency of sensitivity are very good.

More recently, all-electronic instruments have been designed with additional integrated circuits for signalling and tone calling<sup>6</sup>. They give excellent performance, are suited to automated production, reduce restrictions on network evolution and favour the use of press buttons.

Throughout the period, studies of transmission performance have continued<sup>7, 8, 9</sup>, often in collaboration with the CCITT, bringing closer together objective measurements and subjective assessments. The methods for obtaining and quantifying the latter have moved towards ratings of the ease of conversation over circuits by lay subjects. The body of knowledge so acquired has been incorporated in a very flexible computer-aided telephone-network assessment program (CATNAP) which can predict customers' opinions of any connexion for which the electrical and acoustical characteristics are known. Lengthy subjective assessment of new telephone sets or line and switch conditions become unnecessary, unless there are entirely new impairments requiring subjective assessments

before inclusion. Those introduced by recent systems (for example, transmission delay of satellite links) have been included.

### THE LOCAL DISTRIBUTION NETWORK

Although the local distribution network constitutes a considerable proportion of the BPO's assets, its transmission properties rarely feature in research studies. They have come to be regarded merely as adequate for carrying signals in the audio-frequency range; for example, speech, Telex and Datel (up to 9.6 kbit/s). But an additional mode of usage could have big advantages in the near future when digital transmission reaches to local exchanges, and new digital services are offered which are well suited to working rates of 64 kbit/s; for example, high-speed facsimile and electronic mail services. Studies were accordingly made in the mid-1970s to suggest how best such signals could be fed to and received from exchanges without the need to lay new cables all the way to customers<sup>10</sup>.

Fig. 5 outlines one promising method. Customers retain their existing pairs to the exchange for their audio services, but are grouped at primary cross-connexion points for the purpose of transferring their outgoing 64 kbit/s signals, time-division multiplexed at a bit rate of 2048 kbit/s, to an additional cable pair to the exchange, with intermediate regenerators if needed. A second pair serves for the return direction. From his new terminal, each customer will have his outgoing 8 bits per 125  $\mu\text{s}$  frame transmitted in a burst—effectively at the 2048 kbit/s rate—in one of two time slots allotted to him. His incoming signals will have been similarly time-compressed into the other slot. There will thus be time-division duplexing for the new service. In town centres, where the new services will initially be most called for, the distances between customers, their distribution points (DPs) and primary cross-connexion points will be small and the transmission times correspondingly short, allowing a group to approach 30 in number. Elsewhere the group may be smaller, and regenerators needed on occasion between the DP and cabinet (the cross-connexion point). Because little of the energy of the 2048 kbit/s digital stream is contained below 20 kHz, simple filtering will remove sufficiently all interference between the retained audio and new digital channels.

### HUMAN FACTORS

Human factors<sup>11</sup> enter wherever customers or BPO staff meet the telecommunications or postal systems; for example, when using the telephone or operating a manual switchboard or postal coding desk. The subject can involve such disciplines as physiology, applied psychology (where a consultancy with the Medical Research Council's Applied Psychology Unit has been of much assistance) and ergonomics, additional to, and possibly conflicting with, the more traditional ones. Access to a large number of subjects, required for some studies, was assured by the suburbs of London around Dollis Hill and by Ipswich for Martlesham. Opinion ratings, reaction times, error rates, measures of strain and fatigue and training time to acquire a new skill often figure as parameters in human factors studies. The only studies mentioned here will apply to telecommunications; postal problems relate mainly to sorting,

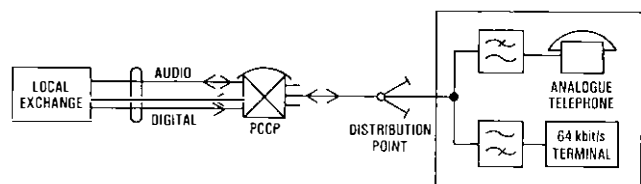

PCCP: Primary cross-connexion point

FIG. 5—A proposed local-line system

with much reference to coding desks and keyboards.

The determination of the range of inclination of a dial, satisfying both easy viewing and quick and error-free operation, was an early exercise. Keying, a much faster alternative to dialling for inserting digital information into the system, required attention to the layout of the keypad, the size and spacing of the buttons and the feedback to the user which assures him that he has completed a key depression. Quite small increases in button size and spacing, from the smallest contemplated, increased the speed of use and reduced double button depressing. The best compromise for the angle of mounting of the keypad was found to be  $25^\circ \pm 5^\circ$  to the horizontal for a table telephone and  $20^\circ \pm 5^\circ$  to the vertical for wall-mounted keyphones.

International direct dialling is now widely used in the UK, by visitors as well as nationals. Studies have detailed the difficulties encountered by callers in setting up their required connexions, often due to lack of knowledge or understanding of unfamiliar instructions, procedures and network responses. Steps have been suggested to lessen the difficulties, including improvements and standardization of procedures, and wider and better presentation of the instructions to users.

Light emitting diodes are, for engineering reasons, attractive alternatives to lamps in customer equipments, switchboards and apparatus rooms, because of their lower power consumption, longer life and compatibility with integrated circuits. But they have currently a lower light output and a restricted viewing angle and colour range, all disadvantageous as quantified by human factor experiments.

### CIRCUIT TECHNIQUES FOR INLAND TRANSMISSION

Before 1965, research directed to improvements and additions to the inland transmission network were largely confined to frequency-division multiplexing of analogue signals. Thereafter pulse-code modulation (PCM), time-division multiplexing and digital transmission became increasingly competitive with both the suitability of many types of existing cable to carry the digital signals, and the availability of cheap transistors and, later, cheap digital integrated circuits. In the main, the conventional digital circuit techniques sufficed for the new PCM systems (described in another article); for example, in analogue-to-digital (A/D) converters and their inverse and in the multiplexing, regeneration and synchronization of the digital trains. Much research effort was needed to establish international standards for digital networks.

As examples of more specific associated circuit techniques for the inland network, two will be mentioned; filtering and adaptive equalization. As electronic equipment became miniaturized and operational amplifiers became available, interest was revived in active filters<sup>12</sup>, if only to eliminate bulky inductors. The negative-impedance converter formed the basis of one approach, but gave results inadequate for use in telecommunications. An alternative, using amplifiers with resistor/capacitor networks in their feedback paths, showed more promise. But an entirely new approach, proposed in 1966, offered simulated inductors by the use of gyrators. The BPO developed the first electronic gyrator of adequate stability, using operational amplifiers (by then very cheap), four resistors and one capacitor, to simulate inductors having a high Q-factor over frequency ranges up to 50 kHz. One notable application has been to a miniaturized receiver for the AC9 signalling system, with very great savings of space and cost.

Effective filtering after A/D conversion of signals to a PCM format can be achieved by numerical processing of samples involving principally time delay, addition and multiplication by preset constants<sup>13</sup>. Very briefly, the digital train is in part smoothed by averaging out the short-term fluctuations, and has unwanted components rejected by choice of these constants. Where the digital System X network interworks

with the analogue network, such filtering will be necessary to detect tones encoded in PCM channels. An example is given elsewhere.

The switched network of 4 kHz telephone channels carries much of the Datel service, but its non-linear phase/frequency relationships set a limit, 2400 bit/s at best, to the data rate that can be used without introducing unacceptable inter-symbol interference. Adaptive equalization was therefore sought, to raise the limit. This requires passing the incoming signal, with its inter-symbol interference, along a delay line with tapings at unit intervals of the signals. Weighted samples are taken from the delay line and summed. The weightings are critical and must adapt to the idiosyncrasies of the link, first as a result of comparing a prescribed training sequence, as received, with the same sequence locally generated. Thereafter the phase and amplitude of each sample of the equalizer output are regularly monitored, and the departures from their ideal state counterparts minimized by further adjusting the weights. The training time is usually less than 1 s, even for data rates of 9600 bit/s. Large-scale integration will provide the necessary compact equipment.

### SUBMARINE TELEPHONY

Since 1943, when it developed the first submerged repeater, for insertion in a cable to the Isle of Man, the BPO has been extensively involved in submarine telephony. Important improvements have followed: in its lightweight cable (now universally used or copied for deep-water use); cable laying and recovery; repeater design; supervisory systems; and terminal equipment. The key active devices for repeaters are described elsewhere in this article and the resulting systems in the article on the International Network.

The lightweight cable had a successful sea trial in 1956 and was first used in CANTAT I<sup>14</sup>. For the laying of that system, a new method of handling the rigid repeaters (each 3 m long and weighing 500 kg) was devised<sup>15</sup>. Previously, with the ship stopped, a rope was attached to the cable ahead of a repeater to take the tension of the cable already laid, the cable removed from the conventional capstan drum, the repeater manhandled to a hoist transferring it outboard and the cable replaced on the drum—a slow process, hazardous for both crew and cable. A five-sheave gear was substituted, through which the cable passed without completing a turn round any one sheave. As each repeater approached, a by-pass rope attached to the cable, before and after the repeater, passed through the sheaves, maintaining the tension while the repeater moved past on a slipway, and the cable duly returned to the sheaves. Even so, the ship had to slow to 1–2 knots, the more time consuming as repeater spacings decreased in systems of increasing bandwidth. The five-sheave equipment was installed on CS *Monarch* in 1959.

To speed up laying, the linear cable engine (see Fig. 6) was later developed. It consists essentially of 18 pairs of in-line rubber-tyred wheels, each pair pressed together by hydraulic

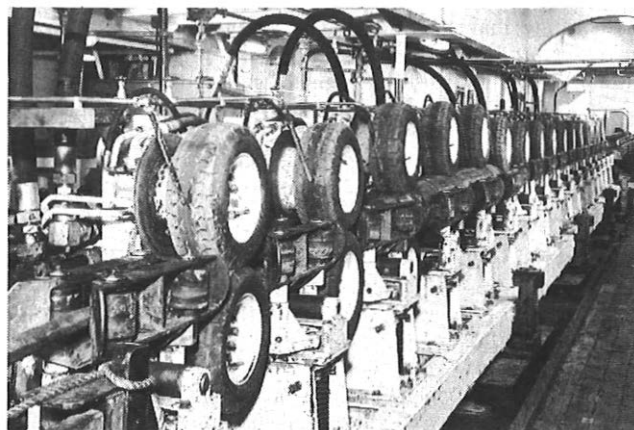

Fig. 6—The linear cable engine with repeater passing through

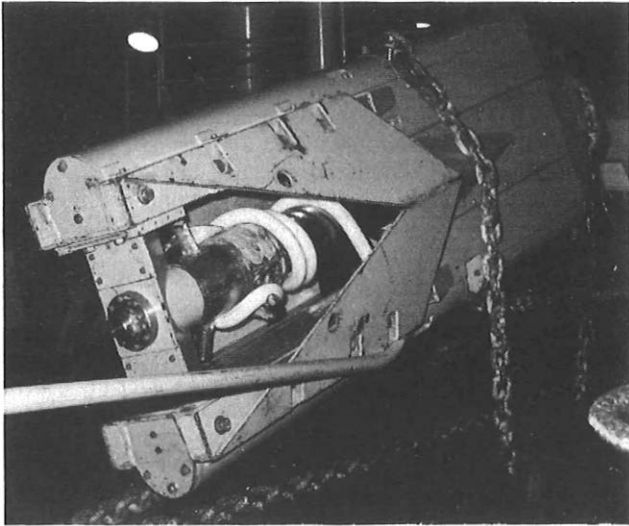

FIG. 7—The cut-and-hold grapnel, with lightweight cable held

rams. Each wheel can be driven or braked individually. The cable passes between the wheels, hydraulic linking ensuring proper sharing of the cable tension. When a repeater enters the engine it forces apart the pairs in turn, without loss of tension on the cable. The engine was very successful, calling for very little slowing of the ship. It was installed first on CS *Alert* in 1970 and, later, on five other cable ships, British, Canadian and French.

Faults, though infrequent in the large network of submarine cable systems owned jointly by the BPO with other countries, demand quick attention if considerable revenue is not to be lost. The supervisory equipments in the repeaters aid fault location. A hydraulically powered cutting grapnel has been developed for cable recovery in shallow waters where, despite the heavy armouring of the cable, most faults occur. It is dragged at right angles to the line of the cable, catching and severing it. For use in deep water, a cut-and-hold grapnel (see Fig. 7) was designed, also acting hydraulically, locally powered by high-pressure nitrogen. It is fully automatic, signalling its progress sonically to a hydrophone trailed by the ship. In field trials it enabled cable from depths of over 5 km to be successfully recovered. It has since seen service in the North Atlantic.

For the earlier systems the BPO had contributed greatly to the design of the repeater's amplifier which handles the signals from both directions brought together, and separated after amplification, by directional filters. But from the mid-1960s the design was largely left to the repeater manufacturers while the BPO concentrated more on system and reliability aspects. It did make one very notable contribution to terminal equipment<sup>16</sup>, which had hitherto followed the practice of land systems. Largely by improved filtration and a novel method of assembling channels, the capacity of the conventional group was increased from 12 to 16 channels, the frequency band of the audio signals being only marginally reduced to 200-3050 Hz.

The next step forward may well be revolutionary; namely, digital transmission over glass fibres (see the section on optical communications).

## RADIO RESEARCH

Aspects of radio research under investigation in 1956 included further attempts at minimizing the effects of fading on radio telephony, comparison of caesium-beam resonators with the highly-stable quartz Essen rings made by the BPO, modifications to microwave radio-relay links to extend their use beyond that of carrying television signals to that of large blocks of telephony circuits, propagation studies, and better designs of aerials and of intermediate-frequency equipment.

Important new topics were added later; of the total those now briefly described have been chosen to illustrate the width of the range.

## Lincompex

Earlier efforts to combat the detrimental effects of fading on the quality of high-frequency (HF) radio telephone links had included the use of constant-volume amplifiers in both transmitters and receivers. However, accentuation of atmospheric noise during pauses in speech could be disturbing and loop-gain considerations made singing suppressors necessary, with some susceptibility to clipping of transmitted speech. The variable gain of the links had ruled out the use of compressors and expanders until the Lincompex system (*linked compressor and expander*)<sup>17</sup> was proposed (see Fig. 8). It uses essentially 4-wire working, there being no interconnexion between send and receive directions. Speech to be transmitted passes through a compressor acting at almost the syllabic rate to a low-pass filter which restricts its highest frequency to 2700 Hz. Independently, its incoming level is assessed to provide a DC control signal which both governs the variable loss circuits of the compressor and modulates the frequency of an oscillator within the range 2810-2990 Hz, a signal from which is combined with the compressed speech within the normal 3000 Hz band for passage to the radio transmitter. On reception, the speech and control channels are separated and amplified to constant level. The demodulated control signal is used to set the expander gain, thereby restoring the original range of amplitudes to the speech signals. Field trials confirmed that much immunity to fading had been achieved, since when the system has found considerable use.

## Participation in Project TELSTAR

Collaboration by the BPO with the American Telephone and Telegraph Co. in the testing of the experimental, active, communications satellite TELSTAR, launched into an elliptical orbit by NASA in 1962, involved much development<sup>18, 19</sup> in a short time, the more so as a second US satellite RELAY, to be tested a little later, had its receiver tuned to a very different frequency from that of TELSTAR. One British firm built the 26 m diameter steerable paraboloid aerial dish on its horizontal turntable at Goonhilly. Another provided a

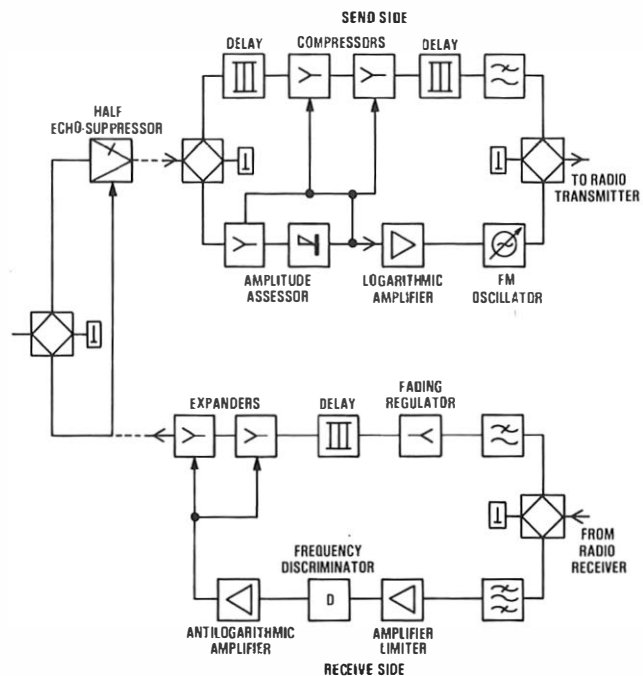

FIG. 8—Block diagram of the Lincompex equipment



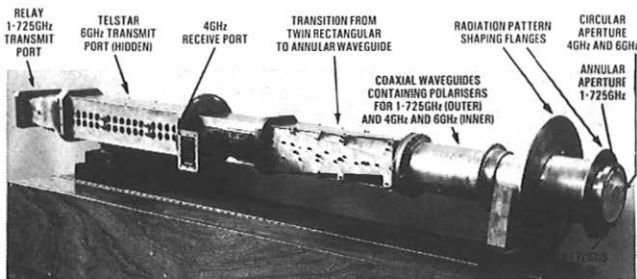

FIG. 9—Composite feed unit for the TELSTAR/RELAY tests

maser as the low-noise input stage of the receiver, which, requiring to be operated at liquid-helium temperatures, was too bulky to be sited at the focus of the dish. Linking the aerial to the receiver and to each separately of the two microwave high-power transmitting valves (one for each satellite tested) was made more difficult by the need to include rotating joints or twistable sections in otherwise conventional rectangular waveguides. Good voltage standing-wave ratios and low attenuation were essential. There could be a power ratio, transmit-to-receive, at the feed aperture of  $10^{16}$ . The loss in the feed to the maser had particularly to be minimized because every 0.1 dB of loss increased the noise temperature by 7K. Conversion of linear polarization to circular had also to be included. The feeds were satisfactorily designed, but needed much attention to detail in their construction. For some later tests, a composite triple-frequency primary feed (see Fig. 9) was constructed; it embodied three rectangular waveguides into a coaxial structure. The intermediate-frequency equipment, centred on 70 MHz, and the means for modulating the transmitters were based on designs studied for microwave radio-relay systems but covered larger bandwidths. Automatic frequency control proved an aspect requiring particular attention. Before the launching of TELSTAR, overall testing of the Goonhilly installation included the use of a radio star to confirm its tracking accuracy and to measure the narrowness of the beam-width of the aerial. The excellent results obtained with the TELSTAR experiment did much to hasten further developments of communications satellites, and to establish the excellence of the Goonhilly type of aerial, even though its full steering capability has not since been called upon.

### Propagation Studies

Several studies of radio propagation were carried out during the past twenty-five years. Tropospheric-scatter propagation (TSP)<sup>20</sup> was investigated, collaboratively in part, as a means of transmitting telephony and television, where conventional methods would have been very expensive. Three links were tested, over distances of 150, 240 and 270 km, at frequencies of 1370, 950 and 876.5 MHz respectively, with interesting results in terms of excess loss (over the basic) and its periodicity, and of noise and interference. It was concluded that acceptable television transmission would be possible with careful design. However the only applications that have so far arisen for the use of TSP have been those for telephony and data services between the UK and North Sea oil platforms.

With the view to quantifying the potential of line-of-sight systems carrying high-speed digital signals on carriers around 11, 20 and 37 GHz, an experiment was carried out jointly with the Appleton Laboratory, in an area close to Mendlesham radio station<sup>21</sup>. Several combined transmitting and receiving stations were set up, affording eight links in all, with fast acting rain gauges in their vicinities and with radars tracking rainstorms. The attenuation/kilometre attributable to severe rainstorms was considerable at frequencies around 20 GHz, setting a limit to hop length, but was much less at 11 GHz where more attention had to be given to multipath effects<sup>22</sup>.

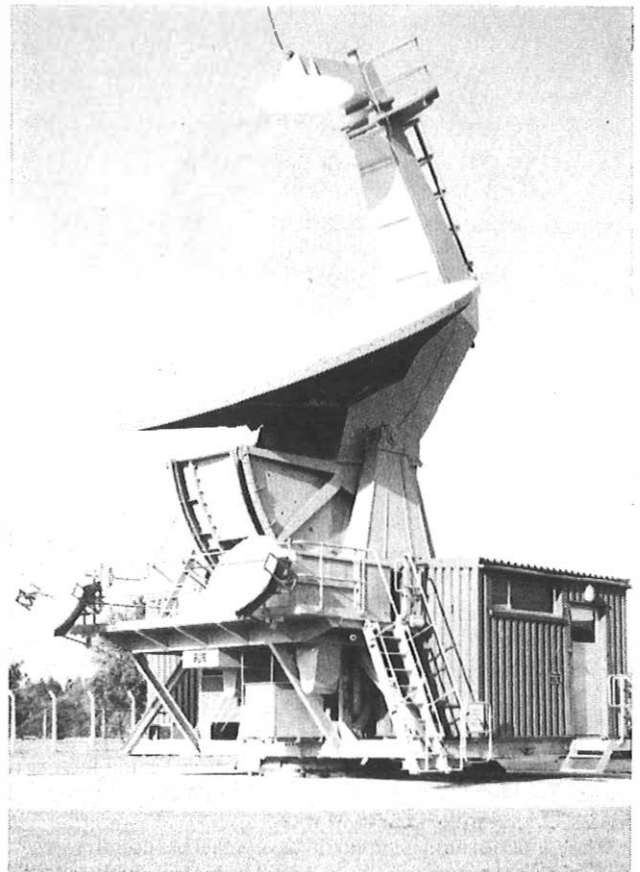

FIG. 10—The Martlesham 6 m diameter steerable aerial

More recently, the usefulness of frequencies above 10 GHz as carriers for satellite systems has been studied. Use was made of the beacons transmitted from the ATS-6 satellite (at 20 and 30 GHz), of the Orbital Test Satellite (transmitting in an 11 GHz band and receiving at 14.5 GHz) and of the 6 m diameter and smaller aerials at Martlesham (see Fig. 10). Radiometer measurements at all these frequencies were also made. Data at the lower frequencies has been relevant to planned systems.

### A Millimetric Waveguide System

In contrast to free-space radio-relay systems, no statutory limitations of frequencies apply to electromagnetic waves guided in tubes, for which a low-loss mode of propagation in a circular guide had been suggested in 1936. The field configuration of the mode has no lines of electric intensity terminating on the guide wall to give rise to wall currents, while the magnetic field induces circumferential currents only, decreasing as the frequency is raised. The guide must avoid mode changing by being accurately circular, of constant diameter ( $d$ ) and very straight, and the signal frequency must exceed some lower limit,  $f_c$ , proportional to  $1/d$ . When  $d$  is 50 mm, a good practical size,  $f_c$  is about 10 GHz, and the loss very acceptably low from 30–100 GHz.

But no reliable source of microwave power existed at such frequencies until the IMPATT diode showed its promise. The feasibility of a long waveguide then rested on making and laying a suitable guide<sup>23</sup>. The BPO chose to develop a helical guide. A fine enamelled wire (diameter 0.122 mm) was wound as a tight helix on an accurately machined circular steel mandrel (3 m long) and overwound with layers of glass fibres impregnated with epoxy resin, cured to provide a rigid jacket when the mandrel was removed. Simple means were incorporated for coupling such lengths together. A 250 m length

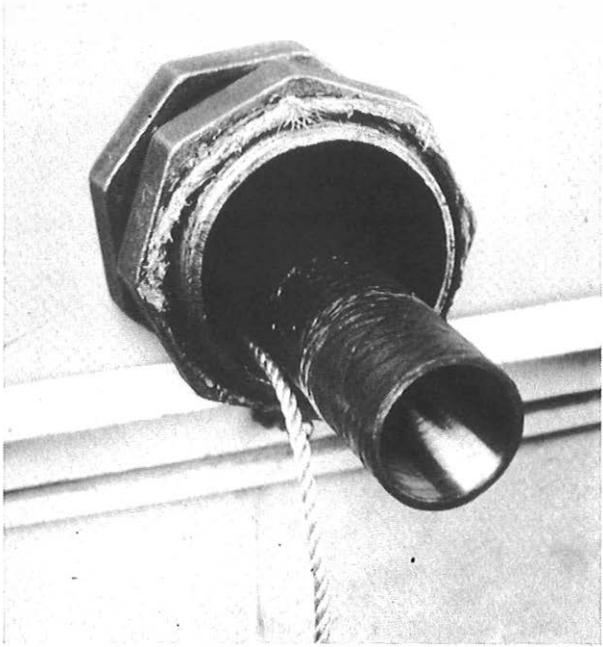

FIG. 11—Millimetric waveguide in its steel duct

was laid and extensively tested at Martlesham, before the BPO in collaboration with BICC Ltd. set up a small factory to make the 14.2 km needed for a system field trial between Martlesham and Wickham Market.

The routeran alongside carriageways, across country, over a stream and through a marsh. A 100 mm steel duct, laid at a depth of 1.2 m carried the guide (see Fig. 11), affording mechanical protection and decoupling from small earth movements. The route selected was as straight as possible, with the radius of curvature almost always greater than 300 m and never less than 100 m, except at three places where 90° bends of radius 1.5 m, in 18 mm dielectric-lined guide, were inserted between waveguide tapers, each with a loss of 0.25 dB.

The guide's attenuation is shown in Fig. 12. Six of the 64 channels were equipped, demonstrating all salient features, including the phase-shift modulation, multiplexing and demultiplexing of carriers, channel filtering and the regeneration of digital streams. Some terminal equipment is shown in Fig. 13. Digital colour television signals were successfully transmitted over four channels connected in tandem, a total route length of 57 km. The excellent results of the trial prompted the planning of an operational system between Reading and Bristol, suspended only because optical communications over glass fibres for trunk use were showing even greater promise.

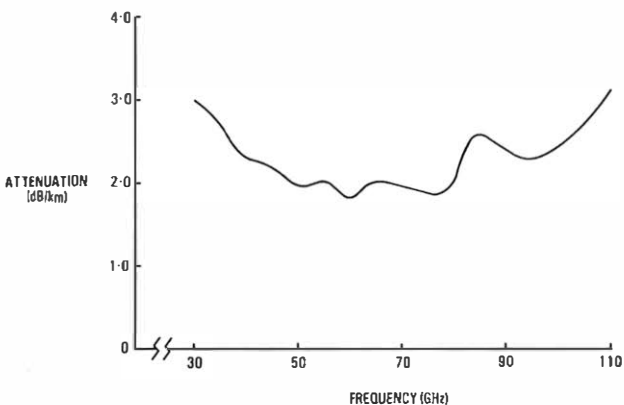

FIG. 12—Average attenuation of the 14 km field-trial route including three sharp 90° bends

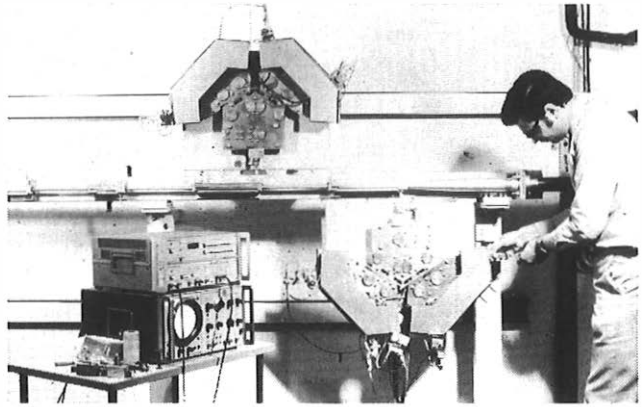

FIG. 13—Some terminal equipment of the millimetric waveguide system

### 19 GHz Radio-Relay System

A study of the feasibility of a microwave radio-relay system using carriers of frequencies around 19 GHz had to take account of the appropriate propagation results. Hop lengths would be restricted, making necessary more intermediate stations, each of which should accordingly be cheap, and light and compact to ease their mounting. Within these constraints, designs centred around a digital system capable of a rate of 140 Mbaud. They led to a field trial, starting in 1975, between one terminal, building-mounted at Martlesham, and the other mounted on a 30 m high pole 5 km away. Results were so promising that details of longer, service routes were further examined, with interesting findings.

Because intense local rainstorms, rather than widespread

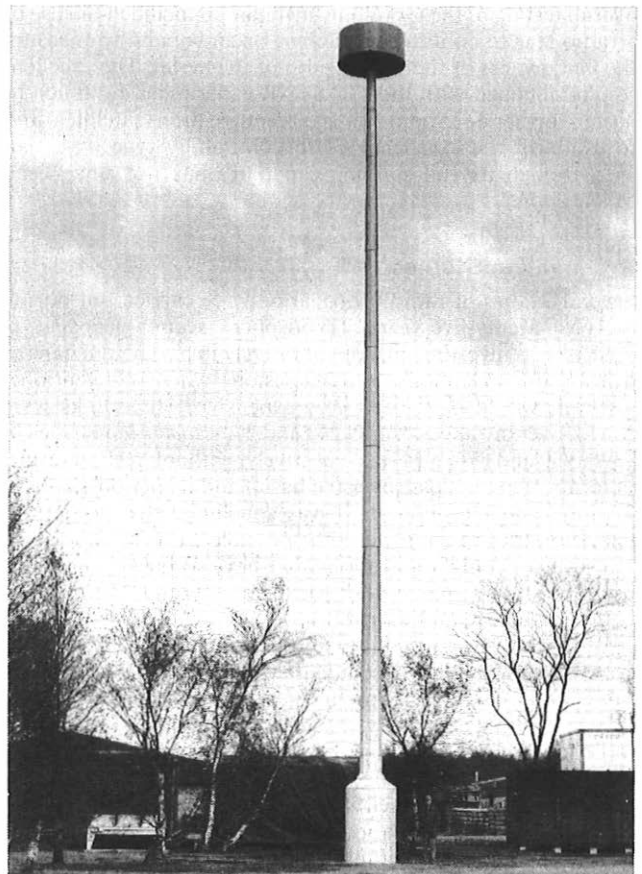

FIG. 14—An intermediate station for the proposed 19 GHz radio-relay digital system

heavy rain, cause almost all of the unacceptable fading, space diversity afforded by dual routes 10 km apart will allow each route to have hop lengths of 20 km except that where the two converge 8 km only can be allowed. The frequency of simultaneous unacceptable fading on both routes is then very low and less than that on a single route with hop lengths of 10 km. Where no buildings already exist for the intermediate stations, the poles required to carry the elevated back-to-back aerials can be slightly modified motorway lamp standards (see Fig. 14). They are rigid enough to resist undue angular deflexion in extreme weather conditions and allow the use of paraboloid reflectors of diameter 750 mm, having very useful gains. The poles can carry, lower down, the remainder of the station's equipment (similar to that for the 11 GHz systems) subject to a total loss in doing so of up to 3.5 dB. Twelve radio-frequency (RF) channels in the band 17.7–19.7 GHz are proposed (6 in each direction). With digital modulation at 140 Mbaud using quaternary phase-shift keying, the capacity of a dual path route will be 20 000 telephony circuits. IMPATT diodes are available as oscillators and RF amplifiers at these frequencies.

### OPTICAL COMMUNICATIONS

Before 1965, there was little prospect for optical communications in a civil network, whether in free space or guided. But three advances prompted a fresh look: light-emitting diodes (LEDs) and lasers showed promise as optical sources switchable at rates of many megabits/second; solid-state optical detectors responded equally rapidly; and glass could be much purged of light absorbing impurities. As a result, studies began at Dollis Hill in 1966 of the components for transmission systems using glass fibres. Many advantages could accrue (for example, high immunity to electrical pick-up and electromagnetic interference and easy screening from stray light) with prospects of long repeater spacings and high digital rates<sup>24, 25</sup>.

Initially, monomode transmission was the objective, in low-loss fibres having a very fine core (diameter about 5  $\mu\text{m}$ ) surrounded by cladding of a lower refractive index ( $n$ ). But events soon suggested that multimode working could bring earlier operational systems. The core diameter could now be larger (for example, 50  $\mu\text{m}$ ) but desirably with  $n$  graded parabolically from the centre of its cross section outwards, to equalize the time delay of transmission of rays of different launching angles.

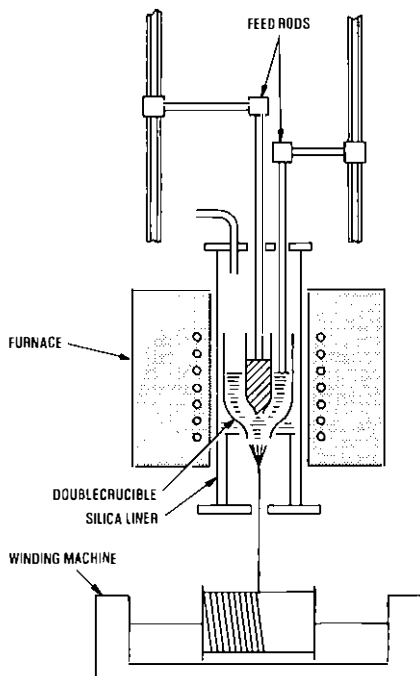

FIG. 15—Double-crucible fibre drawing

By 1970, fibre of high silica content had been made in the USA with losses consistently less than 20 dB/km at the wavelength ( $\lambda$ ) of emission of the gallium arsenide (GaAs) LED and laser,  $\lambda \approx 0.9 \mu\text{m}$ . At that stage however, it did not have the desired index profile. The BPO studied alternative glass compositions, particularly borosilicates of lower melting points<sup>26</sup>. Fibre drawing was eased, and diffusion in a double-crucible technique (see Fig. 15) made possible the index grading. Losses less than 5 dB/km were obtained by 1974, in lengths of several kilometres. Meanwhile, a modified chemical vapour deposition (MCVD) process had produced high-silica fibres with losses of only 2 dB/km. That process requires gases and vapours to be fed through a heated high-purity silica tube depositing on the inner wall further silica containing small amounts of various dopants, notably germania, in quantities programmed to give, when the tube is collapsed and drawn into fibre, the required index profile.

Because useful room-temperature operation of the simple GaAs laser proved unobtainable, attention turned to a double-heterojunction laser, having additional features which lowered the threshold current for laser action<sup>27</sup>. It used gallium aluminium arsenide,  $\text{Ga}_{1-x}\text{Al}_x\text{As}$  or (GaAl)As, grown on a substrate of GaAs with which it lattice matches. It proved a big step forward, but its room-temperature life under continuous operation was very short. The BPO joined the search for the causes of failure and identified a most powerful one: the lengthening of any dislocations threading the active region, aided by the high rate of recombination of carriers inherent in laser action, leads to increased non-radiative recombination, and hence to a rise of threshold current. Its elimination and that of lesser causes led to big improvements in life. The surface emitting LED in the same material, though its light emission was near isotropic, non-coherent and less monochromatic, nevertheless remained a possible optical source, switchable at rates as high as 140 Mbit/s.

System field trials were planned in 1975. Commercial silicon avalanche photodiodes would suffice as the input devices of repeaters or terminal receivers. Fibres could be protectively coated and made up in cable form. Methods of jointing together fibres of consecutive cable lengths with very little loss (for example, 0.2 dB) and usable in the field, had been developed. The first UK operational system, laid in 1977

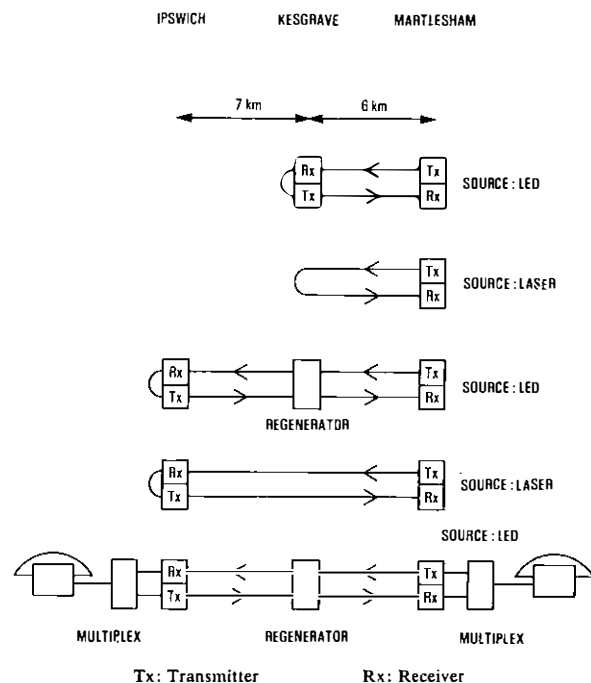

FIG. 16—System arrangement of the Martlesham-Kesgrave-Ipswich optical-fibre trials

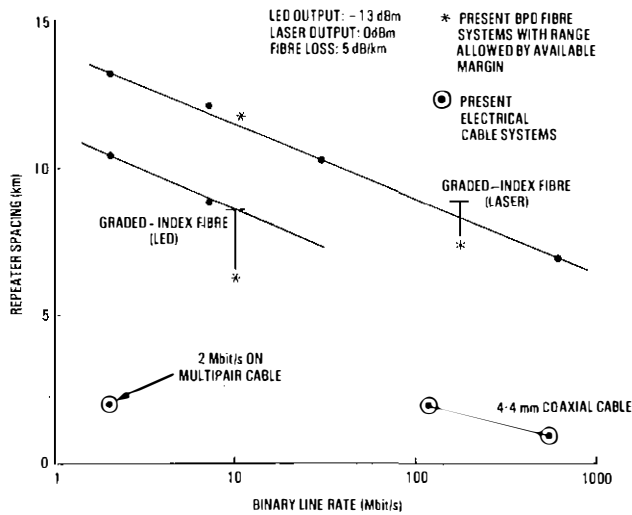

FIG. 17—Repeater spacings for optical-fibre systems

between Martlesham and Ipswich (13 km), had the modest digital rate of 8 Mbit/s<sup>28</sup>; the second, in the same year between Martlesham and Kesgrave (6 km), had a rate of 140 Mbit/s. Fig. 16 shows the system arrangements of the first, the performance of which, monitored for three years, had seasonal variations of  $\pm 1$  dB in the total fibre loss of 40 dB, and good margins-of-error rates. The second, using laser transmitters, demonstrated the 6 km (later 8 km) repeater spacing capability of the cable and equipment. Fig. 17 is based on the findings of the trials. It confirms the promise of optical communications, indicating substantial savings for digital trunk systems. Based on the designs and results of these trial systems and others made and installed by industry a little later, plans have been made for 15 main network and junction routes to carry 8, 34 and 140 Mbit/s systems, ready for service in 1980-82.

Research, since 1977, has intensified on many aspects, aimed at both a low bit-rate (2 Mbit/s) system, essentially non-repeated, competing directly with 30-channel PCM systems on new audio pair-type cables in the local and junction networks, and a second generation of systems of greater channel capacities, greater repeater spacings and longer life for equipments. The borosilicate glass and double-crucible technique for continuous fibre drawing will suffice for the low bit-rate application, with attenuation of 4 dB/km. The transmitters will use LEDs, possibly no longer surface-emitting but edge-emitting from structures resembling lasers, affording much more efficient coupling to multimode fibres. The avalanche photodiode, which requires a high-voltage supply (200 V or more), will be replaced by a combination of the p-i-n diode (whose wide intrinsic region sandwiched between the p and n regions will absorb most of the received radiation)

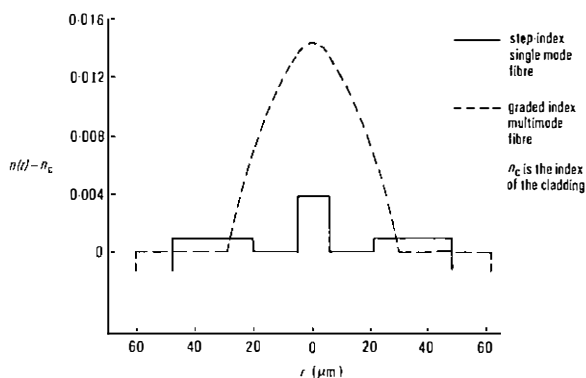

FIG. 18—Refractive index profile,  $n(r)$ , of a step-index single-mode fibre and of a graded-index multimode fibre

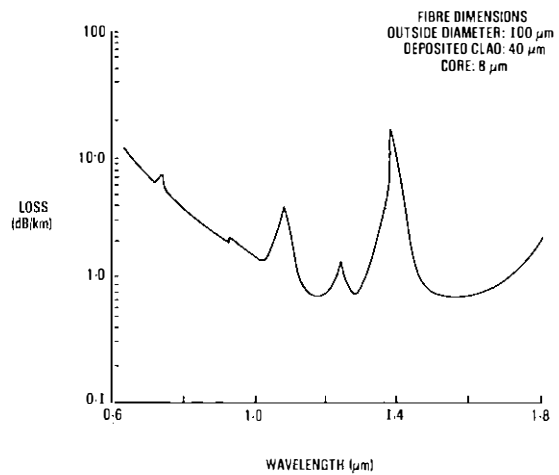

FIG. 19—The total attenuation of a single-mode fibre having a cladding of silica doped with  $P_2O_5$  and F

and the field-effect transistor (FET) in a hybrid package.

For the systems of higher digital rate, the relative merits of multimode and monomode transmission warranted reconsideration. Their index profiles are shown in Fig. 18. The graded-index fibre demands very careful attention to its profile to reduce pulse spreading to 1 ns/km or less to allow 10 km repeater spacing at rates of a few hundred megabits/second. Monomode working readily allows pulse dispersions of only 10 ps, though the much smaller core diameter makes low-loss jointing more difficult. The MCVD process was re-examined at Martlesham, for making monomode fibre. The aim was to improve the poor fibre geometry resulting from deformation of the support tube during the deposition at the high temperature required with the dopants preferred for the cladding and core. Different dopants were found, permitting lower temperatures while preserving low losses. Fig. 19 shows one result with its transmission windows at wavelengths around 1.15, 1.3 and 1.6  $\mu\text{m}$ . Moreover it is possible to design fibres for use at 1.3 and 1.55  $\mu\text{m}$  to have near-zero pulse broadening, thereby not jeopardizing the prospects of high bit-rate operation. But the windows clearly cannot be exploited unless transmitting and receiving devices for these wavelengths can be found. The best prospects so far lie with ternary and quaternary compounds of the elements indium and gallium (of group III of the periodic table) with arsenic and phosphorus (of group V). Thus laser action had been demonstrated in structures of  $In_{1-x}Ga_xAs_{1-y}P_y$  in 1976. The BPO has been optimizing one design for use at 1.3  $\mu\text{m}$ , and with different values of  $x$  and  $y$  has achieved success at 1.6  $\mu\text{m}$ . p-i-n diodes in a ternary compound,  $In_{0.53}Ga_{0.47}As$ , have proved efficient photodetectors over the wavelength range from 1.2 to 1.6  $\mu\text{m}$ .

Much work has already gone into the second generation of main-network systems to ensure reliable operation with very low error rates; field trials are planned for 1982.

## VISUAL SERVICES

### Television Transmission

By 1956 the BPO had established the principle of time-domain equalization of links carrying television signals by waveform correction in marked preference to frequency-domain techniques. It consolidated its position during the next few years<sup>29</sup> by developing equipments (pulse-and-bar waveform generators, echo waveform correctors, oscilloscopes and graticules) for use by field staff in setting up links to a prescribed objective standard.

Meanwhile, studies were being made of the additional problems which the coming of colour television would bring. Thus there would be gain and delay inequalities between the

luminance and chrominance components of the signal, influencing picture quality as rated by panels of non-expert viewers. Objective work led to new test signals and correctors. Subjective studies proved lengthy and required much analysis of the ratings, on a five point scale, given for a wide range of distortions and interference. But they led to a very useful new finding. Mean quality grading could be transformed to units of subjective impairment, termed *imps*, which had the property of summability<sup>30</sup>. Accurate prediction of overall grading can then be made when several simultaneous unrelated impairments exist, given the separate gradings for each. The CCIR has taken much notice of this and related BPO findings<sup>31</sup>.

Two possible visual services were then studied: Viewphone<sup>32</sup> and Confravision. The first, a face-to-face system, required a transmission bandwidth of 1 MHz. The studies showed that, at that time, the service would not be viable. The second, accommodating five participants at each terminal, with high quality speech and other facilities, was designed largely around existing television practices. Although a survey showed no immediate widespread demand for it at current prices (in competition with the time and cost of business travel), there was sufficient to warrant the setting up of studios, at which users must attend, in some large cities for use by industry and commerce.

Since 1970, research has been increasingly directed to conserving bandwidth for visual services. Methods of removing some of the redundancy in the signals, both within-frame and frame-to-frame, have been developed. Links such as those of Fig. 20 are envisaged for the transmission of moving pictures. The standards conversion will not introduce unacceptable degradation of picture quality. The digital codec will use differential PCM (DPCM). The customers' terminals will be portable, and offer considerable conference facilities.

A slow-scan digital technique<sup>33</sup>, the signals of which can be carried by the public switched telephone network, has been developed for the transmission of pictures not requiring the depicting of rapid motion. The picture is captured as 290 scan lines each made up of 210 elements digitized as an input to a DPCM coder whose output is stored. Release to line, via a modem, can be at 4.8 kbit/s. Reception reverses the processing. The observer sees each new picture gradually overwriting the previous one with a cycle time of 50 s (5 s over private wires capable of transmitting 48 kbit/s). Slow-scan television is expected to be attractive over distances of more than a few kilometres. Many applications are possible, not least in the surveillance field; some are already in operation, more are planned.

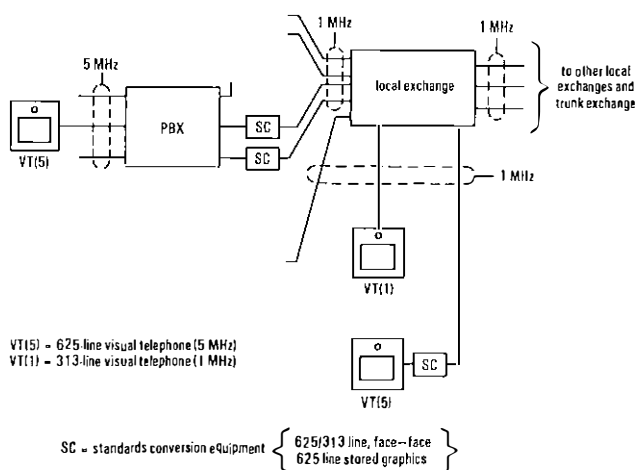

FIG. 20—Evolutionary concept of the visual telephone with teleconferencing as an initial application

## Prestel

Prestel was originally called *Viewdata* until that term became the English-language generic title for all similar information and message systems using the public switched telephone network to connect computers to customers. It was devised by the BPO in the early-1970s to provide a visual service over existing telephone lines without involving expensive terminal equipment<sup>34</sup>.

The objectives were a means of access to computers and hence to data banks containing a wide range of updated information of interest to customers, together with a textual display at the customer's terminal. A keypad, including the digits 0-9 and two internationally agreed symbols for press-button telephones, with very few and straightforward instructions for its use, sufficed as the customer's control. Character generation for the display is performed in the terminal, a 7 bit code defining the character to be displayed (out of a possible 96), typically as a 5 x 7 matrix. A visual display limited solely to Prestel use might have taken various forms, but every endeavour was made to conform with television receiver technology and broadcast Teletext standards where applicable, because of the alternative, later fulfilled, of fitting a Prestel adaptor to the customer's own television receiver. The adaptor incorporates the modem which handles the signals to and from the line, at rates of 75 bit/s and 1200 bit/s respectively. Storage in the terminal was limited to one page of text, initially about 500 characters, later increased to 960. More recently, television sets, with integral decoders designed by the BPO, have become available.

The system is best served, not by a single very large centralized computer, but by distributed computers, those most local to the customers being capable of handling a few hundred simultaneous users. The single-computer Prestel centres are however being linked, as part of a national network, to a hierarchy of computers arranged in a star configuration. The data banks contain pages of information stored as selection trees. Each branch gives access to further, more detailed branches, presented to the customer, level by level, in response to his keyed preferences, until the required level of detail is reached. But additional means of accessing are being studied; for example, by a keyword search. In addition to retrieving information, customers can interact with the computers for placing orders for goods, bookings and reservations, and carrying out some banking transactions. Other enhancements to Prestel can be confidently expected, including that of high-quality photographic insets and the sending of messages to specific recipients.

## EXTERNAL PLANT

Research on external plant continues to require attention to several disciplines and a range of field conditions. The BPO has contributed new designs of plant and tools, and new practices to advance this large area of its work.

Polyethylene, though otherwise preferred to lead for cable sheaths, has finite permeability to moisture. Early methods of providing the necessary additional waterproofing proved expensive. The BPO recognized that molecular bonding of an inner impervious lining to the plastic sheath would suffice and, in conjunction with a cable maker, devised a way of achieving it<sup>35</sup>. The dry cable core was overwrapped with polyethylene-coated aluminium foil, the polyethylene outwards. When the sheath was extruded on to the wrapped core, the hot sheath polyethylene welded to the foil polyethylene, the aluminium remaining firmly bonded. Although the sheath may subsequently take up moisture, there is no exit for it inwards. Great savings have resulted.

The long-standing manual task of jointing cables in the local network had defied simple mechanization until the 1960s, when the BPO provided an answer<sup>36</sup>. The small machine developed (see Fig. 21) is electrically powered and hydraulic-

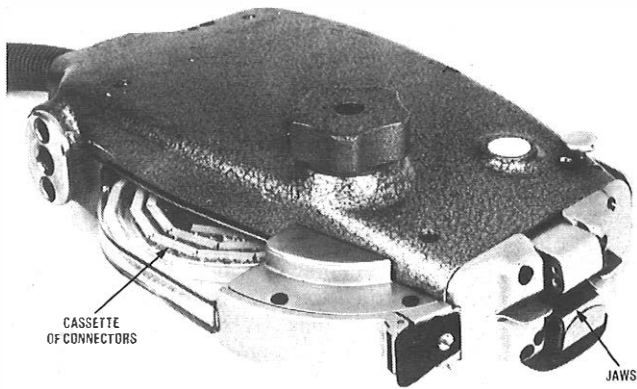

Note: In use the machine is mounted with its jaws uppermost

FIG. 21—The wire jointing machine

ally actuated. It holds an easily inserted cassette of 50 phosphor-bronze connectors, each 17 mm long with an outer polyvinyl chloride insulating covering, fed in turn to the machine's jaws. In use in a manhole it is carried on a simple rig. Having opened the two cable ends, the jointer takes a wire of his choice from each and lays them side by side, taut, in the connector which is in the jaws, paying no attention to their insulation (paper or plastic) or their surplus lengths. The connector has many tangs, pointing inwards, shaped and positioned for maximum effectiveness. Closure of the jaws, at the touch of a lever, flattens the two vertical sides of the connector onto its base, trapping the wires. Fig. 22(a) shows the complete connector on the left with its piece parts on the right; Fig. 22(b) shows a connector after jointing. The tangs, having penetrated the insulation, enter the wires sufficiently to make a physically strong, low-resistance joint (consistently only a few milliohms). The surplus lengths are simultaneously severed at their exits from the connector. The machine has proved robust and reliable in the field. The joints satisfy all the conventional tests. Copper conductors of diameter from 0.3–0.63 mm and aluminium from 0.5–0.7 mm can be handled. Extension to conductors of larger diameter in junction cables would seem possible. The machine has found use overseas.

Despite many attempts in the past to develop simple-to-use methods for locating buried services in roads and verges, with a view to their avoidance during new excavations, none has resulted. However progress is being made on some fronts. A discriminatory borer has its head vibrating up and down. Its operator quickly learns to sense, from the kinetic feedback to the specially designed handle, when contact has been made

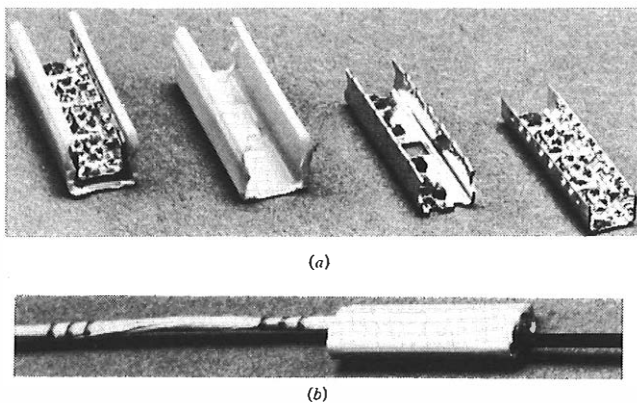

FIG. 22—The connector

with a pipe or cable as opposed to a stone, brick or other isolated hard object. There are prospects of fitting a sensor to the head of the borer which will detect very adjacent metallic services. Quite separately, the principles of the modern metal detector can be better exploited by the addition of a micro-processor, while, in collaboration with Sheffield University, the imaging of buried services, metallic or not, is being sought, effectively by scanning the area under investigation with microwave radiation and sensing the echoes.

## POSTAL MECHANIZATION

Studies of postal mechanization resumed at Dollis Hill just before 1950, with attention first to the segregation of mail and to letter facing, for which purpose a machine was developed and, in 1957, put into field use. Letter sorting was not far behind; a single position keyboard machine was designed to allow sorting to 144 outlets. By the early-1960s, however, the overall aim had become that of limiting each envelope to one reading only by an operator in its passage through the postal system. He would key an easily extracted code which, electronically translated, would be returned for impression on the envelope as a series of phosphor dots. This translated code would be readily recognized by new sorting machines, through which the envelope would subsequently pass, illuminated with ultra-violet radiation to reveal its dots. The first type of translator served only one coding desk; its success led to a second generation designed to be time-shared between several desks. Conceived and made before the advent of integrated circuits, these translators were large equipments.

In the search for suitable phosphors, the conventional inorganic types were quickly ruled out on grounds of high cost and unsuitable mechanical properties. New organic phosphors, based on formaldehyde in combination with the decomposition products of urea, notably cyanuric acid, showed great promise<sup>37,38</sup>. They were cheap, easy to use and to protect from moisture, translucent and thermoplastic—all desirable properties as code marks. They can be ground to fine particles for inclusion in printing inks. Some additives increase phosphorescence, others modify the response to ultra-violet radiation. Extensive use has been made of these phosphors in facing as well as sorting.

A later major project was the design of a fully-automatic letter sorting machine locating and recognizing the postal code, in 0.1 s, when it was typed or machine printed in any Roman fount and correctly placed. In the machine developed, the letter—on the move—is first scanned by a spot of light, from its bottom right corner, right to left, and line by line upwards, until the postcode is located. A camera then scans that location in more detail, digitizing and storing its findings as a rectangular array. A segmenter determines the size and position of each character in the code converting it to a 16 × 24 array in black and white (see Fig. 23); that is, in a 384 dimensional space. The machine is programmed with the positions in this space around which each alphabetical and numerical character clusters. The clusters can be represented as probability distributions, so that the probability of an examined character being each in turn of the full set can be derived and compared, and the highest accepted, subject to a threshold margin. Many problems were encountered; for example, segmenting when adjacent characters were touching or when there was a variable pitch. The machine was given a trial with live mail in 1977–78. Seventy percent of codes were

Croydon

Surrey CR9 1NR

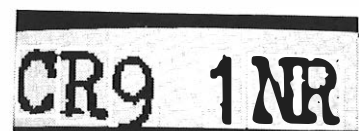

FIG. 23—Portion of a test envelope and segmented postcode characters extracted from this envelope

correctly read, 1% incorrectly and the remainder rejected for hand sorting—approximately the target set. Recognition per character was 99%, with only 0.1% incorrect.

## MATERIALS

Telecommunications uses many materials, some for properties other than those most commonly exploited. Extra attention to preparation and processing may then be called for. Thus, when microwave transmission at frequencies above 10 GHz along dielectric rods was under consideration, a substantial reduction of dielectric loss was needed even in the best materials (for example, polyethylene and polypropylene). It was obtained by a vacuum-melt extraction and casting method of preparation<sup>39</sup> which needed no antioxidants, known to be lossy, and allowed volatile fractions, similarly undesirable, to escape.

Microphones exploiting piezoelectricity are possible competitors to the electret type mentioned elsewhere. Piezoelectric ceramics for this application have a rival in polyvinylidene fluoride, whose film preparation has been studied in detail. Its long chain molecules have first to be made parallel to one another in the production of film. Fig. 24(a) shows the molecular arrangement in the melt-grown polymer (individual chains are internally compensated); Fig. 24(b) shows that a stretched film has regions of net polarity but that the arrangement of these regions is random. After the film has been metallized, corona poling is applied to orient the fluorine and hydrogen atoms attached sideways along the chains in such a way (see Fig. 24(c)) as to maximize the piezoelectric sensitivity and its retention with life. The film's inverse properties may be exploitable also, a driving alternating voltage setting up mechanical strain with audible tone.

In the fabrication of some semiconductor devices, particularly those using compounds from groups III and V of the periodic table (see sections on optical communications and other devices), epitaxial growth of very thin layers plays a major role. Thus gallium aluminium arsenide lasers have been most successfully made by a sequence of stages of liquid phase epitaxy, a process of deposition from a supersaturated solution in liquid gallium of the arsenide with its controlled minute amount of dopant. Chemical vapour deposition, an alternative versatile epitaxial technique, has been used in other contexts.

A direct method of determining the profile, in depth, of the carrier concentration in layers of p or n-type semiconductor has been developed and commercially exploited<sup>40</sup>. It is based on the electrochemical and photoelectric properties of semiconductor/electrolyte interfaces to provide progressive information as the layer is very slowly removed electrochemically by the passage of an electric current of low density across the interface.

Epitaxial layers and their surfaces almost always call for detailed structural analysis in relation to their electronic properties. Many modern powerful physical methods<sup>41</sup> have had to be used, most applicable to examining less ordered surfaces as well; for example, the contacting areas of reed-relay inserts. In some methods an incident beam of electrons after acceleration through a voltage  $V$  is directed at the surface. For values of  $V$  between 10–30 kV, with a scanning beam and general collection of the scattered, secondary, electrons—one

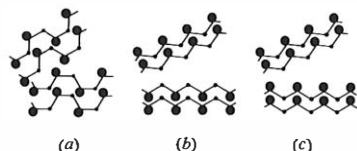

Note: The polar C-F bonds are indicated by the larger filled circles

FIG. 24—Schematic illustration of molecular arrangement of polyvinylidene fluoride film

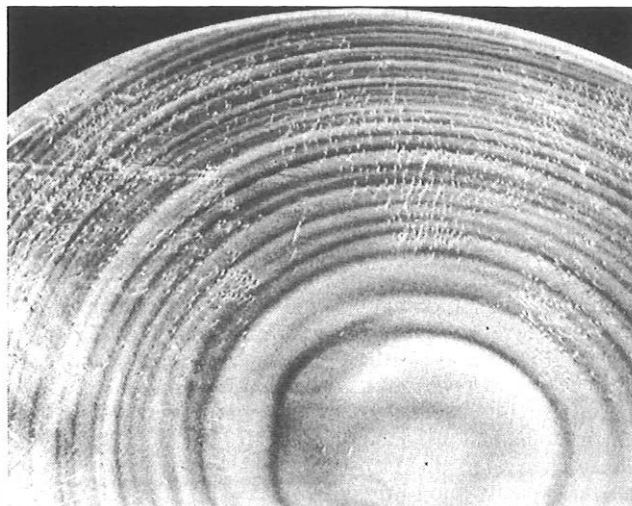

FIG. 25—An X-ray reflection topograph of part of a 50 mm slice of monocrystalline silicon

of several modes of scanning electron microscopy—the topographic structure of the surface can be revealed on a scale much smaller than  $1\ \mu\text{m}$ . An analysis of the wavelengths or energies of the X-rays produced at the same time can identify elements present to a depth of  $1\ \mu\text{m}$ . With  $V$  between 3–10 kV, an energy analysis of the secondaries can also identify elements present, but only those much closer to the surface. In other methods, X-rays form the incident beam. One such method exploits diffraction, in a technique known as *X-ray topography*<sup>42</sup>, to show imperfections in layers or thin slices. Fig. 25 shows the pattern obtained from a slice of silicon, the behaviour of which, in another context, was anomalous. The small detail in Fig. 25 is caused by structural imperfection. The rings are due to swirls of impurities causing very small changes in the lattice parameters.

## ACTIVE DEVICES

### Thermionic Valves

By 1956, a long-life pentode valve (Type 6P12) had been developed at Dollis Hill for submarine systems to Europe, and between Newfoundland and Nova Scotia as part of the first transatlantic telephone cable system, TAT1. It differed from commercial types of similar figure of merit (ratio of transconductance to combined input and output capacitances) in having a passive cathode core of platinum to exclude one cause of short life, more stringent outgassing of all piece parts, and electrode spacings modified to retain performance at lower supply voltages.

Even so, improvements were needed for suitability in future long transoceanic routes; they were realized during the next few years<sup>43</sup>. Unwanted conducting films forming on the mica spacers were avoided by shields and some change of material. Loss of insulation between the heater and the cathode core was rectified by fitting a non-porous sleeve of alumina over the heater filament before insertion into the core; and the long-term activation of the oxide cathode was made even more stable by another change of core material—to a nickel-tungsten alloy, slightly active but not detrimentally so. A new valve (Type 10P) could then be designed, put into production at Dollis Hill and STC's factory at Paignton with which there had been collaboration, validated for reliability, and given a trial in a shallow water system. Three long systems followed in the years 1961–66. They were, CANTAT 1 between the UK and Canada, COMPAC between Vancouver and Sydney and SEACOM between Cairns (Queensland) and Singapore, carrying 80 (3 kHz spaced) circuits and, for one section of SEACOM, 160 circuits. The total length of sub-

marine cable was 32 000 km and the 782 repeaters in it used 4692 valves Type 10P, one half of them from Dollis Hill.

Meanwhile, international telephone traffic pointed to future needs for systems of greater capacity, for which the amplifier designer would require a valve of higher performance, at even lower supply voltages, than that of the Type 10P. For the valve designer it meant very closely spaced cathode, control grid (G1) and screen grid (G2), with very fine wire (diameter 10  $\mu\text{m}$ ) for G1 wound with a tight pitch (about 60  $\mu\text{m}$ ). Designs were sought, at Paignton and Dollis Hill. There was general agreement on electrode geometries, but Paignton's method of winding and accurately spacing G1 and G2, in its Type 5A/109G, was preferred for manufacture. It was chosen for the route, 10 900 km long, between Lisbon and South Africa. Over 600 repeaters, handling 360 (3 kHz spaced) circuits, were needed, incorporating 3700 valves, of which Dollis Hill provided one quarter. The cable was laid in 1968. Thereafter the transistor made possible systems of greater capacity and lower cost, superseding the valve.

### Transistors

Twenty-five years ago the BPO was studying germanium junction transistors made by the alloying technique, not least their reliability. But developments in the US soon made desirable a programme review. Much improved monocrystalline silicon, the rival semiconductor for transistors, was becoming available and a diffusion technique showed the way to making transistor structures in silicon with base widths so narrow as to raise the transition frequency ( $f_T$ ) to above 100 MHz.

From 1959, all BPO effort was concentrated on silicon, influenced by prospects of reliable wideband devices for submarine telephony and fortified later by the advent of the silicon planar technology, with its inbuilt surface protection giving improved reliability<sup>43</sup>. By 1962, studies justified planning a production line, involving the installation of a specially clean room in which to carry out the vital stages of processing silicon slices<sup>44</sup>. At about the same time, a large accelerated life test was mounted on 1500 silicon planar transistors (Type 2N916) purchased from a US firm, chosen because it was supplying to the Minuteman project. Promising results were obtained, meaningful for values of collector-junction temperature,  $T_j$ , up to 300°C. They showed a relationship between failure rates and  $T_j$  that obeyed a long established law for the kinetics of chemical reactions, thereby allowing confident extrapolation to service conditions from the much more quickly obtainable results at elevated temperatures<sup>45</sup>. Such accelerated ageing, on a large scale, came to play a major role in assessing reliability throughout the subsequent fifteen-year programme.

The first BPO transistor (Type 4, numbered as  $f_T$  in hundreds of megahertz) closely resembled the 2N916 structure;

its surface pattern is shown in Fig. 26(a). Its production used much of the current technology, but it incorporated a thermo-compression bonding technique developed at Dollis Hill, avoiding intermetallic vagaries, for connecting very fine aluminium wires robustly to the emitter and base aluminium metallizations. The type was first used in the single amplifying path of each repeater of submarine cable systems, handling 480 (4 kHz spaced) circuits, in home waters in 1967–68, before some 500 with more stringent reliability requirements were supplied for the longer UK–Portugal and Canada–Bermuda routes in 1968, and over 2000 thereafter (some for export orders).

Meanwhile the design of a second reliable transistor (Type 10) of higher performance, but having no commercial counterpart, was under way without major change to production techniques. The STC transistor division, which had become a second source of the Type 4, was contracted to assist. An interdigitated geometry was essential (see Fig. 26(b) for that of the high-power version) An adequate heat sink and its electrical isolation from the collector had to be developed, while the narrower base width (0.5  $\mu\text{m}$ ) and smaller geometry demanded closer controls respectively of the diffusion and photolithographic processes. Production began in 1970 and Dollis Hill provided all the Type 10 devices required for five short systems, capable of handling 23 super-groups, in repeaters having, for system reasons, separate amplifiers for the high and low-frequency directions of transmission, Type 4 devices sufficing for the latter. Supply for a transatlantic system, CANTAT 2, to carry 1840 (3 kHz spaced) circuits, to be laid in 1973–74 was the next big objective. The reliability requirements were formidable; effectively not more than one transistor failure amongst 3000 in 25 years. Much attention to detail and a great amount of reliability assessment enabled Dollis Hill to supply all of the 1500 Type 10 and almost all of the Type 4 transistors.

As soon as production of the Type 10 had begun, the prospects of a further increase of  $f_T$  to 3–4 GHz were examined. Device dimensions would have to be reduced to the then current limits of photolithography. The base and emitter regions would be so thin (see Fig. 27) as to prohibit both aluminium metallization and the provision of the very necessary passive layers of silica by the conventional method of thermally oxidizing the silicon surface. The emitter would need the much steeper profile obtainable with arsenic diffusion than with the conventional phosphorus. A new mounting and encapsulation would be needed, with much reduced parasitic reactances. Moreover, all improvements had to be mutually compatible and retain the very highest reliability. The Type 40 developed (see Fig. 26(c) for the high-power version) met the needs. It was put into production by BPO in 1974, initially for some short systems carrying 3600 (4 kHz spaced) circuits and later for longer ones carrying 5520 (3 kHz spaced) circuits, in all requiring over 3000 such transistors.

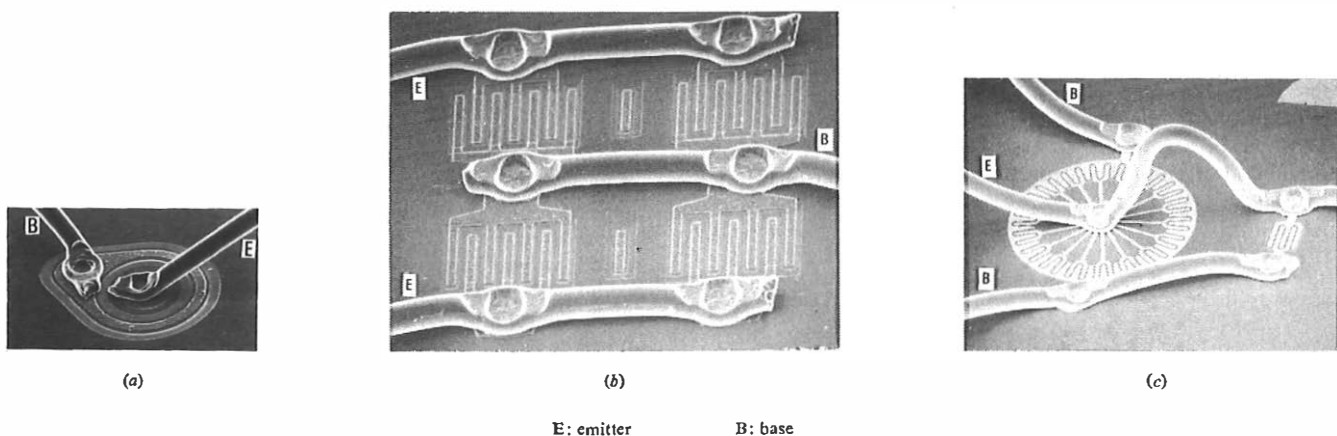

FIG. 26—Surface patterns depicted by scanning electron microscopy of three types of transistors



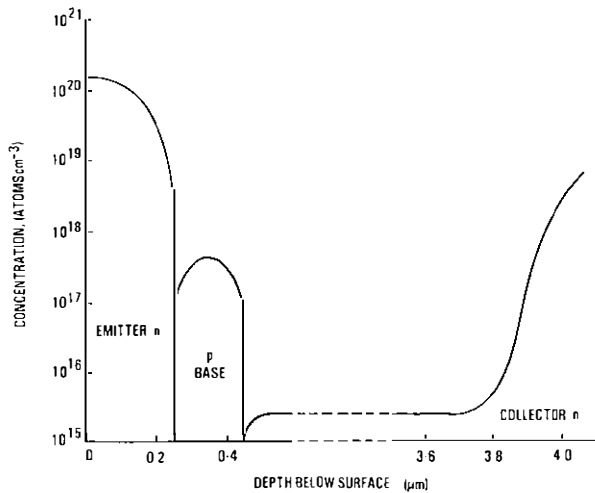

FIG. 27—The profile of the impurity concentration of the Type 40 transistor

The technology developed for the Type 40 is now being extended to the design of extremely fast emitter-coupled logic (ECL) integrated circuits, such as digital systems operating at 560 Mbit/s would require—a very useful spin-off.

### Other Devices

Although silicon has been the predominant semiconductor since about 1960, gallium arsenide (GaAs) has challenged it on a limited front and complemented it elsewhere.

One electronic property possessed by GaAs, but not by silicon, manifests itself as a bulk negative resistance under suitable conditions. Very short bars with ohmic end contacts, supplied with a direct voltage and coupled to microwave resonators produce useful microwave oscillations; they have found considerable use. When higher power is required at microwave frequencies, it can be obtained from suitably designed diodes under reverse bias operating in the *IMPact Avalanche Transit Time* (IMPATT) mode; such a GaAs device can oscillate at least as efficiently as its silicon counterpart. The BPO has made units in GaAs for use at various microwave frequencies, in particular at 11 GHz as alternatives to the travelling wave tube transmitter, with the advantages of longer life and the avoidance of high-voltage supplies<sup>46</sup>.

Field-effect transistors using GaAs can marginally outstrip their silicon rivals at the cost of a little more difficult technology; they may for example find use in the first stage of regenerators handling signals at gigabit/second rates.

GaAs has a second property not possessed by silicon—very efficient emission of light from a forward biased diode—

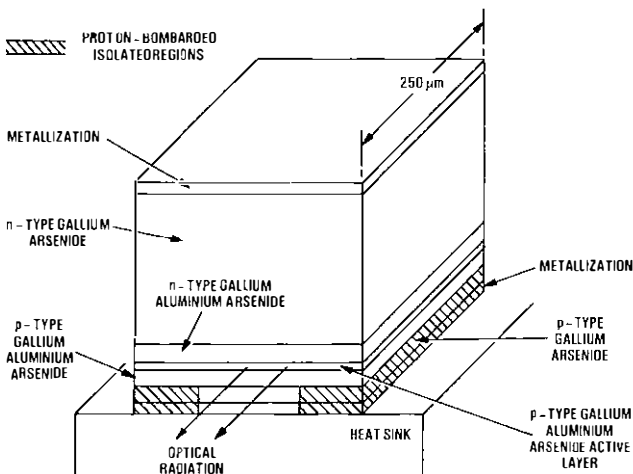

FIG. 28—A stripe-geometry double-heterostructure gallium-aluminium-arsenide laser

which is exploited in the semiconductor laser. The property is not lost when aluminium displaces a fraction of the gallium in some layers of the structure (see Fig. 28). With due attention to the fractions used, the active layer can better contain both the charge carriers whose recombination produces the light, and, as an optical waveguide, that light before it emerges through an end face, reducing the current necessary for laser action and thereby extending life<sup>47</sup>.

### INTEGRATED CIRCUITS

The BPO's involvement with monolithic circuits began with applications of commercially available units based on small-scale integration (SSI) of planar bipolar elements; for example, the diode-transistor (DTL) and transistor-transistor logic (TTL) families, of which the experimental PCM tandem exchange EMPRESS, installed in 1968, incorporated 7000 units<sup>48, 49</sup>.

But the substitution, by the makers of these circuits, of moulded plastic packages for the earlier more expensive hermetic encapsulations gave concern. A short period of laboratory testing and field experience indicated much inferior reliability, the prime cause being corrosion of metallization and bonds by moisture permeating through the bulk plastic. Prolonged studies identified the improvements required to achieve the reliability required for substantial BPO use. Industry delayed its response, but, with more recent improved plastics and chip passivation, standards have risen and penetration of the network is proceeding.

When circuits based on the p-channel MOS transistor became available, proposals were put for BPO applications; for example, in replacements for electromechanical impulse regenerators. Laboratory studies showed that the accelerated ageing which had proved so successful with the bipolar transistor was much less applicable; reliability had to be tackled on a broader front with several competing failure mechanisms concerned; for example, instability of gate-threshold voltage, damage to metallization tracks by electromigration and moisture attack when encapsulation hermeticity was inadequate. Many studies were made of the component parts of these circuits, as they moved to large-scale integration (LSI), leading to methods of process validation and tests on the complex circuits themselves to assure the necessary high reliability required<sup>50</sup>.

An in-house facility for fabricating p-channel MOS circuits in LSI was established in 1970. A few years later it turned to circuits containing up to 10 000 devices per chip using n-channel technology (see Fig. 29) as this became widely used for its higher speed and its voltage compatibility with TTL. A design service accompanies it. The customer supplies either a functionally satisfactory bread-board version made up of smaller circuits and discrete devices, or a logic diagram. The

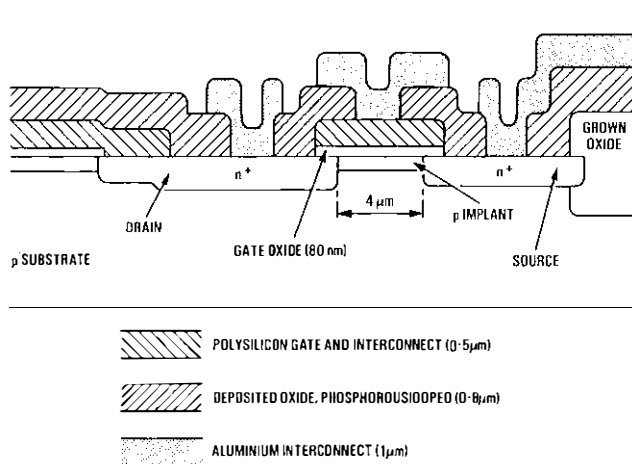

FIG. 29—Cross-section of a basic device produced by the n-channel silicon-gate process

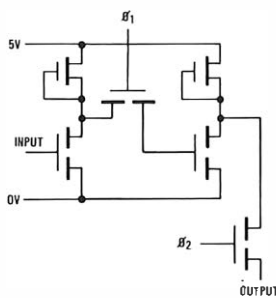
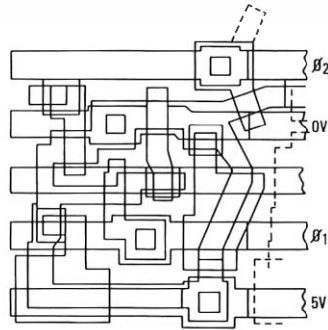
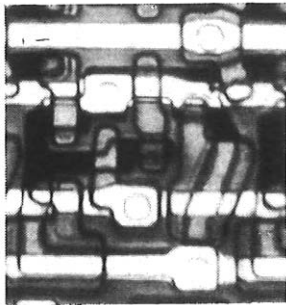
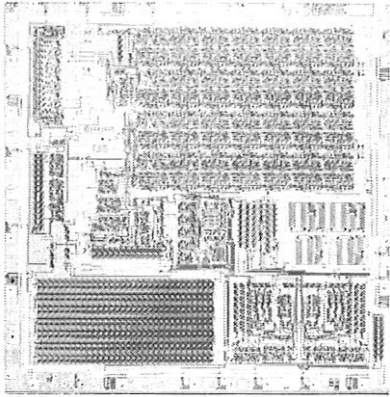

FIG. 30—The FAD integrated circuit

designer derives the equivalent circuit in terms of small cells of his n-channel elements. Layout can then proceed, with grouping of cells and routing of their interconnexions. The technology allows three separated levels: metallic, polycrystalline silicon and heavily doped tracks in the substrate, which can themselves be interconnected as needed. There are stringent design rules to be followed. The BPO layout system using interactive graphics on line (*POLIGON*) greatly assists this task. It is a software package running on a mini-computer with accessories. With it the designer can examine and modify his layout build-up until completed. The information for each of the sequence of masks (seven or so in total) required for slice processing can then be supplied to a pattern generator; this is superseding the earlier flat-bed plotter which produced cut-and-strip rubyliths for subsequent reduction photographically. Fig. 30 shows the filter-and-detect (FAD) chip (see below) and a cell taken from it.

The microtechnology unit at Martlesham has its clean room fully equipped for converting slices of silicon into arrays of LSI chips, summarily tested. Those acceptable are encapsulated in ceramic packages. High yields demand great care at every processing stage; in the conditions applied, timings, avoidance of contamination, general handling and the alignment of successive masks to the very limits of optical accuracy. Ion implantation is used to form n-type shallow regions; for example, the sources and drains. New ways of using scanning

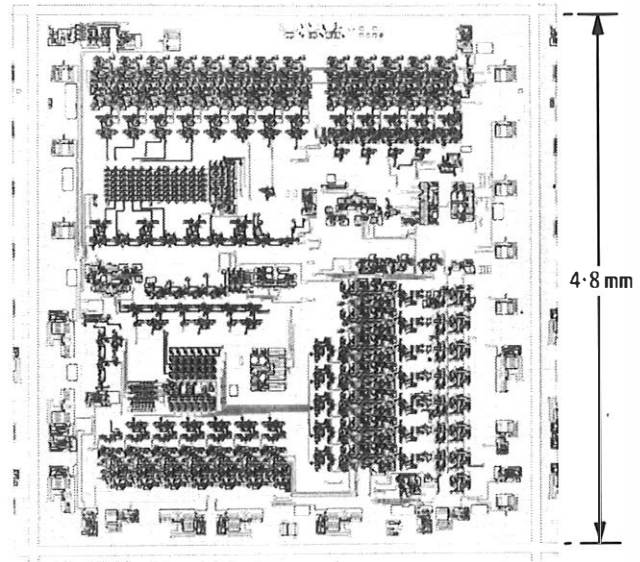

FIG. 31—The CODEC chip

electron microscopy have been developed beyond that of observing the surface topography. One method concentrates on isolating faults such as pin holes in oxide layers, pattern irregularities and junctions susceptible to microplasma breakdown. Another method views circuits under working conditions giving valuable information to the technologist and designer<sup>51</sup>.

Two examples only of novel circuits, conceived, designed and made at Martlesham can be cited here. One is a single channel PCM codec (see Fig. 31) for a customer digital switching system (CDSS1). It uses an intermediate code, delta-sigma modulation, with sampling at the rate of 2048 kbit/s, before conversion to PCM. It substitutes, for analogue complexity and precision, the much cheaper digital complexity and the speed of which n-channel LSI is capable.

The other, a System X development, is the FAD<sup>52</sup>. It forms part of the digital receiver, which is time shared between 8 channels, of a multi-frequency signalling system (SSMF4) to detect combinations of tones of prescribed frequencies and levels emanating from press-button telephones. The digital filters used are made up of second-order recursive sections cascaded if necessary. The coefficients that determine the frequency response of the sections are fed from a commercial read-only memory. Level detection is straightforward. The FAD has great versatility, making it the potential forerunner of a wide range of uses of digital filters.

## CONCLUSIONS

The exploratory, innovative and evolutionary research activities of the BPO during the past 25 years have resulted in better services, increased productivity and reliability, and reduced costs. Specific as they all are to the needs of the BPO, some owe their origins in part to discoveries and progress made elsewhere. Some have made the BPO a world leader; for example, in making and validating the first silicon transistors suitable for submarine cable systems; in developing Lincomplex, low-loss glasses and the double-crucible technique for drawing them into fibres, the linear cable engine and the cable-pair jointing machine; in the equalization of television links and in establishing the unit of impairment of television pictures, the imp; in launching the first viewdata system Prestel; and in the assessments of telephone transmission and of the reliability of integrated circuits.

Histories sometimes conclude with a glimpse of future trends. But not this one. Technological forecasting was in

vogue several years ago, meeting with little success however. In 1956 no one foresaw the big innovations made since, such as communications satellites, feasible PCM techniques, powerful compact mini-computers and microprocessors, large-scale integrated circuits, lasers and optical communications. In 1981, the next 25 years presents an equivalent enigma, although it would seem assured that research in telecommunications will continue apace, with British Telecom still playing a very significant role.

## ACKNOWLEDGEMENTS

The author is indebted to many members of the staff of the British Telecom Research Laboratories at Martlesham—too many to list individually—and to some retired members. They allowed him generous access to their memories of past projects and guided him on many topics. He thanks also staff of the library and the editorial office there for much assistance.

## References

- 1 AYERS, E. W. Research at Martlesham. *POEEJ*, Vol. 71, p. 44, Apr. 1978.
- 2 FLOYD, C. F. The Design of Martlesham Research Centre, Parts 1 and 2. *POEEJ*, Vol. 69, pp. 146 and 253, Oct. 1976 and Jan. 1977.
- 3 FLOYD, C. F. The Move of Research Department to Martlesham. *POEEJ*, Vol. 70, p. 55, Apr. 1977.
- 4 SPENCER, H. J. C., and WILSON, F. A. The New 700-Type Table Telephone—Telephone No. 706. *POEEJ*, Vol. 52, p. 1, Apr. 1959.
- 5 WALKER, R. R., and MORGAN, A. J. The Electret: A Possible Replacement for the Carbon Microphone. *POEEJ*, Vol. 72, p. 15, Apr. 1979.
- 6 The Intelligent Telephone. *POEEJ*, Vol. 73, p. 251, Jan. 1981.
- 7 RICHARDS, D. L. Telecommunication by Speech. Butterworth, 1973.
- 8 RICHARDS, D. L. Transmission Performance Assessment for Telephone Network Planning. *Proc. IEE*, Vol. 111, p. 951, 1964.
- 9 RICHARDS, D. L. Loudness Ratings of Telephone Speech Paths. *Proc. IEE*, Vol. 118, p. 423, 1971.
- 10 GRIFFITHS, J. M. Digital Local Networks. *POEEJ*, Vol. 72, p. 206, Jan. 1980.
- 11 AYERS, E. W., and WILLIAMS, F. E. Human Factors in Telephony. *POEEJ*, Vol. 60, p. 174, Oct. 1967.
- 12 BOWRON, P., and STEPHENSON, F. W. Active Filters for Communications and Instrumentation. McGraw-Hill, 1979.
- 13 ANTONIOU, A. Digital Filters: Analysis and Design. McGraw-Hill, 1979.
- 14 BROCKBANK, R. A., CLARKE, E. F. S., and JONES, F. Anglo-Canadian Transatlantic Telephone Cable (CANTAT): Cable Development, Design and Manufacture. *POEEJ*, Vol. 56, p. 82, July 1963.
- 15 CLARKE, E. F. S., and CHAPMAN, K. J. Anglo-Canadian Transatlantic Telephone Cable (CANTAT): Cable-Laying Gear. *POEEJ*, Vol. 56, p. 91, July 1963.
- 16 LAW, H. B., REYNOLDS, J., and SIMPSON, W. G. Channel Equipment Design for Economy of Bandwidth. *POEEJ*, Vol. 53, p. 112, July 1960.
- 17 WATT-CARTER, D. E., and WHEELER, L. K. The Lincompex System for the Protection of H.F. Radio-Telephone Circuits. *POEEJ*, Vol. 59, p. 163, Oct. 1966.
- 18 TAYLOR, F. J. D. Equipment and Testing Facilities at the Experimental Satellite Ground Station, Goonhilly Downs, Cornwall. *POEEJ*, Vol. 55, p. 105, July 1962.
- 19 BRAY, W. J., and TAYLOR, F. J. D. Preliminary Results of the Project TELSTAR Communication Satellite Demonstrations and Tests 10-27 July 1962. *POEEJ*, Vol. 55, p. 147, Oct. 1962.
- 20 ALLNATT, J. W., MILLS, D. E., THURLOW, E. W., and RICHARDSON, F. S. The use of Tropospheric-Scatter Propagation for Television Transmission. IEE Conference Report Series (GB) No. 5, Paper 4112E, p. 231, 1963.
- 21 HARNDEN, B. N., and TURNER, D. Propagation Studies and the Development of Terrestrial Microwave Radio Systems above 10 GHz. IEE Conference Publication No. 98, p. 1, 1973.
- 22 TATTERSALL, R. L. O., BARNES, B. C., and CARTWRIGHT, N. E. Multipath Transmission Tests at 11, 20 and 37 GHz. IEE Conference Publication No. 98, p. 65, 1973.
- 23 DAVIDSON, C. F. Millimetric Waveguide Systems. *Phil. Trans. R. Society London A*, Vol. 289, p. 123, 1978.
- 24 ROBERTS, F. F. Optical-Fibre Telecommunication Transmission Systems. *POEEJ*, Vol. 67, p. 32, Apr. 1974.
- 25 MIDWINTER, J. E. Optical Fibres for Transmission. J. Wiley, 1979.
- 26 BEALES, K. J., MIDWINTER, J. E., NEWNS, G. R., and DAY, C. R. Materials and Fibre for Optical Transmission Systems. *POEEJ*, Vol. 67, p. 80, Apr. 1974.
- 27 NEWMAN, D. H. Sources for Optical-Fibre Transmission Systems. *POEEJ*, Vol. 67, p. 208, Jan. 1975.
- 28 BRACE, D. J., and RAVENSCROFT, I. A. Optical-Fibre Transmission Systems: The 8.448 Mbit/s Feasibility Trial. *POEEJ*, Vol. 70, p. 146, Oct. 1977.
- 29 MACDIARMID, I. F. Waveform Distortion in Television Links, Parts 1 and 2. *POEEJ*, Vol. 52, pp. 108 and 188, July and Oct. 1959.
- 30 LEWIS, N. W., and ALLNATT, J. W. Subjective and Objective Impairment in Television Pictures. IEE Conference Publication No. 46, Part 1, p. 2/1, 1968.
- 31 MACDIARMID, I. F., and ALLNATT, J. W. Performance Requirements for the Transmission of the PAL Coded Signal. *Proc. IEE*, Vol. 125, p. 571, 1978.
- 32 HILLEN, C. F. J. The Face to Face Telephone. *POTJ*, Vol. 24, No. 1, p. 4, 1972.
- 33 KENYON, N. D. Slow-Scan TV Goes on Trial. *BTJ*, Vol. 1, No. 1, p. 2, 1980.
- 34 FEDIDA, S. VIEWDATA: An Interactive Information Medium for the General Public. *POEEJ*, Vol. 71, p. 21, July 1978.
- 35 GLOVER, D. W., and HOOKER, E. J. A Moisture Barrier for Polythene-Sheathed Cables. *POEEJ*, Vol. 53, p. 253, Jan. 1961.
- 36 HARDING, J. P. A Wire-Jointing Machine for Subscribers' Cables. *POEEJ*, Vol. 62, p. 31, Apr. 1969.
- 37 FORSTER, C. F. Use of Phosphorescent Code Marks in Automatic Letter-Facing and Sorting Machines. *POEEJ*, Vol. 54, p. 180, Oct. 1961.
- 38 FORSTER, C. F. Luminescent Materials used in Postal Automation. *POEEJ*, Vol. 62, p. 120, July 1969.
- 39 DAVIES, G. J., and HAIGH, J. Submillimetre Spectra of Pure High and Low Density Polythene. *Infrared Physics*, Vol. 14, p. 183, 1974.
- 40 AMBRIDGE, T., and FACTOR, M. M. An Electrochemical Technique for Automatic Depth Profiles of Carrier Concentration. Inst. of Physics, Conference Series No. 24, p. 320, 1975.
- 41 HECKINGBOTTOM, R. Physical Methods of Surface Analysis. *Physics in Technology*, p. 47, Mar. 1975.
- 42 HENDERSON, J. C., and HALLIWELL, M. A. The Use of X-Ray Diffraction to Study Defects Occurring During Silicon-Device Manufacture. *POEEJ*, Vol. 59, p. 94, July 1966.
- 43 HOLMES, M. F. Active Elements in Submerged Repeaters: First Quarter Century. *Proc. IEE*, Vol. 123, No. 10R, p. 1081, 1976.
- 44 CORKE, R. L., and SEARLS, A. W. A Clean Room for the Production of Silicon Planar Transistors. *POEEJ*, Vol. 59, p. 34, Apr. 1966.
- 45 ROBERTS, F. F., SANVOISIN, R., and MORGAN, P. M. Some Reliability Studies on Silicon Planar Transistors. *POEEJ*, Vol. 57, p. 122, July 1964.
- 46 PILGRIM, M., and HENDERSON, J. C. An IMPATT Diode Amplifier for 11 GHz Digital Radio-Relay Systems. *POEEJ*, Vol. 72, p. 220, Jan. 1980.
- 47 Semiconductor Laser Development and Production. *POEEJ*, Vol. 72, p. 19, Apr. 1979.
- 48 CHAPMAN, K. J., and HUGHES, C. J. A Field Trial of an Experimental Pulse-Code Modulation Tandem Exchange. *POEEJ*, Vol. 61, p. 186, Oct. 1968.
- 49 KERSWELL, B. R., and JONES, W. G. T. Conclusions from the Empress Digital Tandem Exchange Field Trial. *POEEJ*, Vol. 72, p. 9, Apr. 1979.
- 50 REYNOLDS, F. H., LAWSON, R. W., and MELLOR, P. J. T. Specifications for Integrated Circuits in Telecommunications Equipment. *Proc. IEEE*, Vol. 62, p. 223, 1974.
- 51 CHILD, M. R., RANASINGHE, D. W., and WHITE, D. Dynamic Inspection of LSI Circuits. *Microelectronics*, Vol. 7, p. 43, 1976.
- 52 ADAMS, P. F., HARBRIDGE, J. R., and MACMILLAN, R. H. An MOS Integrated Circuit for Digital Filtering and Level Detection. *Journal of Solid State Circuits*: to be published in 1981.

# THE FUTURE

## The Next Twenty-Five Years

J. S. WHYTE, C.B.E., M.SC.(ENG.), F.ENG., F.I.E.E.†

UDC 621.39 "313"

*In this article, the President of the Institution of Post Office Electrical Engineers discusses those areas in which rapid advances in technology will have the most profound influence on telecommunications. He goes on to show how these changes have already started to shape, and to speculate how they will continue to shape, the future of telecommunications over the next 25 years.*

### INTRODUCTION

Forecasting the future is, at best, a highly inexact science and it is a brave man who is prepared to issue firm predictions in this turbulent world. Nonetheless, I am prepared to state my belief that the most profound technical influences on telecommunications technology will spring from rapid developments in:

- (a) satellites,
- (b) micro-electronics,
- (c) opto-electronics, and
- (d) interactive customer terminals.

### SATELLITES

During the past decade, the advent of high-capacity satellites has had a major impact upon international, and particularly inter-continental, telecommunication services. They have permitted the easy provision of high-quality transmission paths to all parts of the globe.

Just as the submarine-cable system has grown in its traffic capacity by 2 orders of magnitude, a similar development has occurred with the telecommunication satellite. INTELSAT I, launched in 1965 and weighing 38 kg, had a traffic capacity of 240 circuits. INTELSAT V, the largest telecommunication satellite currently in orbit, weighs 861 kg and can carry 12 000 telephony circuits plus 2 television channels. INTELSAT VI, which will be launched in 1986, will weigh 1600 kg (almost twice the weight of INTELSAT V) and provide 37 000 telephony circuits.

### Satellite Evolution

There is much debate and a good deal of disagreement about the pattern of satellite evolution that will be seen during the 1980s. Certainly, the adoption of digital transmission with time-division multiple access (TDMA) and perhaps satellite-switched time-division multiple access (SSTDMA) is expected to be seen. The problems facing the satellite planners and developers include the limited number of orbital slots, the limited frequency spectrum, and the limitations on satellite mass.

A geostationary satellite is constrained to an equatorial orbit for obvious reasons, and optimization of satellite position around this orbit to enable it to illuminate desired parts of the earth's surface fairly quickly leads, with today's technology, to congestion in the orbit. This congestion is not a matter of the physical proximity of the space vehicles themselves, but of the mutual interference between the satellites at

† Managing Director (Major Systems) and Engineer-in-Chief, British Telecom. Mr. Whyte is also the President of the Institution of Post Office Electrical Engineers

radio frequency. Progress will undoubtedly be made by the development of more elaborate antenna systems giving less energy spread. More efficient use of the limited radiated power and reduced interference to terrestrial services from the satellite downpath can be achieved by the use of multiple spot beams. Further progress in the efficient use of spectrum could come from the use of cross-polarization, and reconfigurable active antennae may be introduced.

The space shuttle will give a major increase in the mass of satellites that can be lifted to low earth orbit, but it must be remembered that the shuttle by itself cannot place satellites in synchronous orbit; after separation from the shuttle cargo bay, thrust will be required to lift the satellite from the parking orbit to the synchronous orbit.

There is a school of thought which says that, within the decade, we may expect to see heavy platforms in synchronous orbit, which will give much greater scope for elaboration of the space payload, and the optimists speak of manned construction of such platforms in synchronous orbit. The corollary of this forecast is that manned repair of satellites in orbit would be possible.

It is my opinion that, whilst this might become technically feasible within this decade, it is extremely unlikely to be economically viable for a civil application; the lower launching costs promised by use of the reusable space shuttle suggest that the replacement of a faulty satellite will be more economic than a manned visit for its repair for many years to come.

Two other satellite applications are likely to attract much attention during the decade: direct-broadcasting satellites, and satellites permitting very-high-speed data transmission to small-dish earth stations located on, or near to, the premises of large customers.

### Direct-Broadcasting Satellites

Satellites may be used for television distribution with either direct reception by individual households or reception by a communal earth station from which local cable distribution is provided. Some households and some localities will have difficulty in locating a domestic antenna to obtain a clear line of sight to the satellite, and such situations would encourage the growth of cable distribution systems. Contrary to the belief of some popular commentators, the advent of direct-broadcasting satellite services would not make available vast numbers of new television channels because the amount of radio-frequency spectrum allocated for such services by the World Administrative Radio Conference in 1979 is limited. By its nature, a direct-pick-up satellite broadcasting system gives national coverage, but much of the existing programme distribution in the UK is on a regional basis. Equivalent

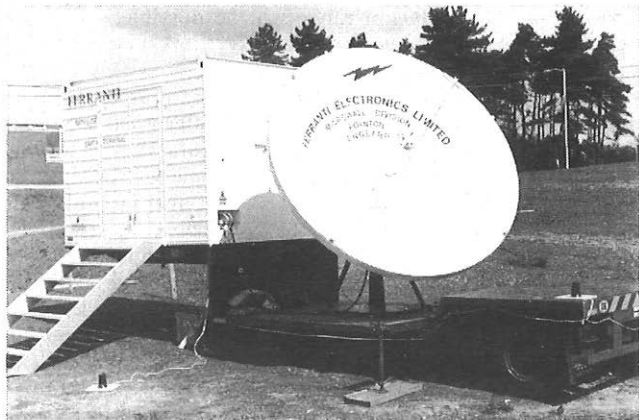

Transportable 3 m small-dish earth station

regional coverage with a direct-broadcasting satellite would require many more down channels than are available at present; the current type of terrestrial television distribution networks offers much greater flexibility in this respect. Nevertheless, commercial and political pressures will probably combine to bring such satellites into service, and a wide variety of specialist entertainment channels, many perhaps on a subscription basis, may be offered.

#### *Small-Dish Systems*

The possibility of the provision of business-communication services by means of small-dish satellite systems has attracted considerable attention in the last 1-2 years. Their advent is unlikely to affect directly the majority of telecommunications users, but there is the possibility of a strong influence on the communication services for the very large business user. As the very big business and industrial customer moves progressively into the era of the so-called *electronic office*, as production plants of growing size are increasingly automated, and as interdependence between production units located in several different countries grows, the symbiosis of computers and telecommunication, for so long predicted by both disciplines but equally long in its real appearance, will become a reality. The role that the satellite will play in this transformation still remains a very open question. Nevertheless, British Telecom will participate in the use of domestic and regional satellites to provide high-speed data transmission to large customers, and trial services will start soon. The trend here is likely to be towards growing European, and later world-wide, cooperation in such facilities.

#### **MICRO-ELECTRONICS**

The second area of technological significance is micro-electronics. The 1970s have seen this technology emerge from obscurity into the forefront of public awareness. "Chips with everything" has been the emotional theme of the popular media in the past year, and a great deal of ill-informed and misleading opinion about the impact on society of micro-electronics has been disseminated.

It is worthwhile to look at the progress made since their inception and to look forward a little into the future. The number of components that can be laid down on a single silicon chip has increased from about 30 in 1965 to nearly a quarter of a million today. We can foresee with confidence that this number will reach one million by the middle of the 1980s.

At the same time as this growth in device complexity was occurring, the cost per function was falling. What would have cost 5p in 1970 is now available for 0.005p, and by the middle-1980s that will fall by a further order of magnitude. These improvements in performance and cost have been

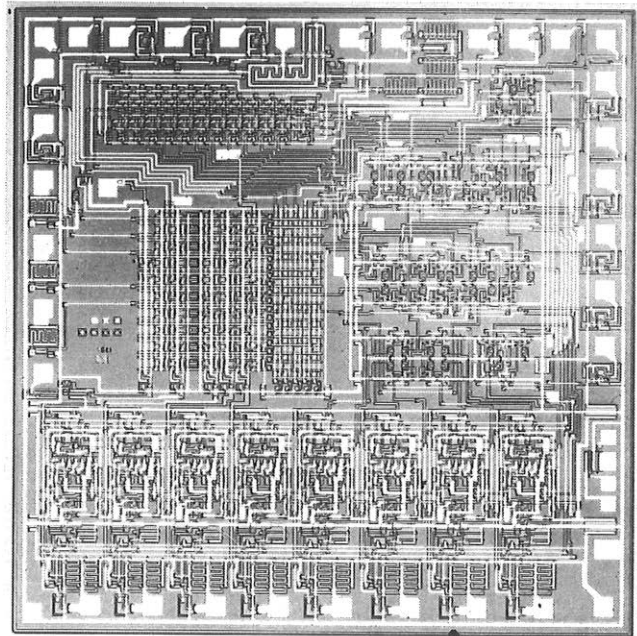

Typical silicon chip (4 mm × 4 mm) containing several thousand diodes, transistors and resistors

made possible by shrinking device geometries from 10  $\mu\text{m}$  in the early-1970s to the order of 5  $\mu\text{m}$  with today's devices, which look set to be reduced to 1  $\mu\text{m}$  or below during the 1980s.

Once the complexity of the chip has reached the stage where a complete microprocessor and memory can be accommodated in one corner of a chip, they could be used to monitor, control and reconfigure the functions of the remainder of the chip. Such a capability would open up the prospect of a microcircuit that could monitor its own status, and take internal corrective action if a fault developed. The predominance of silicon in the manufacture of large-scale integrated (LSI) circuits is likely to continue for a good many years, but many other materials are now under study in research laboratories and, for example, gallium-arsenide field-effect transistor (FET) integrated circuits look very interesting for switching at rates of 1 Gbit/s and above.

Progress in the 1980s will involve new technologies suitable for smaller-scale geometry to increase packing density and to provide higher speeds of operation and lower power consumption. Typical of the technologies that will provide these capabilities in the 1980s is the iso-CMOS process which British Telecom, GEC and Plessey recently announced they propose to adopt for new products, and which is already being produced in Britain in sample quantities.

#### **OPTO-ELECTRONICS**

The third area of crucial future technological importance is opto-electronics. In the last decade, the losses in silica fibre have been reduced from 100 dB/km to less than 0.5 dB/km; in the same period, significant improvements in laser transient and modal performance have been achieved, while their reliability has been improved by at least 5 orders of magnitude.

British Telecom has already put into public service production systems manufactured by GEC, Plessey and STC operating at 8, 34, and 140 Mbit/s. The initial batch of 34 systems has recently been joined by a second order for 77 systems which together will total 10 000 fibre-km. They herald the opening of the optical transmission era and one can say with confidence that the days of the coaxial cable for new long-haul routes are numbered.

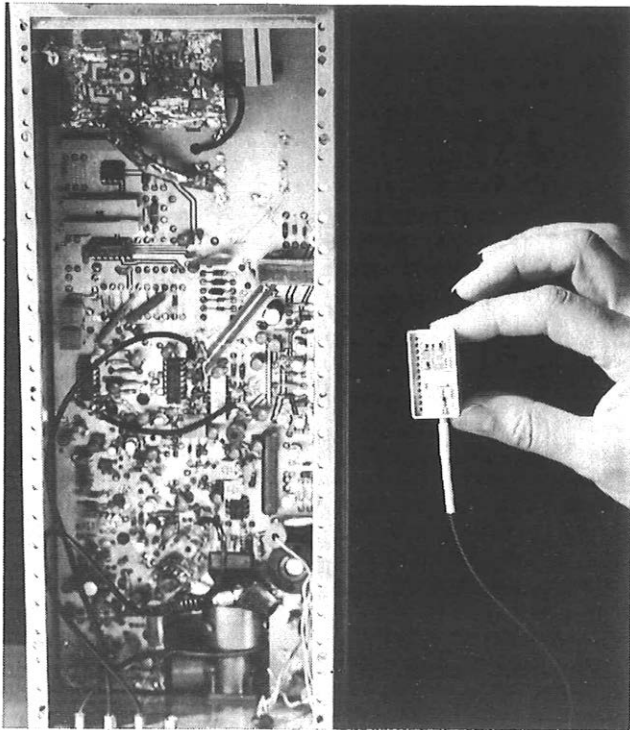

Optical-fibre system transmitter equipment (1978) and the 1981 equivalent (right)

### Optical-Fibre Developments

But what of the next 25 years? Where will this fast moving field take us? Two broad trends are emerging in our research work; these rest, respectively, on very-low-cost fibre and very-low-loss fibre.

#### Low-Cost Fibre

The development of a low-cost fibre from borosilicate glasses using the double-crucible technique developed by the British Telecom Research Laboratories at Martlesham, used in conjunction with simple light-emitting-diode sources, will make possible the production of low-cost systems which will be attractive for those parts of the network where a small size of cable and freedom from crosstalk is the main requirement, rather than an exceptional transmission performance in terms of loss and bandwidth. Such systems are likely to find their application in the local network, where they will be particularly suitable for video transmission. The fact that the technology to provide such systems will become available during the 1980s does not necessarily mean that there will be widespread adoption of switched video transmission on the local network within the same period. This is an area in which economics is the major determining factor. It is not merely a question of having a transmission system which by itself is low cost, but, much more difficult, how to make such a network economically viable over a period when the customers are relatively few and widely dispersed. It may be that the key will be found in sharing the broadband plant between entertainment and telecommunications services.

#### Low-Loss Fibre

The second trend will be primarily relevant to very-high-performance systems. The use of longer-wavelength light allows very much lower fibre losses to be achieved. For example, operating at 1300 nm or 1500 nm (rather than the 840 nm to 900 nm of the first generation systems) enables fibre losses as low as 0.2-0.5 dB/km to be achieved. Following from this, high-performance systems with repeater

spacing in the 50-100 km range will be possible, and these will clearly be attractive for inter-city trunk networks and submarine installations.

These systems, which are likely to operate at bit rates in the 140 Mbit/s to 560 Mbit/s range, will offer great scope for further cost reduction in long-haul transmission, not only because of the simplification of the equipment itself and the reduction in the number of repeaters, but also because their spacings will be such that, for the land network, essentially all the equipment could be housed in the buildings from which power is fed now to remote repeaters. The abolition of remotely powered repeaters then leads to further simplification in servicing and maintenance. Systems of this type will play a major role in reducing the cost of wideband services, and they should hasten the time when more widespread use of video conferencing or other wideband services become economically attractive. British Telecom plans are now well advanced for the large scale use of optical transmission systems in the inland network and probably no new coaxial cables will be installed after 1983.

### Submarine Optical Fibre

The world's first trial length of submarine optical-fibre cable was successfully laid in a Scottish loch by the British Telecom Cable Ship *Iris* on behalf of STC during February 1980. Current programmes look towards a trial system being laid in 1983 in preparation for full-scale production systems being available by about 1987. We may certainly expect to see a transatlantic optical system by about 1988. Such systems are likely to be the backbone of submarine cable provision from the later-1980s and to continue to give the satellite engineers strong competition.

Perhaps the ultimate prize is a repeaterless transatlantic optical system. The effects of Rayleigh scattering probably make this impossible with silica-based glasses where repeater spacings of about 300-400 km seem near the limit, but by the end of the century non-silica materials might have been developed which would carry the story forward into new and uncharted regions.

### CUSTOMER SERVICES

What then about customer services? In looking forward, it is necessary to distinguish between new facilities and new services. In the main, new customer facilities are the most obvious consequence of the introduction of stored-program control (SPC) exchanges. The ease with which new facilities can be added, or changed, on an existing exchange merely by software changes rather than by extensive hardware changes is the key to their introduction.

#### New Facilities

New facilities are basically of 2 kinds: those that can be provided by a single exchange for its own customers, and those that require co-operation between 2 SPC exchanges. Clearly, the rate of penetration of the new exchanges into the network will be a major factor in determining when such facilities can be offered to individual customers. However, for those facilities that require co-operation between 2 SPC exchanges it is obvious that the existence of the necessary high-speed signalling capability between the exchanges is as important as the provision of the exchanges themselves. It is for this reason that British Telecom is paying a great deal of attention to the strategy which it is adopting for the deployment of System X to bring these advantages to the maximum number of customers, and to those customers having most need of the facilities, at the earliest possible time.

The telephone instrument itself will change. For example, British Telecom is already offering to the public an instrument that incorporates a ten-number repertory facility as well as a repeat-last-number capability. This is made possible by

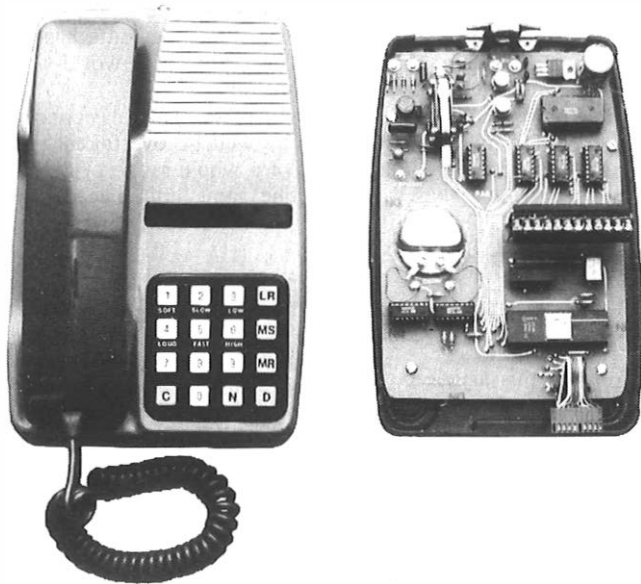

Experimental microprocessor telephone



Sir George Jefferson, Chairman of British Telecom, trying out an experimental microprocessor telephone

incorporating in the instrument 3 LSI chips containing 8000 components. This will certainly be followed by instruments containing a microprocessor and will open up all manner of new possibilities for the customer.

### New Services

Outside the realm of voice communication, the range of possible requirements becomes almost limitless. Whereas speech communication requires a well defined channel bandwidth for its satisfactory transmission, machine-machine communication is not constrained by any natural requirement. It was very natural and economic to provide data-transmission facilities initially by adaptation of the public switched telephone network because an all pervasive infrastructure existed. But the characteristics of that network, designed for speech, were not necessarily ideal for data; as soon as the data requirement reached a sufficient volume, special-purpose networks such as the packet-switched network, which is now established

in the UK and in some other countries too, were a predictable progression.

But this enormous diversity of services poses a problem. British Telecom currently has a telephone network, a Telex network, a packet-switched data network and a number of large private networks. To build separate networks for each new type of service that is devised in the future would be unrealistic. If such a course were followed, the growth of new services would certainly be inhibited because many would be of insufficient volume to be economically viable by themselves and alternative approaches must be sought.

### Integrated Services Digital Network

The British Telecom switched digital network is planned to link 30 centres in the UK by 1986, and 200 centres by 1990. By the latter date the possibility of connexion to the digital network will be available to about 75% of all our customers. If digital transmission plant is also provided in the local distribution network between the local digital exchange and the customer's premises, the new telephone network, based on System X, also becomes a circuit-switched digital service for those customers who need it; a variety of alternative means of providing a 64 kbit/s transmission path in the local network are being developed. All of this leads to the concept of the integrated services digital network (ISDN), in which we have a true multi-purpose, national, high-capability network which will meet the majority of customers' needs well into the twenty-first century. British Telecom will start ISDN services in 1983.

In my opinion, the ISDN is a particularly important concept, and for its successful expansion on an international, as well as a national basis it is very important to secure early international agreement on system characteristics and protocols.

### Peripheral Equipment

Much has been said and written about the electronic office, so far with little sign of equipment in daily use. However we may well be poised at the beginning of a period of proliferation of ideas and diverse equipment, and I would certainly predict that in terms of capital investment the pendulum is about to swing strongly away from the network *per se* over to the peripheral area. The real growth business of the 1980s and 1990s will be the supply of increasingly complex and sophisticated devices exploiting microtechnology and low-cost mass memory, which will transform current concepts of how business and commerce operates. We see the first stirring of this sleeping giant in the new Teletex service soon to be introduced in the UK. There is a high probability that within 20 years it will have replaced today's Telex service.

### Viewdata

Looking back over the last decade, perhaps the most significant single event of all was the invention, at the British Post Office Research Centre at Martlesham, of viewdata. Viewdata enables a centrally-managed computer database to be placed online, via the public telephone network, to specially adapted domestic-type television receivers. In this way, with an extremely simple protocol, both business and domestic users have immediate access to virtually unlimited quantities of information. Under the trade name *Prestel*, British Telecom has launched a public service which is already available in London, Birmingham, Nottinghamshire, Edinburgh, Glasgow, Manchester and Liverpool, and will be progressively extended to other cities in the UK. Already the database capability of the original installation is being expanded from a quarter of a million pages to half a million pages within 2 years, and within 5 years it will be further expanded to several million pages. Here at least is one British invention which has been brought to commercial application ahead of the rest of the world. Britain has the only full-scale public viewdata service in the world, although many other countries have announced their intention to follow our lead.



Prestel, the British Telecom viewdata service

Because the Prestel system is interactive, the scope for new applications seem almost boundless. Already direct selling, including payment by credit cards, is on offer to customers; one can buy a case of wine, make a donation to a charity, interact with the computer to generate poetry, or observe the hourly update of stock exchange share-price quotations. Picture Prestel enables a full-colour high-quality still picture to be inserted on part of a displayed page.

Of particular significance is the recent introduction of the *Gateway* concept. This enables users of one viewdata base to access another, and there is then no reason why world-wide interlinking of databases should not follow.

I do not expect this scene to remain static. The early concept of a single universal database may well be overtaken by a much more complex interlinking of a whole range of specialized separate databases, some public, some limited access and some private. One thing is certain, there is much more to come in the next 25 years.

## THE FUTURE

To close this article on a much more speculative note, one must mention developments in speech synthesis and speech recognition. The former is already with us and is in public service on the first System X local exchange opened at Woodbridge earlier this year. Recognition is a more difficult technological task. Recognition of a limited vocabulary of individual words is already possible, and given a disciplined talker and a heuristic technique, accuracies approaching 99% for a limited vocabulary are already possible. The recognition and interpretation of free speech is altogether another matter. If it were achieved, and if real-time language translation also were achieved, the way would be open for international telephone conversations to be held with each party speaking and hearing in their own language. It is not impossible, but the problems are formidable and I would not expect to see them solved before the centenary year of the Institution.

Twenty-five years on will see us well launched into the next century. It is tempting to imagine that there is something dramatic in the moment of transition from one century to the next. Perhaps there is, but only in our minds; nature acknowledges no such boundaries. The future comes a day at a time.



# Institution of Post Office Electrical Engineers

General Secretary: Mr. R. E. Farr, BTHQ/TE/SES5.3, Room 458, 207 Old Street, London EC1V 9PS; Telephone: 01-739 3464, Extn. 7223.  
(Membership and other local enquiries should be directed to the appropriate Local-Centre Secretary as listed on p. 304.)

## AMENDMENT TO THE RULES OF THE INSTITUTION

Council has agreed the following Rule amendment:-

*Rule 58*, amend the last sentence to read:

For independent Local Associate Section Centres, the annual fee shall be 2p per member.

## CONSTITUTION OF THE COUNCIL 1981-82

Council for 1981-82 is constituted as follows:-

Mr. D. Wray, Chairman.

Mr. A. B. Wherry, Vice-Chairman.

Mr. D. V. Davey, Vice-Chairman.

Mr. A. V. Knight, Honorary Treasurer.

Mr. D. A. Spurgin, representing Group 1 (members in the Headquarters Departments and the London Regions holding posts in bands 1-8 of the Senior Salary Structure).

Mr. W. N. Lang, representing Group 2 (members in the provincial Regions holding posts in bands 1-8 of the Senior Salary Structure).

Mr. R. D. Edwards, representing Group 3 (members in the Headquarters Departments (London) holding posts in bands 9-10 of the Senior Salary Structure).

Mr. F. V. Spicer, representing Group 4 (members in the London Regions holding posts in bands 9-10 of the Senior Salary Structure).

Mr. B. H. House, representing Group 5 (members in the provincial Regions and in Headquarters Departments (provinces) holding posts in bands 9-10 of the Senior Salary Structure).

Mr. P. Walling, representing Group 6 (members in the Headquarters Departments (London) listed in Rule 5(a), with the exception of those in Group 14).

Mr. E. Marmion, representing Group 7 (members in the London Regions listed in Rule 5(a), with the exception of those in Group 14).

Mr. K. Coxey, representing Group 8 (members in the provincial Regions and in Headquarters Departments (provinces) listed in Rule 5(a), with the exception of those in Group 15).

Mr. M. E. Barnes, representing Group 9 (members in the Headquarters Departments (London) listed in Rule 5(b), with the exception of those in Group 14).

Mr. J. D. Overall, representing Group 10 (members in the London Regions listed in Rule 5(b), with the exception of those in Group 14).

Mr. D. F. Ashmore, representing Group 11 (members in the provincial Regions and in Headquarters Departments (provinces) listed in Rule 5(b), with the exception of those in Group 15).

Mr. D. V. Gasson, representing Group 12 (Inspectors in the London Regions).

Mr. N. R. Paul, representing Group 13 (Inspectors in the provincial Regions).

Mr. M. E. Webb, representing Group 14 (Draughtsmen, Illustrators and above, but below the Senior Salary Structure, in Headquarters Departments (London) and London Regions).

Mr. C. G. Suett, representing Group 15 (Draughtsmen, Illustrators and above, but below the Senior Salary Structure, in provincial Regions and Headquarters Departments (provinces)).

Mr. L. Thomas, representing Group 16 (all affiliated members).

Representation for Groups 1, 8 and 16 was contested. The unsuccessful candidates, in descending order of votes cast where appropriate, were:

Group 1 Mr. H. Goodison.

Group 8 Messrs. R. E. Cox, C. I. Wall, J. M. Smith and D. B. Heaton.

Group 16 Mr. F. F. Makin.

## MEETING OF LOCAL-CENTRE SECRETARIES

Local-Centre Secretaries meet annually under the chairmanship of the General Secretary, together with other members of the Secretariat, the Librarian and the Managing Editor of this *Journal*, to discuss organizational and other problems. This year's meeting was held at BTTC, Stone on 17-18 June. Apart from the usual administrative matters, topics discussed at the meeting could be classified under three main headings: the difficulties of obtaining speakers who will ensure a good attendance at meetings and particularly of encouraging those speakers to produce an accompanying paper; the need to continually seek means to reduce Institution costs without decreasing the quality of the service provided to members; and last, but by no means least, the effects of forthcoming changes on the Institution. Ideas were sought, for later discussion by Council, for judging lecturers for medal awards where there is no written paper and for changes to the Institution's rules consequent upon the change of title.

R. E. FARR  
Secretary

## Notes and Comments

### SUPPLEMENT

Because of the special nature of this issue of the *Journal*, the usual *Supplement* containing model answers to questions set

by the City and Guilds of London Institute and model questions and answers for Technician Education Council examinations has not been published. Normal publication will resume with the January 1982 issue.

## Local-Centre Secretaries

The following is a list of Local-Centre Secretaries, to whom enquiries about membership of the Institution should be addressed. It would be helpful if members would notify any change in their own address to the appropriate secretary.

<i>Centre</i>	<i>Local Secretary</i>	<i>Address and Telephone Number</i>
Birmingham .. .. .	Mr. D. F. Ashmore .. .. .	Midland Telecommunications Region, SM1.1, 95 Newhall Street, Birmingham B3 1EA 021-262 4703
Eastern (Bletchley) .. .. .	Mr. D. R. Norman .. .. .	General Manager's Office, ED9.3, Telephone House, 25-27 St. John's Street, Bedford MK42 0BA (0234) 55860
Eastern (Colchester) .. .. .	Mr. P. M. Cholerton .. .. .	Eastern Telecommunications Board, PLG2.1.4, St. Peter's House, St. Peter's Street, Colchester CO1 1ET (0206) 89547
East Midlands .. .. .	Mr. D. W. Sharman .. .. .	General Manager's Office, ES3.3, 200 Charles Street, Leicester LE1 1BB (0533) 534409
London .. .. .	Mr. L. J. Hobson .. .. .	Telecommunications Headquarters, ME/BS3.4.2, Room 4024, Tenter House, 45 Moorfields, London EC2Y 9TH 01-432 1385
Martlesham .. .. .	Mr. R. M. Brooks .. .. .	BT Research Laboratories, R9.2.4, Martlesham Heath, Ipswich IP5 7RE (0473) 643378
North Eastern .. .. .	Mr. R. S. Kirby .. .. .	North Eastern Telecommunications Region, S3.1.2.4, 36 Park Row, Leeds LS1 1EA (0532) 467362
Northern .. .. .	Mr. L. G. P. Farmer .. .. .	General Manager's Office, CI28, Swan House, Pilgrim Street, Newcastle-upon-Tyne NE1 1BA (0632) 327212
Northern Ireland .. .. .	Mr. W. H. Tolerton .. .. .	General Manager's Office, EC1, Dial House, 3 Upper Queen Street, Belfast BT1 6LS (0232) 24777
North Western .. .. . (Manchester and Liverpool)	Mr. W. Edwards .. .. .	North Western Telecommunications Board, F2.3, Telecommunications House, 91 London Road, Manchester M60 1HQ 061-863 7778
North Western .. .. . (Preston)	Mr. R. L. Osborn .. .. .	General Manager's Office, PS, Telephone House, Fenton Street, Lancaster LA1 1BA (0524) 88400
Scotland East .. .. .	Mr. N. A. Braid .. .. .	Scottish Telecommunications Board, S1.1.4, Canning House, 19 Canning Street, Edinburgh EH3 8TH 031-222 2348
Scotland West .. .. .	Mr. G. A. Dobbie .. .. .	General Manager's Office, EX17, Marland House, 40 George Street, Glasgow G1 1BA 041-220 2365
South Eastern .. .. .	Mr. J. M. Smith .. .. .	South Eastern Telecommunications Region, PL/EQ2.3, 52 Churchill Square, Brighton BN1 2ER (0273) 201318
South Western .. .. .	Mr. D. P. Cosh .. .. .	South Western Telecommunications Board, Sv2.3.1, Mercury House, Bond Street, Bristol BS1 3TD (0272) 295578
Stone/Stoke .. .. .	Mr. J. Coulson .. .. .	British Telecom Technical College, PS7.3.4A, Stone ST15 0NQ (0785) 762351
Wales and the Marches .. .. .	Mr. D. A. Randles .. .. .	Wales and the Marches Telecommunications Board, PW3.1.2.2, 25 Pendwyallt Road, Cardiff CF4 7YR (0222) 391370

# The Post Office Electrical Engineers' Journal

## Copyright

The entire contents of this *Journal* are covered by general copyright, and special permission is necessary for reprinting long extracts, but editors are welcome to use not more than one-third of any article, provided that credit is given at the beginning or end, thus: "From *The Post Office Electrical Engineers' Journal*".

The Board of Editors is not responsible for the statements made nor the opinions expressed in any of the articles or correspondence in this *Journal*, unless any such statement is made specifically by the Board.

## Subscriptions and Back Numbers

The *Journal* is published quarterly in April, July, October and January, at 80p per copy (£1.30 per copy including postage and packaging); annual subscription: £5.20; Canada and the USA: \$12.00.

The price to British Telecom and British Post Office staff is 48p per copy.

Back numbers will be supplied if available, price 80p (£1.30 including postage and packaging). At present, copies are available of all issues from April 1974 to date with the exception of the April and October 1975 and April 1976 issues.

Orders, by post only, should be addressed to *The Post Office Electrical Engineers' Journal*, 2-12 Gresham Street, London EC2V 7AG.

Employees of British Telecom and the British Post Office can obtain the *Journal* through local agents.

## Binding

Readers can have their copies bound at a cost of £7.50, including return postage, by sending the complete set of parts, with a remittance, to Press Binders Ltd., 4 Iliffe Yard, London SE17 3QA.

## Remittances

Remittances for all items (except binding) should be made payable to "*The POEE Journal*" and should be crossed "& Co."

## Advertisements

All enquiries relating to advertisement space reservations should be addressed to Mr. N. G. Crump, The Advertisement Manager, *Post Office Electrical Engineers' Journal*, Room 508, 2-12 Gresham Street, London EC2V 7AG (Telephone: 01-357 2089).

## Distribution and Sales

Correspondence relating to the distribution and sale of the *Journal* should be addressed to *The Post Office Electrical Engineers' Journal* (Sales), 2-12 Gresham Street, London EC2V 7AG.

## Communications

With the exceptions indicated above, all communications should be addressed to the Managing Editor, *The Post Office Electrical Engineers' Journal*, NEP12, Room 704, Lutyens House, Finsbury Circus, London EC2M 7LY (Telephone: 01-357 4313).

## Model-Answer Books

Books of model answers to certain of the City and Guilds of London Institute examinations in telecommunications are published by the Board of Editors. Copies of the syllabi and question papers are not sold by *The Post Office Electrical Engineers' Journal*, but may be purchased from the Sales Department, City and Guilds of London Institute, 76 Portland Place, London W1N 4AA.

# THE INSTITUTION OF POST OFFICE ELECTRICAL ENGINEERS

## SUITABLY QUALIFIED CORPORATE MEMBERS

of

## THE INSTITUTION OF POST OFFICE ELECTRICAL ENGINEERS

may now apply for

## MEMBERSHIP

of

## THE FEDERATION OF TELECOMMUNICATIONS ENGINEERS OF THE EUROPEAN COMMUNITY (FITCE)

FITCE is an organization with similar objects to IPOEE and draws its members from the public telecommunications administrations of Belgium, Eire, France, Italy, Luxembourg, the Netherlands and West Germany. Denmark, Greece and Spain are negotiating affiliation. FITCE publishes a quarterly *Journal* from its Brussels headquarters, sponsors multinational study groups (Commissions) to enquire into and report on problems of general interest, and each year organizes a General Assembly/Congress in one of the member countries at which members are invited to present papers.

IPOEE has now been formally accepted into the Federation to represent the UK. Applications for individual membership of FITCE are invited from Corporate Members of IPOEE who hold a University science degree or are Chartered Engineers. The annual subscription for 1981-82, which covers local administration expenses as well as the per-capita contribution to FITCE funds, has been fixed at £3.50. Membership forms are available now from your Local-Centre Secretary (see the list on p. 304).

IPOEE members of FITCE will be known as the FITCE Group of IPOEE. This Group will be subject to the Institution's Rules, including such additional rules that may be introduced with the consent of members to specifically control FITCE Group affairs. Separate accounts will be maintained within the Institution's main accounts so that no charge proper to FITCE affairs will fall upon the general membership of IPOEE. The FITCE Group of IPOEE will be represented on the Executive Committee of FITCE and will be invited to contribute to the Commissions and to send delegates to the 1982 General Assembly and Congress.

**THIS IS YOUR OPPORTUNITY TO PLAY AN ACTIVE PART IN CO-OPERATION WITH TELECOMMUNICATIONS ENGINEERS FROM OTHER EUROPEAN COUNTRIES**

### **APPLICATIONS ARE ALSO INVITED FROM PROSPECTIVE LONDON-BASED IPOEE FITCE GROUP MEMBERS TO FILL AN ADDITIONAL IPOEE ASSISTANT SECRETARY POST**

The successful applicant, who should preferably be able to converse in French, will be expected to take charge of the IPOEE FITCE Group membership records and accounts, and to liaise between the IPOEE Council and the FITCE Secretariat on administrative matters. An Honorarium will be paid, the amount to be determined according to the number of IPOEE FITCE Group members. IF YOU ARE INTERESTED, PLEASE ENCLOSE A LETTER OF APPLICATION TO THE GENERAL SECRETARY, IPOEE WITH YOUR APPLICATION FOR FITCE MEMBERSHIP.

# YOU CAN ALWAYS CONNECT WITH CANNON

The widest line of connectors in the Industry including  
Multiway Switching Connectors  
Two-part edge Connectors  
Printed Circuit Connectors  
Fibre-optic Connectors  
Circular and Rectangular Connectors  
IDC and Ribbon Cables  
Flexible Printed Circuits

The most thorough back-up in the connector business.

A reputation for quality and reliability unprecedented in our industry.

That's what ITT Cannon can offer. To learn more about what we can do for you contact.

Cannon Electric (GB) Ltd.,  
Lister Road, Winchester Road,  
Basingstoke, Hants RG22 4AS.  
Tel: Basingstoke 3171. Telex: 858105.



You can always connect with Cannon.

## INDEX TO ADVERTISERS

### Advertisements

Communications should be addressed to Mr. N. G. Crump, The Advertisement Manager, *POEEJ*, Room 508, 2-12 Gresham Street, London, EC2V 7AG (Tel: 01-357 2089).

*No responsibility is accepted by the Journal for any of the private or trade advertisements included in this publication.*

Birkbys Plastics, Ltd.	.. .. .	11
British Telconsult	.. .. .	9
Cannon Electric (GB), Ltd.	.. .. .	10
Ferranti Electronics, Ltd.	.. .. .	3, 7
GEC Telecommunications, Ltd.	.. .. .	4, 5
Herman Smith (Eurocraft), Ltd.	.. .. .	18
IMO Precision Controls, Ltd.	.. .. .	2
ITT Components Group	.. .. .	15
The M-O Valve Co. Ltd.	.. .. .	13
Plessey Telecommunications, Ltd.	.. .. .	8
Plessey Telecommunications and Office Systems, Ltd.	.. .. .	16
Siemens, Ltd.	.. .. .	17
Sperry Gyroscope, Ltd.	.. .. .	14
Standard Telephones and Cables, Ltd.	.. .. .	12
3 M United Kingdom, Ltd.	.. .. .	6

# Jacks Test with Hinges

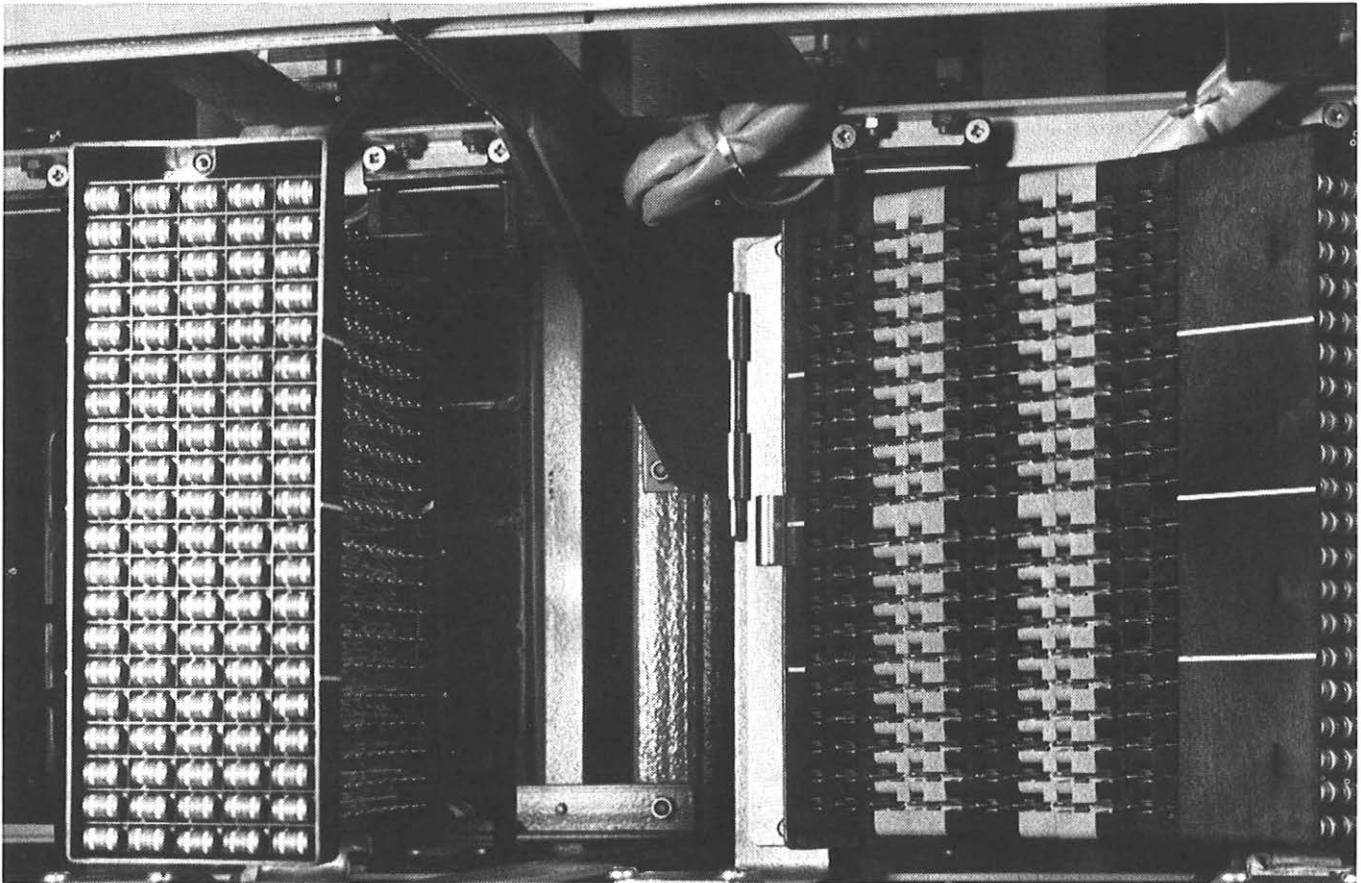

*Jacks Test 39/2B. Hinge opened on right hand unit to facilitate work on wiring face of left hand Jack.*

## Jacks Test 39/2A 39/2B 40/2A 40/2B 42B.

Hinged versions of the existing range have been introduced to provide improved access for jumper wiring. The hinge is fitted between mounting bracket and fanning strip, with a secure latching facility.

**Birkbys Plastics**   
a member of the **PLESSEY GROUP**

Birkbys Plastics Limited, PO Box 2, Liversedge,  
West Yorkshire, United Kingdom WF15 6QA.  
Telephone: Heckmondwike (0924) 403721  
Telex: 55332

An insulator foil protects wiring – fed through the fanning strip – from chafing against the hinge.

## Hinge Kits 381A 381B

Available for retrospective modification of any protected Jacks Test.

NAME	_____
TITLE	_____
ADDRESS	_____
	_____
	_____

*Please send me further details of the hinged version of the Jack Test range.*

Birkbys Plastics Limited, PO Box 2, Liversedge,  
West Yorkshire, United Kingdom WF15 6QA

 0150 2 0046

# We've both come a long way in 75 Years

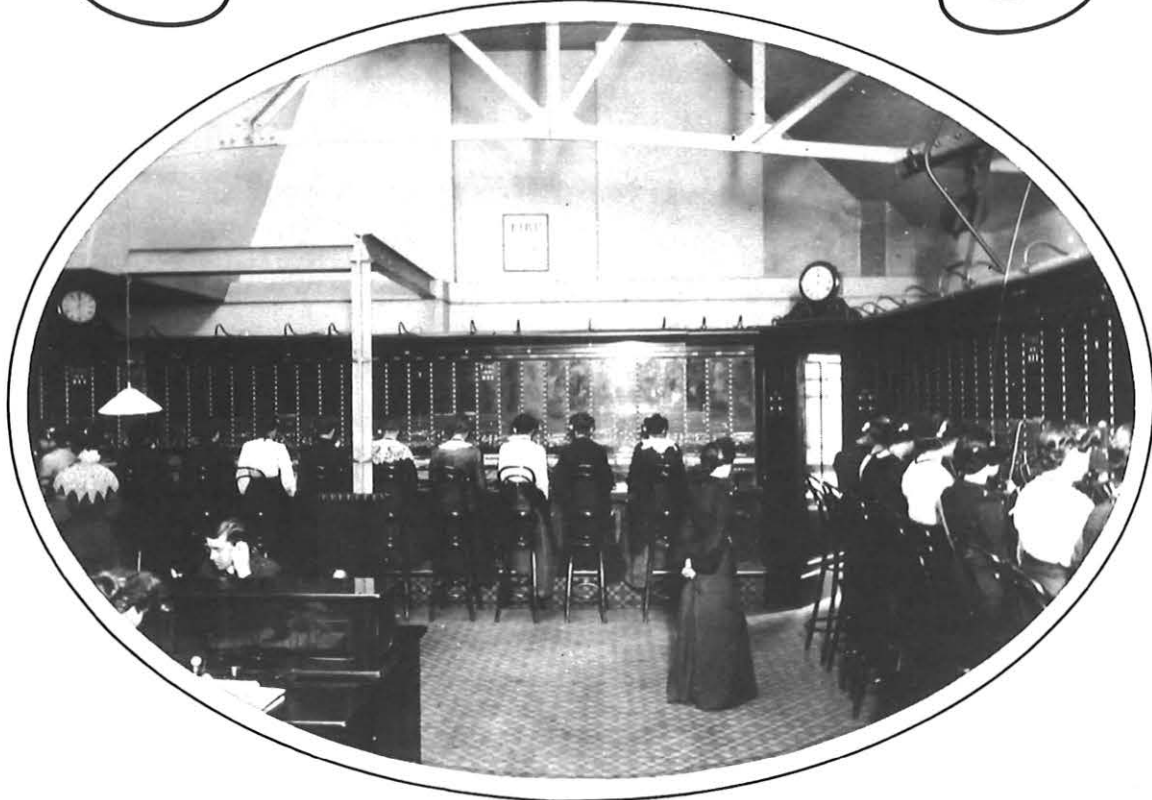

The good ladies of the Holborn manual exchange could certainly not have envisaged the developments in telecommunications over the next 75 years. STC has made some significant contributions to those developments:

- \* an STC scientist invented pulse code modulation.
- \* we installed the first UK medium-to-large local analogue switching exchange.
  - \* we conceived optical fibre transmission.
- \* we installed Europe's first high capacity trunk digital line system.

Your first 75 years has been a period of excitement and innovation and we can both look forward to the next 75 years.

**STC. We help people communicate.**

**Standard Telephones and Cables Limited**

A British Company of **ITT**

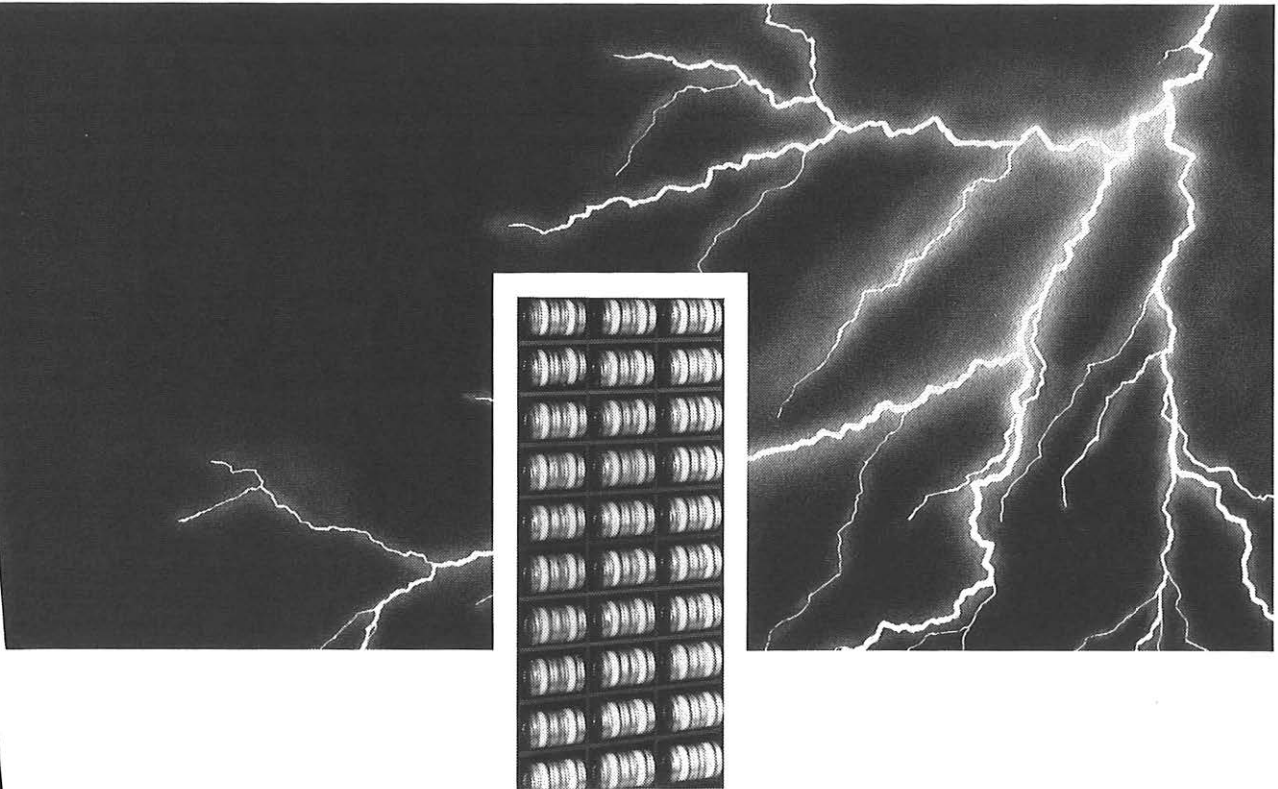

# Survival of the fitted.

This modern telephone equipment has protection "designed-in."

The reasons are well known to engineers - lightning strike or other electrical overloads can knock out whole telephone systems unless they are adequately protected.

Protected with M-OV surge arresters or gas-discharge tubes, if that's how you know them.

Electrical surges are stopped in their tracks by M-OV protection, at minimal cost, at great speed and *every* time.

Why M-OV? Well, not only is M-OV technology world-renowned but M-OV arresters are tested no fewer

than 11 times before they reach you. That's eleven extra reasons for insisting on M-OV.

M-OV protection is fitted by telecommunication authorities round the world from Asia to the Americas as well as being well in the lead in Britain.

If your equipment needs protection, don't wait until you've got a strike on your hands. Get in touch with M-OV today.

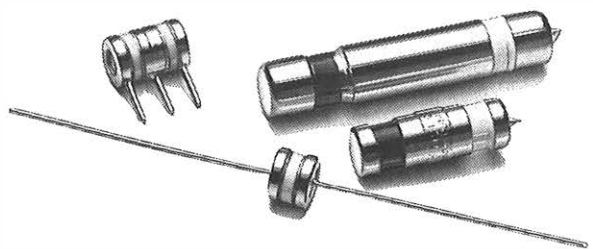

## M-OV

A MEMBER OF THE GEC GROUP

**GEC**

S739



## Knowing how to listen helps us to solve your problems

Sperry serves both the Post Office and British Telecoms with precision engineering and electronics to aid their programmes for advanced automated systems.

For System X Exchanges Sperry supply the vital disc memory system and for the Post Office automatic sorting offices, have produced many of the Postcode translators and automatic sorting and pre-sorting equipment.

Whilst Sperry specialises in engineering and manufacturing projects our adaptable approach includes made to drawing work.

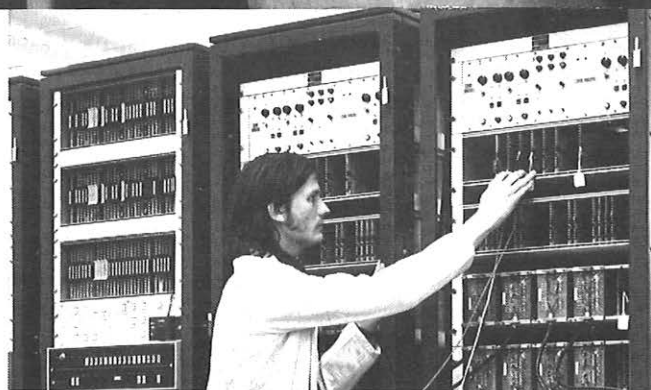

*A Postcode translator undergoing final tests before delivery to the Post Office.*

Just give us a call, we are qualified and we know how important it is to listen.

**SPERRY GYROSCOPE, BRACKNELL,  
BERKSHIRE, ENGLAND RG12 1QL**  
Telephone: Bracknell 3222. Telex: 848129.

 **SPERRY**



# We conceived optical transmission and made it work.

No-one has greater experience than ITT in both fibre optics and laser technology. We've been developing and manufacturing systems and components for almost twenty years.

So, as you would expect, our product range for military, professional and industrial markets is extensive and growing all the time. And the quality of applications advice we can provide on product use has an unbeatable pedigree.

Our fibre optics capability includes modules, couplers, connectors, cables, termination and test equipment, packaged devices and communication kits.

As Europe's leading manufacturer of semiconductor lasers, our product range includes CW laser diodes in a wide range of packages for fibre optics communication systems. Our research centre, Standard Telecommunication Laboratories, is currently developing devices for land and submerged systems of the future.

Summary catalogues for both fibre optics and laser diodes are available on request.

ITT Components Group, Microwave & Opto-Electronics, Brixham Road, Paignton, Devon TQ4 7BE.  
Tel: (0803) 550762. Telex: 42951.

# We have the products to make it work for you.

Components **ITT**

# Solving your system problems and communicating the answers

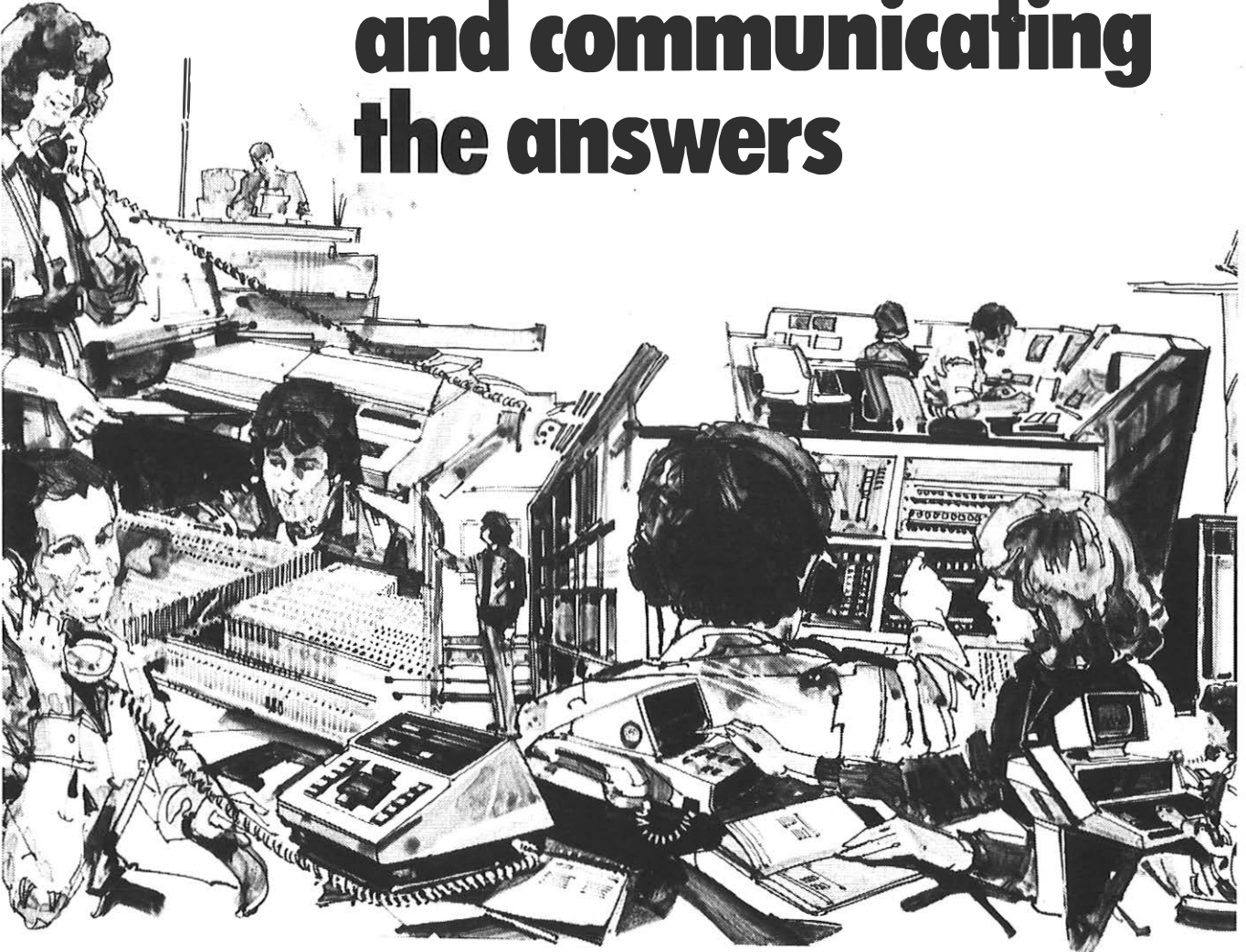

Coming up with the right communication answers takes system strength – in depth.

Plessey demonstrates it – first in the telecommunications switching field by close involvement in System X. Plessey is one of the companies which helped to develop with British Telecom this new digital telephone exchange system.

In carrier transmission and telex, too, Plessey can show what high technology's made of.

The new Plessey TEP 600 digital transmission systems, second generation 30-channel PCM, and modems up to 16kbps – the fastest available commercially anywhere in the world – speed communication, reliably.

So does Plessey packet switching for data networks and System 4660 telex – an advanced stored program control switching system now in international service.

For the integrated communications that

modern business is now beginning to demand in its offices, Plessey supplied the first British Telecom approved private digital telephone exchange in Britain.

It's called the Plessey PDX, and well over 200 businesses in the UK and abroad now have it installed or on order, as their first step in linking all their communications into one coherent, cost-effective network.

Anywhere there's a need for better communication systems, Plessey tackles it.



**PLESSEY**  
*telecommunications & office systems*

Plessey Telecommunications & Office Systems Limited  
Edge Lane, Liverpool, United Kingdom L7 9NW.  
Telephone: Liverpool (051) 228 4830 Telex: 629267

# SIEMENS

## Compact, reliable connectors. Approved for use on TEP.IE.\*

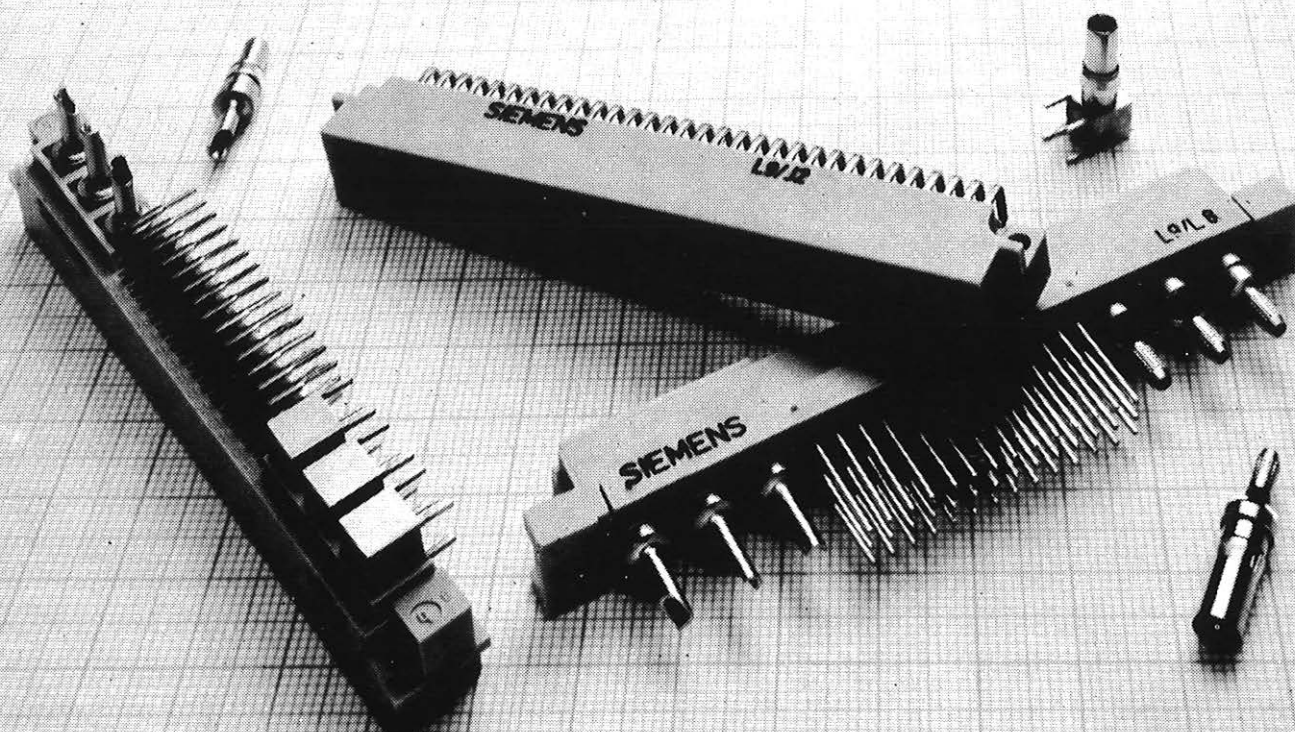

Designed for conditions encountered at speeds in excess of Mach 2, Siemens connectors are the vital links upon which the reliability of today's most sophisticated electronic systems depends. In the continuing development and improvement of our connector ranges, reliability, cost reduction, and space saving are major considerations. Siemens connectors comply with standards specific to communications, electronics and data processing. Two-part connectors are made

according to DIN 41612 and IEC 130-14 standards, with VG95324 military approval, and, therefore meet the demanding environmental requirements of military and avionic systems. These two-part connectors have also been approved by the major UK Government contractors. Siemens Limited, Siemens House, Windmill Road, Sunbury-on-Thames, Middlesex TW16 7HS. Telephone: Sunbury (09327) 85691 Telex: 8951091

## In the world of electronic components Siemens has the answer.

\* Registered trade mark of the Post Office

# Herman Smith



Metal fabrications and electro-mechanical assemblies to customers' requirements, approved to British Telecom and Ministry of Defence standard.

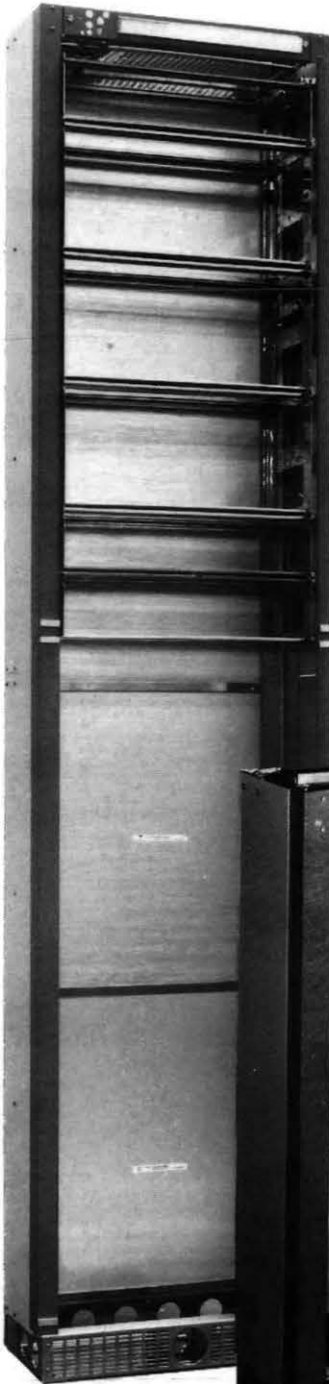

Typical 19" rack, one of several types manufactured suitable for mounting 19" shelves or 8- and 4-unit TEP-1E shelf units, with or without doors.

Ask us to quote for your requirements.

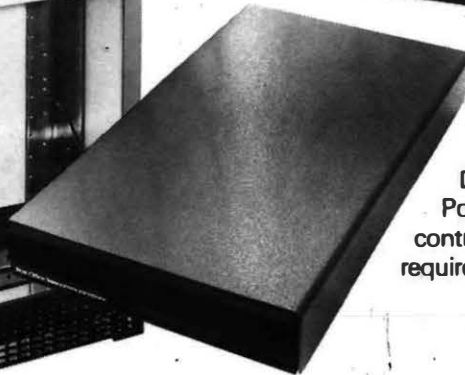
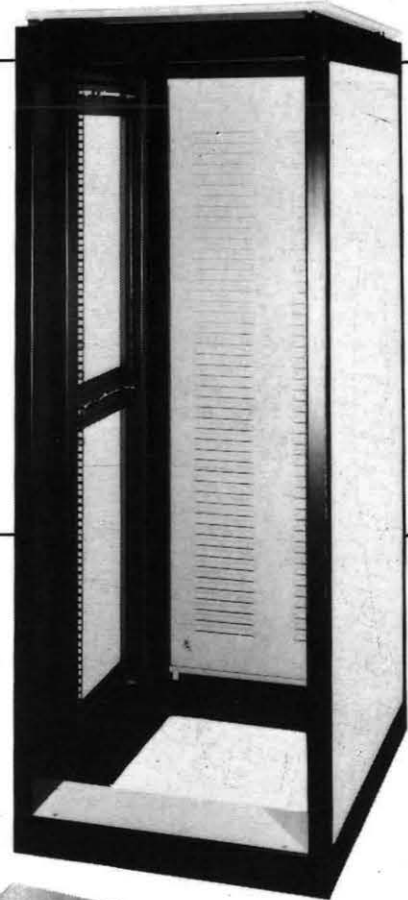

Datel cases to Post Office and contractors' requirements.

\*TEP-1E Rack 80A, 8- and 4-unit shelves in full production. Detailed leaflet on request.

*\*TEP-1E is a Registered Trade Mark of the Post Office.*

## Herman Smith (Eurocraft) Ltd.



A member of the Herman Smith Group of Companies

Fully approved by British Telecom,  
Ministry of Defence to 05/24 standard and C.A.A.  
Netherton, Dudley,  
West Midlands, DY2 9AH.  
Tel: Dudley (0384) 52791.  
Telex: 339962.