

POPULAR WIRELESS, March 1st, 1930.

REGISTERED AT THE G.P.O. AS A NEWSPAPER.

FOUR NEW BLUE PRINTS FREE

Popular Wireless

Every Thursday

PRICE
3d.

No. 404. Vol. XVI.

INCORPORATING "WIRELESS"

March 1st, 1930.

2/- Gift Free!

FOUR SIXPENNY BLUE PRINTS

Inside

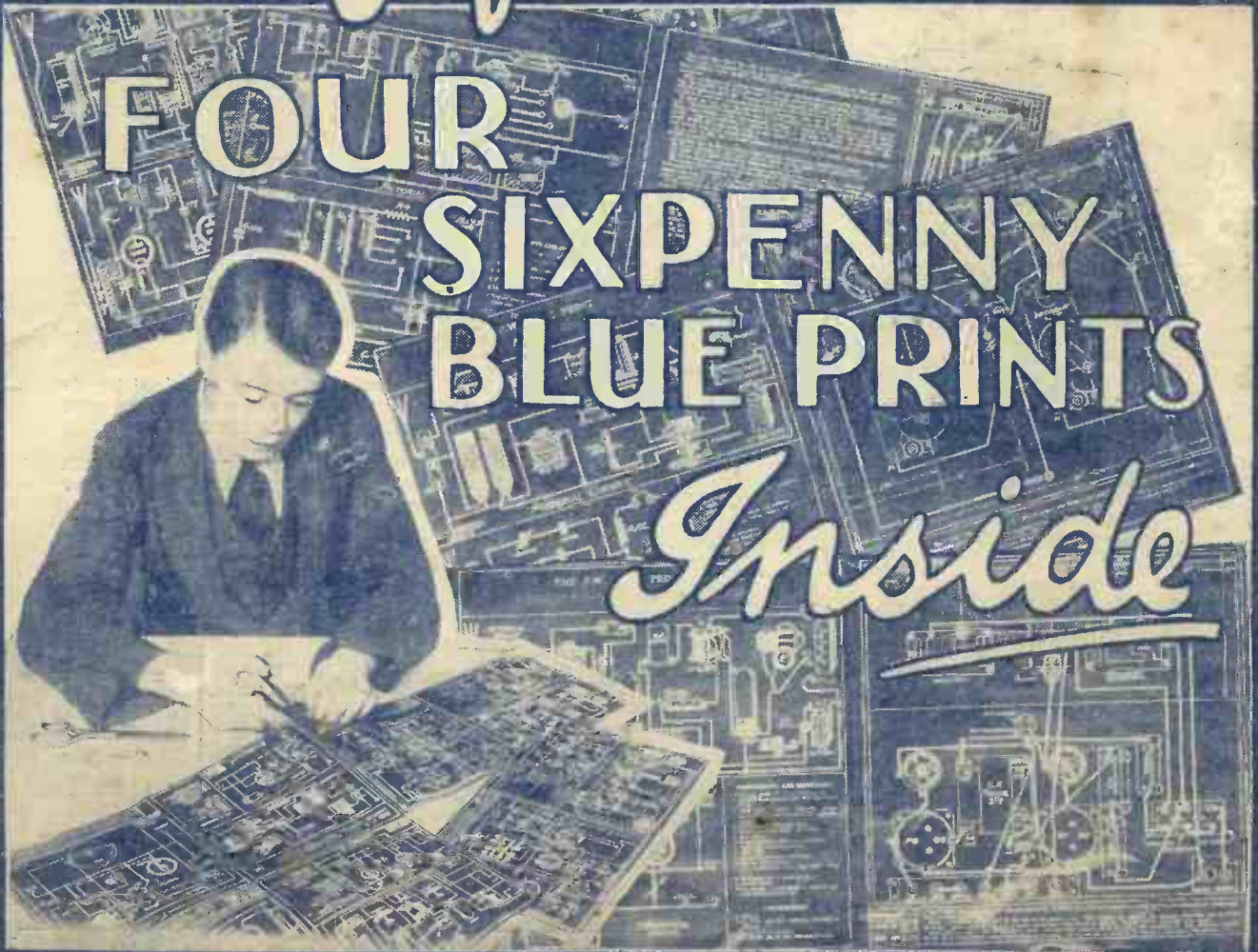

It's *NOT* a "fishing yarn" . . .

" Jan. 23, 1930.
Your advertisements in 'Popular
Wireless' led me to better radio.
I recently built up the 'Magic' Three and put in
coils that I thought were reasonable in price and
quality, with the result that all I could get was
Brookmans Park covering the whole of my tuning dial.
After reading your advert. once or twice I pur-
chased two of your coils and to my amazement I can
now do the following :
(1) Separate the Alternative Programmes
dispensed with my Brookmans Rejector.
(2) Tune in five Continental Stations with both
the Regional Stations going.
This I think to some wireless people would seem a
fishing yarn, but is quite true inasmuch that my other
coils have found their way into the dust bin."
Thanking you for such excellent coils."



Lewcos Dual Binocular Coils (References D.B.A. and D.B.P.) are specified for the "Regional" Four.

Lewcos Centre Tapped Coils as specified for the "Magic" Three and the "Regional" Two Receivers.

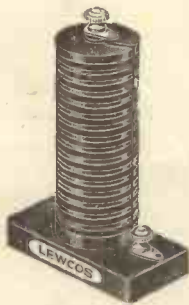

The Lewcos H.F. Choke specified for the 1930 "Titan" Three.

It's a fact that **LEWCOS** *Regd.* COILS

because of their extraordinary powers of selectivity do enable you to cut out local stations and tune in to the most difficult and distant stations across the world.

Lewcos Coils have reached this stage of perfection through a backing of continuous scientific research and the superior materials and workmanship used in their manufacture.

Descriptive leaflets of the Lewcos Coils which are specified for various receivers, and illustrated above, will be sent on request.

THE LONDON ELECTRIC
WIRE COMPANY AND
SMITHS LIMITED
Church Road, Leyton,
London, E.10



Trade
Counter :
7, PLAYHOUSE
YARD,
GOLDEN LANE,
E.C.1

12 MONTHS IN THE JUNGLE!



In wilds of Africa the Court-Treatt expedition makes great British film "Stampede." Hundreds of miles from nearest white men! Yet always in touch with London, *through Marconi Valves*. The expedition's messages, transmitted by Errol Hinds, were heard even in United States—5000 miles away! Marconi Valves were used in his portable wireless equipment. They are used by all British broadcasting stations . . . by all Imperial Airways machines . . . by all Trinity House lightships and beacon stations. For their wide range. For their long life. For their dependability. ● *In cases like these, when unfailing reliability is essential men insist on Marconi Valves.*

FIT MARCONI VALVES



THE FIRST AND
GREATEST NAME
IN WIRELESS

TO YOUR RADIO SET

Give you clearer tone, greater volume, longer range. Cost not a penny more. Fit any set.

For all technical information on valves write to THE MARCONIPHONE COMPANY LIMITED, 210-212 Tottenham Court Road, London, W.1

RADIO'S FINEST MAGAZINE!

THE MARCH NUMBER OF **MODERN WIRELESS**

Contains unprecedented value in the way of constructional, technical, and general articles of absorbing interest to all owners of radio receivers.

This month's MODERN WIRELESS shows you how to deal with the various reception problems that have arisen because of the Regional Station at Brookmans Park, and contains full how-to-make details of Specially Selective Sets designed to meet the new conditions.

All "M.W." Receivers are tested and Guaranteed.

Sir JOHN REITH, Capt. P. P. ECKERSLEY, M.I.E.E., and R. E. JEFFREY contribute special articles on topics of vital importance to all listeners.

The Contents also include:

All-Wave Receivers
Radio in the Sub-Arctic
Broadcasting Organ Music
Outspoken Speakers
Trans-Ocean Transmitters

Preventing Fading
Those High Notes
Choosing Variable Condensers
That Grid Return
Do Filters Filter?

and many other articles of special interest.

Make sure of Your Copy of The MARCH
MODERN WIRELESS

On Sale March 1st.

Price 1/-

TELL YOUR FRIENDS ABOUT THIS!

THE TRANSFORMER THAT PUT 'A1' IN RADIO

RATIO

NOW PUTS 'A1' IN RATIO

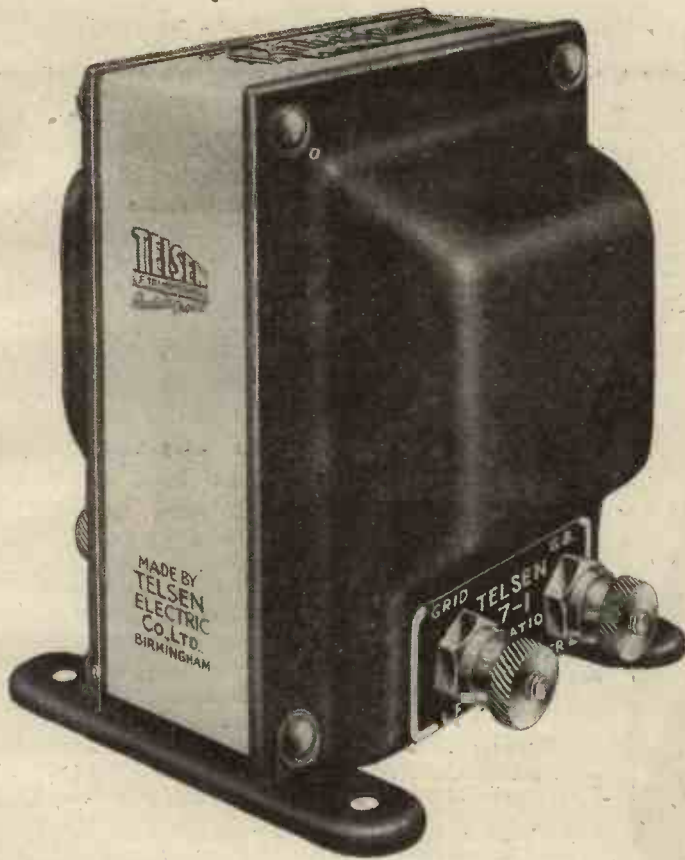

7-1 AMPLIFICATION

This big ratio transformer sets an entirely new standard in Radio reception giving enormous amplification without any trace of distortion, in fact it is equal to another valve stage in many wireless sets, making the reception of foreign stations a pleasure to hear hitherto unknown.

This transformer gives amazing amplification and undoubtedly will be one of radio's greatest achievements.

It is *the* transformer you have been waiting for, go along to your dealer now, and ask for the Telsens New Ratio 7-1 Transformer and delight your family with the amazing reception which only this transformer can give.

You will want to invite your friends round to hear it.

PRICE 17'6

TELSEN

▲ NEW RATIO ▲
TRANSFORMER

TELSEN ELECTRIC CO., LTD.
MILLER ST., BIRMINGHAM.

LOCKED *for* **SAFETY!**

LOCKED *for* **RIGIDITY!**

LOCKED *for* **LONG LIFE!**

—INTERLOCKED!



**2-volt type
now available.**

The NEW Cossor 220 S.G.
(2 volts, .2 amp.) Max.
Anode Volts 150, Im-
pedance 200,000, Ampli-
fication Factor 200. Price - - **22/6**

Cossor 4 and 6 volt Screened
Grid Valves are also available
with similar characteristics at
the same price.

Individual movement of the elements is impossible in the *NEW* Cossor Screened Grid. They are rigidly locked in position, definitely eliminating all risk of internal short circuit. And because they are braced to a girder-like rigidity they are proof against even the hardest blow. As a result the *NEW* Cossor has an exceptionally long life. Nothing short of complete destruction can mar its extraordinary sensitivity and range. Demand the *NEW* Cossor for your Screened Grid Receiver. No other make has Interlocked Construction.

The **NEW**
COSSOR
Screened Grid
Valve

Popular Wireless



Scientific Adviser:
 Sir OLIVER LODGE, F.R.S.
 Chief Radio Consultant:
 CAPT. P. P. ECKERSLEY, M.I.E.E.
 Editor: NORMAN EDWARDS.
 Technical Editor: G. V. DOWDING, Assoc. I.E.E.
 Assistant Technical Editors: K. D. ROGERS,
 P. R. BIRD, G. P. KENDALL, B.Sc.,
 A. JOHNSON RANDALL.

**NEXT WEEK'S
 GREAT GIFT!**
**THE HUSTLERS.
 HEARD HIM ?**

RADIO NOTES & NEWS

**THAT FOWL.
 HIDDEN TREASURES.
 AUSTRALIAN POWER.
 A NEAT SHOT.**

Blue Prints for All.

AS I said last week, to-day is Blue Print Day, and "P.W." once again provides all readers with two-bobs' worth of the very best, fully tried and tested in every detail, and—best of all—"Buckshee!" As you will see by inspecting them, they are real good circuits, and you might think that having produced such a fine crop as this "P.W." would rest on its laurels for a week or two. Not a bit of it! Read on, Mac-Duff, and learn the latest.

Look Out Next Week.

NEXT Thursday you've got another wonderful wallop for 3d. Next Thursday, my lucky lads, you get a book, packed with practical radio wisdom, circuits, hints, tips, how-to-make ideas, and so forth, crammed with the very cream of radio. The sort of book you cannot buy for love nor money. A "P.W." production.

And just a word of warning. Don't miss your copy. There are always radio sharks rushing about ready to snap up the tit-bits and bargains, and once the news gets round they'll give the news-agents no peace till the last "P.W." is sold out! So nip in now and get your order in. "Ariel" hath spoken!

What's Wrong With Yellow ?

AN otherwise charming correspondent from Ballynagard, Londonderry, pulls up short in his soothing flow and comes down heavily upon "P.W." for what he terms the "sickly yellow" colour of its cover. Oh, sir! yellow is hallowed by the poets as the traditional colour of gold, buttercups, sea sand, and the hair of heroines. Candour forbids me to omit reference also to mustard (that's us!), and the "yaller dog" of transatlantic fiction. But "P.W." is of no ordinary yellow. We are *ultra-yellow*. Very important—like ultra-violet!

The Lorry at Large.

I REGRET that I began all that gossip about electrification by high-pressure steam, because as a result the Ballynagard man is haunted by the thought of a steam-lorry which, he believes, had no visible means of "earthing." I gather that he did not touch it in order to make sure! Now he goes to and fro in Bally-er-thingummy picturing that lorry, like a modern Juggernaut, flinging the statically-charged corpses of its victims broadcast into the Londonderry air. Technical remarks passed to the kennels; bouquet handed to

by 10 a.m. I hope that this little wiggle came to the notice of the U.S.A. delegates.

Business Note.

THE radio export trade of the U.S.A. for the first ten months of 1929 totalled £3,647,191 as compared with £1,802,061 for the same period of 1928. Progress! How do they do it? Well, I believe that some of us could say, if we dared. Now place alongside that fact the complaint of a South American firm who said of British manufacturers that as a general rule they do not print "Instructions for use" in the language of the country

where they are trying to sell sets, etc. And the same remark is true of trade lists. Sometimes not even the weight and price are given in the language of the market sought. A word to the wise!

ANOTHER GREAT GIFT FOR READERS.



FREE!

WITH NEXT WEEK'S COPY OF "P.W."

YOU WILL GET THE "P.W." AMATEUR'S GUIDE.

"It's rude to point," they say! But these members of the "P.W." staff simply couldn't help it, for never before has such a splendid and helpful book for the radio man been available (at any price) to "P.W." readers.

Radio for the Blind.

THIS good cause flourishes, as it deserves, though I have no doubt that it can still find room for further contributions. The National Institute for the Blind is giving £1,000 to the British Wireless for the Blind Fund, which now amounts to some £125,000. Objects of universal pity—though gallantly overcoming their handicap so well that they remain unusually

"Pentode"; kind remarks re self blue-pencilled and dropped on Editor's desk. (He didn't bite!—Ed. "P.W.")

cheerful and active members of society—the blind break through every possible argument against the giving of immediate aid

The Hustlers.

IT is perhaps not generally known that the order for installing loud speakers and microphones at St. James's Palace for the Naval Conference was not given to the Marconiphone people until late in the day preceding the opening of the session. But those engineer fellows seemed not to worry. They had all night, hadn't they? So they just carried on through the dark hours, with the result that all was sizzling and ready

Do You Hear Him ?

MR. E. T. PETHERS, 3, Conley Street, Greenwich, London, would be very glad to have full reports from listeners who may hear him on 155 metres, working C.W. and telephony. Call-sign, G 6 Q C. He would particularly like reports from folk living over fifteen miles from Greenwich. Very modest! He might have hinted at Saskatchewan!

(Continued on next page.)

NOTES AND NEWS.

(Continued from previous page.)

The Fowl Magnificent.

WHO is at the back of this nightingale boom? As one who cannot hurl myself into semi-artificial ecstasies on hearing that bird say its piece, I confess I feel haunted by the nightingale. We have had several spasms of B.B.C. nightingalism (ha!), complete with Miss Kennedy and fiddle. Then the recent Turin mystery, not yet solved. (Latest theory: It is a trained Boss-eyed Bat from Nicaragua!) And now a Mr. Karl Reich comes forward with a claim that he can train canaries to make noises like nightingales. M'yes—and book-makers to speak like Aunt Sophy!

Hidden Treasures!

I WONDER whether all our readers realise what a wealth of interesting relics lies "hidden" in the Science Museum, South Kensington? Would it not stir your imagination were you to see the very kite which Benjamin Franklin flew in 1752 for his famous experiment? It's there! There also you may see bits of the wire, glass tube and wooden trough used by Sir F. Ronalds in 1816, in his attempts to convey static charges of electricity along a buried wire. I need hardly add that he was severely discouraged by the Admiralty, who saw no reason to improve on their semaphore.

Financial News.

EVER heard this one? Time allowed is one minute. Mental arithmetic. A man buys a 12s. 6d. valve and pays over a five-pound note. The dealer cannot give the proper change, so he gives 7s. 6d. change. Next day the customer hands the dealer four £1 notes and recovers his fiver. How much did his valve really cost him? (Answer: £3 12s. 6d.) Here is a curiosity. The numbers 1 to 9 (inclusive) added together amount to 45. If you set them out and subtract them from the number which is formed by setting them down in the reverse order, the sum of the figures which compose the answer is also 45.

Radio the Leveller.

VERILY, times are changed! The modern housemaid, the "slavey" of the Victorian era, now faces the microphone and lectures the "missuses" on the subject of her profession. I should have liked to peep into some of the houses of Upper Surburbia during that talk. Again, Bill Sikes—to use merely an accepted term for a law-breaker—leaves His Majesty's hospitable roof and declaims to the listening community on the unprofit of being naughty. With luck we shall soon have a so-called composer apologising for and explaining why he committed Chamber Music.

Proof of the Pudding.

I HAVE recently seen several references in the Press to the regrets felt by the B.B.C. at the indifferent attendance nowadays at their Symphony Concerts. It's the same old tale! Give the public Bartok, Honegger and Stravinsky instead of conventional music! Speaking for myself, I only wish they would present the work of our distinguished countryman, Sir E. Elgar, half as much as that of foreign composers whose imaginations are noise-ridden.

Cheap Engraving.

FROM the feel of it I thought that it was a bar of chocolate, probably a love token from an "expert." But it turned out to be a strip of ebonite demonstrating the panel engraving of J. S. (Holloway, N.). It is done by a cheap but effective process, the tools being a needle, a penny, a six-penny piece, and a piece of a broken wheel, and with these he describes circles, semi-circles, and so forth. Chalk rubbed over the scratches brings them out as plain as a cut on the chin on your wedding-day.

Australian Power.

THE "Wireless News and Musical World" (W. Australia) points out to Big Brother "M. W." that as 6 WF (Perth) and 7 ZL (Hobart) use only 5 kw.

SHORT WAVES.

Government Radio Uncles. With Aunt D.O.R.A. in Children's Hour?—"Daily Mirror."

INTENSIVE STUDY.

"Our contemporary, 'John Bull,' in an open letter to Sir John Reith, of the British Broadcasting Company, recommends announcers to study the King's speech on the gramophone. It is a pleasing picture to think of tired announcers going home after work, and relentlessly playing and replaying the gramophone until it is time to go back again to Savoy Hill."—"Vox."

Counsel (to woman witness, after cross-examination): "I hope I have not troubled you with all these questions."
Witness: "Not at all! I have a small boy and a wireless set at home."

SORRY!

The King's speech at the Disarmament Conference was preceded by a talk from Mrs. H. A. L. Fisher on Keeping Poultry in a Small Way. We suggest that the speeches which followed this should be called Keeping Battleships in a Small Way.—"Vox."

"Peace Speech in a Church. Worshippers hear Bath Broadcast," we read in the "Evening World."

We understand that the sounds of the loofah came over with surprising clarity.

LOWBROW'S LAMENT.

("People should be given what they ought to like.")

There are subjects I love best:
That I really should detest,
And I ought to welcome things
That simply bore me.
But I fear if I should haste
To improve my awful taste
There would always be an endless
Road before me.

For it's clear as clear can be
To a humble chap like me
That, as soon as I acquire
Appreciation
Of the things beyond my sphere,
They, in turn, will soon appear
Much too popular for my
Consideration. —"Sunday Pictorial."

What a pity wireless fans cannot be shut up as easily as the ordinary sort.

there is little chance of picking up their signals outside Australia. Perth used to employ a S.W. 1-kw. set on 100 metres, which sometimes got through to the U.S.A., but I gather that this is not now operated. Thanks and "more power" to the "W. N. and M. W."

A Matter of History.

VIDE page 1150 of our issue dated February 15th, will readers kindly note that the printer ran short of n's and that therefore the name of the man who found out that a Leyden jar will

give "shocks" was spelt, erroneously, Cuneus. It should be Cuneus.

The Truth About Tuning.

MY private hobby of "expert"-baiting, having been reflected in these Notes, has started a fashion amongst our readers, who now regularly produce a good haul of "howlers" for my delectation. We are much indebted to H.E.M. (Glasgow) for his specimens, though several of his best catches are, I fear, likely to be "caviare to the general."

But this is priceless: "We are quite aware that by using a set employing several tuned circuits some sort of selectivity can be obtained, but such schemes are very elaborate, tricky to operate and entail a very heavy expense." (My italics). O, Syntony, thy name is Mud!

This Heavyside Layer Nuisance.

"REGULAR READER" suggests that if wireless waves really do rebound from the Heavyside Layer, communication between earth and the planets by radio is impossible. I am afraid that it is not a simple matter of a clean, fair, "bump and down we go again."

According to the theory which has been built up to fit the observed facts the question of whether the waves are reflected or pass right through the Layer depends upon their length and upon the angle at which they meet the Layer. It is thought that the shorter the wave the less easily is the ray bent over, so that for a given set of conditions in the Layer there is a limiting wave-length at which the waves will penetrate.

A Neat Shot

A PARAGRAPHIST in the "Daily News" got in rather a neat shot at Sir John Reith, who recently announced (according to news reports) that the policy of the B.B.C. is to refrain from giving the public what the public demands. This caused quite a stir in the hearts of newspaper readers, so when the B.B.C. Director was seen lunching at the Savoy, the journalist in question asked whether the chef followed the "dangerous and fallacious" policy of giving Sir John what he wanted. Yes, I wonder how long a restaurant would last if its policy were, "Naughty! To want tripe! You have got to eat sausage-and-mashed here!"

The Latest Anti-Radio.

MENTION of sausages reminds me that it has been reported that an electrical sausage machine has been wiping out reception somewhere. That can probably be remedied, but a much more serious instance is that of the cinema in Hampshire which blots out signals. One report says that the Post Office is helpless to interfere as the proprietor is not willing to let their engineers enter and investigate.

Sleuths, Forward!

G. W. D. (Kensal Rise), carefully omitting the wave-length, states that from 3.30 p.m. to 4.0 p.m., on January 17th, he heard telephony going on between some mysterious stations named Cornflower, Banister (?), Hermiona, Buffalo Blue, Cerise, and Buttercup. Sounds like a chat between race-horses, doesn't it?

ARIEL.

"The REGIONAL FOUR"

Here are some general and operating details of the de-luxe four-valve receiver described in the blue print presented this week with "P.W." The set is a Research Department production, and, besides being easy to build and operate, is capable of providing a stupendous number of programmes at full loud-speaker strength. The "Regional" Two and this year's "Titan" Three will be described next week.

By the "P.W." RESEARCH AND CONSTRUCTION DEPARTMENT.



AMONG the four sixpenny blue prints presented free with this issue of POPULAR WIRELESS will be seen one entitled "P.W. Blue Print No. 56, A 'Regional' Four-Valver." This set really needs very little description, for all the details necessary for making it will be found

is of the binocular type, and which has a switch incorporated in it so that wave-changing can be carried out in a very simple manner. The aerial is auto-coupled to the secondary coil, still further enhancing the selectivity, and then on the other side of the screened-grid valve we find that

quite straightforward, the L.F. side being transformer-coupled in both stages and capable of providing very great magnification, resulting in the reception of a large number of stations on the loud speaker.

If you are going to use this set with a mains unit, it would be advisable to use an output filter for the last stage, connecting the output filter choke across the loud-speaker terminals in this set. For battery working, there is no need for this type of output circuit unless you use long extension leads for your loud speaker, when it is advisable to employ a filter.

The L.F. Stages.

An anti-motor-boating device, in the form of R_1 of 25,000 ohms and C_8 of 2 mfd., is incorporated in the detector anode circuit, and this enables the two transformer couplings to be carried out with its perfect stability.

It is advisable when building this set not
(Continued on next page.)

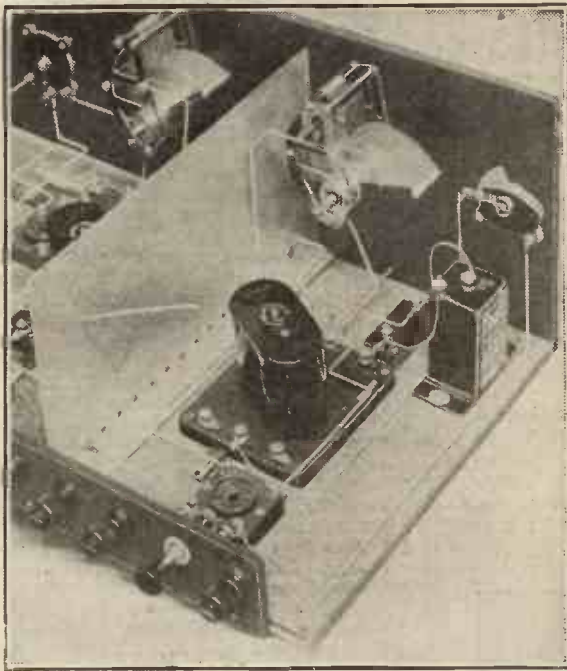

The H.F. end of the set, showing the wave-change coils, and the tuning on the panel. The switch on the terminal strip is for switching off the H.F. valve when the aerial is placed on A.

two selectivity taps are arranged on the primary of the second coil unit, which is of the usual split-primary type, thus taking us a very great step further towards achieving high selectivity. We can afford to have high selectivity even if we lose a little H.F. Amplification for we are using two transformer coupled L.F. stages, which give us all the volume we desire.

In addition, of course, we have two tuned grid circuits, one for the H.F. valve and one for the detector, and as these two circuits are tuned independently, that is, the condensers are not ganged, a further very useful aid to fine tuning is obtained here.

The reaction condenser is of the differential type, so that variations of its capacity have no effect

upon the tuning of the set. This is a great advantage when listening to distant stations, for with ordinary reaction if you want to increase the volume slightly by using reaction, it usually results in throwing the set out of tune, and one has to readjust the tuning every time one alters the reaction.

A Real De-Luxe Set.

As the blue print states, this "Regional" four-valver is a real de-luxe receiver having exceptional selectivity, and, owing to its screened-grid H.F. stage, a very high degree of sensitivity, while its L.F. side makes it a powerful loud-speaker set.

If we look at the theoretical circuit, we see that a variable condenser (C_1) is included in the aerial, so that here we have the first step towards high selectivity.

Then we come along to the aerial wave-change coil, a Lewcos GBA coil unit, which

Differential reaction obviates this trouble, and you can use it on the distant stations and bring up the reaction control without having to alter the tuning. The rest of the circuit is

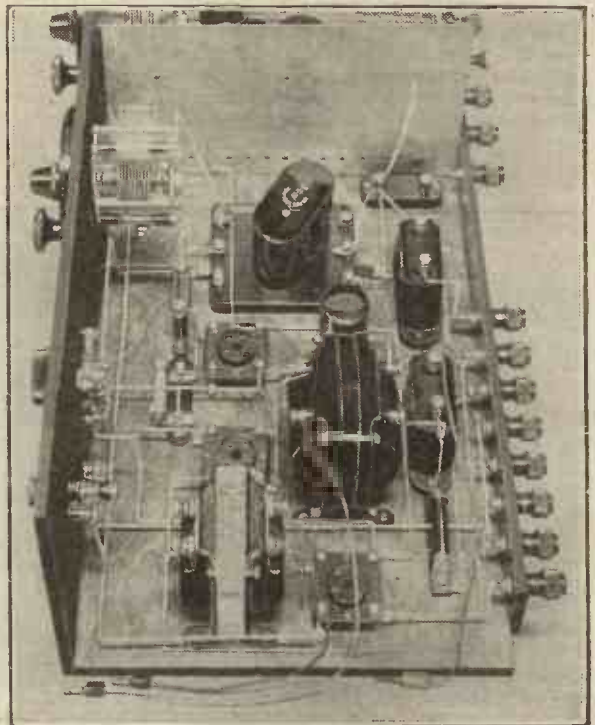

The detector and L.F. section is screened from the H.F. grid circuit by the vertical screen shown in this photograph. Although two transformers are used for the L.F. amplifier, perfect stability is obtained.

THE "REGIONAL" FOUR.

(Continued from previous page.)

to use two transformers of exactly the same make and type. For instance, if you have two transformers of 1 to $3\frac{1}{2}$ ratio they will probably work quite all right in this set, so long as they are not of the same make. If they are of the same make, you may have a little bit of trouble, and it may be necessary to reverse the primary connections of one of the transformers, or even to resort to other wangles in order to obtain L.F. stability.

Transformers of different ratios of the same make are usually quite satisfactory, and in this case it is best to use the one with the lower ratio in the detector circuit, and the one with the higher ratio next. Thus, if you have a transformer of 1 to $2\frac{1}{2}$ or 1 to 3, and another one of 1 to $3\frac{1}{2}$ or 4, use the 1 to $2\frac{1}{2}$ or 3 transformer in the first stage, and the one with the higher ratio in the second.

Handling the Controls.

Variation of the Brookmans condenser, C_1 , in series with the aerial, will of course, slightly alter tuning, but not to such an extent that you will be thrown into confusion when you are using that condenser to assist in cutting out an interfering station. If you live near a powerful local station and you are searching for distant stations, it is best to have condenser C_1 well towards the minimum.

A little practice with the set will show you how to handle this condenser. It is obviously a matter of adjustment until the interfering signal is either at a minimum or disappears, bearing in mind, of course, that the tuning condensers, C_2 and C_3 , have to be moved in step.

For instance, it is useless to expect C_1 to tune out your local station if C_2 and C_3 have not been adjusted. Until the two grid circuits, which C_2 and C_3 tune, are themselves in tune, you cannot judge the selectivity of which this set is capable.

Another refinement of this set is the fact that two aerial terminals are supplied, placed so that you can have either the H.F. stage in or out. If you want to use the H.F. valve, then you have the aerial on A_1 and the switch S_1 in the ON position (that is, pulled out), while if you do not want the H.F. stage at all, you place the aerial on A_2 and push the switch S_1 to the off position.

Suitable Valves.

There is no need to remove H.T. plugs or to alter anything else, but you neglect the condenser C_2 for tuning when the aerial is on A_2 , as the C_2 circuit is no longer in use.

As regards valves, you will find the types are mentioned on the blue print. Either



A simple panel layout, and easily-arranged controls are features of this powerful loud-speaker receiver.

2-, 4- or 6-volt valves can be used, a screened-grid valve being inserted in the first stage, an H.F. type for detector, and an ordinary L.F. valve for V_3 , with a power or super-power for V_4 .

It will probably be advisable always to use a super-power valve in this last stage, whether you are near a fairly powerful local transmission or not, for the set is capable of powerful reception of foreign stations on both high and low waves, and a smaller valve would hardly deal with the grid-swing successfully. When listening to a nearby local station, you will not need the H.F. stage, and you will probably do better to place the aerial on A_2 .

Grid Bias and H.T.

Remember also that grid bias plays a great part in the quality which one gets from the set, so adjust this for the two L.F. valves very carefully, noting the manufacturers' instructions.

It is mentioned on the blue print that

50 or 60 volts H.T. should be supplied to H.T.₃ terminal, which feeds the anode of the detector valve. This low figure is mentioned because it is usually roundabout that voltage that one gets the smoothest reaction, but if you find that you can get smooth reaction control with an H.T. voltage in excess of this, then you will probably find the set will work better and that you will get better all-round results

WHAT YOU WILL REQUIRE.

1 Panel, 21 in. x 7 in. (Resiston, Trolite, Goltone, Trelleborg, Becol, etc.)
1 Cabinet to fit, with baseboard 10 in. deep (Camco, Gilbert, Pickett). Lock, Peto Scott, etc.)

2 ·0005-mfd. variable condensers, slow-motion type or with vernier dials (J.B., Lissen, Lotus, Igranic, Burton, Geophone, Ormond, Dubilier, Bowyer-Lowe, Cyldon, Formo, Colvern, etc.)
2 Vernier dials (Igranic Lissen, etc.)

1 ·0005-mfd. "Brookmans" condenser (Ready Radio).

1 ·0001-, ·00013-, or ·00015-mfd. differential reaction condenser (Ready Radio, Lotus, Lissen, Dubilier, Pye, Burton, Wearite, Ormond, Paroussi, Formo, Magnum, etc.)

2 On-and-off switches Lissen, Benjamin, Igranic, Lotus, Bulgin, Wearite, Keystone, Burton, Jewel, etc.)

4 Sprung valve holders (Formo, Lotus, Igranic, W.B., Benjamin, Magnum, Wearite, Burton, Bowyer-Lowe, etc.)

1 D.B.A. and 1 D.B.P. wave-change coil (Leweos).

1 H.F. choke (Lissen, Varley, Ready Radio, Dubilier, Igranic, R.I., Climax, Bowyer-Lowe, Bulgin, Magnum, Wearite, Colvern, etc.)

2 L.F. transformers of low ratio (Ferranti A.F.5. and Telsen in set). (Igranic, Lissen, Brown, Cossor, Varley, Lotus, R.I., Leweos, Philips, Mullard, etc.)

2 ·002-mfd. fixed condensers (Lissen and Dubilier in set). (Igranic, T.C.C., Clarke, Graham-Farish, Goltone, etc.)

1 ·0003-mfd. fixed condenser (T.C.C., Lissen, Clarke, Goltone, Graham-Farish, Mullard, Dubilier, Igranic, etc.)

2 2-mfd. fixed condensers (Lissen, Ferranti, T.C.C., Hydra, Dubilier, Mullard, etc.)

1 25,000-ohms resistance and holder (Ready Radio, Dubilier, Ferranti, Lissen, Varley, Igranic, Mullard, R.I., Precision, etc.)

1 2-meg. grid leak (Ediswan, Lissen, Carborundum, Loewe, Dubilier, Igranic, Mullard, etc.)

1 Grid-leak holder (Lissen, (Dubilier, Graham-Farish, Igranic, etc.)

1 Standard "P.W." screen, 10 in. x 6 in. (Paroussi, Ready Radio, Magnum, Keystone, Wearite, etc.)

1 Terminal strip, 21 x 2 or 19 x 2
12 Terminals. Belling and Lee, Igranic, Eelex, Burton, etc.)

Wire, screws, G.B. plugs, flex, etc.

How It Will Look When You've Built It

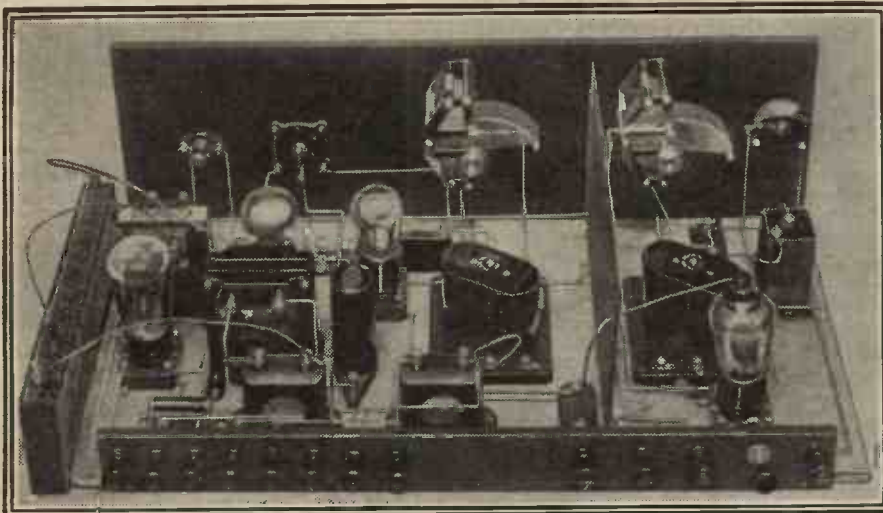

A view of the completed set. The Blue Print gives you full details of layout and wiring, as well as the panel-drilling diagram. It is advisable to keep to the layout as closely as possible.

when the H.T. is higher on H.T.₃. It can often be taken up to about 100 volts or more with advantage on the detector stage, especially when the H.F. valve is in use.

There is very little more to be said about this circuit, except, perhaps, to emphasise the importance of following very closely the layout and the wiring diagram of the blue print.



"IF YOU WANT TO BROADCAST ---"

Read these audition experiences of successful radio stars, who have all had to go through that dreaded testing stage, when a solemn announcer and a still more poker-faced microphone are the only audience. Not an inspiring commencement to the road to radio fame.

MISS MABEL CONSTANDUROS.

For my first audition I walked (trembling) through the gardens towards Savoy Hill on a rainy February morning, and took my place among a pathetic company—for the most part, I judged, of those who had found age a bar to the continuance of their work on the stage or halls.



Mabel Constanduros—the famous Mrs. Buggins.

My name was called, and I was ushered into a dim room which I now know is that from which the Children's Hour is given.—Number Three Studio.

"There is the microphone. Now will you begin, please?" said a voice.

Begin? Every word I knew by heart fled from me. But there is something compelling in a waiting microphone. You feel you *must* do something. So I dashed into one of my own monologues—then some "straight" stuff.

A voice from a loud speaker frightened me by saying, "That's enough, thanks!" *It was!* I felt ill, cancelled an engagement and went straight home to bed.

But the following week I was asked to join the London Repertory Company, so I suppose I didn't do too badly.



Tommy Handley, who is also to be heard in a Talkie.

TOMMY HANDLEY.

Nowadays there is a Radio Doctor at the B.B.C. who looks after those who get severe attacks of Micro-fright during an audition! But things were not so happy in the days when I started.

So there I was, standing in front of an unappreciative

instrument, told to be funny.

What did I do? Well, what would you have done? For a few seconds, which seemed like years, I pondered—knowing all the time that the audition official was waiting, and that my reputation depended on quick thought.

Then in despair I recited what came first into my mind, without any connection with the humorous programme. It was that little couplet—

*Thirty days hath September,
April, June— and so on!*

As I finished the last line the audition man came out of the Silence Cabinet, laughing loudly.

"That'll do," he said, when he had stopped laughing. "It isn't what you said. It's the way you said it."

I give the tip for what it is worth to any amateur humorist about to make a pilgrimage to Savoy Hill.

LEONARD HENRY.

I was engaged to compeere a variety bill on a Wednesday and to produce it on the Saturday! So I didn't have time for a proper audition. My first few words over the microphone were a nightmare to me. I had a tongue several sizes too large, and a thirist one could photograph!



Leonard Henry is always good for a laugh.

This was in the days when variety was played on a small stage in Number One Studio at Savoy Hill. The studio was blacked out, and they had "limes" focussed on the artistes to make the right atmosphere of a stage. The compeere, poor Little Leonard, was left alone in the dark by the microphone, unable to read his own writing!

I shall never forget the following incident. A very large nigger with a very small uke was doing his stuff when a hand reached up out of the darkness and attempted to pull him nearer the microphone.

Unfortunately, it caught the gentleman near the waist line and undid his dress waistcoat, showing him to be the abashed owner of a dress "dickey." Picturo the sniggers of the audience, the amazement on the nigger's face, and add to this the

fact that he was in the middle of a blood-curdling yodel.

Ever since it happened, I have only to think of it to cheer myself up in the studio!

Another Smile was during the preliminary audition for a Charlot Hour. Teddie Gerrard was singing a pulsing love duet with my brother-in-law, Thorpe Bates.

To see Teddie right up to the microphone, almost with her head in it, and Bates right at the other end of the studio with his back to the microphone, singing about "nestling into your arms" and "looking into your eyes," seemed vastly amusing, however well it might have sounded from the outside!

Yes, auditions are rum things.

J. H. SQUIRE.

Gramophone-recording experience is similar to an audition. I'm proud of the fact that my Octet is the only private orchestra which has broadcast *without* an audition. So I haven't much to say about auditions!

As a matter of fact we never experienced any difficulty in facing the microphone, and shortly after our first broadcast we felt so much at home with the radio conditions that we toured the B.B.C. stations from London to Bournemouth, via Belfast and Aberdeen—1,800 miles broadcast tour in eight days!

So broadcasting isn't so "terrifying," after all!



J. H. Squire, the leader of the Celeste Octet.



Miss Vivienne Chatterton has been a microphone favourite for many years.

MISS VIVIENNE CHATTERTON.

Of my first effort I have but a confused memory—of being hastily 'phoned, of being taken to the old familiar room in which hung the telephone-like microphones. I

(Continued on next page.)

"IF YOU WANT TO BROADCAST—"

(Continued from previous page.)

remember distinctly the thrill in being told that my voice was recognised by a friend in the next room:

There was no terror for me in my audition and first broadcast. It was all too experimental.

Since then I have broadcast in oratorio, opera, musical comedy, sketches and plays, have taken part in broadcast Irish, Dorset, Cockney and French pieces, and have met the microphone in the whole gamut of its range of reception. There is nothing terrifying about an audition if you go the right way about it.

RONALD FRANKAU.

Profit by my sorry experience!
There was nothing funny in my audition.



Ronald Frankau and his Cabaret Kitchens need no introduction.

Friends who were with me on my first broadcast told me that I treated the microphone as if it were a full house, making eyes at it, smiling at it, and finally bowing to it!

I made a rush for the studio door when it was all over, leaving music

and everything behind—my one idea being to "make an exit."

During this audition I felt that the microphone really was a living thing, and was standing there watching me.

I confess that even now, when I'm accustomed to it all, the microphone has more terrors for me than the most critical of visible audiences.

CLAPHAM AND DWYER

(Without "Cissie").

From what we have heard of other artistes' audition experiences, we really ought to "give ourselves a pat on the back" (as the song says) with regard to our own first brushing acquaintance with the microphone. Now that it is over, we can say, both blushing with pride, that we never have microphone fright.

Never? Well, hardly ever! Nor did we actually "get the wind up" during our audition at Savoy Hill; we didn't have time to get frightened!

We were shoved in front of a microphone, told to be funny, sing, do our stuff, and all that kind of thing. Verily a *conunda-conunda-cudiddle* that would puzzle any funny men!

Anyway, we tried hard for a hundred seconds or so, and felt that we were falling flat. Never before have we felt that our

self-confidence and stage presence were deflating so rapidly.

So be prepared for this when you go to broadcast.

At the end of a couple of minutes the audition official said "Thank you very muchly. That'll do." And out we went feeling that we'd had enough of broadcasting even before we'd started.

Yet, such is the Friendliness of Fortune and the Fickleness of Fate (just a second while the microphone is dried!). We shortly found that the audition man had been pleased with our turn, and—well, here we are!

Moral: Don't be discouraged.

NORMAN LONG.

Auditions being just like a first broadcast, I had better speak of my first meeting with "Mike." My first broadcast was long before the days of auditions. Actually it



Famous for his sunny smile—Norman Long.

NEXT WEEK:

ANOTHER GIFT FREE

Order your copy of next week's
"Popular Wireless"

NOW and make sure of
THE "P.W." AMATEUR'S GUIDE

a 32-page book presented free with every copy of "P.W."

was during the first month of broadcasting—in a small room on the seventh floor of Marconi House in the Strand.

The room contained more yards of wire than ever I dreamed existed, gadgets fixed up on sugar boxes, microphones like hand-telephones; but principally wire—everywhere wire!

That was my first experience of *Wireless*!



Clapham and Dwyer (without Cissie), our most famous back-chat comedians.

MISS GRACIE FIELDS.

To my mind, what is worse than an audition is the "afterwards"—when a B.B.C. official tells you in honeyed tones that what suits the stage won't always suit the microphone. Instance:

You must stand at such-and-such a distance from the microphone. You must

turn your head from the microphone as you sing a high note.

You mustn't cough, or make *sotto voce* comments. You mustn't take advantage of gestures, because nobody will see 'em. You mustn't say "Thank goodness that's over!" until the microphone is switched off!

There is a stilly silence all round you. There is a stilly silence when you finish. The announcer says: "That finishes with Miss Gracie Fields. Now we'll try out a talk by Professor Booring on 'The Analysis of the Flora and Fauna of Asia Minor.'" You realise with a kick that you're only one of the cogs in the broadcasting machine.

I can't quite remember whether it was during an audition or a first broadcast that I chose to sing a really new number which (keep this secret) I hadn't learned properly owing to shortage of time.

They switched on, and just as I started to sing I couldn't remember the words. So I snatched up the music from the piano and went on singing without a break. The accompanist started to make mistakes, and when I looked round he was motioning to me that he didn't know the number without the music. But we struggled through somehow.

My advice to you, when you are going up for a try-out at the B.B.C., is to practise your turn over and over again in a room alone, at home. Address your song or remarks to the aspidestra, or the hearthrug.

If you don't feel silly, then you can safely face the microphone.



Gracie Fields has a style and charm of her own.

FOR YOUR NOTE BOOK.

An easy method of checking the quality of your reproduction is to insert a milliammeter in series with the H.T. + lead of the last valve, adjusting grid bias and H.T. until its needle does not tend to kick even on loud passages.

The use of large shunting condensers across switch contacts, and similar sources of interference is one of the best means of getting rid of this trouble at the source.

One of the best ways of ensuring long life for your accumulator is to adhere to the makers' instructions in every possible way, and frequently to check the condition of the electrolyte (acid) with a hydrometer.

A hydrometer is usually much cheaper than a voltmeter, and is equally good as an indicator of the condition of your accumulator.

One little-known method of overcoming persistent humming interference is to bring a coil associated with the source of disturbance close to the receiver, and arrange the coupling with the coil so that the effect upon the set shall be equal in intensity and opposite in direction to the disturbance which is being picked up.

THAT 261-METRE WAVE.

Although two powerful programmes instead of one is a clear gain, the new "Regional" situation has given rise to quite new problems, as this article tells.

By THE EDITOR.

OUR readers will remember that, in a recent issue, we referred to a letter we received from a Mr. Hennequin, of Seven Kings, Essex. Mr. Hennequin referred to an article we published in which we stated that the 261-metre (2 L O) wave does not need such effective means of elimination as the 356-metre one; and he went on to say that he held the opinion that a great many people in various districts found it was harder to eliminate the 261-metre wave than it was to eliminate the 356-metre one.

To get rid of the 356 wave, according to Mr. Hennequin, is easy, but 261 is a very difficult job.

For and Against.

We have received a number of letters from readers in connection with this matter, and a consensus of their opinions seems to indicate that about 50% of our correspondents agree with Mr. Hennequin, while the other 50% think just the opposite! It goes to show how conditions vary.

A correspondent living in North London writes that he agrees with Mr. Hennequin that the very name of the London Regional station is a leg-pull! If it isn't, he asks, why is 2 L O stuck out in the country instead of in the centre of its region?

"The B.B.C. are proud of the fact that this station is well received all over Europe. Why? It is admitted that the majority of sets within eighteen to twenty miles are affected, and crystal sets put out of gear almost entirely."

"Well," continues our North London correspondent, "this is the London Regional station, isn't it? Having interfered with about 90% of the sets in London, the B.B.C. are now making frantic efforts to eliminate the interference. It's the B.B.C. that want some attention; not the sets. The transmission on the 261-metre wavelength is undoubtedly the worst I have ever heard, but, I have no doubt, fulfils the mission it was intended for—to blast every other station within about 50 metres of it clean off the dial."

Too Much Power?

Our correspondent ends by saying: "I wish every listener who had been interfered with would write and tell the B.B.C. (1) the transmission is bad, (2) to reduce the power about 75% and make a London Regional station of it and not a European Regional." (We certainly do not agree with his first point, our correspondent is probably seriously overloading his valves.)

Still, that is one point of view which agrees with Mr. Hennequin's. Turning to another letter, we find a West London correspondent saying that he disagrees with Mr. Hennequin, and that the 261 transmission can be tuned out without the aid of the "Brookmans" Twin Rejector; and so on, and so on, indicating that the conditions in which he lives are obviously entirely different to those which affect Mr. Hennequin's reception of 2 L O.

It was very interesting indeed to read through this pile of letters—some agreeing with Mr. Hennequin, and others disagreeing. But, be it noted, an analysis of the letters showed that the majority of our correspondents who agreed with Mr. Hennequin lived in the North or North-east of London, and that most of our readers who disagreed with Mr. Hennequin lived in the South or South-west.

We also received a good deal of correspondence in connection with an article, "What the Public Wants," which we recently published in "P.W."

Our readers will remember that in that article we referred to Sir John Reith's

WHERE THE "TWINS" LIVE.

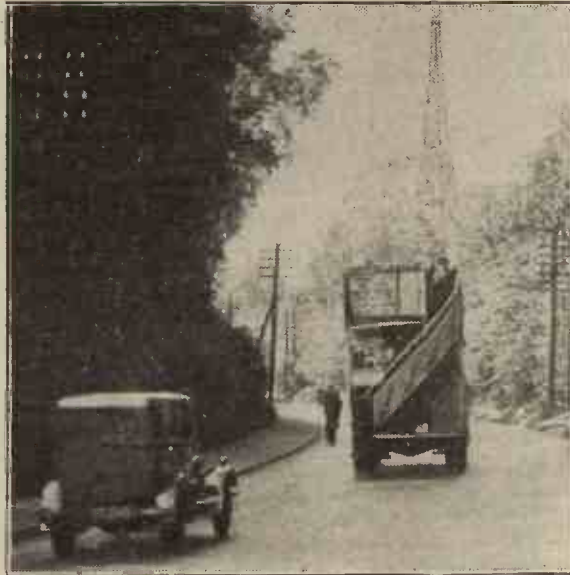

The new 2 L O is the world's first high-power twin-wave station and this view, taken from the Great North Road, shows one of the masts at Brookmans Park, where the 261-m. and the 356-m. transmitters work side by side.

announcement that the public should be given, not what it wants but what is good for it. Everybody admits that the newspaper quotations from Sir John's article gave the impression that Sir John didn't care twopence about public taste; that he had a contempt for it; and that whatever people said, he was going to give the public what he thought it should have.

In fairness to Sir John Reith it ought to be pointed out that these isolated extracts from his article, as published in the newspapers, gave a wrong impression of Sir John's real views, and we should not like our readers to think that Sir John deliberately rides roughshod over public opinion. He does nothing of the sort.

And, furthermore, it must not be thought that we are taking Sir John's side in this controversy. Our business is to be critical and, as far as possible, impartial. Sir John's

job is an extremely difficult one, when one considers what a huge audience the B.B.C. has to cater for.

It is all very well for Mr. Cochran, for instance, to stage a certain kind of show. His audience is definitely the type of audience which likes an amusing, musical and spectacular play, full of cleverness and all the rest of it, but deliberately conceived and planned with the idea of entertaining, and only entertaining.

Trying to Please Everybody.

The B.B.C. cannot take up a line of action as definite as Mr. Cochran's, nor can it take up a line of action as definite, say, as some theatrical producer whose policy is to produce nothing but Shakesperian and other classical plays. The B.B.C. has to try and please everybody, but when Sir John says it is not good policy to give the public what it wants, he really means, we should think, that, under the present difficulties of trying to please two or three million people, the less heed paid to the noisy minority the better.

It is always well to bear in mind that people who are satisfied seldom express their appreciation in letters to the papers,

but those who are dissatisfied usually make the loud-est noise.

The B.B.C. tries to steer a course between the high-brows, the middle-brows and the lowbrows; and, obviously, it can't be done. Therefore, it has to use its wits and knowledge of psychology, and plan programmes which, as near as possible, aim at pleasing the majority of its clients.

Even then, admittedly, they fall short of the ideal. But just ask yourself this: Supposing Sir John and the other Governors decided to give the public what it wanted—how on earth would they go about it? And would not the result be a greater outcry than ever?

What the public wants usually has to be judged from letters, and from newspaper articles, and if you examine the letters that appear in the Press you will find that 5% of them emanate from listeners who want nothing more or less than a constant

stream of jazz and variety entertainment.

The Best Policy.

On the other hand, there are some people who maintain that only classical music should be played, and highbrow talks *ad infinitum*. Supposing Sir John and the other Governors followed that school of thought, and gave that particular public what it wants? Well, the result would be an unholy mess and, in deciding not to give any one section of the public what it wants, in the sense of favouring one section more than another, we venture to think that the B.B.C. have succeeded in finding the ingredients for programmes which, taken over a period, are as varied and as near to achieving a reasonably satisfactory diet for all classes of listeners, than would be the case if the B.B.C. judged "what the public wants" by carping letters from the disgruntled.

ADDING AN H.F. STAGE



"I WANT rather more power on distant stations, but do not wish to scrap my present set, which otherwise suits me perfectly. Would an H.F. unit help me?" A common enough problem, but not a very easy one to settle, because it depends so much on circumstances.

For example, before we can hope to arrive at a correct answer to the question with which we began, we must first of all divide receivers into two main classes, i.e. those *with* and those *without* an H.F. stage already in use. Where the set already incorporates an H.F. stage the addition of a second one is always rather a chancy business, and in general it is scarcely to be advised.

You see, two H.F. stages require to be rather carefully designed and constructed if they are to be stable and work properly, and you have no guarantee that these conditions will be satisfied if you add just any H.F. unit to any set. It is a bit of a risky business at the best of times, but it is likely to be successful in many cases if you add a screened-grid unit to a set containing an ordinary neutralised stage. Adding a screened-grid stage to a set already containing one of the same type is less likely to be satisfactory, and less promising still is the addition of a neutralised H.F. unit to a set containing already a similar H.F. valve.

The "Ranger" Unit.

All these cases of adding another H.F. stage to a set already containing one, therefore, are apt to be a little doubtful. Our second case, of the addition being made to a set of the detector and L.F. variety, is quite straightforward by comparison, because here we can be pretty sure that all will be well, especially if we are careful to choose a good, modern design for our H.F. unit. A good example of such a unit, by the way, is the "Ranger" Unit ("P.W." February 22nd, 1930).

Now there are one or two little points about the use of a separate H.F. unit which do not seem to be quite so clearly understood as

An H.F. stage not only increases the distance-getting powers of a set, but also adds very considerably to the selectivity of a receiver. It is, therefore, a very commendable scheme to fit one to those sets not already incorporating such, now that the High-Power Regionals are coming into operation. This article discusses the use of H.F. stages in handy unit form.

By G. P. KENDALL, B.Sc.

they should be, and I should like to devote a little space to explaining them. First of all, what should we expect such a unit to do?

Well, it ought to increase the volume of distant stations very considerably,

and enable us to receive them with better quality, because we shall no longer have to use so much reaction to get adequate volume. Selectivity will in almost every case be improved a good deal also, because we can now generally have an extra tuned circuit at work. This extra tuned circuit, however, besides giving us more selectivity, means an extra dial to tune, so we must be prepared for a little more difficulty in operating the receiver.

All that this means, really, is that we must expect to spend a little time learning to work the set before we can get the full results of which it is capable. Hence, we must not be disappointed if we do not get quite the results we expected until we get the hang of working the outfit with the two dials with which we now have to contend.

So much for what an H.F. unit will do for us on distant stations. Now what about its effect on the local? This is where many people get something of disappointment when they first handle an H.F. stage, because they expect it to make the local just as much louder as it does the distant transmission. In very many cases it does nothing of the sort, and its only effect appears to be to spoil the quality when the local is fully tuned-in in an endeavour to get the extra volume which the operator thinks he should be able to obtain.

Overloading the Detector.

What this means is simply that in many cases your detector valve is already fairly fully loaded up by the powerful signals of the local station, and so the extra strength of input from the H.F. stage just overloads it, and causes poor quality with little or no apparent increase of volume. This is not the only cause of poor quality when an H.F. stage is at work, because any slight tendency to instability may have the same effect, but it appears to be one of the main reasons in actual practice.

Fortunately, the remedy for both types of trouble is the
(Continued on page 1264.)

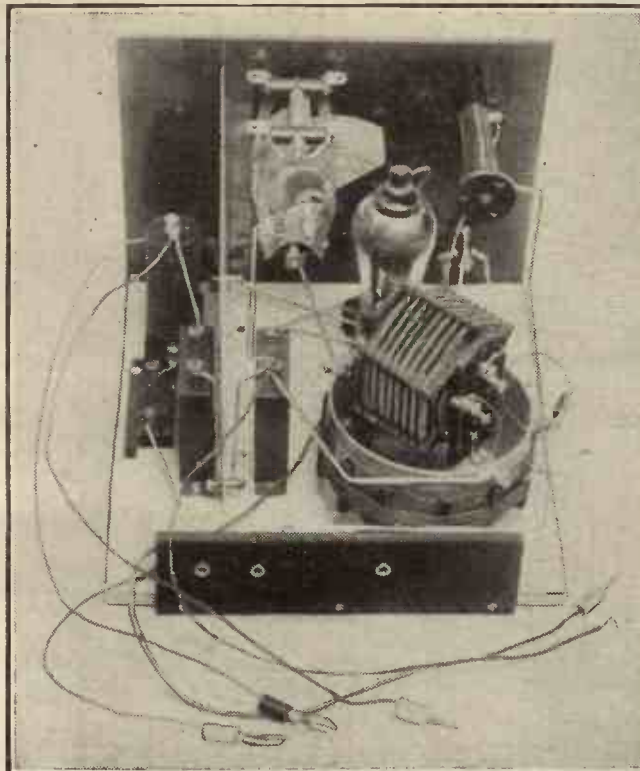

The "Titan" H.F. Unit used an S.G. valve and incorporated a novel wave-change scheme. It proved highly efficient and was very popular.

ANOTHER GREAT GIFT!

With "Popular Wireless," on Sale next Thursday, March 6.

A Magnificent 32-page book, profusely illustrated, and entitled

THE "P.W." AMATEUR'S GUIDE

Packed with practical facts, readably arranged, the comprehensive contents of this remarkable book are not available elsewhere at any price. But you get this fine book with next week's "P.W."

FREE

THE CONTENTS INCLUDE:

N
E
X
T

W
E
E
K

Set-Building Hints	The Valves to Buy
"P.W." Tested Circuits	Short-Wave Sets
Hints on Tuning	The Gramophone Pick-up
Guide to Short-Wavers	The "P.W." Pictorial Guide
How Loud Speakers Work	Using Mains Units

N
E
X
T

W
E
E
K

and

MAKING YOUR SET SELECTIVE

There are also full how-to-make details of Three Fine Sets.
A Selective Crystal Set. THE "MAGIC" TWO. The "Antipodes" Adaptor.

Usual Price
3d.

DON'T MISS THIS
Order YOUR
Copy NOW!

Usual Price
3d.

TELL YOUR FRIENDS ABOUT IT!

LORD CLARENDON EXPLAINS

A few days ago it was announced that Lord Clarendon, the Chairman of the B.B.C., was resigning that post, and would shortly be leaving the country to take up the Governor-Generalship of South Africa.

Who will be the new Chairman of the B.B.C.? In this exclusive interview Lord Clarendon gives his ideas on the subject for the benefit of readers of "Popular Wireless."

By a SPECIAL CORRESPONDENT.

THE Earl of Clarendon was seated in a cosy armchair beside the fire in the spacious drawing-room of his famous old home at Hampstead and ready to talk to me of anything that appertained to his work at Savoy Hill.

What an opportunity to fire off at him, the Chairman of the B.B.C., just a few of those questions which readers of POPULAR WIRELESS—and every listener—would like to ask about the intentions and policy of the B.B.C.

Sorry to leave B.B.C.

I did my best, for within the half-hour Lord Clarendon was good enough to place at my disposal I learned more about the B.B.C. than I had ever succeeded in gleaning from the official statements which are sometimes issued from 2, Savoy Hill.

There was no: "I am unable to discuss the matter," or: "I must refer you to the P.M.G." about Lord Clarendon. He answered each of my inquiries smilingly and with perfect frankness.

At first we talked of his new post as Governor-General of the Union of South Africa, and about his future duties in Cape Town. "I am very sorry," he said, "that it will mean my leaving the B.B.C. It has been most interesting work, and I am keen to go on as long as possible. Unless the Government think I should resign earlier, or unless I have to go to South Africa sooner than I had thought, I hope to stay on until at least the end of July. After that—well, there will have to be a new Chairman of the B.B.C."

"And who will that be?" I interposed. "Ah!" came the reply, "I shall be just as interested to find out as you. But really, I don't think anyone has decided yet."

A Woman Chairman?

"What about a woman chairman?" I queried—my mind turning automatically to Mrs. Philip Snowden.

"Possibly, possibly. At all events, I am sure there is no reason why a woman should not fill the position satisfactorily. But we shall have to wait and see. The appointment, by the way, is made by the Government. When I was appointed it was the Postmaster-General who notified me."

While Lord Clarendon was speaking there came a sound of music from the next room. "Hark!" he said. "The wireless. I listen a good deal, but not as much as I should like, since I am invariably too busy."

It may be of some comfort to those unfortunate listeners whose reception was spoiled by the opening of Brookmans Park to know that the Chairman of the B.B.C.

also had a good deal of trouble at first. "It upset reception for a while, but I soon made the necessary alterations and adjustments," he explained. "It is a pity that the Regional Scheme should be the cause of any trouble like this, but I am certain that except in a comparatively few cases the remedy is fairly simple."

Lord Clarendon considers the Regional Scheme the most important development he has seen in British broadcasting. "We are indebted to Captain Eekersley for that project," he said. "An extraordinarily brilliant young man is Captain Eekersley. I was sorry when he left us."



The Earl of Clarendon, Chairman of the B.B.C.

The lifting of the ban on political and controversial broadcasts is another important development which Lord Clarendon did much to bring about. "I always contended," he said, "that if public interest in the programmes were to be maintained, controversial matter was essential. While it is obvious that the B.B.C. must be non-partisan, and must have no politics and no religion of its own, it is at the same time necessary to have a definite policy to which to adhere at all times."

Reverting to the Regional Scheme again. I pointed out to Lord Clarendon that listeners to the provincial stations, and particularly to the Welsh stations, feared that the B.B.C. might cease to encourage local talent and local programmes. "The B.B.C. will most decidedly not interfere more than is necessary with local programmes and organisation," I was told.

The Centralisation Policy.

"It is the B.B.C.'s intention to centralise to a certain extent, but at the same time we want to do all we can to encourage local patriotism and local talent. Thus, although at each Regional station, one wave-length will continually broadcast the National programme, we shall always reserve the second wave-length for Regional, or local, programmes. Care will be taken not to over-centralise."

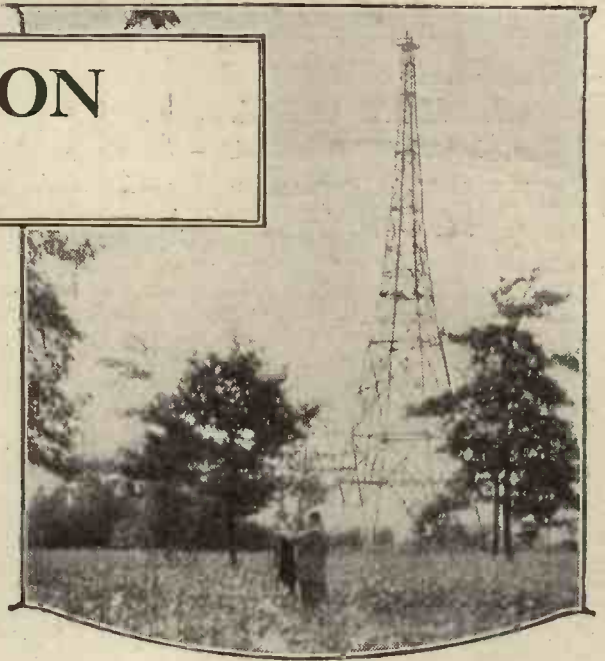

On the subject of Empire broadcasting Lord Clarendon seemed particularly well-informed. In fact, I gathered the impression that the B.B.C.'s Chairman has kept closely in touch with every phase of broadcasting, both in this country and abroad.

"Empire broadcasting," he continued, "has set us a very awkward problem. We naturally want to live up to our motto—'Nation shall speak peace unto nation'—but the difficulties of providing an entirely Empire service are enormous. Not the smallest of the tremendous difficulties in our way is the time problem. What good are 2 L O's evening programmes to listeners in Australia?"

Question of Cost.

"Then, again, it seems hardly just to expect British listeners to pay for the entertainment of listeners in the Dominions. After all, we are an organisation for supplying broadcast entertainment to Britain, not to the world. Nevertheless, we want to do what we can for the Empire, and I have no doubt that eventually we shall find some way out of the difficulties."

BROADCAST BREVITIES

When rather critical H.T. values are required, such as for a screened grid valve, remember that the voltage from an H.T. mains unit is not necessarily exactly the figure marked upon it, so that the effects of slightly different voltages may be tried.

Where H.T. batteries are employed and it is important to reduce the anode current as much as possible, remember that most H.F. amplifying valves will work excellently with from 1½ to 3 volts negative grid bias on the grid, the H.T. current being considerably reduced in consequence.

Do not throw away the leaflets supplied with your valve, or any particulars of the characteristic curve given on the carton, but fasten these into the back of the cabinet with a drawing-pin so that they can be referred to if necessary.

LATEST BROADCASTING NEWS.

**LORD BEAVERBROOK AND
MR. LLOYD GEORGE.**

**A GERMAN WAR DRAMA—
BROOKMANS PARK AT 2,000
MILES—GRIEG'S FRIEND TO
PLAY—Etc., Etc.**

IT is now arranged that Lord Beaverbrook will give a twenty minutes' broadcast address on his Empire Free Trade proposals at 9.15 p.m. on March 31st. Mr. Lloyd George will reply at the same time on April 2nd.

A German War Drama.

"Brigade Exchange," a German war play, which should make an interesting comparison with "Journey's End," will be broadcast from London and other stations on Tuesday, March 25th.

It was specially written for the microphone by Ernst Johannsen, a well-known author who is devoting much of his time to radio work, and it has already been broadcast with conspicuous success from several German stations. Most of the story of the play is told in telephone conversation which takes place in a dug-out telephone exchange.

Brookmans Park at 2,000 Miles.

A striking instance of the long range of the Brookmans Park transmitter is contained in a letter recently received at Savoy Hill from a Liverpool seaman. While on board the steamship "Davisian" he heard the London programme at a distance of 2,380 miles, and was actually able to use a loud speaker up to 1,800 miles. He found reception from both transmitters very good and clear, with the 261-metre wave-length slightly stronger. Other instances of long-distance reception from Brookmans Park have also come to hand during the last few weeks, but that of the Liverpool seaman is a record, unless we consider the claims of an Indian listener who wrote asking how he could cut out Brookmans Park in order to get his local station at Bombay.

Grieg's Friend a Play.

Arthur de Greef, the well-known Belgian pianist, who is now over sixty years of age, is to play Grieg's "Concerto" during the concert at the People's Palace on Thursday, March 6th. This broadcast is particularly interesting in view of the fact that De Greef was an intimate friend of Grieg.

Sea "Atmosphere" at Manchester.

When a party of Birkenhead dock gate-men visit the Manchester studio on Monday evening, March 10th, to give a twenty minutes' programme of sea shanties, they will wear red and blue jerseys, and bring with them a capstan, blocks, and other tackle in order that they may reproduce as realistically as possible the atmosphere in which they actually sung their rollicking songs nearly half a century ago.

The coloured jerseys were the distinguishing dress of the old port and starboard

watches, and the picture will be completed by the accompaniment of the songs on an accordion and banjo—the same ones, "by the way, as were used by these "old-salts" on their voyages.

The idea of the programme is to depict a scene on board the "Roderick Dhu," an old iron clipper which in her day was one of the fastest ships running between Liverpool and Frisco. The "Roderick Dhu" is now at the bottom of the sea, but memories of her great days will be recalled as the men sing a group of traditional shanties, and afterwards other sea shanties of the more modern style.

The Amington Band.

Although formed only twelve years ago, the Amington Band, which comes from a

little mining village of that name on the north borders of Warwickshire, has won a long string of cups and trophies which, naturally, are the pride of the local inhabitants. So, to show their appreciation, the people of Amington, through the local Miners' Welfare Committee, provided the band with a room wherein to practise, and thus secure, they hope, yet more "pots."

The bandroom is equipped with a fine wireless receiving set, to which, no doubt, the villagers will listen on Tuesday evening, March 11th, when the band is playing in the Midland studio in a concert to be radiated from the Midland Regional station (5 G B.). The programme also includes items by Lena Wood (violin) and Joseph Bourns (tenor).

"THE BOYS OF THE OLD BRIGADE."



One of the London newspapers recently installed wireless at the Royal Hospital, Chelsea, to the great delight of the famous Pensioners. How they all cheered when a lively tattoo by the Military Band took them right back to the Boer War, and the brave days of old!

FOR THE LISTENER.

A Specially Contributed Criticism of Current Broadcasting Events.

By PHILEMON.

(Who is deputising for Mr. Cecil Lewis while the latter is in America.)

Looking Backwards.

THESE old men are incorrigible. Mr. Augustine Birrell was asked to look backwards, but would he? Not a bit of it!

So we missed some entertaining memories. The dust of the Gladstonian period was undisturbed. The literary and legal ghosts of fifty years ago were not summoned. Mr. Birrell refused to be taken for a "garrulous old fogey." He simply said that those days were different from these! He seemed much more interested in these! But I thought it a pity that he did not "deliver the goods."

"The Right to Vote."

This was, to my mind, a confused and unsatisfactory debate. Mr. Gerald Barry and Major Elliott kept telling each other that their time was short, and yet they didn't seem able to get to grips.

The subject was not really very interesting, except perhaps for those "study circles" for which apparently the debate

was held. We have all got the vote; but I don't bother much about it, save in a heated moment once every few years.

Certainly very few worry themselves about the duties which are always supposed to go with "rights." Major Elliott seemed inclined to limit the right to vote to the "study circles." I have rarely listened to so much cackling and found so few eggs in the nest!

Scott and Sharkey.

Evidently we are interested in Scott and Sharkey, the boxers. Mr. Tom Webster is being sent all the way to Florida to see them, to draw them lying on their backs, and to make his familiar quips about them. I did not think that he talked as amusingly as he draws.

An Old Lag.

I spent a good deal of time during the war doing physical jerks outside Parkhurst

(Continued on page 1265)

AN ERUPTION OF VOLUME



The volume this valve yields is amazing. You'll be impressed by its volcano of sound.

It is the valve we have chosen for a new 2-valve receiver introduced only 3 weeks ago, and which has taken the trade by storm. The volume this receiver delivers is startling. Largely it is due to this amazing Lissen valve. This valve will do for your set what it has done for Lissen's newest commercial receiver. It is the only valve giving pentode output and pentode quality from batteries without shortening the life of batteries.

Every set employing a single stage of L.F. can be vastly improved by introducing the Lissen Power Pentode Valve instead of an ordinary power valve. Many sets with two L.F. stages can also use it—ask your dealer. But next time instead of buying a Power valve buy a Lissen Power Pentode. Listen to its eruption of volume!

17/6

LISSEN POWER PENTODE P.T.225
(Consumption only 7 milliamps) **17/6**

NEW

LISSEN

POWER PENTODE
- battery driven!

EMPLOYS THE EXCLUSIVE
LISSEN EXTENDED GRID
CONSTRUCTION.

LISSEN LTD., Worple Road, Isleworth, Middlesex, Factories also at Richmond (Surrey) and Edmonton. (Managing Director: T. N. Cole.)



**H.T. CURRENT
FOR RADIO FROM
YOUR LIGHTING MAINS**

**SMOOTH
STEADY
CHEAP**

Lissen H.T. Eliminators deliver smooth, steady current from your house electric supply, and cheaply. The Lissen Eliminators can be put into your set as easily as any battery. From the four types made there will be one to suit you. Send a deposit of 5/- and we will arrange for delivery of the eliminator to suit you, and for it to be properly installed in your set. Send 5/- only. Leave the rest to us. You pay the balance in one sum after installation or by extended instalments.

D.C. Model "A." 100-110 or 200-250v. Cash Price 27/6, or 5/- down and 5 monthly payments of 5/6.

D.C. Model "B." 100-110 or 200-250 v. Cash Price 39/6, or 5/- down and 8 monthly payments of 5/-.

A.C. Model "A." 100-110, 200-210, 220-230, 240-250 v. Cash Price 60/-, or 5/- down and 10 monthly payments of 6/6.

A.C. Model "B." 100-110, 200-210, 220-230, 240-250 v. Cash Price 75/-, or 5/- down and 10 monthly payments of 8/-.

LISSEN
ELIMINATORS

LISSEN LTD.,

Worple Road, Isleworth, Middlesex. Factories also at Richmond (Surrey) and Edmonton. (Managing Director: T. N. Cole.)

Rid yourself of accumulator worries!



Buy an EDISWAN ACCUMULATOR

The demand for Ediswan L.T. Batteries and the increased manufacturing facilities have enabled Ediswan to produce a range of long discharge batteries to sell at amazingly low prices. Here is your opportunity to end your battery worries and save money. Less charging—longer service—wonderful value.

- B.W.G.2. 24 Ampere Hours ... 8/9
- B.W.G.3. 55 Ampere Hours ... 11/9
- B.W.G.4. 68 Ampere Hours ... 13/9

- Midget Loten. 12 Amp. Hrs. 2/9
- Little Loten. 20 Amp. Hrs. 4/9
- Minor Loten. 45 Amp. Hrs. 8/-
- Major Loten. 70 Amp. Hrs. 11/-



THE EDISON SWAN ELECTRIC CO., LTD.,
123/5, QUEEN VICTORIA STREET, LONDON, E.C.4.
Branches in all the Principal Towns.

B.55.

TEAM WORK

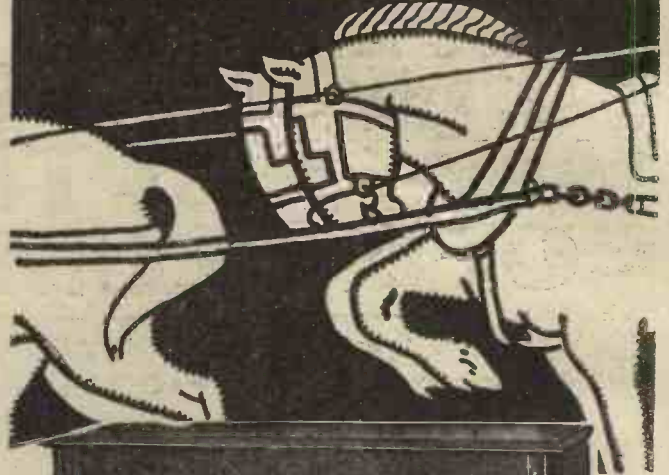

All pulling together!

Every horse stepping as one horse; all the Components working as one Component, one mighty Component—that's the "Empire 3" by BurTon!

Here's the secret—every Component a BurTon Component, all pulling together; that's team work; that's what makes the "Empire 3" such an outstanding success.

£5. 10 Valves, Batteries and Royalties extra.

ALL MAINS MODEL

(self-contained)
Price of Set - £11 : 5 : 0
Price of Valves (Mullard A.C.) £3 : 10 : 0
(Royalties extra)

Identical in appearance to the Battery Model.

THE BURTON EMPIRE 3

EVERY PART A BURTON PART

C. F. & H. BURTON, PROGRESS WORKS, WALSALL, ENGLAND.



CAPT. ECKERSLEY'S QUERY CORNER

Under the above title, week by week, Captain P. P. Eckersley, M.I.E.E., late Chief Engineer of the B.B.C., and now our Chief Radio Consultant, will comment upon radio queries submitted by "P.W." readers. But don't address your queries to Captain Eckersley—a selection of those that have reached the Query Department in the ordinary way will be dealt with by him.

Detector Differences.

L. G. B. (Bournemouth).—"It used to be said that the use of a crystal detector was almost essential to avoid distortion in the detector stage. So much attention is paid nowadays to high quality reproduction that I am surprised to notice the entire absence of crystals from 'quality' receivers.

"Has the anode-bend rectifier entirely superseded the crystal as a distortion-free detector or is the crystal still better?"

The first point is that valve detectors can be made nowadays to have perfectly straight-line rectification characteristics; secondly, that even then they give amplification in the detector stage which the crystal does not; thirdly, they are more robust and easier to maintain than a crystal. So the use of a crystal is not necessary for detection thanks to the improvement in valve rectifier technique.

There are many snares to avoid when using a valve as detector. If you have a robust signal the bottom bend can be made linear in its response because you can work well up the curve.

For small signals and for certain types of valve, however, bottom bend gives square-law response, which is undesirable. The best all-round method appears to be grid-leak detection (a comparatively recent discovery), provided one uses only a few hundred thousand ohms grid leak and lots of H.T. on a proper type of valve.

Paper or Mica for L.F.?

L. D. (Stockton).—"Is there any real disadvantage in using a paper dielectric type condenser for R.C. coupling in an L.F. amplifier? Naturally, I am aware that its working voltage should be sufficiently high to prevent a breakdown in its insulation."

No; I don't think the dielectric losses in a good paper condenser would ever be appreciable in a low-frequency amplifier; it's with high frequency you have to be careful of this point.

Station Separation.

F. C. D. (Bognor Regis).—"Why is it that even a simple portable set is guaranteed to separate the two Brookmans Park transmitters, and yet I am unable to separate these two stations with an efficient four-valver, without the addition of a rejector?"

But you are able to separate them with your four-valver, or I quarrel with the word "efficient" in your description of it.

I'll bet my last farthing that you're using a huge, great aerial, much too big to enable you to get the proper amount of selectivity out of your set. Try a smaller aerial.

By the way, if you listen at Bognor how do you separate 5XX and Radio Paris if you can't separate the two Londons. 5XX and Radio Paris are 18 kilocycles apart, I think, and the two Londons 200 or so! The portable set does it because it has a small aerial.

Which Type of Loud Speaker?

H. K. (Leicester). Is there any particular reason why a balanced-armature loud speaker should not give as good a reproduction as one of the moving-coil type?

There is no real reason why one type should not make just as pleasant a noise as the other.

Nevertheless, I prefer the moving-iron type for certain classes of reproduction, because in a common practice the moving coil is more apt to exhibit resonances than the moving iron. I always maintain that it's a matter for individual choice—neither is perfect.

A Frame Aerial Puzzle.

J. R. W. (Finsbury Park, London).—"Why is it that my four-valve frame aerial set should work satisfactorily on a table in the centre of the room, and yet go very faint when I shift the whole outfit on to the top of a sideboard fitted in the same room?"

"I have made certain there is no metal in the wall (it consists of plaster and laths only) or in the sideboard itself, which is made of wood with the usual mirrors on top."

Frankly, I can't give you your answer pat and with my usual assurance.

I suggest, however, that a lath and plaster wall does create quite considerable electrostatic losses and increases the effective resistance of your frame aerial. Indoor aerials are often better when rigged away from the wall. Earthed metal screens the signals but it does not produce anything like such bad losses as certain dielectrics.

Is your effect worse with long waves? I should think it would be if my diagnosis is correct.

High- or Low-Resistance Moving Coil?

M. U. (Balham).—"I intend to buy a moving-coil loud speaker, but am undecided as to whether it should be of a high or low resistance. I realise the low-resistance moving coil requires a step-down transformer.

But what I want to know is which is better—high or low? Has one of them any outstanding advantages over the other, assuming both are of similar price?"

There's nothing much in it, but lower resistance means thicker wire and thicker wire is more robust—that's all I can really think of to distinguish between the two types.

EVER TRIED THIS?



One of the best ways to heat a soldering-iron is to use a bunsen burner. A stand can be improvised quite easily, the rest for the iron being a piece of brass or copper strip fixed to a tin box. We don't say it's elegant, but we do say, from experience, that it simplifies soldering by heating the iron quickly and cleanly.

The balanced-armature loud speaker has a less possible displacement movement than the moving-coil type, however, and so to do the requisite amount of work in the bass reproduction it has to move a larger radiator. This involves some difficulty in that this larger radiator is apt at high frequency to "break up."

One is drawn to the conclusion that the theoretically perfect loud speaker should use some principle which allows of large displacements of a small diaphragm, and there appears to be difficulty in achieving this performance with conventional types of moving-iron loud speakers.

SHORT-WAVE NOTES.

This week our short-wave expert discusses, among other things, the details of the forthcoming 10-metre tests organised by the R.S.G.B.

By W. L. S.

THIS, as usual, is the time of year that seems to be well filled up with amateur contests and series of tests of an experimental nature. By the time this appears the A.R.R.L. Foreign Contact tests will be nearly over, but almost immediately the R.S.G.B. 10-metre tests begin.

The former, of course, are purely of a "traffic-handling" nature, and the majority of the prizes go to United States and Canadian stations, but there is in addition a prize offered for the station in each foreign country that puts up the highest total score.

Needless to say, this is generally a sure prize for the station that has the greatest amount of time to spend on the air, and the operator who can best do without sleep!

A Strenuous Effort.

The R.S.G.B. 10-metre tests are a strenuous effort to find out a little more about this somewhat fickle wave-length-band, and in order to encourage listening and transmitting at the more "unusual" times the scoring system has been arranged so as to give an advantage to the man who makes contact with stations outside the British Isles at these times, meaning from 20:00-24:00 G.M.T., and 24:00-08:00 G.M.T.

Thus, two contacts with the same station, one made between these times, and the other during the remaining daylight period, may count twice in the score of points.

The 10-metre band is still as freakish in its behaviour as ever, and it seems likely that detailed logs over the same periods from a score or more stations will do a little to "put things straight," and to give those definite details that are the only way of doing this.

Almost immediately after these tests there are the R.S.G.B. Weather Conditions tests on the 160-metre wave-band. This band was, of course, in the old days, the amateur band, and nearly all the work after the 440-metre days was started on the then 150-200-metre wave.

Though this is now cut down to something rather narrower than 150-175 metres there is still plenty of room and very few stations; perhaps these tests will induce some of the old stagers to enter and renew old friendships on this wave.

Readers Can Help.

If any of my readers care to listen for any of these tests and send in their logs to me I will gladly forward them to R.S.G.B., who will be grateful for any particulars, whether from members or non-members. The dates are—10-metre tests, March 2nd, 9th, 16th, and 23rd; 160-metre tests, April 6th, 13th, 20th, 27th.

W. E. S., of South India, badly wants to see a design for a two-stage H.F. amplifier using S.G. valves for short-wave work. I will not say it can't be done, W. E. S., because I have used one myself, but I

candidly do not think there is much in it as a practical proposition.

One stage of S.G. is all very well, but I don't think the second is any more useful than an extra ncte-mag.—it amplifies, but amplifies the mush and everything else, and generally necessitates the use of a volume-control which takes you back where you were before!

However, I am still playing with the idea and will certainly publish anything worth mentioning. Yes, I think the "Magic" Four should receive the Old Homeland without difficulty!

A. R. R. asks whether there is an international directory of amateur call-signs,

the whole of Russia in Asia, Russia not having taken any notice whatever of Washington regulations and prefixes.

EU is kept for Russia in Europe and AU for Russia in Asia, replacing the various prefixes that were used for Siberia, Georgia, Turkestan, etc. X3BK (China) seems wrong to me, especially at the time you mention.

Chinese Stations.

I believe, in any case, that the Chinese amateurs are still using AC and not the new prefix, which should be something between XG and XU. VK5HG is a well-known Australian amateur. XCV5XX is presumably a portable station in Roumania.

Yes, all stations commencing with HAF are Hungarian amateurs.

G. P., of Durban, who was guilty of perpetrating the "Shortadyne S.G. No. 2," which I mentioned a little while back, is still very much in favour of super-hets. for short waves, and says he is still looking out for the "W.L.S.' 9 World-Searcher."

He says the Durban transmission is rotten,

AFRICA'S MOST SOUTHERN RADIO STATION.

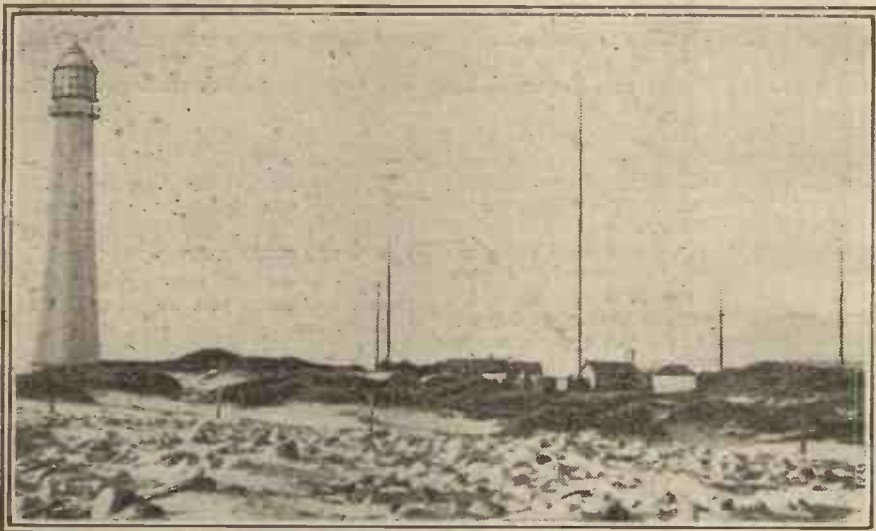

Situated at Cape Town, this station is Africa's southernmost radio post. Incidentally, it has been in fairly regular communication with the exploration ship "The Discovery II."

etc. Yes, A. R. R., I think I gave the address quite recently, but here it is again—the book is the Citizens' Amateur Radio Call-Book, published in the U.S.A. at \$1.10, and obtainable here from Mr. F. T. Carter, Flat A, Glencagle Mansions, Streatham, S.W., or from the R.S.G.B. headquarters. I believe the price to non-members is 4s. The same reader wants to know if anyone has picked up telephony from the R100.

With reference to G2GN, I understand that the "Olympic" is going into dry dock for repairs, and that the work on short waves will probably be taken over by the "Majestic."

Mr. Peter A. Hankey, of Madrid, writes with this information, and also offering to report on any amateur telephony transmissions from this country. He has heard VK2ME (Sydney) referring to reception of G2GN while working London, and also wants to know if anyone has heard W3XAM, the short-wave station of WCAU, Philadelphia. This station works just above W2XE.

R. C. A. asks for enlightenment about sundry amateur prefixes, which I will clear up as well as I can. AU now represents

and barring the fact that he would like it to be brought to their notice, the least said the better! Not yet having heard Durban I cannot give my own opinion, and I don't know that I would dare be quite so candid.

He wants the whereabouts of the telephony station between 14 and 15 metres that works early in the evenings, slightly below PHI.

Short-Wave Super-hets.

On the subject of super-hets., I am certainly going back to one for a while, to see whether it would be possible, by choosing a sufficiently high intermediate frequency, to separate out the second-channel interference from our narrow amateur bands.

With an inter-frequency of 200 kc. this would just about be possible, although this would naturally put commercial I.F. transformers out of court. I propose to use long-wave six-pin coils and to tune them with a small adjustable condenser. I should also welcome notes or details from anyone who has successfully used a screened-grid tuned-anode super-het. for short-wave work.

FERRANTI RADIO



*The three essentials
of satisfactory
radio reception—*

Purity

of tone,

Volume,

and

Selectivity

*—are well and
truly balanced.* ★

MODEL 31

THE FERRANTI "All-Electric" Radio Receiver is designed by experts in the art, and built on sound engineering principles.

★ Whilst we make no extravagant claims we can definitely declare that our Set has been scientifically measured and compared with many others, and found equal to any and better than most in all the three essentials.

*A special order from your dealer
will ensure prompt delivery.*

Write for illustrated book, and, if you are interested, we will arrange for a demonstration in your home.

The price, including valves, is £25 in Oak Cabinet, and £26 in Walnut or Mahogany Cabinet. The Royalty is £1 extra.

This set is available for **Alternating Current Mains only**, voltages 200/250, 40 cycles or over.

FERRANTI LTD.
HOLLINWOOD
LANCASHIRE

THE "Magic" Three is undoubtedly the most popular set in the world. No other design in the previous history of home-constructed radio achieved so immediate and so lasting a success.

There are "Magics" in practically every country, and a striking commentary on the tremendous success of this three-valver is to be found in the fact that its introduction caused widespread shortages in standard components.

The reasons for its great popularity are many and we will summarise them for the benefit of new readers. The following list is quite haphazardly arranged, no attempt being made to give the set's points in any kind of order of importance.

- (1) It is inexpensive and easy to make.
- (2) It is exceptionally easy to handle.
- (3) It covers all wavelengths with simple coil-changing, and brings those fascinating short-wavers within the scope of the ordinary not-too-experienced amateur.
- (4) It is surprisingly sensitive and up to fifty stations on the loud speaker have been "bagged" by many enthusiasts.
- (5) It has power and can, if need be, feed a moving-coil speaker with first-class results.
- (6) It is economical in operation.
- (7) It has reasonable selectivity.

Remarkable Qualities.

So you see the "Magic's" reputation is built on secure foundations, for it has all those qualities that are to be found generally only in the very ambitious type of multi-valver.

We have had an enormous number of appreciative letters from "Magic" en-

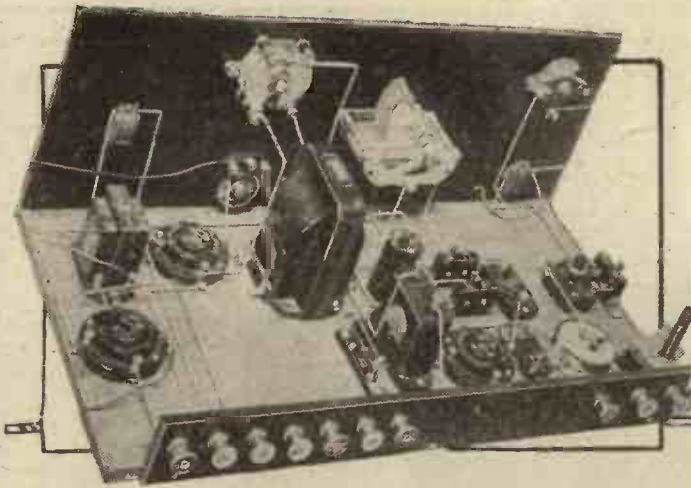

You can make this set, even if you have had no previous experience.

thusiasts, and we have published quite a large number, but such forms but a small percentage of the whole.

So much for the original "Magic," now for This Year's Version. We must point out right away that the original is not now obsolete or even obsolescent. Indeed, it will hold its own for a very long time yet against all-comers.

Powerful Combination.

This Year's "Magic" can be duplicated by all existing "Magic" Three owners with very little trouble or additional expense. We will have some more to say about that later on.

Spread the appropriate blue print out before you and look at the theoretical diagram. At the top left-hand corner you will see a small group of condensers and a coil. Most of these items figure in an arrangement of the equally famous "P.W." "Brookmans" Rejector, that is incorporated in, and is a special feature of this present

This Year's "MAGIC"



"Mag the wi no oth radio succes

"Magic" set. Could any more powerful radio combination be conceived than that of the "Magic" Three and the "Brookmans" Rejector?

Don't run away with the idea that the "B.R." is nothing but a built-in wave-trap—that is very far from being the case. Truly it enables you completely to wipe out any local station, however powerful, but that is only the beginning of its story.

Cannot be Improved.

It also enables you to clean up the reception of any station, more particularly the more distant and less powerful ones. It is possible to clip off heterodyning whistles and such-like nuisances with this wonderful device. So you will see how vitally useful it is to such an ether-piercer as the "Magic" Three, and you will begin to appreciate, we hope, how far This Year's "Magic" Three is from being a mere stunt.

The second innovation in the set design is an efficiently arranged volume control which, you will note, is included in the grid circuit of the second valve.

In all other respects the circuit retains its original form and this cannot be improved upon. The differential reaction scheme, popularised by "P.W.," is still there to provide remarkably smooth reaction, and the potentiometer for adjusting the grid of the first valve for optimum sensitivity and smoothness of regeneration on the short waves is still there.

Thus, all those tens of thousands of new readers can take advantage of all the

that they are all-wavers, the easy to handle and extremely This Year's "Magic" Three minute model and you shor if you don't want to make features not to be found in other receiver o

Designed and De
"P.W." RESEARCH & CO

RECOMMENDED COMPONENT MAKES.

- | | |
|---|--|
| <p>1 Panel 18 in. x 7 in. (Trolite). ("Kay-Ray," Resiston, Trelleborg, Becol, Goltone, Keystone, Paxolin, etc.)</p> <p>1 Cabinet to fit, with baseboard 9 or 10 in. deep (Pickett, Camco, Gilbert, Lock, Peto Scott, etc.).</p> <p>1 .0005-mfd. variable condenser, slow-motion type, or with vernier dial (Lotus, Ormond, Ready Radio, Geophone, Igranic, Burton, J.B., Dubilier, Cyldon, Bowyer-Lowe, Formo, Colvern, etc.).</p> <p>1 Vernier dial (Lissen, etc.).</p> <p>1 Neutralising condenser, baseboard type (Bulgin). (Magnum, J.B., Lissen, Keystone, etc.)</p> <p>1 .00075-mfd. "Brookmans" condenser (Ready Radio).</p> <p>1 .0001-, .00013-, or .00015-mfd. differential reaction condenser (Dubilier, Ormond, Polar, Lotus, Magnum, Lissen, Pye, Ready Radio, Paroussi, Igranic, etc.).</p> <p>2 On-and-off switches (Igranic, Benjamin, Lissen, Lotus, Bulgin, Wearite, Keystone, Jewel, Burton, etc.).</p> <p>1 1/2- or 1-meg. volume control, 3-terminal type (Igranic).</p> <p>3 Sprung valve holders (W.B., Bowyer-Lowe, Magnum, Burton, Formo, Wearite, Benjamin, Lotus, Igranic, etc.)</p> <p>3 Single-coil holders (Lotus, Ready Radio, Keystone, Igranic, Magnum, etc.).</p> | <p>2 L.F. transformers of low ratio (Lissen and R.I. "Hypermite" in set). (Igranic, Brown, Ferranti, Telsen, Cossor, Varley, Lotus, Lewcos, Philips, Mullard, etc.)</p> <p>1 H.F. choke (Keystone, Bulgin, Bowyer-Lowe, Cllmax, Colvern, Wearite, Varley, Magnum, R.I., Lissen, Igranic, Dubilier, Ready Radio, Lewcos).</p> <p>1 Compression-type condenser, max. .001 mfd., or thereabouts (R.I.), Formo, Igranic, etc.).</p> <p>1 .0003-mfd. fixed condenser (Dubilier, T.C.C., Lissen, Mullard, Graham-Farish, Clarke, Goltone, etc.).</p> <p>1 2-meg. grid leak and holder (Lissen, Ediswan, Mullard, Dubilier, Loewe, Carborundum, Igranic, etc.).</p> <p>1 2-mfd. Mansbridge type condenser (T.C.C., Lissen, Ferranti, Dubilier, Mullard, Hydra, Loewe, etc.).</p> <p>1 400- or 200-ohms potentiometer (Igranic, Ready Radio, Lissen, etc.).</p> <p>1 25,000-ohms resistance and holder (Ready Radio, Mullard, Lissen, R.I., Ferranti, Precision, Dubilier, Varley, Igranic, etc.).</p> <p>1 Terminal strip, 16 in. x 2 in. or 18 in. x 2 in.</p> <p>10 Terminals (Elex, Belling & Lee, Igranic, Burton, etc.)</p> <p>Wire, screws, plugs, flex, etc.</p> |
|---|--|

THE SPACE S



You bring the whole world to the "Magic"

TOURS THE WHO

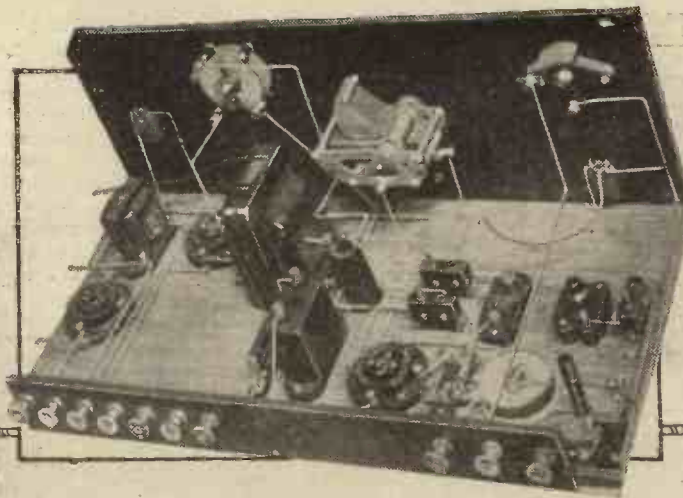

Note the surprisingly few components in this magnificent design.

"Magic" sets are known whole world over; pioneers in the history of have achieved such successes. The reason is that are easy to make, very powerful. It is a right-up-to-the-shoulder read about it even a set. It comprises combination in any of any type.

described by THE INSTRUCTION DEPT.

virtues of the original design (needless to say the copy of "P.W." describing this was quickly out of print), while the new set has, as we have pointed out, gone certain big steps forward.

Now, you thousands of present owners of "Magic" sets, let us address you for a few moments. Your "Magics" become This Year's models if you build in a volume control and tack on a "P.W." "Brookmans" Rejector. These are worth-while additions and we assure you that you will find that they still further enhance the attractiveness of your outfit, even although you may be thinking nothing could improve your results.

Neither is a "stunt," both are vitally useful.

Regarding the construction of This Year's "Magic" Three, there are several most important points that must be brought forward. First of all make sure that all your components are exactly as specified. The differential condenser, in particular, must be one of the recommended makes.

Do not, on any account, accept an ordinary type, it will not do the job. It must be a proper differential.

There are several variable condensers in this set; see that these, too, are exactly of the types specified, and don't mix them up, as they are far from being interchangeable.

Worth the Best Parts.

The I.F. transformers must be chosen with care, because they are veritable keystones in the construction. And let us confidently suggest that the best of anything is only just good enough for the "Magic."

You see, it is just as much to our interest as to yours to have every "Magic" 100

per cent up to scratch! We reckon one failure offsets dozens of successes. But there need be no failures if every constructor "does his bit" towards assembling a real world-beater.

If you feel you can't afford to buy good stuff right out right now, please wait a bit or arrange things with a "Hire-Purchase" concern—the "Magic" is worth it.

And do your wiring carefully. Don't rush this job through. We know you will be all eagerness to get the thing going and test its world-roaming possibilities, but more-haste-less-speed is as true to-day as ever it was.

Really Interesting Assembly.

Get every connection hooked on for keeps at exactly its right point, and check it up by the blue print before proceeding with the next. Every wire tells in such a design as this.

Solder every wire in position if you can, but remember that bad soldering is inferior to a good screwed-down contact.

And when at last your final lead is connected, browse over the completed job and

the diagrams for some little time, asking yourself these questions: "Is it exactly in accordance with that blue print? Is every component exactly in its place? Is every lead joined up correctly? Is there any dust or dirt about? Can my job be improved anywhere at the expense of a little more time and trouble on my part?"

If the answers are honest and satisfactory, your task is accomplished. Or at least the main part is completed. You now have the set as the result of some really interesting assembly work, but you are still faced with the even more interesting task of getting it going.

Next week we will give you some operating notes which will, we trust, be in good time for your first "try-out."

By the way, we have not yet given the *raison d'etre* of that space which is left on the baseboard just behind the first L.F. transformer and valve.

This space is for accommodating a choke-condenser or transformer output arrangement should you wish to include either of these.

Later on we are going to give the details of the simple modifications that this necessitates. Meanwhile, we will leave you to give the main construction its finishing touches.

A 6d. BLUE PRINT OF THIS FINE SET IS ONE OF THE 4 NEW 6d. BLUE PRINTS GIVEN FREE WITH EVERY COPY OF THIS ISSUE OF "P.W."

HIGH SELECTIVITY—GREAT SENSITIVITY

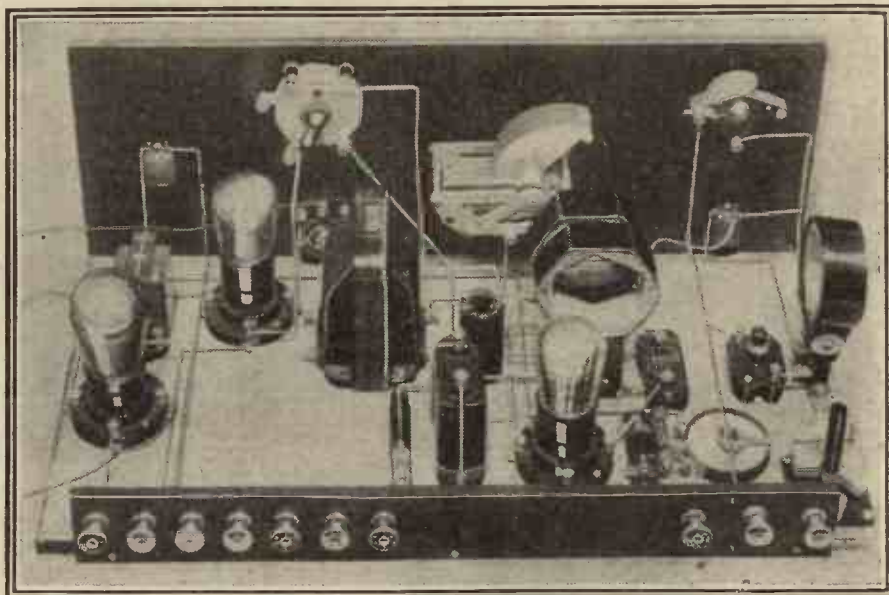

Notwithstanding its comparatively simple back-of-panel appearance, this year's "Magic" covers long and short wave-lengths, has a perfect volume control, and can reject the most powerful local stations on the loud speaker have been recorded on "Magic" Threes.

LE WIDE WORLD

FROM THE TECHNICAL EDITOR'S NOTE BOOK.

Tested and Found-?



PHILIPS MAINS SET.

THE success of the Philips mains set provides some indication of the increasing popularity of the use of the electric power mains for radio purposes. Of course, the Philips set has been extensively advertised, but advertising alone is not enough. The goods must be deserving of the publicity or such publicity will be wasted.

The Philips people have years of experience and a great organisation behind them. The Philips mains set is, in my opinion, one of the most attractive in appearance of any that is on the market. It looks so very efficient. It is apparent that every effort has

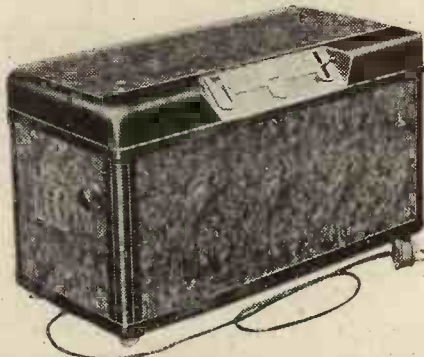

Note the compactness and excellent layout of the Philips Mains Set.

been made to simplify its control, and this is, of course, essential if mains radio working is to be a success.

The catch phrase "simply plug in" is negated if the set's controls are complicated and skill is needed to obtain satisfactory results.

Unfortunately, the Philips set sent us for test did not, for some reason, acquit itself particularly well. Maybe it received some obscure damage in transit. However, perhaps later on we shall have an opportunity of testing a further sample with happier results.

MULLARD PAPER DIELECTRIC CONDENSERS.

A new range of fixed condensers has just been placed on the market by the Mullard Wireless Service Co., Ltd., and forms a very useful addition to the Mullard P.M. series of radio components.

Of the rolled type with paper dielectric, hermetically sealed into metal containers, the condensers are finished in the company's standard matt black enamel. Three ratings, namely 1, 2 and 4 mfd., are available and meet most practical requirements, and at the prices of 2s. 6d. for the 1 mfd., 3s. 6d. for the 2 mfd., and 5s. 3d. for the 4 mfd. sizes, form a distinctly competitive line because the condensers are designed for working pressures of 250 volts D.C., whereas the

majority of condensers at present on the British market and offered at substantially the same price are definitely rated for 200 volts only.

Each Mullard Paper Dielectric Condenser is tested at 500 volts D.C. between plates and flash tested at 1,000 volts A.C. between plates and case before leaving the works.

The method of hermetically sealing together with special processes in manufacture render the condensers immune from damage due to climatic changes and they are, therefore, suitable for

export to tropical countries.

Two points which, although small in themselves, are of very great practical value, are first, the provision of substantial solid terminals and soldering lugs for connecting purposes and second, the extension of the base to form two fixing lugs with fixing holes instead of slots. This gives a convenient and simple method of fixing which is far more satisfactory than the usual slots.

The condensers are attractively boxed and, in conformity with the Mullard standard practice, are sent out complete with two fixing screws.

Once again, my compliments to the Mullard people for a clear, unexaggerated description of one of their lines, for the above wording is entirely theirs without deletions or additions.

The condensers are completely satisfactory, my tests with the sample sent showed it to be every bit as reliable as it is claimed to be and constructors will, as suggested, appreciate the connecting and fixing details.

VARLEY INSTRUCTIONAL BOOK.

I have just received a new set of Varley instructional books. These are excellently prepared and contain much useful information. Each includes a number of well-drawn circuit diagrams. There are some half dozen of these Varley instructional books, each dealing with a specific group of Varley components.

With every Varley component sold the corresponding instructional book is issued, so that the purchaser receives full details regarding his immediate purchase, together with information relative to other Varley products of a like character.

KONECTERKITS.

An idea which should appeal strongly to constructors is the new Peto Scott Konec-terkit. This is a neat little box containing all the connecting wire, wander plugs, wood screws, brass screws and nuts, etc., found necessary in the construction of a set.

The prices of these Konec-terkits range from 2s. 3d. to 5s. 6d., and you can get one suitable for any "P.W." construction. It saves one the trouble of collecting all those little incidentals and in doing this the Peto Scott people will have again earned the gratitude of many of us.

BENJAMIN VALVE HOLDER.

The Benjamin Electric, Ltd., are making a five-pin valve holder designed specially for inclusion in manufactured sets. The construction of this valve holder is of a simple but efficient character, and the Benjamin people say that they are able to quote very attractive prices for it.

The valve holder can be obtained either unmounted or mounted on aluminium strips in gangs of two, three, four or five. It is a development of the four-pin holder of a similar type which the concern has been manufacturing for some time and which has, we believe, been supplied in enormous quantities to the trade.

These are not valve-holders that the amateur constructor could use easily, but they fit excellently into factory built apparatus.

SIEMENS BATTERIES.

Siemens Bros. & Co., Ltd., recently sent me copies of the new edition of their catalogue 641, which gives full details of all their

WHEN YOU ARE BUYING—

(3) AN H.T. BATTERY—

The first thing you should do is to see that it bears the name of a firm known to produce reliable radio apparatus.

Some foreign batteries are excellent, but if you buy a foreigner endeavour to obtain some indication as to its date of manufacture.

From the moment it is made, an H.T. battery begins slowly to depreciate whether or not it is used.

Insist upon a voltage test and see that a reading of 1.5 volts per cell is given. Some so-called "60-volts" batteries have 42 cells and should give a reading of 63 volts. An extra two or so cells are also often included in batteries of higher voltages. If you don't know the shop take your own, or borrow a friend's, voltmeter for the job!

The ordinary size of H.T. battery will not last long if you make it give more than six or seven milliamps. Above that, double or triple-capacity types are advisable.

"Super Capacity" may mean ordinary capacity in an unknown make!

batteries, including primary L.T. types and accumulators. There is also a price sheet dealing with Siemens radio batteries for portable sets.



The Philips Moving Coil Load Speaker is of quite unusual appearance, and it operates very well indeed.

1930

All Ready Radio "Titan" and "Magic" Kits
are officially approved by "Popular Wireless." Large
stocks of all the Components are available to ensure our well-known

IMMEDIATE DESPATCH REPUTATION

"MAGIC" 3 "TITAN" 3

LIST AT A GLANCE

	£	s.	d.
1 Drilled ebonite panel, 18 in. x 7 in.		6	0
1 Hand-polished solid oak cabinet, with baseboard	1	10	0
1 Ready Radio '0005 variable condenser		4	6
1 J.B. slow-motion dial		5	6
1 Bulgin B/M neutralising condenser		5	0
1 Ready Radio '00075 "Brookmans" condenser		3	6
1 Ready Radio Differential condenser		5	0
2 Ready Radio On-off switches		2	6
1 Igranic volume control		6	0
3 W.B. sprung valve holders		3	9
3 Ready Radio single coil holders		2	6
1 Lissen super L.F. transformer	19	0	0
1 R.I. "Hypermite" L.F. transformer	12	6	0
1 Keystone H.F. choke		5	0
1 R.I. '001 compression type condenser		2	6
1 Dubilier '0003 mfd. fixed condenser		2	6
1 Lissen 2-meg. grid leak with holder		1	6
1 T.C.C. 2-mfd. Mansbridge type condenser	3	10	0
1 Igranic 400-ohm potentiometer		1	8
1 Ready Radio 25,000-ohm resistance with holder		2	5
1 Drilled terminal strip, 18 in. x 2 in.		1	8
10 Belling-Lee engraved terminals		2	6
1 Set Ready Radio connecting links		2	6
3 Valves, as specified	1	13	6
5 Lewcos coils (2 No. 50), (1 No. 60X), (1 No. 100), (1 No. 250X)	1	2	9
1 Set Atlas short-wave coils		19	0
Screws, plugs, flex, etc.		1	5
TOTAL (INCLUDING VALVES, etc.)	£9	19	6

Any of the above parts can be supplied separately if desired.

KIT A	less valves and cabinet	£6: 16: 0
KIT B	with valves less cabinet	£8: 9: 6
KIT C	with valves and cabinet	£9: 19: 6

All kits include special Ready Radio connecting links

NO SOLDERING REQUIRED!

LIST AT A GLANCE

	£	s.	d.
1 Drilled ebonite panel 18 in. x 7 in.		6	0
1 Hand-polished oak cabinet, with baseboard	1	10	0
1 Ready Radio '0005-mfd. variable condenser		4	6
1 J.B. slow-motion dial		5	6
1 Polar (type Q.I.) '0031 s.m. reaction condenser		10	0
1 Ready Radio 3-point wave-change switch		1	6
1 Ready Radio L.T. switch		1	3
1 Wearite filament rheostat		1	6
3 Lotus sprung valve holders		3	9
1 Ready Radio 1930 Titan coil unit	15	0	0
1 Lewcos H.F. choke		7	9
1 Wearite combined aerial condenser switch		2	3
1 Varley (Ni-Core 1) L.F. transformer	1	0	0
1 Dubilier '002 mfd. fixed condenser		3	0
1 T.C.C. '0001 mfd.		1	6
1 Lissen '0093 mfd.		1	0
2 Dubilier '25 mfd.		4	0
1 Lissen 2-meg. grid leak and holder		1	6
1 Grid-leak type resistance, 1 meg.		1	3
1 Ready Radio 25,000-ohms resistance and holder		2	5
2 Ready Radio fuse holders, with bulbs		3	0
1 Ready Radio Standard Titan screen		2	0
1 Drilled terminal strip, 18 in. x 2 in.		1	8
10 Engraved Belling-Lee terminals		2	6
1 Set Ready Radio connecting links		2	6
3 Valves as specified	2	5	6
1 Siemens 1.5-volt grid battery		3	6
1 Dubilier 2-mfd. condenser		1	5
Screws, Plugs, Flex, etc.		1	5
TOTAL (INCLUDING VALVES, etc.)	£9	6	6

TOTAL (INCLUDING VALVES, etc.) £9 6 6

Any of the above parts can be supplied separately if desired.

KIT A	less valves and cabinet	£5: 11: 0
KIT B	with valves less cabinet	£7: 16: 6
KIT C	with valves and cabinet	£9: 6: 6

All kits include special Ready Radio connecting links

NO SOLDERING REQUIRED!

There is no need to inform "Popular Wireless" readers of the wonderful success of the "Magic" series. These sets, together with the "Titans," were undoubtedly the most successful receivers designed in 1929, and over 200,000 have already been constructed.

READY RADIO IMMEDIATE DESPATCH SERVICE

When you buy radio parts you naturally want them quickly. You also would be happier with the knowledge that in the event of subsequent difficulties you can obtain technical advice without trouble.

TO HOME CUSTOMERS

Your goods are despatched post free in sealed cartons or carriage paid by rail. Note.—You can if you desire avail yourself of the C.O.D. system.

TO OVERSEAS CUSTOMERS

All your goods are very carefully packed for export and insured, all charges forward.

The designer of the original "Titan" Receivers has now made remarkable improvements which he has incorporated in the 1930 "Titan" 3. It will undoubtedly be even more popular than the original set, the great reputation of which is known not only to "Popular Wireless" readers but to all set constructors.

Telephone No.
Hop 5555
Private Exchange.

Ready Radio

Telegrams:
Ready Hop 5555
London.

159, BOROUGH HIGH STREET, LONDON BRIDGE, S.E.1.

All who prefer Quality
in Cigarettes



Say
Player's
Please

5 for 3d. 10 for 6d.
20 for 11½d.



N.C.C. 722



ACCURACY and APPEARANCE

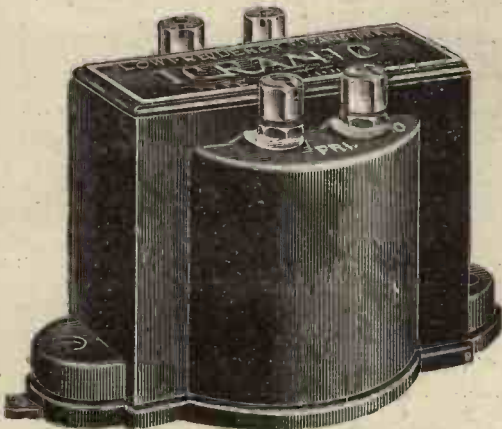

IGRANIC TYPE "J" L.F. TRANSFORMER

Small, neat and handsome, but with a straight line performance and a purity and constancy of amplification far above any transformer in its priced class. Use it and enjoy truly magnificent magnification. Obtainable in two ratios, 3:1 and 6:1. Price 17/6.

IGRANIC ELECTRIC CO., LTD.,
149, Queen Victoria St.,
LONDON, E.C.4.
Works: BEDFORD

Apply to your dealer. If he cannot supply you, please write direct to Dept. R.144.



IGRANIC INDIGRAPH VERNIER KNOB AND DIAL
Handsome and accurate slow-motion dial. Entirely free from backlash. Affords the most popular, simple and reliable vernier control.

Price 6/-. Midget size, 3/-.



The "P.W." MURAL CONE

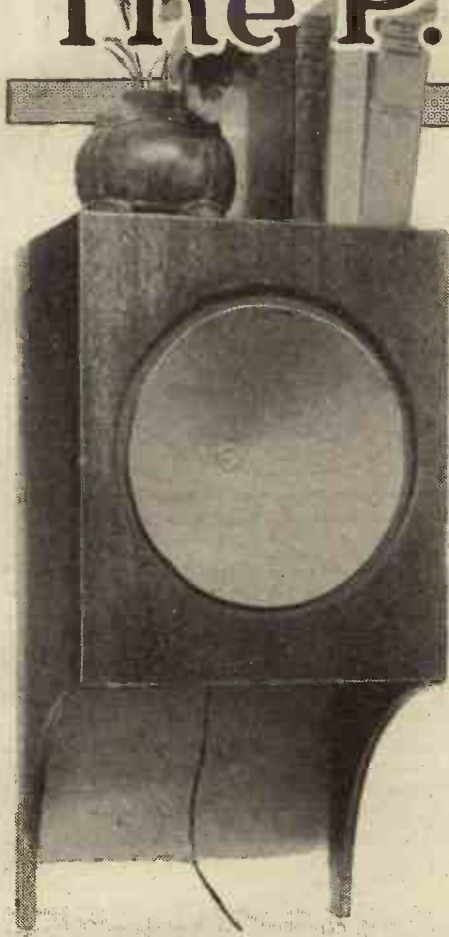

Why not build your own loud speaker? For quite a small sum you can get results hardly distinguishable even by a critical ear from those given by a high-priced instrument. And the work is quite easy and well within your scope. Also, this present model is particularly novel and attractive in design.

Designed and Described by

THE "P.W." RESEARCH AND CONSTRUCTION DEPARTMENT.

The Mural, or, to give it its dictionary definition, the wall-cone, is rather away from the usual run of things, and it embraces several novel features. In the first case the actual cone, which is reed-driven from a unit situated behind, is, to all intents and purposes, free edged.

To be a little more precise, although the more usual method of holding the cone in position is by a ring of felt or other material, the cone in the present design is entirely unanchored apart from four small pieces of gummed tape which are used for centring purposes. (Excluding the connections to the reed at the apex of the cone.)

Lifelike Reproduction.

This particular method of construction tends to give a slightly better high-note response, a very desirable feature, and one closely allied to the question of "brilliance" or crispness.

But naturally there would be little advantage gained were this high-note response only obtained at the expense of bass. In point of fact this is certainly not the case with the Mural-Cone, and under test conditions it compared very favourably from the point of view of low notes with other home-made cone loud speakers against which it was tried.

High Efficiency and Low Cost.

Turning, for a moment, to practical considerations, the Mural-Cone has a platform arranged about half an inch below the top of the framework, so that, quite apart from being an efficient loud speaker and a dignified adornment for the wall, this "shelf" (we prefer, in view of what has been said, to use quotation marks!) can be used as a receptacle for a vase of flowers or for books.

One point, which to most of us is of considerable importance, and which we have not yet discussed, is that of cost.

VERY EASY TO MAKE.

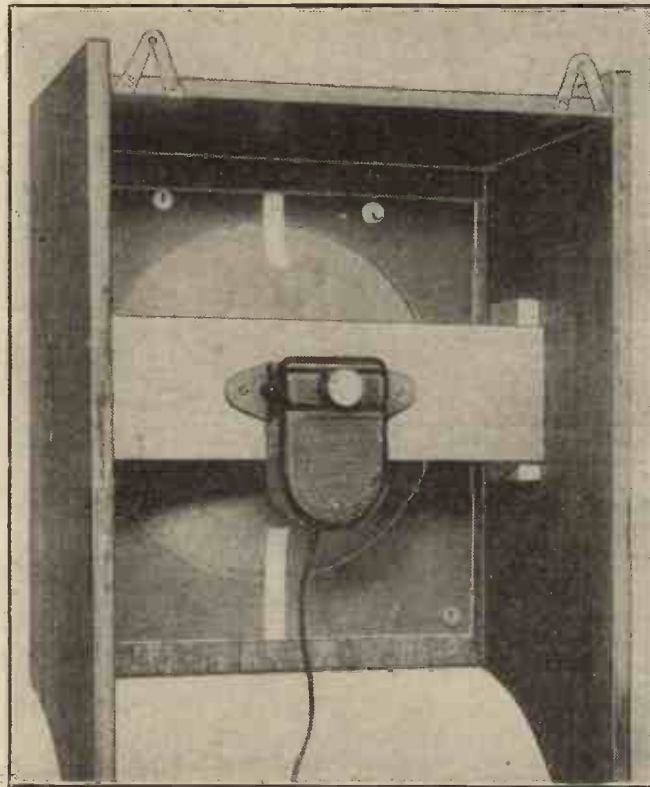

The fixing of the unit is simplicity itself. In this photo you can see the centralising tapes, the hooks that hold the instrument to the wall, and the sheet of cardboard fixed by drawing pins.

ARE you in the habit of standing your loud speaker on top of the set cabinet?

Have you ever noticed how deucedly awkward it is to make adjustments to the set's "innards" with it thus located?

Precisely! So indeed have we. So much so, in fact, that of late we have taken to using in the laboratories a specially designed shelf on which to stand the reproducing instruments so as to leave the numerous benches entirely free for set testing, measurement taking and the various other activities of the Technical Staff.

Hangs On the Wall!

But a shelf in its accepted sense can hardly be considered a desirable adornment when it comes to domiciliary considerations. We need not belabour the possibility of trouble for he who is seen with nails and hammer in the drawing-room!

In all seriousness, though, this question of convenient loud-speaker location (particularly do we refer to those of the home-constructed variety) does present something of a problem. In the case of the commercial article, of course, the finish almost invariably is of such a high standard as to make the loud speaker worthy of a place of honour as an article of furniture on the sideboard.

In presenting to readers the "P.W." Mural-Cone it has been our aim to produce a loud speaker, not for the adornment of the set cabinet or for the sideboard, but something entirely novel and new, in the shape of a bracket to hang on the wall.

A considerable number of loud-speaker units, in fact almost all of those which are now available on the market are offered at prices ranging between about twelve and twenty-five shillings, so that, taking the highest example given and allowing five shillings for the other material required, the total cost should not much exceed thirty shillings.

If you choose one of the cheaper units, then naturally the overall cost will be less; but even at thirty shillings we consider the Mural-Cone to be a remarkably cheap proposition when the results it is capable of giving are considered.

The material required for the construction of the actual bracket consists of a plank of

(Continued on next page.)

THE "P.W." MURAL- CONE

(Continued from previous page.)

wood 6 ft. 6 in. long by 8 in. wide, and another piece, 13 in. by 11 in., this latter to form the front. Unless you happen to be a particularly handy man with a plane, it is recommended that you buy ready-planed material.

The Wood-work is Easy.

In constructing the original case we found it convenient to use mahogany, chiefly because, on account of its colour, it suited our purpose better from the photo-

This is carried out with what is known as a keyhole saw, which, if you do not possess and are unable to borrow one, can be bought for about 1s. 6d. or 1s. 9d.

The hole should first be marked out with a compass and the compass point should be placed on the spot where the two diagonals of the front piece of wood cross. When you have succeeded in cutting out the disc of wood, the edge of the hole should be finished off with sandpaper, or, if you have one, with a spokeshave.

At the bottom of each side-support also, a rounded piece must be removed with the keyhole saw, after which sandpaper should once again be pressed into service for finishing off purposes.

When the front, sides and top are ready you can proceed to assemble the cabinet, after which construction of the cone should next occupy your attention. This is made from what is known as "Kraft" paper and when buying it you should ask for the material which goes 120 to the ream.

The paper should be cut out to the shape and size shown in the drawing, after which it can be stuck together by means of the $\frac{3}{8}$ -in. wide piece allowed for overlap.

The finished cone, when quite dry, can temporarily be mounted on the reed of the unit. If, as in the original you use a Brown "V" unit, then providing your cone is fairly accurate you will find that the front of the wooden cross support requires to be exactly 4 in. from the back of the cabinet. You will see

from the sketch on this page that its position depends on where the cross pieces

are supported. To allow for any slight variations either in your cabinet or cone construction you must make quite certain of this dimension before finally fixing the side pieces into position.

Even in the case of other cone units the position is easily found by trial, and perhaps at this juncture we should mention that among those we know to be

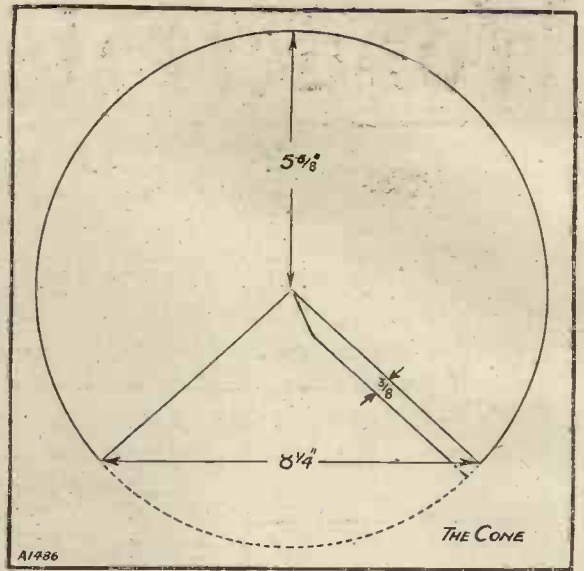

Take your cone-cutting measurements from this drawing.

NOTE THESE DETAILS.

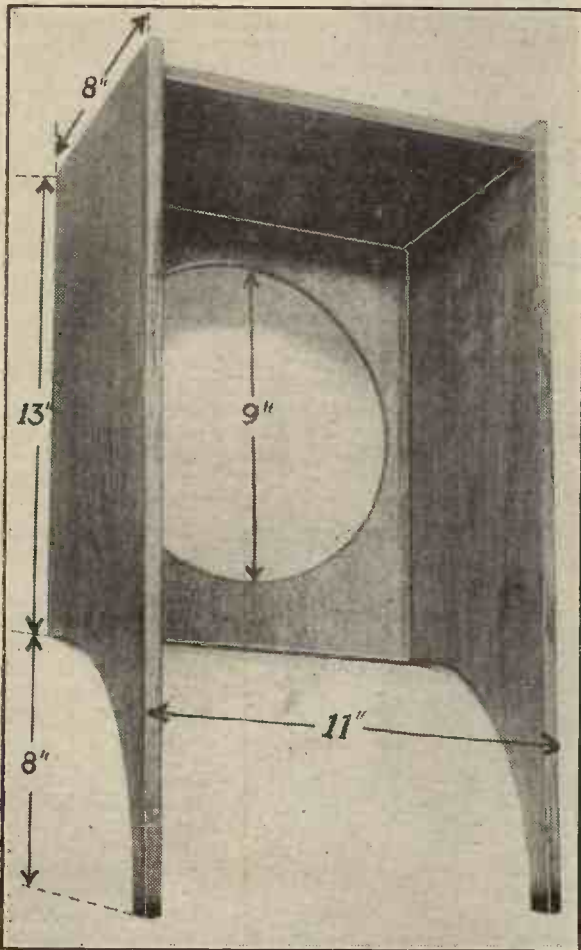

This special photo shows better than could the best drawing all the dimensions of the attractive cabinet.

graphic point of view. The actual type of wood used is, however, quite immaterial, but do not choose wood which is prone to split or chip very easily.

Full details of the measurements of the sides, front and top are given in one of the accompanying illustrations, and with this to guide you it seems hardly necessary to add anything further.

Perhaps, however, for the benefit of readers who may not previously have attempted the construction of "baffle-boards" we should just say a word or two about the cutting of the hole in the front piece of wood.

suitable for this loud speaker, apart from the one used in the original are the Blue Spot, W.B., Lissen, Wates, Triotron, Hegra, Ormond, and Watmel.

The Final Touches.

As the cone will not fit closely enough in the large hole in the case, a cardboard back must be fitted inside this, to come as close as possible to the cone without actually touching it.

Next, therefore, prepare this cardboard. The diameter of the hole in it should be just slightly less than the diameter of the finished paper cone. For convenience it can be fixed in position with drawing-pins as in the original. (See photograph on preceding page.)

The final job, having fixed the cone and unit in position, is in the fitting of four strips of gummed tape.

These are purely for centring purposes, and serve to hold the cone away from the cardboard ring. Without them, the cone might, after a time, tend to sag and touch the cardboard, and this might be sufficient to cause a buzz, thus spoiling reception. Make quite certain, therefore, when fixing these strips that in no place does the paper cone touch the cardboard surrounding it.

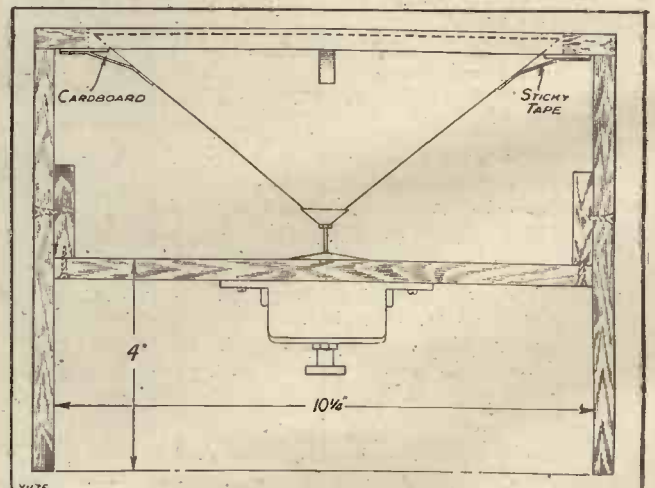

This shows you exactly how the cone is fixed in place. Note the cardboard ring that encircles the wider edge to prevent sound escaping back.

Wonderful Wireless Offer

**FINEST 3-VALVE CIRCUIT KNOWN TO SCIENCE
OFFERED TO YOU ON EASY PAYMENT TERMS**

To approved orders, we will send this magnificent Bowyer-Lowe Screened Grid 3-Valve Receiving Set for a first payment of 15/- only, and if you are perfectly satisfied, the balance of price may be paid by

monthly instalments of 15/-. Your money will be refunded immediately in full, in the unlikely event of your being disappointed. Whether a beginner or an expert, this Radio Set is guaranteed to give you good results

**15'-
WITH
ORDER**

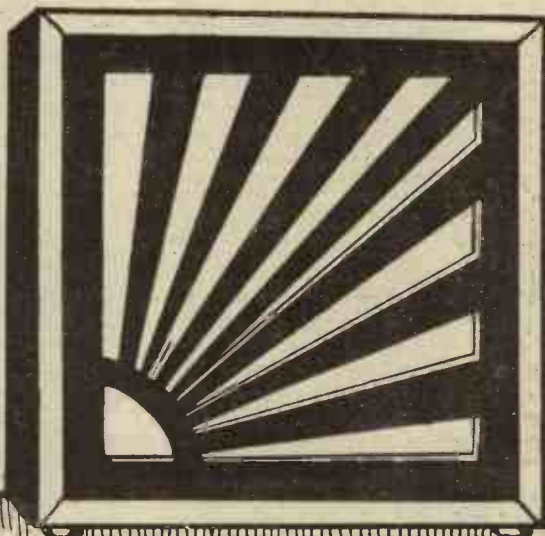

**15'-
MONTHLY**

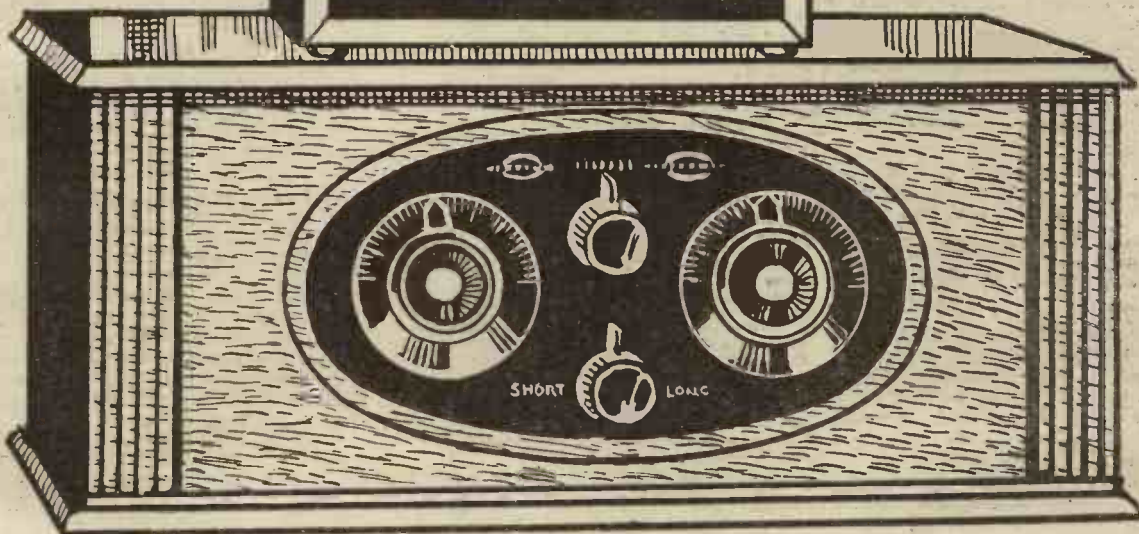

SPECIFICATION: This superb set comprises the famous BOWYER-LOWE 3-Valve Pentovox (latest type Mullard Screened Grid, Detector and Pentode Valves—the latter practically equal to two stages of ordinary low frequency amplification) complete with 4-volt Exide Accumulator, 108-volt de luxe large capacity high-tension Battery, 9-volt Grid Battery and latest type 4-pole balanced armature Loud Speaker. The Pentovox Set and Loud Speaker are in beautifully finished Oak Cabinets, as illustrated, every component being the best of its kind. The performance of this

set is perfectly amazing, and tuning through slow-motion dials is simple yet marvellously selective. A simple switch controls the change of wave-length.

This set is specially designed for selective reception under the new Regional Scheme

FULL PRICE (complete with valves, all accessories and Royalties) **Twelve Guineas**

Carriage and Packing free

Terms: 15/- with order, 15/- monthly
(Overseas and Irish Free State, full cash only)

POST ORDER AT ONCE TO

AMBROSE WILSON, Ltd., Dept. 634, 60, Vauxhall Bridge Road, LONDON.

FREE

A 4/6

TONEX

H.F. CHOKE



WHAT IT IS LIKE—

The neatest choke you ever saw, highest efficiency over all wave-lengths is assured by the special method of sectional winding. The windings are protected by a really handsome moulded Bakelite case, which takes up only small base-board space. Terminals have slot for screw-driver, a boon in awkward places, and soldering tags are provided. Ask your dealer to show you one, and put it in your set to-day. The finest choke on the market and at a price you can afford.

WHAT TO DO—

to get a TONEX H.F. CHOKE FOR NOTHING. Just write to us for details of TONEX PRODUCTS, and give the name of your Wireless Dealer. You must mark your envelope "P.W." in the top left-hand corner. All letters received up to 3 o'clock on Monday afternoon, March 3rd, will be "shuffled" and the writers of the first 50 letters opened will be sent a TONEX H.F. CHOKE entirely without cost. Everybody has an equal chance. All letters must be fully stamped. To EVERYBODY who writes, we will send a FREE FULL SIZE BLUE-PRINT of the well-known TONEX THREE 3-valve set, and a very useful log chart to pin inside the lid of your cabinet. Don't delay—write now.

WHERE TO WRITE—

THE TONEX COMPANY,
WALKER STREET,
BLACKPOOL . . . LANCs.



RADIOTORIAL

All Editorial communications to be addressed to the Editor, POPULAR WIRELESS, Tallis House, Tallis Street, London, E.C.4.

The Editor will be pleased to consider articles and photographs dealing with all subjects appertaining to wireless work. The Editor cannot accept responsibility for manuscripts or photos. Every care will be taken to return MSS. not accepted for publication. A stamped and addressed envelope must be sent with every article. All inquiries concerning advertising rates, etc., to be addressed to the Sole Agents, Messrs. John H. Lile, Ltd., 4, Ludgate Circus, London, E.C.4.

The constructional articles which appear from time to time in this journal are the outcome of research and experimental work carried out with a view to improving the technique of wireless reception. As much of the information given in the columns of this paper concerns the most recent developments in the radio world, some of the arrangements and specialities described may be the subject of Letters Patent, and the amateur and the trader would be well advised to obtain permission of the patentees to use the patents before doing so.

QUESTIONS AND ANSWERS.

JUDY'S TRANSFORMERS.

H. A. C. (Peckham Rye).—"With reference to the transformer for 'Judy' II. Would it be possible to put a fixed condenser across the primary of the transformer and so save the cost of having to get another transformer of the special type named?"

"I have just had a good transformer required by the makers so that it should give good performance, and I have a good supply of fixed condensers ranging from 1 mfd. to '0003 mfd. How should it be fixed?"

From the point of view of reaction requirements a rather small condenser connected across the primary terminals of the L.F. transformer will enable the set to function. Probably not more than '0005 mfd. would be required, and it might be less than the '0003 mfd. named by you, though this partly depends upon circuit conditions, and thus the best value for reaction effects in any given instance can be found only by experiment.

The advantage of using one of the low-frequency transformers named in our article on 'Judy' II is that these particular instruments are designed to work with capacity connected across their primaries and such a condenser-connection has no detrimental effect on the quality. Where other transformers are used there is a tendency for the higher notes in the musical scale to be bypassed.

As the transformer you name is a very good one and as (presumably) the set will not be used for very powerful reproduction, its reproduction might not suffer noticeably, and we should certainly try the effect of a small condenser across the primary.

THE "MAGIC" THREE.

B. G. (Cowley, nr. Oxford).—"The truth of the matter is that I am hard up, now and always. Consequently, I always make my H.T. batteries last as long as possible, and of the various sets I have tried my chief trouble has been howling, motor-boating and in general a sort of L.F. instability when the batteries lose their first kick.

"Your 'Magic' Three tempts me, but I am afraid that its high sensitivity and distance-getting powers would make it out of the question for batteries run-down as mine often are. Have you a three-valver which is noticeably free from battery-coupling troubles, etc., so that I could continue to annoy the H.T. battery manufacturers by nursing my volts instead of throwing the whole thing into the dustbin at the first sign of trouble?"

Although, as you say, the "Magic" Three has a high sensitivity factor, the layout of the L.F. side was very carefully planned and in practice the set has proved to be unusually stable. In series with the lead to the detector valve you will notice a resistance

(which in the original set was 25,000 ohms), and this with a large capacity condenser shunted down to L.T. from the junction point of the resistance and the primary of the first low-frequency transformer, constitutes an "anti-motor-boating" device.

We think that on the whole, you could not do better than the "Magic," even in the very difficult circumstances you outline, which are the very worst possible conditions in which a set can be run. Still, if you must use old H.T. batteries, when they ought to be thrown away you will find that the "Magic" Three will stand up better than most sets to a test of this kind, especially if you have on hand a 2-mfd. condenser which you can place in parallel with the C₂ (2 mfd.) condenser at present in the decoupling circuit.

This will bring the effective capacity up to 4 mfd. and you will find the set far steadier with an old battery than the ordinary two-L.F. transformer-coupled set. By the way, you should not use cheap

WHAT DO YOU THINK ABOUT THIS?

An artist reader of "P.W.," living at Hendon, complained of a sudden failure in quality and strength from his set (Det. and 2 L.F.). Knowing nothing of wireless, he never touched the set except to switch on or off. (Its accumulator was joined up every week by the service man who changed it.)

One day the set was working all right—the next it was very unsatisfactory, though the fresh accumulator had been put on that day and the H.T.B. was only a fortnight old.

WHERE WAS THE FAULT?

N.B.—There is no prize for answering this, but from time to time we shall give a radio problem (followed the next week by the answer) in the hope that readers will find them both interesting and instructive. (Look out for the answer to above next week.)

Last week's puzzle was that of the Birmingham reader who had to sit on the floor to get good signals! Probably you guessed his trouble—a faulty 'phone-cord, which gave poor contact only when the phones were placed lower than the set. Naturally, signals were best when he "got right down to it"!

transformers, or two of the same type, unless you have proved by experience that they work well together, as generally it is far better to use two different makes.

Do not forget, too, that if the set has a tendency to howl owing to battery trouble which cannot be remedied in the usual way, it is sometimes possible to effect a marked improvement by reversing the primary or the secondary of one of the transformers, and the old-fashioned plan of connecting a high

(Continued on page 1258.)

READY RADIO

1930 TITAN COIL

Chosen and Used for the famous 1930 Titan Set.

FOR REGIONAL RECEPTION

See your Coil is stamped

READY RADIO
1930
TITAN COIL **15/-**

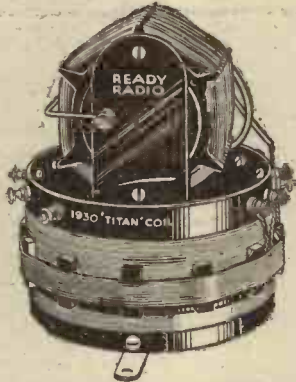

READY RADIO COMPONENTS
Specified and used in Sets described in this issue.

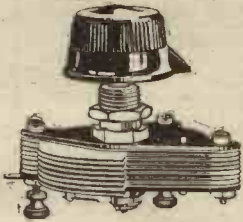

THE BROOKMANS
CONDENSER

·00075 **3/6** each.
·0005

READY RADIO VARIABLE CONDENSER

You are safe in fitting this wherever a '0005 variable condenser is needed.

4/6

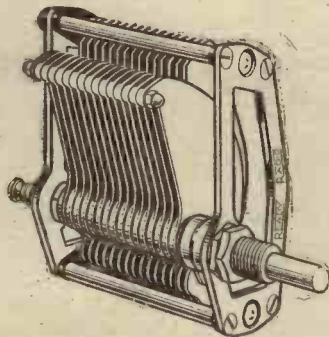

SLIDE POTENTIOMETER 400 ohms 2/9	DIFFERENTIAL CONDENSER 00015, 5/-	TITAN SCREEN (Aluminium) 10" x 6", 2/-
SAFETY FUSES Complete, 1/6 each.	ANODE FEED RESISTOR 25,000 ohms. Price with holder, 2/5	

Obtainable from all Dealers. If any difficulty, write direct

Ready Radio

159, Borough High St., London Bridge, S.E.1.

Telephones No. : Hop 5535.

VARLEY NICORE I
for the
1930 TITAN

Read what "Popular Wireless" says about VARLEY NICORE I, the L.F. Transformer specified for the 1930 "TITAN":

"... used in the ordinary way, exceedingly fine results are given, the amplification curve being straighter than was dreamt possible a couple of years ago. Varley Nicore I stands right in the very front rank, and it is the sort of component that the discriminating constructor must have above all others."

That is why you should use Nicore I in your set. In addition to the N.P.L. curve being straight the amplification is almost 80. Whatever your set, VARLEY NICORE I helps to give you radio that will live—VARLEY radio.

NICORE I L.F. TRANSFORMER
Price £1

Write for Section D of the Varley Catalogue containing full particulars.

For
RADIO
MANUFACTURE

Varley

Advertisement of Oliver Pell Control Ltd., Kingsway House, 103, Kingsway, London, W.C.2. Telephone: Holborn 5303.

TWO NEW BOOKS for the HOME CONSTRUCTOR

Sets for Every Purpose and Every Pocket

6d.



Contains complete constructional details for the following inexpensive and easy-to-build receivers. All have passed the most exacting tests before being published.

A ONE-VALVER

Of novel construction, using a home-made cabinet, and plug-in coils. Covers ordinary and long waves.

A TWO-VALVE ALL-WAVE-LENGTH SET (Det. and I.F.)

Capable of loud-speaker results under good conditions on both short and long waves. Uses standard parts and plug-in coils. Easy to operate.

THREE-VALVE RADIOGRAM RECEIVER

Circuit based on Det. and 2 L.F., very selective and high quality reproduction of either radio or gramophone records.

FOUR-VALVE "POUND-PER-STAGE" SET

Costing about £4. Uses home-made coils. Circuit employed being H.F., Det. and 2 L.F. Strongly selective.

All these sets are for MODERN CONDITIONS, and will enable constructors to take full advantage of the dual programmes under the Regional Scheme.

A SUPER-SELECTIVE ONE-VALVE SET

For ordinary and long waves. Easy wave-change and very simple operation. Includes the famous "Brookmans Rejector" to cut out strong interference.

A TWO-VALVER (Det. and I.F.)

For all waves including short. Special wave-change switch enables wave-range to be altered without changing coils.

An UP-TO-DATE THREE-VALVER

Using S.G., Det. and Pentode. Highly selective; employs plug-in coils and has volume control and switch for radio or gramophone records.

An ALL-FROM-THE-MAINS "FOUR"

A powerful set for A.C. mains, and comprises H.F., Det., and 2 L.F. stages with the special new A.C. Valves. Covers long and ordinary waves, and is very easy to operate.



6d. each from all Newsagents and Booksellers everywhere, or 7d. post free (Home or Abroad), from "Best Way" 291a Oxford Street, London, W.1



It's firmly clamped

Unvarying capacity is positively assured with a Dubilier Mica Condenser. Take, for instance, the Type 610 Condenser illustrated—before the "element" is sealed into the moulded case it is tightly clamped, so that absolute constancy of capacity is ensured. This is just one example of the way in which Dubilier safeguard the efficiency of their Condensers—Condensers which have gained a world-wide reputation for absolute reliability.

DUBILIER MICA CONDENSERS

Type 610 (Horizontal) and Type 620 (Vertical). Test Voltage, 500 A.C.

- 00005 to ·0009 2/6
- 001 to ·006 3/-
- 007 to ·009 3/6

Type B775. Tested at 500V. D.C.

Specially suitable for use in resistance-capacity coupled amplifiers, also where a condenser is required to withstand potentials of several hundred volts.

·01, 4/-; ·1, 8/6; ·5, 37/6.

Intermediate capacities at proportionate prices.

If unobtainable from your dealer, write direct to us giving his name and address. Dubilier Condenser Co. (1925) Ltd., Ducon Works, Victoria Road, North Acton, London, W.3.

Ask your dealer for the Dubilier Booklet—
"A Bit about a Battery"—it's free.

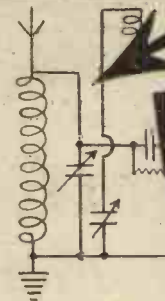

"GOLTONE" 1930
DUAL WAVE COIL
MOST EFFICIENT
PRODUCED
Price 8/- Each

Designed and recommended to obtain maximum selectivity, to comply with new Regional requirements.
More efficient and convenient than old-fashioned Plug-in coils. Just switch over from High to Low Wave band. Reaction on High and Low Wave lengths is fully obtained. Range 200-600 and 1000-2000 metres.
No. D.W/8 8/- each.
Full particulars see Radio Catalogue just issued. FREE on request.
From all first-class Radio Dealers. Refuse substitutes. If any difficulty write direct.



With every FREE diagram is given of connections and particulars of components required for several circuits, incorporating the "GOLTONE" Dual Combination Coil, including a unique 3-valve screened super circuit



IT'S BEST AND CHEAPEST THE "OSBORN" WAY

ASSEMBLE THIS "OSBORN" WIRELESS CABINET YOURSELF



FOR £2

Machined ready to assemble: in oak, £2; in mahogany, £2 5s. Assembled ready to polish: in oak, £2 12s. 6d.; in mahogany, £2 17s. 6d. Assembled and polished: in oak, £3 5s.; in mahogany, £3 10s. Carriage paid to your door.

3 ft. high, 2 ft. 1 in. wide and 1 ft. 4 in. deep. To take panel size 21 in. x 9 in. (or smaller).

CHAS. A. OSBORN THE REGENT WORKS, Arlington Street, London, N.1. Telephone: Clerkenwell 5095. Open to 7.30 p.m. Sat., 4.30 p.m. And at 21, Essex Rd., Islington, N.1. Phone: Clerkenwell 5634. Open until 8 p.m. Sat., 9 p.m.

SENSATION!

BROOKMANS PARK CONQUERED

DOUBLE WAVE TRAP

THE "BIJECTOR"

The "Bijector" will cut out either or BOTH of London's two new powerful transmitters broadcasting from Brookmans Park and WILL allow stations to be received between and either side of 261m. and 356m. without interference from these stations.

TWO REJECTORS IN ONE UNIT
PRICE 18'6 EACH. Full instructions enclosed with each "BIJECTOR."

At all principal Dealers, or direct from Manufacturers:

GONTAL RADIO LIMITED, 8, Spital Square, London, E.C.1

Cleaver BC 292/31

RADIOTORIAL QUESTIONS AND ANSWERS

(Continued from page 1254.)

resistance (grid leak of about $\frac{1}{2}$ megohm) across the secondary terminals of the first or second L.F. transformer should not be forgotten.

Remember, too, the great importance of spacing and try to ensure that all filament and plate leads are well away from grid leads, as this can give trouble even with a good H.T. supply.

A PICK-UP TROUBLE.

M. T. G. (Huddersfield).—"The pick-up worked fine at first, but lately there is a hanky-panky effect of running irregularly, apparently due to some fault in the motor. Is there anything I can do for this?"

If you refer to "Radio Notes and News" of a few weeks back you will find that "Ariel" has been troubled in the same way, and many useful suggestions were made by readers, the gist of them being to look to the grease supply in the spring barrel, as the trouble appears to be due to a sticking effect in the unwinding of the spring.

THE "MAGIC" THREE ON SHORT WAVES.

"HOME-MADE COILS" (Leyton, E.).—"What coils are required to take the 'Magic' Three down to the short waves, and are there any special tips to bear in mind about the operation of the set when going down below the broadcast band?"

For the short waves you want a set of the special short-wave plug-in coils now sold by a number of manufacturers (Atlas, Igranic, etc.), and for the L_2 socket you require a No. 4 for the interesting band of waves from about 20 to 40 metres. For L_1 a No. 6 is usually suitable. A little experimenting with this coil (the reaction) is needed, just as on the broadcast band.

For the next interesting wave-band, namely the range from about 40 to 60 metres, you will require a No. 6 coil for L_1 and a No. 9 for L_2 , and with these two pairs you will be able to cover practically the whole of the short-wave broadcasting stations. On this second pair you will also be able to pick up the amateur stations on 45 metres, and quite an interesting time you will have listening to them.

The aerial coupling arrangement is slightly different on short waves, and you will find that in general the most convenient operation will be with the aerial connected to No. 1 terminal. This brings the series condenser C, into circuit, and it will usually suffice to keep this at maximum. If you have any difficulty in getting reaction at some particular place on the tuning dial, however, try altering the capacity of

"P.W." TECHNICAL QUERY DEPARTMENT

How's the Set Going Now?

Perhaps some mysterious noise has appeared, and is spoiling your radio reception?—Or one of the batteries seems to run down much faster than formerly?—Or you want a Blue-Print?

Whatever your radio problem may be, remember that the Technical Query Department is thoroughly equipped to assist our readers, and offers an *unrivalled* service.

Full details, including scale of charges, can be obtained direct from the Technical Query Dept., POPULAR WIRELESS, The Fleetway House, Farringdon Street, London, E.C.4.

A postcard will do. On receipt of this an Application Form will be sent to you free and post free immediately. This application will place you under no obligation whatever, but having the form you will know exactly what information we require to have before us in order to solve your problems.

LONDON READERS PLEASE NOTE: Inquiries should NOT be made by phone, or in person at Fleetway House or Tallis House.

C₂. On small aerials, by the way, you may not need to use C₂ at all and can keep the aerial on terminal No. 2 permanently.

The tapping lead to the coil L_2 should be provided with a crocodile clip for use on the short waves (quite convenient for the "X" coils also), and this clip should be connected to a suitable turn on the coil. If you use the bare wire coils it is quite a simple matter to make the connection, bending the turns apart slightly, if necessary, to make sure that the clip does not touch more than one turn at a time.

You will not injure the coil in any way by doing this. The best position for the clip is usually at 1, 2 or 3 turns from the earthed end of the winding, but when the aerial lead is on terminal No. 1 you can take it as a general rule that the clip should be somewhere about the centre of the coil, and no particular adjustment will be needed.

By the way, you may wonder how you are to find out which is the earthed end of the winding. This is how you can do it. Notice which end of the wire composing the coil winding goes to the socket of the holder. That is the earthed end.

A NEW BROOKMANS' REJECTOR.

S. P. R. (St. Albans).—"It wants to be a Brookmans Rejector, as this is the only type that does the trick successfully. But I want to make the coils myself. Have you published one like this?"

A Rejector with home-made coils will be described in P.W. very shortly.

THE NEW CRYSTAL.

"CRYSTAL USER" (Nr. Wantage, Berks).—

"So getting tired of the whisker I got a new crystal detector in a tube with a little knob at one end of it. They said it was 'semi-permanent,' but although it lasted for some long time without much readjustment, it seemed to break up inside when I turned it to get a more sensitive spot. Should it break up like this, or was it a dud?"

If you had examined the inside of your detector you would have seen that instead of being one crystal with a cat's-whisker bearing on it, like the first one you used, it consisted of one crystal of one kind making contact with another crystal of a different kind. There are certain advantages of a contact of two crystals as compared with a 1-crystal-wire contact, and the only difficulty about them is that you must be a little more careful how you adjust the crystals than when you have only one crystal and a wire to deal with.

If there is a screw adjuster, proceed to use it *carefully*. If there is a spring adjuster, on no account twist the knob of the crystal detector when you wish to make a new adjustment.

Instead, take hold of the handle, pull it out a little, then turn it so as to present a new surface to the other crystal and then *slowly* let it go back until the two surfaces are in contact again. If

(Continued on page 1260.)



The Junior "R.K." Unit has a 6in. straight-sided cone with moving coil, having an impedance of 10-15 ohms at 50/4,000 cycles. Copper damping rings are fitted to reduce the impedance at the higher frequencies.
Price £ 6/6/0.

Fidelity

— in Tone
& Performance

WITH B.T.H.

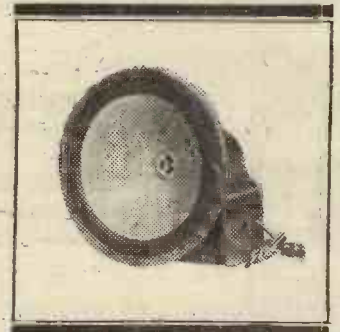

Senior "R.K." Unit with A.C. Field Excitation.—This "R.K." Unit has a 10in. corrugated cone with moving coil, having an impedance of 10-15 ohms at 50/4,000 cycles. The pot magnet is mounted in a pressed metal base which also contains a mains transformer, Mazda U.U. 60/250 rectifier valve, and smoothing condenser for the supply of field current.
Price £ 11/10/0.

REPRODUCERS



THE EDISON SWAN ELECTRIC CO., LTD.

Radio Division,
1a, Newman Street, Oxford Street, W.1.
Showrooms in all the Principal Towns.

EDISWAN

The B.T.H. "R.K."—justly described as the world's finest reproducer—first appeared in 1926 and its advent created a new standard of reproduction.

Four years have elapsed since then, but still the "R.K." maintains its leadership.

The new range of models includes the 10in. cone "Senior," with or without built-in rectifier for use with A.C. mains supply, and the "Junior" with 6in. cone.

THE CONSTRUCTION OF A CONDENSER

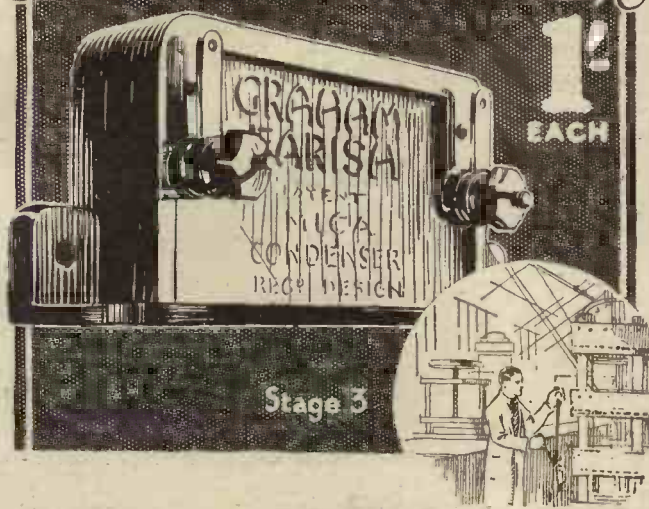

Moulding



MICROFICIENT
Variable Condenser

Logmidline capacity. Brass vanes. Bakelite dielectric, small but robust. .0005, 4/6; .0003 and .00015 4/3



ELECTROFICIENT
Mains Transformer

Complete range of every description. For use with valve & metal rectifiers. Price 39/6.



AUDION
R.C. Units

Employs "Ohmite" and "Megite" Resistances. Scientifically designed to give even amplification over entire audible range of frequencies. Price 5/6 each.

THE handsome highly-polished outer case of a Graham-Farish Condenser is produced by moulding—an interesting and intricate process.

The raw bakelite is first carefully weighed and pressed into tablets, then placed in highly polished chromium steel moulds heated to high temperature. These moulds are swung under hydraulic presses and subjected to pressures up to 50 tons.

After removal, the moulds are separated under smaller presses and the complete moulding appears, outwardly a finished article. Graham-Farish were the first to adopt this unique process which gave to components their highly-polished finish.

The Graham-Farish Fixed Mica Condenser has the finest flawless India Ruby Mica as a dielectric. An exclusive feature is the alternative upright or flat mounting. Every condenser is tested three times and a written guarantee given with each.

Bakelite case. Upright or flat mounting, terminals, soldering tags and series-parallel grid leak clips up to capacities 0005. .00005—.002 1/-; .003—.006 1/6; .007—.01 2/6.

"Ohmite" Anode Resistance 2/3 "Megite" Process Grid Leak 2/-
"Multiwave" H.F. Choke 5/-

GRAHAM FARISH

BROMLEY

KENT

Look for this sign



in a dealer's shop.

RADIO from INCOME

A new addition to the well-known Ready Radio Service is our "Radio-from-Income" system of monthly or weekly payments for complete kits of parts. Our close attention to customers' detailed requirements and the well-known Ready Radio After Sales Service ensure complete satisfaction whichever way you buy.

1930 MAGIC 3

- | | | | | |
|-------|------------------------------|--------------|--------------------------------|------|
| KIT A | 12 equal monthly payments of | 12/6 or 20/- | down and 12 weekly payments of | 10/3 |
| KIT B | 12 equal monthly payments of | 15/9 or 20/- | down and 12 weekly payments of | 13/3 |
| KIT C | 12 equal monthly payments of | 18/6 or 20/- | down and 12 weekly payments of | 16/- |

1930 TITAN 3

- | | | | | |
|-------|------------------------------|--------------|--------------------------------|------|
| KIT A | 12 equal monthly payments of | 10/3 or 20/- | down and 12 weekly payments of | 8/- |
| KIT B | 12 equal monthly payments of | 14/6 or 20/- | down and 12 weekly payments of | 12/- |
| KIT C | 12 equal monthly payments of | 17/3 or 20/- | down and 12 weekly payments of | 14/9 |

REGIONAL 4

- | | | | | |
|-------|------------------------------|--------------|--------------------------------|------|
| KIT A | 12 equal monthly payments of | 15/- or 20/- | down and 12 weekly payments of | 12/3 |
| KIT B | 12 equal monthly payments of | 20/- or 20/- | down and 12 weekly payments of | 17/6 |
| KIT C | 12 equal monthly payments of | 23/- or 20/- | down and 12 weekly payments of | 20/- |

REGIONAL 2

- | | | | | |
|-------|------------------------------|--------------|--------------------------------|------|
| KIT A | 12 equal monthly payments of | 8/6 or 20/- | down and 12 weekly payments of | 6/6 |
| KIT B | 12 equal monthly payments of | 10/9 or 20/- | down and 12 weekly payments of | 8/6 |
| KIT C | 12 equal monthly payments of | 12/9 or 20/- | down and 12 weekly payments of | 10/6 |

See page 1249 for the complete list of approved parts for the 1930 "Magic" and the 1930 "Titan" Three. Lists for the "Regional" Four and the "Regional" Two can be obtained on application. All kits include Ready Radio non-soldering links.

Ready Radio

159, BOROUGH HIGH STREET,
LONDON BRIDGE, LONDON, S.E.1.

Telephone: HOP 5555.

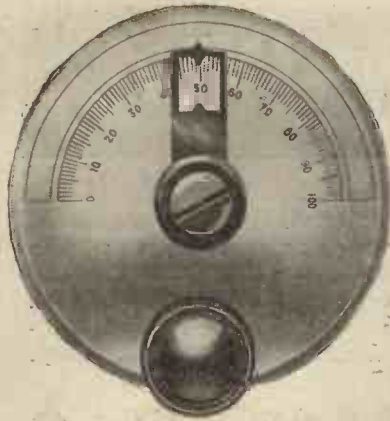

J.B. VERNIER DIAL SPECIFIED for the 1930 TITAN and the MAGIC 3

The friction drive in this J.B. Vernier Dial gives smooth action and complete freedom from backlash. The clear cut pointer makes tuning accurate and is extremely easy to read.

The dial is constructed almost entirely of metal—it is completely insulated from the condenser—and is beautifully finished in oxidised silver. Price

5/6

ALSO SPECIFIED: J.B. Neutralising Condenser, Price 3/6, and 0005 Log Condenser, 9/6.



PRECISION INSTRUMENTS

Adv. of Jackson Bros., 72, St. Thomas' St., London, S.E.1. Telephone: Hop. 1837.

RADIOTORIAL QUESTIONS AND ANSWERS

(Continued from page 1258.)

an unsatisfactory position is obtained do not merely twist, and grind the two faces of the crystals together, but pull the knob out again before turning, reset it to a different position, and then slowly replace it until you have found a sensitive and satisfactory spot.

Used in this way it will last for years and be very stable in operation, and in fact the only thing which is likely to damage it is to do what you did last time—namely to grind the two faces of the different crystals together, instead of bringing one gently on to the other in the correct manner.

IS IT NECESSARY TO SWITCH OFF H.T.?

This subject seems to have created a great deal of interest, and a Ryde reader has very kindly forwarded the following letter dealing with it.

"If A. W. P wishes to try the recommendation made in 'P.W.' January 18th, with which I am personally in entire agreement, the simplest method he can utilise without in any way altering his set or connections is to obtain from Messrs. Bulgin a connecting wire on-and-off switch (price 2s., catalogue

POPULAR "WIRELETS"

Here is the Answer to No. 3.

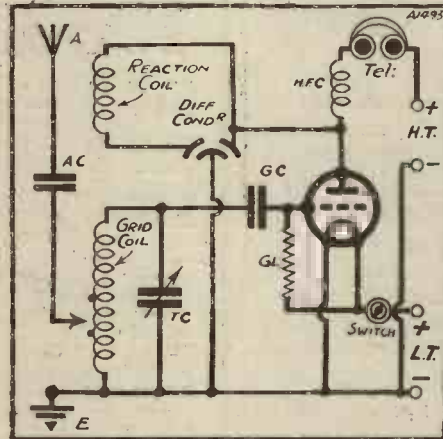

Note: "Wirelet" No. 4 will appear next week.

No. S18.) All that will be necessary will be to incorporate this very simple component in the existing H.T. — lead.

"In my opinion the incorporation of a switch for 'breaking' the H.T. — is a first-class insurance against the use of the set by unauthorised persons, who ignorant of what to do, will get no result by turning on the set by the normally obvious method."

ADDING A SEPARATE AERIAL COIL.

R. D. A. (Hampton Wick).—"The extra aerial coil certainly has improved the selectivity, but I am not sure of the proper coil sizes for the different holders. What should they be?"

In the old aerial circuit (now the tuned secondary coil), use a No. 60 or 75 coil. In the new (aerial) socket a 25, 35 or 50 will be needed. For Daventry a No. 200 or 250 in the aerial, and a 75 or a 100 in the new aerial socket.

"P.W." ABROAD.

"SAILOR BOY" (Malta).—"And now I am out here I do not like it much. For one thing I cannot get 'P.W.' especially back numbers. Where can I order a back number of 'P.W.'?"

Back numbers of "P.W." which are still in print can be obtained by post from The Amalgamated Press, Ltd., Back No. Dept., Bear Alley, Farringdon Street, London, E.C.4. The inland postage is 1d. ("4d. per copy post free"), but for Malta the rate is 3d. plus 11d. postage.

BROWNIE



SELECTIVITY UNIT (WAVE TRAP & SELECTIVITY UNIT)

Screen-Grid Selectivity with an ordinary set—that's what you get with the Brownie Combined Wave Trap and Selectivity Unit! Used as a wave trap, it immediately cuts out the interfering station: used as a selectivity unit, it provides razor edge tuning throughout the entire range. Its performance is amazing—yet it costs only 10/6! Your dealer will tell you all about it.

BROWNIE WIRELESS CO. (G.B.) Ltd., Nelson St. Works, London N.W.1.

"BUILD YOUR OWN DRY BATTERIES" A NEW WIRELESS HOBBY.

We supply super capacity Dry Cells and all parts for building your own dry battery at home. This is the best and cheapest form of H.T. yet offered. Super Capacity Cells, each 1.5 volts, 22 milliamps, 3/6 per doz. Send 14d. stamp for Booklet, "How to Build a Dry Battery at Home," to—

THE LEYTON BATTERY CO., 305, Church Road, Leyton, E.10.

FAMOUS "RADCROIX" POWER TRANSFORMERS.

Filament Heating Transformer, MA2A.



List Price **12/6** Wiring Diagrams Free

This Filament Heating Transformer will supply filament current at 4 volts from A.C. Mains to 5 indirectly heated A.C. valves, or a rectifying valve which requires a 4-volt filament supply. It has a tapped primary 200/250 volts. Secondary 4 volts centre-tapped, 5 amperes.

Applications from travellers thoroughly conversant with Power Transformers are invited. Sole Distributors: THE WHOLESALE WIRELESS CO., 103, Farringdon Road, London, E.C.1. Telephone: Clerkenwell 5312.

EUREKA

The L.F. Transformer that gives Really First Class Reproduction at a low cost

Baby Grand 1st or 2nd stage	8s. 6d.
Concert Grand 1st stage	10s. 6d.
Concert Grand 2nd stage	9s. 6d.
Smoothing Chokes 20h.40m/a.	10s. 6d.

All Post Paid by return. Money refunded if not satisfied in 7 days. Sole Manufacturers: L. PERSON & SON (Dept. 2), 63, Shaftesbury Street, London, N.1

The Picture Paper with the MOST News. **SUNDAY GRAPHIC**



"Have always held a leading position . . . production of thoroughly sound variable condensers . . ."—*Vide Press.*

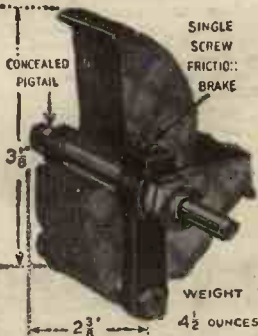

'1930' LOG (MID-LINE) CONDENSER

In four Capacities.
 *0005
 *00035
 *00025
 *00015

4/6

each.

* Double spacing of vanes for Ultra Short-wave work.

THERE IS ONLY ONE GENUINE FORMO - DENSOR



as used by designer and specified for The BROOKMANS REJECTOR The WAVE-CHANGE REJECTOR and The KENDALL REJECTOR.

F. Max. *0001 2/- G. Max. *0001 2/-
 Min. *000005 2/- Min. *0002 2/-

J. Max. *0003 2/- H. Max. *002 3/-
 Min. *000025 2/- Min. *001 3/-

Length 2 1/2 in.
 Width 1 1/2 in.

The FORMO Co. Crown Works, Cricklewood Lane, N.W.

..... "I received my Eliminator A.C.16 and had my set working inside 10 minutes with marvellous results. My... III is now equal, even better than some, All-Mains Sets I have heard."

The above is an extract from a letter which has reached us, and is typical of many we are receiving daily from delighted users of our New Super H.T. Battery Eliminator Model A.C. 16.



OUTPUT: 150 Volts at 25 m/A.

Model A.C. 16

for Alternating Current. Provides three Tappings, two fixed of 120 and 150 volts respectively, and one variable of 0/100 volts. This is the finest H.T. Unit yet produced at the price, and is suitable for any Set from one to five Valves, and specially caters for Sets using Screen-Grid, Detector and Pentode Valves. It is also ideal for use with any Portable Set when used in the home. It is yours for

Get your High Tension Supply from the Mains

Using this "ATLAS" Eliminator you can get all the High Tension you require for your Set from the mains—constantly powerful and at practically no cost.

All you have to do is to connect it to a lamp socket or wall plug, attach the terminals to the Set in the same way as a Battery, and switch on.

Imagine what it means to you to have this everlasting H.T. Unit—never runs dry and never needs renewing. Compare the cost of H.T. Batteries—using them you must be incurring an expense of anything from 50/- to £6 per annum, and tolerating anything but the best from your Set.

Whatever your needs are, there is a Model in the "ATLAS" Range to meet them. Our new Folder No. 44 gives full details.

"ATLAS" H.T. Units can be obtained from any Wireless Dealer.

10/-
DOWN

(less than the cost of an H.T. Battery). The balance you pay in nine monthly easy instalments.

CASH PRICE
£4-10-0

There is no hum or motor-boating, and maximum safety in use is ensured.

CLARKE'S
"ATLAS"
 BATTERY ELIMINATORS

are British to the last screw and are fully covered for twelve months by the 'ATLAS' guarantee

THIS YEAR'S "MAGIC" THREE
 THE "REGIONAL" FOUR
 THIS YEAR'S "TITAN" THREE
 THE "REGIONAL" TWO

Send for special leaflet containing particulars of components for these fine new receivers.

Again specified!

WEARITE
COMPONENTS



WEARITE H.F. CHOKE for all wave-lengths from 10—2,000 metres. Can be supplied centre tapped for scratch filters. Price 6/6.

A.C. VALVE HOLDERS, 1/3 each. Horizontal-type for S.G. Valves, 1/9 each.

RHEOSTATS, 4, 7, 15 ohms, 1/6 each; 30 ohms, 1/9; 50 ohms, 2/-

POTENTIOMETERS 300, 400 ohms, 2/6.

VOLUME CONTROLS, 0.5, 1, 2 meg-ohms, 4/- each.

Write for free illustrated lists to:

WRIGHT & WEAIRE LTD.,
 740, High Road, Tottenham, N.17
 'Phone: Tottenham 3847/8.

POST THIS Please send me your new Folder No. 44 along with particulars of your easy payment scheme.

COUPON

Messrs. H. Clarke & Co. (M/cr.) Ltd. (Dept. 3), Atlas Works, Old Trafford, Manchester
 NAME.....
 ADDRESS.....

TO-DAY

Post in unsealed 1d. stamped envelope. Please use BLOCK LETTERS.

TUNGSRAM A.C. VALVES



NOW STOCKED EVERYWHERE

You can buy TUNGSRAM A.C. Valves from your own dealer. He stocks the whole range—including Indirectly Heated A.C. Valves. They'll cost you nearly 50 per cent less than Association valves, too. But they're of better quality—they have the famous Barium filament.

Why pay a higher price when you cannot get a better valve?

Indirectly Heated Valves, 9/6
4 v. A.C. Power Valves ... 8/-

**TUNGSRAM
PHOTO-
ELECTRIC CELLS**
3 Types
Standard, £2: 10: 0
Nava E, £2: 17: 6
Nava R, £2: 17: 6



**GO TO YOUR
DEALER HE
HAS THEM**

TUNGSRAM BARIUM Valves

**TUNGSRAM ELECTRIC LAMP WORKS
(GT. BRITAIN) LTD., Radio Dept.,
Commerce House, 72, Oxford Street,
London, W.1**

Factories in Austria, Czechoslovakia, Hungary, and Poland.

Branches: Belfast, Birmingham, Bristol, Cardiff, Glasgow, Leeds, Manchester, Newcastle, Nottingham.

CORRESPONDENCE.

THE "MAGIC" FOUR

**"KICKS LIKE A MULE"—
RUNNING DOWN YOUR BATTERIES—
A MAGNIFICENT SET.**

Letters from readers discussing interesting and topical wireless events or recording unusual experiences are always welcomed; but it must be clearly understood that the publication of such does in no way indicate that we associate ourselves with the views expressed by our correspondents, and we cannot accept any responsibility for information given.—EDITOR.

THE "MAGIC" FOUR.

The Editor, POPULAR WIRELESS.

Dear Sir,—I recently constructed the "Magic" Four, which I found a great improvement on my previous set, and I am exceedingly pleased with the set. At first test I obtained thirty stations at good loud-speaker strength, the volume of such stations as Rome, Oslo and Toulouse being extraordinary.

The changing of coils and replugging of connections to pass from the lower to the higher broadcasting wave-band is a troublesome business. An amended circuit providing for four X coils, two for the lower band and two for the higher with switches, would, I am sure, be welcomed by a large number of your readers.

A fifty reaction coil appears to suffice for both wave-bands.

Yours truly,
W. B. CUMBERLAND.

Bristol.

The Editor, POPULAR WIRELESS.

Dear Sir,—Towards the end of last December I completed the above set, with very poor results.

After trying and testing all the component parts, rewiring, etc., etc., I eventually found the trouble lay in a faulty S.G. valve, which Messrs. A. C. Cossor replaced without question when I took it to their Leeds branch for examination.

I can only say that the performance is excellent, and in describing its capabilities, I think you erred rather on the side of safety. You certainly did not exaggerate.

Using an inside aerial 50 ft. long, the results are "great." One evening I was able to obtain twenty-one stations on the lower wave-band alone whilst the local station was transmitting. Three evenings in succession—the 22nd, 23rd, and 24th—I have been able to receive Schenectady (W 2 X A D), and one evening Westinghouse station (W 8 X K), all at good telephone strength.

What pleases me most, however, is the quality on most stations this is excellent.

Wishing you every success,

Yours faithfully,
J. H. GIBSON.

Leeds.

"KICKS LIKE A MULE" I

The Editor, POPULAR WIRELESS.

Dear Sir,—I have been a regular reader of your valuable paper, and feel I must write to you concerning the "Magic" Four, which I have just built. The results I get are simply amazing, the reaction is like velvet, and last but not least—purity. I was rather dubious about this set, as it is the biggest I have ever tackled, but I am glad I did. I think it is the best four-valver I have heard, and has a kick like a mule. I wish your paper every success for turning out the best ultra-long distance set, and am very proud to be the owner of such a set.

Yours sincerely,

N. ZONAKAS.

North Shields.

RUNNING DOWN YOUR BATTERIES.

The Editor, POPULAR WIRELESS.

Dear Sir,—I beg to submit the following as a point of interest to use as you may think fit.

I had occasion recently to purchase some reservoir condensers, and asked the salesman for T.C.C. His answer was "Out of stock, sir. I have—guaranteed and tested to 500 volts, sir." I purchased two—1 mfd. condensers, took them home, fixed one in a set, and purely by chance roughly tested the other by a charge from a 120-volt H.T. battery. An immediate test for the usual spark proved its absence. This led me to take the other condenser out of the set and do likewise, with the same result. To cut a long story short, the insulation resistance of these condensers was 95,000 ohms (not megohms) and 97,500 ohms respectively. Here is a possible answer to that oft heard remark: "What, that new H.T. run down already!" Let us consider a newcomer to radio full of enthusiasm for the set he is going to build, say the "Magic" Four. He buys three reservoir condensers, two 1 mfd. and one 2 mfd. It is reasonable to suppose that if a 1-mfd. condenser has an insulation resistance of 95,000 ohms, a 2 mfd. will be in the neighbourhood of 50,000 ohms. These

(Continued on next page.)

HEAYBERD

ALL-MAINS TRANSFORMERS

Used in conjunction with Westinghouse Rectifiers—Heayberd Power Transformers make the most efficient eliminators. Accurate design, long life and service, trouble-free working—big points of all Heayberd Transformers—are at their best in the latest—



TYPE

21/- **W.14** 21/-

Write for List.

F. C. HEAYBERD & CO.,
10, Finsbury Street, E.C.2.

Telephone. Clerkenwell 7216.

SUPER-MICROPHONES

New, highly sensitive, made on the latest principle, a vast improvement over all other types; will pick up whispered words from a distance of several yards, also strongly amplify and transmit speech and music over a distance, through Loud-speaker or Headphones. Splendid instruments for making Detectors, DEAF AID, LOUD-SPEAKING TELEPHONE, announcements through Loud-speaker, Amplifier for Crystal or Valve Sets, Electric Sound Detector, BABY ALARM or INVALID CALL from bedroom through distant Loud-speaker, Experiments, etc. NO OTHER MICROPHONE OF EQUAL SENSITIVENESS KNOWN; each instrument finely hand-enamelled and fitted with a 3ft. return post silk flexible connecting cord.

Despatched by 8/6

SPECIAL MICROPHONE TRANSFORMER for connecting Super-Microphone to Radio Headphones, Loud-speaker, Valve Set or Valve Amplifier 6/-

SMALL 10 OHMS EARPIECE for use with Super-Microphone as a HIGHLY EFFICIENT DEAF AID, or Detectors, etc.; thin 3ft. silk connecting cord fitted earpiece Fine Black Enamelled 6/-

Full directions for use of Super-Microphone for many purposes and Diagrams of connections free

FREDK. A. BOLD, Actual Maker, Phone Museum 27, Fitzroy Street, London, W.1. 8-19

AMPLIFY!

The "NEW MAGNO" Micro-amplifier is GUARANTEED to amplify 3 to 10 times when connected to any crystal (or valve) set. For 2/6 we supply the micro parts—i.e. ample length of sensitive electrode, sponge rubber blocks, rods and screws—for amplifier, with full clear diagrams, drawings and instructions EASILY and CHEAPLY made. No alterations to your set required, and no buttons, valves, H.T., etc. Worked by 1½ dry cell only. Agent: L. Cook, 182, Cranston Road S.E. 22

RELIABILITY
WIRELESS GUIDE NO 296

A Complete List of all that is best in Radio at Keenest Prices. Trade Enquiries Invited

J. H. TAYLOR & CO
4 Radio House, MACAULAY STREET, MUDDERSFIELD. Phone 341.

POST FREE ON REQUEST

PLEASE MENTION "POPULAR WIRELESS" WHEN REPLYING TO ADVERTISEMENTS

CORRESPONDENCE.

(Continued from previous page.)

three in parallel across the H.T. will have an insulation res. of approx. 25,000 ohms (that is giving a bit). Inquiries show that the majority of listeners do not disconnect their H.T. batteries when not in use, in which case this 25,000 ohms is continually in circuit.

By Ohms Law current = $\frac{E}{R}$

Current = $\frac{120}{25,000} = .0048$ amps = 4.8 milliamps.

Let us suppose that this same enthusiast purchases a Working Man's H.T. Battery, with a working life of 5,000 milliampere hours capacity.

In $\frac{5,000}{4.8}$ hours his battery is "napoo" = 1,042

hours = 6 weeks 1 day 10 hrs. If we add the valve consumption, this is, of course, considerably lessened.

I feel it my duty to bring to your notice, to test yourself, or do as you may think fit, this so-called condenser, with a view to saving newcomers to our hobby disappointment and expense, and a possible saving to those of your readers who are unfortunate enough to be in possession of these. I may add that I have been a reader of "P.W." since the old white cover No. 1.

Wishing you every success,

Yours faithfully,

New Cross, S.E.14.

R. T. JAGO.

[The make of fixed condenser mentioned by Mr. Jago is not advertised in "P.W." Readers are once again warned by a correspondent's unhappy experience that reputable makes of components must be used everywhere in a set.—TECH. EDITOR.]

"A MAGNIFICENT SET."

The Editor, POPULAR WIRELESS.

Dear Sir,—I have read, in "P.W.," many letters in praise of the "Magic" Three, and I feel ashamed of

NEXT WEEK

Full descriptions will be given of

The "Regional" Two

and

This Year's "Titan" Three

the Blue Prints of which are given away with this issue of "P.W."

Also in Next Week's number you will find

More About

This Year's "Magic" Three

providing you with still further operating details of this remarkable receiver.

Don't Miss Next Week's "P.W."

Out on Thursday.

Price 3d.

myself for not joining in sooner in congratulating the "P.W." staff or giving us amateurs such a magnificent set.

Like a few others, I had a little difficulty at first—mine, however, was confined to the long waves. I found it impossible to control reaction above 1,000 metres, and almost impossible to control my temper! My faith, however, in "P.W."—although I am a novice and a new reader—encouraged me to persevere and think matters out. At long last I discovered the source of the trouble—it was the H.F. choke! This is my first set.

Just a moment, though! No, I am not out of my troubles! My trouble now is that no one will believe it is a home-constructed set!

I use an Igranic J. and a Formo transformer; 250X and 100, 60X and 50 coils; Formo variable cond.; Cosor H.F. 210, Triotron H.D.2 and Tungsram P.215 valves; Polar .00015 differential (an Ormond will work equally as well); and 7/22 enam. copper wire aerial, 33 ft. high, sloping down to 22 ft., then lead-in to set. I have had excellent results with the aerial 15 ft. high. My friends are as equally amazed at the results as I am, and my advice to those who are puzzling what circuit to adopt, is—The "Magic" Three! I say this unhesitatingly.

The set has not been tested for short-wave work yet, but I hope to try it out shortly. The Radiogram "Magic" Three, also, is to have my attention. Can we have a coil (six-pin base) to cover the broadcast and long waves, to save changing coils?

More power to your elbow, and best wishes to your very interesting POPULAR WIRELESS.

Yours faithfully,

E. WILLIAMS.

Llanely.

STANDARD CARTRIDGE



H.T. POWER

BETTER PURER

LASTS

FOR

YEARS

RECHARGES ITSELF OVERNIGHT

SAVE POUNDS cut out the expense of costly dry batteries

The wonderful Standard Permanent Wet H.T. battery has brought to thousand of listeners the boon and satisfaction of permanent H.T. at low cost. Its super capacity cells maintain a steady, smooth-flowing pressure of current that ensures a truly amazing purity and clarity of reception. On comparative test lasting over a period of 69 weeks, the Standard Battery proved

57% CHEAPER THAN DRY BATTERIES

Years of experiment and research have gone into the Standard Battery. The workmanship is British and a thorough attention to detail and the latest scientific principles of construction have made the battery in every way efficient and requiring minimum attention. After months of hard service (cases are on record of over 12 months use before recharging was necessary) the battery can be recharged with the greatest of ease at home, by simply replacing the used-up cartridges with Refills. Think before you buy another dry battery. It will pay you first to write for the free illustrated booklet giving full particulars and information. Post coupon below.

Read What Delighted Users Say

The following are extracts from unsolicited testimonials. The originals of which can be inspected at our office

Teddington, 6/6/29.
Power Station Electrician writes: "never had less than 6 hours work per day on a three-taire set, average consumption 7 to 9 m.a. On making test I got an average of 1.21 volts per cell. This seems little short of marvellous. In addition quality of reception increased considerably." (Signed) N. A. W.

Brighton, 3/10/28.
"vastly superior to dry batteries." (Signed) C. S. F.

S.W.8, 19/2/29.
"best H.T. I have ever had." (Signed) H. B.

Standard Batteries have also been used by Capt. Eckersley and Mr. G. P. Kendal, B.Sc., in the "Modern Wireless" Research Laboratory.

Complete batteries assembled. Cash or on our famous "No Deposit, No refs." terms. Obtainable from all good dealers, Curry's or Hallord's.

GREAT ADVERTISING OFFER

- 5' DOWN** H.2. 10,000 M.A. capacity, 48 No. 3 cells, 72 volts, in 2 trays with lid. Cash £2 3s. 6d. or 5/ down and 5/ monthly payments of 8/2.
- 4' DOWN** H.4. Over 10,000 M.A. capacity, 72 cells, 108 volts in 3 trays with lid. Cash £3 4s. 0d. or 10/ down and 5/ monthly payments of 11/8.
- 3' DOWN** J.6. Over 20,000 M.A. capacity. 96 No. 4 cells. 144 volts in 3 trays, with lid. Cash £5 10s. 3d., or £1 down and 5 monthly payments of 19/2. **£1 DOWN**

COUPON

Post to Standard Battery Co., Dept. P.W., 184-188, Shaftesbury Avenue, London, W.C.2, for free battery booklet.

Name

Address

LOTUS COMPONENTS

are specified in the "MAGIC" THREE

Good components produce good results. Lotus Components are made from the best materials, and are reliable, neat, strong and accurate. Always ask for Lotus Components.

Apply to your dealer for the Lotus Components Catalogue or write to address below.

LOTUS COMPONENTS

Made in one of the most modern radio factories in Great Britain.

GARNETT, WHITELEY & Co.,
Limited,
Lotus Works, Mill Lane, Liverpool.

Can. ton

ADDING AN H.F. STAGE.

(Continued from page 1237.)

same—namely, a little judicious de-tuning. Just detune your first dial a little below the true wave of your local station and the other dial a little above, and you will presently find the unpleasant quality disappears and you will get as much volume as before.

This scheme of detuning one dial a little below the true wave and the other a little above is most valuable, since not only does it stop the overloading of the detector valve, but also, as a rule, it wipes out any little troubles due to a tendency to instability, which may only be perceptible on the extra strong signals of the local station.

Preventing Instability.

Mention of the question of instability reminds me of one or two little practical points concerned with the fitting up and use of a separate H.F. unit. You should not get any serious tendency to instability with one of these units, but the point is that only a very, very slight tendency indeed may show up as a deterioration in quality on the local station until you adopt the detuning scheme I have just mentioned. Even a good unit, however, may give you a little trouble with instability if you do not take certain simple precautions in connecting it up.

The main point is to see that a certain critical lead is kept as short and direct as possible between the unit and the set. That lead is from the output terminal of the unit to the old aerial terminal on your set, or to whatever point you wire up the output from the unit. It is decidedly important to keep this lead short and direct, and also well away from all overhead wires, particularly from the aerial lead. It is really the only critical lead in fitting up an H.F. unit, and if you treat it with due respect you are not likely to strike any trouble.

Where To Put The Unit.

Just one other point about the placing of the extra unit. As a rule, a little screening is provided in the design for an H.F. unit to prevent interaction between the circuits therein and those in the receiving set, and for this screening to work out properly it is usually necessary for the unit to be placed at the left-hand side of the receiving set, so that its panel forms an extension to the left of the main receiver.

This is the natural place to put it, and no doubt most of my readers would place it there without any hesitation, and I merely mention it in order to bring in a warning against yielding to the temptation to place the H.F. unit on top of the set, which might strike you at first as being a convenient spot. If you put it here there is a considerable risk of interaction between the circuits of the unit and those in the receiver, because the screening provided in the unit may no longer do its job properly in this position.

There, I hope these notes may have given you a somewhat clearer insight into the whys and wherefores of H.F. units, and perhaps will enable you to get better results from any unit you may have built or decide to build.

Finds Fault instantly!



Patented throughout the World.

The C.F. Radio Controller saves hours.

It immediately finds faults in the filament plate, or grid circuit; in the L.T. or H.T. voltage under load.

It tests the valves, transformers, speaker, potentiometer and all connections in the set, batteries, and in accumulators.

The C.F. Radio Controller

RETAIL 21/-

was an instant success at the Manchester and Paris Exhibitions, and has since built up big sales on its own merits.

Obtainable from Wholesale Factors or direct from Sales Agents for British Isles:—

FONTEYN & CO., Ltd.
2, 4, 5 & 6, Blandford Mews,
Baker Street, London, W.1.
Telephone: Welbeck 4144 (2 lines).

Build with this Cheap & Simple Wavetrap Kit.

Join two wires only and it is ready for use. Then all your selectivity problems are abolished. A great idea where the Regional Plan has found the weak spot in your old set. Your dealer will show and tell you all about the efficiency of the Sovereign Wavetrap Kit. "Always Better": It consists of a specially designed coil with the correct gauge and turns to eliminate the local and Sovereign Type J3 (.0003 mfd.) Compression-Type Condenser. Sold complete with straightforward diagram and wiring plan. Supplied already assembled, on Mahogany baseboard, on 4/-

The Sovereign Compression-Type Condenser is made in three sizes: Type F1, .0001mfd. Type G2, .0001mfd. Type J3, .0003mfd. Price 2/- From all dealers.



Produced by J.R. WIRELESS CO. 6-8, Rosebery Avenue, London, E.C.1

W. C. R. S. CONE UNIT CHASSIS AND CONE for Moving Coil Quality.

This Chassis is drilled to receive any make of unit—e.g., Bluespot, Tritron Ormond, etc. Gives unequalled and uncannily true reproduction of the high and low notes of the musical scale. The 11" Cone is made from specially manufactured two-ply fibrous material (a new discovery), suspended by means of stude reinforced with pure linen; plastic non-metallic cone washers are fitted. Price 10/6. Special offer for this month only 7/6. Post paid. Three days' free trial. Special terms to trade Sent C.O.D. if desired. Phone: Terminus 6777. WEST CENTRAL RADIO SUPPLIES, 259, Gray's Inn Rd., Kings X, London, W.C.1.

"BROADCAST" Plug-in Coils

NOTE THE LOW PRICES.

25 .. 1/-	50 .. 1/2	125 .. 1/6	250 .. 2/3
30 .. 1/-	60 .. 1/3	150 .. 1/6	300 .. 2/6
35 .. 1/-	75 .. 1/3	175 .. 1/9	400 .. 3/-
40 .. 1/2	100 .. 1/6	200 .. 2/-	500 .. 3/6

Centre-Tapped 6d. extra. "X" Coils 1/- extra. Post paid two coils or over. Trade Supplied.
G. BRICE, 34 Savernake Rd., London, N.W.3

FOR THE LISTENER.

(Continued from page 1240.)

prison, and was mightily pleased with the glimpse of the inside of it which the ex-burglar gave the other night. He was an intelligent fellow, as all the big burglars must be. And he was frank enough to say that burglary is a mug's game.

I liked his little touches; the rocks which are the reincarnation of old warders, old "screws"; the mice which the convicts are allowed to keep as pets, and which have kept more than one man from going "barny." He said he was now going straight; so here's luck to him!

Organ Music.

During the week covered by these notes there have been no fewer than fifteen organ recitals! Some from cinemas, some from churches; among the latter were two important ones by Dr. Alcock and Dr. Rhodes (from Coventry). I did not hear them all. Alas! I did not hear the important ones!

I like the cinema ones the best, because I get them the best on my set. Do cinemas broadcast better than churches? Church music usually comes to me rather confused and blaring. Pattman is a favourite of mine, and so is Reginald Foort.

A Scotch Play.

Radio drama has been taking a little rest. A play from Glasgow called "The Dawn" was quite good, but was spoiled somewhat by the bad casting of the part of "The Traveller," who was Charles Stuart in disguise.

His voice had less Scotch in it than a cup of water just drawn from the well! He sounded as if he were English to the backbone. I am looking forward to Lance Sieveking's production of "The Exiles," a play with a Russian setting. Mr. Sieveking is one of the "Big Four" (or is it Five?) in radio drama.

Song of the Earth.

I thought the most interesting musical item of the week was Mahler's "Song of the Earth," played by the Birmingham City Orchestra, and conducted by Dr. Adrian Boult. If Mr. Ernest Newman is right in saying that the touchstone of great music is its universality, then this is great music.

The final movement, the "Song of Farewell," was superb, and finely rendered both by the soloist and the orchestra.

Valentines.

St. Valentine's Day was duly honoured by the B.B.C. programmes. It gave Mr. Harold Nicolson a text, and it provided the Surprise Item.

Mr. Nicolson was not at his ease, for he had mislaid his manuscript, and it was amusing to listen to him struggling to revive his memory of it accurately. He did very well, but I thought he sounded very relieved when the extempore ordeal was over.

Old Times.

The revival of "Love in a Greenwich Village" was thoroughly justified, with its gay atmosphere and tuneful ditties—a very bright entertainment. The singing was very good, and the speaking parts were poor; but when Dr. Arne's songs are on the carpet, it is the singing that counts.



"PILOT" KITS for "P.W." SETS

Include all components approved by "Popular Wireless." Necessary coils, drilled panels and requisite connecting wire, screws, etc., and specified valves and cabinet.

1930 "MAGIC" THREE, £9 : 11 : 2 or 12 monthly payments of 17/6.

The "REGIONAL" FOUR, £12 : 9 : 9 or 12 monthly payments of 22/8.

Any parts supplied separately. Detailed lists on application.

FINISHED INSTRUMENTS. All the most popular "P.W." Sets, including the above, are available as finished instruments, built in our own factories, and aerial tested and guaranteed. Full details on application.

1930 "MAGIC" THREE, £11 : 17 : 6 or first payment of 37/6 and 11 monthly instalments of 19/-.

The "REGIONAL" FOUR, £14 : 14 : 0 or first payment of 54/- and 11 monthly instalments of 24/-.

The above, and all other "P.W." Sets are also available in Console or Radio-Gramophone Models. Details on application.

Send us a list of your requirements for a quotation by return. Post coupon for our magnificent 48-pp. catalogue.

PETO-SCOTT CO., LTD.,

Free Demonstrations and advice by Qualified Engineers at our Shops:—

77, CITY ROAD, LONDON, E.C.1. Telephone: Clerkenwell 9406-7-8.

62, HIGH HOLBORN, LONDON, W.C.1. Telephone: Chancery 8266.

4, MANCHESTER STREET, LIVERPOOL. Telephone: Central 2134.

33, WHITELOW ROAD, CHORLTON-CUM-HARDY, MANCHESTER. Telephone: Chorlton-cum-Hardy 2028.

KITS, SETS & ACCESSORIES

In addition to their own extensive range PETO-SCOTT offer Every Known Radio Receiver, Kit, Component or Accessory on

EASY TERMS with SERVICE AFTER SALES

ACCESSORIES

THE "BROOKMANS" REJECTOR UNIT. Exactly to "P.W." specification; assembled, wired, and tested, 12/6.

A WAVE-CHANGE "BROOKMANS" REJECTOR. Exactly to "P.W." specification; assembled, wired, and tested. Coils included, 18/6.

EXIDE 120-VOLT H.T. ACCUMULATOR. Type W.L., 2,500 m/a. In Crates, Cash £3 15s., or 12 monthly payments of 6/11, Type W.H., 120 volts, 5,000 m/a. In Crates, Cash, £4 13s., or 12 monthly payments of 8/6.

OSRAM MUSIC MAGNET. Cash £9, or 12 monthly payments of 16/6. Valves included.

REGENTONE W.I.B. S.G. (A.C. Mains). For S.G. and Pentode Sets. Cash £4 19s. 6d., or 12 monthly payments of 9/2.

CELESTION C.12 LOUD-SPEAKER, in oak. Cash £5 12s. 6d.; or send only 10/4, balance in 11 monthly payments of 10/4; in Mahogany, Cash £5 17s. 6d., or 12 monthly payments of 10/9.

ULTRA AIR CHROME DOUBLE LINEN DIAPHRAGM SPEAKERS in oak or mahogany table model cabinets. Type-K chassis, £4 4s. 0d., or 12 monthly instalments of 7/6.

Mail coupon in unsealed envelope under 3d. stamp.

COUPON

Please send me your 48-page Illustrated Catalogue, describing the 1929-30 products of all the leading makers.

NAME.....

ADDRESS.....

P.W., 1.3.

1930 EDITION

THE

WIRELESS MANUAL

By CAPTAIN JACK FROST.

The popular, practical and non-technical guide to choice of set, and installation, use and maintenance of set. It is written to enable the listener-in to understand the main principles of Wireless, and to learn how to secure perfect reception.

Fully revised. 5/- net. Illustrated.

Of a Bookseller, or

SIR ISAAC PITMAN & SONS, LTD.,
Parker St., Kingsway, London, W.C.2.

AGENTS WANTED to sell Wireless goods, all makes in sets, components and accessories. Cash or Easy terms. Liberal commission. NEW AUTO SUPPLY CO., 241, Park Rd., ASTON, Birmingham.

PARAMOUNT TRIPLE

CONE

WITH TUNABLE CONES.

18 x 18 x 8	Cherry and Wire	2 5 0
	Complete in Oak Cabinet	4 10 0
22 x 22 x 8	Cherry and Wire	3 0 0
	Complete in Oak Cabinet	5 10 0
	Console Cabinet	10 10 0

Cherry Model takes any Unit. All Chassis Silk Covered. Prop. Pat. No. 3343/29 FROM YOUR DEALER OR

PARAMOUNT REPRODUCERS
153 Devonshire St. Sheffield.

PLEASE MENTION "POPULAR WIRELESS" WHEN REPLYING TO ADVERTISEMENTS.

Michael Arlen

tells of Don Vincente Rodriquez Alvarado—his loves and his death—in "The Executioner," which appears in the MARCH issue of the LONDON MAGAZINE. In this issue, too, Margaret Chute describes how

SONNY BOY

was found by his "Mammy Man," in a fascinating article—

Davey and Al Jolson

There are many other splendid features in this grand issue of the

LONDON MAGAZINE 1/-

Buy the March issue NOW.

BUILD WITH THIS COMPLETE CHASSIS



Sold in all radio shops. If out of stock send dealer's name and address to us.

Ideal acoustic conditions for the natural reproduction of broadcast music, speech and song exclusive to factory-made Double Linen Diaphragm Speaker. Small diaphragm for high, large diaphragm for low audible frequencies. Accurately balanced for area, juxtaposition and mutual tension. Hear the chassis form at your dealer's. Available in four sizes from 42W.

ULTRA ELECTRIC LIMITED
661-663, Harrow Road, London, N.W.10

ULTRA AIR CHROME SPEAKER

Baldru Ad. U 131



KAY'S CABINETS

This Cabinet soundly constructed of Oak and equipped with Baseboard Runners. Tall Front, Hinged Top. Polished rich Jacobean, 36" 45" high. For panels up to 18" wide. Also made to accommodate any Popular Set. Greatest Range of Wireless Cabinets. Illustrated Lists Free.

H. KAY Cabinet Manufacturer,
Mount Pleasant Road, London, N.17
Phone: WALTHAMSTOW 1626.

Fit ROTOR-OHM Volume Controls with the greatest confidence because they are standardized by the most important manufacturers in Great Britain

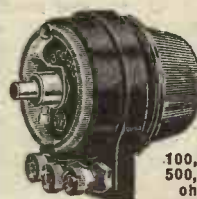

TWO-TERMINAL ROTOR-OHM 5/9
POTENTIOMETER TYPE 6/6
1,500 ohm, 2,000, 5,000, 10,000, 20,000, 25,000, 50,000, 70,000, 100,000, 200,000, 250,000, 500,000, 1 megohm, 2 megohms, and 7 megohms.

Write direct to us if substitutes are offered, mentioning dealer's name.

ROTOR ELECTRIC LTD. (Dept. P.W.), 2-3, Upper Rathbone Place, London, W.1
Telephone: Museum 2611-2642

ONE HOLE FIXING 1'6" EACH

GRIPSO

STANDARD PUSH-PULL INDICATING SWITCH

ADAPTABLE DOUBLE DIAL READINGS ON AND OFF-LONG AND SHORT WAVE

ROBUST CONSTRUCTION
LISTS FROM MAKERS

THE GRIPSO COY.
32, VICTORIA STREET, LONDON, S.W.1

PLEASE MENTION "POPULAR WIRELESS" WHEN REPLYING TO ADVERTISEMENTS.

By Dr. J. H. T. ROBERTS, F. Inst. P.

TECHNICAL NOTES.

Wave-length and Reflection.

EVERYONE knows that short-wave transmission is definitely subject to various types of reflection; the well-known "skip" effect with short waves is believed to be due to repeated reflections between the earth and the so-called Heaviside Layer. The beam system of transmission is, in fact, based upon the principle of the reflection of short waves.

This leads many people to wonder why the reflective properties should apparently be confined to short waves and why it should not be similarly possible to reflect longer waves, such as broadcast wave-lengths, and to concentrate such waves into a beam so as to conserve energy.

Question of Dimensions.

The fact is that the longer waves are subject to reflection in precisely the same way as the shorter ones. But so far as using them for beam purposes is concerned, this depends upon having a reflector the dimensions of which bear the same relation to the dimensions of the wave as in the case of beam reflectors and short waves.

Perhaps I can explain this best by referring to the analogy of light waves and sound waves. Although one of these is electromagnetic waves and the other atmospheric waves, and they are therefore quite different in nature, we can for the moment assume that the only difference between them is one of wave-length, light having a wave-length of an extremely small fraction of a centimetre, whilst audible sound may have a wave-length of several feet.

Light will be "regularly reflected" from any comparatively smooth object, but if the surface is irregular the light will be reflected in small beams in various directions, and is then said to be "scattered." Ground glass, for instance, has the effect of scattering light which passes through it or falls upon it, and so prevents undistorted vision.

If, however, the irregularities of the surface are made very much finer, so that they become of the same order of magnitude as the wave-length of the light, then another phenomenon arises and the light undergoes a transformation and is said to be "diffracted."

The Long Waves.

In other words, it is very easy to get regular reflection of light and to concentrate it by means of reflectors or lenses of ordinary size, because the wave-length of the light is so exceedingly small that a lens or reflector of convenient size is enormously larger than the wave-length.

With sound waves, however, we have to use quite a large reflector even when reflecting high-pitch (short wave-length) sound; and when we come to the lower notes, of much longer wave-length, we find that the dimensions of the necessary reflector become so large that they pass entirely out of the range of practical politics.

Now when we are dealing with wireless waves of a wave-length of several hundred metres we see that the dimensions of the

(Continued on next page.)

CLIX FOR CONTACT

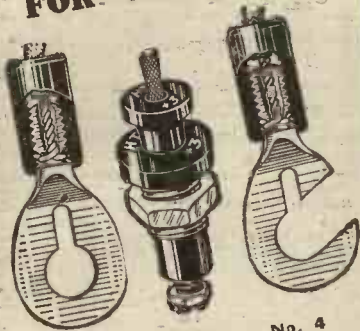

No. 5. CLIX RING TERMINAL 2d.
No. 15. ALL-IN PLUG & SOCKET 8d.
No. 4. CLIX HOOK TERMINAL 2d.



Nos. 5 and 4 can be supplied with engraved insulators for 1d. extra. Wide range of markings.

Write for the Clix leaflet, "A Matter of Connection"

LECTRO LINK LTD.
254 Vauxhall Bridge Road, S.W.1.

EVERYTHING WIRELESS ON EASY TERMS

THE MOST FAVOURABLE OBTAINABLE.

ALL COMPONENTS, KITS OF PARTS for all Circuits, MULLARD ORGOLA, COSSOR MELODY MAKER, etc. Complete SETS, H.T. UNITS, LOUDSPEAKERS, etc., etc.

CALL or SEND A LIST OF YOUR REQUIREMENTS; a Quotation of our BEST MONTHLY TERMS will be sent BY RETURN.

The P.D.P. COMPANY LTD.
(Dept. P.W.),
121, CHEAPSIDE, LONDON, E.C.2.
Phone: National 9846.

BARGAINS.

DIFFERENTIAL CONDENSERS 3/6.
"Sovereign" COMPRESSION CONDENSERS 2/-.
"DAILY MAIL" Wave-Trap Coil. SILK WIRE on high-class tube, with instructions 2/-.

"KLEER-KUT" COILS

25. 30. 35. 1/-, 40. 50. 1/2-, 60. 75. 1/3-, 100. 125. 150. 1/6-, 175. 1/9-, 200. 2/-, 250. 2/3-, 300. 2/6. Centre Tapped 6d. "X" Coils 1/- extra.

Everything by return Post—Post Free.

L. BRUCE, 99, King Henry's Rd., LONDON, N.W.3
6 years coil maker to the Wireless Trade.
Phone: Primrose 1303. Trade supplied.

PLEASE MENTION "POPULAR WIRELESS" WHEN REPLYING TO ADVERTISEMENTS.

TECHNICAL NOTES.

(Continued from previous page.)

reflectors would need to be enormously large in order to be "large compared with the wave-length"—a necessary condition for regular reflection.

This explains in a general way, without going into the details of wireless-wave reflectors, how it is that short waves are so much more amenable than medium or long waves.

With light-waves, owing to the smallness of the wave-length, we are almost always dealing with reflection, and it is difficult to get objects or irregularities small enough to bring us into the domain of "diffraction."

With sound waves and wireless waves, on the other hand, we are almost always dealing with diffraction, owing to the large dimensions of the waves, and it is difficult to get objects large enough to bring us into the domain of regular reflection.

Radio-Gramophone Outfits.

Many of you who use a combined radio-gramophone outfit, or an electrically amplified gramophone, may find that the volume of reproduction is not sufficient for all occasions, and I have often been asked whether it is a simple matter to add an additional stage of amplification in these cases.

Of course, the extra amplification is not always required, and it is, therefore, useful to have the additional stage in a form in which it can be readily connected or removed.

The addition of a stage of L.F. amplification is, as a rule, a comparatively simple matter, and the particular form which it takes depends naturally upon the details of the existing amplifier to which it is to be added.

For example, if the amplifier already has an output choke circuit, the output choke and condenser may be used as the coupling between the final valve of the amplifier and the valve which it is proposed to add.

Before going further I should say that although the design of chokes has been much improved of late, there is still a certain amount of prejudice against chokes as compared with transformers, owing to the fact that the latter give in general a greater amplification per stage.

At one time it used to be reckoned that three stages of choke-coupled amplification were about equivalent to two transformer stages. Then designers set to work to improve the choke, and this disparity was overcome, but at the same time improvements took place in the transformer.

R.C. Amplification.

Resistance-capacity amplification is still fairly popular, owing mainly to the developments in special valves designed for this type of coupling.

To return to the question of adding amplification, if the output choke and condenser are already present in the amplifier it is only necessary to have the additional valve which, of course, should be a power valve or, if you please, a super-power valve, together with the accompanying grid leak, or better still, L.F. choke, and provision for extra grid bias.

The loud speaker is now connected in series with the last valve and it is important to ascertain that the connections are made the right way round, otherwise the introduction of the H.T. current into the speaker may cause trouble.

(Continued on next page.)



BULGIN

BRITISH MADE

The choice of critics

QUALITY, VALUE & SERVICE



Three reasons why Bulgin components have won first place in the estimation of wireless constructors since Broadcasting first commenced. Use wherever possible in

THIS YEAR'S "MAGIC" THREE.
THE "REGIONAL" FOUR.
THIS YEAR'S "TITAN" THREE.
THE "REGIONAL" TWO.

BULGIN GUARANTEED PRODUCTS

De Luxe "On" and "Off" Switch	Price
(List No. S22)	1/6
Baseboard Neutralising Condenser	
(List No. N7)	4/9
Standard High Frequency Choke (No. HF2)	5/6
Three-Spring Wave-Change Switch	
(List No. S39)	1/3
Bakelite Spring Grip Grid Leak Holder	9d.
Single Type Fuseholder (List No. F5)	9d.
Compta "Branded" .06 Fuses	6d.

Ample stocks are always available, and should be obtainable from any dealer. In case of difficulty or substitution write direct.

SEND 2d. STAMPS for our 56-PAGE CATALOGUE

A. F. BULGIN & CO.,

— Radio Manufacturers —

9, 10, 11, CURSITOR STREET, CHANCERY LANE,
LONDON, E.C.4.

Telephone: Holborn 1072 and 2072.

WET H.T. BATTERIES

Solve all H.T. Troubles.

SELF-CHARGING, SILENT, ECONOMICAL

JARS (waxed), 2 1/2" X 1 1/2" sq. 1/3 doz.

ZINCS, new type 10d. doz. Sacs 1/2 doz.

Sample doz. (18 volts), complete with bands and electrolyte, 4/1, post 3d.

Sample unit, 6d. illus. booklet free.

Bargain list free.

AMPLIFIERS, 30/-. 2-VALVE SET, £5.

P. TAYLOR, 57, Studley Road,
STOCKWELL, LONDON.

EASY TERMS

We SPECIALISE in the supply of all Good Quality Radio Sets, Components and accessories on Easy Terms. We will give you efficient service. Send us your list of requirements and a quotation will be sent by return

LONDON RADIO SUPPLY COMPANY
11, Oat Lane, Noble St., London, E.C.2

NATIONAL 1977.

REPAIRS

Any make of L.F. Transformer, Loudspeaker or Headphones repaired and despatched within

48 HOURS—TWELVE MONTHS' GUARANTEE

with each repair. 4/- post free.

Terms to Trade.

TRANSFORMER REPAIR CO.,
"Repairs" Dept.,
214, High Street, Colliers Wood, London, S.W.19.

HEADPHONES REPAIRED 4/-

Transformers 5/-, Loudspeakers 4/-, All repairs re-magnetised free. Tested, guaranteed and ready for delivery in 24 hours.

Discount for Trade. Clerkenwell 9069.

E. MASON, 44, East Rd., City Rd., N.1.

EXACT TUNERS

250 to 2,000 metres.

Thousands of these tuners are in use, and we can strongly recommend them. No further coils are required. Send P.O. for particulars and circuits. FREE.

THE EXACT MANUFACTURING CO.,
Croft Works, Priory Place, Coventry.

E E L E X



SPADES, PINS, HOOKS & EYES.

All parts interchangeable.
6 colours 2d. each.
Write for list T93.



20L. 20P. 20S. 20H.

E E L E X

EARTH BOWL.

Supplied with 9 ft. rubber-covered lead and connector. Price 5/8 ea.

J. J. EASTICK & SONS,
Felex House,
118, BUNHILL ROW,
LONDON, E.C.1.

GRAMOPHONES. Latest Horns and parts. Catalogue free. Cash or terms. Build £12 model for £3. Instructions 3d.

V. BURT, 185, High St., London, S.E.8.

ALWAYS LIQUID

THE IDEAL GLUE FOR MAKING SETS & SPEAKERS



LE PAGE'S

LIQUID GLUE

SOLD BY IRONMONGERS, STATIONERS AND STORES

TUBES 6/- BOTTLES 10/- AWARDED 16 MEDALS

ALREADY

LE PAGES GLUE CO. LTD., 4-10 HATFIELD ST., LONDON E.C.1.

ALL APPLICATIONS for Advertising Space in "POPULAR WIRELESS" must be made to the Sole Advertising Agents, JOHN H. LILE, LTD., 4, LUDGATE CIRCUS, LONDON, E.C.4.

ELECTRADIX

FOR

GRAMO - ELECTRICS

GRAMO-MOTORS with Turntable. Mains Rheostats, Scratch Filters, Tone Controls, Panatropes B.T.H. Amplifiers. Ask for Special Sale Leaflet.

WHEATSTONE BRIDGES. G.P.O. and Dial types, £7 10s. Mirror Galvos Reflecting Beam, by Paul Gambrell, Sullivan and Tinsley, £3. Standard Resistance Boxes and Universal Shunts, 35/-. Electrostatic Voltmeters, £4. Capacity Bridges, £8.

INDOOR PROJECTORS, with lenses fitted 100-watt focus lamp, 39/6. Xmas 14-lamp Festoons, 220 v., 12/6. Torpedo spring-driven Gyroscopes, 15/-. Neon Tubes, 2/6. Holders, 8d. Osram B.E. Power Valves, for Eliminators, 4/6. Selenium Cells up to 200v., ratio 30-1, 15/-. Double Scale Taylor-Hobson Protractors, double-arm, 5/6.

MEGERS AND OHMMETERS. Four "Evershed" 100-volt Meggers. Special low reading model, 1,000 ohms to 10 megs., £15. Three O.K. 500-volt, 2-set "Evershed," recalibrated and tested O.K. to 50 megs., £10 10s. Two used 200-volt, 2-set Meggers, "Evershed," recalibrated and tested O.K. to 10 megs., £8 10s. One Metrohm, E.E., 250 volts to 20 megs., £13. Ten E.J. new 200/400-volt combined Voltmeter. Ohmmeter and Generators, £9 10s.

TESTING SETS. Crompton, Nalder, Elliott, Evershed: Amps. 500, 150, 15, 1.5 and 15 milliamps. Volts, 600, 300, 150, 30, 3 and milli-volts. Complete with all shunts in polished case, £10. Silvertown Universal Testing Set, fitted galvanometer and multi shunts calibrated Res. Dials, for measurements from .01 ohm to 1 meg., £8. Guaranteed. Nalder Test Sets. Brass-cased suspended moving coil, calibrated milli-volts and microamps., multiplying shunts and standard resistance 50,000 ohms. Measures from .01 ohm to 1 meg., milli-volts and microamps., £7 10s. Guaranteed. Portable 20,000-volt Breakdown Tester, No. 7/46 Silvertown, fitted 100-volt motor generator, d.c. to a.c., step-up transformer, in oil, interrupter, mica 30,000-volt condenser. With coils, high frequency, £8 10s.

"DIX-ONEMETER," in case, reading 40 microamps. per div., with 5 multipliers, £4 10s.

WESTON MICRO GRID-METERS. One should be on every wireless set. Sensitive. Excellent as Millivoltmeter, Bridge Galvo, Micro-ammeter, or Heterodyne Wave Indicator, centre zero. These fine meters are listed 65/., but are offered during sale at 35/.

CONDENSERS. Fixed W.D., 250 v., 2 mfd., 1/6 : 4 mfd., 5/6 ; 6 mfd., 7/6. New Sterling Mansbridge Smoothing for up to 400 v., 2 mfd., 2/10 ; 500 mfd. Dry, 12 v. for L.T., mains supply L.T. Filters, 10/-. Dubilier .01 Type 577 1,000 v. List, 7/-. Sale, 1/8.

VARIA. CONDENSERS. Polar. Sq.-Law. .0003 mfd, 2/3 ; .0005 mfd., 3/-. list. 12/6. Atlas SLF, 3/9. Bebe Cydon, Sale 4/-. Panel 3-gang Triple, 5/6 list, 15/-. 1-hole fixing Variable Condensers, 2/-; Polar Rheo., 6d. Polar Panel 2-way Coil Holders, 2/-, list 7/6. Polar Variable H.F. Transformers, 300/500, 3/-, list 8/6. Polar Variometer and dial, list 21/-. Sale 4/6. Polar Detectors, Everset, 1/-.

4-WAY INDOOR CABLE for Loud Speaker and remote control circuits combined. Suitable for multiple telephones also.

THE VIOLINA CABINET LOUD SPEAKER DE LUXE. Wonderful reproduction, complete tonal range. Beautifully polished mahogany. List £5. Sale price, 22/6. Moving-coil Loud Speakers, £3 10s.

Final Edition of our Surplus Bargains in Radio and Electrical Goods ready. Send stamped addressed envelope for large sale list.

SAVES RADIO USERS POUNDS
ELECTRADIX RADIOS,
218, Upper Thames St., E.C.4

Blackfriars Bln. Underground Rly. City 0191

TECHNICAL NOTES

(Continued from previous page.)

Although the above-mentioned arrangement will serve the purpose, it is better to use a separate choke and condenser, as in this way the danger I have just referred to, as well as other possible troubles, may be avoided.

Use of Push-Pull.

If you are building up an amplifier for radio-gramophone purposes, a very good circuit is one which starts with an anode-bend rectifier—the virtues of which I was dealing with a week or two back—resistance-capacity coupled to the next low-frequency amplifier, and then a final push-pull stage. The anodes of the two valves of the push-pull stage are taken to a special output transformer.

Volume control may be provided for by introducing a potentiometer into the grid circuit of the first low-frequency amplifier.

Studio Atmosphere.

It is curious how opinions differ on the question of studio broadcasting and stage broadcasting. Some people consider that items broadcast from the studio, in which there is as a rule little or no echo effect or "atmosphere," are preferable to those relayed from, say, the stage of a theatre.

It is true that the latter type of broadcast suffers from certain drawbacks which are peculiar to itself; it is naturally not nearly so simple a matter to arrange the microphone pick-up for a large stage in which the artistes are moving about and in circumstances in which, in any case, they are generally at a fair distance from the microphone.

In the studio conditions can be completely controlled—there may be only one microphone and the artiste may be placed at any desired fixed distance from it.

But, apart altogether from this, I was referring to the question of "atmosphere." Now that artificial echo can be introduced into a studio broadcast, "atmosphere" (of sorts) can be manufactured.

But, personally, I always think that studio broadcasting is very "dead" compared to outside broadcasts, and I prefer to put up with the little peculiarities of the latter in view of its naturalness.

All this, however, is and must be a question of personal taste and in this, as in the question of programmes, it is impossible to please everybody.

Personally, for example, I find the applause of those present in the studio very irritating, whereas the applause in a theatre or public building forms, to my mind, a natural part of the broadcast.

Conditions for Reproduction.

The conditions in the studio which give the peculiar "dead" effect are associated with the presence of thick carpet upon the floor, draperies upon the walls and so on, and it is useful to bear in mind that, just as these conditions affect the microphone pick-up, so similar conditions will affect the reproduction from the loud speaker at home.

Everyone knows how an empty bare room produces echoes and resonance effects, whilst a hot stuffy room full of people and draperies will have precisely the opposite effect.

The echoes in an empty room or building often have a flattering effect upon the voice of a would-be singer, whilst on the other hand even professional singers find their style cramped in a room which is devoid of such resonance properties.

ENGINEERS!

Can't we get together?



WRITE FOR THIS BOOK TO-DAY IT'S FREE!

All we ask is the chance to prove that you can earn £300, £400, £500 per year or more. Other men are doing it, and you can do the same.

We have an unrivalled and world-wide organization waiting to help you whether you be novice or expert. If you wish for something more than a "bread and butter" job you owe it to yourself to investigate our Service.

Our handbook "Engineering Opportunities" has pointed the way to better things to over 20,000 of your fellows. It contains details of A.M.I.Mech.E., A.M.I.E.E., A.M.I.C.E., A.M.L.A.E., A.M.I. Struct.E., London Matric., C. & C., G.P.O., etc., Exams., outlines home study courses in all branches of Electrical, Mechanical, Motor and Wireless Engineering, and explains our unique guarantee of

NO PASS—NO FEES

In a Brilliant foreword Prof. A. M. Low shows clearly the chances you are missing.

"Engineering Opportunities" and our advice are quite FREE. Don't neglect this offer—give vent to that "upward urge" and send a postcard NOW, stating Branch, Post or Exam. which interests you.

British Institute of Engineering Technology,
101, Shakespeare House, 29-31, Oxford Street, W.1

EASY PAYMENTS

The first firm to supply Wireless Parts on easy payments. Five years advertiser in "Popular Wireless." Thousands of satisfied customers. Send us a list of the parts you require, and the payments that will suit your convenience, and we will send you a definite quotation. Anything wireless. H. W. HOLMES, 29, FOLEY STREET, Phone Museum 1414. Gt. Portland St., W.1

Make
THE DAILY SKETCH
YOUR Picture Paper.

ESSENTIAL FOR MAINS RECEIVERS

Look at it—completely insulated, essential where high voltages are concerned—ample contacts—impossible to burn out valves.

The first plug and socket in which both parts are engraved and entirely insulated when connected or disconnected. Engravings on both Plug and Socket make for easy connections.

Price 9d.
(Panel Portion 5d.)
(Flex Portion 6d.)
Ask your dealer, or send to us, for Free Belling-Lee Handbook "Radio Connections."



BELLING-LEE
FOR EVERY RADIO CONNECTION

Advertisement of Belling & Lee Limited, Queensway Works, Ponders End, Middlesex.

P.R. VALVES

BRITISH
MADE

LIST OF P.R. SUPER GOLDEN SERIES.						
4'6"	Type	Fil. volts.	Amp.	Imp. ohms.	Amp. fac.	
EACH Post 4d.	GPR 2	2	.095	24,000	13.5	H.F. Det.
	GPR 3	2	.095	12,000	9	L.F.
	GPR 4	2	.095	40,000	32	R.G.
	GPR 9	3.5-4	.09	22,000	14.5	H.F. Det.
POWER 7/6 EACH Post 4d.	GPR 10	3.5-4	.09	10,000	9	L.F.
	GPR 11	3.5-4	.09	44,000	41	R.G.
	GPR 17	5-6	.14	20,000	17.5	H.F. Det.
	GPR 18	5-6	.14	11,000	9.5	L.F.
SUPER POWER 12/6 EACH Post 4d.	GPR 20	2	.15	6,000	7	Power
	GPR 40	4	.15	6,000	7	"
SCREENED GRID 15/- EACH Post 4d.	GPR 60	6	.15	6,000	7	"
	GPR 120	2	.3	2,000	4.5	Super Power
	GPR 140	4	.2	3,500	4.5	"
	SG 25	2	.2	220,000	150	S.G.

ABSOLUTELY ASTOUNDING

The new Golden Series of P.R. Valves give the most astounding results. The amplification is simply enormous and the selectivity abnormal. This is due entirely to the new filament coating, which is applied with scientific exactitude. It does not matter how much you pay for a valve you will not get better than a P.R. Golden Series at 4/6. Send for one NOW. You are protected by a "straight" Guarantee that fully covers any possible failure.

PERFECT RESULTS OR MONEY BACK

All postal breakages replaced free. Each valve has attached to it a written guarantee covering 7 months. In the event of the valve losing emission or becoming inefficient in any way during this term, a new valve will be supplied under the terms of the guarantee. If not fully satisfied that the valves received are equal to any they should be returned within a week, full refund will be made by return of post.

35/- for 19/6

POST 9d.

For a limited time to introduce our P.R. Speaker we have arranged to supply the complete KIT to make up this wonderfully powerful speaker for 19/6.

The KIT consists of our Balanced armature P.R. Speaker Unit, the Special P.R. Fabric Cone, 3-ply oak-front Baffle, 4 heavy, natural oak, cabinet-finished sides, cut ready for assembly, 4 pieces oak front moulding, 4 rubber feet, 3-ply unit eradic, screws, etc.

The whole sent safely packed by return of post ready for you to assemble, with full instructions.



Please note that the above consists only of a complete kit READY TO ASSEMBLE and is UNPOLISHED.

2 Valves or more sent POST FREE. Matched Valves 1/- extra per set.

Sent C.O.D. if desired. Ask your dealer for them. Accept no other.

P.R. PRODUCTS,

37, P.R. HOUSE, NEWGATE STREET,
LONDON, E.C.4

(Opposite G.P.O. Tube Station)

Telephone: CITY 3788

PAREX

SCREENS

COMPONENTS

For "THE REGIONAL 4"

Mottled Aluminium Stand, Screen 10 x 6 2/-
TRELLEBORG Ebonite Panel 21 x 7 6/6
Ebonite Strip 21 x 2 2/-

*00013 DIFFERENTIAL CONDENSER (Approved) 5/-
ON-OFF SWITCH 1/- H.F. CHOKE 3/6

THIS YEAR'S "MAGIC 3"

Diff. Cond. and Switch: see above. NEUTRALISING CONDENSER (baseboard) 4/6

E. PAROUSSI 10, Featherstone Bldgs., High Holborn, W.C.1.

Phone: Chancery 7010.

Wireless troubles are less troubles..



with FLUXITE

FLUXITE is sold in tins, price 8d., 1/4 and 2/8.

Another use for Fluxite: Hardening Tools and Case Hardening.

Ask for leaflet on improved methods.

FLUXITE LTD.

(Dept. 324), Rotherhithe, S.E.16.

SOLDERING SET Complete

7/6

or LAMP only 2/6

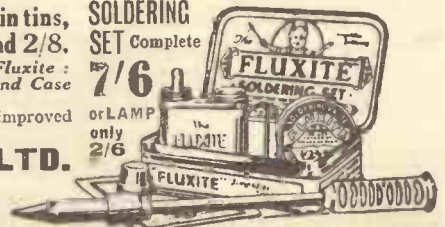

- IT SIMPLIFIES ALL SOLDERING



1/9
POST FREE

WHAT STATION WAS THAT?

Why be limited in your choice of programme? Thousands of wireless sets are installed throughout the country which could bring boundless pleasure if their owners could use them to full advantage. With the B.G.L. RADIO STATION FINDER the choice of the world's finest programmes is yours.

IDENTIFY THE STATION CALLING—TUNE IN THE STATION YOU LIKE
40 to 50

stations ought easily to be picked up by any modern set. The B.G.L. RADIO STATION FINDER enables you to identify any station calling or to tune in to any of the

WIRELESS STATIONS you like. No technical knowledge necessary. Eliminates oscillation. Can be used with any valve set. The readings of every station within the range of your set are

GUARANTEED

by the manufacturers or your money refunded.

THE B.G.L. RADIO STATION FINDER attractively finished, complete with full instructions. 1/9, post free.

BRITISH GAMES LTD. (DEPT. P.W.), 19, CLERKENWELL CLOSE, LONDON, E.C.1

Trade Enquiries Invited.

READ WHAT SATISFIED USERS SAY:
"I congratulate you on the great improvement you have made. It is surprisingly accurate."—H.B. Paignton.
"I am very pleased with the Station Finder you sent me and should like you to send one to a friend... please have one sent to—"
F.H., London.
"I have logged definitely about 30 stations. A gadget like your Finder is invaluable."—A.R., Colchester.

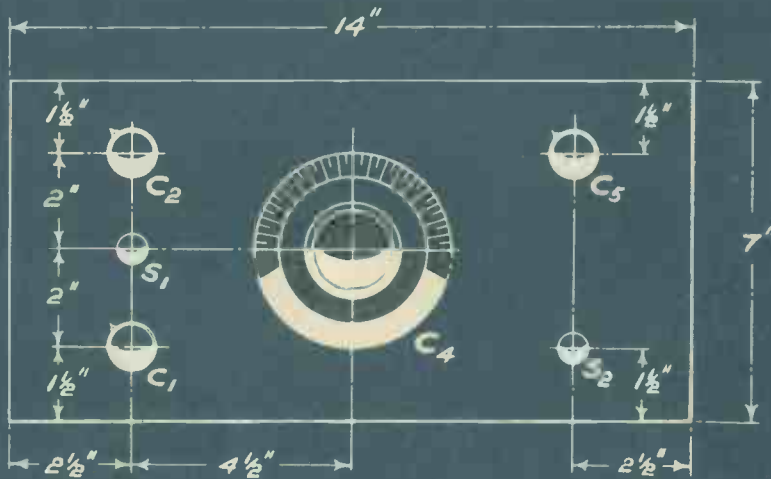
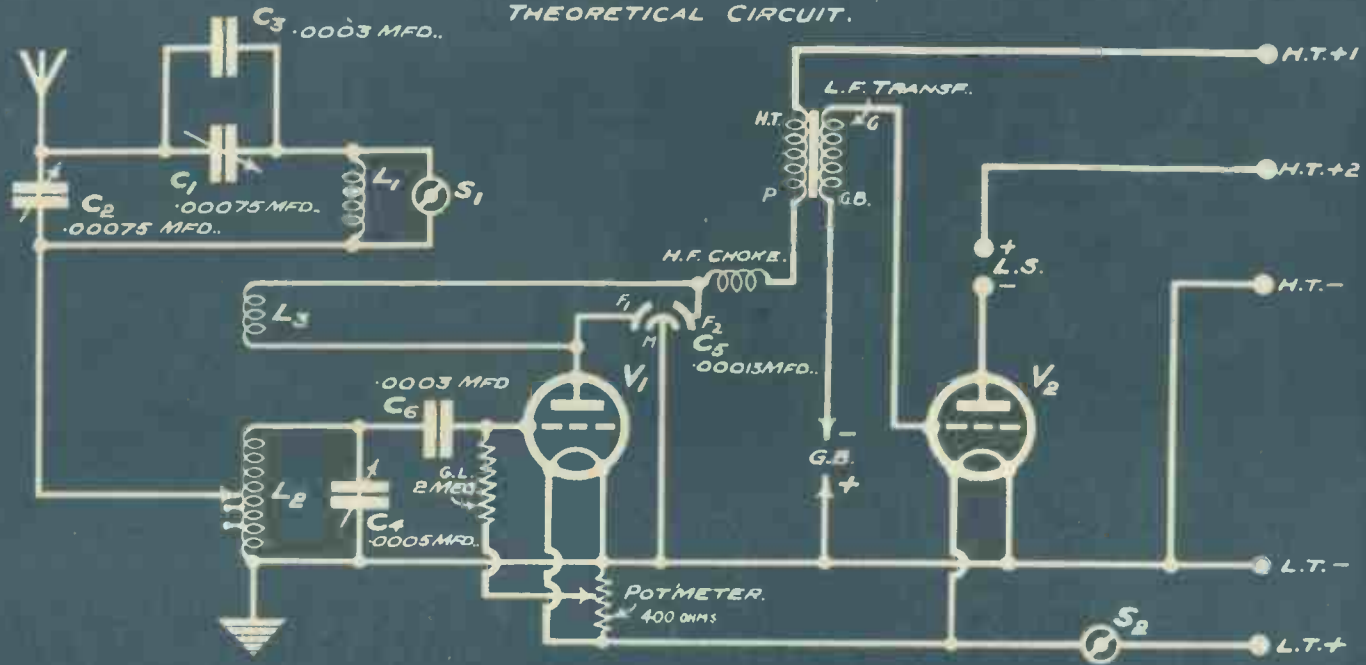

PANEL LAYOUT.

**"Popular Wireless" Blue Print
No. 53 Price 6d.**

The "Regional" Two

- 1 Panel, 14 in. x 7 in.
- 1 Cabinet to fit, with baseboard 9 in. deep.
- 1 .0005-mfd. variable condenser, slow-motion type or with vernier dial.
- 2 .00075-mfd. "Brookmans" condensers.
- 1 .0001-, .00013-, or .00015-mfd. differential reaction condenser.
- 2 On-and-off switches.
- 3 Single-coil holders.
- 2 Sprung valve holders.
- 2 .0003-mfd. fixed condensers.
- 1 2-meg. grid leak and holder.
- 1 H.F. choke.
- 1 L.F. transformer.
- 1 400- or 200-ohms baseboard potentiometer.
- 1 Terminal strip, 14 in. x 2 in.
- 9 Terminals.
- Wire, screws, flex, plugs, etc.

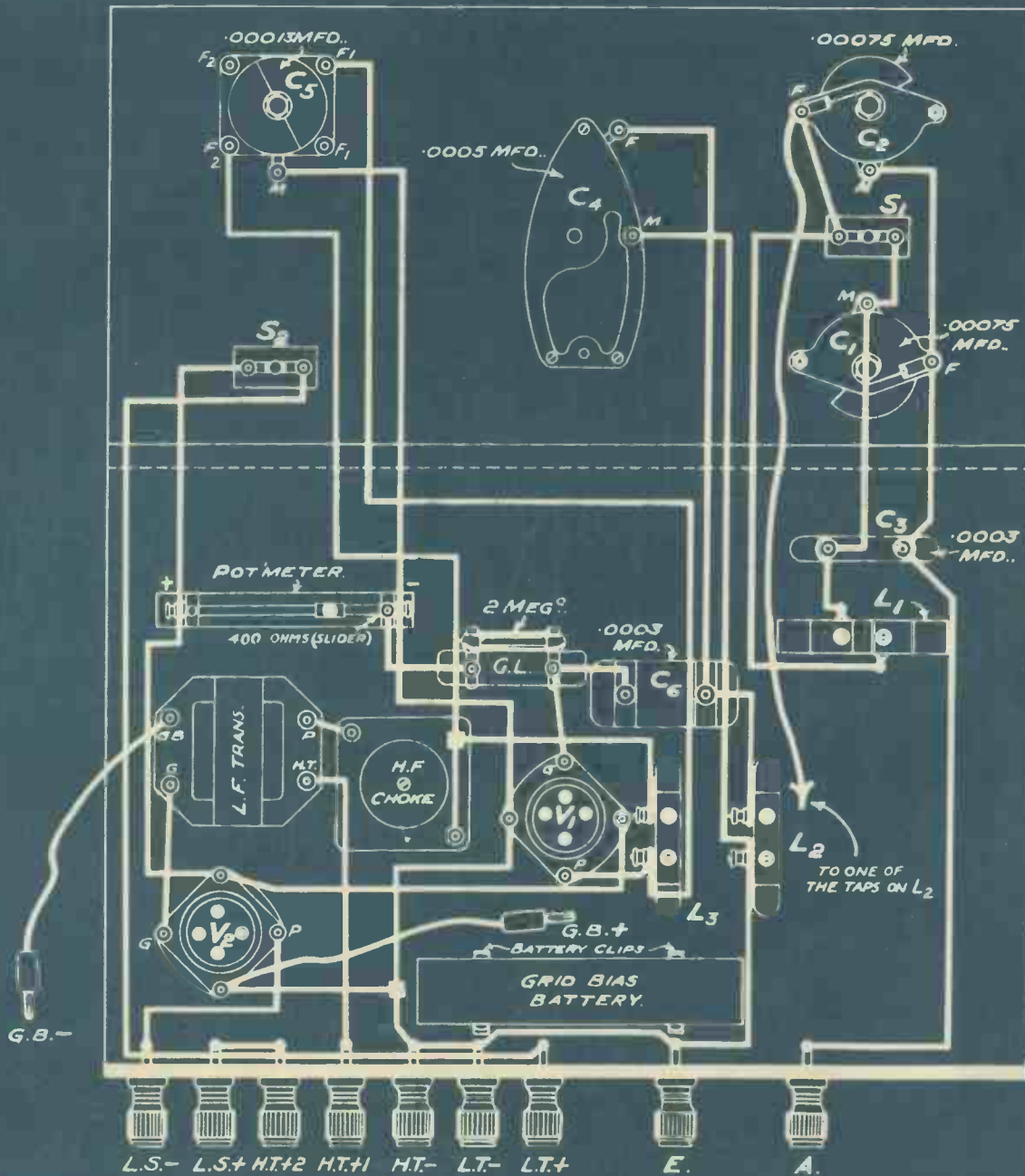

DRAWN BY *ADY*
 CH'KD. BY *KLB*
 SERIAL NO. 53

"P.W." Blue Print No. 53. The "Regional" Two. A simple but highly efficient little set specially designed for the Regional Scheme, incorporating a form of the "P.W." "Brookmans" Rejector. Coil L_1 (rejector circuit), No. 50; L_2 , No. 60 X (250 X for long waves), L_3 , No. 50 or 60 plain (100 or 150 for long waves). Switch S_1 cuts rejector out when not required. Adjust potentiometer for smoothest reaction. 60 to 70 volts on terminal H.T. + 1, 100 or 120 on H.T. + 2. H.F. type of valve for detector and power for second socket.

THEORETICAL CIRCUIT.

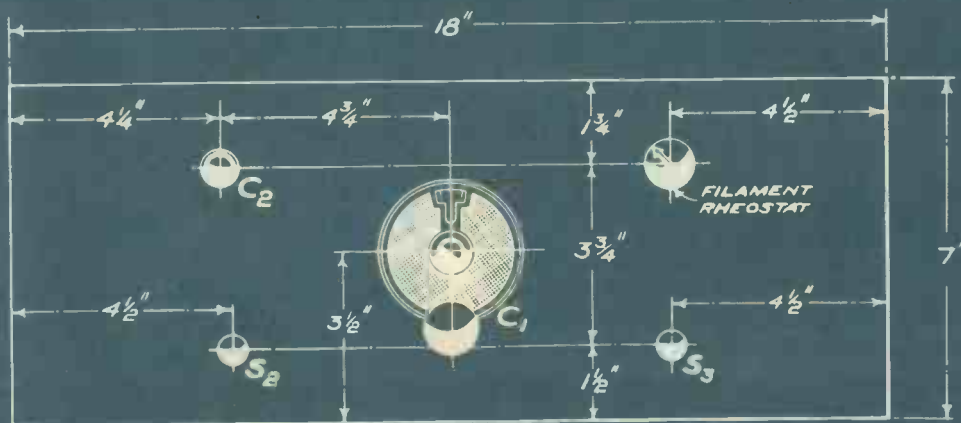
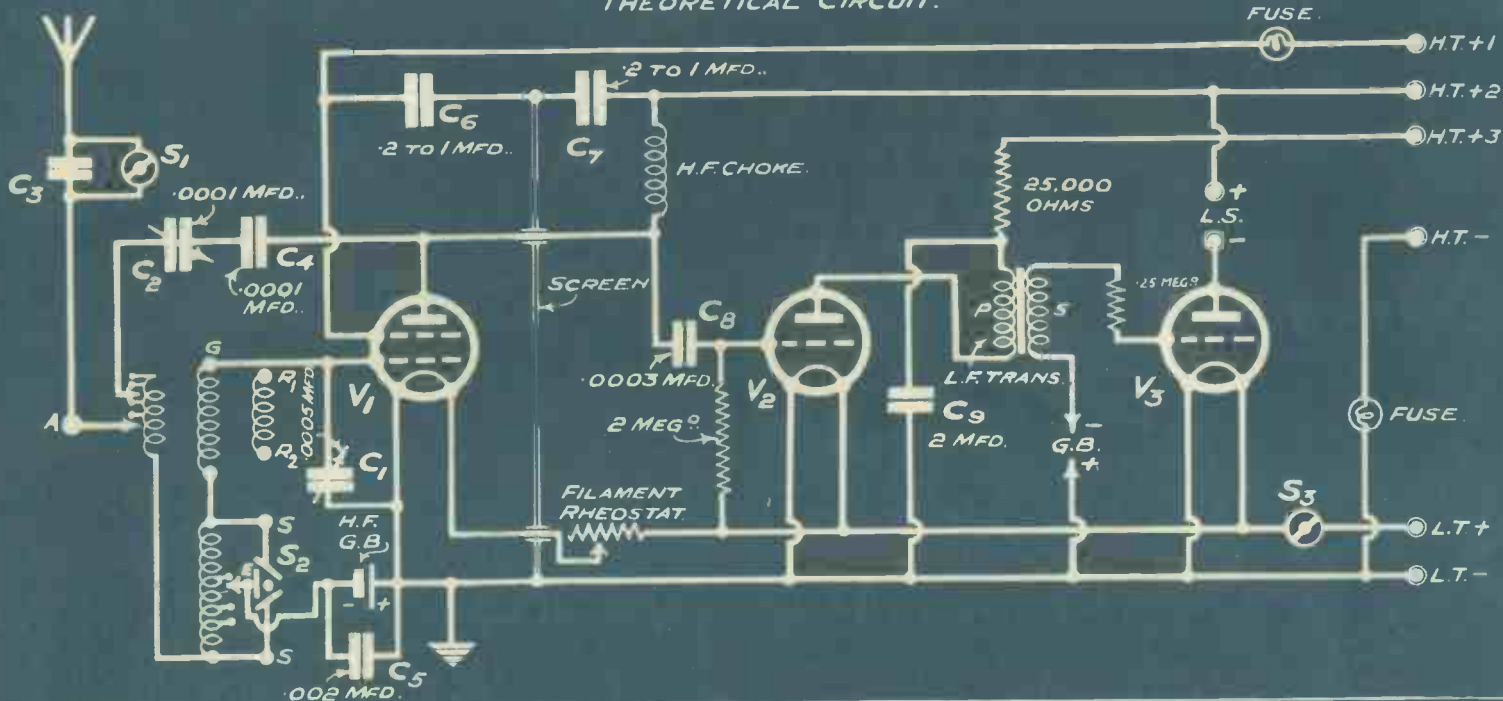

PANEL LAYOUT.

"Popular Wireless" Blue Print
No. 54 Price 6d.

This Year's "Titan" Three

- 1 Panel, 18 in. x 7 in.
 - 1 Cabinet to fit, with baseboard 10 in. deep.
 - 1 .0005-mfd. variable condenser, slow-motion type or with vernier dial.
 - 1 .0001-mfd. reaction condenser, preferably slow-motion.
 - 1 3-point wave-change switch.
 - 1 L.T. switch.
 - 1 Filament rheostat, 10 ohms for 2-volt valves 20 or 30 ohms for 6-volters.
 - 3 Sprung valve holders.
 - 1 "Titan" coil.
 - 1 Combined series aerial condenser and shorting switch.
 - 1 H.F. choke.
 - 1 L.F. transformer.
 - 1 .002-mfd. fixed condenser.
 - 1 .0001-mfd. fixed condenser.
 - 1 .0003-mfd. fixed condenser.
 - 2 .25-mfd. fixed condensers.
 - 1 2-mfd. fixed condenser.
 - 1 2-meg. grid leak and holder.
 - 1 25,000-ohms resistance and holder.
 - 1 1/2-meg. grid-leak type resistance with terminals.
 - 2 Fuse holders and bulbs.
 - 1 Standard "P.W." screen, 10 in. x 6 in.
 - 1 Terminal strip, 18 in. x 2 in.
 - 10 Terminals.
- Wire, screws, plugs, flex, etc.

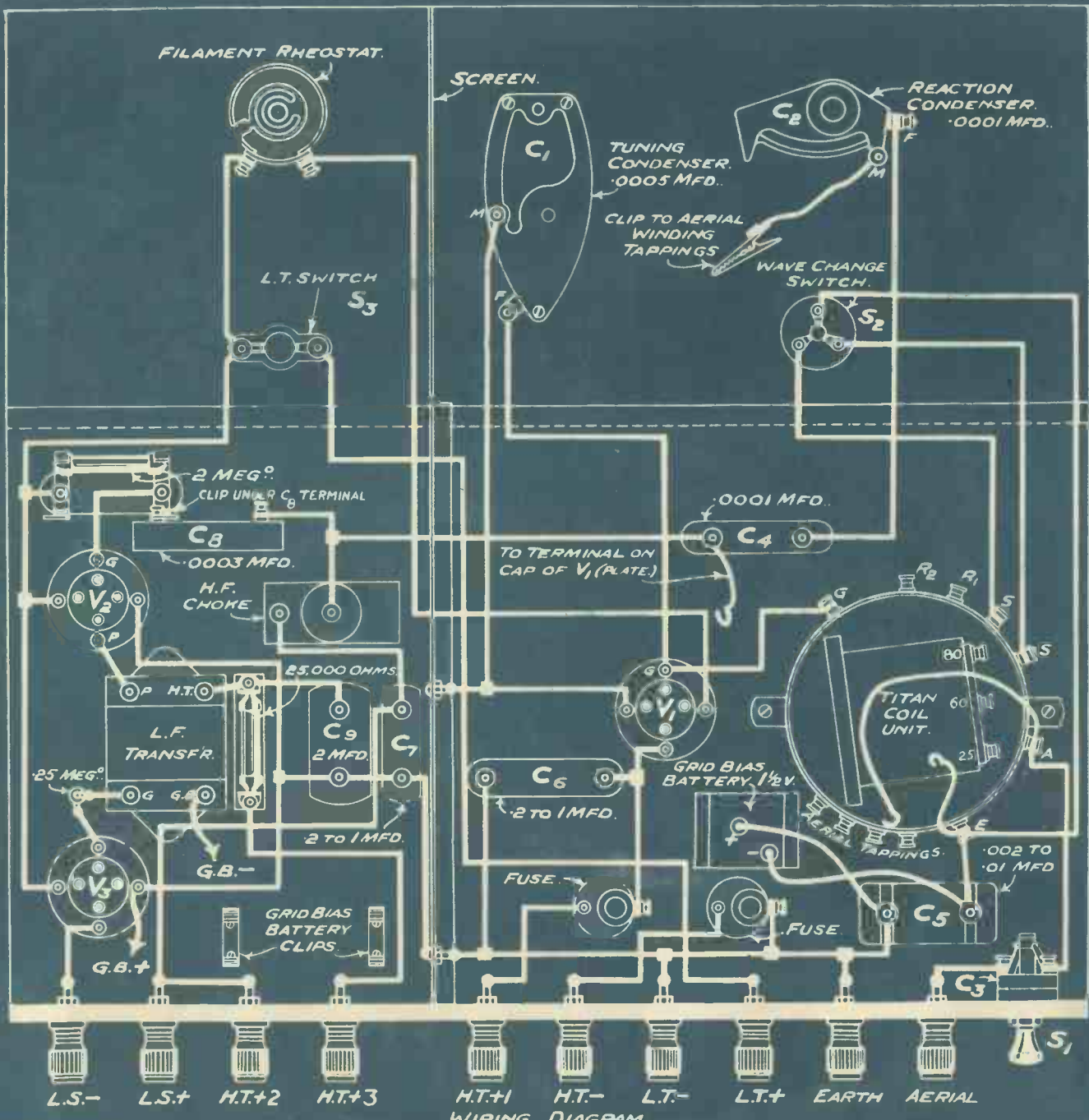

DRAWN BY *OMG*

CHK'D BY *R.B.S*

SERIAL NO. 54

"P.W." Blue Print No. 54. This year's "Titan" Three. One of the best of all single-control three-valvers of the H.F. type, with many up-to-the-minute refinements. The ideal set for use at some distance from the local station, and on poor aerials, where an H.F. stage is desirable. 60 to 80 volts on H.T. + 1, 120 on H.T. + 2, about 70 on H.T. + 3. Upright type S.G. valve for V_1 , H.F. type for V_2 , power for V_3 . Pull switch S_2 outwards for medium waves, push inwards for long. Place flex from A on coil unit on various primary tapings to adjust selectivity on medium waves, flex from E on unit to 25 or 60 on loading coil. S_1 gives another control of selectivity.

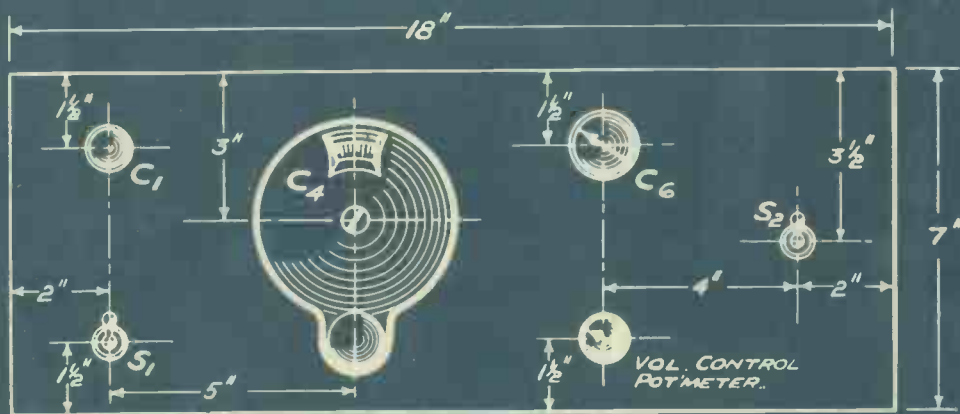
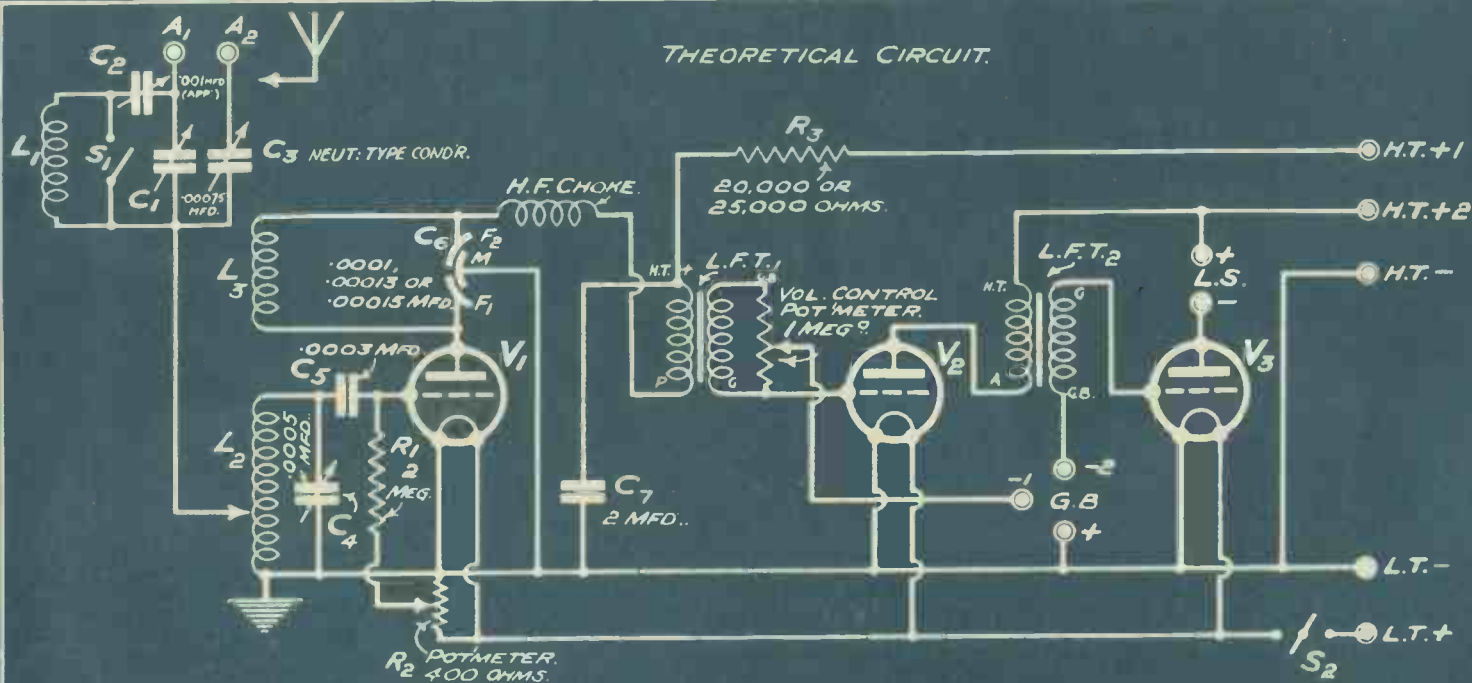

**"Popular Wireless" Blue Print
No. 55**

Price 6d.

This Year's "Magic" Three

- 1 Panel, 18 in. × 7 in.
- 1 Cabinet to fit, with baseboard 9 or 10 in. deep.
- 1 '0005-mfd. variable condenser, slow-motion type or with vernier dial.
- 1 Neutralising condenser, baseboard type.
- 1 '00075-mfd. "Brookmans" condenser.
- 1 '0001-, '00013-, or '00015-mfd. differential reaction condenser.
- 2 On-and-off switches.
- 1 1/2- or 1-meg. volume control, 3-terminal type.
- 3 Sprung valve holders.
- 3 Single-coil holders.
- 2 L.F. transformers.
- 1 H.F. choke.
- 1 Compression-type condenser, max. '001 mfd., or thereabouts.
- 1 '0003-mfd. fixed condenser.
- 1 2-meg. grid leak and holder.
- 1 400- or 200-ohms baseboard potentiometer.
- 1 25,000-ohms resistance and holder.
- 1 2-mfd. condenser.
- 1 Terminal strip, 16 in. × 2 in. or 18 in. × 2 in.
- 10 Terminals.
- Wire, screws, plugs, flex, etc.

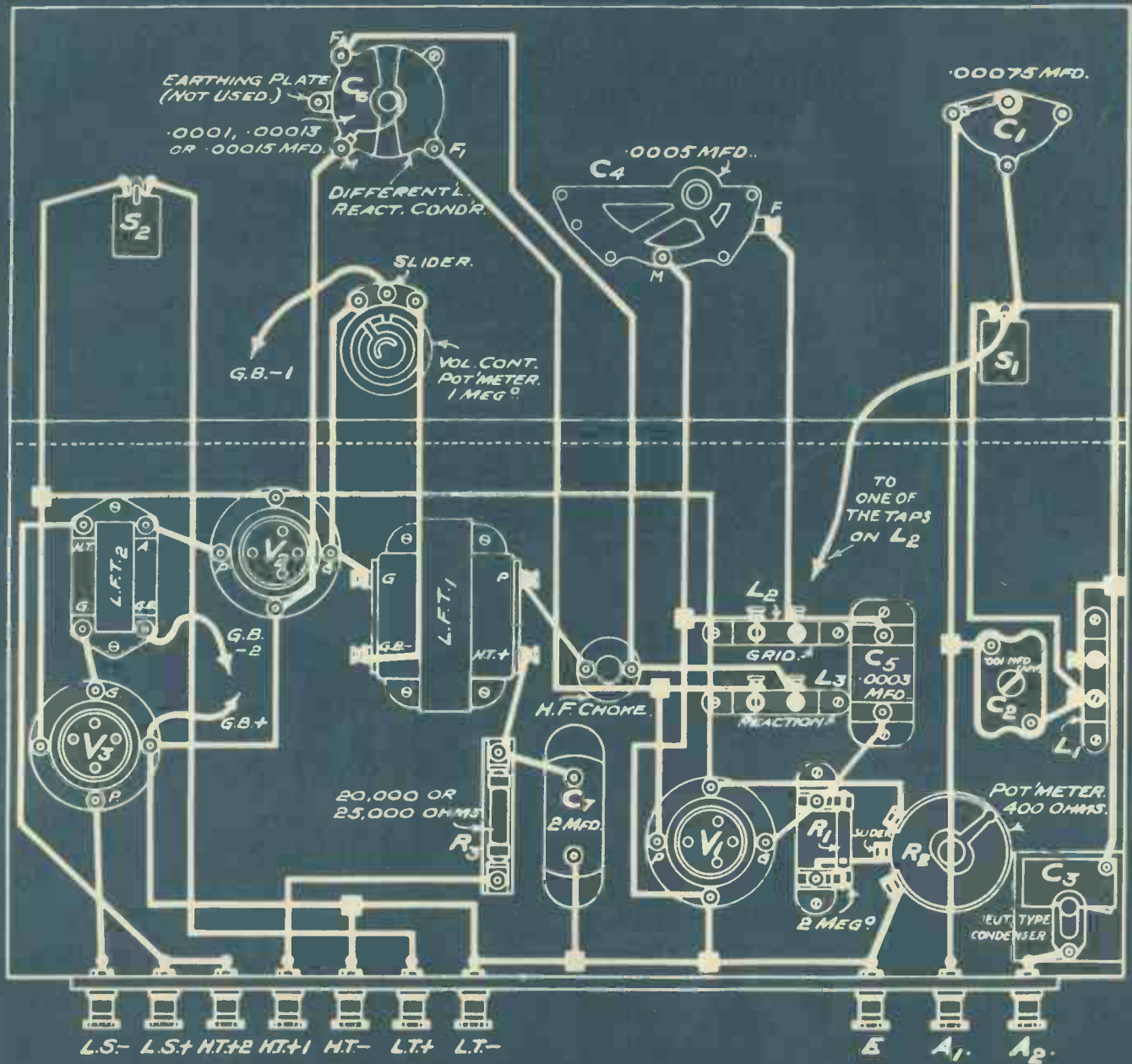

DRAWN BY. LT
 CH'G'D. BY. KRL
 SERIAL No. 55

"P.W." Blue Print No. 55. This year's "Magic" Three. All the original special features of the famous "Magic" Three, with its super-sensitivity, remarkable ease of handling, and great power, with additional refinements, notably a form of "Brookmans" Rejactor for the elimination of even the most powerful local station. Switch S₁ cuts this out when not required. Coil L₁, No. 50; L₂, 60 X (250 X for long waves), L₃, 50 or 60 (100 or 150 for long waves). 60 to 70 volts on H.T. + 1, 120 volts on H.T. + 2. Attach aerial to A₂ for short waves (below 100 metres), adjust C₃, and use short-wave coils for L₂ and L₃. H.F. valve as detector, L.F. for V₂, and power or super-power for V₃.

THEORETICAL CIRCUIT.

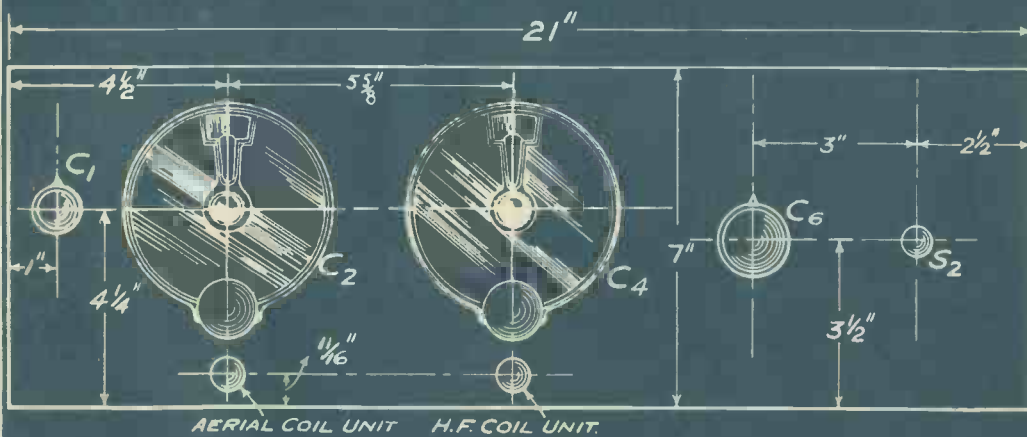
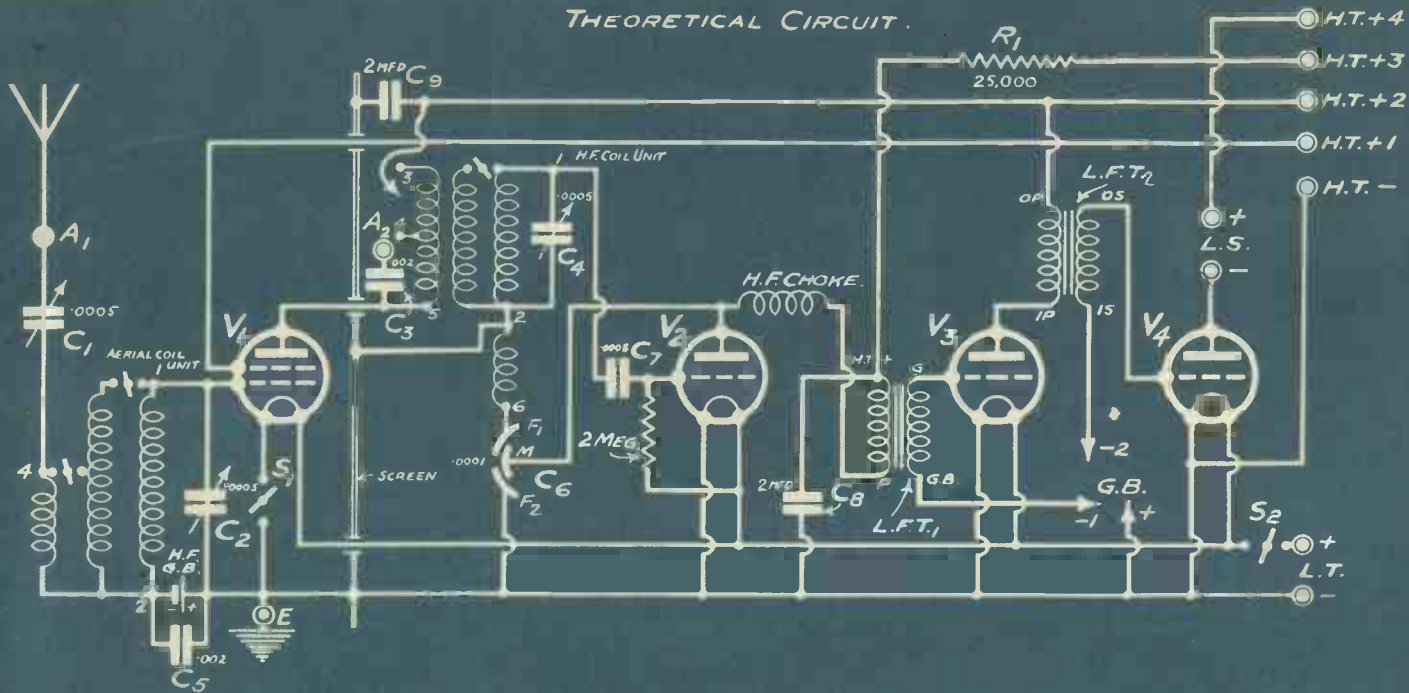

PANEL LAYOUT.

"Popular Wireless" Blue Print
No. 56 Price 6d.

The "Regional" Four

- 1 Panel, 21 in. x 7 in.
 - 1 Cabinet to fit, with baseboard 10 in. deep.
 - 2 .0005-mfd. variable condensers, slow-motion type or with vernier dials.
 - 1 .0005-mfd. "Brookmans" condenser.
 - 1 .0001-, .00013-, or .00015-mfd. differential reaction condenser.
 - 2 On-and-off switches.
 - 4 Sprung valve holders.
 - 1 D.B.A. and 1 D.B.P. wave-change coil.
 - 1 H.F. choke.
 - 2 L.F. transformers.
 - 2 .002-mfd. fixed condensers.
 - 1 .0003-mfd. fixed condenser.
 - 2 2-mfd. fixed condensers.
 - 1 25,000-ohms resistance and holder.
 - 1 2-meg. grid leak.
 - 1 Grid-leak holder.
 - 1 Standard "P.W." screen, 10 in. x 6 in.
 - 1 Terminal strip, 21 in. x 2 in. or 19 in. x 2 in.
 - 12 Terminals.
- Wire, screws, G.B. plugs, flex, etc.

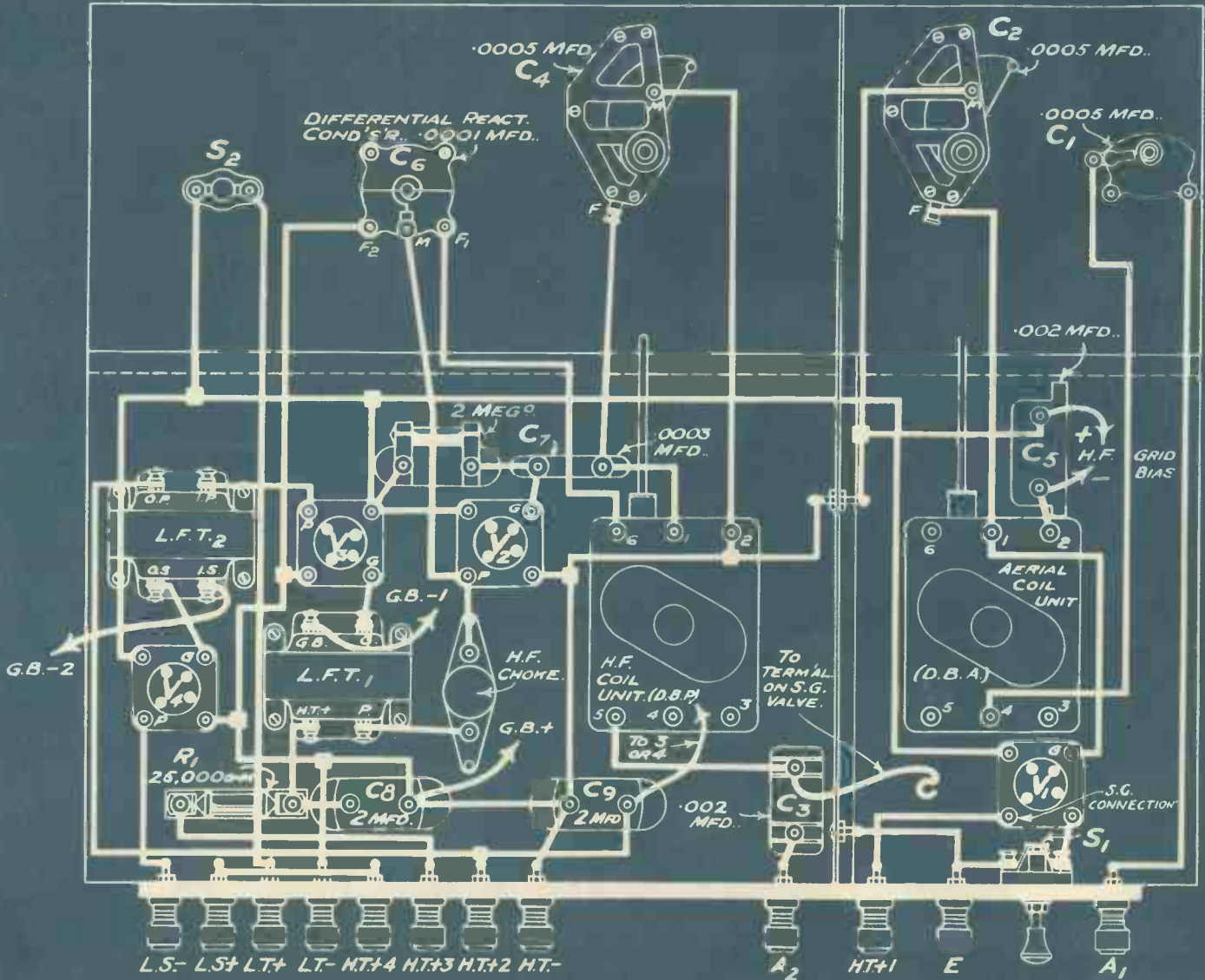

WIRING DIAGRAM.

DRAWN BY.	amg
CHECKED BY.	lps
SERIAL No.	56

"P.W." Blue Print No. 56. The "Regional" Four. A real "de-luxe" receiver of exceptional selectivity, with a screened-grid H.F. stage, two powerful L.F. stages, and many refinements. Coil units have wave-change switches built in. Push knobs on panel inwards for long waves and pull outwards for medium waves. Use of the taps 3 or 4 on H.F. coil unit and adjustments of C₁ vary selectivity. H.F. grid bias 1½ to 3 volts. Upright S.G. valve for V₁, H.F. type for V₂, L.F. for V₃, power or super-power for V₄. 60 to 80 volts on H.T. + 1, 120 volts on H.T. + 2, 60 to 70 volts on H.T. + 3, 120 volts or more on H.T. + 4. To cut out H.F. stage put aerial on A₂ and turn S₁ off.

TRUMPHS

OF BRITISH RADIO RESEARCH



FIRST HYPERMU

THE WORLD'S ACKNOWLEDGED BEST L.F. TRANSFORMER

The "Hypermu" makes modern circuits successful for experimenters. Its enormous amplification and perfect uniformity constitute a remarkable performance unequalled by any other intervalve transformer. It is the proved best for sure results in set construction and is specified in all star circuits for 1930.

Ask your dealer or us for the "Hypermu" latest N.P.L. Curves, taken in conjunction with modern values.

The "Hypermu," metal shielded and encased in Bakelite. Weight, 14 özs. Size, 3" x 1½" x 3". **21/-**

AND NOW THE HYPERMITE

**Weighs only 7 özs. yet
possesses a Primary In-
ductance OVER 50 Henries**

The "Hypermite" is the first transformer giving ample reproduction of the low notes without loss of the higher frequencies, that is available at a low price. Obtain one from your dealer and test it in your set, and note the exceptional fidelity of reproduction it occasions, or ask him for the "Hypermite" leaflet containing full description and diagrams. This is your chance to test out a modern nickel iron transformer.

The "Hypermite," a transformer of amazing performance and value. Weight, 7 özs. Size, 2¾" x 1¾" x 2¼". **12/6**



R.I., LTD., 12, HYDE STREET, LONDON, W.C.1.

ANOTHER GREAT GIFT FOR READERS

Popular Wireless

Every Thursday
PRICE
3d.

No. 405. Vol. XVI.

INCORPORATING "WIRELESS"

March 8th, 1930.

Presented Free with "Popular Wireless"

The "Popular Wireless" Amateur's Guide 6d.

CONTENTS INCLUDE

- "P.W." TESTED CIRCUITS
- THE VALVES TO BUY USING MAINS UNITS
- THE GRAMOPHONE PICK-UP
- Full Instruction For Making
- "THE ASTIPODES ADAPTOR"
- "THE MAGIC TWO" and
- A SELECTIVE CRYSTAL SET
- HOW LOUDSPEAKERS WORK
- SHORT WAVE SETS - HINTS ON TUNING
- CHOOSING MAINS VALVES
- THE "P.W." PICTORIAL GUIDE
- THE SET BUILDING HINTS
- MAKING YOUR SET SELECTIVE

THIS BOOK FREE Inside!

ALSO THIS WEEK

Long Illustrated Articles About

THE "REGIONAL" TWO

THIS YEAR'S "TITAN" THREE

THIS YEAR'S "MAGIC" THREE

YOU AND THE B.B.C. PROGRAMMES

BIASSING WITHOUT BATTERIES, Etc., Etc.

A Special Article By Our Radio Consultant-in-Chief, CAPT. ECKERSLEY, M.I.E.E.

In addition to his regular "QUERY CORNER" Feature

"The Most Efficient Choke We Have Tested"

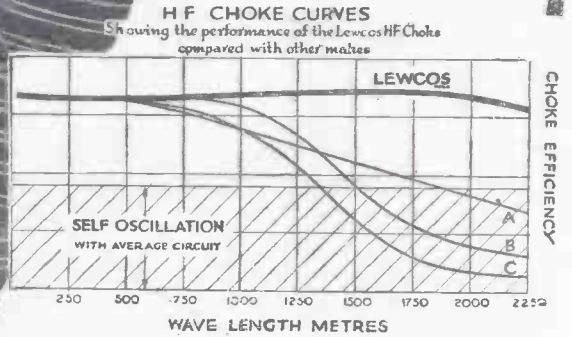
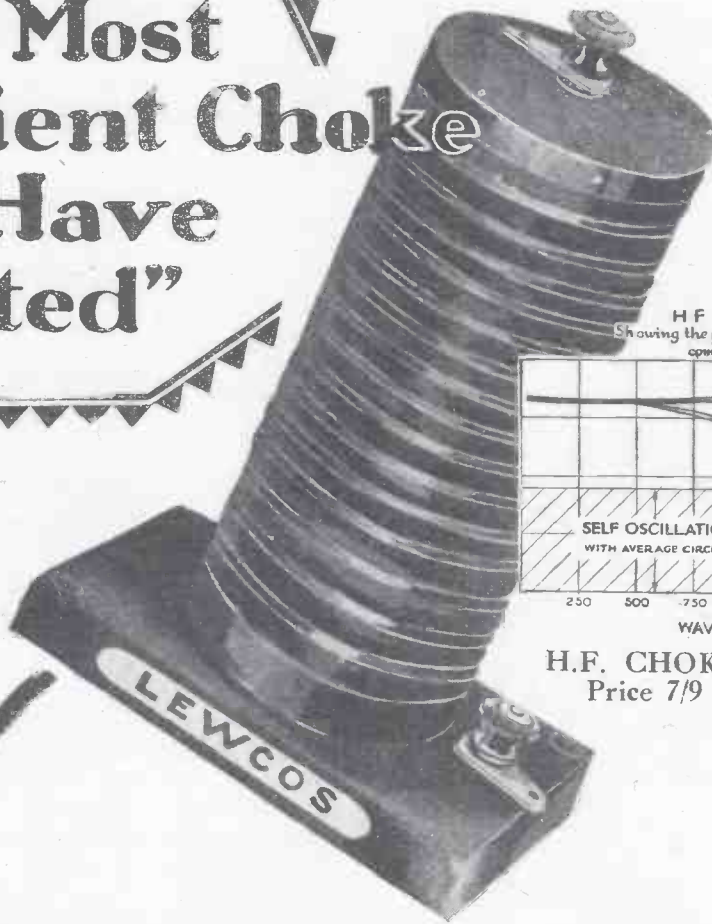

H.F. CHOKE
Price 7/9

"We are pleased to report that the Lewcos H.F. Choke is, in our opinion, the most efficient Choke we have tested, there being no sign of instability even when using 150 volts H.T. on the Anode of the S.G. Valve. The construction is massive and well finished, and its design places it in the front rank of high-class components."

An appreciation from Industrial Progress (International), Ltd., Bristol

The above letter is a further appreciation of the unique qualities of the Lewcos H.F. Choke. The fine materials and the high-class workmanship used in its manufacture make it supreme. The terminals are arranged one at the top and the other at the base of the Coil, to eliminate the risk of additional self-capacity in the wiring of the receiver.

The H.F. Choke curves illustrated above show the astonishing performance and advantages of the Lewcos Choke over other makes.

THE LEWCOS H.F. CHOKE IS SPECIFIED FOR THIS YEAR'S "TITAN" THREE.

Lewcos Centre Tapped and "X" Coils are specified for the "REGIONAL" TWO Receiver described in this issue.



PRICES :

C.T. 25-75 ..	3/6
C.T. 100-300 ..	4/6
X. 60-75 ..	4/9
X. 200-300 ..	6/6

FULLY DESCRIPTIVE LEAFLETS OF THE TWO LEWCOS COMPONENTS ILLUSTRATED ABOVE WILL BE SENT ON REQUEST. PLEASE QUOTE REFERENCE NUMBER (H.F. CHOKE, R.33; C.T. AND "X" COILS, R.34).

LEWCOS

THE LONDON ELECTRIC WIRE COMPANY AND SMITHS LIMITED,
CHURCH ROAD, LEYTON, LONDON, E.10.
Trade Counter : 7, PLAYHOUSE YARD, GOLDEN LANE, E.C.1.

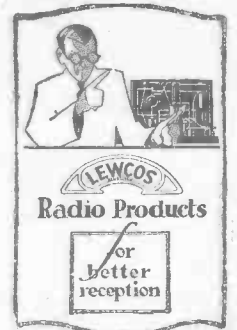

In TONE



With
Beautiful Surroundings

The fine appearance of the B.T.H. Cone is as notable as is its wonderful tone, its full volume and its faithful reproduction of all sounds—from the gruff voice of the test engineer to the delicate trill of the piccolo.

It is inexpensive and its ornamental grills, backed with old gold gauze form an artistic addition to any existing decorative scheme.

PRICE £3.

B.T.H. CONE
LOUDSPEAKER



THE EDISON SWAN ELECTRIC CO., LTD.,
 Radio Division,
 1a, Newman Street, Oxford Street, W.1.
 Showrooms in all the Principal Towns.

EDISWAN

[W.71]

The FERRANTI

A.C.
Mains
Receiver

Available for Alternating Current Mains only. Voltages: 200/250. 40 cycles or over.

In Oak - - £25
 In Mahogany - £26
 In Walnut - £26
 Royalty £1 extra.



The Ferranti A.C. Mains Receiver is a 3-Valve Set giving reproduction nearly true to life. It relieves the user of the constant expense and inconvenience of battery charging and renewals. Reliable in operation, it requires no technical skill to manipulate, and there are no maintenance charges.



Electro-Dynamic
Speaker

Models:

A.C. - £18 0 0
 D.C. - £14 10 0

Designed for those who desire quality of reproduction above all else, the Moving Coil Speaker is capable of exceptionally good performance. This Speaker, in conjunction with the Ferranti A.C. Mains Receiver constitutes a Radio combination difficult to excel.

FERRANTI LTD. HOLLINWOOD LANCASHIRE

100% BETTER REPRODUCTION FROM YOUR GRAMOPHONE RECORDS !

*Electrical recording demands
electrical reproduction*

Far clearer reproduction, far greater detail . . . by using a Marconiphone electrical pick-up in place of the sound box and tone arm on your gramophone: The music is reproduced through your receiver and loud speaker . . . gloriously rich and vivid, achieving the full brilliance of the high notes, the deep power of the bass, bringing out the subtlest shades of tone. The skilful design of this pick-up reduces needle scratch to the absolute minimum—and your records last far longer than before. It costs only £3. 3. 0. Ask any Marconiphone dealer for a demonstration. The Marconiphone Company Limited, 210-212 Tottenham Court Road, London, W.1.



PLAY YOUR RECORDS WITH A

MARCONIPHONE PICK-UP



The first and greatest name in wireless

Popular Wireless



Scientific Adviser:
Sir OLIVER LODGE, F.R.S.
 Chief Radio Consultant:
CAPT. P. P. ECKERSLEY, M.I.E.E.
 Editor: **NORMAN EDWARDS.**
 Technical Editor: **G. V. DOWDING, Assoc.I.E.E.**
 Assistant Technical Editors: **K. D. ROGERS,**
P. R. BIRD, G. P. KENDALL, B.Sc.,
A. JOHNSON RANDALL.

**THOSE TWINS!
 QUICK THINKING.
 MORE HOWLERS.
 A SHOCKING AFFAIR.**

RADIO NOTES & NEWS

**THE RADIO ORGAN
 TURIN'S BIRD!
 LOOKING AHEAD.
 "RADIOSMELLERY"**

Taming Those Twins.

BEFORE I go into the week's news I've got to thank "B. C. M.," of St. Albans, for a rare and refreshing letter on wave-traps. He's got them all taped, believe me!

Always interested in selectivity, this correspondent says that he's tried all the schemes offered to the public, and they're 99 per cent dud or decrepit, the one exception, of course, being the "Brookmans" Rejector circuit.

"There's one thing about 'P. W.,'" he says, "it did come out with a *new* idea, for the *new* conditions of regional reception." Then he warms up and goes on:

It Does Work.

THESE other old schemes under new names that I've tried are chiefly time-wasters and money-losers, but thank goodness 'P.W.' stood apart from this poisonous lot of failures that we've had lately. Whatever you say about the Brookmans Rejector you've got to admit *it does work!*" etc., etc.

And whatever you say about "B. C. M.," of St. Albans, you've got to admit that he speaks his mind! The late St. Alban might have disapproved of the invective, but personally I found "B. C. M.'s" a most refreshing epistle.

"The High Jump."

DISTRESSING as it is, I must part company with friend "Philemon" on the subject of Sir John Reith's recent declaration of the B.B.C. policy of giving us not what we want, but what the B.B.C. thinks is good for us. "Philemon's" only censure in this respect is that Sir John "showed his hand." Now, my view is that the B.B.C.'s policy may be suitable for public reformers, but it is not suitable for the B.B.C. To ask us to pay to be uplifted is a bit cool, surely! When did the B.B.C. get a mandate to redeem us from our deplorably low tastes in recreation and our slothful habit of refraining from study during the few hours between dinner and bedtime?

Quick Thinking.

CONGRATULATIONS are due to Mr. H. Vivian, of the Columbia Broadcasting Company, U.S.A., on his ready initiative and plucky performance at the time of the King's speech. A broken wire, vital to the functioning of the system, was his problem, and he solved it like a real man and a thinker. Realising that repairs would take too long, he grasped the ends of wire and held them together, thus keeping the circuit intact and enabling the public to hear the King. Vivian was slightly burned and no doubt shaken by his ordeal, from which I hope he has recovered. Plenty of folk will do the right

"P.W." STILL GROWING FAST!



A few weeks ago we published a photograph of the new annex to the "P.W." Research and Construction Department, where an enlarged staff is now going ahead with some splendid new designs. We are still growing, and the above photograph shows a further small annex being fitted up for Technical Research and Construction work.

thing, given an hour's notice, but Vivian was "Johnny on the spot."

Howlers.

FOLLOWING the fashion, I offer readers these examples of schoolboy "howlers" in the hope that they may believe them to be genuine. "Brookmans Park is where they have motor-boat races." "Pronunciation is what announcers do when they can't speak properly." "The nightingale is a bird which interferes with radio. It is excited by a chello." "Noiseless background means absolutely still and

quiet, like the B.B.C. Bord of Guvviners." "Talks are edducatton and are used by the B.B.C. to test the microphone before people start listening." "When you put volts on a valve to stop contortion it is called grid buyers."

The Perfect Needle.

MY search for the perfect "grammy" needle, noiseless, non-destructive, tone-true, etc., is most amusing, albeit expensive and possibly exasperating at times. For look you, I am compassed by a multitude of counsellors (all boys of the best calibre, to be sure!)—but—"some like it hot, some like it cold." Some swear by steel; others, like "E. P." (Limpsfield), by hawthorn spikes culled *au naturel*. What I gain on the swings I lose on the thingummies. Ample detail and sharp tone are accompanied by an infernal scratch; lack of scratch means loss of tone and detail. Now I am looking for a hairpin, dropped by a beauteous blonde named Stringer, on a foggy forenoon!

Short-Wave Note.

IF any of you have missed W 8 X K lately, be of good cheer, for W. F. M., of Uxbridge, has found him. The culprit, who was formerly an occupant of 62.5 metres, may now be found lower down the street, just below W 2 X E on 49 metres. By the way, I don't hear very much nowadays about work on 10 metres and under. I believe that there is still room in the ether to found an empire, and I should like to see an intensive attack on ultras.

What a Shocking Affair.

MORE about Cuneus. My attention has been drawn by C. A. J. to that good old classic, Deschanel's "Natural Philosophy," which, I confess, I overlooked resting as it does, together with Ganots' "Physics," in the dust of a top shelf. Well, according to Deschanel, the whole episode belongs to Cuneus, who devised the experiment and "put it over." Muschenbroek was probably sitting in his office with a pipe and a drop of schnapps.

(Continued on next page.)

NOTES AND NEWS.

(Continued from previous page.)

Cuneus wrote to Réaumur saying that he would not take a second shock for the crown of France. When one gets into a bit of historical research one's faith in Macaulay & Co. begins to wobble.

The Magic "Magic" Three.

THANKS to a note in these columns and the friendliness of W. G. T. J., our friend F. B., who lent his "Magic" Three issue of "P. W." to a friend—for ever!—is by now probably comforted. W. G. T. J. is hereby created an honorary Fairy—and I hope he likes it. What a stirring-up this "Magic" Three has given my fairies. You wouldn't believe them if they told you the amount of trouble they went to in order to frisk up the "Magic" number of "P. W." for A. J. W. B.! It's enough to turn them into goblins!

Go Up One.

GOING up one, we come to the "Magic" Four, and from W. W. (Banffshire) come magic words—magic, because on reading them five members of the 'tec staff split their hats with loud twangs. "I cannot find words of congratulation strong enough for the designers." (Wow!) "Here is a fine set, as sharp as a knife, capable of overloading the best loud speaker or of making the floor shake on foreigners or even of lifting the roof off a 'local,' if required." W. W. gets W G Y and W G P every morning for a pick-me-up as easily as we hear next-door's baby.

New Scenery.

SO little belief have the firm of "R.I." in the imminent ruin of the Empire and the radio trade that they are building a new factory—and it is going to be a corker. The new R.I. place will be on the Croydon by-pass, so look out for signs of it when you next whizz down to Brighton in the Sunday queue. If you have a puncture nearby and are at a loss for occupation I dare say that the men will let you pass some bricks, just like Winston!

Radio Instruments.

WELL, good luck to Radio Instruments, Ltd. I remember their beginning, when the genial sportsman who adventured left Sullivan's to start for his own hand. And now he is going to have this fine modern factory, with all the latest improvements in lighting and whatnot. Oh, and a Clock Tower, with real time made at Greenwich, so that the pillion-girls can glance up and mutter, "That's ten minutes I've kept on." (Bless their clinging ways!) And a bee-utiful illuminated "R.I." sign, all done in Neon lamps, for a lighthouse to the queue as it toots homewards after a day's parking and punctures.

The Radio Organ.

THE radio organ, to which I referred some time ago, has actually been "on the air" through K D K A, and January 21st is the date which will appear in future history-books as that on which organ music was first played on electrical circuits instead of vibrating columns of air in pipes. The basis of the invention is the utilisation of "howling" valves, arrangements being made to regulate the pitch

of the "howls," which are operated by a keyboard. What with this and the Theremin, we shall soon be having bands played by electricians on switchboards, conducted by television, etc.

The "Olympic" Games.

THE telephony trials which are being conducted by the "Olympic" have brought too many letters for me to acknowledge singly. The information gleaned is: G 2 G N, "Olympic"; W O O, Deal, New Jersey; W 2 X G was an experimental station at Rocky Point, Long Island; G 2 A A was once a station of the Radio Communication Co. at Slough; W N D, Ocean Township, belonging to American Telephone and Telegraph Co. W. F. S. (Barrow-on-Humber), J. N. S. (Belfast), and S. H. C. (Willesden) sent the best accounts of these experiments.

The Dicky-birdo of Turino.

F. T. C. (Streatham) by the way, took a gloomy view of the matter when he said that the "Olympic" is getting ready "for the summer mob who want to telephone from their bunks and annoy

SHORT WAVES.

"FROM PRISON TO BROADCASTING." Sometimes the process should be reversed.

FOOTBALL BY RADIO. Where wireless scores.—"Daily Mirror."

CONSOLATION. Although the B.B.C. is strongly criticised, it can still boast a Reith at its head.—"Sunday Pictorial."

"The execution of the relay of this lecture was exceptionally good," writes a B.B.C. critic. We hope all lecturers will not meet with the same fate.

"Is wireless music influencing people to take up, or go back to, piano-playing?" asks a correspondent in the "Shields Daily News." Oh, but surely it's not quite so bad as that!

AND NOW HALIFAX.

The implacable green detector van has moved on to Halifax in its relentless search for licenceless homes. We may take it that Hell and Hull have already been subjected to a comb-out.—"Vox."

With fingers weary and worn,
With eyelids heavy and red,
Trying to escape from 5 S C,
I nearly am off my head.

Talk! Talk! Talk!
In poverty of music and glee,
We simply are getting quite sick of our lives.
'Twas bad enough when we had only our wives—
But now we have 5 S C.—
"Daily Record and Mail."

people on shore on either side." He is more cheerful when explaining a zoological matter of which I was ignorant, namely, that it is a million times more difficult to persuade a nightingale to sing at any given moment than to make a parrot talk to order. I'll bear it in mind. One would almost believe that F. T. C. was invalidated from the "outside stunt" department of the B.B.C.!

Honesty.

A WELL-KNOWN firm of manufacturers is trying to find the person who sent them four shillings because a dealer had sold him a transformer at a price less by that sum than the conditions

of sale imposed by the makers warrant. Presumably they wish to reward him, but a man who will act as he did will not easily be found. Anyway, should honesty be materially rewarded? I don't think so! Pity there is not more of it amongst the gentry who play fast and loose with their commercial obligations.

For the Slightly Deaf.

THERE is to be broadcast from Belfast on March 12th a work which should appeal to persons who are somewhat hard of hearing, and also to men who work in boiler-making factories. I refer to C. Lambert's "Rio Grande," which is alleged to be the first choral work in which pure jazz technique is employed. I am not so sure about that claim; I have been to the "talkies."

However, it is, I believe, going to be a glorious hullabaloo.

Looking Ahead.

THOSE nervous, restless North Americans are already trying to foresee the state of radio in 1931, as though it were not in a sufficient "state" at the moment. As a result of their labours they have concluded that as the domestic receiver—in America—is already perfect the only improvement at home can be that sets will be "built in," presumably like fireplaces and safes. Further, they state that the rooms of the future will have walls of which loud speakers are ordinary constructional units. Do they have telephones all over their houses now?

Is "Piracy" So Rife?

IT is somewhat distressing to read that as a result of the visit of a detector van to the Manchester district 4,000 new licences had been taken out. I would prefer to have positive evidence that this is genuinely an instance of cause and effect, though *prima facie* it looks black. If, however, a van can squeeze fees to the amount of £2,000 out of one district, it would be profitable to treble the number of vans. But isn't it all rather disheartening and sad?

Radiomellery.

PROF. A. M. LOW ought to be a proud man to-day. We have playfully crossed walking-sticks and pens with him on the subject of his repeated prophecies that some day we shall be able to smell and taste by radio, and now the "Manchester Guardian" publishes an American report of a Paris man's experience in radiomellism. This person said that he was "listening-in" to a service broadcast from Notre Dame Cathedral and that at the same time he smelt the smoke from the church candles.

Synesthesia.

THOSE who believed him called it synesthesia—which explains it all perfectly, of course. The wise men say that this confusion of sensations is fairly common, especially in the form of colour hearing, when a certain sound produces the sensation of a certain colour. I think that the smoke-smeller of Paris imagined the scene, saw in his mind's eye the smoky candles—and there you are! The smell was not transmitted by radio, though the cause of it was.

ARIEL.

FIVE FAMOUS RADIO PERSONALITIES DISCUSS—

YOU — and the B.B.C. PROGRAMMES

TOMMY HANDLEY, the B.B.C.'s own "funny man," has something to say. "Yes, of course, there is a strong link between you and the B.B.C. programmes: but I really *refuse* to speak about the funny side of the programmes.

"The pet bee in my bonnet at the moment is in connection with that magic part of a radio set called a *switch*. People just won't use their switches—even Scotsmen—and there's all that low-tension "juice" running to waste in providing some programmes which some people don't want to hear.

There are folk I know who think nothing of having the radio blaring out from the lunch-time broadcasts to the midnight jazz music, no matter whether it is Tannhauser, a topical talk or tripe!

"Surely they can't be so catholic as to appreciate all of it?"

"No, of course not. "What happens is that for every one thing they like there are two things they don't like. So the B.B.C. post-bag is regularly swelled by a further letter of complaint:

"Silly?"

"Yes, but so many of my acquaintances do it. Switching off often saves tempers and cuts down those trips to the accumulator charging station!"

"Do, please, be *patient* with your loud speaker."

When Television Arrives

• **HARRY TATE** says: "You grouse, but the programmes still go on! And those dreary Sunday programmes. But still: never mind. A passing thought as I put pen to paper is that it will be rough luck on some folk when television arrives. I mean, frankly, we haven't all first-class faces, have we? And the mere

We often grumble at the fare the B.B.C. provides for us, but it is rarely that we hear the opinions of the other side. Here we have some refreshing ideas from well-known and popular broadcasters.

thought of broadcasting some of them—oh, horrors!

"But still, Nature is kind in that while she gives us our faces we are allowed to pick our own teeth!"

"Seriously, though, there's going to be a big future for seeing by radio, when the apparatus is perfected, and the job of the radio humorist will be much easier when

he can stand in front of the microphone and "clown" in the old familiar stage style.

"But please don't expect me to be serious just now. I claim to have invented a really new, fresh and original radio joke! List, and ye shall hear.

"Old Lady: "And can you

really get the German stations on that machine?"

"Weary 'Fan': "Yes, grandma. Every Nauen then!"

"What? You say you always did like that one? O unlucky radio humorist! Is there *nothing* new under the sun for you to broadcast?"

"One final word about you and the B.B.C. programmes. Could you do better yourself? If so, please try!"

LESLIE HENSON "sticks to his last" and talks about you and the B.B.C. humorous programmes: "Some people write and tell me that I must be frightfully

blasé in regard to broadcast humour, and they picture me with bored contempt switching off every time a 'funny-man' turn is announced.

"Believe me, I don't. I take a very active interest in radio humour of all kinds, and I know—having had it vividly impressed upon me—how hard it is for a humorist accustomed to the footlights of the stage to be funny via the microphone. It's a bad business. Personality—that essential of humorists and humoristes—is almost lost through the medium of radio.

"If you've any doubt at all about the matter, and perhaps fancy your powers of being a wag, try to persuade the B.B.C. to give you an audition. The task accomplished you will—unless you are a super-funny person—come away from Mr. Microphone sadly disillusioned."

Home Made "Broadcasts"

FRED ELIZALDE, who used to broadcast dance music, advises you to use a radio set and gramophons records, so that you can make the most of the B.B.C. programmes:

"Every set for dance purposes should have provision for electric reproduction of a gramophone. It is so easy to do this that I wonder it is not almost a standard arrangement, and not only for dance music.

"Perhaps one day the B.B.C. will be able to provide an alternative programme of almost continuous dance music, though who could carry on such a never-ceasing babbling brook I don't know.

(Continued on next page.)

Leslie Henson takes a very active interest in radio humour of all kinds.



Tommy Handley—the B.B.C.'s own "Funny Man."



Harry Tate is doubtful whether or not television would be an advantage.



AN ATTIC OUTFIT.

THE photo shows a receiving set installed below the aerial in the loft of a bungalow house. A carbundum detector ("stabilising detector unit") provides phone supply, while a 2-valve amplifier may be switched on for the loud speaker.

The set is entirely unpretentious: all components are high-class, but they are installed in a cheap wooden box. The set is tuned-in to the local B.B.C. station 5 to 6 miles away. For all practical purposes it is forgotten—it is visited only about every four months for L.T. cell charging, while H.T. battery renewal is yearly.

Owing to the bungalow form of house, each room is readily reached by bell-wire leads running over the joists and thence to 2-pin plugs fitted beside windows or beds. The actual arrangement as regards availability of "radio supply" is as follows:

The Switchboard.

In the box-room is mounted a switchboard by which the output of either crystal or amplifier may, by plug device, be sent through to any room; the amplifier can be switched on, or controlled as regards volume, by a rheostat embodied in the switchboard; a further occasional refinement makes it possible in the case of illness for the loud speaker to be installed at a bedside and switched on there by the bedridden person.

Thus an assured "radio supply" is as simply and readily available as the supply of electrical energy from the local network.

SENSITIVITY AND SELECTIVITY.

A SINGLE-VALVE set could be made sufficiently selective to pick up one of two broadcasting stations with a difference in wave-length of only but comparatively a few metres.

This set would not, however, be capable

"Until then, the radio-gram is the easiest way out of the difficulty, for the B.B.C. obviously is limited in the dance-music time it can allot. With a gramophone as a stand-by (and with electric reproduction, of course) one has an almost unlimited source of syncopation."

SANTOS CASANI, the famous creator of dance steps who has frequently broadcast, has something to say about you and the B.B.C. programme critics:



Fred Etizalde, the leader of a well-known dance-band.

"I know that there are many people who strongly criticise the B.B.C. They should remember that it is always easy for the onlooker to criticise the game, but he won't benefit the players very much, nor get many thanks.

"Generally I find, in my experience, that those

IDEAS FOR CONSTRUCTORS.

of receiving the distant stations that would be well within the powers of a three- or four-valve set.

Sensitivity, on the other hand, is a set's power of obtaining stations, selectivity being a state whereby any of the stations received can be listened to without interference from another station.

It is quite easy to see that a set that is not exceptionally sensitive can still be quite selective. We are often able to receive a station with a single-valve which we are unable to pick up with a non-selective three-

valve, simply because this is swamped by another station.

Lack of selectivity evinces itself in two ways, although the effect is similar.

- (1) Interference from a powerful local station.
- (2) The inability to separate distant stations of equal strength.

Lack of sensitivity in a receiver can be due to three main kinds of faults:

- (1) Unwanted resistance somewhere which results in "damping."
- (2) Coupling faults between coils and circuits.
- (3) Incorrect inductance-capacity ratios in tuning circuits.

CEMENTING BROKEN EBONITE.

A PANEL possessing chipped-away corners is apt to look very unsightly when fitted in the cabinet. Furthermore, such a panel may provide difficulties in screwing in position.

In such cases, therefore, the following ebonite cement will be found to be most serviceable in making a neat and efficient repair.

Dissolve a quantity of finely powdered shellac in hot methylated spirits until a thick varnish is made. Into this varnish stir gradually a quantity of molten Chatterton's Compound, until the resultant mixture has attained an almost solid consistency.

For use, apply the cement fairly liberally, and in a hot condition, to the ebonite surfaces to be joined. Quickly wipe off any surplus cement which may protrude over the edges of the join, and then place the cemented article under pressure for twenty-four hours. A strong and enduring joint will be the result.

The above cement is not only of use for cementing up broken corners of ebonite panels, but also for repairing broken knobs, dials, and other insulating portions of radio instruments, no matter whether they be of an ebonite or composition nature.

WELL OUT OF THE WAY.



A novel receiver situated in the roof of a bungalow.

YOU—AND THE B.B.C. PROGRAMMES.

(Continued from previous page.)

who listen most criticise least, and vice versa. Those who condemn the B.B.C. obviously forget that in its broadcast service it corresponds to a variety stage; it can't be *always* high-brow, or *always* low-brow. It is both in turn.

"At any good variety turn you find popular items and classical items—and the audience numbers perhaps only a thousand or so. But with the B.B.C. we are considering not thousands, but millions, and the need for variety of every kind is, therefore, even greater.

"My own opinion is that the B.B.C. really is doing its level best.

Alternative Programmes.

"The advent of alternative programmes through the medium of a growing number of high-power stations is beneficial in this respect, and most listeners are finding that it is now possible to have a choice of two or three programmes from high-power stations at roaring strength. This is all to the good, and is a great aid to the call for variety.

"Nowadays, if you don't like one programme, you tune to another station: in the early days of broadcasting, you just had to switch off and wait.

"The attitude of a tired business man to radio is always 'Turn that thing off!' if the loud speaker starts to 'spout'—which indicates that the hours suitable for education talks and jazz music are poles apart!

"As one who is an enthusiastic listener and an occasional broadcaster, I recommend all those who fill the B.B.C.'s post-bag with complaints to be patient. The B.B.C. can't always put out a programme to suit you: they *sometimes* have to please the man next door!

"And don't forget that a man who stands at the table can criticise easier than the man who is playing the card."



Santos Casani, famous dancer exponent.

The "REGIONAL" TWO

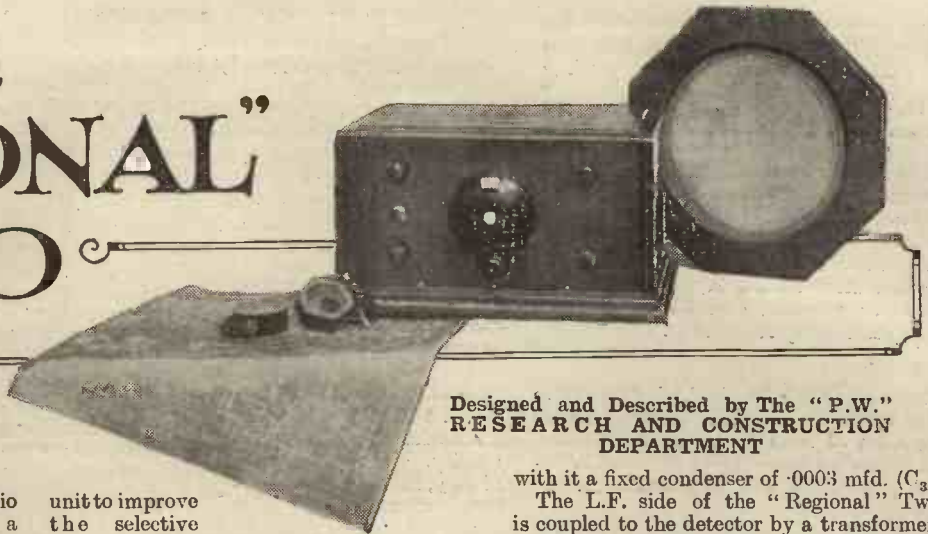

A Det.-L.F. loud-speaker set that can ignore the most powerful local, and bring in distant stations.

Designed and Described by The "P.W." RESEARCH AND CONSTRUCTION DEPARTMENT

MANY listeners derive their radio enjoyment from the possession of a simple receiver designed to give good quality reproduction of the "local" station. In a great number of these cases the receiver will quite probably be a two-valver with the very simplest of tuning arrangements. Such a set, using a good stage of transformer-coupled L.F. amplification, is capable of providing a great amount of pleasure indeed to the average family circle.

Cheap to Install

Undoubtedly, much of the attraction in this type of apparatus lies in its economical aspect, because a two-valve set is cheap to install and makes but moderate calls on the family exchequer for maintenance.

Recently, however, the introduction of the B.B.C.'s Regional Scheme has given rise to some feelings of alarm among this large circle of simple set owners. This scheme, as you know, makes provision for the simultaneous broadcasting from one station of two dissimilar transmissions. Since both these transmissions originate at exactly the same geographical position, they will, of course, be received by any listener within their range at fairly equal strengths.

Moreover, the strengths at which they will be received will be greater than many listeners have hitherto experienced owing to the vastly increased power which the Twin transmitters are using.

For either one of these transmissions to be received without interference from the other, it is necessary for the listener to rely solely on the qualities of his receiver. The quality which it is most essential that the receiver should possess is that of selectivity, and that is just the one characteristic which, hitherto, has been most lacking in the popular simple two-valver or equivalent receiver.

Cuts out the Local

And the necessity of providing a simple means of coping with the selectivity problem of the Regional Scheme has resulted in the invention of that new form of rejector circuit, the "P.W." "Brookmans" Rejector.

This arrangement has become exceedingly popular, and has undoubtedly done much towards making the B.B.C. Regional Scheme as beneficial to the ordinary listener as the instigators of the scheme intended it to be.

Hitherto, the rejector circuit has most frequently been used as a separate external

unit to improve the selective powers of sets.

The "Regional" Two, however, goes one step further than this. It is the logical outcome of the popularity of the rejector circuit, and sets a new standard in receiver design by virtue of its incorporating, as an integral part of the circuit, an efficient rejector circuit.

In all other respects, too, the set is also of exceptionally good design, especially with regard to the special method of reaction control. A differential reaction condenser is employed. This contributes a delightfully smooth reaction control of reaction, which has but little tuning interlinkage.

REJECTS THE UNWANTED STATION.

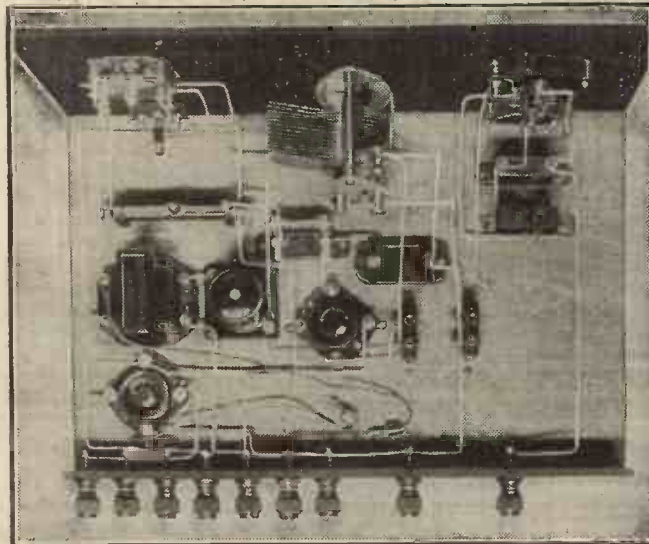

This definitely is a set that anyone can build and operate. Inexpensiveness throughout has been aimed at, and achieved, without sacrificing the wonderful power and smoothness of control that are features of the circuit employed.

In addition to good loud-speaker reception of the "local," this set will bring in many distant stations in favourable circumstances. Its capabilities in this direction are, of course, very much assisted by the action of the rejector, which keeps the "local" right off the tuning dial when you are listening to distant stations.

If you examine the circuit of the receiver you will see that the rejector circuit consists of a No. 50 coil, marked L₁, and a coupling condenser C₂. Then there is the rejector tuning condenser, C₁, which has in parallel

with it a fixed condenser of .0003 mfd. (C₃). The L.F. side of the "Regional" Two is coupled to the detector by a transformer, and we would urge the constructor of this receiver to use the best transformer he can afford. So much depends upon using a good quality transformer.

Commencing Construction

With regard to the construction of the receiver it is best to start operations on the panel. It will be noticed that the layout of the panel components is very symmetrical, and this, with the aid of the blue print, makes it very easy to locate the components correctly. The tuning condenser is placed in the centre of the panel, and the correct position for this component can very easily

be found by marking off two lines from each opposite corner of the panel. These lines should be marked on the back of the panel. The hole for the condenser shaft is then drilled where the two lines cross.

If two more lines are drawn parallel to, and 2½ in. in from the shorter edges of the panel, it will be found very easy correctly to locate the other panel components. Looking at the back of the panel the left hand line has the differential reaction condenser and the filament switch disposed on it.

The hole for the reaction condenser is drilled 1½ inches from the top edge of the

panel, and that for the switch the same distance from the bottom edge. On the other line (right of tuning condenser) there are three components; two condensers and one switch.

Very Easy to Build

The holes for the two condensers are drilled as before, 1½ in. from the top and bottom edges of the panel, and the hole for the switch takes its place centrally between the other two holes.

(Continued on next page.)

THE "REGIONAL" TWO.

(Continued from previous page.)

It is usually best to fix all the baseboard components before attaching the panel and terminal strip. It will be easiest to find the positions of the components on the baseboard by referring to the blue print. Your assembly should be as exact a copy of this as possible, especially with regard to the positioning of the coils.

Suitable Valves.

When all is ready, put in the detector valve socket a valve of the H.F. variety having an impedance of from 20,000 to 30,000 ohms. A medium-size power valve of about 5,000-ohms impedance will be suitable for the other position.

A No. 50 coil goes in the rejector coil holder (L_1), and a No. 60X coil (of good make, such as Lewcos or Lissen) is plugged into the aerial socket (L_2). For reaction, either a No. 50 or No. 60 should be inserted in the remaining coil holder (L_3). It is a good plan always to use a reaction coil of

actually to test the receiver. Make sure the L.T. accumulator is connected to the right terminals and that the correct values of H.T. are being used.

These will generally be found to be about 60 on H.T. + 1 and 100 to 120 on H.T. + 2. The G.B. - lead should be plugged into the grid battery at a value recommended by the makers of the second valve, corresponding with the value of H.T. you apply to H.T. + 2.

Now tune in the "local" without troubling about the rejector circuit. You will not have much difficulty in finding the "local," which will come in at wonderful strength and quality. If reaction is ploppy, move the potentiometer arm away from the positive end, where it should be set for initial adjustments.

When the "local" is properly tuned in, the rejector circuit can be brought into operation

by pushing in the switch S_1 . Set C_1 to its maximum, and then adjust C_2 until the local either disappears altogether or is reduced to a mere whisper.

When this point is found your dial will be clear of the "local," and searching for other transmissions can be indulged in without any trouble at all. All you have to do to bring the "local" back again is to pull out the rejector switch, when he will once again be very much in evidence.

The rejector, by the way, is capable of a different adjustment from the one just described, and this may be more convenient to use in some cases. To do this, reduce C_1 a little, and then adjust C_2 until the local is as weak as can be obtained with the new setting of C_1 .

By experimenting with the adjustment of C_1 and C_2 in this way, a setting will be found where it is possible to tune in the "local" with the rejector in circuit. But the tuning will be very sharp, so that, although the local is still on the

dial, he covers very little of it, and, consequently, is no more a source of interference than with a super-selective multi-valve receiver.

Listeners who have to cope with Brook-

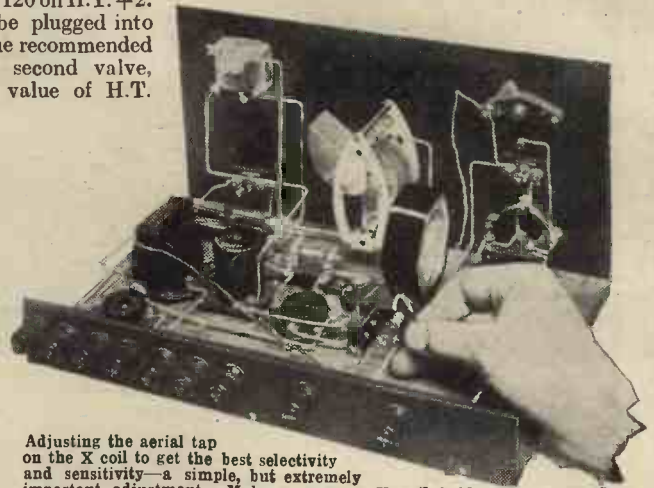

Adjusting the aerial tap on the X coil to get the best selectivity and sensitivity—a simple, but extremely important adjustment. Make sure your X coil holder is placed and connected correctly—the socket should be nearest the panel.

BOTH VALVES WORK HARD.

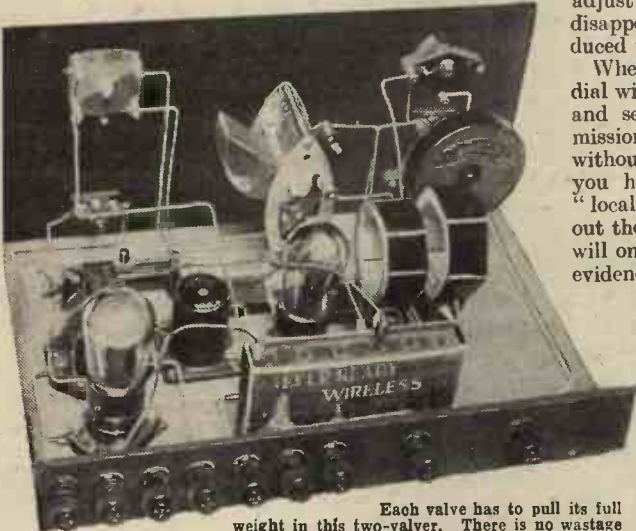

Each valve has to pull its full weight in this two-valver. There is no wastage of power, and surprising results were obtained when the set was tested under the most adverse conditions.

the same make as the aerial coil so as to ensure that the two coils are wound in the same direction.

When the flex lead is connected to one of the tappings on the X coil, you are ready

mans Park should, in most cases, set the rejector to eliminate the "Regional" transmitter on 356 metres, as it is usually found that the "National" transmitter doesn't spread as much over the dial.

If it is found that the 261-metre transmission interferes with reception of the longer wave, as well as the other way round, you will have to use the rejector when you want to listen to either of the twins.

First, switch out the rejector and tune in the Brookmans Park transmitter you do

A 6d. Blue Print of this set was one of four given away with every copy of "P.W." last week.

not want. Then switch in the rejector and proceed to eliminate the unwanted twin that you have just tuned in by the method described before.

When complete (or nearly complete), rejection of the unwanted transmission is obtained, all that has to be done is to tune to the other twin which you will find quite clear of any interference.

The receiver is, of course, perfectly capable of receiving 5 X X, and other long-wave stations, by using larger coils.

COMPONENTS RECOMMENDED FOR THE "REGIONAL" TWO.

- | | | |
|---|--|---|
| 1 Panel, 14 in. x 7 in. (Keystone, Trolite, Resiston, "Kay-Ray," Trelleborg, Goltone, etc.). | Ready Radio, Lissen, Magnum, Polar, Ormond, etc.). | Ediswan, Igranic, Phillips, Lissen, Carborundum, Loewe, Mullard, etc.). |
| 1 Cabinet to fit, with baseboard 9 in. deep (Camco, Gilbert, Lock, Peto, Scott, Pickett, etc.). | 2 On-and-off switches (Bulgin, Lissen, Benjamin, Lotus, Wearite, Igranic, Magnum, Jewel, Burton, etc.). | 1 H.F. choke (Dubilier, Varley, Lewcos, Ready Radio, Igranic, R.I., Lissen, Bulgin, Bowyer-Lowe, Climax, Colvern, Wearite, Magnum, etc.). |
| 1 .0005-mfd. variable condenser, slow-motion type or with vernier dial (Lissen, Igranic, Lotus, J.B., Burton, Gecophone, Ormond, Dubilier, Bowyer-Lowe, Cydon, Formo, Colvern, etc.). | 3 Single-coil holders (Lotus and Wearite in set). (Lissen, Ready Radio, Magnum, Keystone, Wearite, Igranic, etc.). | 1 L.F. transformer, low ratio (Lotus, R.I., Ferranti, Igranic, Varley, Cossor, Phillips, Telsen, Lewcos, Lissen, Brown, Mullard, etc.). |
| 2 .00075-mfd. "Brookmans" condensers (Ready Radio). | 2 Sprung valve holders (Benjamin, Magnum, Igranic, Formo, Lotus, Burton, W.B., Wearite, Bowyer-Lowe, etc.). | 1 400- or 200-ohms potentiometer (Ready Radio, Igranic, Lissen, etc.). |
| 1 .0001-, .00013-, or .00015-mfd. differential reaction condenser (Lotus, Pye, | 2 .0003-mfd. fixed condensers (T.C.C. and Dubilier in set). (Igranic, Clarke, Lissen, Goltone, Graham-Farish, etc.). | 1 Terminal strip, 14 in. x 2 in. |
| | 1 2-meg. grid leak and holder (Dubilier, | 9 Terminals (Belling and Lee, Eelex, Igranic, Clx, Burton, etc.). |
| | | Wire, screws, flex, plugs, etc. |



CAPT. ECKERSLEY'S QUERY CORNER

Under the above title, week by week, Captain P. P. Eckersley, M.I.E.E., late Chief Engineer of the B.B.C., and now our Chief Radio Consultant, will comment upon radio queries submitted by "P.W." readers. But don't address your queries to Captain Eckersley—a selection of those received by the Query Department in the ordinary way will be dealt with by him.

Methods of Coupling for S.G. Valves.

K. M. T. (Blackheath).—"I notice that there are two main methods adopted for coupling screen-grid H.F. amplifying stages. One makes use of a tuned anode and the other a tuned grid.

"Is either of these methods more efficient than the other. The tuned-anode method seems superior in respect to economy in components; are there any other 'snags'?"

The tuned-anode circuit has certain advantages. Firstly, if it is not used you have to use a choke instead—this has to have low D.C. resistance to get plenty of H.T. on to your valves.

A choke is apt to give greatly different values of effective anode impedance over the wide range of frequencies used in modern sets.

The tuned-anode circuit has a disadvantage in that the condenser and inductance mounting has to be all insulated for the full H.T. voltage from earth, whereas the tuned grid needs only to insulate against the grid negative potential or, where this is not used, can be earthed on one side.

Short Waves and Local Re-radiation.

R. B. (Putney).—"Why is it I can hear London re-radiated from a neighbour's crystal set on my short-wave receiver?"

It's a little strange, but for what it's worth here is a possible explanation.

Of course, your neighbour's crystal set could intensify the harmonic very considerably thus: Currents are set up in the neighbouring aerial of frequency of about 800,000 cycles per second. The effect is that your neighbour's aerial does re-radiate waves of about 360 metres. (This is not re-radiation by a valve causing oscillation, but every receiving aerial gives a feeble re-radiation; it must do to receive.)

But your neighbour's aerial, by having a rectifier directly connected to it, distorts the wave form of the aerial currents, and consequently re-radiates frequencies of 1,600, 3,200, 6,400, 12,800, and so on; in fact, wave-lengths of not only 360 metres, the fundamental, but 180, 90, 45, 22.5, 11.25, and so on metres.

You pick up one of these strong harmonic waves. Which is it? Does it do it if the crystal is disconnected, or is it weaker then? It will be interesting to try and prove or disprove my theory.

Mixing R.C. and Transformers.

A. J. (Chelmsford).—"If the low-frequency stages of a receiver consist of both transformer and resistance-coupled stages, is it preferable for the transformer stage to precede the resistance stage or vice-versa? Is there, apart from possible increase of amplification, any advantage in 'mixing' the stages?"

Transformers have so improved that it's only gilding the lily to use resistance capacity these days. The loud speaker is cutting off far more than you would lose by transformers.

tact with your "sacred" leads to the wood you might get leaks different in both cases and hence different reactions.

All rather strange, but I think you should always insulate your connections. You may have done so, in which case I must frankly say I don't understand it.

Can Crystals Amplify?

H. V. M. (Richmond).—"If a transformer and another valve are connected to a single-valve set, or even to a crystal detector, a fair degree of amplification is obtained.

"Why, then, is it not possible to obtain amplification by coupling two crystal detectors by means of a step-up transformer?"

Only a valve will amplify; you put A.C. volts on to the grid of a valve which controls the flow of current in the anode filament valve circuit.

This flow of current is given by the H.T. supply, and you get increased energy which is supplied by the battery. There is no battery from which to draw energy with a crystal, so it won't amplify.

Choke-Coupled H.F.

H. J. (Edinburgh).—"I have a four-valve set consisting of an H.F. Det. and 2 L.F. The H.F. valve is choke-coupled to the de-

tector, and I am unable to get good results on the long waves. Could the fault be due to a poor H.F. choke?"

Very likely. The impedance of the choke is proportional to the frequency times the inductance. If the frequency is low the impedance of the inductance goes down and your amplification suffers.

Try a higher inductance choke for the long waves. Are you sure the shorter waves are not in themselves stronger in your locality? The Edinburgh relay station is much stronger than 5 X X, for example.

But, of course, if you mean you pick up lots of medium-wave stations well at night, but no long waves—well, then I think your diagnosis is probably right.

JUST A REMINDER!

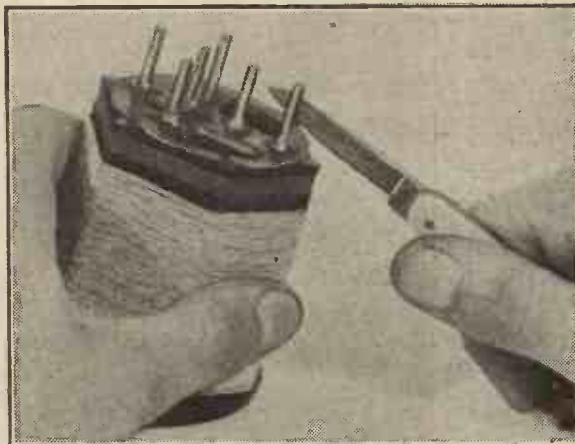

Don't imagine that the legs on a coil are only a convenient means of standing the coil in place. First and foremost they are contacts, so occasionally they want opening out, as shown, with a penknife.

Besides, you can get more out of transformer connection, and get it with decent stability. So I see no reason, for ordinary purposes, to mix the stages and can think of no guiding principle to tell me whether, if you did mix them, what to put, where, and why.

A Baseboard Puzzle.

K. E. (Clapham).—"I recently constructed a set, using a baseboard of perfectly dry beech. This set, however, was extremely unstable on the L.F. side.

"Another set, using the same components, but using a baseboard of oak, solved the above problem. Is it possible for the baseboard to cause coupling?"

Most extraordinary. I suppose by using uninsulated connections and making con-

SCOTLAND AND THE REGIONAL SCHEME.

An article about the important developments in broadcasting north of the Tweed.

By THE EDITOR.

IT appears that many thousands of listeners in Scotland are uneasy about the B.B.C.'s policy in that country, especially as it is understood that the Scottish headquarters of the Corporation are likely to be transferred from Glasgow to Edinburgh.

There is no doubt that the rumours which have been current for some time past concerning developments at the Scottish stations are not without foundation, and we are given to understand that under the Regional Scheme which will directly affect Scotland later on, the present B.B.C. system of four distinct Scottish stations will be scrapped.

Instead, there will be substituted a Scottish headquarters—in short, a Scottish Savoy Hill, similar in style to the North of England Regional Headquarters recently established in Manchester.

Headquarters at Edinburgh.

These new Scottish headquarters will be in Edinburgh. Inquiries at the B.B.C. fail to elicit exact information as to when the transfer of the main body of the B.B.C. staff in Scotland from Glasgow to Edinburgh will take place, but there is every indication that this change-over will be made during the next six months.

Scottish listeners can rest assured that, although certain changes will take place, they will not be detrimental to their interests. It simply means that Scottish broadcasting as a whole will have for its headquarters Edinburgh instead of Glasgow.

But it should be borne in mind that Glasgow will not lose in importance because of this change, and the Glasgow station will still be maintained until the high-power Regional transmitter is ready for operation. Even when the station is dispensed with, the Glasgow studio will be maintained permanently.

Of course, there are a good many Scottish listeners who maintain that there should be a National Scottish Broadcasting Company, and that, like the demands made by a certain section of the Welsh public recently, the Scottish programmes should be distinctly national. But it is maintained at Savoy Hill that Scottish broadcasting is now administered as a national unit, and that when programmes come up for consideration, the Regional Programmes Board for Scotland takes into consideration the whole area served by the Scottish stations, and the likes, dislikes, and characteristics of Scottish listeners.

This personal consideration for Scottish tastes will, the B.B.C. state, always be maintained.

Licence Figures Increasing.

Lord Clarendon himself stated the other day that: "Through the medium of the microphone, it is our desire, it is our intention to introduce to all the firesides of this country which have the means of

listening-in, the great thoughts, the great inspirations of all the great thinkers and leaders of thought existing in our midst to-day."

Lord Clarendon who, as our readers know, is Chairman of the B.B.C., but who will shortly be resigning to take up duties in South Africa, stated that in December last year 328,344 new licences were taken out by people who had not had sets during the previous twelve months, and throughout the length and breadth of the land to-day there were very nearly three million listeners. That growth had not been reached by spasmodic bursts, but by a steady and progressive increase throughout the seven years the service had been in existence.

Lord Clarendon said he thought, therefore, that so far as the B.B.C. was concerned,

ON "THE FLYING SCOTSMAN"



Programmes for passengers is the interesting idea behind experiments recently carried out on "The Flying Scotsman," when a radio-gramophone set was used to relieve the tedium of the long journey.

he was entitled to say that there were indications that what the B.B.C. were privileged to give the public was, to a very great extent, enjoyed by them.

The New Chairman.

The aim of those who are in charge of the B.B.C., said Lord Clarendon, was to provide not only the lighter forms of entertainment, but to weave into the programmes informative talks, which, in their view, were absolutely indispensable constituents of the programmes.

As we go to press with this issue of POPULAR WIRELESS, the big question of the day in broadcasting circles—which has not yet been settled—is: "Who will succeed Lord Clarendon as Chairman of the B.B.C.?"

Possibly, by the time this issue is on sale,

that problem will have been solved, and the Government will have named Lord Clarendon's successor. But, at the moment, there is still a considerable amount of mystery as to who that successor will be. Mrs. Snowden has been named in many quarters, as a very likely candidate and one who would be widely approved should she be nominated as "Chairman."

Another name mentioned is that of Lord Lee, while again Lord Gainford has a strong backing.

The B.B.C. and Parliament.

If by any chance Lord Clarendon's successor has not been nominated by the time this issue is on sale, we hope that the Government will not delay in quickly making public the name of the new Chairman.

Although Lord Clarendon will not assume the Governor-Generalship of the Union of South Africa until next January, it is considered important that the new Chairman of the B.B.C. should be nominated and installed in office as soon as possible. In many quarters it is being urged that the Government should make the appointment one of greater importance than it has hitherto been in public estimation.

The Prime Minister is being urged to select for the post a strong personality of

Cabinet rank who, besides having administrative capacity, is known by the public to possess all those qualities which are so essential in the character of the person who holds such an important post as the Chairman of the B.B.C., and who also possesses a large measure of public confidence.

There is a common complaint among Members of Parliament that the B.B.C. has been placed under a system which does not allow full scope for public criticism. For example, it is a fact that questions regarding broadcasting are not allowed in the House of Commons unless they directly concern the policy of the B.B.C.

Consequently, Parliament is unable to give expression to public criticism, and, as our readers well know, there is a good deal of justification for public criticism of a corporation such as the B.B.C.

The question of programmes, for instance, cannot be brought up in the House of Commons unless definitely linked with that of the policy of the B.B.C.

In short, there is a good deal of justification in the demand that the appointment should be regarded in the future as one of paramount importance.

NEXT WEEK.

THE 5/- BROOKMANS REJECTOR

THE "BROOKMANS" REJECTOR.

The Editor, POPULAR WIRELESS.

Dear Sir,—In a recent number of POPULAR WIRELESS, you say that you are always pleased to hear from readers, if they have anything useful to say on your recent device, the "Brookmans" Rejector. I do not intend to say how superlatively good it is, as that has already been said by so many of your readers, that it is quite unnecessary. I thought, however, that you might possibly find my method of using the Rejector interesting. The one I have is made according to the first description you published, and it is therefore in its simplest form, being a single Rejector cutting out only one station at a time, and having no switch. In using it, I have three coils, of about 100 mics., 150 mics. (these two being home-made), and 350 mics. (this last being a 75 Burndept coil). Having cut out the London Regional station, using the 150 mics. coil, I then find I can cut out the National Transmitter, simply by plugging in the 100 mics. coil, and 5 G B, similarly, by plugging in the Burndept coil, no change being required in the setting of the Rejector for the different stations, except a slight touch in the case of 5 G B.

If you have time for more, I would just like to say that when you brought out your "Standard" Wave-trap, I converted a tuning panel I have into one of these, using a coil according to your specification. The var. condenser, however, is an old one by the Met. Vickers Co. of .001 mfd., which I use with a fixed condenser of .001 mfd. in series, thus reducing the strength to .0005 mfd. Although this elder child of yours (the wave-trap) may not be quite up to the standard of his younger brother (the Rejector), I would like to say a few words in his favour. In the first place, with it I can cut out completely (my four-valve set, of course, working at reduced strength), the National, the Regional, and 5 G B transmissions, in turn, without, as far as I can see, interfering with the strength of the other stations. Then, using this wave-trap in series with the "Brookmans" Rejector, I can cut out the National with the wave-trap, and the Regional, or 5 G B, simultaneously, so that combined they make a twin rejector.

There is one advantage which my wave-trap enjoys over, say, the "Brookmans" Rejector, and that is that the variable condenser having a scale, I am able to set it to any of the local stations, at once, and without any trouble. It is therefore very suitable for use by elderly people, and by those who may find the "Brookmans" Rejector tuning rather complicated.

As an illustration of what the wave-trap can do, I would like to say a few words of how I get Oslo with it, whilst 5 G B is working. Oslo, with its 50-kw. transmission is, of course, an easy station to get when 5 G B is silent, but not quite so easy when it is transmitting. My method is to cut out 5 G B with the wave-trap, tune in Oslo (which on my set is 2.5 deuces up the scale from 5 G B), and then by slowly detuning the wave-trap, Oslo comes in. 5 G B is then only to be heard faintly or not at all.

My opinion is that the two brothers, the "Standard" Wave-trap and the "Brookmans" Rejector are hard to beat.

Yours faithfully,
DUNCAN J. REID, M.B., C.M.

CORRESPONDENCE.

THE "BROOKMANS" REJECTOR.

"KNOCKS OUT THE INTERFERING STATION"—CUTTING OUT 2 L O—JUDY II.

Letters from readers discussing interesting and topical wireless events or recording unusual experiences are always welcomed; but it must be clearly understood that the publication of such does in no way indicate that we associate ourselves with the views expressed by our correspondents, and we cannot accept any responsibility for information given.—EDITOR.

"KNOCKS OUT THE INTERFERING STATION."

The Editor, POPULAR WIRELESS.

Dear Sir,—Your statement (in the description of "Reg the Nat." on page 1125) that the Brookmans Rejector knocks out an interfering station "without reducing the efficiency of the set," prompts me to suggest that the "P.W." Research Department is suffering from that rare disease—an excess of modesty.

My experience with a "Titan" Three is that the virtue of the rejector in this respect is not merely negative, but actually positive, inasmuch that when set to cut out one station, it appreciably increases the volume from some other stations on other parts of the dial. For instance, in this immediate district 5 G B does not come through too well, but with the rejector cutting out London (although not needed for

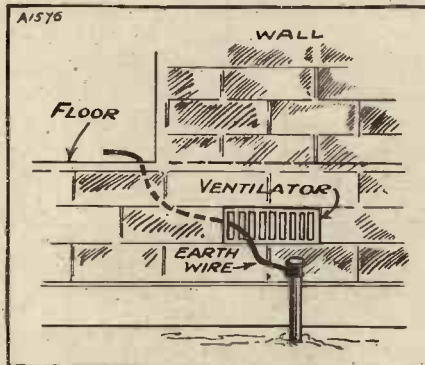

Mr. Ross Watt takes his earth lead through a ventilator grating.

separation purposes) the volume on 5 G B goes up very appreciably in strength. In fact, I now use the rejector to strengthen 5 G B in preference to using reaction. The same phenomenon is noticeable on Radio-Paris when the rejector is used to cut out 5 X X.

There are certain variations which may be used in balancing the two rejector condensers to cut out a station, and it seems to me there are one or more relative settings which give this increased volume on other stations, while other settings (which cut out the unwanted station) do not give this magnification effect.

The same thing has been noticed by the owner of a Ferranti A.C. Mains Receiver for whom I made up a long and medium wave-change rejector.

Yours truly,
Furley. J. M. SELLORS.

CUTTING OUT 2 L O.

The Editor, POPULAR WIRELESS.

Dear Sir,—I have improved the results obtained on my "Magic" Three by using it in conjunction with the "Brookmans" Rejector. The coil I use in the Rejector is a home-made 80-turn one on a 2 in. former, and this works extremely well.

Although I do not live far from 2 L O, the Rejector cuts it right out and I am able to receive such stations as Hamburg, Toulouse and Frankfurt without interference. The London 261-metre transmission comes in much better with the aid of the Rejector. Wishing "P.W." increased success.

Yours faithfully,
J. B. F.

London.

AN EARTH-WIRE TIP.

The Editor, POPULAR WIRELESS.

Dear Sir,—Whilst hunting for a short lead to earth which would not run parallel with the lead-in from the aerial, I discovered that there was a ventilating brick almost directly underneath the floor where my receiver stands. I bored a hole through the floor, passed a piece of string down, then went outside and hooked it through the ventilating brick. After that it was an easy matter to connect the earth wire to the string, pull it through, and connect to the earth tube. Actually my earth wire only measures three feet. I pass this tip on in case others might benefit from it.

Yours faithfully,
G. ROSS WATT.

Orpington.

JUDY II.

The Editor, POPULAR WIRELESS.

Dear Sir,—Having built up your Judy II, I wish to write you a few words of praise for this excellent little two-valver.

Having been a wireless enthusiast for five years, I find this set one of the best I have built. I was so pleased with it that I have added another valve.

Wishing your paper every success, I remain,
Yours faithfully,
E. L. GEORGE.

Yorkshire

SHORT-WAVE NOTES.

By W. L. S.

category of "broadcast for general information," but they are so powerful sometimes that one would think they were!

A Belvedere reader has logged "Buttercup," "Buffalo Red I," "Buffalo Red II," "Buffalo Blue II," "Buzzard Red I," "Ferrell," "Cornflower," and "Ermine." He also reports G 6 V M, Marconi, Chelmsford, in communication with G 6 M A, Marconi Bristol Fighter.

A Cambridge reader remarks that, with few exceptions, amateur telephony has wonderfully improved in technique lately. Yes, "G. M.," I agree, but the exceptions really are ghastly examples. No names, no pack-drill, of course. G 5 T Z, at Cowes, Isle of Wight, is the best transmission I have heard for a long time. G 6 R G and G 2 X V are also good.

Incidentally, the craze for raw A.C. on the continent has now given place to "fonic," I should imagine from a few moments' reception on a Sunday morning. One Frenchman calling: "Hullo ze Breetish

station in ze Isle of Wight" was very funny to listen to, but at the same time was turning out telephony worthy of the B.B.C.

Does anyone listen to the amateur fraternity of the 150-175-metre band nowadays. Quite a new enthusiasm has appeared for this wave-length, and on Sundays it is well filled.

There is no getting away from the fact that London amateurs in particular ought to use this wave for local work and thus free the Q R M on the shorter bands, which could be put to the purpose of long-distance tests only.

Crystal Control.

Indirectly the Washington conference has been responsible for the improvement in telephony, for it is now such a heinous crime to be "off wave" that a large number of stations are using crystal control, and naturally the unlovely forms of modulation that were formerly so popular on account of their simplicity are now not very useful, as they gave a big percentage of frequency modulation which naturally is not possible to anything like the same extent with crystal control.

Choke control is, after all, the only system of modulation within the average amateur's capabilities that will give reasonable results, and this, with a crystal-controlled transmitter, is ideal and offers plenty of scope for experimental work.

THE majority of short-wave enthusiasts who read these notes seem to agree with my statement that the 40-50-metre wave-length range, as far as broadcast telephony is concerned, is the most exciting nowadays. Unfortunately, to get the Americans in the 49-metre region at really good strength it is best to stay up till about 2 or 2.30 a.m., which is inconvenient and cold.

W 2 X C X on 49.34 is among the best of them, but can anyone place a station just above him? I have heard this station once or twice, and now a Harrow reader mentions the same station, and, like myself, has failed to get an announcement yet. It is probably W 2 X B R.

This same reader reports W 3 X A L, New Jersey, at 6 a.m. at full loud-speaker strength or rather more.

Among the Ether-Shakers.

R.A.F. transmissions continue to puzzle readers. They certainly seem to crop up on all sorts of wave-lengths, whether in the "mobile" bands or not, although I suspect those that are out of these bands are fixed stations.

It is a question, by the way, in view of the well-known clause in the licences, whether either my readers or I myself ought to "divulge" messages received from such stations as these. They are certainly not to be described as coming in the

LATEST BROADCASTING NEWS.

GRAND NATIONAL
PLANS

RUNNERS AND RIDERS—THE
VALLEY OF ENCHANTMENT—
RE-LAYS OF ANCIENT ROME—
"THE PROPHETIC CAMERA."

AN intimation has already been given that the broadcast running commentary on the Grand National, which is to take place at Aintree on Friday afternoon, March 28th, will this year be carried out on more ambitious lines than anything previously attempted by the O.B. Department at Savoy Hill.

Hitherto it has been impossible to properly describe the race from one position, as the commentator has been unable to see the horses throughout the whole of the race, but this difficulty is to be overcome by having two commentators stationed at widely separated points. By this means it is hoped to give listeners an adequate commentary on the world's greatest steeplechase, but it is also desirable from the programme point of view that the description of the race should be continuous, and that the second commentator will not "barge in" on the functions of the first.

Runners and Riders.

The first part of the race will be described by Mr. R. C. Lyle, the well-known sporting journalist who has done a good deal of similar work for the B.B.C. After a preliminary description of the scene by Mr. H. B. Brenan, who will acquaint listeners with the names of the runners, the riders, jockeys, and other items concerning the crowd from his stand at the top of Messrs. Topham's private stand, Mr. Lyle will comment on the race over the part of the course west of a point between Valentine's Brook and Becher's Brook, following which Mr. Brenan will announce a change-over for a continuation of the commentary by Mr. Hobbs, who will be stationed at the Canal Turn.

Other arrangements have also been made to keep listeners informed of possible incidents after the change-over from one commentator to the other has been made, such as falls which are often a feature of the race. This process will be repeated when the horses pass round the course for the second time and there may even be incidents of the race to describe after the first three horses have passed the post. Altogether the commentary promises to be exceedingly interesting.

Certainly the B.B.C. are sparing no efforts to make it so, and are, we understand, committing themselves to an expenditure well over £200 in order that those who cannot see the race will be able to visualise its progress.

"The Valley of Enchantment."

With the revival of the fantasy, "The Valley of Enchantment," on Thursday, March 20th, Midland listeners will meet once again that wandering philosophising fiddler, "John o' Dreams," who was created by John Overton in the early days of broadcasting. John Overton hides the name of Mr. Percy Edgar, the popular Regional

Director at Birmingham, who was responsible for those "interludes protean" in which John o' Dreams was always so successful.

The incidental music for the production on March 20th has been specially composed by Nigel Dallaway, and will be played by the Midland Pianoforte Sextet.

Re-lays of Ancient Rome.

A revue entitled "B.B.C.—B.C." described as a "Fantastic Re-lay of Ancient Rome," will be broadcast from the Midland and London Regional transmitters on Saturday evening, March 22nd. Its author is Graham Squires who wrote it after a little argument in the Birmingham Studio (where it will be performed) with another radio revue writer on the question of whether broadcasting existed in the days of ancient Egypt, Greece and Rome.

Mr. Squires contended that some such service must have been available and

"B.B.C.—B.C." is intended to reflect his ideas of what broadcasting was like in those dimly distant days.

"The Prophetic Camera."

Some years ago Mr. L. de G. Sieveking, a member of the staff at Savoy Hill, wrote a story called "The Prophetic Camera," which concerned a peculiar photograph taken by a pawnbroker in the Euston Road with a camera pledged with him and never redeemed. Mr. Sieveking has adapted the story to the microphone—how successfully listeners will be able to judge for themselves when it is produced in the London studio on Saturday, March 15th.

Judging by the almost everyday broadcasts of Jack Payne and the B.B.C. Dance Orchestra, there would appear to be little time for this excellent combination to accept any outside engagements, but apparently this is not so, since they have just signed a contract for a run to open at the Palladium on April 7.

How's Your Uncle?

The second of Philip Ridgeway's "period" programmes is down in the London programme for Monday, March 10th, when "How's Your Uncle?" or the "Barber of Bishopsgate," a play first produced in London in 1838 will be performed.

However much it may be disputed, the concert on Wednesday, March 12th, which Ulster listeners are to hear relayed from the Belfast Mental Home, Purdysburn, is the first broadcast from a lunatic asylum.

DID YOU HEAR THEM?



These two little German girls offered to sing a duet before the microphone, and when the time came everyone thought they'd be scared! But not a bit of it—they treated "Mike" as coolly as the most hardened announcer, and listeners enthusiastically agreed that they were a great success.

FOR THE LISTENER.

A Specially Contributed Criticism of Current Broadcasting Events.

By "PHILEMON."

(Who is deputising for Mr. Cecil Lewis while the latter is in America.)

Purple Passages.

LADY CYNTHIA MOSLEY, M.P., was debating the question of "Social Conventions." She used the word "guts." It is a good word, but I don't think it has been broadcast before! I wonder what the B.B.C. censor thought about it. A very unconventional lady. That morning she had walked down Bond Street without a hat!

"When Lady Betty walks abroad at Vauxhall in the morning!" She called conventions "the slogans of the lazy-minded." Every now and again she drifted into purple passages which sounded as if they might have been eloquent echoes of her speeches at the hustings; wherein she was not quite so amusing.

Maggie Teyte was singing in another place while Lady-Cynthia was talking. I tried to make the best of both worlds. How happy could I have been with either! I had to dodge in and out between 2 L O and 5 G B. Maggie Teyte was too good to miss. "Had I Heaven's embroidered cloths"—what a gorgeous title for a song!

A Golden Voice.

What a lovely voice she has, and with what artistry she uses it!

Lady Cynthia was saying, "It's far better to kick over the traces and be something than be a nobody," so I switched over just in time to hear Maggie Teyte begin the second verse—"I sent thee late a roay

(Continued on page 1301.)

AERIAL CORROSION.

By M. LEEUWIN.

BY corrosion, a word derived from the Latin "rodere," meaning to "gnaw," we understand phenomena which occur with any material exposed to the weather and other destructive influences.

Geologists have ascertained that in the course of ages even mountains have been worn down and ground into sand under the action of erosion, a special form of corrosion, which shows that sooner or later even the strongest materials will succumb. Popularly expressed, erosion and corrosion phenomena could be called the "teeth of time."

When previously perfect radio reception becomes unsatisfactory, this may be due to a defect in the aerial installation, caused by corrosion. The destructive influences which can effect an aerial are:

- (1) Wind and weather; differences in temperature.
- (2) Chemical action.
- (3) Electrolysis (chemical decomposition by electric current).

If a really reliable radio installation is wanted, attention must therefore be paid to the materials used in its construction.

Earth Connection.

Corrosion of the earth connection occurs with practically every radio installation.

If water-mains are not used as an earth, but instead an earthing pipe or earthing plate, strong electrolysis will occur at the place where the earth connection is unprotected and leaves the earth. In this way the connection will soon be corroded. The same is applicable to the contact tube or earthing plate. Both must be of the same material, because otherwise a galvanic element may be formed which results in electrolysis. If a copper wire is connected to an iron pipe the connection will soon be destroyed. The earth connection must be protected by a piece of clay pipe at the place where it leaves the earth. It is recommended to cover joints with a well-insulating lacquer.

Aerial.

A case of corrosion which frequently occurs with aerials is the rusting of unprotected steel wire, which is often used for the rigging up of aerial poles.

It is obvious that fracture of stay wires may be dangerous.

In order to avoid such occurrences the steel wire used should be galvanised or otherwise protected. In manufacturing towns it is found that an unprotected steel wire of 3 millimetres diameter is entirely rusted within a few months.

Another still more disagreeable occurrence often met with in the case of insulated lead-in wires is that electrolysis seems to set in at points where there are kinks in the wire. This may lead to entire corrosion of the copper at the affected point, until finally there is a break in the continuity of the wire inside the installation, although the flaw cannot be detected with the naked eye.

As in such cases there still remains a weak conductivity formed by a layer of metal or metal salt, it is sometimes extremely difficult to detect the fault, if one does not know beforehand in what direction to look for it.

Every amateur or expert will have noticed that even the hardest bronze wire, after having been exposed to the atmosphere for a year or two, will have lost a good deal of its hardness. This must also be attributed to the corrosive influence of the air.

Considerable corrosion occurs with stranded wire. Some of the thin wires very soon get broken, causing not only a diminution in signal strength, but also "artificial atmospherics." Under such conditions the aerial is liable to break down during the first storm.

Moisture and water containing rust can penetrate into an unglazed insulator, so that not only is the insulation likely to become less efficient, but there is also a risk of bursting in case of frost.

Switches.

It is not only with conductors that corrosion makes itself felt, but also more frequently with switches and safety devices which are not proof against atmospheric influences.

As a rule it is found that after having been exposed to the air for a few months the copper parts become hard and brittle

PLUGGING-IN PROGRAMMES.

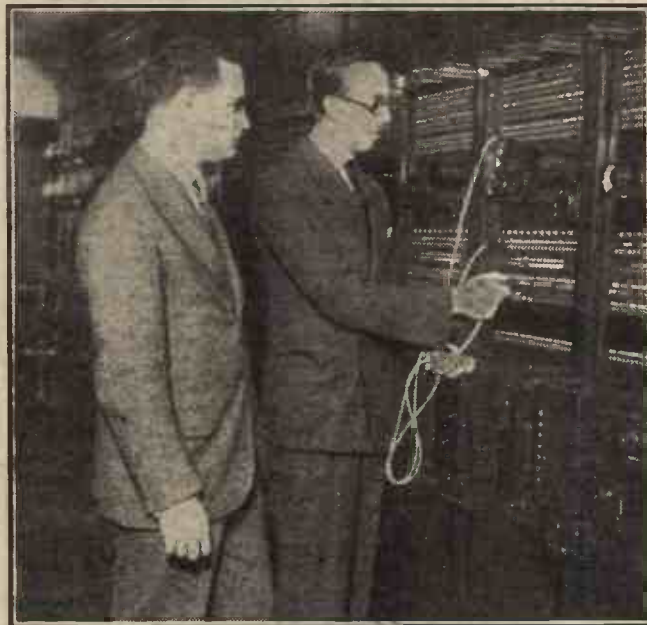

The switchboard that figures in some of the most spectacular of American Simultaneous Broadcasts. And on such occasions as the broadcasting of the King's Speech hundreds of stations are linked together by this means.

or lose their resilience, which in both cases leads to breaks or bad contacts. Moreover, insufficiently protected switches are soon covered with a thick coating of rust, so that their functioning is impeded. Obviously this may be dangerous in the case of lightning arresters.

Some of the very few materials that are proof against atmospheric influences are certain kinds of glass and well-glazed porcelain. For this reason one of the best known aerial dischargers is mounted in a glass container on which a porcelain cowl is screwed, which is provided with an inside rubber ring for proper closing. A design of this kind complies with all requirements for safe outside use.

Therefore, always ensure that your aerial is constructed of the best materials—the risk of breakdown will then be greatly minimised.

LINKING THE NATIONS TOGETHER.

(Continued from previous page.)

should like to hear a reply by an apologist for continuation in the status quo. Why not? Are we all to be treated to this assumption of our stupidity and therefore not to be allowed to hear and understand?

As to music, this plays a secondary but suggestive rôle. People may get some romantic thrill out of the fact of hearing the Queen's Hall orchestra in Brisbane, but that really means nothing. And this Big Ben complex is pure nonsense resting upon ephemeral foundations—once heard, once thrilled; thrice heard, thrice interested; n times heard, and n times bored.

The Effect of Music.

If music can be heard with perfect quality it plays a greater part, because we can collect it from where it is best performed and rediffuse it where it is most appreciated, but if it is a secondary consideration.

For inter-country linking music stands of greater importance, because quality can be good and often the programmes can be better done.

It seems to me, though, that for linking continents where music quality is poor, we want to use this great romantic facility for great and thinking things and not mess about with jazz from America and Cockney from England.

Tell me. Why is it and why must it be that we cannot do the fine thing and use this marvellous facility technicians have given us in the cause of peace, goodwill, and understanding? A hundred million Americans, fifty million British people, and every white inhabitant of the Empire, can be made

to hear simultaneously.

Devalitised Accounts.

It can be done and it has been done, but why should they only hear the carefully filleted, devalitised accounts of events instead of the turbulent realities in the minds of thinking men? Transport has made us mutually dependent each upon the other, but we are too far away to meet and talk and think together. Communication in its particular manifestations of broadcast gives us a chance to know each other much better. I offer you the chances of introduction. Britain meet America, Empire meet Empire, World meet Humanity.

"MODERN WIRELESS"
For Modern Wireless.

THERE'S A PROUD REPUTATION BEHIND EVERY ORMOND PRODUCTION!

Designed to carry out their work faultlessly and smoothly, Ormond components reveal in every detail the highest standard in construction and design.



Four-pole Adjustable Units, fitted large Cobalt Magnet and beautifully polished bakelite cover. Price 12/6

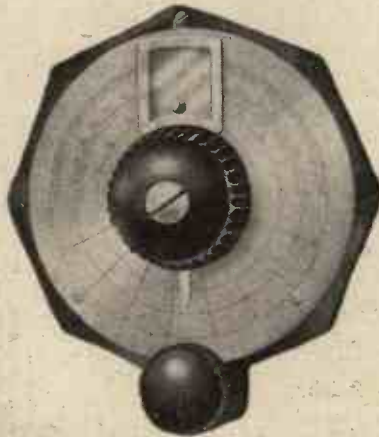

Duo Dual Indicator Dial. Operated either by direct drive from the central control knob or by the slow-motion drive. (Ratio 16-1.) Price 6/-

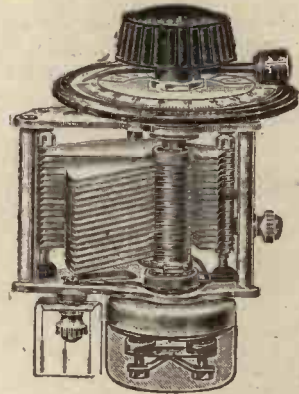

Small Logarithmic Condenser with Pointer Dial and slow-motion movement. Constructed mainly of Aluminium.

Cap.	Price
.00025	9/-
.00035	9/3
.0005	9/6

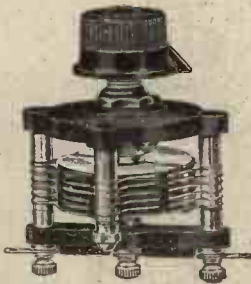

Differential Condenser. Insulation is provided between fixed and moving vanes, obviating all danger of short circuiting. One-hole fixing. Ideal for use as reaction control. Price 4/-



Jack Switch. Of entirely new design, brass frame, heavily nickel-plated, springs of nickel silver, the contacts being riveted in. The control contact is of the push-pull type. Prices from 2/9 to 4/6

Three-Point Push-Pull Switch. May be mounted on a metal panel and insulated by means of the ebonite brush if necessary. Complete with knob terminals and soldering tags. "One-Hole" fixing. Price 1/6. Two-Point Type, Price 1/3

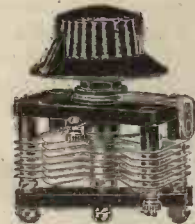

Midget Condenser. Can be mounted on panel or baseboard. Minimum Capacity, .0000015 Mfd. Maximum Capacity, .0001 Mfd. Price 4/-

Fixed Condensers. Available in all the usual capacities. May be secured either direct to valve sockets or supported on the wiring. Prices from 7d. to 1/9



Radio Frequency Choke. High Inductance. Low Self-Capacity. Impedance is constant up to 4,000 metres. Price 7/6

Chassis and Cone. Produced for use with the loud-speaker unit. Constructed of aluminium, 11 3/4 ins. in diameter with a cone of specially selected material. Price 7/3



For Quality!

For Value!

THE ORMOND ENGINEERING CO., LIMITED,
 ORMOND HOUSE, Rosebery Avenue, LONDON, E.C1
 Phone: Clerkenwell 5334/5/6 & 9344/5/6. Telegrams: "Ormondengi, Smith."

Do You Know-

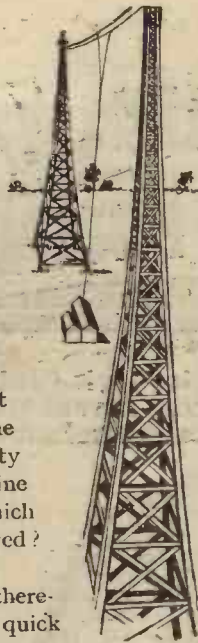

that every portable radio set with a self-contained aerial is directional, which means that to obtain the loudest volume and the greatest selectivity the set must be in direct line with the station from which signals are to be received?

A Portable Receiver, therefore, must be capable of quick and easy manoeuvring in any direction, and the Benjamin ball-bearing Turntable will enable your set to do this without any alteration to its existing design.

Attractive crystalline finish, ball-bearing, and with hinged and folding legs. These folding legs enable the set to be used out of doors, raising the Receiver above the damp ground and thereby considerably reducing capacity to earth. The legs can be folded up for indoor use. Price 7/6 complete.



BENJAMIN

Send for illustrated leaflets on all Benjamin Radio Components.

The Benjamin Electric Limited
Brantwood Works, Tottenham, N.17

A .0003 mfd. is a .0003 mfd. if it's a T.C.C.!

THAT'S the big point about a T.C.C. — you know that if you ask for a .0003 mfd. you'll get a .0003 mfd. Whatever the specification of a T.C.C. condenser may be, the initials T.C.C. guarantee strict adherence to that specification. The "condenser in the green case" has thus become the recognised standard amongst condensers and, as such, their accuracy and dependability are acknowledged facts. Insist on T.C.C. always and be sure.

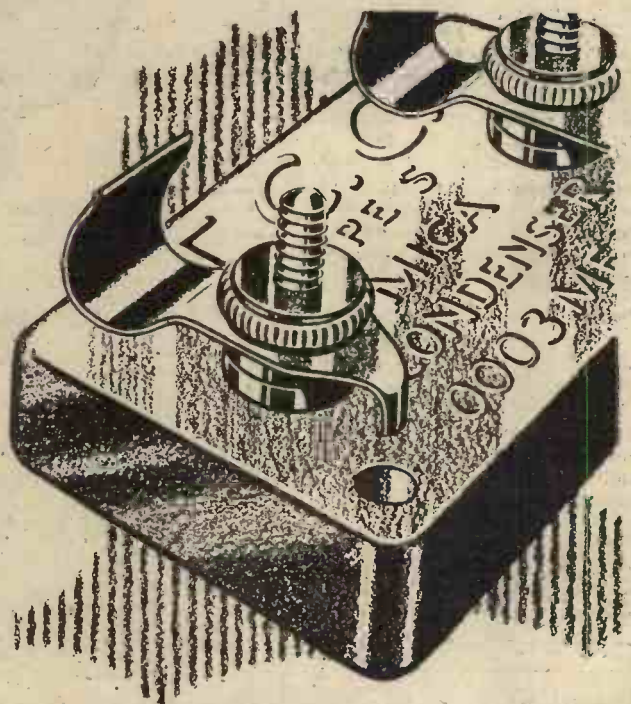

Here are the new prices of the Flat Type Mica Condensers.

mfd.	s. d.
.0001 to .0009	1 3
.001 to .004	1 6
.005 & .005	2 0
.01	2 6



Tested to 500v. D.C. to work at 250v. peak.

Admt. Telegraph Condenser Co. Ltd.
Wales Farm Road, N. Acton, London, W.3.

BIASSING *without* BATTERIES



SCREENED-GRID valves are greedy devices—some of them want as much in the way of H.T. current as power valves of quite respectable sizes. It is not unusual to meet an S.G. that needs as much as 10 milliamps.

This is a serious matter for the man who has to use dry batteries or who can afford a mains unit of only a smaller type.

It is extraordinary to find the H.F. side of the set taking as much H.T. as the L.F. side. At one time the H.T. consumption of the H.F. valves was reckoned as being almost negligible; at the most a milliampere or two was apportioned to the H.F. valve, but the factor that decided the type or capacity of the H.T. battery was the power or super-power valve used.

Terrific Current Tax.

Properly biased, an ordinary super-power valve will take no more than 15 milliamps or so. A 6-volt power valve suitable for a set such as the famous "Titan" Three may demand 10 milliamps. This is a heavy tax, but should an S.G. valve add another 10 milliamps the total begins to assume proportions that are nightmarish to the average amateur not having mains.

The remedy is grid biasing; grid biasing applied to the H.F. valves as it is always applied to L.F. valves. Proper biasing will not interfere with the operation

The S.G. valve is a wonderful H.F. amplifier, but it is apt to consume rather a lot of H.T. current. But this article describes a scheme for running S.G.s economically that has very considerable possibilities.

By H. A. R. BAXTER.

But here is a simple way of doing the necessary biasing without introducing an extra battery. My solution to the problem is for those who use 6-volt valves to employ a 2- or 4-volt S.G., and for 4-volt enthusiasts to use 2-volt S.G.s. (This at once will reduce the H.T. consumption, although, as I will show later, it can be lowered even more.)

The 6- or 4-volt H.F. or Detector has little practical superiority over the 2-volt types. You may feel that you need your 6-volters in the L.F. stages, but there is little to choose between the performances of 2- and 6-volt H.F. valves.

There is another thing that makes the scheme I am about to describe an attractive one, and that is the consistency of the modern valve. You know exactly where you are and can give definite details, and do not have to legislate for wide filament characteristic discrepancies.

Results Improved.

Well, all you have to do is to retain your 6-volters for all the other stages, and in the H.F. stage use a 2- or 4-volter with a resistance in series in order to cut down the filament current to the required dimensions. (Fig. 1.)

When the grid return is connected as shown the grid is biased to the extent of the volts dropped in the resistance R.

Supposing it is a 2-volt valve that passes a filament current of .1 of an ampere. You have got to drop 4 volts, and this is the maximum G.B. you have available.

To drop 4 volts at .1 amp. you need 40 ohms of resistance, for $R = \frac{V}{A}$.

Using a 4-volter with a 6-volt outfit you have 2 volts negative (or positive if you want it for anything!) grid bias available.

If you run 4-volt valves there will be 2 volts spare for G.B. purposes if you use a 2-volt H.F. valve.

The ideal way is to use a 2-volter with a 6-volt outfit and make R in Fig. 1 a poten-

tiometer of the resistance needed. You can then run the grid return up and down and get any G.B. between zero and 4 volts.

You will notice that I have carefully avoided giving any definite grid-bias values, but I do not want you to jump to the conclusion that G.B. can be indiscriminately applied to H.F. valves.

On the other hand, I have made careful observations with various receivers, and find that most of the S.G. types will take anything up to 4-volts negative with very little effect on their sensitivity, although with very great saving of H.T. currents. Also I am bound to say that a certain amount of negative G.B. somewhat considerably improves the results given by some S.G.s.

Note These Points.

Some people keep their S.G. H.T. currents down by reducing their H.T. voltages. In this way the effectiveness of the S.G. as an H.F. amplifier can be reduced very greatly! Indeed, a popular form of volume control is a reducer of an S.G.'s H.T. voltage.

It is, of course, far better to crowd on the H.T. volts and check the current with grid bias. And the method I have briefly outlined is as good, if not better, than any other.

But if you adopt it be careful that you connect the resistance in the right filament

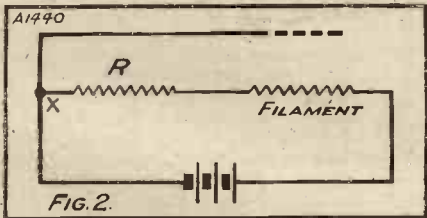

This drawing will help you to understand how the grid is biased by including a resistance (R) in the filament circuit.

of an S.G. valve; in cases, an improved performance is the result, while there is considerable saving in H.T. current.

An Attractive Remedy.

It is not advisable to use the same G.B. battery that is used for the L.F. valves. The one battery could be made to do all the work, but in many cases only by the introduction of moderately complicated separating devices.

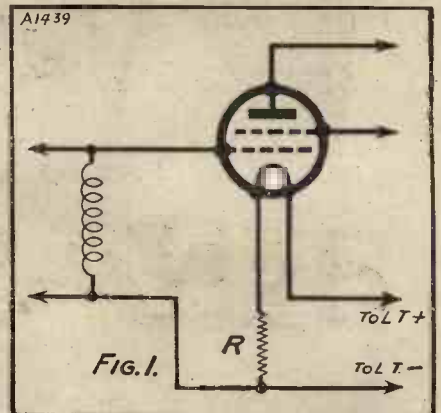

The voltage drop across "R" is the voltage at which the grid is biased.

lead and join the grid circuit up properly. If you should happen to reverse the order you will send up the H.T. current of a 2- or 4-volter to a figure equalling, if not exceeding, that of a 6-volter!

RECENT advances in the direction of more and more powerful "Detector and 2 L.F." receivers have done much to make this type of set almost the ideal general-purpose outfit, but there always remains a situation in which the H.F., Detector, and L.F. type of "Three" has decided advantages.

The point is this: where the station upon which you depend for your programme only comes in rather weakly, an H.F. stage is a help in obtaining the best possible quality. You see, with just a detector and a powerful L.F. amplifying

be preferable where you are some distance from the nearest station, or when you are compelled to use an indoor or a very poor and small outdoor aerial.

In such situations an H.F. stage can be a real help, because it gives a good lift-up to the signals before they reach the detector, and so you do not need to use so much reaction. Not merely does this mean that quality tends to be better, as we have seen, but also tuning does not become so sharp and critical as it does when reaction is being used intensively. So long as there are not too many dials to operate, the working of the set is rather simpler, and it is therefore rather easier for the non-technical members of the family to handle.

Of course, that point about the number of dials to operate, is obviously a vital one. Otherwise one might argue that a five-valve receiver which requires no reaction whatever, and does not tune very sharply in each circuit, would be easier still. But this is not the case.

Easy Tuning.

The majority of five-valvers have three separate dials, and are really almost a hopeless proposition for the entirely non-technical operator, unless he is provided with a chart of the dial readings of the

stations he wants.

It really amounts to this. At considerable distances from the local station, and where only a poor aerial is available, an H.F. stage is desirable; but it really ought to be designed so that the set remains a single-dial affair, in order that it may still be quite easy to operate. This point applies chiefly, of course, to sets intended for use

AN EXCELLENT L.F. STAGE.

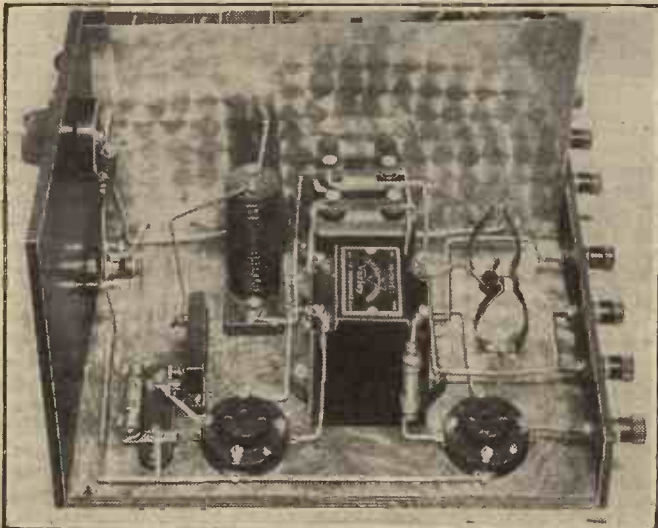

Subsequent to really efficient H.F. amplification by the screened-grid valve the energy reaches this excellent detector and L.F. section of the set.

circuit you have to use a fair amount of reaction if the initial signal is weak, and most people feel that quality would be better if this were not necessary.

Increasing Input.

Evidently, then, an H.F. stage is valuable in such cases, because it generally means that you need not use so much reaction. Hence, a set of the H.F.-Det.-L.F. type may

PLENTY OF PROGRAMMES ASSURED.

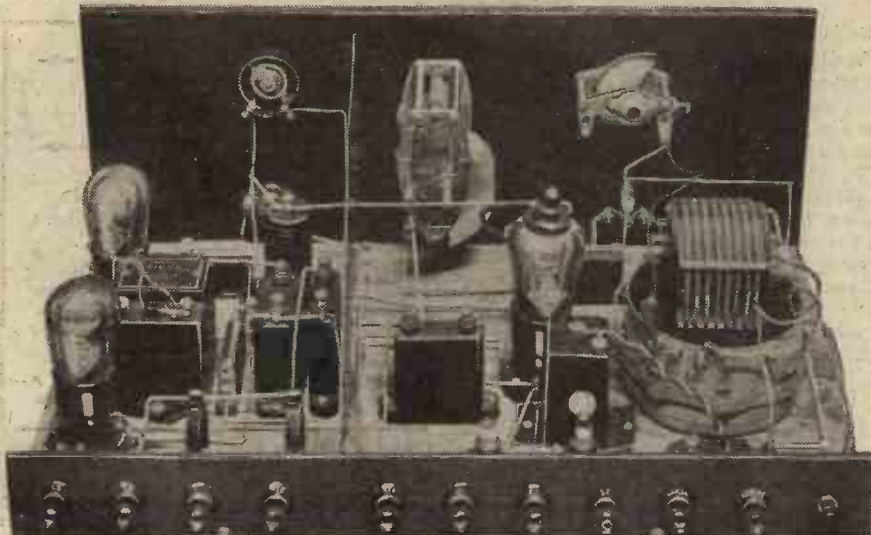

As before, an S.G. H.F. valve is used in This Year's "Titan" Three, but a special form of coupling is employed, and this enables all the tuning to be done on one ordinary variable condenser.

THIS YEAR'S "TITAN"



by various members of the family without skill in tuning. When a receiver will be used almost entirely by a comparatively skilled operator matters are rather different, and two dials become quite in order.

In some cases, too, it may be quite necessary to go to two or even three tuned circuits in order to obtain the very high selectivity now required in certain parts of the London area where the two Regional transmissions are so difficult to cut out.

In the situations we are considering, however, one good tuned circuit will serve our purposes, giving all the selectivity that is needed, and

A sixpenny blue print of this fine set was a four sixpenny blue prints presented free every copy of "Popular Wireless" last year. This Year's "Titan" is a magnificent set from all points of view, and in its class is just as wonderful as its famous brother, the "Master Three". In the "Titan" you have the simplest unified control ever conceived for a set having such potentialities.

Long-distance results are ensured by S.G. valve, and a remarkably effective wave change. And all this in an inexpensive easy-to-build set!

By The "P.W." RESEARCH DEPT.

THE COMPLETED SET



READY FOR ETHER ROAMING

COMPONENTS—THE MAKES RECORD

- | | |
|--|---|
| 1 Panel, 18 in. x 7 in. (Beco, Trolite, Trelleborg, Resiston, Keystone, Goltone, etc.). | 3 Sprung valve holders (Lotus, Benjamin, Igranic, W.B., Lissen, Formo, Wearite, Bowyer-Lowe, Burton, Precision, etc.). |
| 1 Cabinet to fit, with baseboard 10 in. deep (Camco, Peto Scott, Gilbert, Lock, Pickett, etc.). | 1 "Titan" coil (Ready Radio, Magnum, Paroussi, Goltone, Wearite, etc.). |
| 1 .0005-mfd. variable condenser, slow-motion type or with vernier dial (Lissen, Formo, Cyldon, Burton, Ormond, Dubilier, Bowyer-Lowe, Colvern, Igranic, J.B., etc.). | 1 Combined series aerial condenser and shorting switch (Wearite). |
| 1 Vernier dial (Igranic, Lissen, etc.). | 1 H.F. choke (Lewcos, Colvern, Wearite, Magnum, Bulgin, Bowyer-Lowe, Climax, R.I., Lissen, Igranic, Dubilier, Ready Radio, Varley, etc.). |
| 1 .0001-, .00013- or .00015-mfd. reaction condenser, preferably slow-motion (Polar, Ormond, Magnum, Wearite, Pye, Burton, Dubilier, Lissen, Lotus, Ready Radio, etc.). | 1 L.F. transformer, low ratio (Varley Ni-Core 1, Ferranti, Brown, Telsen, Lissen, Lewcos, Cossor, Mullard, Lotus, Philips, etc.). |
| 1 3-point wave-change switch (Bulgin, Wearite, Ready Radio, Ormond, etc.). | 1 .002-mfd. fixed condenser (Dubilier, T.C.C., Lissen, Mullard, Igranic, Clarke, Goltone, Graham-Farish, etc.). |
| 1 L.T. switch (Lissen, Igranic, Benjamin, Wearite, Bulgin, Lotus, Burton, Keystone, etc.). | 1 .0001-mfd. fixed condenser (T.C.C., Lissen, Dubilier, Mullard, Igranic, Clarke, Graham-Farish, Goltone, etc.). |
| 1 Filament rheostat, 10 ohms for 2-volt valves, 20 or 30 ohms for 6-volters (Wearite, Lissen, Ready Radio, Igranic, Burton, etc.). | |

NEW VERSION OF A F

THREE

one of
with
week.
ceiver
ust as
agic"
mplest
aving
y the
wave-
nsive,

retaining to the full the easy operation of the Detector and 2 L.F. type of set. It is to meet exactly these needs that we are presenting This Year's "Titan" Three, which represents a thoroughly modernised and up-to-the-minute version of that famous receiver the "Titan" Three.

As the reader may perhaps remember, the "Titan" Three was one of the most extraordinarily popular designs ever produced for the home-constructor.

We pointed out, when the original "Titan" appeared, that it was a set which would not go out of date quickly; and, indeed, it is far from obsolete even now. However,

RECOMMENDED.

- 1 .0003-mfd. fixed condenser (Lissen, T.C.C., Dubilier, Mullard, Clarke, Golione, Graham-Farish, Igranic, etc.).
 - 2 .25-mfd. fixed condensers (Lissen, etc.).
 - 1 2-mfd. fixed condenser (Lissen, Ferranti, T.C.C., Dubilier, Hydra, Mullard, etc.).
 - 1 2-meg. grid leak and holder. (Lissen, Igranic, Dubilier, Mullard, Ediswan, etc.).
 - 1 25,000- or 20,000-ohms resistance and holder (Ready Radio, Lissen, Ferranti, Dubilier, Mullard, R.I., Precision, Varley, Igranic, etc.).
 - 1 1/2-meg. grid-leak type resistance with terminals. (Lissen, etc.).
 - 2 Fuse holders and bulbs.
 - 1 Standard "P.W." screen, 10 in. x 6 in. (Paroussi, Magnum, Keystone, Wearite, Ready Radio, etc.).
 - 1 Terminal strip, 18 in. x 2 in.
 - 10 Terminals (Igranic, Belling & Lee, Eelex, Clix, Burton, etc.).
- Wire, screws, plugs, flex, or Keystone Connectorkit.

prolonged experience with this set in our hands, and in those of our readers, has suggested a number of valuable refinements which we feel free to incorporate in such a de-luxe version as the present one. (Some of these were considered for inclusion in the original design, by the way, but were finally barred for reasons of simplicity).

To be more specific, this is what our various new features are intended to do. First certain of them make the set easier and pleasanter to work; another reduces the H.T. consumption of the screened-grid valve in order to cope with the more greedy modern specimens. One provides an effective volume control, and yet another serves to make the set safer from motor-boating when used on various types of mains units.

The inter-valve coupling is just an H.F. choke, which gives a good degree of amplification, and does not require to be tuned, and so we get rid of one of the usual dials. In combination with this is the fact that reaction is taken from the H.F. valve instead of from the detector, the aerial coupling winding on the coil unit being used for the purpose.

Reaction is adjusted by means of the condenser C_2 . This only requires to be of very small capacity, and in the original set we used one of .00005 mfd. In this new version, however, we have used one of .0001 mfd., and got the desired effect by putting a fixed condenser of only .0001 mfd. in series with it.

Efficient Wave-change Switching.

The reason for this is not a technical

one, but purely practical; it is usually easier to get a reaction condenser of about .0001 mfd. (any capacity round about will serve) than one of .00005 mfd.

The other special feature of the "Titan" is the special coil unit which we introduced for it. This coil gives very efficient wave-change switching, with a special close adjustment of aerial coupling which gives an excellent control of selectivity and enables you to suit your aerial very exactly.

The rest of the circuit is very straightforward, and consists of the usual grid-leak detector and one transformer-coupled

SIMPLE BUT EFFICIENT SCREENING.

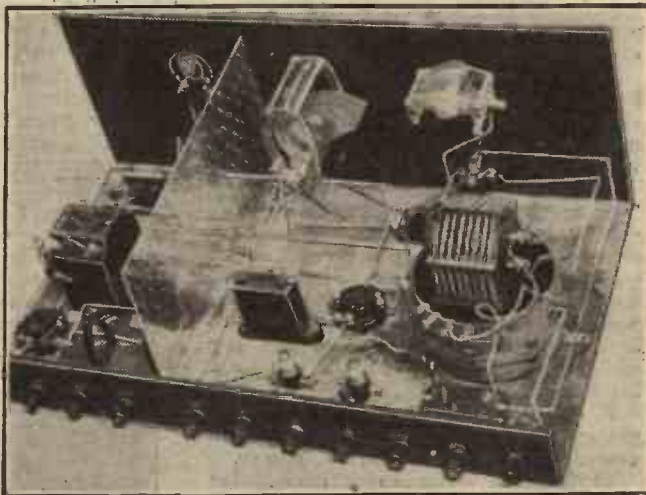

The "Titan" Three is extraordinarily inexpensive and easy to build, and it has no rival in its class.

L.F. stage. The whole assembly, as you will now see, is really very simple, but the results it gives are quite surprising in view of its wonderful ease of operation, and hosts of our readers have reported extraordinary success with it.

Next week we shall be telling you more about this wonderful receiver, and will give you the necessary very simple operating instructions.

NO COIL CHANGING—JUST A SWITCH!

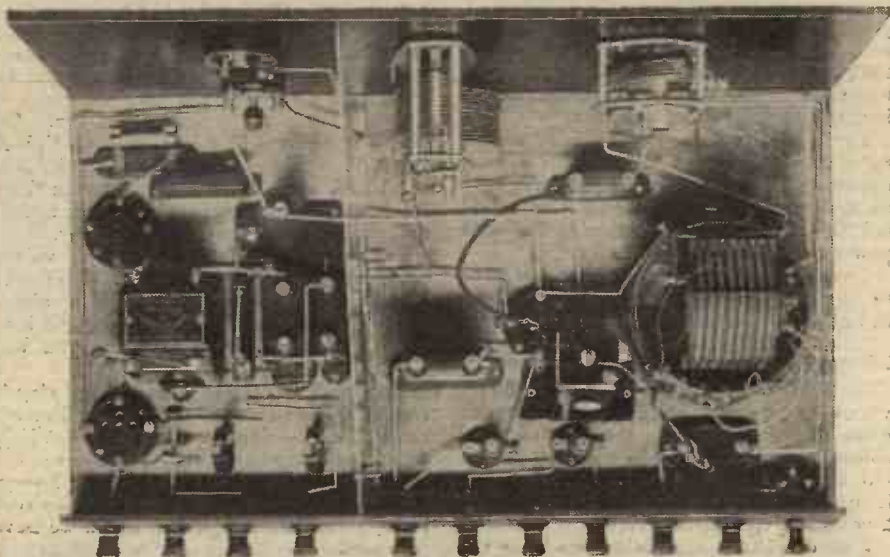

The very well-known "P.W." "Titan" coil unit figures in this set, and figures in an exceptionally effective wave-change scheme. No coils have to be changed. You go over from the one wave-band to the other merely by operating an ordinary panel switch.

FAMOUS SET

OPERATING THIS YEAR'S "MAGIC" THREE.

Some hints on the adjustments and control of this up-to-the-minute receiver, which will help you to take full advantage of its remarkable programme-pulling properties.

BY THE "P.W." RESEARCH AND CONSTRUCTION DEPARTMENT.

WHEN the original "Magic" Three receiver was brought out we decided to give the necessary operating instructions in a separate article, knowing that space would be limited in the one describing the construction.

When we came to write this second article, however, we discovered that one of the most attractive features of the set was going to make things awkward for us, because there was so little to be said!

The fact is that the operation of any "Magic" set is so extraordinarily easy and simple that only the briefest instructions are needed. That applies to "This Year's" model just as it did to the earlier ones, of course, in so far as the receiver portion proper is concerned, but this time there are certain refinements and an auxiliary gadget (the rejector) which will call for a little more explanation.

First of all let us clear off the ordinary general working data, such as valves to use, coil sizes, H.T. voltages, and so forth.

The choice of valves is very simple, being just the same as that for almost any other "Det. and 2 L.F." three-valver. The detector should be of the H.F. type, with an impedance of perhaps 20,000 to 30,000 ohms, or thereabouts.

Values and Volume.

For the first L.F. stage (V_2) you have a choice between two types. For normal purposes, with the best quality on strong signals and the greatest stability, you want here a valve of the L.F. or G.P. type, impedance perhaps 10,000 ohms to 18,000 ohms (very roughly).

A valve of the H.F. type, however, will give a little more magnification and so is, perhaps, helpful on the weaker foreign stations. You will probably find, however, that the tremendous amplification given by this set, even with a valve of the L.F. type, is ample for all normal purposes.

For the third valve (V_3) you really want a super-power, because the set gives such extremely strong signals. If you have only an ordinary power valve here you would only be able to use a fraction of the total power available without overloading.

Even with a super-power type you have to be a little careful to avoid over-loading it, and so spoiling the quality.

Filament Voltages.

Naturally, you can use either 2- or 6-volt valves as you wish, and there is little to choose between them in this receiver. Of course, the "sizes" are just a little better, but the difference is very much less than it used to be, and the economy of the 2-volters is very attractive.

Just one little point before we leave the question of valves: It is advisable to choose specimens of good, well-known makes, of which here are a few examples: Mazda,

Mullard, Cossor, Dario, Marconi and Osram, Six-Sixty, etc.

The H.T. voltages are simpler with the "Magic" Three than with most sets, because there is generally no need to adjust the voltage on the detector to get smooth reaction. (You do that by adjusting the potentiometer.) All you do is to put about 60 or 70 volts on H.T. +1, and all you've got on H.T. +2, and that's that.

Plenty of H.T.

By the way, the full 120 volts or more is really desirable on H.T. +2, so that your last valve may be able to handle the powerful signals as well as may be without overloading. Remember that the higher the H.T. voltage the more volume the valve can

TUNING TIPS.



The operating controls are really only the large dial in the centre (tuning), the one to the right above (reaction) and to the right below (volume). Those to the left control the rejector, and only require occasional manipulation. Remember that the rejector setting is sharp and calls for care.

handle before overloading begins, assuming that grid bias is properly adjusted.

However, the set will still work well if you have to use a lower voltage, such as 100. It will make practically no difference to its long-distance powers, but you will no longer be able to handle such powerful signals, and must use the volume control very carefully or you will get bad distortion due to overloading.

Grid bias is a simple matter, too. On G.B. -1 you want $1\frac{1}{2}$ volts negative if V_2 is of the H.F. type, and either 3 or $4\frac{1}{2}$ volts if it is an L.F. valve. To decide between these latter figures, try both on a strong signal, and note which gives the best quality.

Different power and super-power valves vary so much in their grid-bias requirements that there is not much that we can say about G.B. -2. You will have to be guided here by the maker's data slip which you will receive with the valve.

Now coil sizes. In the rejector circuit (socket L_1) you definitely want a No. 50, or a No. 250 for the rejection of 5 X X. For L_2 you want an "X" coil of one of the good makes (Lewcos, Lissen, etc.). Everything depends upon the quality of this coil, so note that word "good" which we have just used.

The correct sizes for L_2 are No. 60 for the ordinary wave-lengths, and No. 250 for the long waves. The reaction coil (L_3)

is of the plain variety, and size No. 50 will generally be right for the ordinary waves, and No. 100 for the long. If, however, your detector valve is a rather sober fellow and does not oscillate easily, you may want a reaction coil a size larger in each case.

Next, one or two miscellaneous adjustments, before we go any further. Mention of the coils has reminded us that there is a selectivity control on L_2 . The flex lead from switch S_2 goes to one or other of the tapping points on this coil, and you get two different degrees of selectivity in this way. One of them, by the way, usually gives rather better volume than the other, especially if your aerial is small.

With so much clear you are ready to try the set, and make the remaining adjustments as you do so. Really, all you have still to do is to set the potentiometer for the best results, and this will only take you a few moments.

First cut out the rejector by putting S_2 to the "on" position, then start with the potentiometer slider right along at the positive end. (The negative side is the one wired to earth.)

Now test the reaction control. Probably you will find it rather floppy. If so, take the "potmeter" slider gradually along towards the negative end until the control just becomes really smooth and silky.

Remember This.

At this point let us remind you to see that the volume control is not set to minimum, or you will hear nothing. (Minimum is with knob turned fully to the left.) By the way, the volume control connections are not quite the usual ones, but they are correct for all that.

With these points attended to you are ready to give the receiver a trial, except that you have not yet got the rejector set to eliminate the local when desired. We may as well do this next, for it is very simple.

Put switch S_2 to "off," so bringing the rejector into circuit. Set the tuning of the receiver so that the local is heard at something rather less than full volume. Adjust C_2 to maximum (knob screwed downwards), and then turn to C_1 on the panel. Adjust this carefully until you find the point at which the local suddenly disappears, and on either side of which it re-appears.

Setting The Rejector.

This is the rejection point, and when you have found it as accurately as possible, you will probably discover that the local has vanished right off the dial so long as no reaction is used. You may hear just a trace of it still at one point, but all the rest of the dial will be quite clear for foreigners.

To hear the local again, of course, just put S_2 to the "on" position, so cutting out the rejector. Alternatively, you could set the rejector to give less drastic elimination so that the station is still heard at moderate strength when fully tuned in, but does not spread round the dial.

In the London area there are two interfering stations to consider, of course, and so you will need to set C_1 to reject one or other of them. As a rule, you will find that it is practically always only one or other of the Brookmans Park transmissions which interferes with the particular foreigner you want to hear, and so this scheme is perfectly effective.

The subject of short wave working we must reserve for another article next week.

TITAN

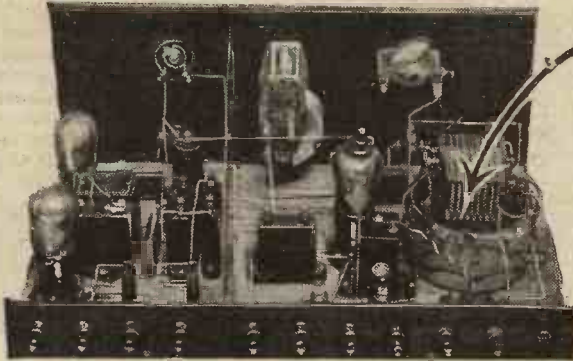

This is the Ready Radio 1930 Titan coil chosen and used by the designer of the 1930 TITAN THREE

Price 15/-

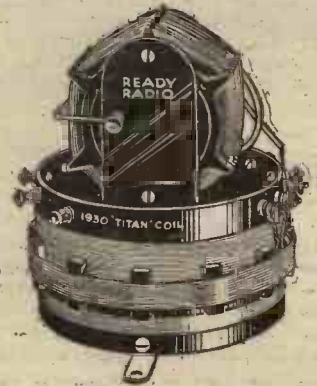

AVAILABLE IN COMPLETE KITS OF PARTS

READY FOR IMMEDIATE DESPATCH

LIST OF APPROVED PARTS

	£	s.	d.
1 Drilled ebonite panel, 18 in. x 7 in.	1	10	0
1 Hand-polished oak cabinet, with baseboard	4	6	0
1 Ready Radio '0005-mfd. variable condenser	5	6	0
1 J.B. slow-motion dial	10	0	0
1 Polar (type Q.J.) '0001 s.m. reaction condenser	1	6	3
1 Ready Radio 3-point wave-change switch	1	6	3
1 Ready Radio L.T. switch	1	6	3
1 Wearite filament rheostat	1	6	3
3 Lotus sprung valve holders	3	9	0
1 Ready Radio 1930 Titan coil unit	15	0	0
1 Lewcos H.F. choke	7	9	0
1 Wearite combined aerial condenser switch	1	0	0
1 Varley (Ni-Core 1.) L.F. transformer	1	0	0
1 Dubilier '002 mfd. fixed condenser	3	0	0
1 T.C.C. '0001 mfd. " "	1	6	0
1 Lissen '0003 mfd. " "	1	0	0
2 Dubilier '25 mfd. " "	4	0	0
1 Lissen 2-meg. grid leak and holder	1	6	3
1 Grid-leak type resistance, 1 meg.	1	3	5
1 Ready Radio 25,000-ohms resistance and holder	2	5	0
2 Ready Radio fuse holders, with bulbs	3	0	0
1 Ready Radio Standard Titan screen	1	8	0
1 Drilled terminal strip, 18 in. x 2 in.	2	6	0
10 Engraved Belling-Lee terminals	2	6	0
1 Set Ready Radio connecting links	2	5	6
3 Valves as specified	2	5	6
1 Siemens' 1.5-volt grid battery	3	6	0
1 Dubilier 2-mfd. condenser	3	6	0
Screws, Plugs, Flex, etc.	1	5	0
TOTAL (INCLUDING VALVES, etc.)	£9	6	6

Any of the above components can be supplied separately if desired

ALL READY-RADIO KITS ARE APPROVED BY "POPULAR WIRELESS."

KIT A	less valves and cabinet	£5 : 11 : 0
KIT B	with valves less cabinet	£7 : 16 : 0
KIT C	with valves and cabinet	£9 : 6 : 6

All Kits include special Ready Radio connecting links.

NO SOLDERING REQUIRED!

READY RADIO IMMEDIATE DESPATCH SERVICE

When you buy radio parts you naturally want exactly what you order and you want them quickly. You also would be happier with the knowledge that in the event of subsequent difficulties you can obtain technical advice without trouble.

TO HOME CUSTOMERS

Your goods are despatched post free in sealed cartons or carriage paid by rail. Note.—You can if you desire, avail yourself of the C.O.D. system.

TO OVERSEAS CUSTOMERS

All your goods are very carefully packed for export and insured, all charges forward.

Telephone No.
Hop 5555
Private Exchange.

Ready Radio

Telegrams :
Ready Hop 5555
London.

159, BOROUGH HIGH STREET, LONDON BRIDGE, S.E.1

(Three minutes from London Bridge Station.)

FROM THE TECHNICAL EDITOR'S NOTE BOOK.

Tested and Found—?



A VARLEY TRANSFORMER.

THERE are times when a transformer is required at a point in a set where a fairly heavy current has to pass through its primary winding. For instance, a transformer may be needed for coupling a small power valve to a super-power valve.

No ordinary L.F. transformer will carry more than about five milliamps of current without its core saturating, and its performance going all to pieces. For such jobs those excellent choke and transformer specialists, the Varley people, have a heavy duty intervalve transformer.

The specification of this is as follows: Primary D.C. resistance 2,300 ohms, primary inductance 91 henries, ratio 5 to 1. The above inductance figure is taken when no

current is passing through the primary winding, but there is still a useful 44 henries when there is 5 milliamps and 27 henries at 10 milliamps.

Actually, the windings will take up to 15 milliamperes without the performance of the component being anything else but quite creditable. As with all other Varley gear this transformer is most substantially constructed, and its terminals are widely and accessibly placed. A soldering tag for earthing the core is provided. The retail price is 23s. 6d.

LOEWE FIXED CONDENSERS.

The Loewe Radio Co., Ltd., informs me that Loewe fixed condensers are now available in two types, namely, condensers with soldering tags and fixing lugs for manufacturers, and condensers with soldering tags, screw terminals, and double-sided fixing lugs (for horizontal or vertical base-board mounting) for home-constructors.

Readers will remember that in a favourable review of a Loewe fixed condenser I advised the makers to supply a terminal

model for constructors. They have done so and, as you will see, added the further good feature of universal mounting.

WHEN YOU ARE BUYING—

(4) VALVE HOLDERS.

You should make sure that they are properly designed and constructed.

You can be fairly certain that they are if they are stamped with the trade marks of reputable firms.

See that each valve holder has sound terminal-socket connections. Any looseness in any securing screws that may be present indicates faulty assembly.

Distrust coal-tar substitutes for bakelite or ebonite in the insulation moulding. The material should not scrape easily with a knife or, if it does, should show a brownish tint—not polished black.

Take along or borrow a valve and see whether or not it will fit easily into, and can be taken easily out of, the holders.

A valve holder to be used for a detector valve should always be of the "anti-microphonic" type.

DUBILIER BATTERY BOOK.

The Dubilier people have produced a booklet with the attractive title of "A Bit About a Battery." This deals with Dubilier grid bias and H.T. batteries and contains useful and interesting information of a general nature.

(Continued on 1292)

AVAILABLE
MARCH
10TH

Combined H.T. Unit with L.T. Charger

to fit inside any Portable



PATENTS PENDING
AND
DESIGN REGISTERED.

and suitable for
all popular 2-3&4-
valve receivers.

Write for FREE ART BOOKLET "Radio from the Mains,"
and for particulars of Regentone Hire Purchase Terms.

SPECIFICATION. COMBINED MODEL.

For A.C. Mains, 100 volts, 200/220 or 230/250. 40,100 cycles.
Incorporates Westinghouse Metal Rectifier on H.T. and L.T. side.

Size - - - 9" x 5" x 3½" L.T. - Trickle Charger for 2-,
H.T. Output, 120 volts at 15 m.a. 4-, or 6-volt accumu-
lators.

H.T. Tappings, 2 variables (one S.G.) and one Power. Price - - - £5-17-6



For Radio from the Mains

NO BATTERIES NO ACCUMULATORS

An All-Electric Radio Set for £12. 17. 6

or on Easy Payments

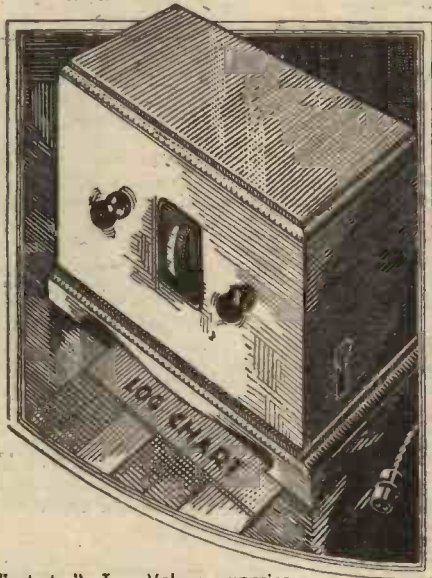

Model P.2 (illustrated) Two Valves, superior to ordinary three valve sets - £12. 17. 6
Model S.G.P.3 (Three valve) - £21. 0. 0
(Prices include valves and royalties)

Plug-in the "Ekco" adaptor to your electric light or power supply—Switch on—and know what it means to receive radio in the modern way. No batteries to run down—no accumulators to recharge—no bother—no mess.

"Ekco-Lectric" Radio Receivers are in hand-polished Walnut cabinets—with volume and selectivity controls—sockets for gramophone pick-up—Westinghouse Rectification in A.C. models—and they are British made for D.C. or A.C. Mains.

There are also "Ekco" Power Supply Units for electrifying or partly electrifying your present set. Write for Free Booklet and details of Easy Payments to

E. K. COLE LTD. (Dept. A), "EKCO" WORKS, LEIGH-ON SEA



Plug-in—That's all!

EKCO-LECTRIC RADIO RECEIVERS



Read what "Popular Wireless" says about VARLEY NICORE I, the L.F. Transformer specified for the 1930 "TITAN":

" used in the ordinary way, exceedingly fine results are given, the amplification curve being straighter than was dreamt possible a couple of years ago. Varley Nicore I stands right in the very front rank, and it is the sort of component that the discriminating constructor must have above all others."

That is why you should use Nicore I in your set. In addition to the N.P.L. curve being straight the amplification is almost 80. Whatever your set, VARLEY NICORE I helps to give you radio that will live—VARLEY radio.

NICORE I L.F. TRANSFORMER

Price £1

Write for Section D of the Varley Catalogue containing full particulars:



Advertisement of Oliver Pell Control Ltd., Kingsway House, 103, Kingsway, London, W.C.2 - Telephone: Holborn 5303.

TESTED AND FOUND—?
(Continued.)

THE FERRANTI MAINS RECEIVER.

Until comparatively recently there were few commercial sets on the market that were equal to the best that were brought within the scope of the home constructor. Indeed, many of the commercial receivers were replicas of home constructional designs of a period or two ago.

Nowadays, there is a rather different state of affairs, more particularly in regard to mains-driven receivers. For instance, the Ferranti A.C. mains receiver, a sample of which recently was put through its paces in the laboratory, is distinctly a very much up-to-the-minute design.



Note the mains connecting lead and plug.

Moreover, it is scientifically constructed, and when I say it is a good factory production I mean that it appears to have the advantages of the best home-constructed layout plus a

finish and compactness that is far removed from the kitchen table assembly.

Mind you, I am not decrying the home-constructed receiver one jot, and still think that, generally speaking, the home constructor can keep well ahead of the manufacturer, but any A.C. mains-drive outfit must be an engineering proposition that only the more advanced amateur can tackle.

The Ferranti A.C. mains-receiver is a three-stage outfit incorporating a screened-grid H.F. valve, and it derives H.T., L.T. and grid bias from the mains. It also has an output transformer and provision is made to enable it to be used with a gramophone pick-up.

Also, and this is very important, it complies with the rules and regulations of the Institution of Electrical Engineers and with the requirements of the leading supply authorities. It takes remarkably little current and its installation is no more complicated than that of plugging an electric iron into the nearest available light socket. Apart from such plugging in there are only the aerial and earth and loud-speaker connections.

Unusual Appearance.

The appearance of the instrument is somewhat unusual, and the accompanying photographs give you a good idea of it. It is available in dark oak at £25, or in mahogany or walnut at £26, plus an additional £1 in each case for royalties. Immediately you switch this set on the dials are illuminated from behind.

I noticed that the Ferranti people claim for this set a "fair measure of selectivity." This is modest, because in fact this set is

one of the most selective of its kind that I have tested. Brookmans Park, a few miles distant, covers but two or three degrees on the dials. The set is stable and sensitive.

The quality of reproduction is higher than the average, and there is ample volume for the operation of a moving-coil loud speaker from a number of stations. Indeed, taking everything into consideration it is, in my opinion, an outstanding proposition, and one that should meet with considerable success.

HIRE-PURCHASE RADIO.

The terms at which the goods of Loewe Radio Co., Ltd., are sold on hire purchase have been revised and are much more

advantageous to the dealers. The dealer now receives immediately for each hire-purchase sale 90 per cent of the full retail price of the goods, whilst the remaining 10 per cent is paid at the end of the hire-purchase agreement. The hire-purchase system is arranged by Associated Distributors, Ltd., of Castle Boulevard, Nottingham.



The Ferranti mains set.

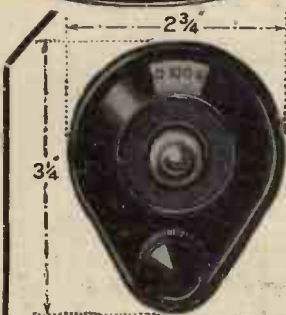

MECHANICALLY PERFECT. POSITIVE BRASS CONTACT drive on SOLID BRASS SCALE ensuring smooth movement with absolutely NO BACK-LASH. ROBUST in Construction and Trouble Free.

PRICE

3/-

THERE IS ONLY ONE GENUINE FORMO-DENSOR



Length 2 1/2 in. Width 1/2 in.

- F.** Max. .0001 Min. .000005 **2/-**
- J.** Max. .0003 Min. .000025 **2/-**
- G.** Max. .001 Min. .0002 **2/-**
- H.** Max. .002 Min. .001 **3/-**

THE FORMO CO., CROWN WORKS, CRICKLEWOOD LANE, N.W.2.

"1930" LOG (MID-LINE) CONDENSER

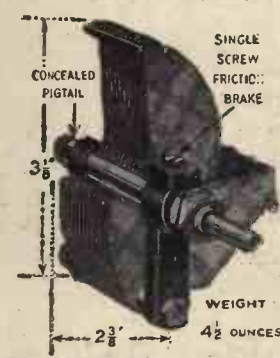

In four Capacities:
.0005
.00035
.00025
***.00015**

4/6
each.

WEIGHT **4 1/2 OUNCES**
 *Double spacing of vanes for Ultra Short-wave work.

The type H.T.3



METAL RECTIFIER

Suitable for incorporation in high-tension eliminators requiring up to 20 milliamps at 120 volts.

Costs only 21/-

There are a number of other types also, from which any type of eliminator or charger can be constructed. Full details are given in "The All-Metal Way 1930," our new 32-page book which shows you how to run your set entirely from your A.C. mains. Send 2d. stamp with your name and address to:—



A tested and recommended circuit.

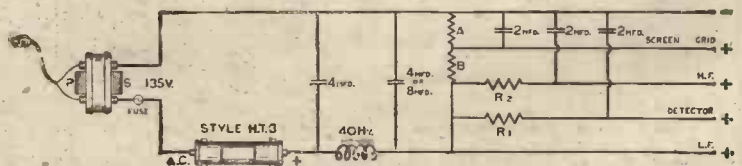

The Westinghouse Brake & Saxby Signal Co., Ltd., 82, York Rd., London, N.1.

Those terrible UNEMPLOYMENT figures

Is Britain harder hit than America or Germany?

What do unemployment figures really mean? Newspapers have recently published statistics which seem to show that Germany and the United States are about as badly off as Britain. But are they? In an intensely interesting article in this week's **THIS AND THAT**, a distinguished economist analyses and discusses these important figures. Be sure you read it and grasp the actual truth.

This and That

The bright paper that tells you all you want about everyday subjects.
Every Thursday 2d.

**BEST RESULTS
WITH
GOLSTONE
"TITAN"
COIL
UNIT**



GOLSTONE "TITAN" COIL UNIT

A Super-efficient and High-Grade Unit
for "P.W." "TITAN" Circuits. **15/-**

List No. R.9/15. EACH.....

*From all first-class Radio Signs, Refuse
Substitutes. If any difficulty write direct.*

GOLSTONE "NEGROLAC" AERIAL

Your set is capable of far better results by using the
"NEGROLAC" Aerial. Let us send you pamphlets giving
extracts from technical reports, testimonials and full par-
ticulars with sample.

Send for interesting
illustrated Radio
Catalogue FREE on
request.



Ward & Goldstone
PENDLETON MANCHESTER

London Depot:
5 & 6, Eden Street,
Hampstead Road,
N.W.1.

PAREX

SCREENS
COILS, Etc.



**THIS YEAR'S
'TITAN 3' COIL**

(Latest Design) **15/-**

STANDARD SCREEN
10" x 6" as specified **2/-**

DIFFERENTIAL COND. **5/-**

H.F. CHOKE . . . **3/6**

Orders Executed by Return of Post.

E. PAROUSSI, 10, Featherstone Bldgs.,
High Holborn, W.C.1.

Phone: Chancery 7010.

HIGH GRADE QUEEN ANNE STYLE FIGURED OAK CABINET

Designed to take Sets, Loud Speaker, Accumulators, Batteries, etc. Height 40 ins., Loudspeaker compartment 18 ins. x 21 ins. x 14 ins. For panels up to 21 ins. x 7 ins. Baseboards up to 12 ins.

£5 : 12 : 6

Carriage paid.
Prices of other sizes in proportion.
Manufacturers of all types of wireless cabinets. "Specials" at competitive prices.
Illustrated list free

**GILBERT,
CABINET MAKER,
SWINDON.**

Estimates Free. Estd. 1866.



THE NEW GOLDEN P.R. VALVE

ABNORMAL SELECTIVITY AND VOLUME

By a special process employing an extremely rare element in minute and precise quantities, in the coating of our Golden Series, we have been able to turn out a valve of extraordinary efficiency. Although the L.T. Filament consumption has been kept more or less to our standard to secure robustness, the emission has been increased BY OVER 50 PER CENT.

INSIST ON THE GOLDEN P.R.

For selectivity and volume we believe a better valve cannot be obtained anywhere with such a low consumption of H.T. and L.T. The glass bulbs are of a distinctive golden colour, and each valve has a golden guarantee band.

GUARANTEE. All valves despatched under guarantee of Money Back in Full if not satisfied and returned within 7 days. All valves are carefully packed and breakages replaced.

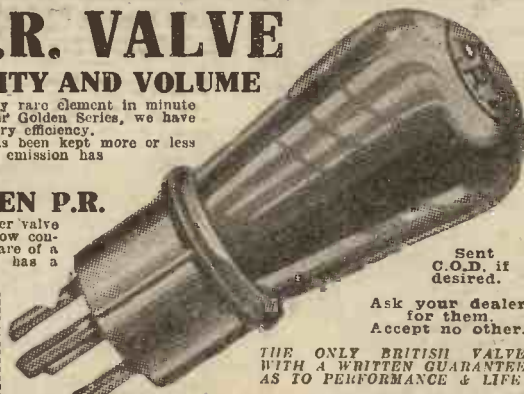

Sent C.O.D. if desired.

Ask your dealer for them. Accept no other.

THE ONLY BRITISH VALVE WITH A WRITTEN GUARANTEE AS TO PERFORMANCE & LIFE

Tel.: City 3783.

P.R. PRODUCTS, 42, P.R. HOUSE, NEWGATE STREET, LONDON, E.C.4
(Opposite G.P.O. Tube Station)

LIST OF P.R. SUPER GOLDEN SERIES.						
	Type	Fil. volts.	Amp.	Imp. ohms.	Amp. fac.	
4/6	GPR 22	22	.095	24,000	13.5	H.F. Det.
	GPR 32	32	.095	12,000	9	L.F.
	GPR 42	42	.095	40,000	32	R.C.
	GPR 9 3.5-4	3.5-4	.09	22,000	14.5	H.F. Det.
7/6	GPR 10 3.5-4	3.5-4	.09	10,000	9	L.F.
	GPR 11 3.5-4	3.5-4	.09	44,000	41	R.C.
	GPR 17 5-6	5-6	.14	20,000	17.5	H.F. Det.
12/6	GPR 18 5-6	5-6	.14	11,000	9.5	L.F.
	GPR 19 5-6	5-6	.14	75,000	41	R.C.
15/-	GPR 20 2	2	.15	6,000	7	Power
	GPR 40 4	4	.15	6,000	7	"
	GPR 60 6	6	.15	6,000	7	"
15/-	GPR 120 2	2	.3	3,000	4.5	Super Power
	GPR 140 4	4	.2	3,500	4.5	"
	SG 25 2	2	.2	220,000	150	S.G.

2 Valves or more sent POST FREE. Matched Valves 1/- extra per set.

BROWNIE SELECTIVITY UNIT

Mr. F. T. Collins, of East Barnet, writes: "Although I am within 6 miles of Brookmen's Park, I find the Brownie Selectivity Unit enables me to separate either wave length without the least difficulty. I feel that your Unit is the only relief for listeners in this area." Screen-Grid selectivity with any set—

that's what you get with the Brownie Selectivity Unit, at a cost of only 10/6! Your dealer will tell you all about it.

10/6



BROWNIE WIRELESS CO., (G.B.) LTD., Nelson St. Works, London, N.W.1.

RADIOTORIAL.

All Editorial communications to be addressed to the Editor, POPULAR WIRELESS, Tallis House, Tallis Street, London, E.C. 4.

The Editor will be pleased to consider articles and photographs dealing with all subjects appertaining to wireless work. The Editor cannot accept responsibility for manuscripts or photos. Every care will be taken to return MSS. not accepted for publication. A stamped and addressed envelope must be sent with every article. All inquiries concerning advertising rates, etc., to be addressed to the Sole Agents, Messrs. John H. Lile, Ltd., 4, Ludgate Circus, London, E.C. 4.

The constructional articles which appear from time to time in this journal are the outcome of research and experimental work carried out with a view to improving the technique of wireless reception. As much of the information given in the columns of this paper concerns the most recent developments in the radio world, some of the arrangements and specialities described may be the subject of Letters Patent, and the amateur and the trader would be well advised to obtain permission of the patentees to use the patents before doing so.

QUESTIONS AND ANSWERS.

SELECTIVITY WITH AN X COIL.

T. C. (nr. Wembley).—"I bought the X coil as suggested, but am still disappointed with results. The selectivity has improved so little that I am not at all sure when listening to the set whether it is employing the old coil or the new X coil. I have looked up the wiring carefully and discovered that the pin of the coil-holder connection is connected to earth, which you say is the right arrangement. Why is it that the coil does not give an improvement in selectivity?"

You do not mention the make of X coil which you purchased and unfortunately several manufacturers of this type of coil have, for some reason of their own,

reversed its connections. Consequently, with such a coil, in order to give the extra selectivity for which the coil was designed, the coil-holder connections must be reversed.

Possibly you have one of these non-standard coils, so we should try the effect of changing over the connections of your X coil holder, as if your X coil is

"P.W." TECHNICAL QUERY DEPARTMENT

How's the Set Going Now?

Perhaps some mysterious noise has appeared, and is spoiling your radio reception?—Or one of the batteries seems to run down much faster than formerly?—Or you want a Blue Print?

Whatever your radio problem may be, remember that the Technical Query Department is thoroughly equipped to assist our readers, and offers an *unrivalled* service.

Full details, including scale of charges, can be obtained direct from the Technical Query Dept., POPULAR WIRELESS, The Fleetway House, Farringdon Street, London, E.C. 4.

A postcard will do. On receipt of this an Application Form will be sent to you free and post free immediately. This application will place you under no obligation whatever, but having the form you will know exactly what information we require to have before us in order to solve your problems.

LONDON READERS PLEASE NOTE: Inquiries should NOT be made by phone, or in person at Fleetway House or Tallis House.

one of those with reversed connections you are at present running the aerial through a large proportion of the windings instead of through only a few turns.

A SIMPLE WAVE-CHANGE SWITCH.

T. M. (Hoddesdon).—"On the baseboard there were three coil holders next to one another in the usual way, and then between (Continued on page 1296.)"

MAGNUM H.F. CHOKE



7/6

For the 1930 "Titan" Three.

MAGNUM "TITAN" COIL

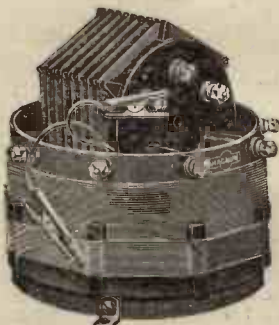

15/-

For the 1930 "Titan" Three.

"TITAN" 3 1930 MODEL

	£	s.	d.
Model 1. Including Valves and Cabinet	9	0	0
Model 2. As above, but less Valves & Cabinet	5	10	0
Model 3. As Model 1, but ready wired and tested, and Royalty Paid	10	10	0

"MAGIC" 3 1930 MODEL

	£	s.	d.
Model 1. Including Valves and Cabinet	9	12	0
Model 2. As above, but less Valves & Cabinet	6	15	0
Model 3. As Model 1, but ready wired and tested, and Royalty Paid	11	0	0

Any parts supplied separately as desired.

Full particulars, including a list of leading Short-Wave Stations, free on request.

BURNE-JONES & CO., LTD.,

"Magnum" House, 296, Borough High Street, London, S.E.1
Telephone: Hob 6257, 8.

FOR THE

"MAGIC" 3 "TITAN" 3
"REGIONAL" 3 "REGIONAL" 4

Be sure of best results
Use the recommended

WEARITE COMPONENTS

	s.	d.
H.F. CHOKE	6	6
ON-OFF SWITCH	1	0
SERIES AERIAL CONDENSER WITH SWITCH	2	3
WIRE-WOUND FIXED RESISTANCE (25,000 ohms)	4	0
POTENTIOMETERS (200 or 400 ohms)	2	6
VOLUME CONTROL (1/2 or 1 megohm)	4	0
3-POINT WAVE-CHANGE SWITCH	1	6
COIL HOLDERS (Real Low Loss)	1	6
STANDARD "TITAN" COIL	15	0

PAXOLIN PANELS AND TERMINAL STRIPS (Mahogany or Black Finish)

For particulars of other Wearite Recommended Components, write for Special List and Illustrated Booklet.

WRIGHT & WEAIRE, LTD., 740, High Road, LONDON, N.17.

Phone: Tottenham 3847-3848.

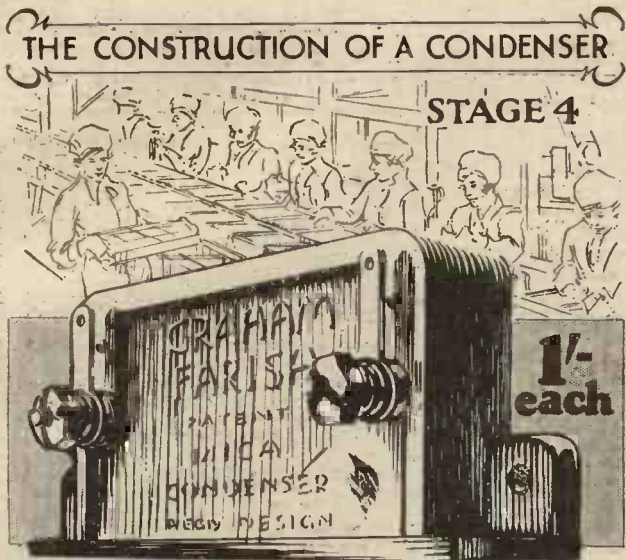

Assembling



MULTI-WAVE
HF Choke

Employs solenoid winding followed by sectional winding. High impedance. Low D.C. resistance. with base. 5/- each.



OHMITE
New Process
Anode Resistance

Hermetically sealed in Bakelite. Better than wire-wound. Negligible self-capacity. All values. 1,000 to 500,000 ohms. 2/3 each.



ELECTROEFFICIENT
Eliminator Choke

Heavy design with large safety factor. Gives impedances of 30 Henries at 50 milliamperes. 22/6.

THE Condenser has now reached its fourth stage—**assembling.**

At the Graham-Farish factory, the position of every machine—every employee, every tool even, has been carefully planned.

As each part of a condenser is fitted—so swiftly moving conveyor bands carry it to its next stage. Power-driven screw-drivers, and other time and labour-saving tools secure efficiency of working.

Only such skilful organisation—mass production on such modern lines could produce the components that bear the name "Graham-Farish."

The Graham-Farish Fixed Mica Condenser has the finest flawless Indian Ruby Mica as a dielectric. An exclusive feature is the alternative upright or flat mounting. Every condenser is tested three times and a written guarantee given with each.

Bakelite Case. Upright or flat mounting, terminals, soldering tags and series—parallel grid leak clips up to capacities .0005, .00005—.002, 1/; .003—.006, 1/6; .007—.01, 2/6.

- "Megite" New Process Grid Leak - 2/-
- "Electroefficient" Mains Transformer - 39/6
- "Microefficient" Variable Condenser 4/3—4/6

GRAHAM FARISH

BROMLEY

KENT

Look for this sign



in a dealer's shop.

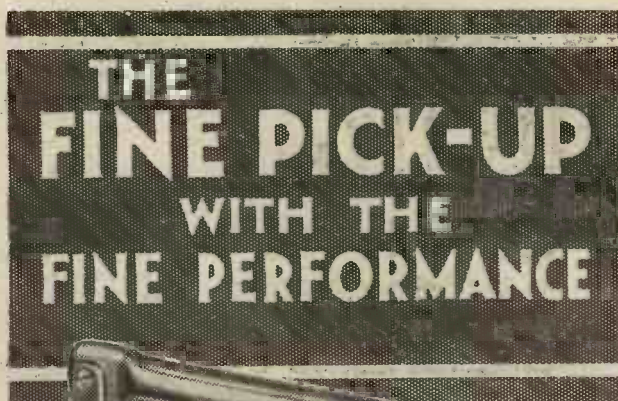

The new B.T.H. pick-up has been specially designed to give fine tonal quality throughout the whole musical range.

The degree of damping has been very carefully balanced so that unwanted resonances are avoided on the one hand and record wear is avoided on the other.

The B.T.H. pick-up is used in the best known makes of radio gramophones—good reason why you, also, should make use of the undoubted advantages of the more music—less wear pick-up.

PRICE **45/-** COMPLETE

Pick-up and Adaptor for Standard Tone Arms

Price 27/6 Complete



PICK-UP & TONE ARM

"THE MORE MUSIC — LESS WEAR PICK-UP"



THE EDISON SWAN ELECTRIC CO., LTD.,
Radio Division,
1a, Newman Street, Oxford Street, W.1.
Branches in all the Principal Towns.

EDISWAN

W.69.

RADIO FROM INCOME

A new addition to the well-known Ready Radio Service is our "Radio-from-Income" system of monthly or weekly payments for complete kits of parts.

1930 MAGIC 3

- KIT A** 12 equal monthly payments of **12/6**
or 20/- down and 12 weekly payments of 10/3
- KIT B** 12 equal monthly payments of **15/9**
or 20/- down and 12 weekly payments of 13/3
- KIT C** 12 equal monthly payments of **18/6**
or 20/- down and 12 weekly payments of 16/-

1930 TITAN 3

- KIT A** 12 equal monthly payments of **10/3**
or 20/- down and 12 weekly payments of 8/-
- KIT B** 12 equal monthly payments of **14/6**
or 20/- down and 12 weekly payments of 12/-
- KIT C** 12 equal monthly payments of **17/3**
or 20/- down and 12 weekly payments of 14/9

REGIONAL 4

- KIT A** 12 equal monthly payments of **15/-**
or 20/- down and 12 weekly payments of 12/3
- KIT B** 12 equal monthly payments of **20/-**
or 20/- down and 12 weekly payments of 17/6
- KIT C** 12 equal monthly payments of **23/-**
or 20/- down and 12 weekly payments of 20/-

REGIONAL 2

- KIT A** 12 equal monthly payments of **8/6**
or 20/- down and 12 weekly payments of 6/6
- KIT B** 12 equal monthly payments of **10/9**
or 20/- down and 12 weekly payments of 8/6
- KIT C** 12 equal monthly payments of **12/9**
or 20/- down and 12 weekly payments of 10/6

See page 1289 for the complete list of approved parts for the 1930 "Titan" Three. Lists for the "Regional" Four and the "Regional" Two can be obtained on application. All kits include Ready Radio non soldering links.

Ready Radio

159, BOROUGH HIGH STREET, LONDON BRIDGE, LONDON, S.E.1

Telephone: HOP 5555.

RADIOTORIAL QUESTIONS AND ANSWERS

(Continued from page 1294.)

that and the panel there was a fourth one, the other components on the panel being the valve holder, leak and condenser, H.F. choke and fixed condenser, terminal strip, etc. On the panel were the two variable condensers, the on-off switch and a simple wave-change switch that is causing all the trouble!

"I was fool enough to try another circuit, and although I have varied this two or three times, I never got the results as I did with the original one with the simple wave-change, and I should like to go back to it. Unfortunately, I have lost the details and should be glad if you could tell me again. (Coils Nos. 25, 35, 50, 60, 200 centre-tapped, and one 50). There are two switches on the panel, one with a flex lead to the plunger."

The following are the connections: Aerial terminal to nearest coil holder, other side of this coil holder to the socket of the coil holder that stands by itself parallel to the panel, to the moving vanes of tuning condenser, to one side of the wave-change switch, and to the plug of the coil holder nearest the grid condenser. Other side of this coil holder to the moving vanes of the reaction condenser.

Fixed vanes of this to the .001 fixed condenser on the baseboard. The H.F. choke and the plate of

POPULAR "WIRELETS" No. 4

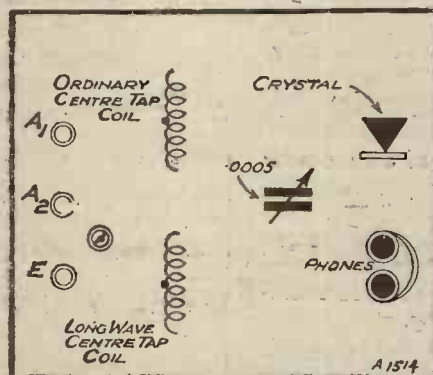

Here are the "components" for a crystal set to cover both long and ordinary wave-lengths, the change-over being made by having two aerial terminals and an ordinary on-off switch to short the long-wave coil.

Can you wire up the circuit? Look out for the answering diagram in next week's "P.W."

the valve holder are joined to the remaining side of this fixed condenser. Other side of this H.F. choke to one 'phone terminal and other 'phone terminal to H.T. +.

Grid socket of the valve holder goes to one end of the grid leak and to the .0003 fixed condenser. Other side of the grid leak goes to one of the filament terminals on the valve holder and to one side of the on-off switch, the other side of this going to L.T. +.

L.T. - goes to H.T. -, to the remaining filament terminal on the valve holder, to earth, to the centre of the wave-change switch by means of a flexible lead, and by means of another flexible lead to the centre tapping on the centre-tapped coil, which is the one that is placed parallel with the panel (the isolated one).

The fixed vanes of the tuning condenser are joined to the remaining side of the grid condenser, and to the plug of the centre coil holder. The socket of this goes to the plug of the isolated coil holder and to the remaining side of the wave-change switch, thus completing the wiring. (This set was the "Wave-change One." P.W. Blueprint No. 47).

THE BROKEN SECONDARY

T. C. E. (Hastings).—"Reception was beautiful on the ordinary broadcast, but Davenport (5XX) was rotten. In fact, not worth listening to, and trying to find what could be wrong I discovered the secondary wire was broken.

(Continued on page 1298.)

1930 MAGIC THREE

PRICE LIST OF PARTS

	£	s.	d.
1 Drilled Ebonite Panel, 18 in. x 7 in.	1	6	0
1 Hand-polished Solid Oak Cabinet, with baseboard	1	10	0
1 Ready Radio .0005 Variable Condenser	4	6	0
1 J.B. Slow-motion Dial	2	6	0
1 Bulgin B/M Neutralising Condenser	5	0	0
1 Ready Radio .00075 "Brookmans" Condenser	3	6	0
1 Ready Radio Diff. Condenser	5	0	0
1 Ready Radio On-off Switches	2	6	0
1 Keramo Volume Control	2	6	0
3 W.B. Sprung Valve Holders	3	9	0
3 Ready Radio Single Coil Holders	2	6	0
1 Lissen Super L.F. Transformer	19	0	0
1 R.I. "Hypernite" L.F. Transformer	12	6	0
1 Keystone H.P. Choke	5	0	0
1 R.I. .001 Compression Type Condenser	2	6	0
1 Lubliner .0003-mfd. Fixed Condenser	2	6	0
1 Lissen 2-meg. Grid Leak with Holder	1	6	0
1 T.C.C. 2-mfd. Mansbridge Type Condenser	3	10	0
1 Keramo 400-ohm Potentiometer	1	2	0
1 Ready Radio 25,000-ohm Resistance with Holder	2	5	0
1 Drilled Terminal Strip, 18 in. x 2 in.	1	8	0
10 Belling-Lee Engraved Terminals	2	6	0
1 Set Ready Radio Connecting Links	2	6	0
3 Valves, as specified	1	13	6
5 Lewcos Coils (2 No. 50) (1 No. 60X), (1 No. 100), (1 No. 250X)	1	2	9
* 1 Set Atlas Short-wave Coils	12	0	0
Screws, Plugs, Flex, etc.	1	5	0
TOTAL (INCLUDING VALVES, etc.)	£9	19	6

Any of the above components can be supplied separately if desired.

- KIT A** less valves and cabinet **£6:16:0**
- KIT B** with valves less cabinet **£8:9:6**
- KIT C** with valves and cabinet **£9:19:6**

REGIONAL FOUR

- KIT A** less valves and cabinet **£8:2:0**
- KIT B** with valves less cabinet **£10:18:0**
- KIT C** with valves and cabinet **£12:10:0**

Full list of approved components can be had on application.

REGIONAL TWO

- KIT A** less valves and cabinet **£4:12:6**
- KIT B** with valves less cabinet **£5:15:6**
- KIT C** with valves and cabinet **£6:18:0**

Full list of approved components can be had on application.

ALL READY RADIO KITS are approved by "Popular Wireless," and contain the official Blue Print and special connecting links which eliminate all soldering.

READY FOR IMMEDIATE DESPATCH

Ready Radio

159, BOROUGH HIGH STREET, LONDON BRIDGE, LONDON, S.E.1

Telephone: HOP 5555.

STOP INTERFERING!

IT is very easy to separate interfering programmes by fitting a Watmel Wave Trap between your aerial and the set. It does not matter what length your aerial is, this Wave Trap will sharpen tuning and make reception clearer and more powerful. It is so reasonable in price that to try and make a similar piece of apparatus yourself you would have to spend more money and waste a considerable amount of time.



8'6

**THE WATMEL
WAVE TRAP**

WATMEL WIRELESS CO., LTD.,
Imperial Works, High St., Edgware
Edgware 0323.

M.C. 3.

The **BALANCED ARMATURE UNIT**

Genuine four - pole unit. Highly sensitive. Perfect reproduction of both high and low frequencies. Will handle large volume without overloading, and is particularly suitable for operating linen diaphragm speakers as well as cones.

Price . . .

18'6

The **DOUBLE RANGE TUNER**

Does away with all coil-changing. Highly selective and can be incorporated in any receiver. Complete with wave-change push-pull switch.

Price ..

12'6

Send for our Folder No. B.90 showing you how to make up a fine loud speaker; also Folder and Blue Print for building a modern 3-valve Set.

Build the "Modern Wireless" "KUTTEMOUT" CRYSTAL SET

An up-to-the-minute design incorporating an automatic wave-change rejector, making the set ideal for use with the new "Twin" stations. In addition to the above, the MARCH MODERN WIRELESS contains full constructional details of

The "FORTE-FORTY" FOUR

A powerful household loud-speaker set.

The "REJECTOR" TWO

A simple selective set for the new "Regional" conditions, and

The "M.W." DOUBLE REJECTOR

This remarkable little gadget enables you to cut out either or *both* of two local programmes, leaving the ether clear for the reception of more distant transmissions.

All "M.W." sets are Thoroughly Tested and are Guaranteed.

Don't Miss Your Copy of the March

MODERN WIRELESS

Price 1'.

NOW ON SALE

Price 1'.

The LOTUS All Mains Unit



converts an
Osram
"MUSIC MAGNET"
to an
ALL-ELECTRIC SET
with minimum trouble
and maximum effect

In less than five minutes, by using the Lotus All-Mains Unit, you can turn your Music Magnet Receiver into All-Electric.

Make this change and effect a saving of nearly £4 a year, by dispensing with batteries.

Cash Price £7 : 7 : 0 (or 14/6 down and 11 similar monthly payments).

Send for full particulars.

Made in one of the most modern radio factories in Great Britain.

GARNETT, WHITELEY & Co.,
Limited,
Lotus Works, Mill Lane, Liverpool.

Causton

RADIOTORIAL QUESTIONS AND ANSWERS

(Continued from page 1296.)

"Not wishing to buy a new coil-I removed it as carefully as possible, but lost count of the turns. I am enclosing a length for you to tell me what size it is and how many turns to put on. The winding was between pins Nos. 1 and 2."

The wire is single silk-covered No. 40. You require 300 turns on the standard former connected across pins 1 and 2.

CONTROL OF LOUD-SPEAKER VOLUME.

Arising out of the query submitted by S. H. M. (and published in 'P.W.' No. 398, dated January 18th), the following hint has been received from a kindly-disposed reader of "P.W." who apparently solved the same problem in a completely satisfactory manner.

"If S. H. M. does not wish to alter his set in any way I suggest he tries using the 'P.W.' Station Selector, which was described in

WHAT DO YOU THINK ABOUT THIS?

A Dundee reader who built a "P.W." crystal set got complete satisfaction from it for over a year, but then wrote to complain that sudden "fading and distortion" appeared and disappeared.

Sometimes the set kept O.K. for days together, but then it would suddenly get weak—even in the middle of a programme. And even when the person wearing the 'phones was sitting perfectly still!

Different 'phones and a different crystal failed to cure it: Aerial, earth and connections were all O.K.

WHERE WAS THE FAULT?

N.B.—There is no prize for answering this, but from time to time we shall give a radio problem (followed the next week by the answer) in the hope that readers will find them both interesting and instructive. (Look out for the answer to above next week.)

The Hendon reader's set—described last week—which went wrong suddenly though the batteries were fresh, was found to be suffering from a careless service-man, who had joined its neg. to the positive terminal, and vice versa.

'P.W.' April 27th, 1929. The coils to use in this are 250 for long waves and 60 for the broadcast band.

"When used with the 'Titan' Three I connect it to aerial 2. The reaction can be set at zero and the station selector will act as a volume control, ranging from a whisper to almost blowing the listener out of the room."

DETAILS FOR THE "MAGIC III."

"MAGIC" (Ipswich).—"Since hearing the 'Magic' and reports upon it I am keen on building it, but I am up against difficulties. At first they were, I must admit, mostly financial, but even when I had gathered the shakels together I found my troubles were not over, because the description of it had gone out of print. Can you put me wise as to where I can get full constructional details?"

Your letter was dated 26th Feb., 1930; and the very next day the "March 1st" issue of P.W. was on sale, and contained a free blueprint giving all the necessary details. We hope you didn't miss it this time!

A QUESTION OF WIRING.

H. C. S. (Sheffield).—"When you gave the details of the original "Magic" Three you said it brought the whole wide world to your fireside.

(Continued on page 1300.)

THE STAR OF ALL UNITS

36/-
From your Dealer
or direct.

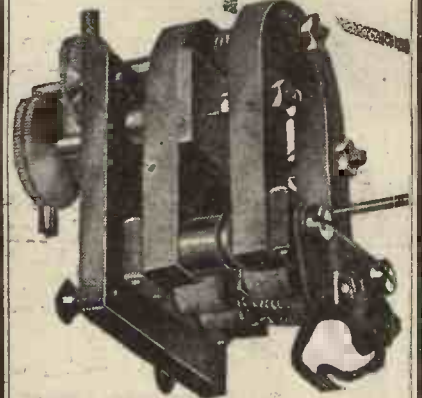

MAGNIFICENT TONAL BEAUTY.

If you are in search of all that is best in reproduction, then you need the Wates Star Unit. This wonderful unit is the heart and soul of the famous Wates Star Speaker. In conjunction with the Wates Double Cone Chassis you can build up a speaker that will give you unequalled quality and superb emission at every point of the musical scale. Exclusive principles of construction. 12 poles, double magnets, 4 coils.



WATES STAR LOUD SPEAKER UNIT

WATES
DOUBLE CONE
CHASSIS
Pat. No. 309214
as above.

12/-

WATES STAR
LOUDSPEAK'R
IN CABINETS.
Oak £4 0 0
Mahog. £4 6 0

Telephone:
Temple Bar 6195.

THE SHAFESBURY RADIO CO. (Dept. P.W.),
184-188, Shaftesbury Avenue, London, W.C.2. [M.2.]



KAY'S CABINETS

This Cabinet soundly constructed of Oak and equipped with Baseboard Runners. Full Front, Hinged Top. Polished rich Jacobean. 36" 45/- high. For panels up to 18" wide. Also made to accommodate any Popular Set. Greatest Range of Wireless Cabinets. Illustrated Lists Free.

H. KAY, Cabinet Manufacturer,
Mount Pleasant Road, London, N.17
'Phone: WALTHAMSTOW 1626.



WET H.T. BATTERIES

Solve all H.T. Troubles.

SELF-CHARGING, SILENT, ECONOMICAL
JARS (waxed), 2 1/2" x 1 1/2" sq. 1/3 doz.
ZINCS, new type 10d. doz. Sacs 1/2 doz.
Sample doz. (18 volts), complete with
bands and electrolyte, 4/1, post 9d.
Sample unit, 6d. illus. booklet free.
Bargain list free.

AMPLIFIERS, 30/- 3-VALVE SET, 25/-
P. TAYLOR, 57, Studley Road,
STOCKWELL, LONDON.

Make
THE DAILY SKETCH
YOUR Picture Paper.

TWO NEW BOOKS for the HOME CONSTRUCTOR

Sets for Every Purpose and Every Pocket

6^{d.}



Contains complete constructional details for the following inexpensive and easy-to-build receivers. All have passed the most exacting tests before being published.

A ONE-VALVER

Of novel construction, using a home-made cabinet, and plug-in coils. Covers ordinary and long waves.

A TWO-VALVE ALL-WAVE-LENGTH SET (Det. and L.F.)

Capable of loud-speaker results under good condition on both short and long waves. Uses standard parts and plug-in coils. Easy to operate.

THREE-VALVE RADIOGRAM RECEIVER

Circuit is Det. and 2 L.F. Very selective and gives high quality reproduction either of radio or of gramophone records.

FOUR-VALVE "POUND-PER-STAGE" SET

Costing about £4. Uses home-made coils. Circuit employed being H.F., Det., and 2 L.F. Highly selective.

All these sets are for MODERN CONDITIONS, and will enable constructors to take full advantage of the dual programmes under the Regional Scheme.

A SUPER-SELECTIVE ONE-VALVE SET

For ordinary and long waves. Easy wave-change and very simple operation. Includes the famous "Brookmans Rejector" to cut out interference.

A TWO-VALVER (Det. and L.F.)

An UP-TO-DATE THREE-VALVER

Using S.G., Det. and Pentode. Highly selective; employs plug-in coils and has volume control and switch for the reproduction of radio or of gramophone records.

An ALL-FROM-THE-MAINS "FOUR"

A powerful set for A.C. mains, which comprises H.F., Det., and 2 L.F. stages with the special new A.C. Valves. Covers long and ordinary waves, and is very easy to operate.



6^{d.} each from all Newsagents and Booksellers everywhere, or 7d. post free (Home or Abroad), from "Best Way," 291a, Oxford Street, London, W.1.

DARIO

VALVES

Best Way to All Stations!

NEWEST TYPES

SCREENODION

Enormous Range

BIVOLT ·15 amps.
FORVOLT ·075 amps.

15'6

SUPERBLY SELECTIVE

The best Screen Grid in the world.

SUPER HF

BIVOLT ·15 amps.
FORVOLT ·075 amps.

5'6

Also the New Super DETECTOR (2 or 4 v.) 6'6

HYPERPOWER

BIVOLT ·3 amps.
FORVOLT ·15 amps.

9'6

Designed to carry enormous volume by reason of an exceptionally large grid swing.

UNIVERSAL RESISTRON

SUPER POWER and the Super Power PENTODION

5'6 7'6 18'6

DARIO L.F. TRANSFORMER

A little marvel. Guaranteed for two years. Completely shrouded. Perfectly designed and perfectly made.

5'

5-1 or 3-1.

Write for Free Folder to:

IMPEX ELECTRICAL LTD.,
Dept. B, 538, High Rd., Leytonstone,
London, E.11.

RADIOTORIAL QUESTIONS AND ANSWERS

(Continued from page 1298.)

That's what I want, but at the moment it has brought quite a large spot of perplexity to my fireside!

"This being my first home-made set, I have wired it up very slowly and painstakingly, with much checking, and although the blue print is clear enough, with regard to the connections to the differential condenser, when I check these by the photographs they do not seem to be quite the same.

"Is the blue print O.K., and if so, how do we get four leads shown in the photographs, going to the differential condenser instead of three, as shown on the blue print?"

Connect up exactly as shown in the blue print which is correct in every detail. As you have probably noticed, it often happens that one point in any given set (such as for instance the earth terminal), is connected to half-a-dozen other points. If it now becomes necessary to join one of the differential connections to earth also, the lead may be taken either to the earth terminal itself, or to any of the components to which it is directly connected by a wire.

Just exactly which is the best place for it to run depends upon the layout of the set, components used and various other factors, and it often happens that a lead may be tried in two or three places to see which gives the best results.

Thus, a photograph taken at one stage of the construction might differ slightly from a photograph taken at another stage, and yet, fundamentally, the connections would be the same in both instances.

CONDENSERS JOINED IN SERIES.

T. E. P. (Shrewsbury).—"Not long ago in 'P.W.' you gave figures for calculating the capacity of condensers when they are joined

"SORRY YOU'VE BEEN TROUBLED"

by interference from your local station, but you can solve your problem in one go with **The 5/- BROOKMANS REJECTOR**

Fully described in next week's "Popular Wireless" With **ONE KNOB CONTROL** and **HOME-MADE COIL** nothing could be simpler to build than this **MARVELOUS LITTLE ETHER CLEARER**, which, by the turn of a knob,

WIPES YOUR INTERFERING STATION RIGHT OFF THE DIAL.

You will be astounded by the results.

GET RID OF THAT INTERFERENCE! SEE NEXT WEEK'S "P.W." Out on Thursday. Price 3d.

in series. I found this very useful, especially when it can be applied simply, as in the case of, say, two '001 condensers which when placed in series give a capacity of '0005 mfd., which is equal to the half of one of the condensers.

"Even for different capacities, when the values are all alike, the capacity of two in series appears to be half the capacity of one of the condensers, i.e.—the capacity of two 2-mfd. condensers is 1 mfd. when in series, and the capacity of two 4-mfd. is 2 mfd. when in series.

"Does this rule hold good for THREE condensers in series, or for any number more than three, as well as for two?"

Yes. The very simple rule of dividing the capacity of one of the condensers by the total number of condensers joined in series holds good providing that all the capacities are exactly the same.

For instance, suppose you are dealing with a group of fixed condensers all having a capacity of 10 mfd. If there are five of them and you join them in series the resultant capacity will be five into ten = 2 mfd.

Similarly, if you have four condensers, all of '001 mfd., and you join them all in series, the total effective capacity will be '001 divided by 4 = '00025 mfd.; but note that this very simple method of finding capacity can only be applied where all the condensers have identical values. If the values are different you can find the total effective value by the rule recently quoted in "P.W."

"Layerbilt"

-every inch a battery!



Every inch of the "Layerbilt" Battery is a store of electricity. The Columbia patented process of layering layer upon layer of flat cells gives "Layerbilt" 1 1/2 times the electrical capacity of any other battery of equal size and weight. The increase in its life is even greater. "Layerbilt" is the best and most economical battery in the world.

Buy "Layerbilt" now — don't risk spoiling your programmes with exhausted batteries.

25/-

"Layerbilt" No. 4486 for 18 m/a. 25/- No. 4780, 60 volts, 20/- No. 4721, 60 volts, 10/6 No. 4755, 90 volts, 18/-

Columbia

RADIO BATTERIES

J. R. MORRIS, Imperial House,
15, Kingsway, London, W.C.2.
Scotland: J. T. Cartwright, 3, Cadogan St., Glasgow.

1930 EDITION

THE WIRELESS MANUAL

By CAPTAIN JACK FROST.

The popular, practical and non-technical guide to choice of set, and installation, use and maintenance of set. It is written to enable the listener-in to understand the main principles of Wireless, and to learn how to secure perfect reception.

Fully revised. **5/-** net. Illustrated.

Of a Bookseller, or
SIR ISAAC PITMAN & SONS, LTD.,
Parker St., Kingsway, London, W.C.2.

AGENTS WANTED to sell Wireless goods, all makes in sets, components and accessories. Cash or Easy terms. Liberal commission. **NEW AUTO SUPPLY CO.,** 241, Park Rd., ASTON, Birmingham.

BASEBOARDS

5-ply Birch Baseboards. Size 17 ins. x 9 ins. x 1/2 in. Packed 110 pieces in a bundle, price 25/- bundle. Carr. forward. Cash with order. Despatch by return.

UNICA CABINET CO.,
73, Camden Street, London, N.W.1.



EELEX

MOISTURE RETAINING EARTH BOWL

Supplied with 9 ft. rubber-covered lead connector price 5/6 each.

Write for List T94.
J. J. EASTICK & SONS,
Eelox House, 113, Bunhill Row, LONDON, E.C.1.

PLEASE MENTION "POPULAR WIRELESS" WHEN REPLYING TO ADVERTISEMENTS.

FOR THE LISTENER.

(Continued from page 1280.)

wreath." So, like a pendulum, I swung between Time and Eternity!

The Murder of Molière.

There are some plays which it is a sin to touch. "Le médecin malgré lui" is one of them. Henry Fielding's adaptation is bad enough, but an adaptation of an adaptation is bound to be so patchy and bloodless an affair that I was astonished to find it in the programmes. It was a failure, as (I think) it deserved to be. Most of the wit, and all the savour, of the original had gone. Why waste time over these stunts?

From the West.

I hope you didn't miss the Orpheus Society broadcasting from Gloucester the other night. This is one of the most famous of male voice choirs in the west country. The singing of glees and part-songs by a choir so wonderfully balanced and so finely trained comes about as near to perfect pleasure as the wireless is ever likely to bring us.

A Scientific Point of View.

The whole level of the present "Points of View" series was lifted by the remarkably candid address given by Sir James Jeans. It served, as it seemed to me, precisely the purpose for which such a series should exist. It was temperate, critical, and provocative.

Nobody switched off without a subsued kind of feeling that something important had been said to him, something that he must bear in mind in forming his opinion of the movements, ideas and ideals of to-day.

His courageous expression of doubt as to the future of democracy, and of our present social morality, may not command conviction, but should command attention; and the nobility of his belief, if only a tentative one, that "the universe is nearer to a great thought than to a great machine" was very impressive.

New and Old.

It was an interesting idea to give us a set of old musical comedy songs alternating with modern songs of a similar type, so that we might judge between them. It seemed to me to be the same dish, but a different cook. The difference between one cook and another is largely a matter of sauces.

The same ingredients were in the old "Moonstruck" as in the modern "Crazy Rhythm," but a different sauce. On the whole, the modern palate seems to like the sauces hotter, and so American cooks are in demand. But our own "cordon bleu," Noel Coward, knows how to mix them subtly.

The Man in the Street.

You don't like Epstein's "Day" and "Night" on the station building at St. James's Park. You don't quite know why, but there it is! Mr. Stanley Casson, whose talks on sculpture are well worth listening to, agrees with you, and gives artistic reasons.

The reasons are debatable; but your instinct, which Mr. Casson would trust as against all the experts in the world, is not to be reasoned with. But, of course, the tar-and-feather business is, he thinks, a fool's game.

★ STILL LEADS!



Patent No. 322,558.

The Wates "3-in-1" meter is recognised by experts and listeners as the first choice for accuracy, reliability and usefulness.

No other meter can equal its wonderful performance, and it stands supreme as the original "3-in-1" meter.

Gives the three essential readings to accurate set handling, all on one clearly calibrated dial. Any expert will confirm it! Ask your dealer. Fully descriptive literature free on request.

READINGS:
0-150 VOLTS.
0-6 VOLTS.
0-30 MILLIAMPS.
Res. 5,000 Ohms.

WATES
"three in one"
VOLT-AMP
RADIO TEST METER

PRICE
8'6
Standard Model.

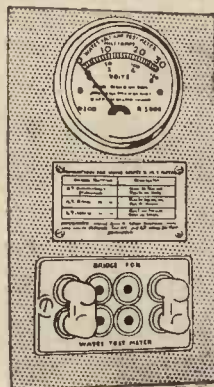

AND—a panel model too!

Supplied complete with instructions for fixing to panel. Readings on three scales obtained by varying position of plugs, in coloured sockets.

METER CASE. For standard model. Satinette lined base and lid. Crystallised black finish, substantial fittings, 2/6.

MILLIAMMETERS
0-25 or 0-50
M.A. with jewelled bearings.
9/6.

13'9



M.B.



WILL THERE BE MUSIC ?

To-night there will be music. To-night there may not be music for you unless your condensers are Hydra—the condenser that never fails.

HYDRA CONDENSERS

LOUIS HOLZMAN,
37, NEWMAN STREET LONDON, W.1.
Telephone : Museum 2641.

SUPER-MICROPHONES

New, highly sensitive made on the latest principle a vast improvement over all other types; will pick up whispered words from a distance of several yards, also strongly amplify and transmit speech and music over a distance, through Loud-speaker or Headphones. Splendid instruments for making Detectaphone, DEAF AID LOUD-SPEAKING TELEPHONE, Announcements through Loud-speaker, Amplifier for Crystal or Valve Sets. Electric Sound Detector, BABY ALARM or INVALID CALL from bedroom through distant Loud-speaker Experiments, etc. NO OTHER MICROPHONE OF EQUAL SENSITIVENESS KNOWN; each instrument finely black enamelled and fitted with a 3ft. return post silk flexible connecting cord. Despatched with 8/6

SPECIAL MICROPHONE TRANSFORMER for connecting Super-Microphone to Radio Headphones Loud-speaker, Valve Set, or Valve Amplifier 6/-

SMALL 10 OHMS EARPIECE for use with Super-Microphone as a HIGHLY EFFICIENT DEAF AID, or Detectaphone, etc.; 3ft. thin silk connecting cord fitted Earpiece Fine Black Enamelled 6/-

Full directions for use of Super-Microphone for many purposes and Diagrams of connections free.

FREDK. ADOLPH, Actual Maker, Phone: Museum 8229
27, Fitzroy Street, London, W.1.

EASY PAYMENTS

The first firm to supply Wireless Parts on easy payments. Five years advertiser in "Popular Wireless." Thousands of satisfied customers. Send us a list of the parts you require, and the payments that will suit your convenience and we will send you a definite quotation. Anything wireless.
H. W. HOLMES, 29, FOLEY STREET, Phone: Museum 1414. Gt. Portland St., W.1

GRIPSO
PATENT NAMED PLUGS & SPADES
LISTS FROM MAKERS
THE GRIPSO COY.
32 VICTORIA ST. LONDON, S.W.1

2nd EACH
CRID—
WITHOUT NAME
1/2 EACH

PLEASE MENTION "POPULAR WIRELESS" WHEN REPLYING TO ADVERTISEMENTS.

By Dr. J. H. T. ROBERTS, F. Inst. P.

TECHNICAL NOTES.

How a Crystal Rectifies.

I SUPPOSE there are still quite a large number of listeners who use crystal sets owing to their cheapness in first cost and upkeep.

In the current Proceedings of the Edinburgh and District Radio Society is an account of an excellent lecture on crystal reception from various points of view, together with some attempt at a theory of the rectifying action of crystals in general.

The essential difference in crystal and valve reception is this. In the case of valve reception the energy which is emitted as sound from the telephones or loud speaker comes from a local source, namely the batteries (or their equivalent) of the valve receiver; the function of the electromotive forces picked up by the aerial is mainly the control of this supply of energy from these local sources and, within reasonable limits, this local supply of energy may be made as large as is required for any given purpose.

In the case of crystal reception, on the other hand, the whole of the energy available for conversion into sound has to be drawn from the ether by means of the aerial, and there is no way of adding to this energy by means of any local supply.

This means that with crystal reception, the aerial system and tuning arrangements must be as efficient as possible if the best results are to be obtained.

Most of the crystals at present on the market are composed of artificial galena and are prepared by the fusion and crystallisation of lead sulphide with the addition, sometimes, of small quantities of other compounds such as silver sulphide.

Crystalline Structure.

Substances with rectifying properties appear to occupy an intermediate place between good conductors and good insulators. The rectification takes place at the point of contact, and in the case of a comparatively low resistance rectifier like galena this contact must be light; if there is too great a pressure, simple conduction results.

So far as I am aware, no completely satisfactory theory of crystal rectification has been put forward. My own opinion has always been that the rectifying action is a thermo-electric one, heat being generated at the very small point of contact and so setting up thermo-E.M.F. which assists currents tending to pass in one direction, and resists those tending to pass in the opposite direction.

It is true that the voltage generated by a single thermo-electric junction of this kind is comparatively small but, at the same time, the applied alternating voltages with which it has to deal are also very small. It is very significant that those substances (such as galena) which are good wireless detectors are also substances which exhibit thermo-electric effects very strongly.

Most of such substances are of a crystalline or similar structure, and the rectifying

(Continued on next page.)

RD 40

"RED DIAMOND"

2/-

THE RECOGNISED DETECTOR FOR ALL CIRCUITS USING CRYSTAL RECTIFICATION. By insured Post 2/3 or 2/9 with shield. Can be mounted on brackets or through panel. Once set always ready. Not affected by vibration. Each one is tested on broadcast before despatch and is perfect. TRADE MARK

"RED DIAMOND" 2-WAY COIL HOLDER RD 32

4/-

EACH

Parallel working. Fine adjustment. Worm-driven. Coils cannot fall. Easy movement. Perfect finish. By Insured Post 4/6.

Of all high class Radio Dealers, or Sale Makers:

JEWEL PEN CO., LTD.
(Radio Dept. 46).
21-22, Great Sutton St., LONDON, E.C.1

SOVEREIGN WAVE TRAP

PRODUCED by the Specialists in Selectivity. Exactly as advocated by the daily press. Consists of an improved coil with terminal connections, Bakelized former, silk-covered wire, and a "Sovereign" Type J Compression-Type Condenser. Sold complete with straightforward diagram and wiring plan. From all Radio shops. If your dealer cannot supply "Sovereign" parts, do not accept substitutes. "SOVEREIGN" ARE "ALWAYS BETTER."

4/-

The "Sovereign" Compression-Type Condenser is made in three capacities. Type P1. .0001 mfd. Type G2. .001 mfd. Type J5. .0003 mfd. Price 2/-. From all dealers.

SOVEREIGN

Produced by J.R. WIRELESS CO.
6-8, Rosebery Avenue, London, E.C.1

PATENTS, TRADE MARKS.
Inventions Advice Handbook and Consultations FREE.—B. T. KING, C.I.M.E., Regd. Patent Office (G.B., U.S. and Canada), 146a, Queen Victoria Street, London, E.C.4. 43 years' references. Phone: Cent. 0682.

EASY TERMS

We SPECIALISE in the supply of all Good Quality Radio Sets, Components and accessories on Easy Terms. We will give you efficient service. Send us your list of requirements and a quotation will be sent by return.

LONDON RADIO SUPPLY COMPANY
11, Oat Lane, Noble St., London, E.C.2
NATIONAL 1077.

THE PICTURE PAPER WITH THE MOST NEWS

SUNDAY GRAPHIC

"KLEER-KUT" COILS

PUT FORM INTO PERFORMANCE

25. 30. 35. 1/-, 40. 50. 1/2, 60. 75. 1/3, 100. 125. 150. 1/6, 175. 1/9, 200. 2/-, 250. 2/3, 300. 2/6. Centre Tapped 6d. "X" Coils 1/- extra.

L. BRUCE, 99, King Henry's Rd., LONDON, N.W.3
6 years coil maker to the Wireless Trade.
Phone: Primrose 1303. Trade supplied.

PLEASE MENTION "POPULAR WIRELESS" WHEN REPLYING TO ADVERTISEMENTS.

TECHNICAL NOTES.

(Continued from previous page.)

action appears to be definitely associated with the internal structure. So far as I am aware, these substances invariably lose their rectifying and also their thermoelectric properties if the structure is destroyed, as, for example, if a crystal is ground up into a fine powder.

Concerning Indoor Aerials.

Amongst the various points raised by readers in letters during the past few days is one with regard to the best form for an indoor aerial. Another reader asks for information with regard to counterpoise aerials, so I will deal with these two matters together.

The form of the indoor aerial is generally determined by considerations of convenience, rather than of efficiency. You know, of course, that an indoor aerial is, in any case, much less efficient as a pick-up of broadcast energy than the usual outdoor aerial, and it can only be efficient with certain types of sets.

At the same time, provided the set is of the proper type, the indoor aerial has the advantage of being practically invisible, and, not being exposed to weather conditions, it requires practically no maintenance.

Multiple Wires.

Several correspondents have asked at different times whether it is worth while to have a series of parallel wires stretched across the room, the down-leads being taken from the ends of the various wires.

In general, I would not recommend this arrangement, as obviously it is very disfiguring to a room of a dwelling-house to have wires stretched across, and the advantage in the way of efficiency does not make up for this disadvantage.

For general purposes it is quite satisfactory to have a length of insulated wire, preferably insulated with rubber, stretched round two or three walls of the room, a convenient way being to lay it along the picture-rail, if there is one.

Counterpoise Aerials.

Now with regard to counterpoise aerials, these seem to have a certain fascination for some wireless experimenters who often complain that they are getting unsatisfactory results "owing to an inefficient earth," and who want to know whether they might not get much better results by using a counterpoise.

Now the counterpoise is not nearly the wonderful thing that many people seem to think. It is, in the first place, quite an elaborate affair to fit up, if done properly. Moreover, it is only in exceptional cases that a counterpoise can be used, owing to the fact that it must be placed fairly low down near the ground, and generally will cause interference and obstruction.

Even these disadvantages might not seem very serious to some of you if the efficiency of the counterpoise were much better than that of an earth connection.

Comparison with Earth.

The fact is, however, that in all ordinary cases a counterpoise is not to be compared with a good earth for efficiency, for when,

(Continued on next page.)



BULGIN

BRITISH MADE

The
choice
of
critics

QUALITY, VALUE & SERVICE



Three reasons why Bulgin components have won first place in the estimation of wireless constructors since Broadcasting first commenced. Use wherever possible in

THIS YEAR'S "MAGIC" THREE.
THE "REGIONAL" FOUR.
THIS YEAR'S "TITAN" THREE.
THE "REGIONAL" TWO.

BULGIN GUARANTEED PRODUCTS

De Luxe "On" and "Off" Switch	Price
(List No. S22)	1/6
Baseboard Neutralising Condenser	
(List No. N7)	4/9
Standard High Frequency Choke (No. HF2)	5/6
Three-Spring Wave-Change Switch	
(List No. S39)	1/3
Bakelite Spring Grip Grid Leak Holder	9d.
Single Type Fuseholder (List No. F5)	9d.



Ample stocks are always available, and should be obtainable from any dealer. In case of difficulty or substitution write direct.

SEND 2d. STAMPS for our 56-PAGE CATALOGUE

A. F. BULGIN & CO., 8, 10, 11, CURSITOR STREET, CHANCERY LANE, LONDON, E.C.4.
— Radio Manufacturers — Telephone: Holborn 1072 and 2072.



The CLEVEREST

way to house YOUR SET! Speaker and Batteries.

NOTE.—Improved Baffle and sound chamber as used in "B.F.S.," "All-Electric Two," etc.

For ALL Sets or Radio-Gram

The sort that people desire to possess and keep. Graceful design—sound construction—hand french-polished (plano finish), snug, compact, adding to the life of your set.

Over 3,000 delighted clients.
(Used by Radio Press—by W. James, Percy Harris, etc.)

For your OWN set!

"Radiola" de luxe, from £5 5 0 to £11 11 0
"Popular" Oak Model, from £3 15 0

Cash or easy payments.

Sent ON APPROVAL—direct from the makers. If you wish to part with it we will willingly refund FULL MONEY.

Photographs and full particulars FREE!

PICKETT'S, RADIO FURNITURE MAKERS,
"P.W." WORKS, BEXLEY HEATH, KENT
Established since the beginning of Broadcasting.

GRAMOPHONES. Latest Horns and parts. Catalogue free. Cash or terms. Build £12 model for £3. Instructions 3d. V. BURT, 185, High St., London, S.E.8.

RELIABILITY

WIRELESS GUIDE No 296

A Complete List of all that is best in Radio at Keenest Prices. Trade Enquiries Invited.

J. H. TAYLOR & CO
4 Radio House, MACAULAY STREET, HUDDERSFIELD. Phone 341.



POST FREE ON REQUEST

PLEASE MENTION "POPULAR WIRELESS" WHEN REPLYING TO ADVERTISEMENTS.



"JOURNEY'S END" as a Novel

"Journey's End" as a play has been acclaimed in all countries as the finest story of our generation.

"Journey's End" as a book is appearing in ANSWERS for the first time in any paper!

Here is the story you must not miss. Written by R. C. Sherriff and Vernon Bartlett, it tells you the truth about the War with a ruthless sincerity and realism which will hold you spellbound.

Begin reading it TO-DAY in

ANSWERS

Buy YOUR Copy NOW - - 2d.

ELECTRADIX SEASON BARGAINS

Of Broadcast Receivers and Speakers at a fraction of cost: These sacrifice prices cannot be repeated when stock is sold.

One-valve Sterling, steel-clad units, 139/153, 15/-, Marconiphone 1 valve, and Detector, RB10, with valve, 15/-, 1 Valve TMC, 17/6, Valve, 3/6.

Two-Valve, Ditto, RB10 H.F. and L.F., enclosed in leatherette-covered Cabinet, 30/-, Ditto Ediswan, 2 L.F., 30/-, Valves, 3/6 ea.

Three-valve Efesca, H.F., Det. and L.F. 200/4,000 metres, 40/-, fine Vertical Set, brand-new.

Three-Valve R.A.F. Aircraft, in portable case, 27/6, Valves, 3/6 ea.

Three-valve Sterling, Desk type, 40/-.

Three-valve Fellows, Table set 40/-.

Four-Valve Polar, H.F., Det. and 2 L.F., vertical polished Mahogany, 70/-, Four-valve Fellows Giant Table Set, oak case, 70/-, Five-valve R.A.F. 10, with Valves, oak American type Cabinet, 80/-, Aircraft model, with valves, 60/-, Ditto, without remote control, 40/-, R.A.F. 7v. Receiver-Amplifier, 60/-, Marconi No. 55 7-valve H.F. screened No. 39, 60/-.

Power Amplifiers, for gramo-motors and Western Electric 2-valve, mahogany case, 45/-, Sterling ditto, 45/-, W.D. M.K. IV., 40/-, Sterling 1-valve 15/-, Panatone, for D.C. mains, 65/-.

Send addressed envelope for our Sale List of Electrical bargains.

ELECTRADIX RADIOS,
218, Upper Thames Street, E.C.4
Blackfriars Stn. Underground Rly. City O191



**BIG
PACKET
OF
LOVE-IN-A-MIST
SEEDS
FREE**

in this week's

**POPULAR
GARDENING**

Buy Your Copy NOW - - 2d.

TECHNICAL NOTES.

(Continued from previous page.)

using an earth connection you are, in fact, bringing into action the best of all possible counterpoise aeriels, namely, the earth itself.

I know it is true that in some cases a good earth connection cannot be obtained, but I doubt very much whether, even in such cases, a comparatively inefficient earth is not, in fact, superior to the best counterpoise that the average amateur can provide for himself.

It is sometimes pointed out to me by readers that counterpoise aeriels are occasionally employed in large transmitting stations. Whilst this is true, it really has little or no bearing on the question of amateur receiving aeriels, since considerations enter into the question of transmitting aeriels and transmitting circuits altogether different from those which apply in the case of the broadcast receiver.

Theory of Action.

Before leaving this subject, and in case any of you may not be familiar with the theory of the counterpoise aerial, perhaps I should say that it is in principle simply a second or duplicate aerial which is placed near the ground, instead of being placed high up, and which acts partly as a capacity

ARE YOU BEING SWAMPED?

Wipe that interfering local right off the dial with

The 5/- BROOKMANS REJECTOR

No Power Lost. Easy to Make.

Doesn't Alter Tuning. Only One Knob.

CAN BE FITTED TO ANY SET

and, moreover,

IT WORKS!

Full details in "Popular Wireless" Next Week.

so that oscillations are set up between the upper aerial and the lower or counterpoise aerial.

The receiver, being inserted into the down-lead or connection between the two, is able to take advantage of the oscillations between them. It will generally be found preferable to arrange the counterpoise aerial vertically below the aerial proper.

Condenser Losses.

Another query which often turns up relates to the relative advantages of mica and paper condensers for use in various parts of the receiver.

Speaking very briefly, the advantages of mica over paper are, first, its very much higher resistance to electrical rupture or breakdown (that is, it will stand a very much higher voltage between its opposite surfaces for a given thickness), and secondly, its comparatively low figure for dielectric loss.

On the other hand, mica is very much more expensive than paper insulation, particularly when it comes to sheets of more than an inch or two square.

The result of this is that, for fixed condensers of comparatively small capacity, and where it is very important to avoid dielectric losses, mica condensers should be used.

ENGINEERS! Can't we get together?



THE FIRST STEP WHICH HAS LED THOUSANDS TO SUCCESS

**WRITE FOR THIS
BOOK TO-DAY
IT'S FREE!**

All we ask is the chance to prove that you can earn £300, £400, £500 per year or more. Other men are doing it, and you can do the same.

We have an unrivalled and world-wide organization waiting to help you whether you be novice or expert. If you wish for something more than a "bread and butter" job you owe it to yourself to investigate our Service.

Our handbook "Engineering Opportunities" has pointed the way to better things to over 20,000 of your fellows. It contains details of A.M.I.Mech.E., A.M.I.E.E., A.M.I.C.E., A.M.I.A.E., A.M.I. Struct.E., London Metric, C. & G., G.P.O., etc., Exams., outlines home study courses in all branches of Electrical, Mechanical, Motor and Wireless Engineering, and explains our unique guarantee of

NO PASS—NO FEES

In a Brilliant foreword Prof. A. M. Low shows clearly the chances you are missing.

"Engineering Opportunities" and our advice are quite FREE. Don't neglect this offer—give vent to that "upward urge" and send a postcard NOW, stating Branch, Post or Exam. which interests you.

British Institute of Engineering Technology,
101, Shakespeare House, 29-31, Oxford Street, W. 1

HEADPHONES REPAIRED 4/-

Transformers 5/-, Loudspeakers 4/-. All repairs re-magnetised free. Tested, guaranteed and ready for delivery in 24 hours.

Discount for Trade. Clerkwell 9069.
E. MASON, 44, East Rd., City Rd., N. 1.

REPAIRS

Any make of L.F. Transformer, Loudspeaker or Headphones repaired and despatched within 48 HOURS—TWELVE MONTHS' GUARANTEE with each repair. 4/- post free.

Terms to Trade.

TRANSFORMER REPAIR CO.,

"Repairs" Dept.,

214, High Street, Colliers Wood, London, S.W. 19.

The Secret of its POWERFUL GRIP..

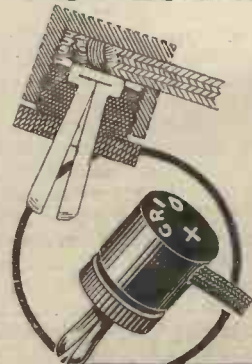

The Powerful grip of the Belling-Lee Wanders Plug and its adaptability to any size battery socket are due to the long prongs made of special spring metal 15 Engravings, side entry. Wire, rubber and braiding firmly gripped.

Price
4d.

Ask your dealer, or send to us, for FREE Belling-Lee Hand-book "Radio Connections."

BELLING-LEE
FOR EVERY RADIO CONNECTION

Adv. of Belling & Lee Ltd., Queensway Works,
Ponders End, Middlesex.

BETTER THAN A 2-VOLT PENTODE

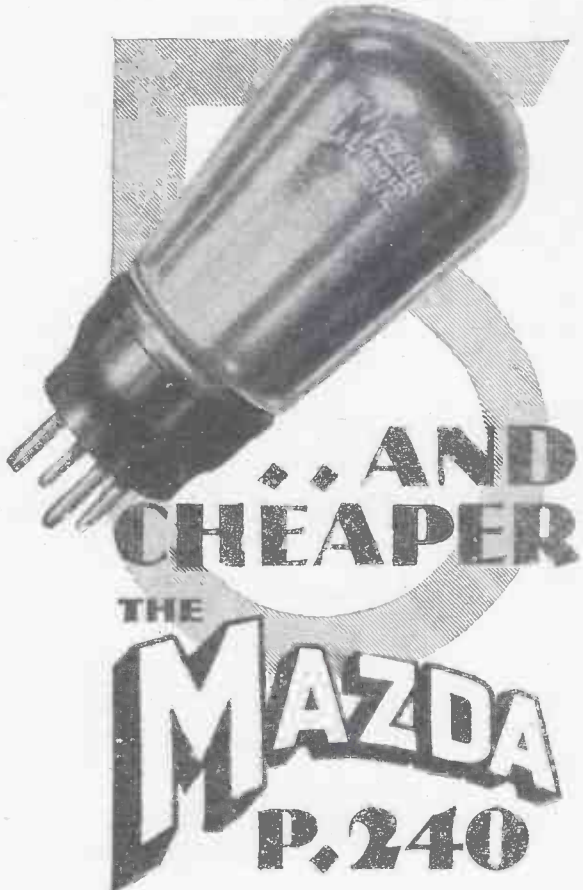

**... AND
CHEAPER**
THE
**MAZDA
P.240**

Here is a valve that will, by reason of its high amplification factor and very low impedance, give you a power output that is equal to that of a pentode while at the same time giving a far better reproduction of the bass notes.

The Mazda P.240 is more robust and more economical, too, the H.T. current being only about two-thirds of that consumed by a pentode, whilst its cost price is considerably lower.

**PRICE
15/-**

Write for Catalogue. Sold by all reputable dealers



THE EDISON SWAN ELECTRIC CO., LTD.,
Radio Division,
1a, Newman Street, Oxford Street, W.1.
Showrooms in all the Principal Towns.

EDISWAN

V.23



Clarke's
"ATLAS"
ALL-ELECTRIC
UNIT

Model
A.C. 86
for Alternating
Current

A NEW FEATURE IN ALL MAINS UNITS

CLARKE'S "ATLAS" ALL-ELECTRIC UNITS

OUR EASY PAYMENT SYSTEM

For a first payment of 10/- down either of these models is yours. The balance you pay in monthly easy instalments. No unnecessary questions or investigations are made, and you receive the model on making your first payment.

Without any alterations whatever to your present Set, providing you have Electric Light in the home, these new "ATLAS" Units will provide from the Mains all the H.T. and L.T. supply necessary for your Set, at a cost of a few pence per month.

H.T. Battery Eliminators and Trickle Chargers combined, these instruments incorporate the Westinghouse Patent Metal Rectifier, and give every facility for making your set in every way equal to an expensive ALL MAINS SET. Model A.C.86 (illustrated), for Alternating Current, provides 3 H.T. Tappings—one Fixed of 150 Volts and two variable of 100 Volts and 120 Volts respectively, and gives Output of 150 Volts at 30 m/A. On the Low Tension side facilities are provided for maintaining the charge of either 2, 4, or 6-Volt Accumulators.

Price 10/- down and nine monthly easy instalments, or

CASH PRICE, £8 15 0

MODEL A.C. 84

This is a cheaper Model suitable for any Set requiring up to 15 m/A Output, and provides two fixed H.T. Tappings of 90 and 120 Volts respectively, and one variable of 100 Volts. The Trickle Charger on this Model provides for maintaining the Charge of 2-Volt L.T. Accumulators only.

Price 10/- down and 6 monthly easy instalments, or

CASH PRICE, £6 17 6

Ask your Dealer for Folder No. 49, which gives full details of

"CLARKE'S ATLAS"

ALL MAINS UNITS

Ask your Dealer about them or **POST THIS COUPON TO-DAY** in unsealed stamped envelope.

Messrs. H. Clarke & Co. (M'er.), Ltd. (Dept. 3), Atlas Works, Old Trafford, Manchester.

Please forward Folder No. 49, along with particulars of your easy payment scheme.

NAME

ADDRESS

Please use **BLOCK LETTERS.** P.W.I

**YOU MAY NOT UNDERSTAND THEIR
LANGUAGE
BUT YOU CAN
ENJOY THEIR
MUSIC
FOR A CHANGE**

EVER READY IS
THE BATTERY for
all distances and wave
lengths.

They give beautifully
clear and pure recep-
tion from the Continent
or anywhere abroad.

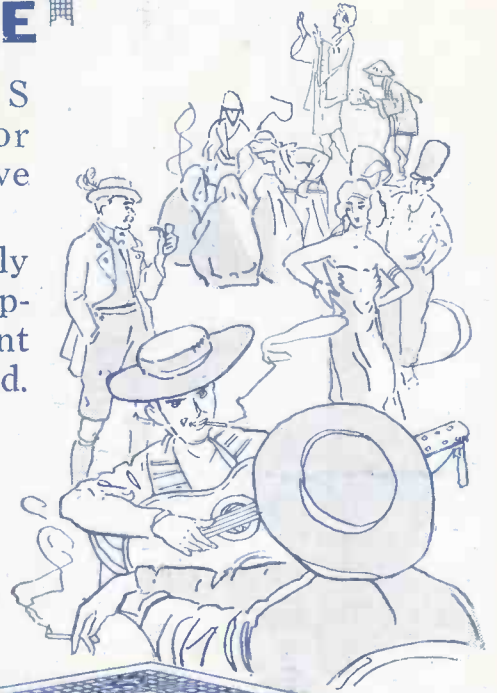

No matter who made your
wireless set you will get
the best results with the
"EVER READY" Battery.

SIR OLIVER LODGE WRITES THIS WEEK

Popular Wireless

Every Thursday
PRICE
3d.

No. 406. Vol. XVI.

INCORPORATING "WIRELESS"

March 15th, 1930.

Cross it off Your Dial
with the
5/- "BROOKMANS"
REJECTOR!

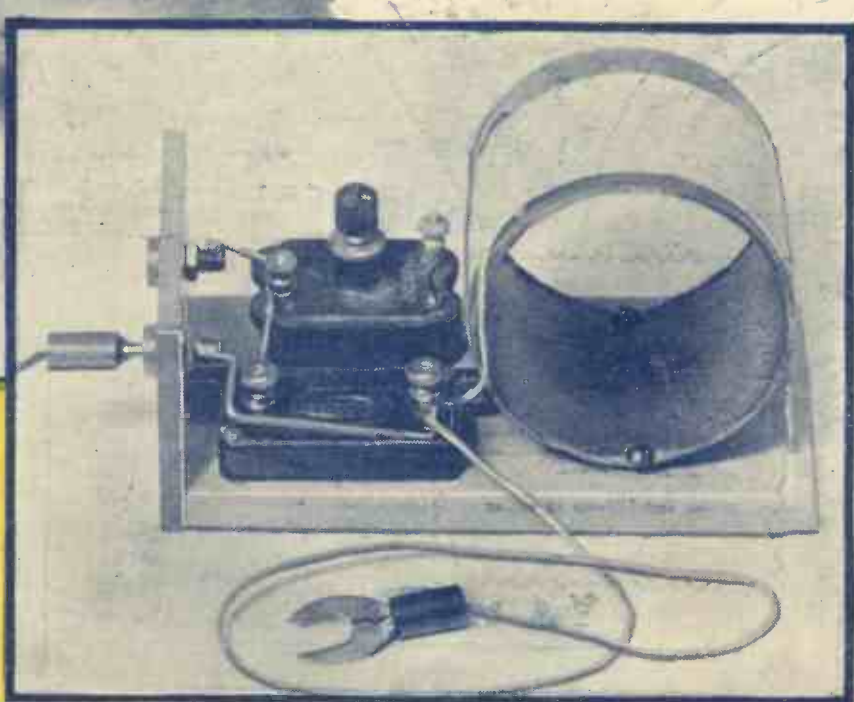

OTHER SPECIAL FEATURES

HOW TO MAKE "P.W."
"SAFE-POWER" JUNIOR
THE SET OF THE FUTURE
By Capt. P. P. Eckersley, M.I.E.E.

AN ARTICLE
BY GERSHOM PARKINGTON

ACCLAIMED BY EXPERTS

THE LEWCOS 3-VALVE KIT ASSEMBLY

Reproduced by kind permission of "POPULAR WIRELESS."



PRICE
£7

(WITHOUT VALVES)

The LEWCOS 3-Valve Kit Assembly illustrated above has been subjected to severe tests by experts, and the results elicited paeans of praise for its extraordinary capacities.

This LEWCOS Chassis constitutes the most compact Assembly Kit yet produced. All the vital wiring is done for you, and the scientifically arranged lay-out permanently put into practice before you start. The Screened

Grid, Detector and Pentode Units are wired and mounted, as illustrated, on a chassis ready for connecting to condensers. Results are certain with this Kit—the simplest job ever set in Radio Assembly. Write for descriptive leaflet R58.

A TESTIMONIAL

"I have purchased one of your 'Three-valve kit assembly' units, and am writing to say that it is a complete success. Up to the present I have received 34 stations at loud-speaker strength, and here, in Ealing, with an aerial 60 ft. long and 25 ft. high, the two Brookmans Park stations can be separated without any 'background'."

Name and address of writer will be given on request.

THE LONDON ELECTRIC WIRE COMPANY AND SMITHS LIMITED,
Church Road, Leyton,
LONDON, E.10.



Trade Counter:
7, PLAYHOUSE YARD,
GOLDEN LANE,
E.C.1.



—Foundation of Performance

The eight—team work—rhythmic movements—all working together with a swing and a go that only team work can bring.

It's the same with the BurTon "Empire 3." A team of BurTon Components, every one chosen to do the right job in the right way, all working together with a swing and a go that only team work can bring.

£5 10

Valves, Batteries and Royalties extra.

ALL MAINS MODEL (self-contained)

Price of Set - - - - - **£11 : 5 : 0**
Price of Valves (Mullard A.C.) **£3 : 10 : 0**
(Royalties extra)

Identical in appearance to the Battery Model.

THE BURTON EMPIRE 3

EVERY PART A BURTON PART

C. F. & H. BURTON, PROGRESS WORKS, WALSALL, ENGLAND



THE NEW COLLOIDAL VALVE with the Highest Efficiency Factor yet obtained

H.F. and General Purpose.....6/-
Super Power.....7/-
Shortly available: Vatea Colloidal
Screen Grid, Pentode and A.C.
Mains Valves.

Ask your local dealer for full particulars

ABBAY RADIO, 47, Victoria Street, Westminster, London, S.W.1
Telephone: Victoria 3914

**THE IDEAL
POWER
VALVE**

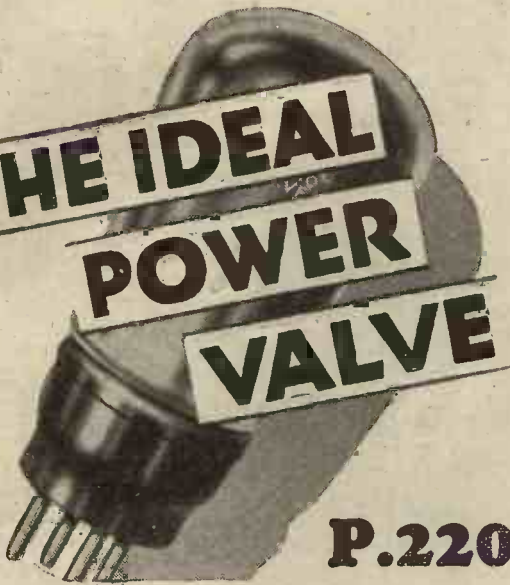

P.220

*for Portable and
Battery-operated Sets*

The life of high tension batteries being of prime importance to users of battery operated sets, the Mazda designers set themselves to produce a valve of large power handling capacity which required a minimum of H.T. battery current.

This has resulted in the production of the P220, a very sensitive loudspeaker valve of high magnification, and so proportioned that it will operate at strength, and without distortion, the type of loudspeaker incorporated in most portable sets, with the small H.T. battery consumption of 5.5 milliamps.

PRICE **12'6**

Write for Catalogue. Sold by all reputable dealers.

ALWAYS ASK FOR

MAZDA
RADIO
VALVES



THE EDISON SWAN ELECTRIC CO., LTD.,
Radio Division,
1a, Newman Street, Oxford Street, W.1.
Branches in all the Principal Towns.

EDISWAN V.24.

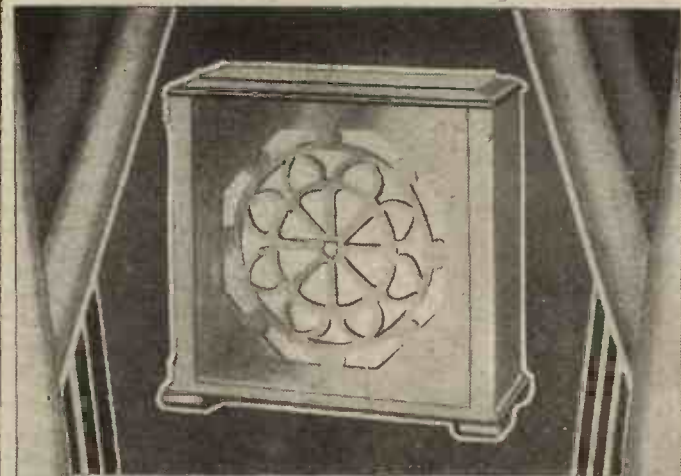

The New
CELESTION
LOUD - SPEAKER
MODEL Z.20

"Renowned for brilliancy and quality . . . speech and music particularly good . . . a handsome instrument."

PERCY HARRIS in "Wireless Constructor."

The modern receiver must be selective. But selectivity alone is not enough. Any programme worth hearing at all is worth hearing well. To appreciate it fully you must hear it with the realism of tone for which Celestion is renowned.

Model Z 20 is designed specifically to give the finest possible results with any set from a Two-Valve to a Power Amplifier. Crowned with the Celestion hall-mark — a beautifully designed and hand-polished cabinet.

In Oak	£7. 15. 0.
Mahogany	£8. 5. 0.
Walnut (to order)	£9. 0. 0.
Other models from	£3. 15. 0.

WRITE FOR AN ABSORBING 'FREE BOOK ON 'SOUND-RECREATION'

CELESTION LTD.,
DEPT. B.,
KINGSTON-ON-THAMES.

London Showrooms:
106, Victoria Street, S.W.1.

CELESTION
The Very Soul of Music

Write to us about the new Celestion Electrical-Gramophones and Radio-Gramophones . . . the finest yet.

Popular Wireless

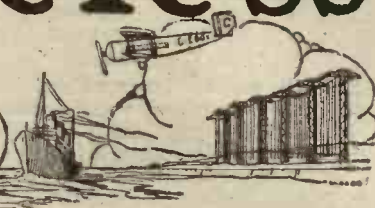

Scientific Adviser:
 Sir OLIVER LODGE, F.R.S.
 Chief Radio Consultant:
 CAPT. P. P. ECKERSLEY, M.I.E.E.
 Editor: NORMAN EDWARDS.
 Technical Editor: G. V. DOWDING, Assoc.I.E.E.
 Assistant Technical Editors: K. D. ROGERS,
 P. R. BIRD, G. P. KENDALL, B.Sc.,
 A. JOHNSON RANDALL.

MY "GRAMMY."
 SMILE AND BLOW!
 FLOTSAM AND JETSAM.
 "HELLO BUTTERCUP."

RADIO NOTES & NEWS

THAT NIGHTINGALE.
 THE ROBOT.
 A NOVEL IDEA.
 "P.W." LOOKS IN.

My "Grammy" Capitulates.

BECOMING exasperated with the wretched thing and its sluggish liver, I performed a major operation on my gramophone and had its innards out into the light of day. I do not pretend to understand how the people who repaired it expected it to work in an environment of cylinder oil. However, I wiped off as much of the muck as I could and squirted sewing-machine oil here and there, with the happiest of results. She now works like a little lady and the children have ceased from sneering.

Indian Broadcasting.

WELL, the Indian Government has decided to take over broadcasting for two years, and the business will be run by a Board of Control composed of eight members. Better than nothing! But, properly handled, radio could do much to improve matters in India and it is a great pity that the Government does not realise this. If only "Mahatma" Gandhi would squat on his little mat and "listen-in," instead of trying to be a national hero on the strength of some sahibs' ideas he doesn't fully understand!

Notice to Would-be Contributors.

WE should be glad if readers who aspire to contribute articles to "P.W." describing their sets, loud speakers, etc., would take note that in all cases, before an article will be considered, the original model must be submitted to us for examination and testing by the Research Department. This ruling is made in the interests of contributors and readers alike.

A Smile and a Blow.

THE B.B.C. has been severely criticised for prohibiting Sir A. Conan Doyle's talk on the supernatural, but after thinking all round the matter I conclude that they were right. Sir Arthur would most assuredly have been unorthodox in the extreme and I think it would have proved harmful. We are not all strong-minded enough to stray without dismay into esoteric fields of thought. The B.B.C. did attempt the spectacular when it tried to "put over" that haunted house business, though. And it will do so again if it fulfils its threat of broadcasting the roar of Niagara.

Flotsam and Jetsam.

THE B.B.C. transmissions on 261 metres have been received nearly three thousand miles away by one of the crew of the s.s. "Davisian."

Sir Henry Wood could play the piano excellently when he was six years old and at the age of fourteen he was Deputy Organist to St. Sepulchre's, London.

A 17 years' old Japanese "fan" has been authorised to open a private radio telegraph

Buffaloes and Buttercups.

G. W. D. (Kensal Rise), the explorer amongst the short waves, who tumbled into a patch of ether which resounded with strange cries such as "Allo Cornflower," "Hermione calling Buffalo Blue and over to Cornflower," "Buffalo Blue calling Buttercup," is naturally curious to know who these stations are; unnaturally he omits to give their wave-lengths. However, if they weren't "Ariel's" fairies at work they were most likely R.A.F. aircraft. Perhaps some reader, ex-R.A.F., can tell us for certain.

"Some" Query.

F. C. S. (London, N.22) sends in eight and a half quarto pages of query about his set, the trouble with which has so far baffled the experts, including those of a contemporary radio publication. There is lots of explanation but no diagram of the set, which would be of more use than many words. After having tried everybody he can think of—except "P.W.'s" Queries Dept.—he turns to me with an S.O.S. Well, here's a lifeline; I hope it will hold. But don't breathe a word to those technical fellows downstairs!

The Symptoms.

HIS little worries are due to a fluctuation of 5 to 6 milliamps in the anode circuit of the output valve, no matter what type of valve he uses, the changes being not rapid but sometimes at intervals of half an hour; also, he is the victim of "mains hum" from his eliminator. The hum, by the way, was not present until he tinkered with the eliminator chokes, which are now obviously saturated and should be converted to their original condition, as a start.

The Possible Cure.

HAVING consulted my squad of fairies, I advise F. C. S. to rebuild his set in accordance with any "P.W." design which may take his fancy and not to spend any more time in making shots at condenser values, etc. But before he does so, perhaps he will (1) re-make the eliminator, and (2) Try a 30,000-ohms resistance in the Det. H.T. circuit, the order being, anode, then anode res., then 30,000 ohms, then H.T. pos. Then put a 2-mfd. condenser from the anode side of the 30,000

(Continued on next page.)

THE "BROOKMANS" REJECTOR.

Dear Sir,—You will be interested to learn that the "Brookmans" Rejector described in recent issues of "Popular Wireless" has been used with advantage by a number of our customers in connection with three- and four-valve sets supplied by us as far back as 1922.

At that period the tuned anode was the recognised form of H.F. coupling, and at that time this method was found reasonably selective on account of the limited number of stations working on the broadcast wave-band. Now that the Brookmans Park Regional Transmitter is operating on the new wave-lengths, the selectivity of these tuned-anode sets has been found to be very inefficient, and we have recommended a number of our customers to use the "Popular Wireless" "Brookmans" Rejector, with advantage, and have received letters from satisfied users who have greatly appreciated this simple device. I myself have tested it under various conditions, and find it extremely valuable, as it undoubtedly overcomes the difficulty experienced by owners of sets of old design, and avoids the necessity for expensive devices to improve the selectivity.

I am sure there must be many thousands of readers of your Journal who have found the "Brookmans" Rejector equally useful.

Yours faithfully,
 RADIO INSTRUMENTS, LIMITED.
 (Signed) J. Joseph,
 Managing Director.

and telephone station in Tokio. It is said that with his S.W. gear he can communicate with all parts of the world.

The Terror in the Air.

WHY town councils are so afflicted with terror at the thought of overhead wires is a mystery to me. I wonder that they can sleep o' nights for thoughts of all those drefful telephone wires menacing life, limb and property. Once again the local Dogberrys have spoken on the subject, this time at Bromley (Kent), where they have refused to allow a firm to carry wires across their streets in connection with a scheme for a wireless relay exchange. The excuse given is "Safety first"!

NOTES AND NEWS.

(Continued from previous page.)

ohms to H.T. neg., or to "earth." The condenser between the anode side of the anode res. and the grid of the next valve should be not less than .01 mfd.

"Slow Motor-Boating."

F. C. S. seems to have suffered from the complaint which we may call "slow motor-boating," and I hope that the symptoms may be recognised and cured by other readers whose sets do not behave properly. I must not, however, enroach again upon the province of our technical department to such an extent, so in future you must leave your uncle "Ariel" out of the plot when you write about your technical troubles. (Not that I should not be only too delighted, etc.) Will F. C. S. let us know how he gets on?

News of the Nightingale.

OUR friend, A.P., of Turin, is a delightful humorist and we are indebted to him for the true explanation of his town's now famous nightingale. Nature-lovers, aviarists, ornithologists, pigeon-breeders and mechanical engineers will be charmed at the news. The notorious songster conducts his own performance and not through the lips of the announcer, whose voice, says A.P., is more like that of a buzz-saw, though we don't believe that for a moment.

The Robot.

NO, our mysterious *rossignol* is a true (mechanical) bird, closely related to the family of decoys employed by bird-catchers. When the announcer forgets the oil-can A.P. alleges that the noise of the gears and pistons is mistaken in æsthetic circles for Chamber Music by Honegger. This bird was captured in a wave-trap and is officially known as a nightingale, though Italian listeners insult it by calling it everything from sparrow to blackbird. So there is the truth—and we hope that A.P. has not endangered his eternal welfare by plagiarising Munchausen.

More About the Leyden Jar.

WHO did discover the blessed thing? The difficulty of making sure of the least little fact—and then you cannot—breeds suspicion of everything one reads outside of fiction. I am now informed by W. H. L. (Reigate) that G. D. Knox in his book entitled "All about Electricity" gives priority in the discovery to Von Kliest. I wonder what authority Knox had for that. To me the hero of the piece is still Cuneus.

The Van in the Van.

THOSE live wires, Philips, tell me that their famous travelling B.B.C., "Dennis the Van," is having a huge old time. Always in the van of progress, it officiated on February 22nd at a footer match at Mansfield, which was played by artificial light—also supplied by Philips. On March 22nd, April 21st, May 9th-10th, June 9th, August 4th, September 20th, and October 4th Dennis will be at Brooklands Race Track helping the announcers.

Short-Wave Data.

THERE appears to be a lot of ignorance about that most useful book called the Radio Amateur Call-Book. Hence I make known to all whom it may concern that it is the annual and log-book of the Radio Society of Great Britain, that the price is four shillings, and that the Society's address is 53, Victoria Street, London, S.W.1. Whilst I am on the subject I should like to record the fact that Mr. K. C. Wilkinson, of Herne Hill, owner of G 5 W K, has succeeded in establishing two-way communication with South Africa on 10 metres. His set is crystal-controlled, with Marconi L.S.5B. and D.E.T.1S. valves.

For Once They Were Wrong.

JUST over ninety years ago an American gentleman rejoicing in the names of Samuel F. B. Morse, having invented a system of signalling called the "telegraph," offered his invention to the U.S. Government for £20,000. The then Postmaster-General, who seems to have been possessed

available in the middle of some desert country, off-will go the lorry. Rather a bright idea, I think. The gear comprises a medium-wave ¼-kilowatt telephone set and a 100-watts portable telegraph transmitter.

The B.B.C. Chairmanship.

AT the time of writing the name of the successor to the Earl of Clarendon on the Board of Governors of the B.B.C. has not been revealed; it is not even known to the public whether the selection has been made. With a gift of £3,000 p.a. in its pocket the Government will no doubt take its time and pick out the most useful, "all-round," democratic, harmless, peer it can find. Personally, I don't see why the Earl of Clarendon can't retain the position; he might then press the matter of a short-wave Imperial broadcasting station with success.

Quieter Courts.

IT has hitherto been customary to station a sergeant-major in the hall of Buckingham Palace for the purpose of calling out the names of the debutantes as their cars arrived at the door. "Sarge" is now ousted by a Marconiphone loud-speaking equipment, but he has done good work in impressing so many American ladies with the fact that there's still a good pair or so of bellows over here. As a matter of fact, he has brought about his own dismissal by shouting so loudly that the poor dears had to have "triplex" glass in their horn-rimmed!

A Job for the B.B.C.

DR. F. VIZETELLY, of New York, has been using up some time by pondering the pronunciation of the word "radio." Much to my delight his verdict is for "ray-dio" and not for "raddio" with a short "a." His reason is, however, not so acceptable, for it is simply that he associates radio with "ray." Have the B.B.C. Committee settled this pressing problem? Dr. Bridges should revel in it if, as I think, the word is from the Greek.

"P.W." Looks In.

HAVING unwrapped a large mysterious-looking parcel which arrived the other day, the Technical Staff discovered a Baird Televisor. This will have to be hooked up to an amplifier delivering the necessary 400 volts, and a sharp look-out kept on 2 L O's television transmissions.

In view of the important claims made for it the Televisor is being taken very seriously by "P.W." A report is being prepared, and readers will be told of results as soon as possible.

A Considered View.

I NOTE with amusement the interesting fact that one of our contemporaries had a Televisor delivered at the same time as "P.W.," and—determined to be first in the field for once—has already rushed out a report upon it. Not so "P.W."

In order to obtain the necessary data, the Televisor will be given an exhaustive test, over a period, before critical comment is made.

ARIEL

SHORT WAVES.**MID-ATLANTIC BROADCAST.**

For B. E. Sea listeners.—"Daily Mirror."

We are told of a dear old lady who removed all the valuables from her room before listening-in to the ex-convict's talk from 2 L O the other day.—"Punch."

Hubby (in midst of heated argument): "Mary, will you listen to me?"
Mary: "Only when you're broadcasting, my dear."

THINGS WE WOULD LIKE TO HEAR.

On the Wireless: "It has been decided to abandon all talks on worms, London's landmarks, the correct method of making suet puddings, how to post a ledger, the cure of squint-eyed children, and other dull subjects, and to substitute instead some light music, as well as relays from the best musical comedies and from the music-halls."—
"The Star."

"M.P.'s may listen in."—Cynics maintain that they deserve it.—"Sunday Pictorial."

"Alternative programmes for the B.B.C." we read. But the only alternative about the new B.B.C. programme seems to be that it doesn't matter which station you tune in—you get both programmes in either case! (Unless you use the Brookmans Rejector!)

MY DAY'S WORK.

A new series of talks is to be given under this heading. We can imagine nothing better than the Income Tax Collector gloating noisily, or a Whitehall servant lurching between sleeps. For complete and utter silence over the radio, however, let us have the B.B.C. Talks Department thinking hard in an endeavour to find the worst possible critics for every possible subject.—"Vox."

of no more "vision" than his brothers in this country, turned the offer down, solemnly averring that the telegraph could not pay its way. The world to-day sends about 520 millions of telegrams annually, 'tis computed, of which nearly one half are sent by Americans.

A Novel Idea.

I LEARN from Marconi's that they are supplying to the Egyptian State Telegraph Department three radio stations mounted in motor lorries (British made!) intended to provide extensions of the land-line telegraph and telephone system when and where required. Thus if an emergency demands that communication facilities be

DIVIDING THE ETHER

By Sir Oliver Lodge F.R.S.

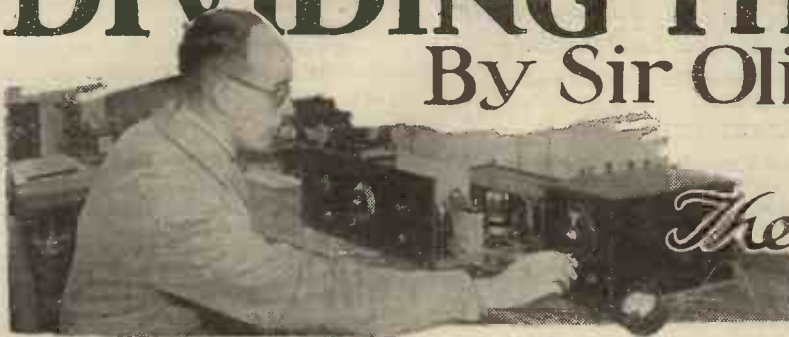

PART I

The PRINCIPLES OF TUNING

A FRIENDLY controversy has recently arisen in the columns of "Nature" between Sir Ambrose Fleming and other wireless experts as to the margin of frequency, or the width of what is technically known as the wave-band, that must be allowed

to each station in order to secure clear and well-articulated transmission of notes of every pitch, without danger of overlapping by other stations.

The question is a practical one, because the number of stations is now considerable and likely to be growing, and because the total range of frequency at present allowed is limited.

Mathematics v. Physics.

Sir Ambrose Fleming has indeed raised the question whether the wave-band is a mathematical figment, and whether it has any real existence; since the actual wave sent out from any station is a single, not a multiple, wave, but is one with a modulated or fluctuating amplitude.

Everyone admits this; but most experts consider that this is most conveniently represented as if it were a multiple wave or wave-band of many adjacent frequencies, which therefore to all intents and purposes has a real existence. A metaphysical question seems to be involved as to whether mathematical equivalence is the same thing as physical equivalence; in other words, whether a device legitimately employed for convenient treatment corresponds with reality sufficiently to be completely justified, or whether an artificial method of regarding a phenomenon might lead designers into unnecessary difficulties.

Tuned Reception.

Apart from this controversy (which will probably soon be settled) the whole subject of tuned reception must have aroused widespread interest among amateurs; and the technique of wireless transmission is so recent that probably many have not yet found time to become acquainted with it; so that, although it really involves a little simple mathematics, a non-mathematical treatment of it may be welcomed by readers. Accordingly, I have drafted a sort of historical survey of the main points involved in tuning.

The principle of tuning applied to wireless transmission and reception was first laid down in my patent of May 10th, 1897, No. 11575. This patent would naturally have expired in 1911, when its validity was

"This is the first of a short series of articles which, though elementary in form, are the result of thought and calculation, and embody the germ of a nascent invention, having for its object the narrowing down of wave-band reception, so that sending stations may be attuned more closely together without overlapping. It is possible that Dr. Robinson's 'Stenode' is based on something of the same kind."—Sir Oliver Lodge.

upheld and its term extended for seven years by Lord Parker, after legal trial in the Courts.

It was then acquired by the Marconi Company, who had already performed using it, and who had extended and improved it by multiple tuning and other devices, and made it applicable to speech and music (which originally it was not) by the adoption of the Fleming valve with the De Forest supplement, which enabled them to emit a continuously maintained wave with every detailed modulation receivable, instead of the comparative discontinuities of the Morse code.

It is the transmission of speech and music which has aroused widespread interest in wireless telegraphy, and is its most remarkable feature. The precision, and so to speak perfection, with which this transmission is accomplished by radio engineers,

OUR SCIENTIFIC ADVISER.



A recent photo. of Sir Oliver Lodge. He has been responsible for many wonderful radio inventions and discoveries which are famous throughout the whole world.

in a comparatively short space of time, is a notable achievement.

And the bonus of a previously unsuspected ionised layer in the upper atmosphere, due to the atom-shattering properties of sunlight, which has made world-wide reception possible,

must have a beneficent influence on the international future of mankind. Hence the whole subject has become of more than technical and scientific importance.

The Three Factors.

A tuned receiver is primarily an electric circuit, containing capacity and self-induction, which has a natural period of vibration of its own, and which can respond to waves sent out from the sending station with special facility if they are approximately or accurately of the same frequency as it is itself attuned to; that is to say, a receiving set is a system which responds to "forced" vibrations, and must follow the known laws of such vibrations.

The general theory of free electric oscillations was laid down by Lord Kelvin so long ago as 1853, in the form of a differential equation of the second order, with three coefficients, two of which were essential, while the third was inevitable.

One of the essentials was even then called capacity; the inevitable one was resistance; and the second essential had then no name, and was largely unknown. Kelvin called it "the electrodynamic capacity of the discharger": It corresponded to the magnetic field due to the current. Its effect had been called extra current by Faraday, and was much later named self-induction by Clerk Maxwell.

The Kelvin equation, though now so familiar, may be cited for completeness:

$$L \frac{dI}{dt} + RI + \frac{1}{C} \int Idt = E$$

when E is the stimulating E.M.F., and is zero during discharge. I, of course, is the current strength of each instant.

This equation represents the free oscillations of a circuit stimulated in any convenient manner—as by an electric shock or spark, or by a sudden twist of the circuit in a magnetic field—and then left to itself, so that the excited oscillations die away.

Kelvin, even in 1853, pointed out that the resistance of the circuit would affect the frequency to a subordinate extent, and that if it was too great—if, for instance, R was

(Continued on page 1334.)

MORE ABOUT THIS YEAR'S "TITAN" THREE.

Some practical notes on the preliminary adjustments of the new set and its manipulation in actual operation.

By THE "P.W." RESEARCH DEPARTMENT.

BEFORE we go on to deal with operating matters proper it will perhaps be just as well to explain the special details in which this year's model differs from the original "Titan" Three. The subject comes opportunely here, because most of these new features are matters affecting the ease and convenience of working of the set.

Hence, they provide a natural interlude between the description we have already given of the general features of the receiver, and the operating instructions which will follow.

Selectivity and Volume.

A good example of the kind of simple and inexpensive little refinements we have incorporated in the new set is the device marked C_3 and S_1 on the blue print. On the original set there was an optional fixed condenser which could be brought in series in the aerial circuit or cut out at will by transferring the aerial lead from one terminal to another.

In the new set the same effect (a variation of selectivity) is obtained more conveniently by working the switch S_1 . This controls a useful little component (placed on the market since the original set appeared) which actually incorporates the necessary fixed condenser in the body of the switch.

Then there is the rather difficult problem of volume control. This is neatly solved by the provision of a filament rheostat on the panel to control the filament current of the H.F. valve. You will find this gives you an excellent adjustment of volume. By the way, quite a low-resistance rheostat (6 or 10 ohms, say) is best with 2-volt valves, but 6-volters call for something of the order of 20 or 30 ohms here.

Economising H.T. Current.

The anti-motor-boating filter in the detector H.T. lead does not call for much explanation. It consists of a resistance of 25,000 (or 20,000) ohms and the 2-mfd. condenser C_0 , and it is intended as a safeguard for those who use a mains H.T. unit.

The remaining new features are the grid bias on the H.F. valve, and the modified reaction arrangements. Both are intended to allow for the peculiarities of the latest types of S.G. valves. The former serves to keep down their H.T. consumption, which tends otherwise to be rather heavy, and the latter compensates for the fact that they mostly oscillate rather more easily in a "Titan" circuit than last season's types.

In the original set the aerial winding (lower wave) on the coil was used for reaction as well as aerial coupling, and no separate adjustment was possible. In the new design provision is made for the separate adjustment of the portion of the coil used for reaction and that which gives the aerial coupling.

This brings us really to operating matters, and we may as well go into it in detail.

When you examine your coil unit you will see that the low-wave aerial winding has tapings upon it, and there is a flex lead from the "A" terminal on the unit which can select any of these by means of a plug and socket device, a row of little terminals on the upper edge of the main tube of the coil, or some similar scheme.

This gives you your control of aerial coupling, and hence selectivity, on the lower wave-band. You will find that at one end of the range of adjustment you get broad tuning but great volume, while at the other end of the range of tapings tuning is very sharp and volume reduced a little.

It is just a matter of a little testing to find out which tapping gives you the degree of selectivity you require in your particular circumstances, and it will not take you

All these adjustments affect the use of the set only on the lower wave-band. When you go over to long waves (by pushing the knob of switch S_2 inwards) there is again an adjustment of selectivity to be attended to, but a very simple one this time. There is no further adjustment of the reaction circuit.

Long Wave Controls.

Examine the coil unit again, and you will see that there is another flex lead from the "E" terminal thereon. This is intended to go on one of the tapping points on the loading coil, but the ones likely to be used in this particular set are "25" and "60." The latter with the series aerial condenser in circuit (S_1 knob pushed inwards) gives an adjustment which suits many aerials, but try all the possible combinations.

Those are really all the adjustments which we need explain, for everything else is so simple, and the odd details you will want are quite clear on the blue print. Thereon you will find concise notes giving you the correct H.T. voltages (note that 120 volts must be provided for this and all other S.G. sets), and suitable valves.

The latter, of course, will normally be of the two-volt type, but "fours" and "sixes" can be used if desired, and all give very good results in this receiver.

ALL READY FOR WORK.

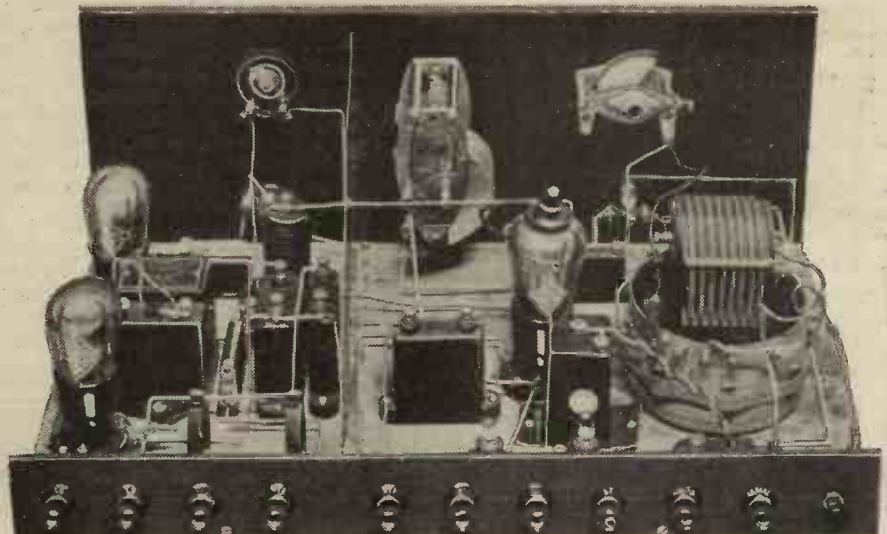

Here you see some of the points at which adjustments are made in putting the set into use and in its subsequent operation. The rheostat on the panel acts as a very effective volume control. On the coil unit you will note the arrangement of flex leads and tapings which provide a variation of selectivity, and beside it stands the G.B. cell for the H.F. valve.

long. Once found it will not be likely to require alteration in normal working, although it is sometimes necessary with a large aerial to change to one of the higher selectivity taps when working near the bottom of the dial.

Reaction Adjustment.

Now about the reaction scheme. Take a look at the blue print, and you will see a flex lead coming away from C_2 and carrying a "crocodile" tapping clip upon its end. This clip is to be placed upon one or other of those same tapping points that we have just been discussing. It is again a case for testing, the idea being to find a tapping which gives a good control of reaction with the reaction condenser only perhaps half-way in.

L.F. HINTS.

Where no output filter is used, the loud-speaker terminal which is joined to the plate of the last valve should be marked -; the other terminal being marked with a +.

Always make sure that the loud-speaker lead which is marked +, or coloured red, is joined to the + loud-speaker terminal on the set.

When a certain valve is recommended for use with a particular L.F. transformer the valve referred to is the one preceding the transformer and not the one to which its secondary is joined.

The 5/- "BROOKMANS" REJECTOR



It costs only five shillings, but it does do the job. This astounding little gadget (see how small it is compared with a set) immediately transforms any receiver, no matter how flat its tuning, into a masterpiece of selectivity. And, mind you, the 5s. "Brookmans" Rejector does this without causing the slightest loss of sensitivity; in fact, you will get more stations when you use the rejector than when you are without it. Don't endure that annoying "wipe-out" from your local any longer, but spend just five shillings and wipe the interfering station right off the dial!

By

THE "P.W." RESEARCH AND CONSTRUCTION DEPARTMENT.

The use of a "Brookmans" Rejector is not

HERE is a "Brookmans" Rejector that really is a wonderful proposition. It is easier to make than any wave-trap, and is just as easy to adjust, but it has all those qualities that have made the original "Brookmans" Rejectors famous. It will completely wipe out any one powerful local station, and it will do this without decreasing the sensitivity of the set.

Indeed, in many instances it will be found that the ether-piercing powers of the receiver are increased.

Quite often you find that a sluggish outfit is most noticeably enlivened when you couple a B.R. to it. Nevertheless, we must make it clear that we do not claim that the

necessarily confined to owners of inselective sets who want merely to separate the two transmissions from Brookmans Park. Those who possess long-distance, loud-speaker outfits will find it wonderfully helpful in cleaning up distant programmes. With the help of a "Brookmans" Rejector a lot of the inevitable "mush" can be cleaned off, and it is frequently possible even to clip off interfering heterodynes.

The 5 G B transmission, for instance, is sometimes accompanied by a very high-pitched whistle due to a heterodyning foreigner. With careful adjustment of the rejector, such a heterodyne can generally be completely silenced.

Very Few Components.

Now this particular "Brookmans" Rejector is suitable only for the normal broadcasting band. It could be applied to the long-wave stations such as Radio-Paris and 5 X X by removing the present home-made coil and using in its place a plug-in coil of 250 turns. Alternatively you could, of course, wind a suitable solenoid on the lines of the present one.

As you will gather from the accompanying list of parts, very few components are needed for this rejector. Needless to say, you must not deviate from the values specified for the condensers, or from the constructional details of the coil.

The layout of the parts is less important and you can, if you like, enclose them within a small box. Also, instead of sockets, for the aerial connections you can use terminals. The reason why sockets are employed in the original model is to facilitate the cutting in and out of the device.

You fix an ordinary wander plug to your aerial lead-in, connect the rejector to the aerial terminal of the set by means of the flexible lead fitted to the rejector, and then, by moving the aerial plug from the one

ALL YOU NEED FOR THIS EASY-TO-MAKE "STATION STOPPER"

- 2 Small sockets or terminals (Clix or Eelex, etc.).
 - 1 .0005-mfd. fixed condenser (Lissen or Dubilier, T.C.C., Mullard, Goltone, Magnum, Clarke, etc.).
 - 1 Compression-type adjustable condenser, max. capacity about .001 mfd. (R.I. or Formo type G., Igranite Pre-set, etc.).
- Materials for coil, a small piece of wood, a small piece of ebonite, etc. (as per text).

socket to the other, the rejector is switched on and off in a matter of moments.

Here are the assembly details of the device. The small panel measures 2 in. x 2 1/4 in. x 1/8 in. thick. We should advise you to use

(Continued on next page.)

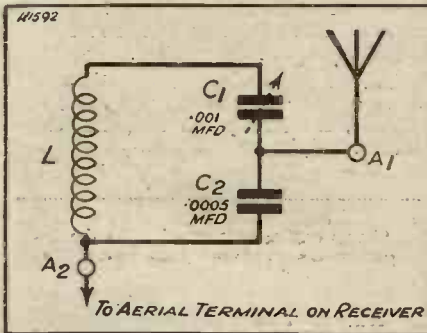

Nothing could be simpler than the above circuit, and nothing could do the job better.

"Brookmans" Rejector acts as an amplifier. In producing a device that wipes out interference without occasioning loss we achieved an ideal at which radio designers have been aiming for a very long time.

Set's General Selectivity Improved.

The "Brookmans" Rejector having attained this goes one point further on yet another score. This is that it frequently improves the general selectivity of a set. That is to say, it not only "muzzles" the powerful local, but also in many cases makes it easier to separate rather closely situated foreigners at other dial readings.

And talking about foreigners, there is a further vital advantage that must be brought forward.

NO MORE INTERFERENCE!



Here we see the complete rejector—a simple coil, a fixed condenser, a small pre-set variable, and there you are! Build it to-day and enjoy radio to the full.

THE 5/- "BROOKMANS" REJECTOR.

(Continued from previous page.)

ebonite for this, although a good hard wood would serve. The positions of the sockets (or terminals if you use them) are of no great consequence; those in the original model are spaced by $1\frac{1}{2}$ in. and placed $1\frac{1}{2}$ in. up from the bottom edge of the panel. The baseboard measures $2\frac{3}{4}$ in. \times $5\frac{1}{4}$ in. \times $\frac{3}{8}$ in. thick. You can use 5-ply for this, although any fairly decent timber will serve.

The coil needs a former $2\frac{1}{2}$ in. in diameter and about $2\frac{1}{2}$ in. in length. Start the winding operations by piercing two small holes with a bradawl, knitting needle or some other such device, about a quarter of an inch in from one end of the former. These small holes can be a quarter or three-eighths of an inch apart.

Making the Coil.

Thread the wire through these holes, leaving two or three inches for connecting purposes, and then wind on 50 turns. It does not matter a scrap in which direction you wind the wire. But wind the wire fairly tightly and keep the turns packed closely together. You can do this by running your thumb nail along the wire, pressing it against the preceding turn as you wind.

On reaching the 50th turn, make two more holes like those at the beginning, thread the wire through and break it off,

again leaving a couple of inches or so for connecting purposes. You can then fix the coil to the baseboard with two $\frac{1}{2}$ -in. wood screws, passing these through the ends of the former.

Having fixed the other parts in position you can then wire them up. This process will not take you long, although we would advise you to solder the connections if you are sure that you can make a good job of it.

Use the proper rubber-covered flexible wire for the receiver lead (you can get an adequate length for a penny or two).

Operating details for this Five-Shilling "Brookmans" Rejector are almost unnecessary, as it is so simple to use, but for the sake of those new readers who are unable to read the simple theoretical diagram we will briefly indicate the adjustments of the device.

You disconnect the aerial lead from the aerial terminal of the set, and join to this (instead of the aerial lead) the flexible lead from the rejector. Now when the aerial lead is joined to the A1 socket of terminal of the "Brookmans" Rejector this remarkable device is in operation; when you take the aerial lead off the A1 socket or terminal and put it on to the A2 terminal the rejector is completely out of circuit and the set is then functioning exactly as formerly.

Simple Adjustment.

Now we will suppose that you want to wipe out a powerful local station. Join the aerial lead to the A1 terminal and bring the rejector into service. Turn the tuning controls of your set until the interferer is at his loudest, and then very carefully adjust the little knob of the compression variable condenser on the "Brookmans" Rejector until the station vanishes.

You should turn that knob very, very slowly, first in the one direction and then in the other.

At the first sign of weakening on the part of the local station, make your adjustment even slower. When the local has completely disappeared, readjust the receiver controls, when you will probably find that he will come back rather loudly at a slightly different setting. If you want a complete wipe-out a further small readjustment of the rejector will effect this.

But do not forget that the "Brookmans" Rejector can only completely stop any-

thing from passing through from the aerial to the set. In cases where there is a direct pick-up—that is to say, when an extremely powerful local breaks through even with no aerial on the set, do not blame the "Brookmans" Rejector if there is not a complete wipe-out! However, even in such an abnormal case as that probably the local will occupy such a small part of the dial as to be impotent in interfering with other stations.

We particularly want you to note how wonderfully this little rejector does its job.

It really is remarkable that such a "trap-

ONLY FIVE BOB—BUT IT DOES THE JOB!

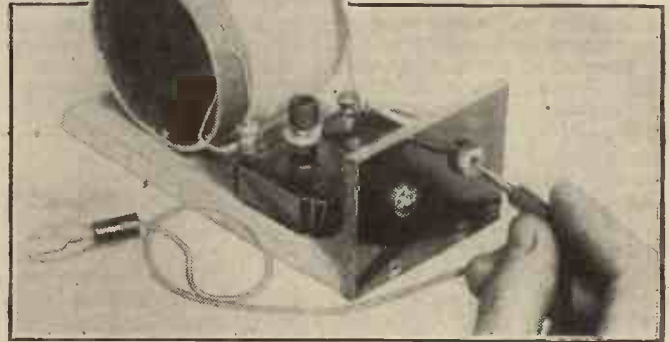

When the aerial plug is in the right-hand socket (see above) the rejector is cut out and the local station is then at full power. Transfer the plug to the left-hand socket and the rejector comes into circuit, wiping the interfering station right out.

ping" as the "B.R." can do is possible without reducing the power of the set for picking up other stations.

Also, it is remarkable that it can "trap" any one station so completely and then go on to add to the general selectivity of a receiver.

At least, we should add, these things must seem remarkable to those who do not understand completely the novel theoretical aspects of the rejector.

And we must admit that, although we expected the "Brookmans" Rejector to be efficient, it actually exceeded our expectations.

"I was particularly struck with the ingenious design of the "Brookmans" Rejector Circuit, because this method does appear to give the most efficient performance I have ever come across."
Capt. P. P. ECKERSLEY.

The ordinary series wave-trap and, generally, the parallel type of interference-eliminating device do their jobs quite well.

A Very Big "But."

But, and this is a very big "but," their results have to be paid for mostly in sacrifices of sensitivity; you do not find it quite as easy to pick up the stations you do want.

And we do not think they can ever add to the general selectivity of any receiver and make it easier to sort out other stations.

And that is just where the "Brookmans" Rejector scores heavily over all other devices of a like nature, and that without being anything but most easy to make and operate.

EXTREMELY EASY TO BUILD.

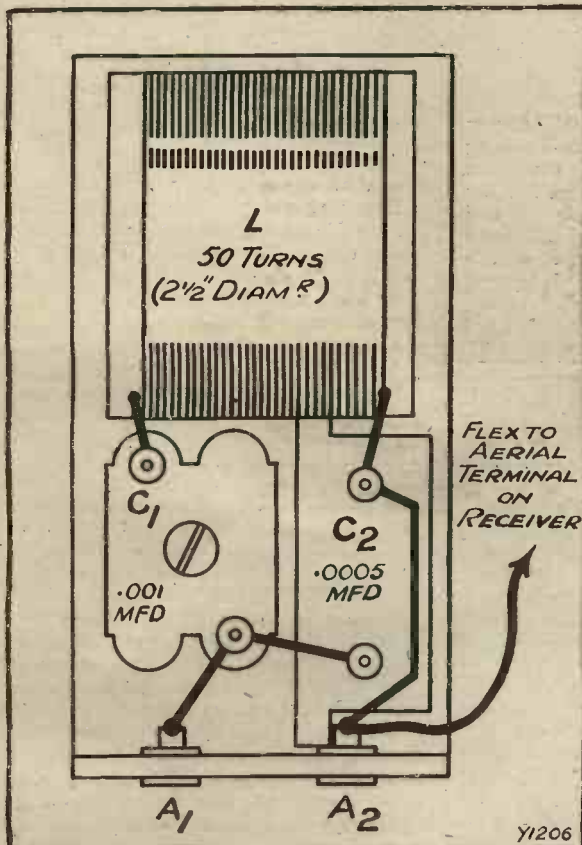

Y1206

This is the "wiring" diagram, but as you see, it is by no means a complicated business to connect up the components. A few minutes will suffice to complete the whole rejector.

The SET OF THE FUTURE



BY CAPT. P. P. ECKERSLEY M.I.E.E.

IT'S rather interesting to discuss what type of set will survive during the next decade.

To-day we have the following points as the merits and demerits of each type.

The great merit of the portable is that it is so portable. There are, however, batteries to charge, there is cramped design, and quality which, while sufficient for certain purposes, can and ought to be surpassed by mains-operated and outside-aerial models.

The great merit of an A.C. transportable, i.e. a portable set that works off the mains, is that it is portable (when one wants exercise), but the degree of its useful range is the limit of where one finds alternating-current mains. This is usually one's own or possibly a friend's house. One should seldom expect to find A.C. on a punt on the river, a country mansion, house, or cottage, or on a motor-car. About 15 per cent of the population have access to the alternating-current mains.

The merit of the aerial and earth set is that it can be extremely cheap, for as the aerial increases in size the field strength gets stronger.

Design need not be compact, and one can do with few valves and simple circuits (sounds just like a quotation, something to do with hearts and coronets) what the portable and the transportable have to do with many valves and complicated circuits.

Will the Aerial Die?

The aerial-earth set, if the aerial has to be pretty large to make the set cheap, suffers from lack of selectivity, does not always give the owner a great range of programmes, and has to sit in one place all its life.

There is an obvious future for the combined radio and gramophone set. In this case you have both what you want when you want it (and the youngest member of the family to change the records), and what you don't want whenever you don't want it, but without any trouble at all.

I think one of the points which stands out is that with the variability of conditions and the variability of desires we shall not see one type alone oust all the rest.

I class future sets, therefore, as follows:

First, the portable set is bound to survive practically in its present form. Wanted, a high-tension battery that has a very long life, even with a high discharge rate, and also cold emission so that the low-tension battery dies.

The transportable set will survive in two forms, first for reaching out, second for only the local station. The former will be more expensive than the latter.

During the past few years receiver design has advanced by leaps and bounds, until it would seem that further progress is almost impossible. Our Chief Radio Consultant, however, has some novel ideas for the future. He predicts a great drop in prices of all types of receivers which, incidentally, he says, will be adaptable for use with home talkies, as well as providing for the electrical reproduction of gramophone records.

People will put these transportable sets into a gramophone, when you get the combined instrument and have local stations and gramophone or distant and local stations and gramophone.

The aerial and earth set will, in my opinion, finally die. One cannot foresee that the future will be satisfied with the troubles incident to the installation of

the death of the individual receiver. Thus you take a given town, which we will call Zonk, where individual reception conditions are poor. We postulate that Zonk has a weakish field strength, a good deal of interruption, crowded houses with little room for aerials and a poorish population.

Suppose we now install a good wireless receiver outside Zonk, away from trains and interference. This will be fitted with special directional aerials and every device known to get perfect quality and freedom from interruption.

A Community Super-Set.

Then wires are run from this receiver all over the town to subscribers, and all the listener has to do when he wants to listen is to plug a loud speaker into a hole in the wall. Properly rigged up there are two holes, one for one programme, and one for the other. This can be done for sums like 2s. 6d. and 5s. a week, and cover the cost on reasonable numbers.

We see at once that the consumer does not gain much in actual cost for the service. He also loses the possibility of reaching out and is limited sometimes to one programme, at others to a choice of two.

He gains enormously, though, in that he gets a no-trouble service, has no serious capital cost, and is not in fear of obsolescence.

In my own mind, the future will see the portable, transportable, mobile radio gramophone, and rediffusion, all satisfying the needs of different classes of individuals.

I am sure in my lifetime I shall see the

practical elimination of the outside aerial and earth. I shall see programmes diffused not only by wireless but through the mains.

I shall see the cost of a radio gramophone with first-class quality down to £10 to £15 and such simple sets as transportables down, to £5 to £7. The sets will be adapted as attachments for home talkies, and many more people will use their gramophones for their favourite musical pieces because we shall have the continuous record storing a whole opera or symphony.

A GOOD TEST FOR LOW NOTES.



Mr. E. O'Henry at the organ of the Madame Tussaud Cinema, whence many popular broadcasts are made. It takes a good receiver to do justice to transmissions of this nature.

aerials and earth. The greatest seller to-day is the portable, only because it is self-contained and complete.

Phones will, of course, die, except for very poor people. A gradual cheapening process in design and manufacture will, I think, bring about all the changes I have indicated. How it will be done will be another story.

But what is to go on about this rediffusion business?

Rediffusion, where it is adopted, means

LATEST BROADCASTING NEWS.

MYSTERY OF THE CUP FINAL.

LORD HEWART ON LAW—
POLITICAL BROADCASTING—
LONDON REGIONAL FEATURES
—NEWS FOR WALES.

ALTHOUGH negotiations between the B.B.C. and the Football Association for the broadcasting of the English Cup Final are apparently coming to nothing for the second year in succession, arrangements have been made to broadcast a running commentary on the Association football match between England and Scotland which is to take place at the Wembley Stadium on Saturday, April 5th. Thousands of listeners are wondering what the B.B.C. intends to do about the Cup Final.

The Battle of Wembley.

Last year, it will be remembered, a description of the game was broadcast by eight or nine people at short intervals by means of a microphone situated outside the ground. This was quite all right in its way, but most people are hoping that the B.B.C. has something even better up its sleeve to circumvent what is thought to be the autocratic attitude of those who control the greatest football fixture in the world. Whatever happens this year, feeling is running so high that there may be a struggle on the ground.

Lord Hewart on Law.

There are few more brilliant or entertaining speakers than Lord Hewart, the Lord Chief Justice of England, who is to broadcast the fifth of the B.B.C. National lectures on Monday, March 24th. His subject will be "Law, Ethics and Legislation."

Political Broadcasting.

As already exclusively announced on this page, Lord Beaverbrook will broadcast on March 31st on Empire Free Trade, and Mr. Lloyd George will reply on April 2nd. It is now certain that the arrangements will be extended to include both a Conservative and a Labour statement, and there is a strong probability that Mr. Baldwin will give the Conservative view.

London Regional Features.

A combination of part-singers known as the Templars, and consisting of former choristers at the Temple Church, whose first broadcast attracted considerable attention recently, are to be heard by listeners to the London Regional Transmitter on Monday, March 17th.

On the following evening the second of the series of Triangular International Programmes, which on this occasion is to be divided between England, Belgium, and Germany, will be heard.

Nigel Playfair Produces for B.B.C.

The National Programme on Wednesday, March 19th, contains an operetta entitled "There's No Fool Like a Young Fool," which is to be produced by Nigel Playfair. The piece was recently presented at the Arts Theatre Club.

Dr. Boul's Farewell to Birmingham.

Dr. Adrian Boul makes his final appearance as conductor of the City of Birmingham Orchestra at the eighth and last of the series of this season's symphony concerts which is to take place at the Town Hall at 7.30 p.m. on Thursday, March 27th.

As most listeners are aware, Dr. Boul is succeeding Mr. Percy Pitt as Music Director to the B.B.C., and if, as wiseacres say, a straw is an indication of the way the wind blows, quite a lot of changes in the musical personnel and activities of the B.B.C. are to be expected in the near future.

The programme on March 27th will consist entirely of the works of Beethoven, including the Eighth Symphony in F, the "Coriolanus" Overture, and the Fourth Piano Concerto, which is to be played by Dr. Ernest Wolff, whose reputation is pro-

bably much better appreciated in Germany, Holland and Austria than in this country.

This concert, like others in the series, will be broadcast to Midland listeners, as will also the speeches at the subsequent farewell ceremony to Dr. Adrian Boul.

News for Wales.

Sir Thomas Beecham is paying a visit to Newport, Mon., on Tuesday evening, March 25th, to conduct a concert by the National Orchestra of Wales, at the Central Hall, in aid of the Imperial League of Opera, when the programme will be broadcast to Cardiff and Swansea listeners between 7.45 and 9 p.m.

The National Orchestra of Wales is also taking part in the "Daily Express" Community Singing Concert which Welsh stations are relaying from the Capitol Cinema, Cardiff, on Sunday evening, March 23rd. Mr. Gibson Young will conduct the singing, the soloist being Tudor Davies (tenor).

Further opportunities to hear the N.O.W. are afforded on Saturday, March 29th, when the Orchestra will give an afternoon concert for broadcast from the National and West Regional Transmitters, and again the same evening, when Cardiff and Swansea are relaying a concert from the Central Hall, Tonymandy, in which the vocalist will again be Tudor Davies.

JOURNEY'S END.

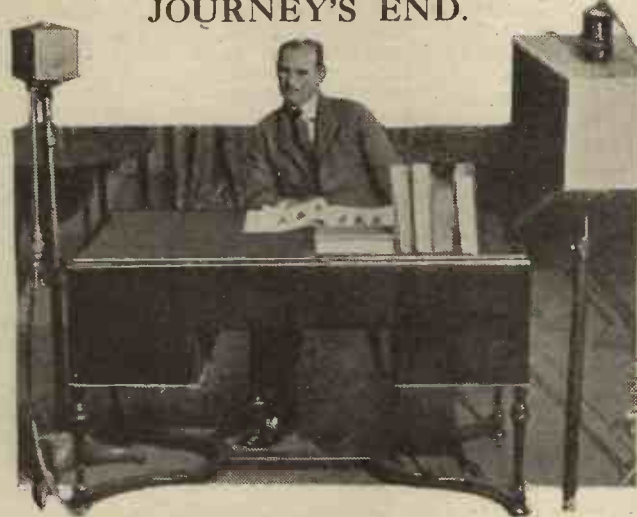

This photograph shows Capt. R. C. Sherriff, author of "Journey's End," the great War drama. Unfortunately, it was not for broadcasting purposes that he faced the microphone, but for the making of a "talkie."

FOR THE LISTENER.

A Specially Contributed Criticism of Current Broadcasting Events.

By "PHILEMON."

(Who is deputising for Mr. Cecil Lewis while the latter is in America.)

The Twins.

BY the time these Notes appear in print, the Twins will be let loose. We already know that they can talk quite nicely; the question now is, what will they say when they are both talking together? If we get genuinely alternative programmes, we shall bless them. Several times lately there has been so much of a muchness between London and Daventry that a listener, switching to and fro, has found himself between the devil and the deep sea!

Across the Ocean.

I missed it. An excited friend rang me up to ask if I had just heard the wireless message from the "Majestic," 1,300 miles out on the Atlantic. He said that it was as clear as a voice speaking from Manchester. One of the dramatic moments in the history of wireless. And for fear lest I should miss another of these unexpected tit-bits, I now

go about the house all day with the ear-phones on and the battery running down!

The Naughty 'Nineties.

The message from the "Majestic" arrived just before Mr. E. F. Benson gave his talk on "The Inventive 'Nineties." The 'Nineties are not so very far away. I flourished in them—and am still flourishing! Yet, in 1894, as Mr. Benson reminded us, "Sir Oliver Lodge discovered wireless telephony," and now we were hearing a voice in a ship, clearly, 1,300 miles away! Some stride!

All sorts of wonders began to make their appearance in the 'Nineties—the motor car, the aeroplane, electric light, gramophones, telephones, the cinema. Why they were called "The Naughty 'Nineties" I don't know. Mr. Benson said that they might just as well have been called "the noble, the nitrogenous, or the nutritious 'Nineties!"

(Continued on page 1336.)



LISTENING — THE NEW ART

BY GERSHOM
PARKINGTON

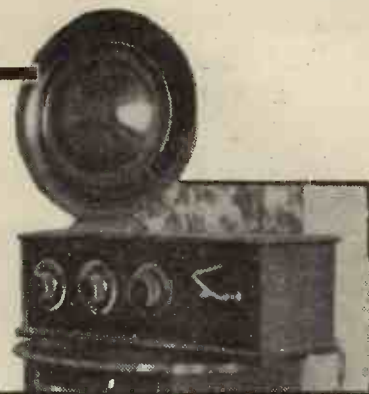

NOW that wireless has cast off its swaddling clothes, it becomes increasingly evident that it has brought into being a new art—the art of listening. It is an art which has to be cultivated by radio listeners so that they may make the most of the programmes offered to them without surfeit or boredom or unjustifiable complaint.

And while every day many listeners are realising the necessity of turning their wireless listening into an art, and steadily discovering its technique for themselves, many others still continue to listen-in in a haphazard, unorganised fashion which brings only dissatisfaction and disappointment in its train.

Are YOU Selective?

For every art is really two arts; the art of execution and the art of appreciation. The art of appreciation has to be acquired, and, moreover, it is peculiar to the medium in which the artist happens to be working.

Wireless is a new art. Here and there are people who would dispute its present claim to be included with painting, the drama, and sculpture, but that it will in time develop into an art on its own, related to but not the same as the others, cannot be denied.

As a new art, with a new medium and a new technique—that of sound without vision—it demands a new kind of appreciation from its adherents. This new sort of appreciation is nothing more than the art of listening.

If more people were to realise the necessity of this new art, there would be far fewer complaints concerning the wireless programmes. I do not mean by this that everyone will ever blandly welcome every item broadcast from London and Daventry and the other stations of the B.B.C. The art of listening is not the art of liking everything; far from it. No individual with any personality or ideas of his own could possibly like everything. But it has been said many times that all art is selection, and selection is certainly the first principle of the art of listening.

The Switch-Forgetter.

How many people let their loud speakers have their own way and blare forth into the room whatever happens to be on the ether! I am reminded of the aggrieved listener who complained that immediately after the end of a Beethoven symphony he was shocked beyond measure to hear a music-hall star broadcasting low comedy. He said that the incongruity of it all disgusted him. And yet his complaint was so illogical.

He did not have to listen. The remedy

In this very interesting article the man who gave his name to the now famous Quintette deals with your end of the broadcast performances—the Art of Listening.

was at hand; he could have looked up the programme and shut off immediately the last note of the symphony was heard, just as he would look up the theatre list in a newspaper and reject one that he did not like the look of!

But this apparently did not occur to him. Instead he listened and complained. Why has he never complained because hardly a night in the year passes without Beethoven and broad comedy being played simultaneously in different places in the West-End? Automatically he would visit the former and eschew the latter, but in the matter of wireless the same intelligent course does not seem to suggest itself to him.

The first step, then, for the listener who



Mr. Gershom Parkington.

really wants to get the maximum of enjoyment from radio is selection—selection of those items which really interest him, and an avoidance of those which he knows will seriously annoy him. It seems almost a fatal attraction for the Jazz fiend to know that classical music is being broadcast, or for the symphony lover to realise that dance music, if anything, would make itself heard from his loud speaker! They are not content *not* to listen. On the contrary, they seem unable to drag themselves away from the hated symphony or dance music. Almost glorying in their martyrdom, they suffer. And write a letter to the Press about it!

This, of course, is in direct contradiction to the rules of the art of listening. There must be selection, or one will be swamped

and bewildered by the variety of material broadcast. And there must be tolerance of the other fellow's point of view. No two listeners have the same tastes, and so for every radio enthusiast there is a personal art of listening which he must develop for himself, subject to certain broad rules created by the very nature of broadcasting.

Every wireless listener makes one discovery at some point in his career which henceforth alters his whole conception of what wireless is and what it can do. He probably starts with the notion that it is a substitute for the theatre, for the concert hall, or for the music hall; he may even go so far as to suggest that it superseded them.

Give Artists a Square Deal.

It is a natural enough assumption. But then, one day, he suddenly realises that wireless is neither of these things; neither is it a substitute for them, nor does it supersede them. It suddenly comes home to him that wireless is something entirely new which happens to have borrowed theatrical and other material, temporarily, for the sake of convenience. The realisation of this fundamental fact is a further great step in his mastery of the art of listening.

He listens henceforth with a new understanding. Because broadcasting is young, and, as it were, uncharted, he listens with interest to experiments which may be hopeless failures, or may, on the other hand lead to important developments. He appreciates that there is a vast difference between a thing seen and heard, and a thing merely heard.

There is one sort of listener who is likely to hinder the forward march of wireless unless he can be persuaded to practise the art of listening. I refer to those who "switch on the wireless" merely as a background for whatever they happen to be doing, and do not listen at all in the real sense of the word. They are simply aware that something is happening. This is manifestly unfair to the artist, for no fair criticism can be based on inattention.

The Best Way.

Perhaps the common human tendency to despise that which is cheap and easily obtainable is partly to blame. It is so absurdly inexpensive to hear opera and music and plays—just a matter of twiddling a knob! But one thing is certain. Unless we practise the art of listening by selecting those items which we want to hear and giving them the same attention which we would give if we had paid for a seat in a theatre, we shall never know what it is to get the maximum of enjoyment from radio. And we shall go on writing these desperate letters to the Press!

A QUEER CASE OF SCREENING.

Some notes on a very interesting problem raised by a reader of "P.W." who placed his portable set on a sideboard, and found this made a surprising difference to the strength of reception.

By THE EDITOR.

THAT the majority of readers of POPULAR WIRELESS are pretty smart at spotting the cause, or causes, of all sorts of difficulties in connection with radio reception is evidenced by the large number of letters we have had in connection with a recent technical query dealt with in the feature "Captain Eckersley's Query Corner."

One of the questions submitted to Captain Eckersley was from "J. R. W.," of Finsbury Park, London, who asked: "Why is it that my four-valve frame aerial set should work satisfactorily on a table in the centre of the room and yet go very faint when I shift the whole outfit on to the top of a sideboard fitted in the same room?"

Due to the Mirrors.

J. R. W. went on to say that he had made certain there was no metal in the wall, or in the actual sideboard itself—which, in fact, was made of wood with the usual mirrors on top.

Dozens of readers have pointed out that J. R. W.'s trouble was probably due to the screening effect of the silvering on the sideboard mirrors.

This is perfectly true, and some of our readers who may wonder that an ordinary mirror in a sideboard should cause such a screening effect should try placing a frame aerial set—any portable would do—backing on to a sideboard which has a mirror fixed in it.

The screening effect is most noticeable, and we are very much obliged to the numerous correspondents who have sent us very interesting details concerning the various degrees of screening they have noticed under such conditions.

Baird Televisors.

We have received this week one of the first three Baird Televisors to leave the manufacturers' hands. It is now reposing in our Test Room, and a special amplifier is under course of construction for use in connection with this long-awaited instrument.

Although one of our contemporaries has produced a report on one of these televisors, we ourselves intend to take our time before publishing our considered opinion. But, at this stage at any rate, we can congratulate the Baird Company on producing a televisor of very good appearance, and of what seems to be first-class workmanship.

We anticipate some very enjoyable hours in the Test Room handling this first example of the commercial televisor receivers, and readers may rest assured that directly we feel justified in giving our considered opinion of its merits we shall do so—but, in fairness to the Baird Company, we shall not rush into print until we have put the instrument through a series of most exhaustive tests and bench inspections.

We are getting so many letters concerning the "Magic" series of radio sets, which we recently introduced to our readers, that it is quite impossible to publish them all in POPULAR WIRELESS. Selections are made, as our readers will have noticed, from week to week, and published in the "Correspondence" columns. But other letters, often full of most interesting details, have to be held over because of lack of space.

Mr. Roberts, of Torquay, wrote to us the other day and said that after many years of set construction, he had built the "Magic" Radiogram receiver, and was so well satisfied that he had made up his mind that something revolutionary would have to occur in designs before he altered his present set.

Success was instantaneous, station after station being received. And these, continues Mr. Roberts, were happily spread

PORTABLE PLEASURES.



This happy snapshot shows a group of listeners in the South of France, and the portable set which keeps them in touch with the home news.

over the dial, not, as in many cases, only on the upper half.

"I have enormous volume from the pick-up and find the volume control absolutely vital in operation."

"The Terrible Twins."

Mr. Tonkin, of South Woodford, writes in connection with our recent article "All Round The Dial," and regarding the experiences we recounted of a Mr. Hennequin, of Seven Kings. Our South Woodford correspondent points out, though, that in his opinion Mr. Hennequin and ourselves have missed the point!

"The B.B.C. was called into being," writes Mr. Tonkin, "to provide a broadcasting service paid for by people who

took out licences. We do not pay our licence fee to be told that if we want to receive a broadcasting service we must forthwith purchase new apparatus in order to listen to one or two programmes.

"Your correspondent comes nearer to the real objection when he refers to the monopolisation of the ether by the B.B.C. Living, as I do, in the swamp area, I think it is an outrage, but I object mostly to being told that I must spend more money on wireless or else I can't listen."

A Narrow View.

We certainly sympathise with our correspondent and admit that he has a case for the argument. But surely it is rather a narrow case? Nobody expects wireless to stand still and never progress, and whatever may be said about the Regional Scheme, it is a progressive scheme; and, although causing trouble at the moment, not to such a degree that it cannot be eliminated for a very small expenditure.

Nobody wants the B.B.C. to stand still and just rely on the same sort of service transmissions. More varied programmes, better power and many other advantages admittedly accrue from the Regional Scheme, and we feel that Mr. Tonkin has not many supporters when he says he objects to paying a few extra shillings because, by unfortunate circumstances, he lives in the swamp area of Brookmans Park.

He goes on to say: "However, for those who don't mind being forced by the B.B.C. to further expense, and who don't realise that we are the masters and the B.B.C. our servant, here is a tip for the swamp listener: If one builds the original "Brookmans" Rejector, use J type Formodentons and a 75-turn coil or over instead of a 50."

Coil Data.

Our correspondent states that he uses 80 turns on a 2½-in. former. This, he says, will work in the swamp area where, in other cases, results are not satisfactorily obtained. The 50 coil

and G condensers, according to our correspondent, only remove 356 metres effectively, and the 261-metre wave, which has much greater spread and more power, is not much effected in his case.

Although this suggestion rather departs from the specification we gave, perhaps some of our readers will find that, under their own particular circumstances, our correspondent's tip helps them more satisfactorily.

After all, it is difficult to give a distinct specification to apply in all cases, and so any tips from readers of this nature would be very gratefully received here, and included in articles from time to time, such as this one, for the general benefit of readers.



ANYONE will tell you that the grid condenser in an R.C.C. stage must be a mica condenser because it has to stand up against the H.T. voltage. Presumably, providing it is mica, everything is O.K., and the component can be screwed down on the baseboard and then forgotten.

And perhaps it can if it is a well-made condenser, and it is mounted so that there is little danger of dust settling on it or something short-circuiting its terminals. But let us analyse its position in the circuit and then you will see exactly how important it is that it should offer a complete barrier to the flow of direct current.

At Fig. 1 a complete R.C.C. stage is illustrated theoretically, and the all-important condenser is indicated by an X.

Making a New Circuit.

The anode resistance will have a resistance of at least 100,000 ohms and the grid leak a resistance of somewhere around about half a megohm, perhaps a little more; I am giving this component 4 megohms for the sake of easy working.

Our H.T. is going to be 150 volts and the grid bias 10 volts for the very same reason. Nevertheless, these values are not freak ones and you frequently meet them in actual practice.

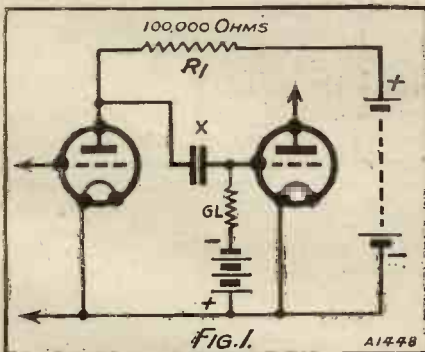

The "vital item" in this circuit is marked by an "X." It is the coupling condenser used in a conventional manner.

Now it is all very well to insist that the coupling condenser shall have a mica dielectric so that it does not break down when fairly high voltages are impressed on it, but it is every bit as important that its insulation shall be of a very high quality, and this is not the same thing at all.

Supposing it were built into a composition casing of such poor material that instead of insulating the device its two ter-

One tiny condenser, not quite up to the mark, can throw your whole receiver out of gear. Read this article and note how seriously a million or so misplaced ohms can mar a set's operation.

By G. V. DOWDING, Assoc. I.E.E.

minals were connected by a conductive path. The condenser then becomes something of the nature of a grid leak or resistance.

A condenser of unknown make having copper plates and mica dielectric that I tested quite recently had a resistance between its terminals as low as 1/2 megohm!

It is interesting to note that a first-class mica condenser that had been allowed to become covered with a layer of the quite ordinary sort of dust that accumulates in a house showed a leak of 6 1/2 megohms.

The moment that anything like this happens (when the condenser is in an R.C.C. stage) a circuit such as is indicated at Fig. 2 is constituted.

Current can flow from the H.T. battery and the grid-bias battery through the grid leak and the coupling condenser and so on through the anode resistance. The grid battery joins the H.T. battery as a common supplier of current for this new circuit.

The current flow may be a small one, but it will persist even when the L.T. battery is disconnected and the set is supposed to be at rest. Thus the first serious effect is that the H.T. battery has to supply some small current for 24 hours per day every day of the week.

Terrific Distortion.

The second effect is rather more interesting, though it is, in its way, just as serious. The grid bias is completely upset and terrific distortion can result.

As there is a current flowing through the grid leak there will be a difference of potential between its two ends which, owing to its position in the circuit, correspond with the grid and the filament. If you have a look at Fig. 2 you will see that this voltage will make the grid positive in regard to the filament in opposition to the grid-bias battery, which is endeavouring to make it as many volts negative in relation to the filament.

Rather odd, isn't it, that while the grid-bias battery joins the H.T. battery in endeavouring to send a current round this

new circuit, that it opposes it when it comes to biasing the grid?

Let us bring some figures into operation. Supposing the coupling condenser developed a leak of 2 megohms (2,000,000 ohms), then the resistance of the complete new circuit it brings into being will be 2,000,000, plus 100,000 (anode resistance) plus 400,000 (grid leak) ohms, i.e. 2,500,000 ohms.

The voltage will be 150 (H.T.) plus 10 (grid bias) volts, i.e. 160 volts.

The current flow in the circuit is $\frac{160}{2,500,000}$ amperes. Now if $\frac{160}{2,500,000}$ amperes is flowing through a grid leak of 400,000 ohms resistance the voltage drop across it will be $160 \div 2,500,000 \times 400,000$.

These figures work out at 25 2/3 volts. That is, the grid is being made 25 2/3 volts positive in relation to the filament. But there is 10 volts of grid bias acting in the other direction; $25 \frac{2}{3} - 10 = 15 \frac{2}{3}$. The grid, instead of being 10 volts negative, is actually 15 2/3 volts positive!

The Other Extreme.

If we had a leak across our coupling condenser of 1/2 megohm (500,000 ohms), the grid would be 70 volts positive!

At the other extreme it is worth pointing out that even if the leak were one of 10 million ohms the grid would be offered over 6-volts positive potential!

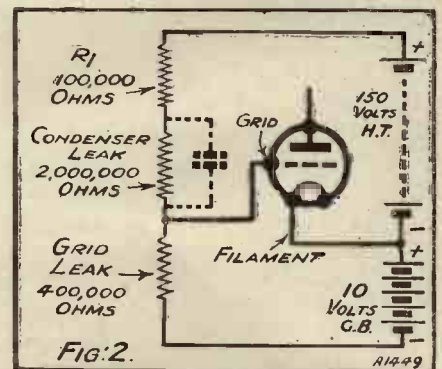

This diagram illustrates the effect of a leaky condenser being used for coupling purposes in an R.C.C. stage

It inclines one to advise the use of two first-class mica condensers joined in series and carefully mounted on glass pillars under an airtight glass covering, but I don't think it is as serious as all that!

Nevertheless, it is something to bear in mind; I think you will agree that it is of some importance.

REVERSING THE L.T.

The Editor, POPULAR WIRELESS.

Dear Sir,—I have been interested in the articles on Mains Units, and I think my experience with these may be of interest. Our mains here are 230 volt D.C.

Some time ago I made up a four-valve set—Screen Grid, Det., and 2 L.F. (transformer coupled) and used a mains unit for H.T. For some time I could not make much of the set, owing to its being so unstable. As soon as I got it up to any volume it would suddenly burst into a loud howl or seem to overload on louder notes. Also there was a fair amount of hum and a slight whistle all the time.

After trying various remedies without much result, I thought I would try changing over the L.T. leads, H.T. and L.T. negatives having been common as in usual practice. The set at once became perfectly stable. All hum and whistling disappeared and the tone, with M.C. speaker, very excellent. Foreign stations come in with great power. I use no earth.

I have recently made a radio gramophone, using an H.T. unit of different make. I wished to do away with any earth wire and made up the amplifier in the usual way with the two negatives common. Results were very powerful but there was a great deal of hum. I then changed over the L.T. leads, and results, although not so powerful, were very good. By putting another valve in front of the first transformer and earthing the core of this, etc., results are now beautiful without a trace of hum.

I do not know how to account for this, and I do not know which side of the mains is earthed, although I should imagine the positive, but I hope the above may be useful to some of your readers if you care to publish it.

Yours faithfully,

R. T. BODLE.

Sussex.
[ED. NOTE.—An article on "Reversing the L.T." will shortly be published in "P.W."]

A USEFUL TESTER

The Editor, POPULAR WIRELESS.

Dear Sir,—Many people, when trying a set out (like myself until I blew three valves up) insert all the valves, risking their lives. The sketch I enclose shows how I overcome the trouble.

All one needs is the bottom of a burnt-out valve, a bulb holder and bulb. I think the sketch explains everything else.

Another way in which I use it is for showing a light in the set when re-soldering a wire or tightening nuts or terminals.

This may prove useful where a set like mine is situated in a dark corner.

In conclusion, may I thank "P.W." staff for the "Magic" Three, which I built the following week it was published. I have tried it on short waves and received the following: W8XK Pittsburg, W2XAF, Schenectady (loud-speaker strength at

CORRESPONDENCE.

REVERSING THE L.T.

A USEFUL TESTER—THE "MAGIC" ;
64 STATIONS—THE "MAGIC" THREE—
THE "MAGIC" FOUR.

Letters from readers discussing interesting and topical wireless events or recording unusual experiences are always welcomed; but it must be clearly understood that the publication of such does in no way indicate that we associate ourselves with the views expressed by our correspondents, and we cannot accept any responsibility for information given.—EDITOR.

(times), and three others which I have not identified. By the way, this is my first short-wave, and I have only had coil a fortnight.

Yours truly,

H. HAMMILL.

Greasbro,
Near Rotherham.

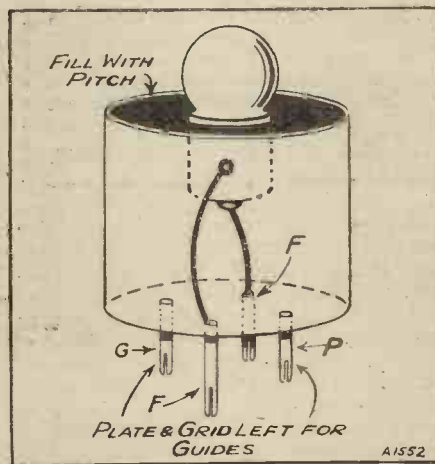

You just plug the gadget with the valve holder.

SHORT-WAVE NOTES.

By W. L. S.

band from 500-200 metres with programmes of all kinds, and there is very little to be said against this band on the score of general efficiency and carrying power.

Then, as the next step, the amateurs were gently but firmly removed to the band of waves between 150 and 200 metres, "quite useless and impracticable—why, it was impossible to make a receiver oscillate below 300 metres!" Before two years' work had been completed on the new wave-length, though, two-way communication with the United States (the first ever achieved except by commercial stations with inputs of many kilowatts) had been established and repeated.

The Next Step.

The next step—down to 130 metres—was the most interesting of all for, although this band (as, indeed, all of them, as one went down) seemed unreliable, it was soon proved to have wonderful properties for long-distance working, and all the "big noises" in the amateur world were soon breaking records there.

I could go on with this ad lib.—there are tales to tell of the various "dives down"

THE "MAGIC"—64 STATIONS.

The Editor, POPULAR WIRELESS.

Dear Sir,—Allow me to congratulate you and your staff on the "Magic" Three. Sixty-four stations, and well over half of them on the loud speaker, is my record.

I have built many of your sets, and the outstanding successes have been the "P.W." Combination, "Trinadyne," "Chitos," and "Magic" Three.

Yours sincerely,
LAURENCE LEE.

London, N.19.

THE "MAGIC" THREE.

The Editor, POPULAR WIRELESS.

Dear Sir,—Such a lot has been written by readers of "P.W." in praise of the "Magic" Three that I feel convinced you will be interested to learn of my own experience with this particular circuit.

In the first place I built the set as originally described in "P.W." mainly with parts taken from my old outfit, some of which had been in use for some considerable time, and found it was a real globe trotter, and very easy to handle.

As I wanted a set that would hold H.T. batteries, accumulator, loud speaker, and everything, and at the same time be more or less a transportable set, I decided to rebuild the "Magic" Three into a cabinet, measuring 12 in. by 17 in. by 8 in., more in the way of an experiment.

It is finished, and I am delighted to say that the performance is wonderful, considering that the whole of the parts as originally specified are on the baseboard, which measures only 12 in. by 7 in. Foreign stations come in quite easily, and at full loud-speaker strength, without any sign of wooliness, or harshness, and the set is still simple to operate.

Yours very truly,

W. A. BROOMFIELD,

Essex.

THE "MAGIC" FOUR.

The Editor, POPULAR WIRELESS.

Dear Sir,—I should like to add my congratulations to the many already expressed, in relation to your "Magic" sets, particularly the "Three."

I recently constructed this set from the "Junk Box" and was astonished.

Therefore, I decided to rebuild to your exact specification, and have come to the conclusion that somewhere tucked away there is some magic. Tone, volume and selectivity cannot be bettered.

Thanking you for many happy hours spent in and out of your books, and eagerly waiting the next set.

I am,

Yours faithfully,

B. H. PADGETT.

Herts.

It does one good to look back occasionally, instead of perpetually looking into the future and feeling rather frightened at what may happen some day. Looking back into the early days of amateur radio, one realises suddenly that the development of the short wave-lengths into workable and practicable form has really been extraordinarily rapid, and it is hard to believe that we shall ever come up against anything like a stone wall as still further progress is made.

Down, Down, Down!

Amateurs all over this country at the present time are very keen on turning the 10-metre band of wave-lengths into a reliable, usable wave-length, even if only for local work, for it is one of the widest bands they have been allotted and shows signs of becoming very popular.

There are, however, all sorts of little snags and big snags that are rather apt to make one lose faith; looking back, however, who can say that equally serious snags were not met with as the various wave-lengths were first used.

It seems ridiculous that anyone should ever have looked upon 440 metres as a "short wave-length"! Yet that was the case when, between 1920 and 1922, the amateurs were gradually vacating the 1,000-metre band in favour of the "short wave" of 440 metres, having found that this new wave to which they were relegated was not quite as useless as they anticipated. And now look at the 440-metre band! Veritable giants of the ether fill the entire

to 80 metres, then 40 metres, then 20 metres, and the extraordinary thing about the whole transition is that each new and shorter band seemed at first to be thoroughly unreliable, but to have greater powers for real long-distance work than its predecessor. And, as everyone knows, the present holder of the record is the 20-metre band, where with low power any amateur who knows what he is doing can work with all six continents and hold communication with the Antipodes at dawn or dusk.

"Untameable" Band?

The question now, of course, is—what next? The 10-metre band certainly upholds the record as far as unreliability goes, but many consider it out of all proportion to the others, and go so far as to say that it will never be "tamed." Personally, I think that if the "unreliability factor" varies as the square of the frequency this 30,000-kc. band is just about right!

The only puzzle is this: How can it possibly turn out to be a greater distance-getter than 20 metres? Where are we going to go to next? And when two London amateurs "hook up" on 10 metres are the signals due to "ground wave" or are the genuine radiated signals going upwards and being reflected, or perhaps circling the world on the way? I, personally, am keeping a very detailed log of everything I find out about 10 metres, and, to my knowledge, many amateurs are doing the same. There is no doubt that the literature thus collected should make interesting reading in a few years.

FERRANTI

CONDENSERS



Type C1.



Type C2.

The British workman is second to none in the world: British knowledge is second to none in the world: and British Condensers made by the British workman backed by British knowledge are second to none in the world. When the best that can be made are British made—at Hollinwood—it's just as well to stipulate

Ferranti Condensers

and let your dealer understand that you know what's what!

PRICES:

Type C1 - 5/6 Type C2 - 3/6

TRANSFORMERS



1. Ferranti Audio Frequency Transformers are definitely the most suitable for any set.
2. Ferranti Transformers do not require replacement year by year—they last indefinitely.
3. As Transformer experts we can demonstrate beyond dispute that any good set is better with Ferranti Transformers.

You must have a good Transformer—and the best is Ferranti.

With more selective tuning a desirability.

K.C. CONDENSERS are a necessity

K.C. CONDENSER

Tuning is velvet smooth and free from backlash. With knob, dial and slow-motion device, 12/-
Without knob, dial or slow-motion device, 8/-
-0003 or -0005

K.C. DRUM CONTROL CONDENSERS

With Drum Control and slow-motion device, -0003 or -0005 15/6
Triple K.C., each condenser -0003 or -0005 38/6
Triple K.C. Combinations of -0003 and -0005 40/-



MIDGET CONDENSER
A small variable condenser for panel mounting.
-00005, -0001 or -0002.
5/6

If you have any difficulty in obtaining Dubilier products write to us direct giving the name and address of your dealer.

DUBILIER VARIABLE CONDENSERS

Free for the asking—"A Bit about a Battery." There's a copy for you at your dealer's.



Dubilier Condenser Co., (1925), Ltd., Ducon Works, Victoria Road, N. Acton, London, W. 3.

Cleaver BC298/V

In TONE

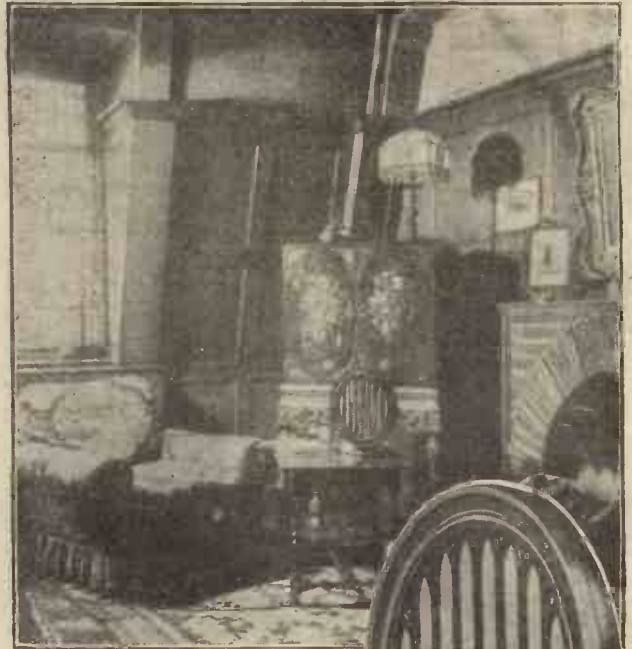

With Beautiful Surroundings

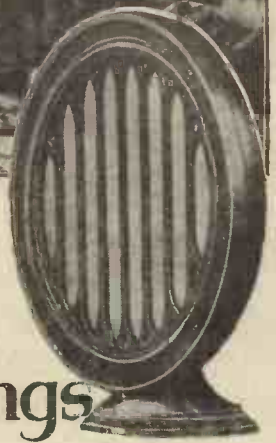

The fine appearance of the B.T.H. Cone is as notable as is its wonderful tone, its full volume and its faithful reproduction of all sounds—from the gruff voice of the test engineer to the delicate trill of the piccolo.

It is inexpensive and its ornamental grills, backed with old gold gauze form an artistic addition to any existing decorative scheme.

PRICE £3.

B.T.H. CONE LOUDSPEAKER



THE EDISON SWAN ELECTRIC CO., LTD.,
Radio Division,
1a, Newman Street, Oxford Street, W.1.
Showrooms in all the Principal Towns.

EDISWAN

IN. 71



CAPT. ECKERSLEY'S QUERY CORNER

Under the above title, week by week, Captain P. P. Eckersley, M.I.E.E., late Chief Engineer of the B.B.C., and now our Chief Radio Consultant, will comment upon radio queries submitted by "P.W." readers. But don't address your queries to Captain Eckersley—a selection of those received by the Query Department in the ordinary way will be dealt with by him.

Interference With Mains Unit.

N. O. Y. (Caithness).—"Since operating my receiver with a battery eliminator, I have experienced a great deal of interference from an electric flashing sign. Using an H.T. battery, this interference is not noticeable. Why should this be?"

I should think the mains leads (which are all part of the same electric system as is connected to the flashing signs) are acting as radiators of electric waves set up by the flashing sign. Being brought very near your set, as they must be, allows you to pick up from them.

Try screening the leads in lead-covered cable. But I am not guaranteeing a cure even then.

Transformer for Pick-Up.

B. J. D. (Norwood).—"I am thinking of inserting an electrical pick-up in my set. Would you advise me to use an input transformer? If this is inserted what effect will it have on results?"

Certainly use a transformer near the set. I hate the idea of a grid lead wandering about all over the place. It will also help you to get more bingie if the transformer is stepped up a bit.

Using a Double-Wound Choke.

E. H. J. (N. Wales).—"I have a double-wound filter choke, and wish to use only one winding. What will be the effect on the inductance of shorting the second winding and, secondly, of leaving this winding unconnected?"

Shorting the idle winding would enormously reduce the inductance of the choke, and it would stop its filtering properties by so doing, so leave it idle if you are not going to use it in series with the other winding.

This latter connection would—if it turns on each winding are comparable in number—increase your choke inductance, and so increase its powers of "choking."

Strength With Big Coil and Small Condenser.

H. P. D. (Worthing).—"Why do I find that I often receive stations louder when I use a large coil and less condenser than when I use a small coil and a greater capacity?"

The voltage across a resonant circuit is $\rho \lambda \iota$ where ρ is about six times the frequency, λ is the inductance of the coil, and ι the circulating current.

Making λ bigger makes $\rho \lambda$ greater and if you do not add too much resistance,

and ι does not go down proportionately as λ goes up, the whole product $\rho \lambda \iota$ is greater, so the voltage is greater and so the signals are louder.

Reversing Transformer Connections.

P. M. L. (Dundee).—"Why is it that reversing the leads to the secondary of the low-frequency transformer will sometimes cure instability in an amplifier?"

A SHORT-WAVE HINT.

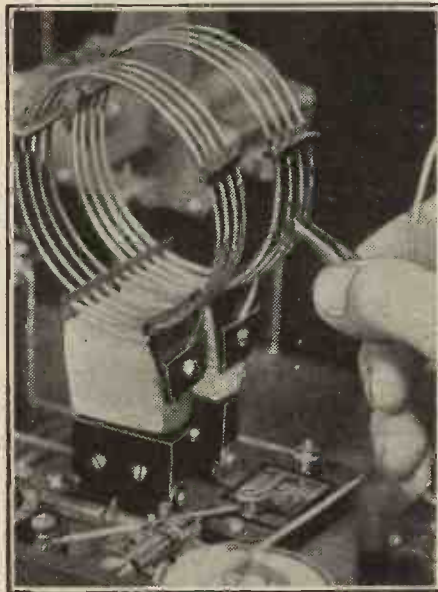

Trouble with reaction and reluctance to oscillate can often be overcome by altering the position of the clip which governs the number of "aerial" turns in circuit.

It sometimes stops retroaction effect. If you have effectively two coils, one in the anode circuit of a valve, the other in the grid, the system can be made to oscillate, as you know. But it will only oscillate if the grid and anode coils are connected such a way round as to produce regeneration in the system.

Reversing a coil from its sense when it will create oscillations will stop oscillations. A low-frequency amplifier can oscillate, but reversing the sense of one winding in the chain puts paid to regeneration.

G.B. for S.G. Valves.

L. H. W. (Streatham).—"I have often noticed that a small 1½-volts bias battery

is used in certain circuits to bias the S.G. H.F. valve. When is it necessary to use this battery?"

It just depends on the characteristics of the valve, and its conditions of working.

Some valves require this battery, some don't, some do with such-and-such an applied voltage, etc., some don't. Consult your valve-makers if you cannot read the characteristic yourself.

The Howl in the Cabinet.

A. E. C. (Slough).—"My set, which is a detector and two transformer L.F., is perfectly normal until I put it into a cabinet. It then commences to set up a howl which remains of one constant frequency irrespective of the tuning condenser position.

"As soon as the set is removed, it again becomes quite normal. Why should this be?"

When your set is in the cabinet, by some combination of circumstances the sound waves from your loud speaker impinge on the valves of the set so strongly that these "pong"—a noise you can produce from your loud speaker by flopping a valve with your finger-nail.

This "ponging" makes the loud speaker give out the "pong" note, which impinges on the valves which give out more pong, which makes the loud speaker give out more sound of the pong sort, and so on, until a howl sets up.

Cure: screen your set from being affected by the loud speaker—to wrap up your valves in cotton wool is a good scheme.

Frame Aerial or Indoor?

F. A. (Ilford).—"I have a four-valve set with screen-grid, H.F. det. and 2 L.F. I am not, however, able to erect an outside aerial. The set will be used about 16 miles from Brookmans Park, so would it be preferable to use a frame aerial or an ordinary indoor aerial?"

An ordinary indoor aerial is usually more sensitive than a frame. A frame looks nicer, though. There's usually quite 1 H.F. stage difference.

Interference From Ships.

A. R. (Dover).—"I am troubled with Morse interference from ships in the Channel. Is there any method of cutting this out?"

None, probably; but write to the B.B.C., who will, if it is a curable case, represent your troubles to the proper authority.

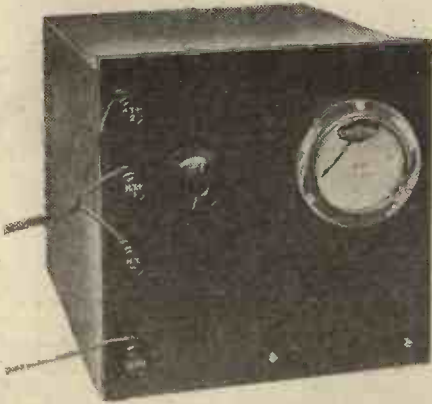

There are no unnecessary knobs!

unless the mains are good and give little hum. The point about these latter sets is that their magnification is so high that if there is any hum getting through to the detector they will amplify it up strongly.

A good example of this type of receiver is the "Magic" Three, which has been tried with the "Safe-Power" Junior. Although

WE recently gave our readers a general idea of the simpler questions involved in producing a thoroughly rational and efficient D.C. mains H.T. unit, and in this article come to the practical side of the matter.

We have not yet covered all the problems encountered in the design of the larger type of unit, of course, but so far as the smaller ones are concerned we are ready to begin. Accordingly we are presenting the first of our series of rationalised units, which is to be the junior model for small and medium-sized sets.

Let us be quite clear about this, because one of the commonest causes of trouble and disappointment with mains units is to be found in the use of instruments unsuited for the job they are called upon to perform. The "Safe-Power" Junior, then, is definitely intended for running comparatively small sets.

What It Will Do.

For a two-valve set of the H.F. and detector, or detector and one L.F. type, it is perfectly satisfactory, and, of course, for single-valvers, although no one is likely to use it for such a small receiver as that. It will also serve satisfactorily for some types of three-valvers. These types are the older form of H.F., Det., L.F. circuits, using an ordinary neutralised H.F. stage, and some detector and two L.F. sets.

It will not serve for sets with a screened-grid valve, and it is not really advised for very powerful detector and two L.F. sets,

Here is an exceedingly simple unit for getting your High Tension from Direct-Current (D.C.) Mains. It is the result of extensive experiments and investigations carried out by the "P.W." Research Dept. and described recently in "Popular Wireless." No unnecessary components are used and—this is important—IT'S SAFE! You can't put a careless finger inside it and get a nasty shock, because it's enclosed in a metal case which you can't open unless you disconnect the mains first! Designed and Described by THE "P.W." RESEARCH AND CONSTRUCTION DEPARTMENT.

it was quite stable and free from motor-boating (of course, an output filter was added: this is essential in all sets to work from D.C. mains), there was a decided hum on the "P.W." laboratory mains, which are particularly noisy and rough ones. "Safe-Power" Junior has not sufficient smoothing for sets of this sort, which call for a more elaborate unit, such as one of the later models in this series.

Not For Large Sets.

To sum up, then, this is what the "Safe-Power" Junior is intended for: small and

So much for what the "Safe-Power" Junior unit is intended to do. Now let us see what

it is. In as few words as possible, it is an exceedingly simple H.T. unit for use on D.C. mains, in which every component does a useful job of work, and everything is done to obtain the greatest possible efficiency at the least possible expenditure.

SIMPLE! SIMPLE!

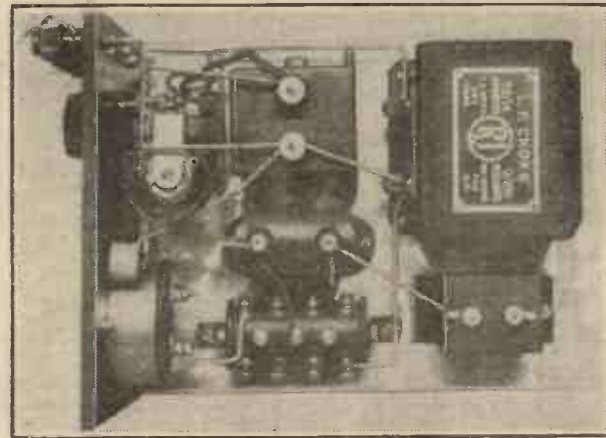
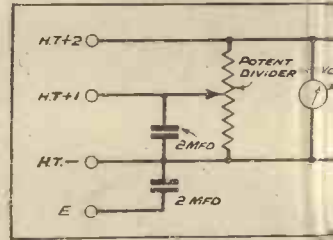

If you compare this bird's-eye view with the wiring diagram on a following page, you will agree that the wiring is simplicity itself.

LIST OF COMPONENTS

- 1 "Safe-Power" Junior chassis, lid and panel (Ready-Radio, Magnum, Wearite, Paroussi, Keystone, etc.).
- 1 25,000-ohm variable resistance, potentiometer type (Varley).
- 1 0-to-250 or 0-to-300 voltmeter (Sifam, Ferranti, Weston, etc.).
- 4 Engraved insulated terminals (Belling-Lee, Igranic, etc.).
- 1 Heavy-duty smoothing choke, 20 to 40 henries (R.I. 28/14, Ferranti B2, Varley, Wearite No. 3, etc.).
- 1 4-mfd. high-voltage type condenser, working voltage to be not less than

medium-sized receivers requiring only two separate H.T. positive tapplings. These are chiefly two-valve designs, although quite a number of three-valvers will also work satisfactorily with this unit, provided that they are of the detector and two L.F. type with one stage of R.C.C. and one of transformer.

Special Features.

Very powerful detector and two L.F. receivers like the "Magic" Three are likely to give a good deal of hum when used with the "Safe-Power" Junior unless the mains are unusually quiet ones. For such receivers we advise one of the later "Safe-Powers."

Special features are an arrangement to eliminate the guess-work as to voltages which is such a stumbling block to the beginner in mains working, careful provision to prevent motor-boating, a simplified earthing scheme, and a special new system of construction which makes a particularly workmanlike and almost professional-looking job, and at the same time provides very important safety features. Some of these features you

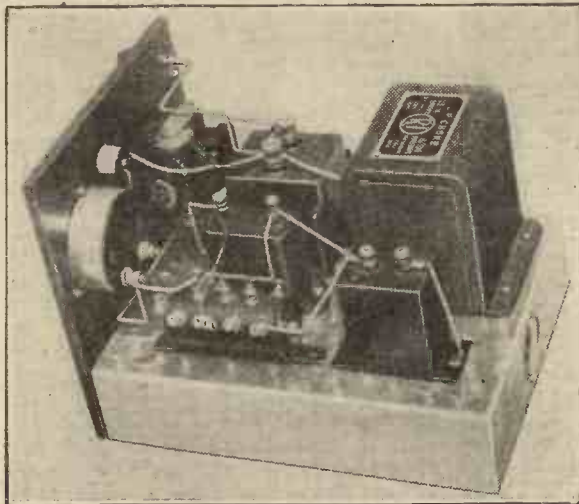
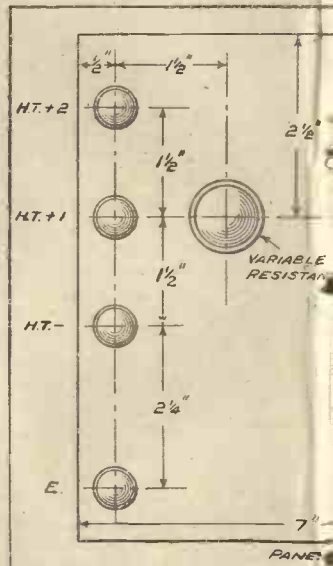

The potentiometer with numbered terminals (in the foreground) enables you to pick just the right voltage for your detector.

UNIOR



normally be used for the L.F. and power valves in your set, and here you will generally want either 120 or 150 volts, according to the rating of the particular power or super-power valve you are using. Accordingly, you will connect the unit up to your set, and with the valves working with the correct grid bias you will turn the knob of the main controlling resistance until the voltmeter shows either 120 or 150 volts.



SAFETY FIRST—you cannot “get at the works” until you have disconnected the mains!

can see clearly in the circuit diagram, so let us just run over these particular items first. Observe that

MENT! SAFE!

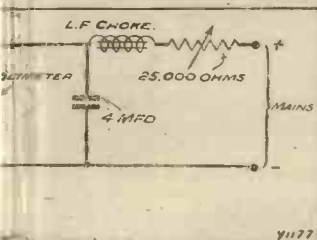

where the positive lead enters the mains unit it encounters immediately a variable resistance, and this is used as a main control of voltage. Passing on from this resistance there is one large choke,

is no need to worry about the reading being upset by the voltmeter, because that cannot happen with our arrangement. The voltmeter is connected permanently in circuit, and so is always showing exactly what the voltage is. The voltage would only be upset, of course, if you were to disconnect the meter, which is not necessary with our arrangement.

The Detector Voltage.

That takes all the uncertainty out of the question of what voltage the L.F. and power valves are getting. But what about the detector? Well, there is a very simple way of finding out just what is happening here also. By using one definite type of

know how to get any particular voltage for your detector valve, we have determined experimentally the voltages on the different tappings on the potential divider when a known voltage is across the whole circuit—that is to say, between the negative and the H.T.+2 terminal, where it is shown upon the voltmeter.

Thus, if you adjust the main resistance to give 120 volts on the meter, and therefore on the L.F. and power valves when the set is actually working, you will get a certain series of voltages from the various tappings on the potential divider, which are available on the H.T.+1 terminal according to the position of the flex lead. If you adjust matters so that you are getting 150 volts on the meter, than you will get another set of figures on the potential divider tappings, and by referring to the notes which we are just about to give you will be able to find any particular voltage for your detector.

A Simple Guide.

To get these voltages, of course, you will understand that the flex lead running from one side of the 2-mfd. condenser inside the unit should be placed upon one or other of the intermediate tapping terminals on the potential divider. The figures we are about to give are the voltages obtained on these tappings when a detector valve is drawing an average amount of current from the H.T.+1 terminal.

(Continued on next page.)

COMPONENTS.

- 200 volts (T.C.C., Mullard, Lissen, Dubilier, Ferranti, Hydra, Loewe, etc.). (Note: must not exceed 4½ ins. in height. Two 2 mfd. units can be used in parallel.)
- 2-mfd. ditto (Dubilier, Lissen, etc.).
- 2-mfd. ordinary receiving-type condenser (Lissen, Mullard, T.C.C., etc.).
- 20,000-ohm potential divider (Bulgin). (Other types such as the Wearite, Climax, etc., can be used, but the voltage figures given in the text apply only to the make specified.)
- Wire, screws and nuts, a short piece of Flex, etc., or Keystone Koneceterkit.

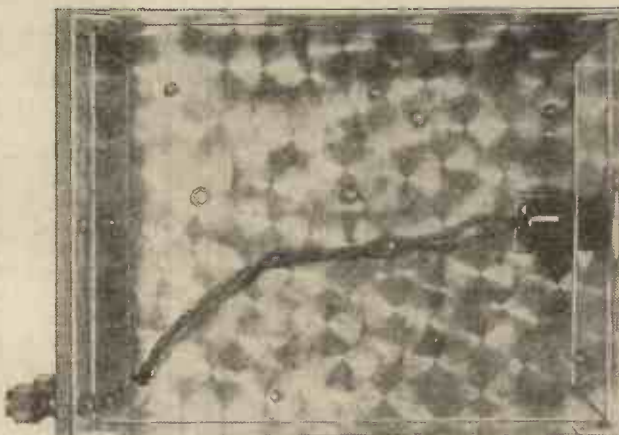

This view shows the ingenious arrangement below the metal “baseboard” that automatically locks the case whilst the unit is in use.

with, upon its further side, a 4-mfd. reservoir condenser, these two together forming the main smoothing filter.

Connected right across the circuit is a voltmeter, and this in conjunction with the main resistance provides us with the means of finding out just what voltages we are getting, and adjusting it as desired. The idea is this. The H.T.+2 terminal will

potential divider we have been able to prepare some data which will tell you with quite sufficient accuracy how to obtain the right voltage for your detector.

De-Coupling.

You will observe in the circuit diagram that a tapping is taken off the potential divider and goes to terminal H.T.+1, from which there is another condenser of 2 mfd. connected down to the negative. In order that you may

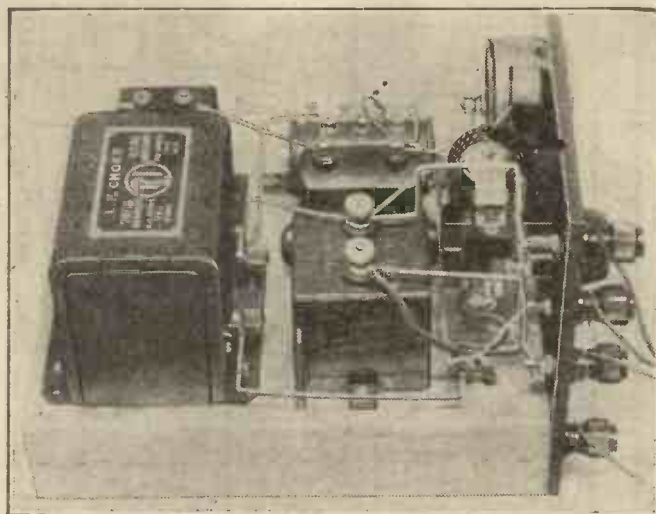
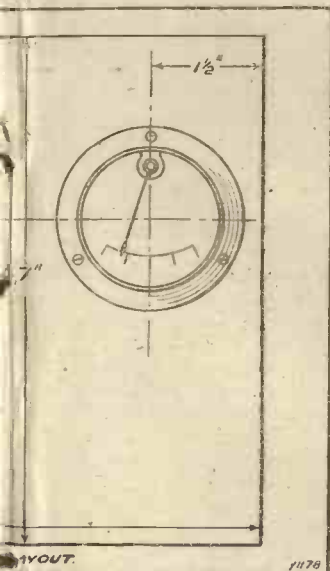

Most of the connections can be seen in this view, and it will be noted that there is no “crowding” of components—often a trap for the unwary!

THE P.W. "SAFE-POWER" JUNIOR.

(Continued from previous page.)

They will vary a few volts either way, according to the exact current your detector draws, but this is really a matter of no particular importance. All you want to know is quite roughly the voltage the detector is getting, since naturally you will try various tappings until you find the

voltage which gives you the best reaction. Here are the figures: When the voltmeter is reading 150 volts and the set is working, you will find that you get approximately 45 volts from terminal 2 on the potential divider, 54 volts from terminal 3, 65 volts from No. 4, 70 volts from No. 5, 80 volts from No. 6, 95 volts from No. 7, 110 volts from No. 8, and 125 volts from No. 9.

Under the alternative condition, when the voltmeter is showing 120 volts you will get the following approximate figures available on the potential divider: 40 volts from No. 2 terminal, 50 volts from No. 3, 55 volts from No. 4, 60 volts from No. 5, 75 volts from No. 6, 82 volts from No. 7, 90 volts from No. 8, and 105 volts from No. 9.

How It Is Earthed.

The earthing scheme is a very simple one, and you can see exactly how it is arranged on the circuit diagram. Inside the unit there is the necessary 2-mfd. condenser which must always be brought in series with the earth lead to prevent shorting D.C. mains under some circumstances, and what you do is this: Disconnect the earth lead from your receiver and connect it instead to the terminal E on your mains unit. Make no connection whatever be-

COMING SHORTLY!

Another splendid "Safe-Power" design specially intended for use with large receivers.

SIMPLE! SILENT! SAFE!

tween the earth terminal on your set and the mains unit.

So much for the general arrangement of the circuit. Now we come to the very important point of the practical make-up of the unit, which comprises those questions of safety precautions which are so important in mains working. We have been so impressed by the importance of these matters in the course of our experimental work that we have decided to take a definite step forward and scrap all the old methods of construction involving wooden baseboards and wooden cabinets, with all their undesirable features which are only too familiar.

Safe and Easy.

Instead, we are introducing an all-metal system of assembly which we believe will be found a very definite step forward. It might look at first sight as though it were going to make the construction of the unit more difficult, but as a matter of fact you will find that this difficulty is far more apparent than real.

It merely means in actual practice that instead of fastening your parts down on a wooden baseboard with ordinary wood screws, you will have to drill a few holes in soft metal and do your fastening down with small brass B.A. screws and nuts. It is a perfectly easy process and you will find that the drills you have been using in the past for ebonite will run through the soft aluminium sheet we have employed for the construction as if it were cheese, and the job will really not take you any longer than it used to do with the old method of construction. This point and others we shall be taking up next week.

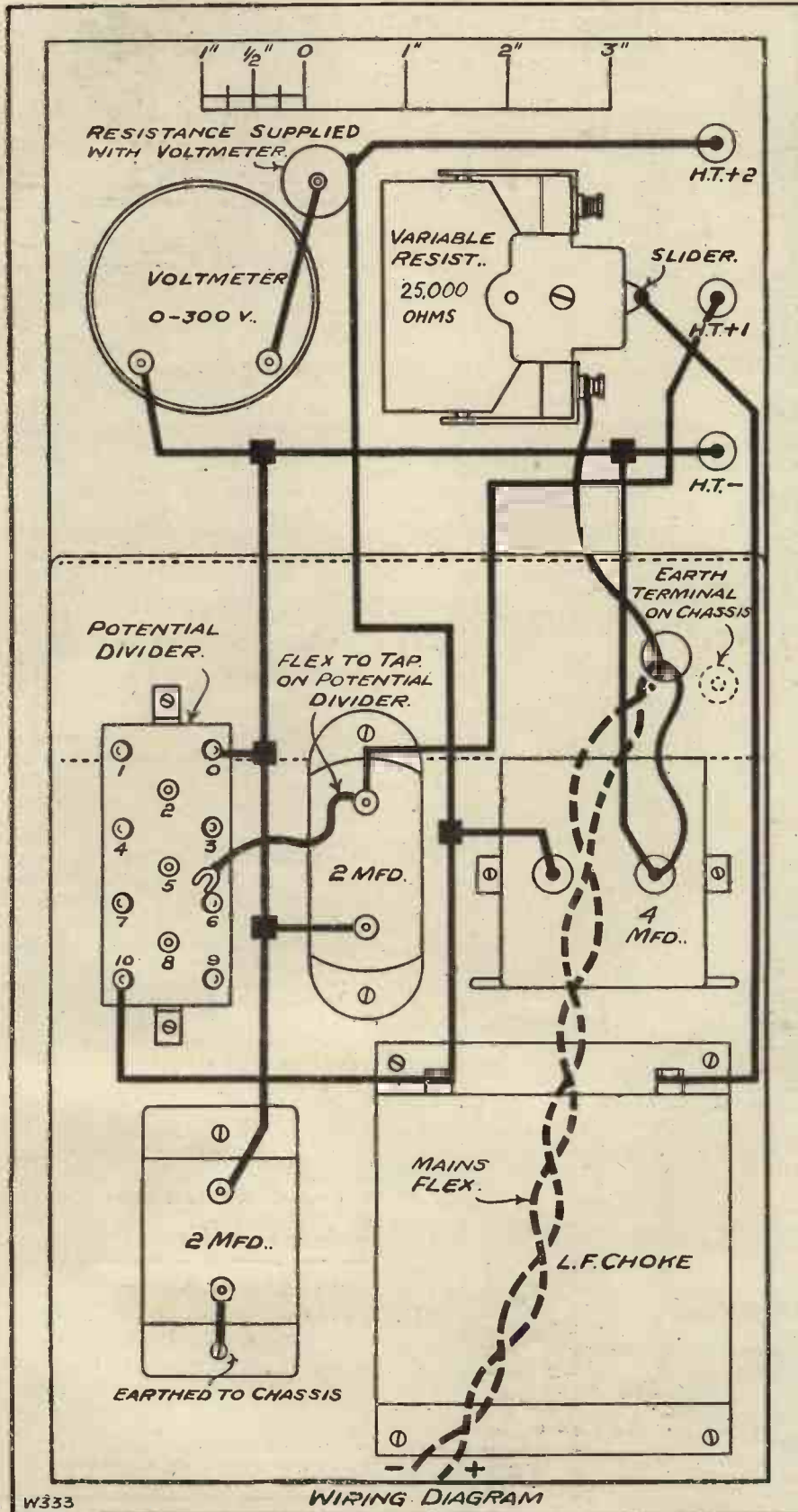

THE BIG STRIDE



FORWARD

IN BATTERY PERFORMANCE



IT COSTS NO MORE!

NEW design, new materials, new methods of construction all combine to make the Full O' Power Battery of outstanding merit. The exclusive employment of seamless drawn zinc cylinders of exceedingly high purity—
AVOIDS : corrosion.
GIVES : larger output of current.
ENSURES : longer service.
GUARANTEES : maintenance of a high standard of efficiency over a long period.
 Size No. 1210. 60 Volts.

Are You Earning 'Enough'?

THEN WHY NOT MAKE MORE IN YOUR OWN TIME?



If you want to earn more Money here is your Chance! Seize it with both hands, for it is not every day that such an Opportunity is put before you. Write for Free Particulars TO-DAY of THE BIG NEW HOME INDUSTRY which the enormous expansion of Wireless and Electricity has created.

You can make a start on your Kitchen Table in your spare time to build a lucrative business by manufacturing at home our enormously successful patents—Big Profits are being made in the Wireless and Electrical Industry, and my Patents will enable you to participate in them. They are in increasing demand everywhere because they are such a great improvement upon all others.

Both Men and Women are Making Money this way.

The work is not only interesting and Profitable but easy. Even the Family can help you. You need no previous knowledge of Electricity and no special skill. No expensive "Plant" or Machinery is required. You need only a few simple tools and hand presses—most of which you can make yourself if you like at small cost. Your Business will be protected under Royal Letters Patent so that no unlicensed person can copy you. Your "Field" will be unlimited—your

Profits Guaranteed!

Anything up to £300 a year can be made on your own premises—your profit is only limited by the amount of time you have to spare. You have a FREE HAND in selling, but if necessary we will purchase sufficient of your stocks to ensure a weekly profit to you providing they reach the required standard of efficiency which can be easily attained, and we undertake to continue your training FREE until that Standard is reached—could anything be more definite or more fair?

You can start NOW on the road to Success and a Bigger Income by sending for FULL FREE Particulars of this Proposition. NOW you can turn those spare hours into GOLDEN Hours, Pleasurably, Easily! The Wireless and Electrical Industry is still expanding at a tremendous rate—here is YOUR chance to "jump in" and benefit! Post off the form below *instantly*—seize hold of this Genuine, Honest proposition and start forward to becoming an Independent Master Man!

This Form will bring You Full Particulars

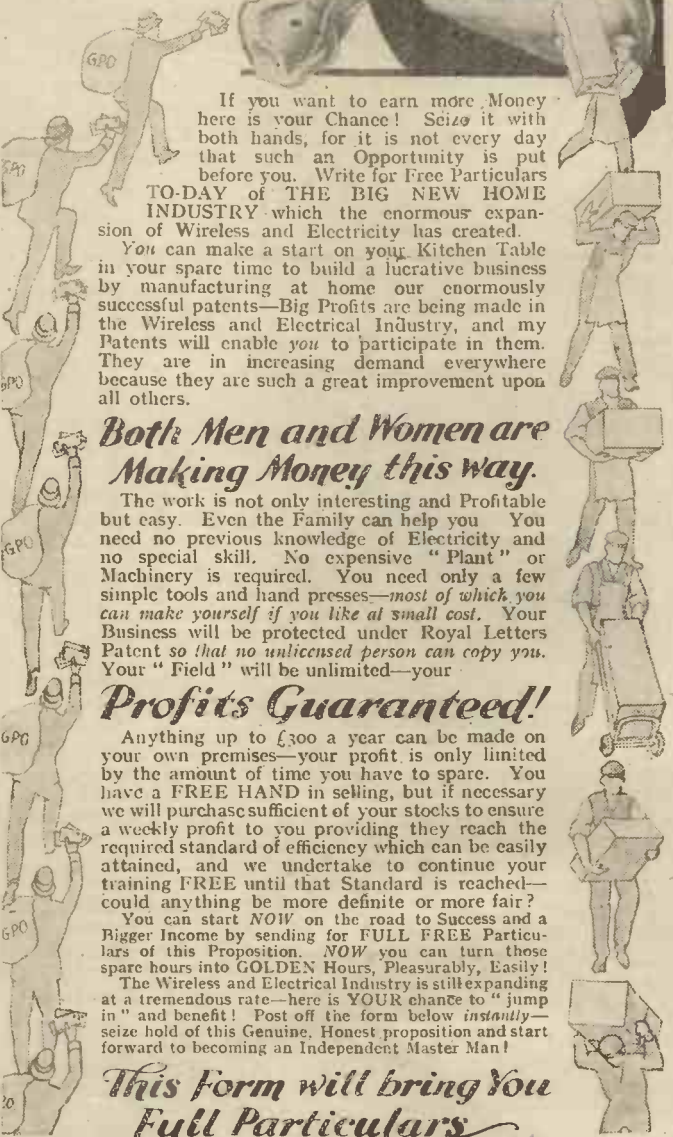

HOW CAN I MAKE £'S

To Mr. V. ENGLAND-RICHARDS, THE ENGLAND-RICHARDS, CO., LTD., 1121, King's Lynn, Norfolk.

Sir.—Please send me at once, and FREE, full details as to how I can Make Money at Home in my spare time. I enclose 2d. stamp for postage.

Print your name and address boldly in capital letters on a plain sheet of paper and pin this coupon to it. "Popular Wireless," 15-3-30.

FROM THE TECHNICAL EDITOR'S NOTE BOOK.

Tested and Found-?



SOME WEARITE COMPONENTS.

MESSRS. WRIGHT & WEAIRE are supplying their very good rheostats and potentiometers with metal bridge pieces that enable them to be mounted on baseboards (otherwise they are, of course, one-hole panel-mounting devices).

The 400-ohm potentiometer costs 2s. 6d., and this is particularly reasonable for a reliable make. Slotted terminals are fitted



This artistically executed envelope contained an urgent order for condensers for a "P.W." "Brookmans" Rejector.

on both potentiometer and rheostats, so that a screw-driver can be used for tightening them up. I like the movements of these Wearite components; they are distinctly silky, albeit their contacts are good.

Quite a new Wearite production is a baseboard-mounting grid-leak holder which embodies several good points. A leak is easily inserted and it is held central by the specially shaped clips.

POLAR H.F. CHOKE.

I do not know whether "P.W." readers find me boringly reminiscent this season, but nearly every time I take up my pen to contribute to this page, nowadays, I find my

TRANSFORMERS FOR THIS YEAR'S "TITAN"

It was quite by accident that the R.I. Hypermite L.F. Transformer was omitted from the list of L.F. transformers specified for This Year's "Titan" Three last week. Actually of course, the Hypermite is particularly suitable for such a set.

thoughts flying to the past. For instance (and now I am off again!), there were times when our radio ideas ran strongly to bulk and we despised small radio stuff. Unless our coils were huge and our transformers fat and heavy we regarded them with suspicious eyes,

But physical dimensions go for nothing these days. For example, I have before me as I write a couple of Polar H.F. chokes. That one which covers from 20 to 5,000 metres is smaller than the bowl of a small tobacco pipe. It is sectionally wound and it does cover the 20 to 5,000 metres range with ease, its self-capacity being remarkably low.

The 10- to 200-metre Polar H.F. choke is single-layer wound and is equally small and neat, although its insulated moulding is red instead of black and its shape is somewhat different. It is equally effective, and, indeed, I have no hesitation in recommending either type to "P.W." constructors.

The importance of the H.F. choke has frequently been stressed in "P.W." for its work in some circuits is of a vital character. You can include these Polars in the select half-dozen that are dependable for all jobs.

By the way, the Polar people have issued a book entitled Condensers. It is written by Mark Potter in collaboration with Major Ozanne. It is a 36-page book full of hints that will put the less expert constructor on the right track. It is free to all those who are interested.

NEW PREMISES.

Messrs. Tungram Electric Lamp Works (Gt. Britain), Ltd., makers of Tungram Electric Lamps and Tungram Barium Radio Valves, announce that on February 24th their Leeds branch was moved into larger premises at Britannia House, 74, Wellington Street (corner of Britannia Street).

It is stated that these new premises, which are conveniently situated near the centre of the town, became necessary as the original branch was unable to cope with the demand for Tungram Products, the sales of both Electric Lamps and Radio Valves having increased enormously during the past few months.

FOR RADIO-GRAM ENTHUSIASTS.

Messrs. Pickett, the well-known cabinet makers of Bexley Heath, are supplying a unit which should prove of considerable interest to radio-gram enthusiasts. It is, in a sense, a complete pick-up chassis.

It comprises a shelf or motor-board, which is fitted with a double-spring motor incorporating an automatic stop, and a B.T.H. pick-up

and arm. The price of this outfit, complete with turntable, is five guineas, or with a cheaper motor, playing only one 12-in. record, £3 15s. These prices are distinctly attractive. You should remember that the B.T.H. pick-up costs 45s., and is worth it, and the double-spring Collaro motor and its 12-in. turntable costs 50s. retail. And that is good value for money, too.

You will gather from the above figures that the Pickett people only charge ten shillings for their excellent woodwork and the assembly of the accessories thereon. The whole arrangement drops neatly into a Radiola cabinet, the one sent along to us was built to fit the model D in conjunction with a "Magic" Radio-gram set. You just slide the set in on its baseboard in the usual way, drop in the Pickett pick-up

WHEN YOU ARE BUYING—

(5) VALVES :

Keep strictly to the types specified for the set in which they will be used. Impedances are vital factors whatever some shop assistants may say.

Take a note of the filament consumption. Some power valves take as much as half-an-ampere. You would have to decide whether you could run the slightly larger accumulator needed to operate one of these, plus two or three other valves.

See the cartons opened before you pay your money and ascertain that the maker's operating details are enclosed.

Observe the valves filaments being tested in the shop, or obtain an assurance that "duds" will be replaced.

Don't accept obsolete types—many valve improvements have been made within the last year.

Take note of the H.T. voltage and current requirements of the complete group of valves you will use, and make sure you can provide an H.T. supply that will cope adequately with them.

unit, join up the wires and you have a fine radio-gram outfit ready for use.

IGRANIC LEAFLETS.

The Igranic A.C. Two Receiver and the Igranic Phonomotor (an A.C. induction motor for electric gramophones) form the subjects of two further Igranic leaflets, copies of which I have received.



The complete pick-up unit that Messrs. Pickett are now manufacturing.

THE CONSTRUCTION OF A CONDENSER

STAGE 4

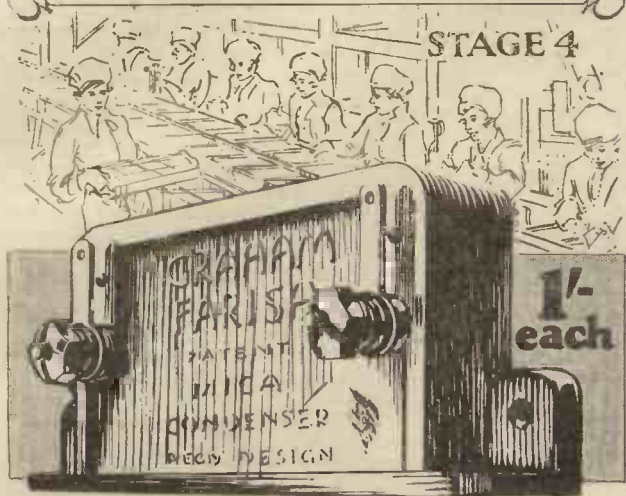

Assembling



MULTI WAVE H.F. Choke

Employs solenoid winding followed by sectional winding. High impedance. Low D.C. resistance. with base. 5/- each.



OHMITE New Process Anode Resistance

Hermetically sealed in Bakelite. Better than wire-wound. Negligible self-capacity. All values 1,000 to 500,000 ohms. 2/3 each.



ELECTROFICIENT Eliminator Choke

Heavy design with large safety factor. Gives impedance of 30 Henries at 50 milliamperes. 22/6.

THE Condenser has now reached its fourth stage— assembling.

At the Graham-Farish factory, the position of every machine— every employee, every tool even, has been carefully planned.

As each part of a condenser is fitted—so swiftly moving conveyor bands carry it to its next stage. Power-driven screw-drivers, and other time and labour-saving tools secure efficiency of working.

Only such skilful organisation— mass production on such modern lines could produce the components that bear the name "Graham-Farish."

The Graham-Farish Fixed Mica Condenser has the finest flawless Indian Ruby Mica as a dielectric. An exclusive feature is the alternative upright or flat mounting. Every condenser is tested three times and a written guarantee given with each.

Bakelite Case. Upright or flat mounting, terminals, soldering tags and series—parallel grid leak clips up to capacities .0005, .00005—.002, 1/-.003—.006, 1/6; .007—.01, 2/6.

- "Megite" New Process Grid Leak - 2/-
- "Electroefficient" Mains Transformer - 39/6
- "Microefficient" Variable Condenser 4/3-4/6

GRAHAM FARISH

BROMLEY KENT

Look for this sign in a dealer's shop.

AGE 16 TO 45.

I WANT YOU.

LET ME BE YOUR FATHER



J.B. Bennett

THE MOST SUCCESSFUL AND MOST PROGRESSIVE CORRESPONDENCE COLLEGE IN THE WORLD

I want you to realise that I have helped thousands of people to qualify for and obtain good positions. Our gigantic connection brings us in touch with all the big employers, therefore, although we do not undertake the work of an employment agency, we certainly do know where the demand exceeds the supply. If you think you are in a rut, or if advancement seems slow, write to me telling me your age, past experience, present employment, and anything else that may help, and I will tell you what chances there are; if they are suitable for you, and, if so, how you may attain your objective.

IT COSTS NOTHING TO ENQUIRE

We have full particulars in connection with any of the following courses, or special courses can be combined to meet all requirements. We specialise in preparation for all examinations; most moderate fees, payable monthly.

COMMERCIAL.

- Accountancy
- Advert. Writing
- Salesmanship
- Army Certifed. Courses
- Auctioneering and Estate Agency
- Auditing
- Banking
- Book-keeping
- Civil Service
- College of Preceptors
- Commercial Arithmetic
- Commercial Law
- Company Law
- Costing
- Economics
- English and French
- Executorship Law
- Foreign Exchange
- General Education
- Modern Business Methods
- Police Entrance and Promotion Courses
- Secretaryship
- Shorthand
- Workshop Organisation

INSURANCE.

- Exams. for Agents and Officials, F.C.I.I.
- Motor, Fire, Life, Marine.

INSURANCE.—Con.

- Employers' Liability
- Auctioneers F.A.L.P.A.

TECHNICAL.

- Teacher of Handicrafts
- Applied Mechanics
- Architectural Drawing
- Building Construction
- Clerk of Works' Duties
- Boiler Engineering; Boiler Making
- Chemistry
- Civil Engineering
- Concrete and Steel
- Draughtsmanship
- Electrical Engineering; Practical Mechanical Engineering
- Engineering Costing
- Quantities and Specifications
- Foundry Work
- Heat Engines
- Heating, Ventilating and Lighting
- Internal Combustion Engines
- Marine Eng., B.O.T.
- Mathematics
- Matriculation
- Metallurgy
- Motor Engineering;

TECHNICAL.—Con.

- Naval Architecture
- Pattern Making
- Post Office Examinations
- Costing and Estimating
- Builders' Quantities
- Road Making and Maintenance
- Sanitation
- Shipbuilding
- Structural Engineering
- Surveying and Levelling
- Surveyor of Works, R.E.
- Telegraphy and Telephony
- Town Planning
- Transport A.M.Inst. T.
- Wireless Telegraphy
- Works Managers' Course
- MINING.
- Fireman's Exam.
- 2nd Class Mine Mangr.
- 1st Class Mine Mangr.
- H.M. Inspector
- Mining Elect. Engineer A.M.E.E.
- Mining Mech. Engineer
- Mine Surveyor

WE TEACH BY POST IN ALL PARTS OF THE WORLD.

Also ask for Our New Book (FREE OF CHARGE).

THE HUMAN MACHINE. Secrets of Success.

Note Address Carefully: THE BENNETT COLLEGE LTD., Dept. 106, SHEFFIELD.





My wireless sets are placed on top of a large cabinet made to hold the H.T. and L.T. batteries, and L.S. is on same table as set, but

WHAT DO YOU THINK ABOUT THIS?

Even an experienced constructor sometimes gets caught. A Salford reader of "P.W." who had made a dozen or more sets built a handsome cabinet four-valver (H.F., Det., 2 L.F.), using components, batteries, etc., that had all given satisfactory service, but found on switching on that he could hear only one station, horribly distorted and weak!

As everything in the set had been working before, he suspected that he'd made a silly mistake in wiring, but on checking by the blue print he found all connections appeared O.K. It took him all one evening to find the fault, owing to its simplicity! Can you guess

WHAT WAS WRONG?

N.B.—There is no prize for answering this, but from time to time we shall give a radio problem (followed the next week by the answer) in the hope that readers will find them both interesting and instructive. (Look out for the answer to above next week.)

The trouble with the Dundee reception on a crystal set (which was described last week) was found to be "local interference" from a neighbour's valve set, which when switched on and allowed to oscillate (too much reaction) "wiped out" the programme on the neighbouring crystal set.

all the sets are perfectly steady when out of their cabinets.

(Continued on page 1330.)

All Editorial communications to be addressed to the Editor, POPULAR WIRELESS, Tallis House, Tallis Street, London, E.C.4.

The Editor will be pleased to consider articles and photographs dealing with all subjects appertaining to wireless work. The Editor cannot accept responsibility for manuscripts or photos. Every care will be taken to return MSS. not accepted for publication. A stamped and addressed envelope must be sent with every article. All inquiries concerning advertising rates, etc., to be addressed to the Sole Agents, Messrs. John H. Lile, Ltd., 4, Ludgate Circus, London, E.C.4.

The constructional articles which appear from time to time in this journal are the outcome of research and experimental work carried out with a view to improving the technique of wireless reception. As much of the information given in the columns of this paper concerns the most recent developments in the radio world, some of the arrangements and specialities described may be the subject of Letters Patent, and the amateur and the trader would be well advised to obtain permission of the patentees to use the patents before doing so.

QUESTIONS AND ANSWERS.

WHEN THE CABINET CAUSES DISTORTION.

J. B. (Co. Wexford, Ireland).—"I was interested in the article in a recent 'P.W.'—'Your "Magic" Sets.' I would like to draw your attention to a fault or peculiarity that I have experienced but never saw mentioned in 'P.W.' in the hope that you may deal with it in a future article.

"I built the 'Radiano Titan' some time ago. After finishing wiring I immediately put it on test, but not in its cabinet. It came through every test and was as stable as a rock. Afterwards, when put into its cabinet and connected up it had the well-known rippling whistle in L.S., which was made much less noticeable by keeping L.S. out of line of end of set, moving it partly behind the set.

"Removed out of its cabinet, the set was again as steady as a rock, no matter where the L.S. was. Later, another Det., 2 L.F. set gave me exactly the same results, and only to-day I have seen a 'Magic' Three do exactly the same thing.

CONTROL..

Perfect control over your condensers, the most vital part of your receiver, is the only way by which you can achieve the ideal—gliding easily and quietly from one station to another; from one country to another.

Here are two condensers that respond easily yet firmly to your touch—and give you complete control over your receiver.

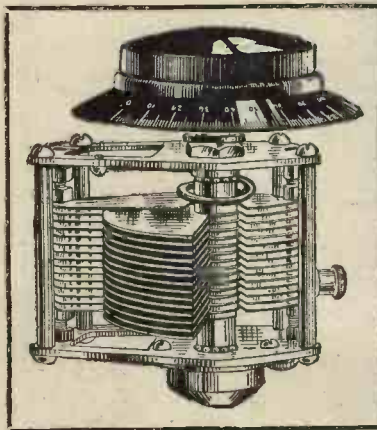

POLAR "IDEAL"

A Fast and Slow Motion Tuning Condenser. Has a definitely wider tuning range than most. "Dead-on" tuning is obtained resulting in increased volume and better quality reception. Silent in operation, excellent for long or short-wave work. Robustly built throughout of chemically cleaned brass.

- 0003 - 12/-
- 00035 - 12/3
- 0005 - 12/6



FREE, 36-page Booklet, "Choosing and Using Condensers." 1½d. stamp to Dept. P.

WINGROVE & ROGERS LIMITED
188-9 STRAND, LONDON, W.C.2
Polar Works, Mill Lane, Old Swan, Liverpool

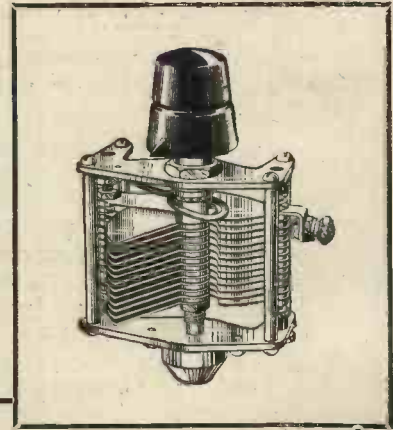

POLAR "Q.J."

The Fast and Slow Motion movement of the "Q.J." makes reaction control a pleasure. The "Q.J." is for use as a Reaction Condenser, for closed circuit tuning or balancing where large capacities are unnecessary and combines all the strong features of the Polar "Ideal." Small in size. Light in weight. Rigid in construction. Made entirely of chemically cleaned brass.

- 0001 - 10/-
- 00015 - 10/3
- 00025 - 10/6

Can be supplied with dial to match "Ideal." When fitted with this dial it makes an excellent short-wave tuner.



1930 TITAN COIL

Ready Radio

1930 TITAN COIL

CHOSEN AND USED FOR 'THIS YEAR'S' TITAN SET

For Regional Reception Be Sure Your Coil is Stamped 1930 TITAN COIL

15/-

BROOKMAN'S CONDENSERS

CHOSEN & USED FOR THIS YEAR'S MAGIC SET 3/6



READY RADIO

159, BOROUGH HIGH STREET, LONDON, S.E.1.

Telephone: Hop 5555.

Wireless troubles are less troubles..

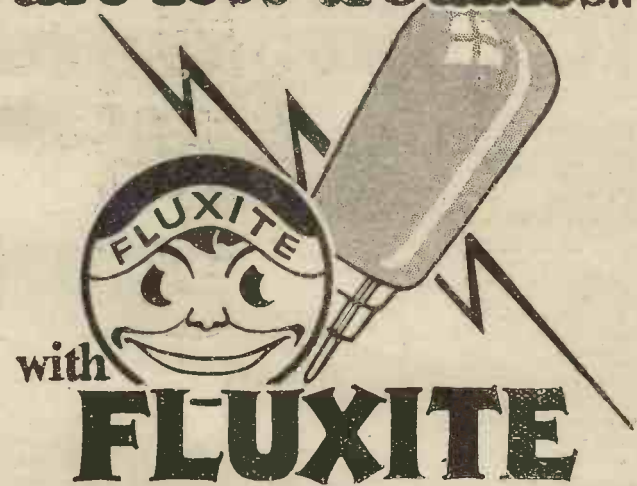

FLUXITE

FLUXITE is sold in tins, price 8d., 1/4 and 2/8. Another use for Fluxite: Hardening Tools and Case Hardening. Ask for leaflet on improved methods.

FLUXITE LTD.
(Dept. 324), Rotherhithe, S.E.16.

SOLDERING SET Complete 7/6
or LAMP only 2/6

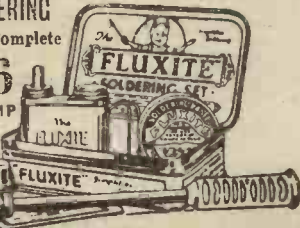

- IT SIMPLIFIES ALL SOLDERING



Model A.C. 16
For Alternating Current

The 'ATLAS' Super H.T. Unit which has amazed thousands of Listeners

10/- DOWN
and it's yours.

The balance you pay in nine monthly easy instalments, or

CASH PRICE £4-10-0

No matter what your needs are, there is an "ATLAS" Unit to suit them and every model is guaranteed for twelve months.

DAY after day we are receiving an endless number of letters from Radio Listeners, complimenting us on this magnificent model—A.C.16.

It has been specially produced to meet the demands of Listeners with sets from one to five valves. The low price, coupled with the exceptional facilities, make this "ATLAS" model the finest H.T. unit yet produced to come within the reach of every Radio Listener.

It provides three tapplings, one variable giving 0/100 volts, and two Fixed, giving 120 and 150 volts respectively, and gives maximum output of 150 volts at 25 m.a. The variable tapping makes this model specially suitable for sets using Screen-Grid, Detector and Pentode Valves.

"Popular Wireless" says:—

"The Clarke's Unit is, in my opinion, quite safe—as safe as any vacuum cleaner of good make, and it operates quite well. It does not impose a liability to motor-boat and its outputs are up to specification."

"CLARKE'S"
'ATLAS'
BATTERY ELIMINATORS

Ask your Dealer for Folder No. 44, or **POST THIS COUPON TO-DAY**

Messrs. H. Clarke & Co. (M/cr), Ltd. (Dept. 3) Atlas Works, Old Trafford, Manchester.

Please forward your Folder No. 44 and particulars of your easy payment scheme.

NAME.....

ADDRESS.....

.....

in unsealed & stamped envelope Please use **BLOCK LETTERS.** P.W.3

RADIOTORIAL QUESTIONS AND ANSWERS

(Continued from page 1328.)

"The cabinets are of the sizes specified, or perhaps a little smaller, made of hard mahogany, polished on the outside with methylated spirit and shellac in which a little burnt umber was used for colouring.

"Can you throw some light on the mystery?"

Your experience is a striking demonstration of the fact that the working of a wireless set takes place not merely inside the components but in the space surrounding them. When the set is working, unseen lines of force exist around the components, magnetic fields rise and fall in the adjoining space, and in fact around every wire in the set are the unseen forces associated with the currents flowing in that wire.

It is this that makes spacing so important in wireless work, and from a practical point of view it is difficult to over-estimate the great importance of allowing all components plenty of "magnetic elbow-room."

Every lead is surrounded by moving magnetism, so it stands to reason that if a loud-speaker lead, for instance, is run close to a grid lead, energy may be returned to the grid circuit and re-amplified, with disastrous results to stability.

A GOOD FOUR-VALVER.

S. J. (Norbury).—"I am enclosing herewith a list of my parts, valves, etc., but as I am fed up with this portable I should like to know where I can get a full description of a good four-valve set."

It is always very difficult to advise a design without full details of the results required—volume, quality, range, etc.; and you say nothing about this. We presume that you are hoping for what is commonly known as "four-valve results," i.e.—really big volume on three or four stations, and good loud-speaker strength on another half-dozen or so as alternative programmes. (A set that will give this will generally bring in about 20 or 30 stations at least, but all such extra programmes are not very enjoyable owing to fading, heterodyning, etc.)

To get results of this kind you have to choose a modern design, able to cope with the now conditions imposed by two-programme stations like Brookmans

Park. The opening of this station (and shortly of others under the Regional scheme) completely changes the position as compared to six or eight months ago. And although several of your components would be O.K., to use them all now in a new four-valve set would be very unsatisfactory.

We are afraid that a circuit for use to-day is bound to differ quite a lot from that for your previous set, especially as this was a portable. What we suggest, therefore, is that you build one of the new designs

"P.W." TECHNICAL QUERY DEPARTMENT

How's the Set Going Now ?

Perhaps some mysterious noise has appeared, and is spoiling your radio reception?—Or one of the batteries seems to run down much faster than formerly?—Or you want a 'Blue Print'?

Whatever your radio problem may be, remember that the Technical Query Department is thoroughly equipped to assist our readers, and offers an *unrivalled* service.

Full details, including scale of charges, can be obtained direct from the Technical Query Dept., POPULAR WIRELESS, The Fleetway House, Farringdon Street, London, E.C.4.

A postcard will do. On receipt of this an Application Form will be sent to you free and post free immediately. This application will place you under no obligation whatever, but having the form you will know exactly what information we require to have before us in order to solve your problems.

LONDON READERS PLEASE NOTE:
Inquiries should NOT be made by 'phone, or in person at Fleetway House or Tallis House.

suitable for present conditions, but possibly with fewer valves, owing to the higher efficiency of the modern components.

In fact, for use in your district with an outdoor aerial, a really good three-valve set should fulfil all the above-named requirements and we would prefer it to four, unless there were special reasons for the extra valve. The set which comes nearest to your list of components is called The "Eckersley" Three, and

there was a description of this with blue print in the December issue of "Modern Wireless."

From this it will be seen that your L.F. transformer, H.F. choke, valves, etc., can be used and whilst there are certain extra components required, they are comparatively few considering the quality, selectivity, etc., that is gained. Moreover, you would have a spare detector valve on hand because only three valves would be employed instead of four, but we have no hesitation in saying that the results would be far better than those obtainable with your old-fashioned four-valver.

The "Eckersley" Three is not a difficult set to build and we feel confident that you would be very pleased with the results from it. No extra wave-trap would be required and several speakers in different rooms could be worked from it easily.

CONNECTING THE H.F. UNIT.

R. T. E. (Seaborough).—"I am afraid I am a bit thick at understanding your instructions for connecting up the 'Magic' H.F. Unit. I have got it built and it looks good, but what am I to do with the H.T.+1 lead? Does it go direct to the battery, or the plus at the equivalent voltage on the set? In fact, how should I proceed to connect up the two, lead by lead?"

The first thing to do is to take your aerial lead and fit it with a plug which will go into the socket on the H.F. Unit. Next undo the earth lead on the set and place this on the earth terminal on the unit.

(If you have not had much experience at connecting up batteries, etc., we advise you at this point to undo the L.T. leads at the accumulator end and take the H.T. plugs out of the battery because it is very easy to do some damage to one of the valves if either of the batteries are connected, but there is no such danger when the leads from the set are merely "dangling in the air" near the battery.)

At the present moment we have the aerial and earth satisfactorily disposed of, and now the L.T. and H.T. batteries are disconnected, so we will deal with the other leads.

The first thing to do is to take a length of insulated flex and connect the L.T.—terminal on the unit to the L.T.—terminal on the set (this will still be provided with a lead dangling near the battery, which eventually will be connected there again).

Similarly take a flexible insulated lead from the L.T.+ terminal on the unit to the L.T.+ terminal

(Continued on page 1332.)



RELIABLE IGRANIC COMPONENTS

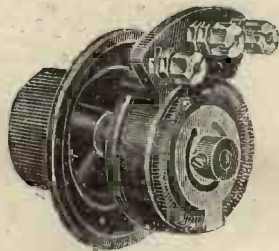

IGRANIC "Megostat"
Volume Control.

Made in 4 sizes. 50,000
ohms, 500,000 ohms,
1 megohm and 5 megohm
Price 6/-

You can purchase an
IGRANIC

GUARANTEED COMPONENT
TO REPLACE ANY
COMPONENT IN ANY SET.

IGRANIC Components include
Transformers, Variable Condensers,
H.F. Chokes, L.F. Chokes, High
Resistance, Low Resistance Potentiometers,
Tuning Coils, Knobs and
Dials, etc.

If your dealer cannot supply you, please
write at once to Dept. R. 145.



IGRANIC
MIDGET RADIO
SWITCH

Definite in action, sound
electrical contact.

Price 1/6

IGRANIC ELECTRIC CO., LTD., 149, Queen Victoria Street, London.



All who prefer Quality
in Cigarettes

Say
Player's
please



5 for 3d. 10 for 6d.
20 for 11½d.

N.C.C.722



MECHANICAL-
LY PERFECT,
P O S I T I V E
B R A S S - C O N T A C T
drive on
S O L I D B R A S S
SCALE ensuring
smooth movement
with ab-
solutely NO
B A C K - L A S H.
R O B U S T
Construction and
Trouble Free.

PRICE
3/-



THERE IS ONLY ONE GENUINE

FORMO-DENSOR

as used by designer and specified for the **BROOKMANS REJECTOR**, The **WAVE-CHANGE REJECTOR**, and The **KENDALL REJECTOR**.

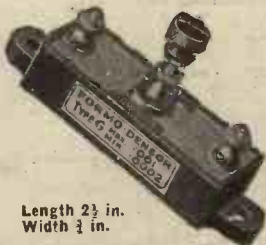

Length 2 1/2 in.
Width 1 in.

- F. Max. .0001
Min. .000005 2/-
- J. Max. .0003
Min. .000025 2/-
- G. Max. .001
Min. .0002 2/-
- H. Max. .002
Min. .001 3/-

"1930" LOG (MID-LINE) CONDENSER

In four Capacities:

- .0005
- .00035
- .00025
- *.00015

4/6
each.

*Double spacing
of vanes for
Ultra Short-
wave work.

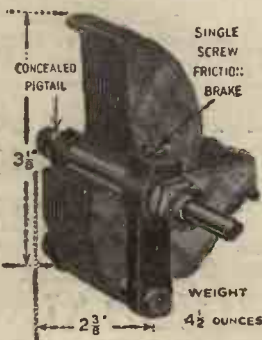

THE FORMO CO., CROWN WORKS, CRICKLEWOOD LANE, N.W.2.

ASK FOR
P.R.

The only British
Valve with a
written Guar-
antee as to
performance
and
life.



& SEE THAT YOU GET THEM!

Why pay fancy prices when you can get a perfectly finished British-made valve with a superior coating giving astonishing selectivity with a minimum H.T. consumption, which is the general opinion of the thousands who use P.R. valves. There are many valves on the market, but none are guaranteed—ask yourself why. The P.R. guarantee covers seven months, with the right—not a favour, remember—but a right to exchange the valve under the guarantee. All you have to do is to post any defective valve to us, complying, of course, with the terms of the guarantee which is attached and enclose a note stating defect.—You will receive a new valve by return of post.

ALL ORDERS EXECUTED ASK YOUR DEALER FOR THEM.
BY RETURN OF POST. ACCEPT NO OTHER.

Sent C.O.D. if desired.
2 Valves or more sent POST FREE.

Matched Valves 1/- extra per set.
P.R. PRODUCTS, 39, P.R. HOUSE, NEWGATE ST., LONDON, E.C.4.
Opposite G.P.O. Tube Station. Phone: City 3788.

LIST OF DULL EMITTERS

	Type	Fil. Volts	Amp.	Imp. Ohms.	Amp. Fac.	
3/6 EACH Post 4d.	PR 2	2	.095	28,000	13	H.F. Det.
	PR 3	2	.085	15,000	8	L.F. R.C.
	PR 4	2	.095	60,000	32	L.F. Det.
	PR 9	3-5-4	.063	24,000	14	H.F. Det.
	PR10	3-5-4	.063	15,000	8-7	L.F. R.C.
	PR11	3-5-4	.063	65,000	40	L.F. R.C.
	PR17	5-6	.1	24,000	17	H.F. Det.
	PR18	5-6	.1	15,000	9	L.F. R.C.
	PR19	5-6	.1	80,000	40	L.F. R.C.
	POWER 6/6 EACH Post 4d.	PR20	2	.15	7,000	6
PR40		4	.15	8,000	6	"
PR60		6	.1	8,000	6	"
SUPER POWER 10/6 EACH Post 4d.	PR120	2	.3	3,800	4	Super Power
	PR140	4	.2	4,000	4	"
Screened Grid 15/- EACH Post 4d.	SG 25	2	.2	220,000	150	S.G.



RADIOTORIAL QUESTIONS AND ANSWERS

(Continued from page 1330.)

on the set so that, in fact, you have extended your leads from L.T. and they now run not only to the set but continue on to the unit's terminals also. So far so good.

There is no H.T. - terminal on the unit to worry about and the H.T. - terminal on the set is left alone and will eventually be connected up exactly as it was before you started to use the unit. The loud-speaker terminals on the set carry the L.S. leads, as usual, and these also will not be interfered with in any way.

All that now remains is an H.T. +1 and an H.T. +2 terminal on the set, and an H.T. +1 and an H.T. +2 terminal on the unit. Let us deal with the H.T. +2 terminals first. All you have to do in this instance is to join a flexible lead across to the H.T. +2 on the set from the H.T. +2 on the unit (exactly as was done in the case of the L.T. battery), because both these H.T. +2's require the same voltage from your battery, so that one lead can very well do the job for both of them.

Now we have only the H.T. +1's, and you can (for simplicity's sake) take a lead between these two, as was done in the case of the H.T. +2 just referred to. But as in order to get the best results from a screened-grid valve you may like to juggle about with its position on the battery a little, the best plan is to leave the H.T. +1 lead on the set with its own red plug, and to provide the H.T. +1 lead on the unit with a flexible lead of its own and a red plug of its own.

Let this dangle down out of harm's way for a moment and then join up your leads to the batteries in just the ordinary way as you used to do before you had the unit to trouble about. When this is done

1930 TITAN 3

- KIT A less valves and cabinet £5:11:0
- KIT B with valves less cabinet £7:16:0
- KIT C with valves and cabinet £9: 6:6

For full list of approved components see previous issue.

1930 MAGIC 3

- KIT A less valves and cabinet £6:16:0
- KIT B with valves less cabinet £8: 9:6
- KIT C with valves and cabinet £9:19:6

For full list of approved components see previous issue.

REGIONAL FOUR

- KIT A less valves and cabinet £8: 2:0
- KIT B with valves less cabinet £10:18:0
- KIT C with valves and cabinet £12:10:0

Full list of approved components can be had on application.

REGIONAL TWO

- KIT A less valves and cabinet £4:12:6
- KIT B with valves less cabinet £5:15:6
- KIT C with valves and cabinet £6:18:0

Full list of approved components can be had on application.

ALL KITS APPROVED BY
"POPULAR WIRELESS"

IMMEDIATE DESPATCH

Ready Radio

159, BOROUGH HIGH STREET,
LONDON BRIDGE, LONDON, S.E.1

Telephone: HOP 5555.

POPULAR "WIRELETS" No. 4

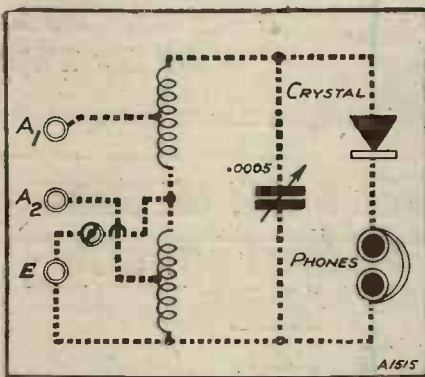

The dotted lines show the connections for the wave-change crystal set referred to last week. When the switch is "on" the long-wave coil is shorted, and the aerial is used on the A₁ terminal.

For long waves the switch is turned to the "off" position, and the aerial is placed on A₁.

the aerial terminal of the set should be joined to one of the unit's output terminals, and the set to its batteries, with the sole exception of the H.T. +1 plug, on the unit which will be lying idle.

Take this plug and put it into the H.T. battery somewhere between 60 and 80 volts, and you are ready to leave the back-of-panel connections alone and turn your attention to the aerial. Insert the aerial plug in the left-hand socket of the unit (seen from the front), switch on, and the H.F. stage will get busy in great style.

Then when you desire to receive the local station you simply transfer the aerial plug to the right-hand socket of the unit, switch off the filament of the screened-grid valve and so get your local station.

"AN AWFUL DISAPPOINTMENT."

"H.T. BATTERY" (Beckenham, Kent).—
"It seemed to be exactly what I wanted, but when I came to consider carefully there was an awful disappointment. I see there is an H.T. + 1 and an H.T. + 2. I cannot afford two H.T. batteries, and anyhow, it is not clear how to connect them up. Could I join those two together and run them from one battery, as otherwise the set is exactly what I require?"

We are afraid that you have not been reading your "P.W." very carefully, or you would know that you do not have to have two H.T. batteries just because you have an H.T. + 1 and an H.T. + 2. Where

(Continued on page 1334.)

RADIO from INCOME

A new addition to the well-known Ready Radio Service is our "Radio-from-Income" system of monthly or weekly payments for complete kits of parts.

1930 MAGIC 3

- KIT A 12 equal monthly payments of 12/6
or 20/- down and 12 weekly payments of 10/3
- KIT B 12 equal monthly payments of 15/9
or 20/- down and 12 weekly payments of 13/3
- KIT C 12 equal monthly payments of 18/6
or 20/- down and 12 weekly payments of 16/-

1930 TITAN 3

- KIT A 12 equal monthly payments of 10/3
or 20/- down and 12 weekly payments of 8/-
- KIT B 12 equal monthly payments of 14/6
or 20/- down and 12 weekly payments of 12/-
- KIT C 12 equal monthly payments of 17/3
or 20/- down and 12 weekly payments of 14/9

REGIONAL 4

- KIT A 12 equal monthly payments of 15/-
or 20/- down and 12 weekly payments of 12/3
- KIT B 12 equal monthly payments of 20/-
or 20/- down and 12 weekly payments of 17/6
- KIT C 12 equal monthly payments of 23/-
or 20/- down and 12 weekly payments of 20/-

REGIONAL 2

- KIT A 12 equal monthly payments of 8/6
or 20/- down and 12 weekly payments of 6/6
- KIT B 12 equal monthly payments of 10/9
or 20/- down and 12 weekly payments of 8/6
- KIT C 12 equal monthly payments of 12/9
or 20/- down and 12 weekly payments of 10/6

See previous issues for the complete list of approved parts for the 1930 "Titan" Three. Lists for the "Regional" Four and the "Regional" Two can be obtained on application. All kits include Ready Radio non-soldering links.

Ready Radio

159, BOROUGH HIGH STREET,
LONDON BRIDGE, LONDON, S.E.1.

Telephone: HOP 5555.

FOR THE
 "MAGIC" 3 "TITAN" 3
 "REGIONAL" 3 "REGIONAL" 4

Be sure of best results
 Use the recommended

WEARITE

COMPONENTS

	s. d.
H.F. CHOKE	6 6
ON-OFF SWITCH	1 0
SERIES AERIAL CONDENSER WITH SWITCH	2 3
WIRE-WOUND FIXED RESISTANCE	
(25,000 ohms)	4 0
POTENTIOMETERS (200 or 400 ohms)	2 6
VOLUME CONTROL (1/2 or 1 megohm)	4 0
3-POINT WAVE-CHANGE SWITCH.	1 6
COIL HOLDERS (Real Low Loss)	1 6
STANDARD "TITAN" COIL	15 0

PAXOLIN PANELS AND TERMINAL STRIPS
 (Mahogany or Black Finish)

For particulars of other Wearite Recommended
 Components, write for Special List and Illustrated
 Booklet.

WRIGHT & WEAIRE, LTD.,
 740, High Road, LONDON, N.17.

Phone: Tottenham 3947-3848.

170



**"GOLSTONE" 1930
 DUAL WAVE COIL
 MOST EFFICIENT
 PRODUCED**

Price 8/- Each

Designed and recommended to obtain maximum selectivity, to comply with new Regional requirements. More efficient and convenient than old-fashioned Plug-in coils. Just switch over from High to Low Wave band. Reaction on High and Low Wave lengths is fully obtained. Range 200-600 and 1000-2000 metres.

No. D.W/8 8/- each.

Full particulars see Radio Catalogue just issued. **FREE** on request.

From all first-class Radio Dealers. Refuse substitutes. If any difficulty write direct.

Ward & Goldstone
 PENLETON. MANCHESTER

FREE

With every Coil a diagram is given of connections and particulars of components required for several circuits, incorporating the "GOLSTONE" Dual Combination Coil, including a unique 3-valve screened super circuit

"POPULAR WIRELESS" ADVERTISEMENT RATES

Whole Page £40	Quarter Page £10
Half Page £20	Eighth Page £5

Narrow Column Advts. (3 cols. to page) per inch 30/-
 Minimum Space accepted half in-h 15/-

NO SERIES DISCOUNTS. ALL ADVERTISEMENT COPY SUBJECT TO EDITORIAL APPROVAL

COPY AND BLOCKS MUST BE IN HAND 11 DAYS BEFORE DATE OF ISSUE TO ENSURE PROOFS

ALL communications respecting ADVERTISING must be made to:—

JOHN H. LILE, Ltd., 4, Ludgate Circus, London, E.C.4
 and NOT to Editorial or Publishing Offices.

IT'S BEST AND CHEAPEST THE "OSBORN" WAY

ASSEMBLE THIS "OSBORN" WIRELESS CABINET YOURSELF



FOR £2

No. 205.
 Write for Catalogue "P.W."

Machined ready to assemble: in oak, £2; in mahogany, £2 5s. Assembled ready to polish: in oak, £2 12s. 6d.; in mahogany, £2 17s. 6d. Assembled and polished: in oak, £3 5s.; in mahogany, £3 10s. take panel size 21 in. x 9 in. Carriage paid to your door. (or smaller).

CHAS. A OSBORN THE REGENT WORKS, Arlington Street, London, N.1. Telephone: Clerkenwell 5095.
 Open to 7.30 p.m. Sat., 4.30 p.m.
 And at 21, Essex Rd., Islington, N.1. Phone: Clerkenwell 5654.
 Open until 8 p.m. Sat., 9 p.m.

Such beautiful Tone!

Here is the new No. 100 Cradle, the latest addition to the Squire Range.

Modern speaker design is tending steadily in the direction of free edge cones, particularly for small cones whose duty it is to reproduce the higher frequencies.

The Squire No. 100 has a free edge small cone, and we can emphatically state that the reproduction afforded is the finest yet.

The beautiful tone and ample volume obtainable when this Cradle is used in conjunction with any reputable make of Unit is truly wonderful.

It is equally responsive on all frequencies.

Ask your dealer to demonstrate one, or in case of difficulty write to us direct.



Price, inclusive of Cones and Octagonal Front, **28/6**
 Price of the two Cones, supplied complete, riveted together, with metal washers attached & packed in box **6/6**

FREDERICK SQUIRE LTD.,
 10, Leswin Place, Stoke Newington, N.16.

RADIOTORIAL QUESTIONS AND ANSWERS

(Continued from page 1332.)

there are several H.T.+ terminals on a set you can use one H.T. battery and several leads with wander plugs.

Join a lead with a black wander plug to the H.T.— terminal and put that into the H.T.— of the battery. Then fit each H.T.+ terminal with a lead terminating in a red plug, and give H.T.+ 1, say, 60 volts, or whatever the figure may be that is recommended, and H.T.+ 2 the full voltage, etc., so that you have one black plug in the negative of the battery and several red plugs dotted about for the required voltages to the different valves.

In this way each H.T.+ lead takes off the correct voltage that it requires but only one battery is needed for the set.

WATCH YOUR G.B. CONNECTIONS.

"PLUG LOOSE" (Margate).— "As the quality seemed very poor I investigated inside the set, and noticed among other things that one of the L.F. valves seemed to be running hot. The set had been on several hours, but I feel sure that even when it has been on as long as that before there was no heating up of the valve like this.

"Trying to account for it, I noticed that its grid-bias plug had come loose out of the battery. I am pretty sure I did not do this while interfering with the inside of the set, and am wondering whether, if this had been undone all the time, it could possibly have caused the valve to get hot?"

You have hit upon the correct solution. No doubt the G.B. plug had been removed from its socket for some little time, the effect being greatly to increase the plate current of that valve, just as though an excessive H.T. voltage had been used.

The effect upon quality in such cases is immediate, but still more serious is the effect upon the filament, for when overrun in this way the increased emission is very detrimental to it, and has no doubt shortened its life considerably. For this reason we advise you never to put up with a faulty or badly fitting G.B. plug (especially that to a power or a big I.F. valve), for the provision of correct grid bias has a very important safeguarding effect upon the operation of the set.

DIVIDING THE ETHER.

(Continued from page 1309.)

not less than $2\sqrt{\frac{L}{C}}$ —it would prevent

oscillations altogether, the disturbance then degenerating or subsiding into a leak; whereas if the resistance were kept small, and the inductance fairly big, the oscillations could continue for an appreciable time; so that the beaded luminosity of such an alternating spark could be photographed, as Feddersen first did, in a revolving mirror.

In 1899 I secured the co-operation of Sir Richard Glazebrook in order to perform this experiment in a metrical manner. This was done by photographing a small spark, at a gap in a circuit with accurately determined self-induction and capacity, on a photographic plate revolving in its own plane a known number of times a second (usually 64); thus verifying the law with precision, and making a reasonably close determination of the Maxwellian electro-magnetic constant, equivalent to the velocity of light. (See the Stokes Memorial Volume published by the Cambridge University Press, pages 136 to 196.)

This Paper received a Prize entrusted by Elihu Thomson to the University of Paris. It represented many months of work, conducted for the most part in the Cavendish Laboratory, Cambridge; the subsequent micrometric photographic plates being for the most part made with the assistance of Mr. J. W. Capstick, of Trinity: to whom I express indebtedness.

FIT any UNIT
with this **DOUBLE CONE CHASSIS**
in **15 MINUTES**

AND IMPROVE RECEPTION

Hear your unit as you have never heard it before—with the wonderful Wates Universal Double Cone Chassis. The verve and new life of its reproduction will amaze you, whilst you will immediately realize the great significance of the Double Cone principle. With a separate cone to deal with the high notes and another for the lower frequencies, you will hear everything with a new perfection—the more subtle notes are brought out magnificently. The Wates Universal Double Cone Chassis is specially designed to take practically any present-day L.S. Unit. The cones are scroll cut to obviate a direct line through the sound frequencies and specially treated for constant crispness. Whether you use your present unit or are purchasing a new one, specify the Wates Universal Double Cone Chassis and enjoy 50 per cent. improvement in results. CAN BE FITTED WITH THESE UNITS: BLUE SPOT, LISSEN, AMPLION B.A.2, BROWN VEE, ORMOND, WATMEL, LOEWE, HEGRA, SILVER CHIMES, G.E.C., TRIOTRON, W. & B., B.T.H., etc., etc. Complete with universal bracket, instructions and all screws for mounting unit. **11/6**

If your dealer does not stock, obtainable direct. Full details free on request.

THE SHAFTESBURY RADIO CO., Dept. P.W. 184-188, SHAFTESBURY AVENUE, LONDON, W.C.2

Telephone: Temple Bar 6195

WATES

UNIVERSAL

PAT. NO. 309214

DOUBLE CONE

CHASSIS

M.B.

14,000 SUCCESSES is the record of **The T.I.G.B.**

If you, too, wish to advance to a well-paid post in any branch of engineering T.I.G.B. home-study training offers you the surest means of achieving the success you desire.

Free!

ENGINEERS

124 PAGES

This 124-pp. book furnishes the most complete information ever published about the many professional qualifications open to engineers, such as A.M. Inst. C.E., A.M.I. Mech. E., A.M.I.E.E., A.M. Inst. B.E., etc.; describes nearly 200 Courses; the widest selection of engineering courses in the world; and is crammed with matters of interest to every engineer. If you are ambitious, The T.I.G.B. can help you—write **TO-NIGHT** for your **FREE** copy of "The Engineer's Guide to Success," stating branch or exam. that interests you.

The Technological Institute of Great Britain, Established 1917.
26, Temple Bar House, London, E.C.4.

DOMINION

VERNIER DIALS

2/6

Only Brownie's ability to produce **2,000 Dominion Vernier Dials a day** enables them to keep the price as low as **2/6**. The special non-backlash design (for fine tuning) and the splendid finish (smooth black or beautifully grained mahogany bakelite) coupled with the low price, makes the Dominion Vernier Dial a real radio bargain.

BROWNIE WIRELESS COMPANY (G.B.) LIMITED, NELSON STREET WORKS, LONDON, N.W.1

BROWNIE

WIRELESS

EXACT TUNERS

250 to 2,000 metres. Thousands of these tuners are in use, and we can strongly recommend them. No further coils are required. Send P.O. for particulars and circuits, **FREE**.

THE EXACT MANUFACTURING CO.,
Croft Works, Priory Place, Coventry.

GRAMOPHONES. Latest Horns and parts. Catalogue free. Cash or terms. **Build £12 model for £3.** Instructions 3d. **V. BURT; 185, High St., London, S.E.8.**

WET H.T. BATTERIES

Solve all H.T. Troubles.

SELF-CHARGING, SILENT, ECONOMICAL

JARS (waxed), 2" X 1 1/2" sq. 1/3 doz. ZINCS, new type 10d. doz. Sacs 1/2 doz. Sample doz. (18 volts), complete with bands and electrolyte, 4/1. post 9d. Sample unit, 6d. Illus. booklet free. **Bargain list free.**

AMPLIFIERS, 3c/- 3-VALVE SET, 4s.

P. TAYLOR, 57, Studley Road, STOCKWELL, LONDON.

ZAMPA H.T. ELIMINATOR KIT. comprising Rectifying Unit (incorporating transformer, condensers, Westinghouse H.T.3), necessary condensers, choke, panel, terminals, flex, baseboard, etc. Output 120 volts at 20 m/a. Complete 45/-. 7 days' approval against cash. Other Zampa Kits and transformers on request.—**Mic Wireless Co., Market St., Wellingborough.**

E E L E X

2DS **2DH**

2DF **2DI**

SPADES, PINS, HOOKS & EYES

6 Colours. 2d. each.

Write for List T.95.

J. J. EASTICK & SONS,
118 Bunnhill Row, London, E.C.1

PLEASE be sure to mention **"POPULAR WIRELESS"** when communicating with Advertisers. **THANKS!**

FOUR USEFUL HINTS.

In old-fashioned short-wave receivers, reaction was often "ploppy," due to the absence of a potentiometer control of the detector's grid potential.

Do not assume that a short-wave circuit is not good for long-distance reception owing to ploppy reaction until you have tried varying the H.T. voltages on the detector; a different valve; wide variations of aerial coupling; variable control of filament resistance; and a small indoor aerial.

One possible cure for rattling and dithering cone loud speakers is to tighten up the small nut fastening the cone to the reed, as frequently the locking nut will be found to be a bit loose, thus giving rise to rattling.

If a fairly large nail is driven up through an old baseboard a reel of wire may be placed over this when coil-winding is carried out, and if three or four other small nails or staples are "staggered" over the baseboard and the wire threaded between these, the desired tension when winding may be obtained.

WORKSHOP HINTS.

ONE of the most useful tools is the file, and every radio experimenter finds a use for it very frequently. Quite often files are sold without handles, and sometimes the wooden handle supplied split or, in some other way, became useless. A good file handle can be made in the following way.

A few inches of stout lead tubing of the right size for the job is procured, and the one end beaten flat over the tang of the file. The lead tubing is then covered in its turn with rubber tubing that fits over it tightly. A very excellent handle, and one that can be gripped easily and comfortably, results.

By the way, a file should be worked only in the one direction. Push it forward hard over the work and completely release the pressure on the return stroke; do not drag it or you will break the teeth.

Cleaning a File.

You sometimes see people rubbing away with a file as though it were a piece of sand paper. This is all wrong and quickly destroys the keenness of the article.

In the course of time a file will become clogged with dust both of metallic and other natures, but the tool can be cleaned by soaking it in a strong solution of soda for twenty-five minutes or so. After this it should be brushed vigorously.

Screwdrivers, pliers and other such articles are liable to become strongly magnetised after they have been in radio use for some time. The amateur may find this useful—and, on the other hand, he may find it a nuisance. But the tools can be demagnetised fairly completely by rubbing them once or twice in the one direction with a permanent magnet.

Rub in the wrong direction, and you increase the magnetism; rub too much in the same direction and you merely reverse the magnetism. It is a matter of trial and error!

**NEW FULL-COLOUR Art Work of
Supreme Beauty**

**Modern Masterpieces
of British Art**

Not more than 25 Fortnightly Parts. Complete in One Volume

Price 1/3 Each



THE SLAVE MARKET—by FRANK BRANGWYN, R.A.

This is a very small reproduction of Frank Brangwyn's beautiful picture which is reproduced in COLOUR on the Cover of PART I, and is also included among the EIGHT choice colour pictures in this part.

WHEN complete MODERN MASTERPIECES OF BRITISH ART will contain over 200 gorgeous reproductions of the finest paintings from the leading Art Galleries of the British Isles—embodying the most extensive collection of modern paintings ever brought together. It is, without doubt, the most ambitious all-colour part publication ever produced in this country. Each part will contain at least eight pictures of varying interest, accompanied by notes giving particulars of the artist and other points of interest. A special feature will be a series of separate colour plates for framing which will be given loose in various parts.

Exquisite FLOWER STUDY
Ready for Framing

FREE with PART 1

This delightful flower study—"Michaelmas Daisies," by J. B. Manson—is exhibited in the Tate Gallery. The colour reproduction is exceptionally fine. The following world-famous artists are represented in Part 1.

- SIR WILLIAM ORPEN, R.A.
- FRANK BRANGWYN, R.A.
- SIR JOHN LAVERY, R.A.
- AUGUSTUS JOHN, R.A.
- P.H. CALDERON, R.A.
- PETER GRAHAM, R.A.
- FRANK BRAMLEY, R.A. HERBERT DRAPER.

PART 1 NOW ON SALE—BUY A COPY TO-DAY 1/3

FOR THE LISTENER.

(Continued from page 1314.)

Sea Shanties.

I always listen to sea shanties, though I am the landiest-lubber that ever was. "Fire down below" is my pet thrill. Usually they are sung by a trained chorus; but the other night, broadcast from the Hotel Cecil, at the dinner of the Seven Seas Club, we had the real thing. Sailor songs sung by real sailor men.

There was not much style, but any amount of "go," about it. The leader sang in a wheezy voice, often out of tune, always liable to crack on the upper notes, and the company roared the chorus. That is how the shanty must really sound "on its native heath," so to speak—and very good it was to hear it.

Hot Water.

Harold Nicolson must be one of the friendliest, as he is one of the most amusing, souls alive. He is talking every week about "People and Things." Usually he talks about living people and present things. And because he says what is in his bright mind, he gets into hot water.

The other night he began, "I shall talk about the Past rather than the Present, because I got into hot water over my last talk." Who are these intolerable nuisances with such tender corns that they cannot stand being trod on by so light a foot?

Congratulations.

Two series of talks have just concluded; one by Mr. Kaines Smith on Italian Painting, and the other on Sculpture by Mr. Stanley Casson. These may not have appealed to the widest circles of listeners; but they have been non-technical talks of absorbing interest to all lovers of beauty. Both these gentlemen deserve to be warmly congratulated.

A Footnote.

I do not understand why the official programme relegates Professor Hill to a footnote. He talks on the "Wonders of Modern Science," and the other night had some extraordinarily good stories of deep-sea diving.

In the programme you read "Daventry only," accompanied by a smudge meant for an asterisk; and if you don't happen to recognise it as an asterisk, and cast your eye on the footnote, you will miss Professor Hill. And that would be your loss!

Speed Again!

Miss Mitchell, the champion typist of Europe, was the Surprise Item the other night. She typed in 49 seconds a letter which she took down in shorthand in 58 seconds.

It contained about 90 words; and some of the words were like "terminological inexactitude"! Her machine sounded like several machine-guns sweeping No Man's Land—only quicker!

WATES METERS.

POPULAR WIRELESS readers can obtain fully descriptive free literature regarding the range of Wates Meters, including the popular standard "3 in 1" model, the three-scale panel type, and the Wates Milliammeters, as advertised in last week's issue, direct from The Standard Battery Co., 184/188, Shaftesbury Avenue, London, W.C.2.

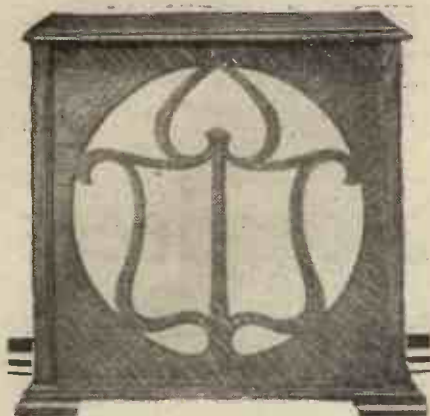

VIVID REALISM! CONVINCING FIDELITY!

The reproduction of the Wates Star is matchless in its vivid reality. The superb aplomb of its emission at every point of the musical scale combines with a depth and richness of tone that is a delight to hear. Nothing is missed or over emphasised; you hear only the truth, a facsimile reproduction of the original. The complete cabinet speaker in oak, £4; Mahogany, £4 6s. Or you can build up a magnificent speaker with the Wates Star Unit and Double Cone Chassis, as illustrated below.

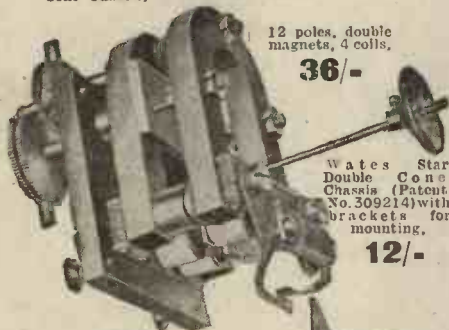

12 poles, double magnets, 4 coils.

36/-

Wates Star Double Cone Chassis (Patent No. 309214) with brackets for mounting.

12/-

WATES STAR LOUD SPEAKER UNIT

If your dealer does not stock, obtainable direct. Full particulars free on request.

THE SHAFTESBURY RADIO CO., Dept. F.W., 184-188, Shaftesbury Avenue, London, W.C.2.

PHONE: TEM BAR 6195.

M.B.

The Picture Paper with the MOST News **SUNDAY GRAPHIC**

ALWAYS LIQUID

THE IDEAL GLUE FOR MAKING SETS & SPEAKERS

LEPAGE'S LIQUID GLUE

SOLD BY IRON MONGERS, STATIONERS AND STORES

TUBES 6/- BOTTLES 10/- AWARDED 16 MEDALS

ANDREADY

LEPAGE'S GLUE CO. LTD., 4-10 HATFIELD ST., LONDON E.C.1

ENGINEERS! Can't we get together?



All we ask is the chance to prove that you can earn £300, £400, £500 per year or more. Other men are doing it, and you can do the same.

WRITE FOR THIS BOOK TO-DAY IT'S FREE!

We have an unrivalled and world-wide organization, waiting to help you whether you be novice or expert. If you wish for something more than a "bread and butter" job you owe it to yourself to investigate our Service.

Our handbook "Engineering Opportunities" has pointed the way to better things to over 20,000 of your fellows. It contains details of A.M.I.Mech.E., A.M.I.E.E., A.M.I.C.E., A.M.I.A.E., A.M.I. Struct.E., London Matric., C. & G., G.P.O., etc., Exams., outlines home study courses in all branches of Electrical, Mechanical, Motor and Wireless Engineering, and explains our unique guarantee of

NO PASS—NO FEES

In a Brilliant foreword Prof. A. M. Low shows clearly the chances you are missing.

"Engineering Opportunities" and our advice are quite FREE. Don't neglect this offer—give vent to that "upward urge" and send a postcard NOW, stating Branch, Post or Exam, which interests you.

British Institute of Engineering Technology, 101, Shakespeare House, 29-31, Oxford Street, W.1

REPAIRS

Any make of L.F. Transformer, Loudspeaker or Headphones repaired and despatched within 48 HOURS—TWELVE MONTHS' GUARANTEE with each repair. 4/- post free.

Terms to Trade.

TRANSFORMER REPAIR CO.,

"Repairs" Dept., 214, High Street, Colliers Wood, London, S.W.19.

AGENTS WANTED to sell Wireless goods, all makes in sets, components and accessories. Cash or Easy terms. Liberal commission. NEW AUTO SUPPLY CO., 247, Park Rd., ASTON, Birmingham.

"Where did that one come from?"

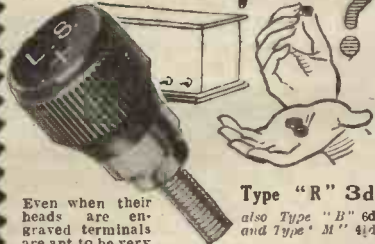

Type "R" 3d.

Even when their heads are engraved terminals are apt to be very muddling—if the tops come off. The tops of Belling-Lee terminals cannot possibly come off—one of the many advantages to be gained by using these excellent little products. Ask your dealer, or send to us for FREE Belling-Lee Handbook, "Radio Connections."

BELLING-LEE FOR EVERY RADIO CONNECTION

Advt. of Belling & Lee, Ltd., Queensway works, Ponders End, Middlesex.

By Dr. J. H. T. ROBERTS, F. Inst. P.

TECHNICAL NOTES.

I WAS talking a short time ago about filter circuits, and in view of the interest in this subject I should like to add one or two further observations which I hope may be useful. Several readers want to know whether an output circuit of the filter-feed type should be used with different specified types of sets.

In cases where a comparatively small amount of power is handled on the low-frequency side, for example, a set with say, one stage of L.F. and perhaps a single stage of H.F., a filter circuit need not be used, but where the voltage on the last valve is much higher than normal with the correspondingly heavier anode current a filter circuit may be very useful.

EXIT "REG"

the Regional transmission from Brookmans Park, and

EXIT "NAT"

the National programme, at the same time, if you build

THE "DOUBLE" REJECTOR

It enables you to cut out either or both of your interfering stations

AT ONE GO.

see full constructional details in "Popular Wireless"

NEXT WEEK.

Price 3d.

Price 3d.

With two low-frequency stages and, in some cases, with two high-frequency stages a filter circuit will generally be found advantageous.

Of course, there is always the question of the cost of a filter circuit to be borne in mind, and naturally the experimenter does not want to go in for this additional equipment unless it is actually necessary. In battery-operated sets, particularly with the popular three-valve type, one high-frequency and one low-frequency stage, the filter circuit is sometimes unnecessary.

Abuse of Reaction.

There is often an impression, more particularly amongst beginners in radio, that reaction may be used to compensate for the inefficient design of a circuit or for the use of poor components. Perhaps I should say that good components are sometimes used in a way which does not give them a fair chance.

The amateur is sometimes apt to think that, no matter what the losses in the set may be, their effect can always be overcome by piling on plenty of reaction.

Now this view is quite wrong and should not be encouraged. It is true that reaction is considerably used and is very valuable, but at the same time you should always bear in mind the fact that reaction tends

(Continued on next page.)

"PILOT" Kits For "P.W." Sets

INCLUDE all specified components, necessary coils, drilled panels and requisite connecting wires, screws, etc. "A" Kits include also specified valves and cabinets, whilst "B" Kits exclude these items.

1930 "MAGIC" THREE

KIT "A"	KIT "B"
CASH £9:11:2	CASH £6:12:8
or 12 monthly instalments of 17/6	or 12 monthly instalments of 12/2

1930 "TITAN" THREE

KIT "A"	KIT "B"
CASH £9:12:1	CASH £6:1:7
or 12 monthly instalments of 17/7	or 12 monthly instalments of 11/2

"REGIONAL" FOUR

KIT "A"	KIT "B"
CASH £12:9:9	CASH £8:6:3
or 12 monthly instalments of 22/8	or 12 monthly instalments of 15/3

Any part supplied separately. Detailed lists on application. **FINISHED INSTRUMENTS.** All the most popular "P.W." Sets, including the above, are available as finished instruments, built in our own factories, and aerial tested and guaranteed. Full details on application.

The above, and all other "P.W." Sets are also available in Console or Radio-Gramophone Models. Details on application.

Send us a list of your requirements for a quotation by return. Post coupon for our magnificent 48-pp. catalogue.

PETO-SCOTT CO., LTD.

Free Demonstrations and advice by Qualified Engineers at our Shops:—
 77, CITY ROAD, LONDON, E.C.1. Telephone: Clerkenwell 9406-7-8.
 62, HIGH HOLBORN, LONDON, W.C.1. Telephone: Chancery 8266.
 4, Manchester Street, Liverpool. Telephone: Central 2134.
 33, Whitelaw Road, Chorlton-cum-Hardy, Manchester. Telephone: Chorlton-cum-Hardy 2028.

FAMOUS "RADCROIX" POWER TRANSFORMERS.

Tapped Power Transformer, TMV2. Full Wave Rectification.

List Price 15/9

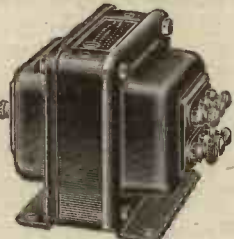

Wiring Diagrams Free

This Super-Power Transformer will operate on 200/250 volt 40/100 cycle mains. It has two secondary windings:—
 1. High Tension Smoothed Output 35 m/a at 200 volts, or 45 m/a at 160 volts.
 2. Rectifier filament heater winding delivering 1 ampere at 4 volts.
 Designed for Rectifying Valves, "Tungsram" PV 475, "Philip" 506, or "Mullard" DU 2.
COMPLETE KIT OF PARTS GIVING SORENEED GRID 60. DETECTOR 30. LOW FREQUENCY INTERMEDIATE 120. POWER 35 M/A AT 200 VOLTS. £2 11s. 0d.

Applications from travellers thoroughly conversant with Power Transformers are invited.

Sole Distributors:
THE WHOLESALE WIRELESS CO.
 103, Farringdon Road, London, E.C.1.
 Telephone: Clerkenwell 5312.

YOU ARE INTERESTED IN RADIO!

Therefore you need our 224-page catalogue of Receivers and Accessories, fully illustrated, 9d. post paid. **COOPER & CO., CASTOR, PETERBOROUGH.**

EASY TERMS

We SPECIALISE in the supply of all Good Quality Radio Sets, Components and accessories on Easy Terms. We will give you efficient service. Send us your list of requirements and a quotation will be sent by return.

LONDON RADIO SUPPLY COMPANY
 11, Oat Lane, Noble St., London, E.C.2
 NATIONAL 1977.

PLEASE MENTION "POPULAR WIRELESS" WHEN REPLYING TO ADVERTISEMENTS.

The Easy Way TO PERFECT RADIO

KITS, SETS & ACCESSORIES

In addition to their own extensive range, PETO-SCOTT offer Every Known Radio Receiver, Kit, Component or Accessory.

ACCESSORIES

THE "BROOKMANS" REJECTOR UNIT. Exactly to "P.W." specification; assembled, wired, and tested, 12/6.

A WAVE-CHANGE "BROOKMANS" REJECTOR. Exactly to "P.W." specification; assembled, wired, and tested. Coils included, 18/6.

EXIDE 120-VOLT H.T. ACCUMULATOR. Type W.J., 2,500 m/a. In Crates. Cash £3 15s. or 12 monthly payments of 6/11. Type W.H., 120 volts, 5,000 m/a. In Crates. Cash, £4 13s. or 12 monthly payments of 8/6.

OSRAM MUSIC MAGNET. Cash £9, or 12 monthly payments of 16/6. Valves included.

REGENTONE W.I.B. S.G. (A.C. Mains). For S.G. and Pentode Sets. Cash £4 19s. 6d., or 12 monthly payments of 9/2.

CELESTION C.12 LOUD-SPEAKER, in oak. Cash £5 12s. 6d., or send only 10/4, balance in 11 monthly payments of 10/4; in Mahogany, Cash £5 17s. 6d., or 12 monthly payments of 10/9.

ULTRA AIR CHROME DOUBLE LINEN DIAPHRAGM SPEAKERS in oak or mahogany table model cabinets. Type K chassis, £4 4s. 0d. or 12 monthly instalments of 7/6.

Mail coupon in unsealed envelope under 3d. stamp.

COUPON

Please send me your 48-page Illustrated Catalogue, describing the 1929-30 products of all the leading makers.

NAME.....

ADDRESS.....

P.W. 153



"JOURNEY'S END" as a Novel

"Journey's End" as a play has been acclaimed in all countries as the finest story of our generation.

"Journey's End" as a book is appearing in ANSWERS for the first time in any paper! Here is the story you must not miss. Written by R. C. Sherriff and Vernon Bartlett, it tells you the truth about the War with a ruthlessness and realism which will hold you spellbound.

Begin reading it TO-DAY in

ANSWERS

Buy YOUR Copy NOW - - 2d.

fixed!

Send for the illustrated leaflet No. 940 which shows you

HOW TO BUILD THE HEAYBERD H.T. ELIMINATOR

A complete kit of parts, including a Westinghouse metal rectifier, costs only 59/6. Easy to assemble. Write NOW

F. C. HEAYBERD & CO.,
10, Finsbury St., LONDON, E.C.2
Telephone - - - Clerkenwell 7216

SUPER-MICROPHONES

New, highly sensitive, made on the latest principle, a vast improvement over all other types; will pick up whispered words from a distance of several yards also strongly amplify and transmit speech and music over a distance through Loud-speaker or Headphones. Splendid instruments for making Detectaphone, DEAF AID, LOUD-SPEAKING TELEPHONE, Announcements through Loud-speaker, Amplifier for Crystal or Valve Sets, Electric Sound etc. NO OTHER MICROPHONE OF EQUAL SENSITIVENESS KNOWN: each instrument fitly black enamelled and fitted with a 3 ft. silk flexible connecting cord. Despatched by return post. 8/6

SPECIAL MICROPHONE TRANSFORMER for connecting Super-Microphone to Radio Head-phones, Loud-speaker, Valve Set, or Valve Amplifier. 6/-

SMALL 10 OHMS EARPIECE for use with Super-Microphone as a HIGHLY EFFICIENT DEAF AID, or Detectaphone, etc.; thin 3-ft. silk connecting cord fitted. Earpiece finely black enamelled. 6/-

Full directions for use of Super-Microphone for many purposes and Diagrams of connections free. (2,000 ohms)

The MIDGETPHONE 4,000 ohms

A wonderful miniature Wireless Receiver which equals in volume and purity of reproduction the best Wireless Headphones known. Fits every Ear, large or small, perfectly, and does away altogether with the discomforts of large Earphones and Headbands. NO Headband. NO Headaches. NO Hot and Painful Ears. Splendid volume of sound from any Crystal Set. Wonderful reproduction from Valve Sets. A production from Valve Sets. A little scientific instrument. Held to ear by neat wire loop. Also made in 10 ohms resistance for use with the SUPER-MICROPHONE as a highly efficient DEAF AID. The Midgetphone weighs 1 1/2 ounces, including thin 14/6 but strong 6-ft. silk connecting cord. Post Free

FREDK. ADOLPH, Actual Maker,
27, Fitzroy Street, London, W.1.
Phone: Museum 8329.

ALL APPLICATIONS FOR ADVERTISING SPACE IN "POPULAR WIRELESS" must be made to the Sole Advertising Agents, **JOHN H. LILE, LTD.,** 4, LUDGATE CIRCUS, LONDON, E.C.4. Phone: City 1261.

TECHNICAL NOTES.

(Continued from previous page.)

to introduce distortion. It is important, if you want really good results, to pay particular attention to coils and condensers—I am assuming, of course, that you have in the first place chosen an efficient circuit—and of these two components the coil is the one which probably has the greatest influence upon the functioning of the circuit.

Inefficient Use of Coils.

There are good and bad coils, and there are good coils which may behave like bad ones if they are not used under proper conditions. For example, a coil may be placed too close to a metal surface, with the result that serious losses may be introduced and these losses have eventually to be made up.

On the other hand, the change in the effective inductance of a coil, brought about by the presence of a metal shield, may mean simply that a different tuning capacity is necessary for a particular wavelength.

The high-frequency resistance of a coil is a point which needs careful consideration, and, although it is impossible to do away with the H.F. resistance altogether, its value should be kept as low as possible.

The influence of resistance and corresponding damping is particularly noticeable when we come to the question of selectivity, and here the difference between a circuit with a good coil, operating under efficient conditions, and a circuit with a bad coil or with a coil operating under inefficient conditions is very noticeable.

Question of Load.

"How is it that a mains-supply unit which will operate one set perfectly will produce a hum when operating another set of similar type?" I have before me a query which is typical of many in which the writer says that he has worked a two-valve set perfectly from D.C. mains, but when running a three-valve set from the same mains, and using the same eliminator, the hum is almost unbearable.

Of course, if there is any difference in the nature of the circuits, this may well account for the different results obtained; for, as you know perfectly well, some kinds of circuits are very much more sensitive to the hum produced by an eliminator than others.

Assuming, however, that the circuits are of the same type, and the only difference is the difference in the amount of H.T. current drawn from the eliminator, this, again, is sufficient to account for a difference in behaviour.

A D.C. eliminator may be said to consist essentially of a system of chokes and condensers for smoothing out any ripple or hum on the D.C. supply, together with any necessary resistances to permit of different voltages being obtained.

Rated Capacity.

Now, in designing such an eliminator the capacity of the condensers and the impedances of the chokes, as also the design of the condensers and chokes, are governed by considerations of the current and voltage which the unit is intended to pass.

(Continued on next page.)

RD 40
2/-

"RED DIAMOND"
THE RECOGNISED DETECTOR FOR ALL CIRCUITS USING CRYSTAL RECTIFICATION. By insured Post 2/3 or 2/9 with shield. Can be mounted on brackets or through panel. Once set always ready. Not affected by vibration. Each one is tested on broadcast before despatch and is perfect.

"RED DIAMOND" TRADE MARK
2-WAY COIL HOLDER **RED DIAMOND**
RD 32
4/-
EACH

Parallel working. Fine adjustment. Worm-driven. Coils cannot fall. Easy movement. Perfect finish. By Insured Post 4/6. Of all high class Radio Dealers, or Sole Makers:

JEWEL PEN CO., LTD.
(Radio Dept. 46).
21-22, Great Sutton St., LONDON, E.C.1

"APTUS" LINEN DIAPHRAGM TRIPLE CHUCK ADAPTER
FITS ALL UNITS

COMBINED BRASS AND CELLULOID WASHERS. PREVENTS RATTLE.
EXPERTS SAY—"The most Successful Centre yet Devised."

PRICE 2/6 POST 3d.

"APTUS" DOPE, 10 oz. .. 2/9
DOPE BRUSH .. 6d.
IRISH LINEN for 22 in. 7/6
8 ANGLE BRACKETS with SCREWS .. 1/6
RUBBER .. 6d. yard
SET (4) 2 B.A. RODS (16 NUTS and WASHERS) .. 1/6

UNITS. Post Free.
APTUS 17/6 BLUE SPOT 25/-
HEGRA 19/- CHIMES 16/6 ETC.

Orders Over 10/- Post Free.
Makers of "APTUS" specialities.

MOORE & CO.
(Est. 50 YEARS)
101 & 103, Dale St., LIVERPOOL
Phone: Cen.5284. Grams: "Solutions."

For the Best in Radio

WILL-DAY LTD.

(THE BEST IN THE WEST)
10 LIRE STREET, LICHFIELD SQUARE, LONDON, W.C.2.
Telephone: ABBOTT 3101. Telegrams: Will-Day, London.
OPEN TILL 7 P.M.
WRITE FOR OUR CATALOGUE
POSTAGE 4d FREE TO CALLERS

"PURATONE" NEW RADIO VALVES NEW PRICES

H.F. Det. 5/- Super-Power 8/-
L.F. & R.C. 7/- Screen-Grid 10/-
Power - - - 7/- 2, 4 or 6 volts.

Ask your dealer for particulars or write to the Manufacturers:

RUBON LTD., 189, New Kings Rd., London, S.W.6

KAY'S CABINETS

This Cabinet soundly constructed of Oak and equipped with Baseboard Runners. Fall Front, Hinged Top. Polished rich Jacobean. 36" 45"-high. For panels up to 18" wide any Popular Set. Greatest Range of Wireless Cabinets. Illustrated Lists Free.

H. KAY, Cabinet Manufacturer,
Mount Pleasant Road, London, N.17
Phone: WALTHAMSTOW 1626.

Make **THE DAILY SKETCH**
YOUR Picture-Paper.

Cifel Tubus Condenser

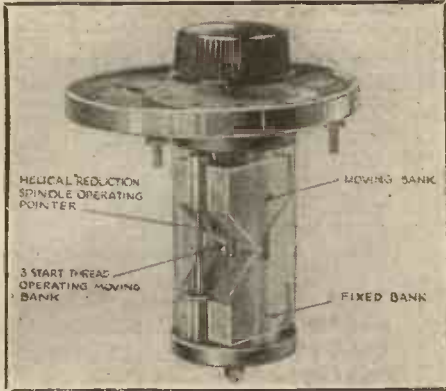

A new and unique condenser. Completely enclosed, dust proof. Rapid travel, and yet positive variations of 1,000th, combined with extraordinary smooth motion.

A Precision Condenser with Knife-edge Tuning.

12/6 of all Dealers. Write for illustrated leaflet and copy of "A.W." Test Report.

FONTEYN & CO., LTD.,
2, 3, 4, 5 and 6, Blandford Mews, Baker St., W.1.
Telephone: Welbeck 4144 (3 lines).

STEEL MAST SPECIAL GUARANTEE!
This vastly improved model is made of best British Steel throughout (not iron) and is very easy to erect. We guarantee that if MAST becomes damaged from ANY cause **WHATEVER** within 6 months of purchase we will replace entirely **FREE OF CHARGE** any damaged part caused through any accidents—gales—or mishap during erecting. No other MAST bears this guarantee.

26 ft. STEEL MASTS, tapering 1 1/2" to 1". Carriage: 14/- London, 1/6; Midlands, 2/6; Elsewhere, 3/6. Weighs 28 lbs.
30 ft. Tapering 1 1/2" to 1". Carriage: London, 2/-; Midlands, 3/-; Elsewhere, 4/-; Weighs 36 lbs.
34 ft. Tapering 1 1/2" to 1 1/4". Carriage: London, 2/-; Midlands, 3/-; Elsewhere, 4/-; Weighs 40 lbs. 20/-
NOTE. Our Masts are stayed at 4 ground points (not 3) which ensures safety.
Mast complete with Galv. Wire, Pulley, Cleat, Solid metal Foot Rest and stay fasteners. Accessories—Manilla Halyards, 60 ft., 1/6; 100 ft., 2/6. Special Anti-Rust Paint, 1/6.
C. F. MAST CO., 48, High St., PENGE, S.E.20.

HEADPHONES REPAIRED 4/-
Transformers 5/-. Loudspeakers 4/-. All repairs re-magnetised free. Tested, guaranteed and ready for delivery in 24 hours.
Discount for Trade. Clerkenwell 9069.
E. MASON, 44, East Rd., City Rd., N.1.

EASY PAYMENTS
The first firm to supply Wireless Parts on easy payments. Five years' advertiser in "Popular Wireless." Thousands of satisfied customers. Send us a list of the parts you require, and the payments that will suit your convenience and we will send you a definite quotation. Anything wireless.
H. W. HOLMES, 29, FOLEY STREET,
Phone Museum 1414. Gt. Portland St., W.1

"KLEER-KUT" COILS
PUT FORM INTO PERFORMANCE
25. 30. 35. 1/-, 40. 50. 1/2, 60. 75. 1/3, 100. 125. 150. 1/6, 175. 1/9, 200. 2/-, 250. 2/3, 300. 2/6.
Centre Tapped 6d. "X" Coils 1/- extra.
L. BRUCE, 99, King Henry's Rd., LONDON, N.W.3
6 years coil maker to the Wireless Trade.
Phone: Primrose 1303. Trade supplied.

PLEASE MENTION "POPULAR WIRELESS" WHEN REPLYING TO ADVERTISEMENTS.

TECHNICAL NOTES.

(Continued from previous page.)

If the current is well within the rated value, and the unit is properly designed, the ripples of the D.C. supply should be properly "ironed out"; but if a heavier load is thrown upon the unit, the conditions are more severe than those contemplated by the designer, and the chokes and condensers may not be adequate to the task which is imposed upon them.

As a matter of fact, I have found that some of the H.T. supply units on the market are very far from being perfect, and in order to get anything like decent results it is necessary to keep the load much below the maximum load specified. All this emphasises once more the importance of buying a unit made by a reputable manufacturer.

De-tuning and Volume Control.

Now that the two new high-power stations are working, the question of selectivity becomes important, even for comparatively short-range sets.

Having got your receiver so arranged that you can readily separate the one station from the other, the next question

The MARCH issue of MODERN WIRELESS

is NOW ON SALE and the CONTENTS include:

- Preventing Fading Those High Notes
- H.F. on the Mains
- Loud Speakers (By Capt. P. P. Ekersley)
- Trouble Tracking Religion and Radio
- On the Short Waves

Choosing Variable Condensers and

FOUR FINE CONSTRUCTIONAL ARTICLES.

Don't Forget YOUR Copy!
1/- MODERN WIRELESS 1/-

is one of volume. If the volume is too great, you may adopt the very simple dodge of de-tuning slightly; but, as you know, this is really a very unsatisfactory way of controlling volume, since it introduces distortion. In some cases the distortion is so serious as to render the method quite useless.

In addition to all this, in de-tuning from one station you may, if other stations are very close to it on the dial, run into another station, so that you get not only distortion but also interference.

A Simple Arrangement.

It is altogether much more satisfactory to use a proper form of volume control. A simple and satisfactory control consists of a high resistance (potentiometer) of, say, a total of 1/2 megohm, connected across the secondary of the first low-frequency transformer, or connected in place of the grid leak in the case of an R.C. stage.

The grid of the first L.F. amplifying valve is connected to the variable contact (slider) of the potentiometer, instead of

(Continued on next page.)

YOUR DEALER HAS THEM—



A.C. VALVES

Your dealer can now supply you with Tungram Indirectly Heated A.C. Valves. They are among the Tungram range he stocks. They are valves of better quality—the secret is the famous Barium Filament. And, with all their better quality, they cost nearly 50 per cent less than Association Valves.

Indirectly Heated Valves, 9/6
4 v. A.C. Power Valves .. 8/-



TUNGGRAM PHOTO-ELECTRIC CELLS (3 Types)
STANDARD .. £2:10:0
NAVA E .. £2:17:6
NAVA R .. £2:17:6

GO TO YOUR DEALER—HE HAS THEM

TUNGGRAM BARIUM Valves

TUNGGRAM ELECTRIC LAMP WORKS (G.T. BRITAIN) LTD., Radio Dept., Commerce House, 72, Oxford Street, London, W.1.

Factories in Austria, Czechoslovakia, Hungary, and Poland.

Branches: Belfast, Birmingham, Bristol, Cardiff, Glasgow, Leeds, Manchester, Newcastle, Nottingham.





BULGIN
RADIO PRODUCTS

NOW SPECIFIED FOR THE "P.W." SAFE-POWER JUNIOR IN THIS ISSUE



THE BULGIN 20,000 OHM POTENTIAL DIVIDER

A sound engineering production, fitted with air-cooled perforated metal case and terminals. Wound on bakelite former. Will give an excellent range of useful tappings and has fully satisfied the critical Radio Engineers of this journal. Each **7/6**

32 Henry Smoothing Choke . . . Each 12/6
2 mfd. Bakelite Condensers . . . " 3/-
4 mfd. Metal Case Condensers . . . " 4/4

Ample stocks are available. In case of difficulty, or attempts at substitution, write direct.

A. F. BULGIN & CO.,
9-10-11, CURSOR STREET,
CHANCERY LANE, LONDON, E.C.4
Telephones: HOLBORN 1072 & 2072.

TECHNICAL NOTES.
(Continued from previous page.)

being connected to one of the terminals of the secondary.

If the slider is put to the "maximum end" of the potentiometer—that is, to the terminal of the transformer to which the grid would otherwise have been connected—the maximum voltage reaches the grid of the L.F. amplifier and signals are loudest.

As the slider is moved away from this position, however, it picks up less and less voltage from the output of the transformer, this voltage being communicated to the grid of the L.F. amplifier, and so the volume becomes less and less correspondingly. The purpose of the potentiometer, in short, is to enable lower output voltages to be picked up from the transformer, and this without distortion of the signals.

If you use a volume control of this kind, and you are searching for other stations, it is best to set the volume control at the

TECHNICAL TWISTERS

No. 1.—AERIALS

CAN YOU FILL IN THE MISSING LETTERS ?

- (1) The aerial should always be erected as . . . as possible, to avoid screening by neighbouring buildings, trees, etc.
 - (2) The down-lead should come from one . . . , or from the of it.
 - (3) Good contact throughout is essential, so avoid having any , if possible.
 - (4) Don't forget to your aerial when it is not in use.
- (Look out for the missing words next week)

"maximum" position, so that signals are loudest, as otherwise you may over-run a distant station or one giving comparatively weak signals.

AN OPPORTUNITY FOR PICTURE LOVERS. SUPERB NEW COLOUR WORK. BRITISH ART.

A unique opportunity is offered to our readers by the publication in fortnightly parts of MODERN MASTERPIECES OF BRITISH ART, Part 1 of which is now on sale, price 1s. 3d. By subscribing to this new work you will be able to secure 200 gems of British Art, reproduced in full colours, and eight superb loose framing pictures.

Each part of this—the most brilliant colour publication yet issued in this country—will contain no fewer than eight perfect reproductions of pictures selected from the Art Galleries of Great Britain, each one of which, if purchased separately, would cost much more than the complete part itself.

The work will be completed in 25 parts, and at the finish can be bound up into one splendid album of art treasures.

Owing to the great expense of producing this work only a limited number of copies have been printed of Part 1, and it will be some time before any reprint can be ready. We advise all our readers to secure Part 1 without delay.

ELECTRADIX BIG BARGAINS

Another large quantity of snips for keen buyers from Fellows' liquidation, surplus.

Royal, Efesca, Ediswan, G.E.C. and Air Force just in! 2, 3, 4, and 5 valve Sets, Eliminators, Chargers, Portable Sets and Cabinets, Accumulators, Coils, Aerials, wire and lead in, Mains Transformers and Rectifiers, Public Address Mikes and Speakers, Valve Test Panels, Meters and Meggers. Torches and Lamps. Motors and D.C. or A.C. Motor generators.

Sale List addition in print. Send addressed envelope if you cannot call. Prompt despatch of goods everywhere.

ELECTRADIX RADIOS,
218, Upper Thames Street, E.C.4
Blackfriars Stn. Underground Rly City O191

HIGH-GRADE FIGURED OAK RADIO-GRAMOPHONE CABINET

Height 3' 6". Depth 1' 6". For Panels up to 21" x 8". Baseboards up to 11". £7:7:0 Carriage Paid. Prices of other sizes in proportion.

Manufacturer of all types of wireless cabinets and furniture of every description. Illustrated lists free

GILBERT, Cabinet Maker, SWINDON.
Estimates Free. Estd. 1866



FREE Packet of ROSE MALLOW SEEDS

in this week's

Popular Gardening

Get your Copy NOW! 2d.

THE LITTLE CELLS THAT SATISFY

Leyton Primary H.T. Battery. P1 Porous Pot Cells S1 and S2 Sac Cells. All complete for assembly.

	1-cell.	6-cell.	12-cell	30-cell
P1	6/d.	3/3	5/9	14/-
S1	6/d.	3/-	5/3	12/-

"Easeful" Filler, 1 pint 1/-, pint 1/6. Post free 3d. ex. Send 1/d. stamp for booklet giving full particulars to

THE LEYTON BATTERY CO.,
305, CHURCH ROAD, LEYTON, E.10

EVERYTHING WIRELESS on EASY TERMS

THE MOST FAVOURABLE OBTAINABLE

ALL COMPONENTS, KITS OF PARTS for all Circuits, MULLARD ORGOLA, COSSOR MELODY MAKER, etc. Complete SETS, H.T. UNITS, LOUD-SPEAKERS, etc., etc.

CALL or SEND A LIST OF YOUR REQUIREMENTS; a Quotation of our BEST MONTHLY TERMS will be sent BY RETURN.

The P.D.P. CO. LTD.
(Dept. P.W.),
121, CHEAPSIDE, LONDON, E.C.2.
Phone: National 9846.

PLEASE be sure to mention "POPULAR WIRELESS" when communicating with Advertisers. THANKS!

A REVOLUTION IN RECEIVERS!

BUILD THE **"VI-KING" THREE** The Most Remarkable Broadcast Receiver Ever Designed.

This easily built and inexpensive three valver enables your family to listen to two different programmes at the same time, receiving each perfectly clearly and free from interference from the other. It operates on *any wavelength*, and requires only one set of batteries, and one aerial and earth.

Fully described by VICTOR KING in THE APRIL

WIRELESS CONSTRUCTOR

ON SALE
 M
 A
 R
 C
 H
 15th.

ALSO IN THIS ISSUE

A
 SPECIAL ARTICLE
 By
NOEL ASHBRIDGE
 B.Sc. A.M.I.E.E.
 (Chief Engineer of the B.B.C.)

ON SALE
 M
 A
 R
 C
 H
 15th.

Price 6d.

DON'T MISS YOUR COPY

Price 6d.

A1
- and now
'A1' IN RATIO

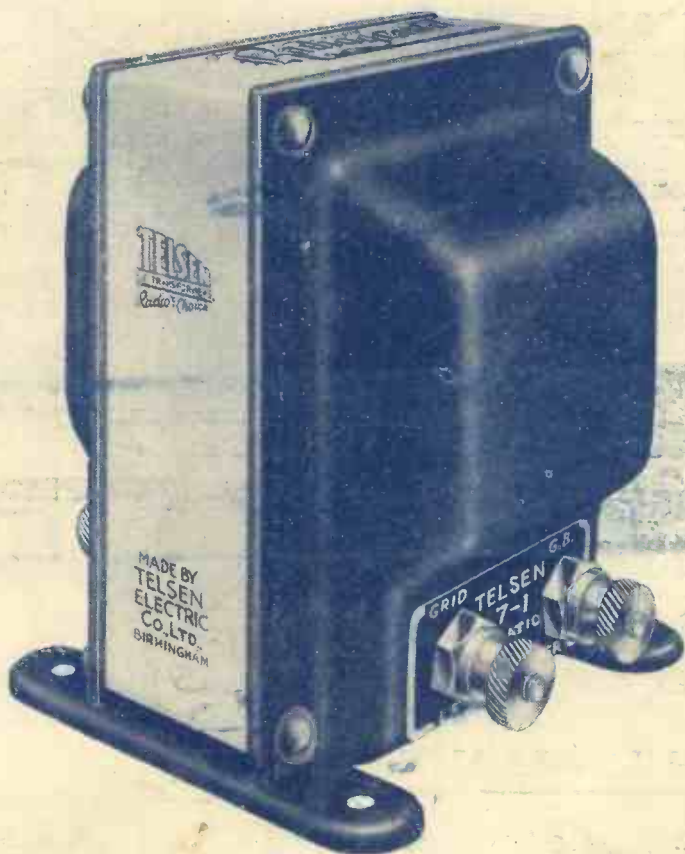

7-1
AMPLIFICATION

This big ratio transformer sets an entirely new standard in Radio reception, giving enormous amplification without any trace of distortion whatever. This new ratio transformer is, in fact, equal to another valve stage in many wireless sets, making the reception of foreign stations a pleasure and delight to hear, hitherto unknown.

This is the transformer you have been waiting for; go along to your Wireless Dealer now and ask for the Telsens New Ratio 7-1 Transformer and delight your family with the amazing reception which only this transformer can give—and then you will want to invite your friends round to hear it too.

The Telsens New Ratio 7-1 Transformer is undoubtedly one of Radio's greatest achievements during the last few years.

PRICE 17'6

**TELSEN ELECTRIC CO. LTD.,
MILLER ST., BIRMINGHAM.**

TELSEN

**NEW RATIO
TRANSFORMER**

SEI

ONALS (See Page 11)

Popular Wireless

Every Thursday
PRICE
3d.

No. 407. Vol. XVII.

INCORPORATING "WIRELESS"

March 22nd, 1930.

THE "P.W." TWIN REJECTOR

Will
Blot
Them Out!



Other Special Articles This Week

IN SEARCH OF A. J. ALAN
THAT PATENT ROYALTY QUESTION
By Capt. P. P. Eckersley, M.I.E.E.

GERMANY'S SUPER-POWER STATIONS

THOSE SIDE-BANDS
By Sir Oliver Lodge, F.R.S.

MORE ABOUT "SAFE-
POWER JUNIOR"

BRING EAST TO WEST



Through the **LEWCOS** 3-VALVE KIT ASSEMBLY

PRICE £7
(Without Valves.)

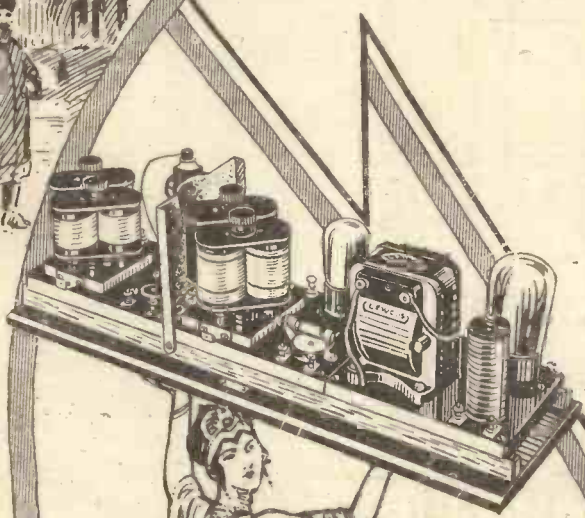

THE Lewcos 3-valve Kit Assembly illustrated above has been subjected to severe tests by experts and the results elicited pœans of praise for its extraordinary capacities.

It has been found incredibly simple to bring the atmosphere of the East into the homes of the West through the medium of speech and music.

LEAFLET GIVING FULL PARTICULARS OF "THE EASIEST KIT-ASSEMBLY YET PRODUCED," WILL BE SENT ON REQUEST. (Please Quote Ref. No. R.58.)

A TESTIMONIAL

"I have purchased one of your 'three-valve kit assembly' units and am writing to say that it is a complete success. Up to the present I have received 34 stations at loud-speaker strength, and here, in Ealing, with an aerial 60 ft. long and 25 ft. high, the two Brookman's Park stations can be separated without any 'background.'"
Name and address of writer will be given on request.



THE LONDON ELECTRIC WIRE COMPANY
AND SMITHS LIMITED
Church Road, Leyton, London, E.10
Trade Counter: 7 PLAYHOUSE YARD, GOLDEN LANE, E.C.1



Popular Wireless

Scientific Adviser:
 Sir OLIVER LODGE, F.R.S.
 Chief Radio Consultant:
 CAPT. P. P. ECKERSLEY, M.I.E.E.
 Editor: NORMAN EDWARDS.
 Technical Editor: G. V. DOWDING, Assoc.I.E.E.
 Assistant Technical Editors: K. D. ROGERS,
 P. R. BIRD, G. P. KENDALL, B.Sc.,
 A. JOHNSON RANDALL.

NEWS FROM 'FRISCO.
 A GREAT FIGHT.
 TIMELY WARNING.

RADIO NOTES & NEWS

AROUND THE DIAL.
 THE "P.W. B.P. 34."
 DE-GLUEING THE
 GRAMMY.
 A HUMBLE TRIBUTE.

Ariel Flutters His Wings.

THE sight of a cat walking pensively over my tulips reminded me that if we are lucky enough to have a Spring this year, Spring will soon be upon us—if we are lucky. Which led me to realise that I'm feeling radio-worn and ready for my Spring breakaway! What shall it be? A "bus-man's holiday" with a portable in Picardy, or a loaf through the English villages, gathering novel ideas in aerial design, and the collected opinions of Jarge and 'Energ? Let's flip a coin! Where is my double-headed penny?

The Scots Revolt.

AGITATION for a special Scots brand of Board of Control continues to seethe on t'other side of the border, and it is evident from letters received here that the dissatisfaction extends as far north as the Shetlands, where the ponies are "passively resisting," and refusing to have their tails trimmed. Is not all this somewhat ungrateful to Sir J. Reith, who has in many ways shown that he is not unmindful of the special interests and prejudices of Scotsmen?

News from 'Frisco.

"MODERN WIRELESS" has received a nice letter from Mr. W. Werner, 4424, Fulton Street, San Francisco, Cal., U.S.A., who likes to correspond with radio "fans" anywhere. Mr. W. has kindly told us all about the sort of programmes available to Californians, and we are impressed chiefly by the wide variety of items. Sunday transmissions begin at 8.30 a.m. (I'm feeling more like one large English breakfast than radio at that hour.) There are five stations to listen to, and they pour out gramophone stuff, Bible readings, and odds and ends of bits and pieces of tags and rags of all kinds till 1 A.M. Rather a bewildering variety, but plenty to choose from!

The Great Fight.

BY sending me a copy of "The Rag Bag" for 1930, David, of Old Trafford, has done more to banish the lingering germs of 'flu than the quarts of chemistry which have entered my system lately—and I thank him and the merry lads of the University of Manchester who built up this

joyous ebullition of nonsense and skittery. One item deals with the "Mullard-Cossor Fight," and ends, "An eye-witness said, 'I had just returned from the bar and so had some difficulty in seeing clearly, but at the time the sponge was thrown up, all four men were fighting strongly.'"

A New Complaint.

POOR DAVIE, too, needs the "Rag Bag," because he has suffered from a vile crackling in his set, which takes H.T. from the mains. The source of the trouble

enough, one would think, to make a maiden's heart sound like a blacksmith's shop. It is rumoured that a special excursion is being arranged in order to bring down a host of little Aberdeen children suspected of having swallowed ha'pennies.

Arrived at the hospital, the kids each swallow a "tenpenny" nail—for fivepence—and are then violently shaken; if the apparatus registers a click an operation is performed and you get your money back.

Timely Warning.

IT would be advisable for you to have a good look round the latest designs and do your soldering before the mad onrush of Spring woos you into the great out-of-doors. For instance, this month's "Modern Wireless" contains some very interesting designs, including the "M.W." Double Rejector, the "Kuttemout" Crystal (a set for the new National and Regional programmes), the "Forte-Forty" Four, and the "M.W." "Rejector" Two. Think it over and do it now!

Around the Dial.

DESPITE the fact that we hear it can't be done, etc., people persist in writing the most enthusiastic letters about the delightful times and wonderful results they get with "P.W." sets. I notice, however, that the best letters and the best logs come from those who really have learnt something about radio receivers, and therefore are able to tackle the ether intelligently. There is much more in tuning in, and the general manipulation of a modern

receiver, than the mere twisting of knobs. It is 20 per cent twisting and 80 per cent thinking.

The "B.P.34" at Work.

LET the sceptical and the downhearted consider the case of J.W. (Mill Hill, N.W.7), who uses the "B.P. 34." With an aerial consisting of a wire placed round the picture-rail he has logged about 60 European stations. He says, "No mere noises were logged—absolutely clear programmes of varying length have been received from all those mentioned."

He adds that "a run round the dials" produces a bag of 20 to 25 stations without
 (Continued on next page).

THE RADIO ROBOT!

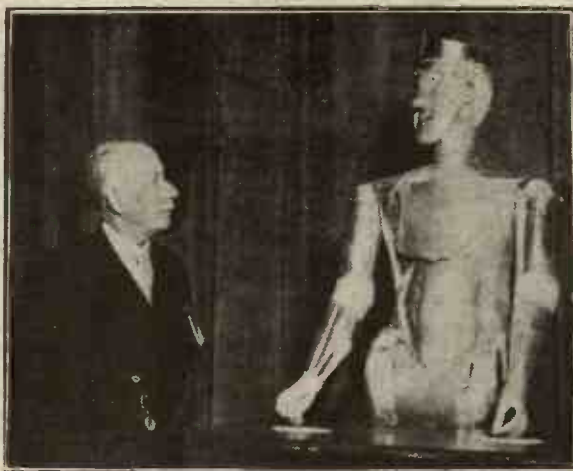

Clad in shining armour like a knight of old, the "person" on the right is a very up-to-date fellow, for he is completely controlled by wireless. Beside the automaton is Capt. Richards, the inventor, at whose command the robot will do almost anything, from shaking his fist at you to giving himself a pat on the back!

has been traced to the electric meter, but our friend hesitates to approach the authorities because of their dislike of mains-driven sets; hence he is "up against a brick wall." Has any reader met and cured this trouble?

I will ask the fairies also, David, but meantime I advise you to tell your borough electrical engineer about the matter, and send him a copy of the "Rag Bag." That will melt his casing.

A Hearty Shake-Up.

UNIVERSITY COLLEGE HOSPITAL has installed a new apparatus by means of which a patient's heartbeats can be amplified without disturbing him. In all there are seven stages of amplification,

NOTES AND NEWS.

(Continued from previous page.)

special searching. It is perfectly obvious from his letter that he is not the kind of man who is content to wallow in a fool's paradise of anonymous squeaks. Therefore, I bid the disappointed pluck up heart, try again, and put a little headwork into the game.

One. More Example.

J. H.S. (London, E.), an old-stager, who has made almost every type of set evolved since Carborundum was a boy, has come to a stop for the time being because the "Magic" Three beats creation. Here, again, is a fellow who knows "what's what." You can't content or fool him with anything less than the real stuff.

Why? *Because he has been through the mill, and knows what he is doing.* He declares that any night he can have a choice of 12 programmes, and that he uses a volume control because de-tuning only brings in another station! Talking of the "Magic" family reminds me that A.J.W.N. (Cape Town) can get 5 S W, P C J, 7 L O, and several Americans on his "Magic" Two.

Mystery of A.J.W.B.

R. E.B. (Plymouth) sends a card to suggest that the A.J.W.B., of Hull (who has so far failed to respond to the fairy who sent him the "Magic" designs when he had failed to secure the back numbers), may be his father who recently died. I appreciate R.E.B.'s kindly thought but believe that he is mistaken. The A.J.W.B. who wrote to us said that he *wished to make* a "Magic" set, whereas, according to R.E.B., his father had already done so.

More Free Licences.

MY note under this heading on February 22nd has brought me a letter from a Yorkshire collier who states that at the age of 32 he is permanently bedridden and would gladly exchange his sight for the ability to get up and walk. I suppose that an able-bodied person cannot enter into the feelings of either the blind or the paralysed sufficiently to weigh up their respective burdens. Anyway, I broached the subject of free licences for the bedridden impersonally. Now that my sympathy has been enlisted in a special instance I cannot very easily develop my argument, can I?

Radio on the Toy 'Plane.

FORD'S latest achievement in luxury-fittings is a radio set with remote control, which is a feature of his new tri-motor club 'plane. The controls are in a cabinet which fits into a combined writing-desk and bookcase built in the forward part of the cabin, the set being at the rear of the 'plane. The batteries are under the pilot's floor, the loud speaker is built into the ceiling amidships and the aerial is supported by a 5-ft. mast on the roof. The walls and ceiling of the cabin are padded with two inches of sound-proof material. Reception of stations within a radius of 150 miles is possible with this layout.

De-Glueing the Grammy.

SO M.T.G. of Huddersfield has been suffering from reluctance of gramophone motor! I feel almost glad to think that I was not alone in my sorrow. Yes, the trouble is probably due to the glue-like lubricating stuff which the makers pour over the works. Take off the tin jacket, wipe off as much of the glue as you

can, especially from the governor pad and the cogwheels, and give the works a good sluicing down with sewing-machine or type-writer oil. In the hot weather, I expect, we shall have to use something with more "body." Don't throw the "glue" away; keep it for mending china, etc.!

A Big Year's Work.

THE National Broadcasting Co., of the U.S.A., reports that during 1929 it added 14 stations to its system making a total of 73. Its gross revenue was £3,000,000, the whole being put back into the business. It increased its mileage of line connections by 5,400, making a total of 32,500 miles. It received over a million letters from listeners. The President spoke

SHORT WAVES.

"Hallo, Twinge!" as the wireless uncle said when his rheumatism made itself felt again.—"Daily Sketch."

"A son of 'Abdul the Damned' is said to have been performing in a jazz band," we read in "Punch."

That must be the one we heard on the wireless the other evening.

One thrill that we always get out of both our new-style 'phone and our radio—we never know what we'll get when we dial.—"Judge."

Errand Boy to Broadcast.—A sort of dawdling commentary.

Grand National Broadcast.—A running—and jumping—commentary.—"Daily Mirror."

"Wireless wonders" runs a headline in the "Clarion."

And so does Jones—when he's going to get one programme at a time on his set instead of two!

A correspondent from Norbury writes to say that the only fault he can find with his set is flat tuning.

From the floor below?

TWO COMICS.

An irreverent correspondent with little history and less sense of decency tells us that there have been two great comic characters in our island's story—Falstaff and B.B.C. staff—and that the latter is the real comic of the two.

We hope this latter will not suffer the same fate as Falstaff, and hear the P.M.G. say in hurt tones "How ill white hairs become a fool and jester."—"Vox."

M.: I see a broadcasting comedian has just been sentenced to fifteen years in prison.

N.: I say, doesn't that seem a little too severe?—"Answers."

over the network thirteen times and there were 27 addresses by Cabinet Ministers.

Savoy Hill English.

ONE cannot refrain from smiling at the B.B.C.'s solemn attempt to teach its young to speak. I refer to its Advisory Committee on Spoken English which, amazingly, includes an Irish jester but not Uncle Tom Cobby. The lists of words published by the Committee do not impress me, because I know how to speak English better than an Irishman.

A Humble Tribute.

THE death of Mr. A. A. Campbell Swinton last month must have come as a shock to many who knew that quiet, talented, kindly personality. I never thought of him as one who would grow old though he was 66. "A Fellow of the Royal Society, a mighty champion of amateurs of radio, the backer and champion

of Hughes, a generous donor, a competent and faithful lover of science and a charming gentleman!" That is the wreath "P.W." offers to his memory

Statistical Section.

IT is just reported that a New York "beak" has sentenced a woman of 29 to imprisonment for life for "shop-lifting." The prevailing craze for stealing portable receivers would, I presume, merit hanging.

The total radio audience of the U.S.A. is said to be forty-one millions. During the year ending June 30th, 1929, the U.S.A. spent £125,629 on radio legislation, regulations, etc.

Pye's of Cambridge.

BEING a confirmed and incorrigible "Light Blue," and feeling that I had better let the boys in the boat know that they have my support, I went down to Cambridge recently and dawdled round my old college, Magdalen (which you will please pronounce "Maudlen.")

This is the Coll. at which old Sam Pepys was admonished for having been "scandalously overserved with ale." Then I thought me of Pye's, and paid them a visit.

A Synonym for Efficiency.

STIMULATED by the thought of Maudlen, Pye's people produce perfect parts. Can they help doing so when they labour under such an intelligent and humane system? The firm's slogan is "Progress," and if an increase of factory area from 29,500 sq. ft. to 75,000 sq. ft. in one year isn't progress, what is it? And the methods of running the factory are a dream of efficiency.

It is easier to steal a policeman's helmet in Cambridge than one of Pye's components! No wonder so many Americans go to Cambridge; under the pretext of learning to scull they are merely spying on Pye's!

His Stringless Banjo.

A LONDON reader, J. V. H., who has a "research" mind, had the curiosity to connect a crystal and cat's-whisker in the place of the grid-leak resistance of his set, a one-valve Reinartz modified. Thereupon he found that the set sang with a clear and steady note, the timbre being like that of a banjo.

It is not quite clear how J. V. H. could receive signals with the set twanging like that. However, perhaps the explanation of the note is that the set was oscillating and producing a "beat," at audio-frequency, with a "carrier" wave.

He Missed a Sight.

MR. G. V. DOWDING tells me that a young fellow on business' bent called at his wigwam and inquired whether, if there happened to be a radio set installed therein, he could be given the job of maintaining it and keeping it in good order. What an escape! Had he been allowed to peep at that menagerie of radioite he would never have smiled again!

A distinguished New Yorker who was allowed to put his nose inside D.'s wireless playroom backed away muttering, "Death Valley!" One of our office boys who was sent there in January to fetch a bundle of short circuits is still in there—somewhere!

ARIEL.

DIVIDING THE ETHER

BY SIR OLIVER LODGE F.R.S.

PART 2.

THOSE SIDE BANDS

AT that time (Sir Oliver is referring to certain experiments carried out by him in 1899.—EDITOR) the best known method of exciting oscillations was by the sudden disruption of a spark, analogous to the plucking or striking of a stretched string—*plucking*, if it were done by steady charge gradually rising to overflow, or *striking* if it were done by the impulsive rush of a current into an uncharged system.

The Valve as Modulator.

But the late Mr. Duddell devised a plan of continuously maintaining the oscillations by means of an electric arc, which acted somewhat as the blast of air acts at the lip or aperture of an organ-pipe, gradually throwing the column of air into vibration, and maintaining it during the continuance of the blast; the electric arc, like the stream of air, being sufficiently docile and controllable as to be dominated and responsibly governed by the oscillation frequency appropriate to the rest of the circuit, or to the column of air.

Subsequently it was found that an arc could be replaced by a vacuum tube; and although the current so produced was much smaller, it could be magnified without distortion by a Fleming De-Forest amplifying vacuum valve, which had by that time come into use.

Tuning the Circuit.

The action of these valves, depending as they do on the docility and mobility of free electrons, is excessively prompt, and the response is so accurate that successive magnifications are possible. Hence a small current such as could be modulated by a microphone of proper design can be magnified, with additional energy imparted to it by relays, until it is strong enough to be sent out into the ether as a wave of considerable intensity, preserving its features in spite of the amplification.

All that a distant receiver had to do now was to submit itself to the etheric vibrations which reached it, and to which it could respond freely when its own natural tune corresponded to that of the received wave.

It must be understood in speaking of "tuning" of the receiver that it has noth-

In this second article of a short series Our Scientific Adviser discusses the effect of tuned circuits on the reception of radio transmissions and shows how the side-band theory affects radio practice.

ing to do with acoustics or acoustic frequency; the transmitted wave is not altered in frequency by the modulations of the microphone; it is only its amplitude that is modified periodically by the acoustic vibrations.

Waves of constant frequency are sent out in groups of varying amplitude; the

A TELEVISION TRANSMITTER.

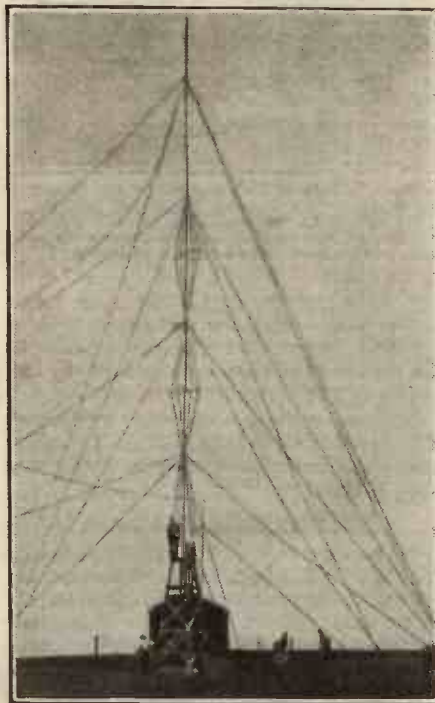

The television transmitter, W2XCR, in New Jersey, which is used for experimental purposes. The future of television broadcasting is likely to be very closely wrapped up in the debated question of sideband interference.

succession of groups corresponding to the pitch of the note thus indirectly conveyed. The receiver, therefore, has first of all to be attuned to the frequency of the carrier-wave, and then at that constant frequency to follow all the variations of amplitude which may be impressed on that wave.

The ultimate appeal has to be made to the human ear by a telephone; and as neither of those instruments can respond to anything far above acoustic frequency, such as is possessed by the ether-wave oscillations, these must first be rectified by a valve device, such as has been familiar since the days of coherers and crystals, but of which the Fleming valve is the most perfect representative.

The Thermionic Detector

Its action depends on the fact that when a hot wire and plate face each other in a vacuum, electrons easily leave the wire to go to the plate, but do not leave the plate to go to the wire: so alternate pulses are suppressed. The telephone, therefore, responds to the succession of rectified group waves, each group embodying the varying amplitude of a large number of high-frequency oscillations in the carrier-wave.

With this introduction, we come to the subject under present discussion, which concerns the reception of a carrier-wave of fluctuating amplitude by a freely oscillating circuit, whether it has a collecting aerial attached, or whether it is a magnetic or portable "frame" receiver; the circuit being attuned to the high-frequency oscillations of the carrier-wave.

Preserving Proportion

And already it becomes fairly apparent that if the receiving circuit is a persistent oscillator, that is one with hardly any resistance, or with very low damping, then it may have some hesitation in adapting itself to the fluctuations of amplitude, even though it responds perfectly to the main frequency; it may respond even too well and too persistently, and carry on the greater disturbances into the region where they ought to subside and give way to the smaller ones.

(Continued on page 28.)

TWO POINTS FOR ARGUMENT.

It often happens that points of great interest first get a public "airing" in the columns of "P.W." Here are two typical instances for readers to ponder over.

By THE EDITOR.

MANY of our readers who have consistently watched the Correspondence columns of POPULAR WIRELESS will have gathered some idea of the enormous number of letters we have received concerning the "Magic" Three and other sets of the "Magic" series.

Most of these letters have been laudatory in character; in fact, we have been quite embarrassed by the deluge of praise which this set has been receiving! So it is interesting when we open our post one morning and find a letter from Mr. Woods, of Chorlton-cum-Hardy, offering a distinctly critical comment upon the "Magic" Three.

"So many amateurs have been building this set," writes Mr. Woods, "and have given it their blessing, that it seems almost a sacrilege to criticise it in any way. But I venture to do so on one point."

"More Trouble Than It's Worth."

Mr. Woods then refers to the Potentiometer in the grid circuit of the detector valve. "I have come to the conclusion," he writes, "that, useful as this component is as regards sensitising the valve, it is more trouble than it is worth in the long run."

What do our readers think about this? Have they found this so, and do they agree with Mr. Woods' reasons, which are as follows:

"When the potentiometer is adjusted for the best results on the first occasion," he says, "and much depends upon external conditions prevailing at the time, all may seem quite O.K. Perhaps a few nights later, however, the stations that came in well on that occasion are not so satisfactory, or are missing, due to changed external conditions."

"This, of course, is not unusual, and applies to all sets more or less: but," goes on Mr. Woods, "with the 'Magic' Three sometimes a small variation in the setting of the pot'meter will improve matters and, although this may seem a point in its favour, here, in my opinion, is the snag: by so doing conditions are often upset for other stations, and consequently one is always requiring rather a little more or a less little bias one way or the other to get the best results under the prevailing conditions. And the pot'meter, being where it is in the set, makes the task of adjustment a tedious business."

Mr. Woods thinks that those who like fiddling with their controls, perhaps won't mind this point, but he ventures to think the majority will. We wonder. After all, surely it is worth while adjusting the pot'meter for various conditions if it enhances the selectivity of the set and may, perhaps, with practice, enable the amateur greatly to enlarge his "bag" of foreign stations.

What Do YOU Think?

However, Mr. Woods thinks that for the proper or easier control of the grid potential, the pot'meter should be on the panel—although he admits that this would mean

longer leads and would probably give rise to other undesirable results.

"I have used pot'meters before, but have always found them a source of irritation rather than anything else, and my opinion has not altered with respect to its use in the 'Magic' Three. Given a suitable detector valve, one can very well dispense with it and still rope in a satisfactory number of stations by a careful use of the differential condenser alone."

Mr. Woods concludes his letter by expressing the opinion that, at any rate, the differential condenser is a great improvement on the usual type, and far more satisfactory in its way than is a pot'meter with its many vagaries.

Mr. Woods certainly raises an interesting point in his letter, and we wonder whether

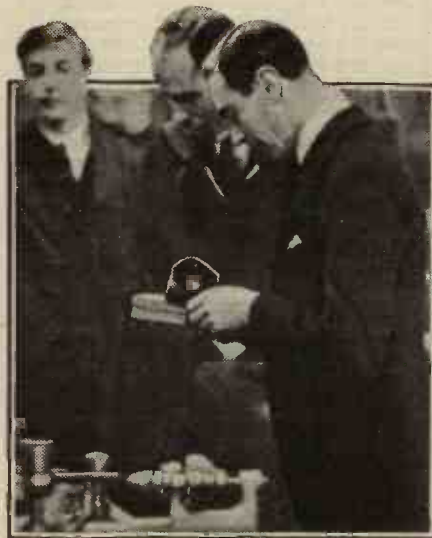

When the Duke of York recently opened the new buildings of the Borough Polytechnic Institute, Borough Road, London, S.E., he was greatly interested in the mechanical and radio-constructural work of the boys of the Institute.

his views are supported by any great majority of our readers. It seems to be a question of whether the merits of the pot'meter are sufficiently outweighed by the merits of the differential condenser.

Anyway, perhaps some other readers of POPULAR WIRELESS have built the "Magic" Three, and would like to express their views upon the matter.

NOTE BY RESEARCH DEPT.

We are afraid we must disagree completely with Mr. Woods' initial assumption that the setting of the potentiometer depends upon external conditions. It is our experience that if it is once set no further adjustment is needed unless there is a change of valves or battery voltages.

It is to be remembered that our object in providing a pot'meter is to make it easy to get really smooth reaction, otherwise a

difficult matter with a powerful L.F. side, particularly on short waves. The instructions we gave for setting the pot'meter enable the user to locate the correct adjustment for this quite easily and quickly.

We venture to suggest that our correspondent gives his case away when he suggests that the pot'meter can be dispensed with "given a suitable detector valve." The necessity for picking and choosing detectors is just what we have tried to avoid!

Another of our correspondents writes concerning Captain Eckersley's "Query Corner." In a recent issue, our Chief Radio Consultant expressed the opinion that the use of the crystal is not necessary for detection, thanks to the improvement in valve rectifiers.

Captain Eckersley, it will be remembered, gave three distinct reasons:

1. Valves can be made to give perfectly straight line rectification.
2. They can amplify whilst detecting.
3. They are more robust and easier to maintain than a crystal.

One of our correspondents finds against these three points that there are at least five very good reasons in favour of the crystal. To begin with, he refers to the carborundum crystal, which can be made to give quite as pure rectification as the valve.

Controlling Feed-Back.

Secondly, it serves as a valve—or rather, it leaves to the real valve its proper job of amplifying; while thirdly, a carborundum crystal is more robust than a valve and the trouble of maintenance is nil. For a fourth reason, our correspondent states that if mounted direct on the grid of the reaction H.F. valve it has the effect of neutralising the valve by preventing feed back, and thus permits much greater amplification.

Our correspondent says he has actually controlled reaction on an unscreened screened-grid valve in this way; and, lastly, he maintains that a carborundum crystal, properly used is a very sensitive detector, even without H.F., and only needs a good L.F. amplifier to bring in all the important European stations on the loud speaker.

According to him, at the moment of writing the letter he sent us, he was listening to Frankfurt coming in very purely at good strength on two speakers in series (one a balanced-armature double cone, and the other a logarithmic horn), and he winds up by suggesting that, in addition to the foregoing advantages, might be mentioned a greater ease in obtaining selectivity and a decided minimising of static.

Rather Exaggerated?

It isn't often these days that we get a eulogistic letter about the crystal, but, nevertheless, it is interesting to note that there are still amateurs who cling to their first love. We are not by any means decrying our correspondent's adherence to the crystal, but we rather think he is stretching it a little when he attributes so many superior qualities to the crystal over the valve.

But here again we suggest that we should be pleased to hear from correspondents who have views upon this subject, for these are the sort of little debates between our readers which we like to encourage and which we feel sure are of general interest to all our readers.

IN SEARCH OF A. J. ALAN



IT was in no light-hearted manner that I undertook my search for A. J. Alan—the mystery man of wireless. In response to my enquiries, an official of the B.B.C. politely informed me that I should be wasting my time, and that many better journalists than I had tried to interview Mr. Alan, and had failed.

No, he didn't know Mr. Alan's address, and was not in the position to give me any particulars regarding the gentleman.

An unpromising start, to say the least. However, armed more with the pertinacity of youth than the wisdom of experience, I determined to go ahead with my task, formidable though it seemed. After all, I argued, there must be more than one way of tracing the famous raconteur. But, no matter how I tried, I could not get my thoughts far from Savoy Hill.



"My game's plumbing. Spells me name the same as that there bloke wot does broadcast, though. No relation."

Which ever way I set about it, it seemed that the B.B.C. headquarters would have to be my starting-off point, whether the powers that be were willing to help me or no. Perhaps if I smuggled myself into the studios I might speak with one of the announcers. I might hear a stray word or sentence that would provide me with a clue.

Of course I should have to disguise myself. My experience in amateur theatricals helped me here considerably. My make-up was nothing more complicated than a black, broad-brimmed hat and an empty violin case. I think it was Napoleon who said that simplicity in manœuvres was the key to success.

Subterfuge—wicked subterfuge! Yes, I admit it. But then anyone who knows the rigid rules of the B.B.C. will tell you that any unauthorised person who attempts to enter a broadcasting station never gets further than the front door. As for getting into the studios—well, one might as well try to move Mount Everest with a squib. However—

Getting Past the Doorkeeper.

My heart beat a little faster as I approached the portals of the great building. I had chosen my time well, for it was a dirty, foggy evening early in February, and I trusted to the darkness and general gloom of the surroundings to help me with my deception.

Mounting the steps of Savoy Hill two at a time, I startled the porter with a cry of "Artiste!" and, pushing my way through the swing doors, flew up the stairs as fast as my legs would carry me.

On the second floor I paused to listen for pursuing footsteps. But there were none. Evidently my ruse had succeeded. Around me was the silence of the grave. To the right, a long corridor opened out, with a number of red lights dotted along the walls at regular intervals.

A large notice—"SILENCE," and in smaller lettering "Studios," warned me that I was on holy ground. As from afar I heard the voice of a woman raised in song and the tinkle of a piano accompaniment.

Softly I tiptoed along the corridor to turn startled as I heard a door quietly opened behind me. I found myself regarding a handsome man faultlessly attired in evening dress.

Where Does He Live?

"Good evening," I said. "Are you an announcer?"

"That is so," he replied, eyeing me with obvious suspicion. I flourished my violin case to disarm him.

"I have come on a mission of the greatest urgency. I want to find A. J. Alan. Do you know where he lives?"

The other raised his eyebrows in alarm. "Sh!" he whispered, putting a warning finger to his lips. "Come here." As he spoke he pulled me towards a dark corner of

the corridor. "This matter is of importance?"

"Most important," I assured him. "It is a risk, but I will tell you then. A. J. Alan lives at Ham—"

At that moment a terrific noise from below interrupted his speech. For one fatal moment I turned my head. When I looked

A. J. Alan is the mystery man of the ether, and he and the B.B.C. work together in a conspiracy of silence. When Mr. Alan broadcasts he has a studio to himself, and not one of the millions of listeners who know his voice so well know anything regarding his personality, character or habits. This article, written by S. Howard Jones, tells of the amusing experiences of a journalist who endeavoured to interview Mr. Alan.

round again my informant had disappeared. Panic-stricken, I fled along the corridor, and almost fell over myself in my anxiety to get down the stairs.

"What was that awful noise?" I gasped as I met the hall porter.

"That, sir," he said without looking up

(Continued on next page.)



"Good evening," I said, "Are you an announcer?"

AFTER accumulators have been in use for some while faults frequently appear. By far the most common fault is that of the accumulator failing to retain its charge for any length of time, even though it may not have been used very much.

This state indicates an internal "short," and most likely it will be found that a deposit of paste from the plates has fallen to the space at the bottom of the container. The paste, when it reaches the bottom of the plates, provides a path for the discharge of the stored energy.

The usual method adopted to remedy this fault—with the celluloid type—is to

open the case, which is a somewhat difficult job. The plates are then withdrawn, the container washed out, and the cell re-assembled again.

The fact that the paste had already come out of the plates when the accumulator was in use is an indication that the paste is loose. When the method previously described is used, and the plates are disturbed, the

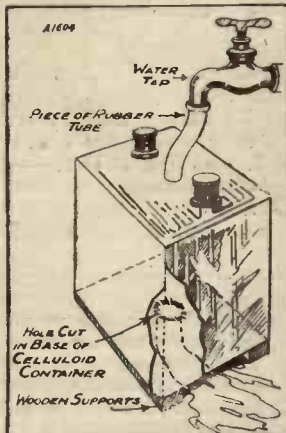

The water passing through the accumulator carries sediment and loose particles of paste away with it.

REMOVING ACCUMULATOR SEDIMENT.

frequent result is that the plates fall apart, the paste drops out, and the cell is ruined. Even if one is successful in removing the plates intact and cleaning the cell, getting them back again is no easy job.

All this trouble may be avoided if the process shown in the sketch is followed; the procedure is easy. First empty the acid from the cell, then cut a hole in the base of the celluloid case—shown in the sketch, as seen through the wall of the case. This hole is best cut with a large twist drill. Make a hole right through first, then open this out with the large drill.

Place two pieces of wood under the cell as shown, connect a piece of rubber hose to a water-supply tap and to the vent-hole of the accumulator. Carefully turn on the water, and the sediment will be flushed away through the hole cut in the base. Move the cell about to ensure that any pieces stuck be-

tween the plates will be dislodged. When all sediment is removed drain the cell and allow to dry thoroughly. Cut a piece of celluloid to cover the hole, allowing sufficient surplus at the edges. Scrape both the patch and the case where the patch will rest with a sharp knife.

Make a solution of scrap celluloid in acetone. Apply the solution to the patch and ease liberally, allow it to get "tacky": put the patch in position. Bind a block of wood in position to apply pressure to the patch, and let the solution set. The cell will now be ready for charging again.

The term of service given by a cell, overhauled as suggested, will be considerably lengthened.

RADIO IN THE FAR EAST.

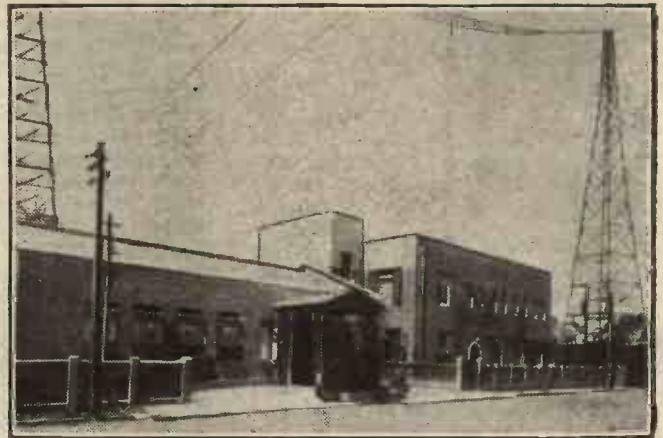

The broadcasting station at Nagoya, in Japan. This is one of the stations which recently broadcast a speech by the leader of the Japanese Naval Delegates, which was transmitted from England by Beam Wireless.

from a sheaf of papers, "was Teddy Brown arriving. Good night!"

"A. J. Alan lives at Ham. A. J. Alan lives at Ham." The phrase repeated itself over and over in my mind. The luckless announcer's last words had given me a most valuable clue.

Alas, for all my hopes! The village of Ham has some two thousand inhabitants, of whom I interviewed one thousand one hundred and twenty-two.

The Policeman's Clue.

These were named Allan, Alom, Allen or Allin. One gentleman, a rubicund publican, actually assured me that he was A. J. Alan. On closer questioning, however, he admitted his name was Wilks, and that he was "aving me on."

And so my search of the little Surrey village proved fruitless. But I did not give up hope. The announcer's message got me as far as "Ham—" and it suddenly struck me that this opened up all sorts of possibilities. For instance, he might have meant Hampshire. Then there were such places as Hampton Court, Hampton Wick, Hammer-smith, and East and West Ham.

With the exception of making a tour of Hampshire, I visited them all. At Hammer-smith I drew a blank, and the Court and Wick provided me with no better luck. This left me only East and West Ham.

Bravely, I continued my quest. At East Ham there were plenty of Alans, but no A. J. So I pushed on to West Ham. There a policeman told me that A. J. Alan had been resident in the district for many years.

IN SEARCH OF A. J. ALAN.

(Continued from previous page.)

What is more, he gave me the address. This news revived the excitement of the hunt, and I set off post haste for the house.

The appearance of the street surprised me. It was mean and dirty. But the house itself staggered me. The windows were curtainless and weather-stained, the garden neglected, and the paintwork faded and falling. That A. J. Alan should be reduced to this was indeed a tragedy.

But victory was in sight, and I gave three rousing knocks on the door. It was immediately thrown open by a burly, thick set individual with a broken clay pipe in the corner of his mouth, and a bowler hat stuck on the back of his head.

The Girl Who Knew!

"Ere," he said, "stop a-knocking of my door down!"

"I'm sorry," I returned. "I'm anxious to see Mr. A. J. Alan."

"That's me!"

I stared stupidly for a few moments.

"Have you ever broadcast?" I asked, weakly.

"Me broadcast? No blinkin' fear, gov'nor! My game's plumbing. Spells me name the same as that there bloke wot does broadcast, though. No relation."

"Thank you, Mr. Alan," I said, turning

wearily away. "I'm afraid there's been some mistake."

As I reached the roadway a little girl ran up to me.

"I heard you speaking to the man next door about broadcasting," she said shyly. "Do you want to know something about the A. J. Alan?"

I agreed that I did.

"Well, I can tell you just a little bit about him, 'cos my father used to work at the B.B.C. I should get in an awful row if he knew I had told you anything."

Light Breaks Through.

A half-crown changed hands.

"He need never know," I said.

"Well, A. J. Alan isn't the real name of the gentleman who tells the wireless stories. He only uses it when he's broadcasting. He is about forty, and lives at Hampstead. G'bye!"

And so, Mr. A. J. Alan, whose name isn't really Alan at all, I have found out *that* much. I suppose it is better than nothing. But if this account of my adventures should meet your eye, I trust it will melt your heart, and that, for the sake of the millions of listeners who are genuinely interested in you and your stories, you will grant me an interview.

For, although we don't believe all you tell us about burglars and beautiful maidens, Mr. Alan, we do like to hear of your adventures. So please remember that a letter addressed to me in care of this magazine will always find me. Thank you, Mr. Alan!

MORE ABOUT "SAFE-POWER" JUNIOR

Here we have a few further details about the new "Safe-Power" Junior, which was described last week. As readers will remember, this is the outcome of a series of investigations into the whys and wherefores of mains units, and is the first of a number of specially designed units that are guaranteed to be not only powerful and silent in operation, but perfectly safe to handle. Designed and described By the "P.W." RESEARCH DEPARTMENT.



WE mentioned last week that we have adopted a special metal construction for the "Safe-Power" series, and gave some preliminary details. Now let us see just what the scheme is.

The essence of the idea is this. First of all there is a sheet-metal hollow base piece, measuring, in the case of the present instrument, 7 in. \times 9 in. \times 1½ in. deep. At one end of this an ebonite panel, 7 in. \times 7 in., is attached by means of three brass screws and nuts passing through the turned-over edge of the base piece, and over the whole thing fits a metal lid secured in place by means of a few more screws and nuts.

An Important Feature.

This lid, of course, is only attached permanently when the unit has been finished and tested and all adjustments made. You can see at once what a very much safer and sounder job results from a system of construction like this. Everything is stronger and more rigid.

We have not yet mentioned one of the most important of all the features of our new method of assembly. Now, one of the greatest drawbacks of the old wooden cabinet arrangement was that it was possible for anyone to come along and open the lid and start messing about inside when the mains were switched on, with the possibility of a painful or even dangerous shock. Accordingly, we have taken steps to arrange that the lid cannot be removed from one of the Safe-Power Units without first disconnecting the mains lead.

An Automatic Safety Stunt.

We have provided a very simple method of connection for the mains, which can be undone in a moment without detaching any wires, by means of a simple lamp-socket type of connector arranged in the back of the base piece at the lower edge.

Once this is in position you cannot move the lid, but you can detach the lamp socket in a moment when desired, so that the lid can be taken off. This, of course, will require to be done while you are making the preliminary adjustments of the unit and before the lid is finally secured in place.

Now we come to various constructional points which we must clear up so that you can get on with the job of assembly and wiring. First of all the panel requires to be drilled for the various parts, and you will see that first of all there are four terminals, the upper three of these being the negative and the two positive terminals, while the

lower one is for the earth lead. The shank of this terminal goes right through the ebonite panel and through a corresponding hole in the lower edge of the base portion of the metal work, with which it makes contact, so earthing the whole of the metal frame. No connection is made to the back of this terminal whatever.

On the panel you must also mount the 25,000-ohm variable resistance, which you will find is actually a potentiometer with three terminals. Only two of these terminals are actually used, namely that for one end of the resistance, and that for the sliding arm. The voltmeter requires a circular hole to be cut, and here we strongly advise you to use a simple hand fretsaw.

While we are mentioning the meter, we should perhaps explain that the particular make we employed is supplied with a special

SIMPLE! - SILENT! SAFE!

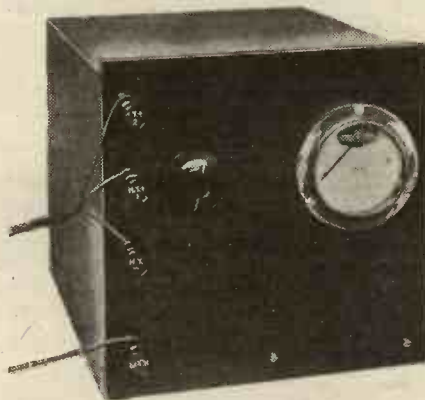

The metal case and panel can be purchased ready made if desired.

resistance for connection in series with it. Other types of meters will be found to work without such a resistance. In these cases the positive side of the meter should be connected straight to H.T. +2 terminal.

Having got these parts in place, attach the panel to the metal base piece by means of its three screws along the lower edge, and set to work to mount up the components on the metal body. These are held in place by means of small brass screws and nuts, as we have explained, and you will find that if you put a suitable size of drill in your brace or hand drill you can run through all of them in a very few minutes.

Having got all your parts mounted on the base you are ready to start wiring, and

the first step is to take a short piece of twisted flex, and connect one pair of ends to the plug adaptor ready mounted up in its special holder on the underside of the base. Now run the other end of this piece of flex through a ¼-in. hole in your metal base in the position which you will see indicated.

Some Practical Details.

Find out where your flex will touch the edges of this hole when it is pulled fairly tight, then take it out and bind it round this portion with either black insulating tape or else adhesive surgical tape such as you can obtain from any chemist. (This is merely to prevent the flex from being chafed by the sharp edges of the hole and so causing a short circuit.) Having done this, take your flex through the hole once more, and connect up one of the free ends to one side of the 4-mfd. condenser, and the other end to one side of the variable resistance on the panel.

Now comes the general job of wiring up, and here we would first advise that you should get yourself a supply of Systoflex sleeving and tinned copper wire of suitable size. Now, when you are ready to make a start, let us recommend you to put in one particular lead first of all.

The lead in question is one from the 2-mfd. condenser which is placed right at the rear of the base. This lead runs from one terminal of the condenser down to the head of the fixing screw which holds the condenser in place. In other words, it runs down and makes contact with the metal of the base.

The rest of the wiring you will find just a simple matter of following out the wiring diagram, and we only need to mention that the lead from one side of the other 2-mfd. condenser should naturally be of flex.

The Final Connections.

We do not think you will find any difficulty in completing the wiring-up job, and when this is done you should just drop the lid over the unit without fastening it in place by means of its screws and nuts, and then place upon the plug adaptor the necessary lamp-holder on the end of a flex lead from a mains point. Having done this, connect up the H.T. negative terminal of the unit to the H.T. - terminal on your set; H.T. +1 terminal of the unit to that H.T. terminal on your set which feeds the detector, and the H.T. +2 unit terminal to the L.F. and power terminal on your receiver.

LATEST BROADCASTING NEWS.

THE BOAT RACE
COMMENTARYSOME PROGRAMME PICKINGS—
BAND CONCERTS FOR
MIDLANDS—
AN INTERESTING TALK—
APRIL FOOL'S DAY.

ONCE again a description of the world-famous boat-race between the Universities of Oxford and Cambridge is to be broadcast to listeners, throughout its progress from Putney Bridge to the winning-post at Mortlake on Saturday, April 12th. Listeners have grown so accustomed to hearing this running commentary, that it seems almost superfluous to give the customary warning of the possibility of a breakdown in the elaborate and somewhat delicate arrangements on which the broadcast depends.

As most listeners are aware, the race is described from the launch "Magician" which follows the rival boats, communication with Savoy Hill being maintained first by a short-wave transmitter working between the launch and a point on the shore and thence by land line to the Control Room.

Up till now everything has functioned splendidly, but one can never tell how long the luck will hold. The B.B.C. apparently realise this, and this year receiving apparatus will be installed at two points instead of one, the spots selected being at the Marconi International Marine Communication Company's premises at High Street, Barnes, and on the roof of Harrods' Depository, Arundel Terrace, Barnes.

Temporary lines will be run from both points to Savoy Hill. Preliminary tests will be made daily on four days before the race, and, it is hoped, that given reasonable conditions the broadcast will be as enjoyable and as exciting as its predecessors. The commentators are Mr. G. O. Nickalls and Mr. J. C. Squire, and the race is due to begin at 12.30 p.m. A ten-minute introductory talk describing the scene will precede the race, and the whole broadcast is expected to occupy just over half-an-hour.

Some Programme Pickings.

Mr. R. D. Blumenfeld, a former editor of "The Daily Express," will be heard by listeners to the National transmitter on Tuesday, April 8th, when he contributes his reminiscences to that interesting series of talks, "Looking Backwards."

The evening programme from London on Saturday, April 5th, will include excerpts from Jack Hulbert's revue, "The House that Jack Built," relayed from the Adelphi Theatre.

Two sports talks are to be broadcast from Cardiff on Saturday, April 5th, the first by Mr. J. E. Dunn, the Honorary Secretary and Treasurer of the Welsh Hockey Association, and the second by Mr. Norman Edgar, of Bristol, who will describe the progress of outboard motor-boat racing in the West.

Two miniatures in sound have been arranged for the National programme on Thursday, April 3rd. One, "Sally in Our

Alley," will describe how the famous old song came to be written, and the other, "Gather ye Rose-buds while ye May," contains the moral of the quotation. This programme will be given by the Wireless Orchestra conducted by Alfred Reynolds.

Band Concerts for Midlands.

Three military band concerts have been arranged for Midland listeners during the week beginning Monday, March 31st, the first is at 7 o'clock that evening, when a programme by the Creswell Colliery Institute Band will be relayed from the National Trades Exhibition at the Bingley Hall, Birmingham.

On the following Thursday evening, at the same time, the Station Military Band will give a programme under the conductorship of Mr. W. A. Clarke, who, before he was appointed to the Broad Street Studios, was associated with the Southport Corporation Band. Mr. Clarke has been conducting since he was sixteen years of age.

"FULL TIME REPORTS!"



Here is a group of newspaper men in the Press Box at an Arsenal v. Everton football match, listening to the B.B.C. commentary on the game by Mr. George Allison.

The third Band programme will be heard on Saturday afternoon, April 5th, when the Dunlop Works Band, all the members of which are employed at Fort Dunlop, will provide a popular programme under the conductorship of Arthur Tomlinson.

An Interesting Talk.

A particularly interesting talk is in the Scottish programme for Thursday afternoon, April 3rd, when Mr. Alexander MacDonald will describe his adventures in film-making in New Guinea.

The title of the talk is "Film Artists Among the Cannibals," and Mr. MacDonald will recount not only his own experiences, but those of his leading lady, Miss Wendy Osborne, who is the only woman who has ever entered Cannibal territory in New Guinea where the film was made.

Miss Osborne is an Australian by birth, has travelled seven times round the world, and claims the distinction of being the first woman to cross the Australian Gulf country by motor-car.

April Fools' Broadcast.

A talk on the origin of some of the stupid jokes associated with "All Fools' Day" will be given to Northern listeners on Tuesday, April 1st, by Col. G. B. R. Spain, whose ability as a broadcaster is already well known for his talks on research work in connection with the great Roman Wall across the North of England, and for his arrangements of other special historical programmes.

On the same day Mr. A. Muir Burn will give a similar talk to Scottish listeners in which he will indulge in a little "leg-pulling." This will take the form of an imaginary talk on Scotland as seen by "Professor Hesketh Halfogh," a visitor from Patagonia from where the talk is supposed to be relayed by some mysterious mechanism which translates speech while it is being produced.

FOR THE LISTENER.

A Specially Contributed Criticism of Current Broadcasting Events.

By "PHILEMON."

(Who is deputising for Mr. Cecil Lewis while the latter is in America.)

The Poetess and the Megaphone.

WE are not likely to hear her again in the same way, so that it is worth putting on record that we did hear Miss Edith Sitwell reciting some of her poems through a megaphone to the facetious music of William Walton. It was pretty bad.

First Nights.

Mr. Edward Knoblock, who with Arnold Bennett was responsible for "Milestones," was delightfully reminiscent as he turned over some old theatre programmes, recalling his first-night experiences as a "pittite" thirty years ago.

Irving, in "Peter the Great"; Irene Vanbrugh, in "The Gay Lord Quex"; Winifred Emery, in "The Little Minister"; Charles Hawtrey, in "A Message from Mars." And how charmingly he told of Ellen Terry, on the occasion of the first

night of "Robespierre," at the Lyceum, coming to the pittites as they stood wearily in the queue outside, and having some hot tea sent out to them!

Some Modern Dramas.

If you are interested in the theatre at all—and who isn't?—you ought not to miss the series of talks recently begun by Desmond McCarthy on "Some Modern Dramas and How to Appreciate Them." His first talk, on the "Ideal Spectator," had all that critical wisdom and urbanity which we have learned to expect of him. Among other things he said: "The best and the only really effective advertisement of a play, is by word of mouth."

De Courville's Hour.

A good many of us must welcome the return of Mr. Albert de Courville as an

(Continued on page 26).

THAT PATENT ROYALTIES QUESTION

by Capt. P. P. ECKERSLEY M.I.E.E.



THERE is a band of enthusiasts who declare that it is most unfair for those who manufacture sets to have to pay royalties on patents to those who own the patents. There are some who say they are willing to pay royalties but that these must include any new patents discovered by the people whom they pay.

Until we have a state of true Socialism, when a central body under the advice and direction of a wise authority will give all discoveries made free to all who need them (when knowledge is the basis of public service and not private greed), it is quite absurd to suggest that either of the above arguments is sound.

Private Enterprise.

So long as we have private enterprise we must have it and prove (or disprove) its efficiency. One cannot expect large firms to keep a body of experts supplied with apparatus and money for the benefit of the public. It must be for the benefit of the private firms. This is elementary.

On this question of wireless royalties, however, I do suggest that we can preserve the status quo and the private profits but nevertheless advance our trade, both internal and external, to the benefit of the present system we submit to.

At the present moment we pay royalties not ad valorem on the set but on its inherent design. The tax on valves necessarily cramps the design of sets. The Americans, for example, are able to think purely of the performance of the receiver as such; their designers are not hampered by having to make, say, five valves do the work of seven.

The British designer may take theory as the basis of his work, but find himself more able to meet the requirements of wireless reception by using to the utmost that which makes wireless reception possible—the valve.

I should like to know what would have happened if the B.B.C. had had to pay a tax on each valve in their amplifiers; I do not think factor of safety would have been studied in the degree it merits.

Monotonous Designs.

There is no essential difference in the problem when you come to a receiving set; one wants to use plenty of valves sometimes to get a decent result, but finds oneself hopelessly penalised in a competitive system.

If, of course, there were no price competition, the excellence of the result would be taken more as the criterion, but tax on valves, and competition inevitably produces a sameness in essential design that is monotonous in its mediocrity.

The Americans have realised long ago that it is not the number of valves which counts, it's the ultimate performance that alone matters. I agree with them that it's far better to have a seven-valve amplifier

Although not long ago the Marconi royalties payable on commercial sets were reduced, they nevertheless still constitute a barrier to the production of cheap radio receivers. In this article our Chief Radio Consultant expresses his views on this important feature of wireless commerce, and the effect that royalties have on the design of sets.

which requires no independent adjustment of reaction than a four-valve arrangement which, to work, has to add this complication.

The effect on valve design is furthermore disastrous. Everyone wants to get as much out of one valve as possible, naturally, but this can go to absurd limits if stability is not taken as the limiting factor. To-day there are hundreds and hundreds of different

The tax is bad enough but when it comes to valve prices, design problems are increased square-fold; and the designer is driven back once more upon the necessity of using few but sensitive valves.

It is to the interests of the valve manufacturers themselves to cut down the price, because not only would there be more consumption of valves for the simple reason of price reduction (vastly more these days), but designers would be more inclined to take the plunge of using more valves and so the effect would be regenerative.

A Further Point.

There is another point to show how the remission of a tax on valves and its institution as a proportion of total cost of the set would aid development. We are struggling for higher impedance valves and steeper slope. There comes a limit in that the impedance of the high-frequency anode

A NEW FRENCH INVENTION.



M. W. Loth, a French inventor, explaining to the French Air Minister, and the President, how his radio-controlled aeroplane operates. Complete control by wireless is claimed for this remarkable invention.

types of valve where tens of different types would meet the needs of a sensible designer.

I repeat I would rather see a many-valved, but stable, amplifier, than one which, with a far less number of valves, gave the same result, except that it behaved like a pin balanced on its head.

The super-heterodyne principle has many advantages, but it has one fatal imposed drawback, it uses another two valves and so costs another £1 to £2 with valve costs and royalties. You may use your utmost ingenuity to make such a set competitive in price with a set having a sensibly similar sensitivity, but you are done down every time by this arbitrary tax ruling.

impedance must be proportionately increased to get full benefit of the newer designs.

If we could be certain of equal performance, moderate impedance, low-priced untaxed valves we could use two valves where one now has to suffice and get everything we want out of them.

The screened-grid valve is an advance in the technique of forcing up "mag. per stage," but the fact that the screen is only partial, the impedance and the cost rather high, makes one realise why the Americans have so far not made extensive use of the device in their sets which sell so well in our Dominions and Colonies.

THE "MAGIC"—FIFTY STATIONS.

The Editor, POPULAR WIRELESS.

Dear Sir,—Although I am a fairly regular reader of "P.W.," the continual increase of praise from readers for the "Magic" Three, which no other set seemed to get, caused me to build one and see for myself.

Well, it is all you claim it to be and more. I am in a basement with a 24-ft. outside aerial, 7 ft. from the ground, and have no trouble in getting all the main foreign and home stations. My only failures are the short-waves.

I have No. 2, 4, 6 and 9 coils, and 6 and 9 are the only ones that bring in anything, and that only a few amateurs. Due no doubt to local conditions, Ed.

This week-end I took the set out to Strichen, a village 36 miles north of Aberdeen. Strichen lies in a valley and fairly well screened, but if the results in town were considered good well they were nothing compared to the Strichen end.

They were simply beyond all expectations. Now this is no fool exaggeration, but I logged, on the Sunday night, fifty stations on the loud speaker. The speaker is an Ormond Cone, and stands 10 ft. from the set, and every station came through clear and distinct. On many stations a volume control is certainly needed.

I am using Dario valves, otherwise the set is a standard "P.W."

My hearty congratulations to the "P.W." staff for so splendid a set.

I remain,

JOHN M. GRAY.

Aberdeen.

THE "MAGIC" ONE.

The Editor, POPULAR WIRELESS.

Dear Sir,—Many thanks for the greatest one-valve receiver ever—the "Magic" One.

I completed this set one Saturday and in half an hour had logged about a dozen stations on the medium wave-band. Since then I have definitely accounted for the following, all at good phone strength:

Konigsusterhausen, Radio Paris, 5 X X, Eiffel Tower, Budapest, Munich, Rome, 5 G B, Vienna, Langenberg, Bratislava, London (356 m.), Toulouse, Oslo, Frankfurt, Turin, Barcelona (EH 5 1), Milan.

In addition to the above I have received five stations which I am unable up to now to identify.

I may mention that the aerial is an indoor one and that I use slightly different coil sizes than those specified. Those used are 60 "X" and 75 for medium, and 250 "X" and 200 for long waves.

Once again thanking you for a really "hot" one-tube set, and the many useful hints to be found in "P.W.," I remain,

Yours faithfully,

H. U. ARMSTRONG.

Lincoln.

CORRESPONDENCE.

THE "MAGIC"—FIFTY STATIONS.

THE "MAGIC" ONE—BROOKMANS PARK—CAPT. ECKERSLEY "CAUGHT NAPPING"—"AMERICA ON A MOVING PUNT."

Letters from readers discussing interesting and topical wireless events or recording unusual experiences are always welcomed; but it must be clearly understood that the publication of such does in no way indicate that we associate ourselves with the views expressed by our correspondents, and we cannot accept any responsibility for information given.—EDITOR.

BROOKMANS PARK.

The Editor, POPULAR WIRELESS.

Dear Sir,—During recent weeks a good deal of controversy has arisen from the test trials of London's twin-wave station at Brookmans Park as to the elimination of these two powerful transmitters for perfect reception other than local. As the most of POPULAR WIRELESS readers are of the "DX" breed, it is only natural that you should study their interests as far as this matter goes, which I must say you have done admirably, both in the past and at the present.

Well, with the advent of the "B.P." Rejector everything seems rosy again except that the 356 transmitter gives more trouble than the 261, to some, and vice versa to others. In my case, using the "Magic" Three without other refinements for tuning than those in the circuit, I can tune to within 15 degrees above 2 L O, and when conditions are good I can get Toulouse within five degrees of the same with only a faint background on Toulouse, and 5 G B, Vienna, Brussels, Budapest and Danzig.

But on the 261-band my trouble is the same as is that of Mr. Hennequin, of Seven Kings, except that when this one is not working the following are well heard on two speakers, without any interference from 2 L O. Algiers, Hamburg, Turin, Nurnburg, Cologne, Leipzig, Berlin and dozens of others yet to be identified, and at time of writing Berlin is giving dance music and lesson sufficient to fill two rooms of moderate size.

Wishing "P.W." more success than ever,

Yours truly,

HERBERT E. GILL.

South Tottenham, N.15.

CAPTAIN ECKERSLEY "CAUGHT NAPPING."

The Editor, POPULAR WIRELESS.

Sir,—Several correspondents have called my attention to the reply on page 1243 of your issue of POPULAR WIRELESS dated March 1st to J.R.W. I have certainly been caught napping in the reply to this question.

The question asked was why a portable set would work satisfactorily on a table in the centre of the room but would not work anything like so well when put on a sideboard. The sideboard had a mirror on it. This last point escaped me, and your correspondents have pointed out to me that the metal in the mirror would act as a partial screen and so reduce the signal.

I am glad to say that I began my answer with the remark that I could not give an answer with my usual assurance. Certainly the fact that there were mirrors had escaped me and certainly the fact that they are there is responsible for the effect.

Yours faithfully,

P. P. ECKERSLEY.

"AMERICA ON A MOVING PUNT."

The Editor, POPULAR WIRELESS.

Dear Sir,—I have read with interest W.L.S.'s notes and articles in your excellent paper, and think details of my reception may interest your readers.

I have logged some 200 high- and medium-wave stations, including several U.S. stations, a station in Rangoon, India, etc.

On short waves I have received quite 400 telephony stations, among them being V K V I S, 2 M E 2 B L, 2 F C, Sydney, V I Z and 3 L O, Melbourne, H S 1 P J Bangkok, Siam on 29.8 m., a Japanese station on .30 m.; P L E, P L F, P L R, P L G, A P V, Java; Buenos Aires and Monte Grande, Argentine Republic, on several wave-lengths, F K 7 L O, Nairobi and African amateurs using telephony, an amateur in Madras, India, a Costa Rican amateur, San Juan and Manila, Philippine Islands, G L Y K, the motor-yacht "Adventures" when well north of the Arctic Circle; C F A (and other Drummondville stations), C K A and 9 C H, Nova Scotia; C J E X, Winnipeg, and of course many U.S. stations.

On a moving punt (10 feet by 3 feet) I have logged W N D 2 X O, 2 X K, and 2 X A D, Schenectady; W N D (34 m.) and W N C (15.5 m.), Ocean Township, 2 X G, Rocky Point; P L E and A P V, Java; P H I, Huizen, Zeesen on 31.38 m.; G 6 G A British station and several unidentified stations.

I am, yours faithfully,

LESLIE W. ORTON.

P.S.—I tuned P L E, Java, in while in a punt on the river, and a few moments after finding him P L E was heard consistently well although the boat was being rowed up-river.

I grant that if you are one of the unfortunates with a long earth lead or one that for some other reason places the receiver several volts "up in the air" a metal panel is worse than useless, but I do not think a large group of listeners are so affected.

The scheme I mentioned once of tuning the earth lead appears to have proved effective in quite a number of cases, judging by letters I have received from readers who have tried it out.

"Tuning" the Earth.

For the benefit of newcomers, I might mention that the idea is simply to place a variable condenser in series with the earth lead and to set it at the point where hand-capacity trouble either reaches a minimum or disappears altogether.

Naturally, if one has a poor, high-resistance earth it is a very useless idea to connect various pieces of apparatus together and to "ground" them all, as it simply introduces a common resistance into the circuits and makes things worse than ever. In such cases it pays to forget that an earth is necessary, and to let the accumulator under the bench do duty in this way.

Counterpoises are sometimes useful, but not to the extent that they used to be on the longer wavelengths. I remember then that it used to be an axiom that the less sky one could see from one's garden the better! In these days a short single-wire aerial and either a small counterpoise or direct earth will fill all requirements.

SHORT-WAVE NOTES.

By W. L. S.

AS I recently made some very uncomplimentary remarks about the interference to short-wave receivers caused by vacuum-cleaners, electric heating-pads, refrigerators, and other doubtless very useful accessories, I speak very feelingly when I say that they are apparently becoming more and more popular with my immediate neighbours.

The time is coming when I can no longer content myself by dipping my pen in aqua regia and making rude remarks about them, and I can see that I shall have to take some active steps to regain my peace of mind and a whole pair of ear-drums.

Something Must Be Done!

Since it is clearly impossible for me to call on Mrs. X and ask her with great tact whether she really enjoys using the vacuum-cleaner after 10 p.m., and on Mr. Y to find out whether it is essential that he leaves his car with the engine ticking over for thirty minutes continuously during the evening, I shall have to do something at my own end, and just what that is going to be I really do not know.

Incidentally, I have found more and more that interference of this kind is more troublesome on the broadcast wave-lengths than I previously imagined it to be.

I have been testing a five-valve portable recently, and I was using my transmitter one evening, with the portable running in the same room on 2 L O, and I noticed that while with 50 watts input to the transmitter absolutely no interference whatever was caused to 2 L O, the noise of a neighbour's

heater-pad broke through at good strength. Likewise a "power-leak" or some similar noise due to a poor and intermittent contact on one of the mains leads.

It was rather remarkable, incidentally, that while a neighbour a hundred yards away is very much troubled when I start up the transmitter during broadcasting, the portable went on serenely on 2 L O, 5 G B and even Toulouse when standing within a yard of the transmitter, without the slightest trace of keyclicks or wipe-out.

Metal Panels and Cnassis.

A Belfast reader has kindly sent particulars about the station working just above W 2 X C X, that I mentioned some time ago. Apparently it is W 9 X F, as he has heard this station relaying W E N R on 49.83 metres. The same reader, on the subject of amateur telephony transmitters, mentions G 5 N W, G 6 B J, G 2 V Q and G 6 R G as worthy of special praise.

Why is it that there appear to be very few believers in the metal-panel and the "Chassis" system of wiring for short-wavers? Generally speaking, short-wave enthusiasts do not seem to have taken kindly to either class of set.

SEPARATING *the* REGIONALS



At the present time there are quite a few sets of types which were popular three or more years ago. These receivers, although giving perfectly good volume, are, nevertheless, in many cases sadly lacking as regards selectivity.

The advent of the first Regional station has made the question of selectivity a vital one. In the case of most of these older sets,

If you have an old, unselective set you may find that the simple alterations outlined in this article will do a great deal to help you increase the sharpness of your tuning. In these days of high-power transmissions a fair degree of selectivity is essential if you are not to be confined to the programmes of one station. All owners of radio receivers should read this practical article.

By A. JOHNSON-RANDALL.

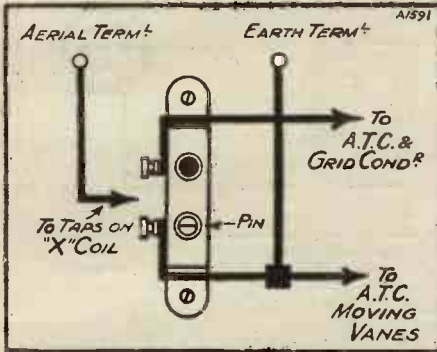

This diagram shows the connections required when the ordinary aerial coil is replaced by an "X" coil.

however, quite a lot can be done to improve the sharpness of tuning, and the total cost of the modification should not exceed a few shillings.

Improving the Tuning.

A very common circuit which is still in use is the old plain aerial detector circuit with "flip-flop" reaction. Obviously, the selectivity of such a circuit is quite hopeless in the light of present-day developments. Yet it is quite easy to improve the tuning of such a receiver.

The most straightforward scheme of all is to replace the aerial coil with one of the "X" type. An "X" coil is an ordinary winding with tapings at, say, 12 and 15 turns in the case of the 60-turn coil. The only essential is that the coil holder must be connected up in a certain way.

With the Lissen and Lewcos coils, for instance, the tapings are nearer the end of the coil which is joined to the socket of the coil mount. Therefore, the pin of the coil holder must be connected to earth.

The Coil-Holder Connections.

Before using an "X" coil in your set, just take a look at the connections to the coil holder. If the receiver has plain aerial tuning the aerial lead will go to one side and the earth lead to the other side of the coil holder, which, of course,

is connected in parallel with the aerial tuning condenser.

What you have to do is to see that your earth lead is connected to the pin of the coil holder and the lead going to the grid condenser to the socket. Then you can insert an "X" coil in place of the existing aerial coil with a consequent increase in selectivity. On the coil itself you will find two or three terminals which go to the tapings on the windings.

The Aerial Lead.

Since you are using an "X" coil you will not need the existing lead from the aerial terminal on the terminal strip to the coil holder. Remove this lead, and instead take a flexible from one of the tapings on the coil direct to the aerial terminal. This flexible lead can be joined to each of the tapings in turn until the required degree of selectivity is obtained.

For instance, if the jamming is very bad use the lowest tapping, because the fewer turns there are in the aerial circuit the sharper the tuning. The correct "X" coils to use are a No. 60 for the medium broadcast wave-band, and a No. 250 for the long waves.

Incidentally, you will find that a smaller reaction coil can now be used, and if you were using a No. 50 before you will now probably need a No. 35 or 40. Also on the long waves, instead of a No. 150 or 200, a No. 100 will now probably be quite adequate.

"Aperiodic" Coupling.

Apart from the use of an "X" coil, there is also another method which makes use of what is called "aperiodic" coupling. In this case the aerial is connected to one side of a No. 25 or 35 coil, and the earth is taken to the other side. This coil is placed close to a second coil, which is connected to the grid and filament respectively of the detector valve.

The method of modifying the set is as follows: Disconnect the two leads which go from your existing coil holder to the aerial and earth terminals of your set. This coil holder will now become the secondary

winding coil holder. Obtain a second coil holder and place it alongside of the first one, so that when the two coils are placed in position they practically touch.

Join one side of the new coil holder to the aerial terminal on the set and the other side to the earth terminal. You have now an aperiodic aerial circuit. For reception on the medium broadcast wave-band insert a No. 25 or 35 coil in the new coil holder, according to the degree of selectivity you require.

In the secondary socket insert a No. 60 and also reduce the size of your reaction coil. This latter expedient is not essential, but it is usually necessary in order to obtain smooth reaction control. On the long waves the aperiodic aerial coil should be a No. 100 and the secondary a No. 200 or 250.

Using a Series Condenser.

If you require still greater selectivity insert a .0001- or .0002-mfd. fixed condenser in series between the aerial lead and the aerial side of the aperiodic coil holder. The .0001 condenser will give you maximum selectivity, but, of course, it will reduce signal strength a little.

I have said nothing about old-fashioned receivers with high-frequency amplification, because I fear that if any modifications

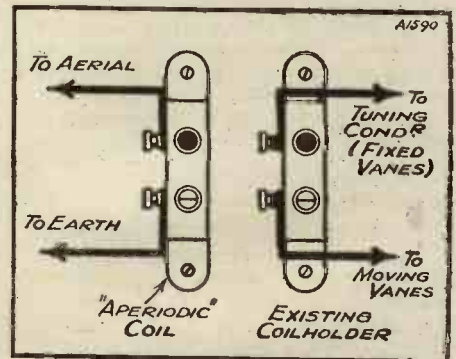

In many cases the use of an aperiodic aerial coil is sufficient to increase selectivity to a high enough degree for the separation of the Brookmans Park programmes.

are made to this type of set, at any rate to the high-frequency stage, there will be a marked tendency for instability to result. The only way, I am afraid, is to alter the method of coupling, which, of course, entails the use of a screened-grid valve or a neutralising scheme.

It is, however, surprising what a big increase in selectivity can be obtained with the ordinary conventional detector type of receiver by the simple alterations which I have described.

The scheme in which an "X" coil is employed can be put into operation in about half-an-hour, and the cost is merely that of the new coil.



CAPT. ECKERSLEY'S QUERY CORNER

LOSS OF HIGH NOTES—THE BEST AERIAL WIRE—WHEN THE SET “FADES”—USING A.C. VALVES—NOISE FROM AN ACCUMULATOR?—THE DETECTOR'S POTENTIOMETER—MAINS UNIT CONDENSERS.

Under the above title, week by week, Captain P. P. Eckersley, M.I.E.E., late Chief Engineer of the B.B.C., and now our Chief Radio Consultant, will comment upon radio queries submitted by “P.W.” readers. But don't address your queries to Captain Eckersley—a selection of those received by the Query Department in the ordinary way will be dealt with by him.

Loss of High Notes.

F. E. (Ipswich).—“I see that the majority of L.F. transformers show a noticeable drop in the amplification of the higher frequencies. Is there any method of maintaining or increasing these upper frequencies?”

The drop in frequency characteristic is due to there being what is called leakage

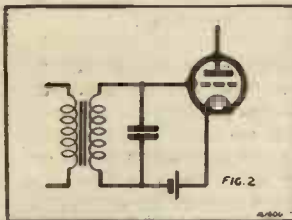

This and the diagram opposite illustrate the reply to F. E. (Ipswich).

and can be considered as an outside inductance in series with the transformer, as drawn in the accompanying Fig. 1.

As the frequency rises the impedance of this

inductance gets greater, and, consequently, there is less output.

A condenser of suitable value connected so as to neutralise the inductance kicks up the characteristic a bit, according to the capacity value. Try a very small condenser, as shown in Fig. II, but I doubt if you'll notice much difference with a good transformer.

The Best Aerial Wire.

O. D. M. (Norwich).—“Is it possible to differentiate between various metals and also the number of strands for use as an aerial?”

Practically and electrically ordinary copper wire is the best (silver is, theoretically, better—but I don't suppose you'll try it!). Mechanically, if the aerial has to stand wind-pressure, or is stretched, copper

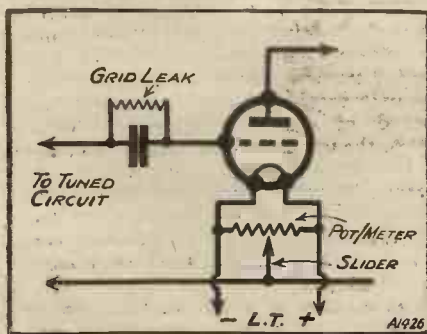

One lead from the tuned circuit goes to the potentiometer's slider.

is bad, so phosphor bronze or hard copper is commonly used.

Stranded wire is used to prevent breakages due to movement in an outdoor aerial. For receivers the whole problem is mechanical. Electrically, any old copper wire is perfectly good.

When the Set “Fades.”

F. C. W. (Ealing).—“After my set has been working for a short time, reception fades right away. On pulling out H.T. + wander plug which feeds the H.F. and det. valves, pausing a short time and then replacing same, the transmission is again at full strength. Why should this happen?”

It may be that your battery is run down, and while it may store up a little energy after it's had a rest, it fails completely when asked to continue working in its run-down state.

Using A.C. Valves.

G. C. (Stratford).—“I have a three-valve set in which the detector-valve grid leak is connected to a potentiometer. I am arranging the set to use indirectly heated A.C. valves. Can I still use the potentiometer?”

Yes.

Noise from an Accumulator?

J. P. (Erdington).—“Can an accumulator which is gassing badly cause a slight crackling noise in the loud speaker?”

If it's connected to the set, yes, I should say so.

The Detector's Potentiometer.

L. V. (Ealing).—“I have noticed that a potentiometer should be provided across the detector filament to ensure that the correct amount of positive bias is obtained. How does one find the best position? And does it matter whether the grid leak is in series or parallel?”

The best position is the best position to give best results, loudness and quality, usually when full positive is applied to the grid positive, though not always, hence the adjustment. I do not understand the last part of your question. Anyway, the connection is shown in the figure given on the left.

Mains Unit Condensers.

W. R. (Chigwell).—“I am told that the size of the condenser immediately across

the output of an A.C. H.T. transformer has a distinct effect on the rectified current obtainable. Can you give me an idea of the size of condenser I should employ for the

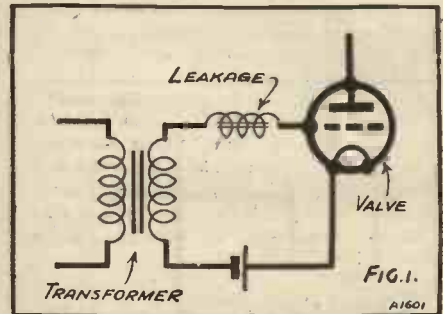

Transformer leakage prevents the high notes from being reproduced in their full proportions.

purpose, and the factors governing its capacity?”

Do I take it that you refer to the method of getting rectified A.C. from the H.T. supply? If so, the connections are as shown in the sketch.

The condensers C_1 and C_2 do make a difference, but if they're only almost 0.5 or so of a microfarad, they won't help smooth the stuff much.

Or do I take it that some people connect capacities K , as shown dotted, and that it's this that you're asking about?

The capacity K makes a lot of difference, making the power factor of the transformer nearer unity as the effective inductance L and capacity K make the circuit resonant to the periodicity of the supply.

Be very careful about K . It may produce excessive voltages.

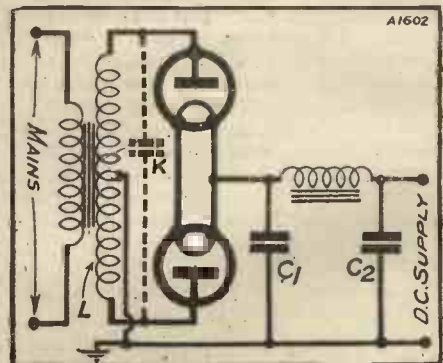

These are the connections referred to under the heading “Mains Unit Condensers.”



WHILE the B.B.C. has slowly been maturing the plan of the Regional stations, carefully calculating their power and the financial ways and means of realising the plan, Germany has been seemingly content with its present state of affairs; a number of medium-power stations and a number of relays.

While the B.B.C. was considering international development and restriction of wave-lengths and the welfare of the listeners, and providing a contrasting programme, Germany was content to develop along programme lines, with the exception of the new Zeesen station, a relay here and there, and the "S.W." station.

Surrounded by Stations.

With a number of decisions in the countries surrounding Germany, decisions regarding the erection of a number of high-power broadcasting stations, Germany finally discovered last year that she was being "eingekreist," i.e. was being closed in by high power stations on all sides.

Gently the public were first made to realise that the power of the German stations was not what it seemed to be. Formerly, the power of broadcasting stations was expressed in kilowatts in the aerial when emitting a telegraphic dash, or in kilowatts of the anode circuit of the last valve. These numbers were higher than our present ratings.

Then, at the instance of the International Radio Union, at Geneva, broadcasters internationally referred to power as kilowatts-in-aerial, meaning the power in the aerial when the broadcasting station was radiating the carrier-wave. And to-day the broadcasting stations adhere to this formula.

At the recent Hague conference it was decided to mention the power of the stations when at maximum distortionless modulation, but this definition still requires the sanction of the Madrid conference in 1932. Anyway, according to the Geneva formula, the formula by which the B.B.C. stations are rated, the old 2 L O at 3 kw., and Brookmans Park at 30 kw., the German stations were rated as having 4 kw-in-aerial in the case of the main stations.

Calculating the Power.

Well, after the discovery last year that Germany was being closed in, the public was gently informed that they were quite wrong in thinking that the power of the German stations was 4 kw.; quite on the contrary, it was stated to be 1.5 kw.

Although Britain leads in the race for the Blue Riband of the ether where broadcasting is concerned, Germany is determined to go one better in the near future. You will appreciate what a titanic struggle it is if you compare our own Regional Scheme with the system of high-power stations now being built on the Continent, and which are described in this article.

By A. A. GUILLILAND.

I am told that both figures refer to the Geneva definition of power-in-aerial, and I am also told that there are many ways of arriving at this number of kilowatts, so the only way I can explain this sudden change of advertised power is that in Germany the calculation of the power-in-aerial has been modified.

I regret to say that, whereas the B.B.C. was kind enough to give me full information regarding the rating of their stations, the German authorities in question acknow-

low power of the present German stations, and the imminent danger of their being drowned by powerful neighbours, plans began to form. Any amount of printer's ink was spilt—and then, quite suddenly, came the definite plan to install eight new transmitters in Germany, each with 60 kw.-in-aerial power (it is not clear if B.B.C. reckoning or the new German formula applies to this), and, at the same time, to keep all the present transmitters in operation!

The super-power stations will obtain the exclusive wave-lengths, the remaining stations working on national or international common wave-lengths!

At the first one wondered if all the eight stations were going to be erected together, or one at a time. After further consideration it has been decided to erect two or three of these stations this year and following on the results obtained by these to erect the remainder.

First of the Eight.

The first station has definitely been decided upon. It will be placed near to Mühlacker, about half-way between Karlsruhe and Stuttgart, and will be completed by September next. This part of Germany is worse off at the moment regarding reception.

The next transmitter will be erected somewhere near Frankfurt and the third will be situated in Eastern Prussia. The remaining five stations, to be erected later on, will probably be situated as follows: one inland from Hamburg, a fifth between Berlin and Breslau, a sixth in Central Germany, a seventh in Bavaria, and the eighth will consist of the further increase of Langenberg's power. At least, that is the plan as far as it has

A "WORLD BROADCASTER."

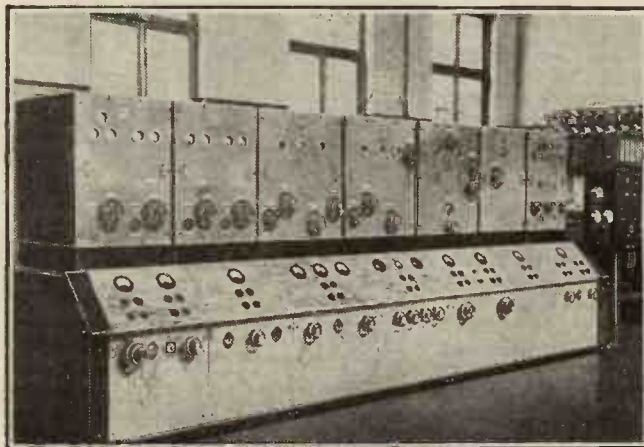

This is the new short-wave transmitter at Königswusterhausen, whose task it is to carry German programmes to the far corners of the earth.

ledged my request four months ago, but have hitherto refrained from supplying the desired information. Therefore, I can only surmise as to the reason of the sudden change in the kilowatt figures.

The public having been prepared as to the

been sketched out, as yet. Germany certainly intends remaining the "big noise" on the continent.

With the erection of the new transmitters a certain amount of re-grouping of the

(Continued on next page.)

A WAVELENGTH MYSTERY.

By D. GLOVER.

ONCE upon a time (a very long time ago) someone stumped me very badly at a lecture I was giving. This is the question he asked, and it is a question that may or may not make familiar reading. (In any case, I can clear up a point that puzzles most amateurs at some time or another.)

"We are told that radio telephone transmitters must be separated by at least 10,000 cycles or they will heterodyne each other. Then you say that, whereas this necessary 10,000 cycles separation forbids us using more than a dozen or two stations between 1,000 and 2,000 metres, a hundred stations can be crowded in a half-metre wave-band between, say, 4 and 4½ metres, down on the very short wave-lengths.

A Knotty Problem.

"How is it that the 10,000 cycles frequency is not the same on all wave-lengths, as Frequency divided into Velocity (which is constant) gives you Wave-length?"

"What you mean," I said, "is that you cannot see why 10,000 cycles should be different when they are added or subtracted from a short wave-length from when they figure in the higher wave-bands."

And when the amateur agreed, I pointed out that 10,000 cycles alone represented a wave-length of 30,000 metres, and it was obviously absurd to think of dealing with such on any ordinary wave-band: a feeble reply!

"Then why don't you add 30,000 metres or take away 30,000 metres when you allot station separation on short wave-lengths. You say a short-wave station must be separated by 10,000 cycles from, say, a lower wave-length station. You add 10,000 cycles to the station's frequency. Wave-length is Velocity divided by Frequency, and 10,000 cycles represents a wave-length of—"

A "Difference Quality."

At this point I loudly called the meeting's attention to some other beautiful aspect of the theory of radio. I was not so sure of my ground in those days! Remember, it happened nearly 20 years ago, and I must add that the question was framed slightly differently. I have modified it to meet modern conditions.

Actually, the 10,000 cycles referred to as a necessary separation cannot be detached. It is a "difference quality."

And until you can clearly see it as such you are sure to get mixed up. On the short-wave-lengths you may have one station operating with a frequency of 200,000,000, and another with a frequency of 200,010,000.

The wave-length of the first will be $\frac{300,000,000}{200,000,000}$ metres, and that of the second $\frac{300,000,000}{200,010,000}$ metres. The one has a frequency of 10,000 more than the other, and the separation is adequate.

You cannot subtract the frequency of one from the frequency of the other and then divide the answer (10,000) into

300,000,000 and say the wave-length separation is 30,000 metres. You must work out the individual wave-lengths of the stations, and then work from that to find the wave-length difference.

In the wave-length formula, Wave-length = $\frac{\text{Velocity}}{\text{Frequency}}$, you have two variable

factors and one fixed, the fixed one being velocity. In fact, the formula can stand at Wave-length (in metres) \times Frequency = 300,000,000.

From this you can see that if one variable factor goes down the other must go up, and vice versa.

If you are not convinced let us bring in our old friend Ohm to illustrate the point. There will be but few who are not fairly familiar with Ohm's Law.

An Easier Example.

Supposing for some reason you had to use electric lamps of differing resistances. Supposing the rule was that electric lamps used in the same house had to be different one from the other by a resistance of 10 ohms. (That represents our frequency difference.)

Now the voltage will be constant at any one house according to the source of supply. It might be 200 volts. (That represents our velocity.)

Current (which represents our wave-length) according to Ohm's Law, equals Voltage divided by Resistance.

One lamp must be 10 ohms more or 10 ohms less than another lamp. Ten ohms; if a piece of apparatus of 10 ohms resistance were attached to 200 volt mains 20 amperes of current would flow. But obviously, the 10-ohm difference of lamp resistance doesn't mean a 20 ampere current difference.

You cannot dissociate the 10 ohms like that, it is merely a difference between, say, 600 ohms and 610 ohms, $\frac{1}{3}$ and $\frac{2}{3}$ ampere of current flow in our rather laboured example.

If you get four apples for a shilling, they cost you threepence each, and if you are

BRATISLAVA'S BROADCASTER.



This is the 124-kw. transmitter at the Bratislava station. It is of the same type as that used by 5 G B, and a similar transmitter operates at Bucharest.

given six for the same figure they cost you twopence each. There is a two-apple difference between the two purchases, but not a $\frac{1s.}{2}$ per apple price difference!

If there is any confusion in the Frequency-Wave-length business still in your minds it is because you are not yet able to see that the frequency-difference is a comparative difference, and that it doesn't exist at all unless you have two stations to be different!

GERMANY'S SUPER-POWER STATIONS.

(Continued from previous page.)

programme companies will have to take place. It is intended to give the listeners a double and contrasted programme wherever possible. The geographical situation does not allow of the grouping of five double Regional transmitters.

This grouping of the independent programme companies began with the co-operation between Frankfurt and Stuttgart, now already developing into very close interlacing of the items contributed by each station to the joint programme. A new group has recently been formed, by Berlin, Breslau, and Leipzig, deciding to interchange programme items, thus creating S.B. from these three main stations and their relays for a number of items.

Two Main S.B. Groups.

These are the two main groups. Western Germany with Cologne-Längenberg will probably remain isolated or interchange with the Northern group; Hamburg, Eastern Prussia, with Königsberg, will link up with Berlin; Bavaria will remain isolated. At least, that would be the natural development of events, as they are slowly taking place.

In connection with the new transmitters, I read a very interesting suggestion made by a German engineer the other day, as regards the reallocation of wave-lengths. He stresses the need for broader wave-bands. And I agree with him here. The quality of broadcast music requires 20,000 kc./sec. to be more or less perfect, and television still broader wave-bands. Now this gentleman suggests that instead of giving, for instance, Britain, ten exclusive wave-lengths, give it five exclusive wave-bands, 20 kc./sec. in breadth, or even three exclusive wave-bands of 33 kc./sec. breadth.

First of all, this would prevent interference from neighbouring (in wave-length) foreign stations, and, further, it would permit the national broadcasting authorities to divide up the broad wave-bands into smaller ones for broadcast stations, one person having thus control of neighbouring stations and being able to prevent interference without international complications, also

leaving one broad band for television.

A Good Suggestion, But—

I think his suggestion quite one of the best made in this direction; but, if we are to have wave-bands, who is to have the high ones and who the low ones? Knowing the geographical requirements of mountainous countries and the way our waves propagate themselves, I am afraid that here we have the main difficulty.

The **FERRANTI**
Electro - Dynamic
Speaker



Models :

A.C. £18 : 0 : 0

D.C. £14 : 10 : 0

THE Ferranti Electro-Dynamic Speaker gives reproduction very nearly true to life, and is a definite step nearer to perfection.

FERRANTI LTD. HOLLINWOOD LANCASHIRE

THE
FINE PICK-UP
WITH THE
FINE PERFORMANCE

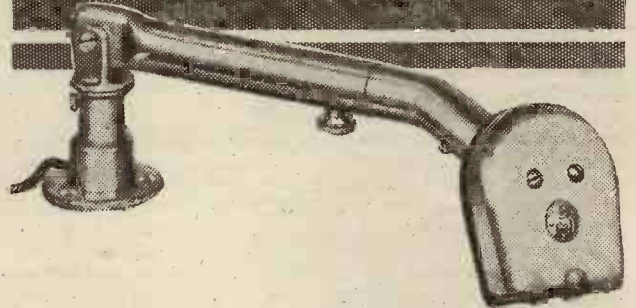

The new B.T.H. pick-up has been specially designed to give fine tonal quality throughout the whole musical range.

The degree of damping has been very carefully balanced so that unwanted resonances are avoided on the one hand and record wear is avoided on the other.

The B.T.H. pick-up is used in the best known makes of radio gramophones—good reason why you, also, should make use of the undoubted advantages of the more music—less wear pick-up.

PRICE **45/-** COMPLETE

Pick-up and Adaptor for Standard Tone Arms,

Price **27/6** Complete



**PICK-UP
& TONE ARM**

“THE MORE MUSIC — LESS WEAR PICK-UP”



THE EDISON SWAN ELECTRIC CO., LTD.,
Radio Division,
1a, Newman Street, Oxford Street, W.1.
Branches in all the Principal Towns.

EDISWAN

W.69.

FOUR condensers, two switches, a couple of home-made coils, a few odds and ends like screws and wire—and that is all! But, nevertheless, one finds it difficult to recall a "box of tricks" more satisfactory and surprising than this one, in all the seven successful years of "P.W." set design!

Everybody knows "a good wine needs no bush," and this Twin Rejector is quite capable of doing its own talking. Its compactness, its simplicity, and the sheer uncanny ability of the way it works, are all the recommendation it requires. But before we get down to details we should like to tell you how the Twin Rejector came about, of the pleasure we had in making it, and the pleasure which you are going to get out of it.

It's really a very simple story. You all remember how broadcasting began a few years ago; how people listened in and liked it; how they clamoured for more programmes; and how new stations sprang up and aeriels multiplied like mushrooms. The more programmes we had the better we liked them, until in the end the B.B.C. took its courage in both hands and handed out a surprise packet to all listeners.

Problem of the Missing Foreigners.

"Every set in the country," they said, in effect, "shall have two programmes. We will divide the country up into areas, put a really high-power station in every region and every station shall send out two programmes at the same time."

This idea is known as the Regional Scheme. Brookmans Park, the new 2 L O, is the first Regional station, and everybody who has heard its stentorian voice agrees that the B.B.C. has kept its word—the high-power which was promised has duly come to hand!

Even if you live a long way from Brookmans Park you are in this business, because other regional stations are following as fast as possible. And when you get one

in your locality, you will know it! With two high-power programmes poured over your doorstep as it were, you cannot say you are not getting value for your licence money!

But the fly in your ointment is the fact that the foreigner often now takes a back seat. The lady announcer at Rome no longer comes on and rolls her "Romas" at you. In many cases the Regional scheme threatens to muzzle Munich, put the lid on Madrid, and take Toulouse right off the map. And that is where the Twin Rejector comes in!

Capt. Eckersley's Surprise.

What made the problem—such a sticky one is the fact that the B.B.C., in generously giving away double programmes, is to be praised and not blamed. Having determined in the generosity of their hearts to give you two big, fat programmes, you can safely reckon that sooner or later those two programmes will land on your aerial—and then what about Rome, and Oslo, and Brussels and all those other attractive foreign places?

Worse still, what if your set will not separate the two new locals? What if

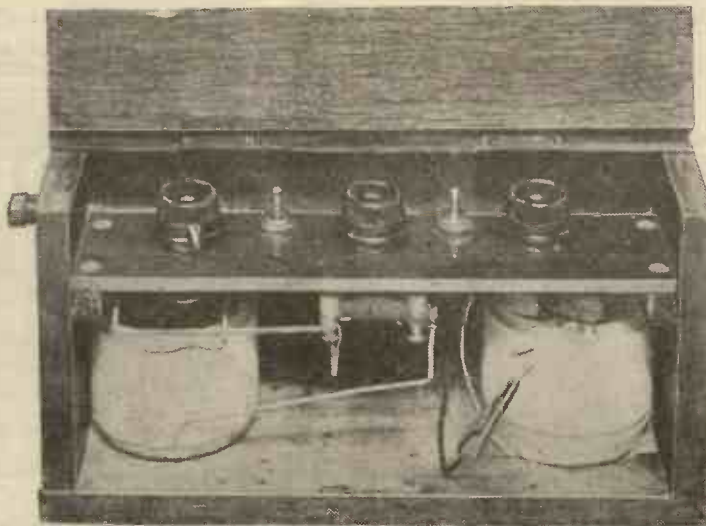

One of the beauties of this little gadget is its simplicity. Practically all the "doings" are mounted on a little strip, as shown, the switches being for regular use, and the condensers requiring only a first adjustment, after which you need not touch them again!

This easily-made little box of tricks, which fits on your set as shown above, contains two switches. One "puts paid" to "Reg." (356 m.), the other to "Nat." (261 m.) right off the dial! Or any other two stations that are passing on your dial can be selected, and switched off in a second when you wish to find some foreigners. You can make the Twin Rejector in an hour or two, fit it to any set in a moment, and always rely on it to remove maddening interference, even if from high-power stations! And when your friends say, "Where did you get that circuit?" you can tell them it was

DESIGNED AND DESCRIBED BY THE "P.W." RESEARCH DEPARTMENT

you hear Jack Payne "Tip-Toeing Through The Tulips," whilst at the same time Prof. Tickemoff insists in telling you, "How to Chew Cheddar Cheese"? And your set will not separate those two!

The problem facing the "P.W." Research Department was to evolve some gadget, not too costly to make, nor too difficult to build, which could be added to any set, and which could "put paid" to any unwanted programme in a simple, silent and satisfactory manner.

"Could it be done?" said the wiseacres and the sceptics?

"Brookmans Rejector" answered POPULAR WIRELESS! And everyone who has tried it knows that that was a completely satisfactory answer!

The "Brookmans" Rejector circuit (which is embodied in the Twin Rejector), is a simple one evolved by "P.W." for "P.W." readers. As Capt. Eckersley is a "P.W." reader, we asked him his views when the first one was completed, and he was tremendously tickled by it. His face was quite a study when he

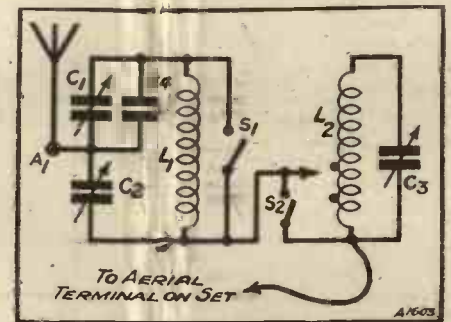

switched the new which he mark yo complet bent per machine

Taming w Having cut the "P.W." thing w sibilities

HERE IS ALL YOU NEED TO BUILD THE TWIN REJECTOR

- 1 2 1/2" diameter Piratoid or Paxolin tube, 4" long.
- 2 .00075 "Brookmans" Variable Condensers } Ready Radio.
- 1 .0005 "Brookmans" Variable Condensers }
- 1 .0003 Fixed Condenser, Lissen, or Dubilier, Mullard, T.C.C. Clarke, "Goltone" Igranic, Etc.
- 2 On/Off Switches, Igranic, or Lotus, Lissen, Benjamin, Jewel, Ormond, etc.
- 1 Strip of Paxolin or Ebonite, 9" x 2".
- 1 Aerial Terminal, 1 Crocodile clip, 1 pair of hinges and wood for case, fixing screws, 4 oz. wire (usual No. 24 d.c.c.), etc.

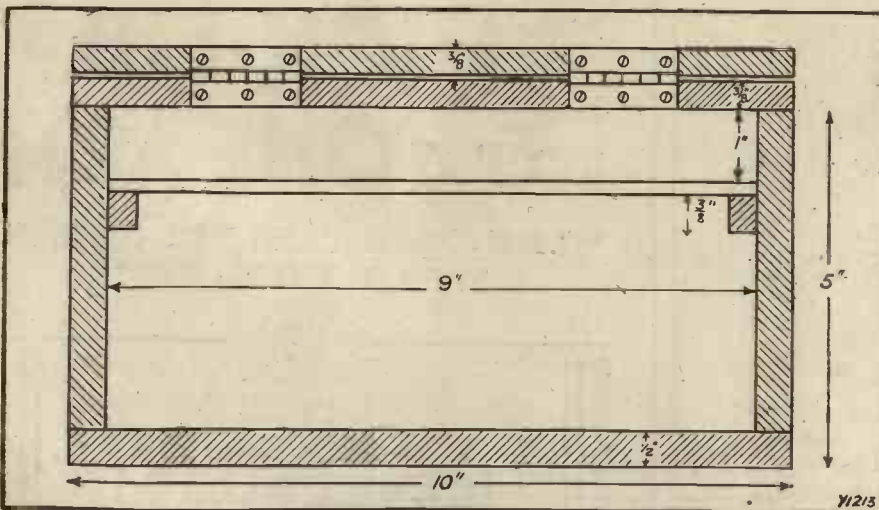

You need not be a carpenter or cabinet-maker to make a success of the woodwork! From the photographs and sketches you will see that one side of the "box-of-tricks" is left open, and the top is halved and hinged to form a lid.

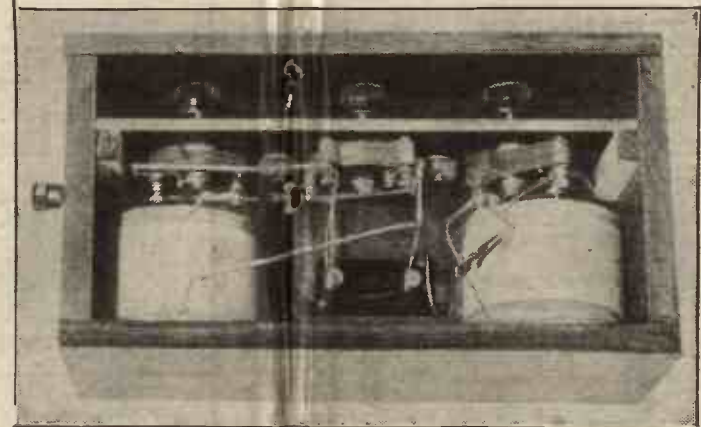

This view shows how the fixed condenser is secured on the inside of the box.

OR

bove,
ocks
tres-
a you
hour
that
your
was
T.



The coil on the right has a number ofappings to one of which a clip is taken, as shown. This adjustment has only to be made in the first instance when "setting" the Rejector, after which you flick the switch on, and out goes the unwanted programme!

it on and found that high-power 2 L O—himself had designed, u! —was rejected as ly and finally as a ny in a seaside slot!

he Twins.
g found in this cir- right solution for readers, the next as to prove its pos- in the different forms required by them for different conditions. Some readers wanted plug-in coils with it, others wanted "deluxe" versions, and finally, especial-ly as the merits of the scheme became more and more known, and one old pal told another about it, there grew an irresistible demand for a Twin Rejector incorporating home-made coils (that could easily be tacked on to any set), with high capabilities and low cost of construction. Well, here it is! And now, having made a good clean breast of the reasons for this article, we can get on with it and tell you in a few words exactly how to duplicate the design.

The parts that you will require are set out in a separate little list and you will see for yourself that you can put the whole lot in your overcoat pocket without making it bulge. The variable condensers are all quite little fellows, the capacities being as named in the list. The two switches are of the simple on-off type, but do not forget that they really must go on and off with a good positive action, and not merely dilly-dally, half-way on and half-way off, or make contact by the parts merely leaning up against one another, instead of pressing firmly into place.

You will see from the diagram that the coils employed each consist of 50 turns of No. 24 D.C.C. wire, wound on cardboard (or, better still, Pirtoid or Paxolin) formers, in simple solenoid fashion. Each winding occupies about 1½ in. along the former, so a 4-in. tube of 2½-in. diameter (cut into two, to form two 2-in. lengths), will form the bases for the coils.

Very Easy to Make.

The box in which the Twin Rejector is encased has a top with hinged lid, and one side open, the idea that it should be fixed up against the side of the set, the wood

switches are mounted on this.

Small fillets of wood screwed to the sides hold this panel in position, the single fixed condenser being mounted centrally on the inside of the case, and between the two coils, as shown in the photographs. The coils themselves are very easily fixed if a cross-piece of wood is fitted inside each at the bottom, a screw passing through this into the baseboard, and thus holding the coil rigidly in place.

Constructing the Coils.

You will see that the aerial terminal on the Twin Rejector passes right through the outer wood of the case, just behind the fillet that holds the panel at the C₂ end. On the diagram below you see how, when the lid is open, the panel is disclosed in place beneath, all the measurements for drilling the panel being given on this. The variable condensers are lettered C₁, C₂ and C₃, and the switches S₁ and S₂.

The mounting of these components upon the panel, etc., is the work of only a few minutes, but do not forget that each little unit will continuously handle high-frequency

(Continued on next page.)

ITS SMALL—BUT IT DOES A BIG JOB!

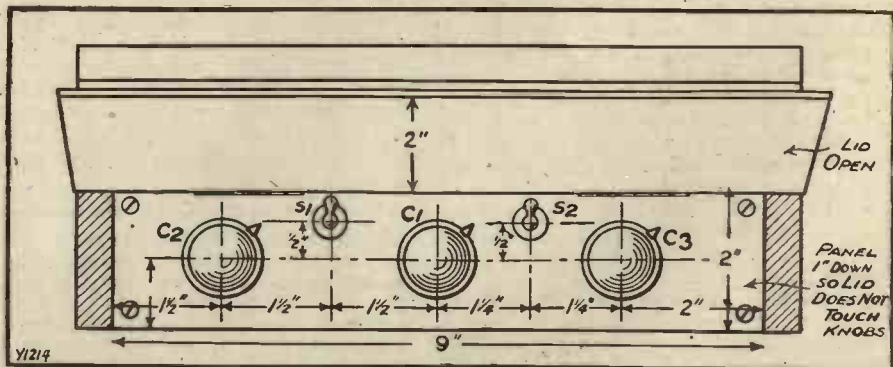

After drilling the little panel to the dimensions shown above, and mounting the three condensers and two switches on it, you secure it to the fillets at the sides at a distance of about one inch below the lid.

THE P.W. "TWIN" REJECTOR.

(Continued from previous page.)

current and that correct spacing between the various parts and wires is therefore an essential condition for good working.

The making and mounting of the coils is such a simple business that no more need be said about them except to remind you that one of them is tapped at the 6th and 12th turns, the wire at these points being bared so that connection can be made by means of a crocodile clip. This clip is on a flexible lead coming from S_2 , as shown in the wiring diagram, and another flexible lead must be taken from the fixed vanes of C_3 , by any convenient and short route to the aerial terminal on your set.

The rest of the wiring should be done in accordance with the wiring diagram, and good soldered connections are recommended to ensure good contact throughout. When finished, fix the Twin Rejector to the side of your set, join the flex from it to the aerial terminal on your set, and the aerial lead-in to the new A_1 terminal on the unit, as explained, and you are ready for the preliminary adjustments.

If you look at the theoretical diagram, you will see that we have two circuits, one consisting of L_2 and C_3 , controlled by S_2 ; and the other one consisting of the coil L_1 , condensers C_1 , C_2 and C_4 , the controlling switch being S_1 . This latter combination of three condensers, coil and switch forms a complete "Brookmans" Rejector, and it is designed to cut out the high-power transmission that troubles you most.

Cuts Them Both Out !

The other circuit (L_2 - C_3) is a complete auto-coupled wave-trap. Although not novel, this part of the circuit is singularly suitable for our use here, because it is quite capable of cutting out the spreading of a second powerful programme, whilst the "Brookmans Park" Rejector is taking the sting out of the principal offender!

Each of these two circuits is brought in or out of action by its switch, and either one of them or both together can be cut in or out as desired. But the first time that you connect up the Twin Rejector each circuit will have to be "set" to the required wave-length.

Once this has been done, there is no more fiddling adjustment but all that is necessary is to use one or both switches. This preliminary adjustment only takes a few minutes, but it must be done carefully

and correctly if the instrument is to function efficiently. So to make it clear we will consider a typical case and go through the process step by step.

Preliminary Adjustments.

We will suppose that the listener who is going to use the trap is in the London area, that he gets tremendous punch from the 356 Regional transmitter, and almost as loud a programme from the 261 National transmission at Brookmans Park (though this station, being at the bottom of his tuning dial, probably does not interfere with foreign reception so strongly.)

As already stated, the circuit controlled by S_1 will take care of the chief offending transmission, so the switch S_1 is opened for action, and S_2 is closed. First tune-in

tapped turn if necessary.) Slowly adjust C_3 in the same way as the other condensers, until the point of maximum reduction or fade-out is found.

As the Twin Rejector is such a simple little contrivance to make and operate there is not much more to be said, but perhaps the following points are worthy of mention. The fixing of the unit to the set, for instance, may not always be possible in the fashion shown by the photograph, where a couple of screws through the set's cabinet hold it in position. But, fortunately, any other position close to the set's aerial terminal will do (so long as the unit's coils don't couple with those inside the set, of course!)

If you live within about half a dozen miles of a powerful station, and wish to muzzle it by means of the L_2 , C_3 circuit, you may find that the 12-turn tapping on L_2 gives a hardly sufficient coupling, in which case you can simply bare the wire a little lower on the coil—say up to half-way—and clip the "crocodile" there instead of on the 12th turn. In this position it may affect the tuning a little on some sets, so keep as close to the 12th turn as you can to avoid this.

When once these preliminary adjustments have been made, the condensers' settings are left alone and in order to make either one or both of the circuits act, you simply operate the switches controlling them. And it is certain that you are not likely to forget to use those switches, for you will find

they make an extraordinary difference to your reception, cutting out the interference and enabling you to get the foreign stations once again!

ODDS AND ENDS FOR THE CONSTRUCTOR.

Instead of taking out a loading coil and replacing it by a shorting plug, a filament switch or other on-off switch can be fitted across its two terminals, and thus bring the coil in or out of action when desired.

One of the great objections to swinging-coil reaction is the fact that by this method the tuning is not so independent of the setting of the reaction, as when a condenser is used for the latter.

When a long passage or hall is not available for an indoor aerial and it has to be placed in a very small room, it is generally advisable to try the effect of different positions for the wires.

Defects in the wiring of a set can often be detected easily by testing with a pair of 'phones and dry cell. (The method has frequently been described in Radiotorial.)

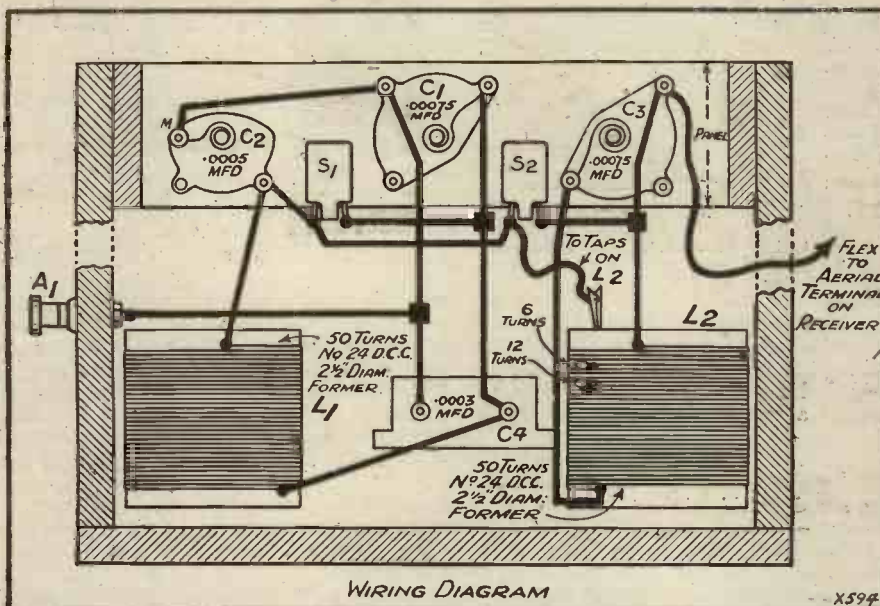

This sketch shows the front of the coils and the underside of the little panel on which the variable condensers and two switches are mounted. The numbering and lettering of the components in this wiring diagram (L_1 , S_1 , C_1 , etc.) agree with the theoretical connections on the preceding page, so you can check your wiring from that diagram also if you wish. Don't forget that close, parallel wiring should be avoided, so you must give every lead plenty of space to itself.

as usual on the set till the 356-metre transmission is strong, set C_1 near to its minimum position (all out) and C_2 about midway.

Now adjust C_1 slowly until you find a setting which causes the signals to go down to practically nothing, and on either side of which point they reappear. (On many sets they will vanish completely.) You will find that C_1 and C_2 are somewhat interdependent, so that if you adjust one you must reset the other to find the rejection point.

Generally, it is best to keep C_2 fairly small and C_1 rather large (near the "all-in" position). Take your time over the adjustments and remember that as the condenser controls are small and fairly large capacities are being handled, careful adjustment is necessary.

A Few Final Hints.

Having tamed the main transmission, and shown by the operating switch S_1 what an enormous difference the Twin Rejector makes to selectivity when it is in circuit, you can tune to 261 metres (on the set) and turn your attention to C_3 and to the other switch S_2 . Open the switch S_2 and try the crocodile clip on one of the tappings. (You can remove this later to a different

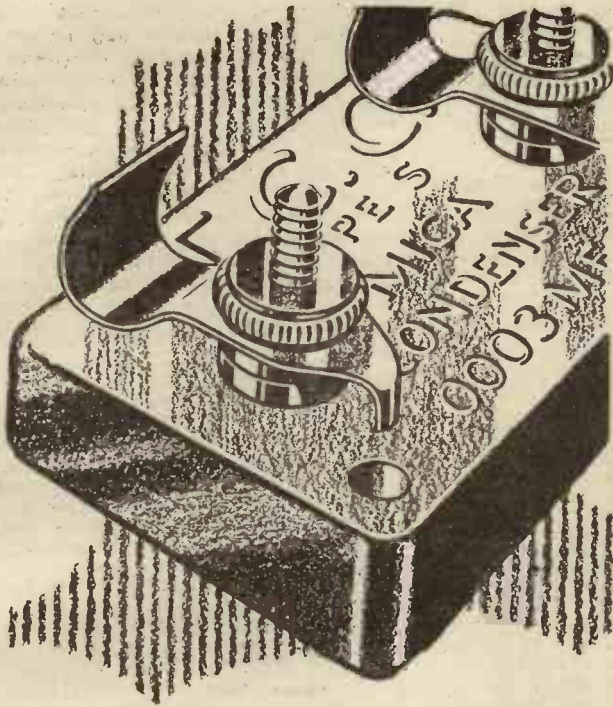

A GENUINE T.C.C. Condenser for 1/3

There's no excuse now for using cheap and doubtful condensers. A genuine T.C.C. costs no more. When a set designer specifies a .0003 mfd. fixed condenser he assumes you will get a .0003 mfd. exactly, not about .0003 mfd. Be certain yourself of getting a condenser of guaranteed capacity —get a T.C.C. Ask for T.C.C. always and be sure. Here are the new prices.

T. C. C. MICA CONDENSERS Flat Type

mfd.	s. d.
.0001 to .0009	1 3
.001 to .004	1 6
.005 to .006	2 0
.01	2 6

*Tested to 500v. D.C.
to work at 250v. peak.*

Advt. Telegraph Condenser Co. Ltd.
Wales Farm Road, N. Act n, London, W.3.

4102



10 m/A
20 m/A
30 m/A
40 m/A
50 m/A
60 m/A

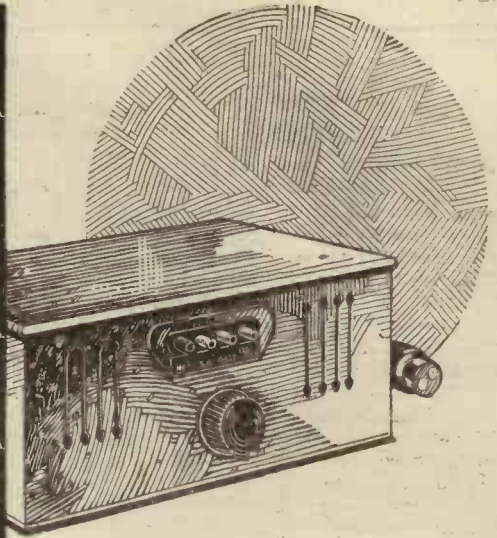

Whatever the
consumption of your
set . . . "Ekco-Lectrify" it!

By connecting an "EKCO" Power Supply Unit to your set in place of batteries you are assured of troublefree, reliable radio, without a trace of hum.

You can completely electrify your set with an "EKCO" All-Power Unit or eliminate H.T. or L.T. batteries with an "EKCO" H.T. or L.T. Unit, respectively. "EKCO" Power Supply Units are fitted in a few minutes without alterations to the valves, set or wiring. They are British Made for D.C. or A.C. Mains with Westinghouse Valveless Rectification in A.C. Models.

The "EKCO" H.T. Unit, illustrated, is Model IV.20 for A.C. Mains. Suitable for one to five valve sets, or those not requiring more than 20 m/a. Tapping for S.G. Valve, also at 0-120 and 120/150 volts £4 . 12 . 6. D.C. Model (exactly as above) £2 . 10 . 0.



Plug-in—That's all!

POWER SUPPLY UNITS



Write for details of Easy Payments and Free Booklet containing full particulars of the above Units and "EKCO-LECTRIC" Radio Receivers, radio's supreme two and three valve sets. E. K. Cole, Ltd., Dept. A "Ekco" Works, Leigh-on-Sea

FROM THE TECHNICAL EDITOR'S NOTE BOOK.

Tested and Found—?



THE MAGNUM DISSOLVER

WHEN gramophone pick-ups first became popular adaptors were, and still are, available which enable you to connect the pick-up to a receiver by removing the detector valve and fixing the adaptor in its place. Then came radio-gram sets with switches on their panels enabling one to go over with a click to either radio or record.

The latest luxury is the fading scheme. Instead of a change-over switch, a device

is fixed to the panel of the set which is rather like a potentiometer in appearance. It acts both as a volume control for radio and a volume control for the gramophone pick-up, and you go to a

maximum volume of either from the central zero position.

Thus you can fade out radio and fade in a gramophone record with real B.B.C. finesse.

The "Magnum" dissolver, which is a product of Messrs. Burne-Jones, Ltd., is the kind of component with which you can obtain this double control. As I have indicated, it has somewhat the appearance of a potentiometer, except that it has four terminals. It is well made and is an attractive component. The price is 10s.

THE ATLAS RHEOGRAD.

Messrs. H. Clarke & Co., Ltd., of Manchester, are in production with a new line, the "Atlas Rheograd," a continuously variable resistance covering from practically zero to 2 megohms. It is of the compression type and is built into a solid nickelled casing.

It is designed for one-hole panel mounting, and I notice that there is a recess nut which enables the component to be gripped on to the panel so that it cannot turn. The "Rheograd" can be used in both sets and mains units, and its price is 8s. 6d.

NEW SIEMENS H.T. BATTERY.

Have you ever wondered why it is that H.T. batteries of practically all makes are

similar in design and appearance? It is true that some are blue in colour and others are black, while a few are daringly encased in jackets of vivid colouring. Nevertheless, they are all rectangular in shape, and all have sockets dotted about their tops.

Standardisation of technical specifications is excellent, but standardisation of appearance is apt to become rather boring. I, at least, have often longed for an H.T. battery oval or even plum-pudding-shaped! However, we have a goodly measure of relief in the new Siemens Full-o-power H.T. battery, which is a distinct departure from accepted practice.

This excellent battery has its tapping sockets arranged along one side. Personally, I would welcome it purely as a variation in form, but I am inclined to think that I prefer the side tapping scheme to the conventional top sockets. It certainly makes for neater lead running. Instead of having the wires spraying out from the top from little plugs stuck in like cribbage markers, you can, if you like, run the leads from the back, keeping them out of sight as we do with the external connections of most modern sets.

I have always found Siemens batteries to be good, but purely as a matter of form, I have been subjecting the new Full-o-power to the usual tests, and it is holding up excellently. It is quite unnecessary for Messrs. Siemens Bros. & Co., Ltd., to suggest that we should test the accessory over an extended period. "P.W." readers; at least, will know my views on the subject of H.T. battery tests by now!

VARLEY L.F. CHOKE.

I have frequently been asked whether an output filter is really worth while. Let me take this opportunity of putting the doubts of my correspondents at rest. In any set with pretensions to giving good quality loud-speaker reproduction an output filter of some kind is a necessity. It may take the form of a special output transformer when certain types of speakers are involved.

In the ordinary course of events, the arrangement makes use of an L.F. choke and a fixed condenser. The L.F. choke replaces the loud speaker in the anode circuit of the last valve, and the fixed condenser and loud speaker form a shunt between the plate of the valve and H.T. — or L.T. —.

Quite a number of advantages follow. First of all the loud speaker is no longer under the influence of the polarising direct anode current. This may be anything between 20 and 30 milliamps when a super-power valve is used. Some loud speakers cannot carry such a current, while most will be harmed if, inadvertently, such current is passed through them the wrong way round.

Then again, long loud speaker leads can be run, without the necessity of any special precautions in regard to insulation, as they no longer carry the anode current. The third advantage (I am not giving them in order of importance) is that an output filter arrangement acts to some very considerable extent as a decoupler, thus minimising the possibility of feed-back and L.F. instability.

Fourthly, the available H.T. supply can be made better use of, inasmuch as there will be a smaller potential drop through a good choke than through the average loud-speaker.

A further advantage is that a good L.F. choke will retain a high inductance with-

WHEN YOU ARE BUYING—

(6)—A LOUD-SPEAKER UNIT

There are many excellent loud-speaker units on the market, and one of these in conjunction with a "Cone Chassis" of a suitable character will provide you with a complete loud speaker which will compare favourably with any other.

And this is a very economical method of acquiring a good loud speaker.

But get one of the well-known makes of unit.

And make sure that it will fit on the "Cone Chassis" you have in mind. You can get a "Chassis" minus a cone and still further cheapen the outfit by making your own cone. But you don't save much, and it's a fairly tricky job.

A cabinet, or better still, a large baffle board generally improves results to some considerable extent.

out core saturation effects, and in this way it adds still more to the assets side of the good reproduction account.

You will notice that I make particular reference to a *good* L.F. choke. It is not *any* L.F. choke that will perform the tasks successfully. The choke must be of low resistance and capable of carrying heavy current, while it must of course be able to retain a workmanlike inductance while so doing.

It is very much worth while paying 21s. for a Varley Constant Inductance L.F. choke. This can handle up to 100 milliamperes, retains the respectable inductance of 20 henries, and has a resistance of only 500 ohms.

It is most substantially constructed, and has unobtrusively placed ventilation holes in its casing. It is, of course, specially suitable for use in H.T. eliminators, where its current carrying capacity is adequate for any ordinary purpose. Perhaps I have rather too much stressed its use as an output filter choke, but I could not miss the opportunity for impressing you with the necessity of buying a really sound component for such a job. If you don't there may be little gained.



The Magnum Dissolver.



The Varley L.F. Choke.

The BRITISH better-service BATTERY

You'll get better service from your Ediswan H.T. battery—longer life—more even discharge—and a wonderful freedom from background noises, thus ensuring a sparkling, lifelike quality of reproduction that will be the envy of your friends.



- W.L. 204P. 66v. 9/6.
- W.L. 205P. 66v. 17/6.
- W.L. 208P. 103v. 15/6.

EDISWAN DRY BATTERIES



THE EDISON SWAN ELECTRIC CO., LTD.,
123/5, QUEEN VICTORIA STREET, LONDON, E.C.4.
Showrooms in all the Principal Towns.

B.57.

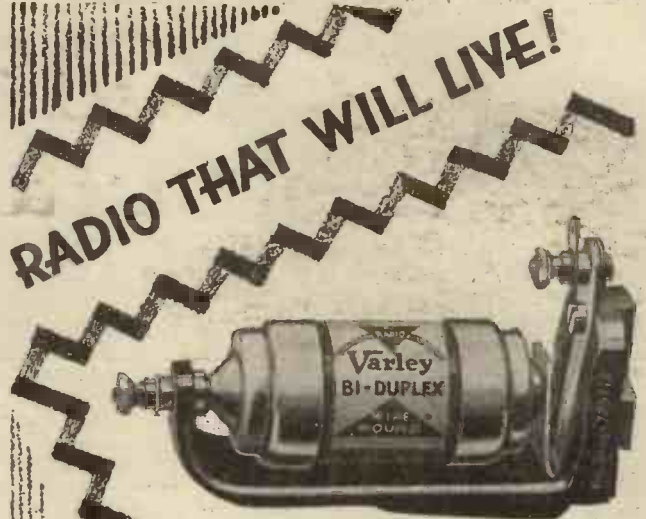

RADIO THAT WILL LIVE!

THE VARLEY BI-DUPLEX WIRE-WINDING, invented over a quarter of a century ago and used in all our ANODE RESISTANCES, TAPPED RESISTANCES and VARIABLE RESISTANCES, is almost a classical achievement in Radio. No other method of winding can compare with it for performance.

VARLEY ANODE RESISTANCES, which are accurate to within five per cent, are supplied in a universal holder—an original Varley feature enabling the resistance to be mounted either vertically or horizontally.

Write for Sections B and C of the Varley Catalogue which gives details of the 16 models in the Varley range of ANODE RESISTANCES, varying from 5,000 to 500,000 ohms.

Prices from 4/6 to 17/6

For
OLIVER PELL RADIO MANUFACTURE

Varley

Advertisement of Oliver Pell Control Ltd., Kingsway House,
103, Kingsway, London, W.C.2. Telephone: Holborn 5303



The fact remains

The chassis is supplied in two sizes—the "Minor" as illustrated costs 12/6

The larger Model the "Major"—costs 15/-

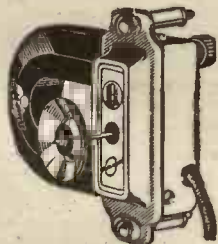

The 66K Unit costs 25/- and is guaranteed.

Whatever the tests, whatever the comparison, the fact remains that Blue Spot 66K Unit is the world's best unit.

To enable the unit to give of its best Blue Spot have designed a special chassis. In three minutes you can fit the unit to the chassis and then you possess a speaker that is unequalled for quality of reproduction.

BLUE SPOT CHASSIS

H. A. HUGHES & CO., LIMITED
204-6 Great Portland Street, London, W.1
Phone: Museum 8630 (4 lines)

Distributors for Northern England, Scotland and North Wales: H. C. RAWSON (SHEFFIELD & LONDON) LTD., 100 London Road, Sheffield (Phone: Sheffield 26006); 22, St. Mary's Parsonage, Manchester (Phone: Manchester City 3329).



Model A.C. 16
For Alternating Current

The 'ATLAS' Mains Unit with no equal near the price

10' DOWN

and it's yours.

The balance you pay in nine monthly easy instalments, or

CASH PRICE
£4-10-0

No matter what your needs are, there is an "ATLAS" Unit to suit them and every model is guaranteed for twelve months.

PRODUCED at a specially low price to come within the reach of every Radio listener, this 'ATLAS' Model A.C. 16 is without doubt the finest H.T. Battery Eliminator yet produced at anywhere near the price

All you require is Electric Light in the home, and without any alterations whatever to your Set, Model A.C. 16 will provide continuously powerful and smooth H.T. Current to your Set from the Mains at practically no cost.

It provides three-tappings, one variable giving 0/100 volts, and two Fixed, giving 120 and 150 volts respectively, and gives maximum output of 150 volts at 25 m/a. The variable tapping makes this model specially suitable for sets using Screen-Grid, Detector and Pentode Valves.

"Popular Wireless" says:—
"The Clarke's Unit is, in my opinion, quite safe—as safe—as any vacuum cleaner of good make, and it operates quite well. It does not impose a liability to motor-boal and its outputs are up to specification."

"CLARKE'S" ATLAS BATTERY ELIMINATORS

Ask your Dealer for Folder No. 44, or POST THIS COUPON TO-DAY in unsealed & stamped envelope

Messrs. H. Clarke & Co. (M/cr), Ltd. (Dept. 3), Atlas Works, Old Trafford, Manchester.

Please forward your Folder No. 44 and particulars of your easy payment scheme.

NAME.....
ADDRESS.....

Please use BLOCK LETTERS. P.W.4

The LOTUS All Mains Unit

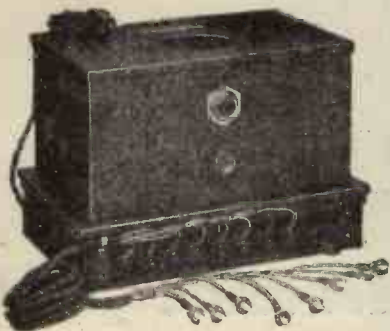

converts an
Osram
"MUSIC MAGNET"
to an
ALL-ELECTRIC SET
with minimum trouble
and maximum effect

In less than five minutes, by using the Lotus All-Mains Unit, you can turn your Music Magnet Receiver into All-Electric.

Make this change and effect a saving of nearly £4 a year, by dispensing with batteries.

Cash Price £7 : 7 : 0 (or 14/6 down and 11 similar monthly payments).

Send for full particulars.

Made in one of the most modern radio factories in Great Britain.

GARNETT, WHITELEY & Co.,
Limited,
Lotus Works, Mill Lane, Liverpool.

Carston

RADIOTORIAL QUESTIONS AND ANSWERS

(Continued from page 22.)

SHORT-WAVE AERIAL.

B. A. D. (Leicester).—"Having seen what the 'Magic' can do on the ordinary waves and with the long waves, I am very anxious to get down to the short waves, even though I suppose it means an entirely new aerial? What is the best type of aerial to use and what is the minimum height from which I can get good results?"

Contrary to your expectations, a short-wave set is NOT very particular about the kind of aerial to which it is attached. Most people would imagine (as you have done) that in short-wave work the aerial is all-important, but in practice short-wave results do not vary with different aeriels half as much as one would expect, and a short indoor aerial or a low aerial is quite capable of doing extraordinarily good long-distance work.

On the other hand, although it does not matter very much what kind of aerial you use, it *does* matter very much how you connect that aerial to the receiver. If your aerial is short or low, you may find not much difficulty, but a long aerial which is too closely coupled to the grid circuit might stop any short-wave set from oscillation.

In the "Magic" sets this is easily overcome by

WHAT DO YOU THINK ABOUT THIS?

An Ilford reader of "P.W." who used an S.G.-Det.-2 L.F. set noticed one day a small spark at the point where an H.T. + lead passed through his screening box. Hurriedly switching off he examined the lead in question and discovered its insulation was defective, so he replaced it by a new lead. But on switching on the set was "dead"—no "H.T. clicks," and, in fact, no sign of H.T. at all, though all connections now appeared O.K. Can you guess

WHAT WAS WRONG?

N.B.—There is no prize for answering this, but from time to time we shall give a radio problem (followed the next week by the answer) in the hope that readers will find them both interesting and instructive. (Look out for the answer to above next week.)

Did you guess the Salford reader's trouble? (Last week's poser.) He had reversed his Grid Bias Battery connections!

connecting the Aerial to the A1 terminal and adjusting the neutralising condenser to give the required loose aerial coupling. Even with a long aerial this arrangement will enable smooth reaction to be obtained, especially if at the same time care is taken to adjust the 400-ohm potentiometer and the H.T. + plug to the detector till best results are obtained.

NEW VALVES IN AN OLD CIRCUIT.

J. L. (Beighton, Nr. Sheffield).—"You will see from the circuit diagram enclosed that it is rather an old-fashioned arrangement, and I am wondering what would be the effect of using modern valves. They are supposed to be of higher efficiency, but before I buy them, do you think they will be quite suitable, or would a newer circuit be better?"

The new valves give greater amplification and better results than the older types which were in use when your circuit was drawn up, so that, provided the high-frequency side of the circuit remains stable, the modern valves would improve reception with it. But there would be great risk of instability occurring if efficient dull emitter valves of recent type were installed, though with such modern valves you might be able to dispense with the high-frequency stage altogether.

In this case your aerial terminal could be disconnected from its present wiring, and joined instead to the point shown on your diagram (which is returned herewith).

On the low-frequency side, your circuit is quite good, and the use of a power or super-power valve will enable a bigger grid swing to be handled, and in consequence there will be a smaller chance of distortion occurring on loud signals.

'POPULAR' TRANSFORMER

Make your new set a better set with the Brownie POPULAR Transformer. Although it costs only 9/6, its purity of amplification gives a more vivid clarity of reproduction throughout the musical scale, while its sturdy British build ensures that once it is fitted the words "transformer troubles" can be eliminated from your list of worries.

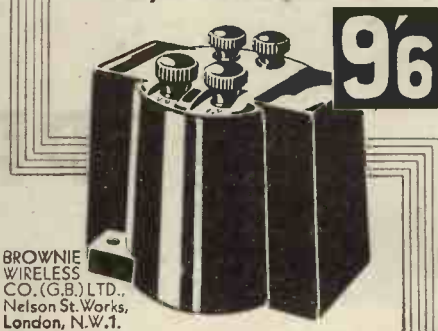

BROWNIE WIRELESS CO. (G.B.) LTD., Nelson St. Works, London, N.W.1.

BROWNIE WIRELESS

"Layerbill"

Every inch of space is used in making the famous Columbia "Layerbill" battery. The result—concentrated power from top to bottom and an electrical capacity half as great again as any other battery in the world of the same type and size. Not a single soldered connection.



Also No. 4780. 60 Volts. For multi-value sets. 20/- No. 4755. 99 Volts. specially recommended for portables. 18/-

by Columbia RADIO BATTERIES

J. R. MORRIS, Imperial House, 15, Kingsway, London, W.C.2.

Scotland: J. T. Cartwright, 3, Cadogan St., Glasgow.



The Junior "R.K." Unit has a 6in. straight-sided cone with moving coil, having an impedance of 10-15 ohms at 50/4,000 cycles. Copper damping rings are fitted to reduce the impedance at the higher frequencies.
Price £ 6/6/0.

Fidelity

— in Tone
& Performance

WITH B.T.H.

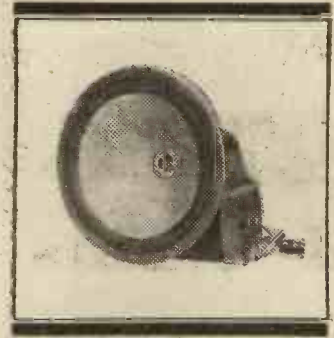

Senior "R.K." Unit with A.C. Field Excitation.—This "R.K." Unit has a 10in. corrugated cone with moving coil, having an impedance of 10-15 ohms at 50/4,000 cycles. The pot magnet is mounted in a pressed metal base which also contains a mains transformer, Mazda U.U. 60/250 rectifier valve, and smoothing condenser for the supply of field current.
Price £ 11/10/0.



REPRODUCERS



THE EDISON SWAN ELECTRIC CO., LTD.,
Radio Division,
1a, Newman Street, Oxford Street, W.1.
Showrooms in all the Principal Towns.

EDISWAN

The B.T.H. "R.K."—justly described as the world's finest reproducer—first appeared in 1926 and its advent created a new standard of reproduction.

Four years have elapsed since then, but still the "R.K." maintains its leadership.

The new range of models includes the 10in. cone "Senior," with or without built-in rectifier for use with A.C. mains supply, and the "Junior" with 6in. cone.

W.68.

A REALLY NEW SET DESIGN

is provided by the

"VI-KING" THREE

The Most Remarkable Broadcast Receiver Ever Built

This marvellous three-valve receiver, which is easy to build and simple to handle, provides your family with two different programmes *at the same time*, each programme being completely clear from the other. You can choose any two stations you require, *no matter what their wave-lengths*. The "Vi-King" Three covers all wave-lengths, and, moreover it is inexpensive to build and to operate.

ONE Aerial, ONE Earth, ONE Set of Batteries

But—

Two Separate Programmes at Once!

For Full Constructional Details See the APRIL

WIRELESS CONSTRUCTOR

Price 6d.

NOW ON SALE

Price 6d.

BUILD THE WORLD'S WONDER SET!



FOR THE LISTENER.

(Continued from page 8.)

organiser of a vaudeville hour. All that he does goes with a snap. And there is a certain continuity in a programme arranged on his lines which, I find, distinctly improves upon the separated items of the usual vaudeville hour.

It is miniature Revue against miniature Music-Hall. By the way, I didn't quite appreciate the point of the innovation according to which the items in the vaudeville programme were announced by the ringing of a bell—"One Bell," "Two Bells," and so on—instead of orally by the announcer. I'm bound to say it was a nice bell; but if you didn't happen to have the programme handy, you wouldn't learn much from it!

Czecho-Slovakia.

There were dull moments in the National Programme broadcast in honour of Czecho-Slovakia, and I thought that much of the in-between talking was much too high-falutin' and "heroic" in manner; but the description of the death of John Huss, the great Bohemian reformer, was extraordinarily well done and quite memorable.

The Diptych.

Mr. A. J. Alan's appearances at the microphone are separated from each other by too-wide intervals for my liking; but appetite is whetted by delay. His story of how a couple of Jews were "done" in the matter of a Diptych was a characteristic effort; a long, rambling, lingering sort of yarn, made interesting by the peculiar way he tells it, often amusing, and ending with a surprise "curtain" which must be the envy of story-tellers.

Mr. Alan is in a class by himself.

"That Triumphant Invalid."

How swiftly some things move! A statue to Mrs. Pankhurst; and it seems but yesterday that the suffragettes were smashing windows and slashing pictures and doing hunger-strikes in prison!

Mr. Baldwin did full justice to her memory at the unveiling; but it was left to Mr. Harold Nicolson, broadcasting the following night, to coin a phrase which will probably go down with her to posterity—he called her "that triumphant invalid."

Hoaxes.

Talking of surprises, the series of "Great Hoaxes" to be given by Mr. Douglas Jerrold, and beginning on the March 22nd, should be excellent listening stuff. Do you remember Kopenick, and Louis de Rougemont?

RADIO from INCOME

A new addition to the well-known Ready Radio Service is our "Radio-from-Income" system of monthly or weekly payments for complete kits of parts.

1930 MAGIC 3

- KIT A** 12 equal monthly payments of **12/6**
or 20/- down and 12 weekly payments of 10/3
- KIT B** 12 equal monthly payments of **15/9**
or 20/- down and 12 weekly payments of 13/3
- KIT C** 12 equal monthly payments of **18/6**
or 20/- down and 12 weekly payments of 16/-

1930 TITAN 3

- KIT A** 12 equal monthly payments of **10/3**
or 20/- down and 12 weekly payments of 8/-
- KIT B** 12 equal monthly payments of **14/6**
or 20/- down and 12 weekly payments of 12/-
- KIT C** 12 equal monthly payments of **17/3**
or 20/- down and 12 weekly payments of 14/9

REGIONAL 4

- KIT A** 12 equal monthly payments of **15/-**
or 20/- down and 12 weekly payments of 12/3
- KIT B** 12 equal monthly payments of **20/-**
or 20/- down and 12 weekly payments of 17/6
- KIT C** 12 equal monthly payments of **23/-**
or 20/- down and 12 weekly payments of 20/-

REGIONAL 2

- KIT A** 12 equal monthly payments of **8/6**
or 20/- down and 12 weekly payments of 6/6
- KIT B** 12 equal monthly payments of **10/9**
or 20/- down and 12 weekly payments of 8/6
- KIT C** 12 equal monthly payments of **12/9**
or 20/- down and 12 weekly payments of 10/6

See previous issues for the complete list of approved parts for the 1930 "Titan" Three and "Magic" Three. Lists for the "Regional" Four and the "Regional" Two can be obtained on application. All kits include Ready Radio non-soldering links.

Ready Radio

159, BOROUGH HIGH STREET, LONDON BRIDGE, LONDON, S.E.1.

Telephone: HOP 5555.

1930 MAGIC 3

- KIT A** less valves and cabinet **£6:16:0**
- KIT B** with valves less cabinet **£8: 9:6**
- KIT C** with valves and cabinet **£9:19:6**

For full list of approved components see previous issue.

1930 TITAN 3

- KIT A** less valves and cabinet **£5:11:0**
- KIT B** with valves less cabinet **£7:16:0**
- KIT C** with valves and cabinet **£9: 6:6**

For full list of approved components see previous issue.

REGIONAL FOUR

- KIT A** less valves and cabinet **£8: 2:0**
- KIT B** with valves less cabinet **£10:18:0**
- KIT C** with valves and cabinet **£12:10:0**

Full list of approved components can be had on application.

REGIONAL TWO

- KIT A** less valves and cabinet **£4:12:6**
- KIT B** with valves less cabinet **£5:15:6**
- KIT C** with valves and cabinet **£6:18:0**

Full list of approved components can be had on application.

ALL KITS APPROVED BY "POPULAR WIRELESS"

IMMEDIATE DESPATCH

Ready Radio

159, BOROUGH HIGH STREET, LONDON BRIDGE, LONDON, S.E.1

Telephone: HOP 5555.

CELESTION LOUD-SPEAKERS

MODEL C10 (OAK) MODEL C12 (OAK)

CASH £3 15 0 CASH £5 12 6
Or 10/5 down and 12 weekly payments of 5/9 Or 15/- down and 12 weekly payments of 8/9

Ready Radio

159, BOROUGH HIGH STREET, LONDON BRIDGE, LONDON, S.E.1.

Telephone: HOP 5555.

COMBINED H.T. UNIT WITH L.T. CHARGER

to fit inside any Portable

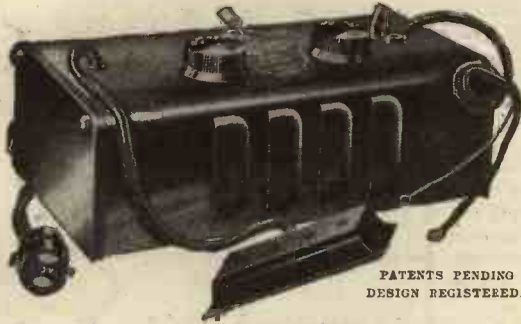

PATENTS PENDING
DESIGN REGISTERED.

For A.C. Mains Only.
100, 200/220 or 230/250 volts. 40/100 cycles.
Incorporates Westinghouse Metal Rectifier on
H.T. and L.T. side.

H.T. Output : 120 volts at
15 m.a.
H.T. Tappings : 2 variables
(one S.G.) and one Power.
L.T. Trickle Charger for
2-, 4- or 6-volt accumu-
lators.

Size, 9 in. x 5 in. x 3½ in.

PRICE :

£5:17:6

and suitable for
all popular 2·3·&4-
valve receivers

Write for **FREE ART
BOOKLET** "Radio
from the Mains."



for Radio from the Mains

REGENT RADIO SUPPLY CO. 21, Bartlett's Bldgs. Holborn Circus, London, E.C.4. Telephone Central 8745 (3 Lines)

Has Science made us happier?

By

SIR OLIVER LODGE

In to-day's THIS AND THAT Sir Oliver Lodge, Scientific adviser to "Popular Wireless," writes a challenging article. He analyses the changes brought about by scientific discovery, the application of which has not been an altogether unmixed blessing for mankind.

Out of the turmoil of the nineteenth century, however, Sir Oliver believes that we are now beginning to see signs of hope.

He concludes his article with the striking words: "Surely we may have faith that greater knowledge of the universe in which we live, keener appreciation of the part that we and other living creatures are privileged to take in it, and more thorough realisation of the Destiny of Man, will assuredly tend towards the evolution of a sane and wholesome and permanent joy."

Make sure of every issue of

This and That

BUY YOUR COPY AT ONCE 2d.

DON'T FORGET YOUR COPY OF THE MARCH MODERN WIRELESS

It contains exceptional value in the form of con-
structional articles, besides a wealth of information
on all branches of Radio.

Such eminent authorities as

SIR OLIVER LODGE, F.R.S.

SIR JOHN REITH

SIR AMBROSE FLEMING, F.R.S.

CAPT. P. P. ECKERSLEY

R. E. JEFFREY

—to name only a few—write for

MODERN WIRELESS

Become a MODERN Reader and

KEEP UP TO DATE

Price 1/-

Price 1/-

DIVIDING THE ETHER.

(Continued from page 3.)

In other words, the notes might be prolonged by the too perfect resonating qualities of the receiving circuit, as the notes of a piano wire are prolonged when the damper is raised or when no damping is applied to the wire.

Whether in practice such a too resonating circuit is often experienced may be doubted. But it is easy to imagine a circuit with next to no resistance? for instance, a circuit endowed with super-conductivity; and in that case the response would probably be very confused, since all the received groups of waves would be continued and merged into each other.

Why Damping is Necessary.

What we want is for the oscillations to cease in the receiver as soon as they cease to be stimulated. We do not want the receiver to go on vibrating on its own account, like a freely suspended pendulum, or a tuning fork; there must be a certain amount of damping.

Now damping can be achieved either directly by extra resistance, or indirectly by imperfect tuning; for if the vibrating system is not accurately in tune with the stimulant, the phase of its oscillations will not perpetually agree with the phase of the received waves; sooner or later they will be in opposition, or get out of step, and the oscillation will be wiped out.

It is argued by upholders of the wave-band theory—if it be granted that a wave-band actually exists, having a certain range of frequency on each side of the main emission—that as a receiver cannot be in perfect tune with every frequency of such a band-wave it is better for it to be broadly tuned so as to accept all; and that the defect of precise tunability, however achieved, by enabling it to receive the whole band, will compel it to give clear and articulate response. But if, as Professor Fleming argues, the wave-band is an imagination, then this kind of broad reception is put out of court; we must depend, then, more directly on resistance damping.

For if a receiving circuit is capable of prolonged and persistent tuning, we may have to put up with the confusion arising when notes are merged over one another, because one does not stop before another begins, but a number sound at once; as when the dampers of a piano are taken off the strings by depressing the loud pedal.

The Selectivity Factor.

It would seem, then, that on any hypothesis a certain amount of damping is necessary for good reception, and that it is possible to have tuning too precisely accurate. A damped circuit will not give sharp selection, such a receiver will respond to waves not precisely in tune with it.

It will respond, in fact, to a certain range of frequency equivalent to a wave-band. But then it may respond to other stations; too; hence in regulating the frequencies allowable to each of a number of sending stations, an interval of sufficient magnitude must be allowed between them, else their receivers will begin to respond to other stations as well as to the one desired; or, in other words, the wave-bands will overlap. Some compromise, or some new device, is necessary. (To be continued.)

THE STAR OF ALL UNITS

36' From your Dealer or direct.

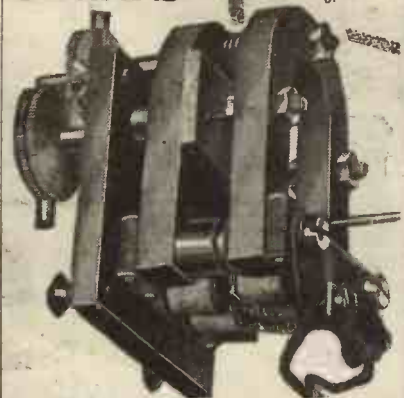

MAGNIFICENT TONAL BEAUTY.

If you are in search of all that is best in reproduction, then you need the Wates Star Unit. This wonderful unit is the heart and soul of the famous Wates Star Speaker. In conjunction with the Wates Double Cone Chassis you can build up a speaker that will give you unequalled quality and superb emission at every point of the musical scale. Exclusive principles of construction, 12 poles, double magnets, 4 coils.



WATES STAR LOUD SPEAKER UNIT



WATES DOUBLE CONE CHASSIS Pat. No. 309214 as above.

12/-

WATES STAR LOUDSPEAKER IN CABINET of Oak £24 0 0 Mahog. £24 6 0

Telephone: Temple Bar 6195.

THE SHAFESBURY RADIO CO. (Dept. P.W.), 184-188, Shaftesbury Avenue, London, W.C.2.

GRAMOPHONES. Latest Horns and parts. Catalogue free. Cash or terms. Build £12 model for £3. Instructions 3d. V. BURT, 185, High St., London, S.E.8.

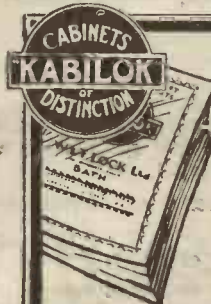

If you are requiring a cabinet for that receiver, loud-speaker or radio gramophone, send first for the KABILOK CATALOGUE which contains a splendid selection of cabinets.

Free on request.

W. & T. LOCK LTD. ST. PETER'S WORKS BATH LONDON: 11, Red Lion Sq., W.C.1



DARIO VALVES

Best Way to All Stations!

NEWEST TYPES

SCREENODION

Enormous Range
BIVOLT .15 amps.
FORVOLT .075 amps.

15'6

SUPERBLY SELECTIVE
The best Screen Grid in the world.

SUPER HF

BIVOLT .15 amps.
FORVOLT .075 amps.

5'6

Also the New Super DETECTOR (2 or 4 v.) 6'6

HYPERPOWER

BIVOLT .3 amps.
FORVOLT .15 amps.

9'6

Designed to carry enormous volume by reason of an exceptionally large grid swing.

UNIVERSAL RESISTRON

5'6

SUPER POWER

7'6

and the Super Power PENTODION 18'6

DARIO L.F. TRANSFORMER

A little marvel. Guaranteed for two years. Completely shrouded. Perfectly designed and perfectly made.

5'

3-1 or 3-1.

Write for Free Folder to:

IMPEX ELECTRICAL LTD.,
Dept. B, 538, High Rd., Leytonstone, London, E.11.

Ready Radio

1930 TITAN COIL

CHOSEN AND USED FOR 'THIS YEAR'S' TITAN SET

For Regional Reception Be Sure Your Coil is Stamped 1930 TITAN COIL

15/-

BROOKMAN'S CONDENSERS

CHOSEN & USED FOR THIS YEAR'S MAGIC SET

3/6



READY RADIO

159, BOROUGH HIGH STREET, LONDON, S.E.1.

Telephone : Hop 5555.



This is the MASTER CABINET



90/-

Finished Oak or Mahogany.

Suitable for panels 18 in. by 7 in., or 21 in. by 7 in.

The Loud Speaker Compartment will take 12 in. Cones and Batteries.

The MASTER CABINET is IDEAL

for any Set working off the Mains.

Call and see full range at our Showrooms.

CARRINGTON MANUFACTURING CO., LTD.,

NEW Showrooms : 24, Hatton Garden, Holborn, E.C.1.

Factory : Canco Works, South Croydon. Phone : Holborn 8202.

A SOUND MECHANICAL JOB



METAL RECTIFIERS

have no moving or fragile parts, and are UNAFFECTED BY SHOCK OR VIBRATION, otherwise they could not form part of the equipment of the Francis-Barnett Motor Cycle (shown here by courtesy of the Villiers Engineering Co., Ltd.). Their mechanical strength is one of the reasons for their widespread adoption for radio mains equipment.

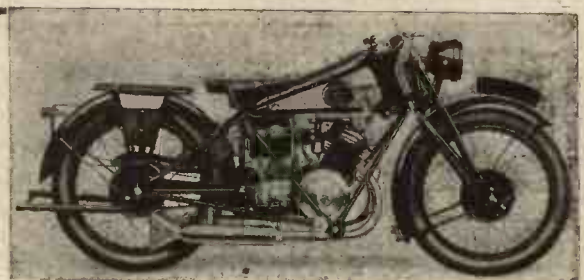

The Westinghouse Brake & Saxby Signal Co., Ltd.,
82, York Road, King's Cross, London, N.1.



ARTHUR PREHN & CO LTD



Length 2 3/4 in.
Width 3 in.

THERE IS ONLY ONE GENUINE FORMO-DENSOR

as used by designer and specified for the BROOKMANS REJECTOR, The WAVE-CHANGE REJECTOR, and The KENDALL REJECTOR.



Length 2 1/2 in.
Width 1 in.

"1930" LOG (MID-LINE) CONDENSER

In four Capacities:

- 0005
- 00035
- 00025
- 00015

4/6

each.

*Double spacing of vanes for Ultra Short-wave work.

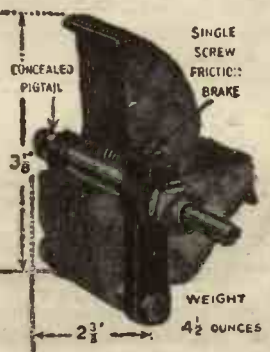

WEIGHT 4 1/2 OUNCES

THE FORMO CO., CROWN WORKS, CRICKLEWOOD LANE, N.W.2.

ENGINEERS!

Can't we get together?



WRITE FOR THIS BOOK TO-DAY IT'S FREE!

All we ask is the chance to prove that you can earn £300, £400, £500 per year or more. Other men are doing it, and you can do the same.

We have an unrivalled and world-wide organization waiting to help you whether you be novice or expert. If you wish for something more than a "bread and butter" job you owe it to yourself to investigate our Service.

Our handbook "Engineering Opportunities" has pointed the way to better things to over 20,000 of your fellows. It contains details of A.M.I.Mech.E., A.M.L.E.E., A.M.I.C.E., A.M.I.A.E., A.M.I. Structural, London Matric., C. & G., G.P.O., etc., Exams., outlines home study courses in all branches of Electrical, Mechanical, Motor and Wireless Engineering, and explains our unique guarantee of

NO PASS—NO FEES

In a Brilliant foreword Prof. A. M. Low shows clearly the chances you are missing.

"Engineering Opportunities" and our advice are quite FREE. Don't neglect this offer—give vent to that "upward urge" and send a postcard NOW, stating Branch, Post or Exam. which interests you.

British Institute of Engineering Technology, 101, Shakespeare House, 29-31, Oxford Street, W.1

EASY TERMS

We SPECIALISE in the supply of all Good Quality Radio Sets, Components and accessories on Easy Terms. We will give you efficient service. Send us your list of requirements and a quotation will be sent by return.

LONDON RADIO SUPPLY COMPANY
11, Oat Lane, Noble St., LONDON, E.C.2
NATIONAL 1975.

AGENTS WANTED to sell Wireless goods, all makes in sets, components and accessories. Cash or Easy terms. Liberal commission. **NEW AUTO SUPPLY CO.**, 241, Park Rd., ASTON, Birmingham.

The Secret of its POWERFUL GRIP.

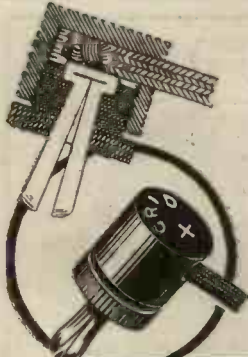

The Powerful grip of the Belling-Lee Wander Plug and its adaptability to any size battery socket are due to the long prongs made of special spring metal. 15 Engravings, side entry. Wire, rubber and braiding firmly gripped

Price 4d.

Ask your dealer, or send to us, for FREE Belling-Lee Handbook "Radio Connections."

BELLING-LEE
FOR EVERY RADIO CONNECTION

Adv. of Belling & Lee Ltd., Queensway Works, Ponders End, Middlesex.

By Dr. J. H. T. ROBERTS, F. Inst. P.

TECHNICAL NOTES.

Selectivity and Tuning.

MY remarks a week or two back on the question of de-tuning have brought me a letter from a correspondent who points out that in certain cases de-tuning may be an advantage.

You may remember that I said that de-tuning, as a means for volume control, was undesirable for two reasons—in the first place, it is liable to introduce distortion and, in the second place, if the tuning is sharp (in which case the distortion caused by de-tuning is generally more pronounced), there is a danger of running into another station and getting interference as well.

My correspondent points out that in cases where H.F. amplification is used with very sharp tuning, it is sometimes possible to get better quality when the circuit is slightly off the actual maximum tuning point. I thought of mentioning this at the time, but I did not do so, as I was afraid of complicating the simple explanation.

As a matter of fact, I have a set myself in which this effect is very marked, and I always find that the quality is much improved by very slight de-tuning. This is probably due to the fact that the upper frequencies are apt to be cut off when the set is exactly in tune, whilst with a little de-tuning, although the volume is distinctly lessened, the quality is very much clarified.

Of course, this is not intended to be used as a volume control and moreover it cannot be recommended as a reliable method for improvement of quality; it is just one of those little accidental points of which advantage may sometimes be taken.

Magnification Ratio.

The amplification or magnification produced by a high-frequency amplifying stage is dependent upon the magnification ratio of the valve itself and upon the constants of the stage in which it is used. Owing to the latter, it is unfortunately impossible to obtain an amplification anything like equal to the magnification figure given for the valve.

I often receive enquiries as to the actual amplification which is obtained, as many experimenters seem to think that a high-frequency stage does not really earn its keep.

Although the magnification actually obtained will not be equal to the magnification ratio of the valve, it will nevertheless be proportional to this quantity. It depends also upon the inductance of the H.F. transformer and upon the capacity and resistance of the H.F. coupling.

The effective resistance in the primary circuit of the H.F. transformer bears a relation to the calculated resistance which depends upon the transformer ratio, but the effective resistance is always less than the calculated resistance, and may in some cases be a comparatively small fraction of the latter. For this reason, amongst others, it is not easy to give any very simple formula for calculating the amplification obtained.

(Continued on next page.)

AMAZING RESULTS with the DOUBLE CONE

LARGE FOR LOWER FREQUENCIES **SMALL FOR HIGHER**



PRICE 11/6 with Universal Bracket.

50% IMPROVEMENT with any unit!

The richness, reality and verve of your unit will delight you when you use the wonderful WATES Universal Double Cone Chassis. Two cones for high and low frequencies give you perfect emission, non over-emphasis at any point—truly the chassis for superb results. Fits any of the following units:—BLUE SPOT, ORMOND, WATMEL, EDISWAN, BEGRA, G.E.O., LISSEN, TRITOTRON, BROWN VEE, AMPLION B.A.2, LOEWE, W. & B. SILVER CHIMES, GRAWOR 2-pole, GRAWOR 4-pole, GRASSMAN, TEFAG, SIX-SIXTY, KUKOO.

THE SHAFTESBURY RADIO CO. (Dept. P.W.) 184/188, Shaftesbury Avenue, London, W.C.2
WATES UNIVERSAL
PAT. No. 309214
DOUBLE CONE CHASSIS

EASY PAYMENTS

The first firm to supply Wireless Parts on easy payments. Five years advertiser in "Popular Wireless." Thousands of satisfied customers. Send us a list of the parts you require, and the payments that will suit your convenience and we will send you a definite quotation. Anything wireless. **H. W. HOLMES, 29, FOLEY STREET, Phone Museum 1414. Gt. Portland St., W.1**



KAY'S CABINETS
This Cabinet soundly constructed of Oak and equipped with Baseboard Burners. Full Front, Hinged Top. Polished rich Jacobean. 36" 45" high. For panels up to 18" wide Popular. Also made to accommodate any Popular Set. Greatest Range of Wireless Cabinets. Illustrated Lists Free.
H. KAY, Cabinet Manufacturer, Mount Pleasant Road, London, N.17 Phone: WALTHAMSTOW 1626.

The Picture Paper with the MOST News **SUNDAY GRAPHIC**

TECHNICAL NOTES.

(Continued from previous page.)

The effective resistance of the coupling unit and the impedance of the valve between them determine the magnification obtained, and this will be approximately equal to the effective resistance divided by the impedance of the valve or, to be more accurate, the ratio just mentioned will give the proportion of the valve magnification which represents the magnification in the primary circuit of the stage.

For instance, suppose the ratio referred to is one-fifth, then the primary circuit magnification obtained will be one-fifth of the magnification represented by the magnification factor of the valve itself. If the magnification factor should be, say, 180, the actual magnification in these circumstances will be roughly 40. Then there is the transformer ratio to be considered.

This magnification is that obtained in the primary circuit of the H.F. transformer, but we have to bear in mind that a step-up voltage will be produced by the transformer itself, with the result that the actual output voltage amplification will be the value obtained in the above way multiplied by the transformer step-up ratio.

Valve Performance.

Talking about valves, I have often been asked by readers of these notes how long a valve may be expected to last. This is one of those questions to which the proper answer can only be "It all depends."

Clearly the life of a valve will be shortened the more it is actually used, but a curious thing is that a valve will not necessarily last indefinitely even if it is used very little. In the early days of valve-making there was a large element of luck attached to [the selection of a valve, and different samples of valves by the same manufacturer would differ greatly not only in life but in performance.

With the intensive research which has been devoted to the question of filament manufacture and to evacuation processes, as well as to the equally important question of the construction and mounting of the filament and other electrodes, valves have become very much more standardised and although there is still a certain element of speculation, it is now true to say that if you purchase a valve of a high-class make you are unlikely to go very far wrong.

As to the question of the life of the valve, however, this it is impossible to say, and undoubtedly valves do vary considerably in this respect. But it is also true to say that the high-class present-day valve should give satisfactory service for a very long period. I have known valves to last, even with frequent use, for years. In fact, in one of my own sets I have five valves which have been in frequent operation for over four years, and not one of them has ever needed to be touched!

The Use of Rejectors.

Since the inauguration of the Brookmans Park transmitter, and the consequent double programme, we have heard a good deal of various dodges to enable the listener to separate the one station from the other. A large number of listeners have experienced trouble owing to the two stations being received together.

(Continued on next page.)



Peto-Scott

for KITS and SETS

"PILOT" KITS FOR "P.W." SETS

INCLUDE all specified components, necessary coils, drilled panels and requisite connecting wires, screws, etc. "A" Kits include also specified valves and cabinets, whilst "B" Kits exclude these items.

THE SPACE-SMASHER



1930 "MAGIC" THREE DE LUXE
Add 25/- to each cash price above, or 2/3 to each monthly instalment.

1930 "TITAN" THREE

KIT "A"	KIT "B"
Cash £9:12:1	Cash £6:1:7
or 12 monthly instalments of 17/7	or 12 monthly instalments of 11/2

FINISHED INSTRUMENT, aerial tested and guaranteed. Valves and Royalty included. £11:17:6
 Or first payment of 37/6 and 11 monthly instalments of 20/-

1930 "MAGIC" THREE

KIT "A"	KIT "B"
Cash £9:11:2	Cash £6:12:8
or 12 monthly instalments of 17/6	or 12 monthly instalments of 12/2

FINISHED INSTRUMENT aerial tested and guaranteed. Valves and Royalty included. £11:17:6
 Or first payment of 37/6 and 11 monthly instalments of 20/-



1930 "MAGIC" THREE DE LUXE
Add 25/- to each cash price above, or 2/3 to each monthly instalment.

1930 "TITAN" THREE

KIT "A"	KIT "B"
Cash £9:12:1	Cash £6:1:7
or 12 monthly instalments of 17/7	or 12 monthly instalments of 11/2

FINISHED INSTRUMENT, aerial tested and guaranteed. Valves and Royalty included. £11:17:6
 Or first payment of 37/6 and 11 monthly instalments of 20/-

Any Parts supplied separately. Detailed lists on application.

PROPRIETARY KITS,

THE "BROOKMANS" REJECTOR UNIT. Exactly to "P.W." specification; assembled, wired, and tested, 12/6.

A WAVE-CHANGE "BROOKMANS" REJECTOR. Exactly to "P.W." specification; assembled, wired, and tested. Coils included, 18/6.

EXIDE 120-VOLT H.T. ACCUMULATOR, Type W.J., 2,500 m/a. In Crates. Cash £3 15s., or 12 monthly payments of 6/11. Type W.H., 120 volts, 5,000 m/a. In Crates. Cash, £4 13s., or 12 monthly payments of 8/6.

OSRAM MUSIC MAGNET. Cash £9, or 12 monthly payments of 16/6. Valves included.

ACCESSORIES, ETC.

REGENTONE W.I.B. S.G. (A.C. Mains). For S.G. and Pentode Sets. Cash £4 19s. 6d., or 12 monthly payments of 9/2.

CELESTION C.12 LOUD-SPEAKER, in oak. Cash £5 12s. 6d., or send only 10/4, balance in 11 monthly payments of 10/4; in Mahogany, Cash £5 17s. 6d., or 12 monthly payments of 10/9.

ULTRA AIR CHROME. DOUBLE LINEN DIAPHRAGM SPEAKERS in oak or mahogany table model cabinets. Type K chassis, £4 4s. 0d. or 12 monthly instalments of 7/6.

Mail coupon in unsealed envelope under 1d. stamp.

PETO-SCOTT CO., LTD.,

Free Demonstrations and advice by Qualified Engineers at our Shops:—

77, CITY ROAD, LONDON, E.C.1. Telephone: Clerkenwell 9408-7-8.

62, HIGH HOLBORN, LONDON, W.C.1. Telephone: Chancery 8266.

4, Manchester Street, Liverpool. Telephone: Central 2134.

33, Whitelaw Road, Chorlton-cum-Hardy, Manchester. Telephone: Chorlton-cum-Hardy 2028.

VISIT STAND No. 441, WIRELESS SECTION, IDEAL HOME EXHIBITION

WET H.T. BATTERIES

Solve all H.T. Troubles.

SELF-CHARGING, SILENT, ECONOMICAL

JARS (waxed), 2" X 1 1/2" sq., 1/3 doz. ZINGS, new type 10d. doz. Sacs 1/2 doz. Sample doz. (18 volts), complete with bands and electrolyte, 4/1, post 9d. Sample unit, 6d. Illus. booklet free. Bargain list free.

AMPLIFIERS, 30/- 3-VALVE SET, £5.

P. TAYLOR, 57, Studley Road, STOOKWELL, LONDON.

"KLEER-KUT" COILS

PUT FORM INTO PERFORMANCE

25. 30. 35. 1/-, 40. 50. 1/2, 60. 75. 1/3, 100. 125. 150. 1/6, 175. 1/9, 200. 2/-, 250. 2/3, 300. 2/6.

Centre Tapped 6d. "X" Coils 1/- extra.

L. BRUCE, 99, King Henry's Rd., LONDON, N.W.3
 6 years coil maker to the Wireless Trade.

Phone: Primrose 1303. Trade supplied.

ELECTRADIX RADIOS

New Edition of Special Bargains in Radio and Electrical Apparatus at sacrifice prices cut to clear. Send addressed envelope for THE LIST THAT SAVES POUNDS.

ELECTRADIX HOUSE,
 218, Upper Thames Street, London, E.C.4
 City 0191

ALL APPLICATIONS for Advertising Space in "POPULAR WIRELESS" must be made to the Sole Advertising Agents, JOHN H. LILE, LTD., 4, LUDGATE CIRCUS, LONDON, E.C.4.

STANDARD

SAC LITHIUM



H.T. POWER

RE-CHARGES ITSELF OVERNIGHT

BETTER, PURER, SAVES POUNDS

Cut out the expense of costly dry batteries. Solve the problem once and for all—install the wonderful STANDARD Permanent Web H.T. Battery. Many thousands of listeners all over the country have paid testimony to this economical, reliable, and trouble-free H.T. It lasts literally for years.

PROGRAMME AFTER PROGRAMME

is heard with a purity and clarity that is delightful. The product of a British firm, scientifically constructed and designed, the acme of simplicity in use, easily recharged at home with the wonderful cartridge refills (cases are on record of over 12 months' use before recharging was necessary, and, above all this, you get better reception because of the smoothness of current which no other source of H.T. can equal. Thousands have done it. Why not you? Write to-day.

LET THE AMAZING FREE BOOK

GREAT OFFER! CONVINCE YOU

5/- H.2. 10,000 M.A. capacity, 48 No. 3 cells, 22 volts, in 2 trays with lid. Cash or 10/- down and 5 monthly payments of 8/2.

Standard Batteries are sold in neat Unibloc containers on our famous cash or "no deposit" terms, by all good dealers, Halford's and Curry's, or direct.

10/- H.4. Over 10,000 M.A. capacity, 72 cells, 108 volts, in 3 trays with lid. Cash £3 4s. 0d or 10/- down and 5 monthly instalments of 11/8.

Write for free book.

The STANDARD BATTERY CO. (Dept. P.W.)
184/188, Shaftesbury Avenue, London, W.C.2

ZAMPA H.T. ELIMINATOR KIT, comprising Rectifying Unit (incorporating transformer, condensers, Westinghouse H.T.5), necessary condensers, choke, terminals, baseboard, etc. Output 120 volts at 20 m/a. Complete, 45/-. 7 days' approval against cash. Other Zampa Kits and Transformers on request. **Mic Wireless Co., Market St., Wellingborough.**

EUREKA

The L.F. Transformer that gives Really First Class Reproduction at a low cost.

Baby Grand 1st or 2nd stage ..	8s. 6d.
Concert Grand 1st stage ..	10s. 6d.
Concert Grand 2nd stage ..	9s. 6d.
Smoothing Chokes 20h.40m/a. ..	10s. 6d.

All Post Paid by return. Money refunded if not satisfied in 7 days.
Sole Manufacturers: **L. PERSON & SON**
(Dept. 2), 63, Shaftesbury Street, London, N.1

REPAIRS

Any make of L.F. Transformer, Loudspeaker or Headphones repaired and despatched within 48 HOURS—TWELVE MONTHS' GUARANTEE with each repair. 4/- post free.

Terms to Trade.

TRANSFORMER REPAIR CO.,
"Repairs" Dept.,
214, High Street, Colliers Wood, London, S.W.19.

TECHNICAL NOTES.

(Continued from previous page.)

If the set is not already selective, the usual addition, in order to cut out one of the stations whilst receiving the other, consists of some form of wave-trap, and as many references have been made during the past few weeks to wave-traps, it may perhaps be useful if I say a word or two on this subject.

Of course, "P.W." readers know all there is to be known about rejectors and realise that the "P.W." "Brookmans" Rejector is the most effective interference eliminator there is.

But to many people I have found that there appears to be some mystery surrounding the operation of an acceptor wave-trap.

TECHNICAL TWISTERS

No. 2—THE EARTH CAN YOU FILL IN THE MISSING LETTERS ?

- (a) The soil around the earth-plate should always be kept
 - (b) Don't twist the and wires together, as used thus they form a small
 - (c) If you use a water-pipe don't twist the round it, but use a proper
 - (d) Unlike the aerial, the earth wire need not be
- It should be kept as as possible, as a earth wire sometimes means flat tuning and hand-capacity.

(Look out for the missing words next week)

The missing words last week (In order) were: High; End; Middle; Joints; Earth.

The acceptor type of wave-trap is so called because it "accepts" the waves from the unwanted station and disposes of them in its own way, which may be likened to throwing unwanted papers into the waste-paper basket. This type of wave-trap is introduced across the aerial and earth terminals of the set, and its function is to provide an alternative path for the incoming signals.

When the wave-trap is properly adjusted for waves of a particular wave-length, it is much easier for those impulses to pass through the wave-trap than through the receiver, and consequently the trap, so to speak, short-circuits the receiver, so far as these waves are concerned, and runs them to earth by an easy path, thereby preventing them from passing through the receiver.

"PURATONE" RADIO VALVES

NEW TYPES NEW PRICES

H.F. Det. L.F. & R.C.	5/-	Super-Power	8/-
Power	7/-	Screen-Grid	10/-

2, 4 or 6 volts.

Ask your dealer for particulars or write to the Manufacturers:

RUBON LTD., 189, New Kings Rd., London, S.W.6

SERVICE MODEL STEEL MASTS

NO HOLES TO DIG

THE JOY OF "SURPLUS POWER"

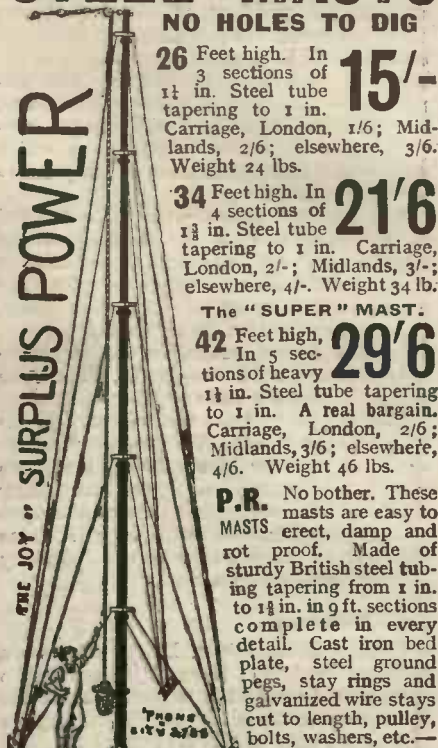

15/-

21'6

29'6

26 Feet high. In 3 sections of 1 1/2 in. Steel tube tapering to 1 in. Carriage, London, 1/6; Midlands, 2/6; elsewhere, 3/6. Weight 24 lbs.

34 Feet high. In 4 sections of 1 1/2 in. Steel tube tapering to 1 in. Carriage, London, 2/-; Midlands, 3/-; elsewhere, 4/-. Weight 34 lb.

The "SUPER" MAST.

42 Feet high, In 5 sections of heavy 1 1/2 in. Steel tube tapering to 1 in. A real bargain. Carriage, London, 2/6; Midlands, 3/6; elsewhere, 4/6. Weight 46 lbs.

P.R. No bother. These masts are easy to erect, damp and rot proof. Made of sturdy British steel tubing tapering from 1 in. to 1 1/2 in. in 9 ft. sections complete in every detail. Cast iron bed plate, steel ground pegs, stay rings and galvanized wire stays cut to length, pulley, bolts, washers, etc.—No Further Outlay.

P.R. PRODUCTS (26), P.R. HOUSE, NEWGATE STREET, LONDON, E.C.4.
(Opposite G.P.O. Tube Station.) Telephone: CITY 3788.

HEADPHONES REPAIRED 4/-

Transformers 5/-. Loudspeakers 4/-. All repairs re-magnetised free. Tested, guaranteed and ready for delivery in 24 hours.

Discount for Trade. Clerkenswell 9069.

E. MASON, 44, East Rd., City Rd., N.1.

NEW PUBLIC ADDRESS and Broadcasting MICROPHONE

The Ideal Instrument for addressing an Audience through Loudspeaker (via Valve Amplifier or L.F. stages of Wireless Set), and for relaying Speech and Musical Entertainment to any distance.

Powerful Loudspeaker Reproduction with perfect Fidelity.

Pedestal Type.—Highly Sensitive Microphone, guaranteed entirely free from distortion or microphonic noises, absolutely silent background; far superior to ordinary Microphone Transmitters; for use with Valve Amplifier or Valve Set (through leads of Gramophone Pick-up if desired) at Open-air Meetings, in Cinema, Theatre, or Concert Hall. Operates from 2 Volt tapping of L.F. Accumulator, through Microphone Transformer. Current consumption one-tenth Ampere. Provided with Detachable Sound Collector and a 9ft. silk connecting cord, and fixed by rubber-cord suspension in nickel-plated stand 11in. high; for mounting on Speaker's Platform, in Pulpit, on top of Camera Stand, or for suspension from ceiling. As illustration. **25/-**

MICROPHONE WITHOUT STAND, 16/-

The above Microphones are rendered Directional by attaching the Sound Collector.

Special Microphone Transformer for the above 3/-. FULL PARTICULARS and DIAGRAM OF CONNECTIONS FREE.

FREDK. ADOLPH, Actual Maker,
27, Fitzroy Street, London, W.1. MUSEUM 8329.

RELIABILITY WIRELESS GUIDE No 296

A Complete List of all that is best in Radio at Keenest Prices.

Trade Enquiries Invited

J. H. TAYLOR & CO
4 Radio House, MACAULAY STREET, HUDDERSFIELD. Phone 341.

PLEASE MENTION "POPULAR WIRELESS" WHEN REPLYING TO ADVERTISEMENTS.

TWO NEW BOOKS for the HOME CONSTRUCTOR

Sets for Every Purpose and Every Pocket



Contains complete constructional details for the following inexpensive and easy-to-build receivers. All have passed the most exacting tests before being published.

A ONE-VALVER

Of novel construction, using a home-made cabinet, and plug-in coils. Covers ordinary and long waves.

A TWO-VALVE ALL-WAVE-LENGTH SET (Det. and L.F.)

Capable of loud-speaker results under good conditions on both short and long waves. Uses standard parts and plug-in coils. Easy to operate.

THREE-VALVE RADIOGRAM RECEIVER

Circuit is Det. and 2 L.F. Very selective and gives high quality reproduction either of radio or of gramophone records.

FOUR-VALVE "POUND-PER-STAGE" SET

Costing about £4. Uses home-made coils. Circuit employed being H.F., Det., and 2 L.F. Highly selective.

All these sets are for MODERN CONDITIONS, and will enable constructors to take full advantage of the dual programmes under the Regional Scheme.

A SUPER-SELECTIVE ONE-VALVE SET

For ordinary and long waves. Easy wave-change and very simple operation. Includes the famous "Brookmans Rejector" to cut out interference.

A TWO-VALVER (Det. and L.F.)

For all waves including short. Special wave-change switch enables wave-range to be altered without changing coils.

An UP-TO-DATE THREE-VALVER

Using S.G., Det. and Pentode. Highly selective; employs plug-in coils and has volume control and switch for the reproduction of radio or of gramophone records.

An ALL-FROM-THE-MAINS "FOUR"

A powerful set for A.C. mains, which comprises H.F., Det., and 2 L.F. stages with the special new A.C. Valves. Covers long and ordinary waves, and is very easy to operate.



6^{d.} each from all Newsagents and Booksellers everywhere, or 7d. post free (Home or Abroad), from "Best Way," 291A, Oxford Street, London, W.1.

ROME-

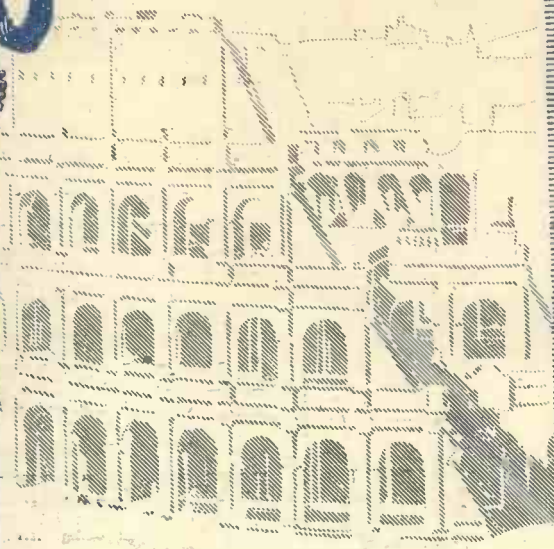

**CLEARER
& SWEETER
THAN EVER**
with this new
**HIGH
POWER
BATTERY**

Another advance in H.T. Battery production for High Power sets. Research has enabled us to produce the **HIGH POWER SIXTY** which will give 40% greater service on high emission receiving sets than our famous Popular Power batteries at a small increase in price.



In 60 volt units only
Tapped at 0, 15, 27, 39,
51, 60
HIGH POWER SIXTY - 15/6
Popular Power Sixty . . . 13/6

Write for list of sizes suitable for every receiving set, THE EVER READY CO. (G.B.), LTD., 27, Hercules Place, London, N.7.

Printed and published every Thursday by the Proprietors, The Amalgamated Press, Ltd., The Fleetway House, Farringdon Street, London, E.C.4. Advertisement Offices: Messrs. John H. Lile, Ltd., Ludgate Circus, London, E.C.4 (Telephone: City 7201). Registered as a newspaper for transmission by Canadian Magazine Post. Subscription Rates: Inland and Abroad, 17/4 per annum; 8/8 for six months. Abroad (except Canada), 19/6 per annum; 9/9 for six months. Sole Agents for South Africa: Central News Agency, Ltd. Sole Agents for Australia and New Zealand: Messrs. Gordon and Gotch, Ltd. Saturday, March 22nd, 1930. S.S.

FINDING THOSE FOREIGNERS (See Page 49)

Popular Wireless

Every Thursday
PRICE
3d.

p. 408. Vol. XVII.

INCORPORATING "WIRELESS"

March 29th, 1930

THIS YEAR'S

"MAGIC DE-LUXE"

See Inside



ALSO IN THIS ISSUE

NOTES FROM THE NORTH
REVERSING THE L.T.

By G. V. Dowding, Assoc. I.E.E.

RECEPTION PROBLEMS

By Sir Oliver Lodge, F.R.S.

RADIO AND THE TALKIES

By Capt. Eckersley, M.I.E.E.

WE TEST A TELEVISOR

It's *NOT* a "fishing yarn" . . .

Jan. 23, 1930.
 Your advertisements in Popular Wireless led me to better radio. I recently built up the Magic Three and put in coils that I thought were reasonable in price and quality, with the result that all I could get was Brookmans Park covering the whole of my tuning dial. After reading your advert. once or twice I purchased two of your coils and to my amazement I can now do the following:
 (1) Separate the Alternative Programmes
 (2) Dispense with my Brookmans Rejector.
 (3) Tune in five Continental Stations with both the Regional Stations going.
 This I think to some wireless people would seem a fishing yarn, but is quite true inasmuch that my other coils have found their way into the dust bin.
 Thanking you for such excellent coils.

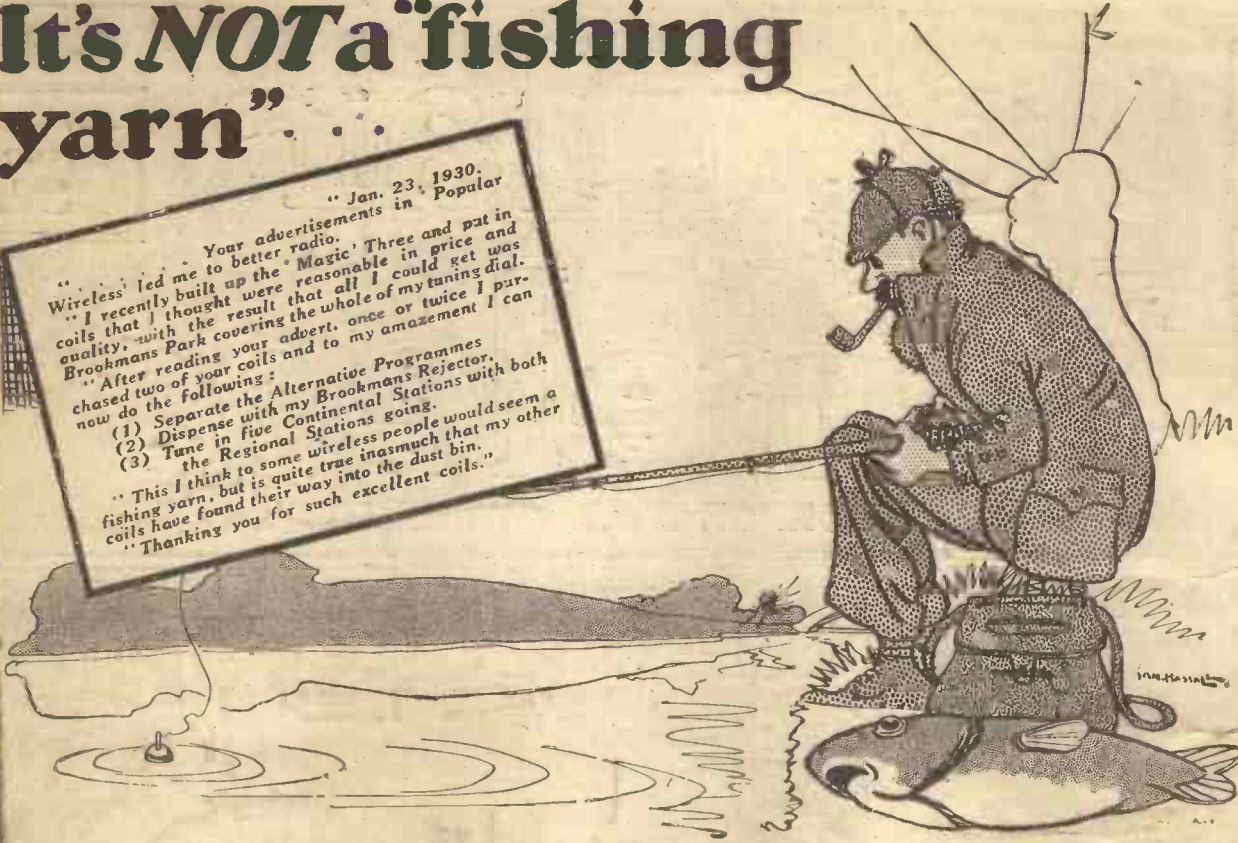

LEWCOS
Centre Tapped
COIL

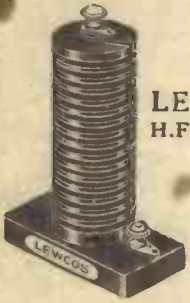

LEWCOS
H.F. CHOKE



LEWCOS
"X" COIL

It's a fact that **LEWCOS** COILS

because of their extraordinary powers of selectivity do enable you to cut out local stations and tune in to the most difficult and distant stations across the world.

Lewcos Coils have reached this stage of perfection through a backing of continuous scientific research and the superior materials and workmanship used in their manufacture.

Descriptive leaflets of the Lewcos Coils which are specified for various receivers, and illustrated above, will be sent on request.

THE LEWCOS MAGIC THREE!
 ("X", CENTRE TAPPED AND H.F. CHOKE) AS ILLUS. ABOVE ARE SPECIFIED FOR THE "MAGIC THREE DE LUXE" DESCRIBED IN THIS ISSUE.

THE LONDON ELECTRIC WIRE COMPANY AND SMITHS LIMITED
 Church Road, Leyton, London, E.10



Trade Counter:
 7, PLAYHOUSE YARD,
 GOLDEN LANE,
 E.C.1

'WARE ICEBERGS!



In mid-Atlantic. Wireless operator picks up urgent message from ice-patrol: "Icebergs on Liverpool-New York route!" At once, liner alters course. Disaster avoided, hundreds of lives saved from deadly peril . . . by warning received through Marconi Valves. Most British passenger-carrying ships use Marconi Valves. So do all Imperial Airways machines . . . whole Norwegian whaling fleet . . . all British broadcasting stations . . . Empiradio Beam Wireless . . . Metropolitan Police. For their dependability. For their wide range. For their long life. ● In cases like these, when unflinching reliability is essential, men insist on Marconi Valves.

FIT MARCONI VALVES TO YOUR RADIO SET



Give you clearer tone, greater volume, wider range. Cost not a penny more. Fit any set.

THE FIRST AND GREATEST NAME IN WIRELESS

For all technical information on valves, write to The MARCONIPHONE COMPANY LIMITED, 210-212 Tottenham Court Road, London, W.1



Model A.C. 16
For Alternating Current

The 'ATLAS' Mains Unit with no equal near the price

10'-
DOWN

and it's yours.

The balance you pay in nine monthly easy instalments, or

CASH PRICE
£4-10-0

No matter what your needs are, there is an "ATLAS" Unit to suit them and every model is guaranteed for twelve months.

PRODUCED at a specially low price to come within the reach of every Radio listener, this 'ATLAS' Model-A.C. 16 is without doubt the finest H.T. Battery Eliminator yet produced at anywhere near the price.

All you require is Electric Light in the home, and without any alteration whatever to your set, Model A.C. 16 will provide continuously powerful and smooth H.T. Current to your Set from the Mains at practically no cost.

It provides three tapings, one variable giving 0/100 volts, and two fixed, giving 120 and 150 volts respectively, and gives maximum output of 150 volts at 25 m/A. The variable tapping makes this model specially suitable for sets using Screen-Grid, Detector and Pentode Valves.

"Popular Wireless" says:—

"The Clarke's Unit is, in my opinion, quite safe—as safe as any vacuum cleaner of good make, and it operates quite well. It does not impose a liability to motor-boat and its outputs are up to specification."

"CLARKE'S" 'ATLAS' BATTERY ELIMINATORS

Ask your Dealer for Folder No. 44, or POST THIS COUPON TO-DAY

Messrs. H. Clarke & Co. (Mer), Ltd. (Dept. 3), Atlas Works, Old Trafford, Manchester.

Please forward your Folder No. 44 and particulars of your easy payment scheme.

NAME.....

ADDRESS.....

in unsealed & stamped envelope

Please use BLOCK LETTERS. P.W.5

TWICE THE AMPLIFICATION OF ANY OTHER SCREEN-GRID VALVE



The enormous amplification factor of the Mazda A.C./S.G. renders it possible to design a receiver giving an extremely high H.F. gain. This means that as a large proportion of the total amplification of the set is done at high frequency less magnification is needed at low frequency and consequently there is no need to have an intermediate stage between the detector and output valve.

The Amazing

MAZDA VALVES

The A.C./S.G. valve has two screened grids. This duplex screened grid is responsible for the remarkably low inter-electrode capacity of 0.0045 c.m. The enormous amplification of the Mazda A.C./S.G. valve is due to the combination of three features:—

- (1) High amplification factor of 1200.
- (2) High mutual conductance of 1.5 milliamps per volt.
- (3) Low inter - electrode capacity.

**MAZDA AC/SG
PRICE 25/-**



THE EDISON SWAN ELECTRIC CO., LTD.,
Radio Division,
1a, Newman Street, Oxford Street, W.1.
Branches in all Principal Towns.

EDISWAN

Popular Wireless



Scientific Adviser:
 Sir OLIVER LODGE, F.R.S.
 Chief Radio Consultant:
 CAPT. P. P. ECKERSLEY, M.I.E.E.
 Editor: NORMAN EDWARDS.
 Technical Editor: G. V. DOWDING, Assoc. I.E.E.
 Assistant Technical Editors: K. D. ROGERS,
 P. R. BIRD, G. P. KENDALL, B.Sc.,
 A. JOHNSON RANDALL.



LADY DISDAIN
 INEXPERT ADVICE
 MORE NIGHTINGALE-ISM
 SULPHATING L.T.

MISSING MUSICIANS
 CURRENT CRITICISM
 LEARNING MORSE
 THE LATEST BOGEY

RADIO NOTES & NEWS

This "Daddy" Business.

THE sweet faith with which youngsters believe their fathers to be the founts or repositories of all knowledge is beautiful—but apt to wear one down. "Daddy, do paraminigan prefer eau-de-Cologne or oranges?" My boy has been coughing of late, and last night I paused at his door to listen to his breathing just before I retired. He heard me, and fired: "I say, dad, do you think that wireless disturbs fishes?"

Dear Lady Disdain.

THE other one, a girl, is almost as amusing. Some time ago I fitted up a simple set for the kids to use, and this came in for a little attention at first, but has fallen into neglect. I asked Miss Fifteen the other day why she did not use it nowadays, to which she made answer, in her most chilling and superior tone, "Well, as a matter of fact, I don't like the men you have on it!"

Personal.

THE President of the Institute of Radio Engineers for 1930 is Dr. Lee De Forest, the inventor of the three-electrode valve. Col. A. G. Lee, of the British Post Office, has been elected Vice-President. Sir E. Rutherford, Cavendish Professor of Experimental Physics at Cambridge University, has been awarded the Faraday Medal by the Institution of Electrical Engineers. Madame Ernestine Schumann-Heink, the famous singer, has been appointed "Operatic Counsel" to the National Broadcasting Co. (of U.S.A.).

Inexpert Advice.

A DISGUSTED "P.W." reader sends me a cutting from a Sunday paper (our special source of joy) containing the rotten advice that it is cheaper and better to use a dry battery for H.T. than the "mains." My friend received it from a customer who bimbled into his shop in a state of mental unrest, not knowing whether to buy a battery or a rectifier.

The "expert," who seems to ignore the fact that some mains are D.C., puts the life of a rectifying valve at 1,000 hours. Well, with ordinary luck, I think that figure

might be multiplied by 5. My rectifier has long passed its second birthday.

The H.T. Supply.

I AM not going into calculations. It will no doubt appeal to the commonsense of practical men if I say that the world agrees that "mains" working is in principle quite the most satisfactory method, on balance, and in the long run more economical than dry battery working. Even the best dry battery is a wasting asset, whether in use or not. On the contrary, a mains-driven set has always the full "punch" behind it. Excellent results are obtainable from dry batteries, but John Citizen will always hanker after a mains-driven set.

IN A TELEVISION STUDIO.



The artiste sitting in the armchair is being "Televised," whilst on her left is a microphone to pick up the piano music at the same time.

Radio Society Note.

I AM pleased to hear that the Ebbw Vale and District Radio Society is growing healthily and becoming very active. It held its first social on March 20th and all the items of the programme were provided by the members. Meetings are held on Thursdays at 7.30 p.m. and further members are cordially desired. The Hon. Sec. is now Mr. W. J. Evans, 8, Glanffrwd Terrace, Ebbw Vale, Mon.

More Nightingale-ism.

READERS refuse to drop this subject. Some wax as lyrical as poets, some present theories full of beauty—and nothing else. Others say dogmatically that

it is a converted cuckoo clock. W. S. D. says that with a "Magic" Three and an indoor aerial he solved Turin's mystery and confirms that the bird is worked mechanically. J. A. W. points out that according to "World Radio" the noise is made by a gramophone. We are still not in sight of the solution. Why won't the station director relieve our anxiety?

New Type of Aerial.

IT is planned to erect for K D K A's new transmitter at Saxonbury, Penn., a type of aerial designed to prevent "blanketing" of the surrounding territory and yet to send out strong signals to a long distance. It is said that by reversing the action of this aerial the reverse conditions can be secured, strong signals being received locally and interference at a distance lessened. In form this antenna will show a circle of eight vertical aeriels.

What Causes "Sulphating"?

A READER who I think must be connected with the "millingtary" draws my attention to a statement in "Military Engineering," Vol. 2. "Electrical Engineering," p. 317, to the effect that too low a charging rate will cause "sulphating" in an accumulator.

As our friend points out, "trickle" chargers apparently have not reached the War Office yet. I have always understood that too rapid a discharge, or electrolyte too weak, or a long period in a state of "discharge" are the causes of sulphating, but

if some British major-general can instruct me I am open to learn.

Puzzle Without Prizes.

REYNOLDS' Radio Riter is enthusiastic about those cage aeriels which one sees occasionally stuck up on a roof, but one remark of his baffles me. He says, "The hint may be taken by those who do not possess outdoor aeriels, never very slightly and now often necessary." I do not doubt that this enshrines some pearl of wisdom, but up to now whenever I read it I feel as if I need a tonic—not very slightly, either.

(Continued on next page.)

NOTES AND NEWS.

(Continued from previous page.)

New North African Station.

I AM informed by Philips Radio that the Colonial Section of the French Posts and Telegraph Department have decided to erect a broadcasting repeater station at Oran. The new station will be of 6 kilowatts power and will be ready in the summer.

Primarily it is designed to relay the Algiers programmes, but it will on occasion give a "show" of its own. Another fish in the pond for "Magic" users.

The Missing Musicians.

HERE is an amusing little yarn, with a moral. A man who had made up a set with too little regard to the suitability of the bits and pieces was horrified to hear an orchestra playing with five members absent, to wit, the flautist, the clarionetist, the 'cellist, the "counter bass," and the drummer. He thought that either he or the station director had gone crazy.

Eventually a radio detective found the remains of the drummer in the loudspeaker, and the clarionetist in the power valve. The 'cellist was found wandering between two valves, one having kicked him out and the other having refused to take him in. The "counter bass" was found hanged in a transformer winding, and the flautist had been mistaken for a violinist.

Philanthropy in Alaska.

UP north where they used to scabble in the dirt for the dirt called gold they now "prospect" the ether instead. Being "off the map," they have to rely to a great extent on the short-wave stations, and needless to say, P.C.J. is a hot favourite.

One man who is particularly successful with the Dutchman offers to put him on the telephone line to anybody who calls him on Thursdays or Fridays between 8 and 9 o'clock, and he is inundated with calls!

Current Radio Criticism.

CERTAINLY I must secure a post as a programme critic; it looks like the easiest thing in the world. Here is a bit I have picked from an article published on March 8th. "Most speakers have come over very distinctly lately." And another. "There have been one or two momentary breakdowns in transmissions. What is the reason for this?" Why not ring up the Chief Engineer and see if he will tell you? But I say! What penetrating "criticism"!

Learning Morse.

PROBABLY for the sake of the fun which is to be derived from listening to transmissions from exploring expeditions, aircraft, ships, etc., there appears to be a slight but distinct reaction in favour of Morse. I am glad to see it, and will do what is possible to encourage our readers to seek proficiency in reading code. The gramophone records which were prepared by the Marconi Company for the training of wireless operators are six in number, cost three shillings each, and are exceedingly well and interestingly done.

Not Convincing.

A GENTLEMAN has written to the "Morning Post" stating that he has proved water-divining with a rod or twig to be wireless. Be it far from me to cast any unwelcome reflection upon a

correspondent of that most respectable newspaper. Yet, somehow, his words do not convince me that he knows anything whatever about wireless. I call that a mild expression. When I read the letter I experience a shiver. But perhaps I am too sensitive. Try it yourself.

SHORT WAVES.

MODERN IMPROVEMENT.

A few years ago we used to hiss political orators; nowadays we merely turn on to Radio Paris or somewhere like that.—"Sunday Pictorial."

B-ACH B-ACK C-HAT.

Why, indeed, if the B.B.C. decrees 'Take it or leave it' can't these three million listeners say: 'Very well, thank you' instead of getting their Bach up and cantating up and down the house in paroxysms of rage every Sunday afternoon?—
"Sunday Chronicle."

"Scores of claims are being received by the London County Council for the refund of money paid twice over for dog licences. Owners of wireless sets have also been known to pay twice," we read in the "Sunday Express."

We doubt it.

Education by Wireless.—And the switch is less painful.—"Daily Mirror."

"Sir John Reith makes a wise remark when he says: 'Continuous listening wearies,' we read in the "East Anglian Daily Times." And how!

ANSWER WANTED.

"Since people complain so bitterly that no broadcast programme is any good, why do they write letters to the papers complaining of oscillation? Their sets should surely not be working!"—"Vox."

THE BROADCASTER TO HIS LOVE.

My mind becomes a vacuum tube
Where'er I think of you;
My heart gets quite ecstatic,
My headband goes askew.
Your eyes that flash like unquenched sparks,
Your hair like copper wire,
Break down my high resistance
Like a transformed amplifier.
I really think we're both in tune,
And ere through life we roam,
Suppose you book up now with me
And share my humble ohm!
—"West Australian Wireless News."

This Week's Puzzle.

"THE spring, or ore, is the transmitting station, the twig as aerial, and the points where the twig emerges from the little finger Right (positive) and Left (negative); the tuning discs as it were. Call the distance between right and left the wave-length, each thing having life or movement: spring, ore, grass, etc., has its wave-length, I found. The heart is as a magnet with a crossbar, and with a douser, when right and left are in tune, the crossbar is right and left, transferred as a line between, and the twig turns to the douser's heart as a magnet beyond the crossbar."

I think that this must be a bit of a poem which has escaped from the Home Page!

Switzerland Goes Regional.

ONE of the most difficult countries in the world for broadcasting, Switzerland, plans to set up a "regional" system, comprising three high-power stations, the largest (60 k.w.) being destined for Munster, Berne, Zurich, and Basle. Crystal-users in N.W. of Lucerne. The programmes for Munster will be provided by studios at Basle and Berne will have $\frac{1}{2}$ kilowatt stations all to themselves. No doubt Basle will welcome a full-time station as a change from the aerodrome transmitter which has hitherto served it.

A Record and a Medal.

FOR what is claimed to be a record for South Africa, Mr. V. Cohen, of Muizenberg, has been presented with a gold medal by McMichael's South African agents. Mr. Cohen has logged twenty-three stations on the loud speaker with a "Screened Dimic Three." That list may not seem wonderful to a European, but it should be remembered that there are only three broadcasting stations in South Africa, all the rest of the "bag" being some thousands of miles away.

Beware of Non-Imitations.

WE warn readers who may contemplate buying a "shop" set to be very careful not to be deceived by inferior sets bearing names of those described in "P.W." Whilst some traders may make up genuine "P.W." products, others merely borrow the names and possibly the circuits, and use components of doubtful value. "Regular Reader" has been good enough to draw our attention to an instance in which a manufacturer has played fast and loose with our "Magic Three. *Caveat emptor.* (Swank!)

The Latest Bogey.

FROM Canada comes the theory that the action of radio waves upon the human body is poisonous. This old bogey in a new dress has arisen from an inquiry into a number of deaths under anaesthetics, and the report declares that they were due in some instances to causes other than anaesthesia. Under the action of ether waves the ether fumes are supposed to become conductive. The patient is then supposed to become charged from the electric lamp and other nearby electrical gear, and then, on being touched, he is "discharged to earth and electrolysed" as a result. I think it a pity that the Toronto Academy of Medicine and Sir G. Filner did not take expert advice before publishing this farrago.

Alleged New Invention.

A NOTTINGHAM paper reports the invention by Mr. J. Woolley, of a method by which a more rapid electrical transmission of photographs than is at present possible can be accomplished.

"P.W." "MAGIC" AND "TITAN" SETS.

A LETTER TO THE EDITOR.

Dear Sir,—A large number of appreciative letters from our customers has been received regarding the "Titan" and "Magic" sets, and your technical staff is to be congratulated on producing receivers which, when compared with the average modern radio sets, are so far in advance with regard to results, simplicity in design, and resultant low cost.

I have no doubts myself that the great interest shown in set building during the past twelve months is very largely attributable to the fine circuits published in your journal.

Yours faithfully,

For Ready Radio,

Ivor W. E. Hustler,

(Managing Director.)

It is stated that the photographic plate does not require development, and that it need not even be removed from the camera. At the receiving end, the picture, says the report, appears as a print and not as a negative. All this sounds highly attractive to journalists, and I hope that we shall hear more of it.

ARIEL.

DIVIDING THE ETHER

BY SIR OLIVER LODGE F.R.S.

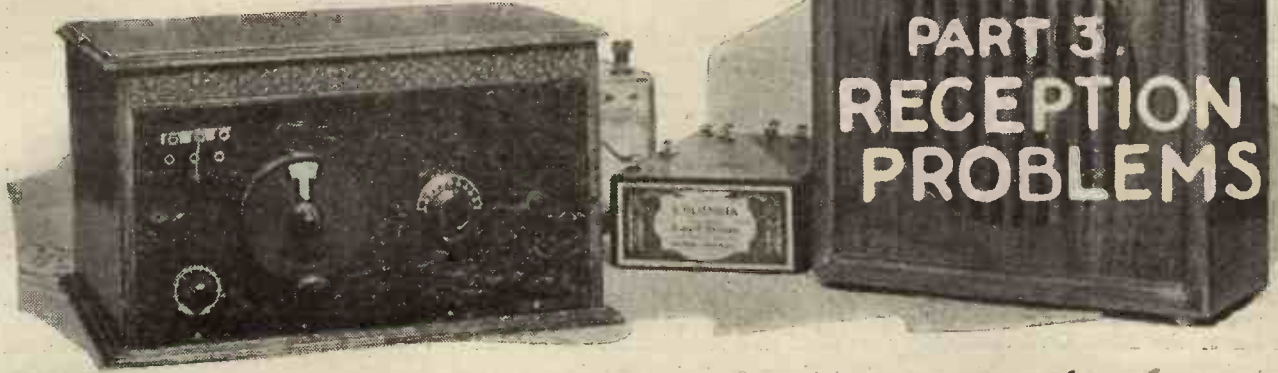

EVERYONE must agree that if good reception could be obtained with a narrow wave-band, it would tend towards the "uncrowding" of the ether, and enable more stations to be accommodated with an allotted frequency within the prescribed total range.

In order to devise an apparatus which shall satisfy an ideal condition, it is generally wise to consider what the ideal condition involves, and what theoretical requirements have to be satisfied, if it were in any way possible to satisfy them; and to do this before beginning to invent anything for the purpose. In other words, it is well to aim at an ideal, even before we see any chance of reaching it.

Alm at an Ideal.

The problem might be expressed by saying that we want to receive a single wave of one unique frequency, to which the receiver might be attuned, and be able to follow all the fluctuations of amplitude in that single wave, without allowing the larger amplitudes, or what in sound would correspond with the louder noises, to prolong themselves so as to encroach upon and overpower the smaller amplitudes, or in other words, the intervening times of comparative silence.

The problem must have been met and solved in the early days of cable telegraphy. If a battery contact were applied to one end of a cable, the cable would gradually become charged; and the signal would arrive at the distant end in a long-drawn-out condition, like any other leak from a condenser.

Cut-off on Cables.

the signal consisted only of dots, produced by momentary contacts, this defect would be minimised; but a dash would be liable to prolong itself unduly, and smear over or obliterate a subsequent dot. Indeed, the dots would tend to draw themselves out into dashes; and signalling would perforce be slow.

Lord Kelvin, therefore, devised the method of curbed signalling. Directly a pulse was sent into a cable, it was sharply checked or terminated by an opposite pulse sent after it, so as to cut it down quickly. No contact was allowed to last an appreciable time; each effect was curbed by a still more momentary contact of the other pole of the battery.

The problem of "uncrowding the ether" is one to which our Scientific Adviser has devoted a considerable amount of time and research.

At the present day, with high-power stations springing up all over Europe, the problem is becoming more and more acute, and this short series of articles is of special interest.

In that way, even without taking self-induction into account (which, as Heaviside showed some years afterwards, would have a tendency to sharpen the signals, so that increased self-induction would increase the rapidity of signalling), the curb method did what was wanted, up to a point, and was an improvement.

To take another analogy of the same

kind, though a less practical one. If anyone tried to signal by means of a rise of temperature at the far end of a copper rod, say a yard long, by employing a quickly responding thermometer at the distant or receiving end and a flame at the near or sending end, the heat-pulse given by the flame to the rod would travel by diffusion, and would take a long time in being sufficiently obliterated for the next signal to be given.

Sharpening Signalling.

If, however, after a momentary application of the flame, some ice or a freezing mixture were applied to the same end of the rod, the tail of the hot pulse would be cut off, and the signalling would be sharpened.

In Kelvin's day this was thought to be an exact analogy to cable signalling; for the same kind of analysis which Fourier

(Continued on page 63.)

THE CAUSE OF ALL THE TROUBLE!

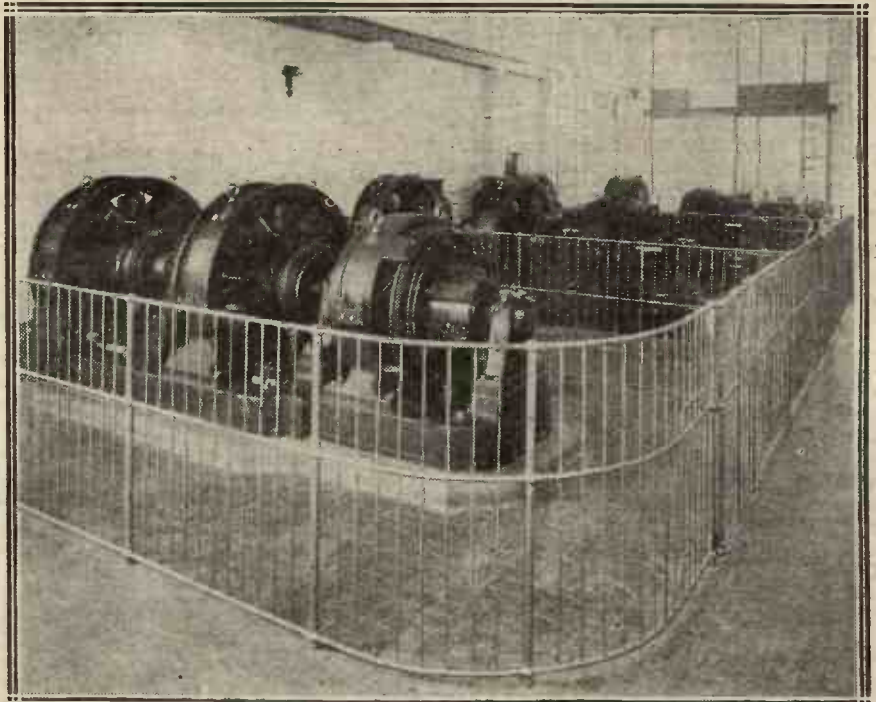

The giant generators at Brookmans Park, the highpower of which has caused a great deal of discussion on the subject of ether crowding.

WE TEST A TELEVISOR.

1. General Results and a Verdict.

By THE EDITOR.

THE Televisor sent to us for test by the Baird Televisor Co. has now been in daily use in our laboratory for over a fortnight, and we feel that we are now in a position to offer a report to our readers.

In this article we propose briefly to explain, non-technically, our experiences with the Televisor, and in next week's issue to publish a more detailed technical account.

To begin with, when the Televisor was delivered it was found necessary specially to construct (and in fairness to the Baird Co.) a powerful amplifier as per the specification of the Baird Co.'s technical engineers.

Very Small Images.

We rigidly adhered to this specification and constructed the amplifier in due course. However, that story will be technically dealt with next week. When the amplifier was complete, tested and found O.K., we started to tune in, every morning at 11 a.m., the Baird Co.'s experimental television transmissions.

As our readers know, by glancing at photographs of Baird Televisors which we have reproduced from time to time, the orifice in the Televisor, into which one peers in order to see the television images, is small—approx. 8 in. by 6 in., and the circular lens installed therein is about 6 in. in diameter.

The actual size of the televised images vary from 2 in. to 4 in. in length, and 1 in. to 2 in. in width.

These figures are, of course, approximate; but in any case the reader will observe that the pictures are very small, and that a "crowded" scene—such as a quartette singing, could not be received.

As for the actual images received, we say without hesitation that they show an improvement in detail and general clarity on the results we observed about a year ago; we feel that, from the experimenter's point of view, they are distinctly interesting, and that keen amateurs will find a good deal of fascinating interest in experimental work carried out with a Televisor.

Not Worth While.

But as entertainment value we do not consider the Televisor offers anything worth while. The pictures are too small, they flicker very conspicuously, they are not easy to tune in, and, when tuned in, great difficulty is experienced in retaining the image, or images, for more than a minute or so.

Synchronising is the difficulty here, and very careful, almost micrometer adjustment, of the motor regulator is repeatedly necessary.

We feel in complete agreement with Captain E. H. Robinson (G-5 Y M) who wrote about television as follows in a recent issue of the "Observer":

"At present it is in about the same relative state as was wireless telegraphy thirty years ago, four years after Marconi had taken out his first patent. It is quite probable that neither Mr. Baird nor any of the many scientists who are investigating the problems on the Continent and in the United States will

discover their complete solution. Possibly a real discovery is required, akin to Fleming's historic work on the thermionic valve, or Lee de Forest's invention of the grid or control electrode."

Captain Robinson, referring to results obtained when tuning-in the experimental television transmissions, also wrote as follows:

"At present results are crude, but very interesting from the laboratory view-point. Much has been done; but very much remains to do. What all investigators are seeking is some means of freeing television from its studio head and shoulders limitations, and making it available for use anywhere, in the theatre, the concert hall, the football field. When this is done we may expect to see television apparatus as simple and nearly as cheap as broadcast receivers."

The above quotation exactly expresses our own point of view.

We are more than ever convinced, after our experiences with the Baird Televisor,

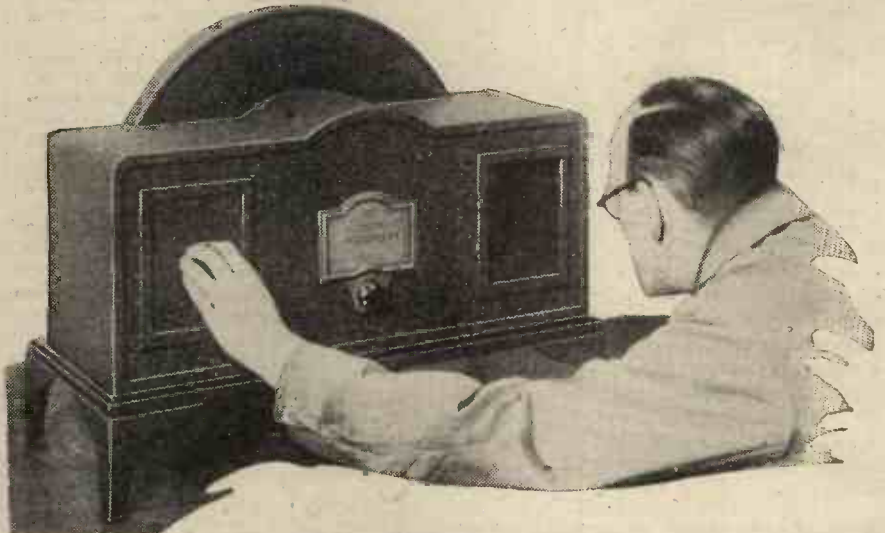

The picture appears at the back of the aperture at the right, and it is difficult for more than one or two people clearly to view it. The synchronisation is adjustable by a knob on the left, and this knob requires very careful adjustment indeed. The centre knob is for "framing" the pictures.

that television is not yet in a state of development which will ensure for it a wide public popularity. That many amateurs will, for technical reasons, be deeply interested, we do not doubt, and for that reason we are glad the B.B.C. have granted the Baird Co. special facilities, and that Televisors can be obtained, in limited quantities, by the general experimenter.

But as regards the ordinary listener, we are convinced that television in its present state will make little or no appeal. Once again we find ourselves absolutely in agreement with Captain Robinson when he writes (*inter alia*):

"... despite these very real successes, those who have the best interests of the science and art of television at heart cannot but view with concern the proposal of the Baird Company to put upon the market a large number of television receivers. In its present form the apparatus cannot appeal to the general public. Apart altogether from the extremely limited programme matter available, the apparatus requires, to work it, additional receiving apparatus of the power-handling capabilities usually associated with what are known as "public address systems." An output valve capable of delivering at least ten times the power of the type commonly used in domestic wireless receivers is required, and really good results can only, at present, be had when this

power is multiplied by two or four. Television is just out of the egg. Its mouth is open wide for sustenance, both financial and mental; but the way to help it to grow its wings is emphatically not by attempting to sell it, all unfledged, to the man in the street."

With the above candid and straightforward opinion we wish to associate ourselves, while at the same time emphasising our opinion that *bona fide* radio experimenters should avail themselves at the earliest opportunity of acquiring a complete television outfit. The field for research is obviously very wide, and the more keen minds that are busy with the problems associated with television, the sooner a really practical public service system is likely to be discovered.

Tiring To The Eyes.

The general public will, we think, not be interested in television as it is to-day, but the experimenter will. The man in the street has heard so much about the "possibilities" of television, the "not distant date," etc., when the boat-race and other events will be seen by wireless, that he is not likely to be satisfied with a flickering head and shoulders portrait of an un-

known man or woman, the whole in flickering orange (from the Neon lamp) and more often than not disappearing suddenly in a whirling mass, which a very tiring effect on the eyes.

No, we cannot see television in the home catching on yet. In fact, in concluding this article, we again find that we cannot do better than quote once more from Captain Robinson's article:

"It is easy to moralise on the unwisdom of allowing dividend-seeking finance to be associated with the early days of scientific research. It is easy to say that children and fools should not be shown unfinished work. In this case the thing has been done. The ultimate triumph and general availability of television will not be affected by the present public apathy; but it is a pity that Mr. Baird's work could not have been backed up by some organisation less concerned with immediate returns. We should have expected less at the present, and might have had more."

And with that we will leave the subject until next week, when technical details concerning the Televisor, and the experiments we have been conducting, will be described by Mr. G. P. Kendall, of our Research Department.



RADIO and the TALKIES

BY CAPT. P. PECKERSLEY M.I.E.E.

RUMOUR keeps telling me that I have gone in for the talkies. Rumour proves her proverbs and is a lying jade. Some of my friends tell me I ought to go in for talkies. Perhaps they are right, but I still have ambitions and I still want to try and design a wireless receiver which is "ever so different."

But while I have not gone in for talkies I frequently go to talkies. And by choosing with discretion I am more and more impressed with the possibilities of the medium. I am driven sometimes to doubt what I used to say that the cinema should be put under unified control. Perhaps broadcasting under unified control has done so much to raise our taste that only the good cinemas survive. Perhaps they don't, perhaps there are a lot of bad cinemas and lots of good broadcasting. I have been very lucky about cinemas!

Eyes and Ears.

When it comes to quality of reproduction, however, I am simply amazed how bad it is on talkies, and how little it matters. The cinema auditorium darkens, the pedal notes of the organ cease to agitate the diaphragm and there starts a thin, harsh blasting noise which makes one's technical soul shudder; one gropes for one's hat, but just in time there is a lion barking with a noise like an asthmatic cat, and as one's eyes take up attention one's ears seem less offended.

And then, if the production is good, one remains looking and looking and incidentally listening. The last plop of the kiss goes home to one's very marrow and one is there still—holding one's hat!

Is YOUR Loud Speaker Perfect?

It is really quite curious how the poor sound is helped by the photography, and how if one were to shut one's eyes one would be forced to open them again; it's a commentary on what I always maintain, that quality need not be real to please. It's got to have a greater resemblance to reality, of course, when it alone exists to capture the imagination, but it's pleasing to confirm one's theory by the above illustration.

There is another particular point relevant to the argument. The man who listens always to one loud speaker is moderately content. How often have I not heard the

"The talkies are succeeding in making an art out of it far quicker than broadcasting," says our Radio-Consultant-in-Chief, and in this article he gives his reasons in his usual racy, readable manner.

words: "My loud speaker is perfect. I have listened to all my friends' loud speakers and they are not a patch on mine!"

As all the friends say this, too, one is led to the conclusion that everyone becomes accustomed to a particular interpretation, and from habit this becomes the one they most like, and it is therefore obvious that



A photograph about to be transmitted by radio from the London General Post Office. Photos are regularly sent to America and other distant places by this means.

they reject at the first shock a newer, even if from the technician's point of view a better reproduction. Thus I well remember presenting a new loud speaker to a "very important person" who I felt he must have the best.

He surprised me by rejecting his present and preferring the old. Nor was this his habit of reaction; it was true. So I persuaded him to listen for a week to the new while the old was stored for future reference. And then after a week we put on the old. The very important person was surprised he could ever have tolerated the old.

The most unenviable task is to be a technician constantly keeping an open mind. It's like a wine taster who in the end can never know the sweet delight of becoming pleasantly maudlin on a half-bottle of med(i)oc(re). I hardly ever get pleasure out of loud speakers.

It has to be a programme very much to my taste to make me, as a keen technician forget the means and appreciate the reality. Perhaps that is why people tell me I am hyper-critical; perhaps that is why. On the other hand, perhaps not.

Micky Mouse!

Realism!—the bugbear of art. I went the other day to a talkie acted and produced with such restraint and lack of realism that my heart pumped tears into my eyes. The quality was unreal, the photography gave one views one could never see, and it was the most moving thing; its reality was its power to produce emotion in the audience. Micky Mouse! Anyone seen Micky Mouse? Forswear wireless for one night and visit that supreme creation of unreality and laugh till your sides ache. Micky Mouse, with an absurd face plucking music out of fishing nets while a Walrus sings a passionate *basco profundo*. And the quality has to be unreal, a tinkly, twankly little jingle, while everything dances.

"Art is Not Realism."

One day we shall move on again in wireless. Art is not realism and we must not try and force the technical side so that it ever seduces the artist into the impossibly difficult task of trying to give us the real thing.

The talkies are succeeding in making an art out of a science far quicker than the broadcasting people. It took the cinema years to stop photographing stage plays; it's taking broadcasting too long to stop broadcasting actors and actresses used to the adventitious aids of scenery.

The effects room will begin to mean something when they blow a whistle to signify a forest and forget that an explosion in a munitions factory sounds in our loud speakers as loud as "I have just played."

We, as technicians, must find out in terms of acoustics what gives the synthesis of reality, then tell the artistes and then get on with the job, all of us!

LATEST BROADCASTING NEWS.

**THE B.B.C.
CHAIRMANSHIP STAKES
HONOURING MR. C. P.
SCOTT—DR. DEVON'S PRO-
GRAMME—ITEMS TO NOTE—
THE ARCHBISHOP OF YORK.**

AT least one leading bookmaker has added the B.B.C. Chairmanship Stakes to his quotations on the other two approaching classics, the Grand National and the Derby. We shall give exclusive news of the state of the market from week to week. Here are the latest figures:

- 7-1.—Sir John Reith.
- 10-1.—Lord Gainford.
- 100-6.—Mrs. Philip Snowden.
- 20-1.—Major C. R. Attlee, M.P.
- 20-1.—Lord Cecil.
- 20-1.—Lord Lee.
- 20-1.—Lord Passfield.
- 20-1.—Lord Eustace Percy.
- 33-1.—Sir Arthur Stanley.
- 33-1.—Captain Ian Fraser.
- 100-1.—Others.

Honouring Mr. C. P. Scott.

Both National and Northern Regional listeners are to hear an interesting outside broadcast on Tuesday, April 8th, when the ceremony of conferring the Freedom of the City of Manchester on Mr. C. P. Scott, late editor and now Governing Director of the "Manchester Guardian," will be relayed from the Manchester Town Hall.

Mr. Scott, who is rightly regarded as the "G.O.M." of journalism, took over the editorship of the "Manchester Guardian" as far back as 1872, and under his direction the newspaper achieved a world-wide reputation for honesty of principle.

It is just a little unfortunate perhaps that the ceremony of conferring this greatest honour that Manchester can bestow should have to take place between 12.15 and 1 p.m., when only a small section of those who would like to listen to such an interesting broadcast will be able to do so.

Dr. Devon's Programme.

The next "My Programme" in the series arranged by Scottish Stations, which is to be broadcast on Friday evening, April 11th, will be devised by Dr. James Devon, and will consist mainly of songs and readings.

Dr. Devon points out that the programme is not constructed to please himself, but is built to his idea of what will please "ordinary folk sitting at ordinary firesides from John O'Groats to the Mull of Galloway."

The songs, he says, will probably be better known to the older generation than they are to-day, and the readings are of a type which used to be popular with Scots folk many years ago. The songs will be sung by Robert Burnett, with pianoforte accompaniment by David Stephen.

Items to Note.

Another Old Folks' Programme is to be broadcast to Midland listeners on Wednesday, April 9th, and in order to meet many requests from older listeners, who cannot sit up as late as the younger members of

their families, this programme has been timed to begin at 8.35 p.m.

General Higgins is to conduct the Salvation Army service which is to be relayed from the Queen's Hall on Sunday, March 30th, for broadcast as part of the National programme.

Violet Loraine, the famous revue star, is making another appearance before the microphone on Tuesday, April 1st, to take part in a revue which is to be performed in the London studio. The production is by Eric Little, with music by William Walker and George Posford, the latter also being

LOWERING BROOKMANS' AERIAL.



This close-up was taken at Brookmans Park, and shows the foot of one of the London masts, with the winding gear for raising and lowering the aerial.

composer of the music "For the World We Listen in."

John Masefield's play, "Philip the King," a story of Spain and the Armada, is to be broadcast as part of the London Regional programme on Tuesday, April 1st. It will be repeated on the following evening for listeners to the National transmitter.

The third of the series of old time vaudeville programmes, arranged by Philip Ridgeway, will be heard by London listeners on Friday, April 4th. It will consist mainly of music-hall ditties so popular during the days of the war.

Mrs. St. Leo Strachey, whose husband was for many years editor of "The Spectator," will broadcast her reminiscences for listeners to the National programme on Tuesday, April 1st.

The Archbishop of York.

An interesting broadcast for Northern and London Regional listeners on Wednesday, April 9th, will be the Presidential address of the Archbishop of York to the Annual Meeting of the Classical Association, which is to be relayed from Hull's new University College.

Dr. Temple, who is no stranger to the microphone, is well-known as a brilliant speaker, and there is no doubt that all who can listen at 5.30 on that day will hear a scholarly discourse on the subject of "The Excellencies of Latin and Greek."

By the way, the Northern Region is particularly proud of the fact that the Classical Association is holding its meeting in that area for the second time within a few years, the last occasion being in October, 1926, when a speech by Lord Hewart of Bury, another distinguished Northern personality, was broadcast from Manchester University.

FOR THE LISTENER.

A Specially Contributed Criticism of Current Broadcasting Events.
By "PHILEMON."

(Who is deputising for Mr. Cecil Lewis while the latter is in America.)

Alternatives.

THE time to test the value of the alternative programmes is when you are being bored stiff by some particular item. When you are enjoying yourself, alternatives don't matter. I happened to be not very much interested in the "Looking Backward" talk by Sir Hugh Bell the other evening; so I looked up alternatives, and found that I could get the Amington Band on the Midland Regional or a Musical Comedy programme on the London Regional. That was good.

A day or two later, finding myself disinclined towards "The Youth of Industrialism," I got a "Pot-Pourri" on the London Regional. That wasn't bad either. But on the same night a friend of mine who hates music found that he had to choose between a Hallé Concert, a Military Band, and the Gershon Parkington Quintet! So he was angry when he telephoned me!

"Old Cloes."

I did not bother about alternatives when Jack Kelly was unburdening his soul. A

very jovial lad, this rag-and-bone man! "Well, people!" he began, "lend me your ears, as Carnera says!" and he rambled along in undiluted Cockney.

I felt that he would have given his barrow to be allowed to tell us what he said to the lady who tried to sell him a bundle of hay out of her rabbit-hutch, but the wires wouldn't stand it without fusing!

"Keep your ears and your eyes open, and let your money be the last thing you part with!" he said. If they are all like Jack Kelly, I feel I should like these "trotters!" Their entertainment value is pretty high.

Diversions.

My own high hopes were not quite realised in the first instalment of "Diversions." The Scotch Pipers were kept on too long. The round of Brookmans Park was not so interesting as I had expected it to be; due probably to my complete ignorance of engineering plant.

I could visualise little, and the noises made by power rooms conveyed nothing

(Continued on page 62.)



MRS PHILIP SNOWDEN

By A Special Correspondent

SUPERLATIVE. but not excessive, tributes have been paid by many people to the personality, character, and ability of Mrs. Philip Snowden, whose outstanding place in history was assured long before she became a Governor of the B.B.C.

But what has not yet been told is the story of Mrs. Snowden's work and ideals in broadcasting, and that it may be realised how admirably Mrs. Snowden is equipped to tackle broadcasting problems it is necessary only to glance at her previous career.

Mrs. Snowden is the daughter of Alderman Richard Annakin, J.P., now Mayor of Harrogate. Educated at Leeds and Edge Hill College, Liverpool, Miss Annakin entered the teaching profession. In 1905 she married the Rt. Hon. Philip Snowden, M.P., Chancellor of the Exchequer, who at the time of the marriage was Chairman of the Independent Labour Party.

World-wide Fame.

Natural fluency of expression, a resonant and pleasant voice, charm of manner, and exceptional beauty, were endowments soon turned to account by great spiritual and intellectual gifts, all animated by passionate devotion to public service.

Mrs. Snowden's earliest recorded public speech was made at Pembroke Chapel, Liverpool, when, still in her teens, she pleaded with characteristic courage against the South African War, then actually in progress. Since that time, Mrs. Snowden's advocacy of measures of social reform and betterment has been heard nearly all over the world, and without the aid of broadcasting.

She has spoken in every town in Great Britain, in 40 out of the 48 states of the American Union, from coast to coast in Canada, throughout New Zealand, and in cities as far apart as Stockholm and Tifis, Moscow and Jerusalem.

There is no space here to give even a list of the causes that have had good reason to be grateful to Mrs. Snowden. For over a decade she addressed two

Mrs. Philip Snowden is a Governor of the B.B.C., and her name has been mentioned in regard to the Chairmanship of the Corporation vacated by the Earl of Clarendon. Her appointment to the position would be a popular one, for Mrs. Snowden has shown that she possesses every bit of the necessary energy, tact, and ability to make a big success of such an onerous task as the direction of the B.B.C. board.

hundred meetings a year on behalf of the Constitutionalist Suffrage movement, being for many years Vice-President of the National Union of Women's Suffrage

Societies. As a member of the National Executive of the Labour Party, Mrs. Snowden was a delegate to several international Congresses and Conferences.

In 1920 she visited Russia, then in the early stages of the Bolshevik

regime. A confirmed adherent to, and advocate of, all practical progressive movements, Mrs. Snowden was, nevertheless, discriminating and independent in judgment. Some of her colleagues in the 1920 visit to Russia accepted the Bolshevik claims at their face value; but Mrs. Snowden's predisposition to be friendly did not blind her to realities.

Her subsequent book, "Through Bolshevik Russia," created a great sensation. With the same courage that impelled her to oppose the South African War, Mrs. Snowden revealed both sides of the picture in Russia; she did not deny all good in Bolshevism, but she declined to hide its merciless methods and shortcomings.

Extremely Energetic.

In 1921 Mrs. Snowden represented the Second International in an investigation of the Social-Democratic Government of the Republic of Georgia; in 1923 she investigated Zionism in Palestine; and in the following year she toured Canada as the guest of the Overseas Education League.

Mrs. Snowden's public offices are nearly as numerous as her good works. Here are just a few taken at random: an early member of the Save the Children Fund; an original member of the Executive Committee of the Royal Institute of International Affairs, continuously holding office up to the present; a member of the 1924 Royal Commission on the Food Supply; a member of the Executive Committee of the Y.W.C.A. Forward Movement. She is also deeply interested in the success of the London Club for City Women Workers; a member of the National Council of the Playing Fields Association,



A RECENT PORTRAIT OF MRS. SNOWDEN.

(Continued on next page.)

MRS. PHILLIP SNOWDEN.

(Continued from previous page.)

a member of the Executive Committee of the Victoria League, a Justice of the Peace, and so on.

In 1926, Mrs. Snowden was invited by the then Prime Minister (Mr. Stanley Baldwin) to become a Governor of the British Broadcasting Corporation on the creation of that body by Royal Charter.

Seeing in the B.B.C. yet another opportunity of effective public service, Mrs. Snowden accepted on the understanding that thenceforth, for as long as she remained a Governor, broadcasting would be her predominant interest.

Mrs. Snowden Joins the B.B.C.

It was not only that Mrs. Snowden would not regard any appointment as a sinecure, or accept £700 a year for no positive return in effort—this indeed was a factor—but the real consideration was that broadcasting appealed tremendously to her imagination in its potentiality for good. And despite the fact that Mrs. Snowden has returned to No. 11 Downing Street, and as the zealous helpmate of the Chancellor has had an important share in the success of his policy at the Hague Conferences and elsewhere, her main concern remains broadcasting; and this in the face of obstruction and opposition that would have daunted any less courageous public servant.

Mrs. Snowden came to the B.B.C. full of admiration for the organisation which had created such a wonderful instrument of public service. She looked forward to the thrill and gratification of working alongside the pioneers with her colleagues of the new Board, in what was still the early stage of a great adventure, for the entertainment, well-being, and peace of humanity.

Humanising Broadcasting.

But her offer of whole-hearted and joyous co-operation was not welcomed at Savoy Hill. Not only was there no apparent desire to take advantage of Mrs. Snowden's great gifts of exposition and of counsel; there was something more like definite active opposition towards her whenever she made an effort to earn her money and "get on" with the job!

What is Mrs. Snowden's policy? Does it contain any elements which merit the opposition of Savoy Hill? Mrs. Snowden

stands for the steady scientific development of all parts of the broadcasting service. She believes that it has reached the stage where increasingly specialised and scientific effort is called forth. She also believes in keeping broadcasting intensely human, and to this end she wants to bring about human conditions of employment for the staff of the B.B.C.

Taking Up the Cudgels.

Always a friend of the under-dog, Mrs. Snowden has taken up the cudgels for the hitherto despised announcers, and generally for the juniors in the service of the B.B.C. Moreover, she has called for open diplomacy in broadcasting politics; she would take the public fully into her confidence and make the B.B.C. the genuinely co-operative effort which it should be, and which it is meant to be. Not that she would lower standards in any direction; on the contrary, by consistent and intelligent exposition, Mrs. Snowden would make the educational and ethical value of the B.B.C. vastly greater than it is at present.

Full support for executive authority; full co-operation between Governors and staff,

A COTTON 'SPEAKER.



Mr. Samuels with two of his patent loud speakers (one is in an unfinished condition). They are made of compressed cotton, and Mr. Samuels applies the same principle of manufacture to the production of synthetic wood.

as between both and the public; steady movement forward; these are the high-lights of the policy which Mrs. Snowden has expounded in broadcasting for the past three years.

For some time Mrs. Snowden was isolated on the new Board, her colleagues preferring to try the old methods. But it was not long before they realised that she was right, and that the exercise of trusteeship for the public meant more than acquiescence in methods and policy of which they all disapproved in some important particulars.

And so it appears that the Board began to move, with the result that internal conditions at the B.B.C. began at once to improve, notably in the status and pay of announcers. But every improvement, however small, was gained only at the cost of great effort and much patience. Nevertheless progress has been made in the past year.

And now there is to be a change in the Chairmanship, Lord Clarendon going to the Union of South Africa. Many names have been canvassed for the succession; many members of the House of Lords have been mentioned. And it is significant that in organs of opinion widely divided on most public issues, there is unanimity that Mrs. Snowden's appointment to the Chairmanship would be felicitous from the standpoint of broadcasting.

But it is objected that a Labour Prime Minister might find it embarrassing, if not impossible, to nominate the wife of his Chancellor of the Exchequer for a post such as this. But is this timidity really justified? Are the interests of broadcasting to be jeopardised for hesitation which may not survive examination?

Consider the political implications. It is true that Mrs. Snowden is the wife of a Labour Chancellor of the Exchequer, and, if she had been appointed to the B.B.C. by a Labour Prime Minister, then obviously the objection would be serious.

The New Chairman.

But she was chosen by and received her invitation from Mr. Baldwin as Prime Minister of a Conservative Government. Moreover, Mrs. Snowden enjoys the personal friendship and esteem of leaders of all three parties; Mr. Lloyd George would be as little likely to criticise her appointment as would Mr. Baldwin, who "discovered" her for broadcasting.

It is of the very greatest importance to the future of broadcasting that Mrs. Snowden should receive every facility to continue the good work which she has started. To offer her the chairmanship is the step indicated by an understanding of the issues at stake.

If, however, there is not enough courage or statemanship in high quarters to spare for this purpose, then it is even more important that the new Chairman should be acceptable to Mrs. Snowden, both personally and in point of view.

FOR YOUR NOTE BOOK.

For ordinary broadcast wave-lengths there is no objection to the use of a metal supporting mast for the aerial, provided that the insulation of the latter be good.

Do not secure the stays for a tall mast to an ordinary wooden stake driven in the ground, as damp soil is very liable to render this form of anchorage insecure.

In the absence of a wall, post, etc., to which the stays for a mast can be attached, the best method is to use a buried stay footing.

A good stay footing for securing a high mast can be made from a length of 2-in. by 4-in. timber, with an iron stay bolt firmly secured to the centre, the whole arrangement being buried 2 or 3 ft. deep, with only the top of the stay bolt projecting above the surface.

When fitting a new valve remember that the grid bias required by it may be quite different from that formerly used.



NOTES FROM THE NORTH.

Among other matters of special interest to Northern listeners our special correspondent deals with the question of the effects of the new station at Moorside Edge and says that with its tall masts and fine position, the North Regional station will be one to be proud of.

THE first instalment of the regional scheme having been completed with the opening of London Regional as a regular service, public attention will now be transferred to the second instalment—the North Regional station. Work on the heights of Moorside Edge, near Huddersfield, in the construction of the building to contain the two high-power transmitters (which will be replicas of those at Brookmans Park) is proceeding apace.

Beating Brookmans.

Moorside Edge, in fact, looks like being like Brookmans Park "only more so," which will satisfy the North-countryman's traditional delight to go one better than his Southern kinsmen, although when it is pointed out that this process of "only more so" will apply, for one thing, to the amount of interference trouble experienced by listeners, we Northerners are not so pleased!

The population in the vicinity of Moorside Edge is probably much greater than that near Brookmans Park. Trouble may therefore be expected to be more widespread than it has been in connection with the London Regional station.

The North Regional station will stand at a high altitude, and will have aerial masts of 500-600 ft., compared with London's 200 ft. Consequently it may be expected to have more "kick" than London, and the difficulty of cutting out either transmitter will be so much greater.

That "Bleak Moor."

The North Regional station will not stand on a wild and deserted moor miles from civilisation, as some writers have graphically and imaginatively stated. The site is certainly on a bleak moor, but there are houses in the immediate vicinity and the station, standing on a high plateau, will look down into the street of the busy little town of Slaithwaite.

Moorside Edge is on the ridge of hill-land, which, though rugged, is comparatively narrow, separating the busy manufacturing areas of Yorkshire and Lancashire. Halifax, with a population of 99,000, is only six miles away, as the crows (and the radio waves) fly, and Huddersfield, with 110,000, is a mile nearer.

about ten miles distant. Thus, ignoring the numerous smaller towns, we have within a radius of ten miles 644,000 people—and 12 miles away there is Bradford with another 286,000, and 18 miles away Leeds with another 500,000, and, at the same distance, Manchester with 730,000.

With its tall masts and fine position, the North Regional station will be one to be proud of. Already the North boasts a control room and a studio (at Manchester) which are superior to anything at Savoy Hill. London, of course, will come up-to-date in this respect when the new Broadcasting House is completed.

As the B.B.C. is to put "northern" programmes on one of the Moorside Edge wave-lengths, everything that may help to make these programmes worthy of their separate wave-length must be encouraged.

It is good news that Mr. J. R. Gregson, the Yorkshire playwright, has become

B.B.C.'s efforts to develop radio drama as a separate and distinct art.

He expressed to me the hope that the B.B.C. would encourage Northern dramatists and players to produce plays of a Northern character. This is, in fact, the policy of the B.B.C.

There is likely to be close collaboration throughout the North of England between the various repertory and amateur theatres and the B.B.C. One of the next products of this policy will be a broadcast by the Newcastle Repertory Company.

Lack of Light Material.

Northern programmes have hitherto been criticised for lack of light material, and I have frequently pointed out to the B.B.C. in the North that this side will have to be developed if the future Northern programme is to be a success.

When Mr. H. J. Dunkerley, of the B.B.C., Manchester, attended the annual conference of the Yorkshire Adult School Union at York recently he was asked whether educational talks could be put on later in the evening, it being urged that the present times are too early for those who wish to follow the talks regularly. He promised to bring the suggestion to the attention of the appropriate authorities.

It appears to be probable that when Moorside Edge starts there will be talks at, say, 8 o'clock or 8.30 p.m., probably on the "regional" wave-length. But under present conditions, with most Northern listeners tied down to one programme, the B.B.C. would not



HAVE YOU HEARD THESE CHIMES?

In between items the Bratislava broadcasting station radiates a melodious interval signal to show that it has not closed down. This photograph shows the three electrical gongs, the microphone and the controlling apparatus.

enthusiastic about radio drama. Hitherto Mr. Gregson has confined his rich talents to the stage, but recently his play "The Devil a Saint" was broadcast by the North Regional stations, and the experience has so fired his imagination that we can count on hearing more of him in the broadcast programmes.

Mr. Gregson tells me that he is considering the adaptation of a Bronte novel for broadcasting. And some day we may see a Gregson play written specially for the microphone, for he warmly approves the

be justified in introducing mid-evening educational talks. When an alternative programme is available for those who would object to such talks—yes.

In an address to the York conference Mr. Dunkerley said that in a referendum taken in Manchester recently talks came out very close to the top among the features of broadcast programmes. It would be interesting to have further details of this referendum. All sorts of contradictory things about B.B.C. programmes have been "proved" by such means in the past few years.

SHORT-WAVE NOTES.

Have you ever tried the reception of short-waves on a portable set? You will find much to interest you if you do, and the subject is dealt with this week by our short-wave expert.

By W. L. S.

I WONDER how many self-styled "short-wave enthusiasts" are really enthusiastic enough occasionally to take out a portable with them for short-wave purposes? A friend of mine recently brought to my notice the excellent scheme, for those who possess an ordinary broadcast portable, of taking it out together with a short-wave adaptor in compact form.

One then has broadcast on tap, and also the advantages of quite a good short-wave receiver comprising the adaptor and the note-mags. of the portable. The adaptor, naturally, is plugged in the detector socket and the H.F. valves withdrawn from their sockets, to economise in H.T. current.

A Hill Test.

Having recently become the proud possessor of a five-valve portable, I took this out the other day, and also a commercial short-wave adaptor, the chief advantage of which is its very small size.

Even so the combination would have been far from comfortable, it is true, without the aid of a car. Given all three, however, one can make some very interesting tests on screening, local freak effects, and such phenomena.

I went quite a distance out into the Surrey hills, and the one point that seems absolutely certain is this: that, in general, short-wave signals are no stronger on the top of a high hill than at the bottom!

Time and time again I tuned in a signal at the top of a hill, left the set carefully tuned to it and went down to the bottom, and general reception, mush, and the particular signal referred to all seemed exactly the same.

I certainly came across one or two spots that seemed exceptionally good during the course of the "tour," but I cannot say that I found any particularly bad ones, although reception on the whole was certainly better than in my own locality.

This, however, was probably due to the fact that the only aerial used was a short length of wire strung up inside the hood of the car, and screening from houses and other buildings in my own neighbourhood probably accounted for an appreciable loss in signal strength.

Finding The Majestic.

It can certainly be recommended as interesting work to those who are keen on portables to undertake something of this kind, and it would be easy for those who are acquainted with an amateur transmitter to arrange with him for a schedule transmission. Reception of this at various spots should be capable of providing some useful data on directional effects, local screening, etc.

Quite a batch of readers have written to tell me that the short-wave broadcast of WCAU, on 49.5 metres, is W3XAU and not W3XAM. C. J. B., of Belfast, finds that W3XAU is quite equal in

strength to W2XE, and is only excelled in strength by W8XK on 62 metres. He finds a deep depression on the lower short-wave broadcast bands, but the 49-metre region appears to be very lively.

Two or three have also found the Majestic working on 35 metres, but when jamming is bad he appears to dive down to 16 metres. Several want to know where the London end of the system is situated, and whether it is G2GN or not. Any further information will be welcomed.

G. W., of Basingstoke, sends an interesting account of the reception of Sydney, VK2ME, on 28 metres. He finds them

RADIO IS GRADUALLY PENETRATING TO THE REMOTEST PARTS OF THE WORLD.

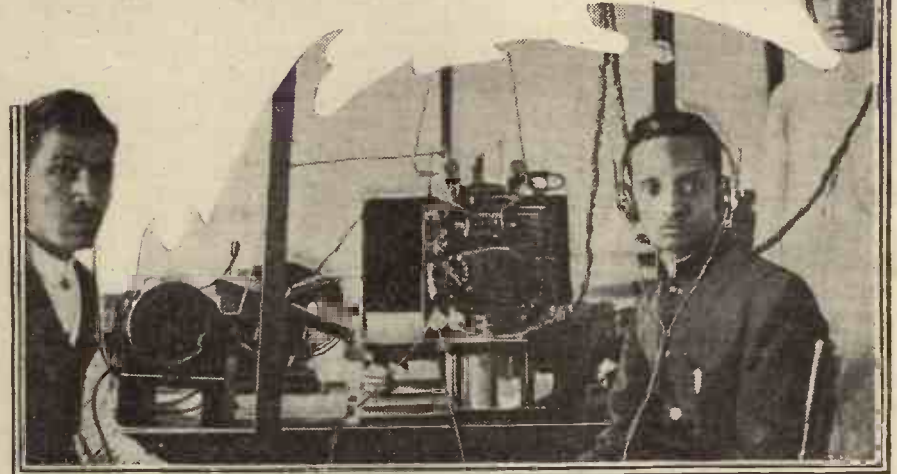

One of the countries most recently to take an active interest in radio is Arabia. Here we see the native operators of the wireless station at the port of Yanbe.

stronger than any of the Americans, and could hear the engineer's assistant in the background chuckling at some of the remarks.

He also suggests that it would be an excellent idea for the B.B.C. to start with a course of Morse instruction on the lines of that already run by Radio Roma.

There certainly is much to be said for this, and I think a large number of listeners, particularly those interested in short-wave work, would welcome such an innovation. Perhaps, as the B.B.C. are so much on the look-out for novelties nowadays, they will think this over before finally "sitting on it"!

Reliable Information.

As two readers have asked the old question of where to obtain reliable information on the subject of the technique of short-wave transmission and of rather more advanced data on reception than "P.W." usually gives, I will repeat my previous advice: obtain a copy of the A.R.R.L. Handbook.

This really is an excellent publication, containing abstracts from all the more

useful articles that have appeared in "QST" during the last few years, and is now in its fifth or sixth edition. I could enlarge on the details contained *ad lib.*, but must content myself with saying that there does not appear to be a branch of short-wave reception or transmission that is not comprehensively dealt with.

The full title is "The Radio Amateur's Handbook: A Manual of Amateur Short-Wave Radiotelegraphic Communication." It can be obtained for 4/- from the R.S.G.B., 53, Victoria Street, S.W.1.

For some reason best known to themselves, various readers have expressed themselves as keen on doing a little detective work and endeavouring to "spot" my transmitting station. Two gentlemen in particular have hazarded guesses (both wrong, but very flattering) as to the call-sign thereof, and others want to arrange schedules.

To give a stimulus to the Scotland-Yard habit thus shown, I am giving away the game to the extent of admitting that every Sunday after this appears in print I shall

be working with telephony on the 160-metre band, and will be pleased to arrange schedules for some special test work that I want to do in connection with directional effects on this band with a certain type of aerial that I am trying out.

Has anyone solved the problem, by the way, of making a receiver that will just cover all the amateur bands, including the 150-175-metre band, without the ghastly effect of having the whole band crammed into 10 degrees or so on 10 metres, 20 degrees on 20 metres, and so on?

I think the only way out is to use two variable condensers in parallel, one of about .0003 capacity and the other rather smaller than .00005. The smaller one will just about cover the lower bands (while the larger can be set to allow for this, or shifted to make possible the reception of broadcast), and on the upper bands the large condenser itself can be used.

A receiver that really is to cover all waves from 10 metres to 175 in such a way needs a good deal of planning! It has to cover about 26,000 kilocycles in all (twenty-six times the width of the 200-600-metre broadcast band).



REVERSING THE L.T.

Set constructors sometimes get better results with their receivers when they reverse the L.T. connections. There is no mystery about this, and the following article clearly explains why such a modification affects the operation of a set.

By G. V. DOWDING, Assoc.I.E.E.

positive side of the L.T. battery via the filament leads of the valves

The effect of reversing the connections to the L.T. battery is to take the grid leak to the negative side of the L.T. battery. The detector valve may

be operating in a less sensitive condition, but quite often the reaction control is better and, indeed, the whole outfit may become too lively.

Stability and Selectivity.

The positive connection makes for greater stability and a more staid reaction control. But in a set connected to a large aerial, or in a set having not-too-good coils, there might be a trifle too much stability, so much, indeed, as to make the set "puddeny" and flat in its tuning.

It is then that a reversal of the L.T. connections may be accompanied by distinct improvements in the set's liveliness and selectivity.

When the grid leak is joined to the positive of the L.T. battery there is a tendency for a grid current to flow. (The grid is made somewhat positive in relation to the filament). And grid current means in-selectivity through excessive damping.

There is often a distinct advantage in being able to obtain some midway position for the grid-leak connection, especially in a short-wave set. This is made possible by the provision of a potentiometer such as in the "Magic" sets.

Potentiometers For Detectors.

The connections are quite simple and are given in Fig. 2. You will see that as the arm of the potentiometer is moved the grid return can be taken to any point between the limits of completely positive and completely negative.

In the short-waver this often permits of the elimination of troublesome threshold howl, while "ploppy" reaction in ordinary receivers can be cured by such an adjustment.

A potentiometer is an extra expense, but it really is worth it in most sets, although by the judicious adjustment of H.T. voltage on the anode of the detector, and the careful choice of reaction coil sizes it is not so difficult on the normal band to get very comfortable reaction control.

Effect on H.F. Valves.

If the set has an H.F. stage the reversal of the L.T. has a similar effect on the H.F. valve, but frequently in the reverse direction. That is to say, an unstable set can often be stabilised by the change-over of its grid return.

This is generally accompanied by a loss

of sensitivity and the tuning becomes flatter. And here again in the H.F. stage a compromise can be made by the use of a potentiometer.

Now what does the reversal of the L.T. do to the L.F. stages? To some extent it will upset the grid bias. Instead of the grid-bias battery's positive terminal being joined to L.T. negative it is now taken to L.T. positive.

The slight reduction in grid bias that is occasioned may not materially affect the operation of the set. Indeed, it is quite likely that it may give you a resultant grid bias somewhat nearer what really is needed.

This is where just the one power valve is concerned. In the case of an L.F. valve having only two or three volts of bias this will be thrown out badly. The H.T. current consumption will go up, and the quality of reproduction go down.

A Clumsy Improvisation.

The reversal of a six-volt L.T. battery will naturally have a greater effect than that of a two-volt supply.

With a one-valve set reversed L.T. is almost legitimate, but it is not the right thing to do in the care of a three- or four-valve outfit. You cannot be putting every valve right—one or more of them may be considerably upset.

If you reverse the H.T. connections to any set by joining the negative of the battery to the positive terminal of the receiver, invariably the result is that the outfit just does not work. On the other hand, it quite often happens that a reversal of the L.T. connections to some extent appears to improve the performance of a receiver.

Many amateurs find this very puzzling. Some wonder why the connections were not given in the reverse order in the original design of the set, while others question the safety of such battery terminal reversals.

This subject has, of course, been dealt with before, but not, I think, quite as fully as it might have been. There is no one question that can be dismissed with a simple negative or affirmative (I nearly wrote

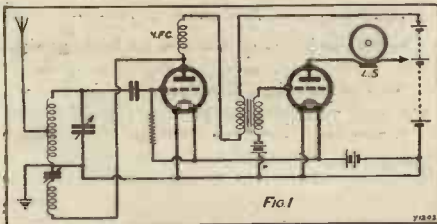

This is quite an ordinary sort of circuit. What happens when you reverse its L.T. connections? The accompanying article explains in detail.

positive!), there are several rather important considerations.

Improving the Reaction.

But first let me set at rest the minds of the "safety" quicrists. In no battery-driven set, or even a set using a mains unit will the reversal of the L.T. battery cause any damage to the valves or other accessories or components. Sometimes, there is an inappreciable effect on results, sometimes the set becomes either more or less sensitive or the reproduction gets better or worse.

Any effects of these natures will be due primarily to the alteration in the grid return connection of the detector valve. At Fig. 1 you see the circuit of a simple Det.-L.F. two-valver of a perfectly standard variety.

The type of detector valve arrangement employed figures in the vast majority of ordinary sets. A grid leak and condenser are employed for rectification purposes. The former is shown connected to the

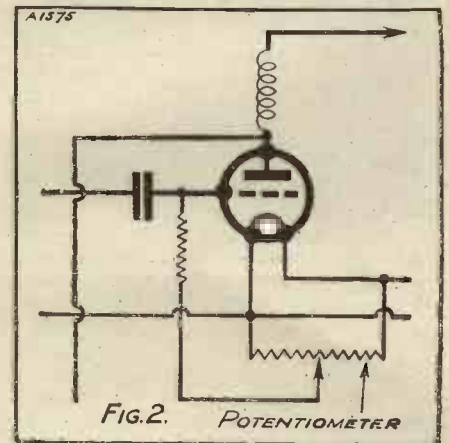

The potentiometer that figures in many short-wavers (the "Magics" use potentiometers) does a certain job better than an L.T. reversal.

No, the designer of a set connects his grid returns to the points that are correct, and if some slight improvement or even if great improvement seems to follow an L.T. reversal you can be fairly certain that all is not as it should be.

Aim at putting things right in an orthodox manner rather than by what is a most clumsy improvisation.

FROM THE TECHNICAL EDITOR'S NOTE BOOK.

Tested and Found—?



THE "VOXKIT" CONSOLE.

CONSTRUCTORS of sets such as the "Magic" and "Titan," should be particularly interested in the "Voxkit" Console, which is made by the British Radio Gramophone Co., Ltd., of 57, City Road, London, E.C.1. The "Voxkit" is an excellent cabinet provided with set and speaker sections. It will take any set with



The above photo of the "Voxkit" shows a This Year's "Titan" fitted in it.

anything up to an 18 in. by 8 in. panel, and there is room for all the batteries. Even a mains unit and a frame aerial can be accommodated if desired.

It is supplied complete with an Ultra Air Chrome Chassis speaker, in oak, at £6 17s. 6d., or in mahogany at seven guineas. The cabinet only, without the speaker, is available at 4 guineas in oak, or in mahogany at £4 13s. 6d.

The back of the cabinet is removable providing access to the set, loud speaker and batteries, and I should mention lest I forget it, that when ordering one of these cabinets one has but to specify the name of the set that it is proposed to fit in it together with the dimensions of the panel and baseboard, and the British Radio Gramophone people

are prepared to make slight modifications in accordance with these special requirements.

I like the Voxkit Console. It is very good value for money indeed, and the craftsmanship and finish appear to me to be first rate. You will be able to judge how handsome the affair looks from the accompanying

photograph, and I would assure "P.W." readers that it really is worth while building one's set into a decent cabinet of this nature. By the way, the Air Chrome speaker embodied is a fine proposition, and gives results approaching those of a moving-coil.

CALVERT'S MECHANIC'S ALMANACK.

The 1930 edition of this useful publication is entirely rearranged, and a great deal of completely new matter is included. It comprises 190 pages, and costs only 6d.

USEFUL LOUD SPEAKER ACCESSORY.

Makers of cone loud speakers will appreciate the "Aptus" triple chuck adaptor, which is sold at 2s. 6d., by Moore & Co., of 101 and 103, Dale Street, Liverpool. It is a device for fixing the diaphragm at its centre to a unit.

One small chuck enables it immediately to be fitted to any existing spindle, and the cone washers, which comprise a combination of brass and celluloid and which fix into position by means of two further small chucks, can be adjusted to any position.

THREE MAZDA VALVES.

The H.L.210 type Mazda valve is a general purpose 2-volter of an exceptionally interesting character. Its impedance is 21,000 ohms and its amplification factor 26, and these are surprisingly good characteristics for a 2-volter taking 1 amp. filament current.

It makes a very fine detector in the majority of circuits, while it can be used in many H.F. and some first L.F. positions with great advantage. It fits in very well in either the Det. or first L.F. position of the "Magic" Three. Using two H.L.210's enormous amplification is achieved. The price of the H.L.210 is 10s. 6d.

The type 230 P is the Mazda 2-volt pentode, which takes 3 amp. filament current. It needs about 150 volts although it operates very well on 125 or even less H.T. and, properly biased, it does not absorb a seriously high anode current.

A special feature of the 230P is that its electrodes are so arranged that should

they be damaged by rough usage the insertion of the valve in a set cannot burn out the other valves owing to an internal H.T. short circuit. This valve costs 25s.

The Mazda type 215 S.G. is, of course, the screened grid H.F. amplifier. It is a 2-volter taking 15 filament current. Its amplification factor reaches the colossal figure of 450, which is surprising when it is considered that the mutual conductance of the valve is over 1. The top terminal of the valve is fitted with a metal cap so that either a spade or spring clip connection can be used.

READY RADIO "MAGIC" KIT.

The Ready Radio people recently sent us one of their "Magic" Three kits of parts. It is identical in every respect with those that are advertised in "P.W.," and was in fact, drawn from stock quite haphazardly.

The components are all of approved makes and the whole kit is neatly boxed up.

There is everything in favour of buying

WHEN YOU ARE BUYING—

(7) COILS.

These are very important accessories indeed, and can do a great deal towards making or marring a set's results.

There are but A FEW dependable, really efficient makes (you see most of them mentioned in "P.W." constructional articles), the remainder are dangerously doubtful.

Don't buy any but the specified makes. Readers have experienced complete failures through using dud makes of coils in their sets.

X coils especially must be very, very carefully chosen.

Also see that your coil sizes are exactly as specified, otherwise your wave-range will be thrown out and, possibly, your reaction control upset.

a complete kit of parts and nothing against it.

You get all the little items such as screws, etc. and your panel is neatly drilled for you.

Moreover, you are certain that every component is suitable for the set—that is if you purchase an approved kit such as is sold by Ready Radio.

We strongly advise "P.W." readers to follow such a course—it helps to ensure 100% efficiency in a "P.W." design.

And don't be tempted always to use any old components for new sets—it doesn't always pay.



The Ready Radio kit of parts for This Year's "Magic" Three.



**Today, more than ever,
the four years old
Celestion C.12 is re-
cognised as Radio's
Richest Voice:**

Many good Loud-speakers have been made, but none that were selling four years ago are selling well today, except the C.12 Celestion, the supreme standard model made by the foremost name in sound reproduction. Today this most famous of Loud-speakers is actually selling in increasing numbers.

At its remarkably low price of £5.12.6 in Oak, £5.17.6 in Mahogany, and £6.6.0 in Walnut, it is radio's greatest prize.

It continues to sell, not only because of its clarity and purity of tone, but because of its enduring qualities under all conditions with all types of sets, and because of the beautiful cabinet in which it is housed.

You have only to see and to hear to know that our statements are not exaggerations.

There is also the new range of Celestion Loud-speakers, the Z Models. These are higher in price but higher also in their results. Prices from £7. 15. 0.

Write for interesting Booklet on sound reproduction and particulars of the new Celestion Electrical-Gramophones and Radio-Gramophones.

CELESTION LTD., DEPT. B,
KINGSTON-ON-THAMES

London showrooms:
106, VICTORIA ST., S.W.1

CELESTION
The Very Soul of Music

**FEATURES
THAT MATTER**

IT'S when you begin to look into J.B. Condensers that you appreciate the skill, the accuracy, the endless patience with which they are designed and made.



This is the Universal Log — one of the new models. It is the Condenser of the season, and has already featured in many of the Star Circuits. The frame construction is such that complete rigidity is assured.

This bush is removable, enabling the Condenser to be fixed to Panel either end, left or right hand.

PRICES:

·0005 9/6 ·0003 9/-
·00025 8/9 ·00015 8/9

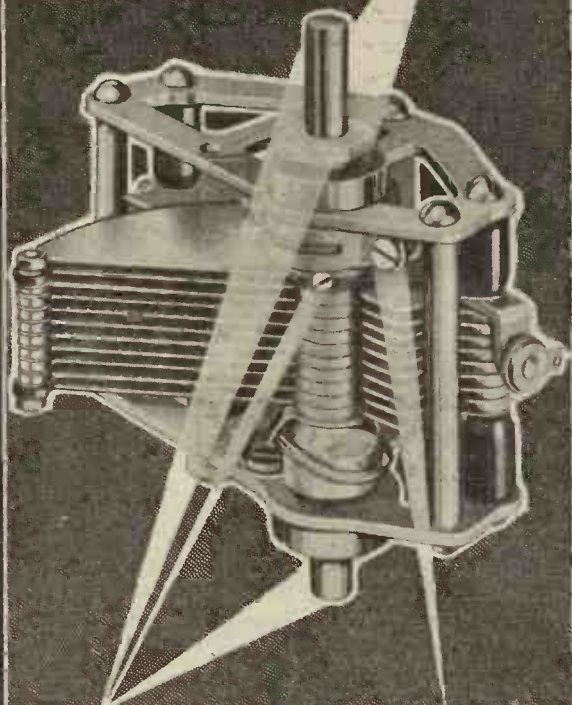

Steel Centre Spindle, adjustable for length and particularly useful for hanging and attaching to Thumb or Drum Control.

Showing the well-known J.B. Adjustable tension to Centre Spindle.



Gentleman:
 "Excuse me Madam
 would you mind if
 I smoked a . . .

*Player's
 Please*

Lady:
 Certainly not, I'll
 have one with you."



N.C.C.821

FOR THE
 "MAGIC" 3 "TITAN" 3
 "REGIONAL" 3 "REGIONAL" 4

Be sure of best results
 Use the recommended

WEARITE COMPONENTS

	s.	d.
H.F. CHOKE	6	6
ON-OFF SWITCH	1	0
SERIES AERIAL CONDENSER WITH SWITCH	2	3
WIRE-WOUND FIXED RESISTANCE		
(25,000 ohms)	4	0
POTENTIOMETERS (200 or 400 ohms)	2	6
VOLUME CONTROL ($\frac{1}{2}$ or 1 megohm)	4	0
3-POINT WAVE-CHANGE SWITCH.	1	6
COIL HOLDERS (Real Low Loss)	1	6
STANDARD "TITAN" COIL	15	0
PAXOLIN PANELS AND TERMINAL STRIPS (Mahogany or Black Finish)		

For particulars of other Wearite Recommended
 Components, write for Special List and Illustrated
 Booklet.

WRIGHT & WEAIRE, LTD.,
 740, High Road, LONDON, N.17.

Phone: Tottenham 3847-3848.

Such beautiful Tone!

Here is the new No. 100
 Cradle, the latest addition
 to the Squire Range.

Modern speaker design is
 tending steadily in the
 direction of free edge cones,
 particularly for small cones
 whose duty it is to reproduce
 the higher frequencies.

The Squire No. 100 has a
 free edge small cone, and
 we can emphatically state
 that the reproduction af-
 forded is the finest yet.

The beautiful tone and
 ample volume obtainable
 when this Cradle is used
 in conjunction with any
 reputable make of Unit,
 is truly wonderful.

It is equally responsive
 on all frequencies.

Ask your dealer to de-
 monstrate one, or in case of
 difficulty write to us direct.



Price, inclusive of Cones **28/6**
 and Octagonal Front,
 Price of the two Cones, supplied com-
 plete, riveted together, with metal
 washers attached & packed in box **6/6**

FREDERICK

SQUIRE LTD.,

10, Leswin Place, Stoke Newington, N.16.

FINDING THOSE FOREIGNERS

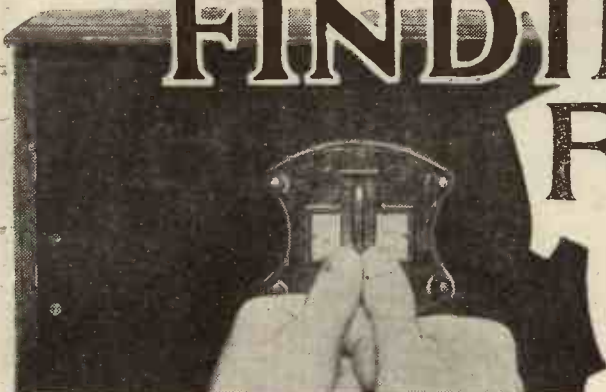

No navigator sails the seas without a chart. And no keen long-distance listener should be without HIS chart, which tells him exactly where he is on the dial!

This article tells you exactly how to draw up a tuning scale that will make all your foreign stations "toe the line."

By P. R. BIRD.

"FOREIGN stations simply swarm in on the tuning dial, but I never know who they are."

How often one hears that remark, or something to the same effect! And how unnecessary it is to have a lot of strange stations dropping in on the dial, when by taking a little trouble one evening when you have nothing much else to do, you could identify the lot.

An Easy-to-Make Chart

All you want is a list of European stations and wave-lengths, a pencil, a rule, and a sheet or two of squared graph paper. You can get the latter from any stationer's for about twopence or threepence, and for this modest sum and with this simple equipment you can make those elusive foreigners "toe the line."

The first job is to prepare your graph paper. Look at the sketch on this page. It shows a partly finished calibration chart, and along the bottom of it you will see the numbers from 0 to 180 corresponding with the numbers on your dial.

"But suppose," say you (trying to be awkward), "that my dial is not marked to 180, but 0 to 100?" Well, wouldn't it be just as easy to mark out the paper 0 to 100 as from 0 to 180? Of course it would!

With this nicely squared paper you can make a scale as long as you like or as short as you like. Every fifth and tenth line on the paper is usually printed a little heavier than the others so that marking out is simplicity itself. When you have got the 10, 20, 30, and so on in their correct relative positions to correspond with the dial, you leave the bottom of the chart alone and turn to the side.

Preparing the Paper

On one side of the chart you have to put the wave-lengths ranging from the lowest station you can receive to the highest. Suppose, for instance, you are using a coil which is supposed, when used with your tuning condenser, to cover the wave-band from 250 to 550 metres. These are the wave-lengths that must be shown on the side of the chart, but just for safety's sake you can begin a little lower than 250 and go up a little higher than 550 if you like.

Thus the calibration chart illustrated on this page shows wave-lengths starting from 240 and going right up to 600. You need not do exactly the same figures, of course, but this is a very useful range, with the 2 L O "National" coming in near the bottom of the dial, and Budapest right near the top.

You know roughly the range you will have to cover, by listening-in first for a

station at the bottom of the dial and then another station at the top of the dial. Allow a little margin on each side of these stations' wave-lengths, and that is the range you require to plot on the side of the chart

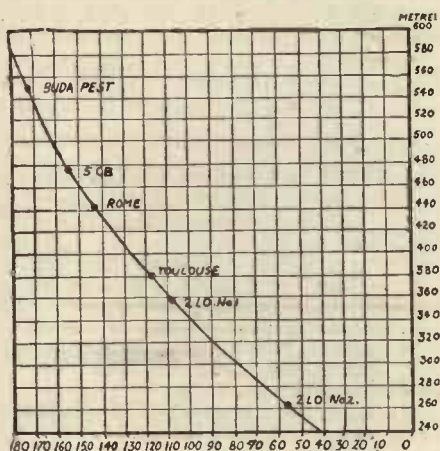

FROM BUDA-PEST TO 2 L O. Why not make a chart like this and identify ALL the stations you hear?

Just as every square along the bottom line represents a certain number of degrees on the dial, so every square on the side line represents a certain number of metres, or "wave-lengths."

Having got the degrees along the bottom and the wave-lengths up the side, you have formed the framework of your chart, and all that now remains is to fill in the curve by the aid of some of the regularly-received and well-known stations. On your first rough chart (you will draw a nicer one later on) it is a good plan to first put your station's dial-reading at the top of the chart.

On my set, for instance, 2 L O No. 1 regional programme comes on 109 degrees on the dial, so continue the line corresponding with 109 degrees up from the bottom to the top of the chart, and put a dot there to correspond with 2 L O. (For simplicity's sake the top dots are not shown on the sketch.) Then the idea is to fix half a dozen stations or so on the chart. In this case the first half a dozen that came to hand were chosen, namely: 2 L O's

two transmitters, Toulouse, Rome, 5 G B, and Budapest.

Any other stations will do, and you can get more than half a dozen if you like. In fact, it is an advantage to get as many stations as possible before drawing the curve.

Probably you already know most of their positions so there is not much difficulty in this, and we are now getting to the exciting part. For once you have them fixed on your new chart the unknown others will simply fall into place like ninepins. (While you are about it, try and get one station as near the top of the dial and another as near the bottom of the dial as possible.)

Filling in the Dots

Now the next thing to do is to get your wave-length table out and to look for those stations on it. Start at Budapest, for instance, and you will find that Budapest's wave-length is 550 metres.

Halfway between 540 and 560 metres you have the line running right across the chart and corresponding with 550 metres. Put your rule along this line and then "bring the Budapest dot down" by making a dot on the chart where the 550 metre line crosses the line corresponding with 173 on the dial. (Your own dial reading may not be 173, but you see the idea?)

Turn your back on Budapest and concentrate on the 5 G B dot. The 5 G B dot was on the 154 mark on this dial and the wave-length chart says that its wave-length is 479 metres. So 5 G B's dot goes on the chart where the 479 metre line crosses the 154 line.

Identifies All Your Stations!

Write 5 G B against this dot and pass on merrily to Rome and Toulouse. You've got the idea by now so we needn't give more instances here. Fill in all your stations like that, and then lightly pencil a line across the chart connecting all these points together. It will not be a perfectly straight line, but it will be a perfectly wonderful line for foreign stations. For once that line is in you have got the European stations at your finger-tips. Suppose, for instance, an unknown foreign station comes in at, say, 73 on your dial and starts "chirping." Who is he? You find that 73 on the curve you have drawn corresponds with a wave-length of 291 metres, and on your wave-length chart 291 metres is shown to be Turin (the home of the nightingale that has been worrying "Ariel" so much lately.)

Every station you find in this way makes the curve more nearly accurate, and consequently no matter where a station comes in on the dial your chart will tell you who it is!

ONE of the most attractive things about such an outstanding receiver as the "Magic" Three is that when once you have built it you are almost certain to be so pleased with it that you will want to keep it for some considerable time, and so it becomes worth while adding little refinements now and again. Thus, ere very long, you will find yourself in possession of a set not merely of outstanding capabilities in the first place, but possessing all those little special devices so dear to the heart of the enthusiast.

Of course, the original design incorporated everything really necessary, and several special refinements in addition which were really in the nature of luxuries, yet we felt it necessary to keep it reasonably simple in order that it should be easy and not too expensive to build.

Now for Refinements.

Having presented the design in its standard form, we are now free to go on and indicate one or two little extra refinements of a nature which we think will appeal to a good many readers and explain how they may be incorporated. In this way those who desire to run merely the standard design can do so, while those who always aim at a "de luxe" equipment will be able to go ahead and add the special devices which we are about to discuss.

First of all, there is the question of an output filter for the loud speaker. This is always a desirable feature in a set, but very much more so in some cases than in others, consequently, it was not thought that it should be made a definite part of the standard design. The fact is that, in some cases, it is of only very slight benefit, and so it seems a pity to increase the cost of the standard design by a matter of over £1 by including it.

When a Filter Helps.

When you are using only an ordinary power valve with a moderate amount of H.T., say 100 volts, an output filter is of only small benefit, and no doubt many users of the "Magic" Three will be operating it under these conditions. When, on the other hand, the last valve is a super-power, an output filter becomes very desirable indeed, while when a mains unit is employed

for the H.T. supply it is essential in order to avoid risks of severe shocks when handling the loud-speaker connections. This is particularly the case when the mains are of the direct current type.

Again, when long-extension leads are used for the loud speaker, an output filter may become not merely desirable but absolutely essential, since such leads may result in an otherwise perfectly well-behaved set going into a low-frequency howl, if no filter is provided.

So much for what the output filter will do. Now let us see what has to be done to include it in the set. We originally left a vacant space for the extra parts upon the baseboard so that it is quite an easy matter to include it. The actual parts you will require will be either one output filter choke, and one 2-mfd. condenser, these being for use with either batteries or an alternating current mains H.T. unit, or else for work on D.C. mains, a choke (as before) and two 2-mfd. condensers.

The diagram reproduced this week actually shows the arrangement for batteries

EXTRA COMPONENTS REQUIRED

- 1 Output filter choke, about 20 henries (Varley, or Ferranti, R.I., Igranic, Wearite, etc.).
- 1 or 2 2-mfd. condensers (see text). (Lissen, or Dubilier, T.C.C., Hydra, Mullard, Ferranti, etc.)
- 1 On-off switch (Utility, or Lissen, Igranic, Burton, Lotus, Bulgin, Benjamin, Keystone, Ready Radio, Magnum, Wearite, etc.).
- 2 Small panel mounting sockets (Belling and Lee, Burton, Eelex, Clix, etc.).

or alternating current mains, but we will explain later on how the extra 2-mfd. condenser is worked in for use with a D.C. mains unit.

The extra parts should be placed upon the baseboard in the manner illustrated in the photographs and wiring diagram, and these are the alterations you will require to make in the wiring. In the original simple form of the set you will remember that the plate of the third valve is wired to the loud speaker negative terminal, the loud-speaker positive terminal being connected to the H.T. +2 terminal.

How to Do It.

Remove both these wires for a start. Instead, wire the plate of the third valve (V_3) to one terminal of the output filter choke, the other terminal of this choke being connected to the H.T. +2 terminal.



minimal. Connect also the plate of V_3 to one side of your 2-mfd. condenser, the other terminal of which should be connected to the loud-speaker negative terminal.

The loud-speaker positive terminal should be joined to a convenient point on the wire running from the L.T.—terminal round to the filament terminals of the various valve holders. That completes the modification, and it is just interesting to note that the loud-speaker terminals no longer have any polarity, so it does not matter which way round you connect up your loud speaker.

For Direct Current Mains.

For use on D.C. mains, as we have explained, you must include an extra 2-mfd. condenser, and you

A REAL WIRELESS

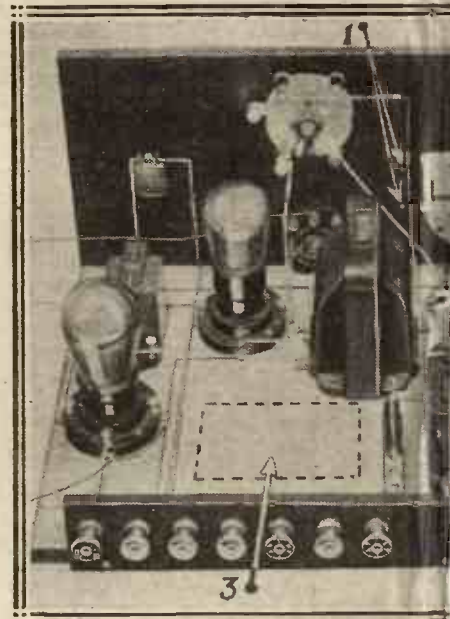

where the additions go in: (1) denotes the two picks and (3) is where the

will find that there is room for this between the output filter choke and the V_3 valve socket. The only alteration is that instead of wiring the loud-speaker positive terminal to a point on the L.T. circuit, wire this terminal to one of the terminals on your extra condenser. The other side of this condenser should

WHERE THE PUNCH COMES FROM.

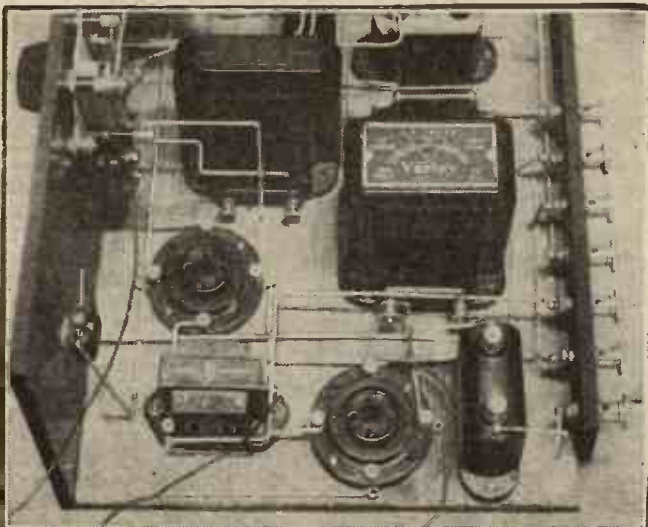

The output filter in position and wired up. There is still room on the baseboard for a 9-volt G.B. battery

ANNIHILATE SPACE WITH T

Year's "MAGIC" De-Luxe

Here we have the last word in three-valvers. The receiver described below is the result of a great deal of experiment, and is the logical outcome of the famous "Magic" Three. This year's "Magic" De-Luxe enables you to choose your programme when and where you will. You are not bound down to any particular station, or any range of wave-lengths, for the set is invulnerable to interference, and operates equally well on 20 metres or 2,000. In addition, you have provision for a gramophone pick-up, so that you would tire of the radio fare to be found on short waves, medium waves and long waves, you can turn to the radiogram for your own home-made programme. What more could you want?

Designed and Described by the "P.W." Research Dept.

be wired to any convenient point on the L.T.— circuit, for example, to one of the filament terminals on a valve holder. That is all.

What You Have Gained.

When you have reached this stage and completed the incorporation of your output filter, you will have the satisfaction of knowing that not merely is your loud speaker protected from the effects of the anode current of your last valve (which may possibly be injurious if the valve is of the super-power type) and the loud-speaker circuit insulated from the H.T. current so that it is no longer possible for any incautious person to get a shock, but also that practically the full H.T. voltage is actually reaching the plate of your power valve.

LESS WIZARD!

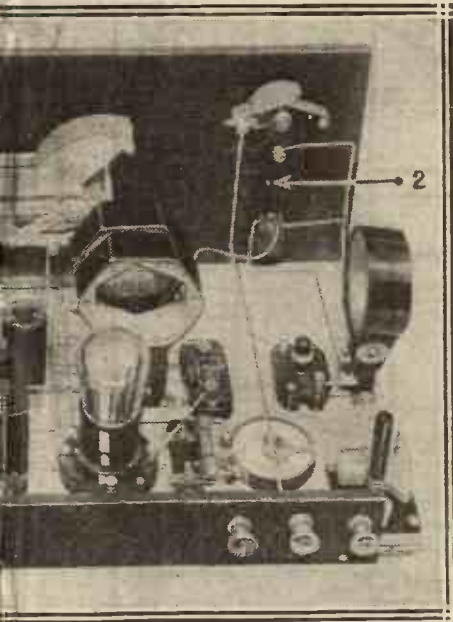

up sockets; (2) is the position for the extra switch; output choke is placed.

In other words, you have cut out any possible voltage drop across the high resistance of the loud speaker, which otherwise might be preventing a considerable portion of your H.T. voltage from reaching the last valve.

The other refinement we are suggesting in this

article is the fitting of a very simple little modification to enable the set to be used, with a gramophone pick-up, for the electrical reproduction of records. Carried out in a particularly simple fashion, this is one of the easiest of all refinements to add to such a set as the "Magic" Three.

You already have here a very powerful L.F. amplifier extremely suitable for gramophone work, provided that a good-sized power valve is used for the last stage, and all that you need to do is to make provision for connecting the input of your pick-up into the circuit at a suitable point.

It is here that we begin to appreciate one of the incidental advantages of a set with so powerful a low-frequency amplifying side as this one possesses. In many re-

short waves, however, matters are rather different and hence the expedient is not a very desirable one in this set.

The scheme we have adopted has been found to work admirably in the case of the "Magic" Three, and only requires the use of the second and third valves, the detector being switched off. You thus do not interfere in any way with the important parts of the detector circuit, and, moreover, the actual conversion is rendered extraordinarily easy.

Using an Input Transformer.

By the way, the reader may be interested to understand how it is that in the case of this set just two valves are sufficient to give ample volume. Well, this is how it is done. We have already provided in the set two transformer inter-valve couplings, and by using the first of these as an input transformer between the pick up and the first L.F. valve a very large increase in volume is obtained.

Now let us see just what we have to do

to make the conversion. First of all, we have already mentioned that the detector valve will not be required and so we must arrange to switch off its filament separately from those of the rest of the valves in the set. To do this we just mount an extra on-off switch on the panel. Next we must make provision for connecting the pick-up to the first inter-valve transformer, and to do this we shall need to mount a couple

ANY PROGRAMME, ANY TIME!

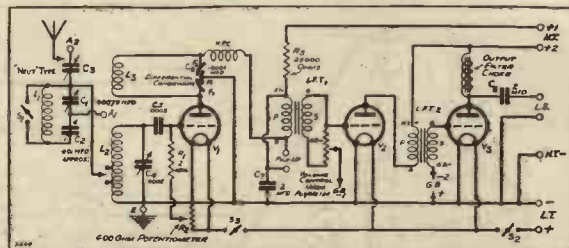

A simple circuit isn't it? But what results it can give!

ceivers where the low-frequency stages give less magnification it is necessary to use three valves to get adequate volume from many pick-ups, and so one has to switch in the pick-up in front of the detector. Although to do so is perfectly practical, and is a necessary expedient with many receivers, it is not altogether an ideal method.

In the first place, there is the obvious waste of L.T. current involved in using three valves when two might otherwise have done, and then again there is the fact that it is not a very nice thing to do to introduce switching into the grid circuit of the detector. For one thing, it necessarily means that some of the grid wiring is lengthened in a way which is not altogether desirable, and then there is always the possibility of losses in the switch itself.

Not on Short Waves.

No doubt by carrying out this wiring carefully and using a really good switch, the effect can be regarded as negligible, at least so far as the broadcast wave-lengths are concerned. On the very

RADIO OR GRAMOPHONE AT WILL.

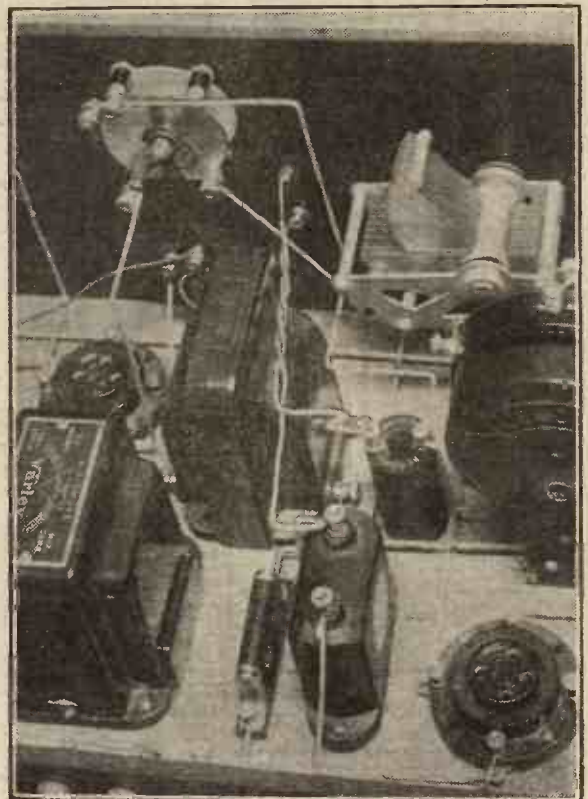

This view shows just how the new twisted leads for the pick-up connections are fitted in place.

THIS YEAR'S "MAGIC" DE-LUXE!

THIS YEAR'S "MAGIC" DE LUXE.

(Continued from previous page.)

just to the right of the tuning dial and between the dial and reaction condensers and volume control.

One of these sockets is to be connected to that terminal of the H.F. choke, which is already wired to one of the primary terminals of the first transformer. The other socket should be wired to that terminal on the 2-mfd. condenser C_7 , which is already connected to the other primary terminal of the transformer, and to one side of the resistance R_3 .

The effect of these connections, as you will see, is to place the two extra sockets across in parallel with the transformer

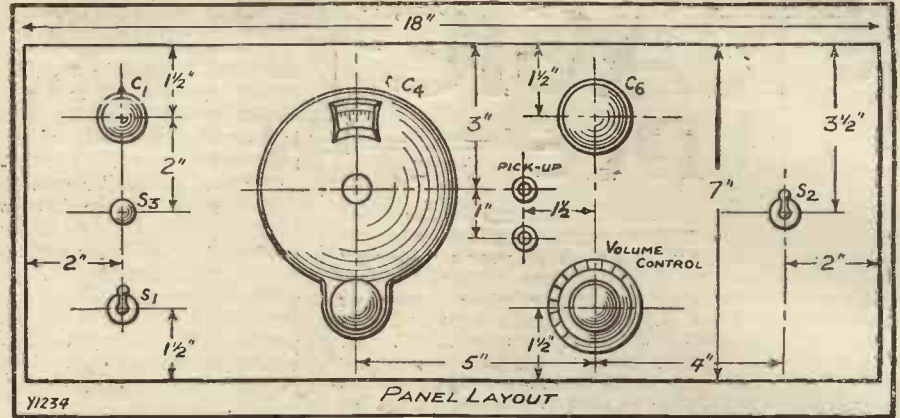

Y1234

PANEL LAYOUT

The operation of the set is simplicity itself, and you cannot help getting stations on it.

primary. Thus, when you insert in these sockets a pair of suitable small plugs upon the ends of the twin leads from the pick-up,

the latter is connected through to the transformer primary in the desired fashion (See also "Radiotutorial.")

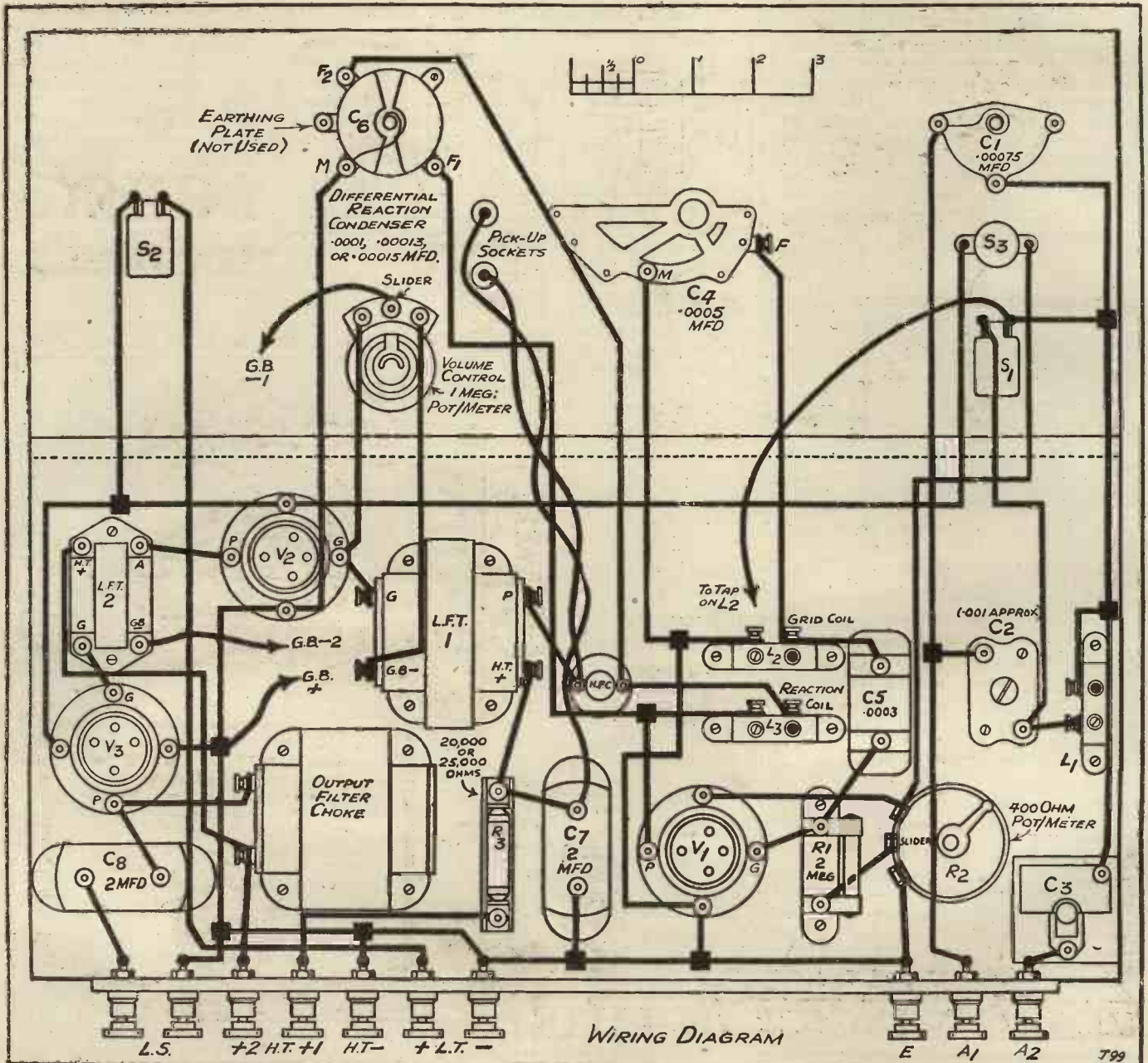

WIRING DIAGRAM

T99

Here is the wiring diagram and layout chart. You should keep as closely to this as possible, if you want to be sure of getting the record-breaking results that were achieved by the original receiver.

BETTER THAN A 2-VOLT PENTODE



...AND CHEAPER THE **MAZDA** P.240

Here is a valve that will, by reason of its high amplification factor and very low impedance, give you a power output that is equal to that of a pentode while at the same time giving a far better reproduction of the bass notes.

The Mazda P.240 is more robust and more economical, too, the H.T. current being only about two-thirds of that consumed by a pentode, whilst its cost price is considerably lower.

**PRICE
15/-**

Write for Catalogue. Sold by all reputable dealers.



THE EDISON SWAN ELECTRIC CO., LTD.,
Radio Division,
18, Newman Street, Oxford Street, W.1.
Showrooms in all the Principal Towns.

EDISWAN

THE **BIG STRIDE**



FORWARD

IN BATTERY PERFORMANCE



IT COSTS NO MORE!

NEW design, new materials, new methods of construction all combine to make the Full O'Power Battery of outstanding merit. The exclusive employment of seamless drawn zinc cylinders of exceedingly high purity—
AVOIDS: corrosion.
GIVES: larger output of current.
ENSURES: longer service.
GUARANTEES: maintenance of a high standard of efficiency over a long period.
Size No. 1210. 60 volts.

Telephone: Woolwich 1161
SIEMENS BROTHERS & CO., LTD., WOOLWICH, S.E.18.



CAPT. ECKERSLEY'S QUERY CORNER

Under the above title, week by week, Captain P. P. Eckersley, M.I.E.E., late Chief Engineer of the B.B.C., and now our Chief Radio Consultant, will comment upon radio queries submitted by "P.W." readers. But don't address your queries to Captain Eckersley—a selection of those received by the Query Department in the ordinary way will be dealt with by him.

Half- or Full-Wave Rectifying?

P. A. (Highgate).—I intend building an A.C. H.T. battery eliminator and am undecided as to the type of rectifier I should choose. If I use a rectifying valve, which type would you advise me to choose, half-wave or full-wave?"

The full-wave rectifier is more efficient and *a priori* requires a cheaper smoothing system. But there's rather a point about this, because if you have a given slightly insufficient H.T. smoother (i.e.—one which *does* give an audible hum), the single wave is better than the double wave because the note is lower in the former and therefore less likely to be reproduced in the loud speaker.

I mention this point because someone wrote to tell me the substitution of the double wave rectifier resulted in more hum. But my advice is the double-wave, but don't skimp the smoothing. You get greater efficiency and it feels nicer all round, somehow.

Loud Speaker Position Affects Howl.

L. D. W. (Yarmouth). "My receiver is a straight three-valver, consisting of Det. and 2 L.F. stages, using R.C.C. coupling throughout. Whenever the loud speaker or 'phone leads are brought anywhere near the set a howl is set up. Is it possible to eliminate the above fault?"

Well, there's no royal road to preventing the trouble.

You are bringing the output of the set near the input. So the strong output may induce a feeble current into the input. And the input passes this on and magnifies it till it becomes a stronger output which makes a stronger input which—well its got to stop somewhere, and does—with a howl.

You could try screening your loud speaker leads; putting a rather larger H.T. battery condenser might help; reduce the value of your grid leaks and so reduce sensitivity; try screening your closed circuit a bit.

Anything and everything to stop output inducing into input, and for cutting down sensitivity to the point where things are stable.

Value of Grid Condenser.

M. L. (Plymouth). "Can you tell me why a capacity of .0003 mfd. is chosen for the grid condenser for a detector? I have some of .0001 and .0002 capacity—would one of these do and, if so, must I expect to lose a certain amount of signal strength?"

No, don't worry to such fine limits as this. I should say the .0002 would do perfectly well.

A grid leak detector system works to let the high frequency get on to the grid through a condenser having not too high an impedance to high frequency, but preventing the rectified impulses getting back. Thus it must not be so big that it has a low impedance to frequencies of 10,000, nor so small that it has a high impedance to frequencies of the order of 150,000.

Overloading From The Aerial.

H. A. T. (Hampstead). "I believe my leaky grid detector is being overloaded now that the new Brookmans Park transmitter has come into regular operation.

"If, however, I reduce the sensitivity of my aerial circuit I am unable to separate the two programmes. Shortening the aerial prevents my receiving foreign stations.

"Is there any simple means of controlling volume before detection, which does not

introduce the disadvantages I mention? I use a loose-coupled aerial tuner."

I suppose when, by reducing the sensitivity of your aerial circuit, you not only can separate the two programmes but you also get good quality. But by reducing your available amount of pick-up of ether energy you reduce your sensitivity so much that you haven't got enough to get weak foreign stations.

Therefore your only solution is to increase the *sensitivity of your set* (not of the current of your aerial pick-up) without decreasing its selectivity. Increasing or decreasing your aerial merely influences sensitivity at the expense of selectivity.

The only way is to put on another valve with a selective high frequency stage and keep your aerial loose-coupled, i.e.—increase selectivity very much and sensitivity some.

The Best Set.

S. J. L. (Manor Park). "I intend building a three-valve receiver chiefly for reception of my local station, which is the new 2 L O twin-wave transmitter.

"What, in your opinion, is the best arrangement of the three valves?"

It's that word "chiefly" in your first sentence that worries me! If you ever want to do some searching abroad it's better to have one high frequency, one detector, and one note mag.

You get just that extra measure of selectivity necessary, not only to cut out your local but to choose between two equal-powered distant stations. But if you honestly truly, faithfully say "no, two local programmes is all I want ever and for ever," you'll do all right with a detector and two notes, and some reaction of course.

WATCH THOSE LOUD SPEAKER LEADS!



The position of the loud speaker and of its leads may have a marked effect upon results, and very often a howl can be cured by moving the loud speaker.

Which make of
RESISTANCE
do you use?

MAKESHIFT

OR

"MAKE SURE"

FIT
DUBILIER
RESISTANCES
AND
MAKE
SURE

With the Dumetohm you make sure of absolute constancy, however much the voltage and temperature may vary. All Standard Values, each 2/6. Holder (Horizontal or Vertical) 1/-.

Filament Resister, any	
Holder	Standard Value - 1/-
Duwireohm	1/-
Holder for Horizontal type	5/- to 11/6
	1/6

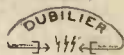

If unobtainable from your dealer write direct to us giving his name and address.

Dubilier Condenser Co. (1925), Ltd., Ducon Works, Victoria Road, N. Acton, London, W.3.

We shall be pleased to see you on our STAND No. 466, Main Hall Gallery, Ideal Home Exhibition, Olympia.

Introducing



THE NEW
COLLOIDAL VALVE
with the
Highest Efficiency Factor
yet obtained

H.F. and General Purpose 6/-
Super Power 7/-
Shortly available: Vateca Colloidal Screen Grid, Pentode and A.C. Mains Valves.

Ask your local dealer for full particulars

ABBEY RADIO, 47, Victoria Street, Westminster, London, S.W.1
Telephone: Victoria 3914



All Editorial communications to be addressed to the Editor, POPULAR WIRELESS, Tallis House, Tallis Street, London, E.C.4.

The Editor will be pleased to consider articles and photographs dealing with all subjects appertaining to wireless work. The Editor cannot accept responsibility for manuscripts or photos. Every care will be taken to return MSS. not accepted for publication. A stamped and addressed envelope must be sent with every article. All inquiries concerning advertising rates, etc. to be addressed to the Sole Agents, Messrs John H. Lee, Ltd., 4, Ludgate Circus, London, E.C.4.

The constructional articles which appear from time to time in this journal are the outcome of research and experimental work carried out with a view to improving the technique of wireless reception. As much of the information given in the columns of this paper concerns the most recent developments in the radio world, some of the arrangements and specialities described may be the subject of Letters Patent, and the amateur and the trader would be well advised to obtain permission of the patentees to use the patents before doing so.

QUESTIONS AND ANSWERS.

THE RATTLING LOUD SPEAKER.

D. J. M. (Glasgow).—"What is the cause of rattling in a loud speaker?"

It just depends upon what you mean by "rattling." In the sense commonly given to this word, "rattling" means the disturbing and irritating vibrations due to a mechanical defect or a defect in adjustment, such as a screw which has worked loose, a diaphragm which is touching the magnets, or any

other part of the mechanism which has become a little loose and which consequently responds to the variations of the loud speaker in a way in which it is not intended to do.

Such rattles are usually noticeable chiefly upon loud passages, and can usually be located if the instrument is carefully examined when working. Although it sometimes happens that such a rattle is not easy to trace, it is usually spotted at once by anyone with several years' experience of wireless, and usually it can be put right in a few moments.

Quite a different meaning is sometimes given to the word rattling, as some people use this to designate resonance on certain notes. True rattling is due to a mechanical defect, as explained above.

Resonance occurs not when something is loose but when one note, or one particular set of notes, get amplified by the loud speaker to an extent

altogether greater and out of proportion to the impulses which cause them. The natural acoustic properties of some types of horn loud speakers did not permit proportional amplification of the various frequencies in music, but accentuated and greatly over-produced those frequencies which corresponded with the natural frequency of vibration of the air column within the horn, or some other inherent

"P.W." TECHNICAL QUERY DEPARTMENT

How's the Set Going Now?

Perhaps some mysterious noise has appeared, and is spoiling your radio reception?—Or one of the batteries seems to run down much faster than formerly?—Or you want a Blue Print?

Whatever your radio problem may be, remember that the Technical Query Department is thoroughly equipped to assist our readers, and offers an unrivalled service.

Full details, including scale of charges, can be obtained direct from the Technical Query Dept., POPULAR WIRELESS, The Fleetway House, Farringdon Street, London, E.C.4.

A postcard will do. On receipt of this an Application Form will be sent to you free and post free immediately. This application will place you under no obligation whatever, but having the form you will know exactly what information we require to have before us in order to solve your problems.

LONDON READERS PLEASE NOTE: Inquiries should NOT be made by phone, or in person at Fleetway House or Tallis House.

frequency that came within the range of audibility. The extra amplification was due to the fact that the note being reproduced and the reproducer itself were in resonance, i.e.—vibrating at exactly the same frequency, and thus it is that this class of loud speaker defect is more properly described as resonance than as rattling.

(Continued on page 58.)

THE TRANSFORMER FOR YOUR PORTABLE

IGRANIC

TYPE "J" L.F. TRANSFORMER

See how small it is. Though it only weighs a few ounces, it is by far the best of its kind. Use it in your portable, and enjoy truly magnificent magnification. Rich bass and clear high notes. If you want the best results from your portable, get to know the Igranitic range. Made in two ratios, 3 : 1 and 6 : 1.

PRICE 17/6



Igranitic "J" Transformer



IGRANIC ELECTRIC CO., LTD.,
149, QUEEN VICTORIA STREET,
LONDON, E.C.4

Write for Lists to Dept. R.146.



TEAM WORK

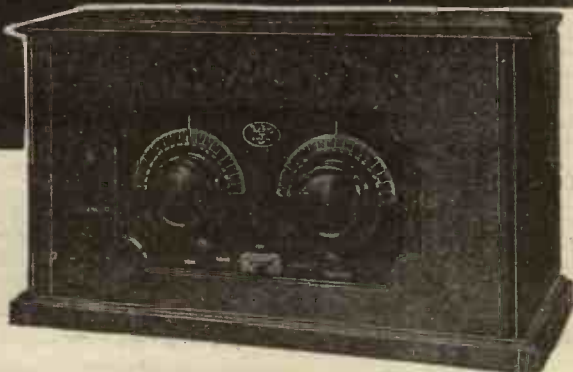

—EVERY PART A STAR PERFORMER

Every part played in the show is played by a star performer! Every part in the Empire 3 is a star part with a star performance! Every part a Burton part—all working together like one mighty whole—that's team work—the secret of performance—the secret of the Empire 3.

£5 10

Valves, Batteries and Royalties extra.

ALL MAINS MODEL

(self-contained)
 Price of Set £11 : 5 : 0
 Price of Valves (Mullard A.C.) £3 : 10 : 0
 (Royalties extra)

Identical in appearance to the Battery Model.

THE BURTON EMPIRE 3

EVERY PART A BURTON PART

C. F. & H. BURTON, PROGRESS WORKS, WALSALL, ENGLAND

All-Electric facilities for your Set

Clarke's "Atlas"
 All-Electric Unit
 Model A.C.86

Incorporating the Westinghouse Patent Metal Rectifier. For Alternating Current 200/250 Volts. 40/120 Cycles.



The latest feature in All-Mains Units

No Alterations Necessary

Without any alterations whatever to your present Set, providing you have Electric Light in the home, these new "ATLAS" Units will provide from the Mains all the H.T. and L.T. supply necessary for your Set at a cost of a few pence per month.

Combining H.T. Battery Eliminator and Low Tension Trickle Charger, these new "ATLAS" Units, Models A.C.86 and 84X, incorporate the Westinghouse Patent Metal Rectifier and give every facility for making your Set in every way equal to an expensive All-Mains Set. Model A.C. 86 (illustrated), for Alternating Current, provides 3 H.T. Tappings—one fixed of 150 Volts and two variable 0/100 Volts and 0/120 Volts respectively, and gives output of 150 Volts at 30 m/A. On the Low-Tension side, facilities are provided for maintaining the charge of either, 2, 4, or 6-volt Accumulators. Price 10/- down and nine monthly easy instalments or

CASH PRICE, £8 . 15 . 0

10/- DOWN

brings either of these "ATLAS" Units into your home. The balance you pay in easy instalments. They are fully guaranteed for twelve months and are absolutely safe.

MODEL A.C. 84X. This is a cheaper Model suitable for any Set requiring up to 15 m/A, output, and provides two fixed H.T. Tappings of 90 and 120 volts respectively, and one variable of 0/100 Volts. The Trickle Charger on this Model provides for maintaining the Charge of 2-volt. L.T. Accumulators only. Price 10/- down and 6 monthly easy instalments, or

CASH PRICE, £6 . 17 . 6

Can be obtained from any good wireless dealer, or direct from the makers.

"CLARKE'S ATLAS" ALL-MAINS UNITS

Ask your Dealer for Folder No. 49, or POST THIS COUPON TO-DAY

Messrs. H. Clarke & Co. (M'er.), Ltd. (Dept. 3), Atlas Works, Old Trafford, Manchester.

Please forward your Folder No. 49 and particulars of your easy payment scheme.

NAME.....

ADDRESS.....

in unsealed & stamped envelope Please use **BLOCK LETTERS.** (P.W.4.)

RADIOTORIAL QUESTIONS AND ANSWERS

(Continued from page 56.)

HOW MUCH H.T.?

B. W. (Pendleton).—"The only thing I am not certain about is how much H.T. do I need for good two-valve results?"

The H.T. voltage required depends upon the valves you are going to use, and the conditions under which you hope to work them. With every valve supplied you will find the makers give a valve curve or a chart showing how different values of H.T. affect its performance.

For really high quality reproduction and to handle very large volume it is essential to have the higher H.T. value recommended by the valve makers, but for ordinary household use near a powerful local station the H.T. may safely be reduced to the lower limit given on the chart, and for an ordinary det.-power-valve receiver used under average conditions a standard battery will be perfectly satisfactory.

AN OLD-TIME CIRCUIT.

M. F. A. (Oxsted, Surrey).—"I expect you will laugh, but I am still using the 'P.W.' Blue Print No. 20, Det. and 2 L.F. Moreover it has been perfectly satisfactory all this long time, although, of course, a good many H.T. batteries have fallen by the wayside, the valves are all newcomers, and recently I got a cone loud speaker instead of the old piping horn (what a difference!).

"With this new speaker the only thing is that a trace of harshness which I found before is now a little accentuated, and a wireless friend looking over the circuit was horrified to find that one of the low-frequency valves has no grid bias. Can it be fitted easily, and do you think it would be an improvement?"

Yes, we definitely advise you to put grid bias to the first L.F. stage as well as to the second. We are not sure how your low-frequency transformer is marked, as sometimes the secondary is marked OS and IS, while other makes use other markings for the secondary, such as "G.B. —" and "G."

or "G" and "L.T. —" or "G" and "C"—(the latter being an American designation.)

In any case, all you have to do is to examine the wiring of the secondary to your first low-frequency transformer, noting that one end of this goes to the

WHAT DO YOU THINK ABOUT THIS?

A Leicester reader of "P.W." was greatly puzzled by a "rushing" noise, lasting several minutes, which developed on a set that had hitherto been singularly free from faults. It was chiefly noticeable when first switching on, and often would suddenly right itself without apparent cause.

Outdoor aerial and earth were faultless. Loud speaker, grid bias, 6-volt L.T. battery, and 150-volt wet H.T. battery all appeared O.K., and the wiring and components were thoroughly tested, but the trouble persisted.

Can you guess

WHERE WAS THE FAULT?

N.B.—There is no prize for answering this, but from time to time we shall give a radio problem (followed the next week by the answer) in the hope that readers will find them both interesting and instructive. (Look out for the answer to above next week.)

Last week's "poser" was really a very ordinary but easy-to-overlook affair! The reason that the restoration of the lead did not restore H.T. was that the flash-lamp fuse had blown when the H.T. lead was shorted. After this had been replaced the set was O.K. again.

grid of the second valve and the other end goes to a point on the set that is connected to L.T. —

The wire which goes from the secondary to grid is O.K. and need not be altered in any way. That other side of the secondary which now goes to L.T.

must be disconnected from there, and the secondary terminal must be provided with a flexible lead ending in a black wander plug.

This wander plug should be put into the grid-bias battery at about 1½ volts negative, and this is all the alterations that are required.

H.F. TRANSFORMER WINDING.

H. M. B. (Lincoln).—"As you suggested, I found the whole trouble was due to the split-secondary H.F. transformer. So I purchased a new former and intended to rewind it, but unfortunately it is a bigger job than I thought it was, and I am not quite sure that I shall get it right unless you can tell me turn numbers, etc. (I lost count of the number of turns of the small winding, and also I am not very sure as to which pin it is connected to.) If this is successful I should like to try also the Daventry coil. What would be the turns for that also?"

For the secondary, on the outer (two-inch former) you will need about 80 turns of 28 D.S.C. This is made up as two separate windings of 40 turns each. The primary is wound on the 1½-inch former placed centrally inside the secondary, and consists of 20 turns of No. 30 D.S.C.

This primary is connected across pins 1 and 2. One half of the secondary winding is connected across pins 3 and 4, and the other half across pins 5 and 6.

The Daventry coil range is very similar, but in this case the secondary consists of 170 turns of No. 40 enamelled wire wound in two sections of 85 turns each, the primary placed centrally as before, consists of 60 turns of No. 30 D.S.C. wire.

THE "P.W." STATION SELECTOR.

H. W. (Seaford, Sussex).—"A wave-trap is not good enough, but since hearing it I fancy the 'P.W.' Station Selector would be just the thing I require. I have a good .0005-mfd. variable tuning condenser on hand and a variety of coils.

"If I could use one or all of these I should like to make it up. What types would be required and what are the connections?"

(Continued on page 60.)



Another Benjamin Component Success!

Exhibiting at Ideal Home Exhibition, Stand No. 460 Gallery, Main Hall, Olympia.

Once again the Benjamin Electric, Ltd., have designed a radio component of outstanding merit. The new Benjamin ball-bearing turntable is indispensable where Portable Receivers are concerned, it being equipped with hinged and folding legs which enable the Receiver to be used out of doors, with the best possible results. For indoor use the legs are folded up, being equipped underneath with rubber buffers so as to avoid damage to furniture, etc.

Price 7/6d. complete. Write for illustrated leaflets on all Benjamin Products.

BENJAMIN

BALL-BEARING TURNTABLE

Buy Benjamin & buy the Best!

The Benjamin Electric Ltd., Brantwood Works, Tottenham, N.17.

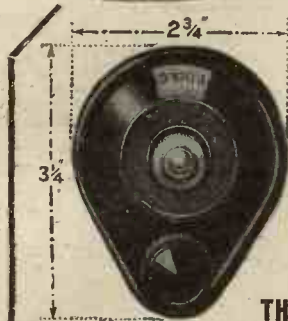

MECHANICALLY PERFECT, POSITIVE BRASS CONTACT drive on SOLID BRASS SCALE ensuring smooth movement with absolutely NO BACK-LASH. ROBUST in Construction and Trouble Free.

PRICE
3/-

THERE IS ONLY ONE GENUINE

FORMO-DENSOR

as used by designer and specified for the BROOKMANS REJECTOR, The WAVE-CHANGE REJECTOR, and The KENDALL REJECTOR.



Length 2 1/2 in.
Width 1 in.

- F. Max. .0001
Min. .000005 2/-
- J. Max. .0003
Min. .000025 2/-
- G. Max. .001
Min. .0002 2/-
- H. Max. .002
Min. .001 3/-

"1930" LOG (MID-LINE) CONDENSER

- In four Capacities:
- 0005
 - 00035
 - 00025
 - 00015

4/6
each.

*Double spacing of vanes for Ultra Short-wave work.

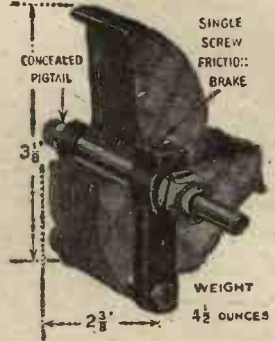

THE FORMO CO., CROWN WORKS, CRICKLEWOOD LANE, N.W.2.

CHEAPER & BETTER

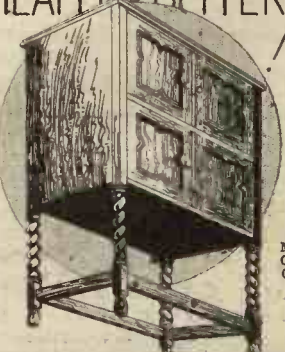

This **"OSBORN"** READY-TO-ASSEMBLE FIGURED OAK **RADIO CABINET** for £1/15/0

(Model No. 191.)
Machined Parts ready for assembling - £1 15 0
Cabinets assembled ready for polishing £2 7 6
Cabinets Finished ready for use - £3 0 0

3 ft. high, 2 ft. wide, 1 ft. 4 ins. deep.
Panel size 21 ins. X 8 ins. (or smaller).
Four doors opening top and front.

Send 3d. in stamps for 56-page Illustrated Catalogue.

CHAS. A. OSBORN

(Dept. P.W.), THE REGENT WORKS, Arlington Street, London, N.1.

Open to 7.30 p.m. Sat., 4.30 p.m. And at 21 Essex Rd., Islington, N.1. Telephone: Clerkenwell 5095.

Phone: Clerkenwell 5654. Open until 8 p.m. Sat., 9 p.m.

"POPULAR WIRELESS" ADVERTISEMENT RATES

Whole Page £40 Quarter Page £10
Half Page £20 Eighth Page £5
Narrow Column Advts. (3 cols. to page) per inch 30/-
Minimum Space accepted - - - - half inch 15/-

NO SERIES DISCOUNTS. ALL ADVERTISEMENT COPY SUBJECT TO EDITORIAL APPROVAL. COPY AND BLOCKS MUST BE IN HAND 11 DAYS BEFORE DATE OF ISSUE TO ENSURE PROOFS

ALL communications respecting ADVERTISING must be made to:-

JOHN H. LILE, Ltd., 4, Ludgate Circus, London, E.C.4 and NOT to Editorial or Publishing Offices.

Wireless troubles are less troubles..



with

FLUXITE

FLUXITE is sold in tins, price 8d., 1/4 and 2/8. SOLDERING SET Complete
Another use for Fluxite: Hardening Tools and Case Hardening. 7/6

Ask for leaflet on improved methods.

or LAMP only. 2/6

FLUXITE LTD.

(Dept. 324), Rotherhithe, S.E.16.

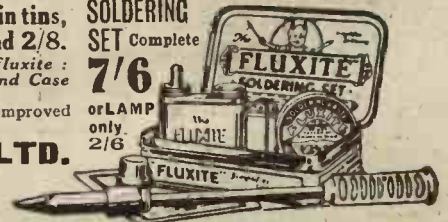

- IT SIMPLIFIES ALL SOLDERING

THE NEW GOLDEN P.R. VALVE
ABNORMAL SELECTIVITY AND VOLUME

By a special process employing an extremely rare element in minute and precise quantities, in the coating of our "Golden" Series, we have been able to turn out a valve of extraordinary efficiency. Although the L.T. Fluorine consumption has been kept more or less to our standard to secure robustness, the emission has been increased BY OVER 50 PER CENT.

INSIST ON THE GOLDEN P.R.

For selectivity and volume we believe a better valve cannot be obtained anywhere with such a low consumption of H.T. and L.T. The glass bulbs are of a distinctive golden colour, and each valve has a golden guarantee band.

GUARANTEE. All valves despatched under guarantee of Money Back in Full if not satisfied and returned within 7 days. All valves are carefully packed and breakages replaced.



Sent C.O.D. if desired.

Ask your dealer for them. Accept no other.

THE ONLY BRITISH VALVE WITH A WRITTEN GUARANTEE AS TO PERFORMANCE & LIFE.

Tel.: City 3788.

LIST OF P.R. SUPER GOLDEN SERIES.

	Type	Fil. volts.	Amp.	Imp. ohms.	Amp. fac.	
4/6	GPR 22	-	-.095	24,000	13.8	H.F. Det.
	GPR 32	-	-.095	12,000	9	L.F.
	GPR 42	-	-.095	40,000	32	R.C.
EACH Post 4d	GPR 9	3.5-4	-.09	22,000	14.5	H.F. Det.
	GPR 10	3.5-4	-.09	10,000	9	L.F.
	GPR 11	3.5-4	-.09	44,000	41	R.O.
POWER 7/6	GPR 17	5-8	-.14	20,000	17.5	H.F. Det.
	GPR 18	5-8	-.14	11,000	9.5	L.F.
	GPR 19	5-8	-.14	75,000	41	R.C.
SUPER POWER 12/6	GPR 20	2	-.15	6,000	7	Power
	GPR 40	4	-.15	6,000	7	"
	GPR 60	6	-.15	6,000	7	"
EACH Post 4d, SCREENED GRID	GPR 120	2	-.3	3,000	4.5	Super Power
	GPR 140	4	-.2	3,500	4.5	"
15/- Each Post 4d	SG 25	2	-.2	220,000	150	S.G.

2 Valves or more sent POST FREE. Matched Valves 1/- extra per set.

P.R. PRODUCTS, 41, P.R. HOUSE, NEWGATE STREET, LONDON, E.C.4
(Opposite G.P.O. Tube Station)



A.C. VALVES SIR!
TUNGSRAM-
 I have them in stock

"I have stocks of TUNGSRAM A.C. Indirectly Heated Valves. In fact I carry stocks of the whole range. They're really wonderful valves. Better in quality than any Association valve—they have the famous Barium filament—yet they cost nearly 50 per cent less. A tip-top valve at a rock-bottom price."

Indirectly Heated Valves, 9/6
4 v. A.C. Power Valves .. 8/-



TUNGSRAM PHOTO-ELECTRIC CELLS
 3 Types
 Standard, £2:10:0
 Nava E, £2:17:6
 Nava R, £2:17:6

TUNGSRAM BARIUM Valves

TUNGSRAM ELECTRIC LAMP WORKS (GT. BRITAIN) LTD., Radio Dept., Commerce House, 72, Oxford Street, London, W.1

Factories in Austria, Czechoslovakia, Hungary, and Poland.

Branches: Belfast, Birmingham, Bristol, Cardiff, Glasgow, Leeds, Manchester, Newcastle, Nottingham.

RADIOTORIAL QUESTIONS AND ANSWERS

(Continued from page 58.)

The parts incorporated in this unit are as follows: One .0005-mfd. variable condenser, one coil socket of the baseboard-mounting type, one neutralising condenser, one terminal strip about 3 in. by 2 in., carrying three terminals, and a baseboard measuring about 8 1/2 in. by 6 in. (Also tinned copper wire, flex, etc.).

In the original Station Selector the variable condenser was of the baseboard mounting type, but if yours is not in this category, you can arrange to mount it by means of a strip of ebonite or other suitable means. Arrange the terminal strip on one of the 6-in. sides of the baseboard, the condenser being mounted at the opposite side.

Slide by side between these two mount the plug-in coil holder and the neutralising condenser. The wiring is as follows:

One terminal, called A, carries a flex lead, which plugs on to the coil to be used. Next to it is the earth terminal, which is connected to one side of the .0005-mfd. variable condenser and to one end of the coil holder. Remaining side of the variable condenser and the remaining side of the coil holder are joined together and to one side of the neutralising condenser. The remaining side of the neutralising condenser goes to the A terminal. In use A goes to the aerial terminal on the set, and the aerial lead is taken to A, the tapping attached to the terminal being varied as required.

For the ordinary wave-lengths you require a 60-turn X coil, and for long waves a 200 or 250 X coil. (If you have tapped coils these can be used instead of X coils, to provide selectivity.)

ADDING GRID BIAS TO THE ALL-WAVE H.F. UNIT.

J. H. R. (nr. Manchester).—"Some time ago I built the 'All-Wave' H.F. Unit described in 'P.W.' January, 1929. I must say it has been very successful. Many more stations are coming in and volume and tonal quality are much better than I had on an ordinary tuned-anode H.F. set.

"I understand that grid bias applied will lessen the consumption of H.T., and if this is so and I only need a 4 1/2-volt G.B. battery, please say what connections are necessary."

You will have to undo the connections from the moving vanes of the tuning condenser and from the "earth" side of the aerial coil. Join these two points together and take them to the neg. plug of the new G.B. battery. The positive end of this will go to earth, and theoretically you need a condenser across it (.001 or so), but possibly you may find this can be dispensed with.

IMPROVING A CRYSTAL SET.

F. L. W. (Wandsworth).—"Although the name on the box is a good one, the results from it are rotten. As the idea was to help a rather deaf lady to pass the time away, it is quite useless, and I am wondering whether you have got a blue print or anything showing how to build a two-valve amplifier. Do you think this would bring it up to loud-speaker strength, and would a two-volt one be O.K.?"

If the strength of reception from the set sounds fairly good to normal ears, the addition of a two-valve amplifier would bring the signals to loud-speaker strength, and certainly it would be quite loud enough for a rather deaf person to hear in comfort, even though in this case 'phones were necessary instead of the loud speaker.

A good two-valve amplifier of the kind required is described in the "P.W." Blueprint No. 38, which is obtainable from our Back No. Dept., Bear Alley, Farringdon Street, London, E.C.4. (The price is 6d., and a stamped addressed envelope should be enclosed.)

Two-volt valves would do excellently for the amplifier, and as it is quite easy to make, we think this would be the best way out of your difficulty. One other point. As your present set is apparently not up to standard, we advise you to get into touch with the makers' service department, for although they may not be able to improve it sufficiently to give you good service from a crystal alone at the distance at which you are situated, there is no reason why you should not have an efficient set handling as much power as possible to the amplifier.

J. L. LANELLY S.O.S.

A correspondent who lives near Llanelly is anxious to get in touch with Mr. E. Williams, whose letter appeared in "P.W." 404 (March 1st). As the address has now been mislaid we hope that if this meets Mr. Williams' eye he will let us have his address again, so that a letter to him can be forwarded.

SHORT WAVE AND LONG DISTANCES.

"INTERESTED" (Gloucester).—"Why is it that short-wave stations have such tremendous ranges when compared with ordinary and long-wave stations using the same power?"

Short-wave transmissions have the peculiarity that although their direct wave energy is quickly absorbed (and consequently they have a small service area around their own locality) the efficiency of their free wave radiation is very high. As their "free" wave, which is not earth-bound, is the one that affects very distant receivers, the short-wave transmissions are received well where ordinary wave-length transmissions, using the same power, could not be picked up.

CONNECTIONS FOR AN X COIL.

J.M. (Ealing).—"I am a bit tied up over the correct way of connecting the coil holder which is to hold an X coil. Which side should go to earth?"

The standard connections are, in the case of the aerial coil, for the holder to be joined so that its pin side is to the earth terminal of the receiver. If there is no separate aerial coil but the aerial is tapped in on the grid coil, the pin of this coil holder, also, should be connected to the earth terminal.

POPULAR "WIRELETS" No. 5

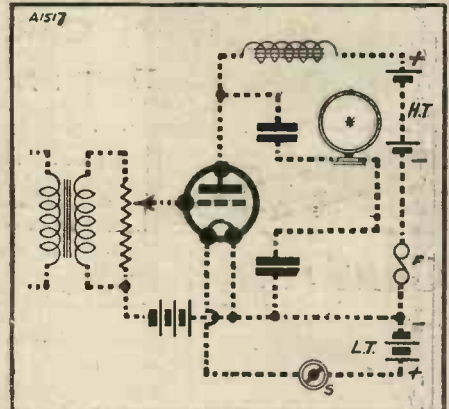

The dotted lines show the connections for the L.F. amplifier (with volume control and filter output given in last week's "P.W.")

THIS YEAR'S "MAGIC-DE-LUXE."

All you will have to do when you desire to use the gramophone attachment, you will understand, is first of all to plug the pick-up leads into the two sockets on the panel, and then switch off the filament of the detector valve, leaving the main control switch of the set (S₂) turned on. Thereafter all you have to do is to run the gramophone pick-up in the ordinary manner, and adjust the volume control to the desired point.

By the way, here is a tip you may find useful. If you are using the gramophone to fill in a gap in the programme when something is going on which you do not desire to hear, and you want to find out whether the talk or whatever it was has finished, you can leave the pick-up connected and just turn on the new switch S₃, which controls the detector. As soon as you turn this on, you will hear the broadcast programme coming through at somewhat reduced volume, and you can thus find out what is happening.

To get back to normal conditions, of course, you will have to pull out the two pick-up sockets, which is naturally to be desired in any case, because one does not, as a rule, wish to leave the leads from the gramophone trailing to the set.

LET 'EM ALL COME!

THE
“ETHER SIFTER”

will sort out all those wave-length tangles that prevent your enjoyment of distant programmes.

DON'T BE CONFINED TO YOUR LOCAL,

but pick your items when and where you will. You can easily do it if you build this remarkable little unit, which

CAN BE ADDED TO ANY RECEIVER.

Full constructional details are given in the

APRIL
MODERN WIRELESS

Also in the same number is described a new way of using the screened-grid valve, which enables you to cut down your running costs, improve your selectivity, and which gives you much clearer reception.

All valve set owners should read

“REVOLUTIONISING THE S.G.”

Make sure of your Copy of

MODERN WIRELESS

Price 1/-

On Sale APRIL 1st

Price 1/-

STANDARD

SAC PERMANENT



RE-CHARGES ITSELF OVERNIGHT

BETTER, PURER, SAVES POUNDS

Cut out the expense of costly dry batteries. Solve the problem once and for all—install the wonderful STANDARD Permanent Wet H.T. Battery. Many thousands of listeners all over the country have paid testimony to this economical, reliable, and trouble-free H.T. It lasts literally for years.

PROGRAMME AFTER PROGRAMME

is heard with a purity and clarity that is delightful. The product of a British firm, scientifically constructed and designed, the acme of simplicity in use, easily recharged at home with the wonderful cartridge refills (cases are on record of over 12 months' use before recharging was necessary) and, above all this, you get better reception because of the smoothness of current which no other source of H.T. can equal. Thousands have done it. Why not you? Write to-day.

LET THE AMAZING FREE BOOK

GREAT OFFER!

5/- H.2. 10,000 M.A. capacity, 48 No. 3 cells, 72 volts, in 2 trays with lid. Cash £2 3s. 6d. or 5/- down and 5 monthly payments of 8/2.

CONVINCE YOU

Standard Batteries are sold in neat Umbloc containers on our famous cash or "no deposit" terms, by all good dealers, Balford's and Curry's, or direct.

Write for free book.

10/- H.4. Over 10,000 M.A. capacity, 72 cells, 108 volts, in 3 trays with lid. Cash £3 4s. 0d. or 10/- down and 5 monthly instalments of 11/3.

The STANDARD BATTERY CO. (Dept. P.W.), 184/188, Shaftesbury Avenue, London, W.C.2

Line diaphragm double cone collet with set screw fixing, 9d. Extension Rod, Cd. Single Cone collet, Cd. Straining rods and nuts, per set, 2/6. Write for full particulars of new Super Twin-Mag Unit. GOODMANS, 21, Farringdon Street, London, E.C.1.

"KLEER-KUT" COILS PUT FORM INTO PERFORMANCE

25. 30. 35. 1/-, 40. 50. 1/2, 60. 75. 1/3. 100. 125. 150. 1/6. 175. 1/9. 200. 2/-, 250. 2/3. 300. 2/6. Centre Tapped 6d. "X" Coils 1/- extra. L. BRUCE, 99, King Henry's Rd., LONDON, N.W.3. 6 years coil maker to the Wireless Trade. Phone: Primrose 1303. Trade supplied.



KAY'S CABINETS
This Cabinet, solidly constructed of Oak and equipped with Baseboard Runners, Fall Front, Hinged Top, Polished rich Jacobean, 36" 45/- high. For panels up to 18" wide. Also made to accommodate any Popular Set. Greatest Range of Wireless Cabinets. Illustrated Lists Free.
H. KAY Cabinet Manufacturer, Mount Pleasant Road, London, N.17. Phone: WALTHAMSTOW 1626.

FOR THE LISTENER.

(Continued from page 40.)

to me. The gramophone records of Javan and Persian musicians, and of the "Chinese Gracie Fields," were interesting as curiosities. I have friends, however, who thought it all first-rate. They are probably right. I may have been in the wrong mood.

A Sportsman's Day.

The Scotch Pipers were on their way to Twickenham for the International Rigger match. This turned out to be a battle royal, with everybody, including the commentator, at the top of their form.

In the evening, Mr. Abrahams gave an interesting account of the 'Varsity Sports; but he did not suggest that a broadcast of the Long Jump or Putting the Weight should be an item in the next "Diversions."

A New Light on Harps.

I have never reckoned much of the Harp—except perhaps the Jew's harp!—as a musical instrument, and have desired heaven on other grounds; but came near to changing my mind the other evening when I listened to Jeanne Chevreau who made music like the sound of laughing water. She must have wrists of iron and finger-tips of silk.

Vaudeville.

No doubt the majority of listeners measure the entertainment value of the programmes by the quality of vaudeville; and it is pleasant to record that this is distinctly improving. Albert de Courville has gingered it up a lot.

George Clarke was very amusing with his running commentary, à la Allison, on a heavy-weight boxing bout. Tommy Handley is a perennial who flowers anew all the year round. But what is chiefly gratifying is that the general average is now so much higher. There is less padding and make-shift, and fewer dreadful experiments.

Radio Plays and Alternatives.

Included in a recent vaudeville programme was a sketch by Holt Marvell, "Evidence for the Defence," which I thought particularly well done. This is the sort of stuff which can be rendered better by wireless than on the ordinary stage; for the lady who brought the "evidence" was the ghost of the murdered woman!

Quite a good thrill, and acted in exactly the right key. "Fulk o' the Forest" on the other hand seemed to me rather pretentious, and I lost interest.

The alternatives on this occasion were Capt. Kingdon Ward talking about the attempt to climb Kamehenjunga this summer, and Harold Samuel in a delightful pianoforte recital. Good again for the programme builders!

Talking About Ghosts.

Talking about ghosts, the versatile Desmond McCarthy blossomed into a new rôle with a ghost story about a man who was haunted by himself. It was a painful tale. You can make ghost stories as grim and as terrifying as you like, if only I can believe when it is over that it couldn't be true. But I horribly felt that Mr. McCarthy's tale might easily be true! I slept badly!

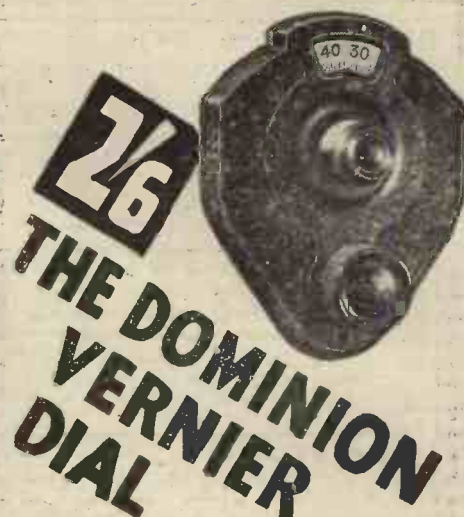

Only Brownie's huge production enables them to offer this really splendid dial for 2/6. The special non-backlash design makes hair-breadth tuning a matter of delightful ease, while its handsome appearance (black or beautifully grained mahogany bakelite) will add to the good looks of that new set you are building. BROWNIE WIRELESS COMPANY (G.B.) LIMITED, NELSON STREET WORKS, LONDON, N.W.1.

BROWNIE WIRELESS.

SUPER - MICROPHONES



New, highly sensitive, made on the latest principle, a vast improvement over all other types; will pick up whispered words from a distance of several yards, also strongly amplify and transmit speech and music over a distance through Loud-speaker or Headphones, splendid instruments for making Detectaphone DEAF-AID, LOUD-SPEAKING TELEPHONE Announcements through Loud-speaker, Amplifier for Crystal or

Valve Sets, Electric Sound Detector, BABY ALARM or INVALID CALL from bedroom through distant Loud-speaker, Experiments etc. NO OTHER MICROPHONE OF EQUAL SENSITIVENESS KNOWN. Each instrument finely black enamelled and fitted with a 3-ft. silk flexible connecting cord. Despatched by return 8/6 of post.

SPECIAL MICROPHONE TRANSFORMER for connecting Super-Microphone to Radio Headphones, Loud-speaker, Valve Set or Valve Amplifier 6/-

SMALL 10 OHMS EARPIECE for use with Super-Microphone as a HIGHLY EFFICIENT DEAF AID, or Detectaphone, etc. thin 2-ft. silk connecting cord fitted, Earpiece Fine Black Enamelled 6/-

Full Directions for use of Super-Microphone for many purposes and Diagrams of connections free.

FREDK. ADOLPH, Actual Maker, Phone: 27, Fitzroy Street, London, W.1. Museum 8329.

CABINETS AT BARGAIN PRICES

Solid Oak Cabinets, well made and highly polished, American Type, Open Top, complete with Baseboards.
12" x 8" x 8" 9/6 18" x 7" x 10"
14" x 8" x 8" 9/6 21" x 7" x 10" 12/6
16" x 8" x 8" 12/6 21" x 7" x 10" 12/6
Postage and Packing 1/3 extra.
Any size & shape made to order in 7 days. W.C.R.S. TURNABLE for portable set users. Diameter 6", ball-bearing movement, fitted with rubber base. Finished in gilt, 3/9 post free.
SEND FOR CATALOGUE LIST, POST FREE. Sent C.O.D. if desired. Phone: Terminus 6777. WEST CENTRAL RADIO SUPPLIES, 259, Gray's Inn Rd., King's X, London, W.C.1

PLEASE be sure to mention "POPULAR WIRELESS" when communicating with Advertisers. THANKS!

DIVIDING THE ETHER.

(Continued from page 37.)

applied to heat was applicable to cable transmission also, so long as self-induction was not taken into account.

When Heavyside did take it into account, a much more complete theory was given; and he arrived at what was considered by telegraph engineers the paradoxical recommendation to increase the self-induction of a cable as much as possible, though hitherto they had regarded it as a bugbear. It is now generally known that, after much opposition, this has been actually done; and both cable and land transmission have been thereby improved and made more rapid. So it may be some day with wireless telegraphy, if every feature in the complete theory is attended to, and if some as yet uninvited device is forthcoming for accomplishing the desirable end.

Another analogy, and perhaps a more useful one, can be drawn from the practice of instrumental music. A piano string once struck, especially if struck forcibly, will go on sounding for an appreciable time, unless damped, and will thereby give a more or less confused sound.

A Piano Parallel.

If this compound sound is interesting or harmonious, it may be desired for musical purposes, and in that case the strings are not damped. In other words, the dampers are then taken off them by depression of a so-called loud pedal, which does not really make any string louder than before but enables it to continue for a longer time, so that the total sound is increased by the summation of separate tones.

But when the result is inharmonious, or when successive tones are wanted for rapid melody, then each key once struck is rapidly allowed to rise again, so that the damper attached to it is immediately re-applied to the struck string.

We can then play a scale or succession of notes, each fairly independent of the others. If the damper were always on the string, it would not vibrate much; its response to the blow would be feeble, and the tone would be dull and depressed. To get a clear response, the damper must be raised; and to get a sharp response the damper must be immediately restored. What we want is a free vibrator at the instant of excitation, and a quick cessation or forcible stopping afterwards.

Persistence and Tuning.

Now applying this to a resonant wireless receiving circuit: we want it to be a free vibrator of minimum resistance, and accurately tuned, for purposes of excitation. But since it has to respond to a whole sequence of fluctuations of amplitude, that is virtually to another group immediately afterwards we want the effect of each to die away rapidly, and give place to the next.

In the ear and the eye, provision for this rapid succession of impulses is actually made. The eye has a certain persistence of vision, but it is very short. Directly the light ceases, the effect on the retina subsides in the one-twelfth of a second, and therefore within that fraction of time we

(Continued on next page.)

YOUR CHOICE OF THIS YEAR'S SETS COMPLETE NON-SOLDERING KITS READY for IMMEDIATE DESPATCH

Ready Radio kits are specifically approved by "Popular Wireless," and you ensure 100% efficiency from your receiver by obtaining your complete kit from a Radio House that specialises in "P.W." circuits.

1930 "MAGIC" 3 1930 "TITAN" 3

PRICE £6:16:0 CASH **KIT A** PRICE £5:11:0 CASH

OR
12 equal monthly payments of 12/6 LESS VALVES AND CABINET 12 equal monthly payments of 10/3

PRICE £8:9:6 CASH **KIT B** PRICE £7:16:0 CASH

OR
12 equal monthly payments of 15/9 WITH VALVES LESS CABINET 12 equal monthly payments of 14/6

PRICE £9:19:6 CASH **KIT C** PRICE £9:6:0 CASH

OR
12 equal monthly payments of 18/6 WITH VALVES AND CABINET 12 equal monthly payments of 17/3

"REGIONAL" 2 "REGIONAL" 4

PRICE £4:12:6 CASH **KIT A** PRICE £8:2:0 CASH

OR
12 equal monthly payments of 8/6 LESS VALVES AND CABINET 12 equal monthly payments of 15/-

PRICE £5:15:6 CASH **KIT B** PRICE £10:18:0 CASH

OR
12 equal monthly payments of 10/9 WITH VALVES LESS CABINET 12 equal monthly payments of 20/-

PRICE £6:18:0 CASH **KIT C** PRICE £12:10:0 CASH

OR
12 equal monthly payments of 12/9 WITH VALVES AND CABINET 12 equal monthly payments of 23/-

CELESTION LOUDSPEAKERS

Model C 10 (Oak)

PRICE £3:15:0 CASH

OR
8 monthly payments of 10/3

Model C 12 (Oak)

PRICE £5:12:6 CASH

OR
12 monthly payments of 10/3

DE-LUXE "MAGIC" CONVERSION KIT

£ s. d.

1 Varley Output filter choke about 20 henries 1 0 0

1 Dubilier 2 mfd. condenser - - - - 3 6

1 Ready Radio on-off switch - - - - 10

2 Small panel mounting sockets - - - - 2

£1 4 6

Total Extra Cost of "de Luxe" additions to all Magic Kits.

Ready Radio

159, Borough High Street, London Bridge, S.E.1

Telephone No.: Hop 5555 Private Exchange

Telegrams: Ready Hop 5555 London

Finds Fault Instantly

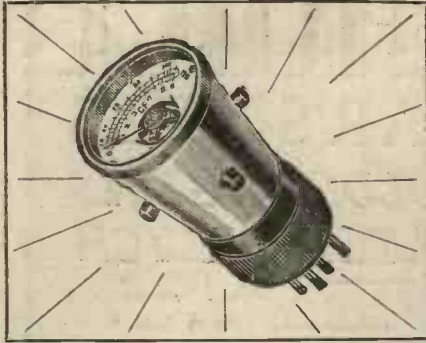

The C.F. Radio Controller

Saves hours searching in the dark. It *immediately* finds any fault in the filament, plate or grid circuit or in the L.T. or H.T. voltage under load.

It tests the Valves, Transformers, Speaker and Potentiometer and checks all connections in the set, batteries and accumulators.

The C.F. Radio Controller is patented throughout the world and is used by dealers and listeners everywhere.

Of all Dealers.

21/- Write for illustrated leaflet to:

FONTEYN & CO., LTD.
2, 3, 4, 5 & 6, Blandford Mews, Baker St., W.1
Telephone: Welbeck 4144 (3 lines)

EASY TERMS

We SPECIALISE in the supply of all Good Quality Radio Sets, Components and accessories on Easy Terms. We will give you efficient service. Send us your list of requirements and a quotation will be sent by return.

LONDON RADIO SUPPLY COMPANY
11, Oat Lane, Noble St., LONDON, E.C.2
NATIONAL 4977.

REPAIRS

Any make of L.F. Transformer, Loudspeaker or Headphones repaired and despatched within **48 HOURS—TWELVE MONTHS' GUARANTEE** with each repair. 4/- post free.

Terms to Trade.

TRANSFORMER REPAIR CO.,
"Repairs" Dept.,
214, High Street Colliers Wood, London, W.14

ALWAYS LIQUID
THE IDEAL GLUE FOR MAKING SETS & SPEAKERS
LEPAGE'S LIQUID GLUE
SOLD BY IRONMONGERS, STATIONERS AND STORES
TUBES 6/- BOTTLES 10/- AWARDED 16 MEDALS
ANDREADY
LEPAGE'S GLUE CO. LTD., 4-10 HATFIELD ST., LONDON, E.C.1

THE PICTURE PAPER WITH THE MOST NEWS
—SUNDAY GRAPHIC—

DIVIDING THE ETHER

(Continued from previous page.)

are able to look at another object, and thus see things one after another, as we want to.

A photographic plate has not this power. The impression once made persists; and if you focus on another object you get double exposure; or if you move the camera over a landscape you get a mere smudge. A photographic plate is an extreme case of retention of impression. The eye has sufficient retentivity for convenience, especially for the convenience of a kinematograph operator, and yet none too much.

Exactly how the impression on the eye is obliterated I am not prepared to say. If the stimulus is too strong, the check apparatus is put out of order. Once having looked at the sun, it is difficult to see anything else.

Probably vision is due to the liberation of electrons in some prepared nerve-filled retinal tissue, the energy of the escaping electrons being well calculated to stimulate a nerve. And if vision is due to this kind of photo-electric effect, it is not surprising that the response is practically instantaneous, and its cessation, too, very rapid.

For promptness is characteristic of all photo-electric effects; otherwise television would have a poor chance! It may be that in the case of the eye, no actual "damping" is required.

Damping of Ear and Voice.

But in the case of the ear there is actual damping, and a good deal of it. The organ of Corti, on which all musical sensation depends, is apparently a fibrous membrane or assemblage of fibres, so attached to soft tissue, and so embedded in fluid, that the wonder is that they can vibrate at all.

They do, however, appear to vibrate fairly selectively, each to its own particular tone, for the membrane is gradated, inside the cochlea, like the strings of a harp or piano. A very small sequence of vibrations, probably two or three, are sufficient to give the sensation of tone and enable the pitch to be recognised. And then violent damping supervenes, the note is blotted out; and the rest is silence till a new note arrives.

Similarly the human voice is thoroughly damped by the soft tissues of the throat and mouth, and by the soft attachments of the membrane of the larynx, so that directly the air ceases to be blown through it, it subsides; even a loud shout is not prolonged into a roar, except, it may be, by outside walls or reverberating dome-shaped cavities—or, indeed, by many a lecture-hall, where, on account of its acoustic defects clear speech is hardly possible.

(ED. NOTE: The fourth and final article in this exclusive series by Sir Oliver Lodge will appear in "P.W." next week).

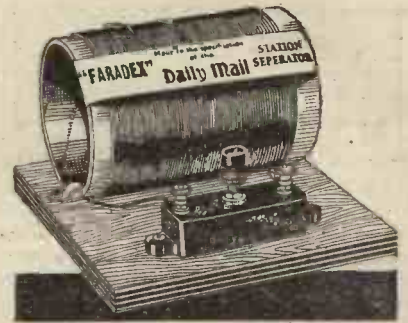

BUILT TO DAILY MAIL

SPECIFICATION. SEE FEBRUARY 14th ISSUE

No more disappointing radio! The wonderful little FARADEX WAVE TRAP is here to the rescue—here to separate the bothersome B.B.C. Twins, 261 and 365 metres. The FARADEX WAVE TRAP is made to the "Daily Mail" specification: 80 turns of 22 S.W.G.; D.C.C. wire wound on 2 1/2" x 4" former, with 2 aerial tappings; .0003 FARADEX Compression type Condenser, moulded on stained board. All complete and ready for instant use! Price 2/11. Obtainable from all leading Radio Stores (1 extra for postage and packing).

Faradex WAVE TRAP

Over 20,000 already sold. Beware of imitations! Look for name-band on coil and refuse all others.

2/11

You should use FARADEX Compression type Condensers. Values: F, .0001—0.000075; J, .0003—0.00025; G, .001—0.002. Price 1/9 each.

Manufacturers: **ROOKE BROS., LTD., 55, Cardington Street, Euston, LONDON, N.W.1.**

HEADPHONES REPAIRED 4/-

Transformers 5/- Loudspeakers 4/- All repairs re-magnetised free. Tested, guaranteed and ready for delivery in 24 hours.

Discount for Trade. Clarendon 9069.
E. MASON, 44, East Rd., City Rd., N.1.

EXACT TUNERS

250 to 2,000 metres. Thousands of these tuners are in use, and we can strongly recommend them. No further coils are required. Send P.O. for particulars and circuits. FREE.

THE EXACT MANUFACTURING CO.
Croft Works, Priory Place, Coventry

ELECTRADIX RADIOS

New Edition of Special Bargains in Radio and Electrical Apparatus at sacrifice prices cut to clear. Send addressed envelope for **THE LIST THAT SAVES POUNDS.**

ELECTRADIX HOUSE,
218, Upper Thames Street, London, E.C.4
City 0191

Don't Forget

that if you want to give yourself a radio treat you ought to get the **APRIL**

MODERN WIRELESS

ON SALE Price
NEXT WEEK. 1/-

ALL APPLICATIONS for ADVERTISING SPACE in "POPULAR WIRELESS" must be made to the Sole Advertising Agents,

JOHN H. LILE, LTD.,
3, LUDGATE CIRCUS, LONDON, E.C.4.

TECHNICAL NOTES.

By Dr. J. H. T. ROBERTS, F.Inst. P.

Pick-up Quality.

IN view of the popularity and recent improvements in the design of electrical pick-ups, it is surprising that better results are not obtained in the majority of the home-made radio-gram receivers.

I expect this remark will meet with a good deal of opposition from many of you, but I venture to think that in nine cases out of ten, where electrical reproduction is used, the quality is not to be compared with that which is obtained from the record reproduced on a good gramophone in the ordinary way.

I have listened to, I suppose, practically every type of combined radio-gramophone, and only in a small minority of cases could it be said that there was any advantage whatever (other than the doubtful advantage of greatly increased volume) over ordinary gramophone reproduction. In fact, the quality of reproduction from electrical gramophones can very well do with an all-round improvement.

Overloading of Valves.

The causes of this bad quality are not always easy to find, for, as a matter of fact, it requires a great deal of skill in design, as well as the greatest care in the selection and use of components, to produce a really good electrical reproducer.

So far as the amateur and experimenter are concerned, the main fault lies, I am convinced, in the overloading of the amplifier.

To begin with, in a large number of cases the amplifier which is used is the L.F. part of the radio receiver, and, as you know, it is not at all easy to make a radio receiver operate at anything like maximum efficiency as a combined receiver and gramophone amplifier. Personally, although it costs more, I always think it preferable to keep the radio set and the gramophone amplifier separate.

So far as the amplifier is concerned, probably the most fruitful source of distortion and trouble generally is the improper use of grid bias, and overloading the valves. In some cases, with a powerful amplifier, the necessary grid bias may run up to a very high value, and unless this is carefully attended to, you can never hope for really satisfactory reproduction.

Naturalness and Volume.

Then, again, there is a great temptation to overdo the volume, and although, for some curious psychological reason, many people like an amplifier with plenty of "punch," you should bear in mind that as soon as the reproduced volume seriously exceeds the natural volume, there is an apparent unnaturalness even though the actual quality may be fairly faithful to the original.

For instance, if a human voice is reproduced with a volume several times greater than the natural human voice, it is already unnatural for that reason alone.

(Continued on next page.)

FIRST CHOICE!

The Wates Meter stands unrivalled. Accept no other, and obtain that accuracy, reliability and usefulness that only the genuine Wates can give. Have you learnt what accurate set handling means, with the aid of this famous meter? Ask your dealer—he stocks it.

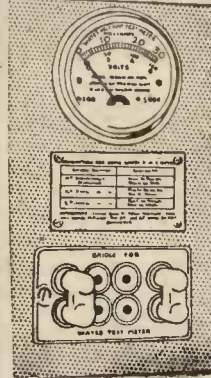

PANEL MODEL:
Complete with instructions for fixing to panel. Readings on three scales obtained by varying position of plugs in coloured 139 sockets.

METER CASE:
For standard model, Satinette lined base and lid, Crystallised black finish, substantial fittings, 2/6.

WATES "three in one" VOLT-AMP RADIO TEST METER

READINGS:

0-150 VOLTS

0-6 VOLTS

0-30 MILLIAMPS

Res. 5,000 Ohms.

Sold by all good dealers. Halfords, Currys, or direct. Descriptive Literature, free on request.



STANDARD
MODEL

8'6



In the interests of listeners generally, the Wates Meter has now been patented. No. 322,558.

If any difficulty in obtaining write to:
The STANDARD BATTERY COMPANY (Dept. P.W.), 184-188, Shaftesbury Avenue, London, W.C.2
or 'Phone: Tem. Bar 6195.

TECHNICAL NOTES.

(Continued from previous page.)

I would just say, before leaving this matter, that if you are going in for enormous volume, you are certainly going to make it very difficult to get anything like good quality.

There is also the quality of the electrical pick-up to be considered, and it is quite wrong to assume that one pick-up is as good as another. It is really surprising what great variations there are between different pick-ups on the market.

It is a very good plan to make an earth connection to the pick-up holder, or, in fact, to the frame of the pick-up itself, as this helps to prevent oscillation and generally improves quality. This simple point is very important.

The pick-up leads, of course, should not be unduly long; and, being in the grid circuit, they should be carefully kept away from any extraneous electrical interference which may be picked up.

There are a dozen other precautions to be observed with low-frequency amplification of this kind, but the above are the principal ones.

I have spoken previously about the importance of using sufficient negative grid bias, especially on power valves, and, judging from letters which I have received, some readers seem to run away with the idea that the more grid bias is piled on the better. This, of course, is not the case, and although grid bias may be a good thing, it is possible to have too much of it.

You should remember that the high-tension voltage which is applied to the anode of, say, the power valve is often not up to expectations. For one thing, the H.T. battery or the mains unit may not be delivering the full rated voltage (this is usually the case), whilst for another thing a certain proportion of the H.T. voltage may be lost in the loud speaker.

Again, the magnification factor of the valve, especially if of recent purchase, may perhaps be rather higher than that of the valves which you have been using previously, and may require a somewhat smaller value of grid bias.

I have explained before how increasing the grid bias reduces the anode current, and although this is important up to a point, naturally, if the proper point is passed, the quality of reproduction suffers.

It is very important, therefore, when introducing a new valve into the set, to study carefully the specification sheet supplied with it, and to make sure that the grid bias which is applied is appropriate to the high-tension voltage which you are using. Before you can do this properly you need to know the high-tension voltage actually applied to the anode under working conditions.

A Common Complaint.

Readers of these Notes write to me from time to time with regard to the falling-off in the sensitivity of their receivers, and want to know what is the cause of it. So I think it may be useful to say a few words about causes—for there are more than one—which may account for this effect.

It is scarcely necessary to mention that the gradual running-down of the batteries,

(Continued on next page.)

ALL UNITS

★ BLUE SPOT AMPLION B.A.2
WATMEL
G.E.C. TRIOTRON HEGRA
SILVER CHIMES LOEWE
W.E.B. LISSEN
B.T.H. BROWN VEE
ORMOND

50% BETTER RESULTS

Listen to the thrilling power, enchanting tone, brilliant emission, superb handling of the bass, the perfect pitch of the treble—that's what you get from your unit when you use the **Wates Universal Double Cone Chassis**. With a separate cone for high and low frequencies, can you wonder that reception is 50% better? It is the amazing double cone feature that is making the **Wates Universal** famous as Radio's greatest chassis. Both cones are scroll cut to avoid a direct line through the sound frequencies and specially treated for constant crispness. If your dealer does not yet stock, obtainable direct. Full particulars free on request.

The **SHAFTESBURY RADIO CO.**,
(Dept. P.W.),
184, 188 SHAFTESBURY AVENUE, LONDON, W.C.2.
Price, complete with Universal brackets and instructions for mounting unit.

11/6

WATES UNIVERSAL DOUBLE CONE CHASSIS

DX THE STANDARD PLUG-IN COIL

Sold everywhere from 1/-
DX COILS LTD., LONDON. E.8

ALL APPLICATIONS for ADVERTISING SPACE in "POPULAR WIRELESS" must be made to the Sole Advertising Agents, **JOHN H. LILE, LTD.**, 4, LUDGATE CIRCUS, LONDON, E.C.4.

WET H.T. BATTERIES
Solve all H.T. Troubles.
SELF-CHARGING, SILENT, ECONOMICAL
JARS (waxed), 2 1/2" X 1 1/2" sq. 1/3 doz. ZINCS, new type 10d doz. Sacs 1/2 doz. Sample doz. (18 volts), complete with bands and electrolyte, 4/1, post 9d. Sample unit. 6d. Illus. booklet free. Bargain list free.
AMPLIFIERS, 30/- 3-VALVE SET, 25.
P. TAYLOR, 57, Studley Road, STOCKWELL, LONDON.

BUILD YOUR OWN S. G. PORTABLE

LEATHER CASE WITH FRAME AERIAL WOUND FOR L.W. & S.W. POLISHED FRET AND BATTERY COVER

42/-

AS ABOVE, BUT IN BLACK REXINE CASE

30/-

SPEAKER UNIT & CONE 15/-
"MIOCARTA" PANEL .. 6/6

All necessary parts in stock.

HENRI & CO.

79, ROCHESTER ROW, VICTORIA, S.W.1.
Tel.: VICTORIA 436r.

The **CLEVEREST** way to house **YOUR SET!**
SPEAKERS and BATTERIES

Patent Speaker Sound Chamber
Prov. Patent No. 8123.

For ALL Sets or Radio-Gram
The sort that people desire to possess and keep. Graceful design—sound construction—piano finish, adding to the life of your set.
Over 3,000 delighted Clients.
(Used by Radio Press—by W. James, Percy Harris, etc.)
De Luxe Models £5. 5. 0 to £11. 11. 0
"Popular" £3. 15. 0 Cash or Easy Payments.
Sent ON APPROVAL—direct from the makers.

RADIO-GRAM
Outfit for **YOUR SET**

Photographs and full particulars FREE!
PICKETT'S, Radio Furniture Makers,
(P.W.) Works, Bexleyheath, KENT.
Established at the beginning of Broadcasting.

Advertisements

As far as possible all advertisements appearing in "Popular Wireless" are subject to careful scrutiny before publication, but should any reader experience delay or difficulty in getting orders fulfilled, or should the goods supplied not be as advertised, information should be sent to the Advertisement Manager, "Popular Wireless," 4, Ludgate Circus, London, E.C.4

EVERYTHING WIRELESS on EASY TERMS

THE MOST FAVOURABLE OBTAINABLE

ALL COMPONENTS, KITS OF PARTS for all Circuits, MULLARD ORGOLA, COSSOR MELODY MAKER, etc. Complete SETS, H.T. UNITS, LOUD-SPEAKERS, etc., etc.

CALL or SEND A LIST OF YOUR REQUIREMENTS; a Quotation of our BEST MONTHLY TERMS will be sent BY RETURN.

The P.D.P. CO. LTD.
(Dept. P.W.),
121, CHEAPSIDE, LONDON, E.C.2.
Phone: National 9846.

TECHNICAL NOTES.

(Continued from previous page.)

both high tension and low tension, will account for a very pronounced diminution in the volume of the reproduction; this is so obvious and well known that I merely mention it in passing. Some types of circuits are very sensitive to a slight change in the filament voltage, so that as the L.T. battery runs down it is necessary to make from time to time an adjustment of the filament rheostat.

I think the importance of this effect is not so commonly realised as it should be. Where, however, the falling off is very gradual—extending over a period of months—it is more probably due to a diminution in the emission from the valve filaments.

As you know, the filament of the valve does not maintain for ever the same rate of emission as it had when new; and, quite apart from any question of burning out, the useful life of a valve is limited by the above-mentioned cause.

Testing Emission.

If you have any reason to suspect that the emission from your valves is not up to standard, it is a good plan to test them carefully by means of a reliable milliammeter. This test should, of course, be carried out with the rated current flowing through the filament and also with the correct grid and H.T. voltages applied. I need hardly say that any variation in these quantities may make a considerable difference to the anode current, and, unless they are more or less accurately known, the test will be of no value.

Falling Off.

If you do not happen to possess a milliammeter suitable for this purpose, it may be that you can get a friend or the local radio dealer to make the test for you. If you find that a valve has fallen off seriously in its emission it is the best plan to replace it with a new one, as there is very little that can be done to revive the emissivity of the filament, and the dodges which are sometimes recommended are, in my opinion, not worth while.

Not a Fixture.

Another important point which I should perhaps mention before leaving this subject is the value of the grid-bias voltage. I have already mentioned this, but in a somewhat different connection.

Owing to the fact that the function of the grid-bias battery is chiefly to maintain a voltage, many people think that it does not deliver any current at all and therefore ought to last indefinitely. It is surprising how many people regard the grid-bias battery as just as much a permanent fixture as the coils or the condensers. This, of course, is quite wrong, for the grid-bias battery actually does deliver a current, although a small one: and in any case, even if it did not deliver any current at all, its activity will decay with time just as it would do if lying on the dealer's shelf. A new grid-bias battery costs very little, and it is an excellent plan to try one, say, every six or twelve months.

Two-Volt Valves.

Whilst on the question of valves I should refer to other queries which I am continually receiving. They relate to the use

(Continued on next page.)



The MAGNIFICENT VOXKIT CONSOLE
SPECIFIED FOR THE
1930 "MAGIC" DE LUXE
(see this issue). Also ideal for accommodating
1930 "TITAN" THREE
"REGIONAL" TWO

or any other receiver not exceeding 18 in. x 8 in. panel.
With 52/- ULTRA AIR CHROME SPEAKER.
WITH SPEAKER, WITHOUT SPEAKER
Oak - - - £6 17 8 Oak - - - £4 4 0
Mahogany - £7 7 0 Mahogany - £4 13 6

PILOT KITS FOR "P.W." SETS
INCLUDE all specified components, necessary coils, drilled panels and requisite connecting wires, screws, etc. "A" Kits include also specified valves and cabinets, whilst "B" Kits exclude these items.

1930 "MAGIC" THREE
KIT "A" KIT "B"
Cash £9:11:2 Cash £6:12:8
or 12 monthly instalments of 17/6 or 12 monthly instalments of 12/2
FINISHED INSTRUMENT, arial tested and guaranteed. Valves and Royalty included £11:17:6
Or first payment of 37/6 and 11 monthly instalments of 20/-

1930 "MAGIC" THREE DE LUXE
Add 25/- to each cash price above, or 2/3 to each monthly instalment.
1930 "TITAN" THREE
KIT "A" KIT "B"
Cash £9:12:1 Cash £6:1:7
or 12 monthly instalments of 17/7 or 12 monthly instalments of 11/2
FINISHED INSTRUMENT, arial tested and guaranteed. Valves and Royalty included £11:17:6
Or first payment of 37/6 and 11 monthly instalments of 20/-

"REGIONAL" FOUR
KIT "A" KIT "B"
CASH £12:9:9 CASH £8:6:3
or 12 monthly instalments of 22/8 or 12 monthly instalments of 15/3
FINISHED INSTRUMENT, arial tested and guaranteed. Valves and Royalty included, £14:14:0
Or first payment of 54/- and 11 monthly instalments of 24/-.

Any parts supplied separately. Detailed lists on application.
Send us a list of your requirements for a quotation by return. Post coupon for our magnificent 48-pg. cat.

PETO-SCOTT Co., Ltd.
Free Demonstrations and advice by Qualified Engineers at our Shops—
77, CITY ROAD, LONDON, E.C.1.
Telephone: Clerkenwell 9406-7-8.
62, HIGH HOLBORN, LONDON, W.C.1.
Telephone: Chancery 8266.
4, Manchester Street, Liverpool.
Telephone: Central 2134.
33, Whitelaw Road, Chorlton-cum-Hardy, Manchester. Telephone: Chorlton-cum-Hardy 2028.
Mail coupon in unsealed envelope under id. stamp.

COUPON

Please send me your 48-page Illustrated Catalogue, describing the 1929-30 products of all the leading makers.

NAME.....
ADDRESS.....

P.W. 29/3.

CABINETS
16x7x11. Hinged lid, slot for leads, hand finished, with or without oval front which measures 10" x 6". Cash or C.O.D. Portable Cabinets 16" x 16", body 6 ins., lid 1 1/2, complete arial, frame and fret, lid hinged, fitted 2 lever lock. Cash only 20/-. All above carriage paid. Only a few left.
F. W. RAMSEY,
63, Shaftesbury St., London, N.1. Clerk. 7159

5/6 UN-POLISHED
7/6 HAND MAHO-CANY FINISHED

Big Packet of Candytuft Seeds FREE

Nothing makes a brighter show in the garden than the glorious, many-hued blooms of the Candytuft.

This sweet-scented flower is very easy to grow. Now is the time to plant it, and there's no need to bother about the seeds, for a FREE packet is presented with this week's POPULAR GARDENING.

Make sure of your copy of this splendid paper EVERY week. Place a regular order with your newsagent.

Popular Gardening

Buy a Copy To-day 2d.

ENGINEERS!

Can't we get together?



WRITE FOR THIS BOOK TO-DAY IT'S FREE!

All we ask is the chance to prove that you can earn £300, £400, £500 per year or more. Other men are doing it, and you can do the same.

We have an unrivalled and world-wide organization waiting to help you whether you be novice or expert. If you wish for something more than a "bread and butter" job you owe it to yourself to investigate our Service.

Our handbook "Engineering Opportunities" has pointed the way to better things to over 20,000 of your fellows. It contains details of A.M.I.Mech.E., A.M.I.E.E., A.M.I.C.E., A.M.I.A.E., A.M.I. Struct.E., London Matric., C. & G., G.P.O., etc., Exams., outlines home study courses in all branches of Electrical, Mechanical, Motor and Wireless Engineering, and explains our unique guarantee of **NO PASS—NO FEES**

In a Brilliant foreword Prof. A. M. Low shows clearly the chances you are missing.

"Engineering Opportunities" and our advice are quite FREE. Don't neglect this offer—give vent to that "upward urge" and send a postcard NOW, stating Branch, Post or Exam. which interests you.

British Institute of Engineering Technology,
101, Shakespeare House, 29-31, Oxford Street, W.1

EASY PAYMENTS

The first firm to supply Wireless Parts on easy payments. Five years advertiser in "Popular Wireless." Thousands of satisfied customers. Send us a list of the parts you require, and the payments that will suit your convenience and we will send you a definite quotation. Anything wireless.

H. W. HOLMES, 29, FOLEY STREET,
Phone Museum 1414. Gt. Portland St., W.1

"BUILD YOUR OWN DRY BATTERIES"

A NEW WIRELESS HOBBY.

We supply super capacity Dry Cells and all parts for building your own dry battery at home.

This is the best and cheapest form of H.T. yet offered.
Super Capacity Cells, each 1.5 volts, 22 milliamps. 3/6 per doz.

Send 1d. stamp for Booklet, "How to Build a Dry Battery at Home," to—
THE LEYTON BATTERY CO.,
305, Church Road, Leyton, E.10.

AGENTS WANTED to sell Wireless goods, all makes in sets, components and accessories. Cash or Easy terms. Liberal commission. **NEW AUTO SUPPLY CO.,** 241, Park Rd., ASTON, Birmingham.

WIRELESS CABINETS
MAKE YOUR OWN
with our guaranteed R.T.A. Furniture Sets.
Send P.C. for Free Catalogue and Price List.
Dept. P.W., London Woodworkers Supply Co. Ltd.
199, High Road, Lee, London, S.E.13.

For the Best in Radio

WILL-DAY LTD.

(THE BEST IN THE WEST)
10 LISLE STREET, LEICESTER SQUARE, LONDON, W.C.2
Telephone: 2320 (Night 2882 and 2922) Telegrams: "Will-Day, London"
OPEN ALL WEEK
WRITE FOR OUR CATALOGUE
POSTAGE 6d. FREE TO CALLERS

TECHNICAL NOTES.

(Continued from previous page.)

of 2-volt valves. There seems to be a certain amount of prejudice against 2-volt valves, as compared with the 6-volt; but although I had at one time myself a decided preference for the 6-volt type, I think the 2-volt and 4-volt valves have now been so very much improved that there is little or nothing in it. I am often asked whether it is better to use the 2-volt battery direct with 2-volt valves or to introduce a regulating resistance.

Variations.

It is not very easy to give a reply to this question, as the answer depends to some extent on circumstances, but perhaps I should say that a low-resistance rheostat could be used to compensate for variations in the voltage of the 2-volt battery. You know that a freshly charged accumulator will often indicate a terminal voltage of as much as 2.1 or even 2.2 volts, whilst after some prolonged use the accumulator may only be showing 1.8 volts.

As a matter of fact, many so-called 2-volt valves are really intended to operate at about 1.8 volts, and unless there is some

TECHNICAL TWISTERS

No. 3—THE LOUD SPEAKER.

CAN YOU FILL IN THE MISSING LETTERS?

- Don't forget there is a and a lead to your loud speaker.
- The loud speaker leads must always be connected the way
- The goes to H.T.—where an output filter is not used.
- Don't forget to your loud speaker occasionally, to make sure of getting maximum sensitivity.

(Look out for the missing words next week)

The missing words last week (in order) were: moist; aerial; earth; condenser; earth; wire; clip; insulated; short; long.

means for compensating these comparatively large-percentage voltage variations you are liable to get decided variations in the behaviour of the set.

At the same time, this is not to say that the battery may not be connected direct on to these valves, and many readers employ them in this way.

Frame Aerial Problems.

Following my remarks recently on the use and properties of frame aeriels, a reader wants to know why it is that his four-valve frame-aerial set, which works perfectly satisfactorily when placed on the table in the centre of the room, "goes very faint" when moved to another table at the side of the room.

It is most probable that the removal of the set to the second position brings it rather close to some metal object or objects such as electric-light or telephone wires, gaspipes or waterpipes.

BUILD THE HEAYBERD H.T. ELIMINATOR

The eternal cost of replacing H.T. batteries is the busbear of Radio. And most eliminators on the market are too costly to be generally adopted. Realising this, Heayberd's have designed an H.T. unit so simple and inexpensive that everybody can purchase a kit of components incorporating Westinghouse metal rectifiers and construct it themselves!

59'6

buys the complete kit, together with assembling and working instructions. Running cost—6d. a year!

Write for explanatory Leaflet No. 940.

F. C. HEAYBERD & CO.

10, Finsbury St., E.C.2

Phone: Clerkenwell 7216.

MAKE A GRAMOPHONE

at a quarter shop prices, or buy Cabinets for Wireless. Order Set as shown, British spring motor, velvet turntable, swan arm, metal soundbox, amplifier, needle cups, for £1.17.3 p.p., and build your own Cabinet. Portable Gramophone from 21/-. Motors from 8/6. Lists free. 64-pp. Catalogue Drawing and How to Make Gramos, 3d.

REGENT FITTINGS CO. (P.W.), 120, Old St., London, E.C.1.



THE IDEAL COMBINATION

BOTH engraved—no mistakes—easy connections. The handle of the Spade Terminal is fully insulated—the prongs are sprung—connecting up is a one-hand job. Entire flex—copper, rubber and braiding individually gripped without use of tools.

Belling-Lee Spade Terminal 4½d.
Belling-Lee Terminal
Type "B" 6d. Type "M" 4½d. Type "R" 3d.
Ask your dealer, or send to us for FREE Belling-Lee Handbook. "Radio Connections."

BELLING-LEE FOR EVERY RADIO CONNECTION

Advertisement of Belling & Lee, Ltd., Queensway Works, Ponders End, Middx.

THE DAILY SKETCH

YOUR Picture Paper

Read—

THE ESCAPING CLUB

The Most Thrilling Book the War Has Yet Produced
By Major A. J. EVANS

THE ESCAPING CLUB, tells the story of a prisoners' camp in Germany, where English, French, Belgium, and Russian officers were herded together, and where the chief recreation was that of escaping. Among those who succeeded in escaping was Major Evans.

The story of how he crossed Germany, and entered Switzerland, is one of the great epics of the War, and the exclusive serial rights of this thrilling story have been secured for **THIS AND THAT**.

The first long instalment appears TO-DAY.

This and That

Buy a copy To-day 2d.



**VARLEY
L.F. CHOKE**

**SPECIFIED FOR THE
"MAGIC DE LUXE"**

Described in this issue.

**VARLEY STANDARD
L.F. CHOKE £1**
Inductance 20 henries

Write for Sections D & E of
the Varley Catalogue.



Advertisement of Oliver Bell & Co. Ltd., Kingsway House, 103, Kingsway,
London, E.C.4. Telephone: Harbourn 5303.



BLUE SPOT GOLIATH

£6.6.0

The name "Blue Spot" represents all that is faithful and true in loud-speaker reproduction.

And the finest model of all is Blue Spot Goliath, Blue Spot's greatest speaker.

Ask your nearest dealer to demonstrate this speaker and you will hear the finest reproduction that to-day is possible.

Six guineas is the price of this superb instrument.



F. A. HUGHES & CO., LIMITED,
204-6 Great Portland Street, London, W.1.
Phone: Museum 8630 (4 lines).

Distributors for—*W. & A. Mason* (England, Scotland and North Wales); *H. C. RAWSON* (Sheffield and London); *Ltd.*, 100, London Road, Sheffield (Phone: Sheffield 26006), and 22, St. Mary's, Parsonage, Manchester (Phone: Manchester City 3359).

David and Goliath

and the

HYPERMITE

L.F. TRANSFORMER

AN ANALOGY



David dispelled with a single stone the fallacy of superiority and strength as ascribed to bulky giants. A modern analogy is the "Hypermite," the smallest and most efficient of low-frequency transformers, which banishes for ever the obsolete idea that bulky transformers are most efficient.

The use of an improved nickel alloy metal, due to modern research, is applied most efficiently in the "Hypermite," giving the

REMARKABLE INDUCTANCE OF OVER 50 HENRIES thereby ensuring retention of the *low notes without sacrificing the high*, and guaranteeing true musical quality which is desired, and when obtained is appreciated by everybody.

The low price and unique performance of this transformer places it in the forefront of modern radio developments. Now the "Hypermite" is available, there is no excuse for indifferent amplification.

Ask for a free copy of the "Hypermite" leaflet, it contains diagrams and full particulars.

"Hypermite." Weight, 7 ozs. Encased in moulded Bakelite. Size, $2\frac{1}{2} \times 1\frac{1}{2} \times 2\frac{1}{2}$ ins.

12/6



12, HYDE STREET,
LONDON, W.C.1

The "Popular Wireless"

6d

Amateur's Guide

CONTENTS INCLUDE

"P.W." TESTED CIRCUITS
THE VALVES TO BUY - USING MAINS UNITS
THE GRAMOPHONE PICK-UP
A GUIDE TO THE SHORT-WAVERS

Full Instructions For Making
THE "ANTIPODES ADAPTOR"
THE "MAGIC" TWO and
A SELECTIVE CRYSTAL SET

HOW LOUD SPEAKERS WORK
SHORT-WAVE SETS - HINTS ON TUNING
CHOOSING MAINS VALVES
THE "P.W." PICTORIAL GUIDE
SET-BUILDING HINTS
MAKING YOUR SET SELECTIVE

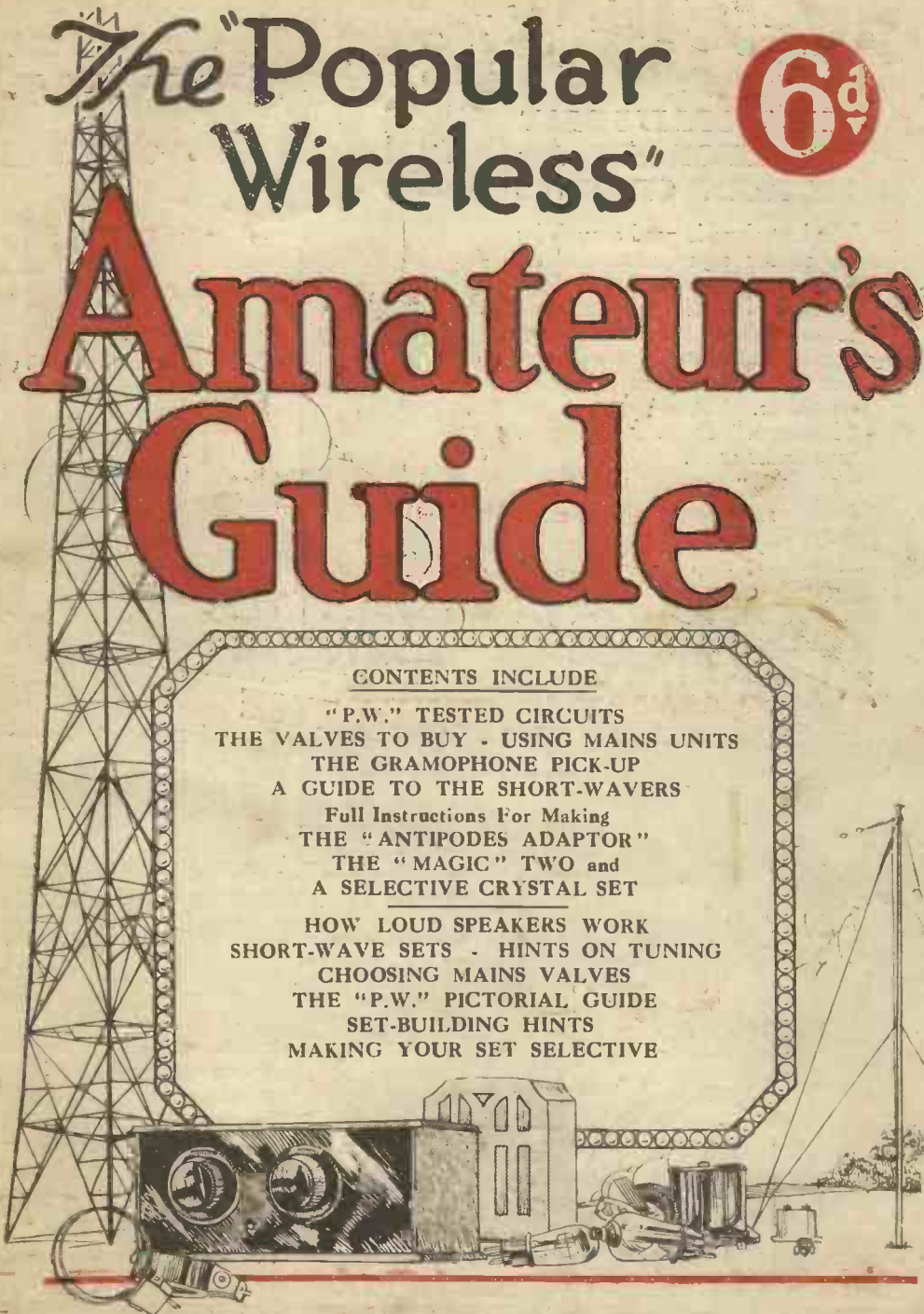

EFFICIENCY FIRST !!!

THE HYPERMU

THE WORLD'S BEST
TRANSFORMER for
MODERN CIRCUITS

The best alone is good enough for the serious experimenter and set builder. "Hypermu" has been tested and found best by expert and amateur. The latest N.P.L. curves prove amazing superiority of performance under ordinary working conditions. Get a copy of the "Hypermu" Curve Leaflet from your dealer or us.

"Hypermu" with nickel alloy core.
Metal screened and neatly encased in
Bakelite. Weight 14 ozs. 21/-
Size 3' x 1½' x 3'.

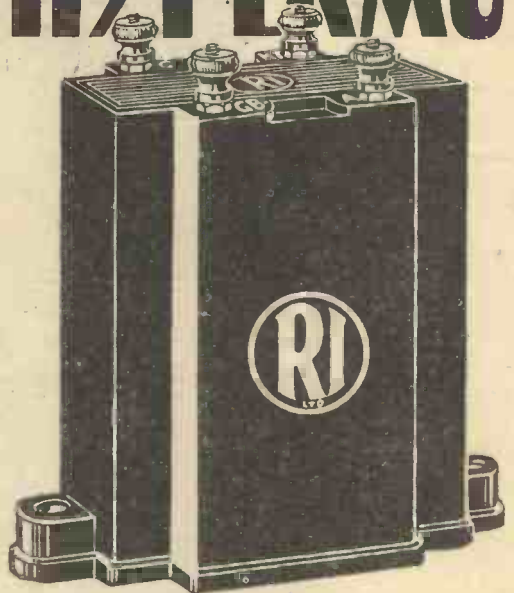

AND THE HYPERMITE

The 7 ozs. transformer
with a Primary Inductance
of OVER 50 HENRIES

Then at last is a transformer built with a core of a new nickel alloy of enormous permeability, yet sold at a price within the reach of all. Its high inductance with retention of the high and low frequencies ensures performance eminently better than that of many bulky higher priced models. Ask for a copy of the "Hypermite" leaflet—it contains diagrams and full particulars. This is your chance to test out a modern nickel iron transformer.

"Hypermite." Weight 7 ozs. Encased
in moulded Bakelite. Size 2½' x 1½' x 2½'. 12/6



The

Pioneers of Transformer Production

12, HYDE STREET, LONDON, W.C.1.

THE "P.W." AMATEUR'S GUIDE

Every phase of home-constructor radio is covered in this comprehensive sixpenny handbook, and it should prove a most valuable addition to the amateur's bookshelf. It has been specially compiled by the Technical Staff of "P.W." and is presented free with "Popular Wireless," week ending March 8th, 1930.

CONTENTS

	PAGE		PAGE
Set-Building Hints	3	Hints On Tuning	17
The "P.W." Pictorial Guide ..	4	The Tuning Controls	18
The Valves to Buy	5	The "Antipodes Adaptor" ..	19
The "Magic" Two	7	Short-Wave Sets	22
Using Mains Units	9	"P.W." Tested Circuits	24
Choosing Mains Valves	11	Current Carrying Components	26
How Loud Speakers Work	13	Using Fixed Condensers	28
Mixed Currents	14	A Selective Crystal Set	29
The Gramophone Pick-Up	15	A Guide to the Short-Wavers ..	32
Making Your Set Selective ..	16		



SET BUILDERS!

use Lotus components
for easy assembling!

Follow the advice of the technical experts and use Lotus Components in the new set you are building. Almost every necessary unit is included in the Lotus range.

Pre-eminent in design and appearance, their performance and finish justify their reputation.



Lotus H.F.
Choke, 5/6



Lotus L.F. Intervalve
Transformer, 12/6



Lotus L.F.
Power Choke,
15/-

LOTUS COMPONENTS

ASK YOUR RADIO
DEALER
TO GIVE YOU A
COPY OF THE NEW
LOTUS CATALOGUE
OR SEND DIRECT
TO THE MAKERS
AND IT WILL COME
POST FREE

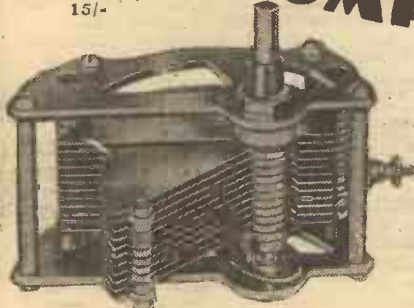

Lotus Logarithmic
Condensers in all
capacities from 5/-



Lotus All Mains
Unit, £7 7s.



Lotus Power
Transformer
£1 15s.

Made in one of the most modern radio factories in Great Britain.

GARNETT, WHITELEY & CO., LTD.
(Dept. A.G.), Lotus Works, Mill Lane, Liverpool.

Set-Building Hints

The first thing to do when building a set, of course, is to collect together the various components required, such as buying fresh components where you are out of stock of particular items, or using up old ones where permissible. Incidentally, it is in this latter point that quite a number of constructors "drop a brick."

It is not always advisable to use a particular component that you may have on hand simply because you think it "will do" in place of the one recommended by the designer of the set you intend to construct. In such cases as that of coils or of transformers, or L.F. chokes, these should be carefully considered before any substituting components are employed.

Do not forget that a modern L.F. transformer is a vastly different thing from the transformer which was on the market two years ago, and if you have some of the old stock knocking about do not think that because they are labelled "L.F. Transformers," and have what you think is the correct ratio of turns, that they will do in a modern set.

They will give results, but you are almost certain to lose in quality if not in amplification.

Although modern manufacturing methods are greatly improved compared with those of a couple of years ago, one still gets an occasional "dud" in the form of a valve holder which will not make proper contact, or a grid leak or anode resistance which is a little bit off colour, or a switch which makes contact only every now and then.

It is best, therefore, carefully to examine all components such as those mentioned, and if any doubt arises to check them with a pair of 'phones and a flashlamp battery, or with a battery and a lamp, according to the type of component you are testing.

FAULTY VARIABLE CONDENSERS.

Variable condensers also have a happy knack of going a little bit astray, causing noisy tuning and all sorts of little troubles, and volume controls also are prone to little faults of bad contacts on occasions.

It must not be taken from this that these faults are very liable to occur. They may only occur in 1 per cent, or perhaps one in every thousand components, depending, of course, upon the make and the age of the component; but that one per thousand may happen to come along to you, and if you are to guard against such an aggravating occurrence it is best to examine every component before you put it into a set, especially if it has just come out of another set.

Especially is this the case in anything which has

to take a sliding or pressure contact, such as a valve holder, coil holder, or switch.

Then having made sure your components are "above board," if you are planning a set on your own without any blue print or layout diagram, do not attempt to save time by rushing the thing together.

Careful thought in the arrangement and position, and also the orientation of valve holders, transformers, and the like, will make all the difference when wiring the set up and in results when the set is placed on an aerial.

In the case of a set which is described and designed by another person, and for which you have a wiring diagram, it is most important to follow the designer's instructions as closely as possible, for in no other way can you expect to duplicate the results obtained in the original receiver.

WATCH YOUR WIRING.

A great point has been made of taking the connecting wires in a receiver as straight as possible from point to point. Generally speaking, there is everything to be gained by doing this. Nevertheless, no harm is likely to eventuate if a tiny bit of right-angle bending is done here and there for the sake of appearances, more particularly on the L.F. side. Indeed, quite a lot of this can be done at the L.F. end of the set without jeopardising the performance of the instrument one little bit.

All this is providing you are working fairly closely to some particular design of receiver. One of the primary objects of a set designer of standing is to arrange his layouts so that there is no necessity for connecting leads that really matter to wander around areas that do not concern them.

Some leads must be treated much more carefully than this. For instance, leads joining the grid terminals of valve holders to other points must be as short and as direct in their travelling as possible.



A small soldering iron of convenient size for radio work.

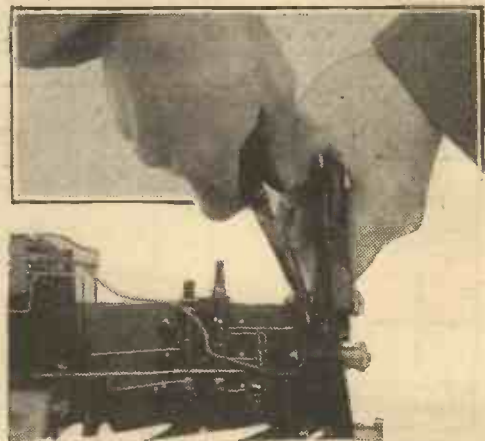

You should tighten up the terminals after soldering leads to them.



THE "P.W." PICTORIAL GUIDE

On the right you see the piano scale, together with the frequencies of all the notes. This will give you a very clear idea of what we expect a modern set to do. It has to handle all these frequencies equally well if it is going to be perfect. No set can be perfect, but we are gradually getting nearer the ideal. You will find the scale of great value to refer to on various occasions.

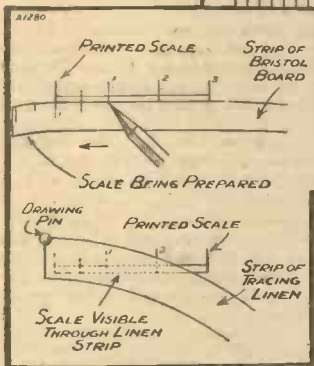
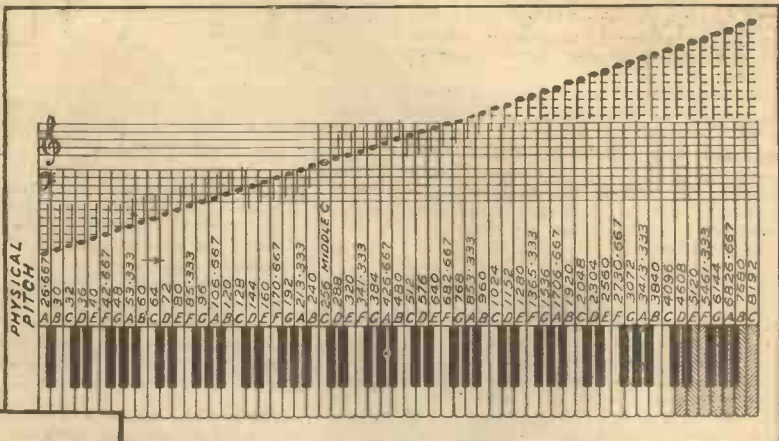

Most of the wiring diagrams that accompany "P.W." sets have scales printed on them, and these scales enable you to ascertain exactly the positions of all the components. The drawing on the left shows you how to use these diagram scales. At the top is indicated how the scale can be transferred to a strip of bristol board. This then becomes a rule with which you can measure on the diagram all the details you wish to check. Another scheme is, as shown, to use a piece of tracing linen.

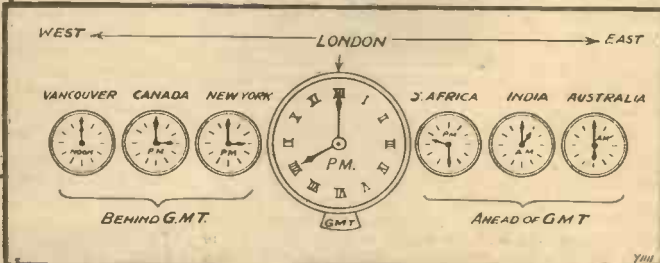

Short-wave enthusiasts will find the world's clocks on the right very useful when they are searching the ether for programmes.

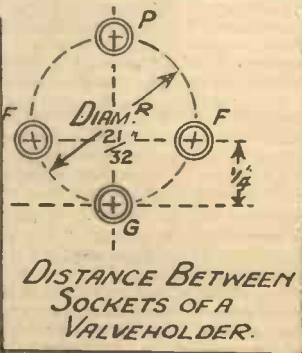
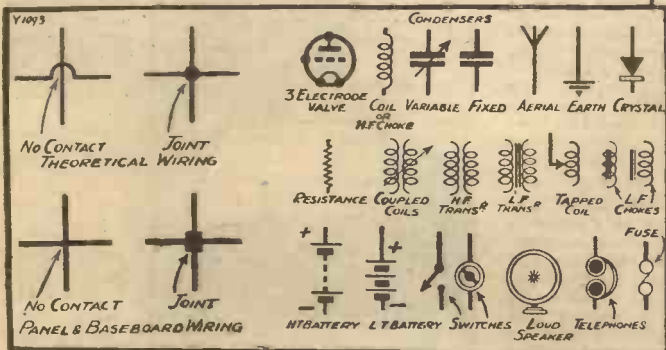

Above you will see the dimensions of the valve holder, together with a chart giving practically all the symbols that are used in "P.W." theoretical circuits.



The Valves —to—Buy—

Let us consider what has been done for the average user of 2, 4, or 6-volt valves during the last year. Two years ago the screened-grid valve had been known for about twelve months in this country, and the upright model of screened-grid valve was being placed upon the market more or less tentatively, much argument being indulged in as to the relative merits of the horizontal and vertical types of these valves. We saw the death of the horizontal type, and there are now vertical screened-grid valves of all three voltages, and their efficiency is such that, to put it colloquially, the old horizontal type has been "knocked into a cocked hat."

With the advance of the screened-grid valve we have an equally rapid advance of the pentode, which is now available in some makes in all three voltages, and in some other makes in the 2- and 4-volt series, and which is a valve to be thoroughly relied upon, for modern production methods have enabled even this difficult job of assembly to be done with a remarkable degree of standardisation.

MANY NEW COSSOR TYPES.

Incidentally, at least two valve concerns have put on the market super-power pentode valves taking H.T. voltages up to 300, and possessing considerable grid swings.

The old B.T.H. valves have been removed; the Cosmos valve is no more, as such, and the Edisvan valves have been taken from the market. All three are now put out in the form of Mazda valves, both in the ordinary battery types and in the mains types.

Valve users will, of course, notice that the Cosmos A.C. mains valves are still available to users of these while stocks last, but that the valves have been redesigned and have been placed on the market with the new five-pin bases and are known as Mazda valves. But we will come to those valves in due course under the letter "M" for Mazda.

Dealing with individual valves, we will start by those made by A. C. Cossor, Ltd. Here a very great deal of re-designing has been carried out, and the Cossor valves are deserving of serious consideration.

Taking the 2-volters first, we have the 210 H.F.,

20,000-ohm impedance and a magnification factor of 20; followed by the 210 L.F., 12,000 ohms and 10; and the 210 R.C., which is 50,000 and 36. The H.F. valve is an extremely good little valve, and can be recommended strongly as either a detector or as an H.F. amplifier.

INTERESTING POWER VALVES.

Then we have some interesting power valves in the 220P (having an impedance of 4,000 ohms and a magnification factor of 8), which gives a mutual conductance of 2. This is a remarkably good figure, and the valve is capable of a grid swing of somewhere about 18 volts total at 150 volts H.T. A little larger valve is the 230XP (2,000 ohms, with a magnification factor of 4), taking 3 amp. at 2 volts. The anode current for this valve at 150 anode volts and -15 volts bias is about 30 milliamps.

The screened-grid valve in the 2-volt range is known as the 220SG, and has an impedance of 200,000 ohms, with a magnification factor of 200. It is a lively little valve which is excellent for screened-grid work. It takes about 4 milliamps at 120 volts anode and 70 volts on the screen.

The pentode is a newcomer to the Cossor range, and has a magnification factor of 40, with an impedance of 20,000 ohms. This is an unusual figure for a 2-volt pentode, and the Cossor pentode is unlike those of other makes in this respect. In operation, however, it is efficient, and carries quite a reasonable grid swing. When properly biased at 180 anode volts, which is the highest recommended by the makers, it takes 10½ volts grid bias and 14 milliamps.

4-VOLT PENTODE.

Among the 4-volters must be mentioned the 4-volt pentode, the 415PT, which has roughly the same characteristics as the 2-volter; and the 415XP, which

is an exceedingly useful little super-power valve, taking about 30 milliamps at 16 volts grid bias, and 150 H.T. This valve can be recommended for use in small gramophone amplifiers and as the last valve in a radio set. Similar to this is the 610XP, which, however, has a slightly steeper slope and not quite so large a grid swing. So far there is no

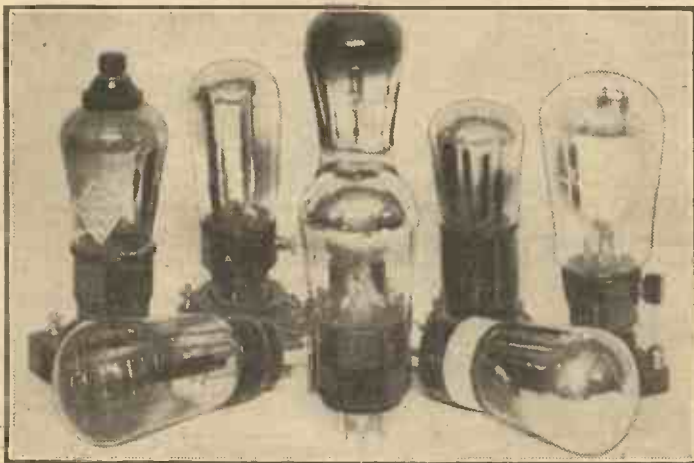

A representative selection of modern receiving valves,

6-volt pentode in the Cossor range, though there is a 6-volt screened-grid valve.

The 4-volt mains valves also should be mentioned here. These are of the new five-pin centre type, and consist of the following: The 41MHF, 41MLE, 41MRP, 41MP, 41MXP, and the 41MSG. In the case of the S.G. valve the impedance is still 200,000, although the amplification factor has gone up to 400.

Two well-known low-price valve makes are also well to the fore. These, the Cleartron and the Dario valves, have been greatly improved, and many new additions to their ranks have been made. In the case of the latter, new screened-grid and "Pentodion" valves have been placed on the market.

THE LISSEN RANGE.

Now we come to the valves of Messrs. Lissen Ltd.

Lissen 2-volters are the result of considerable research and the results are certainly not to be despised. The R.C. valve is of the "210" class, having an impedance of 58,000 ohms and an amplification factor of 35.

The L210 is an L.F. valve of merit, having an impedance of 10,000 ohms and amplification factor of 10. As a first-stage L.F. valve this should find a home in many sets.

The third valve is the P220. This has the best characteristics of the three, giving a slope of 1.5. It has an impedance of 4,700 ohms and an amplification factor of 7.

As a last stager for a small set this should be very useful. They are sold at the usual prices.

The Lissen power Pentode is specially designed as an output valve for two- or three-valve receivers, and portable sets running off H.T. batteries.



Test your L.T. accumulator at regular intervals, and never let the voltage per cell drop below 1.8 volts.

The whole idea of this valve is to provide a pentode that can be used with an H.T. battery of the small type. Thus if a detector and pentode be used in such a set as the "Magic". Two, only 7 to 7½ milliamps of H.T. will be consumed—not an excessive current for the ordinary H.T. battery to supply.

Thus the Lissen P.T.225 is a low consumption pentode, as it takes only 7 milliamps, and can be used as an alternative to a power output valve without fear of ruining the H.T. battery due to overrunning it.

VERY REASONABLE PRICE.

The valve has a very high amplification factor (90), quite as high as the average pentode, with an impedance of 84,000 ohms. The auxiliary grid takes from 80–150 volts, and the anode from 100–150 volts. A very good working figure is 120 and 120, though voltages of 100 and 100 (for auxiliary grid and anode) enable excellent results to be obtained.

The Lissen pentode is undoubtedly a valve well worth serious consideration. In a 2-valver (or a 3-valver some way from a powerful station) it will provide an increase in strength comparable with that obtained by ½ an L.F. stage, so that instead of the 2-valver we have what one could call a 2½-valve set.

Sold at 17s. 6d., the price is reasonable, and the running costs are exceedingly low. In addition we have the super-power 3-volt pentode which will carry a total grid swing of 18 volts.

The Mazda people, actually the B.T.H.-Cosmos-Ediswan combine, have brought out a remarkable

range of 2-volters, which certainly deserve attention. They consist of the R.C. valve, which unfortunately is designated H; the H.L., high- and low-frequency amplifier; a low-frequency marked L; a power; a super-power; a screened-grid valve, and a pentode.

THE MAZDA SERIES.

Taking them in order, we find that the H210, which is the R.C. valve, has a magnification factor of 47 and an A.C. resistance of 59,000—quite a useful little valve. The HL210 has an amplification factor of 26 and an A.C. resistance of 21,000 ohms, giving a mutual conductance of 1.25, and this is extremely useful as a detector or H.F. valve. On test it has given extremely good results, and can be thoroughly recommended.

The L210 is a remarkable valve in that it has a mutual conductance of over 1.5, having an A.C. resistance of 10,000 and an amplification factor of 15.5. This carries quite a reasonable grid swing, in spite of the steep slope, and at an H.T. voltage of 150 takes only 4–5 milliamps with proper grid bias.

The power valve and the super-power valve are both designated with the letter P. The ordinary power is P220 and the super-power P210. The first of these two has an amplification factor of 12.5, and an A.C. resistance of 3,700; and a mutual conductance, as you will see, of 3.4.

The grid swing is not tremendous, but the magnification is exceedingly large, and so one is well compensated for a shortening of the grid swing due to the steep slope.

The L210 power has a very low impedance, and is suitable for moving-coil speakers and for really heavy work. It has an amplification factor of 7, an impedance of 1,900, and a mutual conductance of 3.7.

The SG215 is one of the best screened-grid valves among the 2-volt ranges, and has an inter-electrode capacity of only .005 micro-microfarad.

MULLARD AND M.O. VALVES.

Among the Mullard valves we find that the range includes a very complete series of 2-, 4-, and 6-volt valves, including one or two extremely interesting types.

For some time Messrs. Mullard have been putting 2-, 4-, and 6-volt pentodes on the market; now they are putting on a 4-volt super-power pentode, the P.M.24A, whose filament takes .275 amp. at 4 volts, and which is designed for a maximum H.T. of 300 volts. In this case the auxiliary grid voltage is 200, the amplification factor being 53 with 88,000 ohms impedance. This valve is specially designed for use in output stages of L.F. amplifiers where heavy anode currents are available, and where very loud volume is required.

There is a recently added special 6-volt detector on the market having a very steep slope for use as detector or gramophone amplifier, having an impedance of 9,000 and an amplification factor of 18.

The Marconi and Osram valves stand very much as they were, with the exception that the KL type and the KH type have been taken off the market, and are now being brought into line with the new mains "M" valves of the five-pin variety. The Marconi and Osram Valve Co. have brought on the market a 6-volt screened-grid valve which gives excellent results.

A new super-power valve brought out recently by the Marconi and Osram Company will interest the heavy-power enthusiast. This is the LS6A, which is a 1.6-amp. filament valve specially designed for very heavy working, with an amplification factor of 3 and an impedance of 1,300 ohms.

It takes 6 volts on the filament and 400 volts on the plate. The total anode dissipation is 25 watts, and the plate current required is anything up to between 60 and 70 milliamps.

THE "MAGIC" TWO

A wonderfully powerful set for the reception of the very short wave as well as the normal wave broadcasting stations. Its special feature is an extraordinarily smooth reaction control.

The actual building of the set is the usual straightforward job of drilling the panel in accordance with the diagram, mounting up the parts, and attaching the panel to the baseboard with the usual row of screws along the lower edge. Next, lay out the parts on the baseboard carefully in accordance with the wiring diagram, referring to the photographs

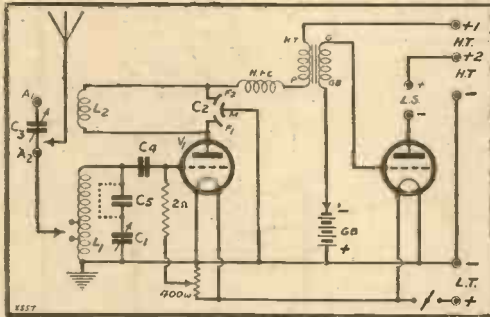

where necessary to clear up any particular point, and screw them down.

Wiring up can be done with any material you fancy, such as one of the special covered materials like Glazite, or bare wire, or, again, bare wire and Systoflex sleeving. Just take a little pains to space out the wires nicely in the tuning and reaction circuits, and run them as directly as you can between the various points.

You will not require a very large grid-bias battery. There is ample space for the size you are likely to be using, which will probably be only a 9-volt unit, or even a 4½-volt one, if you work with a moderate amount of H.T., such as something up to perhaps 100 volts.

COIL SIZES.

Coil L_1 should be of the "X" type for use on the normal broadcasting and long waves, the sizes being respectively a No. 60 and a No. 250. The flex lead coming off one side of the series condenser C_2 goes to one or other of the tapping points on this coil, these two points giving you a different degree of selectivity.

Coil L_2 is the reaction coil, and this should be about a No. 50 for the ordinary broadcast waves,

and a No. 100 or thereabouts for the long waves.

For short-wave work you require some of the special short-wave plug-in coils of the spaced bare wire kind, such as the Igranic and Atlas types. The sizes for short-wave work should be these. For the tuning coil L_1 you require a No. 4 for the interesting band of wave-lengths from about 18 to 40

LIST OF COMPONENTS

1 Panel, 14 in. x 7 in. 1 Cabinet to fit, with baseboard 9 in. or 10 in. deep. 1 '0005-mfd. variable condenser, slow-motion type or plain type with good vernier dial. 1 differential reaction condenser, maximum capacity any figure from '0001 to '00015 mfd. (the one actually used had a capacity of '00013 mfd.). 1 On-off switch. 2 sprung valve holders. 2 Baseboard-mounting single-coil sockets. 1 H.F. choke. 1 low-ratio L.F. transformer. 1 200- or 400-ohm baseboard-mounting potentiometer. 1 baseboard-mounting neutralising condenser. 1 '0003- and one '0005-mfd. fixed condensers. 1 2-meg. grid leak and holder. 1 Terminal strip, 12 in. x 2 in. x ½ in. 10 terminals (Belling & Lee, Clix, Ealex, Igranic, etc. Wire, screws, tapping, clip, flex, G.B., plugs, etc.

metres or so, and a No. 6 for reaction. Try a No. 9 for reaction if your detector valve is of one of those types which do not oscillate very easily, from about 30 to perhaps 60 metres, you require a No. 6 coil for L_1 , and a No. 9 or another No. 6 for the reaction coil L_2 .

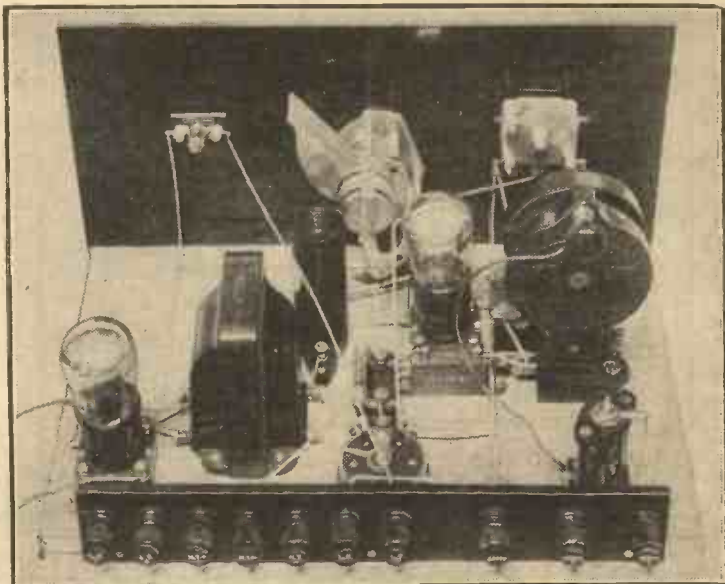

Complete kits for the construction of this set are obtainable from the Ready Radio Co., Messrs. Peto Scott and other concerns.

USING MAINS UNITS

Before making or buying any kind of mains unit or set, you should read these interesting and informative details regarding power supplies.

It is not wise for the newcomer to radio to experiment with mains devices. Some elementary knowledge of electricity should first be acquired. Commercial mains units and mains sets, at least those due to reputable manufacturers, are as harmless as any domestic appliance, such as a vacuum cleaner, or an electric iron, providing the instructions for use are carried out.

It is a different matter altogether when the amateur starts to connect all sorts of home-made apparatus to the mains. It is then that certain facts in connection with the distribution of power must be known.

A.C. AND D.C.

There are two distinct types of supply, these are A.C. and D.C.; A.C. (alternating current) is in some ways safer and, in other ways, more dangerous to handle. Its greater safety is to be found in the fact that the current is seldom led direct to its destination. Invariably, a transformer is interposed, and the primary of this is fed from the mains connection via the light or power socket.

This, in a certain way, isolates the distribution lines from anything to which the secondary of the transformer is connected, but alternating current is more physically harmful, and if what is known as a step-up transformer is



employed to increase voltages it is possible to get very nasty "packets" indeed.

It should be noted that alternating current reaches a voltage much greater than its rating. For instance, 210 volts A.C. touches a maximum pressure of about 300 volts. Alternating current, as its name suggests, flows first in one direction and then in the other, and it rises to a maximum and falls to zero in each case.

The complete operation of rising to maximum, falling from maximum to zero in the one direction and then rising to maximum and falling again to zero in the other direction, is known as a cycle. With a 50-cycle supply there are fifty of these complete reversals per second.

THE MEANING OF "PHASE."

The effective voltage is 70 per cent of the maximum, and it is this that is given as the rating; so do not forget that if you have the A.C. mains you are up against a voltage much greater than that which is inscribed on your electric-light bulbs and other devices. This greater voltage will not be taken into account in the ordinary working of domestic electrical apparatus, except in that these devices will have to be designed with greater safety factors than is necessary for D.C.

You may often have seen the terms "single phase," "double phase," and "three phase," as applied to A.C. mains, but these terms are of more interest to the engineer than to the household user of electricity. They refer to systems of distribution. Single-phase working is the generating and distributing of a single alternating current, as described above. In double-phase working two currents of the same voltage, but out of phase—that is to say, the one is

rising to maximum in the one direction before the other—are generated, and pass out for distribution.

In the case of three-phase there are three currents of the same voltage, but all out of phase with each other, developed for distribution in a rather complex manner. But, as we have said, you do not have to worry about this.

With D.C. mains the point of vital importance is that one of the power wires is almost sure to be earthed. Having seen the electrician fix the wires and take every precaution against these coming into contact with anything, it may strike you as curious that one of the wires should be earthed. But this is almost sure to be the case and may cause complications unless you are aware of it.

Also, it may be either of the wires, and not necessarily the negative one, as shown in Fig. 1. With this negative power wire earthed it means that you short the mains completely if the positive wire happens to come into contact with anything else that is earthed. For instance it might so happen that the positive wire brushed a water pipe or a gas pipe, and the result would be the same as if you brushed the positive wire against the negative.

THE "THREE-WIRE" SYSTEM.

At best a fuse would go; at worst, a red-hot wire would cause a conflagration of minor or major character. We have said that it might be either the negative or positive wire that is earthed. The cause of this is to be found in what is known as the three-wire distribution system, which is almost universally adopted where there are D.C. supplies.

The purpose of the three-wire system is to enable the economical distribution of two voltages to be carried out. The high voltage, which will be double that of the low, will be used for driving power machinery in factories, and for operating tramcar systems and so on, while the low voltage will be fed to houses for domestic purposes.

A very simple plan of a three-wire scheme is shown in Fig. 2. There are three output mains wires from the power station, and these are known as the negative, positive and neutral. The full voltage of the supply will exist between the negative and positive leads, and the lower one between either of these and the neutral. The neutral wire is almost invariably earthed.

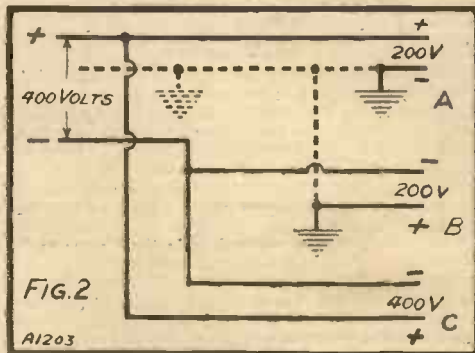

The houses in one road of a district might be served with the neutral and positive wires, as at A in Fig. 2. The voltage difference between these will be 200 volts if the full voltage of the mains is 400, and the neutral becomes the negative connection.

The houses in another area (it might be only the other side of the same street) could be served with the negative and neutral feed, and, in this case, the neutral would become the positive connection, and this is, of course, earthed.

The point "C" with 400 volts, gives the full pressure of the supply, such as may be needed by tramcars and so on, as we have before mentioned.

A SIMPLE EXPLANATION.

Because of the almost invariable earthing of the negative H.T. and L.T. in radio sets, it has become something of a legend that negative is always taken to earth, but this is very much not the case when applied to the mains. The three-wire system is rather difficult for the non-technical man to grasp, but he may find it easier if we apply it to a simple battery arrangement such as is shown in Fig. 3.

The battery symbols indicate that there are six cells joined in series, and if these were accumulator cells the total voltage across them would be 12 volts. Now, supposing a wire were joined to the point connecting the third and fourth cells. There would be a voltage difference of 6 between this wire and either of the other two wires shown in Fig. 3. and the

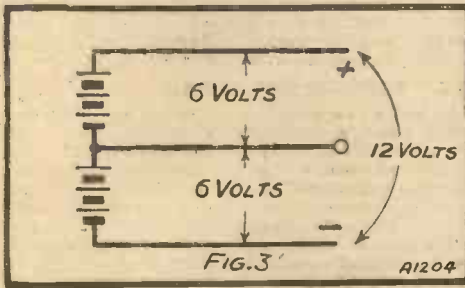

middle wire would be 6 volts positive to the negative connection.

But also that central connection would be 6 volts negative to the positive connection, or, which is exactly the same thing, the positive connection is 6 volts positive to the central connection and 12 volts to the negative connection.

Thus the central tapping can be either negative or positive. It is positive in relation to the one end of the battery, and negative in relation to the other. This you will see is obvious, in that the wire is connected to the positive of the third cell from the bottom and the negative of the third cell from the top, these two points being joined together.

REMEMBER THE SET'S EARTH.

However, you do not get three wires coming into your house unless you have special permission for the use of the full voltage of the local supply station. You have only got two wires, and the point to remember is that either one of these may be earthed. And unless you know for certain which one is so connected and carry out your experiments accordingly, there are precautions you must adopt to prevent accidents happening.

The vital thing to remember is that your radio set has an earth connection, and that if you connect a mains unit to it, either L.T. or H.T., or both, you must remove the direct earth connection on your set or you may cause wires to go red-hot, fuses to blow, and other things to happen.

The best thing to do is to discard the earth connection altogether, for it is quite unnecessary if you use a mains unit of either the L.T. or H.T. variety. In that the mains are earthed, or at least one of the wires is, a further connection to the ground is quite unnecessary. Indeed, it is liable to introduce hum.

THE SERIES CONDENSER.

If for any abnormal reason you find that an earth to the set is necessary, then the connection must be made via a fixed condenser: that is to say, you take a 1-mfd. or a 2-mfd. condenser and join one of its terminals to the earth terminal of the set. The other lead is then taken to the other terminal of the fixed condenser.

It is necessary for a fixed condenser used in such a way to be capable of withstanding the full voltage of the mains, the ordinary low-voltage variety will not prove sufficiently robust. A condenser of the type used in mains units for smoothing, with a working voltage of double that of the mains rating, is the sort of thing you want. But even after having dispensed with the ordinary earth connection, or having arranged a series condenser as described, you have by no means obtained safety.

In the ordinary way, one does not worry about the various things that are connected to earth through a radio set. The result is that you may find in your output all sorts of screening, wires and components that, far from being adequately insulated, are not catered for at all in this respect.

A VERY "LIVE" WIRE.

You have an earthed main, this is assuming that you are using a mains device, coming via various resistances and so on, into the set, and, what is much more important, you have another very "live" main. It is this last that you have got tenderly to nurture. Supposing it happens to be the negative main that is earthed. In this case there is not much to worry about, because it will go to L.T. — and the normally grounded parts of the set, but supposing the negative main is the unearthing connection, then it is a very different story.

If you look at the theoretical diagram of any set you will find that the negative L.T. or H.T. point is joined to a whole hoard of things, such as coils, transformers, and so on.

As your negative main is very "live," all these points are at the full voltage of the mains potential above earth.

THE DANGER OF SHOCKS.

If you were standing on a fairly conductive floor, or if you happened to be resting your hand against a not-too-good-insulator of a wall or touching something else that was even more directly earthed, and then with the other hand touched a coil or transformer winding, or anything else that was joined metallically to the earthed side of the set, you would get the full voltage of the mains passing through your body, and a nasty shock it might prove.

This indicates that you should not touch the interior of the set or any of its terminals or metallic parts while the mains are switched on. In all probability the aerial will be metallically connected to the L.T. — H.T. — points via the windings of a coil, and in this case the aerial itself becomes merely an extension of that live mains connection, and sparks would fly if it swayed against a drainpipe, or scraped against a wet wall.

To prevent this happening a fixed condenser can be joined in series, close to the set or inside the set, in the same sort of way as the one described for the earth.

(Concluded on page 12.)

CHOOSING MAINS VALVES

The various types are reviewed, and interesting comparisons are made with ordinary battery-operated valves.

It is impossible to use the majority of "ordinary" valves for operation with raw A.C. on the filament owing to the fact that the fineness of filament will cause such heat variations due to the current variations that the valve would be noisy in operation. In other words, we would get a hum. The long filaments cause considerable voltage drop, and also every time the A.C. current drops to zero and then begins to rise again we get a definite fall in temperature, then an increase in temperature and then a fall again, so that the electron stream is very unsteady all the time.

TWO TYPES AVAILABLE.

We must have constant electron emission from the filament if we are to have proper reception and amplification. Accordingly, we have to turn our attention to one or other of the two types of special A.C. valves which are on the market. Although perhaps not the best known type, we will mention first the point 8 type of valve. This is a valve with a very short filament taking .8 amp. at only .8 volt, with the exception of the detector, which takes 1.6 amp., so that we get little voltage drop across the filament and little change in temperature as the A.C. fluctuates in value. These are made by the Cossor, Marconi and Osram Companies in the usual types: screened grid, H.F., detector, L.F., power, and so on.

Unfortunately, however, we have as yet no super-power valve in this series, the lowest impedance being the P-8 valve, which has an amplification factor of 6 and an impedance of 6,000 ohms. These valves are useful for small sets but where very great volume is required it is necessary to use something which will give a rather more "beefy" output, such as the L.S.5A, with its different filament voltage or turn our attention to the indirectly-heated cathode variety.

These are valves which, instead of having the ordinary filament as we know it, have a special type of coated tube as cathode, the coating on which is carefully prepared so that a large electron emission is obtained at a comparatively low temperature.

INDIRECTLY HEATED CATHODE.

Now in order to heat this cathode a heating element which carries the A.C. current is placed inside it, quite close to it, but not in connection with it, and through this element is passed raw A.C. of a value of about 1 amp. at 4 volts. This heating element gives off quite a considerable heat, which by radiation heats up the cathode, which in turn emits the

electrons. These valves take a little time to heat up, and, of course, some little time to cool down, thus the slight fluctuations due to the dying down at reversal of the A.C. current in the heater element has no effect upon the temperature of the cathode itself, and therefore no effect upon the electron emission of that cathode.

VERY EFFICIENT VALVES.

The trouble of hum, therefore, is got over in a very ingenious manner, and by careful design it has been possible to make valves of the indirectly-heated cathode type extremely efficient; in fact, the mutual conductances of these valves are often much higher than those of valves with ordinary filaments, and especially in the super-power class is the high magnification factor with low impedance valuable.

For instance, in the Mazda range the power valve has an impedance of about 2,500 ohms, while the amplification factor is 10, while the Cossor 41 M.P. has a magnification of 10 with impedance of 5,000 ohms.

We have a tremendous amount of choice in these A.C. valves, and constructors who live where A.C. is available should think very carefully indeed before they decide whether their next set shall be of the battery variety or whether it shall be an all-from-the-mains receiver. Taking the H.T. from the A.C. mains is, of course, a very valuable procedure, but it is still more useful to run the whole set, including the filaments of the valves, from the mains.

For "big" loud-speaker reproduction some of these big A.C. valves are invaluable, while the new Mazda

screened-grid A.C. valve is capable of giving a colossal magnification. In fact, the magnification from this is so great that exceptionally careful screening has to be adopted, and the coils in the screened-grid circuit have to be extremely carefully designed.

CHANGING OVER.

As a matter of fact, it is not possible to make full use of the magnification obtainable from this valve, but it can be made to give results comparable to one and a half or even two screened-grid valves of the battery-heated variety.

One early drawback in the A.C. indirectly-heated valve was the fact that it had to have a special valve holder, but holders are now being made standard, and the valves are being made in the five-pin variety instead of the three- or four-pin and special cathode connections. So if you change your set from ordinary



On the left is a four-pin mains valve, the extra cathode terminal being on the side of the base. The other two are five-pin mains valves.

valves to indirectly-heated cathode valves, or vice versa, you will be able to use the same valve holders.

There is, however, one point which must not be forgotten when wiring up the actual heater element leads in the set which have to carry the L.T. current from the transformer, and that is that these leads should be made of either twisted flex or be lead-covered with the cover earthed, in order to stop A.C. hum being introduced into the adjacent wires of the receiver and thus causing an annoying background.

SPECIAL TRANSFORMER NECESSARY.

It is sometimes possible, in the case of certain super-power valves of the ordinary type, to run them quite successfully with raw A.C. on the filaments if care is taken that the correct voltage is applied. Such valves as the L.S.5A, which has a comparatively fat filament, can be used in this manner, and there have been cases in which the P.625a and the P.625 have been used with raw A.C. on the filaments with good results.

It must not be forgotten that a special L.T. transformer of the step-down variety is required.

In the case of the special .8 valve, the transformer has to be of such a ratio that it will deliver 2 amps. or so at .8 volt. On the other hand, in the case of the indirectly-heated cathode type we want several amps. at 4 volts, so as to supply the 1-amp. heating elements at 4 volts.

We would not hesitate a moment in recommending constructors who have a certain amount of experience in the construction of valve sets, and especially in loud-speaker sets, to go in for A.C. mains receivers, and if they do so to go in for the indirectly-heated filament type, which will give them, in our opinion, more satisfaction than will the .8 variety.

These latter, however, are quite useful for the man who wants to convert his ordinary set to raw A.C. without re-wiring the same, and he can do this by just changing the filament leads into twisted flex leads, and buying a transformer suitable for stepping down the mains voltage and using a potentiometer for the grid returns.

But he must not expect exceptional results. The characteristics of these valves are very much the same as those of the ordinary valves, and the amplification factors are not as great as those of valves of the indirectly-heated cathode types.

THE L.T. POTENTIOMETER.

If one has a choice between indirectly-heated and directly-heated filament valves, and it does not matter which is employed in any particular set, it is easy to see which type is going to prove the more effective stage for stage.

The indirectly-heated valve will give you more mag., but, because of this mag., back-coupling effects and instability are more likely to occur in the H.F. stages. The screened-grid indirectly-heated valve needs very careful screening if anything like real stability is to be obtained.

When mains valves are employed great care should

be taken that correct bias is provided and that a potentiometer be placed across the filament—or heater—wiring, the slider being taken to earth and the grids either direct through the circuit or via a grid-bias battery.

The A.C. valve when used as a detector on the leaky-grid principle needs positive bias on its grid, for the filament is taken to A.C. supply and the grid return is taken to the slider of the potentiometer. In the case of the indirectly-heated valve the cathode also goes to this point.

Thus should you mix the valves, as is done sometimes in sets where a change over from batteries to mains is carried out, and have the point 8 screened-grid valve, with indirectly-heated detector and note-mags., you need to be extra careful about the filament and cathode leads.

The point 8 S.G. valve will require a transformer winding giving it the correct voltage and current, and a potentiometer across it, while the indirectly-heated valves require a 4-volt transformer winding and another potentiometer. Both potentiometer sliders are taken to earth, and all earthed points.

AVOIDING HUM.

Finally, it must be remembered that all filament and heater wiring must be of twisted flex, to avoid setting up A.C. hum, which would be induced into the rest of the wiring and the components if it were not neutralised by the twisted A.C. wiring.

It must not be forgotten that whereas in the case of the point 8 valve the filament is the cathode (as in the case of the ordinary valve), the filament (or heater) has nothing to do with the electronic emission in the case of the indirectly-heated valve.

In this case the cathode is the specially prepared tube round the heater, and that is why it has to be earthed. Obviously, then, in the detector stage the valve has to be given an applied positive grid bias in order that it may operate on the leaky-grid principle efficiently. It is, of course, usual in the case of the ordinary valve to take the grid leak to the positive filament lead, but this is impossible in the case of A.C. valves, and therefore an applied potential usually has to be provided.



Reversing the primary connections of an L.F. transformer often cures L.F. instability.

USING MAINS UNITS

(Concluded from page 10.)

It is quite a common practice to use single-way on-off mains switches which break only the one wire: but then it might so happen that this one wire were the earth connection, and in this event the live connection would still be carrying the full potential above earth to any of the points to which it was connected.

Therefore, complete switching can only be obtained by withdrawing the plug or using a switch of the double-pole type. But whatever the scheme is, and whatever the switching used, the golden rule in mains working is never to make any adjustment of any kind while the apparatus is connected in any way to the mains unless it is absolutely vital.

Be sure to wear rubber gloves for any adjustment.

You can, of course, handle the tuning controls of the set quite freely providing the various precautions against leakage are taken and that the metal parts of variable condensers, and so on, do not come into contact with the fingers.

And our last word on the subject for the time being will be (unless all the foregoing is well and truly understood, and perhaps a little more besides), treat the mains with great circumspection—if you deal with them at all!



How Loudspeakers Work

A really readable article of an informative character.

Loud speakers take many forms, and there are many different qualities, but even the worst of them can speak up for itself or imitate music in a way which could hardly be expected of anything so utterly dumb and unmusical. How is it done?

Everyone who has tried to play the piano knows that it is not easy to make real music. And even speech, if we consider it alone, is quite a complicated business, so that it takes the most intelligent baby several years to progress from the "mum-mum" and "dad-dad" stage to a real command of words. If a super-intelligent mother's joy or a father's pride takes so long to learn to speak properly, how can a bleak-looking contraption like a cone express itself so perfectly?

To get any idea of the process involved we must first ask what is sound, and how do the various sounds differ from each other? And immediately we attempt to analyse it, sound casts off its disguise as a familiar and commonplace effect and becomes, instead, a marvel and a mystery.

That may appear to be a far-fetched statement, but consideration will show that it understands rather than exaggerates. Let us but sketchily realise what sound really is, and we shall attain to a new respect for the loud speaker!

WHAT WAS THAT SOUND?

For the purpose of analysis we will take a common sound—say the note middle C of a piano. Imagine that someone plays it, and that after lingering on the ear for a moment or two the sound dies away. Exactly what happened in those moments? What WAS that sound?

It was caused by the movement of a formerly stationary object—a piano "string"—which, suddenly tingling into life, moved for those few moments in an entirely individualistic dance of its own.

In moving it "shook" the air around it, and thus set up a wave disturbance that travelled outwards and finally reached your ear, agitating the ear-drum into motion.

This ear-drum movement was a reproduction of the string's movement, retaining all the little individualities and peculiarities.

No other note would have sounded just like that one, and no other instrument playing middle C would have given you the piano effect. And when you examine those sound-waves, and ask why one note differs so markedly

from another, you find that sound is anything but "simple."

You find that sound—any ordinary sound—lives a life in time, as you and I do, has a character of its own, as we have, and is, in effect, quite an individual. What sort of an individual is our friend piano middle C?

CERTAIN TINY VARIATIONS.

Its first peculiarity is that it always vibrates 250 times per second—that is its "frequency." Next, being kicked into life by a key, it always starts off at its maximum, and then slowly dies away, getting weaker and weaker, until inaudible. (An organ middle C would not have behaved like that, for although it too would favour middle-C frequency (256) it would have no sudden "kick" behind it, but only a steady pressure.)

To these two main and fundamental characteristics our piano middle C adds certain tiny variations, complexities, "qualities" of its own—slight but perceptible peculiarities of movement, that make the "tone." And every different make of piano adds them in a different way, so that to the trained ear no two pianos sound quite alike.

Thus piano "tone" depends partly upon the make of instrument; and it will further be influenced by the piano's surroundings; so that both heredity and environment effect the character of a piano note, very much as they affect human character. All this, mark you, arises from playing one note—a simple sound of known frequency.

THE DIAPHRAGM AT WORK.

Speech, on the other hand, is not a simple sound. Speech is really a very complicated succession of sound waves so articulated, modulated and moulded for every different word and tone that the sound waves of which it is formed are continually altering in amplitude and in frequency. Most of the credit for the artificial re-creation of speech goes not to the loud speaker, but to the electric currents fed into it; for these currents, suitably handled, can correspond with every fine gradation and syllable, tone and inflexion with astonishing fidelity. The loud speaker is fed with these constantly changing currents, and its task is to make them audible.

This it does by setting up sound waves—by alternately compressing and rarefying the air surrounding the diaphragm. The diaphragm or cone, stodgy as it appears, is really incredibly alive when in operation, trembling and tingling now at this frequency and



The famous "Blue Spot" loud-speaker unit.



One of those very popular Celestions.

now at that, fast or slow, strongly or softly, with just those necessary combinations of speeds and of strengths which are required to reproduce the voice, the music, or the combination of both of which the programme consists.

The actual movement is imparted to the cone or diaphragm by magnetism. Every electric current has its magnetic counterpart, exactly corresponding with it.

And if the current rises and falls, say 256 times in a second, the magnetic field will build up and collapse at exactly the same speed, and to the same degree. So if we harness a sound-producer—or "diaphragm"—to this magnetism, the current will vibrate it and so set up the corresponding sound wave.

THE OLD HORN TYPE.

In the old-fashioned horn-type of loud speaker the diaphragm itself was placed in the magnetic system, close against the magnets. Here the currents so pushed and pulled the diaphragm that its tremors corresponded to the current flowing. The diaphragm itself had, of course, to be made of magnetic material.

Usually a thin disc of soft iron was employed (of the kind seen in telephone ear-pieces), it was small and it was incapable of handling great volume. As there were other inherent disadvantages of the magnetic diaphragm the cone loud speaker was introduced.

In this the actual to-and-fro movement vibrating the diaphragm was imparted to it by a separate



This is one of the very excellent Mullard loud speakers.

armature—the diaphragm itself being non-magnetic and the armature being non-sound radiating—the two being joined by a short reed fastened to the apex of the cone. With the cone the area of diaphragm can be enormously greater than the old-fashioned horn-type of speaker, and the sound-chamber horn is not required. But although the armature movement was not perfect, the

system had certain distinct advantages.

The actual movement of armature or of diaphragm is caused by a dual magnet, consisting of a permanent magnet and an electro-magnet working in conjunction with each other. (Normally, and even when the speaker is not in operation, the diaphragm (or armature) feels the attraction of the permanent magnet.)

AN IMPORTANT DIFFERENCE.

Around the poles of the magnet is wound the fine wire of which the electro-magnet consists, this also being able to pull on the diaphragm, but with this important difference. The electro-magnet pulls only when electric currents flow through the wire, and it pulls at the frequency that the current flows, and with the strength that the current dictates.

So every tiny alteration in the current brings about a corresponding alteration in the magnetism. Consequently the pull on the diaphragm is in effect either strengthened or weakened exactly as the current strengthens or weakens.

MIXED CURRENTS

A radio set is a maze of electrical circuits. Some deal with radio-frequency currents, some with audio-frequency currents, and others with direct current. Every valve will have a grid circuit, an anode circuit and a filament circuit, while there will be an aerial tuning circuit and, in the case of a mains set, various smoothing and rectifying circuits.

And it is the aim of a radio set designer to get every one of these individual circuits connected to earth as effectively as possible. In doing this he aims at a maximum degree of stability. Any circuit that is not so treated is reckoned to be "up in the air" and a possible source of instability.

THE CONNECTIONS TO EARTH.

You will notice in any radio receiver that there are more things connected to the earth terminal directly by wires than to anything else. And there are other earthing connections which are not metallic, these being via fixed condensers.

In the case of a set employing screens, these naturally are grounded and thus form convenient points to which earthing connections for various parts of the set can be taken.

Branch connections simplify wiring and make for tidiness. If you are told to connect one terminal of a certain component to the earth terminal of the set you can join the wire to the nearest lead that goes to this point. This is, of course, a common practice, as you will see by referring to any wiring diagram.

ALL KINDS OF CURRENTS.

The result is that it frequently happens that through one piece of wire all kinds of current flow.

The L.T. minus terminal may be placed close to the earth terminal and a short length of wire join them together. Another lead may go to the earth terminal from a large fixed condenser that happens to be placed in series with the loud speaker in accordance with the familiar choke-capacity shunt scheme.

One terminal of an H.F. transformer has to be taken to earth, and, to shorten the necessary wiring, the lead may be joined to that L.F. shunt condenser wire which happens to be passing close by. And the same thing applies to the L.T. minus terminal of a valve holder.

NO CONFUSION WHATEVER.

Therefore, through one short length of wire pass L.F. impulses that have negotiated and operated the loud speaker: H.F. impulses that have been generated in the secondary winding of the H.F. transformer, and a steady uni-directional current which flows from the battery through the filaments of the valves.

There is no confusion whatever and the H.F. does not interfere with the L.F., the L.F. with the D.C., or the D.C. with either of the others. In actual fact they are not three different kinds of energy. It would be more correct to refer to them as variations of the same energy.

You can think of the direct current as a steadily flowing stream to which is added further currents of an alternating nature, either high- or low-frequency, or both. A heavy buoy in a river or sea will bob up and down as waves pass it, but only the size of the waves will determine the movement of that buoy, and it does not matter whether the water is 10 ft. or 100 ft. deep, the buoy will bob up and down to the same extent.

THE GRAMOPHONE PICK-UP

An impartial review of the possibilities of this device when used with ordinary radio sets.

We are often asked whether the use of a pick-up is really justified when one considers the wonderful results that can be obtained with a modern gramophone.

That there is a difference cannot be denied, because a good electrical reproducer has an uncanny naturalness about it which even the best gramophone appears to lack, though it must be said that if the electrical reproducer is at all off-colour, then it may give results far inferior to the average gramophone.

The advantages of using a pick-up, provided you have a good amplifier and good loud speaker, are many. One, of course, is that you have complete control of volume from a mere whisper right up to as loud as you can possibly stand it in the room without in any way altering the tone or quality of reproduction. With an ordinary gramophone, as you know,



The Igranic Phonovox Pick-up with carrier all ready for standing on a gramophone platform.

alteration of volume often means that a certain amount of tonal quality is lost, for by shutting the doors the sound is reflected back from the doors to the sound-box, and as the doors are shut more and more a point is reached when they so choke the sound that the reaction on the sound-box becomes apparent. This makes itself felt in a peculiar chattering which is very unpleasant.

If one has a wireless receiver, it is easy to combine the electrical gramophone reproduction with the ordinary wireless set, with only the extra cost of the pick-up and possibly either a cheap gramophone, or a turntable and a motor

AN EXCELLENT ALTERNATIVE.

So to all those who have good wireless sets we would certainly say, "Go and get a pick-up, and use your gramophone, or get a motor and turntable and enjoy your entertainment to the full." Many a dull half-hour of programme can be whiled away by the substitution of half-a-dozen gramophone records, and when a good receiver is employed, together with a good loud speaker and pick-up, it is exceedingly difficult for those not in the know to decide whether wireless or the gramophone is being used.

It is essential, however, to have a good amplifier, one which will carry a fair volume without distortion, and which will provide undistorted radio results to the loud speaker.

Here, again, a good loud speaker is another essential. It is of little use to use a pick-up with an ordinary

horn loud speaker. One of the best models of cones or moving-coil types is really essential if we are to beat the gramophone at its own game.

That is where a great deal of this talk about pick-up reproduction being inferior to the gramophone has originated. People have gone in for pick-ups and placed them on very doubtful two- and three-valve sets, with still more doubtful loud speakers, and heard the results, and promptly decided that it is not so good as the average gramophone.

Under those conditions reproduction is not as good as from the gramophone.

The average gramophone reproduces its records well in spite of certain defects. Those defects have been reduced and eliminated as far as possible, but certain defects do still exist, and it is in spite of these defects that the gramophone does as well as it does. A good wireless amplifier should have far fewer defects, and should, therefore, be able to bring out all the frequencies that have been recorded on the record in their true proportions, and it is in this respect that it beats the gramophone.

GETTING THE BEST RESULTS.

Those of our readers who really want the best reproduction from their gramophone records should, therefore, see that their wireless sets or amplifiers are in good condition, and that their loud speakers are above reproach.

Those, on the other hand, who wish for a pick-up and pick-up reproduction to be a foolproof sort of way of playing a gramophone will be rather disappointed. It has to be done properly if undistorted results are to be obtained.



The famous Lissen Pick-up which makes the needle itself act as an armature.



This Amplion volume control was specially designed for Pick-up work.

MAKING YOUR SET SELECTIVE

Here are some simple schemes for improving the selectivity of your set. The new high-power broadcasters have made many of the older designs quite useless. But even these can be dealt with providing you go the right way about it.

The first photo shows how a separate aerial coil can

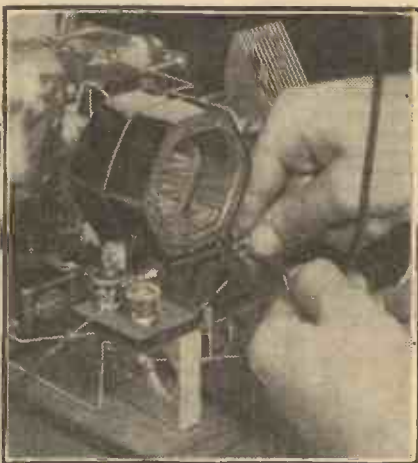

be improvised for a set having only the one untapped tuning coil in its aerial circuit.

You wind quite roughly in a hank of about the same size as the plug-in coil, twenty or thirty turns of 24-gauge cotton-covered wire, which you fasten to the coil with cotton, as shown.

One end of this new coil should be joined to earth, and the aerial lead is removed from its terminal on the set and joined to the other end of the new coil.

Coils known as the "X" type, which are shown in two others of the photos, will give you much greater selectivity than the plain, untapped plug-in coil.

You use an "X" coil in this way. It replaces the ordinary aerial coil in the set and the aerial lead is taken direct to one or other of the "X" coil terminals instead of to the usual aerial terminal on the set. These two terminals give you alternative degrees of selectivity.

SHORTENING THE AERIAL.

The centre photo shows how a separate aerial coil can be wound over a cylindrical coil. Its size and connections will be the same as for the plug-in coil above.

Another scheme is to connect a small fixed condenser in series with the aerial lead. One of .0001-mfd. capacity is generally about right for ordinary conditions.

In a bad case of inselectivity the aerial should be shortened considerably.



Hints on Tuning

Some tips that show you how to handle a set so that you get the utmost out of it.

With an ordinary simple one- or two-valve set there is only one way to pick up foreign stations with any degree of regularity, and that is by taking the trouble to learn how to handle the receiver. Twisting the dials haphazard here and there may result in accidentally bringing in a foreign station—but it is certain to interfere with your neighbour's programme; it is selfish and unnecessary, for by taking a little trouble the knack may be learned, and foreign stations brought in with certainty.

MAKING THE SET SENSITIVE.

You can learn how to handle a receiver properly in about half an hour or so, if you will take the trouble to set about it properly as outlined below. The first thing to do—and this is important—is to choose a time when no broadcasting is on, say either late at night or before the afternoon programme commences. Wear 'phones if you have them, but if not, prop up the loud speaker at an angle where you can get your ear close to it, so that you can study every sound coming from the set.

When everything is switched on, turn the reaction dial to its minimum, set the tuning dial (left hand) half-way round, and listen. If you have chosen a quiet time of the day all you will hear is a very faint suggestion of sound, a kind of ghostly background that tells you the set is "alive."

Now put your right hand on the reaction control and slowly "increase" it, listening carefully all the while. Perhaps for the first five or ten degrees you will notice no difference, but if you are listening closely you will observe that although no stations are coming in the tiny sounds referred to are getting louder. The set is becoming more sensitive.

Continue slowly to revolve the reaction control until these sounds, getting louder and louder, suddenly terminate in a kind of "pop," followed by a soft rushing sound. This indicates that the set is oscillating.

MASTERING THE MAIN PRINCIPLES.

Just to make sure of it, wet your forefinger and touch the grid terminal of the detector valve holder. This will give rise to loud double clicks as your finger connects and disconnects with the metal. Turn back the reaction knob again and these signs of oscillation stop.

Practise bringing the set up to oscillation in this way several times, until you can be sure you know just when the set is oscillating and when not. The

point is that when you have passed the oscillation point the set will cause interference with your neighbours, and you are getting too much reaction for good results. If, on the other hand, you slack off the reaction too far the set will become insensitive, so the object is to get as near the oscillation point as possible *without actually oscillating*.

You have now mastered the main principles, but the next thing to do is to apply this in practice, —i.e. to turn the reaction properly in conjunction with tuning. To do this, set your tuning control about half-way, bring the reaction right up near the oscillation point, until the set is in its most sensitive condition, and then leave the reaction dial alone and turn your attention to the tuning dial.

USE BOTH DIALS TOGETHER.

First of all, tune it *upwards*, that is, increase the wave-length, noticing at the same time exactly how this affects the reaction symptoms to which you have been listening. You will find that as the wave-length is increased reaction seems to fall off.

Next, turn the tuning dial slowly downwards to decrease wave-length, and you will find that even when the reaction dial is left alone the set goes into oscillation! Reaction is to some extent interlinked with tuning.

So in order to bring the set close to the oscillation point you must always tune-in with one hand on the reaction dial and one on the tuning dial.

QUITE SIMPLE.

If you are slowly moving the tuning dial "up" in order to keep the set sensitive, you must slowly increase the reaction at the same time. If you are slowly turning the tuning dial *down* towards the lower wave-lengths, you must at the same time slowly *slacken off* the reaction, or the set will go into oscillation.

It is quite a simple matter with the left

hand to turn the tuning dial from the lowest to the longest wave-length, and simultaneously with the right hand to keep the set really sensitive. And when you do that the stations simply roll in.

Searching for stations with two tuning dials and a reaction control is quite tricky, although it generally happens that tuning with the one dial will be much flatter than with the other. This means that you can proceed very carefully with the one and use this as the main locator, as it were, while with the other hand you keep the other dial moderately in step.

You can always set the dials so that their readings correspond fairly closely with each other. You can



Don't forget that readjustments of an aerial tapping may alter your tuning quite a bit.

do it by tuning in one of the more powerful stations very closely, and then loosening the dial of one condenser and turning it (without rotating the vanes) until the reading corresponds with that of the other condenser. The dial can then be tightened up.

SIMPLIFYING STATION SEARCHING.

Approximate reaction condenser settings should be noted for various readings of the tuning dials. Normally, less reaction will be required for the lower dial readings, so that the reaction condenser can be brought a little more in at every ten or fifteen degrees on the tuning dials. Provided your set has S.G. valves or properly neutralised H.F. stages, you do not have to worry about oscillation causing interference with other listeners. Little or nothing will get back to the aerial from the detector stage, so that it is quite safe to operate close to the oscillation point.

This naturally facilitates searching, for you can keep your tuning variables in step by the multitude of carriers that you will pass through. You can resolve the carriers as you reach them by reducing

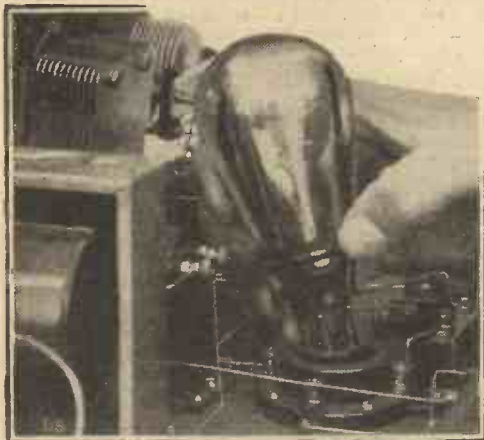

Valves should be inserted into their holders carefully and their pins examined from time to time to see that they are clean and making good contact with their sockets.

the reaction a trifle and slightly readjusting the tuning controls.

With three tuning dials you really need three hands! In any case, some preliminary searching will have to be carried out in order to build up some sort of calibration chart to provide a guide to the various settings.

THE TUNING CONTROLS

A chat about multi-dial sets, "ganging," and drum-drives.

There are two alternatives to a row of individual dials. A ganged condenser can be employed, all the individual variables being controlled by the one knob. Alternatively, thumb-controlled drum-drive variables can be used. In this case the drum drives can be placed together so that they can be controlled individually or collectively as desired.

SCREENING AND BALANCING.

There is no technical value in having a number of separate dials. Ganging or drum drives can be

equally efficient, but both are much more expensive and tend to make the construction of the receiver more complicated. One of the difficulties is that of arranging effective screening, while, with the complete ganging, the various circuits have to be balanced to a nicety or considerable sensitivity will be lost.

This you will see is obvious, as if the circuits are unbalanced it will render it impossible to get them in tune together, but with ganging satisfactorily arranged you can do everything on the one dial which can be done with two, three, or four. Of course, an efficient slow-motion control is extremely desirable.

You will gather from all this that you cannot judge the power of a set by its panel. Likewise the external controls will bear no relation to the circuit employed.

No doubt a number would feel they were getting more out of a set if it had two or three dials to manipulate than if it only had the one. The panel controls of a set are just as important items as anything on the baseboard.

Some people have a sixth sense with any sort of control. They are the kind of folk who can grasp the geography of a motor-car gear-change in one short lesson. There are other people who never seem thoroughly to master anything of this nature. Between these two are others who are moderately slow or moderately fast to acquire such technique.

THE DESIGNER'S PROBLEMS.

Before buying a radio set, one is well advised to consider one's own personal capabilities. The designer of a wireless set has to lay out the panel in accordance with three requirements.

First of all, the panel components must be placed so that they are efficiently disposed with regard to the electrical operation of the receiver. He cannot crowd all the tuning variables down in the right-hand of the set among the L.F. components and have H.F. leads wandering right across the outfit.

Secondly, he has to obtain a moderately artistic appearance; and last, but by no means least, the panel components have to be placed so that they make the set as easy to handle as possible.

In one case out of a hundred it might happen that all these requirements can be satisfied by 100 per cent. The only possible places to put the variables and so on to get the highest possible efficiency, with short, direct wiring and ample separation, etc., might also be accompanied by an artistic appearance and accessibility.

In the ninety-nine other cases compromises will have to be made. In order to preserve panel appearance, it may happen that one or two leads, or the spacing of components, are not quite as they should be; or, on the other hand, a little must be taken away from the accessibility factor to give proportionately more to efficiency or to appearance.

SETS PAST AND PRESENT

If sets can be made-to-measure, they cannot be designed by rule of thumb, and it sometimes takes as much as a week of experimenting in order to arrive at the 100 per cent layout for a set; and this after all the circuit details have been completed.

You need not worry about the circuit efficiency of a set; you can leave that to the designer. What you are more concerned with is its appearance and ease of handling. The multi-valver of five or six years ago had a large, broad panel studded with an ugly array of controls.

A five-valver might have four tuning variables, a reaction condenser dial, five filament rheostats, and one or two odd switches. Against this the most complicated panel of the present day would look quite simple and handsome.

THE ANTIPODES ADAPTOR

A modern two-valve version using a separate reactor valve of Mr. G. T. Kelsey's famous short-wave converter.

Having mounted the "panel" in the manner shown in the back-of-panel drawing, proceed by fitting the tuning and reaction condensers, the L.T. switch, and the slow-motion "machinery."

A certain amount of care will be necessary when making the dial in order to ensure that the extension handle comes flush against the circular drive at any position of the condenser.

The metal spring will, of course, take up the slack within certain narrow limits, but it is essential to see that the circular piece of wood marked B in the drawing is quite round, otherwise the dial may slip in places.

NOTE THIS SPECIAL POINT.

In this connection it is a sound scheme to stick a piece of fine glass-paper round the rim of the wooden disc, as shown in the drawing. In most other respects the drawing will be found self-explanatory. The hole into which the wooden extension arm is fitted should not go right through the wooden upright.

With the aid of the back-of-panel drawing you cannot go far wrong in the main constructional work, since the wiring and general layout are so very simple. There is one point, however, which calls for special mention. In order to obtain the most sensitive results from the detector valve, it is necessary for the grid return to go to L.T. positive, which means to say that there is a right and wrong way in which to connect the filament circuit to the adaptor plug.

The flex leads from the actual adaptor should be

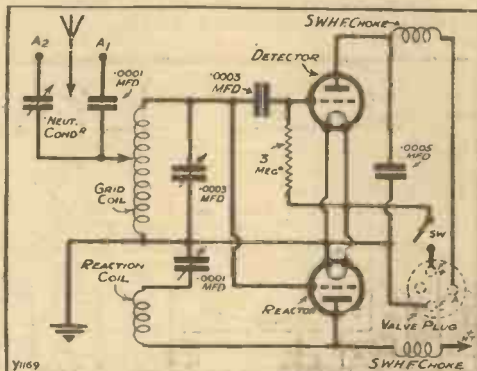

connected to the plug in such a way that the one from the L.T. switch is joined to L.T. plus of your existing set when the plug is inserted into the present detector valve socket.

Having completed the wiring and the connections to the plug adaptor, with the insertion of suitable coils and valves the unit is all ready for testing.

First remove the detector valve from your set and join the plug from the adaptor to the valve socket thus vacated. Place the detector valve

(preferably of the H.F. type) in the detector socket of the adaptor, and if your present receiver has any H.F. stages, proceed by removing these valves, one of which can probably be used in the reactor position.

THE REACTOR VALVE.

The most suitable valve for the reactor position is not at all critical, and if you happen to be in the fortunate position of having spare valves, the best course would be to find a valve by experiment.

The grid coil (the fixed one) should be a five-turn plug-in short-wave coil, and the clip—the best position for which will have to be found ultimately by experiment—can, as a start, be attached to the centre turn. For reaction, again, the most suitable size is a matter for experiment, but in

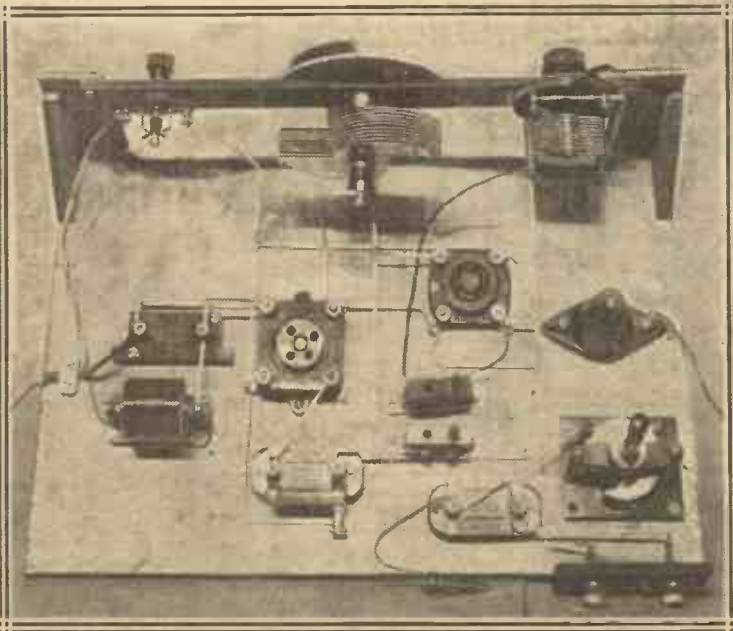

Here you will be able to see all the components that are used.

most cases a four-turn coil will answer the purpose. With the aerial joined to A₂ (the terminal on the neutralising condenser), the earth to its appropriate terminal, and the phones to the output terminals of your existing set, all is ready for testing. With, roughly, 30 volts on the reactor valve and anything up to 120 on the detector, slowly advance the reaction condenser and note whether the set can be made to oscillate. If reaction is present, but "ploppy," try readjusting the voltage on the reactor and altering the setting of the neutralising condenser.

If you are unable to obtain a reaction effect, try reversing the leads to the reaction coil holder, a higher anode voltage on the reactor, and, if necessary, a larger reaction coil or another valve in the reactor position. It is imperative for the reaction control to be absolutely smooth, and this should not be difficult to obtain since reduction of the H.T. voltage on the reactor valve will usually do the trick, and the efficiency of the detector valve will not in any way be affected by this procedure.

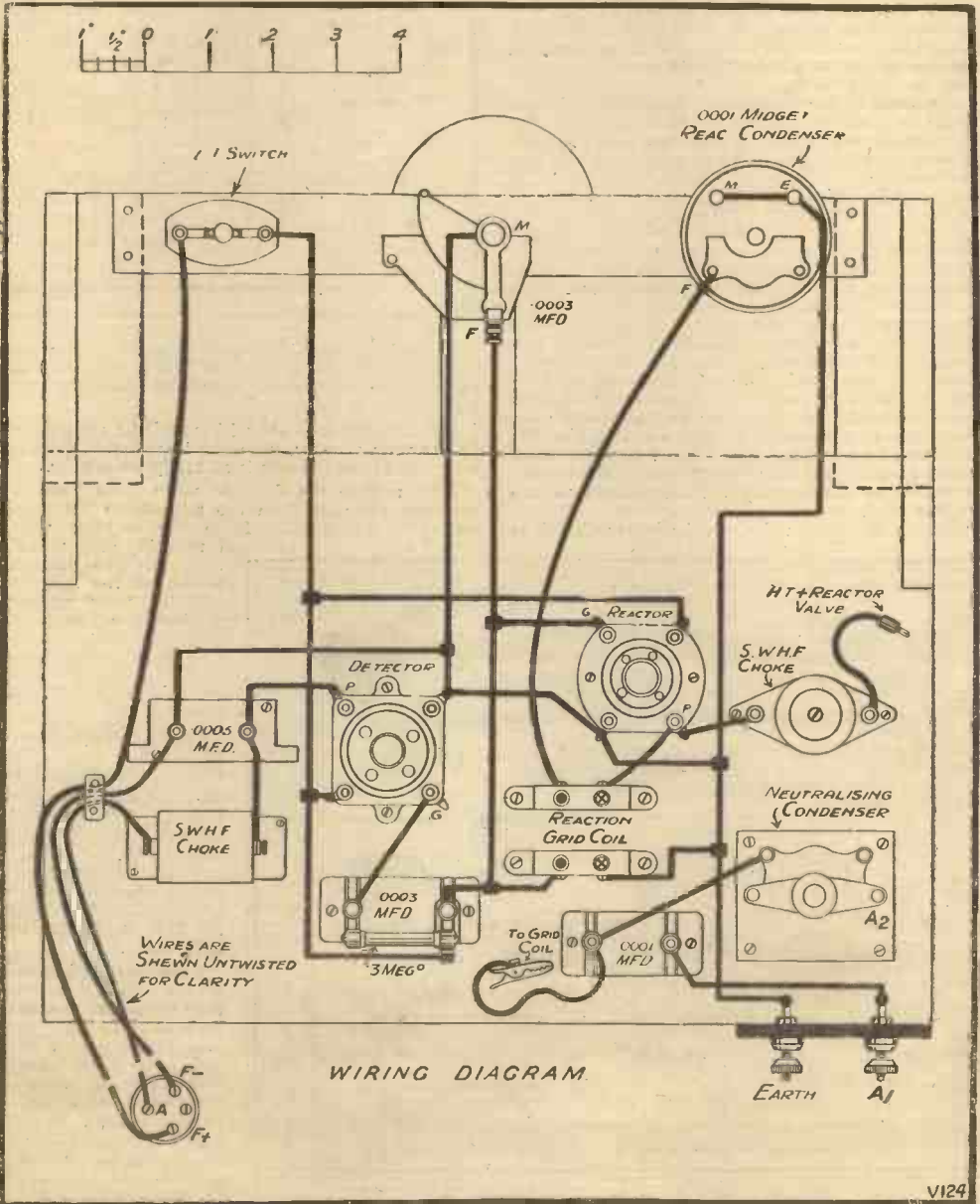

Variation of the capacity of the neutralising condenser may also be found helpful when adjusting the receiver, particularly if you strike any "dead spots," which, "translated," means narrow bands of the tuning range over which the set refuses to oscillate.

In this connection, you may at times find it necessary to alter the position of the tapping clip on the grid coil, but in general, this clip should be used as near to the grid end of the coil as possible, providing the set will oscillate satisfactorily over the whole range.

CURING "FADING."

A very common trouble on short waves is that of "hand capacity" when tuning the receiver, and unfortunately trouble of this nature is not always easy to overcome. To give an example of the sort of thing meant by hand capacity, supposing a station can be tuned in at good strength when the hands are on the tuning condensers, but that as soon as they are removed the station vanishes, seemingly quite automatically.

If you should experience anything of this nature, do not try and work the "Maskelyne stuff" on the rest of the family, but try a new earth. You will probably find it will make a great difference.

Now a few words as to the stations "receivable" on the new model, and the positions in which you will probably find them. But first let us emphasise the necessity for dead slow rotation of the tuning condenser with the receiver just oscillating.

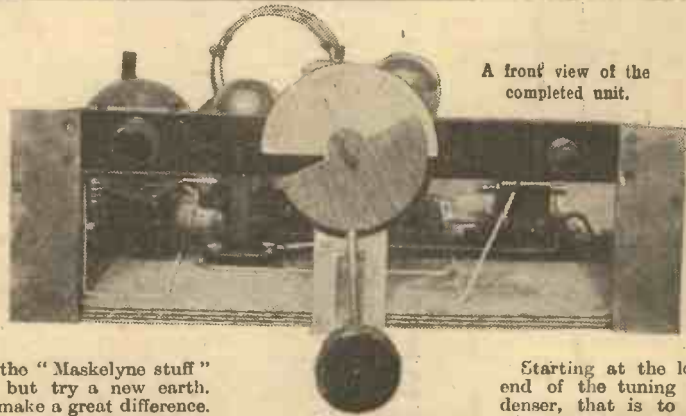
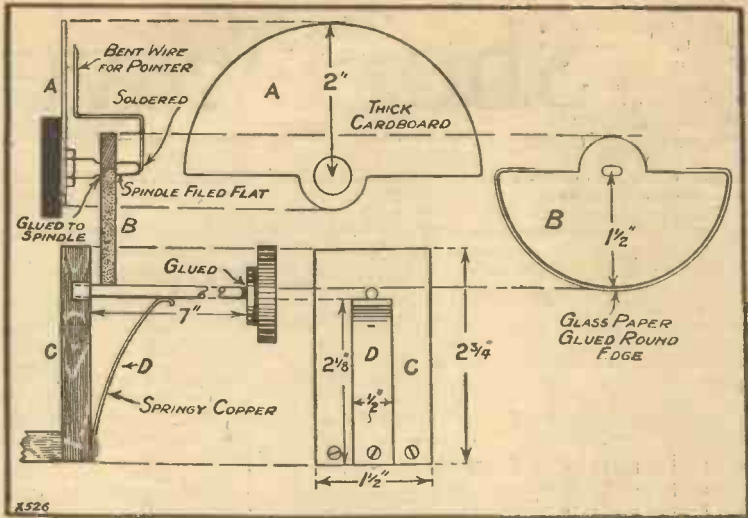

A front view of the completed unit.

Starting at the lower end of the tuning condenser, that is to say, with the plates all out, the first station (probably to your disgust!) will most likely be the British one, 5 S W. Just above the setting for this station comes K D K A at roughly 25 metres.

We now jump a band of about five metres and strike our popular friend 7 L O on 31 metres. This is where the fun begins, and you should find P C J (Holland), 2 X A F (America), and 3 L O (Australia) all within the next few degrees.

ON BROADCAST WAVES.

By using a No. 60 centre-tapped or X coil in the grid socket, and a No. 35 or 50 coil in the reaction holder, the "Adaptor" can, under certain circumstances, be used on the broadcast band. On this band, the '0001 condenser and A₁ come into use.

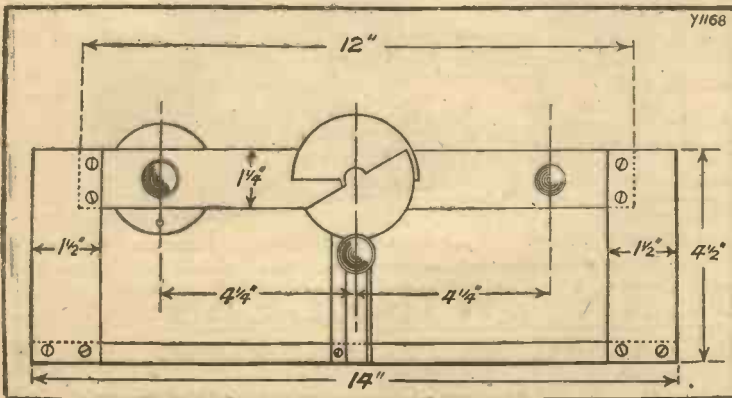



Short-Wave Sets

Most valve-set owners have at some time or another picked up foreign programmes and enjoyed the fun of listening to a strange announcer talking in a strange language. But the real fascination that lies behind long-distance work can never be appreciated except by a listener who has successfully explored the short waves. For on the short waves anything may happen, and not only will American announcers make the loud speaker fairly dance, but even Australia is within earshot and all the world seems waiting on your aerial.

ADAPTING ORDINARY SETS.

Most successful short-wave sets use circuits very similar to those which are



Many short-wave receivers have potentiometers to set their detectors just right for smooth reaction control.

you are a novice on the short-waves you will at first turn the dials much too quickly for success under the new conditions.

The tuning dial must be rotated not merely slowly, but absolutely "dead slow," or otherwise you will miss the short-wave carriers altogether. So easily can a transmission—even a powerful one—be passed over that short-wave enthusiasts practically always wear 'phones instead of using the loud speaker, so as to make sure that nothing escapes notice when tuning.

VERY CAREFUL TUNING NECESSARY.

At the faintest sign of a chirp or whistle the tuning should be very, very carefully adjusted, the reaction being slackened off so as to keep the set only on the very verge of oscillation.

So sharp are the tuning effects that very often it will be found that when condenser-controlled reaction on the Reinartz principle is being applied even a slight alteration of the reaction condenser will throw

THE TUNING AND OTHER ADJUSTMENTS OF THESE FASCINATING INSTRUMENTS



the tuning so far out that all trace of the faint whistle disappears!

Therefore both hands must be used, one on the tuning control and one on the reaction, and the two must work together in perfect accord, the tuning dial following up or down the carrier or whistle which is being investigated, whilst the reaction is being varied to the necessary degree.

gated, whilst the necessary degree.

Only the lightest possible touch is required, and the co-ordination between the two dials must be close and complete if the various signals which are received are to be fully investigated.

Apart from the very fine degree of tuning and of reaction control that are required, there are other simple stunts which make or mar short-wave reception. One of the most important is aerial coupling, which in nearly all cases of operation by a novice is made far too tight.

Unless the aerial is really loosely coupled by means of a very small coil, a very small neutralising condenser, or a few turns of the grid-circuit coil, it will be impossible to obtain smooth oscillation, and the sensitivity of the set will be destroyed. Particular attention should be paid to this, as once the importance of correct aerial coupling is realised a few moments spent in experiment will prove that there is a harvest of stations awaiting the operator who knows how to search for them.

AN IMPORTANT ADJUSTMENT.

Another very important adjustment is that of the H.T. positive wander-plug which serves the detector. The usual fault in this connection is to employ far too high a voltage for smooth reaction control. If with slow tuning and good, loose aerial coupling the stations are still elusive, owing to floppy reaction or to too sudden oscillation, try the effect of varying the detector valve's H.T. until really smooth reaction control is obtainable.

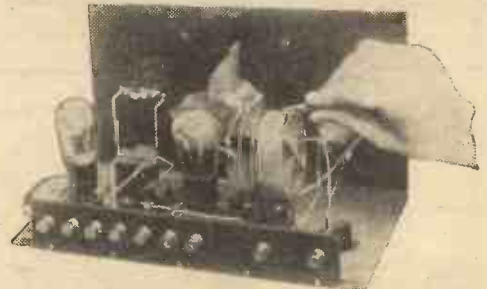

Adjusting the aerial tapping of a short-wave receiver.

MODERN WIRELESS
IS THE LEADING RADIO MAGAZINE

Every Month - - - Price 1/-

"P.W." TESTED CIRCUITS

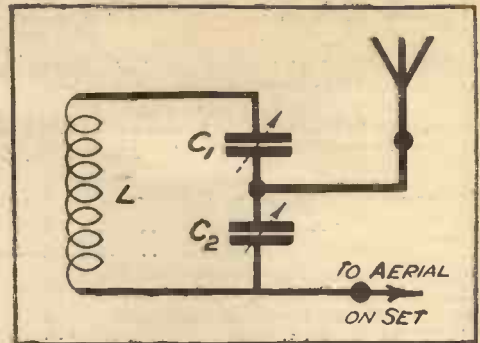
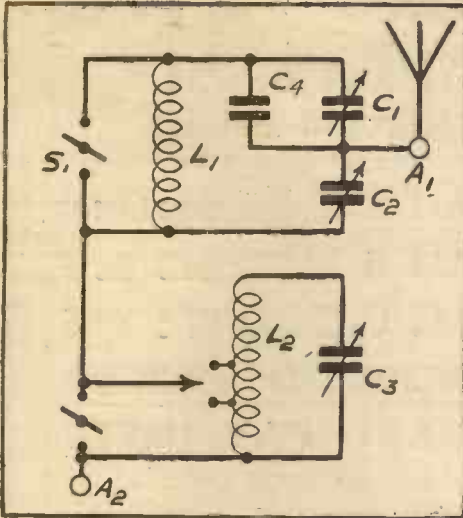

Left, a special double-wave interference eliminator for the exclusion of both Brookmans Park transmissions at once. L₁, No. 50 plug-in; L₂, No. 60 "X"; C₁ and C₂, .00075 or .001; C₃, .0005; C₄, .0003. Above, the famous "P.W." Brookmans Receptor. C₁ and C₂, .001 or thereabouts; L, No. 50 coil. All the above variables can be of the cheap compression type.

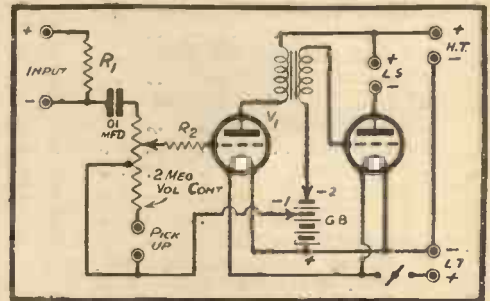
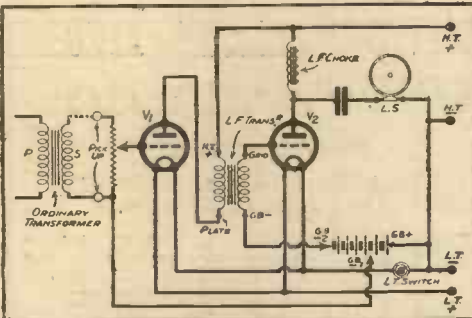

Left, a powerful two-stage L.F. amplifier using transformer coupling in both stages. Note the volume control and output filter. Right, a two-stage L.F. amplifier for use where less magnification is required. The volume control is of the "fader" type for changing over to the pick-up. R₁—100,000 ohms, R₂—250,000 ohms.

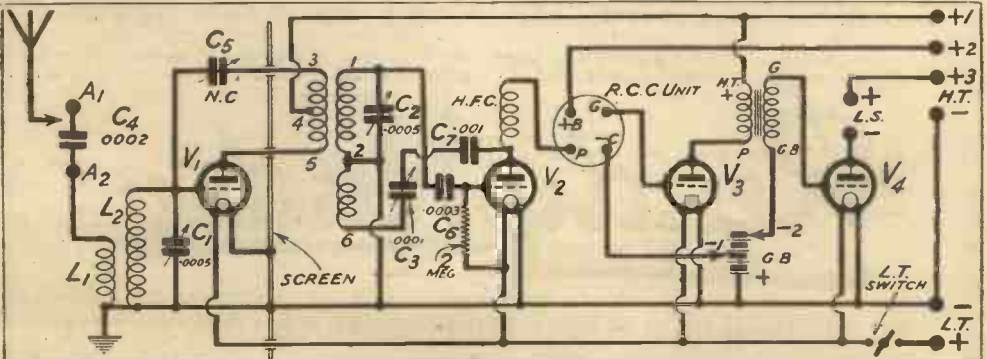

A long-range loudspeaker set for use where the H.T. supply is limited. Note the ordinary neutralised H.F. stage, with a split-primary 6-pin transformer. Coils L₁ and L₂ are of the plug-in type. A 6d. Blue Print of this set is available (M.W. No. 8.)

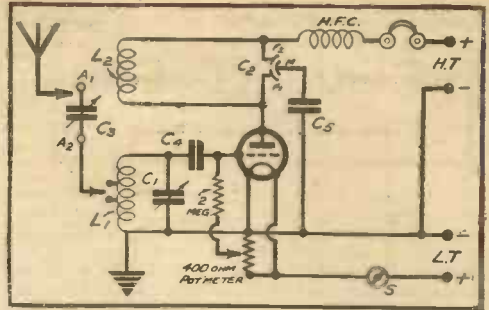
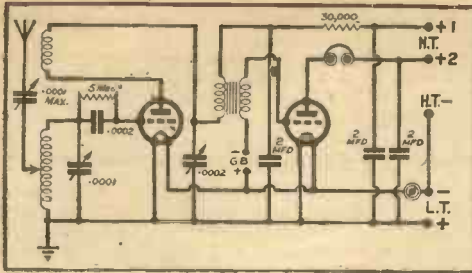

Above, a very simple short-wave set for bare wire plug-in coils. Note the de-coupling filter for the detector. Above, right, a very excellent single-valve circuit for the detector. Above, right, the famous "Magic" Three circuit in its simplest form, showing the special schemes of improved differential reaction, potentiometer bias for the detector, etc.

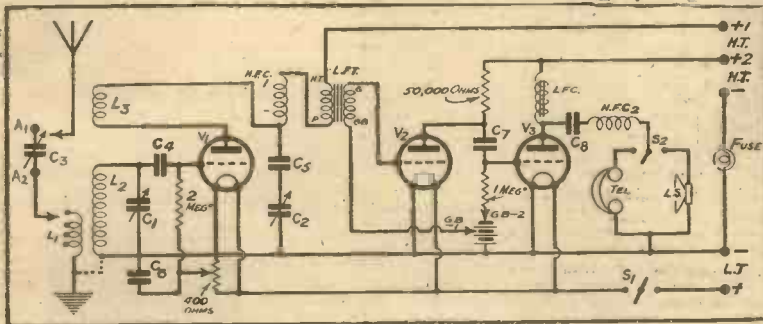
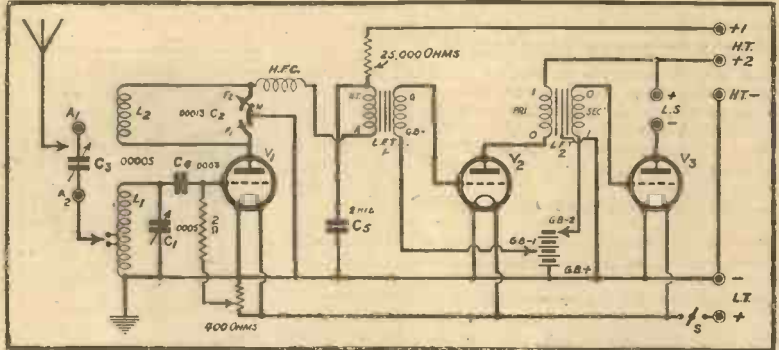

Left, a "de Luxe" type of short-waver, with throttle-controlled reaction, potentiometer control of detector grid voltage, special arrangement of the L.F. side, choke to keep H.F. currents out of 'phones, etc.

- C₁—00025 mfd.
- C₂—0002 mfd.
- C₃—001 mfd.
- C₄—001 mfd.
- C₅—001 mfd.
- C₆—0001 mfd.
- C₇—01 mfd.
- C₈—1 mfd.

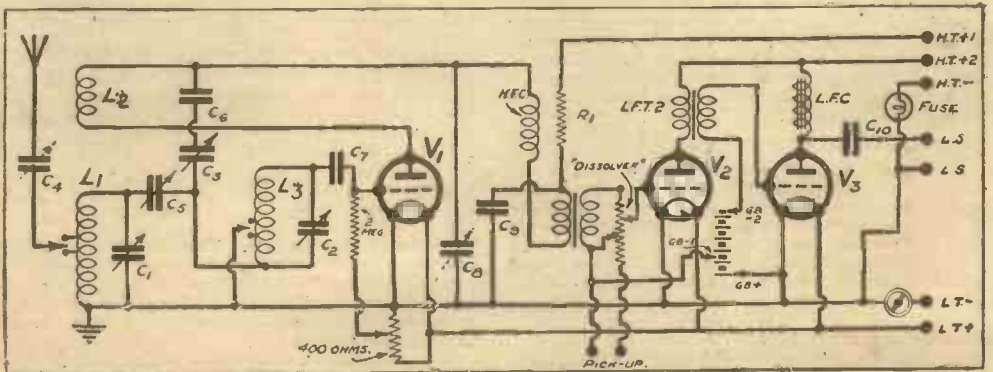

A special ultra-selective three-valver with band-pass filter tuning. Coils L₁ and L₂ are No. 60 "X" type, L₃ a No. 50 plain, and C₃ is a neutrodyne type condenser used for coupling. The volume control is of the "ladder" type.

CURRENT CARRYING COMPONENTS

Some facts of especial interest to the constructor who wants his set to be reliable and efficient.

Every radio component has a definite voltage or current limitation. If we impress too much voltage across a fixed condenser we destroy its internal insulation. Likewise, excessive current in the filament of a valve can burn it out. As a general rule, components are worked well within their safety limits. In one or two instances, however, care must be taken that the right standard or type of component is used for a definite job.

MICA AND PAPER CONDENSERS.

A typical example of this is the fixed condenser which figures in resistance-capacity L.F. couplings. This condenser is joined between the plate of one valve and the grid of another. The grid of this second valve will also be joined through a grid leak and the grid bias, to L.T. -, earth, H.T. -, and so on. Thus practically the full voltage of the H.T. supply will be impressed upon that coupling condenser.

Obviously, then, this particular component must be of such construction that it can withstand that pressure. For this reason, you generally see that for such work a mica condenser is advised in set specifications. Mica condensers are quoted for the

simple reason that mica di-electric condensers of any origin are invariably capable of standing moderate voltages, whereas there are a good many paper di-electric condensers which are not quite as satisfactory as they should be in this respect.

This is unfortunate for the one or two very satisfactory paper condensers that are

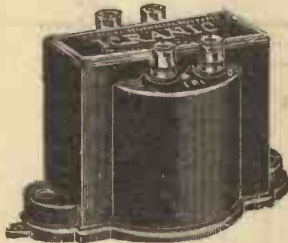

A reliable L.F. transformer, the Igranite type "J" which is wonderfully compact in design.

available. In mains units one has to be very careful in regard to fixed condensers. Here you are liable to get the full voltage of the mains impressed across the terminals of such a component.

And with A.C. mains you come up against greater voltages than nominal ratings. The specified voltage of A.C. mains will be calculated on a basis of what is known as a root mean square. The alternating current is rising and falling from zero to a maximum all the time.

LOUD-SPEAKER PRECAUTIONS.

You do not have to take this into account in any ordinary current-resistance calculations, but it is of importance in regard to fixed condensers, and that is why you are advised to use condensers that are tested at voltages round about double that at which your mains are rated. Additionally, of course, in mains units one comes up against voltage surges which have to be taken into account.

A properly constructed air condenser is practically indestructible, but, as the di-electric constancy of air is unity, this scheme can only be employed at the sacrifice of compactness. A 4-mfd. air condenser suitable for a mains unit would assume something of the dimensions of a bookcase.

Turning to the current handling capacities of other components, do not operate on the assumption that, provided the gauge of wire used seems to be such that a certain amount of "juice" can be passed through it, you are safe if you work within those margins. An obvious example is the loud speaker.

By passing current of a D.C. character through the wrong way, you can demagnetise the permanent magnets which figure in many kinds of speakers.

The result will be insensitivity. In the case of an L.F. choke, too much D.C. may temporarily reduce the inductance to a value worthless for the purpose.

Injury can be done to some types of L.F. transformers of small sizes. By short-circuiting the primary winding across the H.T. supply the core characteristic can be completely upset. The smallness of these L.F. transformers is generally achieved by using a nickel and iron



A transformer with a name for dependability and efficiency, the Ferranti.

alloy for the core stampings, instead of Stalloy, which is a silicon steel.

NICKEL-IRON TRANSFORMER CORES.

By the way, these nickel-iron alloys, of which Permalloy is a well-known example, are rather remarkable materials. A 25 per cent nickel and 75 per cent iron alloy can exist in either a magnetic or non-magnetic condition according to its previous heat treatment.

The content of nickel in Permalloy however, is much greater, being 78.5 per cent. Permalloy has a much higher magnetic permeability to low magnetic forces than iron. For this reason it is, of course, ideal for L.F. transformers.

The designer of a mains set always endeavours to keep the filament

current as low as possible. This is more particularly the case with D.C., where voltage conversion cannot be carried out. Thus, you find the filaments of valves wired in series; a not too happy arrangement, but one that effects a great saving in power consumption.

You can run an eight-valve set with the valves wired in series at less cost than a two-valve set having paralleled valve filaments, the same voltages and rating of valves figuring in both instances.



This is the famous B.I. Hypermu, one of the most modern of all L.F. transformers.

The POWER that made

WIRELESS POPULAR

EVER READY
is the Battery
for all distances
and wave-lengths. You
may not understand all
foreign languages but
you will be glad to hear
their music for a change.



EVER READY
"Popular Power"
(For 10-16 M.A. Emission)

60 VOLTS	..	13/6
64	"	.. 14/6
99	"	.. 22/-
105	"	.. 24/-
120	"	.. 27/-

USING FIXED CONDENSERS

Some valuable information concerning the various types of these ubiquitous components.

An ordinary wire-wound anode resistance, rated at, say, 20,000 ohms, is a hard path for any current to pass through. Even if the wire of which it were wound would carry it, it would take an electrical pressure of 20,000 volts to drive a current of one ampere through this component. Its resistance would be about the same for alternating as for direct current.

FACTS WORTH REMEMBERING.

A fixed condenser, however, will not pass direct current, although it will offer a path to alternating currents effects, and the higher the frequency of the alternating current the lower the resistance a condenser of a given capacity will offer, and the larger the capacity of the condenser the lower its A.C. resistance.

These are facts the constructor should bear in mind. It would be no use using a .0002-mfd. fixed condenser in connection with a loud-speaker bypass shunt. The effective A.C. resistance such a component would offer to a frequency of 1,000 is somewhere around 8 megohms. For such work a condenser having a capacity of 2 mfd. is generally specified, and, at the same frequency, its effective A.C. resistance would be only 80 ohms (this is small in comparison with the resistance of the average type of loud speaker).

For the .0002-mfd. fixed condenser to assume an effective A.C. resistance of 80 ohms the current handled would have to have the frequency of a million cycles, and this is not a low frequency, but a radio frequency such as is encountered when 2 L O is tuned in (at this frequency the 2-mfd. condenser would offer an impedance of a mere 1/12th of an ohm).

H.F. BYPASS CONDENSERS.

Condensers of the 2-mfd. order are frequently used as H.F. shunts or bypasses. A 2-mfd. condenser is often connected from the "priming" grid of an S.G. valve to earth, and, as you can see, it offers a very short-cut to H.F. currents. The resistance of the H.T. battery might be 100 or 200 ohms, but not much H.F. would reach this while there was an

alternative path available of only 1/12th or so of an ohm in resistance.

And regarding condensers, comparatively recently the electrolytic variety has become available for general use. The electrolytic condenser is a remarkable device in that it achieves an enormous capacity with remarkable compactness. An electrolytic condenser rated at 2,000 mfd. will be a matter of only a few cubic inches in size.

HOW ELECTROLYTIC CONDENSERS WORK.

In principle it is something like a battery that has no depolarising agent. When a voltage is applied across its two terminals, thin films of gas are formed on the plates that are immersed in the chemical solution. The plates and the electrolytic solution act as do the plates in an ordinary condenser, while the thin film of gas forms the dielectric. And it is because the gas film is so thin that the great-capacity is obtained.

You will notice that it is by the application of voltage that the gas film is formed, and that therefore this type of condenser cannot be used purely for A.C. work. A steady potential must be applied for the device to function. It can, of course, deal with alternating currents that are super-imposed on D.C., such as are met with across the output terminals of an L.T. unit, but the A.C. must not exceed a certain proportion of the total current.

Electrolytic condensers are most effective as smoothers of irregularities in L.T. supplies. Here one often meets low-pitched hums of the order of 120 or so cycles. At this frequency an electrolytic condenser of 2,000 mfd. will have an A.C. resistance of only two-thirds of an ohm, while its resistance to pure D.C. will be at least a thousand or two ohms.

SURPRISINGLY LOW RESISTANCES.

You may be surprised that these devices have resistances of such a character and not of almost infinity, as in the case of the ordinary type of condenser, but you must remember that it is, as its name implies, of an electrolytic character!

At a frequency of 1,000 cycles, such as one might come across in the commutation ripple of D.C. mains, the 2,000-mfd. electrolytic condenser will have an A.C. resistance of about 1/12th of an ohm, and its resistance to frequencies of the order of 3,000 cycles will drop to 1/40th of an ohm. These are remarkably low resistances in comparison with the resistance of a filament circuit, which will at least be of the order of tens of ohms.



The T.C.C. people have Electrolytic, mica, and paper condensers.



Messrs. Dubilier manufacture all varieties of fixed condensers.



Messrs. Lissen also have all kinds of dependable condensers on the market

A SELECTIVE CRYSTAL SET

Here is just the set you want for the alternative programmes. It is sensitive and selective and you can go from one station to the other at the touch of a switch.

The selectivity and sensitivity of this little set are both very good, and it possesses, in addition, a special feature which we think will make it very attractive as a standard receiving equipment for domestic use. The gadget in question is simply a switching wave-change arrangement for going over from one of the Regional transmissions to the other, and although it means only a very slight extra complication in the design, you may be sure it will prove a very decided improvement when you come to use the set regularly.

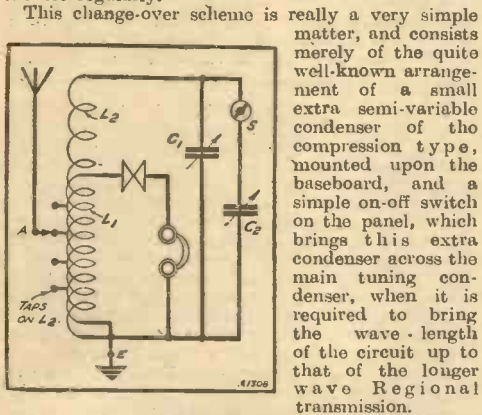

This change-over scheme is really a very simple matter, and consists merely of the quite well-known arrangement of a small extra semi-variable condenser of the compression type, mounted upon the baseboard, and a simple on-off switch on the panel, which brings this extra condenser across the main tuning condenser, when it is required to bring the wave-length of the circuit up to that of the longer wave Regional transmission.

In use, it is intended that the lower wave Regional transmission shall be tuned in by placing the wave-change switch in the off position, and operating the main tuning dial. Then, to receive the longer wave Regional transmission, all you will have to do is to close the wave-change switch, whereupon you should hear it if the compression-type variable condenser on the baseboard has been correctly set.

You will have to attend to this latter question when the set is first finished, of course, but when the adjustment has once been made it should not need to be touched in future, and changing over from one station to the other will be merely a matter of operating the wave-change switch.

VERY SUCCESSFUL DESIGN.

Before we pass on, we may perhaps just as well give you the necessary instructions for setting the extra loading condenser. This is how you should set about it, it being assumed that both the Regional transmissions will be available when you come to make this adjustment. First of all, tune in the lower wave Regional (the one which began regular work early in the Year) upon the main tuning dial with the wave-change switch knob pushed inwards.

Next, pull out the wave-change switch, and turn your attention to the "Formodensator" marked C₂ upon the baseboard. Starting with the knob on this condenser unscrewed to the limit of its effective travel,

screw it down gradually until you begin to get the longer wave Regional station, instead of the lower wave one.

Then simply treat C₂ as a tuning control, and adjust it so that you hear the longer wave station as loudly and clearly as possible, after which you can tighten up the clamping collar of the adjustment screw of the condenser, and leave it set permanently. Thereafter, all you will need to do is to operate the wave-change switch in the manner which we have just described.

COMPONENTS REQUIRED.

- 1 Panel, about 6 in. x 7 in.
- 1 Cabinet to fit, with baseboard 6 in. or 7 in. deep.
- 1 .0005-mfd. variable condenser.
- 1 On-off switch.
- 1 Panel-mounting crystal detector.
- 1 Type J Formodensator.
- 1 Pirtoid or Paxolin tube, 3 in. diameter.
- 2 oz. No. 24 D.C.C. wire.
- 1 oz. No. 32 D.S.C. wire.
- 1 Terminal strip, 4 in. x 2 in.
- 4 Terminals.

The circuit we have chosen to use in this receiver to meet the new conditions is exactly the same as that very successful design, the "Inductocrys" receiver, which has not yet been beaten in our experience on either selectivity or sensitivity. This circuit is a little out of the ordinary, and for the benefit of those readers who may not have seen the original design we just explain its main features very briefly.

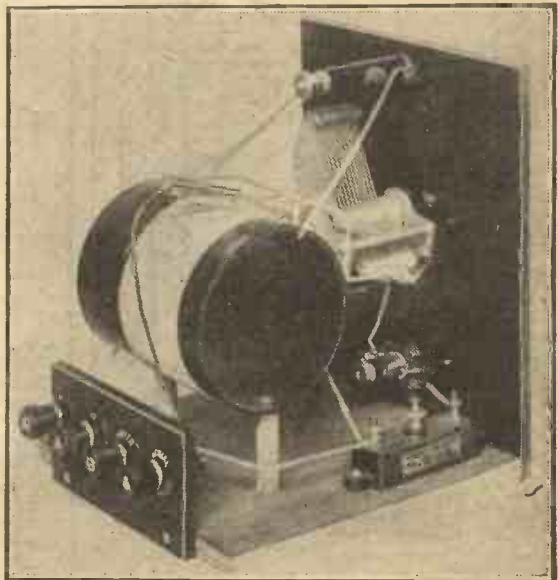

This photo clearly shows the coil construction.

First of all, there is the usual tuned secondary circuit, consisting of a suitable coil and a .0005-mfd. variable condenser, to which circuit the aerial is auto-coupled by means of the customary tapping arrangement.

Instead of connecting the 'phones and crystal directly across the whole or part of this circuit, a special crystal winding of quite fine wire is arranged so as to be very closely coupled to the tuned circuit, and it is this feature which gives the circuit its high efficiency. By using a suitable number of turns on this fine wire crystal winding the equivalent of a "crystal tap" is obtained, with its well-known effect of improving selectivity and volume.

As a matter of practical importance, it is very necessary that extremely tight coupling should be provided between the crystal winding and the main

tuned winding, and you will see presently how this is obtained in practice.

Now let us take a look at the constructional work. The set is assembled in the conventional manner on a small vertical front panel and a wooden baseboard, the intention being that the set shall be housed in the usual vertical-front type of cabinet. The aerial and earth and telephone terminals are placed on a small terminal strip at the back of the set, and the controls are placed on the front panel, these including the wave-change switch, the tuning condenser, and the crystal detector.

On the baseboard you will find only the coil and the compression type condenser, which last we have seen is intended to load the circuit up to the longer wave transmission when desired.

You will now be able to see just how much of a job it is to make this set. So far as the panel is concerned, there are only three holes to be drilled, and then you can screw it to the baseboard. Upon the baseboard you have to mount the condenser C₂, the coil unit and, lastly, the terminal strip has to be attached at the back. Wiring up you will find is very simple, since there are so very few connections.

WINDING THE COIL.

The main part of the work is obviously the winding of the coil, and although many people are rather apt to be put off by any mention of winding, there is really no justification for apprehension in the present case, because it is such an extremely simple job.

First of all, you want a piece of good insulating material, 3 in. in diameter and 3 or 3½ in. long, Pirtoid or Paxolin being recommended. This tube carries first of all a winding of 50 turns of No. 24 D.C.C. or D.S.C. wire, with tapings made at 10, 15, 20 and 25 turns, by the usual method of twisting up a small loop in the wire, which is later to be scraped bare so that you can make contact where desired with a tapping clip of the "Crocodile" type.

Over the top of this thick wire winding you have then to put on another of 30 turns of some quite fine gauge of wire, such as No. 32 D.S.C., with no tapings. - This fine wire winding should begin over one end of the thick wire winding, and you should put it on turn by turn above the first winding, fitting the fine wire into the spiral groove formed between the adjacent turns of the thick wire winding. Imagine that the thick wire winding has formed a sort of screw thread upon the former, and wind your thin wire into the groove of this screw thread. You can secure the ends of the thick wire winding, by the way, by passing them through small holes drilled in the tube, and to one of these (the earth end according to the marking on the wiring diagram) you should solder the beginning end of the fine wire winding. The finishing end of the fine wire winding can be held in place with a small dab of sealing wax, leaving about half an inch of wire projecting for the connection which goes off into the crystal detector.

ONE FIN^Y POINT.

In the original set, by the way, we adopted a slightly neater scheme, which consisted in making a small hole through the tube, and passing the fine wire down through this inside the tube. If you do likewise be rather careful not to damage the turns of the thick wire winding in making the hole. Push the two turns apart slightly in order to clear a small space for the drilling of the hole.

One final point requires to be made clear about the coil winding. When you put on the thick wire winding, start with the end which is marked on the wiring diagram as being the earthed end, and count onwards from here in making the tapings. The number 50 turn will then be the one which is marked in the wiring diagram as being the top end of L₁.

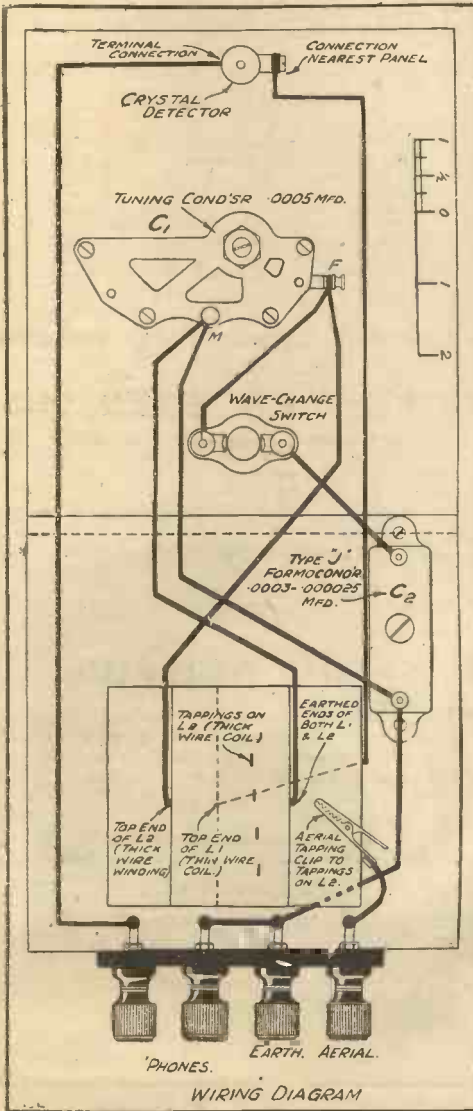



KITS

OUR TEST ROOM IS YOURS

Every Pilot Kit contains a leaflet describing our special free Test Room Service, available to all Pilot customers. Buy from the Pioneer firm who GUARANTEE GOOD RESULTS.

PILOT KITS INCLUDE all specified components, panels and requisite connecting wires, screws, etc. "A" Kits include also specified valves and cabinet, whilst "B" Kits exclude these items.

	"A" KITS.		"B" KITS.	
	CASH PRICE.	Or 12 monthly instalments of	CASH PRICE.	Or 12 monthly instalments of
1930 MAGIC THREE.	£9 11 2	17/6	£6 12 8	12/2
1930 TITAN THREE.	£9 12 1	17/7	£6 1 7	11/2
REGIONAL FOUR.	£12 9 9	27/8	£8 6 3	15/3
REGIONAL TWO.	£6 15 4	12/5	£4 12 4	8/6
THE MAGIC TWO.	£7 6 8	13/5	£5 7 2	9/2

Any parts supplied separately. Detailed list on application.

IMMEDIATE DELIVERY to all approved orders

ACCESSORIES, MANUFACTURERS' KITS, etc.

OSRAM MUSIC MAGNET. Cash £9 0s. 0d., or 12 monthly payments of 16/6. Valves included.
COSSOR 1930 THREE-VALVE KIT. Cash £8 15s., or 12 monthly payments of 16/-.
EXIDE. 120-volt H.T. Accumulator TYPE W.J., in crates. Cash £3 15s., or 12 monthly payments of 6/11. TYPE W.H., 120 volts in crates. Cash £4 13s., or 12 monthly payments of 8/6.
REGENTONE W.1 B. S.G. (A.C. Mains). For S.G. and Pentode Sets. Cash £4 19s. 6d. or 12 monthly payments of 9/2.
THE "BROOKMAN'S" REJECTOR UNIT. Exactly to "P.W." Specification, assembled, wired and tested 12/6.

A WAVE-CHANGE "BROOKMANS" REJECTOR. Exactly to "P.W." Specification, assembled, wired and tested. Coils included 18/6.
ULTRA AIR CHROME SPEAKER. Special model at special price. Type K. chassis in handsome Oak or Mahogany cabinet. Cash £4 4s., or 12 monthly instalments of 7/6.
CELESTION C.12 LOUD SPEAKER in oak. Cash £5 12s. 6d., or 12 monthly payments of 10/4; in Mahogany £5 17s. 6d., or 12 monthly payments of 10/9.
PHILIPS CONE SPEAKER, Type 2016. Excellent value. £2 10s., or send only 6/-, balance in 8 monthly instalments of 6/-.

UP-TO-THE-MINUTE RADIO SERVICE



Qualified engineers in attendance at all our branches.

77, City Road, London, E.C.1. Telephone: Clerkwell 9406-7-8. 62, High Holborn, London, W.C. Telephone: Chancery 8266. 4, Manchester Street, Liverpool. Telephone: Central 2134. 33, White-low Road, Chorlton-Cum-Hardy, Manchester. Telephone: Chorlton-Cum-Hardy 2028.

All leading sets, kits and accessories supplied for cash or on our famous "EASY WAY" system. Free Technical advice. Visit our Showrooms, or post coupon for 48 page Illustrated Catalogue, post free.

Mail coupon in unsealed envelope under 1d. stamp.

COUPON.

Please send me your 48-page Illustrated Catalogue, describing the 1929-30 products of all the leading makers.

NAME

ADDRESS

F.W.B./1930

A GUIDE TO THE SHORT-WAVERS

The following details of the most important of the short-wave broadcasters were very carefully checked, on the day of going to press, with the very latest available information. All times are G.M.T.

SHORT-WAVE STATIONS.

METRES	METRES
104.5 Perth (Australia), 6 W F, 0.25 kw.	31.8 Posen (Poland), 0.25 kw. TUES., 6.45 to 9.45 p.m. THURS., 6.30 p.m. to 1 a.m.
99 Motala (Sweden). Relays Stockholm.	31.65 Paris Experimental Radio, 2 kw. 9 p.m. weekdays, 3 p.m. on Sundays.
80 Constantino (Algeria), 8 K R. MON. and FRI.	31.6 Lyngby (Denmark), C X Y (Experimental).
70 Vienna (O H K 2). Transmits on SUN. for 15 minutes after each hour from 5 p.m.	31.48 Schenectady (General Electric Co.), N.Y. W 2 X A F, 10 kw. (Aer.). MON. 11 p.m. to 4 a.m. TUES., THURS. and SAT., 11 p.m. to 5 a.m. Relays W G Y. Australian programme weekdays, 11 a.m. to noon.
67-85 Döberitz (A F K), 5 kw. MON., WED. and FRI., 10 a.m. to 11 a.m. and 6 to 7 p.m.	31.38 Zeesen (Germany). Relays Königswusterhausen daily: Hours irregular.
62.5 Pittsburg, East (Westinghouse Electric), W 8 X K. Relays K D K A.	31.28 Eindhoven, Holland, P C J, 25 kw. THURS. 7 to 9 p.m., in English; 12 midnight to 1 a.m. in Spanish. FRI., 1 to 2 a.m. in Portuguese; 2 to 4 a.m., in Spanish; 7 to 9 p.m., in English. SAT., 1 to 2 a.m. in Dutch; 2 to 5 a.m., in English, French and Spanish; 5 to 7 a.m., in English.
61 Radio LL (France).	31.28 Sydney, 2 F C.
58 Prague (Czecho-Slovakia). TUES. and FRI., 7.30 to 9.30 p.m.	31.25 Bergen, L G N.
54-02 New York City W 2 X P H. Relays W C G U.	31 Nairobi (Kenya), 7 L O. Daily, 4 to 7 p.m. Relays 5 S W occasionally from 7 to 8 p.m.
52 Bergedorf (Germany), A F L, 3 kw.	30.75 Agen. TUES. and FRI., 9 to 10.15 p.m.
50 Moscow (R F N). TUES., THURS. and SAT., 12 to 1 p.m.	28.9 Bangkok (Siam).
50 Barcelona Radio Club, E A J 25. SAT., 8 p.m. to 9 p.m. News and gramophone records.	25.6 Winnipeg (Canada), C J R X, 2 kw. DAILY (except SUN.), from 10.30 p.m. to 12.30 a.m. SAT., 6 a.m. to 7 a.m.
49-83 Chicago, Ill., W 9 X F. Relays W E N R, 5 kw. SUN. 4 to 6 p.m. Daily from Midnight to 6 a.m.	25.53 Chelmsford (G 5 S W), 15 kw. (Aer.). DAILY (except SAT. and SUN.), from 12.30 to 1.30 p.m., and from 7 p.m. to 12 midnight.
49-83 New York (W 2 X B R). Relays W B N Y, 1 kw.	25.25 Pittsburg East (Westinghouse Electric), W 8 X K. Relays K D K A from 11 p.m. (TUES. and THURS., 10 p.m.)
49-67 New York (W 2 X A L). TUES., 12 midnight to 5 a.m. WED., 12 midnight to 2 a.m. SAT., 12 midnight to 3 a.m. 0.5 kw.	24.7 Vienna (Austria), 0.24 kw. TUES. and THURS., 2 to 4 p.m.
49-5 Cincinnati (Ohio), W 8 X A L. 0.25 kw. Relays W L W from 11.50 p.m., except FRI. and SAT.	24.5 Manila (Philippine Islands), K 1 X R. Relays K Z R M. Weekdays, 10.30 a.m. to noon: also Sunday morning.
49-5 Council Bluffs (Iowa), W 9 X U. 0.5 kw. Relays K O I L.	23.35 Oakland (California), W 6 X N. Relays K G O. TUES., WED. and FRI., from 5.30 to 9 p.m. 5 kw. WED., also 2 a.m. to 8 a.m.
49-4 Vienna (U O R 2). 0.4 kw. Testing TUES. and THURS., 10 a.m. to 12 noon; WED. and SAT. after evening programme.	23.35 Schenectady, W 2 X O. TUES., THURS. and SAT., 5 to 10 p.m. Relays W G Y (Tests).
49-34 Newark (N.J.), W 2 X C X. Relays W O R.	19.72 Pittsburg, East (Westinghouse Electric), W 8 X K. Relays K D K A.
49-02 Richmond Hill (N.Y.), W 2 X E. Relays W A B C. Weekdays, 11 p.m. to 5 a.m. SUN. 3.50 p.m. to 5.30 p.m.	19.56 Schenectady (General Electric Co.), W 2 X A D, 6 kw. MON. and WED., 10.30 p.m. to 4 a.m. TUES. and THURS., 5-10 p.m., FRI., 7 to 8 p.m. and 10.30 p.m. to 5 a.m. SAT., 5 p.m. to 5 a.m. SUN., 7.30 to 10.40 p.m. Relays W G Y.
49 Motala (Sweden). Relays Stockholm daily.	17.34 Schenectady (W 2 X K). TUES., THURS. and SAT., 5 to 10 p.m. Relays W G Y (Test).
48-8 Manila (Philippine Islands), K Z R M. Daily 8 a.m. to 3 p.m. (Except Monday).	16.9 Bangkok (Siam), H S P, 20-kw. 12.30 to 2.30 p.m. SUN. only.
44 San Lazaro (Mexico), X C 51. 7 a.m. and 7 p.m.	16.88 Huizen (Holland), P H I, 40 kw. Usually transmits from 3 to 5 p.m.
43-8 Georgetown (British Guiana), V R Y.	16.8 Bandoeng (Java), P L F, 30 kw.
43-6 Coethen (Germany), D 4 A F F. Testing.	16.3 Kootwyk (Holland), P C K. From 6 a.m.
43-5 Rome (Italy), 1 M A. SUN., 4 to 6.30 p.m.	15.5 Nancy (France), 9 to 10 p.m.
43 Madrid E A R 110. TUES. and SAT., from 10.30 p.m. to 12 midnight.	15.02 Buenos Aires (Monte Grande), L S G.
42 Perth (Australia), 6 A G, 10.30 a.m. and 3 p.m.	
41 Radio Vitus. Testing.	
40-2 Lyons (Rhône), Y R. Daily except SUN. from 4.30 to 5.30 p.m.	
40 Döberitz, A F K (or D O A). 5 to 7 p.m. daily; occasionally other times.	
37 Vienna (E A T H). MON. and THURS., 9.30 to 11 p.m.	
34.5 Schenectady, W 2 X A C (General Electric Co.). Relays W G Y to Byrd Antarctic Expedition.	
32.5] Sydney (2 B L).	
32.5 Paris, Eiffel Tower (F L). Time Signal 8.56 a.m. and 8.56 p.m.	
32 Berne (Switzerland), E H 90 C.	

IGRANIC COMPONENTS FOR ALL CIRCUITS

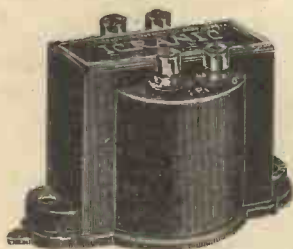

"J" Type Transformer.



"Lokvane" Variable Condenser.



"Indigraph"
Vernier Knob and Dial.



Midget Switch.

To bring Radio step by step nearer perfection is the aim of Igranic Engineers. Day by day experiments and tests are carried out, with this objective in view, and not until each component is as good as it can be is it offered to the public. Igranic Components are suitable for all types of Radio Reception.

IGRANIC TYPE "J" TRANSFORMER

Small and neat in appearance. Made in two ratios, 3-1 and 6-1. Price 17/6 each.

IGRANIC "LOKVANE" VARIABLE CONDENSER

A really sound engineering job that will give years of faultless service.

.0005 mfd. . . 10/6. .0003 mfd. . . 9/6.
.00015 mfd. . . 8/6.

IGRANIC INDIGRAPH VERNIER KNOB AND DIAL

A first-class component. Handsome, accurate and reliable. Free from backlash. Reduction Ratio 8-1. Price 6/-.

Midget size, Price 3/-.

IGRANIC MIDGET RADIO SWITCH

A small, neat switch. Definite in action, providing for sound electrical contact. Price: 1/8 with terminals, 1/6 with soldering tags only.

If you are unable to obtain Igranic Components from your dealer, please write direct to Dept. R143.



IGRANIC ELECTRIC Co., Ltd.,
149, Queen Victoria Street, London.

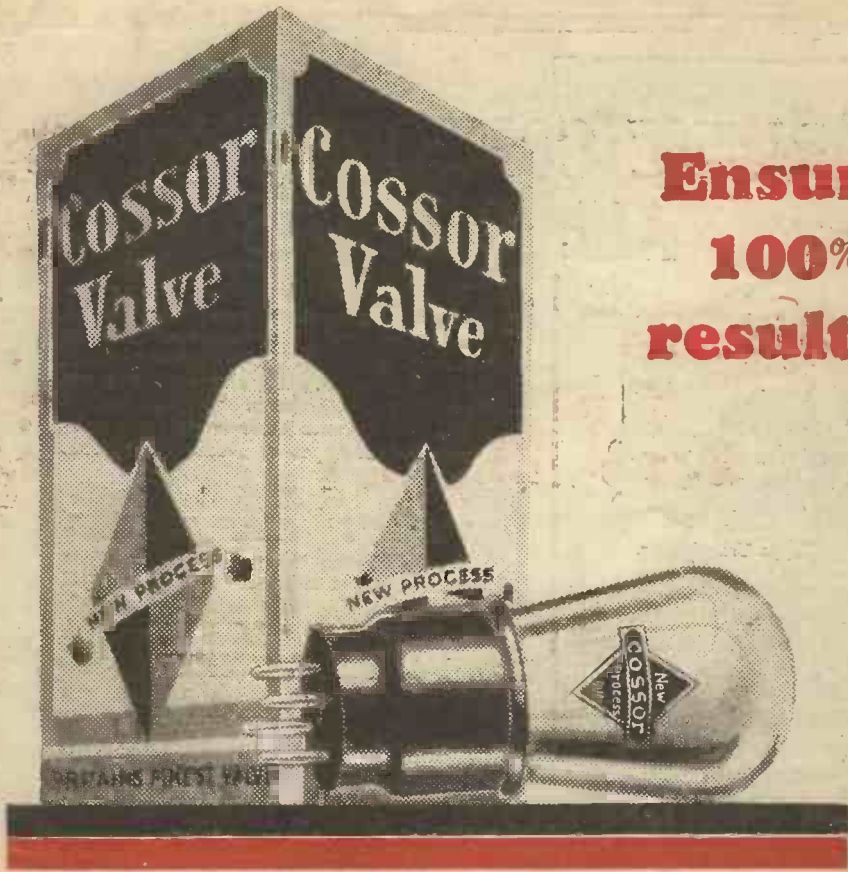

**Ensure
100%
results!**

The
NEW

CHOOSE your components carefully—follow closely the designers instructions and then fit the wonderful NEW Cossor Valves. The NEW Cossor will make your Set far more efficient—more powerful—more sensitive than you ever hoped it would be—they ensure success. They make old Sets like new. They improve even up-to-date Receivers. Your dealer stocks the 2-volt range.

COSSOR

for better wireless!