

EXTRA
EVERY
MONTH!

2607
16 "Practical Photographer"
Page **PULL-OUT SUPPLEMENT**

13

PRACTICAL MECHANICS

EDITOR : F. J. CAMM
AUGUST: 1958



CONTENTS

- A Transistor Portable Radio
- Making a Cottage Tent
- The U.S. Satellite Programme
- Building a Wood Planer
- Attaché Case Repairs
- Is the Earth Hollow ?
- Electro Gravitic Lift
- Special Section for Juniors, etc.

A Room-to-Room Telephone



SEE THE
SPRING
YOU NEED HERE ?

Cut production costs with **TERRY Wire Circlips** (Square Section)



We make first-class Flexible Shaft too. May we quote you?

No? Well, it would take all the pages of this magazine—and a lot more—to show in full the immense range of **TERRY'S ASSORTED SPRINGS** in all their variety—compression, expansion, heavy, light, long, short, any gauge you want. But in our **BOXES OF ASSORTED SPRINGS** you'll certainly find the very spring you've been looking for. Why not let us send you our full illustrated list of **BOXES**—post free?

Interested in Spring Design? Send for 'Spring Design and Calculations'—Post free 12/6



HERBERT TERRY & SONS LTD. REDDITCH, WORCS
(Makers of quality Springs, Wireforms & Presswork for over 100 years)

- No. 757.**
Extra Light Compression, 1 gross Assorted, $\frac{1}{8}$ " to $\frac{1}{2}$ ", $\frac{1}{2}$ " to 2" long, 27 to 20 S.W.G. 15/- each.
- No. 758.**
Fine Expansion Springs. 1 gross Assorted $\frac{1}{8}$ " to $\frac{1}{2}$ ", $\frac{1}{2}$ " to 2" long, 27 to 20 S.W.G. 15/- each.
- No. 753.**
3 doz. Assorted Light Expansion $\frac{1}{8}$ " to $\frac{1}{2}$ " diam., 2" to 6" long, 22 to 18 S.W.G. 10/6 each.
- No. 98A.**
3 doz. Assorted 1" to 4" long, $\frac{1}{8}$ " to $\frac{1}{2}$ " diam., 19G to 15G. 5/6 each.
- No. 388.**
 $\frac{1}{2}$ gross Assorted Small Expansion Springs. $\frac{1}{8}$ " to $1\frac{1}{2}$ ". 18G to 21G. 9/6 each.
- No. 760.**
3 doz. Assorted Light Compression Springs. 1" to 4" long, 22 to 18 S.W.G., $\frac{1}{2}$ " to $\frac{1}{2}$ " diam. 6/6 each.
- No. 1024.**
20 Compression Springs 12"-long. $\frac{1}{8}$ " to $\frac{1}{2}$ " diam., 24G to 18G, suitable for cutting into shorter lengths; and 30 Expansions $1\frac{1}{2}$ " to 12" long, 5/32" to $\frac{1}{2}$ " diam. 22G to 16G. 24/- each.

HT23A

TYZACK'S "WIZARD" TOOLKIT

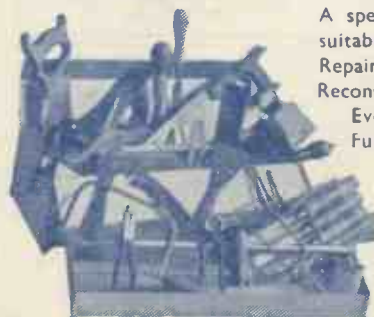

A specially selected set of Tools suitable for Furniture Making and Repairing, General Household Reconstruction & Decorating, etc. Every Tool first quality and Fully Guaranteed.

First Payment **£1-10-0**
Nine Equal Payments **£1-8-4**
CASH PRICE **£12-10-0**

CONTENTS :

- | | | |
|--|--|--------------------------|
| 22in. Handsaw | Adjustable Iron Smooth Plane, American pattern | Wood Rasp. |
| Bin. Tenon Saw | 2ft. Boxwood Rule | Joiner's Square, 6in. |
| Hammer | Nail Punch. | Bin Level |
| Pincers | Carpenter's Brace set of 3 Bits | Hatchet. |
| Set of 4 Chisels in handsome protective plastic wallet, $\frac{1}{2}$, $\frac{3}{8}$, $\frac{1}{2}$, 1 in | Beech - handled Screw-driver. | Coping Saw & six blades. |
| Footprint Wrench | Combination Pliers, Glass-cutter. | Metal Hacksaw |
| Bradawl | | Wall Stripper. |
| | | Putty Knife. |

FREE WITH EACH TOOLKIT. Handsome Cloth-bound Fully Illustrated Instruction Book.

ALL COMPLETE IN STEEL TOOL CHEST WITH REMOVABLE TRAY OVERALL SIZE 21" x 8" x 8".

S. TYZACK & SON LTD. Tel.: SHOREDITCH 8301.
341-345 OLD ST., LONDON, E.C.1.

SCHOOLBOY STRONGMAN!

AGE 14

Malcolm Baker (right) was encouraged to take up Maxalding by his father to increase strength and improve his physique. He has since developed into a champion athlete, because all muscle built by Maxalding is supple and fast, and both speed and stamina increase in proportion to the amount of muscle developed.

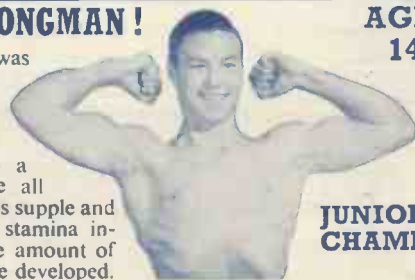

JUNIOR CHAMP.

BIG GAINS AT 37!

Postal Pupil S. J. Noller (left) wanted a heavyweight development when he started Maxalding at 37 years of age. He reported at the conclusion of the course: "Chest now 45 $\frac{1}{2}$ in. Weight 13 stone 5 lb. I shall continue to tell all my friends of the benefits to be gained from Maxalding."



COMPREHENSIVE INSTRUCTION

Maxalding courses are planned and prepared in accordance with individual requirements and cover a wide range of instruction for muscle development, height-increase, speed, strength and stamina training, fat reduction, etc. etc.

FREE EXPLANATORY LITERATURE

PROFUSELY ILLUSTRATED EXPLANATORY LITERATURE showing nearly 200 photographic reproductions of pupils from 14 to 65 years of age will be sent **WITHOUT COST OR OBLIGATION** on request. All Maxalding literature is dispatched in sealed covers free from any external advertising matter. (Postage for 4 ounces—6d. in U.K.—is appreciated.)

MAXALDING (PM8) SHEPHERDSWELL, DOVER, KENT.

PLEASE SEND FREE LITERATURE TO :—

Name..... Age.....

Address

..... (PM8)



17" T.V. CHASSIS, TUBE & SPEAKER, £19.19.6.

17" Rectangular Tube on modified chassis. Supplied as single channel chassis covering B.B.C. channels 1-5, or incorporating Turret Tuner which can be added as an extra at our special price to chassis purchasers 50/-, giving choice of any 2 channels (B.B.C. & I.T.A.). Extra channels can be supplied at 7/6 each. I.F.'s 10.5-14 Mc/s. Chassis size:—12" x 14 1/2" x 11". Valve line up:—6SN7G, 6P25, EY51, 2-6D2's, EL38, EL41 & 7-6F1's. Similar chassis were used by well-known Rental and Hire Companies because of their stability and reliability. With tube and speaker, £19.19.6. With all valves, £25.19.6. Complete and working with Turret Tuner, £28.9.6. 12 months' guarantee on the tube, 3 months on the valves and chassis. Ins., Carr. (incl. tube), 25/-.

14" T.V. CHASSIS, TUBE & SPEAKER, £13.19.6.

As above with 14" Round Tube. Chassis, valves and tube guaranteed for 3 months. With Tube & Speaker, £13.19.6. With all valves, £19.19.6. Complete and working with Turret Tuner, £22.9.6. Ins., Carr. (incl. tube), 25/-.

HOME RADIO, 79/6.

5 valve (octal) superhet. 3 waveband receiver. A.C./D.C. Universal mains can be adapted for gram. P.U. in wooden cabinet. 9 1/2" x 18 1/2" x 11 1/2". Ins., Carr. 7/6.

COMPASS, 12/9. Ex-A.M. Azimuth 0.2 A. No. 4 6" dia. Also ex-A.M. type P.A.A. 6 1/2" dia. Ideal for boats, cars, etc. Please state type required. Ins., Carr. 3/6.

CAR AERIALS, 6/9. Whip antennae 50" long collapsing to 11". One-hole fixing. P. & P. 1/-.

SOUND & VISION STRIP, 25/6. Sound I.F. 10.5 Mc/s. Vision I.F. 15 Mc/s. Valve line-up: 6-6F1's, 2-6D2's (not included). Any single channel I.S. supplied, a turret tuner is easily fitted. Supply from Power Pack, 200 v. H.T. 6.3 v. heaters. P. & P. 2/6.

T.V. CHASSIS, 25/6.

Ideal only for spares. Although this chassis has a wealth of components, it is considered uneconomical to attempt rebuilding. This chassis is in 3 separate units. Power Pack, T/Base and S/vision Strip. I.F.S 16-19.5 Mc/s. Drawings Free. Ins., Carr. 10/6.

CLOCKWORK MECHANISM, 1/9. A perfectly engineered clockwork unit. Ex-W.D. (type ROF(B) 40S1). Can be modified for use as a darkroom timer. Clock or any mechanism requiring activation. Post 1/-, 4 for 5/-. Post 2/6.

SOUND & VISION STRIP, 10/6.

Superhet. Complete vision strip valves. Not tested. Drawings Free. Postage 2/6.

TIMEBASE, 4/9. Containing scanning coil, focus unit, line transformer, etc. Less valves. Drawings free. P. & P. 2/6.

POWER PACK & AMPLIFIER, 19/6. Output stage PEN45 O.P. trans., choke smoothed H.T. 325 volt at 250 mA. 4 v. at 5 amp. 6.3 v. at 5 amp. 4 v. at 5 amp. centre tapped valve base for rectifier. Octal or 4-pin. Output is taken from standard plugs. Less valves. Not tested. Ins., Carr. 5/6.

GANG CONDENSERS, 1/9. 2 & 3 gang 500 pF. Standard, Tested. P. & P. 1/3.

TERMS AVAILABLE

RECTANGULAR T.V. TUBES. 17" £7.10.0. 12 MONTHS' GUARANTEE. 14" £5.10.0.

6 months' full replacement, 6 months' progressive. Made possible by the high quality of our tubes. Ins., Carr. 15/6. 9", 10", 14", 15", 16" round tubes. Our special offer of these sizes, £5. 12" T.V. TUBES, £6. Three months' guarantee on round tubes. Ins., Carr. 15/6.

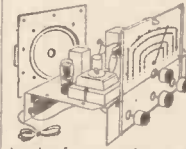

SUPER CHASSIS, 99/6

5 valve superhet chassis, including 8" P.M. speaker and valves. Four control knobs (tone, volume, tuning w/change switch). Four w/band with position for gram. P.U. and extension speaker. A.C. Ins., Carr. 5/6.

INSULATED TAPE, 1/6. Large roll in sealed metal container. BARGAIN. 75ft. x 1/2" wide. It's a must at this price. Post 9d. N.B.—Postage on 6 tins is only 2/- Buy "NOW" and save money.

TELEPHONE SETS, 7/9. Ex-W.D. Wireless remote control unit. E. Mk. 11 (ZA1194). New condition. Morse tapper, switched, jack plugs, etc. Less 'phone. Ins., Carr. 3/6.

EXTENSION SPEAKER, 29/9.

Complete. Fitted with 8" P.M. speaker. "W.B." or "GOODMANS" of the highest quality. Standard matching to any receiver (2-5 ohms). Flex and switch included. Money refunded if not completely satisfied. Ins., Carr. 3/6.

8" P.M. SPEAKER, 8/9. Ideal for kitchen and bedroom extension. P. & P. 2/6.

TRANSFORMERS

MAINS POWER TRANS., 9/9. 350.0-350 v. 250 mA. 6 v. heater at 5 A. 4 v. at 5 A. 4 v. centre tapped. Drop through type. Primary 200-250 v. (4 1/2" x 5" x 5"). Postage 3/9.

MAINS TRANS., 3/9. 280.0-280 mA. 6 v., 4 v. heaters. 200-250 v. prim. Post 2/3.

HEATER TRANS., 3/9. 1-2 Ratio auto trans. 2 v. at 1.4 amp. primary. 4 v. secondary. Post 1/9.

O.P. TRANS., 1/3. Std. size. 2-5 ohms. Post 1/-. 20 for £1. Post 5/6.

ION TRAPS, 5/-. For all and any type of tube requiring a trap. Post Free.

DUKE & CO. ILFORD 6001/3. (Dept. 4) 621/3, ROMFORD ROAD, MANOR PARK, E.12. OPEN ALL DAY SATURDAY.

Closed Thursday 1 p.m. Send for Catalogue. LIVERPOOL STREET TO MANOR PARK STATION, 10 MINUTES.



Do it yourself with a

BEN HANDISPRAY OUTFIT

- Ideal for
- HOME HANDYMAN
- MODEL MAKER
- CAR OWNER
- AMATEUR DECORATOR

- Various applications include
- SPRAY PAINTING
- CREOSOTING
- TYRE INFLATION
- DISTEMPERING
- INSECTICIDE SPRAYING

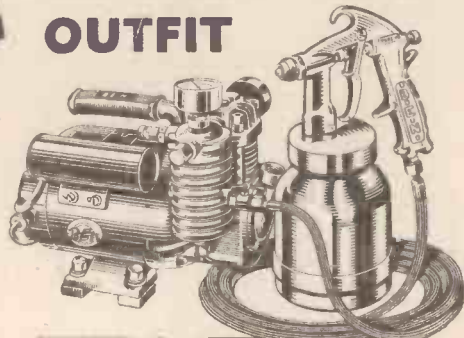

Also suitable for vacuum work—ideal for use in laboratory and instrument testing—Ask for details of Handivac.

Write for Leaflet CB. 112

B. E. N. PATENTS LTD. (Division of Broom & Wade Ltd.), P.O. Box No. 10, Dept. X, HIGH WYCOMBE, BUCKS. Tel.: High Wycombe 1630

E.D. 1.49 c.c. "FURY"

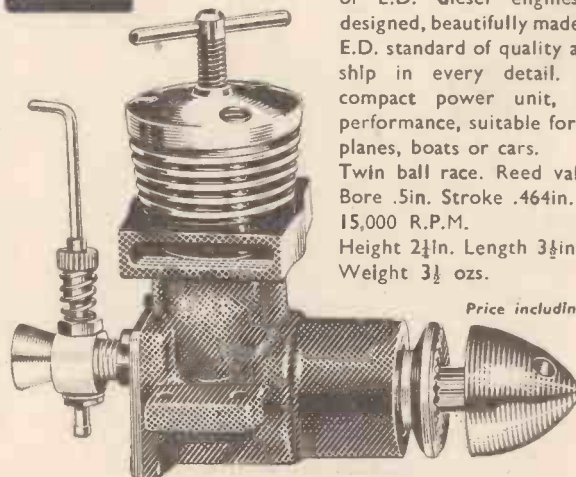

The latest addition to the famous range of E.D. diesel engines. Cleverly designed, beautifully made and up to the E.D. standard of quality and workmanship in every detail. An exciting, compact power unit, with a high performance, suitable for use in model planes, boats or cars. Twin ball race. Reed valve induction. Bore .5in. Stroke .464in. B.H.P. .15 at 15,000 R.P.M. Height 2 1/4 in. Length 3 1/2 in. Width 1 1/2 in. Weight 3 1/2 ozs.

Price including Purchase Tax
AIRCOOLED MODEL £3. 17. 10
WATERCOOLED MODEL £5. 2. 2

E.D. RADIO CONTROLS

E.D. now produce 6 models that will adequately meet the demands of most enthusiasts.

- E.D. "Boomerang" E.D. Mk. V. "Everest"
- E.D. Mk. IV "Miniature" E.D. "Airtrol"
- E.D. "Transitrol" E.D. "P.C.1" Transmitter

Details of all these models are contained in our new illustrated list, free on request.

Order from your Model Shop.

ELECTRONIC DEVELOPMENTS (SURREY) LTD
DEVELOPMENT ENGINEERS
ISLAND FARM RD, WEST MOLESEY, (SURREY) ENGLAND.

* Permanent Magnets in action *

Pins and needles

Avoid dangerous loose pins and needles — use a magnet as your pincushion. Every housewife can use a magnet for countless jobs about the home. Ask your tool dealer for the new descriptive literature.



**PERMANENT
MAGNETS**

Made by James Neill & Company (Sheffield) Limited and obtainable from all tool distributors

Part 44

Follow the **FLUXITE** way to Easy Soldering



No. 4. TINNING THE BIT

Cut off small piece of solder and lay it, together with a little FLUXITE, in a shallow tin lid. Quickly rub faces of heated bit in FLUXITE then on solder. Surplus solder can be wiped off with cloth.

FLUXITE is the household word for a flux that is famous throughout the world for its absolute reliability. In factory, workshop and in the home FLUXITE has become indispensable. It has no equal. It has been the choice of Government works, leading manufacturers, engineers and mechanics for over 40 years.

FLUXITE
SIMPLIFIES ALL SOLDERING

Fluxite Limited, Bermondsey Street, London, S.E.1

MAINS BLOWER, 200/250 v. A.C./D.C., 4-amp., 5,000 r.p.m., consists of the motor with attached enclosed fan, and funnel intake 1 1/2 in. dia., side outlet 1 in. x 1/2 in., plinth base 5 in. x 4 1/2 in., finish black crackle and die cast aluminium, size overall 9 in. long; 4 1/2 in. wide, 5 in. high, weight 7 1/2 lb., a very superior blower, offered at a fraction of original cost, new, unused, 25/- Post 3/6.

ELECTRIC PUMPS, suitable for most liquids the popular cylindrical immersion type 2 1/2 v. at which they deliver 10-g.p.m. at 20-ft. head also give excellent performance at 12 v., new in sealed cartons, 4 ft. long, 35/-, carriage 5/-.

HUGHES MOTORS, shunt wound, 12 v. 1 1/2-amp., speed 5,000 r.p.m., reversing, size 3 1/2 in. long, 1 1/2 in. dia., 1 in. shaft, weight 20 oz., a very superior motor designed for anti-radar equipment, new unused 10/-, post 1/6. 25 per doz., carriage paid, ditto fitted reduction gear, giving a final drive (1 in. shaft) of either 320 or 160 r.p.m., state which required, 12/6, post 1/6; 26 per doz., carriage paid.



K TYPE CYLINDER LOCKS, deadlocking and thiefproof, has 7 concentric tumblers instead of the usual 5 in line, interchangeable fitting with ordinary cylinder locks, latchbolt reversible, for right or left hand doors (no need to specify), complete with 2 keys, all fittings and instruction booklet, new, boxed, 5/-, post 1/6; 4 for 20/-, post paid.

RANGEFINDERS by Barr and Stroud, 1-metre base coincidence type, a hand held instrument giving the distance of any object, from 500 to 20,000 yds. (12 miles). The 14x variable focusing right-eye-piece provides two images of the object viewed, one from the right objective; the other from the left. When these two images are brought into coincidence by a thumb wheel control, the distance in yards can immediately be read in the left eye-piece. Fitted two filters and other refinements. A very superior high quality instrument, original cost £180, our price in new or near new condition, supplied in stout fibre cases 25/-, carriage 100 m. 7/6, 200 m. 10/-, 300 m. 12/6 N.I. 20/-.

SIGHTING TELESCOPES by Ross, Taylor Hobson, etc., these high quality instruments contain four 40 mm. dia. achromats, 2 of 3 in. focal length, 2 of 3 1/2 in. focal length, also a 18 mm. dia. image erector achromat, 4 screw fine adjustment cross graticule, length 16 in., weight 7 lbs., new and boxed, 35/-, post 3/6.

GUNSIGHT TELESCOPES, has 4 lens high grade optical system with cross graticule, approx. 2x, all brass, 13 in. long, 1 1/2 in. dia., makes an ideal rifle sight, or astro telescope star marker, perfect condition, in metal cases, 20/-, post 1/6.

TELEPHONE SETS, consists of two combined microphones and receivers, which when wired up by ordinary twin flex, provides perfect 2-way communication, excellent results at 1 mile range have been reported, self-energised, no battery required, set complete, new unused 7/6, post 1/3; suitable twin 14/36 p.v.c. up to 300 ft. lengths at 1d. per ft. supplied, postage each 20 ft. flex 3d. extra.

CHARGING SETS, only 46 lbs. weight, easily carried, 4-stroke air-cooled, runs for 18 hours from 1 gall. petrol, D.C. output 12-18 v. at 18 watts, complete with exhaust and silencer, starter cord, etc., size 14 1/2 in. x 14 1/2 in. x 7 1/2 in., completely works reconditioned and now as new, supplied in stout wood cases, our price 28/10/-, carriage, (inland only) 100 m. 12/6, 200 m. 16/6, 300 m. 20/-.

GRAMOPHONE MOTORS by famous maker, 200/250 v. or 100/130 v. A.C. mains, 1 in. long, 5/32 in. dia. shaft, speed 1,350 r.p.m., size 2 1/2 in. x 2 in. x 1 1/2 in., weight 18 oz., fitted rubber bushing mounting bracket, recent manufacture and brand new, 15/-, post 1/6.

OIL TEMP. GAUGES, 2 1/2 in. square flush mounting, graduated 0-120 deg. "C", basically a very fine quality moving coil milliammeter, new in sealed cartons, 3/6, post 1/6.

Many other Bargains: send stamped, addressed envelope for lists.

MIDLAND INSTRUMENT CO., Moorpool Circle, Birmingham, 17

TEL: HAR 1308

Here's the new Handyman Workbench even better than before!

As demonstrated on B.B.C. T.V.—now complete in every detail. Spacious tool cupboard, flush fitting drawer, "Woden" Bench Stop and Holdfast are obtainable as additional extras to the standard model. Made in solid hardwood throughout. Also latest model 7 in. "Woden" Quick Release Woodworkers' Vice type A.120, fitted as illustrated.



Easy Terms

Deposits from

30/-

Length 3' to 6'

Prices carriage paid from £7 upwards

To: J. POWELL & SON LTD. (Dept. D),
PENSNETT, BRIERLEY HILL, STAFFS.
Telephone: KINGSWINFORM 3036

Please forward illustrated folder and comprehensive price list.

NAME.....

ADDRESS.....

FREE - AN IMPORTANT BOOK

about YOUR CAREER · HOBBY...



...SPARE TIME WORK, etc....

... IN ANY OF THESE SUBJECTS:—

- | | |
|--------------------------------------|----------------------------------|
| Accountancy | Maintenance Eng. |
| Advertising | Mathematics |
| Aeronautical Eng. | M.C.A. Licences |
| A.R.B. Licences | Mechanical Eng. |
| Art (Fashion Illustrating, Humorous) | Metallurgy |
| Automobile Eng. | Motor Eng. |
| Banking | Painting & Decorating |
| Book-keeping | Photography |
| Building | P.M.G. Certs. |
| Business Management | Police |
| Carpentry | Production Eng. |
| Chemistry | Production Planning |
| City & Guilds Exams. | Radar |
| Civil Service | Radio |
| Commercial Subjects | Radio Amateurs (C. & G. Licence) |
| Commercial Art | Radio & Television Servicing |
| Computers | Refrigeration |
| Customs Officer | Sales Management |
| Draughtsmanship | Sanitary Eng. |
| Economics | Salesmanship |
| Electrical Eng. | Secretaryship |
| Electrical Installations | Servo Mechanisms |
| Electronics | Shorthand & Typing |
| Electronic Draughtsmanship | Short Story Writing |
| Eng. Drawing | Short Wave Radio |
| Export | Sound Recording |
| General Certificate of Education | Telecommunications |
| Heating & Ventilating Eng. | Television |
| 'Hi-Fi' Equipment | Time & Motion Study |
| High Speed Oil Engines | Transistors |
| Industrial Admin. | Tracing |
| Jig & Tool Design | Welding |
| Journalism | Workshop Practice |
| Languages | Works Management |
| Management | and many others |

Also courses for GENERAL CERTIFICATE OF EDUCATION, A.M.I.H. & V.E., A.M.S.E., A.M.Brit.I.R.E., A.M.I.Mech.E., A.M.I.E.D., A.M.I.M.I., A.F.R.Ae.S., A.M.I.P.E., A.M.I.I.A., A.C.C.A., A.C.I.S., A.C.C.S., A.C.W.A., City & Guilds Examinations, R.T.E.B. Servicing Certificates, R.S.A. Certificates, etc.

NEW PRACTICAL DO-IT-YOURSELF COURSES

YOU CAN MAKE AND SAVE MONEY IN:—

- RADIO & T/V BUILDING & SERVICING
- ELECTRICAL APPLIANCE REPAIR
- CHEMISTRY · PHOTOGRAPHY
- HI-FI EQUIPMENT, ETC.

All the above special courses include practical equipment as part of the training.

- Personal and Individual Tuition given by named tutors
- All equipment yours to keep
- Courses for Beginner or Advanced student

EMI INSTITUTES

E.M.I. Institutes
is associated with
"HIS MASTER'S VOICE",
COLUMBIA,
ETC.

POST TODAY

To:— E.M.I. INSTITUTES, Dept. 144K, LONDON, W.4.

Please send, without any obligation, your free Book to:—

NAME _____ AGE _____
(if under 21)

ADDRESS _____

Subject(s) of interest _____ With* } equipment
Without } equipment

(We do not employ travellers or representatives)

*Delete as required

IC.118

AUG.5d

The only Home Study College run by a World-wide industrial organisation

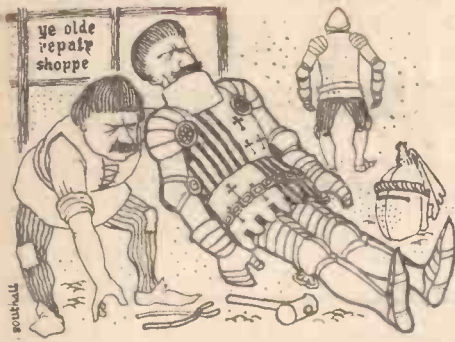

to-day
the
'old hand'
has a
**THIRD
HAND**

In days of old when knights were bowled—over, how useful the Mole Wrench would have been. Known today to thousands over the world as their 'third hand,' the Mole Wrench locks on to the job-in-hand and remains locked, tightly with both hands free—a 'third hand' that also serves as super-pliers, clamp, hand vice and so on. Fitted with the quick release lever it is available in two sizes, 7in. for 12/6 and 10in. for 15/-. from Ironmongers, Motor and Motor Cycle Accessory Dealers. You'll be glad you bought

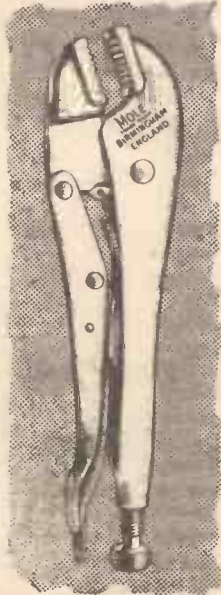

**THE
MOLE
TRADE MARK
SELF-GRIP
WRENCH**

Ask for a genuine Mole Wrench—
Look for the name on it

If in any difficulty write to:
M. MOLE & SON LTD., BIRMINGHAM, 3

M&W ENGINEERS' PRECISION & HAND TOOLS

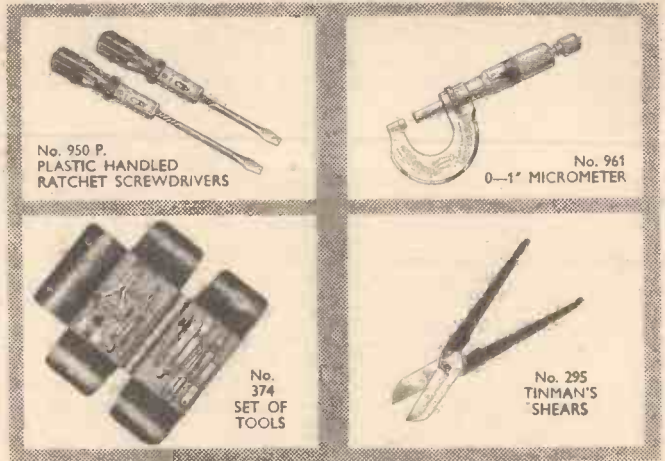

MEASURE UP TO ANY JOB

The next time you buy tools, remember that it pays to buy good tools, tools upon whose accuracy you can rely **M&W** tools are made from the finest material. and are guaranteed to conform to British Standard Institution Specifications where they exist. The next time you buy tools ask your dealer for **M&W** Engineers Precision and Hand Tools.

Send 10d. in stamps for a copy of our catalogue, mentioning this journal.
MOORE & WRIGHT (SHEFFIELD) LTD., 14/28, NORTON LANE, SHEFFIELD, 8

4D1	6/9	9D2	6/9	DF86	5/9	EZ40	8/9	UU6	7/9
5Y3	8/9	11E3	5/9	EA50	1/9	EZ90	8/9	U52	8/9
8AM5	3/9	12A6	8/9	EABC80	9/9	FW4500	10/9	VR85	6/9
8AN6	1/9	12A17	8/9	EAF32	3/9	KTW81	5/9	VT52	6/9
8B7	1/9	12BE6	6/9	EB34	1/9	KTW83	8/9	VT501	6/9
6B8G	3/9	12K7	8/9	EP36	5/9	L410	1/9	VW36	1/9
6F12	7/9	12Y4	8/9	EBC33	6/9	NR41	3/9	TT11	6/9
6F14	8/9	35Z4	8/9	ECC81	8/9	PEN45	6/9	W75	8/9
6H6M	1/9	35L6	8/9	ECH2	8/9	PEN36	6/9	W81	3/9
6J6M	2/9	83SPT	2/9	EP37	4/9	PEN220A	3/9	Z77	7/9
6K7M	3/9	77	3/9	EP39	3/9	PLB2	8/9		
6SJ7M	8/9	210VPT	5/9	EF42	8/9	PM202	1/9		
6V6M	8/9	7193	3/9	EP50	2/9	PE225	3/9		
6P28	12/6	AR6 (2V)	1/9	EP50RED	5/9	PY81	8/9		
6S47M	3/9	AR735	3/9	EP90	8/9	P51	6/9		
6SG7	3/9	CV1083	3/9	EP85	8/9	RL37	1/9	UX TYPES	
6SG7M	2/9	D1	1/9	EP91	7/9	SE81	6/9	18	3/9
8D2	3/9	DH76	8/9	EP92	3/9	U22	10/9	78	3/9
8D3	7/9	DK96	8/9	EL84	10/9	UF41	8/9	25RE	3/9

T.V. AERIALS. 25.6. For all I.T.A. channels. Outdoor or loft. 3 element, half normal cost. P. & P. 2/6.
CAR AERIALS. 6/9. Whip antennae. 50in. long, collapsing to 11in. 1 hole fixing. Post 1/-.
GANGED CONDENSERS. 1/9. 2 or 3 gang. Salvage, guaranteed. .0055. Post 1/3.
I.F. TRANSFORMERS. 1/-. Pair. 465 kc/s. Tested, guaranteed. Post 1/-.
I.F. HINGES. 1/9 pair. Chrome. New. 7in. long. Post 6d.
RESISTANCE LINKS. 4d. each. "Bulgin" super wire-wound resistance links. New. in maker's boxes. Sizes 240 and 1,500 ohms. 2/6 doz. Post 6d.
CHOKES. 250 mA, 4/9, p. & p. 2/6; 10 for 30/-, p. & p. 7/6; 80 mA, 2/9, p. & p. 2/-; 10 for 20/-, p. & p. 7/6; 60 mA, 1/9, p. & p. 2/-; 10 for 10/-, p. & p. 6/6. All salvage guaranteed.
TORCH LANTERNS. 6d. each. Ex W.D. Including 2 bulbs, uses 600 battery. Post 1/6. 5/- doz. post 3/-. Crates of 48, 22/-, carr. 10/-.
T.V. SLIDER CONTROLS. 9d. 10 K. and 2 K. only, wire wound. Post 6d. 4 for 2/6. 8 in. P.M. SPEAKERS. 8/9. Ideal gift if fitted in small cabinet. "Treat the lady at home." Fit one in kitchen or cupboard door. With O.P. trans. 10/- Post 2/9.
RECTIFIERS. 2/9. 250 volt 100 m/a. Full or half-wave. Salvage, guaranteed. Post 1/3.
ION TRAPS. 5/-. For all and any type of tube requiring a trap. Post 6d.
RESISTORS. 6d. doz. 270 ohms. 1/2 watt ceramic. Post on 1 doz., 6d.; on 4 doz., 1/-; on 10 doz., 2/6.
INSULATING TAPE. 1/8. 75 ft. by 1/2 in. wide. Post on 1.9d.; on 6 only 2/-.
SOLDER REELS. 1/8. 60.40, 3 core En8. 20 ft. on plastic spool. Post 6d.
O.P. TRANSFORMERS. 1/3. Salvage guaranteed. 2-5 ohms. Matching Pentode or Tetrode. Post 1/9. 20 for 1/-. Post 5/6.
HEADPHONES. 1/9. Single earphone and band. C-LR type. Grand bargain. Ideal for Crystal sets, extension on T.V. or radio. Post 1/6.
CO-AX CABLE. 6d. yard. Cut to any length. Good quality. Post on 20 yds., 1/6. 45/- per 100 yards. Post 3/6.
DROPPERS. 9d. each. 750 ohms 2 amp. Post 9d. 5/- doz. Post 2/6.
CHASSIS. 1/- each. 6 or 8 valve, latest type midge valve design for A.M. or F.M. New. Cadmium plated on s.w.g. steel. 12 1/2 in. x 7 1/2 in. x 2 1/2 in. Post 1/9. 4 for 4/-. Post 3/-. 12 for 10/-. Carr. 5/-.
VOLUME CONTROLS. 1/9. 1 msc. ohm. Long spindle. New, boxed. Post 1/6.
CLOCKWORK MECHANISM. 1/9. A perfectly engineered clockwork unit, with a fully enclosed clock-type spring, gear train and escapement. Ex W.D. (type TOF (B) 40 SL). Can be modified for use as a darkroom timer. Free drawings. Postage 1/-.
VALVE SCREENING CANS. 1/- doz. Latest midge type. Aluminium 2 1/2 in. dia. Post 6d.
NICKEL CHROME WIRE. 1/- .014 dia. on 50 yard spools. .032 dia. on 25 yard spools. Packed in ready-use tins, with run out mechanism, special dulled finish. Rust proof. Ideal for gardeners and outdoor-use. Post 9d. 25 for 1/-. Post 2/6.
SPRING STEEL WIRE. 6d. .014 dia. on 50 yard spools. Post 9d. 25 for 10/- Post 2/6.

P. P. COMPONENTS LTD. 219, ILFORD LANE, ILFORD, ESSEX. Phone: ILF 0255.
Send 9d. stamp for FREE catalogue.



BUILD YOUR OWN

20x PRISMATIC TELESCOPE

WEIGHS ONLY 12oz.—EASILY CARRIED IN THE POCKET!

For the first time ever, you can now buy a kit from which you can make your own Prismatic Telescope. It is supplied with easy-to-follow instructions as described and approved by the "Model Engineer" and comes to you with optically ground prisms. This wonderfully designed optical system is fully corrected and will give excellent light transmission for day or night use. With its wide field of view, this high powered telescope also has a focusing eyepiece, it is only 6in. long and is ideal for sport, bird watching, spotting and astronomy.

79/6
Complete kit
of Lenses &
Prisms



35/-

finest Clinometers available today. Made of Gunmetal, it comes to you complete with leather case.

CLINOMETERS

SINE-BAR

This highly accurate instrument will measure any given angle, instantly, from 0° to 90° to 1 minute through its unique sine-bar mechanism which also incorporates the spirit level.

GENERAL PURPOSE

These instruments are made for the high precision measurement of angles up to 90°. In gun metal with circular 2-way spirit level, length 7 1/2", height 2 1/2". Also ideal for setting milling and drilling tables and general workshop use. Manufactured to Government specification, they are offered at a fraction of the original price.

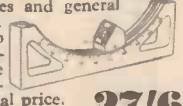

27/6

UNITED TECHNICAL SUPPLIES LTD
DEPT. PM2, 3, HARROW ROAD, LONDON, W.2. Tel.: PAD 1133
Opposite Edgware Road Station. 5 mins. Marble Arch.

Model Engineer EXHIBITION



NEW HORTICULTURAL HALL, WESTMINSTER

AUGUST 20-30 11 a.m.-9 p.m. Closed Sunday.
Admission 3/-, juniors 1/6.

1,000 perfect models. Continuous workshop demonstrations. Steam-driven locomotives on a raised track. Radio-controlled ships. Model car racing. A very special model railway layout and many other features.

DON'T MISS THIS WONDERFUL SHOW!

For garage or workshop



FRACTIONAL HORSEPOWER MOTORS

A.C. or D.C.

BTH motors and associated control gear are second to none in quality and proved performance.

Types and sizes are available to suit any application.

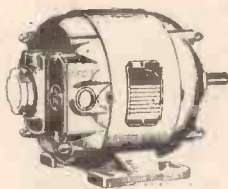

THE BRITISH THOMSON-HOUSTON CO. LTD., NEWCASTLE (STAFFS). ENGLAND
an A.E.I. Company. A5186

Training with I.C.S. THE WAY TO SUCCESS

The great and growing demand of today is for TRAINED men. Thousands more are needed, but there is no worthwhile place for the untrained.

Through I.C.S. Home Study you gain the specialised knowledge that marks you out for promotion, for SUCCESS! I.C.S. teaches you in your own time—expertly, quickly and easily. It is the world's largest and most successful correspondence school, offering courses for almost every branch of trade, industry and the professions. No books to buy.

ADVERTISING & SALESMANSHIP

Account Executives' Mail Order Copy Writers' Advertisement Managers' Commercial Travellers' Sales Management

EXAMS: Joint Inter. A.A. & I.P.A. Finals. Inc. Sales Mngrs. Ass. United Com. Travel. Association.

ARCHITECTURE & BUILDING

Drawing and Designing Quantity Surveying Builders' and Surveyors' Clerks' Bricklaying Carpentry & Joinery Construction and Steelwork Heating and Ventilating

EXAMS: Roy. Inst. of Br. Archts. Inst. of Quant. Surveyors. Roy. Inst. of Chartered Surveyors. Inst. of Builders. Inst. of Mun. Engrs. (Bldg. Inspectors'). Inst. of Clerk of Works.

COMMERCIAL ART

Elementary Art Training Poster Work Sketching

COMMERCIAL TRAINING

Bookkeeping and Accountancy Costing and Auditing Company and Private Secretarial

EXAMS: Chartd. Inst. Secs. Corp. of Secs. Ass. of Cert. & Corp. Accts. Inst. of Cost & Works Accts. Inst. of Bookkeepers.

ELECTRONIC ENGINEERING

Industrial Electronics Electronic Computers

CIVIL ENGINEERING

Highway Engineering Surveying and Mapping Structural and Concrete Engineering

EXAMS: Inst. of Civil Engineers. Inst. of Mun. Engrs. Inst. of Structural Engrs.

DRAUGHTSMANSHIP

(State which Branch) Architectural Drawing Office Practice & Machine Design Structural Drawing Maths. & Machine Drawing Woodworking Drawing

ELECTRICAL ENGINEERING

Illumination and Heating Electricians'

EXAMS: Society of Engineers. C. & G. Cert. in Elec. Eng. Practice. C. & G. Cert. in Elec. Installations. C. & G. Cert. in Illum. Engg.

FARMING & HORTICULTURE

Arable Farming Pig & Poultry Keeping Livestock Farming Farm Machinery (Maintenance) Flower, Vegetable & Fruit Gardening Rock & Shrub Gardening

FIRE ENGINEERING

EXAMS: Inst. of Fire Engineers. Fire Service Promotion

GENERAL CERTIFICATE OF EDUCATION

Principal Subjects at Ordinary or Advanced Level Engineering Joint Board Preliminary

MANAGEMENT

Foremanship Industrial Management Business Management Methods Engineering **EXAMS:** British Inst. of Mngemt. Intermediate, Final and Certificate of Foremanship

MECHANICAL ENGINEERING

Subjects include: Welding, Fitting, Turning, Erecting, Jig & Tool Design, Production, Draughtsmanship, Mathematics, Inspection Diesel Engines, Diesel Electric Locomotives, Refrigeration.

EXAMS: Inst. of Mech. Engineers. Inst. of Production Engineers. Society of Engineers

MOTOR ENGINEERING

Diesel Transport Engines Motor Body Rebuilding Owner Drivers' Running and Maintenance

PHOTOGRAPHY

A basic Course including Colour Work

RADIO AND TELEVISION ENGINEERING

Service Engineers' Television Servicing and Engineering Practical Radio with Equipment

RADIO SERVICE & SALES

EXAMS: Br. Inst. of Radio Engrs. C. & G. Radio Servicing Cert. (R.T.E.B.), P.M.G.'s Cert. in Wireless Telegraphy C. & G. Telecoms. Engineering. C. & G. Radio Amateurs'

WRITING FOR PROFIT

Free Lance Journalism Short Story Writing

NEW—PRACTICAL PHOTOGRAPHY COURSE
Learn camera technique and how to produce first-class negatives and prints in monochrome or colour.

INTERNATIONAL CORRESPONDENCE SCHOOLS

Dept. 169D, International Buildings, Kingsway, London, W.C.2.

Please send me free booklet on.....Age.....

Name..... Occupation.....
(USE BLOCK LETTERS)

Address

Addresses for Overseas Readers

Australia: 140, Elizabeth Street, Sydney. Eire: 3, North Earl Street, Dublin
India: Lakshmi Bldg., Sir Pheroza Mehta Rd., Fort Bombay, New Zealand: 182, Wakefield Street, Wellington. N. Ireland: 26, Howard Street, Belfast.
South Africa: Dept. L. 45, Shortmarket Street, Cape Town.

INTERNATIONAL CORRESPONDENCE SCHOOLS

VALUABLE NEW HANDBOOK FREE TO AMBITIOUS ENGINEERS

Have you had your copy of "Engineering Opportunities"?

The new edition of "ENGINEERING OPPORTUNITIES" is now available—without charge—to all who are anxious for a worthwhile post in Engineering. Frank, informative and completely up to date, the new "ENGINEERING OPPORTUNITIES" should be in the hands of every person engaged in any branch of the Engineering industry, irrespective of age, experience or training.

**We definitely Guarantee
"NO PASS—NO FEE"**

This remarkable book gives details of examinations and courses in every branch of Engineering, Building, etc., outlines the openings available and the essential requirements to quick promotion and describes the advantages of our Special Appointments Department.

WHICH OF THESE IS YOUR PET SUBJECT?

MECHANICAL ENGINEERING

Gen. Mech. Eng.—Maintenance — Draughtsmanship—Heavy Diesel—Die & Press Tool Work—Welding—Production Eng.—Jig & Tool Design—Sheet Metal Work—Works Management — Mining — Refrigeration—Metallurgy.

AUTOMOBILE ENGINEERING

Gen. Automobile Eng.—Motor Maintenance & Repairs — High Speed Diesel—Garage Mngment.

ELECTRICAL ENGINEERING

Gen. Elec. Eng.—Elementary & Advanced Elec. Technology — Installations Draughtsmanship—Supply — Maintenance — Design — Electrical Traction — Mining Electrical Eng.—Power Station Equipment, etc.

CIVIL ENGINEERING

Gen. Civil Eng.—Sanitary Eng.—Structural Eng.—Road Eng.—Reinforced Concrete—Geology.

RADIO ENGINEERING

Gen. Radio Eng.—Radio Servicing, Maintenance & Repairs—Sound Film Projection — Telegraphy — Telephony — Television — C. & G. Telecommunications.

BUILDING

Gen. Building—Heating & Ventilation—Architectural Draughtsmanship — Surveying — Clerk of Works — Carpentry and Joinery — Quantities — Valuations

WE HAVE A WIDE RANGE OF AERONAUTICAL COURSES AND COURSES IN FORESTRY, TIMBER TECHNOLOGY, PLASTICS, G.P.O. ENG., TEXTILE TECHNOLOGY, ETC., ETC.

One of these qualifications would increase your earning power

WHICH ONE?

A.M.I.Mech.E., A.M.I.C.E., A.M.I.P.E., B.Sc., A.M.Brit.I.R.E., A.F.R.Ae.S., A.M.I.M.I., L.I.O.B., A.R.I.B.A., A.M.I.H. & V.E., M.R.San.I., F.R.I.C.S., A.M.I.E.D., CITY & GUILDS, COMMON PRELIM., GEN. CERT. OF EDUCATION, ETC.

**THE BRITISH INSTITUTE OF
ENGINEERING TECHNOLOGY**



410A, COLLEGE HOUSE,
29-31, WRIGHT'S LANE,
KENSINGTON, W.8.

Phone: WESTern 9861

WHAT THIS BOOK TELLS YOU

- ★ HOW to get a better paid, more interesting job.
- ★ HOW to qualify for rapid promotion.
- ★ HOW to put some valuable letters after your name and become a "key-man" quickly and easily.
- ★ HOW to benefit from our free Advisory and Appointments Depts.
- ★ WHERE today's real opportunities are . . . and HOW you can take advantage of the chances you are now missing.
- ★ HOW, irrespective of your age, education or experience, YOU can succeed in any branch of Engineering that appeals to you.

**144 PAGES OF EXPERT
CAREER-GUIDANCE**

You are bound to benefit from reading "ENGINEERING OPPORTUNITIES," and if you are earning less than £15 a week you should send for your copy of this enlightening book *now*—FREE and without obligation.

POST NOW!

TO: B.I.E.T. 410A, COLLEGE
HOUSE, 29-31, WRIGHT'S LANE,
KENSINGTON, W.8.

Please send me FREE and without obligation, a copy of "ENGINEERING OPPORTUNITIES." I am interested in (state subject, exam., or career).....

NAME

ADDRESS.....

WRITE IF YOU PREFER NOT TO CUT THIS PAGE



Only 2d. stamp is needed if posted in an unsealed envelope.

THE B.I.E.T. IS THE LEADING INSTITUTE OF ITS KIND IN THE WORLD

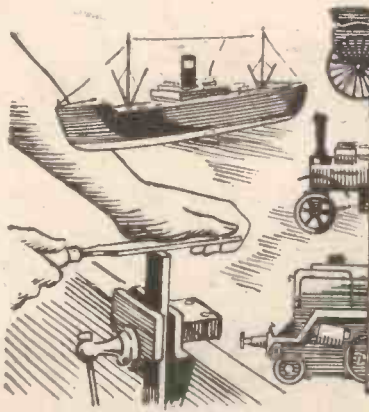

Practical Mechanics

Vol. XXV. No. 294

AUGUST, 1958

"The Cyclist" and "Home Movies" are temporarily incorporated



FAIR COMMENT

TV ON TAPE

ONE of the difficulties with the production of television programmes is that hitherto it has not been possible to record the vision side of the programmes on tape, wire or wax; the only method of recording has been by teleciné, and this has certain inherent drawbacks. The wide frequency band involved has always been considered a major problem impossible of solution. The recent demonstration of the Ampex system of tape recording of vision and sound on one tape must be considered as a development of the first magnitude. Tape recording of television programmes, however, is not new. In the first place, once a programme has been produced and recorded, it can be repeated at a later date without the cast having to be present and even an entirely new programme can be recorded to suit the convenience of the actors long before its initial production. It will also cheapen the television programmes. Recording on tape is much cheaper than film and it has the advantage that it may be immediately played back, whereas there is a lapse of time when the programme is recorded by film. Thus television is provided with a recording system equal to that of sound radio. The vision and sound tracks are on one tape.

FOUNTAIN PEN CAPS

I HAVE recently been presented with a fountain pen of the very latest type, one costing several pounds. Unfortunately, however, it has the same defect as all other fountain pens—when writing, the movement of the wrist causes the cap to come loose and fall off. This is a defect common to all fountain pens and I am surprised that manufacturers have not yet eliminated this defect, which is comparatively easy of solution. The cap is intended to grip on the tapering end of the barrel and it is well known that a male and female taper is one of the best means of obtaining a grip. The fact that no manufacturer of fountain pens has yet produced a pen where the cap would not fall off would seem to indicate that they do not understand the correct use of the taper for the purpose. Fountain pen caps only make line contact with the barrel and thus can drop off. If the internal taper of the cap were made to grip on the barrel for about $\frac{1}{16}$ in. the trouble would vanish. It is an irritating fault of which most fountain pen users complain. Rather too much attention has been given to the styling of pens and too little to their actual use. Few of them hold sufficient quantity of ink for continuous writing, and I am somewhat surprised that pen manufacturers do not adopt some of the designs we published a few years ago for improved fountain pens. The replacement of broken caps which have dropped on the floor and been trodden on must be a highly lucrative side line for the pen manufacturers.

"A BEGINNER'S GUIDE TO TELEVISION"

COPIES of "A Beginner's Guide to Television" (a companion work to "A Beginner's Guide to Radio") are now available at 7s. 6d. from booksellers, or 8s. 3d. by post from the Book Department, address as on this page. The book is in the form of a series of lessons; it is written in elementary language and it is free from mathematics. It has been specially written for the student and teacher.

TWENTY-FIVE YEARS OLD

MY recent note that we shall celebrate 25 years of continuous publication with our October issue has brought a large number of congratulatory messages from readers, contributors and advertisers. There will be many special features in our birthday number, and we plan to make it a souvenir issue.—F. J. C.

The September issue will be published on August 29th. Order it NOW!

Editorial and Advertisement Offices
"PRACTICAL MECHANICS"
George Newnes, Ltd., Tower House,
Southampton Street, Strand, W.C.2
© George Newnes Ltd., 1958

Phone: Temple Bar 4363
Telegrams: Newnes, Rand, London

SUBSCRIPTION RATES

Including postage for one year

Inland 20s. per annum.
Abroad 18s. 6d. per annum.
Canada 18s. 6d. per annum.

Copyright in all drawings, photographs and articles published in "Practical Mechanics" is specially reserved throughout the countries signatory to the Berne Convention and the U.S.A. Reproduction or imitations of any of these are therefore expressly forbidden.

CONTENTS:

	Page
Fair Comment	503
Making a Cottage Tent	504
The U.S. Satellite Programme	507
Building a Wood Planer	509
Attache Case Repairs	512
Is the Earth Hollow?	513
Electro-gravitic Lift	514
A Transistor Diode Portable	515
Science Notes	517
A Carnival Spinner	518
A Room to Room Telephone	520
Alton Towers OO Gauge Railway	522
Using D.C. Motors on Different Voltages	523
Making a Liquid Rheostat	525
JUNIOR SECTION	
An Introduction to Ship Modelling	526
A Realistic Wooden Snake	528
Letters to the Editor	530
Puzzle Corner	533
Trade Notes	534
Your Queries Answered	537
Information Sought	538
CYCLIST SECTION	
What I Think	41
Hints About Mudguards	42
PRACTICAL PHOTOGRAPHER SUPPLEMENT	
A Simple Synchroniser	66
View Photography	67
A Focusing Magnifier	68
Copying	69
People and Portraiture	71
A Basic 35 mm. Camera	72
A Cine Film Rewinder	74
Photography in Town	75
When the Tide is Out	76
The Camera Lens	77
Replies to Readers' Queries, Your Opinion, Trade Note	78

CONTRIBUTIONS

The Editor will be pleased to consider articles of a practical nature suitable for publication in "Practical Mechanics." Such articles should be written on one side of the paper only, and should include the name and address of the sender. Whilst the Editor does not hold himself responsible for manuscripts, every effort will be made to return them if a stamped and addressed envelope is enclosed. All correspondence intended for the Editor should be addressed: The Editor, "Practical Mechanics," George Newnes, Ltd., Tower House, Southampton Street, Strand, London, W.C.2.

CAMPING EQUIPMENT

Making a Cottage Tent

By F. Hook

This is the Second Article of the Series and Contains Full Details for Making a Family Tent



Fig. 1.—The cottage tent, ideal for family camping.

FOR general family camping what has come to be called the Cottage Tent cannot be bettered. The main characteristics of this type of tent are:

Ridge pole tube



Solid end to ridge pole pinned into tube and drilled to slide on spike of the separator

1. The height of the ridge of the tent is sufficient to allow the camper to stand erect inside.

2. The walls of the tent are made relatively high, between 2ft. and 3ft., so that the family may sit on low camp chairs inside the tent at any place on the floor area of the tent without touching the roof.

When the tent walls are made high the slope of the roof will not be very steep. This is a disadvantage in wet weather. So for real weather-worthiness a flysheet is generally used over the tent. The flysheet has many advantages. No rain will fall directly on the tent; at the worst only a fine spray will penetrate to the tent itself. This will enable the

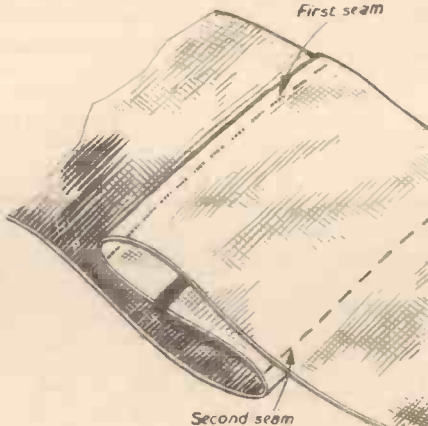
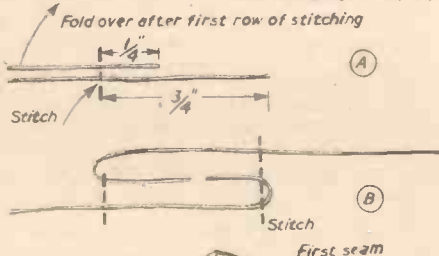
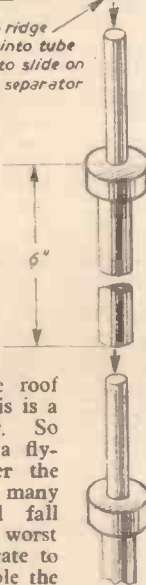

Fig. 4.—How to make the flat fell seam.

Fig. 2. (Left)—Arrangement of ridge pole and extension pieces with the poles of the tent.

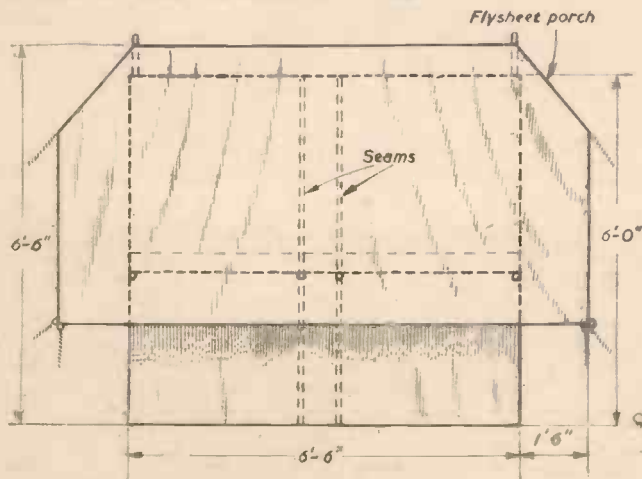

Fig. 3.—Main dimensions of the cottage tent and flysheet.

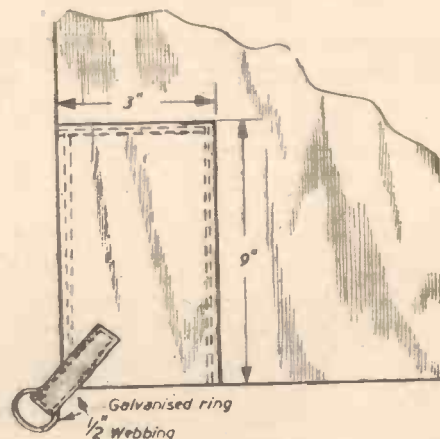
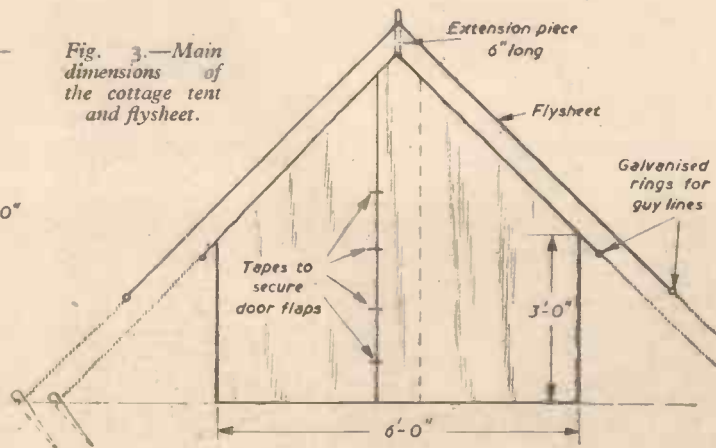

Fig. 5.—Strengthening corners of the roof with patches.

tent to be touched from the inside in the heaviest of downpours without starting a leak as would happen if the tent were exposed directly to the rain. Also in hot sunny weather the direct rays of the sun are not on the tent so that conditions inside the tent will be much cooler. Another advantage is discovered when striking camp in the rain. The tent may be taken down under the protection of the flysheet and will thus be dry for erection at the next site, a useful asset when touring.

The main features of the design for this tent are shown in Figs. 1 and 3. The tent floor is 6ft. 6in. long and 6ft. wide. The height from floor to-ridge is 6ft. The walls are 3ft. tall.

The flysheet is held 6in. above the ridge of the tent by a pair of separators placed on the tops of the tent pole points. The ridge of the flysheet is held perfectly horizontal by the use of a ridge pole which rests on the top of the separators. This arrangement is

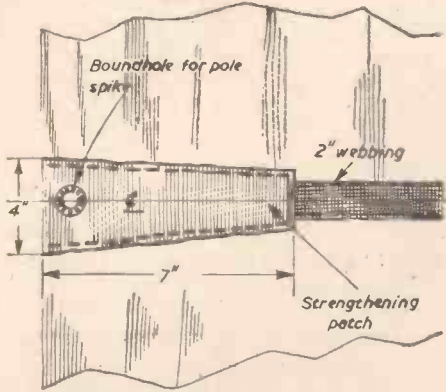

Fig. 6.—Strengthening the ridge.

shown in Fig. 2 and it will be noticed that by this means it is unlikely that the flysheet can touch the tent.

There is a wide variety of materials available at the present time for the making of tents, and before commencing construction it is a good plan to write for samples

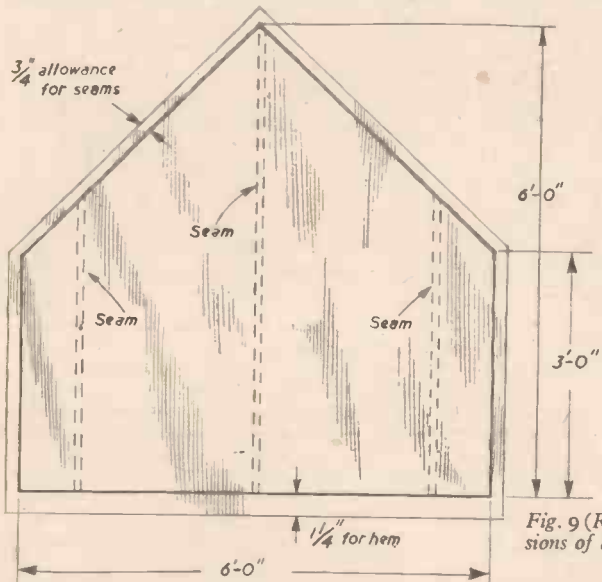

Fig. 7 (Left).—Plan of tent end.

Fig. 9 (Right).—Dimensions of door end of tent.

of the various cloths from the supplier. For the tent shown in the illustrations some 50z. green Willesden proofed material was used for which the author has a preference.

Construction

In all the dimensioned drawings of the tent and flysheet, unless definitely specified,

In making the tent only two stitching processes are used. The widths of material are joined together by a flat fell seam and the ends of the strips, as for example at the eaves of the tent, are



Fig. 8.—The finished tent.

no allowance has been made for turnings and hems, so that these allowances must be added by the reader when setting out the material. Most tent-making material to-day is 36in. wide. Therefore, when commencing to make the roof it will be noticed that two full widths of canvas are used with a narrow panel joining them to make up the 6ft. 6in. overall length. In a way this is an important feature of the design of the tent as the two seams joining the three strips come mid-way in the length of the tent, and, with a guy line at the end of each seam, this gives strength and stability to the tent.

It is presumed that the reader will have the use of the usual home sewing machine for making up the tent. Set the machine to a medium length stitch and use linen thread throughout the construction.

Two full width strips of material plus a strip 8½in. wide and each 9ft. 6in. long are needed for the roof. Make an allowance of 1¼in. at each end of each strip for the hems.

As two similar width pieces of material are needed for the walls of the tent, as used in the roof, but each 3ft. 2in. long, it is a good plan to seam up enough material for the roof and walls at the same time and then cut off the two wall pieces and set aside for use until required.

When cutting material always use a good pair of dressmaking or tailor's scissors. Ensure that all the cuts across the material are at right angles to the selvedge edges. This can be ensured by folding the material with the edges together or by drawing a line with soft pencil across the full width with the aid of a set-square or T-square.

to meet the shorter and bring the top piece over the two adjoining edges and crease down along the first seam. Turn the material over and seam down as shown at B.

When these three pieces of cloth have been seamed together cut off the piece for the roof and the two pieces for the walls. The two ends of the roof pieces are turned in and hemmed.

At the four corners of this roof piece strengthening patches are stitched on. They

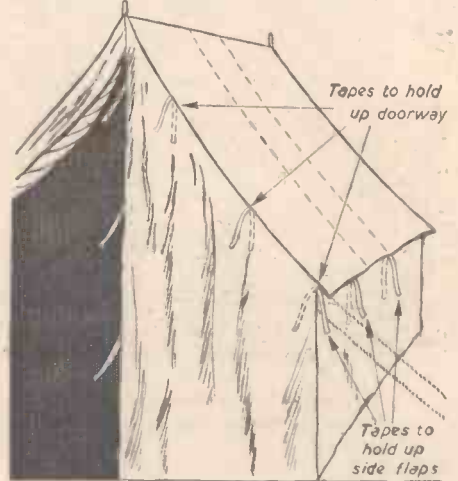
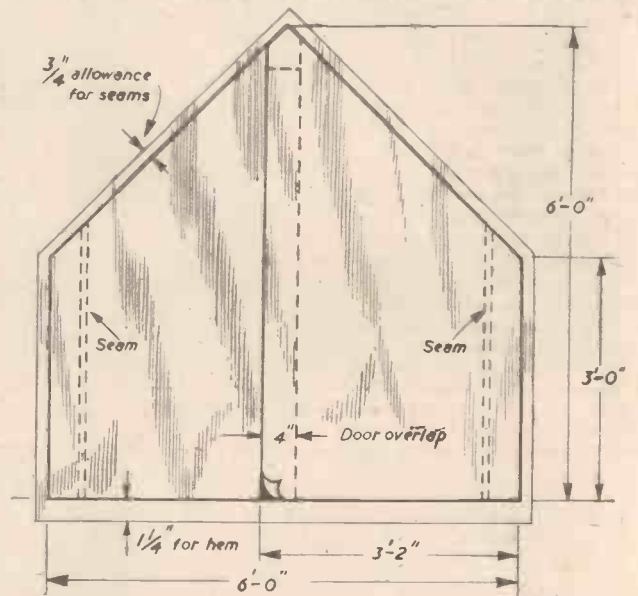

Fig. 10.—Tapes sewn in when wall is attached.

should be cut with about ¼in. for turnings all round and applied on the under side of the roof with two rows of stitching (Fig. 5).

Now fold the roof material in half to find the centre line which will form the ridge of the tent. At each end of this centre line a triangular strengthening patch should be applied to give additional strength where the



hemmed. A diagram of the flat fell seam is shown in Fig. 4 and it is done in two stages. The two pieces of cloth are seamed together as shown at A with a short overlap about a third of the longer overlap. Then turn in the longer piece

of the pole passes through its eyelet hole (Fig. 6). Additional strength will be needed along the entire ridge and for this use some 2in. width webbing. When this webbing is in place the two holes for the pole spikes may be worked.

To finish the roof at each corner and at the ends of each of the centre seams some ½in. galvanised rings are sewn on with some ½in. webbing. It is these rings to which the guy lines are secured at a later stage. It is advisable to sew the corner tapes at an angle of 45 deg. (Fig. 5).

The Ends of the Tent

Some campers like to have their tents to

open at both ends. There is perhaps some merit in the idea, but for the all-weather camper, one fixed end has its advantages as this end may always be pitched towards

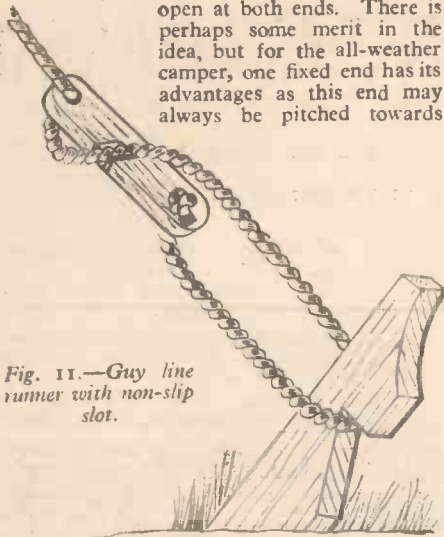

Fig. 11.—Guy line runner with non-slip slot.

the direction of the prevailing wind thus keeping the inside of the tent free from direct wind.

It is helpful to make a stout paper pattern to the exact shape of the end of the tent so that the material may be placed on it as it is seamed up. Two full widths and two narrow widths of material will be needed for the fixed end as shown in Fig. 7. Remember to make the allowances for the seams to the roof and walls and for the hem at floor level.



Fig. 12.—The cottage tent with flysheet.

The door end of the tent is made of two flaps each 38in. wide thus giving an overlap of 4in. Each flap will be made up of a full width of material, seamed to a narrow strip as shown in Fig. 9. At the ridge the two flaps are stitched together overlapping 4in. for a distance of 7in. down from the ridge. For securing the tent, door tapes are sewn on to the flaps at 6in. intervals (Fig. 10).

Fitting the Walls

The two wall pieces are now hemmed at the top and bottom ends. Make a 1in. wide hem at the bottom and a narrower one at the top end, which is then stitched in place under the eaves of the tent. When stitching on the walls it is a good plan to stitch in a 12in. length of tape, one end each side of the wall, at each end and at each seam. These tapes are used to tie up the sides of the tent during the day so that the tent may be aired (Fig. 10).

For securing the bottom of the walls to the ground some 1/2in. galvanised rings are

sewn with tape to the bottom hem of the walls on the inside of the tent.

It now remains to fit the two ends of the tent into position, first of all pinning or tacking in place and then finishing with a flat fell seam as described for making the roof.

Grass Cloth

To minimise draughts under the tent walls, a 9in. wide strip of material is sewn on the inside bottom edge of the walls. When the tent has been erected the ground sheet is placed over this strip.

These days there is a vogue to copy the method used by mountain campers of sewing a groundsheet permanently in place to the foot of the walls of the tent. The method has some advantages, but there are some disadvantages, too, for the ordinary camper.

The tent is now practically ready for erection. It is important to go over all the ends of stitching and finish them off securely so that they will not be able to come undone gradually when the tent is in use.

Guy Lines and Runners

For the guy lines, buy some Italian hemp cord of about 3/8in. dia. Each side guy will require about 5ft. 6in. of cord. Whip each end with some linen thread

slot is cut in the middle of the runner through which the guy can be passed to prevent slipping (Fig. 11). The making of these runners is a job probably not favoured by most people who would prefer to buy them very cheaply from the camp supply stores when buying the pegs.

Poles

Two 6ft. poles are needed for the tent.

No doubt the very keen practical mechanic would like to make these himself. It is doubtful if very much financial advantage

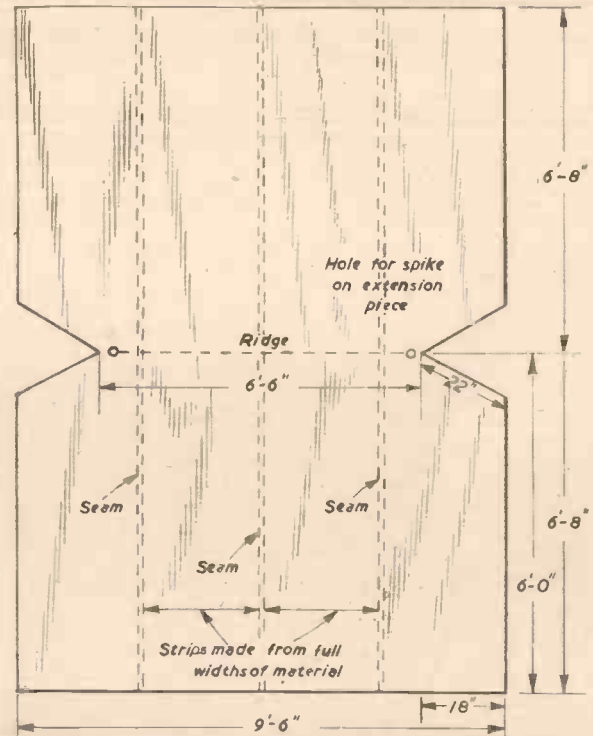

Fig. 13.—Setting out the flysheet.

to prevent unravelling.

Runners can be made from some strip aluminium 3/8in. wide and about 1/10in. thick. A hole 5/32in. dia. is drilled at each end. A

will accrue as a three piece steel pole, stove enamelled, can be bought for about 13s., as can one in light aluminium.

For supporting the flysheet over the tent two 6in. separators and a ridge pole will be needed. These can be in steel or aluminium as desired (see Fig. 2).

The tent when erected will appear as in Fig. 8.

(Concluded on page 533)



Fig. 14.—The extended porch.

THE U.S. SATELLITE PROGRAMME

Part 2.—The Satellite Orbits and Various Methods of Tracking

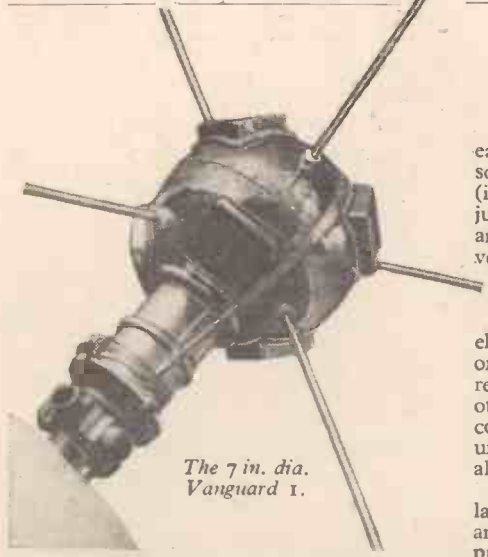

The 7 in. dia. Vanguard I.

THE initial American satellites were given orbits which took them over a broad band around the waist of the world (see Fig. 11). This band, about 4,700 miles wide, covered about 125 million square miles of the earth's surface. The orbits of Explorer I and III were at an angle of 34 deg. to the equator, and that of the first Vanguard miniature, 6.4 in. test sphere, at an angle of about 33 deg. To enable them to pass over such a large part of the earth's surface, the Explorer and Vanguard test satellites were launched in a south-easterly direction. This added both to the volume and the value of the information obtained from their instruments, and made it possible for them to be observed in latitudes where most of the world's scientific equipment is located.

Their orbits crossed the equator, so that the satellites moved back and forth between the northern and southern hemispheres. After one of them crossed a point on the equator the rotation of the earth carried this point eastward. Thus when the satellite returned for another crossing it passed a point on the equator lying farther to the west.

The Problem of Orbiting

The problem of projecting a satellite on a nearly circular path concentric with the

earth's surface requires a sufficient velocity so that the satellite's centrifugal acceleration (its tendency to fly away from the earth) will just balance the earth's gravitational pull. For an altitude of 300 miles, the required velocity is 25,034 feet per second, or slightly less than 5 miles per second. Should the velocity differ from this value, either greater or lesser, the orbit will be an ellipse with the earth's centre as one focus. Also, an elliptical orbit results from any projection direction other than tangential to a circle. The conditions for a circular orbit are unique; actual satellite orbits have all taken an ellipse.

The requirements for a satellite launching vehicle, its size, weight and performance, are governed primarily by the satellite's weight and the desired orbit. It takes 1,000

pounds of launching vehicle to place one pound of satellite in a stable orbit.

The orbit parameters of prime importance are (1) the inclination to the equator, (2) the height of perigee (closest approach to the earth) and the height of apogee (farthest recession from the earth).

The inclination is related to the choice of launching site and determines the velocity

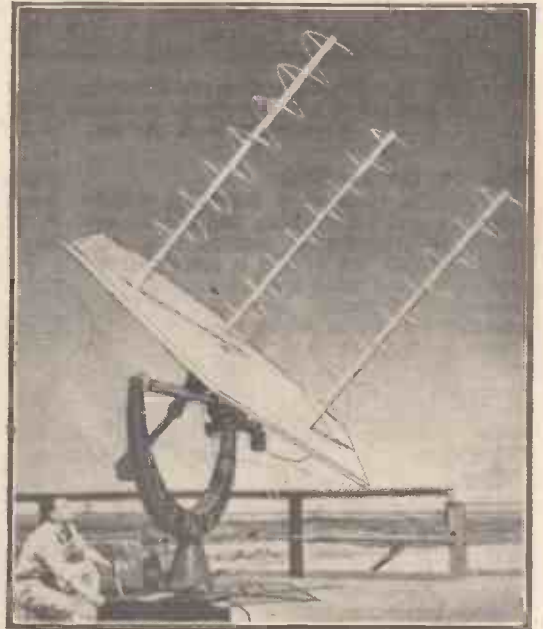

Figs. 12 and 13.—Two types of telemetry receiving antennae installed at the launching base to monitor the performance of satellite-carrying rocket flights.

imparted to the launching vehicle by the earth's rotation. This earth rotational velocity is a gift, so to speak, of which the launching vehicle may take advantage by favourable choice of launching site and direction. Obviously, the best condition would be to launch

due east at the equator, in which case the velocity gift would be 1,515 feet per second. The velocity decreases with latitude becoming 1,340 feet per second for an eastward launching from Cape Canaveral, Florida (28° 28'N. latitude) the site chosen for Vanguard. However, an eastward launching from this site gives an inclination of 28 deg.

The minimum perigee has been established at 200 miles. An altitude of 300 miles is assumed as the nominal projection height. For a given projection altitude, the perigee is determined by two factors—the projection velocity and elevation angle.

From the foregoing it is apparent that the orbit requirements involve a balance between velocity performance and guidance precision—the more velocity available, the less precision required. A launching vehicle that had only a small margin of excess velocity would need a very precise guidance system.

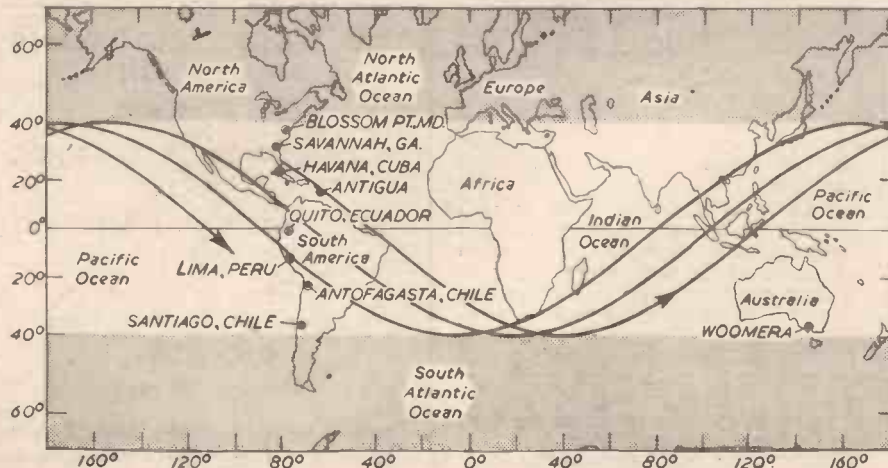

Fig. 11.—The orbits of the first U.S. Satellites and positions of the "Minitrack" observation stations.

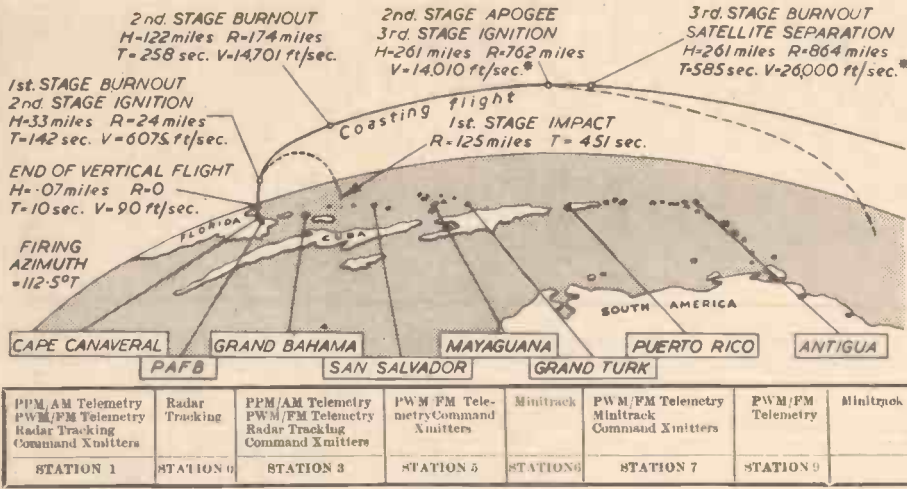

Fig. 14.—Trajectory data and Electronic Ground Station locations. H=Altitude in nautical miles; R=Range in nautical miles; T=Time elapsed in seconds; V=Velocity in ft. per sec. *=Relative to inertial axis.

Tracking the Satellites

From the moment a launching vehicle leaves its pad, both vehicle and satellite are locked to ground-radio stations (Fig. 14). At the outset, the vehicle is monitored by ground stations using specially-developed electronic systems, antennae for two of which are shown in Figs. 12 and 13. When the satellite begins its free flight in space, its location is continually pin-pointed by both radio tracking and optical observation.

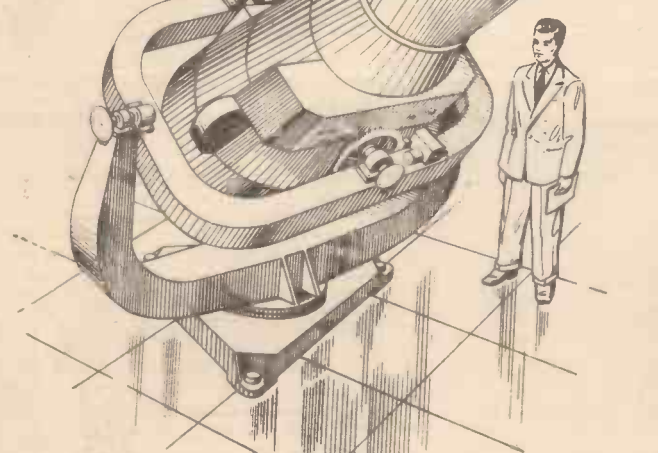

Fig. 15.—The Baker-Nunn satellite-tracking camera.

Information received by radio during the early revolutions of each satellite is fed into high-speed electronic computers, and quickly establishes the approximate orbit. Observers throughout the world can then train their instruments on the satellite, and telescopic cameras can make photographic measurements of its position.

The radio tracking is carried out by a system known as Minitrack, developed by and operated under the supervision of the United States Naval Research Laboratory. This system has the advantage of being relatively free from interference by weather conditions. It makes fast observation possible.

The most precise optical observations are made by Baker-Nunn telescopic cameras (Fig. 15), working under the direction of the Smithsonian Astrophysical Observatory.

These cameras are so accurate that they can measure a satellite's position to within 25 ft. along the direction of travel and to within 10 ft. of either side of its course.

Pictures taken by these cameras will also enable scientists to make precise measurements of "bulges" in the earth's surface.

Radio Tracking

Although the power output of the satellite's tiny Minitrack transmitter is only 20 milliwatts—a thousandth of that consumed by the smallest electric light bulb in common domestic use—yet its signals can be picked up four thousand miles away.

To receive these messages, a network of 10 powerful radio receiving stations has been set up to cover the zone across which the satellites are to pass during their circuits of the earth.

Minitrack stations are located in or near Washington, D.C.; Savannah, Georgia; Havana, Cuba; Antigua, British West Indies; Quito, Ecuador; Lima, Peru; Antofagasta, Santiago, Chile; San Diego, California; and Woomera, Australia. See Fig. 11. Observations

from all these stations are fed to central computing bureaux at Washington and Cambridge, Massachusetts. The Governments concerned have been fully co-operative in all arrangements.

Eight arrays of 46-foot antennae at each Minitrack station pick up the signals; electronic equipment then fixes the position of the satellite. By comparing the path length from one transmitter to one antennae with the path length from the transmitter to a second antennae, it is possible to locate the satellite in its orbit, determining its angular position by radio phase-comparison methods. Similar measurements with another set of antennae, at right angles to the first, help to fix the pattern accurately.

The pattern of the Minitrack antennae is fan-shaped and, at satellite heights, the beam is several hundred miles wide. In

this way, stations stretching in a chain from latitude 35 deg. north and south are able to track the satellite.

Optical Tracking

The Baker-Nunn satellite-tracking camera (Fig. 15) is a wide-angle telescopic camera of the Schmidt type. The optical system consists of a 31in. spherical mirror and three 20in. correcting lenses. Strip film is stretched over a curved surface at the focus of the mirror. The camera can be turned to face any part of the sky and operation is automatic once the controls have been set in accordance with the satellite's expected orbit.

The camera takes two pictures on each strip of film. The first is taken while the camera is fixed on and following the satellite, with the time to the nearest 0.001 second recorded on the picture by a crystal clock. The second exposure is made while the

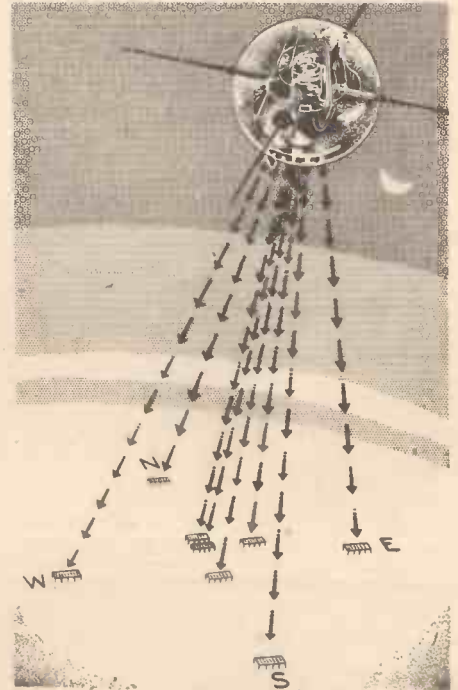

Fig. 16.—Tracking in operation.

camera is fixed on back-ground stars and moves with them thus providing a point of reference for locating the satellite. There are twelve optical tracking stations using this type of camera.

This information is reproduced by permission of the U.S. Information Service.

FOR THE MODEL MAKER

THE MODEL AEROPLANE HANDBOOK
12/6 (13/7 by post)

MODEL BOAT BUILDING
5/- (5/9 by post)

THE HOW-TO-MAKE-IT BOOK
12/6 (13/9 by post)

RADIO CONTROLLED MODELS
12/6 (13/6 by post)

From George Newnes, Ltd., Tower House, Southampton Street, Strand, W.C.2

Building a Wood Planer

Full Constructional Details of a Versatile Machine for the Woodworker

By "Josev"



THIS miniature planing machine is of the type known in England as a surfacer for the rather obvious reason that it produces a smooth, true surface on any rough piece of wood. The high speed cutters can deal effectively with crossgrained timbers, and those of "Striped" grain such as Obechi, Sapeli mahogany and Merranti, in which the direction of grain changes with every stripe, and which are extremely difficult to work with hand planes. In addition to straight-forward planing the machine can be used for chamfering, stop chamfering, rebating and for tapering table legs and similar articles.

Description

This is for the benefit of those who may not be familiar with the principles of wood

will be noticeable as a series of ridges giving the work a corrugated appearance. To obtain a good finish a fine feed is essential together with a high rate of revolution at the cutter block. The recommended speed is about 5,000 r.p.m. and a 1/2 h.p. motor is required to drive it at this speed.

General Construction

The machine illustrated is constructed mainly of hard wood and this has proved perfectly satisfactory. The wood must be close grained and well seasoned. Beech or maple are excellent. Birch would also be satisfactory. The various metal parts are made by

bending them out of steel rod, or they could be made up by a local garage or blacksmith. It is not recommended that the cutter block be made by the constructor. This requires some very precise machining in order that the cutters may be securely locked and dynamically balanced. If this is not done there is great danger of cutters flying out at speed, possibly causing a serious accident. A suitable

above the motor can be enclosed with plywood panels, and fitted with a door, forming a useful cupboard in which to keep spare cutters, sharpening stone and spanners, etc. It might be thought that the 3ft. in. tables are unduly long overall, but this is a valuable feature of this machine. The longer the tables the more accurate the planing. In some commercial models the tables are as long as 6ft. The fence, mounted on the lead-on table, is used when it is required to square up the edges of boards as is being done in the heading photograph. Two very important features

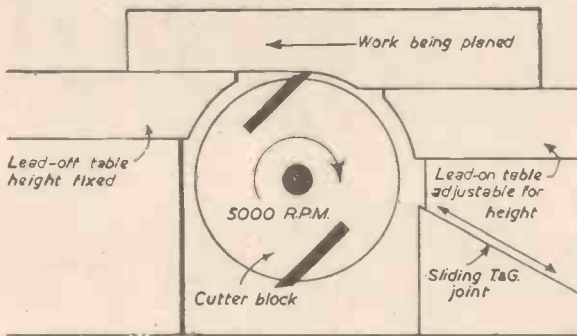

Fig. 1.—How a wood planing machine works.

planing machines. The front table, or to avoid confusion, the "Lead-on" table, is adjustable for height so that heavy or light cuts can be taken off the wood. The back, or "Lead-off" table is of fixed height, this height being exactly the level of the planer knives when they are in their highest position. The wood to be planed is placed on the lead-on table and fed slowly and firmly over the top of the rapidly revolving cutter block. Firmly fixed in the cutter block are two sharp, flat cutters, or knives, each of which cuts a little chip from the wood, thus producing what is, for all practical purposes, a flat surface, see Fig. 1. If the wood is fed too rapidly, the cuts made by the knives

cutter-block assembly, complete with a one-piece bearing casting fitted with ball bearings, and a guard and Vee pulley, can be purchased from S. & G. Sergent, Old Costessy, Norwich, Norfolk. This unit is shown in Fig. 2.

The complete machine, mounted on a suitable stand, is shown in Fig. 3 and, in section, in Fig. 4. The shavings bin indicated is a useful feature. It is simply a light plywood box placed so that the shavings fall into it instead of spreading all over the floor. The contents are emptied out at suitable intervals. The vacant space

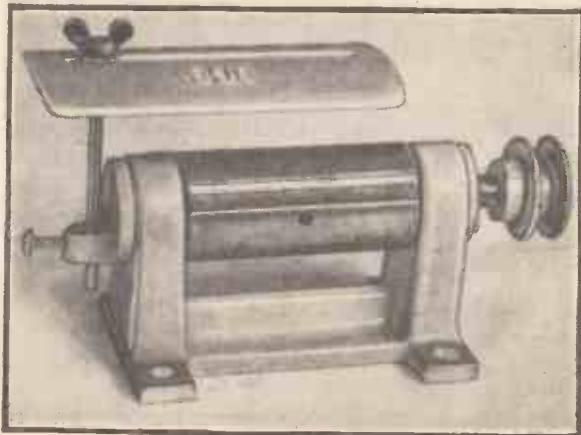

Fig. 2. (left)—The complete cutter block assembly.

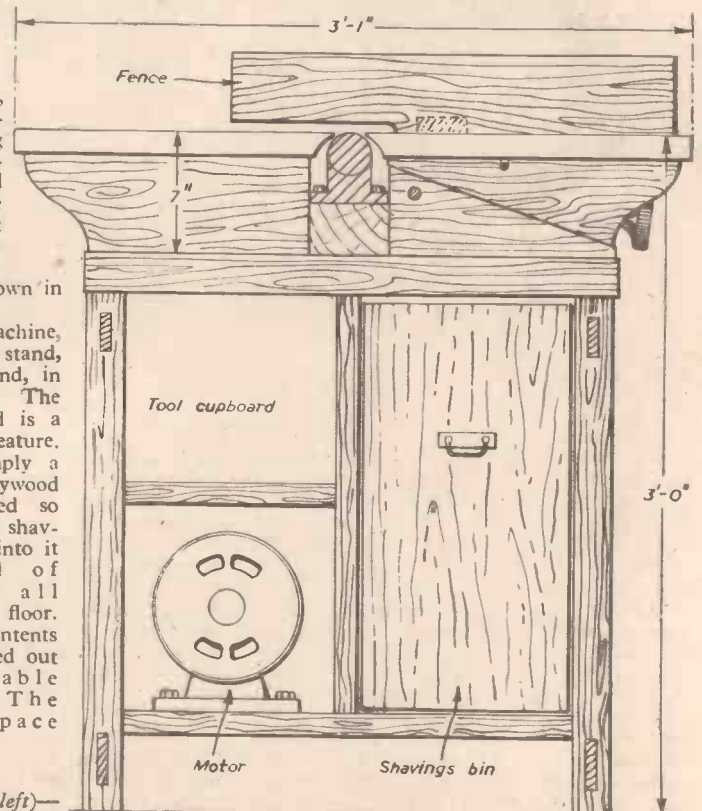

Fig. 3.—A front view of the planing machine mounted on its stand.

in a planing machine are rigidity and stability. Rigidity is obtained by screwing and gluing the various members together, using a resin or a P.V.C. glue; stability by spreading the legs of the stand apart, using heavy timber for the stand, and by placing the motor low down in the frame. These measures dispense with the need to secure the machine to the floor as would otherwise be necessary.

Woodwork Details

The details of the wooden portions are shown in the exploded view (Fig. 5). The base is 2ft. 4in. long \times 7in. wide \times 2in. thick. A packing block 4in. wide and approximately 3in. thick (precise thickness will be determined later) will be fitted in the centre of the length of the base. Immediately in front of this a square hole is cut through the base 4in. wide and 4in. long to allow the shavings to drop through the base into the bin. A 2in. long \times 4in. wide slot is cut at the other side, midway between the packing block and the end of the base. This slot is for the bolt which holds down the lead-off table, and it allows this table to be slid back from the cutter block when it is necessary to sharpen the cutters.

The lead-off table is 18in. long \times 7 1/2in. wide \times 1 1/2in. thick. One end is cut to an angle of 45 degrees, and this bevelled cut hollowed out a little to clear the circular path of the cutters when it is pushed up close to them. The table is glued and screwed down to the boxed support formed of two sides 15in. long \times 5 1/2in. wide \times 1 1/2in. thick, with 1in. thick spacers housed in, glued and screwed. These spacers should not go right down to the bottom, but should be kept about 1in. narrow to allow a space under-

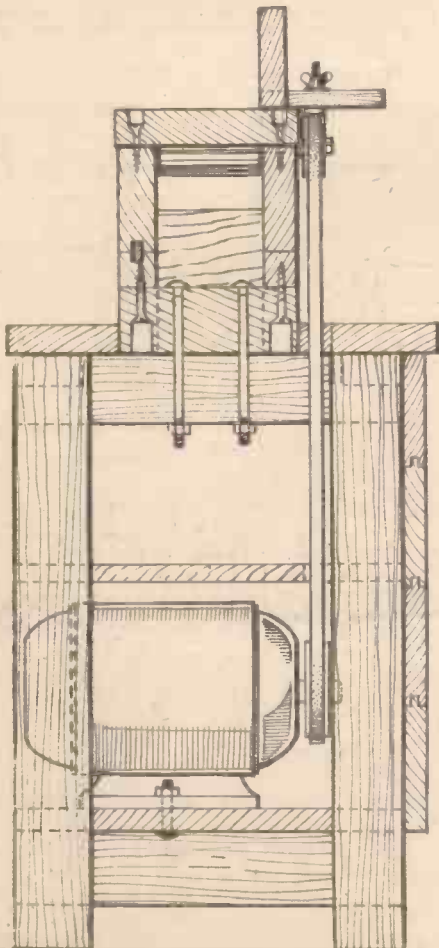

Fig. 4.—Sectional view of the planing machine.

neath for stray shavings to escape. A 2in. \times 2in. block should also be housed in to receive the bolt which holds this table down to the base. The screws which hold the table top down to the boxed support should be sunk about 1/2in. below the surface and covered with wood plugs glued in and dressed off level.

The lead-on table is similar in size and shape to the lead-off table, but it is necessary to have a rise and fall adjustment so as to enable the cut to be varied when the machine is in use. Fig. 6 shows the method adopted to enable this rise and

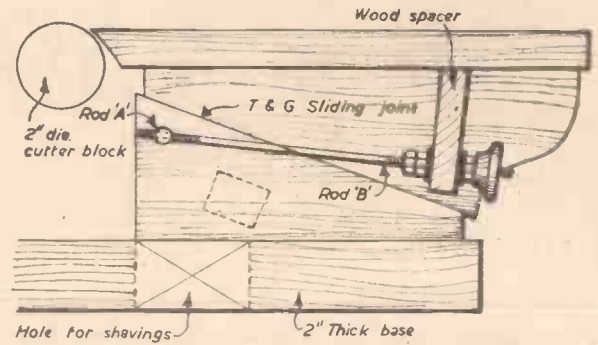

Fig. 6.—The rise and fall adjustment for the lead-on table.

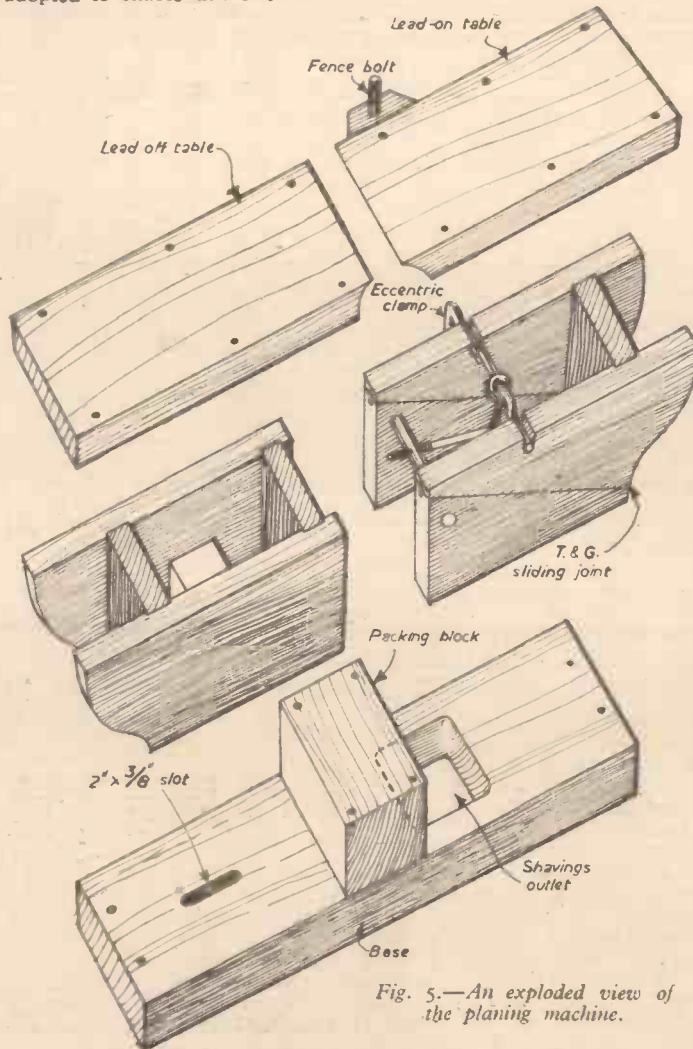

Fig. 5.—An exploded view of the planing machine.

fall adjustment to be made. The two side supports are cut across on the slope as shown. The exact angle of slope is not important, but it is essential that the two slopes are straight, square and "out of twist" with each other. To keep the upper and lower portions of the support in line with each other a tongue and groove joint is made in the front piece. This is done by working a groove in each piece, and gluing a hardwood spline, into the lower piece. This tongue and groove joint must slide smoothly and easily, but without any side play.

The table is adjusted for height by means of the screwed rod and hand-wheel "B" working in a tapped hole in the short cross rod "A." As the handwheel is turned in a clockwise direction, the table slides up the slope thus raising the table whilst still keeping it level. When the handwheel is turned

anti-clockwise, the table is lowered. However, the table is still loose, and some method must be found of clamping it firmly down when the necessary height adjustment has been made. An eccentric clamp is quicker than a screw clamp, so this was the method adopted. It is shown separately in Fig. 7 so as to avoid confusion with the rise and fall gear. The 3/4in. dia. steel rod "C" passes through bearings in both side pieces. It is extended at the back and bent to form a handle. The centre portion of this rod, between the two side pieces, is bent about 1/4in. out of line so that when it is turned it revolves eccentrically. The hooked rod "D" is looped over the eccentric portion of rod "C," and its lower end is threaded and fitted with a nut and washer bearing against the hardwood spacer tenoned in between the lower side pieces. This nut may be tightened so as to clamp the two portions of the lead-off table together, but a simple movement of the eccentric rod handle releases the clamp to enable

the table height to be adjusted. A close examination of the rise and fall gear (shown in Fig. 6), and the clamping gear (Fig. 7), will show that if rods "B" and "D" are both in the centre of the machine they will interfere with each other. To avoid this they are both spaced 1/4in. from the centre, one one way and one the other, as detailed in Fig. 8.

The lead-on table is glued down to the 2in. thick base and screwed into position with long screws passing up through the base into the side supports. The lead-off table is secured in position by means of a 3/4in. dia. bolt passing down through the 2in. \times 2in. block provided for it, through the slot in the base. A wing nut and washer underneath the base provide a ready means of clamping this table down. The slotted hole in the base is to allow the lead-off table to be slid back out of the way when it is required to change

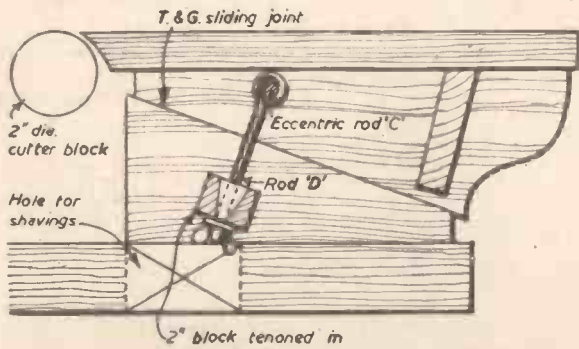

Fig. 7.—The eccentric clamp for the lead-on table.

the cutters or to sharpen them. To keep this table parallel thin sliding ribs can be glued and screwed down to the base. The wing nut is accessible from the tool cupboard, and it must be kept screwed up tightly whenever the machine is in use.

If the setting out and the cutting of the various parts has been done accurately the two tables should be straight in line with each other and level across. Check this by laying a straight edge across them. Screw the adjustable table up or down, as may be required, until the two tables are as near as possibly level. Any discrepancies can be corrected by planing the table tops with a hand plane, preferably a long trying plane. It is of supreme importance that the finished tables shall be perfectly straight, true and level. Any inaccuracy in this respect will be reflected in similar inaccuracy of every piece of work planed. Care should be taken to ensure that the gap between the two tables is as small as possible. This is a safety precaution to prevent fingers being damaged. It should be possible to maintain a gap of not more than 1in.

Fixing the Cutter Block

The finished table height determines the exact height at which the cutter block must be fixed. A hardwood packing block must be prepared, 7in. long, 4in. wide and about 3in. thick. The thickness must be adjusted, by planing, until the solid portion of the cutter block (not the cutters) is 3/32in. below the table surface. The cutter block is bolted down, through the packing, to the base with four 6in. long \times 1/4in. dia. bolts.

When the cutters are inserted into the block they should project not more than 3/32in. This projection can be adjusted by tapping the cutters farther in by means of a hammer and a hardwood block, or, if they are too far in they can be tapped out by means of a pin punch (supplied with the cutter block) working through holes drilled in the block at the back of the cutter slots. The projection must be adjusted so that each cutter just scrapes the edge of a straight edge held on the lead-off table, when the cutter block is revolved by hand (Fig. 9). The projection must be checked at both ends of the cutters.

The Fence

A fence is necessary to hold the work square when planing the edges of boards for jointing. This is shown in Fig. 10. It consists of a hardwood board 24in. long, about

4in. wide and 1in. thick. Into the base of this is slotted a sliding piece, screwed and glued at right angles to the fence, and projecting at the back. This sliding piece is 6in. long \times 3in. wide \times 1/4in. thick. It is slotted to slide over a 1/2in. bolt. It is necessary to pass this bolt through a small piece of hardwood glued and screwed to the back edge of the lead-on table. This projection is to enable the fence to be pushed back, leaving the whole width of the cutter block useable. The fence is secured in position with a wing nut and washer. It is

The Motor

A suitable half-horse-power motor is bolted down to the lower shelf through slotted holes to allow for adjustment of belt tension. The motor pulley must be of such a size that it will drive the 2in. diameter cutter-block pulley at about 5,000 r.p.m. The belt is an endless Vee belt of 1/2in. section, and its tension should be adjusted so that it runs without "whipping." Too tight a belt only wastes power, and is liable to cause wear on the bearings. A control switch should be mounted in a convenient position on the machine so that the motor can be switched off immediately in an emergency. A long 3-core lead, which can be connected to any 5-amp socket, will be found very handy because this enables the machine to be moved to any convenient position. When a stack of timber has to be planed it is often quicker to move the machine to the timber than vice versa.

Finishing

All the woodwork, with the exception of the table tops, should be sanded down and given two coats of good quality paint. This is not only to improve the appearance, but also to prevent moisture being absorbed into the wood, and so avoid warping and twisting. The table tops are subject to a great deal of wear, but if they are treated by applying raw linseed oil at intervals, well rubbed in, they will acquire a highly polished and wear-resistant surface like the soles of the old time craftsman's wooden planes. A better method is to cover the table tops with steel plates screwed down to the wood. The only snag with this method is that any warping which may occur throws the plates out of line and this is not easy to correct. If steel plates are fitted it is advisable to wait at least six months to enable the wood to "settle down." Then the plates can be screwed down with a good chance that they will remain true.

Modifications

The machine illustrated and described here is of a small size suitable for the home workshop. The 4 1/2in. wide cutter block will cope effectively with most of the woodwork

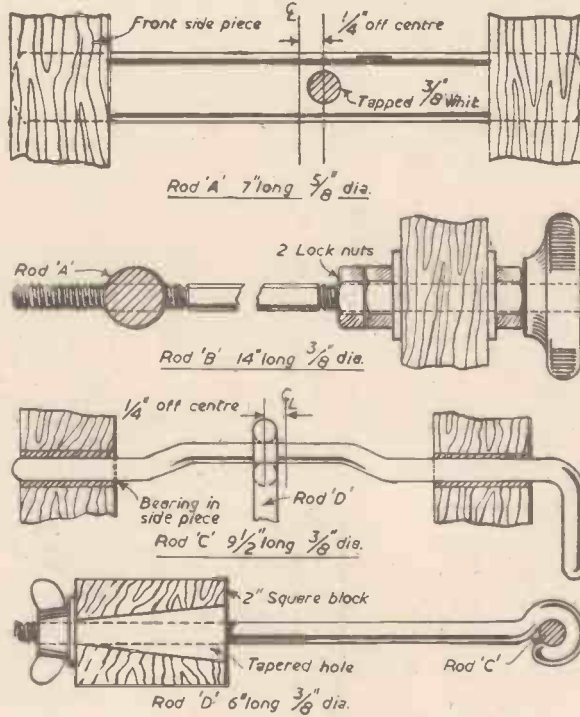

Fig. 8.—Details of the rise and fall gear and the eccentric clamp.

set parallel by eye. When planing certain varieties of wood it is an advantage to slew the fence a little out of parallel with the table top, thus giving a shearing cut across the grain.

The Stand

A substantial, heavy stand is essential to prevent vibration and to ensure stability. The one shown is made from 3in. \times 2in. hardwood, in the form of two end frames mortised and tenoned together, glued and wedged. A strong shelf is well screwed to the bottom rails to carry the motor. The base of the planer is bolted down through the top rails, and 1in. boards screwed down at either side of the base. It will be noted that the stand projects in front of the planer. This is to enable the length of the motor to be accommodated within the stand. The projection forms a handy shelf on which a number of pieces can be placed awaiting their turn to be planed. The back of the stand may be covered in with either tongued and grooved boards or with stout plywood, well screwed or nailed on, to prevent "racking." The two ends may also be covered in. A central upright division of tongued and grooved boards is fitted, also a shelf over the motor to form the tool cupboard. A guard, in the form of a plywood box, is also necessary to cover the portion of belt exposed at the back of the machine above the stand.

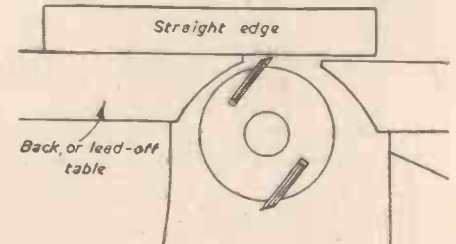

Fig. 9.—Setting the projection of the cutters.

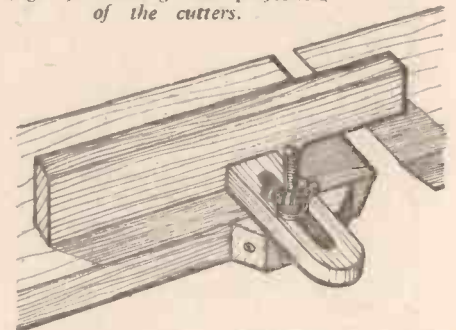
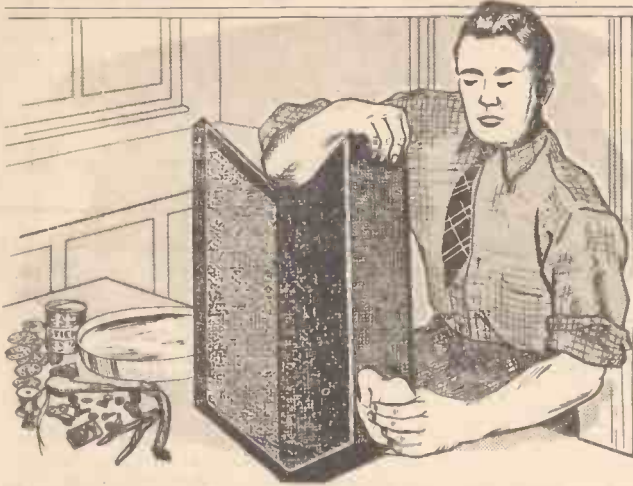

Fig. 10.—Back view of the fence.

handled by the amateur woodworker. If a bigger machine is required, cutter blocks of 6in. and 8in. are available. In addition a 3in. dia. cutter block can be fitted to the unit by the makers, at an extra cost. This enables rebating to be carried out to a depth of 1/4in.

Attaché Case Repairs



How to Restore Them to New Condition By John Dee

but are leather covered can also be cleaned as above, though treatment must not be quite so vigorous, especially at edges where a cross-section of the material is open to the air. With these cases it is definitely best to finish with a coat or so of leather varnish, as they will not stand up so well to vigorous rubbing.

SEVERAL materials are used to make the small, general utility carriers that come under the generic name of "attaché cases," but the true article is always made of leather. Other substances used are:—
(a) Cardboard with a thin leather covering.
(b) Compressed card, glazed to give a weatherproof surface.
(c) Compressed fibre—also glazed.

If glossed cardboard or fibre is the material, then the wiping over should be of the lightest, the cloth being kept fairly "dry" throughout. This cleaning, as before, will remove unsightly marks; when everything is as fresh as possible, apply leather varnish.

Cleaning and Polishing

Start renovation operations by giving the case a good general cleaning. This, it may be found, is really all that is necessary to bring a rather delapidated article back to a state of presentability.

If the case is of real leather throughout, scrub with soap and warm water, sponge with water only and finally wipe over with a solution made by dissolving about two pennyworth of oxalic acid in ¼ pt. of warm water. The main point is that the surface of the leather must be thoroughly dampened before applying the oxalic acid—the whole effect of the cleaning depends on this. Water will not harm the leather.

Let the case dry out perfectly by natural means; do not put it near a fire. Drying this way make take some little time, depending largely on the state of the atmosphere, but when the drying is completed, give a good application of any leather or wax polish. Brown boot polish or floor polish will do quite well. Finally polish in the usual way with a soft cloth till a glossy surface has been secured. One point to be noted is that the washing and acid application must be *even* all over the sides, ends, top and bottom of the case. Patchy cleaning looks very unsightly.

On the market are solutions known as "leather varnishes," and one of these may be applied in lieu of the polish. These varnishes preserve the leather, but the boot and floor polish methods are quite effective in this direction also.

If while doing the cleaning you come across a very stubborn stain that refuses to disappear, try treating it with a strong solution of oxalic acid. Rub steadily, *but only on the stain*. If the surrounding leather is worked on, an over-light area may result, which can look as bad as the stain.

If the main trouble with the leather is that it has become dry and hard through many years' use and too much exposure to heat, give several applications of olive oil and then polish as just described, working in an extra liberal coat of the agent in question so that it penetrates deep into the surface.

Attaché cases that have a cardboard base

Initials

Initials on the side improve a case. If there are no letters, then it is worth put-



Fig. 1.—How to draw initials.

ting some on, or if there have been letters which have got rubbed away, time spent on their renewal is time well spent. Letters can be added after the polishing, using matt black and a small brush. If new letters are being put on, outline these with a fine pencil first. Fortunately, attaché-case letters are always of the square type, which are easy to draw, as the lines of all the angular letters can be ruled (see Fig. 1)

Repairs should be done after a first general clean, a second and final clean being given when the repairs are finished.

Corners

In most cases corners give trouble first. If they have become very ragged new corner-pieces should be put on. A saddler will

sometimes be able to sell you these pieces ready made, and they are fixed by running a copper rivet through each of their faces and the underlying leather. New caps can, however, be made from not too thick circles of leather. Shape first as shown in Fig. 2. Bought corner-pieces are pressed out of one sheet of leather, but made ones leave a gap along one edge, so only giving strength along two faces. Unless the corner is very bad, however, this gives all the tidying up necessary.

Prior to putting on either type of corner, any broken stitches up towards the corner should be repaired. Employ a wax thread and use the original stitch holes in the leather. Should the holes have become filled up, clear them out with a fine awl, aligning two at a time as the row proceeds. Other places that often need stitching are the edges of the handle and the leather pieces which sometimes hold the handle rings. The method of stitching is shown in Fig. 2

Handles and Fittings

Sometimes the handle rings themselves give trouble by opening up. Press them together with a pair of pliers and when in contact apply a touch of solder to the ends. Thus treated they will give no further trouble.

Handles are usually fastened by metal plates, or, as just mentioned, by leather sections. The latter are generally stitched on but sometimes are stitched and riveted. The plates are always either riveted or held by tabs that pierce the material and turn up on the under side.

With constant use, both plates and tabs have a knack of pulling away. Where there are rivets the plates can be tightened by putting a strip of tinplate on the inside of the case and then fitting new rivets (readily obtainable at a saddler's). Should there be metal tabs that turn under, carefully straighten these and after putting a strip inside, in which are holes for the tabs, push through and again bend over (Fig. 2). When the metal plates pull away or become loose, the holes in the leather invariably have become too large, but this is cured by the strips on the inside. If there are stitches also and these have broken away, renew as with the corners. When putting on new rivets the inside strip can be part of a pan-mender with the centre hole enlarged enough to take the rivet, or it can be just a suitably sized thin washer. When inside strips have been fitted it is a good idea to reline that part of the case and so hide them.

(Concluded on page 519)

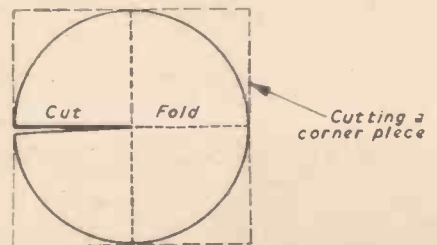

Fig. 2.—Fitting a new handle plate, making a leather 'corner' and stitching with two lengths of thread.

IS THE EARTH HOLLOW?



Although Most People are Willing to Accept the Theory That We Live On the Outside of the Earth, There are Some Who Argue Against It

addition some phenomena which have baffled astronomers and other scientists are cleared up in very elegant fashion.

Field Theory of the Universe

What, then, is this field theory? Accord-

find it interesting to try a few transformations for himself.

This process is known as inversion geometry, and apart from its application to the "inside concept" of the universe, it is a very interesting field of study in itself.

To most people the very thought of questioning the facts of astronomical science seems almost like sacrilege. Who, for instance, would question that the earth is a planet which travels in an elliptical orbit around the sun: or that it is a solid oblate spheroid? These things are accepted generally, and form the basis for many logical deductions which are in turn accepted as facts, especially as these deductions agree very well with observation.

From time to time, however, there arise attempts to challenge these fundamentals. For instance, some years ago the "Flat Earthists" had a considerable following, but of recent years we have heard very little of them.

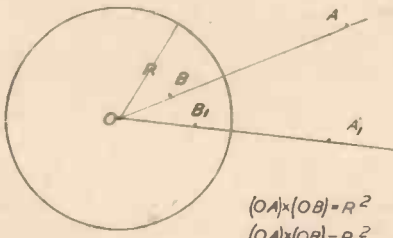

Fig. 1.—The basis of the field theory.

Since the advent of Einstein and Planck, scientists have been a little less sure of themselves than they were at the close of the last century. Astronomy has "grown up," and is reaching that mature state of mind when it realises how much it does not know. Theories which had come to be thought almost axiomatic are coming under critical scrutiny, and new theories of quite a revolutionary character are being quite calmly studied.

The "Inside Concept"

Possibly the most revolutionary of these is what has been called the "inside concept," with which is associated the field theory of the universe.

According to the "inside concept" the earth is a hollow oblate spheroid, of the shape and size accepted in orthodox geodesy and astronomy, but with a concave instead of a convex surface.

This at first sight appears quite ridiculous yet when the theory is studied it is found that actually it is quite feasible, and well worthy of careful examination.

Immediately the "inside concept" is mentioned, dozens of objections to it are apparent. The well-known phenomenon of the ship disappearing "hull-down" on the horizon. Why cannot we see right across to Australia? Where are the sun and the stars, and why are we not burnt up by their heat if they are contained within the hollow earth? The shape of the earth's shadow on the moon; and so on.

These and a hundred other objections are easily explained by the field theory, and in

This provocative article was published originally in our issue dated March, 1938, and is reprinted here in response to a steady demand through the years. Our readers may like to write exposing the fallacy of this theory or, perhaps, supporting it.

ing to this theory, the earth is a hollow sphere, on the inside surface of which we live, and the sun, stars, and other heavenly bodies are near the centre. The space inside this sphere is not, however, euclidean space, as we presume the space outside our earth to be under orthodox theories, but increases progressively in density towards the centre according to a very simple mathematical law. This concentration of space has the effect of refracting light and other forms of radiant energy in such a way that objects near the centre are magnified through 180 degrees.

The basis of the field theory is illustrated in Fig. 1. If a point, A, outside a circle is taken at a distance OA from the centre, it is obvious that another point, B, can be found inside the circle, at a distance OB from the centre, such that (OA) x (OB) is equal to the square of the radius of the circle. The point B is then said to be the geometrical inverse of the point A.

In a similar manner any number of points outside the circle can be transferred to the inside as geometrical inverses, and so lines and figures outside can be transferred inside. Fig. 2 shows how this transformation appears for some simple figures. The reader will

Geometrical Inverse of Infinity

One or two points about the type of field this inversion geometry produces inside the circle are immediately apparent. In the first place it will be seen that for every point outside the circle there is a corresponding point inside, so that the whole of the infinite space outside can be got into the space within the circle. Again, it can be seen that

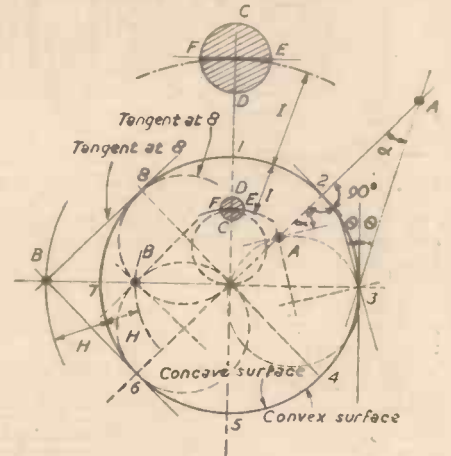
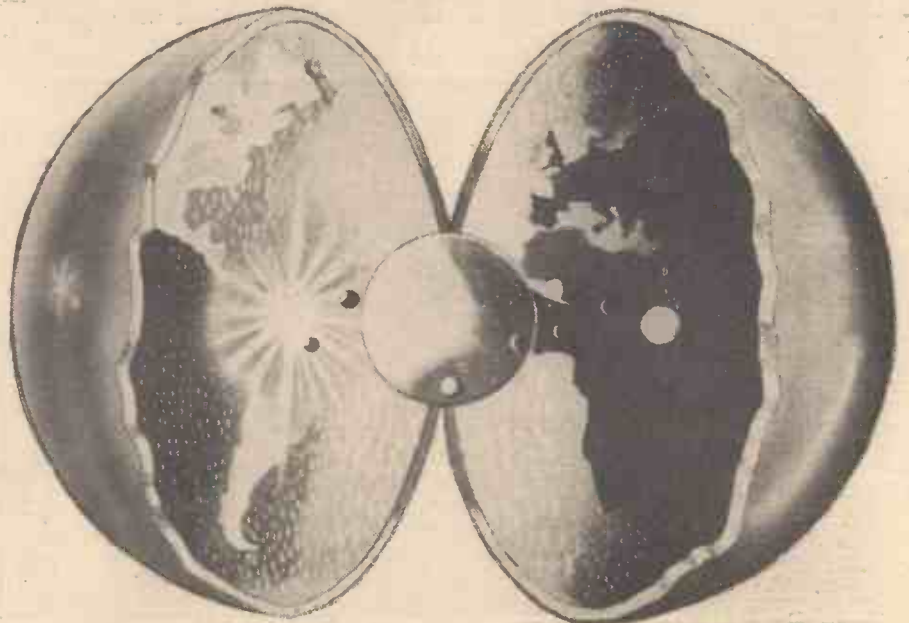

Fig. 2.—Transferring a number of points on the outside of the circle to the inside.

as the point A recedes from the centre, the point B approaches it, but B only reaches the centre when the point A recedes to infinity; therefore, the centre is the geometrical inverse of infinity.



A pictorial representation of the field theory of the universe.

A further and most important point which is not at first apparent, but follows logically, is that if lines of sight outside the circle are transferred inside, their directions as seen by an observer on the surface are not altered. Thus, if we imagine an observer on the outside, i.e., in orthodox space, at the point 3 (Fig. 2), he sees an object, A, at an angle (θ) above his horizon. His geometrical inverse on the inside sees the geometrical inverse of A at the same angle (θ) from his horizon.

The reader can check this up with other angles and arrangements, and he will find that in so far as angular observation is concerned the observer has no means of telling whether he is on the inside or the outside.

Strange as it may seem, there is evidence to support the belief that the surface of the earth is indeed concave instead of convex.

One phenomenon which has long puzzled scientists is the observed fact that the cosmic rays appear to fall perpendicularly on the earth's surface wherever they are observed. This would be easily understandable if the

earth were a hollow sphere and the source of the cosmic rays were at the centre.

An Elaborate Experiment

It may not be generally known that in the year 1897 a very careful and elaborate experiment was carried out in the U.S.A. to determine the curvature of the earth without optical aid. This development was devised by Prof. U. G. Morrow and was carried out by a staff of experienced geodetic engineers. It consists in producing a straight line 3,800 metres long (4,180 yds. approximately) by purely mechanical means, and measuring the offsets from this line to a "level" line produced by means of mercurial levels.

This experiment gave the astonishing result that the physically straight line approached the level line, and the offsets agreed almost exactly with a concave curvature equal to the convex curvature which would be expected under orthodox assumptions.

In this experiment the most scrupulous

care and the most elaborate precautions were taken to eliminate all possible sources of error and, finally, it was repeated in the opposite direction to check the results, which were found to be correct.

A Remarkable Case

Another remarkable case occurred at the Calumet Mines, Michigan State, U.S.A., in 1901. In connection with certain works which were being carried out, two plumb-lines were dropped down two deep shafts (4,250ft. deep) and the distance between their lower ends was carefully measured and was found, to the astonishment of all concerned, to be greater than the distance between their upper ends. This so puzzled the engineers that they called in the Geodetic Survey Department of the U.S. Government, whose representative verified the measurements, but could not explain them.

Whether the inside concept is true or not, it is a very interesting theory, and it is hoped that these notes may stimulate some investigation on the subject.

• ELECTRO-GRAVITIC LIFT •

THE fundamental difference between this source of aerial lift and all others is that, whereas the latter depend on some form of aerial reaction, this new source of lift is independent of the air.

Whether we use planes, vertical propellers, or rotating cylinders, the effort in each case aims at overcoming the downward pull of gravity. Each known method of overcoming this pull gives an indirect solution of the real problem, more or less effective, but still not by direct action on gravity itself.

The new source of lift derives from direct action on gravity through a newly discovered method of applying electrical energy to that end, this having followed from continuation of a research initiated by Faraday a century ago which sought a connection between electricity and gravity.

Clearly, once this connection is known, with unlimited electrical power available a wide field of practical utility is opened up, in which its applicability to aviation is of prime importance.

After many hundreds of costly experiments, the connection was discovered in 1908, but, thereafter, many hundreds more were needed before the electrical factors implicated

were known with sufficient certainty. Even now there are technical difficulties to be overcome before these factors can be raised to values that will give a lift of the magnitude required in aviation.

Briefly, the present position can be thus stated. It has been found that: $L=ABC$ where L is the lift, A and B the factors implicated and C a constant based on hundreds of quantitative experiments. This relation holds so accurately for all easily reached values of A and B that extrapolation may be considered justifiable; and giving them values that are commonplace in other

This description by W. D. Verschoyle was first published in our February, 1942, issue, and is reprinted here in response to many requests from readers. It is of even greater interest to-day when it may provide the answer to the question of the flying saucer's power unit.

electrical departments it can be shown that L should easily reach 116 lb. per h.p. correctly applied.

Furthermore, the theoretic limit which L approaches as the values of A and B are raised is many times greater than 116 lb., for the eventual limit may be expected to come, not from the values of A and B, but from limitations of gravitic response. But astronomers assure us that this response may be thousands of times greater than anything known on this earth, and consequently the limit of L may be far above any practical value the aviation engineer will demand.

For reasons which will be obvious, it is not deemed advisable to publish full details

of electro-gravitic methods beyond indicating briefly how the problem has been attacked.

A new working theory of material constitution had first to be formulated, under which gravity becomes the principal binding force, not only in the macrocosm, but also in the microcosm. Under the guidance of this theory, the gravity field existing between the earth and any external mass of matter, such as an aeroplane, became the point of attack. Some new kind of ray had then to be found capable of affecting this field, and in what are called Y-rays here, the necessary agent was found. These rays have extraordinary characteristics, but are of such a nature that their generation presents only small technical difficulty in design and manufacture of the necessary generators. We may then safely contemplate the future generation of Y-rays of sufficient intensity to deal with the gravity field existing between the earth and an aerial machine weighing one or a hundred tons, and such a possibility opens up wide avenues of advance in aviation.

Employing electro-gravitic principles, the aerial machine of the future will have no wings, rotating cylinders, or vertical propellers, and something like 40 per cent. of resistance to translative motion will thus be eliminated. Needing no initial high ground velocity to get into the air, it will rise straight up from, or alight anywhere on, the earth's surface, proceeding then to its destination at velocities very much greater than any yet attained. It may be any weight from 400 lb., the equivalent of a motor cycle, to 400 tons.

But for the aeromotor, as it is proposed to call this machine, the introductory difficulties greatly exceed what the aeroplane had to contend with. Sixty years ago it was thought in high places "the heavier than air machine is scientifically impossible," and the aeroplane is an interesting innovation, but will never be of any use for war purposes." Now, I am assured in the same high places, "you must be working on a fallacy." We can never hope to overcome gravity in the way suggested." My balance gives assurance to the contrary, and I have more confidence in its judgment. Besides, as long ago as 1936 I demonstrated an electro-gravitically actuated model aeromotor going to my laboratory ceiling, and a film of the same operation was shown in the principal London cinemas.

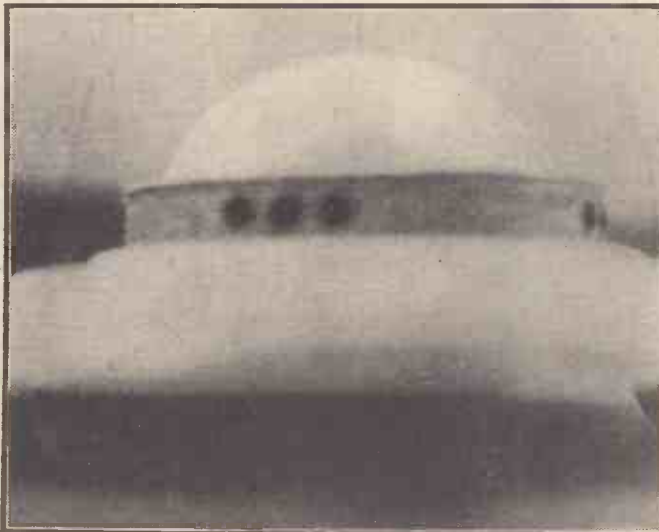

Does the source of lift described here power the "Flying Saucer" ?

A TRANSISTOR DIODE PORTABLE

A Set Using the Latest Radio Technique

THE small size of transistors, the low power requirements and the few components required compared with valve circuits lead inevitably to the development of midget receivers. However, apart from the novelty there can be no point in producing such a receiver unless complete portability is desired and achieved at reasonable cost. A midget set requires a midget speaker, and transistors are not at their best when working these. Furthermore, to eliminate aerial and earth at least two H.F. stages in a straight circuit are needed for only moderate results with present available types. Otherwise, an even more costly superheterodyne circuit is required.

Although designed primarily for the bedside the little receiver, shown in Fig. 1, will obviously have other applications, and it should be noted that it is designed for use with an aerial and earth. For bedside use the aerial was 50 feet of plastic-covered aerial wire fastened to the picture moulding by insulated staples. The earth wire was taken to the cold water inlet in the cylinder cupboard. The locality required long wave



Fig. 1.—The completed receiver.

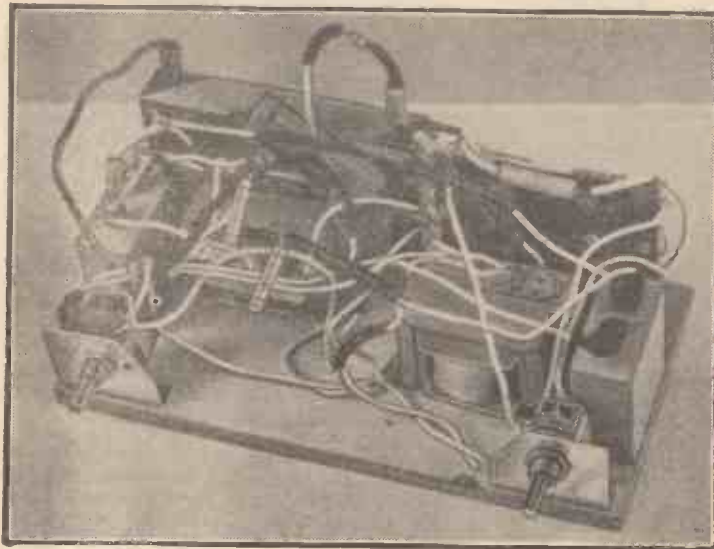

Fig. 2.—A view of the components and wiring.

tuning for the Light programme. The power supply was to be 9 volts, and the size of the speaker limited to 6in. These considerations, and the desire to keep costs down by using a minimum of transistors, governed the choice of circuit.

The Circuit

The circuit, as shown in Fig. 3, consists of a diode detector stage followed by two stages of L.F. amplification using junction transistors. To obtain maximum volume from such a combination transformer coupling is required. Resistance-capacity coupling gives less volume. Quality may be somewhat better, but it takes a very discriminating ear to notice any difference. With resistance-capacity coupling there may be sufficient volume for the listener from a circuit employing a diode

R.E.P. dual-wave crystal coils chosen for their modest price (2s. 6d.), and reasonable efficiency. No single dual-wave coil was found to be satisfactory such that a fair compromise between sensitivity and selectivity could be attained. The coils are pretuned by trimmers C1, C2, C3, C4 each 250 pF. Station selection is by a double-pole on/off switch SW1, giving medium-wave Home service or long-wave Light programme. The value of the coupling condenser, C5, is 40 pF, but any value between 10 and 100 pF may be tried.

Any diode may be tried, but preferably a good one such as the GD3 should be used. Results with cheap diodes are often disappointing, giving poor quality reception and a marked diminution in volume.

The Amplifier

Bipolar junction transistors are used; a 3X/301N(TJ2) in the first stage followed by a 3X/302N(TJ3).

The output from the crystal feeder is matched into the input of the first transistor by a step-down transformer, ratio 5 to 1. A similar transformer is used to match into the second transistor. Suitable transformers can be purchased from Whiteley Electric Co., Mansfield, or H. Ashworth, Bradford. Much ex-Service equipment contains suitable transformers; ratios 4 and 6 to 1 step-down can be used as the ratio is not critical.

V1, across the secondary of T1, controls volume; it may be any value 5,000 to 10,000 ohms and should have an on/off switch for the battery. When operating the set the volume control should be used judiciously, otherwise distortion may occur due to overloading the transistors.

Coupling condensers C6 and C7 may be any value 2 to 8 μF. Electrolytics should be connected with polarity as shown in Fig. 3. Decoupling condenser C8 may be 25 or 50 μF, 25 or 50 volt test.

A diode is connected in the battery lead as a safety measure. A cheap diode may be used, provided it is tested first by con-

and two junction transistors if an 8in. speaker is used, or, if the listener is situated in a good reception area, even with a 6in. speaker. For readers who wish to try this, an alternative circuit is given in Fig. 6 (see notes later).

The Detector Stage

This is a simple crystal diode feeder employing two tuned circuits. The coils are

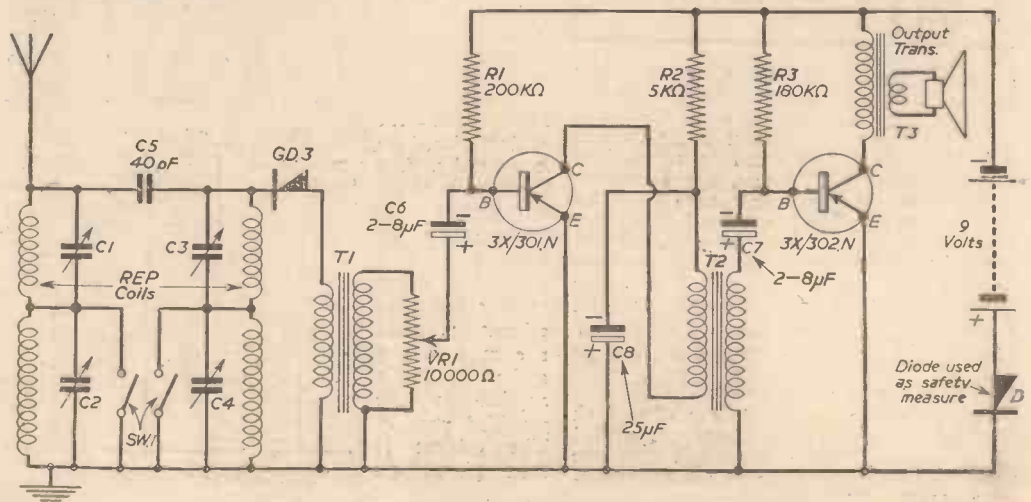

Fig. 3.—Theoretical circuit of the portable.

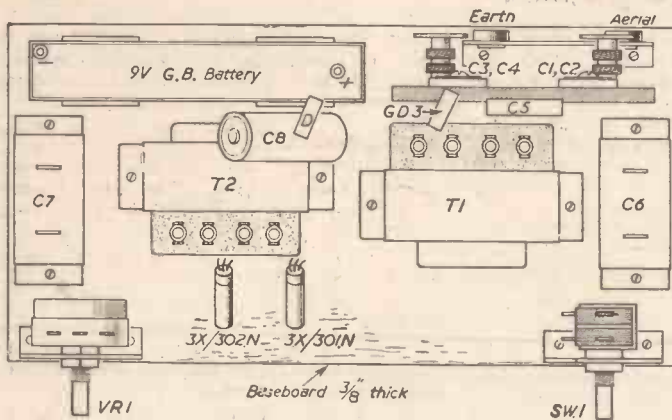

Fig. 4.—Layout of the components.

necting it in series with a voltmeter across a 9-volt battery. Connected with anode of diode to positive of battery, voltage should be about $8\frac{1}{2}$ volts. Reversing diode should result in scarcely any reading. With such a diode inserted in the battery lead the minute reverse current which would pass through the diode if the battery were accidentally reversed would cause no damage to the transistors in the set.

The values of resistances R1, R2, R3 were found experimentally having due regard for the maximum ratings of the transistors as given in the manufacturer's literature. The

LIST OF COMPONENTS

- Two R.E.P. crystal coils (coils 1 and 2).
- Four trimmers, each 250 pF (C1, C2, C3, C4).
- One condenser 40 pF (C5).
- Two condensers, each 2 μ F (C6 and C7). These may be electrolytics and any value 2 to 8 μ F.
- One condenser 25 μ F, electrolytic 25-volt test (C8).
- One switch, double pole on/off (Bulgin or similar), SW1.
- Two transformers, step-down, ratio 5 to 1 (T1 and T2).
- (Whiteley Electric Co., Mansfield, or H. Ashworth, Bradford.)
- One transformer, output to match speaker (T3).
- One volume control, 10,000 ohms with on/off switch (VR).
- One resistance, 200 K., $\frac{1}{2}$ watt (R1).
- One resistance, 180 K., $\frac{1}{2}$ watt (R3).
- One resistance, 5 K., $\frac{1}{2}$ watt (R2).
- One 6in. P.M. loudspeaker (W.B. or similar).
- One 9-volt G.B. type battery or two 4½-volt flash-lamp batteries connected in series.
- One diode GD3, Brimar, and one diode (D), GD5, or cheap one passing test.
- One transistor 3X/301N (T1) Brimar.
- One transistor 3X/302N (T2) Brimar.
- Connecting wire, solder, plugs, plywood, rexine, Bostik (white), small nails, aluminium sheet, insulating tape, wood screws (½in. and ¾in.), knobs, handle, plastic grille, chromium domes.
- If it is desired to use other makes of junction transistors a 5 mA meter should be inserted in series with the collector leads and the values of R1, R2, R3 and voltage supply adjusted to conform to manufacturers' ratings.

collector current of Trans. 2 is about 4 ma.; allowing for the voltage drop in the output transformer and the diode there will be about 26 milliwatts output to the speaker. This may seem very small in comparison with modern valve outputs, but a surprisingly useful volume and tone can be obtained from a good quality loudspeaker. A good output transformer to match the speaker is also a decided asset. If the constructor can afford the room, a larger speaker than 6in., preferably mounted on a large baffle board, will enhance the quality considerably.

The Cabinet

Home constructed sets do not often look well as few radio enthusiasts are skilled cabinet-makers. This difficulty is overcome by making the cabinet of plywood and covering with rexine cloth.

The dimensions are as follows: Front,

10in. \times 7½in.; depth, 5½in. (outside). Front and sides are cut out of ¾in. plywood; one front piece 10in. \times 7½in. and two side pieces 7in. \times 4½in. Top and bottom are two pieces of ½in. plywood, each 10in. \times 5½in. A hole for the speaker, 4½in. \times 3½in., centrally placed 1½in. from the top edge of the front is cut out before nailing the pieces together. Two holes are required at the top for the carrying handle and two holes in the front

turned over and the rexine smoothed and pressed down with a cloth. Cuts are made in the rexine diagonally to the corners; the two side pieces are stuck down and trimmed to the edges, followed by the same procedure with the top and bottom pieces, using the same adhesive. The wrap-over pieces are then trimmed diagonally at the corners of the back and stuck down. From the back, small holes are pierced in the centre of the loudspeaker hole, and in the centres of the two spindle holes. Cuts are made from the centres to the edges of these holes and the strips of rexine stuck down.

A rectangular plastic grille is screwed to the front and decorated with four chromium-plated domes at the corners. Finally, the back is cut out of ½in. plywood, size 9 3/16in. \times 6½in., drilled with several vent holes (three rows ½in. dia.) and holes for the trimmers and aerial and earth plugs. This

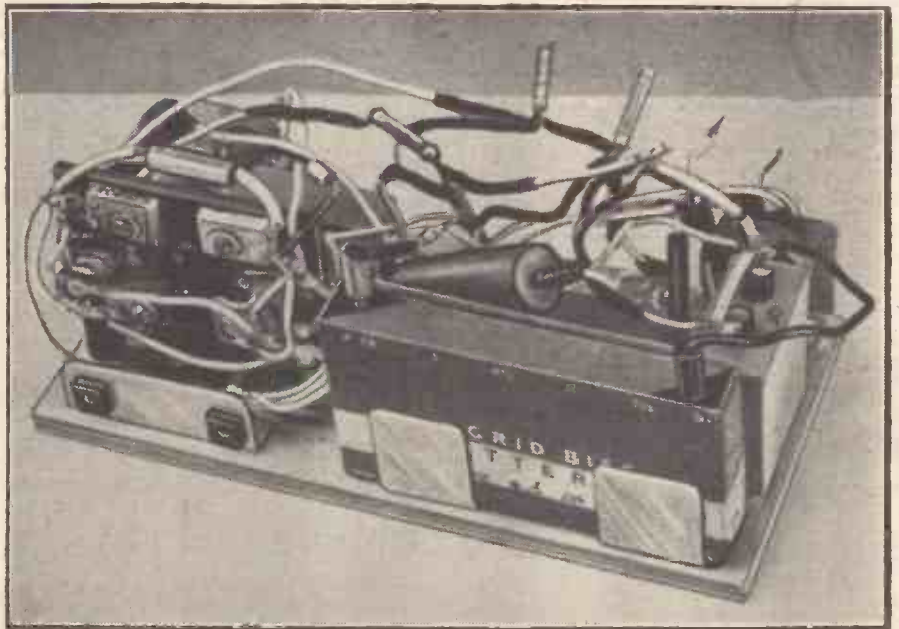

Fig. 5.—A further view of the components and wiring.

panel to take the control spindles. The position of these is best found by mounting the two controls on the baseboard (described later), rubbing chalk on the ends of the spindles and pressing on to the back of the panel.

Covering

A piece of rexine cloth 23in. \times 20½in. is required. Rexine cloth can be purchased in many shades and it is not difficult to obtain a suitable pattern to match any desired colour scheme. Alternatively the cabinet may be covered with Formica.

The rexine is placed face downwards on the bench and the cabinet placed on it centrally, face downwards. Pencil marks are made round the front edges and round the speaker hole; the cabinet is then removed and white Bostik applied to the pencilled portion. The cabinet is then placed on top face downwards, the whole

is covered with rexine, and the holes cut round with scissors and trimmed with a small round file. The back is screwed to two small triangular corner pieces at the top corners of the back of the cabinet, cut from ¾in. plywood and screwed to the baseboard at the bottom corners. The carrying handle holes are pierced and the handle screwed in position. If care is taken before covering to ensure that there are no projecting nails or

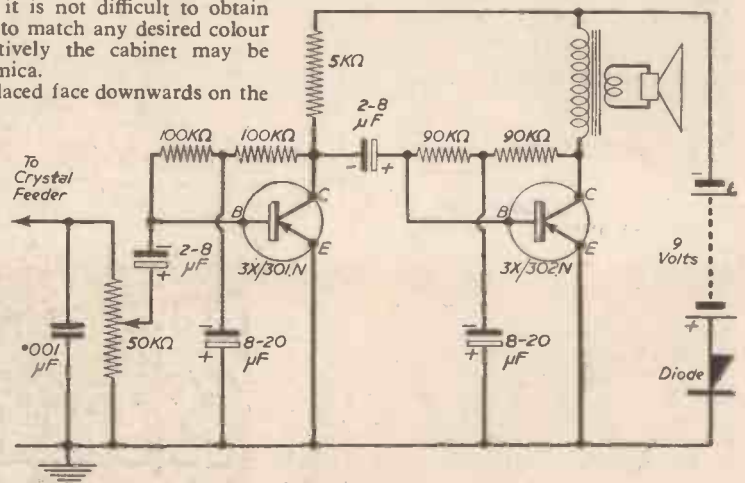

Fig. 6.—An alternative circuit arrangement.

rough edges the finished cabinet should present a pleasing appearance.

Mounting the Components

The components are mounted on a plywood baseboard, size 9 1/4 in. X 4 1/2 in. X 3/8 in. thick. The switch, volume control and two plugs (aerial and earth) are mounted on small brackets made from scrap pieces of aluminium sheet, and screwed to the baseboard with wood screws. Two strips of aluminium sheet, bent twice and screwed down to the board, form clips for the battery. The coils and trimmers are mounted on a piece of paxolin, 3 in. X 3 in., bolted to a bracket and screwed to the baseboard. The position of all these components is shown in Fig. 4, and a better idea of the finished appearance of the chassis can be gained from Figs. 2 and 5.

Wiring

Care should be taken when soldering the transistors; they can be damaged by heat. The leads should not be cut short, and should be held with pliers, tinned and soldered to the connecting leads, using a minimum amount of heat, and allowed to cool before removing the pliers. Then each lead should be covered with insulating tape right up to the body of the transistor. The diode leads should also be held with pliers when soldering. Leads and plugs to the

battery should be of a distinctive colour, preferably red for positive and black for negative connections. Brackets and condenser cans are earthed. It is advisable to cover all exposed joints and wires with insulating tape to avoid any possibility of any wires touching and causing a reversal of the battery connections.

Apart from these precautions the wiring is straightforward. To avoid a muffled tone due to small cabinet size, the speaker is mounted on four small pieces of plywood 1/4 in. thick.

Testing and Adjusting

Before switching on, the wiring should be rechecked, paying particular regard to the base, emitter and collector connections of each transistor, and also the battery connections. A reversal of polarity will quickly destroy the transistors. On this account it is wise to plug in to a low voltage (3 volts) for preliminary testing. The medium-wave trimmers should be adjusted first on a low setting of the volume control, followed by the long-wave trimmers. If everything seems to be in order the voltage should be increased to maximum and the process repeated. Howling indicates a fault in the wiring. If this occurs the set should be switched off and the fault found before proceeding any further with the testing.

The final result should be satisfactory to the constructor, who should have a receiver providing ample volume for bedside listening and presenting a pleasing appearance.

Alternative Circuit

Fig. 6 shows an alternative resistance capacity coupled circuit. This will be satisfactory only under the following working conditions:

- (i) Using a 6 in. speaker in a good reception area and indoor aerial.
- (ii) Using an 8 in. speaker in a moderate reception area and same aerial.
- (iii) Using either type of speaker with a good outdoor aerial or, in a few districts, with a good indoor aerial.

To obtain maximum volume from a resistance capacity coupled circuit it is necessary to eliminate regenerative feedback caused by the biasing resistances connected between base and collector. To do this the resistances are divided equally and the centre by-passed to earth through a condenser value 8 to 20 μF.

This circuit is given solely for the benefit of those readers who are experimentally minded. Anyone in doubt should keep to the transformer-coupled circuit (Fig. 3) which will be satisfactory under all but the most adverse conditions.



Wheel Flange Lubrication

A NEW method has been developed for lubricating the flanges of train and crane wheels in order to reduce wear when the flange and rail grind heavily against one another on corners. This method utilises a graphite lubricating rod, which consists of soft graphite material encased in a harder carbon tube. The lubricant is applied only to the flanges and being solid cannot creep on to the tread and cause skidding. In use the rod is applied constantly to the flange.

Cosmic Data from "Explorer III"

THE violent elliptical orbit of the American Satellite, Explorer III, is unexpectedly supplying valuable information on cosmic rays. Its orbit varies from 117 to 1,740 miles above the earth and at its lowest point almost overlaps the cosmic ray data obtained from vertical rocket firings. The transmitters and tape recorders are working correctly and a continuous stream of information is telemetered to earth on temperatures and micro-meteorites as well as cosmic rays.

Recoverable Satellites

IN the U.S. it has been forecast that in 1959 or 1960 satellites will be available which can be launched with a payload of 100lb. and afterwards recovered.

Robot Can Hear

AN electronic computer has been devised which can recognise the sound of numbers from zero to nine. It can understand both male and female voices and in a test achieved 98 per cent. accuracy.

Nuclear Batteries

THE electrical and electronic systems in satellites and space vehicles may in the future be powered by nuclear batteries. These are being developed by the U.S. Army Signal Engineering Laboratory and will act

as thermoelectric converters. An isotope produces radiation energy which produces heat. Thermocouples convert this into electrical power. The two chief advantages of this type of power unit are high current with a low current drain and long life.

Testing a Tug's Pull

THE crane weigher, shown below, has been found a new use recently—that of testing the pulling power of a diesel tug throughout its full range of engine power and revolutions. The makers of the crane weigher are Geo. Salter & Co. Ltd. The crane weigher has also been used in the same way at Bantry to test the engine power of trawlers.

Rockets to the Moon

A SERIES of attempts to land rockets on the moon or at least to fire them near the moon is scheduled to start in America late this year. It is thought at present that the first rockets will be fired

past the moon rather than around it in orbit or to make an actual landing. Factors to be determined by such a rocket will include the presence of a magnetic field, the detection of radiation, if any, measurement of distance from the earth to the moon and calculation of the moon's true weight. Anything landed on the moon, scientists all over the world agree, must be completely sterilised so as not to interfere with the accuracy of biological information which may be gathered, by introducing viruses from earth.

Supersonic Barnacle Remover

IN Australia, an electronic device has been perfected which prevents barnacles from growing on steel hulls of ships. Supersonic waves which shake off the barnacles are sent through the ship's hull. A high frequency current is transformed into actual vibrations, which cannot be felt by the passengers and crew of the ship, but which dislodge barnacles effectively.

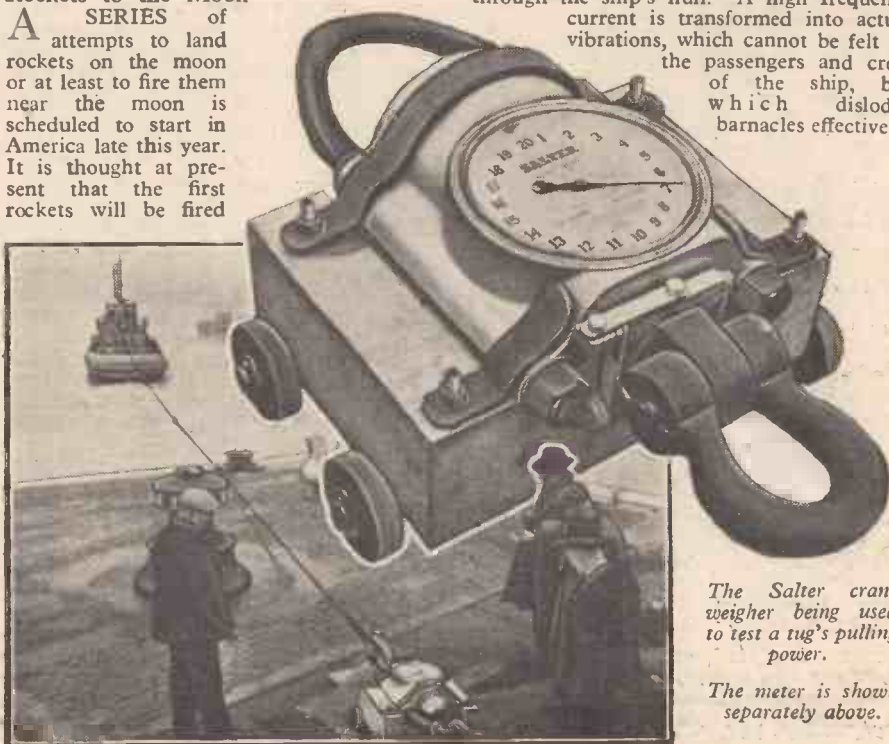

The Salter crane weigher being used to test a tug's pulling power.

The meter is shown separately above.

A CARNIVAL SPINNER

This Sideshow Could be a Money Spinner at Your Local Garden Party, Fête or Carnival



(Concluded from page 478, July issue.)

base could well be birdsmouthed as well as being provided with the stop shown. The cross blocks of 1½ in. X 1 in. are inset ½ in. into the standards as shown in Figs. 9 and 10 and are 3 ft. 6 in. from ground level; this gives a height of 7 ft. 6 in. to the top of the spinner.

necessity of removing the socket on the end of the mains lead or switching off from a remote point. Fix the spare end of cable referred to above to one of the two small pins on the plug and from the other run a short length of cable to one side of the switch.

Now measure the distance from any lampholder to the centre of the board, add about 3 in. for play, and cut off 20 lengths of cable. Bare both ends for about ½ in. and connect one end of each into the lamp-

NEXT drill three holes in each lug—two for bolts or rivets about ¼ in. dia. to fasten them to the angle iron, and one to clear the ¼ in. bolts. Clamp each lug in turn at the extreme ends of the angle iron and drill through, using the holes in the lugs as templates. Bolt or rivet them together—one lug at each end—and fasten the guides to the main frame ensuring that the inside distance between them is sufficient to take the width of the standards (nominal 3 in.) with ease but without too much play.

Standards Construction

This is a straightforward carpentry job. The main uprights, 5 ft. 6 in. long, are of 3 in. X 2 in. deal and are stub tenoned into the base-plates (5 ft. X 6 in. X 1 in.) and braced either side about 2 ft. up by 4 in. X 1 in. braces. Figs. 10 and 11 show the method employed. None of these mea-

The Indicator

Construction is now complete with the exception of the indicator, an arrow in this case. It can, of course, be an indicator of any design, but, whatever form is adopted, it should be reasonably well balanced. The arrow, details of which are given in Fig. 12, is so constructed that it balances in the centre, i.e., the extra weight added by the arrow head is counter-balanced by an equal weight at the "flight" end. A good quality ½ in. ply was chosen as a suitable material; well painted it will stand the weather, and it is easy to work. Metal could be used, but it would have to be at least ½ in. thick and would be difficult to work. In wood, it should not be thicker than 5/16 in. since it has to thread on to the sprocket, be adjusted by lock nuts, and be perfectly clear of the hardboard front.

A final procedure, but one that should be borne in mind, is that the arrow must align with the lights within a very narrow compass, and once positioned must be rigidly fastened so as to be proof against the meddling of children and others. Another advantage of making the arrow of plywood is that balancing adjustments too slight to be corrected on the wheel can easily be made by adding a round-head screw of adequate weight at one end. The length of 3 ft. gives the arrow a good swing and also brings it within reach irrespective of the position in which it stops.

Wiring

Almost any class of cable may be used for this purpose, since the lamps are only 15 watts and, therefore, demand only a very small amount of current from a 230-250 mains supply. Rubber covered cable with a 1/18 conductor was used, and three similar cables linked together at intervals with insulating tape were used for the 60 ft. of mains lead. Remove the strut from the main frame, insert the lampholders and wire one terminal of each to its immediate neighbour. There is no need to cut the cable; bare about 1½ in. as each terminal is reached, loop it in and screw it down, then pass on to the next. When the twentieth lampholder is arrived at, leave two or three feet of spare cable for connection to the socket. Note that if wiring is commenced at the bottom left-hand corner it will finish there and be quite near the 3-pin plug, which may be temporarily fixed at this stage. Close to it should be fixed a two-point 5 amp. switch. This will enable the current to be isolated from the machine without the

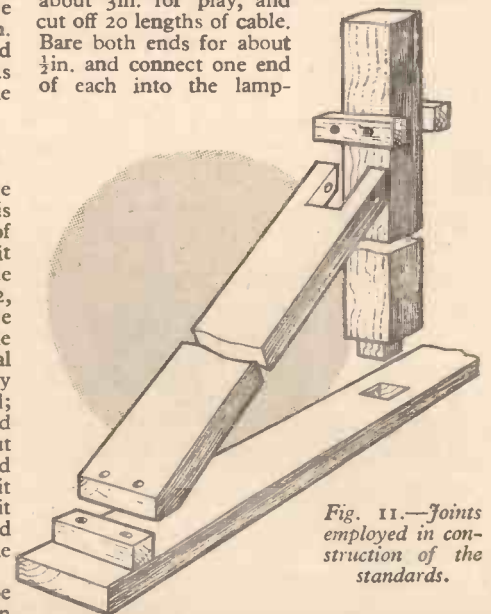

Fig. 11.—Joints employed in construction of the standards.

holders in turn. It will now be necessary to fix the wheel to the strut but this time put under the spindle washer the bared end of a 5 ft. length of cable. This will act as an earth lead, the other end being run to the large pin on the plug. This completely isolates the wheel and other metal parts with which it comes in contact and obviates any chance of a shock should a "short" develop in the circuit. Now screw the strut to the main frame.

The wires may now be connected between each lampholder and each stud. It doesn't matter where you start, but after the first connection the others must follow

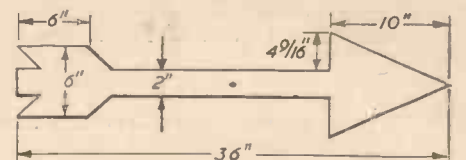

Fig. 12.—Dimensions and design of indicating arrow of good quality ½ in. or 5/16 in. plywood.

in order, i.e., the next lampholder on the right (or left) must be wired to the next stud on the right (or left) and so on until the 20 connections are made. Now from the lone terminal on the ¼ in. ply ("A" in Fig. 5), run a length of cable to the other side of the switch. This completes the wiring except for the long lead which needs to be a triple cable. This can be bought as a three-core cable which contains, in one rubber sheath, three separately

N.B. Figs. 1-9 appeared last month.

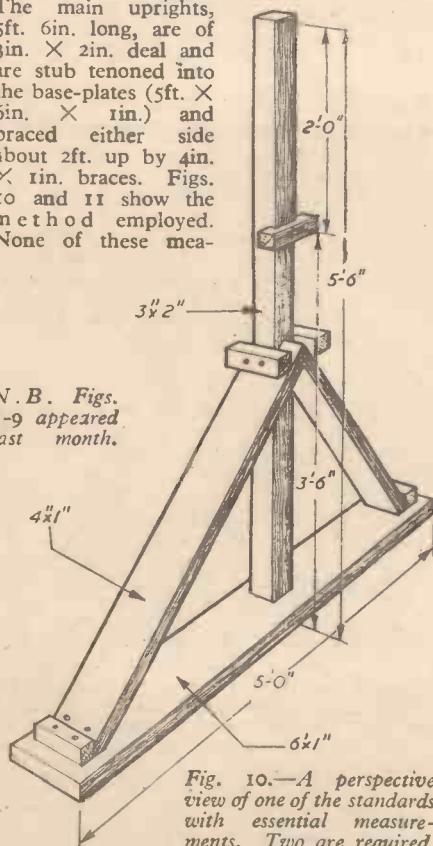

Fig. 10.—A perspective view of one of the standards with essential measurements. Two are required.

surements is critical, except that the height should not vary greatly, and timber in stock or readily available may be used. The standard should not be of less substance than 3 in. X 2 in. The bottom joint of the brace and

insulated cables, one red, one black and one usually green or brown. The red lead goes to the "L" (live) terminal of a 3-pin socket, the black lead to the terminal marked "N" (neutral) and the green lead to the terminal "E" (earth).

If you are making up this long lead from three individual cables, take care to wind around both ends of one cable a short piece of red Sellotape and around both ends of another one of the cables a piece of black or other coloured Sellotape before you begin to combine them as one cable by wrapping together at intervals with insulating tape. This is to enable you to recognise which cable is which and connect them properly at the spinner end socket and the distant plug.

It will be necessary to bore two holes in the half-door so that the socket may be inserted and the switch operated when the door is closed.

Final Adjustments

The spinner may now be tested. Immediately you plug in and switch on, one of the lamps should light. For the moment there is no need to worry where the arrow is pointing. Revolve it slowly and note carefully that each lamp lights up in consecutive order. Correct the wiring if necessary.

thinner or thicker one. It is not reliable enough to turn the locknut anti-clockwise because by the time you have replaced the arrow and tightened up with the second locknut something will have shifted. Cardboard washers can be considerably compressed and, with the fine thread sprockets have, a complete turn of the arrow makes very little lateral difference. Do not be afraid to exert strength in turning; carefully done it is surprising how far round it can be forced—and you are aiming at the tightest fit possible! When it is adjusted to your satisfaction, cover with a circle of hardboard screwed to the arrow centre. This will hide the spindle, etc., and also serve to cover the edge of the hole cut in the hardboard front in order to clear the hub shell.

From Fig. 8 it will be seen that a rectangular framework of slats has been fixed and some of the cables fastened to it with insulating tape. This ensures that any slack cables will not come into contact with the wheel and thus retard its motion. It is doubtful if it is really necessary.

Nameplates

The nameplates are of 3/16in. plywood painted two coats matt white. They are 9in. X 3in. and the corners are rounded. After the lettering is done in cobalt blue poster paint, the matt surface is varnished. A box with buckle and strap was used to hold these plates when not in use. Similarly a box was made to hold two dozen Pigmy lamps (in their corrugated wrapping) and furnished with a fall front.

Also in Fig. 8 can be seen two short lengths of wood about 1in. away from the top and bottom of the wheel. These are actually about 4in. wide and were used to overcome a slight tendency for the hardboard front to bow inwards. Although it came nowhere near the wheel-rim, it did approach rather too close to the spokes near the hub; hence it was packed out with these two blocks. If the board has an opposite tendency and thus threatens to foul the arrow, the same method could be employed, the blocks being screwed to the strut and to the hardboard front.

Decoration

From a protective point of view the spinner should be given three coats of good quality paint. In particular, the undersides of the base-plates of the standards should be treated liberally since they will probably stand on damp grass for long periods. The face was treated with two coats of matt white, the lettering and design painted on, and then two coats of copal varnish applied.

The lettering was carried out in alternate red and blue as an aid to quick reading, the letters being necessarily rather close together. The semi-circle idea was adopted in order to increase the writing space and,

even so, it was necessary to confine the towns to an average of five letters. The letters are rim high.

A design and colour chart of the engine is given for those who might wish to use it—see Fig. 13. One thing not shown either in Fig. 13 or 14 is smoke coming out of the funnel. This was added later. Such refinements as the two engine lamps being actually lighted up or a beam-light from the top of the frame could be added with little trouble.

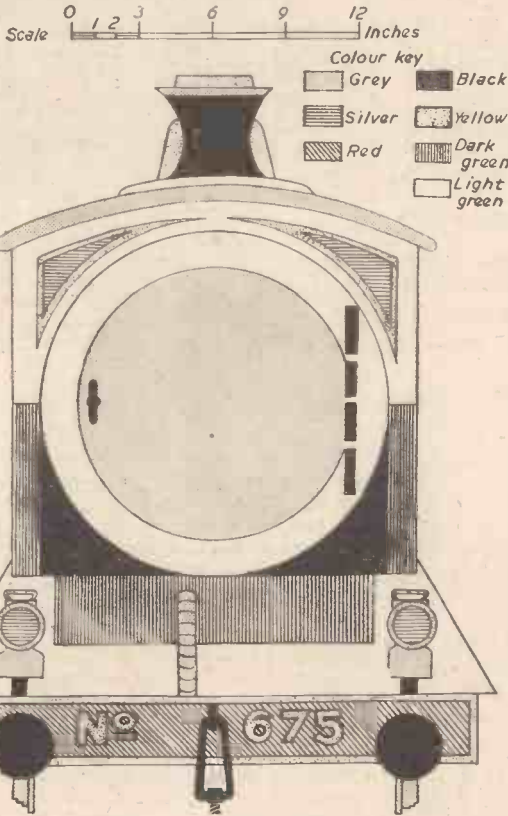

Fig. 13.—Design and colour plan of engine.

To adjust the arrow turn it very slowly and listen for the click which denotes that the spring has just left one stud and engaged with the next. Note which lamp is alight and, holding the wheel perfectly still with one hand, force the arrow round to the beginning of that town which the lamp illuminates. If it will not go far enough, remove it by still holding the wheel and turning it (the arrow) anti-clockwise, and turn the locknut further to the right. If it is already at its limit then pack a cardboard ring over it, put the arrow back and try again. It is all a matter of trial and error, replace the cardboard washer with a

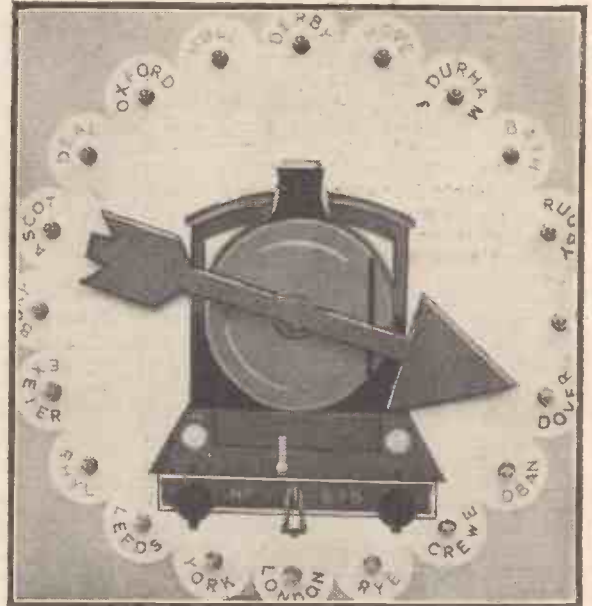

Fig. 14.—Close-up of the front of the spinner.

The front, outside the semi-circles, was painted light blue; the wooden framework red; and half-doors and standards dark blue. Aim for contrast and brightness in colouring—it attracts attention!

Attache Case Repairs

(Concluded from page 512)

Sometimes the handle itself goes to pieces as the stitches give way down either side. The repair here is obvious, but at times a new handle can be picked up at a saddler's, or a sound one obtained from some discarded article.

Locks

These can give a lot of trouble and should be carefully overhauled. Locks are seldom actually broken, and if refusing to work it is probable that they are just full of dirt and rusty. Four tabs generally hold the lock to the leather, and two tabs hold the corresponding part on the other side. With the aid of a screwdriver the lock can be removed and soaked in paraffin or otherwise repaired. Usually a good soaking is all that is needed—after which a slight oiling with any not too thin lubricant.

The lock is refitted by putting the tabs through the original holes and again riveting over. If the lock has become loose on the leather, treat as with the handle plates and put a thin strip on the underside before tapping over the tabs.

For the Householder:
THE HOME ELECTRICIAN
 By F. J. Camm
 12/6 or 13/6 by post
 from: Geo. Newnes, Ltd., Tower House,
 Southampton Street, London, W.C.2.

A ROOM TO ROOM

Details of a Simple H



IT is strictly forbidden to tamper in any way with the G.P.O. telephones, and it becomes necessary to buy or make a telephone outfit if any experimenting is to be carried out. A simple telephone system from one room to another also has to be constructed or purchased. If purchased much of the interest is undoubtedly lost through not knowing how it operates.

Materials Required

The main items required are: (1) Two pairs of phones. They need not be new as their sensitivity need not be of a high order. (2) Two cigar boxes. The 50-type should prove large enough. (3) Two buzzers. There are many of these on the market, the only important detail being size; they must not be too bulky. (4) Two flashlamp batteries; and (5) two neat bell-pushes. These, supplemented with odd pieces of brass, screws and nuts, are the main items.

Construction

The receiver hook claims attention first, and Fig. 1 illustrates its functions. The lever B pivoted at G can move up or down and touch either of the two contacts D and E. In its released position, i.e., whilst using the phone, the spring C keeps it in the top position, making contact with D. At the finish of the conversation the receiver is hung on the end H, the weight overcoming the spring and changing the contact from D to E.

A is a supporting pillar fixed to the back with a countersunk screw, the spring being likewise fixed. F is a slot in the side of the "cabinet" to take the receiver hook. A flexible lead is soldered to the latter and completes the most difficult part of the outfit.

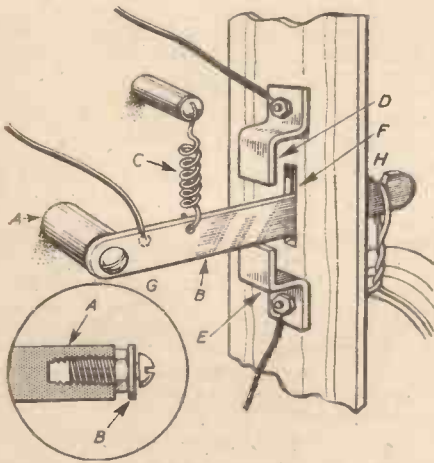

Fig. 1.—The receiver hook and switch showing constructional details.

Battery and Buzzer

The battery is placed inside the cabinet and two brass strips make connection with the contacts. The battery rests on the bottom (see Fig. 2) and fixed on the inside of the lid, at a height sufficient to clear the battery, is the buzzer. It is fixed on the lid in preference to the back, as the former acts as an excellent sounding board with consequently increased volume.

On the lower half of the lid (outside) is fitted the bell-push, the top being reserved for the microphone; a glance at Figs. 3 and 5, which shows the completed unit, will make this clear.

Microphone and Earpiece

The microphone is made from one of the earpieces, and requires slight alteration. The

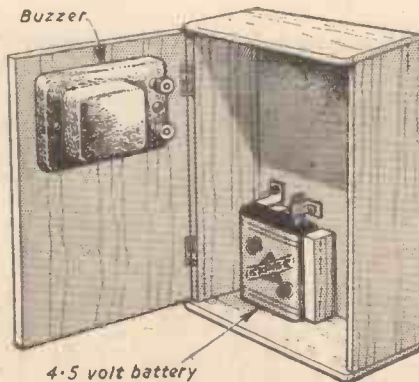

Fig. 2.—Fitting the battery and buzzer.

cap is first removed and the centre hole made larger, either by filing or with a fret-saw. A mouthpiece, constructed from stout paper or thin cardboard, is fixed to the cap with glue and allowed to set thoroughly. Fig. 4 shows this.

Meanwhile the microphone can be secured to the lid, the method of fixing depending upon its internal construction. It may be possible to drill two holes in the back and use nuts and bolts, or it may be necessary to solder two brackets on the sides, these being fastened with nuts and bolts. If soldering is out of the question, possibly due to the case being made of aluminium, two further nuts and bolts can be used. This detail is of necessity an individual one, and some simple method will soon suggest itself to the enthusiast. For the time being the other earpiece is used as the receiver,

The other earpiece is used as the receiver,

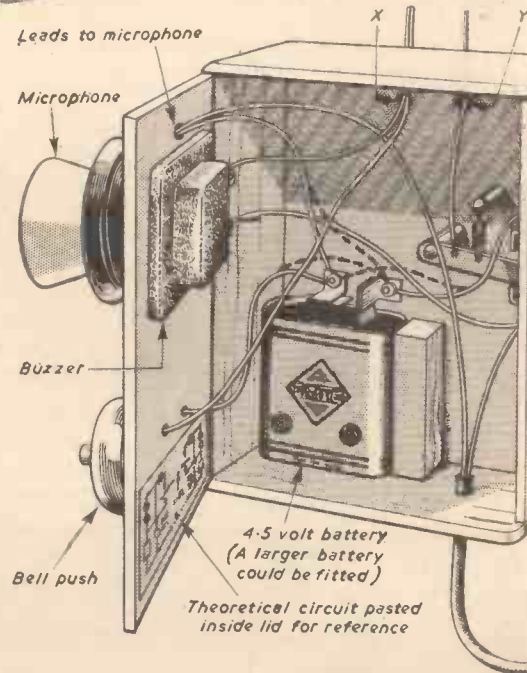

Fig. 3.—The wiring of one of the units. Note that battery connections are reversed for the alternate

and only requires the addition of a hook to complete it. This again is a simple, but individual problem which can easily be decided.

Wiring

It will be appreciated by now that only one unit has been described. This point is immaterial as both units are identical, the second being a duplicate of the first.

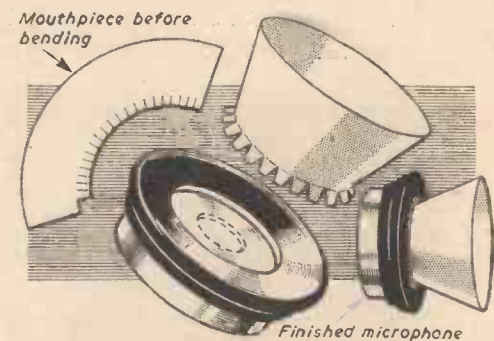

Fig. 4.—Making a microphone from an earpiece.

HOME TELEPHONE

House Communication System

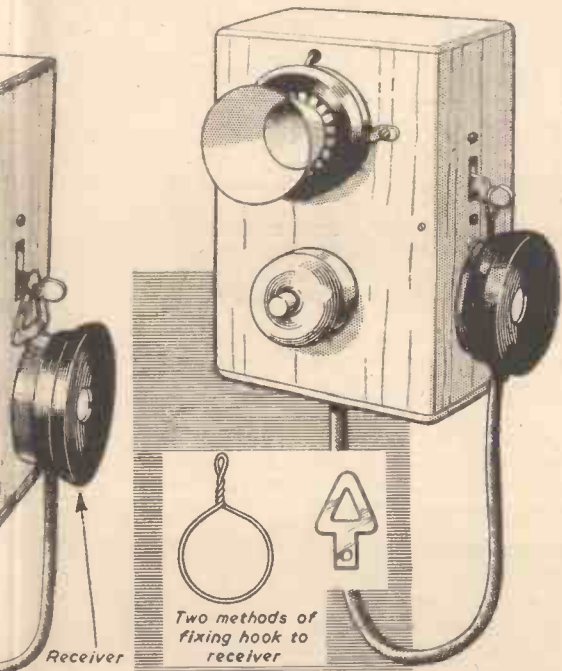

Fig. 5.—The workmanlike appearance of the finished telephone.

The wiring presents no difficulty. Two terminals are fitted for the "line," the details given in Fig. 3 then being followed. The

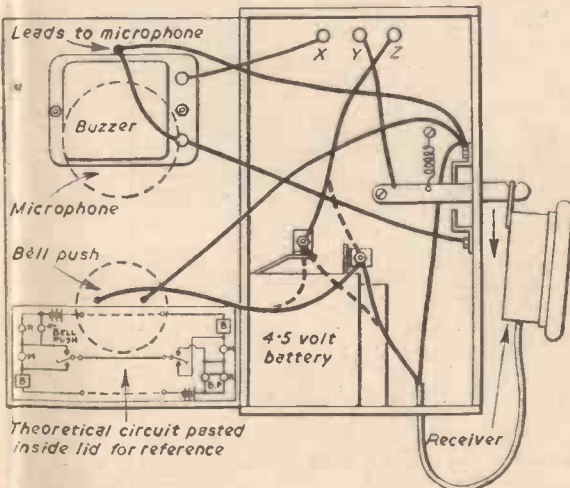

Fig. 6.—An alternative wiring plan for the home telephone.

two units differ slightly at this point, the polarity of one of the batteries is reversed as shown by the dotted connection.

When the transmitter caps have been replaced, the units are ready for test. Bell wire can be used for the "line," but it is essential that terminal X of one unit is connected to terminal X of the other unit, otherwise the batteries will be in opposition, and in the event of no signals the effect of changing the "line" wires should first be tried.

Operation is simple. Caller A lifts his receiver and presses the button. This

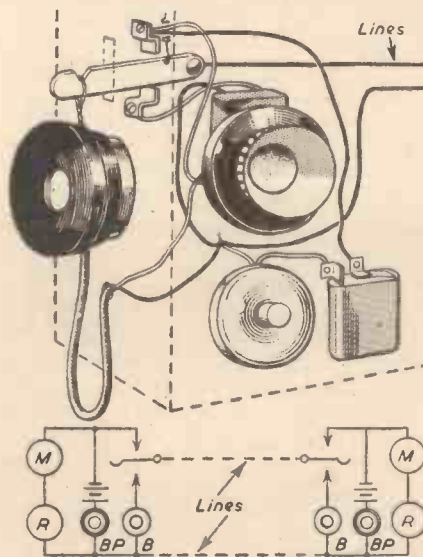

Fig. 7.—A modification of the circuit.

operates the buzzer of listener B, who lifts his receiver, putting the buzzer out of action, because although it is still in circuit the current which now has to pass through the transmitter and receiver as well is insufficient to operate the magnets and it acts simply as a low resistance. The action in the reverse direction is similar.

Two Minor Faults

This completes the details, and the constructor should now have a handy telephone which should prove reliable and trustworthy. Nevertheless, owing to its extreme simplicity it has one or two minor faults.

Perhaps the worst of these is that the speaker also operates his own receiver, and as a result "listens" to his own voice. With a twin line this could only be eliminated by a complicated method of switching, but for those readers who are prepared to use a triple line the alternative wiring is given in Fig. 6. This method of wiring also has the advantage of cutting out the listener's microphone from his own receiving circuit, resulting in a definite increase in volume.

In this case, although it would appear from first sight that the current might take the outside circuit through both microphones and receivers, it will be noted that the batteries are in opposition, thus virtually isolating the two circuits. It is still necessary to lift the receiver before calling up the other unit.

Construction of either of these units should not prove in any way difficult. It will be appreciated that no detailed dimensions can be given owing to the variation in material such as phones and cigar boxes, but this omission should not hinder in any way. It must also be understood that an earpiece used as a microphone leaves much to be desired as far as sensitivity is concerned, and the substitution of cheap microphones would doubtless prove beneficial, but if economy is the prior consideration the earpiece will prove a reasonable substitute.

If, however, the reader desires to experiment with the telephone he should try out the circuit shown in Fig. 7. This will be found quite efficient, and has the advantage of costing nothing to run, as the batteries are only used to work the buzzers.

The reader might also like to try the construction of his own microphone, as shown in Fig. 8. The case consists of three wooden discs 2 1/4 in. dia. and 1/4 in. thick, two of which are drilled centrally 1/4 in. The 1/2 in. and 1/4 in. discs shown black are cut from a carbon rod 1/8 in. dia. The diaphragm is cut from a cocoa tin and is 2 1/4 in. dia.

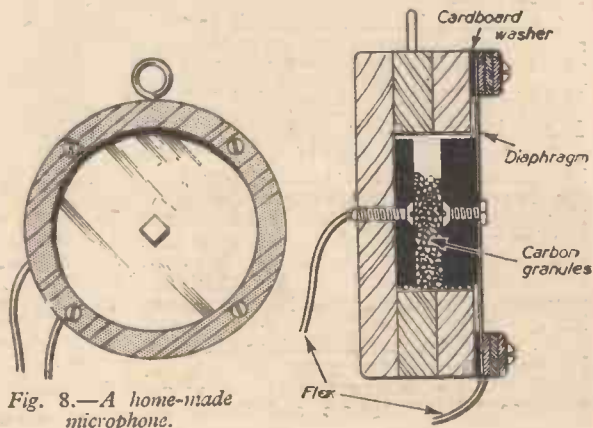

Fig. 8.—A home-made microphone.

Alton Towers 00 Gauge Railway

A General Description and Some Facts and Figures

by A. F. Bagshaw

NEAR Uttoxeter, Staffs, is the former seat of the Earls of Shrewsbury—Alton Towers. The well-known gardens have been open to the public since 1924, but this year, a new attraction has been added—a spectacular model electric railway.

Gauge "00"

In order to include as many features as possible in the layout, a standard scale of 4 mm. feet was employed in which locomotives and rolling stock of several nationalities are available.

800 Square Feet

The railway is built on a platform of

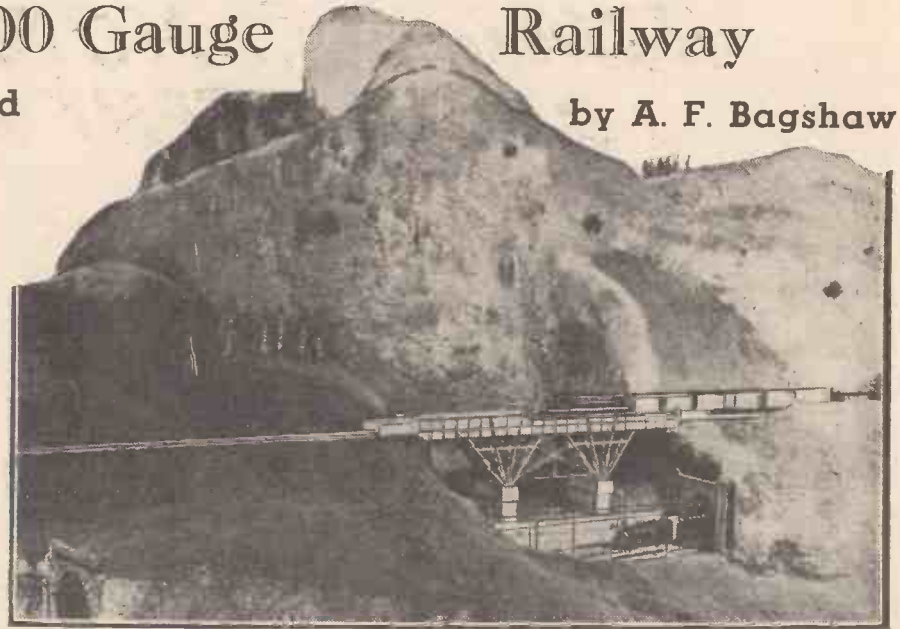
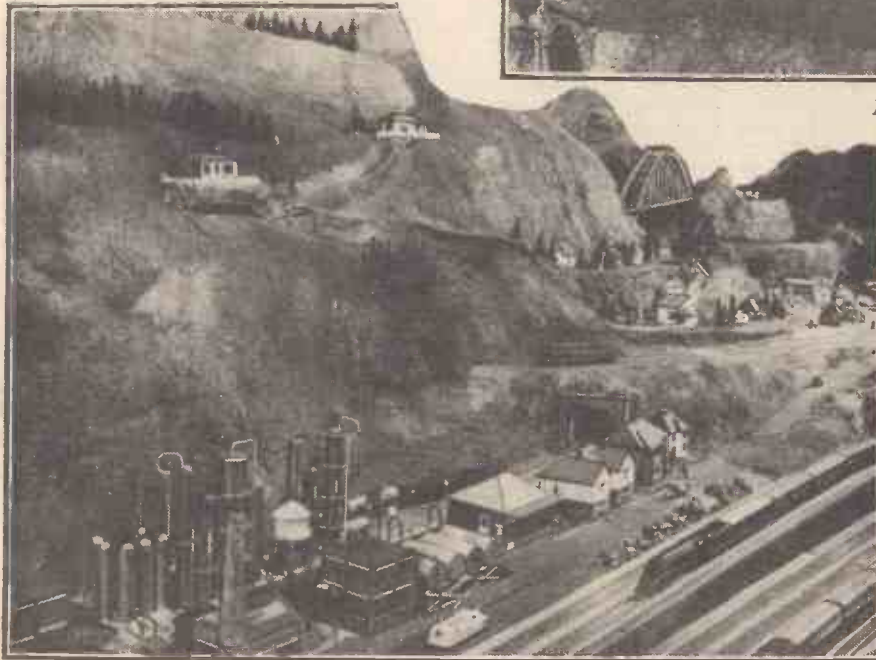

Part of the Mountain Section.

its own speed and position which in turn affects the one immediately following it. The 14 main line trains run simultaneously on a 420ft. circuit, but none of them ever catches another up. Furthermore, on approaching a station they automatically slow down and accelerate upon departure (unless the selector switches set the signals to danger in which case the train stops). The remaining 22 trains operate on the other circuits in a similar manner, with one important and entertaining exception. The American circuit is single track but two trains use it—in opposite directions. This is achieved by a loop line with points concealed in one of the mountains and is the cause of considerable mystification to the spectators.

The Scenery

The track is built on several levels so that

4in. X 3in. timbers on brick columns and is 50ft. in length and 16ft. wide. The scenery consists of 1/4in. wire netting roughly conforming to wooden formers overlaid with mutton cloth and builders plaster. The track is of rustless nickel-silver alloy laid on cork ballast strips glued to 1in. boards. The actual length of track is 1,490ft. representing about 22 scale miles.

45,000 Nails

The track is held down by nails or track spikes, the rail-joints are all connected by a soldered wire loop to allow for temperature variations and to ensure good conductivity.

Method of Operation

The layout is operated entirely on 12 volts D.C. supply for the trains and 24 volts D.C. for the automatic control system. All signalling, point operation, track selection and starting and stopping of trains is controlled by a system of 497 electro-magnetic relays, numerous selector switches and 18 timing motors. The controls are housed in two large glass-fronted cabinets.

As each train progresses along the track it passes over switches (incorporated in the actual track) which operate in the proper sequence relays, selectors and finally the timers. The timing motors control the track

The Oil Refinery



Some of the many features packed into this model railway layout.

selection (which includes operating the points where appropriate) and the stopping and starting of trains in the stations. Trains only stop and start when the signals are correctly set on their particular section.

Block System

Contrary to general belief, no spacing of the trains is necessary or indeed practicable due to the differing speeds of the locomotives and the weight of loads. Each train controls

some trains run through flat country and others through mountains and gorges. The mountains reach a height of about 8ft. and the tallest is capped by snow. There are 1,400 trees both in large and small groups. A river has its source in the mountains and meanders through a lead-lined channel and 3 lakes with 4 waterfalls. The main lake contains about 750 gallons of water which is re-circulated by a 240 volt electric pump. The model villages contain hundreds of houses and other models.

USING D.C. MOTORS ON DIFFERENT VOLTAGES

By J. L. Watts

How to Adapt a Spare Electric Motor to Suit the Supply Available

IT is sometimes required to use a D.C. motor on a different voltage to that for which it was designed. Generally speaking, a D.C. motor can be used on a voltage which is appreciably lower than that marked on the nameplate, without any modifications. However this naturally affects the output and characteristics of the machine.

Types of Motor

Small D.C. motors fall into two categories mainly, series or shunt motors. A series motor has field coils wound with comparatively thick wire which are connected in series with the armature; in a small motor the field coils are often connected on opposite sides of the armature as in Fig. 1(a). The field coils of a shunt motor are wound with many turns of comparatively thin wire, which are connected in parallel with the armature when the motor is running, as in Fig. 1(b). The larger motors have a graduated resistance starter to limit the starting current and starting torque. Such a starting resistor is connected in series with a series motor. However, a D.C. motor should

$k_2 \times T \times N$(5), where k_2 is another constant for the motor.

Under all stable conditions, i.e., when the motor is running at a steady speed, the torque developed by a motor is exactly equal to the resistance torque of the load to which the motor is coupled. If the load on the motor is increased, the speed falls to some extent, depending on the design of the motor. With a given proportionate increase of load, the speed of a series motor is likely to fall more than that of a shunt motor. The fall of speed reduces the back E.M.F. (formula 2) so that the armature current I_A increases, as may be seen from formula 3. Formula 1 shows that the increased armature current I_A automatically increases the motor torque T . The speed becomes steady when the motor torque has risen to the same value as the increased load torque. However, if the motor is loaded to more than its rated torque or horsepower, even on rated voltage, it will take more than its rated value of armature current, and may overheat or even burn out if overloaded for any length of time. If an excessive load is applied, the motor may stall, and it is liable to burn out if left stalled. The opposite effects occur if the load is reduced, the armature current I_A and the armature heating decreasing, with some rise of motor speed.

similarly rewound except in the case where the motor is to be used on half the rated voltage. In this case the two sets of field coils can be reconnected in parallel with each other as in Fig. 2(a). Care must be taken to alter the connections so that the relative direction of the currents in the field coils is unchanged, as indicated. If the field coils were connected on opposite sides of the armature they will, of course, have to be reconnected on the same side of the armature. When the armature is rewound for half voltage it will be able to carry twice the current for which it was previously rated. Thus each parallel-connected field coil will then carry its normal rated current I_A on the permissible load.

Use of Shunt Motors on Lower Voltage

If a shunt D.C. motor is used without modification on a lower voltage than that for which it was designed it is permissible to use it to drive a load such that the rated armature current I_A passes. However, on reduced voltage the shunt field current I_f and the magnetic field strength F will be reduced. Thus the permissible load torque will be reduced to some degree depending on the design of the field magnets, though the permissible load torque may not be reduced to the same extent as the voltage. On such a load the motor speed will be reduced, though probably not in the same ratio as the voltage. The permissible horsepower loading will be reduced practically in proportion to the voltage.

If a shunt motor is to be used on half-rated voltage, its torque can be increased by reconnecting the field coils in parallel with each other, as in Fig. 2(b), again taking care not to alter the relative direction of the current through each field coil. On half voltage each field coil will then pass its normal value of field current I_f . The motor could then safely be loaded up to a value which passes the rated current I_A through the armature and the motor would then develop its rated torque, it would run at approximately half its rated speed and could develop

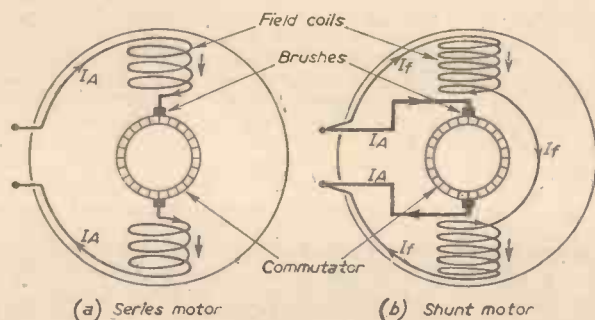

Fig. 1.—Connections of the two main types of small D.C. motors.

be started with its maximum field current, thus the starting resistor for a shunt motor is connected in series with the armature only.

Governing Factors

The characteristics of D.C. motors are governed by certain fundamental relationships. The torque T developed is proportional to the product of the magnetic strength F of the field magnets and the value I_A of the armature current. Thus $T = F \times I_A \times k$(1), where k is a constant for the motor. When the motor is running a back E.M.F. or voltage E is generated in the armature windings due to them revolving in the magnetic field. E is proportional to the product of the motor speed N and the magnetic field strength F . Thus $E = N \times F \times k_1$(2), where k_1 is another constant.

The armature current I_A taken by the motor when running is equal to the difference between the applied voltage V and the back E.M.F. E , divided by the resistance R_A of the armature in ohms. Thus $I_A = \frac{V - E}{R_A}$(3). It follows that the motor speed N is equal to $\frac{E}{k_1 \times F}$ or to $\frac{V - I_A R_A}{k_1 \times F}$(4). The h.p. H developed by a D.C. motor is proportional to the product of the torque T and the speed N , thus $H =$

armature, due to the increased centrifugal forces caused by the increased speed. When using a motor under different conditions, it is advisable to limit the current through the armature and field windings to no more than the rated value, as will be described, in order to avoid such troubles.

Use of Series Motors on Lower Voltage

If a series D.C. motor is used on a lower voltage than that for which it was designed it can generally be used, without modification, on a load such that the normal rated current I_A passes through the armature and field windings. On such a load the motor will have normal field strength F and develop its rated torque T . The motor speed N will be reduced practically in proportion to the voltage V , so that the permissible horsepower loading will also be roughly reduced in proportion to the voltage.

If it is required that the motor shall run at its normal speed, and develop its normal rated torque and horsepower on reduced voltage, it is necessary to rewind the armature, as will be described later. The field coils should be

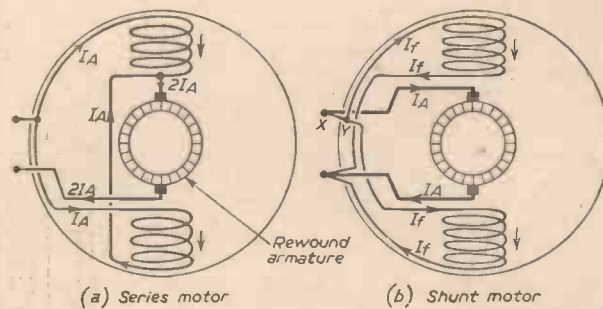

Fig. 2.—Methods of using motors on half-rated voltage.

approximately half its rated horsepower. If the armature was rewound for half voltage, as described later, it could then pass twice its rated current I_A , the motor would then develop its rated torque, would run at its rated speed, and develop its rated horsepower.

If a shunt motor is run on less than half the rated voltage, it is generally advisable to rewind the field coils and armature so that the motor can develop its rated torque and

horsepower at its rated speed. Otherwise, the field coils may be reconnected in parallel. If the armature is then used without rewinding it could be used on a load corresponding to the rated armature current I_A on reduced speed and torque, with horsepower practically proportional to the voltage. The effect of reconnecting the field coils is to reduce the speed but raise the permissible load torque.

If a shunt motor is to be used on a voltage between 50 and 100 per cent. of rated value, the field coils could be similarly reconnected in parallel, with a resistor connected in the field circuit, i.e., the resistor being connected between the points X and Y in Fig. 2b instead of the solid connection. The resistor must, of course, be capable of carrying the total field current ($2 \times I_f$) without overheating. With the field coils reconnected in parallel, it is desirable that the voltage applied to the

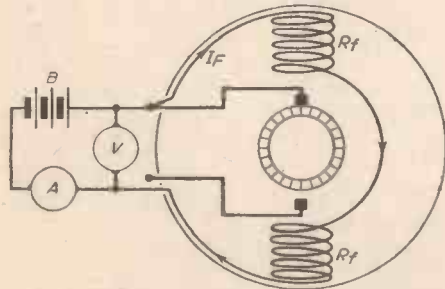

Fig. 3.—Method of measuring the resistance of shunt field windings.

field windings be limited to half the rated voltage, i.e., $0.5 V$. Thus, the volt drop across the resistor in the shunt field circuit should be equal to $V_1 - 0.5 V$, where V_1 is the new supply voltage. Thus, the resistor to be connected in the shunt field circuit should have a value of $\frac{V_1 - 0.5 V}{2 \times I_f}$ ohms.

Measurement of Field Winding Resistance

Fig. 3 indicates a method of measuring the resistance of the field windings, so that the rated field current I_f can be calculated. A battery is connected across the field windings alone, the armature circuit being disconnected. Current from the battery is passed through the ammeter A, whilst the volt drop across the field windings is measured by the voltmeter V. Then the reading of the voltmeter divided by the reading of the ammeter gives the resistance of the series-connected field coils, i.e., the value $2 \times R_f$. Then the rated current I_f of each field coil is found by dividing the rated voltage of the motor by $2 \times R_f$. When thus reconnected with a resistor in the shunt field circuit, the permissible armature current will be the rated value I_A . The speed on that load will be approximately proportional to the voltage, as will also the permissible horsepower, the motor developing its rated torque.

The shunt motor could be used to develop its rated torque, speed and horsepower on 50 to 100 per cent. of rated voltage by rewinding the armature and field coils, or by rewinding the armature and reconnecting the field coils with a series resistor as described above. Table I gives suitable sizes of Eureka resistance wire for various currents, together with the resistance per yard of wire.

Use of Series Motors on Higher Voltage

A series motor can often be used without modification on a slightly increased voltage, say about 15 per cent. excess voltage. The motor can be loaded up to its rated current I_f and will then develop its rated torque; the speed and horsepower will then be

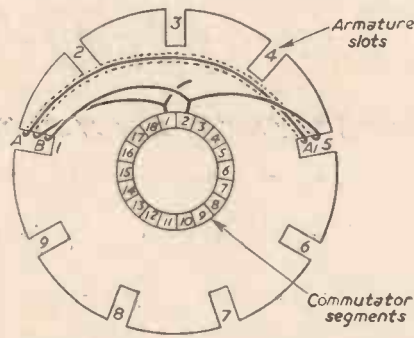

Fig. 4.—Start of an armature winding.

increased practically in proportion to the voltage.

If a series motor is to be used on a still higher voltage, it is advisable to reduce the voltage applied to the motor or, preferably rewind the machine. A resistor of R_s ohms could be connected in series with the motor, this resistor being designed to carry the rated current I_f amps. without overheating. If a series motor designed for a voltage V is to be used on a higher voltage V_2 the series resistor should be designed to have a volt drop $V_2 - V$ when carrying the motor current. The motor will then develop its rated load torque at rated speed with rated horsepower. In order to limit the motor current to the rated value I_A the series resistor should have a value of $\frac{V_2 - V}{I_A}$ ohms.

There are, however, disadvantages in using such a series resistor.

Since the volt drop across this resistor is proportional to the resistance and to the current which passes through it, the volt drop across the resistor will fall when the motor current falls if its load is reduced. Thus the voltage applied to the motor will rise on reduced load unless an increased resistance is then connected in series. Almost the full supply voltage might be applied to the motor if it became unloaded, with risk of electrical and mechanical breakdown. Thus a series resistor is generally unsuitable for operating a series motor on a higher voltage if the machine may become unloaded, as might occur due to a driving belt slipping off a pulley. It is better to rewind the armature and field coils as described later.

Use of Shunt Motors on Higher Voltage

A shunt motor can often be used on about 15 per cent. excess voltage by simply connecting a resistor in the shunt field circuit to

limit the field current to its normal value I_f . Thus, if the motor rated at V volts is used on a higher voltage V_2 , the resistor connected in the shunt field circuit should have a value of $\frac{V_2 - V}{I_f}$ ohms. The field coils will then pass normal current and will develop normal field strength. The armature can then be loaded up to its normal current, when the motor will develop its rated torque, with speed and horsepower proportional to the voltage.

If a shunt motor is to be used on a still higher voltage a series resistor may be connected in the armature circuit, in addition to one in the field circuit. The motor could then be loaded up to its rated armature current I_A , on which current it would develop its rated torque and horsepower and run at its rated speed. The resistor in the armature circuit should have a value $\frac{V_2 - V}{I_A}$ ohms.

However, as in the case of a series motor, the volt drop across this resistor will vary with the motor loading and armature current. The voltage applied to the armature, and the motor speed, would then rise unless a higher value of resistance was connected in the armature circuit on reduced load. A much better plan is to rewind the armature; and, preferably, rewind the field coils to avoid having to use a resistor in the field circuit.

Rewinding a Motor

Before rewinding an armature or field coil it is first necessary to ascertain the number of turns in the original winding. In the case of an armature, the number of armature coils may be equal to the number of armature slots; or to a multiple of the number of slots if the commutator has more segments than the armature has slots. All the conductors at the back of one armature slot may be cut through and counted. The number of turns per slot will be half the number of conductors per slot. The number of turns per coil, or per coil section, will be equal to the number of turns per slot \times Number of armature slots

per slot \times Number of commutator segments
If the number of commutator segments is more than the number of slots, as is usual, there may be more than one separate coil per slot, or each coil may be divided into sections with loops brought out for connection to the commutator. For example, in Fig. 4 the armature has half as many slots as there are commutator segments. The coil sides A and A₁ in slots 1 and 5 are one section of a coil, a loop being brought out for connection to the intermediate segment 2 before the start B of the second section of the coil in the same slots 1 and 5. The end of the second section will be connected to segment 3, to which segment the start of the first section of the coil in slots 2 and 6 will be connected. The coil span on the original winding should be carefully copied in the new winding, as should also the lead between the armature coils and commutator segments. The latter is particularly important if the brush position is fixed.

For use on a different voltage each coil must be rewound with a number of turns proportional to the voltage, the cross-sectional area of the wire used being changed in inverse proportion to the voltage. Thus if the armature or field coil of a motor designed for a voltage V has S turns of wire of cross-sectional area A square inch and is to be rewound for use on a voltage V_1 , each coil should have S_1 turns, equal to $\frac{V_1 \times S}{V}$.

The cross-sectional area of the wire used should be A_1 square inch, equal to $\frac{V \times A}{V_1}$. It should be noted that the latter formula refers to the cross-sectional area of the wire, not its diameter. Table I gives the diameters and cross-sectional areas of various gauges of wire.

Gauge of wire (s.w.g.)	Diam. of wire (inch)	Cross sectional area of wire (sq. inch)	Current (amps)	Resistance (ohms per yard)
13	0.092	0.006648	12.7	0.101
14	0.080	0.005027	9.5	0.134
15	0.072	0.004072	7.4	0.165
16	0.064	0.003217	6	0.209
17	0.056	0.002493	5.3	0.273
18	0.048	0.001810	4.3	0.372
19	0.040	0.001257	3.7	0.536
20	0.036	0.001018	3	0.661
21	0.032	0.000804	2.8	0.837
22	0.028	0.000616	2.2	1.093
23	0.024	0.000452	1.8	1.487
24	0.022	0.000380	1.5	1.77
25	0.020	0.000314	1.25	2.142
26	0.018	0.000254	1.05	2.645
27	0.0164	0.000211	0.9	3.186
28	0.0148	0.000172	0.76	3.914
29	0.0136	0.000145	0.68	4.634
30	0.0124	0.000121	0.59	5.575
31	0.0116	0.000106	0.52	6.37
32	0.0108	0.0000916	0.47	7.35
33	0.010	0.0000785	0.42	8.571
34	0.0092	0.0000665	0.37	10.128
35	0.0084	0.0000554	0.33	12.149
36	0.0076	0.0000454	0.28	14.840
37	0.0068	0.0000363	0.26	18.536

Table I.—Details of Eureka Resistance Wires.

(Concluded on page 538)

Making a Liquid Rheostat

How to Build One at Home

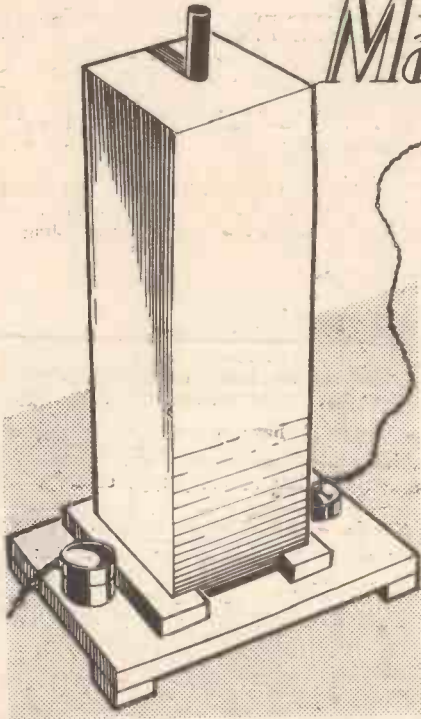

THE finished rheostat is shown in perspective in Fig. 1, while Fig. 2 shows the main part of the apparatus. The plugs can be purchased at any multiple store, and the glass tube can be obtained from a firm of laboratory suppliers. The remainder of the apparatus is made from light brass, vulcanite, and either pine or white wood.

Construction

The glass tube is a resistance glass test tube, 8 in. \times 1 in., having walls of from 1 to 1.5 mm. in thickness. From thin sheet brass (about .5 mm. thick) cut out two discs of such a size that they will pass fairly easily

up and down the tube (Fig. 2). Next obtain a piece of $\frac{1}{8}$ in. brass rod 8 $\frac{1}{4}$ in. long and thread the two ends to take No. 5 nuts. Fasten one disc to one end by two nuts, as shown, and push it to the bottom of the tube.

Fit over the brass rod a piece of glass tube 7 $\frac{3}{8}$ in. long to insulate it. The glass tube may be easily cut to the required length by making a small notch at the necessary point, placing the thumbs together on the opposite side from the notch and going through the action of attempting to bend the tube, when it will snap off neatly and cleanly at the notch.

Take a similar brass rod, 8 $\frac{1}{4}$ in. long, and thread the two ends as before. With a rat-tail file cut out a circular slot in the second disc so that it can slide fairly easily over the glass tube as shown in Fig. 2. Fasten it to one end of the second rod by two nuts and place it in the test tube.

The Wooden Support

All the woodwork shown is $\frac{1}{2}$ in. thick. First of all prepare a rectangular baseboard, 10 in. \times 5 in., and if small blocks are screwed to the corners it greatly assists the stability of the apparatus, and the ease and neatness of the wiring. The uprights are 7 $\frac{1}{2}$ in. high and 2 in. wide, and the platform top is 4 in. \times 2 in., with a circular hole bored in it to allow the test tube to pass through easily. A good fit is ensured if a piece of baize or other cloth is glued round the inside of the hole and the centre of the baseboard should be countersunk slightly to keep the bottom of the tube steady. Next screw on to the platform two rectangular pieces of vulcanite, 1 in. \times $\frac{3}{4}$ in. \times $\frac{1}{4}$ in., to act as insulators.

From the sheet brass cut out two strips 5/16 in. wide, one 1 $\frac{1}{2}$ in. long and the other 1 $\frac{3}{4}$ in. long. Drill two holes in the 1 $\frac{1}{2}$ in. brass, one to take the rod and the other for a wood-screw. A corresponding hole is drilled in the vulcanite, also to suit the wood-screw. Fasten the rod by means of a nut and screw the brass strip down to the vulcanite. The rod then becomes a fixture and is insulated (see Fig. 2).

With a rat-tail file cut a circular notch in the other strip, 1 $\frac{3}{4}$ in., to fit the other brass rod. Bend the strip as shown. Drill the strip and the vulcanite to take two wood-screws and fasten them to the platform. If the curve of the strip is adjusted it will be found that the second brass rod will slide up and down the test tube while maintaining contact with the strip brass.

A $\frac{1}{2}$ in. rod of vulcanite, or other insulating material, 8 $\frac{1}{2}$ in. long, is drilled and tapped one end so that it can be screwed on to the brass rod. About $\frac{1}{2}$ in. up from the bottom a screw is fixed to act as a stop.

Join the brass strip to one side of the socket and take the other out as one half of a piece of flex. The other half of the flex should be joined to the other side of the socket.

To cover any "live" parts, construct a box having a hole in the top to allow the $\frac{1}{2}$ in. vulcanite rod to pass through. The outline of this box is shown by dotted lines in Fig. 1. To maintain it in position fast-

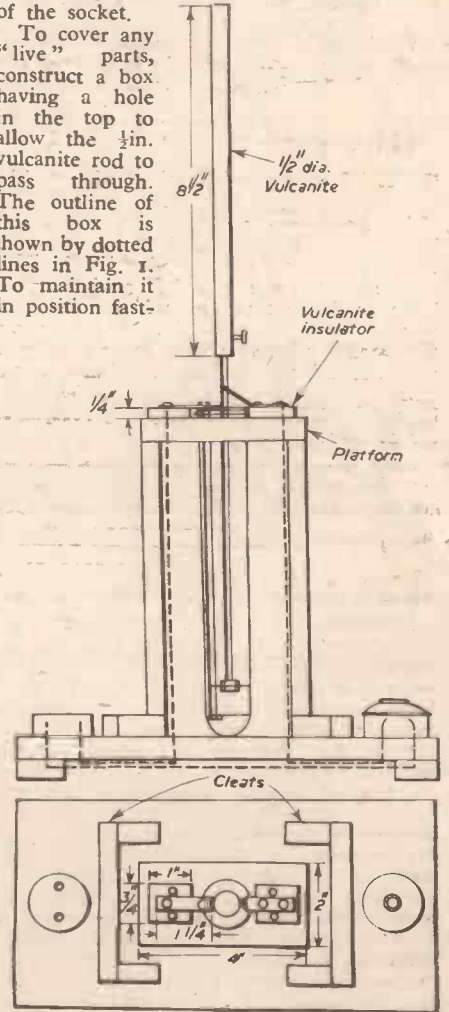

Fig. 3.—Side elevation and plan views.

en wood strips to the baseboard, but not so close to the box that it cannot be lifted easily. Finally, it is necessary to fill the tube with the electrolyte, which is a 5 per cent. (approximately) solution of sodium sulphate.

The apparatus is now ready for use. The twin flex is fitted with a plug and plugged into the mains and the lamp or motor, etc., plugged in at the other side. If the movable disc touches the fixed one at its lowest point there is no resistance in the circuit. On raising the movable rod the resistance is increased in the circuit, and the amount of current passing is reduced. The movable rod must be moved up and down slowly to allow the liquid to flow past the disc attached to it.

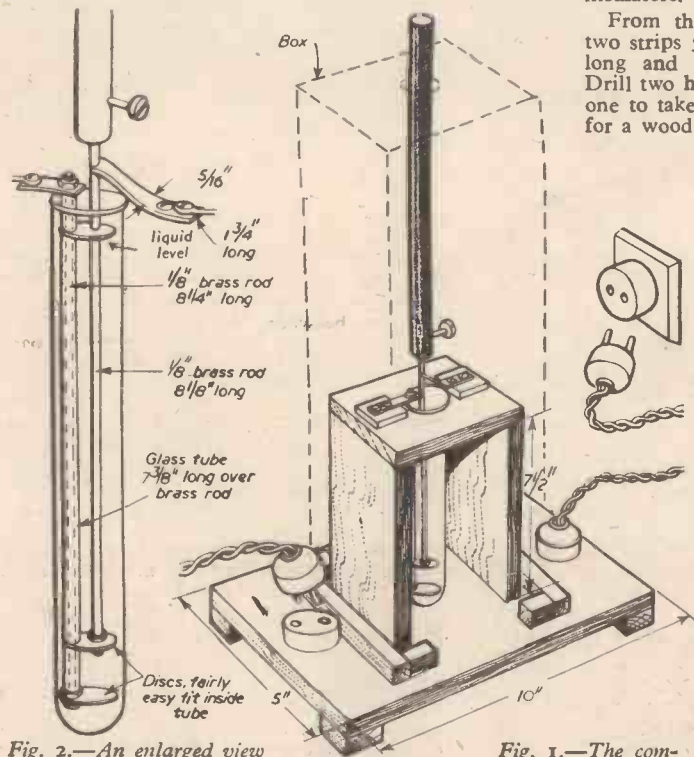

Fig. 2.—An enlarged view of the tube assembly.

Fig. 1.—The completed rheostat.

An Introduction to Ship Modelling

Waterline, Scale, Galleon and Sailing Models

Described by
G. M. GAYNOR

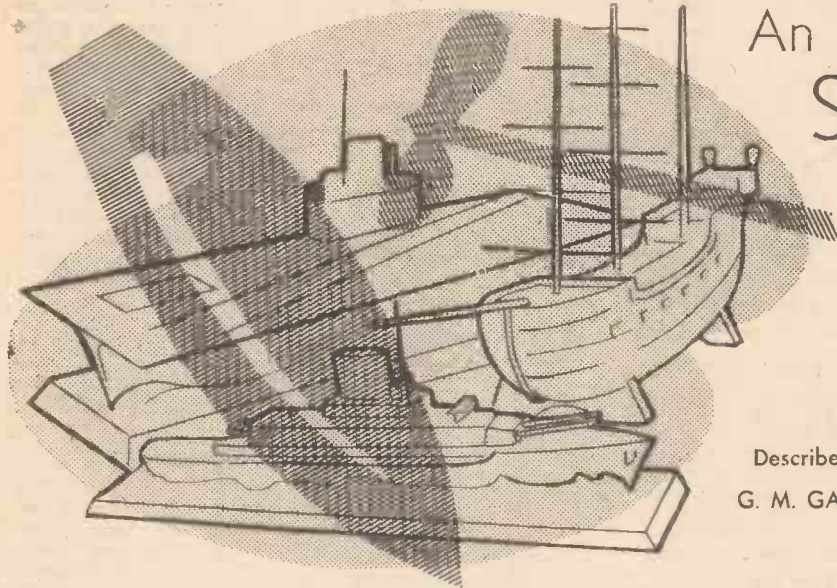

THE first impression gained of any ship is of that portion above the waterline, i.e., hull, bridge, funnel and masts. To make the simplest possible type of model this is all that need be considered.

The only tool required is a sharp pen-knife and the materials will consist of a piece of wood $6\text{in.} \times \frac{3}{4}\text{in.} \times \frac{1}{4}\text{in.}$, some thin cardboard (empty shoe boxes are ideal), pins, needles, glue and some ordinary water paint. A picture of a passenger liner can be obtained from some shipping companies for nothing.

aft is made from a "T"-piece cut to the width of the ship with the centre of the "leg" along the centre line of the ship. The main bridge is made from card cut to shape, and an extra intersection may be needed to make the higher bridge. The funnel is made by painting the appropriate colours on a piece of paper, rolling to shape and gluing. The lifeboats are cut from flat pieces of card and glued along the "boat deck." They can be very effectively shown by bending pins to the shape of davits and gluing the boats to the underside of these pins.

The masts are made from pins or needles. Make sure that the masts and funnel are on the centre line from the tip of the bow to the stern; also, looking at them abeam, they should all be parallel.

Paint the model with water paints. These, of course, only give a matt finish, but nevertheless they provide good practice.

A Scale Model

Don't choose anything too elaborate, a popular liner, either

passenger or cargo is suggested. Most modelers use a scale of 100ft. to 1in., or 50ft. to 1in., these being the handiest to work with, that do not call for intricate detail. A plan will be required and there are some very good plans on the market such as Tudor Model Plans. This firm has a very good selection of plans of every type of ship.

Materials

For all model ships there are only two kinds of wood to use, obeche or resin bonded ply. The tools required are the same as before—a good, sharp knife and



Fig. 1.—The super-structure of a water-line model.

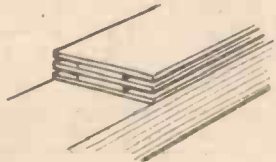

Shaping the Hull

Start paring the wood to make the bow and stern. For the stern, just keep cutting the small corners off until the shape is approximately correct. A point to remember here is always to keep the fingers behind the blade of the knife. The bow is easier to shape, all that is required being two straight diagonal cuts which must be started at an equal distance on both sides from the eventual point of the bow.

The Decks

The decks in this case are made from shoe boxes. Cut four pieces the same width as the hull and about half its total length, then cut one of these exactly in half along its length. Sandpaper the hull smooth and then glue the first piece of card in an amidships position as shown in Fig. 1. Along the centre of this is glued one of the half-pieces, then one of the full-width pieces, another half-width piece and finally a full-width piece. The stern section, or poop, is built up in the same way, small pieces being cut to shape and glued on. The bow can be made by gluing two pieces cut to shape but without the half inter-sections. The "docking bridge"

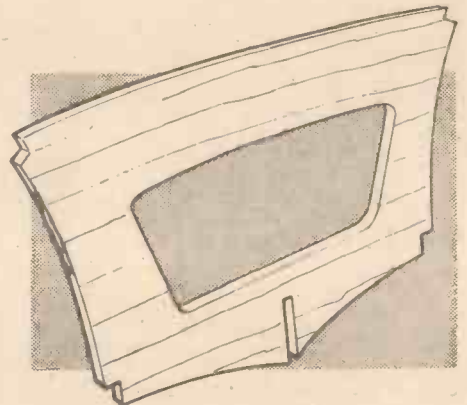

Fig. 2.—A typical bulwark for building a power model.

some fine sandpaper and, of course, model-makers' glue, such as "Casco." The advantage of this product is that you need only mix enough for immediate needs.

Construction

Trace the lines of the plan on to the wood carefully, then start cutting out the various parts. This completed, gluing can be commenced. Do not soak the layers with glue or it will ooze out over the sides, causing bubbles, which have to be removed later.

While waiting for the decks to dry, be shaping the funnel, cutting the masts and derricks, etc. The former will be made out of dowelling and the latter from piano wire. The correct positioning of these can be obtained the same way as for the last model, and checked by looking from bow to stern to make sure they are all in line. If ratlines are required these are made from black thread or cotton.

Painting

Obeche has a very fine grain, which needs to be filled with a good paint filler. Let the first coat thoroughly dry and rub down with fine, wet sandpaper. Repeat the process until the grain is properly filled, then finish with either the colour to choice or the colour as per plan. Do not look for short

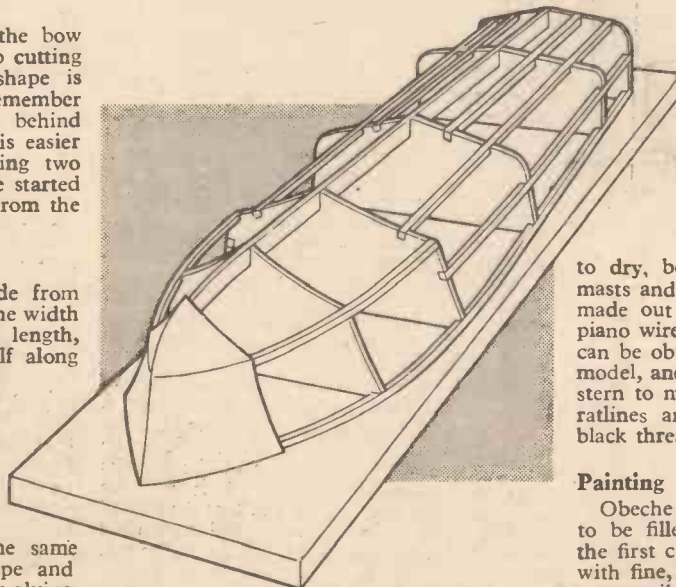

Fig. 3.—The assembly stage in building a sailing model.

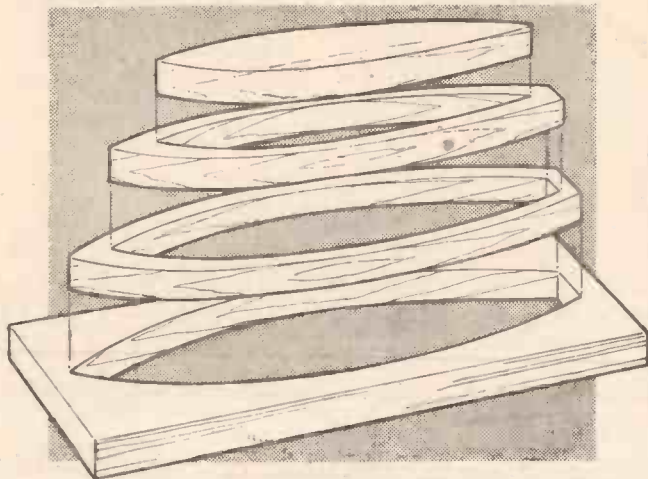

Fig. 4.—Cutting several "bread-and-butter" layers from one plank.

cuts. No one can or should expect to get a good job of painting done by just opening a tin of paint and brushing away till the surface is covered. The secret is, of course, to know the materials used. Only by trial and error will it be appreciated how, for example, a much better finish will be obtained by either "brushing in" or "flowing on." Brushing in is more an action of dabbing paint into every crevice, while flowing on explains itself, being a smoother action.

It often enhances the final coat to give it an extra coat of metal polish, and rub lightly off with a soft cloth. This gives a protecting skin that minimises scratches and dents which would otherwise necessitate re-painting.

"Wet sanding," mentioned earlier, is a simple process. It is a most important process in wood sealing, and the best way to learn about it is to pay a visit to the local coach painter and watch him.

The woods that are used in modelling are very open grained, and balsa is the worst of them all. It is a very lightweight, open-grained wood that is used in the construction of galleons, etc., but not so much

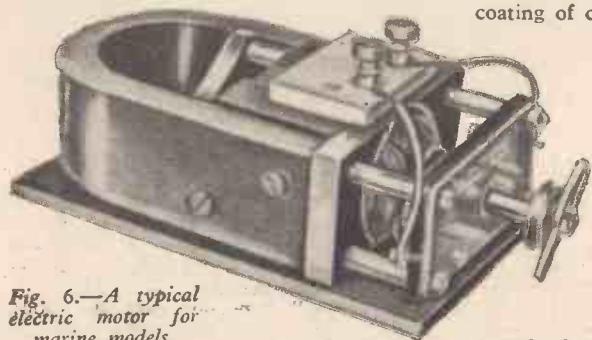

Fig. 6.—A typical electric motor for marine models.

in the type of model being dealt with at present. With balsa, both wet and dry sanding are needed, and probably will take up to nine sessions, whereas obeche rarely needs more than two sessions of sanding. The commonest type of paint used is "dope," a highly synthetic cellulose paint that plays havoc with your brushes unless they are washed after each and every process with a good quality thinners or acetone. Don't try thinning dope with turps or the paint will just coagulate,

A Galleon

A full-hulled ship that is very easy to make, the next model is a galleon made out of balsa wood. It will be purely a show piece; not a sailer.

Materials

Plywood 9in. X 6in. X 3/16in. will be required and a piece of block balsa 12in. X 2 1/2in. X 2in. Cut the balsa into two lengths of 6in. and the plywood into two widths of 3in. Take each piece of balsa and shape for bow and stern. Remember that each piece represents half the hull, so only one side of each is shaped. Make sure that one piece is cut right hand and the other left hand. By fitting the two pieces together and roughly marking the contours, this will be ensured.

Take one piece of plywood and shape the keel, having drawn a rough outline on this from the plywood in a piece of plywood 3in. deep and two blocks of balsa 2 1/2in. deep. Place all three together so that the plywood forms the centre line of the ship and glue them together so that the top of the ply is flush with the tops of the balsa. While the glue is drying, use the other piece of plywood to shape the deck-houses, poop and fore-castle. Two equal lengths of 1/4in. dowel make the masts, which are glued in position.

Before positioning these, it would be better to carry out the wet sanding, dry sanding and painting. As this is not a sailing model, a stand to sit it on will be required. This is made from dowels and plywood that is left over from the previous operation.

Sails

These should not be too elaborate. A fine cream vellum paper that has had a coating of clear varnish is suggested. The spars are made from a slightly thinner dowel than the masts, and it is advisable to paint these before erecting. Once again good quality black twine is used for the rigging.

A Sailing Model

There are two major ways of building a boat that sails, firstly, the bulwark type or the plank-built (or, as this is called, "bread-and-butter" hull). The former is

completely made of plywood and is the usual method of making launches, etc.: the latter is where the hull is built up in layers and is the approved method for liners, etc. With the plank-built type, obeche is used throughout, so naturally the model is heavier. Both methods leave a natural space amidships for a motor and so eliminate the laborious hollowing-out process.

Hulls built by the bulwark method are sometimes referred to as "Chine Line" hulls. Get to know both ship and plan before starting cutting. One other point before deciding on the

method used. Unless you are a craftsman do not try to diagonal plank your first hulls. Stick to the tried way of sheet planking the full length of hull. The first essential in this method is to have a sound framework built on a sturdy keel. This framework is made from plywood as per plan, with the centre of the bulwark cut out as in Fig. 2 to save weight. These pieces will go a long way towards making deck fittings, etc., to say nothing of being able to cut down expense. Fig. 3 shows how the bulwarks will look before the skin is attached. This is rarely shown on the plan. This method of longitudinal sheet covering, where the grain runs fore and aft, is the most popular because of its ease of assembly and its strength and lightness. During the actual assembly stage it will be found a lot easier to assemble the frames on a flat surface as Fig. 3 shows.

Propulsion

There is only one method that is satisfactory for this type of craft and that is the small electric motor run off an ordinary flat battery as used in flashlamps. Here is one final hint: the socket for the prop shaft must be dead centre and carefully aligned with the motor bearers.

The Bread-and-Butter Hull

This type of hull is assembled layer on

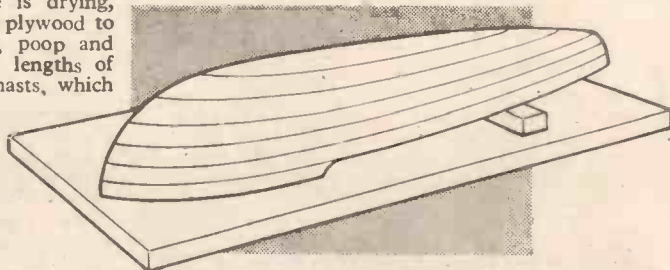

Fig. 5.—Hull layers nailed together ready for shaping.

top of layer, and although this method takes the most work and, of course, most accuracy, the art is displayed in its finest form. These ships, ranging from the humble tug to the mammoth liner, not only give most pleasure, they lend themselves more easily to modern methods of propulsion in steam, diesel and also for radio control. One good point about bread-and-butter-built models is that if one layer is spoilt, only that layer has to be replaced and not the whole hull. The wood used is best-quality obeche as this wood has no knots and the grain is very fine and very straight.

On the plan may be shown about 10 layers from keel to deck, but less than 10 planks will be required. Each plank is usually 3ft. long and varies from 3in. to 6in. in width. By cutting the biggest layer out carefully, the centre of this plank will serve for one or more of the lower layers. Fig. 4 shows this.

Before starting the actual making, get to know the ship and plan thoroughly before starting to cut. If personal contact is not possible, buy a good photograph; there are

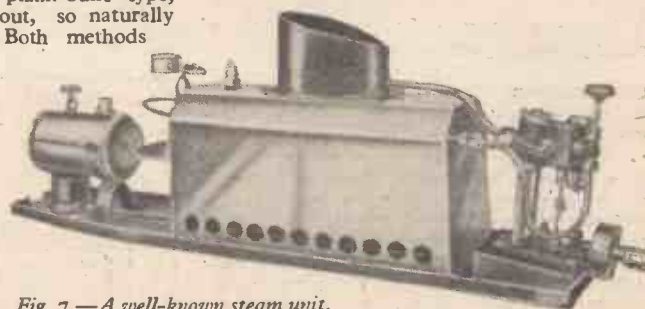

Fig. 7.—A well-known steam unit.

many good postcards in this category.

• Make your own templates by tracing the outlines of the plan on to thin cardboard, which is then cut out accurately. These contours are then retraced on to the wood and cut just as accurately. The advantage of doing this is that if the plan is lost work does not stop. The template will show the contours of the outer cuts, then allow $\frac{3}{16}$ in. width all the way round for the inner cutting. This width will be found necessary when the final stage of planing down is reached. If the inside cut is made first, this will give more strength to the plank while making the outer cut. The centre piece is then used for another layer, and only needs the inner cut making as the outer side is already shaped from previous cut. This process is repeated again for a further layer, making the most economical use of the timber and cutting down waste and expense.

Having cut out the planks as marked, assemble the layers with screws—no gluing yet (Fig. 5). Now pare off the outer sides to conform with the plan, using the templates to check the progress. When the hull is nearly in perfect shape, drill the stern tube and rudder shafts; this part must be dead centre and true. Now take the screws out and glue, rescrewing to hold in place. The glue on each layer must be dried before adding the next layer. Next plane down to

correct pitch, wet and dry sand and leave for at least a day to harden.

The Motor

Hardwood stringers will have to be fitted to take the engine, and, of course, the size of these depends on the size and shape of the respective engine. Once the motor is in place the decking can be put in place, but do not forget that the motor will have to be accessible.

Deck Fittings

These can be had from a reputable firm who specialise in this type of work. A model will be ruined by shoddy deck fittings and the reader who is not a craftsman is advised to purchase them.

Propulsion Methods

The simplest method is the rubber band method, where a rubber band is attached to the inner end of the propeller shaft and the other end of the band to a hook in the midships hull. The best method is the small electric motor, driven off an ordinary flat battery or small accumulator. These motors are light in weight and very efficient. A $\frac{3}{16}$ in. launch can be run for two hours and still not exhaust the battery. Some enthusiasts

prefer the accumulator to the dry battery as these can be very easily charged and will last longer. Another point is that navigation lights, saloon lights and, of course, radio control can all be worked off the same power source, thus cutting down weight.

The third method is the diesel motor, but up to now this has not been adaptable to radio control generally. Direction can be controlled but not speed. The marine diesel engine is gaining in popularity, and the model version has made great strides. This engine can be obtained with water-cooling jacket and is specially made for the confined space in a model hull. Another feature is the fly-wheel, which can be fitted as an extra for easier starting. The ship is in motion at a regular speed for as long as there is fuel in the tank.

The Steam Engine

Those who are not engineers either by trade or hobby and who wish to use steam propulsion are advised to invest in a commercial engine, such as the "Stuart Turner" engine or the Streamlinia, shown in Fig. 7, which is available from Bassett Lowke Ltd.

The water-line enthusiast who wants a complete kit, with hull cut to shape and sheered, can obtain this from Caledonian Model Accessories, 10, Mark Street, Wallasey.



THE snake is made from two pieces of stripwood, $\frac{1}{2}$ in. by $\frac{1}{2}$ in., which can be anything from 18 in. to 24 in. long. American yellow pine, Canary whitewood, or Virginian red cedar are the best woods to use because of their capacity to hold glue.

With a plane taper one end and shape the wood as shown in Fig. 2. This also shows a section across the centre of the snake to indicate how the edges are rounded. Taper the tail and finish with a file and sandpaper. Cut the open mouth with a saw and shape the head with a knife. Glue to the inside of the mouth a piece of tape, fork-shaped, to appear like a tongue.

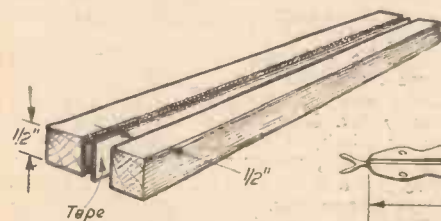
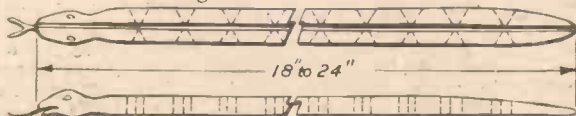

Fig. 1.—Sandwiching the tape.



Cross section of the snake
Fig. 2.—Shaping the body.

Yellow deal, spruce fir, satin walnut, or mahogany are good alternatives.

Construction

Plane one side of each strip so that when the strips are placed side by side they fit close together. Then get a piece of $\frac{1}{2}$ in. tape and put it between these two planed sides, as shown in Fig. 1. Glue the tape and the strips of wood together and hold them in cramps for about 24 hours until the glue is thoroughly hard and dry. You now have a strip of wood $\frac{1}{2}$ in. thick and about 1 in. wide.

Cutting the Body

Next, V-shaped pieces of the snake's body have to be cut away, so that it can bend and writhe about. The best way to do this is by using a bench block, as shown in Fig. 3. This is quite easy to make. The two kerfs, or saw-cuts, are at 60 deg. to the top of the block and are used to guide the saw when cutting the snake. A strip of wood B is fastened on the bottom board C to hold the snake secure, and the strip marked D is gripped in a vice. When sawing out the wedges of wood take particular care to avoid cutting the tape.

When this stage is reached the snake is already quite lifelike but its effectiveness can be tremendously improved by the colours

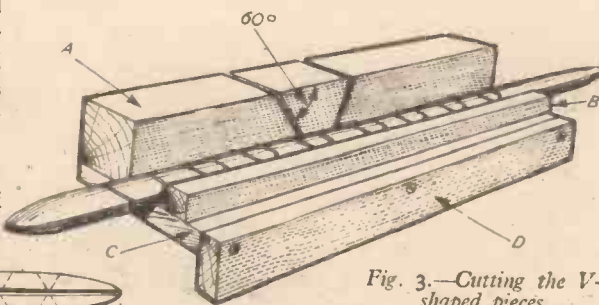

Fig. 3.—Cutting the V-shaped pieces.

selected for painting. Green and black looks very lifelike and yellow and brown is another good colour scheme. When one snake has been made and the method of construction becomes familiar, the shape can be improved and other improvements introduced.

SECOND PRACTICAL MECHANICS HOW-TO-MAKE-IT BOOK

By F. J. Camm

192 pages. Hundreds of illustrations, 15/- 16/3 by post.

The articles included in this book, which are extensively illustrated with photographs and diagrams, include an aqualung; electric hedge trimmer; folding outboard motor boat; potter's wheel; synchronised electric clock; midget camera; bathroom scales, etc., from:

GEO. NEWNES LTD., Tower House, Southampton Street, London, W.C.2.

A WONDERFUL MONEY-SAVING OPPORTUNITY FOR READERS OF PRACTICAL MECHANICS!

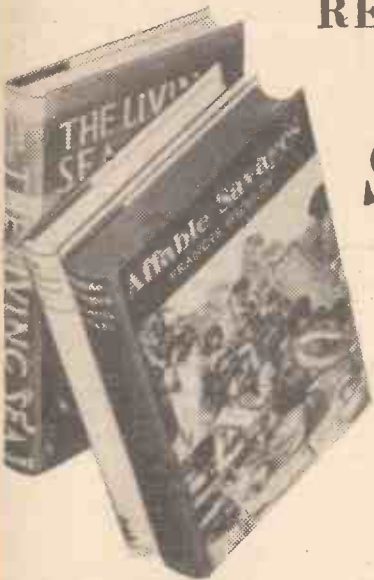

Now's the time to join the
Scientific Book Club

121 CHARING CROSS RD., LONDON, W.C.2

A FIRST-CLASS SCIENTIFIC BOOK EVERY MONTH FOR **ONLY 4/-**

FULL LENGTH FULL SIZE!

ALL THESE GREAT TITLES!

Recent and forthcoming selections—at only 4s. to members—include:

★ **AFFABLE SAVAGES**

by Francis Huxley
Published at 25s.
4/- TO MEMBERS

★ **ONCE ROUND THE SUN**

by Ronald Fraser
Published at 16s.
4/- TO MEMBERS

★ **ATOM HARVEST**

by Leonard Bertin
Published at 20s.
4/- TO MEMBERS

★ **THE PAST IN PIECES**

by P. E. Cleator
Published at 21s.
4/- TO MEMBERS

★ **MAN UNLIMITED**

by Heinz Gartmann
Published at 18s.
4/- TO MEMBERS

In addition to the selections listed above, Scientific Book Club members have received books by these great authors: Dr. J. Bronowski, Prof. J. B. S. Haldane, Ritchie Calder, Sir Harold Spencer Jones, Dr. Julian Huxley, Leonard Cottrell, Kenneth Walker.

Gift Offer!
CONTEMPORARY 'Tidy Tub'

You can obtain a gay contemporary "TIDY TUB" Wastepaper Basket or Flowerpot Holder free if you enrol a friend in the Club. Send your friend's name and address with 5s. (4s. plus 1s. postage) for the first book, mentioning this offer, and your "Tidy Tub" will be sent to you.



★ Each month, the Scientific Book Club brings to its members the fascinating story of the march of modern science, told in thoroughly dependable books by the front-rank scientific writers of our time—vivid, vital, constructive contributions to Man's unceasing struggle to solve the problems of the Universe. And although the ordinary editions of these books are sold to the general public at 12/6, 15/- or 21/-, THE PRICE TO MEMBERS OF THE SCIENTIFIC BOOK CLUB IS ONLY 4/-. Remember, too, that Scientific Book Club selections are full-length and unabridged. They are printed on good quality paper, well-bound, with an attractive picture jacket. These are, we say with certainty, books that you will be glad to read, proud to own. The Scientific Book Club brings these great books to you each month; helping you to build up, at remarkably low cost, a first-class collection of scientific books. Now is the time to join!

EXCELLENT PRODUCTION

Legible modern type is used for all Scientific Book Club selections. The pages are designed with ample margins and every book is carefully planned for comfortable reading. The Scientific Book Club's selections have been widely praised for the high standard of their production.

FILL IN THIS ENROLMENT FORM TODAY

To the Scientific Book Club, 121 Charing Cross Road, London, W.C.2.

I wish to join the Scientific Book Club and agree to purchase the selected book issued each month to members at a cost of 4s. (postage 1s.). I agree to continue my membership for a minimum of six books and thereafter until I cancel.

You may enrol through your usual bookseller (if he is a member of the Booksellers' Association).

* I will pay for selections on receipt.

Or if you wish to save time, postage and postal-order costs, you may send an advance subscription. Six months 30s.; twelve months 60s.

* I enclose 30s./60s. (strike out amount not applicable).

*Place ✓ in the space above, as required.

Prac. Mech. Aug. '58

The Scientific Book Club is owned and controlled by Foyles, the world-famous booksellers.

Name
BLOCK LETTERS, PLEASE

Address

Overseas enrolments should be accompanied by an advance subscription. Prices 3s for inland (except South Africa, Australia, New Zealand).



Letters to the Editor

The Editor Does Not Necessarily Agree with the Views of his Correspondents

Exploiting an Invention

SIR,—With the greatest respect to the author of the above article in your June edition, I feel I must write to express my disagreement with most of the advice he tenders to would-be inventors.

I do not claim to be an authority on the subject but I have learnt a great deal the hard (and expensive) way in the course of making application for patent on at least fifteen occasions during the past ten years and I know for a fact that the cost of patenting even a simple idea in ten countries (including the U.K.) would be at least £750 if, as the author rightly suggests, the services of a patent agent are utilised.

No wonder the author writes, "Having got the invention fully protected, normally the home-trader has not sufficient money to go further. . . ." but do your readers appreciate the likely cost or that there is a much simpler and cheaper way of exploiting an idea?

Assuming that an idea is genuinely worth while and that a provisional application for patent has been filed in the U.K., the cost

involved should be the limit of the amateur inventor's investment. If the idea appeals to a manufacturer, the question of foreign patent applications and the cost thereof is a matter for mutual agreement and should present no real problems.

If, on the other hand, the idea cannot be "sold" during the statutory 12 months period, it is probably unsound commercially and the inventor would generally be wise to cut his losses and forget all about it. The total amount to be written off would possibly be under £20.—A. S. L. OWENSMITH (S.W.3).

New Theory of Gravitation?

SIR,—Gravitation, we are led to believe, is the natural pull of one body to another. The Earth, for instance, is supposed to pull everything on it towards its centre, but my theory is that nothing is pulled at all. Everything is pressed to the earth by outside pressure and this is brought about by constant bombardment of matter from space. Any body, no matter of what substance it is composed, will take the line of least resistance and nothing can alter this logical fact.

Let me take this reasoning further by

using it to explain the origin of the planets. The suns in space eject matter of varying mass and speeds which eventually loses its momentum through collision and then starts to orbit round the sun which has the most influence; i.e., the sun with the least resistance. The speed of orbit is very slow at first and it is this period in which particles of matter become attached more easily to one another to eventually become planets.

In our own solar system the planets have been, through time, orbiting round our sun with increasing speed, as they draw nearer to it due to the decreasing pressure, not the sun's gravitational pull. My theory is that the planet Mercury when it was in the same orbit as the Earth is today, had life on it just the same as the Earth has, and the same applies to Venus. The planet Mars will support life when eventually its orbit nears our own. The planet Mercury is the next to be absorbed by the sun, then Venus, our own Earth, and all other planets of the solar system in their turn. This state of affairs comes about by the lowering of the density of space between them and the sun, due to the nuclear fission taking place on the sun's surface. Nuclear fission creates a very large area of extremely low density, due to tremendous atomic disturbance and this then is the line of least resistance and not gravitational pull.—J. CLAYTON (Staffs).

SIR,—All the facts—and many more—which are related in the extract from the pamphlet of the Athenius Society (page 402, May, 1958, issue), are common knowledge among "saucer" enthusiasts. The definitions contained in the letter are known facts and are no longer disputed. They represent the core of our knowledge on the subject. One major fact still eludes us and that is the way in which the craft are propelled. We know the principle but the method of application remains a mystery.

From an analysis of sightings a number of very interesting theories on this propulsion problem have been evolved. Rolling them all into one something like the following is obtained:

"Flying saucers derive their power from the natural force which pervades all space (commonly referred to as etheric or creative rays which create all matter and electromagnetic waves. They travel from a fixed point in space—God?—in an alternating motion). This natural force is somehow modulated by the space vehicle, producing a field of force which can be projected some distance away from the craft in any direction. It can also be varied in intensity. A vehicle powered by this means would have a wide range of manoeuvres—high acceleration and 180 deg. turns would be possible, due to unlimited power. The occupants of the vehicle would, of course, suffer no ill effects because every particle in the ship would be attracted with equal power by the force field. . . ."

As it is impossible for flying saucers to originate from the Earth, attention must be turned to other planets—Mars and Venus. We should not pay much attention to spectroscopic analysis of their atmospheres. There

More About FLYING SAUCERS

are too many sources of error.—A. J. SAWYER (Solihull).

SIR,—I see that in his reply to my letter in the March issue of PRACTICAL MECHANICS dealing with the origin of UFOs and their propulsion method Mr. V. A. Milburn takes me up on the matter of "g" force and says, ". . . we all know under what circumstances "g" force becomes apparent, it is still nevertheless a force in itself." I am not going to split hairs; the force symbolised by "g" is a product of motion, the "backward pull" as Mr. Milburn describes it. Being as nothing is in a state of equilibrium (except in relation to the Earth or another body) and "motion" exists everywhere, we can perhaps say "g" force is synonymous with motion but it is not a fundamental as is gravity, which is synonymous with mass.

As Mr. Dixon (in the March issue) says, "Gravity is a fundamental attraction between all bodies and will never be 'neutralised.'" To reverse "g" force we would have to produce a "negative velocity" which is clearly impossible. However, we do seem to agree on the broad principle of the UFO propulsion method and as I say, we shall not split hairs. The UFO intelligences long ago realised the Earth scientists' dream, the "production" of artificial gravity and at least one saucer tome author has realised what the UFO intelligences had done. L. G. Cramp in "Space, Gravity and the F.S."—

page 82, says, ". . . if by some means the mass of the Earth were controllable and alternately increased and decreased, so proportionately would our acceleration fluctuate." Mr. Cramp goes on to suggest that it is possible to create an artificial gravitational field and that this field be controllable, i.e., it could be "produced" in any position relative to our space ship.

A thorough study of UFO flight characteristics will show there is no reversal of "g" force—but the creation of a "g field."—D. WIGHTMAN (Hindley).

SIR,—In commenting upon H. E. Ford's letter, May issue, 1958, I should like to say that "saucers" being on a spiritual mission is just about the loftiest of all the tallest stories!

Your correspondent states that the "saucers" are capable of various feats which have astounded observers, i.e., the ability to hover and then suddenly accelerate; the ability to climb sharply upwards at great speed; the ability to attain speeds of 25,000 miles per hour, and the ability to turn 90 deg. and acute angles, as well as reverse instantly.

If the above feats are supposed to come from some unearthly high intelligence, then there must be something radically wrong somewhere. I say this because all the feats of the "saucer" which are more in number than has been mentioned above, are just too, too simple to achieve. But one has to know one's gravity to be able to know exactly how these feats are carried out.

It has been said that gravity can have only one direction; this is not true, the gravity of the flying vehicle itself can be controlled, and used as the driving force.—V. A. MILBURN (Sittingbourne).

RAWLPLUG FIXING DEVICES and TOOLS...

Backed by the Name that Carries the Weight

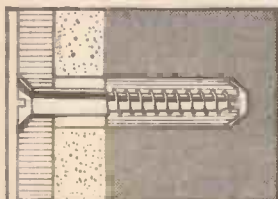

For firm Screw Fixings. The specially treated fibrous construction of the Rawlplug provides the most effective stronghold for wood-screws in any masonry. The simple method of making the hole, inserting the Rawlplug and driving home the screw enables firm fixings to be made quickly without mess or damage to walls or decorations. Sizes are from the tiny No. 3 to the 1" diameter No. 30.

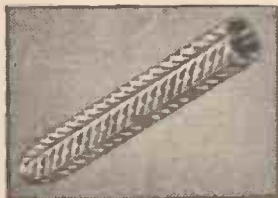

On the occasions where a metal plug is preferred or advised, such as for wet or acid situations, there is the choice of Rawlplug Screw Anchors or White Bronze Plugs, but for these Cadmium plated screws should be used.



Heavy Duty Fixings. RAWLBOLTS are expansion bolts which only require a hole in the masonry in the same way as a Rawlplug. By turning the bolt the metal segments are locked within the hole and the fixing will take very heavy loads with complete safety. Sizes are from 3/16" to 1" diameter.

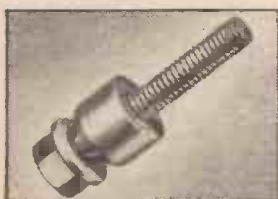

Wet or Acid Situations. Rawlplug Bolt Anchors and Rawltamps are made for heavy duty bolt fixings in places where the exposure to corrosion is extremely high. The Bolt Anchor can be set deep down in thick concrete whereas the Rawltamp enables a threaded insert to be fixed in shallow concrete.



Thin or Cavity Walls. Proprietary building materials often present fixing problems because of being either hard and thin or thick and soft. The Rawlplug Company have devised several clever devices for making firm fixings to such materials including lath and plaster ceilings, hollow pot, panel doors, etc.

The upper illustration shows how one of the devices will make the almost impossible fixing of a metal plate to a pipe and the bottom illustration shows how the wings of a Spring Toggle spread the load over a plasterboard ceiling.

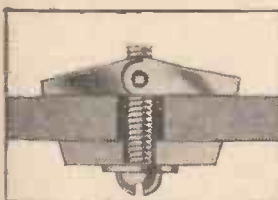

Rawlplug Fixing Devices and Hole Boring Tools are sold by Ironmongers, Hardware Dealers, Builders Merchants and Stores. If you experience any difficulty in obtaining the type and size you require please send details to the following address.

Rawldrills. Standard sizes for Rawlplugs Nos. 3 to 30 and Rawlbolts A. B. C. D. E. and G. Adaptable Rawldrills need only three holders for the 10 sizes Nos. 3 to 22. There is also a very useful Universal Tool-set with a knurled holder to take Universal Rawldrills Nos. 6 to 20.

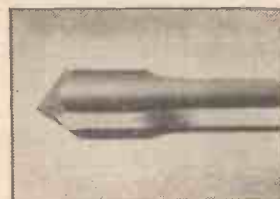

Durium tipped Drills. For faster, silent penetration of masonry and tiles Durium drills are the answer. They can be used in hand or suitable electric drills. Sizes for Rawlplugs Nos. 6 to 30; for C. D. E. and G. Rawlbolts, and a long series for drilling right through walls. Free resharpening Voucher given with every Durium drill.



Rawlplug Stardrills. An inexpensive one piece tool for use on jobs needing a small number of holes. Twenty sizes from 11/32" to 2 1/2" are made, of which eight are for Rawlbolts "A" to "K", and it is only necessary to quote the reference letters of the Rawlbolts when ordering Stardrills to use with them.



Wall Boring Tools. Specially designed for rapid boring right through walls. This triple fluted percussion tool with hexagon handle in one complete unit has been proved to make a 3/4" hole right through a 9" stock brick wall in nine minutes. Lengths 18" and 24", diameters from 5/16" to 1 1/2".



Tubular Boring Tools. Will bore a clean hole in soft brick wall quicker than any other hand percussion tool. The serrated edges saw through masonry and the dust is collected in the channel and ejected through the elongated slot. When working in deep holes the tool should be withdrawn periodically and the dust tapped out. Size are from 1/2" to 1" diameter.

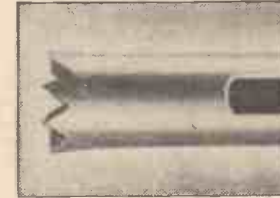

Power Tools. In addition to the hand tools listed above special Rawlplug tools are made for use in electric and pneumatic power tools. Details of these can be had on application.

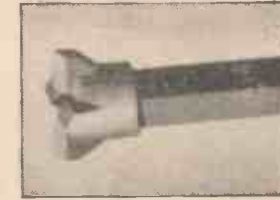

B597

EMI "HIS MASTER'S VOICE" MARCONIPHONE · COLUMBIA

Announce NEW PRACTICAL WAY OF LEARNING AT HOME

NEW — completely up-to-date methods of giving instruction in a wide range of technical subjects specially designed and arranged for self-study at home under the skilled guidance of our teaching staff.

NEW — experimental outfits and lesson manuals are despatched on enrolment and remain the student's property. A tutor is allotted to each student for personal and individual tuition throughout the course.

Radio and television courses, with which specially prepared components are supplied, teach the basic electronic circuits (amplifiers, oscillators, detectors, etc.) and lead, by easy stages, to the complete design and servicing of modern Radio and T/V equipments.

If you are studying for an examination, wanting a new hobby or interest, commencing a career in industry or running your own full-time or part-time business, these practical courses are ideal and may be yours for moderate cost. Send off the coupon to-day for a free Brochure giving full details. There is no obligation whatsoever.

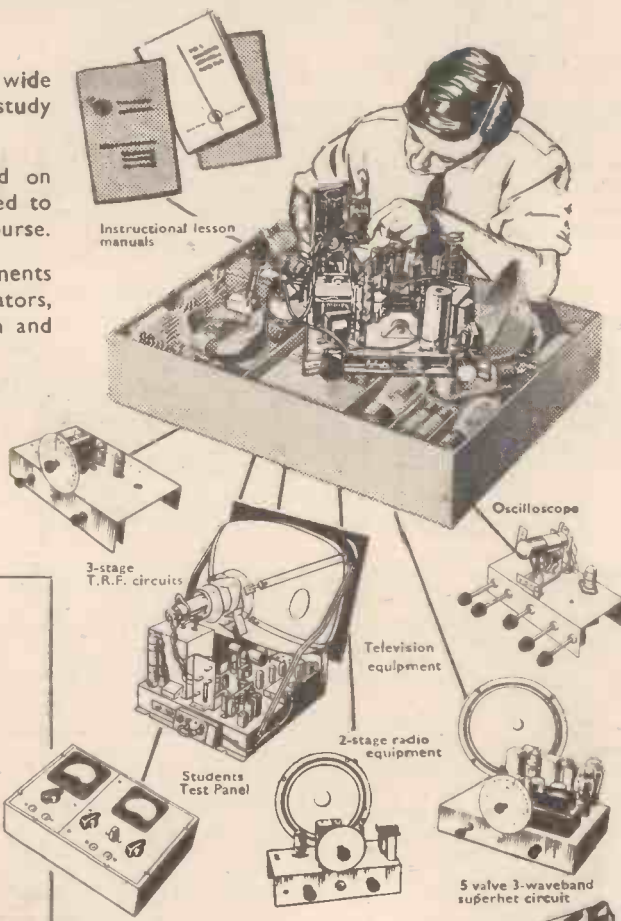

Courses with Equipment

- RADIO · SHORT WAVE RADIO
- TELEVISION · MECHANICS
- CHEMISTRY · PHOTOGRAPHY
- ELECTRICITY · CARPENTRY
- ELECTRICAL WIRING
- DRAUGHTSMANSHIP · ART, etc.

E.M.I. Factories at Hayes, England.



EMI INSTITUTES

The only Home Study College run by a World-wide industrial organisation

Fill in for FREE BROCHURE

E.M.I. INSTITUTES, Dept. 144 x, London, W.4.

NAME _____

ADDRESS _____

Age _____
(if under 21)

BLOCK CAPS PLEASE

I am Interested In the following subject(s) with/without equipments

(AUG/58) (We shall not worry you with personal visits)

IC.107



Raising the Standard

SIR,—I was very interested in "The Cyclist" leader "Can We Raise The Standard?" in the May issue. While I agree with many of the views written, I think the author did slightly exaggerate. I am a club member and have not found anything resembling "bun throwing" going on at tea-houses. True some people on cycles do not have much respect for other road users, but I would not call these people "cyclists."

I do not agree that most cyclists imagine that motorists want them off the road. However, many motorists definitely treat the cyclist with contempt. I have twice been nearly knocked off my cycle by the door of a car being opened while I was overtaking on a busy road. Very few motorists dip their lights when meeting a cyclist on the road at night. Pedestrians have little respect when crossing the road in a town. I wonder how many other cyclists have had a woman's shopping bag banged into their rear wheel; by a careless lady crossing the road?

As for the militant attitude of the N.C.U., most of this would probably have been spent, until recently, in hostility against the B.L.R.C.—H. LECHNER (Worcs.).

Light v. Heavy Cycle

SIR,—I must disagree with your statement in "The Cyclist" leader for June, that a heavy cycle requires less effort to keep it moving than a light one does. I became rather interested in the mathematics of the problem, and here present a simple proof to the contrary.

Let the light cycle and rider be of mass m

and heavy cycle, same rider, have mass M . To simplify the problem, assume the friction in the bearings and the air resistance to be the same in both cases and let the work done against these be A (a constant).

Further, assume the speed is constant at all stages of the motion.

Considering (as an example) the light cycle, we have two basic principles, thus:

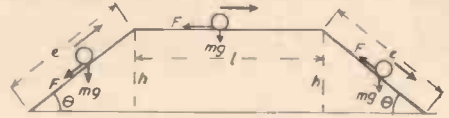

1. Frictional force between tyres and road = constant \times reaction perpendicular to the road, i.e., $F = \mu mg \sin \theta$.

2. Work done by rider = frictional force \times distance moved + potential energy gained + A .

i.e., $W = Fl + mgh + A = \mu l mg \sin \theta + mgh + A$.
Work done going uphill $W_1 = mg(\mu l \sin \theta + h) + A$.

Work done on flat $W_2 = \mu mg l + A$.

Work done going downhill $W_3 = mg(\mu l \sin \theta - h) + A$.

If m is changed for M , then in all cases (except the last, when h may be numerically greater than $\mu l \sin \theta$), more energy is expended when a heavy cycle is used than when a light cycle is used.—ROBERT R. SHOBBROOK (Leicester).

The Cycle Show

SIR,—With reference to your leader entitled "The Cycle Show," that appeared in "The Cyclist" page of PRACTICAL MECHANICS for June, 1958, I have read

this article with the keenest interest and agree with every word of it.

Naturally one is disappointed that the show is now only a bi-annual affair, but with the present trend of development, or lack of it, this seems to be inevitable.

It is painfully evident that bicycle design has crystallized over the last fifty years and, as you point out, the only change in the roadster models are in the colour schemes now introduced—and how revolting are these new "two-tone" liveries; most unsuitable for a bicycle. Compare the motor cycle of 1908 with that of 1958 and the roadster bicycle of the same period. Also, nowhere can one find the workmanship and finish of the old Marston-Sunbeam or Lea-Francis machines.

Why is no effort made to market a really comfortable "lightweight roadster" as well as the hideous "lightweight" on which manufacturers appear to lavish most of their attention?

As you point out, there is ample scope for development in the present "roadster" model. Why have the possibilities of the "cross frame" not been explored? Such a model was, I believe, designed by the late Sir Alliot Verdon-Roc, shortly after the last war, but this was never marketed. It seems remarkable that no attempt has been made to introduce a simple form of spring frame. Again, there is certainly a crying need for improvement in braking systems.

I note with pleasure that, on this page, you also refer to the Dursley-Pedersen bicycle. I well remember this fine machine; with its unconventional frame, hammock type saddle and generally excellent finish.—R. M. WOOLLEY (Cricklewood).

Making a Cottage Tent

(Concluded from page 506)

Making the Flysheet

After making the tent the reader will have little difficulty with the flysheet. It is made to extend a short distance beyond the end of the tent at both ends in the form of a little porch. The layout of the material for this sheet is shown in Fig. 13. Four strips of material are required. The two centre ones are the full width of the material, but the end two are only 30in. wide to make up the 10ft. width of material required. About 13ft. 8in. of length will be required. The ends of the flysheet are sloped off as shown in Fig. 12 and the V cuts made on the ridge line. The sides of the "V" are brought together and seamed. The sloping sides are then hemmed as are also the eaves of the flysheet. A strip of 2in. webbing is then sewn on the inside of the fly along the ridge and down to the ends of the seamed "V."

Holes are then worked in the ridge at a distance of 6ft. 6in. for the spikes of the separators placed on the top of the tent pole spikes. Galvanised rings are sewn on with ½in. tapes to the eaves at the bottom of each seam and at the ends of the two "V" seams. At the extreme corners two rings are sewn on as shown in Fig. 3.

An Extended Porch

The arrangement of tent and flysheet as shown in Fig. 12 may suit adult requirements, but when there are children it is of great advantage to have an extended porch some 6ft. beyond the entrance to the tent and which is formed by continuing the flysheet width. In such a case the sloping porch described for the first flysheet would be only required on the closed end of the tent (Fig. 14). For supporting the extended porch an additional 6ft. ridge pole and a 6ft. 6in. pole will be required.



A Problem of Pints

A DAIRYMAN has two churns, one full of milk, the other empty. He wishes to put 7 pints of milk in the empty churn, but has only two measures, one of 5 pints, the other of 3 pints. Can you show him how to do it?

Answer

Fill the 3-pint measure and pour it into the 5-pint measure. Fill the 3-pint measure again and pour as much of it as possible into the 5-pint measure. This leaves 1 pint in the 3-pint measure. Pour this 1 pint into

the empty churn. Now fill the 3-pint measure twice and pour the milk into the churn along with the 1 pint to make the required 7 pints.

What Shape?

BROWN is rather proud of his allotment because of its unusual shape. It is a ridiculous shape for an allotment, but he makes a point of telling everyone about it. All its sides are equal and they are straight, and what is more, there is a right angle between each pair of adjacent sides. No, it is not a square—it has twelve sides! Now, can you draw the shape of the allotment?

Answer

The allotment is in the form of a cross. If you drew a square, then divided each side equally into three and rubbed out the four small corner squares, you would have the ground plan of the plot.



PRACTICAL MOTORIST & MOTOR CYCLIST

Edited by F. J. CAMM

August Issue Now On Sale

Principal Contents

- The Problem of Overheating
- The Mobilgas Economy Run
- The Beginner's Guide to the Motor Car
- Overhauling the Jaguar 1½-litre
- A New Ignition System
- Your Insurance Simply Explained
- Overhauling B.S.A. A-Type Vertical Twin Engines

- Carburettor Maintenance
- Maintaining the Pre-War Morris 10-cwt.
- Water as an Aid to Fuel Economy
- Overhauling the Triumph Mayflower
- Reducing Noise in the Volkswagen
- Maintenance of the Standard Flying 9
- Garage Mechanic's Diary
- and many other interesting articles.



A Review
of New Tools, Equipment, etc.

"Selecta" Speed Changer



The Selecta speed changer.

KNOWN as the Selecta "Speedor" and made by Selecta Power Tools Ltd., Hampton Road West, Hanworth, Feltham, Middlesex, this device will fit popular $\frac{1}{4}$ in. drills and enables the correct cutting speeds for drilling copper, brick, marble, tiles, vitrolite, asbestos, soft metals, etc., to be obtained. The speeds can be increased or reduced in a ratio of four to one. For example a drill with no load could have a speed of 2,500 r.p.m.; this could be reduced to 625 r.p.m., or increased to 10,000 r.p.m. The makers claim instant fitting and other features of the "Speedor" are an epicyclic gear box and ball bearings throughout. The price is 48s. 6d.

The Dafilé Handipak

DAFILE flexible tension files will shortly be available in a convenient pack for use by the handyman and model-making enthusiasts. The Handipak will contain a set of three (rough, medium and smooth cut) Dafilé flexible tension files with links for use in any standard 10 in. hacksaw frame together with a similar set of Dafilé Adapta-files which will fit any standard 6 in. (junior) hacksaw frame.

Dafilé tension files cut in any direction and may be used to produce the most intricate profiles in metal, wood, hardboard, plastics or, indeed, in practically any material in sheet, bar or tubular form. The teeth on Dafilé tension files are accurately cut to filemakers' specifications and are designed to minimise clogging, even when used on the softest materials. The price of the Handipak, which will be available next month, will be 5s.

New Dexion Slotted Angle

AN improved version of Dexion 140 slotted angle is now available. Strength has been increased and rigidity improved by eliminating the series of slots which ran parallel to the heel of the angle and leaving a wide solid strip of metal in the middle of the angle. It can be used in a number of applications where previously a larger and more costly angle was required. The price of the new 140 angle has not been increased.

Twenty new type cornerplates will be included in each packet of Dexion new 140/ steel to provide new standards of rigidity in steel structures. Further information is available from the makers, Messrs. Dexion Ltd., Maygrove Road, London, N.W.6.

Kabi Unit Terminal Blocks

FROM Precision Components (Barnet) Ltd., 13, Byng Road, Barnet, Herts., we have received details of 0B.A. and 2B.A. unit terminal blocks. The 30-amp. Kabi 2B.A. unit terminal block (U.30) is moulded in 4-way units (see photo), and the 60-amp. Kabi 0B.A. unit terminal block U.60 in single units which can be built up as multi-way banks on M.S. bearers. Both blocks are available with or without cover. Prices range from 6s. 3d. for the 4-way

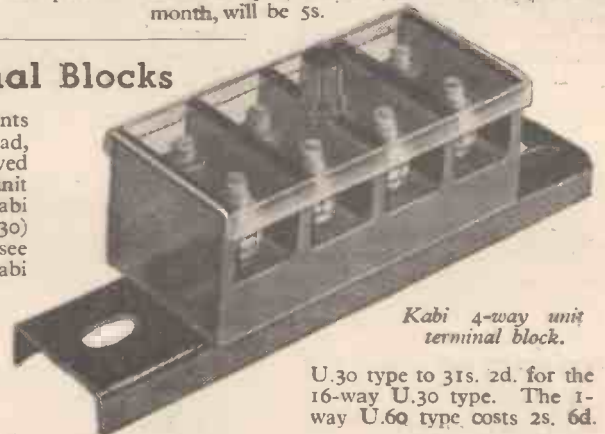

Kabi 4-way unit terminal block.

U.30 type to 31s. 2d. for the 16-way U.30 type. The 1-way U.60 type costs 2s. 6d.



(Above). The universal table being used with the jig saw.

(Right). The 6 in. portable saw and groover.



TWO NEW WOLF "QUARTERMASTER" ATTACHMENTS

washers to cut grooves of up to $\frac{1}{8}$ in. in width.

A spring-loaded telescopic guard is permanently fixed in position on the attachment, thus ensuring perfect safety to the operator under all working conditions. A special sawdust extractor is a new feature.

The unit is quickly and easily fitted to the "Quartermaster" power unit. A pressed steel soleplate is fitted and is adjustable by means of wing nuts for either depth or bevel cutting. A pressed steel rip fence is also incorporated in the soleplate assembly so that accurate cuts may be made without the use of scribe or pencil guide lines. A fine tooth 6 in. saw-blade, suitable for plastics, Perspex, etc., is available as an extra.

A 6 IN. saw and groover attachment has been introduced by Wolf for use with their "Quartermaster" high speed power unit. In addition, a universal saw table has been designed to convert this attachment for bench use.

Apart from straight and bevel cutting up to 45 deg., the blade of the saw and groover can be adjusted by means of tapered

The price is £4 19s. 6d. (excluding power unit).

The saw and groover attachment is very quickly converted into a highly efficient bench saw and groover with the universal table. This consists of a strong steel table with brackets for firmly fixing to edge of work bench, a back centre support for the "Quartermaster" and an adjustable straight edge. The price is 37s. 6d.

The National Do-It-Yourself Magazine

PRACTICAL HOUSEHOLDER

Edited by F. J. CAMM

August Issue now on Sale

PRINCIPAL CONTENTS:

Buying a Carpet?

Modernising Old Walls

A Modern Desk

Ball Valves

A Wheeled Garden Lounge Chair

Child's Dual Purpose Car Seat and Pushchair

Landscape Gardening

Paths from Gravel, Bricks and Paving

Operating Costs of Electrical Appliances

Smoke Control Areas

About Fences and Gates

and many other interesting articles.

(Continued from previous page)

FOR SALE

AIR COMPRESSORS, single cylinder double action, 2 1/2 cu. ft. at up to 400lb. pressure, condition as new but slightly soiled, cost over £10, bargain at 35/- each. N. Cooper, 10, Fowler Street, Nechells, Birmingham, 7.

You can repair that broken drill housing or lathe bed. You can join metal without costly welding equipment. There's a million and one jobs you can do with our "Fibreglass" Kits. Try one from the Firm who use "Fibreglass" every day. . . .

AUTO PLASTICS (OLDHAM) LIMITED
Green St., Oldham, Lancs.
Car Body Repairers and General Fibreglass Moulders.

The Best "Fibreglass" Kits at the lowest prices. With full instructions price 10/- and 17/6, plus P. & P. 1/6.

"ASTRO TELESCOPE MAKING"
standard Ramsden push-in Eyepieces 1/4 in., 3/8 in., 1/2 in. focus, 35/-, S.A.E. List Astro and non-Astro Object Glasses, Newtonian Mirrors, Eyepieces, etc. W. Burnet, Grand Sluice, Boston, Lincs.

U.S.A.A.F. Centrifugal Tachometer, range 500-3,500 r.p.m., graduated each 20 r.p.m., luminous markings, 3 in. dial brand new, 18/6, post paid. 18 in. Flexible Drives to suit, 5/6. Litco Flight Aids, Corner Hall, Hemel Hempstead, Herts. Box 1564.

"MAINS" from 12v. Battery.—Brand new American Dynamotor Unit in beautiful black crackle case; weighs about 38lb., but neat and compact; thousands of uses, no conversion required. In seconds makes marvellous, powerful 200-250 AC/DC electric motor, electric fan, dynamotor (gives 250 volts at about 100 watts from 12 volt car battery), runs mains radio bulbs, etc. Makes ideal rotary transformer, battery charger, etc. Continuous duty, quiet running, doesn't overheat. Worth £25—our price 80/- with instructions; carriage paid; satisfaction guaranteed. Send remittance with order. Dep. C. Scientific Products, Manor Works, Cleveleys, Blackpool.

HOUSE SERVICE METERS, credit and prepayment; available from stock. Universal Electrical, 221 City Road, London, E.C.1.

CHEMICALS AND APPARATUS.—Free booklet of 100 Experiments with orders over 15/-. Send 3d. stamp for catalogue and details of special offers. Scientific & Technical Supplies (Nottm.) Ltd., Dept. M. 9, Wellington Circus, Nottingham.

COMPRESSORS FOR SALE.—Twin Piston with tank 2 1/2 c.f.p.m., £4. Single Cyl., £2. All types Motors. S.A.E. for list. Wheelhouse, 13 Bell Road, Hounslow. (HOU 3501.)

1 OZ., 2/3oz. and 1oz. hand-operated, 2 Bench-Type Thermoplastic Injection Moulding Machines for Hobbies and Industry. Dohm Ltd., 187, Victoria Street, London, S.W.1.

PHOTO-CARDS (including colour photography). Famous liners, yachts. Send 1/9. list, specimens, Elder, c/o 38, Westview Road, Barrow-in-Furness.

FIBREGLASS

PLASTIC UNITS

Experimental Glass Fibre Unit, 14/9. Plastic Metal for Gear Casting, Plastic Dies, etc., 14/3. Porcelain-hard Cold Setting Finish for food preparation surfaces, baths, washing machines, etc., 16/9 pt. in white, cream, black, sky blue, red clear and aluminium. S.A.E. for information list, price list, etc. **SILVER DEE PLASTICS** (Dept. 3), Hartington, Staveley, Chesterfield, Derbyshire.

PATENTS

PATENTS. Qualified service. Advice. O. L. Browne, 114, Greenhayes Ave., Banstead, Surrey.

! A GOOD IDEA! CAN MAKE MONEY FOR YOU
LET US ASSIST YOU PROFESSIONALLY TO SELL YOUR INVENTION.
WRITE FOR FULL DETAILS.
PATENT, DEVELOPMENT & MARKETING CONSULTANTS
16 Gore Court Rd., Sittingbourne, Kent.



THE FAMOUS "DELSTAR" ARC WELDER

For rapid and efficient welding of metals up to ANY THICKNESS. High quality and robust construction. One man portable, operates from nearest mains power point. Indispensable for Workshop, Factory, Garage, etc. 3 current settings, snap action switch. 12 months Guarantee

MINOR 60 AMPS £34.13.0
MAJOR 100 AMPS £42.10.6

Immediate delivery. Carriage 7/-.
Prices inclusive of all necessary fittings, face mask and supply of assorted gauge electrodes.

HARRIS ENGINEERING CO.,
(Dept. P.M.25), 269 Kingsland Road, London, E.2. Phone: Shoreditch 5583.

BOWMONK FIREPROOF GARAGES



From £33.10.0 with FREE delivery
STEEL FRAMED—EXTENSIBLE
LOWEST MONTHLY TERMS
of any manufacturer including FREE "Peace-of-Mind" INSTALLMENTS INSURANCE.
Write NOW for — Free Colour Catalogue

BOWSER, MONKS & WHITEHOUSE LTD.
(Dept. ME13), Spring Gardens, DONCASTER

FREE POCKET MANUAL

"How to fit STEAM TRAPS"

Unique guide to the correct selection and installation of steam traps for mains drainage, heating systems, process steam units of all kinds; including best condensate-lifting installations. Concise directions; clear illustrations. Copies free on request to:

SPIRAX-SARCO LTD.

(TECHNICAL DEPT.), Cheltenham, Glos.

You Can Become a HANDICRAFTS TEACHER

Experience not essential

Men who enjoy making things in wood or metal can turn their hobby into a permanent and interesting career. Short hours, long holidays and security in a job you would really enjoy can be yours if you become a Handicrafts Teacher. Let us send you details of the easiest and quickest way to get the necessary qualification.

We definitely guarantee "NO PASS—NO FEE"

If you would like to know about our unique method of preparing you for one of these appointments write to-day, and we will send you an informative 144-page Handbook—FREE and without obligation. Mark your letter "Handicrafts Teacher."

BIET BRITISH INSTITUTE OF ENGINEERING TECHNOLOGY
591, College House,
29-31 Wright's Lane, London, W.8.

PLAY THE PIANO

REED ORGAN or ACCORDION in 3 months

New Home method. Definitely the easiest and quickest. Even if you have never played a note, you will be able to read music at a glance.



Write today without obligation for FREE LESSON state instrument

KLAVARSKRIBO (B.Z.6)
10a HIGBURY PLACE, LONDON N.5

SERIES III NUCLEAVE PRESS



CROPS RIVETS PUNCHES
Ask your Tool Dealer or send for details to:—
Sole Manufacturers.

FITZNER LTD.
197-199, KINGS ROAD, KINGSTON-ON-THAMES

GOVERNMENT SURPLUS BARGAINS

TRIPODS. Unused. 38" long, only 5 lb. wt. Immensely strong. Carrying sling. Bracs cap easily adapted to camera, etc., etc. Each 12/6, post 2/6.
BATTERY CHARGING TRANSFORMERS. 11 v. & 17 v. A.C. (for 6 & 12 v. charging at 1 amp.), ea. 17/6, post 1/9.
RECTIFIERS to suit above, ea. 9/-, post 8d.
(These transformers & rectifiers will run the above low voltage motors.)
TEST METERS. Moving Coil, 0/15 v., 0/3 v., 0/60 m.Amps.; 0/5,000 ohms. In beautiful case 4" x 4" x 2 1/2" with selector terminals and switch. Wonderful Bargain. 15/-, post 1/6.
POCKET VOLTMETERS. Moving Coil 0/15 v., 0/250 v., 15/-, post 1/6.
MOTORS. 200/250 v. A.C./D.C. P.H.P. approx. 80 watts. High speed. 1" shaft. (Converted ex R.A.F. motor generator—power about equal to sewing machine motor.) Useful addition to workshop, ea. 30/-, post 2/9.
Send 3d. stamps for list of other Motors. Transformers, Pumps, Lamp, Switches, etc., etc.

MILLIGANS
24, Harford Street, Liverpool, 3.
Money Back Guarantee.

BUILD YOUR OWN CANOE
Printed illustrated instructions 1/6
TYNE FOLDING BOATS LTD.
206 Amyand Park Road, St. Margaret's, Twickenham, Middx.

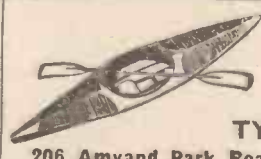

August, 1958
SAWBENCHES
ALL SIZES & TYPES 6"-30"
Bench & Floor Models Rise/Fall Unmotorised Petrol Electric
Send for Free Leaflets.
HOGG & PUDSEY
10 Folly Lane, Leeds, 11 — 76154

SPECIAL OFFER
G.E.C., B.T.H. & WESTINGHOUSE GERMANIUM CRYSTAL DIODES
1/- each. Postage 3d.
Diagrams and three Crystal Set Circuits Free with each Diode.
A large purchase of these lully GUARANTEED diodes: from the manufacturers enables us to make this attractive offer

COPPER INSTRUMENT WIRE ENAMELLED, TINNED, LITZ, COTTON AND SILK COVERED
All gauges available
B.A. SCREWS, NUTS, WASHERS, soldering tags, eyelets and rivets.
EBONITE AND BAKELITE PANELS, TUFNOL ROD, PAXOLIN TYPE COIL FORMERS AND TUBES ALL DIAMETERS

Latest Radio Publications. SEND STAMP FOR LISTS

CRYSTAL SET
INCORPORATING THE SILICON CRYSTAL VALVE
Adjustable iron Cored Coil

RECEPTION GUARANTEED
Polished wood cabinet, 15/- post 1/3. A REAL CRYSTAL SET NOT A TOY

POST RADIO SUPPLIES
33 Bourne Gardens, London, E.4

Save on Repairs

with **GLASS FIBRE**
Reduced Prices Plus More Materials Post
KIT I 12/6 2/-
KIT II 25/- 2.3
KIT III 30/- 2/6
KITS FOR CARS, ETC. £5.10 £9.10
carriage paid

These kits carry a comprehensive range of materials, with full instructions to suit all forms of car body repairs and model making. "Glass Reinforced Plastics" New Illustrated Booklet, 2/6 Post Free.

WESTPOLE MOTORS LTD.
89, BRAMLEY RD., LONDON, N.14. PAE 6231

ACCURATE SHOOTING
Webley
AIR PISTOLS
AIR RIFLES · ACCESSORIES
Write for catalogue WEBLEY & SCOTT LTD.
106 WEAMAN ST., BIRMINGHAM 4, ENGLAND





Your Queries Answered



Wrought Iron or M.S.? Direction of "Grain"

WROUGHT iron parts have to be annealed. Mild steel does not. Could you please inform me whether there is any simple method of telling wrought iron from mild steel?

In making clamps, etc., for lifting tackle, it is usual to have them made with the grain of the steel (the direction of the rolling of the material). Is there any great loss in strength if the article is made with the grain across?—H. Lohmann (E. 6).

MILD steel is perhaps a little brighter in colour and the texture is not so coarse. The easiest way to distinguish these materials is to obtain a known bar of each metal; examine each closely, turn them, using both rough and finish cuts, mill each piece and watch the swarf and finally, if you have the machine, shape both examples. We feel you will gather first-hand experience in this way and the result is more definite than any description we can give.

The "grain" of a bar of material is secured during the rolling process, and one can liken it to a plank of wood. We need not dilate on the strength of a long board and the short piece which will snap in the hands when twisted—similarly the grain in a piece of steel can strengthen or weaken it. Occasionally on workshop drawings there appears a note "Direction of Grain," indicating that the grain must run that way. This frequently occurs on sheet metal drawings, and it is an established fact that if a bend is attempted with the grain the metal will crack, while the same operation carried out across the sheet, however severe, is easily accomplished. There is considerable difference in the strength of various parts made with and against the grain.

Invisible Printing

PLEASE explain to me how invisible printing is done, as in children's painting books where you just brush on water and the picture comes up in colour.—Wm. Brade (Preston).

CERTAIN inorganic crystalline salts possess the property of colour change when their "water of crystallisation" has been driven off by heat and the original colour can be restored by replacing that water. This is the basis of "magic painting." The colourless dehydrated salt is impregnated into the paper and as soon as water is brought into contact with the invisible pattern by means of a brush the image appears in the appropriate colour. For example, cobalt chloride is pink when brought into contact with water. Copper sulphate, a whitish powder when heated above a certain temperature, becomes blue when the water is restored.

Artificial Stone

COULD you supply me with a formula for making artificial stone? I require this for casting small articles. The material

QUERY SERVICE RULES

A stamped, addressed envelope, a sixpenny, crossed postal order, and the query coupon from the current issue which appears on the inside of back cover, must be enclosed with every letter containing a query. Every query and drawing which is sent must bear the name and address of the reader. Send your queries to the Editor, PRACTICAL MECHANICS, Geo. Newnes, Ltd., Tower House, Southampton Street, Strand, London, W.C.2.

when set must have a reasonably high crushing point, be waterproof and preferably white in colour.—C. S. Furrell (Cornwall).

THE following formula is suggested:

Alum rock	59 parts
Alabaster powder	22 parts
Alabaster plaster	17 parts
Water	2 parts

The alum rock is fused, the other ingredients are added and the mass moulded.

Alternatively we suggest you send in your query to: The Director, Royal College of Arts, South Kensington, S.W.7.

Adhesives

PLEASE supply me with formulæ for a paste suitable for sticking cuttings in a child's scrapbook and a gum as is used on stamps or the back of envelopes.—B. J. Daniels (Devon).

THERE are many cheap pastes on the market, complete with brush, suitable to use for scrapbook work by children. However, you can make a flour paste by stirring two or three teaspoonfuls of flour with a little cold water to a paste and then adding boiling water until it thickens. Starch can be used in the same way.

An alternative method is to dissolve 100 parts of glue in 200 parts of water and add a solution of 2 parts of bleached shellac in 10 of alcohol. Stir constantly while adding. Keep the temperature below 90 deg. F.

Gum for stamps, etc.:

(a) Dextrin	150 gms.
Sugar	20 gms.
Water	280 gms.
(b) Lime water	10 gms.
Vinegar	40 gms.

Mix solution (a) with solution (b).

Wire Clock Chimes

I HAVE been trying to make some clock chimes from lengths of wire, but without success. When various lengths are all gripped firmly in my bench vice their tone is perfectly satisfactory, but when they are fixed in any other form of bracket or clamping device their tone immediately disappears. Could you please inform me what method clockmakers adopt to fix them into their clocks?—G. F. Walker (Northumberland).

IT is evident from your own experiments that the support for the fixed ends of the chiming wires must be very solid and be carried by some part of the clock which is practically immovable. The fixture must be incapable of taking up any of the vibrations of the wires and the better and heavier the nature of the fixing the louder and more pure will be the tone. Your bench vice is an example of this. It is heavy and cannot, therefore, take up the high frequency of the vibrations of the wires. So will your fixings in the clock have to be though they cannot be so heavy as your vice. They can be made of gunmetal and this can be screwed down, or bolted, to some portion of the clock if this is heavy enough or, if it is not, to the clock case. The wires should be of tempered steel. All the notes should be of stout gauge and differences in tone be obtained by varying the length.

Softening Water

CAN you tell me of a cheap powder to soften water for use in a washing machine?—L. W. T. (Ipswich).

TRY using sodium metaphosphate or sodium metaborate, using the minimum quantities according to degree of softening required. Supplies and further advice could be obtained by writing to: Newlands Bros. & Mumford Ltd., 141, Kensal Road, London, W.10.

THE P.M. BLUE-PRINT SERVICE

- 12FT. ALL-WOOD CANOE. New Series. No. 1, 4s.*
- 10-WATT MOTOR. New Series. No. 2, 4s.*
- COMPRESSED-AIR MODEL AERO ENGINE. New Series. No. 3, 5s. 6d.*
- AIR RESERVOIR FOR COMPRESSED-AIR AERO-ENGINE. New Series. No. 3a, 1s. 6d.
- 'SPORTS' PEDAL CAR. New Series. No. 4, 5s. 6d.*
- F. J. CAMM'S FLASH STEAM PLANT. New Series. No. 5, 5s. 6d.*
- SYNCHRONOUS ELECTRIC CLOCK. New Series. No. 6, 5s. 6d.*
- ELECTRIC DOOR-CHIME. No. 7, 4s.*
- ASTRONOMICAL TELESCOPE. New Series. Refractor. Object glass 3in. diam. Magnification x 80. No. 8 (2 sheets), 7s. 6d.*
- CANVAS CANOE. New Series. No. 9, 4s.*
- DIASCOPE. New Series. No. 10, 4s.*
- EPISCOPE. New Series. No. 11, 4s.*
- PANTOGRAPH. New Series. No. 12, 2s.*

- COMPRESSED-AIR PAINT SPRAYING PLANT. New Series. No. 13, 8s.*
- MASTER BATTERY CLOCK.* Blue-prints (2 sheets), 4s. Art board dial for above clock, 1s. 6d.
- OUTBOARD SPEEDBOAT. 11s. per set of three sheets.
- LIGHTWEIGHT MODEL MONOPLANE. Full-size blue-print, 4s.
- P.M. TRAILER CARAVAN Complete set, 11s.
- P.M. BATTERY SLAVE CLOCK, 2s. 6d. "PRACTICAL TELEVISION" RECEIVER. (3 sheets), 11s.
- P.M. CABIN HIGHWING MONOPLANE. 1s. 6d.*
- P.M. TAPE RECORDER.* (2 sheets), 5s. 6d.

The above blue-prints are obtainable, post free, from Messrs. George Newnes, Ltd., Tower House, Southampton Street, Strand, W.C.2.
An * denotes constructional details are available free with the blue-prints.

Soil Heating

I AM seeking information regarding soil heating for a greenhouse (see sketch).

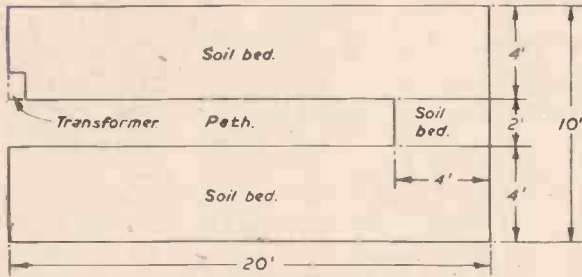

Plan for a greenhouse.

Can you give a suitable circuit, a list of components required and a source of supply? —B. Pearson (Stockport).

SOIL heating itself will not appreciably raise the temperature of the air in the greenhouse, but will help to protect the plants in the early stages and give optimum root conditions and acceleration of growth and cropping. Low voltage soil heating wires may be laid in zigzag fashion at a depth of 6 in. in the soil. A given size of wire is required for a given current (amps.) through the wire, but it is not detrimental if the transformer is capable of greater current output on full load than is required by the wires.

For use with a 12 volt transformer, having an output of not less than 75 amps. you could use six elements in parallel, each element consisting of 130ft. of 12 s.w.g. annealed galvanised steel wire, having a

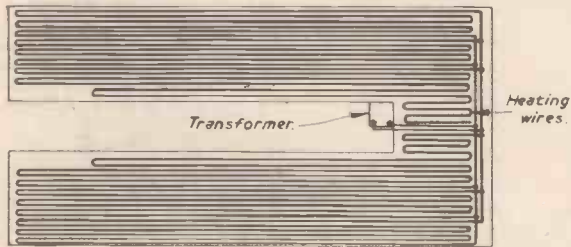

Suggested wiring.

cross sectional area of 0.0084 sq. in. One of the following firms may be able to supply the required wire:—S. B. Jackson Ltd., 12, Rampayne Mews, London S.W.1.; Hall & Pickles Ltd., Ecclesfield, Sheffield; Kayser, Ellison & Co., Ltd., Sheffield; Peter Stubbs Ltd., Warrington, Lancs.

The wires may be laid as indicated in the diagram above.

Coudé-type Telescope

I HAVE a 6in. mirror for a telescope which I want to use on the Coudé system. What is the best size of convex mirror to use, its focal length and the position of the two plano mirrors?

The main mirror has a focal length of 40in.—N. Chetwood (Shropshire).

IN order to construct a Coudé-type telescope you will require one circular flat mirror and an object glass. The flat mirror would be of about $\frac{2}{3}$ the dia. of the object glass. That is all except for the eyepiece. We know of no arrangement of a Coudé type in which all mirrors can be used. The main mirror, the paraboloidal one, would have to be placed below the flat mirror and the latter would cut off the image reflected by the main.

However you are proposing to use the mirrors, the focus of your main mirror is very short for 6in. dia. and we would advise making a Newtonian type. For this

all you would have to fit would be a small elliptical flat to reflect the image from the main mirror at right angles into the eyepiece.

Tungsten Carbide Inserts

I HAVE made up some boring cutters with tungsten carbide inserts for boring holes in hard granite rocks. My trouble is that these tungsten carbide inserts crack off whilst in operation as they are too hard and brittle. How can I soften the tungsten carbide slightly so that it is not brittle but hard enough for drilling rocks?—Mok Thai Yong (Hong Kong).

IT is impossible to soften tungsten carbide. You evidently imagine that this material is a form of steel—an easy mistake as they have the same appearance, but the carbides are definitely not steel and in their initial condition they resemble pieces of chalk in hardness.

Undoubtedly you are using the wrong grade of this material; there are of course several and each is used according to the material being machined.

We suggest you write to the following firms and state your requirements in this field; they will no doubt recommend a grade of carbide for your needs.

Messrs. A. C. Wickman Ltd., Torrington Avenue, Coventry. Messrs. English Steel Corporation, Openshaw, Manchester. Messrs. Alfred Herbert Ltd., Coventry. Messrs. Hall & Pickles Ltd., Port Street, Manchester.

The latter are suppliers of bits and Messrs. L. M. Van Moppes & Son Ltd., Basingstoke, Hampshire, are makers of diamond drilling bits for this work.

Using Lenses

I POSSESS two lens units 20in. and 14in. focal length and both with iris.

To what purpose could they be put?—D. A. Jones (Essex).

YOUR 14in. lens would be excellent for use on an episcopes and the 20in., owing to its longer focus, on an epidiascope. Both of these instruments are used for projecting small pictures such as postcards, either coloured or uncoloured, on to a screen where they are very much enlarged.

Another use for the lenses will be found in photography where they would be used on a large camera. They were probably made for this purpose.

A third use would be to mount one of the lenses (preferably the 20in.), on a camera and use this for astronomical photography. The camera would have a sheet metal or wooden case. It would be on an equatorial mount and the polar axis of this would be driven by a clock so that the camera keeps sidereal time. Such a clock-driven camera would be of great use in searching for comets and asteroids. The plates or films would need to be exposed for several hours, that is why a driving clock is necessary.

Barograph Construction

I HAVE constructed a barograph to indicate atmospheric pressure changes and I would be grateful for details of the type of pen used on the arm to record a positive trace of the atmospheric changes.

What type of ink is used?

Can the hourly timing mechanism of an

alarm clock be modified to give a rotation of 7 days instead of the normal daily rotation? —D. G. Walters (Carmarthen).

THE pen is a shallow cup of triangular form and is shown in the sketch. The ink is a thick viscous fluid and is violet in colour. It could be made by dissolving copying lead in water and adding a few drops of glycerine to stop evaporation. This ink can be purchased at any scientific instrument shop.

It is impossible to convert a 30-hour clock to run for 7 days. Your best plan

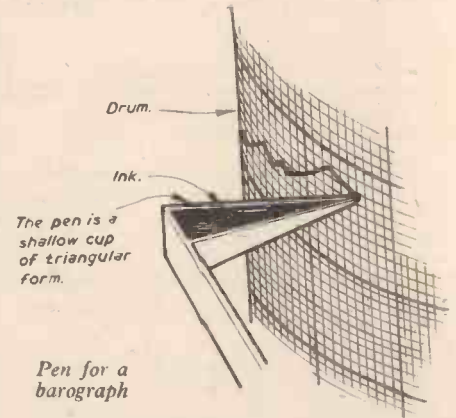

will be to wind the clock every night if you want to use an alarm movement. Even then you will require a 2 to 1 gear between the hour hand drive and the drum, because the latter will make 1 rev. in 24 hours. Whereas the hour hand spindle makes 1 rev. in 12 hours. Have you considered an electrical drive to a pendulum which by a simple train of gears will move the drum at seconds intervals?

Information Sought

Readers are invited to supply the required information to answer the following queries.

Antique Finish

I HAVE recently successfully restored some old pistols, but the new parts are bright and new, looking out of place with the rest of the guns. Can you tell me how to give an aged look to both the steel and brass parts?—A. M. ROWLAND (Shropshire).

Renovating Cellulose Acetate

SOME time ago I purchased a quantity of ex-Government glass substitute (cellulose acetate) on fine wire netting. I now wish to renovate this; could you advise me as to how to make up a solution for this purpose or tell me where I could obtain it? Would clear cellulose be suitable?—K. E. BURCH (Herne Bay).

Using DC Motors on Different Voltages

(Concluded from page 524)

If a motor is to be rewound for a much higher voltage it may be necessary to use better insulation in the slots, etc., to avoid risk of insulation failure. When a motor is thus rewound for a higher voltage it will operate with rated torque, horsepower and speed, with a reduced full-load current. Similar characteristics will be obtained after rewinding a motor for a lower voltage using the above formulae, but in this case the full-load current will be increased. If a motor is rewound for a much lower voltage than its rated value it may be necessary to fit new brushgear to accommodate larger brushes to deal with the increased current.

See these fine BARGAIN OFFERS!

- MOTOR PUMPS. Stuart-Turner 12 V. D.C. Model No. 10. New, capacity 100 g.p.h., lift 2 ft., head 10 ft., ideal for caravans and motor boats, 90/-, post 5/-.
- ROTARY CONVERTERS. D.C./A.C. 200 wats, 24 V. D.C. input, 50-110-230 V. A.C. 50 c/s, S.P., 200 wats output through transformer. Converter and transformer, new and works, tested, £8.10.0, carr. 10/-.
- PARALEX HOLE CUTTERS. Adjustable, 1-4", 3 1/2", 1 1/2"-6 1/2", 35/-, 2-10 1/2" 75/-, nylon taper shank, brand new, perfect rigidity, with lead screw for fine adjustment.
- MINIATURE MOTORS. 4 1/2 V. D.C. for model work. Weight 1 oz., size 7/8" x 1/2" thick, with driving spindle. Ideal for model aeroplanes, motor boats, remote control, etc. New, 10/9, post free.
- PERISCOPES. In aluminium cases each containing angle prism. Size 3 1/2" x 4 1/2" x 1 1/2", easily extended to any height required by wood or metal strips. 6/3 per pair, post 1/9.
- RATCHET COUNTERS. 5-digit, with spring return 2-hole mounting, 12/6, post 8d.
- D.C. MOVING COIL METER MOVEMENTS. 2 1/2" flush panel, all complete with scale and pointer, 2/6, post 1/2.
- D.C. MOVING COIL METERS. Iron-clad switchboard type, 200 V., 30/-, 250 V., 45/-, 50 amps 35/-... Many other readings in stock. Send us your enquiries!
- MAGNETS. Swift Levick S.L.S.36, circular horseshoe 1 1/2" diam., 3/4" thick, with 1/2" polar gap, drilled holes, 2/6, post 6d. Alni disc magnets, 1/2" diam., 3/4" thick, 3/16" centre hole 3/6, post 6d.
- ELECTRO MAGNETS. 6 V. D.C. twin coil, weight 10 ozs., lift 4 Vbs.; 6/6, post 1/-.

ELECTRADIOS
Dept. H. 214, Queenstown Road, London, S.W.8. MACoulay 2159

GAMAGES



TYPE D-6 Saves Time and Money! HAND OPERATED STARTER

Fit a Type D-6 Push-button, hand operated thermal overload release starter in your Electric Drill and Motor Circuit. It will save you time and money by guarding against overloading and burn-outs. Easy to fix instructions supplied with each Starter.

Will suit Motors up to 1 H.P. 230 volts, Single Phase and 4 H.P. 415 volts, 3 Phase. **39/4** Post and Pkg. 1/8 outside our extensive van area.

TYPE 'A' DRUM REVERSING SWITCH

Application. Any application where reversal of direction is required by means of reversing the associated A.C. or D.C. motor. For the Handyman, Light Machine or Hand Tools. Capacity. The Switch is capable of switching an A.C. or D.C. Motor up to the following maximum horse power, 3 Phase.—3 H.P. at 220-240 volts. Single Phase.—1 H.P. at 220-240 volts. D.C.—1 H.P. at 200-240 volts. Connections. With each switch is supplied complete instructions for connecting up to the various types of motors. Leaflet on request. **38/1-** Post and Pkg. 2/- outside our extensive van area.

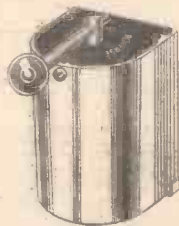

BLOW LAMPS Finest quality. Polished solid Brass body. Fully Guaranteed. Similar to illustration. 3/4 pint capacity.



Post & Pkg. 2/3 if outside our van area. **36/6** 1 pint capacity. Post & Pkg. 2/6. **46/6**

Soundly Constructed WORK BENCH At a Special Price!

All-iron frame and legs with wood top. Ironwork painted green. Approx. size 36 in. long x 18 in. wide x 31 in. high. 1 in. thick top. Suitable for Garage, Workshop, Kitchen, Loft, etc., etc. (Mount your Electric Tool Kit upon it! Supplied assembled.)



BARGAIN PRICE **57/6** Carr. & Pkg. 5/6 Gt. Britain, outside our own van area.

Tool and Motor Accessory List FREE

GAMAGES, HOLBORN, LONDON, E.C.1. HOL 8484

THE PEOPLES ARC-WELDER £15-12-0d
Complete with all accessories shown. Ready for plugging into 13amp socket 200/250 V. A.C. mains. Infinitely variable control of welding current by hand-wheel. Welds up to any thickness & down to 22g sheet. For the Motorist, Householder & Engineer.
£15-12-0d CASH WITH ORDER. CARRIAGE APPROX. 7/- AFTER DELIVERY.
Uses 1/4 8 1/2 Standard Flux Coated Electrodes. One box of each supplied with Welder. Extra Electrodes 7/- 15/- per lb.

NEST OF DRAWERS
Overall size 7" wide x 5" deep x 11" high. 12 drawers, each measuring 3" wide x 4 1/2" deep x 1 1/2" high. Useful storage for the engineer, motorist and householder for nuts, bolts and small components. Green enamelled. £1. P. & P. 3/-.

TRANSFORMERS ALL 220/250 V. A.C. INPUT
6-12-18-24-30 V. at 12 Amps.
Rectifier to suit, £2.18.0.
8-9-12 V. at 65 Amps.
5 V. at 300 Amps.
Auto 110/120 V. at 5 Amps.
EACH £4.12.6. CARRIAGE 6/- EXTRA

'POP' RIVETERS (Lazy Tong)
Easy to operate. Widely used for Motor Body Repairs. Ideal for Sheet Metal Work, Plastics, Hard-board, etc. Universal Collet takes 'POP' Rivets, 1/8", 5/32", 3/16" and 1/4" dia., £4.11.0.
'POP' RIVETS

In constant use by Repairers. Three Assortments available:
MTL : 1,000 Rivets—All diameters—33/4.
MTP : 1,000 Rivets—1/8" & 5/32" dia.—29/4.
MOTORISTS' RANGE : 200 Rivets—1/8" & 5/32" dia.—11/-.

HARMSWORTH, TOWNLEY & CO.
Jordan Street, Knott Mill, Manchester, 15

TAKE UP PELMANISM For All Times and Circumstances



PELMANISM has stood the test of time. During the last half century, in peace and war, in times of prosperity and of depression, it has helped and encouraged men and women in all the affairs of life. Now in these times of strenuous endeavour two facts stand out against a background of evidence—the increasing number of men and women, who want to make a success of life, enrolling for the Pelman Course; the continued support of serving and ex-Servicemen of H.M. Forces.

A True Philosophy
Pelmanism is a true philosophy of living for ordinary sensible people who wish to make the best of themselves at all times and under all circumstances. The general effect of the training is to induce an attitude of mind and a personal efficiency favourable to the happy management of life.

This increasing demand proves the creative and re-creative value of Pelmanism. Minds under stress and strain are sorely in need of restful recreation and soothing stimulus. Pelmanism gives all this and more. It is the way to clear thinking and calm but determined action under all circumstances. You cannot be harassed by anxieties, fears and worries, or feel helpless, mute and fearful in times of sudden emergency when imbued and buoyed up by the friendly personal guidance of Pelmanism. Take the Course to-day and possess those self-reliant attributes permanently enjoyed by over a million grateful Pelmanists.

Send for the Free Book
The Pelman Course is simple and interesting, and takes up very little time. The books are printed in a handy pocket-size enabling you to study them when travelling or in spare moments during the day. You can enrol on the most convenient terms. The Course is fully described in a book entitled "The Science of Success," which will be sent you, gratis and post free, on application to:—

PELMAN INSTITUTE
130, Norfolk Mansions
Wigmore Street, London, W.1.

LONDON WHOLESALE WAREHOUSE
165 (P.M.), QUEEN'S ROAD PECKHAM, S.E.15
Tel: NEW Cross 7143 or 0890.

SEE EARTH SATELLITES



ASTRONOMICAL TELESCOPES 107/6 !!
COMPLETE SET, £8.15.0. Postages 15/- OR 25/- DEP. 10/- WEEKLY
OUR NEW SUPER MODEL
See the Moon at Close Quarters. Examine the Immense Craters, Mountain Ranges, etc. Observe Saturn's Rings, Nebulae, Sputniks, etc.
Specification. 2 in. dia. Length 39 in. Mag 53 X Linear (equivalent 2809 X Area). Weight approx. 2 lb. 2 ozs.
Registered postage and packing including strong stowing cylinder, 12/-.

Altazimuth Portable Clamp Stands. Extra 37/6, P.P. 2/6. Fixes anywhere. High Power Eyepieces 80 X, 30/- P.P. 2/-. (Equivalent 6400 X Area.)

Stamp for Full Particulars. Photographs 1/- set (returnable). Lists and Terms Made to order.

HOLMES, WILSON & CO.
SCIENTIFIC INSTRUMENT MAKERS
(Dept. P.M.37), Martins Bank Chambers, 33, Bedford Street, North Shields, Northumberland.

POST THIS FREE COUPON TODAY.....
Pelman Institute
130, Norfolk Mansions, Wigmore Street, London, W.1.
"The Science of Success," please.
Name,
Address,
Established over 60 years. WELbeck 1411



VOL. XXVI

AUGUST, 1958

No. 433

All letters should be addressed to the Editor, "THE CYCLIST," George Newnes, Ltd., Tower House, Southampton Street, Strand, London, W.C.2

Phone: Temple Bar 4363
Telegrams: Newnes, Rand, London

WHAT I THINK By F. J. C.

THE HOME OF THE CYCLE TRADE

A NEW building on a fresh site in Coventry is to be built to house the British Cycle and Motor Cycle Industries Association. The present address has long been inadequate to house the existing staff. The new site will be near Coventry station, which will be found convenient by the large numbers of people who have to visit the Association. Coventry has always been considered the home of the bicycle, for it was in that city of three spires that most of the early pioneers of the bicycle set up their factories. The Coventry Machinists, Humber Ltd., and many other cycle manufacturers founded their businesses in Coventry. I hope that the opportunity will now be taken for inaugurating a records department, by which I mean records of the industry, and that an attempt will be made by someone to write a history of the cycle trade. The industry, in fact, at present has no records department and reliance has to be placed on the memories of old members of the trade. I hope also that the building will house a cycling museum. Where it is not possible to obtain originals of early bicycles the industry itself could be invited to manufacture replicas. Not only of bicycles, but of important accessories. The bicycle, after all, was the father of the motor cycle, the motor car and the aeroplane, for it was from cycle factories mostly that the early machines in these fields originated, and it is about time that someone produced a history of cycling from the point of view of the pastime and the sport. A few isolated attempts have been made in this direction, and the most notable, of course, is Griffin's famous work, secondhand copies of which are now much sought after. A recent publication of S. F. Caunter, of the Science Museum, is also valuable. It is true that the late H. O. Duncan produced a most voluminous work dealing with the early days of cycles and motor cars, but it is a hopeless heterogeneity of unrelated facts slung together in any old order, and is largely a collection of Press cuttings. H. O. Duncan was a vainglorious Scotsman. He thought he was the industry and the pastime, and he simply oozed conceit from every pore, notwithstanding that he was a nonentity, a sort of barnacle which had attached itself to cycling. This very large tome has no index and you might spend several days leafing your way through its pages in the hope of finding some important piece of cycling lore. Important facts are omitted, and personal narrative, quotations from newspapers, and backscratching, pack the pages. The work was apparently collated for Duncan by Jean Vavin and Duncan and Vavin backscratched one another in the preliminary pages. The work is no tribute to Vavin as a redactor. Both Duncan and Vavin were obviously too lazy to undertake the tedious task of compiling an index. The main source, however, of all history on cycling is Griffin's book, the copyright of which is owned by the proprietors of this journal. It was, and it remains, the first and only history of cycling

up to the period of Griffin's death. It was a source book for the late H. W. Bartleet.

MIXING RELIGION WITH SPORT

RELIGION and politics should find no place in sport. To make an appeal to those of a particular political bent or following a particular religious faith is wrong.

This thought is prompted by an appeal recently issued by the St. Christopher's Catholic C.C. The appeal was for Catholic cyclists. Membership is apparently confined to Roman Catholics, and would seem to imply obloquy for Anglican Catholics. I would strongly advise my readers not to join any club which ties itself to religion or politics. There is bound to be a narrow-minded outlook in the conduct of such clubs,

organisations lays it down that this should be the basis of the training and should be standardised. But R. C. Shaw was the author of the handbook and is an interested party. It is quite right that a disinterested and unbiased party should be responsible for the appointment. No doubt the CTC had it in mind that the national organiser and the paid regional supervisors could be selected from the ranks of the CTC. This, like the NCU, is a militant body, mainly engaged in "fighting for cyclists' rights."

THE BUS STRIKE

CYCLISTS, as well as motorists, found the roads freer to travel on during the bus strike. The absence of buses from the



East Glandon, Surrey—a charming unspoilt village.

which are, in my view, subtle forms of propaganda.

CHILD CYCLISTS

I OBSERVE that the Minister of Transport has adopted the report prepared by a so-called working party on a safe-cycling scheme for children. The fact that the Royal Society for the Prevention of Accidents has been selected to appoint a national organiser and the paid regional supervisors has caused resentment in the Cyclist Touring Club camp. It is stated that the plan was conceived by R. C. Shaw, Secretary of the CTC. The Child Proficiency Training Code of R.O.S.P.A. and the two cycling

roads indicated very clearly the real cause of obstruction. Now that the buses have returned, they find that many of the customers have deserted the bus for other forms of transport. They are unlikely to return to the archaic, cumbersome and uncomfortable leviathan of the road, with its uncivil, and in some cases uncouth, staff. It is admitted that the bus is on its way out, its heyday having passed. Many passengers have bought bicycles and they find it more pleasant as well as quicker than being fidgeted from place to place, from bus stop to bus stop. Let us hope that the buses will soon vanish from our roads. They have been losing money for years and have to be propped up out of the taxpayers' money. F. J. C.

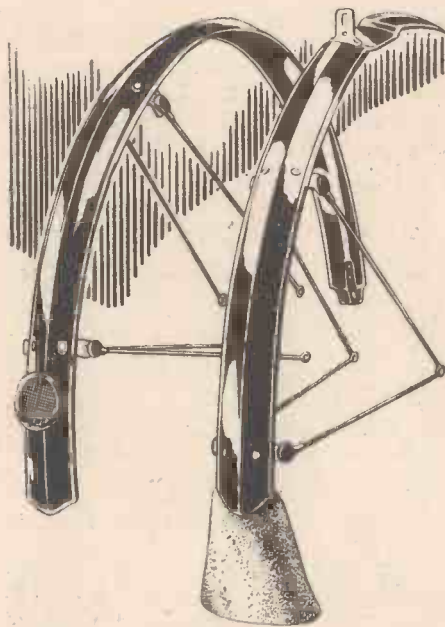

HINTS ABOUT MUDGUARDS

Fitting, Cleaning and Repairs

for length. The two usual methods of adjustment are shown in Fig. 2. When the correct position for the mudguards has been obtained, the ends of the stays must be either snipped off with a powerful pair of wire cutters or cut off with a small hacksaw. Do not cut the stays too closely to the point of adjustment—a $\frac{1}{2}$ in. of stay left over will allow later adjustment to clear a deeper tyre, or in the case of the rear wheel a smaller sprocket. The protruding end of the stay will usually lay alongside the dome of the mudguard and can be bent inwards slightly to stop it catching. The end of the cut stay should be cleaned up with a file to prevent sharp edges from causing cuts and scratches when future adjustments are being made. It should never be necessary to bend

front fork drop outs, making sure that the spindle nuts clamp the wheel firmly into position. This is not a really satisfactory solution, but is the only thing to do when riding a machine which has only this minimum clearance.

Cleaning

When overhauling the machine, the inside of the mudguards is the first thing that should be cleaned out. The reason for this is that when the machine is upside down and the wheels removed (the only position for cleaning inside the guards) the dirt, as it is brushed out, will fall over the rest of the machine. Use a stiff brush for the job.

Celluloid guards are best cleaned with soap and water. There is no need to remove them completely for this, but a better job can be made of it if they are.

Alloy mudguards, when they have been fitted for some time loose their shine, due to corrosion. They can be restored to their original lustre by means of a fine grade of wire wool and metal polish. On any type of mudguard, if the nuts and bolts, clips, etc., are of steel, keep a thin film of oil over them to prevent rust.

Repairs

On the heavier type of steel guards nothing very serious in the way of repairs is likely to be required. The plate holding the stays may possibly be torn through the metal of the mudguard, and provided the stays are long enough, this fault can be remedied by drilling new holes for the bolts and positioning the stays an inch or so higher. The small L-shaped clip which fixes by means of a small bolt to the chain stay bridge may also be torn loose in the same way and the remedy for this is to purchase and fit a

IT becomes necessary at least once during a cycle's term of usefulness to replace the mudguards and whatever the type of mudguard purchased, fitting does not usually present any difficulty, provided they are the right type for the machine. Common sense will guide the purchaser and also the mudguards being replaced will show the correct pattern. Heavy enamelled steel mudguards for the roadster usually have a different method of fitting to the lightweight sports type.

Fitting

The points of attachment to be attended to first are the fork crown for the front mudguard and the bridges across the chainstays and the fork stays for the rear guard.

With the roadster type, the supporting stays cannot be adjusted for length, except by cutting or bending them, as they consist of one long piece of heavy gauge wire, attached

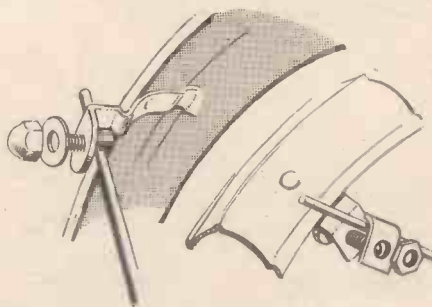

Fig. 2.—Two types of stay adjustment.

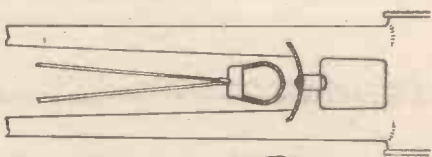

Fig. 3.—Cutting away the mudguard to aid clearance.

these stays. The looped ends of the stays will fit, by means of a bolt to threaded lugs on the front forks and rear seat stays. These nuts, due to vibration often work loose and nuts can be used with extra long bolts as an additional safeguard. Spare nuts and bolts for mudguards should always be carried with the tool kit.

Clearance

With all types of mudguards, they should be adjusted to a position as close to the tyre as possible, at the same time allowing reasonable clearance for the wheel. With the roadster machine, no difficulty is usually encountered, but the lightweight machine, designed to have a short wheelbase, often has very little clearance for mudguards. Often when touring tyres are fitted it is found impossible to eliminate "rubbing" at the point where the bottom of the guard fits inside the chainstays. The solution is to remove the sides of the mudguard with a pair of tin snips as shown in Fig. 3. Alternatively a longer chain must be used and the wheel moved further back in the rear drop-out slot.

When fitting the front mudguard, it may be found that there is little clearance under the fork crown and that the tyre rubs on the underside of the guard. The only solution here is to drop the wheel slightly in the

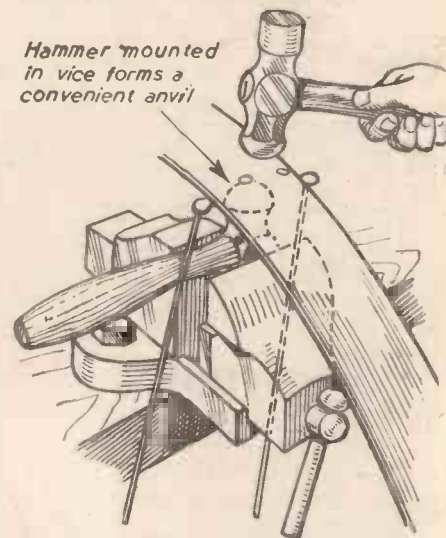

Fig. 4.—Set-up for tightening rivets and removing dents.

mudguard bridge which fits by means of bent tabs. Dents in steel and alloy mudguards can be beaten out by using the set-up shown in Fig. 4. A similar arrangement may be used for tightening loose rivets. When rivets which hold the small metal strip to which the stays are secured are pulled right through the metal, the strip can be refitted using small nuts, bolts and washers.

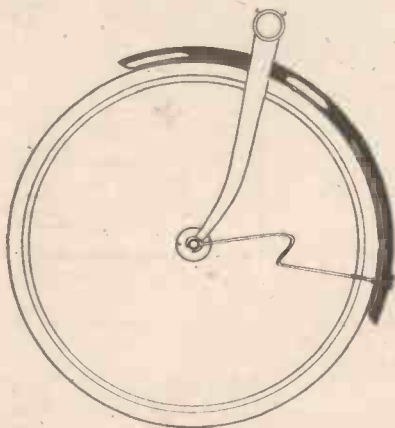

Fig. 1.—Bent stays do not look unsightly if neatly done.

to the mudguard at the centre point and being bent into a small diameter loop at each end for fixing to the wheel spindles. If bending has to be done, it can be made quite neat as shown in Fig. 1. If they have to be shortened, use a hacksaw for cutting and pliers and an old spindle as a former to bend new loops.

Lightweight mudguards, whether of celluloid or alloy construction, have an extra set of mudguard stays on both front and rear mudguards and all the stays are adjustable

HIGHSTONE UTILITIES

EX-R.A.F. 2-valve (2 volt) Microphone Amplifiers, as used in "plane intercom." in self-contained metal case: can be used to make up a deaf aid outfit, intercommunication system, or with crystal set, complete with valves and Fitting Instructions, 20/-, post 2/-. Useful wooden box with partitions to hold amplifier, 2/- extra. Amplifier, containing resistances, condensers, transformers, switches, etc., but less valves, 10/-, post 3/-. Hand Microphones, with switch in handle and lead, 5/6. Battery, 7/-, Similar instruments, moving coil, 3/6. All post 1/6. Mask type with switch 3/6, post 6d. Throat Mikes, 5/-, post 7d. Mike Buttons (carbon), 2/-. Moving coil, 3/6, post 4d.

Soldering Irons.—Our new streamlined iron is fitted with a pencil bit, 200/250 v. 50 watts, 11/6. Standard iron with adjustable bit, 200/250 v. 60 watts, 13/6. Heavy Duty Iron, 150 watts, 18/6, all post 1/-. These irons are guaranteed, and all parts are replaceable.

Meters.—20 amp 2in., m/c, 8/6; 20 v. 2in., m.c. 2/-; 150 v. 2in., m/c, 10/-; 3.5 amp. 2in., T.C., 6/-; 4 amp., 2 1/2in., T.C., in case with switch, 9/6; 100 mA., 2in., m.c., 7/6; all post extra. Meter Movements, Units with 2-500 microamp. 9/-, post 1/6.

Bell Transformers.—These guaranteed transformers work from any A.C. mains giving 3, 5 or 8 volts output at 1 amp., operate bulb, buzzer or bell. Will supply light in bedroom or larder, etc., 9/-, post 1/6. Similar transformer but output 1, 6 or 12 volts, 12/6, post 1/6. BUZZERS for use with either the above or batteries, 4/3, post 5d. G.E.O. Telephone Hand Comb. Sets, 12/6, post 1/6. Telephone Hand Generator, 3/6, post 2/-. S.B.C. Neon Indicator Lamps, for use on mains to show "live" side of switches, etc., 2/6, post 4d. Neon Indicator, complete with condenser, pencil type, with vest-pocket clip, 7/6, post 5d.

Crystal Sets. Our latest model is a real radio receiver, fitted with a permanent crystal detector. Have a set in your own room, 12/6, post 1/-. Spare Permanent Detectors, 2/- each. When ordered separately, 3/6; with clips and screws, 2/10, post 3d. Bodes, 2/6. Variable Condensers, 2/6, post 8d. Headphones, brand new, S. G. Brown, G.E.C., etc., super-sensitive, 30/- a pair. Headphones in Good Order, 6/-, Better Quality, 7/6 and 10/-. Balanced Armature Type (very sensitive), 13/6. All post 1/6. New Single Earpieces, 3/6. Bal. armature type, 4/6 (two of these will make an intercom set). EX-R.A.F. earpiece, 2/6, post 6d. Money refunded if not completely satisfied.

HIGHSTONE UTILITIES

58, NEW WANSTEAD, LONDON, E.11. New Illustrated List sent on request with 2d. stamp and S.A.E. Letters only.



A "FERROUS" ELECTRIC ARC WELDING SET will complete your workshop equipment. For joining and reinforcing, from approx. 1/16" up to any thickness, Mild Steel, Wrought or Malleable Iron. Type F.M.60 Heavy Duty complete with all equipment, 150/240v. Single ph. 10/15 amp. (or domestic power supply) delivered free, ex stock, Cash (or C.O.D.) £23.10.0 H.P. Terms available. Illus. leaflet from manufacturers. FERROUS PRODUCTS (P.M.) LTD., Church Rd., Croydon, Surrey. CR0 8351/3

MAKE MONEY — making casts

with **VINAMOLD**

A grand spare-time occupation

WITHOUT any previous experience you can mass-produce any object from a chessman to a candlestick, statuette or model ship, in plaster, resin, concrete, etc. . . . with "VINAMOLD" the flexible mould that gives the BEST results. Easy to work, can be used over and over again. Needs NO special equipment, provides a profitable and enjoyable spare-time occupation with minimum outlay.

Write for full details and Instructions. Also available: Illustrated booklet describing "VINAMOLD" methods of heating and melting, preparation of models and moulds, etc. Price 1/6 post free, from:—

VINATEX LTD. (Dept. P.M.3), CARSHALTON, SURREY



SOLID LEATHER BLACK ARMY DESPATCH RIDERS BOOTS ONLY 25/-

NEW. Send 25/- only. Plus 3/- post & handle on free 7 days' approval. Cash plus return postage instantly refunded if not worth £6.6.0. Take them to your boot dealer for independent valuation. Full chrome leather of finest quality calf length. Soles & heels are of finest HEAVY LEATHER, sewn, pegged and riveted. By best makers in country, every pair bearing maker's name which cannot be published. Unissued. Ideal M/Cyclists, Outdoor workers, Farmers, Riding, Fishing, etc. Ideal Jackboot. Sizes 5 to 13.



NEW! NEW! NEW! ALL LEATHER ARMY BOOTS

Sizes 5 up to 14 inclusive. The greatest Ex-Ministry Army Boot offer ever made! New, super quality manufacture and all leather materials. Made specifically for hard wear in all conditions & full Govt. specification, therefore there can be no harder wearing Boot, irrespective of price. A tremendous parcel enables us to offer at this silly price of 18/6, post, etc., 2/6. Money back guarantee if not worth treble. Unissued. **LISTS, CLOTHING, FOOTWEAR, WATCHES, RINGS, JEWELLERY, TENTS, ETC. TERMS.**

HEADQUARTER and GENERAL SUPPLIES LTD.

(DEPT. PMC 34), 196-200 COLDHARBOUR LANE, LOUGHBOROUGH JUNCTION, LONDON, S.E.5. Open all Saturday. 1 p.m. Wednesday.

IMMERSION HEATERS. 2 kW. or 3 kW., 11in. and 16in., £3.8.4. Thermostat for either of above heaters, £1.10.0.

THERMOSTATS. BW/1, 5 amps, 15/6. Post 6d. SN/40 1/2 amp., 5/6. Post, 4d. C. S. Convector Thermostat 15 amps, 25/-, Post, 10d. Model MB for Immersion Heaters, 15 amp., £2. Post, 2/-. PF Room Thermostat 15 amps, £2. Post, 10d. M.L. Greenhouse Thermostat 10 amps, 35/-, Post, 10d. P.J. Miniature Thermostat for Hotplates, 5 amps, 9/3. Post 6d.

FLEXIBLE ASBESTOS ELEMENT WIRE. 15 or 25 ohms/yd. 1/- per yard.

REPLACEMENT ELEMENTS Send 4d. stamp for lists.

TELEVISION SUPPRESSOR KIT, for appliances up to 1 amp., 3/6. Post Free.

BI-METAL. Hi-Flex 45 3/16in. x .010, 6d. per ft. Standard 6in. x 1/2in. x .036, 6d.

NEON ILLUMINATED INDICATOR SWITCH. 2 amps, 240 v. A.C., 10/6.

MAGNETS. Sintered Bar Magnets of great power and stability 3/4in. x 3/16in. x 1/16in., 9d. each. 8/- doz. Post 5d. We also supply Silver Contact Screws and Rivets. Porcelain Interlocking Insulating Beads. Send 4d. stamp for list.

THE TECHNICAL SERVICES CO., Banstead, Surrey

THE JEFFERY TRANSFORMER CO.

(Winders to the late Galpins) 199, EDWARD ST., NEW CROSS, LONDON S.E.14 TIDeway 4458 Leaflets sent gladly, on request

AUTOMATIC (TIME) SWITCHES

New and reconditioned 15 day clock-work and electric switches. from 35/- Send S.A.E. for Illustrated details to:— DONOHUE (TIMERS) 1 & 2 UPPER NORFOLK ST., NORTH SHIELDS, NORTHUMBRLAND

CRYSTAL CLEAR FLEXIBLE P.V.C. TUBING

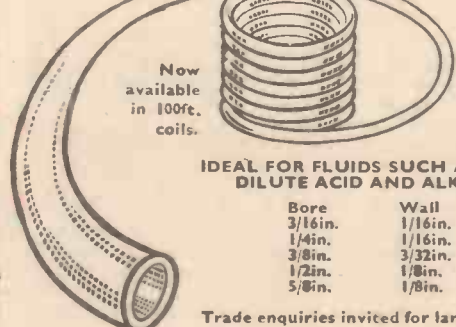

This non-perishing thermoplastic tubing, which possesses glass-like clarity, has a multitude of industrial uses.

IDEAL FOR FLUIDS SUCH AS CUTTING OILS, FUELS, DILUTE ACID AND ALKALI SOLUTIONS, ETC.

Bore	Wall	Per 100ft. coil
3/16in.	1/16in.	£1.11.0 P. & P. 2/-
1/4in.	1/16in.	£1.19.0 P. & P. 2/3
3/8in.	3/32in.	£4.16.0 P. & P. 3/3
1/2in.	1/8in.	£7.14.0 P. & P. 3/6
5/8in.	1/8in.	£9.17.0 P. & P. 4/-

Trade enquiries invited for large quantities at special prices.

TENSILE PRODUCTS LTD. 70, Willoughby Road, HARPENDEN, Herts. Tel.: Harpenden 3515

WATSON'S SPECIAL OFFERS



LIGHTWEIGHT CHARGING SETS. 12/18 v. 80 watt. Extremely neat and compact, powered by a 4-stroke engine and UNUSUAL. Easily carried. WEIGHT ONLY 46 lb. PRICE £12.10.0. Carr. 12/6.

HAND INSPECTION LAMPS. H.D. Safety Model with waterproof glass cover and protective guard complete with 10 yds. T.R.S. cable NEW, 27/6 each. Post 2/6. **BOLT OR WIRE CROPPERS** will cut up to approx. 5/16in. MILD STEEL BOLTS, 10/6. Post 2/6.

PIPE CUTTERS, by "RECORD." Three-wheel type to cut any size pipe from 1/2in. to 2in. Gas, 35/- each. Post 3/6.

SLEDGE HAMMERS. 7 lb. Nosed with ash handle, 9/6. Carr. 2/6.

AIR FILTERS OR MOISTURE TRAPS. Approx. 6in. x 3 1/2in. diam. with inlet, outlet and moisture drain. 10/6. Post 2/6.

BRASS DRAIN TAPS. 1 1/2in. GAS THREAD NEW & BOXED, 2/6. Post 4d. CANVAS TOOL ROLL. 17in. x 10in. provision for eight tools, also pocket and fastening tapes, 1/4 each. Post 4d. 1/4-doz. DINGHY MASTS, Telescopic aluminium extending from approx. 2ft. to nearly 9ft. Very light and strong, 9/6. Post 3/6.

BALL RACES taken from predictor, 5/12in. bore, 7 7/8in. diam., 1 1/4in. wide. Five for 14/-, Ten for 26/-, Post 1/4.

SMALL TRANSFORMERS. Input 230 or 110 v. A.C. Two separate outputs of 5 v.—35 watts. Extremely useful for powering electric bells, models, low voltage inspection lamps, etc. from mains supply. BRAND NEW. PRICE 17/-, Post 2/6.

ALSO AVAILABLE TRANSFORMERS with 200/250 A.C. input 12 volt 100 watts output. PRICE 30/-, Post 3/6.

Hundreds of other bargains available. Send 6d. stamp for MONSTER LIST.

EASTERN MOTORS ALDEBURGH, SUFFOLK Phone: 51

THE FAMOUS HARRIS ELECTRIC WELDER and Complete Kit

For Welding, Soldering, Brazing and metal construction & repairs in the home on the car or cycle. Instant heat 6,000° F. Works from 6v. or 12v. car battery or transformer from A.C. mains. Complete kit of Welding Tools, 9 ft. cable, clip, carbons, cleaning fluid, fluxes, filler rods, goggles, instructions, hints. Thousands in daily use. As supplied to Dept. of H.M. Government, I.C.L., Standard Telephone, etc. Welds all Metals. Up to one-eighth inch. **57/6** C.O.D. IF REQUIRED. Obtainable only from: Post Free U.K. only HARRIS ENGINEERING CO. (Dept. P.M. 25) 269 Kingsland Road, London, E.2.

Terms: 11/- dep. & 5 wkly. pmts. of 10/-

GENERAL CERT. OF EDUCATION

THE KEY TO SUCCESS & SECURITY

Essential to success in any walk of life! Whatever your age, you can now prepare at home for the important new General Cert. of Education Exams on "NO PASS—NO FEE" terms. You choose your own subjects—Educational, Commercial or Technical. Recently announced big extension of subjects gives everyone the chance to get this valuable Certificate.

SEND FOR FREE 134 PAGE BOOK Full details of how you can obtain the General Cert. are given in our 134-page Guide—Free and without obligation. Personal advice on request. Write today, School of Careers, Dept. 160, 29-31, Wright's Lane, London, W.8.

The School of Careers

men only

presents another sensational best seller . . .

INSIDE RUSSIA TODAY

by JOHN GUNTHER

You have been waiting for this. And so has the whole free world. "Inside Russia Today" is probably the *first* book to present the true profile of the Soviet nation. The man in the street . . . the children of the streets . . . how they live, how they work, how they relax.

This important new book . . . condensed in this month's MEN ONLY . . . is written in John Gunther's own words in the authoritative and comprehensive, yet at the same time immensely readable style that he has made so particularly his own. It takes you inside this continent-sized country and reveals it geographically and historically . . . in political, industrial, scientific, and above all, human terms.

Here are the sights and sounds of Russia ; the weather, the food, the essential atmosphere. Here are personal glimpses of every sort of Russian in almost every walk of life. "Inside Russia Today" is essential reading for everyone who hopes to understand the struggle for power and the chances for peace in today's world.

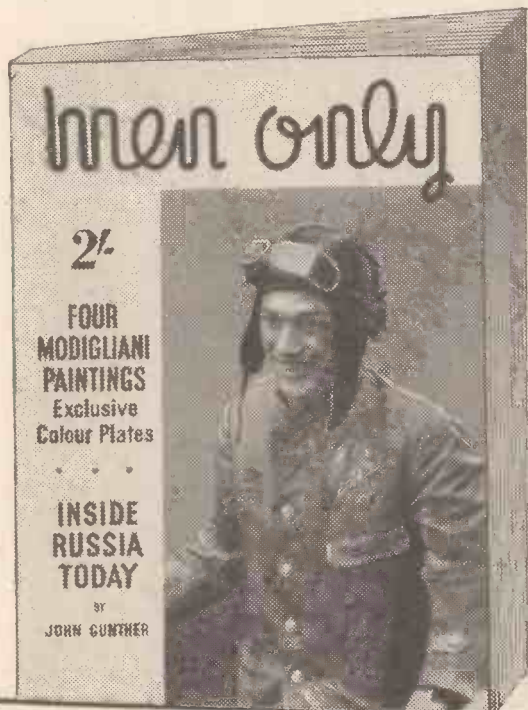

"THE MOST OBJECTIVE AND INFORMATIVE BOOK EVER WRITTEN ABOUT THE U.S.S.R." SUNDAY TIMES

"Crammed with the kind of information people are always asking for . . . a very true picture of Soviet life in its vast extent and infinite complication." OBSERVER

"Never before has so much information been provided in one book on Russia. For anyone who wishes to know something about the Soviet Union, this is the ideal book." GLASGOW HERALD

men only

SEPTEMBER NUMBER

OUT AUGUST 14th 2/-

STEEL SHELVING

72 in. HIGH
34 in. WIDE
12 in. DEEP

- Brand new—Manufactured in our own works.
- Shelves adjustable every inch.
- Heavy gauge shelves will carry 400 lbs. each.
- Stove enamelled dark green.
- 6 shelves per bay—Extra shelves 8/- each.
- Also available in white at £5 per bay.
- Quantity discounts.

Delivered free £3 15s.
Ready for erection.

N. C. BROWN LTD.

Green Lane Wing

HEYWOOD · LANCS

— the manufacturers !



ALL OTHER SIZES available at equally keen prices.

Deliveries Free to England, Scotland and Wales.

Telephone :
Heywood 69018
(3 lines)

RIGHT!



for good braking

USE

Fibrax

BRAKE BLOCKS

FOR SURE STOPPING

AND A LONG LIFE

FIBRAX BRAKE BLOCKS stand up to the toughest test—the split-second emergency. Yet they brake smoothly and firmly. Two types: SOFT RED for alloy rims, BLACK for steel rims.

Ask your dealer for "FIBRAX"

FIBRAX LTD., 110, ORMSIDE ST., OLD KENT RD., LONDON, S.E.15
New Cross 6785/6 F356A

Over 75 years
experience and world-wide
reputation for quality

THORNTON

DRAWING INSTRUMENTS
MINERVA SERIES PROFESSIONAL QUALITY
TECHSET SERIES STANDARD QUALITY
KINWEST SERIES SCHOOL QUALITY



Write for
illustrated leaflets
and address
of your
nearest stockist to:

A.G. THORNTON LTD.
P.O. BOX 3, WYTHENSHAW, MANCHESTER

MANUFACTURERS OF FIRST QUALITY DRAWING INSTRUMENTS
P.I.C. SLIDE RULES AND DRAWING EQUIPMENT

The Bestfriend "ZEPHYR" (M) Motor and Accessories



A silent, shaded pole motor, A.C. only, 200/250 volts, 2,600 R.P.M., 25 watts. 3½" x 2½". Precision built and specially suitable where absolute silence is essential. Continuously rated and designed for use in construction of table and extractor fans, projector cooling units, fan heaters, cupboard airing devices, etc. An extremely high-class product.

designed by engineers with a quarter of a century of experience in motor construction.

37/6
Post Free

An anti-vibration stand for above motor. Horizontal or vertical mounting. Supplied in breakdown form for home constructors. 8½" x 2½" x 2". Three point suspension. Steel, Cadmium plated. **7/6**
Post Free

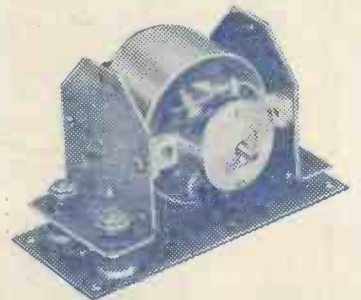

FANS

4 Bladed Metal 4" diam. 5/-
BAKELITE 3 Blades 8" diam
7/6 Post Free

The Bestfriend Electrical Co. Ltd.
BANSTEAD SURREY

Tel. : BURGH HEATH 1432

Free Guide — SUCCESS IN ENGINEERING

One of the following Courses taken quietly at home in your spare time can be the means of securing substantial well-paid promotion in your present calling, or entry into a more congenial career with better prospects.

132-PAGE BOOK FREE!
SEND FOR YOUR COPY

ENGINEERING, RADIO, AERO, ETC.

Aero. Draughtsmanship	Elec. Draughtsmanship
Jig & Tool Design	Machine
Press Tool & Die Design	Automobile
Sheet Metalwork	Structural
Automobile Repairs	R/F Concrete
Garage Management	Structural Engineering
Works M'gmt. & Admin.	Mathematics (all stages)
Practical Foremanship	Radio Technology
Katefixing & Estimating	Telecommunications
Time & Motion Study	Wiring & Installation
Engineering Inspection	Television
Metallurgy	Radio Servicing
Refrigeration	Gen. Elec. Engineering
Welding (all branches)	Generators & Motors
Maintenance Engineering	Generation & Supply
Steam Engine Technology	Aircraft Mainten. Licences
I.C. Engine Technology	Aerodynamics
Diesel Engine Technology	Electrical Design
Ordnance Survey Dr'p.	

BUILDING AND STRUCTURAL

L.I.O.B.	A.I.A.S.	A.R.S.H.	M.R.S.H.
A.M.I.P.H.E.	A.A.L.P.A.	A.F.S.	A.R.I.C.S.
Building Construction	Builders' Quantities	Builders' Quantities	
Costs & Accounts	Carpentry & Joinery	Carpentry & Joinery	
Surveying & Levelling	Building Inspector	Building Inspector	
Clerk of Works	Building Draughtsmanship	Building Draughtsmanship	
Quantity Surveying	Heating and Ventilating	Heating and Ventilating	

GENERAL, LOCAL GOVERNMENT, ETC.

Gen. Cert. of Education	Common. Prelim. Exam.
Book-keeping (all stages)	A.C.I.S., A.C.C.S.
College of Preceptors	A.C.W.A. (Costing)
Woodwork Teacher	School Attendance Officer
Metalwork Teacher	Health Inspector
Housing Manager (A.I.Hsg.)	Civil Service Exams.

BECOME A DRAUGHTSMAN—LEARN AT HOME AND EARN BIG MONEY

Men and Youths urgently wanted for well paid positions as Draughtsmen, Inspectors, etc., in Aero, Jig and Tool, Press Tool, Electrical, Mechanical and other Branches of Engineering. Practical experience is unnecessary for those who are willing to learn—our Guaranteed "Home Study" courses will get you in. Those already engaged in the General Drawing Office should study some specialised Branch such as Jig and Tool or Press Tool Work and so considerably increase their scope and earning capacity.



★ OVER SEVENTY YEARS OF CONTINUOUS SUCCESS ★

NATIONAL INSTITUTE OF ENGINEERING

(In association with CHAMBERS COLLEGE—Founded 1895)
(Dept. 29)

148, HOLBORN, LONDON, E.C.1

SOUTH AFRICA: E.C.S.A., P.O. BOX NO. 8417, JOHANNESBURG
AUSTRALIA: P.O. BOX NO. 4570, MELBOURNE

This remarkable FREE GUIDE explains:

- ★ Openings, prospects, salaries, etc., in Draughtsmanship and in all other branches of Engineering and Building.
- ★ How to obtain money-making technical qualifications through special RAPID FULLY-GUARANTEED COURSES.

MANY INTERESTING COURSES TO SELECT FROM!

A.M.I.Mech.E., A.M.I.M.I.,
A.M.Brit.I.R.E., A.M.I.P.E.,
A.M.I.C.E., A.M.I.Struct.E.,
A.M.I.Mun.E., M.R.S.H.,
A.M.I.E.D., A.F.R.Ae.S.,
London B.Sc., Degrees.

Fully guaranteed postal courses for all the above and many other examinations and careers. Fully described in the New Free Guide.



THE ACID TEST OF TUTORIAL EFFICIENCY SUCCESS—OR NO FEE

We definitely guarantee that if you fail to pass the examination for which you are preparing under our guidance, or if you are not satisfied in every way with our tutorial service—then your Tuition Fee will be returned in full and without question. This is surely the acid test of tutorial efficiency.

If you have ambition you must investigate the Tutorial and Employment services we offer. Founded in 1885, our success record is unapproachable.

ALL TEXTBOOKS ARE SUPPLIED FREE
PROMPT TUTORIAL SERVICE GUARANTEED
NO AGENTS OR TRAVELLERS EMPLOYED

Free Coupon

To: NATIONAL INSTITUTE OF ENGINEERING
(Dept. 29), 148-150, Holborn, London, E.C.1.

Please Forward your Free Guide to

NAME

ADDRESS

My general interest is in: (1) ENGINEERING
(2) AERO (3) RADIO (4) BUILDING
(5) MUNICIPAL WORK

(Place a cross against the branches in which you are interested.)

The subject of examination in which I am especially interested is

To be filled in where you already have a special preference.
(2d. stamp only required if unsealed envelope used.)



FOUNDED 1885 - FOREMOST TODAY

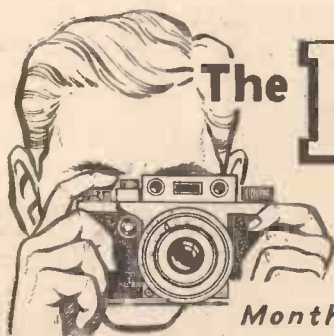

The Practical Photographer

No. 5. AUGUST, 1958

Monthly Supplement to "Practical Mechanics"



Masking a 120 Film for 16 Exposures

By E. G. GAZE

THE user of 120 size film with eight exposures $2\frac{1}{2}$ in. \times $3\frac{1}{2}$ in. can double the number of shots per spool by masking the negative frame aperture to $2\frac{1}{4}$ in. \times $1\frac{1}{2}$ in., thus getting 16 frames instead of eight.

The Mask

Many cameras have a mask built in for this purpose; but it is simple to make a mask and stick it carefully over the negative aperture with the camera back open. Use thin but stiff card (black if possible to minimise any light-throw), accurately cut to the new negative size and carefully centred on the negative frame opening in the camera. It must be thin to avoid displacing the film emulsion when the spool is in, but most cameras have a slight recess between the 'spool runners' which is just enough depth to take a thin, firm piece of card. It can always be removed as simply when not required.

Exposure Counting

Cameras with inbuilt masks designed for this type of film saving have two red, winding windows for counting exposures. The frame numbers of the back of a 120 spool run in three series, for 16-on, for 8-on, and for 12-on. The 16-on series run at the top, the 12-on in the middle, and the 8-on at the bottom: so the top window is used with the mask in place for 16-on, and the bottom for 8-on exposures. But converting your own 8-on camera need not entail drilling holes and making an extra safety winding window. It does, however, call for a little extra work in the darkroom before the spools are used as 16-on.

Reversing the Spool

Place the spool in the camera and wind up on the take-up spool as usual; in the darkroom—when the film emulsion comes across the negative aperture frame cut it free from the sticky tape holding it to the backing paper and continue winding until the free end of the film comes up—then fasten that end to the backing paper with sticky tape or Sellotape.

You now have a normally rolled up spool with the free and fastened ends reversed; place it in the camera and lead across as usual to the take-up spool. The 16-on number series will now come at the bottom where the red winding window is for your normal 8-on. The numbers will run in reverse sequence—from 16 to 1—and there will be no warning hand or dots to show when the first exposure frame is coming up to the window, but with a little practice it is possible to "feel" the emulsion crossing the aperture and taking up on the take-up spool.

Do not simply stick down the other end as well, as sometimes this may lead to "binding" and buckling of the emulsion

HINTS AND TIPS

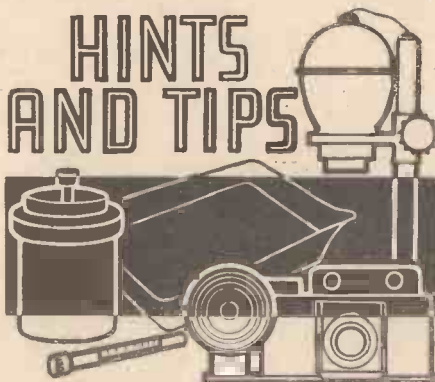

owing to extra tension as the film moves on the spool. The leading end can be freed out of the camera (in the darkroom, of course), and the spool wound to the take-up spool in the hand, which does away with the difficulty sometimes found in getting the now free end on to the take-up spool without fumbling. Hand-winding, however is not so accurately tensioned as using the normal camera winding system.

It now only remains to make a small mask to fit over the viewfinder to show this smaller field of view. This can be done by measurement from the centre of the viewfinder so that just half the view normally comprising the $3\frac{1}{2}$ in. side of the negative is seen. For extra accuracy place a piece of ground glass over the smaller negative frame

aperture—note the exact limits of the image formed on the glass by your lens, and mask the viewfinder to include those limit points and no more.

A viewfinder mask made from stiff card, can be pressed or clipped over the finder, and removed as easily as the negative frame mask if you wish to revert to normal 8-on exposures.

Negative Storage

An Extract from "Photographic Processing" (to be published shortly by Geo. Newnes Ltd.).

AS soon as negatives are dry they should be placed in bags and kept in a box with a lid until required. Only envelopes made specially for negatives should be used, because they are made of chemically inert material—either paper or cellophane which cannot harm the emulsion or image. Ordinary stationery envelopes should never be used, or it is possible that, after a few months, stains and other marks may appear. In addition the inner surfaces of these envelopes are usually rough and release countless particles of paper every time a negative is inserted.

"One negative—one bag," should be a firm rule with all sizes other than 35mm. film, and these should be cut into lengths of six negatives and stored in the bags made specifically for this purpose. On no account should negatives of any size be stored in rolls, or scratches are bound to occur.

Multiple Exposures With an Interlocked Shutter

By A. E. B.

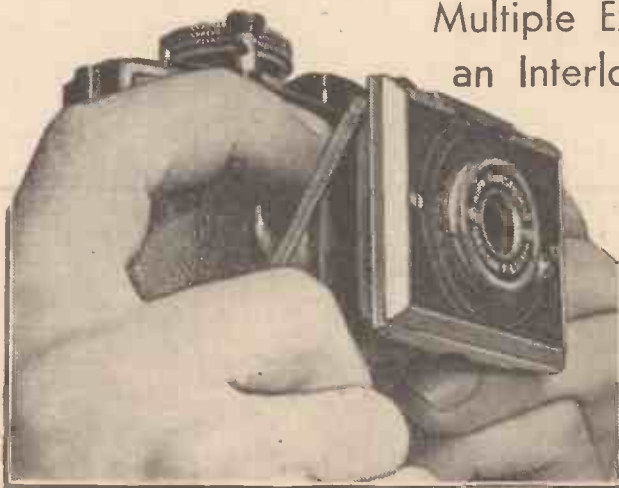

By-passing the interlock mechanism

Undoubtedly, this safeguard is most useful but, at times, it would be desirable to have the shutter operate more than once without having to move the film. This could be necessitated when multiple exposure trick photography is being undertaken, or on those admittedly rare occasions when the shutter is inadvertently released while the lens protection cap is still in place.

With most cameras of this type, the interlock occurs at the body release

MANY bellows-type folding cameras have their shutter releases interlocked with the film wind knobs. By this means, when using the camera normally, it is impossible to advance the film until the frame behind the lens has been exposed. In addition, after making an exposure, the shutter will not operate again until a new frame has been moved into position.

for the shutter, and not at the shutter itself. By making the second and subsequent exposures through the movement of the connecting rod from the body release to the shutter, the interlock is avoided. There is, of course, no possibility of causing damage to the mechanism by adopting the method outlined here.

A Simple Synchroniser

Suitable for Any Camera With a Tensioning Lever on the Shutter
By David Brown

and then gently shut. The positions in the arc of travel at which the blades are respectively opened and shut remain constant irrespective of the speed setting employed.

The movement of the lever is used to control the firing of the bulb.

A microswitch is just depressed into the off position when the tensioning lever is fully pushed up. The instant the lever is released, and before the shutter is opened, the electrical circuit through the bulb is completed. Thus there is no interference with the mechanism of the shutter and no drilling or other alteration is required to any part of the camera or its mountings.

Limitation of Shutter Speed

On a Compur-type



Fig. 3.—Power unit, bulb and reflector.



Fig. 1.—The complete outfit.

THIS particular flashbulb synchroniser is not suitable for shutter speeds faster than 1/50th second.

The unit is illustrated in the form to suit an Agfa Karat, but it may easily be modified in layout to suit any camera with a Compur or similar type shutter having a tensioning lever.

The Principle of Operation

This may best be explained by considering an ordinary Compur shutter. When the tensioning lever is pushed up, the shutter is wound. If now the shutter release is depressed whilst gently restraining the motion of the tensioning lever, it will be seen that as the lever is allowed slowly to move down, the blades of the shutter are opened, allowed to remain open



Fig. 2.—The synchroniser with camera removed.

those which will enable the greater portion of the light given out by the bulb to be employed.

This may best be demonstrated by the following table:

Type of bulb	Approximate percentage of light accepted at the given shutter setting		
	1/25sec.	1/50sec.	1/100sec.
Philips P.F.14	100	50	—
" P.F.25	100	60	15
" P.F.56	95	60	15
Mazda speed midget	100	100	50

Construction

A general view of the synchroniser is shown in Fig. 1. It consists of a multi-ply wooden base fitted with two small wooden strips to locate one end of the camera with a bush for a tripod screw bolt (in my case a moulded accumulator terminal) at the other end. In this way the camera position is maintained constantly aligned within perhaps 0.01in., which is necessary to ensure smooth working. On the end of the wooden base is secured a 2oz. tobacco tin which houses the battery and "wiring" and the bulb holder and reflector mounting bush, as shown in Fig. 3.

A wooden bracket rigidly screwed and glued to the wooden base and the tobacco tin is used to carry a standard microswitch, secured by two 1in. No. 8 wood screws through the body of the switch. These switches have three terminals and can be connected either to "make" when the switch is pressed or to "break"; the latter condition is required to ensure that when the tensioning lever releases the switch plunger the bulb will be fired.



Fig. 4.—Linkage to the shutter tensioning arm.

shutter, at speeds up to 1/250th of a second, the time from releasing the shutter to the blades beginning perceptibly to open is of the order of five milliseconds. This introduces the only limitation of the device, since clearly it is not possible to use shutter speeds faster than

A small piece of copper tube is soldered around the switch plunger and bent and filed in such a way that it will pick up solidly against the end of the shutter tensioning lever (Fig. 4) without blocking vision through the viewfinder. One hint necessary on the construction is that only the lower screw should be fitted to hold the micro-

(Concluded on page 71)

View Photography

Some General Pointers
Given By
Albert Benson

two considered practically essential are those mentioned above.

3D Effect

The principal requisite of a view photograph is that it should show the subject in a manner closely related to the natural conditions. This means that the picture, a purely two-dimensional image,

render the three-dimensional effect. If the light is insufficiently strong to permit the entire depth of field to be sharply focused, the point of accurate focus should be towards the foreground. The eye will make allowance for an unsharp background in a photograph of this nature, but it requires the nearer objects to be quite well defined.



Fig. 1.—The archway of a ruined castle used as a frame.

FIRST, which sort of camera is most suitable for view work? Many people prefer cameras having large focusing screens, as the scene can be viewed in reasonable proportions, and the composition arranged before the negative is made. Hand and stand cameras and single and twin lens reflex instruments are the most commonly used items of this type. However, familiarity with the smaller viewfinders of miniature and folding cameras enables the user of this equipment to compose his pictures almost as easily as the users of the other types mentioned above.

A lens hood is essential for pictorial photography, for it is often necessary to use the camera under conditions where a fair amount of stray light could otherwise easily enter the lens and cause a flattening of the image contrast. The view photographer will also find it necessary to own a few filters and, as these are frequently to be used in out-of-doors conditions, it is advisable to obtain optically ground glasses which have been colour dyed during manufacture. For normal colour correction and slight haze penetration, a light yellow or yellow-green filter is ideal, and for over-correction to produce the dark sky effect so beloved of many pictorial photographers, an orange or light red filter is most suitable. Many other filters are available, but the only



Fig. 3.—Using human figures to concentrate interest in the required area.



Fig. 4.—Contrasting a human figure with other features.

Foreground Interest

When no atmospheric conditions can be brought into use to assist in giving an effect of depth, a similar result can be achieved by employing other devices to the same end. The ability of the camera lens to select a particular plane in the picture for sharper focus than any other is most useful. Sharp focus at any point ensures that the interest will be concentrated there, but that point must, by its nature, form an important part of the composition. Fig. 3 shows a photograph which has received this treatment. The two figures on the seat draw the eye by virtue both of sharpness and depth of tone. The foreground and background are less sharp and of far lighter tone, so avoiding competition with the point of interest. The branch sweeping in from above, and the tree trunk to the right, play their parts in confining the viewer's gaze to the required area.

Never hesitate to use people as the points of interest in view photographs. The sensible placing of a human figure can go a long way towards putting life into an otherwise static picture and, by relating its size to other features, a sense of scale can be achieved (Fig. 4). With very few exceptions, any people included in view photographs should be sharply focused and not blurred by movement. It is not even essential that they should be performing any useful function as long as they assist in binding the various elements together.

"Framing"

An especially useful method of improving an otherwise barely interesting view is to enclose it in some form of framing. The trunk of a tree together with a down-sweep (Concluded on page 76)

must show the third dimension—that of depth—by some form of apparent recession of planes into the distance. A photograph of a large area, taken on a day when a slight mist is present, will show the foreground subject matter clearly and sharply defined, while the middle distance is still sharp but slightly veiled. The background, as seen in Fig. 2, becomes very slightly unsharp due to the light-scattering effect of the mist, and rather weaker in tone. This is one way to



Fig. 2.—A view where the mist gives a 3D effect.

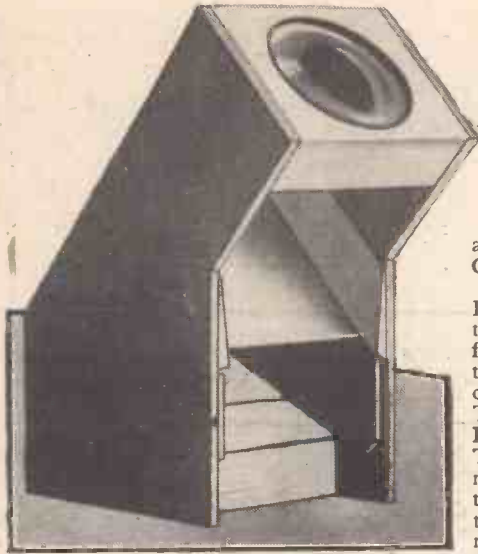

Fig. 1.—Partially completed focusing magnifier.

WHEN enlarging a dense negative it is difficult to see, from the dim image on the baseboard, whether it is in precise focus or not. With the focusing magnifier shown in Fig. 1 a much brighter image is reflected by a mirror on to a ground-glass screen, which is then viewed through a magnifying lens enabling critical, needle-sharp focusing to be obtained quickly and easily.

The prototype was made from wood and hardboard, but plastic or metal could be used.

Fig. 2 illustrates the principle of working. The projected image from the enlarger, which normally falls on to the baseboard, is intercepted by the mirror, set at an angle to the baseboard. The image is reflected from this mirror on to the ground-glass screen, set at an angle which is twice that of the mirror. Any angles can be used, but the ones used in the original are $22\frac{1}{2}$ degrees for the mirror and 45 degrees for the ground-glass screen. These are easy to set out, and they make the instrument convenient for viewing.

Only a small portion, about 2in. square, of the projected image can be seen through the instrument, but this is an advantage, as it enables focusing to be concentrated on the most important part of the photograph. In addition, by moving the instrument to the corners of the photograph, any falling off in definition can be quickly spotted and corrected by stopping down the enlarger lens.

Construction

The perspective view, Fig. 3, clearly shows the details of construction. Fig. 4 shows the method of setting out one side, using only a pair of compasses. When this side has been set out and cut the opposite side can be marked from it. Then the two sides can be clamped or lightly glued together for finishing to ensure that they are identical. To set out the first side, take a piece of hardboard about 6in. square. True up the base line A-B and square up the edge B-C. Set off the points D and E on the base and edge, each 6in. from corner B. Draw the line D-E, which is at 45 degrees to the base. With the point of the compasses at D draw the arc B-F. With the compass point first at B and then at F bisect the arc and draw the line D-G. Now draw line H-J parallel to D-E, and at a distance from it equal to the focal length of the lens to be used. From G draw the line G-J at right-angles to D-E. Draw H-K parallel to G-J

A FOCUSING

An Accessory for Use
With the Enlarger



By J. VOSE

and 2in. from it. Draw K-L parallel to C-B and $3\frac{1}{2}$ in. from it.

The following points should be checked. It is essential that the line D-G, which is the line of the silvered surface of the mirror, forms an angle with the base exactly half that formed by line D-F, which is the line of the ground surface of the glass screen. The other essential is that the measurement F-G must equal the measurement G-B. These dimensions are, as near as can be measured, $2\frac{1}{2}$ in. It will be seen that these two requirements ensure that the path of the light rays from the enlarger, to the mirror, and then from the mirror to the ground-glass screen, is exactly the same distance as is the direct path from the enlarger to the baseboard.

Minor errors in construction can be corrected at completion by either raising or lowering the instrument from the baseboard, and for this reason it is suggested that a $\frac{1}{2}$ in. strip of hardboard be cut from the bases of the two sides, this $\frac{1}{2}$ in. to be replaced in the completed instrument with a $\frac{1}{2}$ in. thick wood base, or adjusted to the precise thickness required, as determined by tests.

The bevelled seating block for the mirror should now be prepared from a piece of sound, well seasoned wood about $2\frac{1}{2}$ in. wide and 2in. thick. The bevel must be carefully planed to the correct angle and checked against the full-sized setting out until it fits perfectly. It is best to start with a piece of wood about 6in. long, as this is easier to handle, and to cut it off square to the required length when it has been shaped.

The block which holds the magnifying lens is also of well seasoned wood 2in. square and $\frac{1}{2}$ in. thick. It should be bored

out $\frac{1}{4}$ in. less in diameter than the lens, and then counterbored out to allow the lens to be seated. The lens may be secured with a wire ring, sprung in. If a suitable magnifying glass is not to hand, one may be obtained cheaply from a well-known chain store in the form of a miniature reading glass $1\frac{1}{2}$ in. dia. and about $2\frac{1}{2}$ in. focus. The metal rim can remain on the glass, but the small handle should be removed by bending it gently backwards and forwards until it breaks away from the rim.

Two wedge-shaped pieces of hardboard should now be cut and planed to the $22\frac{1}{2}$ deg. angle between the mirror and the ground glass. If one is cut first and fitted accurately to the setting out diagram it is an easy matter to pin or glue the other

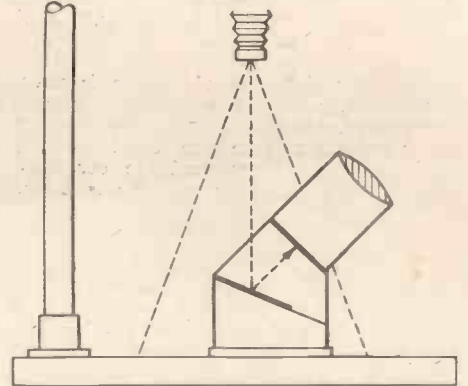

Fig. 2.—Principle of operation.

piece to it before trimming. In this way the two pieces are sure to be identical. Note that it is only the angle which requires to be accurate at this stage. The two pieces may be left longer than required to facilitate handling. The surplus length can be cut off after finally fitting and gluing in position.

Two short lengths of strip wood about $\frac{1}{2}$ in. \times $\frac{1}{2}$ in. are required to hold the ground-glass screen in position. These may also be left long to start with, for cutting off later.

The Mirror and Ground Glass

A piece of thin mirror 2in. square is required. It is an advantage if this is face silvered. A piece cut from a handbag mirror proved perfectly satisfactory in the prototype. It must, of course, be dead flat and free from distortion. The ground glass is also 2in. square, and it must be very finely ground. Accurate focusing is impossible with a coarsely ground screen. An easy way to make a suitable screen is to obtain two discarded photographic plates, clean off the emulsion with boiling water and grind the two pieces together with household scouring powder and water. The powder quickly loses its bite and has to be constantly renewed, but a quarter of an hour's grinding will produce two finely ground screens, one of which may be kept as a spare.

(Concluded on page 70)

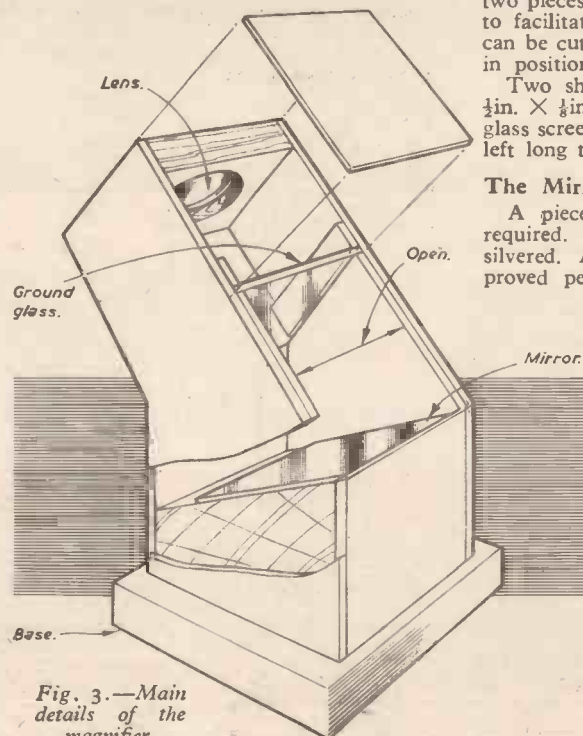

Fig. 3.—Main details of the magnifier.

Copying

The Apparatus and Method for Duplicating Colour Transparencies and General Copying

By JOHN A. JACOBS, F.S.M.C.

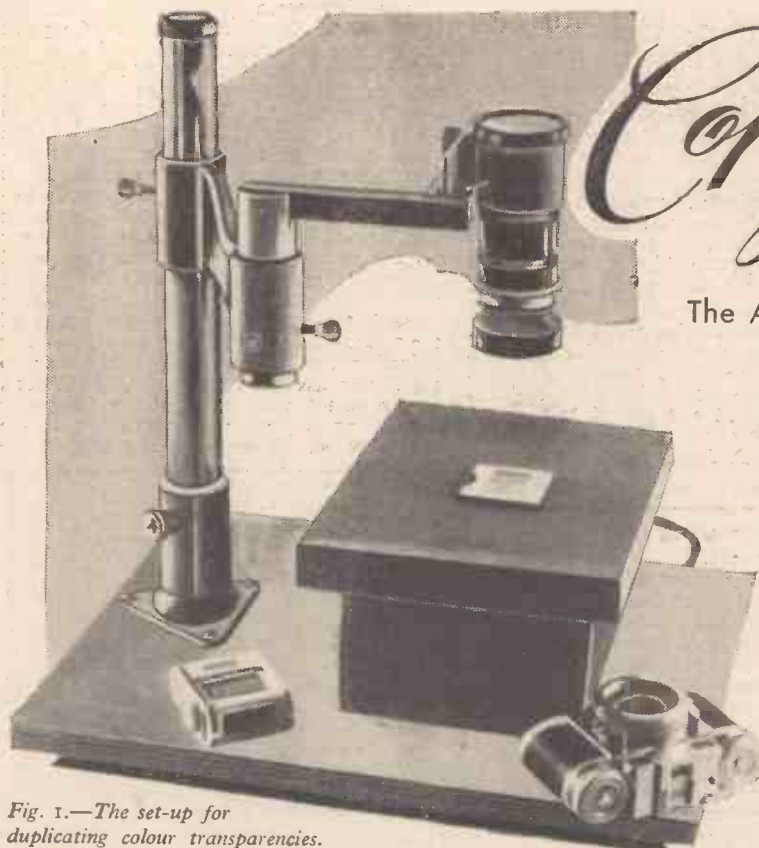

Fig. 1.—The set-up for duplicating colour transparencies.

THE writer has for several years processed his own colour film, both reversal and negative-positive processes, using the excellent formulae published in the *British Journal Almanac* and subsequently some manufacturers' published formulae. Small quantities of solutions only need be compounded, and expense is considerably reduced.

The next logical step is to find a method of copying transparencies accurately without the equipment used by the commercial processing houses.

Apparatus Required

Group 1 consists of equipment already possessed by most keen amateurs.

1. Enlarger base board.
2. Enlarger extension column and bracket.
3. Miniature camera with interchangeable lens mount and cable release. (Paxette II in the author's case.)
4. Exposure meter.
5. Camera case-retaining screw.
6. 7in. X 5in. safelight.

Group 2 consists of apparatus to be purchased.

1. Lens extension tube length equivalent to focal length of camera lens (or combination of tubes), 45 mm. for the Paxette.
2. Ground glass focusing adaptor.
3. Piece of flashed opal glass 7in. X 5in. to take the place of normal safelight screen.
4. Two gelatine Wratten filters 80A and 82B (only needed if daylight balanced colour film is used).

The Camera Support Bracket

This can be constructed in little over 10 minutes by anyone possessing a hacksaw, two drills and a file. The materials required are a 3in. length of 1½in. dia. aluminium tube—the size of most enlarger columns—to fit in the enlarger extension column bracket. A 4in. length of 1in. aluminium T-section. A 3in. length of aluminium channel. Three ½in. BA nuts and bolts. All these items were purchased from

will just locate in these saw cuts. The channel is then tapped into the top of the tube with its end flush to the side. After making sure that it subtends an angle of 90 deg. to the tube, a hole is drilled right through, passing through both sides of the channel. This assembly is held in position by a 1½in. 4BA bolt passing through the holes.

The T-section is placed with the cross-piece down, i.e., an inverted T. A 5/16in. hole is drilled in the centre of the upright section; the centre of the hole corresponds to the distance from the front edge of the camera to the centre of the tripod bush. This distance on the T is measured from the top surface of the cross-piece up the vertical section of the inverted T. The T is secured at one end to the channel—still inverted—by drilling two holes, one each side of the upright section, passing through the flat top section of the channel. The holes in the T-section are countersunk and the bolts are fitted, the nuts locating on the underside of the channel.

The camera or the focusing adaptor can now be attached to the front of the bracket thus made by passing the case-retaining screw through the 5/16in. hole and into the tripod bush. The front of the camera will now bear against the top of the lower front section of the inverted T. It will be found necessary to file away some of the metal from this section to avoid fouling any projections on the camera.

Setting Up

The safelight is placed face up on the enlarger baseboard with a 60-watt pearl tungsten lamp fitted. The flashed opal glass is placed in position of the normal safelight screen. Now a piece of cardboard

a good quality or thin sheet metal, at least 8in. square with an aperture 24mm. X 36mm. cut in the centre, is placed on top of the safelight. This is used to mask off all the unwanted light. In Fig. 1 a bromide paper box is used for this purpose. It will be noted that as the opal glass is so close to the bulb, the light will not be diffused evenly over its whole surface, but there will be a large patch of homogeneous light at the centre, more than enough to cover a 24mm. X 36mm. transparency. The aperture in the mask is placed over this region.

Two saw cuts are made parallel to each other across the top of the 1½in. tube. The cuts are ½in. apart and just over ½in. deep. It will be found that the ½in. channel

of thin sheet metal, at least 8in. square with an aperture 24mm. X 36mm. cut in the centre, is placed on top of the safelight. This is used to mask off all the unwanted light. In Fig. 1 a bromide paper box is used for this purpose. It will be noted that as the opal glass is so close to the bulb, the light will not be diffused evenly over its whole surface, but there will be a large patch of homogeneous light at the centre, more than enough to cover a 24mm. X 36mm. transparency. The aperture in the mask is placed over this region.

If daylight balanced colour film is in the camera it will be necessary to convert the colour temperature of tungsten light—2,800°K to that of daylight, about 5,000°K. This is done by placing the Wratten colour temperature correction filters 80A and 82B together or Gevaert filter CTB16 over the aperture in the mask. Of course, if artificial light film is used, this step is unnecessary.

Transparency Duplication

The selected transparency is thoroughly cleaned and placed, still in its mounting, emulsion side down over the filters lining up with the aperture in the mask.

Now a meter reading is taken from the illuminated transparency. It was found that if the meter was used without an incident light attachment, i.e., the reflected light setting, better results were obtained. The light transmitted through the transparency is measured from a distance of 6in., and the exposure is calculated from the reading thus obtained. This method allows for varying densities in transparencies and even the possibility of improving on the contrast of the original. The exposure is doubled to allow for the increased image distance caused by the lens extension tube.

The safelight should now be temporarily switched off to save overheating the filters and transparency.

The enlarger extension bracket is now mounted on the column and the camera bracket attached to it, and the complete assembly is fitted to the baseboard. The

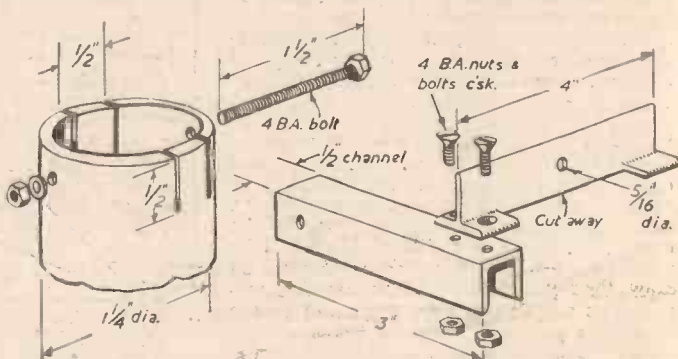

Fig. 2.—Bracket construction details.

camera lens set to infinity and extension tube are fitted to the focusing unit and mounted on the camera bracket. A lens hood should be used.

The whole assembly is swung into position over the transparencies and lowered so that the lens is approximately 90mm. from it.

The safelight is now switched on again and the image is adjusted into position and focused on the ground glass screen on the focusing adaptor. This image should be examined with the aid of a magnifier or linen tester to make sure optimum sharpness is obtained by slightly raising or lowering the assembly. Once set up all screws are tightened. After switching off the safelight the focusing adaptor is carefully removed. The lens and extension tube are transferred to the camera body and the shutter is cocked and the cable release is fitted. The camera is now mounted on the bracket in place of the focusing adaptor, the safelight is switched on, and the exposure is made. The film is processed according to the normal procedure.

Other Processes

The same set-up has been used to make separation negatives on monochrome film through tri-colour filters Wratten 29, 47B, 61, which have been very successfully used in the production of trichrome Carbro prints. For this purpose the filters are passed in sequence in front of the camera lens, as the transparency must not be moved until the three separation negatives have been exposed. Care must be taken that no movement occurs in the setting when operating the film transport and shutter cocking lever. In the writer's case, the filters were mounted in line in a 2in. glass sandwich cut from an old photographic plate and bound together permanently with cellulose tape. The resulting slide is supported by a carrier which clips on to the lens hood. This carrier is supplied at moderate cost, it is marketed as a support for Pakolor tri-colour filters on an enlarger lens, but serves admirably for the purpose described above. Care must be taken in the exposure of these separation negatives. A soft working film such as HP3 is ideal and is exposed according to the filter factor given in Kodak data sheet FT7, i.e., red 7, blue 29, green 15.

Grey Scale

A grey scale negative should be incorporated at the end of the frame, sacrificing about 3 mm. of the transparency so that the subsequent bromide prints from each separation negative can be balanced before Carbro processing. This will necessitate removing the transparency from its mounting and placing it in an adapted mounting to which the grey scale negative is permanently in position. Good separation negatives can thus be obtained from Ferranicolor transparencies.

Negatives on monochrome film for the production of normal bromide prints can also be made in this manner using no filters at all, although in very contrasty transparencies a softer result is obtained by using the colour temperature correction filters.

Copying

The equipment is very useful for normal copying, in which case the safelight is removed and the baseboard is used as an easel to mount the print or page to be copied. A range of extension tubes will be needed for this. Illumination is provided by two No. 1 photofloods. Monochrome transparencies can be made for projection by the reversal process, indeed, very fine results have been thus obtained, using Ilford Pan F film.

A Focusing Magnifier

(Concluded from page 68)

Assembly

The bevelled base block is first glued to one of the side pieces, making sure that the bevelled surface is lined up precisely with the marked out line D-G. Note that this line represents the mirror silvering, so if, instead of an ordinary piece of mirror, a special face silvered mirror is used the bevelled block must be set down the thickness of the glass so that the mirror surface will line up with line D-G.

The lens block is also glued in position. A couple of fine panel pins driven through the hardboard side into these two blocks will prevent movement whilst the opposite side is being glued and pinned in position. Stand this part assembly on end on a flat surface and check that it is square and free from twist.

Parts Required

- 1 sq. ft. hardboard.
- 1 piece of dry wood 6in. \times 2½in. \times 2in.
- 2 fixing fillets 2in. \times ½in. \times ½in.
- 1 lens block 2in. \times 2in. \times ½in.
- 1 base block 3½in. \times 3½in. \times ½in. approx.
- 1 piece of thin mirror 2in. \times 2in.
- 1 piece of ground glass 2in. \times 2in.
- 1 magnifying lens 1½in. dia. About 2½in. focus. A reading glass from a chain store is suitable.
- Glue, panel pins and leathercloth. Matt black paint.

The square of mirror is placed in position on the bevelled block. A touch of adhesive will prevent it from sliding about. The wedge-shaped pieces of hardboard are glued to the side pieces, their lower edges being hard in contact with the mirror and their upper edges lined up exactly with the line D-F representing the ground side of the screen. The 2in. square screen may now be fixed in position, ground side down, by means of thin wood fillets.

Testing

The partly completed instrument is now as shown in Figs. 1 and 5, and is ready for

testing. Prepare a test negative by scratching a grid of fine lines with a needle point on a dense discarded negative. Focus this very accurately on to a piece of smooth white card on the enlarger baseboard. The card should preferably be lightly glued down, to avoid any chance of buckling, and it is worth while examining the image with a magnifying glass to ensure that the scratched lines are critically sharp. Now place the instrument on a temporary base of ½in. thick wood, place it on the white card, and cover up the space J-F to prevent the projected image impinging directly on to the ground glass. On viewing the ground-glass screen through the magnifying lens, the image of the test negative should be quite sharp. Try adjusting the focus a little either way to see if any improvement results. If it does, then adjust the thickness of the temporary base by packing up or planing down, as the case may be. When it is certain that the



Fig. 5.—Partly completed focusing magnifier.

focus on the ground glass is precisely the same as the focus on the white card, a new base can be made, of a thickness as determined by the test, and glued into place.

Finishing

The open front and back may now be

closed in with pieces of hardboard glued in place. Note that the portion F-G must be left open as a window to allow the image from the enlarger to strike the mirror. This opening also allows access for cleaning both the mirror and the ground glass. All interior surfaces must have a matt black finish to avoid annoying reflections. They can be painted with special camera black paint, or treated with Indian ink. The exterior may be covered with leather cloth to give a professional finish. Leather paper, which is cheaper, could also be used. Readers may, however, find it more convenient to finish the instrument in a hard white gloss paint, making it easier to find in the dim light of the darkroom.

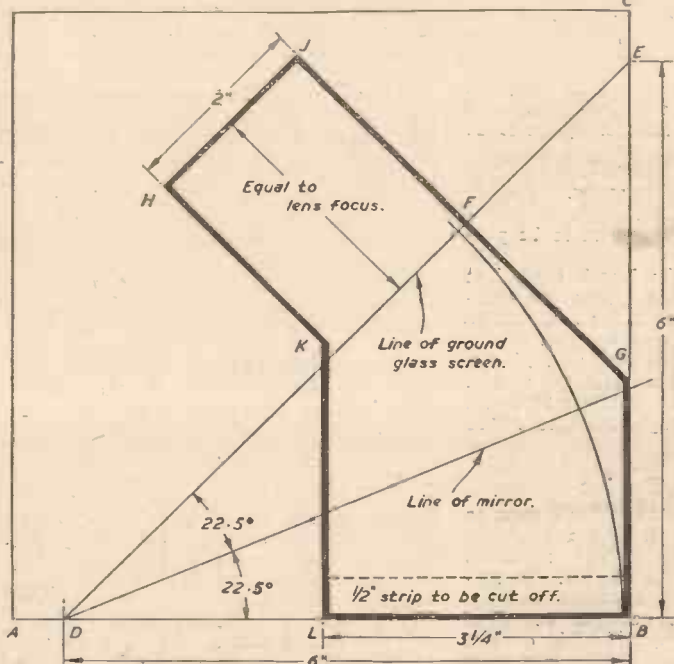

Fig. 4.—Method of setting out one of the sides, using compasses.

People and Portraiture

An Individual Approach to the Subject Described by W. Hunnisett

WHEN a photographer is first attracted to the idea of taking portraits he often finds difficulty in knowing where to begin. According to temperament and pocket, some decide that an attractive model is the first essential, while others

beginner, but can prove to be trying on the patience of both model and photographer.

Standard Technique

You can learn from books that a low viewpoint helps to minimise a prominent nose, or that top lighting will help hide bags under the eyes. You know what a prominent nose looks like, and can recognise bags under the eyes when you see them—or can you? If an uninteresting person has these features your attention will wander from the conversation and you will recognise the pitfalls and be able to avoid them. On the other hand, if your attention is completely captured by someone with a more pleasing personality, the chances are



Rolleiflex H.P.3 developed in Promicrol 1/10 at f/4. Weak tungsten lighting.

more positive, you are in your actions, the easier you will find it to keep your sitter relaxed.

"Natural" Portraits

The photographs illustrating this article are not portraits in the usually accepted sense of the term. It is not even suggested that you try this type of photography, but to be successful at portraiture it is almost essential to be able mentally to note similar scenes. They are fleeting, but are constantly occurring wherever there are people. To emphasise this, photographs taken within a few days of each other have been used.

For a time, you will probably find it necessary to remind yourself to watch the way the light plays on a face as the head is turned. The more you do it, the more it will interest you. You will find that it is not always the prettiest faces that make the best subjects. They are often free from faults, but sometimes a fault can serve to

emphasise the good points. It is not intended to elaborate on that aspect, as personal taste determines the ideal face.

A sympathetic recognition of moods and expressions is only possible by someone who is interested in people. Assuming that you have the necessary interest, and portraiture will be boring without it, you should find the study absorbing.



Rolleiflex H.P.3 developed in Promicrol 1/50 at f/4. Sunlight through small skylight plus light through open door.

settle for a varied collection of lighting equipment.

The author's opinion is that both of these, although undoubtedly very useful sooner or later, are not only unnecessary for the



Rolleiflex H.P.3 developed in Promicrol 1/10 at f/4. Weak tungsten lighting.

that you will never notice the faults unless they are very pronounced.

Many people who are normally confident and self possessed become nervous and uneasy in front of the camera. It will help matters not at all if you are uncertain how to place your lights, and this you will certainly be if you are unable to assess the good and bad features at a glance. The

A Simple Synchroniser

(Concluded from page 66)

switch, then when the wiring is completed in accordance with Fig. 5 an ordinary torch bulb may be connected in place of the flashbulb and the microswitch may then be swung about the lower screw until the light is just extinguished each time the shutter tensioning lever is pushed up.

The reflector employed is an aluminium saucer obtained through the good offices of a canteen manager friend. The concave surface was roughened by etching (fine grinding

with an abrasive would do) and a small spring clip enables it to be quickly fitted over the bolt in the top of the battery box.

Finally, a coat of crackle black enamel gives a professional appearance.

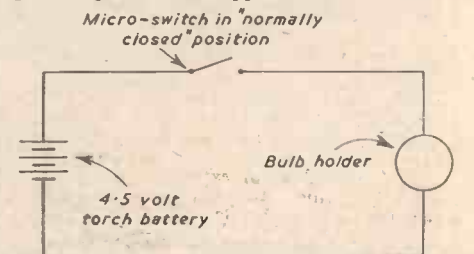

Fig. 5.—The electrical circuit—the three components are in series.



Rolleiflex H.P.3 developed in Promicrol 1/250 at f/8. Outdoors, cloudy, without sun.

THE simple 35mm. camera shown in Figs. 1 and 4 was made as a result of the need for a snapshot camera without the multitude of adjustments usually found in commercial models of this size; one that could, if necessary, be carried in the pocket, ready for instant use and economical as well.

The camera has been used for a year or more and will produce a good picture, taking into account the simple lens system used. This, in fact, was composed of two meniscus lenses from old box cameras placed convex to convex, with a small air gap between, and working at *f*8. A better lens has since been fitted.

The shutter is also simple, with a single speed of about 1/25 sec., with provision for "Time" if necessary.

Most of the camera body is made from aluminium alloy sheet which can be finished to resemble the satin finish of modern cameras. The only purchased parts were two cassettes.

The Body

This consists of one piece of alloy sheet 2in. wide and 9in. long, bent to the shape

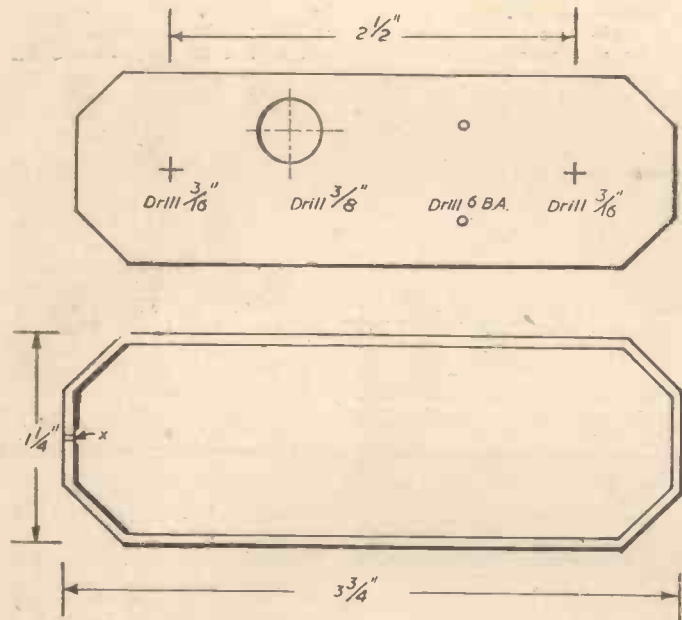

shown in Fig. 2. The join is made at "X." This is made as accurately as possible and then covered with a strip of black linen fixed with a contact adhesive. The base is a piece of alloy sheet cut to the size of the body, plus an extra 1/4in. all round. This is then cut at the corners and bent up to

Fig. 2 (Above and right).—Details of the body.

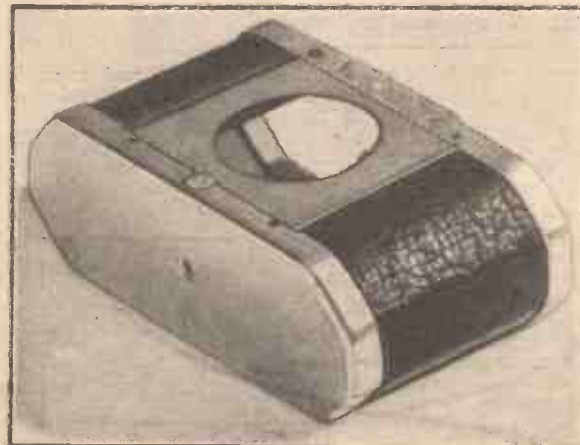

Fig. 3.—The completed body.



Fig. 1.—The completed camera.

A B A S

This Instrument Camera, but and More Etc



form a snug fit over the body, with a 1/4in. turn-up all round. This was well filled along the sides with adhesive and pressed into place. Half a dozen aluminium rivets with the heads sunk and filed off finished the job.

Around the top is a 1/4in. wide aluminium rib with its join in the middle of the front. This projects above the top as shown and was also stuck and riveted. The only remaining parts are the two top plates. The inner top plate fits down behind this rib while the outer

A 1in. hole must be cut in the centre of the front and the space between top and bottom ribs covered with leather. An old leather belt was used on the prototype. A 1/4in. hole is also drilled in the centre of the bottom for the screw which holds the interior mechanism in position, and later four holes tapped 8 B.A. to hold the front plate to the body. The completed body is shown in Fig. 3.

The Front Assembly

This part holds the lens and shutter and is fixed to a 2in. X 2in. alloy plate secured to the front of the body by four 8 B.A. plated screws, one in each corner. These go into the ribs on the body. Care is needed in placing them so that they do not foul the recess at the body top. This plate has

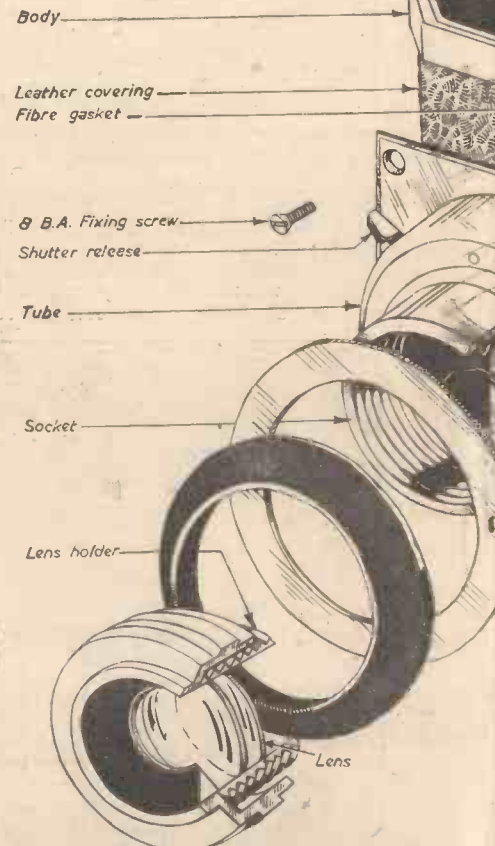
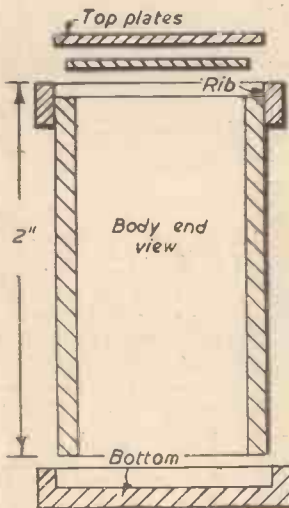

top plate fits on top of it, thus making a double light-tight joint. The large 1/4in. hole in the outer top plate is not carried through to the inner plate. All other holes. These two plates are held together by the two screws which secure the viewfinder shoe, and the two knobs. The outer can easily be removed for repolishing.

a 1in. hole at its centre and screwed to it is a bakelite block 1/4in. thick. Hardwood would suit quite well and it could be riveted in place. The plate carrying the shutter is

IC 35mm CAMERA

ent Approximates the Performance of a Box
is Smaller, Easier to Handle
onomical By A. L. Jackson

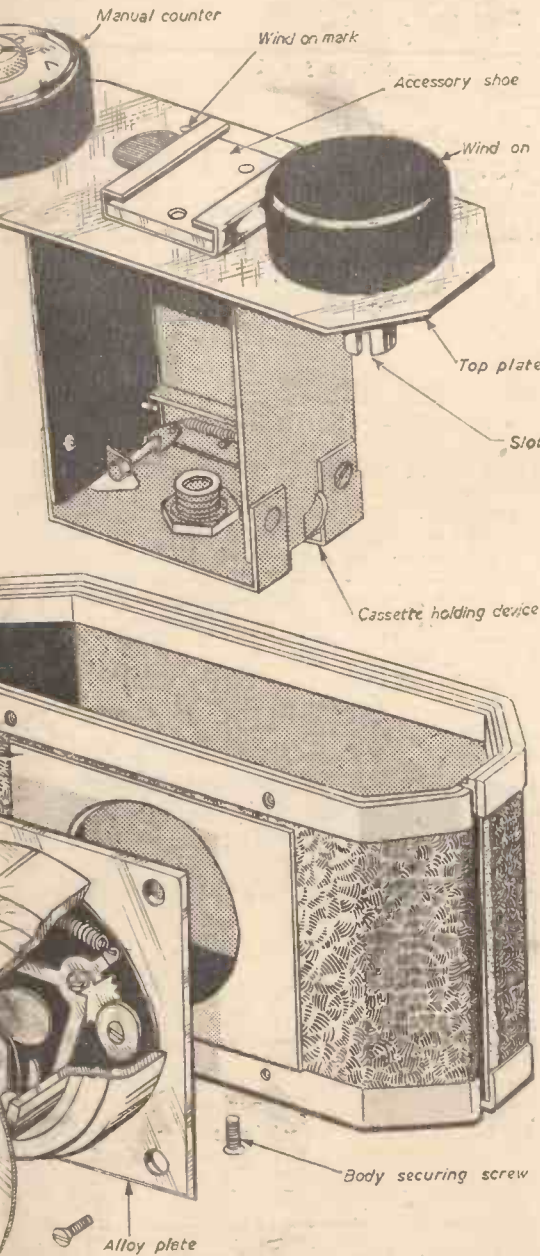

Fig. 4.—An exploded view showing the various parts of the camera.

screwed to this block. It must also have a 1/16 in. hole, see Fig. 5.

The purpose of the block is to carry the tube which fits firmly round the block. A slot in the tube side allows the shutter trigger to protrude. This tube has its outer end closed by a well-fitting disc. If brass is used the whole can be soldered. In the centre of this disc is also soldered a 1/16 in. gas socket turned down as shown. The lens holder is a piece of 3/16 in. gas pipe which screws into the socket and allows for focusing. If a slot is made along one thread

and another across the thread, a portion of the lens holder thread may be bent very slightly outwards to ensure a tight fit. Most gas fittings fit too loosely. The lens in the prototype turns without shake or end play. An average movement for a 2 in. focus lens from 6ft. to infinity is about 2mm. or about a turn and a half. Calibration could be similar to that of a micrometer. A simpler method is to work with fixed focus to the hyperfocal distance for the fixed stop in use. With f8 this is about 15ft. when all objects beyond half that distance to infinity are in focus.

The lens holder barrel is turned out to leave a thin shell and one end turned down to take a well-fitting washer on its outside. A piece of thin tube, knurled at one edge, fits over the washer to form a thimble, fitting closely over the gas socket. A piece of metal or wood, coned as shown, fits inside the end to provide the usual coned surround to the lens. All these parts were soldered.

The Film Carrier

The whole of the interior mechanism is fitted to the inner top plate as can be seen in Figs. 6 and 8. In the

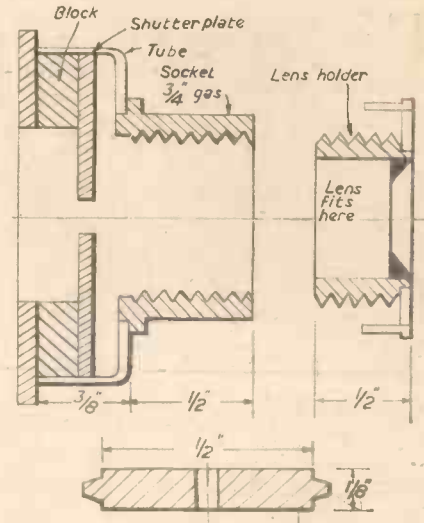

Fig. 5.—Details of the front assembly.

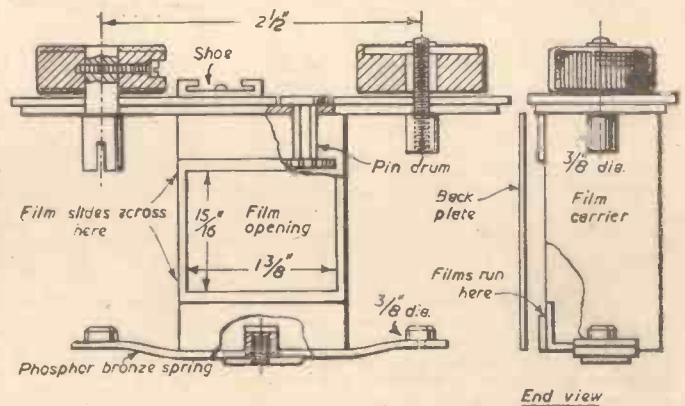

Fig. 6.—The interior mechanism. Note that an alternative method of holding the cassettes is shown so that in Fig. 4. Either method may be used.

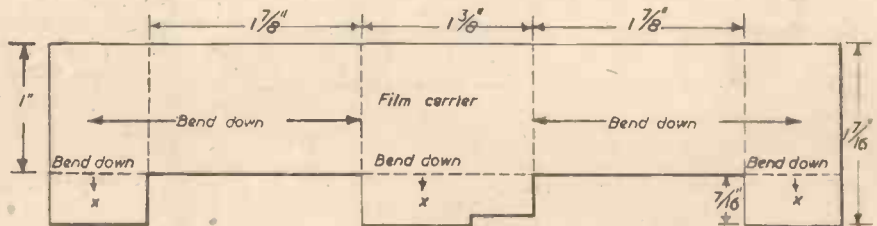

Fig. 7.—The shape and dimensions of the metal to form the "box."

prototype, thin brass sheet was cut to the dimensions shown in Fig. 7. It was then bent to form a box shape, open at one side and partly closed at the other leaving an opening the size of a 35 mm. frame ready for exposure, 1 1/2 in. long x 15/16 in. wide. Parts "X" in Fig. 7 are bent down so that they lie inside the sides to form a flat surface across the back. At top and bottom of these are soldered two pieces of brass to leave a gap 1 1/2 in. wide for the film to slide in. The little slot seen in one of these turned down pieces is to allow the pin drum which marks the winding on of one frame, to project and be turned by the film perforations.

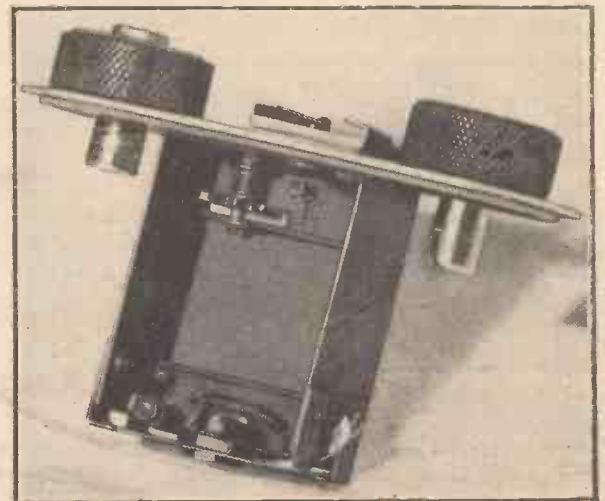

Fig. 8.—The completed interior mechanism.

(To be continued)

A CINE FILM REWINDER

An Aid to Handling
and Editing Your
Own Film

By
J. Drummond

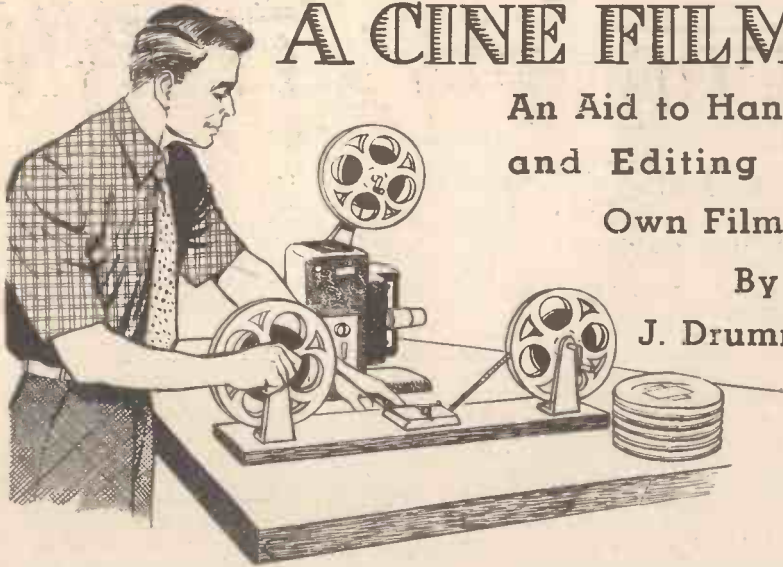

A FILM rewinder is a useful accessory to your cine equipment as it is much more satisfactory to rewind film on such a device (Fig. 1) than on the projector. It has the additional advantage that you can edit your own film with the aid of a film splicer. The apparatus in Fig. 2 shows a splicer in position. The only difference between the two models is that the second has a longer base and another hand drive in place of the supporting pillar. If you desire a dual-purpose model, or if you feel that the reel-supporting drive in Fig. 1 is beyond the tools at your disposal, then construct the model shown in Fig. 2.

The rewinder, if two drives are included, can take spools of 8mm., 9.5mm. and 16mm. with no additional fittings. This is due to the drive spindle being of a small diameter, and the reel is held in position by a wing-nut. The model in Fig. 1 has only one drive, the reel on the other pillar being supported by a bearing as shown in Fig. 4.

The Drive

The drive consists of a hand-driven grindstone available from any multiple chain store for 5s. 6d. and modified as shown in Fig. 3. The modifications are: the removal of the tool-supporting bracket, shortening of the bracket lugs by $\frac{1}{4}$ in., cutting away of the bench screw and a 4BA hole drilled and tapped as shown.

In place of the grindstone, the film reel

is held between the original washers and fingertip tight by a 2BA wing-nut, which replaces the hexagonal nut.

The pillar support consists of $\frac{1}{16}$ in. mild steel folded at right angles top and bottom to give a finished height of $2\frac{1}{4}$ in. Two 4BA screws and nuts hold it to the metal base and two similar screws are screwed into the shortened lugs of the winder. Another screw goes through the part of the winder which held the original clamping screw, see Fig. 3.

The lugs are shortened in order to give clearance for the cine reel.

Retaining Pillar

The reel-retaining pillar for the model in Fig. 1 is shown in Fig. 4. The height from the base to the spindle centre is $4\frac{1}{2}$ in. The spring is one as supplied for cigarette lighters and the collar with the grub screw is from a construc-

tional set and has an inside diameter of $\frac{5}{32}$ in. Hence a $\frac{5}{32}$ in. diameter is required for the spindle.

This part of the apparatus, as mentioned earlier, may not be easy to construct for readers who have not the proper tools. If this is so, the alternative is to replace this pillar by a hand drive similar to the model shown in Fig. 2.

Base and Finish

The base is made of $\frac{1}{16}$ in. thick mild steel sheet, 4in. to 5in. broad, and folded



Fig. 3.—Hand-driven grindstone modifications.

over about $\frac{1}{2}$ in. The folding gives a rigid base and sufficient clearance for the pillar retaining screws. The length, like the breadth, is of no great importance and can be 15in. as in Fig. 1, or 22in. as shown in Fig. 2.

Base and pillars were lacquered green and

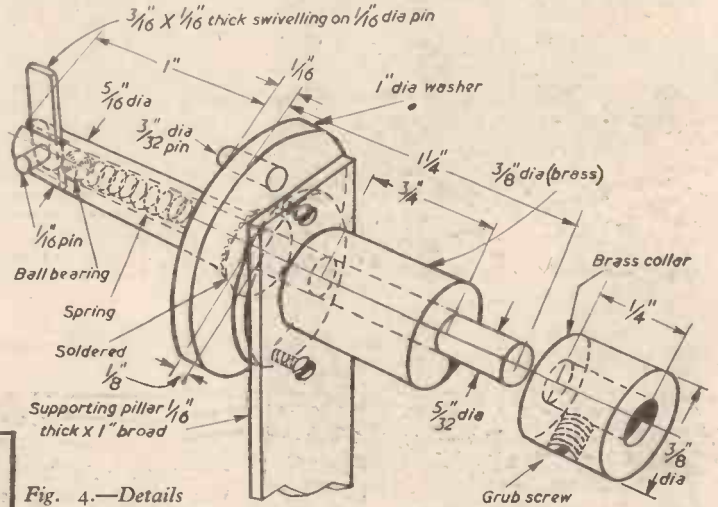

Fig. 4.—Details of the reel retaining pillar.

the hand drives left the original red, saw cuts were touched up with a matching colour.

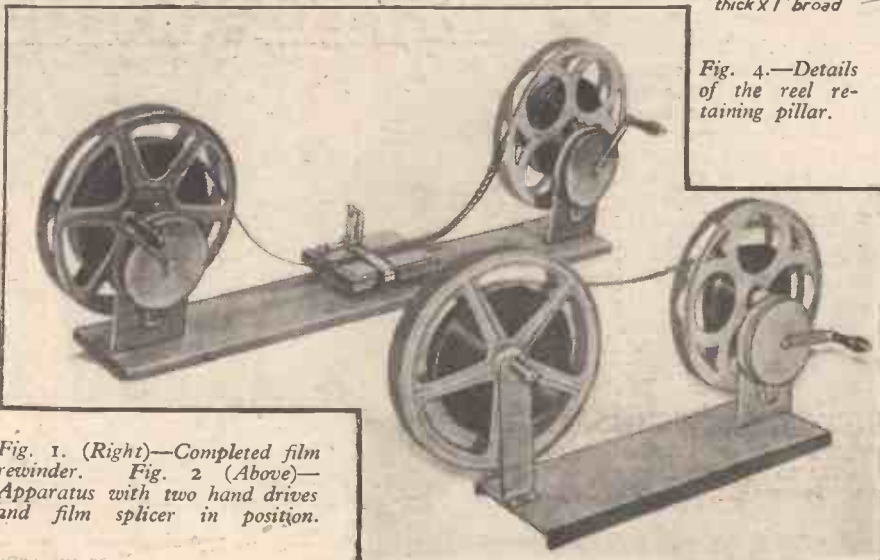

Fig. 1. (Right)—Completed film rewinder. Fig. 2 (Above)—Apparatus with two hand drives and film splicer in position.

Books for Photographers

- MANUAL OF THE MINIATURE CAMERA
21/- or 22/6 by post.
- COLOUR PHOTOGRAPHY FOR THE AMATEUR
21/- or 22/6 by post.
- INDOOR PHOTOGRAPHY
15/- or 16/1 by post.
- ENLARGING FOR THE AMATEUR
6/- or 6/9 by post.

from Geo. Newnes, Ltd., Southampton Street, London, W.C.2.

Photography in TOWN

Can You Spot the Potential Pictures in Your Town?

By A. E. Bensusan

point of strolling down those little lanes and narrow streets from time to time, so that the effects of various lighting conditions can be seen. When you find a suitable subject, and have determined the best time of day to take a photograph, consider whether the inclusion of some human figures would add life to an otherwise static subject (Fig. 1).

A Different Viewpoint

Another picture-finding method is to visit the well-known features of your town or city and find out how they appear when viewed from a different angle. Sometimes the inclusion of a suitable frame can alter the entire nature of the shot, as shown in Fig. 2, and if this is striking in its form, so much the better.

Yet a further means of converting broad and otherwise rather ordinary subjects into pictures, is to contrast them against supporting elements of a totally different nature. This has been done in

Fig. 3, where a softly defined view taken across the River Thames in the heart of London, has been partially framed with the strong lines of a parapet and the dark and ornate profiles of the lamp standards. Here, there is contrast in form as well as in tonal depth; a valuable picture-building method.

High Level Pictures

When searching out pictures in town, remember to look upwards for possible subjects as the majority of towns have many interesting features well above normal levels. Again, contrasts can be used in these high-level shots, particularly where there is a strong cloud pattern. Never be afraid to tilt or swing the camera at an angle to obtain a better composition, but if you do



Fig. 2.—“Framing” an everyday subject changes its entire appearance.

MOST people, contemplating taking some pictorial photographs, go out of town to do so. This article sets out to show that this movement to other regions is not at all necessary, for the range of worthwhile subjects available in many towns could be productive of almost any number of pictures. Familiarity with the normal everyday surroundings is a natural



Fig. 1.—Including human figures adds life to a picture.

cause of the usual inability of the townsman to find suitable subjects in his own territory, but once the habit of viewing commonplace items has been acquired, there should be no real lack of useful subject matter.

Old Buildings

A large number of towns have old quarters, with buildings dating from many years ago and still in common use, and it is here that many interesting photographs can be taken. True, these pictorial possibilities have to be sought out, for all that is old is not necessarily beautiful. Make a



Fig. 4.—People included to act as a foil to the severe lines of the other features.

use this method, use it boldly so that it is obvious that the angle has been obtained by design, and not unintentionally and as a result of inefficient camera work (Fig. 5). Even ruined buildings can be photographed satisfactorily, using this technique, and studying the effects of the choice of viewpoint and different lighting conditions.

In town, watch out for really strong lines in the composition of pictures, and use them to the best advantage. Since these straight lines, by themselves, sometimes tend to lead the eye out of the picture space, instead of concentrating the interest as they should do, it is often advisable to include some people in photographs of this sort (Fig. 4). The less rigid lines of the human figure tend to act as a useful foil to the harsher profiles formed by their surroundings and cause the figure, or figures, to serve well as the centre



Fig. 3.—Contrasting a soft picture with a strong-lined base and side frame.

of interest. Never have these people looking self-consciously directly into the camera lens but, if possible, wait until they assume natural positions of their own accord. It follows that people unaware of the presence of the camera will adopt natural positions more readily than those who realise that they are being photographed. Therefore, work quietly and unobtrusively to obtain the best results.

Quiet times and busy times, all have photographic possibilities if you keep an eye open to the various facets of life in towns and cities, as they are presented and, in fact, it is often quite possible to build up a comprehensive collection of interesting pictures showing the progress made in your own environment. Recording the passage of time may not appear particularly fascinating just at present but the appeal of such photographs, when viewed in many years' time, will prove the point.

Camera Technique

Where possible, use a tripod for pictures taken in towns, as they so often rely on sharply defined detail, either right through the photograph or in particular areas, for their attraction. Under heavy traffic conditions, or on narrow footpaths, this is not always permissible and the camera has to be held in the hand. Unless you are absolutely certain that you can make the exposure



without movements, take several shots.

When lighting conditions are good, and particularly where the inclusion of people near to the camera is not intended, use a medium speed film of the panchromatic type. This will permit a satisfactory degree of enlargement when making the prints and, at

Fig. 5.—(Left) Tilting the camera.

the same time, ensure accurate colour rendering in terms of black and white. Since most exposures made in town will include reasonably large shadow areas which require the rendering of some detail, the exposures should not be cut too short, and accurate development will retain the desired characteristics.

FILTERING

This is an extract from "Photographic Processing," a book shortly to be published by George Newnes, Ltd.

ALL photographic solutions should be filtered after they have been freshly prepared and again after use. It is common for the developer only to be filtered, but because the fixing solution also collects foreign matter in the form of particles of emulsion, paper and sediment, etc., this also should receive attention. The usual procedure is to prepare solutions in the mixing vessel and then filter them into their respective bottles.

Filtering can be done in several ways. One method is to use specially prepared filter papers, but this is a comparatively slow process because the speed of filtering is controlled by the texture of the paper, but a fluted funnel gives quicker filtering than a plain one. The method most commonly used in photographic practice is to pass the solution through a tuft of good quality cotton-wool placed in the neck of the funnel. One other system of filtering deserves mention because it appears to be little known outside of laboratories. This uses a glass funnel, in the lower portion of which is incorporated a disc of sintered glass.

When the Tide is Out

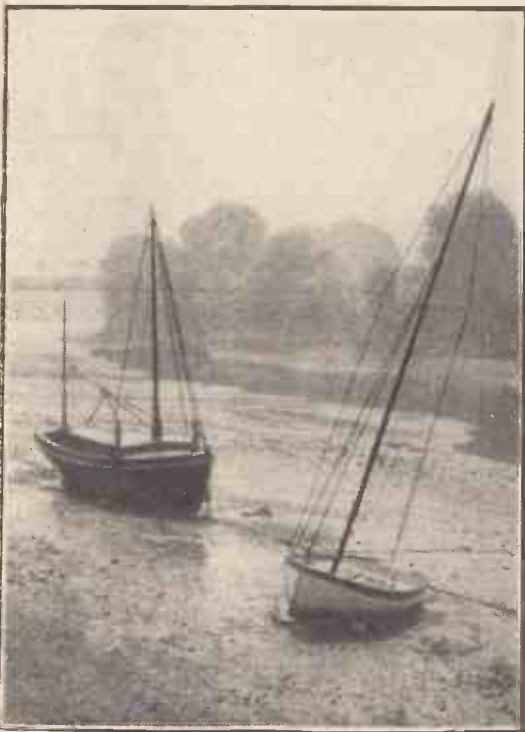

"When the tide was out"

WHEN working near a tidal river, or on the sea shore, remember that many interesting pictorial possibilities are presented as the water recedes. In fact, with some care devoted to the choice of viewpoint, lighting and the depth of sharp focus, and the occasional aid of suitable atmospheric conditions such as light mist, some useful shots can be obtained in quite mundane surroundings. The photograph on the left, entitled "When the tide was out," was taken on a backwater of the River Thames, only a hundred yards or so from a busy thoroughfare. From the road, the chances of any interesting pictures looked rather remote, but a change of angle showed that the boats could be outlined satisfactorily against the wet mud and the background, already softened by a slight haze, could be further thrown back into the distance by careful choice of lens aperture and focusing point. Apart from eliminating background detail, which could compete against the subject matter for attention, an impression of depth was obtained.

The policy of looking for photographs in unexpected places sometimes pays rich dividends.

View Photography

(Concluded from page 67).

branch can be used. An archway or doorway is another form of framing, and the general effect can be seen in Fig. 1. Without the archway of the ruined castle, the scene would be flat and lifeless, but now, the arch encloses and frames the picture, concentrating the gaze on the headland beyond. This is aided by the light-coloured path which leads the eye from the arch towards the distant view. It is a curious fact that few people can resist walking through an archway such as this, with the result that a path almost invariably exists under these circumstances. As an aid to photographic composition, there is much to be said for this practice.

The sharply focused arch, the path leading through the picture, and the softly defined cliffs behind carry on the principle of breaking the picture down into planes and thus imparting a sense of depth.

Film

The choice of film depends upon the individual, but the writer prefers to use medium speed panchromatic films so that good-sized enlargements can be made from any selected negatives, without loss of quality. Adequate exposure and no trace of overdevelopment result in negatives of excellent enlarging quality, particularly when processed in a very fine grain developer.

The surface of the bromide paper used for enlargements of view photographs needs some consideration. If the picture relies to a large degree on its finely detailed subject matter as the pictorial theme, the choice should be one of the velvet-surfaced varieties. A subject relying on its general mood will require a broader effect, such as can be obtained with a rough lustre surface.

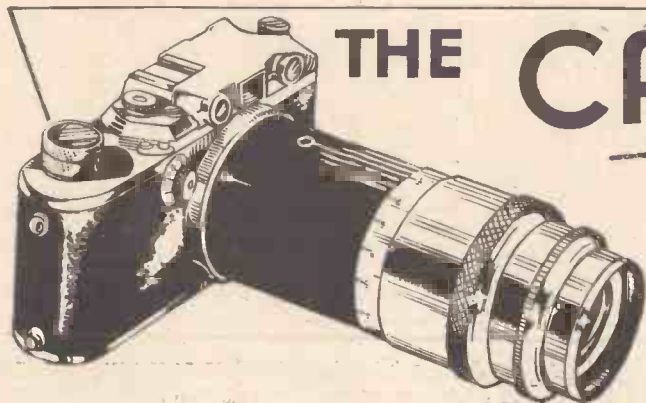

THE CAMERA LENS...

By J. C. Lowden

Part 3 of a Short Series Which Explains in Simple Language How the Camera Lens Works

(Concluded from July issue)

Astigmatism

ASTIGMATISM was a rather more difficult aberration to eliminate. A lens is said to suffer from astigmatism when it is unable to focus vertical and horizontal lines in the same plane. A simple example might be to describe the effect of photographing a wire fence with such a lens. The upright metal posts would be perfectly depicted as sharp lines, while the tightly stretched wires would be blurred and out of focus, or vice versa (See Fig. 13).

This would usually apply more to the

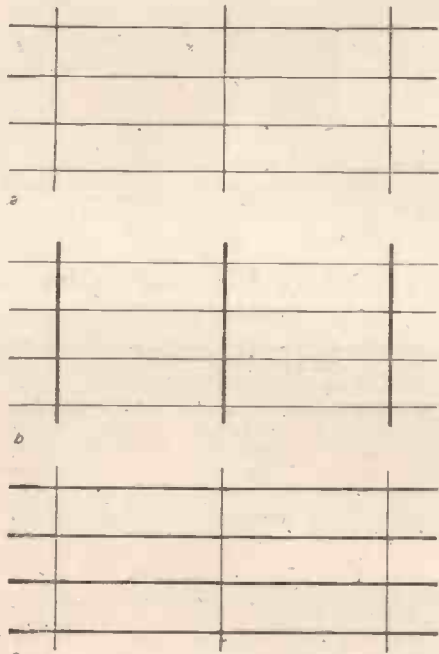

Fig. 13.—The effects of astigmatism. (a) The fence undistorted; (b) and (c) the fence resolved by lenses which suffer from astigmatism.

edges of the picture, definition would be little impaired if the fence were more or less on the axis of the lens.

The Anastigmatic Lens

The greatest single advance in lens design since Dollond's original achromat came about at the end of the 19th century. The great German designers Abbe and Schott, working at the famous optical centre at Jena, produced a new compound lens. Using newly discovered glasses and working to a high degree of precision they evolved the anastigmatic lens. This lens focused blue and yellow rays together, gave a truly flat field image and generally set a standard for all lenses. Thus the last great foe, astigmatism, was overcome. To-day any lens supplied for serious photography is fully anastigmatic.

From the first anastigmats evolved the famous lenses of to-day. British and foreign firms turn out anastigmats with apertures between $f/6.3$ and $f/11$. This development goes on unchecked and it is impossible to visualise the ultimate end of the efforts of the designers in their search for perfection. As the lenses increase in efficiency and accuracy, they rise in complexity and precision (Fig. 14).

Blooming

Post-war lenses are obvious, even to the tyro, by the plum-coloured sheen on them. This coloration is the visible result of "blooming" or coating (the terms are synonymous). The sheen is given by the presence of a microscopically thin deposit of a metallic substance, usually magnesium fluoride. This deposit is sprayed on the glasses in conditions of high vacuum.

The purpose of blooming is two-fold. The first advantage claimed is that the powers of light transmission are improved by a small but measurable degree. The second, and much greater advantage of coating is the elimination of internal reflections within a compound lens: in such a lens, consisting of several elements with air-spaces between them, it is obvious that some light will be reflected from each surface. These multiple reflections are, together, liable to cause "flare" within the lens, with consequent deterioration of the image.

Now that the blooming of lenses has become routine production procedure, it probably adds but little to the cost of the lens. An uncoated lens can be bloomed, but it is not an inexpensive process, as the lens must be fully repolished before blooming can be done.

Only efficient coating can improve the performance of the lens; if a lens is coated it must be fully coated, including the finer surfaces, which the user never sees, but through which light does pass, and from which it can be reflected.

Lens Hood

Among the powers which we would certainly give to the perfect lens would be the ability to transmit only that light reflected from the object to be photographed—all other "stray" light would be excluded. Failing this impossible standard of perfection the lens should be shielded to exclude, as far as possible, such stray light. The ideal hood would be of rectangular or square shape in the proportions of the negative. There are hoods of such a shape available for certain cameras, and many amateurs build collapsible hoods with "lazy tongues" devices and old camera bellows. Generally speaking, commercial lens hoods are more usually designed as tubes, for simplicity and cheapness. The longer the tube the more efficient it is, but, of course, the hood must not be so long as to encroach upon the picture area. What-

ever type of hood is used, the inner surface must be matt black. Most commercial hoods are capable of some degree of adjustment, or are spring loaded, so as to be capable of use on lens cells of different diameters. A few hoods are in the shape of truncated

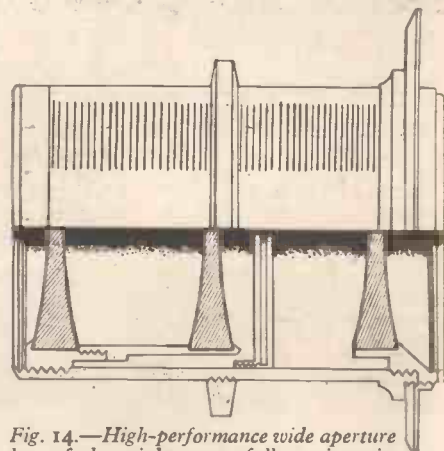

Fig. 14.—High-performance wide aperture lens of the triplet type, fully astigmatic.

cones, and some combine the functions of a hood and a holder for filters or supplementary lenses.

Care of the Lens

Optical glass is soft and highly susceptible to damage by abrasion. Generally speaking, it should not be cleaned except by gentle brushing with a soft lens brush. In severe cases the lens may be wiped gently with a soft, clean, much-washed linen handkerchief, after every solid particle has been brushed away. In a really bad case it may be permissible to use a minute amount of lens cleaning fluid, or even methylated spirit, applied with a clean camel-hair brush. Take great care in this process—no "flooding" of spirit can be tolerated. Any excess might seep under the lens rim and attack the cement uniting the glasses.

Never permit the glass to be touched with fingers. The acid sweat exuded by the papillary ridges of the skin will etch indelible fingerprints into the glass with disastrous results.

Keep the lens dry and guard it especially by the seaside. Spray flies from the waves for a long distance, and sea water is extremely corrosive. If a small amount should fall upon the lens, swab it away lightly with a handkerchief damped with fresh water and cleanse with cleaning fluid at the earliest opportunity. In case of a major wetting, rush the camera to a reliable dealer and be prepared to face a bill for skilled cleaning if a valuable lens is to be saved.

Lens caps can be bought for most sizes. Unless the construction of the camera is such that the lens is protected by the case when not actually in use, such caps are a valuable protection.

Replies to Readers' Queries



Transparency Projector

I WISH to make a projector for 35 mm. coloured positives using a 100 watt lamp. The lens I have is a Victor f 2.9—5 cm.; can this lens be used for a projector? Presuming it can be used, what other lenses are required, and where can they be purchased?

What are the distances between the lamp, lenses, film, etc., and the general proportions of a projector?—C. Charlton (Coventry).

THE lens which you have appears to be perfectly suitable for fitting to a projector. The only other lens you will require will be a condenser which is made up of two very short focus plano-convex lenses

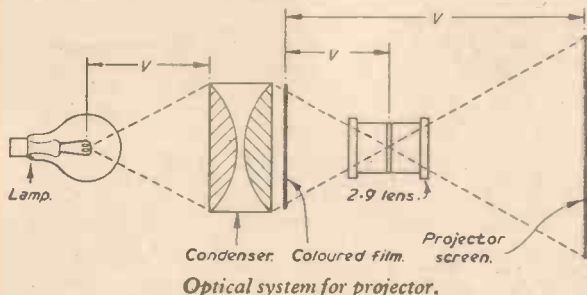

mounted with their convex surfaces towards each other and nearly touching. The arrangement of the whole assembly will be as shown in the sketch.

We cannot give measurements as we do not know the degree of enlargement you want nor the foci of the condenser lenses, therefore measurements are shown as variable. The lens will in any case be made to slide. The lenses of the condenser should be not less than 60 mm. in diameter and have foci of about the same amount. Try our advertisers for these then, when you have all the parts, fit it all up temporarily before making the projector.

Enlarger for Paper Negatives

PLEASE give me some information on building a printer-enlarger for paper negatives. Would it be possible to use the focusing unit and lens (4½ in. × f/7.7) of my enlarger?—D. Roberts (Hull).

PAPER negatives are illuminated from the front, exactly as in the picture in an episcopes, the image being thrown by reflection.

Queries

You will require two 100-watt lamps, one each side of the negative, to obtain even illumination. With the 4½ in. lens, negative and lens will require to be about 5 in. to 6 in. apart (according to degree of enlargement), but an aperture larger than f/7.7 would be helpful, in view of the relatively low brilliance of the reflected image. Printing by means of the f/7.7 aperture will be slow, except for small enlargements.

As the lamps are between lens and negative, a little to each side, internal baffles must be fitted to prevent light from them reaching the lens direct. The lamp-house is best made from metal, as this will help conduct away heat. The actual shape or size is immaterial, provided the bulbs can be accommodated.

Whether or not the existing focusing unit can be used will depend upon how close the lens can be brought up to the new lamp-house, as the paper negatives will be 3 in. or more farther away than would an ordinary negative enlarged by transmitted light.

Flashgun Construction

I AM making a battery capacitor flashgun, using an old bicycle lamp as the battery holder. Will the usual twin-cell type 3.5 volt battery fire a flashbulb and will it last a reasonable length of time before deteriorating?—P. A. Carroll (Eire).

THE usual type of two-cell dry battery is 3 v., not 3.5 v. Such a battery is suitable for firing flashbulbs, and would fire 12 to 24 over a period of a month or so. If only a few bulbs are fired, the battery will be run down very little, since the current is only momentary. However, a 3 v. battery in poor condition would not be satisfactory. For 3 v. firing, no condenser, etc., is required. Instead, the battery fires the bulb direct. Wire one battery point to the bulb. Wire remaining battery tag and bulb contact to the flash contacts.

TRADE NOTE

Kodak Cameras

TWO cameras for the keen amateur photographer are made by Kodak, Ltd.; they are the "Junior" (Models I and II), and the "Sterling II." The "Junior" is a folding camera and can be seen in the photograph below. It takes eight pictures 2½ in. × 3½ in. on 620 film. The Kodak Junior I is fitted with a meniscus lens and a shutter giving instantaneous and brief time. The price is £5 4s. 6d. The Junior II is fitted with a

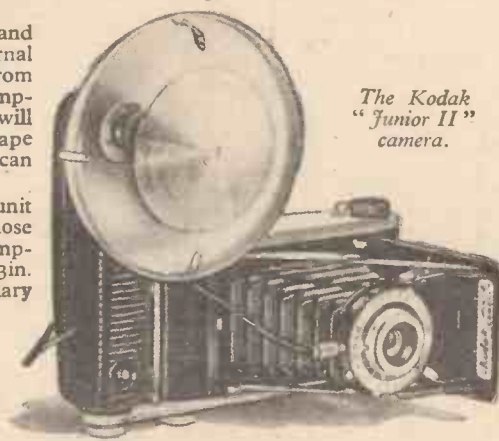

The Kodak "Junior II" camera.

f/6.3 Anaston lens focusing from 3½ ft. to infinity, a two-speed shutter (1/25 and 1/50 second time and brief time) and can also be fitted with the "Kodak" flashholder. The price is £7 10s. 7d. A carrying case is available in leather for 35s. 3d., or in plastic for 9s. 7d.

The "Sterling II" is more advanced than the "Junior" models and is fitted with a Kodak "Anaston" f/4.5 lens, which can be focused from 3½ ft. to infinity. The Pronto shutter has speeds of 1/25, 1/50, 1/100 and 1/200 second, brief time and delayed action device. Like the "Junior" models, it can be fitted with the "Kodak" flashholder and takes eight pictures 2½ in. × 3½ in. on 620 film. Good quality pictures are possible in widely varying lighting conditions with this camera, the price of which is £10 9s. 2d. Prices of the carrying case are the same as for the "Junior" models.

YOUR OPINION

A Bottle Warning

SIR,—I have noticed from time to time both in the PRACTICAL PHOTOGRAPHER and in other photographic journals that stock solutions are often recommended to be kept in bottles and diluted for use when required. I should like to make the point that care should be exercised never to use bottles which have contained liquids for human consumption (e.g., beer) as these are returnable and may some day find their way back to the manufacturers and be used again. Many photographic solutions are poisonous, and although great care is taken to avoid the use of bottles which have become contaminated, it does sometimes happen that these are used again with the result that some innocent member of the public may be made very ill. The best way to avoid this mischance is for the public not to use these bottles for storing chemicals, etc.—K. R. M. (Bristol).

A Washing Hint

SIR,—Print washing at the end of a long evening of printing is often the most tedious job in photography. Here is a method which will ensure thoroughness and remove some of the boredom. Obtain two lengths of rubber tubing and fit one of the pieces (2ft. 6in. long) to the tap. The hanging end goes into the washing bowl and is curled round inside it to give a circular motion to the water. The other piece of tubing (about 18in. long) is hung over the edge of the bowl with the inside end touching the bottom. Suck the outside end for a moment to create a siphon which will empty the water inside the bowl as long as the level in the bowl is higher than the outside end of the tube. Hypo solution is heavy and tends to lay on the bottom of the washing bowl and this tube will remove it as fast as the swirling tap water frees it from the prints.—D. G. (Manchester).

The fabulous
FELICA



NO! not just another box, but a precision-made camera providing crystal-clear pictures under any conditions

and only 58/3

AVAILABLE IN GREY OR BLACK

The new Felica camera takes 12 crystal-clear pictures 2 1/2" x 2 1/2" on standard 120 roll film and though this camera is sufficiently comprehensive to take photographs under any conditions it is particularly simple to use.

Though the Felica is really low priced it features a true smooth operating body release which virtually eliminates camera shake which is frequently the cause of failure in amateur photographs. The shutter has two speeds to accommodate different lighting conditions and brief time exposures for interior photographs is also provided. Two lens apertures are built in, one for use in sunny conditions and the other for use in dull light. For parties and other interior photographs the shutter is synchronised and simply by fitting a 30/- flash unit into the shoe fitted on to the camera, flash pictures can be taken. The lens fitted to the Felica is of the focusing type to enable sharp pictures of both close and distant subjects to be taken. The lens mount is engraved with the three necessary positions for portraits, groups and landscapes.

The Felica has a built-in yellow filter which not only makes the colour rendering of the picture better but also darkens the sky, producing a beautiful cloud effect—always providing clouds are present in the sky.

Send for free leaflet P.M.4.

NORTH STAFFS PHOTOGRAPHIC SERVICES
BALL'S YARD · NEWCASTLE · STAFFS

Telephone : 64548 P.B.X.

London Office : 36, Wardour Street, Piccadilly, London, W.1. Telephone : GER 4575.

GET YOUR PICTURE PERFECT

Study the I.C.S. *practical* Photography Course and put yourself "in the picture". Expert training will help you to achieve the professional touch—makes your hobby more rewarding—increases your skill. You carry out practical assignments, and receive the criticism and advice you need after personal examination of negatives and prints.

Ten practical lessons include : CAMERA CONSTRUCTION —WHAT TO BUY—TESTING—MATERIALS—COLOUR WORK—LIGHTING—HOW TO HANDLE YOUR SUBJECT —PICTORIAL EFFECT—MOUNTING AND PRESENTATION and PHOTOGRAPHY AS A CAREER OR HOBBY.

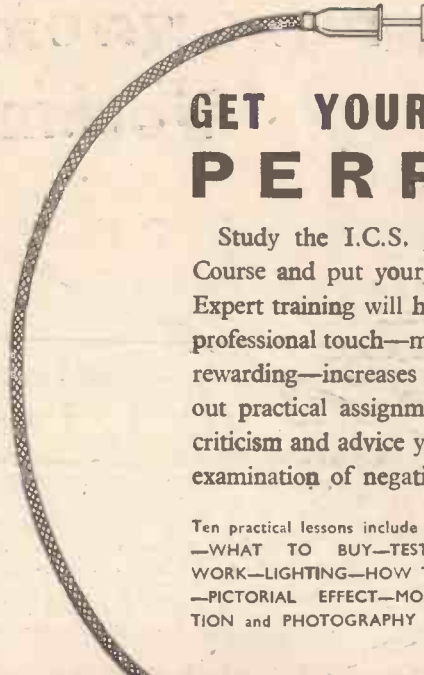

POST THIS COUPON TODAY

for details of
Photography
Course

INTERNATIONAL CORRESPONDENCE SCHOOLS
DEPT. 264A, INTERNATIONAL BUILDINGS, KINGSWAY, LONDON, WC2

NAME

ADDRESS 8.58

INTERNATIONAL CORRESPONDENCE SCHOOLS

PHOTOGRAPHERS!

DO YOUR OWN DEVELOPING



Here's a quick way to the mastery of developing photographic films. The Roto One tank is designed for easy loading. You have everything under control from the outset. Adjustable to take 120, 127 and 88 roll films or 20 exposure 35 mm. films. From Photographic Dealers with full instructions, £1.10.0.

IT'S EASY AND EXCITING WITH

JOHNSON Roto ONE DEVELOPING TANK

JOHNSONS OF HENDON LTD

IT'S KODAK FOR COLOUR!

KODACOLOR negative films 120/620, 10/10 each; processing charge, 6/6.
KODACOLOR PRINTS, 3 1/2 in. x 5 in., superb quality and value, 2/9 each.

KODACHROME 35 mm. 20-exp. cassettes, 23/-, inclusive of processing.

EKTACHROME E.2 high-speed reversal transparency films, 35 mm., 14/6 each; 120/620, 19/6.

KODAK COLOUR PRINTS (from the above or any other type of colour trans.), 3 1/2 in. x 5 in., 3/6 each; 5 in. x 7 in. (from 35 mm. only), 12/6 each.

EKTACHROME or **ANSCOCHROME** processing, 35 mm. or roll-film, 9/-.
FERRANACOLOR processing, 7/6.

ILFORDCOLOR, **AGFACOLOR**, **GEVACOLOR** & **ICICOLOR** prints at standard rates. All colour films and equipment supplied. 1958 Catalogue now ready, free on request. C.W.O.

COLORCHROME

77 Cranleigh Rd., Southbourne, Bournemouth.

ELECTRONIC FLASH

Condensers, Pulse Coils, Resistors, etc., surplus to requirements but guaranteed new and unused. Send S.A.E. for full list and circuit diagram for 50-joule instrument.

Langham Photographic Insts., Ltd., 132, Stanley Park Rd., Carshalton, Surrey.

WHY PAY CREDIT CHARGES?

We can supply your Photographic Goods on short-term credit without additional charge. Cameras, Exposure Meters, Enlargers, Cine Films (inc. Colour), Photographic Processing Outfits from 13/6, etc., etc. Send stamp for catalogue, etc., from: **LORELL PHOTOGRAPHIC SERVICES** (Dept. PP3), 36, Jodrell St., New Mills, Nr. Stockport, Ches.

SCREEN FABRIC MAKE YOUR OWN PROJECTION SCREEN

High Grade Fabric as used by Commercial Cine Screen Manufacturers. 48in. wide, any length cut at 18/- per yard.

Or—

CUT PIECES

48in. x 36in. 18/- 48in. x 48in. 24/-
60in. x 48in. 30/- 72in. x 48in. 36/-
Send 3d. stamp for samples and instructions for making your own "Roll Up" Screen.
SPRING ROLLERS (Self Acting), 1 1/2 in. dia. Swedish Manufacture, complete with Brackets.
36in. 10/3; 42in. 10/9; 48in. 11/9; 54in. 13/3.

SAWYERS LTD.

ST. SEPULCHRE GATE DONCASTER

CHEMISTRY APPARATUS

Send 3d. stamp for

COMPLETE PRICE LIST



Booklets:
"Experiments" 1/2
"Formulas" 1/2

"Home Chemistry" new ed., 2/10

(Post Pa'd.)

BECK (Scientific Dept. A)
60 HIGH STREET
Stoke Newington, London, N.16

Let this book give your film-making the professional, workmanlike touch . . .

... an authoritative guide on the art of film-making and projection. Written by an expert, it solves the many problems confronting the amateur and gives much valuable advice for the advanced enthusiast.

MAKING and SHOWING YOUR OWN FILMS

by GEORGE H. SEWELL, F.R.P.S.

THIS practical and up-to-date book shows how to make and present to an audience films of real interest and entertainment value, and not the series of static "lantern slides" so often produced by the beginner.

When the film-maker faces a subject, however simple, he has to answer several questions. What do I want to say about this subject? What are the best points of view to see it from? How much of it do I want to see at any one moment? What action is to take place while the camera turns? How long do I want to keep each "shot" on the screen? How do I change from one shot to another in the finished film?

The solution to these problems is only a small part of the

essential information on narrow-gauge film-making and presentation given in this book.

Written by an expert with many years of practical filming experience, the first part of the work deals with cameras, loading systems, methods of film processing, and other information which must be studied and understood if successful pictures are to be produced.

The second, and major portion, devoted to actual film-making and projection, covers such essential subjects as Lighting, Exposure, Filters and Colour Interpretation, Sound Tracks, Prints, Duplicates and Cuts. **150 illustrations**

CONTENTS

- Part I. CAMERAS, FILMS AND ANCILLARY EQUIPMENT
Film Sizes, Camera Mechanisms and Accessories. Lenses. Ancillary Apparatus. Film and Film Stock.
- Part II. THE TECHNIQUE OF FILM-MAKING AND FILM PROJECTION
Lighting. Exposure. Filters and Colour Interpretation. Handling the Camera. The Parts of a Film. Preparation and Completion. Words and Sound in Films. Prints, Duplicates and Cuts. Film Projectors and Projection. Projecting Narrow-gauge Films.

**21s.
net
FROM
ALL
BOOK-
SELLERS**

... or in case of difficulty simply complete the order form on the right.

ORDER HERE

Please send me Cash on Delivery one copy of
MAKING AND SHOWING YOUR OWN FILMS (21s. net).

Name

Address

NOTE.—Simply complete and post this C.O.D. Order to George Newnes Ltd., Tower House, Southampton Street, London, W.C.2. Send no money now—just pay on delivery plus C.O.D. charges. (If you prefer, send a remittance for 22s. 3d.)

P.M.
Aug. 58

