

# Practical Television '61

JANUARY  
1961

AND TELEVISION TIMES

*How to  
make  
attenuators*



## Contents

EHT GENERATION  
OSCILLOSCOPE FAULTS  
SERVICING TUNERS  
FAULT-FINDING WITH  
A SIGNAL GENERATOR  
ETC., ETC., ETC.

**More** for less...



**19 Ranges**

<b>D.C. Voltage</b>	<b>A.C. Voltage</b>
0—100mV.	0— 10 V.
0— 2.5 V.	0— 25 V.
0— 10 V.	0—100 V.
0— 25 V.	0—250 V.
0—100 V.	0—1000 V.
0—250 V.	
0—1000 V.	
<b>D.C. Current</b>	
0—100µA	
0— 1mA	
0—10mA	
0—100mA	
0— 1A	
<b>Resistance</b>	
0—20,000Ω	
0—2MΩ	

List Price: **£9:10s.**  
 complete with Test Leads and Crocodile Clips.  
 Leather case if required 39/-  
 Size: 5½ x 3½ x 1½ in.  
 Weight: 1 lb. approx.

MM12

Designed to offer the widest possible range of accurate and reliable measurements at the lowest possible price, the versatility and usefulness of the Multiminor are now further extended by specially designed leads. These new leads, available at no extra cost, will accept crocodile clips or PRODClips. The Multiminor takes full advantage of the possibilities of printed circuit techniques to achieve outstanding compactness and economy of weight. The scale is clear and open. The fine red coloured pointer and effectively damped movement facilitate easy and rapid reading. For use in Radio, TV, Electronics, Motor Vehicles, domestic appliances, workshop equipment, you'll find the Multiminor a great little meter.

Use PRODClips with the MULTIMINOR (Pat. No. 748811)

These cleverly designed spring-loaded insulated prods are the complete answer to a long-standing problem. Press the trigger to open, release to grip. Keep your hands free no matter how difficult of access your test points may be. **15/- per pair.**

...with the **MULTIMINOR**

Write now for illustrated literature to:—

**AYO LTD**

AVOCET HOUSE - 92-96 VAUXHALL BRIDGE ROAD  
 LONDON - S.W.1 VICtoria 3404 (12 lines)

A MEMBER OF THE METAL INDUSTRIES GROUP OF COMPANIES

**AERIALS**

BAND I    BAND II    BAND III

**Combined Arrays I and III**

- 1+3 Element Loft Mounting .. 38/3
- 1+5 Element Loft Mounting .. 48/9
- 1+3 Element Wall Mounting .. 45/3
- 1+5 Element Wall Mounting .. 61/-
- 1+3 Element Chimney M'ting. 57/10
- 1+5 Element Chimney M'ting. 66/9

**Band I**

- Single Dipole Wall Mounting .. 24/7
- Single Dipole Chimney M'ting. 40/2
- X Aerial Chimney Mounting .. 62/3
- H Aerial Chimney Mounting .. 87/7

**Band III**

- 3 Element Yagi Wall Mounting 33/-
- 6 Element Yagi Wall Mounting 43/-
- 9 Element Yagi Wall Mounting 58/-
- Chimney Lashing Mounting add 10/-
- Double 6 Array, only with clamp 83/-

**Band II**

- Single Dipole Wall Mounting .. 20/5
- Single Dipole Chimney M'ting. 29/9
- H Array Chimney Mounting .. 52/4

**REPAIR KITS**

- Band III Folded Dipole With Insulator, Complete .. 9/3
- Band I Insulator With Two ½ inch Dipoles For 1 or ½ inch Booms, Complete .. 19/5
- 6 inch Lashing Kit, 12/11. 7 inch Lashing Kit .. 14/8
- 6 inch Wall Bracket With U Bolts. .... 7/10
- 1-4: 1-1 inch Clamps. 3/10. 1-2 inch Clamps Universal .. 5/4
- Bracket Repair Kit, J Bolts; U Bolts; 20ft Lashing Wire; Thimbles; Corner Plates .. 6/-
- Insulators, All Types .. .. (Enquire)
- Co-Ax. Semi Air Spaced, 7d. yd. .... Plugs. 1/2

Send 6d. for Lists. Please state Channel when ordering.  
 Cash with Order. Post and Packing 3/- extra.

**SATISFACTION OR MONEY BACK GUARANTEE**

**WALKER & SQUIRES**

PINNOX STREET, TUNSTALL, STOKE-ON-TRENT

Phone: Stoke-on-Trent 88767

**1000's & 1000's**

OF SATISFIED PEOPLE  
 VIEW ON

**E.M.S.**

**REBUILT TELEVISION  
 TUBES**

- ★ A NEW GUN IN EVERY TUBE
- ★ BUY DIRECT FROM THE FACTORY
- ★ 12 MONTHS' GUARANTEE

**12 inch £5.0.0    14 inch £5.10.0**  
**17 inch £6.10.0**

Immediate dispatch on receipt of Remittance

Carriage and insurance 12/6 extra  
**£1 Refunded on receipt of your old Tube**

SPECIAL TERMS TO THE TRADE

**MARSHALL'S for TELEVISION LTD.**

131 St. Ann's Road, Tottenham, London, N.15  
 STAMFORD HILL 3267

# ANNOUNCING . . .

## THE OFFER OF THE YEAR!

### HARVERSON'S SUPER STEREO KIT

The product of a world-renowned manufacturer, this stereo amplifier is composed of a number of compact "ready-built" units, only requiring interconnection. This system has the big advantage of being easily adaptable to fit any cabinet. Each unit is extremely well made from first-grade components, and all valves employed (ECL82, EZ80 range) are genuine Mullard. The comprehensive instructions supplied with each kit make the simple interconnection of units easy even for the novice.

#### THE KIT COMPRISES . . .

**TWO MIDGET AMPLIFIERS** each capable of 3W output. The reproduction is good, enabling you to get the best from both your stereo or monaural recordings. Both amplifiers are complete with well-designed output transformers providing perfect matching to standard 3-7Ω loudspeakers, and have remote bass, treble and volume controls. Size 5" x 2½" x 3" high (each amplifier).

**CONTROL UNIT**, this is a flying panel fitted with three 2-gang potentiometers, enabling the bass, treble and volume controls of each amplifier to be positioned in the most convenient place in your layout. These dual controls are equipped with attractive cream and gold knobs and an escutcheon is provided for the complete panel.

**SEPARATE POWER PACK** complete with valve rectifier although of midget size (5" x 2" x 3¼" high), provides power for complete amplifier equipment.

**ISOLATED MAINS TRANSFORMER** of robust construction is a separate unit and may be mounted independently.

**VOLTAGE SELECTION PANEL.** Consisting of a panel fitted with the "valve base" type of mains input selector and a channel output socket.

**ONE LOUDSPEAKER**, a good quality 5-inch speaker, specially selected for this equipment. (Note: The second speaker may be purchased from us for an additional 14/6.)

**CREAM DOUBLE PUSH BUTTON SWITCH** of attractive design gives positive on/off switching action.

**INDICATOR LIGHT.** This pilot light provides visual indication that the equipment is operating, and is complete with an attractive gold-finished escutcheon.

This kit, which is complete in every way, is exclusive to HARVERSON'S, who are proud to present it at the amazing price of —

# 59'6

PLUS 6/6 POST & PACKING

FOR MORE BARGAINS SEE OUR OTHER ADVERTISEMENT  
On PAGE 210.

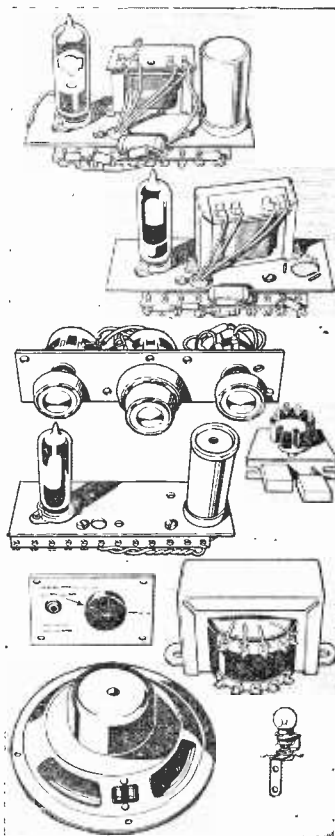

## HARVERSON SURPLUS CO. LTD.

83 HIGH STREET, MERTON, S.W.19

CHerrywood 3985/6/7

BENTLEY ACOUSTIC CORPORATION LTD.

38 CHALCOT ROAD, CHALK FARM, LONDON, N.W.1.

Telephone: PRIMROSE 9090

EXPRESS POSTAL SERVICE! ALL ORDERS DESPATCHED SAME DAY AS RECEIVED. TELEPHONE AND TELEGRAM ORDERS FOR CASH ON DELIVERY SERVICE ACCEPTED UP TO 3.30 P.M.

Table listing electronic components such as OZ4, IA3, IA5, etc., with their respective specifications and prices. Includes sections for Transistors and diodes at the bottom right.

ALL GOODS OFFERED ARE NEW AND COVERED BY THE MAKER'S GUARANTEE. VALVES INDIVIDUALLY BOXED. WE DO NOT STOCK USED GOODS OR MANUFACTURERS' REJECTS

VOLUME CONTROLS METAL RECTIFIERS Full List with ratings free for S.A.E.

Table listing volume controls and metal rectifiers with specifications like 'All with Long Spindle and Double-pole Switch', 'DRM1B 13V', 'RM-1', etc.

JUST OUT. MIDGET SILICON RECTIFIERS. OUTPUT 120 VOLTS AT 1/2 AMP. TWO IN SERIES GIVE 240 VOLTS AT 1/2 AMP. NO LARGER THAN A RESISTOR. 10% EACH.

Table listing electrolytic condensers with specifications like 'Standard Can', '16 x 8 x 8 mfd., 500 v. 4%', '60 x 250 mfd., 275 v. 9%', etc.

Post/Packing Charge 6d. per item. Orders over £3 post free. C.O.D. 2/6 extra. Full List, with Terms of Business, 6d. Any parcel insured against damage in transit for only 6d. extra. Shop Hours 8.30-5.30. Early Closing Saturday.

The decision is YOURS. To be a success in your chosen career; to qualify for the highest paid job . . . to control a profitable business of your own. ICS home-study courses put your plans on a practical basis; teach you theory and practice; give you the knowledge and experience to take you, at your own pace, to the top.

Choose the RIGHT course :

RADIO & TELEVISION ENGINEERING  
INDUSTRIAL TELEVISION

RADIO & TELEVISION SERVICING  
RADIO SERVICE AND SALES

VHF/FM ENGINEERING : ELECTRONIC  
COMPUTERS & PROGRAMMING

ICS provides thorough coaching for professional examinations:

Brit. I.R.E., City and Guilds Telecommunication Technicians, C. & G. Radio & TV Servicing (R.T.E.B.); C. & G. Radio Amateurs.

### LEARN AS YOU BUILD

*Practical Radio Courses*

Gain a sound up-to-professional-standards knowledge of Radio and Television as you build **YOUR OWN** 4-valve T.R.F. and 5-valve superhet radio receiver, Signal Generator and High-quality Multi-meter. At the end of the course you have three pieces of permanent and practical equipment and a fund of personal knowledge and skill. ICS Practical Radio courses open a new world to the keen Radio amateur.

# Technical Training in Radio, Television and Electronics Engineering with

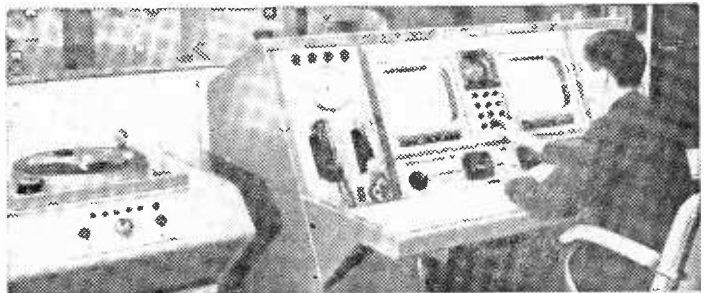

**THERE ARE ICS COURSES TO MEET YOUR NEEDS AT EVERY STAGE OF YOUR CAREER. FILL IN AND POST THIS COUPON TODAY.**

You will receive the FREE 60 page ICS Prospectus listing examinations and ICS technical courses in radio, television and electronics PLUS details of over 150 specialised subjects.

Other ICS courses include: MECHANICAL, MOTOR, FIRE, ELECTRICAL & CHEMICAL ENGINEERING. FARMING, GARDENING. ARCHITECTURE & WOODWORKING. SELLING & MANAGEMENT. ART. PHOTOGRAPHY, etc., etc.

**PLEASE STATE ON COUPON SUBJECT YOU ARE INTERESTED IN . . .**

**INTERNATIONAL CORRESPONDENCE SCHOOLS**  
 (DEPT. 170), INTERTEXT HOUSE, PARKGATE RD., LONDON, SW11

PLEASE SEND FREE BOOK ON.....

NAME .....

ADDRESS .....

.....

OCCUPATION..... AGE.....

1.81

# FIRST IN QUALITY - FOREMOST IN ECONOMY



**SUFFOLK TUBES LTD**



SUFFOLK HALL, 1-3 UPPER RICHMOND ROAD, PUTNEY, S.W.15

Telephone: VAN 5267, 4304



Suffolk's reputation for reliability accounts for the rapidly increasing popularity of Suffolk rebuilt tubes. Now you can obtain C.R. Tubes of all types completely rescreened and aluminised—at an exceptionally low price!

12" £5. 14" £5.5. 15" & 17" £5.10.  
21" £8.

Sensational value with the existing range of picture tubes!

12" £4.10. 14" £4.15. 15" & 17" £5.  
21" £7.

Suffolk's FULL 12 MONTH GUARANTEE is your assurance of satisfaction. You get FREE DELIVERY anywhere in the U.K. when you trade with Suffolk, the largest independent tube rebuilders in London.

## BRAND NEW TUBES

12 months' guarantee

TOP CLASS MAKE

CARR. & INSURANCE PAID

12" MW 31-74 etc. £5.5.0

14" MW 36-24 etc. £6.6.0

17" MW 43-64; 43-69 £7.0.0

CRM 171, 172

NEW, BOXED, ex Factory

WHITE SPOT TRANSISTORS, 4/- ea. WHILE SUPPLIES LAST! VALVES!! B.V.A. types (Mullard, Brimar). Unused. Ex new equipment. Fully Guaranteed 3 months. ECC81-12AT7, 5/-; ECC82-12AU7, 6/-; ECC83-12AX7, 6/-; 6CH6 (Video OP valve—high gain) 8/-; EF91-6AM6, 9/-; EF91-6AM5, 3/6; 12E1 (rect.), 12/6. Post 6d. per valve. insurance in transit FREE.

### BBC TRANSISTOR RADIO

Two transistors and diode. Medium and Long wave. Complete kit with circuit and wiring instrns. 32/6. Earphone 6/6 extra. Miniature Earpiece, plus lead. etc. 12/6 extra. Full details, 6d.

MAINS TRANSFORMERS—SPECIAL! Semi-shrouded, drop-through. Ex new equipment. By well-known manufacturer. 350-0-350 v. at 80mA 5.3 v. at 3 amp 5 v. at 2 amp. ONLY 12/6 ea. plus 2/6 P & P.

TRADE ENQUIRIES INVITED

## LINE OUTPUT TRANSFORMERS

Direct Replacements for 500 sets.

Baird, T29, T163	..	53/-
T164, T167, T172, 2014, 1712	..	60/-
Bush, TV 11A, B; 12A, B; TVF 12A, TUG 12A, B; TRG 12A, B	..	45/-
TV12AM; TV22, 24; TRG24, TUG 24	..	60/-
Cossor, 930, 931, 933, 934, 948, etc.	..	58/-
Ekco, TS146; TS113-114; T161, 164; T222, 231; TSC311, etc.	..	47/6
Ferguson, 841, 2, 3; 941 to 945	..	55/-
990T-998T; 103-145T; 203-246T	..	68/6
Ferranti, 14T3, 14T4, 17K3, 17T3	..	45/-
14T2, T1205, T1315, T1225, T1325, T1405, T1415, T1425, T1505, T1625	..	85/-
G.E.C. and H.M.V. mostly 55/- to	..	80/-
Invicta, T101-104; T108-110	..	52/-
T114-126; T138-142	..	60/-
Murphy, V114C, V116C, V118C	..	45/-
V120C, V180, V178, V200, V202C	..	57/6
Philips, 114 UF/UM, 1115 U, 1437 U, 1440 U, 1726 U, 1746 U, 1747 U	..	65/-
353A, 463A, 563A, 693A	..	60/-
Pye, LV30, 16T, CS17, etc.	..	60/-
CTM4 V4, VT4; VT7, VT7; VT17	..	59/6
Add 2/6 post. S.A.E. with enquiries.		

### SPECIAL! NEW L.O.T. COMPLETE

with: — Linearity and width controls. — EY85 base and top cap. — Valve connectors. — E.H.T. leads. — Circuit diagram. Beautifully made. **ONLY 11 post 2/6.**

### IS IT THE L.O.T.?

Be SURE with the SKANTEST. The most compact low-priced line output and time base component shorting turn tester. Will indicate even one shorting turn. 27/10.0. Carriage 5/-.

## RECORD PLAYERS

Famous B.S.R. U.A. Autochanger. 4 speeds, plus manual play; intermixes 7, 10 and 12in. discs. With Full-FI crystal turnover head. £6.15.0. The Supreme COLLARO CONQUEST—1960, 4-speed, mixer, autochanger, plus manual. With turnover crystal P.U. £7.15.0. Collaro Junior, 4-speed, studio P.U. Single play. £4.10.0. Carriage, etc., on all record players 5/-.

### TAPE RECORDER DECK

The Collaro "Studio" Transcriber. Latest 1960 model. 3 speeds—3 separate motors, digital counter, press button switching, provision for extra stereo head. Brand new—guaranteed. With spare 7in. spool. £12.10.0. Carr. 5/- (list price £16.16.0)

RADAR KILOVOLT. A servicing "must". Checks accurately and safely. Actual E.H.T. volts at C.R.T. E.H.T. rectr., etc. £3.17.6. carr. 2/6.

### SUPERB CABY MULTI-METERS

Sensitive—Accurate—Durable Model A.10: D.C. volts (Sensitivity 2K ohms/V) 10, 50, 250, 500, 1000V. A.C. volts. (Sensitivity 2K ohms/V) 10, 50, 250, 500, 1000V. Resistance, 10K ohms, 1 Meg. ohm D.C. current, 0.5mA, 25mA, 250mA. Measures decibels. £4.17.6. Model B.20: D.C. (Sensitivity 10K ohms/V), 0.5, 2.5 (Sensitivity 4K ohms/V), 10, 50, 250, 500, 1000V. A.C. volts (Sensitivity 4K ohms/V), 10, 50, 250, 1000 V. Resistance, 2K ohms, 200K, 2 Meg., 20 Meg. D.C. current, 100 micro-amp, 2.5mA, 25mA, 250mA. Measures decibels. £6.10.0. S.A.E. for leaflet. With test prods. instruction book, batteries.

HI-FI JASON Constructional Kits Also Leak, Quad, Trix, Wharfedale, Rogers, Goodmans, etc. Leaflets available. Let us quote for your requirements.

S.A.E. with enquiries please.

5 Westward Way  
Preston Road, Harrow, Middx.

# WESTWAY RADIO

# DOUBLE BEAM

## "SCOPE"

for D.C. & A.C. APPLICATIONS

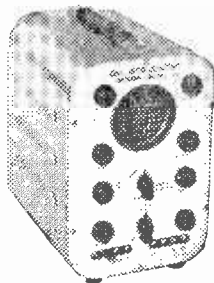

Engineered to precision standards, this high-grade instrument is made available at the lowest possible price, incorporating the essential features usually associated with luxury instruments.

This "SCOPE" will appeal particularly to Service engineers and Amateurs. A high gain, extremely stable differential Y-amplifier (30 mV/C.M.). Provides ample sensitivity with A.C. or D.C. inputs. Especially suitable for measurements of transistor operating conditions where maintenance of D.C. levels is of paramount importance. Push-pull X amplifier. Fly-back suppression; Internal Time-base Scan Waveform available for external use; pulse output available for checking TV Line O/P Transformers, etc.; Provision for external - I/P and CRT Brightness Modulation. A.C. mains 200/250 v. £19.19.0, plus P. & P. 7/6, or 50/- deposit, plus P. & P. 7/6 and 12 monthly payments of 33/4.

Y-amplifier (30 mV/C.M.). Provides ample sensitivity with A.C. or D.C. inputs. Especially suitable for measurements of transistor operating conditions where maintenance of D.C. levels is of paramount importance. Push-pull X amplifier. Fly-back suppression; Internal Time-base Scan Waveform available for external use; pulse output available for checking TV Line O/P Transformers, etc.; Provision for external - I/P and CRT Brightness Modulation. A.C. mains 200/250 v. £19.19.0, plus P. & P. 7/6, or 50/- deposit, plus P. & P. 7/6 and 12 monthly payments of 33/4.

FULL 12 MONTHS' GUARANTEE INCLUDING VALVES AND TUBE

### ALIGNMENT ANALYSER TYPE MC12

A.C. mains 200/250 v. Provides: "Wobulator" (Swept Frequency) operation, for FM/TV alignment linear frequency sweep up to 12 Mc/s. From 400 kc/s-80 Mc/s. Capacitance Measurement. Two ranges provided 0-60pF and 0-120pF. Special Facility enables true resonant frequency of any tuned ckt., I.F. transformer, etc., to be rapidly determined. Cash price £6.19.6, plus 5/- P. & P. H.P. terms 25/- deposit plus 5/- P. & P. and six monthly payments of 21/6.

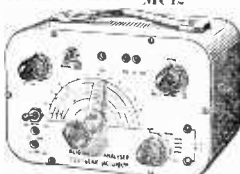

### LINE E.H.T. TRANSFORMER

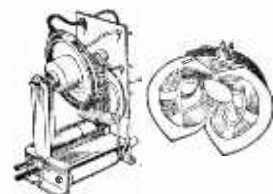

With built-in line and width control, 14 KV. Scan coil, 90deg. deflection, on ferrite yokes. Plane O.P. transformer pl. 18 KV. smoothing condenser. Can be used for 14in., 17in. or 21in. tubes. Complete with circuit diagram.

29/6 Plus 4/- P. & P.

As above, but for 625 lines, £2.10.0, plus 4/- P. & P.

Focus Magnet suitable for the above (state tube). 10/-, plus 2/6 P. & P.

### CYLDON TURRET TELETUNER

I.F. 34/38Mc/s. Brand new, complete with biscuits for channels 2, 4, 8, and 9, but less valves. Valves required P.C.C. 84, P.C.F. 80. 10/- plus 2/6 P. & P.

### MAINS TRANSFORMERS

All with tapped primaries. 200-250 volts, 0-160, 180, 200 v., 60 mA. 6.3 v. 2 amps., 10/6, 280-0-280 80 mA. 6.3 v. 2 amp., 6.3 v. 1 amp., 10/6, 350-0-350 v., 70 mA. 6.3 v. 1 amp., 6.3 v. 2 amp., 10/6, 250-250 v. 70 mA. 6.3 v. 2 amp., 10/6. Postage and packing on the above, 3/-.

### SURFACE BARRIER TRANSISTORS

Type SB305, 15 Mc/s, 7/6 each. 100% AUDIO TRANSISTORS, 5/- each.

### TRANSISTOR TESTER

For both P.N.P. and N.P.N. transistors incorporating moving coil meter. In metal case, size 4 1/2 x 3 1/2 x 1 1/2 in. Scale marked in gain and leakage. Complete and 19/6 Plus 2/6 P. & P., ready for use.

### A.C./D.C. POCKET MULTIMETER KIT

2in. moving coil meter, scale calibrated in A.C./D.C. volts, ohms and milliamps. Voltage range A.C./D.C. 0-50, 0-100, 0-250, 0-500. Milliamps 0-10, 0-100. Ohms range 0-10,000. Front panel, range switch, wirewound pot (for ohms zero setting), toggle switch, resistor and rectifier. 19/6, P. & P. 1/6. Wiring diagram 1/-, free with kit.

## SIGNAL GENERATORS

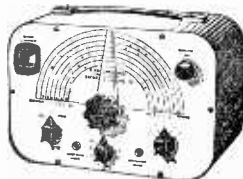

£6.19.6 or 25/- deposit and 6 monthly payments of 21/6, P. & P. 5/- extra. Coverage 100 Kc/s-100 Mc/s on fundamentals and 100 Mc/s to 300 Mc/s on harmonics. Metal case 10in. x 6in. x 5in., grey hammer finish. Incorporating three miniature valves and Metal Rectifier. A.C. Mains 200/250. Internal Modulation of 400 c.p.s. to a depth of 30%; modulated or unmodulated R.F. output continuously variable. 100 milli-volts, C.W. and mod. switch, variable A.F. output. Incorporating magic-eye as output indicator. Accuracy plus or minus 2%.

Cash £4.19.6 or 25/- deposit and 4 monthly payments of 21/6. Plus Postage and Packing 5/-.

Coverage 120 Kc/s-84 Mc/s. Metal case 10in. x 6in. x 4 1/2 in. Size of scale 6 1/2 in. x 3 1/2 in. 2 valves and rectifier. A.C. mains 230-250 v. Internal modulation of 400 c.p.s. to a depth of 30% modulated or unmodulated R.F. output continuously variable. 100 milli-volts C.W. and mod. switch variable A.F. output and moving coil output meter. Grey hammer finished case and white panel. Accuracy plus or minus 2%.

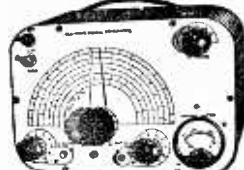

## SIGNAL & PATTERN GENERATOR

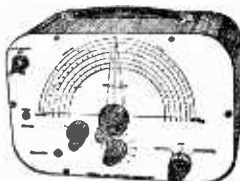

£6.19.6 P. & P. 5/-.

Or 25/- deposit. P. & P. 5/- and 6 monthly payments of 21/6. Coverage 4.6 Mc/s-210 Mc/s, in five bands, all on fundamental, slow motion tuning and audio output. 8 vertical and horizontal bars, logging scale. In grey hammer finished case with carrying handle. Accuracy ±1%. A.C. mains 200-250 v.

## CHANNEL TUNER

Will tune to all Band I and Band III stations. BRAND NEW by famous manufacturer. Complete with P.C.C. 84 and P.C.F. 80 valves (in series). I.F. 16-19 or 33-38. Also can be modified as an aerial converter (instructions supplied). Complete with knobs.

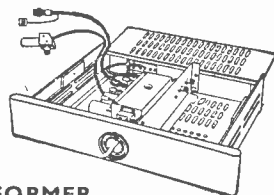

32/6 Plus 3/6 P. & P.

## HEATER TRANSFORMER

To suit the above, 200-250 v., 6/-, Plus 1/6 P. & P.

## 8-WATT PUSH-PULL AMPLIFIER

COMPLETE WITH CRYSTAL MIKE AND 8in. LOUDSPEAKER

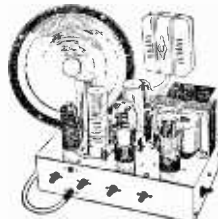

A.C. mains 200-250 v. Size 10 1/2 in. x 6 1/2 in. x 2 1/2 in. Incorporating 6 valves, H.F. pen., 2 triodes, 2 output pens and rectifier. For use with all makes and type of pick-up and mike. Negative feed back. Two inputs, mike and gram., and controls for same. Separate controls for Bass and Treble lift. Response at from 40 cycles to 15 Kc/s., in grey hammer finished case with carrying handle. Output transformer tapped for 3 and 15 ohm speech coils. For use with Std. or L.P. records, musical instruments such as Guitars, etc. £4.19.6 Plus 2/6 P. & P., ready for use.

Or 20/- deposit Plus P. & P. 7/6, and 4 monthly payments of 23/-.

## RADIO & T.V. COMPONENTS (Acton) LTD.

23c HIGH STREET, ACTON, LONDON, W.3.

All enquiries S.A.E. GOODS NOT DESPATCHED OUTSIDE U.K.

## BRAND NEW AM/FM (V.H.F.) CHASSIS AT £13.6.8. (P. & P. 10/-)

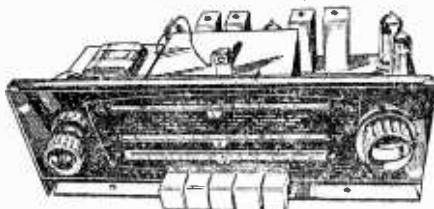

Tapped input 220-225 v. and 226-250 v. A.C. ONLY.  
Chassis size 15 x 9 1/2 x 5 1/2 in. high. New manufacture.  
Dial 1 1/2 x 4 in. in gold and black.  
Pick-up. Extension Speaker. Ae. E., and Dipole sockets. Five "piano" push buttons—OFF, L.W., M.W., F.M. and Gram. Aligned and tested. With all valves & O.P. Transformer. Tone-control fitted.  
Covers 1,000-1,900 M.; 200-530 M.; 83-98 Mc/s.  
Valves EZ30 rect., ECC81, EF89, EABC30, EL84, ECC85, Speaker & Cabinet to fit chassis. 47/8. 10 x 8 in. ELLIPTICAL SPEAKER, 20/-

TERMS:—(Chassis) £4.16.8 down—10/- carr.—and 6 Monthly Payments of 30/-, or with Cabinet & Speaker £5.9.2 down and 7 Monthly Payments of 32/-.

A FEW CHASSIS, DUSTY AND TARNISHED THROUGH STORAGE at £10 (10/- P. & P.). Working and unused but only 3 months' guarantee.

### "READY TO USE" ITA CONVERTER

We are specialists in ITA Converters. Our converters give direct switching ITA to BBC, metal rectifier, co-axial plug. Can be fitted in 5-10 mins., and need no alteration to your set. ALL AREAS. ALL SETS. ALL CHANNELS. 12 months' guarantee (3 months on valves).

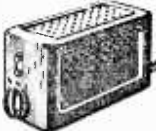

Separate gain controls. Valves PCF80 and PC084. Switch positions ITA (1)—ITA (2)—BBC. Bakelite moulded cabinet 8 1/2 x 4 x 6 in. Last 500 at 70/- (3/- P. & P.).

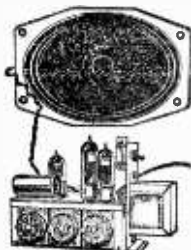

**3-VALVE AMPLIFIER (INC. RECT.).** Capable of giving 4 watts. Mains and output transformers. Valves ECC83, EL84, and EZ80, 3 Controls, volume, bass and treble. On/Off switch. Fully guaranteed. Chassis size 6 1/2 x 3 x 2 1/2 in. (6 1/2 in. round or 7 x 4 in. elliptical speaker, state which).

Not suitable for microphone input.

67/- (3/- p. & p.)

### OFFER OF 13-CHANNEL INCREMENTAL TUNER

I.F. 34-38 Mc/s without valves. Removed from chassis but in working order. PCF80 and PC084 required.

7/6 (2/6 P. & P.). Knobs 2/6 extra.

### CYLDON TURRET TUNER

34-38 Mc/s. Brand new, with PCF80 and PC084. With coils for channels 1-5 and 8-11. OUR PRICE 22/6 (Post 1/6). Knobs 2/6 extra.

**NEW ITA AND BBC TUNER.** By well-known manufacturer for superhet TVs with 35-38 Mc/s I.F. For all areas; covers all 13 channels. Switch gives BBC and two ITA selections. Suits G.E.C. sets BT4343, 4544, 5146, 5147, 5543, 5642, and 6641

without alteration. Easily adapted as aerial converter, and instructions can be provided free. Has ITA and BBC co-axial sockets and separate gain controls.

WITH VALVES PCF80 and PC084. 22/6 (P. & P. 3/-).

Some without valves at only 12/6 (P. & P. 3/-).

**AUTOMATIC RECORD CHANGERS, COLLARO CONQUEST** with manual play also. Turnover crystal pick-up, 4-speed, A.C. mains 200-250 v. see illus.

£7.10.0 (5/- P. & P.)

B.S.R. 4-speed UA14, auto-changer £7.10.0 or STEREO UA8 for only £6.17.6. Mono UA8 £6.10.0. (carr. 5/- on each.)

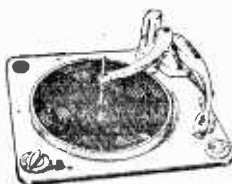

### THE "CABY" TEST METERS

In moulded case. Prices include Test Prods., Batteries, Instruction Book, FULLY GUARANTEED. Also measure db. Accuracy: A.C. 3 per cent; D.C., 2 per cent.

A-10 £4.17.6

B-20 £6.10.0



A-10—2K ohms/v. on A.C. and D.C. volts (10, 55, 250, 500 and 1000 v.); 10K and 1M ohms; 1 mA, 25 mA and 250 mA. D.C. Size: 5 1/2 x 3 1/2 x 1 1/2 in. Weight 17 ozs.

B-20 10K ohms/v. on 0.5 v. and 2.5 v.; 4K ohms/v. on 10, 50, 250, 500 and 1000 v. A.C. and D.C. Resistance, 2K, 200K, 2M and 20M-ohms; D.C. Current, 100 microA, 2.5 mA, 25 mA, 250 mA. Size: 6 1/2 x 3 1/2 x 2 1/2 in. Weight 24 ozs.

### THE BRAYHEAD TURRET TUNER,

£7.7.0 post free. Complete with booklet and fitting instructions. State set and model number when ordering. Converts your 5-channel BBC only set to receive ITA as well.

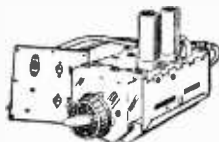

**ITA AERIALS** clipping to existing mast 1-2 in. dia. 3-element, 22/-; 5-el., 30/-; 9-el., 50/-; Loit mounting, 3-el., 20/-; 5-el., 26/-; Combined single BBC and 5-el. ITA, 75/- with chimney-lashings; Co-axial cable semi-air-spaced, 7 ft. yd. or 30 yds., 11/-; Aerial prices carr. paid. Postage on cable 1/-.

**NEW WAXED TUBULARS**, 350 v. or above. 0.001, 0.002, 0.005, 0.01, 0.02, 0.05, 0.1, 0.25, 0.5 mF. Total 21 for 4/6, post 9d.



**GRAMOPHONE AMPLIFIER** with 5 in. SPEAKER. On Fabric-covered Baffle 12 x 5 in. Mains and Output Transformers. Valves EZ40 and EL41. Tone and Volume Controls. On/Off switch. Plenty of Volume. Fully Guaranteed. Two Knobs supplied. Ready to play. Useful for Stereo.

ONLY 57/-, post 3/-



### SELF-POWERED VHF/FM TUNER CHASSIS.

Fully built VHF/FM Tuner covers 88-95 Mc/s sec. Wired, aligned and tested. Two diodes ECC85, EF91 and EF91. Mullard permeability Tuner. No frequency drift. Mains transformer. 200-240v. A.C. Supplied in chassis form, dimensions 10 1/2 x 5 1/2 in. high x 4 1/2 in. Metal rectifier. The complete set with ECL82 amplifier can be provided for 89m/s. (carr. 4/-) and this is in a metal cabinet with 3-core mains lead and cabinets is illustrated above.

£7.10.0

(3/- P. & P.).

Delivery by return. C.O.D. 2/- extra. Terms: Cash with order or one-third down and balance plus 7/6 (up to £7.10.0) in four equal monthly payments. Balance over £7.10.0 add 1/- in £1 and pay in not more than 6 monthly payments. See special terms for A.M.-F.M. chassis. All new goods unless stated. Send 6d. for NEW 20-page catalogue.

## GLADSTONE RADIO

(Camberley closed Sats. Bristol & Portsmouth closed Weds.)

### POSTED ORDERS TO CAMBERLEY PLEASE

58A HIGH STREET, CAMBERLEY, SURREY. Tel. 2791  
56 Stokes Croft, Bristol, and 347 NEW ROAD, PORTSMOUTH



# Practical Television

AND TELEVISION TIMES

VOL. 11, No. 124, JANUARY, 1961

## TV IN INDUSTRY

Editorial and Advertisement  
Offices:

**PRACTICAL TELEVISION**

George Newnes, Ltd., Tower House  
Southampton Street, W.C.2.

© George Newnes Ltd., 1961

Phone: Temple Bar 4363.

Telegrams: Newnes, Rand, London.

Registered at the G.P.O. for trans-  
mission by Canadian Magazine Post.

### SUBSCRIPTION RATES

including postage for one year

Inland - - - - £1.20 per annum  
Abroad - - - - £1.06 per annum  
Canada - - - - 19s. per annum

## Contents

	Page
Editorial ... ..	179
Practical Television Olympic	180
Servicing Tuners ... ..	184
Fault-finding with a Signal Generator ... ..	187
Telenews ... ..	190
Oscilloscope Faults ... ..	192
EHT Generation ... ..	197
How to make Aerial Attenuators ... ..	200
Servicing TV Receivers	203
Letters to the Editor	208
Underneath the Dipole	211
Trade News ... ..	215
Your Problems Solved	219

The Editor will be pleased to consider articles of a practical nature suitable for publication in "Practical Television". Such articles should be written on one side of the paper only, and should contain the name and address of the sender. Whilst the Editor does not hold himself responsible for the manuscripts, every effort will be made to return them if a stamped and addressed envelope is enclosed. All correspondence intended for the Editor should be addressed to: The Editor, "Practical Television", George Newnes, Ltd., Tower House, Southampton Street, London, W.C.2.

Owing to the rapid progress in the design of radio and television apparatus and to our efforts to keep our readers in touch with the latest developments, we give no warranty that apparatus described in our columns is not the subject of letters patent.

Copyright in all drawings, photographs and articles published in "Practical Television" is specifically reserved throughout the countries signatory to the Berne Convention and the U.S.A. Reproductions or imitations of any of these are therefore expressly forbidden.

TO the lay mind, the word "Television" stands only for a medium of mass entertainment and certainly most of us meet TV only in this guise. However, domestic TV now appears to be reaching saturation point and until either new bands (IV and V) are brought into use, or different transmission standards, for both monochrome and colour, are exploited, it seems that TV for entertainment will remain much as it is at present. However, it cannot be said that development of television is not proceeding; in the field of "industrial television"—an all-embracing term—many new uses and techniques are appearing. In fact, such is the importance of TV in industry that an exhibition of industrial photography and television was held at the Royal Albert Hall, London late in November. It is significant to note, that at this exhibition, the stands appeared to be divided almost equally between photographic equipment and television equipment.

In industry, the main use of TV seems to be concerned with observation of areas normally hazardous to personnel—owing to radiation, for example—or with areas which are inaccessible. To judge from the exhibition, another major use of TV is the quick transmission of information from one point to another without ambiguity. This simple transmission of documents such as cheques constitutes a form of information processing similar in principle to the processing of information of punched card and computer techniques. In most computer systems, information must be converted from the symbols which are normally used—letters of the alphabet and figures—into what might be termed "computer language". This procedure is often known as "programming" a computer. It is normally achieved by transcribing the information, using a human operator, on to a number of cards in which holes are punched to represent the information. This transcription is very slow compared with the rate of working of the computer and prevents maximum efficiency being reached. The need has therefore been evident for some time for a machine capable of "reading" directly the information to be processed without the intermediate stage involving punched cards. Such a machine—now in production—was recently shown to members of the press and to achieve recognition of characters it employs a system similar in principle to television. Lines on tally rolls from cash registers are "read" by forming a raster on a CRT and projecting an image of the raster on to the tally roll. The varying amount of light reflected as the light spot moves over the white paper and the dark, inked characters is picked up photo-electrically and gives an output of pulses which can then be analysed, recognised and processed in logical circuits in the same way as the information derived by more conventional methods.

The possibilities for such machines are great and, no doubt, more advanced types will eventually make their appearance. Meanwhile, television will be used more and more in industry both directly and indirectly.

Our next issue, dated February, 1961, will be published on January 20th.

# The Practical Television

# OLYMPIC

## ALIGNING THE CIRCUIT

By D. R. Bowman

(Continued from page 168 of the December issue)

**A**FTER having carried out the majority of the mechanical construction of the tuner as described last month, the inter-stage screen is now put into position and screwed down, and the wiring continued. The last

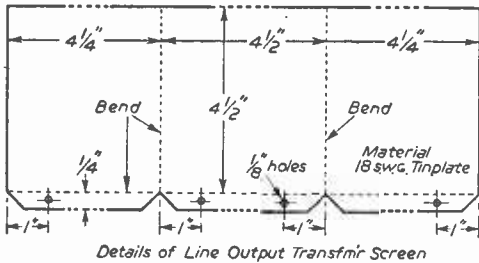
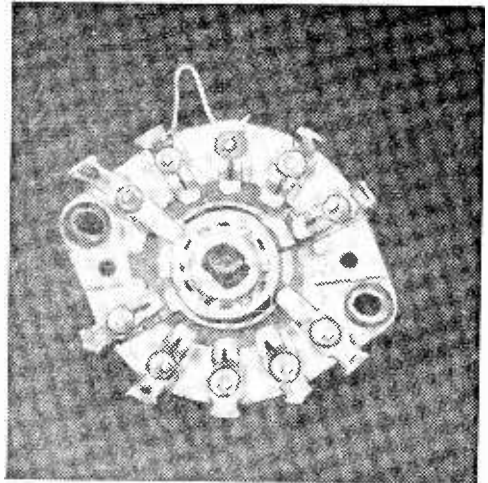

Fig. 10.—The dimensions of the line output transformer screen.



A view of one of the tuner switch wafers showing the Band III loading inductor.

wafer is put into position again with the correct spacers, and the wiring completed. It will be realised that if any mistake is made it may be necessary to take the whole tuner down again. During development this had to be done at least

eight times, but if great care is taken, the constructor should be able to make it correctly at the

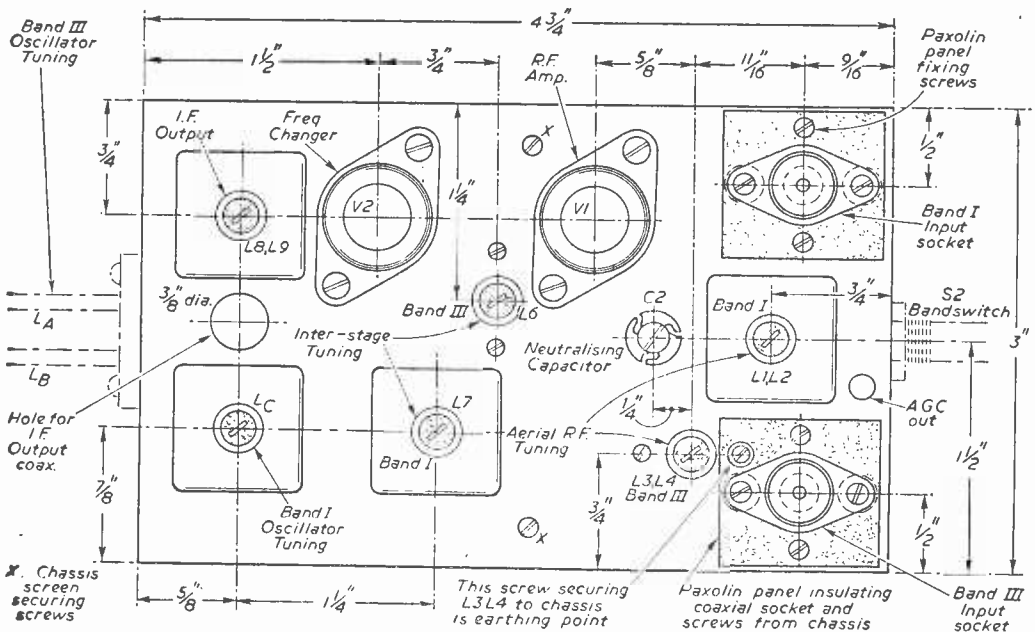

Fig. 11.—The above-chassis layout and dimensions of the tuner chassis.

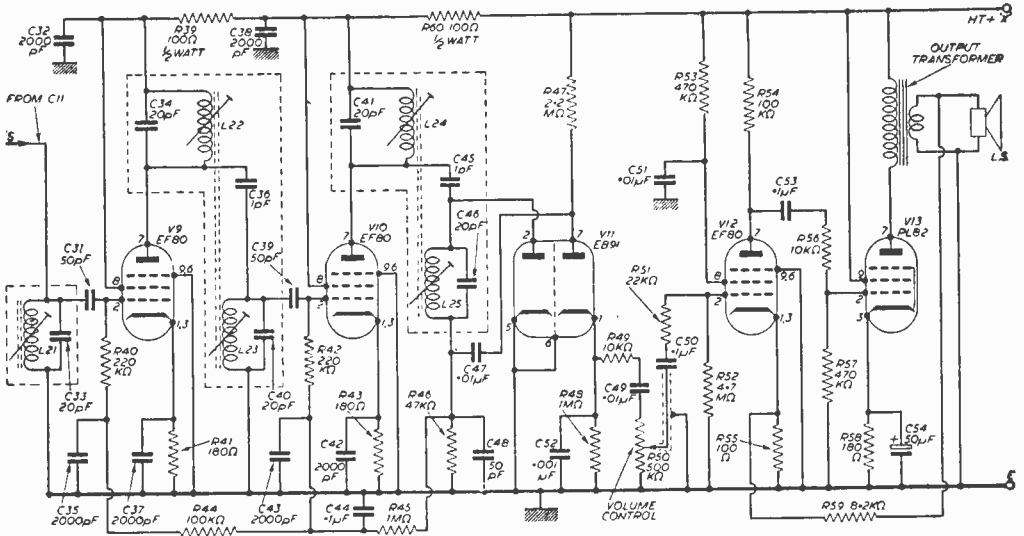

Fig. 12.—The circuit of the sound I.F. amplifier, detector, and amplifier stages.

first attempt. Care and thought and frequent comparison between wiring diagram and circuit diagram during wiring will be rewarded. The anode resistor (R11) to the oscillator valve

is large, and it will be seen from the wiring diagram that it lies in between the rods which carry the switch wafer. Care should be taken that adequate insulation is used so that no accidental

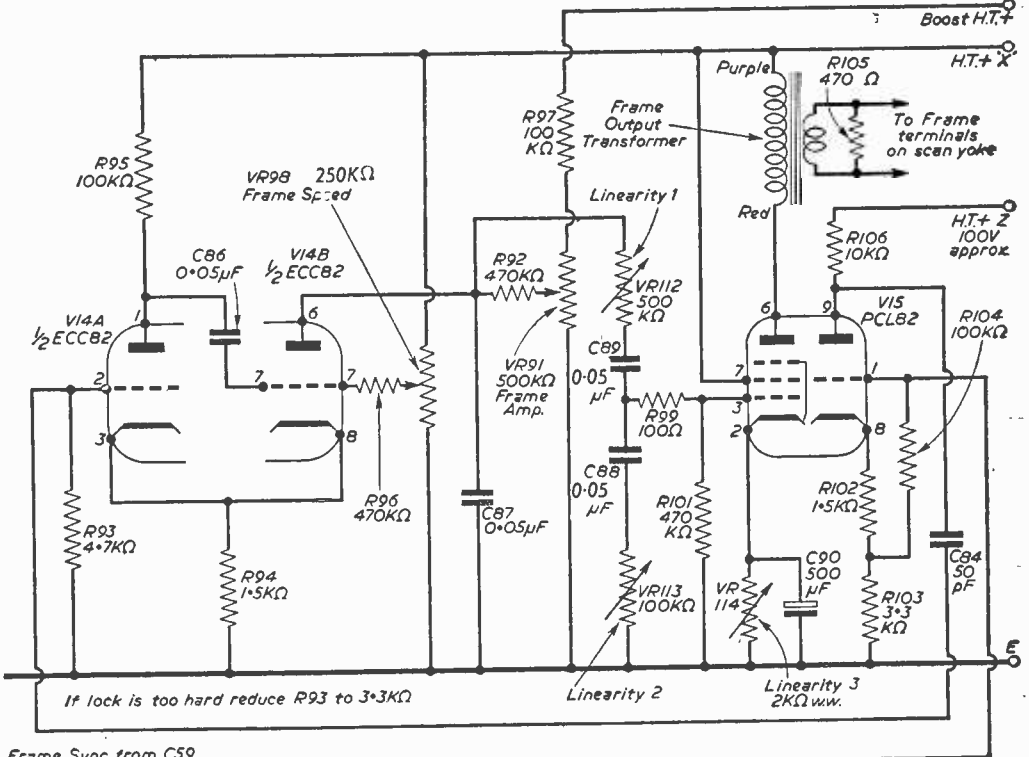

Fig. 13.—The frame multivibrator and output circuits.

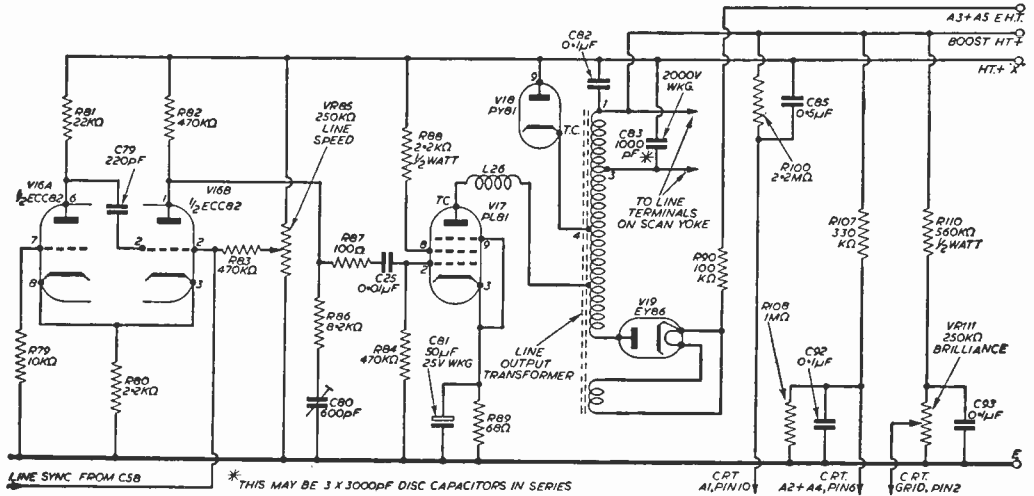

Fig. 14.—The line multivibrator and output circuits.

short-circuit may deprive the oscillator of its H.T. supply.

The inter-stage screen must, of course, be cut away to clear the small components on the base of the PCC89. This is best carried out by trial and error, care being taken not to cut away so much material that screening is impaired. In wiring it is important to keep the second anode of the PCC89 "out of sight" of its cathode capacitor. C4 may be used, properly positioned, to assist in this screening. C67, C68, the heater decoupling capacitors, may also be positioned so as to fill up any holes in the inter-stage screen.

The oscillator wafer should be wedged firmly to the shaft to ensure constancy of its position

Fig. 15 (Right).—The delayed AGC circuits.

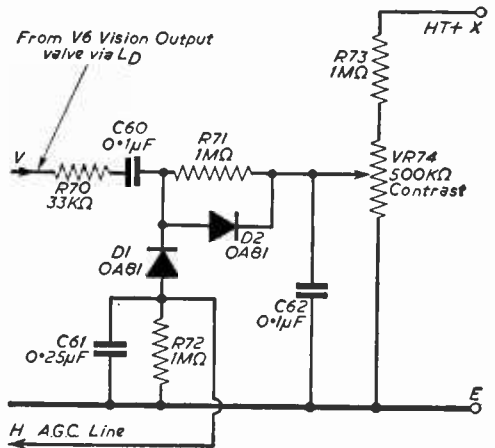
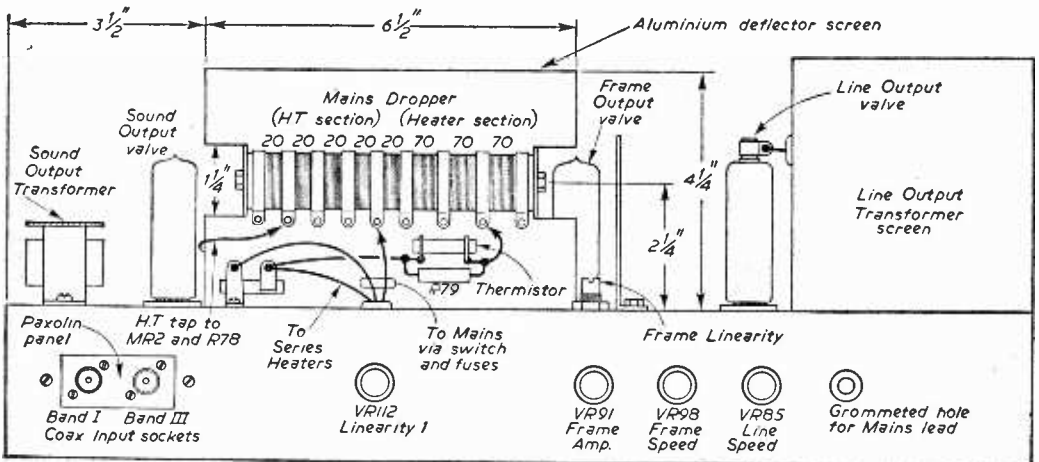

Fig. 16 (Below).—A rear view of the chassis showing the mains dropping resistor and its heat-deflecting shield.



when rotated. This is achieved by inserting a fine needle between wafer and shaft, and tapping it lightly into position. The excess can then be broken off.

It may be noted here that R1 and R2 together afford the AGC delay potential to the grid of V1, the PCC89. The total value is 14.7M, but if a 15M resistor is available it may be used instead by itself. Condenser C4 in particular must be soldered into position with the absolute minimum length of leads. It is really preferable to use two 500pF capacitors in parallel to minimise the inductance between the grid of the second triode and chassis, provided lead length can be reduced. However, the 1.000pF capacitor specified is of very suitable physical construction and no difficulty has been met with it.

The mains-dropping resistor is located at the back of the chassis and is contained in a mounting made from a piece of polished aluminium bent to shape. This acts as a heat reflector and deflector to assist in keeping the chassis cool. It has not been found necessary in the prototype receiver to provide any fine tuning control, even for Band III because care has been taken to minimise "drift". If however, the chassis rises in temperature to any great degree some drift may be expected, and proper precautions need to be taken for ventilation. Unfortunately the valves themselves generate most of the heat produced, but the use of the

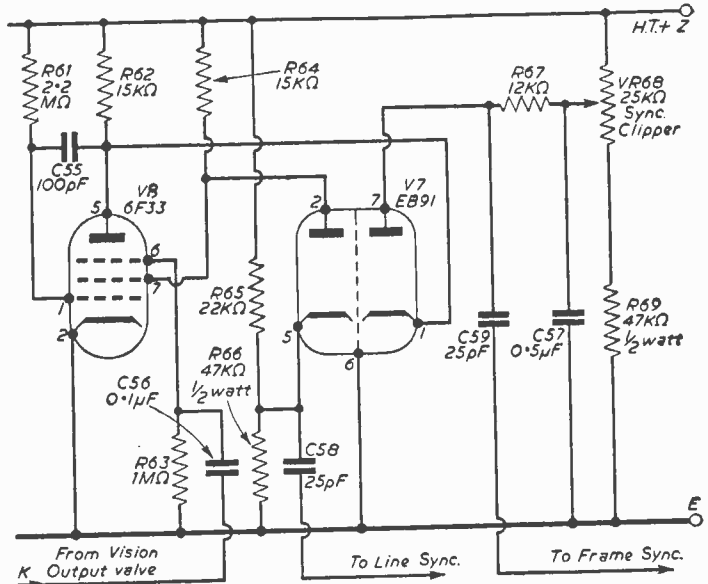

Fig. 17.—The sync separator and clipper circuits.

new silicon rectifiers for the H.T. removes one source of unwanted heat.

Within the mains dropper mount is also situated the surge limiting thermistor, which is suitable for 0.3A valves. This is paralleled by a 500Ω 10W resistor to enable the warming-up period to be shortened. The surge on switching on does not exceed 0.38A on the heater chain, and this causes no trouble.

The silicon rectifier for H.T. supplies are said by the manufacturers not to require parallel resistors to equalise peak inverse voltages. Nevertheless these have been incorporated as a safety precaution, and are made of 1/4W rating to minimise temperature rise. They are yellow in colour and do not radiate heat well. In no circumstances must less than 20Ω appear between the mains lead and these rectifiers, or the charging current into C66 will damage them when the set is switched on. With this precaution, mains voltages as low as 190 will give full performance with this receiver.

In order to minimise rise in temperature of the valves no valve screens are specified at all with the exception of the two tuner valves and the sound detector. The EF80 valves do not really need screens since they have a screen inside the valve envelope. Valveholders designed for a can are used in both vision and sound I.F. amplifiers however, because the skirt of the holder gives

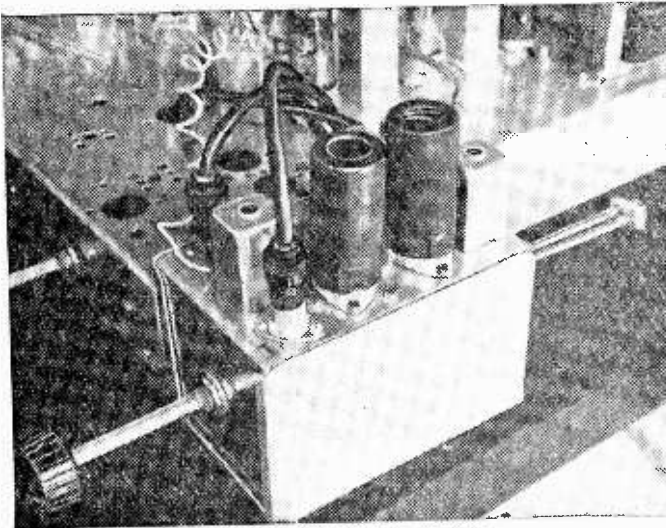

A view of the completed tuner.

(Continued on page 216)

# SERVICING TUNERS

**S**INCE the advent of television in Band III, from about 1954, all television receivers have featured some method of selecting stations in Bands I and III. Several methods of channel selection have been used, and these include tuners with pre-set tuning over two or three channels, usually two channels in Band III and one in Band I, with a two or three position rotary switch for channel selection. G.E.C. receivers of early Band III years employed such a method of channel selection. Ferranti receivers were also made with a similar two position switch for band changing. In the Band I position the set is pre-tuned internally to a BBC channel, while in Band III position a continuously variable permeability tuner is switched into circuit. This operates over the whole of Band III. Combinations of these ideas were also adopted with different makes and models.

## Multi-channel Tuners

The most popular method of station selection today is provided by the so-called multi-channel tuner. This is made in two forms: the well-known turret tuner and the switch tuner, such as is used extensively in Pye receivers. The turret tuner, as is well known, consists of a rotatable drum or turret carrying a maximum of twelve pairs of coil biscuits around its periphery. When the turret is rotated on its shaft by means of the channel selector knob, the contacts on the coils corresponding to the required channel locate on strips of spring metal folded into loops. Contact is then secured between the required coils and the tuner circuits.

The basis of the switch tuner, as would be expected, is a 12-position rotary switch. The switch is made up of a bank of switch wafers each having a rotor made in the form of one or more contacts, and a stator comprising a ring of low-loss material—in which the rotor operates—and bearing around its periphery 12 contacts. The switch wafers are rather like those employed in ordinary broadcast receivers for changing the wavelength, but are more substantial and made of a material having lower losses. The tuning coils, being of small dimensions and self-supporting, are mounted

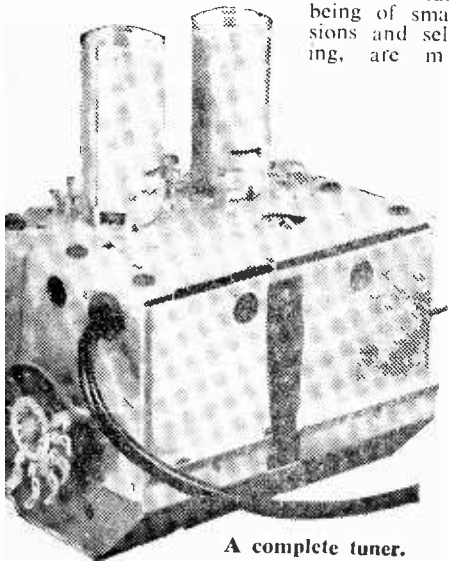

A complete tuner.

## THE MECHANICS AND THEORY OF MODERN TURRET TUNERS

By G. J. King

directly on the wafers between adjacent tags. It is thus possible to alter the inductance of the total circuit in increments corresponding to adjacent channels by turning the rotary switch.

## Servicing the Turret Tuner

The mechanical construction of a Cyldon turret tuner (which is typical of most tuners of this kind) is shown in Fig. 1. This exploded diagram clearly reveals the turret which bears the pairs of coil biscuits. The side panel assembly carries the spring metal contacts which bear upon the contact studs of the coils. The turret proper is held in position in the chassis of the tuner under spring pressure by means of the front and rear spindle support springs. The turret is divided into two sections by a centre disc. This is suitably shaped around its edge to allow the small roller of the locator spring and wheel assembly to provide positive location of each channel position under spring pressure. The dividing disc also screens the aerial coil (L1) side of the turret from the R.F. and oscillator coil (L3, L4 and L5) side to avoid interaction and instability.

In common with most multi-channel tuners, the turret tuner of the type under discussion incorporates a fine-tuning control to permit the user to counter slight drift of the oscillator frequency and also establish optimum oscillator setting after changing channel. The fine-tuning comprises a variable capacitor (C14) which is formed by the stud of the fine tuner, the condenser bracket and the cam and sleeve assembly. The sleeve of the cam slips over the turret shaft, so that a dual control knob can be used for channel selection and fine tuning. Alteration in value of the fine-tuning capacitor is achieved by variation of dielectric constant brought about by the insulated cam entering the air-gap between the condenser bracket and fine-tuner stud. The cam is so shaped as to provide a progressive increase or decrease in capacitance over a very small range. The cam and sleeve assembly is held under spring pressure against the condenser bracket by means of the condenser tension spring which is held in position by the turret spindle.

## Connections

If it is necessary to remove the tuner from the receiver cabinet or chassis for servicing, all the wires connected to it must be disconnected, but *not* before making an easily read sketch of their

positions on the various tags and a note of their colours. For certain troubles, it may be necessary to return the tuner to the makers for servicing and it is virtually impossible to be sure of the wiring otherwise after two or three weeks.

If necessary, the tuner can be dismantled to the stage shown in Fig. 1 without disturbing the circuit on the chassis assembly. It is, indeed, most important to avoid disturbing the wiring and position of the components as the self-capacitance of the circuit generally was taken into account during the alignment of the tuner, and it is not a simple matter for the experimenter to undertake realignment and hope to secure the best results.

The bottom screen and side screen of the tuner are both simply clipped into position and are fairly easily removed. The side panel assembly is held in position by two screws, while the fine tuning assembly can be dismantled by first removing the two screws securing the condenser bracket. The turret assembly can be removed by disengaging the two spindle support springs and allowing the turret to fall from the bottom of the chassis assembly.

**Wedge Springs**

The aerial coil assembly and mixer coil assembly are located in grooves in the centre disc of the turret assembly and are held firmly in position by means of spring metal clips fitted to the two outside plates. In some tuners, the available coil space is not fully occupied, and the blank positions wedge springs are used to take the place of the coil biscuits and to hold the coils which are used firmly against each other. Thus, if additional chan-

nels are required it is first necessary to remove the wedge springs and then introduce the required coils. It must be observed that two coils are required for each channel, and that they must both correspond to the channel to which it is required to tune. There is never much success in using a coil of a different channel and hoping to secure optimum tuning of the required channel by altering the number of turns or the spacing between the turns. Similarly, it is essential to ensure that the coils used are, in fact, designed for the particular make of tuner in which they are to be used. The coils also differ between tuners of the same make but different model. The tuner oscillator frequency and I.F. combination have a major bearing on the exact type of coils required.

Each coil contains a tuning slug made either of brass or of iron dust, and these are held firm in the coil formers by the slug locating springs pressing against their threads. The slug in the oscillator coil corresponding to the channel to which the tuner is switched is accessible for adjustment through a hole in the facing side of the chassis assembly, slightly below and to the right-hand side of the fine tuner when viewing from the front.

**Oscillator Slug Adjustment**

Generally, the hole in the front of the tuner coincides with a hole in the front of the receiver cabinet, often beneath the channel selector knob, which first has to be removed. Thus, to adjust the oscillator slug it is rarely required to remove the turret tuner. If the fine tuning control falls short of the centre of its travel for optimum tuning of vision and sound of all channels, the fine tuning

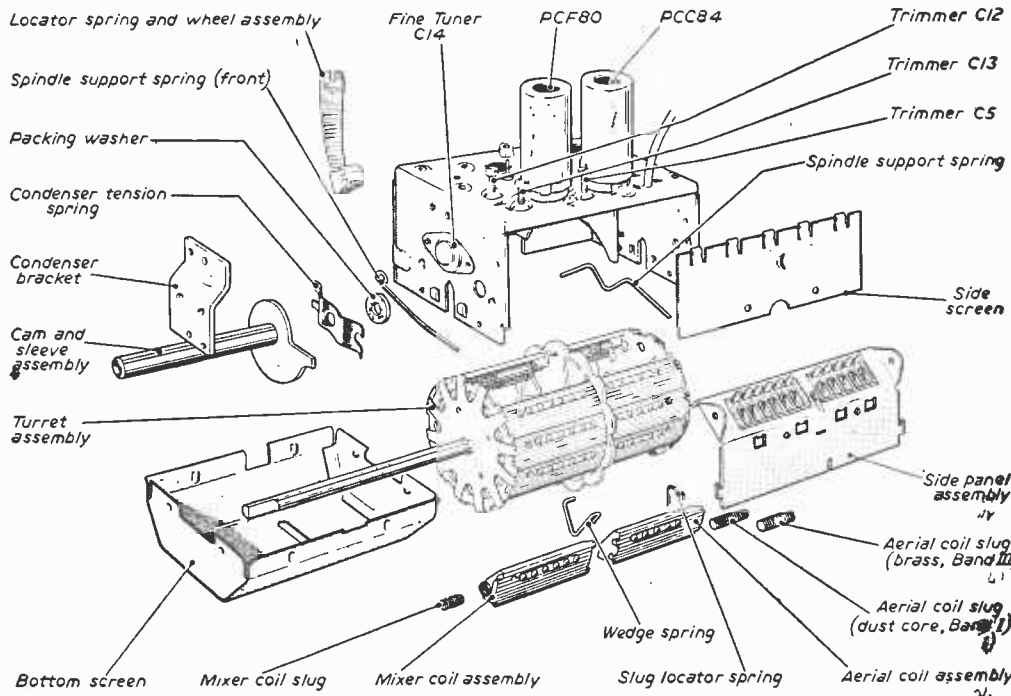

Fig. 1.—The construction of a typical turret tuner.

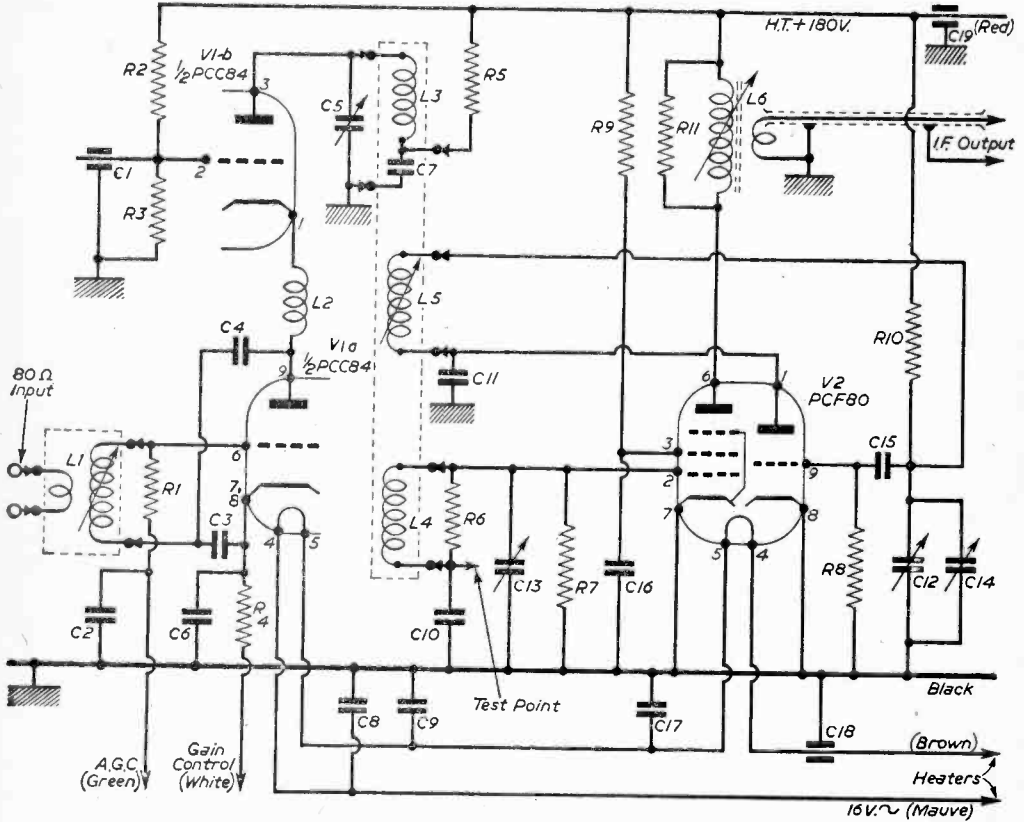

Fig. 2.—The circuit of the tuner illustrated on page 185.

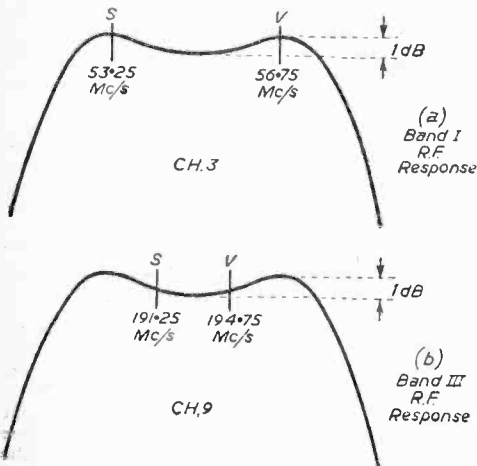

Fig. 3.—Response curves of the R.F. stage of a tuner on Bands I and III.

control should be adjusted to its mid-position and the oscillator slug should be adjusted very care-

fully for maximum sound consistent with minimum sound interference on vision.

Adjustment must be carried out with a slim non-metallic trimming tool, and a plastic knitting needle shaped to form a screwdriver is ideal for performing this adjustment. Care should be taken to avoid unscrewing the core too far out of the coil former, as it may disengage the thread and locator spring and fall from the former into the inside of the tuner unit.

**Aerial Coil**

The slug in the aerial coil former rarely requires similar adjustment, and in most tuners it is not usually possible to adjust this slug while the set is working. In any event, the tuning of this circuit is very broad and in normal signal strength areas it is difficult to establish an optimum tuning point.

Several small trimmers, such as C5, C12 and C13 in the unit under consideration, are located in various parts of the circuit and accessible from the top of the chassis. These are *not* for general adjustment, but are included for standardising the stray capacitances and to aid in the initial alignment at the factory.

(To be continued)



# FAULT-FINDING WITH A SIGNAL GENERATOR

## COMPREHENSIVE GUIDE TO TEST PROCEDURE

By L. E. Higgs

**S**IGNAL-GENERATORS are second only in importance to the multi-range test-meter when used for TV fault-finding. Much has been written on the construction and features of test oscillators for the amateur, but little on the essential quick check tests used to localise a defective stage in a receiver.

The tests explained in this article are intended as a guide for the home constructor and the techniques and refinements of R.F. measurement will not be found. The author has endeavoured to show how to perform the various tests and how to analyse the results obtained.

These tests are based on a typical 13 channel superhet TV, the standard design of which has settled down over the last five years. Quite likely a number of sets will be found to vary slightly. When this is so, the equivalent points can be chosen to correspond and the results interpreted accordingly.

It is suggested that familiarity with the signal generator can best be built up by working through these tests on a TV in good running order and notice taken of the results. These observations

conjunction with the given test points. It is assumed that a normal raster is obtainable and that the vision or sound is missing, else very weak; or alternatively both are missing or weak together. Another assumption is that the receiver has been working satisfactorily up to the moment of failure and that the I.F. and R.F. tuning adjustments have not been thrown out of alignment. If it is known that realignment is needed, then reference must be made to the maker's alignment instructions as no rule of thumb can be applied to this tricky operation that will give good results on all sets. Never try to save time or money by attempting to adjust tuned circuits without the proper information. The cans of a TV chassis all look alike, even to an expert unfamiliar with that receiver and there is no certainty which is which. All receivers have their own peculiarities of adjustment, dampers, etc., without which only a rough approximation can be obtained, so better still do not touch them. It is most unlikely that a receiver will suddenly cease operating because the alignment went off tune.

Connect a termination unit as shown in Fig. 1. The purpose of this is to match the output lead approximately and to block off the H.T. when connecting from anodes and chassis. This lead should be used for all tests. Remember that most TV chassis are connected to mains and so connect the plug correctly before starting.

### Sound Section

The method used is to work back from the speaker, stage by stage, injecting a suitable signal and when hearing the expected output tone from the speaker move back another stage until a point is reached where no signal is received. It can then be assumed that the defect is between the last two test points. As the signal is applied nearer and nearer to the aerial when working back, the output volume

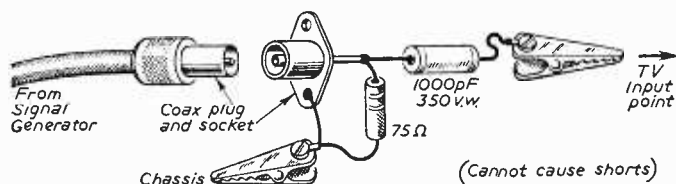

Fig. 1.—A signal generator connector which is safe for injecting signals at points carrying H.T. and at valve grids.

will help the user in future to recognise and appreciate differences in performance when a fault exists, and speed the tracing of the faulty stage.

Signal generators (or test oscillators) vary enormously in price and complexity, but they all supply the following services:—

- 1 An accurately tuned unmodulated radio frequency (CW).
- 2 An optional internal modulation to the above. (Modulated CW).
- 3 An adjustable audible frequency tone voltage (A.F.).
- 4 Control of the output of 1 and 2 to a very small amount. (Attenuator). The attenuator on the cheaper instruments is often far from accurate but provided it effectively cuts down the output to a very small degree that is all that is required. Crystal checks, output metering and other refinements are not required here and the maker's handbook will explain these points.

The tests are listed in the tables under the headings of "Sound" and "Vision", and are used in

increases as more gain is used. Test Point 1. (See page 188).

Identify the grid of the sound output valve from circuit or valve information. Apply the full output from the signal generator A.F. socket to the grid and chassis and when a moderate sound is heard in the speaker move to the next test point.

Test Point 2.

Apply the A.F. leads between the top of the volume control and earth. (Take care not to foul the mains connections on the rear of the volume control.) The normal output is now much louder and the A.F. could be reduced. The volume control operates and should now be kept turned up. Test Point 3.

Find the sound intermediate frequency of your particular receiver. Tune it in on the manual tune knob and ensure that the correct range on the signal generator is selected. Feed in the full output of the generator when switched to modulated CW, to the sound I.F. valve anode and chassis. This point is about 200V positive and so switch off when connecting and later when disconnecting. **A**

## Table of Test Points and Results

### SOUND TESTS

Test point	Input type	Location	Normal result	Fault result	Remarks
1	Strong A.F.	Output valve grid and chassis.	Loud volume.	No sound shows output stage fault.	Volume control ineffective.
2	Reduced A.F.	Top of volume control and earth.	Very loud volume.	No output shows A.F. stage fault.	Volume control effective—turn up full.
3	Strong mod. CW sound I.F.	I.F. valve anode via capacitor and earth.	Moderate volume.	No output shows detector stage fault.	Weaker output due to sig. gen. mismatch. Oscillator clip now H.T. +.
4	Reduced sound I.F. mod. CW.	I.F. valve control grid and earth.	Loud volume.	No output shows I.F. stage fault.	
5	Weaker sound I.F. mod. CW.	Common I.F. valve control grid and earth.	Very loud volume.	No output shows common I.F. stage fault.	Some effects on screen—weak bars.
6	Very weak sound I.F. mod. CW.	Mixer grid from test point top of tuner, or coil proximity.	Very loud sound. Disturbed raster.	No output shows mixer stage fault.	Channel fine tuner should not affect signal.
7	Weak sound signal frequency.	As above if accessible.	Very loud sound. Disturbed raster.	No output shows oscillator fault.	Channel fine tuner will need resetting for maximum sound. Sig. gen. must be accurate.
8	CW signal $\pm$ or the sound I.F.	Proximity injection mixer or direct on osc. coil (with aerial fitted).	Sig. gen. "tunes" in sound. Proves local osc. faulty.	No output shows combined mixer oscillator defect. (L.C. valve).	Heterodyning when TV fine tuner is altered proves local osc. is running satisfactorily.
9	Sound signal frequency.	Direct into aerial socket.	Loud sound tuned by turret fine tuner.	Weak sound, grain on screen rushing background.	Faulty R.F. (cascode) stage. Contrast and sensitivity to be turned up.

### VISION TESTS

10	Strong A.F.	Cathode pin of picture tube.	Weak horizontal rolling bars.	Blank raster shows tube circuit fault.	Adjust brilliance for weak illumination. Apply A.F. via capacitor.
11	Reduced A.F.	Video valve grid.	Strong horizontal rolling bars.	Blank raster shows video amplifier fault.	Vision limiter to be kept down.
12	Strong vision I.F. mod. CW.	Anode, vision I.F. valve via capacitor.	Weak horizontal rolling bars.	Blank raster shows faulty vision detector or detector circuit.	Injection point 200V+ above earth.
13	Reduced vision I.F. mod. CW.	Grid vision I.F. valve.	Strong horizontal rolling bars.	Blank raster shows faulty vision I.F. valve circuit.	Contrast turned up full.
14	Weak vision I.F. mod. CW.	Grid common I.F. valve.	Very strong horizontal rolling bars.	Blank raster shows fault in common I.F. stage.	Contrast and sensitivity up full. Possibly slight sound breakthrough.
15	Weak vision I.F. mod. CW.	Grid mixer valve if accessible.	Very strong horizontal rolling bars	Blank raster shows faulty mixer stage.	Full contrast and sensitivity.
16	Strong CW vision I.F. $\pm$ signal frequency.	Proximity injection to oscillator coil.	For suspect stopped local osc. Tune channel from sig. gen.	Stations "tuned" in by sig. gen. Prove local oscillator stopped or faulty.	Aerial to be connected.
17	Weak vision signal.	Direct in aerial socket.	Tuned by turret tuner (fine) strong.	Weak, grainy or no result shows R.F. stage fault.	Full contrast and sensitivity.
18	Strong A.F.	Grid vertical output valve.	Raised irregular raster of criss-cross lines.	No raising or disturbance of the thin bright horizontal line—vertical output stage faulty.	For use with "no vertical" faults—a thin bright horizontal line.

moderate volume should be obtained and it may be necessary to adjust the tuning of the signal generator very slightly to produce a maximum output. Do not alter the tuning again once this is done until the remainder of the sound tests are completed.

#### Test Point 4.

Connect the signal generator output to the sound I.F. valve grid and chassis. A great increase in sound should be heard and the attenuator can be used to reduce the signal to prevent overloading. Contrast and volume must be kept full on.

#### Test Point 5.

Move back again to the grid of the common I.F. stage with the signal generator tuning untouched but again reduce the input to a very weak amount to give the equivalent sound as before. There may

be some disturbance of the raster now if the input is too high but this is not abnormal.

#### Test Point 6.

This point is often nearly inaccessible as it may be in the turret. It is better to leave this test than to disrupt the wiring or turret coils if this is the case. Sometimes a test terminal is provided on top of the turret. Otherwise connect the chassis clip of the signal generator to chassis and clip the input clip as close to the mixer coil as possible. A metallic contact is not always needed, this is proximity injection and the signal generator may need to be turned down even with this improvised injection.

#### Test Point 7.

Keep the connections as in Test Point 6 and change the tuning of the signal generator to the

sound signal frequency of the channel selected on the TV turret. With a weak input a strong sound output should be received if the local oscillator is working, or at the correct frequency. The fine tuner on the set should now operate. If no output can be obtained then the local oscillator may have ceased and the next test will prove this.  
 Test Point 8.

Tune the signal generator to the sound signal frequency minus the intermediate frequency of the sound; e.g. for channel 1,  $41.5\text{Mc/s}$  and a sound I.F. of  $38.15\text{Mc/s}$   $\therefore 41.5 - 38.15 = 3.35\text{Mc/s}$ . Inject this CW signal into the local oscillator coil by clipping direct on to the winding and at a high strength. If the sound can be tuned in from the signal generator this time, then it proves that the oscillator section of the frequency changer has stopped. The aerial must be connected during this test. If proximity injection is tried and severe sound heterodyning produced, then it indicates that the local oscillator is still operating.  
 Test Point 9.

Insert the signal generator output direct into the aerial socket and tune to the signal sound that the TV channel is set to. With a strong input but a

pin and earth or grid. An output of bars shows that the CRT circuit is sound.  
 Test Point 11.

This test checks the video stage. Reduced A.F. should be used and the limiter (vision) be kept turned off.

Test Point 12.

Switch to the vision centre I.F. frequency on modulated CW and use a strong input. A rolling bar output confirms that the detector is all right. Remember this point is at H.T. above earth.  
 Test Point 13.

This tests the vision I.F. valve. Reduced input must be used here and contrast and sensitivity kept full on. The AGC circuits will otherwise mask the gain variation.  
 Test Point 14.

Reduce the signal generator's output again at this point as a tone breakthrough on the sound is normal with too high an input level. Severe breakthrough can also mean that the generator is off-tune or that the TV rejector may be out of alignment. Do not attempt to adjust the tuned circuits however but continued with the tests. Alignment, if wrong, can be attended to when the fault has been cleared.

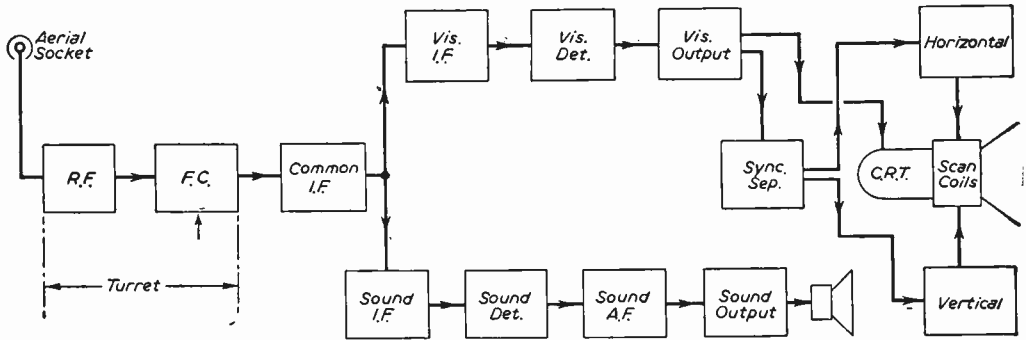

Fig. 2.—Points in TV receivers at which test signals may be injected. (Use this diagram in conjunction with the table of test points.)

weak output sound, tunable now by the fine tuner, a fault is indicated in the R.F. stage—usually the cascode circuit. The weak result is often accompanied by rushing background and grain.

**Vision Sections**

The procedure here is similar to that used in the sound sections. Instead of using the speaker as an indication of output, the video modulation of the screen raster is observed. In complete vision alignments an output meter is used. This is properly the method of stage gain tests and measurement. In our case however, we are interested in a quick run through check to find a stage that has ceased functioning and a visual estimate is sufficient. The vision circuit is easily overloaded and care must be taken to avoid "swamping". Do this by keeping the input as low as possible to give a well contrasted output. The output will appear as horizontal rows of black and white bars across the screen when modulated CW or A.F. is fed in. Usually eight bars appear for 400c/s modulation.  
 Test Point 10.

Inject strong A.F. directly into the tube cathode

Test Point 15.

As with the sound Test Point 6 this point may be inaccessible. With proximity injection an increase in input may be needed to produce an output. Avoid pulling the oscillator circuit about.

Test Point 16.

This test, like the sound equivalent is only needed for suspect failure of the local oscillator. Use strong CW and vary the signal generator output around the signal vision frequency minus the vision I.F.; e.g. for channel 1,  $45\text{Mc/s} - 35\text{Mc/s} = 10\text{Mc/s}$  (assuming a standard I.F. of vision  $35\text{Mc/s}$ ).

It should be mentioned here that normally the TV local oscillator is in nearly all cases above the signal frequency so the same result is possible for both vision and sound with an injected CW of 70Mc/s. This may be tried, but many signal generators do not cover this high range, in which case there is no option but to use the lower, stronger minus frequency. The aerial should be connected for this test. Production of the channel picture and sound, tuned from the signal generator indicates a faulty local oscillator.

(Continued on page 202)

# TELENEWS

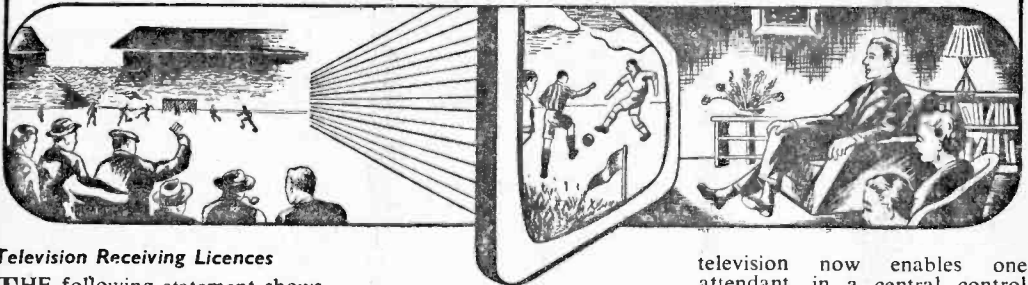

## Television Receiving Licences

THE following statement shows the approximate number of Television Receiving Licences in force at the end of October, 1960, in respect of television receiving stations situated within the various Postal Regions of England, Wales, Scotland and Northern Ireland.

Region	Total
London Postal	1,880,898
Home Counties	1,497,651
Midland	1,681,424
North Eastern	1,773,080
North Western	1,445,616
South Western	620,593
Wales and Border Counties	660,157
<b>Total England and Wales</b>	<b>9,839,419</b>
Scotland	970,081
Northern Ireland	153,367
<b>Grand Total</b>	<b>10,962,867</b>

## Television Appointments

MR. N. T. ATKINSON, formerly head of Ekco Television Development, has been appointed to the post of Chief of Television and Radio Development. Mr. Atkinson has been concerned with the development of Ekco television receivers since 1938 and in his new position he will be directly responsible to executive director and chief engineer Mr. A. J. Brunker. Mr. E. W. Maynard, formerly in charge of export television development, succeeds Mr. Atkinson as head of Television Development.

## New Canadian TV Stations

THE two 18kW sound transmitters for each of the two new commercial TV stations in Montreal are being supplied by Marconi. One outlet is French, while the English outlet is owned by the Canadian Marconi Company. The order, received through Canadian Marconi Company, is to the value of £200,000.

Both stations' transmitter facilities will be housed in the

same building on top of the picturesque Mount Royal mountain in the heart of Montreal. The vision equipment consists of 4kW BD366 transmitters driving 18kW amplifiers (BD369), and the sound equipment consists of 1kW transmitters (BD317) with 10kW amplifiers (BD360). The transmitters are suitable for colour television.

The new stations are expected to go on the air early in 1961.

## Remote Control by Television

THE man who reads the meters in Britain's newest gasworks at Sunderland no longer has to leave his chair. Closed-circuit

television now enables one attendant, in a central control room at the gasworks, to take all the necessary operational readings from meters, gauges and other instruments situated in different parts of the building.

The system, installed by Pye TVT Limited's Industrial Division, works on 625 lines and has five TV cameras strategically positioned throughout the gasworks to send pictures to an 8½in. screen in the control room. Using a five-way camera switching unit, the attendant can bring to the screen pictures from any one of the cameras. The camera is then directed by remote control on to any instrument which the attendant wishes to read.

Closed-circuit television enables

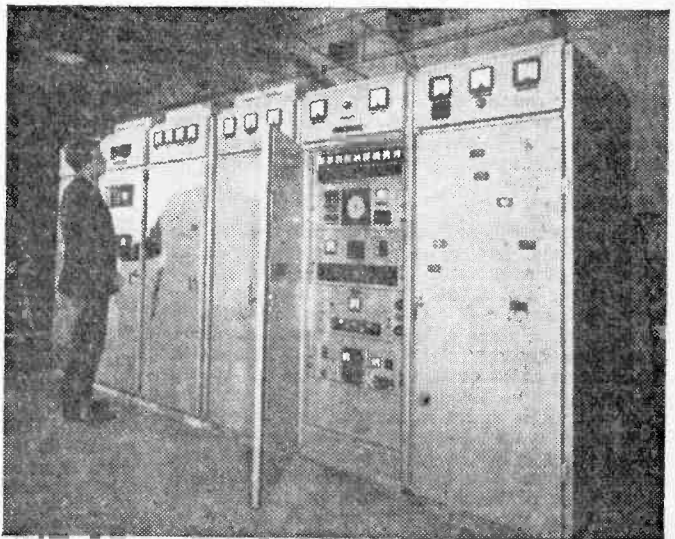

The 18kW vision transmitter being supplied for TV stations, by Marconi.

routine hourly checks on all important instruments to be made in a matter of minutes, and makes it unnecessary for an attendant to patrol the gasworks at regular intervals.

### **British Electronic Component Expansion**

BRITAIN'S radio and electronic component industry, with exports last year exceeding £11 million, and now running at the rate of £1 million a month, aims at increasing this figure considerably when, from May 30th to June 2nd next year, for the first time at Olympia, London, it holds its 17th Radio and Electronic Component Show.

The Component Show has grown too big for Grosvenor House, Park Lane, London, where it has been held for many years, and in its home at Olympia it will be three to four times its previous size.

### **Marconi Underwater TV Helps Fish and Hydraulic Research in Scotland**

RECENTLY ordered by the North of Scotland Hydro-Electric Board, a Marconi-Siebe, Gorman underwater TV camera will be used for research into fish and hydraulic problems on Scottish lochs. Among other things the camera will inspect the huge fish screens which guard the turbine intakes and prevent smolt (young salmon between one and three years old) from being swept into the turbines. The job of inspecting these screens—which also guide the migrating fish into the fish passes and hence to the sea—was previously done by divers.

The camera will also be used to study fish behaviour in the fish passes and to inspect the tunnels linking the dams and power stations. Engineers will therefore be able to report on the condition of the tunnels without dewatering, a costly job in men and materials.

The Hydro-Electric Board have already carried out satisfactory tests with underwater TV equipment, using the camera to inspect fish screens which may be 120ft below the surface. The 14in. monitor supplied with the camera was found to give better pictures than a diver could see in murky water.

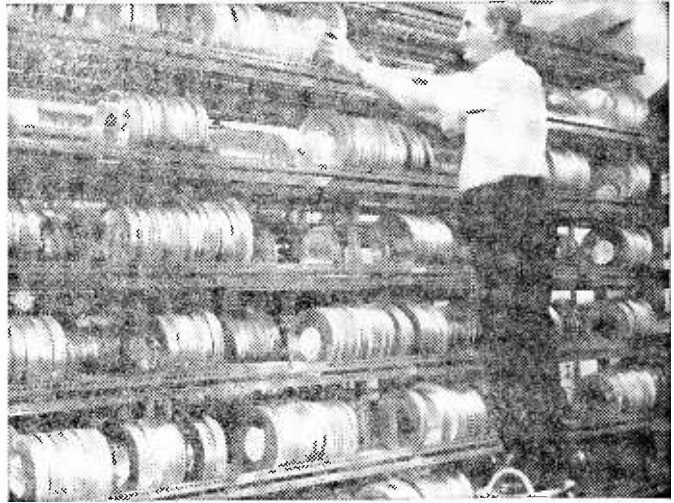

**The new ATV film library, where millions of feet of film are stored on racks made by the Dexion group.**

When in general use the Marconi equipment will be taken from loch to loch all over Scotland for these on-the-spot investigations.

### **BBC Television and V.H.F. Sound Station at Radnorshire**

THE BBC has placed a contract with Ernest Deacon Ltd., Kington, Herefordshire, for the construction of the building for the new television and V.H.F. sound broadcasting station at Llandrindod Wells, Radnorshire.

This is one of several low-power stations which the BBC is building to extend and improve the coverage of its television and VHF sound services.

The Llandrindod Wells station will bring BBC television within reach of some 12,000 people in Central Wales, and it is hoped to complete it during the summer of 1961.

### **Canada Buys British Instrument Landing System**

THROUGH Pye Canada Ltd., Pye Telecommunications Ltd. have received a contract from the Royal Canadian Air Force for the supply of a Pye Instrument Landing System for installation at the R.C.A.F. Airfield, Trenton, Ontario.

Pye I.L.S., incorporating a directional localiser, operate as an internationally specified approach aid at many civil airfields and it

is used by the Royal Air Force. It is the primary guidance element in the pilot-less landing of V-bombers. Over 100 Pye installations are now in use throughout the world. This is the first installation of British I.L.S. on the other side of the Atlantic.

### **TV Cameras for Mexico**

TELEVICENTRO, Mexico's television organisation, has ordered three complete television camera channels from E.M.I. Electronics Ltd. The units, which were delivered immediately the order was finalised, will replace existing United States equipment. They are the first British 4½in. Image Orthicon cameras to be imported into Mexico.

Each channel comprises a camera, control units, power supply unit, picture and waveform monitors, control console and ancillary equipment.

E.M.I. Electronics' television equipment has already been exported to Canada, U.S.A., Norway, Poland, Italy, Switzerland, Hungary, Australia and China.

A mobile demonstration unit has recently toured Europe, showing the company's Image Orthicon camera to leading television organisations. As a result, several further enquiries have already been received.

# Oscilloscope Faults

## IMPROVING THE CIRCUITRY AND ELIMINATING HUM

By W. Cleland

**A** TEST instrument has to be reliable if it is to be of any use for checking, so any internal faults of an oscilloscope have to be cleared up before it is used, and oscilloscopes require to be particularly free from spurious effects. The types of oscilloscope used in servicing TV and radio sets are simple when compared with the advanced instruments that have been developed for research purposes, but it would be unwise to assume that even a simple oscilloscope can be hastily planned and constructed without encountering any snags. The amateur who carries out such a project without making preliminary experiments is likely to find that the completed oscilloscope is almost unusable because of the trace being marred by hum pick-up, cross-talk, astigmatism, unsatisfactory focusing, mains fluctuations, and other effects.

### Mains Transformer

The first thing to be considered is 50c/s magnetic hum from the mains transformer. Some cathode ray tubes are particularly affected. For example a VCR97 without a mu-metal shield is slightly affected by the magnetic field of a mains transformer when situated as much as a yard away. This suggests the building of a separate power supply connected to the oscilloscope by a cable. The main difficulty here is conveying the EHT supply, taking account of insulation requirements and the risk of shock. This can be overcome by the use of a suitable cable and plugs, and this method is used in some large oscilloscopes. It is also possible, of course, to house the EHT unit inside the oscilloscope while keeping the main power supply separate.

Usually, however, it is considered that a separate power supply is too cumbersome, especially in small oscilloscopes, intended to be portable. By careful positioning of the mains transformer, or balancing of the fields of two or more transformers, together with the use of a mu-metal shield on the cathode-ray tube, it is possible to make the oscilloscope compact without having the trace spoiled by the unwanted magnetic deflection.

### 50 c/s Hum

The effect of 50c/s hum when the timebase generator is running at a high frequency may be to thicken the trace, and so can be mistaken for poor focusing or for astigmatism.

When the horizontal deflection is switched off, it should be possible to obtain a small sharply-focused spot. Unwanted magnetic deflection will elongate the spot, but astigmatism can have the same effect along either the X or Y axis. If there is also a slight 50c/s ripple voltage on the plates, this may combine with the magnetic deflection to produce a tiny hysteresis loop, resulting from hysteresis in the laminations of the mains transformer.

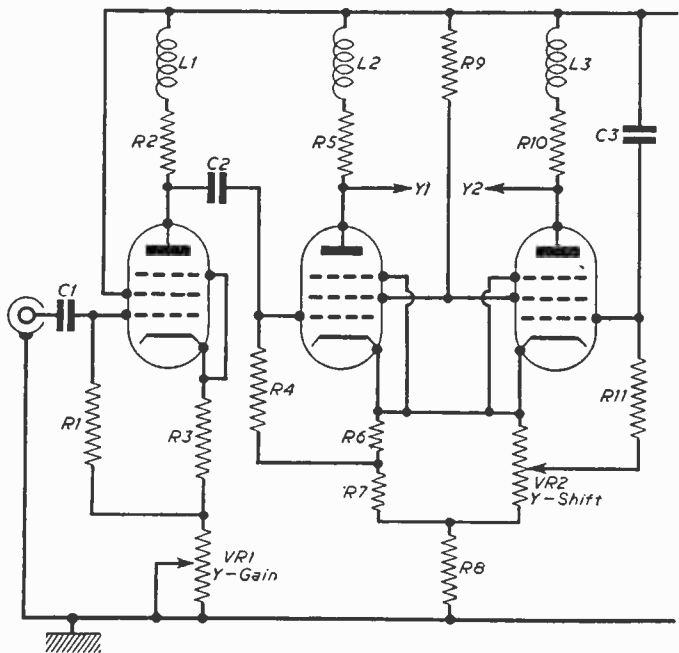

Fig. 1.—The Y-amplifier of a small oscilloscope.

The test for deflection due to magnetic hum is to rotate the cathode ray tube by itself. If the spurious deflection is due to magnetic hum it will remain stationary, while if in reality it is due to ripple on the plates, it will rotate with the tube. If both are present there will, of course, be some change with rotation, and it will be necessary first to eliminate the ripple voltage before the test can give distinct evidence of magnetic deflection.

### Hum Voltages

To a complete beginner, spurious deflections can be a mystery because the deflections may be caused by a number of simultaneous causes, all of

which have to be cleared up before the oscilloscope can be a success. However, with practice and experiment, the sources of the troubles can be tracked down.

The input of any sensitive high impedance apparatus has to be screened to prevent hum pick-up, especially when, as in the case of an oscilloscope, it is connected to the mains. Screening involves increased capacitances and so diminishes the high frequency response, but it can only be avoided by using low resistances, which is not usually practicable. Quite often the gain control in the Y-amplifier alters the cathode feedback on the first valve, so that reducing the gain increases the input impedance. Thus the amplifier remains sensitive to hum even at minimum gain, because the high input impedance means that a correspondingly higher hum voltage can be picked up at the input. A finger placed on the input connection gives full-screen hum deflection. Inputs must therefore be either from low impedance sources or else screened ones, if hum pick-up is not to be troublesome. In addition, leads should not be longer than necessary.

#### "Mains Jump"

Hum can also be introduced inside the amplifier itself. Push-pull or symmetrical deflection assists in cancelling this out, and makes less smoothing necessary in the H.T. supply. If hum arises within the amplifier it may be necessary to increase decoupling arrangements. Decoupling is less effective against "mains jumps". The mains voltage is subject to random fluctuations as the consumer load varies, and the result can be a jumpiness in the trace, which might easily be attributed wrongly to switch contacts or to a faulty potentiometer, although such possibilities cannot be overlooked.

The best way to deal with "mains jumps" is to use symmetrical valve arrangements. In fact, many oscilloscopes use symmetrical arrangements throughout, i.e. two valves in each stage. This is not, however, absolutely necessary. A single valve input stage followed by a symmetrical output stage is satisfactory, providing both coupling capacitors of the output stage are connected towards the H.T. + line, as shown in Fig. 1. This ensures that mains fluctuations, as represented in the H.T. voltage, will affect both valves equally and so will have no effect upon the trace.

Usually the amplification is too small for noise to be troublesome, but in a cathode-follower probe stage preceding the input of an oscilloscope, using a valve that was probably defective in this respect, a considerable amount of noise originated. This differs from other displays in being completely fortuitous, and appears on the screen as a jostling population of spikes with no particular frequency or amplitude.

#### Astigmatism

One feature of hum is that cancellations can occur if it arises from two or three different sources. One source might be an EHT supply of the mains type with insufficient smoothing; another hum pick-up in the amplifier from inadequate decoupling. When one source of hum is removed it may thus be found that hum deflection on the screen is worsened, and it is necessary to deal with all the probable sources of hum at the same time, and to find which have the most effect.

Slight residual hum, thickening a higher frequency trace, could be mistaken for poor focusing, so care should be taken to ensure that a sharp spot can be obtained. If the spot is elongated when hum troubles have been eradicated it will be due to astigmatism, caused by the mean voltages of the plates and final anode being different. The remedy is to adjust the voltage of the final anode relative to the mains voltages of the plates until a perfectly round spot is obtained. The type of shift system used should, if possible, be one which does not vary the mean voltage of the plates, i.e. the

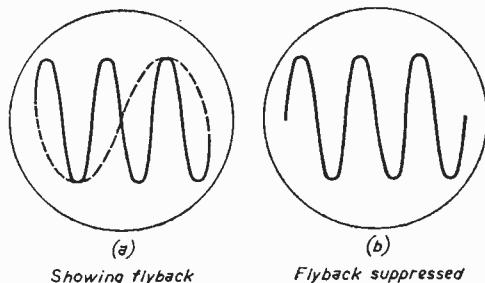

Fig. 2.—Oscilloscope traces with sinusoidal input.

voltage on one plate of the pair in question should rise by the same amount as the other falls.

This is sometimes done by using ganged potentiometers for the shift controls, or if the output stage is of the self-balancing symmetrical type, using two valves with direct coupling to the C.R.T. plates. A single potentiometer, controlling one grid, will give the same result, one anode rising in voltage by the same amount as the other falls.

If the shift controls are to work satisfactorily, the capacitors incorporated must be of good quality. Besides preventing the shift controls from functioning properly, leakage reduces the time constant, and may cause distortion.

A capacitor can be tested by placing it in series with a neon lamp and a 22k limiting resistor across an H.T. supply. The interval between flashes depends upon the difference in voltage between the striking and extinction potentials of the neon lamp, and also upon the capacitance value multiplied by the leakage resistance of the capacitor. A small capacitance can be expected to have a higher leakage resistance, making the interval between flashes about the same as for a larger capacitance of the same working voltage and construction, although the flashes will be weaker. However, we are really concerned with coupling capacitors of, say, 0.25 $\mu$ F. and with good ones, the time between flashes should be counted in minutes rather than seconds.

#### The Amplifier

Parasitic oscillation occasionally gives trouble in oscilloscopes. High frequency oscillation builds up negative bias and can stop itself momentarily until enough of this charge has leaked away via the grid resistance of the valve. The interruption may be at an audio frequency and the bias variation has a saw-tooth waveform. The trouble is overcome by earthing the amplifier circuit to the

Fault	Characteristics	Cure
Effect of transformer field	50c/s deflection, unaffected by rotating C.R.T.	Careful positioning of mains transformer mu-metal shield on C.R.T.
Hum voltages "Cross-talk" R.F. pick-up from E H T unit	50 c/s deflections which rotate with C.R.T. Closed loop on screen High-frequency ripple on trace	Improve smoothing, screening and decoupling
H.F. oscillation	Deflection at interruption frequency	One-point earthing, grid-stoppers short connections
Noise	Random deflections	Replace faulty component
"Mains Jump"	Jumpiness of trace	Symmetrical valve and coupling arrangements
Astigmatism	Spot elongated in X or Y direction	Adjust mean potentials of plates relative to final anode
Poor focusing	At optimum adjustment of focus and brightness small spot or sharp trace still not obtained	Increase smoothing of E H T. Increase E H T voltage. Eradication of spurious deflections
Flyback visible	Return trace superimposed on forward trace	Flyback suppression circuit, or increase of speed of flyback
Leaky capacitors	Shift controls unsatisfactory	Replace with capacitors of high insulation resistance

chassis at one point only, and by including grid stopper resistances of about 100Ω. Long connections or loops in the wiring are also to be avoided.

Cross-talk from the timebase generator to the amplifier produces a closed loop on the screen, since the X and spurious Y deflections are then of the same origin and therefore the same frequency. The steps taken to counteract it are: improved

screening between the Y-amplifier and timebase generator, increased decoupling of the Y-amplifier from the H.T. supply line, and sometimes capacitive balancing of the stray capacitances between the X and Y plates.

If an R.F. EHT supply is used, similar measures may have to be taken to keep the R.F. wave out of the amplifier, and an R.F. filter can be included in the H.T. lead to the EHT unit. Pick-up from the R.F. EHT supply is easily recognised by the presence of a high frequency ripple on the C.R.T. trace. It may also be possible to pick up R.F. on loops in the wiring, and therefore long connections are to be avoided.

#### Focusing

Good focusing depends upon a well-smoothed EHT supply, and this is most easily obtained using an R.F. unit. The grid bias to the cathode ray tube is decoupled to avoid any residual ripple between grid and cathode. Focusing becomes sharper as the EHT voltage is raised, and a brighter trace is obtained, but the sweep voltages required are increased proportionately, so an EHT of 1kV is regarded as suitable in a small portable oscilloscope without post-deflection acceleration, and this enables full-screen deflection to be obtained without making the H.T. voltage required for the output stages unusually high.

In normal applications the horizontal sweep represents a linear time scale of milliseconds or microseconds, and is a saw-tooth voltage provided by the time base generator. The screen pattern is completed by flyback. At low sweep frequencies the portion of the sweep cycle spent in flyback is so small that it is practically invisible, but at high sweep frequencies where it may become as much as a quarter of the sweep cycle, it becomes noticeable, and may be an undesirable or confusing addition to the display (Fig. 2). It is often possible to include a circuit for blanking flyback by driving the C.R.T. grid more negative during flyback, or less negative during the forward trace period. In the latter case, the flyback suppression may affect the brightness of parts of the trace, and it may be preferred to make the use of the flyback suppression circuit optional by including a switch to turn it off or on as required. It is then possible to see quite clearly which part of the trace is flyback and which is not.

## JOIN THE PRACTICAL GROUP

PRACTICAL WIRELESS... .. 1/6  
Every Month

PRACTICAL MECHANICS ... 1/3  
Every Month

PRACTICAL MOTORIST ... 1/6  
Every Month

PRACTICAL HOUSEHOLDER 1/3  
Every Month

Owing to lack of space, the series "Line Oscillators and Sync Circuits" has been held over and will be continued next month.





# KENDAL

**THE ALL NEW  
COMPLETELY REPROCESSED  
PICTURE TUBES**

Real performance with brand new Mullard, Mazda, etc. gun units

Fully rescreened with latest type small particle silver activated screens

ALL tubes are DIRECT plug-in replacements

All tubes aluminiumised for brilliant day-light viewing

Specially selected reprocessed glass envelopes

**FULLY GUARANTEED 12 MONTHS**

EXACT replacements for ALL MULLARD, MAZDA, COSSOR, E.E., GEC, FERRANTI, BRIMAR, EMITRON, EMISCOPE (Incl. hard glass) types:

12" . . . . .£4.15.0	Gladly refunded on 14-15-17" sizes if you return your old tube.
14" . . . . .£5. 9.0 10/-	
15"-17" . . . . .£5.17.6	

C.W.O.-C.O.D. Post & Ins. 7/6 (pass.)

**LEASGILL  
MILNTHORPE  
WESTMORLAND**

## RST

**MAIL ORDER DEPARTMENT**  
211 Streatham Road, Mitcham, Surrey  
**ALL VALVES LISTED ARE NEW STOCK**  
● Terms C.W.O. or C.O.D. Postage 3d. per valve.  
MITCHAM 6201

AZ31 15/6	EF92 5/-	PCF82	UY85 7/6	6K8G 7/6
B65 8/6	EL42 10/-	VF4B 17/6	W81M 5/9	6K8GT 12/6
DAF91 7/6	EL64 7/-	PLC82 9/6	W142 9/-	6L1 15/6
DAF96 9/6	EL90 8/6	PLC83 11/6	W179 7/6	6L6G 7/6
DF91 4/-	EM80 10/-	PENA4 12/6	W727 7/6	6L18 12/6
DH19 7/6	EM81 10/-	PEN4V 17/6	X73 21/-	6L19 21/-
DR91 9/-	EY81 10/6	PEN4VA 221 12/6	X79 21/-	6N7G/GT 7/6
EABC80 7/6	EY84 10/6	Z21 12/6	Z77 4/9	6SL7GT 6/6
EAF4210/-	EY86 9/6	PL36 17/6	Z152 6/6	6SN7GT 5/6
EB91 5/-	EZ35 7/-	PL81 14/9	Z179 7/6	6V6G 5/6
EBC41 9/6	EZ40 7/6	PL82 8/-	Z195 9/-	6X5GT 5/-
EBF80 9/6	EZ41 7/6	PL83 10/6	5U4G 4/6	6X5GT 5/-
EBF89 9/6	EZ80 7/6	PL83 10/6	5V4G 9/6	7S7 10/6
EC91 9/6	EZ81 7/6	PY80 8/-	5Y3GT 8/6	8D3 4/-
ECC33 5/-	FC2 21/-	PY81 7/6	5Z4G 10/-	10LC11 15/-
ECC81 8/-	FC4 17/6	PY82 8/-	6A8GT 10/-	12AH8 10/-
ECC83 9/6	FC13 17/6	PY83 8/6	6AL5 6/-	12AT6 9/-
ECC84 9/6	FC13C 21/-	R10 21/-	6AM6 4/-	12A17 8/-
ECC85 9/6	GZ32 11/6	R19 19/6	6AN5 7/6	12A17 8/-
ECF80 12/6	H30 5/6	TD4 17/6	6AQ5 9/3	12AX7 9/6
ECF82 12/6	H63 9/6	TP22 17/6	6A8G 7/6	12BA6 9/6
ECH4210/-	HBC90 9/6	U142 7/-	6BE6 7/6	12BB6 9/6
ECH81 9/-	HL133D 10/-	U147 7/-	6B6J 7/6	12BH7 15/-
ECL80 9/-	H30 5/6	UABC80 9/6	6BR7 15/-	12J7G/GT 9/6
ECL82 12/6	KT66 17/6	UAF42 9/6	6BW6 8/6	12K7GT 9/6
EF37A 8/6	LZ319 12/6	UBC41 9/6	6BW7 6/6	12K8GT 9/6
EF40 15/-	MKT45 (or 7) 17/6	UBF80 9/6	6BX6 6/-	12Q7 8/6
EF41 9/3	ML4 15/-	UCH42 12/6	6D2 5/-	12Q7GT 12/6
EF42 10/6	MSP4 17/6	UCH81 9/-	6F1 15/6	12K8GT 8/6
EF50(A) 4/-	MU4 9/-	UCL83 9/-	6F12 4/9	12Q7GT 8/6
EF80 6/-	MX30 17/6	UF1 13/6	6F3 17/6	12Q7GT 8/6
EF85 6/6	N142 9/6	UF89 9/-	6G5G 4/6	35Z4GT 8/6
EF86 11/-	N153 11/6	UL41 9/-	6K7 4/6	50L8GT 7/6
EF89 10/-	PCC84 9/6	UL34 9/6	6K7G 3/-	50L8GT 9/-
EF91 4/9	PCF80 10/6	UY41 7/6	6K7GT 10/6	

**SEND FOR LISTS.**

Quotations given for any types not listed. Obsolete and old types a speciality.

# Become a Television expert this easy way

*The Bennett College offers you a complete course*

**Y**ou have to be really in the know to keep up with television these days. And the value of this special new course prepared by The Bennett College is that you are taught *all* the latest methods and techniques. You have the advantage of studying this profitable and fascinating medium in the quiet of your own home. And personal tuition by The Bennett College makes all the difference.

The Bennett College offers you a course that's non-mathematical and particularly easy to follow. It contains clear diagrams which cover everything you want to know from beginning to end (and

even includes the basic principles of sound radio if you wish).

The complete home-study course covers *everything*: Production of the signal, scanning and reproduction of picture from signals. Aerials, types and purpose. The cathode-ray tube. Time-base oscillators, and output circuits. Synchronisation. Video frequency amplifiers. The TV tuner, turret incremental, etc. Television test gear. Television faults.

For more details, please fill in the coupon below. Your studies cost very little and the book you need is included in the cost.

**To THE BENNETT COLLEGE**  
(Dept. A55 NTV, Sheffield)

*Please send me details of the new  
TELEVISION SERVICING  
COURSE*

NAME.....	
ADDRESS.....	
	AGE.....

# EHT Generation

By G. K. Fairfield

## No. 2—THE USE OF TRANSISTORS

**L**AST month the use of thermionic valve circuits for EHT production was described. Transistors may also be used for this purpose and possess a number of advantages that valves lack; such as, high efficiency of conversion and their ability to operate from a much lower value of supply voltage. For this latter reason they lend themselves to incorporation in EHT supply units for portable use.

### Efficiency of Conversion

The improved efficiency of conversion from a low voltage to the several thousands of volts that are required for cathode ray tube work arises from the fact that a transistor acts as an extremely effec-

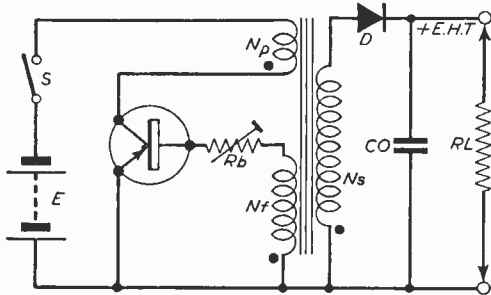

Fig. 1.—A ringing-choke circuit.

tive switch. A thermionic valve when passing its maximum permissible current has a minimum anode voltage of about 50 or so. The transistor, on the other hand, has a minimum potential in the current saturating condition of the order of millivolts. Consequently the ratio of its "on" to "off" voltage can be very much greater than the valve and very low power dissipation occurs in the "on" or conducting condition.

To use the transistor as a switch in EHT supply circuits two methods are possible. The first of these is very similar to the "ringing-choke" method described previously and is capable of providing a large value of EHT at high conversion efficiency.

The second method uses a pair of transistors acting as an inductive multivibrator and is used where rather larger amounts of output power are needed together with extremely good regulation.

### Ringing-Choke Circuit

A typical self-oscillating circuit is shown in Fig. 1. The transistor has one winding,  $N_p$ , of a transformer included in its collector circuit and a feedback winding,  $N_f$ , connected in the base circuit such that an increase in a collector current results in increased base drive.

The switch (S) is made and the transistor begins to draw current. A rising current flows through the primary winding  $N_p$  whilst a constant current flows to the base of the transistor because of the feedback action from  $N_p$  to  $N_f$ . This continues as long as the collector current is smaller than the product of transistor current gain ( $\beta$ ) times the base current flowing.

As soon as the collector current exceeds this value, the voltage across the transformer windings reverses and a state of resonance occurs, i.e. ringing of the transformer with its stray capacity takes place.

The energy stored in the primary is then transferred to the EHT secondary winding and the rectifier D conducts to allow  $C_o$  to charge up to a high value. As soon as  $C_o$  is fully charged then the diode is cut-off as the transistor conducts once more. The action is similar to that of the blocking oscillator used in a television timebase, the frequency of oscillation being governed by the transformer primary inductance.

By controlling the amount of base current with the resistance value of  $R_b$  then the amount of oscillatory power transferred to the storage

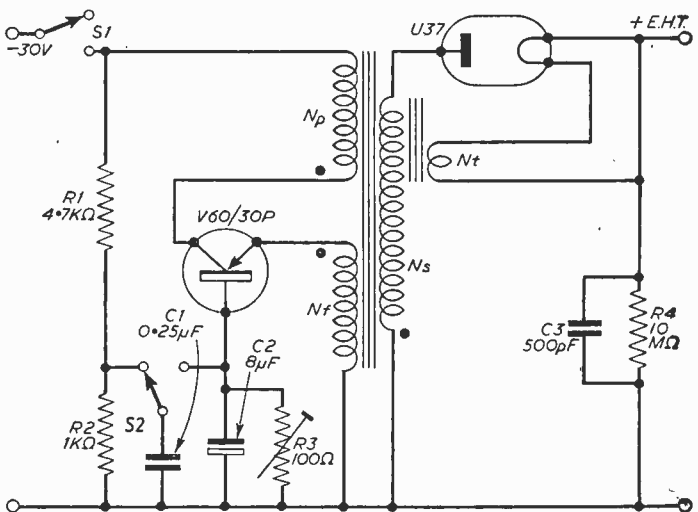

Fig. 2a.—A circuit capable of providing 5kV.

capacitor  $C_o$  can be adjusted. The value of EHT generated depends on the H.T. supply voltage  $E$  and the transformer ratio  $N_s/N_p$ .

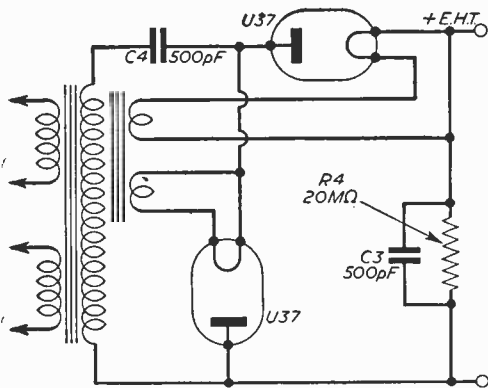
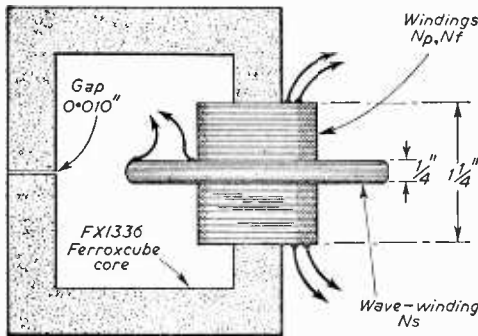

Fig. 2b (above).—This voltage-doubling rectifier circuit gives 10kV.

Fig. 3 (below).—The transformer for the ringing-choke circuit (Fig. 2a).



**Practical Circuit**

A circuit capable of providing 5kV of EHT at output currents up to 2mA is shown in Fig. 2a. If a voltage doubling rectifier circuit is used then 10kV may be obtained at a load current of 1mA as shown by the alternative connections of Fig. 2b. The input voltage is only 30V so that this arrangement can be made very suitable for a portable EHT unit.

One feature not present with thermionic valve circuits is the difficulty of initiating oscillations upon switch-on. As the transistor contains no slow-heating filament then very little initial current variations are present to start the circuit into a state of oscillation. Consequently a starting circuit is necessary to provide the initial transient and in Fig. 2a this is obtained by charging capacitor C1 to about 1V with switch S2 in position shown and to discharge this capacitance via the base circuit of the transistor when S2 is thrown in the opposite direction. S2 thus acts as a "starting" switch and

may be ganged to the supply switch such that the action of switching on the oscillator will be to make S1 a fraction of a second before S2 when oscillation will commence.

The efficiency of this circuit is fairly high, of the order of 60 per cent to 70 per cent, and since the oscillation frequency will be about 10kc/s then a small value of smoothing capacitance is required for C3.

The transistor used is a V60/30P and is capable of withstanding a peak collector voltage of 60V. This is necessary since the voltage across the collector winding of the transformer reverses when the transistor is switched off and the peak collector voltage rises to almost double the supply voltage. Care must be taken always to connect a load resistance across the output terminals to absorb the supply current. If this is not done then the voltage across the collector-base terminals of the transistor may rise above the permitted maximum value (60V) of the transistor and it will be damaged. A fixed resistor of 10M or 20M (for 5kV and 10kV respectively) may be connected across C3 for this purpose.

A diagram of the transformer is shown in Fig. 3. The core consists of two Mullard ferrite U-core type FX1336 with a gap of 0.01in. paper in each limb of the core.

**WINDING DATA FOR FIG. 3**

Winding	No. of turns and wire gauge
Np	35 turns of 0.040 enamelled copper wire.
Nf	7 turns of 0.0124 enamelled copper wire.
Interleave two turns of 0.002in. polythene tape between windings Np and Nf and over Nf.	
Ns	4,900 turns of 0.0048 enamelled and single-silk copper wire.
Wavewound gears (Douglas wavewinding machine).	
A	44
B	29
C	32
D	48
E	60
F	80

By the addition of a further winding on the transformer core it is possible to control the regulation of the EHT supply so that the output voltage remains constant as the load current alters.

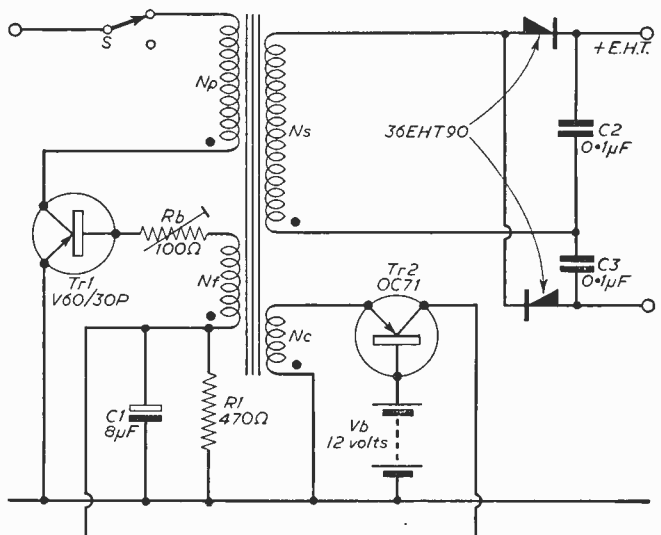

Fig. 4a.—This shows a circuit of a stabilised EHT source.

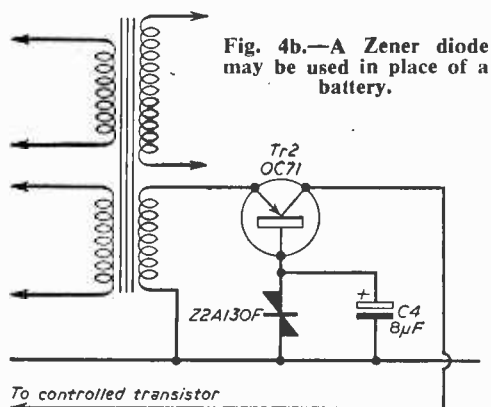

Fig. 4b.—A Zener diode may be used in place of a battery.

Referring to Fig. 4a, a second transistor Tr2 is added with its emitter connected to the fourth winding Nc. A battery Vb is connected between base and ground as shown.

The collector current of the transistor is applied to Tr1 as a controlling bias and is proportional to the difference between the fixed voltage Vb and the peak voltage developed across Nc. As more current is drawn from the EHT output terminals, so the output voltage tends to fall and hence the voltage Vc.

This causes Tr2 to pass more collector current, which in turn allows Tr1 to conduct further during its conducting half cycle. This additional current through the transformer primary, Np, is transferred to the EHT winding and compensated for the increased current drawn by the load. Similarly if the load current falls then Tr2 conducts less and a smaller current is supplied to the EHT load by Tr1.

The battery Vb may be replaced by a voltage reference or Zener diode chosen for the operating voltage required as shown in Fig. 4b.

The effect of improvement in regulation is shown in Fig. 5 which shows the variation in supply voltage as the load current is varied.

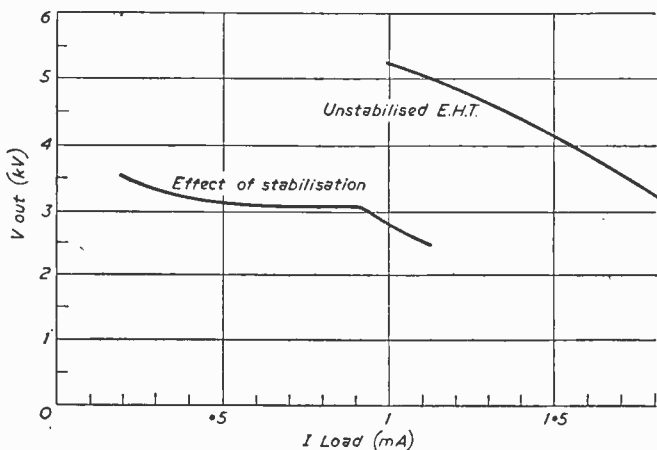

Fig. 5 (above).—The regulation curves for the stabilised EHT circuit.

**Inductive Multivibrator**

The second form of EHT converter is shown in Fig. 6. This requires two transistors connected to individual feedback windings such that the turning off of one transistor will initiate the turning on of the second and vice-versa, thus constituting a multivibrator action. This may be explained as follows:—

Referring to Fig. 6, let transistor Tr1 be conducting and Tr2 non-conducting. The primary current through winding P1 will rise linearly and a constant voltage induced in the feedback windings F1 and F2. The polarities of these induced voltages will be such as to maintain conduction of sequences Tr1, while keeping Tr2 cut-off.

Eventually so much current will be flowing in P1 that the transformer core will begin to saturate. When this occurs the inductance of its windings will fall and the primary current will increase rapidly. When this reaches a value of  $\beta$  times the base current then the feedback voltage will begin to fall. The fall in collector current, which then occurs, will result in reversal of the polarity of the feedback voltage and Tr1 will be rapidly cut off whilst Tr2 is turned on.

A square wave is developed across the primary windings which can be increased by transformer action for subsequent rectification and use as EHT supply voltage.

If the secondary (EHT) winding Ns has a fixed load across it then a constant load current will be imposed on the rising inductive load.

(To be continued)

Fig. 6 (below).—An inductance multivibrator circuit.

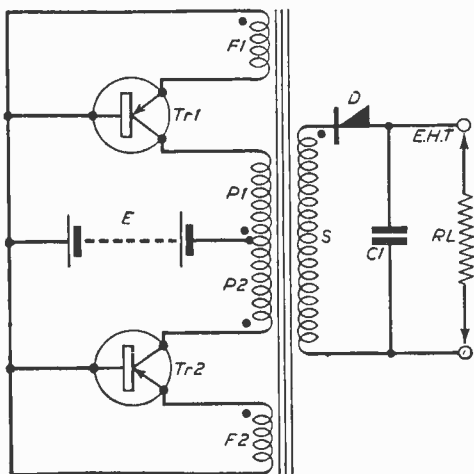

# How to make AERIAL ATTENUATORS

"T", " $\pi$ " AND SPLITTER CIRCUITS

By N. Mears

IT frequently happens that the aerial signal, if fed direct to the input terminals of a television receiver, overloads the R.F. frequency changer or the I.F. valves, or produces too much "drive" at the cathode ray tube. With more modern receivers effective automatic gain control is usually provided and the problem is not so severe. However, there are many occasions when too much aerial signal is not a good thing, and this is especially true when—for the purpose of cutting out "ghosts" or reducing interference—a high-gain aerial has to be used well within the service area of a transmitter. It will be realised that if an aerial is picking up interfering signals from a direction, not that of the transmitter, an improvement will be obtained by greater directivity, but this may well reduce the interference and increase the signal, even to the point of annoyance!

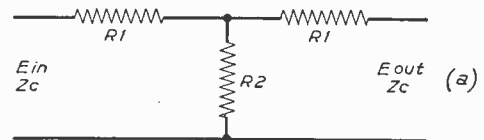

Fig. 1a (above).—T-section attenuator.

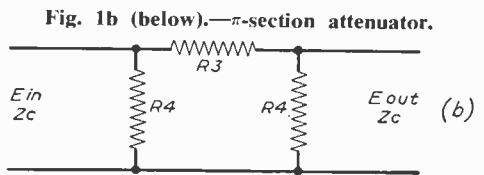

Fig. 1b (below).— $\pi$ -section attenuator.

## Interference Problem

The problem then simplifies itself to that of reducing the voltage available at the receiver input and with it a much reduced interference signal. To do this effectively, however, certain conditions must be fulfilled.

## Unwanted Effects

First, serious mis-match must not be introduced between feeder and input terminals, because not only will this reduce the amount of power transferred from the aerial to the input circuits (the object of the exercise) but will cause more than one unwanted effect.

The first of these is an increase in noise level. Nowadays the need is fully recognised, in designing a television receiver, to arrange for the input matching to be for minimum noise rather than for maximum signal. This is especially the case where Band III is concerned, and when Bands IV and V come into use the requirement will be equally exacting, if not more so.

The second undesirable effect is that of loss of resolution. A simple qualitative analysis will show how this may occur. If the mis-match between feeder and input exceeds a certain quantity, an appreciable amount of energy will be reflected back from the input terminals and will travel back to the aerial. If the aerial is accurately matched to the feeder, this will be absorbed and nobody

Left.—This clearly shows the simplicity of an attenuator.

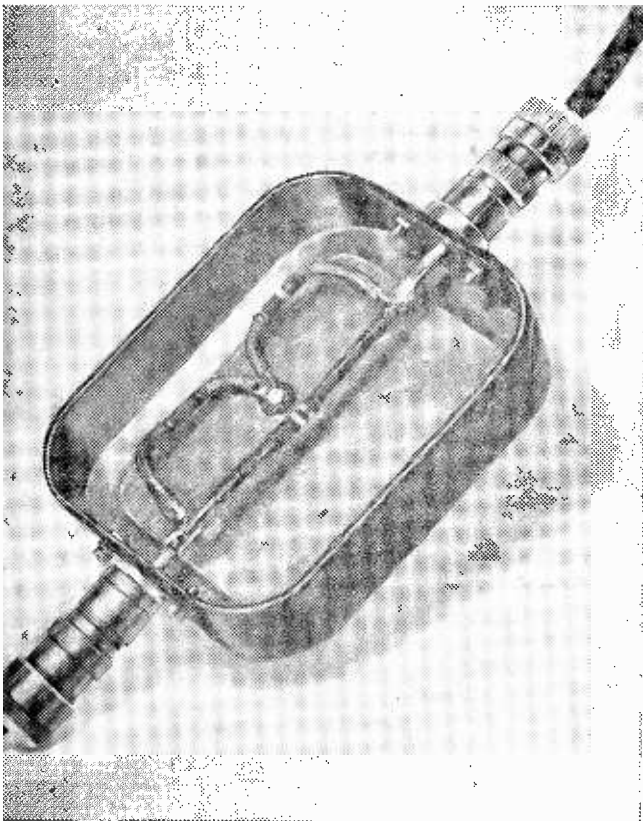

will be the worse—except perhaps a neighbour who receives a delayed signal as well as the desired one and whose picture may thus conceivably be impaired. Of course this is unlikely to be serious unless perhaps his aerial is only a few feet away from the radiating one.

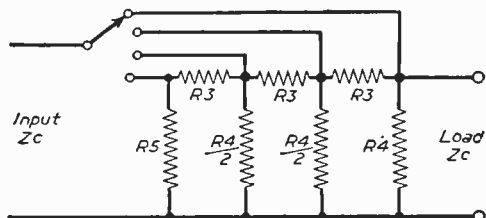

Fig. 2.— $\pi$ -section ladder attenuator.

The more likely case is the effect on the reader's receiver. If the match between feeder and aerial is exact, no reflection takes place at the aerial. This condition is seldom achieved except where a plain dipole is used. Where directors and reflectors are involved there is usually some mis-match in commercial practice. This will involve a further partial reflection, and the re-reflected signal will travel again down the coaxial cable and arrive at the input terminals once more. Further reflection at this point and at the aerial can be neglected because by now the reflected signal will be much weakened.

The total length of coaxial cable so far traversed by the signal may now be 180ft. Although normally by now it will be much weaker than the signal which has not suffered reflection at all, if severe mis-match occurs it may produce a visible signal on the tube face. If it does, it will be delayed about  $\frac{1}{3}$   $\mu$ sec and resolution of the 2.5Mc/s and 3Mc/s bars in Test Card C will be impaired, perhaps lost altogether.

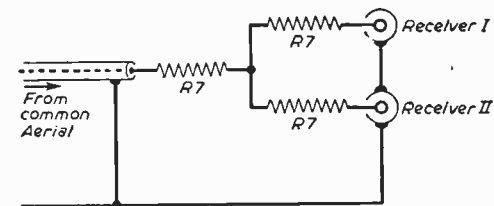

Fig. 3.—"Splitter" circuit for an aerial common to two receivers.

A further effect will be that of changing the damping imposed by the aerial on the input circuits. In correct design, the natural damping caused by the total input resistance of the R.F. valve and its circuits, is just about doubled. Where mis-match occurs the damping will be increased or decreased. If the former, noise will increase; if the latter, phase distortion, or reduction of bandwidth, or both, will occur.

**"T" and " $\pi$ " Type Attenuator.**

Any attenuator placed between aerial and input must therefore introduce the minimum amount of mis-match, and this feature has to be kept constantly in mind in design. The most usual feeder is the coaxial, of 80 $\Omega$  nominal impedance, and this is an "unbalanced" structure. The choice is between "T" type and " $\pi$ " type attenuators, as shown in Fig. 1.

**T and  $\pi$  Section Constant Impedance Attenuator**

Tables 1 and 2 give design data for values from 1dB to 10dB of voltage attenuation. Both T and  $\pi$  sections are included, but it must be remembered that this is for 80 $\Omega$  nominal impedance only. For other values of feeder characteristic impedance, Zc, the resistor values must be multiplied by Zc/80.

It will be observed that only seldom do the resistors approximate closely to "preferred values". While this would be important from a manufacturing point of view, and would restrict the range of attenuators available, it matters little to the home constructor who can select, from his stock, values within 10 per cent or so of those listed.

It is unwise to attempt to obtain more than about 10dB attenuation in one attenuator. This is because of the inevitable capacitances and inductances associated with practical components,

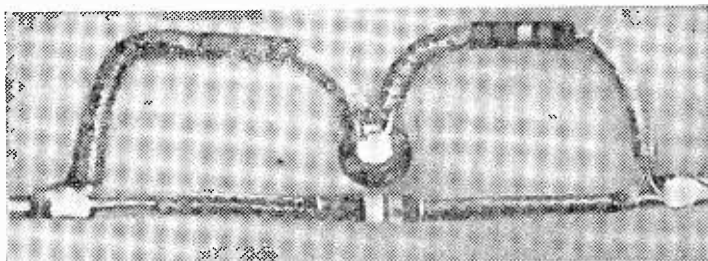

The layout of components for a  $\pi$ -section attenuator.

which introduce unwanted coupling between input and output. Instead, where attenuation in excess of 10dB is required several sections can be cascaded.

**Constructing an Attenuator**

In constructing an attenuator, the output should be separated as far as possible from the input. At the same time, the smallest possible physical size of resistor should be used, because although it brings the output terminals nearer to the input terminals, capacitances and inductances will nevertheless be reduced. If the attenuator is to be a permanent fixture it is also best to avoid the use of coaxial sockets and plugs; these have appreciable capacitance and are often badly matched to the cable. However, where only a temporary component is needed (as in experimental work), they can be used as long as care is exercised.

An actual case is considered. It is desired to reduce the amplitude of a signal by a factor of  $\frac{1}{2}$ , or 6dB. The characteristic impedance of the low-loss cable to be used is 75 $\Omega$ . A short calculation shows that, for a T-section, R1 is 25 $\Omega$  and R2, 100 $\Omega$ . Both these types are readily obtainable—preferred values are 27 $\Omega$  and 100 $\Omega$  which are near

TABLE 1.—T-section.  
(Resistors as in Fig. 1(a).)

	Decibels Attenuation									
	1	2	3	4	5	6	7	8	9	10
R1( $\Omega$ )	4.6	9.2	13.7	18	22.4	26.6	30.5	34.5	38	41.5
R2( $\Omega$ )	690	345	226	168	131	107	90	75	65	56.2

TABLE 2.— $\pi$ -section.  
(Resistors as in Fig. 1(b).)

	Decibels Attenuation									
	1	2	3	4	5	6	7	8	9	10
R3( $\Omega$ )	9.3	18.5	28.2	38	48.7	60	71.5	85	98.5	114
R4( $\Omega$ )	1390	700	467	365	285	242	210	185	169	154

enough. Had a  $\pi$ -section been chosen, R3 would be  $56\Omega$  and R4,  $225\Omega$ —again, close to preferred values of resistor. Here the choice may be made according to what resistors are in stock.

A further practical case, using  $80\Omega$  cable, may be taken. Suppose an attenuation of 10dB is required, accurately; the choice is between a T-section with resistors of  $41.5\Omega$  and  $56.2\Omega$  and a  $\pi$ -section with resistors 114 and  $154\Omega$ . Here the former would be chosen, because it would be easier to select from stock (preferred values  $39\Omega$  and  $56\Omega$  as compared with  $120\Omega$  and  $150\Omega$ ).

#### Multiple Section Attenuators

Sometimes it is desired to arrange a variable attenuator, operated by a switch. The "ladder" attenuator results from cascading a number of T or  $\pi$  sections, as shown in Fig. 2. However, this simple type is characterised by considerable variation of input impedance, as will be seen from the diagram. The output impedance also varies, but to a lesser degree.

The resistance values correspond to those in Table 2, R5 being given by  $R4 \cdot Z_c/R4 + Z_c$ .

An improvement in the constant value of impedance is obtained by inserting a resistor of value  $Z_c/2$  in series with the switch.

#### An Attenuator for two or more Receivers

Another use of a resistor network exists where several receivers have to be connected to the same aerial. A moment's consideration will indicate that if two receiver inputs are paralleled, the impedance presented to the feeder cable is half that of either. If three receivers, the effective load on a feeder of characteristic impedance  $Z_c$  is  $Z_c/3$ . This will cause serious mis-match and can prevent receivers operating correctly. All that is required to overcome the difficulty is to equalise impedance, by means of series resistors, as shown in Fig. 3.

The calculation of R7 is as follows. Assuming all characteristic and input impedances are  $Z_c$ , the impedance at either receiver input, with the aerial feeder disconnected, is  $R7 + R7 + Z_c$ .

The aerial feeder will see an impedance, for  $n$  receivers, of  $R7 + (R7 + Z_c)/n$  and for correct matching this is equal to  $Z_c$ .

$$\text{Thus } nR7 + R7 + Z_c = n \cdot Z_c$$

$$\therefore R7 = \frac{Z_c (n-1)}{n+1}$$

Thus, for two receivers with  $Z_c$  equal to  $80\Omega$ , the resistors R7 must be  $27\Omega$  which is a preferred value in the  $\pm 10$  per cent range of resistors.

The signal present at each receiver is however reduced by half, and so this type of splitting is only really possible when plenty of signal is available. If several receivers have to be fed from a common aerial in a fringe area it will be preferable to use a pre-amplifier or a much better aerial, or both.

## FAULT-FINDING WITH A SIGNAL GENERATOR

(Continued from page 189)

### Test Point 17.

The input of strong signal frequency modulated CW with a weak grainy output proves a faulty R.F. stage.

### Test Point 18.

This odd test does not come into the other categories but is used to test the vertical output valve circuit. The A.F. sine wave is injected direct on the grid, and if this valve and section is functioning, the faulty condition of a single brilliant horizontal line across the screen is raised into a wobbling raster of criss-cross lines. If the vertical circuit is driven, then the fault is in the vertical oscillator. But if it is a multivibrator then fault in the coupling or other section is indicated.

Check the accuracy of your signal generator by beating it against a known radio station on each range and at both ends of that range.

Once the defective stage is located ordinary component, voltage and valve checks are used to pinpoint the trouble. Band III signals can be obtained from a signal generator that does not rise to that frequency by setting it to one quarter of the Band III frequency and the fourth harmonic, although weak, is useful for R.F. section tests. As can be seen, pattern generators are not essential for many TV tests and the humble radio signal generator can fulfil many of their functions.



# Servicing Television Receivers

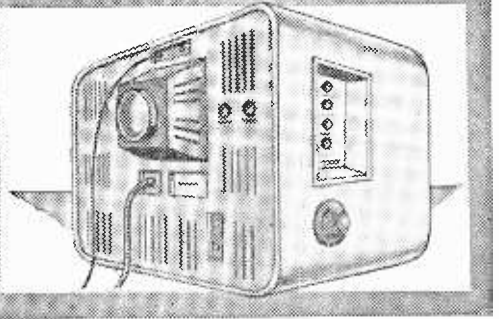

No. 63—THE DEFIANT TR1456T AND TR1756T SERIES

By L. Lawry-Johns

**Lack of Width**

A LOW emission contact cooled rectifier will cause lack of width and compression of the lower part of the picture when its internal resistance rises, causing a large voltage drop across it, thus leaving the H.T. line low. A voltmeter check from the H.T. fuse to chassis will show whether the rectifier is at fault or not. If the H.T. falls much below 200V the rectifier should be changed. If the H.T. is about 200V or more, check the 20P4 line output valve and check the setting of the line drive control TC1. Adjustment of TC1 should produce a kink or white line down the screen centre when compressed (tightened). If the H.T. is in order and the time base valves are proved efficient but lack of width persists, despite adjustment of TC1, check C90 and C91, either of which can become leaky.

The correct setting for TC1 is to tighten until a white line or kink appears and then slacken off until this kink just vanishes. It should not be slackened beyond this point.

The screen feed resistor of V12, R99, should not escape attention when lack of width is being investigated.

**Variation of Picture Size**

If the picture expands and defocuses, finally failing altogether when the brilliance or contrast is advanced, when a bright scene is transmitted or when changing from a weak signal to a strong one (e.g., ITV to BBC in some areas), suspect a low emission U25 EHT rectifier. Should the reverse be the case, as far as the width is concerned, that is, a brighter screen causes the picture to contract from the sides, check the line time base valves and components as for lack of width.

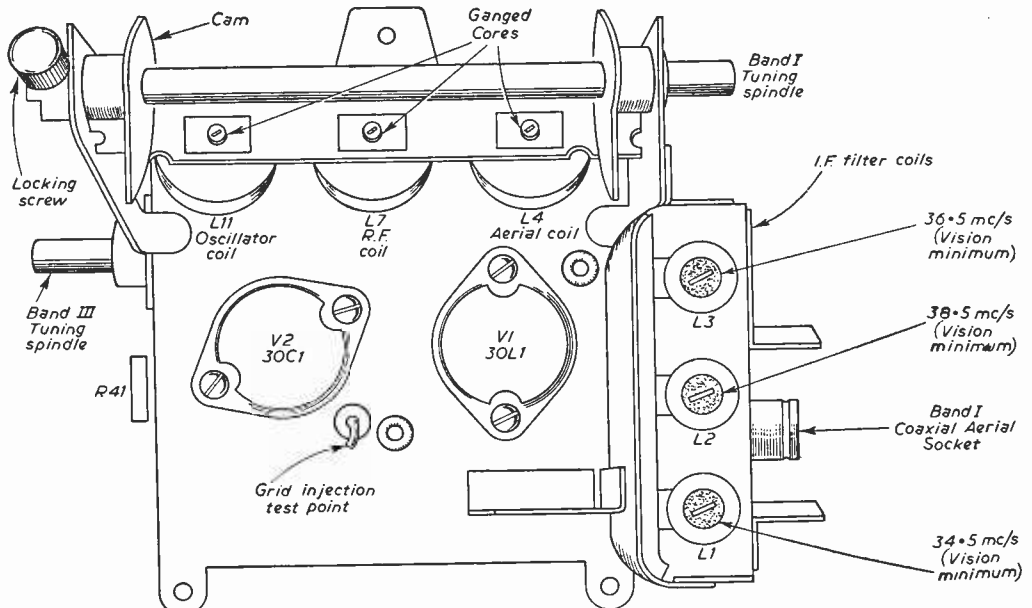

Fig. 5.—The top view of the tuner unit.

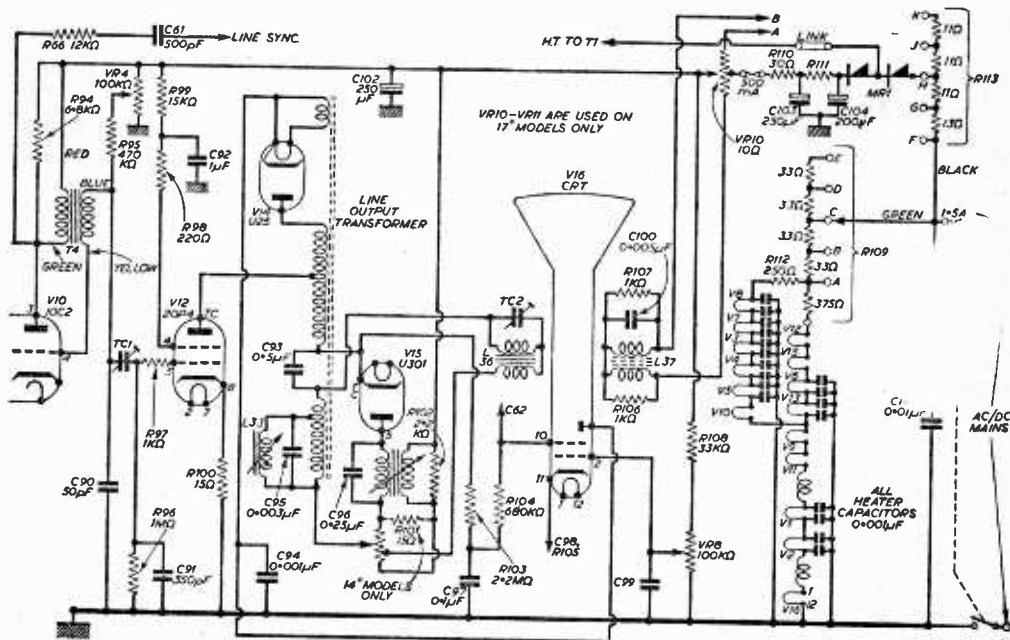

Fig. 6.—Line oscillator, tube and power circuits. (Note: The link from MR1 is not normally joined but the H.T. is derived from the junction of R110 and R111—this point is joined to "L" of the link.)

When advancement of the no raster at all but the unaffected, carry out the usual spark test at the U25. If a healthy spark is available at the anode (single wire end), but the U25 does not glow (heater) and the normal spark is absent at the double wire end, in all probability the U25 is at fault with an o.c. heater. If the U25 has a blue glow, perhaps a red-hot anode, check C94 .001μF 15kV. If there is no spark at the anode and the time base whistle is absent or subdued, check the 20P4, U301, 10C2 and C93 (0.5μF).

If a fine whistle is still audible when the hold control VR4 is rotated, the 10C2 may be assumed in order, together with T4, etc. In stubborn cases where a fine whistle is audible, the line output transformer may be suspected. If the 20P4 overheats and the valve itself is not at fault, check the 10C2, TC1, C90, C91 and ensure that H.T. is reaching pin 3 of the 10C2. The green-red winding of T4 could be o.c. leaving low H.T. at pin 3 (remember that H.T. will still be applied via R94).

sound continues

Vertical rulings on the left side of the screen may be minimised by adjustment to TC2 on the

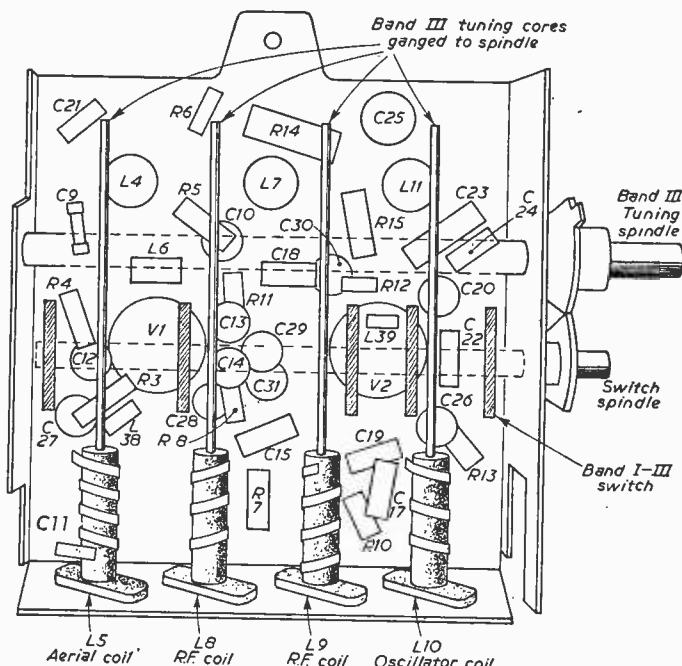
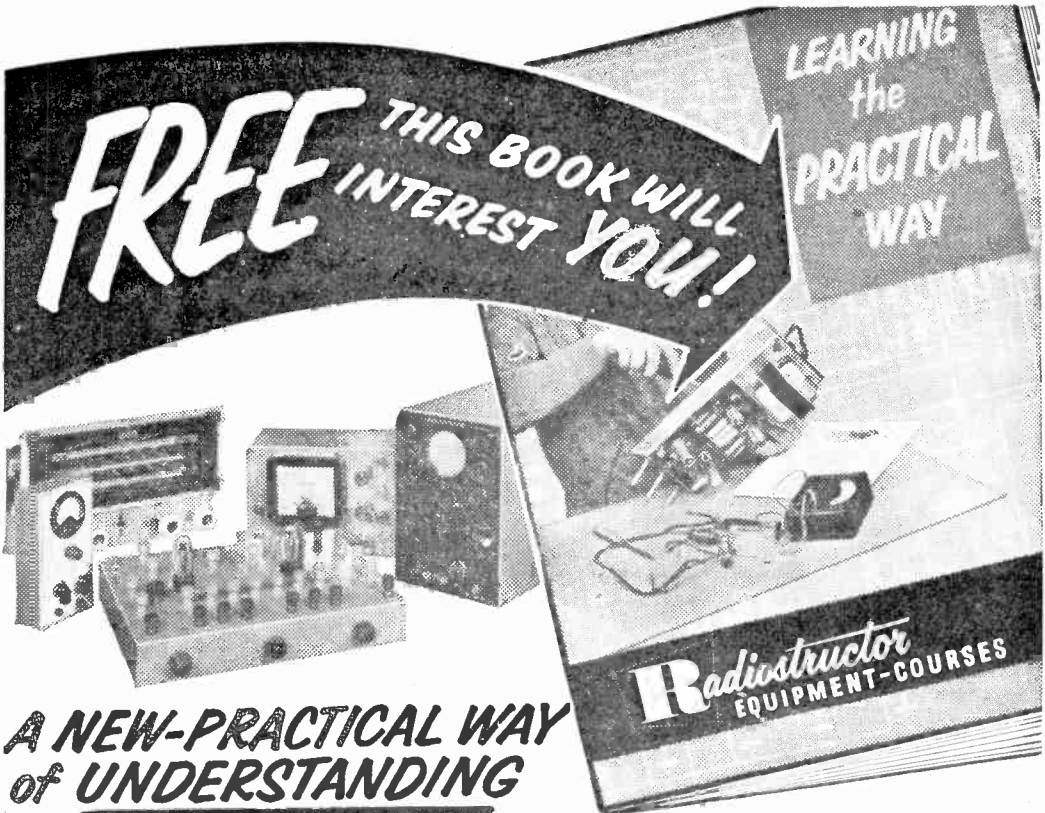

Fig. 7.—Underside view of the tuner.



**A NEW-PRACTICAL WAY  
of UNDERSTANDING**

**Radio • Television • Electronics**

*Including: Transistors; VHF/FM; Hi-Fi equipment; Computers; Servo-mechs; Test Instruments; Photo-electrics; Nucleonics, etc.*

**FOR ...Your Career...Your Own Business...An Absorbing Hobby**

Radiostructor—an organisation specialising in electronic training systems offers a new self-instructional method using specially designed equipment on a "do-it-yourself" basis.

You learn by building actual equipment with the big kits of components which we send you. You advance by simple steps, performing a whole series of interesting and instructive experiments—with no complicated mathematics! Instructional manuals employ the latest techniques for showing the full story of electronics in a practical and interesting way—in fact—you really have fun whilst learning! Post the coupon below, now, for full details—

**RADIOSTRUCTOR**  
**LEADS THE WORLD**  
**IN ELECTRONICS TRAINING**

**POST NOW**

To RADIOSTRUCTOR (Dept. G102)  
READING, BERKS.

Please send brochure, without obligation, to:

★ Name \_\_\_\_\_

Address \_\_\_\_\_

1/61

★ **BLOCK CAPITALS PLEASE**  
(We do not employ representatives)

## EVERYTHING FOR RECORD PLAYERS



### EXTENSION SPEAKERS 19/9

In polished oak cabinet of attractive design. Complete, fitted with 8in. P.M. speaker of the highest quality, flex and switch. Ready for use. Ideal for kitchen or workshop, etc. Ins. & Carr. 3/9. **CONTINENTAL DESIGN EXT. SPEAKER, 19/9.** Ideal for that extra stereophonic speaker. Covered in smart two tone leatherette colour scheme. Contains 8in. P.M. Speaker. Ready for immediate use. P. & P. 3/9.

8in. P.M. at 5/9. Limited quantity of these modern type speakers. They are tested and they have a slight cone fault, that is repaired, not affecting the quality. P. & P. 2/6.

8in. P.M. at 6/9. As above, but with O.P. fitted. P. & P. 2/6. 8in. P.M. at 9/9. Of highest quality, fitted with O.P. Trans. P. & P. 2/6. **ELLIPTICAL SPEAKERS, 15/9.** 8 x 3in. and 7 x 4in. Brand new. Specially made for Record and Tape Recording Cabinets. P. & P. 2/9.

**TV AERIALS, 23/6.** For all I.T.A. channels. For outdoor or loft. 3 elements. Sold at half the normal price. Suitable for channel eleven. Post and packing 2/6. **TV AERIALS, 35/-.** Combined BBC and I.T.A. New. Postage 2/6. **TV AERIALS, 15/9.** B.T.C. indoor type. Folded dipole with 12ft. co-axial cable fitted. Aluminium. P. and P. 1/9.

**HEATER TRANSFORMER, 7/9.** 12V at 1A, 0-200-250V primary. P. & P. 2/9. **OUTPUT TRANSFORMER.** Our Price 1/3. Salvage guaranteed. Standard size. 2-5 ohms matching pentode or tetrode output valve. P. & P. 1/9. 20 for 20/- Packing and Carriage 5/6.

**350-0-350V at 250mA, 7/9.** 6.3V at 4A, 4V at 4A, 4V at 7A, 4V centre tapped at 1A. Primary 200-250V, 50 cycles. P. & P. 3/9.

**MAINS AUTO.** Our Price 5/9. 0-205-225-245V at 300mA. Isolated windings of 6.3V at 2-6A, 6.3V at 3-6A, 2V at 1-4A. Postage 3/9. **I.F. TRANSFORMERS, 1/- per pair.** 465 kc/s. All tested and guaranteed. P. & P. 1/-.

**SOUND/VISION STRIP, 2/9.** "Plessey". I.F.'s 10.5Mc/s sound, 14Mc/s vision, 8 valve holders (6-6F1's and 2-6192's, not included). Size 8 1/2 x 5 x 4 1/2in. Circuit incl. P. & P. 2/6

**SOUND/VISION STRIP, 1/-.** Not tested. Complete sound and vision strip, 8 valve holders (6F1's, etc., not included). I.F.'s 16-19.5Mc/s. Size 8 1/2 x 4 1/2 x 4 1/2in. Drawings FREE with order. P. & P. 2/6.

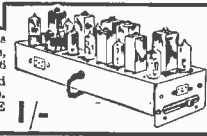

### NEW LOOK AMPLIFIER

59/6

Ideal for stereo attachment, well styled cabinet in Brown/Ivory with carrying handle.

Contains 8in. high flux speaker. For use A.C. or D.C. mains. 3 valves 10P1, 10P14, and U404. Max. O.P. 4.5 watts. Size 14 x 11 x 6 1/2ins. Wonderful for HOME, HALL, AMATEUR THEATRICALS. 2 units can give a world of amusement and special stereo effects. Ideal for works, and offices as Loud Hailer, for Election Speaker and Public Address. Ready for immediate use. 12 months' guarantee. P. & P. 5/9. EXTRAS: Mike 27/6. Record Changer, £7/19/6. Extra Loudspeaker in Continental Cabinet, 19/9. P. & P. Extra.

**PORTABLE AMPLIFIER Mk.D.I. 59/6.** Brand new. Latest design. Famous manufacturer. Size 7 x 2 1/2 x 5in. A.C. only. 4W output incorporating ECL82 push gain valve. Volume and tone controls. Knobs 2/6 extra. P. & P. and Ins. 3/6. **TAPE AMPLIFIER, £7/19/6.** 3 valve amplifier. Output 3.5W. Valves ECC83, ECL82, EL84, 6M54, 6Z80. Input for Microphone, Radio and Gram. Controls—Record Playback, volume, tone and OFF/ON. size 8 1/2 x 3 x 4 1/2in. Ins. and Carr. 4/6.

**NEW LOOK JNR. AMPLIFIER, 49/6.** For use with A.C. or D.C. mains 3 valves 10P1, 10P14, and U404. Max O.P. 4.5W. size 7 x 5 x 4in. Ready for immediate use. Salvage guaranteed. P. & P. 3/6.

**COLLARO 4-SPEED AUTOCHANGER, £7/19/6.** Incorporating auto and manual controls. Complete with dual turn over type studio crystal pick-up and sapphire stylus. Four speed. A.C. mains. 200-250V. Pack. & Ins. 5/6.

**VOLUME/TONE CONTROLS, 2/6 per doz.** Assorted volume and tone controls, stripped from working chassis. P. & P. 2/-. **FRAME OUTPUT TRANSFORMER, 1/9.** To match our low impedance scanning coils. P. & P. 1/6.

**SCANNING COILS—ALL 2/9 each.** Wide angle 90°, 38 m.m. Low imp. Postage 1/3. Also Brand New 38 m.m. Low imp. Postage 1/3. And Low imp. 35 m.m. Post and Packing 1/6.

**GANO CONDENSERS, 1/9.** Salvage guaranteed. Standard size two gang 0.0013 (300pF). Also standard size two and three gang 0.0005 (500pF). All tested and guaranteed. P. & P. 1/3.

**RECTIFIERS, 2/9.** 250V, 100mA. Half wave. Salvage guaranteed. Why hunt for those obsolete rectifier valves when you can cheaply replace with a modern selenium rectifier. P. & P. 1/3

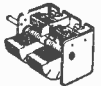

REMEMBER

**COMPONENTS LTD.**

of 219 ILFORD LANE, ILFORD, ESSEX

# YOUR C.R.T. completely FACTORY REBUILT

*New heater and Cathode assembly*

12 months' Guarantee

COMPARE OUR PRICES

★ 12 in. **£3.0.0** ★ 14 in. **£3.10.0**  
(Money back if not completely satisfied)

★ 17 in. **£4.0.0** ★ 21 in. **£5.0.0**

*Carriage and Insurance add 12/6*

PASSENGER TRAIN DISPATCH FOR SPEED

All Mullard and Mazda Types Rebuilt—Fast Service  
Send your Tube now — Terms C.W.O. or Pro-forma Invoice

**KING'S TELE SERVICE CO.**

101-111, DAWES ROAD :: FULHAM, S.W.6

scanning coils panel, but when these are severe R102 (2.2k) on the lower right side of the line output transformer should be checked. This will also affect the linearity of the line scan.

**Low and Distorted Sound**

If the sound tends to distort more as the contrast is advanced or on a strong signal, suspect R85, which will normally be found to have risen in value. Also check R91 if the volume is very low. If these items are not at fault, check V7, V8 and V9 and the voltage supplies to each. The circuit of V7 is very similar to that shown for V8. Voltages at pins 2 and 4 of these bases should fall between 175-200V, with a cathode voltage of about 2-3V. Check C81.

**No Sound at all**

This means that there is no response from the speaker and no trace of hum. If V9 is in order, check for voltage at pin 6. If absent check blue lead connection (H.T.). The same remarks apply for T1 as for T3, the resistance reading being about 500Ω.

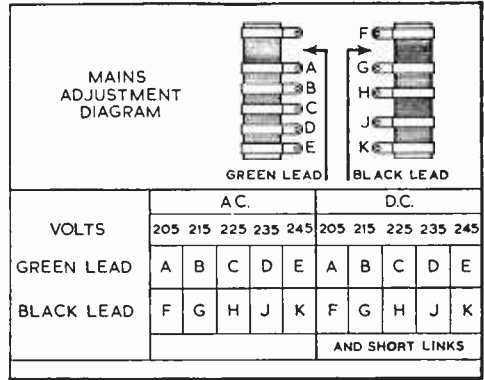

Fig. 9.—Mains adjustment.

Dropping the fluid down the spindle at the front is not generally successful. A switch cleaner of the solvent type will not stop a noisy control for any useful length of time and it is more satisfactory to replace the unit than use this type of fluid.

**No Vision or Sound Signals**

(Raster present when the brilliance is advanced and the speaker alive.)

Check the tuner unit V2 30C1 (PCF80) and then if still absent V1 30L1 (PCC84). The replacement of one of these will normally restore normal conditions. If this is not so, check V3 (10F1) and then the voltage supplies to the tuner unit (we presume the aerial and connections are not at fault!). Approximate voltages are: V1, pin 9 100V, pin 3 175V, pin 7 and 8 varies with R.F. gain control, but should not be less than about 1.8V; V2, pin 6 170V, pin 1 115V, pin 3 175V.

**Poor and Grainy Picture**

This particularly occurs on Band III. The 30L1 will normally be found at fault and a replacement will restore normal conditions, check aerial and the setting of R.F. gain control.

**Vision Buzz on Sound**

This will normally only be noticeable on BBC and denotes overloading (reduce R.F. gain) or incorrect tuning. Slacken the thumb screw on Band I tuning shaft and reset the cam for maximum sound. The cores of L11, L7 and L4 should not be separately tuned unless they have already been disturbed.

(Continued on page 223)

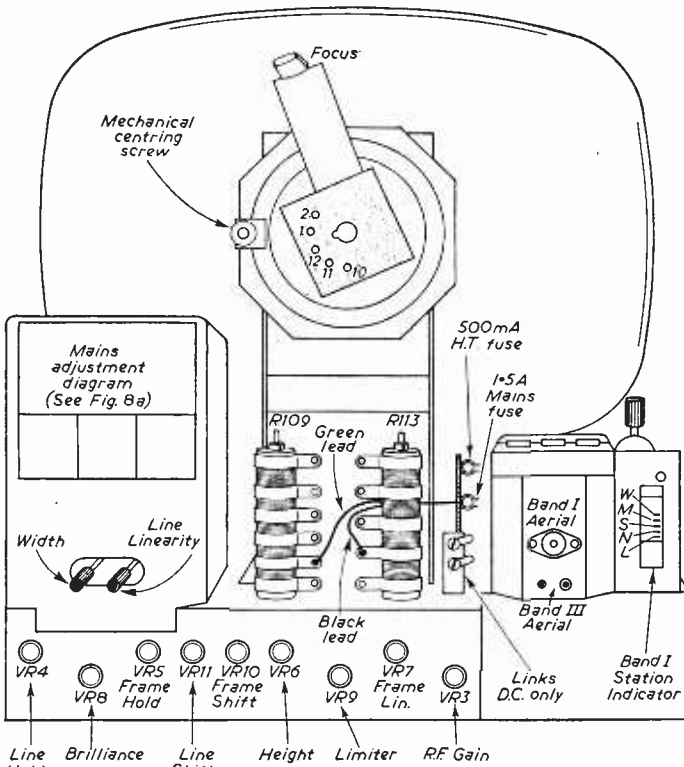

Fig. 8.—Rear view of the chassis.

**Noisy Volume Control**

A few drops of "Electrolube" into the track of the control where the three volume control tags are brought out will normally clear up this trouble.

# Letters to the Editor

The Editor does not necessarily agree with the opinions expressed by his correspondents

**SPECIAL NOTE:** Will readers please note that we are unable to supply Service Sheets or Circuits of ex-Government apparatus, or of proprietary makes of commercial receivers. We regret that we are also unable to publish letters from readers seeking a source of supply of such apparatus.

## UNIT CONSTRUCTION

SIR.—In looking through some of the service manuals of up-to-date sets, I note that there is a tendency to go back to an old idea, and one which although I believe it was adopted by one firm seems to have sunk into disuse. I refer to the use of units in the assembly of a set—the latest idea being to use printed circuit boards of a plug-in type. This idea is surely what we all need as one can easily service a set and it does not become necessary to turn a heavy and cumbersome chassis on its end in order to get at some component, and in other ways servicing becomes very simple. I think other readers would agree that plug-in units are highly desirable, and I trust that in any future designs which are sponsored by "Practical Television" this will be borne in mind.—H. Rawlings (Hove).

## THE "OLYMPIC"

SIR.—I must congratulate you on the design of your latest television receiver, and I would mention that I have built all the P.T. designs, up to and including the Supervisor. This has given major service and although still working I am trying my hand at your latest. (I hope to sell the Supervisor when the Olympic is finished.) I have made up most of the set and tried to get it working, but there has been no circuit of the timebases yet, and I tried to use valves from my own theoretical knowledge, using the blueprint as a guide and parts of the various articles which have been published, including the one on Interlace by the designer Mr. Bowman. I get very indifferent results on the frame section and think perhaps I may have made some error in the values here, and should be glad if a list could be given showing the correct R and C values.—R. Towney (Hammer-smith).

*[We are including in this issue all the remaining circuits of the Olympic, but in view of the very advanced design we thought it better not to include these until explanations had been made in the text to cover certain features.—Ed.]*

SIR.—Your welcome series on the "Olympic" TV appeared just as I was half-way through building a new set for myself, and I have been able to incorporate several of its features. A couple

of points from my experience may be of interest:

1. Page 80, November issue—L17/18. I took the information literally and had the ends of the winding touching. The 300V P.D. between the windings which exists before the valves warm up promptly broke down the enamel insulation. Two or three turns of silk thread are indicated to ensure safety.

2. Page 30, October issue, Fig. 2—surely diode D3 should be connected the other way round.

One more point, I would like to incorporate spot wobble or elongation in this set, which uses an AW43/80. Have you published any articles on this subject?—F. J. TEMPLETON (Keymer Hassocks).

*[We imagine that Mr. Templeton forced the windings L17/18 tightly together, leaving no space for polysstyrene cement between. By "ends touching" was meant "just touching" and no difficulty was found with the prototype receiver. However, a space between the windings of the thickness of a piece of cotton thread (say 0.01in.) would have little effect on the coupling and would certainly provide an extra safety margin.]*

Spot wobble is simple enough to arrange (an article appeared in the June and July issues, 1959), but when a 21in. tube is used, we suggest it is hardly worth the trouble. The lines cannot be seen at 6ft on the 17in. tube unless noise impairs interlace (and even Patchett's sync separator can do little about noise!).

## VALVE RADIATION

SIR.—I recently experienced a fault which leads me to think that everything is not yet known about the valve. I know that in some cases screens are placed over valves to prevent certain forms of instability, but I wonder if many experimenters know that this also prevents or limits radiation from the valve. Although there are no inductive components or circuits in a valve I recently had trouble through line and frame interaction, and nothing in the circuit would remedy this. I changed the positions of all R's and C's and also the direction or run of the wiring and finally went to the trouble of unscrewing the valveholder and mounting all the leads to the base of two extra pieces of flex (3in. in length). This enabled me to lift the valve in its holder and to lay the valve in various positions. It was found that when placed horizontally, even in the original place on the chassis, the trouble was avoided, and as the valve was turned through 90deg it could be reintroduced. Placing a valve screen on only partially removed the trouble, presumably because the contact between screen and skirt was not 100per cent efficient.—R. Langbourne (N.W.6).

**For Safety's Sake**  
use  
**AVO Prodclips**

Pat. No. 74811

.. with Trigger-Action Spring-Loaded Clips

PRESS TRIGGER TO OPEN  
RELEASE TO GRIP

Safety first every time with these patented spring-loaded AVO Prodclips.

Cleverly designed for use as insulated prods, they are invaluable for reaching and holding test points which are difficult of access.

Suitable for use with AvoMeter, Multiminor and Avo Electronic Test Meter Leads.

Post Free  
15/-  
per pair.

**AVO LTD** • AVOCET HOUSE,  
92-96 VAUXHALL BRIDGE ROAD, LONDON, S.W.1.  
VICtoria 3404 (12 lines)  
A MEMBER OF THE METAL INDUSTRIES GROUP OF COMPANIES

**"Better get the best—  
it costs less"**

**VIDIO**

Offers you the finest rebuilding service available today. Each tube is completely rescreened aluminised and fitted with a new Gun Unit. Available now — for IMMEDIATE DELIVERY.

12"—£5.    14"—15"—17"—  
£5. 10.    21"—£8.

VIDIO'S SECOND CHOICE  
—GUN UNITS.

12"—£4. 10.    14"—£4. 15.  
15"—17" £5.    21"—£7.

ALL TUBES GUARAN-  
TEED FOR ONE YEAR.

Get full details now from.

**VIDIO REPLACEMENTS LTD.**

Hales St., Deptford High St.  
London S.E.8. Tel: TID 4506



**VITAL. UP-TO-DATE WORK  
for AMATEUR or ENGINEER**  
**TV SERVICING  
HANDBOOK**

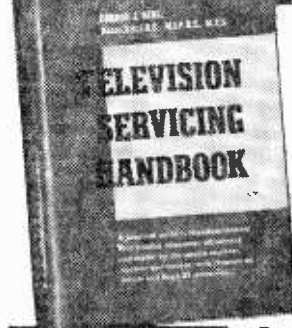

- How to deduce from any fault-symptom the most likely cause of trouble.
- How to locate the circuit section or component concerned and what action to take.
- Methods of converting single-channel receivers to Band III operation.

**280 PAGES**

Nearly 200  
**Illustrations**

Practical handbook of servicing and repair methods intended mainly for the service engineer, but will also prove invaluable to radio amateurs, students and apprentices. Designed to render immediate assistance to the busy man are the Procedure Charts, which show at a glance all likely fault symptoms, possible causes, etc. Beautifully bound in grey buckram, yours for only 30/- inc. post, packing, etc.

**DO THIS NOW!**

Simply fill in form and post in 2d. stamped, unsealed envelope to Dept. H.F.37, Odhams Press Ltd., Basted, Sevenoaks, Kent. Offer applies U.K., Eire only. closes January 31! Hurry!

by  
**GORDON J. KING**

Assoc. Brit. I.R.E.,  
M.I.P.R.E., M.T.S.

Contents Cover:

No sound, vision or raster. No raster—normal sound. No sound or vision — raster normal. No vision — sound and raster normal. Fault tracing in the sound channel. Servicing the timebases. Synchronizing faults. Vision A.G.C. systems. Picture-tube faults. Receiver alignment. Miscellaneous faults. Aerials and feeders. Band III Conversion.

**SEND NO MONEY NOW!**

To: Dept. H.F. 37, Odhams Press Ltd., Basted, Sevenoaks, Kent:  
WITHOUT OBLIGATION TO PURCHASE reserve me "Television Servicing Handbook" and send Special Invoice with "100% Satisfaction or No Charge" Guarantee

BLOCK LETTERS BELOW

NAME \_\_\_\_\_

Full Postal ADDRESS \_\_\_\_\_

H.F.37/Jan. '61

**TRANSISTOR**

**Read these testimonials**

**THE ORIGINALS MAY BE SEEN AT THIS OFFICE**

**Mr. J. Brown, Glamorgan, S. Wales.**

"My Pocket 3 arrived safely. I must say I am very pleased with it indeed. It is absolutely wonderful. Thank you very much. I now enclose 16/6 for your conversion parcel to Pocket 4".

**Mr. J. Bell, Wolverhampton.**

"I am writing to express my satisfaction at the standard of your kit for your Pocket 4 Transistor set and also to state that it has come up to my expectations in regard to performance".

**Mr. E. Edwards, Boreham Wood, Herts.**

"I have completed the assembly of your Pocket 3 and I are very pleased with the results".

**Mr. N. Elliott, Pontypool.**

"I have completed the assembly of your Pocket 4 radio and am pleased to say that it works from the first switching on".

**Mr. F. Jackson, Ickenham, Middx.**

"I have built the Pocket 4 and am more than pleased with the results".

**Mr. G. Bamford, Ramsgate.**

"I find this set even better than you claim it to be and most certainly up to your usual standard of quality. I feel that nobody could fail to build it and get results. Even the first-time-ever novice, as your circuit diagrams and instructions are so clear and precise".

**Mr. Graham, Birchington-on-Sea.**

"Re Pocket 4. I must say that it is all you say of it. The stations roll in, and good volume too".

**Mr. R. Dobbin, Rinkwood, Worcester.**

"I wish to inform you that I am very pleased indeed with the Pocket 5 Transistor Radio set I recently purchased from you, I wish to say the reception is quite good".

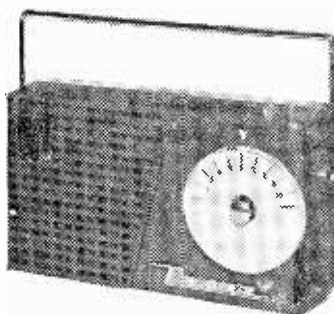

Now available with first grade transistors.

Circuit comprises 2 HF transistors reflexed to equal 4 stages. Permanent germanium diode and high gain AP output stage, fitted with miniature speaker, proper tuning condenser, volume control and in case with handle as illustrated (less tonogram), completely portable. No aerial or earth required.

Pocket 4 uses 3 transistors and 1 diode, price 52/5, 67/6, post 2/6.

**Results Guaranteed**

Nothing can be more disappointing than to find that despite care in making up, your radio just will not work or needs a long high aerial and water pipe earth. We guarantee good results in all areas.

Send in confidence. Money refunded if parts or guarantees not up to your expectations. Plans free with parts, or separately 1/6. More details S.A.E.

**POCKET RADIOS**

**Mr. S. Rigby-Jones, South Molton, N. Devon.**

"I was delighted to receive my Pocket 4 Transistor set. After I assembled and tested it I was amazed such a small receiver had such good reception".

**Mr. E. Balcombe, Manchester.**

"I have constructed your Pocket 4 Loudspeaker radio and am delighted with its performance and appearance, for the cost I consider it excellent".

**Mr. R. Belt, Newcastle-on-Tyne.**

"I have built your Pocket 5 Transistor set I am very pleased with it".

**Mr. R. Morse, Birchington-on-Sea.**

"I know nothing whatever about radio but I have just made up your transistor set from the kit of parts you sent. I am happy to say that it works perfectly and does all you claim of it. As you can see, I live a good way from London, yet the B.B.C. comes in quite loud. The little set can be heard working in a good size room. Quite a number of other stations can be heard at night time with quite good separation. Wonderful value for money".

**Mr. J. Hawden, Bolton, Lancs.**

"I have had great pleasure in buying from you a Pocket Transistor 5. I have built it up and it is perfect".

**Mr. A. J. Simmons, Welling, Kent.**

"I purchased from you a week ago the Pocket 4 Transistor Kit. I put it together last night in 1 1/2 hours on switching on the set, I was right on Radio Luxemburg. I must say thank you, because not only has the set a very attractive appearance, it also behaves fantastically".

**ELECTRONIC PRECISION EQUIPMENT LTD.**

★ Orders received by post are despatched from our warehouse, Dept. 5, 66, Grove Road, Eastbourne, and to save time, please post your order to this address. Please include enough for postage. Callers, however, should use one of the following addresses:

Electronics (M.P.) Ltd., Electronics (Ruiship) Ltd., Electronics (Croydon) Ltd., Electronics (Finsbury Park) Ltd.,  
520 High Street North, 42-46 Windmill Hill, 268 London Road, 29 Stroud Green Rd.,  
Mansor Park, E.12, Ruiship, Middx., Croydon, Finsbury Park, N.4.

**FACTORY REBUILT**

**TELEVISION TUBES**

After considerable development work and extensive trials under working conditions, the manufacturer is confidently offering an

**18 MONTHS' WRITTEN GUARANTEE**  
on all tubes

To ensure extreme reliability, not only are the best available materials used under controlled conditions, but all tubes are given

**12 THOROUGH TESTS**  
after completion of the processes

12" ... ..	£5.7.6
14"—16" ... ..	£5.10.0
Allowance on old tube 10/-	
17" ... ..	£6.19.6
Allowance on old tube 20/-	
21" ... ..	£8.19.6
Allowance on old tube 30/-	

C.W.O. or C.O.D. Carr. and Ins. 10/-

**TELEVIEWER SUPPLIES**

95 Caldmore Road, Walsall, Staffs.

**SPECIAL OFFER!**

TO THE FIRST 100 CUSTOMERS

**COSSOR 10" TUBES**

Brand New NOT A Regun

**108K 15/- plus 6/- carr & ins**

**75K 15/- plus 6/- carr & ins**

12 MONTH GUARANTEE

**ION TRAP MAGNETS**

Suitable for all bent gun type tubes

**2/9 EACH Plus 6d post & pack**

**DON'T MISS THE MOST FANTASTIC OFFER YET!**

SEE PAGE 173

**HARVERSONS SURPLUS CO. LTD.**

83 High Street, Merton, S.W.19

CHerrywood 3985/617



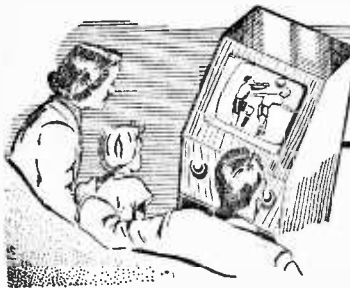

## UNDERNEATH THE DIPOLE

TELEVISION PICK-UPS AND REFLECTIONS

By *Iconos*

### Acquired Tastes—on TV

A PALATE for paté de foies gras, oysters and Plymouth gin indicates a taste acquired by the gastronomically adventurous, those who seek an occasional escape from the usual joint and two veg. (tinned, of course) and suet pudding. The unusual dish, however, does not always please at the first mouthful—it is often an acquired taste. There are many writers who tell us what we should eat and drink for good health, good fellowship, good taste or merely for slimmness. Critics tell us what books to read, films to see or television shows to remember.

### Television Critics

The newspaper television critic deals in the past. He is different from the literary and film tipsters in that he can only give his opinion on what you ought to have liked or disliked. He's seen the TV show he's writing about—with eight million other viewers, maybe—and it's over and done with. All these musings are leading up to an evaluation of the amazing reactions of the press critics and the public to the off-beat "progressive" comedy series "The Strange World of Gurney Slade", starring Anthony Newley. The critics unanimously praised it. The viewers—a large section of them, that is—hated it. Was it good? Who is right?

This is an interesting situation because of the enthusiastic unanimity of the television critics in the national newspapers and the trade papers. With the film critics, one can generally anticipate the remarks of the "egg-heads" (usually female) who rarely give a good notice to a non-Continental film though they show a fondness for "kitchen sink" dramas and other works by the "angry boys". On the other

hand, one can also give a reasonable forecast of film criticisms by the popular, less high-brow critics.

With one voice, the TV scribes hailed the Anthony Newley series as a new trend in progressive comedy. They accepted the new production as the natural successor of "Fred", "Son of Fred". "Yes, It's the Cathode Ray Tube Show", and similar goon-like deviations from the orthodox and traditional laughter-raisers. But I hear that thousands of viewers disliked "Gurney Slade" so much that they choked A.T.V.'s telephone board with angry complaints.

A.T.V.'s Programme Department became anxious. The TAM rating was low. The advertisers sardonic. Question: why should anyone be interested in a teenage pop-singer, a dreamer, exchanging confidences with a dustbin, a

dog, or with himself, searching for a soul mate or contemplating the infinite? Well—Gurney Slade is an unusual individual who is still trying to find his feet, and I, for one, was of the minority on the side of the TV critics. I was interested in the new avenues of thoughtful humour opened up. My one criticism: the poor photographic values of the exterior filmed shots evidently taken in bad weather. The episode in which Gurney Slade was put on trial for having no sense of humour was an all-interior episode, technically first-rate and, for me, worth waiting up for at its new late-night timing. The main mistake, however, was to start this mentally surrealistic comment on life at a peak viewing time. That's the time when most viewers are devouring their "pease pudden" of Westerns and give-away shows.



The site for the proposed Westward TV Studios at Plymouth. The architect explains points to Westward's technical general manager and local building contractors.

### Candid Camera

Having placed myself on the minority side of "Gurney Slade", let me now comment upon another new approach to comedy which, though not in the top ten, is collecting quite a good crop of viewers. I refer to A.B.C.'s Candid Camera in which a hidden 16mm camera records the reactions of the ordinary man in the street in out-of-ordinary situations, such as being invited to rescue a young lady whose toe was trapped in a bath tap; asked to take part in the blowing up of the House of Commons; waiting on the pavement holding a pile of books for a lady who disappears. These incidents are more or less trivial, excepting the first one—and the viewers' amusement arises from the picture and sound being recorded without the knowledge of the victims, who later on are invited to view the resultant film and give permission for it to appear in this programme.

The joke is good—sometimes very good—especially when Jonathan Routh, one of the authors of this feature, plays the part of the foil. In the episode in which he acted as a tailor's assistant, fitting a plump Lancashire publican with a ludicrously ill-fitting suit, his superb "deadpan" sales talk was a gem of its kind and, like his client's suit, was completely "off the cuff".

It was nice to see also on the screen the immediate sequel to this jape, as the camera continued to turn when it was disclosed to the publican that the whole thing was a hoax. It is much nicer to see actual evidence that a practical joke has created no ill-feeling. Bob Monkhouse's assurance that the victim has taken it well is clear enough. The showing of the denouement after the victim has been let into the secret, provides a better ending. This publican laughed heartily, was pronounced a "good sport" by Monkhouse, by the viewers and—I'll be bound—by a capacity attendance of well-wishers at his hostelry that night! Good health, sir, too!

### Sound Blasts

Commercial television advertisers used to blow the heads off viewers in their zeal to punch home their advertising message. The mood is changing and the "soft sell" has become

the mode in smart advertising circles. Sometimes the "soft sell" results in a sickening diapason of lisping sibilants on sound accompanying an ingratiating archness on the picture. The resultant appeal usually carries glutinous background music with syrupy heart-throb beats. I'll wager that before the commercial reaches its inevitable glissando on the harp, a good many males are half-way to the local pub for a revive—or else they turn over to the BBC for musical entertainment of a more brittle character. If they happen to switch over to Alan Melville's quite bright "Parade" feature, their ears will, as often as not, be assaulted with a musical accompaniment so busy and strident that the vocalists take second place. This always impresses TV studio audiences. When will TV orchestral conductors realise that the viewers count more than the studio audience?

The Beverley Sisters, a good-looking act of conventional type, have pleasant soft voices that blend nicely with soft lights and sweet music. But if words are of any importance at all, they should be heard and if faces are easy to look at, they should not be back-lit in the studio like a frying-pan full of sausages in a commercial. The poor girls fought a losing battle against a musical score overloaded with sforzandos on the brass, percussion and what-have-you. Even the harp in the "Old Fashion Girl" number acquired an aggressiveness usually

reserved for the last thirty-two bars of Tschaiakowsky's "1812".

Whose fault was this? My guess is that the BBC's sound balancer was fooled by having a loud-speaker of super-hi-fi quality which gave the Beverley girls an intelligibility of speech far better than it was on the ordinary viewers' set, especially those with footling little loud-speakers around the back.

The remedy? Monitor screens and loud-speakers in the BBC control rooms should be adjusted to good average viewing quality and the sign "ff" should be taboo in the scores of vocal accompaniments. Sh - sh - sh! Tacet! Try the soft pedal, Harry—the one on the left—and let the trumpet players save their spittle for Sousa's rousing "Stars and Stripes" march.

### Travelogues

I must admit that I like to see the world from my armchair even more than from a cinema seat, though in this day and age, one is plain and the other coloured. Mere pictorial views are insufficient and impersonal. Motion picture views of foreign parts have to be linked with strong and interesting personalities, either in the picture or on the commentary.

Early documentary films, such as Ponting's film of Scott's Antarctic Expedition, or Cherry Kearton's African Safaris, or Capt. Noel's film record of the first Everest Expedition, were the first monumental records of this kind—which are still of absorbing interest.

## PRACTICAL WIRELESS

### Chief Contents of the January Issue

#### Now on Sale, 1/6

A 4W AMPLIFIER

CIRCUITS FOR ACORN VALVES

USING PORTABLES IN THE CAR

COMBINED RADIO AND TABLE LAMP

A SIMPLE SIGNAL GENERATOR

REFLEXING TRANSISTORS

RELIABLE RADIOGRAM

CLUB NEWS

ETC., ETC., ETC.

# LASKY'S RADIO

## MAKER'S SURPLUS COMPONENT BARGAINS

- WIDE ANGLE 38 mm.**  
 Line E.H.T. Trans. Ferro-cube core, 9-16 kV..... 19/8  
 Scanning Coils, Low imp. line and frame..... 19/6  
 Ferro-cube cored Scanning Coils and Line Output Trans., 10-15 kV. EY51 winding Line Trans. with width and linearity controls, circuit dia., pair.... 50/-  
 Frame Output Transformer Frame or line block osc. Transformer..... 4/6  
 Focus Magnets Ferro-core P.M. Focus Magnets, iron Cored..... 12/6  
 Duomag Focallisers..... 15/-  
 300mA Smoothing Chokes 10/6
- STANDARD 35 mm.**  
 Line Output Transformers 6.9 kV. E.H.T. and 6.3 v. winding, Ferro-cube... 17/6  
 Scanning Coils, Low imp. line and frame..... 7/6  
 Frame or line blocking oscillator Transformer.. 4/6  
 Frame Output Transformer 7/6  
 Focus Magnets:  
 Without Vernier..... 9/6  
 With Vernier..... 12/6  
 200mA Smoothing Chokes 7/6

## LIMITED QUANTITY ONLY NEW AND UNUSED 17" TV CHASSIS

200-250 v. A.C./D.C. Complete with 13 new Brimar valves, latest Fireball turret tuner covering all channels Bands I and III (i.e. 33-38 Mc/s). Ferroxcube line output transformer and wide angle 90° scanning coils, ion trap, latest electrostatic focus. All first quality components. Printed circuit construction. Overall dimensions: 8in. x 15 1/2in. Valve line-up: 3 PCF80, 1 PCC84, 3 6BW7, 1 PCL84, PCL82, PY82, PL81, PY83, EY61.

**LASKY'S PRICE £18.19.6**

Carr. & Ins., 7/6.

Special Offer. Brand new Brimar C17SM 17in. C.R. TUBE, .3 amp heater, electrostatic focus, 90° deflection, guaranteed 12 months. List 10 Gns.

Lasky's Price **£6.19.6** Carr. & Ins., 12/6.

**SPECIAL OFFER OF CHASSIS AND ABOVE BRIMAR C.R.T. £23.19.6**

Carr. & Ins., 19/6.

SEND FOR LASKY'S COMPONENTS CATALOGUE OVER 100 ILLUSTRATED PAGES, SIZE 8 x 5 1/2in. Price 2/-, Post 6d.  
 Latest 12-page BARGAIN BULLETIN included free.

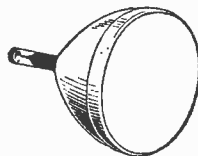

## G. R. TUBES NEW, UNUSED AND GUARANTEED

FERRANTI 12in., T12/44, 4 volt heater. **LASKY'S PRICE 49/6**  
 Carr. & Insur. 12/6.  
 Also 9in. T9/3, same price.

FERRANTI 17in. type TR17/10, 6.3 v., 0.3 amp. heater. **LASKY'S PRICE £6.19.6**  
 Carr. & Insur. 12/6.

16in. METAL CONE, famous make, type T801/A, 6.3v., 0.3 amp. heater. **£6.9.6**  
 Carr. & Insur. 21/-

**RE-GUNNED C.R. TUBES GUARANTEED for 12 MONTHS**

Type	Carr. & Ins.
12in. round.....	£5 10 0 12/6
14in. rect.....	£5 10 0 12/6
15in. & 16 round.....	£5 10 6 12/6
17in. rect.....	£5 10 6 12/6
21 in. rect.....	£7 19 6 21/-

## LASKY'S (HARROW ROAD) LTD.

42 TOTTENHAM COURT ROAD, W.1

Telephone: MUSEUM 2605.

Open all Day Saturday.

Early Closing, Thurs.

207 EDGWARE ROAD, LONDON, W.2.

FADdington 3271/2.

Mail Orders to Dept. P.T., Edgware Road.

# TRUE ECONOMY Depends on Quality

Midland rebuilt C.R.T.s conform to the highest standard of reliability—offering you the finest value available today. Each tube is completely rescreened, aluminised and fitted with a new gun unit.

Midland's reputation for quality and the rapidly growing demands for these dependable tubes are your assurance of satisfaction.

12 and 14in.—£5.0.0 15 and 17in.—£5.10.0 21in.—£8.0.0 (all types).

Reliable Rebuilds at Popular Prices.

Exceptionally low-priced Midland Rebuilds—the tubes you can always depend on.

12in.—£4.10.0 14in.—£4.15.0 15 and 17in.—£5.0.0 21in.—£7.0.0 (all types).

ALL TYPES COVERED BY MIDLAND'S 12 MONTH GUARANTEE AVAILABLE NOW—FROM STOCK

# MIDLAND TUBES LTD.

37 GEORGE STREET, MANCHESTER, I. Telephone: CENTRAL 4568/9



**SALE! FAMOUS MANUFACTURERS SURPLUS STOCKS**

**FAMOUS TAPE RECORDER**

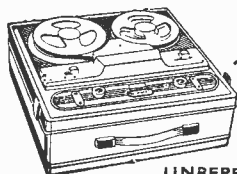

LISTED 28 gns.  
**NOW 18 gns.**  
UNREPEATABLE VALUE

Huge purchase at this amazing price. Beautifully styled, rexine covered cabinets. Colours: Red, Grey, Black. Storage space for 4 tapes, mike and lead. Incorporating the latest B.S.R. Deck. EXPENSIVE FEATURES. Superimpose and electronic eye. Size 14 1/2 x 14 1/2 x 7 1/2 in., only 21 lb. 5 1/2 in. std. tape. Terms available. Carr. & Ins. 12/6. Microphone 27/6 extra. Tapes 19/9. **PORTABLE AMPLIFIER Mk. DI. 79/6** Famous manufacturer, latest design, A.C. only. Size 7 x 2 1/2 x 5 in., 1 valve, volume and tone control. P. & P. 3/6. **PORTABLE AMPLIFIER Mk. DS. 39/6** Simple circuit employing ECL80. A.C. only. Single control. P. & P. 3/6.

**RECORD PLAYER CABINET RP2**



59/6

Made by a famous manufacturer. In polka-dot cloth with clipped lid and carrying handle. Size 16 x 14 1/2 x 8 1/2 in. deep. Carr. and ins. 4/5. Will take B.S.R. Monarch 4-speed Auto-changer £6.19.6 7 x 4 in. Elliptical Speaker 15/9 and our Mk. D.2A Portable Amplifier 79/6.

**RECORD PLAYER CABINET RP9 19/6**

Exceptional offer. A lightweight portable player Cabinet in two-tone Rust and Cream. Famous manufacturer. Size: 14 1/2 x 11 1/2 x 6 in. Complete with moulded deck board of attractive design. Takes B.S.R. TU9 single player. 2 control Amplifier; 5 in. round Speaker. Post, Packing & Ins., 4/6.

- B.S.R. MONARCH, 4-speed Autochanger ... .. £6.19.6
- T.U.9 B.S.R., 4-speed single player ... .. 99/6
- Collaro CONQUEST, 4-speed Autochanger ... .. £7.19.6

**SOLO SOLDERING TOOL 12/6**



110 v., 6 v. or 12 v. (special adaptor for 200/250 v., 10/- extra). Automatic solder feed including 20ft. reel of Ersin 60/40 solder and spare parts. It is a tool for electronic soldering or car wiring. Revolutionary in design. Instantly ready for use and cannot burn. In light metal case with full instructions for use. Post 3/6.

**TAPE RECORDER AMPLIFIER £7.19.6**

Compact, well designed 5 valve amplifier. Output 3.5 watts. Valve line up—ECC83, double triode first audio amplifiers, ECL82 triode pentode further audio amplifier and output valve, 6BV6 bias and erase oscillator, EM84 record level indicator. EZ80 H.T. rectifier. Input for mike, radio and gram. Controls: record playback volume and on/off playback tone. Dia. 8 1/2 x 3 x 4 1/2 in. ins. and carr. 4/6. Terms. **EXTRAS:** Knobs 2/6 per set. Beautiful Perspex dial plate, Complete with sockets for mike, radio and superimposed switch 3/6.



**REPLACEMENT, REBUILT TV TUBES**

- 21" TUBE £8.10.0
  - 17" TUBE £7.10.0 **£2** Allowed on old Tube
  - 12" 14" 15" TUBES £5.10.0 **£1** Allowed on old Tube
- 12 months' Guarantee  
Terms available over 10 weeks)  
Carr. & Ins. 15/6

**DUKE & CO.**

(LONDON) LTD.  
621/3 Romford Road,  
Manor Park, E.12  
ILF 6001/3  
Send for a FREE CATALOGUE

**CLARKSON'S TUBE CHANGE**

120 COMMERCIAL ROAD, LEEDS 5  
We are now able to offer SUPER SCREEN TV TUBES with 12 months' guarantee at the keenest exchange price ever.

Example:

Tubes all types	Cash allowance on return of old tube	Actual Cost of Tube
12" - 14" £5	15/-	£4. 5. 0
15" - 17" £6	25/-	£4. 15. 0
21" £8	30/-	£6. 10. 0

Carriage and Insurance 10/- extra.

These tubes are COMPLETELY REBUILT by experts, with the most up-to-date electronic equipment, and are fitted with the famous American Superior Electron Gun. Many thousands of these tubes are in service today. Our factory is open to inspection to readers of "Practical TV". Technical advice and queries are answered free of obligation. All tubes are dispatched with adhesive paper and return labels. Cash allowance is sent on receipt of old tube.

**TELEVISION SPARES**

We can supply from stock almost any component from a Resistor to a Tube.

**NEW OR USED**

- Line Output Transformers from 25/- S/Coils from 15/-
- Line or Frame Blocking Osc. Transformers from 3/6
- Frame Output Transformers from 10/-
- 12 Channel Turret Tuners from 40/-, 10-16-38 Mc/s. State which.
- Ion Traps, 2/6 each. Resistors, mixed (25). 2/6. Speakers for TV, 7/6. Cabinets, New or Secondhand, from 10/-.

**Spares list:**

- PYE V/4, V/7, FV1, etc.
- EKCO 141, 161, 221, 231, 283, etc.
- FERGUSON 988, 988, 992/4/6/8, 204/6, 306/8, etc.
- H.M.V. 1807 to 1840 series, etc.
- MURPHY 214, 200, 240, 250, etc.

These are only examples of stocks, we have spares for nearly any make and model.

**FIRST-CLASS PICTURE TUBES (used)**

- 9in. 6d 12in. 35/- 14in. £2.10.0 17in. £3.0.0
- 7-DAY MONEY BACK GUARANTEE if not perfectly satisfied.

**REGUNNED TUBES:**

- 12in. £4.0.0 14in. £4.10.0 17in. £5.0.0
- 12 months' guarantee.

**SOME OF OUR VALVES, e.g.**

- |           |          |            |          |
|-----------|----------|------------|----------|
| EBF80 6/- | EF80 4/- | PCC84 7/-  | PL81 8/6 |
| ECC81 5/- | EF91 3/6 | PCF80 7/-  | PY81 6/- |
| ECL80 7/- | PY51 6/- | PCL83 11/- | U25 12/6 |
- Send 3d. for lists.

**CALL, WRITE OR PHONE**

**D and B TELEVISION**  
131A, Kingston Road, London, S.W.19

CHE. 3955.

S.A.E. all enquiries. Terms: C.W.O. or C.O.D. 2/6 extra. Postage on Valves 6d. each. Picture Tubes 12/6 inc. insurance. Enquiries answered and orders despatched by return post. Advice and technical information free—we are always pleased to help.

# Trade News

## NEW PROSPECTS AND DEVELOPMENTS

### Stub-matched 3-element Array.

**THIS** new Antiference Band 1 fringe aerial comprises a stub matched Band 1 dipole with wide spaced reflector and director. It has a 1in. diameter boom and  $\frac{1}{2}$ in. diameter elements loaded with anti-resonance plugs. Optimised models are available for all Band 1 channels 1—5. The matching stub is supplied ready connected and terminated in a watertight junction unit which can be easily attached to masts up to 2in. diameter. Arrays are supplied complete with universal clamp for masts up to 2in. diameter, permitting vertical or horizontal mounting.

The 135 Array, which retails at 75/-, can be supplied with or without mast or lashings, and a wide selection of alternative mountings are available. *Antiference Ltd., Aylesbury, Bucks.*

### Linear Scan Coils for 110deg Tubes

**RECENTLY** introduced by the Plessey Company Ltd. is a series of scan coils for 17 to 23in. 110deg TV tubes. The coils are wound on a polypropylene moulding and can be used at all temperatures likely to be encountered in TV receiver service.

Special form jigs are used in winding the coils to ensure undistorted raster shape and good focus overall. Minimum coupling between line and frame coils means that full advantage can be taken of modern trends in simplified frame timebase circuits.

The coils are available with high or low impedance windings and there is a choice of fixed or adjustable magnets for picture control.

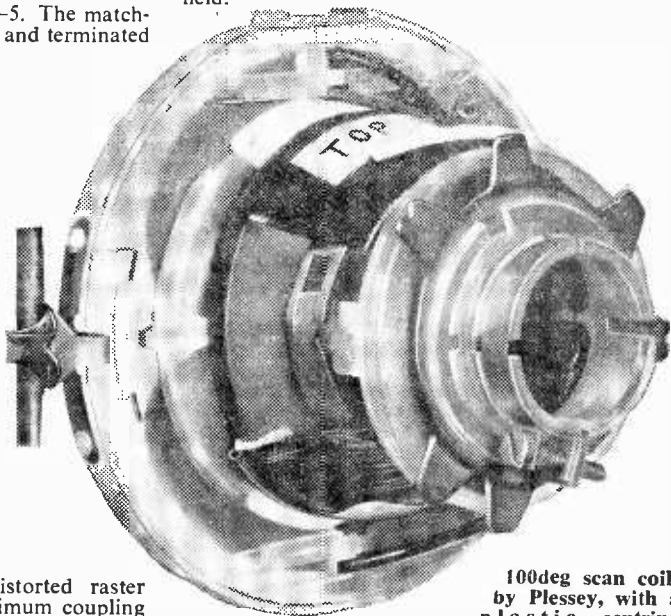

100deg scan coils by Plessey, with a plastic centring magnet.

The coils are produced by the *Plessey Co. Ltd., Ilford, Essex.*

### "Olympic" Coils

**SETS** of coils for the "Olympic" TV receiver are now available from Ajax Electronic Products.

Ceramic insulated beads are supplied loose so that they may be slid over the coil wires after mounting them on the chassis. *Ajax Electronic Products, 572 Fulham Road, London, S.W.6.*

### New Aerial Isolator

**A** NEW introduction to the Egen range of components is an Aerial Isolator Type 364. It provides aerial isolation of A.C./D.C. television receivers in a single compact and rugged unit which complies fully with the individual requirements of

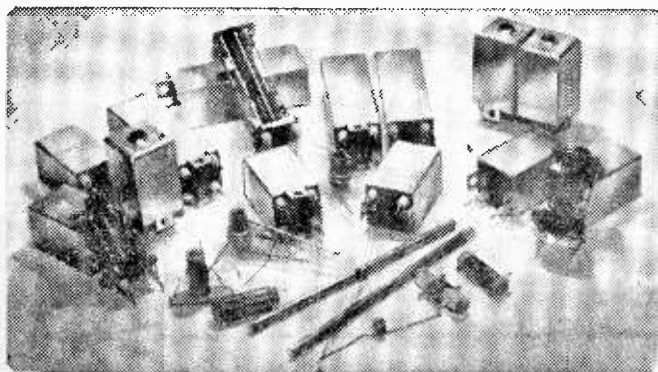

The complete set of "Olympic" coils.

**BS415.** Insertion loss is very low and its electrical specification ensures maximum performance at all frequencies envisaged for domestic receivers.

It is completely co-axial with full screening of the inner conductor. The series inductance of the feed-through capacitor in the outer conductor is exceptionally low. The feed-through capacitance is 470pF in both conductors, tested to 3,000V D.C.

Provision is made for direct mounting to the chassis or a separate bracket and it can be supplied with any required length of co-axial cable, already attached, for connection to the receiver input circuit. The external socket accepts a standard co-axial plug to R.E.C.M.F. specification. *Egen Electric Ltd., Charfleet Industrial Estate, Canvey Island, Essex.*

**New Wander Plug and Socket**

A NEW miniature wander plug and socket by Clix, particularly suited to printed circuit mounting, is introduced by the radio components and special products department, A.E.I. radio and electronic components division, 155 Charing Cross Road, London, W.C.2.

The socket mounting pin diameter is 0.05in., conforming to the 0.1in. module printed circuit technique, and the socket can be mounted on a 0.2in. centre using the standard, nominal 0.05in. diameter mounting hole. The overall diameter of the socket body is 0.19in. and the diameter of the plug is 0.19in.

All metal parts are brass, silver plated, and the insulation is nylon. Standard colours are red or black, but other colours can be supplied against special order.

**THE "OLYMPIC"**

(Continued from page 183)

additional necessary screening around the base of the valve.

Where screens are necessary they are blackened internally and externally. This is carried out in the following way.

A finger is inserted in the top of the can, the internal spring first being removed. Photographic "Dead Black"—obtainable from any good supplier of photographic equipment—is painted on the outside rapidly with a water-colour brush, and allowed to dry. (Gentle heat may be used.) When dry, further coats are added rapidly until a matt black finish is obtained. When completely dry the insides are prepared in the same way, taking care

not to cover the part which will engage with the skirt of the valveholder. The spring is inserted last.

**Amendments**

In the blueprint given away with the October issue, (i) a wire is required from the tag-board (near the VR74, R50), the end of R73 to the positive terminal of C65; (ii) on the valveholder of V11 (EB91), the apparent wire connection between pins 2 and 5 should be ignored.

In Fig. 2 on page 30 of the October issue the diode D3 should be reversed in polarity.

On page 80 of the November issue, in the inductance winding table, L1 and L2 should read L3 and L4 respectively, and L3 and L4 should read L1 and L2, again respectively.

(To be continued)

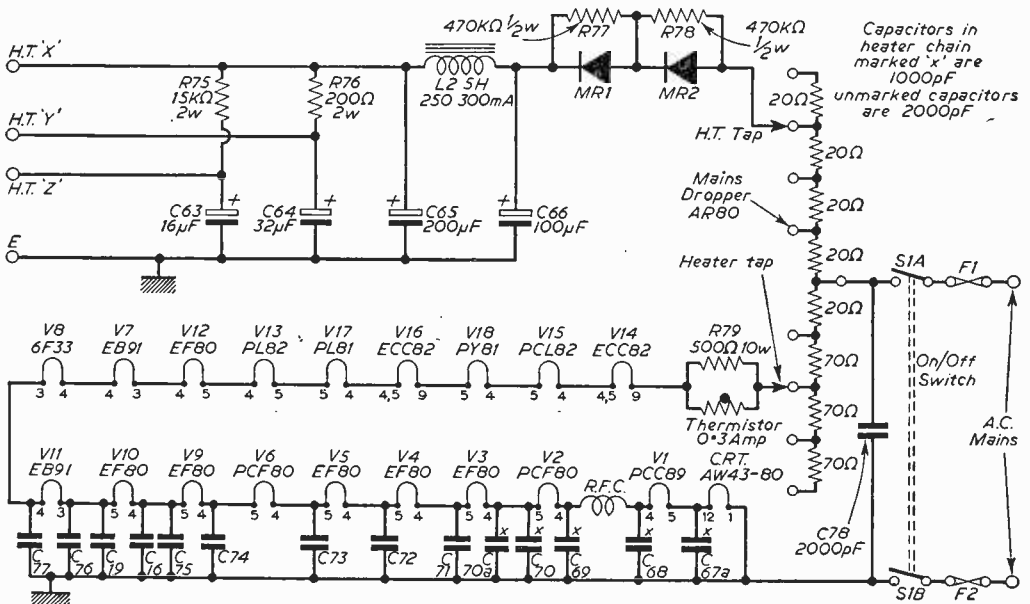

Fig. 18.—The H.T. supply circuit and the heater chain wiring details.

# R.S.C.

(Leeds) Ltd.

## BRADFORD, LEEDS and MANCHESTER

54.56 MORLEY ST. (Nr. Alhambra) BRADFORD  
57 COUNTY ARCADE, BRIGGATE, LEEDS, I  
8/10 BROWN St. (Market St.), MANCHESTER  
Mail orders to Dept. N., 29-31 Moorfield Rd., Leeds, 12

Post Terms C.W.O. or C.O.D. No C.O.D. under £1. Postage 1/9 extra under £2. 2/9 under £5. Open to callers 9 a.m. to 6 p.m. Wednesdays until 1 p.m. S.A.E. with enquiries please. Trade supplied.

### R.S.C. TRANSFORMERS

Fully Guaranteed  
Interleaved and Impregnated  
Primaries 200-230-250 v 50 c/s screened  
**TOP SHROUDED DROP THROUGH**  
260-0-260 v 70 ma. 6.3 v 2 a. 5 v 2 a... 17/9  
350-0-350 v 80 ma. 6.3 v 2 a. 5 v 2 a... 18/9  
250-0-250 v 100 ma. 6.3 v 3.5 a... 19/9  
250-0-250 v 100 ma. 6.3 v 4 a. 5 v 3 a... 23/9  
250-0-250 v 100 ma. 6.3 v 2 a. 6.3 v 1 a... 21/9  
300-0-300 v 100 ma. 6.3 v 4 a. 5 v 3 a... 23/9  
350-0-350 v 100 ma. 6.3 v 4 a. 5 v 3 a... 23/9  
350-0-350 v 150 ma. 6.3 v 4 a. 5 v 3 a... 29/9

**FULLY SHROUDED UPRIGHT**  
250-0-250 80 ma. 6.3 v 2 a. 5 v 2 a  
Midget type 2i-3-3in... 17/11  
250-0-250 v 100 ma. 6.3 v 4 a. 5 v 3 a... 25/9  
300-0-300 v 100 ma. 6.3 v 4 a. 5 v 3 a... 27/9  
350-0-350 v 100 ma. 6.3 v 4 a. 5 v 3 a... 27/9  
350-0-350 v 150 ma. 6.3 v 4 a. 5 v 3 a... 35/9  
425-0-425 v 200 ma. 6.3 v 4 a. C.T.  
6.3 v 4 a. C.T. 5 v 3 a... 49/9

**FLUORENCE TRANSFORMERS**  
All with 200-250 v 50 c/s Primaries: 6.3 v.  
1.5 a. 5/9; 6.3 v 2 a. 7/6; 0-4-5.3 v 2 a. 7/9;  
12 v 1 a. 7/11; 6.3 v 3 a. 8/11; 6.3 v 6 a. 17/9.

**CHARGER TRANSFORMERS**  
200-230 v 0-9-15 v 1 a. 12/9; 0-9-15 v 3 a. 16/9;  
0-9-15 v 5 a. 19/9; 0-9-15 v 6 a. 23/9/9

**OUTPUT TRANSFORMERS**  
Midget Battery Pentode 66:1 ... 3/9  
Standard Pentode 5,000 to 3 ohms ... 3/9  
Small Pentode 5,000 to 3 ohms ... 5/9  
Standard Pentode, 7/8,000 to 3 ohms ... 5/9  
Push-Pull EL84 to 3 or 15 ohms ... 18/9  
Push-Pull 10-12 watts 6V6 to 3 or 15  
ohms ... 18/9  
Push-Pull 10-12 watts 6V6 to 3.5, 8 or  
15 ohms ... 19/9

**SMOOTHING CHOKES**  
100 ma 10 h 250 ohms ... 8/9  
80 ma 10 h 250 ohms ... 5/6  
60 ma 10 h 400 ohms ... 4/11

### SELENIUM METAL RECTIFIERS

Special quotes for quantities of 50 to 5,000  
H.T. (H.W.) F.W. (Bridge)  
250 v 50 ma... 3/11 6/12 v 1 a... 3/11  
250 v 80 ma... 5/11 6/12 v 2 a... 6/11  
250 v 100 ma... 6/11 6/12 v 3 a... 9/9  
6/12 v 4 a... 12/3  
6/12 v 5 a... 14/6  
6/12 v 6 a... 15/6  
250 v 75 ma... 6/11 6/12 v 10 a... 25/9  
F.W. (Bridge) 8/11 6/12 v 15 a... 27/9

**SPECIAL OFFER! EX. GOVT. SELENIUM RECTIFIERS.** 12 v 15 amp with large, square cooling fins. 19/9 each.

**BATTERY SET CONVERTER KIT**  
All parts for converting any normal type of Battery Receiver to A.C. mains 200-250v 50 c/s. Supplies 120 v. 90 v or 90 v at 40 ma. fully smoothed and fully smoothed L.T. of 2 v at 0.4 to 1 a. Price including circuit, 49/9. Or ready for use, 9/9 extra.

**ALL DRY RECEIVER BATTERY ELIMINATOR KIT.**—All parts for the construction of a unit (metal-case 54-41-2in.) to supply Battery Portable receivers requiring 90 v and 1.5 v. Fully smoothed. From 200-250 v 50 c/s mains. Price, inc. point-to-point wiring diagrams. 39/9. Or ready for use, 46/9.

**D.C. SUPPLY KIT.**—Suitable for Electric Trains. Consists of mains trans. 200-250 v 50 c.p.s. A.C. 12 v 1 a Selenium F.W. Bridge Rectifier, 2 Fuseholders, 2 Fuses, Change Direction Switch, Variable Speed Regulator. Partially drilled Steel Case, and Circuit. **33/9**

**AUTO (STEP UP/STEP/DOWN) TRANSFORMERS**  
0-110/120-230/250 v. 50-80 watts. 11/9.  
0-110/120-200-230-250 v. 150 watts. 27/8.

### TELEVISION RECTIFIERS

250 v. 200 ma. Size 3 x 10ins. Brand New. 6/9.  
**MICRO-AMMETERS.** 3in. dia., 0-50 micro-amps. 39/6; 3 1/2in. dia., 0-500 micro-amps. 59/6.  
**MULTI-METERS.** Ferranti Universal. A.C./D.C. 59/6.  
**C.A.B.Y. A.M.** Basic meter sensitivity 155 micro-amps. A.C. and D.C. ranges. £4.10.0.  
**C.A.B.Y. B.30.** Sensitivity up to 10,000 ohms per volt. A.C. and D.C. £6.10.0.  
**EX-GOVT. SMOOTHING CHOKES**—  
60 ma 5-10 h 250 ohms ... 2/11  
80 ma 10 h 150 ohms ... 6/9  
100 ma 5 h 100 ohms Tropicalised ... 3/11  
100 ma 8-10 h 100 ohms Parmeko ... 6/9  
120 ma 12 h 100 ohms ... 8/9  
150 ma 10 h 150 ohms ... 8/9  
200 ma 8-2 h 100 ohms Parmeko ... 7/9

**POWER PACK KITS. ONLY 18/11**  
Fully smoothed. H.T. output of 250 v. 60 ma. and L.T. supply of 6.3 v. 1.5 a. Consisting of Double-wound Mains Transformer, 230/250 v. 50 c.p.s. A.C. primary. Sel. rectifier, smoothing choke, double electrolytic condenser, aluminium chassis and circuit.  
**BATTERY CHARGERS**  
For 200/250 v 50 c/s A.C. mains. 12 months guarantee. Attractive, well ventilated hammer finished cases, 6v or 12 v, 4 amp. with meter, and variable charge rate selector, as illustrated. **69/9**

car. 5/-  
Or Deposit 13/3 and 5 monthly payments of 13/3. 6 v or 12 v 1 amp type. Also suitable for electric train power supply. Only 29/9 post 2/9.

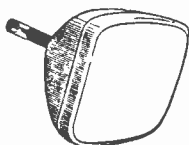

**TOP QUALITY AT  
LOWEST PRICES**  
with 12 months' Guarantee.

**VIRTUALLY AS NEW  
COMPLETELY REBUILT TUBES**

**TERMS—C.W.O.** MULLARD - MAZDA AND HARD GLASS TYPES

12-14 inch	£6. 0.0	} ELECTROSTATIC TYPES 10/- EXTRA.
15-17 inch	£6. 10.0	
21 inch	£9. 0.0	

**TRADE ENQUIRIES WELCOMED**

PRICES SUBJECT TO RETURN OF OLD TUBE

Pass. Train, Carr. & Ins.-To You-& return of old tube. in special containers. All covered for 20/- extra anywhere in U.K. or N. Ireland. BRAND NEW TUBES WITH 2 YEARS' GUARANTEE—NOW AVAILABLE (i.e. 17 inch at £10.). From:—

**SABRINA C. R. TUBE CO.**  
Electron Works, North Bar,  
**BANBURY - OXON**

Phone: 2390.

# LINE OUTPUT TRANSFORMERS

Most types available. State Make and Model.  
Number of Receiver when ordering.

S.A.E. please with all inquiries

## HOWORTH

51 POLLARD LANE, BRADFORD 2, YORKS.

Tel. 37030

**ACT NOW!**

Get information-packed literature FREE. Mail coupon today.

**PRIME ELECTRICS DEPT. G.A. 11.  
36-38 Queensdale Rd., London W.11.**

Please send me your FREE brochure and tell me how I can make EXTRA MONEY in my spare time by introducing your new product which sells on sight to all TV viewers.

NAME (Please Print and send 3d. stamp for postage)

ADDRESS UNITED KINGDOM ONLY.

# TELEVISION SPARES

**All Makes All Models By return of post**

**LINE OUTPUT TRANSFORMERS FRAME OUTPUT TRANSFORMERS  
DEFLECTOR COILS**

**LINE AND FRAME BLOCKING OSCILLATOR TRANSFORMERS**

**ALL POTENTIOMETER AND SLIDER CONTROLS**

**MAINS DROPPERS**

**METAL RECTIFIERS**

**GERMANIUM DIODES**

**FOCUS MAGNETS**

**ION TRAPS**

**E.H.T. CONDENSERS**

Our Range of Spares is probably the most extensive in the country and includes all Spares for Tape Recorders, Radio and Record Player Units.

Technical Advice Free. Service Manuals supplied on loan.

Terms: C.W.O. or C.O.D. All Components are supplied at list prices, plus 2/6 p.p.

Please enclose S.A.E. with all enquiries.

## NEWBURY RADIO

272 ROMFORD ROAD, FOREST GATE, LONDON, E.7.

MARyland 3100

### VALVES SAME DAY SERVICE NEW! TESTED! GUARANTEED!

**SETS** IR5, IS5, IT4, 3S4, 3V4, DAF91, DF91, DK91, DL92, DL94 .. any 4 for 19/6  
DAF96, DF96, DK96, DL96 .. .. 4 for 27/6  
6K7G, 6K8G, 6Q7G, 6V6G, 6X5G, or 5Y3G .. .. 5 for 27/-

1A7GT 11/6	6K8GT 9/3	25L6GT 9/-	EBL21 13/6	EZ40 6/9	T41 9/6
1D5 8/-	8L1 14/-	25Z4G 7/6	EC92 11/-	EZ41 7/-	T414 19/6
1B3GT 10/-	6L18 10/3	25Z6T 9/6	ECC91 5/-	EZ80 6/3	U22 2/6
1N5GT 10/-	8LD20 8/-	35A5 9/6	ECC82 6/3	EZ81 7/-	U25 13/-
1R5 5/6	6P1 13/6	35L6GT 9/-	ECC83 7/-	FW4/500 8/-	U26 10/-
1S4 8/-	6P25 9/-	35Z4GT 9/-	ECC84 8/9	GZ30 8/6	U50 6/-
1S5 5/3	6Q7G 9/-	35Z6GT 8/6	ECC85 8/3	GZ32 8/6	U52 4/6
1T4 4/-	8Q7GT 8/6	50L6GT 8/9	ECP80 8/6	HBC90 7/-	U78 4/9
1U5 5/9	8SL7GT 6/3	AC/TH1 10/9	ECP82 8/6	KT33C 7/-	UABC80 7/9
3A5 9/-	8SN7GT 4/9	AZ31 9/6	ECH21 13/6	KT41 11/6	UAF42 9/-
3Q4 7/-	8U4GT 11/-	B38 8/9	ECH35 8/3	KT44 8/6	UBC41 7/9
3S4 7/-	8V8G 5/-	CL33 12/3	ECH42 8/9	KT51 10/6	UBF80 8/9
3V4 7/-	8V8GT 6/9	DAC32 10/-	ECH81 8/-	KT63 6/6	UBF89 8/-
5U4G 4/8	8X4 4/9	DAF91 5/3	ECL80 7/3	MU14 7/6	UC92 12/6
5V4G 2/6	8X5GT 5/-	DAF96 7/6	ECL82 9/6	MX40 9/6	UCC84 12/9
5Y3GT 8/6	7B8 9/-	DCC90 9/-	EP39 4/6	N18 7/-	UCB41 7/9
5Z4G 7/9	7B7 7/6	DF33 10/-	EP41 8/3	PCC84 7/6	UCF80 14/-
6AL5 3/9	7C5 7/6	DF91 4/-	EP42 8/9	PCC89 11/-	UCH21 13/6
6AM6 3/6	7C6 7/6	DF96 7/6	EP80 5/6	PCF80 7/6	UCH42 8/-
6AQ5 6/-	7H7 7/6	DH76 4/9	EP85 8/7	PCF82 8/-	UCH81 8/-
6AT6 6/9	7S7 9/-	DH77 6/9	EP86 9/9	PCL82 7/6	UCL82 10/9
6BA6 5/9	7Y4 3/9	DK32 11/6	EP89 7/-	PCL83 11/-	UCL84 13/3
6BH6 5/9	10C1 11/6	DK91 5/6	EP91 3/8	PCL84 7/6	UF41 8/9
6BU6 5/9	10C2 17/6	DK92 7/6	EP92 4/3	PEN44 11/-	UF85 8/6
6BR7 9/9	10P13 14/6	DK96 7/6	EL33 10/9	PEN38C 8/-	UF89 7/-
6BW6 5/9	12A7 7/-	DL33 9/-	EL41 8/6	PEN45 7/6	UL41 8/6
6BW7 5/9	12A7T 7/6	DL38 9/6	EL42 9/-	PL36 11/6	UL84 7/6
6C9 9/-	12A7T 7/6	DL92 6/-	EL81 12/-	PL81 9/-	UR1C 8/-
6CD8G 28/9	12X7 7/-	DL94 7/-	EL84 7/-	PL82 7/6	UY21 11/3
6F1 12/6	12K7GT 5/3	DL96 7/6	EM34 6/9	PL83 7/6	UY41 8/6
6F8G 6/6	12K8GT 11/6	EABC80 7/-	EM80 8/6	PL84 10/-	UY85 6/6
6F13 11/-	12Q7GT 4/9	EAF42 8/6	EM81 8/6	PY32 11/-	UY1N 10/9
6F14 16/6	12Z3 7/6	EB91 3/9	EM84 10/-	PY80 7/6	VP4B 9/6
6K7G 2/6	14S7 16/9	EBC33 5/-	EY51 7/6	PY81 6/6	VP41 5/-
6K7GT 5/-	20F2 17/6	EBC41 8/-	EY81 9/-	PY82 8/6	WT5 5/3
6K8G 6/3	20L1 17/6	EBF30 8/6	EY84 10/9	PY83 7/9	WT7 4/8
	25A6G 8/-	EBF88 8/9	EY86 7/6	PZ30 17/-	Z77 3/6

**READERS RADIO**  
24 COLBERG PLACE, STAMFORD HILL  
LONDON, N.16  
STA. 4587

Post 6d. per valve extra.  
Any Parcel insured Against Damage in Transit 6d. extra.  
Any C.O.D. Parcel 2/6 extra.

### “AS-NU” Regunned TV Tubes

Supplied from stock, and despatched by British Railways same day.

#### COMPLETE NEW GUNS

fitted in every tube and fully guaranteed for TWELVE MONTHS.

12 in. ...	Mullard	Mazda
14 in. ...	£4.10.0	£4.10.0
15 in. ...	£4.15.0	£5.10.0
16 in. ...	£6.10.0	—
17 in. ...	£5.10.0	£5.17.6
21 in. ...	£8.10.0	£8.10.0

Plus 10/- Carr. & Ins.

PLEASE NOTE OUR NEW ADDRESS

Other types available. Please contact:

### J. P. WRIGHT

103 Carr House Road, Doncaster  
Sole Distribution Agent  
Phone: DON 2636



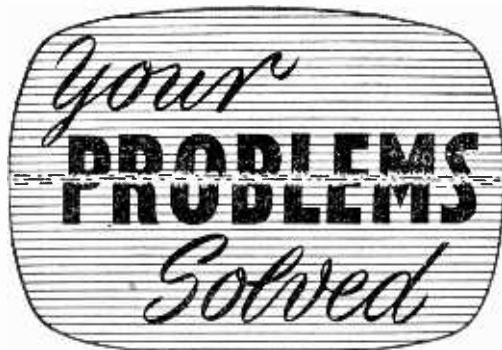

*Whilst we are always pleased to assist readers with their technical difficulties, we regret that we are unable to supply diagrams or provide instructions for modifying surplus equipment. We cannot supply alternative details for constructional articles which appear in these pages. WE CANNOT UNDERTAKE TO ANSWER QUERIES OVER THE TELEPHONE. The coupon from p. 223 must be attached to all Queries, and if a postal reply is required a stamped and addressed envelope must be enclosed.*

#### H.M.V. 1840

The trouble is erratic line hold. I have changed valves 7 and 8, 9 and 11 as numbered on the service sheet, without success.—J. Morlidge (Newcastle-on-Tyne).

Check the 330k resistors wired from the hold control to pin 2 of the PCF80. If replacement resistors do not effect a cure check the 270pF to pin 2. If the loss of hold is not complete, i.e. the picture pulls in sections, check the aerial which may be picking up reflected signals.

#### VIDOR CN4226

This set has a Brayhead converter fitted to it. Three faults have now developed in the receiver. First, there are vertical lines like a heavy curtain, more prominent on the left-hand side of the screen. Secondly, heavy horizontal lines appear at the top and bottom of the screen. The third fault is a hum rather like a very distant motor which increases as the volume is turned up. I have had all the valves checked and they are in order. When I use the set without the converter the trouble is still there but not so prominent.—H. Wilks (Southampton).

You should check the 100μF capacitor under the front of the chassis between the large smoothing capacitor can and the smoothing choke. Then, if necessary, check the 3.3k resistor associated with the horizontal linearity coil and the 5.6k across the width coil. Also if necessary, check the ECL80 valve immediately to the left of the tube neck.

#### R.G.D. 1756

To remove the chassis, I took off the two front inner and outer knobs, four screws from below and also the loudspeaker but the chassis appears to be holding at the front somewhere and will not come out. There is a clip at the top of the tube at the screen end. Has this anything to do with chassis binding?—W. Clark (Glasgow N.I.).

When the four fixing screws are removed there is no reason why the chassis should not slide out

except that the corners may be bedded into the cabinet at the front owing to the screws having been tightly driven home. You should therefore gently lift the front of the chassis to free it.

#### PHILIPS 1229

I am unable to trace the fault on this receiver. I have had all the valves tested and they are in order. I can obtain a weak spark on the anode on the tube, but the EY51 becomes overheated and red hot. On removing the smoothing capacitor on the side of the EHT transformer, the set gives good results and a good picture and the EY51 goes back to normal. I have tried two smoothing capacitors but the EY51 becomes red hot again.—E. Owens (Bolton).

The set will function quite well without the capacitor but if you want to trace the actual fault and you are sure the replacement capacitors were rated at over 12.5kV we would suggest that either the presence of the capacitor raises the EHT and causes a short in a weakened EY51 or the tube itself has a fault which only shows, as would the EY51 short, when the voltage is above a certain figure. It is possible that the replacement capacitors, however, did not have a sufficiently high voltage rating.

#### EKCO 330F

After being switched on the picture will break up into horizontal lines, but it can be restored by turning the horizontal hold, sometimes up and sometimes down. Occasionally this has to be carried out 9 or 10 times in an hour, nearly always after switching on. There is a slight whistle all the time and this becomes louder when the picture goes off. The sound is perfect. — D. Peacock (Bawdsey).

Suspect the 6/30L2 valve near the EHT compartment. This is the line oscillator and all that may be necessary is to exchange it for the AGC valve behind the I.F. strip. Also suspect the fly-wheel line discriminator diodes especially if they are a D321YZ unit in a small black plastic capsule. If they are, try replacing them with the standard D321Y which is pea-sized, grey in colour and with a yellow label.

#### MURPHY V320C21

The picture collapsed into a jagged white flash in the centre of the screen, momentarily and as this happened, I noticed the U191 valve (efficiency diode) arcing internally. I replaced the U191 with another which in size is about 1in. longer (glass envelope) than the original but I managed to fit the top cap connection without lengthening the wire. I am unable to obtain a picture with this valve (which has been tested) but the picture presents itself when I replace the original which is quite good apart from intermittent arcing. Is the valve type correct? Mazda U191?—E. Brentishaw (Stockport).

The U191 comes in two sizes and although either should work, the larger valves are no longer produced. The ideal U191 to fit is one of the small ones coded "NL". Suspect your 30P4 and try replacing it, preferably with one coded "MR" on the label.

**K.B. QUEEN DE LUXE**

This set has sound on vision on BBC. (ITV is perfect.) The fine tuner does not correct this. Would the oscillator need adjustment and if so could you please give the location?—V. Curtis (Neath).

Remove the switch knob and fine tuner and retune the oscillator coil core through the exposed hole with a long, plastic or bone knitting needle with one end filed so that it may be used as a screwdriver. If the trouble persists, instal a Band I aerial attenuator to reduce the input signal.

**DECCA DM45**

The picture on this set is 1in. from the bottom of the screen. I can fill the screen by operating the height control but I lose some of the picture at the top.—R. Houston (Glasgow S.W.3.).

You should be able to adjust the picture by resetting the two pre-set controls on the lower right side (at the rear) in conjunction with the height, although the bottom centre PL84 may be losing emission.

**INVICTA 119T**

On turning up the brightness control the picture fades and becomes grey and a large drop in EHT occurs. Also the vertical size of the raster varies with operation of the brightness control giving a short frame scan when turned down and over-scan when turned up. The EY51 has been renewed also the frame output valve. — J. Bentham (Co. Durham).

You should check the PL81 and PY81 valves after having ensured that the ion trap magnet on the rear of the tube neck is in the correct position (maximum brightness). Then check the top cap and cathode  $47\Omega$  resistors of the PL81, the setting of the line drive pre-set capacitor under the chassis and the 3.3k resistor to pin 8 of the PL81.

**FERGUSON 205T**

This set has two faults. After a period of 20 to 30 minutes viewing, the picture becomes negative. Adjustment of the fine tuner usually results in clearing this fault but, naturally, leads to patterning and an unsteady picture. The second fault is that bright lines come in from the right-hand side of the screen, usually after dark objects.—J. Wheatcroft (Chesterfield).

Interchange the AGC amplifier EF80 valve (V7) with a valve of the same type in some other position. We are not clear on the symptom of white lines to which you refer, but there is a possibility that flashover in the line output transformer owing to impaired winding insulation may be responsible.

**EKCOVISION T161**

This set is a 12in. model with a modified time-base, which I am rebuilding as a hobby. When first received the EHT smoothing condenser was covered with oil, and I assumed it was faulty. After repairing the set, I tried connecting the condenser, but it has no observable effect on the screen and it does not retain any charge. Is there any danger to the EHT transformer by running the set without the condenser? There is no

"Metrosil" on this model. What would be the effect of connecting a good condenser? Should the screen show extra brightness?—A. Tarlington (Montgomeryshire).

It is quite in order to omit your EHT condenser and Metrosil provided that the small bright spot seen on switching off does not persist for very long. The only improvement provided by the addition of these two components is better focusing of the white parts of the picture.

**PAM 501A**

When dark scenes appear on the screen, lines appear vertically down the left-hand side of the screen. In normal scenes, the picture is perfect and contrast is good except that recently a narrow dark line appears around objects, e.g. a man's coat or collar. Interlacing is good, but not perfect, although it can be made so but will not hold and the lines are generally slightly paired.—H. Crooke (Doncaster).

We would say that you have more than one fault. The "curtain" effect on the left can be due to the failure of one of the large resistors in the line circuit, especially the 10k and 3.9k across the width and linearity controls, and the 3.3k across L13, one of the scancoils. The black-after-white effect is usually due to faulty alignment but it is difficult for us to pinpoint one single circuit which is at fault.

**MURPHY V240**

The trouble is that the picture will not widen out—there is about a 3in. gap at either side. Also, the picture is split in two. I have renewed the following valves: 20P4, 20P3 and 20L1. I do not have a service sheet for this model.—A. Johnson (Manchester 19).

Low H.T., perhaps owing to faulty main smoothing, can cause your trouble as can a shorted scancoil, especially if the picture you have is tapered. The commonest cause is, however, the failure of the efficiency diode smoothing condenser which is a 0.25 $\mu$ F situated beneath the holders of the line output and efficiency diode valves.

**PYE TUNER**

I wish to use the above tuner, type 47, with a Ferguson 992T series 14in. television set. Can you please give me some details as to any modification in the circuit? I have your March 1960 issue in which you state that this tuner can be used with my set. Also, do I still use the ECC81 in the unit valveholder?—G. Byrne (Ilford).

To adapt your 47 unit to the 992 remove the EF80 (V1) and plug into its socket the power supply plug from the 47 unit. Remove the "tin box" from the end of the screened cable and connect the screened cable across the 2.2k cathode resistor of the mixer section of the ECC81 (leaving the valve in circuit). Remove the 0.001 $\mu$ F decoupling condenser from across the 2.2k resistor and also remove the anode and grid wires from the oscillator section of the ECC81. Short the mixer grid to chassis. The valve then acts as an impedance match from the 47 unit to the first I.F. transformer and has no gain. It is wise to make

# LAWSON EXACT REPLACEMENT Completely Reprocessed TUBES

(3) New Mullard, Mazda, Emiscope, etc., electron guns.

(2) Exact plug-in replacements.

## POINTS FOR PERFORMANCE

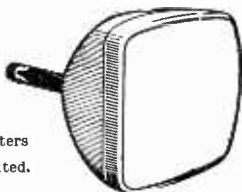

(6) New getters and regraphited.

(1) Silver activated screen

(4) Micro fine aluminised

(5) Specially reprocessed glass envelopes.

**(2) EXACT PLUG IN REPLACEMENTS**  
What a great advantage it is when fitting a new tube, to be sure it is an exact replacement for the old tube. We pride ourselves at Lawsons that our tubes are exact replacements. The Brand new guns fitted, have the correct characteristics, (No focusing, brightness chains or video modifications to make). All types are fitted with correct heater voltages, and all bases and base connections are exactly as the original tube. Simply slide out the old tube and plug in the new, for real picture perfection.

12 MONTHS' NEW TUBE GUARANTEE

ALL MAKES ALL TYPES FROM STOCK

12" - £5.10.0

14" - £5.19.0

15-17" - £6.10.0

ALL MATERIALS AND COMPONENTS USED IN THE MANUFACTURE OF THESE TUBES ARE COMPLETELY NEW, EXCEPT THE GLASS ENVELOPE AND ONLY ENVELOPES WHICH WILL PASS INSPECTION TO NEW GLASS STANDARD ARE USED.

## LAWSON TUBES

156 PICKERSLEIGH RD., MALVERN, Worcs. MAL. 3798

20/-

Gladly refunded if you wish to return your old tube.

Carr. and Ins. 7/6 (express passenger).

# FREE TO AMBITIOUS ENGINEERS

— THE LATEST EDITION OF ENGINEERING OPPORTUNITIES —

### Have you sent for your copy?

ENGINEERING OPPORTUNITIES is a highly informative 156-page guide to the best paid engineering posts. It tells you how you can quickly prepare at home for a recognised engineering qualification and outlines a wonderful range of modern Home Study Courses in all branches of Engineering. This unique book also gives full details of the Practical Radio & Electronics Courses, administered by our Specialist Electronics Training Division—the B.I.E.T. School of Electronics, explains the benefits of our Employment Dept. and shows you how to qualify for five years promotion in one year.

We definitely Guarantee  
**“NO PASS — NO FEE”**

Whatever your age or experience, you cannot afford to miss reading this famous book. If you are earning less than £25 a week, send for your copy of “ENGINEERING OPPORTUNITIES” today—FREE.

BRITISH INSTITUTE OF ENGINEERING TECHNOLOGY (Incorporating E.M.I. Institutes)  
(Dept. SE/20), 29 Wright's Lane, London, W.8

### WHICH IS YOUR PET SUBJECT?

- Mechanical Eng.,
- Electrical Eng.,
- Civil Engineering,
- Radio Engineering,
- Automobile Eng.,
- Aeronautical Eng.,
- Production Eng.,
- Building, Plastics,
- Draughtsmanship,
- Television, etc.

### GET SOME LETTERS AFTER YOUR NAME!

- A.M.I. Mech. E.
- A.M.I.C.E.
- A.M.I. Prod. E.
- A.M.I.M.I.
- A.I.O.B.
- A.F.R. Ae.S.
- B.Sc.
- A.M. Brit. I.R.E.
- City & Guilds
- Gen. Cert. of Education
- Etc., etc.

### PRACTICAL EQUIPMENT

Basic Practical and Theoretic Courses for beginners in Radio, T.V., Electronics, Etc., A.M. Brit. I.R.E. City & Guilds Radio Amateurs' Exam. R.T.E.B. Certificate P.M.G. Certificate Practical Radio Radio & Television Servicing Practical Electronics Electronics Engineering Automation

### INCLUDING TOOLS!

The specialist Electronics Division of B.I.E.T. (Incorporating E.M.I. Institutes) NOW offers you a real laboratory training at home with practical equipment. Ask for details.

**B.I.E.T. SCHOOL OF ELECTRONICS**



### POST COUPON NOW!

Please send me your FREE 156-page "ENGINEERING OPPORTUNITIES"  
 (Write if you prefer not to cut page)  
 NAME.....  
 ADDRESS.....  
 .....  
 .....  
 SUBJECT OR EXAM THAT INTERESTS ME..... (SE/20.)

**THE B.I.E.T. IS THE LEADING ORGANISATION OF ITS KIND IN THE WORLD**



## Fly as an Air Electronics Officer in today's R.A.F.

After technical training as an Air Electronics Officer, you fly in V-bombers or on Coastal Command reconnaissance. You are the link with your base; you are in charge of the whole electrical power system of your aircraft; you control all electronic warfare devices. You are a vital member of your aircraft's crew.

### Types of Commission

For fit young men of 17½ to 25 there are several types of commission available. Method of entry depends on educational qualifications (the minimum is G.C.E. at 'O' level, or equivalent, in 5 specified subjects). Pay, pensions and gratuities are generous. A Flying Officer of 21 earns £950 a year, and a Flight Lieutenant of 25 can earn, with full allowances, over £1,750 a year.

Write for full details,

stating age and educational qualifications, to

Group Captain J. N. Ogle, A.F.C., A.F.M.,

Air Ministry (PTN735a), Adastral House, London, W.C.1.

**TODAY'S TOP JOB IS THE R.A.F.**

## SPECIAL VALVE OFFER For Limited Period

EB91	4/-	UF42	7/-	6L1	8/-
ECL30	7/6	UL41	7/6	6L18	9/-
ECL32	8/-	UL44	7/6	6P25	6/6
EF80	5/-	UL46	7/6	6LD20	7/6
EF91	4/-	UBC11	7/6	6SN7GT	5/6
EL38	10/6	UCH42	7/6	6P28	8/6
EY33	7/6	U35	8/6	737	9/6
GZ32	8/-	5P81	2/6	10F1	6/-
KT33C	6/6	3D8	2/6	10P14	6/6
PCL83	12/6	6AT8	6/6	12AT7	6/-
PL33	8/-	6CH8	7/-	20D1	7/6
PL32	7/6	6GG6G	10/6	UY41	5/6
PL31	7/6	6F1	6/-	N37	8/-
PY80	7/-	6F13	6/-	ECC83	7/-
PY82	7/-	6F14	6/-	807	7/6
PZ30	11/-	6F15	6/-	PY31	6/-
UAF42	8/6	6J5GT	5/-	1825	7/6

Postage 4d. per Valve.

Coaxial Cable. 75 ohms. 6d. yd. Ion Traps. 5/-; Midget 2 Gans. 6/6; New 7 x 4 P.M. Speakers. Large or Small Magnet. 15/-.

TV AERIALS: We carry large stocks; send S.A.E. with your requirements and we shall reply and send leaflets by return.

**MAIL ORDER ONLY - NO CALLERS**

Terms: C.W.O. or C.O.D. minimum C.O.D. 3/-; postage, packing other than valves. under £2. 1/6; under £5. 2/-; aerials, 2/6.

## ELECTRO SERVICES & CO.

221 BATTERSEA PARK RD., S.W.11

Mac. 6832/4

## NEW VALVES!

Guaranteed Set Tested  
24 HOUR SERVICE

1R5, 1S5, 1T4, 3V4, 3V4, DAF91, DF91, DK91, DL92, DL94, SET of 4, 18/6.  
DAF86, DF86, DK96, DL96, SET of 4, 20/-.

1D5	7/-	DL92	5/11	PCF82	7/6
1R5	5/-	DL91	6/9	PCL82	7/6
1S5	4/6	DL93	6/9	PCL83	10/6
1T4	3/9	EB41	3/-	PCL84	7/6
3S4	5/11	EB41	7/6	PL36	10/9
3V4	6/9	EBF80	7/9	PL81	8/9
5U4C	4/3	EBL21	12/6	PL82	7/-
5Y3GT	5/6	ECC81	4/9	PL83	7/-
5Z4G	7/3	ECC82	5/9	PL84	9/6
6AM6	2/9	ECC83	6/3	PY33	10/3
6K7G	1/9	ECC84	8/-	PY80	7/-
6K8G	4/9	ECC85	7/9	PY81	6/3
6Q7G	5/6	ECF80	8/3	PY82	6/3
6V6G	4/9	ECF82	8/3	PY83	7/3
6V6GT	6/6	ECH21	12/6	U25	12/-
6X6GT	4/9	ECH42	7/9	U26	10/-
12K7GT	4/9	ECL80	7/-	UABC80	7/6
12R8GT	11/-	EF41	7/6	UF42	8/6
12R7GT	4/6	EF30	4/9	UBC41	7/-
35L6GT	8/6	EF65	5/6	UBF80	8/6
35Z4GT	5/3	EF86	9/6	UCC85	7/-
AZ31	8/9	EF89	6/9	UCH21	12/6
CL33	11/9	EF81	2/9	UCH12	7/6
DA32	6/6	EL11	7/3	UCH81	8/-
DAF91	4/6	EL84	6/3	UCH82	10/-
DAF96	6/9	EY51	7/3	UCL33	13/-
DF33	8/6	EY88	7/6	UY41	7/9
DF91	3/9	EZ40	6/-	UY85	8/-
DF96	6/9	EZ41	6/9	UF89	6/6
DH77	6/-	EZ80	5/9	UL41	7/-
DK32	11/-	EZ81	6/6	UL84	7/-
DK91	5/-	GZ30	8/-	UY85	11/-
DK92	7/3	MU14	7/-	UY41	5/9
DK86	6/9	PCC84	7/3	UY85	6/3
DL33	8/6	PCC89	10/-	VP45	8/6
DL35	9/6	PCF80	7/3	Z77	2/9

Postage 6d. per valve extra. Any Parcel Insured Against Damage In Transit 6d. extra. Any C.O.D. Parcel 2/6 extra. Office address, no callers.

**GERALD BERNARD**  
90 CARR MANOR AVENUE  
LEEDS 17

## REBUILT TV TUBES

FULLY GUARANTEED  
12 MONTHS

Complete New Gun fitted in every Tube

12in., 14in. ...	£5.00
15in. ...	£5.10.0
17in. ...	£6.00
21in. ...	£8.00

Immediate Delivery  
Carriage and Insurance 10/- extra  
Allowance on old tube

## NU-GUN TELETUBES LTD.

3 The Mews, Duckett Rd.  
Harringay, London, N.4

Telephone: MOUntview 2903

## RES/CAP. BRIDGE 38/-

p. & p. 2/-  
Checks all types of resistors, condensers  
6 RANGES

Built in 1 hour. Direct reading  
READY CALIBRATED  
Stamp for details of this and other kits.  
**RADIO MAIL (Dept. GY)**  
Raleigh Mews, Raleigh Street, Nottingham

### NEW THIRD EDITION

## TELEVISION ENGINEERS' POCKET BOOK

Much new information has been added to the enlarged and fully revised third edition. Experienced engineer and the new-comer to the service work will find this handy book invaluable for the on-the-spot repairs.

Edited by  
J. P. Hawker

12/6.

Postage 6d.

**PRACTICAL TV TROUBLE-SHOOTING** a Gernsback Lib. Pub: 18/6. Postage 9d.

**A BEGINNER'S GUIDE TO RADIO**, by F. J. Camm, 7/6. Postage 6d.

**PRACTICAL AUTO RADIO SERVICE & INSTALLATION**, by J. Greenfield, 23/- . Postage 1/-.

**A TO Z IN AUDIO**, by G. A. Briggs, 15/6. Postage 9d.

**THE WALTER TAPE RECORDING BOOK**, a Focal Pub: 12/6. Postage 6d.

**WORLD RADIO HANDBOOK** for Listeners, 1961 ed. 16/6. Postage 1/-.

## THE MODERN BOOK CO.

BRITAIN'S LARGEST STOCKISTS  
of British and American Technical Books

19-21 PRAED STREET,  
LONDON, W.2.

Phone: PADington 4185.  
Open 6 days 9-6 p.m.

sure that plenty of signal is available before conversion as some gain will inevitably be lost.

#### SOBELL SC270

The picture and sound on ITV is in order. The picture is fair but there is almost no sound on BBC. If the volume is increased there is a noise but little signal. The V.H.F. sound is poor but this has always been the case, but the BBC was in order until recently.—A. Turner (Slough).

Switch to BBC, set the fine tuner midway and remove the switch knob and cover to expose the oscillator cores. Adjust the lower core, nearest the fine tuner spindle, for maximum BBC sound. It would appear that a properly sited V.H.F. aerial is required.

#### K.B. FV30

This set has a turret tuner fitted for ITA. The set was perfect until a broad white line appeared across the centre of the screen. There was no picture or raster. I replaced the frame output transformer and got the raster back but still no picture. I have changed a few charred resistances. When the brightness is turned up I can obtain a round ring shadow in the centre of the tube about 3½ in. wide. When the set is switched off there is a square instead of the ordinary spot.—G. Nuttall (Whittingham).

You will no doubt find the fault is concerned with one of the inner row of valves, just to the right of the tube. These valves are 6AM6/8D3 and 6AL5. Check these and the voltage supplies to pins 5 and 7 of each 6AM6/8D3 valve base if the valves are in order.

#### H.M.V. 1847

Recently I decided to overhaul this set which is a 21in. model. In doing so, I removed the tube for external cleaning generally. Since replacing the tube all is well on sound and vision apart from interference, which is very severe, there being a very high-energy discharge around the tube to frame support and from the tube to the coil housing. I believe this could be due to having destroyed the outer coating around the tube. Can you advise me on what can be done to restore this to normal?—D. Collett (Downend).

You should smear the area around the EHT connection with MS4 grease or similar anti-corona compound. Ensure that the outer coating of the tube is well bonded to chassis. If the discharge persists, you will find it necessary to replace the line output transformer.

#### ALBA AB81

This set is about five years old and the only number I can find is that quoted above. The picture is a narrow band across the middle of the screen about 3in. from top to bottom with a hum on sound. The picture which is visible is very

"jumpy". I was told by a TV engineer that there were two condensers that had failed. I have replaced R12, and both valves PY81 and 82. These have been found to be in order.—J. Watson (Sunderland).

You should change the front large can-electrolytic (100+200µF) and check the left centre PL82 valve and associated components. We assume the model number is T304.

#### MW43-69 TUBE

Can a line output transformer, together with a set of scanning coils, also frame output transformer (with scanning coils) which were made to scan a 90deg deflection tube, be used to scan a 70deg deflection tube such as MW43-69, MW36-44 (the original type of wide angle tube)? If they can be used what, if any, will be the effects on the visible raster when displayed on the 70deg deflection angle tube?—R. F. Stout (Sheffield 12).

The 90deg deflection components can be used but although the frame height will be easily adjusted, you may find some overscan on the line. The width control may not reduce the scan sufficiently but this should not be serious.

## SERVICING TELEVISION RECEIVERS

(Continued from page 207)

#### Sound on Vision

If this only appears on BBC proceed as above. When present on both stations, however, retune L21 and L17. If ineffective, check C102. When signal generator is available tune L21 for minimum vision at 38Mc/s, L17 for minimum vision at 38.5Mc/s.

#### Dismantling

The chassis is secured by four screws below the front knobs pull off and the speaker leads have press-stud contacts at the speaker. The chassis is removed complete with the tube for easy servicing.

#### Note

The alignment instructions are not always the same and when the sound I.F. is given as 37.5Mc/s and the sound I.F. are aligned to this figure, the alignment of L21 should be the same. L17 remains at 38.5Mc/s.

### QUERIES COUPON

This coupon is available until JANUARY 20th, 1961, and must accompany all Queries sent in accordance with the notice on page 219.

PRACTICAL TELEVISION, JANUARY, 1961.

**SETS & COMPONENTS**

**IN SCOTLAND  
RENVU**

**For BETTER VALUE**  
Completely REPROCESSED TUBE  
(New Gun, Rescreened,  
aluminised)

- 6.3v. .3 amp. 17" types ... £7. 0.0
- 6.5v. .3 amp. 14" types ... £6.10.0
- 12.6v. .3 amp. 17" types ... £7. 0.0
- 12.6v. (round)  
.3 amp. 14" types ... £6.10.0
- 12.6v. .3 amp. 15" types ... £7. 0.0
- 2v. 15" types ... £7.10.0
- 2v. 12" types ... £6.10.0

**ELECTROSTATIC 90° TUBES**  
10/- extra.

10/- allowed on old tube.

**RENFREW ELECTRONICS LTD.,**  
ANDERSON DRIVE  
RENFREW  
Tel.: RENfrew 2642

**VALVES, RECORD** Changers and  
Players, Speakers, Rectifiers, Valve  
Testers, Condensers, Resistors. Send  
for list. H. P. JAMES, 21, Claremont  
Road, Twickenham, Middx.

**TELEVISION TUBES!** Rebuilt, new  
guns, twelve months' guarantee. 14in.,  
75/-, 17in., 79/6. Quantity discounts.  
3, Park Ave, New Barnet, BAR 3185.

**TV TUBES,** New gun, 17in. £5. Twelve  
months' guarantee. Dealers supplied.  
Aerials and Coax cheap. TV ELECTRIC  
& CYCLE CO., 1, High Street,  
Chalvey, Slough. Tel.: Slough 21860.

**TELEVISION PICTURE TUBES**

Manufacturers' Guarantee  
Twelve Months

- Tubes for All British-made Sets**
- 10 inch .. .. £4. 0.0
  - 12 inch .. .. £5. 0.0
  - 14 inch .. .. £5.10.0
  - 15 inch .. .. £7. 0.0
  - 16 inch .. .. £7. 0.0
  - 17 inch .. .. £7. 0.0
  - 21 inch .. .. £8.15.0

32/6, with order. 20/- monthly.  
NEW tubes for ALL HMV &  
Marconi TV sets from £5 to £7.  
4 speed auto-change record players  
15gns. 18½gns. AM/FM Radios for  
12gns.  
TAPE RECORDERS 30% below  
list.

Despatched B. R.'s Passenger. 48-  
hour service.

**Cathode Ray Tube Service**  
35 BROOMWOOD ROAD  
ST. PAULS' CRAY, KENT  
Orpington 21285

**RATES:** 4/- per line or part  
thereof, average five words to line,  
minimum 2 lines, Box No. 1/- extra.  
Advertisements must be prepaid  
and addressed to Advertisement  
Manager, "Practical Television"  
Tower House, Southampton St.,  
London, W.C.2.

**SETS & COMPONENTS**  
(continued)

**REBUILT TELEVISION TUBES—12in.**  
£5; 14in. £5/10/-; 17in. £6/10/-.  
Twelve months' guarantee. 10 carr.  
**BRAYHEAD TURRET TUNERS—**  
£8/19/6. Carriage paid. State coils.  
All types BBC and ITA AERIALS.  
**AIRSPACED COAXIAL CABLE** from  
6d per yard. **TELEVISION SPARES**  
**AND EXACT REPLACEMENTS.** The  
latest BSR UA14 four-speed Changer  
£9/10/-. Carriage paid. All leading  
makes of **TAPE RECORDERS, TAPES,**  
**AMPLIFIERS, TAPE DECKS,**  
**RECORD PLAYERS, TELEVISIONS**  
**and RADIOS.** All new goods on  
Easy Hire Purchase Terms. **TRANS-**  
**SISTORS RED SPOT 5/6.** **TRANS-**  
**SISTORS WHITE SPOT 5/6** each.  
**GERMANIUM DIODES 1/-** each.  
Stamped addressed envelope, please.  
For inquiries and callers are welcome.

**DEVIZES TELEVISION SERVICE**  
29-30, The Nursery, Bath Road,  
Devizes, Wilts. Tel.: Devizes 1100.

"HEATHKITS" can now be seen in  
London and purchased on easy terms.  
Free brochure. **DIRECT TV REPLACEMENTS LTD.,** Dept PT/22/12, 138,  
Lewisham Way, S.E.14. Tideway 6866.

**TV SPARES**

**London's Largest**  
**Range—New or Used**  
**LINE OUTPUT TRANS-**  
**FORMERS and SCAN COILS**  
for nearly every make and model  
New from 45/-. Used from 20/-.  
Just a few examples from our extensive  
range **IN STOCK.** Add 2/6 for P. & P.  
**TELEPHONE ORDERS SENT SAME DAY**  
C.O.D.

**NEW LINE O.P.**  
**TRANSFORMERS**

**Pye V4/7, VT4/7, 52/6; LV30, FV1, 52/6.**  
**Ferranti 14T2/3/4/5, 45/-; T1225, 62/6.**  
**Ferguson 992/6/7/8, 66/9, 941-55, 57/6.**  
**Ekco T221/231, 50/-; T161, etc., 45/-.**  
**H.M.V. 1824-9, 58/6; 1840-8, 59/6.**  
**Coscor 930-9, 58/6; 916-25, 75/-.**  
**Alba T301/504, 45/-, 362/441, 47/6.**  
**Murphy V240/250, 62/6; V200, 49/6.**  
**Ultrat V79-17, etc., 108/6, with U25.**  
**New Scan Coils for Pye, V4/7, VT4/7, 62/6.**  
We also stock a complete range of spares  
for nearly all makes and models, e.g.  
LOPT's, Line and Frame Blocking Trans.,  
Frame Output Trans., valves, resistors,  
capacitors, ion traps, etc., etc.  
**PLEASE SEND S.A.E. FOR IMMEDIATE**  
**QUOTE.**

Used Chassis or most of the older sets at  
only 50/- plus 20/- carriage.

**TELEVISION CONSUMER**  
**SERVICES LTD.**

**28 BROCKLEY CROSS, S.E.4.**  
TIDeway 5394  
**112 CAMBERWELL RD., S.E.5.**  
RODney 7917

**SETS & COMPONENTS**  
(continued)

**BOURNEMOUTH**

14in., 15in., 17in. Round and Rectangular  
TV Tubes, £8.19.6 (10/- allowed on your  
dud tube), 12 months' guarantee, 3 element  
ITV/BBC aerial with wall bracket, 34/6.  
Both carr. paid.

EF80 7/6	EZ80 7/6	ECC81 7/6
EL81 8/6	EF91 6/6	ECC82 7/11
PY82 8/9	PL81 12/6	ECC83 7/11
EY51 11/6	PL82 11/6	PCF80 11/6
6V6 5/6	PY81 8/9	PCCB4 10/8
12AT7 7/6	EC91 4/-	ECL80 10/8
12AX7 7/11	12AU7 7/11	ECC91 5/-

Complete range of capacitors, resistors,  
Hi-Fi radiogram chassis, amplifiers, motors,  
pick-ups, mono and stereo.

**BOURNEMOUTH'S HI-FI AND**  
**CONSTRUCTORS' CENTRE**

**NATIONAL RADIO SUPPLIES**

66 HOLDENHURST RD., BOURNEMOUTH  
Tel. 25232

**AJAX TV SIGNAL BALANCER.** Gives  
both programmes with identical  
brilliance. 10/- post free. **AJAX**  
**ELECTRONICS, 572, Fulham Road,**  
**S.W.6.**

IT4 3/6	EB91 3/6	PCF80 7/6
IL4 1/9	EF91 3/6	PCC84 7/6
IR5 3/6	ECC81 5/-	PL81 8/6
IS5 3/6	ECC82 3/6	6K8G 5/6
DK92 8/-	ECH42 9/-	6SN7GT 4/-
DK96 8/6	ECL80 7/6	6V6G 4/6
DL92 6/6	EY51 7/6	12AH7 4/-
DL96 6/9	EY86 7/6	954 1/3
DL94 7/6	EF86 9/6	EF50 1/6

All brand New and Boxed. C.W.O. Over 200  
Types Available, **Woodward, 16 Aubrey**  
**Road, Sherwood, Nottingham. 65504.**

**TV SPARES** New, Used; LOT from  
20/-, etc. Valves from 2/6. S.A.E.  
quotation: **BOYD LANGFORD, 162,**  
**Church Street, London, N.16.**

**Television Tube Shop**

now stock

**Tubes for every make of set**

NEW REDUCED PRICES

- 12 inch, Mullard type .. .. £4. 5.0
  - 12 inch, Mazda type .. .. £4.15.0
  - 14 inch, Mullard type .. .. £5. 9.0
  - 14 and 15 inch, Mazda type .. .. £5.15.0
  - 17 inch, All types .. .. £8.10.0
  - 17 inch, Slim line 110" .. .. £8.17.6
  - 21 inch, All types .. .. £8.10.0
- Also G.E.C., BRIMAR, F.M.I. types.  
Add 10/- for delivery to your door within  
48 hours or 5/- B.R.S. Terms £2 down.  
All Tubes Carry 12 months' guarantee.  
A few shop-soled tubes available. Good  
picture. Fully guaranteed, from 50/-.  
Spare-time Service Engineers—send for  
details of our rebate scheme.

**TAPE RECORDERS**

- Latest Collaro "Studio" 3-speed  
Tape Deck, complete .. .. £13.17.6
- Fitted to Motor Board with 1,200  
feet E.M.I. tape, knobs etc. to fit  
into your own cabinet .. .. £15.15.0
- 5.3 watt Amplifier, specially de-  
signed for the "Studio" complete  
with power pack knobs, etc. .. .. £10.10.0

**VALVES**

A very wide range at 50% off list price. Send  
for complete price list of these and other  
Bargains.

**TELEVISION TUBE SHOP**

48 Battersea Bridge Road, LONDON  
S.W.11 EAT 8859. Open Saturdays.

**SETS & COMPONENTS**

(continued)

**C. EDWARDS**

1070 HARROW ROAD  
LONDON, N.W.10  
LADBROOKE 1734

Offers  
S/H TV in  
First-class  
Condition

12in. £5.0.0  
14in. £7.10.0  
17in. £13.10.0  
(all 5 channel)  
+ 15/- carriage.  
Guaranteed  
VALVES



10F1, 10/-; 10C2, 10/6; 20D1, 6/-; PF30, 5/-; SP61, 7/-; 6K25, 8/-; 20P1, 10/-; 2P20, 8/-; PL33, 7/-; ECL80, 8/-; EB91, 6/- Plus 6d. post.  
S/H 12in. tubes, 50/- plus 7/6 post.

**FERGUSON, EKCO**

**RECLAIMED VALVES.** All tested and Perfect; modern and obsolete; huge stocks; all one price. 5/-, plus 6d. postage each, delivered by return. LEWIS, 46, Woodford Avenue, Ilford, Essex.

**SPARES - VALVES - TUBES**

1930-1960

Guaranteed Perfect, set tested, ex-working equipment. L.O.T.s from £1. F.O.T.s, Osc. Tr. Def. Colls, etc., cheap. TUBES, guaranteed 6 months. FITTED FREE. Picture shown to callers. 9in., 30", 12in. 50/-, 14in. 60/-, 17in. 70/- VALVES. 3,000 types stocked. EF50, SP61, 1/-; EF91, EB91, 6H6, Z77, D77, 6J5, 2/-; PF80, UF42, 6F1, 8F13, 6AG3, UB41, 20D1, 3/-; 10F1, B36, 6V4, KT61, 6SN7, EL32, B36, EP3, 4/-; PC384, PC980, PL81, PL82, P31, ECL41, PCL83, 6K25, EBC91, EY51, EL33, 6U4, 5/-; KT33C, 10P14, 10C1, UCH42, UL41, ECH5, HVR2, 7C5, 7Y4, 6/-; EL38, KT36, PVL, U22, U35, U261, U16, 7/6, PL38, PZ30, ZNE1, 20P3, 185BT, U18, U24, U25, 10/-; L801, 20P4, 6CD6, 27SU, U37, 12/6. Pre-war 4, 5 and 7 Pin, 5/- each Postage 6d. "Constructor's Parcel." 2 lbs. assorted resistors, condensers, pots, etc., from modern TVs, 7/6. Postage 2/6. Write or phone. Send S.A.E. for list or with enquiries. "ST. JOHN'S RADIO", 156 St. John's Hill, S.W.11. BAT. 9638

17-INCH TUBES 75/-, new guns. all sizes available, guaranteed. STAR TUBES, Brief Street, Bolton.

**LIVER TUBES**

Fully Guaranteed 12 months  
All makes — 12" to 21"

**BLANE & MARTIN  
ELECTRONICS**

70 High Street, Wavertree  
**LIVERPOOL**

Details on request  
Tel. SEF. 3428

**SETS & COMPONENTS**

(continued)

**SALVAGED VALVES**

2/6 each

Tested on Mullard High Speed Valve Tester  
**New and Boxed Valves  
all at 10/- each**

S.A.E. FOR LIST

**ARION TELEVISION, 4 Macted Road,  
S.E.15  
NEWX 7152**

**SPARE VALVES (TV).** Set of 8 for 25/-. Also sold separately. List 2d. 85, Charninster Ave. Bournemouth.

**TUBES — AERIALS — VALVES**

Regunned tubes, guaranteed one year, prices from £5, allowance on old tube. Revacuumed tubes, all sizes. 50/-; guaranteed 6 months. Full range of aerials at trade prices, double eye costs only 56/- Full range of valves, example PCC84 cost 8/-, ITV pre-amplifiers, £3.15.0. self-contained in case. ITV converters, 25. Breadth tuners, £4.12.6. New TV sets and transistor radio supplied, ask for quotation. Low loss co-axial, 1/1 yd.; Standard 6d. yd. Diplexers, 8/8 each. All items carriage extra. S.A.E. for lists.

G. A. STRANGE

**BROADFIELD, NORTH WRAXHALL,  
Nr. Chippenham, Wilts. Tel. Marshfield 236**

**VALVES, SALVAGED.** Picture tested, EF80, EF91, EB91, 6F1, 10F1, ECL80, PY80, PY82, 6P28, All 2/6 each. Post free from: TELESALES (Swi) LTD., 223, Manchester Road, S.W.1, M/C.

**GUARANTEED VALVES**

IIA	2/6	12A77	6/6	EF91	3/-
6F1	6/6	20D11	6/6	EL32	3/-
6F13	5/6	20P2	7/6	PC984	6/6
6F14	7/6	2U11	8/6	PV30	6/6
6F13	7/6	D77	3/6	PY82	6/6
10C1	7/6	EABC80	7/6	UL41	7/6
10F1	6/6	EF80	5/-	U648	7/6

Postage 6d. each List 3d.

**SERVICE SHEETS, BOOKS, COMPONENTS.**

Lists 3d.

Hamilton Radio (T), 18 Western Rd., St. Leonards, Sx.

**BRAYHEAD TURRET TUNERS** for any area. Will convert over 600 models. Complete with fitting instructions. State set, model and 2 channels when ordering. 10n/c and 35m/c models £5/15/-. 16m/c £6/8/-. External cabinet (if required) 24/-. Carriage paid. C.W.O. or C.O.D. DURHAM SUPPLIES, 175, Durham Road, Bradford 8, Yorkshire.

**H.P. on Regunned  
C.R.T.s.**

**At No Extra Charge  
12 Months' guarantee**  
12" & 14" .. £3.10.0  
17" .. £4.10.0  
21" .. £5.10.0

Phone or Call only:  
Rod 778

**P. J. F. Andrews**  
61-63 ROSEMARY RD.  
LONDON, S.E.15

**TV TRANSFORMERS**

PHONE BY 3 p.m.  
SENT SAME DAY C.O.D. ON ALL ITEMS BELOW IN STOCK

**LINE OUTPUT TRANSFORMERS**

Makes	Models	Prices
ARGOSY:	T2, CTV517 .. .. .	59/6
DECCA:	D17 & C .. .. .	59/6
DEFIANT:	TR1758 .. .. .	59/6
R.G.D.:	601T, 7017C, C84 .. .. .	59/6
REGENTONE:	17C, VT1, VT Comb. .. .. .	59/6
BAIRD:	2014, 2017, 2114, 2117 .. .. .	49/6
COSSOR:	930 & T, 931, 933-4-5, 937, 938 & A & F, 939 & A & F, 948T, 946 .. .. .	59/6
H.M.V.:	1824 & A, 1825 & A, 1826 & A, 1827 & A, 1829 & A .. .. .	65/-
MARCONI:	VT68DA, VT69DA .. .. .	65/-
SOBELL:	T817, T346 .. .. .	63/-
FERGUSON:	906T, 908T .. .. .	63/-
H.M.V.:	1853, 1859 .. .. .	63/-
FERGUSON:	992T-997T, 998T .. .. .	69/9
PYE:	V4, VT4, V7, VT7, CTM4 .. .. .	55/-

All other makes available (3-5 days)

**S.A.E. ALL ENQUIRIES**

Makes	Models	Prices
ARGOSY:	LINE BLOCKING OSC. TRANSFORMERS	8/6
DECCA:	D14, D17, D17C .. .. .	8/6
DEFIANT:	TR1454-5-6, 1552, 1754-5-6 .. .. .	8/6
MARCONI:	VT63DA .. .. .	8/6
REGENTONE:	14-5-7T, 143T, 173T .. .. .	8/6
R.G.D.:	6014-5-7T series .. .. .	8/6
H.M.V.:	1824 & A, 1825 & A, 1826 & A, 1827 & A, 1829 & A, 1840-1-2-3-4-5-6-7-5 .. .. .	14/6
MARCONI:	VT68DA, VT69DA, VT180, VC & VT131, VC152-3 .. .. .	14/6
FERGUSON:	992T-997T, 998T .. .. .	18/9
PYE:	V4, VT4, V7, VT7, CTM4 .. .. .	18/9

Makes	Models	Prices
<b>FRAME BLOCKING OSC. TRANSFORMERS</b>		
ALBA:	T301, 304, 312, 372 & B, 394, 483 & B series .. .. .	12/9
ARGOSY:	D14, D17, D17C .. .. .	12/9
DECCA:	D14, D17, D17C .. .. .	12/9
DEFIANT:	TR1454-5-6, 1552, 1754-5-6 .. .. .	12/9
MARCONI:	VT63DA .. .. .	12/9
R.G.D.:	6014-5-7T series .. .. .	12/9
REGENTONE:	14-5-7T, 143T, 173T .. .. .	12/9
VIDOR:	CN4218, CN4225 series .. .. .	12/9
PHILIPS:	835U, 485U, 492U, 685U, 704A, 1502U .. .. .	15/-
STELLA:	1822U .. .. .	15/-
PHILIPS:	1400A, 1700A, 1800A, 2347A, 1822U .. .. .	15/-
PHILIPS:	E.H.T. Osc. Tr. 1400A, 1700A, 1800A, 2347A .. .. .	15/-
PHILIPS:	1101U, 1200U & VF, 1400A, 2337, 2347A .. .. .	16/-
PHILIPS:	1114UM, 1116U, TG1437U, 1446U & 445, 1726U, 1746U & 445, 1747U .. .. .	16/-
STELLA:	8314U, 8317U .. .. .	16/-
PYE:	FV4 & C, PV92, V2, PV40 & CDLL .. .. .	11/6
PAM:	904, 906, 932-3-4, 955 .. .. .	11/6
INVICTA:	T105, 107-8, 110-1-2-4-5-7-8-9, T120 .. .. .	11/9

Makes	Models	Prices
FERRANTI:	1478-4-5-6, 1778-4-5-6, 2074-5-6, 2174-5-6, 2424, T1392, 1025, 1825 .. .. .	14/6
SOBELL:	T817, T144, T145 & C, T174 & C, TRG174, T175 & LC, TRG 175, T274, T277, T346 .. .. .	18/-
BANNER:	BT14, BT117 & C .. .. .	18/-
COLUMBIA:	509, 505-6 .. .. .	18/-
H.M.V.:	1814, 1816, 1821, 1824 & A, 1825 & A, 1826 & A, 1827 & A, 1828 & A, 1840, 1941, 1842, 1843, 1844, 1845-6-7-8 .. .. .	14/6

Makes	Models	Prices
MARCONI:	VC65DA, VT69DA, VC68DA, VC68DA, VT68DA, VT69DA, VT160, VC & VT151, VC152-3 .. .. .	14/6
PYE:	V4, VT4, V7, VT7, CTM4 .. .. .	11/9

**FRAME OUTPUT TRANSFORMERS**

Makes	Models	Prices
BANNER:	BT114, 117 & C .. .. .	25/-
COLUMBIA:	C503, C505, C506 .. .. .	25/-
SOBELL:	T817, T121, T126, T148, T144, T145 & C, T174C, TRG174, T175 & LC, TRG175, T176, T224, T274, T277, T346 .. .. .	25/-
PYE:	V4, VT4, V7, VT7, CTM4 .. .. .	21/-
FERGUSON:	992T-998T .. .. .	21/-

All Makes Available

**SCAN OILS**  
V4, VT4, V7, VT7, CTM4 .. .. . 59/6  
992T-998T series .. .. . 69/6  
FERGUSON: T217, TC178, TC196, T205, 290 .. .. . 29/6  
EKCO: T300 .. .. . 29/6

All Makes Available for ALL Models.  
S.A.E. ALL ENQUIRIES

Post and Packing all items. 1/6. C.O.D. 1/6 extra.

**Wyndson Television Service**  
ST. ALBANS ROAD  
BARNET, HERTS.  
BAR. 1769. Closed Thursday 1 o'clock

**FOR SALE**

**VALVE CARTONS** at keen prices. Send 1/- for sample and list. J. & A. BOXMAKERS, 75a, Godwin Street, Bradford 1.

**SERVICE SHEETS:** also Current and Obsolete Valves for sale. JOHN GILBERT RADIO, 20, Extension, Shepherd's Bush Market, London W.12 (Phone: SHE 3052).

**1,000 TELEVISIONS**, all makes, from £3 working, 10/- not. Callers only 9 till 6 including Sats. 39, Whitehorse, Laue, Stepney, London.

**TELEVISIONS**

All sizes including Projections. Require attention from £3. In working order:—  
12in. BBC from £5.  
12in. and 14in. BBC/ITA from £10.  
Regulated CRT £6 extra 17in. from £25.  
Send for Lists. Carriage Paid.

**CADMANS**

SERVICE DEPARTMENT  
BRYAN STREET, HANLEY  
STOKE-ON-TRENT

**BE PROFESSIONAL** and Ship-shape with our COMBINED VALVE, COMPONENT TOOL BOXES. Now released for general sale. For three years sold exclusively to the Trade. With or without tools. Write direct to our manufacturers for details. GEO-PAT SUPPLIERS LTD., Lambridge Street, Larkhall, Bath.

**SECOND-HAND RE-GUNNING** equipment consisting of drop sealer pump oven and induction heater, capable of re-gunning TV tubes. Current supply required 40-50amps.—K. H. WOOSTER, 18 Gateland Lane, Leeds 17, or phone Leeds 32846/8.

**100 BAYS** Brand New Adjustable Steel Shelving, 72in. high x 34in. wide x 12 in. deep; stove enamelled dark green, sent unassembled. Six shelf bay £3 6s 0. Sample delivered free. Quantity discounts. N. C. BROWN LTD., Eagle Steelworks, Heywood, Lancs. Tel.: 69018.

**WANTED**

**NEW VALVES WANTED.**—EY51, ECL80, PCC84, PCF80, PCL83, PL81, PCL82, PY81, K19, U801, 30P4, etc. Best Cash prices by return. DURHAM SUPPLIES, 175, Durham Road, Bradford 8, Yorkshire.

**WANTED** Service Sheets. No quantity too large, highest prices paid. SULTAN RADIO, 29, Church Road, Tunbridge Wells, Kent.

**A PROMPT CASH OFFER** for your surplus Brand New Valves, Speakers, Components, Test Instruments, etc. R.H.S., 155, Swan Arcade, Bradford 1.

**BEST PRICE** paid by return for new Valves and equipment. STAN WILLETS, 43, Spon Lane, West Bromwich, Staffs. Tel: WES 2392.

**NEW TV VALVES WANTED.** Send valves, cash by return to: P. J. F. ANDREWS, 61-63, Rosemary Road, London, S.E.15.

**WANTED—VALVES.** Modern TV and radio types. Large or small quantities. Box No. 22.

**AERIALS****MAKE YOUR OWN AERIALS**  
SAVE 22s

TV aerial manufacturer offers "do-it-yourself" kits, 50 components include castings, pressings, mouldings, tubes, brackets, can be utilized to make 100 different models, TV, V.H.F., amateur. Brochure gives full illustrations, element dimensions and prices. Discounts for quantities.

THE RICHARD MAURICE

EQUIPMENT CO.

Portsmouth Road, Cobham, Surrey.  
COBHAM 3239.

**MISCELLANEOUS**

**HOW TO USE EX-GOV. LENSES AND PRISMS.** Nos. 1 and 2 2/6 ea. List free for S.A.E. H. W. ENGLISH, 469, Rayleigh Road, Hutton, Brentwood, Essex.

**SERVICE SHEETS**

**SERVICE SHEETS** Radio, TV, 5,000 models. Lists 1/-. S.A.E. enquiries: TELRAY, 11, Maudland Bk., Preston.

**FAULTFINDER FILES** (TV) showing common faults that each receiver is prone to and other useful servicing information. 2/- each. List 9d., plus postage. S.P. DISTRIBUTORS, 11, Old Bond Street, London, W.1.

**SERVICE SHEETS** for sale, all types from 1/-, with free fault-finding guide, 125 Radio/TV sheets covering 370 popular models 20/-, S.A.E. Lists/Enquiries. HAMILTON RADIO (T). 13, Western Road, St. Leonards, Sussex.

**SERVICE SHEETS.**—We have the largest stock of Radio and TV Sheets in the country for sale at 4/- ea. Radio and Television Service Sheet List 1/-. Also Manuals for sale or hire. List 9d. S.A.E. please. Mail Orders Only. S.P. DISTRIBUTORS, 11, Old Bond Street, London, W.1.

**SERVICE SHEETS, TV 3/3** each, radio 2/9 each Post free. DARWINS, 45, Shaw Street, St. Helens, Lancs.

**SERVICE SHEETS, TV 4/-** ea. Radio 3/- ea. List 1/-. All orders dispatched on day received. Also manuals for sale and hire. SULTAN RADIO, 29, Church Road, Tunbridge Wells, Kent.

**PUBLIC APPOINTMENTS**

**MEN** with knowledge of basic principles of Radio and Radar required in the Meteorological Office. After short initial training, those appointed will maintain and operate radio and radar equipment, including facsimile apparatus. There are vacancies in various localities in the United Kingdom and opportunities to serve overseas. Starting salary for Radio (Meteorological) Technicians is £670 (national) at 25 or over, rising annually to £795 subject to deduction for each year below the age of 25. These rates are subject to a small deduction at certain provincial stations and to a small increase in London. Good promotion prospects and allowances for overtime, night duty, etc. Applicants must be British subjects.

Applications to **METEOROLOGICAL OFFICE**, (M.O.10R/M/T), Victory House, London, W.C.2, or any employment exchange quoting King's Cross 3298.

**SITUATIONS VACANT****Television Engineers**

Are you satisfied with your present position—Does it carry high wages and commission—Is it permanent and pensionable—Are conditions of work good?

If you would like to work in the Wrexham area, for a rapidly expanding, old established company with an excellent reputation offering all the above advantages — Apply in the strictest confidence to (own staff know of this advertisement). Manager, SEGGERS LTD., Henblas Street, Wrexham.

**ENGINEERS REQUIRED** in London Area for servicing telephone answering machines, dictating machines and other electronic equipment. Apply in writing: WESTTEX CO., LTD., Ealing Road, Wembley.

**BOOKS**

**FIND TV SET TROUBLES IN MINUTES** from that great book "The Principles of TV Receiver Servicing." 10/6 all book houses and radio wholesalers. If not in stock from: Secretary, I.P.R.E., 20, Fairfield Rd., London, N.8.

**EDUCATIONAL**

**RADIO AND TV SERVICING**, all aspects from basic principles. Guaranteed Coaching for City and Guilds, R.T.E.B. Cert., Brit. I.R.E., etc. Study at home under highly qualified tutors. No books to buy. Write for FREE Prospectus, stating subjects, to I.C.S., Intertext House, Parkgate Road (Dept. 516A), London, S.W.11.

**Radio  
Television  
& Electronics**

Learn at home with the world's largest home study organisation. Brit. I.R.E.; City & Guilds; R.T.E.B., etc. Also Practical Courses with equipment. No books to buy.

Write for FREE prospectus stating subject to

Dept. 516  
**I.C.S.**  
Intertext House, Parkgate Road,  
London, S.W.11.

"HOW AND WHY" of Radio and Electronics made easy by a new, non-maths practical way. Postal Instructions based on hosts of experiments and equipment building carried out at home. New courses bring enjoyment as well as knowledge of this fascinating subject. Free brochure from Dept. 12, P.T. RADIOSTRUCTOR, 40, Russell Street, Reading.



**EDUCATIONAL**  
(continued)

FREE FROM THE I.P.R.E. Syllabus of famous radio and TV Courses. Membership Condition booklets 1/- Sample copy of the Practical Radio Engineer 2/- post free. Secretary, 22, Fairfield Road, London, N.8.

★ **LEARN** ★  
**RADIO & TV**  
**SERVICING**  
for your **OWN**  
**BUSINESS/HOBBY**

● by a new exciting no-maths system, using practical equipment recently introduced to this country.

FREE Brochure from:—  
**RADIOSTRUCTOR**  
DEPT. G78  
**READING, BERKS. 1/61**

**CUT THE ADS!**  
**ARMCHAIR VOLUME CONTROL**  
unit, easily fitted, perfectly safe.  
30/-. C.W.O. Post free, C.O.D. 2/6.

**DURHAM SUPPLIES**  
175, Durham Road,  
Bradford 8, Yorkshire.

**DARWINS "LANCASHIRE"**

**TESTED TELEVISION TUBES**

Completely rebuilt and guaranteed fully for 12 months  
12" £5. 14" £5-5. 15" £5-10. 17" £5-15,  
21" £8-10.

Carriage and insurance paid to your doorstep.

**GEORGE E. DARWIN**

45 SHAW STREET, ST. HELENS, LANCASHIRE  
Telephone: St. Helens 4246

**B.B.C. - I.T.V. - F.M. AERIALS**



**R.B.C. (BAND 1).** Telescopio lot. 19/6. External. S/D. 26/3.  
**I.T.V. (BAND 3).** 3 Element loit array. 24/7. 5 Element. 32/6. Wall mounting. 3 Element. 33/0. 5 Element. 41/3.

**COMBINED R.B.C. + I.T.V.** Loit 1+3 Element. 41/3. 1+5 Element. 48/9. Wall mounting. 1+3 Element. 56/3. 1+5 Element. 63/6. Chimney and mast mounting units also available.

**F.M. (BAND 2).** Loit "H". 28/- 3 Element loit. 52/6. S/D loit. 12/8. External S/D. 26/3. State channel when ordering. C.V. or C.O.D. P.P. 2/6. Coaxial cable 8d. yd. Coaxial plugs, 1/3. Send 6d. stamps for illustrated lists.

**K.V.A. ELECTRONICS (Dept. T.P.)**  
3B Godstone Road, Kenley, Surrey

**TRANSISTORS**

Red Spot 3/- White Spot 4/6  
OC70 9/- OC44 20/-  
OC45 16/- OC170 45/-

Crystal Diodes 1/-

OA70, OA81, GD4, GEX34,  
GEX35, all 4/- each

**Connecting Wire**, six assorted colours, 1 yd. each colour, 1/9, 2 yds. each, 2/9, 10 yds. each 10/6  
**Valveholder**, can and spring complete 1/6, size B7G or B9A

All prices post paid

**OAKFIELD RADIO**

121 MACCLESSFIELD ROAD, HAZEL GROVE,  
STOCKPORT, CHESHIRE  
MAIL ORDER ONLY

**Special MAINS DROPPER RESISTORS**  
SMD1 Philips 205U . . . . . 6/3  
SMD8 Ultra Twin 50 . . . . . 5/3  
SMD7 Ultra Twin 50 . . . . . 5/3  
SMD15 Philips 141U and Stella ST105U . . 5/3  
SMD27 Pye P16P . . . . . 6/9  
SMD30 KB Rhapsody MP151/1 . . . . . 6/9

**CLAROSTAT POTENTIOMETERS FOR STEREPHONIC AMPLIFIERS, etc.**  
50K x 50K Log. 100K x 100K Log. 500K x 500K A/Log. 1 Meg x 1 Meg. 250K x 250K Log. 1 Meg x 1 Meg. Linear, 500K x 500K Linear. All 8/6 each.

**WAVE CHANGE SWITCHES**  
3 pole, 4 way 3/- each. 4 pole, 3 way 3/- each. 1 pole, 4 way 2/- each. 1 pole, 12 way 3/- each. 2 pole, 6 way 3/- each. 4 pole, 4 way 4/6 each. 3 pole, 3 way 3/- each. 3 pole, 3 way, 2 bank 2/3 each.

**Best quality Recording Tape**  
1,200ft. on 3in. spool . . . . . 21/-  
850ft. on 5in. spool . . . . . 18/6  
600ft. on 3in. spool . . . . . 13/9  
200ft. on 3in. spool . . . . . 5/3

**Collaro Junior**  
Single 4-speed record player unit in cream, complete with pick-up fitted turnover cartridge. Special Price 75/- each. Post 3/6.  
**Garrard G2 Crystal Cartridge.**  
Black moulded case complete with Standard and I.P. styl. Price 15/6  
**4BA Terminals, Red and Black,** suitable for Battery Chargers, etc. 1/6 each.  
**PANL-Air-drying Paint, Black Crackle** (Crystalline Black). 3/- tin.  
**Tuning Indicator Escutcheon,** suitable for EM80 type of valves. 2/- each.  
**TELEVISION TUBES REGUNNED 12 MONTHS GUARANTEE**  
MW31/74. £5.10.0. CRM152. 1.5. 48. MW36/24. £5.10.0. CR1141. £5.10.0. CRM123. £5.10.0. MW43/69. 48. CR1171. 28. Carriage and Insurance 10/- extra. Allowance on old tube if returned.

**ALPHA RADIO TERMS.**—Cash with order or C.O.D. Postage and Packing charges extra, as follows: Order value 10/- add 1/3; 20/- add 1/3; 40/- add 2/6; £5 add 1/6. Minimum C.O.D. Free and Postage 3/-. For full terms of business see inside cover of our catalogue. Personal Shoppers 9 a.m. to 5 p.m. Monday to Friday. Saturday 10 a.m. to 1 p.m.

**ALPHA FOR VALVES AND SPARES FROM STOCK. RETURN POST.**  
**103 LEEDS TERRACE, WINTOUN STREET, LEEDS 7.**

**ALPHA RADIO SUPPLY CO.**

**VALVES GUARANTEED ALL TESTED BEFORE DESPATCH**

A21	10/-	G232	11/8	394	7/8
A231	10/-	PC084	8/8	3V4	3/3
DAF96	8/-	PC085	11/6	5Y3G	5/-
DP96	8/-	PCF80	8/9	3Z4G	4/-
DL96	8/-	PCL82	12/-	6AL5	4/-
DL96	8/-	PCL83	13/6	6F1	14/-
EAF42	8/6	PL36	15/-	6F15	14/-
EB33	8/6	PL36L	26/8	6J7G	6/6
EB41	8/6	PL81	11/-	6K7G	6/6
ECC81	7/6	PL82	8/6	6K8G	6/6
ECC82	8/-	PL83	8/6	6K25	19/11
ECC83	8/-	PY32	17/11	6L6M	9/6
ECC84	10/-	PY81	8/6	6AM5	4/-
ECF80	12/-	PY80	7/-	6U7G	7/6
ECH42	10/6	PZ22	19/11	6V8G	6/6
ECH42	9/6	PT25	10/-	6V8GT	7/6
ECH81	9/-	U25	13/6	6X5GT	7/-
ECL90	9/6	U26	10/-	7B6	10/6
EP36	5/6	U37	26/8	7H7	8/-
EP41	9/6	U281	19/11	7S7	8/6
EP80	7/-	U801	20/10	7Y4	3/-
EP86	12/6	UAF42	8/6	10F1	15/-
EL33	14/-	UE31	8/6	10P13	17/6
EL41	9/-	YCH42	6/6	12AT7	7/6
EL42	10/6	UP41	9/-	12AX7	8/6
EL84	9/-	U141	9/-	12AU7	8/6
EM34	9/6	U18	26/6	20P1	26/8
EM60	9/6	UY1N	12/6	25A6G	10/6
EY51	9/6	UY41	7/6	25Z4G	9/6
EY86	10/-	1R5	7/6	275U	19/11
EZ40	7/6	185	9/6	35L6GT	10/-
EZ81	7/-	1T4	5/6	35Z4GT	7/-

**CATALOGUE**  
Our 1961 catalogue is now available. Please send 1/- in stamps for your copy. Trade catalogue also available. Please attach your business letter heading.

**METAL RECTIFIERS**

Alpha Range of Guaranteed Bridge Rectifiers suitable for Battery Chargers, 6 and 12 volt output; 2 amp. 7/-; 4 amp. 12/6; 3 amp. 10/-; 5 amp. 14/6.

**Elstone Multi-ratio Output Transformer, 10 watts, 230V.**  
Westinghouse LW9 Rectifier. 250v. 260mA. 9/19/6  
**W.B. Stentorian HF1012, 10 watts, 95/- ea.**  
BSR Monarch UA8 Record Changer. £6.19.8.  
**Scotch Recording Tape 150/18. 7in. Spool, 50/-.**  
Wireless World Radio Valve Data Book, 5/-  
**Taylor Model 127A Multi-Meter, £10.0.0.**  
High Resistance Headphones 4000ohms, 13/6.  
Renanco F52 Ferrite Slab Aerial, 7/6.  
Multicores Savbit Solder, 5/-  
**Henley Solon Instrument Iron, Model 625. 24/-.**  
J.B. "O" Gang Condenser, 365pF, 1 gang, 7/6.  
Beiling Lee Diplexer L138, 11/-  
Output Transformer, 500/30hms, 60mA, 5/8.  
**10in. Elac Loudspeakers, 25/-.**  
Collaro Conquest, with Studio Pick-up, £6.19.8.  
**Acos Crystal Stick Mic, 39/1, £11.9.8.**  
Decamatic Amplifier with speaker, 85/-  
Bib Recording Tape Splitter, 18/6.  
Mullard Circuits for Audio Amplifiers, 8/6.  
**TRF Kit, Complete, £5.10.0.**  
Line O.P. Transformer for Pye V4, etc. 55/2.  
**Repanco DRR2 Dual Range Coil, with Reaction, 4/-.**  
J.B. SLS Spin Wheel Drive Assembly, 27/8.  
J.B. Solid Dielectric Condensers, .0005 4/6 ea.  
Ion Trans. Type 176, 1T9, BC11, 5/6 each.  
**TCC Visconol Condenser, .001 20kV, 10/-.**  
Potentiometer SP5 for English Electric T40, etc. 13/6.

**DID YOU KNOW**

**COYNE'S NEW TROUBLE-SHOOTING SERIES TAKES HEADACHES OUT OF ALL SERVICING PROBLEMS?**



*Pin-Point*  
**TV troubles in 10 minutes**

Find the exact sound or picture trouble in ANY TV set from 700 possibilities! Latest Edition now has 332 pages of solid, down to earth TV service.

ing information: 300 diagrams, check charts, 31/6. Postage 1/-.

*Pin-Point*  
**Transistor troubles in 12 minutes**

Trouble-shoot every type of circuit in ALL transistorized equipment! 525 pages; hundreds of illustrations; 120 check charts. 47/6, postage 1/6.



**SIMPLE CHECK CHART SYSTEM SAVES TIME**

These amazing practical handbooks with **ENTIRELY NEW METHOD** show you how to find the trouble in ANY TV, or transistor circuit **FAST!** Index tells you where to look; famous Check-Charts help you to pin-point the exact trouble in minutes! These on-the-job books quickly pay for themselves in profitable new business and valuable time saved!

**SEND NO MONEY**

Just mail coupon for free trial. After 7 days send only low price or return books and pay nothing! If you keep both books send only 19/- after 7 days and £1 a month until a total of 79/- has been paid. If ordering one book, pay one half after seven days and the other half in 30 days.

**FREE TRIAL OFFER Mail Coupon Now for FAST RETURN SERVICE**

Mail Order Division, SIM-TECHBOOK COMPANY, Gater's Mill, West-End, Southampton, Hants.

- Rush 2-book PIN-POINT Series for 7-day FREE TRIAL per offer (postage free).
- I do not require both books, please send me the following book as per offer.
- TRANSISTORS, 47/6, plus postage.
- TV TROUBLES, 31/6, plus postage.

Name .....

Address .....

City..... County.....

Check here if enclosing full price; we pay postage. Same 7-day money-back guarantee.

**NYLON · P.T.F.E.**

ROD, BAR, SHEET, TUBE, STRIP, WIRE  
No Quantity too small  
List on application

**ALUMINIUM, LIGHT ALLOYS, BRASS, COPPER, BRONZE**

**H. ROLLET & CO., LTD.**

6 CHESHAM PLACE, LONDON, S.W.1.  
BELgravia 4300

Works:  
36 ROSEBERY AVE., LONDON, E.C.1  
Branches at Liverpool, Manchester, Birmingham, Leeds.

**FIRST-CLASS TELEVISION and RADIO COURSES**

**GET A CERTIFICATE!**

After brief, intensely interesting study undertaken at home in your spare time—**YOU** can secure your professional qualification or learn Servicing and Theory. Let us show you how.

**FREE GUIDE**

The New Free Guide contains 132 pages of information of the greatest importance to those seeking such success-compelling qualifications as **A.M.Brit.I.R.E., City and Guilds Final Radio, P.M.G. Radio Amateurs' Exams, Gen. Cert. of Educ. London B.Sc. (Eng.), A.M.I.P.E., A.M.I.Mech.E., Draughtsmanship (all branches) etc.**, together with particulars of our remarkable Guarantee of

**SUCCESS OR NO FEE**

Write now for your copy of this invaluable publication. It may well prove to be the turning point in your career

**FOUNDED 1885—OVER 150,000 SUCCESSES**

**NATIONAL INSTITUTE OF ENGINEERING**  
(Dept. 462), 148 HOLBORN LONDON, E.C.1

S. Africa: P.O. Box 8417, Jo'burg.  
Australia: P.O. Box 4570 Melbourne.

**A SUPER SPECIAL TV TUBE OFFER**

New tubes made by world-famous manufacturers complete with 12 months' maker's guarantee. 17in. Tube to replace the MW43-64 43-69, 171K, 172K, 17 ASP4, 17 AXP4, C17-1, C17-A, CR-17-22, C17-FM, MW 43-80. Our Unbeatable Price **£8.10.0.** Also available brand new 14in. to replace 36-24, 36-44, TR14-21, TR14-22, 14 KP4A, 14-LP4, 141K, C36-24, or for AW 36-20, 36-21 12in. brand new 31 MW 31-74, all at 87 each. Post packing and insurance 10/- extra.

**NEW MAX ELECTRONICS**

For London's Finest Bargains in electronic and radio equipment. Also Largest Selection of Tape Recorders in the U.K. All Guaranteed.

**220, Edgware Road, London, W.2.**  
Tel. PAD 5607

**EDDY'S (Nottm.) LTD.**

172 ALFRETON ROAD, NOTTINGHAM

**CAR RADIO KIT 7 TRANSISTORS.** L and M Wave, 2W output. R.F. stage and Auto Gain Control. 10 1/2 gns. P. & P. 5/-, 6 or 12 v. (state which) with full instructions. Size 7 1/2 x 7 1/2 x 2 1/2 in. Speaker extra 17/11.

**GUITAR PICKUPS.** Super Hi-Fi, non-acoustical universal fitting. High output. With lead, plug, and full instructions. 49/11 P. & P. 2/6.

**POCKET RADIO.** 2 Transistor with miniature speaker, 2 wave bands. Complete with all parts, wiring diagram and full instructions. 27/6. Batteries 1/-, P. & P. 1/6.

**DYNAMOTORS.** 200 v. D.C. to 13 v. D.C. Ideal for train sets, etc. 19/11. P. & P. 2/6.

**NIFE ACCUMULATORS.** 1.25 v. Size 3 x 2 1/2 x 1/2 in. 7 amp hrs., weight 13 ozs. 17/11 ea. P. & P. 1/6 only. Add 9d. per cell.

**CRYSTAL SETS.** 2 wave bands. High gain, 19/11; also with transistor amplifier, extra, 9/11, P. & P. 2/6.

**HEADPHONES.** High Resistance to suit above crystal sets. Good quality. 13/11 pair. P. & P. 1/6.

**HEADPHONE CORDS.** High quality 6ft. lengths, 1/11. Post 6d.

**THROAT MIKES.** 1/- each. Super quality model, 2/- each. Post 6d. Could be used for electrifying musical instns., etc.

**DIMMER SWITCHES.** Ideal for train speed regulators, 1/11. Post 9d.

**LUXEMBOURG AERIALS.** Expanding. Complete and easy to fit. No technical knowledge required. Greatly improves reception. 3/11. Post 6d.

**ALL ABOVE NEW & GUAR.**

New or Surplus Valves, Guaranteed and Tested, by Return.

1D5	7/6	7C6	7/3	ECF82	9/1-
1L4	3/6	12A6	5/3	ECH42	8/3
1R5	5/6	12AT7	5/3	ECL80	7/6
1S5	4/9	12AT6	7/6	ECL82	10/-
1T4	3/11	12AU7	6/-	EF36	3/-
3D6	4/11	12AH7	6/6	EF41	7/9
3S4	5/11	12K7	5/3	EF42	7/6
3V4	6/9	12Q7	5/3	EF50	1/9
5Z4G	7/6	20D1	9/6	EF80	5/-
5Z4M	11/-	25L6GT	8/11	EF86	9/9
5U4G	4/9	25Z4G	7/6	EF91	4/6
5Y3G	5/9	35L6GT	8/11	EF93	7/6
6AG5	4/-	35V4	6/11	EL41	4/3
6AQ5	6/-	35Z4	5/3	EL42	9/3
6AT6	7/-	90A4	4/3	EL84	6/6
6BB8	2/11	807B	3/9	EL85	10/3
6BA6	5/11	954	1/6	EL91	4/6
6BJ6	5/11	955	3/6	EY51	7/11
6C4	3/6	956	2/6	EY86	7/5
6C6	4/9	9001	3/11	EZ40	6/3
6CH6	9/-	9004	3/11	EZ80	6/-
6F6M	7/-	9006	3/11	EZ81	6/5
6F33	6/9	AZ1	12/6	KT33C	6/6
6H6M	1/11	CY31	12/6	KT66	15/6
6J5G	2/9	DAF91	4/9	MU14	7/6
6J5M	4/3	DAF96	6/11	PCC84	7/3
6J6	4/-	DF91	3/11	PCF80	7/3
6J7G	5/-	DF96	6/11	PCF82	7/6
6K7G	1/11	DK96	6/11	PCL82	7/6
6K7M	7/6	DL96	6/11	PEN25	4/6
6K8G	5/3	DM70	7/6	PEN46	5/6
6L6G	7/11	EABCO		PEN36C	8/-
6P28	9/6		6/11	PY80	6/11
6Q7G	6/-	EAF42	8/11	PY81	6/3
6S47M	5/9	EB34	1/3	PY82	6/6
6S67M	4/9	EB41	6/11	PY83	7/3
6SH7M	4/6	EB91	3/6	PL36	10/9
6S7M	5/-	EB4C1	7/6	PL81	9/-
6SN7GT	4/3	EBF80	8/-	PL82	7/6
6U4GT	10/6	ECC35	6/9	PL83	7/3
6V6G	4/11	ECC81	5/3	P61	2/3
6V6GT	6/-	ECC82	5/11	TDD4	7/6
6V6M	8/6	ECC83	6/6	U25	12/6
6X5G	4/11	ECC84	8/3	UBC41	7/3
7C5	7/6	ECC85	7/11	UCH42	7/6

All parcels insured against damage in transit for only 6d. extra per order. All uninsured parcels at customers' risk. Postage and Packing 6d. per valve extra. C.W.O. or C.O.D. only. C.O.D. charge 3/- extra. S.A.E. with enquiries.

# Build your own Aerials...

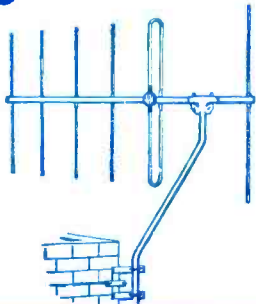

## AT HOME

**AERIAL FITTINGS FOR BAND III, BAND I & RADIO F/M.** Useful formulæ and hints for constructing your own aerial quickly and cheaply. Catalogue illustrating our increased range of Diecast Alloy Fittings, including Band III to Band I Mast Couplers, Reflector and Director Rod Holders, Insulators (both "Inline" and "H" types), Masthead Fittings, Masts and Elements, Chimney Brackets, etc. Send 1/- in stamps for the above, to:—

*Fringe*vision Ltd.

MARLBOROUGH, WILTS. Phone : 657/8

# TELEVISION TUBES REBUILT BY "RE-VIEW"

PRICE:

SAVE £££s

12in.	...	...	...	£5. 0.0
14in.	...	...	...	£5. 0.0
15in.	...	...	...	£5.15.0
17in.	...	...	...	£6. 0.0
21in.	...	...	...	£8.10.0

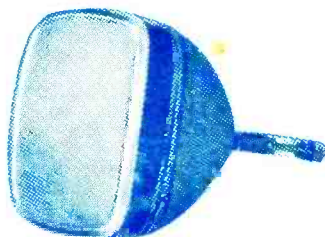

**TWELVE MONTHS' GUARANTEE**

*Carriage and insurance 10/-.*

*Be one of our satisfied customers. Call and see our TUBES REBUILT and TESTED*

**RE-VIEW (London) LTD., 10 High St., Colliers Wood, London S.W.19**

*Terms to the Trade*

TEL.: LIBERTY 3272

**C.R.T. BOOSTER TRANSFORMERS**  
**TYPE A. OPTIONAL 25%, and 50% BOOST.**  
**2 V. OR 4 V. OR 6.3 V. OR 10.5 V. OR**  
**13.3 V. MAINS INPUT. 12/6**  
**TYPE A2. HIGH QUALITY. LOW CAPACITANCE.**  
**10/15 pF. OPTIONAL BOOST 25%, 50%,**  
**75%. MAINS INPUT. 16/6**  
**TYPE B. MAINS INPUT. MULTI OUTPUT 2,**  
**4, 6.3, 7.3, 10 and 13 VOLTS. BOOST 25%**  
**AND 50%. LOW CAPACITY. 21/-**

TRIMMERS. Ceramic. 30, 50, 70 pF. 8d; 100 pF. 150 pF. 1/3; 250 pF. 1/6; 500 pF. 75d. pF. 1/8.  
 RESISTORS. Preferred values. 10 ohms to 10 meg. 1/4 w. 4d.; 1 w. 6d.; 1 1/2 w. 8d.; 2 w. 10/1.  
**HIGH STABILITY. 1 w. 1%, 2 w. 2%.** Preferred values 10 to 10 meg. Ditto, 5%, 1000 to 5 meg. 9d.  
 3 watt } **WIRE-WOUND RESISTORS** 1/3  
 10 watt } 25 ohms-10,000 ohms 2/6  
 15 watt } 100 ohms-10,000 ohms 3/3  
 12.5K to 50K 10 w. 1/3

**AMERICAN "BRAND FIVE" PLASTIC RECORDING TAPE**

Double Play 7in. reel. 2,400ft 60/- Spare  
 5in. reel. 1,200ft 37/6 Plastic  
 Long Play 7in. reel. 1,800ft 35/- 7" Reels  
 5in. reel. 1,200ft 23/6 Clear  
 5in. reel. 900ft 18/6

Standard 7in. reel. 1,200ft 25/- Metal  
 5in. reel. 600ft 18/- 2" ea

"Instant" Bulk Tape Eraser and Head Defluxer, 200/250 v. A.C., 27/6. Leaflet. S.A.E.

**O.P. TRANSFORMERS. Heavy Duty 50 mA. 4/6.**  
 Multiratio, push-pull, 7/6. Miniature, 3/4, etc. 4/6.  
 Push-pull 10 v. 35/6. L.F. CHOKES 15/10 H. 60-65 mA. 5/-; 10 H. 85 mA. 10/6; 10 H. 150 mA. 14/-.

**MAINS TRANSFORMERS 200/250 v. A.C. STANDARD.** 250-0-250, 80 mA. 6.3 v. 3.5 A. tapped 4 v. 4 A. Rectifier 6.3 v. 1 A. 0 v. 2 A. or 4 v. 2 A. ditto. 350-0-350 22/6  
 MINIATURE 250 v. 20 mA. 6.3 v. 1 A. 10/6  
 MIDGET. 250 v. 45 mA. 6.3 v. 2 A. 15/6  
 SMALL. 220-0-220, 50 mA. 6.3 v. 2 A. 17/6  
 STD. 250-0-250, 65 mA. 6.3 v. 3.5 A. 17/6  
 HEATER TRANS. 6.3 v. 11 amp. 7/6  
 Ditto, tapped sec. 2, 4, 6.3 v. 11 amp. 8/6  
 Ditto, sec. 6.3 v. 3 amp. 10/6  
**GENERAL PURPOSE LOW VOLTAGE.** 2a. 3, 4, 5, 6, 8, 9, 10, 12, 15, 18, 24, 30 v. 2/6  
**AUTO TRANSFORMERS.** 150 w. 0, 10, 120, 200, 230, 250 v. 22/6

**ALADDIN FORMERS and core.** 1in., 8d.; 1/2in., 10d. 0.3in. FORMERS 5937 8 and Gate TV1 2. 2in. sq. x 2in. and 3in. sq. x 1 1/2in. 2/- ea., with cores.  
**SOLOID Soldering Iron.** 220/40 v. 25 w. 24/-.  
**REMPLOY Instrument Iron.** 220 v. 25 w. 17/6.  
**MAINS DROPPERS.** 3in. x 1 1/2in. Ad. Sliders, 0.3 amp., 1,000 ohms, 4/3. 0.2 amp., 1,000 ohms, 4/3. 0.3 amp., 60 ohms per ft., 0.2 amp., 100 ohms per ft., 2-way, 6d. per ft., 3-way, 7d. per ft.  
**LOUDSPEAKER P.M. 3 OHM.** 5in. Rola. 17/6. 8in. Plessey. 18/6. 6in. x 4in. Rola. 18/6. 6in. Rola. 18/6. 10 x 10in. 27/6. 10in. Rola. 30/-.  
 Hi-Fi Tickers, 25/-, 1 1/2 in. R.A., 30/-.  
**STENTORIAN HP1012.** 10in. 3/4 to 1 1/2 ohms 100 ohms per ft., 2-way, 6d. per ft., 15 ohms 10/-, 95/-.  
 12in. Baker 15 watt 3 ohms, or 15 ohms 105/-.  
**CRYSTAL DIODE (G.E.C.). 2/-.** GEK34. 4/-.  
**HIGH RESISTANCE PHONES.** 4,000 ohms. 15/- or MIKE TRANSF. 50, 1.375 ea. 100, 1.1. Potted. 10/6.  
**SWITCH CLEANER.** Final wound, about. 4/3 1/2 in.  
**TWIN GANG TUNING CONDENSERS.** 350 pF. miniature 1in. x 1 1/2in. 10/-, 0.0005 standard with trimmers, 9/-; less trimmers, 8/-; midjet. 7/6.  
**SINGLE.** 50 pF. 2/6; 75 pF. 100 pF. 160 pF. 7/6. 800d. dielectric 100, 500 pF. 3/6.  
**SPEAKER FRET. GOLD CLOTH.** 1 1/2in. 25/-; 2 1/2in. 35/-; 3 1/2in. 10/-; Tylan 4 1/2in. wide, 10/-; 2 1/2in. wide, 5/-; 1/2in. Brown, green or red. Samples S.A.E.

New and Boxed VALVES 90-day Guarantee.

113	7/6	6884	7/6	EAB780	8/6	HARCO	
185	7/6	6155	10/6	EB91	8/6	HR24	12/6
184	6/-	687M	6/6	EB93	8/6	HV12A	6/6
232	3/6	6047	8/6	EB141	9/6	M14	8/6
384	7/6	68A7	6/-	EB150	10/-	PS1	3/6
3V4	7/6	68J1M	6/-	EB154	9/6	PC24	9/6
6C4	7/6	68N7	6/6	EB159	9/6	PC90	9/6
6X3	7/6	675G	6/6	EB142	10/6	PCL2	11/6
6Z4	6/6	68A	7/6	EB125	8/6	PCN5	6/6
6AM6	5/-	63N5	6/6	EB182	10/6	PL8	10/6
6H8	5/-	12A7T	8/6	EB139	5/6	PY80	7/6
6HE6	7/6	12A7U	8/6	EB141	8/6	PY81	9/6
6BH6	9/6	12AX7	8/6	EB180	8/6	PY92	7/6
6BE6	9/6	12BE6	8/6	EB151	8/6	SP61	3/6
6D6	6/6	12K8	8/6	EB141	8/6	TC41	8/6
6F6G	7/6	12Q7	8/6	EB192	5/6	EB142	9/6
6H6	3/6	35L6	6/6	EB182	5/6	ET41	9/6
6J5	5/6	35Z4	2/6	EB184	8/6	UL41	9/6
6J7	5/6	80	8/6	EB181	9/6	UY41	8/6
6J7G	6/6	80	8/6	EB182	9/6	VE10	8/6
6K8GT	6/6	92A	5/6	EB230	7/6	VE105	8/6
6K7G	5/6	EA50	1/6	EB148	1/6	VE130	9/6

**TELEVISION REPLACEMENT LINE OUTPUT TRANSFORMERS**  
 70/- ea. from stock.  
 For Makes and Models  
**Argosy: T2, CTV517. Decca: D17 & C. Defiant: TR1753. RGD: 6017T, 7017C, C54. Regentone: 17C, 17T, 17 Comb.**

**Cossor: 930 & T, 931, 933-4-5, 937, 938 & A, 937 & F, 939 & A & F, 943T, 946.**

**Decca: DM1, DM2C, DM3, DM4, DM4C, DM5, DM17, 444, 555.**

**Ferguson: 103T, 105T, 113T, 135T, 142T, 143T, 145T, 990T, 991T, 992T, 993T, 994T, 995T, 996T, 997T.**

**H.M.V. 1824 & A, 1825 & A, 1826 & A, 1827 & A, 1829 & A, 1865, 1869.**

**Marconi: VT681A, VT69DA.**

**Pye: V4, V4, V7, V7, CTM4.**

**Sobell: TS17, T346.**

**Ferguson: 306T, 308T. Most other makes available (7 days). S.A.E. with all enquiries.**

**LINE BLOCKING TRANSFORMERS, 10/- to 18/6.**

**FRAME BLOCKING TRANSFORMERS, 13/6 to 21/-.**

**FRAME OUTPUT TRANSFORMERS, 27/6 to 39/-.** Most makes available (7 days). S.A.E. with all enquiries.

**HIGH GAIN TV PRE-AMP KITS BAND I BBC**  
 Tunable channels 1 to 5. Gain 15dB. EOC84 valve. Kit price 29/6 or 49/6 with power pack. Details 6d. (PCOC84 valves if preferred.)  
**BAND III ITA**—Same prices.  
 Tunable channels 1 to 13. Gain 17dB. EOC84 valves. (PCOC84 valves if preferred.)

**CRYSTAL MIKE INSERT** by Acos, precision engineered. Size only 2in. x 3 1/2in., 6/6.

**ALUMINIUM CHASSIS.** 15 s.w.g. un drilled. With 4 sides, riveted corners and latrine fixing holes. 2 1/2in. sides. 7 x 4in., 4/6; 9 x 7in., 5/4; 11 x 7in., 6/9; 13 x 9in., 8/6; 14 x 1 1/2in., 10/3; 15 x 14in., 12/6; 18 x 10 x 1 1/2in., 18/6.

**JASON P.M. TUNER COIL SET.** 26/- H.F. coil, aerial coil, Oscillator coil. Two I.F. trans. 107 Mc. Ratio detector and heater choke. Circuit board using four 6AM6's. 6/6.  
**COMPLETE JASON F.M. KIT.** FMT1, with set of 4 valves, etc., 85.5/0.

**BBC TRANSISTOR RADIO.** Med. and Long Wave. Two transistors and diode. Complete kit, 32/6. phones 7/6 extra. Beat Aid Earpiece with special lead. 15/-. Details 6d.

**CYLDON TURRET TELETURNER**  
 I.F. 33/38 megs. complete with frame and valves, 3001, 30L15. With coils for channels 1 to 5. 8/- and 1 to 11. Brand new, price 45/-, operating data and circuit supplied. IDEAL for P.T. "OLYMPIC".

**RECORD PLAYER BARGAINS**



The Brilliantly Simple  
**Maranch**  
 World's First Speed Autochanger

4 Speed Autochangers, B.S.R., U.A.8 88.15.0  
 4 Speed Autochangers, U.A.8 Stereo 87.10.0  
 Collins Conquest 87.18.6  
 Garrard Model 310 110.10.0  
 4 speed Single Players, EM1 88.18.0  
 Garrard TA Mk II, GC8 Head 88.8.0  
 Garrard 4 HP Transcription, GC8 117.19.0  
 Garrard Stereo Head, 22 extra  
 Suitable player cabinets (except 4 H.F.) 49/6  
 Amplifier player cabinets (except 4 H.F.) 63/-  
 2-valve amplifier and 6in. speaker 79/6  
 3-valve amplifier and 6in. speaker 95/-

*Wired and tested ready for use with above.*

**Volume Controls 80 ohm CABLE COAX**  
 Long spindles. Guaranteed 1 year. Midget 5K ohms to 2 Meg. 30 Sw. D.P. Sw. 3/-  
 3/4 or 1/2 4/8  
 Air or Long Trimmers  
 Semi-air, spaced. 2in. dia. Losses cut 50% 6d. yd.  
 Fringe Quality Air Spaced! 1/- yd.

**COAX PLUGS 1/- LEAD SOCKET 2/-**  
**PANEL SOCKETS 1/- OUTLET BOXES 4/6**  
**BALANCED TWIN FEEDER yd. 6d.** 80 or 300 ohms  
**DITTO SCREENED per yd. 1/6.** 80 ohms only  
**WIRE-WOUND POTS. 3 WATT.** Pre-set. Min. Tu. Type. All valve 25 ohms to 25 K. 3/- ea. 30 K. 50 K. 4/- (Carbon 30 K. to 2 meg. 3/-)  
**WIRE-WOUND 4 WATT.** Pots. Long Spindle Values, 100 ohms to 50 K. 8/6; 100 K. 7/6.  
**CONDENSERS New Stock.** 1,000 mfd. 7 v. K.C.C. 5/6; Ditto, 20 v. 9/6; 0.1 mfd. 7 v. 9/6; Titanium 500 v. 0.001 to 0.05 mfd., 9d.; 0.1, 1/-; 0.25, 1/8; 0.5, 300 v. 1/9; 0.1, 1,350 v., 9d.; 0.01, 1,000 v. 0.01, 1,000 v. 1/8; 0.1 mfd., 2,000 volts, 3/6.  
**CERAMIC COND.** 500 v. 0.3 pF. to 0.01 mfd. 9d.  
**SILVER MIKA CONDENSERS.** 10% 5 pF to 500 pF. 1/-; 600 pF. to 3,000 pF. 1/8. Close tolerance (+/- 1 pF.) 1.5 pF. to 47 pF. 1/8. Ditto 1% 80 pF to 815 pF. 1/8; 1,000 pF. to 5,000 pF. 2/-.

**I.F. TRANSFORMERS 7/6 pair**  
 465 Kc/s Sing Tuning Miniature Can. 1 1/2 x 1 1/2 in. High Q and good bandwidth. By Pye Radio. Data sheet supplied.  
**WEYMOUTH.** Standard size, 465 Kc/s, 12/6 pair.

**NEW ELECTROLYTICS. FAMOUS MAKES**

TUBULAR	TUBULAR	CAN TYPES	
1,450 v. 2/-	50/350 v. 5/6	16/500 v. 4/-	
2,300 v. 2/3	100/250 v. 2/-	32/350 v. 4/-	
4,450 v. 2/3	250/250 v. 2/6	100/270 v. 5/6	
8,450 v. 2/3	500/12 v. 3/6	2,500/3 v. 4/-	
8,500 v. 2/9	8,450 v. 3/6	3,000/3 v. 4/-	
16,450 v. 3/-	8,450 v. 3/6	32-32-34/450 v. 6/6	
16,500 v. 3/6	8,450 v. 3/6	32-32-32-32/350 v. 7/6	
32,450 v. 3/9	16,450 v. 4/3	50-50/350 v. 7/6	
32,250 v. 1/9	16,450 v. 6/6	61-120/350 v. 11/6	
50,500 v. 2/-	32-32/350 v. 9/6	100-200/275 v. 12/6	

**RECTIFIERS SELENIUM** 400 v. 85 mA, 7/6.  
**CONTACT COOLED** 250 v. 30 mA, 7/-; 60 mA, 8/6; 85 mA, 9/6; 200 mA, 21/-; 300 mA, 27/6.  
**COILS WEARTEC "T" type.** 3/- each. Osborn Midjet "Q" type adj. dust core from 4/-.. All ranges.  
**TELETRON. I. & Med. T.R.F.** with reaction, 3/6.  
**FERRITE ROD AERIALS.** M.W. 8/9; M. & L. 12/6. T.R.F. COILS A.H.F. 7/- pair. H.F. CHOKES, 2/6.  
**FERRITE ROD.** 8in. x 3 1/2in. dia. 2/6.  
**FULL WAVE BRIDGE SELENIUM RECTIFIER.** 2, 6 or 12 v. 1 1/2 amp., 8/9; 2, 6 or 11, 4/-; 17/8.  
**CHARGER TRANSFORMERS.** Tapped input 200/250 v. for charging at 2, 6 or 12 v. 11 amps., 15/6. 2 amps., 17/8; 4 amps., 22/6. (Circuits included.)  
**VALVE and TV TUBE EQUIPMENT.** books, 5/6.  
**TOGGLE SWITCHES.** S.P. 2/-; D.P. 3/6. D.P.5.T. 4/-.  
**WAVECHANGE SWITCHES**  
 5 p. 4-way 2 wafers long spindle 6/6  
 2 p. 2-way, or 3 p. 2-way short spindle 2/6  
 2 p. 6-way, or 4 p. 2-way, or 4 p. 3-way long spindle 3/6  
 2, 4-way, or 1 p. 12-way long spindle 3/6  
**VALVE HOLDERS.** Pax Int. Oct. 4d. EP50, EA50, 6d. H12A, CRT. 1/8. Eng. and Amer. 4, 5, 6 and 7 to 5. 1/-.  
**MOULDED MAZDA and Int. Oct. 6d.**  
 7 pin. B9A, B8G, B9A, 8d. B7G with can. 1/6.  
 B9A with can. 1/9. CERAMIC EP50, B7G, B9A, Int. Oct. 1/-. S/CANS B7G, B9A, 1/- ea.

**RADIO COMPONENT SPECIALISTS**  
 OUR ONLY ADDRESS  
 337 WHITEHORSE RD., WEST CROYDON  
 Post and Packing 1/-, over £2 free. (Export post Extra.) C.O.D. 1/6. (Wed. 1 p.m.) THO 1665 Buses 133 or 68