

Practical and Wireless

★ PRACTICAL TELEVISION ★

EVERY WEDNESDAY

Vol. XV. No. 376. Dec. 2nd, 1939.

EDITED BY
F. J. C. AMM

Staff:

W. J. DELANEY, FRANK PRESTON,
H. J. BARTON CHAPPLE, B.Sc.

ROUND THE WORLD OF WIRELESS

Radio at Christmas

THE radio normally fulfils its function as a provider of music and other entertainment during the year, but at Christmas-time it is generally called into use to give fuller play to its possibilities. Many amateurs carry out a little home broadcasting at this time of the year, although for the remainder of the time this aspect of radio is overlooked. The addition of a microphone may, however, lead to many interesting developments, either for room-to-room communication or for other "telephonic" purposes. The old idea of enabling one to hear a baby in a distant room, without having to switch off the wireless to listen, is well known, but there are many other interesting applications which will appeal to the individual after reading the article on home broadcasting in this issue. Gramophone reproduction is receiving more attention, but there are still many listeners who are content with the playing of discs with a simple pick-up added to the set. The use of contrast expanders and other special circuits are not so popular as they should be, but those who have tried them can vouch for their effectiveness in improving record reproduction.

Physical Jerks

AS already announced, next Monday will see the inauguration of an experimental series of physical exercises, to be broadcast for ten minutes, starting at 7.35 a.m. each weekday. On Monday, Wednesday and Friday, a male instructor will direct the exercises for men, while Tuesday, Thursday and Saturday will be given over to women listeners with a woman instructor at the microphone. At the moment the exercises are designed for

listeners under 40 years of age, though if the experiment proves popular it is possible that the over-forties will be catered for later on. The exercises will be specially designed for listeners with little space in their homes, and no expensive equipment will be necessary.

'Phone Books in Broadcast

TELEPHONE books, numbering into the hundreds, each consisting of 500 pages, are used in selecting the name of the telephone subscriber who gets the lucky 'phone call during Horace Heidt's "Pot o' Gold" programme each Tuesday evening over WLW and NBC.

In examining 'phone books from all over the country, it was found that some have 12 pages and some have 1,200. So it was decided, in order to be completely fair, to bind all the books into volumes of 500 pages each.

Thus, when the selector chooses Book 47, it may mean that that volume will contain 'phone books of a half-dozen small towns. When it selects Book 108, it may contain only half the pages of the Cleveland telephone directory, while the other half of the directory is included in another volume bearing another number.

Frank J. Drouin, the wood-worker of Andover, Mass., who was presented with \$1,000 on one programme, reports that he

was advised by Western Union that the money was waiting for him about five minutes after Ben Grauer talked to him on the 'phone during the programme.

Heidt's "Pot o' Gold" is heard at 8.30 p.m., E.S.T., Tuesdays, over the NBC-Red Network.

Burbleton Comes Back

IF one wished to know what the England outside London was thinking and doing any time during the last two or three years, one could not have done better than pay a radio visit to Burbleton, that mythical North-country township whose local big-wigs discussed their affairs with such engaging frankness. In pre-war North Region days, Burbleton had a very big following and many people will be pleased to hear that it is coming back to the programmes. It makes its first war-time appearance on December 1st, and all the old well-known characters will be heard debating, in true Burbleton style, the problem of A.R.P. in their town. T. Thompson, the Lancashire author, is responsible for the script.



Glenn H. Bowersox, radio operator of the S.S. North Star on the Byrd Expedition is shown at his instruments aboard the ship as he makes the final check-up.

Chess by Radio

TWO teams, Sydney and Melbourne Universities, recently played chess by communicating the moves over a radio link. Each team played in two groups of four, at different stations. The match ended in a tie at 4-4, persons having the white pieces being successful at all eight boards. This match will probably be the last for some time, as amateur stations have now been taken off the air.

Sets for the Navy

IT has now been announced that following the suggestion for supplying the troops with radio apparatus for entertainment purposes, it has been decided to make similar presentations to the men of the Navy. The receivers will probably be of the all-wave type so that full use of the short-wave transmissions may be made.

Rumanian S. W. Station

EXPERIMENTAL broadcasts are being made by the new Rumanian short-wave station on the 31- and 49-metre bands and also by the station at Kisenev. The power is given as 20 kW. and the wavelength as 212.6 metres.

Editorial and Advertisement Offices:
"Practical Wireless," George Newnes, Ltd.,
Tower House, Southampton Street, Strand,
W.C.2. 'Phone: Temple Bar 4363.
Telegrams: Newnes, Rand, London.
Registered at the G.P.O. as a newspaper and
for transmission by Canadian Magazine Post.

The Editor will be pleased to consider articles of a practical nature suitable for publication in PRACTICAL WIRELESS. Such articles should be written on one side of the paper only, and should contain the name and address of the sender. Whilst the Editor does not hold himself responsible for manuscripts, every effort will be made to return them if a stamped and addressed envelope is enclosed. All correspondence intended for the Editor should be addressed: The Editor, PRACTICAL WIRELESS, George Newnes, Ltd., Tower House, Southampton Street, Strand, W.C.2.

Owing to the rapid progress in the design of wireless apparatus and to our efforts to keep our readers in touch with the latest developments, we give no warranty that apparatus described in our columns is not the subject of letters patent.

Copyright in all drawings, photographs and articles published in PRACTICAL WIRELESS is specifically reserved throughout the countries signatory to the Berne Convention and the U.S.A. Reproductions or imitations of any of these are therefore expressly forbidden. PRACTICAL WIRELESS incorporates "Amateur Wireless."

A Pocket Portable

Constructional Details of a Midget One-valver, which Will be Found Particularly Useful for A.R.P. Work

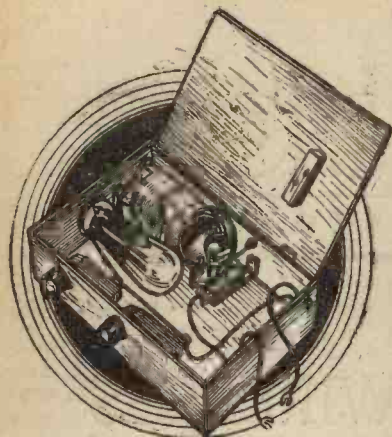

The completed pocket portable ready for the batteries.

THE midget receiver about to be described was made in a cigar box measuring only 5in. by 9in. by 1½in.; a box which holds twenty-five cigars is of suitable size. Although small, the receiver works well, bringing in the Home Service transmissions at good strength on the 'phones on a piece of wire 10ft. long as aerial. The set does not work on the long-wave band, as the coil was not wound for this.

The "Pocket Portable" actually has the necessary 2-volt accumulator of the jellied type fitted in the cigar box, and the complete set will quite easily go into any coat pocket and so, with a pair of head-

leave a reasonable length of wire for connecting up; this is the grid winding. Leaving a space of ¼in. from the start of the grid winding, and using the same gauge of wire, and winding in the same direction, wind on enough wire to fill a space of ¼in., thus completing the reaction coil. A little shellac varnish painted over the windings keeps them taut and firmly in place. For details of the coil see Fig. 1.

Assembling the Parts

To make the receiver, first drill two holes, one above the other, the diameter of a banana plug socket, in the left-hand

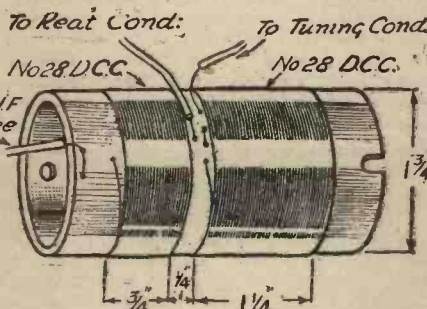

Fig. 1.—Winding details and connections for the coil.

The .0005 mfd. tuning and reaction condensers are now fixed into place, on the front of the box, and knobs attached. Connect the grid of the valveholder to one side of the .0003 grid condenser, and the other side of this condenser to the coil and condenser. Join a piece of fine wire from the moving vanes of the tuning condenser to the moving vanes of the reaction condenser, and allow sufficient length to reach to the right-hand side of the box, to be joined later to earth, the fixed vanes of the latter being now connected to the reaction winding of the coil. The other side of the reaction coil is joined to the plate or anode terminal of the valveholder. A fine wire, insulated with sleeving, now joins the same anode terminal to one side of the H.F. choke. Solder the other side of the choke to the terminal marked A (see Fig. 3) and to one side of the .001 fixed condenser, the terminal C being joined to the other side of this condenser, and by a piece of thin rubber-covered wire to the socket (red) next to the 'phone jack.

Now solder the grid-leak to the grid of the valveholder, joining the other side of the leak to one of the filament terminals, and by means of some thin rubber-covered wire connect it to the terminal marked B on the 'phone jack. The remaining jack terminal D has now a piece of rubber-covered wire soldered to it—about 4in.

COMPONENTS REQUIRED

- 1 4-pin valveholder.
- 2 Bakelite dielectric variable condensers, .0005 mfd.
- 1 Fixed condenser, .0003 mfd., tag type (T.C.C.).
- 1 Fixed condenser, .0001 mfd., tag type (T.C.C.).
- 1 Fixed condenser, .001 mfd., tag type (T.C.C.).
- 1 Grid leak, 2 meg., with wire ends (Dubilier).
- 1 H.F. choke (Bulgin).
- 1 'Phone jack, type P65 (Igranic).
- 1 'Phone plug (Igranic).
- 3 Banana plugs and sockets, red (Clix).
- 2 Banana plugs and sockets, black (Clix).
- 1 Detector valve, type 210 Det. (Cossor).
- 1 2-volt accumulator, jelly type, small, to fit box (Exide).
- 1 Paxolin former, 3½in. by 1½in. One ounce 28 D.C.C. wire, rubber-covered wire, spade terminals, screws, crocodile clip, etc.

side of the cigar box, about 1in. from the back, and mount two red sockets. To one connect one side of the .0001 series aerial condenser. Now, having wound the coil, place it lengthways in the bottom left-hand corner of the box, as close to the back as possible, and solder the input wire of the grid coil to the other side of the .0001 aerial condenser. Continue with this grid coil wire and solder to the other banana socket. Fasten the coil in place, and secure with a very small screw through the paxolin former to the bottom of

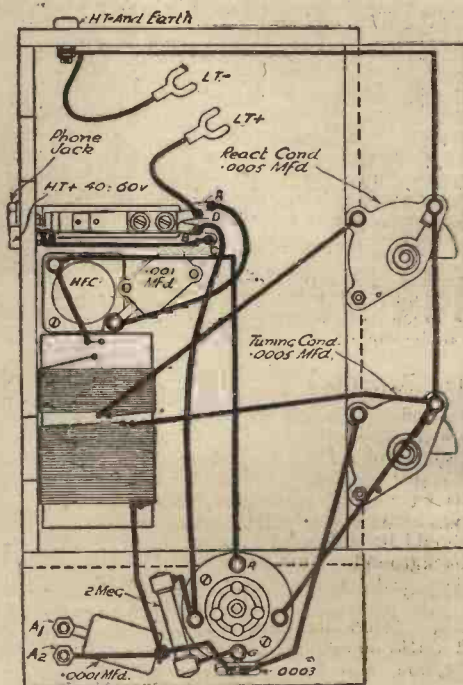
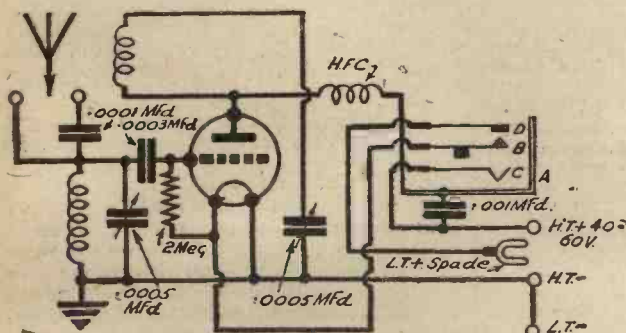

Fig. 2 (Left) Circuit diagram.

Fig. 3.—Wiring diagram of this compact little portable.



phones, one has a complete receiver which is easily carried about.

Winding the Coil

The coil is made on a paxolin former 3½in. long by 1½in. diameter. About the middle of this former, wind on a sufficient number of turns of 28 d.c.c. wire (closely wound) to fill up 1½in., not forgetting to

the box. This can easily be accomplished by inserting the screw at an angle. Screw down at both ends, and it is as well to note that, owing to the thinness of the wood, all screws will protrude through and in consequence will need filing flat.

Next, take the valveholder and screw this as close as possible to the coil, allowing for the width of the glass bulb.

long—at the end being fixed a small accumulator spade, which is for connecting to the plus side of the accumulator. There now remains a black banana socket; this is mounted towards the back of the right-hand side of the box. To a 4in. length of rubber-covered wire is fastened a black accumulator spade, and it is soldered to

(Continued on page 250)

Home Recording

Further Notes on the Production of Gramophone Records and Play-back

In the absence of alternative broadcast programmes, many listeners are now turning to their gramophone section, and there is obviously an increasing interest both in the playing of records and in their production. In the latter connection it must be remembered that much can be done to improve the reproduction by the use of special circuits, such as the contrast expander, whilst in the recording of music

head across the disc, and whilst it is possible to link up a standard pick-up traversing a 12 inch commercial record, thereby making this carry the cutter, as shown in Fig. 1, it will probably be found with an aluminium disc that the cutter digging into the disc will exercise such friction that the needle in the standard disc will jump and spoil the track. Where expense is to be considered the Feigh mechanism described in our issue dated November 18th will be found quite satisfactory. If much recording is to be done and really high-quality results are to be aimed at, then an elaborate tracker such as the V.G. should be obtained. The motor and turntable should be of reliable design capable of exercising a really steady torque without vibration or speed variation. The commercial models of complete home-recording gear generally incorporate a very heavy steel turntable to provide a flywheel effect.

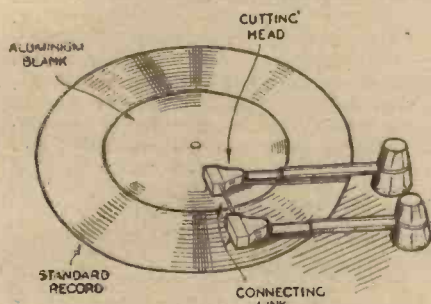

Fig. 1.—How a standard record may be used to avoid a tracking unit.

there is a most interesting field of experiment. It is possible to make discs at home which are absolutely indistinguishable from the commercial product—in fact, some amateurs have claimed that they have obtained better reproduction from home-made discs. But if care is not exercised, both in the selection of materials and in the processing, the results are absolutely worthless. It is useless to expect to get a good record with the aid of a cheap old-fashioned pick-up, a worn-out steel needle, and an aluminium disc. Similarly, it is just as much a waste of time to obtain a most expensive tracking gear, high-quality cutting head and diamond cutter and to connect it to an inferior three-valve battery set with cheap intervalve transformers. But by striking a compromise between these extremes, it is amazing what can be done.

The Amplifier

First of all, the amplifier or radio unit which feeds the cutting head should be capable of reasonable quality and a comfortable output. There is essentially a background of noise from the record when played back and therefore the sound track should be sufficiently great to obscure that background. Furthermore, to accommodate peaks in the volume the output stage should be of adequate power-handling capacity. Generally speaking, not less than 2 watts should be considered in this connection, and 5 to 10 watts will be even better. If a microphone is being used for the recording process this should be of a good type having a quiet background—not the cheap and noisy carbon type. What is probably more important is that there should be no audible hum in the amplifier—a point which is of the greatest importance in A.C. operated amplifiers and equipment. Some reliable apparatus should be employed to guide the cutting-

be replayed by fibre or similar needles, as steel ones will only cut up the recorded track. On the other hand the special discs may be replayed with steel needles after processing, this latter usually consisting merely of wiping over the disc with some special fluid, one acting as a hardening medium and the other as a polisher. They may, of course, be played

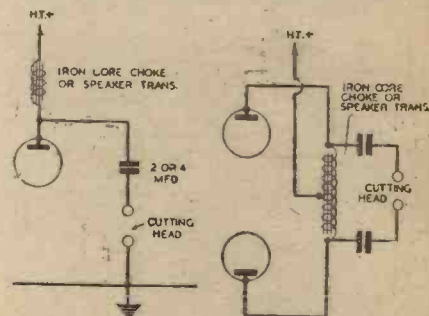

Figs. 2 and 3.—Feeding a cutting head from a single or a push-pull output stage.

Cutting Head and Needle

A really good pick-up capable of handling the input from the amplifier should be used, or one of the special recording heads specially obtained. This should be mounted to track correctly, and in conjunction with it you can use a worn steel needle, a sapphire or a diamond cutter. The latter are expensive, but are definitely worth the money. If the steel needle is used it should be run through on an ordinary gramophone record first and then inserted in the cutting head so that the slightly worn surface offers its cutting edge to the disc. For this purpose a magnifying glass will have to be used when inserting the needle. The sapphire needle will cost from 7s. 6d. to 12s. 6d. Aluminium discs must

back instantly after recording and without processing, but in that case a fibre or other "soft" needle should be employed.

Connecting the Cutting Head

The cutting head should be fed from a filter circuit in the output stage of the amplifier to avoid direct current flowing through it. Fig. 2 shows a circuit for a single output valve, whilst in a push-pull stage two fixed condensers as in Fig. 3 will offer sufficient protection whilst permitting the passage of the signal currents.

"Safeways" Adaptors

MANY houses are not provided with readily accessible power points, or other places where the wireless set or other low-consumption electrical apparatus may be easily connected. Some listeners overcome this difficulty by fitting two-way adaptors to a standard lighting point, and in this connection a really good connector with some form of separate switching is no doubt the best way of overcoming the difficulty. In the Clix range of components will be found several adaptors of this type, some with self-contained switches and others with a form of extension switch which is cord or button operated. In its simplest form this adaptor consists of a straight-through connector with a branch, the former being controlled by the switch. Thus, if any electrical apparatus is connected to the branch it may be controlled from the normal wall switch, and a light fitted to the trunk connector, as it is called, may then be switched off, if not required, by means of the switch on the adaptor. This is a square-section push device in the small

model, and it costs 1s. 10d. A similar model, but with both trunk and branch controlled by separate push-switches, cost 2s. 3d. To avoid the necessity of reaching up to the lamp-holder to switch off, these adaptors are available with a double cord, provided with acorns, or a twisted flex with pear switch at the end. The first model has a cord 15in. long, and the price is 2s. 6d. A patent form of spring anchorage is used to prevent the cords from whipping and also holds them well clear of the adaptor so as to avoid fouling or damage to the lamp. The other model is known as the "Either-lite," and the switch action enables either connector to be switched on, either switched off, or both off. This model costs 5s. 3d., and the cord is 7ft. long. These particular adaptors should not be confused with the cheap models on the market, as they are all provided with screwed shade carriers at the trunk end, and thus a shade may be mounted round the lamp in the ordinary way, the adaptor being above it and more or less out of sight.

The Drawing-room Play

The Microphone and Pick-up are Always in Great Demand at Christmas, and they can be Utilised to the Full in a Home-produced Radio Play — By L. O. SPARKS

WITH the wide popularity of the microphone amongst constructors, and the natural desire of most owners to emulate the B.B.C. studio results, the opportunity afforded at Christmas to entertain one's friends with a real radio play is a chance too good to be missed.

Fortunately, providing one has a good receiver or, better still, an L.F. amplifier having a reasonable output to amplify the microphone currents, the production

to the material forming the foundation and structure of the play.

It is not advisable to commence operations by attempting something far beyond the capabilities of one's equipment. In other words, remember the apparatus available when discussing the selection of the play. As regards the play, it is possible that the producer or someone interested in the project can write one himself. On the other hand, it is often possible to utilise a section of a short story and adapt it to existing requirements. Finally, several very fine plays have been published in past Christmas issues of this journal; therefore, if your volumes are not complete, there is still time to order from our Back Number Department.

handfuls of sand in a large tin or on a stiff sheet of brown paper. It will soon be found that various movements will create very natural effects.

The crackle or roar of flames can be produced by crushing paper plus the wind effect, quite close to the mike, while a matchbox or a piece of wood slowly crushed can sound very much like a most sickening smash.

The clatter of horses' hoofs needs a couple of empty coconut shells lightly beaten on a plain or cloth-covered board, according to the ground they are supposed to be covering. The noise of chains, footsteps, shots and the clash of arms must always be most carefully rehearsed, otherwise there is the great danger of them being reproduced in such proportions to the rest of the sound as to make them obviously unreal and even ludicrous.

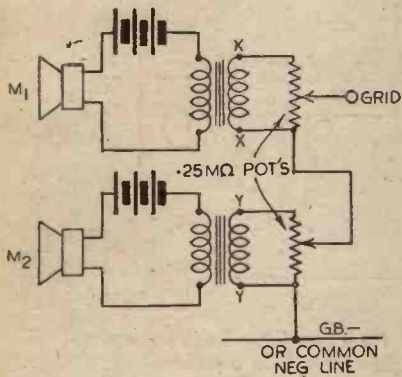

Fig. 1.—An effective but simple mixer circuit to enable two inputs to be controlled.

of a play is not, as might appear at first sight, a costly matter. Unlike ordinary amateur theatrical affairs, no special costumes, scenery or lighting effects are required, while, as regards a suitable cast for the actors, there is, invariably, plenty of volunteers most anxious to try their talent in front of a microphone.

To ensure the complete success of such a venture, it will be appreciated that one person must undertake the rôle of producer, whose job it is to see that everything goes according to plan or script and arrange the presentation of the play in the most striking and natural manner. This does not mean, however, that everything connected with the production must be governed by one man's ideas; there is the technical side of the matter, such as the amplifier, the number and placing of the microphones. Then there is the question of effects, while the selection of suitable music and its production can easily form another person's part. The timing of the individual parts and the mixing of the various microphones, if more than one is used, together with prompting, can easily form a very full-time occupation for, say, the producer during the actual performance.

Requirements

The first thing to secure is, of course, a suitable play, and the time devoted to this matter can go a very long way towards making or marring the splendid effort.

One must remember, that a radio play depends entirely on words, music and effects. The various scenes have to be portrayed by sound alone; the atmosphere has to be created in the listeners' mind by a skilful blending of spoken words, sound effects and, possibly, music; therefore, too much consideration cannot be given

Effects

These have to be introduced to just the right extent. Too little will leave the production wanting in atmosphere, but too much will, like too much seasoning, completely spoil the dish. The right amount will depend on the producer's skill, plus, of course, the close co-operation of the effects man.

The sound of wind can usually be produced by keeping the mouth fairly close to the microphone and going through the process of whistling through the teeth, but don't let it develop into a full whistle. A little practice will soon enable all the

Mikes and Amplifier

The technical man must be fully familiar with the capabilities and peculiarities of his equipment. All precautions must be taken to prevent any trace of feed-back which might cause microphone howl. For this reason alone, it is always best to have a separate room for the studio, thus leaving the audience in a room on their own with a suitable loudspeaker.

The L.F. side of the set or the amplifier should have an output of, say, two to three watts, although this will depend on the size of the room housing the audience and the number in attendance.

If more than one microphone is being used, a simple mixer of the type shown in Fig. 1 is absolutely essential, and change-over switches can be wired to bring others into circuit when and if desired.

For musical interludes, it is really best to use suitable passages of pre-selected records, using, of course, a good pick-up, to reproduce them via the set or amplifier. When required, the P.U. can be brought into circuit in place of one of the microphones by quite simple switching as shown in Fig. 2, but if a separate set can be used for P.U. work only, then that greatly improves matters and gives the operator wider scope.

The connections for the normal type of P.U. are given in Fig. 3, and it should be realised that far less amplification will be required for this component than the microphone.

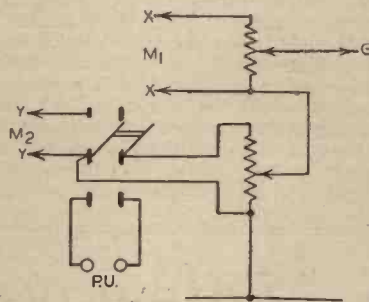

Fig. 2.—Shows how to introduce a P.U. when required by switching.

varying intensities of sound from a gentle breeze to a full-blown gale to be produced at will.

The swish and crash of the sea need be nothing more than two pieces of very fine sandpaper rubbed together, two or three

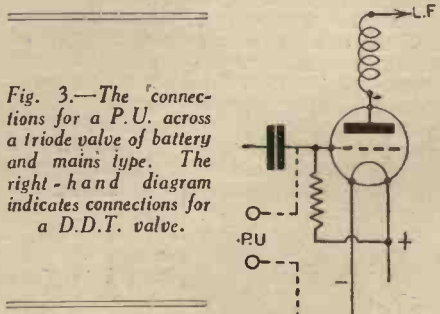

Fig. 3.—The connections for a P.U. across a triode valve of battery and mains type. The right-hand diagram indicates connections for a D.D.T. valve.

THE "THREE-TWO" RECEIVER

An Economical Two-valve Receiver Utilising a Multi-electrode Valve to Provide the Results Usually Only Obtained by a Three-valver
By W. J. DELANEY

WHEN considering problems of economy in the building of a receiver, there are very few things which may be done, apart from the acquisition of components of low cost. Inferior parts, however, will result in inferior results, and therefore it is false economy to obtain such parts. There is a scheme, however, which has been introduced before in these pages, namely, the use of multi-valves in positions other than those for which they are intended. By adopting this scheme, economy may be effected, although owing to the slightly increased cost of such a valve the saving is not considerable. When, however, one considers the associated components which are saved, plus the saving in space and consequent use of a smaller chassis, and the L.T. current, there is at least some small advantage in such a scheme. The receiver to be described is a battery version of a mains set which was built for experimental use, but, unfortunately, the full advantages of the mains set cannot be obtained, and the mains set can only be built with American valves. In the original model a triode-pentode was used in the dual function of H.F. amplifier and detector, whilst a dual triode was used as first L.F. and output stage. The ordinary battery Class B will not, unfortunately, operate as the two-stage valve, and therefore it is necessary to use a single type of valve. This still permits us, however, to build a two-valver which acts exactly in the same manner as a normal three, providing H.F. detector and output-stage in a compact form. It is necessary here, however, to point out that the specified dual-valve must be used, as this has a completely separate pentode and triode section, whereas the majority, if not all remaining valves of this type, have the grid of the triode section joined to the pentode section.

throughout the receiver, and a small chassis only 8in. by 6in. is ample to accommodate them. A Varley standard two-gang coil unit is employed which provides an H.F. transformer input, with a similar inter-valve section, plus reaction. A two-gang condenser with standard slow-motion drive is employed, and the remaining few parts are wired between various points beneath the chassis. To permit of maximum sensitivity under all conditions, a separate fly-lead is provided for the screen voltage of the H.F. pentode, whilst for volume control purposes the L.F. input is controlled by a potentiometer. The triode section of the first valve is perfectly normal, and all other circuit details may be seen from the theoretical diagram below. It will be noted that the triode anode is fed from the maximum H.T. line by using a decoupling resistance. The values of decoupler and coupling resistance have been chosen to provide smooth reaction with stability and avoid the use of a further battery lead. To keep down the number of panel controls the on/off switch is mounted on the rear of the coil unit and is operated by the normal wave-change switch which is provided on this particular



Rear view of the receiver.

unit. Note that a special slotted dolly switch must be used for this purpose, the correct Bulgin type number is S.139. The receiver is perfectly stable, and handles just like a standard three-valver.

The Circuit

Standard parts are otherwise used

Theoretical circuit of the "Three-two" receiver.

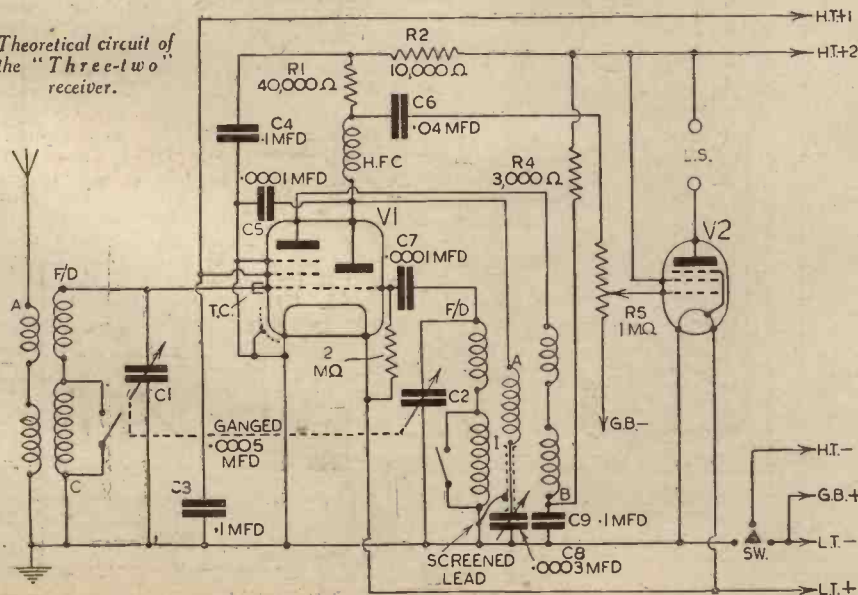

Constructional Data

The chassis requires only two holes for the valveholders, plus two small strips on the rear runner for aerial and speaker. Clearance holes or slots may be cut for the latter, whilst for the valveholders the holes must be 1 1/8 in. for the 9-pin and 1 in. for the 5-pin. Small holes for the connecting leads from the coils are needed, and these may be 3/16 in. in diameter. Two component-mounting brackets are screwed on the underside of the chassis to accommodate the reaction condenser and volume control, and these brackets should be set just beyond the edge of the chassis so that the lock-nuts of the one-hole fixing bush will clear the panel which is used with the set. It will be noted, by the way, that the condenser has been mounted off centre on the chassis to enable the size of this to be kept to a minimum, and, therefore, when placing the chassis in a cabinet, or using a panel, this may be either centred to permit batteries or speaker to be placed at the side, or a larger panel may be used and the panel centred on this.

Adjusting the Receiver

The receiver must be ganged before maximum results are obtained, and for this purpose the condenser should be adjusted to the North Regional or Scottish Regional setting on the calibrated dial so that the

THE "THREE-TWO" RECEIVER

(Continued from previous page)

Home Service transmission may be heard. At first the signals may not be received exactly at these settings and the tuning control should, therefore, be adjusted on either side of the point (according to the part of the country in which you live), until some signal is heard. Reaction should be advanced slightly during this process. As soon as the station is located the trimmer on the section of the condenser nearest to the panel should be adjusted whilst the tuning control is manipulated to keep the signal audible. In this way the tuning setting may be brought to read correctly the wavelength of the received station. Next, the trimmer on the remaining section should be adjusted and as volume increases the reaction control should be set back until reaction is absent. If then the volume is too great, the L.F. volume control should be adjusted. Keep signals as weak as possible, whilst making these preliminary adjustments, and when once set they will require no further touching. There is a wide range of cabinets from which to choose supplied by firms advertising in our pages, and a receiver of this type will make a very neat and compact assembly for general use. It was not thought desirable to include short-waves, although there is no reason why, if short waves are particularly required, a three-band coil assembly could not be used, but the receiver has not been tried out with this particular arrangement.

WIRING DIAGRAM OF THE "THREE-TWO" RECEIVER

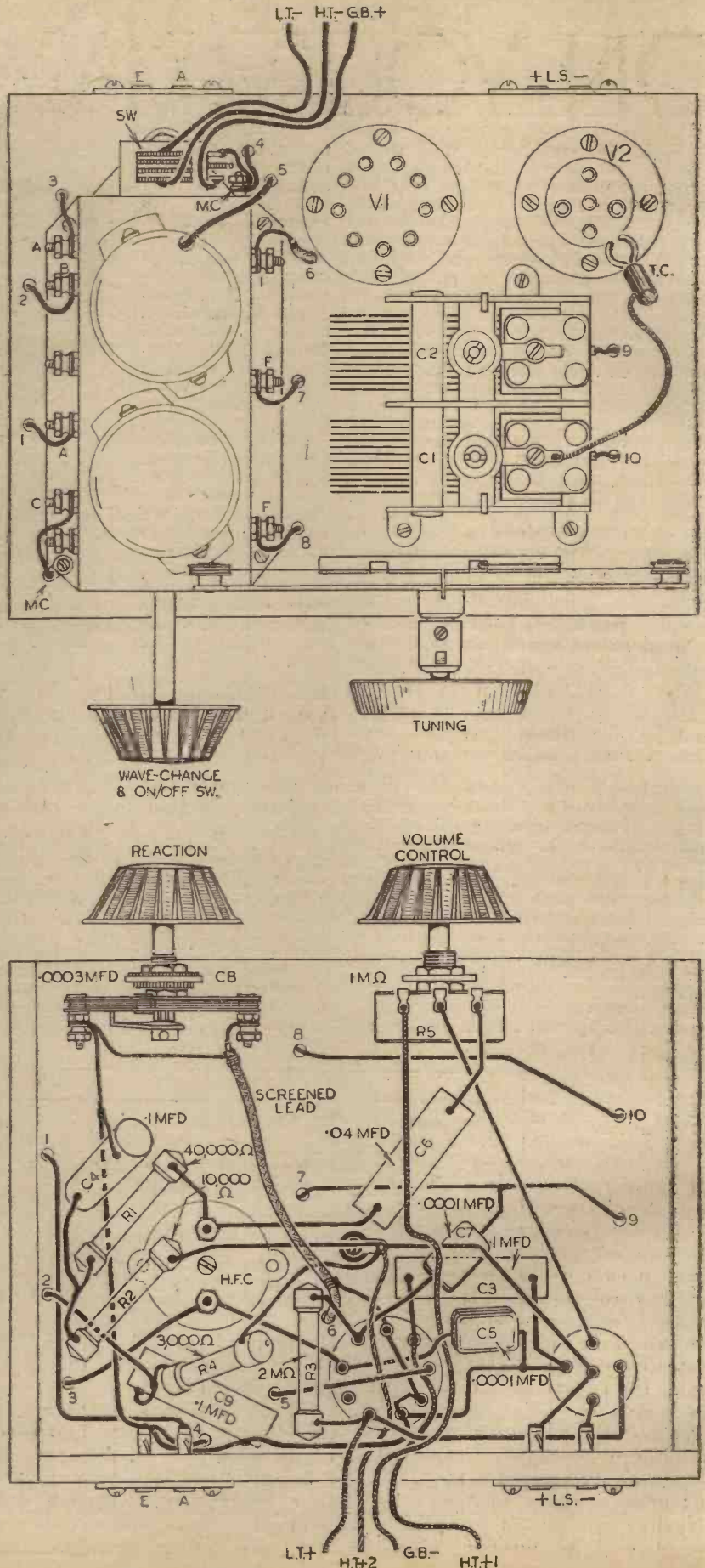

LIST OF COMPONENTS FOR THE "THREE-TWO" RECEIVER

- One "Bar Type" 2-gang condenser (Polar).
- One micro-horizontal drive (Polar).
- One 2-gang coil unit, type BP.114 (Varley).
- One .0003 mfd. Compax reaction condenser (Polar).
- One screened standard H.F. choke, type H.F.9 (Bulgin).
- One 4-point slotted dolly switch, type S.139 (Bulgin).
- One 3,000 ohm 1-watt resistor (Dubilier).
- One 10,000 ohm 1-watt resistor (Dubilier).
- One 40,000 ohm 1-watt resistor (Dubilier).
- One 2 megohm 1-watt resistor (Dubilier).
- Two .0001 mfd. fixed condensers, type 635 (Dubilier).
- One .04 mfd. fixed condenser, type 4602/S (Dubilier).
- Three .1 mfd. fixed condenser, type 4603/S (Dubilier).
- One 1 megohm volume control, type VC 65 (Bulgin).
- One 9-pin chassis type valveholder, type X.112 (Clix).
- One 5-pin chassis type valveholder, type X.112 (Clix).
- One two-socket strip, A.E. (Clix).
- One two-socket strip, L.S. (Clix).
- One top cap connector, type R426 (Clix).
- Two component-mounting brackets (Peto-Scott).
- One Metaplex chassis, 8in. by 6in. with 3in. runners (Peto-Scott).
- One TP.22 triode-pentode valve (Mazda).
- One Pen. 220 output pentode valve (Mazda).
- Connecting wire, insulated sleeving, screws, etc.

THE WIRELESS CONSTRUCTOR'S

ENCYCLOPÆDIA

By F. J. CAMM | 6th Edition | 5/- net.

Wireless Construction, Terms, and Definitions explained and illustrated in concise, clear language.

From all Booksellers, or by post 5/6 from George Newnes, Ltd., Tower House, Southampton Street, Strand, London, W.C.2.

ON YOUR WAVELENGTH



By *Thermion*

Christmas, 1939

FATALISTS will point the tragic finger at the last two digits of this year of grace—39, three thirteens! The first three figures added together make thirteen, and the last two and the first added together make thirteen. I am not a numerologist, and I do not think that numbers have the slightest effect on what we prefer to term luck, which is always of two sorts, good and bad. But there it is. In 1939 we are engaged in a war of major proportions. It is certain that we shall emerge victorious and, let us hope, soon. The year has witnessed the confiscation of amateur transmitting sets, but it has also seen the immense power for good as well as for propaganda which can be made of the broadcast word in time of war.

Wireless had not been introduced in the last war. I am, of course, speaking of wireless telephony, for field telephone sets were in use during the 1914-1918 war. It seems a profound tragedy that the motto of the B.B.C., "Nation Shall Speak Peace Unto Nation," has borne such poor fruit. It is no fault of theirs. Foreign countries have used the power of the ether to fan the flames of hate, and in war similar methods must be adopted finally by all. You must agree with me, however, that the British propaganda is clean, careful, and calculated. It is free from bias and hate. The limitation of programme variety is one of the inevitabilities of war. It does help to cheer us with a form of cheer absent in the last. This issue goes out to countries, save the belligerents, all over the world, and to many my message of cordial goodwill will reach them round about the 25th of December. Because of this, readers in this country will receive it some weeks ahead. I hope that they will not doubt its sincerity, because it must be uttered at a time divorced from the atmosphere of goodwill which steals over the world during the joybell period. I know that many will feel a sense of incongruity this Christmas, but it is not for us to debate these things. We are all experiencing hardships and difficulties, and journals and journalists are not an exception to the rule. I do, however, want to

express to all readers wherever they may be sincere greetings for the merriest Christmas possible under the circumstances. Between now and the 25th a shower of Christmas cards will arrive from loyal readers the world over. In advance, I thank them in the spirit of reciprocity which makes Christmas what it is.

Lincoln Did Not Say It

MAJOR-GENERAL SIR ERNEST SWINTON was speaking over the wireless the other night on war matters. I was not in the least interested in his talk, but I pricked up my ears when I heard him quote that famous phrase: "You can fool some of the people all of the time, and all of the people some of the time; but you cannot fool all of the people all of the time."

The meticulous B.B.C should have vetted that part of Swinton's speech with a little more care, for Abraham Lincoln did not originate that phrase. It is true that he used it in a speech at Clifton, Illinois, on September 8th, 1858. Spofford denied that Lincoln invented it. There are some who think that P. T. Barnham did so. I deny that too, for Pliny and La Rochefoucauld made similar remarks years before. The earliest to use it as far as I have been able to trace in the form in which Lincoln quoted it is Josh Billings. Just as well to have these matters right.

Newspaper Scoops

THE word "News," they say, is compounded of the initial letters of the four points of the compass—North, East, West and South. In these days of small newspapers and restrictions, the lot of the reporter is particularly unhappy, for although in peace time the scoop still lives, in war-time there is no such

thing—for the Ministry of Information sees to that.

It has become increasingly difficult in recent years for the quickest mind to keep ahead of the speed of communications. Radio has eliminated the last few moments of delay.

But the real scoop is still a thrill, and in the splendid Christmas Number of the "Strand Magazine" you will find the story of the most notable newspaper scoops of recent years, specially written by that world-famous journalist, Douglas Reed, who wrote "Insanity Fair" and "Disgrace Abounding."

In spite of war-time conditions this fine issue of "The Strand" lives up to its great tradition. In common with all other magazines it must be ordered from newsagent or bookstall.

Letters to Foreign Countries

ATOPICAL reminder concerning the new regulations governing the dispatch of letters to foreign countries. Under present conditions no printed publications, postage or revenue stamps, plans or photos, maps or similar diagrams, may be sent to the following countries: Baltic States, Belgium, China, Denmark, Greece, Holland, Hungary, Italy, Japan, Luxembourg, Norway, Poland, Portugal, Roumania, Spain, Sweden, Switzerland, Siam, Turkey, U.S.S.R., Vatican City or Yugoslavia. These regulations do not apply to letters, but the sender's address must be written on the back of the envelope, and the words "Written in English" printed. Communications will be opened.

J. H. Thomas Resigns

MY personal regrets that genial J. H. Thomas has resigned his position as Managing Director of A. C. Cossor, Ltd. Mr. Thomas was Chairman of the Radio Manufacturers Association, but I learn that he has tendered his resignation and this will be considered at the R.M.A. Council Meeting on December 15th. Col. G. D. Ozanne, the Vice-Chairman, has also tendered his resignation. The new Managing Director of A. C. Cossor, Ltd., is Sir Louis Sterling, who was formerly Managing Director of E.M.I. He resigned on May 20th.

LOOSE CONNECTIONS

The Importance of Avoiding a Noisy Background is Mainly Dependent Upon the Efficiency of Connections

THE writer, a Service Engineer belonging to a company whose name is a household word, has recently been amusing himself by reading a number of books on service work published both here and in America, also sundry articles appearing in these countries, and gives below a number of faults which, although not uncommon, have been rarely, if ever, mentioned.

Stupid Mains Plugs

A common cause of spluttering in commercially-built receivers is such a stupid one that the engineer never bothers to mention it, and the amateur usually thinks of it last. This is the actual connection between the mains cord and the mains plug. The average mains plug is peculiarly unsuitable for this purpose, having the usual ridiculous hole in which the end of the flex is inserted, which in turn is intended to be gripped by a screw of absurd dimensions, which may, with luck, grip as many as half of the metal strands. This connection very often becomes loose due to one or more strands working out from under the screw, leaving the rest of the bunch a sloppy fit. In the absence of an intelligently designed plug, the best remedy is to bind the strands together so that the screw can be made to grip them without them spreading unduly. Where the cover permits of it, it is a good idea to bare about $\frac{1}{4}$ in., take the strands through the hole, round the outside, and back through the hole again. Obviously the screw should not be tightened to the point where the flex is cut, but it should be tight enough to prevent any possibility of arcing, which sets up most disagreeable interference.

Plugs and Sockets

There is an increasing tendency for manufacturers to terminate the aerial and earth connections of the set with sockets, and to generously provide two particularly nasty little plugs intended for the earth and

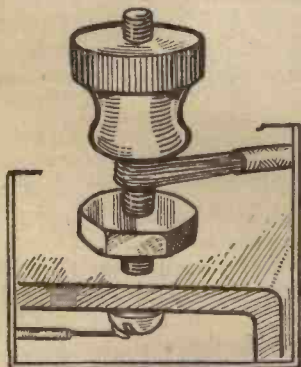

Flex must be carefully handled when used beneath terminals, as loose strands can give rise to noisy backgrounds.

aerial leads. At least one manufacturer recommends 7/22 copper wire for the earth "which should continue unbroken to the actual receiver," but thoughtfully provides a plug in which only three strands will pass

through the hole provided for that purpose. These plugs are in themselves satisfactory, but many of them have a common failing. The wire is intended to be held in place by the metal plug portion which is screwed up against it. Often when screwed right home it will not properly grip a piece of wire of reasonable gauge, and while the wire is clean, all is well, but when the wire oxidizes, nasty scraping noises are heard in the speaker if the lead sways. Trouble of this nature is peculiarly awkward to find, as if the lead is taken and shaken from side to side at an angle that is at all acute, it may bring the wire into perfectly good contact. It should not be necessary to add that such manufacturers go to great trouble to lower H.F. resistance of their tuned circuit, and it is intolerable that resistance should be set up in the aerial plug, which necessarily happens unless the plug grips the wire tight enough to prevent oxidation.

The Elusive Gas Pipe

Many listeners are obliged to use a water pipe "earth" which, at best, must have a fairly high resistance. Along this resistance there is a potential drop, consequently if any metal comes in contact with the pipe throughout its length, which is in turn connected to earth, it will cause some sort of noise to be set up in the loudspeaker. Many years ago a case was investigated where a set made the most alarming noises when a

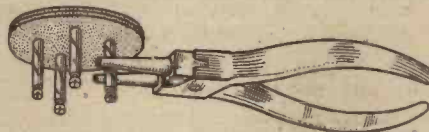

Modern valve sockets may be pinched slightly if valve-leg noise is suspected.

motor-bus went by. This was due to a water-pipe "earth" touching a gas pipe momentarily when the motor-bus caused it to vibrate. Such a trouble as this is not difficult to find, provided the water pipe is visible throughout its length, but, unfortunately, this is rarely the case. To a lesser extent the same trouble can apply where the water pipe touches some other earthed object at a point above (possibly several stories above) where the earth lead from the set is connected.

Ancient Wall Sockets

Wall sockets that have been left undisturbed for a term of years often make very bad connection with the supply wires, due to damp, verdigris, and any of the other troubles which can attack a wall plug not protected by a box at the back. Such a state of affairs often gives rise to a minute arc between the wire and terminal, which in turn can produce a most appalling racket in a sensitive wireless set of the superhet class. The remedy is obvious, and it is sufficient, therefore, to draw attention to it. It will be appreciated that an ordinary A.C. voltmeter is not likely to reveal the trouble, the obvious pointer being whether the set works satisfactorily when plugged into some other socket. The same trouble would, of course, appear with a broken wire, but this usually solves itself, as the broken ends of

electric light cable very soon move apart so that a complete break occurs.

A Screw Loose!

The reprehensible habit of neglecting to "earth" a mains set is getting more and more common. Admittedly in nine cases out of ten reception is not improved, but it is unquestionably desirable from the safety

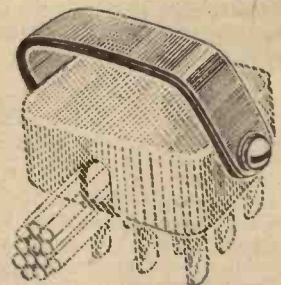

Multi-contact blocks will simplify connections and avoid noisy backgrounds.

aspect. An unearthened chassis brings quite a few lesser troubles in its wake: an example will serve to indicate them. Some chassis are fixed in their cabinets by four nuts and bolts. In due course the base of the cabinet warps, and a nut and bolt which were previously under tension become loose and rattle on the chassis. If the chassis is earthed, this does not matter in the slightest. If it is not earthed, it will still not matter in 99 cases out of 100, but in the odd case it will faithfully record its movements on the loudspeaker by a peculiar scraping noise, which can be imitated by scraping the aerial lead gently with a piece of metal. The trouble, of course, occurs in those receivers which are inclined to be on the verge of instability when the earth is removed, and it is more likely to occur with sets one or two years old, rather than with those of this season, which, taking them all round, are extraordinarily stable.

Declining Selectivity

The selectivity of some receivers is liable to decline gently, until a point is reached where its owner wakes up to the fact that, whereas it used to be possible to get this station free from that station, it has become impossible. Go to the local dealer and he will tell you that it is valves, which is a wise diagnosis, as it is almost, but not quite certain, to be correct. Assuming that the set is not out of gang, all components are O.K., and there are no loose connections, the "not quite" element will be resistance in the actual switch contact. Recently, a troublesome switch was carefully measured for its resistance, and revealed the astonishing figure of .892 ohms, rather more than 25 per cent. of the H.F. resistance of a good grid coil at 400 metres. The trouble was that the wiper blades which formed one half of the switch contact had become tired, had lost the springiness they enjoyed in their youth, and touched the rotor portion of the switch so gently that a piece of tissue paper could be slipped between them without being crumpled.

The Extension Speaker

Technical and Practical Aspects of Remote Listening Points



Extension speakers are available in cabinets to harmonise with various furnishing schemes. This is a W.B. Stentorian model.

It has always seemed very probable that the great vogue at one time enjoyed by the portable and transportable set was in large measure due to the fact that these sets offered the advantage of "radio anywhere in the house."

That they have to some degree gone out of favour does not, we believe, indicate that this feature is no longer appreciated; rather is it the natural result of the introduction of fixed-location sets possessed of desirable attributes absent from the earlier forms of portable.

In short, it appears that radio users have sacrificed the special convenience of being able to take the programme into any part of the house in favour of the good points of the modern "stationary" set. That the former convenience can be regained with the aid of extension loudspeakers does not seem to be very widely realised by listeners.

Here we intend to deal with the technical and practical aspects of that question so that readers may discover how easily the matter may be arranged.

The first consideration must naturally be given to the question of how many rooms are to be served, and whether more than one point is likely to be in use at once. In the majority of cases it will most probably be decided that it will suffice to provide for the use of at the most two additional listening points, and that only one of these will be working at a time.

In such circumstances it is only necessary to acquire one extra loudspeaker, so that the business is both simple and inexpensive; the single loudspeaker can be moved to the room in which it is desired to listen—and the wiring itself is easily installed.

Where two or more additional instruments are expected to be in use at any one time some consideration must be given to the question of power output; in general this arrangement demands a set with a fairly large output of the order of 3 watts as a minimum unless the rooms concerned are quite small. For a single extra point in use at once, on the other hand, almost any receiver giving good volume on its own loudspeaker will suffice.

Volume Adjustment

A word of warning is appropriate here regarding the question of volume adjustment when a number of speakers is in use in rooms of different size. It will be found that if the level is set to suit the bigger rooms it will be quite unpleasantly high in any really small one; rooms less than about 10ft. square are extremely difficult to group in with others more than about fifty per cent. larger.

In all such cases it is necessary to find out by trial how much the volume can be lowered before it becomes inadequate for the biggest room concerned so that a reasonable compromise can be achieved.

In this connection we would offer the general advice that it is best not to be too ambitious in these matters. Rather than

create difficulties of this sort for oneself it is better to decide to leave any very small room out of the scheme and concentrate upon those of roughly equal size. Naturally, the question does not arise in those cases where it is expected that only one extension point will be in use at a time; here it is merely necessary to learn by experience what volume level should be heard in the room containing the receiver to ensure satisfactory listening at the distant point.

The cost of the installation will obviously depend to a large extent upon the style and quality of the loudspeakers chosen. The cost of the wiring will normally be quite small, even if one does the thing in style with plug-and-jack connectors for the distant points.

Apropos the cost of the loudspeakers it may be remarked that a considerable part of the purchase price goes on the cabinet work, so that if a simple and unpretentious style of case is chosen the cost can be kept down without sacrifice of quality of reproduction.

Running the extension wiring is a comparatively simple task. Many readers will no doubt carry out the work themselves and our suggestion is that twin



Here is a chassis Rola model. An energised speaker may be used at an extension point, with separate field energising.

bell-wire of the cotton-covered and paraffin waxed type should be used.

Wiring the House

Insulated staples such as may be obtained from almost any electrician can be used for securing the leads in position; it is a good plan to drive each staple nearly but not quite home, then apply a steady pull to the free end of the wire and give the staple a final sharp tap with the hammer. In this way the leads are kept taut and neat.

Probably the best route for the leads will be found along the lower edge of the skirting board, as close to the floor as possible. If reasonable care is taken the result will not be at all unsightly, indeed, it will be almost invisible if one takes a small brush and touches up both lead and staples with paint to match the colour of the skirting board.

Wiring System

The system of wiring should be such as to place all the loudspeakers in parallel, the series system of connection is only

suitable in certain special cases. Actually, neither method is ideal in theory unless special arrangements are made as to the output circuits of the receiver, but the practical falling-off in quality resulting from the inevitable slight degree of mismatching scarcely justifies the complication and expense of an extra correcting transformer to feed the extension systems as a whole; individual matching of the separate speakers is sufficient.

A convenient method of connecting the loudspeakers to the various terminal points is very desirable unless one is prepared to fit each instrument as a permanency and allow it to work at all times. This is not wanted in most cases, so it becomes essential to provide some means of silencing the unwanted instruments.

If this takes the form of some sort of plug and socket connection scheme, any particular loudspeaker can be put out of action by the simple expedient of withdrawing the appropriate plug. At the same time, it is then made an easy matter to transfer the instrument from room to room as required and one can reduce the total number of reproducers needed.

Quite simple and inexpensive connectors will serve the purpose, the miniature type of two-pin plug available from electrical stores being as good as anything so far as actual efficiency is concerned. Those who are prepared to spend a few extra pence to obtain good appearance and perhaps greater reliability would do well to obtain details of the Bulgin system of wall jacks.

Assuming that some such arrangement of plug and socket connection is used, the extension line system can be kept permanently connected up to the output terminals of the receiver; plugging in a loudspeaker at any one of the distant points then brings the programme into the room concerned.

The alternative method is to connect the extra reproducers permanently to their respective extension points and use some form of switching system at the receiver to bring the required extension into circuit when needed.

The output arrangements of the receiver must be given some little consideration, especially if it is a mains set. Here it is necessary to make certain that there is no chance of high-voltage currents being allowed to get into the extension lines and wander around the house. Some form of output filter or transformer is the only positive protection, and it should always be provided.

(Continued on page 249)

The Trophy 8

Review of the Peto-Scott Communications Receiver

IN this receiver we have a good illustration of the incorporation of all those features which are essential when reliable short-wave long-distance reception is desired. Apart from those factors which are common to the communications type of receiver (B.F.O., A.V.C., etc.), the makers have even gone to the extent of "mixing" the valves. The desirability of reducing valve noise and background noise needs no emphasis, and in this connection it has been found, as we have explained before in these pages, that the majority of such noise is introduced in the first, or signal H.F. stage. Special valves have, however, been introduced to reduce this noise factor, and a typical instance is the Mullard EF8. In the Trophy 8, therefore, the makers have included this particular valve, leaving the remaining stages fitted with American G type valves and the results are fully justified. The frequency-changer is a 6TH8G, with a 6K7G I.F. amplifier, a 6Q7G 2nd detector, A.V.C. and L.F. amplifier and a 6F6 output pentode. The usual B.F.O. stage and separate R.F. oscillator are provided, and the mains section includes a full-wave rectifier. The entire receiver is built into a black-crackle finished cabinet, but the speaker has been omitted and is obtainable in a similar style of cabinet with chromium decoration.

Controls

There are ten "controls" on the cabinet front, four of these being switches and jacks subsidiary to the main functions of the receiver. Phones, for instance, can be used by plugging into the jack, thereby cutting out the speaker and including them in the output circuit, fed through a standard filter. The switches are a "send-receive" on/off switch, B.F.O. on/off and A.V.C. on/off, whilst the remaining controls cover tuning, band-switching, H.F. gain, L.F. gain, tone, and B.F.O. pitch control. There are five bands, covering from 7 to 550 metres and the band switch, and the tuning dial are calibrated in kilocycles and megacycles (43 mc/s to 545 kc/s) continuous.

The receiver has been tested by us on various aeriels and gave a very good account of itself under varying conditions. The efficiency of the R.F. stage is very marked in contrast with other receivers of similar design employing a standard valve. All of the controls function in a smooth and effective manner, the judicious use of the H.F. and L.F. gain controls acting effectively in controlling background noise and interference where the latter is ex-

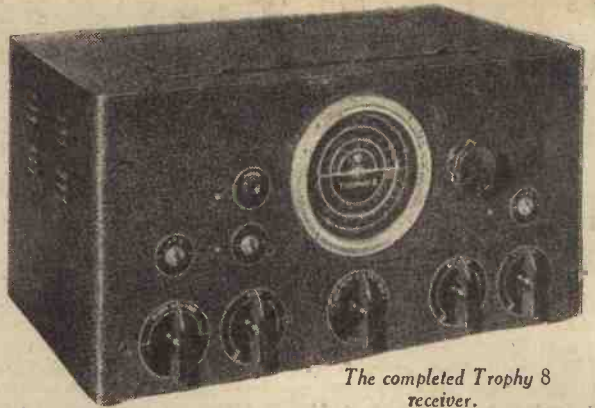

The completed Trophy 8 receiver.

perienced. A.V.C. works well and is fully effective under all normal fading conditions, although as is usual with this particular type of circuit, high-speed fading naturally results in a variation in the signal strength. Each waveband has a separate portion of the dial for calibration purposes, so that no difficulty is experienced in logging any desired station. The price of this receiver is £13 17s. 3d., whilst the speaker is 46s. 3d. extra. Hire-purchase terms are, of course, available at the usual Peto-Scott convenient rates.

The Trophy Six

In the review of this receiver in our issue dated November 25th the price was given as 9½ guineas. Owing to increased costs of materials since the war, the price of this receiver has been increased. The present price is, therefore, £10 19s. 6d.

N.T.S. 3-valver

THE illustration below shows an interesting chassis form of three-valve set which may be obtained for £3 9s. 6d., including valves. This tunes from 14 to 2,000 metres, in four bands, and is available also in a mains form at £3 19s. 6d. In this case, however, the range is slightly narrower, covering from 18 to 2,000 metres. For the medium and long-wave bands the coils are of the screened type, whilst the short-wave coil is situated beneath the chassis and is unscroneed. The receiver is complete with

self-contained switching and incorporates a full vision (clock-face) tuning dial with separate scales for each range. There are three main controls: tuning, reaction and combined on/off and volume control, with a central 4-position wave-band selector. The receiver is assembled on a metal chassis, finished in neat grey cellulose and a gang condenser is used for tuning. The medium- and long-wave coils are separated, as may be seen from the illustration and there is no trace of interaction or instability due to coupling between stray wiring, etc. There is a fuse bulb fitted, and the battery supply is in the form of a multi-cell, rendering the receiver ideal for installation in a small cabinet of the type

types of aerial and gives a very good account of itself, being both selective and very sensitive. On quite a small indoor aerial a very wide selection of stations was received, and the quality given by the output stage, even with 100 volts, was fully up to the normal standard of a battery receiver of this type. The battery cords are colour-coded and the valves provided are of the Hivac type. The suppliers are New Times Sales Co., Ltd., 56 (Pr.W.11), Ludgate Hill, London, E.C.4.

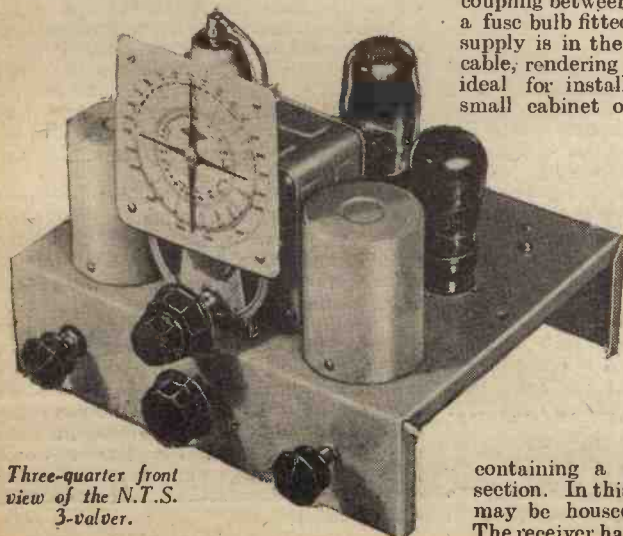

Three-quarter front view of the N.T.S. 3-valver.



The mains version of the N.T.S. 3-valver.

containing a speaker in the upper section. In this case, also, the batteries may be housed behind the speaker. The receiver has been tested on various

Practical Hints

A Simple Capacity Bridge

THE accompanying diagrams show a capacity bridge which can easily be made up from spare parts. It consists of a 10,000-ohm potentiometer placed across an L.F. source, one terminal of a pair of earphones is connected to the sliding contact.

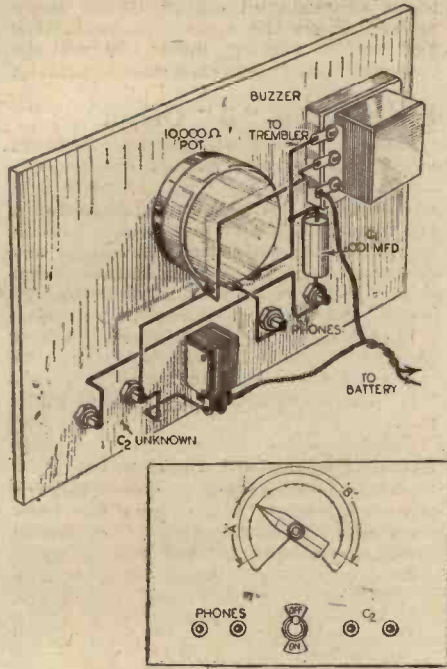

A simple but efficient capacity bridge.

The other terminal of the headphones is connected to the junction of the known and unknown condensers which are connected in series, also across the L.F. source. The L.F. current is obtained from a buzzer, a connection being made to each side of the trembler contacts.

To use the bridge, connect the unknown condenser to the appropriate terminals, switch on the buzzer, and adjust the potentiometer until a position is found where the strength of the note is at a minimum. The scale can be calibrated from standard condensers, or the capacity of the unknown component can be calculated from the following formula:

$$\text{Capacity of } C_2 = \frac{\text{Reading "A"}}{\text{Reading "B"}} \times C_1$$

—K. C. KING (Bromley).

Reducing Mains Hum

IT is interesting to note that 50 cycle mains hum can generally be reduced fairly considerably by inserting a fixed condenser somewhere in the loudspeaker circuit. When using an output transformer the condenser can be connected between one secondary terminal and the loudspeaker; a capacity of .5 mfd. or so will generally prove just about right. If the speaker is fed through a choke-capacity filter it is only necessary to reduce the capacity of the filter condenser to a value similar to that referred to above. The idea in both instances is to provide a comparatively difficult path to the very low frequencies without

THAT DODGE OF YOURS!

Every Reader of "PRACTICAL WIRELESS" must have originated some little dodge which would interest other readers. Why not pass it on to us? We pay £1-10-0 for the best hint submitted, and for every other item published on this page we will pay half-a-guinea. Turn that idea of yours to account by sending it in to us addressed to the Editor, "PRACTICAL WIRELESS," George Newnes, Ltd., Tower House, Southampton Street, Strand, W.C.2. Put your name and address on every item. Please note that every notion sent in must be original. Mark envelopes "Practical Hints." DO NOT enclose Queries with your hints.

SPECIAL NOTICE

All hints must be accompanied by the coupon cut from page 252.

restricting the passage of any others. This can be done quite easily by the methods suggested, and if care is taken in choosing the optimum condenser capacity, the quality of reproduction will scarcely suffer at all.—P. F. (Mill Hill).

Marking Leads Passing Through Chassis Grommets

IT is often difficult to trace leads which connect underside to top-side chassis wiring when two or more are passed via rubber grommets inserted in the intervening chassis. By adopting a simple method of colour-coding and a suitable

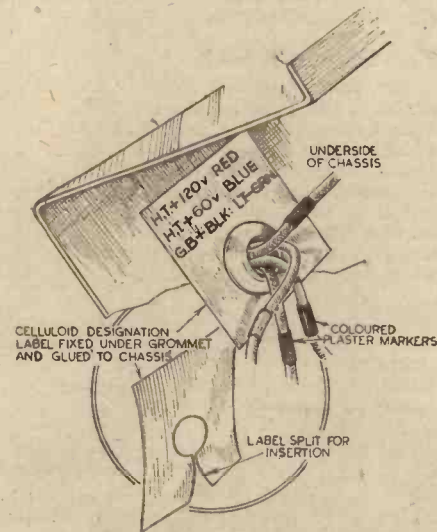

A method of marking battery leads.

marking plate, constant tracing of leads whilst working upon the underside of the chassis can be avoided. Consequently valuable time is saved and the possibility of errors is reduced. Each of the four leads is wrapped round with surgical plaster, tinted with distinctive colours by ink or dye. A split celluloid label is inserted between the grommet flanges and the chassis (to which it is also glued) to indicate the termination of the various leads, and their appropriate colour codes.

The simplicity of the arrangement and its apparent usefulness can be gathered from the accompanying sketch.—Wm. A. HARRISON (Aintree).

A Flexible Driving Shaft

THE accompanying sketch illustrates a simple flexible driving shaft that can be made from an old cycle brake cable (the type that is made of a closely-wound spiral of steel wire), a few spare parts of a

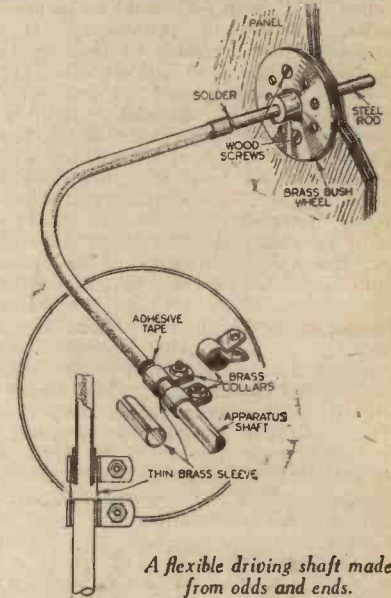

well-known constructional toy, and some odds and ends.

A steel rod is soldered to one end of a length of brake cable as shown. At the other end some insulating tape is wound round to the diameter of the spindle of the condenser or potentiometer.

From some thin brass two collars and a tube are made as shown. The sketch illustrates the method of fixing the brake cable to the condenser or potentiometer spindle. The steel rod passes through the panel through a bush wheel which keeps the rod in a horizontal position. In use the control was found to be free from noticeable backlash, and is perfectly stable.—L. CALLOP (Hendon).

WIRELESS TRANSMISSION FOR AMATEURS

Edited by F. J. GAMM

Explaining how to Learn the Morse Code; Applying for a Licence; Building and Operating a Transmitter. Illustrated by Many Practical Diagrams.

Price 2/6 or 2/9 by post

From George Newnes, Ltd. (Book Dept.), Tower House, Southampton Street, Strand, W.C.2.

Deciding on the Output Stage

WITH the advent of tetrodes, and the wide variation of sensitivity required in the output stage, selection from the many available output systems has become increasingly complicated. The battery user may select a triode, a tetrode, a pentode, or either of the quiescent output systems, namely, quiescent push-pull or class "B" output. The mains user, on the other hand, may choose a triode, tetrode, pentode, bottom bend push-pull, usually referred to as class "C," or normally biased push-pull valves, usually referred to as class "A," or one of the fancy output arrangements (low-loading, etc.). Certain secondary complications arise, inasmuch as class "A" or class "C" push-pull could make use of triodes, tetrodes or pentodes. It is therefore highly desirable to clear up the output question and to indicate which type of output is appropriate for any set of conditions. It is desirable, but not essential, that the output stage should have high sensitivity. It is exceedingly important that no frequency distortion be introduced, i.e., the output valve must amplify irrespective of frequency. It is equally necessary that the output arrangement chosen shall accommodate the desired volume level without distress, and unless it is convenient to arrange the output stage to accommodate the highest instantaneous peak voltage, it is essential that occasional overloading will not be unduly noticeable to the listener. This latter is unquestionably a compromise, but for the battery user there is no reasonable alternative. For convenience, each type of output is dealt with separately, commencing with those which are applicable to either mains or battery working.

Triode Output

Triode output has the unquestionable advantage of simplicity. It will work with anode load grossly unsuited to its needs with little noticeable distortion, and when overloaded on transients to the extent of 50 per cent., the resulting distortion is noticeable only to the chosen few. Its principal disadvantage is its poor efficiency, the output delivered being only about 10-20 per cent. of the power consumption; a serious disadvantage when viewed by the battery user. Anode consumption of, say, 10 milliamps will give seldom more than a 150 milliwatt output. Another disadvantage is lack of sensitivity, but this can, of course, be overcome by providing adequate gain in the preceding stages.

Pentodes

When the pentode was introduced some years ago it was greatly misunderstood, a disadvantage under which it labours even in these enlightened days. There are still many people who calmly remove a triode and substitute a pentode and hope, with unmerited optimism, for good results. It is stated above that the triode is tolerant of an incorrect anode load; it is equally true to say that the pentode is very intolerant. So intolerant, in fact, that it practically precludes the use of a moving-iron speaker, while almost every moving-coil speaker needs to be shunted by a resistance and condenser in series in order to check the tendency for its impedance to rise at the higher frequencies. The great advantage of the pentode is its high efficiency, being of the order of 40 per cent., or more than

A Discussion of the Various Types of Output System for Battery or Mains Receivers

double that of the triode valve. In the case of the higher impedance battery pentodes, colloquially known as "economy pentodes," it has the additional advantage of remarkable sensitivity. In battery receivers where high sensitivity and reasonable output is required, it is an excellent choice where one or other of the quiescent systems cannot be used. Mains pentodes, however, are not necessarily

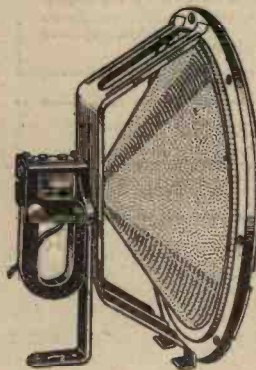

Fig. 1.—An old-type speaker of this pattern will not give such good results as a modern moving-coil model.

more sensitive than mains triodes; in fact, in one well-known valve maker's range it is possible to find a pentode and a triode with approximately similar output, the triode having less sensitivity than the pentode. The pentode will usually be chosen in a mains set where a large output is required, and the use of an adequate triode is restricted either by the H.T. current available or cost.

The Output Tetrode

The tetrode follows logically from the pentode, and differs from it only in that it has no suppressor grid. The absence of this electrode necessarily results in the anode being further away from all other electrodes, and possessing, therefore, less capacity to "earth." The difference between a pentode and tetrode of equivalent characteristics is simply that reproduction when the latter valve is used will be

slightly better in the top register. In a receiver where there is considerable top feed into the output circuit, the substitution of a tetrode for a pentode will give a marked increase in the brilliancy of reproduction. It is purely a matter of personal taste, therefore, which valve is used. Where a tone control is provided there is no question but that the tetrode should be used as, furthermore, this type of valve tends to minimise base resonance. Having dealt with what may be termed "solo" output valves, the question of the various forms of push-pull output comes under review. Since the application in battery and mains working differs, it will be necessary to deal with each class separately.

Battery—Class "B" Output

From the point of view of efficiency, i.e., speech output, against energy consumption, the class "B" valve is still unchallenged. With suitable precautions, and a carefully chosen loudspeaker, quality is really good, but it has the serious disadvantage of poor sensitivity, as the average class "B" valve with driver requires several times the input necessary to load a quiescent push-pull pentode. Under average conditions, however, really good quality is more easily obtained with class "B" output than with a quiescent push-pull.

Pentode Quiescent Push-pull

As already intimated above, the quiescent push-pull output stage possesses comparatively high sensitivity. So sensitive is the small quiescent push-pull pentode that a most excellent local station receiver may be made by using a H.F. pentode followed by a double-diode detector, and finally a quiescent pentode, although for Continental reception the double-diode would, of course, be substituted by a double-diode triode. It has, however, a slightly smaller speech output for a given H.T. consumption, and is also intolerant of incorrect anode load, but quite excellent reproduction is obtainable provided a good loudspeaker is used, having the necessary impedance, and both halves of the speaker primary are shunted by suitable condensers. The correct impedance and suggested shunting capacity are recommended by the maker of each individual type of valve.

Summing-up

After reading the above notes, the reader will almost certainly come to the immediate conclusion that there is a great deal of truth in the old saying "one cannot have one's cake and eat it!" Economy, sensitivity and quality do not go hand-in-hand. For example, push-pull triodes give the best quality, and are the most wasteful, whereas the more economical output arrangements do not give such good quality. The modern commercially built receiver often makes use of pentode or tetrode output, but the shortcomings of these valves are somewhat negated by the use of specially designed loudspeakers, and the control of the response curve by the careful design of preceding stages. The writer admits having been a little harsh in his criticism of the various output systems, but considers that by exaggerating the disadvantages of the various systems the reader will more readily be able to compare them and appreciate the advantages.

P. R.

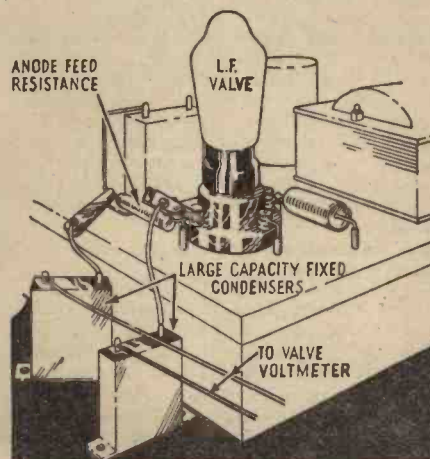

Fig. 2.—The output of a stage, or the audio voltage developed across the load resistance may be measured as shown here.

PRACTICAL TELEVISION

December 2nd, 1939.

Vol. 4.

No. 179.

Television as a War Weapon

AS might be expected, it is the Americans who are forecasting that television is to be the most powerful weapon which this present war will bring quickly to a stage of perfection. Their imaginative minds have been given full play, with the result that, although a long way behind this country in actual service technique, inventors are filing patents for devices that are claimed to be of immense value both in attack and defence. It is always dangerous

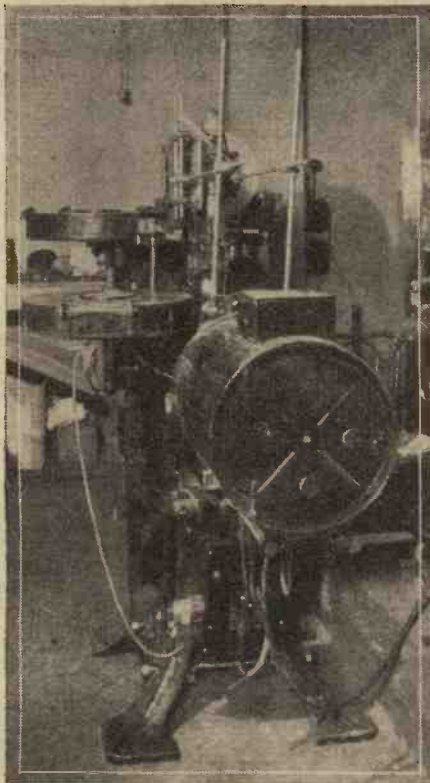

Fig. 1.—A continuous motion film projector in use in America some years ago which is now finding favour among engineers for providing good quality high-definition television film pictures.

to prophesy, and no doubt many of the prognostications savour rather of that apt expression "that the wish is father to the thought," but taking a broad technical view of the whole situation, it seems very likely that just as radio made its most spectacular progress in the last war, so television may be called upon to fulfil a similar function. A recent paragraph in these columns drew attention to the possibility of televising direct from aircraft to ground stations, and now it is claimed in America that designs have been registered for equipment, both receiving and transmitting, that is small and light enough to satisfy the limited space available in airplanes. Ordinary short-wave radio

has proved of inestimable value for maintaining communication between general army headquarters and units in the front line, and it is now suggested that maps, operational plans and orders could be sent via low-powered directional television transmitters from unit to unit, using a process of scrambled signalling in order to ensure secrecy. It is said that this would be preferable to any drawings, etc., being committed to paper as these might fall into enemy hands, whereas a radio vision signal which can be interpreted only by those who know the code would provide no damaging record, as it is only transitory.

Other Devices

ANOTHER television patent for which high hopes are claimed proposes to send a televised picture of an airport to a pilot who is lost in a fog, or who happens to be flying over a strange country. This proposal has been made many times before, but in this case the scheme is to make a small light, moving to scale across the televised picture, show the pilot the exact height and position of his machine in relation to the airfield. Even with a picture definition of 180 lines, it was proved some years ago by special transmissions from the Crystal Palace that a detailed map comes over with very remarkable clarity, especially when a reasonably sized cathode-ray tube is used in the receiver and direct viewing is employed.

Ray-sensitive Spectacles

A CHICAGO inventor has produced special spectacles which he claims are designed to be sensitive to the infra-red rays. By their use a pilot is said to be able to get clear vision through clouds and fog to the ground below, while night observation from the ground, when these glasses are worn, will enable airplane engines to be seen above, since it is also claimed that when heated they radiate infra-red rays. Yet another example of the ingenuity of television engineers is furnished by the story that experiments are now being conducted with television torpedoes. These machines are said to be relatively cheap and simple to manufacture, and carry in addition to their quota of bombs, a television transmitter. This sends back pictures to the base station, and the course of the torpedo is adjusted according to the information obtained in this way, using radio remote control. The timing for the release of the bombs is undertaken as a result of the same information. The idea may not prove so fantastic as at first thought, for although these machines would be very vulnerable to anti-aircraft fire, or the work of fighter squadrons, they could be sent in mass flight formation to their objectives, and man power would be saved. Pilots take a long time to train to a high pitch of skill, and pilotless equipment is, therefore, a possibility to be reckoned with, especially as it is stated that the

Zeiss Optical Works are co-operating in this work. In any case, American experts are studying the possibilities, and more may be heard at a later date.

Film Scanning

THE American engineers are continuing their researches towards finding the best form of film scanning unit. Attention is not confined to the actual form to be taken by the television camera, that is whether of the storage tube or image dissector type, or a combination of both with or without secondary emission multipliers, but attention is also being given to the best type of film projector which can be employed. Opinion is necessarily divided, but many experts now feel inclined to place their faith in the continuous projector, as opposed to the ordinary type which operates on the Maltese Cross principle. By coming to this decision they are reverting to the machine in use several years ago, and also following in the steps of the B.B.C., who effected certain important changes in their film equipment at the beginning of this year. With this type of projector the film is never jerked through the gate in a series of movements but moves forward continuously. This form of machine was used for television purposes several years ago in America, and the appearance can be gauged by referring to Fig. 1. At the rear is the arc lamp or projection lamp housing while to the left can be seen the film spool chambers; the lower one being the main feed chamber and the upper the "take up" box. In the centre of the main body is housed the heavy mirror combination which is motor driven, and upon whose careful alignment depends the principle of this "jerkless" film projector.

Ingenious Operation

IT does not matter at what speed this machine is operated, the film pictures always give the effect of continuous movement, and the scheme will be understood

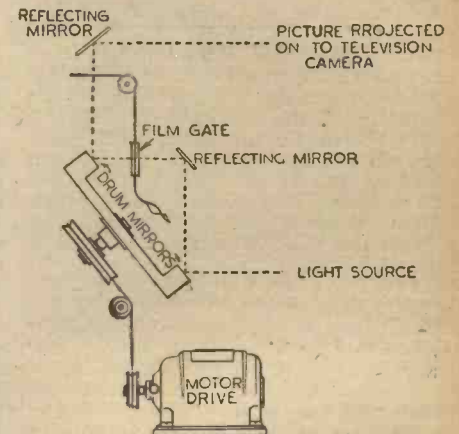

Fig. 2.—The light and picture paths shown simply for the film projector used in television transmission.

better by referring to Fig. 2. Driven round on an inclined axis is a large drum near the periphery of which is mounted a series of flat mirrors. By means of two fixed mirrors and the drum mirrors, the beam of light from the lamp housing has its path deflected four times, and at the same time passes through the film negative as it moves continuously through the gate. Although the film is moving, the individual pictures of each frame are projected on to succeeding mirrors, and due to the mirror movement the frame picture emerging from

(Continued on page 249)

Making Receiver Cabinets

Cabinet Construction is an Interesting "Sideline" as a Change from Set Building and Experimenting, and Provides an Excellent Means of Occupying Spare Time on "Black-Out" Evenings

By FRANK PRESTON

DO not propose to describe any one cabinet, because style and dimensions must be decided by the individual in accordance with requirements. Instead, general constructional details will be given. Experienced woodworkers might decide to make a fairly elaborate piece of furniture—but they will not require instructions. The average handyman is much better advised to tackle a comparatively simple piece of construction, bearing in mind that a well-made rectangular box looks, and is, immeasurably superior to an ornate and "showy" cabinet which is badly made and probably lacking in rigidity.

General Procedure

No matter what the shape, provided that it is a simple one, the general method of procedure is the same. The first step is to make a rectangular frame consisting of the two upright sides, the top and the

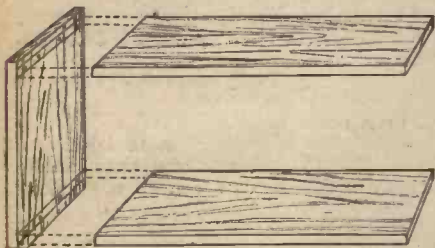

Fig. 1 (Left).—How the boards are set out when butt points are to be used.

bottom. After that, a front panel can be fixed with nails or screws, and a back made which can easily be removed. As an alternative, it might in some instances be preferable to fix the back, leaving the front open so that a chassis, with its own metal or plywood front panel, can be slid into position. It is desirable, in any event, to make either the back or front a fixture, because this will stiffen the assembly to a marked degree.

In the first place, a rough drawing should be made of the proposed cabinet, and this should be carefully and accurately dimensioned according to the set, speaker and possible batteries which it will have to accommodate. The four parts mentioned above will call for prior attention, and should be bought in one length. In estimating the length, bear in mind that the upright sides will probably overlap the bottom and top, and that not less than 2in. of waste should be allowed for sawing and final trimming and smoothing.

Suitable Timber

The wood, which should be well seasoned, can be bought ready planed, for it is not worth while to spend time in planing rough timber. As to the choice of wood, one of the best for the amateur is Japanese oak; this is softer than English oak, is easier to work and less liable to splitting. Another is satin walnut, but the easiest wood of all to work is canary or American whitewood. This will have to be stained

to match existing furniture, since it is yellowish in its natural form.

Do not use wood less than $\frac{3}{8}$ in. thick, bearing in mind that the thickness is always stated as that of the unplaned timber. It will be about $\frac{3}{8}$ in. after planing. If the cabinet measures more than about 20in. in length or height it is better to use $\frac{1}{2}$ in. or $\frac{3}{4}$ in. stuff. Also bear in mind that if the cabinet has to be, say, 8in. deep, the wood must be cut from a board which is initially wider than this, again to allow for planing.

Corner Jointing

After the planed wood has been obtained it is necessary to decide on the form of jointing to be used at the corners, since upon this depends the method of setting out. A professional woodworker would tell you that one of the various forms of dovetailing gives by far the strongest corner jointing. But this method of construction

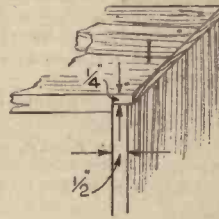

Fig. 2 (Right).—How a corner halving joint is made.

is beyond the ability of the average constructor, who will generally find it better to use either butt or corner-halving. In butt jointing, the ends of two pieces of wood must be made perfectly square so that they will fit closely against the other two. It is standard practice to allow the uprights to "run through," as shown in Fig. 1. The board should be marked out with the lengths of the top, bottom and sides, but a full $\frac{1}{8}$ in. should be allowed between all pieces; this is for the saw kerf or groove. In the case of the uprights, allow an extra $\frac{3}{8}$ in. at each end; this will project when the case is first assembled, but the projections will be planed down flush with the outer surfaces.

Halved Joints

It would appear that butt jointing would be the easiest type to deal with, but that is not necessarily the case, since it is far

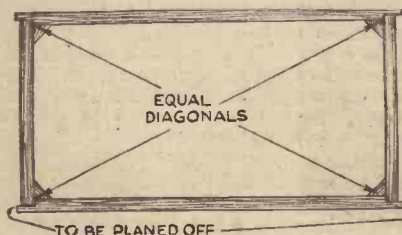

Fig. 4.—Before putting the frame aside for the glue to set it should be made square.

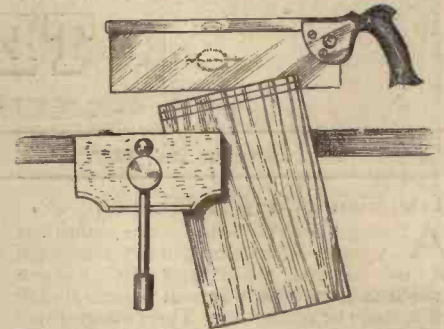

Fig. 3.—When making a corner halving the cut down the grain should be made first.

more difficult than at first appears to square the ends of a board. It is, of course, absolutely important that the end should be square to both the face and the edge of the board. Because of this difficulty it is often better to use corner-halving joints, as shown in Fig. 2. In this case it is better to allow the top and bottom boards to "run through," whilst the uprights should be made shorter than the total height of the cabinet by the thickness of the timber. Also remember that the "tongue" of the top and bottom boards must overlap the surface of the sides by $\frac{1}{8}$ in. to $\frac{1}{4}$ in. so that the sides can later be cleaned down.

Making the Rebates

The method of forming the rebates across the ends of the top and bottom members is to square lines round the ends of the boards, the lines being the thickness of the wood apart; and the outer one being at least $\frac{1}{8}$ in. from the rough, sawn end. Then either gauge or rule a line across the end and a short distance down the two edges, half-way across the wood. Next hold the board in a vice and, with a stiff-back saw, cut across the end with the saw at an angle to the wood, as shown in Fig. 3. Saw down to the shoulder line on the edge nearer to you, and then turn the wood round and repeat at the other edge. Finally, hold the wood vertical and run the saw across just to the depth of the shoulder line. In doing this, the saw kerf or groove should be just inside the waste part of the wood. The rebate is completed by sawing across the face of the wood, to remove the small strip.

Form all four corners in this way, taking care that the rebates at both ends of each are on the same side! Then hold the two pairs of corresponding members together and make sure that they are identical; if not they must be trimmed. When they are right, drill a few small holes—for nails—through the tongues of the rebates.

Final Assembly

To assemble, lightly coat the ends of the uprights with thin, hot glue—one at a time. Hold an upright in the vice, press the adjoining piece closely against it and drive in the nails. Actually, it is best to use $1\frac{1}{2}$ in. panel pins, which are thin, round nails with small heads. Carry out this assembly work as quickly as possible so that the frame can be made square before the glue sets. To make it square, check the two diagonals shown in Fig. 4, with a lath. When equal, the lath can be lightly nailed across one diagonal to keep the frame true.

(Continued on page 244)

FIRST of the American planes for Britain. A dismantled machine being loaded on to barges before transhipment.



Grid Leak—in the Daily Sketch—states, "I find that listening in on a TROPHY is the most exciting experience and wish that all my readers could enjoy the same privilege."

New FAST FLYER!

... But for

ALL-WORLD NEWS

Short-Wave Radio Thrills
and B.B.C. Listening

TROPHY

annihilates distance

GET A TROPHY NOW. ... Enjoy the thrills of all-world radio listening. ... TROPHY range is unlimited. ... In the comfort of your own home, hear—on speaker or 'phones—the amazing variety of broadcasts on the air day and night. On any other set but a TROPHY it is impossible to hear them all. You've always wanted a TROPHY, get yours now, prices may rise.

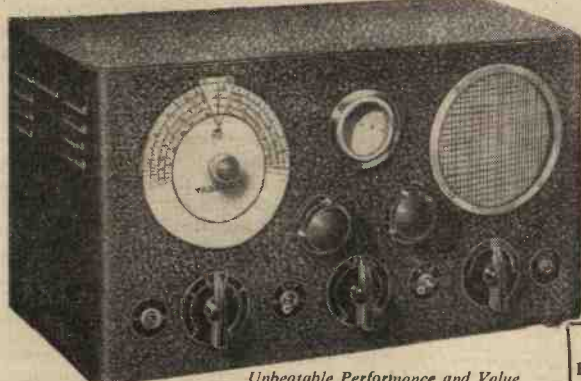

Unbeatable Performance and Value.

Mr. Camm confidently recommends TROPHYS to discriminating listeners.

TROPHY 6

The design and specification of this 6-valve A.C. communications receiver ensures for the user reliable reception of the world's transmissions. Wave-range 6.5 to 545 metres continuous, using switched coil unit. Electrical bandspreading and other refinements, including switched A.V.C. and B.F.O., pitch control. Built-in moving-coil speaker and provision for alternate use of 'phones. For use with ordinary aerial or doublet type. Housed in pleasing cabinet measuring 17ins. x 10ins. x 9ins. deep. Fully tested and ready for immediate use on 200/250 A.C. 40/100 cycles supplies.

Fully Guaranteed. Terms available.

PRICE £10.19.6

RADIO ROYAL installs TROPHY 8's

Europe's largest Press listening post and other official centres too, depend on their TROPHYS for listening to world-wide short-wave and B.B.C. broadcasts. See now about your TROPHY. Go to your Dealer or write or call on Peto-Scott immediately. Whatever model you choose you will quickly understand why TROPHY takes first place as the set for thrilling and enjoyable radio listening.



A Super model for all-world reception.

Wireless World states—"The TROPHY 3 is an amazingly sensitive receiver."

TROPHY 8

The super 8-valve A.C. model of the TROPHY range. Here is a receiver for comfortable listening to the world's War news—flashes and important bulletins always to be heard in English in addition to interesting topical discussions, entertaining programmes and usual B.B.C. transmissions. Wave-range 7 to 550 metres. Solo-control bandspreading. R.F. on all bands. Switched Beat frequency Oscillator and A.V.C. Designed for use with separate P.M. speaker (for pentode output). Connections for alternate use of phones. For single-wire or doublet aerial. Complete in Cabinet size 16 1/2 in. x 9 1/2 in. x 10 1/2 in. deep. Fully tested, for operation on 200/250 v. A.C. supplies. £13.17.3 Fully guaranteed. Easy Terms available.

SPEAKER 8in. sensitive P.M. unit in Cabinet to match, 46/3

TROPHY 3

This amazingly sensitive receiver—available in battery and A.C. versions—is unapproachable by any other radios in the same class for reception on 6.2 to 550 metres (Continuous). Employs single plug-in self-locating coils. At low cost, the TROPHY 3 gives dependable reception from every corner of the earth. Speaker is built-in with provision for 'phones. Metre and band calibrated scale. Complete in cabinet as illustrated and supplied with coils for 12 to 52 metres. Ready for use. Fully Guaranteed. Terms available.

A.C. MODEL Ready for immediate operation on A.C. 200/250v. £6:18:9

BATTERY (Excluding batteries). Fully tested and ready to play. £6:6:6

If required, 5 additional coils for complete coverage, 6.2 to 550 metres, 18/6 extra.

CALLERS. All TROPHY Models to be seen at branches given below. Or call in for Lists.

POST ORDERS. Immediate delivery or send now for FREE Lists on TROPHY Radios.

EASY-WAY ORDERS. Immediate attention on receipt of 25 per cent. value of Order (direct to Peto-Scott), balance over 4 months.

2-Stage Pre-Amplifier



7 to 550 metres.

Double the performance of your present all-wave set by connecting this pre-selector unit. Gives increased range, selectivity, volume and sensitivity and cuts out station interference. Suitable for any battery or mains set. Simply connect (externally) to your set and plug into A.C. 200/240v. mains. Employs spread tuning and 2 R.F. pentodes. £7:8:6 Fully Guaranteed. Price

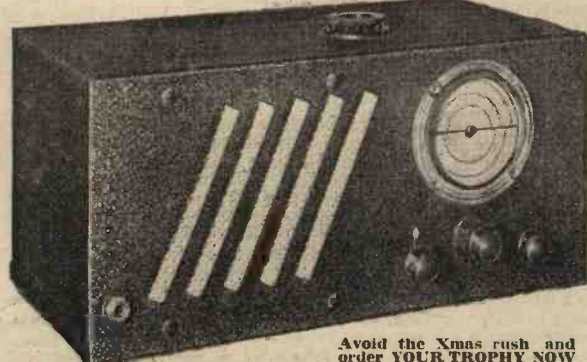

Avoid the Xmas rush and order YOUR TROPHY NOW

PETO SCOTT Co., Ltd.,

77 (FW14) City Road, London, E.C.1. Tel. Clissold 9875.
41, High Holborn, W.C.1. Tel. Holborn 3448

WEST END LONDON DEMONSTRATIONS
R.E.M. LTD., 70, Wigmore Street, W.1.

ARMSTRONG

Regret to announce that on and after December 4th a compulsory increase in all prices of chassis contained in our current catalogue will be 5 per cent. Readers of "Practical Wireless" will appreciate this very small increase does not represent fully the cost of raw materials and manufacturing costs.

In accordance with our policy of fair trading we have made no increase in the prices of our chassis during the first three months of the war.

MODEL SS10

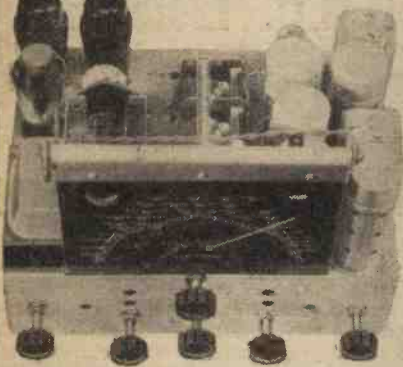

MODEL SS10. "SUPERHET-STRAIGHT"
10-valve High Fidelity Radiogram chassis. All-wave, incorporating 2 independent circuits, Superheterodyne and Straight, having R.F. pre-amplifier, R.C. coupled push-pull Triode output capable of handling 8 watts.
PRICE £12 : 12 : 0 Plus 5% war increase.

MODEL AW38

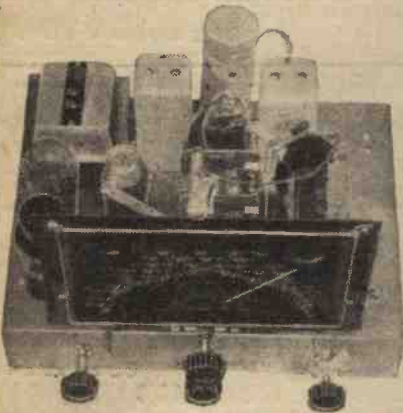

MODEL AW38. 8-valve All-wave Superheterodyne chassis. This All-wave Radiogram chassis has resistance capacity coupled push-pull output capable of handling 6 watts, and gives good quality reproduction on both radio and gramophone, for an economical price of 8 gns. Plus 5% war increase.

Armstrong Push-pull Speaker to match AW38 chassis, £1 : 1 : 0. Plus 5% war increase.

We suggest Model AW38 together with matched speaker at £9 : 9 : 0, plus 5% war increase, complete, represents the most outstanding value on the market to-day.

MODEL 3NBVT. 7-valve (including Cathode Ray) All-wave Radiogram chassis with 34 watt output, supplied complete with 8in. moving coil speaker. Cash £7 : 18 : 6. Plus 5% war increase.

MODEL AW125PP. 13-valve (including Cathode Ray) All-wave Radiogram chassis covering 5 wave bands. Radio Frequency pre-amplifier. 2 I.F. stages with variable selectivity. 10 watts Resistance Capacity Coupled Triode. Push-pull output. Cash £17 : 17 : 0. Plus 5% war increase.

Illustrated Art Catalogue on request
All chassis sent on 7 days' approval

ARMSTRONG MANFG. Co.
WARLTERS ROAD, HOLLOWAY,
LONDON, N.7.

(Adjoining Holloway Arcade)

*Phone NORTH 3213

MAKING RECEIVER CABINETS

(Continued from page 242)

It is better to support the corners, and this can be done by gluing and screwing, or nailing, triangular pieces as shown in Fig. 5. This wood can be rough, and is better in this form because the glue will then have a better grip. When all the glue has had time to set (a full 24 hours for Scotch glue, or about 12 hours for some proprietary glues) all the nails can be punched down just below the surface by means of a nail or pin punch, as shown in Fig. 6. This is better than attempting to drive the nails right down with a hammer,

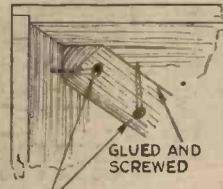

Fig. 5.—Corners may be stiffened by fitting triangular or square-section blocks.

SCREW HOLES
COUNTER SUNK

which would mark the surface of the wood. The projecting ends can then be planed down with a finely-set smoothing or Stanley plane and, if necessary, the wood can be cleaned off with fine glasspaper, working in the direction of the grain only. In planing, work toward the directions indicated by arrows in Fig. 2.

If desired, the nail holes can be filled in with plastic wood or putty coloured with a little of the stain to be used on the completed cabinet. Alternatively, coloured wax can be used after staining, or the edges might be covered with prepared beading. The latter is not recommended, for it gives an "amateurish" finish.

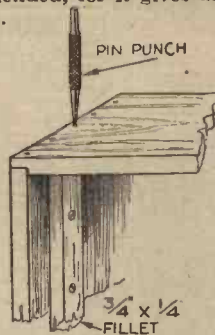

Fig. 6.—Fillets may be screwed to the sides to receive the removable back or front. This illustration also shows how the nails are sunk slightly below the surface by means of a nail or pin punch.

The fixed back or front can be screwed over the whole edge of the frame, or to fillets screwed to the inside faces, as shown in Fig. 6.

Any preparatory stain can be used, but stain-varnish is not recommended if a really good finish is desired. Give one light coat, allow it to dry, lightly rub down with fine glasspaper and apply a second coat. A final finish can well be given with polishing wax; this is better than varnish or polish for the amateur and "comes up" better every time the cabinet is rubbed with a dry duster.

REPLIES IN BRIEF

The following replies to queries are given in abbreviated form either because of non-compliance with our rules, or because the point raised is not of general interest.

J. A. B. (Brockley Cross). The set was described in a contemporary which is no longer on the market. We cannot supply blueprints or other details.

J. B. P. (Elstree). A converter could be used, but probably your previous set did not employ H.F. amplification and this would account for the converter failing to function.

M. F. (Leamington Spa). Owing to changing prices we suggest you write to Messrs. Peto-Scott for a quotation.

THAT TIME CONSTANT

WHEN dealing with the performance of high-quality amplifiers and circuits in which very careful attention has to be given to such factors as phase and amplitude distortion, the expression "time constant" nearly always occurs. The exact meaning of this is somewhat obscure to some readers, but in general terms it is a measure of the rapidity of growth or decay of current in different circuits. For example, if a condenser is required to discharge through a resistance in a certain time but takes too long, then that part of the circuit would be said to have a poor time constant. The expression finds application in two types of circuit, namely, that containing inductance and resistance, and that in which capacity and resistance are embodied. The theoretical conception of what is actually happening in either type of circuit involves a knowledge of mathematics which the average person may find difficulty in assimilating. On the other hand, it is quite common knowledge that if any form of inductance is present in a circuit, then on closing that circuit the current takes a relatively small fraction of time to rise to its steady maximum value, whereas with resistance only present the time taken is zero. The same thing happens when a condenser is included in a circuit for the condenser takes time to reach its charged condition. The actual calculation of the time constant is very simple, however, for with inductance and resistance present the expression is merely $\frac{L}{R}$ where L is in henries and

R in ohms. The general deduction from this is that in a circuit of given resistance the rate of growth or decay of current is directly proportional to the inductance of the circuit, while if it is desired to increase this rate then the resistance should be increased. The time in seconds given by substituting figures of circuit inductance and resistance for the fraction $\frac{L}{R}$, is the time

taken for the current to rise to two-thirds of its final value. In the case of a circuit containing a condenser and resistance, then the time constant is CR, where C is in farads and R in ohms. If the time that should elapse before the current reaches two-thirds of its final value has to be reduced, then either or both C and R must have their values cut down and similar reasoning applies to the case of the condenser discharging. This is particularly important in valve theory, where for various forms of coupling the condenser charge has to leak away as a flow of electrons through a resistance. Not only have the values for these quantities to be considered in the light of frequency response in the amplifier, but the time constant has its degree of importance and circuit values may have to be adjusted in order to satisfy the conditions of design.

D. M. M. (Wick). The field could be used as you suggest—in fact, that is one of the main features of its design. In some cases a 4,000-ohm field is used, but the 2,000 or 2,500-ohm resistance is more general.

W. McF. (Belfast). The makers are Microfuses, Ltd., 4, Charterhouse Buildings, E.C.1.

I. T. G. (Whitton). We regret that we are unable to supply details in the absence of further information regarding your proposed experiments.

J. H. S. (Edinburgh 7). The trouble may be due to a fault or to normal field or speaker energisation arising from the particular types of valve used or circuit employed.

H. A. S. (Lythe). The change in the control would not prevent signals. Is the pick-up in order?

H. W. (Canterbury). It would be preferable to use the MH4 first, then the ML4 and finally the PX4. Full details and data sheets may be obtained from the G.E.C., or we can supply them on receipt of a stamped-addressed envelope.

Get back that P-U-N-C-H in your Set!



With the D.C.
AVOMINOR
Regd. Trade Mark
ELECTRICAL MEASURING INSTRUMENT

This precision built moving-coil D.C. instrument, with 13 ranges covering 0-120 m/A, 0-600 volts, and 0-3 megohms, provides adequate testing facilities for checking valve performance, batteries and power units, etc. It reduces troubleshooting to its simplest terms. In case, with instruction booklet, leads, interchangeable testing prods and crocodile clips.

CURRENT		VOLTAGE	
0-6 m/A	0-6 v.	0-240 v.	
0-30 "	0-12 v.	0-300 v.	
0-120 "	0-120 v.	0-600 v.	
RESISTANCE			
0-10,000 ohms	0-1,200,000 ohms		
0-60,000 "	0-3 megohms		

Write for fully descriptive literature and current prices

RADIO SERVICING SIMPLIFIED 6th Edition

This valuable text-book, written in the light of the latest radio knowledge, covers the whole routine of testing modern radio receivers. Clearly explains causes of faults in receiving and amplifying apparatus; describes all tests in detail. Shows how to use radio testing instruments. 150 pages. Numerous diagrams and graphs.

Sole Proprietors & Manufacturers:

THE AUTOMATIC COIL WINDER & ELECTRICAL EQUIPMENT CO., LTD.,
Winder House, Douglas Street, London, S.W.1. Phone: Victoria 3404-7

L·R·S

CARRY ON THE GOOD WORK OF SUPPLYING
QUALITY RADIO EQUIPMENT

ARMSTRONG CHASSIS

MODEL SS-10 "SUPERHET" STRAIGHT"
10-valve High Fidelity Radiogram chassis. All-wave, incorporating 2 independent circuits. Superheterodyne and Straight, having R.F. pre-amplifier, R.C. coupled push-pull triode output capable of handling 8 watts.

CASH PRICE £12:12:0 plus 5% war increase.
All Armstrong Chassis supplied on Easiest Terms. Full specifications free on request.

LONDON RADIO SUPPLY COMPANY
ESTD. 1925

Late of 11, Oat Lane, London, E.C.2
All communications to evacuation address:
"WINDEN" - ARDINGLY ROAD - BALCOMBE - SUSSEX

Write for quotation and full details

PORTABLE A.R.P. RECEIVERS and other reliable radio apparatus over 22 in value available on our very **CONVENIENT TERMS.**



Christmas without Radio? Impossible thought! So what could be a more suitable gift than a "Stentorian" to bring the radio to an extra room? Your family will appreciate it—and you will too!

Fit a new



Stentorian

The perfect extra speaker for any set

WHITELEY ELECTRICAL RADIO CO., LTD., MANSFIELD, NOTTS.

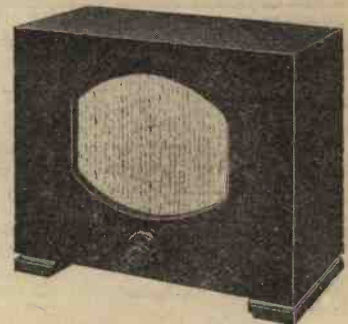

Stentorian Baby Cabinet £1 12 6

Chassis Models

Senior	£2 6 3
Junior	£1 15 9
Baby	£1 6 0
Midget	19 3

Cabinet Models

Senior	£3 9 3
Junior	£2 14 6
Pendant	£2 14 6
Cadet	£2 3 6
Handy	£1 1 6



Junior Chassis 35/9

CLIX

SAFWAYS ADAPTORS

You can use your Radio and other electrical appliances in any room and secure their full benefit throughout your home by fitting a SAFEWAYS Adaptor in your existing lamp-holder.

To nullify the depressing effects of the "Black-out" fit a SAFEWAYS adaptor with a low-wattage lamp in the branch outlet and the usual lamp in the other. You can then enjoy normal lighting knowing that, should it be necessary, dimmed lighting can be switched on at a moment's notice.

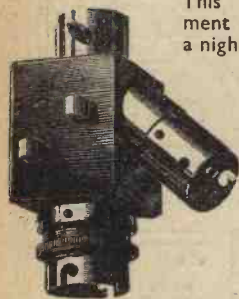

This particular arrangement can also be used as a nightlight for children or invalids, but is merely one of many ways in which SAFEWAYS can increase the convenience of your electrical installation—quickly, cheaply and safely.

ASK YOUR DEALER FOR

"SAFWAYS"

Single Switch, 1/10; Double Switch, 2/3; Cord Control 2/6 each.

A CLIX product made by—

BRITISH MECHANICAL PRODUCTIONS LTD.

1, Church Road, Leatherhead, Surrey.



Moaned Smith "Our old super-het is on its last legs, darling pet."
"Oh no," replied she, "I've mended it, see. With FLUXITE'S cute soldering set."

See that FLUXITE is always by you—in the house—garage—workshop—wherever speedy soldering is needed. Used for 30 years in government works and by leading engineers and manufacturers. Of Ironmongers—in tins, 4d., 8d., 1/4 and 2/8.

Ask to see the FLUXITE SMALL-SPACE SOLDERING SET—compact but substantial—complete with full instructions, 7/6. Write for Free Book on the art of "soft" soldering and ask for Leaflet on CASE-HARDENING STEEL and TEMPERING TOOLS with FLUXITE.

TO CYCLISTS! Your wheels will NOT keep round and true, unless the spokes are tied with fine wire at the crossings AND SOLDERED. This makes a much stronger wheel. It's simple—with FLUXITE—but IMPORTANT.

THE FLUXITE GUN

is always ready to put Fluxite on the soldering job instantly. A little pressure places the right quantity on the right spot and one charging lasts for ages. Price 1/6, or filled 2/6.



ALL MECHANICS WILL HAVE

FLUXITE

IT SIMPLIFIES ALL SOLDERING

FLUXITE LTD. (Dept. W.P.) DRAGON WORKS, BERMONDSEY STREET, S.E.1.

Open to Discussion

The Editor does not necessarily agree with the opinions expressed by his correspondents. All letters must be accompanied by the name and address of the sender (not necessarily for publication).

A Well-equipped Den

SIR,—I enclose a photograph of part of my den which may be of interest to readers. My set is a 5-valve superhet with A.V.C. and push-pull output (PX4s). There is also a 2-valve short-wave converter coupled to it, covering 9-160 metres, with 4-pin plug-in coils. All are home-constructed and work off A.C.230 mains. The speaker is Magnavox 66, and headphones for DX. Aerial is an inverted-L, 30ft. high, 40ft. long, screened by houses and pointing to South America. I also use a piezo-electric pick-up and electric motor.

I would like to exchange QSL cards with anybody at home or abroad, and any reader of this journal is welcome to come down and have a chat at above address.—RALPH ROGERSON, 17, Wellington Avenue, Smithdown Road, Liverpool.

Home-recording: Public Address Work

SIR,—Having read several letters in your past two or three issues on home-recording I, too, would be interested in a few articles on this subject. May I also suggest an article or two on home broadcasting and general public-address work, including a few circuits of high-quality amplifiers. Wishing your excellent paper all the best and continued success in its new form.—J. W. RITCHIE (Bournemouth).

[An article on Home Broadcasting appears in the present issue, and articles on Public Address work were published in the issues for December 17th, 1938, and July 4th, 1936. These issues are obtainable from our Publishing Dept., price 4d. each, post paid.—Ed.]

A Multi-valve Short-waver for Overseas

SIR,—Being a regular reader of your splendid paper since 1934, I do feel it my duty to drop you a line from time to time. I must, therefore, congratulate you on the new appearance of your paper, which is most attractive.

Whilst looking back on the old and new copies of PRACTICAL WIRELESS, I have noticed the lack of a description of a 2-, 3-, or 4-valve short-wave receiver running from A.C. mains 220 volts, covering the bands of 7, 14 and 28 mc/s, and I shall be glad if such a description can be given in the near future. American metal valves of the latest types will be the most suitable. The set should be simple to build and operate with the minimum of controls, and for headphones reception; band-spread tuning will be essential.

I submit herewith my log of 14 and 28 mc/s stations received on my "Halli-crafter's Sky Champion," with the aid of a 33ft. doublet aerial which is only 10 metres above ground and pointed north-west to south-east. I've logged these stations in the period of 1.10.39 till 1.11.39.

W6PUE, CEIAN, VQ5WES, LU7BU, HR5C, W6NNR, W8QXT, YV1AQ, XU8ZA, T07SH, X13, J5CW, YV4AF, H171, YV4AQ, ZS1T, CR6AF, K4FKC, OQ5AB, W5HRD, W6USA, KA1AF, NY1AE, K5AM, KAILZ, ZE1JS.

Last cards here are from PK2LZ VE5OT for 14 mc/s. 'phone and a card from PY4DA for a 7 mc/s. 'phone "hook-up."—REUBEN SOKOLOVSKY, Jerusalem, Palestine.

Radio Athlone

SIR,—I wish to report that Radio Athlone is testing on the 31-metre band, although officially listed as only operating on 16.82 metres.



A corner of Mr. Ralph Rogerson's Den.

I have to-day received verification of reception on this new frequency and included is a schedule which might be useful to other readers, so I give it here.

For the next few weeks Athlone will be operating on 16.82 metres from 12.30 to 13.30, and from 14.00 to 15.00 hrs. G.M.T. every day, and also transmissions will take place on the new wavelength of 31.27 metres at the following times: 17.30 to 21.30 and 22.00 to 23.00 hrs. G.M.T.—R. T. PARSONS (Brighton).

A Militiaman's Appreciation

SIR,—I am a militiaman, and have been in barracks since the beginning of the war. I have PRACTICAL WIRELESS sent to me from home each week, and it arrives on Saturday in time for the week-end. It seems to be about my only connection with the life I lived before the war. Although I am now unable to indulge in any practical work, I still find pleasure in reading of the experiments and work of others.

Of course, everywhere work on radio and television must be seriously hampered by the withdrawal of all transmission licences. We can only make the best of it, and look forward to the time when we may return to our life as it was before the war.

I would say that it amounts to a national duty to continue publication of such periodicals as PRACTICAL WIRELESS and also *Practical Mechanics*, both of which keep the "hams," wherever they may be, in touch with their hobbies although they are unable to practise them.

I trust that PRACTICAL WIRELESS will continue to appear for a good many years to come, and I am sure that it will never lack readers as long as it continues to publish articles of universal appeal to radio amateurs as it does at present.—JOHN B. DORE (Somewhere in England).

The A.R.P. One-valver

SIR—Just a line to let you know that I have built myself the "A.R.P. One-valver," and that I am more than satisfied with it. In the evenings it takes me all over Europe, stations coming in loudly on headphones at every movement of the tuning dial. I want to thank you for putting such a good little set before your readers. In fact, it is the finest little set I ever handled.

I am now going one better, and starting on the "Rapid Two."—W. B. STEVEN (Newcastle-on-Tyne).

Exchanging S.W.L. Cards

SIR,—I should be glad to exchange my S.W.L. card with any "ham" anywhere (Y.L. included).

I enclose a few of my best "catches" on the 20 m. band. They include XE2FC, 2HY, X22DY, XU1B, 8AS, K6BNR, OQE (17.30), K7GPX, VS7RA, PK1OG, and PK4KF.—HARRY ROSKELL, 22, Dale Ave., Longton, nr. Preston, Lancs.

Prize Problems

PROBLEM No. 376

JARVIS had a spare mains transformer with two 4-volt 1-amp. windings on it, and he wished to try an American valve in his mains set. This set was fitted with standard 4-volt valves and he decided to use the spare transformer to supply the heater of the new valve. To obtain the 6 volts necessary he joined the two 4-volt windings in series and took a lead from the centre-tap of one winding, thereby obtaining 6 volts (4 + 2). The results did not come up to expectation, although theoretically there should have been an improvement in the performance of the set. What was wrong? Three books will be awarded for the first three correct solutions opened. Entries should be addressed to The Editor, PRACTICAL WIRELESS, George Newnes, Ltd., Tower House, Southampton Street, Strand, London, W.C.2. Envelopes must be marked Problem No. 376 in the top left-hand corner and must be posted to reach this office not later than the first post on Monday, December 4th, 1939.

Solution to Problem No. 375

When Roberts connected the new transformer he was unfamiliar with the different markings, and misunderstanding these he had mixed primary and secondary windings, connecting one primary and one secondary terminal in each circuit. This obviously prevented signals being obtained.

The following three readers successfully solved Problem No. 374, and books have accordingly been forwarded to them:

- T. W. Welch, 85, Totland Road, Leicester.
- W. G. H. Robson, Forge House, Cleator, Cumberland.
- L. Sanders, 39, Stowell Road, Kingstanding, Birmingham, 23.

NEWNES' TELEVISION AND SHORT-WAVE HANDBOOK

5/-, or 5/6 by post from
GEORGE NEWNES, Ltd., Tower House,
Southampton Street, Strand, London, W.C.2.

—NTS BARGAINS

● LIMITED STOCKS ● PRICES MAY RISE—Make Sure ORDER NOW!

Replacement CHASSIS Bargains

Ready for use



All-wave

ALL-WAVE Battery 3. Mr. Camm fully describes this wonderful chassis offer on Page 238. Amazing performer on all bands. Wave-range 14 to 2,000 metres. Powerful S.G. 3-valve circuit with pentode output. Station-name scale. Size 12in. x 8 1/2in. x 9 1/2in. deep. **BARGAIN:** 69/6, or 17/6 deposit and 4 monthly payments of 14/3. Chassis supplied fully tested and complete with all valves. See also speaker offer.

A.C. 4 MODEL. Mains version of above. Ideal radio or radiogram replacement chassis. As illustrated, with station-name dial. Pick-up sockets. Complete with all valves and ready for connection to A.C. mains 200/250 volts. **BARGAIN:** 78/6, or deposit only 19/6 and 4 monthly payments of 16/6. See speaker offer.

BATTERY Class B4 CHASSIS. Special opportunity for battery set users. Wave-range 200 to 2,000 metres. Powerful S.G. 4 circuit, with Driver and Class B output, giving volume equal to a mains set. Screened coils and ranged condenser. Complete with 4 valves, fully tested and ready for use. **BARGAIN:** 69/6, or 17/6 down and 4 monthly payments of 14/3.

Recommended COMMUNICATION BARGAIN RECEIVER. We cannot repeat! Famous name junior A.C. 5-valve model with continuous wave-range 10-550 metres (switched coil unit), for World News and B.B.C. listening. A.V.C. and B.F.O. switches. Built-in high-fidelity speaker. Employs band-spread tuning. Supplied complete with valves and ready for instant use on A.C. mains 200/250 v. 40 to 100 cycles. **Terms:** 40/- deposit and 4 monthly payments of 35/6. **Pre-War Price £9**

BARGAIN PARCELS. Comprising variable condensers, coils, fixed resistances and condensers, knobs and a brand new cadmium-plated steel universally-drilled chassis, 14 1/2in. x 7 1/2in. x 2 1/2in. Astounding **BARGAIN** at 5/- in special packing and postage 1/- extra. Order Now, stocks rapidly clearing. **COSMOCORD PICK-UPS.** New purchase! Brand new sensitive pick-up, complete with screened lead, usual price 17/6. **BARGAIN:** 8/6, postage 6d. extra.

NEW TIMES SALES CO.,
56 (PrW.14), Luggate Hill, London, E.G.4. City 5167

SPECIAL OFFER of Famous-Name Battery ALL-WAVE 3, No. 8022.

N.T.S. have again secured limited quantity of these superb 3-valve S.G., Pentode output radios. All-wave reception on 18 to 2,100 metres. Station and metre calibrated dial. Concert-grand moving-coil speaker fitted and instrument housed in beautiful Walnut veneered cabinet. Fully tested and ready to play. **BARGAIN** (fraction only of pre-war price) £5 15s. cash (less batteries), or 28/9 down and 4 monthly payments of 23/9. **Or CHASSIS ONLY.** Fully tested chassis only, complete with V.M.H. Pentode, Det., and Pentode output valves. Similar station-name scale, screened coils, etc. Size 11 1/2in. wide, 9 1/2in. high, 5 1/2in. deep. Ready for fitting in your present cabinet. **BARGAIN:** 79/6, or 19/6 deposit and 4 monthly payments of 16/6. **A.C. 4 CHASSIS with P.U. sockets.** For radio or radiogram purposes. Wave-range 200 to 2,000 metres. A.C. 4-valve S.G. bandpass circuit. 3 watts output. Illuminated dial. Fully tested, complete with all valves, ready for use. **BARGAIN:** 61/6 cash. Carriage 1/3 extra.

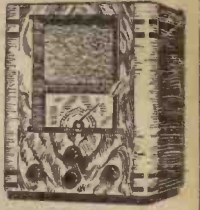

HEADPHONES. Unbeatable offer of lightweight sensitive phones, 2,000 ohms each earpiece. Brand new, ideal for testing or short-wave listening. **BARGAIN:** 6/6, post 6d. extra.

HOME BROADCASTERS.—2 types available for connecting to your present receiver or for use with amplifier, offered below. Sensitive Transverse current type—not to be confused with cheap inefficient units. Supplied complete with microphone transformer and lead, ready for instant use. **TABLE Model,** superior bakelite case, 32/6 cash (carriage paid) or **Professional Telescopic** chromium-plated floor-stand model, 2 gns., special packing and carriage, 1/6 extra. Ideal for party or dance-band use. **Limited Stock.**

AMPLIFIER BATTERY 4-watts model, requiring ordinary 120/150v. H.T. Push-pull output, Mike and Gramo sockets. Can be used also for increasing volume of existing battery sets. Fully tested, with 4 valves. **BARGAIN:** 59/6, carriage paid. Only a few left. **BARGAIN SPEAKERS.** Limited stock of mains energised moving-coil speakers, 2,000/2,500 ohms field suitable for all N.T.S. A.C. radio chassis. **BARGAIN:** 17/6, carriage, 1/- P.M. moving-coil type for battery chassis, 25/-. Model for Class B chassis same price, but add 1/- for carriage and packing.

HAVE YOU HEARD THE RUMOUR

That Winston Has Sunk The German Fleet Single-handed?

It's in

Reginald Arkell's WAR RUMOURS

Everybody is talking about WAR RUMOURS, the new book of hilarious war rumours in verse. It tells how Hitler was arrested by a special constable; what happened when Mr. Chamberlain was dropped behind the German lines, and how Winston Churchill won the war—by himself!

WAR RUMOURS is written in Reginald Arkell's inimitable style, and the illustrations by Edgar Norfield capture the real "rumour" spirit. Read it—enjoy it—and recite its amusing verses to your friends. It is a priceless wartime "possession."

From all booksellers 1/- net, or by post 1/2 from the publishers, C. Arthur Pearson, Ltd. (Book Dept.), Tower House, Southampton Street, Strand, London, W.C.2.

STRIPS

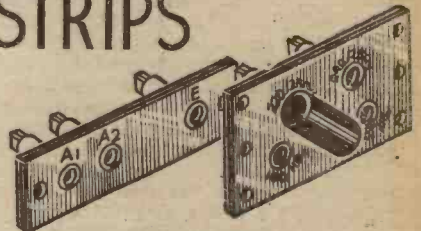

CLIX Chassis Mounting Strips embody the CLIX patent Resilient turned Sockets with screw or soldering terminals. CLIX Voltage Selector Panels provide a speedy and safe means of voltage selection.

AND SOCKETS

The sockets illustrated will give you some idea of the exceptional range of the thirty standard designs available. There are CLIX Turned Resilient types—CLIX Rolled Resilient types—CLIX Embossed Resilient types—CLIX Rigid Tube types and CLIX Insulated Panel Mounting Sockets.

CLIX VALVEHOLDERS AND STRIPS ARE SPECIFIED FOR THE "THREE-TWO" RECEIVER

CLIX

BRITISH MECHANICAL PRODUCTIONS Ltd.
1, Church Road, Leatherhead, Surrey.

In reply to your letter

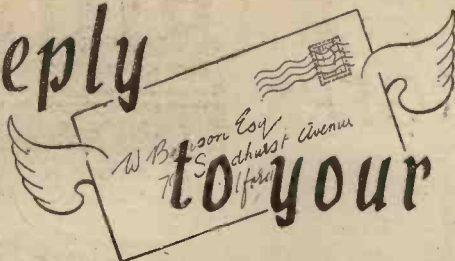

Extension Coupler

"I am building a short-wave experimental receiver, but wish for a long extension control to the tuning condenser. Unfortunately I wish to mount this on a sub-panel and I find it difficult to line it up exactly so that the control will be in line. The usual extension rod, therefore, is rather tight and the slow-motion drive slips. Is it possible to get a long flexible coupler, similar to the small discs with crossed arms as in the Eddystone range?"—R. T. (N.W.9).

THERE is an extension shaft flexible coupler in the Bulgin range, type E.H.12 or E.H.14. The former has a length of rod between the two flexible discs, and the second has a 2½ in. rod. If these are not sufficiently long you will have to make your own by obtaining two of the standard flexible couplers and screwing them to the end of a length of ebonite rod.

Choke Coupling

"I should be glad if you would let me know what is meant by choke coupling. I am familiar with normal transformer and R.C. coupling, but have not yet met this new arrangement. I do not remember seeing any set in your pages employing it."—A. G. (Wealdstone).

THE choke coupling is exactly the same as resistance-capacity coupling, the full term being, in fact, choke-capacity coupling. The difference is that in place of a resistance in the anode circuit, the load is effected by means of a good L.F. choke. The inductance should be high and the main advantage is that it provides a lower D.C. resistance and thus the valve may be permitted to receive more high-tension voltage. There was one form of choke coupling in which the grid leak also was replaced by a choke, and for this purpose

the secondary winding of a burnt-out transformer may conveniently be used.

Aerial Insulation

"Is there any need to go to the expense of fitting the elaborate chain of insulators on an aerial? I am using just one insulator at each end and a friend has told me that if I put a good chain of insulators I shall get better foreign-station reception. Your advice in this connection will be appreciated."—F. R. T. (Cambridge).

ONE good insulator may be better than a chain of inferior insulators badly arranged. If the quality of the small insulators is poor and they are connected

RULES

We wish to draw the reader's attention to the fact that the Queries Service is intended only for the solution of problems or difficulties arising from the construction of receivers described in our pages, from articles appearing in our pages, or on general wireless matters. We regret that we cannot, for obvious reasons—

- (1) Supply circuit diagrams of complete multi-valve receivers.
- (2) Suggest alterations or modifications of receivers described in our contemporaries.
- (3) Suggest alterations or modifications to commercial receivers.
- (4) Answer queries over the telephone.
- (5) Grant interviews to querists.

A stamped addressed envelope must be enclosed for the reply. All sketches and drawings which are sent to us should bear the name and address of the sender.

Requests for Blueprints must not be enclosed with queries as they are dealt with by a separate department.

Send your queries to the Editor, PRACTICAL WIRELESS, George Newnes, Ltd., Tower House, Southampton Street, Strand, London, W.C.2. The Coupon must be enclosed with every query.

together with wire, then there may be a leakage path provided which will negate the effects of the insulators. If a good quality insulator with a long leakage path

is employed, however, it may provide all the insulation that is necessary for reception purposes. In any case it is a good plan to lower the aerial periodically and thoroughly clean the insulators and connecting links, removing the deposit of soot (carbon) which accumulates on them in the course of time.

Battery Charging

"When charging two accumulators of different rating, must the current rate be limited to the rate of the smallest accumulator, or is the fact of the two batteries being in series sufficient to act as a regulator?"—N. D. F. (Settle).

WITH the ordinary home-charging methods the current should be limited to that of the cell having the lowest charging rate. There are, however, several methods of charging, i.e., constant current, constant potential, etc. We assume that your two batteries are of the same voltage, and therefore you should connect them so that the current flowing does not exceed that recommended for the smaller model. An ammeter is therefore essential in this case.

Extension Speaker

"I have tried an extension speaker on my set but it is very weak. It also seems to cut down the volume on the set itself, when both speakers are in circuit. Is it necessary to cut out the built-in speaker when using an extension?"—S. E. (Weston-super-Mare).

IN many cases both speakers may be operated together, but the problem as to the volume thereby obtained will depend upon the circuit. In some cases an extension speaker has to be of high resistance, and in others of low resistance, and it is therefore essential to use the right type of speaker with your set. The maker's instructions should therefore be followed in this respect. We would imagine from your remarks that your set is designed for a high resistance speaker and you are using a low resistance model, thereby short-circuiting the output circuit. See the article in this issue on extension speakers.

The coupon on page 252 must be attached to every query.

A COMMUNICATIONS RECEIVER

is the ultimate in listening

A HALLICRAFTERS COMMUNICATIONS RECEIVER is not a wireless set in the usual sense of the term. It is a good deal more. It is a specialised precision instrument designed and built primarily for the exacting needs of the professional and amateur broadcast technician. At this time, however, when first-hand news and views (as well as rare and refreshing entertainment programmes) from every part of the globe are essential for the accurate valuation of international developments, a communications receiver is of vital importance to every reader of "Practical Wireless." A Hallicrafters Communications Receiver is the ultimate in radio enjoyment—no other type of set is capable of providing short-wave reception with such a high degree of sensitivity, selectivity and range. Ask for latest Catalogue of Communications Receivers. Wide range of models and prices. Attractive easy terms.

WEBB'S
LONDON

THE HOME OF THE SHORT WAVE ENTHUSIAST
14 SOHO ST., OXFORD ST., W.1

(Open 9.30 a.m. to 6 p.m. Telephone: Gerrard 2089

Emergency Branch: 58 Victoria St., St. Albans. Phone: 4924
Birmingham Depot: 41 Carrs Lane. Phone: Mid 5669

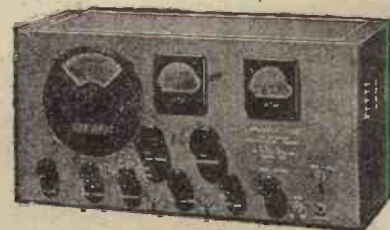

SX24 43.5 to 54mc. (6.8 to 555m.);
Built-in Frequency Meter Tuning;
Built-in Noise Limiter; Variable
Selectivity; Frequency Stability;
Break-in Relay Operation; Crystal Filter; Four
Band Positions; Electrical Band Spread; 9 Valves;
110 to 250-volt A.C. Speaker £24.0.0
£4.12.0

THE 'SKY BUDDY' Another fine model from the Hallicrafters range at the very low price of £11.10s. (including speaker). Remarkable value.

D.C. ELIMINATORS AND L.T. CHARGERS

EVEN in the best regulated offices, slips occur from time to time, and in these days with A.R.P. work and blacked-out offices we regret that we permitted a slip to get into our issue dated November 11th last in the article on Eliminators. Here, the method of calculating one part of the bleeder resistance value was incorrectly stated. Statically, the value there given by the contributor was correct. Unfortunately, however, when such a bleeder resistance is in use there will be a current load to the lower part of the total resistance, and this will lead to an incorrect value, if the method of calculation which was given is adopted. Therefore, the method of calculation should be as follows: First, settle upon an arbitrary current which may be "bled" from the total H.T. and this should be a

small fraction of the total current, say 10 per cent., as already explained. Resistance R1 in the diagram published in the issue in question has to pass this initial current when connected to a working receiver and we require 60 volts at the first tapping above this resistance. Therefore, 60 volts at the initial current, which we took as 2mA will give a value of 30,000 ohms. The next resistance, R2, is calculated exactly as mentioned in the article, namely, the current of the valve which is fed from the 60-volt point, plus the bleeder resistance, gives a total current of 4mA in the example and as 20 volts have to be dropped across that resistance the value is 5,000 ohms as mentioned. Thus it will be seen that all the calculations in the example are quite correct, with the exception of the first section, R1.

PRACTICAL TELEVISION

(Continued from page 241)

the main projection lens at the top of the equipment appears stationary. The angulation of the mirrors one to the other is set to allow this to take place, and the scheme of "picture chasing" is a familiar one, and forms the basis of several pieces of scientific equipment. The actual change from one frame to the other takes place by ensuring that the succeeding frame picture is correctly focused on to the following mirror at the very instant the previous frame is about to disappear from view. By merging the changes in this way the optical expression given to the eye is one of discontinuous movement and is, therefore, ideally suited to use with a disc scanner (as seen in Fig. 1), a storage tube or image dissector tube. The number of pictures per second is governed by the motor drive, and can be made to suit any transmission standard, while the synchronising signals may be injected just where required, for the whole scheme of scanning is really independent of the film motion provided by the projector unit itself. Furthermore, a smooth change over from film to studio scenes and vice versa is possible without any special adaptations, as is the case with the intermittent projector.

The only important defect which has so far been noticed with this apparatus is the possibility of frame flicker, even when the frames per second are at least 50. This is caused by alternate frames of the film reflected from the drum being

of unequal brightness, due to the mirrors getting out of alignment one to the other. This is readily corrected by undertaking a daily check of angulation, although the task calls for great skill because of the very small angles involved.

THE EXTENSION SPEAKER

(Continued from page 237)

The great majority of reputable commercial sets are quite safe in this respect, and if they are provided with terminals for an external loudspeaker, all that is necessary is to connect up the extension leads thereto.

When no such terminals are provided the matter calls for a little care to ensure safety (that is, immunity from risk of shock to anyone handling the extension apparatus). Probably the simplest method is to proceed as follows: connect one lead of the extension pair to one side of the built-in loudspeaker transformer primary through a condenser of 2 microfarads. Connect the other lead of the extension line to the remaining side of the internal output transformer primary, also through a large fixed condenser. To avoid breaking into or otherwise interfering with the wiring of the receiver, the connections from the condensers may take the form of short pieces of flex ending in crocodile clips; these can be attached to the required points inside the receiver without disturbing anything.

Connecting Up

In the case of a home-built set, of course, it may be that no such precautions will be needful; if the instrument already incorporates an output filter the extension line can be connected straight to the loudspeaker terminals of the receiver.

Many of the later commercial sets fitted with terminals for extra loudspeakers give what is called a low-impedance output. With these the ordinary type of step-down transformer often found fitted to extension loudspeakers is not required.

We will conclude our consideration of the practical and technical side of the question by adding a reminder that our earlier suggestion of twin bell-wire for the extension material applies only to lines actually inside the house; for a lead down the garden, something weatherproof must naturally be provided; metal-braided wire is recommended.

BULGIN

RADIO COMPONENTS

FOR EVERY RADIO NEED



BULGIN Transformers—models for all needs. High amplification, nickel-alloy cores, even response curves, high gain and continuous copper windings.

Joints are welded—not soldered. The range covers all requirements.

NEON TEST PROD

A SMALL neon lamp of special design and manufacture is incorporated with a protective resistance. May be used to detect the "live" main of a supply; whether a supply is A.C. or D.C.; continuity where potentials of 180 v. or over exist; etc. **List No. T.P.5. 7/6 EACH**



WATTMETERS

TWO models (for 250W and 125W max.) provide a simple means of ascertaining the power taken by mains apparatus. Fitted with 2 pole 5-A pins and sockets, accuracy + 5 per cent. In a highly polished bakelite case. **List Nos. 17/6 U.M. 12, 14. EACH**



MICROPHONES

TWO carbon microphone elements arranged for push-pull operation, contained in a highly polished chromium-plated case which is substantially non-resonant. Sensitivity is high and excellent output is obtained. The response is exceptionally good and the background noise low. Complete with **12/6** four suspension-springs and full instructions. **List No. M.4. EACH**

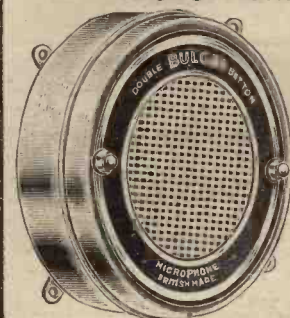

★ Send NOW!

Please send me the NEW 128 pp. Catalogue No. 162, showing full range of Bulgin Products, for which I enclose 3d. stamps.

NAME.....
 ADDRESS.....
 P.W.11.39

Advert. of A. F. Bulgin & Co., Ltd., Abbey Road, Barking, Essex. Tel. RIPpleway 3474 (3 lines).



H. J. Barton-Chapple, a member of our technical staff, and a regular contributor to these pages, has just been granted a commission in the R.A.F. Volunteer Reserve.

Alan R. Barnett, for nearly ten years East Midlands representative for Ekco, has severed his connection with the company.

G. W. Godfrey has given up his position as general manager of the home television sales section of Baird Television, Ltd.

ELECTRADIX

SIGNAL WORK EQUIPMENT.



SERVICE SIGNALERS' DOUBLE HEADPHONES. With flat leather headbands for steel helmet wear, 120 ohms, by S.T. Co., 3/8, 4ft. cords. Single 60 ohm. phones with cord D.L.I. 1/6. **FIELD Telephone Exchanges.** 5-line and 20-line portable. Twin and single cable. **HEADPHONE CORDS.** Service 8ft. fitted 2-pin. plugs and 2-hole socket, 2/- **Radio Phone Cords.** 2/6.

RAID SIGNAL PHONES. Complete sets with 5-line exchanges. **PORTABLE WARDENS' PHONES.** etc. State wants. **LEARNER'S MIKES.** steel-clad Electradix, indestructible; are ears outside your dug-out.

MORSE KEYS. Few Ex W.D. Keys reserved for Services. New Keys for training now in production. A good small key on moulded base TX pivot arm and knob, excellent for learners, 3/6. **Siemens Morse Transmitters.** with key and brass-cased Power Buzzer, 17/6. **Magnet Exploders.** 25/- **Field Telegraph Sets.** Prices on application.

LEARNERS' MORSE PRACTICE SET. Sound Type No. 10, with Key and Buzzer on base, 3/-. **Visual Type No. 2A** with Key and Lamp on base, No. 3A Duplex with Key and Buzzer and Lamp for sound and visual, line plug in on base, 7/-

SIGNAL LAMPS by Lucas and Aldis, hooded for night and day use, telescope sights, key and discs; for tripod or hand use. **Heliographs Mark V.** with spare mirrors in leather case, mahogany tripod.

CRYSTAL SETS. Boudoir, 6/6. **B.M. Table.** 7/6. **WARTIME ELECTRIC SUPPLY.** An independent Emergency or Stand-by Set may be of great value to you. Can be transported on any car. All these Sets are in first-class order and straight from reserve Stores, an opportunity for a low price purchase that certainly cannot be repeated. The Half Kilowatt Set is worth £40, but our price is only £18 with engine and dynamo.

PETROL ELECTRIC GENERATING SETS FOR LIGHTING AND CHARGING FOR £16 ONLY. A 500-watt, single cyl., 2-stroke, water-cooled, self-oiling Stuart Turner engine; mag. ign. coupled to 50/70 volts, 10 amps. shunt dynamo, 1,000 r.p.m., £16. No increase in price, these are 240 sets ready for immediate delivery.

FOR £12. A 150-watt engine and dynamo on similar lines but coupled to 25/30 volts, 6 amps. dynamo. 2/- **Kilowatt and other sizes;** Rotary Convertors and Motor Generators, all ready for immediate delivery. **FIRE ALARM BELLS.** Waterproof mains, Battery or Hand magnet. Cheap. **BELLS.** G.P.O. type trembler Circular Desk Bell, with movement in gong, 1/6. **Wall Bells, trembler.** 2/6. Ditto, large size, 7/6. **Signal Bells, large, metal, 12-volt single stroke Bells,** 10/-

CHARGERS. YOU MUST KEEP YOUR BATTERY CHARGING PREPARED! Battery Charging on A.C. Mains. The A.C. NIT-NDAY will keep your battery fit without attention. **Model N/A6,** 200/250 volts A.C. and D.C. 6/8 volts 1 amp., 15/- **Model N/B6,** 200 250 volts to D.C., 6/8 volts to 1 amp. 25/- **Model N/C6** 200/250 volts D.C. 6.5 volts 2 amps., 35/- **Model N/D6** 200/250 volts to 12 volts 1 amp. 32/- **Ditto,** 12 volts 2 amps., with 6-volt tap, 55/- 5 amp., £4/0/- And many others.

SHELTER CHARGERS, with automatic switchgear for large batteries. **A.R.P. ACCUMULATORS** for stand-by H.T. at 6d. per volt; 3 amp. hours. In 140 cell cases, glass cells, 12/- each. Can be parallel charged off 12 volts. **Fuzzy Dug-outs** or ill-ventilated shelters must be kept fresh. **A.R.P. SHELTER Ventilation and Air Conditioning.** Compact unit, drive off A.C. or D.C. mains, 80 watts; 5in. Blower, 20 cub. ft. fresh air per min. 25/- is a bargain price.

WET SHELTER ELECTRIC PUMPS, for A.C. or D.C. 12v. to 230v. Centrifugal all-bronze pump, throws 120 gals. per hour, 72/6. In special hinged lid, polished mahogany case, 5/- extra. **Type R pumps.** Twin piston type for draining shelters, dug-outs, etc., £3/17/6. Auto. float switch, 45/- **ELECTRIC IMMERSION HEATERS.** Save coal. Armoured bath or tank type with flex, 1,000 watts 230 volts, 25/-

OF GREAT INTEREST IN DARK WAR EVENINGS.

LOW COST Home Recording with the all-g geared FEIGH Electric Recorder, Ball Bearing centre gear box and traverse rod. Is the lowest priced electric home recorder that will fit any gram. The set with Track-in-Gear, Pick-up and tone arm with diamond. 37/6 **Gear only,** 21/6. **Metal blanks,** 3/3 doz.

ACOUSTIC RECORDERS. Cost is low. **New MIVOICE** acoustic sets, complete outfits in carton de luxe, 16/- No. 2 Mivoice, 10/6. Junior, 5/6.

5/- **EMERGENCY PARCELS** of useful stand-by electrical and radio repair material and apparatus, 7 lbs. for 5/- Post Free.

ELECTRADIX RADIOS
218, Upper Thames Street, London, E.C.4
Telephone: Central 4611

LATEST PATENT NEWS

Group Abridgments can be obtained from the Patent Office, 25, Southampton Buildings, London, W.C.2, either sheet by sheet as issued on payment of a subscription of 5s. per Group Volume or in bound volumes price 2s. each.

Abstracts Published

ADJUSTING WIRELESS APPARATUS.—Cole, Ltd., E. K., and Jarvis, H. G. No. 500305.

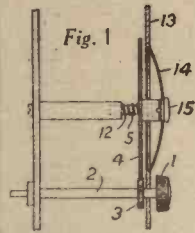

In a remote-control device for a wireless receiver, wherein the tuning element is driven through a flexible shaft from a shaft 2 (Fig. 1) actuated by the tuning knob 1, the tuning indicia are carried on a scale

wheel 4, driven by a gear wheel 3 on shaft 2 and visible through a transparent cover plate 14 in the panel 13. The scale wheel 4 is freely mounted on a stud 5 and for adjustment thereof relative to the tuning element, a preferably sprung cap 15 is removed from the cover plate, when, by means of a screwdriver or like tool, the wheel 4 may be moved axially in opposition to a spring 12 out of engagement with the wheel 3 and then rotated until the correct tuning position is indicated when the wheel 4 is released to mesh again with wheel 3.

NEW PATENTS

These particulars of New Patents of interest to readers have been selected from the Official Journal of Patents and are published by permission of the Controller of H.M. Stationery Office. The Official Journal of Patents can be obtained from the Patent Office, 25, Southampton Buildings, London, W.C.2, price 1s. weekly (annual subscription, £2 10s.)

Latest Patent Applications.

- 29591.—General Electric Co., Ltd., and Aldous, W. H.—High-frequency amplifiers including thermionic valves. November 7th.
- 29590.—General Electric Co., Ltd., and Epsley, D. C.—Apparatus for transmitting television. November 7th.
- 29393.—Hazeltine Corporation.—Automatic control system for television receivers. November 4th.
- 29362.—Marconi's Wireless Telegraph Co., Ltd., and Stewart, J.—Radio-receiving systems. November 3rd.
- 29630.—Modrey, H. J.—Carrier for loudspeakers. November 8th.
- 29400.—Mullard Radio Valve Co., Ltd.—Cathode-ray tubes. November 4th.
- 29372.—Perkins, A. C.—Radio circuits. November 4th.
- 29209.—Walker, W. A. H.—Emergency-signals radio receiver. November 2nd.

29349.—Yardeny, M.—Device for tuning radio sets. November 3rd.

Specifications Published.

- 514155.—Scophony, Ltd., and Rosenthal, A. H.—Television receivers.
- 514170.—British Thomson-Houston Co., Ltd., and Mynall, D. J.—Magnetic deflection of the ray in cathode-ray tubes.
- 514213.—Bosch Ges., R.—Wireless receiving apparatus.
- 514270.—Baird Television, Ltd., and Denisoff, A. K.—Cathode-ray tubes.
- 514271.—Baird Television, Ltd., and Nuttall, T. C.—Television and like receivers.
- 514319.—Marconi's Wireless Telegraph Co., Ltd.—Multi-wave band radio receivers and the like.
- 514331.—Philco Radio and Television Corporation.—Volume-control circuits for thermionic amplifiers.
- 514332.—Philco Radio and Television Corporation.—Device for supporting radio coils and the like.

Printed copies of the full Published Specifications may be obtained from the Patent Office, 25, Southampton Buildings, London, W.C.2, at the uniform price of 1s. each.

A POCKET PORTABLE

(Continued from page 230)

this socket. Also, with a piece of rubber-covered wire, connect the remaining filament terminal on the valveholder and the wire running from the earth side (moving vanes) of the two .0005 mfd. condensers to this same black socket. Fix to the black banana plug two pieces of flex; to one attach a small black H.T. plug, and to the other a crocodile clip.

Testing Out

The set is now completely wired-up, and to test out place the small accumulator in the space left (a piece of wood screwed to the lid close enough to the accumulator will hold this from moving about); join the positive and negative spades to it. Attach to the aerial one of the red banana plugs, and to the other connect some flex. The black plug is put in the negative socket of the H.T. battery and the crocodile clip to an earth wire.

Plug-in the aerial and 'phone jack, and listen. If on turning the tuning knob nothing is heard, increase the reaction, and

you will soon pick up the local station. Now take the aerial plug out of its present socket and replace it into the one with the .0001 series condenser in circuit. On retuning, various other stations should come in quite well, also with a good outdoor aerial quite a good range should be covered. Drop the H.T. voltage to 40 volts if the reaction is too fierce. Withdrawing the 'phone plug automatically cuts off the L.T. and H.T.

With a good one-valve amplifier and extra H.T. the set works a speaker and occupies very little room.

PRACTICAL MECHANICS HANDBOOK

By F. J. CAMM.

400 pages, 6/- or 6/6 by post from

GEORGE NEWNES, LTD.,
Tower House, Southampton Street,
Strand, W.C.2.

Practical Wireless BLUEPRINT SERVICE

PRACTICAL WIRELESS
Date of Issue. No. of Blueprint.

CRYSTAL SETS
Blueprints, 6d. each.
1937 Crystal Receiver PW71
The "Junior" Crystal Set .. 27.3.38 PW94

STRAIGHT SETS. Battery Operated.
One-valve : Blueprints, 1s. each.
All-Wave Unipen (Pentode) .. PW31A
Beginners' One-valver .. 19.2.38 PW95
The "Pyramid" One-valver (HF Pen) .. 27.3.38 PW93

Two-valve : Blueprints, 1s. each.
Four-range Super Mag Two (D, Pen) .. PW36B
The Signet Two (D & LF) .. 24.9.38 PW76

Three-valve : Blueprints, 1s. each.
Selectone Battery Three (D, 2 LF (Trans)) .. PW10
Sixty Shilling Three (D, 2 LF (RC & Trans)) .. PW34A
Leader Three (SG, D, Pow) .. 22.5.37 PW35
Summit Three (HF Pen, D, Pen) .. PW37
All Pentode Three (HF Pen, D (Pen), Pen) .. 29.5.37 PW39
Hall-Mark Three (SG, D, Pow) .. 12.6.37 PW41
Hall-Mark Cadet (D, LF, Pen (RC)) .. 16.3.35 PW48
F. J. Camm's Silver Souvenir (HF Pen, D (Pen), Pen) (All-Wave Three) .. 13.4.35 PW40
Cameo Midget Three (D, 2 LF (Trans)) .. PW51
1936 Sonotone Three-Four (HF Pen, HF Pen, Westector, Pen) .. PW53
Battery All-Wave Three (D, 2 LF (RC)) .. PW55
The Monitor (HF Pen, D, Pen) .. PW61
The Tutor Three (HF Pen, D, Pen) .. 21.3.36 PW62
The Centaur Three (SG, D, P) .. 14.8.37 PW64
F. J. Camm's Record All-Wave Three (HF Pen, D, Pen) .. 31.10.36 PW69
The "Colt" All-Wave Three (D, 2 LF (RC & Trans)) .. 18.2.39 PW72
The "Rapid" Straight 3 (D, 2 LF (RC & Trans)) .. 4.12.37 PW82
F. J. Camm's Oracle All-Wave Three (HF, Det., Pen) .. 28.8.37 PW78
1938 "Triband" All-Wave Three (HF Pen, D, Pen) .. 22.1.38 PW84
F. J. Camm's "Sprite" Three (HF Pen, D, Tet) .. 26.3.38 PW87
The "Hurricane" All-Wave Three (SG, D (Pen), Pen) .. 30.4.38 PW89
F. J. Camm's "Push-Button" Three (HF Pen, D (Pen), Tet) .. 3.9.38 PW92

Four-valve : Blueprints, 1s. each.
Sonotone Four (SG, D, LF, P) .. 1.5.37 PW4
Fury Four (2 SG, D, Pen) .. 8.5.37 PW11
Beta Universal Four (SG, D, LF, Cl. B) .. PW17
Nucleon Class B Four (SG, D (SG), LF, Cl. B) .. PW34B
Fury Four Super (SG, SG, D, Pen) .. PW34C
Battery Hall-Mark 4 (HF Pen, D, Push-Pull) .. PW46
F. J. Camm's "Linit" All-Wave Four (HF Pen, D, LF, P) .. 26.0.36 PW67
All-Wave "Corona" 4 (HF, Pen D, LF, Pow) .. 9.10.37 PW79
"Acme" All-Wave 4 (HF Pen, D (Pen), LF, Cl. B) .. 12.2.38 PW83
The "Admiral" Four (HF Pen, HF Pen, D, Pen (RC)) .. 3.9.38 PW90

Mains Operated.
Two-valve : Blueprints, 1s. each.
A.C. Twin (D (Pen), Pen) .. PW18
A.C.-D.C. Two (SG, Pow) .. PW31
Selectone A.C. Radiogram Two (D, Pow) .. PW19
Three-valve : Blueprints, 1s. each.
Double-Diode-Triode Three (HF Pen, DDT, Pen) .. PW23
D.C. Ace (SG, D, Pen) .. PW25
A.C. Three (SG, D, Pen) .. PW29
A.C. Leader (HF Pen, D, Pow) .. 7.1.39 PW35C
D.C. Premier (HF Pen, D, Pen) .. PW35B
Ubique (HF Pen, D (Pen), Pen) .. 28.7.34 PW36A
Armada Mains Three (HF Pen, D, Pen) .. PW28
F. J. Camm's A.C. All-Wave Silver Souvenir Three (HF Pen, D, Pen) .. 11.5.35 PW50
"All-Wave" A.C. Three (D, 2 LF (RC)) .. PW54
A.C. 1936 Sonotone (HF Pen, HF Pen, Westector, Pen) .. PW56
Mains Record All-Wave 3 (HF Pen, D, Pen) .. PW70
All-World Ace (HF Pen, D, Pen) .. 28.8.37 PW80

Four-valve : Blueprints, 1s. each.
A.C. Fury Four (SG, SG, D, Pen) .. PW20
A.C. Fury Four Super (SG, SG, D, Pen) .. PW34D
A.C. Hall-Mark (HF Pen, D, Push-Pull) .. 24.7.37 PW45

Universal Hall-Mark (HF Pen, D, Push-Pull) .. PW47
A.C. All-Wave Corona Four .. 6.11.37 PW81

SUPERHETS.
Battery Sets : Blueprints, 1s. each.
25 Superhet (Three-valve) .. 5.6.37 PW40
F. J. Camm's 2-valve Superhet .. PW52
F. J. Camm's "Vitesse" All-Waver (5-valver) .. 27.2.37 PW75

Mains Sets : Blueprints, 1s. each.
A.C. 25 Superhet (Three-valve) .. PW43
D.C. 25 Superhet (Three-valve) .. PW42
Universal 25 Superhet (Three-valve) .. PW44
F. J. Camm's A.C. Superhet 4 .. 31.7.37 PW59
F. J. Camm's Universal 24 Superhet 4 .. PW60
"Qualitone" Universal Four .. 16.1.37 PW73

Four-valve : Double-sided Blueprint, 1s. 6d.
Push-Button 4, Battery Model .. PW95
Push-Button 4, A.C. Mains Model .. 22.10.38 PW95

SHORT-WAVE SETS. (Battery Operated.)
One-valve : Blueprint, 1s.
Simple S.W. One-valver .. PW88
Two-valve : Blueprints, 1s. each.
Midget Short-wave Two (D, Pen) .. PW38A
The "Fleet" Short-wave Two (D (HF Pen), Pen) .. 27.8.38 PW91

Three-valve : Blueprints, 1s. each.
Experimenter's Short-Wave Three (SG, D, Pow) .. 30.7.38 PW30A
The Prefect 3 (D, 2 LF (RC and Trans)) .. PW63
The Band-Spread S.W. Three (HF Pen, D (Pen), Pen) .. 1.10.38 PW68

PORTABLES.
Three-valve : Blueprints, 1s. each.
F. J. Camm's ELF Three-valve Portable (HF Pen, D, Pen) .. PW65
Parvo Flyweight Midget Portable (SG, D, Pen) .. 3.6.39 PW77
Four-valve : Blueprints, 1s.
"Imp" Portable 4 (D, LF, LF, (Pen)) .. 10.3.38 PW86

MISCELLANEOUS.
S.W. Converter-Adapter (1 valve) .. PW48A

AMATEUR WIRELESS AND WIRELESS MAGAZINE CRYSTAL SETS.
Blueprints, 6d. each.
Four-station Crystal Set .. 23.7.38 AW427
1934 Crystal Set .. AW444
150-mile Crystal Set .. AW450

STRAIGHT SETS. Battery Operated.
One-valve : Blueprint, 1s.
B.B.C. Special One-valver .. AW387
Two-valve : Blueprints, 1s. each.
Melody Ranger Two (D, Trans) .. AW388
Full-volume Two (SG det, Pen) .. AW392
Lucerne Minor (D, Pen) .. AW426
A Modern Two-valver .. WM400

Three-valve : Blueprints, 1s. each.
Class B Three (D, Trans, Class B) .. AW386
£5 5s. S.G.3 (SG, D, Trans) .. 2.12.33 AW412
Lucerne Ranger (SG, D, Trans) .. AW422
£5 5s. Three : De Luxe Version (SG, D, Trans) .. 19.5.34 AW435
Lucerne Straight Three (D RC, Trans) .. AW437
Transportable Three (SG, D, Pen) .. WM271
Simple-Tune Three (SG, D, Pen) .. June '33 WM327
Economy-Pentode Three (SG, D, Pen) .. Oct. '33 WM337

"W.M." 1934 Standard Three (SG, D, Pen) .. WM351
£3 3s. Three (SG, D, Trans) .. Mar. '34 WM354
1935 £6 6s. Battery Three (SG, D, Pen) .. WM371
PTF Three (Pen, D, Pen) .. WM389
Certainty Three (SG, D, Pen) .. WM393
Mintube Three (SG, D, Trans) .. Oct. '35 WM396
All-Wave Winning Three (SG, D, Pen) .. WM400

Four-valve : Blueprints, 1s. 6d. each.
65s. Four (SG, D, RC, Trans) .. AW370
2HF Four (2 SG, D, Pen) .. AW421
Self-contained Four (SG, D, LF, Class B) .. Aug. '33 WM331
Lucerne Straight Four (SG, D, LF, Trans) .. WM350
£5 5s. Battery Four (HF, D, 2 LF) .. Feb. '35 WM381
The H.K. Four (SG, SG, D, Pen) .. Mar. '35 WM384
The Auto Straight Four (HF Pen, HF Pen, DDT, Pen) .. Apr. '36 WM404

Five-valve : Blueprints, 1s. 6d. each.
Super-quality Five (2 HF, D, RC, Trans) .. WM320
Class B Quadradyne (2 SG, D, LF, Class B) .. WM344
New Class B Five (2 SG, D, LF, Class B) .. WM340

These Blueprints are drawn full size. Copies of appropriate issues containing descriptions of these sets can in some cases be supplied at the following prices, which are additional to the cost of the Blueprint. A dash before the Blueprint Number indicates that the issue is out of print.
Issues of Practical Wireless ... 4d. Post Paid
Amateur Wireless .. 4d.
Wireless Magazine .. 1/3
The index letters which precede the Blueprint Number indicate the periodical in which the description appears : Thus P.W. refers to PRACTICAL WIRELESS, A.W. to Amateur Wireless, W.M. to Wireless Magazine.
Send (preferably) a postal order to cover the cost of the Blueprint and the issue (stamps over 6d. unacceptable) to PRACTICAL WIRELESS Blueprint Dept., George Newnes, Ltd., Tower House, Southampton Street, Strand, W.C.2.

Mains Operated.
Two-valve : Blueprints, 1s. each.
Consocietric Two (D, Pen) A.C. .. AW403
Economy A.C. Two (D, Trans) A.C. .. WM286
Unicom A.C.-D.C. Two (D, Pen) .. WM394

Three-valve : Blueprints, 1s. each.
Home Lover's New All-electric Three (SG, D, Trans) A.C. .. AW388
Mantovani A.C. Three (HF, Pen, D, Pen) .. WM374
£15 15s. 1936 A.C. Radiogram (HF, D, Pen) .. Jan. '36 WM401

Four-valve : Blueprints, 1s. 6d. each.
All Metal Four (2 SG, D, Pen) .. July '33 WM329
Harris' Jubilee Radiogram (HF, Pen, D, LF, P) .. May '35 WM386

SUPERHETS.
Battery Sets : Blueprints, 1s. 6d. each.
Modern Super Senior .. WM375
Varsity Four .. Oct. '35 WM395
The Request All-Waver .. June '36 WM407
1935 Super-Five Battery (Superhet) .. WM379

Mains Sets : Blueprints, 1s. 6d. each.
Heptode Super Three A.C. .. May '34 WM359
"W.M." Radiogram Super A.C. .. WM366

PORTABLES.
Four-valve : Blueprints, 1s. 6d. each.
Holiday Portable (SG, D, LF, Class B) .. AW393
Family Portable (HF, D, RC, Trans) .. AW447
Two H.F. Portable (2 SG, D, QP21) .. WM363
Tyers Portable (SD, D, 2 Trans) .. WM367

SHORT-WAVE SETS—Battery Operated
One-valve : Blueprints, 1s. each.
S.W. One-valver for America .. 15.10.38 AW429
Rome Short-Waver .. AW452

Two-valve : Blueprints, 1s. each.
Ultra-short Battery Two (SG, det, Pen) .. Feb. '36 WM402
Home-made Coil Two (D, Pen) .. AW440

Three-valve : Blueprints, 1s. each.
World-ranger Short-wave 3 (D, RC, Trans) .. AW355
Experimenter's 5-metre Set (D, Trans, Super-regen) .. 30.6.34 AW438
The Carrier Short-waver (SG, D, P) .. July '35 WM390

Four-valve : Blueprints, 1s. 6d. each.
A.W. Short-wave World-beater (HF Pen, D, RC, Trans) .. AW436
Empire Short-waver (SG, D, RC, Trans) .. WM313
Standard Four-valver Short-waver (SG, D, LF, P) .. 22.7.39 WM383

Superhet : Blueprint, 1s. 6d.
Simplified Short-wave Super .. Nov. '35 WM397

Mains Operated.
Two-valve : Blueprints, 1s. each.
Two-valve Mains Short-waver (D, Pen) A.C. .. AW453
"W.M." Long-wave Converter .. WM390

Three-valve : Blueprint, 1s.
Emigrator (SG, D, Pen) A.C. .. WM352

Four-valve : Blueprint, 1s. 6d.
Standard Four-valve A.C. Short-waver (SG, D, RC, Trans) .. Aug. '35 WM391

MISCELLANEOUS.
S.W. One-valve Converter (Price 6d.) .. AW339
Enthusiast's Power Amplifier (1/6) .. WM387
Listener's 5-watt A.C. Amplifier (1/6) .. WM392
Radio Unit (2v.) for WM392 (1/-) .. Nov. '35 WM398
Harris Electrogram battery amplifier (1/-) .. WM399
De Luxe Concert A.C. Electro-gram (1/-) .. Mar. '36 WM403
New Style Short-wave Adapter (1/-) .. WM388
Trickle Charger (6d.) .. Jan. 5, '35 AW462
Short-wave Adapter (1/-) .. AW456
Superhet Converter (1/-) .. AW457
B.L.D.L.C. Short-wave Converter (1/-) .. May '36 WM405
Wilson Tone Master (1/-) .. June '36 WM406
The W.M. A.C. Short-wave Converter (1/-) .. WM403

RADIO CLUBS & SOCIETIES

Club Reports should not exceed 200 words in length and should be received First Post each Monday morning for publication in the following week's issue.

SLOUGH AND DISTRICT SHORT-WAVE CLUB
Headquarters: Toc H Headquarters, William Street, Slough.

Hon. Sec.: K. A. Sly (G4MR), 16, Buckland Avenue, Slough.

Meetings: Alternate Thursdays at 7.30 p.m.

At the meeting held on November 9th, 1939, the chief item of interest was a talk by Mr. Houchin (G3GZ) on the Principles of Radio, the first of a series of lectures to be given at each meeting, in which he dealt with Alternating Currents. Mr. Houchin dealt mainly with the static transformer, and during the talk he cleared up many points which had puzzled members, in the construction of mains transformers. He dealt fully with the safety margins which must be carefully observed in their construction.

Morse practice took place as usual, many members taking part. A new practice set has been built by G4MR for the use of members, and it operates a horn type speaker very efficiently, thus permitting members to take part who have no phones.

Discussions took place on conditions during the past fortnight, with special reference to 28 mc/s. Several new and strange call-signs were reported.

Notes from the Test Bench

Position of Condensers

ORDINARY paper, tubular or mica condensers may be mounted in any position, but some care is necessary when using electrolytic condensers. The wet type of condenser of this variety must be mounted in a vertical position, or at least so that the vent holes are uppermost. When using these components, therefore, look for mounting instructions on the case, as it is generally indicated whether or not they must be mounted in a certain position.

Gramophone Working

THE majority of listeners who use the gramophone section regularly will appreciate that a light so directed that it illuminates the edge of the turntable is a valuable accessory, as it ensures that the needle is correctly placed and also avoids damage to the record. Special small turntable illuminating lamps are available, but an economy may be effected by arranging that these are switched off when the gramophone lid is closed down. On most lids a self-supporting or similar stay is fitted, and usually two contacts may be mounted on this in such a manner that when the lid is lifted the light is in circuit and when the lid is lowered it is open-circuited.

READ

"THE CYCLIST"
3d. Every Wednesday

Classified Advertisements

Advertisements are accepted for these columns at the rate of 2d. per word. Words in black face and/or capitals are charged double this rate (minimum charge 2/- per paragraph). Display lines are charged at 4/- per line. All advertisements must be prepaid. All communications should be addressed to the Advertisement Manager, "Practical Wireless," Tower House, Southampton Street, Strand, London, W.C.2.

RECEIVERS, COMPONENTS AND ACCESSORIES

SOUTHERN RADIO'S Bargains.

ALL Articles Fully Guaranteed. Postage extra.

5/-—Parcel of useful components, comprising condensers, resistances, volume controls, coils, wire, circuits, etc., etc., value 25/- 5/- per parcel.

10/-—Parcel of useful components, comprising 100 articles, including electrolytics, valveholders, etc., etc., value 55/- 10/- per parcel.

15/-—Service man's component kit. Comprising electrolytic condensers, volume controls, tubular condensers, resistances, valveholders, wire, mica and Mainsbridge condensers, etc., etc. 120 articles contained in strong carrying case 9" x 7" x 7", value 65/- 15/- the complete kit.

21/-—Small traders' parcel of components, comprising at least 150 articles, including 24 assorted tubular condensers, 24 valveholders, 30 resistances, 12 Mainsbridge type condensers, 6 electrolytics, etc., etc., value 85/- 21/- per parcel.

5/-—Twelve Mainsbridge type condensers, 1-2-4 mfd.; 5/- per dozen.

4/-—Telsen 3-range meters (volts and milliamps), 4/-; Morse tappers, 2/11.

B—BUZZERS, 1/6; crystal detectors, 2/-; crystal sets, 5/8; crystals, 6d.

2/6—Ormond loudspeaker units, 2/6.

2/-—Tool or instrument carrying cases ex-Government stock. Wood 9" x 7" x 7", 2/- each.

S—SOUTHERN RADIO, 46, Lisle Street, London, W.G. Gerrard 0653.

V—VAUXHALL.—All goods previously advertised are still available; send now for latest price list, free.—Vauxhall Utilities, 163a, Strand, W.C.2.

"STAND-BY" Crystal Set. Specified coil 2s. case 9d., or complete kit of parts, 10s. 3d. post free.—T. W. Thompson and Co., 176, Greenwich High Road, S.E.10.

5/- Bargain Parcel comprising Speaker Cabinet, Drilled steel Chassis, condensers, resistances and many other useful components. Worth £2. Limited number. Postage 1/.—Bakers Selhurst Radio, 75, Sussex Rd., South Croydon.

B—BANKRUPT BARGAINS. Brand new 1938-9 models, makers' sealed cartons, with guarantees, at less 40 per cent. below listed prices; also Midgets, portables, car radio. Send 11d. stamp for lists. Radio Bargains, Dept. P.W., 261-3, Lichfield Road, Aston, Birmingham.

B—BANKRUPT BARGAINS. All new goods. Portadyne A.C./D.C. 1940 mains all-wave superhets, 7 gns. Portadyne superhet battery portables, £6/10/0. 12v. A.G./D.C. all-wave superhets (listed 16 gns.), 9 gns. Many others. State requirements. 5-watt lamps, 12/- dozen. Full stock valves all types. Service parts. Repairs.—Butlin, 6, Stamford Avenue, Brighton.

LOUDSPEAKER REPAIRS

L—LOUDSPEAKER repairs, British, American, any make. 24-hour service, moderate prices.—Sinclair Speakers, Pulteney Terrace, Copenhagen Street, London, N.1.

L.S. REPAIR AND REWINDING SERVICE: 24-hour service. See below:—

R—REPAIRS to moving coil speakers a speciality. New cone assemblies fitted. Speech coils and fields wound or altered. Mains transformers, chokes, eliminators and vacuums repaired, prices quoted. Speaker transformers, Class "B" L.E. transformers and pick-ups rewound at 4s. each, post free. Discount trade. Estimates free. Guaranteed satisfaction. L.S. Repair Service, 6, Balham Grove, London, S.W.12. Phone: Battersea 1321.

STAMPS

F—FREE!! Twenty Unused Colonials, "Neurope" (11d.) 50 for 1/11.—G. H. Barnett, Limington, Yeovil, Somerset.

LOUDSPEAKER CONVERSIONS

BAKER'S Triple Cone Conversions Will Immensely Improve Reproduction of Your Present Speaker. Enables you to bring your speaker right up to date and obtain really realistic reproduction at the cost of a few shillings; free descriptive leaflet from the Pioneer Manufacturers of Moving Coil Speakers since 1925.—Bakers Selhurst Radio, 75, Sussex Rd., South Croydon.

NEW LOUDSPEAKERS

3,000 SPEAKERS from 6/6 each, P.M. and energised 4in. to 14in. including several Epoch 18in.—Sinclair Speakers, Pulteney Terrace, Copenhagen Street, London, N.1.

NEW CHASSIS

A—ARMSTRONG COMPANY have a number of chassis not in the current catalogue, for disposal. These chassis carry the makers' generous guarantee and represent outstanding bargains. An example of one or two models described hereunder.

A—ARMSTRONG Model RFRP/T, 9-valve All-wave Radiogram chassis covering 4 wave bands and incorporating R.C. coupled Triode Push-pull output, capable of handling 8 watts. £7 18s. 6d.

A—ARMSTRONG 7 and 8 Stage Radiogram chassis, complete with Speakers, ready to switch on. £4 10s. 0d.

A—ARMSTRONG have a number of other models at equally economical prices. Kindly send us your requirements.

A—ARMSTRONG will send any chassis on 7 days' approval.

A—ARMSTRONG COMPANY, Writers Road, Holloway, N.7.

MORSE EQUIPMENT

F—FULL range of Transmitting Keys, Practice Sets, Oscillators, Recorders and other Radio Telegraph Apparatus, designed and manufactured by T. R. McElroy, World Champion Telegraphist. Absolutely first-class construction. McElroy Amateur Key 7/6 post free.—Webb's Radio, 14, Soho Street, London, W.1. Phone: Gerrard 2089.

COMMUNICATION RECEIVERS

F—FINEST selection in the country. Sole Agents for famous HALLICRAFTERS Receivers, ranging in price from £11-10-0 to £150. Attractive easy terms. Demonstrations at our London Showrooms, 60-page Catalogue post free 2d.—Webb's Radio, 14, Soho Street, London, W.1. Phone: Gerrard 2089.

TECHNICAL LITERATURE

T—TECHNICAL BOOKS for the enthusiast. Hundreds of constructional theoretical circuits short-wave equipment. Radio Society of Great Britain Handbook, 2/9 post free. 1940 Edition American Radio Relay League Handbook, 6/- post free. American "Radio Handbook," 7/6 post free. R.C.A. American Receiving Valve Manual, 1/6 post free.—Webb's Radio, 14, Soho Street, London, W.1. Phone: Gerrard 2089.

RADIO MAP AND GLOBE

W—WEBB'S RADIO MAP of the World enables you to locate any station heard. Size 40" by 30". 2-colour heavy Art Paper, 4/6. Limited supply on linen. 10/6. WEBB'S RADIO GLOBE—superb 12" full-colour model. Radio prefixes, zones, etc. Heavy oxidised mount. Post Paid, 2/7/6.—Webb's Radio, 14, Soho Street, London, W.1. Phone: Gerrard 2089.

FREE ADVICE BUREAU COUPON

This coupon is available until December 9th, 1939, and must accompany all Queries and Hints.

PRACTICAL WIRELESS, 2/12/39

Regill
173

with - gill - ell

400

A HETERODYNE FILTER— See page 262

A
NEWNES
PUBLICATION

Edited by
F.J.CAMM
Vol. 15. No. 377.

Practical Wireless and

3!

EVERY
WEDNESDAY
Dec. 9th, 1939.

★ PRACTICAL TELEVISION ★

Contents

- DX on the Medium Waves
- ◇
- More About the Three-Two
- ◇
- An A.C. Trickle-charger
- ◇
- Practical Television
- ◇
- Thermion's Commentary
- ◇
- Choosing a Loudspeaker
- ◇
- Practical Hints
- ◇
- Experimental Heterodyne Filter
- ◇
- Auto Grid-bias Circuits
- ◇
- Readers' Letters

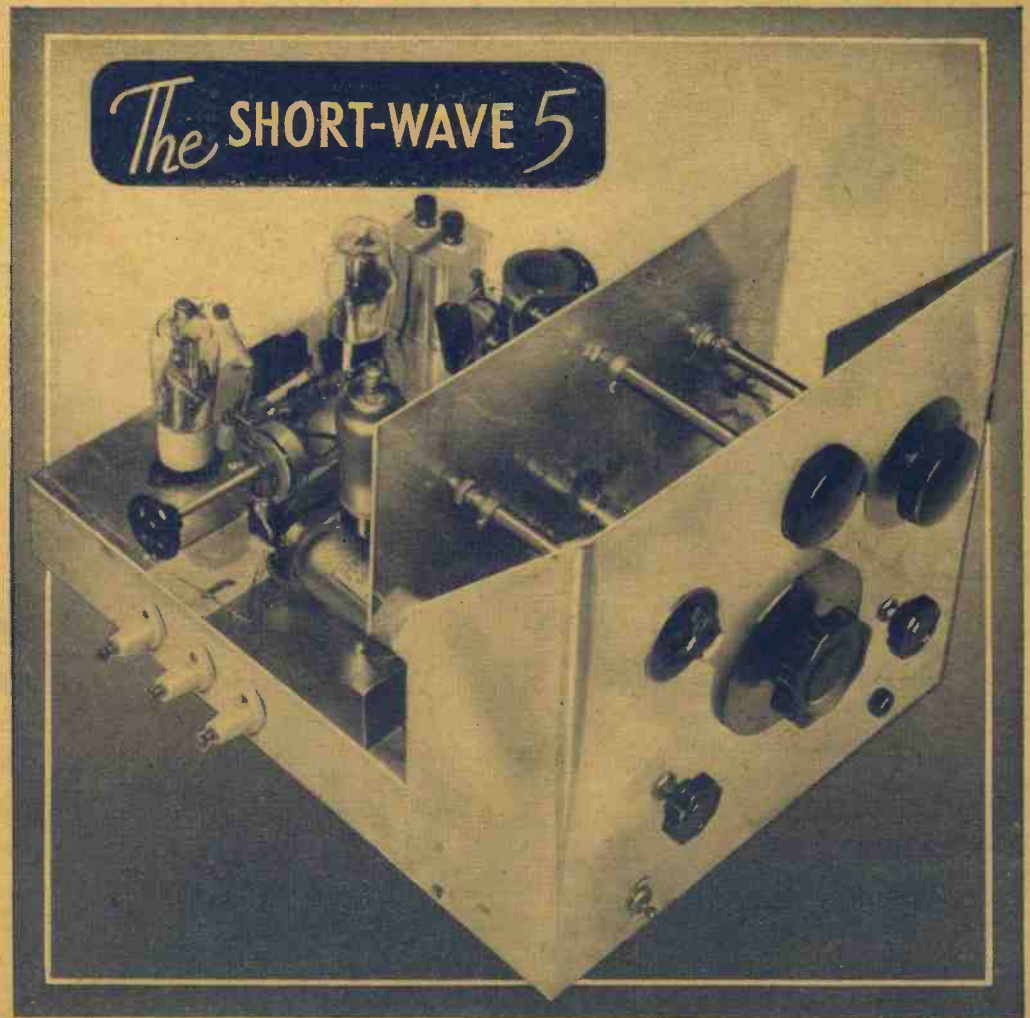

THE OUTLINE OF WIRELESS By Ralph Stranger

This book teaches you everything you need to know about wireless. The entire theory and practice of reception is covered simply and clearly from A to Z. 832 pages with over 500 illustrations and diagrams.

10/6 NET

From all booksellers, or by post 11/- from the publishers, **GEORGE NEWNES, LTD.**, (Book Dept.), Tower House, Southampton Street, Strand, London, W.C.2.

Best Christmas Reading

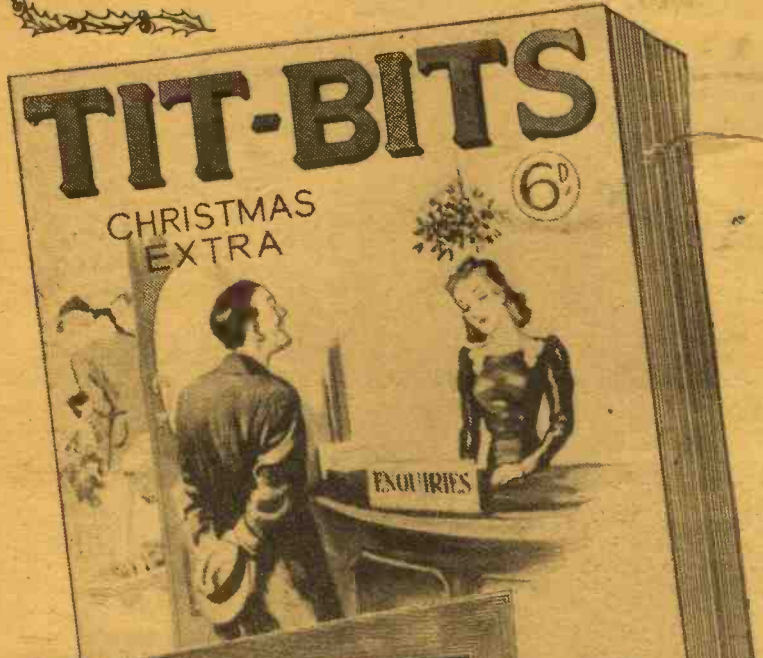

FOR ALL THE FAMILY

Get these three bright bumper issues. They will be enjoyed by everyone, for each is full of good humour and the real Christmas Spirit!

TIT-BITS XMAS EXTRA, 6d.
Four complete stories, many entertaining articles, special contributions by Sandy Powell, Western Brothers, Puzzles, etc., and a Children's Section.



XMAS LONDON OPINION, 6d.

A Christmas tonic for everyone, in the popular pocket size. It keeps the flag of humour flying!

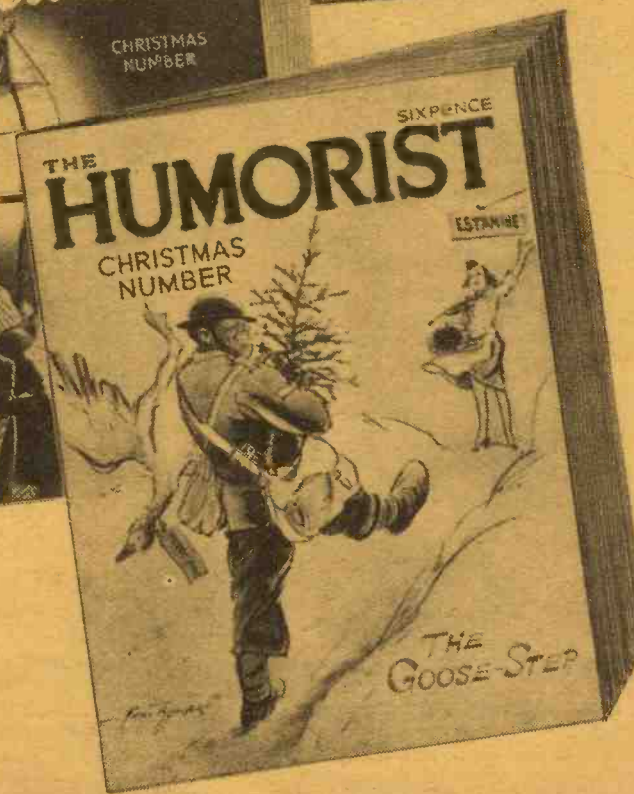

HUMORIST XMAS NUMBER, 6d.

Hundreds of Christmas laughs inside by the most popular humorous writers. Artists include Bert Thomas, Lees, Arthur Ferrier.

FOR THE KIDDIES - 2d. each
CHRISTMAS HOLIDAY COMIC
MONSTER XMAS COMIC

Packed with all the things boys and girls love to read at Christmas.

*Order To-day!
make
Christmas
Gay!*



Practical and Wireless

★ PRACTICAL TELEVISION ★

EVERY WEDNESDAY

Vol. XV. No. 377 Dec. 9th, 1939.

EDITED BY
F. J. C. AMM

Staff:
W. J. DELANEY, FRANK PRESTON,
H. J. BARTON CHAPPLE, B.Sc.

ROUND THE WORLD OF WIRELESS

Short-wave Receivers

THE design of short-wave apparatus lends itself better to the experimenter than that of ordinary broadcast equipment, and although circuits must, more or less, be standardised, there are many refinements which may be incorporated and which will provide scope for experiment. The ideal short-wave receiver is, of course, the communications type of superhet, but it is possible to build a simpler type of receiver and yet still retain many of the features of this special type of superhet. We have already described in these pages various special short-wave receivers, and in this issue we give yet another specialised design, including five valves. Reaction is, of course, the main stand-by of the "straight" receiver, and the more effective that this part of the circuit may be made, the better will be the results. Special attention has, therefore, been paid to this part of the Short-Wave 5, and there are many other features in design which will appeal to the experimenter who requires something different from the ordinary straight three or similar type of set for battery operation on the short waves.

"People's Set" for Troops

THE authorities have approached some of the larger radio firms with a view to obtaining a design of radio receiver for use by the troops. Something on the lines of the "People's Set" is indicated, providing simplicity of operation and reliable results.

Elizabeth Cowell as Broadcast Announcer

THE B.B.C. announces that Elizabeth Cowell, the former television announcer, has returned to broadcasting, by arrangement with the Air Ministry, as a woman announcer in the Home Service programmes. She is to specialise in announcing variety broadcasts.

Miss Cowell joined the B.B.C. as a television announcer in May, 1936, and since then has faced the microphone and

television camera on more than a thousand occasions, at Alexandra Palace, on the stage at St. George's Hall, at Radiolympia and in television outside broadcasts. She has also produced television programmes, specialising in presentations of ballet, which is one of her principal interests. Miss

siderable experience in dress design and display.

Children's Hour Adventure Story

ELISABETH KYLE is well known as a writer for Children's Hour, particularly in the adaptations she has made of folk tales. Now she has made a thoroughly topical play which will be broadcast on December 9th. It opens with Robin and Jean travelling to Glasgow in a train during a black-out. In an old curiosity shop they meet a mysterious stranger and take part in an adventure concerning a parrot, a musical box and the model of a Chinese temple carved out of priceless jade. The play, which is called "The Key to No. 10," will be produced by Christine Orr.



The staff of Broadcasting House, Glasgow, have been doing physical jerks to records, the object being to find out which instructor or instructress they liked best, or whose voice had the most personality. The final choice has been engaged to broadcast the exercises throughout Britain, which commenced last Monday.

Cowell speaks French and German. Before she joined the B.B.C. she had had con-

K. Chesterton, has been adapted for broadcasting and will be produced by W. Farquharson Small on December 16th.

It will be remembered that "The Blue Cross" and "The Man in the Passage" have already been broadcast. The adaptation of "The Hammer of God" has been made by Douglas Cleverdon, who adapted Chesterton's "Club of Queer Trades," a series which was broadcast in monthly instalments between January and June of this year.

In "The Hammer of God," when the Lord of the Manor was found with—to use the doctor's expression—"his skull smashed to bits like an eggshell," the police found an easy and convincing explanation; but Father Brown proves that the explanation is too easy: that, in fact, it leaves out of account several necessary factors. Richard Gooden will play the part of Father Brown, and V. C. Clinton Baddeley will be the Narrator.

"The Doll's House"

IBSEN enthusiasts will be interested to learn that Barbara Burnham is to produce "The Doll's House" on December 8th, with members of the Repertory Company.

Editorial and Advertisement Offices:
"Practical Wireless," George Newnes, Ltd.,
Tower House, Southampton Street, Strand,
W.C.2. Phone: Temple Bar 4363.
Telegrams: Newnes, Rand, London.
Registered at the G.P.O. as a newspaper and
for transmission by Canadian Magazine Post.

The Editor will be pleased to consider articles of a practical nature suitable for publication in PRACTICAL WIRELESS. Such articles should be written on one side of the paper only, and should contain the name and address of the sender. Whilst the Editor does not hold himself responsible for manuscripts, every effort will be made to return them if a stamped and addressed envelope is enclosed. All correspondence intended for the Editor should be addressed: The Editor, PRACTICAL WIRELESS, George Newnes, Ltd., Tower House, Southampton Street, Strand, W.C.2.

Owing to the rapid progress in the design of wireless apparatus and to our efforts to keep our readers in touch with the latest developments, we give no warranty that apparatus described in our columns is not the subject of letters patent.

Copyright in all drawings, photographs and articles published in PRACTICAL WIRELESS is specifically reserved throughout the countries signatory to the Berne Convention and the U.S.A. Reproductions or imitations of any of these are therefore expressly forbidden. PRACTICAL WIRELESS incorporates "Amateur Wireless."

DX on Medium Waves

A Simple Explanation of the Requirements of a Circuit for Long-distance Reception on the M.W. Band, with Brief Details of Such a Circuit
By FRANK PRESTON

POINTING out that the average amateur nowadays thinks of DX reception only in terms of short waves, a very keen experimenter recently asked me for a circuit suitable for a sensitive receiver for medium-wave reception. At first the request struck me as being a surprising one, but after further consideration and after discussing it with other experimenters, I realised that there was a good deal in it.

My querist pointed out that he had been building long-distance sets for a number of years and reminded me of the "Selectone," which I described in PRACTICAL WIRELESS seven years ago. This was a Det.-L.F.-Power type of receiver with a number of features which were unusual at the time. It gave good reception of American medium-wave stations, not only on my own aerial but in the hands of a large number of readers. A suggestion was therefore made that an up-to-date version of this set should prove very popular. But I had to disagree with this, despite the fact that at least one reader has received three or four "Yanks" on it within the past few weeks.

"Straight" Circuit Not Suitable

Unfortunately, a set of this type, however well designed and made, is not sufficiently selective for present conditions. The very nature of the simple type of "straight" circuit makes it unsuitable for 1940 DX. By designing a "straight" set with at least two H.F. stages—and possibly a band-pass filter into the bargain—sufficiently sharp tuning might be obtained; but only at the expense of a certain delicacy of operation and initial trimming. And even if an exceptionally high degree of selectivity were combined with marked sensitivity, I should not favour a circuit of that type. The reason is that the requirements can be met in a simpler and less expensive manner by using the superhet. Regardless of the adverse reactions of many "old hands" to the superhet, there is no doubt that it does present the most convenient method of combining every feature that is most valuable for medium-wave DX work. When "quality" reception purely and simply is the prime need, a very good argument can be made out in favour of the "straight"; for any other purpose the "straight" cannot easily be defended, however much fondness the pre-1930 experimenter has for it.

A Superhet

This leads us to a brief consideration of the kind of superhet circuit best suited to the needs of the M.W.-DX "fan." Personally, I doubt whether I should build a set for long-distance reception of the so-called broadcast bands only. Since a short-wave band can be added at practically no extra cost, and without any sacrifice of efficiency on the 200 to 2,000-metre range, there does not seem to be any very good reason for not including it. Even if it is used only rarely, it does provide an interesting diversion.

A skeleton circuit is given on this page

which shows the general arrangement which may be followed in building a receiver of the type in question. It should be made perfectly clear that the circuit is not complete in every detail, and that it is given rather for the guidance of the experimenter than as a circuit which would appeal to the average constructor. That is why no constructional details will be given, for it is assumed that anyone who proposed to make a receiver round it would have sufficient knowledge and experience to work out his own practical details. There are on the market various makes of coils that could be used, whilst the other components are of standard type. Most readers have their own favourites in the way of valves, and certain resistor values are essentially dependent upon the particular valves employed. The values are generally given in the literature available from the valve manufacturers.

is for a 465 kc/s oscillator coil, with built-in padding condensers. When using this, the tuning condenser can be of the "plain" or non-tracking type, which is sometimes rather cheaper than the special superhet variety. It offers the further advantage that, since it is not essential to use any one section for oscillator tuning, it permits rather greater latitude in component lay-out.

The I.F. Transformer

Of the two I.F. transformers, the first is of the variable-selectivity type including a tertiary winding across which is connected a 5,000 ohm variable resistor; the acceptable band-width is varied simply by operating the resistor. The second transformer includes a third winding, this being used for applying reaction in the second detector circuit. This is a rather unusual arrangement

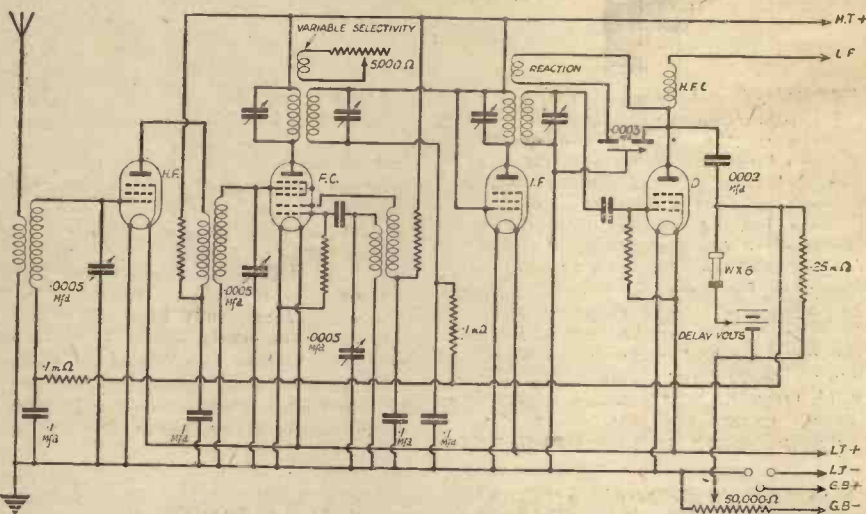

This skeleton circuit shows the principal items referred to on this page, although not being complete in details which follow standard practice.

Valve Sequence

It will be seen that there is a preliminary H.F. stage, followed by a pentagrid frequency-changer (there is no particular reason why a triode-pentode or triode-hexode should not be used if preferred), a single I.F. stage and an H.F. pentode second detector. An L.F. amplifier would be used in most cases, but this can be of any standard type. Since there are two tuned stages prior to the frequency-changer it is quite unnecessary to use a band-pass filter, especially since ample selectivity control can be provided in the first I.F. circuit. Experience generally shows that a preliminary H.F. amplifier is better than a second I.F. stage, since a certain minimum signal input to the frequency-changer is essential for efficient operation; this is an important point when DX is the first need.

A three-gang tuning condenser is required, and the type of this depends upon the oscillator coil employed. My preference

nowadays, but it has at least two advantages for the purpose under consideration. In the first place it permits the second-detector to operate at maximum efficiency, and in the second it allows that valve to be used in an oscillating condition for the reception of C.W. transmissions. It might be argued that a beat-frequency oscillator would provide a better means of obtaining C.W. reception, but we are concerning ourselves not only with efficiency, but also with reasonable simplicity.

Of course, reaction control must have some slight effect on the tuning of the second I.F. transformer, but this is negligible at 465 kc/s provided that trimming is carried out when the reaction condenser is set to a position just below the oscillation point. Additionally, the differential reaction condenser counteracts to a large extent the changes in circuit capacity brought about by reaction condenser adjustment.

(Continued on page 265)

THE "THREE-TWO" RECEIVER

Three-quarter front view of the completed "Three-Two" receiver

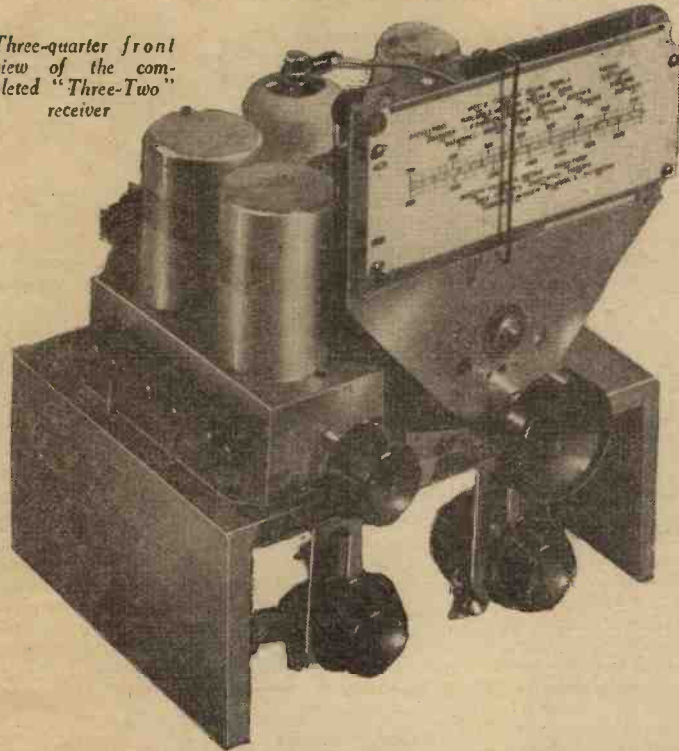

Hotting-up This or any Similar Three-valve Combination — By W. J. DELANEY

gives its maximum performance. For instance, the H.F. stage is provided with a fly-lead for insertion in the H.T. battery. The usual voltage for such a point is round about 80 volts. When, however, this is raised or lowered the H.F. valve acts in a different manner, and in some cases the stage may prove unstable if it is raised or lowered above a certain point. This, then, is the first point where

having values which will ensure the correct voltage being applied. Alternatively, a simple series resistance may be joined between the screen-grid and the H.T. line feeding the output valve, with a 1 mfd. fixed condenser between the screen-grid and earth. To ascertain the correct value of this resistance a milliammeter should be inserted between the fly-lead and the socket on the H.T. battery which has been found most suitable, and the current reading noted. The value of the resistance may then be calculated by subtracting the voltage which is being used from the total of the H.T. battery and dividing this by the current in milliamps. The answer will give the value of the resistance in thousands of ohms, and a 1-watt component will be ample for the position.

Detector Stage

In the detector section or detector stage of a similar circuit it is also possible to improve the performance of modification of certain component values. The grid leak is probably the most critical in this respect, changes in its value affecting not only the sensitivity of the stage, but also the smoothness and efficiency of the reaction circuit. Try values from .1 megohms (100,000 ohms) up to 5 megohms, and note the difference in sensitivity on a weak station, and also the way the reaction control behaves. With some values reaction will go in with a "plop" long

(Continued on page 269)

THE only details which were not given concerning this receiver last week were the drilling dimensions for the panel lay-out. As the receiver must be provided with a panel, or mounted in a cabinet, which will have to be drilled, we give on this page a dimensioned lay-out of the front of the receiver, from which the desired drilling may be accomplished. The holes for the various spindles should, of course, be merely clearance holes, so that the control knobs will cover them. So much for the actual construction. A simple three-valve combination of this kind, however, is remarkably amenable to circuit changes, and much can be done to "hot-up" such a circuit so that each stage

experiment may be carried out to provide an efficient H.F. stage.

Instability

Initial experiments should be carried out with the lead inserted into the socket nearest the 80-volt mark, and it is preferable for this type of receiver to obtain one of the H.T. batteries which has a large number of intermediate voltage sockets. Some, of course, only have sockets at every 15 volts, whilst others are tapped at every 6 volts or so. When a signal has been received and the receiver is found to be operating properly, move this screen voltage lead up and down the battery and note the variation in performance. It will be found that there is a point where sensitivity is at maximum and the set is perfectly stable. No bias is applied to the valve, and, therefore, gain is at maximum with consequent risk of instability if the lay-out is badly carried out. When, however, the screen voltage has been properly set for the valve in use the receiver will be perfectly stable and gain will be adequate. If it is desired then, to avoid the necessity of using the extra fly-lead, or a different type of H.T. battery is to be used, where the appropriate tapping point is not available, the screen may be fed from a potentiometer across the H.T. supply, the two parts of such a potentiometer being provided by two fixed resistors

LIST OF COMPONENTS FOR THE "THREE-TWO" RECEIVER.

- One "Bar Type" 2-gang condenser (Polar).
- One micro-horizontal drive (Polar).
- One 2-gang coil unit, type BP.114 (Varley).
- One .0003 mfd. Compax reaction condenser (Polar).
- One screened standard H.F. choke, type H.F.9 (Bulgin).
- One 4-point slotted dolly switch, type S.139 (Bulgin).
- One 3,000 ohm 1-watt resistor (Dubilier).
- One 10,000 ohm 1-watt resistor (Dubilier).
- One 40,000 ohm 1-watt resistor (Dubilier).
- One 250,000 ohm 1-watt resistor (Dubilier).
- Two .0001 mfd. fixed condensers, type 635 (Dubilier).
- One .05 mfd. fixed condenser, type 4602/S (Dubilier).
- Three .1 mfd. fixed condensers, type 4603/S (Dubilier).
- One 1 megohm volume control, type SG/P (Reliance).
- One 9-pin chassis type valveholder, type X.112 (Clix).
- One 5-pin chassis type valveholder, type X.112 (Clix).
- One two-socket strip, A.E. (Clix).
- One two-socket strip, L.S. (Clix).
- One top cap connector, type R426 (Clix).
- Two component mounting brackets (Peto-Scott).
- One Metaplex chassis, 8in. by 6in. with 3in. runners (Peto-Scott).
- One TP.22 triode-pentode valve (Mazda).
- One Pen 220 output pentode valve (Mazda).
- Connecting wire, insulated sleeving, screws, etc.

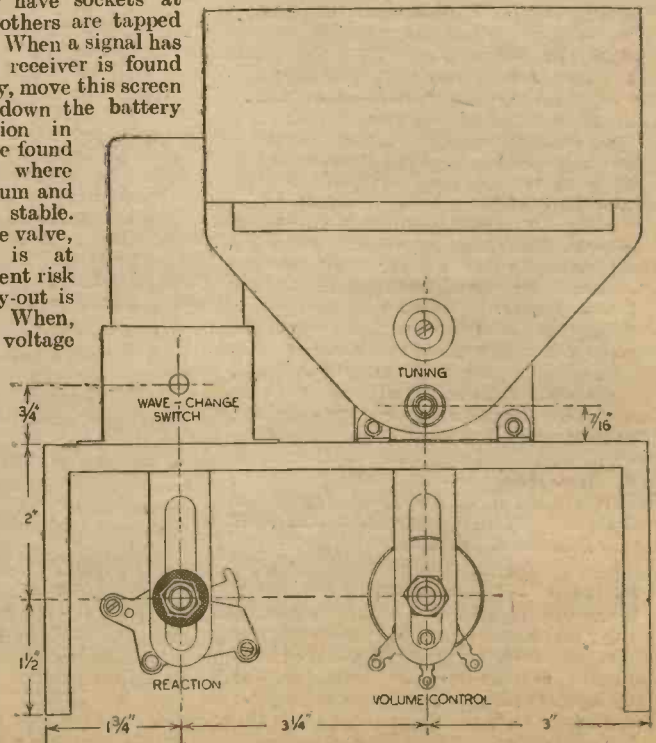

Drilling dimensions for panel or cabinet front for this receiver.

An A.C. Operated Trickle-charger

A Handy Piece of Equipment for Keeping L.T. Accumulators Used for Radio, or Emergency Lighting Work, in a Fully Charged Condition — By L. O. SPARKS

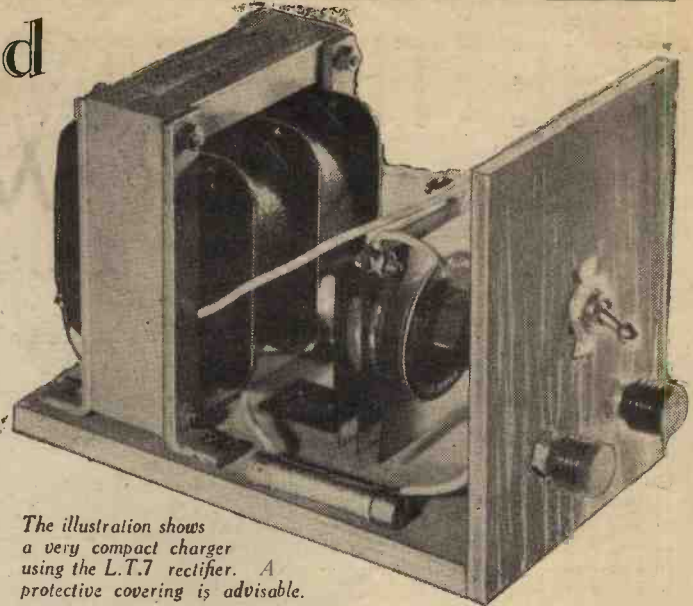

The illustration shows a very compact charger using the L.T.7 rectifier. A protective covering is advisable.

THE problem of recharging, low-tension storage cells forms one of the little, but always present, disadvantages associated with battery-operated apparatus. However careful one might be in keeping a check on the discharge rate and period of an accumulator, there comes a time when the supply unexpectedly becomes exhausted, and for some unknown reason this so often happens when it is least convenient. During normal times, this failure of the L.T. supply to a radio receiver could be sufficiently annoying, but during the present conditions, when one does not wish to lose some special broadcast item, the necessity of preventing such occurrences becomes vitally important. The same

are concerned, the choice can be restricted to two, the valve and the metal rectifier. For amateur purposes, the latter is, undoubtedly, the most simple and economical, therefore it is that type which will be dealt with in this article.

Three fundamental circuits recommended by the makers of the Westinghouse metal rectifier are shown in Fig. 1, where it will be seen that the essential requirements are a mains transformer, a rectifier, and a limiting resistance.

The construction of the mains transformer will depend on the voltage of the mains supply and the type of rectifier employed, i.e., the L.T. charging output required, which, in turn, will be governed by the number of two-volt cells to be charged at any one operation.

The limiting resistance R, although a rather insignificant item, is very important as it is incorporated in the circuit as a safety-device.

The resistance of an accumulator is very low, and it must be appreciated that the current limiting factors of the charging circuit are the resistance of the cell and the difference between the applied voltage and that of the accumulator. If, therefore, any fluctuations exist in the applied voltage, these will be capable of creating fluctuations of a much greater magnitude in the charging current. As each type of rectifier has definite current limitations, and, of course, the same applies to the secondary winding of the mains transformer, it will be realised from the above that unless means are provided to prevent or swamp such current fluctuations, serious harm might be caused to these components. In view of this, the resistance should never be omitted from the practical circuit.

Controlling the Output

When metal rectifiers are used which have an output suitable for the charging of more than one accumulator at a time, some form of output control has to be provided and the two common forms are tapped secondary winding or a reliable variable resistance. The first method is recommended by us in preference to the latter.

There is an exception to this rule, however, and that is when those types of rectifier are used which require a centre-tapped secondary winding, which is shown in Fig. 1.

Design

For ordinary radio requirements, quite a small charging current will be suitable, as it is usual to bring the charger into operation only a sufficient number of hours each day, or every other day according to individual demands, to replace, as it were, the current consumed by the receiver during its period of operation. This process is known as *trickle charging*, and the required apparatus is less costly than that which would have a greater output and which, consequently, would take a less time to charge a given cell.

A small panel is advisable, to carry the mains on-off switch and the output terminals or sockets and, with the larger chargers, a suitable ammeter to enable a visual indication to be obtained of the output or charging current. The circuit shown in Fig. 2 (upper half) makes use of the Westinghouse metal rectifier type L.T.7, which is ideal for all normal 2-volt cell trickle-charging. The mains transformer secondary is centre-tapped to give 4 plus 4 volts A.C., while the fixed resistance must have a value of 2.5 ohms. The charging rate is 0.5 amps. The arrangement in the lower half of Fig. 2 has a greater output and is suitable for charging from 1 to 3 two-volt cells at a current of 1 ampere. The rectifier is the type L.T.4. The limiting resistance must have a value of 1.75 ohms. With the tapped secondary method of control, the secondary A.C. voltages will be 7.5 volts, 9 volts and 11 volts for one, two or three 2-volt cells, respectively. If, however, a variable resistance is used as the control, the secondary voltage must be 11 volts and the following resistance values provided: 5.25 ohms, 3.25 ohms and 1.75 ohms for one, two or three 2-volt cells as before.

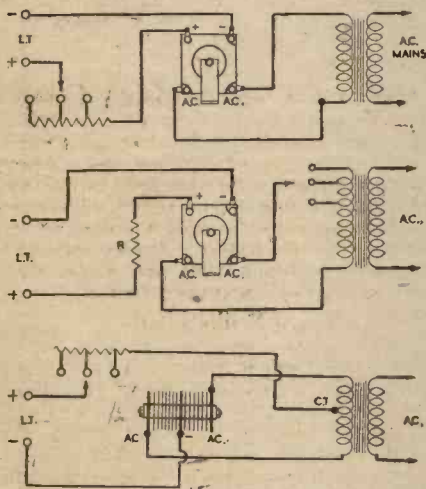

Fig. 1.—The three recommended circuits for use with the Westinghouse metal rectifier for L.T. work.

consideration must now, of course, be given to accumulators which are being so widely used for emergency lighting work, and for portable and stand-by A.R.P. shelter listening points.

It is not always convenient for constructors to make use of some of the well-organised charging services now so well established in most areas, while others who have A.C. mains available naturally feel that they would like their installation to be as independent as possible from outside assistance.

For the benefit of the latter, details are given below of L.T. chargers suitable for most domestic requirements.

Technical Considerations

When dealing with an alternating current supply, it becomes essential to provide some means of converting or rectifying the available current to that suitable for charging purposes, namely, reasonably pure direct current.

For this purpose, various types of rectifiers can be used, but so far as most requirements

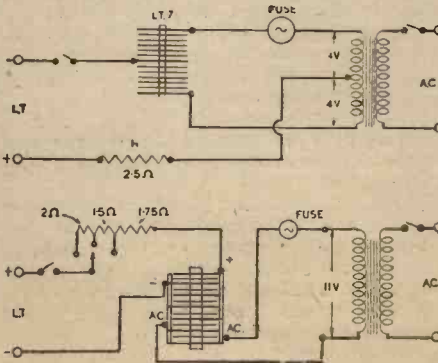

Fig. 2.—The upper circuit is suitable for a trickle charger, while the one below is recommended for greater outputs.

ON YOUR WAVELENGTH



More Prohibition

THE Postmaster-General has announced that he has issued an order prohibiting except under the authority of a post-office permit the acquisition or supply of wireless transmitters and certain other electrical apparatus which may be used as parts of such transmitters; the possession of wireless transmitters, and the use of wireless transmitters. This is to enable the Postmaster-General to exercise in the national interests more effective control than has hitherto been possible over wireless transmissions in and from this country. The acquisition and use of wireless transmitters are not affected where there is a licence still in force under the Wireless Telegraphy Acts authorising the use of it. It will be illegal to possess a wireless transmitter within these limits after December 15th. Applications for permits should be made to the Engineer-in-Chief, Radio Branch, General Post Office, Harrogate, Yorkshire, on forms provided for the purpose. These may be obtained at any head post-office or from the Engineer-in-Chief.

No person may now sell, purchase, let, hire, supply, dispose of, acquire or distribute wireless transmitters whether for telegraphy, telephony, or television, or for use as navigational beacons, or landing beacons, or otherwise for the purpose of indicating position or direction or the remote control of machinery. Nor may they sell, purchase, let, hire, supply, dispose of, acquire or distribute high-frequency inductors, spark coils, quenched and rotary spark gaps, high-frequency equipment, being equipment which generates or uses high-frequency current at frequencies greater than 10,000 cycles per second, and having a maximum output exceeding 10 watts and including equipment intended for use in connection with furnaces and medical apparatus. Thus, the sale of valves capable of an anode dissipation exceeding 10 watts is illegal. Similarly, piezo-electric quartz plates or piezo-electric tourmaline plates, cut to oscillate at any specified frequency, are banned.

The transmitter seems to be in for a bad time!

Overseas Correspondent Wanted

ARTHUR C. H. WALTERS, who is c/o 2DMT and who resides at 18, North Street, Bedminster, Bristol, 3, wants to communicate with one of the fans overseas. He cheerfully says that although an undertaker by trade, his outlook on life is not morbid. He is prepared to swap letters and send magazines weekly as well as an occasional book or novel.

Another Myth

A CORRESPONDENT whose initials and address I refuse to disclose lest some of my fans in the district tear him limb from latchet thinks that the best English is spoken in Dublin and Inverness and in that order! They do not speak correct English in Dublin or Inverness. It is a doggerel patois, and the pronunciations cannot be found in any dictionary whether published in England, Ireland or Scotland.

By Thermion

I have often wondered why it is that a few educated people are not retained in some parts of the British Isles to teach them English pronunciation and grammar.

"Incognito—by Request"

THE pundits of the B.B.C.
Delight in many games.
The latest one they have devised:
To give the announcers' names,
Thinking, no doubt, delightful thrills
Will stir our nerves and bones
Once we're assured the broadcast is
By "P. Algernon Jones."

Too long, they think, 'neath bushel hid
The name of the announcer
Who juggles with the English tongue
When called on to pronounce "her."
Their patronymics all concealed
In modesty, is wrong;
In future they must prefaced be
To story, news and song.

Announcers dear, with all respect,
Your name's not our concern.
We, as the listeners, do not thirst
Your cognomens to learn.
Please tell the pundits, straight from us,
Aid let them learn, dog bite 'em,
The only thing we need from you
Is just—the coming item.

"TORCH."

"The War Weekly"

THE war continues to be baffling. Everyone is saying "There isn't anything happening." This is not true. There is a great deal happening at the Front, on the high seas and in the air. Behind the brief announcements in the Press and a word or so on the radio there are unceasing activities that are slowly shaping the ultimate issue of the war. What these activities are and what is being done by us and the enemy are explained every Friday in *The War Weekly* by a staff of experts.

The War Weekly is no ordinary war paper, but a brilliant pictured story of current events which will build itself up into a permanent record. Diagrammatic pictures, maps and photographs are a big feature of this paper, which gives "what the newspapers don't tell you."

Battisin Belfry

I AM sorry that you will not have the pleasure of learning of the latest creations of Master Battisin Belfry, who

has graced one of our December issues ever since the paper started. The fact is that Arthur Ashdown, who supplied the feature, is in South Africa, searching for gold and diamonds. He posted the manuscript and drawings to us, but Hitler, knowing the epoch-making inventions of Mr. Belfry, and realising that if we published them the war would be over, sent them to the bottom of the ocean in a ship specially chartered to convey the manuscript to us.

Readers on Active Service

I CONTINUE to receive a large number of letters from readers called to the colours but who are helping us to carry on by remaining readers. Where possible I have been able to put them in touch with one another. I hope that every reader called up or otherwise departed from his home will keep me posted of his change of address. It may happen that another reader will be moved to the same district and thus I can put them in touch with one another so that they can meet for pow-wows.

Readers' Change of Address Column

I AM happy to comply with a request I made that I include a regular column of readers' changes of address. Where these addresses relate to the Army, I am, of course, unable to publish them, but I can include the reader's name and district and offer to forward letters. Readers who wish to keep in touch with one another are offered the facilities of this column.

"Wandering Willie's Tale"

ONE of the finest short stories in literature, which could also be classed among the best ten yarns of the supernatural, is "Wandering Willie's Tale," which is none the worse for having been written by the roguish Sir Walter Scott. It has been adapted into dramatic form by the B.B.C. Talks Department, and it will be produced by John Gough on December 8th. The eerie adventures which Wandering Willie, the blind fiddler, happened upon at the Castle o' Redgauntlet make a gripping tale in dramatic form. Scott's own dialogue has been used mainly throughout, and wherever new dialogue has had to be written, the narrative has been closely followed by the adapter, who has made a study of the dialogue of the time. Because in the original the story is told by Wandering Willie himself, this does away with the need for an anonymous narrator, as the linking passages between the various scenes can be told by the central character.

PRACTICAL MECHANICS HANDBOOK

By F. J. CAMM.

400 pages, 6/- or 6/6 by post from

GEORGE NEWNES, LTD.,
Tower House, Southampton Street,
Strand, W.C.2.

PRACTICAL TELEVISION

December 9th, 1939.

Vol. 4.

No. 180.

A Virile Outlook

WITH television transmissions in this country a thing of the past, and apparently a hope for the very distant future, according to the dictates of war, the British public, quite naturally, are apt to overlook what is happening in those neutral countries who are free to apply their scientific knowledge in peaceful channels. The continent of America, however, has been quick to realise the advantage of the situation in which they have been placed, and seem determined to overhaul the lead which this country had established in television. They have made it clear that while the dissemination of pictorial information and a variety of entertainment are the prime factors associated with their steadily growing home service, the future of television is bound up in many directions which even the most courageous scientist would hesitate to prognosticate. Recent events have proved conclusively to the Americans that they must not think of television only in terms of home entertainment. Television in cinemas was becoming an established fact in Britain, and installations in these places of popular entertainment was proceeding at a pace dependent only on the speed with which the television projection receivers could be built. Demonstrations of these large screen pictures in New York have convinced those who saw them that they are entirely free from flicker, and have a degree of definition governed only by the quality of the transmission itself. In other words, the electrical and optical characteristics of the electronic apparatus employed was fully capable of dealing adequately with any transmission which this equipment was called upon to handle. As a result of this aspect of television's development, events of national importance, whether they have a bearing on the political, commercial, or sporting life of the community, can be participated in at the instant they happen, although separated by miles from the place at which they occur. Mass entertainment in this form, as distinct from the fireside atmosphere provided by sets in the home, will always be part of the make-up of the average person's life, and by lifting big-screen television from the realm of conjecture to practical realisation television has destroyed the limitations of human vision, and by harnessing sound and vision together opened up a panorama of events which can be seen without any time delay which characterises a recorded version. In the United States, the whole industry realises that it is, at the moment, only on the threshold of a virgin field and looks forward to improvements in education as a result of big screen installations in schools, so that the specialist can address a class of students numbered in thousands, instead of being confined to the four walls of the classroom. It is felt that television will find divers applications in commercial communication, the telephone, navigation on land, sea and air, so as to still further

reduce the risk of travel which at present is hidebound by nature's idiosyncrasies from the point of view of weather. These items alone are sufficient to convince the fertile brains of that country that television will provide material for an all-embracing industry. It will not be a case of subordinating old industries to the requirements of the new, but of necessity there must be a reassessment of values, and the establishment of a spirit of co-operation so that all may benefit. This is not a case of a scientific miracle occurring overnight, but rather the gradual culmination of a series



An actual example of low-power micro-wave equipment with tripod mounting so that the aerial can be beamed in any direction.

of discoveries in the field of electronic engineering, all of which have played their part in assisting in the progress of what is technically termed "the art of instantaneously producing at a distance a visible image of an actual, or recorded scene, by means of an electrical system of communication."

Visual D.F. Working

THE versatility of the cathode-ray tube is exemplified once more by its application to many forms of direction-finding schemes where it is desired to secure the correct bearing of a signal. Many difficulties have to be contended with, however, and any out-of-balance must be counteracted. One very promising method uses

the usual pair of crossed frame aerials set at 90 degrees to each other, and feeds the signals through to the two pairs of plates of an electrostatically operated cathode-ray tube. In the path from aerial to C.R. tube, however, is interposed two amplifiers and two pairs of reversing switches. These last named are for the purpose of compensating for any out-of-balance in the actual operating characteristics of the amplifiers. Normally a single narrow ellipse would give the required bearing on the calibrated fluorescent screen, but by synchronously operating the reversing switches so that the frame aerial signals pass through each amplifier in turn, any difference in the working characteristics is portrayed by the existence of two narrow ellipses. By taking the mean angle between these two patterns the exact bearing is logged.

Compact Relay Transmitters

FOR both commercial and military purposes, efforts are being directed in many quarters to the perfection of equipment which will serve as efficient relay transmitters when working on very low wavelengths of the order of one to three metres. This in many cases is being supplemented by the development of micro-wave apparatus using carrier frequencies well above 300 megacycles. These transmitters have to be very compact, readily transportable, and possess a low power consumption when employed for field purposes, in order to maintain satisfactory lines of communication between units which may be separated by distances up to 20 miles. A very important point in connection with this apparatus is that it adds materially to the secrecy of the information radiated, since the propagated beams are directional, and distinct from the more common forms of broadcast signals. The actual designs vary in certain respects according to the particular purpose for which the relay of signals is required, but as a basis it is generally found that the main unit comprises a high stability master oscillator working at a frequency dependent on the prime carrier frequency. For example, in the case of a 120-megacycle relay transmitter the oscillator would probably work at 20 megacycles and be followed by a combined separator and low-stage gain amplifier. The third harmonic of the oscillator would be extracted and, after the separator, is doubled to the final working frequency of 120 megacycles before being handled by the output stage. Depending on the form of intelligence it is required to relay from point to point, so the degree of modulation response would be adjusted. The aerial used with this form of equipment often comprises a broad-side array with reflectors, and by careful design a sharp beam is secured which can give a power gain up to a figure of 25. As an actual example of the simple nature of the micro-wave relay apparatus of low power, reference can be made to the accompanying illustration. The special form of vertical antennae is mounted on an extension rod carried on the top of a rigid tripod. Part of the valve equipment is also accommodated on the remote end of the aerial support, with batteries under the tripod.

PATENTS AND TRADE MARKS

Any of our readers requiring information and advice respecting Patents, Trade Marks or Designs, should apply to Messrs. Rayner and Co., Patent Agents, of Bank Chambers, 29, Southampton Buildings, London, W.C.2, who will give free advice to readers mentioning this paper.

Choosing a Loudspeaker

When to Use Permanent Magnet or Mains Energised Speaker Unit, and How to Get the Best from Them.

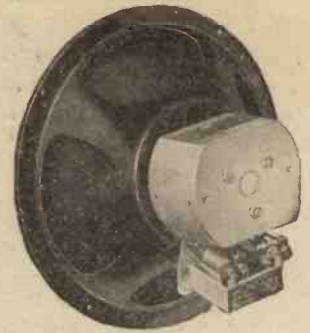

A Rola permanent magnet speaker.

THERE are two principal types of moving-coil loudspeaker, known as permanent magnet (P.M.), and energised. Actually, as most readers now know, both depend upon the use of a magnet, for it is within the field of this that the moving coil—attached to the cone—moves. The audio-current output from the receiver is fed into the speech coil, as it is called, and produces a fluctuating magnetic field round the coil. As the coil is close to a powerful magnet system, the fluctuating magnetic field acts on the fixed field, this causing the speech coil, and hence the cone, to vibrate.

That is a very sketchy outline indeed,

the magnet that is important but the effect of the magnet on the speech coil. And the effect is proportional to the magnet strength and also to the distance between the magnet and the coil; the closer the two can be placed, the greater is the effect of the magnet on the coil.

Kinds of Magnet

A permanent magnet is a magnetised piece of alloy-steel, whereas an electro-magnet consists of a piece of soft iron, or special iron alloy, which does not itself "hold" or retain any magnetic properties, but which can be magnetised temporarily

address and auditorium types of P.M. speaker.

It would not be true to say that the P.M. speaker is more efficient than an energised model of equally sound design, but it can be stated without fear of contradiction that the P.M. type can to-day be as good as the energised pattern. Consequently, the reader might ask why energised speakers are still employed in large numbers by both constructors and receiver manufacturers, and this brings us to the choice of the more suitable type for various purpose.

Energising Current

A source of electrical energy is, of course, required to operate an electro-magnet speaker, and that would appear to be a disadvantage. It is, when dealing with a battery set or even with a mains set fed by a power supply unit capable of giving just the correct voltages and currents for H.T. and L.T. But in many instances, the power unit can provide rather more power than is actually needed by the receiver. In that case, the surplus can well be employed to energise the speaker. Moreover, it can be used very economically, because the magnet winding—referred to as the field coil—can be used as a very effective H.T. smoothing choke. Thus, the normal smoothing choke is not required. That means a saving in the cost of components; additionally, an energised speaker can generally be made rather more cheaply than a P.M. speaker of similar power-handling capacity.

But there are several points which have to be considered before a final choice can be made. The first is concerning the

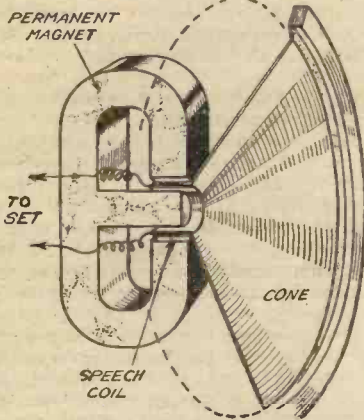

Fig. 1.—Main details of a permanent magnet speaker.

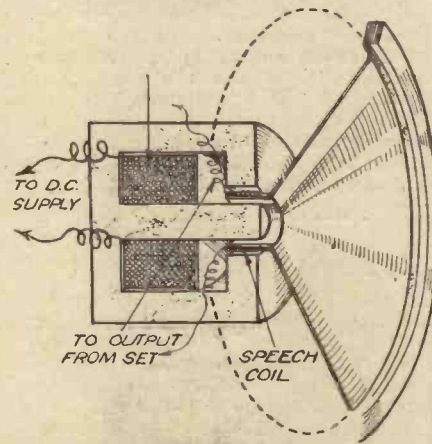

Fig. 2.—Sectional diagram showing the construction of an energised speaker. Compare with Fig. 1.

but it should suffice to clarify the statements that will be made later. It should not be hard to appreciate that the effect on the speaker cone must be more pronounced if the audio currents passed through the speech coil are increased in intensity. That simply means that a greater receiver output provides increased signal strength—there is nothing obscure about that. A point that might not be quite as obvious is that the intensity of the steady magnetic field acting on the speech coil also has a considerable effect on the loudness of reproduction. This means that a greater output can be obtained from a given input to the speaker if the strength of the magnet is increased. Actually, it is not just the strength of

by passing an electric current through a length of wire coiled round it. See Figs. 1 and 2.

In practice, a fair amount of electrical energy is required to energise or magnetise an electro-magnet of the type used for a loudspeaker. An average minimum figure for a smallish speaker is 5 watts, but 7 to 10 watts is desirable. When the moving-coil speaker was first developed, it was generally accepted that an energised or electro-magnet speaker was more sensitive than one of the permanent magnet type, because the field strength could be made so much greater. This idea is still held by some, but it is rapidly becoming less and less true. The reason is that a considerable amount of research work has

been carried out in connection with the production of highly efficient permanent magnets, with the result that it has been possible to make them in such a manner that a tremendously strong field strength can be obtained. Incidentally, the makers of the W.B. "Stentorian" speakers have been pioneers in this field, and are now making even public

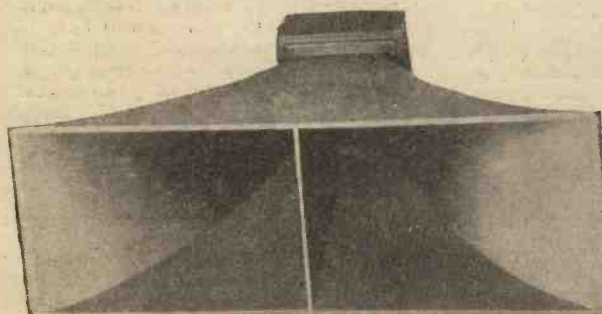

A Horn loudspeaker intended for Public Address work.

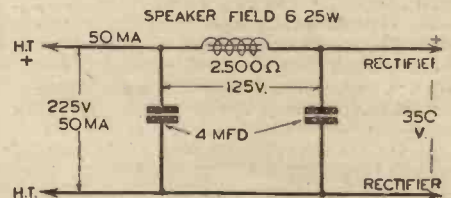

Fig. 3.—How a speaker field winding can be energised in an A.C. receiver.

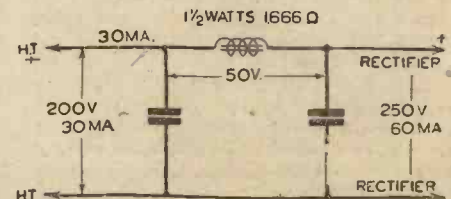

Fig. 4.—In this example the energising wattage available would be inadequate, and a P.M. speaker should be used.

CHOOSING A LOUDSPEAKER

(Continued from previous page)

amount of energising power that can be spared. As mentioned above, a small moving-coil speaker needs at least 5 watts for energising; a larger speaker to handle an audio output of, say, 6 watts needs something like 10 watts minimum; whilst a public address speaker to deal with an audio output of 20 watts needs not less than 15 watts, and should have about 30 watts for maximum efficiency.

Some Practical Examples

Fig. 3 shows a skeleton circuit, where a 2,500 ohm energised speaker field is used for smoothing the H.T. supply in an A.C. receiver. It is assumed that the output

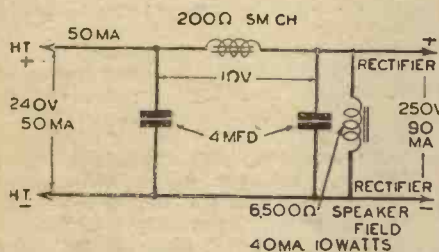

Fig. 5.—A 6,500-ohm speaker-field connected in parallel with the H.T. supply in an A.C. or D.C. receiver.

from the rectifier is 350 volts at not less than 50 mA, and that a voltage of about 225 is required for H.T. purposes. In this case, 50 mA is passed through the field winding, which then produces a voltage drop of 125 volts (Ohm's Law—voltage drop equals current times resistance). The wattage dissipation of the field is therefore 125 multiplied by 50/1,000 (voltage times current in amp.), which is 6.25 watts. That would just be sufficient for a small speaker, and efficiency would be about as high as when using a P.M. model.

But now look at Fig. 4. The circuit arrangement is the same but the output from the rectifier is 250 volts, 60 mA, whereas the receiver valves require not less than 200 volts, 30 mA for efficient working. By using Ohm's Law again, we find that the field should have a resistance of 1,666 ohms to give the necessary voltage drop of 50, when passing a current of 50 mA. In these conditions the dissipation of the field winding would be about 1½ watts. In the first place, the required field resistance is non-standard, so it would be necessary to use a speaker with either a 1,500 ohm or a 2,000 ohm field; in the second place, however, the energising wattage would be entirely inadequate. In conse-

quence, a permanent magnet speaker would be a practical essential in these conditions. Smoothing would then be performed by either a 1,500 ohm smoothing choke, or by means of another standard 30 henry choke of lower resistance in series with a fixed resistor to bring the resistance up to the required value.

Parallel Field Connections

Now let us look at Fig. 5. In this case, the voltage output from the rectifier is only slightly too high for the set, but the current is much greater than is necessary. We could very well make use of a 6,500 ohm energised speaker (the resistance generally used for direct connection to D.C. mains). By connecting this field winding across the H.T. output from the rectifier, we can "absorb" a current of nearly 40 mA, so that the required 50 mA is still left for feeding the valves. Although the field winding in this instance does provide a certain smoothing effect it is not sufficient for this purpose. A normal 200 ohm choke is therefore connected in series with the positive supply lead.

This method of connecting a speaker field is not usual, but it is very convenient in an example such as that considered. Additionally, it has the advantage of acting as a "load" on the rectifier when the set is first switched on; this is most valuable when the valves of the indirectly heated type and the rectifier is a directly heated one, or a metal-oxide pattern.

It is often recommended, when using



A Goodman loudspeaker, which is particularly suitable for outdoor P.A. work.

this form of connection, or when feeding the field directly from a D.C. mains supply, that a neon lamp be connected in parallel with the field to prevent back E.M.F. due to the inductance of the winding. From the various figures on the diagram, it will be seen that the speaker field receives 10 watts energising power, which is adequate for speakers of medium size.

"Free" Bias

Another method of using a speaker field

for energising is shown in Fig. 6, where the winding is in series with the negative H.T. lead. The H.T. voltage required is nearly 400 at 100 mA, and the rectifier provides 500 volts at 100 mA. We could thus use a standard 1,250 ohm field coil, which would produce a voltage drop of slightly more than 120 volts when passing 100 mA (1/10 amp.). The voltage drop can, however, be used for biasing the output valve, by connecting the grid-return lead to the negative side of the winding, as shown. In the example taken the G.B. voltage—120—would be too high, but in many cases it would be possible to choose a field winding more appropriate to the G.B. needed.

Even in our example, however, the correct value of bias could be obtained by connecting a 50,000 ohm potentiometer across the field winding, and taking the grid-return lead to the slider of this; the connections are shown in broken lines. It will be seen that an 8 mfd. electrolytic bypass condenser is used in conjunction with the bias-voltage supply system.

In the Heater Circuit

We will take just one more example of the use of an energised speaker. This is with a D.C. receiver having indirectly heated 16-volt valves, as indicated in Fig. 7. In this instance the field winding is used to drop the voltage applied to the heaters from the D.C. mains supply. As 170 volts has to be dropped, the current being .25 amp., a resistance of approximately 700 ohms is required. This is a standard field coil resistance in some makes of energised speaker, so it could be used very conveniently. If an increased voltage drop were needed, a small fixed or tapped resistance could be connected in series with the field winding. There is no great advantage in this method of using an energised speaker, but it is mentioned as a matter of interest.

From the points that have been raised it will be appreciated that both types of speaker have certain advantages. Both have their adherents, and both have been brought to a high degree of efficiency. At the same time, it is quite evident that more care is needed in designing a set for use with an energised speaker. For this reason the P.M. pattern is specified for the majority of PRACTICAL WIRELESS receivers, and it is most favoured by the home constructor. Additionally, of course, it is more adaptable for use with a variety of different receivers.

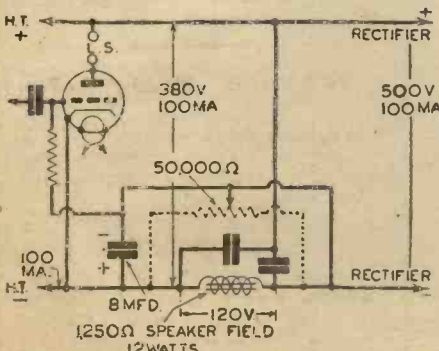

Fig. 6.—Diagram showing how "free" bias is obtained by inserting the field winding in the negative H.T. line.

PRACTICAL WIRELESS SERVICE MANUAL

Edited by F. J. CAMM.

From all Booksellers 5/- net, or by post 5/6 direct from the publishers, George Newnes, Ltd. (Book Dept.), Tower House, Southampton Street, Strand, London, W.C.2.

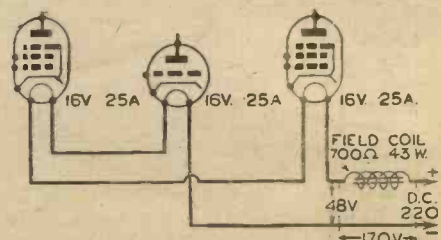

Fig. 7.—For D.C. sets only. Speaker field in the heater circuit. Few speakers could take the 38 watts indicated without overheating, but the circuit could be modified to overcome this difficulty by using a field of lower resistance in series with a resistor.

Practical Hints

An Aerial for an Air-raid Shelter

ON constructing one of your A.R.P. sets for use in my Anderson type shelter, I was puzzled as to what type of aerial to use. I finally decided to use a short, vertical type aerial, which, besides being easily made, does not hinder any placing of earth on top of the shelter.

I took the barrel of a cycle pump and placed it as shown in the sketch. I then

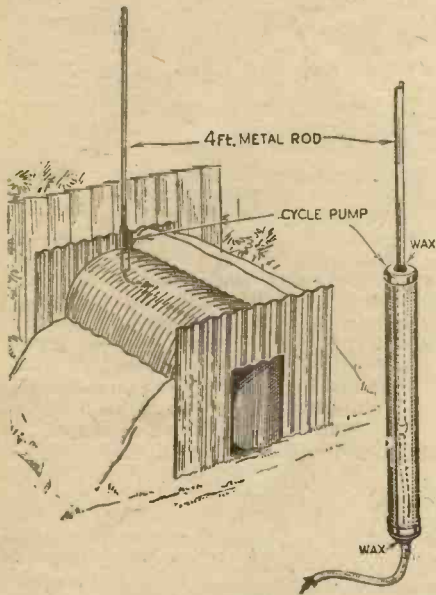

A novel aerial arrangement for an air-raid shelter.

placed a 4ft. length of $\frac{1}{4}$ in. iron rod inside the pump barrel and held it in position with wet sand. The iron rod was a portion of a child's disused cot. The lead-in was led through the small hole in the pump-barrel, and both ends were sealed with sealing-wax. There is no loss to earth, as the pump barrel is celluloid covered.—KENNETH BROWN (Gorton, Manchester).

A Motor-driven Coil-winder.

DESIRING an adaptable motor drive for coil winding and light buffing, I decided to commission the electric motor fitted to the household sewing machine. The motor is so fitted to the sewing-machine that it is a simple matter to remove it without in any way upsetting the mechanism.

It occurred to me that if I constructed some form of temporary chassis mount in which could be incorporated permanently a suitable belt drive, it would be a matter of a few moments to transfer the motor from chassis to sewing-machine or vice versa, as desired.

The accompanying illustration shows the procedure I adopted, using a strong oak mounting chassis.

One interesting feature of this arrangement arose in the methods by which I should mount the motor, since it will be seen that due to the channelled mounting

THAT DODGE OF YOURS!

Every Reader of "PRACTICAL WIRELESS" must have originated some little dodge which would interest other readers. Why not pass it on to us? We pay £1-10-0 for the best hint submitted, and for every other item published on this page we will pay half-a-guinea. Turn that idea of yours to account by sending it in to us addressed to the Editor, "PRACTICAL WIRELESS," George Newnes, Ltd., Tower House, Southampton Street, Strand, W.C.2. Put your name and address on every item. Please note that every notion sent in must be original. Mark envelopes "Practical Hints." DO NOT enclose Queries with your hints.

SPECIAL NOTICE

All hints must be accompanied by the coupon cut from page 272.

arm method of fitment, brought about by the design of the sewing-machine, a similar principle had to be adopted, this proving in the long run to be both rigid and conveniently simple in use.

To take a certain amount of strain off the mounting strips S, I fitted a wood block so that the arm could rest in a groove, as depicted.

The driving band is kept in tension by an idler which forms part of the motor-assembly, and this band drives a home-made pulley, details of which are given in the inset. The only slight modification necessary as far as the motor is concerned, is the fitment of a suitable mains plug which would fit both the chassis and sewing-machine sockets, the sockets on the chassis being series connected to a toggle switch of Bulgin pattern, with the mains supply lead connecting through a noise suppressor unit also of Bulgin pattern; this latter fitment is not shown in the illustration, but as with

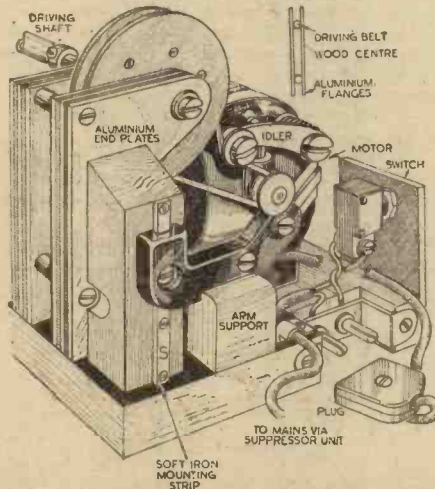

A coil-winding machine utilising an electric motor as fitted to a domestic sewing machine.

the assembly details, there should be little difficulty in following the scheme.—E. C. SOAMES (Chelmsford).

Loudspeaker Switchboard

AS I wished to have two or three distant listening points, and also to have facilities for trying out and comparing different speakers, I fitted up a small switchboard on the lines indicated in the accompanying illustration. It will be seen that this is fed from the L.S. or extension speaker terminals on a receiver and then five separate speakers may be switched for

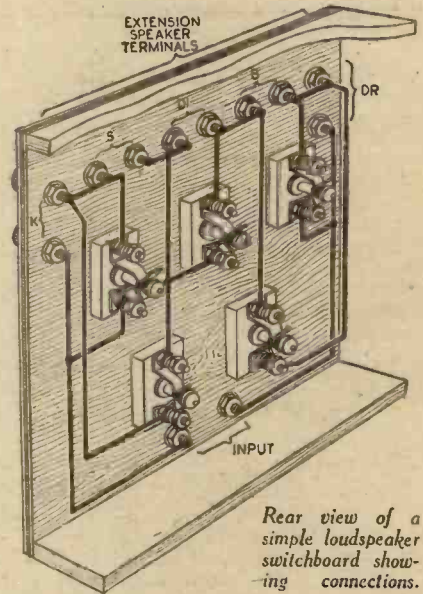

use individually or collectively. By operating the switches when two or more speakers are joined rapid comparisons are possible for test purposes, or if the speakers are fed from a distant point individual rooms may be switched in and out as required.—W. CLOUTING (Bayton, nr. Woodbridge).

Join Newnes' Practical Group!

PRACTICAL MOTORIST

The owner-driver's journal which tells you how to repair, overhaul and obtain the best performance from your car.

3d.—Every Friday.

PRACTICAL MECHANICS

The only English journal of its type. It deals with every branch of Science, Mechanics, Invention, Model-making, Chemistry, Astronomy, Photography.

6d.—Every month.

THE CYCLIST

The leading weekly for every Cyclist, Clubman, Utility Cyclist or Tourist. Join "The Cyclist" Road Club and also take advantage of the FREE Insurance.

3d.—Every Wednesday.

An Experimental Heterodyne Filter

Constructional Details of a Useful Unit for the Short-wave Enthusiast

SHORT-WAVE communication receivers using a crystal filter have an exceedingly high degree of selectivity; nevertheless, when two stations are heterodyning each other with an audible beat note, reception of either becomes impossible from a readability point of view. For this reason a heterodyne filter has recently been introduced in America (now being manufactured commercially) that will reject a single audio-frequency only. Having carried out some experiments with this type of filter, plus some additional modifications, it is thought that this piece of apparatus should be of considerable use to short-wave listeners generally.

The many uses to which such a filter can be put will immediately be apparent. Apart from removing the heterodyne note from

in the top part of the audio scale. The two variable resistances will, of course, be potentiometers, using the slider and one side only.

One method of connecting the filter to the output of a small receiver is shown in Fig. 3. A 1:1 transformer may be used in the anode circuit of the valve which feeds the input of the filter, the output being taken to a pair of headphones. This arrangement can be applied to a standard short-wave receiver or to a two-valve super-regenerative ultra-short-wave set. In the latter case R2 and R3 may be permanently set for eliminating the quench note. The few components needed may be mounted direct on to the front panel of the receiver or, alternatively, on a small sub-panel, as

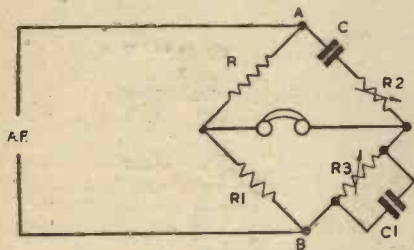

Fig. 1.—Original bridge circuit.

interfering stations, it can also be applied to a super-regenerative receiver to cancel the quench note, and will also attenuate the loud hiss in the supersonic band of frequencies. For short-wave listening generally, an interfering modulated C.W. station in the broadcast short-wave bands can be completely eliminated.

To those who are not already acquainted with this type of filter, a few words of explanation are necessary. First it must be pointed out that it does reject a single audio-frequency completely, and not merely attenuate a band of frequencies as with a normal high or low pass filter.

The circuit is derived from the type of bridge circuit used for audio-frequency measurement. This is shown in Fig. 1. An unknown audio frequency is applied to arms A and B, R2 and R3 are then adjusted until the note in the headphones is cancelled out; when a balance is established. The unknown frequency is then found from the formula $f = \frac{1}{2\pi R_2 C}$ provided that R divided by R1 equals 2, and that R2 and R3, and C and C1 are equal.

Working Filter Circuit

Turning to the working filter circuit of Fig. 2, it will be seen from the circuit values that the above conditions have been complied with. The frequency range over which the filter will work is mainly governed by the value of C and C1. The value shown covers the most useful band

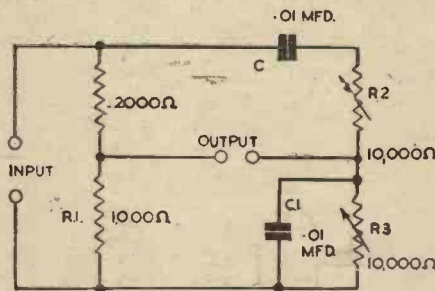

Fig. 2.—Circuit values for the heterodyne filter.

shown in the practical wiring diagram, Fig. 4.

Accurate Components Necessary

It is necessary to mention that the components used should be of a reliable make, so that the circuit values will be accurately matched. Manufacturers tolerances are perfectly acceptable, however, and will not mar the working of the filter circuit. Where the circuit is used for measurement work, extreme precision is required for both the component values, and for establishing balance. Since only the effect of the bridge is made use of some latitude is allowable. However, the more accurate the components used the less will be the drop in gain which must inevitably accompany such a device. There-

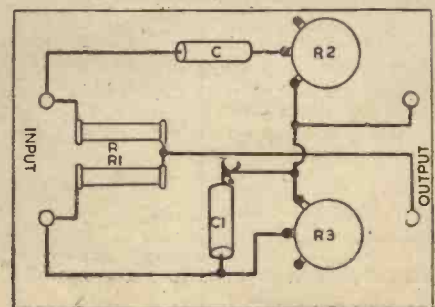

Fig. 4.—Wiring diagram for the few components needed for the heterodyne filter. The components are mounted on a small sub-panel.

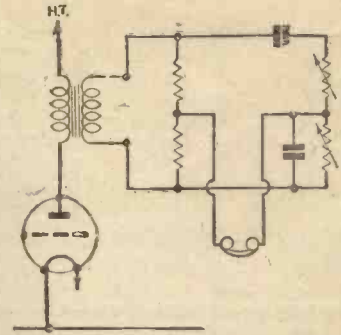

Fig. 3.—One way in which the filter may be connected to the output of a small receiver.

fore, it is advantageous to make use of a little more amplification when the filter is used.

It will be seen that both input and output of the circuit can be connected across transformers, and by using two transformers in this way the filter may be connected between two L.F. amplifying valves of a multi-stage receiver. This method may be regarded as a trifle clumsy, and will not be looked upon with favour by those who dislike audio transformers from the quality point of view.

Accordingly, a circuit was tested out using R and R1 directly in the anode of a valve, as in Fig. 5. It will be seen that a 1 microfarad condenser is inserted between R1 and the junction of R3 and C1. This condenser did not affect the working of the bridge in any way apart from requiring small readjustment from R2 and R3. Also R and R1 have values of 100,000 and 50,000 ohms respectively. This circuit arrangement should be used in the early stages of a multi-valve receiver.

Operating Notes

Regarding the operation of the filter it might be noted that R2 and R3 will be quite sharp in tuning out the unwanted heterodyne note. When a signal is tuned in on the receiver accompanied by a heterodyne, first R2 and then R3 should be rotated until (as will happen in each case) the heterodyne diminishes in strength. Finally both potentiometers must be adjusted until the heterodyne completely disappears. With the elimination of one audible frequency, some distortion must of course take place, though this is not so important on the short waves, and also distortion will be at a minimum where the filter is tuned to the top part of the scale, hence the values shown. Where it is desired to remove frequencies in the lower part of the range, larger condensers must be used at C and C1.

R2 and R3 may also be increased up to a value of 50,000 ohms, in which case a wider band of frequencies is covered.

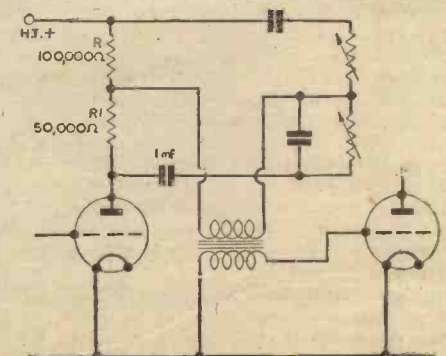

Fig. 5.—The filter used for intervalve coupling.

Auto Grid-bias Circuits

This Article Explains Why Certain Modifications are Introduced Into Simple Auto-bias Circuits in Order to Ensure Better Working, with Special Reference to Mains Apparatus

WHEN an electric current passes through a resistance, a difference of potential, or voltage drop, is produced across the ends of this resistance, and this offers a simple way of providing negative grid bias to receiving valves without using a separate grid battery. The principle will be understood readily by

several different ways in which the bias circuit can be arranged. The reasons are that the diagram shown in Fig. 1, is only fundamental, and needs a certain amount of modification to meet practical conditions, and that different types of valves need somewhat different types of circuit, although all are basically identical.

stands, the bias resistance offers the same amount of resistance to all these components, and the voltage drop across it, which is applied to the grid via the L.F. transformer secondary, will contain an audio-frequency and possibly a hum-frequency modulation, which, acting as spurious signals at the grid, will be re-amplified by the valve and result in low-frequency oscillation, since the action will be cumulative.

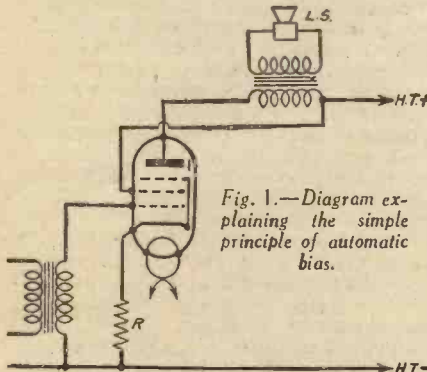

Fig. 1.—Diagram explaining the simple principle of automatic bias.

reference to Fig. 1, which shows the essentials of the grid and anode circuits of a typical output valve, such as an indirectly-heated pentode. Certain components necessary for a practical auto-bias circuit have been purposely omitted for the sake of simplicity, but these are given later in the article.

Brief Explanation

Examining this diagram, it will be observed that the main circuit through which the anode current flows commences at the H.T. plus terminal, through the primary of the speaker transformer to the anode of the valve, through the valve to the cathode, and from the cathode back to the H.T. minus terminal via the resistance "R," usually called the bias resistance. The grid of the valve is connected to the H.T. minus line through the transformer secondary (in the case of a resistance-capacity coupled valve the grid would be connected to H.T. minus via the grid leak, so in both cases the grid is at the same potential as H.T. minus).

Assuming that the anode current of the output valve is 30 milliamps, and that the bias resistance "R" is of 500 ohms, a simple application of Ohm's Law shows that the voltage drop across "R" is $I \times R$ or $.03 \times 500$ or 15 volts. This means that the potential of the cathode of the valve is 15 volts positive with respect to the H.T. minus line, which is exactly the same as saying that the H.T. minus line is 15 volts negative with respect to the cathode. And since the grid is at the same potential as the H.T. minus line, it can be said that the grid is 15 volts negative with respect to the cathode, that is, it receives 15 volts negative bias.

If the theoretical circuits of a number of receivers are examined, it will be noticed that the actual connections employed are far more complex than the simple circuit shown in Fig. 1, while there appear to be

One Case

In describing these different circuits, we will deal first with indirectly-heated mains valves, since these are the most commonly used to-day. Fig. 2 shows the basic circuit of a typical receiver in which auto-bias is applied to four indirectly-heated valves—the screen-grid (or screened pentode) H.F. amplifier, detector, a low-frequency amplifying stage, and an output pentode. The complete circuit through the valve, i.e., the anode current circuit, is drawn in thick line, and the auxiliary components associated with the auto-bias arrangements are drawn in thinner lines. It will be noticed that the essential arrangement, i.e., the inclusion of a bias resistance between the cathode and H.T. minus line is common to each valve. The questions which naturally arise are: why will not the simple arrangement shown in Fig. 1

Suppose, however, that in parallel with the bias resistance is placed some component such as a large condenser which has a very low impedance to alternating currents of audio frequency. It will be found that the steady direct current component of the anode current will be confined to the bias resistance, while practically all the A.C. component will be by-passed through the condenser. Moreover, if the condenser is so large that its impedance at audio frequencies is negligible, the A.C. voltage drop across it will also be very small so that the spurious signals

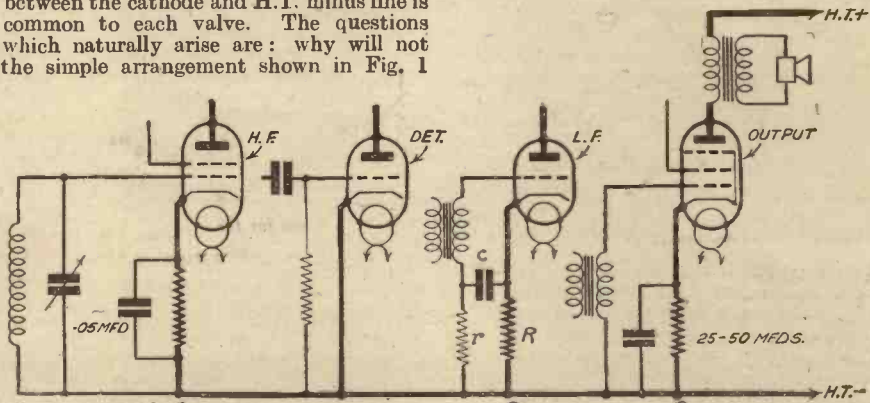

Fig. 2.—Skeleton circuit diagram showing various ways of biasing indirectly-heated valves.

serve in practice? and, if any modification is necessary, should there be any difference in the circuits adopted for the different valves?

The answer to the first question is that all these additional refinements are required in order to prevent the bias arrangement from transferring from the anode circuit to the grid circuit any alternating fluctuations such as audio-frequency or high-frequency signals, hum voltages, and so on, which would undoubtedly result in re-amplified hum and either low-frequency or high-frequency oscillation. In other words, these additions are a form of decoupling to obviate back-coupling.

Feed-back

Consider first the current flowing in the bias resistance in Fig. 1. This will consist of a direct current equal to the mean anode current of the valve and bearing an audio-frequency modulation. Possibly there may be also a certain amount of hum ripple in the anode current—the "residual hum" of the receiver. Now, as the circuit

applied to the grid will also be negligible.

The reasons for adopting different methods of bias decoupling in different valves will be apparent from a study of the conditions under which different types of valves work. Considering first the high-frequency valve, it will be clear that the

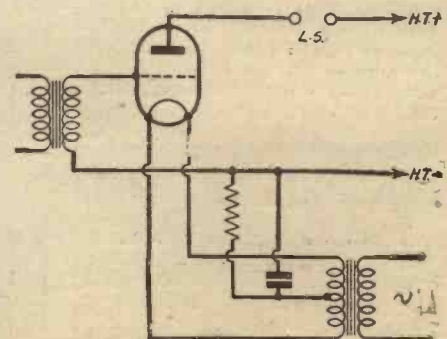

Fig. 3.—Diagram showing the bias scheme for a directly-heated valve.

AUTO GRID-BIAS CIRCUITS

(Continued from previous page)

anode current fluctuations are of radio frequency, in the main and, in fact, entirely if care has been taken in the lay-out to avoid direct pick-up of hum and if the ordinary decoupling circuits are efficient. It will therefore be sufficient to by-pass the bias resistance with a comparatively small condenser which will have a sufficiently low impedance at radio frequencies. A very usual value for this condenser is 0.05 mfd., but a slightly smaller or slightly larger size would make very little difference. It is important that a condenser used in this position is of a type described by the makers as "non-inductive" because, as will readily be seen, any component possessing inductance offers a comparatively large impedance to alternating currents, and thus partially neutralises the low reactive impedance of the condenser.

On the L.F. Side

For low-frequency valves, where alternating components of audio frequency have to be dealt with, the size of the condenser in the grid decoupling circuit must be much greater. When auto-bias was first introduced condensers of 2 and 4 mfd. capacity were about the largest generally available, and a condenser of 2 mfd. has a reactive impedance at 50 cycles of over 1,600 ohms, so that its by-passing effect, when used in parallel with a bias resistance in the region of 1,000 ohms is quite small. Moreover, the effect of such a condenser in this position would be to produce more or less serious attenuation of the bass output of the set. As a result, it became the standard practice to use a modification of the decoupling system as shown at "B" in Fig. 2. Here a decoupling resistance of high value, say, 50,000 ohms or more, is interposed between the secondary of the L.F. transformer and the H.T. minus

line, and the 2 mfd. condenser is connected not directly in parallel with the bias resistance but between the top end of the bias resistance and the lower end of the L.F. transformer secondary.

A moment's study of this arrangement will show that in effect the shunt circuit in parallel with the bias resistance consists of the condenser and decoupling resistance in series. Owing to the high impedance of this combination, only a small proportion of the total A.C. component of anode current will flow in the arm "rc," thus avoiding serious bass attenuation, while with respect to the grid circuit, r and c act exactly in the same way as the decoupling resistance and condenser so commonly

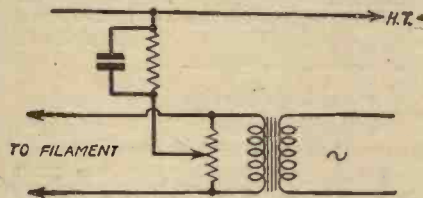

Fig. 4.—An alternative to the centre-tapped filament transformer is a potentiometer.

included in the anode circuits of valves, or the smoothing choke and condenser in an H.T. unit, namely, that the condenser offers a much smaller impedance to the A.C. component than the resistance so that the A.C. voltage drop occurs mainly across the resistance, giving an almost perfectly smoothed voltage at the grid of the valve.

To-day, the decoupling system just described is seldom necessary because manufacturers have now produced low-voltage electrolytic condensers of very high capacity and therefore of correspondingly low reactive impedance, and these may be connected simply in shunt to the bias resistance as indicated in the case of the

output valve in Fig. 2. Capacities of 12, 25, and even 50 or 60 mfd. are available, and these do away entirely with the need for complicated decoupling devices.

We now come to the case of directly heated output valves, which are still used to some extent in broadcast receivers and are, indeed, essential where really big outputs are required. In such valves the filament itself is the cathode, and is, moreover, fed with raw A.C. It is therefore not possible to take the bias resistance from one side of the filament to H.T. minus, as by so doing a considerable amount of A.C. hum would be introduced. What is done, therefore, is to connect the bias resistance between the mid-point or centre-tap of the filament transformer and the H.T. minus line as shown in Fig. 3, by-passing it in the usual way by a condenser of large capacity. If the transformer has been centre-tapped accurately no hum will be introduced, but it is a difficult matter to tap out at the exact electrical centre of a winding. If the accuracy of the centre tap is in doubt when hum is experienced, the usual plan is to connect a potentiometer of fairly low resistance across the filament winding and, disregarding the centre tap, connect the bias resistance to the slider of the potentiometer, which should then be adjusted so that hum is reduced to a minimum (Fig. 4).

It should be noted that this arrangement not only renders the filament of the output valve at a potential above H.T. minus equal to the bias of the output valve, but makes the heaters of any other valves fed from the same L.T. winding also positive with respect to H.T. minus by the same amount. Normally, this should make no difference to the working of the set, but in the case of a large output triode, where the bias voltage may be anything between 30 and 100 it will be safer to use an independent L.T. winding for the output valve and another for the indirectly-heated valves.

LIGHT MUSIC BROADCASTS

VARIOUS criticisms have appeared concerning the alleged disappearance of light orchestral music from the B.B.C. programmes. Actually listeners are hearing a high percentage of the light orchestras which were popular before the war. Under the Defence Regulations, however, the activities of the B.B.C. are curbed in certain directions, but this does not apply to the engagement of light orchestras.

Already the studio programmes have included Mantovani and his Tipica Orchestra; Fred Hartley and the Novelty Sextet, with Brian Lawrence; and among those booked for early inclusion are Troise and his Mandoliers, with Percy Manchester; the Richard Crean Orchestra; Falkman and his Apache Band, with Amelia Magri; Wynford Reynolds and his Orchestra; A. J. Powell and his Banjo Octet; Harry Davidson and his Orchestra; the Palladium Orchestra; Campoli and his Salon Orchestra; and the Alphas.

Recent outside broadcasts have brought listeners performances by the Hotel Victoria Orchestra and the Lewisham Hippodrome Orchestra, and have taken them to the Chiswick Empire to hear Harry Fryer and his Orchestra; to Kilburn for Alfred van Dam and his State Orchestra; to the Savoy Hotel where Arthur Satisbury and his Orchestra have been heard; and to Claridges for music by Geiger and his Orchestra. In the near future listeners will hear Tom Jenkins and his Band at the Grand Hotel, Eastbourne.

ON THE DRAWING-BOARD

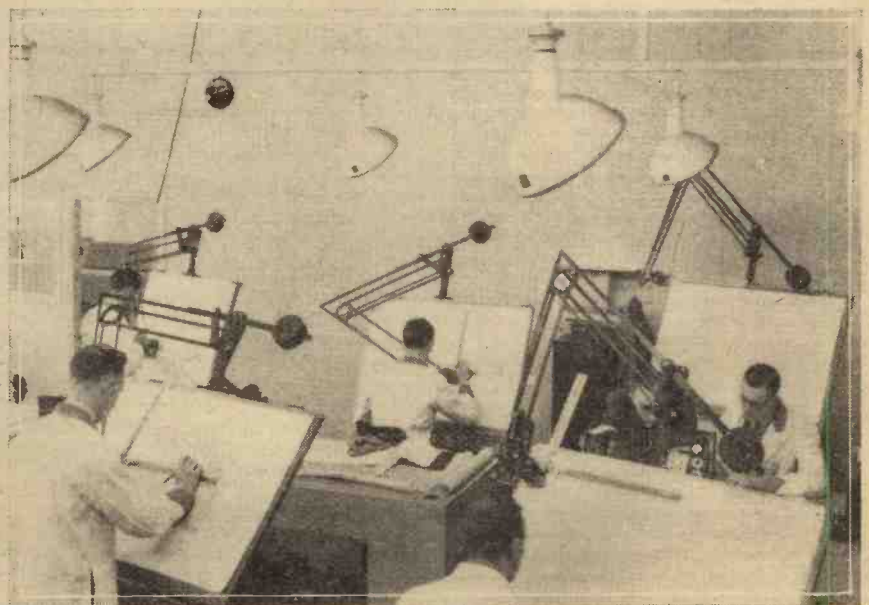

When designing a new receiver, much preparatory work should be carried out on the drawing-board. Some indication of the extent of such work in the factory may be gained from the above illustration which shows the drawing-office at the Ekco works. About 200 blueprints are made out for each set which is designed.

RADIO CLUBS & SOCIETIES

Club Reports should not exceed 200 words in length and should be received First Post each Monday morning for publication in the following week's issue.

SLOUGH AND DISTRICT SHORT-WAVE CLUB

Headquarters: Two H Headquarters, William Street, Slough.

Secretary: K. A. Sly (G4MR), 10, Buckland Avenue, Slough.

Meetings: Alternate Thursdays, at 7.30 p.m.

At the last meeting, held on September 23rd, the chief item of interest was a talk by Mr. Houchin (G3GZ), continuing his series on The Fundamentals of Radio. He interested members by his examination of power-pack details. He described the various types of power-pack, and gave attention to methods of smoothing out mains hum. He emphasised the necessity of using components to give more power output than was necessary. Morse practice took place as usual, and it was observed that speed is gradually increasing. Query corner brought forth many problems which were discussed by the members. A junk sale was held, and provided much enjoyment

DX ON MEDIUM WAVES

(Continued from page 254)

There is one more feature of the circuit given which calls for explanation. This is the method of obtaining delayed A.V.C. When a double-diode is used for second detection in a conventional circuit, A.V.C. can be obtained in a simple manner, but with a pentode detector some alteration in method is required. The WX6 "West-ector" wired across the detector (in series with a fixed condenser, of course) provides the required rectified A.V.C. voltage, whilst a delay voltage is taken from a tapped 41-volt battery separate from the normal G.B. battery. A potentiometer is also used for variable-mu volume control. This system works well in practice, and the delay voltage prevents the sensitivity of the set from being curtailed except when a sufficiently strong signal is being handled for a sacrifice in sensitivity to be permissible.

Reasonable Cost

A set designed around this circuit need not be expensive if use is made of separate screened coils of the type intended for direct bolting to a metal chassis. Four-range coils can be bought for about 10s. 6d. each, whilst high-gain I.F. transformers with tertiary winding will cost about 6s. 6d. each. Thus, the total cost of coils will be under 45s. If 15s. is allowed for the three-gang condenser, a similar amount for a dual-range slow-motion drive of the type with an accurately calibrated circular scale, and 10s. for a wave-change switch assembly, it will be seen that the total cost of the most important components works out at about four guineas. A cheaper tuning drive could be used, but it does not pay to "economise" unduly in buying this important component. Using average valves and 120 volts (maximum) H.T. the current consumption will be in the region of 7 mA, which is within the range of a standard-capacity H.T. battery. Even when a small power pentode is added to the set the current consumption can be kept down to under 12 mA, and this can be obtained economically from a so-called double-capacity dry battery. At a slight sacrifice of efficiency the total H.T. consumption of the set, with L.F. amplifier, could be kept well below 10 mA.

for the members. To close the meeting a general discussion was held, and many interesting subjects were touched upon.

At the next meeting, to be held on December 7th, the agenda will include another talk by G3GZ in his series on Fundamentals of Radio.

Besides this, the meeting will include all the usual items such as Morse practice, query corner, discussion on conditions, and discussions by the research group.

More members are still required, and all who care to attend will be welcome. The subscription is 2s. 6d. per annum, and 3d. extra is payable at each meeting, to cover the cost of rent of the club-room.

ASHTON-UNDER-LYNE AND DISTRICT AMATEUR RADIO SOCIETY

Headquarters: 17A, Oldham Road, Ashton-under-Lyne.

Hon. Sec.: K. Gooding (G3PM), 7, Broadbent Avenue, Smallshaw, Ashton-under-Lyne, Lancs.

At a recent meeting, the members of the above society decided to carry on despite the restrictions imposed on their activities by the war. The old programme of lectures, etc., has had to be cancelled, but efforts are being made to compile an interesting course of lectures by individual members. The chairman and treasurer have already collaborated in a series of instructive talks and demonstrations dealing with "Valve Characteristics."

In order to keep the members together in the meantime, the "social side" has been developed, and it has been discovered that many of the "brass-pounders" can also throw a pretty dart!

Several of the members are now O.H.M.S., as wireless operators or signallers, and all branches of the services are represented.

In order to meet the wishes of several members during the "black-out," meetings are now held every Sunday at 2 p.m. in addition to the usual meetings, at 8 p.m. on Wednesdays.

BRISTOL EXPERIMENTAL RADIO CLUB

Headquarters: 21, King's Corridor, Old Market Street, Bristol, 2.

Publicity Manager: D. J. James (2DCX), 40, Robertson Road, Eastville, Bristol, 5.

Meetings: Alternate Tuesdays, at 7.30 p.m.

The meeting of the above club held on Tuesday, December 5th, was the last before the Christmas Holidays. It is anticipated that meetings will be resumed on Tuesday, January 16th, 1940.

Most members have now settled down to radio experimenting under war conditions. Arrangements are being made to demonstrate several home-constructed Public Address Amplifiers at the first meeting of the New Year. Morse practices at speeds to suit everyone are now a regular feature at all meetings.

Chassis BEST SELLERS!

Amazing Bargain Replacement Radios

All-Wave BATTERY S.G.3

With All Valves Fully Tested 69/6
Mr. Camm fully described this wonderful offer last week. Amazing performer on all bands. Wave-range 14 to 2,000 metres. Powerful S.G. 3-valve circuit with pentode output. Station-name scale. Size 12in. x 8in. x 9in. A.C. MODEL as illustrated. Mains version of above. Ideal radio or radiogram replacement chassis. Station-name dial. Pick-up sockets. Complete with all valves and ready for connection to A.C. mains 200/250 volts. BARGAIN 79/6 or deposit only 19/6 and 4 monthly payments of 16/6.

61/6 Fully Tested 4-Valve RADIOGRAM CHASSIS

REPLACEMENT MODEL, hard to beat in performance and value. Employs powerful 4-valve S.G. Bandpass circuit with pentode output. Wave-range 200 to 2,000 metres. P.U. sockets. Output 3 watts. Size 11in. wide, 7in. high, 9in. deep. Fully tested and complete with all valves. Terms 15/6 deposit and 4 monthly payments of 12/9. Speaker 17/6 extra.

AMPLIFIER for Battery Use

4 WATTS OUTPUT 59/6

With All Valves Specially designed for P.A. work and home use where a maximum of 4 watts amplification is required. Lay-out similar to A.C. model illustrated. Wide sound range and employs 4 valves with push-pull output. Connections for microphone and pick-up. Suitable also for boosting up the volume of existing radio. Complete with 4 valves, ready for use. Terms, 15/- deposit and 4 monthly payments of 12/3.

A.C. 7-WATTS MODEL.-Undistorted output 7 watts. Suitable for large halls and outside sound range of 600ft. radius. 4 valves with push-pull output. For mike or gramophone reproduction. Complete with valves, ready for use. Carriage paid £3 17s. 6d. or 17/6 down and 4 mth'y pmt's of 18/-.

FREE VALVES! All-wave 3 KIT

9 to 2,000 metres. Entirely new battery model with latest slow-motion drive differing slightly from dial illustrated. Employs two S.G., and Pentode output circuit. For use with S.T. 900 type or N.T.S. self-locating coils. Absolutely complete (less coils only), transformer and FREE valves. Cash price 32/6, plus 1/3 only for post and packing. Special Constructors opportunity! SPECIAL OFFER with 10 coils. Above kit with complete set of 10 coils for 10 to 2,000 metres—5 bands—carriage paid, 59/6 plus 1/3 for postage or 15/- down and 4 monthly payments of 12/6.

Powerful CLASS B4 Chassis

Representing the balance of famous maker's stock. Special opportunity for battery set users. Wave-range 200 to 2,000 metres. Powerful S.G. 4 circuit, with Driver and Class B output, giving volume equal to a mains set. Screened coils and ganged condenser. Complete with 4 valves, fully tested and ready for use. BARGAIN. 69/6, or 17/6 down and 4 mth'y pmt's of 14/3. Chassis size, 11in. wide, 9in. deep, 8in. hgh. Speaker 25/-.

COMMUNICATION RECEIVER

Famous-Name 5 Valve Model. Pre-war PRICE £9

10 to 550 Metres. For important short-wave and B.B.C. transmissions. Powerful 5-valve super-het circuit with band-spread tuning A.V.C. and B.F.O. on/off switches. Built-in high-fidelity speaker and lack for 'phones. Fully tested and guaranteed. For all A.C. 200/250 v. supplies (40-100 cycles). Terms £2 down and 4 monthly payments of 38/6.

SPECIAL OFFER! Brand New Fully Guaranteed All-wave Battery 3

Ready to Play Carr Paid. 6 GNS.

Wave-range 18 to 2,000 metres. Amazingly efficient H.F. Pent. Det. Pentode output circuit. Full vision station scale. Simple to tune. All-world listening. Clear-tone moving-coil speaker. Handsome latest style walnut cabinet as illustrated. An exceptional "New Season's" Radio offer which will not be repeated. Ready to play. Less batteries. Terms, 31/6 down and 4 monthly payments of 27/-.

ORDER NOW for XMAS.

Practical Wireless READERS

Order your N.T.S. Component Bargain Parcel NOW, Costs 6/-, Post Free, list value 30/-.

All-Mains 5v. R/Gram.

Chassis £5:19:6 With Valves New season's 6-stage 5-valve model. Wave-range 18-2,100 metres. A.V.C. tone and volume controls. Pleasing station scale, 3 watts output. Ready to play on A.C. or D.C. mains 200-250 volts. Size 11in. by 8in. by 9in. high. P.U. sockets. 29/6 secures, and 4 monthly payments of 24/9. Speaker 27/6.

NEW TIMES SALES CO., 56 (Pr.W.15), LUDGATE HILL, LONDON, E.C.4. (City 5516)

THE SHORT-WAVE 5

Preliminary Circuit and Constructional Details of a New Short-wave Receiver — By W. R. HOBBS

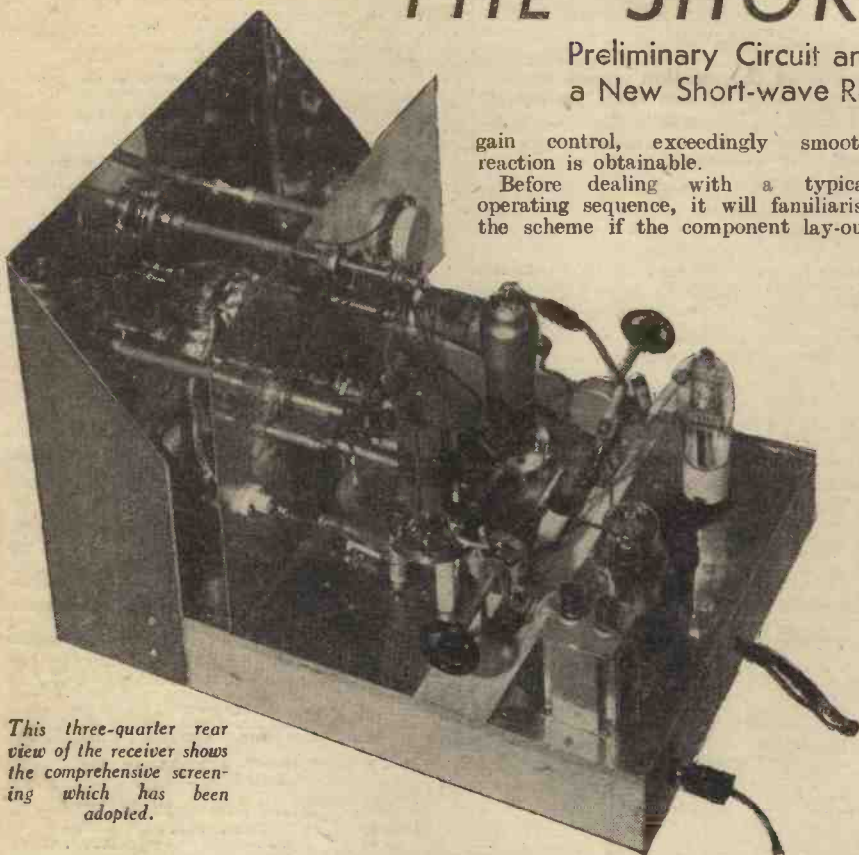

This three-quarter rear view of the receiver shows the comprehensive screening which has been adopted.

gain control, exceedingly smooth reaction is obtainable. Before dealing with a typical operating sequence, it will familiarise the scheme if the component lay-out

the little gain provided by this untuned stage, the valve V1 is mounted in such a way that short wiring results, with, therefore, the removal of various causes for losses and interaction.

The horizontal mounting of the valve in this manner results in not only a conveniently short aerial connection, but also isolates electrostatically the remainder of the connections from the detector stage. Thus we have the valve base mounted behind the intermediate aluminium screen and in the section utilised for the next H.F. stage, which employs a high-frequency pentode, and it is useful to note here that no interaction takes place between V1 and V2, primarily owing to the ample distance and the wiring lay-out.

The Detector Stage

V2 wiring is quite ordinary, but a screen-grid potentiometer is used so that, as will be explained later, a dual form of reaction control furnishing maximum sensitivity is obtainable by the combined adjustment of these two controls.

Ganging accurately with this type of circuit used principally for the short-wave bands, would at first seem unpractical in view of the possible causes for attenuation, instability, and the usual circuit losses, and the writer feels that it should be noted here that the consistency in the operation of the original model in this respect can be attributed mainly to the high precision enjoyed in the design of the Eddystone condensers, whilst, of course, bearing in mind the slight but appreciable advantage obtained by the balancing or fine band-spreading condenser which it was deemed advisable to incorporate for the higher frequency bands.

This balancing condenser is provided solely to counteract any small stray capacities, whilst at the same time proving very desirable as a fine bandspreader when used with the reduction drive as depicted.

The feed to the primary or aperiodic winding of the detector coil is taken directly from the anode of V2 through the medium of two ceramic condensers, one a fixed condenser of 110 mmfds., the other a 50-mmfd. trimmer type, these

It is most desirable and, in fact, necessary, when more serious DX work is intended, to incorporate in the design of the receiver, means for varying certain of the circuit constants at will, so that selectivity and sensitivity may be adjusted more closely relative to reaction and stage gain. In this design, the writer has endeavoured to provide for such considerations without excessively increasing the cost, at the same time providing a sequence of manual control which should be readily grasped after a little practice.

Apart from the extra expense which would be entailed in the housing of the set in an elaborate cabinet, and although a somewhat smaller or more compact component lay-out could have been adopted, this would only detract from the original purpose of an accessible chassis, the use of which could combine the pleasure of both listening and experimenting.

Studying the theoretical diagram given in Fig. 1, it will be seen that, basically, quite a conventional scheme is employed, the principal features being the use of screened grid injection in place of the more customary anode feed, and the advantage of variable-mu characteristics in the detector stage.

In this way, the correct setting of the screen-grid potentiometers will provide both exact operating conditions for the valves and a method of determining the most sensitive setting consistent with reaction and the type of signal being received whether this be 'phone or C.W.

On the higher frequency bands, that is, using the 9 to 14 and 12 to 26-metre coils, this form of "balancing" provides a stable means for getting the most sensitive state of reaction in the detector stage, whilst for the lower frequency bands, and with careful adjustment of the variable-mu

is considered here in connection with the circuit details.

General Scheme

V1 is a screen-grid valve of the short-wave type, having the grid return brought out to the top cap, and is wired for a completely non-resonant untuned H.F. stage.

Now, although normally only a small percentage of stage gain can be anticipated at this point, there is a very appreciable degree of control afforded by using the screening grid of this valve for injection into the aperiodic winding of the following H.F. stage, this adjustment being made through the potentiometer R3.

Again, to conserve as far as possible

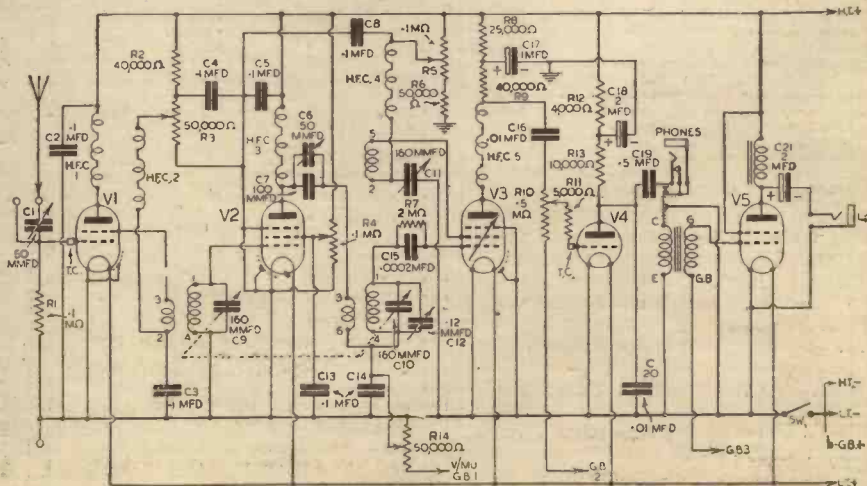

Fig. 1.—Theoretical circuit diagram of the Short-Wave Five.

THE SHORT-WAVE FIVE

(Continued from previous page.)

condensers, as will be noticed, being connected in parallel.

In this manner, a third of the capacity coupling to the coil is adjustable, so that here again, load adjustment can be made at certain frequencies if desired, although for average purposes after a little experiment, the most suitable coupling can be determined and fixed for all bands.

In the interests of short wiring again, the six-pin detector coil-holder is supported on insulating pillars, but one exception to the rule is taken by the necessarily long screen-grid reaction coil return lead. This lead, it will be seen, is screened and adequately earthed to the chassis, being kept as close to the chassis and as rigid as possible.

Tests on the full range of the receiver showed, however, that no instability will arise if the component lay-out is closely followed. The detector valve, V3, is located the other side of the detector tuning section of the ganged condenser, and the variable- μ volume-control is

fitted directly to the chassis intermediate screen in close enough proximity to the valve.

Smooth Reaction

Considering the reaction circuit for the moment, it will be seen that the potentiometer is very conveniently mounted near to the coil-holder, and quite a comfortable manual adjustment can be carried out, whether the receiver be in or out of a cabinet, whilst although it would appear that both the reaction potentiometer and the L.F. volume control R11 were so mounted in the interests of comfortable adjustment, this is by no means so, since it will be noticed that the coupling between the detector and the first L.F. valve V4 is very usefully carried out with a minimum of wiring in the employment of a Hivac PX230 S.W. valve, which employs a top-cap grid return.

Filter feed transformer coupling is used between the L.F. valves, this being interrupted by a 'phone jack so that with or without the loudspeaker in circuit, more critical tuning can be accomplished.

LIST OF COMPONENTS FOR THE SHORT-WAVE FIVE

RESISTORS

- One 4,000 ohms 1/2 watt. Erie Resistor Co.
- One 10,000 ohms 1/2 watt. Erie Resistor Co.
- One 25,000 ohms 1/2 watt. Erie Resistor Co.
- One 5,000 ohms 1/2 watt. Erie Resistor Co.
- Two 40,000 ohms 1/2 watt. Erie Resistor Co.
- Two 50,000 ohms 1/2 watt. Erie Resistor Co.
- One 100,000 ohms 1/2 watt. Erie Resistor Co.
- One 2 megohm 1/2 watt. Erie Resistor Co.

POTENTIOMETERS

- Two 50,000 ohms (without switch), type M. Erie Resistor Co.
- Two 100,000 ohms (without switch), type M. Erie Resistor Co.
- One 500,000 ohms (without switch), type M. Erie Resistor Co.

CONDENSERS (Fixed and Pre-Set)

- One .0002 mfd., type CM5. A. F. Bulgin and Co., Ltd.
- One .0001 mfd., type CM4. A. F. Bulgin and Co., Ltd.
- Two .01 mfd., type PC101. A. F. Bulgin and Co., Ltd.
- Seven .1 mfd., type PCP1. A. F. Bulgin and Co., Ltd.
- One .5 mfd., type PCP5. A. F. Bulgin and Co., Ltd.
- One 1 mfd., type EC14 (electrolytic). A. F. Bulgin and Co., Ltd.
- Two 2 mfd., type EC15 (electrolytic). A. F. Bulgin and Co., Ltd.
- Two ceramic, type R481, 4-50 mmfds. British Mechanical Productions, Ltd. (Clix).

CONDENSERS (Variable)

- Three 160 mmfd., type 1131 (matched as close as possible). Stratton and Co., Ltd. (Eddystone).
- One 12 mmfd., type 1132 (matched as close as possible). Stratton and Co., Ltd. (Eddystone).

REDUCTION DRIVE

- One type E.R.D. Radiomart—G5NI (Birmingham), Limited.

VALVE- AND COIL-HOLDERS

- Three 4-pin, type 949. Stratton and Co., Ltd.
- One 6-pin, type 969. Stratton and Co., Ltd.
- One 7-pin, type X147. British Mechanical Productions, Ltd. (Clix).
- One 4-pin, type X116 (Lemon). British Mechanical Productions, Ltd. (Clix).
- One 5-pin, type X116 (Lemon). British Mechanical Productions, Ltd. (Clix).

CHOKES (H.F.)

- Five, type 1010 (S.W.). Stratton and Co., Ltd. (Eddystone).

CHOKES (L.F.)

- One, type L.F.16. A. F. Bulgin and Co., Ltd.

TRANSFORMERS

- One, type L.F.12. A. F. Bulgin and Co., Ltd.

SWITCHES

- One, type S80T. A. F. Bulgin and Co., Ltd.

BRACKETS

- Two, type E.H.9. A. F. Bulgin and Co., Ltd.

CONDENSER CRADLE

- One, type 1114. Stratton and Co., Ltd.

KNOBS AND DIALS

- One precision (slow-motion dial), type 1,085 (Dunte). Stratton and Co., Ltd.
- One, type K56. A. F. Bulgin and Co., Ltd.
- One, type 1036 (driving head with knob, dial and cursor). Stratton and Co., Ltd.
- Two, type 1086-9. KNOJM, instrument knobs. Stratton and Co., Ltd.
- Two black wheel knobs. Webb's Radio.
- One small instrument knob, type K92. A. F. Bulgin and Co., Ltd.
- One, type I.P.8. dial. A. F. Bulgin and Co., Ltd.

EXTENSION CONTROL OUTFITS

- Three, type 1008. Stratton and Co., Ltd.

JACKS AND PLUGS

- One, type P171 (single-circuit jack). Messrs. Igranic.
- One, type P172 (closed-circuit jack). Messrs. Igranic.
- Two, type P38; jack plugs. A. F. Bulgin and Co., Ltd.

COILS

- One set of 6-pin, type 932. Stratton and Co., Ltd. (Eddystone).
- One set of 4-pin, type 959. Stratton and Co., Ltd. (Eddystone).

INSULATING PILLARS

- Two, type S.M. (1 1/2 ins.). Radiomart—G5NI (Birmingham), Ltd.
- Three, type 1029 (1 1/2 ins.). Stratton and Co., Ltd.
- Four, type 1019 (midget stand-off insulators). Stratton and Co., Ltd.

PLUG AND SPADE TERMINALS

- Six, type MP1A, engraved. H.T.—, H.T.—, G.B.—, G.B.—1, G.B.—2, G.B.—3.
- Two, type R415, engraved, red and black.

VALVES

- One, type SG220, S.W. Hivac, Ltd.
- One, type PX230, S.W. Hivac, Ltd.
- One, type VP215, 4-pin. Hivac, Ltd.
- One, type HP215, 7-pin. Hivac, Ltd.
- One, type Z220, 5-pin. Hivac, Ltd.

PHONES

- S. G. Brown, Ltd. Type A.

LOUDSPEAKER

- W.B. Stentorian Junior.

BATTERIES

- H.T. 120 v. type. Exide, Ltd.
- L.T. 2 v. type. Exide, Ltd.
- G.B. 9 v. type. Exide, Ltd.

CHASSIS

- Complete chassis. Peto-Scott Co., Ltd.

MISCELLANEOUS

- Wood screws (round hd. 1/4 in. to 1 1/2 in. in length). Wiring. A. F. Bulgin and Co., Ltd.
- Screened flex. W.S.2. 3ft. coil. A. F. Bulgin and Co., Ltd.
- Sleeving. A. F. Bulgin and Co., Ltd.
- Flex. A. F. Bulgin and Co., Ltd.

FLEXIBLE COUPLERS

- Two, type F.C. Radiomart—G5NI (Birmingham), Ltd.

ELECTRADIX

CHARGERS. YOU MUST KEEP YOUR BATTERY PREPARED!

Battery Charging on A.C. Mains. The A.C. NITN-DAY will keep your battery fit without attention. Model N/A6, 200/250 volts A.C. and D.C. 6/8 volts 1 amp. 15/- Model N/B6, 200/250 volts to D.C. 6/8 volts to 1 amp. 25/- Model N/C6, 200/250 volts D.C. 6/8 volts 2 amps. 35/- Model N/D12, 200/250 volts to 12 volts 1 amp. 32/- Ditto, 12 volts 2 amps., with 6-volt tap, 55/- 1 amp. 44/10/- And many others.

SHELTER CHARGERS, with automatic switchgear for large batteries.

A.R.P. ACCUMULATORS for stand-by H.T. at 6d. per volt; 3 amp. hours. In 24-volt unit crates, glass cells, 12/- each. Can be parallel charged off 12 volts. Fuggy Dug-outs or ill-ventilated shelters must be kept fresh.

A.R.P. SHELTER Ventilation and Air Conditioning. Compact unit, drive off A.C. or D.C. mains, 80 watts; 9in. Blower, 20 cub. ft. fresh air per min. 25/- is a bargain price.

WET WEATHER ELECTRIC PUMPS, for A.C. or D.C. 12 v. to 230 v. Centrifugal all-bronze pump, throws 120 gals. per hour, 72/6. Type R pumps. Twin piston type for draining shelters, dug-outs, etc., 20/17/6. Auto. float switch, 45/-

WAR EQUIPMENT FOR SERVICE WORK

SERVICE TYPE SIGNALERS
DOUBLE HEADPHONES, with flat leather headbands for steel helmet wear, 120 ohms, by S.T. Co., 3/6. 4ft. cords 6d. Single 60 ohm. phones with cord 11/6.
FIELD TELEPHONE EXCHANGES, 5-line and 30-line portable. Twin and Single Cable.
HEADPHONE CORDS, Service 6ft., fitted 2-pin plugs and 2-hole socket, 2/- Radio Phone Cords, 2/6.
CRYSTAL SETS, Boucsein, 8/6 B.M. Table 7/6.
LEARNERS' MORSE PRACTICE SET, Sound Type No. 10, with Key and Buzzer on base. 3/- Visual Type No. 2A with Key and Lamp on base. No. 3A Duplex with Key and Buzzer and Lamp for sound and visual. line plug is on base. 7/- Siemens Service Set, 17/6.

FIELD SERVICE TESTERS

DIX-MIPANTA VEST POCKET TESTER. A versatile moving-iron multi-range meter for service on A.C. or D.C. THREE ranges of volts: 0-7.5, 0-150, 0-300. Black bakelite case, 2 1/2in. x 2 1/2in. with pair of test leads 19/6 and plugs.

ELIOTT BATTERY TESTERS. Govt. Model 108. Mov. Coil Ammeter and graded theo. 37/6.

LINESMEN'S DETECTORS, Q and I Galvo, in leather Case, 15/-.

HORIZONTAL BRASS-CASED GALVOS, 7/8.

CELL TESTERS, Megger 3-3-3 mov. v coil, Aluminium Case, 25/-

LISTENING MIKES, steel-clad Electradix, indestructible; are ears outside your dug-out.

MORSE KEYS, Few Ex WD Keys reserved for Services. New Keys now in production for training code users. First-class at low prices.

A good small key on moulded base is the TX pivot arm, excellent for learners, 3/6. Full size, well finished key, all brass, solid pivot bar, adjustable tension, etc. B.2. 7/6. Superior Type P.F., fully adjustable, nickel finish, 9/6. High Grade Type IV, plated fittings, polished wood base, a fine key, 10/6. Special Key on 3-switch box for buzzer and 2 lamps, C.A.V.— 8/6.

BUZZERS, small type, with cover, 1/6. Power Buzzers, with screw contact and adjustable spring armature, 2/6. Heavy Buzzer in Bakelite case, 3/6. Siemens Morse Transmitters, with key and brass-cased Power Buzzer, 17/6. Magneto Exploders, 25/-.

Field Telegraph Sets. Details on request.

BELLS, G.P.O. type trembler Circular Desk Bell, with movement in gong, 1/6. Wall Bells, trembler, 2/6. Ditto, large size, 7/6. Signal Bells, large, metal, 12-volt single stroke Bells, 10/-.

SIGNAL LAMPS by Lucas and Aldis, hooded for night and day use, telescope sights, key and discs; for tripod or hand use. Hellographs Mark V, with spare mirrors in leather case, with mahogany tripod, 25/6.

MORSE RECORDING, G.P.O. type inkers, on mahogany base with tape reel under, in first-class order, 46. Lightweight French Army Field Morse Inkers, fold up into wood case, 47/10/- Super Model Army G.P.O. Field H.Q. Morse Inker, brand new, entirely enclosed and fitted every refinement, current indicator, key, tape container, etc., 48. Mahogany Table Recorder, G.P.O., desk top with brass reel in drawer, cost 40/-, for 3/6 only. Morse Paper Reels, 8d.

ELECTRIC IMMERSION HEATERS, Save coal. Armoured bath or bank type with flex, 1,000 watts 230 volts, 25/-

OF GREAT INTEREST IN DARK WAR EVENINGS.

LOW COST Home Recording with the all-g geared FEIGH Electric Recorder, Ball Bearing centre gear box and traverse rod. Is the lowest priced electric home recorder that will fit any grammo. The set with Tracking Gear, Pick-up and tone arm with diamond. Gear only, 21/6. Metal blanks, 3/3.

ACOUSTIC RECORDERS. Cost is low. New MIVOICE acoustic sets, complete outfits in carton de luxe, 16/- No. 2 Mivoice, 10/6. Junior, 5/6.

A.R.P. PETROL ELECTRIC GENERATING SETS FOR LIGHTING AND CHARGING FOR 4/6 ONLY. A 500-watt, single cyl. 2-stroke, water-cooled, self-oiling Stuart Turner engine; mag. ign. coupled to 50/70 volts, 10 amps. shunt dynamo, 1,000 r.p.m., £16. No increase in price, these are £30 sets ready for immediate delivery.

FOR £12. A 150-watt engine and dynamo on similar lines but coupled to 25/30 volts, 0 amps. dynamo.

Half Kilowatt and other sizes; all ready for immediate delivery.

EMERGENCY PARCELS of useful stand-by electrical and radio repair material and apparatus, 7lbs. for 5/- Post Free.

ELECTRADIX RADIOS

218, Upper Thames Street, London, E.C.4

Telephone: Central 4611

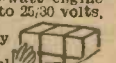
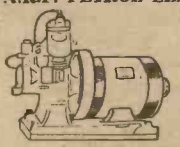
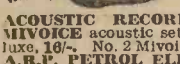
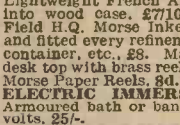

Comment, Chat and Criticism

About Gramophone Records

I POINTED out in my recent article on Gramophone

Records that after accepting the modern miracle of electrical recording, with all its perfection of detail and lifelike representation of a great work of music down to the smallest detail, as a matter of course and an ever recurring certainty, the most vital factor making for the perfect record was the reproduction of the recording artist's personality. The ability to do this on a wax or composition disc, to such a degree of fidelity that, having once heard a powerful personality play a given work, we can at once recognise him as the maker of the record, is, to me, an astounding achievement. There is something romantic and fascinating, as well as scientifically marvellous, in one's ability to "pick up" a performance of a great composition by, say, Caruso, Paderewski or Kreisler, tuck it under your arm, and take it with you to play at a friend's house, as I recently did. Just imagine for one moment. You or I, with these men in our pockets as it were, playing them here, there and anywhere. And all for six shillings a time.

The B.B.C. announcers say, "There are a few moments to spare, so I'll play you a record of . . ." Christopher Stone gives recitals of gramophone records (and probably gets as much for doing so as most of the flesh-and-blood artists). It's all most extraordinary and, in some ways, all wrong. But, like port wine or caviare, we must either bottle it if we want to enjoy it, or else visit Portugal or the Black Sea and get the real thing.

Individuality

That this question of individuality is one that the public is fully alive to would seem to be borne out by the large numbers of recordings one can nowadays get of most of the famous compositions. In fact, it is frequently almost entirely a question of "who do we prefer to play such and such a work" rather than what work do we prefer. With most of the great masterpieces we have a choice of five or six recordings, as well as with hundreds of pianoforte and violin solos and songs, which are arranged before us performed by innumerable artists. With songs it is not quite so remarkable as the various voices, as well as the innumerable types of accompaniment they can be set to, make a large variety of recordings almost a commercially successful certainty. But to store half a dozen different pianists playing the same Chopin study, and half a dozen orchestras and conductors, the same Beethoven Symphony had to be risked and proven wise.

Cortot

As I said in the same article, few artists have succeeded in imparting their own individual style on to the disc to as great a degree as the great French pianist Cortot. There must be something very vibrant in his playing which records very easily, like the tones of the instrument itself. For, apart from the usual faithful

reproduction of those tones, Cortot's records are just like bottles of essence, preserving something vital and necessary. They kill two birds with one stone—they not only preserve a mechanically perfect production of a great piece of music, but they preserve a great performance of it as well. So many recordings succeed in the first of these accomplishments, but not so many in the latter.

Cortot's recordings of the Schumann Concerto, the César Franck Symphonic Variations, and innumerable Chopin pieces, have long been famous. Also of chamber music, notably Beethoven's Archduke Trio. Bach's Brandenburg in D and the Franck Piano Quintet. He is unquestionably the most beautiful Schumann player among all the pianists, and his own distillation of romance into the music of that most incurable of romantics has made a perfect recording of his famous "Scenes from Childhood." If you haven't heard Cortot play "Traumeri," then secure a record of this gem at the first opportunity. He has also just recorded a wonderful and characteristic performance of Chopin's second Concerto—that beautiful bouquet from Chopin's beautiful garden—which I recently heard on the Editor's machine at his residence.

Toscanini

Another superb record I heard on the same occasion was the one and only Toscanini—this time in charge of the National Broadcasting Corporation of America's Orchestra—in the one and only fifth symphony. This sounds somewhat in the nature of an alliance of two perfect souls, and so it is. Toscanini sold Queen's Hall out last summer, for seven concerts in three weeks, within forty-eight hours. And the balcony was ten shillings a time! On these records you can tuck the great little man under your arm and go with him where you will. He is there to the very life. A Beethoven Symphony under Toscanini's baton is probably the greatest achievement in the executive world of music. He has long been recognised as a maestro with the baton, and one of the chief reasons is said

PROGRAMME NOTES

Glasgow Orpheus Choir

SO far as a choir can be regarded as the creation of one man, Glasgow Orpheus Choir is the product of its conductor, Sir Hugh Robertson. They will come to a B.B.C. studio on December 9th to give a concert of the music which they sing better than any other combination. The Orpheus Choir was built up by Sir Hugh Robertson from the Glasgow Toynbee House Choir, until their fame extended across the world. They have sung to the King and Queen, to the British Cabinet and at concerts varying in size between tiny Scots village halls to the largest halls of

to be because he adheres more faithfully to the commands of the composer, as these are recorded on his scores in the form of directions for performance. Thus if Beethoven says that he wants such and such a movement to be played at so many metronome beats to the bar, or such and such a melody to be phrased as he has marked it—then Toscanini says, in effect, "that's good enough for me." It would be impertinence on my part to suggest that I know better than Beethoven how his music should go! As Toscanini is also that rare bird who can infuse his own personality into his readings without having to override the composer's wishes in the matter, it not unnaturally follows that we get from him something as near perfection as well may be. The chief features of this beautiful record are the unflagging, almost fierceness, of the rhythm which impels us through the work almost against our own consciousness; and the seemingly terrific speed of, at least, the first movement. None of those sentimental accessories with which so many conductors unwarrantably adorn this most famous of symphonies with, but the authentic Beethoven granite; a stern, unrelenting struggle with the elemental forces.

Playing Speed

This question of speed enters into a large number of recordings. It seems to be the fashion to drag things, to spin them out and to sentimentalise over them, especially, of course, when there is a melody, and more especially a famous melody. It is all wrong. Firstly, it is not good expression—surely one of the most misunderstood words in the language—and also it robs the work of its sparkle and vitality. There is nothing worse than to let music drag and hang fire. I noticed this the other day on hearing Kreisler's own recording of his beautiful "Caprice Viennois." I had not heard him play it for some time, and the first thing that was borne in on me was how many players, notably those who have arranged the work for various combinations of salon orchestra, have overloaded it with excessive and unwanted sentiment, robbing it of all its Viennese gaiety and charm. Kreisler should know, surely.

London and New York. On December 9th they will be heard in some of the Hebridean songs which, in the arrangements of their conductor, have become so famous.

"To the Public Danger"

THERE is added point in these days of black-outs and higher road fatalities to this play which was written by Patrick Hamilton for broadcasting. "To the Public Danger" was broadcast in the early part of this year and has been brought up to date specially for the revival on December 7th. Listeners will recall that the play deals with the criminality of reckless motoring without regard for the safety of the lives of other people on the road.

Open to Discussion

The Editor does not necessarily agree with the opinions expressed by his correspondents. All letters must be accompanied by the name and address of the sender (not necessarily for publication).

Double-detector Circuits

SIR,—With reference to the letter from Mr. Long, in your issue dated November 25th, I beg to state that I have forwarded to your correspondent the information he requires on the subject of the crystal set.

As the double-detector circuits appear to have created an interest, it would be appreciated if a few readers who have built up either the double-crystal detector circuit or the valve double-detector would report the results they have obtained, I have not tried it on the short waves; has any reader done so?

By the way, the reaction to detector 2 in the published circuit should preferably be taken to L.T. negative.—D'ARCY FORD (Exeter).

A Prizewinner's Thanks

SIR,—I thank you for the book, "Wireless Transmission for Amateurs," which you awarded me in connection with Problem No. 374.

I have recently turned my attention to the transmitting side of wireless, but unfortunately, the present restrictions on the issue of licences, etc., have confined any study to theory, rather than practice. My prize becomes all the more useful for that reason.

I have "dabbled" in wireless for the last 10 years, and have taken PRACTICAL WIRELESS almost from the first issue. The greater amount of my wireless knowledge has been obtained from the many interesting articles in PRACTICAL WIRELESS, and from the careful perusal of your "Wireless Constructor's Encyclopædia," which has been an invaluable help to me.—WM. G. H. ROBINSON (Cleator).

The S.W. "Ranger"

SIR,—Many thanks for your foolproof 0-v-1 Short-wave Ranger described in PRACTICAL WIRELESS of March 11th, 1939. For range and signal strength it's a great DX'er, once the coil is set. I received DJA (R8); TAP, Ankara (R7); Addis-Ababa (R7F); Rome (R9); Buenos Aires (R6F); W9EO (R9+); WNBI (R8); and many unidentified stations. I find the 31 m. (9.6 mc/s) band the liveliest at present. I use headphones only for DX work.—F. W. MCGEE (London, W.).

Exchange S.W.L. Cards

SIR,—I should like to exchange my S.W.L. card with any other S.W.L. I will also QSL 100 per cent. I should also like to correspond with any short-wave fan in U.S.A. or Canada.—D. SHALLCROSS, 1, Corwell Lane, Hillingdon, Middlesex.

S.W. Logs: Correspondents Wanted

SIR,—I have been a regular reader of your excellent paper for several years, and should like to make a suggestion. During the time I have taken the paper I have seen very few of what I call "full" logs, that is those stating listening period exactly, and stating the time the station was received, and also QSA + R or RST so

that others may compare results with them. I should like to see published more logs something like that of R. I. Gaiger in the issue for October 9th, 1939 (+ RST). I do not include a similar log of my own as I have been QRT for some weeks, and do not think readers would be interested in such "ancient" logs.

I should like to get in touch with any SWL, AA or full ticket "ham" in any part of the world (except British Isles) with the view to exchanging 7 mc/s and 14 mc/s logs, also logs of BC stations. I am particularly interested in correspondence with Iceland, Azores, Canaries, Bermudas, West Indies, Pacific and South Sea Islands, East Indies, Australia and New Zealand, but don't let my choice discourage other correspondents elsewhere from writing. I shall answer all correspondence received. I greatly enjoy the present form of PRACTICAL WIRELESS and wish it every success.—J. S. W. BLYTH (Rectory Road, Hockerling, East Dereham, Norfolk, England).

The Kestrel S.W. Four

SIR,—Thank you very much for your advice I asked for recently, concerning the Kestrel S.W.4. The trouble was a simple one—a broken G.B. lead!

Readers may be interested in the following log heard on the speaker, November 10th to 19th. Aerial, 30ft. inverted L facing N.-S.

On 16, 19, 25 and 31-metre bands, WNBI, WGEA, WSLR, WPIT and WCAI. On 19 and 25-metre bands, LRU and XGOY heard faintly.

Prize Problems

PROBLEM No. 377

PETERS made up a three-valve battery set, incorporating band-pass tuning, and with a three-gang coil and three-gang condenser. Instead of using a metal chassis as specified in the description of the receiver he effected an economy by using a wooden chassis, joining the filament circuit to earth instead of to an earthing bolt on the chassis. When he tried out the receiver he failed to obtain any results, although reaction seemed to function correctly and sounds of some kind could be heard in the speaker. What was wrong? Three books will be awarded for the first three correct solutions opened. Entries should be addressed to The Editor, PRACTICAL WIRELESS, George Newnes, Ltd., Tower House, Southamption Street, Strand, London, W.C.2. Envelopes must be marked Problem No. 377 in the top left-hand corner and must be posted to reach this office not later than the first post on Monday, December 11th, 1939.

Solution to Problem No. 376

When Jarvis connected the windings in series he should have made a test with an A.C. meter to ensure that the windings were so connected that they were in phase. If this is not done the voltages will not be additive and in his case they were out of phase, thus failing to provide 6 volts. The valve was, therefore, under-run.

The following three readers successfully solved Problem No. 375 and books have accordingly been forwarded to them:

J. H. Kay, 14, George Street, Darwin, Lancs.
R. B. Jarvis, 3, Woodland View, High Trun, Nr. Sheffield.
J. P. Cook, c/o 20, Salt Hill Way, Slough, Bucks.

The well-known Europeans, such as Zeesen, Rome and Daventry, come in fine, and I have also heard EAQ and TAP and a station announcing itself as being Belgrade.

On November 12th the 20-metre amateur band seemed alive, but I was unable to identify anything on the speaker, and as my 'phones are damaged I unfortunately had to let this pass.

I think this is a very fine set, and when conditions are good the Americans come over very well indeed on the speaker. I shall endeavour to let you have a more comprehensive log at a later date.

Would the Kestrel tune down to about 10 metres satisfactorily, as I have heard that the amateur band on this wavelength is active?—E. ANDREWS (Brighton).

[Although not primarily designed for tuning down to 10 metres, it may be well worth while to try, if suitable coils are used.—ED.]

Correspondents Wanted

SIR,—I wish to get in touch with any young reader who is interested in short and medium-wave reception.—RONALD J. RICHARDSON (188, Kingsley Road, Hounslow, Middx).

SIR,—I shall be glad to get in touch with any reader of this journal residing in this district who is interested in short-wave work.—GORDON RICHARDS (16, Elizabeth Street, Hollinwood, Nr. Oldham).

[We were interested in the photograph of your den, but unfortunately it was not sufficiently clear for reproduction purposes.—ED.]

THE "THREE-TWO" RECEIVER

(Continued from page 255)

before the signal has been built up to suitable strength, whilst with other values it may be found that reaction will not operate even with the reaction condenser at maximum. The value of the grid condenser may also be modified in conjunction with the grid leak, suitable values being found between .0001 and .0005 mfd. The anode by-pass condenser is also a fairly critical component so far as detector sensitivity and reaction control are concerned, and values greater than .0002 mfd. should not, generally speaking, be used. The usual effect of a large capacity in this position is to cut top notes and give rise to muffled reproduction, whilst the absence of a condenser entirely will result in greatly-reduced sensitivity, and in most cases complete absence of reaction.

Aerial Sensitivity

One final point concerns the aerial input. There is no H.F. control on this receiver, and there is thus, under certain conditions, risk of distortion in the H.F. and detector stages due to too great an input voltage. In this case, of course, some form of limit must be imposed on the incoming signal, and this is most conveniently carried out by a series-aerial condenser as it is called. Such a component may be any type of variable or semi-variable condenser having a maximum capacity of .0003 mfd. or .0005 mfd. It is merely joined between the aerial lead-in and the aerial socket on the receiver, and although it will affect ganging slightly the normal way of using the condenser is merely to adjust it until the signal is reduced to the desired level. Slight re-tuning will generally enable the signal to be kept free from distortion.

Practical Wireless BLUEPRINT SERVICE

PRACTICAL WIRELESS Date of Issue.	No. of Blueprint.	Universal Hall-Mark (HF Pen, D, Push-Pull)	—	PW47
CRYSTAL SETS.		A.C. All-Wave Corona Four	6.11.37	PW81
Blueprints, 6d. each.				
1937 Crystal Receiver	—			PW71
The "Junior" Crystal Set	27.8.38			PW94
STRAIGHT SETS. Battery Operated.				
One-valve: Blueprints, 1s. each.				
All-Wave Unipen (Pentode)	—			PW31A
Beginners' One-valver	19.2.38			PW35
The "Pyramid" One-valver (HF Pen)	27.8.38			PW03
Two-valve: Blueprints, 1s. each.				
Four-range Super Mag Two (D, Pen)	—			PW30B
The Signet Two (D & LF)	24.9.38			PW76
Three-valve: Blueprints, 1s. each.				
Selectone Battery Three (D, 2 LF (Trans))	—			PW10
Sixty Shilling Three (D, 2 LF (RC & Trans))	—			PW34A
Leader Three (SG, D, Pow)	22.5.37			PW35
Summit Three (HF Pen, D, Pen)	—			PW37
All Pentode Three (HF Pen, D (Pen), Pen)	29.5.37			PW30
Hall-Mark Three (SG, D, Pow)	12.6.37			PW41
Hall-Mark Cadet (D, LF, Pen (RC))	10.3.35			PW48
F. J. Camm's Silver Souvenir (HF Pen, D (Pen), Pen) (All-Wave Three)	13.4.35			PW40
Cameo Midget Three (D, 2 LF (Trans))	—			PW51
1936 Sonotone Three-Four (HF Pen, HF Pen, Westector, Pen)	—			PW53
Battery All-Wave Three (D, 2 LF (RC))	—			PW55
The Monitor (HF Pen, D, Pen)	—			PW61
The Tutor Three (HF Pen, D, Pen)	21.3.30			PW62
The Centaur Three (SG, D, P)	14.8.37			PW64
F. J. Camm's Record All-Wave Three (HF Pen, D, Pen)	31.10.36			PW69
The "Colt" All-Wave Three (D, 2 LF (RC & Trans))	19.2.39			PW72
The "Rapide" Straight 3 (D, 2 LF (RC & Trans))	4.12.37			PW82
F. J. Camm's Oracle All-Wave Three (HF, Det., Pen)	28.8.37			PW78
1938 "Triband" All-Wave Three (HF Pen, D, Pen)	22.1.38			PW84
F. J. Camm's "Sprite" Three (HF Pen, D, Tet)	20.3.38			PW87
The "Hurricane" All-Wave Three (SG, D (Pen), Pen)	30.4.38			PW80
F. J. Camm's "Push-Button" Three (HF Pen, D (Pen), Tet)	3.0.38			PW92
Four-valve: Blueprints, 1s. each.				
Sonotone Four (SG, D, LF, P)	1.5.37			PW4
Fury Four (2 SG, D, Pen)	8.5.37			PW11
Beta Universal Four (SG, D, LF, Cl. B)	—			PW17
Nucleon Class B Four (SG, D (SG), LF, Cl. B)	—			PW34B
Fury Four Super (SG, SG, D, Pen)	—			PW34C
Battery Hall-Mark 4 (HF Pen, D, Push-Pull)	—			PW46
F. J. Camm's "Limit" All-Wave Four (HF Pen, D, LF, P)	26.9.30			PW67
All-Wave "Corona" 4 (HF, Pen D, LF, Pow)	9.10.37			PW70
"Acme" All-Wave 4 (HF Pen, D (Pen), LF, Cl. B)	12.2.38			PW33
The "Admiral" Four (HF Pen, HF Pen, D, Pen (RC))	3.0.38			PW00
Mains Operated.				
Two-valve: Blueprints, 1s. each.				
A.C. Twin (D (Pen), Pen)	—			PW18
A.C.-D.C. Two (SG, Pow)	—			PW31
Selectone A.C. Radiogram Two (D, Pow)	—			PW19
Three-valve: Blueprints, 1s. each.				
Double-Diode-Triode Three (HF Pen, DDT, Pen)	—			PW23
D.C. Ace (SG, D, Pen)	—			PW25
A.C. Three (SG, D, Pen)	—			PW29
A.C. Leader (HF Pen, D, Pow)	7.1.39			PW35C
D.C. Premier (HF Pen, D, Pen)	—			PW35B
Ubique (HF Pen, D (Pen), Pen)	28.7.34			PW36A
Armada Mains Three (HF Pen, D, Pen)	—			PW38
F. J. Camm's A.C. All-Wave Silver Souvenir Three (HF Pen, D, Pen)	11.5.35			PW50
"All-Wave" A.C. Three (D, 2 LF (RC))	—			PW54
A.C. 1936 Sonotone (HF Pen, HF Pen, Westector, Pen)	—			PW56
Mains Record All-Wave 3 (HF Pen, D, Pen)	—			PW70
All-World Ace (HF Pen, D, Pen)	28.3.37			PW80
Four-valve: Blueprints, 1s. each.				
A.C. Fury Four (SG, SG, D, Pen)	—			PW20
A.C. Fury Four Super (SG, SG, D, Pen)	—			PW34D
A.C. Hall-Mark (HF Pen, D, Push-Pull)	24.7.37			PW45

These Blueprints are drawn full size. Copies of appropriate issues containing descriptions of these sets can in some cases be supplied at the following prices, which are additional to the cost of the Blueprint. A dash before the Blueprint Number indicates that the issue is out of print.

Issues of Practical Wireless ... 4d. Post Paid
Amateur Wireless ... 4d. " "
Wireless Magazine ... 1/3

The Index letters which precede the Blueprint Number indicate the periodical in which the description appears: Thus P.W. refers to PRACTICAL WIRELESS, A.W. to Amateur Wireless, W.M. to Wireless Magazine.

Send (preferably) a postal order to cover the cost of the blueprint and the issue (stamps over 6d. unacceptable) to PRACTICAL WIRELESS Blueprint Dept., George Newnes, Ltd., Tower House, Southampton Street, Strand, W.C.2.

SUPERHETS.				
Battery Sets: Blueprints, 1s. each.				
£5 Superhet (Three-valve)	5.6.37			PW40
F. J. Camm's 2-valve Superhet	—			PW52
F. J. Camm's "Vitesse" All-Waver (5-valver)	27.2.37			PW75
Mains Sets: Blueprints, 1s. each.				
A.C. £5 Superhet (Three-valve)	—			PW43
D.C. £5 Superhet (Three-valve)	—			PW42
Universal £5 Superhet (Three-valve)	—			PW44
F. J. Camm's A.C. Superhet 4	31.7.37			PW59
F. J. Camm's Universal £4 Superhet 4	—			PW60
"Qualitone" Universal Four	16.1.37			PW73
Four-valve: Double-sided Blueprint, 1s. 6d.				
Push-Button 4, Battery Model	22.10.38			PW95
Push-Button 4, A.C. Mains Model	—			PW95
SHORT-WAVE SETS. (Battery Operated.)				
One-valve: Blueprint, 1s.				
Simple S.W. One-valver	—			PW38
Two-valve: Blueprints, 1s. each.				
Midget Short-wave Two (D, Pen)	—			PW38A
The "Fleet" Short-wave Two (D (HF Pen), Pen)	27.8.38			PW01
Three-valve: Blueprints, 1s. each.				
Experimenter's Short-Wave Three (SG, D, Pow)	30.7.38			PW30A
The Prefect 3 (D, 2 LF (RC and Trans))	—			PW63
The Band-Spread S.W. Three (HF Pen, D (Pen), Pen)	1.10.38			PW68
PORTABLES.				
Three-valve: Blueprints, 1s. each.				
F. J. Camm's ELF Three-valve Portable (HF Pen, D, Pen)	—			PW65
Parvo Flyweight Midget Portable (SG, D, Pen)	3.6.39			PW77
Four-valve: Blueprints, 1s.				
"Imp" Portable 4 (D, LF, LF, (Pen))	10.3.38			PW89
MISCELLANEOUS.				
S.W. Converter-Adapter (1 valve)	—			PW48A
AMATEUR WIRELESS AND WIRELESS MAGAZINE CRYSTAL SETS.				
Blueprints, 6d. each.				
Four-station Crystal Set	23.7.33			AW427
1934 Crystal Set	—			AW444
150-mile Crystal Set	—			AW450
STRAIGHT SETS. Battery Operated.				
One-valve: Blueprint, 1s.				
B.E.C. Special One-valver	—			AW387
Two-valve: Blueprints, 1s. each.				
Melody Ranger Two (D, Trans)	—			AW388
Full-volume Two (SG det, Pen)	—			AW392
Lucerne Minor (D, Pen)	—			AW426
A Modern Two-valver	—			WM400
Three-valve: Blueprints, 1s. each.				
Class B Three (D, Trans, Class B)	—			AW386
£5 5s. S.G. 3 (SG, D, Trans)	2.12.33			AW412
Lucerne Ranger (SG, D, Trans)	—			AW422
£5 5s. Three: De Luxe Version (SG, D, Trans)	10.5.34			AW435
Lucerne Straight Three (D RC, Trans)	—			AW437
Transportable Three (SG, D, Pen)	—			WM271
Simple-Tune Three (SG, D, Pen)	June '33			WM327
Economy-Pentode Three (SG, D, Pen)	Oct. '33			WM337
"W.M." 1934 Standard Three (SG, D, Pen)	—			WM351
£3 3s. Three (SG, D, Trans)	Mar. '34			WM354
1935 £6 6s. Battery Three (SG, D, Pen)	—			WM371
PTP Three (Pen, D, Pen)	—			WM389
Certainty Three (SG, D, Pen)	—			WM393
Minitube Three (SG, D, Trans)	Oct. '35			WM396
All-Wave Winning Three (SG, D, Pen)	—			WM400
Four-valve: Blueprints, 1s. 6d. each.				
65s. Four (SG, D, RC, Trans)	—			AW370
2HF Four (2 SG, D, Pen)	—			AW421
Self-contained Four (SG, D, LF, Class B)	Aug. '33			WM331
Lucerne Straight Four (SG, D, LF, Trans)	—			WM350
£5 5s. Battery Four (HF, D, 2 LF)	Feb. '35			WM381
The H.K. Four (SG, SG, D, Pen)	Mar. '35			WM384
The Auto Straight Four (HF Pen, HF Pen, DDT, Pen)	Apr. '36			WM404
Five-valve: Blueprints, 1s. 6d. each.				
Super-quality Five (2 HF, D, RC, Trans)	—			WM320
Class B Quadradyne (2 SG, D, LF, Class B)	—			WM344
New Class B Five (2 SG, D, LF, Class B)	—			WM349
Mains Operated.				
Two-valve: Blueprints, 1s. each.				
Two-valve Mains Short-wave (D, Pen) A.C.	—			AW453
"W.M." Long-wave Converter	—			WM390
Three-valve: Blueprint, 1s.				
Emigrator (SG, D, Pen) A.C.	—			WM352
Four-valve: Blueprint, 1s. 6d.				
Standard Four-valve A.C. Short-wave (SG, D, RC, Trans)	Aug. '35			WM391
MISCELLANEOUS.				
S.W. One-valve Converter (Price 6d.)	—			AW329
Enthusiast's Power Amplifier (1/6)	—			WM387
Listener's 5-watt A.C. Amplifier (1/6)	—			WM392
Radio Unit (2v.) for WM392 (1/-)	Nov. '35			WM398
Harris Electrogram battery amplifier (1/-)	—			WM399
De Luxe Concert A.C. Electrogram (1/-)	—			WM403
New Style Short-wave Adapter (1/-)	—			WM388
Trickle Charger (6d.)	Jan. 5, '35			AW402
Short-wave Adapter (1/-)	—			AW456
Superhet Converter (1/-)	—			AW457
B.L.D.L.C. Short-wave Converter (1/-)	—			WM405
Wilson Tone Master (1/-)	May '36			WM406
The W.M. A.C. Short-wave Converter (1/-)	June '36			WM408

These Blueprints are drawn full size. Copies of appropriate issues containing descriptions of these sets can in some cases be supplied at the following prices, which are additional to the cost of the Blueprint. A dash before the Blueprint Number indicates that the issue is out of print.

In reply to your letter

Gramophone Motor Hum

"I have a radiogram which gives rather pronounced hum, and I attribute this to the motor. Do you advise earthing this, or is there any risk of a mains short-circuit from so doing?"—L. E. (N.W.7).

A LARGE number of electric gramophone motors are provided with an earthing terminal, and where the motor forms part of a complete gramophone unit the mounting plate may be earthed with advantage, thereby earthing the motor. You may find, however, that the hum is not removed by this method of earthing as the windings in the pick-up may interact with windings in the motor, thereby introducing hum, and the turntable itself may not act as a sufficient screen. In these cases probably the only effective scheme is to use a pick-up which is provided with a special hum-bucking coil.

Battery Superhet

"Could you let me know when you last published constructional details of a 3- or 4-valve battery superhet? If you have not done one, perhaps you could say if you intend publishing one in the near future."—R. G. B. (Tonbridge).

WE have published both a 3-valve and a 4-valve superhet for battery operation. A blueprint of the 3-valve is still available, No. PW40, and the constructional details will be found in the issue dated 5.6.37. These are reprinted, as the original issue is out of print. The 4-valve is, unfortunately, out of print, but if you have back numbers you will find the constructional data for the 4-valver in our issue dated 16.11.35.

Coil-winding Machines

"Have you at any time published details of a coil-winding machine suitable for transformer winding, or whether there is a book which gives details?"—A. T. L. (W.C.1).

FOR simple transformer purposes you only need a neat bobbin made from paxolin or similar material, and this may be mounted on a spindle carried in an ordinary twist drill, the number of revolutions for one turn of the handle being found, and then it is not difficult to wind the desired number of turns. An effective coil-winding machine was, however, described in our issue dated 23.10.37, and you may wish to make up an instrument of this type, which will also be found valuable for making tuning coils. This machine is provided with a turns counter and is quite simple to make up.

Sound Detector

"I wish to make up a sound detector to pick up the air-raised warnings and amplify them inside the house. How can I do this? Is it possible to place a microphone outside the house and connect it to a loudspeaker inside? If so, what valves do I use? Have you a diagram which would show me how to do this?"—C. R. D. (New Eltham).

IN its simplest form such a detector could be made by placing a microphone outside the house, fed to a simple amplifier feeding a loudspeaker in any room. However, there are several things to be borne in mind. Firstly, the microphone must be protected from the weather. Secondly, the amplifier will have to be switched on all the time in order that it will be operative when a warning is sounded. Thirdly, there will be the constant sounds from the

RULES

We wish to draw the reader's attention to the fact that the Queries Service is intended only for the solution of problems or difficulties arising from the construction of receivers described in our pages, from articles appearing in our pages, or on general wireless matters. We regret that we cannot, for obvious reasons—

- (1) Supply circuit diagrams of complete multi-valve receivers.
- (2) Suggest alterations or modifications of receivers described in our contemporaries.
- (3) Suggest alterations or modifications to commercial receivers.
- (4) Answer queries over the telephone.
- (5) Grant interviews to querists.

A stamped addressed envelope must be enclosed for the reply. All sketches and drawings which are sent to us should bear the name and address of the sender.

Requests for Blueprints must not be enclosed with queries as they are dealt with by a separate department.

Send your queries to the Editor, PRACTICAL WIRELESS, George Newnes, Ltd., Tower House, Southampton Street, Strand, London, W.C.2. The Coupon must be enclosed with every query.

speaker of traffic, etc. Therefore, we suggest that the microphone is placed at the small end of a fairly large horn assembly to provide the desired waterproof properties, and if this is directed into the air it may, by its directional property, cut out much traffic noise. Secondly, some form of relay would appear desirable to cut down current consumption whilst in a "stand-by" condition. We regret that we have no suitable diagram or blueprint which we could supply in this particular case.

P.A. Amplifier

"I have a commercial 5-valve superhet and am trying to find a suitable amplifier to work with this in a hall about 70ft. by 35ft. by 25ft. high, for dancing, etc. Sometimes it would be used with a pick-up and very seldom with a microphone. It is an all-mains receiver. Have you a suitable design you can recommend?"—W. S. C. (Nr. Liverpool).

IT is desirable in such a case that the amplifier be self-contained, as there would be insufficient H.T. available in the receiver to operate an amplifier capable of giving the desired output. We recommend the 12 watt or the 18 watt amplifiers which we have described, the former in our issue dated 30.10.37, and the latter in the issue dated 31.12.38. Less than 12 watts would no doubt prove unsuitable for dancing in a hall of the size mentioned.

Cabinet Rattle

"I am troubled with a peculiar form of distortion which nothing seems to cure. It takes the form of a kind of buzz on certain notes, and although I have thoroughly examined the speaker and have tried various circuit ideas it is still there. I cannot notice the trouble on weak signals, and this leads me to suspect the speaker, but as this is fairly new and has not been overloaded by any means, I am rather at a loss to account for the trouble. I wonder if you can help me?"—M. C. I. (Hastings).

THE trouble may not be in the set or speaker. A very common cause of such a buzz is found to be due to the cabinet design and manufacture. In some cases the air chamber provided round the speaker will resonate at certain frequencies and the increased amplification so afforded might result in some article in the room resonating at the increased volume. If, however, it can definitely be traced that the sound comes from the set, tap the cabinet all round and you may find that there is a looseness in the plywood laminations which is causing the trouble. A cabinet pin driven through the cabinet at the point and riveted over on the inside should prevent movement of the wood and so reduce or cut out the buzz.

REPLIES IN BRIEF

The following replies to queries are given in abbreviated form either because of non-compliance with our rules, or because the point raised is not of general interest.

A. D. (Liverpool). We do not know of any particular component named as mentioned in your letter. We regret that we cannot complete your circuit diagram as it is too skeletonised.

J. B. S. (Saxmundham). Write to H.F.R., Ltd., Howland Street, Tottenham Court Road, London, W.C.1. A stage-by-stage test in the amplifier in question should be made.

W. W. (Accrington). We recommend our book "Transmission for Amateurs." We would remind you, however, that transmitting activities are suspended during the war and a licence will not be issued.

A. H. M. (Blackburn). Write to the L.S. Repair Company, of 5, Balham Grove, London, S.W.12.

M. E. (Beccles). The item will cost from 1s. 6d. upwards, according to type. Electradix Radios, whose advertisements appear in these pages, can supply.

R. Y. (Harringay). Blueprints and details are now entirely out of print. The circuit has been superseded by modern designs.

J. M. (Glasgow, S.W.1). We would suggest you communicate with the English Philips Company, who may be able to assist you. Their address is Century House, Shaftesbury Avenue, London, W.C.2.

J. E. T. (Reading). We think it would be very difficult to make a satisfactory component of the type mentioned and advise you to obtain a ready-made article.

T. H. A. (Longshaw). We cannot give connections without a type number, as the firm in question made dozens of different types of coil from time to time.

E. E. B. (South Harrow). The valve in question should work quite satisfactorily.

C. E. H. (Stechford). The coil is merely a standard component, having primary and secondary windings. Any standard coil, even if it includes a reaction winding, may be used, ignoring the reaction section. You will find any of the coils in the book in question may be used, but a tuning condenser is essential in conjunction with any of them. The switch is necessary for wavelength changing.

E. A. M. (Denton, Manchester). The indication is that the meter has a high resistance and will accordingly pass only 1 milliamp per volt. It will thus be suitable for measuring detector or screen voltages with a reliable indication, which would not be obtained with a low-resistance meter which passed a very much higher current than this.

H. K. (Bryn, Wigan). So far as we can trace the coil is no longer on the market.

D. H. A. B. (Luton). There is nothing wrong with the meter, and the connections are perfectly standard. You appreciate, of course, that by connecting the meter in parallel with the supply it measures voltage, and in series it indicates the current flowing.

The coupon on page 272 must be attached to every query.

ARMSTRONG

apologise for delay in delivery of some models. This has been unavoidable owing to the difficulty in obtaining materials. However, customers may rest assured that we are doing our utmost to expedite all outstanding orders. In these difficult times we shall be grateful if customers will allow us as much notice as possible when ordering.

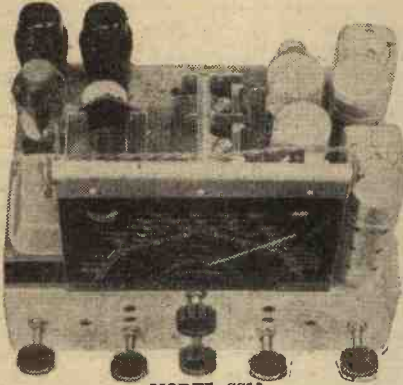

MODEL 8810

"SUPERHET-STRAIGHT" 10-valve High Fidelity Radiogram chassis. All-wave, incorporating 2 independent circuits. Superheterodyne and Straight having R.F. pre-amplifier, R.C. coupled push-pull Triode output capable of handling 8 watts.

PRICE £12 : 12 : 0. Plus 5% war increase.
MODEL AW38. 8-valve All-wave Superheterodyne chassis. This All-wave Radiogram chassis has resistance capacity coupled push-pull output capable of handling 6 watts, and gives good quality reproduction on both radio and gramophone, for an economical price of 8 gns. Plus 5%.

Armstrong Push-pull Speaker to match AW38 Chassis, £1 : 1 : 0. Plus 5%.

We suggest Model AW38 together with matched speaker at £9 : 9 : 0 complete, plus 5%, represents the most outstanding value on the market to-day.

ILLUSTRATED ART CATALOGUE ON REQUEST ALL CHASSIS SENT ON 7 DAYS' APPROVAL

ARMSTRONG MANFG. CO.

WARTERS ROAD, HOLLOWAY, LONDON, N.T.

(Adjoining Holloway Arcade)

Phone NORTH 3213

L.R.S.

(of 11, Oat Lane)

intend carrying on the good work of supplying Quality Radio Equipment.

ARMSTRONG CHASSIS

PORTABLE A.R.P. RECEIVERS and other reliable radio apparatus are available as usual on our very CONVENIENT TERMS.

Write for quotation and full details to our evacuation address:

LONDON RADIO SUPPLY COMPANY

"WINDEN," ARDINGLEY RD., BALCOMBE, SUSSEX.

Important TROPHY announcement

To those PRACTICAL WIRELESS readers who, for some reason or another, have not yet ordered their TROPHYS—please turn to last week's issue of this journal and study the important TROPHY announcement. TROPHY Radios have been recommended more than any others for all-world listening and represent the best value obtainable. Order NOW at present low prices. TROPHY models from £6 : 6 : 6. Terms available.

PETO-SCOTT Ltd., 77 (P.W.15) City Rd., London, E.C.1. Tel. C.L.I. 9875.

West End London dems. | 41, High Holborn, W.C.1. R.E.M. Ltd., 70, Wigmore St., W.1.

FREE ADVICE BUREAU COUPON

This coupon is available until December 16th, 1939, and must accompany all Queries and Hints.

PRACTICAL WIRELESS, 9/12/39

Notes from the Test Bench

Another Soldering Hint

WHEN fine soldering work is being carried out, the quick application of solder is one of the main essentials, but this cannot be done if the iron will only carry a very small layer of solder. A good "bead" of molten solder is essential, but this will not adhere to the iron if the temperature is wrong and if the iron is not clean. This latter point is the one which concerns us at the moment, and a hint which may be new to many is that the desired cleanliness and requirements for making the iron carry the solder may be obtained by rubbing the hot iron on a block of sal-ammoniac, or dipping it quickly in one of the prepared soldering fluids. Some amateurs powder sal-ammoniac and scrape tinman's solder into the powder in small quantities so that the desired cleaning and timing is carried out at one operation.

Wooden Chassis

OWING to increased costs of metal, chassis may prove more economical when made from wood, but there is no need to use very heavy plywood for this purpose if certain points are borne in mind. The top, for instance, may not be thicker than $\frac{1}{2}$ in. provided it carries certain flat components, such as coil units, whereby the amount of flat metal forming the base will act as a stiffener to add strength to the chassis. This must not be overdone, but additional supporting strips may be placed beneath heavy components should the top be found to sag due to excessive weight.

Pick-up Chatter

WITH many types of magnetic pick-up it is often possible to hear the reproduction of a record, during loud passages, through the excessive vibration of the armature, and as this can become very annoying, it is always advisable to take simple precautions to eliminate this as much as possible.

A stout lid should always be provided to cover the turn-table and pick-up when they are in use, and to prevent it acting as a sound-box, the interior of the lid and its edges should be covered with thick felt.

MORSE EQUIPMENT

FULL range of Transmitting Keys, Practice Sets, Oscillators, Recorders and other Radio Telegraph Apparatus, designed and manufactured by T. R. McElroy, World Champion Telegraphist. Absolutely first-class construction. McElroy Amateur Key 7/6 post free.—Webb's Radio, 14, Soho Street, London, W.1. 'Phone: Gerrard 2089.

LOUDSPEAKER CONVERSIONS

BAKER'S Triple Cone Conversions Will Immensely Improve Reproduction of Your Present Speaker. Enables you to bring your speaker right up to date and obtain really realistic reproduction at the cost of a few shillings; free descriptive leaflet from the Pioneer Manufacturers of Moving Coil Speakers since 1925.—Bakers Selhurst Radio, 75, Sussex Rd., South Croydon.

RECEIVERS, COMPONENTS AND ACCESSORIES

SOUTHERN RADIO'S Bargains.

ALL Articles Fully Guaranteed. Postage extra.

- 5/-—Parcel of useful components, comprising condensers, resistances, volume controls, coils, wire, circuits, etc., etc., value 25/-. 5/- per parcel.
- 10/-—Parcel of useful components, comprising 100 articles, including electrolytics, valveholders, etc., etc., value 55/-. 10/- per parcel.
- 15/-—Service man's component kit. Comprising electrolytic condensers, volume controls, tubular condensers, resistances, valveholders, wire, mica and Mainsbridge condensers, etc., etc. 120 articles contained in strong carrying case 9" x 7" x 7", value 65/-. 15/- the complete kit.
- 21/-—Small traders' parcel of components, comprising at least 150 articles, including 24 assorted tubular condensers, 24 valveholders, 36 resistances, 12 Mainsbridge type condensers, 6 electrolytics, etc., etc., value 85/-. 21/- per parcel.
- 5/-—Twelve Mainsbridge type condensers, 1-2-4 in. d.; 5/- per dozen.
- 4/-—Telson 3-range meters (volts and milliamps), 4/-; Morse tappers, 2/11.
- BUZZERS, 1/6; crystal detectors, 2/-; crystal sets, 5/6; crystals, 6d.
- 2/6—Ormond loudspeaker units, 2/6.
- 2/6—Westectors, Type W2, 2/6 each.
- 2/6—Tool or instrument carrying cases ex-Government stock. Wood 9" x 7" x 7", 2/- each.
- SOUTHERN RADIO, 46, Lisle Street, London, W.C. Gerrard 6653.

VAUXHALL.—All goods previously advertised are still available; send now for latest price list, free.—Vauxhall Utilities, 163a, Strand, W.C.2.

BANKRUPT BARGAINS. Brand new 1938-9 models, makers' sealed cartons, with guarantees, at less 40 per cent. below listed prices; also Midgots, portables, car radio. Send 14d. stamp for lists. Radio Bargains, Dept. P.W., 261-3, Lichfield Road, Aston, Birmingham.

COULPHONE RADIO, Ormskirk.—Collaro A.C. Gramophone Motors, 24/-; with pick-up 39/-. Record valves. 12 months' guarantee. H.P. and Output Pentodes, 6/6. Frequency Changers, 7/3. Rectifiers, 5/3. 14d. stamp for 1940 catalogues.

5/- Bargain Parcel comprising Speaker Cabinet, Drilled steel Chassis, condensers, resistances and many other useful components. Worth £2. Limited number. Postage 1/-.—Bakers Selhurst Radio, 75, Sussex Rd., South Croydon.

HEADPHONES. Reconditioned and guaranteed. Brown, G.E.C., B.T.H., Sterling, Nospac, Brunet, Western Electric, Siemens, Brandes, 4,000 ohms, 5/- pair. Telefunken, lightweight, adjustable, 4,000 ohms, 7/6.

CRYSTAL with silver cat's-whisker, 6d. Complete detector parts, 1/-. Glass tube detector on ebonite base, 1/6. Sensitive permanent detector, 1/6. Postage 14d.—Post Radio Supplies, 328, Upper Street, London, N.1.

BANKRUPT BARGAINS.—All new goods offered. Spartan A.C. press button 1939 5v. superhets, £5/15/0. Ditto table radiogram, 9 gns. Truphonic 14 gn. A.C. all-wave superhet, motor tuned, 9 gns. Truphonic 14 gn. 6v. A.C./D.C. all-wave push-pull superhets, 9 gns. Portadyne 1940 A.C./D.C. all-wave superhets, £6/17/6. Portadyne battery baby superhet portables, £6. Portadyne 1939 4v. battery portable, £4/15/0. Truphonic A.C. all-wave 5v. superhets, 11 gn. 1939 models, 7 gns. Good make A.C./D.C. 16 gn. all-wave 4-band superhets, bands medium and three short, 8 watts output, 9 gns. Full stock valves all types. Service goods and repairs. Please state requirements for quotation.—Butlin, 6, Stamford Avenue, Brighton.

LOUDSPEAKER REPAIRS

LOUDSPEAKER repairs, British, American, any make. 24-hour service, moderate prices.—Sinclair Speakers, Pulteney Terrace, Copenhagen Street, London, N.1.

L.S. REPAIR AND REWINDING SERVICE: 24-hour service. See below:—

REPAIRS to moving coil speakers a speciality. New cone assemblies fitted. Speech coils and fields wound or altered. Mains transformers, chokes, eliminators and vacuums repaired, prices quoted. Speaker transformers, Class "B" L.F. transformers and pick-ups rewound at 4s. each, post free. Discount trade. Estimates free. Guaranteed satisfaction. L.S. Repair Service, 6, Balham Grove, London, S.W.12. 'Phone: Battersea 1321.

NEW LOUSPEAKERS

3,000 SPEAKERS from 6/6 each, P.M. and energised 4in. to 14in. including several Epoch 18in.—Sinclair Speakers, Pulteney Terrace, Copenhagen Street, London, N.1.

COMMUNICATION RECEIVERS

FINEST selection in the country. Sole Agents for famous HALLICRAFTERS Receivers, ranging in price from £11-10-0 to £150. Attractive easy terms. Demonstrations at our London Showrooms, 60-page Catalogue post free 2d.—Webb's Radio, 14, Soho Street, London, W.1. Phone: Gerrard 2089.

TECHNICAL LITERATURE

TECHNICAL BOOKS for the enthusiast. Hundreds of constructional theoretical circuits short-wave equipment. Radio Society of Great Britain Handbook, 2/9 post free. 1940 Edition American Radio Relay League Handbook, 6/- post free. American "Radio Handbook," 7/6 post free. I.C.A. American Receiving Valve Manual, 1/6 post free.—Webb's Radio, 14, Soho Street, London, W.1. Phone: Gerrard 2089.

RADIO MAP AND GLOBE

WEBB'S RADIO MAP of the World enables you to locate any station heard. Size 40" by 30". 2-colour heavy Art Paper, 4/6. Limited supply on issue, 10/6. WEBB'S RADIO GLOBE—superb 12" full-colour model. Radio prefixes, zones, etc. Heavy oxidised mount. Post Paid, 27/6.—Webb's Radio, 14, Soho Street, London, W.1. Phone: Gerrard 2089.

CABINETS

A CABINET for Every Radio Purpose. CONVERT Your Set into a Radiogram at Minimum Cost; surplus cabinets from noted makers under cost of manufacture (undrilled), 30/- upwards; motors at wholesale price. UNDRIILLED table, console and loudspeaker cabinets from 4/6. INSPECTION invited; photos loaned to country customers. H. L. SMITH and Co., Ltd., 289, Edgware Road, W.2. Tel.: Pad. 5891.

TELEVISION AND RADIOGRAM CABINETS from £1 each. Makers' cost £7. Particulars:—Cameo Co., 23, Denmark Street, W.C.2. TFM 5900.

PUBLIC APPOINTMENTS

WIRELESS Technical Instructors required in Army units. **E**MOLUMENTS.

PAY 8s. 3d. per day (7 days a week). Clothing, rations and accommodation, or if this cannot be provided, allowances at authorized rates. If married and otherwise eligible family allowances payable in respect of wife and children subject to allotment from pay.

CANDIDATES should preferably be under 35 and over 24 and (a) hold one of the following qualifications:—

Graduateship of the Institution of Electrical Engineers; Final (Grade III) Certificate of City and Guilds of London Institute Examination in Radio Communication;

Higher National Certificate in Electrical Engineering; Certificate of City and Guilds of London Institute in Radio Service work;

or similar qualifications. Or (b) be able to pass an examination on the following syllabus:—

CURRENT Electricity.—Properties of an electric current. Ohm's Law and its application; galvanometers and measuring instruments; electro-magnetism; magnetic materials; conductors, insulators and dielectrics.

ALTERNATING Currents.—General principles; effects of resistance, inductance and capacity; resonance.

RADIO.—General character of a radio signal; knowledge of valves and their simple applications; general knowledge of tuning both transmitters and receivers.

MATHEMATICS.—Knowledge of Algebra and simple Trigonometry.

SUITABLE candidates will be interviewed at local centres, and if successful, will be enlisted and appointed acting Sergeant-Tradesman. For those who are on the Schedule of Reserved Occupations special arrangements will be made to enable them to be enlisted.

APPLICATION forms, obtainable by postcard from the Under-Secretary of State, War Office (F.O.1), Whitehall, S.W.1, to be lodged by December 18th, 1939.

MISCELLANEOUS

DETECTION.—Double detection. Theory, circuits, diagrams, practical experiments. Book 2s., post free.—D'Arcy Ford, Gandy Street, Exeter.

EXPERIMENTER'S Surplus. Bargain half-crown parcels. Postage 6d.—Butler, Christleton, Chester.

PREMIER RADIO—AS USUAL!

SPECIAL PURCHASE

"AIR WARDEN" 5-valve, Midget Receiver FOR A.C. MAINS. 200-250 v. Completely self-contained in well-finished, polished Oak Cabinet, 12 x 9 x 9 1/2 ins. Well built-in Moving Coil Speaker. Wave Range 190-550 metres. Usual Price £6 6s. 0d. Our Price 55/-. The Ideal Stand-by Set.

PREMIER SHORT-WAVE KITS for OVERSEAS NEWS

Incorporating the Premier 3-Band S.W. Coil. 11-86 Metres without collenchanging. Each Kit is complete with all components, diagrams and 2-volt valves. 3-Band S.W. 1 Valve Kit, 14/9. 3-Band S.W. 2 Valve Kit, 22/6.

DE LUXE S.W. KITS

Complete to the last detail, including all Valves and coils, wiring diagrams and lucid instructions for building and working. Each Kit is supplied with a steel Chassis and Panel and uses plug-in Coils to tune from 13 to 170 metres.

- 1 Valve Short-Wave Receiver or Adaptor Kit 20/-
- 1 Valve Short-Wave Superhet Converter Kit 23/-
- 1 Valve Short-Wave A.C. Superhet Converter Kit 26/3
- 2 Valve Short-Wave Receiver Kit 29/-
- 3 Valve Short-Wave Screen Grid and Pentode Kit 68/-

REPLACEMENT VALVES FOR ALL SETS EUROPA MAINS VALVES. 4 v. A.C. Types. A.C. H.L., A.C. L., A.C. S.G., A.C. V.M.S.G., A.C. H.P., A.C. V.H.P. (5-pin), all 5/3 each. A.C. H.P., A.C. V.H.P. (7-pin), 7/6; A.C. Pens. I.H., 6/6; A.C. P.X.A., 7/3; Cct. Freq. Changers, 8/6; Double Diode Triodes, 7/6; 3-watt D.H. Triode, 7/6; 350 v. F.W. Rect., 5/6; 500 v. F.W. Rect., 6/6; 13 v. 2 amps. Gen. Purpose Triodes, 5/6; H.F. Pens and Var.-Mu. H.F. Pen., Double Diode Triodes Oct. Freq. Changers, 7/6 each. Full and Half-wave Rectifiers, 6/6 each.

TRIAD HIGH-GRADE U.S.A. VALVES, all types in stock. Standard tubes, 5/6 each. Octal Base tubes, 6/6 each. 210 and 250, 8/6 each.

PREMIER BATTERY CHARGERS for A.C. Mains. Westinghouse Rectification complete and ready for use. To charge 2 volts at 1 amp., 11/9; 6 volts at 1 amp., 19/-; 8 volts at 1 amp., 22/6; 12 volts at 1 amp., 24/6; 6 volts at 2 amps., 37/6.

MOVING COIL SPEAKERS all complete with transformer. Rola 8 in. P.M.s., 16/6; 10 in. P.M.s., 22/6; G.12 P.M.s., 66/-.

Energised Models. Plessey 8 in., 2,500 or 7,500 ohm field, 7/6; G.12 energised, 59/6.

HUGE PURCHASE OF U.S.A. MAINS TRANSFORMERS at Pre-War Prices. Manufacturers' surplus. All brand new and Guaranteed.

Input 110 v. and 220 v. A.C. Output 325-325 v., 120 m.a., 6-3 v., 2-3 amps., 5 v., 2 amps. (C.T.) 7/6 each. Input 230 v. A.C. Output 325-325 v., 75 m.a., 5 v. 2 amps., 6-3 v., 2-3 amps. C.T. 6/6 each. Input 100-250 v., 300-300 v. 60 m.a. 4 v. 5 a. C.T. 4 v. 1 a., 6/11.

PREMIER Short-Wave Condensers, all-brass construction, with Trolitol insulation. 15 mmf., 1/9; 25 mmf., 1/10; 40 mmf., 2/-; 100 mmf., 2/3; 160 mmf., 2/7; 250 mmf., 2/11.

PREMIER SHORT-WAVE COILS, 4- and 6-pin types, 13-26, 22-47, 41-49, 73-170 metres. 2/- each, with circuit. Special set of S.W. Coils, 14-450 metres, 4/9 set, with circuit. Premier 3-band S.W. coil, 11-25, 19-43, 38-86 metres. Suitable any type circuit. 2/11. 3 Gang Condensers fully screened, 1/6 each.

UTILITY Micro Cursor Dials, Direct and 100.1 ratios, 4/3.

CARDBOARD ELECTROLYTIC CONDENSERS. 8 mf. 500 v., 1/9; 4 mf. 500 v., 1/9; 8 + 8 mf. 500 v., 2/11; 4+1+4 mf. 500 v., 2/11. T.C.C. Dry Electrolytics 8+8+4 mf. 500 v., 2/4 each.

Orders 5/- and over sent Post Free. Under 5/- please add 6d. postage.

YOU MUST HAVE A PREMIER 1940 CATALOGUE
111 PAGES PRICE 6d.
GET YOUR COPY TO-DAY!

ALL POST ORDERS TO Jubilee Works, 167, Lower Clapton Road, London, E.5. Amhurst 4723
CALLERS TO: Jubilee Works, or our New PREMISES, 169, FLEET STREET, E.C.4.
Central 2833
or 50, High Street, Clapham, S.W.4. Macaulay 2381

RECEIVERS, COMPONENTS AND ACCESSORIES

RADIO CLEARANCE, LTD.

FILAMENT Transformers, input 200-250 volts, output 4 volts 4 amps., 4 volts 6 amps. 4/11 each
MAINS Transformers, American windings, input 200-250 volts tapped, output 350-0-350 volts, 100 m.a., 5 volts, 2 amps., 6.3 volts 5 amps. 8/6 each
G.E.C. Mains Transformers, American windings, 350-0-350 volt 65 m.a., 5 volt 2 amp., 6.3 volt 2.5 amp. Suitable for replacements in G.E.C. models, 5/6 each
Auto Transformers, 100-230 volt 6,3 each
24 Mfd. Can Type Electrolytics, 450 volts working 1/6 each

T.G.C. 8 mfd. Can Wet Type Electrolytics, 450 volts working 1/3 each

PRESS BUTTON UNITS with 6 press buttons, ready for wiring into set, with circuit 6/11 each
Set of two WEARITE Iron-Cored Coils, Aerial and H.F. Trans., with diagram 2/11

BULGIN 20 ohms Wire-wound pots 1/- each
Stranded Push-Back Wire, 16, per yd., 12yds. 10d.

CHASSIS Mounting Valve Holders, American, 4-, 5-, 6- and 7-pin, 4d. each. Octal, 6d. each. Loctal, 10d. each. 7-pin English type, 3d. each.

ROTHERMEL Piezo Crystal Speakers, 7 1/2 in. Cone List 55/-. Our price, 10/6 each. 10 in. Cone 12/6 each

CRYSTAL Pick-up, high-grade American Bronze finish, complete with arm 2/- each
POLAR N.S.F. 1-watt resistances, 4d. each. 3/9 doz. All sizes up to 2 meg.

WEARITE Mains Transformers. Made to strict electrical standards, wire end type, all windings centre tapped, screened primaries, tapped inputs. 200-250 volts. Screw adjustment.

TYPE R.C.4. 500-0-500 volts, 150 m.a.; 4 volts 2 amps., 4 volts 2 amps., 4 volts 2.5 amps., 4 volts 5.6 amps. 21/- each

PHILCO Mains Transformers. American Windings, 350, 350 volts, 65 m.a.; 6 volts 3 amps., 5 volts 2 amp. 5/- each
Ditto, but 80 m.a. 6/6 each
Ditto, but 90 m.a. 7/6 each

WEARITE 110 k/c I.F. Transformers 1/- each
AMERICAN C.T.S. Volume Controls, finest made, divided spindles, length 2 1/2 in., with switch 2,000, 5,000, 10,000, 25,000, 50,000, 100,000 2/6 each
Less Switch, 50,000, 100,000, 500,000 1/9 each
Wire-wound 5 watt (less switch), 10,000, 25,000 ohms 2/- each

BATTERY Output Pentodes, well known make. 4/6
WEARITE CHOKES, screened 1/8 each

PLESSEY DRY ELECTROLYTICS. CAN TYPE:
12 x 0 mfd. 500 volts working 1/6 each
12 x 16 " 350 volts " 1/6 each
12 x 8 " 500 volts " 1/6 each
16 x 8 " 475 volts " 1/6 each
6 x 6 " 500 volts " 1/6 each
12 " 450 volts " 1/6 each
8 x 8 x 8 mfd. 500 volts working 2/11 each
16 x 8 x 4 x 4 mfd. 500 volts working 2/11 each
12 x 8 x 8 x 8 mfd. 500 volts working 2/11 each
16 mfd. 450 volts working 1/3 each
16 x 16 mfd. 350 volts working 1/8 each

B.I. CARDBOARD ELECTROLYTICS, wire-end type, 550 volts working, 8 mfd., 1/9 each. 8 x 8 mfd. 4-lead type, 2/9 each. 8 mfd. Midget Tubular, wire-end 550 volt working 2/- each
Bias Wire-end Type. 50 mfd., 12 volt., 1/3 each. 50 mfd., 50 volt 1/6 each
Tubular Wire-end non-inductive paper, all sizes up to 0.1, 5d. each; 4/9 doz.
Metal Case 1 hole fixing Electrolytic Condensers, 550 volt working, 8 mfd., 2/6 each.

STANDARD TELEPHONE HEADPHONES, resistance 2,000 ohms and 4,000 ohms 6/11 pair

VOLUME CONTROLS, 1,000 and 5,000 ohms, with switch 1/3 each
.0005 3-gang Tuning Condenser Units, with trimmers 2/11 each

PLESSEY Energised Speakers, 1,500 ohm field, Sin. Cone, with trans. 7/11 each
10 in. Cone, 2,500 and 1,000 ohm Field, with trans. 12/6 each
6 in. Cone, 2,500 and 1,500 ohm Field 5/11 each

RUBBER GROMMETS 4d. doz.
S.P.D.T. Twist Switches 1/1 each
Battery Output Pentodes, well-known make 4/6 each
Battery Double Diode Triode, well-known make 3/11 each

RAYTHEON First-grade Valves, largest stockists, all types in stock, including Glass Series, Glass Octal Series, Metal Series, Bantam Series, Single-ended Metal Series, and Resistance tubes; all at most competitive prices; send for Valve lists.

All Orders Must Include Sufficient Postage to Cover. Hours of Business: 9 a.m.-8 p.m. Saturdays, 9 a.m.-1 p.m.

RADIO CLEARANCE, LTD., 63, High Holborn, London, W.C.1. Telephone: HOLborn 4031.

The OSRAM VALVE GUIDE

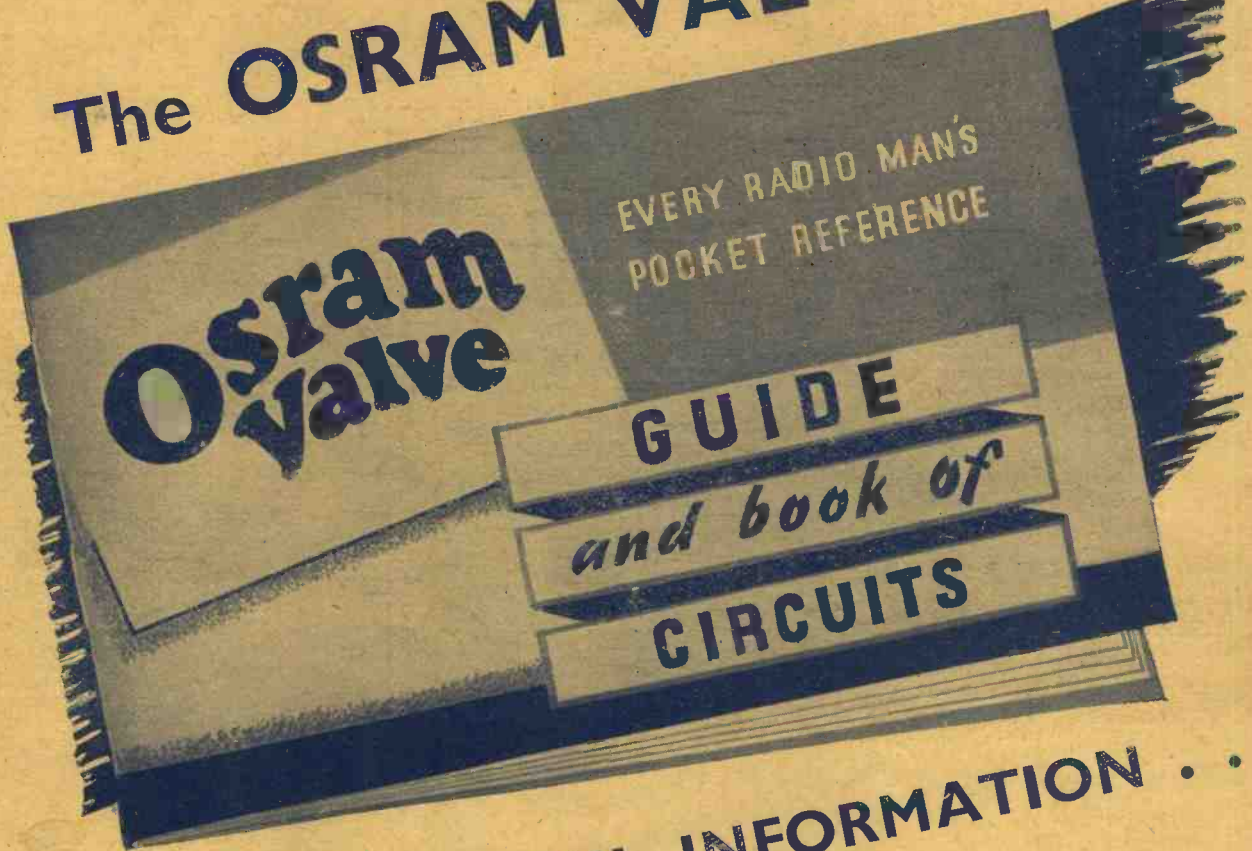

FULL OF HELPFUL INFORMATION . . .

- Technical information and valve operating data.
- Useful Tables of Pin connections.
- ★ Comparative valve Tables.
- Many useful hints for Experimenters.
- 12 Pages of Circuit diagrams

In fact, everything you need to know about valve characteristics and working conditions.

Write for your copy of the OSRAM VALVE GUIDE (sent post free) to the Osram Valve Technical Dept. of:—



In these times of emergency, valve replacements will be required in many receivers. The comparative table shown in the Osram Valve Guide will enable you to select the equivalent OSRAM VALVES.

THE GENERAL ELECTRIC CO., LTD., Magnet House, Kingsway, London, W.C.2

Practical and Wireless

★ PRACTICAL TELEVISION ★

EVERY WEDNESDAY

Vol. XV. No. 378 Dec. 16th, 1939

EDITED BY
F. J. C. AMM

Staff:

W. J. DELANEY, FRANK PRESTON,
H. J. BARTON CHAPPLE, B.S.C.

ROUND THE WORLD OF WIRELESS

Receiver Overhauls

ALTHOUGH receiver faults are not ever-recurring, there are many occasions when a listener feels that results might be improved by an overhaul. Cycles, cars and other working apparatus have to be overhauled periodically, and most wireless receivers pay for a similar overhaul. At such times it may also pay to make modifications to a circuit which has been in use for some time, and without making drastic changes it may be possible to make appreciable improvements in the results with little expense and with a minimum of trouble. The question of straightforward overhaul or clean-up is more simple, but there are many points which have to be borne in mind. An examination of terminal or screwed connections; soldered joints which may have worked loose; dust between moving parts and similar details are probably familiar to every listener, but in view of the many different points which can receive attention at such an overhaul we give in this issue two or three articles on the subject. After a perusal of these it may be found that you can substantially improve your receiver's performance, but remember always to be discriminate in the changes which you introduce.

A Stimulus to Sales

DEALERS throughout the country should find business greatly stimulated by the extensive advertising campaign which has just been inaugurated by The General Electric Co., Ltd., in connection with the marketing of two of its current receivers. This advertising campaign is scheduled to cover a period of several weeks, and the media is a comprehensive one, embracing London national newspapers and a large number of others circulating in all parts of England, Scotland and Wales, Northern Ireland and Eire.

This means that literally millions of people will have their attention directed to these 5-valve, 3-waveband, receivers, for the advertisements are of imposing dimensions and occupy prominent spaces, while they tell a convincing story in a concise and attractive way.

Light Music

OUTSIDE bands and light orchestras are being heard in increasing numbers in the broadcast programmes. In Christmas week, for instance, at least a dozen combinations which were well known to

listeners before the war have been booked, and they include Harry Engleman's Quintet, Falkman and his Apache Band, Orchestre Raymonde, Troise and his Mandoliers, Mantovani and his Tipica Orchestra, Eresno and his Quintet, and Sydney Baynes and his Orchestra.

Many Regional musical combinations are also being engaged so that, within the limits of the single Home Service programme, every effort is being made to give lovers of light music a representative choice.

The Christmas Cuckoo

"THE Christmas Cuckoo" is a play which has been written by Elisabeth Kyle, the Scottish author, from the story in the book by Frances Browne entitled "Granny's Wonderful Chair." It will be broadcast in the Children's Hour on December 14th. It tells the story of two poor cobblers who once upon a time found a cuckoo asleep in a hollow tree root when they were out cutting their Yule log. They were kind to the

bird and in return for their hospitality it promised to bring them gifts when they came back in spring—a leaf from the Golden Tree worth a great price and a leaf from the Merry Tree which keeps folk jolly all the year round. One would think that these gifts would make everything go well for the brothers but it was not quite so simple as that. The play will tell about the luck that the leaves brought them.

"Macbeth, King of Scotland"

GODFREY TEARLE is to play the lead in a special production, "Macbeth, King of Scotland," on December 22nd.

This is the first time that a drama production has been broadcast on this scale since the beginning of the war. Arranged by C. Denis Freeman, and produced by Val Gielgud, this Shakespearean

production is a special adaptation which deals in sequence with the scenes showing the deterioration of the character of Macbeth.

"The Magic Shirt"

HOW a misfortune can be turned into a positive advantage is a theme which never grows old, and J. E. Devenish uses it to advantage in a play called "The Magic Shirt," to be broadcast on December 21st. Lord Wallaby, an elderly statesman, is reaching the peak of his career, thanks to Lady Wallaby, who is described as "the artificer of Lord Wallaby's career"; but a burglar and a chapter from "The Arabian Nights" bring a sudden and astonishing dilemma which does not call for either police or publicity, and Lady Wallaby finds a problem which she cannot tackle.

The part of Lord Wallaby will be played by Bruce Winston, and that of his manservant, Bone, by Barry Kendall. "The Magic Shirt" will be produced by W. Farquharson Small.

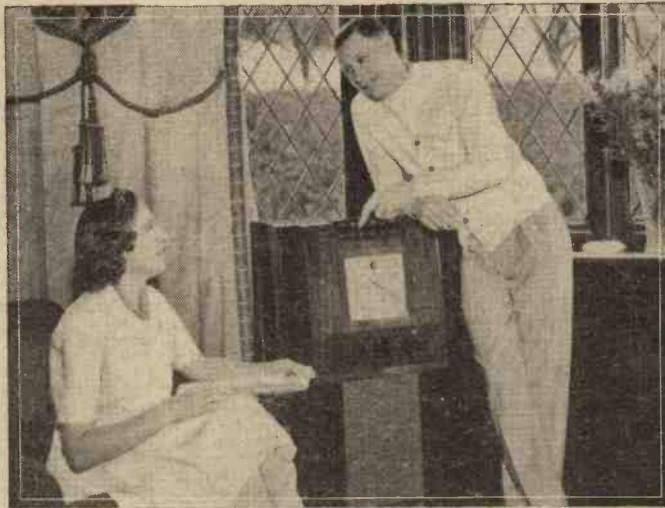

When he's not cleaning windows, George Formby and Mrs. Formby find time for relaxation in their Blackpool home. George is a keen all-wave listener and uses an Ekco console.

Editorial and Advertisement Offices:
"Practical Wireless," George Newnes, Ltd.,
Tower House, Southampton Street, Strand,
W.C.2. Phone: Temple Bar 4363.

Telegrams: Newnes, Rand, London.
Registered at the G.P.O. as a newspaper and
for transmission by Canadian Magazine Post.

The Editor will be pleased to consider articles of a practical nature suitable for publication in PRACTICAL WIRELESS. Such articles should be written on one side of the paper only, and should contain the name and address of the sender. Whilst the Editor does not hold himself responsible for manuscripts, every effort will be made to return them if a stamped and addressed envelope is enclosed. All correspondence intended for the Editor should be addressed: The Editor, PRACTICAL WIRELESS, George Newnes, Ltd., Tower House, Southampton Street, Strand, W.C.2.

Owing to the rapid progress in the design of wireless apparatus and to our efforts to keep our readers in touch with the latest developments, we give no warranty that apparatus described in our columns is not the subject of letters patent.

Copyright in all drawings, photographs and articles published in PRACTICAL WIRELESS is specifically reserved throughout the countries signatory to the Berne Convention and the U.S.A. Reproductions or imitations of any of these are therefore expressly forbidden. PRACTICAL WIRELESS incorporates "Amateur Wireless."

THE IDEAL SET

A Discussion of the Features which Constitute an Ideal Broadcast Receiver - By W. J. DELANEY

If you ask the average listener what, in his opinion, constitutes the ideal receiver you will receive a different answer from practically every one. To some, a three-valver with an output of less than 1 watt suffices, whilst others will listen to nothing less than an 8-valver with push-pull output rated at 12 watts or more. It is thus obvious that in general principles there is no such thing as an ideal receiver, each listener having his own ideas as to what constitutes the ideal. There are, however, many features which can be found common to each one and it is possible to arrive at some conclusion as to the points which should be embodied in a general type

at each end of the frequency spectrum. The true beauty of good recorded music is thus lost unless special means are incorporated in the reproducing apparatus.

On radio also it is a common practice to fit a tone control; this component is, also in most cases, wrongly named.

Tone Control

A tone control should, as its name implies, control the tone of reproduction, but in most cases the component which bears this name merely reduces the higher frequencies, and thereby gives a more balanced effect to the output, although musically the

factory when receiving distant stations, owing to background noises or heterodyne whistles. From this, therefore, one will assume that quality, as such, is only obtainable from a "local" station, and, therefore, a broadcast receiver designed for quality should have a minimum of H.F. amplification, sufficient to load the detector stage satisfactorily, and a really good L.F. section.

Separate Gram. Section

To enable the same set to be used for records, however, a separate amplifier would be desirable, preferably incorporating the contrast expander arrangement, and the switch for radio-gram. Switching should cut out entirely the radio section of such a set and bring into circuit the special record amplifier. One or two commercial receivers have, in fact, attempted to incorporate such a device, but, as mentioned in the early paragraphs of this article, a complete home radio-gram has not, so far as I remember, been built on such lines. Economy is undoubtedly the main feature of such a receiver, but by the use of special multi-section valves, initial expense could be kept down to a minimum, whilst upkeep should not be out of the ordinary, with suitable choice of valves. If the output section of the radio equipment were designed on a reliable push-pull scheme it should be added to the gramophone amplifier section and still further reduce expense, and a suggested scheme is indicated in Fig. 3. It will be seen that the change from radio to gram is made in the L.F. section, and the pick-up is permanently in circuit. By making use of multi switches, such as the small Bulgin components, operated by a single rod, the H.T. to the separate sections, or the L.T. or both, could also be cut out as desired so that the total drain would be constant from the supply section. To obtain the desired high output and good quality such a receiver would have to be mains operated, and the A.C. mains user is in the best position in

Fig. 3.—Schematic diagram of the arrangement of the ideal set.

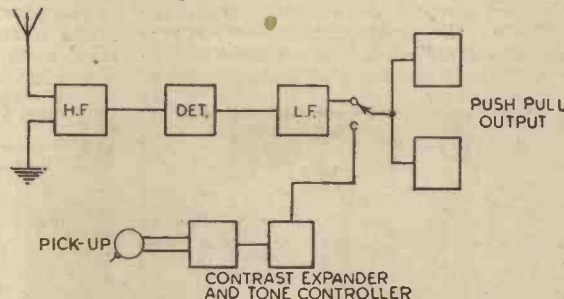

of receiver. For instance, the majority of listeners must have provision for gramophone record reproduction in the receiver, whilst a choice of stations must also be provided. The highest possible quality consistent with low cost of construction and upkeep are also essentials which everyone aims at.

There is, however, one point which is not often stressed and which has not, so far as I am aware, received attention from designers, although perhaps some individual listeners may have thought of the idea, or even included it in their own home-made apparatus. I refer to the separate performances of the radio and the gramo side of a single set.

Quality First

In the majority of receivers the pick-up is connected into the detector or one of the L.F. grid circuits, the connection generally being made permanently and opened or broken by means of a simple radio-gram switch. For normal purposes this serves very well. But when a little thought is given to the matter it is obvious that radio and records require different treatment. Those readers who have made up the Contrast Expander which I described on May 6th last will have appreciated how much better gramophone records sound when they are played through such an amplifier. But, unfortunately, this type of unit is not satisfactory with radio, owing mainly to the different characteristics of the signal. It will be remembered that a gramophone record is mechanically recorded—that is, in a "sound" sense. Although electrical equipment is used to convey the sounds to the disc there are limitations imposed on the method of recording the sound which make it necessary to reduce the contrast and also to limit the volume and amplitude

balance is very incorrect. Again, those readers who built up either of the tone-control units described in the issue dated February 11th last will have experienced the effects which are obtainable when bass or treble or both are amplified or reduced. From this point of view, however, there is a snag to be avoided. If a radio set is properly designed and a "straight-line" L.F. amplifier is included, there should be no need for a tone control. If, for personal preference, one prefers organ music, for instance, to be deep toned, there is no objection to a top-note cut-off control. If the cabinet or room in which the receiver is housed gives undue prominence to the lower frequencies, there is similarly no objection to a low-note cut-off to improve the effective brilliancy of speech and

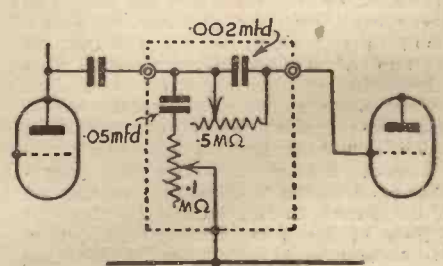
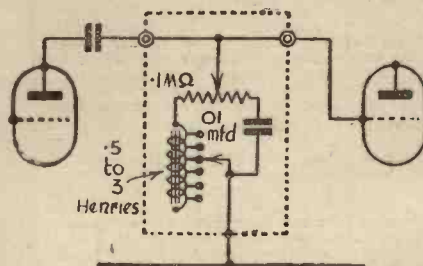

Figs. 1 and 2.—Two tone controls which were described in our issue dated February 11th last.

thereby avoid the leather-lung effect which many speakers appear to have on some receivers. If, however, the set is properly designed to provide even amplification, and a good speaker in a proper cabinet is used, there should be no need for any tonal adjustment on radio signals. The signal put out by practically all broadcasting stations is of a very level nature, but a straight-line receiver may prove unsatis-

this respect owing to the high H.T. which he can obtain from a suitably designed mains unit.

NEWNES TELEVISION AND SHORT-WAVE HANDBOOK

5/-, or 5/6 by post from
GEORGE NEWNES, LTD., Tower House,
Southampton Street, Strand, London, W.C.2.

Modifying Old Receivers

Simple Modifications for Old Receivers Now Being Used as Stand-by Sets - - By L. O. SPARKS

A PART from the vast number of constructors who are, by now, well-established readers of PRACTICAL WIRELESS, fresh recruits to this sphere of radio activity are rolling up in surprising numbers and the majority of them are old-timers returning, once again, to their hobby of several years ago.

This sudden interest on their part is due, according to the many letters received, to their desire to make a stand-by receiver or bring into service one of their earlier efforts which had been put on the shelf when they deserted the ranks, so to speak, and went over to a commercial product. Their skill and knowledge has, of course, become a little rusty, with the result that they now are not too sure how to carry out some of the desirable modifications necessary to bring

overcome any initial troubles which a modern H.F. valve might introduce, but to avoid any unnecessary alteration to the layout, it is always advisable to select a valve having the same type of base. If one wishes to be on the safe side, the valve manufacturers will gladly suggest the nearest equivalent in their present-day products.

Variable-mu Control

The use of a variable-mu type of H.F. valve allows a very satisfactory form of volume-control to be obtained and, at the same time, helps to remove any trace of distortion due to the reception of a very powerful local signal. The modifications for this refinement are quite simple, as Fig. 1 indicates.

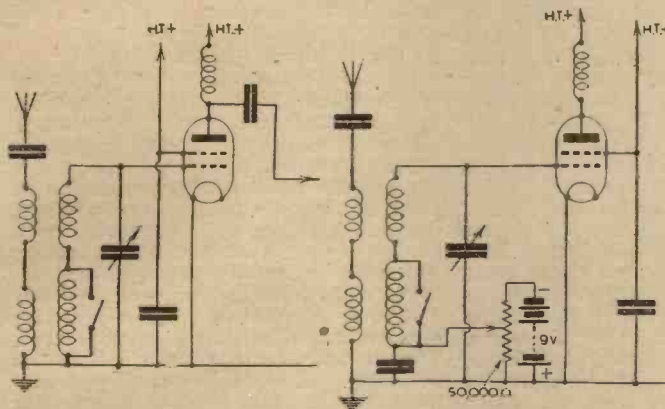

Fig. 1.—The diagram on the left shows an ordinary H.F. grid circuit while that on the right indicates connections for a variable-mu.

the sets in question up to date. The general difficulties seem to be those mentioned below.

Fitting Modern Valves

With many of the older circuits, it is not always an easy matter to substitute modern valves for those originally specified, owing to the fact that the valve of to-day has a much higher efficiency than its earlier counterpart. There is, of course, also the question of the original valveholders being unsuitable for certain types of modern valves and this, in turn, may necessitate alterations to the layout of the components.

The chief danger, due to increased efficiency, lies in the H.F. and output stages. For example, a modern S.G. or H.F. pentode might introduce signs of instability, due to the characteristics of the H.F. coupling and the existing operating conditions governed by the circuit design, being unsuited for use with a valve of high gain. Similarly, if two stages of L.F. amplification are employed, trouble would, no doubt, be experienced if a modern steep-slope L.F. pentode was inserted in the output stage, especially if a power valve had been used in the first place.

Providing screened coils are incorporated in the circuit and that it is possible to adjust the screen and anode voltages of the H.F. valve, it is usually possible to

the coil is disconnected from the earth-line and taken to the moving arm of a potentiometer having a value of 50,000 ohms, and one side of a .01-mfd. fixed condenser, the other side of which is taken to earth. Across the potentiometer is connected a 9-volt grid-bias battery which has its positive socket also connected to the common negative earth line. This connection should be broken, either by means of a switch or by removing the plug, when the set is not in use, to prevent unnecessary drain on the G.B. battery.

Output Pentodes

The pentode was not so widely popular

a few years ago as it is to-day, therefore power or super-power valves were invariably employed. These could handle, within reason, the input from two stages of L.F. amplification which so often formed an essential part of many designs. To-day, however, a modern pentode, with its high gain, will give greater output for a much smaller input, so when replacing the output valve of a receiver of a few years old, it is necessary to remember this fact, otherwise severe distortion will be introduced. The question of matching the loudspeaker also enters into the question. If the original speaker is to hand, then it would not be advisable to use a pentode, as this would necessitate the use of a suitable output transformer to secure satisfactory matching between valve and speaker.

A modification worth while, with a circuit using two stages of L.F. amplification and a power valve and, of course, providing a modern speaker is to be used, is to dispense with one L.F. stage and insert a pentode in the output. Failing this, a simple volume-control should be inserted across the second L.F. stage so that the input to the output pentode can be controlled, thus preventing overloading.

If modern valves have to be fitted in a set with two L.F. stages coupled together by means of L.F. transformers, much better results will be obtained by replacing the second transformer with a resistance-capacity coupling as shown in Fig. 2, which also indicates how the volume can be controlled with such an arrangement. Another item which must not be overlooked when a modern pentode is used, is the tone or load-corrector in its anode circuit. This takes the form of a resistance, having a value of, say, 15,000 ohms, connected in series with a condenser of .01-mfd., and joined across the L.S. terminals or between the anode and earth.

Selectivity

Some of the older types of coils were designed to secure greatest sensitivity and, due to the conditions then existing, the question of selectivity did not receive a great deal of consideration. Apart from the addition of a stage of tuned H.F. amplification or the insertion of a .0002-mfd. variable condenser in series with the aerial lead-in, there is very little that can be done. The most satisfactory course is to fit modern coils.

The diagram at the left shows the normal circuit of a "straight" H.F. screened-grid valve, such as those used in the earlier sets. It will be noted that the aerial coil is connected between the grid terminal and earth. With a variable-mu valve, it is necessary to apply a variable negative bias to the grid of the H.F. valve, and this is done in the manner shown by the circuit on the right of Fig. 1.

The earth end of the coil is disconnected from the earth-line and taken to the moving arm of a potentiometer having a value of 50,000 ohms, and one side of a .01-mfd. fixed condenser, the other side of which is taken to earth. Across the potentiometer is connected a 9-volt grid-bias battery which has its positive socket also connected to the common negative earth line. This connection should be broken, either by means of a switch or by removing the plug, when the set is not in use, to prevent unnecessary drain on the G.B. battery.

Fig. 2.—Converting a transformer-coupled stage to resistance-capacity coupling. By replacing the 1 MΩ leak by a potentiometer of the same value and connecting the grid to its moving arm, an efficient volume control will be obtained.

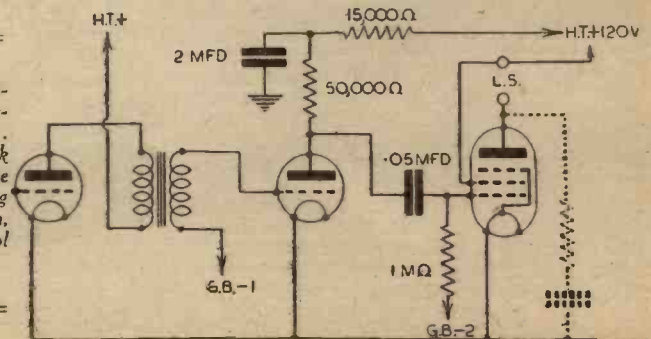

Notes on Servicing

In This Article Some of the Snags in Radio Service Work are Briefly Explained



The Avo Test Meter, which has several separate ranges, easily selected by rotary switches.

MANY of the more experienced service engineers having been called up, it is likely that greater responsibilities will fall on those of lesser experience. As most of these people no doubt realise, there are many snags and pitfalls in radio service work which may be encountered from day to day. An outline of some of these difficulties may, therefore, be of value to service engineers of short experience.

Locating Faults

We will commence with the case of the receiver which is known to be absolutely silent. It is unwise to switch on such a set with the supply connected without first making a rough test for an H.T. short-circuit, as additional components may be damaged by so doing. A quick resistance test between the heater socket of the rectifier valve and chassis, on a mains receiver, will show if such a fault exists. This precaution may save further damage to the mains transformer, L.S. field, rectifier valve, and other components if, for instance, a reservoir or H.T. smoothing condenser has developed an internal short-circuit. When switching on a set for test, a danger sign to look for is a glowing auxiliary grid where the output valve is a pentode. Here is an almost infallible warning of a break in the anode supply to this valve, such as an open-circuited output transformer primary. The overheating could, of course, be avoided altogether on test, by making a continuity test between the H.T. supply and pentode anode, before switching on the set. Once a fault has been located, particularly in the event of burnt-out components, it is wise to search for a possible breakdown of some other component as a cause, or result of the trouble. An intelligent use of the voltmeter will give much useful information on the working condition of the receiver under test. It is, of course, essential to use a high-resistance voltmeter for tests where high series resistance is encountered in the circuit under test, otherwise the

consumption of the meter may seriously affect the reading obtained. A case in point is the taking of voltage readings at the screening grid of an H.F. valve which receives its supply via a resistor of high value.

Anode Voltage

In certain cases an abnormally high voltage at the anode of the output valve, together with low current consumption, can be puzzling. The routine check of components usually associated with these symptoms may reveal no fault. An open-circuited smoothing condenser may be the culprit in such cases. It may cause inaudible oscillation which results in weak or "no sigs." When replacing defective resistors, care should be taken to fit components of ample current-carrying capacity. Occasionally, it may be found that the makers of the receiver in question have cut things rather fine, and it may be advisable to replace with a resistor giving a greater factor of safety. This point should be looked for, particularly where an H.T. potentiometer network is used to feed the screening grids of H.F. valves. Any associated decoupling condensers should, of course, be checked for leakage when a resistor breaks down. It should be remembered that a high-resistance leak may not show when testing with the usual ohmmeter using a single cell. It is necessary in such cases to test at a higher voltage, say 200 volts or so. However, care must be taken not to apply a much larger voltage to the component under test than it is designed to work at. Noisy volume controls are common troubles, though there are pitfalls here for the inexperienced engineer. It is possible for noise and intermittent signals to be

produced on turning the volume control while this component is in perfect working order. Where a coupling condenser is used between the volume control rotor and the grid of the L.F. or output valve, for instance, an intermittent contact in the condenser may cause noise or/and intermittent signals when the volume control is operated. It may be found possible to clear intermittent faults by disturbing valves or components. In many cases this will be an unwise procedure, as the fault may not reappear for a considerable period. If at all possible, some means should be found to localise the fault first. A signal generator will be of great assistance for this purpose. It can be used to inject signals stage by stage in a process of elimination. An output meter will give a better indication than the ear in locating such faults.

Faulty Soldered Joints

Dry or imperfect soldered joints can cause numerous troubles. It is possible for a joint, which appears to be O.K. when tested with an ohmmeter, to offer a high impedance to H.F. A case in point was a fault which appeared in an A.C. Radiogram handled by the writer recently. The instrument was a new one, having been in operation only a few weeks when a complaint was received. The customer reported that signals would fade or suffer a sudden decrease or increase in volume at intervals. A number of service calls were made but the fault did not appear. The set was, therefore, brought into the workshop. A signal generator was connected to the aerial socket and an output meter to the L.S. sockets. The set ran perfectly for some days when the meter showed a decrease in output. The generator

(Continued on page 290.)

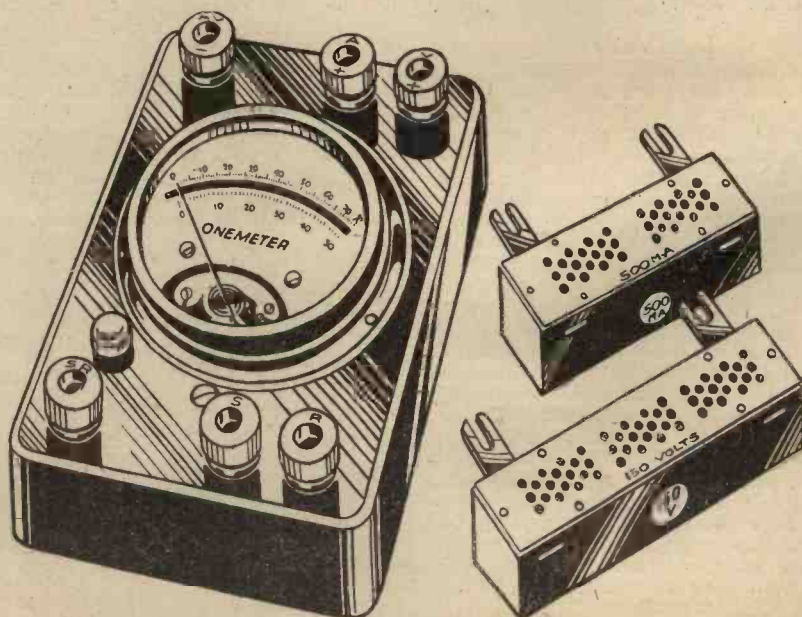

The Dixon Onemeter, and two of the separate plug-in accessories.

ON YOUR WAVELENGTH



A Suggestion for Small Clubs

SECRETARIES of some of the smaller and more recently formed clubs tell me that they are finding difficulty in carrying on. Their members are being called to the colours, and new recruits do not come along in sufficient numbers to fill the gaps. They ask me what they should do. The answer is that they should endeavour to carry on. There are no rules which will apply to every case, for the number of members, the district, as well as the sphere of interest fostered, affect the problem. Clubs must, however, carry on. They owe that to those who have joined the colours. The latter will not feel particularly pleased if they return to civilian life and find that those they left behind were not able to defend their small portion of the home front. In one or two cases, however, I know that the difficulties are very real, and for this reason I make the suggestion that they should endeavour to get some of the larger clubs to absorb them. Some of the old clubs are, too, finding it difficult to keep membership up to strength, and they might be willing to take in some of the smaller clubs, of course with the proviso that when the war is over they will revert to a separate identity. It will be nearly impossible to get the members together again if they are allowed to disband, or if there is no organisation at home which will act as a link.

From an Active Server

BEARING on this matter is a letter from L. Frank, XG₄NLL, who is now stationed at Cosham, Hants. He expresses pleasure that PRACTICAL WIRELESS is continuing to act as the link between constructors. He says it joins his past and his present life. The Liverpool and District Short-wave Club, of which he was hon. sec., started a promising career, but it has been closed for the duration of the war. He would be delighted to hear from readers, or from any of his club colleagues. Any letters sent to me will be forwarded.

Some John Hilton Nonsense

A FEW evenings ago John Hilton gave a talk in which he uttered some remarks which can only be

By *Thermion*

defined as wrong. Here is one of them: "If you are asked to pay higher prices walk away and put your money in National War Savings." I do not know how he thinks that people who cannot pay for hire-purchase transactions are able to buy savings certificates. I suggest that B.B.C. speakers confine their remarks to subjects they know something about. I am yet to learn that Hilton's experience entitled him to speak on business matters, and I would further remind him that textbook economics may be useful playthings, but an ounce of practical experience of them is worth the whole lot of professorial tripe uttered in a didactic I-know-all-about-it-take-it-or-leave-it attitude. There are those in the radio trade who know far more about these matters than John Hilton. He should confine his remarks to subjects on which he is enabled to speak with authority. I also suggest to the B.B.C. that they should not permit speakers, however distinguished, to talk on subjects they obviously can know little about. It offends the ears of those who know as much as there is to know about the subject.

From Overseas

I RECEIVED a letter from D. C. S., who resides at Grahamstown, S. Africa. His letter demonstrates not only that this journal circulates all over the world, but also that our sets are built in the remotest corners thereof. This reader recently came into possession of a secondhand battery-operated superhet four-valve chassis. Browsing amongst some old periodicals at a friend's house, he was scanning our issue dated December 7th, 1935, which contains a description of the A.C. £4 Superhet Four. He at once identified it as

the secondhand set which he had acquired, although the latter had been stripped of some of its components. I was able to send him the information which will enable him to complete the receiver.

New P.O. Regulations

SOME drastic new regulations are now in force regarding the sale, purchase or even acquisition of various pieces of apparatus which are common to high-quality receiving apparatus, as well as standard transmitting equipment. The full details of these regulations, so far as they affect the dealer and listener, are given on another page in this issue, and one point which is probably of the greatest interest is that relating to valves having an anode dissipation of 10 watts or more. Such valves are commonly used in output stages of high-quality broadcast receivers and public-address equipment. The regulation also prohibits the use of remote-control apparatus such as might be used for the radio control of boats, aeroplanes or other working models. Great care is, therefore, necessary in considering the making of wireless apparatus now, and any experiments which you might wish to carry out should bear these new regulations in mind. Fuller details of the new regulations may be obtained from H.M. Stationery Office.

Torch Batteries

I LEARN of a dealer in Dumfriesshire who is adopting the trick I have previously referred to of making torch batteries out of high-tension batteries. He breaks up a 6s. H.T. battery and offers to alter the customers' torches to take two of the cells by soldering on a tin extension. The customer, of course, pays the cost of the alteration. He sells these 3-volt conversions at 4d. and the 4.5 volt batteries at 6d. Thus, in this form he is able to make 13s. 4d. out of a high-tension battery. This is quite apart from the fact that high-tension batteries are unsuitable for a quarter to half an ampere discharge. Battery manufacturers can have the address of this person if they wish. His name has been sent on to me by Mr. W. M., of Dumfriesshire.

Comment, Chat and Criticism

Nationality in Music

Further Remarks on Idioms, Nationalism and Listening
by Our Music Critic, MAURICE REEVE

IN discussing nationality in music a few weeks ago I drew attention to the various harmonic and rhythmic "colourings" and "effects" which go towards making the music of one nation so different from that of any other. The characteristic ornaments that occur in all Spanish melodies, and the use of the melodic minor in such a lot of Russian music—all these things, I explained, had come down to us from the days of the troubadours, and the folk-singers of days gone by, and were now as much a part of musical language in their respective countries as were the various idioms and characteristics of their speech.

This week I would like to emphasise that this is something quite separate and apart from any particular composer's individuality. What really happens is this. A musical idiom gets evolved from the common stock of musical speech of a people in the same way that Yorkshire folk say, "Art coomin', lad?" or Americans, "O.K., toots." Why do they say it? How did they ever get to talk with those accents, and to use those idioms? When did their use commence? Well, doubtless the philologists tell us in their massive tomes and treatises just as the musicographers tell us where the Spaniards got their twists and turns from in their music. But all that concerns the musical man in the street is that they are there, and have been there for several hundreds of years, with the result that it is just as natural—inevitable—unavoidable—for a Spanish composer to write a melody to-day with that certain Spanish flavour in it as it is for two Yorkshiremen or Devonians to greet each other in the characteristic patois of their respective counties. They can't possibly help it; their fathers did, and their fathers, and so on right back.

Composers' Personality

But don't mistake that for a particular composer's idiom something peculiar and individual to himself. That is merely part of himself like his complexion or physique, which would also be stamped with his country's "dye." His individuality and personal idiom lie in the way in which he dresses that up—the harmonic, rhythmic, contrapuntal devices he uses to clothe it in. A genius like Wagner or Beethoven has such infinite resources and such inexhaustible originality in these fields that his personality obtrudes through every page he writes. We do not think of him so much as a German writer, as just "Wagner" or "Beethoven." Although a composer like de Falla is a splendid musician, and has written much beautiful and original music, the idiom that he has inherited from generations of musical forbears is so strong that it predominates over his own musical personality with the result that when we hear his music for the first time, and consequently in ignorance of its composer's name, we instinctively exclaim "that's something Spanish." But when Wagner comes to us from afar it's "Here's Wagner," and never "They are

playing something German." That is why we always think of Spanish, Hungarian, Russian music—as well as such weird noises as Chinese, or Scotch bagpipes—in terms of nationality, and of German, and much English and French music, by who wrote it.

Czech Music

Apropos of this subject, I have just come across a most interesting and illuminating comment from a source where one would least expect to find it. During the week-end, I happened to read No. 15 of the very interesting "Oxford Pamphlets on World Affairs"—"Czecho-Slovakia," by the Headmaster of Charterhouse, Mr. R. Birley. In the paragraph entitled "the revival of the Czechs," Mr. Birley says: "It was to be expected that Czech nationalism would find expression in an artistic revival. Naturally, it took time for a national literature to appear, and it must be remembered that until after the war of 1914-18 there was no call for translations of what was an unknown language. But there is one medium which is peculiarly suitable for the expression of an awakening national spirit, and it is one that needs no translation. It was through their music that the Czechs made themselves known to Europe, and in the works of their composers, especially Smetana and Dvorak, can be seen clearly the peculiar spirit of the Czech renaissance. The Czechs had belonged for centuries to an international culture, and these composers are clearly influenced in style, and form, by the great musicians of their age. But the new Czech culture was inevitably bound up with the spirit of the common people, from whose racial consciousness it had sprung." And I must quote again from Mr. Birley's last sentence "who has watched the flowing Vltava and heard Smetana's Symphonic Poem to the river, where the songs of the people mingle with the surge of the waters."

Mr. Birley emphasises very graphically the power that music has for expressing a nationalistic feeling at the same time as it can paint a picture or tell a story. It is also a lucid and succinct confirmation of my remarks on the origins of nationalism in music. And this dual accomplishment is

manifested in a work like Smetana's Vltava in a way that makes it an admirable example for illustrating this article. (By the way, this work, and the even better-known overture to the opera "The Bartered Bride," will be familiar to Promenade and other Symphony Concert listeners.) In writing a work which merely consisted of limpid runs and arpeggios on the strings and the harp, which the most naïve listener could tell was meant to describe water, plus themes reminiscent of a shady bank and a spooning couple, Smetana might not have done any more than a hundred composers have done when writing of "The Thames on a Sunny Afternoon," or "Niagara's Rushing Cascade." But it is the employment of national harmonies and rhythms which tell us that, first of all, the piece is of Czech origin, and secondly, that it is a picture of a Czech river that we are looking at. Thirdly, Smetana's individual treatment of music's language tells us that it is Smetana who has written the work, and not Dvorak or Bartok. And, lastly, his statement that the picture is of the River Vltava, and not of any other Czech river, must be accepted as binding by the listener.

Critical Listening

If all these factors are considered, and their implications obeyed, whenever music is listened to, then there is absolutely no reason why either the meaning of the work should escape us, or that it should fail to interest us. But don't ever listen to even the most insignificant work without a set purpose. Ascertain the composer's intentions as to what he set out to do. We owe it to him, and we owe it to ourselves. After all, it is only what we do before we start to read the most trifling piece of writing, or before we look at the smallest picture, and they are "concrete" things. So with the abstract language of music, added concentration and preliminary enquiry are necessary. And what a reward such an effort gives us! What thrills, what delights and what sensations are ours if we just take that little trouble before sitting down to listen.

A COMPLETE LIBRARY OF STANDARD WORKS

By F. J. GAMM.

- PRACTICAL WIRELESS ENCYCLOPÆDIA 5/-, by post 5/6.
 EVERYMAN'S WIRELESS BOOK 5/-, by post 5/6.
 TELEVISION and SHORT-WAVE HANDBOOK 5/-, by post 5/6.
 SIXTY TESTED WIRELESS CIRCUITS 2/6, by post 2/10.
 WIRELESS COILS, CHOKES and TRANSFORMERS and
 HOW TO MAKE THEM 2/6, by post 2/10.
 PRACTICAL WIRELESS SERVICE MANUAL 5/-, by post 5/6.
 WORKSHOP CALCULATIONS, TABLES & FORMULÆ
 3/6, by post, 3/10.
 PRACTICAL MECHANICS HANDBOOK 6/-, by post 6/6.

All obtainable from or through Newsagents or from Geo. Newnes, Ltd., Tower House, Southampton St., Strand, W.C.2

Overhauling the Receiver

Some Seasonable Hints on Checking Through the Receiver and on Improving Selectivity - - - By FRANK PRESTON

EVEN with a receiver that is operating satisfactorily, it is a good plan to check through it and carry out at least a minor overhaul about once a year. And this is probably the best time of the year to do it; the set will be required to give of its best during Christmas, and most receivers are being used for a greater number of hours a week, now that the "black-out" evenings are so long, than ever before.

It is not necessarily suggested that any extensive alterations be made—unless some

appreciable slackness, remove the terminal nut and clean the contact face of this and also the looped end of wire. This can be done by scraping with a knife blade or by rubbing with very fine glasspaper; emery cloth is not very suitable, because the fine particles can, in some conditions, form a high-resistance leakage path.

If connections are soldered, look carefully for "dry" joints. These can be detected by the solder being in a dirty blob, instead of its having run smoothly, and also by pulling fairly hard on the wires. If the joint is too weak, in which case it might cause a high-resistance connection, thoroughly clean the parts, apply a trace of Fluxite and re-solder. Do not forget to see that all terminals are tight in the components to which they are attached. In some cases it will be necessary to disconnect and remove the component to tighten any loose terminals.

other hand, should any valve be suspected and there is no convenient means available of making a test, most dealers will arrange for a new valve, or one known to be in good condition, to be tried as a replacement.

Adding Band-pass

While carrying out the examination it might be desired to improve the receiver, either by adding another amplifying stage or by modifying the tuning arrangements to obtain greater selectivity. Full details of both H.F. and L.F. amplifiers have been

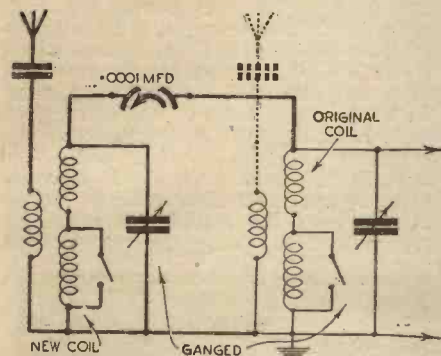

Fig. 1.—A simple method of converting the aerial tuner to a band-pass filter.

simple tests show these to be desirable—but the receiver should be removed from its cabinet and given a good clean. The more accessible parts can be cleaned with a duster, whilst a feather brush or pastry brush is suitable for cleaning many of the other parts. Once the dust has been loosened it can be removed with a vacuum cleaner. When this is of the cylindrical type the best result can generally be obtained by first connecting the pipe line so that an outward draught is produced. Then the tube can be changed and the remaining dust sucked up. For doing this it is usually found best to fit the small brush to the pipe line.

Clean Tuning Condensers

Variable condensers should be cleaned, and to do this it is in some instances necessary to remove the cover plate. With older types in which the vanes are fairly widely spaced, or in a simple type of "straight" set, an excellent method is to run a pipe cleaner between the vanes. This will be still more effective if the cleaner is first dipped in carbon tetrachloride or one of the preparatory cleaning fluids normally intended for fabrics. "Open" the moving and fixed vanes and clean each set separately. Incidentally, the same cleaner dipped in carbon tetrachloride (about three-pence a small bottleful from most chemists) is excellent for cleaning switch contacts, terminals, valve and coil pins or other rubbing contacts.

Test the Wiring

When wiring has been done by clamping the looped ends under terminal heads, run round these with a small pair of pliers and see that all are tight. Where there is

Self-contained Battery Sets

When checking through a battery set, the batteries for which are housed in the cabinet with the set, bear in mind that the fine spray given off by the accumulator when freshly charged has a tendency to corrode insulation and wires near it. Pay especial attention to coil windings and flexible leads. While carrying out the inspection see that all screens and screening cans are tight and making good earth contact. This applies especially to built-up screening boxes.

If a suitable meter is available it is desirable to test the L.T. and H.T. voltages actually applied to the valveholders, whilst the voltage of the G.B. battery might be measured. Too low a voltage will show either that a battery is in need of attention, or that there is a bad connection in the battery circuit. In the latter case, the on-off switch might be at fault. Any switch—on-off or wave-change—can easily be tested by short-circuiting it; should this have any effect it will be obvious that the contact through it is inefficient.

Check the Valves

A valve which is no longer efficient might be the cause of a marked deterioration in quality or of reduced selectivity. Accurate tests cannot be carried out by the average constructor, but many first-class radio dealers are now equipped with an instrument which shows on a marked scale the "goodness" of the valve; the reading is generally in terms of mutual conductance. On the

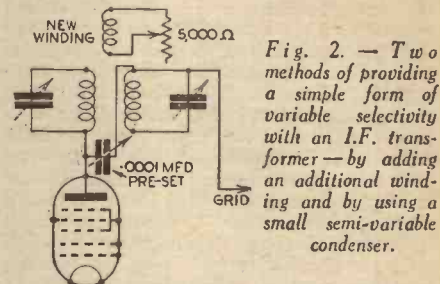
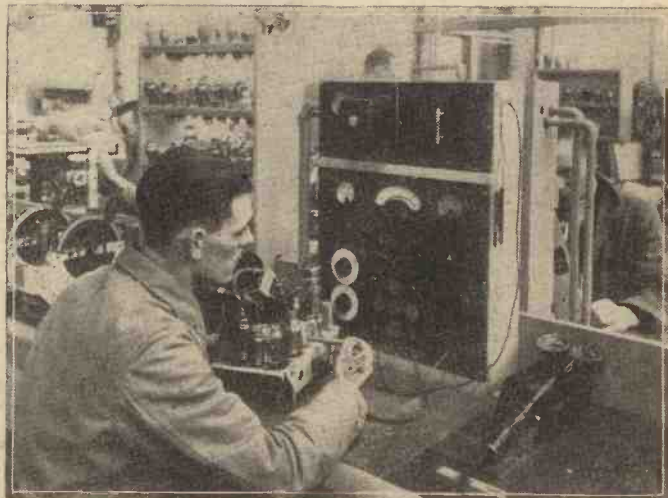

Fig. 2.—Two methods of providing a simple form of variable selectivity with an I.F. transformer—by adding an additional winding and by using a small semi-variable condenser.

given in these pages before, and back numbers of the articles in question are in most cases still available if required. The question of selectivity would not appear to be of great importance now that there is only one B.B.C. "home" programme, but as many readers have discovered of late, interference with the two frequencies employed by the B.B.C. is not uncommon on some evenings. When a single-circuit aerial tuner is used in a Det.-L.F. receiver it might be desirable to change this for a band-pass filter. This can generally be done by replacing the existing single condenser by one of the two-gang type and fitting another coil identical with that already used. Sometimes a second single condenser can be attached to the present one by means of a coupler.

(Continued on page 290)



The amateur does not have the facilities of the factory, but can make very satisfactory overhauls if proper steps are taken. This picture shows a set being tested at the Ekco factory. Note the soldering equipment and elaborate test panel.

PRACTICAL TELEVISION

December 16th, 1939.

Vol. 4.

No. 181.

C.R. Tube Research

ALTHOUGH the need of cathode-ray tubes has been relegated to the background in so far as television is concerned, there is renewed activity in the laboratories for the production of tubes to meet special demands. Various kinds of detecting and measuring devices are now being developed, and although the immediate application is quite naturally for war purposes, it is anticipated that with the ultimate cessation of hostilities this same equipment will find its way into more peaceful channels. That being the case, it is quite natural that those firms who have for the past few years been primarily concerned with improvements in cathode-ray tube technique now find that their labours are by no means curtailed in the research section, but rather the reverse. Each laboratory dealing with questions of high vacuum physics is of a most interesting character and is called upon to solve a multitude of problems in which cathode-ray tubes play a pre-eminent part. The various forms of hard glass used for tube envelopes have to be tested and examined to ensure complete freedom from flaws, and in the case of high-vacuum tubes it is essential to watch for any tendency towards failure at the rounded edges, where considerable strain occurs. The laboratory must contain suitable pumping and baking plant, high-voltage test equipment, and the accompanying illustration is therefore of interest, as it shows the corner of one cathode-ray tube research section engaged on experimental work. The extra high voltage test apparatus is seen on the left just in front of the sink, while a tube which has already been subjected to its various forms of examination is standing on top.

The baking oven will be readily recognised and this is supported between vertical tubular runners, so that the cylindrical chamber can be raised and lowered easily against balance weights and so allow periodic observations to be undertaken. Below the bench supporting the oven is accommodated the high-vacuum pumps, which are kept running during the baking process, and when sealing off the tube. Liquid air, oxygen cylinders, electrostatic voltmeters, high-voltage condensers and a large assortment of chemical materials will always be found within the precincts of these laboratories, and most of these things can be recognised by readers in the photograph shown.

Single Sideband Working

THE Americans have now had several months' experience in the operation of their television service on a single sideband basis, and the consensus of opinion seems to be that it is working quite satisfactorily. This is a very important point, for it might have a marked bearing on future television developments in this country when the time comes for

the whole situation to be reviewed. If the B.B.C. scheme is recalled, it will be remembered that the vision signals were radiated on a carrier wave frequency of 45 megacycles. The maximum modulation frequency for a 405 line, 5 by 4 format picture repeated 25 pictures per second was regarded as 2.5 megacycles, with the result that the vision signal extended from 42.5 to 47.5 megacycles. The sound channel was on 41.5 megacycles, however, so that it was safe to assume that between 41.5 and 47.5 megacycles no other signal could be radiated within the normal reception area without causing interference. With radio communication considerably extended for all forms of national purposes at the present time, the use of such a wide band for television purposes would only be regarded as rather extravagant. If single sideband working had been adopted

of the Atlantic by the methods which the authorities have employed will prove of inestimable value when reviewing the future of British television. Not only single sideband working but also negative modulation as distinct from positive modulation will call for careful study in order to see whether the claims for interference reduction are justified for the former modulation scheme. If a generous view is taken of the present situation, it is possible that good may come out of evil, and the work of America may stand in good stead.

Frequency Modulation

CONJOINTLY with the views expressed in the previous paragraph must be studied this new problem of frequency modulation as distinct from amplitude modulation, for this has loomed into great prominence as a result of the work of Armstrong in the United States. It must not be imagined that frequency modulation is entirely a new aspect of radio, for its benefits on the radio telegraphy side have long been recognised. For example, it is an established principle that a carrier wave which is rich in sidebands is of definite advantage from the point of view of reducing fading for telegraphic services. There are three main advantages which can be cited for frequency modulation over the older methods in this connection. In the first place, by a suitable choice of the depth and frequency of the modulation a greater proportion of the energy can be transferred

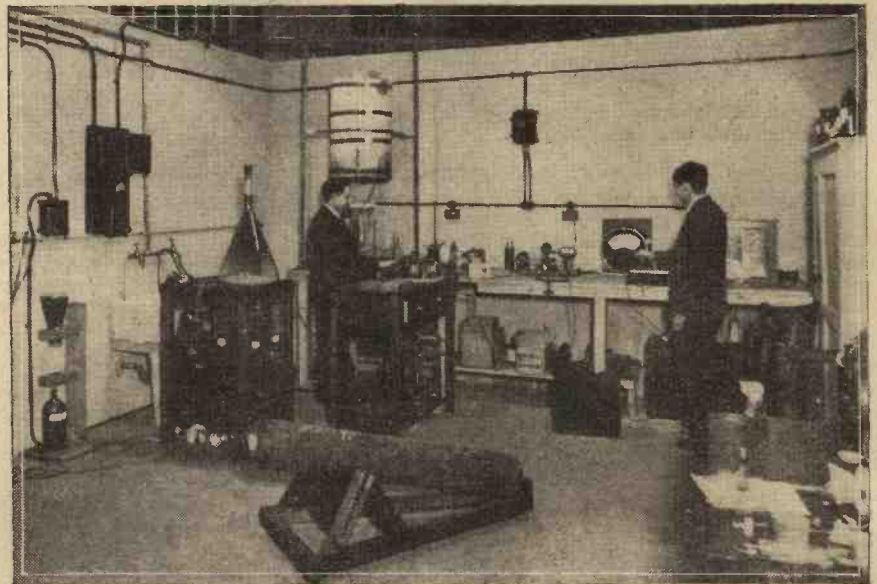

A corner of a cathode-ray tube research laboratory, showing the special equipment employed for some of the work.

originally, however, the position would have been entirely different, and a distinct economy from the point of view of "ether space" would have been effected. Suitable filters at the transmitting end effectively suppress the unwanted sideband, and all the intelligence required is maintained in the signal which remains. When any extension of the service has to be considered, the problem of available frequency bands will necessarily become acute, and before home television sets are counted in their hundreds of thousands instead of in thousands, as was the case three months ago, it is reasonable to anticipate that very serious consideration will have to be given in the light of provincial requirements. It is certain, therefore, that the experience which has been gained on the other side

to the sidebands. Following on this at the same time, the total sideband spread, and in consequence the interference with neighbouring channels, is reduced very considerably. Finally, there is no reduction in the aerial power, whereas with an interrupted continuous wave, such as would be used for morse telegraphic transmission, the power is always half or less, depending on the waveform of the modulation. For broadcast telephony, Armstrong has been demonstrating in America in no uncertain manner that his scheme embraces all the advantages known previously to exist for wireless telegraphy. Whether this same argument will still hold for the ultra-high modulation frequency which is inseparable from modern high-definition television pictures has yet to be investigated.

Practical Hints

A Condenser Improvement

To prevent increasing the minimum capacity of one section of a ganged condenser in my receiver, I hit upon the idea of making up a rather novel movement which simply alters the physical setting of the body of the condenser but leaves the moving vanes stationary. In the accompanying sketches the details of the scheme are clearly outlined, and from

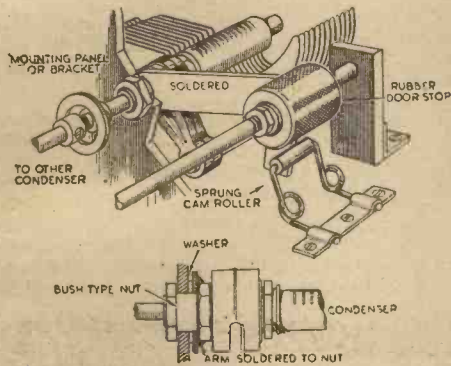

A novel condenser improvement.

these it will be seen that I have made good use of a rubber door-stop for the separate control.

This door-stop is rigidly fitted with a threaded 3/16in. diameter brass shaft which passes through a bush in the front panel and terminates in a 3in. diameter control knob.

This rubber "drive" presses firmly on the edge of a shaped brass operating arm, which is soldered to the brass clamping nut on the condenser bush. The small ebonite roller engages in a recess filed in the arm and located at the maximum setting of the condenser.

The diagram shows the method of assembly, the bush type fixing nut normally supplied with this particular type of condenser being the principal feature in the fitment. It will be apparent that the ultimate smoothness in the movement will depend entirely on the careful choice of thickness in the operating arm, washer, and bracket or panel mount.—G. F. DAVIS (St. Albans).

Insulated Coupling Brackets

RECENTLY when mounting a variable condenser on a rather thin aluminium screen, it occurred to me that whilst the extension rod fitted between the condenser and the front panel afforded some degree of rigidity, the screen and front panel were not sufficiently earthed for a receiver which I expected to operate down to 11 metres.

Due to the particular design of chassis, and in view of the fact that the extension rods were, of course, insulated, the rather large screen would quite possibly introduce noises apart from the movement noises of the old types of variable condensers employed. I therefore devised a number of "coupling" brackets which could be used also for various other purposes apart from that intended.

THAT DODGE OF YOURS!

Every Reader of "PRACTICAL WIRELESS" must have originated some little dodge which would interest other readers. Why not pass it on to us? We pay £1-10-0 for the best hint submitted, and for every other item published on this page we will pay half-a-guinea. Turn that idea of yours to account by sending it in to us addressed to the Editor, "PRACTICAL WIRELESS," George Newnes, Ltd., Tower House, Southampton Street, Strand, W.C.2. Put your name and address on every item. Please note that every notion sent in must be original. Mark envelopes "Practical Hints." DO NOT enclose Queries with your hints.

SPECIAL NOTICE

All hints must be accompanied by the coupon cut from page iii of cover.

Some of these I made insulated by using a bakelite strip in place of a commoning brass strip as used in the ordinary type illustrated. It will be seen that the insulated types can be used in instances where the moving vanes of the condenser are in-

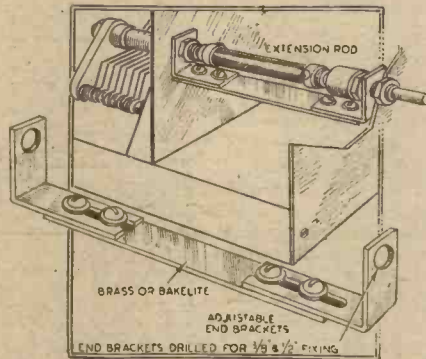

Insulated coupling brackets for extension rods.

directly earthed by a by-pass condenser, as in the case of variable- μ volume control circuits.

There is one other point concerning the use of these couplers, and this is with regard to dial and reduction drive fitments. I have found that with some reduction drives, if careful alignment is not effected, then at certain points in the movement, sluggishness prevents accurate tuning, so here again the couplers have proved useful for maintaining the alignment of the control with the condenser, irrespective of the extension rod when testing and carrying out modifications.—J. L. STEVEN (Manchester).

READ
"THE CYCLIST"
3d. Every Wednesday

Inductance Tapping

To make a tapping on a S.W. coil a crocodile clip is usually employed, but as this only grips half the wire a sound joint is not ensured. A remedy is shown in the accompanying sketches. By cutting a slot in the former about 1/4in. wide, as at A, a tapping can be made by a crocodile clip

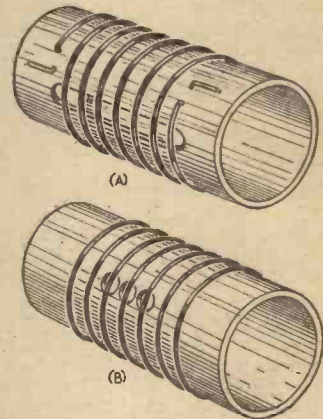

A method of tapping S.W. coils.

from the inside, which will then grip firmly.

If a more permanent and neater job is required, holes, as at B, can be drilled before winding, and tappings soldered on through the former.—K. A. SHONE (Wrexham).

A Single Drive for Two Components

RECENTLY I found it necessary to include two condenser drives in one, so I devised the following idea. A rod about 8in. long was fitted (as shown) underneath the chassis. A 2in. diameter wheel (A) was fitted and this contacted with a wheel (B) of 1 1/4in. diameter. This drove another wheel (C), which was fitted to the spindle of the reaction condenser. Mounted 1in. farther back was another wheel (D), which drove another smaller wheel fitted to the spindle of the volume control.

The components and wheels were mounted on brackets secured to the top of the chassis. To operate reaction, leave the control as shown in diagram; for volume, push in until A engages with D.—M. C. CAMPBELL (Romford).

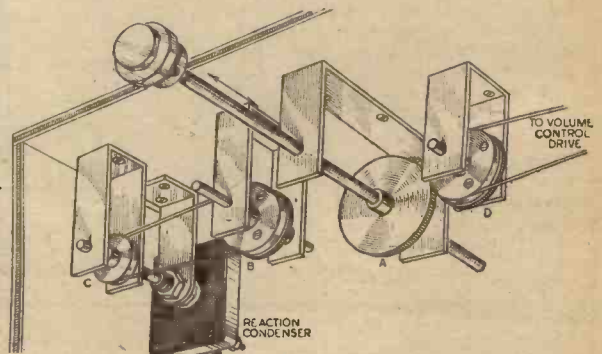

A simple dodge for driving two components from a single spindle.

CHOKE filter output was decided on in this receiver for two reasons, a final precaution against H.F. leakage, and secondly, to interrupt more satisfactorily the output circuit when frequently using the 'phones.

Normally speaking, a straight circuit of this type, where H.F. and L.F. amplification is freely used, brings anticipation of a high noise to signal ratio, but—and this is in no mean way attributable to the performance of the Z220—the results have definitely passed expectations in this respect, and provided an accumulator of, say, 20 A.H. minimum is used, the apparent comparatively but necessarily higher drain of 1 amp. on the L.T. will not prove worth considering, whilst the total anode consumption is reasonably low, being in the neighbourhood of 20 mA.

A wooden chassis was decided upon during the design of this receiver, as it was anticipated that there would most likely be some difficulty in obtaining metal at a reasonable price, owing to the war, and, therefore, as little aluminium as is necessary was used.

To provide adequate screening, however, the H.F. sections only are mounted on a thin gauge aluminium sheet (20 S.W.G.), a similar gauge being used for the intermediate screen.

The front panel is of 18 S.W.G., and as this would prove too flexible if used in the more conventional way, owing to the rather large proportions, it is bent round the sides of the chassis.

The L.F. stages are treated almost as a separate amplifier, being, as will be seen, mounted directly on the wooden part of the chassis and well away from the rest of the H.F. stages.

On studying the wiring diagrams, it will be apparent that to facilitate wiring between the front panel and the screen, the front panel may be very simply removed after a trial assembly by just loosening the extension rod (grub screws and reduction drive), the dial fittings being left assembled excepting

THE SHORT

Further Constructional Details of this New Short-wave

for the screened grid potentiometers, 'phone jack and switch.

Figs. 1, 4 and 5 give the constructional details for the chassis, screen, and panel, but it will be noticed that owing to the design of the chassis and the use of baseboard mounting components, a somewhat different form of diagram from the standard practice of this journal has been made, this illustrating only the essential centres and incidental measurements for the principal components, as it was anticipated that little difficulty is offered by the layout. The 1/16" diameter drillings can be made with a woodworker's bit.

ABOVE-CHASSIS WIRING DIAGRAM

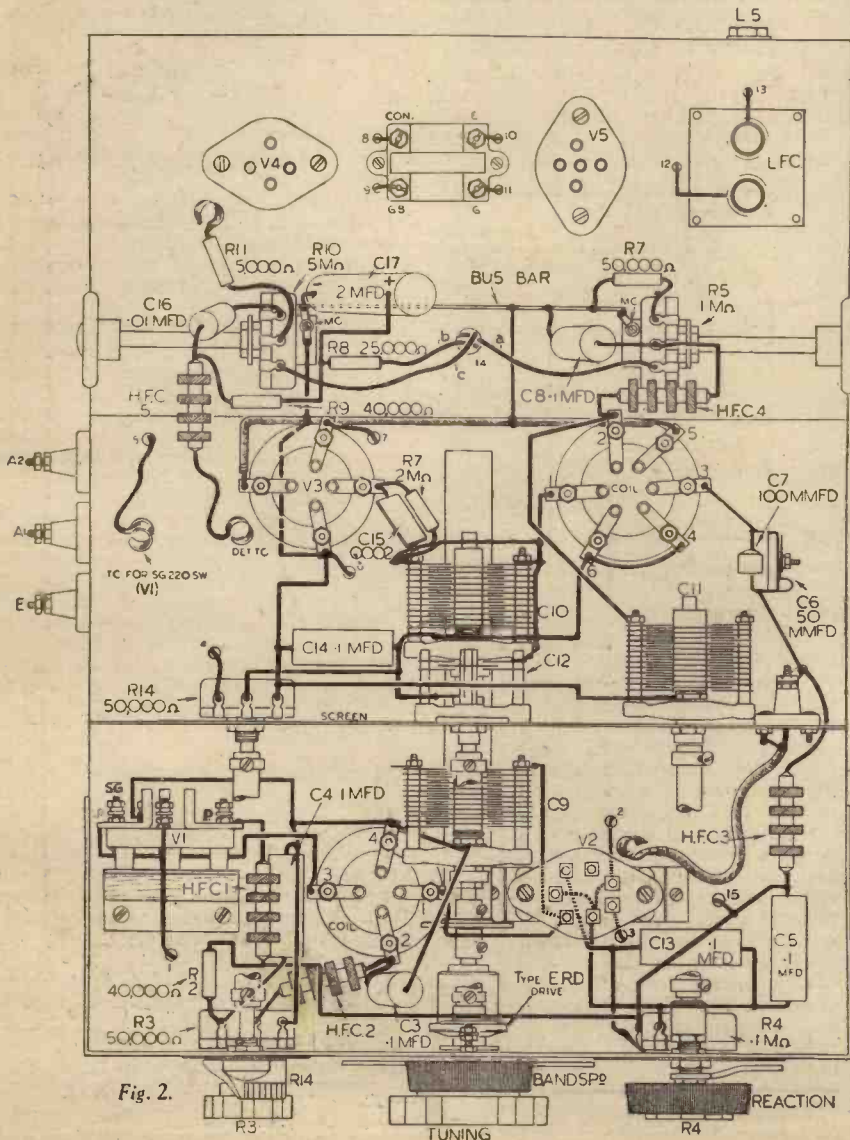

The Layout

Referring to Fig. 4, a few words on the layout and relationship of the components will, no doubt, help. The overall chassis measurements are quite clear, but the portion covered by the base plate—as the aluminium sheet on which the H.F. components are mounted will be referred to during the article—may not be, and this is indicated by the letters "A," "B," "C" and "D." Although for clarity in the diagrams the screw holes for fixing this plate to the wooden chassis are not given as in the case of component fixing holes, it

Full list of receiver will

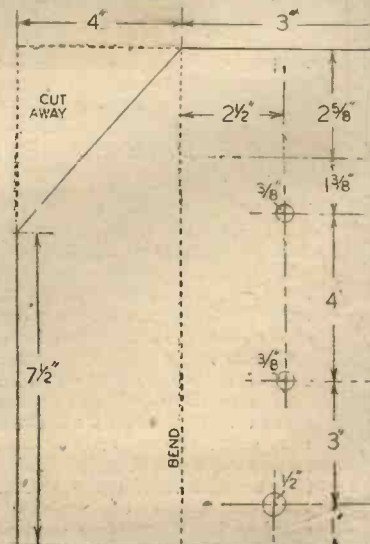

Fig. 1.—Cutting and

T-WAVE FIVE

Details and Full Operating Notes of the Receiver — By W. R. HOBBS

It will be apparent that to prevent this thin aluminium "riding" up at the corners after fitting the components, at least three fixing (wood) screws should be provided along each edge.

Another point which may not be clear is the method of mounting the horizontal valve V1, the centre line for which is depicted in this diagram. Actually the low-loss baseboard type valve-holder for this position is first of all fitted to a simple metal bracket of proportions which are not critical and which may fall in with the constructor's own requirements, but the method adopted by the writer comprised an aluminium bracket which in turn is reinforced with a block of wood, as is clearly defined in the

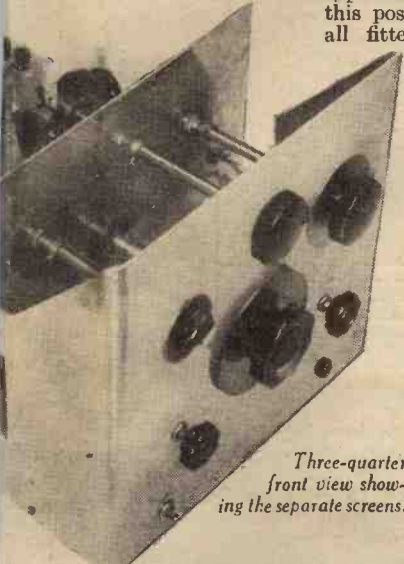

Three-quarter front view showing the separate screens.

wiring diagram given in Fig. 2.

The six-pin coil-holder is supported on 1/4 in. insulating pillars, and it may be found preferable as in the original design, to remove the existing pillar terminal stems, and fix

directly to the coil-holder by substituting long 6 B.A. screws.

The 7-pin valve-holder for the H.P.215 valve (V2) is similarly supported on two midget insulating pillars, which in turn are secured to two home-made aluminium brackets screwed to the chassis.

There is, however, ample room for a modification to be made here if the constructor does not wish to go to this trouble, and this is in the use of a four-pin type pentode with another low-loss type valve-holder as used for V1 and the detector.

The intermediate screen should be fitted with fixing flanges towards the front panel, this resulting in the "cut-out" for the valve V1 being located on the left of the chassis, and so the edge of the flexure will fall along the fixing line shown.

The cut-out in the centre of the screen is carried right through the fixing flanges,

this method providing an easy means for determining the screen's relationship to the location of the ganged condenser cradle to prevent the flexible coupler fouling the edges of the cut-out.

This condenser cradle method of mounting is very clean, consisting simply of an Eddystone condenser cradle of the three-gang pattern with the end ganging bracket removed, mounted on two large insulating stand-off pillars. Unfortunately, there is not space here to detail this more fully, but the assembly will prove quite straightforward when the components are to hand.

There is just one consideration to be made with regard to the front panel diagram, Fig. 1, and this should be made in conjunction with the under-chassis wiring diagram, Fig. 3.

To earth the front panel effectively—and this is most important—the fixing screws located in the side portions in the wiring diagram should not be of the wood-working type, as these pass through both panel and the side runners of the chassis, being finally secured with nuts.

(Continued overleaf)

UNDER-CHASSIS WIRING DIAGRAM

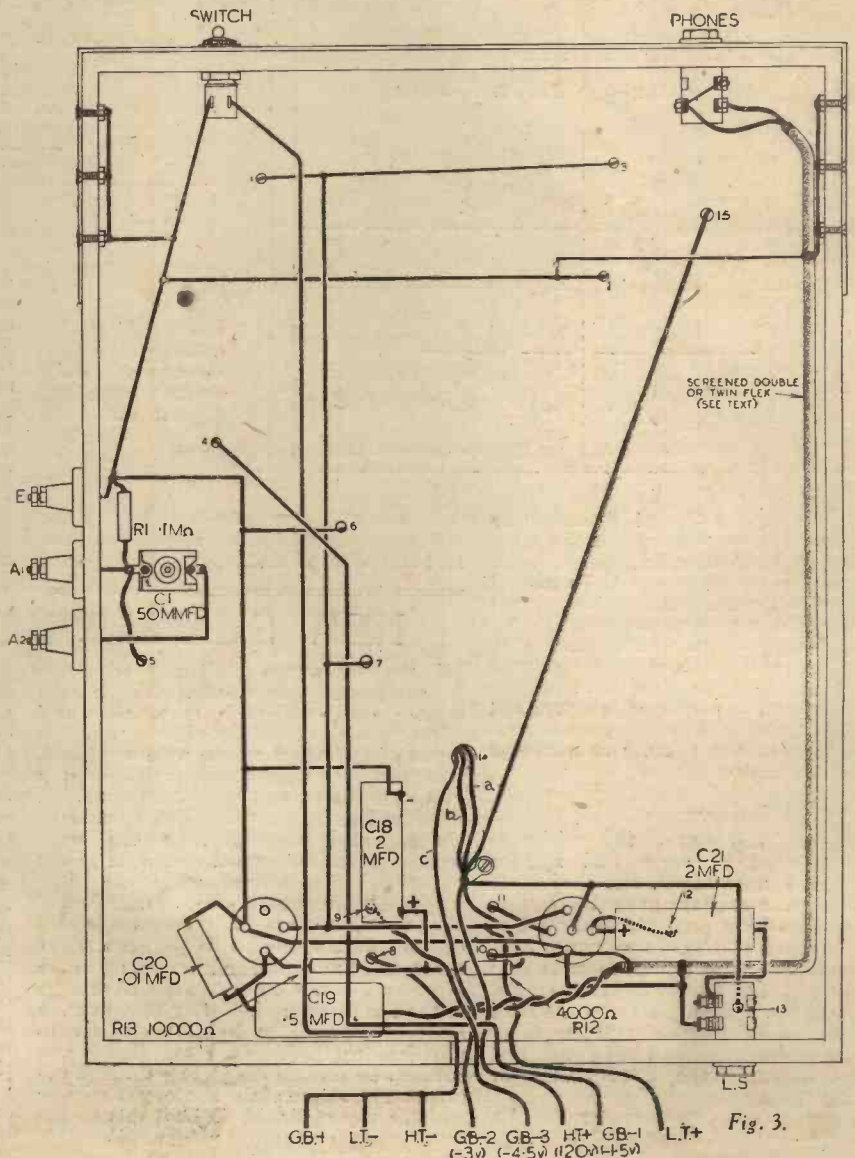
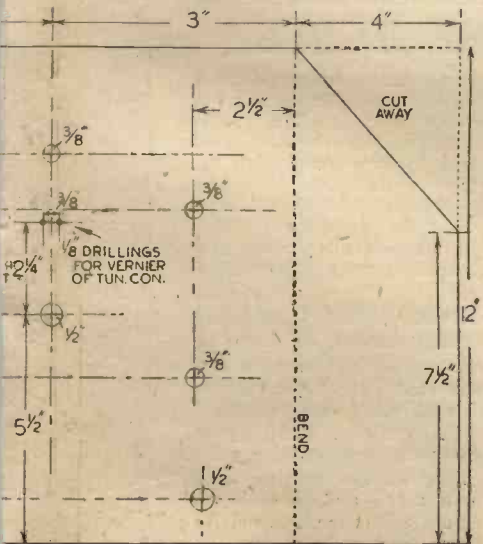

Fig. 3.

components for this be found on page 292.



Drilling details of the front panel.

THE SHORT-WAVE FIVE

(Continued from previous page)

Wiring

Wiring should only be attempted when one is fully satisfied that the various controls are working without any trace of binding, a condition which could quite soon arise in badly aligning the reduction drives. While on the subject of the reduction drives, there is a point concerning the epicyclic drive used for the bandsetter or balancing condenser C12.

It will be seen, on referring to Fig. 2, that three lock-nuts are used on a 6 B.A. bolt in such a way that one secures the bolt

to commence operation a mid-scale setting will suffice.

The immediately important consideration is to get the detector stage steady and with a preliminary degree of smooth reaction, this state of reaction being finally adjusted to maximum intensity of the signal gain through the first stages.

The screen-grid potentiometer in the reaction circuit will therefore have to be considered next, and this is R5. Approximately just over half-scale will serve to determine the state of reaction in relation to the gain-control and variable-mu control R14.

anti-clockwise direction, reducing screen voltage by turning the control R5 back (anti-clockwise).

Now adjust the potentiometer which governs the load on the primary coil of the detector tuning coil, this is R4.

Finally, the combined adjustment of the reaction condenser with R5, followed by the combined re-adjustment of the two potentiometers R4 and R5 should bring the desired signal in at maximum gain.

The full sequence is not by any means as involved as would appear, and a little experiment will soon clarify the relationship of each control, making it possible for

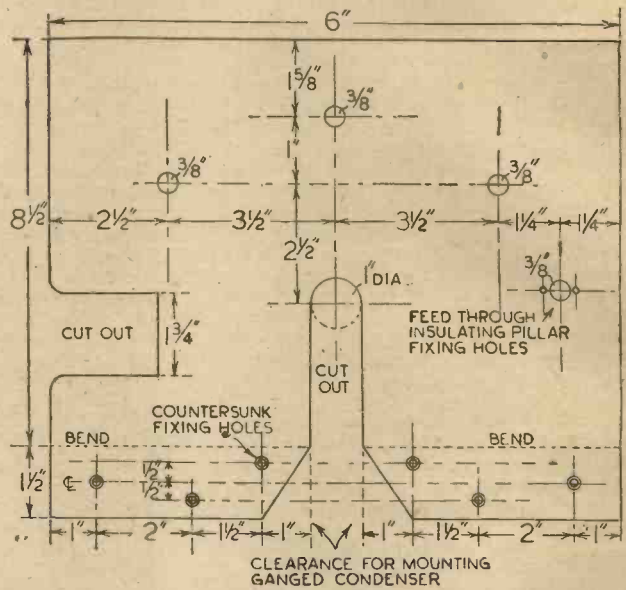
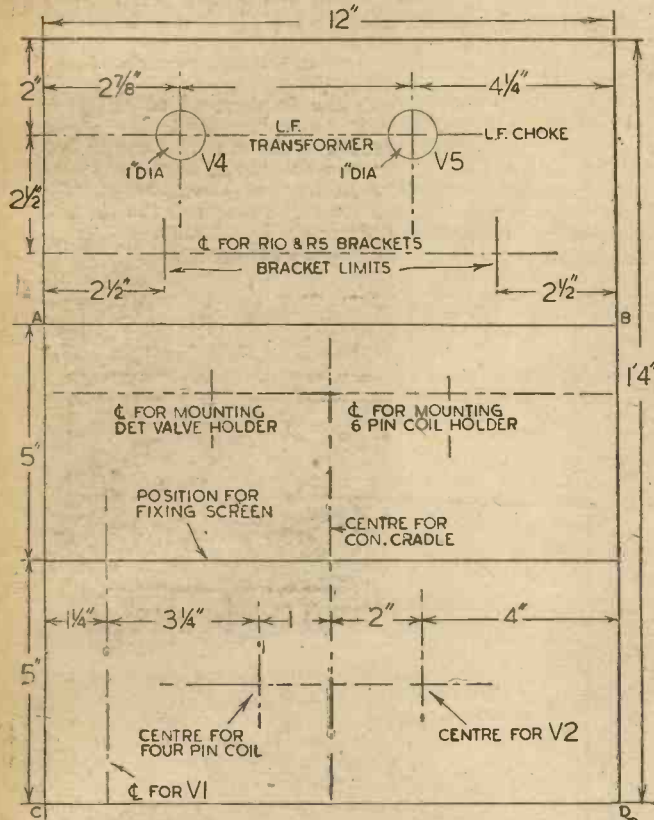

Figs. 4 (left) and 5 (above).—Details of the chassis and vertical mounting screen.

to the panel, whilst the other two act as "distance" lock-nuts, clamping the small fixing lug of the drive very securely.

All pillar connections should be carried out by removing the terminal screws and soldering wires directly and neatly to the heads. Again, to take full advantage of the low-loss characteristics of the coil and valvholders used in the H.F. stages, soldering should be employed, not terminal connection. See that the electrolytic condensers have correct polarity as indicated in the wiring diagrams.

Testing the Receiver

Having satisfied oneself that wiring is correct, the aerial, earth and speaker connections can be made, but the valves and coils remain until the ganged condenser moving vanes have been physically set to as close a ganging as the constructor finds possible, finally adjusting all dials to read correctly and the vernier in very careful adjustment to the tuning dial, zero to zero.

Any errors in ganging will be automatically counteracted as tuning is carried out, by adjusting the bandspreader or balancing condenser.

The screen-grid potentiometer for V1 (R3) should be set at the most sensitive point, which is determined by tuning-in roughly any reasonably weak station, but

Now it will more than likely be that the reaction will be fierce, so the potentiometer R14 should be adjusted by increasing in an

a different sequence to be adopted consistent with the essential principles outlined.

For C.W. signals it will be found possible to modulate the note without "wobble" or any trace of drift, simply by re-adjustment of, say, R4. It is, however, important that the frequent re-adjustment of the variable-mu gain-control, in conjunction with the screen-grid injection control R3, be carried out to obtain the exceedingly smooth reaction which is possible with this receiver, with particularly stable adjustment on the higher frequency bands.

NEW SMALL PROJECTION TUBES

IN the big screen electronic television equipment for cinemas, the manufacture and installation of which ended abruptly with the declaration of war, two forms of cathode-ray tube were employed. One used an opaque screen accommodated in a large glass vessel approximately 16ins. in diameter, so that the picture could be lens-projected directly from the front surface of the fluorescent screen on to the remote viewing screen, while the other was of a more conventional character, and allowed the picture built up on one side of the tube's screen to be projected right through the material, and binder, on to the separate viewing screen. The advantage of the former over the latter idea was the material increase in light due partly to the fact that no loss of brilliance was entailed by passing the picture through the granular structure of the fluorescent powder and the material used to bind this to the inner glass wall of the tube. For this reason steps have been taken to produce smaller counterparts of the opaque screen-

tube, and material success seems to have crowned the efforts of the engineers responsible for the work. The anode voltage employed is of the order of 20 to 25 kilowatts and to save employing an expensive projection lens, attention has been turned to making a lens structured screen of the reflecting type for viewing purposes. Neglecting for the moment the obvious advantages accruing for home viewing in those countries where a television service is still possible, these tubes and remote viewing screens can be used for a variety of scientific purposes, in lieu of the more conventional and lower voltage operated tubes with which most readers are familiar. A compact assembly is possible, brilliance is of a high order, with the resultant trace of the moving spot within the screen area, and there is no doubt that their use will extend, especially if the main operating voltage can be reduced to economical limits and so reduce the size and cost of auxiliary equipment.

IMPORTANT P.O. RADIO REGULATIONS

It is now illegal to sell or even possess certain apparatus, under the Emergency Powers (Defence) Act, 1939

THE Postmaster-General has issued three orders under the Emergency Powers (Defence) Act, 1939, the first and third of which came into effect on November 25th and the second on December 15th. One particular part of the regulations issued is of great interest to dealers and listeners and is as follows:

REGULATION OF USE OF WIRELESS TRANSMITTERS.

The Postmaster-General, in the exercise of the powers conferred on him by Regulation 8 of the Defence Regulations, 1939, hereby orders that on and after the 25th day of November, 1939, no person shall, except under a licence or permit granted by the Postmaster-General, use a wireless transmitter for communicating by wireless telegraphy, wireless telephony, or wireless television; or as a navigational beacon or landing beacon or otherwise for the purpose of indicating position or direction; or for the purpose of the remote control of machinery.

This order shall not apply in relation to any apparatus used in accordance with the terms of a licence in force under the Wireless Telegraphy Acts, 1904 to 1926, authorising the use of the apparatus for transmission.

Applications for licences or permits should be made to the Engineer-in-Chief of the Post Office, stating full particulars of the apparatus concerned, the purpose for which it is to be used, and the name, address and occupation of the person or company who wishes to use it.

Possession of Wireless Transmitters

The Postmaster-General, in the exercise of the powers conferred on him by Regulation 8 of the Defence Regulations, 1939, hereby orders that on and after the 15th day of December, 1939, no person shall, except under the authority of a written permit granted by the Postmaster-General for the purpose, have in his possession or under his control (1) any wireless transmitter which is designed to be used for communicating by wireless telegraphy, wireless telephony, or wireless television; or as a navigational beacon or landing beacon or otherwise for the purpose of indicating position or direction; or for the purpose of the remote control of machinery, (2) or wireless apparatus components capable of being assembled to form such a wireless transmitter, or (3) any wireless receiving apparatus which is designed to be used also as a wireless transmitter or which can be adopted for the purpose of being used as a wireless transmitter by the operation of a switch or by the changing of screwed or plug connections.

This order shall not apply in relation to any apparatus in respect of which there is in force a licence under the Wireless Telegraphy Acts, 1904 to 1926, authorising the use of the apparatus for transmission.

Applications for permits should be made to the Engineer-in-Chief of the Post Office, stating full particulars of the apparatus or article concerned, the purpose for which it is required, and the name, address and occupation of the person or company in whose possession or under whose control the apparatus or article is to be retained.

Control of Wireless Transmitters and Certain Other Electrical Apparatus

The Postmaster-General, in the exercise of the powers conferred on him by Regulation 55 of the Defence Regulations, 1939, hereby orders that on and after the 25th day of November, 1939, no person shall, except under the authority of a permit granted by the Postmaster-General for the purpose, sell, purchase, let, hire, supply, dispose of, acquire or distribute any of the under-mentioned articles:—

(a) Wireless transmitters which are designed to be used or are capable of being used for communicating by wireless telegraphy, wireless telephony, or wireless television; or as navigational beacons, or landing beacons, or otherwise for the purpose of indicating position or direction; or for the purpose of the remote control of machinery.

(b) The following articles intended for use as parts of wireless transmitters, namely, high frequency inductors, spark coils, quenched and rotary spark gaps.

(c) Any wireless receiving apparatus which is designed to be used also as a wireless transmitter or which can be adapted for the purpose of being used as a wireless transmitter by the operation of a switch or by the changing of screwed or plug connections.

(d) Line carrier telegraph equipment or line carrier telephone equipment.

(e) High-frequency equipment (being equipment which generates or uses high-frequency current at frequencies greater than 10,000 cycles per second and having a maximum output exceeding 10 watts) including such equipment intended for use in connection with furnaces and medical apparatus.

(f) Electronic valves capable of an anode dissipation exceeding 10 watts.

(g) Piezo electrical quartz plates or piezo electric tourmaline plates cut to oscillate at any specified frequency.

Applications for permits should be made to the Engineer-in-Chief of the Post Office, on forms obtainable at any Head Post Office or from the Engineer-in-Chief, stating full particulars of the article concerned, the purpose for which it is required and the name, address and occupation of the person or company who wishes to obtain it and of the person or company from whom it would be obtained.

**THIS WONDER
EDDYSTONE
ALL-WAVE ALL-WORLD
RECEIVER SENT
YOU ON 7 DAYS
TRIAL**

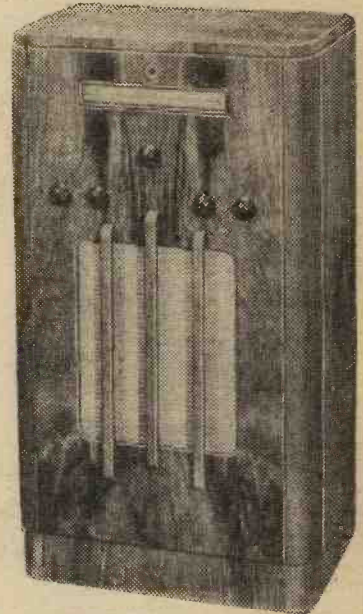

Yes, the headline means exactly what it says—we will send you this Wonder "EddyStone" All-World All-Wave Receiver, carriage paid to your address for you to subject it to 7-days Home Trial, and should you then find it not up to your fullest expectations you are at liberty to promptly return it—when we will cheerfully refund your money IN FULL.

This is an exceptional offer—but we make it because we want YOU to see for yourself what words cannot fully convey—the outstanding capabilities of this Set that makes everyone we show it to wish to obtain it. It is a 7-valve Mains Receiver that will give you intriguingly interesting World-wide reception—something EXTRA—news from all countries of World-wide events, official and unofficial impressions, American Amateurs, etc. It has 4-wave bands (13-33 metres, 31-85 metres, 200-555 metres and 900-2,100 metres), special chassis and coil unit construction, automatic volume control, special intermediate frequency stage, H.F. amplifier, "Magic Eye" for accurate tuning, separate oscillator valve to eliminate frequency drift, tone control, power pentode valve giving 5-watts undistorted output, 12 in. moving-coil loudspeaker, gramophone pick-up and external speaker terminals. In truly magnificent Oak or Walnut Cabinet, for A.C. mains.

25 Gns.

This is a super set, fitting for your requirements. Send the coupon below NOW for full descriptive literature.

STRATTON & Co. Ltd.
EDDYSTONE WORKS, BROMSGROVE STREET, BIRMINGHAM.

POST THIS COUPON

To STRATTON & Co. Ltd., EDDYSTONE WORKS, BROMSGROVE ST., BIRMINGHAM

Please send me full descriptive details of the EEA 7 Receiver offered on 7 Days Trial.

Name

Address

**PRACTICAL WIRELESS
ENCYCLOPÆDIA**

By F. J. CAMM : 6th Edition

(Editor of "Practical Wireless") 5/- Net

Wireless Construction, Terms, and Definitions explained and illustrated in concise, clear language

From all Booksellers or by post 5/6 from George Newnes Ltd., Tower House, Southampton Street, Strand, London, W.C.2.

ELECTRADIX BARGAINS



WINTER CHARGING.
 Fine DAVENSET A.S.C.A., 4 circuit A.C. mains Charger for up to 80 cells. List price, £32. Sale, £14/10/-.

Charge regulators and indicators on panel with switch volt control. Four circuits of 1, 2 and 2 amps., or 3 of 1, 2 and 2 amps., or one of 50 v. 6 amps. 10 amp. Fine set that will quickly earn its cost and show a good profit. A great bargain at £14/10/-.

Other chargers at bargain prices are below. Call and see during daylight. Four A.G./D.C. DAVENSET Type A.C. House, Garage Wall Type Charger, 3 circuits, output D.C. 25 volts 6 amps. Trans. tapped for 15 v., 20 v., 25 v. Two independent circuits, max. cell capacity 40 radio cells, £6/5/-.

A.C./D.C. DAVENSET CHARGER, Type S.P.C., for 230 volts A.C. to 250 volts 250 m.a. D.C., fitted meter and volt regulator. As new, £21/7/6.

TUNGAR CHARGERS. Two types of these famous sets. One for 70 volts, 6 amps., with meters and controls, etc., will handle 100 cells a day. £7/17/6. Another fine Tungar for two 5 amp. circuits with meters and variable volt controls, 15 volts 10 amps. for 200 cells. Bargain, £12/15/-.

Morrison Rectifier Sets for small Arcs, 60 volts 12 amps., £14. Garage A.C./D.C. DAVENSET Type G.C. Wall Type Charger, 3 circuits, output D.C. 25 volts 6 amps. Trans. tapped for 15 v., 20 v., 25 v. Two circuits, max. cell capacity 40 radio cells, complete with valves, £6/5/-.

HOME RADIO AND CAR CHARGERS. The A.C. NITNDAY with Westinghouse Rectifiers will keep your battery always fit without attention. Battery Charging on A.C. Mains. The A.C. NITNDAY will keep your battery fit without attention. Model N/A6, 200/250 volts A.C. and D.C. 6/8 volts 1 amp., 15/-.

Model N/B6, 200/250 volts to D.C., 6/8 volts to 1 amp., 15/-.

Model N/C6, 200/250 volts D.C., 6/8 volts 2 amps., 35/-.

Model N/D12, 200/250 volts to 12 volts 1 amp., 32/-.

Ditto, 12 volts 2 amps., with 6-volt tap, 55/-.

5 amp., £4/10/-.

And many others. We make SHELTER CHARGERS, with automatic switchgear and 12/24 volt Batteries to official specification for large shelters.

ELECTRIC IMMERSION HEATERS. Save coal. Armoured bath or bank type with flex, 1,000 watts 230 volts. 25/-.

SIGNAL EQUIPMENT FOR ARMY & NAVY WORK

SERVICE TYPE SIGNALERS DOUBLE HEADPHONES, with flat leather headbands for steel helmet wear, 120 ohms, by S.T. Co., 3/6. 4ft. cords 6d. Single 60 ohm. phones with cord DIII, 1/6.

FIELD Telephone Exchanges, 5-line and 20-line portable. Twin and Single Cable.

HEADPHONE CORDS. Service 6ft. fitted 2-pin plugs and 2-hole socket. 2/-.

Radio Phone Cords, 2/6.

CRYSTAL SETS. Boudoir, 6/6. B.M. Table, 7/6.

LEARNERS' MORSE PRACTICE SET. High Grade Model for Buzzer and Light Signals of Army and Navy. Walnut cabinet fitted W.D. turret brass swivel lamp, revolving cap, 4 sizes of light aperture. With Osram 2-volt tube bulb and spare. Morse Key and 2-way switch. Adjustable 2-coil Buzzer inside, with battery clips, etc. A superior and useful set, 10/6.

Ex-Army Buzzer Transmitter, with fine key and brass cased quick adjustment power Buzzer on mahogany base, by Siemens and A.T.M. Co., 17/6.

MORSE KEYS. First-class at low prices. A good small key on moulded base is the TX pivot arm, excellent for learners, 3/6. Full size, well finished key, all brass, solid pivot bar, adjustable tension, etc., B.2. 7/6. Superior type P.F., fully adjustable, nickel finish, 9/6. High Grade Type IV, plated fittings, polished wood base, a fine key, 10/6. Special Key on 3-switch box for buzzer and 2 lamps, C.A.V., 6/6.

BUZZERS, small type, with cover, 1/6. Power Buzzers, with screw contact and adjustable spring armature, 2/6. Heavy Buzzer in bakelite case, 3/6. Magneto Exchanges, 25/-.

Portable Field Telegraph Sets. Details on request. Cheap Morse Practice sets available.

CAMP LAMPS. Portable Accumulator Hand Lamps are independent of dry cells. Miners' type, 2 volts. Steel body. Indestructible, 15/-.

Battery, 10/-.

SIGNAL LAMPS by Lucas and Aids, for night and day use. Telescopes, 25/-.

Portable Field Telegraph Sets. Details on request. Cheap Morse Practice sets available.

CAMP LAMPS. Portable Accumulator Hand Lamps are independent of dry cells. Miners' type, 2 volts. Steel body. Indestructible, 15/-.

Battery, 10/-.

SIGNAL LAMPS by Lucas and Aids, for night and day use. Telescopes, 25/-.

Portable Field Telegraph Sets. Details on request. Cheap Morse Practice sets available.

CAMP LAMPS. Portable Accumulator Hand Lamps are independent of dry cells. Miners' type, 2 volts. Steel body. Indestructible, 15/-.

Battery, 10/-.

SIGNAL LAMPS by Lucas and Aids, for night and day use. Telescopes, 25/-.

Portable Field Telegraph Sets. Details on request. Cheap Morse Practice sets available.

CAMP LAMPS. Portable Accumulator Hand Lamps are independent of dry cells. Miners' type, 2 volts. Steel body. Indestructible, 15/-.

Battery, 10/-.

SIGNAL LAMPS by Lucas and Aids, for night and day use. Telescopes, 25/-.

Portable Field Telegraph Sets. Details on request. Cheap Morse Practice sets available.

CAMP LAMPS. Portable Accumulator Hand Lamps are independent of dry cells. Miners' type, 2 volts. Steel body. Indestructible, 15/-.

Battery, 10/-.

SIGNAL LAMPS by Lucas and Aids, for night and day use. Telescopes, 25/-.

Portable Field Telegraph Sets. Details on request. Cheap Morse Practice sets available.

CAMP LAMPS. Portable Accumulator Hand Lamps are independent of dry cells. Miners' type, 2 volts. Steel body. Indestructible, 15/-.

Battery, 10/-.

SIGNAL LAMPS by Lucas and Aids, for night and day use. Telescopes, 25/-.

Portable Field Telegraph Sets. Details on request. Cheap Morse Practice sets available.

CAMP LAMPS. Portable Accumulator Hand Lamps are independent of dry cells. Miners' type, 2 volts. Steel body. Indestructible, 15/-.

Battery, 10/-.

SIGNAL LAMPS by Lucas and Aids, for night and day use. Telescopes, 25/-.

Portable Field Telegraph Sets. Details on request. Cheap Morse Practice sets available.

CAMP LAMPS. Portable Accumulator Hand Lamps are independent of dry cells. Miners' type, 2 volts. Steel body. Indestructible, 15/-.

Battery, 10/-.

SIGNAL LAMPS by Lucas and Aids, for night and day use. Telescopes, 25/-.

Portable Field Telegraph Sets. Details on request. Cheap Morse Practice sets available.

CAMP LAMPS. Portable Accumulator Hand Lamps are independent of dry cells. Miners' type, 2 volts. Steel body. Indestructible, 15/-.

Battery, 10/-.

SIGNAL LAMPS by Lucas and Aids, for night and day use. Telescopes, 25/-.

Portable Field Telegraph Sets. Details on request. Cheap Morse Practice sets available.

CAMP LAMPS. Portable Accumulator Hand Lamps are independent of dry cells. Miners' type, 2 volts. Steel body. Indestructible, 15/-.

Battery, 10/-.

SIGNAL LAMPS by Lucas and Aids, for night and day use. Telescopes, 25/-.

Portable Field Telegraph Sets. Details on request. Cheap Morse Practice sets available.

CAMP LAMPS. Portable Accumulator Hand Lamps are independent of dry cells. Miners' type, 2 volts. Steel body. Indestructible, 15/-.

Battery, 10/-.

SIGNAL LAMPS by Lucas and Aids, for night and day use. Telescopes, 25/-.

Portable Field Telegraph Sets. Details on request. Cheap Morse Practice sets available.

CAMP LAMPS. Portable Accumulator Hand Lamps are independent of dry cells. Miners' type, 2 volts. Steel body. Indestructible, 15/-.

Battery, 10/-.

SIGNAL LAMPS by Lucas and Aids, for night and day use. Telescopes, 25/-.

Portable Field Telegraph Sets. Details on request. Cheap Morse Practice sets available.

CAMP LAMPS. Portable Accumulator Hand Lamps are independent of dry cells. Miners' type, 2 volts. Steel body. Indestructible, 15/-.

Battery, 10/-.

SIGNAL LAMPS by Lucas and Aids, for night and day use. Telescopes, 25/-.

Portable Field Telegraph Sets. Details on request. Cheap Morse Practice sets available.

CAMP LAMPS. Portable Accumulator Hand Lamps are independent of dry cells. Miners' type, 2 volts. Steel body. Indestructible, 15/-.

Battery, 10/-.

SIGNAL LAMPS by Lucas and Aids, for night and day use. Telescopes, 25/-.

Portable Field Telegraph Sets. Details on request. Cheap Morse Practice sets available.

CAMP LAMPS. Portable Accumulator Hand Lamps are independent of dry cells. Miners' type, 2 volts. Steel body. Indestructible, 15/-.

Battery, 10/-.

SIGNAL LAMPS by Lucas and Aids, for night and day use. Telescopes, 25/-.

Portable Field Telegraph Sets. Details on request. Cheap Morse Practice sets available.

CAMP LAMPS. Portable Accumulator Hand Lamps are independent of dry cells. Miners' type, 2 volts. Steel body. Indestructible, 15/-.

Battery, 10/-.

SIGNAL LAMPS by Lucas and Aids, for night and day use. Telescopes, 25/-.

Portable Field Telegraph Sets. Details on request. Cheap Morse Practice sets available.

CAMP LAMPS. Portable Accumulator Hand Lamps are independent of dry cells. Miners' type, 2 volts. Steel body. Indestructible, 15/-.

Battery, 10/-.

SIGNAL LAMPS by Lucas and Aids, for night and day use. Telescopes, 25/-.

Portable Field Telegraph Sets. Details on request. Cheap Morse Practice sets available.

CAMP LAMPS. Portable Accumulator Hand Lamps are independent of dry cells. Miners' type, 2 volts. Steel body. Indestructible, 15/-.

Battery, 10/-.

SIGNAL LAMPS by Lucas and Aids, for night and day use. Telescopes, 25/-.

Portable Field Telegraph Sets. Details on request. Cheap Morse Practice sets available.

CAMP LAMPS. Portable Accumulator Hand Lamps are independent of dry cells. Miners' type, 2 volts. Steel body. Indestructible, 15/-.

Battery, 10/-.

SIGNAL LAMPS by Lucas and Aids, for night and day use. Telescopes, 25/-.

Portable Field Telegraph Sets. Details on request. Cheap Morse Practice sets available.

CAMP LAMPS. Portable Accumulator Hand Lamps are independent of dry cells. Miners' type, 2 volts. Steel body. Indestructible, 15/-.

Battery, 10/-.

SIGNAL LAMPS by Lucas and Aids, for night and day use. Telescopes, 25/-.

Portable Field Telegraph Sets. Details on request. Cheap Morse Practice sets available.

CAMP LAMPS. Portable Accumulator Hand Lamps are independent of dry cells. Miners' type, 2 volts. Steel body. Indestructible, 15/-.

Battery, 10/-.

SIGNAL LAMPS by Lucas and Aids, for night and day use. Telescopes, 25/-.

Portable Field Telegraph Sets. Details on request. Cheap Morse Practice sets available.

CAMP LAMPS. Portable Accumulator Hand Lamps are independent of dry cells. Miners' type, 2 volts. Steel body. Indestructible, 15/-.

Battery, 10/-.

SIGNAL LAMPS by Lucas and Aids, for night and day use. Telescopes, 25/-.

Portable Field Telegraph Sets. Details on request. Cheap Morse Practice sets available.

CAMP LAMPS. Portable Accumulator Hand Lamps are independent of dry cells. Miners' type, 2 volts. Steel body. Indestructible, 15/-.

Battery, 10/-.

SIGNAL LAMPS by Lucas and Aids, for night and day use. Telescopes, 25/-.

Portable Field Telegraph Sets. Details on request. Cheap Morse Practice sets available.

CAMP LAMPS. Portable Accumulator Hand Lamps are independent of dry cells. Miners' type, 2 volts. Steel body. Indestructible, 15/-.

Battery, 10/-.

SIGNAL LAMPS by Lucas and Aids, for night and day use. Telescopes, 25/-.

Portable Field Telegraph Sets. Details on request. Cheap Morse Practice sets available.

CAMP LAMPS. Portable Accumulator Hand Lamps are independent of dry cells. Miners' type, 2 volts. Steel body. Indestructible, 15/-.

Battery, 10/-.

SIGNAL LAMPS by Lucas and Aids, for night and day use. Telescopes, 25/-.

Portable Field Telegraph Sets. Details on request. Cheap Morse Practice sets available.

CAMP LAMPS. Portable Accumulator Hand Lamps are independent of dry cells. Miners' type, 2 volts. Steel body. Indestructible, 15/-.

Battery, 10/-.

SIGNAL LAMPS by Lucas and Aids, for night and day use. Telescopes, 25/-.

Portable Field Telegraph Sets. Details on request. Cheap Morse Practice sets available.

CAMP LAMPS. Portable Accumulator Hand Lamps are independent of dry cells. Miners' type, 2 volts. Steel body. Indestructible, 15/-.

Battery, 10/-.

SIGNAL LAMPS by Lucas and Aids, for night and day use. Telescopes, 25/-.

Portable Field Telegraph Sets. Details on request. Cheap Morse Practice sets available.

CAMP LAMPS. Portable Accumulator Hand Lamps are independent of dry cells. Miners' type, 2 volts. Steel body. Indestructible, 15/-.

Battery, 10/-.

SIGNAL LAMPS by Lucas and Aids, for night and day use. Telescopes, 25/-.

Portable Field Telegraph Sets. Details on request. Cheap Morse Practice sets available.

CAMP LAMPS. Portable Accumulator Hand Lamps are independent of dry cells. Miners' type, 2 volts. Steel body. Indestructible, 15/-.

Battery, 10/-.

SIGNAL LAMPS by Lucas and Aids, for night and day use. Telescopes, 25/-.

Portable Field Telegraph Sets. Details on request. Cheap Morse Practice sets available.

CAMP LAMPS. Portable Accumulator Hand Lamps are independent of dry cells. Miners' type, 2 volts. Steel body. Indestructible, 15/-.

Battery, 10/-.

SIGNAL LAMPS by Lucas and Aids, for night and day use. Telescopes, 25/-.

Portable Field Telegraph Sets. Details on request. Cheap Morse Practice sets available.

CAMP LAMPS. Portable Accumulator Hand Lamps are independent of dry cells. Miners' type, 2 volts. Steel body. Indestructible, 15/-.

Battery, 10/-.

SIGNAL LAMPS by Lucas and Aids, for night and day use. Telescopes, 25/-.

Portable Field Telegraph Sets. Details on request. Cheap Morse Practice sets available.

CAMP LAMPS. Portable Accumulator Hand Lamps are independent of dry cells. Miners' type, 2 volts. Steel body. Indestructible, 15/-.

Battery, 10/-.

SIGNAL LAMPS by Lucas and Aids, for night and day use. Telescopes, 25/-.

Portable Field Telegraph Sets. Details on request. Cheap Morse Practice sets available.

CAMP LAMPS. Portable Accumulator Hand Lamps are independent of dry cells. Miners' type, 2 volts. Steel body. Indestructible, 15/-.

Battery, 10/-.

SIGNAL LAMPS by Lucas and Aids, for night and day use. Telescopes, 25/-.

Portable Field Telegraph Sets. Details on request. Cheap Morse Practice sets available.

CAMP LAMPS. Portable Accumulator Hand Lamps are independent of dry cells. Miners' type, 2 volts. Steel body. Indestructible, 15/-.

Battery, 10/-.

SIGNAL LAMPS by Lucas and Aids, for night and day use. Telescopes, 25/-.

Portable Field Telegraph Sets. Details on request. Cheap Morse Practice sets available.

CAMP LAMPS. Portable Accumulator Hand Lamps are independent of dry cells. Miners' type, 2 volts. Steel body. Indestructible, 15/-.

Battery, 10/-.

SIGNAL LAMPS by Lucas and Aids, for night and day use. Telescopes, 25/-.

Portable Field Telegraph Sets. Details on request. Cheap Morse Practice sets available.

CAMP LAMPS. Portable Accumulator Hand Lamps are independent of dry cells. Miners' type, 2 volts. Steel body. Indestructible, 15/-.

Battery, 10/-.

SIGNAL LAMPS by Lucas and Aids, for night and day use. Telescopes, 25/-.

Portable Field Telegraph Sets. Details on request. Cheap Morse Practice sets available.

CAMP LAMPS. Portable Accumulator Hand Lamps are independent of dry cells. Miners' type, 2 volts. Steel body. Indestructible, 15/-.

Battery, 10/-.

SIGNAL LAMPS by Lucas and Aids, for night and day use. Telescopes, 25/-.

Portable Field Telegraph Sets. Details on request. Cheap Morse Practice sets available.

CAMP LAMPS. Portable Accumulator Hand Lamps are independent of dry cells. Miners' type, 2 volts. Steel body. Indestructible, 15/-.

Battery, 10/-.

SIGNAL LAMPS by Lucas and Aids, for night and day use. Telescopes, 25/-.

Portable Field Telegraph Sets. Details on request. Cheap Morse Practice sets available.

CAMP LAMPS. Portable Accumulator Hand Lamps are independent of dry cells. Miners' type, 2 volts. Steel body. Indestructible, 15/-.

Battery, 10/-.

SIGNAL LAMPS by Lucas and Aids, for night and day use. Telescopes, 25/-.

Portable Field Telegraph Sets. Details on request. Cheap Morse Practice sets available.

CAMP LAMPS. Portable Accumulator Hand Lamps are independent of dry cells. Miners' type, 2 volts. Steel body. Indestructible, 15/-.

Battery, 10/-.

SIGNAL LAMPS by Lucas and Aids, for night and day use. Telescopes, 25/-.

Portable Field Telegraph Sets. Details on request. Cheap Morse Practice sets available.

CAMP LAMPS. Portable Accumulator Hand Lamps are independent of dry cells. Miners' type, 2 volts. Steel body. Indestructible, 15/-.

Battery, 10/-.

SIGNAL LAMPS by Lucas and Aids, for night and day use. Telescopes, 25/-.

Portable Field Telegraph Sets. Details on request. Cheap Morse Practice sets available.

CAMP LAMPS. Portable Accumulator Hand Lamps are independent of dry cells. Miners' type, 2 volts. Steel

Simplified Multi-waveband Switching

A Circuit Incorporating a Coupling-coil Feedback Arrangement for Short-wave Reception

IN designing an all-wave receiver, an important problem to be solved is how to reduce the number of switching contacts to a minimum, it being obvious that the more contacts there are the greater is the chance of faults developing and the complexity of wiring increasing. The problem is usually most difficult where the local oscillator circuit of a superheterodyne receiver is concerned, because of the necessity of maintaining the strength of oscillations constant throughout each waveband, and of providing suitable tracking circuits. The Telefunken Company has solved the problem in one way by using a Colpitts circuit on the longer wavebands and a coupling-coil feedback arrangement on the shorter waveband.

In Fig. 1 is shown only the oscillator circuit of the superhet receiver, which may be connected in any desired manner to the mixer stage. The resistance W_4 and condenser C_1 generate the grid-bias voltage, which matches itself automatically to the instantaneous oscillator amplitude. In order to obtain a sufficient voltage swing, it is necessary to increase the resistance W_4 from the previously usual value of 50,000 ohms up to about 150,000 ohms. In order that the time constant of the combination W_4, C_1 should not be too great, and thus encourage relaxation oscillations in the S.W. range, the capacity C_1 is reduced from about 100 mmfd. to 25 mmfd. The resistance W_3 serves to guard against a rise of the oscillator voltage at the lower end of the S.W. range, when reduction of the grid A.C. voltage rises, due to voltage division between the grid-cathode capacity and the resistance W_3 .

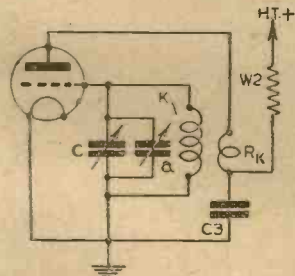
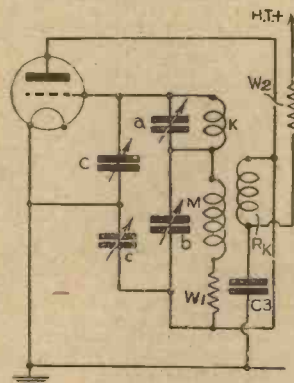

Fig. 2 (left).—Parts of the circuit of Fig. 1, which are operative on S.W. reception.

Fig. 3 (right).—The part of the circuit which is operative on medium waves.



omitted for the sake of simplicity. It will be seen that an inductive feedback occurs between the feedback coil R_K and the grid circuit coil K . The circuit elements M, W, L and C_2 of Fig. 1 are in parallel with the condenser C_3 in the S.W. setting, and are, therefore, in effect inoperative and not shown in Fig. 2.

Medium-wave Reception

On medium-wave reception the switch S_1 in Fig. 1 is open and S_2 closed. That part of the circuit of Fig. 1 which is operative on medium-wave reception is shown in Fig. 3. In contradistinction to Fig. 2, the feedback is done here by means of a Colpitts circuit.

The S.W. feedback coil R_K acts effectively as a conductive connection on medium waves. Therefore, on medium waves, the long-wave additional coil L in Fig. 1 and the auxiliary tracking condenser C_2 are effectively directly short-circuited by the switch S_2 . The parallel capacity C , which serves to increase the initial capacity on long waves, is in effect similarly in parallel with the capacity C_3 . By closing the switch S_2 , the danger of excitation on a short wave is also avoided at the same time, without the expense of a separate switch, since the S.W. anode H.F. current is by-passed via the switch S_2 and the capacity C to the feedback coil R_K . This would also be the case if the capacity C

Short-wave Working

On short waves only, the switch S_1 is closed, so that the lower end of the S.W. coil K is connected direct to earth. A further tracking condenser C_4 may be introduced which is, however, not essential on S.W. reception, since the percentage frequency difference between oscillator and signal frequencies is very small, and adequate ganging is achieved even without this condenser.

Those parts of the circuit of Fig. 1 which are operative on S.W. reception are illustrated in Fig. 2, in which, however, the circuit elements W_3, W_4 and C_1 are

were only in parallel with the coil L . Only the capacities C_3 and C are operative as tracking and feedback condensers. Short-circuiting of these capacities by the H.T. lead is avoided by connecting in the resistance W_2 or a high-frequency choke.

The resistance W_1 in Figs. 1 and 3 is for the purpose of avoiding a rise of the oscillator amplitude at the end of the wave range. The resistance W_1 of about 200 ohms is effective for damping mainly at the upper end of the wave range, since the reactive current in the oscillating circuit is then stronger than at the beginning, on account of the high tuning capacity;

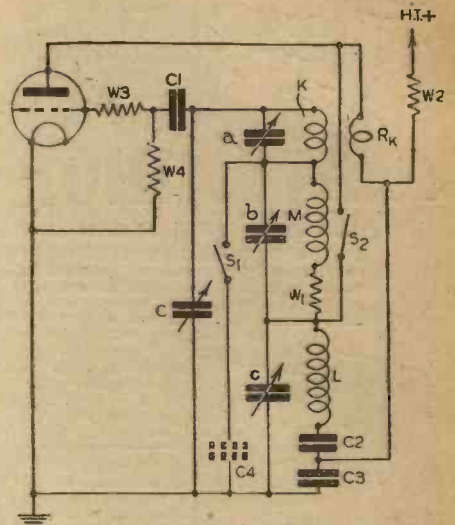

Fig. 1.—The oscillator circuit of a superhet receiver.

and hence the losses increase. The same resistance W_1 serves the same purpose on long-wave reception.

Long-wave Working

When both the switches S_1 and S_2 in Fig. 1 are open, the circuit is ready for long-wave reception. As against medium-wave reception, not only the additional coil L , but also the condenser C_2 comes into operation, the latter being provided to make the tracking capacity smaller than on medium-wave reception. The series circuit of C_2 and C_3 is then operative as tracking capacity. The condenser C_3 is, however, only brought in to the feedback by means of capacitive voltage division, as otherwise the feedback would be too strong. In this way the circuit is further simplified, since a separate switch contact for switching over the upper end of W_2 to the upper end of C_2 becomes unnecessary.

The danger of excitation on a short wave can, if necessary, be eliminated by connecting the parallel capacity c not directly parallel to the coil L , but with its lower end to earth, as shown in Fig. 1. In the long-wave setting, not only does the feedback coil R_K operate as feedback for a short wave, but there is also the feedback voltage arising across the condenser C_3 , since if the capacity c were not connected as above, the low-potential end of the coil K would be connected via the capacity b and the capacity c with the junction of C_2 and C_3 for a short wave. By means of the separate connection of the capacity c , however, the low-potential end of the coil K is for short waves connected via the capacities b and c to earth, avoiding C_3 . The capacity c (about 70 mmfd.) must be large compared with the self-capacity of C .

The connection of the capacity c has no effect on the oscillation generation of the long waves, since for the long waves the oscillating circuit is operative, consisting effectively of the capacity C with the parallel connected series circuit a, b and c , together with the coils K, M and L , and the tracking condensers C_2 and C_3 . It may also be observed that the capacities a, b and c need not be adjustable as shown.

Keep your
Set at
its BEST!

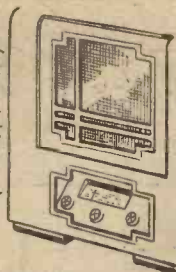

with
the

AVOMINOR

Regd Trade Mark
ELECTRICAL MEASURING INSTRUMENT

Use the D.C. AvoMinor periodically to check up valve performance, batteries and power output. Thus you'll always keep your set in good trim. A 13-range precision-built instrument, it tells you all you need to know, and enables you to locate speedily the seat of any trouble. Direct readings. No calculations. Complete in case, with instruction booklet, leads, interchangeable test prods and crocodile clips.



Voltage	
0-6 volts	0-240 volts
0-12 volts	0-300 volts
0-120 volts	0-600 volts

Current	
0-6 m/amps.	
0-30 m/amps.	
0-120 m/amps.	

Resistance	
0-10,000 ohms	
0-60,000 ohms	
0-1,200,000 ohms	
0-3 megohms	

BRITISH
MADE

Write for fully descriptive literature and current prices of all 'Avo' Instruments.

Sole Proprietors & Manufacturers—

Automatic Coil Winder & Electrical Equipment Co., Ltd.,
Winder House, Douglas St., London, S.W.1. Phone: Victoria 3404/7

CLIX

SAFWAYS ADAPTORS

You can use your Radio and other electrical appliances in any room and secure their full benefit throughout your home by fitting a SAFWAYS Adaptor in your existing lamp-holder.

To nullify the depressing effects of the "Black-out" fit a SAFWAYS adaptor with a low-wattage lamp in the branch outlet and the usual lamp in the other. You can then enjoy normal lighting knowing that, should it be necessary, dimmed lighting can be switched on at a moment's notice.

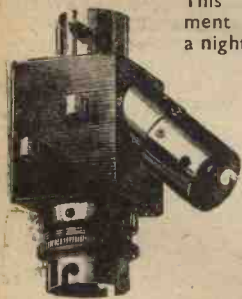

This particular arrangement can also be used as a nightlight for children or invalids, but is merely one of many ways in which SAFWAYS can increase the convenience of your electrical installation—quickly, cheaply and safely.

ASK YOUR
DEALER FOR

"SAFWAYS"

Single Switch, 1/10; Double Switch, 2/3;
Cord Control 2/6 each.

A CLIX product made by—
BRITISH MECHANICAL PRODUCTIONS
LTD.

1, Church Road, Leatherhead, Surrey.

Practical Wireless BLUEPRINT SERVICE

PRACTICAL WIRELESS No. of
Date of Issue. Blueprint.

CRYSTAL SETS

Blueprints, 6d. each.
1937 Crystal Receiver PW71
The "Junior" Crystal Set .. 27.8.38 PW94

STRAIGHT SETS. Battery Operated.

One-valve: Blueprints, 1s. each.
All-Wave Unipen (Pentode) PW31A
Beginners' One-valver 10.2.38 PW85
The "Pyramid" One-valver (HF Pen) .. 27.8.38 PW93

Two-valve: Blueprints, 4s. each.
Four-range Super Mag Two (D, Pen) PW36B
The Signet Two (D & LF) 24.9.38 PW76

Three-valve: Blueprints, 1s. each.
Selectone Battery Three (D, 2 LF (Trans)) PW10

Sixty Shilling Three (D, 2 LF (RC & Trans)) PW34A
Leader Three (SG, D, Pow) 22.5.37 PW35
Summit Three (HF Pen, D, Pen) PW37

All Pentode Three (HF Pen, D (Pen), Pen) .. 20.5.37 PW39
Hall-Mark Three (SG, D, Pow) 12.6.37 PW41
Hall-Mark Cadet (D, LF, Pen (RC)) .. 10.3.35 PW48

F. J. Camm's Silver Souvenir (HF Pen, D (Pen), Pen) (All-Wave Three) .. 13.4.35 PW49
Cameo Midget Three (D, 2 LF (Trans)) PW51

1936 Sonotone Three-Four (HF Pen, HF Pen, Westector, Pen) .. PW53
Battery All-Wave Three (D, 2 LF (RC)) PW55

The Monitor (HF Pen, D, Pen) PW61
The Tutor Three (HF Pen, D, Pen) .. 21.3.36 PW62
The Centaur Three (SG, D, P) 14.8.37 PW64

F. J. Camm's Record All-Wave Three (HF Pen, D, Pen) .. 31.10.36 PW60
The "Colt" All-Wave Three (D, 2 LF (RC & Trans)) 18.2.39 PW72

The "Rapid" Straight 3 (D, 2 LF (RC & Trans)) 4.12.37 PW82

F. J. Camm's Oracle All-Wave Three (HF, Det., Pen) 28.8.37 PW78

1938 "Triband" All-Wave Three (HF Pen, D, Pen) 22.1.38 PW84

F. J. Camm's "Sprite" Three (HF Pen, D, Tet) 20.3.38 PW87

The "Hurricane" All-Wave Three (SG, D (Pen), Pen) 30.4.33 PW89

F. J. Camm's "Push-Button" Three (HF Pen, D (Pen), Tet) .. 3.9.38 PW92

Four-valve: Blueprints, 1s. each.
Sonotone Four (SG, D, LF, P) 1.5.37 PW4
Fury Four (2 SG, D, Pen) 8.5.37 PW11

Beta Universal Four (SG, D, LF, Cl, B) PW17
Nucleon Class B Four (SG, D (SG), LF, Cl, B) PW34B
Fury Four Super (SG, SG, D, Pen) .. PW34C

Battery Hall-Mark 4 (HF Pen, D, Push-Pull) PW46
F. J. Camm's "Limit" All-Wave Four (HF Pen, D, LF, P) 26.9.36 PW67

All-Wave "Corona" 4 (HF, Pen, D, LF, Pow) 0.10.37 PW79
"Acme" All-Wave 4 (HF Pen, D (Pen), LF, Cl, B) 12.2.38 PW83

The "Admiral" Four (HF Pen, HF Pen, D, Pen (RC)) 3.9.38 PW90

Mains Operated.

Two-valve: Blueprints, 1s. each.
A.C. Twin (D (Pen), Pen) PW18
A.C.-D.C. Two (SG, Pow) PW31
Selectone A.C. Radiogram Two (D, Pow) PW19

Three-valve: Blueprints, 1s. each.
Double-Diode-Triode Three (HF Pen, DDT, Pen) PW23
D.C. Ace (SG, D, Pen) PW25
A.C. Three (SG, D, Pen) PW29

A.C. Leader (HF Pen, D, Pow) 7.1.39 PW35C
D.C. Premier (HF Pen, D, Pen) PW35B
Ubig (HF Pen, D (Pen), Pen) 28.7.34 PW36A

Armada Mains Three (HF Pen, D, Pen) PW38
F. J. Camm's A.C. All-Wave Silver Souvenir Three (HF Pen, D, Pen) .. 11.5.35 PW50

"All-Wave" A.C. Three (D, 2 LF (RC)) PW54
A.C. 1936 Sonotone (HF Pen, HF Pen, Westector, Pen) PW56

Mains Record All-Wave 3 (HF Pen, D, Pen) PW70
All-World Ace (HF Pen, D, Pen) .. 28.8.37 PW80

Four-valve: Blueprints, 1s. each.
A.C. Fury Four (SG, SG, D, Pen) PW20
A.C. Fury Four Super (SG, SG, D, Pen) PW34D

C. Hall-Mark (HF Pen, D, A, Push-Pull) 24.7.37 PW45

Universal Hall-Mark (HF Pen, D, Push-Pull) PW47
A.C. All-Wave Corona Four .. 6.11.37 PW81

SUPERHETS.

Battery Sets: Blueprints, 1s. each.
£5 Superhet (Three-valve) 5.6.37 PW40
F. J. Camm's 2-valve Superhet PW52

F. J. Camm's "Vitesse" All-Wave (5-valver) 27.2.37 PW75

Mains Sets: Blueprints, 1s. each.
A.C. £5 Superhet (Three-valve) PW43
D.C. £5 Superhet (Three-valve) PW42

Universal £5 Superhet (Three-valve) PW44
F. J. Camm's A.C. Superhet 4 .. 31.7.37 PW59
F. J. Camm's Universal £4 Superhet 4 PW60

"Qualitone" Universal Four .. 16.1.37 PW73
Four-valve: Double-sided Blueprint, 1s. 6d.
Push-Button 4, Battery Model .. 22.10.38 PW05
Push Button 4, A.C. Mains Model .. 22.10.38 PW05

SHORT-WAVE SETS. (Battery Operated).

One-valve: Blueprint, 1s.
Simple S.W. One-valver PW88

Two-valve: Blueprints, 1s. each.
Midget Short-wave Two (D, Pen) PW38A
The "Fleet" Short-wave Two (D (HF Pen), Pen) .. 27.8.38 PW91

Three-valve: Blueprints, 1s. each.
Experimenter's Short-wave Three (SG, D, Pow) 30.7.38 PW30A

The Prefect 3 (D, 2 LF (RC and Trans)) PW63
The Band-Spread S.W. Three (HF Pen, D (Pen), Pen) .. 1.10.38 PW68

These Blueprints are drawn full size. Copies of appropriate issues containing descriptions of these sets can in some cases be supplied at the following prices, which are additional to the cost of the Blueprint. A dash before the Blueprint Number indicates that the issue is out of print. Issues of Practical Wireless, 4d. Post Paid Amateur Wireless 4d. Wireless Magazine 1/3 The Index letters which precede the Blueprint Number indicate the periodical in which the description appears. Thus P.W. refers to PRACTICAL WIRELESS, A.W. to Amateur Wireless, W.M. to Wireless Magazine. Send (preferably) a postal order to cover the cost of the blueprint, and the issue (stamps over 6d. unacceptable) to PRACTICAL WIRELESS Blueprint Dept., George Newnes, Ltd., Tower House, Southampton Street, Strand, W.C.2.

PORTABLES.

Three-valve: Blueprints, 1s. each.
F. J. Camm's ELF Three-valve Portable (HF Pen, D, Pen) PW05

Parvo Flyweight Midget Portable (SG, D, Pen) 3.6.39 PW77

Four-valve: Blueprint, 1s.
"Imp" Portable 4 (D, LF, LF, Pen) 19.3.38 PW96

MISCELLANEOUS.

Blueprint, 1s. each.
S.W. Converter-Adapter (1 valve) .. PW48A

AMATEUR WIRELESS AND WIRELESS MAGAZINE CRYSTAL SETS.

Blueprints, 6d. each.
Four-station Crystal Set 23.7.38 AW427
1934 Crystal Set AW444
150-mile Crystal Set AW450

STRAIGHT SETS. Battery Operated.

One-valve: Blueprint, 1s.
B.B.C. Special One-valver AW387

Two-valve: Blueprints, 1s. each.
Melody Ranger Two (D, Trans) AW288
Full-volume Two (SG det, Pen) AW392
Lucerne Minor (D, Pen) AW426
A Modern Two-valver WM409

Three-valve: Blueprints, 1s. each.
Class B Three (D, Trans, Class B) AW386
£5 5s. S.G.3 (SG, D, Trans) 2.12.33 AW412
Lucerne Ranger (SG, D, Trans) AW422
£5 5s. Three: De Luxe Version (SG, D, Trans) 19.5.34 AW435

Lucerne Straight Three (D, RC, Trans) AW437
Transportable Three (SG, D, Pen) WM271
Simple-Tune Three (SG, D, Pen) .. June '33 WM327

Economy-Pentode Three (SG, D, Pen) Oct. '33 WM337
"W.M." 1934 Standard Three (SG, D, Pen) WM351

£3 3s. Three (SG, D, Trans) Mar. '34 WM354
1935 £6 6s. Battery Three (SG, D, Pen) WM371

PTP Three (Pen, D, Pen) WM389
Certainty Three (SG, D, Pen) WM396
Minitube Three (SG, D, Trans) .. Oct. '35 WM396

All-Wave Winding Three (SG, D, Pen) WM400

Open to Discussion

The Editor does not necessarily agree with the opinions expressed by his correspondents. All letters must be accompanied by the name and address of the sender (not necessarily for publication).

Exchanging S.W.L. Cards: A Good S.W. Log

SIR,—I would be very pleased to exchange my S.W.L. card with any other S.W.L., A.A. or fully licensed ham in the British Isles or overseas. I QSL 100 per cent.

I also append my log of the stations heard during the last month on a home-built four-valve receiver run off a mains eliminator, and used in conjunction with a horizontal end-on antenna 65ft. long and 30ft. high, directed S.S.E.

C.W. (3.5 mc/s): W1FKI; Fone: W4EQK.

C.W. (7 mc/s): PY4HT; PY4BU; W1ASG, BEH, EVJ, ITJ, KC, KDU, KHE, KX, LL, LTA, MAB; W2ESK, GBK, GCD, GS, KMJ, UK; W3HNN; W3DVM; W6QD; W8DNC, FJG, QES, SKM; W9CK, NAX, PND.

Fone (14 mc/s): EA7BA; K4FKC; PK1OG; PK3WI; W4DRZ, HCM. C.W.: EA1AR, EA3XA; EA7AV; KA1MN; K4ESH; FCV; LZ1ID; OQ5LM; PY2DV, HT; PY7VB; TAI1AA, AR, FX; VO1Y; W6GRL; W9HLF, PNE; YU7AY, BJ.

Fone (28 mc/s): W1CND, JUJ, LEU, LO; W2AOD, JLV, KYO, QF; W3CMO, DQ, MM; W4EJQ; W8AHC, EUO, PPR, RLT, RUL, TOU; W9KDB, TOZ.

Also I have heard broadcast stations: WPTT on 25.27 metres, WGEO, WRUL, Boston, Mass., on 25.45 and 25.58 metres; WCBX on 25 metre-band; XEWW, Mexico City, on 31.58 metres; TGWA, Guatemala City, on 30.98 metres; VLR, Melbourne, Australia, on 31.32 metres; and TAP, Ankara, Turkey, on 31.70 metres.

QSL cards that have been received lately have been VK2ME, VLR, WCAB, W2HNP, XS6AJ, and VS2AK.

In closing, I wish your interesting paper every success.—D. R. HILL, 81, Rye Hill Park, Peckham Rye, London, S.E.15.

SIR—I have been a reader of your excellent paper for about a year now and would like to exchange my S.W.L. card with anybody at home or abroad. All cards will get a prompt reply.—DOUGLAS NASEY, 41, Town Terrace, Leeds Road, Huddersfield, Yorkshire.

Correspondents Wanted

SIR—I would like to get in touch with any young reader of your journal aged about fourteen who is willing to correspond with me at the address given below. I have been reading your paper for the last eighteen months, and have gained almost all my knowledge of wireless from it.—J. A. BLADON, Middleton A, Christ's Hospital, Horsham, Sussex.

SIR,—I have been a reader of your excellent journal for some time now, and I have gained practically all my radio knowledge from it. I am fifteen years old and I am very interested in learning the morse code, and I wondered if any reader living in my district would be kind enough to help me. I should also like a correspondent about my own age interested in short-wave work. In closing, may I wish every success to your fine paper.—D. G.

SHEPHERD, 82, Brantwood Road, Tottenham, London, N.17.

From a Blind "Reader"

SIR,—I feel I must write and tell you how much I appreciate the new PRACTICAL WIRELESS. I have been a reader for quite a long time, and have followed all the articles on short-wave radio. I have twenty-nine cards from sixteen different countries. I would like to mention that I am a blind listener and wish to exchange my S.W.L. card with any other S.W.L. in any part of the world. I will QSL 100 per cent. Also, I would like to correspond with any other listener in any part of the world.—THOMAS J. HORNCOX, 8, Moorbridge Cottages, Bestwood Colliery, Notts.

Heard 77 Countries

SIR,—I am a regular reader of your splendid radio paper and am interested in short-wave radio. My equipment consists of two receivers, the Hallicrafter's Sky Chief, and a ten-valve Ferguson (13 to 70 metres). The aerial is an inverted L, 50ft. long, 30ft. high, direction N. to S., with lead-in at the south end. I am a member of the B.L.D.L.C. and the B.S.W.L. and I hold the B.S.W.L.'s "H.A.C." certificate (S.W. broadcast bands). I have qualified for the V.B.E. but have not yet applied. I listen on the S.W. broadcast bands and have heard seventy-seven countries, thirty-five being verified, QSLs amount to fifty. I think your paper is excellent, but I should like to see the return of the "Leaves from a Short-Wave Log."—V. SMYTHEMAN (Birmingham).

Prize Problems

Problem No. 378

BARCLAY had a spare mains transformer which had two 4-volt 1 amp windings in addition to the H.T. winding. He wished to make up a set in which he needed 4-volts 2 amps for the heaters and decided to use the transformer by connecting the two 4-volt windings in parallel to obtain the desired high current at 4 volts. He did this but when he switched on the transformer commenced to smoke and he accordingly switched off. What was wrong? Three books will be awarded for the first three correct solutions opened. Entries must be addressed to The Editor, PRACTICAL WIRELESS, George Newnes, Ltd., Tower House, Southampton Street, Strand, London, W.C.2. Envelopes must be marked Problem No. 378, in the top left-hand corner and must be posted to reach this office not later than the first post on Monday, December 18th, 1939.

Solution to Problem No. 377

Peters failed to note that the gang condenser has to be earthed in order to obtain a complete circuit from the moving vanes of the condenser to the coils. A metal chassis permits this to be done, but on a wooden chassis, as there is no earthing terminal on the average condenser, he overlooked this fact.

The following three readers successfully solved Problem No. 376, and books have accordingly been forwarded to them:

R. Buckeridge, 17, Browett Road, Radford, Coventry.
E. D. Gunn, 30, Suffolk Road, Ponders End, Enfield, Middlesex.
C. W. Smith, High Street, Studley, Warwickshire.

ALWAYS DEPEND ON

BULGIN

Short-Wave Components

specified for the
"SHORT WAVE FIVE"
AUDIO FREQ. CHOKES

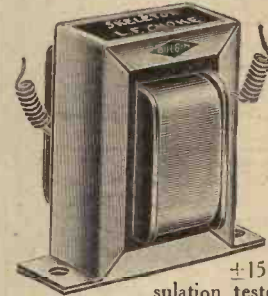

These clamped and shrouded chokes need no introduction; all have mono-metallic windings, and are unequalled for efficiency, reliability, and value. Inductance accurate to ± 15 per cent. Insulation tested at 1 kV. With 6in. leads and finished matt grey.

List No. L.F.16. Price 6/6.

A.F. TRANSFORMER

This component has a primary inductance of 50-80 H. and gives excellent and level quality reproduction.

With a generous nickel alloy core, and with low self-capacity for high amplification. No. L.F.12. 6/6 each.



SWITCHES

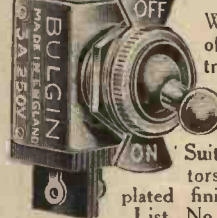

We have the largest range of switches in the industry, and this is a famous and original Mains Toggle type, single-pole 250v., 3A. max. Suitable for sets, eliminators, etc. Polished nickel-plated finish.

List No. S80.T. Price 1/6.

MOULDED JACK PLUG

A new model with nickel-plated contacts and of standard dimensions, but with small moulding, enclosing terminals and cord grip. Single hole for cable entry. List No. P.38. Price 1/3.

Also Specified:

Condensers, Knobs and Dials, Brackets, Chokes, Screws, Wiring, Screened Flex, Slewing, accessories, etc.

★ If you have not yet had a reference copy of our complete catalogue No. 162, showing full range of components, please send at once, mentioning this paper.

INVESTIGATE THE

BULGIN RANGE

Advt. of A. F. BULGIN & CO., LTD., ABBEY RD., BARKING. Tele. R1Ppleway 3474/5/6.



Moaned Smith "Our old super-hot is on its last legs, darling pet."
"Oh no," replied she, "I've mended it, see. With FLUXITE'S cute soldering set."

See that FLUXITE is always by you—in the house—garage—workshop—wherever speedy soldering is needed. Used for 30 years in government works and by leading engineers and manufacturers. Of Ironmongers—in tins, 4d., 8d., 1/4 and 2/8.

Ask to see the FLUXITE SMALL-SPACE SOLDERING SET—compact but substantial—complete with full instructions, 7/6. Write for Free Book on the art of "soft" soldering and ask for Leaflet on CASE-HARDENING STEEL and TEMPERING TOOLS with FLUXITE.

TO CYCLISTS! Your wheels will NOT keep round and true, unless the spokes are tied with fine wire at the crossings AND SOLDERED. This makes a much stronger wheel. It's simple—with FLUXITE—but IMPORTANT.

THE FLUXITE GUN

is always ready to put Fluxite on the soldering job instantly. A little pressure places the right quantity on the right spot and one charging lasts for ages. Price 1/6, or filled 2/6.



ALL MECHANICS WILL HAVE

FLUXITE

IT SIMPLIFIES ALL SOLDERING

FLUXITE LTD. (Dept. W.P.) DRAGON WORKS, BERMONDSEY STREET, S.E.1.

"ENGINEERING OPPORTUNITIES" FREE!



This unique Hand-book shows the easy way to secure A.M.I.C.E., A.M.I.Mech.E., A.M.I.E.E., A.M.I.A.E., A.M.I.W.T., A.M.I.R.E., and similar qualifications. WE GUARANTEE—NO PASS—NO FEE. Details are given of over 150 Diploma Courses in all branches of Civil, Mech., Elec., Motor, Aero, Radio and Television Engineering, Building, Government Employment, etc.

Write for this enlightening Hand-book to-day FREE and post free. British Institute of Engineering Technology, 400, Shakespeare House, 17, 18, 19, Stratford Place, W.1.

The Christmas Gift for Every Boy

ROUND THE WORLD IN INDUSTRY

By Gerald Collins

This stirring book describes how some of the most enthralling jobs in the world are carried out. Travel on the world's most exciting train. Go down under the sea with the divers and tunnellers and up in a plane which a test pilot is throwing about the sky! With many dramatic photographs.

5/- NET

Available from all booksellers, or direct by post 5/6 from the publishers, George Newnes, Ltd. (Book Dept.), Tower House, Southampton St., Strand, W.C.2.

OVERHAULING THE RECEIVER

(Continued from page 279)

One method is shown diagrammatically in Fig. 1, where it will be seen that "top-capacity" band-pass coupling is used, a .0001 mfd. differential condenser being employed for coupling purposes. By varying the capacity of this condenser the degree of selectivity can be modified to suit prevailing conditions. Although usual coil connections are indicated, these are dependent upon the particular type of coil in use.

Re-trimming

When there are two or more tuned circuits in the receiver, selectivity can be restored to maximum by resetting the trimmers should this prove necessary. In most cases, only very minute adjustments will be necessary unless a new valve has been fitted in an H.F., I.F. or detector holder, or unless the wiring has been altered since trimming was carried out initially. If the receiver covers short as well as medium and long waves, it might well be found that re-adjustment of the S.W. trimmers will be repaid by improved reception. Great accuracy of trimming is essential on short waves, and the small changes of capacity which occur while the

set is in ordinary use are sufficient to upset the tuning.

Variable Selectivity

When dealing with a superhet, it will generally be found best to set the aerial trimmers first, and then to deal with those for the primary and secondary of the first I.F. transformer, and finally the primary and secondary of the second I.F., in that order. Selectivity can often be increased to a fair extent by moving the primary and secondary windings about 1/4 in. further apart. After this has been done the trimming should receive attention. Sometimes it is better to move the windings still further apart and to provide a variable-selectivity control. One method is by putting a winding of about 30 turns of fine wire between the primary and secondary, and wiring a 5,000 ohm variable resistor across this. Another method is to connect a .0001 mfd. pre-set condenser between the "anode" and "grid" terminals of the transformer (see Fig. 2). Selectivity can then be varied by adjusting the condenser; increasing capacity reduces selectivity. As a complete alternative to either of the above suggestions it might be thought worth while to replace the first, or both, I.F. transformer by a new one of the variable-selectivity type.

NOTES ON SERVICING

(Continued from page 276)

was connected stage by stage as the fault continued to appear at intervals. Tests were complicated by the fact that the fault at one time appeared to be in the second I.F. stage, and at other times in the output stage. It was suspected that two distinct faults existed, and this was found to be so. The fault in the output stage was caused by the valve making imperfect contact with its holder. Closing the sockets a little cured this trouble. The fault in the second I.F. stage, however, proved to be more troublesome. Individual tests of the components revealed no fault. Eventually, it was found that the fault could be produced at will by disturbing a condenser connected to one of the tags of the second I.F. transformer assembly. The condenser proved to be O.K., so the coils and trimming condensers inside a screening can were examined. All appeared to be in order on making routine tests but the fault remained. A closer inspection of the assembly however revealed a clumsy joint between a stiff tag from the primary trimming condenser and a busbar to which the coils were connected. The tag was bent at an angle to the busbar where it should have been parallel to make a sound joint. In consequence a small space between these parts had been filled with solder. The joint was re-made and the trouble was cured. It would appear that the solder offered a varying impedance to H.F., although a resistance reading on a meter capable of registering as low as .05 ohm, gave a zero reading. The writer had previously experienced cases in which a high impedance to H.F. was offered by an apparently sound joint as shown by the ohmmeter.

Replacement Valves

In conclusion, a few words of warning of the pitfalls to avoid when fitting replacement valves. The characteristics of valves shown as equivalents in makers' lists may not conform exactly to those of the originals, and queer results may follow their use in certain cases. This may be so, particularly in the case of frequency-changer valves. The use of an equivalent here may result in

such troubles as instability or even "no sigs." It may be found that instability occurs at one end of the wave band only, and much good time may be lost in looking for faults which do not exist outside the valve.



A portable radio which should appeal to A.R.P. workers and others who are on patrol duty has now been placed on the market. Weighing only 4lbs., it is carried suspended over the shoulder like a haversack or gas-mask carrier.

In reply to your letter

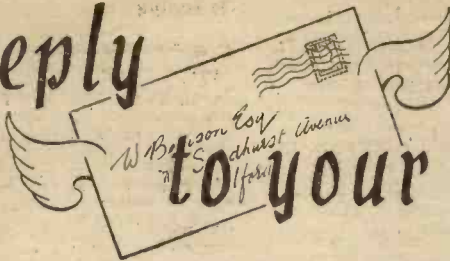

Neutralising

"I have been looking through some old books and in the course of reading found reference with circuit to a neurodyne receiver. I am not very familiar with theoretical circuits and enclose the cutting and should be glad of some further details as to the value of the condenser marked NC and the valve."—L. G. R. (Blackburn).

THE type of circuit referred to was used for H.F. amplification in the days prior to the introduction of the screen-grid valve. When the anode circuit is tuned to the same frequency as the grid circuit, oscillation takes place due to feedback via the inter-electrode capacity of the valve. This prevents maximum amplification taking place in the H.F. stage and it is avoided by fitting the condenser marked NC in the diagram between anode and grid. This should have a similar capacity to that of the valve and thus a very small component has to be used. Special condensers were made for the purpose and are still obtainable from Jackson Bros. The S.G. valve, however, overcomes this difficulty and in addition gives greater amplification and better stability.

Screened Leads

"I have built a set which unfortunately is not very efficient, and in trying to buck things up I have made a number of modifications. I have screened the H.F. section, with a partition round the entire section, screened the anode lead and generally carried out the wiring in the best possible manner. I enclose a sketch of the set and have indicated working voltages and all other data. I wonder if you could assist me in getting this set stable so that it would be worth using."—F. W. S. (Chelmsford).

THE circuit is, in most respects, quite satisfactory and we think you will find that the trouble is entirely due to the long reaction lead running from the detector anode across the chassis to the reaction condenser. If you screen this lead and earth the screening, we think you will find that the set will be quite stable and will experience no further trouble with it.

Coupling Coils

"When making coils I am a little in the dark about the method of winding which is adopted in various makes. In some cases the makers adopt separate sections wound in simple form; in some the windings are on top of each other, and in yet other coils they are on separate formers. Is there any particular rule which has to be followed in this particular connection?"—H. F. (Stockton).

THE aim in winding coils where there is a primary and secondary is to obtain maximum inductive coupling between those windings with minimum capacity coupling. There are several ways of obtaining this desired end. If separate coils are wound and placed side by side (that is, end to end) there will be maximum inductive coupling between them (if they are wound in the correct sense) and minimum capacity. The same end may be obtained by winding the primary over the

secondary, using some form of spacer and winding the primary at a slight angle.

Aerial Static Charge

"When I adjusted my series aerial condenser the other day I got a shock from it. I thought there may be some mains leakage from the set, but a careful inspection showed that there was not. I made a number of tests and finally found that when I touched the condenser in question I did not get a shock, and I have since been unable to obtain one. Can you explain this?"—W. D. C. (Teddington).

RULES

We wish to draw the reader's attention to the fact that the Queries Service is intended only for the solution of problems or difficulties arising from the construction of receivers described in our pages, from articles appearing in our pages, or on general wireless matters. We regret that we cannot, for obvious reasons—

- (1) Supply circuit diagrams of complete multi-valve receivers.
- (2) Suggest alterations or modifications of receivers described in our contemporaries.
- (3) Suggest alterations or modifications to commercial receivers.
- (4) Answer queries over the telephone.
- (5) Grant interviews to querists.

A stamped addressed envelope must be enclosed for the reply. All sketches and drawings which are sent to us should bear the name and address of the sender. Requests for Blueprints must not be enclosed with queries as they are dealt with by a separate department.

Send your queries to the Editor, PRACTICAL WIRELESS, George Newnes, Ltd., Tower House, Southampton Street, Strand, London, W.C.2. The Coupon must be enclosed with every query.

THE effect was no doubt due to a static charge which had collected on the aerial side of the condenser in question. If a good air-dielectric condenser is used this may accumulate quite a large charge during stormy weather, and it may often be seen to discharge with an appreciable flash. A solid-dielectric condenser generally leaks sufficiently to prevent this trouble, however, and there is no need to worry about it except in very thundery weather, when it is desirable to short-circuit the condenser or fit a proper spark-gap in the aerial circuit.

Stepping Down Mains Voltage

"I have an American A.C.-D.C. set which is provided with a 110-volt input. My mains are A.C., but 220 volts, and I have been told that I can use the set if I put a transformer between the mains and the set. If this is so, could you tell me what type of transformer I need and where I can get one. If this is not the case, how can I work the set from these mains?"—M. V. (Long Eaton).

A TWO to one transformer is needed and these are made now by several firms. They are wound to carry the necessary high mains current and may be used either way round, that is, to step down high voltage mains for low-voltage receivers, or for low-voltage mains when a standard high-voltage receiver is to be used.

The coupon on page iii of cover must be attached to every query.

Erie Products

SAME RANGE
SAME QUALITY
SAME PRICE!

Despite increasing costs you can still obtain the full range of Erie Products at pre-war prices. Every item is guaranteed to be of the same high standard of quality always associated with the name "ERIE."

ERIE Insulated RESISTORS

Guaranteed to carry 50% overload with less than 4% maximum resistance change. They give uniformly superior results in all standard tests for load, temperature, voltage, humidity and noise—compact and safe—cannot short or earth even in the smallest installation spaces. The strong ceramic insulating tube will withstand 3,000 volts A.C.

Every Erie Resistor is individually hand-tested.

CARBON RESISTORS

(10 ohms to 5 megohms)

TYPE 0. 1/2 watt ± 10%. Insulated	3d. each
TYPE 3. 1 watt ± 10%. Insulated	6d. each
TYPE 2. 2 watt ± 10%. Non-insulated	1/- each
TYPE 1. 3 watt ± 10%. Non-insulated	1/6 each
TYPE 0. 5 watt ± 10%. Non-insulated	2/6 each

Specified by "Practical Wireless" for the "SHORT-WAVE FIVE" described in this issue.

For Dealers and Service Engineers

ERIE RESISTOR KITS

For efficiency and economy you should have your resistor stock in metal box or cabinet form. No losses—No waste—Easy to find. We give you the metal box or cabinet. You pay only for the resistors, which are an assortment of the most used values.

All these Resistors are RMA Colour Coded. Tolerance + or - 10%.

KIT 1 R 48. 48 One-Watt Resistors 24/- In FREE Pressed-steel box.

KIT 1 R 96. 96 Half-Watt Resistors, 24/- In FREE Pressed-steel box.

KIT 1 R 100. 100 One-Watt Resistors, 50/- In FREE Strong board Cabinet, 8 partitioned drawers.

KIT 1 R 200. 200 Half-Watt Resistors, 50/- In FREE Strong board Cabinet, 8 partitioned drawers.

Subject to usual Trade Discount.

ERIE TYPE "M" (with 2 1/2 in. spindle)

Less Switch	2/6	With Single-Pole Switch	3/-
With Double-Pole Switch	3/6	Centre Tapped with Switch	4/6

Non-standard spindles 6d. per control extra.

DUAL AND GANGED CONTROLS

(Including special replacements)

Less Switch	5/6
With Single-Pole Switch	5/-
With Double-Pole Switch	5/6

The range of ERIE PRODUCTS includes:

Volume Controls, Tone Controls, Vitreous Wire-wound Power Resistors, Ceramicon-Midget Fixed Condensers, Silver Mica Condensers, Car Radio Suppressors, High Voltage Resistors.

Send to-day for full details.

ERIE RESISTOR LTD.

CARLISLE ROAD, THE HYDE, HENDON, N.W.9.

Telephone: Colindale 8011.

RADIO CLUBS & SOCIETIES

Club Reports should not exceed 200 words in length and should be received First Post each Monday morning for publication in the following week's issue.

LIVERPOOL AND DISTRICT SHORT-WAVE CLUB
THIS club, which started its career so prouisingly, has closed for the duration of the war, and the secretary, L. Frank, will be pleased to hear from any of his club colleagues at his present address: Pte. L. Frank, 7611314, Room 22, Portsdown School, Cosham, Hants.

NORTH MANCHESTER RADIO AND TELEVISION SOCIETY

Hon Sec.: Mr. R. Lawton, 10, Dalton Avenue, Thatch Leach Lane, Whitefield, Near Manchester.
As the result of a discussion between the secretary and officers of the above society (which suspended its activities when war was declared), it has been decided to hold a public meeting on Thursday evening, December 14th, 1939, commencing at 7 p.m., at 17-21, Victoria Station Approach, Manchester, 3 (opposite

Victoria Station). Everyone interested in radio and/or short-wave listening is particularly invited to attend. If the meeting is well attended the society will continue to hold meetings in Manchester from time to time during the war, and will at these meetings discuss any public matters concerning difficulty in obtaining radio apparatus, etc., and any other matters concerning radio listeners and enthusiasts, besides the usual society items. The main matters which will be discussed at this first meeting are: 1. Lack of information on short-wave radio now available to public and curtailment of radio publications, etc.; 2. Suspension of television service (a representative of a firm of television manufacturers may give a short talk concerning this matter, apart from the discussion); 3. Confiscated amateur radio transmitting apparatus; 4. Production of radio receivers and components during war-time; 5. Are regular radio meetings of this or a similar type wanted in Manchester? Readers are reminded that they do not have to be very technically-minded to attend these meetings, as they are being made to try to suit all persons interested in radio. The attendance will decide whether these meetings will be continued or not. Further information, if required, can be obtained from the secretary.

WORKSHOP CALCULATIONS, TABLES AND FORMULÆ

By F. J. GAMM

3/6, by post 3/10, from George Neaynes, Ltd.,
Tower House, Southampton St., London, W.C.2.

LIST OF COMPONENTS FOR THE SHORT-WAVE FIVE

RESISTORS

One 4,000 ohms $\frac{1}{2}$ watt. Erie Resistor Co.
One 5,000 ohms $\frac{1}{2}$ watt. Erie Resistor Co.
One 10,000 ohms $\frac{1}{2}$ watt. Erie Resistor Co.
One 25,000 ohms $\frac{1}{2}$ watt. Erie Resistor Co.
Two 40,000 ohms $\frac{1}{2}$ watt. Erie Resistor Co.
Two 50,000 ohms $\frac{1}{2}$ watt. Erie Resistor Co.
One 100,000 ohms $\frac{1}{2}$ watt. Erie Resistor Co.
One 2 megohm $\frac{1}{2}$ watt. Erie Resistor Co.

POTENTIOMETERS

Two 50,000 ohms (without switch), type M. Erie Resistor Co.
Two 100,000 ohms (without switch), type M. Erie Resistor Co.
One 500,000 ohms (without switch), type M. Erie Resistor Co.

CONDENSERS (Fixed and Pre-Set)

One .0002 mfd., type CM5. A. F. Bulgin and Co., Ltd.
One .0001 mfd., type CM4. A. F. Bulgin and Co., Ltd.
Two .01 mfd., type PC101. A. F. Bulgin and Co., Ltd.
Seven .1 mfd., type PCP1. A. F. Bulgin and Co., Ltd.
One .5 mfd., type PCP5. A. F. Bulgin and Co., Ltd.
One 1 mfd., type EC14 (electrolytic). A. F. Bulgin and Co., Ltd.
Two 2 mfd., type EC15 (electrolytic). A. F. Bulgin and Co., Ltd.
Two ceramic, type R481, 4-50 mmfds. British Mechanical Productions, Ltd. (Clix).

CONDENSERS (Variable)

Three 160 mmfd., type 1131 (matched as close as possible). Stratton and Co., Ltd. (Eddystone).
One 12 mmfd., type 1132 (matched as close as possible). Stratton and Co., Ltd. (Eddystone).

REDUCTION DRIVE

One type E.R.D. Radiomart—G5NI (Birmingham), Limited.

VALVE AND COIL-HOLDERS

Three 4-pin, type 949. Stratton and Co., Ltd.
One 6-pin, type 969. Stratton and Co., Ltd.
One 7-pin, type X147. British Mechanical Productions, Ltd. (Clix).
One 4-pin, type X116 (Lemon). British Mechanical Productions, Ltd. (Clix).
One 5-pin, type X116 (Lemon). British Mechanical Productions, Ltd. (Clix).

CHOKES (H.F.)

Five, type 1010 (S.W.). Stratton and Co., Ltd. (Eddystone).

CHOKES (L.F.)

One, type L.F.16. A. F. Bulgin and Co., Ltd.

TRANSFORMERS

One, type L.F.12. A. F. Bulgin and Co., Ltd.

SWITCHES

One, type S80T. A. F. Bulgin and Co., Ltd.

BRACKETS

Two, type E.H.9. A. F. Bulgin and Co., Ltd.

CONDENSER CRADLE

One, type 1114. Stratton and Co., Ltd.

KNOBS AND DIALS

One precision (slow-motion dial), type 1,085 (Dunte). Stratton and Co., Ltd.
One, type K56. A. F. Bulgin and Co., Ltd.
One, type 1036 (driving head with knob, dial and cursor). Stratton and Co., Ltd.
Two, type 1086-9. KNOJM, instrument knobs. Stratton and Co., Ltd.
Two black wheel knobs. Webb's Radio.
One small instrument knob, type K92. A. F. Bulgin and Co., Ltd.
One, type I.P.8 dial. A. F. Bulgin and Co., Ltd.

EXTENSION CONTROL OUTFITS

Three, type 1008. Stratton and Co., Ltd.

JACKS AND PLUGS

One, type P171 (single-circuit jack). Messrs. Igranic.
One, type P172 (closed-circuit jack). Messrs. Igranic.
Two, type P38; jack plugs. A. F. Bulgin and Co., Ltd.

COILS

One set of 6-pin, type 932. Stratton and Co., Ltd. (Eddystone).
One set of 4-pin, type 959. Stratton and Co., Ltd. (Eddystone).

INSULATING PILLARS

Two, type S.M. (1 $\frac{1}{2}$ ins.). Radiomart—G5NI (Birmingham), Ltd.
Three, type 1029 (1 $\frac{1}{2}$ ins.). Stratton and Co., Ltd.
Four, type 1019 (midget stand-off insulators). Stratton and Co., Ltd.

PLUG AND SPADE TERMINALS

Six, type MP1A, engraved. H.T.+, H.T.—, G.B.+, G.B.—1, G.B.—2, G.B.—3.
Two, type R415, engraved, red and black.

VALVES

One, type SG220, S.W. Hivac, Ltd.
One, type PX230, S.W. Hivac, Ltd.
One, type VP215, 4-pin. Hivac, Ltd.
One, type HP215, 7-pin. Hivac, Ltd.
One, type Z220, 5-pin. Hivac, Ltd.

PHONES

Ericsson 4,000 ohms.

LOUDSPEAKER

W.B. Stentorian Junior.

BATTERIES

H.T. 120 v. type. Exide, Ltd.
L.T. 2 v. type. Exide, Ltd.
G.B. 9 v. type. Exide, Ltd.

CHASSIS

Complete chassis. Peto-Scott Co., Ltd.

FLEXIBLE COUPLERS

Two, type F.C. Radiomart—G5NI (Birmingham), Ltd.

RECEIVERS, COMPONENTS AND ACCESSORIES

SOUTHERN RADIO'S BARGAINS.

ALL GUARANTEED. POSTAGE EXTRA.

5/-—Parcel of Useful Components, comprising Condensers, Resistances, Volume Controls, Wire, Circuits, etc. Value 25/-, 5/- per parcel.

15/-—Service Man's Component Kit. Electrolytic Condensers, Volume Controls, Resistances. Tubular, Mica, Paper Condensers, Valve Holders, etc. 120 articles contained in strong carrying case, 9" x 7" x 7". 15/- the Kit.

21/-—Small Trader's Parcel of Components. 150 Articles comprising all types Condensers, Valve Holders, Resistances, Chokes, Coils, Wire, etc. Value 85/-, 21/- the parcel.

5/-—100 Wire-end Resistances, assorted capacities $\frac{1}{2}$ and 1 watt, 5/- per 100.

5/-—6 Volume Controls, 5/-.

TELSEN 3-Range Meters (Volts and Milliamps), 4/-; Ormond Loud-speaker Units, 2/6; Crystal Sets, 5/6; Westectors Type W2, 2/6; Telscn W349 Midget Iron Core Coils, 4/6; Step-up Transformers, 110-250 Volts, 7/-; 8 mfd. Electrolytic Condensers, 500 volts, 1/8.

2/-—Tool or Instrument Carrying Cases, ex-Government Stock; Wood 9" x 7" x 7", 2/-.

SPECIAL Offer, Limited Quantity Torch Bulbs, 1.5v, 21/- per 100; 2.5v. and 3.5v., 17/6 per 100.

SOUTHERN RADIO, 46, Lisle Street, London, W.C. Gerrard 6653.

VAUXHALL.—All goods previously advertised are still available; send now for latest price list, free.—Vauxhall Utilities, 163a, Strand, W.C.2.

"STAND-BY" Crystal Set. Specified coil, 2s., case, 9d.; or complete kit of parts, 10s. 3d., post free.—T. W. Thompson and Co., 176, Greenwich High Road, S.E.10.

BANKRUPT BARGAINS. Brand new 1938-9 models, makers' sealed cartons, with guarantees, at less 40 per cent. below listed prices; also Midgets, portables, car radio. Send 1d. stamp for lists.—Radio Bargains, Dept. P.W., 261-3, Lichfield Road, Aston, Birmingham.

HEADPHONES. Reconditioned and guaranteed. Brown, G.E.C., B.T.H., Sterling, Nesper, Brunet, Westeru Electric, Siemens, Brandes, 4,000 ohms, 5/- pair. Telefunken, lightweight, adjustable, 4,000 ohms, 7/6.

CRYSTAL with silver cat's-whisker, 6d. Complete detector parts, 1/- Glass tube detector on ebonite base, 1/6. Sensitive permanent detector, 1/6. Postage 1d.—Post Radio Supplies, 323, Upper Street, London, N.1.

COULPHONE RADIO, Ormskirk. Collaro A.G. motors 12in. turntable, 24/-; with pick-up 39/-, 1940 K.B. Five-valve Superhets. All-wave £7. 1d. stamp lists.

5/- Bargain Parcel comprising Speaker Cabinet, Drilled steel Chassis, condensers, resistances and many other useful components. Worth £2. Limited number. Postage 1/-.—Bakers Sellhurst Radio, 75, Sussex Rd., South Crodon.

EDDYSTONE "All-World Two" complete with valves, coils and cabinet. Perfect condition, £2/16/-.—G3NM, 430, Bearwood Road, Sneathwick.

NEW RECEIVERS AND CHASSIS

ARMSTRONG COMPANY have complete range of 1940 radio chassis. Armstrong Manufacturing Company, Writers Road, Holloway, London, N.7 (Adjoining Holloway Arcade). Phone NORTH 3213.

LOUDSPEAKER REPAIRS

LOUDSPEAKER repairs, British, American, any make. 24-hour service, moderate prices.—Sinclair Speakers, Pulteney Terrace, Copenhagen Street, London, N.1.

L.S. REPAIR AND REWINDING SERVICE: 24-hour service. See below:—

REPAIRS to moving coil speakers a speciality. New cone assemblies fitted. Speech coils and fields wound or altered. Mains transformers, chokes, eliminators and vacuum repaired, prices quoted. Speaker transformers, Class "B" L.F. transformers and pick-ups rewound at 4s. each, post free. Discount trade. Estimates free. Guaranteed satisfaction. L.S. Repair Service, 5, Balham Grove, London, S.W.12. Phone: Battersea 1321.

NEW LOUDSPEAKERS

3,000 SPEAKERS from 0/6 each, P.M. and energised 4in. to 14in. including several Epoch 18in.—Sinclair Speakers, Pulteney Terrace, Copenhagen Street, London, N.1.

LOUDSPEAKER IMPROVEMENTS — See page 303

A
NEWNES
PUBLICATION

Edited by
F.J.CAMM
Vol. 15. No. 379.

Practical Wireless and

3!

EVERY
WEDNESDAY
Dec. 23rd, 1939.

★ PRACTICAL TELEVISION ★

Contents

- Valve Economy
- ◆
- Constructors' Problems
- ◆
- Loudspeaker Improve-
ments
- ◆
- The Pocket Two
- ◆
- Thermion's Commentary
- ◆
- Practical Hints
- ◆
- A 2½-watt Battery
Operated Amplifier
- ◆
- Beginner's Short-wave
One-valver
- ◆
- Readers' Letters

The Pocket Two

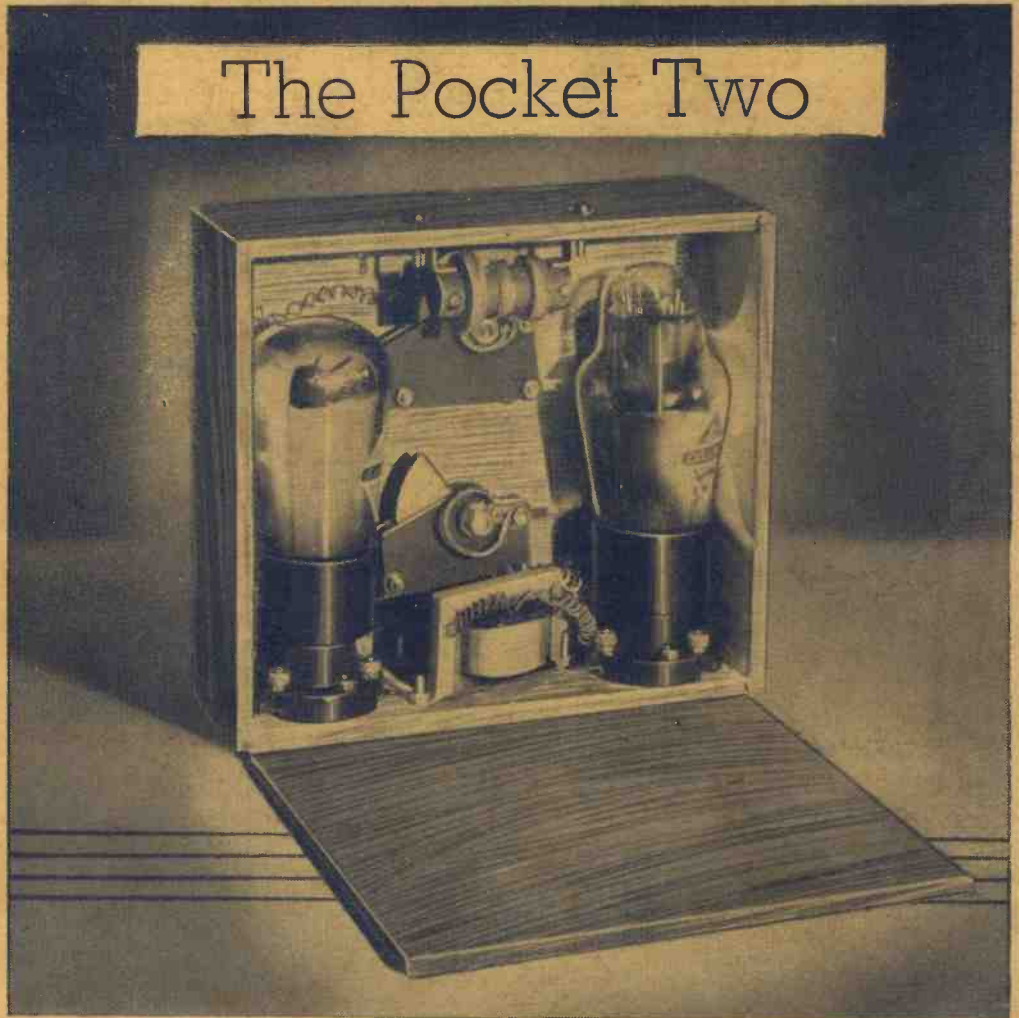

SIXTY TESTED WIRELESS CIRCUITS

By **F. J. Camm**

Circuits for Battery and Mains-Operated Receivers, Adaptors, Units, Portables, Short-Wave Receivers, All-Wave Receivers, Amplifiers, and a Room-to Room Communicator. Diagrams and instructions for assembling and wiring. Details of components and notes on operation.

2/6 NET

From all booksellers, or by post, 2/10, from the publishers, **GEORGE NEWNES, LTD.** (Book Dept.), Tower House, Southampton Street, Strand, London, W.C.2.

COVERS THE WORLD FOR 6^d EVERY MONTH



**READ THE WORK
OF THE CLEVEREST
WRITERS AND
COMMENTATORS**

It would cost you many pounds, and take months of waiting, to obtain by your own efforts the contents of one single issue of P.T.O. You would need to subscribe to hundreds of newspapers and magazines published in every part of the world, and to purchase expensive books. You would need to be a translator of French, German, Spanish and other languages—and you would have to spend weeks in sifting the wheat from the chaff. P.T.O. selects each month the best articles that the world's press and books have to offer. A skilled staff of translators and sub-editors is constantly at work with one object—to keep you well informed! That is why P.T.O. is exceptional value for 6d. monthly.

Some of the 38 Brilliant Contributions in the January issue :

STALIN'S REAL AIM

By Sir WILLIAM OUDENDYK
(From *The Fortnightly*, London)

MY MONKEY-GLAND TREATMENT: THE FACTS

By SERGE VORONOFF
(From *Revue de Paris*)

WHO IS MARSHAL VOROSHILOV?

By V. LENAT
(From *Sevodnia*, Riga)

HOW LONG WILL YOU LIVE?

By AMRAM SCHEINFELD
(From "You and Heredity," published at 12/6)

PILOTLESS BOMBERS

By T. STANHOPE SPRIGG
(From *Flying*, London)

TWO MILLIONTHS OF AN INCH

By DAVID O. WOODBURY
The grinding of the mirror of the world's largest telescope
(From *This Week*, New York)

P.T.O.

PEOPLE

TOPICS

OPINIONS

Place a regular order with your newsagent for P.T.O., the best value in pocket digests to-day!

Pocket-size
6^d.
JAN.

THE BRIGHTEST
DIGEST OF THE
WORLD'S BEST
READING

Better Radio in 1940 with these Handbooks

(1) EVERYMAN'S WIRELESS BOOK

By F. J. CAMM

A Radio Consultant for the Listener, Expert and Amateur Constructor, with Special Chapters on the Principles of Radio Telephony, Installation and Systematic Fault-finding. With 200 illustrations and Diagrams. General Principles of Wireless Receivers. Testing. Special Remedies for local conditions. Noises, their Cause and Remedy. Equipment Troubles. Short-Wave Troubles. Improving the Quality of. Reproduction. Accumulators and Batteries, etc. 5/- net. (By post 5/6)

(2) WIRELESS COILS, CHOKES AND TRANSFORMERS—

And How To Make Them

By F. J. CAMM

Chapters on Coils: Types and Principles. Resistance, Inductance, and Capacity. Choice and Use of Coils. A simple Tubular Coil. Screened Coils: Materials and Construction, Circuits, A Band Pass Unit, Ganging and Switching. Screened Superhet Coils. Short-Wave Coils. Screened Short-Wave Coils. Adjusting and Testing Coils. Coil Troubles and Remedies. 465 kcls I.F. Transformers. An All-Wave Tuner. Coil-Winders. Selectivity. Aerial and Earth Systems. Preventing Breakthrough. H.F. Chokes. L.F. and Smoothing Chokes. Low-Frequency Transformers. Making Mains Transformers. Coil Data and Formulae. With 126 illustrations. 2/6 net. (By post 2/10)

(3) MATHEMATICS OF WIRELESS

By RALPH STRANGER

Essential for the wireless amateur without knowledge of mathematics who desires to gain a fuller knowledge of his subject. Written by one who has the gift of explaining abstruse subjects in a simple fashion. The book gives a simple introduction to Arithmetic, Algebra, Powers and Roots, Differential Calculus, Integral Calculus, Trigonometry, The Slide Rule, Logarithms, Efficiency Curves and Graphs in Wireless, Mathematics and Wavelengths and Frequencies, and a number of problems involved in "wireless" calculations. 256 pages. Fully illustrated. 5/- net. (By post 5/6)

(4) DICTIONARY OF WIRELESS TERMS

By RALPH STRANGER

Mr. Ralph Stranger, who is a master of lucidity, has produced in his "Wireless Dictionary" a valuable and fully-explained synopsis of technical terms that everybody can understand. Indispensable to every wireless enthusiast who reads technical books and journals. It is a comprehensive work of reference for those wishing to understand the more advanced and serious books on wireless, but who do not possess any technical knowledge. 160 pages, well illustrated. 2/6 net. (By post 2/10)

ASK YOUR BOOKSELLER

to get you the book or books you require at the usual price, thus saving postage. Alternatively, send the form to the publishers, with postal order to cover postage, and the book or books will be sent direct to you.

To the Publisher, GEORGE NEWNES, Ltd., TOWER HOUSE, SOUTHAMPTON STREET, LONDON, W.C.2. Please send me by return the book or books encircled below, I enclose Postal Order for the necessary amount.

If you hand this form to your bookseller please state the titles you require.

1. 2. 3. 4.

P.O. No. is Value

Name

Address

P.W. 23.12.39.

Practical and Wireless

★ PRACTICAL TELEVISION ★

EVERY WEDNESDAY

Vol. XV. No. 379 Dec. 23rd, 1939

EDITED BY
F. J. CAMMStaff:
W. J. DELANEY, FRANK PRESTON,
H. J. BARTON CHAPPLE, B.Sc.

ROUND THE WORLD OF WIRELESS

Pocket Receivers

MANY ingenious designs have been given from time to time for small receivers suitable for carrying in a pocket. In some cases these have been merely "designs," and the results have been so poor that it has not been worth while building the set. In others, the portability has been good but the shape has been inconvenient. We have tried out several designs which have been suggested, but there is something lacking in practically all of them, the battery problem undoubtedly being the most difficult of solution. However, as many readers are interested in this type of receiver we describe in this issue a small two-valver, using standard parts and full-size battery valves, and this is built in quite a small cigar box. The batteries must, of course, be housed in a similar or separate box and thus two pockets will be needed if the receiver is being built for carrying about. However, a good overcoat or trench-coat will accommodate the two parts and with a length of wire slung across the body and a pair of headphones, signals may be heard whilst walking.

Radio Act Savings

A GOOD endorsement for banks and an idea for entertainers generally is provided by the Novelty Aces, a quintet heard over WLW Monday to Friday at 8 a.m., E.S.T. The group decided two years ago that they were not going to quit radio broke—when they do. They entered into a pact at that time to save \$2.50 each per week. After the first year this was jumped to \$5 and later was increased to \$7.50.

Their savings account balance, as an act and not as individuals, now is about \$2,150. In order to avoid the temptation of having it handy to draw out, the money is sent each week to a bank in Chicago. The cost of sending it is 10 cents, and each week a different member of the troupe pays this amount. Alan Rinehart is the treasurer and each pay day they all hand over to him \$7.50 without a whimper.

By arrangement with the bank, no money can be withdrawn from the account without the signature of at least four members of the group. Their goal is \$25,000. "When we reach this we'll probably up it to \$50,000," Rinehart said. "At any rate, we're not going to leave radio broke."

Broadcasting at Christmas

THE first war-time Christmas programmes will, as far as possible, follow the traditions of peace time, and listeners will, for a time at least, be able to forget the horrors of war no less than its petty annoyances.

The B.B.C. plans for Christmas Eve include the Pickwick play, "Christmas at Dingley Dell," and will follow with that traditional Christmas broadcast item—carols from King's College, Cambridge. Part 2 of Handel's "Messiah," given by the Halle Society, will be broadcast later in the afternoon. The evening includes a Santa Claus Party, a Nativity Play, and Midnight Mass from Downside Abbey.

Christmas morning will begin with Christmas Greetings—"A sackful of songs and stories, verses and records," "opened" by Lionel Gamlin and Leslie Perowne. Later, listeners will hear a Carol Chain made up of contributions from different parts of the country. It is possible that at nine o'clock the Sistine Choir from the Vatican may be heard, and the morning will also include a Sailors' Christmas Party, a new St. Hilary play for Christmas morning, Carols by the B.B.C. Singers, and a Religious Service from the Chapel Royal.

An Empire programme is in preparation

for Christmas afternoon. This will be followed by Parlour Games, a Christmas Party for evacuated children, and another for the British troops abroad, a P. G. Wodehouse play—"The Crime at Castle Blanding"—and dance music and cabarets from Newquay, London and Harrogate.



If Tex Owens hadn't come down with a case of acute appendicitis eight years ago, he might never have gone into radio. While entertaining a group of children in the same hospital, he decided that singing and playing a guitar was more satisfactory than cow-punching, acting in carnivals and numerous of his other occupations, and was advised to have a try at radio. Since then he has attracted a nation-wide following. Now he's starred three mornings a week over WLW.

Old Scottish Airs

AN orchestral concert which Ian Whyte will conduct on December 22nd includes not only the overture to "A Midsummer Night's Dream," by Mendelssohn, and Grieg's "Holberg" suite in five movements, but also two traditional Scottish airs. One has been arranged by the conductor and is called "The Finger Lock," the other is a Scherzo by Herbert Stephen on the "Wee Cooper o' Fife," a tune which is familiar to those who would like to hear the Scottish-Children's Hour.

Editorial and Advertisement Offices:
"Practical Wireless," George Newnes, Ltd.,
Tower House, Southampton Street, Strand,
W.C.2. Phone: Temple Bar 4363.

Telegrams: Newnes, Rand, London.
Registered at the G.P.O. as a newspaper and
for transmission by Canadian Magazine Post.

The Editor will be pleased to consider articles of a practical nature suitable for publication in PRACTICAL WIRELESS. Such articles should be written on one side of the paper only, and should contain the name and address of the sender. Whilst the Editor does not hold himself responsible for manuscripts, every effort will be made to return them if a stamped and addressed envelope is enclosed. All correspondence intended for the Editor should be addressed: The Editor, PRACTICAL WIRELESS, George Newnes, Ltd., Tower House, Southampton Street, Strand, W.C.2.

Owing to the rapid progress in the design of wireless apparatus and to our efforts to keep our readers in touch with the latest developments, we give no warranty that apparatus described in our columns is not the subject of letters patent.

Copyright in all drawings, photographs and articles published in PRACTICAL WIRELESS is specifically reserved throughout the countries signatory to the Berne Convention and the U.S.A. Reproductions or imitations of any of these are therefore expressly forbidden. PRACTICAL WIRELESS incorporates "Amateur Wireless."

Constructors' Problems

IN spite of the hundreds of letters which are dealt with each week by our Query Service department, it is surprising to note how they can be classified under distinct headings. A careful examination of the records compiled by this department reveal that there are certain problems common to most readers and that these, in turn, can be ranged in order of popularity with surprising regularity. As these details prove that certain facts or formulae are not such general knowledge as one would like to think, in view of the wide range of articles which have appeared in past issues, some of the queries are given in this article, although, for reasons of space, it is obviously not possible to deal with all of them in one issue. It is hoped, by adopting this procedure, that many readers will find the solution to their problem and thus be saved time and postage.

Speaker Matching

Now that the use of extension speakers has become quite common, and the fact that most commercial receivers are provided with sockets for the easy connection of an external speaker, many readers are asking for details concerning suitable ratios for output matching transformers to enable them to use an existing speaker or purchase one of the correct type.

The formula itself is quite simple, namely,

$$N = \sqrt{\frac{R_v}{Z_s}}$$

where N is the turns ratio of the transformer, R_v the optimum load resistance of the valve concerned, and Z_s the impedance or resistance of the speaker. The value R_v can be ascertained from the valve maker's leaflet; similarly, the impedance of the speaker is usually quoted by its maker, so the unknown value N can be calculated with little difficulty.

If a speaker is not already provided with its own matching or output transformer, then the resistance of the speech coil or, in the case of the moving-iron models of a few years ago, that of the speaker bobbins will have to be taken.

Meter Shunt Resistances

The desire to convert an existing single scale reading meter into one of the multi-scale type is very common but, so the post bag reveals, the method of calculating the values of the required shunts, necessary with amp or milliamp meters, is not too well known. It is quite simple and not difficult to remember, whilst its application should not cause anyone any perplexity.

It is, $R_s = \frac{\text{Resistance of meter winding}}{(N - 1)}$

where the resistance of the meter winding is that specified by its maker and N represents the number of times the full scale deflection is to be increased. For example, if the meter has a normal full scale reading of, say, 5 mAs and it is desired to fit shunts to allow it to read 50 mAs at full scale, then N equals 10 and (N - 1) naturally becomes 9.

Stage Gain

When designing and constructing L.F. amplifiers, much trouble and dissatisfaction

can be eliminated if one takes the precaution of calculating the gain or amplification each stage will give. It will be obvious that by adopting this elementary precaution the correct inter-valve couplings and valves can be selected to give the most satisfactory results, while such things as overloading the output stage and the use

Some of the Problems Common to Many of the Vast Number of Readers who make use of the Query Service are Given in this Article by the Technical Staff

of unnecessary valves will be avoided. The Query Service figures show that these facts are now being more widely appreciated, therefore the formula is given below.

Stage Gain = $\mu \frac{R.1}{R.1 + R.a.}$ where R.1 is the

anode load and R.a. the impedance of the valve and μ its amplification factor, the last two values being those given by the valve data sheet for the valve concerned. With L.F. transformers the ratio of the

The chief thing to remember when applying this code is the following order of reading the colours, as it will be found that each resistance carries three indicating colours or markings. These are Body, Tip and Dot. The body will be a certain colour according to its value, but one end or tip of it might be marked with another colour while on the body will be found a dot of another colour. They must be read in the order given, and an example is given to make this quite clear. A resistance having a grey body with a black tip and a red dot would indicate 8, 0, 00 or, written correctly, 8,000.

Frame Aerials

The actual windings necessary for a frame aerial for use on the ordinary broadcast wavebands, i.e., medium and long waves, depends so much on the size of the frame, the spacing of the windings and other details, that it is not possible for the Query Service to calculate the exact number of turns required for each individual application, especially when very brief information is provided, as so often is the case, of the circuit under construction. To



Wiring up a set in the Ekco works. The chassis is already mounted in a "cradle" to protect the components against damage and to make them easily accessible for soldering.

windings must be taken into account, in addition to the amplification factor of the valve, and R.1 then becomes the dynamic resistance of the primary winding. With a resistance coupled L.F. stage, R.1 would, of course, represent the value of the anode resistance.

Standard Resistance Colour Code

Although these details have been published many times they are given in these pages once again, and we would suggest that they are copied out on a stout piece of cardboard and placed in a spot handy to the constructor's bench, thus avoiding much waste of time during experimental work.

Figure	Colour	Figure	Colour
0	Black	5	Green
1	Brown	6	Blue
2	Red	7	Violet
3	Orange	8	Grey
4	Yellow	9	White

enable, therefore, the constructor to have a basis for the start of his experiments, it should be noted that for the medium waves, approximately 75 feet of wire will be required, while for the long wave section, 130 to 150 will be necessary. If the frame is of the type incorporating its own reaction winding, then 40 to 50 feet is suggested for this, but experiments must be made to determine the most satisfactory number of turns in each case.

The medium-wave section should be wound with, say, 24 S.W.G. enamelled or D.C.C. wire and its turns spaced approximately 1/4 of an inch apart. The long wave and reaction can be wound with much finer wire, for example 32 or 34 S.W.G. and the turns should be close together.

PATENTS AND TRADE MARKS

Any of our readers requiring information and advice respecting Patents, Trade Marks or Designs, should apply to Messrs. Rayner and Co., Patent Agents, of Bank Chambers, 29, Southampton Buildings, London, W.C.2, who will give free advice to readers mentioning this paper.

Valve Economy

Novel Valve Arrangements Which May Be Tried in Order to Reduce the Total Number of Valves.
By W. J. DELANEY

WE have already explained in these pages how various economies may be effected in general receiver design, and in one instance have indicated how a multi-electrode valve may be used in an unorthodox way in order to save initial valve expense and to reduce the size and number of components in a receiver. (See the "Three-Two" receiver in our issue dated Dec. 2nd last.) This idea

wishes to go farther can strap two diodes for use as a rectifier or even use two of these particular valves in a straight circuit, making use of some diodes for A.V.C., some for rectification and others for quenching or other special purposes. However, the type of valve which is undoubtedly the most interesting from an experimental point of view is the A.C. double-triode. There are two types of this valve available

Fig. 1.—The circuit of the Three-two receiver using a triode-pentode.

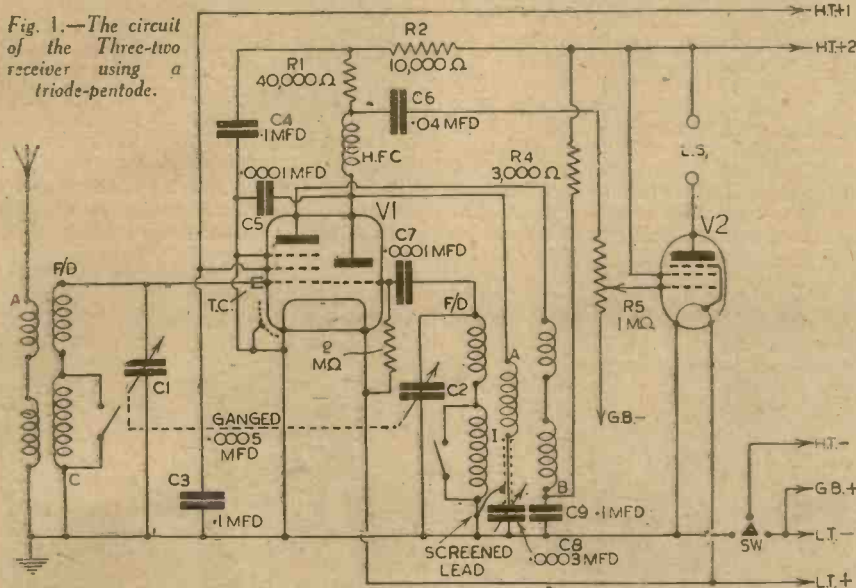

of utilising a dual type of valve may, however, be applied in other directions and similar economies effected. In the article in question it was mentioned that tests had been conducted with a double-triode valve for L.F. and output stages, but these valves are not available in battery types. The standard Class B valve has characteristics such that it will not permit one section to be used as a straight output triode, although each section may be used as a triode. The reason is that the majority operate with no grid bias and thus their handling capacity is low. A low-gain two-stage amplifier could, however, be made up with such a valve, although it is probable that the resultant output would not exceed that given by a good L.F. valve. The total H.T. current would be less, although the L.T. current would be similar to the two valves (each taking .1 amp compared with the .2 amps or more of the Class B valve).

Double Triodes

In the mains types, however, there are several valve designs which lend themselves admirably to special uses, and the double-diode-triodes or double-diode pentodes need not be employed in superhet receivers. The use of the diodes for good-quality signals in a straight set should not be overlooked, and the experimenter who

on the market, one having a single cathode for both sections, and the other having two separate cathodes. Although of American origin, they are available in certain English valves based on the original, although it appears that at the moment only one English firm makes the two-cathode pattern. This separation of the cathodes enables the valve to be used in circuits which are not possible with the single cathode type. Connections and theoretical data are given in Fig. 2.

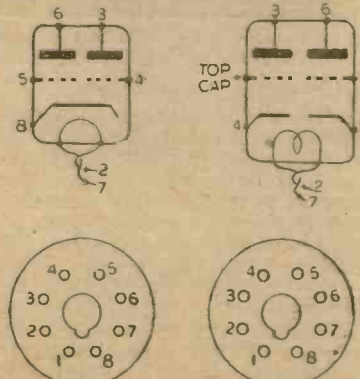

Fig. 2.—Theoretical diagrams of the 6N7G and 6C8G valves and under-valveholder view of pin connections.

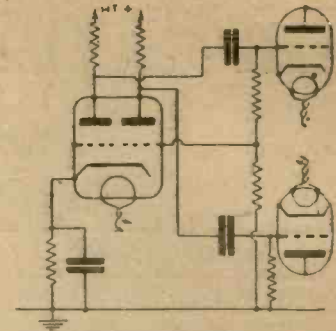

Fig. 3.—Using a double-triode as L.F. and phase-changer with a push-pull circuit.

Push-pull

A very good instance of the effective use of the double-triode, single-cathode type, is in a quality L.F. amplifier wherein one section is employed for L.F. amplification, and the second as a phase reverser. The circuit is given in Fig. 3. It will be seen that the signals, either from a radio section or from a pick-up, are fed into one triode section, and the output is taken through the standard resistance-capacity circuit to one of a pair of output valves arranged for push-pull working. At the same time the signal is also fed to the second section of the double-triode, and the output from this section feeds the second of the push-pull valves. This arrangement has certain features which make it preferable to the more usual scheme of taking the output from cathode and anode of a single valve, and better balancing is possible. The advantage of this particular circuit is, of course, in the saving of space over two separate valves, the saving of one valve-holder and a slight economy in both H.T. and L.T., due to the particular valve characteristics.

Grid and anode of a triode valve may, of course, be strapped to permit the valve to function as a diode or rectifier, and this enables various circuits to be tried out.

(Continued on page 306)

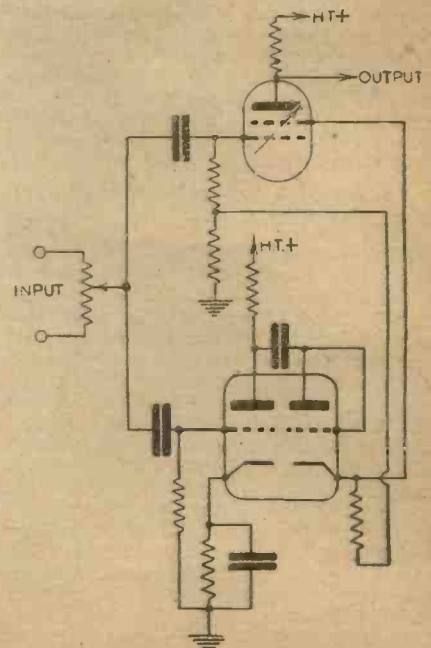

Fig. 4.—Using the double-triode in a contrast expander. Bare details only are given.

PRACTICAL TELEVISION

December 23rd, 1939.

Vol. 4.

No. 182.

An Optical Equivalent

PRINCIPLES which have been firmly established in the field of normal optics are freely borrowed and adapted to meet any special conditions which arise in electronic work. This is particularly the case with one of the ordinary types of cathode-ray tubes where it is found necessary to make the electron stream undergo focusing, refraction or reflection. An interesting application of this has just been made known, and has for its major feature the reduction of spherical aberration. In the usual form of cathode-ray tube the cathode and accelerating anode assembly are mounted at one end of the tube with its fluorescent screen at the other, but in this special tube this assembly is located about the middle point of the glass envelope. The stream of electrons emitted from the cathode immediately comes under the influence of a positive field of force which accelerates the electrons towards a negatively-biased electrode positioned at one end of the tube. Before reaching this electrode, however, the stream must, of course, come under the influence of an equipotential surface which exists between the positive and negative fields. This surface acts on the electrons in the same way as a mirror does to a beam of light, that is, reflects them back towards the remote end of the tube. The stream is then made to accelerate towards a fluorescent screen at the remote end by the action of a high potential additional electrode which brings about a strong focusing action, so that the impact of the stream on the fluorescent screen is evidenced by a sharp, clear-cut, tiny area of light. In addition to the reduction of spherical aberration the total length of the tube is cut down very materially, and this is a very important point for certain uses of the tube, particularly television. The tube housing is reduced in size, and yet normal forms of modulation and spot movement under the influence of a time-base generator can be undertaken.

Oscillographic Uses

THE cathode-ray tube is becoming an indispensable piece of equipment for the multitudinous oscillographic uses to which the device can be applied. No high-class serviceman's equipment is really complete without an oscillograph, while in the laboratory its use has become as common as that of an ammeter and voltmeter. To study the behaviour of circuits and record the changes which occur when alterations are made is of importance to designers, and the accompanying illustration shows a corner of a research laboratory whose bench equipment lends support to these remarks. In addition to the essential meter readings which must be recorded when accumulating experimental data, visual observation of wave-forms on the screen of the cathode-ray tube provides invaluable help in showing what is actually happening in that part of the apparatus to which the electrodes are connected. A recent paper, presented at the

Institution of Electrical Engineers, showed a new application of the cathode-ray tube for measurements in a network analyser. Under ordinary circumstances the calculations involved in the operation and design of modern electrical distribution systems very often present such intricate mathematical equations that their solution by ordinary analytical means becomes practically impossible. As an alternative, therefore, a miniature network, comprising generators, reactors, resistors and other circuit components, is set up to have an equivalent electrical characteristic to the distribution system undergoing investigation. It is here that the cathode-ray tube becomes of such importance, for the nature of the current and voltage distributions can be observed, their phase relationships checked, magnitudes can be measured, and, furthermore, there is the additional advantage that severe overload conditions can be

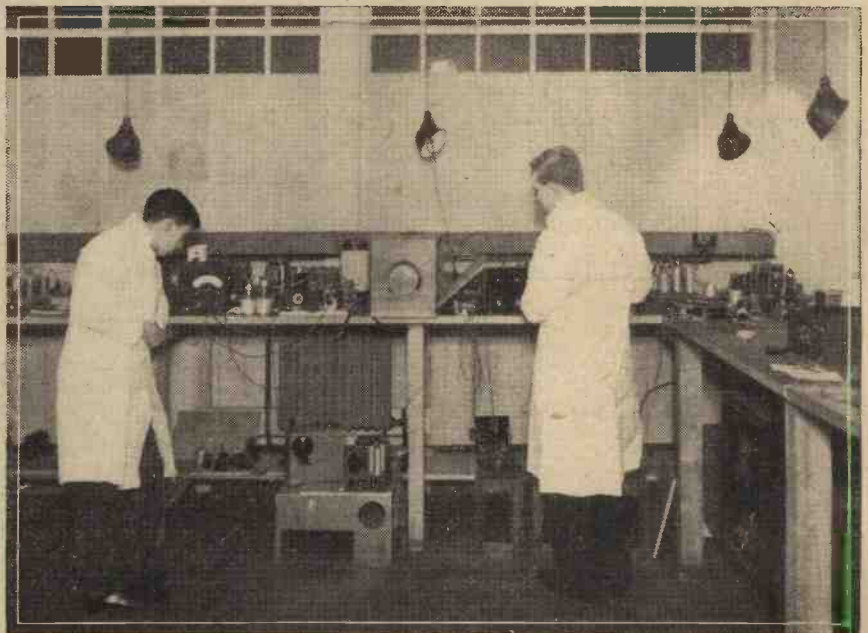

The cathode-ray tube is indispensable in the modern laboratory, for it enables oscillographic records to be obtained in lieu of curves drawn after long mathematical computation.

simulated without damage to the equipment. Transient phenomena in networks is becoming of increasing importance, and when photographic methods are used in conjunction with the cathode-ray traces on the fluorescent screen, proper records can be made in a manner which only hours of laborious calculations and drawing would reveal to those undertaking the investigations.

Shelf Life

MANY home constructors of television receivers, as well as purchasers of complete sets, are wondering if their equipment will in any way deteriorate as a result of the enforced shelf life brought about by the cessation of television transmissions

from Alexandra Palace. As readers know, apparatus which lies idle for any period of time must inevitably accumulate dust, and with the self-imposed restrictions of lighting and heating it is probable that the television set is accommodated in a room which is seldom used. If this should be the case, it is better to move the set into the normal living room where heat is available, and so remove any possibility of damage arising from traces of dampness. If the television set is combined with an all-wave radio which does daily service for listening-in, then all is well, for the local heating from the valves and power pack will ensure that the set's interior in no way suffers. An occasional removal of the back, and the careful use of the suction nozzle of a vacuum cleaner by the radio expert of the household is a wise precaution, and with the very high winds which seem to abound at this time of the year it is as well not to neglect the aerial system. As many installations are a dipole with or without reflector, supported as high as possible above the roof top by a mast, it is a good idea to examine carefully the support fixtures to ensure that they are successfully withstanding the ravages brought about by inclement weather. If there is any movement of the mast in a lateral direction within its bracket support, this will cause damage to the pole and should be remedied by wedging straight away. Also, see that the feeder cable is free from defect and not swaying in the wind or fracture will result. Any exposed soldered joints should be cleaned and taped up. A

little care and attention devoted now to the whole installation will repay the owner, and save the cost of a service call when transmissions are resumed at some later date. The cathode-ray tube of the set will benefit if it is given a short run of between 10 and 20 minutes every alternate week, the brightness control being kept at normal level, or if D.C. is present, advanced a little from its usual running position, so that the scanning field on the tube face is plainly visible. Do not let dust get inside the glass cover plate which protects the tube face, and if the set is examined periodically as advised, then it will in no way suffer during its enforced retirement from household entertainment activities.

ON YOUR WAVELENGTH



By *Thermion*

The End of the Year

I AM necessarily writing this ahead of Christmas, but the message will reach you round about Christmas Eve if we can rely upon the railways to do their stuff and deliver promptly. I mention this point because some readers are complaining that nowadays they are not able to obtain copies with the same meticulous promptitude as hitherto. There are a number of reasons for this. There are restricted train services and restricted collection and delivery services, due to the black-out. We ask for the indulgence of our readers in these difficult times, and if the one and only weekly wireless journal fails to arrive on the Wednesday morning, readers must not presume that we have shut up shop and departed for some unknown destination in the country. The editorial offices of the journal have not been evacuated to the country. Here we are, right in the danger zone defying Hitler to do his worst. I refuse to evacuate my office, unless at some future time a bomb mutilates my sanctum. Even this, however, will not prevent us, like Burgomaster Max in the last war, from publishing our journal.

Anyway, festive greetings and all that.

The Club Dinners

FOR my sins it is part of my job to visit the annual forgathering of clubs around the festive board, for even your energetic Editor has not yet discovered any means of being in two places at the same time. I am, therefore, his unworthy deputy, and one of the toasts which I have to propose, or to which I have to respond, includes the visitors and the Press—gentlemen of the Press, if you please. I do not know why journalists should be referred to as gentlemen, for the definition of a gentleman is one who does not work for his living, or one who would not willingly hurt the feelings of another. The former definition certainly does not apply to me, and I gather from my correspondence that the latter does not either. But, still, here we are at the end of another milestone in the history of the world, and I do want for the nonce to drop the role of splenetic critic, and to extend the

hand of comradeship to all my readers. Most of them understand my gibes, and accept them in the spirit of friendly badinage. Some, however, get quite hot under the collar, and add to the gaiety of my life by scrawling a bitter letter to me disagreeing with my views on this, that or the other. There is substance here for a New Year's resolution on the part of these readers. However, it is pleasant to hear the flattering things which are said at club dinners about the Press. It is realised that it is the Press which keeps the movement together. An industry or a hobby gets the press it deserves, and it is the wireless constructor who has made the wireless press what it is—the first reader to send me a rude answer to this is sacked!

The Past Year

IT has, indeed, been a momentous year, one of alarms and excursions, finally culminating in the declaration of war towards the end of Radiolympia. The cloud of doubt ruined the best show of the lot, and caused it to close down before it had run the usual course of its life. The radio trade has had a bad time, although there are signs, judging from the re-introduction of hire purchase, that it is reviving. Amateur wireless transmitters have had their licences cancelled and their transmitting sets confiscated. The Baird Company has suffered a knock-out blow, for the television transmissions have ceased for the duration of the war. Journals, too, have had their difficulties, but we are encouraged by the continued interest shown in radio construction, as evinced by our net sales, to continue. This, in spite of rising costs and the inevitable problems which a war brings to journals of this character. We are on the

threshold of a new year. We can but hope that another Radio Show will take place in 1940, which means that the war will be over soon.

Midget Receivers

I HAVE received the following interesting letter from A. C., of Rossendale, Lancs:

"From time to time various concerns have produced portable receivers of reasonably small dimensions—one or two sets were really in the 'pocket' class—but for some reason really little attention has been paid to the design of a midget battery receiver.

"In the United States, of course, there is a great business in the sale of A.C.-D.C. midget sets at about 30s. to 45s., and it is difficult to understand why our British manufacturers have never been able to cater for the low-price market.

"I suggest that there is a real need for a pocket portable at present, when so many thousands of people are taking part in some form of National Service. Broadcast programmes are popular with both British and French troops. As one report from Paris states:

"Music has not been, as in 1914, the first victim of the war. Then, the opening roar of the cannon scattered the startled muses. To-day, music goes with the soldiers to the battlefield. Thanks to the radio, the artistic life of a nation is no longer stilled by the crash of arms. Above the military trains, the convoys of supply, the transmission of the wave trains is uninterrupted. They travel, invisible in the air, to ensure the intellectual replenishment of the peoples. . . . The receiving sets can carry to the very edge of the battlefield the comforting, cheering voices of artists who formerly could only occasionally reach the units behind the lines. . . . Just as one sends the soldiers at the front packages filled with good things, so art in its most familiar form gives our defenders a moment's diversion.

"These gifts will certainly be most welcome, but even the smallest commercial portable provides loudspeaker reception and is too big to be taken everywhere.

"Is it impossible to design a low-priced pocket receiver, strong enough to withstand normal use, operating from dry batteries for H.T. and L.T., and providing reception on small headphones?"

Comment, Chat and Criticism

XMAS MUSIC

Our Music Critic, Maurice Reeve, Discusses Carols and the Festive Season

THERE are few spheres of life into which music, in some form or other, does not enter. Nor is there a function or a celebration in which it does not have its allotted place. Whether it be a King's coronation or the Maypole dance, the gathering in of the harvest, or the celebration of marriage nuptials; each and all call on music to play an important role. So with Christmas approaching, it may not be unseasonable if we consider the part it plays in the great annual festival of hope and faith.

It would be as impossible to talk about Christmas music without introducing a reference to its great twin event, Easter, as it would be to write about winter without mentioning summer. Not by way of critical comparison, but simply because it seems inevitable that we should. We all know that Christmas is a festival of rejoicing, whilst Easter is one of mourning. Consequently, the music for the two occasions is naturally of a vastly different character. But that is not the half of it. I think that much more than merely the religious nature and significance of the two rites govern the character of the music used in each. What is the first thing that strikes us about their music, when looked at in retrospect, as it were, and quite without prejudice or favour? Simply this, which is of profound significance. Christmas is a festival of rejoicing. It is the great carnival of the young. It has the widest possible ramifications from turkey to crackers, and mistletoe to mince pie. Everything is spontaneous, natural and free and easy; "we do as we darned well pleez-e." And we do it because we want to do it, unlike Easter, when we do things rather more because we've got to do them. The festival is completely informal and spontaneous—in spite of certain preparations and formalities, much more so than Easter. The result of all this on the musical side of the celebrations is inevitable.

The music of Christmastide is consequently stamped with an informality and a spontaneity which are wholly lacking at Easter. Not only does the religious side of the ceremony lack the formal great masterpieces that Bach and Handel gave to the spring occasion, but the very joyousness of the season sets the whole people music making as part of their merry-making. Which leads me to the core and root of all Christmas music—the Carol.

Carols

What would Christmas be without the carols? No matter how atrocious the vocal effort and regardless of the venality of some of the young urchins who make sport of the occasion, and are quite oblivious of the true meaning of their chants, what would Christmas be without those "Noels" and "Whilst Shepherds Watch," gabbled and croaked through the letter box? What if we were not summoned from our fireside toast or crumpets to answer their imperious knock? Not quite the same,

surely. Celebrants in hotels or restaurants must surely miss a vital part of the season through missing these young rascals, who have been a part of the English winter mythology for ages out of reckoning.

Carols (the word Carol is derived from the French generic name Noël) have had a long and chequered history. They first came into use in the church service when Latin ceased to be the language universally understood and spoken—presumably at the time of the rise of our modern national dialects. St. Francis of Assisi is said to have designed the first examples to stimulate greater enthusiasm in church services than the long Latin sequences could generate.

Classification

Rickert divides English carols into groups according to their subject matter. The earliest dealt with the Nativity, the Incarnation and the Annunciation. Then came the Shepherd and the Epiphany groups followed by those of Christmastide, Wassail and the Boar's Head. Although most of the best carols have come from the Continent, there are many English gems by Byrd, Gibbons, Lawes, and other masters of Elizabethan and Stewart English music. The "First Nowell" is only a portion of a long harangue, and its constant repetition gets very monotonous. "God Rest You Merry, Gentlemen," is a splendid tune, which was used to various political "motifs" in the eighteenth century. "Remember O-Thou Man" (1611) is also a very good one. A very early one is "The Boar's Head in Hand Have I" (1521), and it is sung every Christmas in front of Queen's College, Oxford.

A large number of folk-song carols are based on mystery plays and pageants, notably the "Cherry Tree" carols, the "Carnel and the Crane," "Joseph was an Old Man," "Dives and Lazarus," and "Three Ships," etc.

English carols have suffered strange vicissitudes. They began as popular songs of great beauty, and up to the time of the Reformation—a time of Catholic piety such as we see to-day in any Roman Catholic country—the Virgin and Child was the favourite theme. Henry the Eighth's arbitrary rule, and its profound and lasting effects on the temper of the country, caused a loss of joy and spontaneity to them—they became dull and formal. The Puritans discouraged them altogether, whilst even the Restoration had little effect. But they came back to some favour about 1700 and were more or less stabilised as a hymn for church performance—this being the final test of their quality. "While Shepherds Watched" would be typical of the form which they permanently assumed from then onwards. Perhaps the most beautiful carols are to be found in the lullaby and cradle song categories, the palm going to those originally written in Germany, owing to the wealth of diminutives in that language. There are many collections and

an extensive bibliography. Much research has evidently been given to the subject.

Amateur Talent

Carols, however, are surely at their best when, to a Christmas card setting of frost and snow, fine amateur vocal talent collects in bands or choirs and goes out on its joyful ways singing, with sincerity and skill, for the benefit of deserving charity and to the pleasure of those inside and around their fire. A knock on the door not only gets politely answered and the request for charity generously responded to, but a glass of port and a mince pie are not infrequently the carollers' reward. Alas, we seldom get this near London, nowadays.

It is many years since I can remember seeing it—fourteen miles from Charing Cross. I hope the custom has survived in the country—we can ill spare to shed many more of these pages of Old England's story. But what chances would these songsters have on our modern arterial roads, and in the crowded areas of suburbia? Tip and run is the order of the day there, and unavoidably so, I'm afraid.

King's College, Cambridge, have provided us in recent years with by far the best carol singing, and it has been among the best radio items on Christmas Day for many seasons. I cannot say if we are to enjoy these famous choristers again this year—probably not. But keep a look out in the radio programmes for them, and if you haven't heard them before, don't miss them. If you have, then I know you'll be switching on.

PROGRAMME NOTES

Strausses Galore

GUY WARRACK has chosen some of the music he most loves for the concert which he will conduct on December 23rd. Moreover, it has all been composed by members of the Strauss family. It begins with the overture, "Fanny Elssler the Dancer," by Johann Strauss (son) and followed by Old Viennese Dances, by Oscar Straus; the Galop, "Where one laughs and lives," by Eduard Straus; a waltz scene from "Intermezzo," by Richard Strauss; Galop, "Dr. Piccolo," by C. Strauss; Polka, "Old China," by Johann Strauss (father); and, the best known of all, "The Blue Danube" Waltz, by Johann Strauss (son).

Dream Come True

THIS story gave uncomfortable feelings to the people who heard it; Mrs. Rudolph Pihoda, wife of the WLW staff artist, woke up one morning recently in tears, after a dream that her brother, a German citizen, had been drafted into the army at home and wounded in action. Early this week she received a letter from Germany. It said that her brother had been drafted for army service and several days after hostilities began was wounded.

A 2½-watt Battery-operated Amplifier

Owing to Previous Copies Being Now Sold Out, the Following Details are Reprinted by Request

OWING to amplifiers being so often associated with high-power outputs, it has become common to think of them as being essentially mains operated; therefore, in view of this and the number of requests received for a battery-operated outfit, the unit mentioned above has been designed. To the many readers who have made such requests and who may require something different from that given below, we would draw their attention to the latest edition of "Sixty Tested Wireless Circuits," wherein will be found much valuable information, together with complete circuits, concerning amplifiers and their design.

The first consideration with any battery-

case may be, it is always wise to remember that the ear is not too critical as regards intensity of sound when considered from the point of view of watts. For example, it would take a very experienced ear to differentiate between 3 and 5-watts output; therefore, I have selected a happy medium, remembering other limitations, and decided on an output of 2½ watts.

The Circuit

The valve sequence is one L.L.2, which has an amplification factor of 30, feeding into

The current consumption of the L.L.2, with 135 volts on its anode, is approximately 3 mAs, while each P.P.225, under normal working conditions, will draw as much as 18 mA in the anode circuit and 2 mA in the auxiliary-grid circuit. These figures at first sight seem rather drastic for battery operation, but one must not overlook the fact that with Q.P.P. output the two P.P.225's are so heavily biased that their standing current becomes very low and large current surges only take place during the handling of powerful passages in the input signal.

It is impossible to go into the whys and wherefores of Q.P.P. operation in this article, but it will suffice to say that the whole secret of satisfactory output and distortion-free reproduction is the correct adjustment of the grid bias with relation to the actual anode potentials.

The output from a normal pick-up will provide adequate input for the output valves as the L.L.2 has a fairly high magnification factor, while the coupling transformer has a ratio of 1:9. So far as microphones are concerned, a lot depends on the type and their actual efficiency, and with a high sensitivity model a satisfactory output will be obtained; but with others having a lower output, such as high quality transverse current and moving-coil types, it will be advisable to provide a simple "head" amplifier in the form of, say, a good straight H.F. pentode resistance-capacity coupled to the L.L.2.

Two variable controls are provided to allow two inputs to be controlled and "mixed" before being fed into the grid circuit of the L.L.2, thus allowing two pick-ups or one pick-up and a "mike" to be used, according to individual requirements. This item is always very handy as it increases the uses of the amplifier considerably, apart from giving the operator greater scope so far as results or effects are concerned.

The third control R3 is a combined
(Continued overleaf)

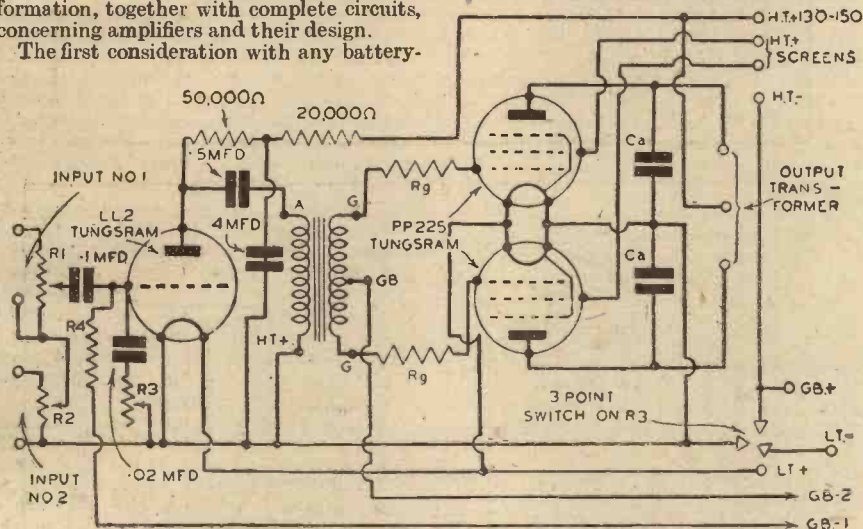

Fig. 1.—Theoretical circuit of the 2½-watt battery amplifier.

operated apparatus is current consumption. The second, at least so far as amplifiers are concerned, is the output obtainable. Bearing in mind the fact that these two requirements are very closely related to each other, and that dry H.T. batteries are likely to be the source of anode current supply, limits to suit both factors had to be selected, and it soon becomes apparent that it is absurd to think in terms of 4, 5 or 6 watts output, as so many constructors would desire.

If one can eliminate the question of dry H.T. batteries by, say, using large-capacity H.T. accumulators or, for example, a Milnes Unit, then the output can be raised considerably, but even so, one cannot soar to the large outputs obtainable from some of the mains-operated "power" amplifiers.

So many pick-up enthusiasts appear to have the impression that unless an amplifier can deliver, say, 5 watts of undistorted output, it is not worth considering for record reproduction. Well, I suppose it is a matter of personal taste, but bearing in mind that one is usually concerned with using the equipment in a room of average size, I would suggest that such power is out of all proportion.

From the reproduction point of view, by which I mean judging aurally, I maintain that an output system capable of handling 2½ watts is more pleasing, when it is fully loaded, than a 5 or 8-watt outfit with the volume turned down to the same output. However, whatever the pros and cons of the

two pentodes, P.P.225's, arranged in quiescent push-pull, the coupling being provided by a Varley Q.P.P. transformer type D.P.36 which is parallel fed to allow the utmost inductance to be obtained from the primary winding to ensure a good bass response.

The normal output of one P.P.225 with 135 volts on the anode and auxiliary grid, and with its grid biased 12 volts negative, is 1,000 milliwatts, or 1 watt; therefore, with two in the above output circuit, it is safe to estimate that at least 2½ watts will be obtained, provided the anode and bias voltages are correctly adjusted.

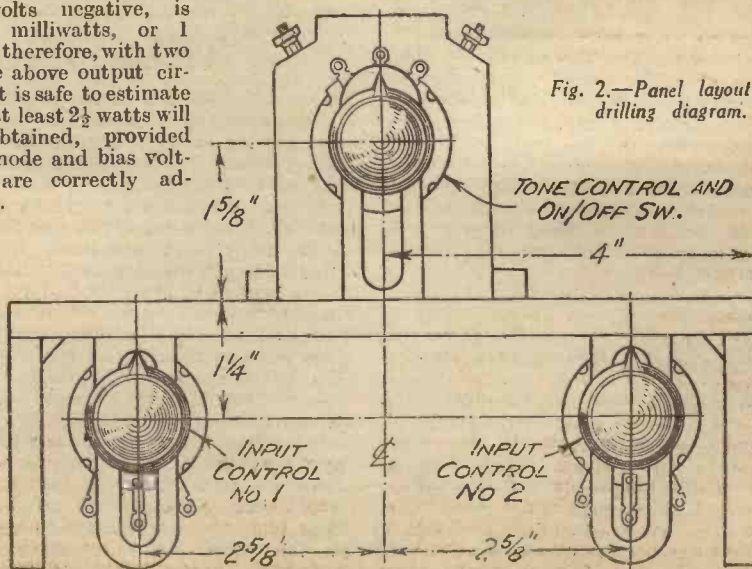

Fig. 2.—Panel layout and drilling diagram.

A 2½-WATT BATTERY OPERATED AMPLIFIER.

(Continued from previous page.)

potentiometer and switch, the potentiometer section being used as a tone control, while the switch is wired to cut off all batteries. It will be noted that the tone control is really a low-note booster or high-note cut off, but the values have been selected to provide a most satisfactory variation in the tonal response, and it will be found very useful for the elimination of record surface noise or needle scratch. It must be appreciated, when considering this arrangement, that the natural characteristics of the amplifier are on the high side, so any additional form of high-note booster is not required; in fact, it would be detrimental.

Layout

It will be seen from the illustrations that a small simple chassis has been used to hold all components, as this allows a clean top deck to be obtained and facilitates wiring. It will be quite an easy matter to build a compact cabinet round the chassis or, if a more professional appearance is required, to make a cover to fit into the top of the chassis out of stout perforated zinc.

The transformer is placed so that the grid leads to the two output valves are short and direct, the resistance Rg being included to prevent, in conjunction with the two fixed condensers, Ca between each anode and the negative line, parasitic oscillations which are sometimes generated in symmetrical push-pull circuits.

The anode circuit of the L.L.2 is decoupled by means of a resistance and a condenser to eliminate any possible instability through battery coupling, but the anodes of the P.P.225's receive their H.T. via the output or speaker transformer. No output trans-

WIRING DIAGRAMS

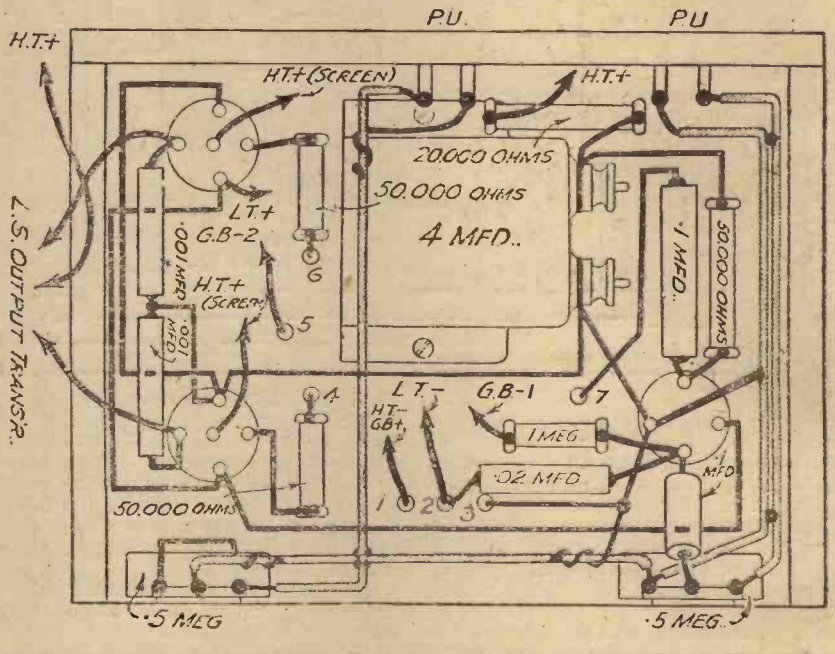
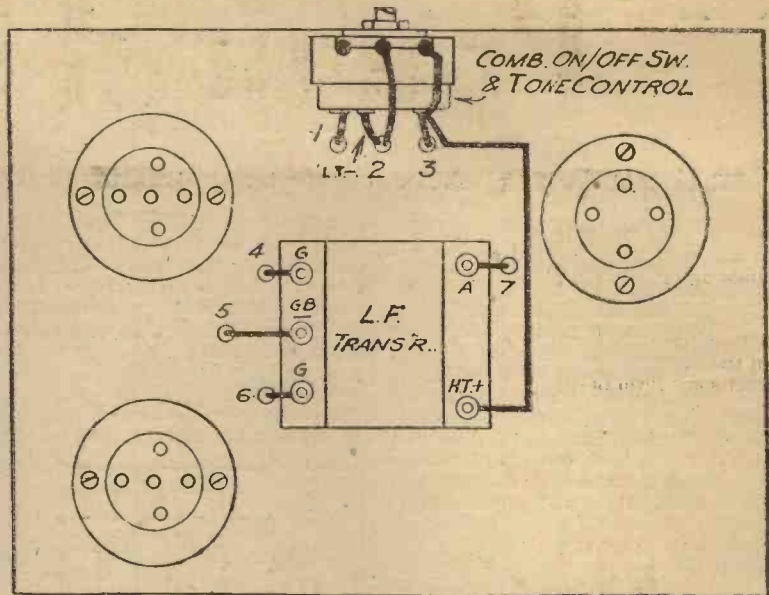

LIST OF COMPONENTS

- One 50,000 ohm 1-watt resistance, Erie.
- One 20,000 ohm 1-watt resistance, Erie.
- Two 50,000 ohm ½ watt resistances, Erie.
- One 1 megohm ½ watt resistance, Erie.
- One 4 mfd. fixed condenser, type 50, T.C.C.
- Two .1 mfd. fixed condensers, type 250, T.C.C.
- One .02 mfd. fixed condenser, type 300, T.C.C.
- Two .001 mfd. fixed condensers, type 300, T.C.C.
- Two 5-pin valveholders, chassis type, Clix.
- One 4-pin valveholder, chassis type, Clix.
- One 25,000 ohm potentiometer, with three-point switch, Erie.
- Two 5 megohm potentiometers, Erie.
- Two socket strips, P.U., Clix.
- One Q.P.P. transformer, type 36, Varley.
- One L.L.2 valve, Tungstram.
- Two P.P.225 valves, Tungstram.
- Wooden chassis, screws, wire and systoflex.

former is included in the amplifier as the majority of modern moving-coil speakers are fitted with a multi-ratio transformer which usually allows satisfactory matching to be secured.

Particular attention must be given to the connecting wires associated with the two input controls. As these potentiometers are in direct contact with the input grid, it is essential to cover all connecting wires with metallised braiding.

“FOR SERVICE READERS.”

READERS who have relations or friends in H.M. Forces will be thanked if they draw attention to our famous contemporary “TIT-BITS” and its page “For Service Readers.” This page, conducted by “Nobby,” who is the Service-man’s Champion, is already famous. Nobby’s offer of expert help is extended to A.R.P. workers and all engaged upon Service for the State. Apart from this feature “TIT-BITS” remains the brightest of all home weeklies and is the ideal paper to send “him” in the next parcel.

TELEVISION IN AMERICA

THOSE nations free from the rigours of war and able to maintain their television services, that is to say, the U.S.A. and Italy primarily, have apparently been studying very carefully the nature of the productions which fortunate viewers within range of the Alexandra Palace signals were able to enjoy in pre-war days. From information which has become available from various sources it has appeared very clear that the authorities charged with providing entertainment through the medium of television, and this applies particularly to America, have begun to recognise that it is far better to make a really honest use of the conventions which the restrictions of television make apparent, than to make fruitless attempts to disguise those limitations by a rather lavish copy of what occurs in either the film studio or on the stage. The producers who are tackling this important problem have come to the very sensible conclusion that it is preferable to exploit fully their own analytical selec-

tion of the visual clues which the new medium is undoubtedly placing at their disposal. It has always been recognised in the entertainment world that the films have the special advantage of post editing, but there is no reason why this factor cannot be offset by paying very careful attention to individual lighting for each item of the production in conjunction with correct continuity movement. A clear lead is established over any film record by the vitality of the television transmission, for there is the knowledge that the event is happening while being watched, and did not occur some months previously in the form of haphazard scenes which the editor has restored to a story with the events in chronological order. In America it has already become apparent that the probationary period of programme productions is likely to be a short one, and although large talent resources will be required this has become an incentive and not a deterrent.

Practical Hints

A Pick-up Lifting Device

THE action of removing and replacing a pick-up on a gramophone record has always struck me as being bad for the tracking, and as I frequently experiment in practising this very function, I decided that in the interests of my records I would construct some form of lifting device which

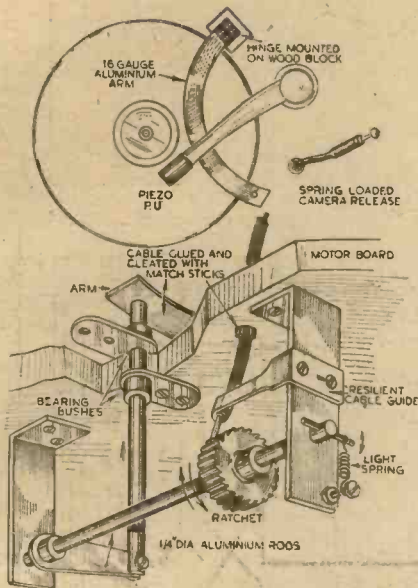

A novel pick-up lifting device.

would provide a further advantage in protecting a piezo head which I use. After weighing the pros and cons of various schemes, I hit upon the idea of using a camera release and ratchet movement along the lines indicated in the sketches.

This camera shutter release is very positive in action, and by adjusting the relationship of the ratchet teeth to the push of the release pin, I very seldom have to make any adjustments. The diagrammatical representation shows the essentials of the completed assembly, the inset illustration clearly defining the function of the hinged record lifting strip.—G. J. GRIMMS (Leicester).

Turntable Illumination

PROPOS the article in a recent issue of "P. W." regarding turntable lighting, I thought that the following idea as used by me for the past few weeks would be of interest to other readers.

I had by me an old shaving stick case, made of a composition similar to bakelite, of which the cap screwed into the body.

I cut a hole in the cap large enough to take a miniature batten holder, as supplied by a popular stores, and then drilled the flange of this cap, and also drilled corresponding holes in the base of the batten holder, this allowing small bolts to be inserted and screwed up tightly to hold the assembly rigid.

Next, I cut a window in the body of the case in such a position as to allow light

THAT DODGE OF YOURS!

Every Reader of "PRACTICAL WIRELESS" must have originated some little dodge which would interest other readers. Why not pass it on to us? We pay £1-10-0 for the best hint submitted, and for every other item published on this page we will pay half-a-guinea. Turn that idea of yours to account by sending it in to us addressed to the Editor, "PRACTICAL WIRELESS," George Newnes, Ltd., Tower House, Southampton Street, Strand, W.C.2. Put your name and address on every item. Please note that every notion sent in must be original. Mark envelopes "Practical Hints." DO NOT enclose Queries with your hints.

SPECIAL NOTICE

All hints must be accompanied by the coupon cut from page iii of cover.

from the miniature bulb (15 watts) to project.

When completed, I gave the whole assembly a coat of brown bakelite enamel, and when this had dried hard I wired the lamp to a small press switch for inclusion on the motor board of my radiogram.—W. CHURCH (West Wickham).

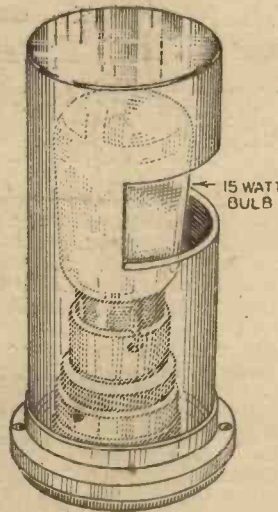

An old shaving-stick case makes an effective shade for a turntable light.

A Calibrated Scribing Tool

AS I do a good deal of home constructional work, I thought it would be well worth my while if I made a calibrated scribing tool having inch and fractional markings. As a steel rule offered considerable difficulties, so far as drilling was concerned, I decided to go to a little trouble in carefully scoring a brass strip down to 1/16th of an inch.

After slightly shaping one end after marking and stamping the scale—the scoring being carried over one edge, as will be noticed in the accompanying drawing—I then drilled a small hole into which would finally be sweated the brass fluted needle holder. To observe the necessary degree of accuracy, I made sure that the centre of the hole corresponded to the exact centre of the zero inch mark.

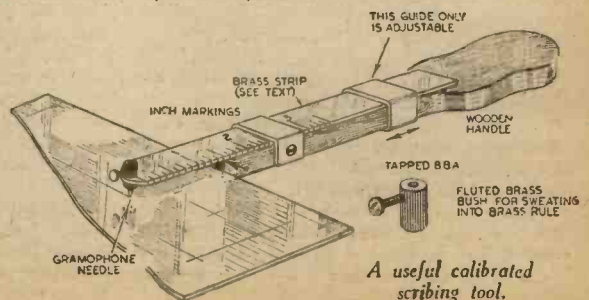

A useful calibrated scribing tool.

Two 18 gauge brass guides, one screwed to the wooden handle, the other free to move up and down the scale and handle, were soon made, and the finished job proved interesting to make and practical in use.—R. C. WENDRIP (Hanworth).

Bandsread Adjustment

THE problem of finding exact settings for a band-set condenser, which, to be fully effective, should be varied in steps, was overcome by me in the following manner. I took a standard small-capacity condenser and mounted this on the chassis—not on the panel. An old three-inch tuning dial of ebonite was then cut as shown in the accompanying illustration. If desired, of course, a disc could be cut from sheet ebonite about 1/4 in. thick to the desired size. A small spring stop device was next cut as shown in the separate illustration, and this was screwed to the chassis on the under side so that it engaged in the notches cut in the edge of the disc. The position of the condenser and the size

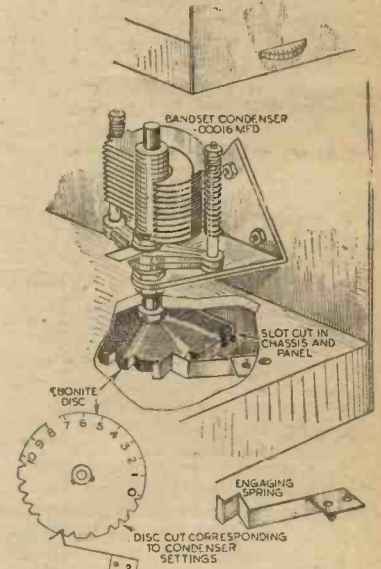

A simple bandsread adjusting dodge.

of the disc are chosen so that a small section of the disc will protrude through a slot cut in the front panel. This portion of the disc is then engraved, and enables the condenser to be adjusted by the thumb and exact settings repeated.—T. HELM (Romford).

The Pocket Two

Constructional Details of a Two-valve Receiver Built Into a Cigar Box

THE design of pocket-receivers can cover many novel features, but generally speaking the true pocket set is only possible when Midget valves and special parts are employed. Even so, the accommodation of suitable batteries then brings the total dimensions rather beyond anything but a large coat pocket or similar receptacle. If, however, the batteries can be separately accommodated then quite reasonable pocket-sets may be made up, even using standard parts. We recently described a one-valver built into a cigar box, and in an endeavour to see just what could be done with this type of box we carried out one or two experiments, and an interesting two-valver which was included in these is illustrated on our cover and described in this article. Standard parts were to be used and a selection of standard cigar boxes was obtained. These varied considerably in shape, but a very useful size was that used for 25's, and this measured 5in. by 5in. by 1½in. deep. This just enables two valves to be accommodated comfortably in standard base-board-mounting valveholders at each end of the box, with sufficient room between them to take a small transformer and the two variable condensers.

The question of a coil was solved by using the Bulgin Midget coil, and this was bolted to the top of the box—the relative positions of these parts all being indicated in the cover illustration.

Battery Problems

This, therefore, only leaves the problem of the batteries, and one easy way of overcoming this is to have a similar box in which may be placed a small jelly-type accumulator for L.T., with three or four G.B. batteries connected in series for H.T. If the receiver is just required as a novelty, then standard batteries could be used in the ordinary way. Leads for the batteries are brought out from the case through a suitable hole, and two-socket strips are mounted on each side for aerial and earth and for 'phones. The cigar-box wood is generally of cedar, and although very thin is easy to cut, and when cleaned down will take a very good polish or may be left in its natural state. The labels are generally well fixed, but a damp cloth pressed on them will enable them to be cleaned off without warping the wood. Do not use too much water, and do not use coarse sandpaper to clean down as this will scratch the soft wood and spoil the surface. Be careful not to damage the cloth hinge, as this is also attached with glue and will not stand up to misuse. When cleaned, drill the two holes in the front (which is actually the bottom of the box in question), using a twist drill to avoid tearing the wood. At the sides drill accommodating holes for the socket strips and then attach valveholders, coil, transformer, and socket strips with short bolts. The wood is too thin to permit of satisfactory screwing. If desired, the valveholders may be wired up—from the

filament point of view, before attachment, although it is possible to get at the various terminals if the position which we adopted is followed. This is shown in the illustration below. Wiring may be carried out with insulated solid wire, or ordinary flex, and is quite a simple matter.

Wavechange Switching

To avoid the fitting of a wavechange

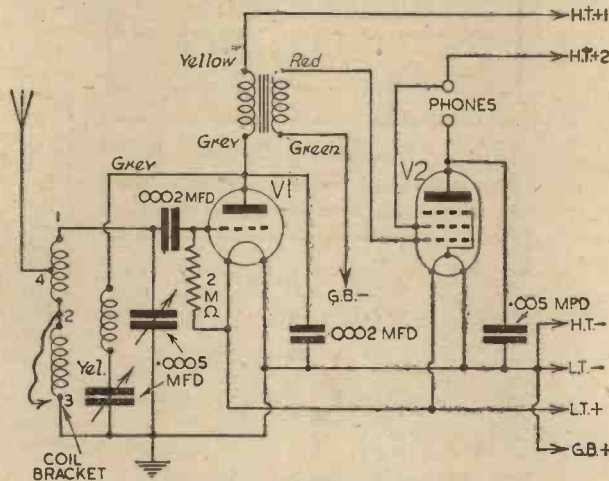

Theoretical circuit of the Pocket Two

switch, the continued operation of which might result in splitting the thin wood of the box, we adopted a crocodile-clip method of wavechanging. A short length of wire is attached to the earth connection on the coil and the clip is attached to the earthed terminal of the tuning condenser when long waves are being received. This is merely to keep the clip from swinging loose and perhaps introducing a short circuit or other trouble. When medium waves are required the clip is attached to connection point No. 2 on the coil. The numbers, incidentally, will be found stamped into the coil-former close to the small eyelets. If the small coloured leads on the coil are not long enough, or you desire to preserve uniformity in the wiring, you can unsolder them and attach separate leads. The fixed condensers and grid-leak are joined to the appropriate terminals and the normal wire ends may be used or, if you make use of

standard mica condensers with terminals, short leads may be attached to them.

The battery leads should, of course, be long enough to reach to the battery box, or position in which the batteries are to be kept. An on-off switch has been omitted for the same reason as the wavechange switch, and the set is switched off merely by disconnecting the L.T. negative lead from the accumulator. Alternatively, a suitable switch may be mounted on a small strip of ebonite, with a strip of metal attached to one terminal of the switch and drilled to accommodate the terminal on the accumulator. The lead is then attached to the remaining switch terminal and thus on-off switching may be carried out in the usual way. If you are interested in making a more comprehensive job of the receiver then automatic bias may be provided by including a suitable resistance with by-pass condenser in the H.T. negative lead in the usual way. This will entail the fitting of an anchoring screw so that the lead may be attached and the secondary of the transformer connected to the H.T. negative lead. Any type of aerial may be used, depending upon the results desired. If selectivity is an important point in your locality, use a small aerial. This may be a length of flex in the form of a throw-out aerial, about 15 to 20ft. being adequate. If a full-size outdoor aerial is connected to the set then selectivity will naturally be rather poor and a series-aerial

(Continued on page 312)

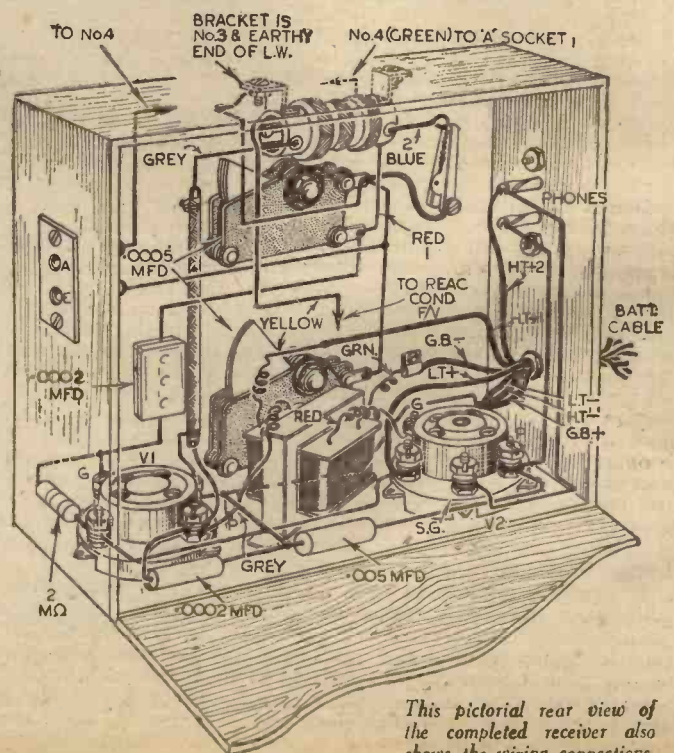

This pictorial rear view of the completed receiver also shows the wiring connections.

Loudspeaker Improvements

How to Obtain Increased Volume and Better Reproduction by Using a Wall-mounted Baffle. Constructional Details are Given in this Article

By FRANK PRESTON

AS most readers are fully aware, speaker reproduction can generally be improved by transferring the speaker unit from the comparatively small receiver cabinet to a good-sized baffle board. It is not as widely known that by this same means it is possible to obtain a greater useful volume of reproduction from a given input. In very many instances an improvement in the speaker mounting will give results as good as those to be obtained by adding an additional amplifying valve.

suspended with cords from the picture rail. This is seldom good practice unless the complete assembly is very heavy and rigid and, preferably, built as an enclosed box of triangular section. My preference is for a baffle board about 3ft. 6in. square firmly fixed to the walls.

One sound method of mounting is by screwing four wooden blocks to the walls, and screwing the baffle to these. The blocks should be shaped and arranged as shown in Fig. 1, where it will be seen that they are not of rectangular section but have one edge bevelled so that it makes an angle of 45 degrees with the wall. The simplest method of finding the correct position of the blocks is to bevel the two upright edges of the baffle, as shown in Fig. 2, and then holding the baffle in the corner and at the correct height so that its position can lightly be marked on the wall with a pencil.

The Mounting Blocks

The blocks of wood used for mounting can be made from planed timber measuring about 2in. by 1in., by about 4in. long. They are best made from a single length because this simplifies the work of making the bevel or chamfer. To mark out for this measure 1in. (or the thickness of the wood) from the corner at each end and draw or gauge a line down one face as also shown in Fig. 2. The corner can then be planed off. Bore a couple of 3/8in. holes in each of the four pieces and countersink these for the screw heads. By holding the blocks in place against the wall the positions of the screw heads can be transferred by pushing screws through the holes or by means of a bradawl.

At the eight points marked the wall should be drilled to receive Rawlplugs of the correct size for 1 1/2 to 2in. screws. As an alternative, a slot can be made in the wall by means of a wall drill or narrow cold chisel; wedges about 3in. long by 1/2in. thick at their wider end can then be made and driven into the wall. The wedges should be only slightly ta-

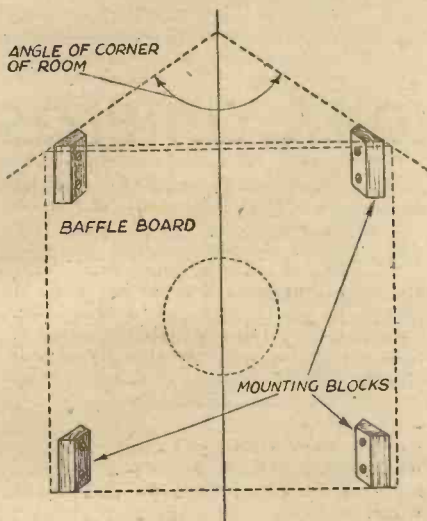

Fig. 1.—How the baffle may be arranged in the corner of the room.

During the past few years it has, unfortunately, become customary to build the speaker into the set, instead of using it as separate unit. This might be a convenience but it is not conducive to high efficiency. One of the best speaker arrangements consists of a large shallow, open box, standing on end, with the speaker unit mounted in the centre of the front; this should be heavily and rigidly built to ensure complete absence of vibration. An objection to this form of construction is that the speaker becomes cumbersome. Another is that in many cases it is not possible—because of its size and weight—to place it in the most satisfactory position in the room.

Large Baffle Area

A better method, which is generally applicable, is to use a large baffle, which is mounted in a corner of the room between the two walls. The baffle board should consist of stout plywood and should be mounted with its centre at a height of about 4ft. It has sometimes been suggested that the speaker baffle of this type may be

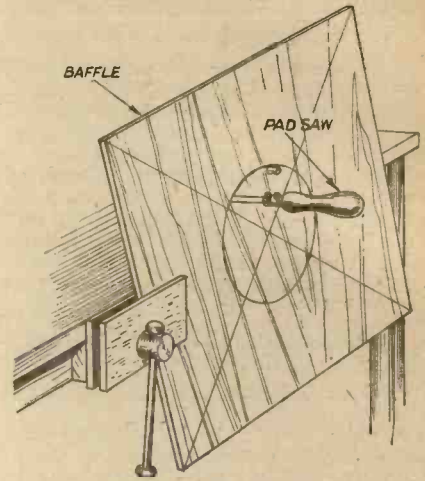

Fig. 3.—The hole in the centre of the board may be cut with a pad or keyhole saw. The board should be held firmly whilst sawing.

pered. For example, if they are 1in. long they should taper from 1/4in. to 3/8in. After the wall has been plugged by either of the methods the wooden blocks should be firmly attached. It is worth mentioning that if plugging tools are not available it is generally possible to provide a sufficiently secure fixing by driving in three 2in. nails. These should be arranged in the form of a flat triangle and should be sloped downward slightly. It should be understood that this is not an "approved" method, and that the nails will obtain a secure hold only when the plaster is hard and of good quality.

To fit the baffle board it is necessary only to bore a hole about 1/4in. from each corner and in the centre of each edge, countersink the holes and mount with screws about 1in. long. A better appearance can be obtained by using so-called fancy screws, the heads of which are drilled and tapped to receive a short parallel-sided screw with a decorative head.

The Baffle Board

In choosing the wood for the baffle it is obvious that the plywood should be faced with a wood which matches the furniture in the room—often oak or mahogany. If this is not possible use first-class alder plywood, which can be well rubbed down and later stained and polished. For a baffle up to 3ft. square, 9 mm. (about 3/8in.) plywood is suitable, but for larger sizes it is better to employ seven- or nine-ply, which is between 1/2in. and 3/4in. in thickness. In the first place, the baffle should be planed perfectly square, and then the two upright edges may be bevelled. After that, the fret or hole should be made in the centre. Actually, it is better and easier to make a simple hole rather than to do any fretting. Since the speaker unit will probably be mounted on a small and separate board, the hole can be of any shape, but either circular or square will usually be preferred. This can be marked out after finding the centre by drawing two diagonals.

Decoration

Whether the hole is to be round or circular it will be cut out with a keyhole or pad saw, as shown in Fig. 3. A 1/4in. hole should be made inside the marked-out line in the case of a circle, or four such holes should be made just within the corners for a rectangular hole. After sawing, the edge

(Continued on next page)

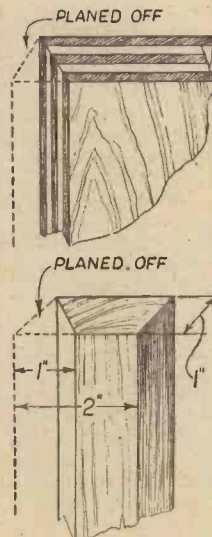

Fig. 2.—The edges of both the baffle board and the mounting blocks are bevelled as shown here.

LOUDSPEAKER IMPROVEMENTS

(Continued from previous page)

of the hole can be smoothed with a rasp and wood file, and finally with glass-paper. Should some form of decoration be desired, this can easily be arranged by fitting strips of half-round moulding parallel to the edge of the board with, perhaps, a stamped wooden ornament at each corner of the decorative square. To fit these decorations, make holes near each end of the strips and about every 6in. in the length with a fine archimedean drill. Apply a very light coat of thin, hot glue to the beading, press it into place after marking out its position, and then fix it by driving in 1/2in. panel pins; drive these nearly to the level of the beading and then slightly sink them with a pin punch.

A piece of silk should be fitted over the back of the hole, and this is best bought ready mounted in a cardboard frame. By buying the silk in this form the difficult job of making it uniformly taut and free from kinks is avoided.

The speaker unit will probably be mounted on a small board, and this can be screwed on to the back of the baffle. In many cases reproduction may be improved, however, by spacing this board from 1/2in. to 1in. from the baffle by inserting felt, rubber or wooden packings, as shown in Fig. 4. This spacing tends to improve bass

reproduction, and it is worth while to experiment with different spacings.

Speaker Connections

Where convenient, it is best to have the speaker fairly near to the set. But if it must be some distance away use good-quality flex for the connection, especially

in the case of a mains set. When using a speaker with separate output transformer it is better to fix the transformer to the baffle so that the secondary leads (which are connected to the very-low-resistance speech coil) are as short as possible. A few ohms resistance in the leads to the primary winding is seldom of any importance.

If the speaker is an energised moving coil use stout vulcanised rubber twin cable for the connections to the field winding, since these carry the full H.T. voltage. It is also generally desirable to keep the leads to the anode of the output valve a short distance away from the field connections so that it cannot pick up any hum from the unsmoothed current passing to the field. As an alternative, use twisted triple cable.

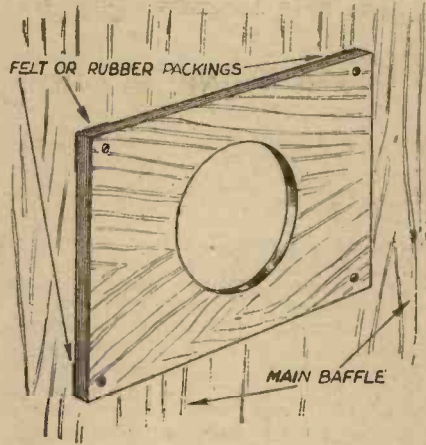

Fig. 4.—It is sometimes better to space the board on which the speaker unit is mounted from the main baffle.

A Better Arrangement

Although the construction is slightly more difficult, and the appearance less pleasing, it is often better to place the baffle with its centre about 5ft. high and to make it slope downward. This can be done by cutting the baffle so that it is, say, 4ft. wide at the top and 3ft. 6in. at the bottom; in marking out draw a centre line and measure half the length out from this to make the board symmetrical. The same form of construction can be used as mentioned above, although the angles will not be perfectly correct.

Remote Control for Television Cameras

CONSIDERATIONS of space often make it difficult to accommodate a large television camera and an operator at a point from which a scene has to be viewed.

This difficulty can be overcome by arranging for the camera to move under the control of a view-finder observing the scene from a more convenient point at which an operator can be stationed.

The accompanying illustration, Fig. 1, shows an arrangement of this kind. It will be seen that the two mutually perpendicular motions of the camera 1 mounted in the gimbal framework 2 are conveyed to a remote view-finder 3 by means of flexible cables or shafts 4 and 5. At the view-finder the flexible shafts control the positions of the two independent cross wires 6, 7, which are within the field of view through the eyepiece 8; their point of intersection indicating the centre of the field of view of the camera. Alternatively, the flexible shafts may control the direction of the whole view-finder in which a rectangular framework would indicate the field of view for the lens being used.

A View-finder Improvement

An improvement upon the viewfinder is shown in Fig. 2 in which the cross wires are accommodated in a subsidiary optical system 1 and superimposed upon the scene visible through the aperture 2 by means of a half-silvered mirror 3. The advantage of this arrangement is that a lens 4 may be included so that both cross wires and object would appear in focus simultaneously.

Although cross wires have been shown, it is preferable that illuminated slots with

a black background should be used in practice, so that the auxiliary optical system will not reduce the contrast of the scene being viewed. Further, as an alternative to two intersecting lines, a gimbal mechanism may be devised which is controlled by the flexible shafts, and which carries a flag (such as a circle of wire) covering the centre of the scene being transmitted.

In the converse arrangement, handles would be attached to the ends of the flexible shafts at the view-finder, and their manipulation would control both movement of the camera and position of cross wires.

It is obvious that instead of the flexible shafts, alternative methods of communicating the movement of the camera may be employed. These methods include Bowden wire mechanisms or an electrical follower arrangement.

Fig. 2.—(Right). A view-finder improvement incorporating superimposed cross-wires.

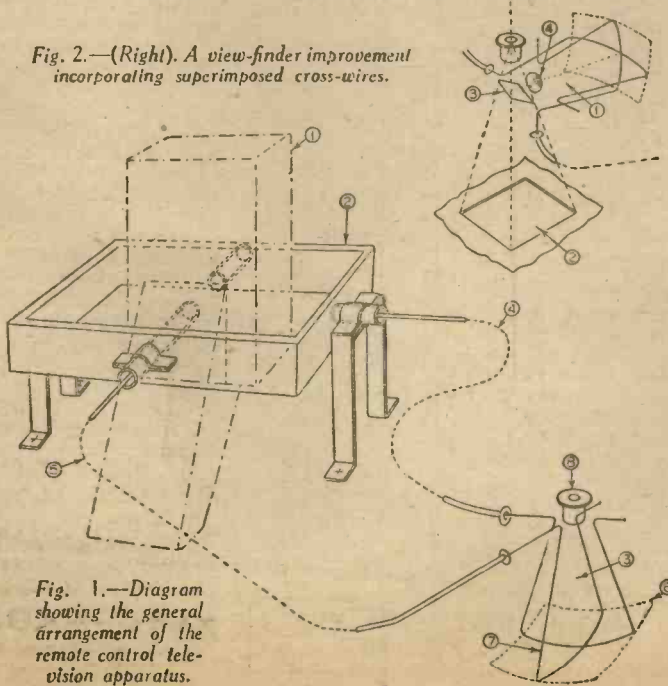

Fig. 1.—Diagram showing the general arrangement of the remote control television apparatus.

PRACTICAL WIRELESS

ENCYCLOPAEDIA

By **F. J. CAMM** 6th Edition **6/-** net.

(Editor of "Practical Wireless")

Wireless Construction, Terms, and Definitions explained and illustrated in concise, clear, language.

From all Booksellers, or by post 6/6 from George Neumes, Ltd., Tower House, Southampton Street, Strand, London, W.C.2.



Impressions on the Wax

A REVIEW OF THE LATEST GRAMOPHONE RECORDS

Parlophone

PATRIOTIC songs, old and new, are linked together on *Parlophone R 2718*. It is a recording by Oscar Natzke, New Zealand's great bass singer, who sings "Land of Hope and Glory" and "There'll Always be an England."

Tauber revives one of his old favourites, "You are My Heart's Delight," on *Parlophone RO 20467*. He couples it with an equally popular song, "Vienna, City of My Dreams." He has also made another record this month with "O, Mary Dear" and "Songs My Mother Taught Me" on *Parlophone RO 20468*.

Symphony orchestras are featured in the Parlophone 12in. Classic Series. A two-part selection from "Madame Butterfly" is played by the Grand Symphony Orchestra on *Parlophone E 11428*, and the Symphony Orchestra have recorded "Slavonic Dance, No. 6" and "Slavonic Dance, No. 8" on *Parlophone E 11429*.

Variety

LESLIE A. HUTCHINSON ("Hutch") sings a popular song of the moment, "Lords of the Air" on *Parlophone F 1562*. He couples it with a hill-billy song, "Ridin' Home." This artist also sings "This Heart of Mine" and "Later On" on *Parlophone F 1570*. Ronald Frankau and Tommy Handley pop up again as Murgatroyd and Winterbottom on *Parlophone F 1564*. There are plenty of laughs in their version of "Good Luck (and the Same to You)" which has been adapted from the march "Colonel Bogey," and "We Must All Stick Together."

Song medleys are always popular at parties, especially at this time of the year, and a number are featured in the Parlophone list. First we have two descriptive song medleys—"Somewhere in France" on *Parlophone F 1589*, a two-part record featuring "Siegfried Line," "Run, Rabbit Run," "There'll Always be an England," "Adolf," "Hullabaloo Belay" and "Wish Me Luck," and "The Fireside Singer" on *Parlophone F 1590*, introducing "Love's Old Sweet Song," "In an Old-fashioned Town," "Where My Caravan has Rested," "Little Grey Home in the West," "Roses of Picardy," and "When You Come Home." Patricia Rossborough plays a piano-medley on *Parlophone F 1584* called "Songs to Sing—and Listen To." From a piano-medley we come to an organ-medley by H. Robinson Cleaver, playing at the organ of the Granada, Welling. It is called "Cleaver Hits, No. 2," introducing popular songs of the moment—*Parlophone F 1585*. Finally, we have The Kerbside Serenaders' "Popular Hits Medley" on *Parlophone F 1588*.

If you wish to spring a surprise on your friends this Christmas by tap-dancing, then you should learn to dance the Victor Silvester Way. Parlophone are issuing four 10in. records, complete in an album, with booklet giving details and instructions,

price 10s. 6d. (booklet 9d.). The records are described by Victor Silvester and compiled and demonstrated by Philip Buchel—*Parlophone F 1579-82*.

Take Your Choice

HARRY ROY and his Orchestra have made three new records this month. "Oh! You Crazy Moon" and "Oh! Ain't it Grand to be in the Navy"—*Parlophone F 1567*; "Out of the Rag Bag" (second edition) which is a medley of popular rags—*Parlophone F 1568*, and finally, "Adolf" and "They Can't Black Out the Moon"—*Parlophone F 1571*.

If you prefer something more sedate, then the Orchestra Mascotte caters for you with "The Skaters' Waltz" and "Tesoro Mio" on *Parlophone F 1575*, and "The Jolly Brothers" and "Valse Bleue" on *Parlophone F 1576*. Or again your fancy may turn to the topic of the moment such as "Going Up the Line," which is a thrilling cameo of the war recorded by some of the boys, on *Parlophone F 1565*.

Decca

FEATURED in the Decca list this month are two records by those two popular comedians, Flanagan and Allen. You can take your choice of "If a Grey-haired Lady Says, 'How's Yer Father?'" (That's Madeoiseille from Arrentierres), coupled with "F. D. R. Jones" on *Decca F 7297*, and "Run, Rabbit, Run," coupled with "We're Gonna Hang Out the Washing on the Siegfried Line" on *Decca F 7265*, but perhaps you'll like them both.

It is now possible to bring the theatre into your own home as the Decca Company have just issued an album entitled, "A Night at the Argyle Theatre, Birkenhead." The album contains three records, and the price is 6s. 6d. The first record, *Decca F 7319*, contains "Overture—Tune-in and be Happy," played by The Argyle Theatre Orchestra; "My Daughter's Wedding Day," sung by Suzette Tarri, comedienne; and "Hitler, Goebbels and Goering," sung by Ribton and Richards, duettists. The next turn is Billy Russell, comedian, who entertains with "On Behalf of the Working Classes" and "Siegfried Line," on *Decca F 7320*, and, finally, we have Billy Scott-Coomber and his Singing Grenadiers singing a medley of "Musical Comedy Successes," finishing with "There'll Always be an England," accompanied by the entire company and audience—*Decca F 7321*. The records can be obtained separately if desired, price 2s.

That famous international star, Hildegarde, makes her first record for Decca this month and sings two old favourites, "Some Day I'll Find You" and "Dance Little Lady"—*Decca F 7310*.

READ "THE CYCLIST"
3d. Every Wednesday.

ELECTRADIX

OUR PARCELS OF EXPERIMENTERS' ODDMENTS AT 5/- POST FREE IS A BARGAIN.



DISC RECORDING FOR 37/6.—Electric FEIGH set has ball bearing centre box and geared traverse rod. Set with Tracking gear, pick-up and Tone-arm fitted diamond. Fitted on a Radiogram enables absent friends to hear your voice. 37/6.

CRYSTAL SETS. Need no battery, work on mattress aerial. 5/6 and 7/6. House 'phones, table and wall, all prices. Bells. Desk type with movement in song, 2/6. Wall bells, 3/-. Large size, 7/6. Large ironclad, single stroke, 15/-. Mains outdoor alarm bells, 10in. song, 17/6. Bell Pushes, 6d. Heavy brass, 1/-. Bell Wire, Twin, 3/- 100 yds.

SWITCH DIALS. 10-point Finger Switch Dials, used on G.P.O. Automatic Telephones. These have spring drive, governor clutch and contacts inside. Price 2/6.

200 TRUE-TWIN CAMERASCOPIES, 2 lens viewers, 1/- post free.

BIGGEST BARGAIN in our Clearance. Parcel for 5/-.

TELESCOPES.—Navy Telescopes, Gun spotters, 25/-. **REMOTE CONTROL "OFF"** Relays or **MAGNETIC SWITCHES.**—4 amps., 7/6; 6 amps., 10/-; 10 amps., 12/-; 15 amps., 14/-; 20 amps., 16/-. Venner 15-day Time Switches "on-off" 1 amp., 6 amps., 10 amps., 200 amps. Cheap.

RELAYS. For microamps, millamps or amps. For remote controls, etc. Low, medium and high res. 5 m.a. Moving Iron, 8/6, 10/6, and 12/6. High Grade Moving Coil, 50 microamps, Weston, 60/-; in bronze watertight case, 70/-. New model W.I., 50 microamps, 1 in. panel type, 55/-.

G.P.O. TYPE B TELEGRAPH RELAYS, with platinum points, 17/6. Less points. Silvertown Horizontal Galvos., two jewels, 5/-, post 6d. Vert. needle G.P.O. Galvos., 5/-.

SINGLE BLADE RELAYS.—No. 1 type 60D, 1,000 ohms "on-off" s.p. 6 volts, 8 m.a., 7/-; No. 2 type, 832 s.p. 2,000 ohms "off" only, 10 volts 5 m.a., 8/-.

MULTI-BLADE RELAYS.—No. 9 type A.G., 1,200 ohms, 2 coil D.P. "on-off" 8/6, 22 volts, 150 m.a. No. 10 type A.H., 1,300/2,000 ohms 2-coil, 3 circuits, 6 blades "on-off" 15 volts, 100 m.a., 9/-; No. 11 type 831, 1,200 ohms, 8 blades, 3 circuits, "on-off" 3 circuits S.P.C.O., 12 volts 12 m.a. Blades removable, 12/6. No. 12 type 27B Spare, 1,000 ohms coil with structure, no contacts, for making relays, 2/6.

DIX-MIPANTA VEST POCKET TESTER. A versatile moving-iron multi-range meter for service on A.C. or D.C. No projecting terminals. THREE ranges of volts: 0-7.5, 0-150, 0-500. Used for MILLIAMPS, reads 0-200 m.a. and 75 m.a. in black bakelite case. Size only 2 1/2 in. by 2 1/2 in., with pair of test leads and plugs, 17/6.

THERMOMETERS. Panel 2 1/2 in. dial, 5ft. ether tube for distant indicating, 0 to 100 deg. Cent., 7/6. Cambridge ditto, 10/6. **FOURNIER THERMOMETERS** by Cambridge Instrument Co., 4in. dial, 10-110 deg. Cent. Fitted adjustable electric contacts, 45/-. 12in. right angle immersion Thermom. to 150 Cent., 3/6.

15-DAY TIME SWITCHES. Venner 1 amp., 5 amps., 50 amps., 100 amps., 200 amps., cheap, 20/-.

MEDICAL SHOCK COILS, 2/-. 300 ENGINE IGNITION COILS 6 or 12 volts plain non-trembler, 4/6. With vibrator, 6/6.

250 NEON LAMPS. Standard size letter neon bulb with holder 220/240 v., 2/6.

WIRE. Special Resistance Barsalt, 45 gauge Eureka 10 m.a. enamelled, 108 ohms per yd. 3/- per lb. 36 gauge Eureka 100 m.a. 1/- per lb. 33 gauge Eureka 250 m.a. 1/- per lb. 29 gauge Eureka 1/- per lb. 27 gauge Eureka 500 m.a. 10d. per lb.

BARE Resistance Wire. 48 gauge nichrome 700 ohms. per yd. 6/- per oz. Heating Strip, chrome 1/32 x 16 thou. 2/6 per lb.

STATIC CONVERTERS. A.C. to D.C. 40 watts output, steel case. Input 230 volt A.C. 50 cycles. output 440 volts 60/100 m.a. D.C. with valves, 45/-. A.C. mains to D.C. 120 watts at 1 amp. for D.C. sets on A.C. 220 v., steel clad with valves, 50/-.

CHARGING METERS, central zero, charge and discharge in all switchboard sizes, from 2 1/2 in. dial up to 15 amps., 7/6. 4in. to 6in. dial switchboard meters.

D.C. GENERATORS.—Shunt wound—110 volts 1 amp., 15/-; 200 volts 1 amp., 17/6; 200 volts 1 1/2 amp., 26/-.

LUCAS AERO. 9.12 volts 120 watts D.C. enclosed, 4,000 revs. As used on Aircraft wireless. Cost 115. Reduced sale price, 12/6.

DYNAMO H.T. DUAL, 600 volts for H.T. 100 m.a. and L.T. 6 volts 5 amps. Reduced Sale Price, 15/-.

PANELS. Aluminium 16- and 18-gauge one side enamelled. Paxolin and Ebonite, any size, from 2 1/2 in. x 2 1/2 in. at low prices.

VARIABLE CONDENSERS. .005 mfd. Tekade, 1/3; .00175 Polar Compax, 1/-; S.W. Formo, 2/-; J. B. Midget, .001, 1/6; 2-gang variable, .0005, 2/6; 3-gang, 3/6.

CONDENSERS. Fixed electrolytic 12 1/4 mfd., 18 mfd., 27 1/2 volts, 1/6; 6+6-12 mfd., 250 volts, 1/6; 8+8-16 mfd., 350 volts, 1/6; 24+8-32 mfd., 400 volts, 2/6; 8 mfd., 500 volts, 1/6; Mansbridge Paper and Mica, 4 mfd., 3/6; 8 mfd., 5/6; 10 mfd., 7/-; Dubilier .01 for 1,000 volts, 1/8; 10,000 volts, 5/-; 25 mfd. mica, 4,000 volts, 6/-. Oil condensers, 1 mfd., 3,000 volts, 5/6. Condenser Barsalt; Western Electric 1 mfd. and 2 mfd., 1/6 doz.; 12/- cross, carriage forward. Ideal for makers of smoothing and filter circuits.

SIGNAL EQUIPMENT LIST "N."—Now ready, stamped envelope, please.

5/- EMERGENCY PARCELS of useful stand-by electrical and radio repair material and apparatus. 7lbs. for 5/-. Post Free.

ELECTRADIX RADIOS

218, Upper Thames Street, London, E.C.4

Telephone: Central 4611

LATEST PATENT NEWS

Group Abridgments can be obtained from the Patent Office, 25, Southampton Buildings, London, W.C.2, either sheet by sheet as issued, on payment of a subscription of 5s. per Group Volume or in bound volumes price 2s. each.

Abstracts Published.

INDICATING - APPARATUS.—Telefunken Ges. Fur Drahtlose Telegraphie. No. 506648.

A dial and pointer indicator, particularly for a radio receiver, comprises a source of radiant energy, emitting a high proportion of waves towards the violet end of the spectrum, for illuminating the dial or the pointer either of which are coated with luminescent material, for example, a composition having a radium content or a phosphorescent paint. Thus, the whole dial may be coated with phosphorescent paint and then coated, for example, blackened, to leave luminescent scale indicia exposed, or a glass scale to be illuminated from behind may be formed by coating the back thereof with black material except at the scale indicia and then coating the whole back surface with phosphorescent paint. A glow discharge tube with a luminescent blue gas is preferably used as the source of radiant energy.

INDICATING DIALS AND SCALES ; ILLUMINATING.—Hausermann Vereinigte Fabriken Chemischer Gravuren Und Metallwaren Ges. No. 507556.

An edge-lit scale for watches, clocks, measuring apparatus, tuning scales for wireless apparatus, etc., is lit from one

edge only and comprises a front transparent plate, bearing the matter to be illuminated, spaced approximately $\frac{1}{10}$ mm. from a dark background plate to which it is secured peripherally by a raised edging or border.

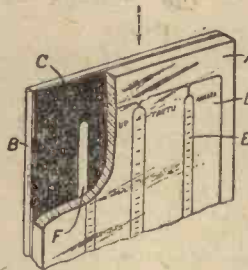

front or rear surface and is secured to the back-plate B of glass, metal, synthetic material, etc., by a raised border C, for example, of Chatterton's compound. The back-plate, if of glass, is rendered opaque or translucent except along strips F lying behind the wave-band scales E through which a luminous tuning spot or pointer moving behind the rear plate may be seen. The several wave-band scales E and lists of station names D may be differentially coloured.

As applied to a wireless receiver, a front transparent plate A of glass, mica or synthetic material (see accompanying illustration) has the scale indicia, D, E, printed on its

VALVE ECONOMY

(Continued from page 295)

No doubt various circuits will suggest themselves to the experimenter, but one idea which has been proved effective is to use the valve as amplifier and rectifier in a contrast expander circuit to take the place of two separate valves. Here the double-cathode type is most suitable, and, in fact, is essential for stability and correct working. The signal is fed into the first triode section which is treated as a separate valve, having the usual bias resistor in the cathode lead. The second section has grid and anode strapped to enable it to act as a rectifier and the load resistance is then included in the cathode of this particular section. The output is then applied to a variable- μ valve to which the input is also fed, and thus the desired combination for effective contrast expansion is obtained. The arrangement is shown, in skeleton form, in Fig. 4, exact values of components depending upon the particular valves which are employed.

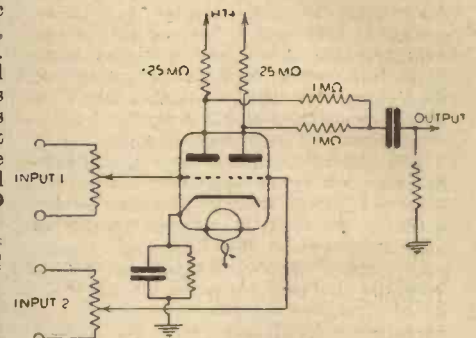

Fig. 5.—Using a double-triode as an input mixer for two "mikes" or pick-up.

Two-channel Mixer

One final circuit will suffice to show how these dual valves may be usefully employed. For home-broadcast performances, or even for small public-address equipment, it is desirable to employ an input mixing circuit so that two pick-ups or a pick-up or mike may be used. In the usual way this is accomplished by connecting a volume control across each component and feeding the grid of a single valve. A more effective circuit is shown in Fig. 5, however, and in this the dual-triode is again employed. It will be seen that the output from one instrument is taken to one of the grids and the output from the other instrument to the second grid, the resultant output component present at the two anodes then being fed to the output coupling condenser through the usual load resistances and decouplers. With the type 6N7 valve the voltage gain from each grid is approximately 9, and thus it will be seen that this is a very effective circuit to employ on the input side as compared with the more usual single triode arrangement.

There are certain characteristics present in some of the double-triode valves which render them very suitable for use as single triodes, for which purpose the two grids and the two anodes are strapped together. For instance, in a powerful amplifier it may be desired to employ a Class B output stage for which really good drive is required. Such an input could be obtained by using the 6N7 valve previously referred to, but connected as a single triode. In that case the bias resistor would be of normal rating and the valve would be regarded as a straightforward low-impedance triode.

NEW PATENTS

These particulars of New Patents of interest to readers have been selected from the Official Journal of Patents and are published by permission of the Controller of H.M. Stationery Office. The Official Journal of Patents can be obtained from the Patent Office, 25, Southampton Buildings, London, W.C.2, price 1s. weekly (annual subscription £2 10s.).

Latest Patent Application.

29769.—Soc. Française Radio-Electrique.—Wireless receiving-apparatus. November 9th.

Specifications Published.

514509.—Marconi's Wireless Telegraph Co., Ltd., and Fewings, D. J.—Synchronising impulse separator circuits for use in television receivers.

514477.—British Thomson-Houston Co., Ltd., Bowen, A., and Welch, D. F.—Optical projection of images. (Cognate Application, 14334/38.)

514481.—Cole, Ltd., E. K., and Shackell, A.—Means for adjusting rotatable control spindles in wireless apparatus. (Cognate Application, 16811/38.)

514486.—Philco Radio and Television Corporation.—Wireless receiving-circuits.

514390.—Telefunken Ges. Fur Drahtlose Telegraphie.—Aerial systems.

514399.—General Electric Co., Ltd., and Hunter, S. G.—Driving means for the tuning-indicators of wireless receivers.

514401.—Baird Television, Ltd., and Nuttall, T. C.—Television and like systems.

514439.—Electrical and Musical Industries, Ltd., and Percival, W. S.—Reduction of interference in electric signal transmission systems. (Addition to 467263.)

514539.—Fernseh Akt.-Ges.—Television transmitting-apparatus.

514554.—Baird Television, Ltd., and Nuttall, T. C.—Television and like systems.

Printed copies of the full Published Specifications may be obtained from the Patent Office, 25, Southampton Buildings, London, W.C.2, at the uniform price of 1s. each.

A COMPLETE LIBRARY OF STANDARD WORKS.

By F. J. CAMM.

PRACTICAL WIRELESS ENCYCLOPEDIA 6/-, by post 6/6.

EVERYMAN'S WIRELESS BOOK 5/-, by post 5/6.

TELEVISION and SHORT-WAVE HANDBOOK 5/-, by post 5/6.

SIXTY TESTED WIRELESS CIRCUITS 2/6, by post 2/10.

WIRELESS COILS, CHOKES and TRANSFORMERS and HOW TO MAKE THEM 2/6, by post 2/10.

PRACTICAL WIRELESS SERVICE MANUAL 5/-, by post 5/6.

WORKSHOP CALCULATIONS. TABLES & FORMULÆ 3/6, by post 3/10.

PRACTICAL MECHANICS HANDBOOK 6/-, by post 6/6.

All obtainable from or through Newsagents or from Geo. Newnes, Ltd., Tower House, Southampton St., Strand, W.C.2.

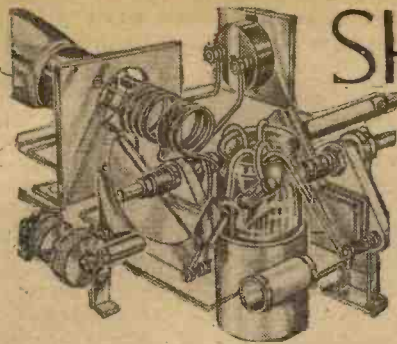

SHORT-WAVE SECTION

Full Details of a Beginner's One-Valver, Which is the Subject of Blueprint No. PW88.

THIS receiver has proved extremely popular, but all copies of the original issue are now out of print. The details are, therefore, reprinted. The receiver is shown in its simplest form, and the blueprint which is available for it shows only the bare necessities. In this condition, however, the receiver may be relied upon to furnish a most comprehensive log and under all normal conditions some really good DX work may be accomplished with it. After it has been in use for some time, however, it will be found that various little improvements may be added, and these are described in this article, so that those who wish to build the set in a more advanced form may do so.

The circuit selected is the simplest reacting detector arrangement, rather than a special circuit utilising an S.G. or H.F. pentode valve. Although home-made coils may be used, a standard 6-pin plug-in coil is specified, but the constructor may build for himself a set of such coils, taking for his data the details given in our issue dated July 24th, 1937, or that which will be found in our hand-book, "Coils, Chokes and Transformers." It should be noted that a 4-pin coil is not recommended, although it can be used. The reason is that the aerial has a marked effect upon the performance of the receiver, and a 6-pin coil permits

cases the larger value will be found of most use. A normal tubular or mica fixed condenser is connected in the grid circuit with a fixed grid-leak of 3 megohms, but again, this value may be modified and up to 5 megohms employed. The choke is most important and although it is possible to make a very efficient component at home it is recommended that a really reliable commercial article be employed. This will avoid difficulties due to "dead spots," erratic reaction, etc.

A simple baseboard form of construction is used, as there are only a few components and a chassis is not called for. A good quality coil-holder should be used, and although a metal panel

connections should preferably be soldered. The tuning condenser specified has a maximum capacity of .00016 mfd., but if desired you may use temporarily a .0005 mfd. standard condenser with a .0003 mfd. fixed condenser in series with it. A .00025 mfd. condenser may, of course, be used, but will give rather more difficult tuning due to the wider wave-range covered with that capacity. A set of coils may be bought or made and with these the receiver may be used to cover all wavelengths from 9 to 10 metres up to 2,000. It is not advisable to try to use a set of this type to tune below 10 metres, and therefore, if it is desired to listen on wavelengths below 10 metres an ultra-short-wave set should be made up.

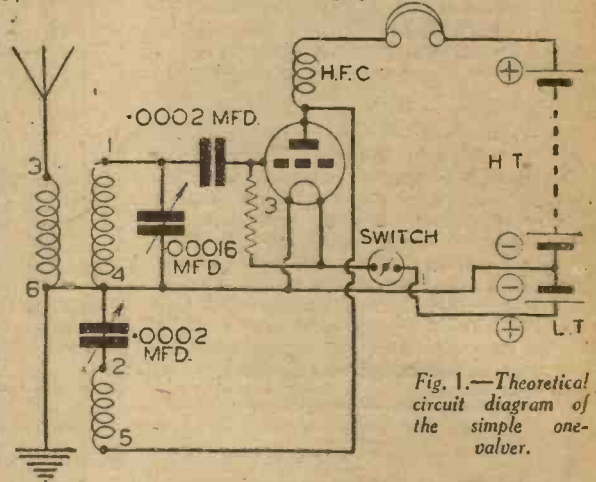

Fig. 1.—Theoretical circuit diagram of the simple one-valver.

BLUEPRINT P.W. 88

Refinements

The receiver is operated by means of a 66-volt battery and the voltage should be adjusted to give a smooth reaction control. By way of refinements the first improvement would be the fitting of a handspreading condenser. This should consist of a small variable condenser having a maximum capacity of about 20 mmfds., and it may be mounted on the panel quite close to the tuning condenser. It is wired in parallel with that condenser, that is, the fixed and the moving vanes of each condenser are connected together, as shown in Fig. 2. When this addition is made tuning will be very much simpler.

The main tuning condenser is simply advanced about one degree at a time, and at each setting the smaller condenser is

turning throughout its range, thus spreading out the waveband which each adjustment of the main condenser covers. Good slow-motion dials will be found of the utmost value in a set of this nature, as they enable the smallest movement of the condensers to be made and many stations which would otherwise be missed will thereby be heard. This

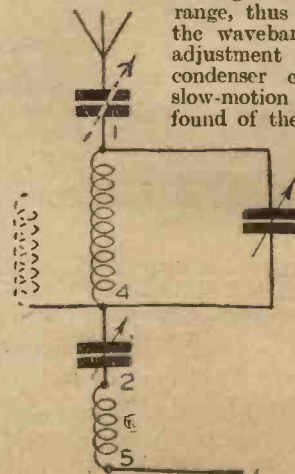

Fig. 3.—How a 4-pin tuning coil may be used. (Continued on next page)

is not a necessity it will be found very useful in assisting in the removal of hand capacity effects. If desired, a wooden or ebonite panel may be employed and a thin sheet of metal or foil fitted behind the panel and connected to earth. It is preferable to cut holes in this so that it does not come into contact with any of the panel components, and then to connect a separate earth lead to it.

Construction

The terminals should preferably be mounted on separate mounts, well separated to avoid any loss which might be introduced by a leakage path between them through inferior ebonite or other material. The coil and valveholders should be firmly attached to the baseboard, and the panel components firmly locked to the panel. Remember that any looseness, in either the mounting or in the subsequent wiring will result in tuning difficulties and perhaps the erratic effects resembling fading. The wiring should be carried out with fairly stiff wire to avoid any subsequent movement, and bare wire may be used and all

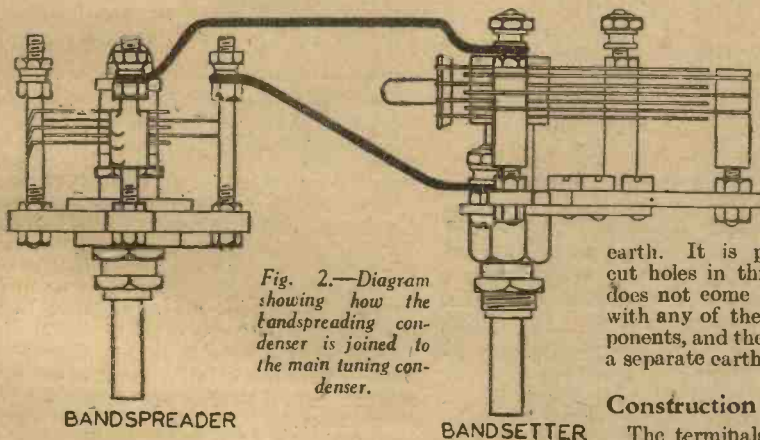

Fig. 2.—Diagram showing how the handspreading condenser is joined to the main tuning condenser.

of a loose coupled aerial arrangement being employed with the result that the damping effect of the aerial is removed. A condenser may, of course, be connected between the aerial and the grid winding (thus omitting the aerial coupling coil), but the effect is not so good as when the coupling coil is employed.

The Circuit

Reaction is obtained by means of a standard reaction condenser and winding on the coil, and a capacity of .0002 mfd. or .0003 mfd. should be employed. In most

SHORT-WAVE SECTION

(Continued from previous page)

will be especially noticeable where two or more stations are found very close together on the main tuning condenser. A slight adjustment of this, and the band-spreading condenser will enable quite a large movement to be made with the dial to separate these stations and overlap will be avoided.

Coil Ranges

In the Eddystone range there are 9 coils of the 6-pin type which may be used, and to enable the constructor to obtain some idea of the ranges covered the following are the type numbers and the bands which are covered with a .00016 mfd. condenser :

6BB	9-14	6P	150-325
6LB	12-26	6G	260-510
6Y	22-47	6BR	490-1,000
6R	41-94	6GY	1,000-2,000
6W	76-170		

If a .00025 mfd. condenser is used, or if the .0005 condenser scheme is adopted, the tuning range will be slightly greater than the above figures, and this will obviously be accompanied by the tuning difficulty already mentioned. It is desirable in a short-wave set to provide as small a tuning band-width as possible, so that difficulties in tuning due to the close proximity of different stations are removed. Another important point regarding tuning

concerns the minimum wavelength to which each coil may be tuned. This is dependent upon the minimum capacity of the tuning condenser and an inferior condenser will obviously tune to a higher minimum wavelength.

WIRING DIAGRAM OF THE SIMPLE ONE-VALVER

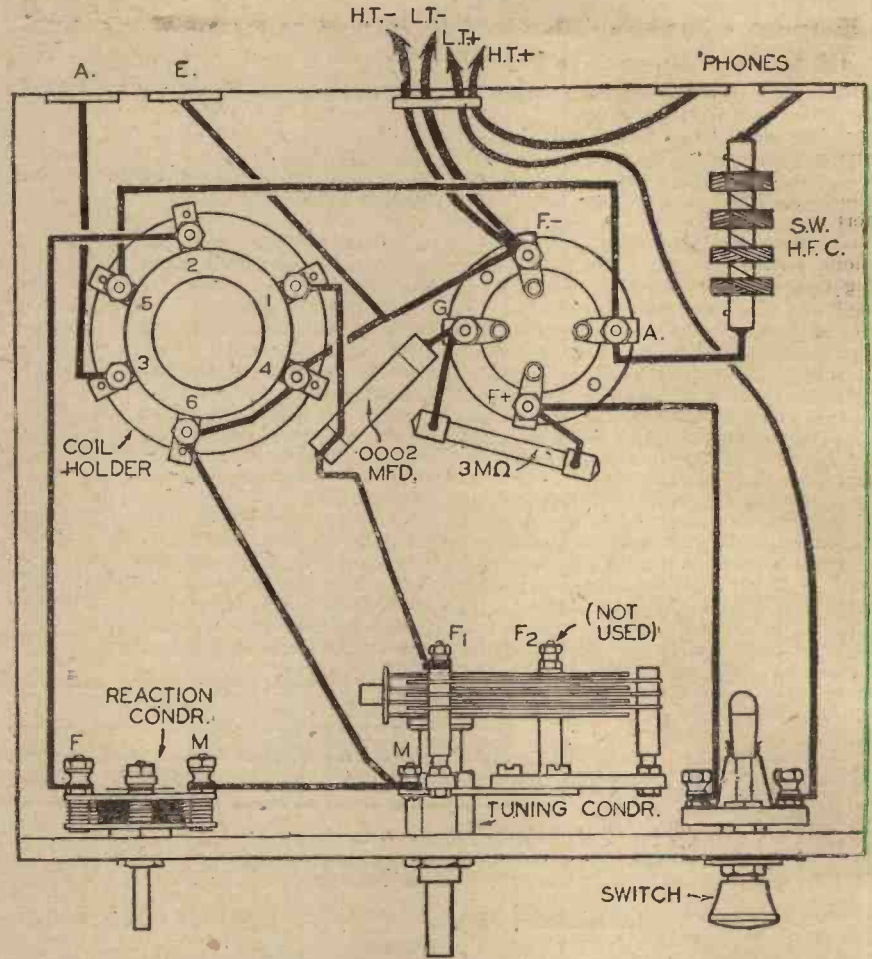

LIST OF COMPONENTS

- One .00016 mfd. tuning condenser (type 922) (Eddystone).
- One .0003 mfd. reaction condenser (Polar).
- One 6-pin coil-holder (type 969) (Eddystone).
- One 4-pin valveholder (B.T.S.).
- One H.F. choke (type 1010) (Eddystone).
- One .0002 mfd. fixed condenser (tubular type) (T.C.C.).
- One 3-megohm grid leak (Dubilier).
- One on/off switch (Bulgin).
- Four terminals (Clix).
- One wooden baseboard 8in. by 7in.
- One ebonite panel (see text) 5in. by 8in.
- Flex, connecting wire, screws.

NEWS FROM THE TRADE

Varley Dry Accumulators

WE recently reviewed a new type of dry accumulator produced by Varley and we are now informed that this special unit is available in a wide range of sizes. These embrace various capacities from 2½ A.H. to 40 A.H. types and the smallest model is suitable for use in a torch. The actual cell measuring 2½in. in height and 1½in. in diameter. This particular cell costs 2s. 6d. and it weighs 6½ ozs. Full details of the complete range may be obtained from Messrs. Varley Dry Accumulators, Ltd., at By-Pass Road, Barking.

Taylor Electrical Instruments, Ltd.

WE are informed that Taylor Electrical Instruments will continue to produce their full range of instruments during the war, without any deletions. The stock position of most models is quite satisfactory, and other types are at present in production and delivery will be available shortly. At the moment no price increases have been announced. Additional new factory space has been taken at Slough for the express purpose of manufacturing a large and comprehensive range of pre-

cision moving-coil meters, full details of which will be released when they become available.

BOOKS RECEIVED

Modern Armaments. By Professor A. M. Low. Published by The Scientific Book Club. 274 pages. Price 2s. 6d. to members.

EVERYONE interested in armaments will find a mine of information on the subject in this new book by Professor A. M. Low, who is an acknowledged authority on all types of modern armaments. The subject matter is dealt with in a simple and popular manner, and is readily understandable to the ordinary reader. The book is divided into seventeen chapters covering, amongst other subjects, Explosives; Small Arms; Artillery; Chemical Warfare; Warships; Mines and Torpedoes; Tanks; In the Air; and Parachutes. Amongst a host of other details the reader is told about the secret of manufacture of big guns; how machine guns and other automatic guns and rifles work; all about explosives and ammunition; how gases and incendiary bombs are made; the development and manufacture of tanks and armoured cars; all

about battleships and aircraft carriers the mass production of aeroplanes; and how that wonderful apparatus, the predictor, works. There are also interesting chapters on the adaptation of weapons to peace-time uses, such as the employment of gas for destroying rats and other vermin. This book which is illustrated with several fine photographic reproductions, can be recommended to all well-informed persons who are anxious to keep up to date with the latest scientific developments in connection with armaments, and to learn how some of the modern instruments of warfare may be turned to good use in peace-time occupations.

Practical Electrician's Pocket Book

THE forty-second edition of this handy book has just been published and a new section of particular importance has been included on "Lifts and Their Maintenance." Dr. A. P. M. Fleming, Director of Research, Metropolitan-Vickers Electric, and past president of the I.E.E., contributes a brilliant technical summary of the Industry's progress during the year. In his preface, the Editor mentions that the "Pocket Book" widened its appeal during the Great War and suggests that it will again prove of yet greater value under present conditions.

Open to Discussion

The Editor does not necessarily agree with the opinions expressed by his correspondents. All letters must be accompanied by the name and address of the sender (not necessarily for publication).

The "Simplest Short-waver"

SIR,—After about three years of short-wave listening I am writing to let you know how pleased I am that I built the one-valve receiver, the "Simplest Short-waver." It certainly is a fine receiver, and I can recommend it to anyone wishing to begin short-wave listening with a small outlay. I certainly was pleased to receive VU2CQ's 'phone with an 0-v-1 version of it, and a long wire aerial. In stating this I must point out that Asia is difficult to receive here owing to the direction of the aerial.

To encourage other listeners who wish to build a low-priced receiver from junk, I am enclosing a list of 14 mc/s DX heard here on an 0-v-1; receiver built, with the exception of the coil former, entirely of B.C. parts with bakelite insulation, and retaining most of the features of the "Simplest Short-waver." The aerial in use is a 33ft. doublet, 15ft. high, N.E.—S.W.

All continents have been received, and all stations are heard on 'phone.

They include: VK4JX, VS7RA, ZC8EC, VE1, VE2, VE3, VE4SS, VO1, VO2, VO4A, W1, W2, W3, W4, W7BVO, W8, W9, H13N, VP6MR, VP9L, VP7NS, CO2LY, HH2B, PY1, PY2, PY3, PY4, PY7, YV1, YV5, CE3AT, SU1, SU2JR, CN1AF, CN8, VQ4, VQ2HC, ZS2X, ZS6DW, FT4AI, FA3, FA8. Rarer Europeans include CT2AB, YR5IC and PB, SV1(3), SP1(2), LY(2), ES5D, OK1SV, OH2OI and ZB1LA.

I wish to congratulate your correspondent in Palestine on hearing PY on 7 mc/s 'phone.

I am hoping your fine paper will continue to keep the spirit of amateur radio alive throughout the war.—R. TAYLOR (Birmingham).

A DX Log from Purley

SIR,—I append my DX log of stations received here recently, in the hope that it may interest other readers:

10 metre amateur band: W1, 2, 3, 4, 5, 6 (13 W6's heard in ten minutes one evening), 8, 9, ZS1E.

11 metres: W2XJI, W2XQO (New York), W9XPB (St. Louis), W8XNU (Cincinnati), W9XJL (Superior) and W4XA (Washville).

13 metres: WRCA, WCBX, WPLT.

16 metres: WNBI.

19 metres: WGEA, WCBX, WPLT, WRUW (ex-W1XAR), TGWA, JZJ.

20 metre amateur band: W1, 2, 3, 4, 5, 8, 9, K4FKC, K5AM.

21 metres: SUZ.

25 metres: WPIT, WCBX, WRUL, HP5J.

27-29 metres: VLK (Sydney commercial station), PMN.

31 metres: VUD3, CXA8, HJ4CAH, LRA1, WGE0, WRCA, WBOS.

48-9 metres: WNBI, WCBX, WDJM (ex-W4XB), WLWO (ex-W8XAL), CFCX, HJ3CAX (very well heard now), HP5B.

61 metres: VUD2.

I am in need of an S.W.L. correspondent in Great Britain or abroad.—T. B. WILLIAMSON, 3, Highland Road, Purley, Surrey.

Exchanging S.W.L. Cards

SIR,—I am a keen short-wave listener, and collect S.W.L. cards. I would therefore like to exchange my card with any full-ticket, A.A. or S.W. listener.—WILLIAM J. OMER, 1, Waterbeach Road, Slough, Bucks.

SIR,—Several months ago I wrote to your paper and asked for correspondents, and as a result of the publication of my letter I received seven letters in three days, and five more a few days later. I have now six regular correspondents who have all been a great help to me in my experimenting.

I wish to apologise to those whose letters I could not reply to owing to the cost, and so I had to keep up a regular correspondence with only the first few that I received.

I now have QSL's from TFJ, 2RO, OLR5A, W2IXY, PY3EN, VE5OC, and have sent reports to various other stations.

I would like to swap my S.W.L. card with readers living in Africa, India, or South America.—M. PARKE ("Norlands," Middlecave Road, Malton, Yorks).

SIR,—I shall be pleased to exchange my S.W.L. card for that of any "Full Call," A.A., or S.W.L. anywhere in the world, and will endeavour to reply to each card per return.

Prize Problems

PROBLEM No. 379

ROBERTSON had a small three-valve battery receiver which worked very well and he decided to fit a gramophone pick-up to it. He therefore broke the grid-circuit of the first L.F. stage in the customary manner and fitted a single-pole change-over switch which he found in his spares box. He connected the pick-up which was a new model and on radio the set performed as before. When he switched over to gram., however, he could obtain no signals, and not even radio could be heard as a background. He checked all connections and these were correct according to diagram, and the pick-up was also tested for him by a friend and proved to be in order. What was wrong? Three books will be awarded for the first three correct solutions opened. Entries must be addressed to The Editor, PRACTICAL WIRELESS, George Newnes, Ltd., Tower House, Southampton Street, Strand, London, W.C.2. Envelopes must be marked Problem No. 379 in the top left-hand corner and must be posted to reach this office not later than the first post on Tuesday, December 26th, 1939.

Solution to Problem No. 378

The idea which Barclay had in mind was quite correct but it is essential to have both windings in the same phase. When connected one way round the two windings will form a closed circuit and thus will heat up rapidly. This was what had happened to Barclay's transformer.

The following three readers successfully solved Problem No. 377 and books have accordingly been forwarded to them:

E. E. Evans, 8, Park Place, Risca, Mon.
H. V. Price, 158, Meadow Lane, Loughborough, Leicester.
J. D. Morrice, 55, Jasmine Terrace, Aberdeen.

I would also like to bring to the notice of readers of PRACTICAL WIRELESS that my friend, Ken Greaves, 296, Hollins Road, Oldham, and I are running a QSL Exchange Service, and any readers who are interested, and will write to either of us, will be given a hearty welcome. This Service is to keep the "Ham Fires Burning" until pre-war conditions are with us again.

In conclusion, I would like to say I greatly appreciate your paper, so "carry on, PRACTICAL WIRELESS."—FRANK CLEMENTS, 11, Lynsted Avenue, Great Lever, Bolton.

Religious Broadcast Services

SIR,—I wish to express my thanks to S. Thernion for his remarks in the issue of PRACTICAL WIRELESS of November 18th, when he states that: "Just about the time when I am able to listen in each evening there is usually some mournful music or a religious service." The number of the services on week-days is increasing, and it would seem that this religious work is being delegated by the clergy to the B.B.C. If there is such a demand for sermons and hymn singing, why do not the clergy open their churches on week-days, and give those enthusiasts a chance of queuing up for admission? A well-known local paper told us recently that these additional week-day services were for the benefit of the aged and infirm, but considering that they take place as late as 10.30 p.m., it is probable that such persons would be resting.—A. DUNOLLY (Newcastle-on-Tyne).

Notes from the Test Bench

Stability

THE ideal receiver should be absolutely stable on all wavebands, and this end can only be obtained by effective screening, rigid leads and proper wiring. It is seldom possible to build a receiver of high sensitivity for use on the short waves in such a manner that when tuned to a very distant station an earried plate may be inserted at any part of the receiver without affecting tuning in the slightest. This end can be obtained, however, if the above points are attended to, and "loose" leads, such as those to the top caps of valves, are anchored or passed through rigid screening tubing.

Directional Aerials

WHEN using directional aerials for selective distant reception, a compass or similar direction indicator is a valuable addition to enable the exact direction in which the aerial is pointing to be determined. If such an indicator, in conjunction with a world map, is employed, it will be found that some interesting results may be obtained from the point of view of the "bending" of radio signals due to some peculiar ground contours in the vicinity. Obviously such experiments are of the greatest value on the higher frequencies.

Practical Wireless BLUEPRINT SERVICE

These Blueprints are drawn full size. Copies of appropriate issues containing descriptions of these sets can in some cases be supplied at the following prices, which are additional to the cost of the Blueprint. A dash before the Blueprint Number indicates that the issue is out of print.

Issues of Practical Wireless ... 4d. Post Paid
Amateur Wireless ... 4d.
Wireless Magazine ... 1/3

The Index letters which precede the Blueprint Number indicate the periodical in which the description appears: Thus P.W. refers to PRACTICAL WIRELESS. A.W. to Amateur Wireless, W.M. to Wireless Magazine.

Send (preferably) a postal order to cover the cost of the blueprint, and the issue (stamps over 6d. unacceptable) to PRACTICAL WIRELESS Blueprint Dept., George Newnes, Ltd., Tower House, Southampton Street, Strand, W.C.2.

PRACTICAL WIRELESS No. of
Date of Issue. Blueprint.

CRYSTAL SETS

Blueprints, 6d. each.
 1937 Crystal Receiver PW71
 The "Junior" Crystal Set .. 27.8.38 PW91

STRAIGHT SETS. Battery Operated.

One-valve : Blueprints, 1s. each.
 All-Wave Unipen (Pentode) .. PW31A
 Regulators' One-valver .. 19.2.38 PW85
 The "Pyramid" One-valver (HF Pen) .. 27.8.38 PW93

Two-valves : Blueprints, 1s. each.
 Four-range Super Mag Two (D, Pen) .. PW36B
 The Signet Two (D & LF) .. 24.0.38 PW76

Three-valve : Blueprints, 1s. each.
 Selectone Battery Three (D, 2 LF Trans) .. PW10

Sixty Shilling Three. (D, 2 LF RC & Trans) .. PW34A

Leader Three (SG, D, Pow) .. 22.5.37 PW35
 Summit Three (HF Pen, D, Pen) .. PW37
 All Pentode Three (HF Pen, D, Pen, Pen) .. 20.5.37 PW39

Hall-Mark Three (SG, D, Pow) .. 12.6.37 PW41
 Hall-Mark Cadet (D, LF, Pen (RC)) .. 10.3.35 PW48

F. J. Camm's Silver Souvenir (HF Pen, D (Pen), Pen) (All-Wave Three) .. 13.4.35 PW40

Camco Midget Three (D, 2 LF Trans) .. PW51
 1936 Sonotone Three-Four (HF Pen, HF Pen, Westector, Pen) .. PW53

Battery All-Wave Three (D, 2 LF RC) .. PW55
 The Monitor (HF Pen, D, Pen) .. PW61
 The Tutor Three (HF Pen, D, Pen) .. 21.3.38 PW62

The Centaur Three (SG, D, P) .. 14.8.37 PW64
 F. J. Camm's Record All-Wave Three (HF Pen, D, Pen) .. 31.10.36 PW69

The "Colt" All-Wave Three (D, 2 LF RC & Trans) .. 18.2.39 PW72
 The "Rapide" Straight 3 (D, 2 LF RC & Trans) .. 4.12.37 PW82

F. J. Camm's Oracle All-Wave Three (HF, Det., Pen) .. 28.8.37 PW78
 1938 "Triband" All-Wave Three (HF Pen, D, Pen) .. 22.1.38 PW84

F. J. Camm's "Sprite" Three (HF Pen, D, Det) .. 26.3.38 PW87
 The "Hurricane" All-Wave Three (SG, D (Pen), Pen) .. 30.4.38 PW89

F. J. Camm's "Push-Button" Three (HF Pen, D (Pen), Tet.) .. 3.9.38 PW92

Four-valve : Blueprints, 1s. each.
 Sonotone Four (SG, D, LF, P) .. 1.5.37 PW4
 Fury Four (2 SG, D, Pen) .. 8.5.37 PW11

Beta Universal Four (SG, D, LF, Cl. D) .. PW17
 Nucleon Class B Four (SG, D (SG), LF, Cl. B) .. PW24B

Fury Four Super (SG, SG, D, Pen) .. PW31C
 Battery Hall-Mark 4 (HF Pen, D, Push-Pull) .. PW46

F. J. Camm's "Limit" All-Wave Four (HF Pen, D, LF, P) .. 26.9.36 PW67
 All-Wave "Corona" 4 (HF, Pen D, LF, Pow) .. 0.10.37 PW70

"Acme" All-Wave 4 (HF Pen, D (Pen), LF, Cl. B) .. 12.2.38 PW83
 The "Admiral" Four (HF Pen, HF Pen, D, Pen (RC)) .. 3.9.38 PW90

Mains Operated.

Two-valve : Blueprints, 1s. each.
 A.C. Twin (D (Pen), Pen) .. PW13
 A.C. D.C. Two (SG, Pow) .. PW31
 Selectone A.C. Radiogram Two (D, Pow) .. PW19

Three-valve : Blueprints, 1s. each.
 Double-Diode-Triode Three (HF Pen, DDT, Pen) .. PW23
 D.C. Acc (SG, D, Pen) .. PW25
 A.C. Three (SG, D, Pen) .. PW29

A.C. Leader (HF Pen, D, Pow) .. 7.1.39 PW35C
 D.C. Premier (HF, Pen, D, Pen) .. PW36B
 Urbica (HF Pen, D (Pen), Pen) .. 28.7.34 PW36A

Armada Mains Three (HF Pen, D, Pen) .. PW33
 F. J. Camm's A.C. All-Wave Silver Souvenir Three (HF Pen, D, Pen) .. 11.5.35 PW50

"All-Wave" A.C. Three (D, 2 LF (RC)) .. PW51
 A.C. 1936 Sonotone (HF Pen, HF Pen, Westector, Pen) .. PW56

Mains Record All-Wave 3 (HF Pen, D, Pen) .. PW70
 All-World Acc (HF Pen, D, Pen) .. 28.9.37 PW80

Four-valve : Blueprints, 1s. each.
 A.C. Fury Four (SG, SG, D, Pen) .. PW20
 A.C. Fury Four Super (SG, SG, D, Pen) .. PW34D

A.C. Hall-Mark (HF Pen, D, Push-Pull) .. 21.7.37 PW45

Universal Hall-Mark (HF Pen, D, Push-Pull) .. PW47
 A.C. All-Wave Corona Four .. 6.11.37 PW81

SUPERHETS.

Battery Sets : Blueprints, 1s. each.
 £5 Superhet (Three-valve) .. 5.6.37 PW40
 F. J. Camm's 2-valve Superhet .. PW52
 F. J. Camm's "Vitesse" All-waver (6-valver) .. 27.2.37 PW75

Mains Sets : Blueprints, 1s. each.
 A.C. £5 Superhet (Three-valve) .. PW43
 D.C. £5 Superhet (Three-valve) .. PW42
 Universal £5 Superhet (Three-valve) .. PW44

F. J. Camm's A.C. Superhet 4 .. 31.7.37 PW59
 F. J. Camm's Universal £4 Superhet 4 .. PW60

"Qualitone" Universal Four .. 16.1.37 PW73
Four-valve : Double-sided Blueprint, 1s. 6d.
 Push Button 4, Battery Model .. 22.10.38 PW95
 Push Button 4, A.C. Mains Model .. 22.10.38 PW95

SHORT-WAVE SETS. Battery Operated.

One-valve : Blueprint, 1s.
 Simple S.W. One-valver .. 23.12.30 PW88

Two-valve : Blueprints, 1s. each.
 Midget Short-wave Two (D, Pen) .. PW38A
 The "Fleet" Short-wave Two (D (HF Pen), Pen) .. 27.8.38 PW91

Three-valve : Blueprints, 1s. each.
 Experimenter's Short-wave Three (SG, D, Pow) .. 30.7.38 PW30A
 The Perfect 3 (D, 2 LF (RC and Trans)) .. PW63

The Band-Spread S.W. Three (HF Pen, D (Pen), Pen) .. 1.10.38 PW68

PORTABLES.

Three-valve : Blueprints, 1s. each.
 F. J. Camm's ELF Three-valve Portable (HF Pen, D, Pen) .. PW65
 Parvo Flyweight Midget Portable (SG, D, Pen) .. 3.6.39 PW77

Four-valve : Blueprint, 1s.
 "Imp" Portable 4 (D, LF, LF, (Pen)) .. 19.3.38 PW86

MISCELLANEOUS.

Blueprint, 1s.
 S.W. Converter-Adapter (1 valve) .. PW48A

AMATEUR WIRELESS AND WIRELESS MAGAZINE

CRYSTAL SETS.

Blueprints, 6d. each.
 Four-station Crystal Set .. 23.7.38 AW427
 1934 Crystal Set .. AW444
 150-mile Crystal Set .. AW450

STRAIGHT SETS. Battery Operated.

One-valve : Blueprint, 1s.
 B.B.C. Special One-valver .. AW387

Two-valve : Blueprints, 1s. each.
 Melody Ranger Two (D, Trans) .. AW388
 Full-volume Two (SG, det, Pen) .. AW392
 Lucerne Minor (D, Pen) .. AW426
 A Modern Two-valver .. WM409

Three-valve : Blueprints, 1s. each.
 Class B Three (D, Trans, Class B) .. AW386
 £5 5s. S.G.3 (SG, D, Trans) .. 2.12.38 AW412
 Lucerne Ranger (SG, D, Trans) .. AW422

£5 5s. Three: De Luxe Version (SG, D, Trans) .. 10.5.34 AW435
 Lucerne Straight Three (D, RC, Trans) .. AW437

Transportable Three (SG, D, Pen) .. WM271
 Simple-Tune Three (SG, D, Pen) June '33 WM327
 Economy-Pentode Three (SG, D, Pen) .. WM337

"W.M." 1934 Standard Three (SG, D, Pen) .. WM351
 £3 3s. Three (SG, D, Trans) .. Mar. '34 WM354
 1935 4s. 6s. Battery Three (SG, D, Pen) .. WM371

PTF Three (Pen, D, Pen) .. WM889
 Certainly Three (SG, D, Pen) .. WM893
 Minutube Three (SG, D, Trans) .. Oct. '35 WM896

All-Wave Winning Three (SG, D, Pen) .. WM400

Four-valve : Blueprints, 1s. 6d. each.
 6s. Four (SG, D, RC, Trans) .. AW370
 2HF Four (2 SG, D, Pen) .. AW421
 Self-contained Four (SG, D, LF, Class B) .. Aug. '33 WM331

Lucerne Straight Four (SG, D, LF, Trans) .. WM350
 £5 5s. Battery Four (HF, D, 2 LF) Feb. '35 WM381
 The H.K. Four (SG, SG, D, Pen) Mar. '35 WM334

The Auto Straight Four (HF Pen, HF Pen, DDT, Pen) .. Apr. '36 WM401
Five-valve : Blueprints, 1s. 6d. each.
 Super-quality Five (2 HF, D, RC, Trans) .. WM320

Class B Quadradync (2 SG, D, LF, Class B) .. WM344
 New Class B Five (2 SG, D, LF, Class B) .. WM340

Mains Operated.

Two-valve : Blueprints, 1s. each.
 Consoclectric Two (D, Pen) A.C. .. AW403
 Economy A.C. Two (D, Trans) A.C. .. WM286
 Unicorn A.C.-D.C. Two (D, Pen) .. WM304

Three-valve : Blueprints, 1s. each.
 Home Lover's New All-electric Three (SG, D, Trans) A.C. .. AW338
 Mantovani A.C. Three (HF Pen, D, Pen) .. WM374

£15 15s. 1936 A.C. Radiogram (HF, D, Pen) .. Jan. '36 WM302

Four-valve : Blueprints, 1s. 6d. each.
 All Metal Four (2 SG, D, Pen) July '33 WM329
 Harris' Jubilee Radiogram (HF Pen, D, LF, P) .. May '35 WM386

SUPERHETS.

Battery Sets : Blueprints, 1s. 6d. each.
 Modern Super Senior .. WM375
 'Varsity Four .. Oct. '35 WM395
 The Request All-Waver .. June '36 WM407

1935 Super-Five Battery (Superhet) .. WM379
Mains Sets : Blueprints, 1s. 6d. each.
 Heptode Super Three A.C. .. May '34 WM350
 "W.M." Radiogram Super A.C. .. WM366

PORTABLES.

Four-valve : Blueprints, 1s. 6d. each.
 Holiday Portable (SG, D, LF, Class B) .. AW293

Family Portable (HF, D, IC, Trans) .. AW447
 Two H.F. Portable (2 SG, D, QP21) .. WM362

Tyers Portable (SG, D, 2 Trans) .. WM367

SHORT-WAVE SETS. Battery Operated.

One-Valve : Blueprints 1s. each.
 S.W. One-valver for America .. 15.10.38 AW429
 Rome Short-Waver .. AW452

Two-valve : Blueprints, 1s. each.
 Ultra-short Battery Two (SG, det, Pen) .. Feb. '36 WM402
 Home-made Coil Two (D, Pen) .. AW440

Three-valve : Blueprints, 1s. each.
 World-ranger Short-wave 3 (D, RC, Trans) .. AW355
 Experimenter's 5-metre Set (D, Trans, Super-regen) .. 30.6.34 AW428

The Carrier Short-waver (SG, D, P) July '35 WM390

Four-valve : Blueprints, 1s. 6d. each.
 A.W. Short-wave World-beater (HF Pen, D, RC, Trans) .. AW434
 Empire Short-waver (SG, D, RC, Trans) .. WM314

Standard Four-valver Short-waver (SG, D, LF, P) .. 22.7.39 WM383

Superhet : Blueprint, 1s. 6d.
 Simplified Short-wave Super .. Nov. '35 WM307

Mains Operated.

Two-valve : Blueprints, 1s. each.
 Two-valve Mains Short-waver (D, Pen) A.C. .. AW451
 "W.M." Long-wave Converter .. WM380

Three-valve : Blueprint, 1s.
 Emigrator (SG, D, Pen) A.C. .. WM352

Four-valve : Blueprint, 1s. 6d.
 Standard Four-valve A.C. Short-waver (SG, D, RC, Trans) .. Aug. '35 WM391

MISCELLANEOUS.

S.W. One-valve Converter (Price 6d.) .. AW329
 Enthusiast's Power Amplifier (1/6) .. WM387
 Listener's 5-watt A.C. Amplifier (1/6) .. WM392

Radio Unit (2v.) for WM392 (1/-) Nov. '35 WM298
 Harris Electrogram battery amplifier (1/-) .. WM399

De Luxe Concert A.C. Electrogram (1/-) .. Mar. '36 WM403
 New Style Short-wave Adapter (1/-) .. WM388

Trickle Charger (6d.) .. Jan. 5, '35 AW462
 Short-wave Adapter (1/-) .. AW456
 Superhet Converter (1/-) .. AW467

H.I.D.L.C. Short-wave Converter (1/-) .. May '36 WM405
 Wilson Tone Master (1/-) .. June '36 WM406

The W.M. A.C. Short-wave Converter (1/-) .. WM403

In reply to your letter

Operating Mains Sets

"We are unfortunately not on the mains, but have our own electric-lighting set consisting of a petrol engine driving a dynamo which charges about 26 cells from which we get 50 volts. Is there any way in which this could be made use of for using mains apparatus as I have often wished to make up sets like the Air Hawk 9 but have so far been unable to do so."—P. H. (Harrow-on-the-Hill).

PROBABLY the simplest and most effective way in your case would be to obtain one of the vibratory rectifiers designed to operate from 6 or 12 volts D.C. This, in conjunction with a suitable transformer, would deliver 250 volts at sufficient current to operate a reasonable mains receiver and should solve your problem. The rectifier and transformer may be obtained from Messrs. Bulgin.

Aerial Position

"I have read an article on aerials and am desirous of knowing whether my aerial, of which I enclose a diagram, would be suitable for short-wave reception as in the article it mentions about screening. The house is well clear of other buildings and except for possible roof screening is ideally situated."—R. D. (S.E.5).

THE effective height of the aerial is the height above the nearest earthed body. As your aerial runs parallel with the roof and is supported on 8ft. poles, then the effective height is only 8ft. This is especially so as the roof immediately below the aerial is lead sheeting. However, as with many radio problems, theory and practice may not run hand in hand, and the results on the aerial may be much better than those you would obtain if you used the same aerial on the 8ft. poles down in the garden. We would suggest, however, that single wire, rather than a double wire system, would be preferable, especially if your wires are not widely spaced.

Choke Coupling

"I noted a recent reply by you regarding choke capacity coupling, but in looking up some old circuits I have found a scheme which does not appear to agree with your remarks and should like to know whether you can explain the idea. It appears that the anode circuit includes a resistance, but the anode is then joined to a condenser which is fed to a centre-tap on a choke and I am not clear how this particular arrangement works."—L. E. (Bath).

THE circuit may have been drawn in the manner you outline, but actually the choke is no doubt a standard L.F. transformer with primary and secondary joined in series. The condenser is fed to the junction and thus we have an auto-transformer coupling, the exact ratio of the transformer depending upon the relationship between primary and secondary and the method of joining the two windings, i.e., in phase or out of phase. Thus the

circuit in question is merely a parallel-fed auto-transformer arrangement.

Bias By-pass Condenser

"Is the value of the by-pass condenser across the bias resistance included in a cathode circuit critical? I have seen 2 mfd. used in some circuits and 25 or even 50 mfd. in other circuits, and I am building a set and wish to use the most correct type of condenser."—F. C. V. (Birmingham, 9).

THE capacity will govern the degree of low-note response, and whilst in most simple types of circuit a 2 mfd. may be suitable the higher capacities are preferable. If, however, small valves and inadequate H.T. are employed it may not be worth while to go to the trouble of using the larger capacity as the low-note reproduction will be poor in any case.

RULES

We wish to draw the reader's attention to the fact that the Queries Service is intended only for the solution of problems or difficulties arising from the construction of receivers described in our pages, from articles appearing in our pages, or on general wireless matters. We regret that we cannot, for obvious reasons—

- (1) Supply circuit diagrams of complete multi-valve receivers.
- (2) Suggest alterations or modifications of receivers described in our contemporaries.
- (3) Suggest alterations or modifications to commercial receivers.
- (4) Answer queries over the telephone.
- (5) Grant interviews to querists.

A stamped addressed envelope must be enclosed for the reply. All sketches and drawings which are sent to us should bear the name and address of the sender. Requests for Blueprints must not be enclosed with queries as they are dealt with by a separate department.

Send your queries to the Editor, PRACTICAL WIRELESS, George Newnes, Ltd., Tower House, Southampton Street, Strand, London, W.C.2. The Coupon must be enclosed with every query.

Heater Leads

"I am making up an A.C. receiver and am rather anxious regarding the wire to be used for wiring up the heaters. In some receivers which I have looked at I find that solid wire is used, whilst in others flex has been employed. Does it matter what type of wire is used, provided that the current-carrying capacity is ample for the total heater circuit?"—H. R. A. (Teddington).

THE usual reason for using flex is that it is more easily bent to follow the run of wiring. If solid wire is employed, for a given current rating it will be heavier than the stranded or flexible wire, and therefore more awkward to twist and bend. Furthermore, the flex must be bared at the points where it makes contact with the various valveholders in the wiring and this means that there are two junctions at each valve heater pin. This may lead to difficulties as there will be an undue thickness of wire at that point. By using solid wire of suitable diameter it may be soldered to a valve pin, insulated sleeving slipped over ready cut to a suitable length, and thus

only one joint has to be made and this is generally simpler for the amateur.

Three-range Coils

"I wish to build up an all-wave receiver as published some time ago in your paper. I am told, however, that the coils are not made now and I should like to know if you can recommend a substitute."—B. D. (N.W.9).

THE coils in question have been withdrawn and there are no exact replicas now available. However, in the Bulgin range you will find some all-wave coils which you may prefer to use, or alternatively you can build up an all-wave unit with the small individual coils which Bulgin are now marketing. They will have to be arranged at right-angles to each other and with suitable switching.

REPLIES IN BRIEF

The following replies to queries are given in abbreviated form either because of non-compliance with our rules, or because the point raised is not of general interest.

M. S. H. (Darlington). In view of the various types of circuit which can be made up, it is not possible to give an estimate of the cost.

H. J. B. (Thornton Heath). Selectivity is bound to be low in such a simple arrangement, but an improvement could be effected by including an ordinary small variable condenser in the aerial circuit. Lack of reaction, however, tends to indicate that there may be some mistake in your coil wiring.

A. S. (Edinburgh). Hamburg is not a short-wave station. There is nothing you can do to improve the crystal set, and much depends upon local conditions.

S. T. (Stratford). Instructions for a charter were given in our issue dated December 9th, which you have no doubt now seen.

C. A. B. (S.W.2). We regret that we cannot insert your request, and suggest you take a small advertisement for the purpose.

M. H. (Edinburgh). Without a type number, it is not possible to give connections as the firm in question have made many coils of the type described.

P. A. S. (Horsham). We are sorry that we cannot give connections from the details given in your letter.

C. T. (Liverpool, 15). We regret that we cannot supply a blueprint of the type mentioned.

E. S. (Doncaster). As the set is a commercial model, we can only suggest you communicate with the makers.

J. R. (Glacton-on-Sea). The condenser may be used, but there may be no need to alter the coil. If, however, reaction does not prove effective add about 10 to 20 turns to the reaction winding.

G. B. (Newcastle). We are sorry that we cannot identify the apparatus and thus are unable to give you connections.

E. W. W. (Upminster). The aerial would probably be no better than a single wire, especially for short-wave work.

R. H. (Stonyhurst College). The resistors cost 6d. each.

J. B. S. (Saxmundham). The glow generally indicates that the valve is being over-run. We cannot reply more fully to your detailed letter in the absence of a stamped, addressed envelope.

R. H. P. (Old Bletchley). It is necessary to trace the fault before you can effect a cure. There are dozens of faults which could give rise to the effect and a stage-by-stage test is indicated.

E. A. (Hammersmith). The resistance generally has a value of 20 to 50 ohms. It is not critical.

P. A. (Hildenborough). A defective valve could give rise to the symptoms mentioned. Have the valve checked.

F. B. (Smethwick). We have no details of the coils or circuits mentioned and the paper in which these were originally described is not now on the market.

A. J. F. (Colchester). We regret that we are unable to send a list of stations, and a complete list of all wavelengths is not at the moment obtainable.

A. T. W. (Saundersfoot). We regret that we have not described a portable of the type mentioned. We have no details of particular local conditions and therefore cannot give a guarantee as to reception on a set of the type mentioned in your locality.

O. P. A. (Glasgow, E.2). There are two or three different ways of carrying out the idea, one being by radiation from the small units. Unfortunately we are unable to give constructional details. Another idea utilises a wire beneath carpets, etc., and a small pick-up frame is included in the separate amplifiers.

The coupon on page iii of cover must be attached to every query.

THE POCKET TWO

(Continued from page 302)

condenser is then desirable to enable certain stations to be separated. The addition of an earth lead will in some cases improve signal strength, but in many cases will not prove essential. Remember, however, that interference can sometimes be removed if an earth connection is used, whilst in other cases the earth lead will result in improved signal strength. A list of the parts which we used is given below.

LIST OF COMPONENTS

Two Variable Condensers, .0005 mfd. type C.V.19 (Bulgin).
One Midget Coil, type C.40 (Bulgin).
One Midget L.F. Transformer, type L.F.58 (Bulgin).
Two Valveholders, type V.H.19 (Bulgin).
Two 2-socket Terminal Strips (Clix).
One .0002 mfd. Mica Condenser (Dubilier).
One .0002 mfd. Tubular Condenser (Dubilier).
One .005 mfd. Tubular Condenser (Dubilier).
One 2 megohm Grid-leak (Erie).
One Crocodile Clip, Connecting Wire, Flex, etc.
One Cigar box.
One 210 Det, one 220 HPT valve (Cossor).

RADIO CLUBS & SOCIETIES

Club Reports should not exceed 200 words in length and should be received First Post each Monday morning for publication in the following week's issue.

THE CROYDON RADIO SOCIETY

Hon. Publicity Sec.: E. L. Cumbers, 14, Campden Road, South Croydon.

MR. R. W. GILPIN gave his maiden lecture at the monthly meeting of the above society on December 6th, in St. Peter's Hut, Ledbury Road, South Croydon. His topic was "Recording and Reproduction of Sound on Film." The loudspeaker assembly proved interesting, and here one H.F. unit operated with two L.F. units. The H.F. unit had a spherical duralumin cone feeding an exponential throat past a series of radial vanes. The bass speakers had moving coils, and soft cones of 15in. diameter, while a filter circuit, which Mr. Gilpin described, ensured that they did only accept bass notes. He finished by touching on the principle of the light cell, the use of the beam power tetrode valve in amplifier, and found time for questions. The next meeting is on Thursday, January 4th, when Mr. P. G. H. A. Voigt will lecture.

THE SURREY RADIO CONTACT CLUB

Hon. Sec.: S. A. Morley, 22, Old Farleigh Road, Selsoad, Surrey.

THE club held its last meeting of the year on Sunday afternoon, December 3rd, at the Café Royal, Croydon, when an extremely interesting talk and demonstration was given by Mr. P. G. H. A. Voigt entitled "High Quality Reproduction." He spoke on the various ways sound waves travelled through the ether, showing how they passed after leaving the transmitter until they reached the human ear. He then spoke about the best type of auditorium for sound reproduction, how various thicknesses of walls and heights of ceilings affected it, and also, how the positioning of the loudspeaker can make or mar a sound transmission.

SLOUGH AND DISTRICT S.W. CLUB

Headquarters: Toc H Headquarters, William Street, Slough, Bucks.

Secretary: K. A. Sly (G4MR), 16, Buckland Avenue, Slough, Bucks.

Meetings: Alternate Thursdays at 7.30 p.m.

AT the last meeting, held on December 7th, 1939, the chief item of interest proved to be the talk by Mr. Houchin (G3GZ), in continuation of his series on "Fundamentals of Radio." The talk followed on from the power pack, which the speaker had described in his last talk, and traced briefly the theory behind transmission and reception of radio signals.

New members will be welcomed by all the members. The subscription is 2s. 6d. per annum: 3d. extra is payable at each meeting for the hire of the room.

SALE AND DISTRICT RADIO SOCIETY

Present Headquarters: The Excelsior Club, Sale.

Acting Secretary: Norman Postles, 104, Cross Street, Sale.

Meetings: Thursday evenings at 7.30 p.m.

SEVERAL members of the society are serving with the Royal Army Signal Corps and the Air Force, but it has been decided to resume the usual Morse practice on Thursday evenings. A short-wave receiver will be available shortly for reception of commercial Morse transmissions, and it is hoped that by this means some useful experience in operating procedure will be obtained.

BRISTOL EXPERIMENTAL RADIO CLUB

Publicity Manager: D. J. James, 40, Robertson Road, Eastville, Bristol. 5.

THE chairman and committee of the Bristol Experimental Radio Club would like to take this opportunity to wish members, both of the club and of the radio fraternity as a whole, a Merry Christmas, a Happy New Year, good D.X., and a speedy return of world peace and amateur transmitting!

The next meeting of the society will be held on Tuesday, January 16th, 1940, at 7.30 p.m.

Classified Advertisements

RECEIVERS, COMPONENTS AND ACCESSORIES

SOUTHERN RADIO'S BARGAINS.

ALL GUARANTEED. POSTAGE EXTRA.

5/-—Parcel of Useful Components, comprising Condensers, Resistances, Volume Controls, Wire, Circuits, etc. Value 25/-: 5/- per parcel.

15/-—Service Man's Component Kit. Electrolytic Condensers, Volume Controls, Resistances, Tubular, Mica, Paper Condensers, Valve Holders, etc. 120 articles contained in strong carrying case, 9" x 7" x 7". 15/- the kit.

21/-—Small Trader's Parcel of Components. 150 Articles comprising all types Condensers, Valve Holders, Resistances, Chokes, Coils, Wire, etc. Value 85/-: 21/- the parcel.

5/-—100 Wire-end Resistances, assorted capacities $\frac{1}{2}$ and 1 watt, 5/- per 100.

5/-—6 Volume Controls, 5/-.

TELSEN 3-Range Meters (Volts and Milliamps), 4/-; Ormond Loud-speaker Units, 2/6; Crystal Sets, 5/6; Westectors Type W2, 2/6; Telsen W349 Midget Iron Core Coils, 4/6; Step-up Transformers, 110-250 Volts, 7/-; 8 mfd. Electrolytic Condensers, 500 volts, 1/8. Crystal Detectors, 2/-; Crystals, 6d.; Marconi V24 Valves, 9d.

2/-—Tool or Instrument Carrying Cases, ex-Government Stock; Wood 9" x 7" x 7", 2/-.

SPECIAL Offer, Limited Quantity Torch Bulbs, 1.5v., 21/- per 100; 2.5v. and 3.5v., 17/6 per 100.

SOUTHERN RADIO, 40, Lisle Street, London, W.C. Gerrard 6653.

VAUXHALL.—All goods previously advertised are still available; send now for latest price list, free.—Vauxhall Utilities, 163a, Strand, W.C.2.

BANKRUPT BARGAINS.—Brand new 1939 models, makers' sealed cartons, with guarantees, at less 40 per cent. below listed prices; also Midgets, portables, car radio. Send 1d. stamp for lists.—Radio Bargains, Dept. P.W., 261-3, Lichfield Road, Aston, Birmingham.

HEADPHONES. Reconditioned and guaranteed. Brown, G.E.C., B.T.H., Sterling, Nesper, Brunet, Western Electric, Siemens, Braides, 4,000 ohms, 5/- pair. Telefunken, lightweight, adjustable, 4,000 ohms, 7/6.

CRYSTAL with silver cat's-whisker, 6d. Complete detector parts, 1/-. Glass tube detector on ebonite base, 1/6. Sensitive permanent detector, 1/6. Postage 14d.—Post Radio Supplies, 328, Upper Street, London, N.1.

5/- Bargain Parcel comprising Speaker Cabinet, Drilled steel Chassis, condensers, resistances and many other useful components. Worth £2. Limited number. Postage 1/-.—Bakers Selhurst Radio, 75, Sussex Rd., South Croydon.

BANKRUPT BARGAINS.—All new goods offered. Spartan A.C. press button 1939 5v. superhets, £5/15/0. Ditto table radiogram. 9 vus. Triphonic 14 gu. A.C. all-wave superhet motor tuned, 9 gus. Triphonic 14 gu. 6v. A.C.-D.C. all-wave, push-pull superhets, 9 gus. Portadyne 1940 A.C.-D.C. all-wave superhets, £6/17/6. Portadyne battery baby superhet portables, £6. Portadyne 1939 4v. battery portable. £4/15/0. Triphonic A.C. all-wave 5v. superhets, 11 gus. 1939 models, 7 gus. Good make A.C.-D.C. 16 gu. all-wave 4 band superhets. bamis medium and three short, 8 watts output. 9 gus. Full stock valves all types. Service goods and repairs. Please state requirements for quotation.—Butlin, 6, Stanford Avenue, Brighton.

GOULPHONE RADIO, Onmskirk. Collar, A.C. gramophone motors, 12in. turntable, 24/-; with pick-up, 50/-; Record valves. Rola Speakers, 10in. P.M., 21/-; 1d. stamp lists.

LOUDSPEAKER REPAIRS

LOUDSPEAKER repairs, British, American, any make. 24-hour service, moderate prices.—Sinclair Speakers, Pulteney Terrace, Copenhagen Street, London, N.1.

L.S. REPAIR AND REWINDING SERVICE: 24-hour service. See below:—

REPAIRS to moving coil speakers a speciality. New cone assemblies fitted. Speech coils and fields wound or altered. Mains transformers, chokes, eliminators and vacuums repaired, prices quoted. Speaker transformers, Class "B" L.F. transformers and pick-ups rewound at 4s. each, post free. Discount trade. Estimates free. Guaranteed satisfaction. L.S. Repair Service, 5, Balham Grove, London, S.W.12. 'Phone: Battersea 1321.

NEW LOUDSPEAKERS

3,000 SPEAKERS from 6/6 each, P.M. and energised 4in. to 14in. including several Epoch 18in.—Sinclair Speakers, Pulteney Terrace, Copenhagen Street, London, N.1.

LOUDSPEAKER CONVERSIONS

BAKER'S Triple Cone Conversions Will Immensely Improve Reproduction of Your Present Speaker. Enables you to bring your speaker right up to date and obtain really realistic reproduction at the cost of a few shillings; free descriptive leaflet from the Pioneer Manufacturers of Moving Coil Speakers since 1925.—Bakers Selhurst Radio, 75, Sussex Rd., South Croydon.

NEW CHASSIS

ARMSTRONG CO. recommending the following economically priced Radio Chassis for good quality reproduction. ARMSTRONG Model AW38.—8-valve All-wave Radio-gram chassis, incorporating the latest circuit, including 6 watts push-pull output. Price £8/8/0 + 5% war increase. Armstrong Co. have many other models of equal interest, please write for catalogue. Armstrong Manufacturing Co., Warrlers Rd., Holloway, London, N.5.

CABINETS

A CABINET for Every Radio Purpose.

SURPLUS Cabinets from noted makers under cost of manufacture.

RADIOGRAM Cabinets from 30/-.

UNDRILLED table, console and loudspeaker cabinets from 4/6.

INSPECTION Invited.

H. L. SMITH and Co., Ltd., 280, Edgware Road, W.2. Tel.: Pad. 5891.

COMMUNICATION RECEIVERS

FINEST selection in the country. Sole Agents for famous HALICRAFTERS Receivers, ranging in price from £11/10/0 to £150. Attractive easy terms. Demonstrations at our London Showrooms, 60-peg Catalogue post free 2d.—Webb's Radio, 14, Soho Street, London, W.1. 'Phone: Gerrard 2089.

TECHNICAL LITERATURE

TECHNICAL BOOKS for the enthusiast. Hundreds of constructional theoretical circuits short-wave equipment. Radio Society of Great Britain Handbook, 2/9 post free. 1940 Edition American Radio Relay League Handbook, 6/- post free. American "Radio Handbook" 7/6 post free. R.C.A. American Receiving Valve Manual, 1/6 post free.—Webb's Radio, 14, Soho Street, London, W.1. 'Phone: Gerrard 2089.

RADIO MAP AND GLOBE

WEBB'S RADIO MAP of the World enables you to locate any station heard. Size 40" by 30". 2-colour heavy Art Paper, 4/6. Limited supply on linen. 10/6. WEBB'S RADIO GLOBE—superb 12" full-colour model. Radio prefixes, zones, etc. Heavy oxidised mount. Post Paid. 27/6.—Webb's Radio, 14 Soho Street, London, W.1. 'Phone: Gerrard 2089.

MORSE EQUIPMENT

FULL range of Transmitting Keys, Practice Sets. Oscillators, Recorders and other Radio Telegraph Apparatus; designed and manufactured by T. R. McEroy, World Champion Telegraphist. Absolutely first-class construction. McEroy Amateur Key 7/6 post free.—Webb's Radio, 14, Soho Street, London, W.1. 'Phone: Gerrard 2089.

COMPONENTS FOR SALE

15/- Beldon doublet aerial kit; 20/- ditto super Kit, both cost double; 25/- Gen-co-motors, 12v./250v./50m.a. 18/9; Malory vibrator converters with filters, 12v./185v./40m.a. Send for list amazing clearance bargains. Satisfaction guaranteed or money refunded.—Aeronautical Radio Company, River Road, Littlehampton 770.

TORCH OR LAMP BATTERIES

SUPPOSE you can, why buy new? When exhausted, revive by simple inexpensive method. Patent applied for. Details, one shilling.—"Revivals." Manesty, Cobham Road, East Horsley, Surrey.

RECEIVERS, COMPONENTS AND ACCESSORIES

EPOCH EX CINEMA PUBLIC ADDRESS MOVING-COIL SPEAKERS. 18in. cone, 15-ohm speech coil, 6-volt field, 27/6 each. C/F

WESTINGHOUSE H.T.10 RECTIFIERS. 200 volts, 100 m/amp. output (new), 7/6 each, post 1/-

WESTON (301) MOVING-COIL MILLIAMMETERS, as new, 0 to 3 m/a., 25/-; 0 to 50 m/a., 20/-; 0 to 200 m/a., 20/- each.

ELLIOTT MOVING-COIL 0 to 3 Amp. TESTING SETS, 5in. dial, with variable resistance, in portable case, 15/- each.

G.E.C. 100-VOLT 1/2 H.P. D.C. MOTORS, 1,750 r.p.m., in good condition, double-ended spindle, 12/6 each. C/F

PHILIPS MAINS TRANSFORMERS. Input 200/240 volts, output 2,000/2,000 volts 200 m/a., also 2 l.f. windings, 25/- C/F

STEEL CABINETS. Useful for transmitting or power amplifier racks. Size, 40 x 24 x 16in., 12/6 each. C/F

ELECTRIC LIGHT CHECK METERS, for Sub-lettings, Garages, etc. 200/250 volts, 50 cy., 1-ph. supply 5, 10, or 20 amps., 6/- each, post 1/-

G.E.C. A.C. INDUCTION MOTORS, 1/2 h.p., 45 volts, 25 cy., 3-phase, but suitable for re-winding to local supply mains voltage (double-ended shaft), 20/- each. C/F

WESTON (501) AND E. TURNER (909) 2in DIAL MOVING-COIL MILLIAMMETERS, as new. 0 to 5 m/a., 17/6; 0 to 25 m/a., 16/6; 0 to 50 m/a., 15/-; 0 to 250 m/a., 15/- each.

MULTI-CONTACT RELAYS, EX-G.P.O., as used in automatic exchange, condition as new, small size, suitable for automatic tuning for press-button control, heavy platinum contacts, 2/6, post 3d.; 2 for 4/- post 6d.; 3 for 6/-, post 6d.

ELECTROLYTIC CONDENSERS, 8 mf., 350 v.; 4 mf., 250 v.; 6 mf., 450 v., 1/3 each, post 3d.; 8 x 8 mf., 450 v., 2/-; 8 x 16 mf., 450 v., 2/-; and 8 x 8 x 2 mf., 450 v., 2/- each, post 3d.

VOLTAGE CHANGING TRANSFORMERS (Auto. wound), 12 months' guarantee, 100/110 to 200/240 volts or vice versa, 250 watts, 21/-; 500 watts, 26/-; 750 watts, 32/6; 1,000 watts, 37/6; 1,500 watts, 50/-; 2,000 watts, 62/6.

HIGH VOLTAGE TRANSFORMERS for Television, Neon, etc. 200/240 v. 50 cy. 1-ph. primary, 5,000 and 7,000 volts secondary, enclosed in petroleum jelly. Size: 5 1/2in. x 4 1/2in. x 4 1/2in., 7/6 each, post 1/- Ditto, skeleton type, 5/6, post 9d. All brand new.

MAINS TRANSFORMERS, 200/240 volts input, 12 and 24 volts at 4 to 6 amps. output (useful for model trains, etc.), 15/- each, post 1/-

EX-G.P.O. GLASS TOP RELAYS, Type B. Useful as Keying Relays, 5/- each, post 6d. Also a few only that need points, which are easily fitted, 2/6 each. P/F

T.C.C. 2,000 MF. ELECTROLYTIC CONDENSERS, 50-volt working (brand new), 5/- each, post 6d.

STANDARD TELEPHONE BELL WIRE, all brand new, 150-yd. coils twin 22 gauge, 4/-, post 9d.; 250-yd. coils, single 18 gauge, 4/-, post 1/-; 300-yd. coils, single 22 gauge, 3/-, post 6d.

MOVING COIL MOVEMENTS, complete in case with pointer, very low m/a., full deflections, 2 1/2in. dia., 5/-, post 6d.; 4in. dia., 6/-, post 9d.; and 6in. scale, 7/- each, post 9d.

PUSH-BACK WIRE, 22 gauge, 220-yd. coils, as new, price per coil, 8/6, post free

CROMPTON SHUNT WOUND DYNAMO, 100 volts 4 amps., 1,750 r.p.m., 35/- C/F

CROMPTON DYNAMO, 4-pole shunt wound, 1,750 r.p.m., 100 volts 10 amps., 70/- Ditto, 50/75 volts 16 amps., 75/- C/F

MACKIE MOTOR GENERATOR, 220 volts 3.35 amps. D.C. input, 10 volts 30 amps. D.C. output, 37/6 C/F

STANDARD TELEPHONE MAINS TRANSFORMERS, input 200/250 volts, output 250/0/250 volts 200 m/a., 3 x 4 volt windings and a 50-volt winding, 12/6 each.

STANDARD TELEPHONE CONDENSERS, 1 mf. 400 volt wkg., 4d. each, or 4 for 1/-; 2 mf. 400 v. wkg. 6d. each. Muirhead, 1 mf. 4,000 volt test, 2/- each. Philips, 1 mf. 8,000 volt test, 5/- each. T.C.C., 2 mf. 1,000 volt test, 1/- each. T.C.C. 2,000 mf. 12 volt wkg., 2/- each.

CALIBRATED 80-OHM VARIABLE RESISTANCES, in teak case. Size: 6 1/2 x 6 1/2 x 4in., 2/6 each, post 9d.

TELEPHONE WALL BOXES, containing twin gong bell for magneto ringing and microphone transformer, 1/6 each, post 9d. Microphone Buttons, 6d. each, post 2d. Telephone Hand Generators, fitted with 3 magnets, 3/6 each, post 1/-

Terms: Cash with Order or C.O.D. Charges extra.
 ALL GOODS SENT ON THREE DAYS' APPROVAL AGAINST CASH
 GALPIN'S ELECTRICAL STORES, 75, Lee High Rd., Lewisham, London, S.E.13. Telephone: Lee Green 5240.

FREE ADVICE BUREAU COUPON

This coupon is available until December 30th, 1939, and must accompany all Queries and Hints.
 PRACTICAL WIRELESS, 23/12/39

PREMIER RADIO—AS USUAL!

SPECIAL PURCHASE

"AIR WARDEN" 5-valve Midget Receiver FOR A.C. MAINS. 200-250 v. Completely self-contained in well-finished, polished Oak Cabinet, 12 x 9 x 9 1/2ins. Well built-in Moving Coil Speaker. Wave Range 190-550 metres. Usual Price £6 6s. Od. Our Price 55/-. The Ideal Stand-by Set.

PREMIER SHORT-WAVE KITS for OVERSEAS NEWS

Incorporating the Premier 3-Band S.W. Coil. 11-86 Metres without coil changing. Each Kit is complete with all components, diagrams and 2-volt valves. 3-Band S.W. 1 Valve Kit, 14/9. 3-Band S.W. 2 Valve Kit, 22/6.

DE LUXE S.W. KITS

Complete to the last detail, including all Valves and coils, wiring diagrams and lucid instructions for building and working. Each Kit is supplied with a steel Chassis and Panel and uses plug-in Coils to tune from 13 to 170 metres.

- 1 Valve Short-Wave Receiver or Adaptor Kit 20/-
- 1 Valve Short-Wave Superhet Converter Kit . . . 23/-
- 1 Valve Short-Wave A.C. Suprhet Converter Kit 26/3
- 2 Valve Short-Wave Receiver Kit 29/-
- 3 Valve Short-Wave Screen Grid and Pentode Kit 68/-

REPLACEMENT VALVES FOR ALL SETS

EUROPA MAINS VALVES. 4 v., A.C. Types, A.C./H.L., A.C./L., A.C./S.G., A.C./V.M.S.G., A.C./H.P., A.C./V.H.P. (5-pin), all 5/3 each. A.C./H.P., A.C./V.H.P. (7-pin), 7/6; A.C./Pens-I.H., 7/6; A.C./P.X.4, 7/3; Oct. Freq. Changers, 8/6; Double Diode Triodes, 7/6; 3 1/2-watt D.H. Triode, 7/6; 350 v. F.W. Rect., 5/6; 500 v. F.W. Rect., 6/6; 13 v. 2 amps. Gen. Purpose Triodes, 5/6; H.F. Pens and Var.-Mu. H.F. Pen., Double Diode Triodes, Oct. Freq. Changers, 7/6 each. Full and Half-wave Rectifiers, 6/6 each.

TRIAD HIGH-GRADE U.S.A. VALVES, all types in stock. Standard tubes, 5/6 each. Octal Base tubes, 6/6 each. 210 and 250, 8/6 each.

PREMIER BATTERY CHARGERS for A.C. Mains. Westinghouse Rectification complete and ready for use. To charge 2 volts at 1 amp., 11/9; 6 volts at 1 amp., 19/-; 6 volts at 1 amp., 22/6; 12 volts at 1 amp., 24/6; 6 volts at 2 amps., 37/6.

MOVING COIL SPEAKERS all complete with transformer. Rola 8in. P.M.s., 16/6; 10in. P.M.s., 22/6; G.12 P.M.s., 66/-

Energised Models. Plessey Sin., 2,500 or 7,500 ohm field, 7/6; G.12 energised, 59/6.

HUGE PURCHASE OF U.S.A. MAINS TRANSFORMERS at Pre-War Prices. Manufacturers' surplus. All brand new and Guaranteed. Input 110 v. and 220 v. A.C. Output 325-325 v., 120 m.a., 6.3 v., 2-3 amps., 5 v. 2 amps. C.T., 7/6 each. Input 230 v. A.C. Output 325-325 v., 75 m.a., 5 v. 2 amps., 6.3 v. 2-3 amps. C.T., 6/6 each. Input 100-250 v., 300-300 v. 60 m.a. 4 v. 5 a. C.T., 4 v. 1 a., 6/11.

PREMIER Short-Wave Condensers, all-brass construction, with Trolift Insulation. 15 mmf., 1/9; 25 mmf., 1/10; 40 mmf., 2/-; 100 mmf., 2/3; 160 mmf., 2/7; 250 mmf., 2/11.

PREMIER SHORT-WAVE COILS, 4- and 6-pin types, 13-26, 27-47, 41-49, 78-170 metres, 2/- each, with circuit. Special set of S.W. Coils, 14-450 metres, 4/9 set, with circuit. Premier 3-band S.W. coil, 11-25, 19-43, 39-86 metres. Suitable any type circuit, 2/11. 3 Gang Condensers fully screened, 1/6 each.

UTILITY Micro Cursor Dials, Direct and 100.1 Ratios, 4/3.

CARDBOARD ELECTROLYTIC CONDENSERS, 8 mf. 500 v., 1/9; 4 mf. 500 v., 1/9; 3 + 3 mf. 500 v. 3/6; 4+4+4 mf. 500 v., 2/11. T.C.C. Dry Electrolytics 8+8+4 mf. 500 v., 2/4 each.

Orders 5/- and over sent Post Free. Under 5/- please add 6d. postage.

YOU MUST HAVE A PREMIER 1940 CATALOGUE
 111 PAGES PRICE 6d.
 GET YOUR COPY TO-DAY!

ALL POST ORDERS TO Jubilee Works, 167, Lower Clapton Road, London, E.5. Author 4723
 CALLERS TO: Jubilee Works, or our NEW PREMISES, 169, FLEET STREET, E.C.4. Central 2833
 or 50, High Street, Clapham, S.W.4. Macaulay 2381

RECEIVERS, COMPONENTS AND ACCESSORIES

RADIO CLEARANCE, LTD., 63, High Holborn, W.C.1.

BRITISH BELMONT 8 Valve plus Magic Eye All-Wave A.C. Superhet Chassis, 4 wave-bands, two short, medium and long, fitted latest Mullard Octal Base American type Valves.
 Size of Chassis, 13 1/2" x 10" x 3". Supplied with Valves and Knobs, but less Speaker.
 Chassis only, £5/19/6 each.
 Speaker for above, 17/6 each.

FILAMENT TRANSFORMERS, input 200-250 volts, output 4 volts 4 amps, 4 volts 6 amps . . . 4/11 each
 G.E.C. Mains Transformer, American windings, 350-0-350 volts, 65 m.a. 5 volts 2 amps, 6.3 volt 2.5 amp. Suitable for replacements in G.E.C. models. 5/6 each

24 mfd. Can type Electrolytics, 450 volts working. 1/6 each

T.C.C. 8 mfd. Can Wet Type Electrolytics, 450 v. wkg. 1/3 each

PRESS BUTTON UNITS with 6 Press Buttons, ready for wiring into set, with circuit 6/11 each

WEARITE Set of two Iron-Cored Coils, Aerial and H.F. Trans. with diagram 2/11 each

BULGIN 20 ohms Wire-wound pots 1/- each
 Stranded Push-back Wire, 1d. per yard, 12 yards 10d.

CHASSIS Mounting Valve Holders, American, 4-5-6 and 7-pin, 4d. each. Octals 6d. each. Octals 10d. each.

7-pin English type, 3d. each.

ROTHERMEL Piezo Crystal Speakers, 7 1/2in. Cone. List 55/-. Our price, 10/6 each. 10in. Cone 12/6 each.

CRYSTAL PICK-UP, high grade American. Bronze finish, complete with arm 21/- each

POLAR N.S.F. 1 watt resistances, 4d. each, 3/9 dozen. All sizes up to 2 meg.

WEARITE MAINS TRANSFORMERS, R.C.B. type. 350-0-350 v. 80 m.a., 5 volt 2 amps, 6.3 volt 5 amps. Type R.C.4. 500-0-500 v. 150 m.a. 4 volts 2 amps, 4 volts 2.5 amps, 4 volts 5.6 amps. 21/- each

PHILCO MAINS TRANSFORMERS. American Windings, 350/350 volts 65 m.a., 6 volts 3 amps. 5 volts 2 amps. 5/- each

Ditto, but 80 m.a. 6/6 each

Ditto, but 90 m.a. 7/6 each

WEARITE 110 k/e I.F. Transformers 1/- each

AMERICAN C.T.S. Volume Controls, finest made, divided spindles, length 2 1/2in. with switch, 2,000, 5,000, 10,000, 25,000, 100,000 2/6 each
 Wire-wound 5 watt (less switch), 10,000, 25,000 ohms, 2/- each

WEARITE CHOKES, Screened 1/6 each

PLESSEY DRY ELECTROLYTICS, CAN TYPE.

12 x 6 mfd. 500 volts working 1/6 each

12 x 16 " 350 volts working 1/6 each

16 x 8 " 475 volts working 1/6 each

6 x 6 " 500 volts working 1/6 each

12 " 450 volts working 1/6 each

8 x 8 x 8 mfd. 500 volts working 2/11 each

16 x 8 x 4 x 4 mfd. 500 volts working 2/11 each

12 x 8 x 8 x 8 mfd. 500 volts working 2/11 each

16 mfd. 450 volts working 1/3 each

16 x 16 mfd. 350 volts working 1/6 each

B.I. Wire-end type, Bias Electrolytics.

50 mfd. 12 volts 1/3 each

50 mfd. 50 volts 1/6 each

Tubular Wire-end non-inductive paper, all sizes up to 0.1, 5d. each, 4/9 dozen.

Metal Case 1 hole fixing Electrolytic Condensers, 550 volts working, 8 mfd. 2/6 each

STANDARD TELEPHONE HEADPHONES, resistance 2,000 ohms and 4,000 ohms 6/11 pair
 Volume Controls, 1,000 and 5,000 ohms, with switch. 1/3 each

.0005 3-gang Tuning Condenser Units, with trimmers. 2/11 each

PLESSEY Energised Speakers, 1,500 ohms field, 8in. Cone, with trans. 7/11 each
 10in. Cone, 2,500 and 1,000 ohm field, with trans. 12/6 each
 6in. Cone, 2,500 and 1,500 ohm field 5/11 each

RUBBER GROMMETS 4d. dozen

BATTERY Output Pentodes, well-known make 4/6 each

BATTERY Double Diode Triode, well-known make. 3/11 each

RAYTHEON First-grade Valves, largest stockists, all types in stock, including Glass Series, Glass Octal Series, Metal Series, Bantam Series, Single-ended Metal Series, and Resistance Tubes, all at most competitive prices; send for Valve Lists.

All Orders Must Include Sufficient Postage to Cover. Hours of Business: 9 a.m.—6 p.m. Weekdays. Saturdays 9 a.m.—1 p.m.

RADIO CLEARANCE, LTD., 63 High Holborn, London, W.C.1. TELEPHONE: HOLBORN 4631.

You'll Want Them This Week-end

ORDER FROM YOUR
NEWSAGENT TO-DAY!

This is the week when you will be buying Christmas magazines, so be sure to get these three bright bumper issues. They will be enjoyed by everyone, for each is full of good humour and the real Christmas spirit.

TIT-BITS XMAS EXTRA, 6d.

Complete stories, many entertaining articles, special contributions by Sandy Powell, Western Brothers, Puzzles, etc., and a Children's Section.

XMAS LONDON OPINION, 6d.

A Christmas tonic for everyone, in the popular pocket size. It keeps the flag of humour flying!

HUMORIST XMAS NUMBER, 6d.

Hundreds of Christmas laughs inside by the most popular humorous writers. Artists include Bert Thomas, Lees, Arthur Ferrier.

FOR THE KIDDIES - 2d. each

**CHRISTMAS HOLIDAY COMIC
MONSTER XMAS COMIC**

Packed with all the things boys and girls love to read at Christmas.

★ **A HAPPY
THOUGHT!**

Why not give an evacuated child a Christmas surprise—send stamps or P.O. 5d. to Post Sales Dept. (Children), George Newnes, Ltd., Tower House, Southampton Street, London, W.C.2, together with the child's name and address, and we will send immediately the children's comics mentioned above, with a special free Christmas card bearing your name.

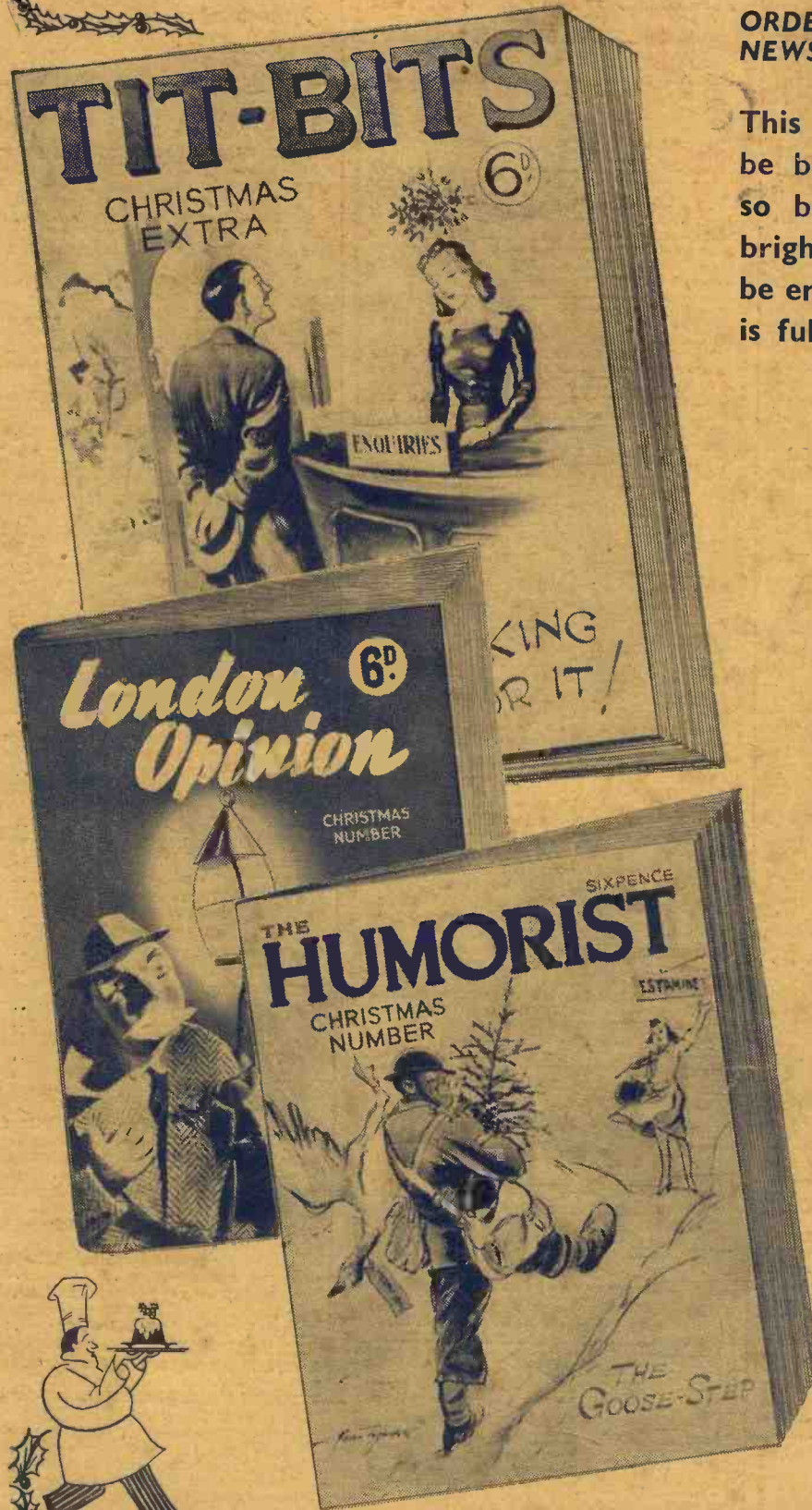

George Newnes, Ltd.

Published every Wednesday by GEORGE NEWNES, LIMITED, Tower House, Southampton Street, Strand, London, W.C.2, and Printed in England by THE NEWNES & PEARSON PRINTING CO., LTD., Exmoor Street, London, W.10. Sole Agents for Australia and New Zealand: GORDON & GOTCH, LTD. South Africa: CENTRAL NEWS AGENCY, LTD. Practical Wireless can be sent to any part of the world, post free, for 17s. 8d. per annum six months, 8s. 10d. Registered at the General Post Office as a newspaper and for the Canadian Magazine Post.

Practical Wireless

★ PRACTICAL TELEVISION ★

EVERY WEDNESDAY

Vol. XV. No. 380 Dec. 30th, 1939

EDITED BY
F. J. CARR

Staff:

W. J. DELANEY, FRANK PRESTON,
H. J. BARTON CHAPPLE, B.Sc.

ROUND THE WORLD OF WIRELESS

Home-made Test Equipment

WE have often described items of interest for the constructor who is anxious to make up test equipment for various purposes. Unfortunately, many such items have to be calibrated against some standard and this often renders such items useless owing to the fact that suitable standards may not be easily available for the calibration process. Outside of such items, however, there are many which may be calibrated by ready-made parts, and when completed they form a valuable addition to the home workshop or even the serviceman's bench. In this issue, for instance, we describe a resistance-capacity bridge, in which standard parts are fitted. The dial has, of course, to be marked off or calibrated according to the components which are used in the instrument, but when completed it forms a ready and accurate instrument for the measurement of components which may be suspected or which are being tested before use in a receiver. With instruments such as these it is worth while remembering that the normal tolerances which the manufacturer allows will have to be taken into account, or special components obtained which have a guaranteed accuracy. Usually there is an additional charge for such components, but this is considered worth while by those who are making an instrument upon which they intend to place great reliability.

Radio Sermon Hits Home

A SERMON broadcast from WLW by the Rev. E. Howard Cadle, of Indianapolis, was recently credited for the surrender and alleged confession of Floyd Waters of Newport, Kentucky, to charges of participating in a hold-up last June. He gave himself up to Indianapolis police. The hold-up occurred at Beverly Hills Country Club in Kentucky, located across the Ohio River from Cincinnati. Tearfully Waters declared that he wished to "pay my debt to society."

The message which Waters heard was broadcast from WLW on Sunday, November 12th, and prompted him to see the Rev. Mr. Cadle in Indianapolis and confess. Waters was reported to have heard the sermon in Dayton, Ohio. His wife is employed at Wright Field army airport located there.

Waters, aged 37, and a former boxer, was

one of five men wanted in the hold-up, Newport, Ky., officials said. Three others, Gus Faeth, Sam Schwachter and Warren McHugh, are in custody at Newport, while a fifth, Marvin Pickett, is still at large.

Whodunnit?

DICKSON CARR has written a detective thriller for production by John

Cheatle on December 27th, under the title of "Whodunnit?" The play is to be produced in three episodes. In the first, listeners will "see" something of the crime through the eyes of a witness, in the second instalment a suspect will be put on trial, and in the third instalment the crime will be reconstructed as it actually took place.



Constructors who have tried to solder the end of a length of fine Litz wire will appreciate the apparatus shown above at the Ekco factory. The small oven burns off the silk covering, the wire is dipped into the three containers, spirit, flux, solder, and a perfect joint is made.

C'est Magnifique!

THE sub-title, "A Collection of War-time Absurdities," is given to the programme called "C'est Magnifique," compiled by John Midgley and M. H. Allen, which is to be broadcast on December 30th. The programme is designed to show some of the more ridiculous aspects of the war, such as "siren suits," dogs' coats sewn with bells to enable them to be found more quickly, and so forth. The feature will be produced by M. H. Allen.

Rise and Shine

THE folly of trying to awaken with only one alarm clock has been made clear to Michael Hinn, WLW broadcaster, who does a morning broadcast Monday to Friday at 8.15 (EST). Because he must write his own script, the commentator rises at 4.40 every morning.

Ordinarily, Hinn, a heavy sleeper, has three alarm clocks, which he sets to ring ten minutes apart, beginning at 4.20 a.m. One Sunday one of the clocks broke, and on Monday a colleague borrowed a second. Hinn retained the one with the loudest ring and placed it at the foot of the bed so that he would have to get up to shut it off.

Tuesday morning, however, he did not come to until 6.15, after being shaken by his anxious sister, who wanted to know what was wrong with the clock. Hinn looked around, but couldn't see it. A ticking beneath his pillow disclosed its whereabouts. True to his plan, Hinn had risen at 4.40, shut off the clock—and then taken it back to bed with him!

Potted Pantomime for Children

A SPECIAL "potted" version of a pantomime is to be broadcast in the Children's Hour on December 28th. This potted pantomime for youngsters is "Mother Goose," from the Francis Laidler production, which will be enjoying a Christmas run at the Alhambra, Bradford. The cast will include Albert Modley as Jack; Marian Dawson as Mother Goose, and Margaret Morgan as Principal Boy.

Editorial and Advertisement Offices:
"Practical Wireless," George Newnes, Ltd.,
Tower House, Southampton Street, Strand,
W.C.2. Phone: Temple Bar 4363.
Telegrams: Newnes, Rand, London.
Registered at the G.P.O. as a newspaper and
for transmission by Canadian Magazine Post.

The Editor will be pleased to consider articles of a practical nature suitable for publication in PRACTICAL WIRELESS. Such articles should be written on one side of the paper only, and should contain the name and address of the sender. Whilst the Editor does not hold himself responsible for manuscripts, every effort will be made to return them if a stamped and addressed envelope is enclosed. All correspondence intended for the Editor should be addressed: The Editor, PRACTICAL WIRELESS, George Newnes, Ltd., Tower House, Southampton Street, Strand, W.C.2.

Owing to the rapid progress in the design of wireless apparatus and to our efforts to keep our readers in touch with the latest developments, we give no warranty that apparatus described in our columns is not the subject of letters patent.

Copyright in all drawings, photographs and articles published in PRACTICAL WIRELESS is specifically reserved throughout the countries signatory to the Berne Convention and the U.S.A. Reproductions or imitations of any of these are therefore expressly forbidden. PRACTICAL WIRELESS incorporates "Amateur Wireless."

Comment, Chat and Criticism

War-time Music

Our Music Critic, Maurice Reeve, Discusses the Regrettable Dearth of Good Music

WHILST conditions have slightly improved since the declaration of war—they could not possibly have gone below the zero mark reached in the first few weeks of the conflict—it cannot yet be said that the performance and broadcasting of good music is in a satisfactory condition. Bad music, yes—alas. But as I make it my job to write wholly about good music, my remarks must be confined to those parts of the wireless programmes provided by the symphony orchestras and the artists who co-operate with them. When I used to write about the Promenade Concert programmes, it was my intention to review future wireless programmes, and to help readers in their choice for those occasions that they devoted to listening-in. I'm afraid this is no longer possible, as I do not get the same amount of advance information as heretofore. Whether conditions will so improve in the near future as to permit of their resumption I cannot yet say. In the meantime a short analysis of existing circumstances, with some suggestions for improvement, may be of interest.

Slump in Good Music

I will take what I consider to be the most important aspect of the present situation first. The slump in the performance of good music is most probably furnishing the chief cause of the lamentable decline in study that is reported from all parts and all classes. It is also reflected in the remarkable decrease in the sales of music which the big publishers are forced to record. It is the most natural thing in the world for a student who was expecting, or at least working to take a place in the musical world during the next year or two, to abandon his studies "for the duration." He sees that there is little or no chance of his talents being engaged owing to the lack of demand in the concert world, and his only prospect is to be compelled to continue his studies, with their attendant expenses, at Hitler's pleasure. There is also the war's immediate aftermath to consider—a very unpredictable period. It is no wonder then, even if private circumstances don't compel him to call a halt, he should voluntarily do so, and to resume where and when conditions are more propitious. The air-raid scare has been a big factor, too, in cancellation of study, more especially with children. But I don't think the economic factor has yet entered into it—at least not to any degree. But the absence of so much good music, and the inferior quality of the performance of much that we do get—is bound to act as a serious deterrent to study, and the consequent replenishment of the market, which is as indispensable to music as it is to anything else. Music needs a shop window and advertising, just the same as any other commercial article. And this has always been provided in the form of the symphony concert, the opera, and the recital. It is very important for the future of the profession that they be restored, both as to quantity as well as quality, as soon as possible.

Lack of Broadcast Programmes

Another reason for the decline is the broadcasting of only a single programme. But this concerns only the quantity of music given us at the present time. The quality of it is really much more important, whilst the decrease in the size of the B.B.C.'s main symphony orchestra might be explained and defended from different angles not visible to the average listener; it is difficult for anyone of average intelligence to understand why the Bournemouth Borough Council should find it necessary to reduce its famous orchestra of over seventy players to a beggarly eighteen. No wonder their popular name is now missing from the *Radio Times*. It makes the performance of symphonic music absolutely impossible, and even of lighter genres very inadequate. And the story has to be repeated all round the country, though seldom to such a drastic degree. The Bournemouth people have long been a splendid body of musicians, and the privileged accompanists of a long line of renowned soloists, which makes this sad decline in their fortunes greatly to be deplored.

Erroneous Theories

Those of us who remember the last war cannot recall any such catastrophic avalanche overwhelming music. Why has it happened this time? So far as the public performance of music is concerned, with the attendant concentration of large numbers of people in buildings and their dispersion afterwards, the air-raid bogey must be held responsible. What is it not responsible for? The prophets of woe have a lot to answer for. We all know that anything may yet happen. But there is now no doubt whatever that the forecasts that "Mr. Knowall" and "Mr. Wisdom" have been making for years past were quite croneously based on the absurd theory that what happened to Spain, Abyssinia and China would happen to London on the outbreak of war—all wars being alike to them. Just in the same way

that a shower of rain will wet the roofs of London houses like it does in Madrid, Addis Ababa and Peking. What a thousand pities. The people cannot be wholly blamed, because the belief entered all classes and was tenaciously clung to by high and low alike. But its baleful influence and results can now be seen in the virtual extinction of the entertainment world, which presents a spectacle comparable to that of a dying man being kept alive by means of artificial respiration. None of these deplorable consequences need have resulted, had a rational and calm point of view been accepted side by side with the obvious precautions which both prudence and common sense alike dictated. But in saying, in effect: "Friends, Romans, countrymen; aerial warfare is possible, although unlikely for such and such reasons. Although you might be bombed whilst listening to a concert or watching a cinema, we think it extremely improbable. We only mention it as a remote possibility because it is our duty to look after you, and in the pursuit of that duty we are placing at your disposal such and such measures of a precautionary character. But go about as usual, enjoy yourselves, and keep a sharp look out." They said, in spirit and meaning: "Good people and imminent victims; war has begun, and we are working on the almost certain supposition that, to-night, you will all be blown up sky-high. Consequently, we should deem it a grave dereliction of our responsibilities if we allowed you to assemble in any place of entertainment, public houses excepted. Nor must you mind not being able to see where you are going, catching the wrong train, or being knocked down in the black-out and perhaps killed. What does it matter, we are all going to be killed anyway. YOUR cheerfulness, YOUR courage, YOUR fortitude will bring us VICTORY." The results are for everyone to see.

A Few Good Concerts

There are a few good concerts on, notably the Philharmonic under Sir Thomas Beecham. But they are at awkward hours, which doubtless prevents many from attending them who would otherwise have done so; and few of them are broadcast. The B.B.C. with its reduced forces are giving their famous series of symphony concerts in the Colston Hall, Bristol. But only half the programme is now put on the air. In listening to orchestral music over the wireless it is easy to tell where the reduction in strength has taken place—in the brass and wood-wind. I suppose these departments are almost impossible to recruit from the many lady musicians who practise nowadays. Were the diminution in the strings there would be little or no trouble. There are some good women flautists and oboists, but I have no idea how many are available for regular orchestral work. It was, of course, the last war which saw the first appearance of a woman in a symphony orchestra—the then Queen's Hall Orchestra, under Sir Henry Wood.

PRACTICAL MECHANICS HANDBOOK

By F. J. CAMM

400 pages, 6/- or 6/6 by post

from
GEORGE NEWNES, LTD.
TOWER HOUSE, SOUTHAMPTON-ST.,
STRAND, W.C.2

An All-wave H.F. Unit

A Simple Unit which Will Improve the Range and Selectivity of "Straight" Receivers By L. O. SPARKS

RECEIVERS of the detector and L.F. type are still quite extensively used, and their degree of popularity is, no doubt, due to the fact that if they are well designed, they are capable of giving very satisfactory results. Their general capabilities are, however, limited, as every user discovers sooner or later, and the purpose of this article is to show how a simple unit can be made which will give an over-all increase in efficiency and likewise eliminate the major limitations.

With an aerial feeding straight into a detector stage, it is not possible to obtain, in all areas, a degree of selectivity sufficient to ensure that the programmes received will be entirely free from interference caused by other transmissions. Similarly, the sensitivity of a detector cannot be increased beyond certain limits and, when these are reached, the addition of further stages of L.F. amplification will not compensate the inability of the detector to pull in a very weak signal.

Fortunately, both of these defects can be overcome to a very great extent by the same remedy, and that is by the introduction of a stage of tuned high-frequency amplification.

While many constructors appreciate these details already, they have refrained from adding the H.F. stage because they did not wish to rebuild or enlarge their existing receiver. These quite sound reasons have been borne in mind when constructing the unit described below, and it will be seen that there is not the slightest need to modify the receiver in any way, as the H.F. stage is made up as a separate item so that it can be placed alongside practically any receiver of the "straight" type, whether designed for short or normal broadcast wavelengths.

The Circuit

The theoretical circuit is shown in Fig. 1. This in itself calls for little explanation, but for the benefit of those not too familiar with H.F. amplification, a few words might not be amiss.

The aerial circuit utilises a coil of the plug-in type, such as those used for short-wave reception, thus allowing the tuning band which the unit will cover to range over the short, medium and long waves according to the coil used. With the specified tuning condenser, a .0005 mfd., it will be necessary to use the B.T.S. "One Shot Inductors," as these are designed to tune over all the wavebands concerned with a condenser of that value.

Although the primary winding of the coil is used as a coupling coil for the aerial, a small variable condenser is provided in series with the aerial connection to provide

an additional means of getting the highest possible degree of selectivity on all wavebands.

The valve recommended is the Cossor 210VPT, of the four-pin type, and as this has variable-mu characteristics, it enables a very fine form of pre-detector volume control to be secured by the simple procedure of varying the bias applied to the grid via the tuning coil. A potentiometer

of the H.F. valve through a small fixed condenser. The purpose of this condenser is to pass on the signal to the second tuned circuit connected to the grid of the detector, without allowing the passage of any of the high-tension which has to be applied to the anode of the H.F. valve via the H.F. choke and the resistance of 10,000 ohms. If an all-wave H.F. choke is to be used, the resistance can be omitted, as it is only included to take care of the higher frequencies of the short waves if these are to be received, and if an ordinary H.F. choke is used. The tuned-grid coupling is the method used in this unit, but in place of the second coil shown in Fig. 2, use is made of the aerial coil in the receiver to which the unit is connected, therefore the only components required for the additional H.F. stage are those shown in the wiring plan.

The output from the unit is taken from the free end of the fixed coupling condenser, as shown in Fig. 1, and fed into the receiver via the normal aerial terminal, the aerial proper being joined to the aerial terminal on the H.F. unit.

Construction

As the circuit is so simple, and as so few parts are required, there is no necessity to use chassis construction, so a five-ply baseboard 8in. x 5in. was used. All the components shown thereon can be fixed in position as soon as the board has been finished off, and the wiring commenced.

The panel 8in. x 6½in. can be cut from a piece of three-ply, oak-faced, and after the holes for the aerial series condenser, the potentiometer, the dial escutcheon plate and the tuning spindle have been drilled as indicated on the panel plan, the surface can be smoothed, stained and polished to suit individual tastes. Once the panel is screwed to the baseboard, the remainder of the wiring can be completed and the unit made ready for test.

Flexible leads must be fixed for the battery supplies to the anode and screening grid of the H.F. valve, namely, 120 volts and 60 to 70 volts, respectively. The

(Continued on next page)

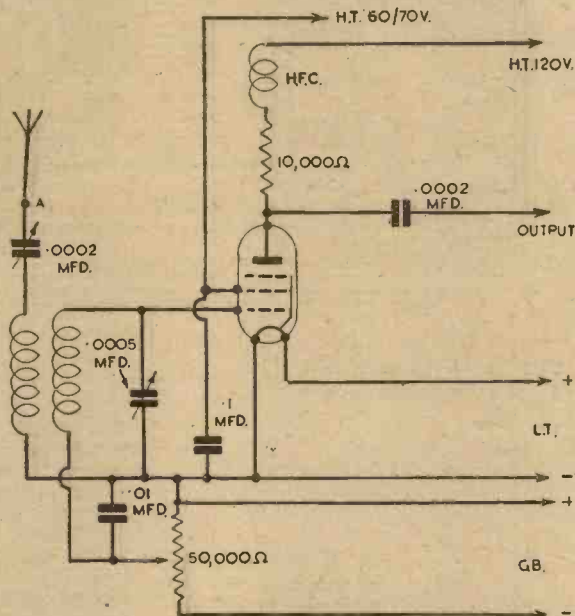

Fig. 1.—The circuit employed for this unit, showing how the variable bias is applied.

meter having a value of 50,000 ohms connected across a 9-volt grid bias battery is all that is required for this purpose.

The simplest form of coupling between an H.F. valve and its succeeding stage, which in this case is the detector in the receiver, is that which is known as the tuned grid coupling, and this is shown in Fig. 2. An examination of this diagram will show that a second coil has been introduced, and that it is coupled to the

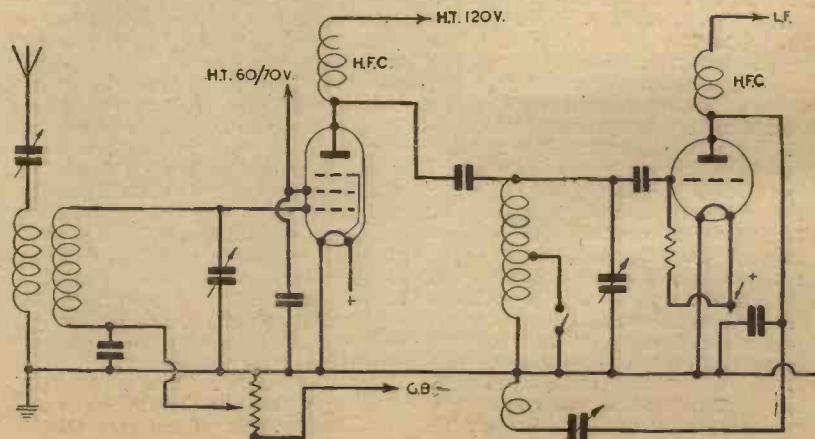

Fig. 2.—The theoretical circuit of a tuned grid H.F. coupling which is the method used in this unit.

AN ALL-WAVE H.F. UNIT.

(Continued from previous page)

filament will require two more leads, which can be connected to the accumulator supplying the receiver, while two more will also have to be fitted for the positive and negative sockets of a 9-volt G.B. battery.

Regarding the battery supplies, there is one point which must be watched, although it is hardly likely to crop up in the majority of modern receivers. It is essential that the H.T. and L.T. negatives of the batteries feeding the receiver are common with the earth connection.

Operation

With the appropriate coil in the H.F. unit, connect the output socket to the aerial terminal of the receiver, after removing the aerial from that point and connecting it to the aerial terminal on the unit. The earth connection can remain on the set in the ordinary way.

When all battery leads have been connected and the set switched on, tune the receiver to the known setting of a station and then tune the H.F. unit, setting the H.F. volume-control at maximum and the reaction at minimum. Now experiment with the last two controls until the best result is obtained. It will be noted that reaction will be more smooth, and it will not be necessary to use so much of it for a given result, compared with the original circuit.

WIRING DIAGRAM

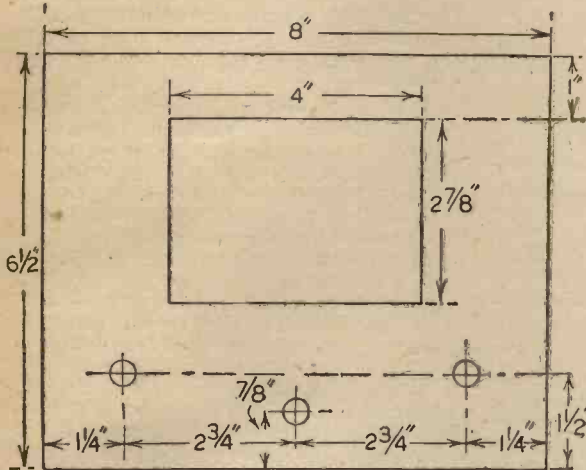
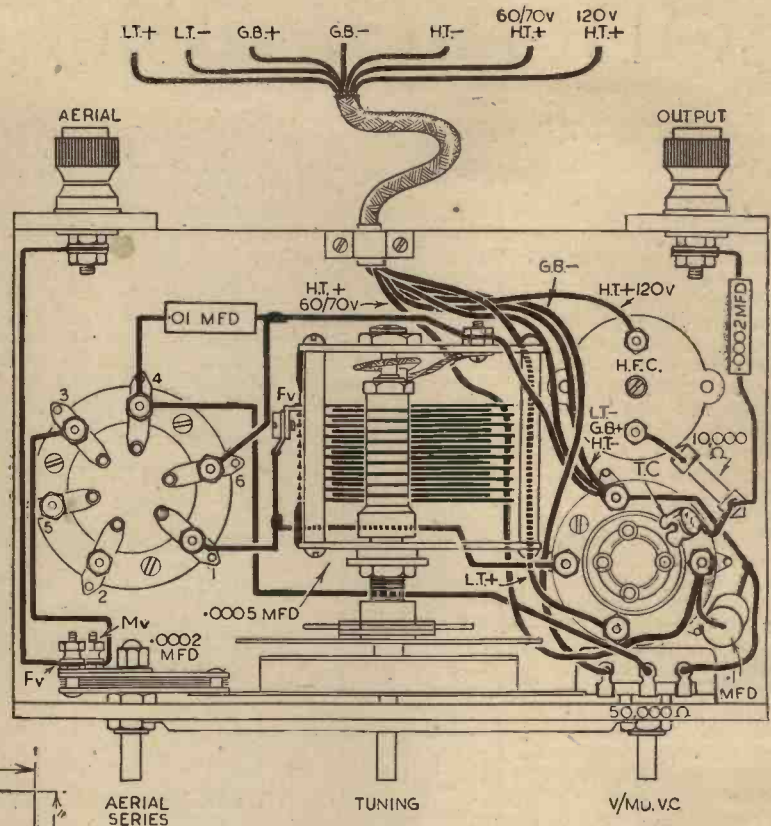

From the above diagram the layout and all wiring can be obtained, while on the left the panel dimensions are shown.

Tune-in other stations that are normally received and note the settings of the two tuning dials and any differences which will, no doubt, exist.

Once the difference has been noted, it should not be a difficult matter to rotate both tuning controls, keeping them out of step by the required amount, and tune-in other transmissions.

It would not be a difficult matter to overcome this possible snag by noting which tuning condenser gives the lowest dial reading, and connecting across it a very small variable condenser to act as a trimmer. The maximum capacity of this additional component should be in the region of, say, 30 mmfds.

Five Ways of Electron Emission

THE recent intensified development of all forms of electronic devices has brought to the fore the fact that there are five practical ways in which electrons can be produced, or released from conductors, by supplying them with sufficient energy to break through the surface of the conductor. Many readers may only be familiar with two or three of these, so in view of the present-day importance of electronic engineering in all its various aspects, it will be interesting to recapitulate the five popular methods. In the first place, the action of a thermionic valve depends on the emission of electrons from the cathode, and this is brought about by heating this electrode either directly or indirectly by the passage of a current of electricity. The cathode of the valve is made from a substance which has the property of releasing electrons through the agency of heat, and their subsequent action under the influence of other electrodes inside the

glass bulb is familiar to every reader of PRACTICAL WIRELESS. Next comes the emission of electrons from such surfaces as caesium, rubidium, potassium, etc., as a result of their being brought under the influence of light. This conversion process is the method by which every photo-electric cell is made to function, and depending on the chemical nature of the substance used for the cathode, so the cell will have a definite colour response to the light which activates it. Then we have the cold emission of electrons which occurs under certain specified conditions when the surface of a metal is subjected to the presence of a very intense electric field of force. The fourth method depends for its action upon the ionisation of gases. That is to say, an electron impacting or colliding with a molecule of gas causes it to release a further free electron which in turn will perform a similar function, so that the effect is cumulative. It is this

principle which is employed so effectively in gas-filled photo-electric cells in order to increase the output current for normal working purposes. The final, and in many respects perhaps the most important, scheme for releasing electrons is that known as secondary emission, whereby the impact on a conductor of an electron travelling at a very high velocity dislodges one or more electrons from the surface of that conductor. According to the method used for preparing the secondary emissive surface, and the nature of the substance employed (caesium appears to be the most generally used at the moment), so the number of secondary electrons released by the impact of a primary electron will vary from one to ten.

PATENTS AND TRADE MARKS
Any of our readers requiring information and advice respecting Patents, Trade Marks or Designs, should apply to Messrs. Rayner and Co., Patent Agents, of Bank Chambers, 29, Southampton Buildings, London, W.C.2, who will give free advice to readers mentioning this paper.

Loudspeaker Design

Some Interesting and Valuable Data Regarding the Design of Loudspeakers for Domestic Use

A GREAT deal of interest has been aroused by articles recently published in these pages regarding loudspeaker design. It is obvious that the problem is one which has the greatest attraction for the average listener, and in view of this, the following details, which are a reprint of part of a paper allocated for reading before the Institution of Electrical Engineers, will undoubtedly prove of value to those who are studying this section of the modern radio receiver. The paper is by W. West, B.A., and D. McMillan, B.Sc. After dealing with the various principles which are introduced into design and into the general features which are necessary in order to obtain high quality reproduction, the authors go on to say that advantage was taken of the great skill and experience which has been acquired by manufacturers, in order that a cheap and efficient product could become available, without avoidable necessity for laying down expensive additional plant. Departures from usual construction have, therefore, been made only where experiment indicated that sufficiently improved quality of performance would result therefrom, and where the modifications involved appeared to be feasible from the constructional point of view.

In this article are summarised the influences, affecting quality of performance, of the various parts which make up a moving-coil loudspeaker, as they have been confirmed or revealed by the experiments. No modifications have been made which affect appreciably the sensitivity, except that any elimination of pronounced resonances tends to reduce the sensation of loudness of transmitted sounds. The discussion is concentrated on frequency distortion, since no evidence has been found that non-linear distortions of well-designed modern loudspeakers exert any comparable adverse influence on the quality, at volume levels suitable for an ordinary living-room.

Magnet

No unexpected features of the effects of magnet design on the performance have been sought or encountered. Most of the experiments were made using a permanent magnet of about 170 cm² overall size, generating about 6,000 lines per cm² in an air-gap of 1.075 in. external and 0.98 in. internal diameter and 0.25 in. deep.

Coil and Coil-former

No substantial evidence was found that commercial methods of construction of coil and coil-former impose any limitation on the performance of the loudspeaker. Additional stiffening of the coil former was not found to make any appreciable change in the frequency characteristic.

Simple auxiliary precautions towards ensuring true axial movement of the coil in the air-gap are: (1) taking out the leads to the coil at opposite ends of a diameter, to ensure symmetry of the mechanical load due to the leads; and (2) taking out the leads at the same winding level, i.e., winding an even number of layers. This eliminates any resultant

current in the coil, in the direction of the axis, which could set up forces tending to twist the coil.

Centring Devices

Both centring devices, commonly known as the "spider" and the "surround," add to the moving system a very small mass and a stiffness which may be, but need not be, appreciable. It is common practice so to adjust the combined stiffness that the main resonance of the moving system lies at the lower extremity of the frequency range which it is desired to transmit. At lower frequencies the effi-

ciency of the air-gap up to at least $\frac{1}{2}$ in. for a diaphragm of about 7 in. diameter.

With a rather small enclosed case, limiting at about 100 c./sec. many types of external spider in current use introduce a stiffness which is not very appreciable. With a larger case, however, limiting at 40 or 50 c./sec. a spider of reduced stiffness, e.g., of thinner material, is required.

Under the influence of the forces vibrating the moving system the spider is liable to vibrate, at certain impressed frequencies, in a mode of vibration, having a natural frequency other than the impressed frequency. This gives rise to audible false tones from the loudspeaker at the particular

frequencies concerned. The effect appears to be more marked when there is tension in the spider.

Framework

This part should not affect the performance of the loudspeaker, but with some commercial constructions it has been found that the apertures in the framework are insufficient to provide complete freedom of movement of the air behind the diaphragm. In such cases it appears that the resonator formed by the air cavity between the diaphragm and the frame in conjunc-

tion with the apertures in the frame acts as an anti-resonator on the output of sound by the diaphragm. This can reduce the efficiency of the loudspeaker somewhat over a range of frequencies, say, 1,500 to 2,000 c./sec., where there is generally some difficulty in maintaining the efficiency of radiation of sound by the diaphragm.

In the design which results from these investigations the effect has been eliminated by limiting the part of the framework between the inner plate (attached to the magnet) and the outer rim to four strips, each $\frac{1}{2}$ in. wide.

Casing

For various reasons the investigations have been concentrated mainly upon loudspeakers with an enclosed case. The influence of the size of the case on the response at low frequencies was very marked. The compromise between size of loudspeaker and limitation of response at low frequencies having been decided, it remains to devise a construction of the case which is adequate for soundproofing and at the same time economical in space and cost.

Two main principles for soundproofing are generally recognised; one is the use of massive non-porous walls, preferably of a

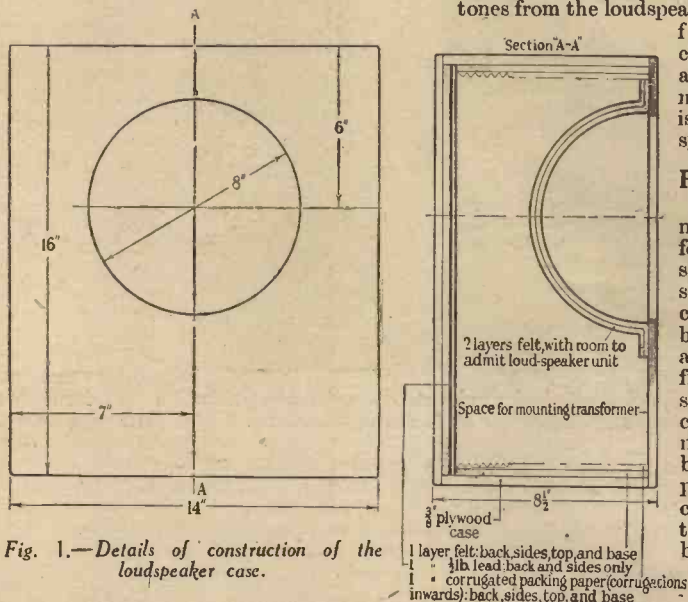

Fig. 1.—Details of construction of the loudspeaker case.

ciency of the loudspeaker must necessarily fall off rapidly, especially when an open casing is used.

For the design of a loudspeaker to be used in an enclosed casing, it is desirable that the contribution of the centring devices to the total stiffness should be negligible. The limitation of the frequency range at low frequencies is then determined by the size of the casing.

The stiffness due to the surround can be quite small with the cloth surrounds that are sometimes used. An alternative construction which introduces still less stiffness and mass, is available by replacing the usual type of surround with an air-gap between the diaphragm and the frame, bridged at a limited number of points (say three, spaced equally round the diaphragm) by straps of tape which support the diaphragm. Each strap is fixed at one end to the diaphragm and at the other end to the frame, with a distance of, say, 0.5 in. separating the fixing points. With this construction the rim of the diaphragm should be made sufficiently rigid, e.g., by forming a circumferential corrugation near the edge. The influence of the air-gap between the edge of the diaphragm and the frame is not appreciable for

(Continued on page 332)

PRACTICAL TELEVISION

December 30th, 1939.

Vol. 4.

No. 183.

Recording the Signals

QUITE naturally, all the important television developments that are taking place in this country, in so far as they apply to war purposes, are being kept secret. The only suggestions of how

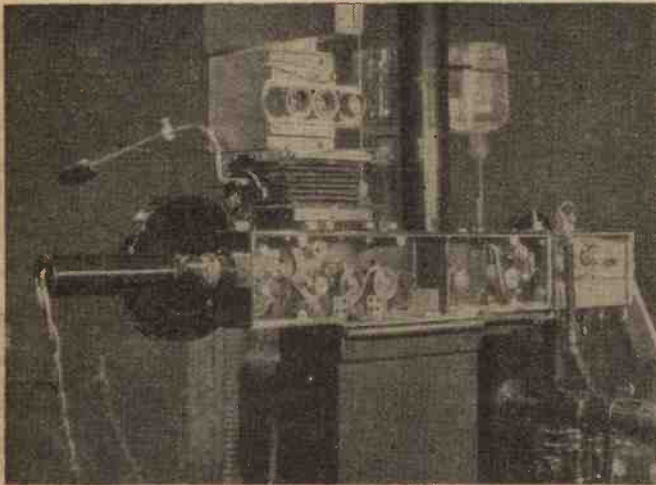

Fig. 1.—One form of I.F. camera and sound recording equipment—together with the cog-wheel drives which feed the film through the tanks.

this special science is likely to be used in schemes of attack and defence emanate from those countries who are as yet not actively involved in the present international situation. In this connection it is learned that the intermediate film method of transmission and reception is finding special applications, because it has the double function of furnishing the requisite television signal at the moment it is required, apart from the few seconds' delay between the enactment of any scene and its ultimate conversion into a modulated electromagnetic wave, and in addition provides a valuable record on the celluloid film for subsequent examination when such a need arises. The intricacies of this scheme are all centred on the photographic side, and a reference to Fig. 1 will show one form taken by the equipment for this purpose. The camera—one of the intermittent type—is seated on the bellows, and above this is the compartment housing the new film spool. Three lenses on a slide carrier are provided to enable the proper form of focusing to be undertaken irrespective of the scene to be recorded and transmitted, while the panning handle to the left enables the operator to encompass the whole field of view. After photographing the scene on the film the latter passes through a sound-recording head so that any sound may be photographed on the appropriate track provided. Cog-wheel drives then feed the film through developing, washing, fixing and final washing tanks, guides ensuring that it passes along swords dipping into the appropriate chemical fluid. The mechanism for this is

clearly seen in the rectangular container which runs from left to right under the camera bellows. The finished film negative in its dry or wet state, as the case may be, is then passed through the television camera in the ordinary way for conversion to a television signal and the film is stored for future reference purposes. This type of equipment has been improved so enormously that the whole apparatus can now be accommodated in a very small compass so that it is readily portable and may, therefore, be set up on sites or in machines in a way which a few years ago was thought impossible. It has been stated in various sources that the compactness is such that a modern aeroplane can be fitted out with a transmitter of this type, and it is in this connection that more may be heard of the intermediate-film method of transmission in due course because of the good pictures derived from a film record.

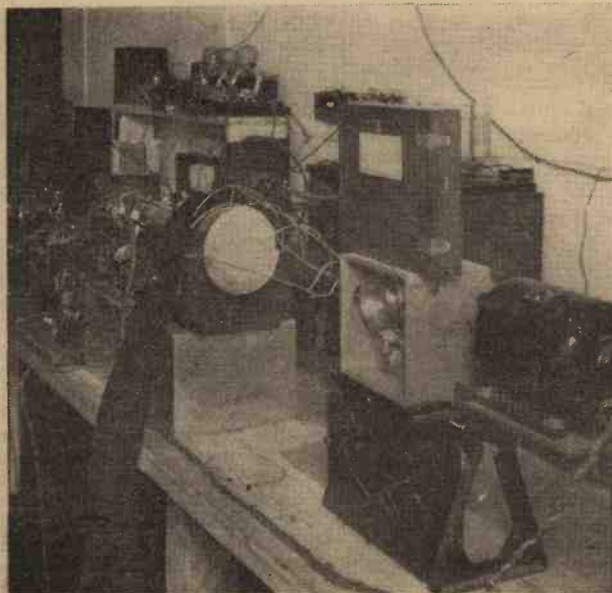

Fig. 2.—The essentials, in unit form, of a cathode-ray tube intermediate-film recording equipment.

Several Forms

IRRESPECTIVE of the source of the radiated signals, whether in the air or on the ground, the next point that arises is what will happen at the point of reception. Here, again, one is confronted with a dual aspect, and the solution will depend entirely upon the purpose for which the transmitted television signals have been provided. Assuming that some form of military or naval activity is made apparent by this television signal, it is of great advantage to be able to refer at any time to what has happened, this being additional to any observations undertaken at the instant the signals are received. Several schemes may be used for this purpose, but the most promising is one which again resorts to the intermediate-film method of working, developments on which have been undertaken both in this country and abroad. The most promising scheme uses a cathode-ray tube working in conjunction with a constant speed drive camera. The essentials of this apparatus are shown in Fig. 2, where separate units are laid out on a bench as distinct from being housed in rack form. The incoming television signals are received in the normal manner by an efficient dipole-aerial array and passed to the television receiver. The output of the set is fed to the cathode-ray tube shown mounted horizontally in a frame support in Fig. 2. In ordinary circumstances a complete picture would be traced out on the screen within the available scanning field of the tube, but with this particular arrangement such a course is unnecessary. The section of the time-base generator providing the frame scan motion is omitted, with the result that each individual line of every picture is traced consecutively over a thin strip of fluorescence running horizontally across the centre of the screen. In front of this is placed a constant speed drive camera topped by a film-spool chamber, and this film is fed over sprocket-drive drums (seen inside the camera, since one face has been removed for inspection). The line trace is focused on to the celluloid film, and since the speed with which the film moves across the back of the lens is such that it corresponds to the picture-frame speed, the picture lines are recorded one after the other and displaced from each other by

a line width. The film fed into the bottom take-up chamber is, therefore, a true record of the radiated television picture which can be subsequently developed, fixed and dried, and passed through a standard 35 mm. film projector for observation purposes at any time it is required. Here, again, the apparatus, which in Fig. 2 is shown laid out on a bench, has been improved to such a degree that it can be assembled in a very compact and neat unit so that it can be employed in quite out-of-the-way places.

TELEVISION & SHORT-WAVE HANDBOOK
Price 5/-, by post 5/6

ON YOUR WAVELENGTH



Is English Irish, Scottish or Welsh? **O**IVE ad a letter from Oireland which as you moight naw is one of ye brrrroight spots of the British Oils. It is a little bit of havven which as the song siz, fell from out the skoi, and got cracked in the process. Irishmen deny that it is a little bit of 'ell, and I agree.

The preceding paragraph is another way of letting you know that I have had a letter from an Oirishman who thinks that the best English comes from Ireland! Notice the refined English of my second sentence. Why, the Irish did not know our language till we taught it to them, and they have not learned it yet. Now it is the turn of the Scots and the Welsh. And a Happy New Year to all of you!

The New Encyclopaedia

ISEE that the seventh edition of the old "Wireless Constructors' Encyclopædia" makes its appearance under the new title of the "Practical Wireless Encyclopædia." As I have remarked before, it is a remarkable work. At 6s. it represents value unobtainable elsewhere for a guinea. Over 200,000 copies of it have been sold and it circulates in every country in the world. The seventh edition has been fully revised and contains a large amount of new matter and many new definitions. It is attractively bound in dark-blue cloth with gold lettering.

Our New Year's Set

IUNDERSTAND that the brains are at work devising the 1940 Boom Receiver. I have been unable to get into the Editor's sanctum because of the slide rules and the reams of calculation. If you have a particular hunch as to features the new set should contain, drop the Editor, not me, a line and let him know. The new design is expected to be released to the public some time in March.

Requests for Old Sets

SOME of our readers now in France want to know if readers at home have any old battery sets in working order which they would like to give to them. I have carefully filed these requests, and if you have any battery set for which you have no further use I should be glad to

By *Thermion*

act as a distributor. Please mark your envelopes "Sets for France."

Other readers are asking for copies of periodicals, and here again I shall be glad to forward any which are sent to me.

Power Grid Detection

AREADER asks me to define the advantages of this particular form of detection. The essential features are a large standing anode current with a lusty signal applied to the valve so as to produce a drop in current of about 15 per cent. Owing to this large anode current, it is necessary to use a valve with an impedance of between 10,000 and 25,000 ohms, and it is also impracticable to use the majority of L.F. transformers owing to saturation troubles. This means that either resistance-capacity coupling or a parallel fed transformer must be used, and it is quite obvious that a large current through a resistance to match an impedance of the order stated will result in a very heavy voltage drop.

Owing to the convenience of A.C. mains it is possible to use between 400 and 500-volts for H.T., and the drop through a suitable anode resistance still permits the valve to receive its maximum H.T. voltage. An alternative method is to use an iron-cored choke with a very high inductance value. Small values are chosen for the grid leak and condenser, usually about .0001 mfd. and .25 megohm. The detector circuit is standard except for these latter values.

Musical Frequencies

ANOTHER reader wishes to know the usual musical frequencies. They are as follow as relating to the piano: A .26, B 30, C 32, D 36, E 40, F 42, G 48, A 53, B 60, C 64, D 72, E 80, F 85, G 96,

A 106, B 120, C 128, D 144, E 160, F 170, G 192, A 213, B 240, C 256, D 288, E 320, F 341, G 384, A 426, B 480, C 512, D 576, E 640, F 682, G 768, A 853, B 960, C 1,024, D 1,152, E 1,280, F 1,365, G 1,536, A 1,706, B 1,920, C 2,048, D 2,304, E 2,560, F 2,730, G 3,072, A 3,413, B 3,840, C 4,096.

Jelly Electrolyte

THE battery and accumulator shortage finds its reflection in the large number of letters I am receiving relating to accumulators and batteries. Requests for the formula for the jelly electrolyte used in unspillable accumulators have reached me by the score. I give it now in the hope that it will stave off a further number.

Prepare jelly electrolyte by adding sodium silicate to the acid (never add acid to silicate) in the proportion of 1 to 3, and immediately pour the mixture into the cell until the usual acid level is reached. Take care not to overfill the cell as this is difficult to rectify once jellification has taken place. If some slight shrinking of the electrolyte occurs, thus exposing the top of the plates, it should be made good by preparing and adding a little more of the mixture.

After filling, the cell should be inverted for six to eight hours to allow any free acid to drain off. It is advisable to give the cell a freshening charge before putting it into service. Pour off any free acid. If the jelly acid hardens add three or four spoonfuls of distilled water before every recharge.

Carrying On

THANKS to the hundreds of readers who have written expressing their gratitude that the proprietors of this journal intend to carry on. This is the only wireless weekly, and in spite of increasing costs, particularly on the paper side, readers will note that we have not increased the price of the journal. All readers for their part can help us by placing an order for the regular delivery of this journal. It helps the newsagents, and it helps us, for it prevents us printing more copies than are actually required in these days of paper shortage.

Tone Control by Negative Feedback

How the Negative Feedback Feature May Be Made Use Of to Control the Tone of Reproduction

THE idea of effecting tone control in a low-frequency amplifier by means of an adjustable negative feedback for the higher audio frequencies is already well known. These arrangements, however, have the disadvantage that the feedback is not effective for the middle and lower audio frequencies, so that reduction of amplitude distortion does not take place for these frequencies, which usually contain the components of greatest amplitude which are most likely to be distorted.

Variable Grid Bias

In order to avoid an undesirably large variation of the grid bias, the resistance R may be selected much smaller than the sum of R_1 and R_k . If such ratio of dimension cannot be obtained for reasons of a sufficient control range an additional current, for instance from the screen grid potential divider of the pre-stage valve, may be sent through R_k in the case of small resistances R_1 and R_k which current increases the potential drop at this resistance so that the grid bias is less influenced by the control at R.

The sliding contact S and the right-hand end of the resistance R are connected with each other by a parallel circuit LC tuned to about 800-1,000 cycles, i.e., the medium frequency of the frequency band to be transmitted. This parallel circuit is permeable for the very low frequencies (from zero to about 200 cycles) and for very high frequencies (from about 2,000-10,000 cycles) (compared

with the resistance R) whereas it offers a comparatively high resistance for the medium frequencies (from about 200 to 2,000 cycles). When the sliding contact S is at the point b, the filter circuit is out of action, and the counter coupling is at its maximum, uniformly for all frequencies. This gives an amplification curve which corresponds with the curve marked b in Fig. 2, in which the amplification V is drawn in relation to the frequency f. When, however, the sliding

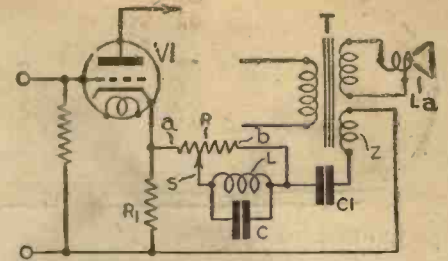

Fig. 3.—A modification of the scheme in Fig. 1.

contact is at the point a this results in an amplification curve such as shown by a. In this curve the amplification for the very high and very low frequencies has only increased very little, because as before, almost the entire output A.C. potential is present at the ohmic resistance connected in the cathode lead. The medium frequencies, however, are subject to a considerable potential drop at the parallel connection R,C,L, so that the counter coupling becomes considerably less, and the amplification therefore considerably higher. The amplification is almost of such value as would be obtained if no counter coupling was present, and which is marked in Fig. 2 by a dotted line.

The circuit shown in Fig. 1, which supplies the control-curve according to Fig. 2, is particularly suitable for such receiving sets in which no completely effective automatic fading control is provided, and in which the tone-control has to be used at the same time as amplification control by hand to compensate different intensities of reception of different transmitters. In this arrangement the local transmitter is reproduced with comparatively small amplification, less distortion factor, and even amplification for all frequencies, whereas a remote transmitter is reproduced with more amplification

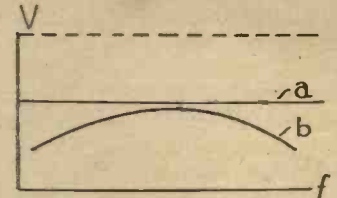

Fig. 4.—Results obtained by the circuit of Fig. 3.

whereby the high- and low-tone frequencies are more neglected. The neglect of the high-tone frequencies means a reduction of atmospheric interference. For the important range of medium-tone frequencies, however, the maximum possible amplification of the amplifier is used, ignoring, however, a far-reaching reduction of non-linear distortions.

A Modification

A modified embodiment of the system is shown in Fig. 3. The A.C. potential used for counter-coupling is taken in this case from a separate winding Z of the output transformer T, and is connected to the series connection of the blocking condenser C_1 of the potential divider resistance R and of the resistance R_1 . The cathode of the valve V_1 is firmly connected with the connection point of the resistances R_1 and R, whereas the parallel

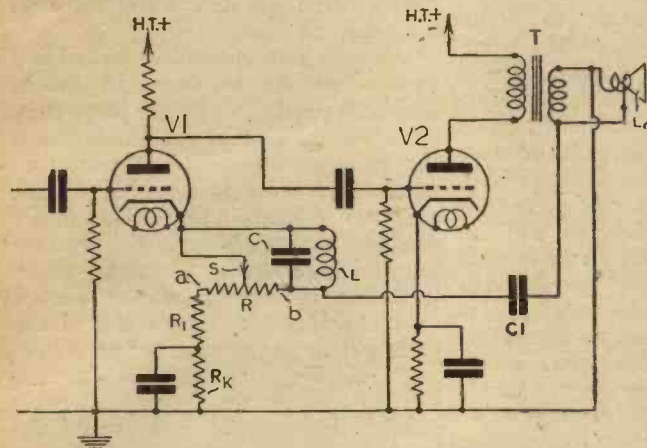

Fig. 1.—A two-stage amplifier with negative feedback.

This disadvantage can be overcome in a manner which will now be described.

Fig. 1 shows the circuit diagram of a two-stage resistance-coupled low-frequency amplifier of a receiver. The oscillations to be amplified are supplied to the control grid of the valve V_1 , and are led after amplification from the output of the output amplifier valve V_2 through the output transformer T to the loudspeaker La . The potential at the loudspeaker is connected at the same time to the series connection of a blocking condenser C_1 and three ohmic resistances R, R_1 and R_k . The resistance R is designed as an adjustable potential divider the sliding contact S of which is connected to the cathode of the valve V_1 . As the lower end of the resistance R_k is connected with the earthed return lead, the part of the resistance R between the left-hand and a, and the sliding contact S, and also the resistances R_1 and R_k are in the cathode lead of the valve V_1 . Therefore, a counter coupling of the output A.C. potential to the cathode of the input valve is caused, as only the resistance R_k which is mainly dimensioned for the supply of the medium grid bias of the valve V_1 is bridged by capacity.

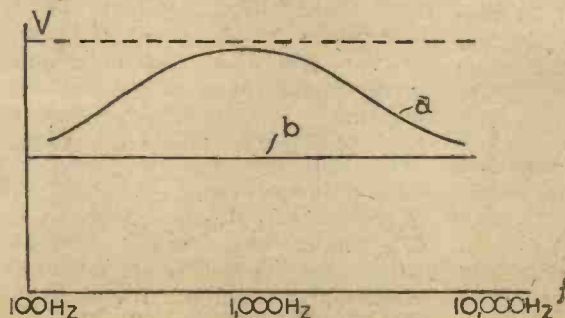

Fig. 2.—Curve showing effects of adjustment of resistance R in Fig. 1.

(Continued on page 332)

Practical Hints

A Soldering Dodge

IN a recent paragraph in "Notes from the Test Bench," mention was made of the difficulty of getting a large blob of solder on the iron. I overcame the difficulty by taking the spout of an old oil-can, and

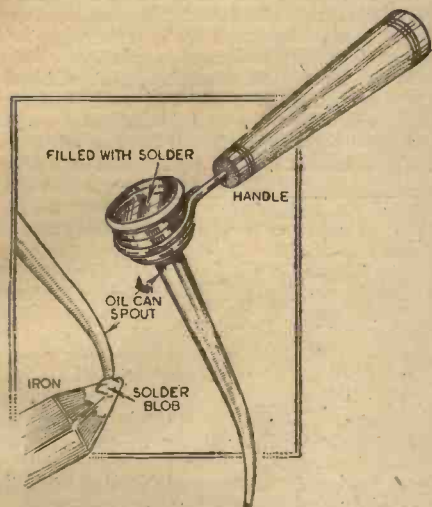

A useful soldering accessory contrived from an old oil-can spout.

fitting a handle on it, as shown in the sketch. By placing the heated iron against the tip of the spout, which had been previously filled with solder, a large blob of solder falls on the place required.—D. B. MACK (Airdrie).

Heat-treatment for Components

ON constructing several receivers, I have found that they would not function properly owing to the fact that there was no reaction. This I found to be caused by the damp atmosphere affecting the coils, so I devised the following simple

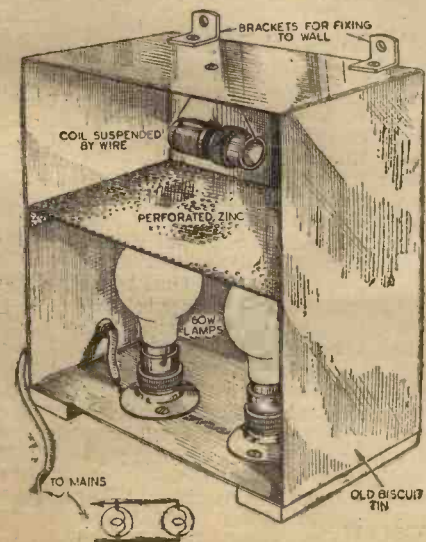

A novel device for the heat treatment of damp components.

THAT DODGE OF YOURS!

Every Reader of "PRACTICAL WIRELESS" must have originated some little dodge which would interest other readers. Why not pass it on to us? We pay £1-10-0 for the best hint submitted, and for every other item published on this page we will pay half-a-guinea. Turn that idea of yours to account by sending it in to us addressed to the Editor, "PRACTICAL WIRELESS," George Newnes, Ltd., Tower House, Southampton Street, Strand, W.C.2. Put your name and address on every item. Please note that every notion sent in must be original. Mark envelopes "Practical Hints." DO NOT enclose Queries with your hints.

SPECIAL NOTICE

All hints must be accompanied by the coupon cut from page iii of cover.

method of treating the coils. First, I obtained a large biscuit tin, soldered in a shelf of zinc, and mounted a pair of lamps as shown in the sketch. The lamps used were 60-watt type. When current is applied the lamps become hot, thus heating the coils till all the dampness is extracted, this taking about one hour. The coils should then be shellacked.—W. FLOWER (Lincoln).

An Insulation Stripping Tool

MANY constructors find difficulty in removing the rubber insulation from single or multi-strand wire. The usual method adopted is to cut and scrape off the covering with a pen-knife, but this often leads to trouble, due to the wire being partly cut through.

A pair of tinman's shears, costing six-pence, will, when converted as shown, enable the constructor to strip the insulation without harming the copper strands.

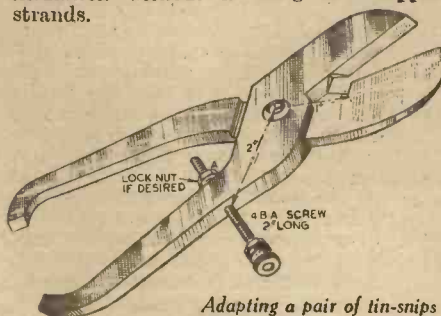

Adapting a pair of tinman's shears for insulation stripping.

On each blade, about one inch from the rivet, file a notch, using a three-cornered file. These two notches should be of such a depth so that, when the cutters are closed, the apex of each notch just covers the other. Both must be carefully bevelled to leave sharp cutting edges. In the side of one handle, about two inches from the rivet, drill a hole and tap 4BA. A two-inch length of 4BA screwed rod, which can have a terminal head locked on one end, is screwed into the hole.

To use the cutters, adjust the screw so that

the notches in the blades are open sufficient to clear the diameter of the wire. Place the insulation in the notches and close the cutters. Hold the wire firmly with the left hand, and give the cutters a quarter of a turn round to make certain that the insulation has been cut through. Pulling the cutters sideways will bring the insulation off and leave the wire unharmed.

Finally, if much wiring is to be done with the same gauge wire, a lock-nut can be run on the screw at A to prevent movement.—ALEC DAVIE (Edmonton, N.).

A Trimming Hint

IN most intermediate-frequency transformers one of the trimmers is connected to the H.T. positive line, whilst the metal screen surrounding the transformer is earthed to prevent interference. Thus, when carrying out the adjustment of the trimmer, should a metal screwdriver come into contact with both screen and trimming screw the H.T. supply is short-circuited. An insulated tool may be employed, but a simple solution is to remove the insulated sleeve from a wander plug or spade end, and drop this in the hole in the transformer screen. It will be found to make an almost

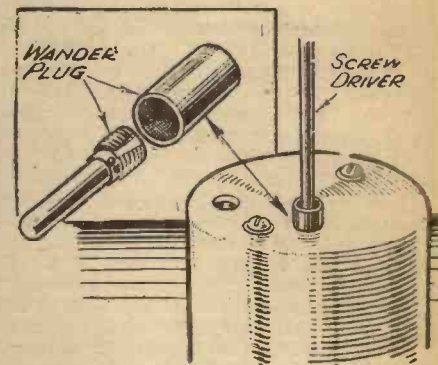

A useful dodge when trimming I.F. transformers.

perfect fit, and a small screwdriver may then be inserted in the insulated bush thus formed for trimming purposes with perfect safety. To avoid unwanted stray capacities the screwdriver should be as thin as possible. The illustration makes the idea perfectly clear, and as the trimming is only to be carried out when the receiver is first installed the bush may be removed from one of the leads to the receiver and afterwards replaced, thus avoiding expense and the necessity for purchasing a component especially for the single use.—D. W. J (Hendon).

WORKSHOP CALCULATIONS, TABLES AND FORMULÆ

By F. J. CAMM

3/6, by post 3/10, from George Newnes, Ltd., Tower House, Southampton St., London, W.C.2.

AN instrument which will measure capacity and resistance values accurately, and with little trouble, is essential to the keen experimenter, and the bridge meter fulfils these conditions exactly.

The bridge meter is a modification of the well-known Wheatstone resistance network for determining the value of an unknown resistance when compared with certain known values of resistance, and as no current is passed through the indicator or indicating device at the point of correct value, this method is very accurate in use. The Wheatstone network is illustrated in Fig. 1 and r_1 and r_2 is the variable resistance, and X the unknown. R is the known resistance, which must be very accurate in value.

The bridge about to be described is based on this circuit, and is adapted to read capacity values as well as resistance values, as above mentioned. It is quite easy to construct and is not expensive.

Description and Circuit

The principle has already been described, and this bridge measures capacity values between .0001 mfd. and 10 mfd. The resistance range covers from 1 ohm to 10 megohms. Either a low-frequency oscillator (similar to that given recently in this journal) or a signal from the mains (obtained from the secondary of a bell transformer) is necessary to give the signal for operating the instrument. The beat-frequency oscillator is the better instrument to use as, due to the higher frequencies which are available for measuring small capacities, a better indication is given. A small-capacity condenser has a high reactance, and therefore a higher frequency will be more easily passed. The mains frequency of 50 cycles would mean that on small-capacity condensers only a very weak indicating current would flow.

Headphones are used in conjunction with the L.F. source to indicate the "null point" of the pointer on the scale. A 10,000 ohm linear wire-wound potentiometer is employed with a series of condensers and resistances of fixed values, and these are selected according to the range desired by a double-pole double-throw and a rotary switch, the former being to change from capacity to resistance or vice versa.

There is an attenuator at the input to control the strength of the input signal, and there is also provision for testing electrolytic

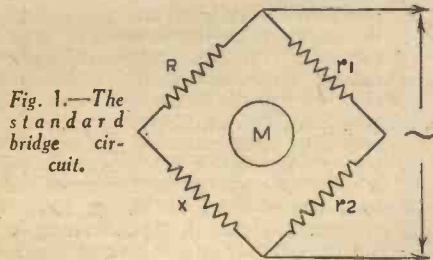

Fig. 1.—The standard bridge circuit.

type condensers. By using a neon tester with this instrument the complete state of a condenser can be found, and by the addition of an amplifier and a cathode-ray "electric eye," as used for tuning receivers, a visual indication is also possible.

The Panel

The panel may be of ebonite, wood, or aluminium, and the writer recommends the latter as it can be earthed and gives the

A Capacity-resist

In This Article Details of Useful Unit for

instrument stability. The size is not critical, but if a scale is being used, and to allow for the addition of the "electric eye," it would be necessary to make it about 14ins. long by 9ins. high. The sockets are of the bushed type, which must be insulated from the metal if a metal panel is being used, and the spindles of the variable resistances and switches must not be attached to the moving contacts, or they would short-circuit. The components are fitted to the panel as shown, and there is room later to drill a hole to take the electric eye; this is shown in the Fig. 2 by the dotted lines. A baseboard will also be required if

is to give the constructor an exact picture of the circuit, but on the panel this will be reversed when seen from the back and will be as shown in Fig. 3. The condensers are wired in order of capacity value from contact 1 to contact 5, and will therefore be .0001 to contact 1, .001 to contact 2, .01 to contact 3, .1 to contact 4 and 1 mfd. to contact 5 (all the readings being anti-clockwise). The 1 mfd. condenser is mounted on the panel as it is of the non-tubular type.

The free ends of the resistances are likewise connected to the bottom section of the switch, and these are joined up so that when the switch arm is on the contact of the .0001 mfd. condenser, the bottom switch arm is on the contact of the 10 ohm resistance.

The battery B1 is an ordinary 4-volt dry cell, and is connected so that its positive side is attached to the positive terminal socket for the testing

of electrolytic condensers. This battery is left in the containing case or cabinet. The rest of the wiring is very simple, and can be done from the circuit diagram. It is only necessary to point out that one side of the input sockets, each volume control, and the two sides of the "unknown sockets" are all connected together, and also to the panel, if this is metal, and these can be earthed in this way.

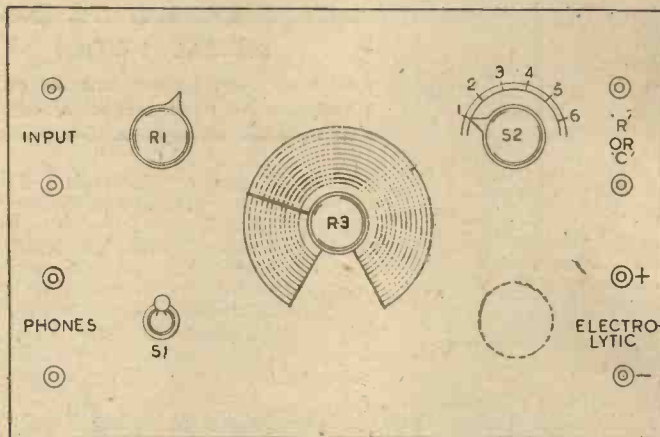

Fig. 2.—Panel layout of the complete meter.

the electric eye unit is being made up, and this can be of wood and can be 14ins. long by 6ins. deep. The front view is given in Fig. 2 and the back in Fig. 3.

Mounting Resistances and Condensers

A piece of cardboard 4ins. long by 3ins. wide is used for mounting the resistances, and a similar piece for the condensers, and these components are fixed to the cardboard by boring two small holes at the ends of the cardboard to take the wire ends of the components; this is shown clearly in Fig. 4. The two panels are then fixed side by side on a block of wood 4ins. long by 1in. square, and this, in turn, is screwed to the panel by screws passing in at the panel front. The wire ends of both the row of resistances and condensers must not come too close to the panel. One side of all the resistances is connected together, and the same with the condensers.

Wiring Up

The wiring is done with insulated wire or sleeve-covered wire, and soldered joints will be necessary. It is essential that all joints are really well made or trouble will be experienced. The making of good soldered joints is not a very hard job, and therefore no trouble should be experienced in this connection.

From the diagram, Fig. 2, it will be seen that the rotary switch is viewed from the front and numbered accordingly, and this

The Dial Scale

To make the dial, take a piece of stiff paper or thin white cardboard and with a compass draw a circle of radius 3 or 4ins., and between the outside of the potentiometer knob and this circle draw in 10 other circles, this will give a total of 11 circles. Each of these circles can then be divided up into resistance or condenser values, six of the circles for resistances and five for condensers, this is shown in Fig. 2. In this way not only can the value be determined from a graph, but plenty of direct values may be taken by the pointer position.

Two lines are then marked at the bottom parts of the circles where the pointer



Resistance-bridge Meter

Construction are Given of a the Experimenter

swing will end, and the potentiometer may need to be turned round to get this effect; the scale is slipped over the spindle during this operation and the knob marked if not already done. The scale is then removed from the potentiometer, and is cut out around the *outside* of the outer circle in order to give room to mark in the values later. The lines at the bottom are then erased, and this gives a number of three-quarter circles with two ending lines to indicate the termination of the pointer swing.

A piece of celluloid is next cut to fit over the scale, and this, together with the scale, is held in place over the potentiometer bushing with the screw nut which holds this in place. The celluloid is not, of course, placed in position until the instrument is calibrated.

The pointer is constructed from a piece of stiff wire, and can be soldered to the potentiometer spindle or soldered to a small strip of tin which can then be clipped to the spindle.

The Cabinet

The cabinet is best constructed of wood, and it is made so that the panel, and base-board if required, can fit in flush with the inside. Small battens are fitted to allow the panel to be secured, and it is recommended that the inside be lined with tin-foil, which can be electrically connected to the panel with a short length of wire.

Calibrating

After the wiring has been completed and the panel placed in the cabinet, including the small battery, the calibrating of the instrument can be undertaken. Two methods are recommended; the graphical, for the subsequent reading of small intermediate values of resistance or capacity,

and the direct readings marked on the dial for quick readings of standard values.

Connect up the external L.F. source (a beat-frequency generator will be assumed to be in use) and plug in the 'phones to the proper sockets. Commencing on the resistances, first put the selector switch at the resistance position (this can be determined before assembly) and the range switch at position 1; then, taking a number of known values of resistances from 1 ohm to 100 ohms connect these in turn in the sockets

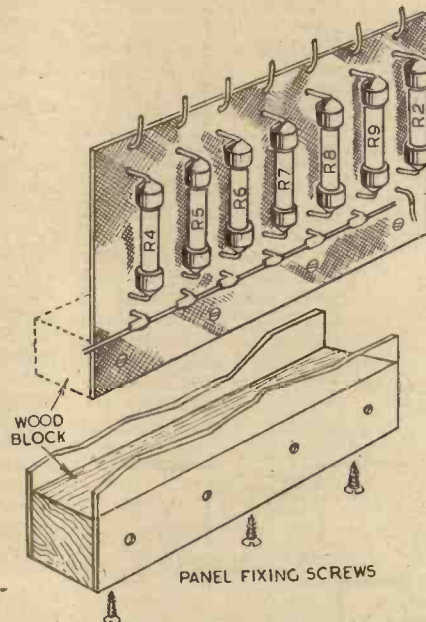

Fig. 4.—How the resistance strip is mounted.

for the "unknown element," and by rotating the pointer take readings for the point where minimum signal is heard in the 'phones. If the signal is too loud, then it can be reduced slightly by the input volume control, and this enables a sharp minimum to be found. These readings can then be marked on the first circle of the dial, and a graph can be also constructed by dividing up the rest of the circle between the known marks into equal divisions, e.g., if we have a number of positions for resistances of values 10, 20, 50, 80, 100 ohms, then these positions are marked on the dial, and from them the intermediate divisions can be marked, and a curve can then be plotted on squared paper.

When the first scale and curve are made, the switch is put at position 2, and commencing with a number of values between 100 and 1,000 ohms a second scale and curve are drawn, and the same procedure is employed with the remainder of the resistances and condensers until all the scales and curves have been constructed. Then the ranges will be for the range switch at positions as shown, and with the selector switch at resistance and capacity in turn:

Selector switch at resistance. Range switch 1. 1-100 ohms.

- Selector switch at resistance. Range switch 2. 10-1,000 ohms.
- Selector switch at resistance. Range switch 3. 100-10,000 ohms.
- Selector switch at resistance. Range switch 4. 1,000-100,000 ohms.
- Selector switch at resistance. Range switch 5. 10,000-1,000,000 ohms.
- Selector switch at resistance. Range switch 6. 1 m. ohm-10 meg.
- Selector switch at capacity. Range switch 1. .00001-.001 mfd.
- Selector switch at capacity. Range switch 2. .0001-.01 mfd.
- Selector switch at capacity. Range switch 3. .001-.1 mfd.
- Selector switch at capacity. Range switch 4. .01-1 mfd.
- Selector switch at capacity. Range switch 5. .01-10 mfd.

From the above tabulated list it will be seen that the ranges slightly overlap, and this is found convenient in use, as one is sometimes saved the trouble of switching over from one range to another when the two values, or more, are in the same range. Actually, it will be found that the instrument reads lower values than the minimum values given above, and these can be marked in, but the above values are taken from the nearest correct calculated value and will be found to be correct in use. A small scale similar to that for the pointer can be used with the range switch to indicate the range covered in different positions.

Once calibrated, the values of other unknown resistances or condensers are easily and quickly found.

Operation

To use the instrument connect as already instructed and, taking the unknown resistance or condenser, put the selector switch

LIST OF COMPONENTS

- R1 1 megohm var. resistance. Volume control.
- R2 100,000 ohm fixed resistance.
- R3 10,000 var. square law wire wound var. resistance. Potentiometer Bulgin VC1045.
- R4 10 ohm fixed.
- R5 100 ohm fixed.
- R6 1,000 ohm fixed.
- R7 10,000 ohm fixed.
- R8 100,000 ohm fixed.
- C1 1 mfd. fixed.
- C2 .1 mfd fixed.
- C3 .01 mfd. fixed.
- C4 .001 mfd. fixed.
- C5 .0001 mfd. fixed.
- R9 1 meg. ohm. fixed.
- S1 D.P.D.T. switch. Bulgin.
- S2 D.P. 6-way. Bulgin S1202 switch.
- 8 insulated bushed sockets.
- 1 4-volt dry battery.
- Aluminium sheet panel 14in. x 9in.
- Pieces of cardboard and wood.
- Wooden case 14in. x 9in. x 7in. inside dimensions.
- Connecting wire, screws, nuts, and bolts and washers.
- Sheet of transparent celluloid.

in the appropriate position. Put the range switch at the highest reading if the operator has no idea of the value required, and swing the pointer knob slowly over the scale. If there is no reduction in the strength of the signal, then the range switch must be put at the next lowest position, and the operation repeated until a range is found at which the signal weakens and fades almost out. Reference to the scale or graph will then give the required value. Should no signal be heard on any range at all, then the component must have an open circuit, and if the signal cannot be reduced to minimum, then the value must

(Concluded on page 332)

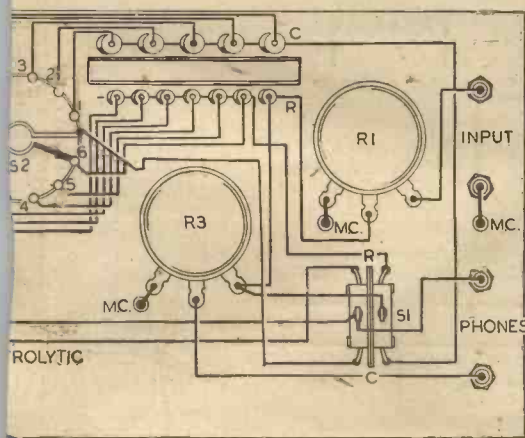

Fig. 3.—Wiring diagram of the meter.

Reaction Distortion

This Article Explains How Auto-tone Balance Can Be Provided

MOST experimenters know that when the sound emanating from a loudspeaker differs from that performed in the studio, "distortion" has been introduced. Distortion can occur in almost every stage of a receiver, but in most cases it is a simple matter to guard against it by using components of good design and high quality and by keeping a careful watch on operating conditions in order to ensure that valves and other apparatus are not overloaded, and that correct grid bias and anode voltages are applied.

crease the volume of sound from the loudspeaker, but it adds also to the apparent selectivity of the set, that is to say, the receiver can be more sharply tuned when a fair amount of reaction is applied than when the reaction control is turned back to zero. But undue sharpening of the tuning has the effect of cutting off some of those all-important side-bands which represent

the higher tones of the musical scale. The reproduction, therefore, tends to become gruff and "drummy"; the brilliance of the treble notes and the tone colour due to the higher harmonies are reduced, and the programme quality becomes decidedly unpleasant.

note losses due to the use of reaction.

The method is, briefly, this: Since the losses in high notes become greater as reaction is increased, can we not find a piece of apparatus or a circuit arrangement in which the high tones are automatically strengthened as reaction is increased? The practical solution to the problem is a development of a method of balancing out losses, well known and practised frequently in the past with varying degrees of success. In the original scheme known deficiencies in one part of a circuit were compensated by known increases in another part of the circuit, and by carefully choosing components with suitable characteristics various elements of distortion and loss were cancelled out.

"Hit or Miss" Principles

Such principles are usually of the "hit or miss" type, and as examples mention may be made of the use of a pentode-output valve in conjunction with a moving-coil loudspeaker known to be rather "boomy." Again, needle scratch in a pick-up circuit, which means, in effect, the addition of extra and unwanted high notes, can be reduced by using a filter to divert all or a part of the notes above a certain frequency from the amplifying stages. Usually, too, no attempt was made to ensure that these compensating devices should be self-adjusting. Based entirely upon the electrical characteristics of various pieces of apparatus, the arrangement was so planned that tolerably good quality resulted under normal conditions; but it was seldom constant for all conditions. Moreover, as it depends largely upon making up for poor design (but having the opposite effect), in a second component, the results could never be more than a compromise, and seldom achieved its purpose perfectly.

In a modern automatic tone-balance circuit, however, matters are better arranged. The rising losses due to the attenuation of the higher musical frequencies when reaction is increased

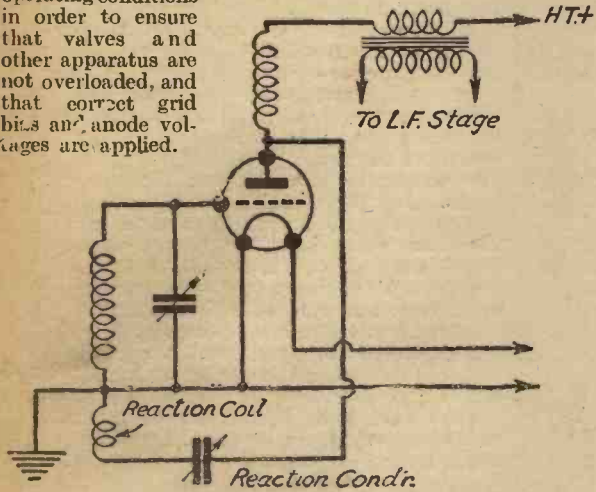

Fig. 1.—The conventional form of capacity reaction control.

There are, however, certain conditions under which a definite amount of distortion is inevitable. It cannot be prevented from occurring, and until recently distortion of this kind has had to be endured with what patience the listener could command.

The Use of Reaction

Distortion of the kind referred to is that due to the effects of reaction. Practically every receiver of reasonable efficiency is capable of reproducing at good volume the programme radiated by the local station without recourse to reaction, and a modern set employing a screened grid high-frequency stage should be able to give a fairly wide choice of programme without the reaction knob requiring attention. If

the more elusive foreigners are to be picked up at comfortable strength, however, the additional fillip to sensitivity given by wisely applied reaction is of great assistance.

As most listeners know, reaction is a process in which part of the energy in the anode circuit or "output" circuit of the detector valve is returned to the grid circuit and is re-amplified. The amount of energy so fed back is controlled in a modern set by a variable condenser, which passes more or less energy, according to the adjustment of the vanes, back to a reaction coil which is coupled to the grid coil, the normal scheme of connections being indicated simply in Fig. 1.

Now not only does reaction greatly in-

Distortion With Distant Reception

How serious this distortion can be is realised by anyone who has ever tried to pick up a very weak and distant signal by pushing reaction to the critical point. The hoarse, croaking voices and the travesty of music issuing from the loudspeaker are scarcely distinguishable as

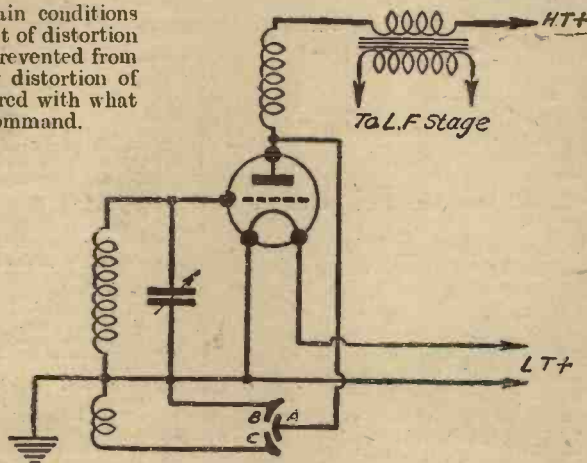

Fig. 2.—Circuit diagram showing the slightly different connections when using a differential reaction condenser.

a programme. Even when a considerably less amount of reaction is used the "top" notes lose much of their quality, and this is quite understandable when it is stated that deterioration may well affect all notes above upper "C" on the piano, and even some notes between the middle and upper "C."

As already stated, until recently no satisfactory method of counteracting this form of distortion has been available. It is now possible, however, to compensate almost completely for high-

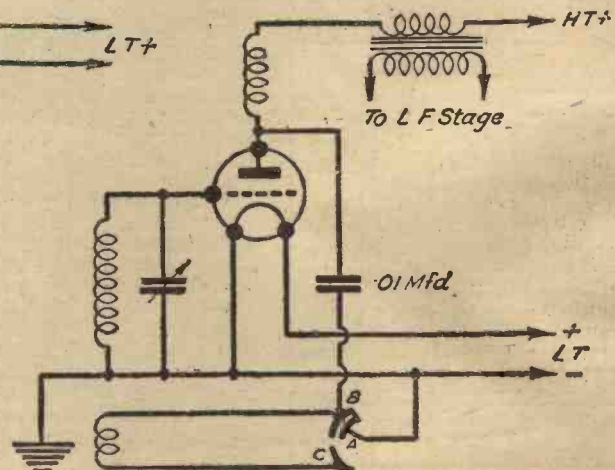

Fig. 3.—Simple connections for an automatic tone balance circuit.

are balanced by an increase in the upper frequency response of a specially-designed low-frequency transformer, which couples the detector valve to the next stage.

(Continued on opposite page)

REACTION DISTORTION

(Continued from previous page)

Transformers With Rising Characteristics

Theoretically, a perfect low-frequency transformer should give a perfectly even response to all musical frequencies. There are, however, certain losses due to the electrical characteristics of a transformer which may, or may not, be compensated for in the design of the component. Most good low-frequency transformers have a frequency response which is substantially level, although most show slight irregularities at some part or parts of the musical scale. A transformer selected for use in an automatic tone balance circuit must have a characteristic in which the voltage amplification, or response at the higher audio frequencies is somewhat greater than at the lower frequencies—what engineers term a "rising" characteristic.

It will be clear that, if due to reaction, the detector stage creates losses in the higher register while the intervalve transformer produces an increased upper register response, there will be one setting of the reaction control at which the high note losses will be balanced exactly by the high note gain. At all other settings of the reaction condenser, however, a perfect balance will not occur—smaller settings will result in a net gain of high-frequency response, with consequent shrillness of reproduction, while greater reaction settings will produce a net loss of high notes, and the reproduction will be gruff.

Automatic compensation, however, can be arranged without a great deal of difficulty. It is achieved by shunting a condenser arrangement across the primary winding of the low-frequency transformer, and so designing the circuit that the value of this capacity shunt is varied simultaneously with the adjustment of the reaction setting. The effect of a fairly large capacity shunted across the transformer would be to reduce the high-note response, while if the capacity were decreased the high-note response would be correspondingly increased. A varying capacity shunt is provided by the use of a differential reaction condenser of somewhat special design, and connected in a manner which differs slightly from the normal.

Reaction Control

The conventional way of connecting a differential condenser for the control of reaction is shown in Fig. 2. The moving vanes are joined to the detector anode, one set of fixed vanes to the reaction coil, and the other fixed vanes to earth. When the moving vanes A are fully meshed with the earthed vanes B, little or no energy can be transferred to the reaction coil. As the position of the moving vanes is altered by turning the knob, their coupling with the earthed vanes B is reduced and the coupling with the reaction vanes C is increased. More energy will therefore pass to the reaction coil but both B and C being at earth potential, the total capacity between the anode and earth will be constant, so that tuning will not be affected by adjustment of reaction.

The automatic tone balance arrangement is shown in Fig. 3. Here the anode is connected to one of the fixed vanes and to one end of the reaction coil, the other end of the

reaction coil is joined to the second set of fixed vanes, and the moving vanes are connected to earth. Further, a fixed condenser of fairly high capacity, say, .01 mfd., is interposed between the anode and the differential condenser, while the reaction condenser is so constructed that, when the moving vanes are fully meshed with the "anode" vanes (i.e., when zero reaction is applied), there is a direct connection between the moving vanes and the "anode" vanes—in other words, one-half of the reaction condenser is shorted to earth.

Examining the circuit when adjusted to zero reaction, as indicated in Fig. 4, it will be admitted that, in effect, the .01 mfd. condenser is connected across the transformer primary. Actually, the shunt consists of the .01 mfd. condenser, the high-frequency choke and the high tension

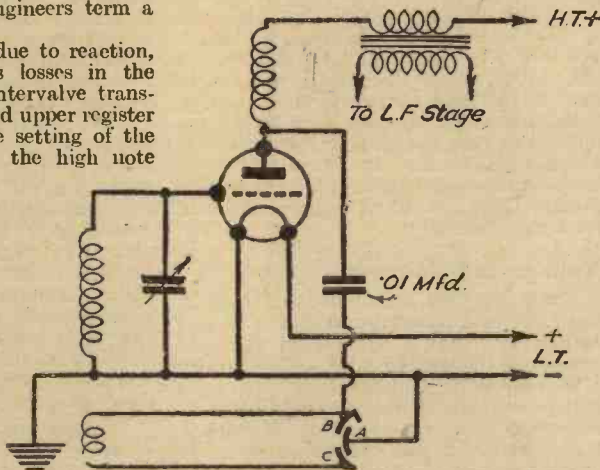

Fig. 4.—When reaction is set at zero, a fairly large capacity is shunted across the L.F. transformer primary winding.

battery in series, but from the audio-frequency and capacity point of view we may neglect the high-frequency choke and the battery.

Now if the reaction control is moved over so that a certain amount of reaction is applied, as in Fig. 3, a certain amount of capacity, i.e., that due to the "anode" and moving vanes of the reaction condenser, is placed in series with the .01 condenser. As most listeners are aware, two condensers in series have together a smaller capacity than either one of the single condensers, so that, as the reaction is increased, and the capacity between "B" and "A" decreases, so the capacity shunted across the transformer is decreased, and the more nearly the frequency response of the transformer approaches its true characteristic. As this characteristic is a rising one, the high-note response will increase in proportion as reaction is increased, thus giving automatic control.

The perfection of this control depends upon two things; first, the actual frequency characteristic of the transformer, and then the correct choice of capacities and condenser characteristics to give the correct balance. It is for this reason that specially designed automatic tone control transformers must be used, and the other essentials of the circuit must follow religiously the types and sizes specified.

NEWNES TELEVISION AND SHORT-WAVE HANDBOOK

5/-, or 5/6 by post from
GEORGE NEWNES, LTD., Tower House,
Southampton Street, Strand, London, W.C.2.

ELECTRADIX

SIGNAL EQUIPMENT FOR ARMY & NAVY WORK

SERVICE TYPE SIGNALERS DOUBLE HEADPHONES, with flat leather headbands for steel helmet wear, 20 ohms, by S.T. Co. 3/6. 40 cords 8d. Signal 60 ohm. phones with cord D11. 1/6. FIELD Telephone Exchanges. 5-line and 20-line portable. Twin and Single Cable; HEADPHONE CORDS. Service 6ft. fitted 2-pin plugs and 2-hole socket. 2/-. Radio Phone Cords, 2/6. CRYSTAL SETS. Boudoir, 6/6. B.M. Table, 7/6. LEARNERS MORSE PRACTICE SET. High Grade Model for Buzzer and Light Signals of Army and Navy. Walnut cabinet fitted W.D. turret brass swivel lamp, revolving cap, 4 sizes of light aperture. With Osram 2-volt tube bulb and spare. Morse Key and 2-way switch. Adjustable 2-coil Buzzer inside, with battery clips, etc. A superior and useful set. 10/6. Ex-Army Buzzer Transmitter, with fine key and brass cased quick adjustment power Buzzer on mahogany base, by Siemens and A.T.M. Co., 17/6. MORSE KEYS. First-class at low prices.

A good small key on moulded base is the TX pivot arm, excellent for learners, 3/6. Full size, well finished key, all brass, solid pivot bar, adjustable tension, etc., B.2. 7/6. Superior Type P.F., fully adjustable, nickel finish, 9/6. High Grade Type IV, plated fittings, polished wood base, a fine key, 10/6. Special Key on 3-switch box for buzzer and 2 lamps, C.A.V. 8/6.

BUZZERS, small type, with cover, 1/6. Power Buzzers, with screw contact and adjustable spring armature, 2/6. Heavy Buzzer in Bakelite case, 3/6. Magneto Exploders, 25/-. Portable Field Telegraph Sets. Details on request. Cheap Morse Practice sets available.

CAMP LAMPS. Portable Accumulator Hand Lamps are independent of dry cells. Miners' type, 2 volts. Steel body. Indestructible, 15/-. Battery, 10/-. SIGNAL LAMPS by Lucas and Aldis, for night and day use, telescope sights, key and discs: for tripod or hand use. Heliographs Mark V, with spare mirrors in leather case, with mahogany tripod.

MORSE RECORDING, G.P.O. type inkers, on mahogany base with tape reel under, in first-class order, £6. Lightweight French Army Field Morse Inkers, fold up into wood case, £7/10/-. Super Model Army G.P.O. Field H.Q. Morse Inker, brand new, entirely enclosed and fitted every refinement, current indicator, key, tape container, etc., £8. Mahogany Tape Container, G.P.O., desk top with brass reel in drawer, cost 40/-, for 3/6 only. Morse Paper Reels, 8d.

Home Recorders, Acoustic, 5/6, 10/6, 15/-. Feigh Electric, 37/6. Flexible track discs, 1/-.

EMERGENCY PARCELS of useful stand-by electrical and radio repair material and apparatus, 7lbs for 5/- Post free.

ELECTRADIX RADIOS

218, Upper Thames Street, London, E.C.4
Telephone: Central 4811



Moaned Smith "Our old super-het Is on its last legs, darling pet." "Oh no," replied she, "I've mended it, see, With FLUXITE'S cute soldering set."

See that FLUXITE is always by you—in the house—garage—workshop—wherever speedy soldering is needed. Used for 30 years in government works and by leading engineers and manufacturers. Of Ironmongers—in tins, 4d., 8d., 1/4 and 2/8. Ask to see the FLUXITE SMALL-SPACE SOLDERING SET—compact but substantial—complete with full instructions, 7/6. Write for Free Book on the art of "soft" soldering and ask for Leaflet on CASE-HARDENING STEEL and TEMPERING TOOLS with FLUXITE.

TO CYCLISTS! Your wheels will NOT keep round and true, unless the spokes are tied with fine wire at the crossings AND SOLDERED. This makes a much stronger wheel. It's simple—with FLUXITE—but IMPORTANT.

THE FLUXITE GUN

is always ready to put Fluxite on the soldering job instantly. A little pressure places the right quantity on the right spot and one charging lasts for ages. Price 1/6, or filled 2/6.

ALL MECHANICS WILL HAVE

FLUXITE

IT SIMPLIFIES ALL SOLDERING

FLUXITE LTD. (Dept. W.P.) DRAGON WORKS, BERMONDSEY STREET, S.E.1.

Transformers— H.F., L.F., and Mains

These General Notes Will Help to Clear Up Many of the Points which are Often Misunderstood. Principles of Transformer Operation are Briefly Explained, Along With Practical Limitations.

MOST readers are so familiar with the use of transformers that they have never stopped to consider how they operate and how their performance is affected by the soundness of design. The type of transformer best known is that employed for coupling in an L.F. amplifier. Essentially, it consists of two windings (having, perhaps, something like 20,000 turns between them) and a laminated iron core. In most cases there are fewer turns on the primary winding than on the secondary, for it is the ratio between the numbers of turns which governs the voltage step-up provided.

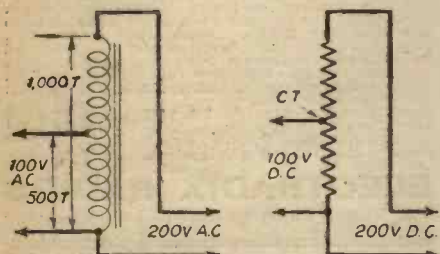

These diagrams show how an auto-transformer used on A.C. can be compared with a potentiometer used on D.C.

Thus, if there were 6,000 turns on the primary winding and 12,000 turns on the secondary the step-up ratio would be one to two. The ratio is often described as—in the example quoted—two to one, but it is better practice to give the ratio as that of the primary to the secondary, so that there can be no confusion. This point is made clear when it is mentioned that output transformers, used to feed the speech coil of a moving-coil speaker, almost invariably have a step-down ratio and are therefore correctly described as two to one, 15 to one, and so on.

More Voltage—Less Current

We have often been asked how a transformer can amplify, “for surely,” it is stated, “a transformer cannot increase the amount of power supplied to it.” That is perfectly true. All an L.F. transformer does is to increase, or step up, the voltage applied to the primary. But if the voltage obtained from the secondary is greater than that applied to the primary, the current must be proportionately lower. For example, if the input were 5 volts at .2 mA (the current has no connection with the D.C. which might be flowing through the primary) and the step-up ratio were two to one, the secondary output would be 10 volts at .1 mA. This is not strictly correct, for it assumes that the transformer is 100 per cent. efficient, which it is not, nor can it be.

In the case of an output or step-down transformer an input of 20 volts at 2 mA

would be changed to 2 volts, 20 mA if the ratio were 10 to one—again neglecting losses. Whether or not we step up or step down the original voltage depends upon whether or not we are supplying a voltage-actuated or a current-actuated device. As you are aware, a thermionic valve is, in most of the methods in which it is used, a voltage-actuated device, since it is the fluctuating voltage applied to its control grid which regulates the corresponding flow of anode current, and hence the amplification produced and the output made available in the anode circuit.

Voltage and Power

But in one form of amplification, class B, the valve is a power-operated device, and current is required to flow in the grid circuits of the double valve. That is why a step-down or sometimes an even-ratio (one to one) transformer is used to feed it. In almost every other case an attempt is made to reduce grid current to zero. It will be remembered that in class B amplification a so-called driver valve precedes the class B valve; it is the purpose of this valve to provide the power required. This should not be confused with the nomenclature generally applied to a large L.F. or output valve. This is a voltage-actuated valve, the purpose of which is to provide power (to operate the speaker) in its output or anode circuit.

The principle of operation of all transformers is the same. An alternating or high-frequency current is passed through the primary winding. This causes a magnetic field to be built up around the winding and the core (which consists of air in the case of an H.F. transformer). The magnetic field also surrounds the secondary winding, with the result that a current is induced in it. The secondary voltage is governed by the number of times that the magnetic field is “cut,” and thus by the number of turns.

The Auto-transformer

Mention has been made above of primary and secondary windings, but a trans-

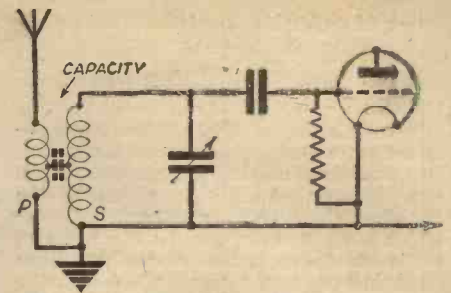

The step-up effect of an H.F. transformer is limited, due to the capacity between primary and secondary windings, and the number of turns required on the primary.

former need not necessarily have two distinct windings. It might consist of a single tapped winding. The component is then known as an auto-transformer. If an alternating current is applied between the ends of the winding, the voltage between one end and a tapping is less than the applied voltage. Whereas, if the input is applied between one end and a tapping, a higher voltage can be obtained by making connection between the two ends. So far as tapping-off a voltage is concerned the auto-transformer can be compared with a potentiometer used in a D.C. circuit. The comparison is illustrated in accompanying diagrams. The principle of the auto-transformer is employed in the case of many resistance-feed L.F. transformers, in which case it is possible to effect a saving in the total amount of wire used because the “primary” winding is also a part of the “secondary.”

The principle of the auto-transformer can be used in an A.C. mains circuit, but such a transformer should not be employed to supply a mains receiver. It is contrary to I.E.E. regulations, since the output (used to feed the rectifier) is not isolated from the A.C. mains.

Mains-transformer Design

In designing a mains transformer of the double-wound type it is first necessary to determine the number of turns required per volt. This is dependent upon the shape, weight and dimensions of the core, and must be such that no primary current flows when the secondary windings are not connected to a closed circuit. In that case the primary can be said to be “tuned” to the supply, just as a coil-condenser circuit is tuned to a signal. When tuning is accurate, the resistance or impedance of the circuit is infinitely high.

Once the number of primary turns has been decided, the number required for each of the secondary windings can be found by multiplying the turns-per-volt figure by the output voltage wanted. After that it is necessary to find the total secondary

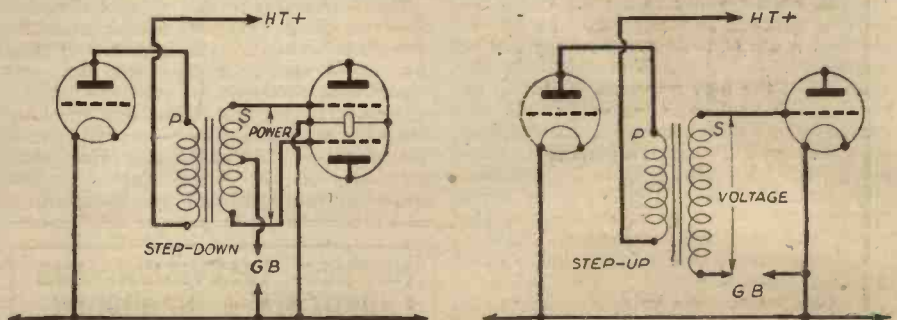

A class B transformer steps down, because the valve is power operated; an ordinary L.F. transformer steps up because the L.F. valve is voltage operated.

TRANSFORMERS—H.F., L.F. AND MAINS

(Continued from previous page)

wattage (voltage times current for each of the windings, the wattage of all windings being added together). That gives the primary wattage, from which the primary current, and hence the gauge of wire needed, can be found. In practice, the total secondary wattage is increased by 25 per cent. to allow for resistance and core losses.

Although the calculation is inclined to be more complicated, the same general principles should be applied when designing an L.F. or output transformer. In this case, however, the number of primary turns is governed by the impedance which the winding must have to match the valve which precedes it. It might appear that any degree of voltage amplification could be obtained, but there is a practical limit. This is because the primary size is, within fair limits, fixed by the required impedance. And if the secondary has an excessive number of turns the capacity between them causes L.F. "leakage" losses which negative the value of the theoretical voltage step-up. In practice, it is seldom satisfactory to go beyond a ratio of one to eight for an L.F. transformer. No such trouble is encountered when making an output transformer, because again the primary size is fixed and the secondary has comparatively few turns.

H.F. Transformers

High-frequency transformers are in a somewhat different category, because it is generally the secondary winding which is tuned. That fixes its number of turns. But if the primary winding is made too small its impedance is so reduced that the voltage which can be developed across it is seriously curtailed. In practice it is seldom possible to gain any advantage by reducing the primary turns to less than one-half those on the secondary. Even then a voltage step-up of two to one is not obtainable because there is a capacitive path between the two windings, which means that some of the available H.F. energy passes from primary to secondary across the "condenser" formed by the two windings, instead of being used to build up the magnetic field. In practice, the chief advantage gained by reducing the number of primary turns, or "tapping down" the coil is that of increased selectivity. In most cases there is a "happy medium" at which the losses brought about by increasing selectivity are largely made up by the step-up or transformer effect.

WORKSHOP CALCULATIONS TABLES AND FORMULÆ

By F. J. GAMM

3/6

or by post 3/10 from
GEORGE NEWNES, LTD.,
Tower House, Southampton St.,
London, W.C.2

LATEST PATENT NEWS

Group Abridgments can be obtained from the Patent Office, 25, Southampton Buildings, London, W.C.2, either sheet by sheet as issued on payment of a subscription of 5s. per Group Volume or in bound volumes, price 2s. each.

Abstracts Published.

VALVE AND AMPLIFYING CIRCUITS.—Baird Television, Ltd., and Truefitt, E. V. No. 508058.

In an amplifying circuit employing a valve having a cathode 1, a control grid 2 to which signals are applied, a screen grid 3, an anode 4 from which output signals are taken, and a secondary-emitting electrode 5, a fixed or

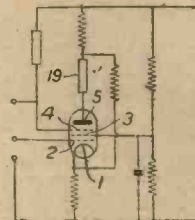

variable resistance or impedance 19 is connected in the circuit of electrode 5 to modify as regards frequency or shift as a whole the level of the curve relating output to input. Specification 508038 is referred to.

NEW PATENTS

These particulars of New Patents of interest to readers have been selected from the Official Journal of Patents and are published by permission of the Controller of H.M. Stationery Office. The Official Journal of Patents can be obtained from the Patent Office, 25, Southampton Buildings, London, W.C.2, price 1s. weekly (annual subscription, £2 10s.).

Latest Patent Applications.

- 30253.—Blue, A. H., and Wood, R. D.—Loudspeakers. November 17th.
30505.—British Thomson-Houston Co., Ltd., and Rushforth, L.—Cathode-ray tubes. November 21st.
30328.—Kolster-Brandes, Ltd., and Smith, W. A. St. Clair.—Cabinets for radio receivers, etc. November 18th.
30567.—Walton, G. W.—Thermionic valves.—November 22nd.

Specifications Published.

- 514723.—Marconi's Wireless Telegraph Co., Ltd.—Superheterodyne wireless receivers.
514776.—Scophony, Ltd., and Rosenthal, A. H.—Natural colour television systems.
514729.—Mayo, C. G., Ellis, H. D. M., and Tanner, R. H.—Thermionic valve amplifiers.
514640.—Johnson Laboratories, Inc.—Image-suppression system for wireless receivers.
514650.—Fernseh Akt.-Ges.—Television or like systems.

Printed copies of the full Published Specifications may be obtained from the Patent Office, 25, Southampton Buildings, London, W.C.2, at the uniform price of 1s. each.

Overcoming Television Flicker

STEPS which had been taken on the continent to bring about different forms of improvement in television receivers are being tried out in those countries able to carry on with their normal activities, and it is anticipated that the finalised results of this work will, where possible, be applied to British equipment at some subsequent date. For example, a close study is being given to various methods for overcoming flicker. It is known that a high picture repetition frequency will achieve the desired aim, but this means an increased frequency sideband. The different forms of interlacing also eliminate flicker, but here again the circuit requirements are apt to be rather rigid, and if not complied with line pairing will result and the picture definition suffer very considerably. In the early days of low-definition television, when the flicker frequency was only $12\frac{1}{2}$ per second, and eyestrain, in consequence, rather pernicious unless the scene enacted was of a sufficiently entertaining character to take the mind off picture defects, attempts were made to supplement persistence of vision with persistence of illumination. The well-known Baird lamp screen was a case in point, for the intensity of illumination of each individual lamp persisted for a period after the signal governing the degree of brightness had ceased to exist. The improvement achieved by this scheme was most marked and subsequent inventors have tried to apply the same principle to modern high-definition television technique in an attempt to provide an alternative solution to the flicker problem. One idea which has been proposed

is an attempt to simulate the afterglow results on the fluorescent screen of a cathode-ray tube, an idea which has long been known to achieve the desired effect but which has proved difficult to obtain in practice. In this scheme each individual line of scan is made to persist or afterglow until the instant when that line is due to be scanned again during the next frame.

Positive Grid

Near the back of the cathode-ray tube's fluorescent screen is placed a positively charged grid, and an auxiliary cathode, in the form of a loop so as not to impede the progress of the main electron stream, is arranged to spray the back of the fluorescent screen with a diffused stream of electrons which must pass through the charged grid. In this way the fluorescent screen areas which glow at a certain intensity as a result of the electronic impact from the main modulated cathode-ray beam are maintained active or glowing, for the simple reason that they emit more secondary electrons than they acquire from the auxiliary looped cathode. Similarly, the darker sections remain so because the emission is less than the number of electrons received. By this means it is claimed that the picture is kept glowing uniformly at each and every area within the field of scan until the new conditions are set up by the advent of the scanning beam of electrons in its next frame traverse when the whole scheme is repeated once more. The idea is a very ingenious one, and worthy of close investigation.

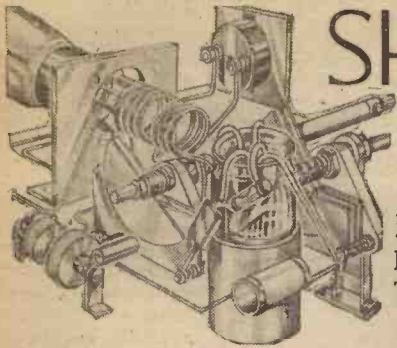

SHORT-WAVE SECTION

IMPROVED SHORT-WAVE RESULTS
How to Make Certain of Getting
Those News Bulletins Satisfactorily
By W. J. DELANEY

MANY listeners own all-wave receivers, but in the past have not made a great deal of use of the short-wave section owing to its unsatisfactory performance. Now that there are many interesting news bulletins being broadcast on the short waves, however, they express a desire to operate on the short waves but do not know why the receiver fails to give the desired performance. If the receiver is a commercial model it may be safely assumed that the design and components are satisfactory and the poor performance may thus be due to the use of an unsuitable aerial or earth, or both. Remember that short waves call for higher insulation than is needed for normal broadcast reception on the medium and long waves, and therefore overhaul your aerial if your set is not bringing in the short-wave stations. Don't make the aerial big and high in an endeavour to improve results. Rather cut down the length of the aerial so that a total of about 15 to 20ft. is in use, and improve the insulation at each end. If there are any joints in the aerial or lead-in, solder them and wrap with insulation-tape to improve the weather-resisting properties. Remember, also, that the receiver must be handled much more gently on the short waves. You cannot expect to run round the dial and pick out a suitable station as you can on the medium waves.

Turn the tuning-knob very slowly and listen for every sound as the needle travels across the scale. At the slightest sign of a signal stop, and then operate the knob so that the pointer travels very slowly backwards and forwards over that spot, at the same time operating the gain or reaction controls which are fitted. Of course, when once a good station has been located the exact position will be noted and it will be possible to return to that setting, but I am dealing now with the operation of a receiver which has not in the past been used for short-wave reception.

Suitable Components

If, on the other hand, the receiver is a home-made model, then it may be quite possible that one or more parts are unsuitable for satisfactory short-wave working and some change will have to be made. For instance, the reaction may be found inefficient, and this may be due to the H.F. choke, the size of the reaction winding or the reaction condenser. A choke may easily be changed, fitting either a proper all-wave choke, or adding a special short-wave choke in series with the existing component, and connecting the new choke on the anode side of the existing choke. If this fails to effect a cure, then a few turns may be added to the reaction winding, or a larger reaction condenser obtained. Such changes as these may, however, affect the performance on the other wavelengths, depending upon the circuit which is used. In some receivers there is a complete change

of coils when the wavechange switch is operated, whilst in others portions of a coil are short-circuited as the receiver is switched to lower wavelengths, and therefore the H.F. choke modification is preferable as this will not affect the medium- or long-wave performance. In some cases a change in the value of the grid-leak or condenser or both may be found desirable. A common trouble experienced on the short waves is that known as hand-capacity effects, and these are evidenced by the loss of a signal as soon as the hand is removed from the tuning control or from the reaction control. In some cases this is due only to the fact that the fixed vanes of these two condensers

therefore, there will be some modification in the capacity when the hand is removed, and therefore the first step in the cure of such a trouble is to earth the moving vanes.

Earth Screens

If, however, the spindles are earthed, then the usual cause of hand-capacity effects may be found to be an inefficient earth connection and an improvement here should be effected. If this does not cure the trouble then a metal plate should be placed behind the panel and connected to earth. Clearance holes should be drilled in it to clear all components mounted on the panel, and it should be fixed to the panel by bolts at two or three places to prevent it from moving and perhaps short-circuit some vital point to earth. If desired, however, the lock-nuts which hold on the tuning and reaction condensers, provided these are already properly earthed, may be used for fixing the screening plate in place.

Fading

Finally, remember that short-wave signals fade rather more noticeably than those on other wavebands, and do not be disappointed if you find, when you tune in a known station, that it cannot be heard. Wait a few minutes and it may return to normal volume. Some commercial receivers are fitted with auto-

matic volume control to compensate for fading, but when switched to short waves the A.V.C. circuit may be cut out. This is because there is a form of fading present on certain short wavelengths which is so rapid that normal A.V.C. circuits cannot cope with it, and the trouble may be accentuated. Do not be disappointed, therefore, and think that the receiver is out of order if you find that your short-wave signals fade. They may pass right out into inaudibility, but this is a perfectly natural function which can only be over-

come by a specially designed receiver, but if you want to be quite clear in your mind concerning this fact, your dealer or the makers of your receiver will inform you whether or not the A.V.C. is effective on the short waves on the particular model which you are using.

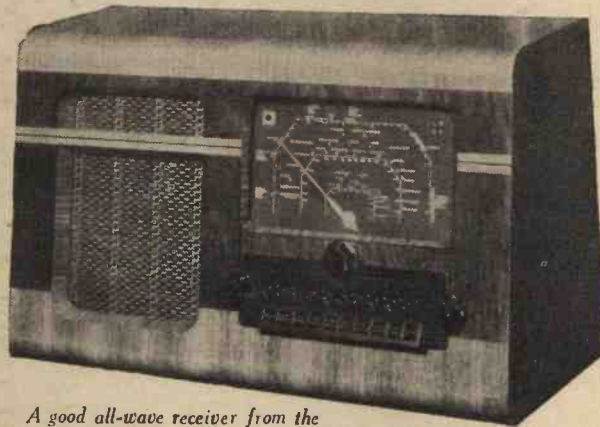

A good all-wave receiver from the R.G.D. range. This is the 16-guinea model 166.

are earthed, instead of the moving vanes. As the moving vanes are connected to the operating spindle, it is obvious that the holding of a control knob is connecting the spindle and thus the moving vanes to earth through the capacity of the body. If these vanes are not already at earth potential,

Notes from the Test Bench

Re-grinding a Screwdriver

WHEN a screwdriver has become damaged and a new edge is to be put on it, be careful that the proper shape is obtained. Some amateurs sharpen the tool on a grind-stone or oil-stone, with the result that in future when a screw becomes tight the driver slips and cuts the head. The working edge of a screwdriver is not sharp, but should be blunt and wedge-shaped so that it fits into the parallel-sided slot of the screw. A taper

is necessary on the driver, however, to accommodate different sizes of screws.

Battery Connections

CERTAIN plugs are manufactured for battery leads in which the end of a length of wire has to be inserted. Usually a small part of the wire is bared, rolled up and this is inserted, the metal part of the plug then being screwed up tightly. A case of trouble was recently investigated where on the L.T. side such a plug was used, but in screwing up the wire the rubber covering was left rather long and when inserted in the plug the rubber made contact with the metal and not the flex wire, with the result that there was no connection to the actual plug and thus the L.T. supply was interrupted.

Open to Discussion

The Editor does not necessarily agree with the opinions expressed by his correspondents. All letters must be accompanied by the name and address of the sender (not necessarily for publication).

Solus Specifications

SIR,—Many thanks for a very fine journal. It is extremely instructive to a newcomer to wireless like myself (I have only been experimenting for three years), and I wish it every success. There is, however, one small "grouse" which I would like to make. With most of the sets described in your paper you specify definite components made by well-known makers, with the result, I think, that quite a number of experimenters like myself who have either not the exact parts or the means of getting them are swayed from building the particular set because of its not coming up to standard. This, I think, could be quite easily overcome by suggesting alternatives or other ways of achieving the same object. For instance, say you specify an H.F. pentode for the H.F. stage of a certain set. Now, I, like many others, haven't got an H.F. pentode, and, therefore, cannot build that set as it stands. If, however, you suggested a screen-grid or a triode for that stage, and gave the modifications necessary I should feel greatly encouraged.—S. W. BROOKS (Edgware).

[The testing of alternative parts would entail considerable extra work. And it is far more desirable to give the constructor the exact parts which we have found to give satisfaction. He then knows that he can duplicate our results, failing which we will service his receiver free of charge.—Ed.]

A DX Log from Nottingham

SIR,—In view of the fine 10-metre conditions prevailing, I am enclosing a log of stations received here from November 15th to November 29th:

Ten-metre: OQ5AB, W5JKB, W5JZK, W5KF, W6PBH, and W6QDH; 20-metre: PY4DA, PY7AL, PK10G, KA1CS, W5CYJ, W5BEK, W5BEW, and EK1AF; 40-metre: (CW), W2CJ, W4CKA, W1MA, and W2MAT. I should like to exchange my S.W.L. card with any reader.—L. STRETTON (74, Raleigh Street, Nottingham).

Stations KZRF and VONG

SIR,—The following information may be of interest to other readers of PRACTICAL WIRELESS and concerns stations KZRF and VONG (Newfoundland).

This station operates on 6,133 kc/s (approximately), from 13.00 to 16.00 G.M.T. and gives the call "Far Eastern Broadcasting, KZRF ("Z" pronounced as Zee), Radio Philippine, Manila, the capital of the Philippines," followed by four musical notes. Programme is usually request dance music, and listeners are invited to send their own requests in, from 15.00 to 16.00. At 16.00 G.M.T., the call is given and the time—"12 midnight, Manila time at the sound of the musical note," then close.

The second transmission starts at 21.28 G.M.T., with musical notes till 21.30, then "Far Eastern Broadcasting KZRF Radio Philippine, and KZRM, Radio Manila, Manila the capital of the Philippines. KZRM on the air!" News in English is given at 22.00 to 22.15 G.M.T., the rest of the programme is mainly light music.

The news is given in the Bisayan tongue from 22.15 to 22.30. It is believed that KZRF and KZRM close at 00.00 G.M.T., but I have not heard them at that time owing to general QRM and weak signal. The latest time to be heard by me is 23.20 G.M.T. No other English short-wave magazine has yet reported this station. No frequency or address has been mentioned, but I have no doubt reports will reach them via the address of other Manila stations: P.O. Box 119, Manila.

A verification just received from VONG states that it operates on 5,970 kc/s, with 300 watts power. VONG has also been heard at 17.45 G.M.T. on 31.6 m. (approximately). QRA, P.O. Box E5,372, St Johns, Newfoundland. Thanks for an excellent weekly.—R. W. HALL (Worksop).

The Hartley Circuit

SIR,—I have been reading your journal each week for over a year now, and being a S.W. "fan," have followed the "Short-wave Section" page with great interest and advantage. Unfortunately, you do not seem to favour the Hartley type of circuit which, I am told, possesses many advantages. May I suggest that you publish at least one article on this type of circuit and its uses on short waves above 5 metres. No doubt many amateur experimenters will agree with me that such an article would serve as a jumping-off point for experiments with unconventional tuned circuits.—K. L. MONPHEW (Blackheath).

[We have, of course, included the Hartley, as well as other special circuits in the S.W. Section from time to time. However, the circuit will be included shortly in a constructional article.—Ed.]

Prize Problems

PROBLEM No. 380

ARTHURS had a three-valve battery set which had given good results over a long period. One day he noticed that signals were slightly weaker, and the following day they seemed still weaker, and finally, after about a week, signals were practically inaudible. He had batteries and valves tested and these were found to be in order. The loudspeaker was tested on a friend's set and also found to be in good working order. What was wrong? Three books will be awarded for the first three correct solutions opened. Entries must be addressed to The Editor, PRACTICAL WIRELESS, George Newnes, Ltd., Tower House, Southampton Street, Strand, London, W.C.2. Envelopes must be marked Problem No. 380 in the top left-hand corner and must be posted to reach this office not later than the first post on Monday, January 1st, 1940.

Solution to Problem No. 379

The switch which Robertson fitted was defective and did not make contact in the second position, and thus failed to bring the pick-up into circuit.

The following three readers successfully solved Problem No. 378 and books have accordingly been forwarded to them:

E. J. Isaac, 114, Tylacelyn Road, Penygraig, Rhondda.

H. Kempson, St. Andrew's Street, Droitwich Spa. C. B. Flindt, 20, St. John's Avenue, Walton, Liverpool, 9.

DX on the Medium Waves

SIR,—It was with the greatest of pleasure I read the article on M.W. DX receivers in the December 9th issue of PRACTICAL WIRELESS, and I feel that many readers with not quite the full technical knowledge to tackle the job on their own would welcome full details of a receiver of this type. Apart from the DX side the extreme selectivity will appeal to many, I feel sure.

As to DX on the broadcast bands this may seem to some new readers rather strange, but I can assure them that if they take the trouble to stay up late enough and keep at the game, their "catches" will be far superior to any S.W. catches.

To be more concrete, I may add that over 400 American stations alone have been heard in this country, and over 80 recorded to my knowledge. The majority of these stations were of powers of 20 kW. and less, and, in fact, stations of power as low as 100 watts have been heard, e.g., KDB Santa Barbara (Cal.) and even the most hard-boiled S.W. fan will admit this is a catch.

I myself heard CMJW (200 watts), Cuba, in August!

Nor does M.W. DX confine itself to the Americas: over 20 Australian stations have been heard here as well as stations from India, Siam, Siberia, Africa, and the Hawaiian Islands.

As to the merits of this type of DX I will leave readers to judge for themselves which is the better feat; a VAC on short wave or a VAC on the broadcast bands.

The answer will be quite obvious, I feel sure.

What do other readers think?—W. BURTON, Assistant European Representative, International DX'ers Alliance (London, E.S.).

Shortening an Aerial: Correspondent Wanted

SIR,—I very much enjoy reading PRACTICAL WIRELESS and am particularly interested in other readers' experiences and experiments. Recently my aerial fell down, and as I needed a new one, I temporarily put up about a quarter of the old aerial. Imagine my surprise at now being able to get the "Home Service" station much better. I found that fading is reduced by a considerable extent, although I must add that volume is also reduced.

Finally, I should like to correspond with any S.W. listener about my own age, which is 18 years. I will answer all letters received. Wishing PRACTICAL WIRELESS continued success.—J. F. POTTER (5, Council Houses, Ducklington, Witney, Oxon).

Correspondents Wanted

SIR,—I have been a reader of your excellent journal for 15 months, and find it very helpful indeed to beginners like myself. I should be greatly pleased if any of your readers would care to correspond with me concerning S.W. listening and transmitting. Also I would be very glad to exchange my S.W.L. card with any full ticket ham, A.A. or S.W.L., at home or abroad.—JOHN HUNTER (49, Twist Lane, Leigh, Lanes, England).

PRACTICAL WIRELESS SERVICE MANUAL

By F. J. CAMM.

From all Booksellers 5/- net, or by post 5/6 direct from the Publishers, George Newnes, Ltd. (Book Dept.), Tower House, Southampton St., Strand, London, W.C.2.

Practical Wireless BLUEPRINT SERVICE

PRACTICAL WIRELESS No. of
Date of Issue. Blueprint.

CRYSTAL SETS

Blueprints, 6d. each.
1937 Crystal Receiver .. — PW71
The "Junior" Crystal Set .. 27.9.38 PW94

STRAIGHT SETS. Battery Operated.

One-valve: Blueprints, 1s. each.
All-Wave Unipen (Pentode) .. — PW31A
Beginners' One-valver .. 19.2.38 PW85
The "Pyramid" One-valver (HF Pen) .. 27.8.38 PW93

Two-valve: Blueprints, 1s. each.
Four-range Super Mag Two (D, Pen) .. — PW36B
The Signet Two (D & LF) .. 24.9.38 PW76

Three-valve: Blueprints, 1s. each.
Selection Battery Three (D, 2 LF (Trans)) .. — PW10
Sixty Shilling Three (D, 2 LF (RC & Trans)) .. — PW34A

Leader Three (SG, D, Pow) .. 22.5.37 PW35
Summit Three (HF Pen, D, Pen) .. — PW37
All Pentode Three (HF Pen, D, Pen) .. 29.5.37 PW30

Hall-Mark Three (SG, D, Pow) .. 12.6.37 PW41
Hall-Mark Cadet (D, LF, Pen (RC)) .. 16.3.35 PW48
F. J. Camm's Silver Souvenir (HF Pen, D (Pen), Pen) (All-Wave Three) .. 13.4.35 PW40

Cameo Midget Three (D, 2 LF (Trans)) .. — PW51
1936 Sonotone Three-Four (HF Pen, HF Pen, Westcopter, Pen) .. — PW53
Battery All-Wave Three (D, 2 LF (RC)) .. — PW55

The Monitor (HF Pen, D, Pen) .. — PW61
The Tutor Three (HF Pen, D, Pen) .. 21.3.36 PW62
The Centaur Three (SG, D, P) .. 14.8.37 PW64

F. J. Camm's Record All-Wave Three (HF Pen, D, Pen) .. 31.10.36 PW69
The "Colt" All-Wave Three (D, 2 LF (RC & Trans)) .. 18.2.39 PW72
The "Rapid" Straight 3 (D, 2 LF (RC & Trans)) .. 4.12.37 PW82

F. J. Camm's Oracle All-Wave Three (HF, Det., Pen) .. 28.8.37 PW78
1938 "Triband" All-Wave Three (HF Pen, D, Pen) .. 22.1.38 PW84
F. J. Camm's "Sprite" Three (HF Pen, D, Tet) .. 26.3.38 PW87

The "Hurricane" All-Wave Three (SG, D (Pen), Pen) .. 30.4.38 PW89
F. J. Camm's "Push-Button" Three (HF Pen, D (Pen), Tet) .. 3.9.38 PW92

Four-valve: Blueprints, 1s. each.
Sonotone Four (SG, D, LF, P) .. 1.5.37 PW4
Fury Four (2 SG, D, Pen) .. 8.5.37 PW11
Beta Universal Four (SG, D, LF, Cl. B) .. — PW17

Nucleon Class B Four (SG, D (SG), LF, Cl. B) .. — PW34B
Fury Four Super (SG, SG, D, Pen) .. — PW34C
Battery Hall-Mark 4 (HF Pen, D, Push-Pull) .. — PW46

F. J. Camm's "Limit" All-Wave Four (HF Pen, D, LF, P) .. 26.9.36 PW67
All-Wave "Corona" 4 (HF Pen, D, LF, Pow) .. 9.10.37 PW79
"Acme" All-Wave 4 (HF Pen, D (Pen), LF, Cl. B) .. 12.2.38 PW83

The "Admiral" Four (HF Pen, HF Pen, D, Pen (RC)) .. 3.9.39 PW90

Two-valve: Blueprints, 1s. each.
A.C. Twin (D (Pen), Pen) .. — PW18
A.C.-D.C. Two (SG, Pow) .. — PW31
Selectone A.C. Radiogram Two (D, Pow) .. — PW19

Three-valve: Blueprints, 1s. each.
Double-Diode-Triode Three (HF Pen, DDT, Pen) .. — PW23
D.C. Ace (SG, D, Pen) .. — PW25
A.C. Three (SG, D, Pen) .. — PW29
A.C. Leader (HF Pen, D, Pow) .. 7.1.39 PW35C
D.C. Premier (HF Pen, D, Pen) .. — PW35B
Ubique (HF Pen, D (Pen), Pen) .. 28.7.34 PW36A
Armada Mains Three (HF Pen, D, Pen) .. — PW33

F. J. Camm's A.C. All-Wave Silver Souvenir Three (HF Pen, D, Pen) "All-Wave" A.C. Three (D, 2 LF (RC)) .. — PW51
A.C. 1936 Sonotone (HF Pen, HF Pen, Westcopter, Pen) .. — PW56
Mains Record All-Wave 3 (HF Pen, D, Pen) .. — PW70
All-World Ace (HF Pen, D, Pen) .. 28.8.37 PW90

Four-valve: Blueprints, 1s. each.
A.C. Fury Four (SG, SG, D, Pen) .. — PW20
A.C. Fury Four Super (SG, SG, D, Pen) .. — PW34D
A.C. Hall-Mark (HF Pen, D, Push-Pull) .. 24.7.37 PW45

Universal Hall-Mark (HF Pen, D, Push-Pull) .. — PW47
A.C. All-Wave Corona Four .. 6.11.37 PW81

SUPERHETS.

Battery Sets: Blueprints, 1s. each.
£5 Superhet (Three-valve) .. 5.6.37 PW40
F. J. Camm's 2-valve Superhet .. — PW52

Mains Sets: Blueprints, 1s. each.
A.C. £5 Superhet (Three-valve) .. — PW43
D.C. £5 Superhet (Three-valve) .. — PW42
Universal £5 Superhet (Three-valve) .. — PW44

F. J. Camm's A.C. Superhet 4 .. 31.7.37 PW59
F. J. Camm's Universal £4 Super-hot 4 .. — PW60
"Qualitone" Universal Four .. 16.1.37 PW73

Four-valve: Double-sided Blueprint, 1s. 6d.
Push Button 4, Battery Model .. 22.10.38 PW95
Push Button 4, A.C. Mains Model .. —

SHORT-WAVE SETS. Battery Operated.
One-valve: Blueprint, 1s. each.
Simple S.W. One-valver .. 23.12.39 PW88

Two-valve: Blueprints, 1s. each.
Midget Short-wave Two (D, Pen) .. — PW38A
The "Fleet" Short-wave Two (D (HF Pen), Pen) .. 27.8.33 PW91

Three-valve: Blueprints, 1s. each.
Experimenter's Short-wave Three (SG, D, Pow) .. 30.7.38 PW30A
The Prefect 3 (D, 2 LF (RC and Trans)) .. — PW63
The Band-Spread S.W. Three (HF Pen, D (Pen), Pen) .. 1.10.33 PW68

PORTABLES.
Three-valve: Blueprints, 1s. each.
F. J. Camm's ELF Three-valve Portable (HF Pen, D, Pen) .. — PW65
Parvo Flyweight Midget Portable (SG, D, Pen) .. 3.6.39 PW77

Four-valve: Blueprint, 1s. each.
"Imp" Portable 4 (D, LF, LF, Pen) .. 19.3.38 PW86

MISCELLANEOUS.
Blueprint, 1s.
S.W. Converter-Adapter (1 valve) .. — PW48A

AMATEUR WIRELESS AND WIRELESS MAGAZINE
CRYSTAL SETS.
Blueprints, 6d. each.
Four-station Crystal Set .. 23.7.38 AW427
1934 Crystal Set .. — AW444
150-mile Crystal Set .. — AW450

STRAIGHT SETS. Battery Operated.
One-valve: Blueprint, 1s.
B.B.C. Special One-valver .. — AW397

Two-valve: Blueprints, 1s. each.
Melody Ranger Two (D, Trans) .. — AW388
Full-volume Two (SG, det, Pen) .. — AW392
Lucerne Minor (D, Pen) .. — AW426
A Modern Two-valver .. — WM409

Three-valve: Blueprints, 1s. each.
Class B Three (D, Trans, Class B) .. — AW386
£5 6s. 8.G.3 (SG, D, Trans) .. — AW412
Lucerne Ranger (SG, D, Trans) .. — AW422
£5 6s. Three: De Luxe Version (SG, D, Trans) .. 19.5.34 AW435

Lucerne Straight Three (D, RC, Trans) .. — AW437
Transportable Three (SG, D, Pen) .. — WM271
Simple-Tune Three (SG, D, Pen) .. June '33 WM327

Economy-Pentode Three (SG, D, Pen) .. Oct. '33 WM337
"W.M." 1934 Standard Three (SG, D, Pen) .. — WM351
£3 8s. Three (SG, D, Trans) .. Mar. '34 WM354
1935 £6 6s. Battery Three (SG, D, Pen) .. — WM371

PTF Three (Pen, D, Pen) .. — WM389
Certainly Three (SG, D, Pen) .. — WM393
Minutube Three (SG, D, Trans) .. Oct. '35 WM396
All-Wave Winning Three (SG, D, Pen) .. — WM400

Four-valve: Blueprints, 1s. 6d. each.
65s. Four (SG, D, RC, Trans) .. — AW370
2HF Four (2 SG, D, Pen) .. — AW421
Self-contained Four (SG, D, LF, Class B) .. Aug. '33 WM331

Lucerne Straight Four (SG, D, LF, Trans) .. — WM350
£5 5s. Battery Four (HF, D, 2 LF) .. Feb. '35 WM381
The H.K. Four (SG, SG, D, Pen) .. — WM384
The Auto Straight Four (HF Pen, HF Pen, DDT, Pen) .. Apr. '38 WM401

Five-valve: Blueprints, 1s. 6d. each.
Super-quality Five (2 HF, D, RC, Trans) .. — WM320
Class B Quadradyno (2 SG, D, LF, Class B) .. — WM344
New Class B Five (2 SG, D, LF, Class B) .. — WM340

These Blueprints are drawn full size. Copies of appropriate issues containing descriptions of these sets can in some cases be supplied at the following prices, which are additional to the cost of the Blueprint. A dash before the Blueprint Number indicates that the issue is out of print.
Issues of Practical Wireless ... 4d. Post Paid
Amateur Wireless .. 1/3
Wireless Magazine .. 1/3
The Index letters which precede the Blueprint Number indicate the periodical in which the description appears: Thus P.W. refers to PRACTICAL WIRELESS. A.W. to Amateur Wireless, W.M. to Wireless Magazine.
Send (preferably) a postal order to cover the cost of the blueprint and the issue (stamps over 6d. unacceptable) to PRACTICAL WIRELESS Blueprint Dept., George Newnes, Ltd., Tower House, Southampton Street, Strand, W.C.2.

Mains Operated.
Two-valve: Blueprints, 1s. each.
Consoelectric Two (D, Pen) A.C. .. — AW403
Economy A.C. Two (D, Trans) A.C. .. — WM286
Unicorn A.C.-D.C. Two (D, Pen) .. — WM394

Three-valve: Blueprints, 1s. each.
Home Lover's New All-electric Three (SG, D, Trans) A.C. .. — AW383
Mantovani A.C. Three (HF Pen, D, Pen) .. — WM374
£15 15s. 1936 A.C. Radiogram (HF, D, Pen) .. Jan. '36 WM401

Four-valve: Blueprints, 1s. 6d. each.
All Metal Four (2 SG, D, Pen) .. July '33 WM329
Harris' Jubilee Radiogram (HF Pen, D, LF, P) .. May '35 WM386

SUPERHETS.
Battery Sets: Blueprints, 1s. 6d. each.
Modern Super Senior .. — WM375
Varsity Four .. Oct. '35 WM395
The Request All-Waver .. June '36 WM407
1935 Super-Five Battery (Superhet) .. — WM379

Mains Sets: Blueprints, 1s. 6d. each.
Heptode Super Three A.C. .. May '34 WM359
"W.M." Radiogram Super A.C. .. — WM366

PORTABLES.
Four-valve: Blueprints, 1s. 6d. each.
Holiday Portable (SG, D, LF, Class B) .. — AW393
Family Portable (HF, D, RC, Trans) .. — AW447
Two H.F. Portable (2 SG, D, P21) .. — WM363
Tyers Portable (SG, D, 2 Trans) .. — WM367

SHORT-WAVE SETS. Battery Operated.
One-valve: Blueprints, 1s. each.
S.W. One-valver for America .. 15.10.38 AW429
Romo Short-Waver .. — AW452

Two-valve: Blueprints, 1s. each.
Ultra-short Battery Two (SG, det, Pen) .. Feb. '36 WM402
Home-made Coil Two (D, Pen) .. — AW440

Three-valve: Blueprints, 1s. each.
World-ranger Short-wave 3 (D, RC, Trans) .. — AW355
Experimenter's 5-metre Set (D, Trans, Super-regen) .. 30.6.34 AW438
The Carrier Short-waver (SG, D, P) .. July '35 WM390

Four-valve: Blueprints, 1s. 6d. each.
A.W. Short-wave World-beater (HF Pen, D, RC, Trans) .. — AW436
Empire Short-waver (SG, D, RC, Trans) .. — WM313
Standard Four-valver Short-waver (SG, D, LF, P) .. 22.7.39 WM383

Superhet: Blueprint, 1s. 6d.
Simplified Short-wave Super .. Nov. '35 WM397

Mains Operated.
Two-valve: Blueprints, 1s. each.
Two-valve Mains Short-waver (D, Pen) A.C. .. — AW453
"W.M." Long-wave Converter .. — WM380

Three-valve: Blueprint, 1s.
Emigrator (SG, D, Pen) A.C. .. — WM352

Four-valve: Blueprint, 1s. 6d.
Standard Four-valve A.C. Short-waver (SG, D, RC, Trans) .. Aug. '35 WM391

MISCELLANEOUS.
S.W. One-valve Converter (Price 6d.) .. — AW329
Enthusiast's Power Amplifier (1/6) .. — WM387
Listener's 5-watt A.C. Amplifier (1/6) .. — WM392
Radio Unit (2v.) for WM392 (1/-) .. Nov. '35 WM398
Harris Electrogram battery amplifier (1/-) .. — WM399

De Luxe Concert A.C. Electrogram (1/-) .. Mar. '36 WM403
New Style Short-wave Adapter (1/-) .. — WM388
Trickle Charger (6d.) .. — AW462
Short-wave Adapter (1/-) .. — AW456
Superhet Converter (1/-) .. — AW457

B.L.D.L.C. Short-wave Converter (1/-) .. May '36 WM405
Wilson Tone Master (1/-) .. June '36 WM406
The W.M. A.C. Short-wave Converter (1/-) .. — WM409

In reply to your letter

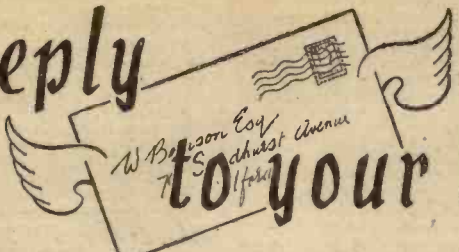

Screening a Valve

"I have built an A.C. set in which the detector is of the plain glass variety. I am troubled with hum and have done practically everything I can think of to cure it without result. I believe that screening the valve would prove useful, but I am uncertain whether this is so, and if it is, how to do it. Could you help me in this problem?"—S. R. (Leominster).

ALTHOUGH the screening of a detector valve will probably result in a reduction in hum, and perhaps in its complete removal, there is one point to watch. In some types of mains valve the screen must be a certain distance away from the electrodes, and you may find, if it is of the type with a top-grid cap, that the grid condenser should be included inside the screen, preferably mounted right on the top cap. Special valve screens may be obtained from advertisers in these pages.

Coupling Winding

"I have some home-made 4-pin short-wave coils but am now rather interested in modifying them to include a coupling winding for aerial—the present windings giving secondary and reaction only. I believe you once published details in which you stated that the aerial winding could be put inside the grid winding, but I cannot find the article although I have looked all through my back numbers. Can you give me any reference to this subject?"—L. E. R. (W.C.1).

WE think you probably refer to a general article on aerial coupling in which three or four different methods of arranging for the coupling were described. A small former is needed, round which the primary winding may be wound, and this is inserted inside the former carrying the other windings. To ensure that the new winding will be held central and rigid inside the outer former, two or three small pieces of cork are cut and fixed to the outside of the new former, the size of these corks being adjusted so that the former is a fairly tight fit. The same idea may be applied to standard 4-pin coil formers.

S.G. Valve for L.F.

"I am making a small amplifier which I need for a deaf-aid, and I wish to get as much gain as possible into the small amount of equipment which will be used in a very small box. I think it is possible to use an S.G. valve in such an amplifier in order to obtain high gain, but I am not sure whether the standard method of feeding the screening grid is employed."—B. C. (Ewell).

IT is certainly possible to use S.G. valves in such an amplifier, and a good design would be to use two such valves feeding a good L.F. valve. In view of the limited H.T. which would be used in a portable deaf-aid amplifier, R.C. coupling would be employed, and with the valves in question an appreciable gain at low H.T. consumption would be obtained. We suggest the Osram special Midget valves, types S.12 for the S.G.s, two being employed with a gain-control in the form of a variable grid-leak,

and for the output an L.12. Forty-five volts should be ample for H.T.

Quality Amplifier

"I wish to build a really good quality amplifier for A.C. work, and for domestic purposes. I believe that a really high output is needed for quality, and am un-

RULES

We wish to draw the reader's attention to the fact that the Queries Service is intended only for the solution of problems or difficulties arising from the construction of receivers described in our pages, from articles appearing in our pages, or on general wireless matters. We regret that we cannot, for obvious reasons—

- (1) Supply circuit diagrams of complete multi-valve receivers.
- (2) Suggest alterations or modifications of receivers described in our contemporaries.
- (3) Suggest alterations or modifications to commercial receivers.
- (4) Answer queries over the telephone.
- (5) Grant interviews to querists.

A stamped addressed envelope must be enclosed for the reply. All sketches and drawings which are sent to us should bear the name and address of the sender.

Requests for Blueprints must not be enclosed with queries as they are dealt with by a separate department.

Send your queries to the Editor, PRACTICAL WIRELESS, George Newnes, Ltd., Tower House, Southampton Street, Strand, London, W.C.2. The Coupon must be enclosed with every query.

certain regarding the best arrangement. I have collected quite a nice array of valves and odd parts and now only need the circuit. Could you help me to arrive at a suitable design?"—J. H. (Hove).

IF you have suitable valves, then undoubtedly a good push-pull circuit is the best. This should preferably be of the all-resistance-capacity coupled type, and a separate phase reverser is desirable. You would need really good valves for such an amplifier, and the output stage should be capable of about 8 or more watts. This would give good handling capabilities without needing to be turned full on, and if a suitable input is provided to the L.F. and phase-reverser stage you should find nothing to complain about from the quality point of view. Do not, however, forget the requirements of H.T. for such an amplifier.

Replenishing Batteries

"Is there any way of renewing torch cells or similar cells such as are used in G.B. batteries? I find that when these are run out they will still give a fairly weak light on a torch, but if I could strengthen them up in any way they would be useful. Have you published any details on making such batteries?"—H. G., and others.

SMALL cells may be given a new span of life, provided the zinc cases are not eaten away. To do this, pierce a number of small holes round the lower part of the cell and then stand it in a solution of sal-ammoniac. This will give a certain amount of improvement, but generally speaking a replacement is the most satisfactory plan. We have not published any constructional data on batteries, and as previously pointed out, it is not an econ-

omical plan to make them. Formula will, however, be found in our handbook on Accumulators, price 1s.

Repairing a Valve

"I have pulled the top of an S.G. valve and wonder if it means that I must get another, or whether I can mend this valve."—M. B. (Perth).

IF the small leading-out wire is not broken off flush with the glass, then a satisfactory repair can be made. The small threaded rod on top of the ebonite cap will be found to be hollow and a hot iron should be applied to the top, and it should then be shaken hard when the small solder blob should come away and leave a clean hole. Failing this, pierce it carefully with a needle so that a clean hole is left. Carefully clean and tin the leading-out wire, but if this has been broken off short, another length of wire must be soldered to it. Do this carefully and then push the cap over the wire so that it projects through the hole in the threaded rod. Solder this and cut off any surplus. The cap is attached to the top of the valve by Chatterton's Compound or any other adhesive.

REPLIES IN BRIEF

The following replies to queries are given in abbreviated form either because of non-compliance with our rules, or because the point raised is not of general interest.

C. F. (Oxhey). You should communicate with the makers of the set as the pick-up may not be usable with this particular combination. The single output stage may provide inadequate amplification, and this is why it was not fitted by the makers.

H. H. (Larkhall). It is not possible to guarantee any receiver to pick up any station in a given locality, without details of local conditions. Any good receiver should prove satisfactory under normal conditions, but inquiries from your local dealer or neighbours will give you an indication as to short-wave results in the district.

J. P. O-S. (Arborfield). You presumably need a straight H.F. amplifier, not converter. Any good H.F. stage may, therefore, be used.

H. W. A. (Gunnorsbury). We regret that we have no details of the makers of the particular make of set mentioned by you.

J. D. (Newport). It would appear that there is a short-circuit, perhaps in one of the electrolytic condensers. On the other hand, remember that as the lead is carrying H.T. there is bound to be a spark when this circuit is made and broken, and thus there may not, in fact, be any fault in the circuit.

B. W. C. (Wellingboro.). The speaker may be used direct, as there is no question of load matching with that particular type of unit.

F. R. (London). We cannot give coil construction details in the form of a reply, and therefore refer you to our book, "Coils, Chokes and Transformers," price 2s. 6d.

T. McG. (Larne). The set may have auto-grid bias which will add to the load, or alternatively there may be need to use a special battery which includes the bias battery in series with the H.T. We suggest you enquire from the makers regarding the matter.

C. J. B. (Norwich). We have given several articles on the subject, but the matter will be found fully dealt with in our new "Short-Wave Handbook."

R. E. (Harwich). The aerial is unsuitable and we suggest a small square frame, about 18in. sides wound with good Litz.

C. W. R. (Perth). The transformer is of the 7 to 1 ratio type and is not now obtainable.

K. E. (Southend-on-Sea). We would not advise the building of the set. Some difficulty will be experienced in obtaining valve replacements.

L. S. (Brecon). The firm is no longer in business.

R. A. S. (Harpenden). The wavelength is in the 31-metre band, which you will find marked on the dial of your set.

N. T. (Dagenham). Not less than 150 volts should be used. The G.B. is 15 volts.

E. M. (Middlesboro.). We think the second alternative desirable and the speaker may be made up on the lines indicated in the article in this issue.

K. R. T. (Co. Antrim). Not less than 50 ft. should be used and the stranded wire is best. Solder all joints.

The coupon on page iii of cover must be attached to every query.

RADIO CLUBS & SOCIETIES

Club Reports should not exceed 200 words in length and should be received First Post each Monday morning for publication in the following week's issue.

EASTBOURNE AND DISTRICT RADIO SOCIETY
Hon. Sec.: T. G. R. Dowsett, 48, Grove Road, Eastbourne, Sussex.

At the society's meeting, held on Tuesday, November 28th, Mr. J. A. Penfold gave a lecture and demonstration entitled "Mains Transformer Design." First he explained the theory of transformers. Examples of laminations were shown made of Stalloy, each one papered on one side for the purpose of reducing iron loss. He next gave complete formulae for the design of mains transformers and also calculated an example on a blackboard. Bobbins were then dealt with; how to cut them out of cardboard was explained.

Lastly, various hints were given as to the design and operation of mains transformers.

THE SURREY RADIO CONTACT CLUB

Hon. Sec.: S. A. Morley, 22, Old Farleigh Road, Selsdon, Surrey.

THE above club held a very successful "Hamfest" and dance at the Café Royal, Croydon, on Friday, December 15th. In spite of the black-out and the inconvenience of night travelling there was a very good attendance, including several lady guests.

The next club meeting is to be held on the first Sunday in January at the same time and venue as in previous months. Why not make a "New Year's Resolution" and come along and meet many of the local "Hams" and have a ragchew.

BRITISH SOUND RECORDING ASSOCIATION

Hon. General Sec.: F. J. Chinn, 170a, Addington Road, Selsdon, Croydon, Surrey.

THE suspension of the B.B.C. Television Service, and the termination of all British Isles' transmitting licences on the outbreak of war, thus closing down all amateur radio stations, has reduced the field for experimental and research work by technical

enthusiasts. These conditions have resulted in an even greater interest being evinced in sound recording activities by amateurs at home, a hobby which has greatly increased in popularity in recent years.

War-time conditions have made it necessary to curtail certain activities of the Association, but by means of publications it is hoped to maintain contact with the members. The Information Bureau is still functioning, and is available to deal with members' technical queries on all aspects of sound recording. Correspondence should be sent to Mr. F. J. Chinn, and letters on technical matters should be superscribed Mr. D. W. Aldous (Hon. Technical Secretary), c/o Mr. Chinn, at the same address as above.

STONE CONTROL BY NEGATIVE FEEDBACK

(Continued from page 320)

circuit L, C is provided between the sliding contact S and the right-hand end of the resistance R. This leads to such amplification curves in relation to the position of the sliding contact S, as is shown in Fig. 4 for the two extreme positions. In this circuit the counter-coupling for the medium frequencies remains always large, resulting over the whole range in a great reduction of the non-linear distortions. It is merely in the one extreme position (a) that the counter-coupling for the high and low tones is equal to that for the medium tones, whereas in the other extreme position (b) the counter-coupling for the high and low tones is greater than for the medium tones. The counter-coupling for the latter is only increased very slightly.

The circuit shown is particularly suitable for receivers with complete fading compensation, or for low-frequency amplifiers for record reproduction in which the medium input A.C. potential is mainly the same, and in which always the same medium volume is required. The effect in this case is that of a pure tone-control.

LOUDSPEAKER DESIGN

(Continued from page 317)

material of a non-resonant nature, such as lead. The other is the use of composite walls consisting of alternate layers of non-porous material and separating layers or pads of vibration-insulating material, such as soft rubber or felt, the mechanical properties of the different layers being very dissimilar.

A number of different constructions were tried, of which the following (see Fig. 1) was considered to be the most generally satisfactory for a reasonably inexpensive product with external dimensions about 15in. by 15in. by 8in.—the outer wall of plywood $\frac{3}{8}$ in. thick; the separating layer of felt $\frac{1}{4}$ in. to $\frac{1}{2}$ in. thick, of the kind used as an underlay for carpets; the inner layer of corrugated cardboard, of the kind used for packing, assembled with the corrugated side inwards. A further slight improvement in soundproofing results from the insertion of a sheet of thin lead between the felt and the cardboard in the back wall of the case which, having the largest area of all the walls, is the most vulnerable to penetration by sound. The layers of felt and cardboard were not found to be necessary on the front wall, which carries the relatively massive load of the loudspeaker unit.

The fixing of these soundproofing layers by glue was found to have a detrimental effect, and it is not necessary. When the cardboard is jammed into position its stiffness is practically sufficient to hold the linings in place, and the use of a few light tacks from the cardboard through to the wood ensures firm fixing. This treatment also provides a useful degree of absorption of sound within the enclosure.

The sound-absorbing covering over the back of the loudspeaker unit may be regarded as part of the casing. Two layers of the same kind of felt as are used for the

lining were found to be required to give the most nearly correct frequency characteristic. Where size of the loudspeaker is a less important consideration, an even response down to lower frequencies can be obtained by using a larger casing. Since the surfaces are greater and the frequencies of effective response are lower with a larger casing, somewhat more soundproofing is desirable e.g., greater thickness of wood and of lead and an additional layer of felt between the lead and the cardboard.

A casing in the form of a cube with 16in. edges (external) gives good response down to about 50 c./sec., and this is used (with the design otherwise unchanged) for special purposes where best quality is required. It was used, in conjunction with a special high-frequency sound radiator, giving reinforcement at frequencies above about 4,000 c./sec., for fidelity.

CAPACITY-RESISTANCE-BRIDGE METER

(Continued from page 323)

be extremely small, or a dead short circuit.

To test electrolytic condensers connect to the sockets marked "electrolytic," the positive side of the condenser being attached to the positive socket and read as for ordinary condensers. It will be found hard to get an exact minimum on these condensers, but the effect of the internal battery helps to produce a minimum sufficiently clear to read most values, and only where the condenser is very old or defective will trouble be experienced, and this will sometimes be an indication of the condenser's state.

There are no snags in the making and using of this little unit, and once made it is quite trouble free, and the last point to mention is that as the condenser to be measured decreases in capacity, so increase the note frequency from the oscillator to compensate for this to some extent.

Classified Advertisements

Advertisements are accepted for these columns at the rate of 2d. per word. Words in black face and/or capitals are charged double this rate (minimum charge 2/- per paragraph). Display lines are charged at 4/- per line. All advertisements must be prepaid. All communications should be addressed to the Advertisement Manager, "Practical Wireless," Tower House, Southampton Street, Strand, London, W.C.2.

RECEIVERS, COMPONENTS AND ACCESSORIES

SOUTHERN RADIO'S BARGAINS.

ALL GUARANTEED. POSTAGE EXTRA.

5/-—Parcel of Useful Components, comprising Condensers, Resistances, Volume Controls, Wire, Circuits, etc. Value 25/- 5/- per parcel.

15/-—Service Man's Component Kit. Electrolytic Condensers, Volume Controls, Resistances, Tubular, Mica, Paper Condensers, Valve Holder, etc. 120 articles contained in strong carrying case, 9" x 7" x 7". 15/- the Kit.

21/-—Small Trader's Parcel of Components. 150 Articles comprising all types Condensers, Valve Holders, Resistances, Chokes, Coils, Wire, etc. Value 85/- 21/- the parcel.

5/-—100 Wire-end Resistances, assorted capacities $\frac{1}{2}$ and 1 watt, 5/- per 100.

5/-—6 Volume Controls, 5/-.

TELSEN 3-Range Meters (Volts and Milliamps), 4/-; Ormond Loud-speaker Units, 2/6; Crystal Sets, 5/6; Westcocks Type W2, 2/6; Telsen W349 Midget Iron Core Coils, 4/6; Step-up Transformers, 110-250 Volts, 7/-; 8 mfd. Electrolytic Condensers, 500 volts, 1/8. Crystal Detectors, 2/-; Crystals, 6d.; Marconi V24 Valves, 9d.

2/-—Tool or Instrument Carrying Cases, ex-Government Stock; Wood 9" x 7" x 7", 2/-.

SPECIAL Offer, Limited Quantity Torch Bulbs, 1.5v., 21/- per 100; 2.5v. and 3.5v., 17/6 per 100.

SOUTHERN RADIO, 46, Lisle Street, London, W.C. Gerrard 6653.

VAUXHALL.—All goods previously advertised are still available; send now for latest price list, free.—Vauxhall Utilities, 163a, Strand, W.C.2.

BANKRUPT BARGAINS. Brand new 1935 models, makers' sealed cartons, with guarantees, at less 40 per cent. below listed prices; also Midgets, portables, car radio. Send 1½d. stamp for lists.—Radio Bargains, Dept. P.W., 261-3, Lichfield Road, Aston, Birmingham.

5/- Bargain Parcel comprising Speaker Cabinet, Drilled steel Chassis, condensers, resistances and many other useful components. Worth £2. Limited number. Postage 1/-.—Bakers Selhurst Radio, 75, Sussex Rd., South Croydon.

"STAND-BY" Crystal Set. Specified coil, 2s. case, 9d.; or complete kit of parts, 10s. 3d., post free.—T. W. Thompson and Co., 178, Greenwich High Road, S.E.10.

RELIABLE Switches, Resistances, and all quality radio and electrical components. Unparalleled range. Send 3d. stamps if you've not yet had catalogue No. 162. BULGIN, BARKING.

LOUDSPEAKER REPAIRS

LOUDSPEAKER repairs, British, American, any make. 24-hour service, moderate prices.—Sinclair Speakers, Pulteney Terrace, Copenhagen Street, London, N.1.

REPAIRS to moving coil speakers. Cones/coils fitted or rewound. Fields altered or wound. Prices quoted, including eliminators. Pick-ups and speaker transformers rewound, 4/6. Trade invited. Guaranteed satisfaction. Prompt service. L.S. Repair Service, 5, Balham Grove, London, S.W.12. Battersea 1321.

NEW LOUDSPEAKERS

3,000 SPEAKERS from 6/6 each, P.M. and energised 4in. to 14in. including several Epoch 18in.—Sinclair Speakers, Pulteney Terrace, Copenhagen Street, London, N.1.

LOUDSPEAKER CONVERSIONS

BAKER'S Triple Cone Conversions Will Immensely Improve Reproduction of Your Present Speaker. Enables you to bring your speaker right up to date and obtain really realistic reproduction at the cost of a few shillings; free descriptive leaflet from the Pioneer Manufacturers of Moving Coil Speakers since 1925.—Bakers Selhurst Radio, 75, Sussex Rd., South Croydon.