

**A THREE-STAGE S.W. RECEIVER—See Page 653.**

# Practical and Amateur Wireless

**3<sup>rd</sup>**  
EVERY  
WEDNESDAY

Edited by F.J. CAMM

a GEORGE  
NEWNES  
Publication

Vol. 9. No. 220.  
February 13th, 1937.

**AND PRACTICAL TELEVISION**

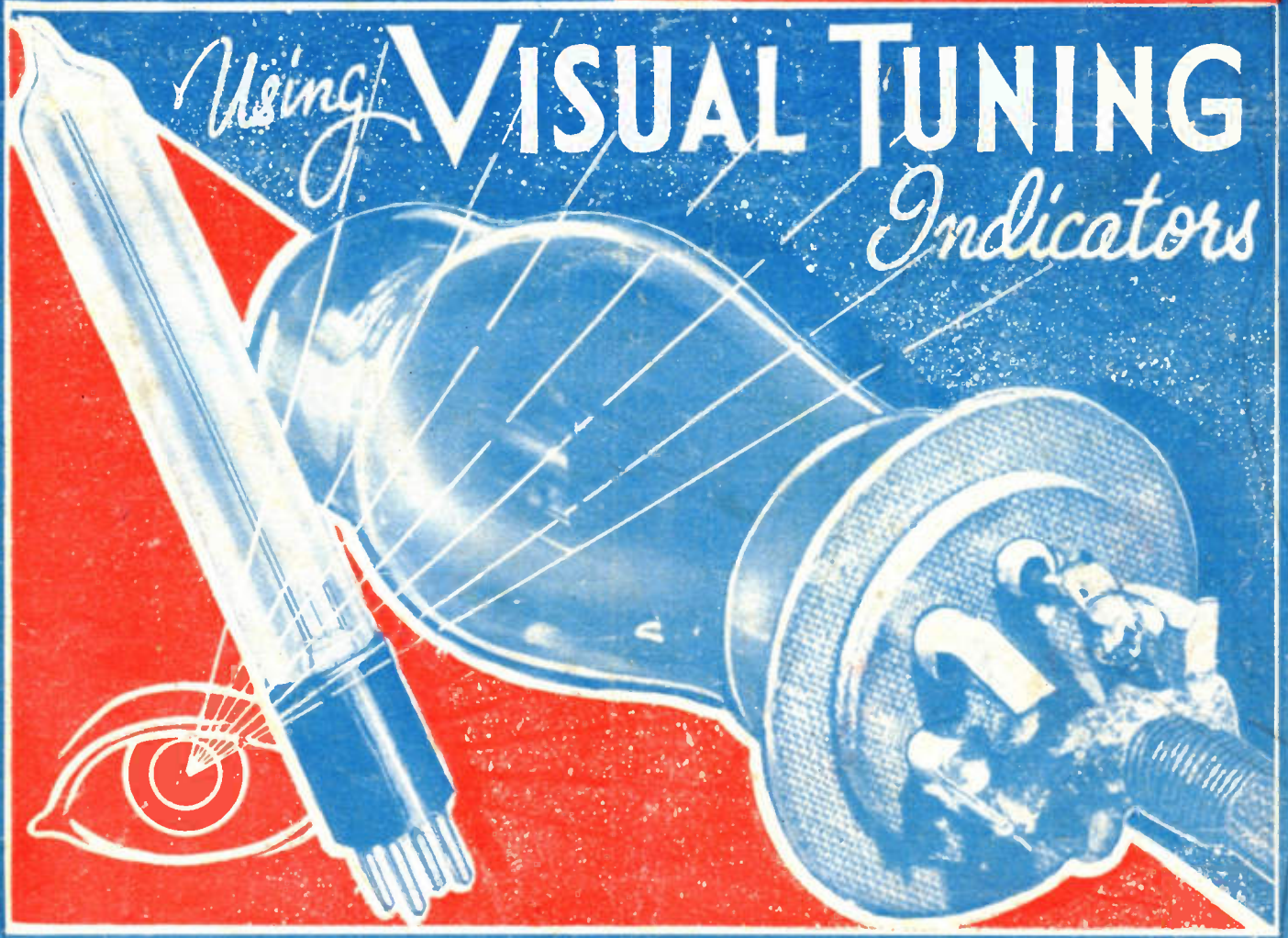

## NEWNES TELEVISION AND SHORT-WAVE HANDBOOK

By F. J. CAMM (Editor, Practical and Amateur Wireless)

EVERYTHING ABOUT—Drums, Mirror Screws, Scanning Discs and other Scanning Systems, Neon Lamps, the Cathode-Ray Oscillograph. How to build Short-Wave Receivers; How to build Ultra-Short-Wave Receivers, straight and Superhet types.

FROM ALL BOOKSELLERS

NEWNES or 4/- post free from Tower House, Southampton Street, Strand, W.C.2. LONDON

Fully  
Illustrated

only  
**3/6**  
net



# FOLLOW the LEAD of the Engineer

You can identify the expert service engineer by the gold-embossed "AVO" Service Sign he displays. You can depend on him to trace and remedy faults in your set with speed and at the least possible cost. This is because he is equipped with the world's most accurate and efficient testing equipment.

You, too, can make tests with the expert's speed and precision if you use the famous AvoMinor.



BRITISH MADE.

Descriptive pamphlet free on request.

**AUTOMATIC COIL WINDER & ELECTRICAL EQUIPMENT Co. Ltd.,**

Winder House, Douglas Street, London, S.W.1. Victoria 34047.

13 Instruments in 1

**VOLTAGE**

0-6 volts. 0-12 volts.  
0-120 volts. 0-240 volts.  
0-300 volts. 0-600 volts.

**CURRENT RESISTANCE**

0-6 m/amps. 0-10,000 ohms.  
0-30 " 0-60,000 "  
0-120 " 0-1,200,000 "  
" " 0-3 megohms.

Deferred Terms if desired. **45/-**

The D.C. **AVO MINOR** 13 TESTING INSTRUMENTS IN 1



**Why do many smokers prefer a MIXTURE?**

Your smoker of Mixture is firmly convinced that no other form brings out so well the quality in a tobacco. If he smokes Airman he is quite likely to be right.

**PLAYER'S AIRMAN MIXTURE**

ALSO OBTAINABLE IN FLAKE OR NAVY CUT



P.A. 51E.

## A Year Crammed with History—1936

- Italo-Abyssinian War*
- Death of King George V*
- Civil War in Spain*
- Hitler re-occupies Rhineland*
- Abdication of King Edward VIII*

All the dramatic events of a remarkable year told in this brilliant book—

# KING - HALL SURVEY 1936

With 200 Illustrations

★ He succeeds so admirably in sorting out the essential from the trivial, neatly packing his facts into watertight compartments, that those most baffled and bewildered by the torrent of news and views can, at a glance, see the way the world is going. *Daily Herald*

★ There is probably no one living who could do a work of this kind more accurately and lucidly. *News Chronicle*

★ It is eminently sane, well-balanced, and written in an easy, readable style. *Illustrated London News*

From all **6/-** booksellers, net  
or 6/6 post free, from—

**GEORGE NEWNES, LTD.,**  
Tower House, Southampton St.,  
Strand, London, W.C.2.



# CAR RADIO PROBLEMS—See page 639



**Practical and Amateur Wireless**

Edited by **F. J. CAMM**

*Technical Staff:*  
W. J. Delaney, H. J. Barton Chappie, Wh.Sc.,  
B.Sc., A.M.I.E.E., Frank Preston.

VOL. IX. No. 230. February 13th, 1937.

## ROUND *the* WORLD of WIRELESS

### Tune by Sight

THE simple receiver is always tuned by ear, the tuning control being set according to the sound as heard from the loudspeaker. Where great volume is obtained the volume-control is usually turned down during the tuning process so that the exact point may more easily be determined. It is well known that with a wireless signal it is necessary to tune to the exact resonant position, or frequency, in order to obtain balanced reproduction, any deviation on either side resulting in a loss of quality. When A.V.C. is fitted, as was explained last week, there is a risk that the exact tuning point cannot be determined, as the increase in volume automatically decreases the H.F. sensitivity, and thus the exact resonant point is hard to determine. The only certain way of obtaining correct tuning, and consequently best quality, is to fit some device which will show, irrespective of the action of the A.V.C. circuit, when the circuits are correctly tuned, and this is the function of the Visual Tuning Indicator. Turn to page 648 and read how the device works, and how to use this useful adjunct to the modern receiver. The details are clearly explained, and circuits are given showing its application.

### Four New Indian Stations

THE Indian Government has just placed a contract with Philips Radio for the supply of four 10-kilowatt short-wave transmitting stations for the All-India Radio organisation. All the stations will work on a wavelength between 30 and 90 metres. The contract was given to Philips after Indian broadcasting engineers had inspected a number of other broadcasting transmitters in the Far East which were supplied by the same company. There are already in India five medium-wave stations and four short-wave ones, in addition to a number of local relay transmitters.

### P.O. Trunk Radio

ULTRA-SHORT-WAVE wireless telephony is to be experimented with by the Post Office authorities with a view to providing trunk telephone services between the Orkney and Shetland Isles and the mainland. The experiments, it is understood, are to be commenced almost immediately and they wish to establish the

suitability at all times of the year of this method of communication.

### A New Insulation Tester

THE usual type of insulation tester is operated by turning a handle, this producing a high voltage in a test circuit. This means that two people must be employed, or the apparatus has to be connected so that the handle may be operated. A new idea is to be shown at the Leipzig Spring Fair, where a test instrument is to be introduced in which

the general crowd scenes, will give ample scope to demonstrate the efficiency of the modern television systems.

### This Year's Radiolympia

IT was anticipated that from this year onwards the Annual Radio Exhibition would be held in the new exhibition buildings at Earl's Court. After considering the matter, however, it has been decided by the R.M.A. that Olympia will again be the scene of the exhibition. A contract has been entered into for three years, with the option of renewal for a further two years. This year's exhibition must fall between August 16th and September 5th.

### Kerbside Kabaret

AS a result of an argument concerning the talent displayed by street performers, B. Martin Marks has arranged to present a programme bearing the above title. Freak performers, such as one-string fiddlers, bottle players and one-man bands are not included. The items will consist of articles of a legitimate type chosen from the city streets, and in introducing them the producer will describe them and tell where they were found. The rehearsals for the programme have been arranged so that all taking part will not be away from their pitches during the "peak" hours. The programme is to be given on February 19th from the London Regional transmitter.

### Test Your Frequency Response

ON February 12th a recital on the double-bass is to be given in the programme "Intermission." This item will give listeners an ideal opportunity of testing the frequency response in the lower register. The nickname of the instrument in America is the "bull fiddle," and the item has been named "The Bull Steps Out." The composer and performer is Norman Hester, who has been double-bass player of the B.B.C. Variety Orchestra since it was formed.

### Has Anybody Logged Tunis?

FRENCH wireless journals report the arrival on the ether of a new short-wave station at Tunis (North Africa). This transmitter is said to be operating daily from G.M.T. 12.00-14.00, and again from 18.30-20.00 or 21.00 on 49.12 m. (6.107 mc/s). No further details are given.

### ON OTHER PAGES

	Page
Car Radio Problems ...	639
Supplying the Grid Voltages	641
Thermion's Page ...	643
Practical Television...	645
Latest Television News ...	646
Readers' Wrinkles ...	647
Using Visual Tuning Indicators ...	648
Receiver Design in 1937 ...	650
A 3-Stage Amateur Receiver	653
Readers' Letters ...	656
Club Reports and News ...	657
Readers' Problems ...	659

the pressure of a button sets the apparatus into action. A dry battery is employed, and the measuring voltage is of the order of 500 volts. A discharge lamp keeps the operator constantly informed as to the working of the apparatus, on which the readings are shown on a large dial. The instrument weighs only 4½lb. complete with straps and batteries.

### No Coronation Television

AS we go to press we are notified that the arrangements for televising the Coronation ceremony in Westminster Abbey have fallen through. It is announced, however, that the outside broadcasts will still be held, and the pageantry of the procession, to and from the Abbey, with

# ROUND the WORLD of WIRELESS (Continued)

## Radio Station to Aid Pilots

WITH the assistance of three pilots of the Chukhotsk aviation squadron, a radio station has been built on the high plateau of the Anadyr mountain range. Hitherto, the work of pilots flying from Cape Schmidt to Cross Bay on the Chukhotsk Peninsula suffered from the absence of a meteorological station in the region of the Anadyr range which could inform the pilots of changes in the weather on the route. All the material required for the radio station, as well as coal, kerosene and foodstuffs, were transported by air.

## Variety in Miniature

MARTYN WEBSTER compères a half-hour programme on February 12th, which will include a short sketch by Francis Durbridge in which the action is supposed to take place just after a Paul Jones dance. Edith Athey, who first broadcast in 1923, will sing; Warwick Vaughan will give impersonations; Dickie Pounds and Ronnie Brandon are to give one of their "Out of the Blue" turns; and Jane Minton and Robert Austin will play duets on two pianos.

## Concert from Torquay

FRANK PHILLIPS (baritone) will be the artist in a concert by the Torquay Municipal Orchestra, conducted by Ernest W. Goss, at the Pavilion, Torquay, on February 16th. This broadcast will be given in the Western Regional programme.

## Three "Music Hall" Dates for Vic Oliver

WE are informed that Vic Oliver, husband of Miss Sarah Churchill, daughter of Mr. Winston Churchill, will be heard during three broadcast programmes in the near future.

As "England's Favourite American Comedian"—he has broadcast over here on four previous occasions—he will take part in "Music Hall" in the National programme on February 13th, March 6th, and April 3rd.



Vic Oliver, the popular American comedian, who is to give three broadcasts in "Music Hall," in the National programme.

## INTERESTING and TOPICAL NEWS and NOTES

### Radio Progress in Russia

ACCORDING to Mr. Proskuryakov, chief of the Radio Development Department of the All-Union Radio Committee, it is proposed to install nearly two million new radio sets and receivers, 50 per cent. of them in collective and state farms. The total number of radio sets and receivers in the Soviet Union by the end of 1937 will be six million. A great deal of work is to be carried out on the reconstruction



Mr. Meredith, of Liverpool, has built a radio set out of old tins, a bottle, a clothes peg, a cigarette and some razor blades—and it works.

of district relay stations. Old equipment will be replaced by modern radio receivers, of which 600,000 will be produced. New relay stations are being built in Kiev, Baku, Tbilisi, Gorki, Minsk, and other cities, and existing radio stations are being enlarged.

### Film Stars in Glasgow!

TWENTY-FIVE minutes of revue will be broadcast on February 12th, consisting first of "Solo Flight" a one-man revue devised and written by Peter Solman, and presented by Ian Sadler; and secondly, William H. D. Joss, in "Six Star Special," or "From Hollywood to Hope Street." The radio reporter will interview several film stars whom the public would never think were in Glasgow. The productions are by Robin Russell.

### Midland Orchestral Concert

ON February 20th, Reginald Redman is to be the guest conductor of the B.B.C. Midland Orchestra in a concert which opens with Dvorak's "Carnival" overture and includes "The Enchanted Lake," by Liadov.

### Variety from Derby

LESLIE HUTCHINSON, better known as "Hutch," tops the variety bill which will be heard from the Grand Theatre, Derby, on February 18th.

### Organ Recital from Aberdeen

ON February 17th, Harold Coombs will play on the organ of the Capitol

Cinema, Aberdeen, Spanish Valse, "Santiago," by Corbin; Foxtrot, "When the Sun says Good-night to the Mountains," by Vincent; and the second New Sullivan Selection, arranged by Higgs.

### Light Fare from Crewe

VARIETY will be broadcast for the first time on February 18th from the New Theatre, Crewe. The bill from which excerpts will be taken includes the Four Hillbillies, Jack Warman (comedian), Lillian McEvoy (violinist), the Hurdles (comedy, singing and dancing duo), and Horace Waynes (radio talent spotting competition).

### William Rees Concert

ELSIE SUDDABY, the well-known Yorkshire soprano, will be the soloist in the William Rees Concert that is to be broadcast from the Milton Hall, Manchester, on February 20th. She is to sing Mozart's "Dove song," from "The Marriage of Figaro." The orchestra, conducted by William Rees, will play a programme including a selection from Rossini's "La Boutique Fantasque" and "Two Pieces" by Cowen.

### League of Nations Broadcasts

DETAILS of the work done during the preceding week by the League of Nations are transmitted every Saturday between G.M.T. 10.30-11.15 through HBL, Prangins, on 31.27 m. (9.59 mc/s), and through HBP, between G.M.T. 22.30-23.15 on 38.18

m. (7.78 mc/s). Several new channels have been adopted by the Prangins stations for relays of Swiss and Austrian programmes for rebroadcast over the N.B.C. and Columbia networks in the United States of America. Those most used are: HBF, 15.83 m. (18.95 mc/s); HBJ, 20.64 m. (14.535 mc/s), and HBO, 26.31 m. (11.402 mc/s).

## SOLVE THIS!

### PROBLEM No. 230.

Cook constructed a short-wave three-valve using a home-made coil. He expected a tuning range of 18 to 40 metres, but when the set was tested it would only tune down to 20 metres. How could the minimum be reduced to 18 metres and what was the cause of the high minimum? Three books will be awarded for the first three correct solutions opened. Address your solutions to the Editor, PRACTICAL AND AMATEUR WIRELESS, Geo. Newnes, Ltd., Tower House, Southampton Street, Strand, London, W.C.2. Envelopes must be marked Problem No. 230 in the top left-hand corner, and must be posted to reach this office not later than the first post on Monday, February 15th, 1937.

### Solution to Problem No. 229.

There was an internal short-circuit in the condenser connected between the cathode of the H.F. valve and earth.

The following three readers successfully solved Problem No. 228 and books are accordingly being forwarded to them: E. G. Sears, 44, Graham Rd., Mitcham, Surrey; J. D. Morris, 17, Lynton Rd., Heaton Moor, Stockport; H. Lloyd, 23, Park View Terrace, Morton Rd., Middlesbrough, Yorks.

# Car Radio Problems

Our Contributors Decided to Unite Forces in Making a Receiver for Motor-car Use, and Tell You about the Problems which Arose

YOU might think that this is not the best time of the year to experiment with car radio. In that case, we do not agree. The person who has to use his car all the year round, probably for business, is entitled to a bit of relaxation during the bad weather—and what better method of obtaining it than from radio? Many a tedious and otherwise tiring journey can be made more enjoyable by switching on "the wireless," and the foolish idea that the music detracts from the safety of driving has, we hope, been completely dispelled by now.

## Power Supply

All of us have been keen on car-radio for a number of years, but until this season we have never been quite satisfied with home-made car sets. The main reason was that we had either to employ expensive H.T.-converter units or otherwise be content with batteries. Now that the Bulgin vibrator-rectifier unit is available there is no reason why a home-made car-radio should be either expensive or less satisfactory than a factory-produced job.

It was after the above points had been discussed that we recently decided to carry out a few experiments in order to see to what extent a reasonably good car-radio outfit could be produced without going to any great expense. One of our number had for some time been using a straightforward type of four-valve battery superhet. with A.C.-type indirectly-heated valves, the filaments being fed from the car battery by making connection to the negative terminal and to the bus-bar inter-cell connector between the second and third cells—in order to obtain the correct voltage of 4. For H.T. he employed a double-capacity H.T. battery and results were commendably good.

Another of our members had consistently used an ordinary four-valve (H.F., Det., L.F., Class B) portable, not differing greatly from the well-known PRACTICAL WIRELESS "Featherweight" receiver. He explained that he had found that the self-contained frame aerial was not very successful in itself, due to the directional effects, and also because of the screening provided by the metal bodywork. However, he had overcome this trouble by fitting a 12ft. length of rubber-covered flex to the underside of the roof, this being arranged in zig-zag formation. The car battery had again been used for L.T. by taking a tapping at 2 volts, so the earth connection was automatically made to the chassis.

## Interference Suppression

In neither case had it been found necessary to screen the receiver, provided that interference suppressors were fitted in the ignition circuit. A set of Belling-Lee suppressors was used, although other makes such as Dubilier were found equally effective. Incidentally, the total cost of these for a four-cylinder car is 15s. 6d., which is very reasonable. The set includes four resistances, with easy-fitting terminal

clips for including between the plugs and their connecting leads, a similar resistance for including between the centre terminal of the ignition distributor (coil ignition) and its connecting lead, a metal-cased fixed condenser for connecting between the

by The Experimenters

positive dynamo terminal and the frame of the car (negative terminal on those cars with positive earth), and a condenser for connecting between the H.T. terminal of the coil and the chassis. The general arrangement of these is shown in Fig. 2.

It was found after a considerable amount of careful experiment that the inclusion of the resistances had little or no effect on the running of the engine—in spite of arguments which have at different times been raised to the contrary—although it was found worth while to advance the ignition timing very slightly. This, no doubt, is due to the minute time lag which the resistances introduce. It is also worth mentioning, for the benefit of those who have not seen these suppressors, that they can be fitted in a few minutes, and that the earth or chassis connections from the condensers are made automatically through the metal cases and mounting brackets with which they are fitted.

## "Parasitic" Interference

We did find in the course of our recent tests that a certain amount of interference was sometimes experienced in spite of the suppressors, but this was due to dirty

contacts in the make-and-break, to the dynamo brushes not bedding-down properly on the commutator segments, or to bad connections in the electrical circuit as a whole. Additionally, it was noticed that the electric windscreen wiper was inclined to cause a little trouble, and that, occasionally, friction between different parts of the bodywork resulted in a few "scratching" noises.

The windscreen wiper could be silenced if this were considered necessary by connecting a 25-mfd. electrolytic condenser between the terminal of the wiper motor and the windscreen frame; connecting the positive condenser terminal to the motor terminal for a negative-earth system, or vice versa for positive earth. Noise caused by bodywork friction could always be overcome either by tightening the parts which were rubbing or by lightly smearing them with graphite grease. A certain amount of noise is inevitable when the direction indicators are operated unless one takes the trouble to fit condensers between the contacts, but this is never an important matter. The point is, of course, that any contacts which are "made" and "broken" cause a small amount of radiation unless a condenser is connected between them to "absorb" the current surge, whilst rubbing parts tend to generate a small amount of current due to electrolytic action.

## The Aerial

Before tackling the new set itself we decided to "pool" our experiences of aerial and earth systems and allied matters. One had found, for example, that the best form of aerial was one consisting of a strip of "Pix" aerial tape fixed round the outside of the roof with the lead-in taken between

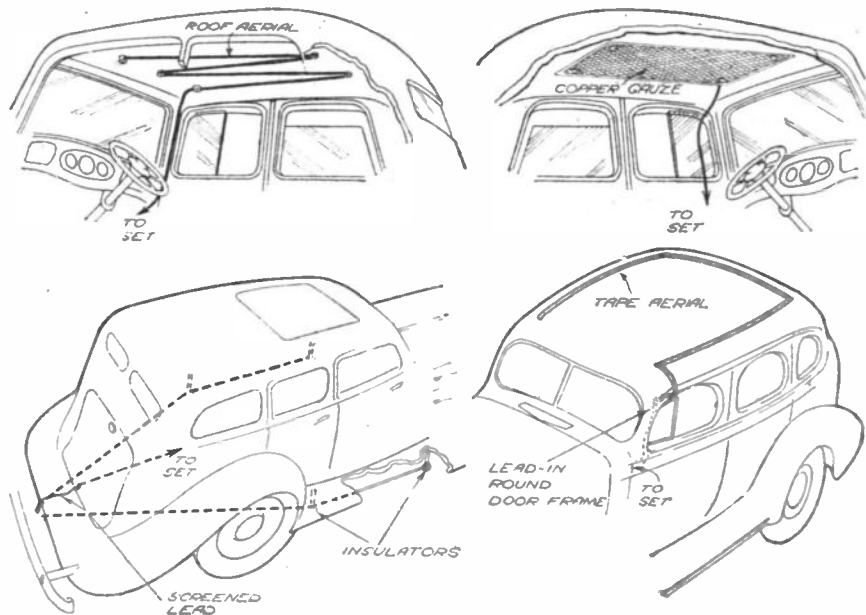

Fig. 1.—Some of the types of car aerial which the Experimenters tried. The most suitable should be found by experiment.

the top of the door and the door frame; another preferred the zig-zag arrangement of insulated wire inside the roof, as mentioned above; another had obtained good reception from a sheet of perforated zinc mounted underneath the wooden running-board on small insulators; another preferred a sheet of copper gauze (he had rather expensive tastes) fixed on the underside of the roof; yet another excellent arrangement was said to be obtained by means of a 12ft. length of insulated wire arranged as a V between the underside of the running-boards and the tail of the body, the lead-in being taken from the point of the V near the tail. For the last-mentioned arrangement it was claimed that interference was reduced due to the "dipole" system. Our "highly-technical" member who preferred this arrangement explained something about the fundamental wavelength of the interference being just above 7 metres, and said that the use of a half-wavelength aerial caused the interference to be cancelled out. We others looked very knowledgeable, even if we were not quite clear on the technicalities, although somebody did say that it was improbable that the fundamental wavelength would be the same for all cars. In the end, we came to the conclusion that it was best to try different aerial systems on each particular car, and this seemed to put a stop to further argument. Fig. 1 shows some of the suggested aerials.

### What Circuit?

When we came to discuss the most suitable type of receiver it looked as though trouble would start again, for although one "went for" a six-valve superhet with delayed and amplified A.V.C., another preferred a simple four-valve "straight" circuit without any of these "new-fangled" refinements. In the end a compromise was struck by our agreement to try out a modification of the famous PRACTICAL AND AMATEUR WIRELESS "£5 Superhet"—A.C. version, with the addition of a simple form of A.V.C. Nobody could give any good reason why this should not prove satisfactory for reception of the local stations

and Dfoitwich, so that point was settled. The reason for deciding on the A.C. version, by the way, was that it was agreed that indirectly-heated valves were more robust than battery valves, and that they provide a greater degree of amplification. In addition to this, it was considered that the A.C. circuit was more readily adaptable

that the set should be "joint property." That settled that point, and it was agreed that, in the first place, set and speaker should be separate.

Then remote control? If the object were to receive several stations the tuning knob must be either on the steering-wheel, or somewhere near it, but if we should be

Fig. 2. — This illustration shows the principal points at which suppressors should be fitted to the engine. Connection of the two condensers varies slightly according to the electrical and ignition equipment of the car, but the general arrangement shown is usually effective. Better dynamo suppression can sometimes be obtained by connecting the condenser to the positive brush.

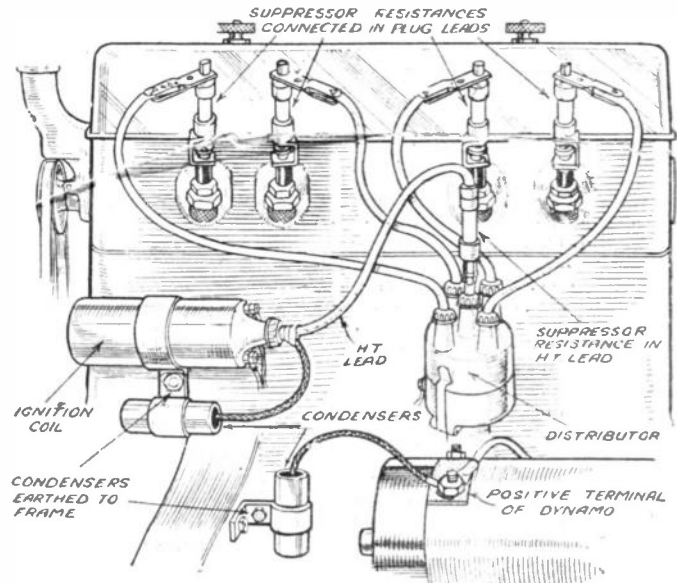

for use with the vibrator unit, which it had been decided to employ.

### Self-contained or Separate Speaker?

The next "spot of bother" arose when the question of whether or not the speaker should be built into the set or mounted separately, and also whether a remote tuning control should be employed. If the receiver and set were all in one unit, that unit would be fairly big, so that difficulty would arise in accommodating it in the "baby" Austin, which one of us was running—and it was a foregone conclusion

content with two or three programmes, it would be good enough to have the condenser knob beneath the dashboard, where it could be reached quite easily when the car were stopped. Temporarily, the matter was dropped, it being agreed that, if necessary, remote control could be added later.

Well—we had intended to tell you something about the set, but as we have exhausted the space placed at our disposal by the Editor, we must leave that until next week.

Until next week!

## MORE ABOUT A.V.C.

(Concluded from last week's issue)

ORDINARY A.V.C., whether of the simple or delayed type, cannot counteract the fading to a great extent. Fading and distortion would be noticeable, but it is surely better to put up with reduced volume for a little while than to have the original volume restored, but with severe distortion.

Delayed A.V.C. seems to have all the advantages and none of the snags. By its use, the sensitivity of the receiver is not impaired, and the control will be more level the greater the delay. Care must be taken, however, to see that the last I.F. valve can deliver the voltage required without overloading, and it is, therefore, often necessary to apply only one fraction of the A.V.C. to this valve or even to operate it with fixed bias only. With this exception, it is best to control as many valves as possible, and in general at least two valves must be controlled.

So far we have not considered the uses and values of the decoupling condensers and resistances used in A.V.C. circuits. A glance at any of the circuits will show that,

developed across the A.V.C. load resistance, there is not only a D.C. voltage but, superimposed on this, there is also an H.F. voltage. These H.F. voltages must not be allowed to reach the grids of the controlled valves and are, therefore, smoothed out by a condenser-resistance combination, in just the same way as we use a decoupling resistance and condenser in the anodes of amplifying valves to remove hum, and prevent interaction and instability.

### The Main Object of Decoupling

The primary object of the decoupling arrangement, however, is to introduce a time lag in the A.V.C. in order to reduce the effect of the modulation on the bias of the controlled valves. The time constant obtained (which is a product of the values of the condenser and resistance) varies between one tenth and one fifth of a second, that is to say, the time taken to charge up and discharge the condenser can be made to vary. In this way, the A.V.C. can be made very sluggish, or very fast. With a large time

constant, and therefore slow A.V.C., interstation noise is greatly reduced because the set has been tuned from one station to another before the A.V.C. volts have been discharged. A disadvantage that will be immediately apparent, however, is that quick fading will not be counteracted. On the other hand, with a low time constant, even very quick fading (of the sort encountered on short waves) is easily controlled, but the set becomes very sensitive immediately it is slightly off tune, and atmospheric noises are greatly amplified.

It will be noticed that all the circuits given are for use in a superheterodyne receiver. This is because, in a straight set, at least two, and preferably three H.F. stages, are necessary in order to be able to effect any control worth while. Certainly the voltage at the detector is much greater in a superhet than in a straight set. Another disadvantage is that the tuning condenser preceding the detector may not be earthed except by the use of a special circuit which, in the case of a mains receiver at any rate, seems to introduce a good deal of hum, and extra screening is necessary. Also due to the fact that the full H.F. voltage is applied across the detector grid leak in a straight receiver, a much more efficient H.F. filter is required than in a superhet, and the circuit again becomes very complicated.





## SUPPLYING THE GRID VOLTAGES

(Continued from previous page)

required so that the variable- $\mu$  properties of these valves can be employed. In both Fig. 1 and Fig. 2 it is assumed that the same bias voltage is to be applied to these two valves—and that is satisfactory in most cases. Because of this, both grid circuits are joined together, although decoupled one from the other—by means of two .1-mfd. megohm resistances in Fig. 1, and by means of two 500-ohm resistances (R.1 and R.2) in Fig. 2.

In the battery circuit, the variable bias voltage is obtained through the potentiometer connected between tapping G.B.3 and earth in Fig. 1; and by means of the variable resistance marked R.3 in Fig. 2. As the various resistances must not impede the free flow of high-frequency currents, they are by-passed by means of .01-mfd. non-inductive condensers in both circuits. Incidentally, it should be explained that the bias connections shown in Fig. 2 are not necessarily complete, because they are sometimes coupled with the potentiometer circuit employed to feed the screening grids of the valves. This does not affect the basic circuit, however.

### "Automatic" Voltage

It is frequently considered desirable to use "automatic" grid bias in a battery receiver, the bias being obtained by the voltage-drop across a resistance, as it is in the mains circuit. This is easy enough where the low-frequency valve is concerned, but there are many difficulties which arise when variable voltages are required for variable- $\mu$  control. In fact, when there is more than one valve which requires a variable G.B. voltage, the problem is well-nigh impossible of satisfactory solution. But when there are no variable- $\mu$  valves, or even when there is a single one which passes a small current by comparison with the other valves in the receiver, the matter is not generally unduly complicated.

Fig. 3 shows the skeleton circuit of a "non-variable- $\mu$ " H.F.-Det.-Pen. receiver in which "automatic" grid bias is obtained by means of the fixed resistance included between the H.T.— and L.T.— terminals. The object of this resistance is to provide a voltage-drop in exactly the same manner as do the bias resistances in Fig. 2. An important difference is that the H.T. current for all of the valves passes through it, instead of the current for one valve only. Thus, the value of the resistance must be calculated by dividing the required G.B. voltage by the total H.T.

current and multiplying the result by 1,000. As an example, it can be assumed that the H.T. currents quoted by the makers as being required for the valves are: 5 mA, 2mA and 10mA respectively, or 17 mA in all; also that the bias voltage required for the output valve is 4 $\frac{1}{2}$ . This means that the correct value for the resistance is approximately 260 ohms. In practice, a 250-ohm component would be used, as being the nearest standard rating; this would be perfectly satisfactory because a small amount of tolerance is permissible due to the fact that the resistance is partly self-compensating.

### Bias Resistance

It should be noted in passing that the

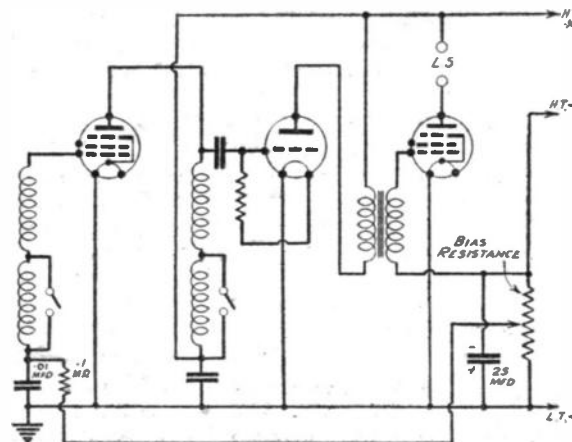

Fig. 4.—A method of obtaining fixed and variable bias "automatically." There are disadvantages in this arrangement and these are described in the text.

bias resistance is shown as being by-passed by a 25-mfd. electrolytic condenser. This is not absolutely essential, but it allows free passage of low-frequency currents, so preventing low-frequency instability. Another point is that when considering the current passed by the various valves and the bias voltage required, these are taken at the maximum H.T. voltage, since the makers do not normally quote the H.T. current at other voltages. A slightly higher degree of accuracy would be obtained by taking the figures which apply at the particular H.T. voltage used, but the beginner might

have some difficulty in finding this, since it would involve either the taking of measurements—by means of a milliammeter—or finding the actual figures from the characteristic curves of the valves.

When the bias resistance required does not approximate in value to that of a standard component, or when it is desired to over-bias the valve on weak signals, it is generally satisfactory to employ a variable resistance and regulate this to the highest value possible without introducing distortion.

### "Automatic" Variable- $\mu$ Control

If it were required to use variable- $\mu$  control in the circuit shown in Fig. 3, fairly satisfactory results could be obtained by following the connections given in Fig. 4. A potentiometer is used in place of the fixed resistance, the slider being connected to the grid circuit of the first valve, in a similar manner to that shown in Fig. 1. There are a few difficulties here, however; first, because 250-ohm potentiometers are not generally available. This objection could be met by using a 500-ohm potentiometer in parallel with a 500-ohm fixed resistance, or, better still, by using a 50,000-ohm potentiometer in parallel with a 250-ohm resistance. In both cases the tapping of the potentiometer would be used to feed the variable- $\mu$  valve.

The second objection is that as the bias applied to the first valve is varied the anode current of that valve is also varied. The means that the current passing through the resistance, and hence the voltage-drop across it, is caused to change as the volume control is operated. In turn, this results in a variation of the bias applied to the low-frequency valve. Provided that the change in current is confined to 2 or 3 mA—and it usually is—this need not be considered as a serious disadvantage, because the change in bias to the output valve would not vary more than a small fraction of a volt.

## New Photographic Services for the U.S.S.R.

WE understand that the Soviet Union intend to put into operation, during the present year, seven new telephotographic transmission lines. It will then be possible to transmit to Moscow over the radio and telegraph any diagrams, portraits, drawings and other documents from Alma-Ata, Tashkent, Sverdlovsk, Baku, Tbilisi (Tiflis), Irkutsk and Khabarovsk. By the end of the year new powerful television centres will be opened in Moscow and Leningrad. In both these cities apparatus will be installed for general demonstrations of television programmes on a screen the size of a postcard. The television centre in Moscow will be equipped with powerful ultra-short-wave transmitters intended for the demonstration of entire performances and sound films. At the same time, the output of high quality television receivers will be commenced.

## ITEMS OF INTEREST

### Interference by Medical Apparatus

ONE of the worst forms of interference which is troubling manufacturers of television receivers is that caused by medical diathermic apparatus. This apparatus is actually a small transmitter working on a wavelength similar to that used for television, which radiates energy for curative purposes. A stray radiation from a powerful apparatus can be picked up by a television receiver a hundred yards away, and manifests itself in the form of a wide band with black serated bars or edges, which occupies about two-thirds of the total screen. At the present time nothing can be done at the receiver end to minimise this interference, other

than to move the aerial to a more favourable position.

### Extending Ultra-short-wave Sound Transmissions

A PROJECT is afoot whereby the ultra-short-wave sound transmissions which have proved of such excellent quality may be extended. Tests are to be undertaken to see whether one or more of the normal B.B.C. sound transmissions can be radiated from an ultra-short-wave transmitter at Broadcasting House, or, alternatively, use the equipment installed at Alexandra Palace. This will give those people with ultra-short-wave sound sets an opportunity of listening to first-class quality reproduction. If this experiment proves successful, it is possible that other ultra-short-wave radio transmitters will be established in the provinces, and these can then eventually be used in the various regions where television stations are to be erected.





# On Your Wavelength

By THERMION

## Good Out of Scotland!

I WAS wrong when I said that a few good things came out of Scotland. I must withdraw that. I have learned better and must apologise to my Scottish friends for straying in my technical juvenescence from the paths of rectitude and veracity. I am caused so to retract my remarks because I read in the paper that at a meeting of schoolboys they unanimously decided to ask the B.B.C. to ban crooning. There's perspicuity and perspicacity for you! An Englishman (note, my dear Scots, the subtle distinction between Englishman and Britisher) is well past the age of maturity before he realises that crooning is a bum art, as our Yanks would say. My thanks also to many Scots who have sought to complete my education by telling me how little I know about history. But, then, what do they know of Scotland who only Scotland know? I have not had one letter from a Scot resident in England; they evidently when in Rome do as Rome does, and forget their hatred of the English which is manifest from so many of their letters.

## The Coronation Not to Be Televised

AFTER all the fuss and bother about televising the Coronation, I learn that it has been decided not to do so. Why? Are there technical difficulties in the way? Are not the television engineers equal to this simple task? Are there political reasons against it? I am all against national flummery, and am fixed in my belief that this country has had far too much of it in the past five years, but a Coronation only happens once or twice in a lifetime, and therefore does not come within that classification.

One critic ingenuously remarks in supporting the B.B.C.'s policy in not televising it, that it would only appeal to those lookers living in London,

and they are within a twopenny bus ride of the ceremony itself. This critic does not deserve a hat through which to talk. Old people are wiser to-day than to wish to be herded about like cattle in a field to watch a ceremony which may not last many minutes from their point of observation.

They would prefer to watch the ceremony from the comfort of their own homes, and with the additional advantage that they would see flashes from various points of the Coronation course. Is it, therefore, part of a plan to drive the public to see the Coronation in order to attract the largest crowd possible? That is, indeed, a very laudable object, for His Majesty's subjects are anxious to demonstrate their loyalty and fealty. I am considering elderly folk who would love to be present, but do not feel equal to the crush; or perhaps it is that the authorities feel that there are not sufficient television sets in operation to make the broadcast worth while. Here again, the actual number of sets in use would not be a true index of the number who would actually see the programme. If there are only 500 television sets in use in London, at least 25,000 people would see the programmes. I hope it is not too late for the authorities to change their mind.

## Longevity of Volume Controls

A .B., of Parkstone, referring to my grouse about volume controls, mentions one for which he paid 9s. 6d., and which he fitted five years ago to the A.C. Super Sixty. It has never been removed from the set, he says, and it has never given any trouble. It does not crackle and works as smoothly and silently as when it was new.

## Tempo Rubato

FROM a daily paper: "Tempo Rubato I may perhaps be permitted to remind you is robbed

or stolen time, meaning a slight deviation to give more expression by retarding one note and quickening another, but so that the time of each bar is not altered in the whole. . . . In a book on symphony published in 1916 I discovered this definition of rhythm: 'The swing or lilt of the music; certain movements, as, for example, the first allegro in Beethoven's Seventh Symphony, are much more rhythmic than others.'" I am glad to know this, as a journalistic friend of mine with a few stock clichés would have said. The correspondent who sent me the above cutting says that jazz bands give him the impression of a blacksmith's shop in the middle of the Zoo. What an insult to a blacksmith's shop in the middle of the Zoo.

## Television Inventions

NOW is the time for the enthusiast to try his hand at television. I am very intrigued with the experiments which apparently may be undertaken in the field of mechanical reception, and I have had one or two shots at it myself. I must admit I have not been very successful, but it would be interesting to know whether any readers have tried experiments in this direction, and if so, with what results. The cathode-ray apparatus is expensive, and no doubt this prevents many from trying their hand at building a receiver. The original disc receiver, such as we used for 30-line pictures, is definitely out of the question. But what about combinations of discs, or lenses and discs, or even the mirror-drum plus disc? The fact that one of the television systems has a definition of 240 lines leads one to suppose that some form of multiplier (eight times the original 30 lines) should give some results, although admittedly, when trying to get the interlaced type of picture with a definition of 405 lines there may be complications. I should like, however, to hear from amateurs who have tried to do something about this.

### New Gramophone Records

NO doubt hundreds of experimenters are interested at the announcement that the sound-on-film method of recording for home use has now been perfected, and that before very long the apparatus will be on the market. I understand that a complete all-wave radiogram will be sold at about 30 gns., and that the records will cost about 10s. 6d. and 21s., the former playing for about half an hour, and the latter for an hour. The material is not standard cinema film, but a special material which is much cheaper to produce, but the ordinary method of reproduction (via a photo-electric cell, etc.) is employed. If the amateur can do his own home-recording on this arrangement (direct from the radio programmes) I can see some interesting possibilities. I can also see some drawbacks, but perhaps I had better not mention these. We shall, at least, be able to record the whole of the Saturday Music Hall programme (when all of it is worth recording) and listen to it on Sunday and on the other days when uplit programmes are in force. And how fine to be able to listen to a complete opera, without surface or background noises.

### Interesting History

MR. E. J. CRAKER, of South Norwood, wonders if any reader can dig up anything prior to the following extract from Addison's Spectator No. 241, Dec. 6th, 1711: "Electric Telegraph Anticipated. Strada, in one of his effusions, gives an account of a chimerical correspondence between two friends by help of a certain lodestone, which had such virtue in it that if it touched several needles, when one of the needles so touched began to move, the other, though at never so great a distance, moved at the same time and in the same manner. He tells us that the two friends, being each of them possessed of one of these needles, made a kind of dial plate, inscribing it with the four-and-twenty letters in the same manner as the hours of the day are marked. They then fixed one of the needles on each of the plates in such a manner that it could move round without impediment, so as to touch any of the twenty-four letters. Upon separating from one another into distant countries, they agreed to withdraw themselves punctually into their closets at a certain hour of the day, and to converse with one another by means of their invention. Accordingly, when they were some



## Notes from the Test Bench

### Speaker Connection

WHEN a constructor converts his battery receiver for all mains operation he often wishes to retain the speaker that was used in conjunction with the battery valves. Although it is possible that the speaker would give satisfactory results when connected in the anode circuit of the mains output valve, it is unsafe to make this connection in all cases. Small permanent magnet speakers designed for use in conjunction with battery type valves usually have a small output transformer attached, and the primary of this is designed to carry an approximate maximum current of 30 mA. Mains pentodes and power valves have a higher consumption than 30 mA, however, and therefore the transformer primary winding is liable to burn out if connected direct to the speaker sockets.

### Parallel Connection

IF a small speaker of this type is to be used, the safest procedure is to connect an L.F. choke having an inductance of 20 to 30 henries and a current carrying capacity in excess of the mains valve consumption in place of the speaker. The valve anode end of this may then be connected via a 2-mfd. condenser to one of the speaker leads, with the other speaker lead connected to H.T.—. Apart from the damage which direct connection is likely to make to the speaker transformer, the output valve can also be damaged due to the application of screen voltage after the anode circuit has been broken.

### Pentagrid or Triode-Hexode?

THE triode-hexode valve is very commonly used as a frequency changer nowadays, but it does not seem to have ousted the pentagrid. It is claimed that the triode-hexode is more efficient than the pentagrid and that it is also more suitable for use in short-wave receivers. In short-wave sets it is advisable to use the triode-hexode if it is desired to tune below approximately 16 metres, but above this wavelength the pentagrid is quite as effective in practice. Although it is customary to tune the oscillator grid circuit of the pentagrid and the oscillator anode circuit of the triode-hexode, both valve types will work with either the grid or anode circuit tuned, and they may be interchanged without altering the wiring of the valve-holder. Experimental work is therefore very easily conducted. When substituting a pentagrid for a triode-hexode permanently, however, the anode and screen voltages should be carefully checked.

hundred miles asunder, each of them shut himself up in his closet at the same time appointed and immediately cast his eye upon his dial plate. If he had a mind to write anything to his friend, he directed his needle to every letter that formed words which he had occasion for, making a little pause at the end of each word or sentence to avoid confusion. The friend, in the meanwhile, saw his own sympathetic needle move itself to every letter which that of his correspondent pointed at. By this means they talked together across a whole continent, and conveyed their thoughts to one another in an instant over cities or mountains, seas or deserts."

### All Waves

WHY is it that several of those listeners who have recently bought all-wave receivers say that short-wave reception is unsatisfactory? We amateurs who have been using short-wave sets for many years merely chuckle, but I am afraid that we often miss the B.C.L.'s point of view. First and foremost is the fact that we know how to operate a short-waver; how to turn the knob very slowly; how to recognise a telephony transmission as it is tuned in; and when to turn the tuning knob backward again after a transmission has been "passed."

Another point is that we have learned that certain wavelengths are more productive of good signals at certain times of day. For example, the 19-metre band is generally best during daylight. Near dusk the 25- and 31-metre bands are better, whilst late at night, signals generally "come over" better on wavelengths from 30 metres upward.

The listener who is accustomed to medium- and long-wave reception only is inclined to expect too much. He thinks that because signals from all over the world can frequently be received at excellent strength, reception should be as reliable as that from the local station. He also overlooks the fact that interference is more noticeable—especially if a suitable aerial system is not employed—without appreciating that if "wanted" short-wave signals travel better than those on the higher wavelength, the "unwanted" signals must behave somewhat similarly. A little patience and practice in tuning, combined with the use of one of the many anti-interference aeriels, would do much in showing many of those who are inclined to decry short-wave reception that they are blaming the set instead of themselves.

# Practical Television

February 13th, 1937. Vol. 3. No. 37.

## THE TIME BASE

The Theoretical Considerations and Practical Methods of Assembling this Section of the Television Receiver. By W. J. DELANEY

THE most fascinating section of the complete television receiver is undoubtedly the time base, as it is this which gives to the spot on the screen of the cathode-ray tube the correct movement to trace out the complete picture area, generally referred to as the "format" or "raster." Under the present system two different types of movement are required. For the Baird system the spot must travel from the top left-hand corner of the screen across to the right, return to the left-hand side at a point slightly lower and travel across beneath the preceding course. This process must be repeated so that a complete picture format is built up consisting of 240 lines, one below the other (Fig. 1), and 25 of these complete picture areas must be completed each second. The distance traversed by the spot (and which forms a line owing to persistence of vision and slight time lag in the fluorescent material from which the screen is made up) must be adjusted by means of the time base so that the complete area possesses a ratio of four horizontal to three vertical, and there must be 25 picture traversals per second.

With the E.M.I. system, however, two separate frames are built up, each of 202.5 lines, and these are interlaced. This means that the spot first travels along as in the Baird picture, but when it returns to the left-hand edge of the picture it drops lower than in that system. If the lines were numbered we should find that the first traversal would be on line number 1, but the next would be on line number 3, and the next on 5, and so on. When the format is completed, the spot returns to the beginning of the space where line number 2 should be, and when this is completed the next line is in position number 4. Thus the complete picture is built up of 405 lines and the frequency of the complete picture is also 25 complete frames per second.

### Trigger Circuits

The movement of the spot is caused by potentials applied to two sets of plates, arranged in pairs at right angles to each other inside the cathode-ray tube, and the electron stream passes between these. The

function of the time base is to apply necessary varying potentials to the deflecting plates, as they are called, and thus there must be four separate outputs in the time base, each working correctly in order

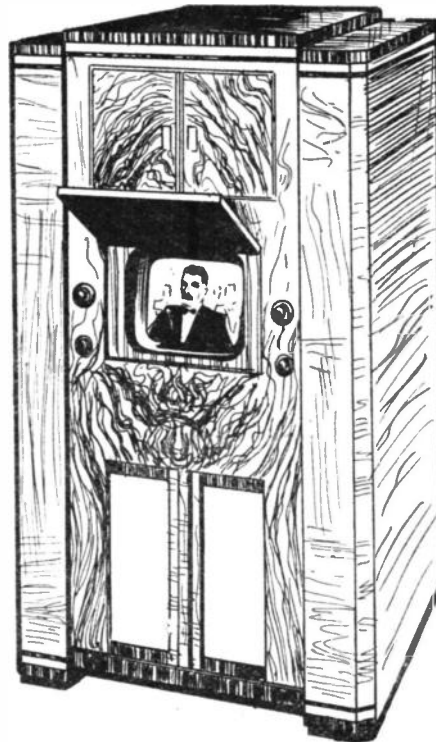

The G.E.C. Television Receiver. Note that the panel controls are reduced to a minimum, and a protecting cover is provided for the end of the C.R. tube.

to give the spot its correct movement. This is carried out, in its simplest form, by the discharge of a condenser, and there are in use at the present time two separate systems for effecting the movement. The more usual system employs a gas-discharge tube, or gas-filled relay, between the anode

and cathode of which is connected a fixed condenser. When a voltage is applied across the condenser it commences to charge up, and at a certain value, it discharges across the relay or discharge tube. The gradually rising voltage is applied to the deflecting plates, and naturally the capacity of the condenser is critical, as it is this which governs the time taken to reach a certain value, as well as the maximum voltage which is obtained.

### Hard Valves

The above description is necessarily brief and non-technical, but it describes the function sufficiently well to understand the complete time-base circuit. An alternative system is the subject of a patent taken out by the Cossor Company, and in place of the gas-discharge tube an ordinary wireless valve is employed. This consists of an ordinary H.F. pentode which is used in conjunction with an ordinary triode. The condenser is connected between anode and cathode of the triode valve, and the grid of this valve is joined to the anode of the pentode. The anode of the triode is also connected to the grid of the pentode. When the condenser is totally discharged the cathode of the triode (which is connected to the anode of a further valve in the time-base circuit) receives the same voltage as its anode. As the condenser commences to charge the voltage on the cathode of the triode drops with the changing difference in potential across the condenser, and as soon as it reaches a value slightly positive compared with the grid anode current will commence to flow. This in turn causes the anode voltage to fall and the pentode receives a corresponding negative potential. The effect of this is to speed up the rate of discharge, and consequently this circuit works very rapidly, and is slightly cheaper to construct than the gas-discharge type. It is true that certain additional valves are needed in the hard-valve time base in order to obtain maximum results, but these compare with the push-pull valves generally employed to obtain a balanced output in the gas-discharge circuit, and it will be found that the general cost of construction is lower, and the efficiency is higher, when the correct values of the various components and the correct working voltages are obtained.

### Constructional Details

The circuits briefly described above have to be duplicated for the two sets of plates, and naturally it is imperative to avoid interaction between the two sections. They may be built end-to-end, or side by side with a fair separation to avoid interference between leads and components. It is also necessary to use separate voltage supplies for certain of the valves to avoid interaction and other defects. The section

(Continued overleaf)



Fig. 1.—The above diagram shows how the picture area of the Baird System is built up in a regular manner. Each line is formed immediately below the preceding one, and it is claimed that the alternative system shown in Fig. 2 avoids flicker. The dotted line shows the course of the spot in its return to the commencement of the picture area.

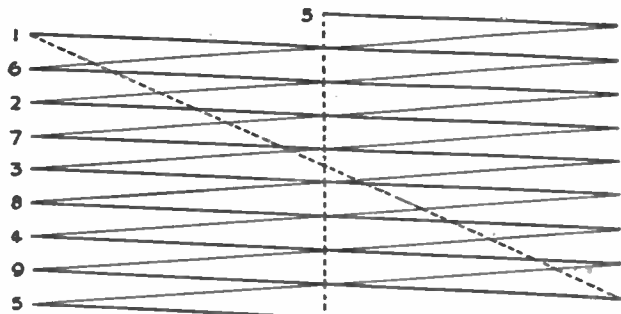

Fig. 2.—How the lines are interlaced to build up the screen in the case of the Marconi-E.M.I. transmissions.



## PRACTICAL TELEVISION

*(Continued from previous page)*

which controls the line movement must be built with a very low capacity to earth, and therefore if a metal chassis is employed some care is necessary to ensure that condensers and leads are kept well clear of the surface. Failure to do so will shorten the length of the line traverse. A number of adjustable controls will have to be fitted, although certain of these may be arranged so that they are convenient to adjust when the circuit is first put into operation, when they may be left alone until some change in valves or other components renders it necessary to readjust them. Of these there will be the line amplitude and line frequency, as well as corresponding controls

on the picture side. There may be an additional control to regulate the input from the radio receiver, unless a gain control is fitted in the I.F. circuits to regulate the signal strength. A switch will have to be fitted to make the necessary change in condensers for use on the two systems of transmitting, although when the B.B.C. adopt a single system this adjustment will be avoided. The leads from the time base to the cathode-ray tube should be kept as short as possible, and if a horizontal tube is desired the mounting for it should be on the time base so that the holder for the tube is in a convenient position for the connecting leads. A better scheme is to mount the tube holder in the centre of the chassis, between the two time-base circuits, when all leads will

be rendered much shorter, and the tube will be easier to mount. This will mean, however, that a mirror or similar reflector will have to be fitted inside the lid of the cabinet in order to view the picture on the end of the tube, and if you are working to a published circuit, the connections to the deflecting plates will have to be reversed as the mirror reverses the picture. A final point, which may eventually be avoided, is that a shelf or screen should be placed above the time base so that the valves are not rendered visible through the glass of the cathode-ray tube. The silvered surface of the valves may catch outside lights and cause brilliant patches of light in the picture. For this purpose certain modern tubes are blackened or enclosed in a metal screen.

## This Standard Question

**W**ITHIN the last few weeks all sorts of rumours have been heard concerning the possibility of the Television Advisory Committee coming to a decision with reference to the choice of a single standard for television transmissions from Alexandra Palace. Unfortunately, confusion has arisen because some writers have used the word "system" for "standard." Either of the two systems now employed by the B.B.C. is capable of working on any given single standard, so that the companies concerned do not enter into the problem in the strict sense of the word. That a standardised form of signal would be a material benefit no one will gainsay, but any hasty or premature choice may cause difficulties. For example, Germany has been radiating signals for three years now with their experimental service, and the standard employed is 180 lines, scanned progressively with a picture speed of 25 per second. The authorities responsible for television development, in that country are still uncertain as to the wisdom of making a final choice for any nation-wide service. Again, in France, the same situation exists, while in America where continuous experiments are being undertaken, most of the demonstrations have been staged on a 343 line definition basis, the scanning being interlaced. The latest news from that continent, however, suggests that the R.M.A. are keen on choosing 441 lines, this figure being recommended to the Federal Radio Commission.

A certain measure of economy in production costs will be effected when the time-base generator is only called upon to provide a single type of potential variation at the given line and frame speeds, but apart from that the present-day television receiver will need no alteration. In addition, the Television Advisory Committee have stated publicly that no question of receiver obsolescence will become evident for a period of at least two years. One of the main ideas behind the choice of a single standard is to provide the B.B.C. with more studio accommodation. In any case, it seems certain now that no public announcement will be forthcoming until after the Coronation. The televising of this pageantry is expected to give the B.B.C. service an enormous fillip, and receiver sales should reach unprecedented figures, while the home construction of sets will be a material factor which is sure to increase the number of viewers at that time.

## Useful Suggestions

**I**N an effort to maintain and, if possible, increase public interest in television, several reasonable suggestions have been

made. One of these is that there should be a "floating" daily period which would enable events (outdoor or studio) to be televised when the time of occurrence does not coincide with the normal hours of transmission. This would be most valuable, for the producer could plan some extremely interesting items either of local or wide-spread application. Yet another scheme proposed is the radiation of a simple still picture, say, a geometrie figure, at certain stated daily periods so as to allow experi-



*In this Marconiphone television receiver a vertical tube is used, and the image on the end of the tube is viewed in a mirror.*

menters and manufacturers to carry out important tests. A signal of known constant modulation levels is most useful for this class of work, for very frequently adjustments are made to sections of the apparatus because of picture changes which are attributed to the receiver, when all the time this is happening at the transmitting end. This is particularly noticeable in film transmissions where changes in the density of the pictures necessitate careful adjustments

in control levels in order to give the required degree of modulation.

## Installation Problems

**E**ACH company now marketing television receivers has built up an efficient department of service and installation engineers to deal with any problems likely to arise in connection with equipping homes with television receivers. While a certain number of difficulties were anticipated, they have not been so numerous as at first expected. This is largely the result of careful research into aerial design, coupled with the development of various types of efficient feeder cables. In some cases a dipole aerial is used with a form of Zepp connection made up as an efficient signal frequency transformer to give the necessary impedance matching between the aerial and the feeder line to the receiver. In other cases a simple dipole, with a flexible twin wire from a split centre point, has been all that is required in order to ensure maximum signal pick-up from the Alexandra Palace transmitter, coupled with the highest signal-to-noise ratio. This simple type of installation is sufficient in those residential areas on fairly high ground well away from any main road traffic. In other cases a single strand metal-screened feeder has to be employed, the centre air-spaced copper conductor constituting the signal feed, while the screening is earthed and acts as the second connection. Inside aerials provide adequate pick-up in some cases, and so simplify installations very materially, but in others sufficient height has to be achieved by using a mast fixed to the main chimney breast or alternatively, positioned in the garden. With the aerial attached to the top of the mast no difficulty is experienced. In every case, however, it is advisable to link both aerial and set by the transmission cable taken over the shortest possible route, with very sharp bends or untoward kinks carefully avoided. Damage to the feeder cable will reduce very materially the signal-to-noise ratio.

**NEWNES' TELEVISION AND SHORT-WAVE HANDBOOK**

3/6 or 4/0 by post from  
**GEORGE NEWNES, Ltd., Tower House,**  
 Southampton Street, Strand, London, W.C.2.

A PAGE OF PRACTICAL HINTS

SUBMIT  
YOUR  
IDEA

READERS  
WRINKLES

THE  
HALF-  
GUINEA  
PAGE

Screening Heater Leads

I HAVE found flexible gas tubing excellent for screening heater leads and H.T. leads in A.C. mains receivers. Its great advantage is that one can get twin flex or

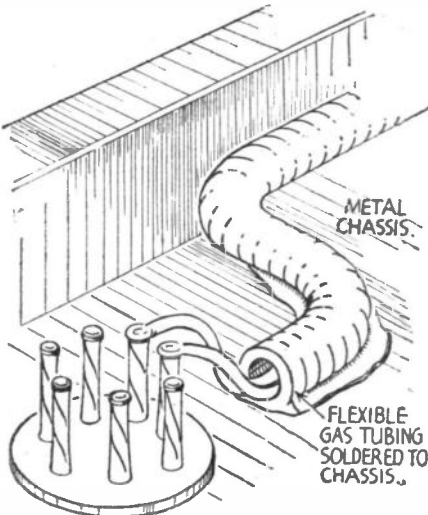

Using flexible metallic tubing for screening heater leads.

several H.T. leads through it at the same time; also, it is very strong and can be fixed down by straps of metal or even soldered to a metal chassis. Care must be taken in cutting to have the ends quite smooth. I have found that tinning them with a liberal coating of solder finishes off the ends nicely. Another use is as a protector for accumulator leads from acid spray while charging is in progress.—JAMES CHRYSTAL (Edinburgh).

Making Cheap and Efficient Stand-off Insulators

GLASS, being one of the best of insulating materials, was chosen to form the supporting pillars for the home-made stand-off insulators shown in accompanying sketches. A length of ordinary test tube (stocked by most chemists) was procured for the purpose, and cut up into short lengths.

The main difficulty was to find a suitable method of fixing the tube to the baseboard, and also securing the terminal at the top. This was accomplished by means of ordinary sealing wax, a few burnt out fuse-bulbs, and the bracket type of holders shown in the sketch.

First of all, the glass bulbs of the fuses were broken, and the remnants of glass and cement cleaned out with a small file, thus leaving small hollow screw caps.

To make an insulator, take one of these caps, place into it a small quantity of sealing wax and heat until melted. The glass pillar is then inserted and held vertical until the wax has set. The terminal at the

THAT DODGE OF YOURS!

Every Reader of "PRACTICAL AND AMATEUR WIRELESS" must have originated some little dodge which would interest other readers. Why not pass it on to us? We pay £1-10-0 for the best wrinkle submitted, and for every other item published on this page we will pay half-a-guinea. Turn that idea of yours to account by sending it in to us addressed to Editor, "PRACTICAL AND AMATEUR WIRELESS," George Newnes, Ltd., Tower House, Southampton Street, Strand, W.C.2. Put your name and address on every item. Please note that every notion sent in must be original. Mark envelopes "Radio Wrinkles." Do NOT enclose Queries with your Wrinkle.

top is fixed in a similar manner, but in this case a small plug of tinfoil is first pushed in to prevent the wax running down the glass tube. The insulator is then complete, except for screwing it into its holder, which in turn is screwed to the required position on the baseboard.

Stand-off insulators made in this fashion will be found quite efficient, and, provided the glass pillars are not too short, there should be no unwanted capacity effect between the terminal and metal fixing holder. It may, however, be found preferable to use bakelite-type holders in place of the metal ones shown, and, of course, the glass pillar could be cemented directly into them if desired. When soldering connecting wires or small components to the tag of the insulator, a piece of damp cloth should

be held against the terminal and glass tube to prevent the wax melting. In any case, the latter will soon re-set hard as soon as the connection is made.

A suggested rib effect may be obtained by heating the glass test tube (before constructing the component, of course) in a blow-pipe flame, and slightly stretching the tube when at melting point, the different points being treated in turn, a shape on the lines of that shown in the sketch being thus obtained.—R. L. GRAPER (Gillingham).

A Simple Morse Recorder

AN easy way to learn the Morse code is to listen to one of the slow-sending amateur Morse transmitters and then to tap out a fictitious reply (having the tapper joined in series with a Morse recorder and a battery), afterwards comparing the record on the paper with the reply.

A simple Morse recorder is shown in the accompanying diagram, and the sizes can

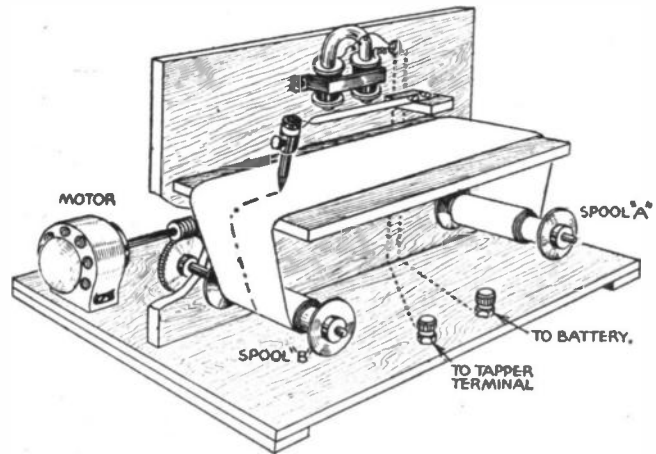

A simple Morse recorder for practice purposes.

be arranged to meet personal requirements. The parts required for making the recorder are: a thin piece of springy steel to which is attached a pencil-holder removed from an old pair of compasses; a spool of paper; a strong electro-magnet; two terminals; a pencil; some wire and a slow-running electric motor, which can be mounted on the baseboard, as shown.

The paper is made to travel from spool A, over a shelf, on to spool B by means of the electric motor. The Morse is recorded, by having the pencil pressing gently against the paper (the pressure being applied through the springy steel arm). The electric motor is then allowed to run, the pencil traces a continuous line along the moving surface of the paper. Any current flowing through the electro-magnet attracts the steel arm, lifting the pencil off the paper and discontinuing the line until the current ceases to flow in the electro-magnet. Thus a short blank will represent a dot, and a long blank a dash.—JOHN McLEOD (Edinburgh).

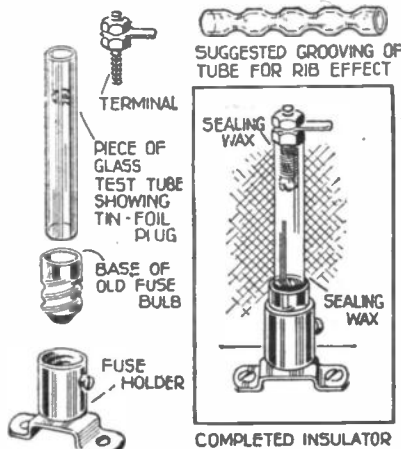

A method of making small stand-off insulators.

# USING VISUAL TU

*In this Article the Author  
Essential in Superhets, and*

If a receiver not fitted with automatic volume control is detuned, the volume of sound increases. It is by listening for maximum volume that the set is correctly tuned to the wanted station. Due to the fact that the selectivity of the H.F. and detector stages of a straight receiver is not so great as that of the I.F. stages of a superhet, slight detuning, providing it does not introduce interference from a station of nearby wavelength to the wanted station, will not cause audible distortion.

Where A.V.C. is fitted, however, the action of the circuit tends to keep the volume in the loudspeaker at its original

decreases, so the signal falls to a value indicated by A.D. Then it increases and decreases again, and so on. The line joining the tips of the successive variations in waveform, B, C, D and E, represents the musical notes.

It will readily be apparent that for true amplification of the musical notes comprising the transmission, the receiver must be tuned to the centre of the group of frequencies transmitted, when the side bands on both sides of the carrier will be faithfully reproduced, that is, of course, if the selectivity has not been made too high, and the L.F. stages are capable of dealing faithfully with all frequencies.

### Result of Detuning

Now suppose that the receiver is not quite correctly tuned, but to a point slightly

removed from the true centre of the transmission, and indicated by the line X. Due to the A.V.C. action of the receiver, the signal in the loudspeaker will tend to remain at constant strength, but it will be apparent that quality will be very poor, due to the fact that part of the sidebands are now being cut. The effect is generally to make reproduction harsh with over-emphasis of the sibilants.

It is due to the action of the A.V.C. in tending to keep the volume output

If we connect a suitable milliammeter in the anode of a valve which is controlled by A.V.C., as shown in Fig. 3, the meter reading will vary in accordance with the strength of the signal and we shall, by tuning to the lowest reading, be able to tune in the wanted station accurately.

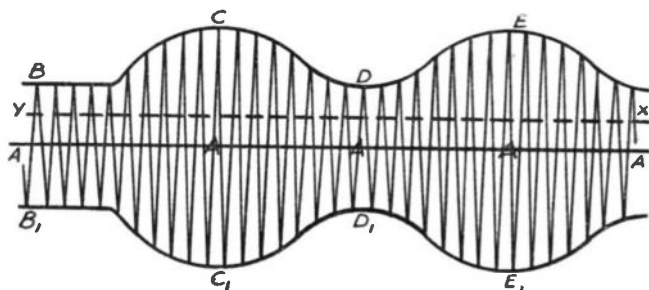

Fig. 1.—Diagram of carrier wave and audio-frequencies, showing correct (A), and incorrect (X) tuning points.

level on detuning. Aural tuning is, therefore, very difficult, and often quite impossible.

### Carrier Wave and Sidebands

It is well known that the received signal consists of a carrier wave on which are superimposed the audio frequencies constituting the transmission. The frequency of the carrier wave, of course, determines the wavelength of the station, and, as such, does not vary in frequency, and is, furthermore, inaudible. The audio frequencies, which are known as sidebands, are spaced equally on each side of the carrier wave by an amount equal to the transmitted note concerned. For instance, the frequency of a particular note may be 5,000 cycles per second, and this frequency, because it is an alternating current, must appear on either side of the carrier.

The carrier wave is thus the centre of the group of frequencies comprising the transmission, and it is this which is tuned. This is depicted pictorially in Fig. 1, where the carrier wave is shown for simplicity as a straight line A.

When the microphone receives a sound pressure wave or a musical note, the equivalent electrical current is generated in the microphone and amplified, and is used to change the amplitude of the signal with changes in the sound wave. As the pressure increases, the signal increases to a value indicated by the wave A.C. As it

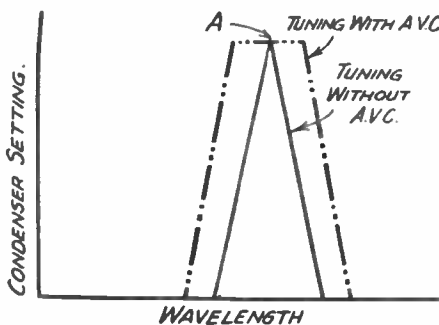

Fig. 2.—A.V.C. tends to give an apparent flattening of the tuning, thereby losing the exact resonant point A.

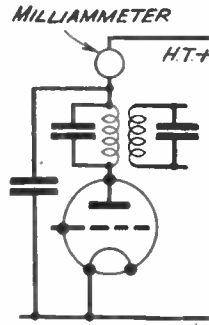
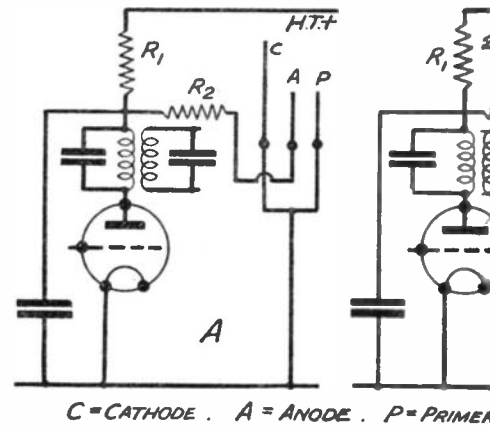

Fig. 3.—Showing the use of a milliammeter as a tuning indicator.



Figs. 4 and 5.—Circuits for using the Cossor neon tube voltage on the anode under conditions of no signal; and this will rise by 30-40 volts as the receiver is

## CALIBRATIC

This Table of Transmissions is for Use described in PRACTICAL AND AMATEUR

W9YAN, Elgin Observatory, Ill. U.S.A.

Date	G.M.T.	Freq. (kcs.)	40 m.	80 m.	20 m.	40 m.	40 m.	80 m.
Jan. 20th	22.00	7,000	40 m.					
	22.08	7,100						
	22.16	7,200						
	22.24	7,300						
Jan. 23rd	02.00	3,500		80 m. Signalling Procedure on each Frequency:				
	02.08	3,600		2 mins. "QST QST QST de W9YAN."				
	02.16	3,700		3 mins. Letter "O" repeated, followed by call W9YAN and statement of freq. being transmitted.				
	02.24	3,800						
Feb. 6th	02.00	7,000	40 m.					
	02.08	7,100						
	02.16	7,200						
	02.24	7,300						
Feb. 10th	22.00	14,000	20 m.					
	22.08	14,100						
	22.16	14,200						
	22.24	14,300						
Feb. 13th	02.00	7,000	40 m.					
	02.08	7,100						
	02.16	7,200						
	02.24	7,300						
Feb. 17th	22.00	7,000	40 m.					
	22.08	7,100						
	22.16	7,200						
	22.24	7,300						
Feb. 20th	02.00	3,500	80 m.					
	02.08	3,600						
	02.16	3,700						
	02.24	3,800						

*N.B.—Only those frequencies usually to be heard in this country are given here. Accurate time-keeping is essential—G.M.T.*



# TUNING INDICATORS

Explains why they are  
Discusses Suitable Circuits

The price of a typical meter specially designed for this purpose is about 8s., and no further components in the shape of resistances and condensers are necessary.

## Neon Tuning Indicators

The Cossor Neon Tuning Indicator (price 4s.) has been found very successful. It is easy to connect, and two circuits which have been successfully used by the author are shown in Figs. 4 and 5, and are simpler than that suggested by the makers. The circuit in Fig. 4, however, is the simplest which can be used, but has the disadvantage that the current taken by the tube itself is now greater, while it is not so sensitive in its action. By suitable adjustment of the resistance R.1, the tube may be made just to glow when no station is received, and to give a large rise of the glow when even a weak station is tuned in. Care must be taken to see that the glow does not reach maximum on local stations before they are accurately tuned in, but even then it is still possi-

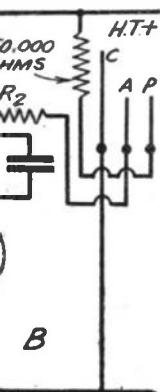

ing indicator. The should be 140-160, correctly tuned.

ble to tune accurately by the actual intensity of the glow after it has reached its maximum level. The resistance R.2 shown may only be necessary if maximum glow takes place too soon, or if the tube does not extinguish properly.

The device operates on the following principle: as a station is tuned in, the

to the tube are sufficient to cause it to glow slightly under conditions of no signal, R.1 should be made as large as possible.

Other types of neon tuning indicator, such as the Micromesh Tunograph, and the G.E.C. Tuneon, use the same type of circuit and work in the same manner.

## The "Magic Eye"

The latest type of indicator is sometimes known as the "magic eye," and consists of a miniature cathode-ray tube combined with a small triode amplifier in the same bulb. The device costs 17s. 6d., and is at present for use on A.C. mains only. This type of indicator varies from the others we have discussed in that it is dependent for its operation not on the variations in anode current of the controlled valves, but on the rectified output of the detector.

As the rectified output increases due to a signal being tuned in, the grid of the tube becomes more negatively biased, and this grid voltage is amplified by the triode portion of the indicator and applied electronically to the ray control electrode, thus increasing the intensity of the electron stream from the cathode to the target. This target is the phosphorescent end of the tube, and the construction is such that the luminous image appearing on it under conditions of no signal is as shown in Fig. 7 (A). As the signal is received, the arms of the cross gradually widen and assume the position shown in Fig. 7 (B), when the station is tuned in accurately. Full details of this system were given in our issue of September 19th last, and it has the advantage that it is extremely sensitive.

A little-known system of visual indication is shown in Fig. 8. Two L.F. chokes are wound on a common core, and choke L.1 is connected in the anode circuit of

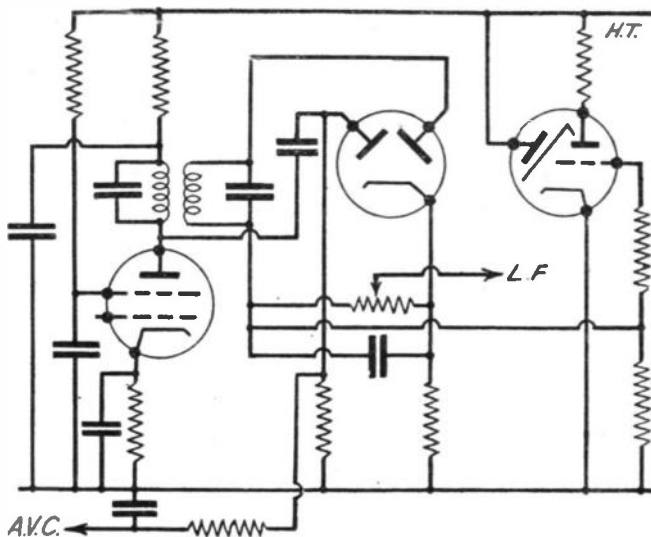

Fig 6.—Connections for the Mullard electron beam tuning indicator (type TV4).

valve becomes more biased due to the A.V.C. voltages fed back, less anode current flows, and thus, by Ohm's Law, the voltage drop across R.1 decreases (in practice, by about 30-40 volts). The voltage applied to the tube, therefore, increases and the glow spreads. It is as well to make R.1 as large as possible in order to get a large

variation in voltage across it as the signal is received. For example, suppose the current flowing through R.1 with no signal is 4 mA, and that it decreases to 2 mA as the station is received. If R.1 is 5,000 ohms, the variation in the voltage drop across R.1 will be only 10 volts, and this will cause little variation in the glow in the neon tube. If, however, we can make R.1 20,000 ohms, we shall have a change in voltage of no less than 40 volts, which will give rise to a large indication in the tube. Therefore, providing the valve will work efficiently, and that the volts applied

# ON SIGNALS

with the Heterodyne Frequency Meter  
R WIRELESS, dated January 16th.

W6XK, Don Lee Broadcast, Los Angeles, Cal., U.S.A.

Date	G.M.T.	Freq. (kc/s.)	40 m.	20 m.	Signalling Procedure on each Frequency:
Jan. 23rd	00.00	7,000	40 m.		
	00.08	7,100			
	00.16	7,200			
	00.24	7,300			
Jan. 25th	00.00	14,000	20 m.		Signalling Procedure on each Frequency:
	00.08	14,100			2 mins. "QST QST QST de W6XK."
	00.16	14,200			3 mins. Letter "M" repeated, followed by call W6XK and statement of frequency being transmitted.
	00.24	14,300			
Feb. 6th	04.00	7,000	40 m.		1 min. Repetition of call W6XK, statement of frequency and announcement of next frequency.
	04.08	7,100			
	04.16	7,200			
	04.24	7,300			
Feb. 20th	00.00	7,000	40 m.		2 mins. Change to next frequency.
	00.08	7,100			
	00.16	7,200			
	00.24	7,300			
Feb. 22nd	00.00	14,000	20 m.		
	00.08	14,100			
	00.16	14,200			
	00.24	14,300			

W.B.—As W6XK is a West-coast station, it is rather more difficult to receive, especially on the 40-metre band.

It will be noted that these two stations W9XAN and W6XK work the schedule "in and out," so that there is a standard frequency transmission regularly available.

Both stations welcome reports to the addresses given.

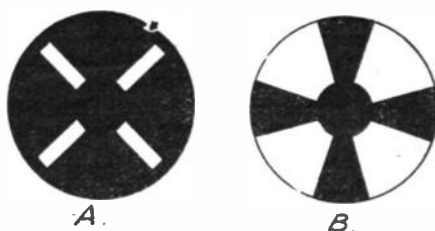

Fig. 7.—The image appearing on the screen of the Mullard electron beam tuning indicator, under conditions of (A) no signal, and (B) maximum signal.

variation in voltage across it as the signal is received. For example, suppose the current flowing through R.1 with no signal is 4 mA, and that it decreases to 2 mA as the station is received. If R.1 is 5,000 ohms, the variation in the voltage drop across R.1 will be only 10 volts, and this will cause little variation in the glow in the neon tube. If, however, we can make R.1 20,000 ohms, we shall have a change in voltage of no less than 40 volts, which will give rise to a large indication in the tube. Therefore, providing the valve will work efficiently, and that the volts applied

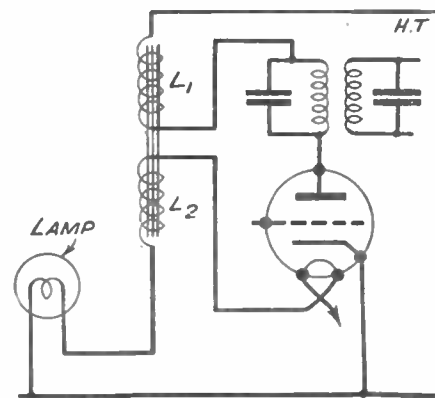

Fig. 8.—A little-known method of visual tuning indication.

# RECEIVER DESIGN IN 1937

In This Article the Author Discusses Possible Improvements in Receivers

**I**N 1936, roughly two million people bought wireless sets. Of these, a relatively small percentage had never owned a set before, whereas the majority discarded their old love for a new one; doubtless a proportion were forced to buy a new set because they were no longer able to hold together some ten years' old contraption.

Many bought a new set because it offered some advantage over their existing one by virtue of the improvements incorporated in it. It may be that their need was greater selectivity, longer range, better tone, or perhaps they desired an all-wave set with which to recapture the thrill of really long distance reception.

With the exception of a few real enthusiasts, the two million referred to will not buy new sets next year, but as there are approximately seven and three-quarter million licences, there are well over five million people, some of whom will purchase a set in 1937, but many of them will only do so if improvements in design will give them sufficiently tempting advantages to warrant scrapping a serviceable instrument.

Manufacturers, trade, and public alike are looking to 1937, all equally anxious to know what advance will be made.

There is, of course, always the chance that somebody will invent something really new. This is a factor which cannot be taken into account, but at the moment of writing nothing of this nature has appeared on the horizon, and in forecasting the 1937 Radio Exhibition attention can only be directed to the possibility of improvement on existing themes. Our investigation along the lines of possible improvements will be greatly facilitated by dealing separately with each of the many desirable characteristics of a radio receiver.

## Sensitivity

Commencing with sensitivity, a moment's thought will serve to show that an increase in this direction, while easily obtainable by

the obvious means of an additional stage, or stages, will definitely add nothing to the usefulness of a receiver, as any good five-valve superhet to-day will bring in every station that is not so weak that the ratio of receiver signal to local interference is bearable. Greater sensitivity will only bring in those very weak stations which are so weak compared to local interference and static that reception becomes a mere farce, sounding like the all too familiar racket suggestive of a giant frying sausages, completely drowning the programme, snatches of which are only heard occasionally. It is suggested, therefore, that although sensitivity can be achieved either by detailed improvements to coils or valves, or by the obvious method of additional stages, nothing will be accomplished from the ordinary listener's point of view.

## Background Noise Suppression

Sensitivity, as already shown, is largely tied up with the question of background noise suppression. It has always been understood that the bulk of static and man-made interference is inseparable from deliberate broadcasting from the transmitter, as owing to the general similarity of characteristics of both forms of ether waves it would be impossible to separate them, in the same way that it would be impossible to separate two glasses of water once they had been mixed together. This problem has received very considerable attention in England by the Radio Research Board and other interested bodies, and also in America. Up to the present, as far as ordinary broadcast receivers are concerned, nothing has been done beyond taking steps to ensure that the background noise on distance reception is not rendered worse than it need be. The very fact that bad design can increase background noise without increasing the desired programme, shows that there is definitely some fundamental difference between the two, and to the writer's way of thinking holds out considerable hope that a new technique may be developed capable of suppressing such interference. If this can be done completely, a Utopian ideal will be reached where practically any station in the world may be received at real entertainment value, the range of a receiver being limited only by its sensitivity (which in turn can be almost unlimited) and atmospheric conditions, which, of course, can sometimes so divert the propagated wave that a specified area is completely blind either always, or at certain times of the day. As far as is known the Americans have made considerably more headway in this direction than anybody else, and it may confidently be expected that vitally important

developments will be made public within a few months.

## Quality Reception

The quality of reproduction is of utmost importance, as good quality reception is prized by both long-distance enthusiasts and local-station listeners. Excellent as the quality of reproduction is in modern receivers, it cannot be denied that there

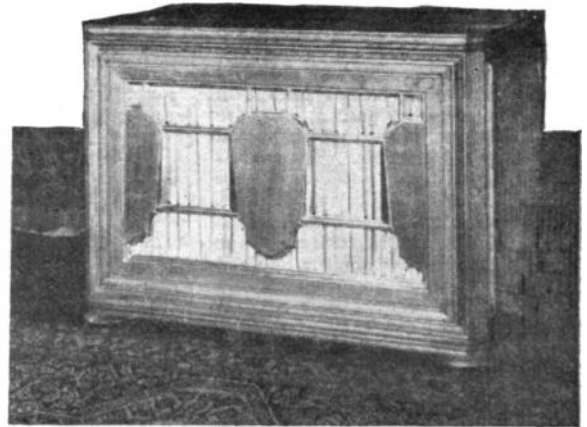

An ultra-modern radio cabinet design, in which all controls and other outward signs of a radio receiver have been avoided.

is considerable room for improvement both in the radio set itself, and in the loud-speaker. Improvement in the latter must necessarily come about in gradual stages as the result of devious and painstaking research, but improvements in the quality of reproduction in the receiver are already well in advance of general practice, as consideration of price makes it impossible for manufacturers of the relatively cheap sets to incorporate the desirable features that are standard in expensive instruments, costing £50 and upwards. Unfortunately the necessity for producing all-wave sets at an economical price has tended to bring about a slight decrease in quality in order that extra sensitivity may be gained. This is frankly a pity, but it is a thing that will sort itself out in the course of time.

Many readers who have well designed, up-to-date receivers, may condemn the writer in what is to them the certain knowledge that the reproduction on their own set is perfect. To this the writer would reply: "Wait until a pianoforte solo is being played, and then strike a few chords on grand piano in the same room, and note the contrast."

## Selectivity

Next let us turn our attention to selectivity. Can any improvements be made in this direction? The modern superhet with band-pass tuning can be adjusted to almost any degree of selectivity, the limitations being the effect on quality. Broadcasting stations to-day cut their frequency range at about 9 kilocycles, as this is the allotted span between stations. To increase the selectivity of a superhet to, say, 6 kilocycles would mean the loss in a musical scale of that section between 6,000 and 9,000 cycles, which would result in everything sounding rather

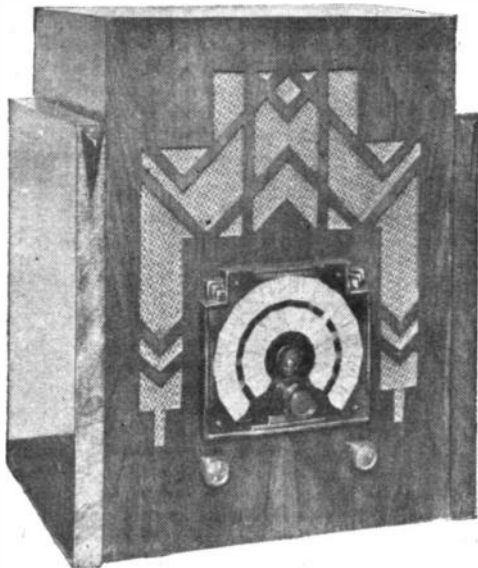

A 1933 receiver noteworthy for its ornate fretworked front and large tuning scale. This may be compared with the illustration of the modern receiver above.

lifeless. Curiously enough cymbals and big drums would be surprisingly affected; half a dozen instruments could be thrown out of a string band without the listener detecting any difference; sopranos and lady speakers would sound as if they had bad colds, and so on. There are, of course, ways of artificially accentuating the higher end of the register by correction in the L.F. section, but such arrangements are not very satisfactory, tend to increase background noise, and render reproduction unconvincing. To sum up, selectivity can be increased without the necessity for any further development, but only at the expense of quality; therefore it would seem that no development can be expected in this direction unless the crystal gate technique can be radically cheapened.

It is necessary to state clearly that by "selectivity," ease of adjacent station separation is intended, and it is not intended to convey interference due to double images breaking through, and kindred troubles, all of which are rapidly disappearing in modern receiver design.

**A.V.C. Systems**

The last twelve months have seen remarkable improvements in the efficiency of A.V.C. systems, and 1937 will definitely bring still further improvements. There is no question that A.V.C. systems should control both the L.F. amplifier (where one is used) and the output stage. Admittedly all sorts of arguments can be put up against controlling the output stage, but the writer is definitely of the opinion that such a course would be advantageous, taking into account all the circumstances. It is obvious that automatic volume control working on the second detector stage can never bring about perfect volume level, as it is the change of volume on the detector that controls the system. This will be more readily understood when it is realised that if the system were perfect, it would mean that the input to the detector remained constant, and if the input to the detector is constant, it cannot control the stages before it, as it is the change in the detector that exercises the control. This may sound rather complicated, but a little thought should make the explanation readily understandable.

If, then, the input to the detector cannot be completely controlled, it is obviously necessary to control the gain after the detector if apparently level volume is to

be maintained from a fading station. In fairness, however, it must be said that automatic volume control as it exists in practice to-day gives volume sufficiently level to appear completely level to the average ear.

Touching on ease of control, the modern superhet is so simple that any further advance in this direction must of necessity be unimportant. The same remarks apply about the individual controls themselves. The smoothness of the volume control is perfectly adequate, and with compensated volume control, as fitted to many 1936 receivers, loss of quality and reduced volume is obviated. There is one factor—reliability—which is unquestionably of paramount importance, but it hardly comes within the scope of development. The same remark is true of price, but it may be mentioned in passing that while it is reasonable to think that 1937 sets will be found more reliable than their predecessors, it is unlikely that there will be any important reduction in cost for a given standard in value. It is hinted in certain usually well informed circles that there may be actually a tendency for prices to rise.

**Items of Furniture!**

In conclusion the writer would like to put forward a belief of his own for manufacturers to realise that nobody wants a wireless set, but merely the sound that comes from it, and it is high time that radio sets ceased to look like the dashboard of a motor-car, and become pleasing additions in the average house. Please do not let it be inferred that the suggestion is to try to make a wireless set look like a clock; by all means let a wireless set retain its individuality, but spare us the sight of knobs, scales, switches and gadgets! The average person does not operate the controls for more than one minute in two hours, and there is no justification for not hiding them. The writer likes to have warmth, light and music in his lounge; to do this, however, he is spared the presence of a gas meter and an electric light meter in the same room. Why, therefore, the works of the wireless set? Some manufacturers have unquestionably already produced cabinets which discreetly hide the knobs, but generally speaking no advance has been made in this direction since the days when the "cat's whisker" had to be easily available for constant adjustment.

**PETO-SCOTT**

**Peto-Scott 1937 ALL-WAVE S.G.3 KIT**

16-2100 METRES NO COIL CHANGING

World-wide programmes on all wavelengths. Every constructor should build his own all-wave set and enjoy the thrill of All-Wave listening that will bring programmes from all over the world. Peto-Scott offer you a Kit which is, in the words of a famous designer, "An amazingly efficient yet simple to build Kit set."

**5/- DOWN**

NO COIL CHANGING. LOW LOSS ROTARY SWITCH. PRESSED STEEL DRILLED CHASSIS. S.G.3. DETECTOR AND PENTODE CIRCUIT. FULL INSTRUCTIONS AND DIAGRAMS.

and 11 monthly payments of 7/3 Complete Kit of components, less valves and cabinet.

**KIT "A" Cash or C.O.D. £3.17.6**  
Carriage Paid

**Peto-Scott BANDSPREAD SHORT-WAVE SUPER 3**

Covering 12-94 Metres.  
Maximum volume and efficiency.  
Detector and 2 L.F. Circuit.  
Slow-Motion Reaction-Condenser.  
Dual Ratio Slow-Motion Dial.  
Matched and Tested Components.

A simple-to-build and highly efficient short-wave 3 that will give you hours of thrilling entertainment on the short-wave band. Simple but efficient construction comprising 3 coils, 2 L.F. valves, ready drilled and enamelled chassis. Bandspread tuning simplifies station finding.

**2/6 DOWN**

**KIT "A" £2/5/0** Cash or C.O.D. or 2/6 down and 11 monthly payments of 4/3. Complete kit of parts, including 3 coils, 12-94 metres, building instructions and wiring diagram, less valves, speaker and cabinet.  
If valves required, add 1/7/6 to cash price, or 5/6 deposit and 11 monthly payments of 5/9.

**NEW AND DIFFERENT! PETO-SCOTT 1937 SHORT-WAVE ADAPTOR - CONVERTER KIT**

13-74 METRES

Convert your battery or A.C. set for operation on short waves with this up-to-the-minute unit. No alterations to your set. Two hours to build—a lifetime of world-wide entertainment.

No coil changing  
Drilled steel chassis.  
Drilled steel panel.

**KIT "A" Cash or C.O.D. 29/6**  
Carr. Paid. Or 2/6 down and 10 monthly payments of 3/-. Comprises all parts for building, with diagram, assembly, and operating instructions, less cabinet.

**2/6 DOWN**

**H.T. for 1d. per WEEK!**

**Peto-Scott H.T. ELIMINATORS**

Costs only 1d. a week to run!

Model A.C.12 Eliminator—Suitable for sets operating on an output of up to 12 mA. A.C. 200/230-v., 40/100 cycles. Output 120-v. at 12 mA. 4 tapplings. 60-v., 75-v., 90-v., and 120-v. Cash or C.O.D. Carriage Paid, 30/-, or 2/6 down and 10 monthly payments of 3/-.  
MODEL MA 10/30 Eliminator and TRICKLE CHARGER, £2/19/6, or 5/- down and 11 monthly payments of 6/8.

**2/6 DOWN**

**W. B. SPEAKERS**

Model 276. Amazing reproduction provided by a new magnet and exponential moulded cone. Microloud matching device. Cash or C.O.D. Carr. Paid £2/2/0. Or 2/6 down and 11 monthly payments of 4/-. Model 277. Matches any receiver as principal or extra speaker. Cash or C.O.D. Carr. Paid £1/12/6. Or 2/6 down and 11 monthly payments of 3/-.  
All Postal Orders should be crossed and made payable to Peto-Scott Co. Ltd. All currency must be registered.

**PETO-SCOTT Co. Ltd.** 77 (Pr. W. 21), City Road, London, E.C.1.  
Telephone: GUYRIOD 9673  
West End: 63 (Pr. W. 21), High Holborn, London, W.C.1.  
EST. 1919

**CINEMA v. TELEVISION BATTLE**

IN one or two quarters the old question of an inevitable clash between the cinema interests and television broadcasting is coming to the front again. On one side it is being stated that television's progress may be slow at the moment, but this is no excuse for inaction. There is a change of front, however, in the assertion that rigid opposition to television will lead nowhere, and vested cinema interests are making every effort to see how they can work in closer association with the new science. After all, the public becomes the final judge, and if they find that some cinemas are willing to show them the latest developments in television they will soon ignore those that do not. A striking example of this is furnished by the

Dominion Theatre, London. Each Friday night the Baird Super Screen is included in the programme with the result that large crowds, interested in the innovation, are drawn to the theatre. It has been reduced to a one-night show simply because there is not room in the programme to make it a daily feature. Besides showing outstanding stage, screen, and broadcast personalities, the audience join in by asking questions and receiving answers from the person being televised. The extension of this idea to other cinemas is, of course, a matter of conjecture at the moment, but it seems certain that 1937 will be a big screen year for television, quite apart from any aspect of home viewing on standard forms of receivers.



## A New 40-Page Booklet—Free



This booklet, which is yours for the asking, gives particulars of the many opportunities open to trained men engaged in the Radio industry. It also gives full information about the specialized instruction offered by the I.C.S.

The industry is progressing with amazing rapidity. Only by knowing the basic principles can pace be kept with it. I.C.S. Instruction includes American broadcasting as well as British wireless practice, and provides ambitious men with a thoroughly sound training.

Here are the I.C.S. Courses:  
**Complete Radio Engineering**  
**Complete Radio**  
**Radio Servicemen's**  
**Elementary Radio**  
**Radio Service and Sales**  
**Television**

Preparatory Courses for:  
**I.W.T. Associateship and Associate**  
**Membership Exams.**  
**City and Guilds Exams. in Radio Com-**  
**munication.**  
**P.M.G. Certificates in Wireless Tele-**  
**graphy.**  
**I.E.E. Graduateship Exam.**

The Complete Radio Course covers equipment and radio principles as well as practice.

Efficient Servicing is of first importance to every wireless dealer and his assistants.

In addition to inculcating the art of selling, the Service and Sales Course provides that knowledge which enables the salesman to hold his own with the most technical of customers.

Television will soon be a tremendous branch of the industry. Our Course deals adequately with this subject, and covers the various important systems.

### SEND FOR OUR BOOKLET TO-DAY

And, if you wish, ask for our free advice on any matter concerning your career. We shall be most pleased to inform you and help you, without placing you under any obligation.



**INTERNATIONAL  
 CORRESPONDENCE  
 SCHOOLS LTD.**

**Dept. 94, International Buildings,  
 Kingsway, London, W.C.2.**

# Facts and Figures

COMPONENTS TESTED IN OUR NEW LABORATORY

### T.C.C. Electrolytics

**E**LECTROLYTIC condensers are always clearly marked as to the correct working and peak voltages with which they should be employed, but many constructors overlook the fact that when switching on (and sometimes when switching off) surges take place. The peak surge voltage can often rise to a value considerably greater than would appear on a rough examination of a circuit, and therefore some care is necessary if damage is to be avoided. The aqueous type of electrolytic is to be preferred when surge voltages are not known, and there is a wide limit permissible in the T.C.C. special surge-proof condensers. For instance, in the type 801 condenser, designed for a maximum continuous working voltage of 460 volts D.C., it is permissible to apply a potential of 500 volts or so. Obviously, however, such a high value must not be applied continuously, but the characteristics of the condenser prevent the value rising above a certain value, and the condenser behaves quite normally when the voltage falls to the correct value as it does not puncture.

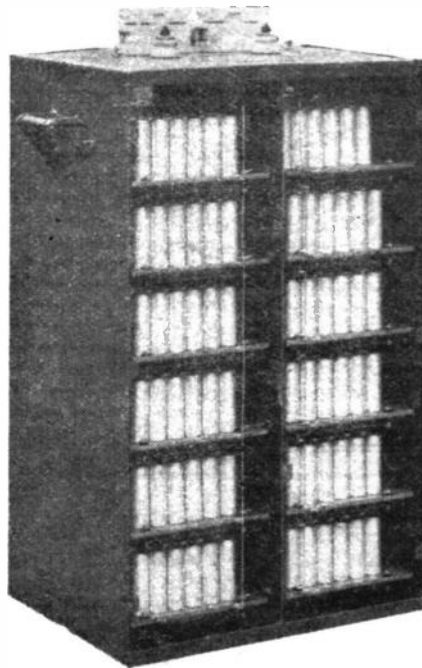

An interesting assembly of T.C.C. surge-proof electrolytic condensers.

The condenser is available in various values from 4 mfd. up to 32 mfd. at prices from 5s. to 7s. As a matter of interest we give on this page an illustration of a bank of these condensers mounted on removable racks and assembled into a steel tank. The total capacity of the unit amounts to 2,500 mfd., and is suitable for working at 600 volts D.C. plus a super-imposed ripple. The particular bank was made for use in an electric tramway station, and similar units are used in film studios.

### High Vacuum Valve Company

**W**E are asked to point out that the telephone number of the High Vacuum Valve Company, of 113-117, Farringdon Road, E.C.1, has been changed to TERminus 2587 and 2588. This company, of course, manufactures the well-known Hivac valves.

### New Lissen Receiver

**A** NEW A.C. mains transportable has been added to the Lissen range of receivers, and is known as Model 8303. The most important feature of this receiver is the special loudspeaker mounting and arrangement for giving improved reproduction, as a result of which the receiver is to be known as the "Set with the Balanced Sound Chamber." The new cabinet design enables reproduction to reach a high level without blind-spots or distorting angles. No aerial or earth are required for the receiver, which incorporates four valves (including rectifier) and is designed for use with a pick-up. Sockets for an external aerial and earth are fitted when it is desired to make use of these outside aids. The price is 10 guineas.

### New Bulgin Valveholders

**A** NEW range of chassis-mounting valveholders for English standard valves is being introduced by Messrs. Bulgin. These are to be made in accordance with recent British Standards dimensions, and are assembled from bakelite plates. A special feature is the inclusion of a special interleaved plate to provide a long leakage path, and this feature has been patented. The holders are of the resilient type, and perfect contact is obtained when the valve is pushed home. Special soldering contacts are fitted, and these are so designed that solder cannot run into unwanted places. The assembly is carried out in such a way that the upper plate forms a guard and prevents the valve from being damaged due to contact between the wrong pins and sockets, and no electrical contact can be made until the valve is correctly arranged. At the moment there are three types, No. V.H. 34 for 4-5-pin valves, No. V.H. 35 for 7-pin valves, and V.H. 36 for 9-pin valves. The prices are respectively 6d., 9d. and 1s.

### New Mazda Tuning Indicators

**T**HE Edison Swan Company announced the forthcoming release of two new visual-tuning indicators of the cathode-ray type, one designed for use in A.C. mains receivers, and one for use in the universal A.C./D.C. type of receiver. The design of this type of indicator, and method of using it, is explained on pages 148 and 149 of this issue, but circuit details of the Mazda component, and technical details have not yet been released.

### Rothermel Microphone

**A**S from February 1st, the price of the model D.104 Piezo electric microphone, supplied by Messrs. Rothermel, has been reduced to £4 10s.

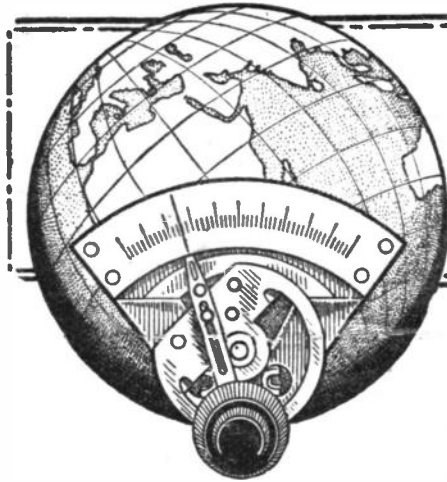

# SHORT WAVE SECTION

## A Three-stage Amateur Band SW Receiver

In this Article the Construction and Operation of a Three-valve Receiver for the Amateur Waveband is Described

### Essential Requirements

The essentials in such a receiver are band-spread, ease of handling, absolute stability even at the highest frequencies, sensitivity, selectivity, an output stage which can be switched to a speaker when signal strength permits, and a wave-range covering the amateur bands of 10 to 160 metres. There are probably few straight receivers which satisfy all these requirements, and superhets designed to cover them are usually somewhat expensive and deficient in other respects, such as having a low signal-noise ratio, the commonest failing

THE intending amateur transmitter and the short-wave listener who finds his main interest in the amateur wavebands both require a receiver which, while it may be suitable for short-wave broadcast reception, is primarily designed for listening on the amateur bands. One very often finds, however, that in the first case the amateur is so taken up with the transmitting side that he more or less overlooks the importance of receiver

will give good service, consider Fig. 1. This shows a battery-operated three-stage arrangement in which the first point to notice is that all feed circuits are decoupled. This may seem a little unnecessary in a battery set, but it results in a marked gain in stability, particularly on ten metres. The first valve, V1, is a screen-grid or H.F. pentode, the input circuit using the arrangement first described by the writer in PRACTICAL AND AMATEUR WIRELESS for February 16th, 1935. The value of an H.F. stage, whether tuned or untuned, preceding the detector valve, has often been pointed out in these columns, and it is now standard practice in a modern straight short-wave receiver. In the present instance, the input circuit C1-L1-R.F.C., is designed to operate tuned on the 160 m. band and untuned on the others. On closing the DPST panel switch S1-S2, C1-L1 becomes the input tuning circuit for 160 m., while on the other bands, with S1-S2 open, C1 is cut out and L1 and R.F.C. put in series to obtain the required impedance across grid-filament of V1. The necessary data is given in the table of values.

### H.F. Input

While on this point, it is worth arranging matters so that H.F. tuning can be used on 80 m. as well, and an alternative input circuit is shown in Fig. 2. L1 is the 80 m. coil, L2 a second coil of similar value, since they

*(Continued overleaf)*

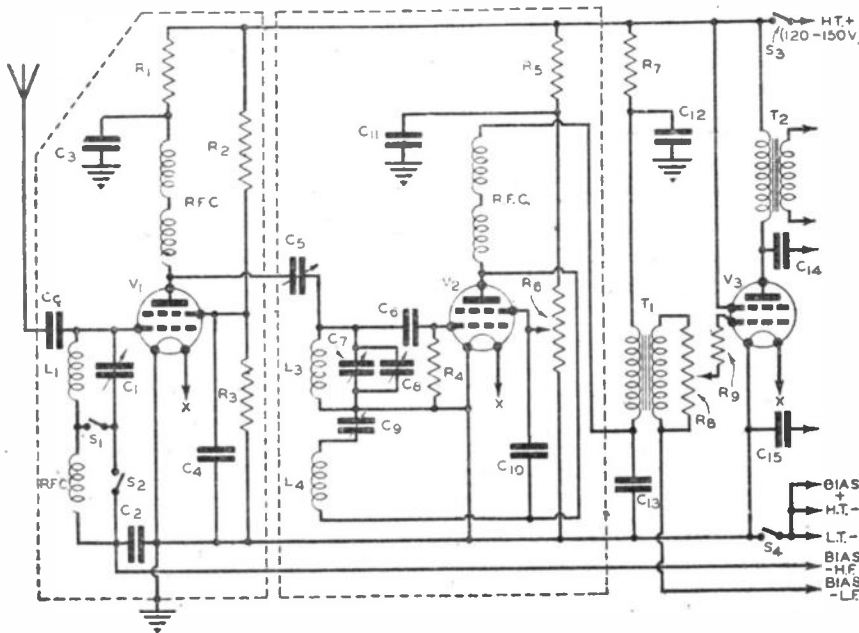

Fig. 1.—Suggested circuit arrangement of Three-stage Amateur Band SW Receiver. Dotted lines indicate separate screening boxes for H.F. and detector stages. For modification of H.F. stage, giving input tuning on 80 and 160 metres, see Fig. 2. All necessary data is given in table of values.

efficiency and as time goes on pays less and less attention to it, with the result that his over-all station efficiency suffers. The SWL, on the other hand, usually finds his way into the amateur wavebands after having either bought or built a short-wave receiver originally designed for general short-wave reception, and which may or may not be fitted with band-spread tuning; the manufactured set is usually not so fitted, and his results are accordingly not nearly as good as they should be.

In this article, therefore, it is proposed to outline the requirements of a straight receiver for operation on the amateur bands, and then to describe a suitable design for the purpose.

in this type of receiver, particularly on the short waves. An amateur short-wave superhet having all the latest refinements and control circuits, such as crystal-gate, noise suppression, A.V.C., band-spread, "single signal" characteristics and so on, is undoubtedly a remarkable performer, but the additional elaboration involves considerable expense which the average amateur would rather devote to the transmitting side.

### A Three-stage Amateur Band Receiver

Coming now to a straight receiver which represents an up-to-date design and which

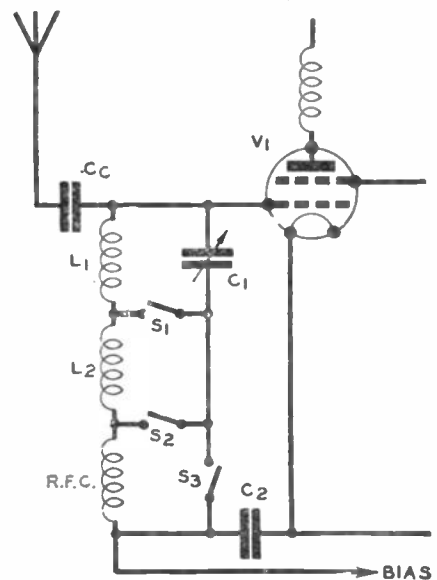

Fig. 2.—Suggested arrangement for H.F. stage tuning on 80 and 160 metres. Coil data is given in the table of values. Switches S1, S2, S3 should be SPST, R.F. type, and mounted on panel.

## SHORT-WAVE SECTION

(Continued from previous page)

are put in series for 160 m., and R.F.C. is the H.F. choke. In practice, L1 and L2 comprise a centre-tapped winding, which itself tunes the 160 m. band. With the switches S1, S2 and S3 closed, L1-C1 tunes the 80 m. band. With S1 open, and S2 and S3 closed, tuning over 160 metres is obtained. With all three switches open, L1-L2-R.F.C. are in series, making the input circuit aperiodic for 40, 20 and 10 metres. A further point to notice is that by closing S3 and leaving S1 and S2 open, the condenser C1 is placed across this aperiodic circuit and can be used as an input volume control. H.F. energy being by-passed as its capacity is increased from minimum towards maximum. If it has a very low minimum capacity, as all good condensers should have, placing it in parallel with L1-L2-R.F.C. at the minimum capacity setting should not involve any noticeable reduction in signal strength on any band from 20 metres up.

## H.F. Output

The output from the H.F. stage is coupled into the grid circuit of the detector through the condenser C5, which is a low-capacity, air-dielectric variable. C5 plays a big part in the performance of the receiver, in that both the input to and the selectivity of the detector grid circuit is controllable. A setting of this condenser can be found to give the best compromise over a wide range of reception conditions. For instance, if the receiver has to be operated through bad local-station interference, the input can be cut down and the selectivity of the circuit L3-C7 increased by adjusting C5 towards its minimum. Similarly, with bad interference on the 40m. band, on which, when conditions are good, large numbers of European stations come in on top of one another, a setting of C5 can be found which will help in sorting them out while still keeping signals at comfortable strength.

## Band-spread Arrangement

The circuit L3-C7-C8 is the usual band-spread arrangement, to which reaction is applied by means of C9-L4. The detector valve is a screen-grid, thus improving the sensitivity and ease of control of the receiver owing to the fact that the screen-grid potential can be closely adjusted by means of the potentiometer R6. This makes it possible to get the smoothest reaction effect.

The output from the detector is coupled, through the high-ratio transformer T1 to a pentode V3 as the final stage, with a grid-blocking resistor at R9. The plate circuit of V3 is arranged for either 'phones or speaker operation by using an output transformer T2 for the speaker—assuming some form of M/C instrument—the phones being put across C14-C15. Low resistance headphones should be connected to appropriate tapings on the output transformer. The H.F. chokes R.F.C., with the exception of that in the grid circuit of V1 which is described in the table of values, should consist of short-wave and broadcast chokes in series. This is particularly important in the plate circuit of V1, where it is possible to get resonance effects with its grid circuit such that "break-through" of broadcast and long-wave commercial stations is experienced as a background to the short-wave signals to which V2 is tuned. The recommended values should, however, obviate this, unless the receiver is used in the vicinity of a powerful station with the input circuit untuned on 80 and 160 metres. Short-wave chokes can be home-

made by putting three sections of 50, 75 and 100 turns each of No. 32 enamelled wire on a lin. diameter former, with about  $\frac{1}{4}$  in. between sections.

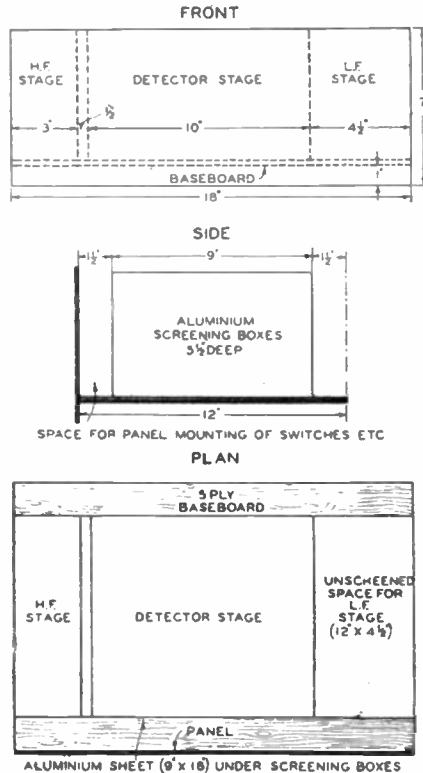

Fig. 3.—Details of construction of baseboard, panel, and screening compartments.

## Main Tuning Control

Condenser C8, the band-spreader, is the main tuning control, and for this is recommended a split-stator type such as the "J. B." midget twin, or the Cyldon "Bebe" series-gap. The grid coil L3 is connected across the two stators only, the rotor being left free. This arrangement also tends to improve stability, and removes any possibility of trouble due to noisy or disconnected pig-tails.

With regard to the coils L3 and L4, for which the data is given for home-construction, it will be found that though the standard manufactured type of plug-in coil can be used instead, their turns values are arranged from the point of view of maximum frequency coverage in a set intended for general S/W reception. This means that in some cases the 20- and 40-metre amateur bands will be found on the same coil, at minimum and maximum capacity of the band-setter C7. Owing to the low L/C ratio thus resulting on 40 metres, this is most undesirable. Another point is that the manufactured type will take up a good deal more room than the home-made variety.

## Coil Construction

The suggested construction of these coils is quite simple and they will be found to be extremely efficient. The former in each case consists of a piece of ribbed ebonite rod lin. in diameter by  $\frac{1}{4}$  in. long. The wire used is No. 32 enamelled, and the turns are close-wound on all except the 10 m. coil, on which they are slightly spaced. These small formers are tapped 4BA at one end—the ribbed rod will be

found to have a hole running through its entire length—and are mounted on a small piece of ebonite about  $\frac{1}{4}$  in. square. This carries four valve-pins to which the coil connections are made, the former then plugging into a low-loss valveholder mounted on a small stand-off insulator. The circuit connections are taken to the valveholder terminals, and the net result is a coil assembly about half the usual size, having a very small field, and a high turns-ratio.

## General Layout

Trouble taken in the layout and construction of the receiver will be well repaid by results. The diagrams in Fig. 3 show a recommended form of construction. The panel is ebonite, though the two first stages V1 and V2 are totally enclosed in aluminium screening boxes, as indicated. These boxes are bolted to a wooden baseboard over which is laid a sheet of aluminium, there being a space of lin. beneath the baseboard for the by-pass condensers and resistors. The condensers C1, C7, C8 and C9 are mounted on brackets with extension rods brought out to the controls on the front panel. Note that this involves drilling both the front of the screening box—plain holes, clearing the rods—and the ebonite panel. This method of construction improves screening and shortens considerably the important grid and plate leads in the detector circuit. The condenser C5 should be mounted in the run of the wiring in the detector stage screening box—it is not necessary to bring it out to the panel—and the connection between it and the plate of V1 should be screened.

If the preliminary adjustments are carefully made, the receiver will be found to be exceptionally "smooth" and easy to handle, and tuning, except on 160 and 80 metres where the H.F. stage is tuned—if the circuit of Fig. 2 is used—resolves itself into "one-knob control," that of C8. Correct adjustment is largely a question of getting R6 at the proper setting to give smooth reaction. This setting will probably be found to vary from band to band, but with the coil values given the reaction adjustment of C9 should hold over a large frequency spread.

(To be continued)

## TABLE OF VALUES.

R1, R5, R7, 10,000 ohms, 1-watt; R2, 40,000 ohms, 1-watt; R3, 50,000 ohms, 1-watt; R4, 4-megohm grid-leak; R6, 50,000 ohm, 2-watt potentiometer; R8,  $\frac{1}{2}$ -megohm volume control; R9, 25,000 ohms, 1-watt. RFC. See text. T1, High-ratio coupling transformer; T2, Output transformer. S1, S2, DPST switch, R.F.; S3, S4, DPST switch, on-off; Cc, see text; C1, .00025 mfd; C2, .01 mfd; C3, C4, C10, C11, C12, 1 mfd; C5, 50 mfd, midget; C6, .0001 mfd; C7, .0002 mfd, band-set; C8, split-stator band-spread, 50 mfd each section, see text; C9, .0002 mfd, reaction; C13, .001 mfd; C14, C15, 2 mfd.

## COIL DATA

Band.	L1.	RFCs.	L3.	L4.
1.7 Mc.	25	60	46	30
3.5 Mc.	L1 and RFC in		25	16
7 Mc.	series below		13	9
14 Mc.	160 metres		5	5
28 Mc.			3	4

All coils wound on lin. diam. formers of ribbed ebonite rod, in  $\frac{1}{4}$  in. lengths, using No. 32 enamelled wire, close-wound, except for 28 Mc, where the turns of L3 should be slightly spaced. The two windings L3/L4 of each coil are spaced about  $\frac{1}{4}$  in.

The various bands will be found with C7 about half to two-thirds in mesh. If the circuit of Fig. 2 is used, coil L1/L2 can be 26 turns centre-tapped.

## VALVES SUGGESTED

	V1.	V2.	V3.
Mazda	VP.215	SG.215	Pen.220A
Hivac	SG.220SW	SG.220SW	Y.220



**REPLIES IN BRIEF**

The following replies to queries are given in abbreviated form either because of non-compliance with our rules, or because the point raised is not of general interest.

**S. G. (Marborough).** It would appear that the trouble is due to some inductive effect in the pick-up leads, and that at a certain setting of the control the input impedance is brought to such a value that the trouble is introduced. We have never met this peculiarity and think it must be due to your control or the circuit you are using.

**E. B. (Maidenhead).** We are sorry that we cannot give the connections, as the coils differ, and the manufacturers in question have made several different types.

**W. W. (Barnes-on-Trent).** You cannot use the alternative coil suggested. There should be no delay in obtaining the coils, and if you let us have details of the dealer, etc., we will take up the matter with the manufacturers.

**A. H. (Rochdale).** C1 may be .01 mfd. and C2 a similar value. R2 should be chosen between .25 and 1 megohm, and R4 between 10,000 and 30,000 ohms. We cannot see how the arrangement is intended to function with the remaining two resistances R1 and R3 and these appear to be unnecessary.

**T. N. (Wansley Castle, Wores.).** An H.F. pentode may be substituted, but you could not use the variable bias on the detector stage. You may have to modify the anode load in order to obtain an improvement in the total volume given.

**F. F. (Southampton).** The volume control may have an incorrect value, and you should communicate with the makers of the receiver or their nearest local service agent regarding the correct method of using the pick-up on this set.

**G. E. (Farnham).** We cannot give full constructional details in the form of a reply. You should obtain the back number, where full constructional and operating details are given. You did not enclose a stamp or addressed envelope with your letter.

**R. B. (Saugham) and Others.** You are quite correct in stating that the accumulator is in opposition to the mains voltage. The current passed will not, therefore, rise to .5 amps. The battery resistance changes whilst it is under charge.

**F. J. U. (Singapore).** You may send your queries in the usual way. We make due allowances for the date of the query coupon in cases such as yours, and you are entitled to the same service as English readers.

**H. F. S. (Harringay).** You could not feed the valve heaters from the eliminator as they take too much current. You need a barretter or series resistance so as to feed the heaters direct from the D.C. mains and a transformer cannot be used on D.C.

**G. P. (W.15).** It is not possible to give the data without the thickness of the core and the material from which it is made.

**A. V. (Sheerness).** It would be preferable to obtain a new receiver, as you have been informed. To try and convert the set so as to use Universal valves might lead to a tremendous amount of trouble and some difficulties might be found insurmountable. We advise you to get a Universal (A.C./D.C.) receiver, so that any future changes which you might have to make would not render the set obsolete.

**B. G. H. (Bramley).** The reception is certainly very good, but you must not overlook the possibility of freak conditions, and the trouble which sometimes arises on an unselective set, of one station being brought in on the carrier wave of another. The stations mentioned do not share their wavelength, but are separated by quite a considerable amount. Your set is not selective enough to separate them.

**P. W. S. W. (Eastbourne).** A suitable circuit will be found in the first article on transmitting, in our issue dated November 28th last.

**K. G. S. (Hertford).** A fixed condenser (as in the usual output filter circuit) is all that is necessary.

**A. J. W. (Sparkhill).** The trouble may be due to a faulty grid condenser or grid leak. We presume that the frame aerial has not been kept near the accumulator, as the acid fumes may have eaten into the wire.

**G. B. (Leytonstone).** A temporary surge to the value mentioned is usual, but the current should not remain at that value. It may be due to the switch not breaking instantly, or to the valve characteristics. A scratch filter is the only cure for the excessive noise mentioned.

**L. C. (Nottingham).** The other side of the reaction condenser should be joined to the earth line. If it is mounted on a metal panel (which is earthed) no connection is needed, as the spindle will be in contact with the panel and the earth connection will be obtained in that manner. The choke is to keep the H.F. currents from the L.F. stage and therefore the connection is in order. The low value of resistance is a stabiliser.

**An Ideal Book for the Beginner!**  
**Everyman's Wireless Book**  
By F. J. CAMM

3/6, or 4/- by post from George Newnes, Ltd.,  
Tower House, Southampton St., Strand, London,  
W.C.2.

**MORE AMAZING BARGAINS**

Here is a small selection only of the many wonderful bargains N.T.S. have to offer. In addition to these we have a large number of battery and A.C. mains receivers of all types, and they are offered at ridiculously low prices that cannot possibly be repeated. Send for comprehensive list of these bargain receivers NOW.

**STRAIGHT 3 CHASSIS BARGAIN**  
LIST PRICE 32/6

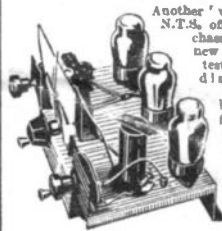

Each chassis brand new and thoroughly tested before dispatch.

**WITH VALVES**

**COMPLETE RECEIVER**

Another wonderful N.T.S. offer! Each chassis brand new and tested before dispatch.

**LESS VALVES**  
**17/6**

Above chassis with 3 British Valves. List Price 45/-, Bargain, 39/6 Cash or C.O.D. or 2/6 down and 11 monthly payments of 2/8.

**BARGAIN CLASS "B" 4 KIT**

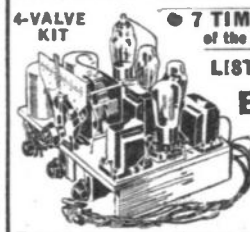

4-VALVE KIT

7 TIMES the VOLUME of the ordinary Battery Set!

LIST PRICE £4:4:0

**BARGAIN**

**45/-** Cash or C.O.D. Carr. Paid.

OR YOURS FOR

**2/6 DOWN**

Label Class "B" Circuit built on METAFLEX. 4 Stages. Variable Mu. Screened Grid high-frequency detector. Class "B" Driver and Class "B" Output Valves. Shielded Coils. Twin gang Air Dielectric Condenser. Range 500-550 and 1,000-2,000 metres. Working Drawings and instructions with each kit.

**KIT "A"** All parts, less valves, cabinet, speaker. Cash or C.O.D. Carriage Paid 58/6, or 2/6 down and 11 monthly payments 4/8.

**KIT "B"** with valves, 53/18/6 or 12 monthly payments 6/0.

**KIT "CS"** with valves, walnut finished console cabinet, and N.T.S. Class "B" M.C. Speaker 55/18/6, or 18/- down and 11 monthly payments 10/0.

**N.T.S. SHORT WAVE 2**  
12-94 Metres **KIT**



With a remarkable range that will give you hours of fascinating short-wave entertainment. Kit comprises all components including metal-sprayed baseboard, 3 variable condensers, .0001, .0002 and .0016 MFD., on/on switch, L.P. Transformer, 3 baseboard mounting four-pin holders, short-wave H.F. choke, 2 terminal mounts, 4 terminals, 3 fixed condensers, slow-motion drive, grid leak, connecting wire, 3 4-pin short-wave coils, 12/24, 22/47, and 41/94 metres, 2 component brackets and wiring diagram. Cash or C.O.D. Carriage Paid 57/6, or 2/6 down and 11 monthly payments of 5/4.

**2/6 DOWN**

**N.T.S. S.W. ADAPTOR**  
12-94 Metres



America and all the World DIRECT on your present set. For only 17/6. Build this reliable short-wave adaptor for use with any BATTERY receiver. Kit comprises all parts, including metal-sprayed baseboard, 2 variable condensers, .00016, .0001 MFD., 2 baseboard mounting 4-pin holders, short-wave H.F. choke, grid leak, fixed condenser, adaptor plug terminal mounts, 2 terminals, 3 4-pin plug-in coils, 12/24, 22/47, and 41/94 metres, 1 component bracket, slow-motion drive, trimming condenser, connecting wire and wiring diagram. Built in one evening. Cash or C.O.D. Carriage Paid 17/6, or 2/6 down and 7 monthly payments of 2/6.

**2/6 DOWN**

**BARGAIN 1-valve S.W. KIT**  
LIST PRICE 35/- BARGAIN

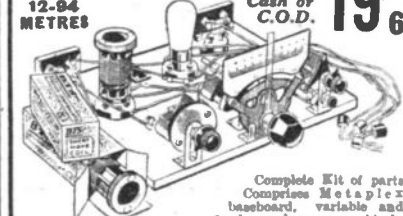

Complete Kit of parts Comprises Metaflex baseboard, variable and fixed condensers, switch, valve and coil-holders, H.F. choke, terminals, slow-motion drive, 3 short-wave coils, connecting wire, and FULL WIRING DIAGRAM. Less valves. Cash or C.O.D. Carriage Paid 19/6, or 2/6 down and 6 monthly payments of 3/8. N.T.S. Lightweight headphones 7/6 pack extra.

Cash or C.O.D. **19/6**

**2/6 DOWN**

**N.T.S. Moving Coil SPEAKERS**  
LIST PRICE 27/6

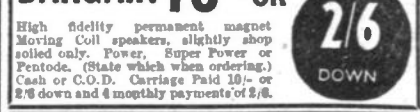

High fidelity permanent magnet Moving Coil speakers, slightly shop soiled only. Power, Super Power or Pentode. (State which when ordering.) Cash or C.O.D. Carriage Paid 18/-, or 2/6 down and 4 monthly payments of 2/8.

**BARGAIN 10/-** OR

**2/6 DOWN**

**N.T.S. H.T. ELIMINATOR**  
LIST PRICE 42/- BARGAIN

For A.C. Mains 200-250 volts, 40-60 CYCLES.

Ideal for all 3-valve sets. Output 12 mA at 120 volts. Tappings for S.G., Det. and Super Power or Power. Supplied complete with plug and mains cord. Employs Westinghouse Metal Rectifier. Bargain price 22/6 or 2/6 down and 11 monthly payments of 2/-.

**22/6**

**2/6 DOWN**

**W.B. SPEAKERS**



MODEL 576 (illustrated on left). A cabinet instrument giving superb reproduction, with power handling capacity of up to 5 watts undistorted. The turn of a switch adjusts it to match any set made. With volume control. Cash or C.O.D. Carriage Paid 22/6, or 5/- down and 11 monthly payments of 2/8.

MODEL 578. Amazing reproduction provided by new magnet and exponential moulded cone. Microleak matching device. Cash or C.O.D. Carriage Paid 22/6, or 2/6 down and 11 monthly payments of 4/-.

MODEL 577 (illustrated on right). Cash or C.O.D. Carriage Paid 11/18/6, or 2/6 down and 11 monthly payments of 2/8.

**2/6 DOWN**

All Postal Orders should be crossed and all currency registered.  
**NEW TIMES SALES CO.,** 56 (Pr.WT), Ludgate Hill, London, E.C.4.

You've paid your Licence  
You've got your set  
AND IF you've used FLUXITE—  
You won't need a "VET."



See that FLUXITE is always by you—in the house—garage—workshop—wherever speedy soldering is needed. Used for 30 years in government works and by leading engineers and manufacturers. Of Ironmongers—in tins, 4d., 8d., 1/4 and 2/8.  
Ask to see the FLUXITE SMALL-SPACE SOLDERING SET—compact but substantial—complete with full instructions, 7/6.  
Write for Free Book on the art of "soft" soldering and ask for Leaflet on CASE-HARDENING STEEL and TEMPERING TOOLS with FLUXITE.

TO CYCLISTS! Your wheels will NOT keep round and true, unless the spokes are tied with the fine wire at the crossings AND SOLDERED. This makes a much stronger wheel. It's simple—with FLUXITE—but IMPORTANT.

**THE FLUXITE GUN**

is always ready to put Fluxite on the soldering job instantly. A little pressure places the right quantity on the right spot and one charging lasts for ages. Price 1/6.



ALL MECHANICS WILL HAVE

**FLUXITE**

IT SIMPLIFIES ALL SOLDERING

FLUXITE LTD. (Dept. W.P.) DRAGON WORKS, BERMONDSEY STREET, S.E.1.

**DANGER FROM LIGHTNING**  
GET A **GARD**  
LIGHTNING ARRESTER  
WITH THE GUARANTEE **2/-**  
OF £200

Act now! Don't run risks. Lightning may ruin your set, your home, your very life. Forget these dangers with a GARD, from all dealers or post free from:

**GRAHAM FARISH LIMITED,**  
Maons Hill, Bromley, Kent.

**"ENGINEERING OPPORTUNITIES" FREE!**

This unique Hand-book shows the easy way to secure A.M.I.C.E., A.M.I.Mech.E., A.M.I.E.E., A.M.I.A.E., A.M.I.W.T., A.M.I.E.E. and similar qualifications.

**WE GUARANTEE—NO PASS—NO FEE.**  
Details are given of over 150 Diploma Courses in all branches of Civil, Mech., Elec., Motor, Aero, Radio and Television Engineering, Building, Government Employment, etc.

Write for this enlightening Hand-book to-day FREE and post free. British Institute of Engineering Technology, 409, Shakespeare House, 17, 18, 19, Stratford Place, W.1.



The Editor does not necessarily agree with the opinions expressed by his correspondents. All letters must be accompanied by the name and address of the sender (not necessarily for publication).

**Club Wanted: S.W. Activities in Australia**

SIR,—I should be very glad to get in touch with a few short-wave clubs near New Southgate. I have in mind a little morse practice, and later on I hope to build your 2½-watt transmitter.

The following paragraph which appears in the "Listener In," an Australian publication, might interest other readers.

"A very interesting state of short-wave affairs is developing in Australia, where the Commonwealth Government, through the P.M.G. Department, is planning to install a number of short-wave broadcasters throughout the Commonwealth. One, of course, will be the new VK3LR, which is to have its power increased to 5 kW. An eventual increase to 20 kW. is projected.

"A.W.A. has planned a new S.W. station which will carry the call sign VK6ME for Perth (W.A.). Little is known of the progress being made with this transmitter, but listeners may rest assured that it will not be long before it is placed in commission."—S. W. GREIG, 30, Park View Crescent, New Southgate, N.11.

[Local club secretaries are invited to get in touch with Mr. Greig.—ED.]

**Loan of Oscillator Required**

SIR,—I would like to get into touch with someone who lives in my neighbourhood, and who possesses a test oscillator which I could borrow for the purpose of ganging a superhet I have constructed. Although particulars of the set were published in your pages, I cannot claim free servicing, as the circuit was gathered mainly from the series "Designing your own Wireless Set." I remain, a great admirer of your paper.—M. C. MATTHEWS, 9, Well Road, Hampstead, N.W.3.

**"Acoustic" Output**

SIR,—Readers at times get a bit confused with the word "output" of a receiver, and perhaps the small experiments which I carried out may explain matters.

I used two commercial all-mains receivers, one delivering 2 watts undistorted output, the other 3.5 watts. The first receiver's volume control was turned full on, the same with the other, resulting in this case in the 2 watts output being much louder than the 3.5 watts output. I then continued to experiment, taking a battery set, with a pentode delivering approximately 1 watt output. A P.M. speaker was then fixed to a baffle a foot square, with excellent results. I then increased the baffle to 2ft. square. Output was greater than with first baffle used. I next placed the 2ft. baffle in a chamber—cube shape—and the volume was up to all-mains standard. Coming back to my two all-mains receivers with which I commenced the experiment, I removed the backs of each, and both sets fed their outputs to P.M. speakers.

The 2-watt receiver's speaker was mounted in a larger chamber, the cabinet being much larger than that of the 3.5-watt receiver. The experiment thus shows that it was "volume of sound" I heard in the first set, and not actually the output.

So if a reader has a set giving 8 watts, it doesn't always mean that it is better than another giving 5 watts: it all depends on its "acoustic" output. I mention that this experiment is on "output" and must not be confused with the "range" of the sets, as my trials were carried out on the local station, but what I am aiming at proving is that it is not necessarily the loudest or "boomy" set that is best.—JOHN W. LEECH (Llandudno).

**The Band-spread S.W. Three**

SIR,—I thank you for your test report on my Bandspread S.W. Threo. You recommended the inclusion of a 20,000 ohms resistor, which I have now fitted, and the set now works well. I give below a list of stations received during the past week: WIXAL, JZI, W2XAO, G5XXN, W2XAF, G8IX, G5NY, G8BK, G5VX, G5PH, G8CP, G8FY, G2IW, G8GM, GSD, 2RO, G5UI, G8IH, G6JW, G2AI, W3EOC, and W2AU, Wishing PRACTICAL AND AMATEUR WIRELESS continued success.—W. B. WENDON (Brandis Corner, Devon).

CUT THIS OUT EACH WEEK.

*Do you know*

- THAT special coupling units are available so that any type of valve may be tested in a single valve-tester.
- THAT when adjusting a television time base, the spot should not be allowed to come to rest on the fluorescent screen.
- THAT the above difficulty may be avoided by connecting some source of continuous oscillation to one pair of deflecting plates.
- THAT when using a chassis-built set and experiencing difficulty from interference, it is often worth while to enclose the bottom of the chassis with a sheet of metal.
- THAT in a similar case, a wooden screened component mounted on a metal baseboard or chassis, may often advantageously be improved by covering the lower side with an earthed metal screen.
- THAT vibration of connecting leads can cause erratic tuning effects in a powerful multi-valve superhet.

The Editor will be pleased to consider articles of a practical nature suitable for publication in PRACTICAL AND AMATEUR WIRELESS. Such articles should be written on one side of the paper only, and should contain the name and address of the sender. Whilst the Editor does not hold himself responsible for manuscripts, every effort will be made to return them if a stamped and addressed envelope is enclosed. All correspondence intended for the Editor should be addressed: The Editor, PRACTICAL AND AMATEUR WIRELESS, George Neveins, Ltd., Tower House, Southampton Street, Strand, W.C.2.  
Owing to the rapid progress in the design of wireless apparatus and to our efforts to keep our readers in touch with the latest developments, we give no warranty that apparatus described in our columns is not the subject of letters patent.

# RADIO CLUBS AND SOCIETIES

Club Reports should not exceed 200 words in length and should be received First Post each Monday morning for publication in the following week's issue.

## The Croydon Radio Society

LECTURES by members of the Croydon Radio Society are always welcomed, but none more so than that by Mr. W. J. Bird, the Society's Chairman, who spoke on "Modern Sound Film Technique" at the meeting in St. Peter's Hall, on Tuesday, January 19th. After members had seen an actual specimen of sound film, lantern slides followed which were very helpful in making the lecturer's points clear. A vital part of sound film reproduction was the exciter lamp shining on to a narrow slit *en route* to the sound track, and thence to the photo-electric cell. The slit must be narrow, as the beam from it must pick out each individual cycle, with a space on the track of only .0018ins. Mr. Bird's account of the photo-electric cell and its circuit was distinctly useful. Typical amplifiers were discussed, and, naturally, much was said about such accessories as field current supply for loudspeakers, converting mains supply to 110 volts A.C., as well as features of the projection room. One loudspeaker did duty from 30 to 2,000 cycles, and another from 150 to 10,000 cycles. On Tuesday, January 26th, in St. Peter's Hall, S. Croydon, the topic was "Radio Interference," by Mr. F. W. Newson, of the G.P.O., and besides describing cures for electrical interference, he demonstrated them on the Society's quality receiver.

In the demonstration, he placed a small Neon sign generator next to the Society's quality receiver, thereby causing a loud crackle. Immediately, the suppression apparatus was switched on, and complete silence, as regards the interference, was at once noticeable. Hon. Pub. Sec.: E. L. Cumbers, Maycourt, Campden Road, South Croydon.

## Portsmouth and District Wireless and Television Society

AT the meeting of the above Society Mr. Pegler demonstrated a two-valve set which covered all wavebands from 9 metres. After giving blackboard diagrams

### USING VISUAL TUNING INDICATORS

(Continued from page 649)

the controlled valves. Under conditions of no signal, the current passing through L.1 is at its highest, and the core becomes magnetised. The inductance, and therefore the impedance, of the other choke L.2, is thus at its lowest. A small flash-lamp bulb is connected in series with L.2, one side of the heater circuit, and earth. Were L.2 a simple resistance, the lamp would thus glow, the intensity of illumination being determined by the resistance. When the impedance of the choke L.2 is at its lowest, the lamp glows brightly as the resistance is now fairly low. As a station is tuned in, however, the A.V.C. action reduces the current flowing through L.1, the magnetisation of the core becomes less and the impedance (resistance) of L.2 rises, with the result that the lamp glows less brightly. Accurate tuning is obtained when the glow is at its minimum, or even extinguished.

of the circuit and aerial used, he tuned in several stations on the loudspeaker. Lieut. Jackson also demonstrated a 3-valve miniature broadcast set which he had built, using an earphone for a loudspeaker.

Meetings will now be held every Wednesday and Morse practice takes place every Monday. We shall be pleased to hear from manufacturers, and others, who would give demonstrations and lectures.—Harold Leigh, 20, King Street, Southsea.

## Halifax Experimental Radio Society

THIS Society carried out some interesting experiments on 40 metres recently, in conjunction with Mr. H. Crewe (G.S.C.B.). The receiver was situated at the Society's club rooms in the Friendly and Trades Club, and the transmitter approximately three miles to the north. Both the receiver and transmitter were made by members of

the Society. Demonstrations were given of the ability of the amateur transmitter to deal with a large variety of broadcasts, among which were included speech, music from gramophone records, and Morse; also a relay of some birds singing was done by taking a microphone near to a local aviary. The results at the club rooms on the receiver were exceedingly good, and particularly the bird singing.

The receiver was a 2-valve (Det. and Power) operated from batteries, and reproduction was by a moving-coil loudspeaker.

The transmitter was crystal controlled, with an input of 10 watts. The microphone was amateur made, being cut from a solid block of slate 6in. by 4in. by 2in. thick, and of the transverse current type.

Hon. Sec.: J. B. Bedford, Oak House, Triangle, Nr. Halifax, Yorkshire.

## YOU HAVE BEEN WARNED BY RADIO—

Professor Hilton, on November 19th, 1936, from the B.B.C., broadcast a warning. The warning was to the effect that while there are many really good and reliable Colleges teaching by correspondence, there are many others which are colleges by name only. He said some so-called colleges rented a couple of rooms in a large building in a well-known street. Some made great promises which they did not intend to fulfil. Some claimed successes they could not prove. In some cases the names of prominent men were quoted who were in no way connected with the working of the College.

### NOW BE ADVISED BY ME.

The big name of a College is no proof of its national standing. The Bennett College has been established over 30 years and our entire building is devoted to Bennett College work. No other business of any kind is either on or attached to The Bennett College. We have seating accommodation for over 10,000. We have a permanent staff of over 190 people on the College premises. Our Professional Staff have all passed their examinations, and our tutors are all experts in their own specialised work. We do not send out any homework to be corrected by tired, spare-time tutors. All students' homework is corrected on the College premises the same day that it arrives, and is returned by evening post. This College is Technical, Scientific, General and Commercial, thus enabling us to cater for all requirements; this is important to Cost and Works Accountants, and all who have to deal with rate fixing, machinery allowances, and it is also of great importance in many of the Civil Service Examinations. This is an entirely British College. Most of our textbooks are written on the College premises by our own professional staff, especially for tutorial purposes. Our tutors specialise in teaching students for the examinations they themselves have already passed.

### THERE IS NO OTHER COLLEGE IN THIS KINGDOM THAT CAN CLAIM ALL THE ABOVE ADVANTAGES.

It is not necessary for students to attend the College; we can send exactly the same tuition to you by post for a reasonable fee payable monthly. Anyone who reads the journals knows that there are many things advertised that one can study, and any kind of study is good. It is training for the brain, but the best thing to study, surely, is a course specially prepared to teach you your own vocation, or prepare you for the examination which you have in view. Knowing that you are master of your job gives you self-confidence and personality, but a Diploma from a College is absolute proof of your efficiency. We have agencies in all English-speaking corners of the world. The nature of our business makes us keep in touch with employment requirements in all parts of the world; therefore we specialise in preparing students for the good positions which we know exist, and for all the worth-while examinations.

### THE ABOVE VAST ORGANISATION CAN HAVE BEEN CREATED ONLY BY THE SUCCESS OF OUR STUDENTS.

There is a tide in the affairs of man which, if taken at the flood, leads on to fortune and success. There are three things which come not back: the sped arrow, the spoken word, and the lost opportunity—this is your opportunity. If it is your desire to make progress and establish yourself in a good career, write to us for free particulars on any subject which interests you, or if your career is not decided, write and tell us of your likes and dislikes, and we will give you practical advice as to the possibilities of a vocation and how to succeed in it. You will be under no obligation whatever. It is our pleasure to help. We never take students they are suitable. Do not forget that success is not the prerogative of over 30 years proves that the outstanding brilliancy.



### LET ME BE YOUR FATHER

Let me tell you how to make a success of your career. If your future is undecided or appears unsatisfactory, let us talk it over together. I want to help, and it will cost you nothing to get my help, you will be under no obligation whatever.

We are prepared to produce, on demand, over 10,000 unsolicited testimonials from successful students, or in default we will hand over £100 to charity.

### A STAFF OF 197

are in daily attendance at this College at your service.

### YOUNG MEN

Young men physically fit and whose careers are not definitely fixed should join the Police Force. We have Special Courses for Entrance and Promotion. 1/- per week brings success. Full particulars Free. Address: POLICE Dept. 104.



THE MOST SUCCESSFUL AND MOST PROGRESSIVE COLLEGE IN THE WORLD.

### ENGINEERS

Engineers, now is your chance to dig yourselves into a Key position and make your future solid. It needs Technical Training: we can give you that by post. Full particulars Free. Dept. 104.

DEPT. 104, THE BENNETT COLLEGE LTD., SHEFFIELD

# ELECTRADIX BARGAINS



**TRANSMITTERS, MORSE AND SIGNAL KEYS.** Royal Air Force model, balanced action, all solid brass bar, tungsten contacts indicator. Type KBSL, a guinea key for 7/6. Other keys from 4/6 to 30/-. Learner's outfit complete, 4/6. Ask for special illustrated Key List. Send 1d.

**ALL-WAVE CRYSTAL SETS** with plug-in coils, 2 tuning condensers, semi-perm. detector, 7/6.  
**HEADPHONES.**—Sullivan 120 ohms, 2/9. Ericsson, Lissen and others, 2,000 and 4,000 ohms, 4/8. Single high res. ear-phones, 2/6.  
**X-RAY VACUUM DISCHARGE TUBES, 10/-.** New Government Hospital Surplus, 7" dia. bulb. Big solid Tungsten electrodes. Emission guaranteed. COST £5. SALE 10/-, Packing, 2/6 extra.



**LIGHT AND RAY CELLS,** Selenium Raycraft, 21/-; Kingston, 15/-. Raycraft outfit with relay and amplifier, 45/-. Photo-Cells, for sound on Film, Television and Ray work, B.T.P., 15/-; R.C.A., 25/-; Beck, Angle Prisms, mounted in carrier, 5/6.

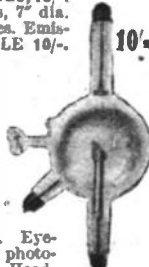

Micrometer adjusters for lens, 1/-. Eyepieces with prism and lenses for photo-cell inspection, 12/6. Service set Head-lamps with Battery Holder, 7/6.  
**MEGERS** as new. Direct Reading .001 ohms to 10 meg. Long scale dial for Resistance makers, 100, 250 and 500 volts, cheap. SILVERTOWN Portable Tester. Combines Wheatstone Bridge, Galvo, shunts and ratios, as new, £8. G.P.O. Plug-in Bridge Resistance Boxes, to 8,000 ohms, 60/-.  
**COMMUTATORS.** For Motors and Dynamos 5 to 500 volts. 2/- each. Fractional H.P. motors all sizes, cheap.  
**H.T. TRANSFORMERS.**—200 40 v. to 10,000 v. 25 m.a., 34/-; 5,000 volts 20 m.a., 19/8; 2,500 v. 15 m.a., 17/6. Large "Butterfly" Neon Signs, 4ft. 2in. x 4ft. 11in. x 6in., on glass panel, ready for use, £5.  
**PUBLIC ADDRESS AMPLIFIERS.**—We can supply from stock 3, 6, 10 or 20 watt Mains or Battery Amplifiers in portable or chassis form at lowest prices. Special Pro. Act or Dance Band Portable with mike and speaker, £12. 10 watt A.C. Mains Amplifier, 200/250 v., new, with valves, steel case, £9-10-6. Large Set for 16 watts output, with 4 speakers, £25. P.A. and Cinema Speakers cheap.  
**MICROPHONES, HAND AND STAND.**—Transverse, Crystal, Condenser and Ribbon. Our Public Address Eisel-Beiss Transverse Current Microphones are far superior and all the best judges use them. Only 55/-  
**TABLE MODEL "N.W.11."**—Wonderful value, only 15/-.

Sale Bargain List "N" for 1d. stamp.

# ELECTRADIX RADIOS

218, Upper Thames St., London, E.C.4.  
 Phone: Central 4611.

## Qualify for a Post in TELEVISION

Full Radio Television Courses, to qualify for A.M.I.R.E. or A.M.I.T.E. degrees, 62 postal Lessons. Special Offer for 1 month to readers of "Practical and Amateur Wireless"

Full Course - £3 3 0 cash.  
 Sample Lesson - - 2/6

Write for particulars to

THE INSTITUTE OF TELEVISION ENGINEERS,  
 6, St. Mary's Chambers, London, W.C.2  
 or Temple Chambers, 65, Lichfield Street, Wolverhampton

# W.B. STENTORIAN SPEAKERS



The Finest Permanent Magnet Loudspeakers on the market, supplied on lowest terms:—  
 87s; Cash or C.O.D. 63/6, or 2/6 down; and 12 monthly payments of 4/-.

**GARRARD TYPE "B" RADIOGRAM UNIT** consisting of Garrard Electric Motor and Garrard High-grade Pick-up. Cash or C.O.D. £3/2/6; or 6/6 with order and 12 monthly payments of 6/6.

PROMPT DELIVERY. Anything and everything Radio supplied on lowest terms.  
**THE LONDON RADIO SUPPLY CO., LTD.,**  
 11, Oat Lane, Noble Street, London, E.C.2.

# Practical and Amateur Wireless BLUEPRINT SERVICE

PRACTICAL WIRELESS.		PORTABLES.	
CRYSTAL SETS.	Date of Issue. No. of Blueprint.	Three-valve: Blueprint, 1s.	
Blueprint, 6d.		F. J. Camm's ELF Three-valve Portable (HF Pen, D, Pen) ..	16.5.36 PW65
1937 Crystal Receiver ..	9.1.37 PW71	Four-valve: Blueprint, 1s.	
<b>STRAIGHT SETS. Battery Operated.</b>		Featherweight Portable Four (SG, D, LF, Cl. B) ..	PW12
One-valve: Blueprint, 1s.		<b>MISCELLANEOUS.</b>	
All-wave Unipen (Pentode) ..	— PW31A	S.W. Converter-Adapter (1 valve) ..	PW48A
Two-valve: Blueprint, 1s.		<b>AMATEUR WIRELESS AND WIRELESS MAGAZINE CRYSTAL SETS.</b>	
Four-range Super Mag Two (D, Pen) ..	11.8.34 PW30B	Blueprints, 6d. each.	
Three-valve: Blueprints, 1s. each.		Four-station Crystal Set ..	12.12.36 AW427
Selectone Battery Three (D, 2 LF (Trans)) ..	— PW10	1934 Crystal Set ..	AW444
Sixty Shilling Three (D, 2LF (RC & Trans)) ..	— PW34A	150-mile Crystal Set ..	AW450
Leader Three (SG, D, Pow) ..	— PW35	<b>PORTABLES.</b>	
Summit Three (HF Pen, D, Pen) ..	8.8.34 PW37	Four-valve: Blueprints, 1s. 6d. each.	
All Pentode Three (HF Pen, D (Pen), Pen) ..	22.9.34 PW30	Midget Class B Portable (SG, D, LF, Class B) ..	20.5.33 AW389
Hall-Mark Three (SG, D, Pow) ..	— PW41	Holiday Portable (SG, D, LF, Class B) ..	1.7.33 AW393
Hall-Mark Cadet (D, LF, Pen, (RC)) ..	10.3.35 PW48	Family Portable (HF, D, RC, Trans) ..	22.9.34 AW447
F. J. Camm's Silver Souvenir (HF Pen, D (Pen), Pen) (All-Wave Three) ..	13.4.35 PW40	Two H.F. Portable (2 SG, D, QP21) ..	June '34 WM363
Genet Midget (D, 2 LF (Trans)) ..	June '35 PM2	Tyers Portable (SG, D, 2 Trans) ..	WM367
Cameo Midget Three (D, 2 LF (Trans)) ..	8.6.35 PW51	<b>SHORT-WAVE SETS.—Battery Operated.</b>	
1936 Sonotone Three-Four (HF Pen, HF Pen, Westector, Pen) ..	17.8.35 PW53	One-valve: Blueprints, 1s. each.	
Battery All-Wave Three (D, 2 LF (RC)) ..	— PW55	S.W. One-valve converter (Price 6d.) ..	AW329
The Monitor (HF Pen, D, Pen) ..	— PW61	S.W. One-valve for America ..	23.1.37 AW429
The Tutor Three (HF Pen, D, Pen) ..	21.3.36 PW62	Rome Short-Waver ..	AW452
The Centaur Three (SG, D, P) ..	— PW64	Two-valve: Blueprints, 1s. each.	
The Gladiator All-Wave Three (HF Pen, D (Pen), Pen) ..	29.8.36 PW60	Ultra-short Battery Two (SG det., Pen) ..	Feb. '36 WM402
F. J. Camm's Record All-Wave Three (HF Pen, D, Pen) ..	31.10.36 PW69	Home-made Coll Two (D, Pen) ..	AW440
The "Colt" All-Wave Three (D, 2 LF (RC & Trans)) ..	5.12.36 PW72	Three-valve: Blueprints, 1s. each.	
Four-valve: Blueprints, 1s. each.		World-ranger Short-wave 3 (D, RC, Trans) ..	— AW355
Fury Four (2 SG, D, Pen) ..	— PW11	Experimenter's 5-metre Set (D, Trans, Super-regen) ..	30.6.34 AW438
Beta Universal Four (SG, D, LF, Cl. B) ..	— PW17	Experimenter's Short-wave (SG, D, Pen) ..	Jan. 19, '35 AW463
Nucleon Class B Four (SG, D (SG) LF, Cl. B) ..	6.1.34 PW34B	The Carrier Short-waver (SG, D, P) ..	July '35 WM360
Fury Four Super (SG, SG, D, Pen) ..	PW34C	Four-valve: Blueprints, 1s. 6d. each.	
Battery Hall-Mark 4 (HF, Pen, D, Push-Pull) ..	— PW40	A. W. Short-wave World-Beater (HF Pen, D, RC, Trans) ..	— AW436
F. J. Camm's "Limit" All-Wave Four (HF Pen, D, LF, P) ..	20.9.36 PW67	Empire Short-waver (SG, D, RC, Trans) ..	— WM313
<b>Mains Operated.</b>		Standard Four-valve Short-waver (SG, D, LF, P) ..	Mar. '35 WM383
Two-valve: Blueprints, 1s. each.		Superhet: Blueprint, 1s. 6d.	
A.C. Twin (D (Pen), Pen) ..	— PW18	Simplified Short-wave Super ..	Nov. '35 WM 397
A.C.-D.C. Two (SG, Pow) ..	7.10.33 PW31	<b>Mains Operated.</b>	
Selectone A.C. Radiogram Two (D, Pow) ..	— PW19	Two-valve: Blueprints, 1s. each.	
Three-valve: Blueprints, 1s. each.		Two-valve Mains short-waver (D, Pen) A.C. ..	— AW453
Double-Diode-Triode Three (HF Pen, DDT, Pen) ..	10.6.33 PW23	"W.M." Band-spread Short-waver (D, Pen) A.C./D.C. ..	— WM368
D.C. Ace (SG, D, Pen) ..	— PW25	"W.M." Long-wave Converter ..	— WM380
A.C. Three (SG, D, Pen) ..	— PW29	Three-valve: Blueprint, 1s.	
A.C. Leader (HF Pen, D, Pow) ..	7.4.34 PW35C	Emigrator (SG, D, Pen) A.C. ..	— WM352
D.C. Premier (HF Pen, D, Pen) ..	31.3.34 PW35B	Four-valve: Blueprint, 1s. 6d.	
Ubique (HF Pen, D (Pen), Pen) ..	28.7.34 PW36A	Standard Four-valve A.C. Short-waver (SG, D, RC, Trans) ..	Aug. '35 WM301
Armada Mains Three (HF Pen, D, Pen) ..	18.8.34 PW38	<b>MISCELLANEOUS.</b>	
F. J. Camm's A.C. All-Wave Silver Souvenir Three (HF Pen, D, Pen) ..	11.5.35 PW50	Enthusiast's Power Amplifier (1/6) ..	June '35 WM387
"All-Wave" A.C. Three (D, 2 LF (RC)) ..	17.8.35 PW51	Listener's 5-watt A.C. Amplifier (1/6) ..	Sept. '35 WM392
A.C. 1936 Sonotone (HF Pen, HF Pen, Westector, Pen) ..	— PW56	Radio Unit (2v.) for WM392 (1/-) ..	Nov. '35 WM393
Four-valve: Blueprints, 1s. each.		Harris Electrogram (battery amplifier) (1/-) ..	Dec. '35 WM390
A.C. Fury Four (SG, SG, D, Pen) ..	— PW20	De-Luxe Concert A.C. Electrogram ..	Mar. '36 WM403
A.C. Fury Four Super (SG, SG, D, Pen) ..	— PW34D	New Style Short-waver Adapter (1/-) ..	June '35 WM388
A.D. Hall-Mark (HF Pen, D, Push-Pull) ..	— PW45	Trickle Charger (6d.) ..	Jan. 5, '35 AW462
Universal Hall-Mark (HF, Pen, D, Push-Pull) ..	9.2.35 PW47	Short-wave Adapter (1/-) ..	Dec. 1, '34 AW456
<b>SUPERHETS.</b>		Superhet Converter (1/-) ..	Dec. 1, '35 AW457
Battery Sets: Blueprints, 1s. each.		B.L.D.L.C. Short-wave Converter (1/-) ..	May '36 WM405
£5 Superhet (Three-Valve) ..	— PW40	Wilson Tone Master (1/-) ..	June '36 WM406
F. J. Camm's 2-valve Superhet (Two-Valve) ..	18.7.35 PW52	The W.M. A.C. Short-wave Converter (1/-) ..	July '36 WM408
F. J. Camm's £4 Superhet ..	— PW58	These blueprints are drawn full size.	
<b>Mains Sets: Blueprints, 1s. each.</b>		Copies of appropriate issues containing descriptions of these sets can in some cases be supplied at the following prices, which are additional to the cost of the blueprint. A dash before the Blueprint Number indicates that the issue is out of print.	
A.C. £5 Superhet (Three-valve) ..	— PW43	Issues of Practical Wireless ..	6d. Post paid
D.C. £5 Superhet (Three-valve) ..	1.12.34 PW42	" .. Amateur Wireless ..	6d. " "
Universal £5 Superhet (Three-valve) ..	— PW44	" .. Practical Mechanics ..	7d. " "
F. J. Camm's A.C. £4 Superhet 4 ..	— PW59	" .. Wireless Magazine ..	1s. " "
<b>SHORT-WAVE SETS.</b>		The index letters which precede the Blueprint Number indicate the periodical in which the description appears; thus, PW refers to PRACTICAL WIRELESS, AW to Amateur Wireless, FM to Practical Mechanics, WM to Wireless Magazine.	
Two-valve: Blueprint, 1s.		Send (preferably) a postal order to cover the cost of the blueprint and the issue (stamps over 6d. unacceptable), to PRACTICAL AND AMATEUR WIRELESS Blueprint Dept., Geo. Newman, Ltd., Tower House, Southampton Street, Strand, W.C.2.	
Midget Short-Wave Two (D, Pen) ..	15.9.34 PW38A		
Three-valve: Blueprints, 1s. each.			
Experimenter's Short-Wave Three (SG, D, Pow) ..	— PW30A		
The Prefect 3 (D, 2LF (RC and Trans)) ..	— PW63		
The Bandspeed S.W. Three (HF Pen, D (Pen), Pen) ..	20.8.36 PW68		





# QUERIES and ENQUIRIES

## Using A Diode

"Is it possible to use a diode or double-diode for A.V.C. on a 'straight' set whilst retaining reaction on the usual triode detector, or could a D.D.T. be used for amplified A.V.C.? If so, could you give me a diagram? I have tried a Westector on my set (a 5-valve straight, 2 var. mu, Det. and Class B), but owing to the tendency to favour the L.F.'s I find there is very little control on medium-waves."—T. M. (Dublin).

THERE should be no difficulty, with a correctly-designed A.V.C. circuit, in using the Westector. This is, in fact, the only way you can obtain the results you desire, and the article on A.V.C. in last week's issue should enable you to arrange the circuit satisfactorily. We do not favour the incorporation of a double-diode or double-diode-triode valve as a separate A.V.C. valve with the ordinary triode as a reacting detector, for several reasons. If you must dispense with the Westector, one circuit which might be tried experimentally, and which might satisfy your requirements, is to use one variable-mu H.F. stage, followed by a triode H.F. amplifier with a separate triode reactor valve, adopting the Carpenter circuit, but there would not be the same gain in this stage, and following the H.F. pentode, you might find difficulty in arranging for satisfactory tuning arrangements, especially if you use a ganged condenser unit.

## An Extension Speaker Problem

"I am contemplating running an extension loudspeaker from the living-room to the sitting-room. From measurements made, the twin flex would be 100ft. long. My receiver is a three-valve, with one S.G. and Pentode output, and I obtain ample volume with the existing speaker. For my extension, I would, of course, use a modern moving coil. Do you think I would obtain comfortable volume from my extension speaker from the above particulars?"—H. B. (Salford, 6).

IF your intention is to include the flex in the anode circuit of the output valve, you would not, of course, obtain satisfactory results. If, however, an output filter is fitted, such as was described in our Christmas number, then the length of the flex does not matter very much. Your mention of twin flex leads us to suppose, however, that you intend to use one lead for each speaker terminal, and thus you may be under the impression that two leads must be used. This is not the case. If an output filter circuit is used, only one lead is

required, this lead running from the condenser in the filter circuit to the distant speaker, the other side of the speaker being joined to the nearest convenient earth point, such as a water pipe, radiator, etc. If you have obtained twin flex, we suggest that you connect the two ends together so that you will be using a single extension lead of double the effective area, and thus will avoid any possibility of losses of certain frequencies due to a high resistance lead.

### RULES

We wish to draw the reader's attention to the fact that the Queries Service is intended only for the solution of problems or difficulties arising from the construction of receivers described in our pages, from articles appearing in our pages, or on general wireless matters. We regret that we cannot, for obvious reasons—

- (1) Supply circuit diagrams of complete multi-valve receivers.
- (2) Suggest alterations or modifications of receivers described in our contemporaries.
- (3) Suggest alterations or modifications to commercial receivers.
- (4) Answer queries over the telephone.
- (5) Grant interviews to querists.

Please note also, that queries must be limited to two per reader, and all sketches and drawings which are sent to us should bear the name and address of the sender. Requests for Blueprints must not be enclosed with queries as they are dealt with by a different department.

If a postal reply is desired, a stamped addressed envelope must be enclosed. Send your queries to the Editor, PRACTICAL AND AMATEUR WIRELESS, George Newnes, Ltd., Tower House, Southampton Street, Strand, London, W.C.2.

The Coupon must be enclosed with every query.

## A Metal Screening Box

"Will you please send me the name of the manufacturer of the Three Compartment Screening Box, which was specified in your article, page 760, February 29th, 1936? It was used in the Beat Frequency L.F. Oscillator."—S. H. (Stockport).

THE screening box is not a standard component, but you may obtain a duplicate from E. Paroussi, 10, Featherstone Buildings, London, W.C.1.

## One-valver for America

"Could you let me know if there is a blueprint available for the 'One-valver for America' described in your issue dated 23.1.37; if not, can you recommend a one- or two-valve set to get America. I want something which is cheap to make and does not require complicated aerial systems. I would like a blueprint which has got a copy of the paper to help in the constructional details."—M. B. (Parkhurst, I.O.W.).

THE blueprint for the One-valver for America is number AW429, price 1s. With regard to the reception of America, it is, of course, impossible to guarantee that this will be obtained every time you

listen. Conditions on the short waves are so variable that you might find on some nights that even a five- or six-valve set will only just get the American stations, and then atmospheric or fading will be so bad that the signals will not offer entertainment value. Under favourable conditions, however, the receiver in question may be relied upon to give you quite good signals, and the logs submitted by readers who have built the receiver confirm this.

## Standard Abbreviations

"I am an interested reader of your short-wave paragraphs, but to my dismay I am not able to understand what such terms as 14-20 G.M.T., QSO, QSA, QSL, etc., mean. Please state what they are, as I am sure many other readers are as puzzled as I am."—F. Y. (Yardley Wood, Birmingham).

THE first reference in the list of abbreviations you give is simply the time, G.M.T. standing for Greenwich Mean Time. The 24-hour system is referred to in the quotation you give, and this particular reference means from 2 p.m. to 8 p.m. The "Q" code, together with some other abbreviations used in wireless transmission, will be given shortly in the Short-Wave Section.

## Television by Disc

"I have a lot of 30-line television apparatus, and I wondered if I changed the disc to 240 lines to scan horizontal at 25 pictures a second, would I obtain a picture using the Duplex neon lamp?"—A. R. (Brixton).

USING a 20in. disc (which was the most popular size) the diameter of the holes for 30 lines was .02in. To increase the definition to 240 lines, you would need 240 holes (using a single disc), and to accommodate these so that no overlapping takes place and to obtain the correct picture ratio, they would have to be so small that you would not only find difficulty in making the holes, but even when made, they would prove ineffective owing to the small amount of light which would pass through them, and the picture would hardly be visible. If you wish to experiment, we would suggest that you use two or more discs, and try the effect of a combination of slots and holes, somewhat on the lines of the high-definition disc transmitter, but we cannot give you any detailed instructions, and have not ourselves yet found any satisfactory way of using a mechanical receiver.

## The 1937 Crystal Set

"Would you please let me know the address of the firm which supplies the crystal detector which is specified for the 1937 crystal set, and the price of the complete crystal, so that I can send direct and save any delay."—D. W. (Inverness).

THE crystal is supplied by the Jewel Pen Co., Ltd., of 21, Gt. Sutton Street, London, E.C.1, price 2s. 6d.

The Coupon on Cover iii must be attached to every query.

# WE OFFER YOU A FULL WEEK'S FREE USE

A PIX is probably the one refinement your set has needed all along to rid it of that annoying muzziness that mars the quality of reception. It will give you a welcome sharpness in the tuning that will bring you real enjoyment from foreign programmes. Send us 2s. or 2s. 6d. to include the Handy Holder illustrated. IF YOU ARE NOT ENTIRELY SATISFIED RETURN IT AFTER THE WEEK'S TRIAL FOR FULL REFUND. You will find it is well worth while. PIX, Southwark Street, LONDON, S.E.1.

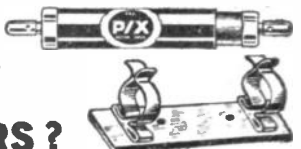

# PIX HAS IMPROVED MILLIONS WHY NOT YOURS?

Miscellaneous Advertisements

Advertisements are accepted for these columns at the rate of 3d. per word. Words in black face and/or capitals are charged double this rate (minimum charge 3/- per paragraph). Display lines are charged at 6/- per line. All advertisements must be prepaid. All communications should be addressed to the Advertisement Manager, "Practical and Amateur Wireless," Tower House, Southampton Street, Strand, London, W.C.2.

RECEIVERS, COMPONENTS AND ACCESSORIES Surplus, Clearance or Secondhand, etc.

RADIOMART SHORT-WAVE SPECIALISTS Announce 1937

SHORT-WAVE MANUAL

Packed with short-wave information and circuits of mains and battery receivers, including straight, superhet and 5-metre transmitters, modulators, etc. Information on transmitting licences, aerials, Class B amplifications, neutralization, superhet alignment, etc. The most comprehensive manual published, written by practical engineers, price 6d., post free 7 1/2d., including catalogue. 1937 Catalogue only (3 times enlarged) price 1 1/2d. post free.

TELESEN screened dual range coils, switched, 2/11 each. Pair 5/3. Milliammeters, 25 ma. upwards, 6/0. Super, 6/3.

AMERICAN mains transformers 230v. fully shrouded, 350/350, 0.3v., 5v., 6/11. Majestic 250/250, 2.5v., 3v., 4/11.

HEAVY DUTY mains transformer worth 35/-, 350/350, 150 ma., 4v. 2.5ACT, 4v. GACT, 12/6. KC/S., 1F transformers, 2/11. Telsen Acc, 1/11. RG4 Radiogrand, 2/9. 2mf. 300v., 9d.

UTILITY straight line wavelength dials, 3/11. Telsen H.F. choke, 1/11.

UTILITY 2-gang unknob and dial, 3/11; 1,500-volt tubular condensers all sizes, 6d.

ELECTROLYTICS 500-volt 5 mf., 1/6; 4 mf., 1/6; 4x4, 1/11; 4x8, 3/6; 25 mf. 25v., 1/-, etc.

SMOOTHING chokes, 20 hy. 120 ma., 3/11; 100 ma. 2/11; 40 ma., 1/11.

PUSHBACK wire, 6 yds., 6d.; heavy 9d.; 2 gross solder tags, 6d.; resin-cored solder, 9ft., 6d.

CENTRALAB pots, all sizes, 1/6; switched, 2/-; tubular glass fuses, 2d.

JENSEN PM speakers, 12/6. Varley iron core-coils, 2/6; matched pair, 4/6.

SPECIAL OFFER Class B valve, driver transformer and valveholder, new, 10/5.

TRADERS' monster bargain parcels, value £4/10/-, for 10/-; also 5/- parcels.

FAMOUS Continental A.C. valves, 4/6; American Duotron, etc., all types, 3/6; battery from 2/3.

TILITY 8/6, microdisc dials, 3/11; Radiophone, 0.00016 short-wave condensers, 3/6; series gap, twin, 3/9.

CERAMIC all brass microvariables, 15 mmfd., 1/4; 40 mmfd., 1/7; 100 mmfd., 1/10; short-wave H.F.C., 9d.

CLEARANCE catalogue 1 1/2d. Goods over 3/- post free. All enquirers must send stamp. Branches: 19, John Bright St., 44, Dale End. Mail Orders, 44, Holloway Head, Birmingham. Telephone, MID 3254.

ALL goods previously advertised are standard lines, still available. Post card for list free.

VUXHALL UTILITIES, 163a, Strand, W.C.2. Over Denny's the Booksellers. Temple Bar 9338.

CONVERSION UNITS for operating D.C. Receivers from A.C. Mains, improved type, 120 watts output, at £2/10/0. Send for our comprehensive list of speakers, resistances and other components. WARD, 46, Farringdon Street, London, E.C.4. Telephone: Houghton 9703.

BANKRUPT Bargains. List Free. All-wave battery, 3v., 70/6. British mains superhets, 5v., £6/10/0. All-wave, £7/10/0. Ormond 3v. A.C./D.C., 57/6. Ormond 3v. H.F. battery sets, 59/6. Large stock valves, speakers, all components.—Butlin, 6, Stanford Avenue, Brighton.

LOUDSPEAKER REPAIRS

REPAIRS to Moving Coil Speakers, Cones and Coils fitted or rewound. Fields altered. Prices Quoted including Eliminators. Loudspeakers Repaired, 4/-. L.F. and Speech Transformers, 4/- post free. Trade invited. Guaranteed. Satisfaction. Prompt Service. Estimates Free. L.S. Repair Service, 5, Balham Grove, London, S.W.12. Battersea 1321.

LOUDSPEAKER Repairs, British and American, any make, twenty-four hour service; moderate prices.—Sinclair, Speakers, Alma Grove, Copenhagen Street, London, N.1.

PREMIER SUPPLY STORES

Offer the following Set Manufacturers' Brand New Surplus Goods at a Fraction of the Original Cost; all goods guaranteed perfect; carr. paid over 5/-; under 5/- postage 6d. extra. Orders under 5/- cannot be sent C.O.D.

ALL POST ORDERS TO JUBILEE WORKS, 167, LOWER CLAPTON RD., LONDON, E.5. 'Phone: Amherst 4723.

CALLERS, AS USUAL, TO 20-22, HIGH ST., CLAPHAM, S.W.4 (Macaulay 2382). And 165 & 165a, FLEET ST., E.C.4 (Next door to Audertons' Hotel), Central 2833. New Branch: 50, HIGH ST., CLAPHAM, S.W.4 (Macaulay 2381).

Have you had our GIANT ILLUSTRATED CATALOGUE AND VALVE LIST? Send 4d. IN STAMPS FOR THIS BARGAIN LIST.

MAINS VALVES, famous Europa 4 v. A.C. types, 4/6 each.

H.L. 1, S.D., Var-Mu-S.G., H.F. Pens., Var-Mu-H.F. Pens., 1, 2 and 4-watt A.C. directly heated output Pentodes. Full-wave rectifiers, 250 v. 60 ma. A.C. D.C. types, 30-volt, .18 amp. S.G., Var-Mu-S.G., H., H.L., Power and P.N. Following types all 5/6 each. Full-wave rectifiers, 350 v. 120 ma. and 500 v. 120 ma. 2 1/2 watt indirectly-heated Pentodes, Octodes, Frequency Changers.

BATTERY VALVES 2 volts, H.F., L.F., 2/3. Power, Super-Power, 2/9. S.G., Var-Mu-S.G., 4- or 8-pip Pentodes, H.F. Pens., V.-Mu-H.F. Pens., 6/-, Class B, 2/6.

AMERICAN VALVES. Genuine American HYTRON and TRIAD semi-grid Valves. 3 months' guarantee. All types in stock, 5/6 each. 218 and 230, 5/6 each. New Metal-Glass Valves, all types, 6/6 each. Genuine American DUOTRON Valves, all types, 8/6 each. Valve holders for all above types, 6d. each. Metal bases, 9d. each.

SHORT-WAVE COILS, 4- and 6-pip types, 13-26, 22-47, 41-94, 78-170 metres, 1/9 each, with circuit. Special set of 3 S.W. Coils, 14-160 metres, 4/- set, with circuit. Premier 3-band S.W. Coil, 11-25, 19-43, 38-86 metres. Simplifies S.W. receiver construction, suitable any type circuit, 2/6. COIL FORMERS, in finest plastic material, 1 1/2in. low-loss tubes, 4- or 6-pip, 1/- each.

SUPER CERAMIC CONDENSERS, S.L.F., .00015, .0001, 2/9 each; double-spaced, .00005, .00025, .00015, 3/- each. All brass with integral slow motion, .00015 tuning, 2/9; .00015 reaction, 2/9.

H.F. CHOKER, S.W. 10-200 metres, 9d.; S.W. screened, 1/6; standard screened 180-2,000 metres, 1/6.

3-WATT A.C. AMPLIFIER, 2-stage, for mike or pick-up. Complete kit of parts with 3 valves, 49/-.

7-WATT A.C./D.C. AMPLIFIER, 3-stage, high-gain, push-pull output. Complete kit of parts with 5 specially matched valves, 84/-.

10-WATT 3-stage A.C. Amplifier Kit with 5 valves, 85/-.

30-WATT 3-stage A.C. Amplifier Kit with 5 valves, 88/-.

ELECTROLYTICS, U.S.A., 4 or 8 mf. 530 v. peak, 1/9 each. Duffiler, 4 or 8 mf. 50 v., 2/-; 50 mf. 50 v., 1/9; 10 mf. 50 v., 6d.; 25 mf. 25 v., 1/2. T.C.C. 4 or 8 mf. 650 v., 4/-; 15 mf. 50 or 100 v., 1/4; 50 mf. 13 v., 1/-.

Paper Condensers, W.E., 250 v. working 4 mf., 2/-; 2 mf. 1 1/2, 1 mf. 6d.; 350 v. working 4 mf., 2/6; 2 mf., 1/6. Duffiler 500 v. working 4 mf., 4/-; 800 v. 2 mf., 6/-.

COSMOCORD PICK-UPS, with tonearm and volume control, 10/6 each. PICK-UP HEADS only, 4/6 each.

PREMIER MAINS TRANSFORMERS, wire-end type with screened primaries, tapped 200-250 v. Centre-tapped Filaments. Guaranteed one year. H.T. 8 & 9 or H.T. 10 with 4 v. 4 a. C.T. and 4 v. 1 a. C.T., 9/6. 250-250 v. 60 ma., 4 v. 1 a., 4 v. 2 a. and 4 v. 4 a., all C.T., 9/6. 350-350 v. 120 ma., 4 v. 1 a., 4 v. 2 a., and 4 v. 4 a., all C.T., 10/6. Any of these transformers with engraved panel and N.P. terminals 1/6 extra. 500-500 v. 150 ma., 4 v. 2-3 a., 4 v. 2-3 a., 4 v. 2-3 a., 4 v. 2-4 a., all C.T., 17/6. Super Model 19/8. AUTO TRANSFORMERS, step up or down, 50 watts, 7/8; 100watts, 10/6. SMOOTHING CHOKES, 25 ma., 2/9; 40 ma., 4/-; 60 ma., 5/6; 150 ma., 10/8. 2,500 ohms, 90 ma. Speaker Replacement Chokes, 5/8.

MILLIAMMETERS, moving-iron, 5mah 9 1/2in., all ranges from 0-10 ma., 6/9. Visual tuning, 6 or 12 ma., 6/9. Moving-coil meters, 2 1/2in. 0-1 ma., 18/6; 3 1/2in. 0-1 ma., 22/6. Multipliers, 1/- each. Ammeters, 0-1, 3, 5, 10 or 30 a., 5/9.

TELESEN Multi-meters, 3 and 30 ma., 8, 16 and 340 v., 5/6 each. Ready A.C. and D.C.

TRANSFORMERS, latest type Telsen E.O.4 (list 12/6), 2/9. Liscen Hypernik Q.P.P. (list 12/6), 5/6.

OUTPUT TRANSFORMERS for Power or Pentode, 2 & 4; Multi-Ratio, 4 & 6; Push-Pull Input Transformers by prominent manufacturer, 4/6 each.

ELIMINATOR KITS for A.C. mains, 120 v. 20 ma., or 150 v. 23 ma., 15/-, tapped S.G. det. and output. Complete Kit with long-life valve rectifier (replacement cost only 2/-).

PREMIER L.T. CHARGER KITS for A.C. mains, including Westinghouse Rectifiers and Tapped Mains Transformer. 8 volts at 1 amp, 14/6; 8 volts 1 a., 17/6; 10 volts 1 a., 19/-; 8 volts 2 a., 22/6.

TELESEN iron-cored screened coils, W.340, 4/- each. Electric SOLDERING IRONS, 200-230 v., A.C./D.C., 2/3.

NEW 1937 1-VALVE SHORT-WAVE RECEIVER OR ADAPTOR KIT 13 to 86 Metres without coil changing. Complete Kit and Circuit 12/6. VALVE GIVEN FREE! DE LUXE MODEL 14 to 150 Metres, complete Kit with Chassis, 4 Coils and all parts, 17/6.

SUPERHET CONVERTER KIT, 13/6. S.W. SUPERHET CONVERTER, for A.C. Mains Receivers, 30/-, A.C. Valve given FREE!

NEW 1937 2-VALVE S.W. KIT, 13 to 86 Metres without coil changing. Complete Kit and Circuit, 19/8. VALVES GIVEN FREE. DE LUXE MODEL, 14 to 150 Metres, complete Kit and Chassis, 4 Coils and all parts, 25/-, VALVES GIVEN FREE.

3-VALVE S.W. KIT, S.G. Det. and Pen., 42/-, VALVES GIVEN FREE!

BAND-PASS TUNING PACK, comprising set of Telsen 3-gang iron-cored coils with switching, mounted on steel chassis with 3-gang condenser, illuminated disc-drive and 4 valve holders, 25/- the lot. All Mains or Battery circuit. FREE!

SPECIAL OFFER. LENSEN TWO GANG SCREENED ALL-WAVE COILS, 12 to 2,000 metres, complete with switching and wiring diagram, 6/11 per set.

3 VALVE BAND-PASS KIT, 200-2,000 metres. Complete kit of parts, including chassis, all components, valves, M.C. speaker and wiring diagram. Battery Model, 50/-, A.C. Mains Model, 70/-.

MAGNAVOX, Mains energised M.C. Speakers, '154', 7in. cone, 2,500 ohms, 12/8; '152', 9in. cone, 2,500 ohms, 17/8; '153 Magna', 9in. cone, 2,500 ohms, 37/8. MAGNAVOX P.M.s.—'254', 7in. cone, 16/8; '252', 9in. cone, 25/8. Reliable P.M.s., 10/8.

ROLA latest type P.M.s. 18/8. GOODMAN'S 8in. mains energised, 1,000 ohms field, 10/6 each. Jensen P.M.s., 10/6. DIALS—Claron Illuminated S.W. slow-motion Dial with 2in. knob, 2/-.

Potentiometers by well-known makers. All values up to 1 meg., 2/- with switch, 3/6. GRAMOPHONES (MOTORS). Collaro Gramophone Unit consisting of A.C. motor, 100-250 v. high quality pick-up and volume control, 45/-; Collaro motor only, 30/-; Collaro Universal Gramophone Motor, 100-250 v. A.C./D.C., with high quality pick-up and volume control, 57/6; Collaro Universal Motor only, 49/6; Edison Bell double-spring motor, including turntable and all fittings, 15/-; Cosmocord Gramo. unit, comprising A.C. motor pick-up and volume control (list 55/-), 35/9.

TUBULAR CONDENSERS non-inductive, all values up to .5 mf., 6d. each.

Wire-end RESISTORS any value, 1 watt, 6d.; 4 watts, 1/-; 5 watts, 1/6; 15 watts, 2/-; 25 watts, 2/6 each.

Reliable HORSE KEYS with Morse Code engraved on bakelite base, 2/- each.

Bakelite case BUZZERS, 1/6; Walnut case "Load-one," 2/6 each.

Super Quality lightweight HEADPHONES, 3/9 pair.

SHORT WAVES

SHORT WAVE on a crystal set. Full building instruction and crystal 1/2 post paid.—Radiomail, Tanworth-in-Arden, Warwickshire.

ALL-WAVE RADIO for 9/6; send for illustrated catalogue of RIDCO short-wave units, from 9/6 complete.—Radio Industries, Birch Street, Hanley, Staffs.

VALVES

NOTHING Letter available. SIX MONTHS' GUARANTEE, complete range of BATTERY, A.C. MAINS, RECTIFIERS always in stock, 2 volt Det., H.F., L.F., 2/3. POWER 2/9, SCREEN GRID PENTODE, H.F. PENTODE 5/-. American types, fully guaranteed, 5/6 each. Nos. 18, 24A, 35, 42, 43, 45, 47, 56, 57, 58, 75, 77, 78, 80, 2A5, 2A6, 2A7, 6A7, 2B7, 6B7, 6C8, 6D6, 25Z5, 25Y5. Write for other prices to Dulci Electrical Co., Ltd., Devonshire Works, Duke's Avenue, Chiswick, W.4.

MISCELLANEOUS

GRAMOPHONE attachments for Radio, electric motors, 25/-; pick-ups, 9/6; portable gramophones, 12/-; spring motors, 4/6; dozen 36", 100 112/10/0, 1,000 £100; walnut pedestal hexagram, 25; soundboxes, tone-arms, horns, cabinets, needles, gears, springs, accessories, cheapest. Quantity buyers obtain lower prices. Catalogue free.—Regentam, 120, Old Street, London, E.C.1.

DETECTION. New theory, system, circuits, book, post free 1s. 1d.—D'Arcy Ford, Gaudy Street, Exeter.

CONDENSERS. Metal Case. British Manufacture (by Specialisation method). 1,000 volt, wkg.: 1 mf., 2/9; 2 mf., 3/3; 4 mf., 4/9; 8 mf., 8/8. 800 volt wkg.: 1 mf., 1/9; 2 mf., 2/3; 4 mf., 3/9; 8 mf., 6/6. 500 volt wkg.: 1 mf., 8d.; 2 mf., 1/2; 4 mf., 1/10; 8 mf., 3/6. Condensers. Tubular, .005 mfd. to 2 mfd. List on application. Condensers. Television, P.A. systems, etc. S.A.E. Mentone Radio Stores, 364, Fulham Road, London, S.W.10.

**RECEIVERS, COMPONENTS AND ACCESSORIES**  
Surplus, Clearance or Secondhand, etc.

**RADIO CLEARANCE**  
63, HIGH HOLBORN, W.C.1.  
HOLBORN 4631.

Special clearance sale now taking place at our London premises: the following bargains are offered to enable our Mail Order customers to participate in this eagerly awaited annual event.

**8-VALVE A.C. MAINS SUPERHET, BY WELL-KNOWN MANUFACTURER**—Fitted Visual Tuning, Volume Control, Tone Control, etc., handsome Bird's Eye Maple Cabinet, size 16ins. wide, 12ins. deep, 23ins. High, Valves as follows: AC/VP1, PC4, AC/VP1, AC/VP1, AC/HLDD, V914, AC2F.0, TWT, 2-2-1F Stage, 2 I.F. Stages, full A.V.C., a major bargain at £6 19s. 6d.

**LISSEN 4 VALVE UNIVERSAL AC/DC RECEIVER**, fitted in handsome dark finish Walnut Cabinet of upright design, clock face tuning, Volume Control, Reaction Control, etc., a really fine receiver, £4 15s. **EXCLUSIVE BRITISH RIGHTS HELD BY US FOR CONSTRUSTRAD KITS (AMERICAN)** During the sale, these Kits are offered as follows:—

- 1 Valve Battery Kit complete with valves, 21/-.
- 2 Valve Battery Kit complete with valves, 25/-.
- 1 Valve AC/DC Kit complete with valves, 29/6d.
- 2 Valve Battery Kit complete with valves, 32/6d.

These are complete sets, not converters, covering a wave band of 15-600 metres by means of 5 interchangeable Plug-in Coils.

**8 VALVE A.C. SUPERHET CHASSIS** complete with valves, details as above, £6 7s. 6d.

**REGENTONE 5-VALVE AC/DC BANO PASS RECEIVER**, fitted in handsome Dark Finish Walnut Table Cabinet, Thermometer tuning, Separate Dials for Long and Medium Waves, etc., complete with Valves, to clear, £4 4s.

**REGENTONE 5-VALVE A.C. SUPERHET**, Fitted in Cabinet as above, with similar salient details, A.V.C., etc., £4 2s. 6d.

**REGENTONE 3-VALVE BATTERY RECEIVER**, Screen Grid, Detector, Pentode Output, fitted in Handsome Walnut Cabinet with Thermometer Tuning, large P.M. Moving Coil Speaker, etc., 52/6d.

**REGENTONE 5-VALVE UNIVERSAL CHASSIS**, fitted complete with built-in speaker, etc. With Valves, 55/-.

**REGENTONE 5-VALVE A.C. SUPERHET CHASSIS**, fitted with built-in Speaker. Complete with Valves, 53/6d.

**FEW ONLY HANDSOME ELECTRIC CLOCKS**, suitable for 200 to 250 A.C. Mains. British Made, to clear, 16/6d. each.

**LISSEN ALL-WAVE COILS**, complete with circuit, switching, etc., in matched pairs, 8/- per pair.

**OITTO SINGLE COILS**, 4/6d. each.

**LISSEN 126 K I.F. TRANSFORMERS**, fully screened, 1/3d.

**G.E.C. 110 K I.F. TRANSFORMERS**, Midget Type, complete with trimmers, 1/3.

**CENTRALAB VOLUME CONTROLS**, with switch, 5,000, 10,000, 25,000, 50,000, 2/3.

**SPECIAL, SPECIAL, SPECIAL.**

**JENSEN 7 1/2 in., 2,500 FIELD PENTODE TYPE MOVING COIL SPEAKER**, 5/9 each. Few Only.

**HANDSOME STRAIGHT BLOW MOTION DIAL**, complete with Escutcheon, 2/3.

The Following Condensers by well-known manufacture:—

8 plus 8 plus 1 Electrolytics, wire end type, metal cases, 3/.

14 plus 8 Electrolytics, Wire end type, metal cases, 2/-.

8 plus 8 Electrolytics, Wire end type, Card-board cases, 3/-.

8 Mid., 550 surge, 500 working, Metal Can, 1 Hole Fixing, 2/11.

8 Mid., 500 surge, 450 working, Metal Can, 1 Hole Fixing, 2/6.

**TUBULAR CONDENSERS**, paper type, all sizes up to .1 Gd. each.

50 Mfd., 50 volt working, condensers, well known manufacture, 1/6.

50 Mfd., 25 volt working, condensers, well known manufacture, 1/3.

25 Mfd., 50 volt working, condensers, well known manufacture, 1/-.

50 Mfd., 12 volt working, condensers, well-known manufacture, 1/-.

**UTILITY 3-RANG CONDENSERS**, Superhet Type, two .0005 Sections, one 110 K/C Section, fully screened, with top trimmers, 2/6.

**LISSEN CLASS B. DRIVER TRANSFORMERS**, type 1-1, brand new, boxed, 1/3.

**BRYCE MAINS TRANSFORMERS AND CHOKES**. British and Guaranteed. Standard for the Season.

250-0-250, 80 m.a., 2-0-2 volts, 2.5 amp., 2-0-2 volts, 4 amp., 8/6.

350-0-350, 120 m.a., 2-0-2 volts, 2.5 amp., 2-0-2 volts, 4 amp 10/6.

350-0-350, 150 m.a., 2-0-2 volts, 2.5 amp., 2-0-2 volts, 4 amp., 2-0-2 volts, 2 amp., 11/6.

500-0-500, 150 m.a., 2-0-2 volts, 2.5 amp., 2-0-2 volts, 6 amp., 2-0-2 volts, 2 amp., 2-0-2 volts, 2 amp., 16/6.

**H.T.8 TRANSFORMER**, 250 volts, 60 m.a., 2-0-2 volts, 4 amp., 8/6.

(Continued at top of column three)

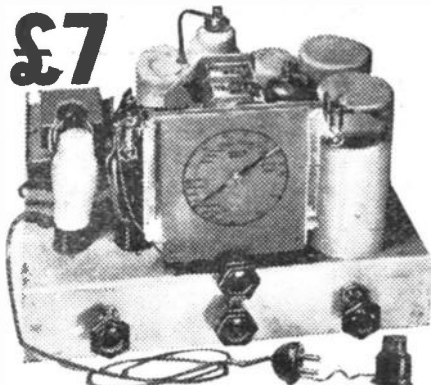

**£7**  
**6 VALVE ALL-WAVE SUPERHET**

(Complete with B.V.A. Valves)  
Improved all-wave superheterodyne for A.C. or D.C. mains. High sensitivity on all three wave-bands (16, 5-50 metres, 200-550 metres, 800-2,000 metres). Many interesting features, including:—  
Illuminated "Airplane" dial with station names.  
Special "squash" valve for inter-station noise suppression, with manual muting control. Octode frequency changer. 8 stages, 7 tuned circuits. Iron Cored I.F. Coils. Delayed A.V.C. 3.5 watts output. Extra heavy Cadmium-plated steel chassis.

£7 cash complete with valves, knobs, pilot lamps, mains cable and plug, etc. Deferred terms from London Radio Supply Co., 11, Oat Lane, E.C.2. 12 months' guarantee. Suitable loudspeakers, cabinets, etc., in stock.

McCarthy Chassis from £4 5s. to £12. Write for illustrated catalogue.

**MCCARTHY RADIO LTD.**  
44a, Westbourne Grove, London, W.2.  
Telephone: Bayswater 3201.

**EARN EXTRA MONEY** by hiring out the M.P.R. 7 special, etc. Complete with Four Valves, Speaker, and Volume Control. Push-Pull output. Will reproduce Gramophone Recordings or Radio at full Band strength. Supplied ready for connecting to pick-up or microphone. For A.C. mains only. Price 55-5-0 net, or 10/- monthly. Send for full particulars. Phone: Romford 338. M.P.R. Electrical Co., 252, Victoria Road, Romford, Essex.

**FREE ADVICE BUREAU COUPON**  
This coupon is available until February 20th, 1937, and must be attached to all letters containing queries.  
**PRACTICAL AND AMATEUR WIRELESS, 13/2/37.**

**1937 Show Model "PYE INVICTA"**  
In Sealed Manufacturers' Cartons with Makers' Full Guarantee, Brand New.  
All Waves. All Electric. All Pentode Output. 4 Mullard Valves. Heavy Duty Large Magnavox Speaker. Tunes from 17 to 2,000 Metres. Cash with order. **£5-19-6**  
LIST PRICE £9-19-6.  
**"SPEED" 732, Romford Road, London, E.12. ILF 2316.**

**ADVERTISEMENT INDEX**

Automatic Coil Winder & Electrical Equipment Co.	Inside Front Cover
Bennett College, Ltd.	.. .. . 657
British Institute of Engineering Technology	.. 656
Electradix Radios	.. .. . 658
Fluxite Ltd.	.. .. . 656
Graham Farish, Ltd.	.. .. . 656
Institute of Television Engineers	.. .. . 658
International Correspondence Schools, Ltd.	.. 652
London Radio Supply Co.	.. .. . 658
M.P.R. Electrical Co.	.. Inside Back Cover
McCarthy Radio, Ltd.	.. Inside Back Cover
New Times Sales Co.	.. .. . 655
Peto-Scott Co., Ltd.	.. .. . 651
Piz	.. .. . 659
Player's Airman	.. .. Inside Front Cover
"Speed"	.. .. Inside Back Cover

(Continued from foot of column one)  
**DITTO WITH H.T.8 METAL RECTIFIER, 18/1.**  
**ALL TRANSFORMERS ARE FULLY SHROUDED.**  
**BRYCE MAINS CHOKES**  
40 m.a., 30 Hys., 500 Ohms, 3/6; 60 m.a., 40 Hys., 500 Ohms, 5/-; 60 m.a., 80 Hys., 2,500 Ohms, for Speaker Replacement, etc., 5/3.  
**BRYCE HEAVY DUTY INTERLEAVED MAINS CHOKES**, 12 Hys., 100 Ohms, 250 m.a., 9/-. Enquiries 1/d. stamp if reply expected.  
Hours of Business, 9 a.m. to 7 p.m. Saturdays, 9 a.m. to 1 p.m.  
All Orders, Value 5/- or Over, Post Free. Orders under 5/- must be accompanied by a reasonable amount for postage.  
C.O.D. Orders under 5/- cannot be accepted.  
Orders from Ireland and Special Parts of Scotland are subject to certain increased postage rates, and customers are advised to apply for details, etc., of postage before ordering.

**SOUTHERN RADIO'S WIRELESS BARGAINS.**  
All Goods Guaranteed and sent Post Paid.  
**RECEIVERS**.—Vidor 3-Valve Battery Sets. Model R.C.N. 212. Complete in attractive Walnut Cabinet with three Mullard Valves, Moving Coil Speaker, Batteries and Accumulator. New in sealed cartons, £3/17/6 (List 64 gns.).

**LUCILLE**.—5-Valve American Midget Sets. Complete with 5 Valves, Moving Coil Speaker. Ready for use on any mains 100/250 volts A.C./D.C. Long and Medium Waves, £3/15/0. New, in sealed cartons.

**RECORD CHANGERS**.—GARRARD Model R.C.4. Plays automatically and changes eight 10in. or 12in. records of any kind. New, in sealed cartons, 56.

**GRAMOPHONE MOTORS**.—COLLARO ELECTRIC Radiogram Units. For A.C. or D.C. mains 100-250 volts. Fully Auto Stop, complete with Pick-ups. Can be used on any mains. Brand new in sealed cartons, 57/6 each. COLLARO ELECTRIC Radiogram Units, complete with Pick-up and fully Auto Stop for A.C. mains only, 37/6 each. COLLARO Single Spring Gramophone Motors with 10in. turntables, complete with all accessories, 11/-. Double Spring Motors with 12in. turntable, 15/-. COLLARO BATTERY RADIOGRAM UNITS, comprising Double Spring Motor and Pick-up mounted on plate, with all accessories, 35/- each. ALL COLLARO MOTORS ARE BRAND NEW IN SEALED CARTONS.

**SPEAKERS**.—CELESTON Soundex, permanent magnet, 10/-; TEISEN permanent magnet with 10-Ratio Transformers to suit any Receiver, 12/6. Teisen Loud-speaker Units, 2/6. ALL BRAND NEW AND BOXED.

**COILS**.—TEISEN Iron Core, W349 (Midget size), 4/-; Type W478 (Twin), 9/- pair. Type W477 (Triple), 16/- per set. Type W476 (Triple Superhet, Selector and Oscillator), 16/- per set. All ganged coils complete on base with switch. TEISEN I.F. TRANSFORMER COILS, 110 k/c, 5/-. TEISEN DUAL RANGE COILS with aerial series condenser incorporated type W76, 4/-. Teisen Aerial condensers with shunting switch, 2/-. ALL TEISEN COMPONENTS brand new in sealed cartons.

**AMERICAN VALVES**. A FULL RANGE OF VALVES FOR ALL AMERICAN RECEIVERS, 6/- each.

**MISCELLANEOUS BARGAINS**. ALL BRAND NEW IN ORIGINAL SEALED CARTONS: TEISEN A.C./D.C. Multimeters test anything radio or electrical, 8/6. Teisen 2-Range Voltmeters, 3/-. 3-Range meters, including milliamps, 4/-. ACE (P.O.), Microphones, with transformer ready for use with any receiver, 4/6; 36 Assorted Tru-ohm Resistances, 1 watt, colour coded and marked, 30 on card, 6/- per card. BELL TRANSFORMERS, 200/250 volts input, 3, 5, and 8 volts output, 3/6. MORSE SIGNAL UNITS incorporating buzzer, tapper and flash with international code, complete with batteries and bulb, 3/9 each. Varley Square Peak Coils, BP5, 2/-. MARCONI V24 and Q Type valves (useful for short-wave experiments), 1/6; Glass insulators, 4d.; Light-weight headphones, double-pole, 4,000 ohms each ear-piece, 3/- pair. A.C. Trickle Chargers, for 2, 4, and 6 volts, 17/6.

**CAR and RADIO BATTERY CHARGERS** incorporating WESTINGHOUSE METAL RECTIFIER. This charger will enable you to keep your CAR BATTERIES FULLY CHARGED for use on 2, 6 and 12 volts, 45/- each.

**REGENTONE ELIMINATORS**, A.C. 200/250 volts, Type W5a, with trickle charger, 37/6.

**SOUTHERN RADIO**.—Branches at 271-275, High Road, Willesden Green, N.W.10; 46, Lisle Street, London, W.C.2. All mail orders to 323, Euston Road, London, N.W.1.

**SOUTHERN RADIO**, 323, Euston Road, London, N.W.1 (near Warren St. Tube). Phone: Euston 3775.

**SITUATIONS VACANT**

**WANTED**—ambitious young men to prepare for well-paid posts in TELEVISION, the great career of the future. Apply for free booklet from BRITISH INSTITUTE OF ENGINEERING TECHNOLOGY, 18-P, Stratford Place, W.1.



# WONDERS OF OUR TIME

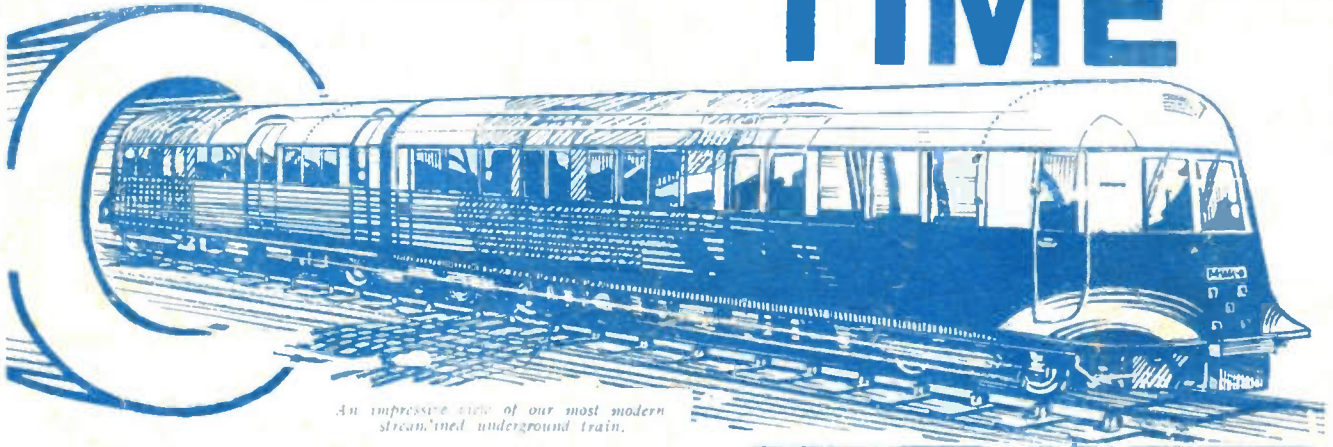

An impressive view of our most modern streamlined underground train.

**E**VERYTHING that is thrilling and new in this wonderful age in which we live is to be found month by month in **PRACTICAL MECHANICS**, the Magazine of Modern Marvels. The February Number, just out, will thrill old and young alike, for its special articles include:

**Underground Trains of the Future**  
**The Conquest of the Eddystone Rock**  
**The Marvellous Experiments You Can Make with Liquid Air**

A sectional view of the present Eddystone Lighthouse. The first one was built by a practical joker!

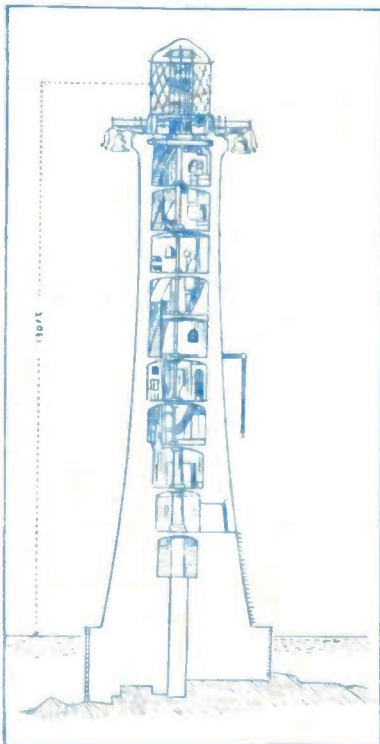

Other Special Features include:

**The A B C of Television**  
**A Petrol-Driven Model Aeroplane**  
**Galton's Wonderful Whistle**  
**A Romance of the Weaving Industry**  
**Aerial Photographs with a Kite**  
**Amazing Sound Detectors**  
**A Model G.W.R. Locomotive**  
**A Lilliputian Village in the Cotswolds**  
**Star-Gazing for Amateurs**  
**The Peculiarities of Pressure, Etc., Etc.**

All profusely illustrated with photographs, diagrams, plans and drawings.

**IN THE FEBRUARY**

# PRACTICAL MECHANICS

6<sup>d.</sup>

Now on sale at all Newsagent and Book-stalls, or by post S.I. from The Publisher, George Newnes, Ltd., Tower House, Southampton Street, Strand, London, W.C.2.

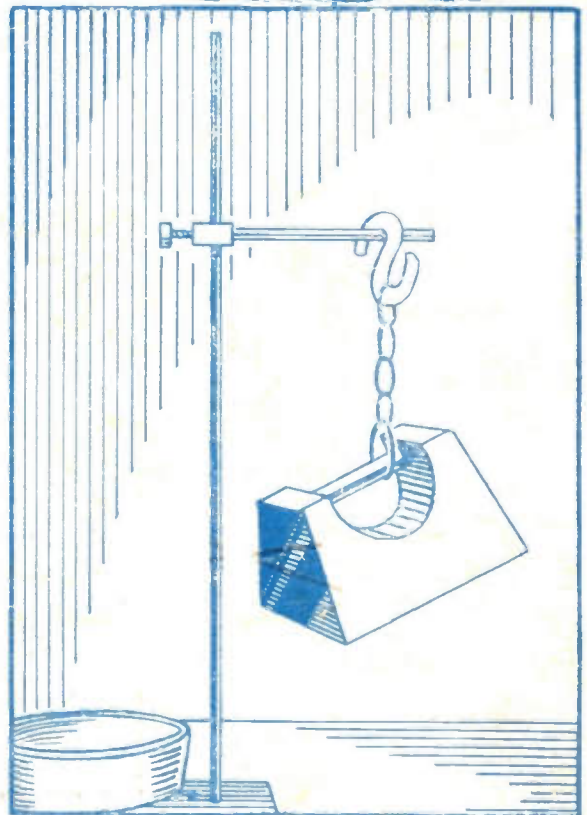

An amazing experiment with Liquid Air. Here you see a hook of mercury, made solid by freezing in Liquid Air, suspending a 7lb. weight.