

Mr. B. Damm
PRACTICAL WIRELESS DECEMBER, 1945.

Mr. B. Damm
ON THE BEAM

Practical ^{9^D} EVERY MONTH Wireless

Editor
F. J. CAMM

Vol. 22 No. 474

NEW SERIES

DECEMBER, 1945

Rear View of a Midget
Battery Three-valver. Full
Constructional Details in
This Issue

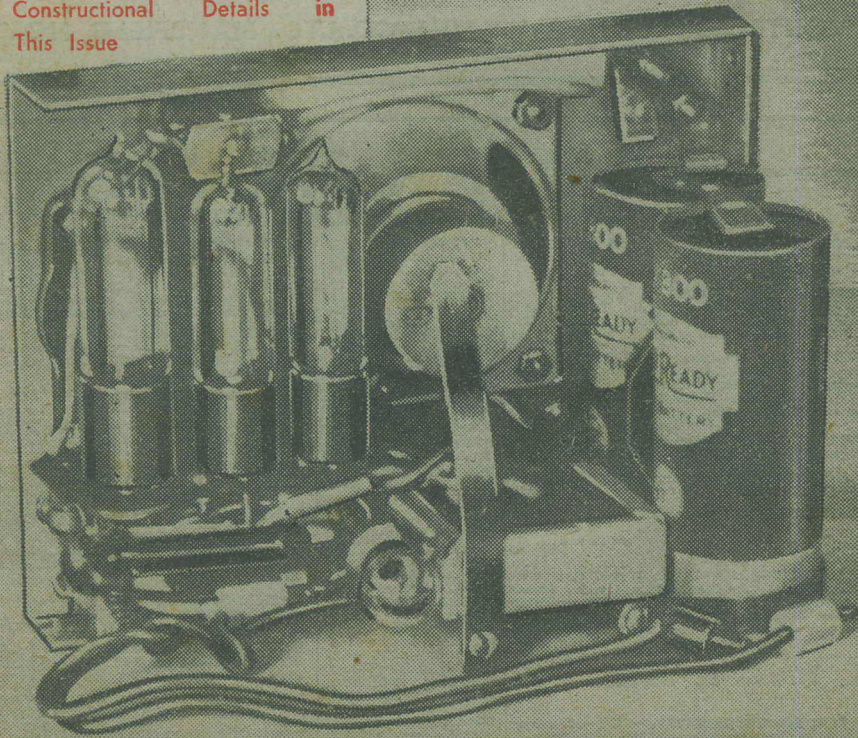

Practical Wireless
PRACTICAL WIRELESS DECEMBER, 1945.

ON THE BEAM.

Practical Wireless

Vol. 22 No. 474

NEW SERIES

DECEMBER, 1945

Rear View of a Midget
Battery Three-valver. Full
Constructional Details in
This Issue

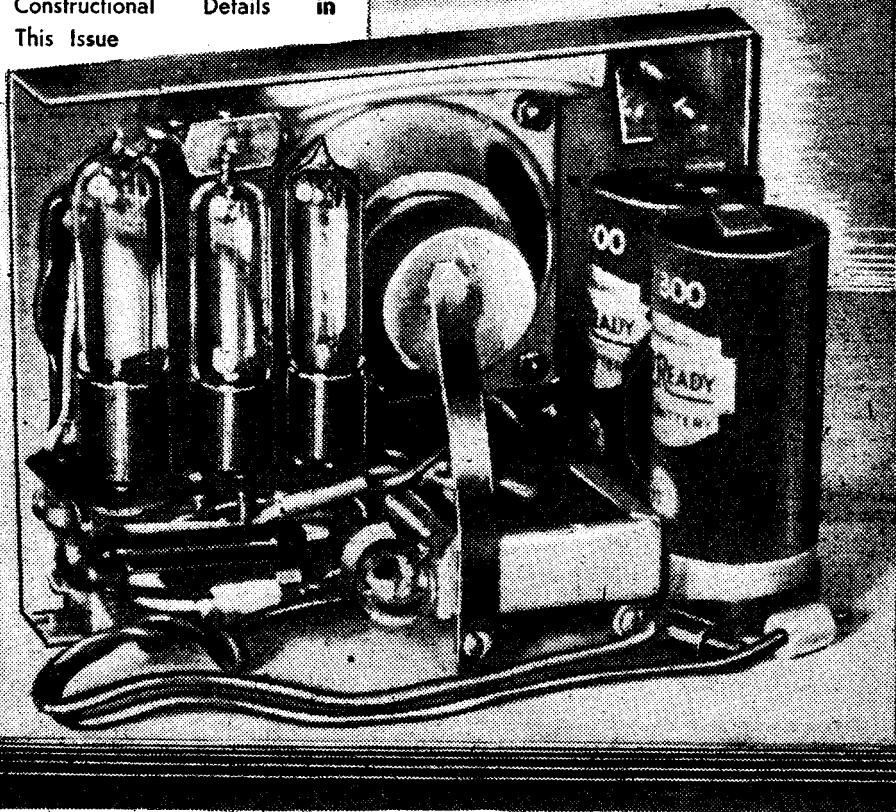

THE PERFECT
EXTRA SPEAKER
FOR ANY SET



Stentorian

EXTENSION SPEAKERS

now available again **29/6**
FROM

The benefits of specialisation make possible really amazing values. The efficient permanent magnet speakers, giving remarkably pleasant reproduction, are housed in most attractive cabinets, complete with VOLUME CONTROL.

WHITELEY ELECTRICAL RADIO CO. LTD., MANSFIELD, NOTTS

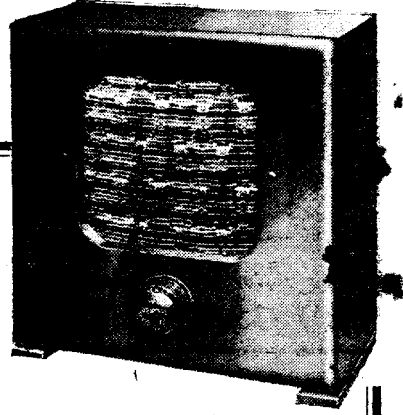

CABINET MODELS NOW AVAILABLE

MINOR TYPE MX (for low impedance extension)	29/6
MINOR TYPE MC (with universal transformer)	35/6
BABY TYPE BX (for low impedance extension)	43/6
BABY TYPE BC (with universal transformer)	49/6

PREMIER RADIO

MORRIS AND CO. (RADIO), LTD.

MIDGET MOVING COIL UNITS 1 1/2" diam. Highly sensitive, may be used as mike or speaker. Complete with trans. (state whether L.S. or Mike trans. required), **22/6**.

10-WAY PUSH-BUTTON SWITCHES complete with Knobs and Escutcheon Plate. Six iron-cored coils. Trimmers and Padders. No circuit or other particulars available. To clear at **12/6**. Original cost **45/-**.

FIRST GRADE METERS, 3/16" diameter, 1 milliamper. **23 12s.**; 500 microamps, **23 18s. 6d.**; 4/16" 1 milliamper. **23 5s. 0d.**; 500 microamps, **23 11s. 6d.** Westinghouse Meter Rectifier for either type, **10/-**. Multiple shunts, 10, 100, 500 m/a., **10/-**. Any value multiplier, **2/6** each.

SUPER QUALITY A.C.D.C. 15 w. AMPLIFIER, 3 stage, high gain, push/pull, in steel cabinet, **215 15s. 0d.**

A.C.D.C. AMPLIFIERS, 5 watts output, high gain, three-stage feedback, **28 8s. 0d.**

BATTERY CHARGERS for 2 v. batt. at 1 a., **25/-**; for 2, 4 or 6 v. batt. at 1 a., **45/-**; for 6 v. batt. at 1 a., **30/-**; for 2, 4 or 12 v. batt. at 1 a., **40/6**; for 6 v. and 12 v. batt. at 4 a., **24/-**.

MAINS TRANSFORMERS, 300+300 v., 60 m/a., three 4 v. 2-3 a. windings, **25/-**; 350+350 100 m/a., three 4 v. 2-3 a. windings, **29/-**; 350+350 150 m/a., 4 v. 2-3 a., 4 v. 3-5a., 4 v. 1-2 a., 4 v. 1-2 a. windings, **30/-**; 350+350 150 m/a., 5 v. 2 a., 6.3 v. 2 a., 6.3 v. 2 a., **35/-**; 500+500 200 m/a., 5 v. 3 a., 6.3 v. 2 a., 6.3 v. 4 a., **40/-**; 425+425 200 m/a., 4 v. 2-3 a., 4 v. 2-3 a., 4 v., 3-0 a., **47/-**; 350+350 150 m/a., 4 v. 1-2 a., 4 v. 2-3 a., 4 v. 3-4 a., **30/-**; 500+500 150 m/a., four 4 v. 2-3 a., LT windings, **47/-**.

1-VALVE BATTERY S.W. RECEIVER, with 2-volt valve, 4 coils, 12-170 m. bandspread tuning, **55/-** including tax.

CHASSIS, 10x8x2 1/2 in., 7/-; 12x9, 7/6; 16x8 in., 8/6; 20x8 in., 10/6.

SHORT-WAVE COILS, fit octal sockets, 4-pin aerial coils, 9-15, 12-26, 22-47, 41-94, or 76-170 m., 2/6 each; 150-350 or 250-550 m., 3/-; 400-1,000 or 1,000-2,000 m., 4/-; 6-pin H.F. trans., 9-15, 12-26, 22-47, 41-94, or 76-170 m., 2/6. S.W. chokes, 10-100 m., 1/3; 5-200 m., 2/6.

SHORT-WAVE CONDENSERS, all brass easily ganged, 15 mmfd., 2.11; 25 mmfd., 3.3; 40 mmfd., 3.3; 100 mmfd., 3.11; 150 mmfd., 4/8; 250 mmfd., 5/8; shaft couplers, 6d.; flexible ditto, 1/-.

MIDGET "P" TYPE COILS, 12-35, 16-47, 34-100, 91-261, 250-750, 700-2000, 200, 557, available as H.F. trans., aerial, or osc. coils, 2/3 each. Suitable Yaxley type wave-change switches, every type available; locators, 2/6 each; wafers, 1/6 each. Suitable small 2-gang condensers, .0005, 12-; suitable matched pairs iron-cored 465 K.C. I.P. trans., 15/- pair; midret type, 21/- pair. Suitable 60 mmfd. trimmers, 1/-; osc. padder 750 mmfd., 1/8.

MOVING COIL SPEAKERS, Rola 5in. 21/6; 6in. 22/6; 8in. 24/-. Goodmans 3in., 30/-. Above are less output than Plessey 8in. P.M. with trans. **29/6**. Midget standard or P.P. trans. for any above. **10/6**. Super quality giant Match-maker output transformers, match any tube single or P.P. to any voice coil, 15-watt, **30/-**; 30-watt, **40/6**; 60-watt, **59/6**.

CHOKES 3H. 300 ohms, 40 m/a., 4/8; 30H., 400 ohms, 60 m/a., 3/6; 30H., 100 m/a., 400 ohms, 15/-; 30H., 185 ohms, 150 m/a., 25/-; 25H., 250 m/a., 120 ohms, 39/6; 15H., 500 m/a., 92 ohms, 65/-.

SMOOTHING CONDENSERS, 50 mf., 12 v., 2/3; 25 mf., 25 v., 2/3; 50 mf., 50 v., 3/-; 2 mf., 250 v., 3/6; 2 mf., 350 v., 4/8; 4 mf., 450 v., 7/6; 8+16 mf., 500 v., 9/6; 16 mf., 150 v., 5/-; 16 mf., 350 v., 6/6; 8+4 mf., 450 v., 7/6; 32 mf., 450 v., 8/6.

SOLDER, 2 mm. Systodex, 2 1/2 yd., resin-cored solder, 6d. per coil or 4/6 per lb.; screened 2-pin plugs and socket, 9d.; ditto, 8-pin, 2/-; Octal sockets, 6d.; ditto, amphenol type, 1/-; Morse buzzers, 1/11. Valve screens, 1.2. Knobs, 6d. Pointer knobs, 1/11. Crocodile clips, 4d. "Gain" and "tone" indicator plates, 7 1/2. Fuses, any size, 5d. Fuse holders, 6d. 6-volt vibrators, 4-pin, 12/6. Crystal pick-ups, **23 18s. 9d.**, including tax. Volume controls, any value, 3/3; with switch, 5/-.

AMERICAN VALVES. Many types in stock at controlled prices, including 8V6, 6X4, 3Y3, 5Z4, 25L6, 75, 6K7, 6A8, 4525, 1C5, 12SK7, 25Z5, 25Z6, 42, 80, 1N5, 1H3, 1T5, 35Z4.

ENAMELLED COPPER WIRE, 1lb. reels, 16 or 18 g., 3/6; 20 g., 3/8; 22 or 24 g., 3/10; 26 or 28 g., 4/2; 30 g., 4/4; 32 g., 4/6; 34 g., 5/-; 36 g., 5/6; 38 g., 6/4.

REACTION CONDENSERS, bakelite dielectric, .0005, 2/6; .0003, 2/11; .0005, 3/3; .0003 ditto, 3/3.

RESISTANCES, 300x150x60x60 ohms, 3 amp., 5/6; 500x100x100x100x100x100, 2 amp., 5/6; 40,000 ohms tapped every 5,000 ohms, 10 v., 5/-; 1/2 w., res., 6d. each; 1 w., 8d. each.

OUR 1945 LIST IS NOW AVAILABLE. All enquiries must be accompanied by a 2 1/2d. stamp.

ALL POST ORDERS TO: JUBILEE WORKS, 167, LOWER CLAPTON ROAD, LONDON, E.5. (Amherst 4723.)

CALLERS TO: 169, Fleet Street, E.C.4. (Central 2833.)

Practical Wireless

14th YEAR
OF ISSUE

EVERY MONTH.
VOL. XXII. No. 474. DECEMBER, 1945.

and PRACTICAL TELEVISION

Editor F. J. CAMM

COMMENTS OF THE MONTH

BY THE EDITOR

Television

THROUGH the Radio Industry Council the radio industry has expressed its approval of the Government's endorsement of the recommendation of the Hankey Committee on Television. They say that the earliest possible resumption of the television service is a step in the right direction and that manufacturers now know where they stand and can proceed with production plans.

Thus the regular transmission of a still test picture becomes more urgent than ever, and an announcement from the B.B.C. on this matter is eagerly awaited.

So far as the manufacture of television receivers is concerned, the labour position, as in all other industries, is still acute, but the industry confidently hopes to have sets ready by the time the television service is resumed. Prices will inevitably be higher than before the war, and if television is to reach the mass-market, as has been confidently predicted, the abolition of the Purchase Tax and the extension of the service to the provinces are necessary. The industry is already planning to urge these considerations in the right quarters.

Owners of pre-war television receivers are waiting expectantly for the day when they can switch them on again. The industry issues a word of warning here. These receivers have been standing idle for over six years and it is most important that they should have an expert inspection before being brought into use. Manufacturers are already making arrangements to this end, but in the meantime dealers are advised to stress this point with their customers. This journal is making arrangements for the publication of designs of television receivers suitable for amateur construction, but we shall not release them until components of a satisfactory type and price are available.

American Receivers and Components

THE American End-lease announcement has naturally caused the Government to review the dollar position. During the war many receivers and components were imported from America. The replacement position was always difficult, particularly with valves. The situation

will now become worse, and owners of such receivers will have to lay them by when they cease to function. On the other hand, the English valve position is improving and there has been a marked increase in home-constructed receivers, as the sales of our blueprints indicate. At the same time there is a shortage of certain components, notably condensers and loudspeakers, and readers are therefore advised to make quite certain that components are available. This they may do by writing to our advertisers and submitting a list of the components required.

The labour position in the radio industry is not likely to improve for at least six months. It is unlikely, therefore, that receivers and radio components will be available in anything but small quantities for some time to come. It is equally unlikely that there will be a radio show next year. The organisation of an exhibition is a vast task and work on it usually commences early in the year when manufacturers have settled their season's programme. That will not be possible until 1946 is well advanced. Dealers will, therefore, make good this omission by running local exhibitions as goods become available.

Design Centres

LARGE exhibitions, like that proposed for next year, in which all British goods will be shown are stimulants to manufacture and to all concerned with the manufacture, sale and purchase of goods. There will, undoubtedly, be a radio section to this Government-sponsored national exhibition which is being organised by the Council for Industrial Design. The exhibition is to be held in London next summer. The Council has announced its plan for carrying out the Government's desire to put design in industry on a basis comparable with scientific and technical research. Design centres are proposed, the functions of which will be to study the problem of design in relation to the products of the particular industry, to collect and make available to the industry information relating to changes in public taste and trade practice in home and overseas markets and to hold exhibitions both at home and overseas; to conduct and encourage research.

Editorial and Advertisement Offices:
"Practical Wireless," George Neuenes, Ltd.,
Tower House, Southampton Street, Strand,
W.C.2. Phone: Temple Bar 4363.
Telegrams: Newnes, Rand, London.
Registered at the G.P.O. for transmission by
Canadian Magazine Post.

The Editor will be pleased to consider articles of a practical nature suitable for publication in "Practical Wireless." Such articles should be written on one side of the paper only, and should contain the name and address of the sender. Whilst the Editor does not hold himself responsible for manuscripts, every effort will be made to return them if a stamped and addressed envelope is enclosed. All correspondence intended for the Editor should be addressed: The Editor, "Practical Wireless," George Neuenes, Ltd., Tower House, Southampton Street, Strand, W.C.2.

Owing to the rapid progress in the design of wireless apparatus and to our efforts to keep our readers in touch with the latest developments, we give no warranty that apparatus described in our columns is not the subject of letters patent.

Copyright in all drawings, photographs and articles published in "Practical Wireless" is specifically reserved throughout the countries signatory to the Berne Convention and the U.S.A. Reproductions or imitations of any of these are therefore expressly forbidden. "Practical Wireless" incorporates "Amateur Wireless."

ROUND THE WORLD OF WIRELESS

Short Waves from Cape Verde

MADRID Radio announced that a new short-wave broadcasting station has been built in the Cape Verde Islands and would operate daily from 1600 hours G.M.T., using a wavelength of 47.5 metres. The transmissions are being heard at good strength in England.

Ankara

ONE of the strongest stations heard in England on the 31-metre band is that of the Turkish station in Ankara. The transmissions are mainly in English, and appear to have an aerial directed on this country. The schedule is unreliable, but always can be heard from 18.00 hours until 22.00 hours. Ankara time is two hours ahead of G.M.T.

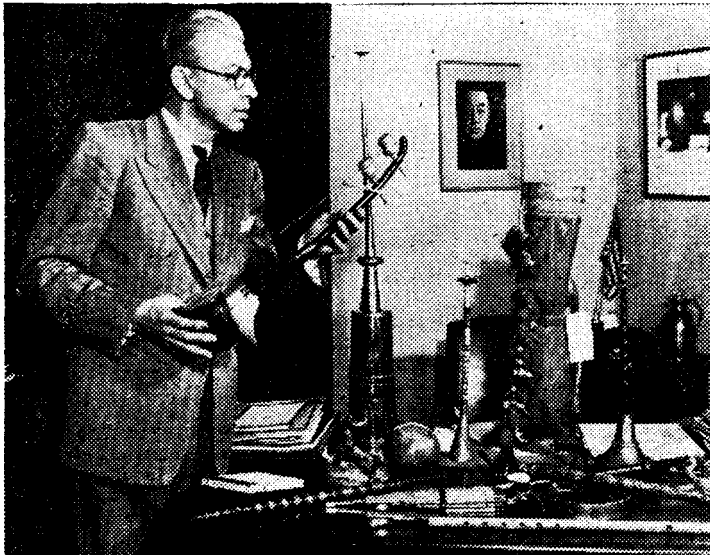

These odd ancient oriental instruments have helped to set the design for many modern music-making devices used in standard symphonic practice. Dr. Frank Black, N.B.C. general music director and conductor, owns a valuable collection of antique instruments. He is here seen pointing out the characteristics of an old violin.

Australia Changes in Schedules

IN an announcement from Sydney it was stated that transmissions for the Forces would in future be on 31.32 and 31.20 metres. These transmissions are now being heard all over Europe at good strength.

Tests from Holland

ALREADY short-wave tests are being made from Eindhoven on a wavelength of 19.71 metres between 09.00 and 11.00 G.M.T. each day. These transmissions are beamed on Dutch East Indies, but reception is good in England. The station should by now be in regular daily service.

Prisoner Broadcasts

BROADCASTS from internees are now being made from Shanghai on a wavelength of 25.9 metres 13.15 hours, G.M.T., on a frequency of 11,580 kcs. As was the case before the war, this station can be well heard in England and its recent broadcasts have been most interesting.

Programmes from the Far East

THE Malayan National Service can be heard in England on 41.55 and 25.29 metres, and amongst the broadcasts are programmes for British troops and news of interest to those with friends in the Far East. This programme is in addition to the Regional programme broadcast on 31.55 metres. Singapore can now be heard in England when using the wavelength of 31.44 metres.

Television from Paris

PARIS RADIO recently announced that television transmissions have been resumed, and that the studio transmissions would in future come from the new Television Centre in the Rue Cognacq-Jay.

Regular transmissions are made from 15.30 to 17.30 daily, Monday to Friday, on the pre-war frequencies.

It will be remembered that viewers in the South of England could, before the war, see quite good pictures from Paris on normal British television receivers.

Amateur Transmitting

THE Government of the Irish Free State have announced that all restrictions imposed on transmitting by amateurs have now been removed and steps are being taken to re-issue licences in the near future. No indication is made of the frequencies that will be allotted.

This lines up with the conditions in America where amateurs are for the time being using a frequency of 144-148 mc/s. until such times as the normal lower frequency bands are cleared for amateur use.

In a broadcast from Sydney it was also announced that restrictions on radio amateurs had been removed and licences would be issued at once.

The situation with the British amateur is that the G.P.O. have allowed applications to be made for radiating licences from those holders of pre-war licences, but no

indication has been given as to when the issue of licences can be expected.

It is almost certain that in the first instance the band given to amateurs will either be 112 to 118 mcs. or 144 to 148 mcs. to line up with the American allocation.

Bandoeng

THE old favourite short-wave station of Bandoeng, Java, that was received in this country so well for ten years before the war, has reappeared in new form as "The Voice of Free Indonesia," operating on a wavelength of 16.6 metres.

Although the station announced that it was also operating on 24.4 metres, no reception on this wavelength has so far been recorded.

CKNC

THE Canadian short-wave broadcasts on 19 and 25 metres have now been supplemented by CKNC on 16.84 metres. This station, which starts up at 12.00

hours daily, is very powerful, and can be heard in England at great strength with the simplest receiver. The programmes are mainly for Canadian troops in Europe.

B.I.R.E. Meeting

AT a meeting of the British Institution of Radio Engineers (London Section), held at the Institution of Structural Engineers, Upper Belgrave Street, S.W.1, on October 17th, a joint paper on "A Symposium of Mathematical Methods for Radio Engineers" was contributed by L. Jofet and M. M. Levy.

New Appointment

WE are informed by Banks (London), Ltd., Mechanical and Electrical Engineers, of Clapham, London, S.W.4, that Captain G. J. Redfern, formerly of Mitcham Works, Ltd., and the Philco Radio and Television Corporation of Great Britain, Ltd., has joined the firm in the capacity of Chief Electronic Engineer, and will be handling all the technical side of Messrs. Banks' business.

Increased Membership of American I.R.E.

ACCORDING to the Annual Report of the Secretary of the U.S. Institute of Radio Engineers the membership has increased by 2,000, bringing the total to 13,137. About 12 per cent. of the total membership reside outside the United States. The increased membership in Great Britain was responsible for the addition of over 100 members in Europe.

Cable and Wireless

Appointment

COL. H. J. WELLINGHAM, who has been Cable and Wireless, Ltd., Press Liaison Officer since February, 1944, has been promoted Manager, London Branches. He will take over his new appointment on December 1st, when Rear-Admiral George P. Thomson, who has been Director of the Press Censorship Division, Ministry of Information, during the war, joins the company to undertake press liaison duties.

Col. Wellingham, M.C., T.D., is a Norfolk man and an engineer by profession; he is M.I.Mech.E., M.I.A.M.E., M.I.E.C., and Associate I.E.E. He joined the Western Telegraph Company—now merged with others into Cable and Wireless, Ltd.—in 1924.

In February, 1944, after some time in the Royal Electrical and Mechanical Engineers, with which he served in the Tunisian Campaign, he was seconded from the Army to establish the newly created Press Liaison Office at Cable and Wireless, Ltd.

Travelling Post Offices

NOW that the travelling post office service has been resumed it is interesting to note that the first travelling post office, which consisted of a horsebox temporarily fitted up as a sorting carriage, ran experimentally in 1838 between Birmingham and Liverpool, and covered 100 miles in four and a half hours. The first travelling post office from London started at Euston in the same year, and finished at a point little north of Bletchley. Later in 1838 this service was extended to Preston.

The first postal train in this country was run by the G.W.R. between Paddington and Bristol on February 1st, 1855. The services rapidly grew until just before the war the whole of Great Britain was covered by a network of more than 70 travelling post offices.

Wireless Receiving Licences

THE following table, showing the approximate number of wireless licences issued during the year ended August 31st, 1945, was recently released by the Comptroller and Accountant General of the Post Office:

Region	Number
London Postal	1,752,000
Home Counties	1,283,000
Midland	1,405,000
North Eastern	1,534,000
North Western	1,349,000
South Western	832,000
Welsh and Border	586,000
Total England and Wales	8,741,000
Scotland	983,000
Northern Ireland	151,000
Grand Total	9,875,000

Radio Dealer's Exploit

THE evening of the first day a dealer displayed a new Philco radio in his window it was stolen. The dealer, Mr. W. Phillips, of Langley Mill, Notts., told this to the Philco Company and they supplied another set.

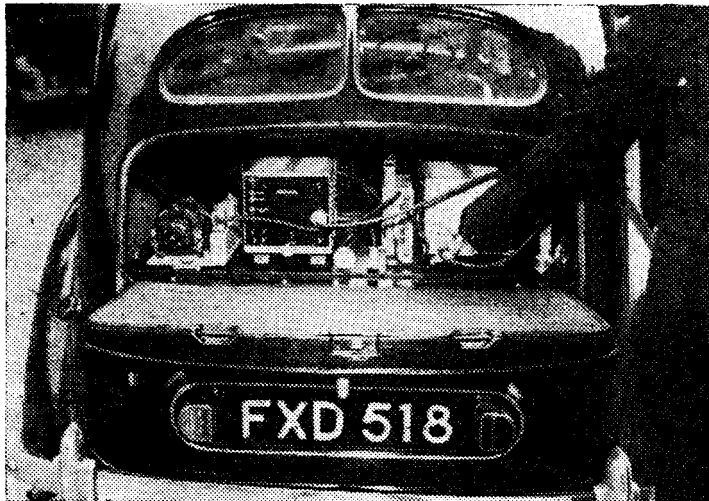

By dialling 999 police can now be brought to the scene of a crime in 60 seconds. This has been brought about by 30 new police cars, one of which is stationed in every Metropolitan borough, that have been equipped with two-way radio. These radio sets are powered by two 6-volt batteries in the boot of the car, and have a range of 20 miles. The sets are so constructed that electrical interference is cut out, and the messages cannot be heard on domestic radios. The illustration shows the set in the back of the police car.

Mr. Phillips was taking no chances this time. When he put the new radio in the window he laced it to all the other sets on display.

The burglar called again, but as soon as he tried to make off with the Philco the other sets followed him. Brought to his bedroom window by the noise, Mr. Phillips saw the thief in the darkness below and jumped. He missed the burglar by a yard and fell heavily, breaking both heel bones. Naturally, the burglar escaped.

No more radio sets are being displayed in the shop window until Mr. Phillips is up and about again. Then he is determined to capture the thief. "If necessary," he said, "I will blow the shop front in on purpose to catch him."

On the Beam

An Explanation of "Standard" Beam Approach—a Radio Aid for Landing Aircraft in Conditions of Poor Visibility.

By FRANK PRESTON

OF the many systems that have been devised to increase the safety of landing aircraft in conditions of poor visibility beam approach is probably the simplest. It is also the only device of this kind which has been extensively used throughout the war.

But it is first necessary to correct certain false impressions that were formed after reading various "stories" in the daily press. These stories were published at intervals during the European War, and left the average reader with the belief that, due to this

German Lorenz system, which was fairly widely used by the civil air lines before the war. For a time the name Blind Approach was used, but it was later considered that the present name was more appropriate.

S.B.A. depends upon the transmission of an ultra-high-frequency tone-modulated beam within which the aircraft can fly toward the transmitter—described as a main beacon. In addition, there are two so-called marker beacons. These feed into horizontal dipole aerials designed to produce an upward beam. These are

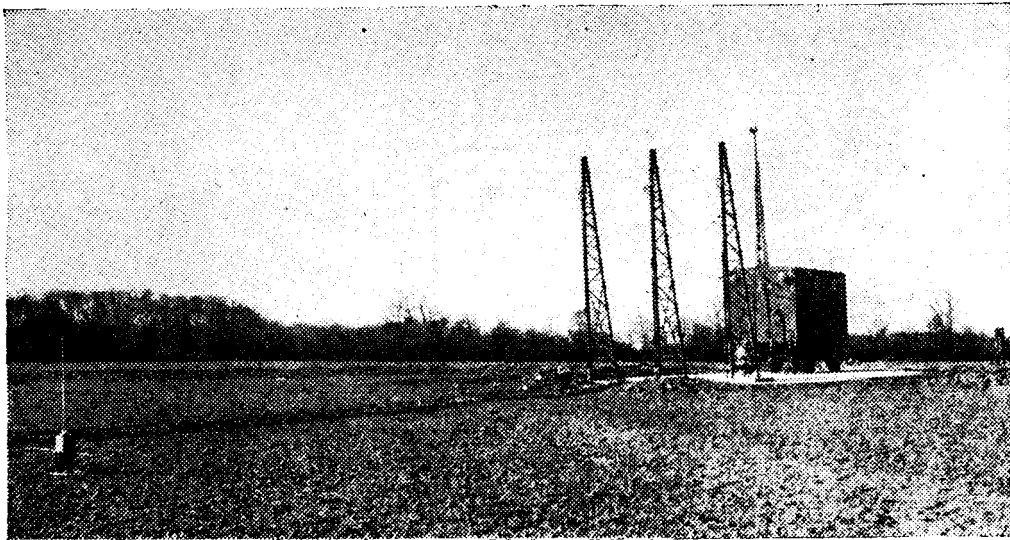

T.U.3. Main Beacon ground installation.

valuable landing aid, our bombers were able to set out and to land safely at their bases in any kind of weather.

That, of course, was sheer nonsense. Fortunately, it was corrected to a large extent by the explanations and demonstrations that were given at the R.A.F. Exhibition held at Dorland Hall, Lower Regent Street, London, during late March and April, 1945.

Beam approach does permit the pilot of an aircraft fitted with the necessary receivers to locate an airfield and to fly over the runway. In fact, the pilot can make an accurate approach, and can do almost everything except make the final touch-down in conditions of zero visibility. For the final landing, however, a certain amount of visibility is necessary.

It has been stated, and proved, by at least one well-known exponent of the system, that he could teach any good pilot to land a four-engined bomber "on the beam" given a horizontal visibility of 100 yards and vertical visibility of 100ft. The claim has never been made authoritatively that a "blind" landing is possible with this aid; the name itself makes quite clear the fact that the system is intended for *approach*, which is entirely different from landing.

The system at present in use by the R.A.F. is known as Standard Beam Approach, the initial word relating to Standard Telephones and Cables, Ltd., who pioneered and developed beam approach equipment in this country. The S.B.A. system is developed from the

situated on the ground at two points along the track of the main beam, and indicate to the pilot his distance from the main beacon. It should be noted that the main beacon is situated at the end of the runway and feeds into a vertically polarised aerial system.

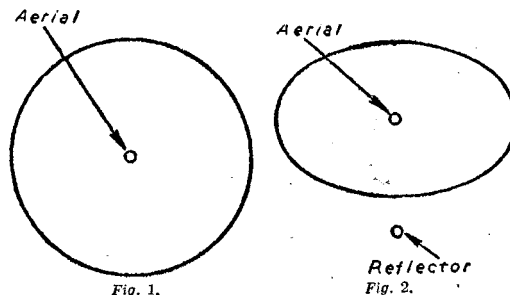

Fig. 1.—The theoretical polar diagram for a vertical aerial without reflector.

Fig. 2.—When a reflector is positioned parallel to and a quarter-wavelength away from a vertical aerial the polar diagram becomes elliptical.

First, let us see how the main beacon operates. There is a transmitter with an output of about 50 watts, and this is tuned to an allotted frequency within the band of approximately 30 to 40 mc/s.; this is equivalent to a wavelength of 10 to 7.5 metres. The transmitter is modulated with a pure tone having a frequency of 1,150 c/s., and the output is applied to a vertical dipole aerial.

It is known that an aerial of this kind gives omnidirectional radiation, the theoretical polar diagram being a circle, as shown in Fig. 1. It is also known that if a reflector (a half-wave rod similar to the aerial) is placed a quarter-wavelength from the aerial the polar diagram is "pushed over" to form an ellipse, as shown in Fig. 2.

Use is made of this fact in the main-beacon aerial system by placing a reflector at each side of the aerial and arranging that the two reflectors are brought into operation alternately. This is done by splitting each reflector in the centre and fitting a relay switch to close the gap between what are, in effect, two quarter-wave rods mounted end to end. Fig. 3 illustrates the arrangement diagrammatically.

It may be seen from Fig. 3 that whereas one relay is spring-biased so that its contacts are in the closed position when the relay solenoid is not energised, the other relay is biased in the reverse manner. The relay solenoids are in series, and are fed from a voltage source through a cam type of contactor. The cam is so cut that the projections are one-seventh as long as the recesses, measured circumferentially. The simple cam illustrated has four projections and four recesses, and therefore if the cam is rotated so that it makes one complete revolution every four seconds the "dot" reflector will be in action for $\frac{1}{4}$ second and the "dash" reflector for $\frac{3}{4}$ second in every second.

From this information the polar diagram shown in Fig. 5 may be plotted. This shows a "dot" area on the right of the aerial system and a "dash" area on the left. Down the centre line, and in line with the radiator, the "dot" and "dash" polar lines cross each other. This means that a receiver operated along this line would reproduce a steady note, due to the spaces left between the "dashes" being filled in by the "dots." If the receiver were moved toward one side of the centre line the "dots" would predominate; if it were moved towards the other side "dashes" would predominate.

Due to the relative insensitiveness of the human ear

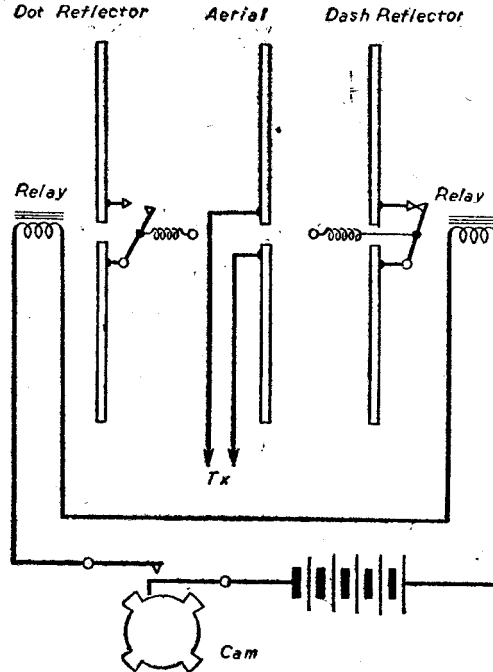
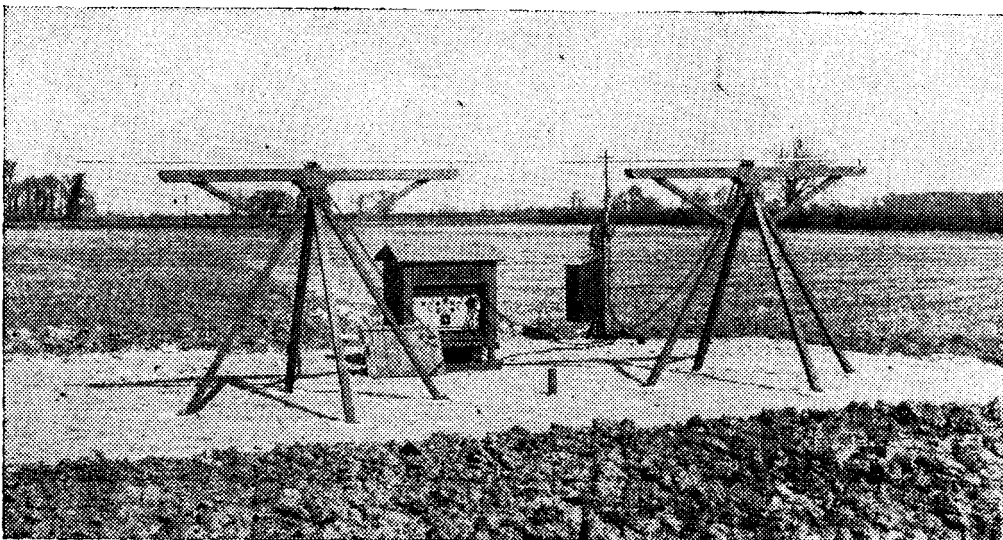
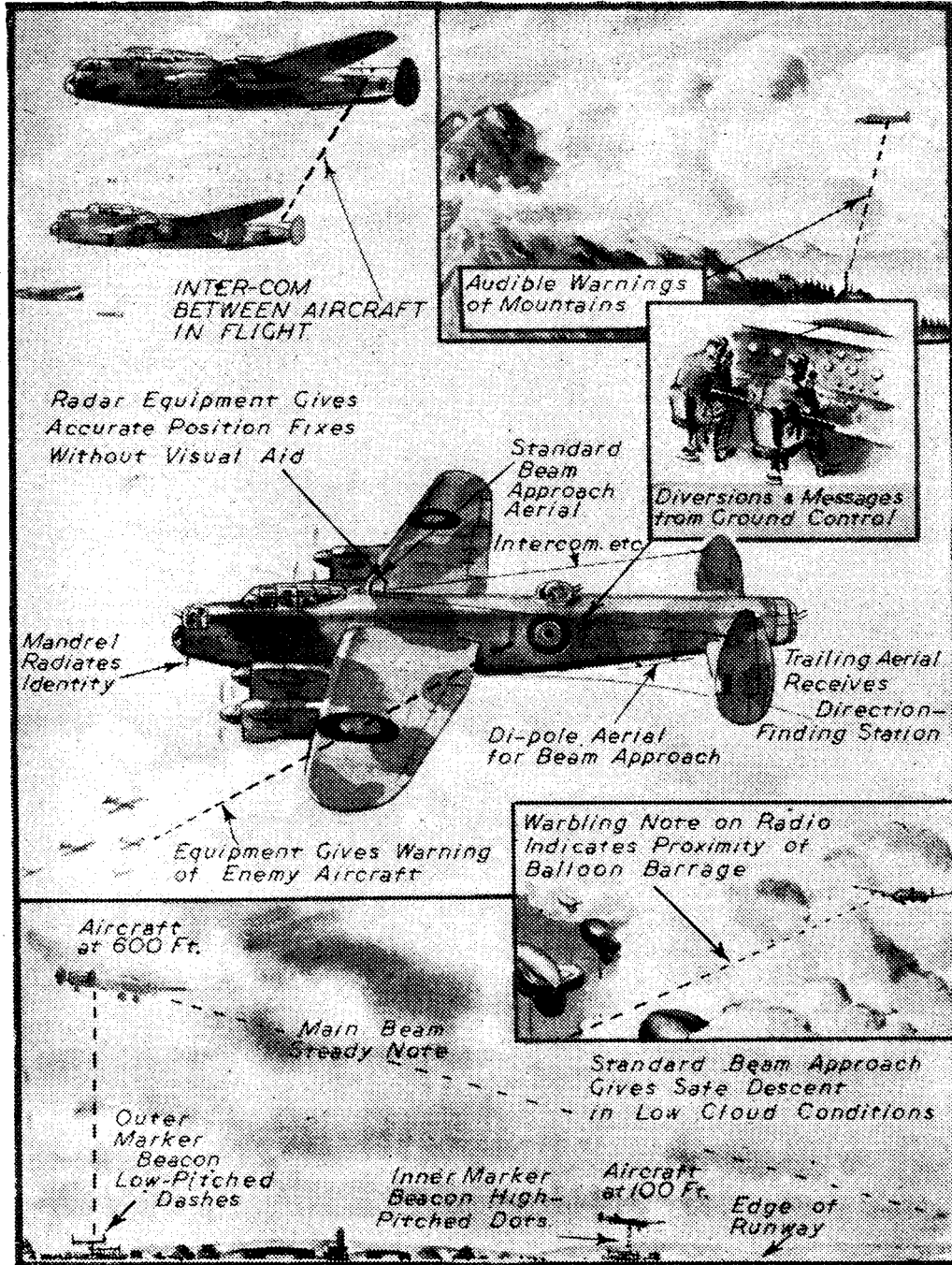

Fig. 3.—This diagram illustrates the principles of the switching system adopted for the reflectors used in conjunction with the vertical half-wave dipole aerial in S.B.A. system.

the steady note can, in fact, be heard over a few degrees on each side of the centre line, the actual width of the "equi-signal zone" being governed by the exact adjustment of the reflector lengths. To permit of their adjustment to suit any particular frequency within the range, and also to give any required beam angle, sliding rods are fitted at each end of the tubes forming the reflector elements.



M.U.3. Marker Beacon installation with dipole aerials.



Some radio aerals used by our bombers.

In general, the reflectors are adjusted so that the effective width of the equi-signal zone is between 1 and 2 degrees, but almost any other beam angle can be provided if required.

As might be expected, there is no sudden change from equi-signal to dots and dashes. Instead, there is what is described as a "twilight zone"; this normally covers an angle of approximately 40 degrees overall. In this zone (there are actually two zones, one on each side of the equi-signal zone) the gaps between the dots or dashes are partly filled in, with the result that the characters are heard superimposed upon a steady background note. This is shown diagrammatically in Fig. 5.

With such a form of radiation as that described, the pilot of an aircraft fitted with a suitable receiver could easily find the approach line, or

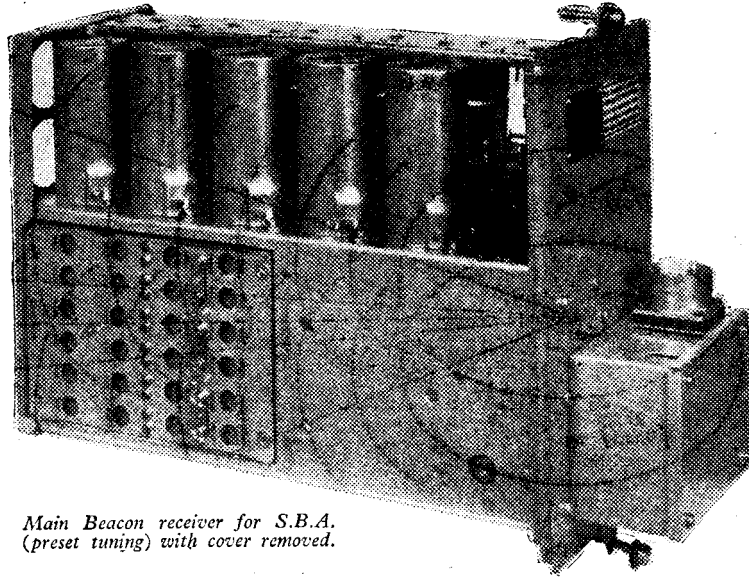

Main Beacon receiver for S.B.A. (preset tuning) with cover removed.

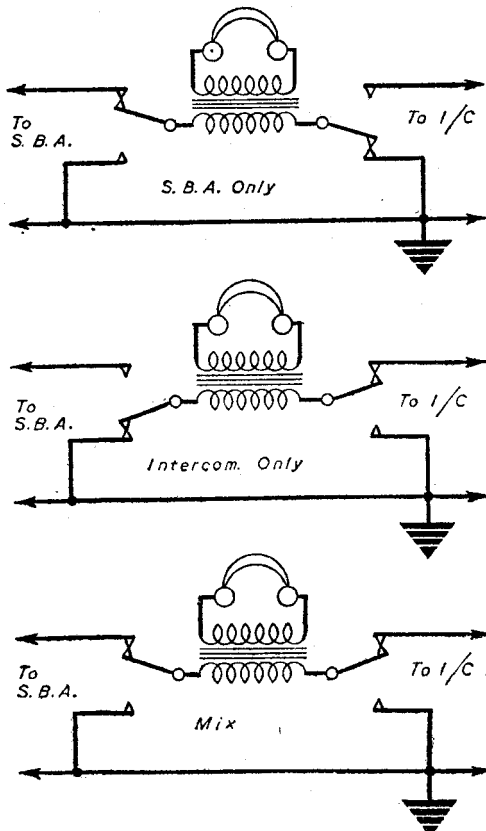

Fig. 4.—Theoretical circuit of the mixer box, showing the positions of the switch contacts for "B.A.," "Mix" and "I/C."

equi-signal zone. He could also, by flying along the line of equi-signal, locate the airfield. In poor visibility, however, he could do little more than this, and he would require more assistance to allow him to make a gliding approach preparatory to landing.

The additional assistance required is provided by the marker beacons which have already been mentioned. One of these is situated on the course line close to the "touch down" end of the runway. The other is situated on the centre line of the main beam about two miles beyond the first. These marker beacon transmitters are described as inner and outer markers respectively, for obvious reasons.

A horizontal dipole—or a pair of horizontal dipoles arranged to provide a narrower beam—is used with the marker beacons to project an upward beam, as shown in Fig. 6.

Each marker beacon transmits a keyed, M.C.W. signal. That from the outer marker consists of dashes transmitted at a speed of two per second on an audio frequency of 700 c/s. The signal from the inner marker is of a more "urgent" character and consists of dots with an audio frequency of 1,700 c/s. sent at a rate of six per second.

A fixed frequency of 38 mc/s. (about 8 metres) is used for all marker beacons, irrespective of the frequency of the main beacon.

In order to receive both main and marker beacon signals simultaneously it is necessary to employ two different receivers in the aircraft. The main beacon receiver is a six-valve superhet with frequency selection over the 30 to 40 mc/s. (approximately) band, and a sensitivity of the order of 50 microvolts. The marker receiver is a simple two-valve set, fixed tuned to 38 mc/s.

The output from both receivers is mixed and can, if desired, be fed into the aircraft intercommunication system by throwing a switch. This switch has three positions marked: "B.A."—"MIX"—"I/C." With the switch in the first position the pilot only can hear the S.B.A. signals without interruption by crew conversation; in the second position S.B.A. reception is superimposed upon the intercommunication; in the third position, intercommunication (generally described as intercom.) only is heard in the phones of the pilot and crew.

Fig. 7 shows in diagrammatic form the layout of the items comprising the aircraft installation; the separate items are all illustrated in accompanying half-tones.

Fig. 5.—This diagram shows the radiation pattern of an S.B.A. main-beacon aerial system when using "dot-and-dash" keying.

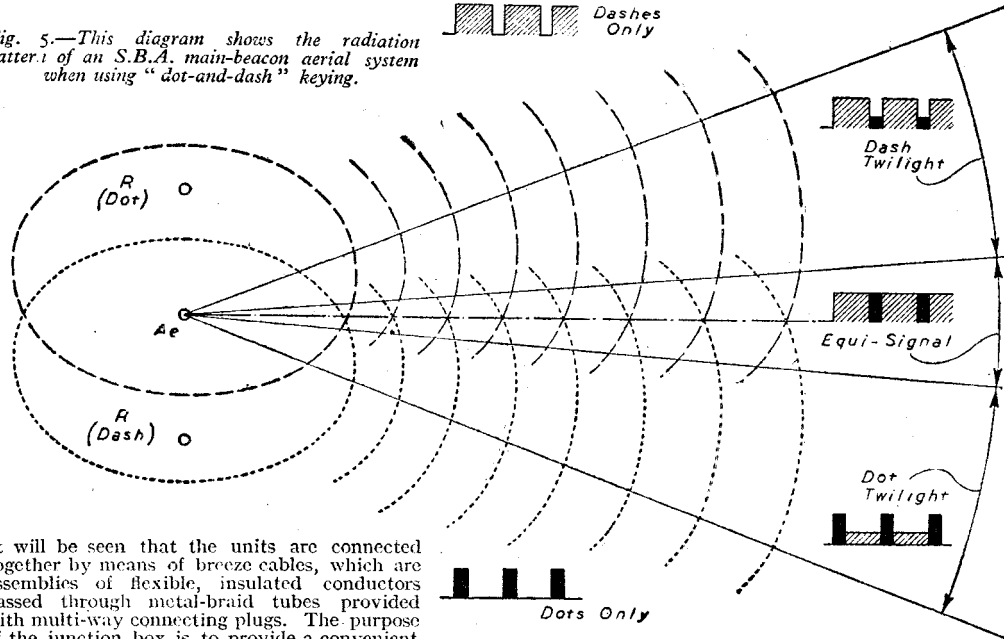

It will be seen that the units are connected together by means of breeze cables, which are assemblies of flexible, insulated conductors passed through metal-braid tubes provided with multi-way connecting plugs. The purpose of the junction box is to provide a convenient means of making multiple connections between the units and to simplify the testing and replacement of any particular cable assembly.

Before describing the receivers in rather more detail it is well to explain briefly the purpose of the various ancillary items shown in Fig. 7.

The power unit is of the rotary converter type and is operated from the main aircraft battery supply—controlled by means of a carbon-pile type of voltage regulator. Models are available for input voltages of either 12 or 24 (nominal) and in either case the consumption approximates to 80 watts. Three output

voltages are provided: 13 volts for L.T., 200 volts for the main H.T., and 120 volts of stabilised H.T. The power unit also contains the necessary smoothing circuits and an H.T. fuse.

Five controls are provided on the pilot's control panel, in addition to a telephone socket for test purposes. First there is an ordinary toggle switch for on-off switching; this actuates a relay in the power unit. At the top left-hand corner there is a "Normal-Test" switch. When this is turned to the "Test" position additional bias is applied to the first I.F. stage in the main beacon receiver. The result of this is that A.V.C. action is

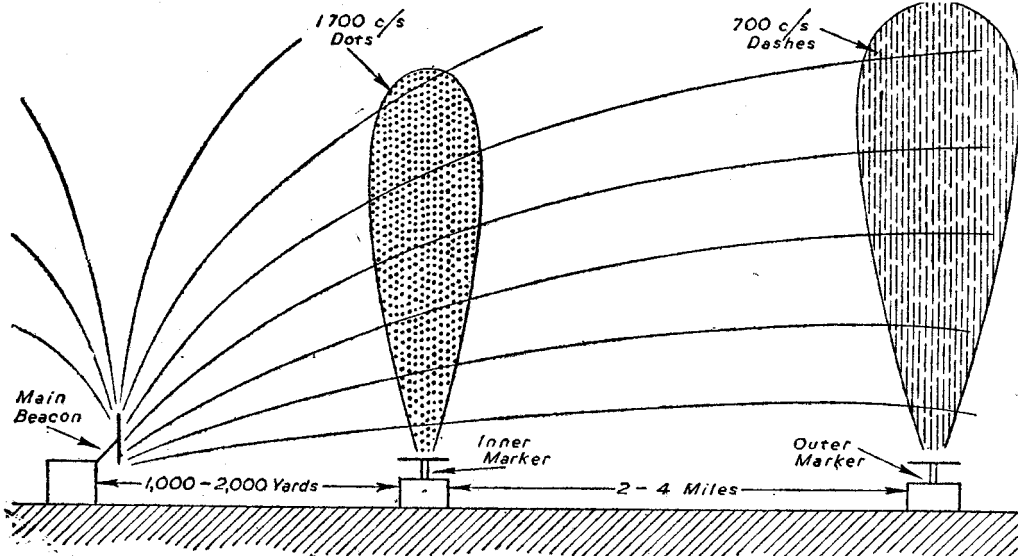

Fig. 6.—The radiation pattern from the marker-beacon horizontal dipoles is shown here, in relation to the radiation from the main-beacon aerial.

restricted so that a signal-strength meter can be used to determine whether the aircraft is flying toward or away from the main beacon when it is within the beam. In the top right-hand corner there is a fine-tuning control which can be used to trim the oscillator portion of the frequency-changer in the main-beacon receiver. A six-position frequency selection switch is situated in the bottom left-hand corner. This simply brings into circuit six sets of four pre-set tuning condensers and, therefore, allows the pilot to tune his set to the known frequency of a particular S.B.A. ground installation. The remaining knob is for a potentiometer volume control, which acts on the signals from the main-beacon receiver only; there is no means of varying the output from the marker receiver.

It should be explained that the particular control panel described is used only with a type of main-beacon receiver which is pre-tuned to six selected frequencies. Other types of receiver, with continuously variable tuning are made, but are of relatively recent design and have not yet come into very wide use. Reference will be made to these receivers later in this series of articles.

The so-called "Mixer Box"—Junction Box type 51, to apply the official description—contains a transformer and three-position switch, the function of which has already been explained. The connections made by the switch contacts in the three positions are illustrated in Fig. 4.

The visual indicator shown in Fig. 7 is normally mounted on the pilot's main instrument panel. It has three functions and comprises two moving-coil meters and a pair of neon tubes. This indicator bears some resemblance to a human face and the parts may be referred to for convenience in terms of features. The "nose" is a signal-strength meter and is used in con-

junction with the "Normal-Test" switch already described. The "mouth" is known as a course meter or kicker meter; the latter name is given due to the fact that the pointer kicks to left or right in certain circumstances. When the aircraft is flying on the "dot" side of the main beam the needle kicks to the right, indicating that the aircraft should be steered in that direction to bring it into the equi-signal zone. When the aircraft is on the "dash" side of the beam the needle kicks toward the left.

The "eyes" are neon lamps mounted behind gauze discs. Their purpose is to give visual indication that the aircraft is flying over a marker beacon. It should be noted that the indicators can be used at the same time as an aural indication is being received, and also that the neons are not always used, the lamps being removed. The neon tubes are actuated by the output from two audio filter circuits connected to separate windings on the output transformer of the marker receiver. When the aircraft is flying over an outer marker the output from a 700 c/s. filter is applied to the neon on the left, marked "O." On the other hand, the 1,700 c/s. audio output received from an inner marker is fed to the right-hand neon, marked "I." An initial stabilised D.C. voltage is applied to the neon tubes, this being adjusted to such a value that the neons just fail to strike in the absence of a signal.

A vertical whip type of aerial is normally employed with the main receiver, but other types of quarter-wave vertical aerials are used in some cases. The aerial is connected to the receiver through a coaxial line. Should the line exceed 20ft. in length, a matching unit is included in it. In practice, it is seldom necessary to exceed that length, even in a four-engined bomber.

(To be continued.)

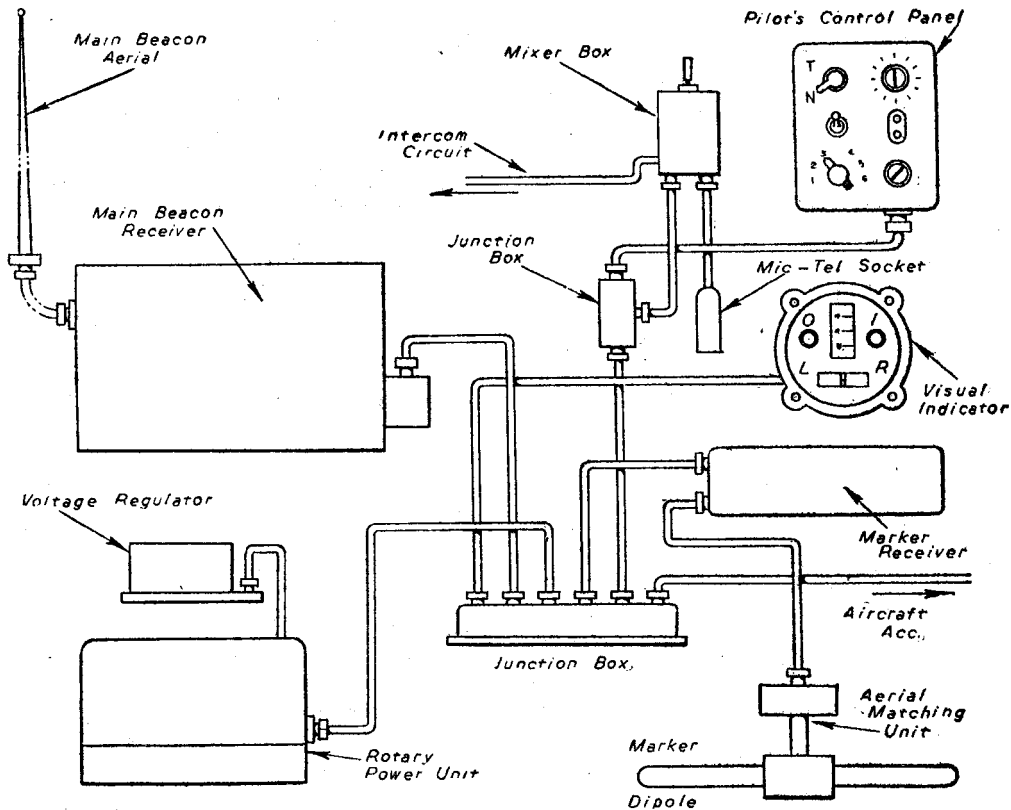
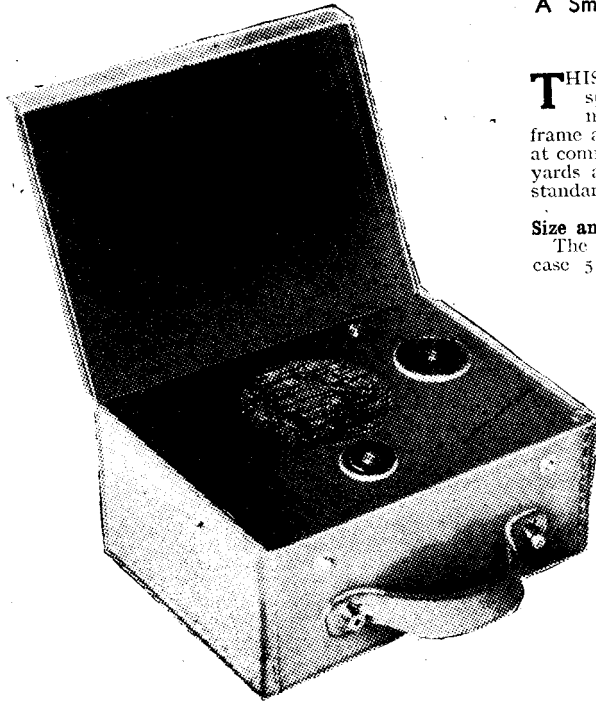

Fig. 7.—Pictorial layout of the S.B.A. receiver installation in a typical aircraft.

Ultra Midget Battery Loudspeaker Receiver

A Small Portable Set Designed to Give Reasonable Reception



The completed receiver in case.

THIS receiver was designed to give reasonable loudspeaker results, and no exaggerated claims are made as to what may be expected. On the small frame aerial the Light and Home programmes come in at comfortable strength. If a throw-out aerial of a few yards and an earth is used, results are up to 3-valve standard, taking into account the size of speaker used.

Size and Weight

The set complete with batteries was fitted into a case $5\frac{3}{4}$ in. \times $4\frac{3}{4}$ in. \times $2\frac{3}{4}$ in., so it can truly be claimed midget. No special ultra midget components or "gadgets" are necessary, and all parts can be bought from any of the dealers advertising in PRACTICAL WIRELESS, excepting the switch.

The total weight of set is under 2lb. so that no one needs to grumble about carrying the set.

The aerial is fitted in the lid of the case, and when opened is clear of batteries, etc.

Another feature is that to operate the set the lid must be opened, when the set automatically switches on. A simple switch is incorporated to switch on when lid is opened and switch off when lid is closed. (This also saves space.) There is no difficulty in the construction, care being taken that the basic layout is adhered to, otherwise instability will result. There is ample space in the set to work in, and nothing has been unduly cramped. The small ebonite knobs make a neat little job and are easily made. The switch is fitted nearest lid of case, and should project about $\frac{3}{16}$ in. above metal panel.

The metal panel and frame aerial are covered with leatherette, the loudspeaker with tinsel thus making a professional job.

All screws holding loudspeaker, etc., to

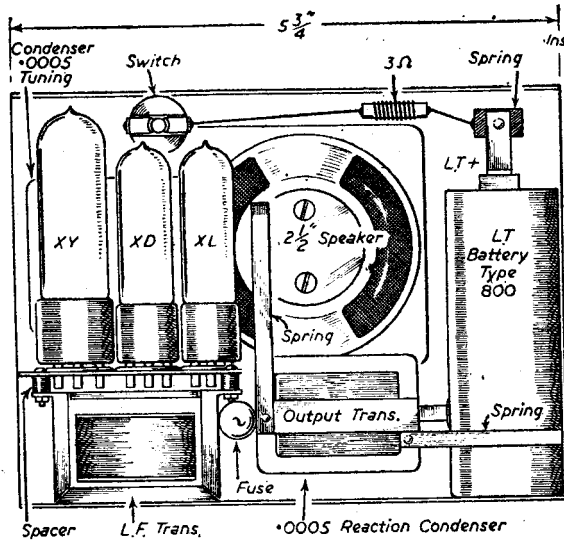

Fig. 1.—Back view of the receiver, showing positions of the various components.

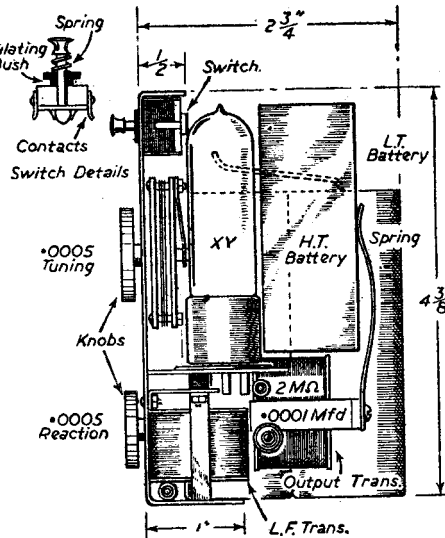
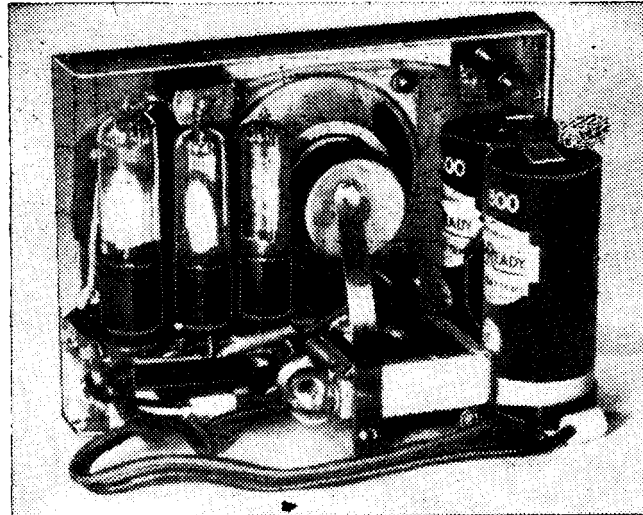

Fig. 2.—Side view of the receiver and details of the switch.

panel are filed flush. Screws on the tuning condenser at the point nearest the panel are also filed down to minimise shorting to the metal panel. Bakelised paper can be inserted between panel and condenser.

A small 2½ in. M.C. speaker (Celestion) is used, and handles volume well. The H.T. battery lies on top of speaker, being held in position by a spring attached to output transformer.

The output transformer (Fig. 4) is mounted on a bracket to clear reaction condenser which is also raised to clear end of loudspeaker. Also attached to bracket is the spring to make contact with L.T.— of type 800 battery. This battery is used because of its long life. It is most important that the connections to the valve holders should be soldered before LF33 (Bulgin) or similar midget transformer is fitted, as it can't be done after. Spacers are used to mount transformer clear of valve holders. The resistances are of the ½-watt type, and fixed condenser of tubular type. 20 S.W.G. is used for connections in valve unit, thin flex used to couple set to aerial. Systoflex covering throughout. The circuit is common (Fig. 7).



Rear view of the midget receiver.

Frame Aerial

Frame aerial is wound on a sheet of stiff cardboard or plywood 5½ in. x 4½ in. An odd number deep are cut around the material used (Fig. 3), as the frame is wound basket coil fashion. This is an efficient and flat aerial. Care should be taken that no turns are shorting.

26 S.W.G. enamelled wire (which writer finds best for midgets) is wound in and out of slots until 17 turns are completed. Then winding in same direction add 2½ turns for reaction. (This depends on care taken with grid winding also type of condenser used.) So this aerial should be wound carefully, as set is built around it.

Switch

This is simply made out of an old on/off switch care being taken that bush for fixing, if metal, is insulated from panel. A small light spring is used to push up plunger of switch (Fig. 2). The projection above panel should not exceed 3/16 in. This gives sufficient movement to clear contacts.

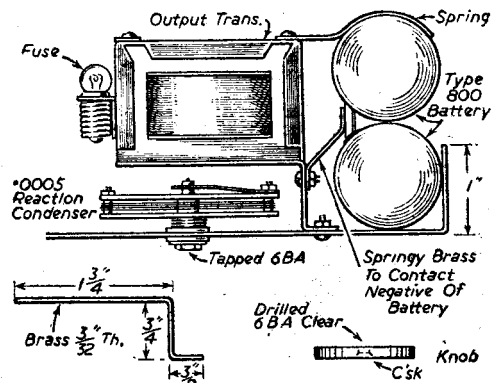

Fig. 4.—View showing the output transformer mounting.

The fixing nut is filed down as thin as possible, so that projection won't be too much to prevent lid closing.

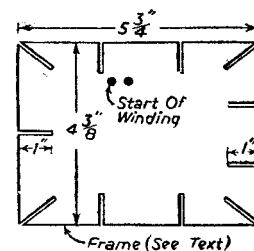

Fig. 3.—The former for the frame aerial, which is wound with 26 S.W.G. enamelled wire.

The tuning and reaction are of the small dielectric type, each having a capacity of .0005 mfd. The method of shortening the bush and spindle to take small ebonite knobs is as follows:

The metal bush through which the spindle passes is cut at the desired length, care being taken not to cut spindle. Spindle is then cut 1/16 in. clear of metal bush, drilled and tapped 6 B.A. The knobs are made out of ¼ in. sheet ebonite and drilled 6 B.A. clearance and countersunk (see diagram). A 6 B.A. screw is fitted. The fixing nuts are filed as thinly as possible.

Resistances

These are of ½ watt type, excepting 3 ohm resistor which is made from Eureka wire.

Constructional Details

The first step is to prepare metal panel (Fig. 6) which is 5½ in. by 4½ in. At top it is ¼ in., bottom rim. The side which supports type 800 battery is ¼ in. (Figs. 1 and 2). Loudspeaker, condensers (tuning and reaction), L.T. switch and bracket on which should be fixed a springy contact to make L.T.— contact, are mounted as shown in the illustration. L.T.+ contact should, of course, be insulated from metal panel.

The valve unit is then wired up (Fig. 5), remembering that all components to valve holders should be soldered before L.F. transformer is fixed in position, using spacers to clear valve holders. See that wiring is neat and tidy and that no blobs of solder or flux are shorting valve pins. The fuse holder (which writer thinks essential in type of this small set) is soldered or fixed on to output transformer frame.

Two small pencil torch batteries in series are used for biasing the pentode valve, and are placed at top of panel above speaker.

Cabinet

The cabinet can be made of wood or thick cardboard (metal must not be used) and can be covered with

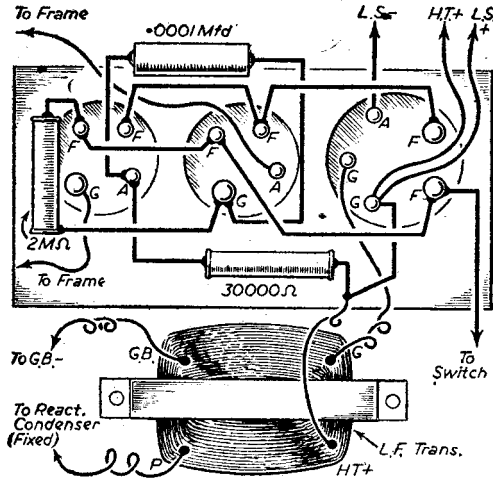

Fig. 5.—Wiring diagram of the valve unit.

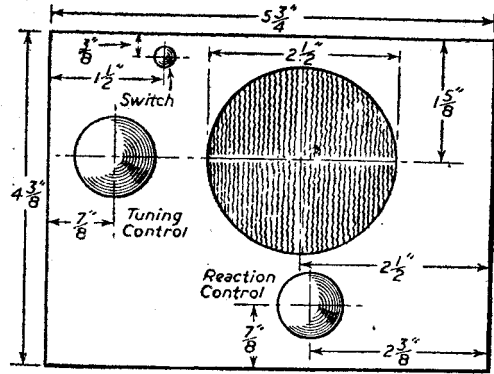

Fig. 6.—The top panel layout of the midget receiver.

leatherette which is plentiful just now in a variety of colours. The lid has two buttons, so that when buttons are fastened the set is switched off. This is the least difficult part of the set, and no doubt other simple ways of making cabinet are at hand.

- LIST OF COMPONENTS**
- Two 4-pin and one 5-pin valve holders (Midget).
 - Two .0005 solid dielectric condensers.
 - One Switch (see text).
 - One .0001 mfd. condenser, fixed.
 - One 30,000 ohm resistance, 1/2 watt.
 - One 2 megohms resistance, 1/2 watt.
 - One 3 megohms resistance (see text).
 - One midget transformer (Bulgin L.F.33).
 - One fuse holder.
 - One 2 1/2 in. M.C. speaker (Celestion).
 - One output transformer, 45 : 1 (Midget).
 - One chassis (see text).
 - Valves: Hivac XL, XD, XY.
 - Connecting wire, etc.
 - 26 S.W.G. enamelled wire for frame.

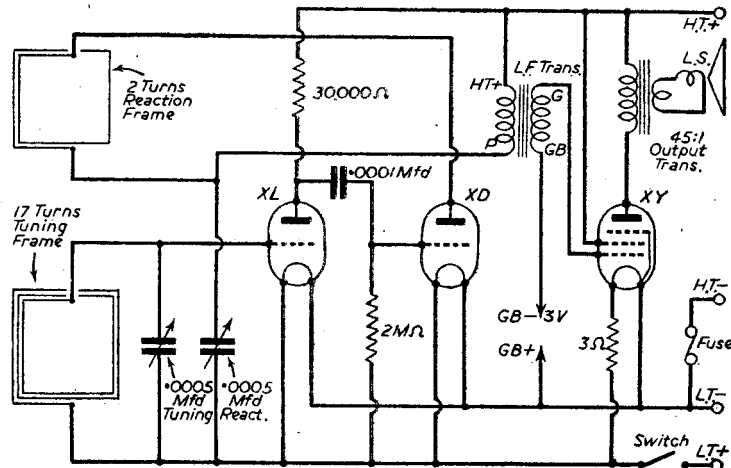

Fig. 7.—The theoretical circuit diagram.

Reconversion of the Radio Industry

DURING recent months the Board of Trade have been dealing with the problem of the reconversion of the radio industry to peacetime production. In normal times receiving sets form the basic product of most firms in the industry, and much has been done under programmes already approved and licensed to ease the difficulties of manufacturers in the present transition period.

At present the manufacture and supply of receiving sets is controlled under the Musical Instruments and Wireless Receivers Order, 1944, S.R. & O. 658/45, and licences have been granted to some 70 manufacturers for the production of about one million sets during the next 12 months. Of this quantity 400,000 are intended for export. Undertakings have been given by the industry that 50 per cent. by value of the production for the home market will be devoted to sets to be retailed at £15 or less, exclusive of Purchase Tax of 33 1/3 per cent. on the wholesale selling price. With the cancellation of war contracts, the supply position in respect of the majority of the principal components required for

civilian production has shown considerable improvement and adequate quantities should be available for the present programme for maintenance of existing sets, and for export.

The supply of timber for radio cabinets, however, is not too good at present, owing to the many important claims on the limited quantities available. During the third quarter of 1945 releases were only about 50 per cent. of the industry's requirements, but the position is improving, and substantial increases will be made in the fourth quarter. This improvement, together with the supplies of plastic materials which are available for cabinets, should go a long way towards overcoming the present difficulties.

Before the war the average annual production of radio sets in this country was about 1.4 millions. Of this quantity the average export was 66,000. It will be seen, therefore, that the present programme visualises an overall production of about 70 per cent. of the pre-war figure, but places considerable emphasis on exports.

in Fig. 3 the switched leads to the medium and long-wave coils are not shown for clarity—they should be wired as for the short-wave coils, the leads for which are shown.

Coil connections are as follows: 1—grid; 2—earth (or H.T. plus in the tuned-anode coupling); 3—reaction condenser; 4—plate. Note that the earth ends of the tuning section of the band-pass coils are not connected to earth, but to the resistor R_r which provides the common-impedance coupling.

It will be seen that the anode leads of the detector are screened to prevent instability. Care should also be taken with the positions of all the wires in the R.F. stages, especially those to the switch and coils. They should be as short and direct as possible, and kept well clear of adjacent connections.

The reaction condenser has a small internal reduction drive and although this is not absolutely necessary it simplifies operation upon the short-wave range. The volume control potentiometer must be insulated from the chassis unless it had a "dead" fixing bush. A small stand-off insulator is used for the aerial. If an earth is used it can be taken to the chassis.

Operation

The voltages shown for battery connections are only approximate and may be modified with advantage with some valves, especially the grid bias and voltage of the H.F. screen.

Having found the receiver to function upon all wave-bands, the circuit should be trimmed. The short-wave band can be taken first. To do this, unscrew the trimmers upon the gang condenser to minimum capacity and tune in a signal near the bottom end of the band. (The reason for choosing a station here is because an alteration in the trimmer capacity will have more apparent effect with the tuning condenser near minimum.) The trimmer on section 2 should now be screwed down. If this causes an increase in volume it should be screwed

COMPONENT LIST

- Resistors: 25,000, 15,000, 50,000, two 5,000 ohm; .25, .5 and 2 megohm. Coupling resistor R₁.
- Condensers: .0002, .0003, .002, .02 and 3 1 mfd. .0003 mfd. reaction condenser.
- 3-gang .0005 mfd. tuning condenser.
- 5-pole 3-way rotary switch.
- 50,000 ohm potentiometer.
- Double pole switch.
- Four 4-pin valveholders.
- Midget "P" type coils: three each for medium and long waves; two for short waves.
- L.F. transformer for direct feed (ratio about 1:3).
- Manufacturer's chassis.
- Stand-off insulator, knobs, etc.

down until further movement causes a reduction in volume—e.g. "peaked" to the signal. If screwing down this trimmer causes a reduction in volume it should be returned to minimum and the trimmer on section 1 screwed down, and the tuning condenser readjusted to the station. The procedure should now be repeated, and if screwing down the trimmer on section 2 causes a reduction in volume the trimmer on section 1 will have to be screwed down even further.

When it is found that tuning or the adjusting of either trimmer brings no improvement in results the circuits are trimmed correctly.

The switch should now be turned to the medium-wave position and the trimmer on section 3 adjusted for maximum response. If screwing this down gives less volume it will be necessary to screw down both trimmers 1 and 2 and re-gang them until trimmer 3 can also be peaked to the signal.

Finally, as a band-pass characteristic is desired trimmer 3 is de-tuned, the amount depending upon the results desired. This will naturally reduce signal strength and if quality is considered satisfactory it may

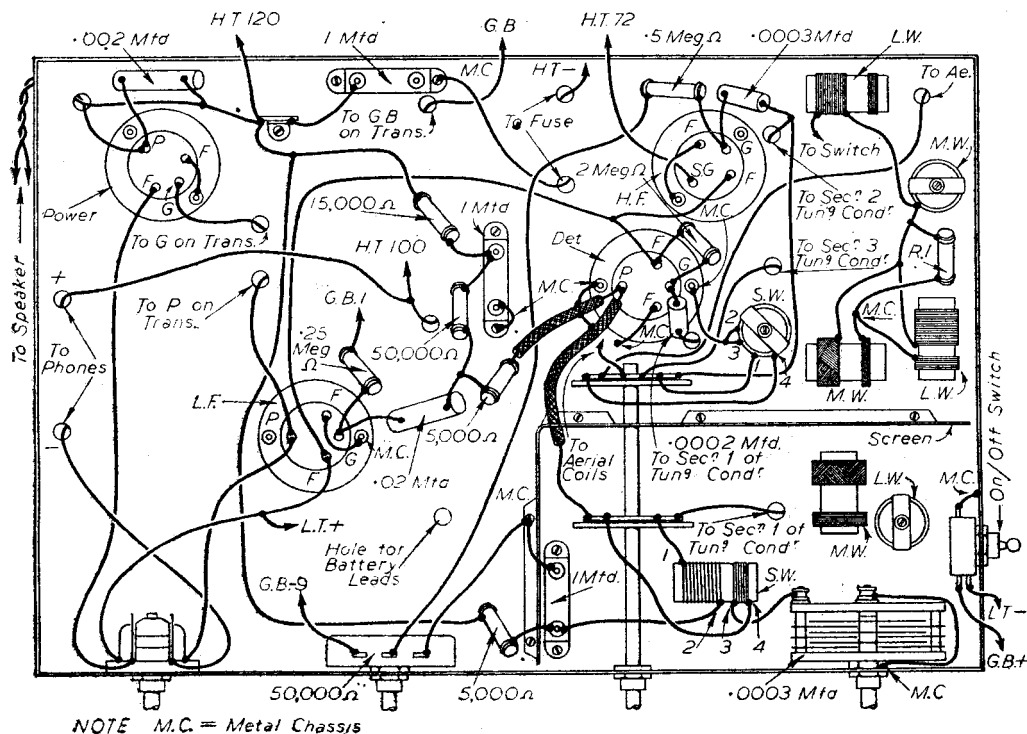

Fig. 3.—Sub-chassis wiring plan.

be left dead on tune. In any case the band-pass characteristic should not be obtained by de-tuning sections 1 or 2 or this will cause lack of volume on short waves.

In some cases it may be found that the circuits can be re-trimmed upon a different setting of the tuning condenser with advantage. If so, the split end vanes of the condenser should be bent slightly in or out to give the additional capacity when required, opening the condenser each time and bending the section just coming into service opposite the fixed plates of the condenser.

When trimmed upon the short-wave range satisfactory results should be obtained upon the other two ranges. If not, the coils are not properly matched and this could

be alleviated by adding a small trimmer to the coils in question.

No value has been specified for R1. Fifty-seven ohms was used in the original set, and the value has a great influence upon the selectivity upon medium and long waves. A lower value will give sharper tuning. If less selectivity is required upon long waves a higher value shunted with a condenser should be used. The condenser will have less effect upon the lower frequencies and tighter coupling will result. The value used depends upon results required.

In any case a high value with no condenser must not be used or the first two tuned circuits will not gang with the third.

A Universal Test Speaker

A Test Speaker which can be Used to Replace Almost Any Type of Speaker when Servicing Receivers.
By F. J. FORBES

THIS test speaker was constructed to replace almost any type of speaker in receivers that were being serviced; it is most useful when a quotation for repairing a set is required and the existing reproducer is also faulty, the receiver can then be tested without touching the internal speaker. In the case of field service, only the chassis need be brought back to the works, thus saving time and avoiding damage or packing to the internal speaker. Obviously these are only a few of the uses to which it can be put, but on these alone is its construction warranted.

There are two circuits in the network, one for field selection, the other for impedance matching and metering the various inputs.

Field Selection

The field selector, S₁, is an eight-pole, single-way switch, enabling the operator to use the more common values of field resistance met in radio service work. In the 100 ohms position an L.F. choke only is used, but for the 400 ohms circuit a 300 ohms resistor is used in series with the choke; 100 ohms fields are usually found in old D.C. sets and are in series with the heaters; therefore this choke was obtained from an old Phillips D.C. receiver, where it is used in series with the heater circuit as a filter. It will carry up to 200 mA without heating up too much.

The rest of the fields are made up of a 600 ohms L.F. choke—inductance 20H and maximum current rating of 150 mA—in series with a resistor to give the required value of field resistance. Three resistors are used in series with the choke, one 330 ohms, 20 watts, and two 785 ohms, 50 watts, the latter have multiple taps and are made for supplying the heater line in universal receivers—sometimes called "mains droppers."

The chokes and resistors need not be adhered to, but in substituting care should be taken to select good quality chokes that will give the necessary smoothing and carry the current, while the resistors should have several taps—for making up extra values of field resistance as required—and be able to carry the required current.

A switch, S₂, enables the field circuit to be isolated from the input circuit, this applies for speakers where the field is in the negative lead, or can be used to substitute a smoothing choke and P.M. speaker at the same time. The "normally closed circuit" jack can be used to check the total H.T. line current.

Since one side of the field circuit will be smoothed and the other the output from the rectifier, the appropriate terminals have been marked with: a sine curve for unsmoothed and a pair of parallel lines for the smoothed side.

Study of the circuit shows that it can be adapted at will for a greater range of fields by adding a selector switch with more positions, and tapped fields can be simulated by connection into the resistor network as

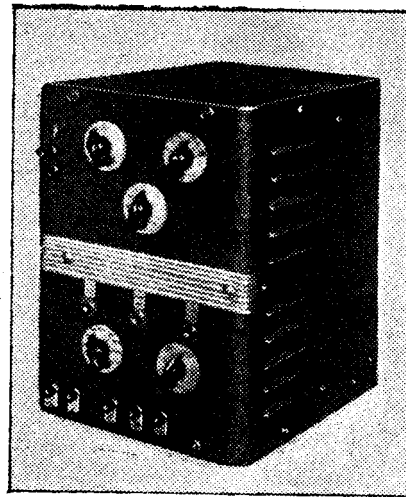

The completed test speaker.

required. Actual speaker field assemblies could be used and the resistors omitted, or a combination of all three could be used.

Input Circuit

Three terminals are used for the signal input, two are for either low impedance or single valve high impedance input, and three for push-pull, Q.P.P. or Class B input as marked. S₃ is a four-pole, two-way switch for measuring the anode current of a single valve, or alternate valves in the case of push-pull, etc., by plugging a milliammeter into the "normally closed circuit" jack.

The input selector is a four-pole, four-way switch, this gives two values of high impedance—when used in conjunction with S₄—push-pull, etc., and low impedance inputs; the ratios and impedances are given in the tables.

Matching is accomplished by S₄, this is a single-pole, five-way switch; the tables give the ratios, etc., of this control on high or low impedance ranges.

The transformer is a W.B. multi-ratio type, carrying a D.C. current of 25-30 mA; it was salvaged from an old "Stentorian" speaker by the same manufacturers. Any good transformer of this type may be used, more

(Continued on page 19)



The "Fluxite Quins" at Work.

"I've fixed up this aerial, see,
With FLUXITE; now just watch me.
Pull hard as you may,
It won't come away . . ."
"But here comes the chimney," yelled EE.

See that FLUXITE is always by you—in the house—garage—workshop—wherever speedy soldering is needed. Used for over 30 years in government works and by the leading engineers and manufacturers. Of all ironmongers—in tins, 8d., 1/4 and 2/8.

Ask to see the FLUXITE POCKET BLOW LAMP, price 2/6.

To CYCLISTS: Your wheels will NOT keep round and true unless the spokes are tied with fine wire at the crossings and SOLDERED. This makes a much stronger wheel. It's simple—with FLUXITE—but IMPORTANT.

The FLUXITE GUN puts FLUXITE where you want it by a simple pressure. Price 1/6, or filled, 2/6.

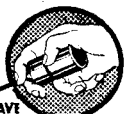

ALL MECHANICS WILL HAVE

FLUXITE

IT SIMPLIFIES ALL SOLDERING

Write for Book on the ART OF "SOFT" SOLDERING and for Leaflets on CASE-HARDENING STEEL and TEMPERING TOOLS with FLUXITE, also on "WIPE JOINTS." Price 1d. EACH.

FLUXITE LTD. (DEPT. W.P.)
BERMONDSEY ST., S.E.1.

It's the hidden details that count

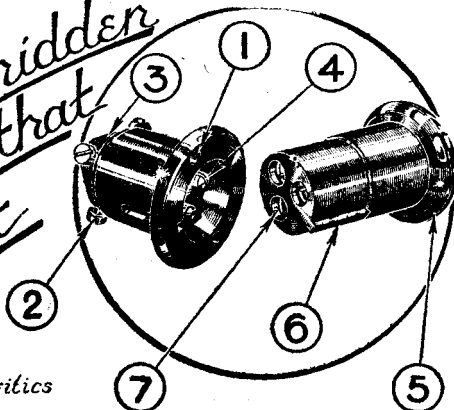

The choice of Critics

R.C.M.F. Standard Radio and light-Electrical 3-pole or 2-pole plus E. Connectors for removably joining mains leads to apparatus. Reg. Design No. 759088.

- 1—Two-hole fixing (6 B.A. at 1-9/32in. crs.) for apparatus-member, with flange outside.
- 2—Terminals accept up to 1 x 16 s.w.g. (or equivalent flexible), firmly clamping connections.
- 3—Adequate insulation between terminals and over surfaces providing excellent creep distances.
- 4—Male contactor pins in apparatus-member (hence "plug") sunk below surface against accidental damage and intended to be wired "dead" as normal for an "inlet" member.
- 5—Flex member or socket provided with large mushroom head for easy extraction and adequate internal space for gripping cord, with screw terminals accepting up to 23 x 36 s.w.g. per pole.
- 6—Locating key which co-operates with slot in plug-member and polarizes the connections.
- 7—Recessed sockets of live member (hence "socket") avoids accidental short circuit. Contact dimensions to R.C.M.F. standard for Radio Mains Connectors for 250 Volts A.C. or D.C. 3 Amp. max., or up to 6 Amp. at lower voltages.

Over 30 types from which to choose.



A. F. BULGIN & CO., LTD.

BYE-PASS ROAD, BARKING, ESSEX.

RIPPLEWAY 3474 (5 lines)

LET ME BE YOUR FATHER

You need help and fatherly advice in difficult times like these. I am in the position to give that to you free.

We teach nearly all the Trades and Professions by post in all parts of the world.

The most progressive and most successful Correspondence College in the world.

If you know what you want to study, write for prospectus. If you are undecided, write for my fatherly advice. It is free.

Distance makes no difference.



EARNING POWER IS A SOUND INVESTMENT

DO ANY OF THESE SUBJECTS INTEREST YOU ?

- | | | | | | | | | | | | | | | | | | | | | | | | | | | | | | | | | | | | | | | | | | | | | | | | | | | | | | | | | | | | | | | | | | | | | | | | | | | |
|--------------------------|----------------------------------|-------------|-----------------------------|-------------------|-------------------|-------------------------------|----------------------|-------------------|---------|-------------|---------|---|--------------|---|----------------------|-------------------------------------|-------------------|---------------|-------------------------|----------------|-------------------------|-------------------------------------|-------------------------------|--|-------------------|-------------------|-------------------------|----------------------|----------------------|-----------|------------|-----------|-------------|---------------|------------|----------------------|--------------------------------|-------------------|-------------|--------------------------------|--------------------|---------------|----------------|--------------|------------------------|------------------------|-----------------|------------------------|-----------------------------|---------------------|---------------------------|------------------------|-----------------------------|------------------------|------------|---------------------------|--------------------|------------------|--------------|----------------------|---------------------|------------------|--------------------|------------------------|-----------|-------------------------|--------------------------|------------|------------------------|------------------------------|--------------------------------|---------|-----------------------------------|----------------|
| Accountancy Examinations | Advertising and Sales Management | Agriculture | A.M.I. Fire E. Examinations | Applied Mechanics | Army Certificates | Auctioneers and Estate Agents | Aviation Engineering | Aviation Wireless | Banking | Blue Prints | Boilers | Book-keeping, Accountancy and Modern Business Methods | B.Sc. (Eng.) | Building, Architecture and Clerk of Works | Builders' Quantities | Cambridge Senior School Certificate | Civil Engineering | Civil Service | All Commercial Subjects | Commercial Art | Common Prelim. E.J.E.B. | Concrete and Structural Engineering | Draughtsmanship. All Branches | Engineering. All branches, subjects and examinations | General Education | G.P.O. Eng. Dept. | Heating and Ventilating | Industrial Chemistry | Institute of Housing | Insurance | Journalism | Languages | Mathematics | Matriculation | Metallurgy | Mining. All subjects | Mining. Electrical Engineering | Motor Engineering | Motor Trade | Municipal and County Engineers | Naval Architecture | Novel Writing | Pattern Making | Play Writing | Police, Special Course | Preceptors, College of | Press Tool Work | Production Engineering | Pumps and Pumping Machinery | Radio Communication | Radio Service Engineering | R.A.F. Special Courses | Road Making and Maintenance | Salesmanship, I.S.M.A. | Sanitation | School Attendance Officer | Secretarial Exams. | Sheet Metal Work | Shipbuilding | Shorthand (Pitman's) | Short-story Writing | Short-wave Radio | Speaking in Public | Structural Engineering | Surveying | Teachers of Handicrafts | Telephony and Telegraphy | Television | Transport Inst. Exams. | Viewers, Gaugers, Inspectors | Weights and Measures Inspector | Welding | Wireless Telegraphy and Telephony | Works Managers |
|--------------------------|----------------------------------|-------------|-----------------------------|-------------------|-------------------|-------------------------------|----------------------|-------------------|---------|-------------|---------|---|--------------|---|----------------------|-------------------------------------|-------------------|---------------|-------------------------|----------------|-------------------------|-------------------------------------|-------------------------------|--|-------------------|-------------------|-------------------------|----------------------|----------------------|-----------|------------|-----------|-------------|---------------|------------|----------------------|--------------------------------|-------------------|-------------|--------------------------------|--------------------|---------------|----------------|--------------|------------------------|------------------------|-----------------|------------------------|-----------------------------|---------------------|---------------------------|------------------------|-----------------------------|------------------------|------------|---------------------------|--------------------|------------------|--------------|----------------------|---------------------|------------------|--------------------|------------------------|-----------|-------------------------|--------------------------|------------|------------------------|------------------------------|--------------------------------|---------|-----------------------------------|----------------|

If you do not see your own requirements above, write to us on any subject. Full particulars free.

COUPON-CUT THIS OUT

To DEPT. 104, THE BENNETT COLLEGE, LTD., SHEFFIELD.

Please send me (free of charge)

Particulars of..... } (Cross out line
Your private advice } which does
about..... } not apply.)

.....

PLEASE WRITE IN BLOCK LETTERS

Name.....

Address.....

Soldering- then ELCO

Elco design and build soldering irons, machines, melting pots, and special furnaces for all soldering needs to suit any voltage from 24v. up. Illustrated are four interchangeable units. There are many others. Write for leaflet to Sole Agent:

ELCORDIA LTD.,
2, Caxton Street, London, S.W.1.
Tel: ABBey 4266.

Get ELCO Solder Soldering Problem!

COVENTRY RADIO

COMPONENT SPECIALISTS SINCE 1925.

A few items from our 1d. ANNIVERSARY LIST containing details of 400 Components.

- 2-GANG '0005 MED. 1st. Grade Condensers ... 11s. 6d.
- WEARITE "P" COILS, all types ... 2s. 3d. & 2s. 6d.
- WEARITE 485 K.C. I.F. Transformers, screened ... 7s. 6d.
- T.R.F. COILS M.W. with circuit, per pair ... 4s. 6d.
- MAINS TRANSFORMERS, 30m a, 4v. or 6v. ... 25s. 0d.
- L.F. CHOKES, 475 ohms, 20 henries, 80 m a... 6s. 9d.

PROMPT SERVICE, COMPLETE SATISFACTION.

COVENTRY RADIO
191, DUNSTABLE ROAD, LUTON

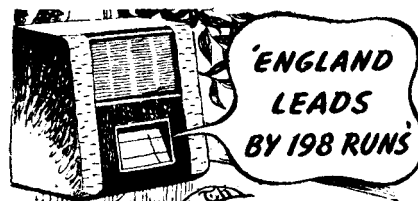

Test Matches on the air; England in the lead; plenty of Dagenite and Pertrix Batteries in dealers' shops everywhere. Times to look forward to soon! Meanwhile we're sorry there aren't enough Dagenite and Pertrix to go round—the boys in the East had to have the best batteries to finish the job out there.

DAGENITE AND PERTRIX

BATTERIES FOR CAR AND RADIO

HOLSUN BATTERIES LTD
137 Victoria Street, London, S.W.1

D13/45

tapping points would be an advantage, and a primary winding to carry a larger D.C. current—say 150 mA—would increase the scope of the test gear.

An output jack is wired across the speech coil; into this an output meter can be plugged during alignment of the receiver with the aid of a signal generator. S_6 open circuits the speech coil when required; this coil should have a D.C. resistance of 2.25 ohms and an impedance of 3.5 ohms, in order to match into the W.B. transformer.

The illustration shows the finished unit; the cabinet is made of mild steel, finished in black crackle enamel, and was sold before the war by Messrs. Premier for 15s. Inside measurements are 11½ ins. × 11½ ins. × 8 ins. which gives plenty of room both for the existing components and any modification as the occasion arises.

Looking at the control panel, and working down from the top left-hand corner, the controls are as follows: Plug and sockets acting as S_6 ; meter switch S_3 ; matching switch S_2 ; input selector S_2 ; output, H.T. mA, and A_1/A_2 meter jacks; field selector S_1 ; field in-out switch S_5 ; and the bottom sockets are: Field un-

smoothed; field smoothed; A_1 /Low impedance; H.T./low impedance; and finally A_2 , completes the input connections.

HIGH IMPEDANCE MATCHING

S_4 in position	A	B	C	D	E	
S_2 on H_1	Impedance	8,500	4,750	2,750	1,550	875
	Ratio	48.75	37	27.75	21	15.75
S_2 on H_2	Impedance	34,000	19,000	11,000	6,200	3,500
	Ratio	97.5	74	55.5	42	31.5

LOW IMPEDANCE MATCHING

S_4 in position	A	B	C	D	E	
(S_2 on Low.)	Impedance	11	6.25	3.5	2	1

(Where impedance is in ohms, and ratio is to 1.)

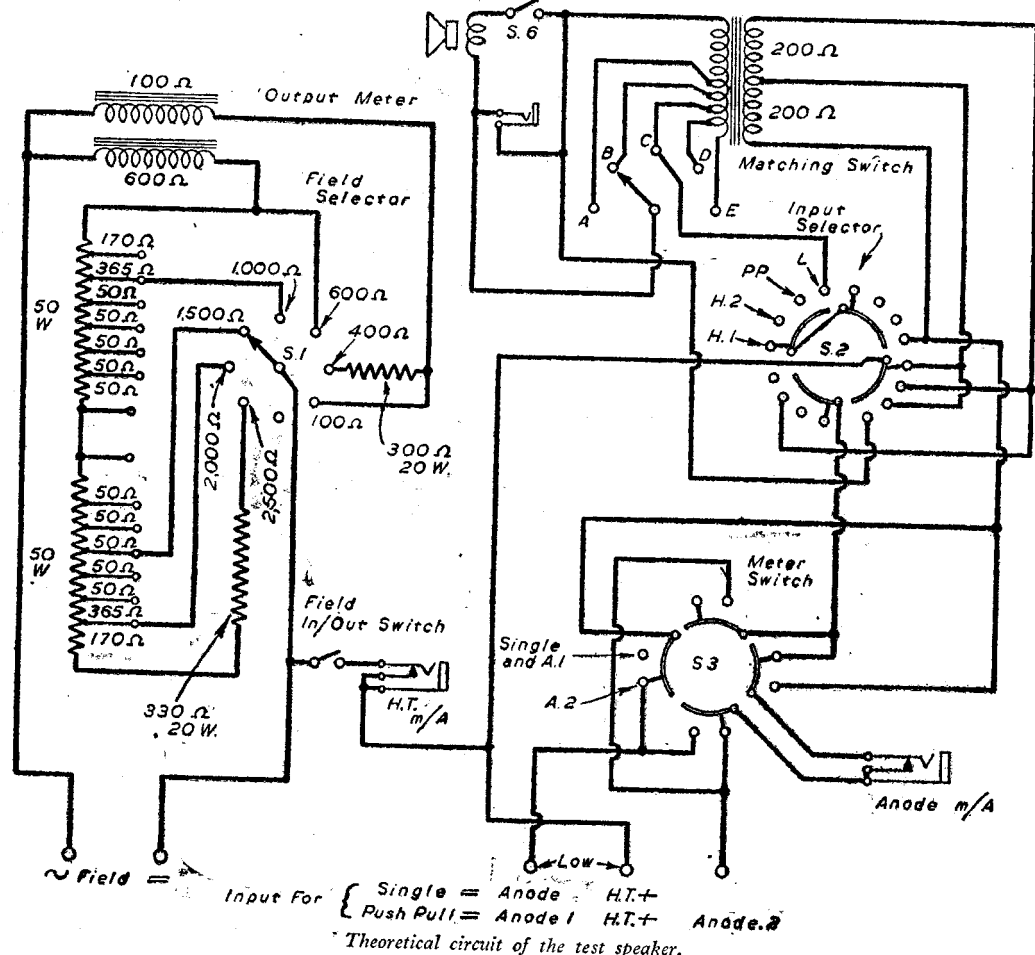

BOOKS FOR ENGINEERS — By F. J. Camm

Gears and Gear Cutting, 6/-, by post 6/6.	Watches; Adjustment and Repair, 6/-, by post 6/6.
Workshop Calculations, Tables and Formulae, 6/-, by post 6/6.	Plant Engineer's Pocket Book, 6/-, by post 6/6.
Engineers' Manual, 10/6, by post 11/-.	Screw Thread Manual, 6/-, by post 6/6.
Engineers' Vest Pocket Book, 7/6, by post 8/-.	Wire and Wire Gauges (Vest Pocket Book), 3/6, by post 3/9.

An Introduction to Communications Receivers—4

This Concluding Article Deals with the Audio-frequency Part of the Circuit and with the Important Subject of Noise Limiters and Filters

By FRANK PRESTON, A.M.Brit.I.R.E.

REFERENCE was made last month to the second detector, but this part of the circuit was treated very briefly for the simple reason that the second detector of the average communications receiver differs little, if at all, from that in any modern superhet. It is just worthy of mention in passing, however, that

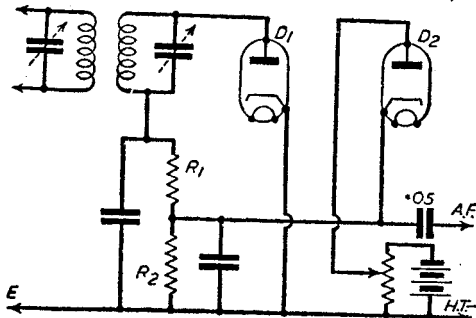

Fig. 1.—Schematic diagram of a parallel limiter, where diode D_2 acts as a short-circuit on the A.F. load R_2 when noise peaks occur. In this case a separate valve would generally be employed for A.V.C.

various systems of delayed and amplified A.V.C. are employed. But as these are generally of standard and well-known form it is not necessary to describe them here.

A very important aspect of the better class communications receiver is the noise-limiter circuit, which is provided between the second detector and the audio-frequency amplifier. The purpose of the limiter, as the name suggests, is to cut down the background noise level. In general, the limiter is effective principally in chopping off the peaks of noise modulation arising from man-made static. It is well known that such interference is generally in the form of spasmodic bursts of static; these give rise to pronounced "crackles" and "bangs" which tend to make reception unintelligible.

Reduction of Static Interference

A limiter can be set to reduce the amplitude of the peaks so that this does not exceed the amplitude of the required signal. The noise is not eliminated by this means, but its effect is reduced to such an extent that the signals can be read through it. The ideal form of limiter is that which is self-adjusting to the amplitude of the signal. That is, the limiter "chops off" any noise peaks which are greater in amplitude than the signal, whether it be modulated or C.W. Many limiters, however, are not self-adjusting in this way, but can be adjusted manually to give any desired degree of "cut" to the noise. Clearly, if the noise is cut to an excessive degree the signal will also be cut. As a result, the signal volume level is reduced and a certain amount of distortion is introduced. In severe cases, however, it is found worth while to sacrifice a certain amount of signal volume and quality in order to

reduce the noise level. After all, the final requirement is a maximum signal-to-noise ratio.

Types of Limiter

There are three or four principal types of noise-limiter circuit, but there are in addition several variants of these which have been developed by manufacturers for inclusion in their receivers. A very simple and old type of noise limiter consists of nothing more than two "Westectors" connected in parallel, but with reversed polarity; these are connected in series with a fixed condenser across the telephone or speaker terminals. During normal reception the rectifiers have a certain, small by-passing effect on the audio signal, but this effect is more pronounced on sudden noise peaks. Two rectifiers are used in reversed polarity so that the device is effective on both positive and negative half-cycles.

Parallel Diode Limiter

It is more customary to use a diode or double-diode valve for noise limiting, and there are two principal ways in which this can be done; the diode may be connected in series or in parallel with the A.F. output from the second detector. Fig. 1 shows a parallel method of connection where D_1 is the second detector and D_2 is the limiter. The resistance marked R_2 is the A.F. load for the second detector, and the A.F. signal is taken from its upper (negative) end. The cathode of D_2 is also connected to this point, however, with the result that, when there is an incoming signal the cathode is biased negatively with respect to earth. If, then, the anode of D_2 were connected to the earth line, D_2 would conduct and therefore act as a short-circuit across the audio load.

But the anode is given a negative bias of such a value that the diode is just prevented from conducting during reception of the signal alone. In the event of noise peaks being applied to the second detector, the cathode of D_2 is made more negative. In consequence of this, D_2 will conduct and so prevent the application of A.F. to the A.F. amplifier. Therefore, during noise peaks, the amplifier is effectively muted.

In Fig. 1 the anode bias for D_2 is shown as being taken from a battery, through a potentiometer. In practice the necessary bias voltage would normally be taken from a convenient point in the H.T. system.

A single-diode series limiter is shown in Fig. 2. In this case, the A.F. supply from the second detector to the amplifier is taken through the diode D_2 . This diode is

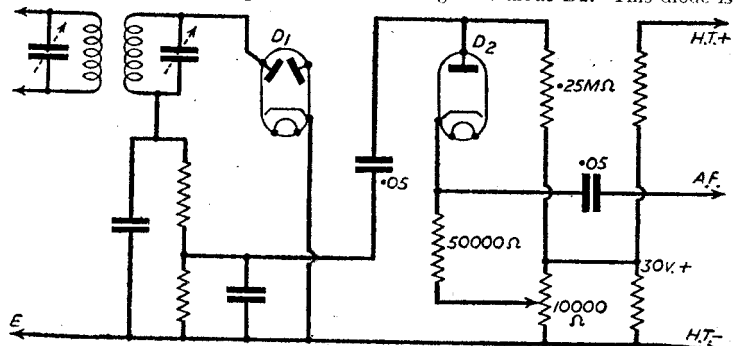

Fig. 2.—A series limiter D_2 acts as a "gate," opening in the absence of noise and closing when noise is present. The second diode of D_1 would be used for A.V.C.

given an initial bias with the result that it is normally conductive. Only when the anode is driven more negative by noise peaks does D₂ cease to conduct, so breaking the A.F. feed and muting the amplifier.

Another method of producing a noise-limiting effect is by operating the first A.F. valve (a triode) at such a low anode voltage that the valve operates close to the saturation point. Noise peaks "kick over" the valve so that it is completely saturated and so becomes effectively muted. This arrangement has obvious

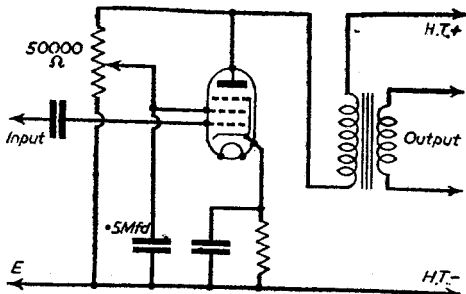

Fig. 3.—A method of noise limiting in which a saturated pentode A.F. amplifier is employed. This system has many disadvantages and is not often used.

disadvantages, chief of which is that a certain amount of distortion is virtually inevitable. An improvement is obtained by employing a pentode, as shown in Fig. 3, by applying a reduced and variable H.T. supply to the screening grid. Saturation again occurs, but better reproduction is possible due to the straighter characteristic of the pentode.

Among the various specialised types of noise limiter is that shown in Fig. 4. This is used in one up-to-date American communications receiver, and is both interesting and efficient. It will be seen that a double-diode is used as both second detector and noise limiter, the two sections of the valve being marked D₁ and D₂ respectively. The limiter under consideration has the advantage of being very largely self-regulating in that the "gate opening" provided for the noise is controlled by the signal being received.

It will be seen that the anodes of both diodes are connected together and to the I.F. transformer. Rectified A.F. voltages appear across the load resistor marked R₂. The cathode of D₂ is positively biased

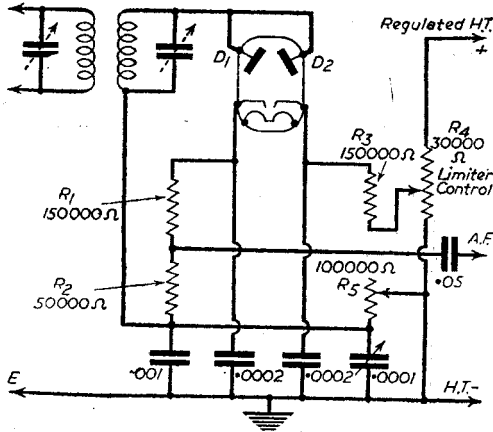

Fig. 4.—A special type of noise limiter using one half of a double-diode. Noise voltages appearing across R₅ are in opposite phase to those appearing (with the signal voltages) across R₂, and therefore cancel out. In this case a separate valve is provided for A.V.C.

through a potentiometer (the front panel limiter control) with the result that this diode cannot operate until its anode is made more positive than its cathode. D₁, on the other hand, will operate when its anode is made only slightly positive. Thus it will be seen that D₁ is always operative in the presence of any signal, whereas D₂ will operate only when a signal of more than a certain amplitude (dependent upon the bias applied to its grid by means of the limiter control) is fed to its anode. In other words, it will operate only when noise peaks are present.

Both signal and noise voltages appear across the load resistor R₂, but only noise voltages across R₅, which may be regarded as the load resistor of D₂. The slider of this variable resistor is earthed and therefore the voltages across R₅ are in opposition to those across R₂. And since the voltages across both of these resistors is applied to the A.F. amplifier, it will be seen that the noise voltages are cancelled.

The action of the circuit may be found rather easier to follow by glancing at Fig. 5, which is a simplified and rearranged version of the same thing.

Referring again to Fig. 4, it should be pointed out that R₅ and the small variable condenser between one end of this and earth are pre-set components, and are set by the manufacturers before the receiver is issued. Resistor R₄ is the normal operating control and is set so that D₂ is biased well beyond cut-off when limiter action is not required. During reception of telephony when noise is present, the control is turned until the required degree

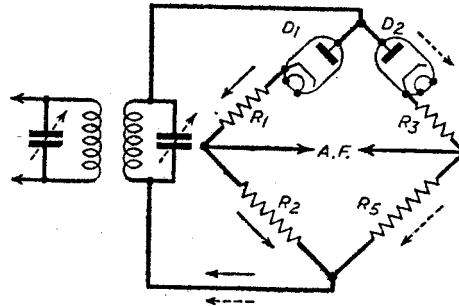

Fig. 5.—A simple bridge circuit which may help to explain the action of the arrangement shown in Fig. 4.

of limiting is obtained. For C.W. reception it is best to turn the R.F. control fully clockwise and to reduce the setting of the A.F. control; this increases the ratio of signal strength to B.F.O. amplitude.

Another type of noise limiter—more correctly, a noise filter—is sometimes used in communications receivers. This takes the form of an A.F. choke in series with a fixed condenser; this is connected in parallel with the audio-frequency volume control by means of an "in-out" switch. The filter is designed to be approximately resonant at frequencies of the order of 1,000 c/s., but produces a sharp cut-off above and below a band around 1,000 c/s. In other cases, the filter cuts off below about 400 c/s., but gives reasonably uniform response at higher frequencies.

The use of a 1,000-cycle filter gives another important advantage: that of increasing the effective selectivity of the receiver, especially on C.W. reception. If the filter is sharply resonant at the frequency mentioned, most of the adjacent-channel interference can be tuned out by careful adjustment of the beat-frequency oscillator tuning control. A sharply tuned filter of this kind is not, however, very satisfactory for use on telephony.

The audio-frequency amplifier of a communications receiver is generally made for only a limited power output; say, 2.5 watts maximum undistorted output. In limiting the output the main object is to reduce the rating of the output valves. This, in turn, is done to ensure that there shall not be an excessive temperature rise after the receiver is first switched on.

A Loud-speaker One-valver

Constructional Details of a Set Based on Experiments
to Obtain the Maximum Volume from Only One Valve

WHEN recalling some of the circuits used many years ago with a view to obtaining maximum volume with a single valve, the writer decided to see what could be done in this direction with a modern valve. After some experiment a circuit was arrived upon which gives good speaker volume from the local stations. The volume is actually greater than that obtained from a normal Det.-L.F. receiver. Of course, even better results could be obtained by using a valve such as a

Old type plug-in coils are used as these give good gain, although modern coils could be tried in the set if desired. There are three coils to the left—reaction, medium-wave and long-wave loading coils. If desired, the long-wave coil holder could be omitted and wave-changing effected by removing the medium-wave coil and plugging in another. The right-hand two coils are also for dual-wave operation in the same way, and if plugging-in is resorted to one holder only will be wanted. The coils are approximately 2 in. in diameter and the turns are as follows: medium-wave, 45 turns; long-wave, 200 turns; reaction, 15 turns. The reaction coil should not be larger than is absolutely necessary, as it is in the anode circuit of the H.F. amplifier.

The transformer should be a good type with step-up about 1:5. The H.F.C. is a binocular model and should also be of good quality, for it has to couple the stages.

A Tellurium-Zincite detector was used, and this is semi-permanent. When the receiver is switched off the H.F. stage naturally ceases to function and no signal is presented to the detector. Because of this a setting will not deteriorate for quite a long period. To facilitate resetting, the detector is mounted above the L.F. transformer, not on the baseboard.

Operation

A H.T. of about 120 volts is wanted, and a valve of the Cossor 220HPT type. Both the wave-change switches must be set to the same range, or similar coils inserted. The detector should then be set and the receiver switched on. Both tuning condensers will have to be adjusted to tune-in the signal, and the reaction coil moved towards or away from the other coils as required. The detector can then be adjusted for maximum volume—which will be good speaker strength from the local stations. Actually it will be found that little or no reaction is wanted unless phones are used and distant stations tuned in. Although operating efficiently on loud signals the detector is not

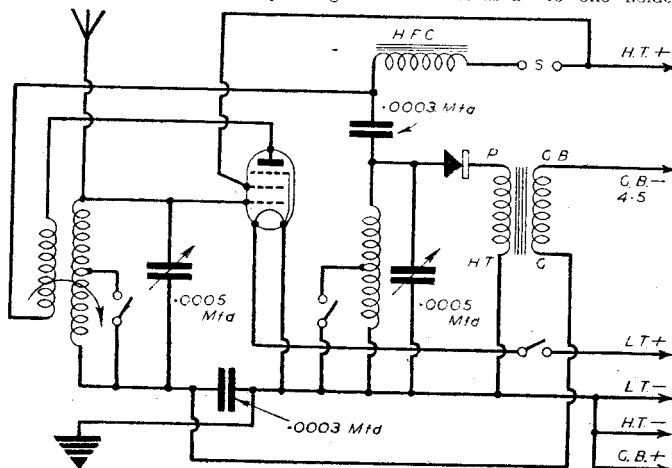

Fig. 1.—Reflex circuit diagram.

triode-pentode, but these are really separate valve elements in the same envelope and cannot be called single valves in the sense used in the old sets.

The circuit is shown in Fig. 1, and is a reflex one. The theory of operation is as follows: the signal is tuned in as usual by the first tuned circuit, and amplified by the pentode in the same way as a normal H.F. amplifier. Reaction is also applied, mainly because it cannot be obtained with the detector as the latter is not a valve. This reaction gives some build-up of the signal, and this is then passed through the .0003 mfd. condenser to the detector, the H.F.C. barring its passage in that direction. It is then tuned by means of the second circuit in the normal way; demodulated and presented to the primary of the L.F. transformer as an L.F. signal. The secondary of this transformer feeds the signal back to the earthed end of the first tuning coil, which presents negligible resistance to its passage so that it reaches the valve and is amplified. The signal then passes through the reaction coil and H.F.C. and is heard in the speaker.

Thus it will be seen that the valve is acting as both H.F. amplifier and L.F. amplifier. The H.F. gain is naturally not as high as would be obtained by using a proper valve (for the pentode must be of the L.F. type for final amplification), but, due to the use of reaction, it does give a considerable increase of volume.

Construction

Fig. 2 shows the panel layout, and a fairly large panel is needed to accommodate the two .0005 mfd. air-spaced tuning condensers. There are also two wave-change switches, and on-off switch and reaction control.

The baseboard and wiring are shown in Fig. 3. Because of the nature of the circuit it is recommended that the layout is followed, and also the run of wiring as shown,

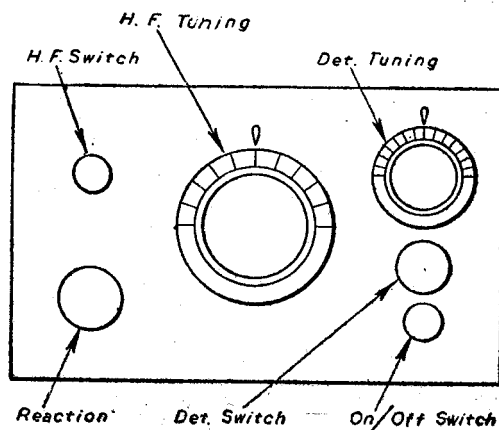

Fig. 2.—Panel layout. (A fairly large panel is required.)

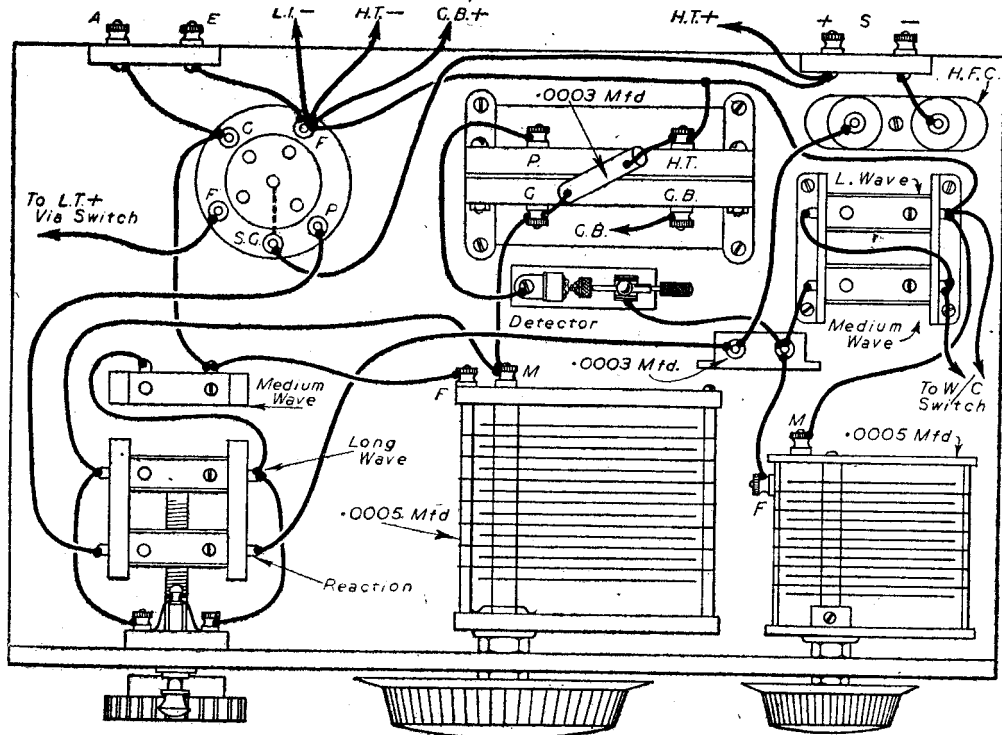

Fig. 3.—The baseboard and wiring diagram.

equal to a valve for the reception of distant signals, and the receiver is not intended for this.

If reaction cannot be obtained the leads to the reaction

coil should be reversed. Care should be taken to see that the medium- and long-wave coils are both connected in the same "sense," as shown in Fig. 3.

A Super Without the Het

Details of a Recent Invention for the Reception of Wireless, Television and Similar Signals.

By D'ARCY FORD

THIS invention relates to circuits, systems, or apparatus for the reception of wireless, television and the like signals, of the type in which the frequency of the incoming signal is changed in the frequency-changer circuits.

The type of frequency-changer receiving apparatus in general use is the superheterodyne, in which a local oscillator is used to generate an oscillation to mix with the incoming signals, and the output of the frequency-changer circuit is at intermediate frequency. The local oscillator is generally variably tuned, and kept at a constant frequency difference from the signal frequency over the tuning range of the receiving apparatus.

In the receiving apparatus which is the subject of this invention, the variably-tuned local oscillator, which generates a local oscillation to mix with the incoming signals, and which is kept at a constant frequency difference from the signal frequency, is not used or required. The frequency-changer circuit or apparatus is so designed or made that it oscillates at the frequency which is required as the intermediate frequency. The incoming signals are fed or injected into the frequency-changer circuit and modulate the

locally generated intermediate-frequency oscillation in any suitable manner or by any suitable method.

The circuits or apparatus in the receiver may be so designed or made that all unwanted frequencies in any part of the receiving apparatus may be filtered out or bypassed in any desired manner, and the wanted frequencies used for the purposes of the invention. Any suitable method of rectification or detection may be employed, and any type of output of the receiver. Radio-frequency amplification, intermediate-frequency amplification, and audio-frequency amplification may be used with this invention in any desired manner. Any form of feed-back may be used if desired, and any types or forms of controls.

Rectification

If desired, the circuits or apparatus may be so designed or made that rectification of the incoming signals takes place in a stage before the frequency-changer circuit. The rectified signals may be injected into the frequency-changer circuit, and modulate the intermediate-frequency oscillation by any suitable method.

In the superheterodyne type of receiving apparatus

there are three fundamental frequencies: (1) The input at signal frequency; (2) The locally generated oscillation frequency; (3) The output of the frequency-changer circuit at intermediate frequency. In the receiving apparatus which is the subject of this invention there are two fundamental frequencies: (1) The input at signal frequency; (2) The output of the frequency-changer circuit at the locally generated intermediate frequency.

As a modification of this invention, there may be provided an additional or second frequency-changer circuit, which locally generates an intermediate-frequency oscillation at a different frequency from the first frequency-changer circuit. The first intermediate-frequency output, before or after amplification, may be injected into the second frequency-changer circuit, and modulate the intermediate-frequency oscillation by any suitable method. The output of the second frequency-changer circuit may be amplified or rectified as desired before the output stage of the receiver. This would be a double frequency-changer, and there would be three fundamental frequencies: (1) The input at signal frequency; (2) the output of the first frequency-changer circuit at first intermediate frequency; (3) the output of the second frequency-changer circuit at second intermediate frequency.

As a further modification, or modifications, the invention as described may be used if desired in connection with or combined with any suitable type of circuit, oscillator, heterodyne oscillator or apparatus for any suitable purpose.

In a convenient manner, or convenient methods of carrying out the invention, circuits or apparatus may be designed or made in any suitable manner, on all or any of the principles described.

Fig. 1 shows an octode frequency-changer valve circuit.

The suggested values for the resistors for a first trial with a Mullard FC2A valve are as follows:

R₁, 150,000/200,000 ohms; R₂, 150,000/200,000 ohms; R₃, 25,000/50,000 ohms; R₄, 25,000/50,000 ohms; R₅, 20,000/40,000 ohms.

One aim in using the invention is to obtain a quiet background. If no noises are coming in from the aerial, there is no point in generating them in the receiver!

A tuned R.F. stage would give added selectivity and improved signal strength, and even then there would be only two variably-tuned circuits—all others are fixed or pre-set.

A.V.C. can be applied to the R.F. and I.F. amplifiers in the usual manner, but A.V.C. to a self-oscillating F.C. valve could be separately studied before being applied.

The frequency-changer valve appears to work best when it is a little more than just oscillating, and this is convenient for the input to the I.F. amplifier.

It is suggested that in an experimental receiver a rectified current meter be used in the "second detector" (say an 0-500 microammeter in the diode lead). This should be watched for the I.F. unmodulated oscillation coming through, and the oscillator kept a little more than just oscillating. For commercial receivers the meter would not be necessary.

Valves

If it is thought that the F.C. valve oscillating so gently would not give a constant voltage of output, a separate oscillator could be used and made to oscillate a little more strongly, and a portion of its output taken from a potentiometer—either a fixed potentiometer with a variable oscillator control, or a variable potentiometer with a fixed O.C. The oscillator anode of the FC2A valve could then be connected to the screen, and a grid leak and condenser used with

the F.C. valve for the input from the oscillator. A.V.C. could probably then be applied to it without difficulty.

The early experiments were with a detector before or combined with an oscillator-frequency-changer valve, and this type of circuit still appears to have possibilities to inject the rectified signal voltages into the F.C. valve.

Any valve in which the oscillator grid of the triode section is connected to G₁ is worth giving a trial. Whether or not any special valves will be developed in the future will depend on the value of the invention.

The experiments have been carried out with an intermediate frequency of about 120 kc/s. A higher I.F. than this could be used for the short waves, and probably also the medium waves, but the best I.F. for a long-wave receiver can be determined later.

Modification

With an experimental type of circuit, the first I.F. transformer and the oscillator coil could be combined in one component, by an extra winding or a centre tap to the I.F. transformer-oscillator coil.

A variably tuned oscillator coil would probably be better in an experimental receiver.

This invention was first thought out in general principles about 10 years ago, and the writer confesses he has worked very hard over it. He very much regrets to say that he cannot possibly promise to reply personally to all correspondents.

An application for a patent has been made for this invention, but its commercial possibilities are at present undecided.

WORKSHOP CALCULATIONS TABLES AND FORMULÆ

Eighth Edition

by F. J. GAMM

A handbook dealing with methods of calculation, solution to workshop problems, and the rules and formulae necessary in various workshop processes. It contains all the information a mechanic normally requires.

From all booksellers, 6/- net,
by post 6/6 from the publisher,

GEORGE NEWNES, LTD. (Book Dept.),
Tower House, Southampton Street, W.C.2.

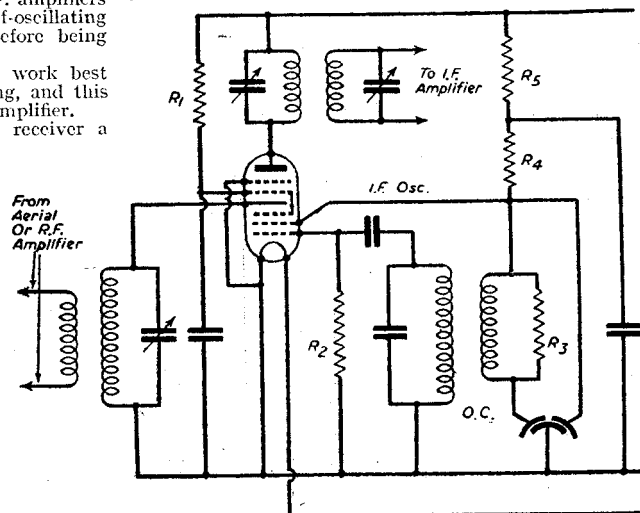

An octode-frequency-changer valve circuit.

A Useful Test Oscillator

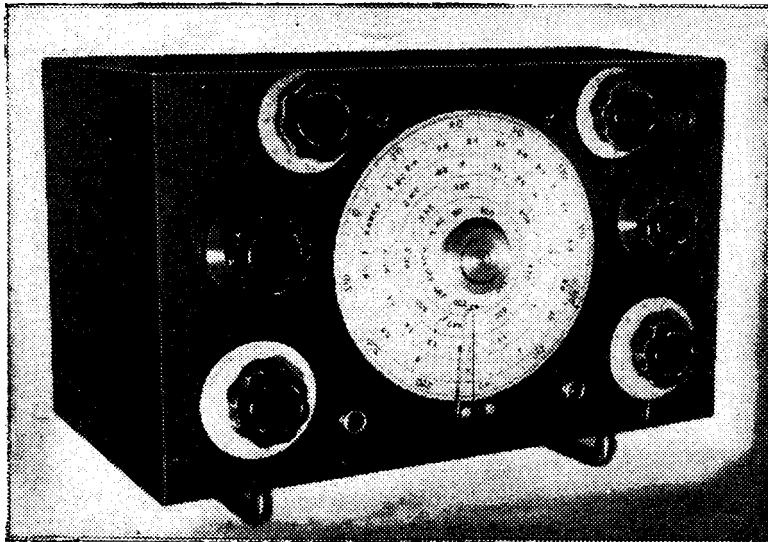

Front view of the finished instrument.

A Handy Accessory
Described by 2ATV

components needed, with the result shown in the accompanying illustration.

The Circuit

Both the oscillator and modulator valves are Osram L63 triodes, working on the Hartley principle. In the interests of stability, the R.F. oscillator tuned circuit has a high C/L ratio, the value of the tuning capacitor, C₄ in Fig. 1, being 500 μF. The R.F. output is taken from a tapping on the grid leak R₄/5, to an attenuator network consisting of R₁, R₂ and C₁. The system of tapping off the grid leak, used also in the audio oscillator, does not permit of a large output being taken off, but it does

THE "ideal" receiver for post-war use was in process of being built (and still is!) and the need arose for a test oscillator with which to align the various tuned circuits. A search in the cupboard and a tour of the local "junk" shops produced the materials and

ensure that the frequency of that output remains unaffected by the setting of the attenuator. The R.F. choke L₂ must be of good quality and suitable for the frequency range it is desired to cover. In practice it is best to use two units in series, a short-wave choke

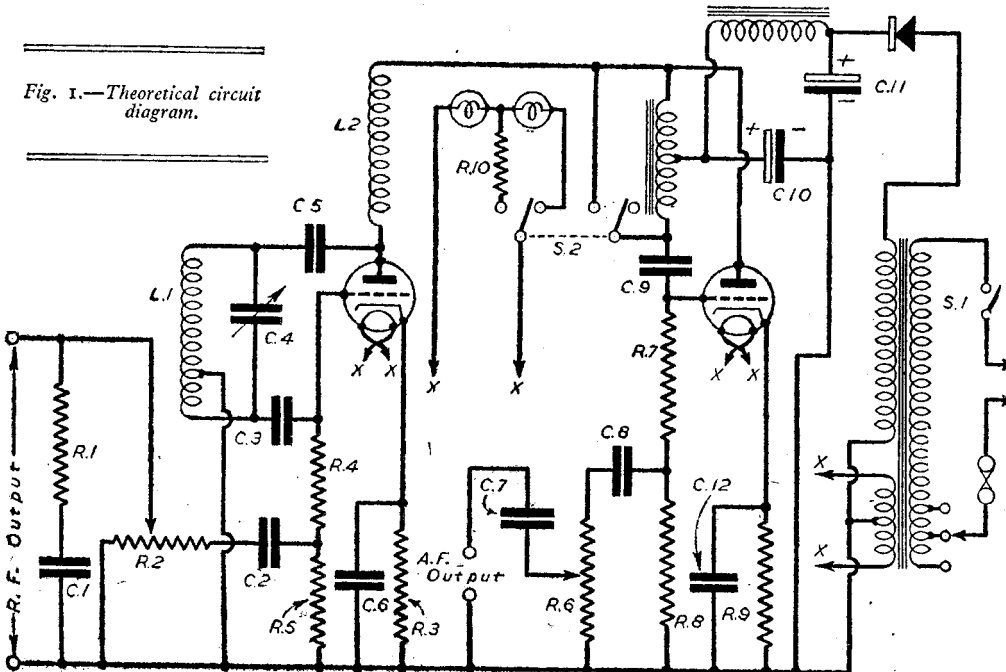

Fig. 1.—Theoretical circuit diagram.

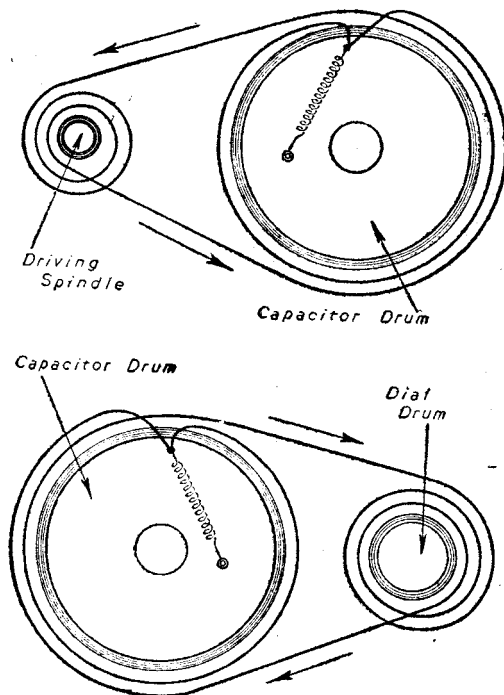

Fig. 2.—The double-cord drive system.

connected to a "broadcast" component, the latter being at the H.T. end of the chain. The Heising system of modulation is used, the audio oscillator being a low-frequency version of the R.F. circuit. When not required, it is switched out of circuit by means of S2 across the A.F. choke winding. A final point is that the outputs are fitted with isolating capacitors, so that they can safely be applied to points at high potential.

Construction

The cabinet and chassis are built up from sheet aluminium, the chassis being fixed to the panel by brackets so that the whole oscillator can be removed as a complete unit, if necessary, for servicing purposes. The carrying handles were made from $\frac{3}{16}$ in. rod bent to shape, the ends being drilled and tapped 2 B.A. for the fixing screws. A hinged lid is provided for easy insertion of the plug-in coils; switched inductances were tried, but discarded as the longer wiring necessitated resulted in parasitic oscillation.

The disposition of the components was not found to be critical, and there was no trouble in obtaining a symmetrical panel layout. Naturally, no chances were taken, the power pack being located at the opposite end of the chassis to the R.F. section, with the audio side in the centre. The change-over switch from R.F. to modulated R.F. is ganged with a similar switch to which are connected panel indication lamps, as shown in Fig. 1.

It should be noted that the tuning capacitor C4 must be insulated from the chassis, which means that the mounting bracket and the extension spindle, if one is used, must be above suspicion. The dial shown in the photograph was home constructed, being larger than is normally obtainable, in order to take full advantage of the space available. The scales were further "opened out" by arranging for the dial to rotate some 330 deg. This was done by the use of a double-cord drive system, a sketch of which is given in Fig. 2. This is self-

explanatory, the one point that perhaps should be explained being that the small drum should have a diameter slightly greater than the radius of the large drum.

Dials

The main dial plate, like the smaller ones, was made of 16 s.w.g. aluminium, the boss being turned from an odd scrap of dural. A small knob could be used for a boss where turning facilities are not available, the best for the purpose being one of the skirt knobs as sold by Raymarts, Webbs and other firms. The 360 divisions were cut with a scriber, as were the individual scale markings after the oscillator had been calibrated. The numerals were stamped in with Imperial number dies, and the dial then cleaned up with emery paper. The satin finish, for the purpose of preventing eye-strain was obtained by soaking the plate for some minutes in a strong solution of household soda. The indentations are blacked in by warming the plate and rubbing over with cobbler's heel-ball, the surplus being removed with a clean rag.

Range

As before mentioned, the various ranges are covered by plug-in coils. The Eddystone standard four-pin type was used on this particular instrument, the primary winding being removed in each case. The secondary winding is then tapped at about one-third the number of turns from the grid end. The range covered by a coil will depend on factors which vary in each individual case, so that it is not possible to give precise figures. But, generally, four coils will be sufficient to cover the popular I.F. ranges, and the medium and short-wave bands. As the unit gives an ample output, harmonics afford adequate signals up to some 100 mc/s. On short waves the type LB coil covers roughly 7 to 25 mc/s., and the R coil from 2 to 7 mc/s. For medium waves, type P ranges from 500 to 1,500 kc/s. In order to provide signals at the modern intermediate frequencies, it is necessary to take off some 60 turns from the secondary winding, using a type BR coil, and the coverage is then some 180 to 530 kc/s.

The remainder of the construction is quite straightforward. It should be remembered, of course, that it is necessary to entirely screen the attenuator network and the output leads, apart from the instrument itself, if a satisfactory low minimum output is to be obtained. Regarding the power supplies, half-wave rectification was found quite good enough, and 150 volts H.T. ample.

LIST OF COMPONENTS

Part	Value	Recommended Makes
R1	100,000 ohms	Erie, Dubilier, Bulgin, etc.
R2	100,000 "	" " "
R3	1,000 "	" " "
R4	75,000 "	" " "
R5	20,000 "	" " "
R6	500,000 "	" " "
R7	75,000 "	" " "
R8	25,000 "	" " "
R9	1,000 "	" " "
C1	.005 mfd.	T.C.C., Dubilier, Hunts, Bulgin, etc.
C3	.00015 "	" " " "
C4	.0005 "	Polar, J.B., Bulgin, etc. "
C5	.002 "	T.C.C., Dubilier, Hunts, Bulgin, etc.
C6	.1 "	" " " "
C7	.1 "	" " " "
C8	.01 "	" " " "
C9	.005 "	" " " "
C2	Very low	Consists of parallel insulated wire 1" long.
C10, C11	and remainder of power supplies: Values not critical provided smoothing efficient, 150 volts H.T. smoothed being ample.	
L3	3 henries	choke, tapped, tuned if necessary by parallel capacitance. Varley.



ON YOUR WAVELENGTH

By THERMION

Our Forces Issue

AS readers in the Forces know, we produced a special edition of this journal during the war, which was issued free to His Majesty's Forces, so that copies were available in most of the Forces libraries. It was a gesture made by the proprietors of this journal to those who were uprooted from their family life and sent to districts where normal methods of distribution were not available. The receipt of their favourite journal kept our readers abroad, and at home for that matter, in touch with their hobby and helped to leaven the tedium of Service life.

I am reminded of this upon receipt of the following letter from Mr. R. C. E. Beardow, whom my readers will remember was G3FT before the war, and Secretary of the Romford Radio Society:

"I should like to thank your organisation for the free distribution of PRACTICAL WIRELESS to men serving in H.M. Forces. I was always fortunate in being able to get hold of it first during my year's stay on the Gold Coast while serving as a P.O. Radio Mechanic with the R.N. Now I have been demobilised I have resumed the reins of the above society and ask if you can give us publicity as you always did pre-war. We have resumed meetings and are holding them every fortnight at 8.30 p.m. at the Red Triangle Club, North Street, Romford, the dates for the month are 9th and 23rd and we would welcome new members. Our programme will be of special interest to A.A. licencees and newcomers."

Mr. Beardow's address is 3, Geneva Gardens, Whalebone Lane North, Chadwell Heath, Essex.

The "Electronic Navigator"

IN order to explore the post-war possibilities of radar in its application to safety-at-sea programmes, the United States Maritime Commission is testing five sets of a new type of radar equipment. The new equipment is called the electronic navigator. While somewhat different from the radar of the armed services, the electronic navigator has indicated possibility of post-war application to Merchant Marine operations. Major sea disasters have resulted from collision at sea under fog or in darkness with icebergs or other vessels. It is expected that the electronic navigator will do much to eliminate this hazard.

Chinese Radio Puzzle

AMERICAN and Chinese authorities are amazed these days at a radio station assumed to be operating somewhere in China on 1,450 kc/s, and being on the air uninterrupted for 24 hours a day. This station is broadcasting only American music of transcriptions and records, with hardly any repetition of the selections. Thus, it is believed that there must be a tremendous store of records from whichever source the station operates—and even more astounding is the fact that not a single spoken word is heard during the entire day's broadcasts.

Our 'Roll of Merit'

Readers on Active Service—Sixtieth List

D. C. Hall (Cfn., R.E.M.E., India Command).
G. Farrow (Cpl., S.E.A.A.F.).
J. Bosher (Cpl., B.A.O.R.).
F. J. Strange (L.A.C., R.A.F.).
E. Gillen (L.A.C., R.A.F.).
L. Taylor (Sgt., R.A.M.C.).
P. J. Lambert (Sgt., K.R.R.C., B.A.O.R.).

What They Say . . .

AMERICAN plans for post-war television are far ahead of any European developments," stated Royal V. Howard, vice-president in charge of Engineering of the Associated Broadcasters, Inc., in an address before the Institute of Radio Engineers at the Engineers' Club in San Francisco, upon his return from Europe, where he headed a special scientific staff.

"What we need if we are to build a good peace is the reverse of what happened at the building of the Tower of Babel . . . I believe that we can achieve that common language which means understanding and working unity among nations and I firmly believe that one of the most important instruments is radio. Where the Tower of Babel brought confusion, the towers of broadcasting can help the world work out a worthy peace."—Edgar Kobak, president of the Mutual Broadcasting System, New York, in a special broadcast to Europe on OWI's Voice of America.

Bits About Here, There and Everywhere

RADIO censorship in the United States ended 24 hours after Japan surrendered. Over a thousand electronic devices are being prepared to do jobs cheaper and better than they can be done by man. A consolation: someone is still needed to turn the button on. James E. Carson has been appointed Network Service Manager of the CBS Cadena de las Americas. The Third Inter-American Radio Conference is to begin on September 3rd in Rio de Janeiro. The Yellow Cab Co., of Washington, asked for the authority to experiment in the radio dispatching of cabs. The Bell System, in the United States, reports that by the end of this year it expects to have 2,000 miles of coaxial cable network manufactured and at least three-quarters of this mileage in the ground.

Plans for Radio in Nigeria

PLANS recently approved by the Nigerian Legislative Council, which will take from 10 to 20 years to implement fully and probably costing some \$160,000,000 in all, provide the erection of a broadcasting service and development of telecommunications in this country.

FRESH FIELDS TO CONQUER

Romantic poets shed salt tears—
It rends their very bones
To leave poor Cupid high and dry
And turn their thoughts to "ohms."
Deserting romance in this way,
The poet's spirit jolts.
How can Divine afflatus rave
Of subjects such as "volts"?
His lightsome fancy soaring high,
To earth falls plunk and rots,
When not for him the lover's sigh,
But simply mundane "watts."

What poppycock! What piffing punk!
How blind the Bard must be
Who cannot in the march of Science
Fresh romance ever see.
Man, now endowed with Godlike power,
Flies hurtling through the skies,
And every day fresh wonders stand
Revealed before our eyes.
This we pronounce in ringing voice
And will not brook defiance:
There's Romance to the nth degree
Found in the March of Science.

"TORCH."

The Decca "Navigator"

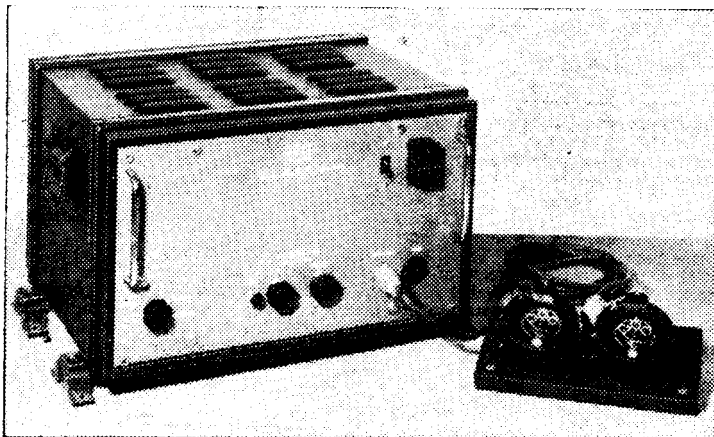

Ships' main model "Navigator."

THIS new navigator, by means of which the leading boats of the mine-sweeping flotilla were steered at H hour on D-day, is comparable to a radio receiving set, and is as easy to operate. No mathematical formulae are involved. Tides and winds can no longer cause drift "off course." The instrument is not subject to polar attraction. By a simple reading of two dials, the pilot of vessel or aircraft now *always knows his dead true course*, and his exact position.

The Decca Navigator receives its power from radio transmission. This power is "stepped up" and converted into energy which operates the two dials. Radio waves travel through the ether in a series of ever widening rings. By placing two or more synchronised transmitters at specified distances, intersection of these rings is obtained, and a "space pattern" emerges. This "space pattern" is subject to mathematical law, and when mapped, produces a positive picture. Each point of intersection charts an exact location.

By such a chart on D-day the mine sweepers were steered. The Decca Navigator was switched on and the dials were set to the reading on the chart given as the point of departure. On the chart every pin point position was marked by the crossing of two lines. The course through the space pattern was noted, and the ship turned on to its course. When the dial readings corresponded to the destination reading on the chart, the voyage was over, and the moment for invasion had come.

World-wide Operation

The Decca Navigator, given the creation of suitable stations, will be operable all over the world. Recent tests have shown it to be five times more accurate than any other known practicable method of navigation. With three radio transmitters placed one hundred miles apart, two space patterns of approximately three hundred divisions or lanes are secured. Each lane is divisible into tenths and hundredths. Thus any craft travelling

A Device for Controlling Ships Coursed by Radio

on the sea or in the air, which carries the Decca Navigator, can plot its position and travel a course to a margin of error which can be reckoned in yards. The accuracy of the system expressed in a measurement of time is $\frac{2}{100,000,000}$ of a second.

The "Navigator" works on different transmissions received simultaneously on the one aerial. The space lines are indicated on the chart by coloured lines. Each line is numbered. The space between adjacent lines is called a "lane." The energy received is converted to readings on the dials which are in the same colours. The dial indicator is known as the Decometer, the reading on which is given by a pointer which indicates on a large dial calibrated in hundredths of a lane. Units, tens and hundreds of lanes are indicated by three dials, the readings of which are visible through small apertures in the main dial.

As a result of one of the many patented features of the design, the Decometer readings are unaffected by static, morse and other forms of interference.

The Decca Navigator differs radically from Radar technique which, in general, is based on short-wave pulse transmissions and the interpretation of these pulses on a cathode-ray tube by a skilled operator; the Decca system utilises unmodulated continuous long-wave transmissions which operate direct reading meters. Because it utilises very long waves its readings are unaffected by intervening objects. It is useful at long range as well as within a mile or two of the transmitting stations, and operates with equal efficiency at ground level or high altitude—over land or sea.



Mr. H. F. Schwarz and Mr. W. J. O'Brien, the inventors of the "Navigator."

Radio Butlin

Description of Equipment Installed at Butlin's Holiday Camp, Filey

THE equipment has been installed to provide a comprehensive and most flexible system for entertaining the camp and for administrative purposes. After the camp was surveyed it was decided that approximately 1 kilowatt of power would be needed to cover all the parts, chalets, swimming-pool, boating lake, skating rink, tennis courts, theatre, etc., and at least 12 separate programmes would be required during the peak entertainment hours of the camp. To provide the most flexible arrangement possible it was decided that the loudspeakers should be installed on as many circuits as possible. Accordingly a total of 60 independent groups was decided upon, which number includes for future extensions, without modifications to the layout of the apparatus, etc. It was decided that the size of the equipment and complex facilities needed would be such that it would be impossible to obtain full control by units mounted on the main amplifier rack assembly, therefore a control console was designed from which immediate control of the entire system and programme selection could be under the care of a single operator. Accordingly the main equipment consists of two assemblies:

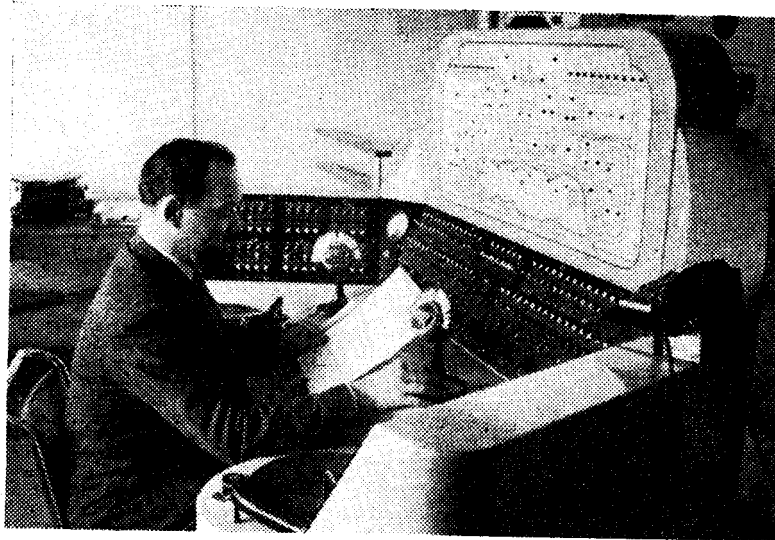

Mr. St. John Cooper at the controls of Radio Butlin.

1. Seven Steel Channel Racks with:

- (a) Sixteen power amplifiers each capable of developing over 60 watts, thus with all channels in operation approximately 1,000 watts of audio power is radiated.
- (b) Remote relay panels for automatically controlling the loudspeaker circuits, selecting power amplifiers, and completing their high tension circuits. Illuminated indicators immediately show when the appropriate amplifiers and circuits have been "made alive" by the operator. These panels are those mounted on the top of the amplifier racks.
- (c) Monitor test, output meter and valve test meters are provided in duplicate, for routine checking, fault diagnosis, etc., whilst monitor loudspeakers are mounted on the same panels for listening to the speech or music output of the apparatus under test.
- (d) Two independent high quality radio units have been provided so that, at all times, it is possible for two separate radio broadcasts to be relayed to the predetermined sections of the camp, thus, for instance, news bulletins can be broadcast to the reading rooms, whilst light musical programmes can be simultaneously broadcast to other rooms, bars and restaurants.
- (e) Time Clock Panel. An electric clock with large dial has been installed for use of the operator in order that he can synchronise the programmes and arrangements to fit in with the camp routine.
- (f) Fuse Alarm Panel. A device has been installed in this unit which in the event of certain troubles, immediately gives oral and visible warning of certain faults; for instance, should a cable be broken or damaged a spring-loaded fuse will be released sounding an alarm, also indicating in which section the cable fault has occurred.

(g) Alarm Signal Generator. This unit is an electronic oscillator which generates three distinctive warning notes without employing any mechanical mixing parts, these signals being controlled by relays from the console, and are used for sounding calls mainly for administrative purposes.

(h) Monitor Amplifier. This is a small, high quality low output amplifier which is normally connected to the loudspeakers fitted in the control room. This amplifier enables the operator at the console to check and listen to all broadcasts before radiating them to the various sections of the camp. The loudspeaker is connected via an automatic relay so that it becomes inoperative when microphone announcements are made from the console, thus there is no possibility of microphone howl. The output of this amplifier is also connected to a special peak reading indicator mounted on the console which enables the operator to measure and maintain the signals available for the inputs of the twelve individual channels.

In addition to the above units, mounted on the main rack assembly there are a number of multi-termination units, main switches and fuses for controlling the supply to the separate units.

For operating the relay, indicator lamps and signalling circuits two heavy current medium voltage rectifier units are used, so that the installation is entirely mains operated, no batteries or accumulators being necessary as used in telephone exchanges.

2. Control Console

This is the heart of the entire installation and from here the incoming programmes are selected, monitored, and distributed as and when required to the various sections of the camp. The main units of this console are:—

(a) *Illuminated Loudspeaker Group Indicator Panel.* This shows the schematic layout of the camp and indicator lamps are illuminated automatically to show the operator which loudspeaker groups are in operation at any one time.

(b) *Loudspeaker Group Selector Panel.* This panel is placed immediately below the illuminated loudspeaker

group indicator panel; it is fitted with sixty group selector switches for controlling the same number of loudspeaker groups; when one of the key switches is depressed it connects that particular section of loudspeakers to the input circuit of the appropriate power amplifier. Simultaneously the correct indicators on the panel above are illuminated. In addition to the above six other switches labelled "sub-masters" are provided. These group the loudspeaker circuits into six sections. These "sub-masters" are in turn connected to one "special master" switch which, when depressed, automatically connects all loudspeaker groups. This special arrangement has been provided to facilitate operation, especially when using the console microphone for "paging" or as a calling system; for instance, if it is known that an executive is in one particular section of the camp and he is required immediately on the telephone, a call may be made via the microphone and that call only transmitted to that section of the camp by depressing the appropriate "sub-master," thus the other programmes or musical entertainment in the other sections of the camp will not be interrupted. If in the event of real urgency the probable whereabouts of the executive is unknown, the "master" switch is operated which will then transmit the call simultaneously to all sections.

It will be noted that the indicator panel notifies the operator immediately which loudspeaker circuits are in commission, but he is also able to listen to the programme being transmitted to any of the loudspeaker lines by depressing a small push-button mounted immediately above the loudspeaker group switches. Similar switches are, of course, provided for the "sub-masters" and "master" switches. Simultaneously with the operation of these monitor switches a special "peak reading" output indicator meter is fitted so that the operator can measure electrically the power being radiated and can adjust the volume controls situate in this panel to the point to ensure that each channel is being injected with the input signal at the correct level. The monitor loudspeaker used for these tests is automatically disconnected when the control console microphones are in use, but the indicator meter is left connected in the circuit. This meter is the one mounted on the left-hand side of the panel.

(c) *Channel Selector Panel.* This is the jack and cord mounted on the right-hand side of the console. It is provided with over 200 "jacks" and cord plugs, which enables the operator to arrange and set up the various plugs for the loudspeaker circuits. Each power amplifier which feeds the respective loudspeaker groups is connected to the jack, and by inserting the appropriate plug into any one of the twelve programmes he can connect them all to one channel or to any combination that may be necessary. Thus it is possible, for instance, that one loudspeaker group can be radiating a news bulletin received via the radio unit, another group can be radiating a light musical programme received by the second radio unit or alternatively a gramophone programme; the swimming pool speakers can be in operation for announcements originating from the microphone installed there, a special programme employing microphones and loudspeakers installed in the theatre can be in use, similarly any one of the four main dining-halls may originate and receive their own programme or any of the programmes can be transmitted to all of the loudspeakers. The operation of this panel is similar to that employed at telephone exchanges.

(d) *Input Selector Panel.* This panel, which is situated on the left-hand side of the console, receives and allocates the 36 input programmes that can be connected to the 12 operational channels. The functioning of this is opposite to that of the loudspeaker selector panel. The latter distributes the 12 channels to the 60 independent loudspeaker groups, whereas this panel connects the 36 incoming programmes into the 12 operational channels. The input programmes are as under:—

Console microphone	No. 1.
Console microphone	No. 2.
Gramophone	No. 1.
Gramophone	No. 2.

Alarm Signal	No. 1.
Alarm Signal	No. 2.
Alarm Signal	No. 3.
Radio	No. 1.
Radio	No. 2.

Swimming Pool microphones.
Boating Lake microphones.
Ballroom North microphones.
Ballroom South microphones.

Four independent circuits from the respective dining-halls, recreation rooms, administrative offices, etc.

Where microphone circuits are concerned an indicator lamp is mounted above the appropriate control switch. The purpose of this is when the microphone is required in operation the person requesting that particular microphone operates a key-type switch at the microphone locality which automatically illuminates the indicator lamp on this panel. The operator at the console on seeing this signal, depresses the selector switch beneath the lamp, which then connects that particular microphone circuit to the required channel. When the signals are ready for transmitting he then operates the small push-button switch mounted beneath the input selector switches. This then "flashes" a signal to the further end of the line so that the person requesting the microphone is then advised that the microphone has been connected and ready for use. This signalling system is also employed for "flashing" the announcer or artist, say, for any reason, the operator at the console requires the remote microphone to be finished with at the earliest moment.

(e) *Gramophone.* Two independent electric gramophone motors with corrected "pick-ups," treble and base controls provided, one on either side of the operator. These are so connected to the input selector switches that both may be in use simultaneously to provide two entirely separate programmes from gramophone records on separate channels, or alternatively by operating separate selector switches both gramophone units may be connected to one channel where "fading" is required or continuity from one record to another. A small indicator lamp is mounted on each playing disc control panel to ensure that the operator has selected the correct switch. This indicator does not become illuminated until the circuit has been "set up."

The above mentioned units are those which are visible from the front of the console, and those units which are employed for normal operation of the installation. Other intricate units are mounted inside the console, being readily accessible by opening doors at the rear. The most important items here are the line amplifiers. These are employed to raise the minute signals originating at the programme source to a sufficient level and power to feed the input circuits of the power amplifiers. There is one amplifier for each channel. They are mounted in pairs per unit and are entirely operated by A.C. mains supplies. These line amplifiers are fitted with an extremely efficient automatic volume control system, making it impossible for distortion to occur; for instance, when any amplifier is in use and the master volume controls for the particular channel set to the desired level for normal speech, should the speaker or announcer raise his or her voice, the special arrangement will control the amplifier, which will continue to give the correct output only. This not only operates on speech but can be adjusted by means of preset controls to operate on musical frequencies.

For an installation of this character a large variety of types of speakers is necessary, each chosen to suit the varying acoustic and the changing functional purposes of the buildings. There are certain circuits which are installed with a large number of low level high voltage units, whilst there are other circuits which are provided with large diaphragm type speakers. For external use there are a number of weatherproof re-entrant horn-type speakers of unique design which are able to radiate both musical and speech frequencies over considerable areas of the camp. These are mainly used for announcing to the chalets, sports fields, tennis courts, swimming pool, boating lake, etc.

Improving Loudspeaker Performance—2

Baffles, Labyrinths, Horns, etc.

By S. O. MAWS

IN Part I we were concerned with methods of extending the frequency response of moving-coil loudspeakers. Suppose that this is now as good as we can make it. In order to get the best reproduction of which the loudspeaker is capable some additional equipment such as a baffle-board, a horn or an acoustic labyrinth or something of this sort is necessary. This article is intended to give an account of these aids to high-quality reproduction.

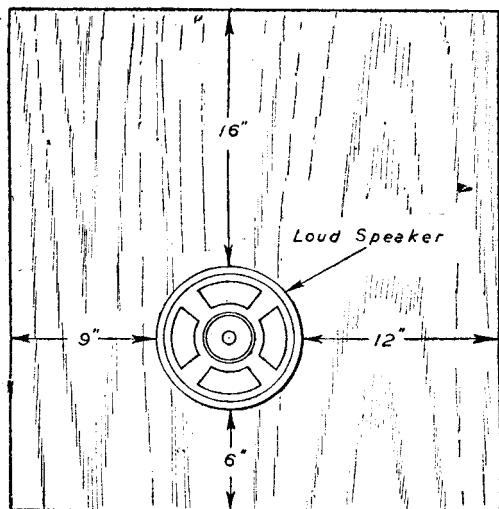
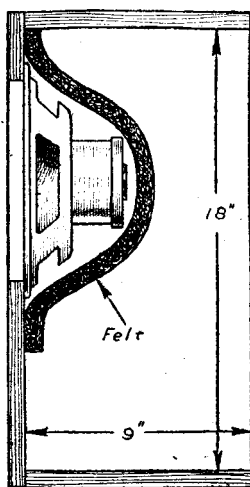

Fig. 1.—A flat baffle-board illustrating an asymmetric mounting of the speaker.

The simplest of these to understand is the flat baffle-board, illustrated in Fig. 1. The function of this is to prevent radiation from the back of the loudspeaker cancelling that from the front at low frequencies. This cancellation and resultant loss of power can occur when the front-to-back distance of the loudspeaker measured around the baffle equals half the wavelength of the radiated sound. The diaphragm of the loudspeaker is quite capable of preventing this cancellation at high frequencies, as its dimensions are considerably greater than the wavelength of high-frequency sound waves.



For example, $\frac{\lambda}{2}$ for a 3,500 c/s note is approximately 2in. and average loudspeakers usually have diaphragms of larger dimensions than this. As the wavelength of a 50 c/s note is 22ft., however, it is fairly obvious that, for a baffle to be successful at low frequencies, its dimen-

Fig. 3.—A baffle in the shape of a cabinet.

sions need to be particularly large. For a loss of 3 db. at 50 c/s, for example, a baffle measuring 8ft. in diameter is necessary: a baffle measuring 3ft. square, a size frequently used by experimenters, gives a loss of about 12 db. at 50 c/s. A point worth remembering, and it is brought out in Fig. 1, is that the loudspeaker should not be mounted centrally in a symmetrical baffle, but should ideally be so positioned that it is a different distance from the various edges of the baffle. The response curve of a loudspeaker mounted centrally in a symmetrical baffle shows a dip and a rise, as shown in Fig. 2, at that frequency for which the front to back distance equals $\frac{\lambda}{2}$. For this reason the use of an irregularly shaped baffle, or—and this comes to the same thing—asymmetrical mounting of the loudspeaker in a regularly shaped baffle, gives a better response than central mounting in a symmetrical baffle.

One way of making a baffle more convenient in size is to shape it into a box or cabinet as in the majority of radio receivers, but this introduces a fresh complication, namely that if the length of the box is at all comparable with its other dimensions, then the box will behave as a resonator and will respond to one frequency better than all others. The value of this resonant frequency will depend on the mass of air contained within the cavity, and for an average table model radio is probably near

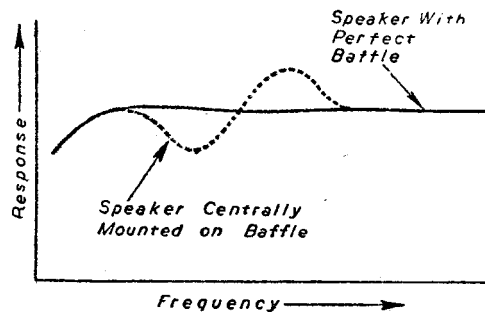

Fig. 2.—Illustrating effect of symmetrical baffle mounting on frequency response.

200 c/s. For the larger cabinets used to house commercial radiograms the figure is nearer 100 c/s, which is unfortunate as it happens to coincide with the bass resonant frequency of the average 8in. moving-coil loudspeaker. There is thus an excessive response at 100 c/s, which accounts for the unpleasant "boominess" of such radiograms. This effect can be considerably reduced by introducing some resistance into the acoustic tuned circuit, and one way of doing this is to place layers of felt (the type that is sold for putting under stair carpets is convenient) around the loudspeaker as suggested in Fig. 3. This acoustic damping is much more effective in closed cavities than in those with open backs. The idea, so often advocated, of lining the box with sound-absorbent material has very little to recommend it, since sound waves obviously have a velocity node at any reflecting surface. If there is little or no air movement at a surface, then any absorbent material placed on it cannot introduce much frictional loss unless it is a particularly thick layer. It is, however, good science to line the sides of the cabinet with felt if they are thin and hence liable to vibrate at their natural period, for this is another source of undesirable colouration in reproduction. The cross-battening of cabinets is another method of avoiding vibration of the sides.

Study of Fig. 3 will show that the cabinet is roughly equivalent to a baffle 3ft. square. If the cabinet is less wide than it is tall, it is also an irregularly shaped baffle, which is a good thing. Moreover, the loudspeaker, being mounted at the top of the box, is asymmetrically positioned in the baffle, which is again good practice.

Acoustic Labyrinths

So far we have regarded the resonance of air in a closed cavity as being undesirable, and if the resonant frequency lies within the frequency range over which the loudspeaker is efficient, then undoubtedly there will be an unwanted peak in the response curve. It is possible, however, to design an acoustic system to provide a boosting effect at a frequency just below the lower frequency

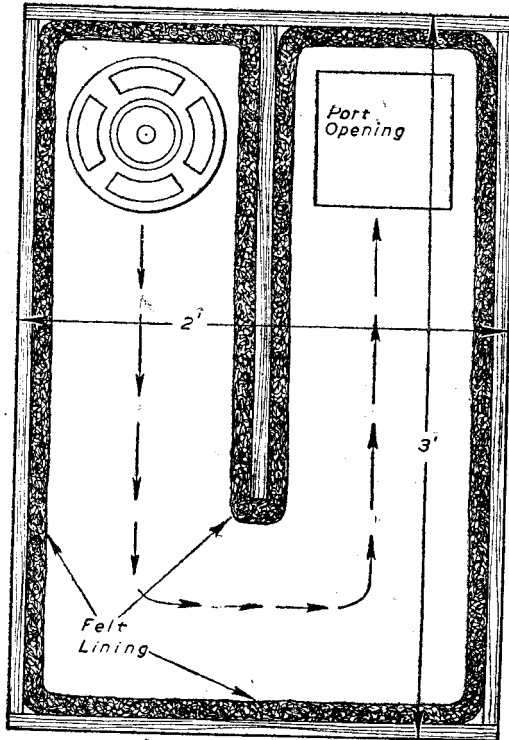

Fig. 4.—An acoustic labyrinth. The front to back dimension is not critical.

limit of the loudspeaker, in which case the boost will help reproduction by holding up the response curve at low frequencies. We can design such a system as suggested in Fig. 4, in which the back has been removed so as to show the internal construction. In this system the front of the loudspeaker radiates both high and low frequencies directly into the room, but the back feeds the acoustic system formed by the two vertical chambers. The total length of the acoustic chamber is designed to be a quarter of a wavelength long at the bass resonant frequency of the loudspeaker used. If this happens to be, say, 50 c/s, then $\frac{\lambda}{4} = 5\frac{1}{2}$ ft., so that each section of the chamber could be 2ft. 9in. long, giving a total length of 5ft. 6in., as required.

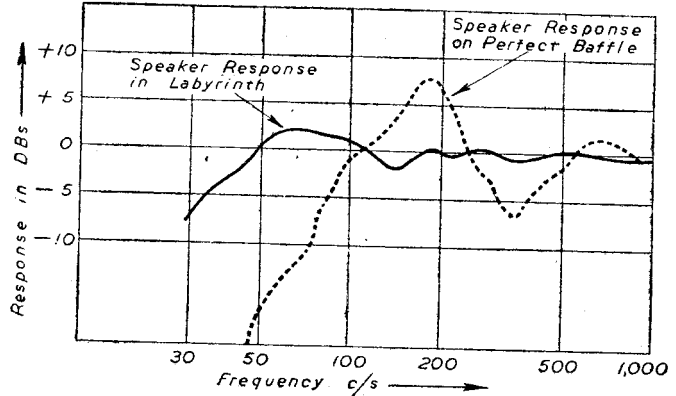

Fig. 5.—Showing the improvement in bass response produced by an acoustic labyrinth.

This is shown in Fig. 4. It is the length of the acoustic path from the loudspeaker to the final opening which is important here; the value of the cross-sectional area of the chamber does not matter much provided it is not smaller than the area of the loudspeaker diaphragm. The theory of this labyrinth is as follows. At the bass resonant frequency of the loudspeaker the labyrinth presents maximum acoustic impedance (it is similar to a quarter-wave aerial in this respect) and thus the amplitude of movement of the cone is reduced considerably. At lower frequencies the radiation from the port at the end of the labyrinth has a component in phase with the radiation from the front.

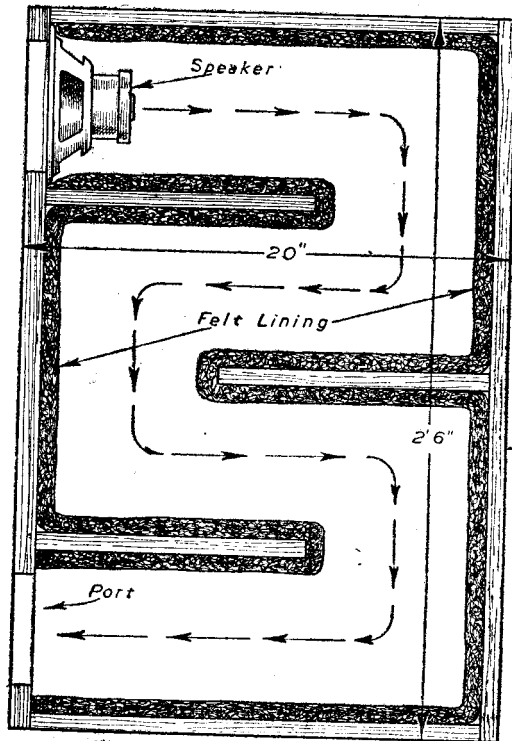

Fig. 6.—A particularly compact labyrinth.

THESE ARE IN STOCK

"ELECTRICAL ENGINEER" REFERENCE BOOK. By Molloy, Say, Walker, and Windred. Price 42/-. Postage 9d.
CLASSIFIED RADIO RECEIVER DIAGRAMS. By E. M. Squire. 10/6. Post 4d.
HIGH VACUUM TECHNIQUE. By J. Yarwood, M.S.C., A.Inst.P. 12/6. Post 4d.
RADIO RECEIVER DESIGN (Part I). By K. R. Sturley, Ph. D., B.Sc., M.I.E.E. 28/-. Postage 7d.
RADIO VALVE DATA POCKET BOOK. By F. J. Camm. 5/-. Post 3d.
WIRELESS WORLD VALVE DATA. Operating Conditions and Base Connections of the Principal Types and makes. 2/-. Post 2d.
AMERICAN MIDGETS—Radio and Valves. By J. Bull. 2/6. Post 2d.
NEWNES TELEVISION MANUAL. By F. J. Camm. 6/-. Post 4d.
THE MATHEMATICS OF W. RELESS. By R. Stranger. 7/6. Post 4d.
CATHODE-RAY OSCILLOGRAPH. By Reyner, B.Sc., A.C.G.I., D.I.C., A.M.I.E.E., M.Inst. R.E. 8/6. Post 4d.
RADIO TECHNIQUE. By A. G. Mills, A.M.Inst. B.E. 12/6. Post 5d.
RADIO RECEIVERS AND TRANSMITTERS. By S. W. Amos and F. W. Kellaway. 21/-. Post 6d.
 Write or Call for Complete List, 1d.
THE MODERN BOOK CO. (DEPT. P.5.),
 19-23, Praed St., London, W.2.

FIRST-CLASS RADIO COURSES . . .

GET A CERTIFICATE !

QUALIFY AT HOME—IN SPARE TIME

After brief, intensely interesting study—undertaken—at home in your spare time—**YOU** can secure your professional qualification. Prepare for **YOUR** share in the post-war boom in Radio. Let us show you how !

FREE GUIDE

The New Free Guide contains 132 pages of information of the greatest importance to those seeking such success compelling qualifications as **A.M.Brit.I.R.E., A.M.I.E.E., City and Guilds Final Radio, Matric., London B.Sc.(Eng.), A.M.I.P.E., A.M.I.Mech.E.,** Plastics Technology, Draughtsmanship (all branches), etc., together with particulars of our remarkable Guarantee of

SUCCESS OR NO FEE

Write now for your copy of this invaluable publication. It may well prove to be the turning point in your career.

FOUNDED 1885—OVER 150,000 SUCCESSES

NATIONAL INSTITUTE OF ENGINEERING
 (Dept. 461), 148, HOLBORN LONDON, E.C.1.

RADIO SPARES

MAINS TRANSFORMERS. Primaries 200/250 volts. Secondaries 350-0-350 volts.
TYPE C. 100 ma. 4v. 5a., 4v. 3a. 34/6
TYPE D. 100 ma. 6.3v. 5a., 5v. 3a. 34/6
TYPE E. 120 ma. L.T.s as Type C 37/6
TYPE F. 120 ma. L.T.s as Type D 37/6
TYPE H. 200 ma. Three L.T.s of 4v. 6a. +4v. 3a. Rectifier 47/6
TYPE I. 200 ma. Three L.T.s of 6.3v. 6a. +5v. 3a. Rectifier 47/6
 Secondaries 500-0-500
TYPE J. 200 ma. Three L.T.s of 6.3v. 6a. +5v. 3a. Rectifier 52/-
TYPE K. 200 ma. Three L.T.s of 4v. 6a. +4v. 3a. Rectifier 52/-
TYPE L. 250 ma. Three L.T.s of 6.3v. 6a. +5v. 3a. Rectifier 56/-
TYPE M. 250 ma. Three L.T.s of 4v. 6a. +4v. 3a. 56/-
 Secondaries 400-0-400
TYPE R. 120 ma. 4v. 5a., 4v. 3a. 40/-
TYPE S. 120 ma. 8.3v. 5a., 5v. 3a. 40/-
SPECIAL UNITS MANUFACTURED TO FRIENDS' REQUIREMENTS.
 Please note that, owing to dimensions and weight of TYPES H to M, kindly add 2/6 for carriage and packing.
HEAVY DUTY MULTI-RATIO OUTPUT TRANSFORMER. 120 ma. 15 watts, tapings for 6L6s in push-pull, 6X4s in push-pull, low impedance triode, low impedance pentode, high impedance triode, 27.6; complete instructions with each unit.
SPEAKERS. Rola or Celestion. 8in. P.M. with transformer 29/6. Less transformer 24/-. 10in. with transformer 45/-.
OUTPUT TRANSFORMERS. Special offer. Multi Ratio 30 : 1, 45 : 1, 60 : 1, 90 : 1, 6/-.
SMOOTHING CHOKES. 20 henrys 100 or 120 ma. 10/-; 20 henrys 150 ma. 12/6; 30, 35 or 40 henrys 200 ma. or 250 ma. 21/6.
DRIVER TRANSFORMER, Class B. 8/-.
LINE CORD. Special offer, 3 amp. 3-way, 180 ohms per yard 1/9. Best quality.
BAKELITE PANELS, 18in. x 6in. x 1/4in., polished brown, 4/6.
 Orders accepted by post only. Please help us to eliminate clerical work by sending cash with order. Please include postage with order. **PRICE LIST 1d. stamp.**
H. W. FIELD & SON, Colchester Road, HAROLD PARK, ESSEX

Use ERSIN MULTICORE SOLDER

contains 3 cores of non-corrosive Ersin Flux

Radio Experimenters are now able to use "The finest Cored Solder in the World," Ersin Multicore. The three cores of extra active flux ensure speedy soldering and eliminate high resistance or dry joints.

Available from electric and radio shops, ironmongers, etc.

Nominal 1-lb. reels:
 13 S.W.G. 4/10 ea.
 16 S.W.G. 5/3 ea.

Size 2 cartons:
 16 S.W.G. 6d. ea.



MULTICORE SOLDERS LTD. COMMONWEALTH HOUSE, LONDON, W.C.1. Tel. CHAncery 5171/2



FOR THE RADIO SERVICE MAN, DEALER AND OWNER

The man who enrolls for an I.C.S. Radio Course learns radio thoroughly, completely, practically. When he earns his diploma, he will **KNOW** radio. We are not content merely to teach the principles of radio, we want to show our students how to apply that training in practical, every-day, radio service work. **We train them to be successful !**

INTERNATIONAL CORRESPONDENCE SCHOOLS

Dept. 94, International Buildings, Kingsway, London, W.C.2.

Please explain fully about your instruction in the subject marked X.

Complete Radio Engineering
Radio Service Engineers
Elementary Radio

If you wish to pass a Radio examination, indicate it below.

British Institute of Radio Engineers
P.M.G. Certificate for Wireless Operators
City and Guilds Telecommunications
Wireless Operator, R.A.F.
Wireless Mechanic, R.A.F.

Special terms for members of H.M. Forces and discharged and disabled members of H.M. Armed Forces.

Name..... Age.....
 (USE BLOCK LETTERS)

Address

(Use penny stamp on unsealed envelope.)



Practical Hints

Simple Indicator Lights

HAVING need of some small indicator lights for a midget receiver, I devised this method of making them easily and cheaply.

I obtained from a chemist a small length of $\frac{1}{16}$ in. diameter glass tubing which I sealed at one end by slowly rotating it in a gas flame. I then made a scratch with a file $\frac{1}{16}$ in. from the sealed end which I then broke off. I repeated this process until I had the required number of

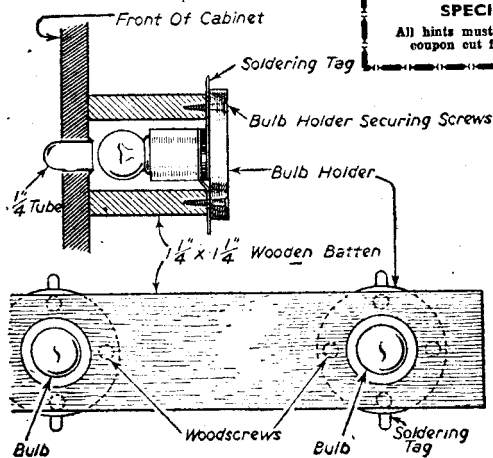

Method of making pilot lights.

small tubes. I then made the same number of $\frac{1}{16}$ in. holes in the front of the cabinet and secured the small tubes in these with a drop of glue at the back. The bulb holders, I mounted in a block of wood an inch square which had $\frac{1}{16}$ in. holes drilled in it at corresponding places to those on the front. The block I secured to the front with a $\frac{1}{4}$ in. wood screw.—M. J. COLLINS (Caterham).

An Adjustable Bench Lamp

AS I have a large number of radio repairs to do at home I found that the "light" question is always a problem, so I devised the adjustable bench lamp shown in the accompanying sketch.

It is made up from 4 lengths of electric light conduit, a piece of wood for the base—15 in. long by $\frac{1}{2}$ in. wide—to hold the plugs, lampholder, conduit base plate and clamp.

The method of making and assembly is as follows:

Cut a piece of wood $\frac{1}{2}$ in. thick by 15 in. long by $\frac{1}{2}$ in. wide and on this mount the wall plate, and plugs, etc., and screw the "G" clamp on the underside.

Cut the $\frac{1}{2}$ in. pieces of conduit to the lengths shown, and with a back-saw cut down centre about $\frac{1}{2}$ in., then prise the cut either way with a piece of bar, round the ends, and drill hole through for O-B.A. bolts. Make spacers to fit inside, and adjust these so that the other piece fits over to make a swivel joint.

The lampholder is either screwed or forced on to the end of a $\frac{3}{16}$ in. piece of tubing and

THAT DODGE OF YOURS!

Every Reader of "PRACTICAL WIRELESS" must have originated some little dodge which would interest other readers. Why not pass it on to us? We pay half-a-guinea for every hint published on this page. Turn that idea of yours to account by sending it in to us addressed to the Editor, "PRACTICAL WIRELESS," George Newnes, Ltd., Tower House, Southampton Street, Strand, W.C.2. Put your name and address on every item. Please note that every notion sent in must be original. Mark envelopes "Practical Hints."

SPECIAL NOTICE

All hints must be accompanied by the coupon out from page iii of cover.

a hole drilled in the bottom of the tin to slide the lampholder through.

The spacers can be made from lengths of brass tube, and the flex is twisted once round, and run through the tube. This saves any pull on the flex when adjusting the lamp.

When completed, the job can be given a coat of black enamel.—H. TANSLEY (Carshalton).

Power Supply Modification

I HAD to make up a separate power pack, for use on 200 or 250 volts A.C. The only transformer available had only one primary winding, namely one for 250 v. The rewinding of the primary not being a job I would undertake lightly, I rewound the two low voltage secondaries to give 5 and 6.3 volts respectively when used from 200 v. These were both tapped to give the same from 250 v.

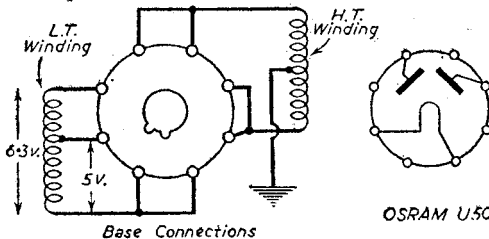

Base Connections

Simple method of varying voltage of power pack output.

The 6.3 v. windings were brought out to 3 terminals to be selected as necessary. The 5 v. supply to the rectifier was connected as shown, and another key slot for the locating peg of the octal base was filed out with a small rat-tail file. Marks were painted on the valve base to indicate which position was for which mains voltage. Hence, simply by removing the valve from its socket and re-inserting it in a slightly different position the change from one voltage to the other can readily be made.

The H.T. can be set to its previous value with a potentiometer if necessary.—A. L. M. (Wolverhampton).

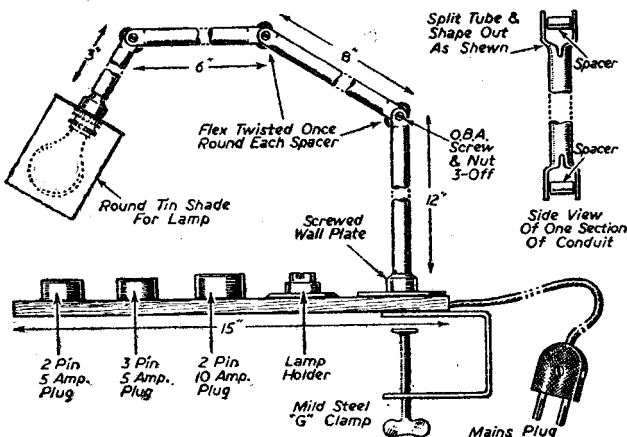

An adjustable bench lamp.

Impressions on the Wax

Review of the Latest Gramophone Records

H.M.V.

GRIEG scored an immediate success when he played, together with other of his works, his "Concerto in A Minor (Op. 16)" during his first appearance in England at the Philharmonic Concert on May 3rd, 1888. The success was not, as in many cases, of a passing nature, in fact, one might well say that time has made this Concerto more and more popular as the years have rolled by. Much has been written about, shall we say, the restricted appeal of classical music, but this work is an exception, and it is this which undoubtedly accounts for its increasing popularity and wide appeal.

Grieg is a master of creating and setting themes so that the full extent of their beauties is revealed, and although his major works are sometimes criticised as regards their form, it is only natural for one whose art is predominantly rich in lyrical tendencies, to modify the generally accepted formation of classical compositions to suit his own ideas.

With the Concerto in question, one enjoys music of a distinctive flavour which is enhanced by delightful melody, and rendered thrilling by its clever rhythmical arrangement. The work, as recorded by H.M.V. on records DB6234-36 (three records—six parts), is performed by Arthur Rubinstein as the soloist and The Philadelphia Orchestra conducted by Eugene Ormody. In this respect, comment is unnecessary, as one does hear what one would expect from such a combination, namely, a perfectly superb performance.

To follow the above recording, I strongly recommend H.M.V. C3455-56, as on these two records one can listen to that beautiful work by Beethoven, "Sonata in C Sharp Minor (Op. 27, No. 2)," played with such skill and expression by Solomon.

The full title of the composition is "Sonata quasi una Fantasia," and the composer directed that it should be played in the manner of an improvisation or fantasia, and it is through the great beauty of the first movement that the name "Moonlight" has been coupled with the Sonata. Solomon's performance recreates the feeling that the greatest improviser in musical history—Beethoven—is himself revealing all the magical beauties and spirit of moonlight over the Lake of Lucerne, as a critic called Rellstab wrote of the first movement.

From the pianoforte, let us turn to a tenor of great ability, and listen to Heddle Nash—with the Philharmonic Chamber Orchestra conducted by Maurice Miles—singing "The Messiah" ("Comfort Ye, My People" and "Every Valley Shall Be Exalted").

These two arias are fine examples of Handel's melodic invention, and Heddle Nash gives us a splendid performance on H.M.V. C3454.

The high-light in the vocals on 10in. records is H.M.V. D.11850, which is an exceptional recording by that great soprano, Elisabeth Schumann, accompanied at the piano by Gerald Moore. Haydn's "She Never Told Her Love" and "The Sailor's Song," are the two delightful songs which Elisabeth Schumann selected for this, her latest recording, and her rendering is an outstanding example of purity of tone, expression and style.

A tenor recording in the Lighter Classical series which will be widely appreciated is that by Robert Wilson, with Orchestra conducted by Henry Geehl, who sings with great quality and expression "Chicken Dinnah" and "You Are My Song Divine," on H.M.V. BD1109.

The Boston Promenade Orchestra, conducted by Arthur Fiedler, have made a fine recording of Tchaikovsky's "Eugen Onegin—Waltz—Act 2, Op. 24." This is a delightful melodic composition, enchanting and creative of the atmosphere of a great Russian ball reminiscent of the Winter Palace. This recording will have a great appeal to those who enjoy fine orchestras and music.

Columbia

SYMPHONY No. 6 in B Minor ('Pathétique' Op. 74) is often stated to be the best known and loved of all Tchaikovsky's symphonies, yet strangely enough, when he conducted its first performance at St. Petersburg on October 28th, 1893, it failed to make any impression, and, a few days later, the great composer was dead. There was a sensation as to the exact cause of his death, and it is a strange coincidence that the day after the first performance, Tchaikovsky told his publishers to issue the work under the title suggested by his brother Modeste, namely, "Pathetic" Symphony.

Following closely on the sensations and publicity given to his death, the second performance received an enthusiastic reception, and although the work now stands on its merits as a symphony, its popularity has never diminished. It is said of the symphony, that it was the saddest music Tchaikovsky ever wrote, but this is very misleading of the work as a whole, as for example the nature of the two middle movements which reveal the lighter, happier and stirring side of his nature. The Columbia recording is by the Philharmonic Symphony Orchestra of New York, conducted by Dr. Artur Rodzinski, on Columbia DX1205-09 (five records—ten parts).

As a distinct contrast to the above, the remaining 12in. Columbia record is by Harry Davidson and his Orchestra, playing No. 16-17 of Old Time Dance Series on Columbia DX1211. This month, he has selected two fine numbers, "The Last Waltz" and "Naval Three Step," and like the other recordings in this series, they should make you feel gay and in a dancing mood.

On the 10in., I recommend Columbia DB2189: "Sonata in F—Allegro" and "Gigue." Both are played by Reginald Keel (clarinet) and Gerald Moore (piano).

Monte Rev has recorded two good numbers on Columbia FB3142. They are "One Day When We Were Young" and "Play Gipsy Play." He is accompanied by orchestra conducted by Eddie Griffiths.

Victor Silvester's Strings For Dancing make a very tempting record for dancers—if you can do the Tango—out of "Amargura" and "Mi Amigo," on Columbia FB3148. Two good tunes well played.

Parlophone

RICHARD TAUBER is in fine form on Parlophone. RRO20541, on which he has recorded "I'll Turn To You" and "My Heart Is In Vienna Still."

Geraldo and his Orchestra offer "There Must Be A Way" and "June Comes Around Every Year"—both fox trots—on Parlophone F2092. Fine dancing tunes, well orchestrated and presented.

Joe Daniels and His Hot Shots in "Drumsticks" play "Nice Going—Medium Bounce" (written by Joe himself) and "Talk Of The Town." These are on Parlophone F2091 and, as may be expected, they are pretty lively.

Harry Roy and his Band have selected two fox trots for their latest recording on Parlophone F2090, "I'd Rather Be Me" and "I Should Care."

Nos. 39 and 40 of The 1945 Super Rhythm-Style Series will be found on Parlophone R2981. They are entitled "China Boy" and "Rosetta" and played by Teddy Wilson (piano) with rhythm accompaniment, and they are snappy in presentation and arrangement.

Regal

THE one Regal I have to mention this month has been recorded by Teddy Foster and his Band, and they play "Takin' The Trains Out" and "Dream."

GALPINS
ELECTRICAL STORES
408, HIGH STREET,
LEWISHAM, LONDON, S.E. 13.
TERMS: Cash with Order. No C.O.D.
All prices include carriage or postage.

ELECTRIC LIGHT CHECK METERS, first-class condition, electrically guaranteed, for A.C. mains, 200/250 volts 50 cy., 1 phase 5 amp. load, each 12/6.

AUTO TRANSFORMERS. Step up or down, tapped 0-110-200-220-240; 1,000 watts, £5.

POWER TRANSFORMER, 4 kW, double wound, 400 volts and 220 volts to 110 volts, 50 cycle, single phase. Price £20.

AUTO TRANSFORMER, step up or step down, 500 watts, tapped 0-110-200-220-240 volts, £3 10s.

METAL RECTIFIERS, large size, output 50 volts 1 amp., 35/-.

SMALL MAINS TRANSFORMERS, input 230 volts, output 11 volts 1 amp., 11/-.

METAL RECTIFIERS, large size, output 12 volts 1 amp., 17/6.

TRANSFORMER CORE for rewinding only, complete with clamps, size approx. 2½ kW., price 25/-.

50 VOLT MOTOR, D.C., input 4 amps., ¼ h.p., ball bearing, double ended shaft ½ in. dia., slow speed, only 500 r.p.m., slant wound, condition as new, also make good slow speed generator. Price 50/-.

MOVING COIL METERS, all 2in. dia., flush mounting, 0-5 m/A., 40/-; 0-20 m/A., 40/-; 0-25 m/A., 40/-; 0-50 m/A., 37/6.

ROTARY CONVERTERS, 210 v. A.C. to 150 v. A.C. at 600 watts, £10; ditto 230 v. D.C. to 150 A.C. at 700 watts, £10; ditto 460 v. D.C. to 300 v. A.C. at 4 kW., £25.

H.T. TRANSFORMER, input 200-250 v., output 3,000-2,500-0-2,500-3,000 v. at 1,200 milliamps, rating 7 kW., £20.

COOLIDGE TUBE filament transformers, 230 v. input, 11 v. output, fitted H.T. insulator, insulation 100,000 volts to earth, £5.

LARGE HEAVY DUTY CHOKES, weight 24lb., wound heavy gauge wire, suitable for rewinding as auto transformers up to 1 kW., price 25/- carr. paid.

LARGE PAXOLINE PANEL, size 14 x 7 x ½ in., fitted massane switch arm, 12 large studs and contact blade, very smooth action, price 7/6 each.

ELECTROLYTIC CONDENSERS, 2,000 mf., 25 v. working, 10/- each.

BLOCK CONDENSERS, 2 mf., 1,500 v. D.C. working, 7/6 each.

BELL TRANSFORMERS, output 3-5-8 volts, 6/- each.

LARGE OUTDOOR BELLS, 110 v. D.C. working, 6in. dia. gong, 17/6.

LARGE FAN MOTORS, all direct current, approx. ½ h.p. 110 v. series wound, in first-class condition, 20/- each; ditto complete with stand, starter, cage and fan, 30/-.

D.C. MOTORS, as above, only for 220 volt, in perfect order, 25/- each; ditto complete with stand, starter, cage and fan, 35/-.

CLOSED half-day Thursday.
OPEN all day Saturday.



Slow-Motion Dials

High grade reduction drives have been in short supply. We can now offer famous Burndept slow-motion dial, dual ratio, panel mounting instrument type, calibrated degrees, 3½ in. overall diameter . . . 12/6

Four-Gang Condensers

Ceramic insulation, 300 m.mfd. per section, capacity increases anti-clockwise 17/6

EDDYSTONE

Specialized radio components are now becoming easier in supply. New designs keep EDDYSTONE the pre-eminent name in Short-Wave technique.

Flexible Driving Shaft

Type S530. Frequentite insulation, drives through 90 deg. Length adjustable between 4½ in. and 6in. 5/1

H.F. Chokes

Type 1010, the best S.W. choke 5/180 metres 2/1

Type 1022, Transmitting 250 m.a. 3/1

Type 1011, U.H.F., 2.5 to 12 metres 1/6

Type 1066, All Wave Choke, 12.5 to 2,000 metres 2/9

Neutralizing Condensers

Type S481.—New and compact design, size 1½ in. x ½ in. x 1½ in. high. 1.5 to 4 m.mfd., Frequentite insulation, silver plated brass. 2,000 v. R.M.S. max. 3/6

Insulators

Type 916.—Beehive type stand-off 1/3

Type 999.—Aerial, low leakage type 1/1

Type 1019.—Midget stand-off 6d.

Type 1018.—Cone type lead through 1/3

Temporary leaflet showing other available EDDYSTONE components 2½d. post free.

WEBB'S RADIO, 14, Soho St., Oxford St., London, W.1. Telephone, Gerrard 2089
Note our revised SHOP HOURS:—
9 a.m. to 5 p.m. Weekdays, 9 a.m. to 1 p.m. Sat.

ELECTRADIX

Interesting and useful Bargains

MAKE YOUR OWN CRYSTAL SET with our Crystal set assembly comprising Condenser, Coil, Detector and Terminals with wiring diagram, 9/6. Catswhisker detectors, 2/6. Spare crystal, 1/-. Semi-perm detectors, 2/6. Spare crystals, mounted, 1/6.

AERIALS. 7/22 copper aerial wire, 50ft. 3/-. 100ft. 5/6. 30ft. Indoor aerial wire on reel, 1/-. Egg and shell insulators, 3d. ea. Lead-in wire, rubber-covered, 3/- doz. yds.

WIRE. Single silk-covered magnet wire, 28 gauge 7/6 lb., 30 gauge 9/- lb., 32 gauge 12/6 lb. Enamelled and S.C.C. wire, 18 gauge 3/2 lb. Twin bell wire 100 yds. for 12/-.
BELLS. Tangent Ironclad bells, 230/50 volts A.C., 6in. gong, as new, 42/-. Klaxon and Secomak super Horns, 230/50 volts A.C., in new condition, few only; 70/- each.

MIKES. Recording and announcer's hand-mikes, multi-carbon, metal clad, service type, by Tannoy and Truvox, with neat switch in handle, 21/-.
CIRCUIT BREAKERS. Ellison make, mounted on sub-base, double pole O/L, 200/230 v. A.C., single phase, 200 amps., 15in. x 13in. x 12in., weight approx. 50lb.; ditto, 300 amps., 17in. x 14in. x 15in., weigh approx. 89lb. 220v. 1,000 amp. S.P. 50 cy., D.P. with no-volt hold-on coil, loose handle, switchboard mounting, oil switches, by Fergusson & Palin. All offered at very low prices to clear.

A.M. CUT-OUTS on base with bakelite cover, 4in. x 3½ in. x 3½ in., D.C. 12 volts, 40 amps., or 24 volts 40 amps., 35/- each.

MOVING COIL HEADPHONES P.M., less headbands. Here is a wonderful opportunity to secure highly sensitive headphones with coils energised by the famous ALNI magnets. These moving coil sound units have a 45 ohm ½ in. coil. They can also be used as miniature mikes, or as a miniature loudspeaker if matching transformer is used. Size 1½ in. overall, in bakelite case with 3in. front flange. As new. Price each 12/6, or per pair 24/-. Moving coil headphones with Brown type double steel headband and cord, 29/6 per pair.

DIMMER RHEOSTAT SWITCHES. 1 ohm to 0 and off up to 3 amps., for regulation of 6 volts A.C./D.C. Charger subcircuit regulators. Model speed control, etc., 1-hole fixing and extra bracket for rack. Hollow knob has base for miniature Bulb to glow when "ON"; in New Aetna Co., U.S.A. Price 2/6 each. Postage 6d.

TURNABLES. Ball-bearing, for table sets, model railways, etc.; bakelite body 4½ in. dia., 2/- ea.
MAGNETS. Midget ALNI perm steel disc magnets, ½ in. dia. with centre hole 3/16 in. dia. of tremendous magnetic force; unlimited uses, 3/6 each. Horse-shoe permanent-steel magnets, various sizes from 3/6 each.
SUNDRIES. R.A.F. 10-way terminal strips 7in. x ½ in. x 1½ in., 2/9. Bakelite sheet 3/32 in. thick, 3/- per sq. ft. Empire tape, 2/6 doz. yds. Empire cloth, 4/6 per sq. yd.

TEMPERATURE. 10-way terminal strips 7in. x ½ in. x 1½ in., 2/9. Bakelite sheet 3/32 in. thick, 3/- per sq. ft. Empire tape, 2/6 doz. yds. Empire cloth, 4/6 per sq. yd.

ELECTRADIX RADIOS
214, Queenstown Road,
Battersea, London, S.W.8.
Telephone MACaulay 2159

Open to Discussion

The Editor does not necessarily agree with the opinions expressed by his correspondents. All letters must be accompanied by the name and address of the sender (not necessarily for publication).

Voltage-dropping Calculations

SIR,—I received the May and June copies of PRACTICAL WIRELESS a few days ago. The May copy having been delayed they arrived almost together. They are the first I've seen for some time now, and they certainly uphold the pre-war reputation PRACTICAL WIRELESS had.

On looking through the June issue, I noticed T. E. Millward's letter on voltage-dropping calculations for condensers in an A.C. heater circuit. While his solution is the correct one, I thought a simplified method would be of use to some of your readers. This method has the further advantage of using Ohms Law, therefore, if we know any two factors we can find the unknown.

The usual formula is $C = \frac{10^6 I}{2\pi f E}$. Where C=capacity in mfd's. I=current in amps. E=desired voltage drop, f=frequency in cycles, $2\pi=6.28$ and $10^6=1,000,000$. As 2π and 10^6 are constants this can be reduced to

$C = \frac{159267.5 I}{f E}$ and as 50 cycles are used in the solution and is the most common mains frequency, we can reduce it still further to $C = 3184.7 \frac{I}{E}$. For 25 c/s. multiply answer by 2 and for 100 c/s. divide by 2.

As C is acting as a resistance we are actually using Ohms Law \therefore if $C = 3184.7 \frac{I}{E}$ $E = \frac{3184.7 I}{C}$ and $I = \frac{E C}{3184.7}$ always remembering E in this case is voltage dropped.

In the case given of four 6.3v. 0.3A and one 40v. 0.3A valves, with a mains supply of 230v. 50 cycles, total heater voltage=65.2v. at 0.3A and as the condenser voltage is in quadrature relation to heater voltage, voltage to be dropped= $\sqrt{230^2 - 65.2^2} = 220.5$

$\therefore C = 3184.7 \frac{0.3}{220.5} = 4.33$ mfd. to two places.

As capacity reactance is negative, there is a voltage lag for 0.25 of a cycle, therefore the current to pilot lights of 0.3 amp., would be in their rated value when the set is switched on.

Thanking you for the prompt despatch of PRACTICAL WIRELESS and wishing you a speedy return to the weekly PRACTICAL WIRELESS.—T. MOORE (S.E.A.C.).

Mains Consumption

SIR,—A very useful estimate of the current consumption of a radio receiver or radiogram can be made without any expensive apparatus using the following method.

First make sure that all electrical apparatus in the house is switched off with the exception of the radio. (N.B.—Clocks can be ignored since their consumption is negligible.)

Next, with the aid of a watch, count the number of revolutions of the disc in the electric light meter for a period of 5 minutes. A shorter time would do, but the longer period gives greater accuracy. Most meters have either a line or spot marked on the disc to facilitate counting.

Once you have this figure the consumption may be arrived at in two ways. The first is only approximate, but usually sufficient for estimating the number of hours running which may be expected from a unit. It consists simply in switching off the radio and then switching on lights until the disc rotates at the same speed as when the set was on.

The combined wattage of the lamps required is equal to the drain imposed by the set: for instance, if a 60-

watt lamp together with a 15-watt lamp give roughly the same number of revolutions on the meter as the set, the figure of 75 watts may be taken as near enough. The drawback of this method is that the wattage marked on lamps is often an approximate one only, and also it is difficult, however one juggles the lamps, to get nearer than 5 watts. Usually this does not matter.

The second method will appeal to the mathematically-minded and is far more accurate.

Firstly, from the number of revolutions counted for the set in 5 minutes obtain the figure for one hour (i.e., multiply $\times 12$).

Next ascertain from the meter the number of revolutions per unit (K.W.H.). This will be marked on the case, and is usually somewhere between 1000-3000.

With these figures one can either work out actual watts consumption as

$$\frac{\text{Set revolutions}}{\text{Revs. per K.W.H.}} = \text{watts}$$

$$\text{or } \frac{\text{Set revolutions}}{\text{Revs. per K.W.H.}} = \text{hours per unit.}$$

As a guide it may be taken that an A.C. set will consume 45-85 watts with an extra 30-45 on gramophone according to the motor used. A.C./D.C. sets usually consume more since the voltage-dropping system for the heaters is less efficient than a transformer.

This latter method is equally applicable to irons, kettles, and other electrical equipment.—G. KEATING (R.A.F.).

Economy Superhet

SIR,—With reference to P. Stearn's Economy Communications Superhet in the July issue of PRACTICAL WIRELESS, I would like to point out one slight error in the circuit diagram as this may cause some constructors a lot of inconvenience.

The A.V.C. diode anode (V₃) is connected directly to the triode anode (V₃) which has about 180v. positive on it. Obviously a condenser should be inserted between the triode and diode anodes. I would suggest .0001 μ F. as a suitable value.

This is only a small point but it would have disastrous results as the diode (A.V.C.) would pass a large current and the grids of V₁ and 2 would become positive resulting in heavy grid current.—R. BADGER (Sussex).

Station ZPA3

SIR,—In the current September issue of PRACTICAL WIRELESS your correspondent G. Elliot gives a station on 11.855 mc/s as having the call ZP13. I think he is incorrect; this station opens at 22.00 G.M.T. under the call ZPA3, and is located in Asuncion. As Mr. Elliot says, it is used in conjunction with ZP3. Its frequency appears to be 11,860 kc/s. On Sundays it appears to open earlier.—C. S. S. LYON (Cambridge).

Condenser in Lieu of Line Cord

SIR,—In the "Practical Hints" of your May edition, Mr. Hedley refers to the use of a condenser in lieu of a line cord or dropping resistor, and says that it uses a negligible amount of power, there being no heat loss.

Now I am aware of the fact that the voltage and current are out of phase through the condenser, but even so there seems to me an unaccountable loss of energy somewhere. The power taken from the mains can be found by multiplying the mains voltage by the current taken. But if the power consumed by the set is worked out, this will naturally be less, and yet the "dropping" condenser uses no power. Where does this "loss" of energy go to?

I hope you or one of your readers can help me.—
DAVID HOMA (N.W.11).

Address Wanted

SIR,—Some time ago The British Short-wave League received an order for our Handbook from a Mr. R. M. Lewis, but we could not forward his copy owing to the fact that he omitted to send his address. Since we have a regular classified advertisement in PRACTICAL WIRELESS advertising the Handbook it is more than likely that Mr. Lewis is a reader of your journal.

Would it be possible for you to insert a small note to the effect that we would appreciate his address so that the Handbook can be forwarded to him?—NORMAN STEVENS (53, Madeley Rd., Ealing, London, W.5).

The Quest for Quality

SIR,—Other readers may be interested in what can be achieved in the realm of quality reproduction without spending much cash.

My domestic set, which dates originally from about 1932, was bought as a S.G. T.R.F. Battery Three constructor kit, with 8in. moving-coil speaker. I converted it to an equivalent mains operated version some years ago; but I see no reason why the improvements I have carried out should not be equally beneficial on batteries.

To begin with, I tried the usual "tone controls," i.e., "top cut" and "bass cut." These are all very well; but they do not touch the middle of the scale, which is usually the loudest. In any case, what is required is an increase of the "top" and "bass" frequencies which are lacking, and the first thing to do is to try to rectify the faults which are causing the attenuation of those frequencies.

My present set-up, which, although not perfect, is far above the average, is as follows:

Beginning on the H.F. side, I use the tighter aerial coupling tap (incidentally sacrificing some selectivity). Then I reduced the grid leak from 1 megohm to 50,000 ohms, losing slightly on volume; but gaining greatly in brilliance. The theory is, of course, that the smaller leak allows the negative grid charge to flow away more rapidly, and thus the grid can respond more readily to the rapid variations associated with high notes.

In this way, fidelity approaches that of anode bend rectification, whilst retaining most of the sensitivity of the grid leak method.

Turning to the L.F. side, parallel feeding of the L.F. transformer gives a noticeable increase in bass range.

I have removed the grid stopper from the output valve circuit. Should this tend towards instability, I recommend as low a value as possible to allow maximum passage of the top L.F.

My speaker is a roin. model, the response of which was enhanced considerably by cutting the cone and replacing the corrugations by linen. The locating device was originally a disc of paper with the usual concentric corrugations. I replaced this with chamois leather.

The greatest increase of bass range was achieved by mounting the speaker on a 3ft. x 2ft. 6in. baffle. Mounting the baffle in a cabinet tends to introduce resonance, whilst placing it near a wall reduces the bass, due to the echo from the wall being out of phase. I compromised by mounting the baffle on a box-like structure, 1ft. deep, and standing it in a recess slightly away from the wall. The speaker should be steadied by a strong bracket, as is done by the best manufacturers.

I have not tried a tweeter, as described in PRACTICAL WIRELESS; but the finishing touch of brilliance is achieved on my layout in an unorthodox way. My original 8in. speaker is connected up in parallel through a condenser, which can be changed to suit, and not mounted on any baffle, thus giving prominence to the top register.

I agree with your correspondents who say that the greatest room for improvement is in the speaker and its mounting; but the small modifications in the circuit are well worth while.

The final effect on my set is surprising and gratifying,

especially considering the simplicity of the set and the almost negligible cost of improvement.—C. FOREMAN (New Romney).

Switching

SIR,—I should like to comment on the remarks of Messrs. Norman, Shine and Carter re "switching." Mr. Carter states that *most* commercial manufacturers fit a fuse bulb; doubtless this practice has developed since the war, it certainly was *not* the practice of most manufacturers before. Mr. Shine then says that I.H. rectifiers are fitted to sets using I.H. tubes. This is a bold mis-statement. I.H. rectifiers are usually only fitted to A.C./D.C. transformerless receivers and sets having transformers with a single heater winding; seldom otherwise.

Mr. Norman goes to some length to prove a point, but how many commercial battery or mains sets fit two switches (one for L.T. and one for H.T.) or "thermal delay." I've yet to see one. I am now speaking of ordinary household receivers, not transmitters or special technical jobs.

Arising out of the above, may I offer the following logical remarks.

In battery sets supplied by H.T. from valve rectifiers. These usually employ fairly low H.T. voltages and the tube takes some time to reach correct operating temperature owing to the thick filament, and the current rises so gradually that it cannot damage a D.H. or battery valve. The current passed by a rectifier is proportional to the filament temperature.

Receivers fitted with mixed I.H. and D.H. or I.H. tubes only heat up so slowly that even if full H.T. is applied to the anodes, plate current only gradually rises from 0 to max., as the ability of a tube to pass current is controlled by the electron flow which in turn is governed by filament or cathode temperature.

On my return from the Forces I find that my own set, eight tubes + rectifier, has operated 10-12 hours daily for nearly seven years without a single valve replacement and is as good as ever. This set employs both D.H. and I.H. tubes, D.H. rectifier and only one switch. Everything goes on together. Whilst abroad, I have built and tested and repaired many sets during the last six years and have had occasion to observe plate current behaviour with meters in circuit in all positions in sets, and my observations bear out the above statements. Even mains sets fitted with selenium rectifiers have operated for years controlled only by one switch. Of the many makes, Minerva (French), Safar, Irradio (Italian), Telefunken, Phillips (Italian and German), all types of American and one Russian set, only one on/off switch has been fitted and the predominant fault has not been valve trouble, but electrolytic condenser breakdown.—Eric J. R. BELLAS (Kendal).

The U.H.F. Bands

SIR,—In recent letters to PRACTICAL WIRELESS, Messrs. Bower and Elliot have made mention of the U.H.F. bands, and I, too, would be pleased to see any reports of DX signals on 28 mc/s and upwards. I have been building up the Ultra Short Battery Two (blueprint No. WM402) exactly to specification, but up to the present, apart from an odd tweet from an unidentified W/T station, I have heard very little on the higher frequencies. The detector circuit oscillates perfectly up to about 60 mc/s, though in my part of the country even local signals seem to be few and far between.

To the Editor and staff of PRACTICAL WIRELESS I wish to express my sincere thanks for the way they have kept up publication of this excellent magazine throughout the difficult years of war. PRACTICAL WIRELESS has survived, where more flamboyant magazines of its sort have perished, because of its retention of subject text interesting and instructive to amateurs and professional together. Let PRACTICAL WIRELESS continue, to be a technical publication, and not, as some readers suggest, have it flooded with chit-chat regarding, for example, dope on B.B.C. performers. Like myself, the greater majority of readers support the magazine.

entirely from a technical side. I like the present size of the magazine, and hope you will not return to the large pre-war type of pages. The present size gives a much neater appearance when bound, and also fits into a normal bookcase shelf more easily.

In conclusion, may I take this opportunity to remind readers of the continued existence of the World Friendship Society of Radio Amateurs. With the ending of the recent hostilities the society is keen to increase its membership. Any interested readers can write direct to me or to our secretary G6AQ, and we shall be only too pleased to supply details, rules and objects of the society, etc.—L. D. COLLEY (E. Yorks).

Our Three-valver

SIR,—I have just completed your 3-valve battery receiver, shown in September issue. I made one or two modifications.

I used a metal chassis and I did not use the aerial winding on the aerial coil, but connected it by a small condenser to the top of the grid winding. I used a .0005 mfd. two-gang condenser with trimmers for tuning, and a .0005 mfd. differential reaction control; this necessitated a slight alteration on the actual connections but gave much smoother reaction.—S. A. MOORE (Stowmarket).

Phase in Amplifiers

SIR,—My letter in your October issue seemed to me, on perusal, while correct in its statements, not very clear without curves to which I referred.

When the grid of a resistance loaded valve is on its positive half cycle, the electrons comprising the alternating component of the anode current are leaving the anode (increasing anode current). This direction of flow corresponds with the anode, as terminal of an imaginary A.C. generator μV_g , going negative, as in fact, it does. When the grid is negative, the alternating electronic flow is relatively towards the anode, decreasing the total I_a , and this is the direction in which electrons would flow on the positive half cycle of a generator. In short, the alternating I_a is in phase with the generator of which the anode is the live terminal; the voltage of this terminal is, as is well known, in antiphase to the grid voltage. Therefore, the alternating I_a is antiphase to the grid voltage.—A. O. GRIFFITHS (Wrexham).

Radio on the Road

SIR,—I wish to point out two slips on page 483 of November issue, 1945, in L. Jackson's article. Centre tap of the primary of the transformer (Fig. 2) should be connected to L.T.+, not L.T.—, otherwise there will be no current flowing.

A minor detail—also Fig. 2—the contact for the vibrator should be on the other side of the reed or it will not "buzz."

I am a very keen midget-set builder and am now working on an entirely self contained set $4\frac{1}{2}$ in. \times $5\frac{1}{2}$ in. \times $4\frac{1}{2}$ in.—R. COLCLOUGH (Loughton).

"P.W." on Parade

SIR,—I would just like to send a word of congratulation on the way that PRACTICAL WIRELESS has always managed to be "on parade" during the difficult days just gone by.

It may be of interest to you to know that copies of our old faithful have been well in evidence in Ceylon, Assam and also in India, although jealously guarded by their owners!

In Calcutta a short while ago I spotted a copy of PRACTICAL WIRELESS in its original size and on closer inspection I found it to be the Radiolympia number for 1935! I sent it home as a real souvenir of the good old days. I have only one little grumble and that is that the local agent near home would not take further orders for PRACTICAL WIRELESS, and so I have had to rely upon the wife scouring the countryside for occasional copies to send me out East. Now that the war is finished maybe

this unhappy state of affairs will disappear, and perhaps also we can look forward to seeing our old friend lying on the mat each week very soon?

I don't lay claim to being the inevitable "reader from No. 1," you know, but of all the mags. that I have browsed through since 1923 I guess yours tops the lot for the average class of enthusiast. Now for a request! Has anyone still got a copy of WIRELESS MAGAZINE for January, 1927, that has escaped the ravages of salvage?—E. BOXSON (London, E.12).

Programme Pointers

(Continued from page 35)

Controversial Subject

This opens a very controversial subject: one which I will not attempt to take sides on here. Many facets of the question would have to be studied very carefully before a satisfactory decision could be reached, such as the probable reaction upon the attendance at the actual concerts and the consequent effect on their commercial success. Would the public stay away in any numbers if they were kept waiting for their beloved Beethoven and Tchaikowsky for an hour while they had to stand and listen to works in which they were not particularly interested.

A questionnaire or "Gallup Poll" at the actual concerts might be the most satisfactory way of answering this and other points.

The fact remains that the boom in the demand for good music is now at its zenith, and in no circumstances should it be allowed to decline. Such an event would be a calamity having the widest repercussions. No doubt the large floating population of foreign soldiers and of displaced persons have helped to increase audiences to their present enormous size. These people are gradually leaving us and many will have gone by next summer. But I am confident that the seed sown by that finest of "musical gardeners" (if I may be permitted the coinage of the phrase), Sir Henry Wood, will ever flourish, provided those in whose keeping the concert and broadcasting world lies, i.e., the impresario and concert manager, play their parts.

Native Music

The encouragement and stimulation that native music has had in recent years, both creative and executive, must not be allowed to wane for one instant. We all want to welcome the foreign virtuoso to our shores again, and artists like Casals, etc., are quite unique.

But after the last war there was a tremendous reaction, or swing of the pendulum, back to the continent, and the old shibboleths denying the Englishman's claim to make good music reigned for many years. This should not be allowed to happen again. Our many native artists of the front rank, though some have gained their places without having to come up against the full force of pre-war competition, should continue to be given every support and encouragement. With a continuation of the present rate of attendance at concerts, there should be room for all.

The "big name" in music has, in the past, been allowed too much space on the hoardings and in the advertisement columns. In days gone by, while we have bought our ticket a month in advance for some famous continental star or other (whose excellence no one would wish to dispute), and waited for his arrival and hung upon every note he played with bated breath, if not with the highest critical faculties, much other excellent music making was allowed, more or less, to perish by the wayside, in the overpowering rays of the great one's glory and omnipotence. This is thoroughly bad for music in all its manifestations. And, whilst there are as yet no signs of its being repeated, it can do no harm to sound a warning in the hope that those in whose hands the problem lies will do all they can to avoid the mistakes of the past.

AMPLIFIERS

The most popular general purpose amplifier.

MODEL A20

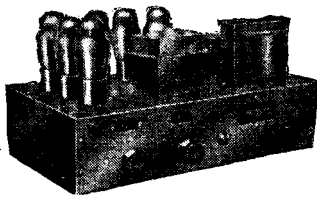

Six valves, with 6V6's in push pull, triode cathode coupled phase changing, with pre-amp. stage. Two inputs with mixer, output transformer for two fifteen ohm speakers. Output 26 watts 6 per cent.

KIT OF PARTS ready to assemble, complete with valves and carrying case. **£14**
Also available wired and tested. **£15.10.0.**
For full specification write for List 485/1.

TRANSFORMERS. Our range includes specially designed amplifier types, all described in List 7.55.

P.A. SPEAKERS. For use with amplifiers 15 ohm speech coils, 8in., 45/-, 10in. 47.6. Exponential metal horns for 8in. units, 27.6. Microphones, stands, cables, etc. Send us your enquiries.

RADIO INSTRUMENT CO.,
294, Broadway, Bexleyheath, Kent.

VALUE/MATT has it

LINE CORD. 2-way, 2/6 per yd.; 3-way, 3/- per yd. (Approx. 60 ohms per foot).
SPEAKERS. "Celestion," P.M., 2 1/2in. less trans. 27/-; 8in. P.M., with trans. 27.6; 6in. P.M. (multi-ratio trans.), 28.6.
Two-gang Condensers. .0005, 12/6. Midget Coils, H.F. and Aerial; 4/6 per pair.
Valve Holders (all types).
Volume Controls, less switch, 2/9, with switch, 3/9.
Mains Transformers, 4 v. and 6 v., 27.6.
Rothermel (Crystal) Pick-Ups, metal, 58. £3.13.6. Senior de Luxe, £3.18.9.
Condensers.—All types in stock, 2's, 8's, 16's, 500 v. working; .1, .01, .25, .05, 25 x 25, etc.
Resistances, 1/2 and 1 watt. All values, 1 watt, 9/- doz.; 1/2 watt, 6/6 doz.
ACCUMULATORS.—Glass, 2 v., 45 amp., 14/6.
All types American and B.J.A. valves in stock.
Let us quote you for ALL your requirements. Cash with order, plus postage.

MATT RADIO SERVICE

(Kingston 4881)

152, Richmond Road, Kingston-on-Thames, Surrey.

NEW DUAL TESTSCOPE



Ideal for High and Low Voltage Testing; 1,30, 100,650 A.C. and D.C.

Send for interesting leaflet (A24) on Electrical and Radio Testing, from all Dealers or direct.

RUNBAKEN MANCHESTER

CLASSIFIED ADVERTISEMENTS

LITERATURE, MAPS, etc.

BRITISH SHORT-WAVE LEAGUE.—S.A.E. for membership details and sample monthly "Review." The S.W. Listener's Handbook, 2/9 post free. Write NOW to H.Q., 53, Madeley Rd., Ealing, London, W.5.
RADIO SOCIETY OF GREAT BRITAIN invites all keen experimenters to apply for membership. Current issue "R.S.G.B. Bulletin" and details 1/- below.

AMATEUR RADIO HANDBOOK (300 pages) paper cover, 4/-; cloth, 6/6. Radio Handbook Supplement (140 pages), paper cover, 2/9; cloth, 5/-.—R.S.G.B., 28-30, Little Russell Street, London, W.C.1.

WEBB'S Radio Map of the World. Locates any station heard. Size 40in. by 30in., 4/6, post 6d. On linen, 10/6, post 6d.—Webb's Radio, 14, Soho Street, London, W.1. GERRARD 2089.

MORSE & S.W. EQUIPMENT

MORSE Practice equipment for class-room or individual tuition. Keys, audio oscillators for both battery or main operation.—Webb's Radio, 14, Soho Street, London, W.1. Phone: GERRARD 2089.

"H.A.C." Short-wave Receivers. Famous for over ten years. Improved one-valve model now available. Complete kit of components, accessories, with full instructions, now 19/3; postage 9d. Easily assembled in one hour. S.A.E. for free catalogue.—A. Bacchus, 109, Hartington Road, London, S.W.8.

RECEIVERS & COMPONENTS

REWINDS and Radio Spares. Armatures, Field Transformers, Pick-ups, Fractional H.P. Motors, Speakers. New Cones and Speech Coils fitted. All work guaranteed and promptly executed. C.O.D. Postal Service. Send S.A.E. for list Valves and Radio Bargains.—A.D.S. Co., 261-5, Lichfield Road, Aston, Birmingham, 6.

PRICE LIST "1d."—Unequaled range. Example values: Yaxley 4 Bank 6 way switches 5/6; 1 Bank 11 way, 2/6.—Taylors, Macaulay Street, Huddersfield.

CLEARANCE SALE.—Universal Avometer, Avo No. 7 Universal Meter, Electrolytic Condensers, Valves, Speakers, etc. List. S.A.E.—Young, 134, Old Shoreham Road, Southwick, Sussex.

SALE.—"Practical Wireless" issues, Feb. 1943 to Oct. 1945, inclusive. As new. Excluding June 1945. Offers to Neal, 95, Albion Street, Otley, Yorks.

BASEBOARD V.H.s, 4 and 5-pin, 9d. and 1/- H.F. Chokes, 1/- and 2/- Coils from 2.6. 1, 2, 3-gang Condensers from 5/- to 15/-. L.F. Transformers and Chokes from 5/-. F. J. Camm's Wireless Encyclopaedia, 7.6. 5-pin Avodaptor, 10/-. Blue Spot moving iron Speaker, 21. Various Service Sheets, 1/- each. All used, but perfect. S.A.E. for details.—G. P. McLean, Rockview, Easthaven, Carnoustie, Angus.

THE SIMPLEX FOUR. Complete constructional data, comprising full scale layout and wiring diagrams, instructions, etc., for the construction of this 4-valve, A.C./D.C. medium wave, T.R.F. receiver (total cost of construction, minus cabinet, £9), a proven success, per copy, 4/6.

MIDGET cabinet, handsome design, in Red or Brown, 25/-.

MIDGET coils, aerial and H.F. medium wave, T.R.F. high-gain coils, 7/6 pair. For the first time, a midget pair of iron-cored M. and L. wave coils, with adjustable cores, T.R.F. complete with circuit, 12/6 pair. For the superhet, a pair of aerial and oscillator coils, all-wave, S.M.L. for an I.F. of 465 kc/s with circuit, 15/-. Midget I.F. transformers, 465 kc/s, matched, 15/- pair; standard size, ditto transformers, 12/6 pair.

MIDGET 2-gang variable 0.0005 mfd. condensers, fitted trimmers, 13/6.

MIDGET all-wave dial, S.M.L. in colours, with station names, etc., latest grouping of stations, 2/6.

SWITCHES, Yaxley 3-way, 4-pole, 4/6; ditto switch, double bank, 6/6.

MIDGET CHOKES, 6/-; speaker transformers, midget, 6/6.

INTERFERENCE suppressors, A.C. or D.C., 2/6. Join our mailing list at 3/- per year. Comprehensive lists issued monthly. 2d. stamp with inquiries, please. Postage on all orders.

O. GREENLICK, 34, Bancroft Road, Cambridge Heath Road, London, E.1. Stepney Green 1334.

PRATTS RADIO

1070, Harrow Road, College Park, Harlesden, N.W.10 (Nr. Scrubs Lane)

SPEAKERS, P.M. less transfr., 2 1/2in. 25/-; 3in. 29/6, 5in. 21/-, 6in. 21/6, 8in. 32/-, with Pen transfr., 8in. 25/-, 8in. 37/-, 10in. 37.6. Mains En, 2,000 ohm field, 6in. 27.6, 8in. 30/- (inc. transfr.). Speaker transformers Pentode 5/9, midget 5/9. Heavy duty 7/6, Multi-ratio 7/6, Power/Pentode 6/- each.

LINECORD, .3 amp, 60 ohms, per ft. 2-way 8d. per ft., 3-way 9d. per ft.

VOLUME CONTROLS (most values), less switch 3/6 each, with switch 5/- each.

SMOOTHING CHOKES, Midget 360 ohms 5/9 each, 60 ma, 500 ohm 6/6 each, 100 ma, 32 Hy, 1,000 ohm 15/3 each.

VARIABLE CONDENSERS, Small, 0005 mfd. 2 Gang with trimmers, 11/- each.

MAINS TRANSFORMERS, Input 200/30/50v., output 350-0-350v. 4v. 21 amp., 4v. 5 amp. or 5v. 2 amp. 6.3v. 21 amp., 25/- each.

ELECTROLYTIC CONDENSERS (all Delco mfg.), 8 x 8 mfd. 6/3 each, 16 x 8 mfd. 6.9 each, 8 mfd. 4/3 each, 25 mfd. 25v. 2/- each, 50 mfd. 12v. 2/3 each. Paper Condensers, most values in stock.

COILS, M.W. H.F. and Detector. Very Selective, 5/6 pair. Superhet Coils, L.M., S.Wave, Aerial and Oscillator. Complete with Circuit diagram, 465 kc/s, 13/- per set.

I.F. TRANSFORMERS 465 kc/s air or Iron Cored, 15/- per pair.

INTERVAL TRANSFORMERS, Ratio 3:1, 7/- each. Driver Class B 7/- each.

VOLTAGE DROPPERS, .3 amp, 800 ohm 5/- each, 2 amp, 1,000 ohm 4/9 each.

BRUSH CRYSTAL MICROPHONES 6/3 each.

MISCELLANEOUS GOODS, Valve Holders 7d. each, Control or Pointer Knobs 7d. each, M.W. Dials 1/6 each, Toggle Switches 2/3 each, Push Back Wire, 12 yds. 1/9.

VALVES. We have a Large Selection. Please submit your requirements. Prompt Delivery. S.A.E. for list or Enquiries. Orders over 10/- post free. S.W.O. or C.O.D. Buses 662, 664, 18B pass Door.

NEW GOODS ONLY.

LET US RAISE A STANDARD TO WHICH THE WISE AND HONEST CAN REPAIR

—George Washington

The following are a few extracts from our Mail Order List which comes to you for 1d. stamp, and states terms upon which every item is fully guaranteed.

Amplifiers.—30 watt, 3 stage. Output 4 6V6's in Parallel Push Pull. Complete in Metal Cabinet. Superb job, £28 10s.

Loudspeakers.—From 2in. to 15in. Examples: 8in. P.M. (less Trans.), 21/-; 10in. P.M. (with Trans.), 35/-.

Volume Controls.—All values. Excellent quality. Less Switch, 3/- With Switch, 4/3.

Chokes.—60-80 ma, 360 ohm, 4/8; 150 ma, 360 ohm, 7/6. Heavy Duty, 360,640,1,000 ohm., 11/6.

Output Trans.—3 ratio 60 ma., 7/6. Midget 42: 1 CT., 4/4. 6L6 Push Pull, Heavy Duty, Sec. 7.5 and 15 impedance, 22/-.

Resistors.—Highest Grade Carbon, 1/2 watt, 5d., 1 watt, 7d., 2 watt, 9d. (Discount for dozen lots.)

Capacitors.—Electrolytic (limited supplies), 8 mfd. 450v., 4/-; 8 x 8 mfd., 450v., 5/4; 16 x 8 mfd. 450v., 6/3; 25mfd. 25v., 1/9; Tubular or Mica, all sizes, from 5d. each.

Tubeholders.—Paxaline Mazda Octal, 5d., Int. Octal, 7d. Moulded Int. Octal, 8d.

Tubes.—All makes and types at List Prices.

Coils.—I.F. 465 kc/s. Brass Cans, L.M. and S.W., L. and M.W., S.W., Osc., T.R.F., Midget, etc., with circuits. See List.

Switches, Dials, Knobs, Wire, Syste-flex, etc.

R. F. ARMSTRONG

(ELECTRONICS) LTD.,

Dept. 474, 69, EVERSLEY ROAD,

SKETTY, SWANSEA, Glam.

Telephone: SKETTY 57419.

Telegrams: ELECTRONIC, SWANSEA.

SPARKS' DATA SHEETS

Full constructional details, circuit, and full-size prints of assembly and wiring plans of Tested and Guaranteed Designs. **LATEST RELEASES.**—One-valve All-dry Midget Portable, med. and long waves, 9 v. H.T., 'phone sigs., 2/6; Midget All-dry Portable, three valves, med-wave, L.S. sigs., 2/6; Midget All-dry Battery Two-valver, powerful 'phone sigs., 9 v. H.T., size 5 1/2 x 5 1/2 x 3 1/2, med-wave, 2/6; Radio Unit H.F. Plus Infinite Impedance Detector, for use with mains-operated quality amplifier, med. wave, 2/6; A.C. Radiogram, for quality radio and P.U. reproduction, P.P. output, 8 watts, med-wave, 3/6; A.C. 8-watt Amplifier, P.P. output, tone and vol. controls, ideal for quality P.U. reproduction, 2/6; Three-Valve Amplifier (Battery) P.P. output, 2/6.

OTHER DATA SHEETS.—Electric Guitar Units, 5/-; Electronic One-String Fiddle, 3/6; Trans-current Mike, 2/6; A.C. Charger, 2/6; D.C. Charger, 2/-; Shocking Coil, 2/6.

AMPLIFIERS.—6-8 watt A.C./D.C. Amplifier, portable, neg. feedback, P.P. output, 3/6; 31-watt A.C. Amplifier, 2/6; Two-Valve Amplifier (Batt.), 2/6. **SETS.**—With full coil details.—A.C. Two-Valver, 2/6; Three-Valve "Straight" Set (Batt.), 2/-; Crystal Set, 1/6 (All med-wave only). S.W. Super Two-Valver (Batt.), Eddystone or Premier Coils, 2/6. Please include stamp with order. Inquiries or for detailed list, L. ORMOND SPARKS (P), The Constructor's Consultant, 9, Phoebeth Road, Brockley, S.E.4.

NEW Stock! Electrolytics, 8 mfd., 200 v., 2/3. 8 mfd., 450 v., 4/-. 4 mfd., 450 v., 3/-. 8-8 mfd., 450 v., 5/6. 8-16 mfd., 450 v., 6/3. Fixing Clips, 3/- doz. extra. Post orders only.—A. Hucklebsbee, "Hazeljohn," Crofton Lane, Orpington, Kent.

NEW Radio Components Cheap. Volume controls, 2/6; with switch, 5/-. Output Trans., 5/6. 60 m.a. Chokes, 6/-. Mains Trans., 4 and 6 v., 22/6. Valveholders, 6d. Resistors, 1/2 w., 6d.; 1 w., 9d.; 3 w., wire, 1/6. Line cord, 3-way, 2/- yd. 2-gang, small, 3005 trimmers, 10/6. 2/6 stamp for List.—Carter, 67, Bell Lane, Marston Green.

MALORY 6-volt, 4-pin, UX Vibrators. New and Guaranteed, 10/- each.—H. English, The Maltings, Rayleigh Road, Hutton, Essex.

WANTED, "Practical Wireless," copy of March, April and June issue, 1945.—A. L., 8, Murrell Road, Clapham Road, S.W.8.

ELECTROLYTIC CONDENSERS

1 mfd. 450 volt, 2/-; 2 mfd. 150 volt, 2/3; 2 mfd. 350 volt, 2/3; 4 mfd. 450 volt, 3/-; 8 mfd. 200 volt, 2/3; 8 mfd. 450 volt, 4/-; 16 mfd. 450 volt, 4/6; 8 x 8 mfd. 450 volt, 5/6; 8 x 16 mfd. 450 volt, 6/3; 25 mfd. 25 volt, 1/9; 25 mfd. 50 volt, 2/6; 50 mfd. 12 volt, 1/9; 50 mfd., 50 volt, 2/9.

MAINS VOLTAGE DROPPERS. .3 amp.

800 ohms, with feet, 5/9. **LINE CORD** .3 amp., 60 ohms per ft., 2-way, 1/9; 3-way, 2/9 per yard.

VALVE HOLDERS. Celestion amphenol octals, 8/- per doz. Mazda Octals, 4, 7, 9-pin B.V.A., 5, 6, 7, U.S.A., 6/- per doz.

SPEAKERS. All types stocked at competitive prices. Please send requirements. We also stock 5,000 Valves of all types. Inquiries invited. S.A.E.

TERMS: C.W.O. Please allow 6d. for Postage.

SCOTT'S, 14, Gardner Street, Brighton.

REWINDS.—Repairs to moving-coil speakers. Cones, Coils fitted. Fields wound or altered. Mains Transformers, Eliminators and Clock Coils rewound. Competitive prices. Speaker-Transformers and Pick-ups repaired, 4/6 each Post Free. Guaranteed satisfaction. Prompt Service. —J.S. Repair Service, 40, Trinity Road, Upper Tooting, London, S.W.17.

SOUTHERN RADIOS' WIRELESS

BARGAINS!

LATEST RADIO PUBLICATIONS: "Radio Valve Manual," Equivalent and Alternative American and British Types with all data, 3/6. "Radio Circuits," Fully Illustrated Receivers, Power Packs, etc., 2/-. "Amplifiers," Fully descriptive Circuits, 2/-. "Radio Coil and Transformer Manual," 2/-. "Short-wave Handbook," 2/-. "Manual of Direct Disc Home Recording," 2/-. "Test Gear Construction Manual," 1/6. "Radio Pocket Book," Formulas, Tables, Colour Code, etc., 1/-. "10 Hows for Radio Constructor," 1/-. Just published, "Radio Reference Handbook," Comprehensive and up to date, covering all branches of Radio, 10/6.

PAPER CONDENSERS. Post Office type, upright, 2 mfd., high working (used but guaranteed perfect), 2/6 each. Brand new 2 mfd. Mainsbridge, 3/6; 1 mfd., 3/-; 1+1+1, 2/6. T.C.C. Electrolytic Reversible, 4-4 mfd., 70 volts, 3/6. **MULTICON MICA CONDENSERS,** 23 capacities in one, 4/-. **ACE "P.O." Microphones,** complete with transformer, usable with any receiver, 7/6. Permanent Crystal Detectors, 2/6. Crystals, 6/- with cat's whisker, 1/-. Insulated Push-back Wire, 25 yds., 5/-. Insulated Slewing, assorted sizes and colours, 3/6 per dozen yard lengths. Single Screened Wire, 10/- per dozen yards. Twin Screened Wire, 10/- per dozen yards.

POWER RHEOSTATS. **CUTLER HARMER,** 30 ohms and 10 ohms, 4/6 each. **PRESS BUTTON SWITCHES,** 3-way, 4/-; 8-way, 6/- (all complete with knobs). Escutcheons for 8-way switches, 1/6. Yalex Type Rotary Switches, 2-way, single bank, 6/6. **KNOBBS:** Instrument Type Pointer, black or brown, 1/- each. All types of Round Knobs, black or brown, 1/- each. All tin holes. Postage Stamp Size Trimmer, Paxoline and Ceramic, 30 pf., 1/-. International Octal Base Valve Holders, Moulded or Paxoline, 1/- each, 10/6 dozen. Mazda Type Octal, 1/- each. Variable Condensers twin gang 0.00015, midget size, 12/6. 0.0005 twin gang, 12/6. **RESISTANCES** brand new wire, 12/6. 1 watt, 100, 1 watt, assorted values, 30/- per 100. 1/2 watt only, assorted values, 20/- 100. 1/4 watt only, assorted values, 22/6 100. Assorted Screws, 5/- per lb. Assorted Soldering Tags, including spade ends, 6/- per gross. Hundreds more bargain lines.

SOUTHERN RADIO SUPPLY CO., 46, Lisle Street, London, W.C. Gerrard 6653.

CHARLES BRITAIN RADIO invite you to their new premises. This month's offers include—**ELECTROLYTIC** Condensers 16 mfd. in All cans, 450 v. wkg., 6/6 each. 8 mfd. tubular 450 v., 4/- ea. Block, 4/3 ea. 25 mfd. 25 v., 2/6 ea. 12 mfd. 50 v., 2/- ea. 50 mfd. 12 v., 2/- ea. **COILS.** All-wave aerial and oscillator coils, 465 k/c with circuit, 14/- per set. Midget A. and H.F. medium-wave Litz wound, 5/- pair. P. type coils A. and H.F., 2/- ea. I.F. Transformers (465 k/c), Litz wound in All cans with trims., 12/- pair. Tuning Condensers, 2-gang midget, 12/6 ea. 3-gang, 10/- ea. Volume Controls with switch, 1, 1 and 2 meg. Morganite and Centralab, 5/6 ea. All values less switch. Dubilier 3/- ea. Knobs: best quality, with brass inserts, 1 1/4 in. dia., 8/- doz. 1 1/2 in., 7/- doz.; black pointer knobs, 8/- doz. Solid brass spindle extenders, 1 bore, 6/- doz. Dials: Marconi, glass vertical type only, 2/- ea. Paper dials for Midgets, L. and M.W., 8/- doz. **SPEAKERS.** 8 in. R.A.P.M., with trans., 23/6 ea.; less trans., 21/- 6 in., with trans., 27/6. Mains energised with (Continued top of next column)

trans., 2,000 field, 30/-. Wavechange switches, 4-pole 2-way or 4-pole 3-way or 3-pole 4-way, 3/6 ea., all single bank. 2-pole 2-way, 2/6. **MAINS TRANSFORMERS.** Type E1: 350-0-350 100 m.a., 4 v. or 6 v., new, 21. Type E3: 450-0-450 250 m.a., 4 L.T. windings, 4 v. or 6 v., 32/6. Type E4: 500-0-500 250 m.a., 6 L.T. windings, 4 v. or 6 v., 35/-. All the above are for standard input and have screened primaries.

VALVEHOLDERS. All types in Paxolin, 6/- doz. Amphenol octal and Mazda octal, 7/6 doz. Push-back wire, stranded, 2/- doz. yds. Slewing 1 m.m., various colours, 2/- doz. yds. Screened grid caps, standard or octal, 9d. ea. Clips, 1/- doz. L.F. Chokes, 60 m.a., 6/6 ea. Phillips Condensers, for prices see previous adverts. T.C.C. metal cased, 0-1 350 v. wkg., 6/6 doz. We have a large stock of slightly used valves at 7/6 ea. Send for list or call.

SPECIAL OFFERS. Steel chassis, drilled for 5 valves, with hole for trans., 2/- ea. Mains trans., to fit above, 4 v. or 6 v., 27/6. Voltage adjustment strips for trans., with tap, 1/- ea. Socket strips engraved A.E. or P.U., 4/6 doz. Resistances stripped from Ekco, 2/6 doz. Tubular conds., ditto, incl. bias types, 4/6 doz. Micacs, 3/- doz. Band-Pass Aerial Coils ex Ekco, 2/6 doz. 2/6 ea. I.F. trans., 110 k/c, in cans with trims., 3/6 pair. Three-gang condensers tracked for 110 k/c, 3/6 ea. Small moving coil Mikes (damaged), 1/6 ea. Send for new list "P." Terms: Cash or C.O.D. over 21. Note our New address.—Charles Britain Radio, Radio House, 2, Wilson Street, London, E.C.2. Phone: BIS. 5985, Ext. 7.

FOR SALE.—"Practical Wireless," Jan., 1942, to June, 1945, except April, May and Sept., 1942, and April, 1944. First reasonable offer for lot.—Howie, 56, Coldstream Drive, Burnside, Rutherglen, Nr. Glasgow.

SITUATIONS VACANT

LAD, keen on Radio, to help in shop. Apply between 10 and 5.—Charles Britain Radio, 2, Wilson Street, London, E.C.2.

"ENGINEERING OPPORTUNITIES"—Free 112-page guide to training for A.M.I.Mech.E., A.M.I.E.E., and all branches of Engineering and Building, with diagram of advice for expert or novice. Write for free copy and make your peacetime future secure.—B.I.E.T. (Dept. 242B), 17, Stratford Place, London, W.1.

TUITION

LEARN MORSE CODE the Candier Way. See advertisement on this page.

WIRELESS.—Students of both sexes prepared for appointments in all branches. Peacetime Radar developments will offer tremendous opportunities. Low inclusive fees. Boarders accepted. 12d. stamp for Prospectus.—Wireless College, Colwyn Bay.

THE Tuitionary Board of the Institute of Practical Radio Engineers have available Home Study Courses covering elementary, theoretical, mathematical, practical and laboratory tuition in radio and television engineering; the text is suitable coaching matter for I.P.R.E. Service entry and progressive exams.; tuition fees at pre-war rates—are moderate. The Syllabus of Instructional Text may be obtained, post free, from the Secretary, 20, Fairfield Road, Crouch End, N.8.

LONDON CENTRAL RADIO STORES

SPECIAL PURCHASE R.A.F. STORES

R.A.F. R.1155 Receiver Chassis. Size 16 x 8 1/2 in. Front Panel 8 1/2 in. high with many components. £5 Less Valves, ...

R.A.F. Receiver Chassis with mounted components, less Valves. Size 10 1/2 x 6 x 3 in. ... 17/6

Large stock of Valves, various types, Condensers, etc.

Will pay you to call and see stocks as they are too numerous to advertise.

23, LISLE STREET, LONDON, W.C.2.

*** FOYLES**

FOR BOOKS ON WIRELESS AND EVERY OTHER SUBJECT

Books Bought

119-125, CHARING CROSS ROAD LONDON, W.C.2.

Open 9 a.m.—6 p.m., including Saturday Tel: Gerrard 5660 (16 lines)

A FREE BOOK

for all interested in

MORSE CODE TRAINING.

There are Candier Morse Code Courses for Beginners and Operators.

Send for this Free "BOOK OF FACTS" It gives full details concerning all Courses.



THE CANDLER SYSTEM CO. (5.L.O.) 121, Kingway, London, W.C.2. Candier System Co., Denver, Colorado, U.S.A.

Practical Wireless BLUEPRINT SERVICE

Practical Wireless	No. of Blueprint.	F. J. Camm's A.C. Superhet 4		
CRYSTAL SETS				
Blueprints, 6d. each		F. J. Camm's Universal 4 Superhet 4		PW59*
1927 Crystal Receiver	PW71*	"Qualitone" Universal Four		PW90
The "Junior" Crystal Set	PW94*			PW73*
STRAIGHT SETS. Battery Operated.				
One-valve: Blueprints, 1s. each.		Simple S.W. One-valver		PW31A*
All-Wave Unipen (Pentode)		Two-valve: Blueprints, 1s. each.		PW85*
Beginners' One-valver		Midget Short-wave Two (D, Pen)		PW93*
The "Pyramid" One-valver (HF Pen)		The "Fleet" Short-wave Two (D (HF Pen), Pen)		PW76*
Two-valve: Blueprints, 1s. each.		Three-valve: Blueprints, 1s. each.		
The Signet Two (D & LF)		Experimenter's Short-wave Three (SG, D, Pow)		PW30A*
Three-valve: Blueprints, 1s. each.		The Perfect 3 (D, 2 LF (RC and Trans))		PW10
Selectone Battery Three (D, 2 LF (Trans))		The Broad-spread S.W. Three (HF Pen, D, Pen) (PORTABLE)		PW37*
Summit Three (HF Pen, D, Pen)				PW63*
All Pentode Three (HF Pen, D (Pen), Pen)		PORTABLES		
Hall-Mark (Cadet (D, LF, Pen (RC))		Three-valve: Blueprints, 1s. each.		PW68*
F. J. Camm's Silver Souvenir (HF Pen, D (Pen), Pen) (All-Wave Three)		F. J. Camm's ELF Three-valve Portable (HF Pen, D, Pen)		PW49*
Cameo Midget Three (D, 2 LF (Trans))		Paro Flyweight Midget Portable (SG, D, Pen)		PW51*
1936 Sonotone Three-Four (HF Pen, HF Pen, Westcot, Pen)		Four-valve: Blueprints, 1s. each.		PW53*
Battery All-Wave Three (D, 2 LF (RC))		"Imp" Portable 4 (D, LF, LF (Pen))		PW56*
The Monitor (HF Pen, D, Pen)		MISCELLANEOUS		
The Tutor Three (HF Pen, D, Pen)		Blueprint, 1s.		PW35A*
The Centaur Three (SG, D, P)		S.W. Converter-Adapter (1 valve)		
The "Colt" All-Wave Three (D, 2 LF (RC & Trans))		AMATEUR WIRELESS AND WIRELESS MAGAZINE CRYSTAL SETS		
The "Rapid" straight 3 (D, 2 LF (RC & Trans))		Blueprints, 6d. each.		
F. J. Camm's Oracle All-Wave Three (HF, Det. Pen)		Four-station Crystal Set		AW427*
1938 "Priband" All-Wave Three (HF, Pen, D, Pen)		Lucerne Tuning Coil for A.W.427, 6d.		PW78*
F. J. Camm's "Sprite" Three (HF Pen, D, Tel)		1934 Crystal Set		AW444
The "Hurricane" All-Wave Three (SG, D, Pen, Pen)		150-mile Crystal Set		AW450*
F. J. Camm's "Push-Button" Three (HF Pen, D (Pen), Tel)		STRAIGHT SETS. Battery Operated.		
Four-valve: Blueprints, 1s. each.		One-valve: Blueprints, 1s.		PW87*
Beta Universal Four (SG, D, LF, Cl. B)		B.R.C. Special One-valver		PW89*
Nucleon Class B Four (SG, D, SG, LF, Cl. B)		Two-valve: Blueprints, 1s. each.		PW92*
Fury Four Super (SG, SG, D, Pen)		Melody Ranger Two (D, Trans)		PW17*
Battery Hall-Mark 4 (HF, Pen, D, Push-Pull)		Full-volume Two (SG det. Pen)		PW34B*
"Acme" All-Wave 4 (HF Pen, D (Pen), LF, Cl. B)		A modern Two-valver		PW34C*
The "Admiral" Four (HF Pen, HF Pen, D, Pen (RC))		Three-valve: Blueprints, 1s. each.		PW46*
F. J. Camm's "Limit" All-Wave Four (HF Pen, D, LF, P)		25 5s. S.G. 3 (SG, D, Trans)		PW83*
Mains Operated				
Two-valve: Blueprints, 1s. each.		Lucerne Ranger (SG, D, Trans)		PW90*
A.C. Radio D (Pen, Pen)		25 5s. Three De Luxe Version (SG, D, Trans)		PW67*
Selectone A.C. Radiogram Two (D, Pow)		Transportable Three (SG, D, Pen)		
Three-valve: Blueprints, 1s. each.		Economy Pentode Three (SG, D, Pen)		
Double-Diode Triode Three (HF Pen, D, T, Pen)		"W.M." (1934 Standard Three (SG, D, Pen))		
D.C. Ace (SG, D, Pen)		1936 48 6s. Battery Three (SG, D, Pen)		
A.C. Three (SG, D, Pen)		PTF Three (Pen, D, Pen)		
A.C. Leader (HF Pen, D, Pow)		Certainly Three (SG, D, Pen)		
D.C. Premier (HF Pen, D, Pen)		Mitube Three (SG, D, Trans)		
Unique (HF Pen, D, Pen)		All-wave Winning Three (SG, D, Pen)		
F. J. Camm's A.C. All-Wave Silver Souvenir Three (HF Pen, D, Pen)		Four-valve: Blueprints, 1s. 6d. each.		
"All-Wave" A.C. Three (D, 2 LF (RC))		65s. Four (SG, D, RC, Trans)		
A.C. 1936 Sonotone (HF Pen, HF Pen, Westcot, Pen)		Self-contained Four (SG, D, LF, Cl. B)		
Mains Record All-Wave 3 (HF Pen, D, Pen)		Lucerne Straight Four (SG, D, LF, Trans)		
Four-valve: Blueprints, 1s. each.		25 5s. Battery Four (HF, D, 2LF)		
A.C. Fury Four (SG, SG, D, Pen)		The H.K. Four (SG, SG, D, Pen)		
A.C. Fury Four Super (SG, SG, D, Pen)		The Auto Straight Four (HF, Pen, HF, Pen, D, T, Pen)		
A.C. Hall-Mark (HF Pen, D, Push-Pull)		Five-valve: Blueprints, 1s. 6d. each.		
Universal Hall-Mark (HF Pen, D, Push-Pull)		Super-quality Five (2 HF, D, RC, Trans)		
SUPERHETS				
Battery Sets: Blueprints, 1s. each.		Class B Quadradyne (2 SG, D, LF, Class B)		
F5 Superhet (three-valve)		New Class B Five (2 SG, D, LF, Class B)		
F. J. Camm's 2-valve Superhet		Mains Operated		
Mains Sets: Blueprints, 1s. each.		Two-valve: Blueprints, 1s. each.		
A.C. 25 Superhet (Three-valve)		Consonelectric Two (D, Pen) A.C.		
D.C. 25 Superhet (Three-valve)		Economy A.C. Two (D, Trans) A.C.		

SPECIAL NOTICE

THESE blueprints are drawn full size. The issues containing descriptions of these sets are now out of print, but an asterisk beside the blueprint number denotes that constructional details are available, free with the blueprint.

The index letters which precede the Blueprint Number indicate the periodical in which the description appears: Thus P.W. refers to PRACTICAL WIRELESS, A.W. to Amateur Wireless, W.M. to Wireless Magazine.

Send (preferably) a postal order to cover the cost of the Blueprint (stamps over 6d. unacceptable) to PRACTICAL WIRELESS, Blueprint Dept., George Newnes, Ltd., Tower House, Southampton Street, Strand, W.C.2.

SUPERHETS				
Battery Sets: Blueprints, 1s. 6d. each.		Varsity Four		WM395*
The Request All-Waver				WM407
Main Sets: Blueprints, 1s. each.				
Heptode Super Three A.C.				WM369*
PORTABLES				
Four-valve: Blueprints, 1s. 6d. each.		Holiday Portable (SG, D, LF, Class B)		AW393*
Family Portable (HF, D, RC, Trans)				AW447*
Tyets Portable (SG, D, 2 Trans.)				WM367*
SHORT-WAVE SETS. Battery Operated				
One-valve: Blueprints, 1s. each.		S.W. One-valver for America		AW429*
Roma Short-Waver				AW452*
Two-valve: Blueprints, 1s. each.		Ultra-short Battery Two (SG, det Pen)		WM402*
Home-made Coil Two (D, Pen)				AW440
Three-valve: Blueprints, 1s. each.		Experimental's 5-metre Set (D, Trans, Super-regen)		AW438
The Carrier Short-waver (SG, D, P)				WM390*
Four-valve: Blueprints, 1s. 6d. each.		A.W. Short-wave World-beater (HF, Pen, D, RC, Trans)		AW436*
Standard Four-valver Short-waver (SG, D, LF, P)				WM383*
Superbet: Blueprint, 1s. 6d.		Simplified Short-wave Super		WM397*
Mains Operated				
Two-valve: Blueprints, 1s. each.		Two-valve Mains Short-waver (D, Pen, A.C.)		AW453*
Three-valve: Blueprints, 1s.		Emigrator (SG, D, Pen) A.C.		WM352*
Four-valve: Blueprints, 1s. 6d.		Standard Four-valve A.C. Short-waver (SG, D, RC, Trans)		WM381*
MISCELLANEOUS				
S.W. One-valve Converter (Price 6d.)				AW329
Enthusiast's Power Amplifier (1/6)				WM387*
Listener's 6-watt A.C. Amplifier (1/6)				WM392*
Radio Unit (2v.) for WM392 (1/6)				WM398*
Harris Electrogram battery amplifier (1/-)				WM399*
De Luxe Concert A.C. Electrogram (1/-)				WM403*
New Style Short-wave Adapter (1/-)				WM388
Short-wave Adaptor (1/-)				AW456*
B.L.D.L.C. Short-wave Converter (1/-)				WM465*
Wilson Tone Master (1/-)				WM406
The W.M. A.C. Short-wave Converter (1/-)				WM408*

HINTS COUPON

This coupon is available until December 10th, 1945, and must accompany all Practical Hints.

PRACTICAL WIRELESS, December, 1945

All applications respecting Advertising in this Publication should be addressed to the ADVERTISEMENT DIRECTOR, GEORGE NEWNES, LTD., Tower House, Southampton Street, Strand, London, W.C.2. Telephone: Temple Bar 4963.

CONDITIONS OF SALE AND SUPPLY: This periodical is sold subject to the following conditions, namely, that it shall not, without the written consent of the publishers first given, be lent, re-sold, hired out or otherwise disposed of by way of Trade except at the full retail price of 9d.; and that it shall not be lent, re-sold, hired out or otherwise disposed of in a mutilated condition or in any unauthorised cover by way of Trade; or affixed to or as part of any publication or advertising, literary or pictorial matter, whatsoever.

The
TAYLOR A-C BRIDGE

MODEL 110A

These instruments give quick and accurate measurements of Capacity and Resistance. There are six Capacity ranges covering from .00001 to 120 mfd. and the Power factor can also be measured on each range. Six Resistance ranges are available measuring from 1 ohm to 12 megohms. This bridge is A.C. mains operated and a leakage test is also available for detecting leaky paper or mica condensers.

Price £14 14s. 0d.

Please write for technical leaflet.

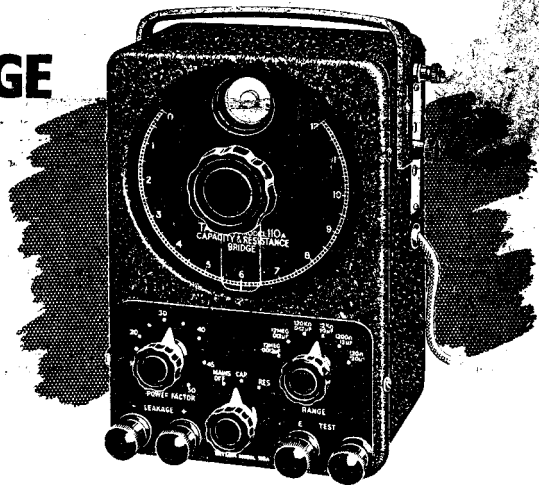

6 RANGES OF CAPACITY
RANGES OF RESISTANCE

Send your enquiries to:—

TAYLOR ELECTRICAL INSTRUMENTS LTD

419-424 MONTROSE AVENUE, SLOUGH, BUCKS.
Tel: Slough 21381 (4 lines) 'Grams: "Taylins", Slough.

Taylor
electrical instruments Ltd



AMBITIOUS ENGINEERS

HAVE YOU HAD YOUR COPY OF "ENGINEERING OPPORTUNITIES"?

Whatever your age or experience—whether you are one of the "old school" or a newcomer to Engineering anxious to hold your position under post-war conditions—you must read this highly informative guide to the best paid Engineering posts.

The Handbook contains among other intensely interesting matter, particulars of **B.Sc., A.M.I.C.E., A.M.I.Mech.E., A.M.I.E.E., A.M.I.A.E., A.M.I.P.E., A.M.Brit.I.R.E., CITY & GUILDS, CIVIL SERVICE,** and other important Engineering Examinations, outlines courses in all branches of **CIVIL, MECHANICAL, ELECTRICAL, AUTOMOBILE, RADIO, TELEVISION, AERONAUTICAL** and **PRODUCTION ENGINEERING, DRAUGHTSMANSHIP, GOVERNMENT EMPLOYMENT, BUILDING** and **PLASTICS** (the great peacetime careers), **MATRICULATION**, etc., and explains the unique advantages of our Employment Department.

WE DEFINITELY GUARANTEE 'NO PASS—NO FEE'

If you are earning less than £10 a week you cannot afford to miss reading "ENGINEERING OPPORTUNITIES"; it tells you everything you want to know to *make your future secure* and describes many chances you are now missing. In your own interest we advise you to write for your copy of this enlightening guide to well-paid posts **NOW—FREE** and without obligation.

BRITISH INSTITUTE OF ENGINEERING TECHNOLOGY

409, SHAKESPEARE HOUSE, 17, 18 & 19, STRATFORD PLACE, LONDON, W.1.

THE B.I.E.T. IS THE LEADING INSTITUTE OF ITS KIND IN THE WORLD

Published on the 7th of each month by GEORGE NEWNES, LIMITED, Tower House, Southampton Street, Strand, London, W.C.2, and printed in England by THE NEWNES & PEARSON PRINTING CO., LTD., Exmoor Street, London, W.10. Sole Agents for Australia and New Zealand: GORDON & GOTCH, LTD., South Africa: CENTRAL NEWS AGENCY, LTD. Subscription rates including postage: Inland 12s. 6d. per annum; Abroad 19s. per annum. Registered at the General Post Office for the Canadian Magazine Post.