

# LONG RANGE SINGLE-VALVER—SEE PAGE 272

A  
NEWNES  
PUBLICATION

Edited by  
**F. J. CAMM**  
Vol. 17. No. 420.

# Practical Wireless *and*

# 6<sup>d</sup>

EVERY  
MONTH  
June, 1941.

★ PRACTICAL TELEVISION ★



# Exide BATTERIES

*'Still keep going  
when the rest have stopped'*



THE CHLORIDE ELECTRICAL STORAGE COMPANY LTD.

(Exide and Drydex Batteries) Grosvenor Gardens House, Grosvenor Gardens, London, S.W.1.

Telephone : VICToria 2299.      Telegrams : Chloridic, Sowest, London

# TROUBLE-TRACKING SIMPLIFIED

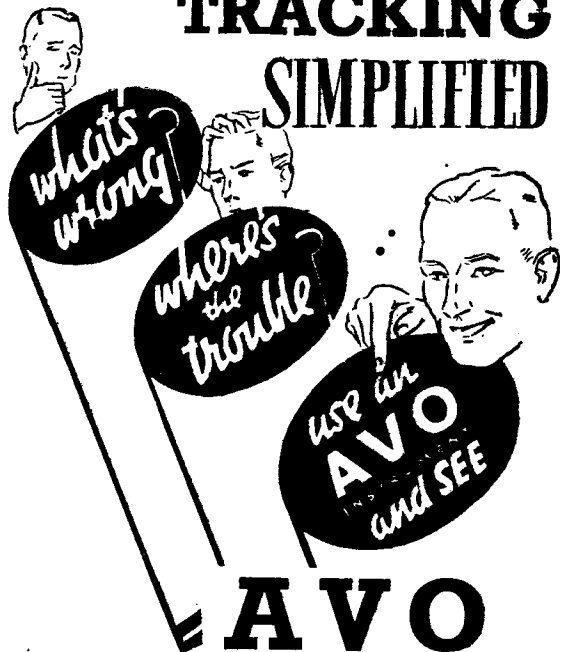

**AVO**  
 Regd. Trade Mark.  
 ELECTRICAL MEASURING INSTRUMENTS

● The Universal AvoMinor and the D.C. AvoMinor put within the reach of the serious amateur a means of rapid precision testing of an accuracy unobtainable with other instruments in their class. Their simplicity and versatility make short work of all the normal trouble-tracking problems. They are worthy members of a range of "AVO" Instruments renowned for their high standard of workmanship and efficiency.

### THE UNIVERSAL AVOMINOR

ELECTRICAL MEASURING INSTRUMENT

D.C. Volts	A.C. Volts	D.C. Milliamps
0-75 milli-volts	0-5 volts	0-2.5 milli-amps.
0-5 volts	0-25 "	0-5 "
0-25 "	0-100 "	0-25 "
0-100 "	0-250 "	0-100 "
0-250 "	0-500 "	0-500 "
0-500 "		

#### RESISTANCE

0-20,000 ohms	0-2 megohms
0-100,000 "	0-5 "
0-500,000 "	0-10 "

### THE D.C. AVOMINOR

ELECTRICAL MEASURING INSTRUMENT

Current milliamps	Voltage volts	Resistance ohms
0-6	0-6	0-10,000
0-30	0-12	0-60,000
0-120	0-120	0-1,200,000
	0-240	megohms
	0-300	0-3
	0-600	

In spite of greatly increased production, most of our output of "AVO" Instruments is being taken by the Services. Delay in delivery of Trade Orders is consequently inevitable, but we shall continue to do our best to fulfil your requirements as promptly as possible.

● Write for fully descriptive pamphlets and current prices



THE UNIVERSAL AVOMINOR

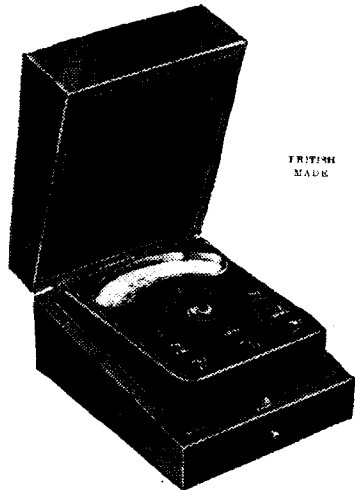

BRITISH MADE

THE D.C. AVOMINOR

Sole Proprietors and Manufacturers :  
**AUTOMATIC COIL WINDER & ELECTRICAL EQUIPMENT Co. Ltd., Winder House, Douglas Street, London, S.W.1.**  
 Phone: Victoria 3404/7



## Cheerfulness

When cheerfulness is in danger of disturbance, light a 'Player,' and with a few 'puffs' put trouble in its proper place. The friendly Sailor, as always, stands for cheery contentment and a guarantee that quality and purity remain unchanged.

KEEP THAT HAPPY EXPRESSION

*Player's Please*



N.C.C.547B

## These Radio jobs are well paid in the R.A.F.

### GROUND

Radio Mechanic  
 Wireless Mechanic  
 Wireless Operator-Mechanic  
 Wireless Operator  
 Radio Telephony Operator

### FLYING

Wireless Operator Air-Gunner  
 Pilots and Observers (a knowledge of Wireless is necessary)

Fit yourself for specialised radio jobs in the R.A.F. by studying practical books. Those below will give you a thorough grounding in the science of wireless, and in servicing and maintenance.

### THE OUTLINE OF WIRELESS

By RALPH STRANGER

(On the Official Admiralty List, and recommended to Wireless Operators)

Covers completely the theory and practice of Wireless Reception. The contents include: Matter and Energy, Magnetism and Electro-Magnetism, Batteries and Accumulators, Wireless Communication and Broadcasting, Modern Valves, Wireless Receiving Circuits. 832 pages. Over 500 illustrations. 10/6 net (By post 11/3).

### NEWNES' SHORT-WAVE MANUAL

By F. J. Camm

Deals thoroughly with the special problems underlying the design of short-wave apparatus, the special circuits which yield the best results, and designs for receivers based on those circuits. Many useful tables are included. 5/- net (By post 5/6).

### RADIO TRAINING MANUAL FOR THE SERVICES AND THE TRADE

Edited by F. J. Camm

This immensely helpful book will aid you in adopting one of the important branches as a profession. The contents are comprehensive and deal with Radio as a career (including Radio in the Forces, Production Servicing, Laboratory, etc.), an Outline of Prospects, Electrical Units Explained, Radio Formulae Simplified, Principles of Receiver design, a Guide to Servicing, etc. Fully illustrated with Circuit Diagrams, Tables and Formulae. 5/- net (By post 5/6).

### RADIO ENGINEER'S VEST POCKET BOOK

By F. J. Camm

Contains in easily-consultable form nearly every fact, figure and formula which service engineers, students, circuit designers, radio-operators, transmitters, constructors and manufacturers require. 3/6 net (By post 3/9).

Of all Booksellers, or by post from **GEORGE NEWNES, LTD. (Book Dept.), Tower House, Southampton St., London, W.C.2.**

# ELECTRADIX RADIOS

## DYNAMO BARGAINS



110-volts, 8 amp. D.C. ball bearing, semi-enclosed. 1,850 revs., 15lb, 6in. x 5in., cheap, Carriage paid. **15/6.**

**DYNAMOS.**—Double Current Govt., cost £15. Two commutators, D.C. 6/8v., 3/5 amps, and H.T. 400/600v., 100 mm., 5 1/2 in. dia., 12in. long. 17 lbs., 4,000 revs., ball bearings, **25/-**. We have some surplus soiled sets, **15/-**.

**SMALL A.C. MAINS MOTORS.**—Enclosed, self-start on load. 230 v., 1/80 h.p., Type 40, 1,500 revs., **18/6**. Split phase, 1/10 h.p., 2,500 revs., **45/-**.

**SMALL D.C. MAINS MOTORS.**—1/40 h.p., Type 60, 220 v., K.B. series, 1,750 revs., **15/-**. Ditto, 1/40 h.p., G.E.C., 230 v. series, 2,000 revs., **16/-**. Ditto, 1/12 h.p., Croydon 110 and 230 v. shunt, 1,700 revs., **30/-**. M.G. for A.C., 220 v. to 100 v., 1 amp. D.C., **77/6**. 100 v., **15/-**. All fully guaranteed.

**D.C. GENERATORS.** 120 watt, 12/16 volts 30 amps., with vee pulley, **45/-**. Shunt wound.—110 volts 1/2 amp., **15 lbs., 10/6**; 110 volts 1 amp., **15/-**; 200 volts 1/2 amp., **17/6**; 200 volts 1 1/2 amp., **28/-**.

**WINDMILL GENERATORS,** totally enclosed, ball-bearing, start charging at 300 revs., 6 to 12 volt, 8 amps., **75/-**.

**D.C. MAINS MOTOR GENERATORS.**—D.C./D.C. 220 v. to 30 v. 10 amps., **£7/10/-**. M.G. Crompton D.C./D.C., 100 volts to 17 volts 6 amps., **£4/7/6**. 200 v. to 16 v. 5 amps., **£5**. Estro M.G. ditto to 6 volts 1/2 amp., **45/-**. Motor generators for all out puts up to 60 amps.

**MOTOR DRIVES.**—Morse 1/2 h.p. Silent Chains, new, 29in. long, with large and small 1 1/2 in. sprockets, ratio 4 to 1, for motor drive, projector, **8/6**.

**GEARS.**—Skew drive Gear Boxes for Cine. or Boat—1/2 or 1 h.p., **10/-**. Ditto on C.I. Pedestal, with fly-wheel, **15/-**. Small 2 to 1 Gear Boxes, **4/6**.

**DRILL STANDS.**—Massive machined steel drill stands, Wolf type, with rise and fall handle and counter weight, height 32in., weight 102lb. Sale price **10/-**. Carr. forward.

**ELECTRIC GOVERNORS.** Centrifugal control, 1,500 r.p.m. contacts, brushes, slip rings for autospeed regulation, **7/6**.

## ALTERNATORS

**MOTOR-ALTERNATOR.**—2 1/2 kW. NEWTON. Vertical, 580 cycles 200 volts 25 amps. 1,600 revs. Motors, 220 volts D.C., **£20**.

**1-PH. PHASE HIGH CYCLES TEST ALTERNATORS.**—The famous 52a WATFORD H.F. Alternators 250 watts at 500 cycles, 20 volts 10 amps. Self-exciting inductor type, slot wound stator. Small size. Cost £30. Sale, **70/-**. WOOLWICH 400 watt 46/W/A 500 cycles 50 volts 3 amps. and D.C. of 70 volts 3 amps., **£5/10/-**. S.M.D. Co. 500 watts 500 cycles 200 volts, high speed, **£8**.

**3-PHASE ALTERNATORS.**—G.E.C. 300 cycles 3 ph. 120 volts 1 amp., fitted reed Tachometer. Self exciting horizontal, **£8/10/-**.

**A.C. HAND ALTERNATOR.**—Permanent steel magnets, wound armature driven by gearing and handle. Output of 80 volts 20 m/a. A.C. For Medical Treatment. A.C. experiments, etc. Sale, **7/6**. Carriage, 1/-.

## 1, 2, and 2 1/2 H.P. ENGINES IN STOCK

**A.C. ROTARY CHARGERS.**—3-phase Motor 200 volts Dynamo 8 volts 15 amps., D.C., **£4/17/6**. R.C.A. 3 ph. Motor 220 volts, 500 volts, 200 m/a., D.C., **£5/10/-**. 230 volts A.C. Motor D.C. Dynamo 16 volts 11 amps., D.C., **£6/17/6**.

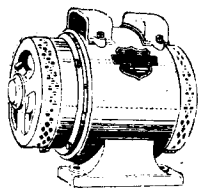

**CRYPTO** Constant Potential Rotary Charger. Single Phase Motor. D.C. output 8 volts 50 amps. L.T. and 200 volts 1 amp. With switchboard, **£30**.

**D.C. ROTARY CHARGER.**—3 h.p. 220 volt D.C. Motor 6 volt 250 amp. Dynamo, **£16**. 200 volt Motor 25 volts 8 amps. dynamo, **£4**. Motor 220 volts 8 amps. dynamo, **£6/10/-**. And others.

## MOVING COIL SPEAKERS

Mains energised 6in. to 6in. All good makes. 6in. cone **7/6**. Few with damaged cones, **5/-**. B.T.H. and Celestion O.K., **12/6**. Few damaged cones. **7/-**. **A.C. MAINS SPEAKERS.** Jensen with rectifier for 230 volts A.C., 7in. cone and transformer, **25/-**. **PERMANENT MAGNET SPEAKERS** for extensions. Various makes and sizes as above, **18/6**. Few with broken cone, **10/-**. Brand new P.M. Speakers, G.E.C. and Rola, **25/-**.

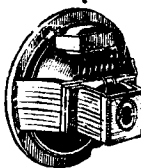

**BATTERY ENERGISED M.C. Speakers,** Kolster-Brandes 4 to 6 volt, 8in. cone, **8/6**. A few reed cone speakers, **7/-**.

**P.A. HORN SPEAKERS.**—Emerson Tone Correct Horn and Slings, as illus. New Perm. Mag. M.C., 15 watts without distortion, 24in. Flare, 40in. long, **£6/8/-**.

**TANNOY AND MARCONI PHONE.** P.M. Short Horn Model P.A., 12-15 watts, as new. 30 in. High Power P.M. Speakers with Aluminium Horn for van top; handles 30/40 watts, **£9**.



**MAINS P.A. AMPLIFIERS.**—For pure sound amplification and Recording. Complete and cased, not naked chassis. Special Bargain, professional portable 5-6 watt Amplifier, A.C. or D.C. in covered cabinet with handle, 20lb. weight only. Ideal for singer, entertainer or gramo., only **£8**. Small preamplifier, Phillips 2-watt A.C. mains, in steel case, only **£4/10/-**. 10-watt steel based Amplifier, quite new **£8/15/-**. All these are complete with valves ready for use. Set by Ardent, fine job, 20 watts pure output, A.C. mains, **£16**. Complete with valves.

**250 NEON LAMPS.**—Standard size letter neon bulb with holder, 220/240 v., **2/6**.

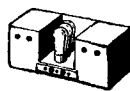

**Medica. Shock Coils,** 5/6 and 7/6. **300 Ignition Coils,** 6 or 12 volts, **3/6**.

**DIAL TUNING.**—10-point Finger Switch Dials, as illus., used on G.P.O. Automatic Telephones. These have spring drive, governor, clutch and contacts inside. Price **2/6**.



**TELEPHONES** for all purposes. House, Office, Garage and Field. Wall and Table models cheap.

**HEADPHONES.**—120 ohm W.D. model. Pocket Headphones, all leather headbands and cords, **4/6** pair.

**TALKIE SOUNDHEADS.**—Brown's Universal, less optical, independent driven soundhead flex shaft, head amplifier, lamp and P.C. Sale **£8**. Soundhead Brown's Standard with head amplifier, new, fits most projectors, **£10**. Cost **£17/0**.

**CINEPHONE SOUNDHEAD** with P.C. and meter, **£7**. B.T.P. Soundhead with Osram P.C., new condition. Beck optical, **£8/10/-**. Mihaly Soundhead, **£3/10/-**.

**SOLO VARIABLE AIR CONDENSERS** for Wavemeters and Single Circuit Tuning, logarithmic blades. .0005 mfd., new, Type F, **2/6**.

**TEKADE,** bakelite dielectric Tuning or Reaction variable condenser, .0005 mfd., **1/6**.

**CAMERASCOPES** True-Twin, 2 lens viewers, folds flat, 1/3.

**CHARGE METERS.**—Weston Model 354. Central zero 1 to 15 amps. D.C. pol. mag. dead beat. Flush panel, 2 1/2 in. dial. Sale price, **9/6**.

**NEW PANELS.**—Paxolin or Ebonite. 24in. quarter-inch Panels. Ask prices.

**ALUMINIUM FOIL,** 12in. by 12in., **9d.** sheet.

**SCREENALL** for lining Cabinets, anti-interference screen, flexible, fireproof thin asbestos faced aluminium foil back and front. Any length cut in 24in. width, 1/- per 2 square feet.

## The ROLLS-ROYCE of BUZZERS is the CAMBRIDGE - TOWNSEND TINY AND SHRILL

Perfect for Wavemeters, ideal for signals. High note model "T" Diaphragm blade. Platinum Contacts. The smallest Buzzer possible. **10/-**.



## SWITCHES

**15-DAY TIME SWITCHES.**—Venner 1 amp., 5 amps., 100 amps., 200 amps. From **30/-**.

**AERIAL-BARTH SWITCHES.**—D.P.C.O., 3/6. Stud Box Switch, 8-way on panel by R.L. for meter ranges, etc., 7/6. Larger type G.P., with 10-way studs, **5/6**.

**YAXLEY & REX WAVECHANGE D.P.,** 3-way roll contact, 1/3. Bulgin 3-point wavechange, **9d**. Tunewell S.P. on-off, **8d**. 20-way panel Stud Switches, contact arms and ring for fitting 300-ohm 1/2 amp., 20-tap resistance, **10/6**. 7-way Stud Switches on 2 1/2 in. panel, with plug sockets, **1/3**. 10-way D.P. ebonite, mounted, 8 amps., **5/6**. 12-way D.P., 5 amps., **4/-**. G.E.C., 10 amp. D.P. linked, **3/-**.

## RELAYS

**SUPERSENSITIVE MOVING COIL RELAYS.**—These work on really tiny currents from photo-cells, etc., and a small rectifier can be used for A.C. For panel use, the small 2in. flush Lexidex meter type W1 works on 50 micro amps. Handles 150 mills. on main contact, **55/-**.



**A 2 ma. TABLE RELAY** for radio work. Compact vertical type, enclosed. Screened 3,000 ohm coils. Platinum contacts. Single pole change-over, 1/2 amp. contacts. Wood base. Metal case. Size 2 1/2 in. diam., 3 1/2 in. high. Price only **8/6**. 10 other models of relays in stock. Send stamp for illustrated leaflet.

**UNUSED X-RAY VACUUM TUBES.**—New Government Hospital Surplus, 7in. dia. bulb. Big solid Tungsten Electrodes. Emission guaranteed. COST **£5**. SALE, **15/-**. Callers only.

**LIGHT AND RAY CELLS.**—Electrocell, Self-generating, **25/-**. Photo-Cells for sound on Film and Ray work. R.C.A., **25/-**. Beck, Angle Prisms, mounted in carrier, **5/6**.

**THERMOMETERS.**—Panel 2 1/2 in. dial, 5ft. ether tube for distant indicating, reading 0 to 100 deg. Cent., **7/6**.

**FOURNIER THERMOMETERS** by Cambridge Instrument Co., 4in. dial, 10-110 deg. Cent. Fitted adjustable electric contacts, **45/-**. 12in. right angle Immersion Thermom. to 150 Cent., **3/6**.

## RHEOSTATS

**SMALL RHEOSTATS.**—Back of panel, one hole, front knob. Rotary Igranite 10 watts, 4 ohms, 2 1/2 amps., **2/6**; 6 ohms, 1.7 amps., **2/6**; 10 ohms, 1 amp., **2/6**; 20 ohms, 1/2 amp., **2/6**; 30 ohms, 3 amp., **2/6**; 30,000 ohms Reg. Volume Controls or Potentiometers for Gramos or Mikes, **2/6**. Resistors, on mica, 8 ohms, 1 1/2 amps., **9d**.



## TEST GEAR

**ELLIOTT BATTERY LOAD TESTERS.**—Government Model 108. Moving Coil Ammeter and graded rheo., **37/6**.

**CELL TESTERS.**—Megger 3-0-3 moving coil. Aluminium bodies, **17/6**.

**230 Volts A.C. 2 kW. RECTIFIER EQUIPMENT,** with 5 kW. transformer and Phillips valve, D.C. output, 230 volts 10 amps., **£15**.

**TEST PANEL,** with 4 meters for full-range works testing. Ranges 5 m.a. to 12 amps., D.C. or A.C., with rectifier and transformer, 5 volts to 500 volts, 7in. dial meter on steel panel, 27in. x 30in., **£12**.

**DISTRIBUTION BOARDS.**—Polished Hardwood, glass door, clip fuses, D.P., four of 12-way, one 8-way, two 6-way, six 5-way: all at **2/-** per way.

## ENGINE SETS

Horizontal Twin Petrol A.B.C. Engine fan-cooled, coupled 1 1/2 kW. D.C. Dynamo 50/70 volts 25 amps., Mag. Ignition. Cost £190. Sale, **£25**. 2 1/2 kW. AUSTIN, 2 Cyl. water-cooled Engine, Mag. Ignition and 110 volts 25 amps. Dynamo, **£28**. Austin 3 1/2 kW., 110 volts, **£48**. Switchboards, **£5**. Send stamp for Special Leaflets.

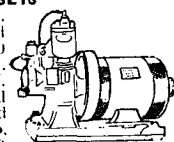

Stamped envelope must be enclosed for ALL replies to enquiries.

POSTAGE must be added to ALL mail orders.

# ELECTRADIX RADIOS

WE ARE STILL AT: 218, UPPER THAMES STREET, LONDON, E.C.4.

Telephone: Central 4611

# PREMIER RADIO

Please Note.—All Short-wave Kits include Purchase Tax.

## PREMIER SMOOTHING CHOKES

Type	Current	Henrys	Res.	Price
C.40/500	40 mA.	20-34 H.	500 Ω	6/-
C.60/180	60 "	8 H.	180 Ω	6/-
C.60/400	60 "	25-34 H.	400 Ω	8/6
C.60/500	60 "	18-30 H.	500 Ω	8/6
C.100/400	100 "	20-34 H.	400 Ω	10/8
C.150/185	150 "	20-34 H.	185 Ω	15/4
C.200/145	200 "	20-34 H.	145 Ω	18/-
C.250/120	250 "	25 H.	120 Ω	20/-

## PREMIER 1941 HIGH FIDELITY AMPLIFIER KITS

Each Kit is complete with ready drilled chassis, selected components, specially matched valves and full diagrams and instructions.

	Kit of Parts with Valves	Completely Wired and Tested
4-watt A.C. Amplifier	£2 14 0	£3 11 6
6-watt A.C.	£6 16 6	£7 13 6
8-10 watt A.C./D.C.	£7 9 0	£7 9 0
15-watt A.C.	£7 18 9	£9 8 0

Black Crackle Steel Cabinet 17/6 extra.

## MAINS TRANSFORMERS

Wire-ends. All L.T. Windings Centre-Tapped

SP. 259	250-0-250 v. 60 m.a. 4 v. 1-2 a., 4 v., 2-3 a., 4 v. 2-3 a.	13/4
SP. 308	300-0-300 v. 60 m.a., 4 v. 2-3 a., 4 v., 2-3 a., 4 v. 2-3 a.	13/4
SP. 301	300-300 v. 150 m.a., 4 v., 2-3 a., 4 v., 2-3 a., 4 v. 1 a., 4 v. 1 a.	17/4
SP. 350A	350-350 v. 100 m.a., 5 v. 2 a. (not C.T.), 6.3 v. 2-3 a.	16/-
SP. 350B	350-350 v. 100 m.a., 4 v. 2-3 a., 4 v. 2-3 a., 4 v. 2-3 a.	16/-
SP. 351	350-350 v. 150 m.a., 4 v. 1-2 a., 4 v. 2-3 a., 4 v. 3-4 a.	17/4
SP. 351A	350-350 v. 150 m.a., 4 v. 3 a., 4 v. 2-3 a., 4 v. 1 a., 4 v. 1 a.	22/-
SP. 352	350-350 v. 150 m.a., 5 v. 2 a., 6.3 v. 2 a., 6.3 v. 2 a.	18/-

**Auto Transformers.** Step up or down. 100-125 v. to 200, 230 or 250 v. A.C., 60 watts, 11/4; 125 watts, 15/-; 250 watts, 22/-.

**L.T. Transformers, all C.T.**  
 4 v. 2-3 a. ... 11/4      6.3 v. 2-3 a. ... 11/4  
 2.5 v. 5 a. ... 11/4      7.5 v. 3 a. ... 11/4  
 5 v. 2-3 a. ... 11/4      12 v. 3-4 a. ... 18/-  
**Push-Pull Driver Transformers** ... 6/6  
**Universal Output Transformers** ... 11  
 Ratios. Single or Push-Pull ... 6/6

## MATCHMAKER UNIVERSAL OUTPUT TRANSFORMERS

Will match any output valves to any speaker impedance.  
 11 ratios from 13 : 1 to 80 : 1, 5-7 watts, 16/10  
 10-15 watts, 21/10. 20-30 watts, 36/10.

**ELECTROLYTIC CONDENSERS.** Cardboard cases. 500 v. working 4 mfd. and 8 mfd., 2/- each. 8+8, 4/-, 4+4 2/11, 4+4+1 3/9, 4+4+4 4/3, 16-8 4/11, 16+16 6/-, 25 mfd. 25 volt, 1/6, 50 mfd. 12 volt, 1/6, 15 mfd. 100 volts, 1/3. Mansbridge type, 1 mfd. 250 volt, 1/-, 2 mfd. 250 volt, 1/9, 4 mfd. 500 volt, 4/8. J+J Mains Buffer, 1/2.

## PREMIER MICROPHONES

**Transverse Current Mike.** High grade large output unit. Response 45-7,500 cycles. Low hiss level, 23/-.

## "LEARNING MORSE"

Premier Morse Practice Key on Bakelite Base and Brass Movement **3/3**  
 General Purpose Morse Key ... **5/10**  
 Bakelite Buzzers ... **2/-**  
 3 Henry Chokes ... **7/6**  
 Complete Kit of Parts for Valve Oscillator as described in W.W. "Learning Morse" ... **25/-**

## NEW PREMIER S.W. A.C. RECEIVER

In response to many requests we have now produced an A.C. version of the popular Premier Short Wave SG3 Kit. Circuit: Pentode H.F. Stage, Pentode Detector, Beam Power Output, and F.W. Rectifier. 200-250 v. A.C. Operation. Built-in Power Pack. Hum-free operation. For use with Phones or P.M. Speaker.

Complete Kit of Parts with drilled chassis, all components, Plug-in Coils covering 13-170 metres, 4 valves and full instructions and circuits. **£6 - 14 - 6**

Battery Version also available Kit £4 15 4 Extra Coils 9-15, 200-2,900 m. also supplied.

★ "The Wireless World" said they were "very much impressed..." ★  
 See full Test Report, PP. 492-3 December issue. Send for full details.

## Premier Pick-ups.

Heads will fit any tone-arm ... 8/9  
 Premier Pick-up with Volume Control ... 17/6

## ANOTHER SPECIAL OFFER

Rothermel Brush Piezo Crystal Pick-ups. Standard, 5.8 model with arm, 34/9.

## MOVING COIL SPEAKERS

All complete with transformer. Rola 6 1/2 in., 15/-; 10 in. P.M.s. 22/6. Goodman 8 in. P.M.s. 20/-.  
**ENERGISED MODELS**  
 Plessey Bin., 175 ohm field, 7/6; 10 in. B.T.H. 1,600 ohm field, less transformer, 11/6.

## PREMIER BATTERY CHARGERS FOR A.C. MAINS

Westinghouse Rectification complete and ready for use

To charge: 6 volts at 1 amp. 26/-  
 2 volts at 1/2 amp. 13/4 12 volts at 1 amp. 28/-  
 6 volts at 1/2 amp. 22/- 6 volts at 2 amp. 43/6

## PREMIER SHORT-WAVE KITS for OVERSEAS NEWS

Incorporating the Premier 3-Band S.W. Coil. 11-86 Metres without coil changing. Each Kit is complete with all components, diagrams and 2-volt valves. 3-Band S.W. 1-Valve Kit, 18/-; 3-Band S.W. 2-Valve Kit, 27/6.

## DE LUXE S.W. KITS

Complete Kit, including all Valves, coils, wiring diagrams and lucid instructions for building and working. Each Kit supplied with a steel Chassis. Panel and plug-in coils to tune from 13 to 170 metres.

1 Valve Short-Wave Receiver or Adaptor Kit	24/6
1 Valve Short-Wave Superhet Converter Kit	28/-
2 Valve Short-Wave Receiver Kit	35/6

## SHORT-WAVE GEAR

**Short-Wave Coils.** 4- and 6-pin types, 13-26, 22-47, 41-94, 78-170 metres, 2/- each, with circuit. Premier 3-Band S.W. Coil, 11-25, 19-43, 38-86 metres. Suitable any type circuit, 2/11.  
**4-pin or 6-pin Coil Formers.** Plain or Threaded, 1/2 each.

**Bakelite Dielectric Variable Condensers.** .0005 mfd. Suitable Tuning or Reaction. 1/6 each.  
**Short-Wave H.F. Chokes.** 10-100 m., 10 1/2 d. each.

**Pye Wound Type.** 15-200 metres, 2/-  
**Lissen Dual Range Screened Coils.** Medium and Long Waves, 2/9 each.

## SHORT-WAVE CONDENSERS

Trolitul Insulation. Certified superior to ceramic. All-brass construction. Easily ganged.  
 15 m.mfd. ... 2/4      100 m.mfd. ... 3/-  
 25 m.mfd. ... 2/6      160 m.mfd. ... 3/7  
 40 m.mfd. ... 2/6      250 m.mfd. ... 4/-

## PREMIER REPLACEMENT VALVES

4 volt A.C. Types, 5-pin, A.C.H.L., A.C./L., A.C./P., A.C.H.P., A.C.V.H.P., A.C./V.M. All 5/6 each.

**Premier I.F. Trans.** 450-470 kc. Air cores, 5/- each. With or without top grid connection.

**Flexible Couplings,** 1/2 in. bore, 1/6 each.  
**Valve Screens** for International and U.S.A. types, 1/2 each.

**Jacks.** Single circuit, open or closed types, 1/9. Plugs, 1/9.

**Electric Soldering Irons.** 200-250 volts, 5/10. Super Model, 11/9.

**Potentiometers.** All resistances, 2/4, with switch, 3/3.

**Beehive Stand Offs,** 2 1/2 in., 7d. each.  
**Mains Noise Suppressors,** comprising double wound Choke and Conds, 6/6 each.

**Microphone Cable,** weatherproof. Shielded and Rubber covered, 1/- yard.

**Microphone Transformers.** Suitable for all mikes. Tapped primaries. A, 20 and 40 : 1; B, 30 and 60 : 1; C, 50 and 100 : 1, 6/6 each.  
**Microphone Stands,** floor type, telescopic, Bin. ring, 32/6.

ALL ENQUIRIES MUST BE ACCOMPANIED BY 2 1/2d. STAMP.  
 ALL ORDERS LESS THAN 5/- 6d. POST EXTRA.

# PREMIER RADIO CO.

ALL POST ORDERS to: JUBILEE WORKS, 167, LOWER CLAPTON ROAD LONDON, E.5. (Amherst 4723).  
 CALLERS to: Jubilee Works, or 169, Fleet Street, E.C.4 (Central 2833), or 50, High Street, Clapham, S.W.4. (Macaulay 2381).

# Practical and Wireless

★ PRACTICAL TELEVISION ★

EDITED BY  
F. J. CANN

Staff:  
FRANK PRESTON,  
L. O. SPARKS.

EVERY MONTH.  
Vol. XVII. No. 420. June, 1941.

## COMMENTS OF THE MONTH

By THE EDITOR

### The Revised Schedule

THE Services have already heavily drawn upon the skilled men, and the radio industry has been no exception. Radio is playing an important part in the war, and it was therefore inevitable that its skilled men would be among the first to be drawn into the war effort. The original age limit, however, did reserve a percentage to deal with the needs of the civilian population. The new schedule drastically reduces that percentage, for, as the Army expands, and with it the Air Force, the needs of the Services increase commensurately. This means that the civilian population will not be able to obtain the same service as hitherto, and coupled with the Limitation of Supplies Order, which reduces the amount of spares and, in some cases, abolishes them altogether, the result must be an ever-increasing difficulty in the maintenance of receivers. Service stations are already complaining that they are unable to cope with the demand. They may, indeed, take a receiver in for servicing and locate the fault, and yet be quite unable to rectify it because spares are not available.

Constructors are not quite so seriously affected, except in so far as complicated receivers are concerned, but for the duration of the war it is obvious that they must confine their attention to the simpler style of receiver, and be prepared to make their own components. Certain of these, of course, are beyond the ability of the constructor, but such items as coils, chokes, transformers, switches, etc., are comparatively simple to make, and it is in this connection that our practical handbooks are proving such a boon, as is proved by the ever-increasing demand for them.

The revised schedule of reserved occupations shows that radio service engineers continue to be reserved at the age of 35 and over, which means that in a comparatively young industry, almost 90 per cent. of the personnel will be called up.

### New Standards

OUR readers will no doubt recollect the differences of opinion between water supply companies and electrical supply companies concerning earth connections. Agreement was reached only about three years ago, when the water and electrical companies agreed upon regulations for earthing. The British Standards Institution have now issued a British Standards Specification, No. BS591/1941, standardising these agreed regulations. The standard recommends certain constructional methods, the most important of which is that the earth wire may not be connected to a screw used for tightening an earthing clamp on the

pipe. The specification does not, however, specifically lay down standards for the design of the earthing clamp. The safety requirements for mains operated apparatus for radio, acoustic and visual reproduction is dealt with in another specification, No. BS415/1941, which revises a previous specification, and is amplified by a section on the installation of apparatus. The specifications cost 2s. 3d. each.

### Wireless Technicians Required

WE learn from those responsible for the London District Signals that this unit is in need of men who have wireless knowledge. The men need not necessarily be experts. They are required for operation and maintenance. Anyone possessing the necessary knowledge, between the ages of 18 and 59, may apply. Those living in London are especially invited to apply. One of their duties will be to maintain a radioservice between the various strategical points in the appropriate area, particularly during a breakdown of the land-line communications.

### The Blitz and P.A.

DURING the recent air attack on the Clydeside, vans controlled by the Ministry of Information traversed the damaged areas for several hours. Each van was equipped with P.A. apparatus and issued instructions concerning clearing stations, food stations and rest centres for those rendered homeless. Thus radio and P.A. are taking part in the war.

### Export Licences for Valves

A LICENCE is now necessary for the export of wireless valves under a new Board of Trade Order. This order also applies to electric insulated wire and cable, cable-making machinery, wire drawing, wire and cable insulating and covering machinery. The order further excludes the export of certain mica manufactures without licence.

### War Damage Liability

A NUMBER of our readers have raised the important question as to who is liable for damage when their receivers are damaged by enemy action whilst on the premises of a dealer. The answer is that the dealer is not liable, for under the Liability for War Damage Act, 1939, it is clearly stated: "Where in the case of the bailment of any goods an obligation is imposed on the bailee by the provisions (whether expressed or implied) of any contract, or by . . . any rule of law or custom; (b) to repair damage to goods; (c) to replace goods in the event of loss; (d) to restore the goods or deliver them up in good repair . . . ; (f) to pay damages or compensation for any loss of or damage to the goods, the obligation shall be deemed not to extend to loss or damage by war."

### Broadcasts to the Services

IT does not seem to be generally known that the Icelandic Broadcasting Company's long-wave station at Reykjavik has been broadcasting for an hour each day, with the exception of Saturday, a programme to the troops in Iceland. Now the experiment is to be repeated for the Forces in the Middle East, and one of the Egyptian broadcasting stations will broadcast on somewhat similar lines. Let us hope that the scheme will be developed to apply to our troops in other countries.

### Postal Service Course

THE National Association of Radio Retailers have provided details of their Postal Course in radio servicing. The course opens with an elementary description of the principles of wireless reception, and this occupies ten lessons, which include instruction on fault-finding. The second part of the course is devoted to the various parts of the broadcast receiver and their respective functions, with instructions on servicing and fault-finding. The second part also occupies ten lessons, each question is, of course, illustrated, and includes questions which the student must answer and submit for correction.

Editorial and Advertisement Offices:  
"Practical Wireless," George Newnes, Ltd.,  
Tower House, Southampton Street, Strand,  
W.C.2. Phone: Temple Bar 4363.  
Telegrams: Newnes, Rand, London.  
Registered at the G.P.O. as a newspaper and  
for transmission by Canadian Magazine Post.

The Editor will be pleased to consider articles of a practical nature suitable for publication in PRACTICAL WIRELESS. Such articles should be written on one side of the paper only, and should contain the name and address of the sender. Whilst the Editor does not hold himself responsible for manuscripts, every effort will be made to return them if a stamped and addressed envelope is enclosed. All correspondence intended for the Editor should be addressed: The Editor, PRACTICAL WIRELESS, George Newnes, Ltd., Tower House, Southampton Street, Strand, W.C.2.

Owing to the rapid progress in the design of wireless apparatus and to our efforts to keep our readers in touch with the latest developments, we give no warranty that apparatus described in our columns is not the subject of letters patent.

Copyright in all drawings, photographs and articles published in PRACTICAL WIRELESS is specifically reserved throughout the countries signatory to the Berne Convention and the U.S.A. Reproductions or imitations of any of these are therefore expressly forbidden. PRACTICAL WIRELESS incorporates "Amateur Wireless."

# A Long Range Single-valver

## Constructional Details of an H.F. Pentode Receiver for Efficient Reception on the Medium-wave Band

Now that there are few amateur transmissions to be received on the short-wave bands, the medium wavelengths often prove more interesting to the constructor enthusiast. Long waves are fairly "quiet," and since there are no British stations on the long-wave band, any type of broadcast receiver can be made to cover a single waveband only. This simplifies design, and makes for increased efficiency; in some respects it brings us back to the position which existed in the early days of broadcasting. At that time phenomenal results were often obtained with a simple single-valve receiver. Partly with that idea in mind, and partly due to considerations of economy; we recently carried out a number of simple tests to find what would be the best type of single-valve arrangement for present conditions, using a modern valve.

### H.F. Pen. Detector

Eventually, we came to the conclusion that a circuit of the type shown in Fig. 1 was as satisfactory and reliable as any. It will be seen that use is made of an H.F. pentode, although similar results would be obtained with a screened tetrode of the non-variable- $\mu$  type. In fact, a valve of that type could be used in the circuit reproduced without making any alterations to the wiring. Some of those who have always relied on a triode valve for detection may ask what advantages are to be gained by the use of a pentode or tetrode. We can answer this question with the one word—"reaction." Every constructor who has attempted to obtain the utmost efficiency from a single-valve or det. L.F. receiver must have found that results depend to a very large extent on the smoothness of reaction control; upon the ease with which the regenerative detector can be brought very gradually up to the oscillation point and then operated almost on the verge of oscillation. If that can be done there is scarcely any limit to the range over which the receiver is effective. In fact, if a single-valve set could be designed which would remain stable (i.e., not suddenly break into oscillation), when it was set to the very edge of the oscillation point, it would have a range almost equal to that of a good superhet.

### Good Reaction Circuit

In practice, this ideal state of affairs cannot quite be reached, but it can be approached very closely if the reaction circuit is well planned, and if the user is sufficiently patient to cultivate the little skill required to get the best from his receiver. The method of reaction control shown in Fig. 1 is not entirely new, although it is not used very widely on broadcast sets. It will be seen that, in addition to the normal control by means of the reaction winding and reaction condenser, there is another control in the form of a potentiometer acting on the screening grid and supplying the S.G. voltage. By striking an accurate "balance" between the S.G. voltage and reaction-condenser setting

for any particular wavelength it is possible to obtain an extremely smooth reaction control, and thereby to obtain good 'phone reception over great distances.

### Coil Design

In addition to the method of controlling reaction the general design of the tuning

*by The Experimenters*

coil is very important. Fortunately, however this matter is simplified by agreeing to make the coil for a single waveband. Details of the coil which we made for our tests, and which we found completely satisfactory, are given in Figs. 2 and 3. The question of coil construction will be dealt with later. It will be seen from the accompanying illustrations that the two windings, tuning and reaction, are wound on the same former and are placed end to end. It will also be noticed that the tuning winding has three tapping points for aerial connec-

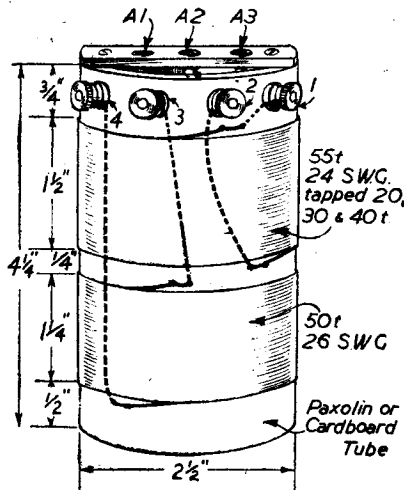

Fig. 2.—Principal winding details of the coil. Connections from the ends of the two windings to the terminals are shown, but the tapping points are omitted for clarity. Approximate dimensions are given, assuming that the turns are kept close together.

tion. By connecting the aerial to one of these points we have the same effect as that produced by using a separate aerial winding with adjustable coupling to the grid coil. In effect, the tapped winding acts as an auto-transformer, and by choosing the best tapping for the aerial system in use it is possible not only to improve selectivity but also to obtain maximum sensitivity.

### "Balancing" Aerial Coupling

In addition to the coupling variation brought about by moving the aerial tapping, there is a pre-set aerial series condenser.

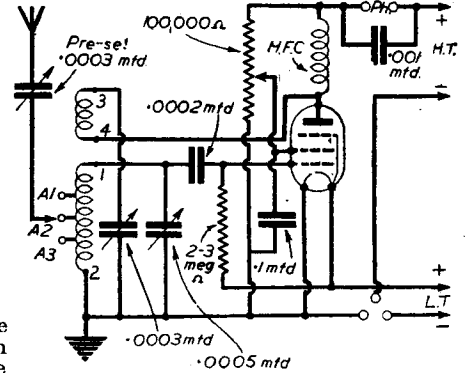

Fig. 1.—Circuit of the "hotted-up" single valver described.

This serves to provide the best setting between any two adjacent tapping points; in other words, if the condenser were set to its maximum capacity and the lead from it were taken to the second tapping point, the effect would be similar to that produced by reducing the capacity of this condenser and connecting the lead from it to the first tapping. Thus, at intermediate settings, the result would be the same as that obtained from a fixed condenser in conjunction with a coil having a dozen or more tapping points. Although a pre-set condenser is shown, it would be still better to use a variable condenser if one is available; that would permit of adjustments being made while actually tuning in a transmission. Nevertheless, it will normally be found that there is an optimum setting, in conjunction with the optimum tapping, for any particular aerial-earth system.

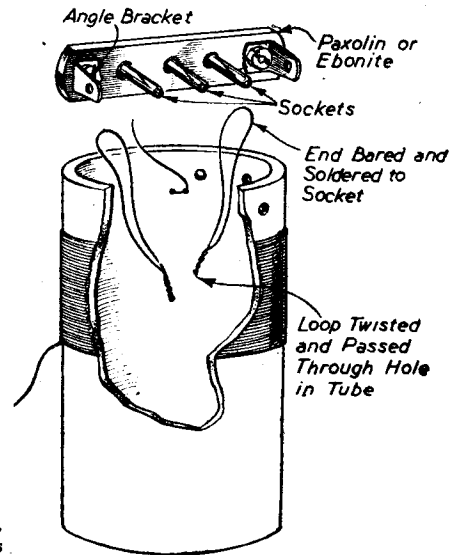

Fig. 3.—How the tappings are made, and a detail of the socket strip which is attached to the paxolin coil former by means of two 6 B.A. screws passed through the holes in the small angle brackets.

### Choosing the Aerial Tapping

In general, it may be stated that the most suitable tapping point when using a long aerial is the lowest (marked A.3), and when using a short aerial of, say, 25ft., the first tapping—A.1. That does not necessarily apply invariably, and therefore it is well worth while to spend an hour or more finding the most suitable tapping in conjunction with the optimum setting of the aerial series condenser. The best method of doing this is to find a fairly weak signal, but one not very subject to fading, near the

lower end of the tuning range, and to try the effect of using each tapping in turn, moving the aerial series condenser through its full range of movement when using each tapping. By this means it will be possible to find the optimum combination of settings. Then repeat the tests on a signal near the upper end of the tuning range after making a note of the previous settings. It may be found that the same settings are best at both frequencies; if not, it will be necessary to strike a compromise.

### Potentiometer Adjustment

The tests described should, preferably, be made with the potentiometer set to about its midway position, the setting being left unaltered throughout the tests. After that it will be possible to check reaction closely, trying various combinations of potentiometer and reaction-condenser settings. When doing this, bear in mind that as the setting of the potentiometer is reduced (arm moved toward the negative end), increased capacity will be required to maintain the valve in the same state of regeneration. It will eventually be found that a potentiometer setting can be obtained at which the valve goes gradually into oscillation. There should not be any "plop" as oscillation commences, but instead, a change from a silent "back-ground" to a faint hiss; the hiss will increase in loudness very slightly, and then pass away again as oscillation starts. Here again, patience is needed to determine the best position.

Although it may sound rather tedious and laborious, it will be worth while to make further tests with the tapping position and series-condenser setting after getting a good reaction balance. This is not essential, but as the whole object of the design is to ensure maximum efficiency it is impossible to be too painstaking. Remember that the results will fully justify the means, and that the inexperienced constructor will gain valuable experience from carrying out these experiments.

### H.T. Voltage

Up to now we have not made any mention of H.T. voltage, since this will depend to a certain extent upon the battery to hand. In practice it will be found that efficiency increases with H.T. voltage—at any rate, up to about 120 volts. In general, however, a voltage between 72 and 120 will provide satisfactory working. When the voltage is comparatively low, the setting of the screen potentiometer will have to be higher than when the battery voltage is in excess of, say, 72 volts. Whenever it is convenient, use an H.T. battery of 120 volts, tapping down slightly if it is found that there is some difficulty in securing the necessary smooth control of reaction. With regard to oscillation, it should not be forgotten that any single-valve or Det.-L.F. set of this type will cause interference with receivers in the same locality if it is allowed to "whistle" when tuned to a station. That is one very good reason why the reaction setting should be so maintained that there is a faint "hiss" in the 'phones when searching for stations. Another reason is that the set is by far the most sensitive when in this condition; sensitivity decreases if the valve is in the oscillating state.

### Baseboard Construction

Fig. 4 shows a suitable method of arranging the components. The exact layout is not very important, and a flat

baseboard is perfectly satisfactory with a simple outfit of this kind. A bakelite, ebonite or shellacked plywood panel measuring 9in. by 6in. is suitable, in conjunction with a baseboard measuring 9in. by 7in. The coil can be mounted on the baseboard by means of small brass angle brackets, or by fitting it tightly over a strip of  $\frac{1}{2}$ in. wood screwed to the baseboard.

### Coil Construction

Now we can consider the coil in greater detail. The wire used for the tuned winding is shown in Fig. 2 as 24 s.w.g., and that for reaction as 26 s.w.g., although either gauge can be used for both windings if preferred; in that case the lengths of winding shown will be modified. Enamelled wire should be used for both windings, and it should be noted that both sets of turns are in the same direction. A  $2\frac{1}{2}$ in. diameter paxolin former is to be preferred, although well-shellacked hard cardboard or fibre board is suitable. Four terminals are fitted near the top of the tube and a paxolin or ebonite strip, fitted with three wander-plug sockets, is eventually attached to the upper end of the tube by means of two small angle brackets. Start by making two small holes just below the terminals, and then thread the wire through these, leaving the end on the inside of the former, so that it can be bared of insulation and soldered or otherwise attached to terminal 1. Keep the wire taut and wind on 20 turns. Still holding the wire, make a small hole through the tube with a sharp bradawl, make a 2in. loop in the wire, twisting it tightly, and pass the loop through the hole. Continue winding until another ten turns have been put on; make another looped tapping; wind another ten turns

and make a third tapping, and then complete the 55 turns and finish off in the same manner as the coil was started. The reaction winding is similar, except that there are no tappings.

Bare the wire at the ends of the tapping loops and then solder the tappings to the sockets—before attaching the socket strip to the tube. Finally, fit the strip in position and the coil is complete. But should it be found that the windings are not gripping the tube tightly they may be given a thin coat of shellac varnish.

It will have been noticed that the reaction winding is smaller than is customary. This is because it proved more

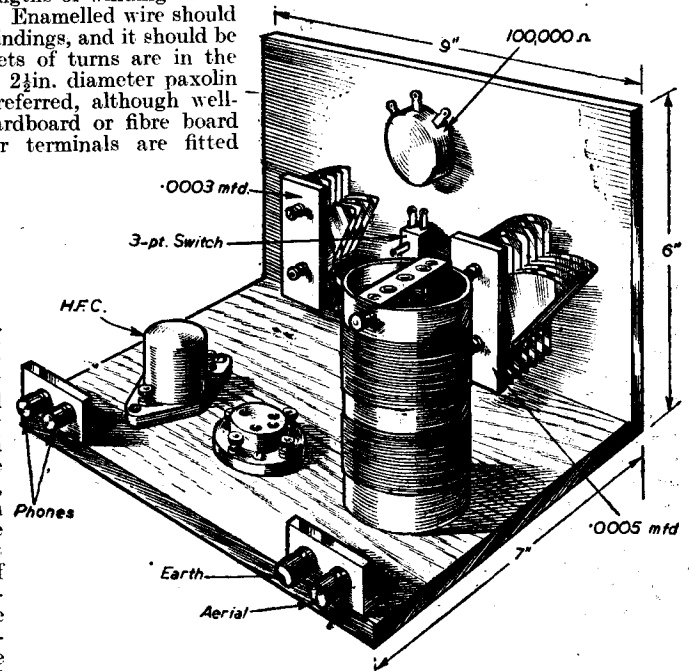

Fig. 4.—A suitable arrangement of components on the baseboard and back of panel.

satisfactory during our tests. If the coil were being used with a triode, however, it would probably be necessary to use an extra 20 turns or to have a .0005-mfd. reaction condenser, unless an H.T. voltage of 60 or more were employed.

## Technical Book Service

IN response to an urgent need which has lately become evident, the National Book Council, 3, Henrietta Street, W.C.2, have compiled a portfolio of information concerning recent technical books from leading publishers. This portfolio provides a free service to British industry, and should help towards a greater and speedier output. A great deal of care has been put into the compilation of the lists of selective and authoritative books, and the portfolio will prove handy for reference. An order slip is included so that any books mentioned in the lists can conveniently be ordered from a bookseller. Fuller particulars of individual titles will be gladly supplied from the above address. It is proposed to circulate future issues of supplementary lists, four or six times a year, and the N.B.C. will be pleased to receive any suggestions with regard to these lists. One of these useful portfolios should be in the hands of all users of technical books.

Another service of the N.B.C. is an Enquiries Bureau, for the use of which there is no charge to members of the National Book Council. The full privileges of membership can be had for half a guinea, and further particulars may be obtained from the secretary.

## Westinghouse Booklets

WE are informed by the Westinghouse Brake and Signal Company that they are continually receiving requests for their booklets, accompanied by coupons cut from their advertisements, but the senders omit their names and addresses. These applicants, of course, have received no reply to their requests, but the Westinghouse Brake and Signal Company will be pleased to forward a booklet to any such reader who makes a further application.

# P.A. EQUIPMENT—2

## The Construction and Operation of Various Types of Microphones

By "SERVICE"

THE microphone is the first link in many types of P.A. installations, and the selection of the right type is essential for satisfactory results, as will be described later. There are five main types of microphones, and these are: (1) Carbon, (2) Condenser, (3) Crystal, (4) Moving Coil, and (5) Ribbon.

### Carbon Microphone

This is one of the most popular of the general-purpose type, as it is cheap, sensitive, and subject to very little trouble if properly used. There are two methods of construction, which may be seen from Fig. 1 and Fig. 2. Fig. 1 shows, diagrammatically, the internal arrangement of the button type of microphone in which the diaphragm is of conducting material and is in contact with a quantity of carbon granules packed into a small cavity in the body of the microphone. At the back of this cavity there is a plate of carbon or other conducting material which is in contact with the carbon granules.

If a voltage is applied between the back plate and the diaphragm, current will flow, and the value of the current will be determined by the voltage applied and the resistance of the carbon granules.

When sound waves strike on the diaphragm the latter will compress the granules and decrease the resistance to the current which will, therefore, increase, and as the sound waves vary in intensity, so will the diaphragm vibrate at different amplitudes, causing sympathetic variations of the current in the circuit.

In series with this circuit there will generally be a transformer which isolates the current from the following circuits unless the microphone is to be very near the main amplifier, which may have its own input transformer.

The usual voltage applied to the microphone of this type is between 4v. and 6v., and a steady current will flow through the circuit even when there is no sound being picked up by the microphone; this is termed the polarising current.

Button type carbon microphones have a relatively high output, but are rather frequency conscious, so that although they may be quite satisfactory for speech, high quality music reproduction cannot generally be obtained from them.

### Transverse Current Microphone

The second type of carbon microphone is the transverse current type, details of which are shown in Fig. 2. It will be seen

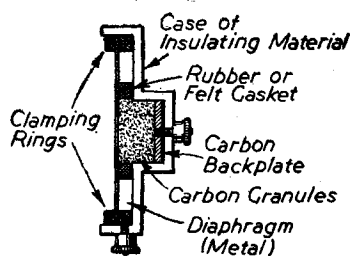

Fig. 1.—Section of a carbon button microphone, showing the carbon granules.

that the diaphragm is of an insulating material such as mica, which varies the resistance of a layer of carbon granules located in a hollow chamber and making contact with two electrodes at each side of the chamber. The current flows across the microphone—hence the term transverse—and the variations of the current are produced by the varying resistance of the



The external appearance of a typical moving-coil microphone—the E.M.I. Service Model P.M. 201.

carbon granules when they are affected by the air pressure of sound waves striking the diaphragm.

It will be appreciated that as there is always a current flowing through carbon microphones, and that as a portion of the circuit comprises a great number of surface contacts, there will be a tendency to background noise or hiss, and that the microphone will be very sensitive to variations which it will quickly translate

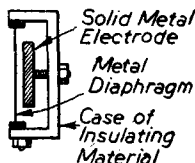

Fig. 3.—Condenser microphone.

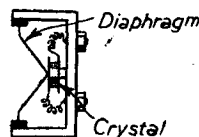

Fig. 4.—Crystal microphone.

into noise. Also, the operating current must be maintained at the proper level, otherwise sparking may occur between the carbon granules or between the granules and the electrodes, which will result in burnt areas which, as the microphone ages, will generally result in increased background hiss.

Another feature of carbon microphones, especially of the transverse type, is that

they must be operated in a vertical position for best results, and this sometimes limits their application.

### Condenser Microphone

The condenser microphone operates on the principle shown in Fig. 3, and it is easy to appreciate that its metal diaphragm forms one plate of a condenser while the more substantial plate, which is close to it but insulated from it, forms the opposite plate of the condenser. If a voltage is applied between these electrodes the condenser will attain a certain charge from the steady potential across the plates. Now, the charge in a condenser depends upon the voltage across its plates and the capacity of the condenser, which is again dependent upon the distance separating the plates. If this is varied, the charge, and hence the voltage across the condenser, is varied.

This is what happens in a condenser microphone when sound waves strike the diaphragm. The vibrations from the diaphragm alter the spacing between the plates of the condenser, and this in turn varies the capacity of the condenser and the varying voltages set up across the plates are applied to the input of the amplifier.

Condenser microphones, because of the nature of their construction, have a very low sensitivity compared with the moving-coil and carbon microphones, but they are very free from background noise, and with a properly designed diaphragm have a good frequency response. Unfortunately, however, the latter characteristic may easily be upset if a long length of cable is used, as the capacity of the cable will be in parallel with the capacity of the microphone, which in most instruments is about .0003 mfd.

Because of this, the condenser microphone must be operated close up to the amplifier, and where a long lead is necessary a pre-amplifier must be used close up to the microphone position and from this amplifier the cable can be run to the main amplifier.

Condenser microphones, like moving-coil microphones, may be operated in any position, but they are not very suitable for use out of doors in inclement weather, as they are very susceptible to dampness and subsidiary charges may be built up on the

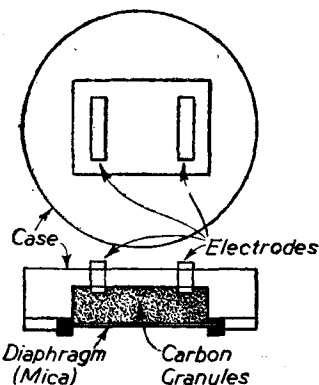

Fig. 2.—Transverse current microphone.



diaphragm assemblies which will give rise to cracking.

### Crystal Microphone

The piezo-electric effect of certain crystals has been the subject of articles in past issues of this journal, so that it need only be mentioned here that this effect produces very small voltages across opposing sides of a crystal when the crystal is mechanically stressed. By connecting a diaphragm to a crystal, the latter may be made to vibrate in sympathy with any sound waves striking the diaphragm, and the varying voltages developed across the crystal may be led off by means of suitable electrodes clamped to the crystal by cable to an amplifier.

In some makes of this type of microphone there is no diaphragm, it being arranged that the sound waves act directly on the crystal. Sensitivity is less than with a diaphragm, but the frequency response is better.

The connections to the thin strips of crystals—more than one often being used to obtain directional properties and other requirements—are generally made by means of metal foils, and consequently an appreciable capacity is a characteristic of the microphone. A common value is .005 mfd., and because of this capacity a long cable to the amplifiers cannot be tolerated. Makers of crystal microphones supply special transformers to match the microphone to the cable, but for runs of over about 50 feet a microphone amplifier close to microphone must be used.

The most commonly used crystal is that of Rochelle salt, which is protected from dampness, to which it is particularly susceptible, by a covering of wax.

### Moving-coil Microphone

The moving-coil microphone is, perhaps, the most popular type where good quality reproduction is required, together with fairly good sensitivity and absence of background noise.

As will be seen from Fig. 5, its construction is similar to that of a moving-coil loudspeaker, and it is as reliable from a maintenance point of view as this type of loudspeaker. The principle of operation, however, is reverse to that of a moving-coil speaker, as the moving coil being attached to the diaphragm generates the voltage across its winding as it moves in the pole gap of the permanent magnet. As sound waves vibrate the diaphragm so will the coil move in the gap, and when there is a complete circuit a varying current will flow in it in sympathy with the vibrations of the diaphragm.

The coil is made as light as possible to ensure a wide frequency response and there is, therefore, a comparatively small number of turns, having a fairly low impedance round about 20 ohms. A transformer is therefore necessary to match the input into the high impedance grid circuit of the first stage of the average amplifier. It is a very hardy type of microphone as it requires no polarising current, and it operates in any position, while there is no background noise, and very little deterioration over long periods.

There are types of moving-coil loudspeakers which, like their counterparts, have a magnet in them of the energised type in order to obtain maximum sensitivity with exceptionally good quality. This type of microphone will, of course, need a voltage supply for the energising current, but as they are not widely used they need not be discussed more fully here.

### Ribbon Microphone

This microphone operates on a similar principle to moving-coil types, inasmuch that a conductor moving in a magnet field has a potential developed across it which may be applied to an amplifier.

From Fig. 6 it will be seen that the ribbon conductor is also the diaphragm, and when this vibrates, due to sound waves

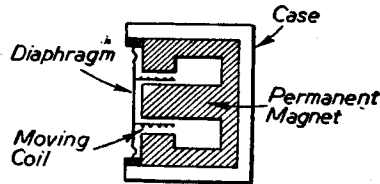

Fig. 5.—Section of a moving-coil microphone.

passing the strip, the varying voltages are an electrical impression of the vibrations. As the ribbon, although corrugated, is short in length compared with a moving coil, the voltage output is very small, but by means of a suitable matching transformer, connection to normal microphone cables is possible if these are kept short.

The ribbon microphone has a very good frequency response and, being directional, is often used for studio work for use by single artists or announcers. It is robust, but unless adequately shielded it is not very suitable for outdoor use, due to wind flutter of the ribbon.

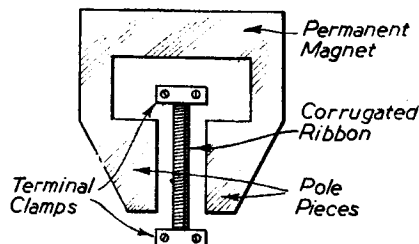

Fig. 6.—Details of a ribbon microphone.

### Microphone Cables

Microphone cables must be of the screened type, and the screening must in turn be insulated and protected to prevent mechanical damage to the cable itself and noise. The microphone circuit being connected to a very sensitive amplifier system will produce unbearable sounds from the loudspeaker if the slightest electrical fault of an intermittent nature occurs. The rubbing of the shielded wire against a metal water pipe, or even on a concrete floor, will produce noises, even if the screening is well earthed. Of course, this trouble will not exist in permanent installations where the microphone is always at one location, and where the

wiring from it to the amplifier may be run in with insulated cable firmly stapled to the wall, or run in conduit.

It is where the microphone is moved about, such as on stage installations, that the cable may give trouble, and it should be periodically inspected by switching on the equipment, and then taking the microphone cable between the two hands and passing it from one to the other, at the same time bending it about. This will soon show up any weaknesses, and will also enable the position of the fault to be quickly ascertained.

The actual earthing of the screening of the cable must be efficiently carried out, otherwise hum will occur and any electrical interference that may be present will be picked up by the unscreened wiring and form an intolerable background noise to the reproduction from the speaker.

A peculiar fault, often due to a corroded earth connection to the cable, is that of receiving a radio transmission on the wiring networks of the installation which is reproduced as a background to any programme being provided by the microphone. This is caused by the screening of the cable picking up the H.F. emanations of the transmissions which are rectified at the corroded joint, thus producing the L.F. signal on the screening which, because of the lack of an efficient earth, is induced into the microphone leads, where they are transferred to the amplifier.

With regard to the length of microphone cable which may be employed, this will depend largely upon the output from the microphone, so that, naturally, this information must be obtained from the manufacturer of the microphone.

### Impedance

The impedance of the microphone also has a bearing on the type of cable which may be used and, of course, a longer run with good quality, low-capacity cable may be used as compared with inferior cable which, however, may be quite satisfactory and therefore economical to use for short runs.

The installation details relating to microphones will be discussed later when the planning and layout of complete systems are being dealt with. It may be said here, however, that where special types of microphones are essential for a certain purpose, and require a long cable, and yet the output from the microphone is not sufficient to overcome the losses in the cable, a very compact single-stage amplifier may be built into the microphone housing. This accounts for the rather peculiar shape of some microphones, which have a large bulk compared with the size of the opening for the sound waves.

## The Navigator's Job

THE navigator must never be "a stranger in these parts." He must know how to get from one place to another, and this is briefly the whole science of navigation. The pilot relies on his navigator for guidance. Dead reckoning is the basis of navigation, and is worked out by reference to maps, to the sun or stars, or to wireless communication. Map reading is the simplest method when landmarks can be recognised and identified on the map. This is called obtaining a "visual fix"—hence the importance of the "black-out," which helps to rob an enemy navigator of his "visual fix," when flying by night.

A "radio fix" is obtained by getting bearings from two wireless stations. They

indicate the lines on which the plane is travelling. These two lines are marked on the map, and where they intersect is the actual position of the aircraft. Then again, the navigator may obtain an "astro" or "celestial fix" from two stars, using the sextant—long familiar to sailors—to calculate his position. Like the sailor he also uses a compass, a smaller edition of that used at sea and built to withstand even rougher treatment. The navigator is also aided by a radio beam which helps him to bring his aircraft safely home in bad weather.

The navigator's job is a full-time one. He must work out his course and ground speed in relation to the speed and direction of the wind. He must be calculating and checking his position the whole time.

# Set Control from Extension Points

## A Novel Remote Control System Utilising Press-button Switching

THE following method of controlling my set from one or other of several extension points occurred to me while trying to find a use for a spare press-button unit.

The unit used consists of a 6-way press-button switch, each button controlling two sets of three contacts each; this allows two circuits to be either made or broken at the same time, as will be understood by reference to Fig. 1. By a closure of any switch the three contacts on either side of the unit

ment the set can now be switched through to any room, and we are able to switch it on or off from that room.

The general arrangement of the control point is shown in Fig. 2. The input from the mains comes in at the top, and is taken through a master switch to the press-button unit mounted directly beneath it, and this is fitted with an escutcheon bearing the names of the various points controlled. The mains output from the unit is taken to the plug-socket mounted on the right-

### Modifications

The above arrangement permits of many modifications, of which the following may be mentioned. If it is not desired to switch the set from the various control points this wiring may be dispensed with, and in its place we may run the loudspeaker extension points as a two-wire system. This method is not so good as the single-wire system, and great care should also be taken when using this method as the wires will carry the plate voltage for the output valve which may be between 200-350 volts.

If it is only desired to have control from two points, then the same method can be employed as in the wiring of two-way switches for lighting purposes (Fig. 3). The loudspeaker extension wiring is kept the same as before, and the appearance of the completed unit remains the same, though the master switch in this case is of the two-way type; another of the same type is fitted at the remote point, the associated wiring being as shown in Fig. 4.

### Important Points

provision also being made on this side for the connection of a speaker. Input from the speaker terminals of the set is brought in at the base. The output lines to the speaker extensions are taken from the base of the unit, while the output lines to the controlling switches are taken out at the side. The whole unit measures approximately 8in. x 3in. x 3in. A suitable switch may be obtained from one of the many firms advertising in this journal.

The following points should be noted: All mains wiring should be carried out in good quality cable, and a suitable kind to employ would be 3/029 V.I.R. tough rubber-covered twin cable. If the single-wire distribution system is used for the speakers then good insulated aerial wire can be used for these; if the two-wire system is employed then the best cable to use would be as specified above for the mains wiring. Another modification to the system would be to use two separate press-button switches—one to control the loudspeaker extension points, the other to control the mains extension points.—E. S.

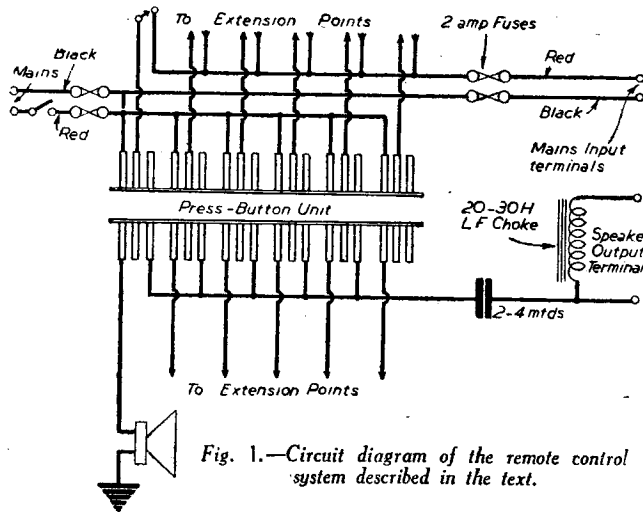

Fig. 1.—Circuit diagram of the remote control system described in the text.

are connected together; the wiring of the unit is as follows:—

An output filter consisting of an L.F. choke of 20-30 henries is connected across the speaker terminals of the set, as shown, and to the side of this which is connected to the anode of the output valve is connected a fixed condenser of about 2-4  $\mu$ F. A single connection taken from this is soldered to the first contact of each set of three contacts on one side of the switch, from the middle contact of each set of three wires leads are taken to the various extension points to be served by the system, this being determined, of course, by the size of the unit employed; the return to the set from each point is made through earth. This deals with the speaker side of the system and we can now switch in any speaker by a press of the button.

### Mains Connections

To turn to the mains side of the unit, the incoming leads from the mains are taken through 2-amp. fuses and then connected in the following manner. The red lead, which will in general be the live lead (if this is not the case, determine which is the live lead, as it is better practice to put all switches in this lead), is connected to the end one of each set of the contacts on the other side of the switch, as shown. From one of the other contacts of each group take a wire to the extension point already covered by that group, connect it through a switch in the normal manner, bringing the return back to a common red lead. The black, or earthed side of the mains, and the common live lead are taken through another set of 2-amp fuses to a standard 5-amp. plug socket, from whence direct connection can be made to the set. By this arrange-

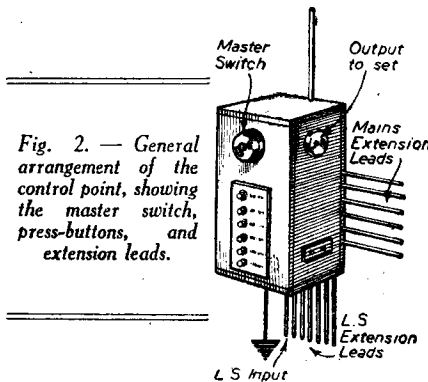

Fig. 2.—General arrangement of the control point, showing the master switch, press-buttons, and extension leads.

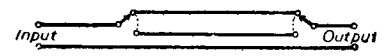

Fig. 3.

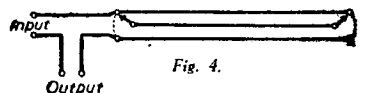

Fig. 4.

Figs. 3 and 4.—Wiring diagrams for two-way switching.

## A COMPLETE LIBRARY OF STANDARD WORKS

By F. J. CAMM.

- PRACTICAL WIRELESS ENCYCLOPÆDIA 10/6, by post 11/.
- EVERYMAN'S WIRELESS BOOK 6/., by post 6/6.
- PRACTICAL WIRELESS CIRCUITS 5/., by post 5/6.
- COILS, CHOKES and TRANSFORMERS 5/., by post 5/6.
- PRACTICAL WIRELESS SERVICE MANUAL 7/6, by post 8/.
- WORKSHOP CALCULATIONS, TABLES & FORMULÆ 5/., by post 5/6.
- NEWNES' SHORT-WAVE MANUAL 5/., by post 5/6.
- WIRELESS TRANSMISSION 5/., by post 5/6.
- DICTIONARY OF METALS AND THEIR ALLOYS 5/., by post 5/6.
- THE SUPERHET MANUAL 5/., by post 5/6.
- PRACTICAL MECHANICS HANDBOOK 8/6, by post 9/.
- RADIO ENGINEER'S VEST-POCKET BOOK 3/6, by post 3/9.

All obtainable from or through Newsagents or from Geo. Newnes, Ltd., Tower House, Southampton Street, Strand, W.C.2.

# ON YOUR WAVELENGTH



## The Oldest Reader

I HAVE received some interesting correspondence on the subject of the doyen, and am astonished to find so many young-old men building wireless sets. F. W. C., of Harrow is a comparatively young man of 54, as keen as ever on building wireless sets. E. S., of Folkestone, is 62. I had another letter from an enthusiast of 75. All of these readers (pro-croonerite jazz-fiends please note!) express the view that jazz music should not be broadcast. One says: "I delight in your mild criticisms of crooners, dance-band leaders and swingers, but would be more delighted to hear that the whole bunch was to be transported elsewhere, and to learn that the B.B.C. cease to make many listeners sick with the tripe it seems to imagine is entertainment under the above headings."

This is what E. S. says: "About eight years ago I was lucky enough to be able to purchase my first set, and I was entirely ignorant of the first thing about wireless. A few weeks later, one of my sons brought in a copy of P. & A.W. with the remark that he thought I might be interested. I can't explain the evolution of my mind from pure ignorance to understanding after a perusal of that copy, but I find that I was quite keen to know more about the subject. I have been a regular reader of your paper ever since, besides having obtained four of the books from your technical library. I do not regret their cost, as the knowledge gained has enabled me to build more sets, to read a theoretical diagram quite easily, to discover and rectify faults in sets belonging to friends. I sincerely wish I had known of these things many years before."

I could quote from many other letters written in similar strain. Now, who is the youngest reader? On the subject of the oldest reader, I had better let "Torch," who bombards me with his verses, have his say. This is what he writes:—

"Thermion says it would be interesting to know who claims to be the oldest amateur constructor reader of PRACTICAL WIRELESS. I happened to mention this to my old friend, Jarge Slocum, of Claypuddle Farm, and he said: 'Oi baint never 'eard o' no Thermion down in these 'ere parts, but 'ee best write an' tell 'im as 'tis Oi what made first wireless set round 'ere, and she be goin' yet—when Oi tickles 'er in roight place!'"

Here is how old Jarge attempts to substantiate his claim:—

The day Oi were eighty—in Nineteen-Nineteen—  
Oi picks hup me paaper an' in it Oi seen  
A pickshur, it sez "is a new diagram,  
To make hup a crystal set." Sez Oi, "Be damn;  
Oi believes Oi could make 'ee," so Oi sends fer the  
paaparts,  
An' when they arrives on the job Oi soon staarts.

Oi gets 'er fixed hup, an' Oi puts hon me phones,  
Oi moves me cat's whisker: an' all through me bones  
Oi gets such a thrill, fer without any seekin'—  
Though yer moighten believe Oi—Oi 'ears folks  
aspeakin'....

Oi've still got 'er goin', me old crystal set,  
Though they tell Oi there's better ones now yer can get.  
But there, Oi don't 'old with this 'ere switchin' hou  
What might heasy hexplode, then yer 'ome 'ud be  
gone.  
But as these 'ere be facts, without any lie,  
When yer asks, "Who's the Doyen?"  
Hit don't need no hargymnt, 'COS IT BE OI!  
"TORCH."

## By Thermion

### Restriction of Supply

HOW fortunate are constructors in possessing junk boxes of discarded components which now provide a source of spares from which to draw when the local retailer is unable to supply, and, in the case of certain components, he will not be able to do so until the war is over. I am receiving requests for designs which incorporate some of the older style of components, including plug-in coils; and here I would remind readers who are thinking along similar lines that "Practical Wireless Circuits," price 5s. (by post 5s. 6d.) contains a full series of circuits, from crystal sets up to multi-valve receivers, and an inter-communication receiver. Many of the circuits have, of course, appeared in this journal, and thus make use of the very components which constructors already have by them. This very useful volume, which is now in its tenth edition (it was formerly known as "Sixty Tested Wireless Circuits" and has regularly been brought up to date), has been in enormous demand lately, and I recommend every reader who has not already done so to purchase a copy whilst the paper position permits copies to be available. The "Radio Engineer's Vest-Pocket Book," already in its second edition, is also in great demand, both in the Services and out of it. Costing 3s. 6d., or 3s. 9d. by post, this valuable book is produced in diary size, and contains 160 pages. It is printed on specially tough but thin paper to reduce its bulk, so that it can be carried in the vest-pocket as a convenient *aide-memoire*; and a reminder that a catalogue of our technical books on

aviation, wireless, engineering and electricity is available free to readers addressing a postcard to The Publisher, Book Department, George Newnes, Ltd., Tower House, Southampton Street, Strand, London, W.C.2.

### Simple Sets

IN these difficult times we must learn to adapt and to improvise. If we cannot have a receiver in accord with our desires, we must put up with something short of them. I accordingly invite readers to submit details of hook-up and simple receivers which they have made during the war. Most readers have at some time made a quick rig-up, and it is these ideas which will be found of great value to those who have been bombed out of their homes, and are now in temporary residences, or who are located in districts where normal receivers are unobtainable. A book prize will be awarded to the sender of every such suggestion published.

### U.S.A. Radio Amateurs Rescue Amarillo

CRIPPLED by the worst ice storm in the history of West Texas, Amarillo, a busy little town set high on the Llano Estacado, or the Panhandle, owes most of its progress in digging out from under the debris to a group of amateur radio operators.

It was during the week-end of November 23rd of last year that a slow drizzle and steady sleet set in over a wide area on the Panhandle, including regions bordering into Colorado and New Mexico. On Sunday, November 24th, the sleet and rain froze into formidable proportions of ice, and under the strain of the huge frozen masses, thousands of telephone and telegraph poles and trees were broken down. Communication lines for at least a hundred miles in each direction were sent crashing to the sleet-covered ground. Power failed, and Amarillo, as well as other smaller Texas cities and towns in the region, was completely isolated from the rest of the world.

With the continuance of freezing weather the situation rapidly grew worse. Practically without power, Amarillo could no longer man the city water pumps and thousands of households went on forced water rations. Small fires caused by short-circuiting high-tension wires blazed in various parts of the city, and motoring was at a standstill owing to fallen trees, poles and debris blocking the streets.

News of the disaster had leaked out to the outside world, but only fragments of the condition could be picked up from stray travellers who fought their way through the storm. At fitful intervals, while power was still available, word of Amarillo's plight went spluttering and crackling out miles over the frigid air by short-wave transmitters operated by more than a dozen amateurs. Power continued to fall until portable power units had to be used.

Necessity became the mother of invention and as a result, many home-made power sets were brought into action. Throughout the first night, and for several days until other communications were established, amateur operators stuck to their controls and sent message after message out of the stricken area.

## Our Roll of Merit

Our Readers on Active Service—Fifteenth List.

- I. L. Taylor (Gunner, R.A.),  
Lincolnshire.
- G. H. Heppel (L/Cpl., 4th Camcroopers),  
Inverness.
- D. Hollis (Sgt., R.A.F.),  
Norwich.
- K. Burfitt (Cpl., R.C.S.),  
Wilts.
- A. Rumble (Sgmn., R.C.S.),  
York.
- J. E. Pickersgill (Pte., R.A.M.C.),  
Leeds.
- C. N. B. Hancock (2nd Lt., R.A.),  
Kent.
- S. G. Haynes (Sgmn., A.S. Sigs.),  
Liverpool.
- J. J. Burke (Trooper),  
Andover.
- A. D. Foyle (A.C.1, R.A.F.),  
Debden.
- K. Mallett (A.C.2, R.A.F.),  
Gatwick.
- W. J. Dunn (L/Cpl., Royal Signals),  
Berkshire.
- W. L. Foster (Gnr., R.A.),  
Iceland Force.

# Television Transmission Over Telephone Cables

Brief Particulars of the Latest Development of High-frequency Transmission

**M**OST radio broadcasts originate in the studios of the broadcasting companies, and are transmitted thence to the radio stations over high-quality programme circuits. There are many times, however, when the "pick-up" point is at a distance from the studio, and circuits to the studio must be provided over telephone cable pairs not normally employed for broadcasting. With television broadcasts such remote pick-up points are also required, but the utilisation of ordinary telephone circuits to link them to the television studio is more difficult because of the much wider band of frequencies employed and certain exacting requirements for television transmission. Because of the experimental state of television broadcasting in the United States, no arrangements for transmitting from these remote pick-up points have as yet been standardised. An experimental circuit of this nature was, however, provided for the National Broadcasting Company in May, 1939, and a somewhat similar one was recently provided for the Columbia Broadcasting System.

## Transmitting Difficulties

The difficulties encountered in transmitting over such circuits are due largely to the very wide frequency band required. For ordinary telephone circuits a frequency band of about 3,000 cycles is sufficient, while for both of these recent experiments, the band extended from 45 to over three million cycles, a range a thousand times greater than the voice band. The effect of the difference in frequency range on loss is indicated in Fig. 2. This shows the energy loss in one mile of local telephone cable made up mostly of 22 and 26-gauge paper insulated pairs. The loss in a coaxial for television transmission is shown in the same illustration for comparison. At three million cycles a mile of cable pair gives a

Fig. 1.—The two amplifiers with their equalisers and power supply are mounted in small portable cabinets as shown.

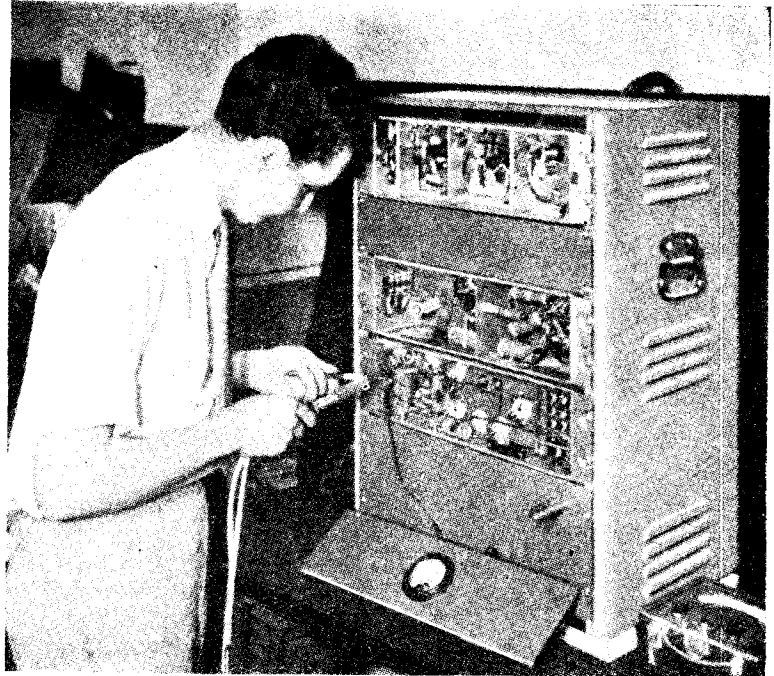

loss a million times greater than that of a coaxial conductor of similar length. For satisfactory television transmission equalisers must be provided to make the overall loss essentially the same for all frequencies. How effectively this is done is indicated in Fig. 3, which shows the losses of one of these experimental circuits of 0.86 mile length, both before and after the installation of the equalisers and amplifiers.

a cable pair can be used for television—therefore, it is necessary to measure the transmission time, and then to provide phase equalisers to correct it. As shown in the upper part of Fig. 4, the equalised line maintains the same transmission time to within plus or minus 0.1 micro-seconds.

In addition to the phase and attenuation equalisers required by such circuits, high-gain amplifiers are needed to overcome the very large loss encountered. These amplifiers provided a flat gain over the entire range of frequencies from 45 cycles to 3,000,000 cycles. Their design is complicated by the fact that the cable pairs are balanced, that is, each wire of the pair has the same impedance to ground, while the television apparatus, in common with most high-frequency apparatus, is grounded on one side. Relatively large currents are likely to be induced on both conductors of a cable pair from nearby 60-cycle power circuits and other noise sources. These currents flow equally over both conductors of a pair.

(Continued on page 281)

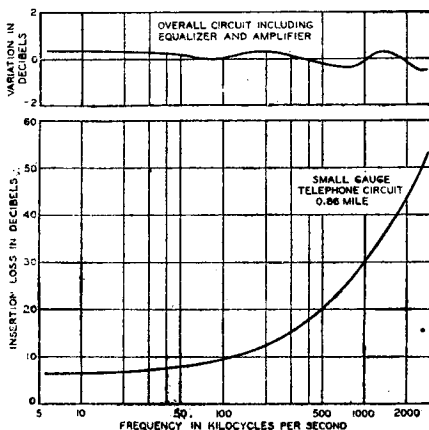

Fig. 3.—Overall loss over the television band for a cable circuit plus amplifiers and equalisers.

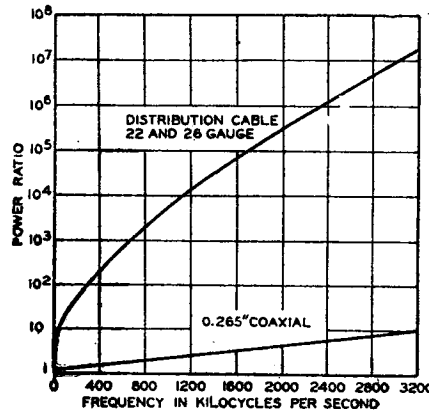

Fig. 2.—Losses in one mile of experimental telephone and coaxial-cable circuits over the television frequency range.

The variation in loss over the equalised line is within plus or minus one-half db.

## Time of Transmission

Besides this variation in loss with frequency there is also a variation in the time of transmission. This variation is too small over the voice range to require correction for ordinary telephone circuits. For television transmission, however, if it is not kept extremely small the detail of the picture will be blurred, and spurious transients and "ghosts" will appear. The transmission time for one of the circuits used in recent tests is shown in Fig. 4. Its variation amounts to about 2.5 micro-seconds, over 10 times the allowable amount. Before

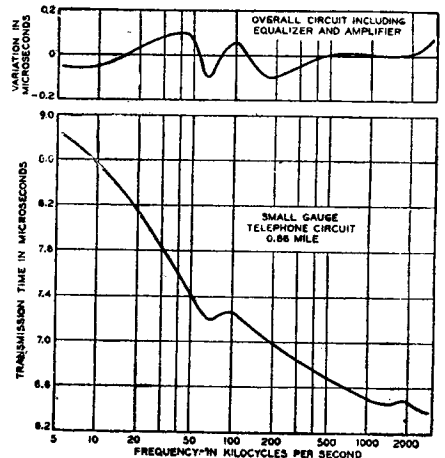

Fig. 4.—Time of transmission before and after equalisation for the same cable circuit.

# RAF *wants* Radio Enthusiasts

## SKILLED & SEMI-SKILLED TRADESMEN —

the R.A.F. needs your knowledge and ability. You can be enrolled as :—

- Wireless Mechanics - (18 to 50)
- Radio Mechanics - - (18 to 50)
- Electricians - - - - (18 to 38)

## UNTRAINED MEN WHO ARE KEEN ON RADIO—

the R.A.F. will quickly train you and add to your knowledge. Recruits are now wanted for training as :—

- Radio/Wireless Mechanics (18 to 32)

(THESE ARE ALL GROUND DUTIES)

Get full details by posting the coupon on the right, or, better still, go to-day to the R.A.F. Section of the nearest Combined Recruiting Centre (address from any employment exchange) and *volunteer* for R.A.F. Wireless Trades.

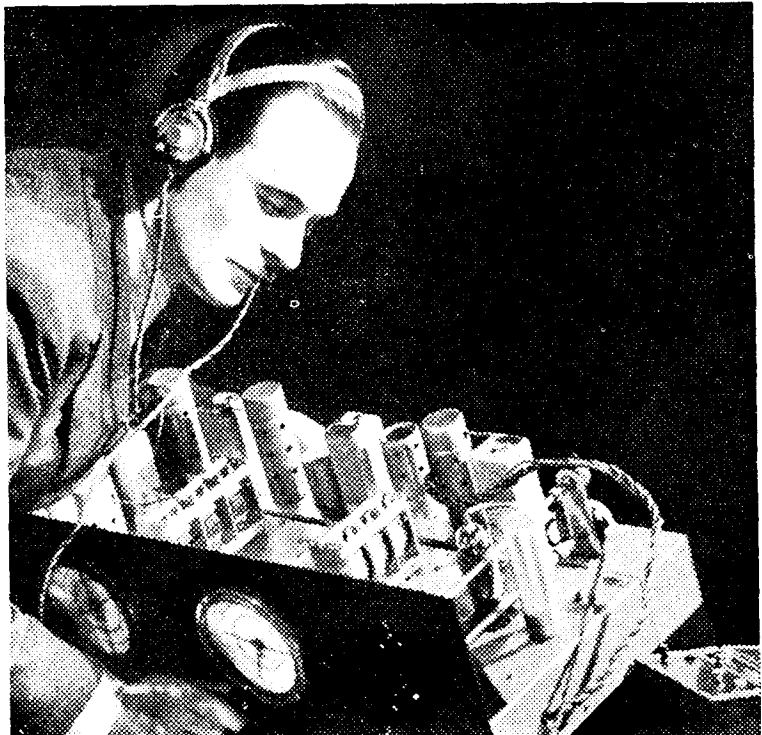

Men are wanted NOW to maintain and operate the wireless installations without which the grand work of the R.A.F. would not be possible. These jobs are interesting, the pay and conditions are good, and you have the satisfaction of doing work of first-rate importance.

-----  
Please send me details of Wireless Trades in the R.A.F.

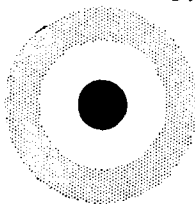

NAME.....

ADDRESS.....

TT13/Ju/A

To Air Ministry Information Bureau, Kingsway, London, W.C.2.

# HUGE TELEVISION PURCHASE CHASSIS, COMPONENTS, CABINETS, C.R. TUBES, ETC.

**N**EVER before has such an opportunity occurred. We have just completed the purchase of the stock of the pioneer Television manufacturer. All stock unused as taken direct from Warehouse and Factory. Chassis, C.R. Tubes, Speakers, Cabinets, Amplifier units, Components and accessories of every description. Enquiries invited from public and trade. To be cleared at ridiculous prices. Inspection invited. There are only a few items.

## £ £ £'s BELOW COST

### POWER PACK and AMPLIFIER CHASSIS

Size 16 1/2 in. x 16 1/2 in. x 4 in. First class examples of how scientific instruments should be built. Planned as the main unit for Television receivers costing many pounds. Includes heavy mains transformer 350-0-350, 120 m.a. with 4-4 volt 5 amp. tappings. High voltage transformer for supplying C.R. Tube. Various condensers including 16 x 16 mfd. 550 volt working, 1-16 mfd. 450 volt working, 50 x 50 x 2 mfd. B.I. Electrolytics, etc., etc. Pentode output transformer; chokes; resistors; trimmers; bias electrolytics; mica coils, etc., etc. The quality of the work highest class. New and unused as actual manufacturer's warehouse. 67/6. Also a slightly smaller chassis fulfilling the same functions but made for a different model, 62/6.

### C.R. TUBES

Included in the consignment are many types and sizes of Cathode Ray Tubes. Brand new in original cartons or mounted on new chassis. Send us your requirements and we will quote by return. C.R. Tubes not available to-day through ordinary channels. Will clear at low prices. Collection by buyer.

and tubular condensers; short-wave kranmanship and components is received from the 67/6. Also a slightly smaller chassis fulfilling the same functions but made

### CABINETS

Cabinets of every description available. Table type, Consoles, and large pedestal lift-up lid. All in first-class condition. Beautiful examples of the cabinet-makers' art. Made to house costly Television receivers. Let us know your needs, or better still, come and inspect.

### VISION UNITS

To fit on above Time Base. Consists of 3 Mullard T.S.E.4 and 1 Mazda D1 Valves. Approximately 25 resistors ranging from 75-75,000 ohms, and about 30 condensers of various values, together with Reflector Grid and various Band Pass Coils, also approximately 10 chokes of various descriptions and W6 Westector. All completely wired and carefully-screened in metal box. Unused as received direct from the manufacturers. 40/- (Complete circuit and service manual available, price 6d. each.)

### MAINS TRANSFORMERS

We have handled many thousands of mains transformers, but truly these are one of the best jobs we have seen. Originally made for Television Power Packs where accuracy and robustness is essential. Weight 12 lb., size 5 1/2 in. x 4 1/2 in. overall, 350-0-350 volts, 120 m.a. Four tappings each giving 4 volt 5 amps. Brand new and unused, 25/-

Space does not permit all lines to be advertised. See Classified advt. on Page 298. Most lines advertised in last month's "Practical Wireless" still available, including 5 watt 4 v. Amplifiers 220/250 A.C. at 6 gns., 3 watt 3 v. 220/250 A.C. Gramophone Amplifiers at 5 gns., Heavy Duty Mics., 30/-, etc., etc.

## LONDON CENTRAL RADIO STORES

23, LISLE STREET, LONDON, W.C.2

GERRARD 2969.

## THIS YEAR—WE CLIMB TO VICTORY

**YOU CAN HELP TO ACHIEVE VICTORY**  
your country and yourself at the same time if you do your best, but you are not doing your best if you waste time.

By becoming efficient in your vocation you can give the best service to your country and to yourself. The more you increase your earning power the better it is for the country and for yourself personally.

War or no war, earning power always brings its possessor to the front. It is no use waiting for better times. The ideal opportunity never arrives. We have to make the best of existing conditions. Therefore, delay is useless; it is worse, it is harmful.



possibilities of a vocation and how to succeed in it. You will be under no obligation whatever. It is our pleasure to help. We never take students for courses unless we feel satisfied they are suitable. Do not forget that success is not the prerogative of the brilliant. Our experience of over thirty years proves that the will to succeed achieves more than outstanding brilliancy.

*J. Bennett*

### EARNING POWER IS A SOUND INVESTMENT



#### DO ANY OF THESE SUBJECTS INTEREST YOU?

- Accountancy Examinations
- Advertising & Sales Management
- Agriculture
- A.M.I. Fire E. Examinations
- Applied Mechanics
- Army Certificates
- Auctioneers and Estate Agents
- Aviation Engineering
- Aviation Wireless
- Banking
- Blue Prints
- Boilers
- Book-keeping, Accountancy and Modern Business Methods
- B.Sc.(Eng.)
- Builders' Quantities
- Building, Architecture and Clerk of Works
- Cambridge Snr. School Certificate
- Civil Engineering
- Civil Service
- All Commercial Subjects
- Commercial Art
- Common Prelim. E.J.E.B.
- Concrete and Struct. Engineering
- Draughtsmanship, All Branches, subjects



- Engineering, All Branches, subjects and examinations
- General Education
- G.P.O. Eng. Dept.
- Heating and Ventilating
- Industrial Chemistry
- Institute of Housing
- Insurance
- Journalism
- Languages
- Mathematics
- Matriculation
- Metallurgy
- Mining, All Subjects
- Mining, Electrical Engineering
- Motor Engineering
- Motor Trade
- Municipal and County Engineers
- Naval Architecture
- Novel Writing
- Pattern Making
- Play Writing
- Police, Special Course
- Preceptors, College of
- Press Tool Work

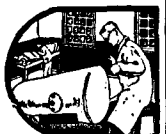

- Production Engineering
- Pumps and Pumping Machinery
- Radio Communication
- Radio Service Engineering
- Road Making and Maintenance
- Salesmanship I.S.M.A.
- Sanitation
- School Attendance Officer
- Secretarial Exams.
- Sheet Metal Work
- Shipbuilding
- Shorthand (Pitman's)
- Short Story Writing
- Speaking in Public
- Structural Engineering
- Surveying
- Teachers of Handicrafts
- Telephony and Telegraphy
- Television
- Transport Inst. Exams.
- Viewers, Gaugers, Inspectors
- Weights, and Measures Inspector
- Welding
- Wireless Telegraphy & Telephony
- Works Managers

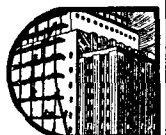

### TIME BASE CHASSIS

For 8in. Cathode Ray Tube. Well-made cadmium-plated chassis, size 17in. x 14 1/2 in. x 2 1/2 in., containing approximately thirteen fixed resistors ranging from 15,000 ohms to 1 megohm, five variable resistors, 2,000 to 20,000 ohms, approximately 14 various tubular and electrolytic condensers, also sundry focus and scanning coils and chokes.

Price 30/- each. (Complete circuit and service manual available, price 6d. each.)

30/-

### TUBE SUPPLY UNITS

For high voltage 16 1/8 in. Tubes. Approx. 6,000 volts output. Includes B.L. 1 x 1 mfd. 7,000 volt d.c. test condensers with porcelain insulators, transformer and rectifying valve, all shielded in metal case. Again, Brand new, 45/- (B.I. condenser supplied separately at 20/- and the transformer at 10/6.)

45/-

### CHASSIS

Beautifully finished, highly-polished new cadmium-plated chassis. Not the ordinary type, but superbly made, 16 1/2 in. x 13 1/2 in. x 4 in., drilled for 6 valves, transformer, etc. 4/- each.

4/-

STUDY AT HOME IN YOUR SPARE TIME



Dept 104, THE BENNETT COLLEGE, SHEFFIELD

EVERY DEPARTMENT IS A COMPLETE COLLEGE: EVERY STUDENT IS A CLASS TO HIMSELF.

IF YOU ATTEND TO THIS NOW IT MAY MAKE A WONDERFUL DIFFERENCE TO YOUR FUTURE.

Coupon—cut this out

To DEPT. 104, THE BENNETT COLLEGE, Ltd., SHEFFIELD

Please send me (free of charge) :-

Particulars of..... } (Cross out line which does not apply.)  
Your private advice about..... }

PLEASE WRITE IN BLOCK LETTERS

Name .....

Address .....

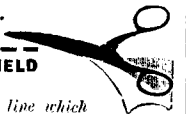

**TELEVISION TRANSMISSION OVER TELEPHONE CABLES**

(Continued from page 278)

which with the earth return comprise the longitudinal circuit. If the circuit, including the termination, is balanced throughout, these currents cannot affect the signal currents flowing in the metallic circuit, and appear as bar patterns on the received picture. The difficulty is avoided in this case not by use of transformers but by applying negative feedback in the amplifier to the longitudinal circuit but not to the metallic circuit currents. This in conjunction with vacuum-tube balances results in a reduction of 75 db. in these induced currents. This feedback is applied both to the output stage of the transmitting amplifier and to the input stage of the receiving amplifier.

The arrangement of the apparatus for the C.B.S. television experiment is indicated schematically in Fig. 5. Amplification and equalisation were provided at both ends of the circuit. The effect of the equaliser at the transmitting end is to predistort the signals, sending out the high-frequencies at a level much higher than if equalisation

were not employed. This tends to decrease the effect of any high-frequency noise, since the induced currents become smaller relative to the higher level of the signal currents. At the receiving end the equaliser is placed between two sections of the receiving amplifier. This results in a higher level at the input to the receiving amplifier and minimises the tube noise, the 60-cycle hum and the microphonic disturbances. The two amplifiers divided the total gain of about 75 db. They operate on 60-cycle power circuits, and with their equalisers and power supply are mounted in small portable cabinets as shown in Figs. 1 and 6.

**Signal Points**

The possible length of such circuits between repeaters is closely limited. The signal currents cannot be allowed to drop too low or else noise and other disturbances will be induced from the adjacent pairs. On the other hand, they cannot be allowed to become excessive or they, in turn, will induce disturbances in the telephone circuits. These two levels fix the distance that may be satisfactorily spanned. For average pairs in local telephone plants this

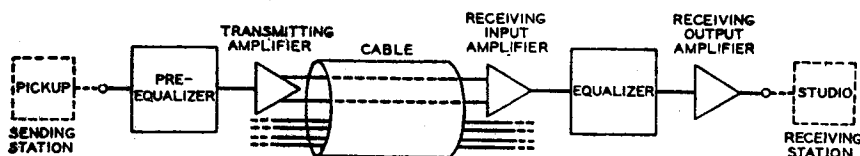

Fig. 5.—Schematic circuit layout for the recent television experiment.

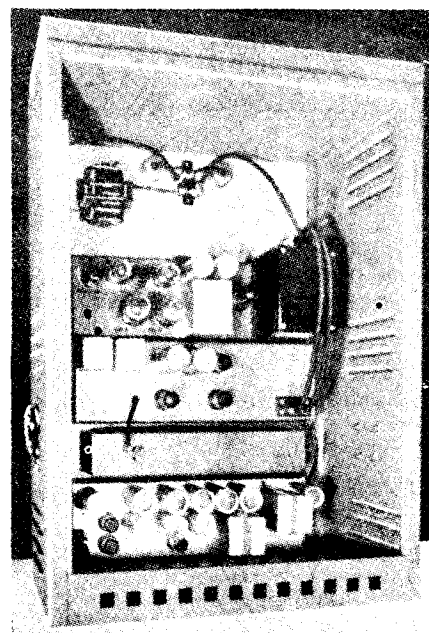

Fig. 6.—Rear view of amplifier-equaliser unit with door removed.

appears to be slightly under a mile, but it may be somewhat greater where relatively quiet circuits or larger-size wires are available.

# An Automatic Morse Transmitter

Operational Details of an Ingenious Motor-driven Apparatus. By G. S. OLDHAM

**F**OLLOWING up Thermion's remarks in the October, 1940, issue concerning the need for a morse transmitting apparatus, I submit the accompanying

**Operation**

In operation, presuming the letter A is to be transmitted, the procedure is as follows: When the key A, Fig. 2, is pressed the whole circuit comes into action. The arm G is arranged so that it first contacts with strip forming the beginning of the symbol—strip P in this case—thus completing the circuit. The motor then starts up, and the magnet D pulls on the armature Y and releases the arm, which then revolves and contacts with strip P, thus tapping out a "dot." The circuit is broken between P and P1, but the arm in rotating contacts with P1, and taps out a "dash," thus completing the letter A. To prevent the arm moving too far the insulated disc F (Figs. 1 and 2) cuts magnet out and releases armature Y, which forms a stop for the arm, which comes to rest at the correct point for commencing another letter A, as required. The pilot bulb then lights and key should be released to prevent further rotation of the contact arm G.

**Important Points**

It is necessary to provide for free movement of the central shaft so that the flywheel (not shown) is not impeded in its movement. The short-circuiting of the

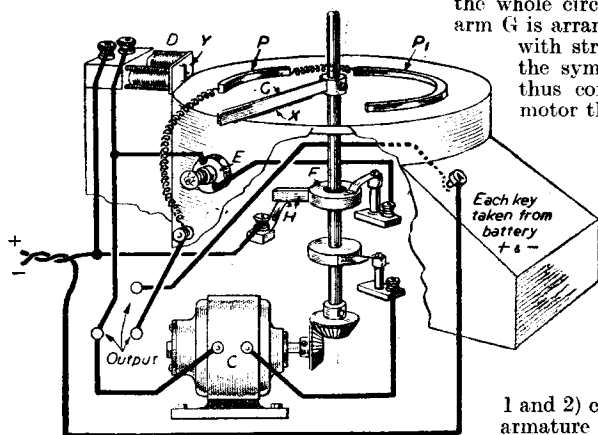

Fig. 1.—General arrangement of the automatic morse transmitter.

description of a morse transmitter I have devised, which may be helpful to other readers interested in the subject.

The pictorial view, Fig. 1, clearly shows the general arrangement of the apparatus, and the disposition of the various components, chief of which are the motor, central shaft carrying the contact discs, and the revolving arm, G, with wire brush which contacts with metal strips P, P1, which form the morse symbols.

Fig. 2 shows the circuit diagram for one letter, viz., A, and all other symbols are connected in series with the battery.

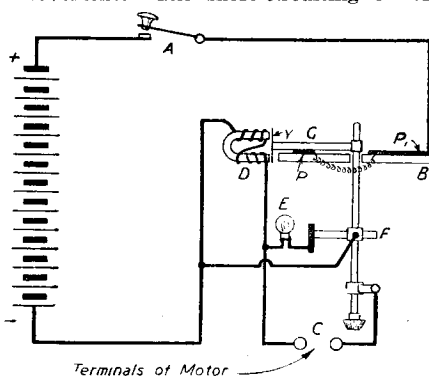

Fig. 2.—Circuit diagram.

magnet should be timed to occur shortly before the arm G meets the magnet armature, so as not to interfere with the next revolution. It is also necessary for the motor to have sufficient current to enable it to start immediately at high speed. When operating, wait till bulb lights before commencing the next letter. The spacing of symbols on the table is dot=3 units, space=3 units, and dash=9 units. In setting out the contact strips for the morse letters, keep the spacing uniform, viz., the distance between the segments of a circle, as shown in the diagrams, Fig. 3. In each of these examples the signals would be of the same length. The output is led to an H.F. transformer, and on to the necessary amplifying valves.

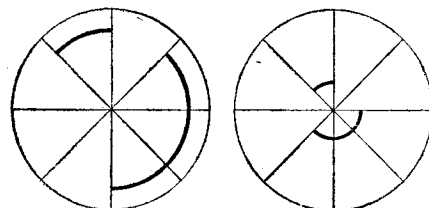

Fig. 3.—Diagrams showing spacing of symbols.

# Experimental Circuits

This Brief Review of Some Old Favourites Should Prove Particularly Interesting to Beginners

RECENTLY I happened to meet a young friend who has always been a keen radio enthusiast, and who had managed to get together the necessary components for his first transmitter just before the outbreak of war. On the commencement of hostilities he had to give up all ideas of transmitting and was complaining to me rather sadly of the lack of interest in radio to-day, and of the fact that he had nothing with which to experiment. As a result I promised to look out a few ideas for him, and in the course of so doing, unearthed a number of radio journals and handbooks which were published around 1925 and upwards, and supplied him with a batch of circuits which were in use then, and which he had never seen before. I suggested he should try these out with modern components or modernise the circuits, and also try them on short-waves. In giving the details of these old circuits

### Reflex Circuit

In those days the Reinartz, on which is based the detector circuit of to-day, was just one of a number of circuits, the general method then of obtaining reaction being by the "swinging coil" means of coupling the grid tuning coil and the reaction coil. A popular circuit of the day was the "Reflex" because it gave results with one valve, equivalent almost, to a two-valver. Fig. 1 shows the most modern reflex circuit I could find. The H.F. transformer in the anode circuit was an untuned transformer which was then in favour. I suggest that this circuit could be modernised by using choke H.F. coupling with ganged coils and condensers, and either crystal or valve detection.

The valve, as you will see, acts both as H.F. and L.F. amplifier, and you could try a screen-grid valve here, but in

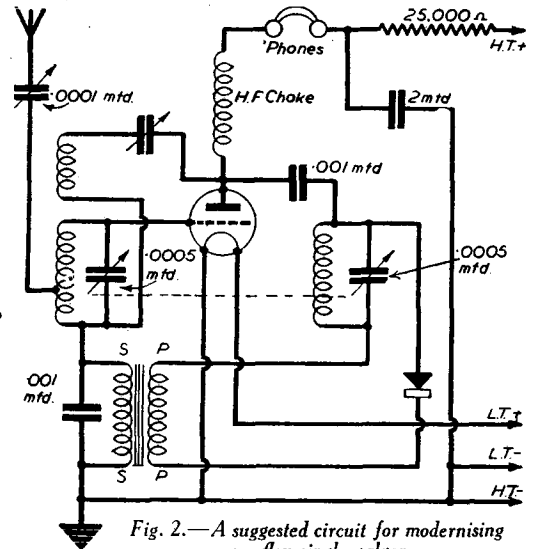

Fig. 2.—A suggested circuit for modernising a reflex single-valver.

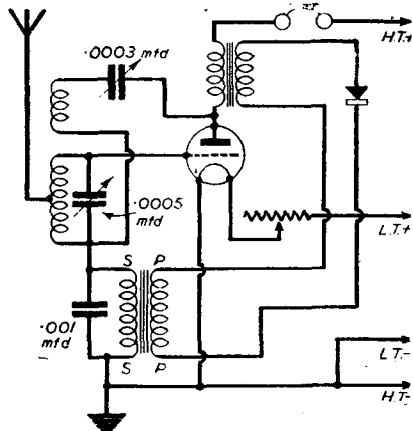

Fig. 1.—A typical single-valve reflex circuit.

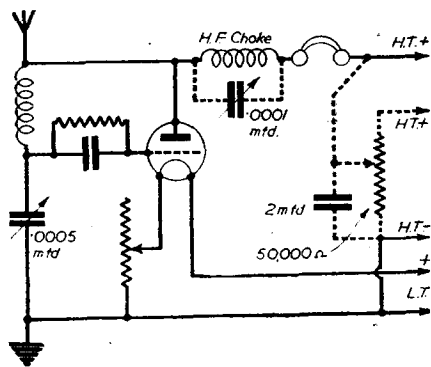

Fig. 3.—The de Forest "Ultra Audion" circuit.

### "Ultra Audion" Circuit

A popular circuit of some 16 years ago was the de Forest "Ultra Audion" shown in Fig. 3. The great difficulty with this circuit was reaction control, and anything was used to control this from a variable grid-leak to a finely controllable rheostat. Two suggested methods are shown in dotted lines on the diagram—one is a control of H.T. voltage, the other is a condenser across the H.F. choke. The former idea is likely to be most successful, although I always controlled reaction, when using this circuit, by means of the filament rheostat. Two more circuits of the time are shown in Figs. 4 and 5. The first, the "monodyne," was an American circuit, and was considered very useful at the time; the other was one of the "special" receivers which used to appear in those days, and I know it worked well. In its original form, everything possible, such as grid leak and grid condenser, was variable, but this should not be necessary to-day.

### Armstrong and Flewellyn Circuits

Figs. 6 and 7 are included as a matter of interest, and show two of the super-regenerative receivers of many years ago—the Armstrong and Flewellyn, respectively. Like the reflex, the idea of such circuits

here, I feel sure some of the "old hands" will revive pleasant memories in seeing them again, and that a great many of the younger generation have never seen them before. They all worked well with the dull-emitter valves and components of their day—how they may work to-day is, I suggest, a matter for a number of interesting experiments.

such a case it would be desirable to feed its output into an L.F. stage by means of resistance-capacity coupling. A suggested circuit is shown in Fig. 2; I have not tried it, but it is put forward as an idea for experiment.

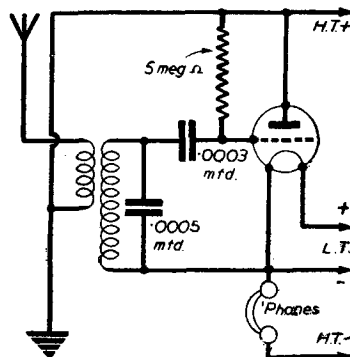

Fig. 4.—An American circuit known as the "Monodyne."

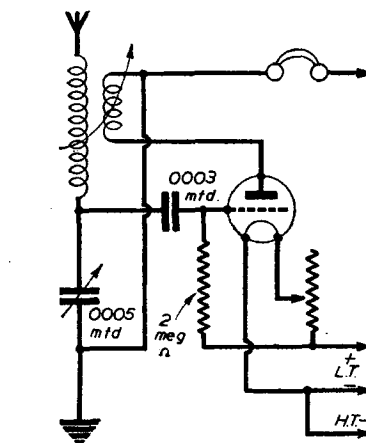

Fig. 5.—Another popular circuit for a single-valver.

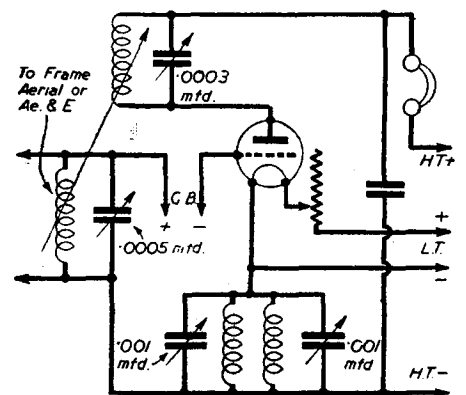

Fig. 6.—The Armstrong circuit.



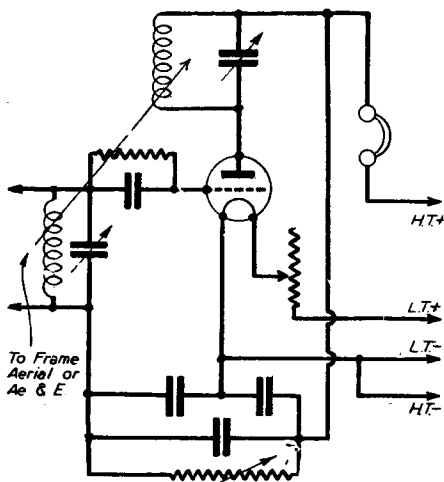

Fig. 7.—The well-known Flewellyn circuit.

was to get the "last ounce" out of each valve.

Finally, here are three more out-of-the-ordinary circuits I can recall—these are more recent, being only about 10 years old. Fig. 8 shows a semi-reflex circuit, actually consisting of a crystal detector, and a stage of L.F. amplification into which a certain amount of H.F.—controlled by the .00005 condenser—is deliberately fed in order to allow reaction to be provided. The circuits given in Figs. 9 and 10 are direct contrasts—Fig. 9 gives an anode-input circuit, whilst Fig. 10 is a filament input circuit, and both were reputed to give excellent results.

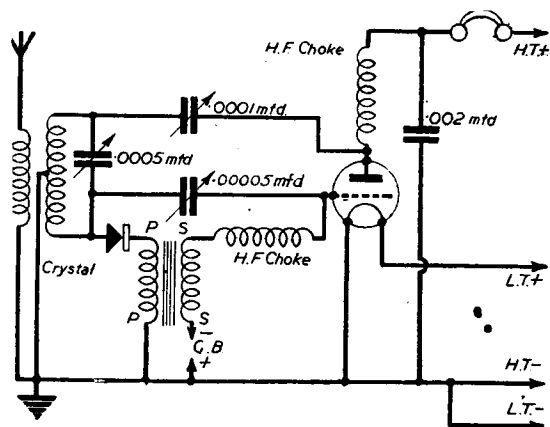

Fig. 8.—A semi-reflex circuit.

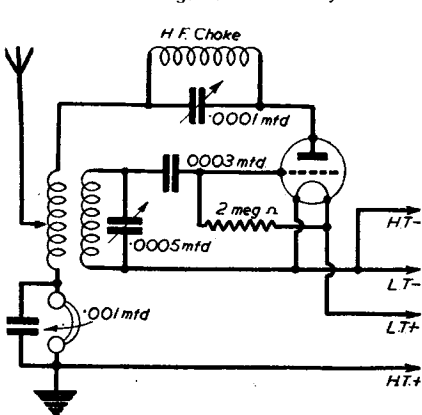

Fig. 9.—An anode input circuit.

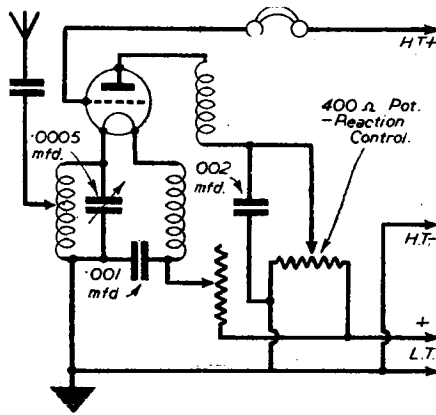

Fig. 10.—A filament input circuit.

It is hoped that these diagrams will bring back pleasant memories to some older hands, and also provide many interesting sources of experiment for the younger readers. All circuits are shown in one-valve form—any L.F. amplification desired can simply be added by connecting the L.F. transformer primary in place of the 'phones shown. The coils originally used, of course, were the plug-in two-pin type, but any suitable form of coil could be used, or special coils wound for the purpose.—G. W. D.

## Recording B.B.C. News Stories

A VITAL task of broadcasting is to give an accurate and vivid impression of contemporary life and current events. The most direct way of doing this is by means of sound pictures which combine the actual sounds of events with the voices of the men and women taking part in them. On occasion, this may be done by roving microphones connected by telephone line to a studio centre, but the most interesting topical material is sometimes to be found at places remote from telephone lines, or at times unsuitable for direct broadcasting. It must then be collected by means of a mobile recording unit. There are two types of equipment, a heavy one mounted in a large van, and a light portable apparatus carried in a saloon car. Each of these has its special uses. The heavy type can work away from its base if necessary for several weeks at a time and, since the equipment is all operated from batteries which can be charged from the engine of the van, it is self-contained and independent of electric supply mains. The light type is essential where a topical new story must be obtained at short notice and the records brought back the same night to a studio centre.

### Heavy Mobile Unit

A mobile unit of the heavier type consists of a motor van, weighing about six tons when laden, the body of which is divided into two compartments. One compartment is acoustically treated so as to form a small studio suitable for speech. The other contains two sets of recording equipment to enable a continuous recording being made by passing from one turntable to the other as each disc is finished, together with the associated amplifiers,

the controlling and switching equipment, and the battery-charging plant. Recordings can be made either of speech from the microphone in the studio compartment, or of speech or other sound picked up by other microphones outside the van and connected to it by cables. The size of the van makes it possible to accommodate the most complete technical equipment for controlling the programme and checking the accuracy of the recording, and also to employ the most robust and convenient form of recording apparatus. The turntables can be made level by hydraulically operated adjustments, so that recordings can be made when the van is standing on a slope. The speed of the turntables can be accurately adjusted, and gramophone pick-ups and a loudspeaker are provided

for reproducing sound from the records when necessary.

The light unit has been designed by B.B.C. engineers to meet the special requirements of being sufficiently compact to fit into an ordinary saloon car, light enough to be carried into a building or set up in an aeroplane, and robust enough to withstand driving over bad roads at high speeds. Although it is normally used in the car, the apparatus had to be readily movable so that it could be carried by hand to places to which the car could not be taken. It had also to be independent of external power supplies and suitable for use not only as a recording unit but also for direct outside broadcasting work where suitable Post Office telephone lines were available to carry a "live" broadcast. The apparatus consists of three main parts: the recording machine, the amplifier and the power supply unit.

## Broadcasts to Schools

ALL the well-established series of broadcasts to schools will be continued during the summer term, which began on April 21st.

"Music Making" will be heard on Wednesday afternoons, and arrangements are being made for giving the broadcasts which Sir Walford Davies was to have given.

As the "Dig for Victory" campaign develops, and the school gardeners increase the yield of food from their plots, the broadcasts in the series entitled "The Practice and Science of Gardening" should have an increasing audience. Food will also figure in the "General Science" broadcasts on Wednesday afternoons, six of which are to be devoted to food and health. They will give a scientific back-

ground to some of the food problems which everyone is having to face.

English, with three broadcasts a week for seniors and two a week for juniors, will still hold an important place in the schools programmes, and Hans, the refugee from Nazi Germany, who recently took part in a broadcast to schools with the President of the Board of Education, will continue to ask questions each week on Friday afternoons about English ways of life in the series called "If I Were British."

The summer term schedule of broadcasts to schools is now published and copies may be obtained from the Secretary, Central Council for School Broadcasting, Bedford College for Women, Regent's Park, London, N.W.1. The schedule gives details of all the summer term broadcasts, with explanatory notes about most of them.

# B.L.D.L.C. The British Long-Distance Listeners' Club

**D**URING the past month we have received so many interesting letters from members concerning their activities and other items of interest, that we are publishing extracts from some of them this month, in the hope that they will encourage other members to write and let us know of their experiences.

## A Neat Den

**M**EMBER 6812 writes as follows: "Since joining your club I have made a lot of pen-friends who were already members, and I have received a lot of interesting schedules and photos of other members' dens. I enclose a photo of my radio room, which was taken about four months ago, and since then I have received a few more QSLs from short-wave stations, but basically the gear is the same. I do a little home recording, both acoustic and electrical, but results have not been very good, due to the shortage of metal discs, and the increase in price of glass ones. The little portable seen in the foreground of the snap is used to amplify short-wave sigs., and the output of this runs through a one-valve amplifier (constructed from '60 Tested Wireless Circuits') on to the pick-up. I also built a wave-trap from a recent issue of PRACTICAL WIRELESS, and it has proved very useful. It even helps my most-used set (which does not appear in the snap) to cut out interference. I have been doing short-wave work since 1937, and have built a good many short-wave sets."

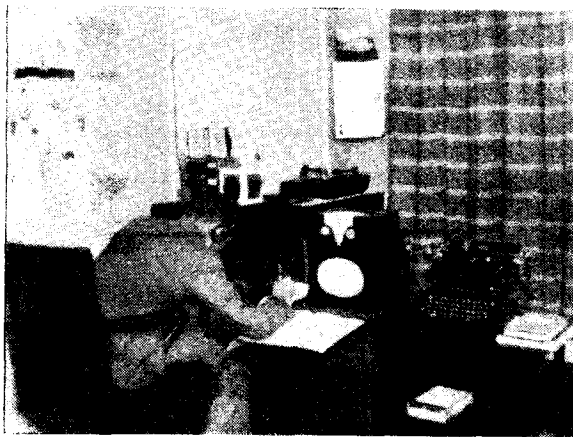

Member 6812 (D. W. Watkin) looks very busy in a corner of his den.

## The "Fleet" Short-wave Two

**A**NOTHER new member, No. 6913, who has had some good results on his "Fleet" Short-wave Two, writes as follows: "My equipment consists of an 0-v-0 battery short-wave set, your 'Fleet' Short-wave Two, and an all-wave mains superhet. It may interest you to know that with your 'Fleet' receiver I have logged WGE0 (9.53 mc/s), WGEA, on both 21.50 mc/s and on 15.330 mc/s; WNBI (17.78 mc/s); and Delhi (9.590 mc/s), all of which I have heard on the loudspeaker."

## Dead Spots

**T**HE following interesting letter has been received from member 6,561:

"I am encouraged to write and give results of some of my experiments by reason of a request from member 6,740 for advice on the matter of dead spots, particularly on higher frequencies (50 m. and under).

"First, let me point out the fact that the member's trouble seems to be bound up with 'straying R.F.' or 'hand capacity.' Therefore, whilst noting that the set has given good results when 'fiddled with,' I am of the opinion the member would find his trouble well repaid if he stripped and then reconstructed the set, paying every care to layout and wiring. (Assuming good quality short-wave components are used.)

"However, to continue with the question of attempting improvements upon a set

giving trouble of this nature, I would suggest the following:

"1. The aerial and earth systems should be first attended to. Good aeriels are often nullified by poor down leads and undue capacity to earth at point of entrance to house. Earths, if very long, should be discarded.

"2. The H.F. choke must be of good quality, and free from peaks and resonances. Chokes can often be replaced by a resistor (10,000 ohm approx.) to advantage.

"3. Wiring—should be of heavy gauge, and soldered connections used wherever possible. Insulated wiring should be kept to absolute minimum in R.F. circuits, thus keeping down stray capacities.

"4. Where condensers are connected in aerial circuit (variable or otherwise) these should always be stood off from chassis, earthed baseboard, and all other earthed objects. (Note here that the member says he uses five such condensers. If these are held to earthed chassis or baseboard, as mentioned, R.F. currents of high-frequency will by-pass to the chassis, via case of condenser, usually bakelite.) Also, in connecting these condensers he may have unduly long leads in circuit. Thus stray capacities, and by-pass effect mentioned, would be even more pronounced.

"5. Reaction circuits where home-made coils are used will always be improved by a series of cut-and-try experiments.

"Also dead spot trouble can often be entirely eliminated by a change over to 'throttle control reaction,' that is, the true throttle control where condenser is connected directly between valve and earth working in opposite direction to usual practice. Anode by-pass condensers play an important part in more usual reaction systems although they are often omitted.

"6. Eliminators can often have far-reaching effects on a set, including dead spot troubles. Leads to eliminator should be kept to shortest length consistent to keeping of eliminator at reasonable distance from R.F. section of set. Older eliminators repay trouble of inserting new smoothing condensers and valve if one is used. Eliminators should also be in earthed metal case whenever possible.

"7. Going back to aerial circuits—

exceptionally good results are possible if care is taken in the matter of coupling coils. A home-made adjustable component often entirely overcomes dead spots.

"It is of interest to note that I have, by means of a variable coupling coil, and ceramic based trimmer as grid condenser, entirely eliminated dead spots in a set that was very prone to this trouble. The coil was wound on a small diameter former inserted within grid coil former.

"8. I have found that grid condenser and grid leak values together with adjustments of reaction coil relative to grid coil can have far-reaching effects on efficiency of simple Det. L.F. receivers.

"9. In general, all experiments tending to increase efficiency of circuits carrying R.F. will help to eliminate dead spots.

"Improvements in insulation, losses and stray capacities are immediately noticed."

## Contact Wanted

**M**EMBER 6,880, who resides at 72, Beacon Road, Loughborough, Leicestershire, writes as follows: "I shall be glad to contact with any other members in the Loughborough district, more especially those who construct straight receivers. My age, by the way, is 19½.

"As there has been so much talk about hotted-up one-valvers lately, I have built a single-valver which, when it has been put through its paces, will be converted into a 2-v-2 by easy stages, with a speaker-phone switch. Until now, I have been one of those persons who has not bothered to learn the code, but I have now purchased a key and mean to get down to it right away."

## Logged on a Single-valver

**M**EMBER 6,923, who is a newcomer to our ranks, sends in the following report of reception on his 0-v-0 receiver:

"Many thanks for my membership certificate. I am reconstructing my 0-v-0 receiver, the log of which has been very satisfactory, in order to employ improved insulation and short wiring. Upon a 10ft. 'inverted-L' type aerial I have so far logged VLR3, WCBX, WNBI, WRUL, WGE0. The four latter stations I receive very regularly, the former station I receive best between 4.0 p.m. and 6 p.m. (B.S.T.) at R6. The other stations are received at R7 to R8 during the hours of darkness. I have received most European countries, and also station TAP is received very well. Now that I am rebuilding my set I hope to send you a more extensive log in the near future. In place of my present indoor aerial I intend to erect an outdoor 'inverted-L' the insulation of which will receive particular attention."

## Help Wanted

**I**N our club columns last month we published a request for help from member 6,454, but omitted to give his name, which is Malcolm Craik. His address is 3, Hilltown, Dundee, Scotland, and he would be glad to hear from any member who could supply him with a complete list of DX stations, operating on the medium waves.

## Co-operation

The B.L.D.L.C. and the R.S.G.B. have proved the great value of co-operation between amateurs. Do not be a lone operator. Get to know as many enthusiasts as possible, especially in your own district, and exchange visits, experiences and results.

# Practical Hints

## Quick Connections

WHEN putting together "hook-ups," I employ short lengths of wire, —1 to 1½ in.—with one end "tinned," and the other end securely fastened in the terminals of various components on hand (C and E). In addition, various lengths of wire are provided—3, 6 and 9 in.—"tinned" both ends (D and F).

If a quick "try-out" of a circuit is required, the components are assembled in place, lengths of the tinned wire are placed alongside the lengths attached to the components (as at A and B), and a hot soldering iron placed underneath. On dismantling, the iron is again placed

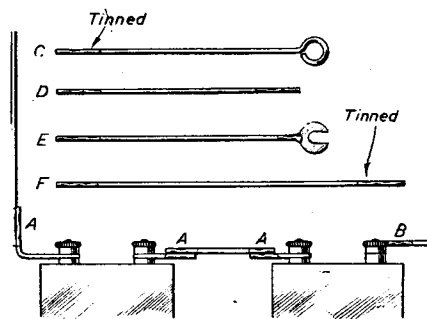

A useful method of making quick connections.

under the joints, and the circuit is broken in a few minutes.

This obviates torn terminals on components, blobs of unsightly solder on terminals, and has the advantage of providing good electrical connection in a few moments.—W. G. SHELLEY (Calne).

## Single-knob Control

THE accompanying sketch shows a simple one-knob tuning and reaction control. It can be made mainly from odd parts usually found in the spares box. These parts are as follows: Two gear wheels, a circular scale, two bushes, one spindle, a weak spring, a connector, knob, some screws and small nuts and bolts, two brackets (made as shown), a tuning and a reaction condenser, and a dial lamp and socket. The large gear wheel is fastened

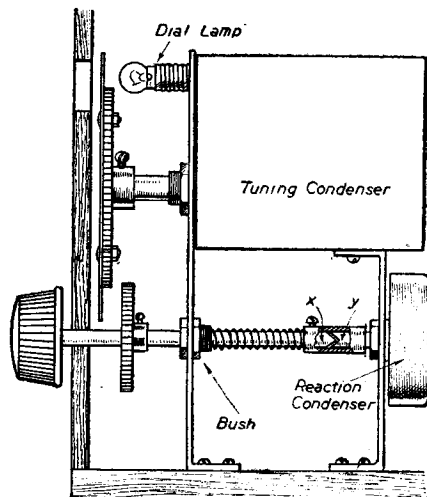

A simple single-knob control.

## THAT DODGE OF YOURS!

Every Reader of "PRACTICAL WIRELESS" must have originated some little dodge which would interest other readers. Why not pass it on to us? We pay £1-10-0 for the best hint submitted, and for every other item published on this page we will pay half-a-guinea. Turn that idea of yours to account by sending it in to us addressed to the Editor, "PRACTICAL WIRELESS," George Newnes, Ltd., Tower House, Southampton Street, Strand, W.C.2. Put your name and address on every item. Please note that every notion sent in must be original. Mark envelopes "Practical Hints." DO NOT enclose Queries with your hints.

## SPECIAL NOTICE

All hints must be accompanied by the coupon cut from page 295

to the scale by means of the nuts and bolts in the manner indicated.

When the control knob is pulled out slightly the tuning condenser is brought into use, and when pushed and revolved the end engages the reaction condenser spindle when reaction may be used.

The gear wheels have their own bushes, the bushes bought separately being used where the control spindle passes through the bracket and the panel. Both the tuning and reaction control spindles may have to be filed to fit the bushes and connector. The connecting tube is fastened only to the spindle on which the knob is fitted, as its use is to guide the clutch on to the end of the condenser spindle. One part of the clutch "X" is filed to a screwdriver end, its other part (the condenser spindle) "Y" is cut with a hack-saw. Care must be taken to see that both condenser spindles are in the earth circuit; if they are not, they must be insulated from each other.—D. COOPER (Reading).

## Prolonging Life of Torch Battery

OWING to the difficulty in obtaining torch batteries I hit upon the following dodge to make them last longer, and to reduce the excessive brightness of the bulb when a new battery is fitted. The dimensions stated are for the large unit torch cell, but can be altered for other sizes.

I took a piece of ebonite ¼ in. thick and cut it as in sketch so that it would fit into the bottom of my torch. Next I cut two discs of carbon one-tenth of an inch thick from a ¼ in. carbon rod taken from an old bell battery, and ground the faces flat with fine emery cloth. I then drilled a hole in the centre of the ebonite so that these discs would slide about freely. I took an old flexible steel rule and cut a piece ¼ in. in diameter and bent it slightly, then cut two 1 in. squares of rigid copper foil and stuck one piece over the hole in the ebonite with Chatterton's compound. Next I put the two pieces of carbon in the hole with the spring steel in between keeping them apart, and stuck the other copper

square over the other side of the hole, after having cut a hole slightly under ¼ in. in the centre to admit the spring which holds the cells in the torch. Care should be taken not to get any compound on the carbons.

I then fitted the device in the bottom

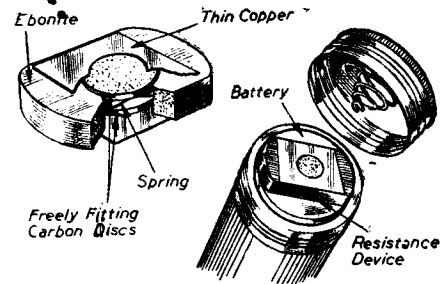

Using a carbon resistor for regulating the current used in a torch battery.

of the torch and screwed the cap on so that the spring in it pressed against the carbon disc through the hole in the copper. The resistance across the carbons is varied by screwing or unscrewing the cap.

When a new battery is fitted, the lamp can be dimmed slightly by unscrewing the cap a little. (The coiled spring in the bottom of the lamp may need compressing slightly so that it does not press too hard on the carbon.) The light is maintained by screwing up the cap as the battery runs down.—E. BITHELL (Middleton).

## A novel pocket tool kit.

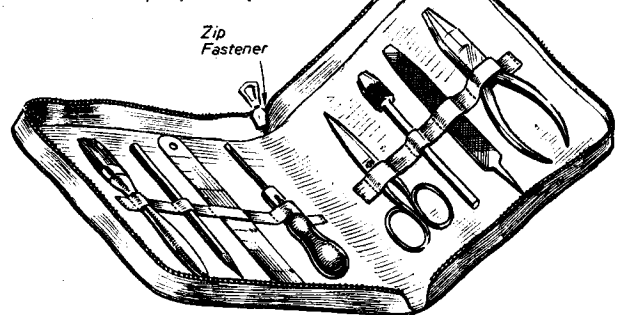

## Pocket Tool Kit

I RECENTLY had need of a comprehensive pocket tool kit, and on looking round for something to use as a container I came across an old dressing-case provided with a zip fastener. I cut out the straps which had previously been used for holding in the toilet requirements, and then had fresh loops sewn in to hold the tools I required. The result is shown in the accompanying sketch, and the idea has proved very useful.—A. RUMBLE (York).

## The PRACTICAL WIRELESS ENCYCLOPÆDIA

By F. J. CAMM (Editor of "Practical Wireless")

Wireless Construction, Terms, and Definitions explained and illustrated in concise, clear language.

10/6 From all Booksellers, or 1/- post 11/- from George Newnes, Ltd., Tower House, Southampton Street, Strand, London, W.C.2.

# Open to Discussion

The Editor does not necessarily agree with the opinions expressed by his correspondents. All letters must be accompanied by the name and address of the sender (not necessarily for publication).

## S.W. Broadcasting Stations

**S**IR.—I should like to give some information to Mr. John Parkin re his identification of S.W. broadcasting stations. The station he heard on 25.2 metres would most probably be VLQ7 on 25.25 m. They welcome reports, and the address is A.B.C., Sydney. The schedule is as follows: 20.25, Music; 20.30, English News; 20.40, Music; 20.45, English Talk; 20.55, Music; 21.00, Close down (with National Anthem). All times are G.M.T.

I should be pleased to know what wavelengths VLQ6 operates on, as until Mr. Thayer logged it I was under the impression that there were only 3 VLQ stations, all of which have been received. These are VLQ, VLQ2, and VLQ7 on 31.2, 25.27 and 25.25 m. respectively. I have received VLQ7 over 20 times, twice on the loudspeaker.

Radio Brazzaville was also mentioned in last month's issue, and it may interest readers to know that they intend to give a broadcast on 16.27 metres at 13.30 G.M.T. The Rx I use is the "Fleet" S.W.2., and the H.T. is from an eliminator which has extra smoothing. The aerial is an 18ft. vertical. All continents have been logged in one evening. Other Dx stations logged on the B.C. bands include: WBOS, WLWO, WPIT, WGEO, WGEA, WNBI, WRCA, PMA, XGOY, JZI, JZJ, JVV4 (an experimental transmission on 31.56 m.), and Leopoldville, Belgian Congo.—FRED TAYLOR (Hale, Cheshire).

## "How to Become a Radio Star"

**S**IR.—I have just read "Torch's" remarks on "How to Become a Radio Star," and although it is rather startling to read, it is certainly no exaggeration, and this can be proved by looking at the titles of many of the so-called songs which occupy the major part of the B.B.C.'s musical programmes. I went in a friend's house recently, and on the radiogram reposed some records with titles such as "Boog It," "Honky-tonk-train Blues," "Missouri Scrambler." These were painful enough to read—but worse to listen to. There is no doubt whatever that African natives beating on a "tom-tom" produce a sound which is far more pleasant to listen to than the rubbish which is "put over the air" nowadays—in fact, one begins to doubt the sanity of those responsible for the broadcasting of such utter piffle. It is high time that the people responsible should change their ways, or give up their positions to someone with a grain of ordinary common sense.—P. J. DARBY (Northampton).

## Radio Brazzaville

**S**IR.—I may be able to offer P. Dickerson (Long Stratton) a little more information about Radio Brazzaville, although I have heard no reference to times of broadcasts from this station. I first heard this station on March 5th, 1941, at 20.30 B.S.T.; signals are quite good—about R.6. The announcement at the beginning of the

English transmission was: "This is the Free French Radio station, broadcasting from Free French Africa, on a wavelength of 25.06 metres." The call-sign appears to be the sound of picks on hard ground. The English news is followed at 21 hours by a programme in French.—R. PAGE (Crowthorne).

## S.W.L.'s Please Note

**S**IR.—Recently at regular intervals I picked up a short-wave station on about 10.3 mc/s at roughly 22.50 B.S.T. The programme is one of Oriental music, but at the above time the station closes down with no announcement whatever. Then an English-speaking voice calls London. After that a private conversation ensues, and at about 23.10 B.S.T. the station closes down for good. I should be very glad if any reader could identify this station for me and at the same time, maybe, help some other S.W. listener.

My log for the last month includes TAP, RKL, RV96, WRUL, WNBI, WRCA, and eleven other "Ws." On April 4th I received a news bulletin from Athens but no call-sign was given. If any reader could help me with this I should be very grateful.

The news from Athens can be heard any evening at 20.45 on the 31-metre band. All my reception is carried out on a battery operated, 3-valve short-wave receiver of my own design and construction. My aerial consists of a 15ft. vertical brass rod, the top of which is 50ft. above ground level.—M. GORSKY (Rhyl).

## Back Number Wanted

**J.** DUFFERN, 2, Owley Wood Road, J. Weavenham, Nr. Northwich, Cheshire, would be glad to get in touch with any reader having a copy of PRACTICAL WIRELESS containing the theoretical circuit-diagram of the A.C. Fury Four Super, and who would either sell or loan him the issue.

## Correspondents Wanted

**W.** F. DAVENPORT, 16, Wycliffe Road, Anfield, Liverpool, 4, who is a beginner, aged 16, would like to get in touch with another reader, about his own age, residing in the Liverpool area.

**E. C. Bayley**, 2, Lansdowne Crescent, Notting Hill, London, W.11, would correspond with any young reader interested in S.W. radio.

**D. W. Watkin**, "Brownhill Court," Wick Street, Nr. Stroud, Glos., who is 17 years old, uses battery sets, and is interested in DX-ing, would like to correspond with another reader with similar activities.

**G. Scopes-Hall**, "East View," Needham Market, Suffolk, would like to get in touch with any reader who has constructed a S.W. receiver from a Premier Radio Co.'s two-valve kit of parts.

**E. Hindley**, c/o 60, Oakshaw Street, Paisley, Scotland, would like to communicate with another reader who has constructed the "Fleet" S.W. Two.

# BOOK RECEIVED

**THERMIONIC TUBES AT HIGH FREQUENCIES.** By A. F. Harvey, B.Sc., D.Phil., A.M.I.E.E., with foreword by E. B. Moullin, M.A., Sc.D., M.I.E.E. Published by Chapman and Hall, Ltd. 234 pages. Price 18s. net.

**T**HE already extensive and the ever increasing use of high-frequency electrical energy, necessitates a wider and deeper knowledge of the performance of electrical components and apparatus at such frequencies. Television, radio communication, measuring instruments and medical appliances are some of the more widely known forms of application of H.F. energy, but in spite of the research work which has already been devoted to this section of electricity, it might be said that it is still in its infancy and, until the publication of the work carried out by Dr. Harvey, there was very little conclusive evidence available to guide and assist the student.

The eight chapters of which the book consists deal with General Properties of Thermionic Tubes, Influence of Frequency Operation, Retarding Field Generators, The Magnetron—Parts One and Two—and Miscellaneous Tubes and Circuits at Very High Frequencies. Numerous diagrams and half-tones illustrate the text.

# Prize Problems

## PROBLEM No. 420.

**S**MITH built a quality receiver, having a push-pull output stage, but found that the reproduction was marred by L.F. instability in the form of a whistle which was noticeable at all points on the tuning coils. What was the most likely cause of this whistle, and what steps should be taken to eliminate it?

Three books will be awarded to the first three correct solutions opened. Entries must be addressed to The Editor, PRACTICAL WIRELESS, George Newnes, Ltd., Tower House, Southampton Street, Strand, London, W.C.2. Envelopes must be marked Problem No. 420 in the top left-hand corner and be posted to reach this office not later than the first post on Monday, May 19th, 1941.

## Solution to Problem No. 419.

Johnson had overlooked a faulty connection between the fixed plates of the differential reaction condenser and the earthed end of the coil. This caused fierce regeneration when the vanes of the condenser were engaged, as all the stray H.F. had to pass through the reaction coil.

The following three readers successfully solved problem No. 418, and books have accordingly been forwarded to them: A. Nixon, 150, Schneider Road, Barrow-in-Furness, Lancs; J. Williams, 25, Cambridge Road, Colchester, Essex; Terry Joyce, 31, Ramsgate Road, Margate, Kent.

# RADIO ENGINEER'S VEST-POCKET BOOK

2nd Edition

By F. J. CAMM

3/6, or 3/9 by post from George Newnes, Ltd. (Book Dept.), Tower House, Southampton Street, Strand, London, W.C.2.

# ROUND THE WORLD OF WIRELESS

## New B.B.C. Bulletin

THE new radio press bulletin, the first to be started by the B.B.C., is transmitted in English daily at 2.45 p.m., British summer and Central European time, on 373 m. and from GSA on the 49 m. band, GSW on the 41m. band, and GSN and GSE, both on the 25m. band. This broadcast supplies day by day advance information on outstanding items of general interest to be broadcast in the Home, World and European Services during the following 24 hours.

## For Women Who Know Physics

THERE are openings in the Women's Auxiliary Air Force at present for women of good education as radio operators. Some knowledge of physics would be an advantage, and candidates who have taken the Intermediate B.Sc. would be welcomed if suitable in other respects. Women of the right stamp would find the work congenial. They should have alert minds, be self-reliant and not liable to be flurried. Their duties would be of a confidential nature. Applicants must be between 18 and 35. They must be prepared to serve anywhere, at home or abroad, and there will be good opportunities for promotion.

## Australian News Commentator

ROBERT FRASER, whose news commentaries on Mondays and Tuesdays are heard in the B.B.C.'s Pacific transmissions, is Australian born and bred, although he has spent many years in London journalism. Having read Classics at Melbourne University, Fraser decided that modern life was of more interest than dead languages, and came to London to study economics. While reading for his degree, he became a leader writer on a national newspaper, and at the same time did a good deal of reporting.

## B.B.C. Theatre Organ Destroyed in Raid

IT was revealed recently that the famous B.B.C. theatre organ was destroyed when St. George's Hall was burned out during a night air-raid on London. One of the largest organs in the world, it was an entirely British instrument, and its cost ran well into five figures.

In an oak-cased console there were 260 stops connected with four chambers arranged at the sides of the hall. These contained 2,000 to 3,000 pipes, a grand pianoforte, all the numerous effects, and the electrone—a pipeless instrument that produced those sounds which thrilled listeners throughout the world.

## Broadcasts for West Indians

GREATLY extended broadcast services from Britain to the West Indies are now in operation. These include three special weekly periods directed to the West Indies, in addition to daily news, news commentaries and a "Radio News-reel," including political commentaries, eye-witness accounts of topical events, and radio pictures of life in war-time Britain. As far as is possible, West Indians and people with West Indian interests are brought to the microphone, and anyone who has connections with those islands and is interested in broadcasting is invited to

write to West Indian Programmes, B.B.C., London, W.1.

## Loudspeakers on the Underground

SEVERAL of the large London Underground stations now have portarettes, who are provided with sound apparatus so that they can make themselves heard. Tannoy power microphones with their associated loudspeaker equipment are used.

In connection with the training of men in the radio department of the U.S. Army, there is this automatic code transmitter that is photo-electrically operated, and sends up to thirty-five words per minute.

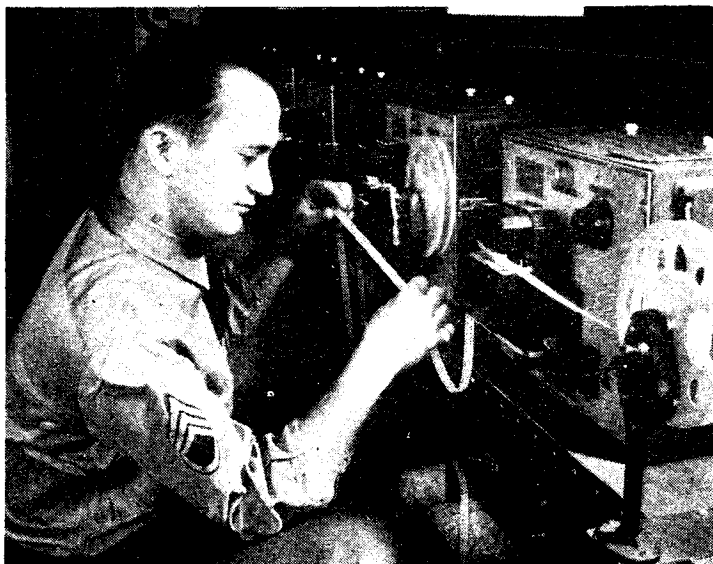

## "What! No Radio?"

AN amusing story comes from Cleveland, Ohio. A motorist of that town pulled up at the kerbside to offer a lift to a "thumber." This person, with one foot on the running-board, looked inside the car, and suddenly exclaimed, "What! No radio? I'll wait for another car. Thanks just as much."

## Latest Australian Broadcast Schedules

STATION VLR, Melbourne, now uses the following wavelengths and call signs:

Call signs: From 6.30 a.m. to 6.15 p.m., VLR7. From 6.30 p.m. to 11.35 p.m., VLR.

Wavelengths: Before 6.15 p.m., 25.33 metres. After 6.30 p.m., 31.32 metres.

Power: 2 kilowatts.

Location: Lyndhurst, near Melbourne. The times given are Australian Eastern Standard.

All mail matter should be addressed to: Australian Broadcasting Commission, Short-wave Section, Box 1686, G.P.O., Melbourne, Australia. Cables and Telegrams, "Abcom," Melbourne.

## Talking-book for the Blind

MR. ALAN HOWLAND, the B.B.C. announcer, is recording Sax Rohmer's "Mystery of Dr. Fu-Manchu" as a talking-book for the National Institute for the Blind.

## Ten-language Broadcasts

SINGAPORE'S new broadcasting station, which is nearing completion, will broadcast in English, Malay, Tamil, Thai, Japanese, Chinese, Javanese, Dutch, French, and German.

## Big Ben and Empire Listeners

BIG BEN appears to be a very popular feature in the B.B.C. Empire broadcasts, according to Miss Margery Anderson, an Empire announcer. At a gathering recently of women doing war-time duties at the B.B.C. she said that scores of letters received from Empire listeners showed that Big Ben headed the list in popularity. "They seem to get a

tremendous comfort from hearing his chimes," she said. "I think they listen to him and feel that all is well with London, so we put him on the air on every possible occasion."

## B.B.C. Welfare Officer

THE first B.B.C. welfare officer appointed to superintend war-time living and working conditions of 4,000 members of the staff is Mr. E. G. D. Liveing, 46-year-old pioneer of broadcasting. His work will be to maintain the efficiency of the staff under the stress of war-time conditions.

## Probing Nazi Radio Secrets

IT is evident that the radio technicians associated with the R.A.F. do not take anything for granted when examining and testing the equipment of shot-down German planes. At a certain experimental establishment there is a very large dossier containing complete specification of the radio equipment. Not only does this give complete specifications, test data and circuit diagrams, but also valve curves and the most minute detail of every part of the equipment.

## A Novel Broadcast

TORGER TOKLE, a 22-year-old Norwegian skier, recently gave a jumping demonstration at Lake Placid, New York State, U.S.A., with a short-wave transmitter strapped to his back. He described his flight through a microphone welded to a catcher baseball mask that he wore. His words were relayed to WGY in Schenectady and there placed on a national network.

# Problems of Amateur Receiver Design—10

Planning the L.F. Amplifier Stages of a Modern A.C. Mains Receiver

By FRANK PRESTON

LAST month we considered some of the problems confronting the designer of the L.F. section of a battery receiver. When an A.C. set is being built there is considerably more scope in the choice of circuits for the L.F. stages, since a large number of varying circuits is available. Despite that fact, however, the single pentode or tetrode output valve is by far the most widely used in broadcast receivers, and this gives practically all that is desired if an output up to something like five watts is considered sufficient—and it is sufficient for most requirements.

We could, therefore, use a circuit on the lines of that shown in Fig. 1, where an indirectly-heated tetrode follows the triode section of a double-diode triode. By making a choice from the wide range of valves available, the maximum output may range from, say, two to five watts. It would be impossible to refer to even a small proportion of the valves which are available, but details can be obtained from one's "pet" valve manufacturers. Here we can deal only in fairly general terms, pointing out the most important factors and leaving the individual reader to make his own final choice.

## Bias and Decoupling

It will be seen from Fig. 1 that the connections are very similar to those employed for a battery tetrode or pentode, with the exception that bias is provided by means of the resistance in the cathode lead. Another point is that, due to the large amount of amplification provided by modern mains valves in the pentode class, some form of decoupling is required in the grid or screening grid lead, or even in both. One of the simplest arrangements is to insert a resistor of about 100 ohms in the H.T. lead to the screening grid, as shown. Another method is to include a resistor of 5,000 to 10,000 ohms in the grid lead, between the grid leak (in the case of resistance-capacity coupling, which is generally to be preferred) and the grid of the valve. This form of grid "stopper" has previously been referred to in these notes.

Component values are inclined to be rather more critical than with battery valves, again due to the high amplification. Thus, although in the majority of cases a .5-megohm grid leak is suitable, the makers sometimes stress that with certain valves the value of this component should not exceed .25 megohms. The grid condenser may, in all cases, have a value of .05 mfd., which is suitable in nearly all R.C.C. amplifiers. It will be noted that the tone control between the anode of the output valve and earth is similar to that used with battery pentodes.

## One or More Stages?

A point which should be watched closely in connection with modern mains pentodes and tetrodes is that some of them have such a high value of mutual conductance (which may be regarded for simplicity as corresponding to amplification), that they would easily overload if preceded by more than one L.F. stage; others have such a high mutual conductance that the makers advise that they should be used immediately after the second detector of the double-

diode type without any intermediate L.F. stage. It is scarcely practicable to state definitely that if a valve has a mutual conductance in excess of any particular figure it should follow immediately after the double-diode, but we may state a very general rule. This is that if the mutual conductance is greater than 6 mA. per volt an intermediate L.F. stage should not be used. But as the figure may vary from about two to 11 mA. per volt, the extremely wide variation is apparent, and it is wise to study the makers' data.

They will also know that if the connections of the reaction coil are in one direction, feed-back will occur in such a direction or sense that the valve will oscillate more readily as the degree of coupling is increased, whilst if the connections are in the reverse sense the oscillation will be "killed" by increasing the coupling—assuming that it could ever be made to commence.

In the case of negative feed-back the current fed back from the anode to the grid circuit must be "out of phase" with the

grid impulses, so that instead of increasing them it tends to cancel them out. The anode circuit is normally out of phase with the grid circuit, and therefore the simple method of connecting a high resistance between the two has the effect of causing the cancellation of oscillation referred to above. That is, briefly, the effect of the resistance-capacity link shown in Fig. 2, if it is remembered that the anode circuit of the triode is in phase with the grid circuit of the tetrode and, therefore, that the one-megohm resistor does actually feed back some energy "in reverse" to the grid circuit.

## Bias for I.H. Valves

Before considering push-pull circuits it will be desirable to deal rather more fully with the practical aspects of the two simpler circuits so far referred to. It is fairly common knowledge that the resistor in the cathode lead provides a bias voltage due to the passage through it of the H.T. current of the particular valve to which it is connected. This is in contradistinction to the auto bias resistor of a battery set, through which is normally passed the total H.T. current taken by the receiver. Thus, the correct value is found by dividing the bias voltage required by the H.T. current (in

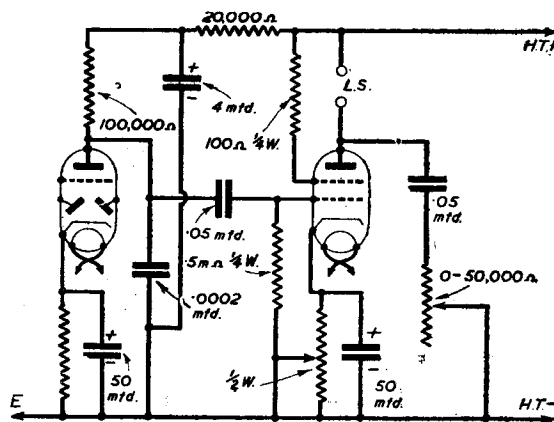

Fig. 1.—One of the most popular output arrangements: a power tetrode, or pentode, following a double-diode triode. Component values are approximate, and wattage ratings should be determined as explained in the text. Note the use of high-capacity electrolytic condensers for smoothing in the auto bias circuits.

## Negative Feed-back

If an L.F. stage is desired, so that there shall be good amplification of weak signals, it is generally worth while to provide a form of negative feed-back, a circuit for which is shown in Fig. 2. In passing, it should be made clear that when reference is made to an intermediate L.F. stage, this is intended to apply to the triode portion of a double-diode triode, and not purely to an additional triode. The purpose of negative feed-back is to prevent instability and low-frequency oscillation, which can easily arise when using modern valves of the type under discussion. In Fig. 2 the feed-back is provided by means of a one-megohm resistor in parallel with a .0003-mfd. pre-set or small variable condenser, connected between the anode of the output tetrode and the anode of the preceding triode. The condenser may be adjusted until the most satisfactory quality is obtained, and until there is complete freedom from L.F. oscillation when the set is tuned to any transmission of any strength.

When using this form of coupling, the additional tone control may not be required in view of the stabilising effect of the negative feed-back. The precise meaning and use of this form of coupling has been dealt with in these pages before, so it is not necessary now to do any more than give a very broad outline. As all readers know, a triode detector valve can be made to oscillate by feeding back some of the energy in the anode circuit to the grid

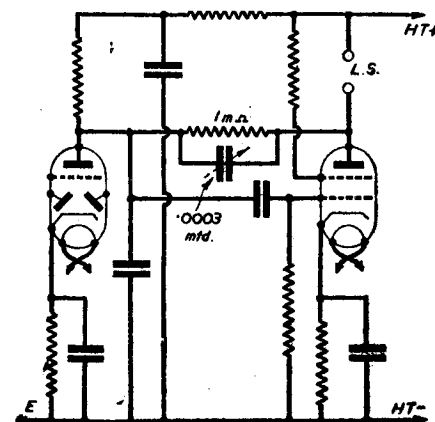

Fig. 2.—This circuit is similar to that shown in Fig. 1, with the exception that negative feed-back is added, and the tone control is omitted.

amps.) taken by the valve. This H.T. current, by the way, is not just the anode current, but the sum of the anode and screening-grid currents. Thus, if we knew that the valve to be used passed an anode current of 35 mA and a screen current of 5 mA at the particular anode voltage at which it was being operated, and that the bias voltage required were 5, the required resistance should have a value of 5 divided by 40 and multiplied by 1,000 (this is to convert the current from mA to amps.). Thus, it should be 125 ohms.

### Wattage Rating of Resistors

The wattage rating of the resistor should also be taken into consideration. This is found by multiplying the voltage drop by the current (in amps.) or by multiplying the resistance rating by the square of the current. Taking as example the case quoted above, we can see that the minimum wattage rating would be five times 40/1,000, or 1/5 watt; in practice we should use a quarter-watt resistor. Using the alternative method of calculation—which is rather better in practice—we find that the rating is 125 times 40/1,000 times 40/1,000, which again works out at exactly 1/5 watt.

This method of wattage determination applies also to the resistor used in the screen lead, although in nearly every case it will be found that 1/2 watt is an ample rating because of the low resistance. The same rating, which is the minimum for commercially-produced fixed resistors, is also suitable for the negative feed-back resistor which passes only a very small current; in fact, one which is almost negligible.

It is important that a mica-dielectric condenser should be used as grid condenser for the output valve because it is subject to high alternating voltages in addition to

the H.T. voltage. An ordinary "paper" condenser or tubular may "puncture" and cause the output valve to be damaged, due to the excessive positive bias which would then be applied.

### Power Supply

Another important practical point concerns the total H.T. current and voltage required by the output valve. In practice it is usual to design the power-supply circuit to meet the requirements of the receiver, but since the output valve generally requires a good deal more H.T. than the rest of the valves together, it is of greatest importance. Most of the modern pentodes and tetrodes of the types under consideration have a maximum anode voltage of 250, and, therefore, either a valve or metal rectifier can be conveniently used. The total H.T. current taken by the output valve at 250 volts will generally be in the region of the figure previously mentioned, and therefore a rectifier supplying 250 volts at 60 mA will be suitable for most receivers.

If an existing rectifier or power unit is to be employed it is important that an output valve be chosen which will operate efficiently on the voltage and current available. Since all the receiving valves will be indirectly heated it is desirable to use an indirectly-heated rectifier when a valve-type rectifier is to be employed. This is so that a large "peak" voltage will not develop across the various smoothing and by-pass condensers during the half-minute or so which elapses while the cathodes attain their working temperature and commence to emit. If a directly-heated rectifier or metal rectifier is used, all H.T. smoothing and by-pass condensers should have a working voltage of at least three times the nominal H.T. voltage. A rating of twice the H.T. voltage

is sufficient when using an indirectly-heated rectifier.

### Heater Voltage

It has been the custom in the past to use 4-volt, 2-amp. indirectly-heated valves, but there is now a wide choice of types in the 6.3 volt-heater class, so that it might be considered desirable to use these. They have international octal bases and may, in general, be considered as rather more efficient than some of the older types with five-pin base. The only objection is that a 6.3-volt winding is required on the mains transformer, in addition to the 4-volt winding which will probably be used for the "earlier" valves in the set. When use has to be made of an existing transformer, having only one L.T. winding rated at 4 volts it will be necessary to keep to a 4-volt valve for the output stage. This type is available with either five- or seven-pin base.

We must defer further consideration of L.F. amplifiers for mains sets until a later article of this series.

**JUST PUBLISHED**

## GEARS AND GEAR CUTTING

By F. J. CAMM

5/-, by post 5/6

from

GEORGE NEWNES, LTD.  
TOWER HOUSE, SOUTHAMPTON  
STREET, STRAND, LONDON, W.C.2

# Address your staff through a

## CELESTION LOUDSPEAKER

—with a volume sufficient to overcome local noise.

The same speaker will carry music to your staff—true music, not just a volume of sound.

The Celestion method of suspension enables the sound to be directed wherever you want it.

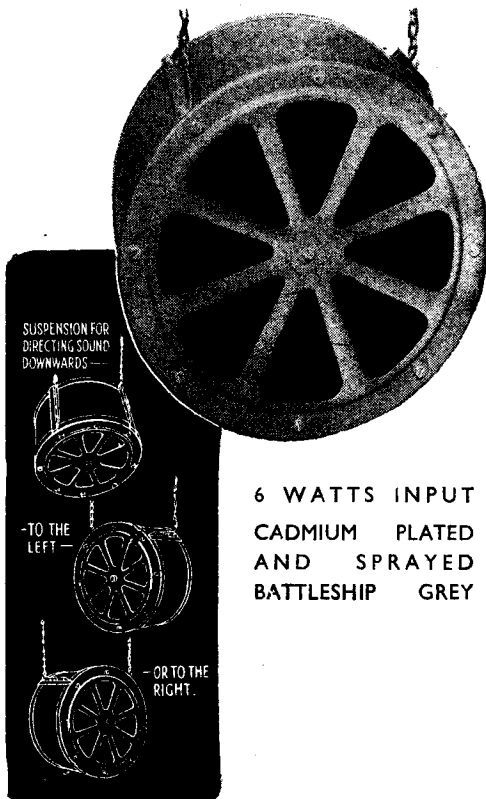

6 WATTS INPUT  
CADMIUM PLATED  
AND SPRAYED  
BATTLESHIP GREY

**Celestion Limited, Kingston-upon-Thames, Surrey**  
Acoustical Engineers Telephone: KINGston 5656-7-8

Comment, Chat and Criticism

## Outline of Musical History—20

Further Notes on the Life and Work of Beethoven.

By Our Music Critic, MAURICE REEVE

**A**T 14, the new Elector, Maximilian Franz, youngest son of the Empress of Austria, Maria Theresa, appointed Beethoven assistant court organist, with a salary of one hundred and fifty guilden. Did father Johann chuckle and rub his hands in glee?

Having already begun composing, and being engaged as a professional musician, this may be a suitable moment to pause in the story of Beethoven's life and say something of the composers who were reigning when he himself first entered the great world of music. Two of these have come down to us, with Beethoven himself, to form part of that little group that we call "the great composers." Mozart and Haydn. Others' music is still heard, but we have ranked it a long way below theirs, and a lot lower than it was placed during their lifetimes. By far the greatest musician alive at the time of Beethoven's youth was Mozart.

In 1783, the date at which we are making this little digression from the main story, Mozart was 27 (he died when he was only 35); Haydn was 51; C. P. E. Bach, 56; W. F. Bach (who died the following year), 74; Cimarosa, 34; Clementi, 31; Dittersdorf, 44; there were many others, too, who were completely eclipsed by their great contemporaries, and the masters who have followed since. It is important that we pause to study the music of Beethoven's youth as, musically, his roots were in Mozart and Haydn, although he early beat out his own track.

**Influence of Mozart**

Mozart was the greatest prodigy that music ever possessed and, with J. S. Bach and Wagner, the only name which can rank in greatness with that of Beethoven himself. Born in 1756 in Salzburg, his feats of musicianship and his accomplishments as composer cannot be discussed here. But that he greatly influenced the young Bonn master is proved both in Beethoven's early style as well as in the famous "Beethoven Sketch Books." In these famous notebooks, which contain the germ, and show the development therefrom, of some of Beethoven's most famous ideas, we have evidence of his close study of Mozartian musical idioms and taste. In spite of his over-towering genius, Mozart was not the "inventor" to the same extent as Beethoven was. He was more content, with the important exception of opera, to follow the beaten track, although his idiom is extremely personal and characteristic. Haydn was born in 1732, so in Beethoven's youth he could well be looked upon, as indeed he was, as the father of music. "Papa" Haydn was, in fact, the affectionate title that the world of music had conferred on him. Beethoven's meeting with both great men were important landmarks in his career.

**Approaching Manhood**

As Beethoven approached manhood, say, from 1784 to 1787, little is known except that he was thrown into a world of music where he may literally be said to have breathed in his art during every minute of his waking hours. He met

many professional musicians regularly, and talked music at the daily table. He learned the business of the orchestra inside out, and became very familiar with religious music at the services, through his duties at the Electoral Court, and in handling the organ and choir. He also played second viola in the orchestra. With the coming of the new Elector, Max Franz, the court grew ever brighter and more artistic and cultured, and at it were to be seen all the leading spirits with whom Ludwig found genial company, and freedom to develop both his art and his personality.

The year 1787 is an important date in the master's life. For three events happened; two were to profoundly affect his future character, and the third was one of those encounters which most people would mark off on their calendars as a "red letter day" if they were so fortunate as to experience such a one. Firstly, he paid his first visit to Vienna, which was shortly to become his home for the rest of his life; and secondly his mother died. The third event was his meeting with Mozart, in Vienna.

So poor was he that, in order to arrange for his mother's funeral, he had to consent to her clothes and at least some of her personal belongings, being sold to help pay for the funeral expenses.

**In Vienna**

Beethoven met Mozart in the spirit of a humble disciple approaching "the Master," or, as the loyalist of subjects bowing before the throne. He had always worshipped Mozart's music, had studied it profoundly, and was obviously greatly influenced by it until he marked out his own path for himself. He had always considered Mozart's music to be the most perfect that had then been given to the world. On one occasion he was listening, with Cramer, to a performance of the piano concerto in C minor when, at one of its loveliest moments, he turned to his companion and whispered: "Cramer, Cramer, we shall never be able to do anything like that."

Mozart was very astonished at Beethoven's remarkable abilities at improvisation, and gave him several themes to handle in that way. He also gave him some lessons, which were doubtless in composition, and which confirmed his love for the work of the great genius who was to die so shortly afterwards at such a sadly early age. It was through him that Haydn's interest in Beethoven was awakened, and which caused him to write: "I should like to know who this Ludwig is."

Mozart's parting comment, to a friend, who was present at the same time, was: "Keep your eyes on him; some day he will give the world something to talk about."

This meeting, of course, was in Vienna for which capital Beethoven left Bonn in late spring of 1787, only to return three months later for his mother's death. He finally settled there in 1792.

**Many Friends**

Amongst the many friends and patrons that he met during his life, a few words

will be of interest on two of the first, the family of Breuning, and Count Waldstein. The Breunings were a cultured family and consisted of Frau Breuning, a widow, three boys and a girl; all, more or less of Beethoven's own age. He gave lessons to the youngest boy and girl, Eleonora, famous for being the girl with whom he first fell in love. But she married Wegeler in 1802, who wrote one of the best lives of Beethoven. It is not known for certain whether Eleonora inspired him in writing his opera *Fidelio* later on, but the fact that the heroine's name is the same (Leonora) is probably more than a coincidence. However, he was on terms of the greatest friendship, and used to spend long periods in their house. They helped him to gain his life-long love of English literature.

The other most important friend encountered at this time was Count Ferdinand von Waldstein, eight years older than Beethoven and a wealthy, aristocratic amateur musician, who came to Bonn to join the Teutonic order, and became the Elector's closest friend. He greatly encouraged the young giant at a time when encouragement was very badly needed, and Ludwig exercised the same charm on the Count that he was to use later on over the nobility of Vienna. He used to visit Beethoven in his poor room; he gave him a piano, and he also helped him with money. But this wasn't given personally; the Count would get the Elector to give it in the disguise of professional remuneration for special services and work.

**Waldstein Sonata**

In 1805 Count Waldstein achieved immortality at Beethoven's hands by receiving the dedication of the magnificent Sonata, Op. 53, which has borne his name ever since. But for *The Waldstein Sonata* and his faithful and disinterested patronage of Ludwig, poor Count Waldstein would, to-day, most likely be completely forgotten.

During the five years' interval between his sudden return from Vienna and his final settlement in that city, Beethoven suffered the extremes of poverty and ill fortune. His father was totally incapable of helping the family, and the care of the children was resting on his shoulders. He managed to get a housekeeper to look after this strange family.

Through all this time of trial, poverty and anxious responsibility, his friends were quietly and loyally working, behind his back, until they finally improved his position and restored his health and happiness. He was at home with the Breunings and Frau Breuning had the wisdom, and the courage, to "put him in his place" when he tended to get "swollen-headed," as he sometimes did; whilst at the same time recognising to herself his true greatness. Another event which remained in his memory—one of several of a similar kind—was a journey in 1791 with a Ritterballet, a kind of masked ball in antique style. It would seem that Count Waldstein arranged it and Beethoven composed the music, though this latter point was not stated at the time. In the autumn, the



troupe accompanied the Elector to Mergentheim; the journey was by water down the Rhine and Main, the weather being perfect and the wonderful country at its best. Beethoven referred to it as "a fruitful source of charming images." During these years, Haydn, then about sixty, passed through Bonn several times on his way to and from England. He and Beethoven met, and the young master was warmly praised and encouraged by the older one, and urged to pursue the vocation of music.

#### Farewell to Bonn

In November, 1792, Beethoven, as it turned out, bade farewell to Bonn and left again for Vienna. Up till then, the Elector himself had taken little notice of the most remarkable member of his orchestra. But during the course of that year, whether he was pointed out to him by Neeffe, Waldstein, Haydn, or whether he eventually noticed him himself is not quite established—he made up his mind to send Beethoven to Vienna, for the study and pursuit of music, at his own expense. Ludwig's parting words to Neeffe have been preserved:

"Thank you for the counsel you have so often given me on my progress in my divine art. Should I ever become a great man you will certainly have assisted in it, which will be all the more gratifying to you, since you may be convinced, etc." Waldstein, the Breunings, Dagenbarb, Koch, and many others, wrote their "good-byes" in an autograph album. Waldstein wrote: "Dear Beethoven, you are travelling to Vienna in fulfilment of your long-cherished wish. The genius of Mozart (died December, 1791) is still weeping and bewailing the death of her favourite. With the inexhaustible Haydn she found a refuge, but no occupation, and is now waiting to leave him and join herself to someone else. Labour assiduously and receive Mozart's spirit from the hands of Haydn. Your true friend Waldstein."

Eleonora's was the last entry. "Friendship with that which is good grows like the evening shadow till the sun of life sinks. Your true friend, Eleonora von Breuning."

#### Studying with Haydn

From this letter, and other evidence, it seems that Ludwig was going to Vienna for the special purpose of studying with Haydn. He was already sufficiently conscious of the great powers and possibilities that lay within him, and, not unduly modest by nature, he hoped that he would quickly supplant Haydn as the reigning king of Viennese musical life. It must be remembered that at the time of his departure, at the age of twenty-two, he was little more than a musician of obviously the greatest genius and the utmost promise—the hope of all those who had the future of music at heart, and who certainly knew what they were talking about—but largely self-taught, and his huge fund of originality in need of discipline and order. Could men like Mozart, Haydn, Cramer, Waldstein, etc., have possibly said what they did and all have turned out wrong? Of course not! that Ludwig van Beethoven was destined to be the next rock on which the giant music was going to come to rest in triumphant march onward seemed but a thing of destiny.

#### Everyman's Wireless Book

6/-, or by post 6/6 from George Newnes, Ltd., Tower House, Southampton St., London, W.C.2.

## COMMUNICATIONS DEPEND....

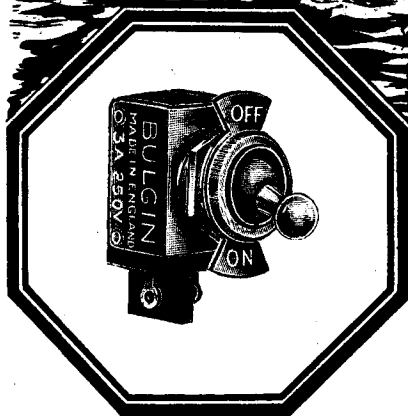

## ON SMALL PARTS....

IN countless instances quite intricate pieces of apparatus are wholly dependant on the proved reputation and reliability of their component parts.

All products from the House of Bulgin are pre-eminent for superior design and workmanship, and every article bearing our Trade Mark has to pass exacting and exhaustive tests during the course of its production.

That is why every manufacture of national importance incorporates Bulgin components.

### The Choice of Critics

#### BULGIN FOR SWITCHES

THE best Radio and small Electrical Switches in the world. Every one is the finest of its class, and the best for any job. Snap-action, low and constant contact resistance, reliable performance for tens of thousands of operations: all these are permanent characteristics. Over 100 types to choose from.

*Let us send you*

Our 80 pp. Radio Service Manual: fully illustrates 280 circuits and diagrams. Over 25,000 copies sold. Price 1/- post free.

## ALWAYS DEPEND ON

# BULGIN

REGISTERED • TRADE • MARK

A. F. BULGIN & CO., LTD., BY-PASS RD., BARKING, ESSEX.  
TEL. RIPPLEWAY 3474 (4 lines).

# Replies to Queries

## P.U. Reproduction Trouble

"Will you please examine the enclosed circuit, and tell me if there is anything the matter with it, as I cannot get satisfactory results when it is used in conjunction with a pick-up. (The circuit is of a 2-valve battery-operated amplifier.) When I made the amplifier, I tried it with a crystal set and the results were really fine, but when I connect a P.U., the volume seems poor at times and loud passages are very distorted."—W. H. (Barrhead).

THE circuit is quite in order, but we do not like the absence of any form of volume control. The input from the crystal set is low compared with that from the pick-up, and the valves are able to handle it without any trouble being introduced. When the P.U. is used, it is obvious from your remarks that the input, especially from loud passages on the record, is sufficient to overload the valves; therefore, it is very advisable to connect across the input a volume control in the form of a potentiometer having a value of, say, .25 megohms or .5 megohms. You could improve matters by increasing the anode voltage of V.1, but as you are using R.C. coupling this would mean using an additional H.T. battery. If you have a good make of L.F. transformer to hand, you could try replacing the R.C. coupling with it, thus allowing a greater anode voltage to reach the valve.

## Using a M.C. Speaker

"I have just bought a good moving-coil speaker for my three-valve battery set, and I am very disappointed to find that there is now a peculiar distortion on certain notes. I thought the speaker was faulty and took it back to the shop, but they tested it and found it quite satisfactory. I tried it again, but results were just the same. My previous speaker was one of the balanced-armature type, and the results were most pleasing, but I bought the moving-coil model to get, as I thought, better results. Can you help me to do this, by telling me how to eliminate the distortion?"—W. R. (Leytonstone).

THE trouble is probably due to the receiver, and is a common occurrence when first using a moving-coil speaker. The response from this is generally of such a true character that it reveals faults in reproduction in a receiver which may have been masked by the original type of speaker; for instance, there may be a falling off at some particular frequency due to the poorness of the L.F. coupling, and at that particular frequency there may be a resonance in the moving-iron speaker. Consequently, the effect would be balanced out and reproduction would sound satisfactory. When using the moving-coil speaker, however, without the inherent resonance, the lack of amplification at that frequency would be revealed. The M.C. speaker also reproduces lower frequencies than the armature type, and this may reveal the lack of bass. It is also essential that the speaker be correctly matched to the output valve, and this point is of greater importance than with the other type of speaker. You should, therefore, watch this point and endeavour to improve the L.F. circuits of your set.

## Function of Leaky-Grid Detector

"I have come up against a difficulty in connection with 'leaky grid detectors,' and hope that you can help me out. The difficulty is this. Assuming the grid leak to be disconnected and an unmodulated sine wave of 2 volts peak value be applied to the circuit, does the anode current finally cease (due to the accumulation of electrons at the grid) or does it take up some value (i.e., does it decrease, finally remaining steady at this decreased value)? This much I have gathered from books: On the first positive half-cycle the left-hand plate of C becomes positive and as C is not changed

### RULES

We wish to draw the reader's attention to the fact that the Queries Service is intended only for the solution of problems or difficulties arising from the construction of receivers described in our pages, from articles appearing in our pages, or on general wireless matters. We regret that we cannot, for obvious reasons—

- (1) Supply circuit diagrams of complete multi-valve receivers.
- (2) Suggest alterations or modifications of receivers described in our 'contemporaries.'
- (3) Suggest alterations or modifications to commercial receivers.
- (4) Answer queries over the telephone.
- (5) Grant interviews to querists.

A stamped, addressed envelope must be enclosed for the reply. All sketches and drawings which are sent to us should bear the name and address of the sender.

Requests for Blueprints must not be enclosed with queries as they are dealt with by a separate department.

Send your queries to the Editor, PRACTICAL WIRELESS, George Newnes, Ltd., Tower House, Southampton Street, Strand, London, W.C.2. The Coupon must be enclosed with every query.

the right-hand plate (that nearest the grid) also becomes positive. As this plate is now positive, grid current flows and the right-hand plate becomes 2 volts negative. On the negative half cycle the left-hand plate is 2 volts negative and the right-hand plate becomes 4 volts negative and no grid current flows. What I want to know is what happens on the next positive half-cycle, and what is the final outcome?

"Secondly, if the wave was modulated would the answer to the above question still apply?"—C. L. Bradbrook (Montrose).

YOU are not quite correct in your assumptions regarding the operation of a leaky-grid detector, although you are thinking along the correct lines.

The point is that if the grid leak were disconnected—and assuming that there were no minute leakage paths between the grid and cathode of the valve—the grid condenser would charge up until it had between its terminals the full voltage of the signal input. And since the grid collects the electrons from the cathode, and the valve is a one-way device, the side of the condenser connected to the grid would be negative in potential. This potential would be applied to the valve as grid bias and, in consequence, the anode current would be reduced to a steady figure.

It does not necessarily follow that the valve would cease to pass any anode current (that is, that it would be biased right back to cut-off) since this is entirely dependent upon the characteristics. It would appear that in the book you have referred to the anode current-grid voltage curve meets the grid volts line at about 4 volts

negative; in that case there would be anode-current cut-off. The same general rule applies when the grid input is modulated, and the peak voltage would be developed across the grid condenser.

## Anode Load Resistor: By-Pass Condenser

"I shall be grateful if you would assist me with regard to two technical points, as follows:

"One often reads of an anode load resistor in a L.F. stage developing a voltage drop which fluctuates with the L.F. signal; yet on reading farther one reads of the following valve receiving an A.C. input, the first half cycle being + say, and the next being -. Does L.F. component of fluctuation automatically convert itself into pure A.C., with a central zero line?

"On studying the output from a detector stage one reads of the inclusion of a high-frequency by-pass condenser being desirable. As far as I can see the L.F. output component consists of unidirectional high-frequency pulses varying in amplitude at L.F. If that is correct I cannot see what part of the output is by-passed to earth.—John G. Taylor (Heacham).

ALTHOUGH the output from an L.F. amplifier produces fluctuating voltages across the anode load, these are in the nature of a sine wave with the zero along an axis which is governed by the grid bias and anode voltage applied. This will be more readily appreciated if you examine an anode-current-grid volts curve and remember that the grid must never swing positive. In other words, the resultant anode current swing is in the nature of a sine wave. This current passing through the anode load produces an equivalent sine wave voltage across the resistor; it is this which is applied to the grid of the following valve.

The L.F. or "modulation" output from a detector is the mean of the H.F. current, it being the function of a detector to modify the mean from a straight line to a sine wave. Consequently, the H.F. is no longer required and must, in practice, be discarded or prevented from passing into the L.F. amplifier, where it would cause instability and distortion. The by-pass condenser you mention is to allow the H.F. to "escape" to earth. Actually, its function is somewhat more complex than that, for it assists in "smoothing" the output. To understand this fully it is necessary to study the action of a diode or of an anode-bend detector. The precise behaviour of this condenser need not, however, be considered as of extreme importance if the facts set out above are fully appreciated.

## REPLIES IN BRIEF

The following replies to queries are given in abbreviated form either because of non-compliance with our rules, or because the point raised is not of general interest.

**H. P. (Ealing).** The makers are no longer in business. A two-gang condenser, with trimmers, could be used, provided that the coils are matched.

**C. S. (Glasgow).** 100 to 150 turns of 28 S.W.G. enamelled wire would be in order for the choke. The resistance shown in the diagram mentioned is inserted for decoupling purposes.

**S. A. (Ipswich).** We cannot undertake to modify commercial circuits. The arrangement you suggest will be satisfactory, but care must be taken with the wiring and the applied potentials.

The coupon on page 295 must be attached to every query

**TALKS FOR DISCUSSION GROUPS**

THE two series of broadcast talks for Discussion Groups in the spring Term, "U.S.A." and "Curtain Up," are being followed in the April/June quarter by two series with very similar appeals: one on public affairs and one literary.

Groups who found the "U.S.A." talks interesting and provocative may wish to continue their discussions on the American continent by following the series of talks called "Latin America" on Mondays at 7.40 p.m. which began on April 21st. The talks will tell briefly the story of the continent, the ancient civilisations, the coming of the Spaniards, and the liberators, like Bolivar. The series will go on to describe the people and their culture, and the lands they live in, with all their variety of race and ways of living. The bulk of the series will deal with the political scene, the struggles for power between opposing parties and principles, the economic scene, the production of raw materials and their export and, finally, with world affairs—the special relationship of Latin America with the U.S.A. (the Good Neighbour policy) on the one hand, and with Europe on the other.

The "Curtain Up" talks, which have been illustrated by dramatic excerpts, have had a wide and enthusiastic following and many listeners to this series will no doubt be interested in the series on verse speaking which are being given under the title "Well Versed" on Fridays at 7.45 p.m., as from April 25th. Few are without opinions on the way in which verse should or should not be spoken. In these broadcasts, poets read their own poems and have to face criticism from actors. Actors in their turn will read and be criticised by poets. In addition, the broadcasts consider the scope of verse and the ways in which it may be spoilt by over- or under-emphasis in reading or by undue attention to footnotes to the text.

A pamphlet giving further information on these two series may be obtained from the Secretary, Central Committee for Group Listening, Bedford College for Women, Regent's Park, London, N.W.1.

**ECONOMICAL SERIES- HEATER CIRCUITS**

WHEN it is required to arrange the heaters of valves in series the difficulty arises of reducing the A.C. mains voltage down to that of the valve heaters in series with a minimum of current consumption and heat dissipation.

The Radio Corporation of America has solved the problem by using an inductive device already employed in the receiver for another purpose to produce the potential drop. For example, in an amplifier for a gramophone pick-up the motor winding is specially designed to operate with a lower voltage than normal and is connected in series with the amplifier valve heaters. In another example, the valve heaters of a radio receiver are connected in series with the primary winding of the H.T. mains transformer. The primary winding, of course, is wound with fewer turns than usual in order that the step-up ratio of the H.T. transformer is increased. This scheme not only has the advantage of reducing the amount of wire on the primary winding, but also eliminates the need for an additional secondary winding for the heater current.

**ENJOY "MUSIC WHERE YOU WANT IT"...**



**INSTALL A W.B. EXTENSION SPEAKER**

BUSY days and evenings in the shelter leave little time for leisurely listening beside the radio set. Yet the need for entertainment is greater than ever. That is why more and more people are adopting W.B. Extension Speaker listening. They are enjoying their favourite programmes in the kitchen, the workroom or the shelter. Thousands are getting the fullest enjoyment from their radio by this means. Why not you? Ask your dealer for a demonstration.

Cabinet Models from 21/6

**Stentorian**

WHITELEY ELECTRICAL RADIO CO., LTD., MANSFIELD, NOTTS.



**FOR THE RADIO SERVICE MAN, DEALER AND OWNER**

The man who enrolls for an I. C. S. Radio Course learns radio thoroughly, completely, practically. When he earns his diploma, he will KNOW radio. We are not content merely to teach the principles of radio, we want to show our students how to apply that training in practical, every-day, radio service work. We train them to be successful!

INTERNATIONAL CORRESPONDENCE SCHOOLS

Dept. 94A, International Buildings, Kingsway, London, W.C.2.

Please explain fully about your instruction in the subject marked X.

Complete Radio Engineering  
Radio Service Engineers  
Elementary Radio  
Television

If you wish to pass a Radio examination, indicate it below.

Inst. of Wireless Technology  
P.M.G. Certificate for Wireless Operators  
Provisional Certificate in Radio Telegraphy and  
Telegraphy for Aircraft  
City and Guilds Telecommunications

Name.....Age.....

Address.....

(Use penny stamp on unsealed envelope.)

**BOOKS are TOOLS**

**MODERN RADIO COMMUNICATION**

By J. H. Reyner, B.Sc. (Hons.), A.C.G.I. A comprehensive guide to modern radio theory and practice. A particularly valuable introduction for prospective recruits for Signals branches of the Services. Deals fully with every point and explains fundamentals in the clearest possible manner. There is no more popular or successful book. 2 vols. 7s. 6d. net each. Sold separately.

"A thoroughly good book." (T. & R. Bulletin.) "Among the most important of elementary textbooks." (Wireless World). "The author has succeeded admirably." (Electronics).

**SHORT-WAVE RADIO**

By J. H. Reyner. A comprehensive practical survey of modern developments in the use of short, ultra-short and micro-waves. It provides a great deal of valuable data concerning the practical methods of their use in radio and television transmission. 10s. 6d. net.

"One of the finest short-wave treatises available." (Journal of the Institute of Engineers, Students Quarterly Journal).

**THE SUPERHETERODYNE RECEIVER**

By Alfred T. Witty, A.M.I.E.E. This is a book you should have if you are interested in modern radio. A practical and handy guide to Superhets, telling you all about their working, construction and maintenance. Specially recommended to radio mechanics serving with the Forces. 4s. 6d. net.

"Remarkably up-to-date." (Wireless World.)

**RADIO RECEIVER SERVICING AND MAINTENANCE**

By E. J. G. Lewis. Everything connected with wireless servicing, maintenance and repair is exhaustively described and is set out for immediate reference. 8s. 6d. net.

"The book is so practical, so replete in facts, and so well arranged that the reader will gain the necessary knowledge to work in a logical manner." (Wireless World.)

**PITMAN'S**  
PARKER ST., KINGSWAY, LONDON, W.C.2

Practical Wireless

BLUEPRINT SERVICE

These Blueprints are drawn full size. Copies of appropriate issues containing descriptions of these sets can in some cases be supplied at the following prices which are additional to the cost of the Blueprint. A dash before the Blueprint Number indicates that the issue is out of print. Practical Wireless (issues dated prior to June 1st, 1940) 4d. Post Paid. Issues dated June 1st to July 27th, 1940, 5d. Post Paid (Issues dated September, 1940 and after) 7d. Post Paid.

Amateur Wireless ... 4d. " " Wireless Magazine ... 14d. " " The index letters which precede the Blueprint Number indicate the periodical in which the description appears: Thus P.W. refers to PRACTICAL WIRELESS, A.W. to Amateur Wireless, W.M. to Wireless Magazine.

Send (preferably) a postal order to cover the cost of the blueprint, and the issue (stamps over 6d. unacceptable) to PRACTICAL WIRELESS Blueprint Dept., George Newnes, Ltd., Tower House, Southampton Street, Strand, W.C.2.

PRACTICAL WIRELESS No. of Date of Issue, Blueprint.

**CRYSTAL SETS**  
Blueprints, 6d. each.  
1937 Crystal Receiver ... PW71  
The "Junior" Crystal Set ... 27.8.38 PW94

**STRAIGHT SETS. Battery Operated**  
**One-valve : Blueprints, 1s. each.**  
All-Wave Unipen (Pentode) ... PW31A  
Beginners' One-valver ... 19.2.38 PW85  
The "Pyramid" One-valver (HF Pen) ... 27.8.38 PW93

**Two-valve : Blueprint, 1s.**  
The Signet Two (D & LF) ... 24.0.38 PW70

**Three-valve : Blueprints, 1s. each.**  
Selectone Battery Three (D, 2 LF (Trans)) ... PW10  
Sixty Shilling Three (D, 2 LF (RC & Trans)) ... PW34A  
Leader Three (SG, D, Pow) ... PW35  
Summit-Three (HF Pen, D, Pen) ... PW37  
All Pentode Three (HF Pen, D (Pen), Pen) ... PW39  
Hall-Mark Three (SG, D, Pow) ... PW41  
Hall-Mark Cadet (D, LF, Pen (RC)) ... PW48  
F. J. Camm's Silver Souvenir (HF Pen, D (Pen), Pen) (All-Wave Three) ... PW49  
Cameo Midget Three (D, 2 LF (Trans)) ... PW51  
1936 Sonotone Three-Four (HF Pen, HF Pen, Westector, Pen) Battery All-Wave Three (D, 2LF (RC)) ... PW53  
The Monitor (HF Pen, D, Pen) ... PW56  
The Tutor Three (HF Pen, D, Pen) ... PW62  
The Centaur Three (SG, D, P) ... PW64  
F. J. Camm's Record All-Wave Three (HF Pen, D, Pen) ... PW60  
The "Colt" All-Wave Three (D, 2 LF (RC & Trans)) ... 18.2.39 PW72  
The "Rapid" Straight 3 (D, 2 LF (RC & Trans)) ... PW82  
F. J. Camm's Oracle All-Wave Three (HF Det, Pen) ... PW78  
1938 "Triband" All-Wave Three (HF Pen, D, Pen) ... PW84  
F. J. Camm's "Sprite" Three (HF Pen, D, Det) ... 26.3.38 PW87  
The "Hurricane" All-Wave Three (SG, D (Pen), Pen) ... PW89  
F. J. Camm's "Push-Button" Three (HF Pen, D (Pen), Det) ... 3.9.38 PW92

**Four-valve : Blueprints, 1s. each.**  
Sonotone Four (SG, D, LF, P) ... 1.5.37 PW4  
Fury Four (2 SG, D, Pen) ... PW11  
Beta Universal Four (SG, D, LF, Cl. B) ... PW17  
Nucleon Class B Four (SG, D (SG), LF, Cl. B) ... PW34B  
Fury Four Super (SG, SG, D, Pen) Battery Hall-Mark 4 (HF Pen, D, Push-Pull) ... PW46  
F. J. Camm's "Limit" All-Wave Four (HF Pen, D, LF, P) ... PW67  
"Acme" All-Wave 4 (HF Pen, D (Pen), LF, Cl. B) ... 12.2.38 PW83  
The "Admiral" Four (HF Pen, HF Pen, D, Pen (RC)) ... 3.9.38 PW90

**Main: Operated.**  
**Two-valve : Blueprints, 1s. each.**  
A.C. Twin (D (Pen), Pen) ... PW18  
A.C.-D.C. Two (SG, Pow) ... PW31  
Selectone A.C. Radiogram Two (D, Pow) ... PW19  
**Three-valve : Blueprints, 1s. each.**  
Double-Diode-Triode Three (HF Pen, DDT, Pen) ... PW32  
D.C. Ace (SG, D, Pen) ... PW25  
A.C. Three (SG, D, Pen) ... PW29  
A.C. Leader (HF Pen, D, Pow) ... 7.1.39 PW25C  
D.C. Premier (HF Pen, D, Pen) ... PW35B  
Unique (HF Pen, D (Pen), Pen) ... PW36A  
Armada Mains Three (HF Pen, D, Pen) ... PW38  
F. J. Camm's A.C. All-Wave Silver Souvenir Three (HF Pen, D, Pen) "All-Wave" A.C. Three (D, 2 LF (RC)) ... PW54  
A.C. 1936 Sonotone (HF Pen, HF Pen, Westector, Pen) ... PW56  
Mains Record All-Wave 3 (HF Pen, D, Pen) ... PW70

**Four-valve : Blueprints, 1s. each.**  
A.C. Fury Four (SG, SG, D, Pen) ... PW20  
A.C. Fury Four Super (SG, SG, D, Pen) ... PW34D  
A.C. Hall-Mark (HF Pen, D, Push-Pull) ... PW45  
Universal Hall-Mark (HF Pen, D, Push-Pull) ... PW47

**SUPERHETS.**  
**Battery Sets : Blueprints, 1s. each.**  
£5 Superhet (Three-valve) ... PW40  
F. J. Camm's 2-valve Superhet ... PW52

**Mains Sets : Blueprints, 1s. each.**  
A.C. £5 Superhet (Three-valve) ... PW43  
D.C. £5 Superhet (Three-valve) ... PW42  
Universal £5 Superhet (Three-valve) ... PW44  
F. J. Camm's A.C. Superhet 4 ... PW59  
F. J. Camm's Universal £4 Superhet 4 ... PW60  
"Qualitone" Universal Four ... PW73

**Four-valve : Double-sided Blueprint, 1s. 6d.**  
Push Button 4, Battery Model ... 22.10.38 PW95  
Push Button 4, A.C. Mains Model

**SHORT-WAVE SETS. Battery Operated.**  
**One-valve : Blueprint, 1s.**  
Simple S.W. One-valver ... 23.12.39 PW88

**Two-valve : Blueprints, 1s. each.**  
Midget Short-wave Two (D, Pen) The "Fleet" Short-wave Two (D (HF Pen), Pen) ... 27.8.38 PW91

**Three-valve : Blueprints, 1s. each**  
Experimenter's Short-wave Three (SG, D, Pow) ... PW30A  
The Prefect 3 (D, 2 LF (RC and Trans)) ... PW63  
The Band-Spread S.W. Three (HF Pen, D (Pen), Pen) ... PW68

**PORTABLES.**  
**Three-valve : Blueprints, 1s. each.**  
F. J. Camm's ELF Three-valve Portable (HF Pen, D, Pen) ... PW65  
Parvo Flyweight Midget Portable (SG, D, Pen) ... 3.6.39 PW77

**Four-valve : Blueprint, 1s.**  
"Imp" Portable 4 (D, LF, LF (Pen)) ... PW86

**MISCELLANEOUS.**  
Blueprint, 1s.  
S.W. Converter-Adapter (1 valve) ... PW48A

**AMATEUR WIRELESS AND WIRELESS MAGAZINE CRYSTAL SETS.**  
**Blueprints, 6d. each.**  
Four-station Crystal Set ... 23.7.38 AW427  
1934 Crystal Set ... AW444  
150-mile Crystal Set ... AW450

**STRAIGHT SETS. Battery Operated.**  
**One-valve : Blueprint, 1s.**  
B.B.C. Special One-valver ... AW387  
**Two-valve : Blueprints, 1s. each.**  
Melody Ranger Two (D, Trans) ... AW388  
Full-volume Two (SG det, Pen) ... AW392  
Lucerne Minor (D, Pen) ... AW426  
A Modern Two-valver ... WM409

**Three-valve : Blueprints, 1s. each.**  
£5 5s. S.G. 3 (SG, D, Trans) ... AW412  
Lucerne Ranger (SG, D, Trans) ... AW422  
£5 5s. Three: De Luxe Version (SG, D, Trans) ... 19.5.34 AW435  
Lucerne Straight Three (D, RC, Trans) ... AW437  
Transportable Three (SG, D, Pen) ... WM271  
Simple-Tune Three (SG, D, Pen) ... WM327  
Economy Pentode Three (SG, D, Pen) ... WM937  
"W.M." 1934 Standard Three (SG, D, Pen) ... WM351  
£3 3s. Three (SG, D, Trans) ... WM354  
1935 £6 6s. Battery Three (SG, D, Pen) ... WM371  
PTP Three (Pen, D, Pen) ... WM389  
Certainty Three (SG, D, Pen) ... WM393  
Minutube Three (SG, D, Trans) ... Oct. '35 WM393  
All-Wave Winning Three (SG, D, Pen) ... WM400

**Four-valve : Blueprints, 1s. 6d. each.**  
65s. Four (SG, D, RC, Trans) ... AW370  
2HF Four (2 SG, D, Pen) ... AW421  
Self-contained Four (SG, D, LF, Cl. B) ... Aug. '33 WM231  
Lucerne Straight Four (SG, D, LF, Trans) ... WM350  
£5 5s. Battery Four (HF, D, 2 LF) ... Feb. '35 WM381  
The H.K. Four (SG, SG, D, Pen) ... WM384  
The Auto Straight Four (HF Pen, HF Pen, DDT, Pen) ... Apr. '36 WM404

**Five-valve : Blueprints, 1s. 6d. each.**  
Super-quality Five (2 HF, D, RC, Trans) ... WM320  
Class B Quadradyme (2 SG, D, LF, Class B) ... WM344  
New Class B Five (2 SG, D, LF, Class B) ... WM340

**Mains Operated.**  
**Two-valve : Blueprints, 1s. each.**  
Consoelectric Two (D, Pen) A.C. ... AW403  
Economy A.C. Two (D, Trans) A.C. ... WM286  
Unicorn A.C.-D.C. Two (D, Pen) ... WM394

**Three-valve : Blueprints, 1s. each.**  
Home Lover's New All-electric Three (SG, D, Trans) A.C. ... AW383  
Mantovani A.C. Three (HF, Pen, D, Pen) ... WM374  
£15 15s. 1936 A.C. Radiogram (HF, D, Pen) ... Jan. '36 WM401  
**Four-valve : Blueprints, 1s. 6d. each.**  
All Metal Four (2 SG, D, Pen) ... WM329  
Harris' Jubilee Radiogram (HF, Pen D, LF, P) ... May '35 WM386

**SUPERHET.**  
**Battery Sets : Blueprints, 1s. 6d. each.**  
Modern Super Senior ... WM375  
Varsity Four ... Oct. '35 WM395  
The Request All-Waver ... June '36 WM407  
1935 Super-Five Battery (Superhet) ... WM379

**Mains Sets : Blueprints, 1s. each.**  
Heptode Super Three A.C. ... May '34 WM359  
"W.M." Radiogram Super A.C. ... WM366

**PORTABLES.**  
**Four-valve : Blueprints, 1s. 6d. each.**  
Holiday Portable (SG, D, LF, Class B) ... AW393  
Family Portable (HF, D, RC, Trans) ... AW447  
Two H.F. Portable (2 SG, D, QP21) ... WM363  
Tyers Portable (SG, D, 2 Trans) ... WM367

**SHORT-WAVE SETS. Battery Operated.**  
**One-valve : Blueprints, 1s. each.**  
S.W. One-valver for America ... 15.10.38 AW429  
Roma Short-Waver ... AW452  
**Two-valve : Blueprints, 1s. each.**  
Ultra-short Battery Two (SG, Det, Pen) ... Feb. '36 WM402  
Home-made Coil Two (D, Pen) ... AW440

**Three-valve : Blueprints, 1s. each.**  
World-ranger Short-wave 3 (D, RC, Trans) ... AW355  
Experimenter's 5-metre Set (D, Trans, Super-regen) ... 30.6.34 AW438  
The Carrier Short-waver (SG, D, P) ... July '35 WM390

**Four-valve : Blueprints, 1s. 6d. each.**  
A.W. Short-wave World-beater (HF, Pen, D, RC, Trans) ... AW436  
Empire Short-wave (SG, D, RC, Trans) ... WM313  
Staugland Four-valver Short-waver (SG, D, LF, P) ... P.W. 22.7.39 WM383  
**Superhet : Blueprint, 1s. 6d.**  
Simplified Short-wave Super ... WM397

**Mains Operated.**  
**Two-valve : Blueprints, 1s. each.**  
Two-valve Mains Short-waver (D, Pen) A.C. ... P.W. 13.1.40 AW453  
"W.M." Long-wave Converter ... WM380

**Three-valve : Blueprint, 1s.**  
Emigrator (SG, D, Pen) A.C. ... WM352

**Four-valve : Blueprint, 1s. 6d.**  
Standard Four-valve A.C. Short-waver (SG, D, RC, Trans) ... WM391

**MISCELLANEOUS.**  
S.W. One-valve Converter (Price 6d.) ... AW329  
Enthusiast's Power Amplifier (1/6) ... WM387  
Listener's 5-watt A.C. Amplifier (1/6) ... WM392  
Radio Unit (2v.) for WM 392 (1/-) Harris Electrogram battery amplifier (1/-) ... WM398  
De Luxe Concert A.C. Electrogram (1/-) ... WM399  
New Style Short-wave Adapter (1/-) ... WM388  
Trickle Charger (6d.) ... AW462  
Short-wave Adapter (1/-) ... AW456  
Superhet Converter (1/-) ... AW457  
B.L.D.L.C. Short-wave Converter (1/-) ... May '36 WM405  
Wilson Tone Master (1/-) ... June '36 WM406  
The W.M. A.C. Short-wave Converter (1/-) ... WM408

The "Fluxite Quins" at Work.

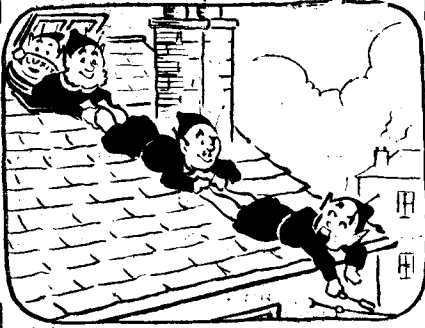

*Cried OI, from the gutter, "Hold tight!  
Till I've soldered this aerial right.  
I can see now quite plain  
Why it's broken again.  
Pass me down, lads, the tin of FLUXITE!"*

See that **FLUXITE** is always by you—in the house—garage—workshop—wherever speedy soldering is needed. Used for 30 years in government works and by leading engineers and manufacturers. Of Ironmongers—in tins, 4d., 8d., 1/4 and 2/8.

Ask to see the **FLUXITE SMALL-SPACE SOLDERING SET**—compact but substantial—complete with full instructions, 7/6.

**TO CYCLISTS!** Your wheels will NOT keep round and true, unless the spokes are tied with fine wire at the crossings AND **SOLDERED**. This makes a much stronger wheel. It's simple—with **FLUXITE**—but **IMPORTANT**

The **FLUXITE GUN** is always ready to put Fluxite on the soldering job instantly. A little pressure places the right quantity on the right spot and one charging lasts for ages. Price 1/6, or filled 2/6.

Write for Free Book on the art of "soft" soldering and ask for leaflet on **CASE-HARDENING STEEL**, and **TEMPERING TOOLS** with **FLUXITE**.

**FLUXITE LTD.** (Dept. W.P.), **BERMONDSEY ST., S.E.1.**

**FLUXITE**  
SIMPLIFIES ALL SOLDERING

**ELEMENTARY HANDBOOK for WIRELESS OPERATORS**

by **W. E. CROOK**

Here is the latest book by Crook, author of **WIRELESS TELEGRAPHY and ELECTRICITY IN AIRCRAFT**. His new book cannot be ignored by any future aircraft radio operator. It is precisely what he needs to assist him during his training, to supplement his official instruction, and will provide a firm groundwork on which to build his knowledge. At least one diagram on net. almost every page!

**4s.**

**PITMAN PARKER ST., W.C.2.**

**WE CAN AGAIN SUPPLY 'AVOMINOR' D.C. TEST METER**



The equivalent of thirteen testing instruments in one. Measures Current, Voltage and Resistance with ease and accuracy. In handsome case with leads, interchangeable crocodile clips and testing prods. Delivery from stock, £2.17.6, plus 6d. postage. Cash or C.O.D.

★ Also the following; **TAX-FREE** white stock lasts:—**W.B. LS Units**, **Morphy Richards Auto Irons** and **Electric Fires**, **Ormond Hair Dryers**, etc.

**THE LONDON RADIO SUPPLY CO.**  
Est. 1925. All communications to Evacuation address:—"Windon," Ardingly Road, Balcombe, Sussex.

**'DE LUXE' SLIDE RULES**

For Quick and Accurate Solutions  
Multiply—Divide—by Mechanical Means.  
Seven Scale, 5-in. Slide Rule. ONLY  
A.B.C.D. Log-Log, Reversed 4/9  
C Scale, with Reciprocals.



12-IN. DESK SIZE DE-LUXE LOG-LOG. SIN-TAN SLIDE RULE. THE 'UNIVERS. AL' RULE. 9 SCALES. SOLVES EVERY CONCEIVABLE PROBLEM. ONLY 8/6d., post 6d., COMPLETE IN CASE.

All Slide Rules British Made and guaranteed for precision and accuracy. Beautifully made from polished mahogany, white celluloid faced, back and front. Clear-view. Unbreakable Cursor.

Approval or Money Returned.

**BRITISH SLIDERULE CO., Dept. 10, 16, BARTER ST., LONDON, W.C.1**

**THE ROYAL INSTITUTION OF RADIO ENGINEERS**  
INCORPORATING THE INSTITUTION OF RADIO ENGINEERS.

**PROFESSIONAL EXAMINATION**

The examinations of the Institution will be held in London and Manchester in May and September of each year. All particulars and application forms can be obtained gratis from the Secretary, Radio House, 393.5, Bury New Road, Manchester, 7, England.

**FREE ADVICE BUREAU COUPON**

This coupon is available until June 7th, 1941, and must accompany all Queries and Hints. **PRACTICAL WIRELESS**, June, 1941.

**TRAINED MEN URGENTLY NEEDED**

**N**EVER before has there been such an urgent demand for trained radio men. There's a job waiting for you; or you can earn good money in your spare time.

**Are you liable for military service?** The **R.A.F.** is appealing for radio men, and many of our students have already been accepted as **Radio Mechanics, Operators and Instructors**. They like the work and the pay is good.

You can study at home in your spare time and become a qualified **Radio Engineer**. Even if you know nothing about radio, we can train you.

Hundreds of our students who had no previous knowledge or experience of radio have secured well-paid employment or spare-time work as a result of our training.

Our Home-Study Courses are praised and recommended by leading **Radio Authorities**. Our fees are reasonable and can be paid by easy monthly instalments.

Wherever you live you can study at home without interfering with your ordinary occupation. Do not delay, but post coupon now for full details of our Courses.

*We have moved from London and Ealing; our new address is:—*

**T. & C. RADIO COLLEGE**  
**29, Market Place, READING.**

(post in unsealed envelope, 1d. stamp)

Please send me free details of your Home-Study Radio Courses.

NAME .....

ADDRESS .....

P. 16.

**TAYLOR VALVE TESTER**

With this precision-built Taylor Valve Tester, Model 45, approximately 1,500 different types of British, American and Continental radio receiving valves can be put through important tests. Accurate measurement of mutual conductance; cathode leakage emission, etc. 17 different types of valveholders are fitted, including new American Bantam, Loktal, Mazda Octal and Midget Deaf-Aid types.

Each valve is tested under correct working conditions.

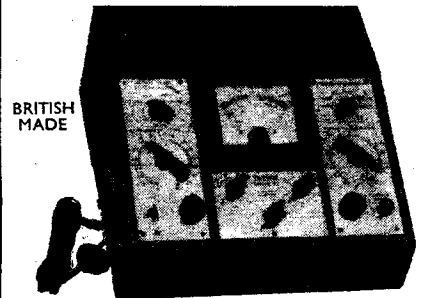

BRITISH MADE

**TAYLOR VALVE TESTER, MODEL 45**

**£14 - 3 - 6**

(Standard Bench Model)

Complete with instruction book and valve manual.

There is a Portable Model at £14-19-0.

Delivery ex stock. Fully tested. Guaranteed 6 months.

**TAYLOR** Electrical Instruments Ltd., 419-422, Montrose Avenue, SLOUGH, Bucks. Slough 21381.

## Classified Advertisements

**ADVERTISEMENTS** are accepted for these columns at the rate of 2s. per line, minimum charge 4s. All advertisements must be prepaid. Each paragraph will commence with the first word in bold face capitals. All communications should be addressed to the Advertisement Manager, "Practical Wireless," Tower House, Southampton Street, London, W.C.2.

### CABINETS

**A CABINET** for every radio purpose. Send measurements of chassis, etc., and say what kind of cabinet required. Stamp for reply. Inspection invited.  
**H. L. SMITH AND CO., LTD.**, 289, Edgware Road, W.2. Tel.: Pad. 5891.

### COMPONENTS FOR SALE

**FORMO CERAMIC** ribbed  $1\frac{1}{2} \times 2$ " Coil Formers, per doz., 3/-; per gross, 30/-; Formo Ceramic Bases for above,  $2\frac{1}{2} \times 1\frac{1}{2} \times 1\frac{1}{2}$ ", 5-hole, without fittings, per doz., 1/6; per gross, 15/-; Heltesens 50 mfd. P.V.12 dry electrolytic condensers, 1/-.—A.C.S. Radio, 44, Wildmore Road, Bromley.

### FOR SALE

"PRACTICAL WIRELESS" for Sale. Volumes 10/15, with 20 others, £1.—Lord, Oakwood Mount, Rochdale, Lancs.

### LITERATURE, MAPS, etc.

**AMATEUR Radio Handbook.** Second edition now on sale. 328 pages, price 4s.—Radio Society of Great Britain, 16, Ashridge Gardens, London, N.13.

**WEBB'S Radio Map of the World** enables you to locate any station heard. Size 40" by 30" 2 colour heavy Art Paper, 4/6, post 6d. Limited supply on Linen, 10/6, post 6d. **WEBB'S Radio Globe**—superb 12" full-colour model. Radio prefixes, zones, etc. Heavy oxidised mount. Post paid. 27/6.—Webb's Radio, 14, Soho Street, London, W.1. Phone: GERrard 2089.

### LOUDSPEAKER REPAIRS

**LOUDSPEAKER** repairs, British, American, any make, moderate prices.—Sinclair Speakers, Pulteney Terrace, Copenhagen Street, London, N.1.

### MISCELLANEOUS

**CELLULOSE STENCILS**, showcard writing outfit, 3/6 Poster, 5/6. Experience unnecessary.—"Printa Sign," 23, Blackburn Street, Glasgow, S.W.1.

**RADIO SOCIETY OF GREAT BRITAIN** invites all keen amateurs to join. Reduced war-time subscriptions. Send 1s. for current issue "T. & R. Bulletin" and details.—16, Ashridge Gardens, London, N.13.

**LECTURED** before Radio Societies. Revolutionary Detection theory; system; circuits; practical experiments. Booklet, 2s. post free.—D'Arcy Ford, Gandy Street, Exeter.

### MORSE EQUIPMENT

**FULL** range of Transmitting Keys, practice sets and other equipment for Morse training.—Webb's Radio, 14, Soho Street, London, W.1. Phone: GERrard 2089.

### MORSE TRAINING

**FREE.** "Book of Facts" tells you all about The Candler System of Code training. Courses for Beginners and Operators.—Write: Candler System Co. (L.O.), 121, Kingsway, London, W.C.2.

**MORSE TRAINER**, self-contained outfit comprising flasher, buzzer, sounder. Adjustable tapper tension, 7/6, worth double. Battery 9/6. Postage, 7d. extra.—Code and instructions free. Pracomorse, 1, Maple Road, London, S.E.20.

### NEW LOUDSPEAKERS

**3,000** Speakers, P.M. and energised, 4in. to 14in., including several Epoch 18in.—Sinclair Speakers, Pulteney Terrace, Copenhagen Street, London, N.1.

### PATENTS

**THE PROPRIETOR** of British Patent No. 290,642, relating to "Improvements in radio telephone signalling," is desirous of entering into negotiations with one or more firms in Great Britain for the purpose of exploiting the invention either by the sale of the Patent Rights or by the grant of Licences on reasonable terms. Interested parties who desire further particulars should apply to Albert L. Mond & Thiemann, of 14 to 18, Holborn, London, E.C.1.

### PATENTS

**THE OWNER** of British Patent No. 330,876, relating to "Improvements on or relating to Signalling Systems," is desirous of entering into negotiations with one or more firms in Great Britain for the purpose of exploiting the invention either by sale of the Patent Rights or by the grant of Licences on reasonable terms. Interested parties who desire further particulars should apply to Albert L. Mond & Thiemann, 14 to 18, Holborn, London, E.C.1.

### PUBLIC APPOINTMENTS

#### WIRELESS TECHNICAL INSTRUCTORS REQUIRED IN ARMY UNITS

**Emoluments.**—Pay 8s. 6d. per day (7 days a week). Clothing, rations and accommodation or, if this cannot be provided, allowances at authorised rates. If married and otherwise eligible family allowance payable in respect of wife and children, subject to allotment from pay.

Candidates should preferably be under 35 and over 24 and—

- (a) Hold one of the following qualifications:  
Graduate of the Institution of Electrical Engineers.  
Final (Grade III) Certificate of City and Guilds of London Institute Examination in Radio Communication.  
Higher National Certificate in Electrical Engineering.  
Certificate of City and Guilds of London Institute in Radio Service Work.  
OR

- (b) Be able to pass an examination on the following syllabus:

Simple algebra, including quadratic equations; simple trigonometrical ratios and identities; vectors.

Properties of electrical currents; heating of conductors; magnetic fields; unit of current; Ohm's Law; resistance in series and parallel; potentiometers.

Magnetic effect of current; fields due to parallel wires; field due to a solenoid; electro-magnets. Meters.

Induction; effect of rotating a coil in a magnetic field.

Mutual and self induction and inductance; effect of inductance on growth and delay of current.

Capacity; charging storage and discharge of condensers; through resistance and inductance.

Alternating currents; vector diagrams; effect of resistance variation; effects of L and C in A.C. circuit; phase difference of currents; resonance in a series circuit; parallel circuit of L and C; Q factor.

Elementary knowledge of valves; simple theory of amplifiers; oscillators and detectors; general principles of radio practice.

**Suitable Candidates** will be interviewed at local centres, and, if successful, will be enlisted and appointed Acting Sergeant Tradesman. For those who are on the Schedule of Reserved Occupations, special arrangements will be made to enable them to be enlisted. In the event of any applicant found to be reserved under Schedule of Reserved Occupations special application will be made or relaxation of the Schedule. No guarantee can be given that this application will be successful.

**Application Forms** may be obtained by post card from the Under Secretary of State, The War Office (A.G.6c), Whitehall, S.W.1.

### READERS' BARGAINS

**SKYSCRAPER** Four chassis, speaker and last 2 valves, minus transformer; 10s., plus post.—Tones, 13, Sunnyside Terrace, Holytown, Motherwell.

**WANTED**, mains valves, any quantity from one upwards, also sets and spare parts.—J. Bull, 4, Melthorne Drive, Ruislip, Middx.

**A.F.5** 7/-, 2, 3, 4 gang condensers, 4/- each. 27 Wireless Parts, Valves, Coils, Chokes, Transformers, etc. All good, 7/- lot, postage extra.—Jessop, 2A, Midland Road, Wellingborough.

### RECEIVERS AND COMPONENTS

**SURPLUS** Stocks. Bargains in Electrical equipment, engineers' tools and materials. Stamp for list.—F. Busfield and Co., Waterhouse Yard, Scarborough.

**SOUTHERN** Radio's Wireless Bargains. Most lines previously advertised still available. New list to be advertised shortly.  
Southern Radio, 46, Lisle Street, London, W.C.  
Phone: Gerrard 6653.

**COULPHONE** Radio, New Longton, Preston. Tung-gram and American Valves. Pick-ups with volume control, 17/6. 10" Roly P.M., with transformer, 22/6. 8" Goodmans P.M., 17/6. Electrolytics, 500-v. 8 mfd., 2/9; 8+8 mfd. 4/9 (4 leads); 16+8 mfd., 6/3; 50v., 50 mfd., 2/9. S.A.E. for New List.

### RECEIVERS AND COMPONENTS

**LONDON CENTRAL RADIO** still supplying the best bargains in Surplus Electrical and Radio Gear. Mostly EX-GOVERNMENT, G.P.O. and SERVICES

**SINGLE** Earpieces. A good line for experimenters with flexible metal sheathing, chromium-plated. Only a few to clear, 2/6 each.

**RESISTANCES.** Assorted values and makes, Eric, T.C.C. American, etc. Resistances are in short supply—get a dozen or so while you can. Low price of 1/6 doz.

**TAPPED** mains resistances. Another good line, for 2 amp. valves. Tapped at 200, 230 and 250 volts. To clear, 4/- each.

**WESTINGHOUSE** Rectifiers. The popular type H.T.S. Slightly used, but guaranteed in good condition and working order. Only 8/6 each.

**SWITCHES.** Heavy duty 3-way 4-pole switches, a good soundly constructed job, will stand up to hard wear, 1/6 each.

**B.I. CONDENSERS.** Block-type oil filled in metal cases with terminals. High quality components, 4 mfd. 450 v. d.c. test, 3/6 each. Also 1 mfd. 1,000 v. d.c. test, 2/6 each and 0.25 mfd. 1,000 v. d.c. test, 2/6 each.

**ALUMINIUM** Panels. Heavy gauge sheets, brand new. Replacements now unobtainable.  $14\frac{1}{2} \times 6\frac{1}{2}$ , 2/6.  $14\frac{1}{2} \times 5\frac{1}{2}$ , 2/3. State size when ordering.

**TRIMMERS.** Twin trimmers on ceramic base, brand new, to clear 6d. each, 5/- doz.

**VARIABLE CONDENSERS.** Well made heavy 3-gang superhet condensers. Die cast frames in first class condition. Low price to clear stock 1/3 each.

**SPEAKERS.** Brand new energised moving coil speakers, ex famous maker, 5/6 each.

**PLESSEY** Small block type condensers, two tappings, .0005 and 0.1 mfd., 350 v. test, 1/- each, 10/6 doz.

**REGENTONE** Chassis. Cadmium plated  $10 \times 4\frac{1}{2}$ " ex midget receivers. Contain five midget valveholders, coils, choke, condensers, transformer, volume control, switch, in fact they are practically complete. 7/6 each to clear.

**WESTINGHOUSE** Rectifier Units. Input 220/250v. A.C. 50 cycles, D.C. output, 9v. 3 amps. Sound, heavy job, built on stout gauge black crystalline finish chassis. Complete with leads in brand new condition. Size overall,  $12 \times 5\frac{1}{2} \times 6$ ", price 55/-.

**RELAYS.** Small relays for operation on 2v. D.C. with 6-way make and break switches. Brand new, many useful applications, 5/- each.

**YAXLEY** type switches, 4 bank, 4-way rotary spindle, 2/3 each.

**VALVEHOLDERS.** Belling-Lee special H.F. 5-pin, chassis mounting in black bakelite, 6d. each, 5/- doz.

**RESISTANCES AND CONDENSERS.** Ex famous television manufacturer. Paxolin strips containing approximately 12 resistances and 6 tubular condensers. Various values. Ideal for servicemen and experimenters, 3/6 each.

**EX TELEVISION MANUFACTURER.** Following oddments at ridiculous prices. See also our advert on p. 280. 7-pin valve-holder on metal bracket containing 2 tag type .0002 mfd. T.C.C. condensers, 1 B.I. Electrolytic Tubular 200 mfd., 1 Tubular .02 mfd., 350 v. D.C. working, 1/3 complete. Also 5-pin valve-holder on bracket with 6-pin connecting socket and 2 resistances.

**9d.** complete. 5-pin frequency valve-holders for short wave work, 9d. each. Paxolin squares  $2\frac{1}{2} \times 2$ " to clear, 9d. doz. Wax impregnated cardboard panels,  $10\frac{1}{2} \times 6$ ".

**1/3** doz. Paxolin panel containing 5 assorted resistances and a .0002 mfd. T.C.C. tag type condenser.

**9d.** each. 30 ohm volume controls wire wound, 1/3 each. Short wave coil 7.23 metres mounted on ceramic trimmer, 1/- each. All above items are high quality television components, new and unused.

**SEE ALSO OUR DISPLAY ADVT. ON PAGE 280. SUFFICIENT POSTAGE MUST BE INCLUDED. REGRET NO C.O.D. ORDERS ACCEPTED.**

**LONDON CENTRAL RADIO STORES, 23, LISLE ST., LONDON, W.C.2.** Phone: Gerrard 2969

**SEE ALSO OUR DISPLAY ADVT. ON PAGE 280. SUFFICIENT POSTAGE MUST BE INCLUDED. REGRET NO C.O.D. ORDERS ACCEPTED.**

**LONDON CENTRAL RADIO STORES, 23, LISLE ST., LONDON, W.C.2.** Phone: Gerrard 2969

**GEE GEE GEE GEE GEE GEE**  
15, LITTLE NEWPORT STREET, W.C.2.

**METAL CHASSIS**, finished battleship grey,  $11 \times 7 \times 2\frac{1}{2}$ ". Brand new condition, fitted 4 seven-pin and 2 five-pin valveholders. Many uses, 4/- each.

**AMERICAN AND B.V.A.** Valves, many types at keenest prices. Send us your requirements.

**SPEAKER TRANSFORMERS.** Ex-G.E.C. stock entirely exhausted. New stocks of superior line, centre tapped, soundly constructed, new, 3/- each.

**SLEEVING.** Best quality wax impregnated linen, 2 mm. sleeving, six 1 yard lengths for 1/6. Also push-back wire, 2 cotton coverings, 2/9 doz. yards.

**ROLA P.M. Speakers.** Genuine Brand New 10" with centre tapped transformer. First class job, 22/6 each.

**SCREENED SLEEVING.** A good line of circular metal wrapped sleeving. Unrepeatable, 6d. a yard.

**CELESTION P.M. Speakers.** Absolutely brand new, latest type 6in., at special low price, 12/6 each.

**MAINS DROPPING RESISTANCES.** 150 ohm flat metal type, most suitable for midget receivers, 1/- each. We carry large stock of mains droppers, 2 amp. and 3 amp. tapped. Tell us your requirements.

**SOLDER.** Very best quality resincore solder, 50 per cent tin, 12 gauge, 6d. a length.

**EX-PHILCO** new American battery valves. Types: 1A4E, 1B4E, 2/6 each.

**VARIABLE CONDENSERS.** 3-gang, .0005 mfd. A fine job with die-cast frame and solid aluminium vanes, 2/6 each.

**Hold large stocks of the above, can quote extremely low terms for large quantities. Postage extra. GEE ELECTRIC, 15, LITTLE NEWPORT ST., W.C.2.**



# FREE!



## THIS IMPORTANT GUIDE TO SUCCESSFUL ENGINEERING CAREERS

After months of intensive effort and research we are pleased to announce that the new edition of our handbook, "**ENGINEERING OPPORTUNITIES**," is now out of the publishers' hands and ready for *free distribution*. Containing 208 pages of practical guidance, this book is, beyond argument, the finest and most complete handbook on Successful Engineering Careers ever compiled. It is a book that should be on the bookshelf of every person interested in engineering whatever his age, position or experience.

The Handbook contains, among other intensely interesting matter, details of **B.Sc., A.M.I.C.E., A.M.I.Mech.E., A.M.I.E.E., A.M.I.A.E., A.M.I.W.T., A.M.I.R.E., A.M.I.P.E., CIVIL SERVICE**, and other important Engineering Examinations: outlines courses in all branches of **CIVIL, MECHANICAL, ELECTRICAL, AUTOMOBILE, RADIO, TELEVISION, AERONAUTICAL and PRODUCTION ENGINEERING, DRAUGHTSMANSHIP, TRACING, GOVERNMENT EMPLOYMENT, BUILDING** (the great after-war Career), **R.A.F. MATHS.**, etc., etc., and explains the unique advantages of our Employment Department.

**WE DEFINITELY GUARANTEE  
"NO PASS—NO FEE"**

If you are earning less than £10 per week you cannot afford to miss reading "**ENGINEERING OPPORTUNITIES**."

In your own interests, we advise you to write (or forward the coupon) for your copy of this enlightening guide to well-paid posts—**NOW**. *There is no cost or obligation of any kind.*

## BRITISH INSTITUTE OF ENGINEERING TECHNOLOGY

Principal: Professor A. M. Low.

**409a, SHAKESPEARE HOUSE,  
17, 18 & 19, STRATFORD PLACE, LONDON, W.1.**

**R.A.F.  
PILOTS  
OBSERVERS  
ETC.**

Special rapid Home-study courses in the essential branches of Mathematics. For full details of this scheme apply or write

**B.I.E.T. (Dept. M409)  
17, Stratford Place,  
LONDON, W.1.**

TEAR OFF HERE  
**FREE COUPON**

To B.I.E.T.,  
409a, SHAKESPEARE HOUSE,  
17, 18 & 19, STRATFORD PLACE,  
LONDON, W.1.

Please forward, Free of cost or obligation of any kind, your 208-page Handbook, "**ENGINEERING OPPORTUNITIES**."

Name .....

Address .....

.....  
.....

Published on the 7th of each month by GEORGE NEWNES, LIMITED, Tower House, Southampton Street, Strand, London, W.C.2. and printed in England by THE NEWNES & PEARSON PRINTING CO., LTD., Exmoor Street, London, W.10. Sole Agents for Australia and New Zealand: GORDON & GOTCH, LTD. South Africa: CENTRAL NEWS AGENCY, LTD. Subscription rates including postage: Inland 7s. 6d. per annum, 3s. 9d. for six months; Abroad 7s. per annum, 3s. 6d. for six months. Registered at the General Post Office for the Canadian Magazine Post.

CONDITIONS OF SALE AND SUPPLY.—This periodical is sold subject to the following conditions, namely, that it shall not, without the written consent of the publishers first given, be lent, resold, hired out or otherwise disposed of by way of Trade except at the full retail price of 6d.; and that it shall not be lent, resold, hired out or otherwise disposed of in a mutilated condition or in any unauthorised cover by way of Trade; or affixed to or as part of any publication or advertising, literary or pictorial matter whatsoever.