

of the

11/6

SHORT WAVE LISTENER AND TELEVISION REVIEW



DEVOTED TO
SHORT WAVE RADIO RECEPTION
AND AMATEUR TELEVISION

FEBRUARY 1951
VOLUME 5 · NUMBER 2

PREMIER RADIO

MORRIS AND CO. (RADIO) LTD.

Please note change of address

All Post Orders To: 740 HIGH ROAD, TOTTENHAM
LONDON, N.17 (Tottenham 5371/2/3)

152 & 153 FLEET STREET (Central 2833) 207 EDGWARE ROAD, W.2 (Ambassador 4037)
Open until 6 p.m. Saturdays!

GREAT CLEARANCE OFFER OF BRAND NEW AND PERFECT CATHODE RAY TUBES AND VALVES

CV No.	Civil'n No.	Dia. in Inches	Focus	Defln. EHT	O.K. for T.V.	Price	Rail, Pkg. and Insur.
279		2.75	E.S.	E.S. 1450	Expmtl	10/-	2/6
600	5CP1	5	E.S.	E.S. 2KV	Yes	25/-	2/6
601	5BP1	5	E.S.	E.S. 2KV	Yes	27/6	2/6
817	3EP1	3	E.S.	E.S. 2KV	Yes	15/-	2/6
1138	VCR138	3.5	E.S.	E.S. 1200v	Yes	10/-	2/6
1140	VCR140	12"	Mag	Mag 4KV	Yes	90/-	12/6
1384		11.5	E.S.	E.S. 4KV	Expmtl	40/-	10/-
1511	VCR511	11.75	E.S.	E.S. 4KV	Expmtl	60/-	10/-
1516	VCR516A	9	Mag	Mag 5KV	No	40/-	10/-
1522	VCR522	1.75	E.S.	E.S. 800v	Yes	15/-	1/6
2880	EM14/1	3	E.S.	E.S. 800v	Yes	17/6	1/6
3776		5.25	E.S.	E.S. } 4KV	Expmtl	20/-	2/6

In addition we offer the following tubes (for one month only) at the ridiculous price of 5/- each (preferably to callers only as packing carriage and insurance amounts to 7/6). Types available, ACR1, ACR2, ACR2X, ACR8, ACR13.

Mullard MW 22/3 Television. Tubes 9 inch diam., Magnetic. Usual Price £11/10/0. To clear, **£6/17/6** plus 12/6 Carriage, Insurance and Packing.

VCR 97 C/R Tubes. Have slight cut-off making them unsuitable for T/V use otherwise perfect. **10/-** each, Base 2/6 plus 5/- Carriage, Packing and Insurance.

Transmitting and Special Purpose Valves. Special Offer. Types 8012, 830B, 878, 705A, 843, 1625, 1616, 4C27, 703A, EL266. Any of the above **5/-** each.

Output Triodes Type DET 5. An excellent Replacement for PX25 **10/-** each. **75/-** per doz. Type P27/500, practically identical with the PX25A **10/-** each. **75/-** per dozen.

UHF Triodes. Type 7193 **1/6** each. **12/-** per dozen. Type E1148 **1/6** each. **12/-** per dozen. Type CV52 **4/6** each.

Bayonet Base (Side contact) Frequency Changers. CV 1123 (EF8) (VR123) 6.3v. **5/-** each. **36/-** per dozen.

Miniature Valves CV 3830 (XH 1.5) **2/6** each. **20/-** per dozen. 9002, 9003 **3/6** each.

1—Kilowatt Pentodes Type 861. **20/-** (callers only).

UHF Oscillators Type RI. 18 **5/-** each, **40/-** doz. TR Box. Type CV115 **5/-** each.

VCR 517C C/R Tubes 6 1/2 ins. diam.:—Green/Blue Screen, Excellent for TV. **20/-**. Base **2/6**. Carriage, Packing and Insurance **5/-**.

Twelve inch Electrostatic Television Tubes. Type 63D/5 Green Screen. 3KV Max EHT **£3/10/0**. Base 2/6 plus 15/- Carriage, Insurance and Packing.

Acorn Valves Type 956 **2/6** each. **20/-** per doz. Type 958A **3/-** each. **24/-** per dozen. Types 9004, 9005 **3/6** each.

Output Pentodes. Type CV 321. Surplus Equivalent of the KT66. **6/6** each. **60/-** per dozen. No extra charge for matching.

Bayonet Base (Side Contact) Output Valves Type EL50 6.3v. **5/-** each, **36/-** per dozen. V/M Pentodes CV 1124 (MSPEN) 4v 7-Pin Base. **5/-** each, **36/-** dozen.

EHT Rectifiers Type 2x2/879 **2/6** each. **20/-** per dozen.

Thyratrons Type CV 1141. **6/6** each, **50/-** per dozen. Type CV 22 **20/-** each.

25 watt Pentodes Type PT 25H. 4v 400v. **3/-** each, **24/-** per dozen.

ARP 3 Valves (9D2) 13v. .2A HF Pentodes **3/-** each, **24/-** per dozen.

THE SHORT WAVE LISTENER AND TELEVISION REVIEW

VOLUME 5

FEBRUARY 1951

NUMBER 50

Conducted by the Staff of
The Short Wave Magazine.

Published on the third Thursday
in each month by the Short
Wave Magazine, Ltd., 53 Vic-
toria Street, London, S.W.1.
(ABBey 2384.)

Single copy, 1s. 6d. Annual
Subscription (12 issues) 16s.
post free.

The British Short Wave League
is associated with the *Short
Wave Listener & Television
Review.* Inclusive BSWL mem-
bership 17s. 6d. (Half-year 9s.)

All editorial and advertising
matter should be addressed to
*The Short Wave Listener &
Television Review*, 53 Victoria
Street, London, S.W.1.

Payment at good rates is offered
for articles of short wave listener
interest.

EDITORIAL

Change

In radio, as in all other human activities, we must be prepared for change. The old order never lasts, no matter how hard one may try to perpetuate it. In the pages of *Short Wave Listener & Television Review* we have mirrored several important changes in our relatively short life of four years.

These changes have been brought about partly by conditions, partly by the pressure on frequency space, and partly by the change in public taste—the most important and significant factor of all.

The mysterious rhythm of ionospheric conditions has started a general move towards the LF end of the amateur spectrum, though the frequency areas above 1700 kc are more crowded now (in terms of amateur population and commercial occupancy) than ever before. But it is conceivable that the pressure on frequencies between, say, 1700 and 4000 kc will increase still more as it comes to be realised that, wait for watt, a transmission on 2000 kc is now almost as effective as on 8000 kc.

These trends are beginning to canalise the activities of radio amateurs. Some have given up DX (at least for the time being), others have turned their attention to television, and a few have become pure experimenters on the VHF bands.

Changes of this kind are fundamental and, in their turn, they will impose changes in the approach of *Short Wave Listener & Television Review* to its subject. For we also must move with the times, and help to develop new trends and encourage fresh interests. Progress is always exciting, but sometimes it can be painful.

CONTENTS

FEBRUARY 1951

Editorial	41
Elements of Amateur Operating	42
No Band for Dabblers	44
Television for Begin- ners, Part IX	46
TV Pre-Amplifier for the Midlands	49
Putting up Sticks	53
Have You Heard?	56
BSWL Review (Members only) facing pp.	60-61
Calls Heard	63
Pse QSL	65
SWL Stations - No. 37	66
The VHF End	67
Starting Home Con- struction	70
TV Questions and Answers	73
DX Broadcast	74
Broadcast Station List, Revision 25.20-30.74 Metres	80

A COMPANION PUBLICATION TO "THE SHORT WAVE MAGAZINE"—
THE JOURNAL FOR THE RADIO EXPERIMENTER AND TRANSMITTING AMATEUR

Elements of Amateur Operating

by G. EDINGTON SUTTON (G3ANQ)

IN spite of the magnificent achievements of Amateur Radio, and the daily work of individuals, there is no doubt that many amateurs fall far short of what they should be as operators.

A hobby is not a business, and it is, perhaps, just as well that Amateur Radio has kept its soul intact all these years, and shows every sign of doing so. But radio does not stand still, and time has already split the British amateur's chosen hobby into two different fields. On the one hand, we are at last able to *communicate* with each other without a basis of "experiment," and on the other, there is the fascinating venture of VHF research.

The growing body of "communications" men in this country, mostly young fellows, are facing a problem, the nature and extent of which they probably do not fully realise. In their solution of this they have a magnificent opportunity to make British Amateur Radio the envy of the world; and out of their own rich heritage can they take the tradition, precept and example on which they may build.

Operating Standards

Throughout the world, regardless of nationality, the standard of wireless operating is lower now than ever before. This is understandable, for a slump occurred on a smaller scale in 1919, after the First Great War, when hundreds of war-trained men were flung on the ether with little or no knowledge of the fundamentals of good operating. Today there are thousands, to be heard in every country.

In this mass of mediocrity, not to say downright incompetence, the British amateur comes out surprisingly well, a good augury for the task before him, for he is now up against the same problem

(We commend the sentiments expressed in this article, written by an operator with many years' commercial experience, to the attention of all those who hope one day to be on the air themselves. Our contributor will find his ideas echoed by all amateur transmitters who can call themselves Old Timers.—Ed.)

as his professional counterparts of some forty years ago: that of interference. Their solution was a masterly combination of official regulation and mutual self-help. The amateur, wisely left to his own devices by authority, may hesitate to adopt the former, but he can well choose the latter way out; and for a shining example of efficiency and commonsense he could afford to study the operators of his own Mercantile Marine, and how they solved their difficulties.

The early years at sea were not unlike the corresponding period in Amateur Radio. A very friendly spirit existed between ship and shore, and communication between stations often opened in a most informal manner, not unlike an amateur QSO; and there could be no keener DX workers than these pioneer hybrids, whom shipmasters scorned to call seamen.

Commercial Standards

All this has long since changed. The International Conference of 1912 ordered the increasing chaos, but with that forthright leaven of commonsense which permeates all sea regulations, much was left to the individual operator. Combining the traditions and precepts of the landline telegraphist with those of the seaman, and blending with both the spirit of the early years, the Marconi men from the old school at Liverpool, and their successors, built up within the regulations a standard of operating which has stood without rival in the Seven Seas.

It is difficult to describe that invisible freemasonry of shipmates which can be felt so distinctly in the wireless cabin of a ship at sea, and which comes to life so vividly at the push of the starter—a freemasonry compounded of perfect understanding, enthusiasm, and seaman-like pride. That "oneness" in purpose through space, each vying with the other in upholding a common aim, is the thing which the sea operator finds so disappointingly absent in amateur contacts, yet so strikingly present in all their literature and social communion. Many may dispute this, but a little

further consideration may make the point clear.

The sea operator calls his fellow for a definite purpose; the prompt and efficient clearance of the traffic before him, and he is bound by regulations to do this with the minimum of signalling. These men, invariably keen and enthusiastic, must, of necessity therefore, make of their work an opportunity for both pleasure and skill, let alone to show the instinctive pride of the seaman in his ship. To this is added the very human spur of personal ambition, for by his smartness on the key, among other things, is an operator judged. Into those short moments there goes an intense power of concentrated effort and spirit, which meets a ready answer from his unseemly fellow, animated by the same purpose. Small wonder that the experts often achieve incredible results.

Amateur Procedure

Viewed in this light, one can say with some reason, that amateurs, in their communication, lack a good deal of this common purpose, and, in so far as they work together in their operating, they seldom achieve that unity of effort through space of their sea-going brothers.

The reason is not far to seek. Each amateur approaches the hobby from his own personal standpoint. Being free to say what he likes *how* he likes, without set regulation, he inevitably fails to establish that operating harmony with his fellow individualist that the sea operator does with his set traffic and unified procedure, *plus* his intense personal spirit.

The remedy lies first of all in establishing a simple, sensible and flexible operating procedure, as was done for commercial radio in 1912, which would be ratified by all amateur bodies throughout the world. This ensures unity of mind across space, which is essential to prevent doubt and misunderstanding.

Next, and perhaps even more important, each national amateur organisation should achieve the voluntary dedication of its members to the fulfilment of these regulations with all the fervour that throbs in Amateur Radio. In this their aim should be to make every amateur in their country feel that however individual he might be in location, outlook and endeavour, *he was linked on the key itself*, with every other amateur in procedure and feeling. And even as he strove to fulfil that code in spirit and

letter for the pride in his station and Amateur Radio, he would be conscious that his distant contact was doing likewise, as well as he himself knew how.

This is not sentimental nonsense. It is the thing that won the War; an intangible force that moves nations, the thing that lifts the sea operator to supreme efficiency. But its main virtue would lie in the fact that it brought into amateur radio that sanest of things, self-discipline. Any who pooh-poohed the idea in word and deed might soon find themselves ostracised on the air; and a few blunt words handed out by a bunch of fellows over pipe and glass would be more effective in policing the bands than any official regulation ever devised, and with far less ill-feeling.

Ultimately, some form of international agreement is imperative, but the founding of a British "freemasonry of shipmates," which would implement such decision in this country is an urgent and vital task. If we set about it immediately we may well shape the pattern of things to come by our innate sense of reason and fairplay.

This is something in which all may share, newcomer and old-timer alike. In a further article it is proposed to discuss the essential, practical means by which this British amateur "freemasonry" can best express itself on the key.

DIRECT SUBSCRIPTIONS

Readers who want to make sure of getting *Short Wave Listener and Television Review* punctually by post every month are reminded that they can become direct subscribers. This costs 16s. for a year of 12 issues (or 17s. 6d. to include League membership and the *BSWL Review* in addition). Order on the Circulation Manager, Short Wave Magazine, Ltd., 53 Victoria Street, London, S.W.1.

P.M.G. CERTIFICATE

NEXT EXAM MAY '51

PREPARE NOW by taking our special POSTAL COURSE. Many former students testify that our tuition was invaluable in ensuring their success in previous examinations.

Full details in FREE BROCHURE from
E.M.I. INSTITUTES, Dept. 51
 10, Pembridge Square, London, W.2.
 Telephone: BAYswater 5131/2

No Band for Dabblers

THE CASE FOR THE UHF EXPERIMENTER

By C. NOALL

I HAVE for many years now been interested in radio as a hobby, but not until quite recently did I investigate the possibility of taking out a transmitting licence. The reason for my rather belated interest in this aspect was a desire to experiment with micro-wave propagation techniques; routine rubber-stamp QSO's on the "long waves" have never, and do not now, make any great appeal to me.

Accordingly, I procured a set of the conditions governing the issue of an amateur licence; but, to my great disappointment, found I lacked all the qualifications necessary, both theoretical and practical, for claiming a ticket. I have never learned Morse; I have no "letters after my name" or other proofs to show my mastery of radio techniques; I have had no practical experience in operating a recognised radio transmitter. Yet, despite this, I am confident I could build and run a station in accordance with the very best practice—on the phone, at least.

Now, I have no objection to learning Morse and passing the PMG's test in that subject; anyone going in for transmitting must, of necessity, be able to read and send Morse. But the theoretical and practical examinations nevertheless present such obstacles that I do not choose to attempt surmounting them. (I should, perhaps, explain that I live in a very remote part of the country, far from all examination centres, radio clubs, and so on.) My decision to proceed no further was taken with regret and reluctance; but happily there are still many other fields in radio which I can explore without suffering the inconveniences which would attend my qualifying as a transmitting amateur.

While we do not necessarily agree with all the opinions and contentions put forward by our contributor, his article is of interest in that it emphasises the difficulties with which the would-be experimenter is faced. On the other hand, it can be argued that the R.A.E. as at present constituted calls only for the basic knowledge which should be possessed by anyone wishing to operate a transmitter on any band. It is a matter for which there is much to be said on both sides.—Editor.

Is it Wise?

This state of affairs, nevertheless, appears to me to be greatly deplored. It is surely a matter of some concern when a would-be investigator is denied permission to carry out his experiments without passing a series of—as they would be, in my case—quite irrelevant "tests." A great deal of scientific and technical knowledge has been won, in the first place, by amateur "dabblers" of no recognised status; is it not the height of folly to place difficulties in the way of such people?

Now, I have already made it clear that I do not wish to operate in the usual amateur bands—160, 80, 40, 20 and so on. If I did, I should consider the PMG's restrictions no handicap. Clearly, it would never do to permit any "ham-handed Harrys" to make nuisances of themselves on these international bands; and the authorities are well justified in assuring themselves of the complete competence of people operating on these frequencies. But what of the 420, 1,200, 2,300, 5,600 and 10,000 mc bands? Such objections hardly apply to them, as any nuisance created would be purely local in character. Why not, then, throw open at least *one* of these UHF bands to anyone who can prove that he is motivated by genuine scientific curiosity?

Possible Solution

If this concession were granted, the PMG would be perfectly entitled to impose stringent restrictions upon the manner in which such a station were run. Limitations on power, strictness of frequency control, non-interference with other services—perhaps even the use of pre-adjusted, locked and sealed tuning units—I would submit gladly to

all these things, and more. It might also be desirable to restrict all transmissions to FM, as it now appears to be a well-established fact that this system is less liable to cause interference to nearby domestic receivers.

I don't know how many people there must be at the present time who find themselves frustrated in this way by the terms of the transmitting licence, but judging from the number of pirates on the air, their number must be pretty considerable. Whilst I have no sympathy whatever with the illegal activities of these people, I can well understand the baffled and angry feelings which led them to adopt these shady practices. The mere existence of these gentry is a very sure sign that all is not well with the Post Office's licence regulationus. It should be possible for *everyone* with a bent for radio to carry out transmitting experiments somewhere within the extremely wide range of frequencies now available for such purposes. As things stand at present, only a fully-qualified radio operator, or a person possessing equivalent training, can obtain permission to go on the air; the

term "amateur," indeed, appears to me to have a very ironical meaning when used in connection with the transmitting licence. It would seem to possess as little significance in this context as it does when applied to certain types of sport. The true amateur is an amateur who pursues his hobby for the sheer *love* of it, without bothering about professional qualifications or professional status. The authorities should either alter their description of this licence, or amend its terms so that the title is no longer a misnomer.

If it be argued that the introduction of the reform I have proposed would lower the standing of the fully-fledged amateur, it is only necessary to reply that those benefiting from it should be issued with a Class C (experimental) licence to show that they are a race apart. We are not proud, we "dabblers"; we would not object to being segregated in a special class—or even a special band!—all to ourselves. All we want is permission to get on with the job—permission to carry out original research work without being tied up in red tape.

SOME TV PROGRESS FIGURES

Facts and figures relating to the past, present and future of the B.B.C. Television Service will be of interest to readers—especially those not yet served by a regional station and who may be wondering when a local service is likely to materialise.

Three new main transmitters will be erected as follows:

Holme Moss (North of England), to be completed mid-1951, serving 11,000,000 pop.

Kirk O'Shotts (Central Scotland), to be completed end-1951, serving 3,500,000.

Bristol Channel (Wales and West of England, mid-1952, serving 3,500,000.

Holme Moss will have the same power as Sutton Coldfield (35 kW), but the other two stations are to be 50 kW installations. In addition to these, five smaller regional stations (of 5 kW) are planned, with the following coverages: **Newcastle**, 1952, serving 2,500,000. **Southampton**, 1952, serving 1,000,000. **Belfast**, 1953, serving 750,000. **Aberdeen**, 1953, serving 250,000. **Plymouth**, 1954, serving 250,000.

When this programme is complete, 85% of the population (40,750,000) will be provided with a television service.

The growth of television enthusiasts continues, and it is interesting to note

the progress made to date, *viz*:

June, 1946 ...	1,300 licences
March, 1948 ...	45,500
December, 1948...	93,000
December, 1949...	240,000
October, 1950 ...	511,000
December, 1950...	555,000

It is estimated that the number of licences will increase to 600,000 in mid-1951, 1,025,000 in mid-1952, and 1,575,000 in mid-1953.

The total expenditure over the past three years (revenue and capital expenditure) has been £722,000 (1947-48), £1,069,000 (1948-1949) and £1,984,000 (1949-50). It is estimated that a total of £2,702,000 will be accounted for from 1950-1951.

Since 1946 a large amount of new equipment has been introduced into the Service. Comparative totals for 1946 and 1950 are:

Studio camera channels:	1946—6;
	1950—14.
Telecine machines:	1946—2; 1950—7;
	expected mid-1951, 10.
Telefilm recording machines:	1946, nil;
	1950—2.
Outside Broadcast units:	1946—2; 1950
	—3; expected mid-1951, 5.
O.B. Radio link units:	1946—2; 1950
	—2; expected mid-1951, 6.

Television for Beginners

AN OUTLINE OF THE SYSTEM

DEFLECTION AMPLIFIERS — LINEARISATION — CURRENT OSCILLATORS

PART IX

By W. N. STEVENS (G3AKA)

THE sawtooth output produced by the scanning generator is not of sufficient amplitude for direct application to the deflection coils of the magnetic cathode ray tube and it has, therefore, to be further amplified. Where small tubes are used, as in bench equipment, the output from a single scanning generator can sometimes be used without further amplification, but the larger magnetic tubes as used for television reception have a somewhat lower deflection sensitivity. The reason is simply that owing to the small spot necessary for adequate definition the tube requires a very high anode voltage; this in turn demanding a more intense deflection force due to the greater velocity of the electron beam.

Where electrostatic tubes are used, push-pull deflection amplifiers are employed to provide the necessary voltage output for application to the internal deflector plates. With magnetic tubes the deflection *current* is applied to the external deflection coils placed round the neck of the tube; a low voltage (at heavy current) is required to energise the coils.

Pentodes or tetrodes are almost invariably used as time base amplifiers, due to a great extent to their high anode impedance and constant current characteristics. Valves of the 6V6 class are common for the frame amplifier and larger valves (such as the 807, EL32, etc.) with an anode dissipation of around 20 watts for the line amplifier. Low impedance feed is hardly practicable for television work since a cathode follower driver stage is required and also in view of the fact that the pulse voltage can be handled more effectively in the anode circuit.

Amplifier Problems

There are numerous practical difficulties in designing suitable amplifiers and these are brought about mainly because

amplifier and the deflection coils, the effects of the coils and the nature of the output waveform. These factors make the retention of a linear sawtooth in the deflection coils a matter of some difficulty.

The frame and line time base amplifiers, whilst being basically similar, are subject to slightly different treatment, and since the line amplifier is the greater problem this will be discussed first.

Difficulties due to the nature of the output waveform have been mentioned. The main trouble is that a sudden reversal takes place during the fly-back periods (at the end of each scan) which produces a back EMF of as much as 1,000 volts. Obviously these high voltage peaks if applied direct to the deflection coils would present extremely difficult problems in regard to insulation. It is therefore customary to feed the coils through a step-down transformer (T₁ in Fig. 38). In addition to reducing the effects of the high voltage pulses on the coils the transformer also blocks the DC anode current of the amplifier which, if allowed to flow through the coils, would result in a permanently deflected spot and lift the raster almost off the tube face—bringing it to the extreme top or bottom of the tube.

Another advantage of the transformer is that since it steps down the voltage it will increase the current transfer, thereby enabling less sensitive coils to be used and demanding a lower initial valve current. Thus, with a smaller number of turns required the coils can be made more compact and efficient. Normally the ratio is in the region of 10:1 and it is essential to use a component with low inherent capacity and leakage inductance if distortion is to be reduced to a minimum. While it is virtually impossible to eliminate every trace of distortion, it is usually kept as low as possible and finally corrected by the use of linearising networks.

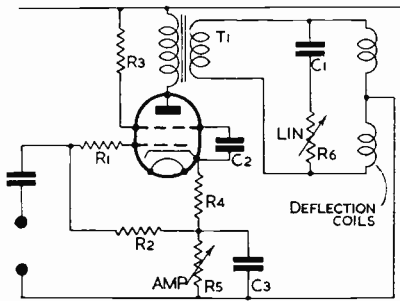

Fig. 38. Typical line scan amplifier, showing linearising components in the output circuit.

Linearity

The desirability of linearity was briefly mentioned in Part VIII of this series and the time is opportune to re-open the subject. As previously stated, linearity is often difficult to obtain and absolute linearity well nigh impossible. However, since any serious degree of non-linearity is all too obvious on a received picture it must be reduced to within tolerable visual limits.

The main obstacles to good linearity are the inductance of the deflection coils, the distortion in the amplifier and the characteristics of the output transformer; each of these factors produces some measure of distortion in the sawtooth waveform. Such inherent faults are, however, sometimes used to advantage.

In order to obtain a linear output waveform it is not necessary to maintain strict linearity throughout the circuit. In fact the sawtooth forward stroke as produced by the scanning generator assumes an exponential curve (see Fig. 39a). This downward curve is further accentuated by interstage couplings. In the output stage, however, more distortion is introduced, as can be seen from the hypothetical anode current = grid voltage curve of Fig. 39b. Since this distortion is in the opposite sense (it is an "upwards" curve) it tends to neutralise the distortion already present so that a linear form is obtained, as at Fig. 39c.

In practice, both distortion and counter distortion are kept low and correction networks introduced to ensure adequate linearity; these are usually placed in the grid circuit of the output stage as the sawtooth is easier to modify at this point. Negative feedback

arrangements are commonly used to improve the linearisation in the output stage and pre-set controls are provided for manual adjustment.

Fig. 38 shows a typical line time base amplifier circuit. The series arrangement C_1/R_6 are the linearising components, and this circuit also acts as damping to limit the inverse voltage induced during the fly-back periods and to prevent the surges which would cause the coils and their self-capacities to oscillate at their natural frequency. Such an occurrence would set up a ring of damped fly-back oscillation which would manifest itself on the screen not only by variations in linearity over the raster but in the evenness of illumination (caused by velocity modulation effects). Some receivers use a diode shunted across the circuit so arranged as to conduct only during the

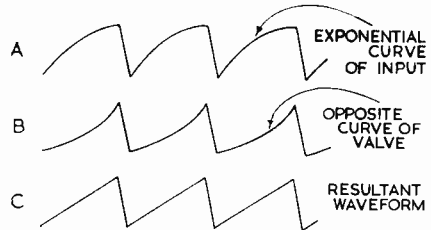

Fig. 39. Showing the (exaggerated) effects of distortion and counter-distortion in obtaining a linear output waveform. Counter distortion (b) is sometimes introduced by inter-stage coupling networks as in Fig. 42.

high voltage pulse periods and so providing a heavily damped load.

The Efficiency Diode

This diode (or occasionally a metal rectifier) can be put to a dual purpose as shown in Fig. 40. During the flyback period the condenser C charges through the valve and since it is effectively in series with the HT feed the rectified voltage is added to the existing HT potential. By utilising the flyback energy in this way an increase in effective HT to the amplifier can be increased by 15% or more. The valve is commonly termed an "efficiency diode."

Referring again to Fig. 38, the resistive element in the linearising circuit is made variable and in this way the manual linearity (or "Form") control is obtained. The remaining components need little comment. The screen grid is fed via R3 and decoupled to cathode by

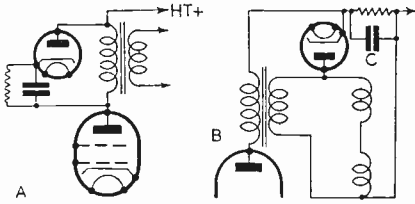

Fig. 40. The use of a diode to damp the high voltage peaks in the line scan output waveform. In the right hand circuit is given the basic arrangement in which the damping diode is utilised to provide a boost in the HT supply—an additive voltage of some 30 volts being developed across C.

C₂. R₁ is a normal grid-stopper and the grid resistor R₂ is returned to the junction of the bias resistors R₄ and R₅, the latter being variable so that by varying the bias the output of the amplifier is adjusted—it is, then, the Amplitude control. Sometimes a potentiometer in the secondary circuit of the transformer is used for amplitude control and occasionally this may be inserted in the generator valve. The frequency control is, of course, in the oscillator stage. In passing, it may be mentioned that stray capacities in the output stage must be kept low, for the output waveform is rich in harmonic content and in order to preserve good linearity harmonics up to at least the fifth must be passed.

Transformer coupling can also be used in the frame output stage and by doing so design problems in deflection coils are eased in that by using a suitable transformer ratio it becomes possible to employ similar coils for both line and frame deflection. Where transformer coupling is used, a high primary inductance is necessary and the introduction of counter-distortion experienced with this component usually makes a manual linearity control unnecessary.

However, since the induced back EMF is less, high impedance coils can be used without a coupling transformer by providing R/C or L/C coupling (usually the former). Fig. 41 shows such an arrangement in a typical frame output stage. The coupling condenser C₁ is made a large value due to the low fundamental frequency (50 c.p.s.) and to avoid distortion. R₁ and C₂ are the bias resistor and by-pass condenser respectively and variation of the resistor moves the operating point along the characteristic curve. In this way a control over linearity is obtained. The

other variable resistor, R₂, is the amplitude control—negative feedback being developed across this component. As with most time base controls there is liable to be some interaction between the two, but this is minimised by careful design.

Inter-stage correction networks are subject to considerable variation; some being fixed networks and others are made variable to incorporate the linearity control. Such a circuit is shown in Fig. 42, the variation of the potentiometer R₃ altering the shape of the sawtooth waveform. In the more elaborate receivers a special valve simply to correct linearity is sometimes encountered, and although this can be simplified by using a twin-triode, or other similar arrangement, it is generally considered to be an extreme measure since by the use of correcting networks non-linearity can be reduced to very small proportions.

The Current Generator

Before concluding the description of time bases and their circuits a few words on the sawtooth *current* generator may

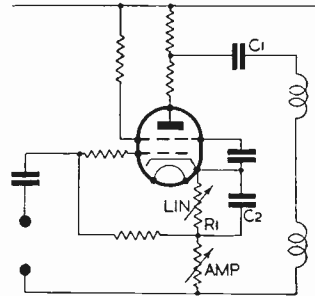

Fig. 41. Typical frame scan amplifier using R/C coupling to the deflection coils.

be of interest. The introduction of such generators has been due to the demand for simplicity to enable costs to be kept low. Since it develops a substantially linear sawtooth *current* waveform, the single valve power oscillator can be coupled to the deflection system without the need for an amplifier stage.

It is not, however, very popular at present, mainly due to design problems and to the fact that the manual controls tend to be inter-dependent (particularly amplitude and frequency). Additionally the slight economy obtained is not important enough for manufacturers to adopt the idea extensively for their

cheaper sets. But it is reasonable to assume that improvements in design may be possible in the future.

The sawtooth current oscillator (either a triode or pentode) is similar in action to the blocking oscillator—it relies on the principle of feedback—but differs in that the anode-grid coupling is very tight and stray capacities only are in circuit across the coils. In contrast to the blocking oscillator, no long time constant system is used in the grid-cathode circuit, but a low time constant arrangement is incorporated for the purpose of frequency control.

The anode inductor builds up when current flows through the valve, much in the way of the more usual charging condenser. As the current rises a positive voltage is induced to the grid circuit via the step-up transformer coupling. The reversing action results in a cumulative process very similar to that of the blocking oscillator. The resultant anode current sawtooth waveform is reasonably linear, with a slight upwards curve.

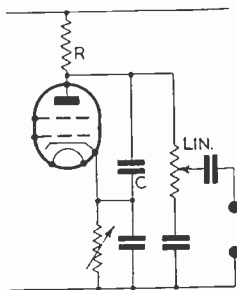

Fig. 42. One form of correction network, incorporating manual control of linearity. This network alters the shape of the sawtooth forward stroke before application to the amplifier grid.

The deflection coils can sometimes be used as the actual anode inductance, although it is more usual to feed the coils through a tertiary winding on the coupling transformer.

TV Preamplifier for the Midlands

FROM THE RF-26 UNIT

By W. N. STEVENS (G3AKA)

THE modifications to the RF25 unit as described in January *Short Wave Listener & Television Review* would, of course, be suitable for reception of Sutton Coldfield providing that the grid circuits are tuned to the higher frequencies required, but it may be that many Midlands readers have an RF26 Unit at their disposal. This unit offers easier conversion for a broadband amplifier for the Midlands station and has the advantage that it was designed initially for reception over the frequency range of 50-65 mc.

The RF26 unit uses type VR136 valves for RF amplification in preference to the VR65 of the RF25 unit which are not entirely suitable for the frequencies

required for reception of Sutton Coldfield. Additionally, components such as by-pass condensers are of values appropriate to the range, whereas those of the RF25 unit would not be so suitable. Obviously, then, if the best results are to be obtained the choice for Midlands reception is the RF26 Unit.

The Circuit

The unmodified circuit diagram is shown in Fig. 1. As with the RF24 and RF25 units it has three stages—an RF amplifier, mixer and local oscillator (in this case VR136, VR136 and VR137)—but differs in that the tuning is not switched but continuous and the local oscillator is a triode. Incidentally, the RF27 unit is substantially similar except that the frequency coverage is 65-80 mc.

The signal is fed to the grid via the coupling transformer T1. The purpose of this component is to match the constant feeder impedance to the varying valve input resistance (due to changes of gain and frequency) and to increase the attenuation of any signals at the IF on which the complete IF section operates.

The tuned circuits employ a series L/C combination in order to preserve a constant bandwidth characteristic. If the parallel L/C system were used the bandwidth is estimated to be subject to

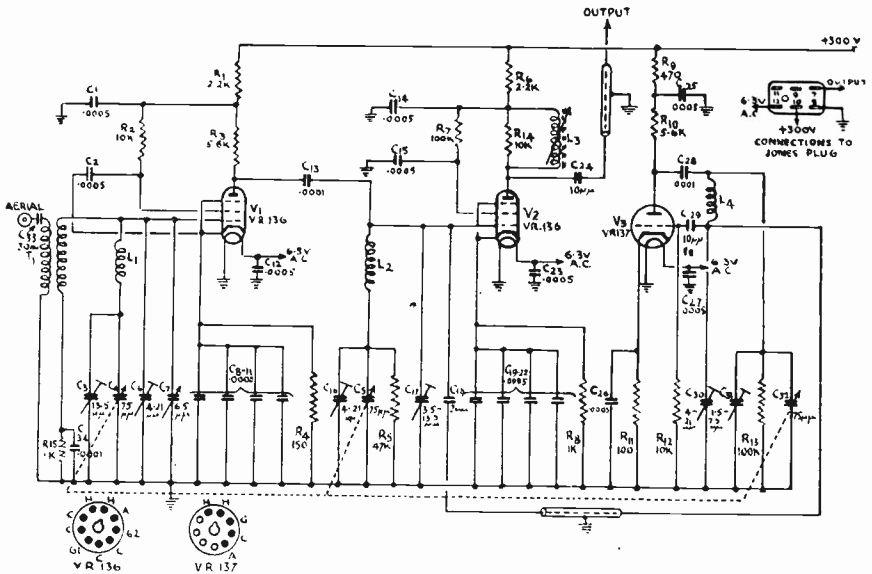

Fig. 1. Circuit diagram of the unmodified RF unit Type 26.

a variation of about four-to-one over the frequency range covered, due to the variation of the input resistance of the valves with regard to frequency changes. The series L/C combination acts as a variable inductance and the circuit tunes with the fixed stray circuit capacities. Such an arrangement enables a bandwidth virtually independent of frequency to be obtained.

Apart from this, the RF amplifier and mixer follow convention and the three tuned circuits are ganged by virtue of a two-sectioned and a single section 7-75 μF variable condenser inter-connected with a coupler. The actual oscillator is a Colpitts circuit which operates a 7.5 mc above the frequency of the RF and mixer tuned circuits.

Modification Considerations

The constructor is faced with the question of how many stages to employ as the television pre-amplifier—two or three? Since the third valve is a VR137 (equivalent EC52, RL16, etc.) this would mean replacing with another pentode and/or in carrying out further modifications. The writer feels that, taking everything into account, the best plan is to settle for two stages of pre-

amplification. A point here is that a really compact unit could be made up by utilising the space left vacant by the unwanted oscillator stage for fitting a small power pack to run the unit. Using miniature components this would be simple enough, but the drain on the main HT supply is hardly likely to cause any undue concern and the extra expense of the additional power pack does not seem to be worthwhile. That is a point best decided by the individual constructor.

Broadly speaking, then, the modifications consist of retaining V1 as an RF amplifier (but with certain circuit alterations), modifying V2 to become another RF amplifier and eliminating the complete V3 stage. The circuit of the modified unit is shown in Fig. 2; unmarked components are those in their original positions, those with references are old components in new positions, and where values are given this implies completely new components.

The First Stage

The first job must be the provision of a pre-set gain control and this takes the same form as the system described in connection with the RF25 unit in the

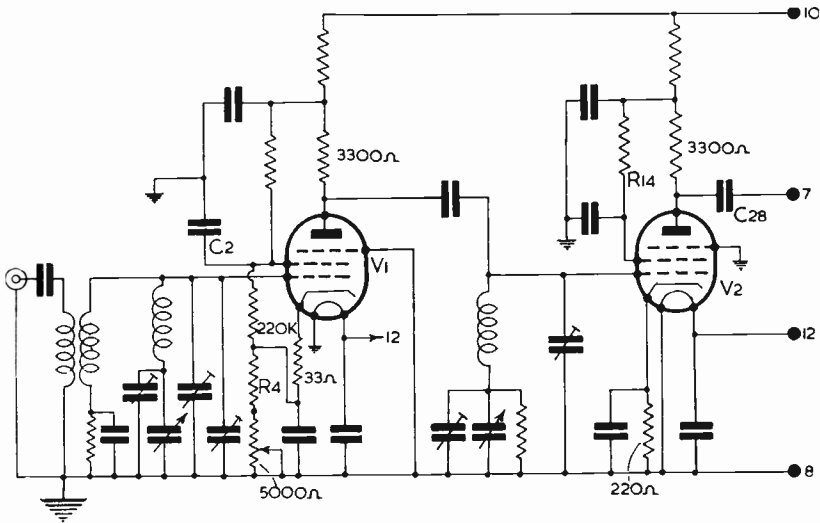

Fig. 2. Circuit of the RF unit Type 26 after modification to a two-stage television broadband RF amplifier. Components unmarked are those in their original positions; those marked are existing parts in new positions; and components given values are additional items. The numerals on the feed lines correspond to the Jones plug markings.

January issue. The reasons for this system and the action of the components will not be dwelt upon here—readers are referred to that issue for full details. In practice the circuit is easily modified.

The screen-grid by-pass condenser C2 is disconnected from the cathode connection and taken to the nearest earth point; this component is found in the compartment housing the V1 anode and V2 grid circuits—return it to a V1 earth connection as this will aid stability. The cathode lead is broken and the 33-ohm negative feedback resistor inserted; then the 220,000-ohm resistor can be fitted between the screen-grid and junction of R1 and the 33-ohm resistor. Note that R11 and R13 taken from the oscillator stage can be used in series to provide 200,000 ohms. To complete the gain control circuit, break the chassis connection of R4 and wire in the potentiometer. This can be taken out as a panel control or fitted below chassis, the latter being simpler and more practical, since once initially set this control need not be touched.

The only other modification (at present) is to replace R3 with a 3,300-ohm resistor, or, if preferred, the new resistor can simply be wired in parallel with R3. The object of lowering the

ITEMS REMOVED

R3, R7, R8, R14 (these may be shunted by new resistors), C24 (may be shunted with C28), C18 and all components associated with the oscillator stage (V3).

NEW COMPONENTS REQUIRED

Resistors: 33 ohms (1); 3,300 ohms (2); 220 ohms (1); 10,000 ohms (existing R12 or R14 may be used here); 220,000 ohms (R11 and R13 wired in series could be used here); 5,000 ohms potentiometer.
 Condenser: 100 μF (existing C28 can be used).

anode load is, of course, to provide further damping to ensure an adequate pass-band.

The Second Stage

The V2 stage here is identical with that of the RF25 mixer circuit, except for the grid components, and the procedure is the same. Replace (or shunt) R14 with a 3,300-ohm resistor and shunt the screen-grid resistor R7 with a resistor of 10,000 ohms. An economy can be effected by simply disconnecting the anode end of R14 and wiring this to the screen grid, but an alternative method is to use R12, which will become

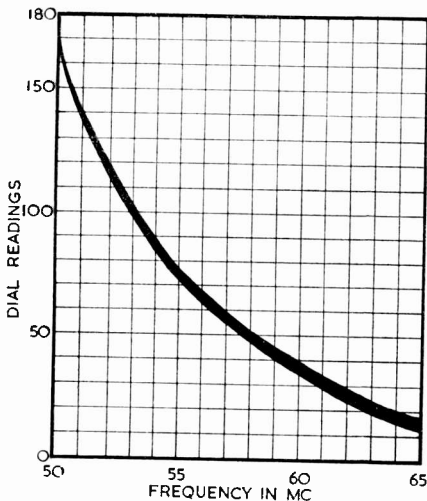

Fig. 3. Calibration curve of the RF unit Type 26. The curve may vary from model to model (noticeably at the higher frequencies) but this error will not exceed two degrees, as indicated by the heavy curve, if the trimmers have not been tampered with.

unwanted when the oscillator components are dismantled. The choke L_3 should be removed whilst carrying out the above modifications.

The only other work for the time being is connected with the grid and cathode circuits. C_{18} , through which the oscillator voltage was originally applied to the mixer grid *via* a pipe, can be removed and the cathode bias resistor R_8 altered to a value of 220 ohms (either by replacement or shunting with the new resistor).

It will be noticed that in the original circuit the suppressor grids are returned to cathode, whereas in the modified circuit they are grounded. In actual fact the latter was tried, but little difference resulted. Again it is a matter of personal choice, it not being proposed to go into discussion on suppressor grid bias in this article—although it should be mentioned that theoretically more gain will be obtained by grounding the suppressor grid.

To conclude the modifications it only remains to remove the unwanted oscillator stage components and wire in a 100 μF condenser across C_{24} . There is no work necessary as regards the con-

nections to the Jones plug at the rear of the unit as all wiring remains identical.

Alignment

There are several alternative methods of aligning the modified unit, but the simplest is possibly to retain the continuous-tuning assembly. By so doing there is only one (or possibly two) condensers to adjust. The unit must have a bandwidth sufficient to pass frequencies from 58.25 mc (the sound channel) to 61.75 mc (the mean frequency of the Sutton Coldfield upper vision sideband). In this respect the two tuned circuits can be peaked at, say, 59.25 and 61 mc respectively in order to provide the necessary stagger tuning.

Constructors without the benefit of a VHF oscillator can make use of the calibrated dial on the unit by rotating the knob until the required peaking frequency of the second tuned circuit is obtained. Thus the stage will tune to 61 mc when the dial is at 35 degrees (see sketch, Fig. 3). It then remains to reduce the mean frequency of the first stage and this is accomplished by increasing the trimmers C_3 and C_6 ; the former is above chassis and is immediately above the single section variable condenser; C_6 can be found fixed to the bottom of the chassis to the right and above the grid section of the V_1 compartment. The other trimmer in this section (C_7) is mounted vertically to the panel flange. For operational use this trimmer was adjusted to maximum capacity and so (apart from making sure that this still obtains) it should not be touched.

A point worth noting is that when removing the oscillator circuit components, C_{32} will have to remain since this forms the second half of the twin gang C_5/C_{32} —the former, of course, being required. However, should the constructor have access to a service oscillator the complete ganged system can be removed and replaced by suitable trimmers.

The calibration of the unit, as described, depends upon the trimmer C_{16} not having been tampered with; this is situated immediately above the (original) mixer section of the twin gang variable. If the calibration is obviously faulty adjustment of C_{16} is indicated. The only other component to affect calibration of the second stage is C_{17} , and this is mounted flat against the bottom of the under-chassis in the compartment containing the V_1 anode and V_2 grid circuits.

For those receiving at extreme ranges, a third stage of amplification could be easily added. Since the valveholders are the same, the VR137 can be replaced by a VR136 (EF54). Coupling between V₂ and V₃ can take the same form as that between V₁ and V₂, using the third section of the gang (C₃₂) as the main grid condenser. Cathode and anode/screen-grid circuits would also be similar to those used in V₂. The grid coil is available by modifying L₄ to match L₂,

simply a matter of reducing the number of turns. With three tuned circuits the stagger tuning sequence would, of course, have to be slightly adjusted.

Normally, however, two stages of pre-amplification are sufficient. It is strongly advised that enthusiasts thinking of building a preamplifier of any kind should first of all make sure that their existing vision and sound receivers are efficient and that the aerial is really giving the maximum signal transfer.

Putting Up Sticks

Erection of An Aerial

by D. H. G. TYRELL-LEWIS

IT is certainly amazing what a business the erection of an aerial can be to the Lone Wolf, especially to the not-so-wealthy one!

I am an enthusiastic short wave listener. My favourite band (as with so many of us), is twenty metres, and for this reason, and to give adequate performance on the other bands, I have always used a half-wave twenty-metre Zepp.

This wire, until recently, had been suspended between two 20-ft. scaffold poles. These had been given to me some nine years previously—at a time when the trees which surround my bungalow were very small and gave the Zepp ample breathing space. In time, however, the greenery attained quite a remarkable height—one of the trees towering above, and within a foot of, the centre of the aerial.

At last, I was able to obtain some tubing of assorted lengths and diameters which the helpful ironmonger thought could be made up into two 38-footers. I accepted, despite the somewhat weather-beaten appearance of the stuff, and in due course it was delivered at the bungalow, together with a bill for £3 10s. It seemed a lot, but . . .

We have often drawn attention to the importance of a good aerial for serious DX reception. Our contributor describes how he provided himself with an efficient, good-looking two-stick system, involving little expense and no outside assistance.

—Editor.

I set to work on it immediately, thoroughly scraping and sand-papering each section of piping to remove the rust. The metal thus exposed proved to be quite sound, as also did the threaded ends. Then I laid them out end to end in the way in which they would, in due course, be screwed together. Two layers of battleship-grey went on and the ends of each section I numbered in black for identification during the process of assembling. It was unfortunate that at this period, however, I had to go away. I greased the ends and stowed the sections away under the shack.

When work could be continued two months later I decided to have the assembling done by a plumber as I had not got the right type of tools for the job. Meanwhile I bought some coils of stranded galvanised iron wire—it seemed ideal for the guys. For clipping the guys to the poles I cut up an old aluminium chassis into strips, bending them round and securing them with bolts.

The First Lift

At last, having dug a three-foot hole in the ground, I decided to erect the first of the masts. All was in readiness: guys attached, a pulley at the top with a nice, strong wire lanyard running from it. Needless to say, I had had no previous experience of steel masts—except in the R.A.F., where 70-footers were raised with all the necessary blocks and tackle. Pressing on regardless, I laid the 38-footer on the grass with its pointed

foot just over the hole. Next I lifted the mast at the top till it rested on a pair of 5½-ft. household steps. In short stages I pushed the steps along under the pole with my left arm and left leg, taking the strain with my right arm. But now occurred an unforeseen snag: The end, which was supposed to enter the hole, was just boring itself into the earth almost horizontally about two inches below the surface! I put out a frantic SOS to the XYL in the hope that an extra pair of hands would be able to force the end down as the pole was raised; they weren't.

That method was abandoned and others were tried, but all to no avail. Came another enforced absence and I had to lay the poles to rest once more. Whilst away I continued to give the problem a considerable amount of thought. How could they be raised without outside assistance, thereby necessitating extra expense? Once up would they stay up—with their great weight and the limited guying area? Should they be sold and a pair of duralumin ones be used instead? But who would want to buy them?

Another Attempt—

When I was finally enabled to carry on with the operation I had a new plan of campaign. First, 10 ft. of each pole should be sacrificed. Secondly, the position of the aerial should be changed to give maximum effective height, a condition which I thought would counteract the resultant not-so-desirable directional characteristics. Thirdly, and finally, a short trench should be dug sloping into each hole.

The XYL and I started man-handling the first pole. We used the steps as a lever, as before. The foot of the pole slid down the trench to the bottom of the hole and stayed there. I ran out three guys and attached them to convenient trees, tightening them up after each advance of the steps.

—Another Failure!

All went well for the first 50 deg. when suddenly: "Clang!" and down came the whole contraption. Having assured myself (to my surprise and satisfaction) that neither of us had been decapitated, investigation showed that the clip holding the guys to the mast had broken under the strain. Operations ceased for the day.

It was clearly obvious then that aluminium was worse than useless. But

a visit to a local builders' store unearthed a length of malleable steel strip—about an inch wide, a quarter of an inch thick, and ready-drilled with alternate round and oval holes from end to end. I sawed two lengths (9-in.) off this; these I bent into loops (no heavy vice and bench being available) by hammering them over the space between two bricks placed on the ground. I found that a pair of holes on each coincided sufficiently for the insertion of a clamping bolt. This sounds easy, but I also found that to get the clamps to grip the masts tightly I had to press the ends together with a vice, tighten up the bolts, and remove the vice. So far, so good! All was now ready for the raising (the final raising, I hoped!) of the poles.

A Successful "Raise"

I put up the steps and by advancing them in easy stages the mast at last rose some 50 to 60 deg. in a seemly and dignified manner. Then I anchored three guys temporarily, two from the top and one from the middle, to selected trees.

The lines of force now bearing down heavily on to the lifting-point, I yelled for the XYL; she steadied the pole—I pushed the steps forward; she steadied steps—I tightened the guys. We went on like this until the pole was about ten deg. short of the vestical, when the steps were discarded. I pushed it up the rest of the way and held it in position while my noble and long-suffering XYL rammed bricks into the hole around the tubing and shovelled in earth, placing pieces of turf on top. I then hauled on the top guys and attached others to further trees—two from the top, two from the middle—and two (from each point) to a stump in the grass.

In comparison with the first, No. 2 mast went up like a lamb! It is true that it was rather lighter than its fellow, but with the experience already obtained nothing could go wrong!

The Aerial System

In conclusion, a little technical data concerning the Zepp: The feeders are a half-wave long, the top and one leg being one continuous length of wire. The whole is of 14 gauge enamelled copper, with the feeders spaced six inches apart with lengths of half-inch dowel rod soaked for 48 hours in a jar of creosote for weather-proofing. I found that 18 of these were needed to give enough rigidity, the feeders being attached to

the dowels by short lengths of 18 gauge tinned copper wire looped and screwed to the ends. A short pole is clamped to the wall of the shack, with the object of giving plenty of head-room underneath the feeders. The fitting for the top of this pole is made as follows: A short length of steel strip some six or seven inches long is bolted to the centre of a $6 \times 2 \times \frac{3}{4}$ in. length of mahogany, to the ends of which are fixed two ordinary egg insulators (closely wired together and fitted with short lengths of 18 gauge wire for looping round each feeder). The resultant T-section fitted loosely to the

end of the 10 ft. pole and the whole assembly was then pushed up against the shack, in between the feeders, and clamped to the wall. Tension and a suitable 90-deg. hang to the "life-lines" were achieved by fixing a length of wire *via* two small insulators to the centre of a convenient spacer and, after pulling it tight, it was secured to give the required pull.

The efficiency, appearance and durability of the whole installation leave little to be desired, and I feel that it was well worth the multitudinous trials and tribulations!

SUPERIOR SHORT WAVE KITS

Proven Performance—Minimum Cost!

NEW JUNIOR "GLOBE KING" KIT 21/- includes: Machine drilled metal chassis, coil, all components, together with simplified "Easy-Build" charts and wiring diagrams. Price includes post and packing.

also available "**GLOBE KING**" Senior Model Kit 49/6d. **RADIOCRAFT "DX-2"** superb new kit, price only 78/6. A.C. operated 2v, using EF50's and latest miniature Eddystone Coils. Write for interesting free literature and catalogue—enclose stamp for postage.

JOHNSONS (RADIO) N/2 · MAGGLESFIELD CHESHIRE - ENGLAND

MORSE CODE Training

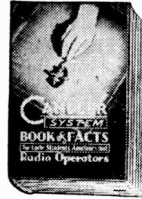

There are Candler Morse Code Courses for

BEGINNERS AND OPERATORS

Send for this Free

"**BOOK OF FACTS**"

It gives full details concerning all Courses.

THE CANDLER SYSTEM CO

(Dept. S.L.) 121 Kingsway, London, W.C.2
Candler System Co., Denver, Colorado, U.S.A.

WORLD RADIO HANDBOOK

NEW EDITION — JUST PUBLISHED

Revised and enlarged to include the Copenhagen Wavelengths and giving essential information covering the World's Broadcasting Stations.

Compiled from authoritative data, **WORLD RADIO HANDBOOK** is an invaluable "Who's Who" and a ready-made log book for all in any way interested in broadcast station listening on a world scale. The detail given is designed to facilitate easy identification of BC stations, covering announcement procedure, interval signals, wavelength, personnel and station addresses.

WORLD RADIO HANDBOOK is recommended by such authorities as the United Nations Organisation, International Radio Union, and the United Nations Educational, Scientific and Cultural Organisation.

PRICE 6s. 6d., POST 3d.

GAGE & POLLARD, Publishers' Agents

49 VICTORIA STREET, LONDON, S.W.1.

Abbey 5342

Have you heard?

GREETINGS once more, and a Happy New Year to you all. May 1951 bring you all the DX that is going—and may there be a little more of it than there was in 1950!

It is a pity that the Christmas break, combined with our early date of publication this month, made it necessary to set such an early deadline. The result of it is that I have had only a fraction of the usual number of letters, and barely enough Calls Heard to fill one page! But it gives me an opportunity to say lots of things that I have been wanting to say for a long time. They have remained unsaid because I didn't want to trespass on your space.

Just let me add, in passing, that we *did* announce in advance (in the December issue) that the deadline for the February issue would have to be December 22—but it seems to have caught most of you on the hop, all the same!

Conditions for December

There are no SLP's to talk about this time, and it is probably just as well, because December conditions were so patchy that we might well have struck a dud one again. On one or two isolated days the 14 mc band became quite interesting, and 28 mc was far from dead, as you will see by the Calls Heard. On the whole, however, no one can deny that December was a Pretty Blank Month.

J. P. Warren (W. Croydon) describes the month as "appalling" and leaves it at that. But he concedes that 7 and 3.5 mc were fairly good, though not so good as in November. Some little while back, A. M. Norden mentioned hearing CX4EG on 7 mc phone, and wondered if he was the most distant station heard on the band. J. P. Warren now busts that one with LU4DJJ, further than any part of Uruguay. (I can't help

feeling that VK and ZI phones have been heard on 7 mc, but am not sure).

J.P.W.'s snap-summary of 1950 is this: On 14 mc conditions started well for South America, then were exceptional for Asia and Oceania, and they finished up good for nothing. The LF bands slowly improved throughout the year and are now quite good.

R. A. Hawley (Goostrey) found 14 mc phone a dead loss during December; on CW he logged FF8AC, HP1DS, HZ1KE, PK3IC, PK5AA and ZS6RN. 28 mc was hardly worth commenting on.

N. S. Beckett (Lowestoft) has listened mostly on 7 mc, where he heard VK's and ST2TC, but, speaking of 14 mc, says "There has obviously been plenty of DX available from 1500-1800." He was only able to take part in it once, and then he logged VK1PG.

More DX on 7 mc

A. M. Norden (London, N.W.11) also squeezed 7 mc pretty hard, and emerged with phones from VQ4AQ, VQ4BF, ZE2KJ, 4X4AT, CO8LG, VP6SD, plus 25 PY stations and plenty of North Africans. On 28 mc phone he heard ZS3O, ZS7C, ZS7T, ZS9F and VP3CW. Phone on 3.5 mc provided him with CN8MI, SP5SG and lots of W and VE.

P. H. Strudwick (London, N.W.11) heard CO2SG, FF3CN and 4X4BC on 7 mc phone in the early evening, and he says it is quite easy to learn enough Spanish to log the masses of PY's and LU's on the band every night. He has just about given up 14 mc listening, as he considers that too many SWL's "plug" the band. Even 28 mc remains "fascinating," however, and he mentions ZS7C, ZS7T and EL6A as among the best phones.

K. Parvin (Thornton Heath) collected new countries on 7 mc phone, in the shape of EK1BA, LU7DAZ, VQ4AQ, 3V8AS and numerous EA8's. On 28

mc he found ZS7C and KV4AQ, and on one day he even heard a solitary Wg working a VE3! 14 mc produced HH3DL, XZ2SY, ZC1AL, ZD4AE and ZS3X, with several JA's and VS's. K.P. also remarks that the band has been good for VK6's in the afternoons; I can confirm that, having heard six of them in a few minutes, one day round about Christnastide.

M. G. Whitaker (Halifax) cashed in on 7 mc and logged EA6AM, ZD4AB, W5GEA/W6, EA9AM, EA9AP and OY3G. On 3.5 mc he heard MD2MD on phone, S9 plus. 14 and 28 mc he found hardly worthy of comment. But he does add that GD3UB reports the W's coming through between 0500 and 0530 GMT on the *Top Band*.

K. M. Parry (Sandwich) thinks 14 mc is improving, but doesn't like the other bands, 28 mc being "appalling," and 3.5 mc being more or less swamped by commercial CW. He proposes to learn Spanish "so that he can listen on 7 mc"!

Top Band Gossip

Let's switch to the 1.7 mc band for a change. We have already heard the rumour about the W's—now T. G. Spencer (Slimbridge) says that he has been told that they are coming through on both phone and CW in the early mornings. And, just as this was going down, we were informed that PY7WS is on 1.8 mc, and that he had been heard (if not worked) by a G. The other item of interest is that quite a lot of people have heard UA3IS and

UA4FC. R. Iball (Worksop) found them both; also HA5BK/1, "so strong that he could have been taken for a G." UA4FC passed on the information that UA3KLA is on the band, as well as UA3IS, but that UA1AA, who had been active there, has now departed.

R.I. is pleased to report that he has had 100 per cent. success with his QSL's on the Top Band—a fact which speaks for itself. He tries to send "period reports" covering at least one week.

F. A. Herridge (London, S.W.12) is another staunch devotee of the band, and has received both the Russians. He also heard a G calling LA7KA, but couldn't find the latter station. He pleads for better Top-Band logs, commenting that many of the lists published include a couple of GW's (presumably regarded as "DX") and a bunch of semi-local G's. Well, I hope that from the next issue onwards we shall have the Top-Band lists graced by W's and VE's, with a sprinkling of TA, EK, ZB1, PY and UA. I wouldn't even mind a VK or two!

Later on I shall be alluding again to the Top Band Trans-Atlantics, so some of you had better get familiar with the idea of early rising on Sunday mornings.

Miscellaneous

JA2BL seems to have been raising a certain amount of dust on 14 mc, several readers having mentioned him in their letters. CR5AD is a new country lurking there in the CW band, too; I have heard him many times in the early evenings. Also, don't forget that

1950 FOUR-BAND MARATHON

Top Ten

LISTENER	SCORE	28 mc	14 mc	7 mc	3.5 mc	COUNTRIES
1. R. S. Stott (Upminster)	470	132	187	106	45	192
2. J. C. Beal (N. Wembley)	405	120	169	85	31	174
3. W. J. C. Pinnell (Sidcup)	373	112	156	80	25	167
4. D. W. Waddell (Hitchin)	366	114	154	75	23	172
5. N. S. Beckett (Lowestoft)	363	87	153	89	34	158
6. P. H. Strudwick (London, N.W.11)	337(P)	127	146	36	28	166
7. D. W. Bruce (Eltham)	337	121	156	38	22	158
8. A. M. Norden (London, N.W.11)	310	122	118	43	27	137
9. R. A. Hawley (Goostrey)	309	102	138	48	21	153
10. M. G. Whitaker (Halifax)	308	100	115	66	27	145

"ZONES HEARD" LISTING (POST-WAR)

Listener	Zones	Countries	Listener	Zones	Countries
PHONE and CW			PHONE ONLY		
M. E. Bazley (Kidderminster)	40	229	P. H. Strudwick (Lon. N.W.11)	37	164
R. S. Stott (Uppminster)	40	222	J. P. Warren (W. Croydon)	37	160
A. H. Edgar (Newcastle)	40	219	A. M. Norden (Lon., N.W.11)	37	156
E. Trebilcock (Victoria, Aust.)	40	216	J. C. Beal (N. Wembley)	37	154
D. W. Bruce (Eltham)	40	215	J. M. Graham (Glasgow)	37	154
O. A. Good (Oswestry)	40	212	K. M. Parry (Sandwich)	37	151
R. A. Hawley (Goostrey)	40	200	G. Moses (Crewe)	37	149
W. J. C. Pinnell (Sidcup)	40	194	R. J. Line (Reading)	37	144
D. W. Waddell (Hitchen)	40	194	E. J. Parish (Watford)	36	164
J. C. Beal (N. Wembley)	40	187	D. G. Martin (Cheltenham)	36	150
B. Davies (Beckenham)	40	171	C. S. Pollington (Chichester)	36	149
N. S. Beckett (Lowestoft)	39	186	R. A. Fowler (Marlow)	36	141
R. G. Goulding (Wrexham)	39	148	T. E. Botham (Walsall)	36	139
L. Singletary (Oxford)	38	177	B. W. Sutton (Liverpoool)	36	128
F. A. Herridge (Lon. S.W.12)	37	156	L. B. Bailey (Stockton)	36	125
G. H. Coulter (Dover)	37	144	S. Mann (Long Island, N.Y.)	35	163
W. Neal (Birmingham)	36	131	H. M. Graham (Harefield)	35	147
C. J. Goddard (Coventry)	36	129	A. L. Higgins (Aberkenfig)	35	137
PHONE ONLY			H. F. Webster (Darlington)	35	129
E. J. Logan (Hertford)	40	201	A. R. Holland (Malvern)	34	122
D. W. Bruce (Eltham)	39	188	A. O. Frearson (Birmingham)	34	114
K. Parvin (Thornton Heath)	39	168	D. Cocking (Farnborough)	34	111
R. G. Poppi (Beckenham)	39	167	W. C. Askew (Melton Mowbray)	33	129
R. A. Hawley (Goostrey)	38	187	G. Musk (Blackpool)	33	116
D. Kendall (Potters Bar)	38	170	N. Roberts (Launceston)	33	116
L. Tombs (Swindon)	38	155	D. C. Stace (New Zealand)	33	116
M. G. Whitaker (Halifax)	38	151	B. L. Steadman (Hawthurst)	33	103
D. Vincent (Beckenham)	38	140	T. R. Lambie (Ardingly)	33	94
D. L. McLean (Yeovil)	37	178	G. Murray (Newcastle)	32	112
O. A. Good (Oswestry)	37	173	O. R. F. Mason (Prittlewell)	32	82

ZS2MI is on Marion Island and counts officially as a "country." He has a peculiar T7 kind of note and works a lot in the evenings, generally at the low end of the band.

J. Jones (Edinburgh) logged LP2J (Jan Mayen Island) as a new one, and also mentions CR4AC, CR5AM, FF8JA and FB8ZZ, the latter being fairly consistent at 0715, round about 14035 kc. On 3.5 mc, J.J. logged ZL3NH (0845), HZ1KE, KI7OK, VP6SJ (0640), MI3SC and VE3AGX.

D. L. McLean (Yeovil) didn't squeeze much out of 14 mc except between 1700 and 1900 GMT; even then it wasn't too good. 28 mc he thought very poor, although he found an opening for W's on December 10 and again on December 17. He mentions the 14 mc phone from VQ6BFC; this station is operated by Bill Wheeler, ex-MT2BFC and G3BFC, and he will be there for at least a year, so don't panic. (See panel for his QTH).

H. M. Graham (Harefield) is no more pleased with conditions than the rest of us, and he devoutly hopes that 1951 will be a better year, although he has

his doubts from the way things are shaping this winter.

I. S. Davies (London, N.13) confirms that December 10 was a good day for 28 mc, as he logged VP3, KP4, PY, HC, XE, ZS7, VP6, YV and, notably, HC1JW at 59 plus. But this last station was running *two kilowatts*, so he should have been good.

J. W. Cave (Parkstone) mentions ZS7C and ZS9F as the "brightest spots" on 28 mc, and R. J. Riding (Wednesfield) says he found EL2X coming in on 14 mc when the band was otherwise dead. K. Ranger (Strood) heard 1R5MA on 3.5 mc phone, 1800 hrs. on December 5.

T. G. Spencer (Slimbridge) seems to have had better results than most, having heard quite a bit on 28 mc in addition to ZS2MI, PJ5RX and a VE7 on 14 mc.

Returned Veri's

I have often wondered why DX stations who say that they can't cope with the expense necessary to reply to all SWL reports don't just return the

said reports with "Verified" stamped on them. Now M. Milne (London, E.18) say that HZIKKE is doing this very thing. He has had his card back, rubber-stamped "HZIKKE" and a verification message, and returned through the Bureau. This practice should be made more widely known, and might result in better returns from some of those rare stations. It entails very little trouble and no expense at all, if the Bureaux are used, except for the postage on an occasional batch of cards.

Of course, I know that some people collect QSL's for the display of pretty wall-paper rather than for the interest of having verification of their reception; but they are not the keen types. In any case, a returned card with a rubber-stamped message would probably be the alternative to nothing at all, rather than a beautiful card in Technicolor!

Notes from Overseas

Eric Trebilcock (Victoria, Australia) sends an interesting letter full of news of what he is hearing out there. He says that there are now six VK1's; VK1HV, 1PG and 1YG are on Heard Island, and VK1JW, 1RB and 1YM are on Marion Island. These two teams of three are due to be replaced in February, so there should be some new calls coming up. Other news from Down Under: FB8ZZ is on Amsterdam Island; VR1E and VR1F are active on Canton Island (British Phoenix Islands), W6RGM/HL1 and W6YOT/HL1 are both on 1.4 mc CW; VT1DF has been heard on 7 mc.

O. Scheremer (4N4-54-SWL) is the first SWL in the State of Israel, and would very much like to join the BSWL; he offers to enrol any British SWL in the Israel Amateur Radio Club as an exchange. Any British SWL who would like to exchange letters with him might care to write direct to him c/o Post Box 4099, Tel-Aviv.

Plans for 1951

You will see, elsewhere on these pages, the list of the Top Ten in the Four-Band Marathon for 1950—and a very creditable effort, too, on the part of all concerned. The winner, R. S. Stott, of Upminster, has been in the lead right through the year, and established such a commanding position that he would hardly have needed to listen at all for the last three or four months. Best work of all, in my opinion, was his feat in logging 106 countries on 7 mc during

the year. Another special bouquet to P. H. Strudwick, of London, N.W.11, for being the only listener to make the Top Ten on a Phone-Only basis.

This leads me on to say that the Four-Band Table is now discontinued—but only for a while. For 1951 so many of you have begged me to reinstate the monthly competition, in some form or another, that I propose to do just that. For the time being we will drop the long-running tables, but I do intend to start a three-months' Marathon right away.

Top-Band Marathon

This will be on the Top Band, and will be run on the basis of (a) Countries Heard, and (b) United Kingdom Counties Heard, the two figures being added together to give the contestants' position in the tables. As you will not be reading this until about January 18, we will begin this little feud on February 1 at 0001 GMT. It will last throughout the months of February, March and April, by the end of which month someone is bound to emerge exhausted but triumphant. So start on February 1 and send me, each month, your list giving one station from each county and one from each country, together with date and time. The rest is up to me!

The Monthly Contests will be a little more tricky than they have been in the past, because your last date for reporting will very often be between the 21st and 28th of the month. So, instead of taking a Calendar Month as a basis, we shall have to fix two dates between which the contest is to run. Some of these "monthlies" will be linked up with the SLP or with anything else that happens to be going on, and some will be on the old-favourite theme of "How Many Zones and Countries?"

We will always try to give you a full month to listen in and to report on, but *watch those dates*, which will always be given in heavy type at the end of "Have You Heard?"

The February Contest

Quite apart from the Top-Band Marathon already mentioned, we will have a fling on the Zones-and-Countries basis, starting on January 22 and ending on February 19; this will just give you time to send in your score for the March issue. All bands included; position on the ladder in order of Zones, not Countries; in fact, just as it used to be 'way back in 1950 and earlier.

'Zones Heard' Listing

Meanwhile, keep on with the present "Zones Heard" list, just as it is, on a pre-war basis. The only major difference to that Table will be that the leader, M. E. Bazley (Kidderminster) has asked to be deleted for ever, since he is now the proud operator of G₃HDA and will be entering his scores in other tables not unconnected with transmitting! Congratulations to M.E.B., and may he have a lot of fun being a thrower-out as well as a puller-in.

Prospects for 1951

This, of course, is where I could easily lose my reputation once and for all. Long-term prophecy concerning short-wave radio is even more chancy than long-range weather forecasting.

Taking a leaf from the books of the more dismal seers of the Old Moore type, however, I advise you not to expect any more from 1951 than you have had in 1950. There is no reason to suppose that 1950 was the worst year in the sunspot cycle; in fact, it *might* even turn out that conditions continue to deteriorate until 1952 or 1953! But let's be more hopeful than that, and plan on the lines of a kind of repetition of last year's conditions.

This leads me to offer you two pieces of advice, neither of which will be popular with the diehards. First: Make more use of the LF bands (1.7, 3.5 and 7 mc); second: Learn Morse and do all the CW listening that you can. It's a funny thing, but taking the plunge into CW always seems an awful business;

DX QTH's

ST2KC	M. D. Kendall-Carpenter, c/o Eastern Telegraph Co., Ltd., Box 99, Port Sudan.
VK1HV	H. Vause, 50 Mitchell St., North Ward, Townsville, Queensland.
VK1PG	J. H. Gore, 12 Pearl Street, Newtown N.S.W.
VK1YG	L. McGorrige, Princes Highway, Engodine, N.S.W.
VK1JW	J. L. Ward, 42 Electra Street, Williamstown, Vic.
VK1RB	T. R. Boyd, 6 Portland Street, Seacliff, S.A.
VK1YM	D. S. Cohen, 35 Devoy St., Ashgrove, Queensland.
VP1NW	L/Cpl. N. Wakefield, Royal Signals Det., Airport Camp, Belize, British Honduras.
VQ6BFC	W. H. C. Wheeler, Airport Manager, Hargeisa Civil Airport, Somaliland Protectorate.
ZD2AJ	H. C. A. Burt, Box 136, Lagos, Nigeria.

yet I have never met anyone who regretted doing it. Far from it—the newly-arrived CW listeners are invariably thrilled to the marrow!

Now is the time to make the break; not when conditions are at their peak. For when things are dull, as at present, you can increase your range and your variety of countries to a great degree by becoming a CW listener. The fortunate man who has just acquired a reasonable copying speed *by now* will find that in 1951, even if conditions are worse than they were last year, he can log more countries than he did on Phone-Only in 1948 or even 1947.

And, of course, with this goes the fact that the DX is good on the LF bands, on which such a small percentage of it is phone.

I almost feel like taking the line now adopted by our BSWL friends, and saying that there will be no discrimination, in future, between CW and Phone listening in the tables. This would mean that the CW men would always occupy the leading positions—but, of course, they deserve to, having taken the extra trouble to acquire their skill with the code.

Spring Conditions

Casting back to the "good old days," I seem to remember that, however bad conditions were, on the whole, there was always an excellent patch in the Spring, lasting well into May or June. So I predict that in the next few months a little early rising will be well worth while for 14 mc listeners—particularly those interested in W6 and 7, VE7 and 8, KL7, KH6 and the like. Whether any of the more exotic DX also appears depends rather upon whether it happens to be on the air at the right time of day. There is no doubt that if we are hearing, say, KH6, we should also hear KM6, KB6, KJ6 and other nice ones; but if these islands only boast about one transmitter "per each," then we mustn't be too optimistic about their times of activity corresponding exactly with our own!

Don't neglect the Trans-Atlantics on the Top Band, and also remember that early mornings on 3.5 mc are apt to be pretty rewarding for the next couple of months. The remaining times and dates for Top Band DX are as follows: January 28, February 11 and 25, March 11—0500 to 0800 GMT on all occasions. There are also "trial periods," during which nothing may happen, between the hours of 2200 and 0200 on the nights of



Grafton were placed fourth in the *Short Wave Magazine* 1.7 mc Club Transmitting Contest ("MCC"), which is fully reported in the January issue of the *Magazine*. Above are Grafton's operators for the event: Front row (l. to r.) G2AHB, G4GA, G2AAN, G3EBA. Back row (l. to r.): G2AOW, G3EIX, G3RX, G3IMP, G3CLV.

January 20-21 and February 17-18. Listen for the W and VE stations mostly between 1800 and 1825 kc; log all that you can hear of them, and also the stations they are calling or working. Your logs will be a very useful check on the Transmitting Tests.

Four-Band Listening

Don't imagine that the Four-Band DX Table has disappeared for good, just because the 1950 Marathon is over. We shall be reinstating it at some time or other, and I have in mind a Four-Band Listening Contest for one of the monthly battles. Keep your logs up-to-date and clearly divided as to bands, so that you all know which stations you have heard on which bands, apart from all the usual How, When and Where.

If only that 21 mc band were thrown open, we could start a nice little Five-Band Table, quite apart from breeding some more one-band specialists. I imagine that quite a lot of you would be tempted to forsake all the other bands for at least a month or so, in order to study the newcomer in detail. Well, it is still promised to us—as it

was in 1945—but there seems little chance, as yet, of getting our hands on it.

The only reason why I don't bring the Top Band in, and make it a Five-Band Table in that way, is that there are quite a number of listeners who don't use it, have no interest in using it, and would drop out of the Table if it were introduced. I know—they've told me so!

The Road to Success

In my mail-bag the other day was one of those unanswerable letters; unanswerable, that is, in less than about ten typewritten pages. The writer simply asked whether I would tell him the secret of successful short-wave listening! Yes, that's all he wanted to know.

Of course, if you want it expressed in one word, I should just say "*Listen.*" (Surprising what a difference this would make to some people, too!) I always think of two friends of mine who went to a big orchestral concert for the first time. Neither of them could be called a music-lover, although they were both prepared to be initiated. One of them

heard the orchestra as "an enormous noise," and wondered why they needed so many instruments, when half of them would still have been able to fill the hall if they had played a bit louder! The other tried to pick out all the musical threads separately, and got so intrigued by the complicated interplay of strings, wood-wind and brass that he went out afterwards and bought a book on orchestral instruments. He can now unravel the most complicated pieces of musical knitting; but the first chap still hears and admires the orchestra merely as a "gorgeous noise."

Well, there are two listeners; but there is no doubt which of them derives the greater amount of pleasure from his listening. The first is the type who, if he applied his energies to short-wave radio instead, would find a band full of terrific signals, whizz around it without hearing anything in particular, and say "Conditions were so good tonight that I didn't hear anything much." The other would immediately start digging and would probably emerge with the proverbial VQ7!

If you want to collect the interesting pieces, and the new countries, in these days of poor conditions, you've got to make listening an act of concentration. Sit there and scrutinise every degree of that dial. Even pause and listen to the blank spaces for a while, because those are the places where you stand a chance of hearing a new signal pop up for the first time.

After all, if a brand-new transmitter in a brand-new country does come on the air, *someone* has got to be the first to hear him. And that someone won't be the listener who waits to read about him in these columns—he will be the one who listens around when the band seems dead or dying or just coming to life.

Listen to *whole contacts* more often. You may think, when you hear someone talking, "Oh, just another VK"—but that VK might possibly be working with a ZM6 or a VR2, and the chances are that the other station is on, or near, his frequency. Some of the very best ones were found by "riding on the back" of another station. So Listen, and then Listen again.

Set Listening Periods

- January 27. 1600-1700 GMT; 14 mc
Phone and CW
January 28. 0500-0800 GMT; 1.7 mc
CW (W and VE only)

February 17, 1500-1600 GMT; 14 mc
Phone and CW

February 18, 1600-1700 GMT; 28 mc
Phone

Note those February dates now; they come immediately after publication of the next issue, and if you wait for that you may be caught on the hop.

Deadline for the February issue is **first post on January 24**, and for the March issue first post on February 21. Please note both these dates carefully, as the calendar is being a bit unkind to us for these two months and there is very little time between publication and closing date.

Let us hope that 1951 starts off well for you all; write and tell me all about it, addressing your letters DX Scribe, *Short Wave Listener & Television Review*, 53 Victoria Street, London, S.W.1. So, for now, 73 and Good Listening—and watch those dates!

Late Flash. As this column was going to press, G6BQ (Gravesend) wrote in to say that on December 31, at 0445 GMT, he called CQ DX on 1793 kc—and back came VE1EA. The resulting QSO was held until 0527, with signals peaking RST-459 and 449 (G6BQ) at best. This is probably the first Trans-Atlantic contact of the season, but we are not sure about that yet.

AND NOW GERMANY

Always taking more than a passing interest in television, even in the early days, Germany is at last to have a public TV service. Four stations are to be built—in Hamburg, Frankfurt, Berlin and Cologne—and are expected to be officially opened in 1951, according to the German Broadcasting Corporation.

BARNES RAD.-ELEC. & WHOLESALE CO.

Mains interference suppressors, 5/-; 80 m/a 20H. Chokes, 5/6; VU120 Valves, 10/-; Crystal pick-ups, 32/- reduced from 50/-; V.C.R.97 Screens, 4/-; S.130 Stabilizers, 10/6 pair; 2-pole 25-way 3 amp. Rotary Switches, 8/6; 2-pole 6-way for test meters, etc., 3/-; Small Neons 80 V. ideal for test prods. with 2 meg. resis., 2/3; R.1116 All Wave Std. battery double superhets (tested), £11, special leaflet, 3d.; Television Condensers, oil filled, .1 mfd 8KV, test, 6/6; .23/.25, 450 V., 7/- doz.; 20 V. meters M.C., 2in., 7/6; 40 V., 6/6; 5 M.A., 6/-; ½ M.A., 8/6.

12 PIPERS ROW, WOLVERHAMPTON, CEN.

CALLS HEARD

SET LISTENING PERIODS

GENERAL

28 mc

T. G. Spencer, Cherry Tree Cottage, Slimbridge, Glos.

PHONE : AR8UN, CM9AA, CX1CA, HC1JW, 10Y, 1SA, OQ5CH, SV0WS, TA3GVU, VS9AH, VU2GJ, XE1PG, ZE2KH. (Rx: Commander.)

R. A. Hawley, Torvieu, Brookfield Crescent, Goostrey, Cheshire.

PHONE : HC1JW, KP4HF, HP1AW, MD2PJ, OQ5AO, VP6MD, W6SJK/MM XE2KW, ZC6UNJ, ZS5JM, 6A, 6JM, 6OY, 6RA, 9F. (Rx: S.504.)

J. W. Cave, 12 Hilda Road, Parkstone, Dorset.

PHONE : AP5A, FF8AH, HC1JW, MP4BAB, OQ5CH, PK3JF, VS9AH, YV1BE, ZD4AD, ZS7C, 9F. (Rx: 0-1-1.)

J. P. Warren, 14 Francis Road, W. Croydon, Surrey.

PHONE : AR8UN, CR7IV, HC1FS, 1SA, H8WTF, HP1LA, 1WM, HR1RM, OA4BR, VK6RU, VP5AY, 6JC, VS9AH, VU2SWL, XE1PY, YS1MS, YV1BE. (Rx: R103/RF24.)

I. S. Davies, 127 Hazelwood Lane, London, N.13.

PHONE : HC1JW, 10Y, KP4HF, 4HZ, 4KP, M13EH, VQ4RF, VS9AH, YV1BE, ZL3LE, ZS3E, 30, 6CY, 6RA, 6SE, 6UR, 7C, 9F. (Rx: R208.)

D. L. McLean, 9 Cedar Grove, Yeovil, Somerset.

PHONE : AR8AB, 8UN, HC1JW, 10Y, KP4FP, 4HZ, 4MM, MD2PJ, M13GH, 3RP, 3XX, 3ZN, MP4BAB, ZC6JM, ZD4AH, ZS1KW, 1T, 6OY, 4X4CR. (Rx: SX28 and AR88.)

N. Roberts, Aspen View, 29 Race Hill, Launceston, Cornwall.

PHONE : HC10Y, VP6FM, ZE3JT, ZS1K, 1T, 6AA, 6CN, 6CY, 6EU, 6PT, 7C. (Rx: SX28A and S750.)

Please note the following simple rules for sending in lists of Calls Heard

28 & 14 mc: No Europeans. No USA except W6 & W7 No VE except VE5, 6, 7 & 8. 7 mc: No Europeans.

Arrange logs in the form given here, with (a) prefixes in alphabetical order, but not repeated; (b) numbers in numerical order and repeated as part of the call sign; (c) call signs in alphabetical order. For example:—VK2GW, 3CP, 4UL, VPIAA, 6CDY, VQ3HJP, 4EJT, W6ENV, 7VY. Please underline each prefix, keep each list to one band, and, in short, make your lists exactly like those below, except that the more space you leave, the better.

14 mc

I. S. Davies, 127 Hazelwood Lane, London, N.13.

PHONE : AP2N, EQ3FM, LU5AK, M13LV, OQ5DL, VK2WT, 3KE, 4EZ, VP4TH, 6HM, 9F, 9G, VQ2EW, 2JD, VS2CP, VU2JP, YV5AB, 5EC, ZL1HY, 2JB, ZS4MP, 3G, 6FN, 6JS, 6OW. (Rx: R208.)

J. P. Colwill, Hay Common, Launceston, Cornwall.

PHONE : CM9AA, EA8AH, 8BE, FF3CL, HH3DL, KP4EF, LU2DJZ, PY1AMJ, 1FR, 4AAP, VE7VO, VK5KN, VP4TH, 5AR, 7NH, W7AJ5, 7JEN, YV5CE, ZL4AW, ZS1BK, 1GG, 4AF, 6DW, 6JB, 6JS. (Rx: Roberts' PAD.)

R. J. Riding, Trewatha, Fibbersley, Wednesfield, Staffs.

PHONE : CN8BV, 8EI, MD2PJ, TA3GVU, VP3PA, 6FO, ZS1GG, 6OI. (Rx: 1-1-1.)

T. G. Spencer, Cherry Tree Cottage, Slimbridge, Glos.

PHONE : CM9AA, CO8GH, DU1AL, EQ3FM, MD2PJ, PJ5RX, PY7XC, VE7AAD, 7VO, 3TK, VK6KW, 6MO, 6RU, VP6FO, 6SD, VQ4RF, VS1AY, 7SV, W7AJ5, 7DL, XE1AC, YS1JR, ZS1KW, 2MI. (Rx: Commander.)

R. W. Cresswell, Cliddesden, Nr. Basingstoke, Hants.

PHONE : CM9AA, EA8BI, MD2AC, 2PJ, PY4AGZ, 6PD, TA3GVU, VO1DZ, W6AG, 7JEN, YV5BQ, 3V8BB. (Rx: 1082.)

C. Gore, Yatesbury, Calne, Wilts.

PHONE : CS3AA, EA6AT, 8AL, 9A1, EK1DI, MD2MD, 2PJ, PY11T, TA3GVU, YV5AB, ZB1AJX, 2A, ZL2JB, ZS1KW, 6CM, 6JS, 6OW, 6OY, 7C. (Rx 9-valve home-built superhet.)

W. G. D. Orsler, 9 Pembroke Road, Erith, Kent.

PHONE : CM9AA, CN8EM, 9AA, CO7RQ, EA8AE, EK1AV, FA3KC, HP1EV, HZIAB, LV3TA, 3UV, MF2AA, 2PJ, OA7DG, PY6PP, VP1DF, 6SD, VS1AX, 1SY, ZI1AB, 2CY, YA1KC, YV5AB, 5EC, ZS6DW, 6JB. (Rx: R1155A.)

R. A. Hawley, Torvieu, Brookfield Crescent, Goostrey, Cheshire.

PHONE : CS3AA, HH2X, VE7VO, VP6FO, 6SD, W7DL, YV5AB. (Cf: 4X4CL, FF8AC, HP1DS, HZ1KE, OX3GD, PK3IC, 5AA, PY7LN, 7WS, TF3NA, UA9KCA, VP6CDI, ZS6RN. (Rx: S.504.)

N. Roberts, Aspen View, 29 Race Hill, Launceston, Cornwall.

PHONE : AP2N, AR8AB, CO7AA, CR6AI, CR7RF, CX2CO, EAQAC, HH3DL, HK1AV, JA2HB, KP4AZ, LU8AZ, OQ5DZ, OX3AD, TT2BS, VK6MO, VQ2WR, 3BVF, 6BFC, W6KPC, W7JEN, ZE3JV, ZL2JB, ZS3S, 9F. (Rx: SX28A and S750.)

D. L. McLean, 9 Cedar Grove, Yeovil, Somerset.

PHONE : AR8AB, FF3CN, KP4AZ, 4HF, MD2PJ, OQ5DL, OX3BD, 3WX, VE8OP, VP6FO, 9G, VQ4RF, W7AJ5, 7JEN, ZD1SS, ZL2JB, ZS1GG, 1KW, 1KZ, 2DY, 6CT, 6JS, 6OI, 6VU. (Rx: SX28 and AR88.)

K. B. Ranger, 89 Station Road, Strood, Rochester.

PHONE : CN8ET, CS3AA, EA8AS, 8AX, 8BB, OQ5DL, 5DZ, OX3BD, VK1YM, 2QR, 3HW, 5RM, VP3DCC, 6SD, VQ2WH, 4RF, VS1AV, 7SV, ZB1AJX, 4X4ES. (Rx: 0-1-2.)

7 mc

K. Parvin, 98 Winterbourne Rd., Thornton Heath, Surrey.

PHONE : CO5RP, CS3AB, EA6AF, 8AL, 8AZ, EK1BA, EA3DS, 8BE, 8BG, 8CC, 9RZ, LU7DAZ, PYIALS, 1NC, VQ4AQ, 3V8AS. (Rx: S640.)

I. S. Davies, 127 Hazelwood Lane, London, N.13.

PHONE : EA8AL, VP4LL, 6SD, VQ4AQ. (Rx: R.1155/A.)

N. S. Beckett, 194 Waveney Drive, Lowestoft.

CW : CO8FH, CT3AV, EA9AM, 9AP, KP4CK, 4KD, LU8AE, PY2SR, 4ACA, 7EX, ST2TC, TA3FAS, UF6AA, VK2WH, 3ZC, 5KU, 5MR, VP4TR, 4X4AO, 4BX, YV5DO, ZB1HF, 2I, ZL2MM. (Rx: Hambander.)

J. P. Warren, 14 Francis Road, W. Croydon, Surrey.

PHONE : CO8AE, CT3AK, EA6AF, 8AL, 8AZ, EK1AD, 1BA, LU4DJJ, PYIARG, 1ALZ, 1DU, 4AZ. (Rx: R.103.)

3.5 mc

M. G. Whitaker, Stile House, Sleaf, Halifax.

PHONE : CT1BW, FA8BG, MD2MD, 2JH, YU3DML. CW : FA9RW. (Rx: 0-V-1.)

H. Grainger, 34 Gordon Road, Mannofield, Aberdeen, Scotland.

PHONE : CT1TX, DL4XZ, G2MF, 2XU, GM2FNF, 3DZB, HB9BX, 9YZ, ITISEM, OE8MR, 13RM, OH2OL. CW : OH2OP, ON4PB, SM3ARE, YU1CAF. (Rx: BC-348.)

J. Jones, 13 Boswall Terrace, Edinburgh 5, Scotland.

PHONE : HZ1KE, KL7OK, M3SC, VP6SJ, VE3AGX, ZL2ACV, ZL3NH. CW : CM9AA. (Rx: S.640.)

1.7 mc

F. A. Herridge, 95 Ramsden Rd., Balham, London, S.W.12.

PHONE : DL2QM, 2SS, GD3UB, GW3CDH, 3ZV, 8BW. CW : GC2FMV, GI3GTR, GM3EGW, 3EH1, 3EQY, GW3EPM, 3FSP, OK1AJB, UA3IS, 4FC. (Rx: Modified R.103.A.)

T. G. Spencer, Cherry Tree Cottage, Slimbridge, Glos.

PHONE : G2AQH, 2BCN, 2DPZ, 2FMN, 2FWJ, 2JL, 2NM, 3ACK, 3DSW, 3ECW, 3EHD, 3EKT, 3FMZ, 3FEW, 3FRN, 3GAW, 5LK, GC4LI, GD3UB, GM3DZB, 8FM, GW2IP, 2XZ, 3CDH, 8AM. (Rx: Commander.)

Robert J. Riding, Trewatha, Fibbersley, Wednesfield, Staffs.

PHONE : G2HC, 2NV, 3BNM, 3TP, 4MI, 8GF, 8SR, GW3ALV. (Rx: 1-V-1.)

R. Iball, 48 School Road, Langold, Worksop, Notts.

CW : G2DKH, 2IP, 2IZ, 3EFX/P, 3EAT, 3FH, 3GVA/A, 3HCK, 3WS, 6VC, 8TL/P, GC2FMV, 4LI, GI3QA, GM3COE, 3EGW, 3HAM/P, 4NK, 6RI, GW4FFE, 3VL, DL2QM, HA5BK/I, UA3IS, 4FC. PHONE : G3FNL, 5AU, 5KM, GD3UB, GM8FM, GW3ZV, DL2QM. (Rx: 0-V-0.)

EXTENSION AT LIME GROVE

The work of converting Lime Grove continues, and the "Gala Variety" programme on December 23 marked the opening of Studio G—the second now in service at the site.

It will be used for light entertainment programmes, has an area of 3,500 square feet and is equipped with four Pye Photicon cameras—similar to those used for outside broadcasts. An interesting feature is that that the studio is air-conditioned, using a ventilation system of a new type, and is the first of its kind to be used in this country. This refrigeration unit will hold the studio temperature at a comfortable level even in summer with the full complement of 300 kilowatts of lighting in use.

The studio has its own apparatus room, in which the electronic gear associated with the cameras is installed, together with monitors and mixing

THE PREFIX LIST

There is always some slight element of doubt or confusion as to what can or cannot be "counted as a country." Apart from that, few of us can be absolutely certain of the country of origin of every prefix we hear, nor can we name correctly the prefix which should be

used by every remote locality or "rare" country. All this is brought together and made clear in our *Country List by Prefixes*, which is an up-to-date guide to the whole subject. The lists are arranged prefix-country-zone and set out on a stiff folding card for use at the operating position. The price is but 6d. post free, of the Circulation Manager, Short Wave Magazine, Ltd., 53 Victoria Street, London, S.W.1.

JOIN THE LEAGUE!

The steady increase in the membership of our British Short Wave League is a sure sign that SWL's generally recognise not only the value of the work the BSWL is doing for them, but also the advantages of membership. One of these is the BSWL Review, incorporated with the *Short Wave Listener & Television Review*, the subscription thus covering the combined journal of 52 pages, free to all League members.

For Further Information and Form of Application write:

The Manager,
British Short Wave League,
53 Victoria Street,
London, S.W.1.



PSE QSL

The operators listed below have informed us that they would like SWL reports on their transmissions, in accordance with the details given. All correct reports will be confirmed by QSL card. To maintain the usefulness of this section please make your reports as comprehensive as possible.

- DLIJO** Kirchfeldstr. 25, Kettwig, Germany. 3.5, 7 and 14 mc phone and CW, 1900-2359 GMT.
- DL3FE** Hauptstr. 46, Post Fischbach-Weierbach, Herrstein/Nah, Germany. 3.5, 7, 14, 28 and 144 mc phone and CW, 1900-2359 GMT.
- DL3FM** Klängenburgstr. 30, Muelheim-Ruhr/Ickten, Germany. 3.5, 7, 14, 28 and 144.65 mc phone and CW, weekends 2200-0100 GMT.
- DL3NL** Domhofgasse 1, Weinheim/Bergstr, Germany. 14 and 28 mc phone and CW, 1600-2359 GMT.
- DL3RK** Ludwigstr. 18, Kaufbeuren, Germany. 3.5, 7 and 14 mc phone and CW, evenings.
- DL3RY** Günter Westermann, Hahnenkle-Bocksweise-Funkst, Bocksberg, Germany. 28.4 and 145 mc phone, Friday 2100-2359 GMT.
- DL3TJ** Kaufbeuren, Oberbeuren 28, Germany. 3.5, 7 and 14 mc phone and CW, 0600-0700, 1200-1300 and 1830-2200 GMT. Details of modulation.
- DL3UK** Dionysiusstr. 44, Bremerhaven, Germany. Reports on 7 and 14 mc CW.
- DL6KW** Dollstr. 12, Ingolstadt/Donau, Germany. 3.5, 7 and 14 mc CW and NB.FM phone, 0400-0600, 1100-1200 and 1700-2359 GMT.
- DL6MP** Fussenerstr. 8, Kaufbeuren/Allgau, Germany. 3.5, 7 and 14 mc phone and CW.
- EA2AH** Plaza F. Moyua 7-20, Bilbao, Spain. 7 and 14 mc phone, 0800-1000 and 2300-2359 GMT.
- EA2BL** Box 171, Zaragoza, Spain. 7 and 14 mc phone, 0800-1000 and 2200-2359 GMT.
- EA5DR** c/Salamanca 29, Valencia, Spain. 7 and 14 mc CW, 2000-2359 GMT.
- EA6AR** P.O. Box 135, Palma de Mallorca, Balearic Islands. 7 and 14 mc phone, 0800-0900, 1500-1700 and 2300-0100 GMT.
- F9QM** 156 Bd Lafayette, Calais, Pas-de-Calais, France. 7 and 14 mc phone, 1800-1900 GMT.
- G3BDS** 34 Tybridge Street, Worcester. 1.8, 7, 14 and 28 mc phone and CW, 2000-2300 GMT, weekends 0700-1200 and 1400-1700 GMT.
- G3FTV** 19 Darnley Avenue, Wakefield, Yorkshire. 1.7, 3.5, 7 and 14 mc phone and CW, 2300-0200 GMT. Outside Europe, except for 1.7 mc.
- G3HCN** 35 St. Luke's Crescent, Totterdown, Bristol. 1.7, 3.5, 7, 14 mc CW. Comparative reports.
- G3HCQ** 99a Peartree Road, Derby. 14050 kc CW, 2000-2300 GMT, weekends 0800-0900 GMT.
- G3HEV** Ravensbourne A.R.C., Childerie Road School, London, S.E.14. 1.8 and 3.5 mc CW, Wednesday and Thursday evenings.
- HB9LN** La Chaux de Fonds, Doubs 137, Switzerland. 3.5, 7 and 14 mc phone and CW, 1900-2300 GMT.
- HP1BR** Box 883, Panama, Rep. de Panama. 14360 kc phone, 0500-0800 GMT; 28320 kc phone, 1600-2200 GMT. Speech quality and modulation percentage.
- HP1LB** P.O. Box 3808, Ancon, Panama Canal Zone. 7, 14 and 28 mc phone and CW, 1900-0300 GMT.
- I1BKK** Via Teatro Vecchio 13, Mantova, Italy. 14 mc phone, 1300-1335 GMT. Modulation.
- I1RO** P.O. Box 75, Modena, Italy. Phone and CW, all bands, 0700-0800 and 1400-1800 GMT.
- I1WYK** Via Milazzo, 2, Udine, Italy. 14 mc phone quality and modulation percentage.
- KP4MT** R. Perez, J. Barbosa Street, Las Piedras, Puerto Rico. 14106 and 14030 kc CW, 2200-0200 GMT, weekends 1300-1400 GMT.
- LA8UB** Haakon Naevdal, Solstua, Gardemoen, Norway. 14023, 14055 and 14090 kc CW, 1500-2300 GMT. Critical reports. DX heard calling LA8UB.
- LU5CK** Galvan 3074, Buenos Aires, Argentina. Reports on 50106 kc phone, 1900-2300 GMT.
- LU8CW** Box 3347, Buenos Aires, Argentina. 14035 and 14305 kc phone and CW, 0600-1200 GMT-28450 kc phone and CW, 1700-1900 GMT.
- M1BXX** A. Smith, A.P.O. 843, c/o P.M., N.Y.C., U.S.A. 14 and 28 mc phone and CW, 1200-1600 GMT.
- OH7NC** Jorma Lahtela, Niinisalo, KTR. 1, Finland. 3.5, 7, 14 and 28 mc CW and 3.5 mc phone, 0600-1100 and 1800-0500 GMT.
- OK1AXW** Nova Paka, Zizkova, 1194, Czechoslovakia. 3.5, 7, 14 and 28 mc phone and CW, 1700-2300 GMT.
- OK1OMP** Nova Paka, Zizkova, 1194, Czechoslovakia. 3.5, 7, 14 and 28 mc phone and CW, 1700-2300 GMT.
- ON4FN** rue Notre Dame du Sommeil 23, Brussels, Belgium. 3.5 and 7 mc CW, at 0700, 1300 and 2100 GMT.
- ON4SF** 26 rue du Meridien, Brussels, Belgium 3.5, 7, 14 and 28 mc CW, 1600-2200 GMT.
- PA0GSSW** Verheijstraat 85, Vlaardingen, Netherlands 3625-3700 kc phone, 2300-2359 GMT.
- PY1FT** R. Francisco Otaviano 33, apt. 101, Capital Federal, Brazil. 14020, 14200 and 28480 kc CW and phone, 2000-2200 GMT and weekends.
- PY4VX** P.O. Box 314, Belo Horizonte, M. Gerais, Brazil. VFO-controlled phone, 2100-0200 GMT.
- PY6DU** Praia de Itapoan 1, Salvador, Bahia, Brazil. 7, 14, 21 and 28 mc phone and CW, 0800-1000 and 2000-2359 GMT.
- PY7GC** Av. Dr. Antonio Gouveia 197, Maceio, Alagoas, Brazil. 14 mc phone, after 2200 GMT.
- SM3** APK Kaalhusgalan 24, Ostersund, Sweden. Reports on 7000-7200 kc CW.
- T12PZ** P.O. Box 1816, San Jose, Costa Rica. 3.5 and 14.7 mc CW, 0100-0500 GMT and weekends.
- VE1US** P.O. Box 403, Liverpool, Nova Scotia, Canada. 4 and 14 mc phone, VFO, 1730 GMT. Quality.
- VE8PI** Baker Lane, N.W.T., via M.P.O. 1015, Fort Churchill, Man., Canada. 14 mc phone and CW, 0600-1200 GMT.
- VK2BR** Rev. Brooke, St. Paul's Rectory, Dora Creek, N.S.W., Australia. 7 and 14 mc CW, 0600-0700 and 1900-2100 GMT.
- VP3LF** 33 Robb Street, Georgetown, Brit. Guiana. 14 and 28 mc phone, VFO, 0001-0500 GMT.
- V57GD** Sunnycroft, Waharaka, Ceylon. 7, 14 and 28 mc phone and CW. QRP, 1130-1230 GMT.
- W2SUJ** 244 17th Street, Brooklyn 15, N.Y., U.S.A. 14 mc phone and CW, 2200-2359 GMT.
- W3HQJ** 105, Landover Road, Bryn Mawr, Pa., U.S.A. 14270 kc phone, 1200-1400 GMT.
- W6EJX** 842 Campodonico Street, Guadalupe, Calif., U.S.A. 4, 7, 14 and 28 mc phone and CW.
- W6ZLN** 1517 Gascony Road, Encinitas, Calif., U.S.A. 28.6-28.7 mc phone, 1200-2000 GMT.
- W8AVT** 3939 Northampton Road, Cleveland Heights, Ohio, U.S.A. 14050, 28100 and 28550 kc phone and CW, 2000-0100 GMT.
- W9MKO** 574 N. Laramie, Chicago, Ill., U.S.A. 14 mc phone and CW, 2200-0100 GMT and weekends.
- ZD6HJ** H. H. Jones, P.O. Mlanje, Nyasaland. 14 mc CW, 1600-2000 GMT.
- ZE3JL** 26 Jameson Street, Bulawayo, S. Rhodesia. 14 mc phone, 1700-2000 GMT. Comparative reports.
- ZE3JO** Box 1976, N.A.D., Salisbury, S. Rhodesia. 14030, 14050, 14100 kc CW, 1645 GMT.
- ZE3JO** "y" Fl., R.A.F. Heany, Bulawayo, S. Rhodesia. Calling Yeovil, 14 mc CW, 1800-1830 GMT.
- ZS3X** P.O. Box 85, Windhoek, South-West Africa. 14 mc CW, VFO, 1800-2000 GMT. Stability.

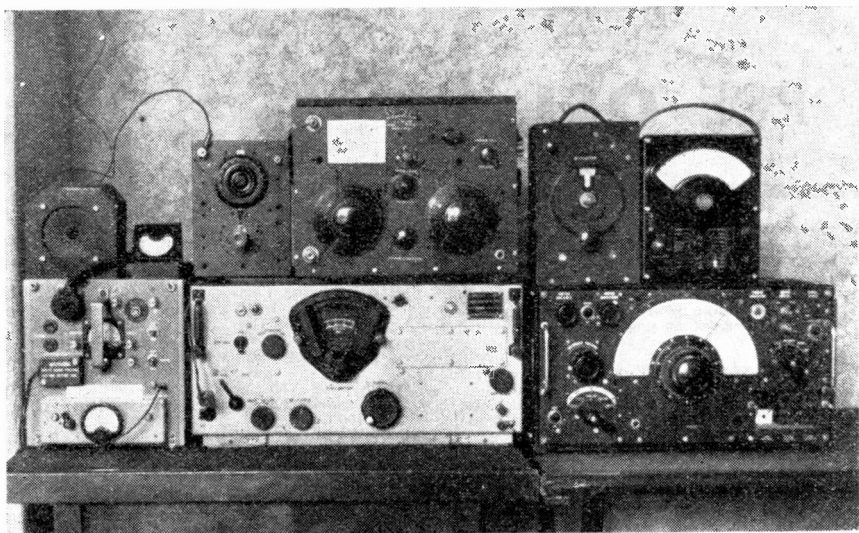

SWL Stations NO. 37

THIS is the station owned and operated by T. Cooper, BSWL 3681, 5 Bishop Street, Accrington, Lancs., who (though he tells us he is not a "hoary old gentleman with a taste for reminiscing") first became interested in radio before the dawn of broadcasting. So his first receiver was a crystal set for listening to the ships on 600 metres and time signals from the Eiffel Tower long-wave transmitter (FL), remembered by all real Old Timers as a standard test signal. This kept BSWL 3681 going until the Manchester BBC station, 2ZY, started up in November, 1922, and his Rx became an O-V-O, using one of those famous "soft" Dutch valves; and on that set in those days (together with many others of us who used to sit up into the small hours in attics and school studies) he received Trans-Atlantic broadcast from such famous medium-wave DX stations as WGY, WJZ, WBZ and KDKA.

Having started thus, BSWL 3681 naturally reads Morse, and he remarks he has never regretted learning it, especially as his favourite pursuit is still off-the-beaten-track listening to shipping and aircraft; in fact, he says his favourite frequency is 500 kc, around which the ships of all nations can be

heard working the land stations up and down our coasts.

Apart from having had the experience of listening-in to the opening of the first Trans-Atlantic commercial radio telephone circuit (Rugby GBT in February, 1926), BSWL 3681 was licensed AA in that year as 2ATC—but there must be few amateurs who, having been issued with a callsign, have never used it; for he did not even get round to building the gear, as with the opening of the then unexplored short wave bands of 90, 45 and 23 metres, there was too much of interest to do on the receiving side.

And now the station of BSWL 3681 has taken the shape shown in the photograph. Lower deck, l. to r., Power unit for all receivers; centre, BC-348; right, R.1155. Above, l. to r., Loud speaker; S-meter; wave-trap for elimination of mutual interference; home-built TRF I-V-I receiver; separate BFO unit; and a multi-test meter. Portable equipment is also available, and '3681 remarks that after 30 years of radio he is as keen and as active as ever. There is something in his story to inspire and enthuse all whose hobby is radio, whatever experiences they may have had.

THE VHF END

by A. A. MAWSE

Survey of the Old Year—

Some Individual Reports—

Conditions Poor Generally—

The Tables and Calls Heard—

ALTHOUGH this issue of *Short Wave Listener & Television Review* is dated February, 1951, it will appear on January 18, and your conductor is writing these words in December, 1950. It therefore seems a fitting occasion to look back over 1950 and recall some of the VHF events of the last twelve months.

The year 1950 opened in grand style by providing the South Coast stations with some excellent DX on the morning of January 1, signals from the Netherlands reaching as far as Devon. Many weeks of generally poor conditions followed, with TV and inactivity both receiving their share of the blame for the lack of signals. But on March 5 came the startling news of the 119-mile contact between G3EJL and G5BY on Seventycems. Although none of our readers were concerned in this, it undoubtedly spurred them to get going on this much higher frequency and paved the way for the achievements which were to follow later in the year.

On Two Metres, however, nothing really exciting happened until the middle of May, when the Midlands and North had an excellent opening to the Continent and 400-mile DX was common. The South of the country did not share in this, but had their share of excitement by following the progress on Seventycems. On May 30, G5BY pushed up the record to 132 miles by working G2XC, and then to 161 miles on June 4 by contacting G6LK. Many of the thrills of this came to listeners, as the participants used two metres to discuss their 70 cm results.

The end of June brought the next good spell to two metres, and this time the Southerners had their share. Three DL's were logged in London, and the excellent conditions provided A. L. Mynett with the opportunity to rise to the top of the "Two Metre DX" table by hearing DL3NQ at 410 miles. Over 3 months passed before the next major openings occurred on the VHF bands, and then came an outstanding evening on Two with DL4XS/3KE working over 500 miles to G5BY and being logged at S9 plus in London by several of our readers. In mid-October, A. L. Mynett again demonstrated his VHF skill by logging 70 cm signals from G5BY and G2XC in the London area. This was the first occasion either of these stations had been heard in London, and it served as an incentive to others to maintain activity. As a result, G5BY was heard in Essex at a distance of over 200 miles.

Summing up conditions for the twelve months, your conductor's opinion, based on your reports and his own listening, is that, with the exception of a few isolated dates mentioned in the above review, things have been just ordinary, and good conditions a rarity. Activity has not been so great as any of us would like, but has probably been greater than many of us imagine. A lot of operators still do not realise the limitations put on two-metre signals when conditions are not aided by additional tropospheric bending. Progress in equipment has undoubtedly been greatest on Seventycems and has been responsible for the new records which have been set up on that band. But there has also been a general improvement on the lower frequency, and the numerous enquiries received by your A.A.M. for details of beam construction shows that that aspect has not been neglected either. An advertiser in a recent issue of *Short Wave Listener & Television Review* mentions "literally thousands of operators on Two these days." Well, we wish a few of them would write in month by month and let us all know what they are hearing! The number of new correspondents during

TWO-METRE DX

A. L. Mynett (Wembley)	DL3NQ	410 miles
G. E. Magrow (Dawlish)	PA0UW	387 miles
E. A. Lomax (Bolton)	PA0IK	340 miles
R. Hastie (Hayes)	F3DC	221 miles
P. Finn (Iver)	G5BY	172 miles
R. A. John (Swansea)	G3BLP	168 miles
R. L. Bastin (Coventry)	G2CPL	138 miles
A. F. Hayton (Palmer's Green)	G5BD	116 miles

Note: All claims for this table must be accompanied by QSL card to verify and must be for distances in excess of 100 miles.

the year has been disappointingly small. Perhaps it is more difficult to get going on Two than we imagined, and those of us who have managed it really have achieved something!

News Items

DL3FM, in a letter to G2XC, says he will be active on Two daily between March 1 and May 1, and hopes to arrange some schedules with G stations during that period. His frequency is around 144.2 mc, and he is located in Mulheim, which is very near to Cologne. DL4XS has now moved to Frankfurt, which is not quite such a good location as his previous "Radio Hill."

Letters are few this month, but A. H. Edgar (Gosforth) writes with some joy to say that he has at last heard some two-metre signals. After re-aligning his converter, he immediately heard G3CYY and G2BCY. Unfortunately, his beam, which is in the roof space, is fixed and all the signals so far heard have been off the back. A.H.E. comments that before he had heard anything he was

quite happy listening to nothing and hoping, but now he becomes rather impatient when nobody comes on. Yes, we are not so sure that the generally low level of activity on Two is not due to something of that sort. When one has experienced a good spell of conditions with DL, PA, ON, and other DX coming in at S₀, it hardly seems worth staying on the band and listening when conditions are such that only 50-mile DX can get through. No doubt the transmitting men are affected the same way. But to return to A.H.E.—he sends the welcome news that there is a possibility of increased transmitter activity in the Newcastle area as a result of a VHF demonstration by G4LX at the local club. A.H.E. asks for ideas for a 6J6 pre-amplifier.

TWO-METRE COUNTIES HEARD

Starting Figure 10

E. A. Lomax (Bolton)	38
P. J. Towgood (Bournemouth)	37
A. W. Blandford (Mitcham)	28
L. A. Whitmill (Harrow Weald)	28
R. L. Bastin (Coventry)	24
W. C. Askew (Melton Mowbray)	19
P. Finn (Iver)	17

While up North, it should be mentioned that G2HQ in Sheffield is active on Two nightly from 2130 to 2200 and wants reception reports.

In the South, P. J. Towgood (Bournemouth) has been overhauling his beam. This activity was prompted by the discovery that an ohm meter across the ends of his co-axial feeder registered only a few thousand ohms. Investigation revealed the fact that the Bostik

VHF CALLS HEARD

Two-Metres

A. H. Edgar, 15 Dene Terrace,
South Gosforth, Newcastle 3.

PHONE: G3CYY.

CW: G2BCY, 3CYY, 4LX.

(Mod. RF26 into S.640, "Short Wave Listener" 4-etc. beam in roof space).

W. C. Askew, Burrough, Melton Mowbray, Leics.

G2FNW, 2HCG, 2IQ, 2XS, 3APY, 3BA, 3BLP, 3DUP, 3EMJ, 3ENS, 3WW, 4HT, 6CW, 6NB, 6VX.

(November 26 to December 26,

G2IQ converter into "Commander,"
4-etc. Yagi, 33 feet high.

P. J. Towgood, 6 Guildhill
Road, Southbourne, Bournemouth, Hants.

150-200 miles: G2XS.

100-150 miles: G3BA, 3WW.

50-100 miles: G2AHP, 3DJX, 3EHY, 4KD, 5TP, 6NB, 6VX, 6XM, 8KZ.

(Rx: 6J6, 6J6, 2X6C4 converter into 9 mc atal controlled converter, into 1.6 mc IFAF amp. Aerial: 4-etc. c/s beam 22ft. high. QTH 86ft. a.s.l. All heard during Dec. 10-20).

L. A. Whitmill, 762 Kenton
Lane, Harrow-Weald, Mdx.

G2AHP, 2ANT, 2BN, 2DL, 2DT0, 2HDZ, 2WJ, 2XV, 2ZI, 3AFT, 3BCY, 3BCA, 3BVA, 3BLP, 3CVO, 3DCU, 3CGQ, 3EHB, 3EHY, 3FD, 3FXG, 3GBO, 3GDR, 3GSE, 3HBW, 3MI, 3WW, GW3EJM, 4DC, 4FB, 4HQ, 4HT, 4RO, 5BC, 5CD, 5KH, 5NF, 5RD, 5UM, 6CB, 6LO/A, 6LR, 6NB, 6QN, 6VX, 6XM, 8LG, 8KZ.

(Rx: 6J6 Preamp into RF27 into S640 5-element beam. November 27-December 18).

compound at the centre of the dipole had taken on the characteristics of a sponge, and was absorbing much moisture. The new set-up has a quantity of polythene-type dielectric (obtained from a length of co-ax) moulded around the connections first and the Bostik applied on top of that. In addition, a moulded lid has been placed over the connections as a form of hat. Conditions in Bournemouth were fairly good on December 20, according to P.J.T., and on December 19 he heard G2XS (Mansfield). He feels that enthusiasm is very low at present and notes that many people vanish for long periods out of sheer disgust, and are then, of course, missing when there is an opening. A queer effect was noticed by P.J.T. on December 18, in that G3EHY (Somerset) was being received from the N.N.E. or about 60 degrees off correct direction.

L. A. Whitmill (Harrow Weald) found December 8, 9 and 10 good evenings. G3EHY, GW3EJM and the Cambridge stations were all good signals on those dates. His score of stations worked has now reached 289. A new 5-element beam is giving L.A.W. a gain of 6 dB

over his previous 3-element.

In Conclusion

This month's mail is about the smallest ever. The seasonal festivities, the early date for reports, plus conditions and activity, are certainly the causes. We are confident it is not lack of enthusiasm! Some of the Tables include names of people from whom we have not heard for months. These will be deleted in the near future. Several correspondents have been sending along the score of stations heard. It is proposed to include these in the Counties Table next month, and, in addition, to run a table showing the counties heard in 1951. The starting figure will be 10, and the All-time Table will continue to appear—so when sending in your scores in future please indicate which table they are for.

Next month's letters should be sent to reach A. A. Mawse, *Short Wave Listener & Television Review*, 53 Victoria Street, London, S.W.1, not later than January 25, and the date for the following month will be February 22. These early dates are much regretted, but are necessary if we are to appear on time.

Come to SMITH'S of EDGWARE ROAD THE FRIENDLY SHOP FOR ALL RADIO COMPONENTS

We stock everything the constructor needs—our 25 years' experience of handling radio parts and accessories enables us to select the best of the regular lines and the more useful items from the surplus market in.

Loudspeakers and Phones	Valves and CR Tubes
Transformers and Chokes	Cabinets and Cases
Meters and Test Equipment	Capacitors and Resistors
Pickups and Turntables	Coils and Formers
Switches and Dials	Plugs and Sockets
Metallwork and Bakelite	Aerials and Insulators
Books and Tools	Motors and Generators
Valve Holders and Cans	Wires and Cables
Metal Rectifiers	Panel Lights and Fuses
Sleeving, Nuts and Bolts, Tags, Clips, Grommets and all other bits and pieces	

NOTHING TOO LARGE—NOTHING TOO SMALL

Everything you need under one roof—at keenest possible prices

No general catalogue is issued owing to constantly varying stocks and prices, but we shall be pleased to quote you. Lists are available for the following lines, in which we specialise, and can thoroughly recommend:—

1. The increasingly popular "Electro-Voice" range of Transformers and Chokes, "As good as the best—yet cost little more than the cheapest."
2. The "G.L.G." 16-gauge Aluminium Chassis. "For the man who takes a pride in his rig."
3. "K-A Products" Television Aerials. "A real engineering job."

H. L. SMITH & Co. Ltd.
287/9 Edgware Rd., London, W.2

Tel. Paddington 5891 Hours 9 till 6 (Thurs. 1 o'clock)
Near Edgware Road stations, Metropolitan and Bakerloo

OPPORTUNITIES IN RADIO

Get this FREE Book!



"ENGINEERING OPPORTUNITIES" reveals how you can become technically qualified at home for a highly paid key appointment in the vast Radio and Television industry. In 176 pages of intensely interesting matter it includes full details of our up-to-the-minute home-study courses in all branches of RADIO AND TELEVISION, A.M.Brit. I.R.E., City and Guilds, Special Television, Servicing, Sound-film, Projection, Short Wave, High Frequency and General Wireless Courses.

We definitely guarantee

'NO PASS-NO FEE'

If you're earning less than £12 a week this enlightening book is for you. Write for your copy to-day. It will be sent FREE and without obligation.

BRITISH INSTITUTE OF
ENGINEERING TECHNOLOGY
926 Shakespeare House,
17-19 Stratford Place, **BIET**
London, W.1.

Starting Home Construction

PART I

NOTES FOR THE NEWCOMER

NEWCOMERS to practical radio work fall into two categories: (a) The old-timers who have newly become interested in construction but have not done anything practical since the halcyon days of the 1920's, when home construction was the vogue; and (b) Those who have had no experience whatsoever in constructional radio.

These two groups, of course, are subject to various sub-divisions, but in the main the newcomer to modern radio construction finds himself confronted with many problems. The first point to be decided is what type of material to use for, say, the projected radio receiver.

No doubt for its very cheapness, speed and ease of construction, and the minimum of working tools required, the "breadboard" will spring to mind. This type of construction, using, as the term suggests, the solid board familiar in the kitchen for pastry-making, is an inexpensive and easily available type of ready-made foundation for mounting the receiver. The term "breadboard" is a throwback to the days when wooden baseboards were, in fact, the foundation for the majority of amateur home-constructed sets.

Advantages of breadboard construction (the board can be of deal or any other sort of softwood) are that components can be screwed to the base board with ease, and the best positioning can be ascertained by trial-and-error methods. Where screening is necessary, this can be quickly fitted and, if required, removed without difficulty. One of the snags of breadboard construction is that leads normally cannot be run below the "chassis" but only along the top. But this can be overcome by nailing the board with runners, so that it is itself raised to allow leads (and small components) to be accommodated "below chassis."

Wooden sides can be added or the whole wooden structure can be built up

It is not always realised that there are many, breaking into radio construction for the first time, who have only the haziest idea as to how to set about the putting together of their own equipment. Even this article, detailed as it is, only makes the preliminary suggestions. Lest it be thought that, therefore, it must fail to be of real assistance to the beginner, let us say that the only way to learn is by personal, practical experience. And there can be no doubt that the discussion which follows does lead the beginner along the right lines.—
Editor.

in the same form as a metal chassis, thereby giving the same sub-chassis facilities. Screening can be added simply by lining with metal foil; aluminium, copper or brass foil can be used for this purpose, with copper and brass as firm favourites on account of the ease of soldering to these metals. It will be seen, then, that for would-be constructors who have limited "workshop facilities" the oft-derided breadboard construction offers interesting possibilities. It should also be borne in mind that this type of construction has everything to recommend it when it comes to experimental hook-ups and, in point of fact, commercial manufacturers frequently use a breadboard lay-out for their experimental work.

Today's Approach

But the ultimate must always be metal chassis construction. For a permanent, rigid, efficient, workmanlike job there is no doubt that the metal chassis leads the field. There are various metals which can be used equally effectively, but heavy gauge aluminium is the universal favourite, since it is very easy to work, it is light, and is easy to obtain. It has one disadvantage: Leads cannot be soldered to it, but this can be overcome without much difficulty.

Steel *can* be soldered, but it is more difficult to work, and is not such an effective RF screen. It is also much heavier. Both steel and aluminium are eminently suitable for radio chassis and cabinet construction, and the choice must be left to the personal preference of the individual. Although the decision will probably go to aluminium, it should be remembered that, though this is softer than steel, tools must still be kept sharp; blunt tools will simply tear at the metal and leave ugly reminders of carelessness in using blunt

tools. Also, aluminium is easily marked, so the newcomer is advised to work the metal carefully to avoid scratches and other blemishes.

Tool Kit

The first tools required are drills and a centre punch—the latter too often overlooked. Always use a centre punch before drilling; it makes for accuracy and saves the drill tip wandering—and components will fit into position first time without having to recourse to filing! When drilling, never put a lot of pressure on the drill—you are supposed to be cutting a hole and not pushing one through! Let the drill run easily, without pressure, and it will cut just as quickly. It will also save trying to straighten out bent drills and replacing broken ones, in addition to keeping the cutting edges keen. So, when it comes to drilling, remember not to put much pressure on the drill; hold the drill vertically and make your working position comfortable—that is, the work should not be too high nor too low, otherwise fatigue and poor work will result.

Large holes, as required for valve-holders, large condensers and so forth, can be cut by drilling a ring of small holes round the circumference (the small holes breaking into each other), then tapping the unwanted metal out and finishing off with a file. However, this only makes hard work of it and, quite often, inaccurate holes. By far the simplest and most effective method is to obtain one of the proprietary "chassis cutters" which are obtainable in various sizes to suit standard valve-holder requirements. These cutters, to suit, for instance, international octal and other sizes (though initially rather expensive) will more than pay for themselves in the saving of sweat, tears and toil!

Larger holes, such as for meters, can be cut on the ring-of-small-holes principle, but here again a more satisfactory solution presents itself. A tank-cutter should be obtained; these, in conjunction with the carpenter's brace, will enable the constructor to cut easily the large holes which are normally so much hard work. The tank cutters are adjustable. Another answer to the large hole problem is the use of a ring saw—not seen often in the radio workshop, but nevertheless very effective for such purposes.

It also happens very often that a square hole is needed. The best way of tackling these is to use a metal-cutting

fretsaw; otherwise a series of small holes, finished off with a half-round file, will do the job. And when it comes to large, uneven shapes, then the best procedure is to make slots large enough to accommodate a hacksaw blade held in a pad handle.

It is well known that a drilled hole is not perfectly round. Should, in any circumstances, a *perfectly* round hole be required, a hole slightly smaller than the finished size should be drilled and then finished off with a reamer. Sometimes it is not possible to drill a hole large enough, due to the fact that the required drill cannot be held in the drill chuck. In such cases, it is often possible to enlarge the hole by using a rat-tailed file (held in a vice) as a reamer. The file will be found to cut better if rotated in an anti-clockwise direction.

More About Holes

Two more points concerning drilling. When embarking on a programme of drilling, get in a supply of cutting oil; this will not only protect the cutting edges of the tools but will make drilling much easier. Secondly, to remove the burr from the underside of a cut hole, a simple method is to take a large drill in the hand, insert the tip in the hole and give it a few turns. The burr will come off, leaving a clean finish to the hole.

Soldering is, perhaps, one of the most common causes of trouble amongst beginners. For the ability to make a good solder joint is one of the first essentials of successful radio work, and the simple art must definitely be mastered before any serious work is undertaken. A dry or high resistance joint is all too often the cause of trouble in a set, and many hours have been spent tracing imaginary faults due to this cause.

Soldering Equipment

First of all, a good electric iron is required, and this should be of around 60 watts or so loading for radio work. The secrets of good soldering are simple enough, but need to be fully understood. Briefly, the iron bit should be kept clean at all times, the work to be soldered must be scrupulously clean, and the work and the iron should be at the right temperature.

Resin-cored solder is recommended for all radio work, but the use of flux is sometimes an aid. Should flux be used, be certain that it is of the non-corrosive type; this being particularly important when soldering fine wire. All traces of

flux should be removed immediately, as they collect dust which, in excess, can build up a high-resistance leakage path. Also, if flux is used, do not heat it by allowing the soldering iron to rest on the container, because this would cause the ingredients to split up and the flux would no longer be non-corrosive!

The two, or more, surfaces which are to be soldered should, after cleaning, be well tinned. That is to say, a fine film of solder should be run on to them. The bit of the soldering iron should also be tinned (dipped in flux and then solder run on), otherwise, with a dirty iron, it will be found impossible to keep the molten solder on it or to keep it under control when solder is being run on to the joint. It should also be remembered that a perfect solder connection is both electrically and mechanically sound; never hang two wires together and then drop solder on to it! Make a good *mechanical* joint first. Then apply the iron to the joint so as to bring the temperature of the work to the same as that of the iron. Only then should the solder be applied, and it should be applied to the iron and allowed to run on to and around the joint to be made. Keep the iron on the joint just long enough for the solder to run over the area of the joint, and then remove it—making sure that the joint is held perfectly still until the solder has had time to set fully.

When doing all this, it must be realised that solder should not be carried on the iron to the joint. If this is done. If this is done, the resin will burn before it has served its purpose and a poor joint may easily result. Resin not only helps in cleaning the surface, but it prevents oxidation. Never use too much solder and remove any surplus resin from the iron at frequent intervals—it is as well to wipe the bit with a rag after every joint so as to ensure freedom from burnt resin and other dirty residue. Observation of these simple rules will ensure good, clean and firm soldering—a soldered joint must be able to withstand considerable strain to break it, strain not normally encountered.

Layout Points

Another very important aspect of construction is in the preparation of the layout. Never rush into a job without first spending a considerable time in thinking out the layout of the components. Study the theoretical circuit and note which leads must be kept short

(*i.e.*, those carrying RF) and which components should be conveniently close to one another (such as panel controls in relation to their associated circuits). Where screening between stages is essential, such as with RF stages, BFO's, and so forth, this should also be noted.

When the above points have been studied, the larger components (*i.e.*, tuning gangs, valves (and transformers) can be placed on the chassis and moved around until the best positions are obtained. This process, known as "playing chess," will enable the best arrangement, with regard to appearance and electrical efficiency, to be obtained. Should long leads be necessary where they should theoretically be short to obtain a uniform layout, then sacrifice the appearance—electrical efficiency is the main consideration every time. It cannot be over-stressed how important layout is; it can make or mar the performance of a set. So, any time devoted to preliminary moving around of the parts is time well spent. And always remember that all circuit diagrams are drawn in such a way as to suggest the best layout.

(To be continued)

VALVES

**Guaranteed New and Boxed
Mostly Original Cartons**

5Z4M, 5U4G, 6F6, 6J7, 6X5, 6C5, AC6PEN, 7Q7, 807, 6AC7, 5Y4, EBC33, EF39, 1C5, EF36, EC52, EL32, EK32. ALL AT 6/- EACH.

80, EFS, H63, 25A6G, 25L6G, EF50, 41, 42, 6C6, 6D6
ALL AT 7/- EACH.

1S5, 1S4, 1R5, 1T4, 3S4, MS/PEN, U18,
ALL AT 7/6 EACH.

6V6G	6/6	954	3/-	9D2	5/-
6V6GT	6/6	955	3/-	SYLVANIA	
6K7	5/6	956	3/-	EF50	8/-
6K7GT	5/6	6SK7	5/6	6L6	9/-
DDL4	4/6	VR54	3/6	PEN46	8/-
CV6	1/9	VR137	5/3	VU111	4/6
6J5	4/-	37	4/9	SP61	3/6
KT66	10/6	KT33C	10/-	SP41	2/6
				6R8	9/6

Send for Component List, C.O.D. or C.W.O.
Carriage Paid over £1 Post Orders Only

ALPHA RADIO SUPPLY CO.
5/6 VINCE'S CHAS., VICTORIA SQUARE,
LEEDS, 1

TV Questions and Answers

DISTORTED RASTER

I am experiencing trapezium distortion which I thought only occurred with electrostatic tubes. Can you suggest the cause?—

G.B. (London, W.3.)

Trapezium distortion is, as you say, mainly confined to receivers using electrostatic deflection. It is due to unbalance in the push-pull deflection amplifiers—often because of a failing amplifier valve. However, although rare, this effect is occasionally experienced with magnetic deflection and the cause can be traced almost without fail to a short circuit or to shorting turns on one of the pairs of deflection coils. Amplitude of scan will also be affected, depending on the exact nature of the short circuit.

POOR INTERLACE

It is difficult to get good interlace on my television (home constructed) and I would be pleased to have your comments.

G.R.G. (Wembley, Middx.)

Poor interlacing is probably the most common defect in TV receivers—including commercial models! Where the trouble is severe, the lines will pair off and sometimes the raster develops a ragged edge.

It usually occurs because of interaction between time bases, normally due to line pulses filtering into the frame time base. In this way, the frame scan generator is triggered at the beginning of each scan and the second frame of lines will be superimposed on the first frame, or will lie close, thus producing "pairing." Commercial receivers often use a suppressor valve to prevent this.

In practice, careful adjustment of the frame hold control will often effect a

cure, as will a mutual adjustment of the contrast control. Loss of interlace can also be due to the presence of hum on either of the time bases, and therefore all decoupling components should be checked and, if necessary, the decoupling improved. Layout can also be the root cause, as stray couplings between the two time bases can throw interlace out—or cause it to be erratic. And it must be remembered that a faulty component in the sync separator stage (especially in the differentiator and integrator networks) is often sufficient to produce the trouble under discussion.

The most satisfactory method of tracing the cause is undoubtedly by the use of an oscilloscope; indeed, it is the only really effective way if it is found that adjustment of the frame hold control has no effect whatsoever. In this case, the frame time base should be rendered temporarily inoperative so that the 'scope can be run over the stage to ascertain at which point the interfering line pulses appear.

Occasionally small things, seemingly unconnected with interlacing, are found to be causing the trouble, and it has been known for a coiled-up feeder (or one which is bent back sharply) completely to upset the interlace.

PREFAB PROBLEM

Becoming interested in television and anxious to build a receiver, I would like your advice concerning the possibility of trouble, as I live in an aluminium prefab.

H.T. (Coventry)

Since dwellings such as yours are completely encased in metal, and earthed, an indoor aerial is completely ruled out. However, no troubles should be encountered if a good outdoor system—erected as high as possible—can be provided. The effect of your own and the neighbouring metal buildings will be to raise the effective "earth" level by a certain amount, and thus you should make sure that your aerial is given as much height as possible—certainly enough to clear your own roof.

TOP BAND TRANS-ATLANTIC TESTS

We would draw the particular attention of all readers interested in DX reception on the LF bands to the *Short Wave Magazine* Trans-Atlantic Tests taking place very shortly on 1.7 mc. Details are given by the DX Scribe in this month's "Have You Heard?" and have

also been covered in recent issues of *Short Wave Magazine*. SWL observations on these Tests will be of considerable value, and we are confident that some extremely interesting things will happen. The whole project is organised as a Test and *not* a Contest.

WORLD WIDE RECEPTION OF SHORT WAVE PROGRAMMES

DX *broadcast*

MONTHLY COMMENT BY R. H. GREENLAND, B.Sc.

THERE is little news from correspondents concerning short wave radio in Australia, but we have found a few tit-bits during our daylight peregrinations.

Outside the island continent, Radio Noumea in New Caledonia is reported to have been testing with transmissions beamed to Paris on 15180 kc at 0700 and on 11750 kc at 0900. P. Fry (Chandlers Ford, Hants) has logged Radio Australia's Pacific Service between 1230 and 1400 on Sundays with "Pacific Mail-Bag" and "Amateur (Talent) Hour" over VLA6, 15200 kc and VLB4, 11850 kc.

Our biggest scoop was VLX, Perth, Western Australia, on 4898 kc with the ABC News at 1500 on November 26; there followed a weather and shipping report, the playing of Tschaikevsky's Barcarolle in B flat and other music, and, at 1528, a reference to the various regional stations carrying the programme. The final announcement ran: "We shall be on the air again at 7 o'clock tomorrow morning. Your announcer has been ———. Good-night, Everybody," and "God Save the King" terminated the proceedings. A week later, VLX was heard again with dance-recordings around 1530; two minutes later the announcer said: "Now it is 28 minutes to twelve."

VLQ3, Queensland, 9660 kc, has been logged at 1315 with the announcement: "Here is the State News," and VLH3, 9580 kc, and VLG10, 11760 kc, have been heard at the same time giving News for the North-West and "Evening Meditation" at 1325.

For the First Test Match at Brisbane we were just able to identify VLB5, 21540 kc, at 0710, but Radio Ceylon, carrying the broadcast on 17730 kc and 21620 kc after 0730 was a decided improvement.

C. P. Turner (Crewe) has received a verification for VLA8, 11760 kc—altogether, he has ten Australian stations confirmed!

Africa

J. C. Catch (South Shields), in advising us that Capt Town has made a slight adjustment in frequency to 5892 kc, says that there is improved reception on the new channel, particularly around 1915. He also spotted Nova Lisboa, Angola, 11924 kc, with popular recordings at 1745; after announcements by a female, the station closed at 1800 with "A Portuguesa." M. Milne (South Woodford, E.18) has heard CR7BE, Radio Clube de Mozambique, 9715 kc, occasionally, around 1700, with interference from GWY on 9700 kc. F. Pilkington (Littleport, Cambs.) noted CR7BU, 4925 kc at 1550 with English News; after the "Young Derby Show" (sponsored) the following direction was heard at 1900: "Lourenco Marques for happy listening in the 42 and 60-metre bands."

J. A. Bagley (Houghton-le-Spring, Co. Durham) has logged the elusive Salisbury, Southern Rhodesia, transmitter on 3320 kc with a relay of BBC News from London at 1800. ZNB, Mafeking, Bechuanaland, 8230 kc, was stronger than usual with the singing of "Old Folks At Home" at 1925 on December 6, and at 1930 came the English announcement: "That ends our programme and we are now closing down"; the National Anthem brought the proceedings to a close. This same station was heard by F. Pilkington with an S8 signal at 1800 on December 9; he writes: "Programmes seem to consist solely of records of popular music."

FIQA, Madagascar, on 9515 kc, was our choice at 1600 on December 9, when, after the clear direction: "Ici Radio Tananarive" and a March, came the

SPECIMEN REPORT AND LETTER IN THE FRENCH LANGUAGE

Model Letter for despatch to French-speaking Stations

Address.
Date in Figures.

The Director,
Monsieur Le Directeur,

Radio Station :
Poste Emetteur
Radio

Town.
Country.

Dear Sir,
Monsieur,

I have been listening to (or I have just heard) the Broadcast from Radio
J'ai entendu (or *Je viens d'entendre*) l'émission de la

Station with the Call-Sign on the
radiodiffusion de Radio, *poste émetteur avec l'indicatif de* sur la
frequency of kc./second.
fréquence de kc./seconde.

The time was from GMT until GMT, on (date).
L'heure était depuis GMT *jusqu'à* GMT, le

My Radio Receiver is a "....." (.....valves), with loud-
Mon poste de réception est un (..... *Lampes*), avec
speaker.
haut-parleur.

Your Signal was QRK..... S.....here.
Votre signal était QSA S..... *chez moi.*

Speech was quite clear.
Les mots étaient très distincts.

I heard musical items atGMT; then at.....
J'ai entendu des morceaux de musique àGMT; *alors à*

.....GMT, the reading of the news in French (or in the English Language).
.....GMT, *la lecture des nouvelles dans la langue française* (or

Finally, the frequency was given (e.g. 12080 kilo-
la langue anglaise). Enfin, on a indiqué la fréquence (e.g. *douze*
cycles per second), and in conclusion, I heard "The Marseillaise."
mille, quatre-vingt kc/sec), et pour terminer, *j'ai entendu "La*
Marseillaise."

Allow me, Sir, to thank you for a most enjoyable hour (or half-hour).
Permettez-moi, Monsieur, de vous remercier d'une heure (or *demi-heure*) *très agréable.*

I would very much like to have a verification of these details, and I trust
Je voudrais bien savoir si ces détails sont exacts, et j'espère avoir
that you will be so kind as to reply to this letter.
le plaisir de recevoir une réponse à cette lettre.

I have the honour to be, Sir, yours very truly,
Agréez, Monsieur, l'expression de mes sentiments les plus cordiaux,

(Signature).

reading of the News (in French); the station was audible first with dance music, followed by a play until after 1730, and it has both male and female announcers. In the equatorial island of Sao Tomé, CR5SC, Radio Clube de Sao Tomé e Principe, on 4807 kc, has been heard after 2015 with musical items, and closing at 2100 with Portuguese directions and National Air. According to *Australian DX'ers*, Radio Douala, French Cameroons, is now using 1 kW on 7287 kc and closes down at 2000; we confirmed this on November 26, when a programme of dance music was followed at 2000 by French announcements and the playing of La Marseillaise.

R. J. Pryde (Woolwich, S.E.18) has been listening to OTC2, 9767 kc, the International Goodwill Station, Léopoldville, in the Belgian Congo, which, he says, has been consistently good, at least until 2150.

FZI, Brazzaville, French Equatorial Africa, has a Mail Bag on Sundays from 1815 until 1830 over 11970 kc.

ZOY, Radio Accra, 4915 kc, was a notable signal on December 13, when, at 1715, we heard a broadcast of historic significance; it was a recorded edition of the proceedings earlier that day at the final meeting of the Gold Coast Legislative Council, which will soon be superseded by an elected House of Assembly. We heard H.E. The Governor, Sir Charles Arden Clarke, bidding the Council farewell, and the voice of the President paying tribute to the work of Sir Charles in his dealings with the Council. F. Pilkington has noted ZOY with the News at 1745 and closing at 1800 with the announcement: "You have been listening to a programme from Accra," and "God Save The King"; and he has found the lately elusive VQGI, Kenya, 4885 kc, with the direction: "This is Nairobi Calling" at 1823, followed by a BBC play, entitled: "Uncle Percy."

The Sudan Broadcasting Service's English broadcast has been logged regularly on Fridays at 1730. There have been talks by the Sudan Commissioner of Labour, and more recently by the Registrar-General, who spoke about "The Town Replanning Ordinance." M. Milne says that Radio Algiers, 9570 kc, has been putting over a good signal of late and particularly with a programme of Cowboy Songs on Sundays at 1820, the frequent direction being: "Ici Radio Algerie." French Morocco has sent J. C. Catch a letter of verification

with the address: Radio Maroc, Services Techniques, 15 Avenue du Congo, Rabat. The schedule for CNR3 is: 6006 kc (2.5 kW): 0700-0830 (Arabic), 1200-1230 (Spanish), 1230-1258 (Arabic), 1258-1430 (French), 1800-1900 (Spanish), 1900-1958 (Arabic), 1958-2300 (French); 7214 kc (50 kW): 1300-1400 (French).

If you listen at 1329 on 15048 kc you will hear the direction: "This is Tangier Calling"; after half-hour chimes at 1330 the final announcement is: "This is the American Radio at Tangier now closing down." Finally, J. A. Bagley has heard CSA93, Ponta Delgada, Azores, 4850 kc, with its final evening session at 2240.

Asia

Dr. T. B. Williamson (Benghazi) is lucky enough to be hearing the Japanese JKI, Nazaki, 4910 kc, at good strength from 2000 most days; and he has logged daily transmissions (except Sundays) on 6240 kc, with programmes of the Oriental type, from 1400 to 1515 and from 0200 until 0500. There has been definite mention of Thailand but no English programme, and he suggests this might be the Bangkok "Home Service." This is probably quite correct, for the reason that Thailand does not appear to occupy the air on Sundays.

T.B.W. also heard Radio Malaya on 6025 kc from Kuala Lumpur, with News in English at 1400. J. C. Catch has been attempting to identify a station heard at 2310 on 9733 kc with a broadcast in the Chinese language. This is, without a doubt, Nanking (supposed to be on 9730 kc), and it carries the same programme as Peking (Domestic Service) on 10260 kc. J.C.C. also heard Khabarovsk in the Far Eastern Region of the USSR—on November 18 at 2120 with a Russian talk, and on November 19 at 1415 with Folk Music—the frequency is 5940 kc.

Saigon is again in the picture! Both J. South (Bournemouth) and J. C. Catch forward its latest English schedules: 9524 kc: 2230-2300, News and music; 0030-0100, Music and News; 11830 kc: 0915-1015, Talk, music and News; 117880 kc: 1300-1510, News (1400) and music. Other frequencies in use, but not for English broadcasts, are 6116 kc and 6165 kc. We listened to the 11780 kc News at 1400 on November 25, when we were told of fog delaying main-line expresses on railways in Great Britain! On 9524 kc, following the call: "Radio France-Asie" at 1400, there was a

French broadcast which concluded with La Marseillaise at 1600.

F. Pilkington reports YDE, 11770 kc, and YDC, 15150 kc, heard at 1530 with the information: "This is the Voice of Indonesia on 15.15, 11.77 and 4.91 mc per second"; the programme: "Jute Box Sunday Night" was then introduced by the playing of the signature tune: "Beyond The Blue Horizon." The Voice of America from Manila on 6120 kc was heard by D. W. Waddell (Hitchin, Herts) with News in English at 1400, and DZH5, "The Station Of The Stars" in Manila, 9690 kc, was only a weak signal with a swing music session when Capt. T. B. Williamson tuned to it at 0400. T.B.W. noted the commercial service from Radio Ceylon on 11975 kc at 1405 and on 7190 kc at 1500. J. C. Catch has a letter from this station, confirming reception both on 11771 kc and on 11900 kc. A religious programme, entitled "The Voice of Prophecy," is well received here on Sundays at 1600, and interested listeners are asked to write to: Box 17, Poona 1, India.

From India itself, P. Fry noted an English programme from VUD3, 11760 kc at 1000, and a broadcast to Indonesia with English recordings over VUD7, 9620 kc, as late as 2245. We logged the Second Unofficial Test Match commentary from Bombay (with India 23 for five wickets at 0640 on December 1) over VUD10, 17780 kc; VUD11, 15190 kc; VUD9, 15290 kc; and VUD3, 11760 kc. VUM2, Madras, 4920 kc, gave News in English at 1530 (J. C. Catch), and on 7260 kc, at 0200, VUM2 was logged with station direction (T. B. Williamson); we hear Srinagar, Kashmir, 4865 kc, with English News at 1531. In Pakistan, the 17770 kc transmission was logged with English News at 0710, and Dr. Williamson hears a similar News at 1530 frequently over APD, Dacca, on 7140 kc.

R. A. Savill (Sevenoaks, Kent) has been getting RAD, Tashkent, 6825 kc, with English News, mainly of Asiatic interest, read by a woman at 1615; he also logged Ashkhabad, 6180 kc with an S7 signal at 0300.

In Iran, EPP, Teheran, 3930 kc, is heard by Dr. Williamson from 1600 to 1900 with a Persian programme, though Western music is also included. J. South has a letter verification from Teheran mentioning the following transmitters: EQB, 6155 kc (Mornings and Evenings); EQC, 9680 kc (Mid-day); EPB, 15100 kc (Evenings and for

foreign broadcasts); EQD, 4830 kc, and EQE, 3333 kc, are not at present in use.

A. C. McElhinney (Warrington) has been requested by the World Zionist Organisation in Jerusalem to furnish reports on their *new* experimental transmissions on 6830 kc, presumably between 2200 and 2245; we listened at 2225 on December 18 with the following results 6830 kc—S9 plus 6 dB: 9000 kc—S9 plus 12 dB. A. C. McE. suggests that other readers may like to send in reports on the 6830 kc transmitter, for which the address is: The Voice of Israel, World Zionist Organisation, Jerusalem. J. A. Bagley gives Kol-Israel, 9000 kc, as S8 at 2000; P. Fry hears them at S9 at 2230; and D. W. Waddell forwards their daily schedule, which is: 2015-2025 (English), 2030-2115 (Yiddish), 2115-2200 (French), 2200-2245 (English). We ourselves recently logged 4X4EA, Tel-Aviv, 6725 kc, with lady announcer at 1930; this Jewish Forces broadcasting station had a programme of swing music including the Balalaika at 1954. At 2000 he heard an announcement which included the words, "Lilah Doh," after which a single bugle signalled: "Lights Out."

Dr. Williamson hears Baghdad, Iraq, on 7092 kc with all-Arabic programmes around 1700-1900; at 1800 it announces as: "Hoona Baghdad," has an interminable series of Oriental vocal musical items which are called "monologues," and at 1900 there are clock chimes for 10 p.m.

Radio Ankara, Turkey, was heard by Cpl. W. G. Gore (Yatesbury, Wilts) over TAS, 7285 kc, with English News at 2100; and R. J. Pryde spotted TAP, 9465 kc, at 2130 with a talk in English entitled: "The Turkish National Library." Australian DX'ers say that TAV, 17840 kc, and TAQ, 15190 kc, are on the air daily from 1000 onwards for the service of Turkish Forces operating in Korea. Tests will shortly be made with: TAN, 6000 kc; TAM, 7240 kc; TAK, 11760 kc; TAD, 17720 kc; TAS, 7285 kc; TAT, 9515 kc; TAO, 11880 kc; TAU, 15160 kc; TAV, 17840 kc; and TAX, 21600 kc.

North and Central America

ONL, Godthaab, Greenland, 5944 kc, was logged with News in Danish at 2130 on November 18 by J. C. Catch; when we heard this one on December 18, the Danish News was in progress at 2200.

In Canada, CKCS, 15320 kc, presented "Canadian Chronicle" at 1715 (W. G. Gore); CJCX, 6010 kc, was clear

at 2315 (D. W. Waddell); and CHNX, 6130 kc, gave identification at 2300 as: "This is CHNX, the short wave station of the Maritime Broadcasting Company." (P. Fry).

B. Mercer (Hulme, Manchester) has again heard Bridgetown, Barbados, on 7547 kc, this time on November 25, at 2110, with a running commentary on a football match between Barbados and Trinidad. J. A. Bagley logged it once at 2120 with a Racing commentary; the station is ZNX₃₂.

B. Mercer would also like to know if ZIK₂, Belize, British Honduras, still operates on 10598 kc. Undoubtedly it does, but as the schedule is 1500-1745 and the power only 200 watts, there is little likelihood of its being logged here. Radio Jamaica, now commercialised, operates on 4950 kc and 3480 kc, and is on the air 1130-0400 Week-days and 1215-0400 Sundays. R. A. Savill considers VP4RD, Radio Trinidad, 9625 kc, to have been the pick of the month; he hears the News at 2345, the Bing Crosby Show at 0045, and a Sports Session at 0100.

J. C. Catch spotted TGWA, Guatemala City, 15170 kc, with marimba band at 1415 (S7); in Costa Rica, TIFC, The Lighthouse of The Caribbean, 9645 kc, operates daily from 2100 to 0500; English sessions are: Sundays: 2100-2200; Mondays: 0400-0500; Other Days: 0430-0500.

The remaining items here are from Capt. Williamson. TIPG, San José, 9618 kc, is a very strong signal after 0001; at 0200 they offer a good musical programme entitled: "La Sala de la Concierto del Aire" (Concert room of the Air!). HRA, 5940 kc, has been logged with the following call at 0020: "Esta es HIRA, La Voz de Lempura en Tegucigalpa, capital de la Republica de Honduras, Centro America"; and HRQ, 6125 kc, is consistent and identifiable by the direction: "Transmite de los estudios HRQ, Radio Suyapa en San Pedro Sula." T.G.W. once heard YSI, Radio Inter-Continental, San Salvador, on 7043 kc, with Latin-American rhythm at 0300.

PJCT, Willemstad, Curaçao, 5010 kc, increases in readability from 0130 until 0300, when it closes with the words: "Guden nachten en wel te resten" and the Dutch National Anthem. HIT, Trujillo, Dominican Republic, is now heard on 5005 kc with "Musica de Colombia" at 0001.

South America

CE920, Punta Arenas, 9197 kc, has been noted by R. R. Savill to be remarkably free from QRM at 0130; it closes down at 0300. J. C. Catch offers ZPA5, Encarnacion, 11948 kc, with a call for ZPA5 and Radio Belgrano, Argentina, at 2200, followed by a five minutes' new cast in Spanish; HJCX, Bogota, 6019 kc, at 0015 with direction: "La Voz de Colombia," followed by chimes; and HCJB, Quito, which was 7 kc higher than its official frequency of 12455 kc. J.C.C. mentions ZFY, Georgetown, British Guiana, 5980 kc, with good signals after 0001; P. Fry says they have been putting out a really fine signal for the BBC News and programme preview at 2300. He also logged Argentina on 11880 kc at 2030, this being LRA (formerly LRS): R. J. Pryde logged the 9450 kc transmission at 2213 with a News Summary in English, and C. P. Turner heard LRA on 9690 kc at 0430 with the English broadcast directed to North America. We understand that the call-letters LRA are now assigned to all frequencies carrying the overseas service of SRI, and that news in English is given at 0005, 0150, 0205, 0350, 0400 and 0445 daily, with a Mail Bag on Mondays at 0345, all on 9690 kc.

In Brazil, PRE9, 6105 kc, was logged by P. Fry at 2100; ZYK₂, 6085 kc, by J. C. Catch with the feature: "Perambuco Speaks To The World" at 0025; and PRL₇, 9720 kc, by R. A. Savill at 2100. We found ZYB₈, 11765 kc, with two deep-sounding gong notes before the call, which was followed by the slogan, "Radio Sport," at 2150; and on successive Sundays at 2030 we have heard ZYK₃, 9565 kc, with its weekly English feature: "Brazil Calling The World." J. C. Catch says that ZYS₈, 4805 kc, at Manaus in the heart of the Amazon forests, has been prominent in the evenings of late, and Dr. T. B. Williamson tells us that OAN_{4Z}, Lima, 5900 kc, is now styling itself as "Radio Nacional del Peru—La prima emisora del pais" (the leading broadcaster in the country!). T.B.W. also listened to 86-metre Venezuelan stations between 2300 and 0200 on November 12. They were: YVOG, YVQL, YVMU, YVMI, YVQN, YVKP, YVMK, YVOE, YVMC, YVQI, YVLD, YVKX, YVKT, YVOC and YVQA; quite a good bag! J. A. Bagley heard YVMG, 4810 kc, with trumpet music and slogan: "Radio Populares" at 2340 on November 6.

SMALL ADVERTISEMENTS

CHARGES: Readers', 2d. per word, minimum charge 3s. Box Nos. 1s. 6d. extra. Trade, 6d. per word, minimum charge 7s. All advertisements must be of radio interest only. Add 25% extra for Bold Face (heavy type) announcements. Copy date for next issue, February 2, addressed Advertisement Manager, Short Wave Listener, 53 Victoria Street, London, S.W.1.

COLLINS Communications Receiver, 1.5 to 12 mc, complete AC power pack and speaker. New condition. £7/10/0 or exchange. Stead, 214 Windleshaw Road, St. Helens, Lancs.

RX1116A 7 valve Battery Superhet, 12—2000 metres. £8, as new. Evans, Tyddyn Valley, Llanddoget, Llanrwst, Denbighshire, N. Wales.

R.1116, 8v battery receiver, 200 kc to 20 mc. Working, but needing re-alignment, £3/10/0. Carriage Paid. Cowley, Flat 3, 37 St. Mary's Street, Ely, Cambs.

WANTED, R208, R107, BC342 or BC348. Consider receivers needing attention if complete. Sale R.1294 500/3000 Mc; R1155A, internal P P, cheap. Exchanges/Others: Box: 040.

FOR Sale. 1224A with eliminator and accumulator, also MK18 receiver in cabinet, and receiver Type 21, 9 valves, not working. £5/10/0 the lot. Box: 876.

MATCHBOX Radio. With the aid of our full instructions you can build a complete radio set in a matchbox, using parts purchased from your radio dealer. Demodulation is achieved by the use of a new type of non-linear impedance unit, and tuning covers the B.B.C. programmes (long and medium waves). Full instructions, working drawings, and theoretical circuit diagram, price 3/- post free. Swift Radio (L), 137 Cotham Brow, Bristol 6. Mail Order Only.

MORSE teaching records; complete course of 10—10ins., £3. Educational Records Dept., Radiovision Services, Rawdon, Leeds.

EDDYSTONE 740 Communication Receiver, new. £26 for quick sale. Box No. 874.

QSL cards. Neat, attractive, at reasonable prices. Samples. Lovedee, BRS15643, Mill Street, Barwell, Leicester.

PRESELECTOR wanted, exchange for M.C.R.I. P Coils, phones, power-pack, as new. Jones, 85 Weald Square, Clapton, E.5.

Europe

E. Kirby (Chapel Allerton, Leeds) is a newcomer to these pages, and so far has logged only European broadcasting stations, and there are plenty! At 1450 on December 10, over SDB2, 10780 kc, King Gustav VI of Sweden was heard from the Concert House, Stockholm, presenting their Nobel prizes to Lord Bertrand Russell, Professor C. F. Powell, of the University of Bristol, and others.

P. Waddell offers Radio Andorra, 5990 kc, which is on the air every evening from 1800 to 2400, and Warsaw with its latest English schedule: 1730-1800 over 6220 kc; 1745-1815 over 6115 kc; 1900-1925 over 6220 kc; and 2100-2130 over 7205 kc. R. A. Savill has received a card from Bucharest which broadcasts over 5990 kc, 6210 kc, 9250 kc and 11900 kc; C. P. Turner also has a card giving their English schedule as 2000-2030 over 6210 kc. On December 17 we heard a broadcast in French terminating at 2000 with the direction: "Ici Romanie Libre" on a frequency of 5935 kc. R.A.S. also received a card from BDN, Salzburg, 9617 kc, which broadcasts the United States AFRS programmes; and he finds

that Radio Italiana has settled on 6230 kc.

W. G. Gore listens to the English lessons from Paris each evening at 1845 over 6200 kc and 6145 kc; and J. C. Catch has found Emissora Nacional, Lisbon, on a new channel of 15384 kc, closing at 1645 daily. R. J. Pryde has obtained from the Swiss Short Wave Service a verification card and a delightfully illustrated booklet, whilst P. Fry comments on the S9 signal from Vatican City for its English News at 1500 over 11740 kc. P. Fry hears FBS, Malta, at 1945 on 6015 kc and 7220 kc.

Finally, F. Pilkington offers some medium-wave DX. He has heard: Radio International, Tangier, on 1232 kc, closing at 2400; MELF, Malta, 1484 kc, at 1910; Trieste, 1367 kc.

We hope to bring you something new each month, so please remember to send in your short wave information—it may be a headline!

The address is: R. H. Greenland, *Short Wave Listener and Television Review*, 53 Victoria Street, London, S.W.1.

And letters should reach us by March 15 at the latest.

SHORT WAVE BROADCAST STATIONS

Revision 25.20-30.74 Metres

Giving Frequency, Wavelength, Callsign and Location

These lists appear each month, covering the 11-128 metre section of the wave band within which all short wave broadcasting services of the world operate. For economy of space, this band is dealt with in five sections, a list of active stations in one of the sections being given in full every month. Such revision is necessary due to constant changes of frequency, callsign and operating schedules. All stations appearing in our lists are normally receivable in this country and are under regular observation.

Fre- quency	Wave- Length	Callsign	Location	Fre- quency	Wave- Length	Callsign	Location
11905	25.20		Rome, Italy	11760	25.51	CKRA	Sackville, Canada
11900	25.21	KW1D1	San Francisco			VUD7	Delhi
		CXA10	Montevideo			OLR4B	Prague
		CE1190	Valdivia, Chile			VLA8	Shepparton, Australia
		OQ2AB	Elizabethville			VLB3	Shepparton
		RTF	Moscow				Athlone, Eire
11895	25.22		Dakar, Senegal				Moscow
			Malta	11750	25.53	GSD	London
11890	25.23	WRCA3	New York	11740	25.55	HVJ	Vatican City
			Manila, P.I.			CE1174	Santiago, Chile
11885	25.24	APK3	Karachi, Pakistan			COCY	Havana, Cuba
			Paris			RW120	Moscow
			Moscow	11735	25.56	LKQ	Oslo, Norway
11880	25.25	LRA	Buenos Aires	11730	25.58	PHI	Hilversum, Holland
		VLH4	Melbourne			KGE12	San Francisco
		XEHH	Mexico City			CE1173	Santiago, Chile
			Singapore	11720	25.60	CHOL	Sackville
11875	25.26	RW111	Moscow			CKRX	Winnipeg
11870	25.27	WBOS1	Boston, Mass.			ZJM7	Limasol, Cyprus
			Munich			PRL8	Rio de Janeiro
11865	25.28	HER5	Berne			HSP5	Bangkok, Siam
11860	25.30	GSE	London				Moscow
		KW1D2	San Francisco	11715	25.61	HE15	Berne, Switzerland
11855	25.31	DZH8	Manila, P.I.	11710	25.62	WRU12	Boston, Mass
11850	25.32	LJK	Oslo, Norway			WLW05	Cincinnati, Ohio
		VUD11	Delhi			WLW03	Cincinnati
		CE1185	Santiago, Chile			VUD7	Delhi
		VLA4	Shepparton			VLG3	Lyndhurst
		ZPA3	Asuncion, Paraguay			KW104	Moscow
			Djeddah, S. Arabia				Johannesburg
11847	25.32	WGE02	Schenectady	11705	25.63	SBP	Stockholm, Sweden
11845	25.33		Karachi	11700	25.64	GVW	London
			Paris				Paris
11840	25.34	OLR4A	Prague	11697	25.65	HP5A	Panama City
		LRT	Tucuman	11680	25.68	GRG	London
			Moscow			HJCQ	Bogota, Colombia
11835	25.35	CXA19	Montevideo	11640	25.76	OTH	Leopoldville
			Algiers	11630	25.79	RW91	Moscow
11830	25.36	WGE02	Schenectady	11570	25.93		Karachi, Pakistan
		VUD4	Delhi	11094	27.04	CSA92	Ponta Delgada, Azores
		RW86	Moscow	11084	27.06	YDQ3	Makassar, Celebes
		WABC1	New York	11035	27.19	CR6KA	Luanda, Angola
		VUD7	Delhi	11027	27.20	CSA29	Lisbon
		FZS4	Saigon, Indo-China	10970	27.35	PZR	Paramaribo, D. Guiana
		VLW3	Perth, W. Australia	10780	27.83	SDB2	Stockholm, Sweden
11822	25.38	XE1R	Hermosillo	10615	28.26		Tananarive
11820	25.38	GSN	London	10598	28.30	ZIK2	Belize, B. Honduras
			Moscow	10220	29.35	PSH	Rio de Janeiro
11810	25.40	KCBR3	Los Angeles, Cal.	10205	29.40	4VRW	Port-au-Prince, Haiti
		VLC4	Shepparton	10080	29.76	YVKC	Caracas, Venezuela
		ZL3	Wellington, N.Z.	10055	29.84	SUV	Cairo, Egypt
			Rome	9987	30.04		Brazzaville, F.E.A.
11800	25.42	GWH	London	9958	30.12	HCJB	Quito, Ecuador
		COBH	Havana, Cuba	9915	30.26	GRU	London
		BED4	Taipei, Formosa	9890	30.33	HJAP	Cartagena, Colombia
11795	25.44	VUD5	Delhi	9885	30.35	4VEH	Cap-Haitien, Haiti
		VUD9	Delhi	9880	30.36		Moscow
11790	25.45	KRCA2	San Francisco	9870	30.40	HC4NN	Manta, Ecuador
		WRU11	Boston, Mass.				Johannesburg
		VUD3	Delhi	9833	30.51	COBL	Havana, Cuba
			Honolulu, Hawaii				Budapest, Hungary
11785	25.46	YDF2	Djakarta, Indonesia	9825	30.53	GRH	London
		CS5SA	Sao Tome	9815	30.57	OAX5C	Ica, Peru
			Vienna	9810	30.58	CR7BE	Lourenco Marques
11780	25.47	ZL3	Wellington, N.Z.	9800	30.61		Moscow
		HP5G	Panama City	9790	30.64	HSP3	Bangkok, Siam
		RW96	Moscow				Moscow
11770	25.49	WRCA2	New York	9785	30.65		Monte Carlo, Monaco
		YDE	Djakarta	9780	30.67		Moscow
		GVU	London	9770	30.71	PRL4	Rio de Janeiro
11765	25.20	ZYB8	Sao Paulo, Brazil	9767	30.71	OTC2	Leopoldville, B. Congo
			Lourenco Marques	9760	30.74	TGWA	Guatemala City

CLYDESDALE

Bargains in Ex-Services Radio and Electronic Equipment

R.C.A. TRANSMITTER ET-4336

for CW or RT (Phone) operation at an approx. input of 1 KW at "full power" or 100 W. at reduced power.

Complete in every detail with valves (2X813, 2X805, 3X807, 4X866,) speech amplifier (4X6J7, 2X6L6, 1X5U4) Key, Microphone and both types of osc., etc. ! Ready for immediate operation.

Clydesdale Price only

£120

Carriage Paid G.B.

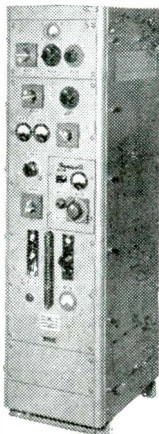

TELEVISION CONSTRUCTORS

Indicator Type 62	£3 7 6
Indicator Type 6H	£3 19 6
R1355 IF/VIDEO Ampl.	£3 7 6
R3515 IF/AF/Ampl. Unit	£3 7 6
12.25 Mc/s I.F. Strip (Valves)	£2 2 0
12.25 Mc/s I.F. Strip (less Valves)	17 6
R.F. 24 (& R.F. 25) Unit	12 6
VCR 97 6-inch Elect. CRT	£1 15 0
3BP1, 3-inch Elect. CRT	£1 2 6

RADIO CONSTRUCTOR

Walnut Wooden Cabinets	£1 5 0
Glass Dials for Above	1 3
Control Knobs Ivory 9d., Brown 8d.	
W/Change Switch 2W. 3P. 4W.	4 6
.00035 Mfd. 2-Gang Tuner	7 6
Loudspeaker 8-inch P.M.	17 6

MISCELLANEOUS

Ex-Canadian Supply Unit Rect.	£16 0 0
P.40 VHF Superhet Receiver	£3 19 6
W.S.-18 Receiver Unit	17 6
ZA-24238 Mine Detector	£5 19 6

Order direct from —

Phone SOUTH 2706-9

CLYDESDALE SUPPLY CO. LTD • 2 BRIDGE STREET GLASGOW G.5

VISIT OUR BRANCHES IN SCOTLAND, ENGLAND AND NORTHERN IRELAND

Have you got The Radio Amateur Call Book?



If you are an active operator on the amateur bands, one of your most pressing needs is a directory of Amateur Radio stations, available for constant reference.

THE RADIO AMATEUR CALL BOOK is this directory, and the only one of its kind. But the CALL BOOK does much more than list amateur stations throughout the world, alphabetically by callsign (for this alone it is worth every penny)—it gives you the Continental area in which each country is included, and the Zone listing of that country. The CALL BOOK also shows the QSL Bureau address for every country. The CALL BOOK also shows many countries of the world are divided for radio purposes, and provides time-conversion charts based on GMT; it also lists the Q-Code, the international language of radio, as used by amateurs all over the world.

The layout and arrangement of the CALL BOOK are such that all this vital information can be obtained in a matter of seconds, whether it is the name and address of an amateur in Tibet or the QSL Bureau for Paraguay.

The RADIO AMATEUR CALL BOOK is a large volume of nearly 400 pages, published four times a year: Spring, Summer, Autumn and Winter. The callsign lists and addresses are under constant revision and each issue is right up-to-date, with hundreds of new callsigns and changes of address.

Winter 1950-51 Issue available from Stock

Prices: Single copy, 16s. (post 10d.)—or for any two issues to choice, 29s.
—or for a year of four quarterly issues, delivered on publication, 53s. 6d.

GAGE & POLLARD, Publishers' Agents

49 VICTORIA STREET, LONDON, S.W.1

ABBey 5342

AMERICAN PUBLICATIONS



RADIO HANDBOOK

Eleventh Edition, 1949. Theory with emphasis on Amateur Radio. 25s. Post 1s. 2d. Twelfth Edition, 1950. Practical and Constructional Material only (see previous advertisements) for the Radio Amateur and Experimenter. Immediate delivery. 25s. Post 10d.

QST

The leading American monthly on Amateur Radio, established over 30 years ago as the official journal of the American Radio Relay League. Subscribers become associate members automatically. For a year of 12 issues. 36s.



ANTENNA MANUAL

Design and Construction of Aerials of every kind for Radio Amateurs, Engineers and Technicians. (300 pages). Immediate delivery.

27s. Post 10d.

CQ

An independent American magazine for Radio Amateurs, published monthly. Full of general-interest and sound constructional articles, with special activity sections. CQ is successor to the well known pre-war magazine Radio. For a year of 12 issues. 29s.



ANTENNA HANDBOOK

Latest edition of the A.R.R.L.'s own publication on Aerial Theory and Installation. Written to be of practical value to amateurs and engineers engaged on the design of all types of receiving and transmitting aerials. Immediate delivery. Post free.

11s. 7d.

AUDIO ENGINEERING

A monthly of quite unusual value and interest to all concerned with the design, construction and operation of audio equipment of every kind. 12 issues. 29s.



HINTS AND KINKS

Useful collection of technical ideas and practical workshop data, with plenty of diagrams, written up in shortened form. Latest edition of a recommended A.R.R.L. publication. Immediate delivery 11s. Post 5d.

POPULAR MECHANICS

America's leading hobbies and handyman's magazine. Monthly 300 pages, many in colour, 125 articles and 500 pictures. Yearly subscription 32s.

"Written so you can understand it."



SURPLUS CONVERSION MANUALS. Giving much detailed practical information on the adaptation of a wide range of American surplus items. Well illustrated with circuit diagrams, drawings and photographs. In two vols. Immediate delivery. per Volume 21s. Post 5d.

RADIO AMATEUR NEWCOMER. As its title suggests, a very useful handbook for the beginner in Amateur Radio. Though American in outlook, it covers much that is common ground on both sides of the Atlantic.

Immediate delivery. Post free 8s. 4d.

GAGE & POLLARD, Publishers' Agents

49 VICTORIA STREET, LONDON, S.W.1.

Abbey 5342.