

BRS42.

# T. & R. Bulletin

Incorporating

## The Journal of the Inc. Radio Society of Great Britain



Vol. 3. No. 5. November, 1927 (Copyright)

Price 1/6

# "EKCO"

## There is an "EKCO" UNIT for every purse and voltage

Every member of the Radio Society knows that Radio of to-day and the future is Mains Power Radio.

"EKCO" Mains Power was the first in the field and to-day is still foremost.

### Safe—Silent—Sound



#### MODEL C.2 COMBINED H.T., L.T., G.B. UNIT FOR D.C.

Provides:

- (a) H.T. 60, 120 and "Power."
  - (b) L.T. Current for 3, 4, or 5.1 amp. valves or for any combination of valves of the *same* filament voltage provided the *sum* total of current consumed by the filaments is not less than .3 amp. and not more than .5 amps.
  - (c) G.B. Tappings at 1½, 3, 4½, 6, 9
- Complete ... .. £6 7s. 6d.

Models range from 17/6.  
Write to Dept. T.R. for illustrated folders.

### E.K. COLE LTD

"EKCO" Works, London Rd., LEIGH-ON SEA.



# Ask for TYPE **W J**

**CAPACITY**  
2,500 milli-amp.  
hours.

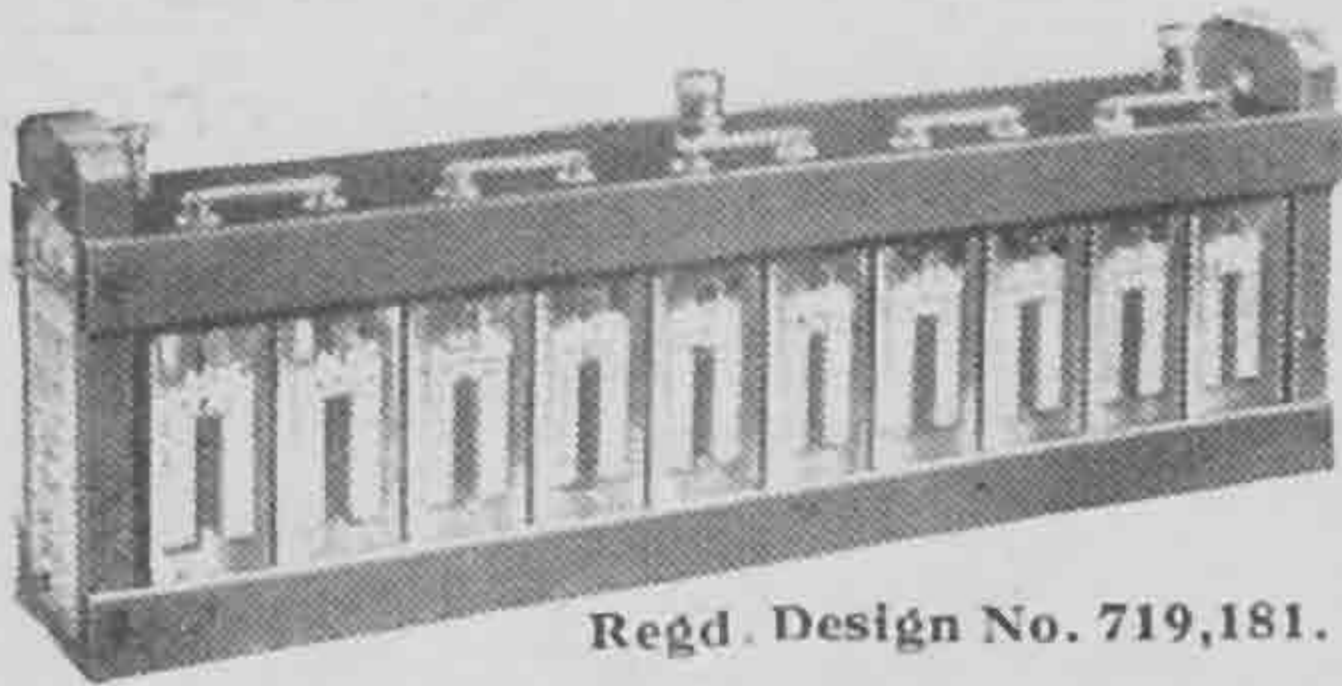

Regd. Design No. 719,181.

## The Supreme High Tension Battery

THIS BATTERY provides the most satisfactory source of H.T. in existence. It will stand for six months at least, without detriment or loss of charge even when partially run down, so that its full capacity is available though the discharge be spread over such periods. It can be recharged, and, reasonably cared for, will last for years. The discharge is steady, free from fluctuations, and ensures pure reception against a silent background that is a revelation.

# Exide

THE  
LONG - LIFE BATTERY

TYPE	2,500 milli-amp. hrs.	9d.
<b>W J</b> PRICE	15/-	
	per 20-volt unit.	per volt.

Advertisement of the Chloride Electrical Storage Co. Ltd.  
Clifton Junction, Nr. Manchester.

# QUARTZ (1927)



A book of 72 octavo pages, comprising 53 pages of specially written text, two sketches, twelve diagrams, bibliography of 60 references, and 22 British patents with index under such headings as "Station design according to wavelength."

By

**A. HINDERLICH, M.A.**



Published by

## Quartz Oscillators LIMITED

**1, LECHMERE ROAD,  
LONDON, N.W.2.**

By post—Inland 2/7. Cheque, P.O. or stamps. Abroad, 2/8. Cheque, Notes, International Money Order, or Postal Order.



## Use a Choke!

By using a "DECKOREM" Choke in high frequency stages, many experimenters have solved all previous difficulties in securing adequate choking effect on a wide range of wavelengths.



This Choke is specially designed to cover from under 300 to over 2,000 metres.

It is wound in several sections to reduce capacity and it is also constructed with an insulated covering and fitted with two terminals. On a Laboratory test the Inductance was 72,000 M.h., Self Capacity 8 m.fds.

OBTAINABLE FROM ALL DEALERS.

PRICE  
**5/6**

Four Catalogues Free on request to

**A. F. BULGIN & CO.**  
9-10-11, CURSITOR STREET,  
CHANCERY LANE, E.C.4.

## HIGH TENSION

Your A.C. Mains can be used for all purposes through the medium of **Suprecision Power Transformers.**

*Made in all sizes, for all Voltages.*

200 volts 20 ma	4 volts .8 amp	..	12/6
200+200 v 20 ma	2+2v 1.6a	..	19/-
150+150 v 20 ma	2.5+2.5v 1.6a	..	17/6
200+200 v 50 ma	2.5+2.5v 4a	..	25/-
250+250 v 50 ma	2.5+2.5v 2a	..	28/-
250+250 v 100 ma	5+5v 3a	..	50/-
1,000+1,000 v	120 ma	..	90/-
3+3 volts	4 amps	..	12/6
2+2 volts	3 amps	..	8/4

### POWER CHOKES:

50 henrys	25 ma	..	14/-
100	25 ma	..	20/-
50	100 ma	..	25/-
100	100 ma	..	30/-

FULL LISTS FREE.

**F. C. HEAYBERD & CO.**  
8/9, Talbot Court, Eastcheap, E.C.3.

## Piezo Electric Quartz Crystals

Messrs. R. A. WEBER beg to advise all interested Radio Transmitters that they are now in a position to supply QUARTZ OSCILLATORS FROM STOCK. Any wave-length from 50 metres upwards by return, and EVERY CRYSTAL SUPPLIED GUARANTEED TO OSCILLATE WITHOUT REACTION AND WITH AIR GAP BETWEEN CRYSTAL ELECTRODES.

Our Electrical Testing Department is under the supervision of an A.M.I.E.E., who has carried out years of research work bearing on the Piezo Electric behaviour of Quartz, and apparatus is installed, whereby **WE CAN GUARANTEE TO WORK CRYSTALS TO A STATED WAVE-LENGTH WITHIN LIMITS OF ONE PART IN A THOUSAND.**

We have supplied Crystals to some of the largest and best known Radio Manufacturers, and during the last three months alone have supplied considerably OVER 100 CRYSTALS TO VARIOUS GOVERNMENT DEPARTMENTS.

If required, Crystals can be supplied mounted complete, ready for use, in special dustproof holders. **PRICES FROM £3 EACH.**

For full details and prices see last month's T. & R. BULLETIN, page 26.

We also specialise in PRECISION QUARTZ RESONATORS. Details and Prices on application. Four years' research work on Quartz Oscillators and Resonators, together with over 30 years' experience in the optical working of QUARTZ, places us in a position to meet your special needs.

**R. A. WEBER,**

MANUFACTURING OPTICIANS and  
QUARTZ CRYSTAL SPECIALISTS,

Works: 303, Hither Green Lane, LONDON, S.E.13

## A Transformer

With Interchangeable Units.

THE

## MULTIFORMER

Will Function as L.F. Transformer (Adaptable to any values of impedance and ratio) and untroubled by breakdowns. Price 25/-.

Can be used as an I.F. Transformer of any peak frequency. Price 21/-.

The "Multiformer" can be made to give the exact characteristics you desire, in fact you design your own instrument. Of inestimable value to experimenters.

Other uses are: As R.C.C. Unit or CHOKE Cap Unit or as a Smoothing Choke.

Prices for Inductance Windings—Non-Inductance Resistance Windings and Condenser Units to suit individual requirements will be supplied on application to Patentee and Sole Manufacturer:

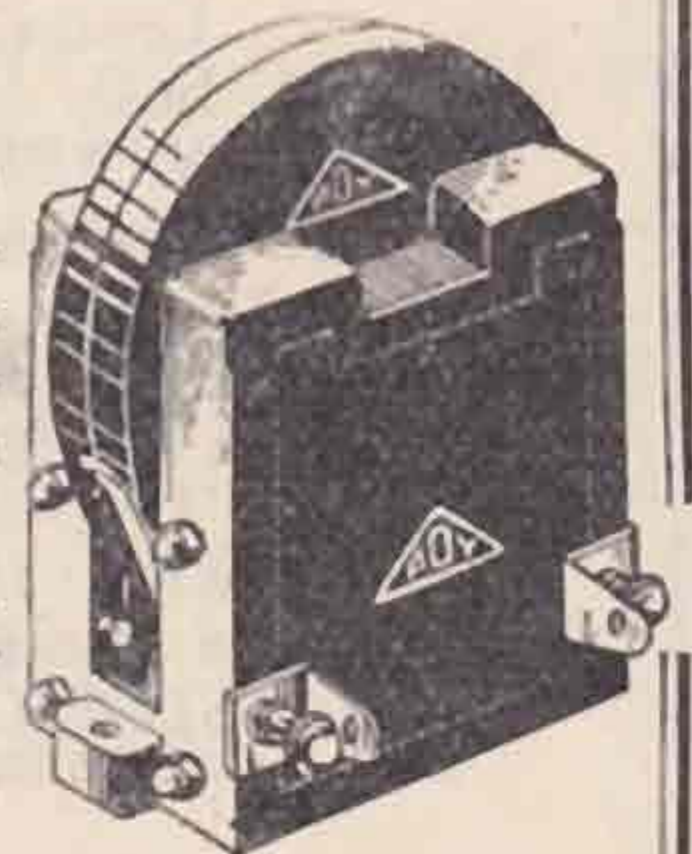

**GEO. E. POHU**

16, Colville Road, London, W.11

Tele.: Park 5307.

Radio 2CO.



# Inc. Radio Society of Great Britain.

**T**HE Radio Society of Great Britain is a virile and progressive body of amateur radio experimenters banded together for promotion of knowledge and brotherhood of those interested in the Radio Art. It exists also with the object of the advancement of the Art, the representation of the amateur in legislative matters, and for the disciplined use of the ether in so far as amateur experimenters are concerned.

The policy of the Society is to accept to its Membership any person or persons who are able to satisfy the Council that they are interested in Radio Art, or who in their opinion are persons whose Membership is desirable in the interests of the Amateur Experimenter.

The Society is recognised by the British Postmaster-General as being representative of the aims and objects of the experimenter. We have members in every corner of the earth, at all times and welcome inquiries from prospective Members. A bona fide interest in experimental Radio work is the only essential qualification.

## LIST OF BRITISH AREAS AND AREA OFFICERS.

### SCOTTISH AREA.

*Area Manager* : J. WYLLIE, Esq. (5YG), 31, Lubnaig Road, Newlands, Glasgow.

Consisting of the whole of Scotland, including the Hebrides, Orkney Islands, Skye, and the other smaller islands on the coast of Scotland, the boundary on the South being formed by the River Tweed and the Cheviots. The town of Berwick is included in the Scottish Area.

### NORTH BRITAIN AREA.

*Area Manager* : S. R. WRIGHT, Esq., Associate I.R.E. (2DR), 14, Bankfield Drive, Nab Wood, Shipley, Yorks.

Consisting of the Counties of Northumberland, Cumberland, Westmorland, Durham, Yorkshire, Lancashire, Lincoln, Nottingham, Derby, Cheshire, and the Isle of Man.

### MID-BRITAIN AREA.

*Area Manager* : CAPTAIN H. J. B. HAMPSON (6JV), 477, Earlham Rise, Norwich.

Consisting of the Counties of Shropshire, Leicester, Rutland, Cambridge, Huntingdon, Northampton, Warwick, Worcester, Hereford, Stafford.

### SOUTH-EAST BRITAIN.

*Area Manager* : F. A. MAYER, Esq. (2LZ), "Stilemans," Wickford, Essex.

Consisting of the Counties of Essex, Suffolk, Bedford, Oxford, Hants, Sussex, Hertford, Buckingham, Berkshire, Hampshire, Surrey, Kent, Middlesex, and the Isle of Wight.

### SOUTH-WEST BRITAIN.

*Area Manager* : Captain G. Courtinay Price, "R" Signals (2OP), 2, St. Annes Villas, Hewlett Road, Cheltenham.

Consisting of the Counties of Cornwall, Devon, Somerset, Dorset, Wilts, Gloucester, and the Scilly Isles.

### LONDON AREA.

*Area Manager* : G. A. EXETER (6YK), 142, Campden Hill Road, W.8.

Area : 25 miles of Charing Cross.

### NORTHERN IRELAND.

*Area Manager* : F. R. NEILL, Esq., Associate I.R.E. (5NJ), "Chesterfield," Whitehead, near Belfast, Co. Antrim.

### SOUTHERN IRELAND.

*Area Manager* : COLONEL M. J. C. DENNIS, C.B., Fortgranite, Baltinglass, Co. Wicklow.

**Q.R.A. SECTION** :—C. A. JAMBLIN (6BT) 82, York Rd., Bury St. Edmunds, Suffolk.

## Membership Subscription Rates.

Town Members (resident within a 25-mile radius of Charing Cross), £1 1s. per annum.

Country Members, 15s. per annum.

Foreign Members, 12s. 6d. per annum.

Associates, 5s. per annum (no notices or BULLETIN is supplied to this grade of membership).

An entrance fee of 10s. 6d. must be paid by new Corporate Members unless they have been members of a Section.



# T. & R. Bulletin

THE INC. RADIO SOCIETY OF GREAT BRITAIN,  
53, Victoria Street, S.W.1



**Patron :**

H.R.H. THE PRINCE OF WALES, K.G.

**President :**

SIR CAPEL HOLDEN, K.C.B., F.R.S., M.I.E.E.

**Acting Vice-President :**

CAPTAIN IAN FRASER, M.P., C.B.E.

**Hon. Treasurer :**

PROFESSOR W. H. ECCLES, D.Sc., F.R.S.

**Hon. Secretary :**

H. BEVAN SWIFT, A.M.I.E.E. (G2TI).

**Hon. Secretary, General Committee :**

J. F. STANLEY, B.Sc., A.C.G.I.

**Hon. Members :**

SIR OLIVER LODGE, D.Sc., LL.D., F.R.S.  
SENATOR G. MARCONI, G.C.V.O., D.Sc., LL.D.

**Editor-Secretary :**

J. A. J. COOPER, Member I.R.E., Grad.I.E.E., F.R.S.A. (G5TR)

**Council :**

GERALD MARCUSE (G2NM).  
O. F. BROWN, M.A., B.Sc.  
F. H. HAYNES (2DY).  
E. J. SIMMONDS, Member I.R.E., F.R.S.A.  
(G2OD).  
R. J. HIBBERD, Member I.R.E., F.R.S.A.  
F. A. MAYER (G2LZ).  
THOS. HESKETH, M.I.E.E.

G. F. GREGORY, A.M.I.E.E., A.M.I.M.E.  
(G5PZ).  
A. HAMBLING, Associate I.R.E. (G2MK).  
H. DE A. DONISTHORPE.  
R. HODGE.  
J. R. HALLIWELL.  
H. S. POCOCK.

**Past Presidents :**

ALAN A. CAMPBELL SWINTON, F.R.S., M.Inst.C.E.,  
M.I.E.E., M.Inst.Mech.E.  
SIR OLIVER LODGE D.Sc. LL.D., F.R.S.

ADMIRAL OF THE FLEET SIR HENRY B. JACKSON, G.C.B.,  
K.C.V.O., F.R.S., D.Sc., M.I.E.E.  
PROFESSOR W. H. ECCLES, D.Sc., F.R.S.

**Vice-Presidents :**

MAJOR BASIL BINYON, O.B.E., M.A., A.M.I.E.E.  
LT.-COL. THE HON. STUART P. BOUVERIE, D.S.O.  
SIR CHAS. BRIGHT, F.R.S.E., M.Inst.C.E., F.R.Ae.S.,  
M.I.E.E.  
SIDNEY GEORGE BROWN, F.R.S., M.I.E.E.  
CAPTAIN P. P. ECKERSLEY, M.I.E.E.  
LE GÉNÉRAL FERRIÉ, C.M.G., LL.D.  
PROFESSOR J. A. FLEMING, M.A., D.Sc., F.R.S.  
L. F. FOGARTY, A.M.I.E.E., F.R.S.A.  
COMMANDER P. HIPPISEY, O.B.E., T.D., D.L., M.I.E.E.  
FRANK HOPE-JONES, M.I.E.E.  
PROFESSOR G. W. OSBORN HOWE, D.Sc., M.I.E.E.

RENÉ H. KLEIN, L.Sc.C., Member I.R.E.  
COMMANDER F. G. LORING, R.N., M.I.E.E.  
PROFESSOR E. W. MARCHANT, D.Sc., M.I.E.E.  
LESLIE McMICHAEL, Fellow I.R.E.  
SIR WILLIAM NOBLE, M.I.E.E.  
THE RT. HON. SIR HENRY NORMAN, BART., P.C., F.Inst.P.,  
A.M.I.E.E.  
EDWARD H. SHAUGHNESSY, O.B.E., M.I.E.E.  
PROFESSOR ERNEST WILSON, M.Inst.C.E., M.I.E.E.  
J. H. REEVES, M.A.  
FEARNLEY OWEN.  
MAURICE CHILD.



## ELECTRADIX SUPPLIES THE NEEDS OF READERS OF THE BULLETIN

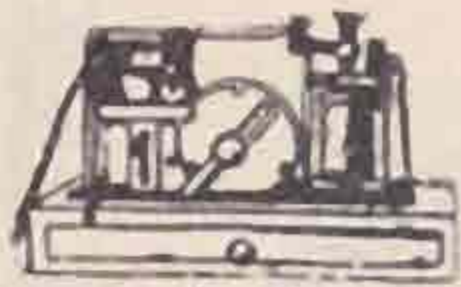

**MORSE WIRELESS RECORDERS.**—Magnificent British work, solid Brass case, fine finish. Mahogany case with drawer for tape reel. Cost £30. Sale £7 10s.; Portable Type ex-Army, £6 10s.

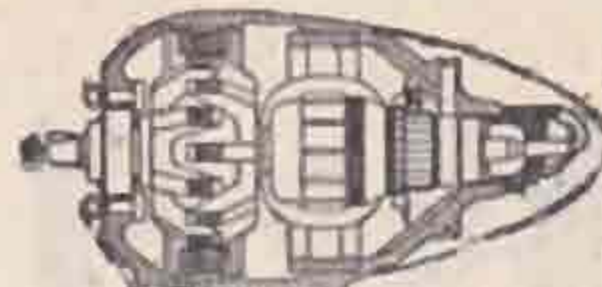

**ALTERNATORS**  
—500 cycle type 52a. The wonderful 200-watt Newton & Watford A.C. self-exciting. Cost £30. Great bargain, £3. All sizes in stock to 2kw.



**D.C. GENERATORS.**—Shunt wound for charging 6/9 volts 8 amperes, ball-bearing enclosed, 50/-. Fitted Auto cut-in-out, £3. 100 volts 4 amps, ditto, £4. 30v. 15a., £6 10s. 22v. 12a., £6. 50/70 volts 10 amps, £8 10s. 50/70 volts 25 amps, £11. 80/100 volts 30 amps, £12. 220v. 12a., £12. 12v. 30a., Mackie, £4.

**MOTOR GENERATORS.**—Westinghouse W.50 D.C., off 25 volts or 50 volts to give 350 volts 100 m/a for H.T., totally enclosed, very neat £4. A.C. 220 volts to D.C., 8 volts 1 1/2 a., 70/-. To 20 volts, 12a, £13. To 30 volts, 15a, £16. H.T. Sets, 2,000 volts, 1 kw and 2kw. in stock.

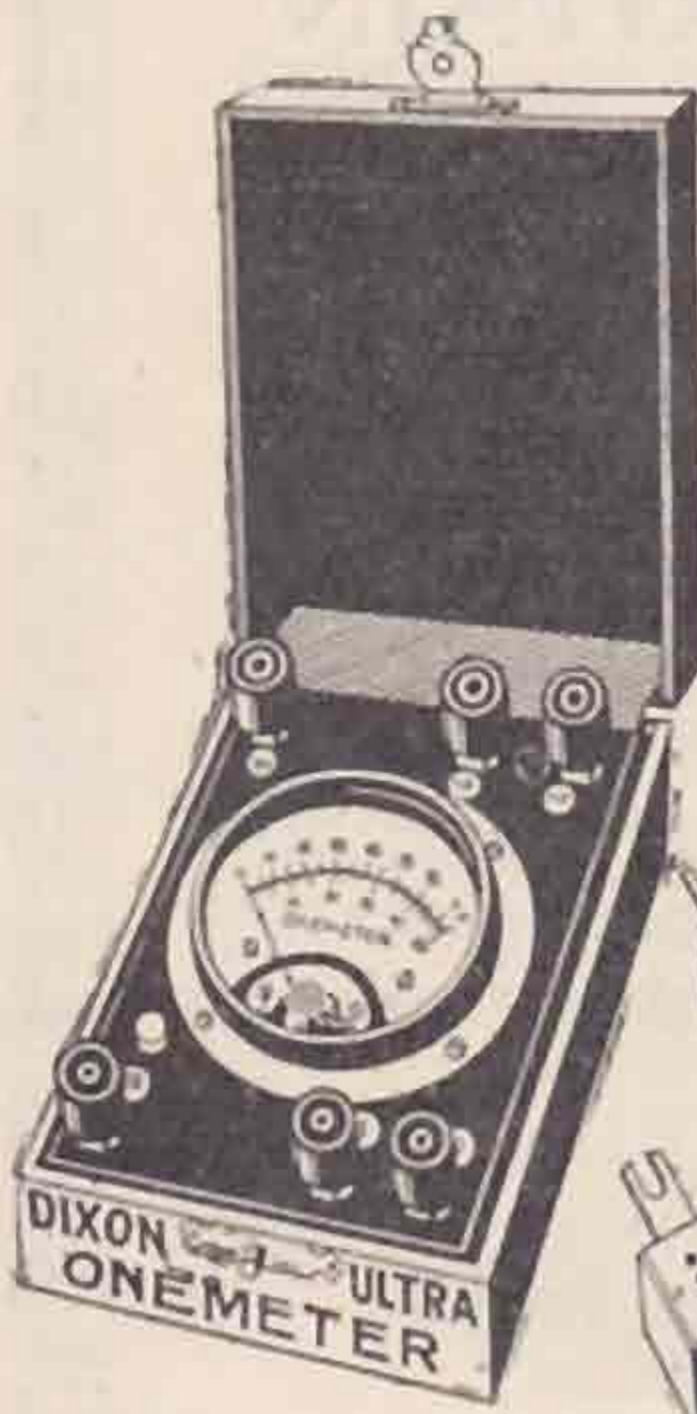

MICRO-AMPS TO  
20 AMPS

MILLIVOLTS TO  
2,000 VOLTS

50 OHMS TO  
50 MEGOHMS

WITH  
ONE  
METER

**THE DIX-ONEMETER** New DE LUXE MODEL THE RECOGNISED RADIO STANDARD.

**HIGHEST GRADE. LOWEST PRICE.**  
The DIX-ONEMETER will measure signals on a Crystal Set, Grid Valve Current or a large Battery Current with equal ease and accuracy. E.M.F. from a millivolt to 2,000 volts or the values of Resistances between 50 ohms and 50 megohms can easily be read on the clear scale with fine knife-edge pointer and reflecting mirror. The resistance of the 100 volt range is 50,000 ohms, as nearly electrostatic as a moving coil instrument can be. The ingenious system of Multipliers at 6/6 enables full scale readings of any value to be made over an enormous range.

**THE DIX-ONEMETER is  
The Rolls Royce of Radio!**

**PRICES:** "DIX-ONEMETER," in case, reading 0-2 m/a, 40 microamps. per div. 55/-.

**PRICES FOR MULTIPLIERS:** Current, all ranges Milliampères to 20 amps., each 6/6. Voltage, all ranges To 100 6/6 To 150 7/6 To 200 9/- To 250 10/6 To 300 11/- To 500 16/6 To 750 27/- To 1,000 36/- To 1,500 57/- To 2,000 74/-  
Cases, with base, for 4 multipliers, 4/-

**RELAY DISTANT CONTROL SWITCH**  
for switching your set on or off from any room. Three types are stocked, H.T. or L.T. Control and the Master Spring-drive. The H.T. is in the Loud Speaker—Anode circuit; the L.T. is fed off L.T. Batt. and takes 6 m/a to operate. The Master needs 4 volts for the fraction of a second only. Either type 15/- each and ready to work. 4-pin plug and socket, with control switch, 4/- only. Weston Moving Coil Relays usually £3 10/-, our Sale price 25/-.

Have you had  
particulars of the

**ELECTRADIX  
T. MICRO-  
VOLTAMMETER**

A good Moving Coil  
Suspension Galvanometer  
at the extremely low  
price of £3 only.

Send us your enquiries for Dynamos and Alternators, Recorders, Relays and Special Apparatus.

Now ready, New Edition of 72-page Illustrated Catalogue, 4d.

**LESLIE DIXON & CO., 218, Upper Thames Street, London, E.C.4** *Parr Ad.*

# Green for safety!



*For your transmitter, choose  
the Condenser preferred  
by the World's experts.*

**D**ON'T take a risk with the condensers for your transmitter. Buy those chosen by the leading technicians throughout the world—T.C.C. Condensers. The letters "T.C.C." on the case of a condenser are a hall-mark of extreme accuracy and utter dependability. Green—the colour of the T.C.C.'s case—is a symbol of the safety assured by the T.C.C. Your Dealer stocks T.C.C. Condensers for Transmitters in the range below.

Condensers for maximum working voltage of 1500 peak value.

4 mfd.	6" x 6" x 2"
2 mfd.	6" x 6" x 1"
1 mfd.	5" x 3" x 1"
.5 mfd.	5" x 3" x 1"

Condensers for maximum working voltage of 2500 peak value.

4 mfd.	6 1/2" x 6" x 8 1/2"
2 mfd.	6 1/2" x 6" x 4 1/2"
1 mfd.	6" x 6" x 2"

The type illustrated is the 2 mfd.—Max. Work. Volts 2500 D.C. Price £2 10s.

## T.C.C.

### Condensers for Transmitters

Advt. Telegraph Condenser Co., Ltd., Wales Farm Road, N. Acton, London, W. 3.

9700



# TEAR

# BULLETIN.

*The only British Wireless Journal Published by Amateur Radio Experimenters*

NOVEMBER, 1927.

Vol. 3. No. 5

## EDITORIAL

### Washington.

Recent Editorials in "Q.S.T." have caused such considerable concern to British amateurs that a few words are necessary to "clear the air" a little.

In the first place it must be clearly understood that the British delegates to the Conference are Government Officials, and as such their utterances and representations are those which might be expected from official sources. The British amateur had no place in the delegation and was not invited to submit his views. British radio legislation as it now stands does not permit the amateur experimenter any control in the administration of the ether, and such is vested entirely in the hands of the Postmaster-General who in turn appears to be guided very largely by the wishes of the W/T Board, a Board composed of representatives of all Government Departments who use the ether, these being mainly the War Office, Admiralty, and the Air Ministry. The British delegation was mainly drawn from these sources and Major T. F. Purvis, Assistant Engineer in Chief, is representing the Post Office and is possibly acting as the chief officer of the delegation.

Our President has been assured by the office of the Postmaster-General that the needs of British amateurs would be borne in mind at the Conference, and further, it has been understood that a cut in amateur wavebands was not contemplated. This is in part borne out by the fact that Mr. Warner, of the A.R.R.L., was informed by the delegation in Canada that the requirements of British amateurs as represented by themselves would receive sympathetic consideration.

For some months prior to the Washington Conference, Mr. Marcuse was in communication with Mr. Warner regarding the representation of British amateurs at the Conference which the latter is attending by reason of the wonderful position of amateur radio in America. Eventually it was agreed that Mr. Warner as secretary of the International Amateur Radio League, and Mr. Maxim, as President of the League, should represent British

amateurs, and that the line of action to be followed was that amateurs of all nationalities should have the same wavebands allotted to their use.

What cannot be understood, however, are the statements made by the British delegates at the preliminary meeting in Canada which is reported by Mr. Warner in his editorial. As predicted by Mr. Warner, the affected ignorance of the delegation as regards the strength of amateur radio in America and at home here "fair makes our hair stand on end." We know that copies of our BULLETIN find their way into the office of the Postmaster-General or his assistants, and for the delegation to display such ignorance merely proves that the delegation has been sadly misinformed as to the position both here and abroad. Also, it seems to show that somebody in official quarters was sadly remiss in instructing the delegation as to the seriousness of our intentions and desires, the general position, and the usefulness of our work taken as a whole. The blame for such a position entirely rests with the authorities responsible, for nobody who has lived in this country for the past ten years, and who has been associated with radio can possibly have failed to note the influence of the amateur on the progress of the art. In addition, our own representations to official circles have from time to time received most careful and sympathetic consideration, and at no time has Council felt that unreasonable opposition has been experienced when our various requirements have been voiced through the medium of our accredited representatives.

Lest there should be any further affectation of ignorance, however, the following remarks are made for the benefit of those who are interested. Previous pages of the BULLETIN disclose our aims and objects. Our strength in Great Britain is 1,200 radio experimenters of all grades of skill, and in the Dominions and elsewhere we have a further 400 members approximately. In addition to this we have a very large number of supporters who are not actually corporate members, but who nevertheless are to be reckoned with, and these consist of a large number of local societies who are affiliated to our Society and whom we represent in matters concerning National Legislation. There are still a large number of persons who are not members of the Society, but on whose behalf we should not hesitate to use our offices if it were necessary.



Most, if not all, of these details are already known to the officials responsible for administering the ether at the G.P.O.

The result of the Washington Conference means a lot to British progress in radio work, and it would be disastrous if the petty jealousies of various concerns crippled facilities for the carrying out of experiments by private individuals. The so-called amateur experimenter is one of the greatest users of the ether from the transmitting point of view, and as such he is entitled to a fair share in the ether spectrum.

To attempt to curtail his activities is akin to attempting to prevent the progress of experiments in aviation or any like art; it cannot be done. The result will be but to delay the progress of civilisation, so far as we are concerned. The immediate consequences will be to cripple this new industry and to lose revenue in foreign competition when nations more favourably placed will have developed the science in advance of ourselves.

One word more. A cablegram has been received from Mr. Warner showing that he is experiencing a great deal of International opposition to his proposals. The British delegates appear to have proposed a series of wavebands for British amateurs similar to that which we at present use, but confined to a width of 100 kilocycles in each case. A special meeting of Council was held and a cable sent to Mr. Warner, urging him to do his utmost to get the wavebands widened. This is the latest news on going to press, and it might be emphasised that now more than ever is it necessary for amateurs to stand side by side and insist on their just dues. In the meantime Headquarters are exerting every influence to keep a grip of the situation, and to bring it to a satisfactory conclusion.

#### Convention, 1927.

On other pages details of the proceedings at the second annual Transmitters' Convention are published. We term it a 'Transmitters' Convention because so many who attended were licensed amateur transmitters, although it was open to all members. Suggestions were made that next year it should be of a longer duration, as we again felt that the time was all too short for the great amount of work which we wanted to do. While it is still fresh in our minds, why not write and let us have any suggestions for 1928?

#### Coming Changes.

Also elsewhere is outlined a scheme for the re-constitution of the old T. & R. Committee. This scheme was brought forward at the Convention and approved unanimously. The idea is that the T. & R. Committee should be re-named the General Committee in place of the old General Committee of Affiliated Societies, which has now ceased to exist. The scheme is that the General Committee shall consist of a number of sub-committees, the members of which shall not exceed five in number and each sub-committee shall be responsible for a portion of our work and shall have one representative on the General Committee, which General Committee has in turn two representatives on Council apart from those of the General Committee, who are already members of Council. The object is to ensure an even distribution of our work amongst as many members as possible, by which means it is hoped to achieve a successful organisation. It might be explained that owing to our rapid growth

of membership and our increased activities some such scheme is essential, for it is no longer possible to carry on under the old system owing to the greater amount of work and thought required of individual members of Committee. It is hoped that the scheme will be sufficiently advanced in theory to allow of it being put into execution in time for the forthcoming committee elections.

J. A. J. C.

## Incorporated Radio Society of Great Britain.

### Election of Council for year 1927-28.

#### NOMINATIONS FOR COUNCIL.

President: Captain Ian Fraser, M.P., C.B.E.  
Acting Vice-President: Gerald Marcuse (2NM).  
Hon. Treasurer: E. J. Simmonds, Member I.R.E., F.R.S.A. (2OD).  
Hon. Secretary: H. Bevan Swift, A.M.I.E.E. (2TI).

#### ELECTED MEMBERS.

O. F. Brown, M.A., B.Sc., H. de A. Donisthorpe, G. F. Gregory, A.M.I.E.E., A.M.I.M.E. (5PZ), A. Hambling, Associate I.R.E. (2MK), J. F. Stanley, B.Sc., A.C.G.I., E. D. Ostermeyer (5AR), Flight-Lieutenant Durrant, R.A.F., K. Alford (2DY).

#### EXTRACTS FROM ARTICLES OF ASSOCIATION.

33. The affairs of the Society shall be managed by a Council consisting of the President, the immediate Past President, the first Past President, the acting Vice-President, the Hon. Secretary, the Hon. Treasurer, eight elected Corporate Members, the Vice-Chairman and Hon. Secretary of the General Committee hereinafter referred to, three members of the General Committee, and not more than three representatives selected by the Council from one or more Sectional Committees.

34. All members of Council shall retire annually in December and shall be eligible for re-election, provided that no president shall hold office for more than two consecutive years, no acting vice-president for more than three consecutive years, and no member of the Council, other than the hon. treasurer and the hon. secretary, shall serve for more than three consecutive years.

35. No person shall be eligible to serve on the Council who is not a corporate member of the Society, and not more than four members of the Council shall be associate members of the Society.

48. Not later than the 24th day of November in each year the Council shall send to each corporate member entitled to vote a list of duly qualified persons whom they nominate for the offices of president, acting vice-president, hon. secretary, hon. treasurer and other elected members of Council in December next following. This list must include at least four names of persons not serving on the existing Council.

49. After the issue of the Council's list, and not later than the fourth day of December next, any ten corporate members (but not more than ten) may nominate any other duly qualified person by delivering their nomination in writing to the secretary, together with the written consent of such person to accept office if elected, but each such nominator shall be debarred from nominating any other person for the same election.

50. If any nomination in accordance with Article 49 has been made, then, and only then, and not later than five days before the date of the annual general meeting, the Council shall send to each corporate member entitled to vote, a ballot paper, containing the names of all persons duly nominated, stating which persons are nominated by the Council, and giving the names of the members or associate members by whom every other person (if any) is nominated.

51. Each corporate member voting shall erase sufficient names to reduce the number of names on the ballot paper, after such erasure, to the number to be elected to the respective offices. The ballot papers shall be returned so as to reach the secretary not later than three days before the date fixed for the annual general meeting, and they shall be so marked and returned as may be from time to time determined by the Council.

**IF WE HAVE NOT RECEIVED YOUR  
SUBSCRIPTION PLEASE ASSIST US  
BY REMITTING EARLY.**



# Incorporated Radio Society of Great Britain.

## Area Election Results.

### ELECTION OF AREA MANAGERS.

The following are the results of elections carried out in accordance with the by-laws passed at the first annual Convention, 1926:—

SCOTTISH AREA.—Mr. J. Wyllie returned unopposed.

NORTH BRITAIN AREA.—Mr. S. R. Wright returned unopposed.

MID-BRITAIN AREA.—Captain H. J. B. Hampson, returned unopposed.

SOUTH-EAST BRITAIN.—Mr. F. A. Mayer returned unopposed.

SOUTH-WEST BRITAIN.—Captain G. Courtinay Price returned unopposed.

LONDON AREA.—Mr. G. A. Exeter returned unopposed.

SOUTHERN IRELAND.—Colonel M. J. C. Dennis, C.B.E., returned unopposed.

NORTHERN IRELAND RESIGNATION.—Mr. F. Neill has resigned in order that Mr. E. Megaw should be returned unopposed.

The foregoing gentlemen will therefore serve as Area Managers as from November 1, 1927, until the date of the next elections, and Mr. Megaw has been appointed Area Manager in Northern Ireland in place of Mr. Neill.

NOTE.—The election of the General Committee (ex-T. & R. Committee) will take place on December 2, 1927, at the Institute of Electrical Engineers. All Area Managers are members of this Committee by virtue of their office, but these are elected in advance of the General Committee, as above.

## R.S.G.B. Calendar.

*This constitutes the sole notice which members will receive concerning forthcoming meetings.*

See notices regarding November in October issue.

†\*DECEMBER 2, 1927.—Mr. F. H. Haynes. Moving Coil Loud Speakers. Annual General Meeting of T. & R. Section.

†\*DECEMBER 14, 1927.—Phillip Coursey, B.Sc. Title to be selected later. Annual General Meeting of R.S.G.B.

Dates to note for future lectures:—

January 13, 25, February 10, 22.

### COMMITTEE AND COUNCIL.

NOVEMBER 21.—Meeting of Council, at 5.45 p.m.

NOVEMBER 25.—Meeting of T. & R. Committee, at 5.45 p.m.

DECEMBER 9.—Meeting of T. & R. Committee, at 5.25 p.m.

DECEMBER 19.—Meeting of Council, at 5.45 p.m.

NOTE.—All meetings at the Institute of Electrical Engineers take place at 6 p.m. All meetings of Council and Committee take place at 53, Victoria Street.

\* Denotes to be held at Institute of Electrical Engineers.

† Denotes preceded by tea at 5.30, in lounge.

## Olympia Exhibition, 1927.

We are glad to be able to announce that the Society's stand at the Exhibition was again a success this year. It is very difficult to gauge the benefit which the Society derives from the holding of the stand each year, but as a criterion we might say that over 200 visitors, members of the Society, signed the visitors' book, and over £50 was taken in cash at the show. About forty people filled in forms of application for membership, and a considerable number of books were sold and a large amount of literature distributed. Unfortunately, our handbook, "What is Amateur Radio?" arrived somewhat late to be brought into action, but we are using this for another purpose later on.

We have to thank all those members who so kindly placed their services at the disposal of the Society during the week of the Exhibition, and particularly would we mention Messrs. Ostermeyer, King, Pollock, Clarricoates, Exeter, our Hon. Secretary, and lastly our office staff, which had a very trying time during this period, since we had also arrangements for the Convention to complete, in addition to the October BULLETIN to prepare for publication. We are very grateful to all these kind helpers for the non-sparing efforts which they put out on our behalf during this period.

## Special Notice.

### List of Members, 1927 28.

We are preparing a list of active members for early publication, and in this connection we would be glad if all members who have changed their addresses and have not notified us at Victoria Street would notify us of such changes as early as possible.

This list will only comprise those whose subscriptions are paid up to date, and in this connection we are also preparing a starred list of amateur call signs, the stars appearing against those transmitters who are members of R.S.G.B. The list will be published in the Annual Diary and Call Book for 1928.

## Back Numbers.

We have a limited number of back numbers of the BULLETIN for sale, and these may be obtained, price 6d. each, on application to the Editor at 53, Victoria Street, S.W.1. The following are available at this reduced price in order to make room for other material:—Vol. 1: Nos. 1, 2, 3, 5, 6, 8, 9, 10; Vol. 2: Nos. 1, 2, 4, 5, 7, 9, 10, 11 and 12; Nos. 4 and 7 of Vol. 1, and Nos. 3, 6 and 8 of Vol. 2 are out of print.

There are also available a small quantity of numbers of the old Proceedings of the Radio Society of Great Britain. These may be obtained price 1s. each number.

## S.O.S.

### WHO IS PAUL POPESCU?

A gentleman of this name paid the sum of £1 5s. to the Society a few weeks ago, but we are unable to trace his address or for what reason he paid this amount. If anybody is able to give us his address this would be greatly appreciated.



# Theory and Adjustment of a Transmitter.

By F. AUGHTIE, G6AT.

## Introduction.

It is proposed in this series of articles to deal with the theory of a transmitter from an elementary starting point, and then to apply this theory to the practical points involved in the adjustment of a transmitter.

Since throughout we are dealing with alternating currents whose behaviour is very different from direct currents, we will first give sufficient theory of A.C. work to carry the amateur through most of the points arising in practice.

## Alternating Currents.

When a magnetic field is threading a coil, since the lines of force are closed loops and each turn may be regarded as a loop also, there are a number of linkages between the lines of force and the turns. If one line links with one turn, there is one linkage, if with two turns, two linkages, and if two lines link with two turns there are four linkages. Now, when the number of linkages changes an E.M.F. is induced in the coil and the value of this E.M.F. is proportional to the rate of change of linkages (with respect to time). If 100,000,000 linkages are added or subtracted uniformly in one second, the induced E.M.F. is one volt.

On connecting up a battery to the coil a current starts to flow and a field commences to build up in it, hence linkages increase (from zero), and therefore an E.M.F. is induced in the coil. This E.M.F. *opposes* the battery E.M.F. and causes the current to rise gradually to its final value (given by  $E/R$ ). On breaking the circuit, the current would stop immediately, but for the fact that as the current falls to zero the linkages also fall; in consequence an E.M.F. is again induced in the coil (in the same direction as the battery E.M.F. this time), and since the rate of change of linkages is high, the E.M.F. is high and causes a spark to jump the gap in the circuit. This spark is momentary because the E.M.F. causing it only exists so long as the current is falling in value.

When an alternating current flows through the coil the field set up is continually changing, except at those moments when the current is a maximum in one direction or the other. (*Note*: Consider an increase in the reverse direction as an increase in the negative direction and hence a continued positive decrease.) Hence, there is an E.M.F. induced in the coil—in one direction or the other—*except* when the current is a maximum. To send a current through the coil there must be a supply E.M.F. to overcome this induced E.M.F. (Since the induced E.M.F. always opposes the supply E.M.F. it is commonly called a back E.M.F.) Thus, there must be a definite voltage across the coil *except* when the current is a maximum. Thus *the current through an inductance is a maximum when the supply volts are zero*. The current, in fact, lags a quarter of a period behind the supply E.M.F.; it is a quarter of a period, or 90 degrees out of phase with the supply E.M.F.

Again, when charging a condenser the current

taken is a maximum at the instant of switching on, when the P.D. between the plates is zero. The current is zero when the P.D. is a maximum. Hence, from an A.C. supply a condenser takes a current which is a quarter of a period out of phase with the supply voltage. The current in this case *leads* the voltage: it comes before the voltage.

## Effective Values (R.M.S.)

Since the magnitude of an alternating current or voltage is continually changing, the question arises, what (instantaneous) value of the current shall we take and call *the* value of the current. The obvious value to take is the maximum value attained. Actually, however, if A.C. is passed through a resistance, the power dissipated is one-half of maximum current multiplied by maximum voltage. For this (and other) reasons the effective value of current and voltage is used in practice; the effective value is 0.707 (one upon root two) times the maximum value. The effective value is most commonly called the R.M.S. value. R.M.S. is an abbreviation for the square root of the mean value of the square of the instantaneous values.

The ratio of the alternating voltage across a coil or condenser to the current through it cannot be called the resistance since the two have their maximum values at different times. It is called the *reactance* of the coil or condenser, its value being expressed in equivalent ohms. Generally the word equivalent is omitted and the reactance expressed simply as so many ohms.

When we have a complex circuit made up partly of reactance and partly of resistance the ratio volts/current is called the *impedance* of the circuit. It should be noted that as a result of the different behaviour of an inductance and a condenser, the reactance of a condenser is *negative*, while that of an inductance is positive. Hence, when a coil and condenser are placed in series the total reactance is less than that of either, and may in some cases be zero; the impedance of the circuit becomes then simply its resistance.

The reactance of an inductance is proportional to the frequency of the A.C. supply and to the inductance, and is given by

$$X = 2 \text{ mfl.}$$

$$F = \text{Frequency.}$$

$$L = \text{Inductance in Henries.}$$

The reactance of a condenser is inversely proportional to the frequency and to its capacity; it is given by

$$X = \frac{1}{2 \text{ mfc.}} \quad C = \text{Capacity in Farads.}$$

The symbol X is used for reactance and Z is used for impedance.

Finally, in an A.C. circuit the product, volts, times, amps., does not usually give the actual power involved since the two may be more, or less, in phase with one another according to the circuit.



This product is called so many volt-amperes and must be multiplied by the *power factor* to give the actual power in watts. The power factor may have any value from zero to unity according to the ratio of resistance to reactance in the circuit.

### The Valve as an Oscillator.

We will now deal with the simple valve oscillator. Although the term generator is commonly applied to a valve and associated circuits, it should be borne in mind that a valve really is a converter of energy from D.C. to A.C.

The most important property of a valve generator of H.F. energy is its great disadvantage. It has a very high internal resistance, which, at once, limits its output and efficiency, and makes it necessary to adopt tuned output circuits. Tuned circuits are never employed in power engineering at commercial frequencies.

The output from a valve generator is of high voltage and low amperage. As an example, take a valve supplied with 50 watts at 1,000 volts D.C., we will take its efficiency to be 60 per cent. (this is a reasonable figure—but more of efficiency later). Now the peak (maximum) value of the H.F. output voltage will be about 600 volts, and hence its "effective" value  $0.707 \times 600$ , say, 420 volts. The output current will therefore be about

$$50 \times \frac{60}{100} \times \frac{1,000}{42} = 71 \text{ milliamps.}$$

The resistance of a radiating system (including "loss" and "radiation" resistance) forms the usual load for a valve generator and a value of 20 ohms may be taken for this for the purpose of the present example. Naturally the figure depends on the actual aerial employed. A 20 ohm resistance will take

$$\frac{420}{22} = 21 \text{ amps. at 420 volts,}$$

rather more than the 71 milliamps available from the valve!

The energy from the valve must be transformed down from 420 volts to a lower figure. From the old equation,  $\text{Power} = I^2R$  and substituting:— (50 watts input and 60 per cent. efficiency gives 30 watts output),  $30 = I^2 \times 20$ .

$$I^2 = \frac{30}{20} = 1.5 \quad I = 1.225.$$

and hence,  $E = I.R = 1.225 \times 20 = 24.5$  volts. We have therefore to step down from 420 volts to 25. Why this cannot be done with an ordinary transformer whose turns ratio is 420 to 25 will be explained in the next article.

## Two Interesting Experiments.

ON CRYSTAL WORK.

This is just an outline of a series of experiments relating to crystal control which the writer intends to carry out in some detail in the next few months, but which may easily be tried by any possessor of a crystal, and any information given will be

suitably acknowledged in the full account which the writer proposes to publish in due course.

There are three questions that every crystal user wishes to have answered:—

- (1) What power will it handle?
- (2) Which is the best valve?
- (3) Will the frequency remain constant?

The first two can be tackled together. Suppose we have the crystal-controlled valve oscillating, but coupled to a dummy aerial or tank circuit consisting of a coil coupled to the c.c. plate coil, a variable condenser, a hot-wire meter, and a resistance. We can get more power into the dummy aerial by using closer coupling. With a low-loss coil and no added resistance the current may reach 6 amperes, but as the power is equal to  $I^2R$ , and we can make a good guess at the power from knowledge of the c.c. valve, it is a simple matter to calculate  $R$  (the total resistance of the dummy aerial) so as not to burn out the aerial ammeter borrowed for the occasion. It is a different matter to measure or adjust  $R$  accurately, but we can most certainly see if we can make the current increase for any given adjustment. We can now see the effect of trying different valves, valves of grid bias, taps on the plate coil, and so on. If  $R$  is known fairly accurately, we can find the actual power available from the crystal. It should be remembered, however, than an oscillating amplifier will feed back power into the c.c. plate coil, so as long as it is known that the system is stable under working conditions, it is not unfair to reckon the increased power as being handled by the crystal.

Our friends abroad cannot as a rule obtain high impedance-valves, and any information about working with low-impedance valves will be of great value to them.

The writer was privileged to see some preliminary results of Prof. Cady, obtained while investigating the modes of resonance of rectangular plates. His method was to cover the quartz thinly with lycopodium powder, and then make the plate oscillate or resonate with an air-gap, whereupon the lycopodium collected in strange lines, indicating the places where there was no motion of the quartz. The peculiar thing is this, that a quartz plate does not always give the same pattern. The change from one mode of vibration to another may be accompanied by a small change in frequency. The most valuable results will be those obtained with an air-gap oscillator (air-gap in this case and not mica-gap), but considerable information can be gained from crystals arranged as resonators and driven by the oscillating amplifier.

If you haven't got any lycopodium, write to my QRA. The only other item required is a means of recording the patterns. A good camera would do, but it is sufficient to lay the quartz plate on a piece of gaslight paper (in a very poor light) and burn some magnesium ribbon above it.

One word of warning. Lycopodium is a very light powder—a breath will blow it away, so dress up for the occasion like a Wild West bandit with a handkerchief over your nose and mouth.

2QY.

### Note.

With the next issue of the BULLETIN we hope to commence the publication of the Proceedings of the Society for the present session.



# A Simple Heterodyne Wavemeter.

By H. C. PAGE, G2AFG.

Now that the 45-metre band, which, the writer imagines interests the majority of transmitters, is becoming so crowded, an accurate wavemeter is a very desirable piece of apparatus.

The heterodyne wavemeter here described has superseded the absorption wavemeter previously used at this station. The cost of construction is not great, and in the writer's opinion is well worth while.

The outstanding advantage of a heterodyne wavemeter is the fact that use can be made of its harmonics, thus enabling one coil to be used for several wavelength ranges. Also a quicker and more accurate reading can be taken.

The instrument here described is used for either 23, 45, 90 or 200 metres. The actual range of the coil is from 30 to 65 metres.

The circuit used is nothing new, merely a series fed Hartley. This was chosen in preference to the shunt fed arrangement, as no chokes are necessary.

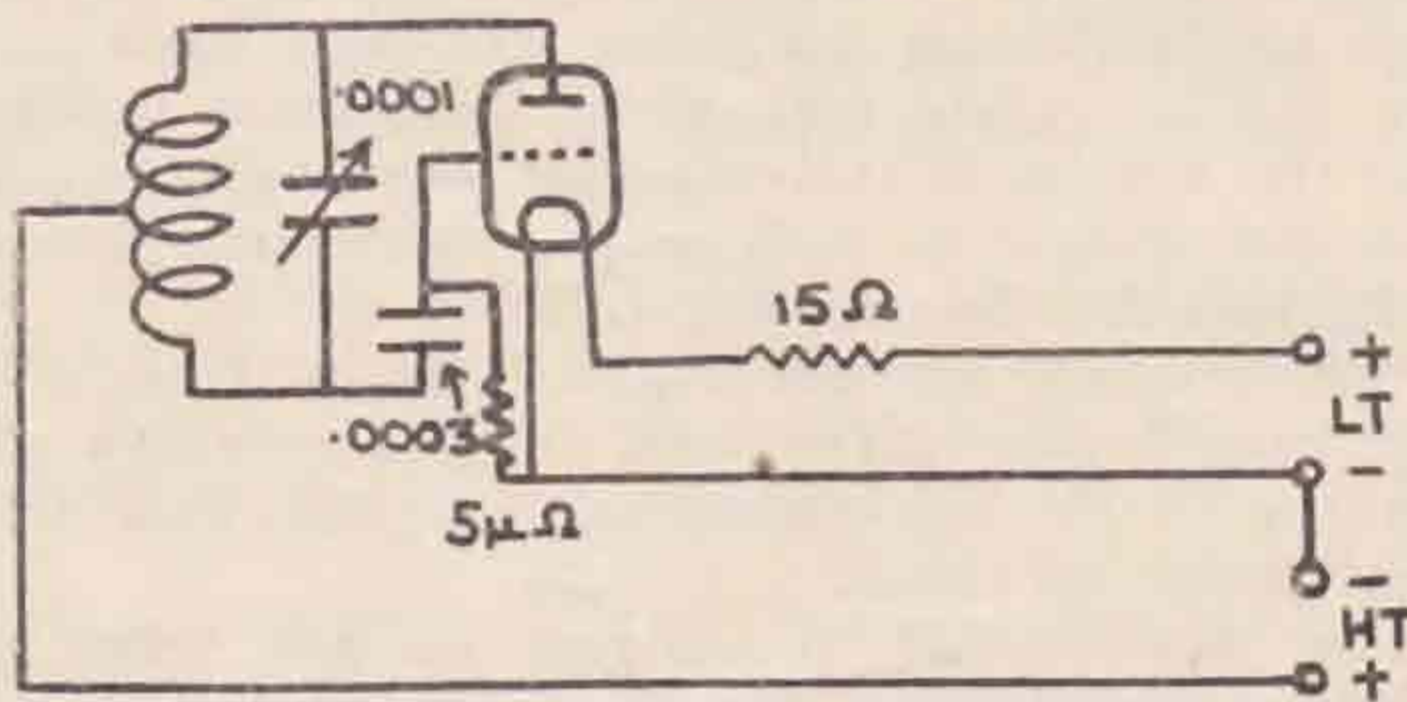

This is a great advantage, as chokes are quite capable of variation and this would upset the calibration of the instrument. Oscillation is fairly even over the whole condenser scale, a very necessary feature in a wavemeter.

From the circuit diagram it will be seen that the H.F. currents flow through the H.T. battery; this, however, does not seem to have any ill effect.

The coils used in the instrument are of rather unusual design. No ebonite former with a screw thread on it being available, a flat basket coil former of quarter inch ebonite was made. The diameter of the coil is four inches and there are five slots half an inch wide and one inch deep, cut at equal distances round the circumference.

For 45 metres twelve turns of No. 16 gauge double cotton covered wire were wound on. The ends of the winding and the connection from the centre tap being brought out to valve pins arranged in a triangle in the centre of the former.

A small hole was drilled in the centre of the triangle so formed and tapped 2 B.A. This was fitted with a short piece of 2 B.A. screwed rod. A shield of 3-16 ebonite of the same diameter as the former was then constructed and a 2 B.A. clearing hole drilled through the centre. This was then slipped on to the 2 B.A. rod and the whole locked down with a condenser knob. By using this method a coil of very solid construction is obtained.

The condenser used has a capacity of about

.0001 mfd. No special make is employed, but the best parts of several were incorporated. The plates are double spaced and are double the ordinary thickness.

Referring to the circuit diagram, it will be seen that a 15 ohm resistance is included in the positive filament lead. This is to enable a three-volt valve to be used with the usual four-volt accumulator. The valve used is an American one. This is used merely because the writer has several of the same type, and their characteristics being all the same an interchange can be effected without upsetting the calibration.

The H.T. required is from 30 to 40 volts. Alteration of the H.T. voltage does not affect the calibration at all.

The wiring of the instrument was carried out with 14 gauge wire covered with sistoflex. A small push pull switch is located on the panel. This controls the L.T. accumulator.

A second coil has been constructed for use between 14 and 32 metres and works quite well, although tuning is very critical and a Vernier dial would be an advantage. The dial in use is an ordinary four-inch one marked 0 to 180.

In conclusion, any wavemeter, however well made, is of very little use unless it is accurately calibrated. The method described by the writer in the August BULLETIN can be employed where accuracy of not more than .1 of one meter is desired. Better still, send it up to headquarters and let them do it.

## Beam Antenna Systems for 5 Metres.

*A Summary of the Talk given at the Convention held at the Institute of Electrical Engineers on Friday, September 30, 1927.*

By E. J. SIMMONDS.

It may be useful and stimulate interest in five metre work if I say a few words about some simple forms of antenna systems, incorporating tuned reflectors particularly adapted for use in our five-metre experiments. We are all familiar with the vertical type of full wave antenna, the theoretical current distribution of which may be represented as in Fig. 1.

The vertical component of the radiated field characteristic of this form of antenna has been theoretically calculated and practically platted, and may be indicated as shown in Fig. 2.

It will be seen that the principal radiation is projected at an angle of approximately 30°, giving a low angle emission particularly adapted for long distance transmission.

Assuming an aerial clear of any earthed bodies, the radiation will be equally distributed all round the antenna, and if, as is often the case, communication is desired with one fixed point, such a system as outlined above becomes wasteful of power, and causes unnecessary interference with other transmitters by giving a signal in localities where no signal is necessary or desirable. Now, in the short time at our disposal, see what can be done by incorporating some simple forms of tuned reflectors. As before we have the vertical full



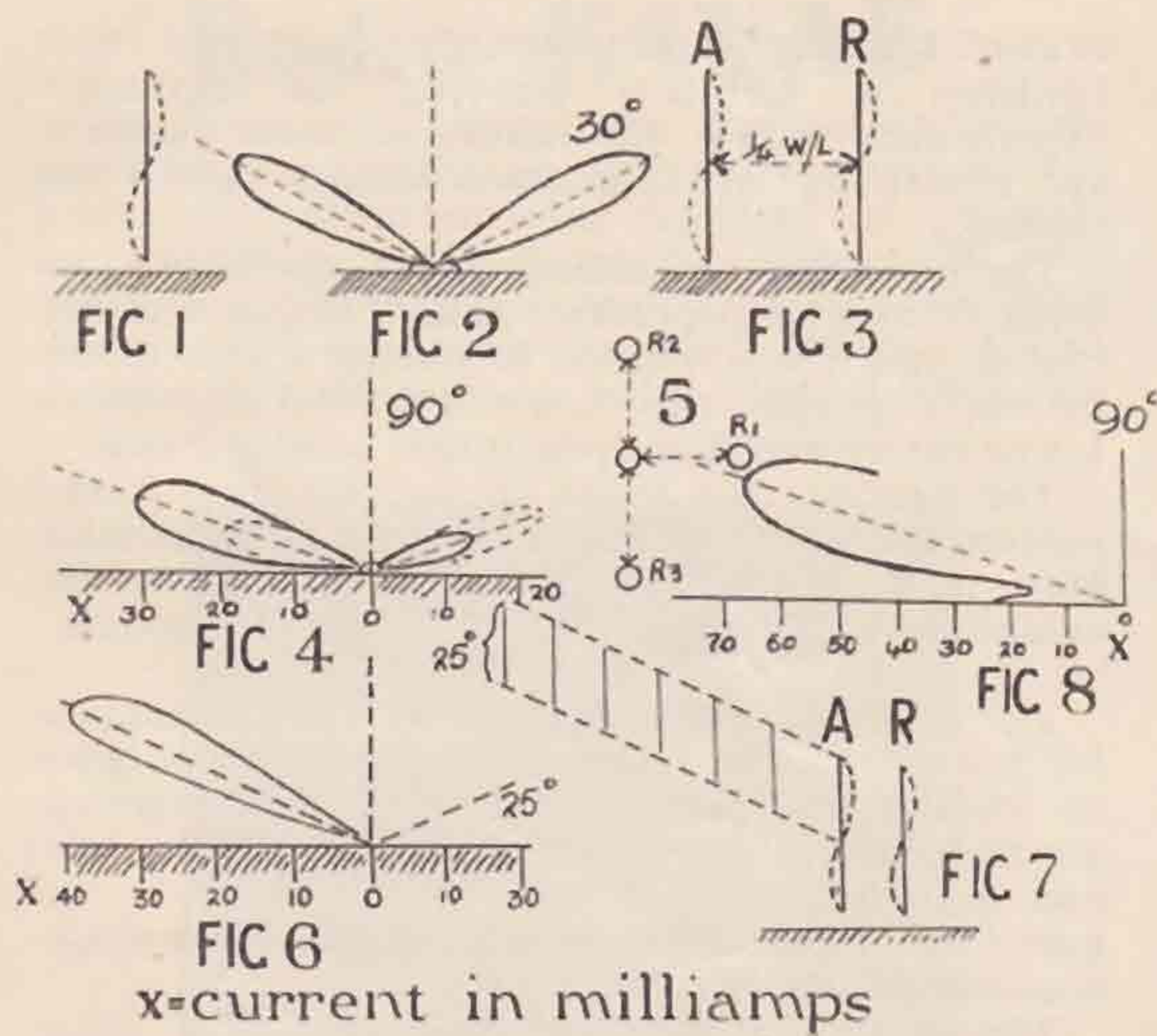

wave antenna A, but we place behind it at a distance of a  $\frac{1}{4}$  wavelength another vertical wire R of the same physical dimensions as A. As is well known, this wire R will act as a reflector, and as it is tuned to the same frequency as A, the angular radiation of A will be intensified in the forward direction, and reduced behind R, so that we get a radiation characteristic much like Figs. 3 and 4.

The full line indicates the field strength and increased directive effect of the single reflector R, and the dotted lines show the simple full wave antenna, without the reflector R. This arrangement has not, however, reduced the sideways radiation to any extent, and therefore let us develop the system further, and place two more reflector wires, one on each side of the antenna A at a distance of half a wavelength. Thus, looking down from above, our antenna-reflector system will appear as in Fig. 5.

The radiation characteristic of such a system as this compared with our last figure will be represented here, when the great gain in forward radiation will be noted. These additional reflectors R2 and R3 have also reduced the sideways radiation to a small value (Fig. 6).

Now carry the development a step further, and arrange in front of such an antenna system as just described a series of vertical wires D, such wires or wave directors being arranged along an inclined plane, the angle of which coincides with the principal angular radiation of our antenna system, as in Fig. 7.

By the addition of these wave directors D, we have arranged a wave channel which acts as a means of focussing and converging the radiated energy along a definite and sharply defined path.

The resulting field strength of such a system is as in Fig. 8, and we see that this comparatively simple reflector system has practically eliminated high angle radiation to sides and back of aerial, and greatly increased the forward radiation. Compare last diagram with the simple antenna without reflectors. It has been suggested that such a system may provide a means for the transmission of considerable power by electro-magnetic waves

and a full report of the experimental work which forms the basis of this short talk will be found in an excellent paper in the May proceedings of the Institute of Radio Engineers, contributed by S. UDA, of Japan.

## The Second Annual Convention, 1927.

BY OUR SPECIAL CORRESPONDENT.

The second annual convention was held at the Institution of Electrical Engineers, Savoy Hill, on September 30 and October 1, 1927. The proceedings opened at 6 p.m. on September 30, after a very welcome tea in the lounge.

The President, Sir H. C. Holden, opened the convention by reading the notices published in the last issue of the BULLETIN. These were received with great acclamation.

Mr. K. Alford, who was scheduled to open a discussion upon "Short Wave Transmission," was unfortunately unable to attend, and his place was taken by the Editor of the BULLETIN, who can always be relied upon to fill up gaps (his natural function in life.—Ed.). He outlined some facts and fallacies which are not generally recognised by the amateur.

Mr. E. J. Simmonds (2OD) described a most interesting 5-metre beam system (reported in detail elsewhere) and showed how, by means of comparatively simple arrangements of reflectors, the strength of radiation could be increased in any desired direction from a value of two without such reflectors to a value of seven with the system in use. Mr. Simmonds very rightfully pleaded for serious consideration of some such system by members who wish to carry out serious experimental work.

Mr. J. Clarricoats discussed the difficulties resulting from QRM on the 45-metre band, and Mr. A. Hinderlich, M.A. contributed some interesting remarks upon peculiarities and phenomena associated with piezo quartz oscillators as might be expected from his wide experience with these subjects. (See article elsewhere in this issue.)

Some really interesting and excellent films of amateur stations were shown by Mr. F. E. King (5AD QSL, manager) who was ably assisted by Mr. Pollock (5KU), whose help *avec* Chattertons compound and multi stranded steel fuse wire is always forthcoming in time of need. The films were made possible through the courtesy of the Kodak Company, who kindly loaned one of their cameras and projectors for the occasion. The stations filmed included 5TR, showing the BULLETIN in the course of making, the setting, being very charming, so much so that some speculated as to whether the picture could possibly have been taken this *summer*. (This was a colossal fake, and we do not get the opportunity to do the job in the open air as a rule. We are more accustomed to a rather tight squeeze between index cabinets and other solid bodies.) Other stations which appeared were 5AD, 5KU with his bank of H.T. accumulators, 5KS and 5NJ. The latter was greeted with some applause, as his work in Northern Ireland on behalf of Irish amateurs in the days that there were no licenses is well known to many of those present.

On the following morning members re-assembled at the I.E.E. to take part in a discussion upon



"The General Policy of the Amateur," which was opened by Captain H. J. Hampson, 6JV, the Mid-Britain area manager.

Considering the subject under two main headings: (A) Domestic, and (B) Foreign, the suggestions made by Captain Hampson include:—

(1) That a deputation of accredited T. & R. and R.S.G.B. members should interview the P.M.G. with regard to the general policy of permits.

(2) That after his explanation of the existing position with regard to 32-metre permits, the speaker expressed the opinion that it would be wise to proceed very cautiously in the matter of applications for permits on this band.

(3) That with the exception of special cases where interference with broadcasting would not result, it was a good general rule to refrain from transmitting upon any wave during normal broadcasting hours.

(4) That members be encouraged to keep an experiments log, in which they should record all their tests, with a view to being able to produce conclusive proofs of useful work done by members, both individually and collectively.

(5) That in future area reports should indicate the matter which the stations reporting will investigate during the following month, with the result of last month's tests, instead of valueless details of local and foreign contracts made.

(6) That the time had arrived to consider the possibility of again extending the scope of the R.S.G.B. to include the Dominions, and to form with them some form of British Empire Radio League which would be worthy of the Empire and stand beside the A.R.R.L. and other existing national organisations with the I.A.R.U.

These suggestions generally were accorded a very favourable reception, proposers, seconders, coming forward readily. Matters with which the Convention were unable to pass through without the sanction of the Council were referred to that body with recommendations from the meeting. Mr. J. A. J. Cooper (5TR) then outlined proposals for re-organisation of the committee in such a way that every member of this body would be elected to perform a definite task.

Briefly, the scheme is that the committee shall consist of sixteen members, eight of these will be area managers, who will be elected upon the same lines as last year.

The remaining eight members will be elected from the London area at the annual general meeting. These members will be known as "Responsible Members," and will be in charge of some department, e.g., publications, licenses, social events, society instruments, etc.

Each responsible member will co-opt to his own sub-committee not less than two or more than four other members to assist him in his work. Further details of this scheme will doubtless appear in due course, and it will suffice to say here that the entire proposals were approved unanimously, which speaks volumes for the care and thought with which they had been prepared.

The principal business of the convention had been concluded by lunch time, and the afternoon proceedings were concluded shortly after 3 p.m. The principal matters discussed included a proposal by Mr. Clarricoats to ban fone on the 45-metre band. As the discussion proceeded, it became

evident that any such arbitrary ruling would cause hardship to members carrying out legitimate experiments within the terms of their permits, and eventually Mr. Clarricoats himself moved the closure.

The questions of holding future conventions in other centres of population than London was discussed, and it was decided to obtain a vote of the membership upon the choice of several alternative towns before deciding upon future arrangements.

The meeting then broke up, and members joined parties under the direction of the several London area managers which proceeded either to the exhibition at Olympia or to "Tours of London," etc.

The task of reporting the convention would be far from complete unless readers were conducted to Pinoli's Restaurant at 7 p.m. that evening, for there were assembled some 75 members who had gathered together in order to enjoy a real ham-feast organised by managers under the chairmanship of Mr. Exeter (6YK).

The dinner was excellent, and the Q.R.M. occasioned to the culinary department and staff by failure of the electric light and ultimate substitution of candles affixed to upturned dinner plates (with KU's ever present Chatterton) failed to Q.R.T. the enthusiasm of the gathering.

After "The King," various members found that the "string of their tongues" had been loosened, and some short speeches followed.

Mr. Exeter welcomed the members, and had a special word for the provincial representatives. Mr. Clarricoats showed the true Ham spirit in explaining that the whole desire of London was to welcome country members, and appealed to all in the London area to back this attitude, both individually and collectively. Mr. K. Alford (2DK) reminded members of the dignity attached to amateur radio, and expressed the hope that he would see more of the older members upon the next occasion.

Mr. J. A. J. Cooper was optimistic regarding the present and the future of the Society, and received a well-merited ovation. After this, members proceeded to a room above which had been reserved for rag-chewing purposes, and 5AD, again assisted by 5KU, proceeded to set up the cinematograph (and to blow all the fuzes). This little difficulty was eventually overcome, thanks to a reel of tinned copper produced by 5KU and generously applied by this gentleman. There was a little unofficial betting as to which would blow first: the main fuze or that which had been substituted for the bar which had proved unable to subtract the "load" of the projection. However, all was well that time, and the second annual convention was at length concluded, and if the good spirits which prevailed throughout, and the total absence of grumbles may be taken as a measure of its success, the verdict must surely be F.B., and the omens can only be regarded as auspicious for 1927-1928.

**HAVE WE HAD  
YOUR SUBSCRIPTION?**



# Radio K4YAE

The first thing noticed is the power control panel for controlling the generators. You see the power line voltmeter, lying direct at one phase of the incoming three-phase 50 cycles 220 volt power line. From there the power goes to the main motor switch that controls a 3-h.p. motor. Direct coupled with the motor is a 1,5 kilowatt 500 cycles

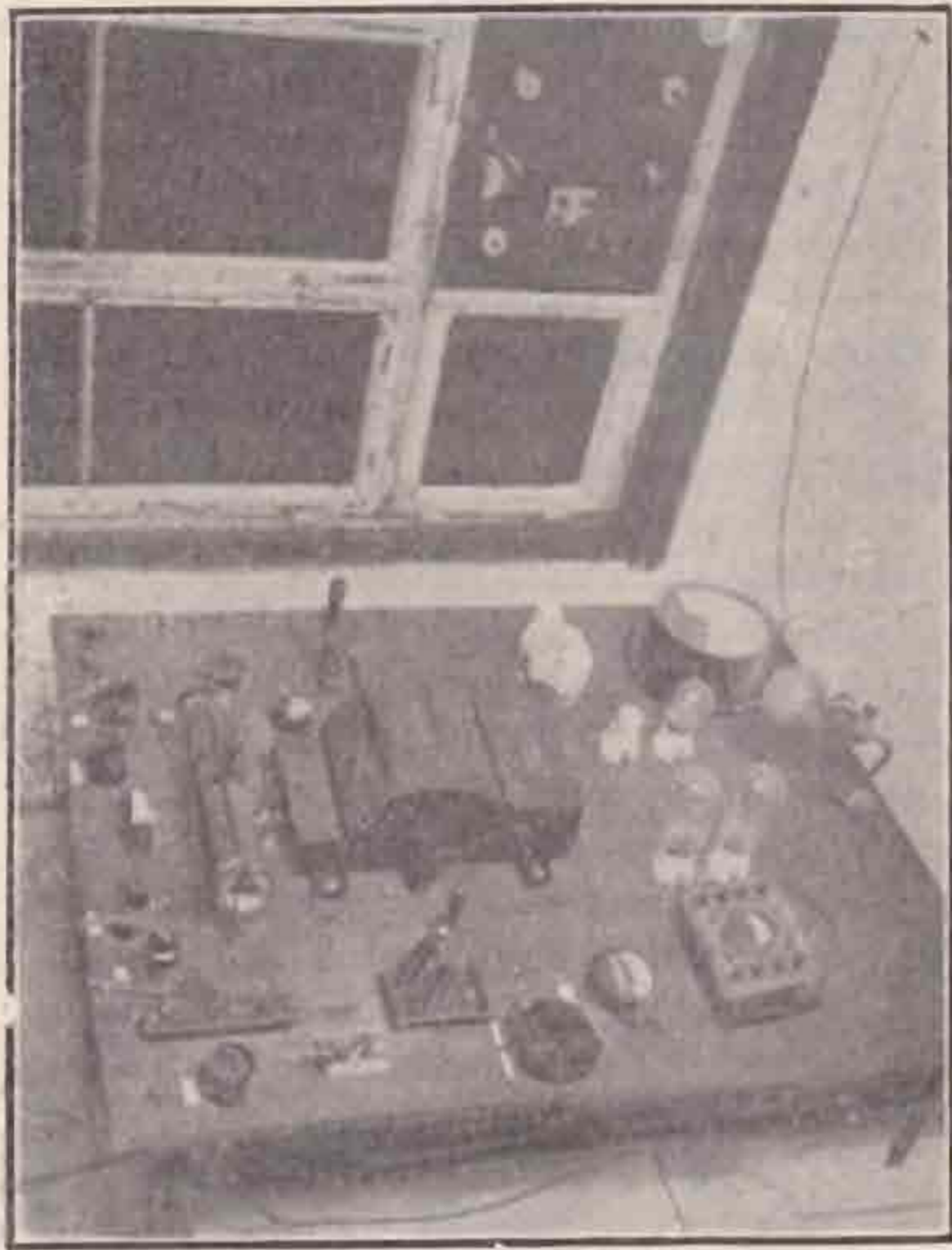

alternator, giving 220 volts, having built in the exciting D.C. generator. The current from the latter is used for battery charging and for the filament of the oscillator tube. Two other machines are driven from the motor with belts, a 500 volt D.C. generator for 30 watts, and a second alternator like the first, but for only 300 watts output. The exciting generator of the small alternator is used for exciting the field of the 500-volt generator. The meters and control switches for all this are on the panel.

The transmitter is crystal controlled and works on 42,9 metres. The crystal oscillator is the small apparatus at the right in the photo. A Müller telotron valve is used with 2,2 amps. D.C. filament and 400 volts plate power without filter. The crystal oscillates without any help, and is of 0,83 millimetre thickness, 23 millimetre diameter, and gives an output of 10-12 watts. (It was grounded

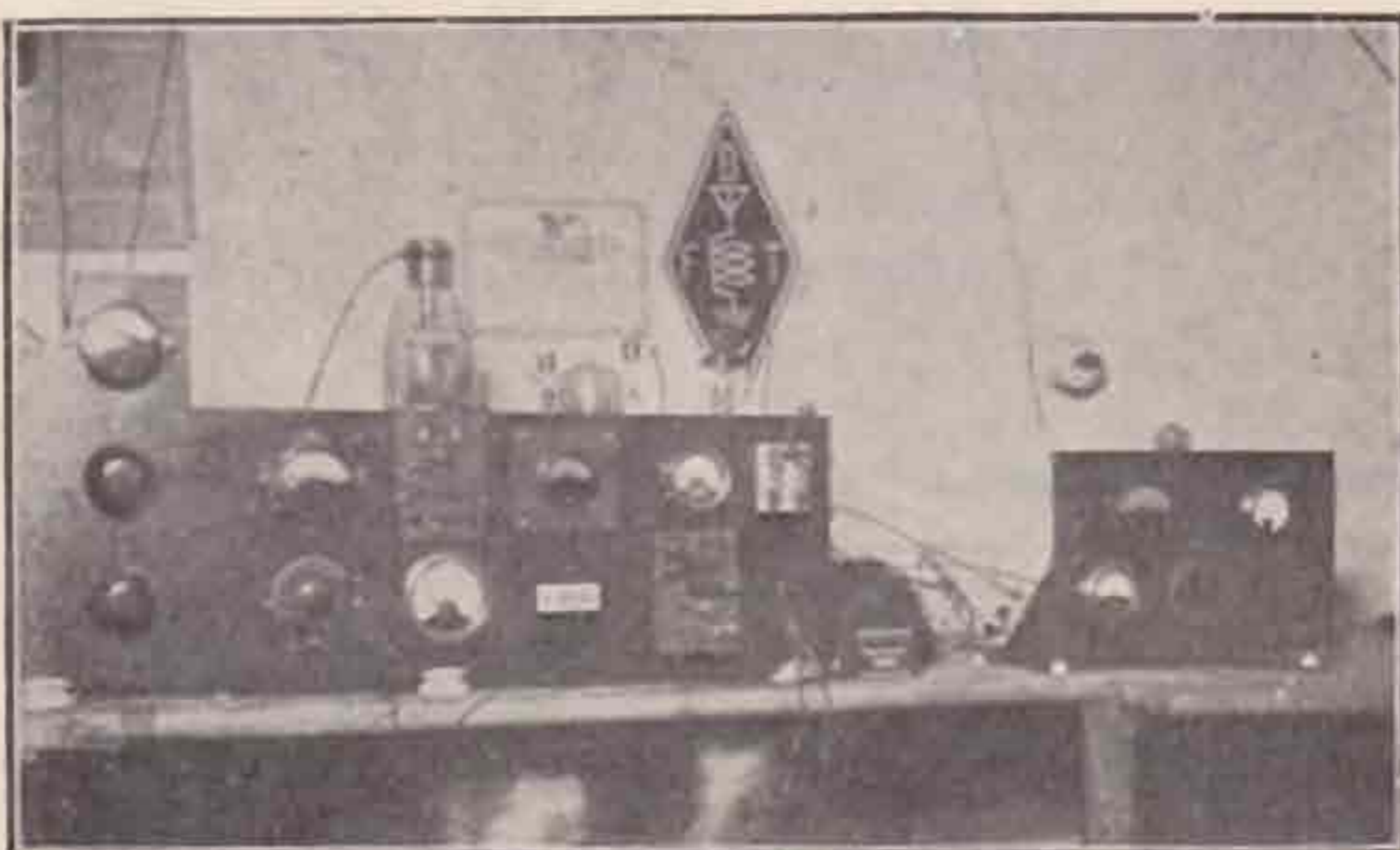

by a German manufacturer and cost only about 18s.) The oscillators wavelength is 85,8 m.

As you can see from the diagram, the P.A. is capacity-coupled with the oscillator. All coils are built self-supporting.

The P.A. tube is a 500-watt bottle, also from Müller. The filament comes from a transformer

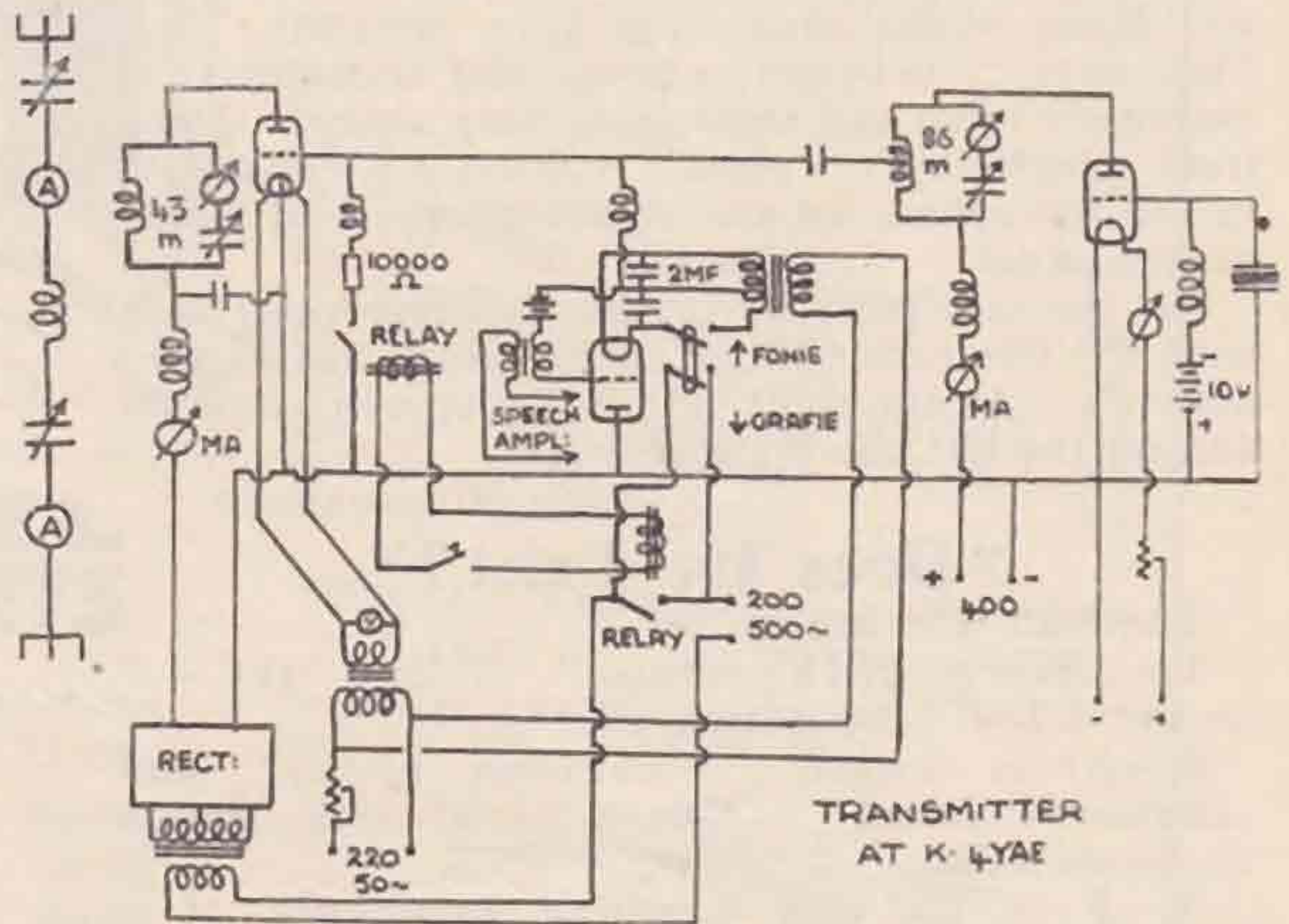

50 cycles 220/20 volts. Filament current 8.2 amps. The filament of the P.A. tube has a centre tap, so that a centre tap on the filament transformer is unnecessary.

Next we come to the plate power rectifier, a very fine thing and little known, as it seems. It consists of a Wehnelt tube built by the Akkumulatoren-Fabrik A.-G. Berlin. Inside the tube there is a platinum spiral heating a piece of calcium-oxyde by means of a 2 volt 10 ampere current sent through the spiral and taken out of a transformer specially built for the high voltage between primary and secondary. In the two glass arms of the tube are two carbon anodes and the tube is filled with neon or argon gas and evacuated. And this rectifier works up to 3,000 volts D.C. up to 1 (one) ampere. Hi! The price is about 40s. to 45s. in Germany.

No filter is used, only a 2 mfd. condenser lies in parallel with the H.T. The tone is reported as very pure D.C. To prevent the condensers from being punctured and to ensure the signals being clean cut, two relays, as shown in the diagram and in the photo, are used. The grid relay shuts precisely at the same time as the relay in the primary of the H.T. transformer. This is effected by operating the different screws on the relays, while keying and listening on a receiver.

For 'phone work a special tube is built in. It is a Telefunken RS5 transmitting tube for 10 watts. The modulation is done by taking the variable resistance of the tube instead of the grid-leak used for code. The microphone current passes through a one-tube speech amplifier and controls the grid of the modulator tube. This system is used by the German broadcast transmitters and works very well. It is called Gitter-Gleichstrom-Modulation, translated in English "Grid-Direct-Current-Modulation." Results are that telephony is reported as being the best 'phone ever heard on short waves. When, for instance, the code signal strength is R7, the 'phone is reported as R6-7. The advantage is that with this modulation system nothing is very



critical, neither the filament current of the modulator tube nor its grid voltage. All may be easily controlled by hearing the telephony in a tuned circuit with a detector. In this manner concerts of the Stuttgart broadcasting are often relayed. The aerial current with code is about 0.7 amp., the antenna system being excited in the third harmonic, and being of the usual cage type inverted "L." The coupling between antenna and transmitter is extremely loose and the tuning very sharp. Going from telegraphy to 'phone, it is only necessary to throw the switch on the right upperside of transmitter panel.

On the last picture you see the receiving table with the two-tube Schnell tuner, which has its own antenna. At the right side is the speech amplifier and on the left the microphone.

ROLF HORKHEIMER.

### "Does He Exist?"

The man who has:—

- 1.—Never pinged a pet tube! . . . put "HT + " on to "LT + " by mistake.
- 2.—Never logged "Conditions rotten," and afterwards found his main aerial-earth switch disconnected!
- 3.—Ever had the uncanny experience of a *successful* demonstration of his receiver in the presence of friends! (and critics!!)
- 4.—Got a posh receiver to work OK on *first* test!
- 5.—Been able to suppress his feelings and think "sweet nothings" when another ham "butts in" on a DX station he's been trying to identify for some few minutes, with his "blobberty-blop," just as the station in question is about to announce!
- 6.—Never exaggerated the "R strength" of his latest "DX" when "explaining," to his rival!!
- 7.—On dismantling his best receiver, found that he had never connected his 'phone leads when testing!

BRS92.

## The Contact Bureau.

I have been asked to organise a "Research Bureau" which of necessity must be limited in scope at the commencement. At the same time I hope it will be of great service to experimenters not only in Great Britain but abroad, and will, as time goes on, develop in many ways. For the time being the Bureau will be known as the "Contact Bureau."

Many of us are working on various problems, aeriels, crystal control, fading, echo effect, five-metre work, etc., and we are not aware of just how many are working on the same problems and perhaps may be of use to us. This Bureau is to form a link between workers on the various problems; Mr. A., of London, is interested in the angles of radiation of various aeriels and after working alone for some time wishes he knew of someone doing the same thing, so that he could discuss various points and perhaps carry out tests. He writes to the Bureau, enclosing a stamped and addressed envelope, and makes known his needs. We look up our files and find that several members are also interested in his subject, and we send him their names and addresses.

Mr. B., of Shetland, is not a transmitter, but he reads Morse and would like to report on real honest-to-goodness tests if some transmitter would

make use of him. He sends us details of his receiving station and the days and hours he usually is available.

Mr. C., of Carlisle, needs honest reports on his scheduled transmissions, and writes to us asking for the names and addresses of receiving stations who would co-operate. We refer again to our files and see that Mr. B. is available on the days mentioned by Mr. C., and we forward Mr. B.'s name along with all the others we may have who are available at the times mentioned. They can then make the schedules to suit each other by direct communication.

Where, Mr. Reader, do you come in? Well, you must surely be interested in some branch of experimental work or you would not have obtained a licence, so just send a card to me at 59, Marlborough Park North, Belfast (N.1), giving the following particulars:—

- (a) Name and address.
- (b) Call sign, if any.
- (c) Present experimental work.
- (d) Subjects interesting you which you would like correspondence upon.

These details will be filed, and when occasion arises we will refer other experimenters to you, and then you can get together.

You may be willing to co-operate from your station, at definite times, with anyone wishing to carry out tests. If so, please let me have your name and times, just the same as if you were going to do the tests yourself.

When you have been working along definite lines or have noticed anything of interest from the technical point of view, I want you to drop me a card, as I wish to give a summary each month of what is being done by the members from the experimental standpoint.

You would be interested in little items giving the results of definite tests, would you not? Someone will have reported them, and why not you? Give the other members the benefit of your experiences.

A few points to remember:—

- (1) Write now with details that I have asked for.
- (2) If a reply is required enclose a stamped envelope.
- (3) Report everything of an experimental nature, and don't refrain because you "don't think it is of much use."
- (4) Address all communications to 6YW, 59, Marlborough Park North, Belfast (N.1).
- (5) Notices of test schedules for publication must reach here at latest on the 15th of the month, *i.e.*, at least a month before tests.
- (6) Read over the above and decide that it is "up to" every member to assist in some way, and it will be a small matter for you to drop a postcard to me, and it will be a big help to get the Bureau started.
- (7) Stamped postcards for replies may be sent if you so desire.

T. P. ALLEN (GI6YW).

### Obituary.

We regret to announce that William Le Quex, novelist and member of the Society passed away last month. We shall miss him greatly for he was one of the original amateur transmitters in the country.





## EXCEL TERMINAL TAGS

### "COLLETT" PANEL BRACKETS

**PRICES**  
No. 1 (6x6) **1/9** PER PAIR  
No. 2 (3 1/2 x 3 1/2) **1/3** PER PAIR

ADJUSTABLE BRACKETS

for Sloping Panels Permits the panel to be fixed at various angles, the position being maintained by use of a lock nut. Improves and completes any set. Ideal for experimenters. No. 3. 5"x 5" Price 3/- per pair.  
No. 4. COLLETT Sub-Panel Brackets. 1 1/2" x 1 1/2", 3d. per pair.

Per doz.

No. 1.	Small, BRIGHT BRASS ..	5d.
No. 1.	Small, NICKEL BRASS ..	5 1/2 d.
No. 1.	Small, TINNED COPPER ..	6d.
No. 2.	Large, BRIGHT BRASS ..	6d.
No. 2.	Large, NICKEL BRASS ..	6 d.
No. 2.	Large, TINNED COPPER ..	7d.
No. T.1.	Telephone, TINNED ..	6d.
No. T.2.	Telephone, TINNED ..	9d.
No. S.3.	BRIGHT NICKEL ..	6d.
No. S.4.	BRIGHT NICKEL ..	5d.
No. SP.	BRIGHT NICKEL ..	6 1/2 d.
(Large S.4 type with 1/4" hole.)		
No. S.5.	BRIGHT NICKEL ..	5d.
No. 8.	BRIGHT NICKEL ..	7d.
No. 9.	Small, Round Hole, TINNED	7d.
No. 10.	Large, Round Hole, TINNED	8d.
No. 12.	EXTRA LARGE ..	9d.

1/4" open gap, or 1/8" round hole.  
"EXCEL" TAGS also sold in 1/- Cartons.  
"COLLETT" HOLDTITE CLIPS for making temporary connections. The Clips with 101 uses. Price 5d. each.



"COLLETT" & "EXCEL" PRODUCTS  
From all Good Dealers.  
Manufactured by  
**S.H. COLLETT MFG. CO.**  
60, PENTONVILLE RD., LONDON, N.1

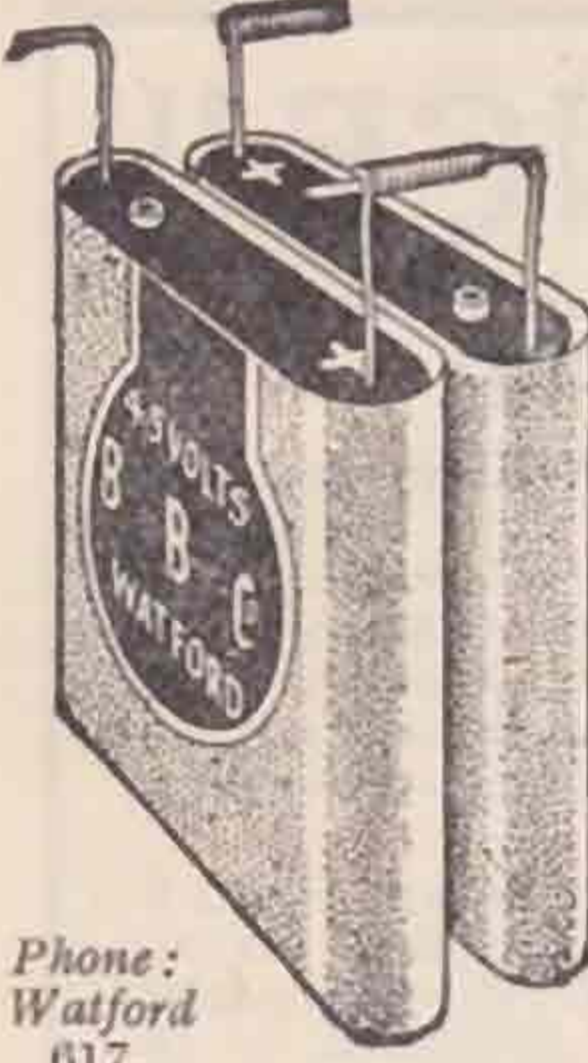

Phone: Watford 617.

## BUILD UP

*the voltage you need!*

OUR No. 1 W Standard Pocket Lamp, Size 4 1/2 volt Batteries with Patent Spiral Wire Terminals and Wander Plug Socket, ensures permanent connections without soldering. To connect in series insert straight terminal in spiral of next battery. (See illustration.)

**7/- PER DOZ. WITH PLUG**  
(Carriage Paid.)  
New Illustrated Price List now ready. Contains full details of our new DIAL CONTROL Battery and B.B.C. Cabinet Types.  
(Guaranteed British made)

**BRITISH BATTERY CO., LTD.,**  
Clarendon Road, Watford, Herts.

### High Class American Type WIRELESS CABINETS

**FOR THE AMATEUR  
CONSTRUCTOR**

The outstanding feature of these high-class cabinets is the ease with which the set may be withdrawn for alterations without interference to the wiring. Made from well-seasoned Mahogany or Oak and polished by hand.

Prices:	12	14	18	21	24	28 inches
Oak	17/-	17/6	18/6	19/6	20/6	21/6
Mahogany	17/6	18/-	19/-	20/6	21/6	22/6

Obtainable from all reliable dealers, if any difficulty write to the Manuf'rs.  
The 12-14 and 18 in. are 8 ins. wide inside.  
The 21-24 and 28 in. are 9 ins. wide inside.

**FRANK RIDDIOUGH & SON, Westgate, Bradford**  
Phone: 4309 Bradford.

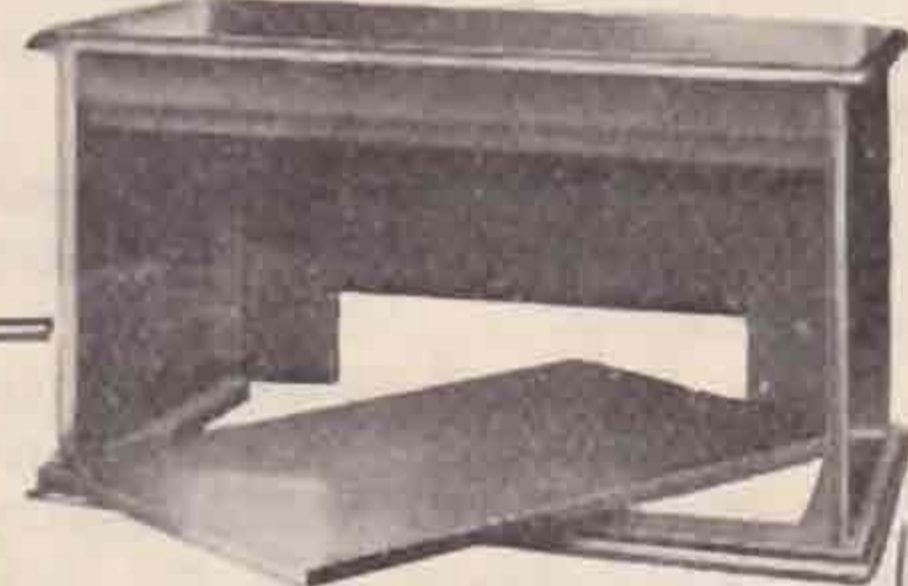

**Distinctive**  
**Q. S. L. CARDS**  
(as supplied to G.S. BT.)

A Style to Suit Every Taste.  
SAMPLES FREE ON REQUEST.

100 ..	5/6	500 ..	15/6
250 ..	9/6	1000 ..	19/6

Let us quote for your Private Note Paper, Business Letter Headings, etc. We are Specialists in all classes of Radio Printing.  
TERMS: Cash with Order.

**PAUL & MATHEW**  
11, Butter Market, Bury St. Edmunds, Suffolk

Est. 30 years.

## URIAH BEATON'S

### BARGAINS

**45, CHALK FARM RD., N.W.1.**

Radiation Meters, .5 - 5/- New.  
Recording Tape - 2/- doz. rolls.  
Postage and Packing Extra.

**OTHER BARGAINS TO FOLLOW.**



## "Threshold Howl."

F. CHARMAN (G6CJ).

As a result of a heated discussion at the T. & R. meetings, on the effect commonly known as "threshold howl," the writer decided to make some experiments in the direction of overcoming the trouble.

In Fig. 1 is shown a common arrangement for receiving short-wave signals, and it is found in many cases when such a receiver is set up that an annoying L.F. howl starts just as the reaction control ( $C_3$ ) is passed over the threshold of oscillation, thus rendering very difficult to receive c.w. signals. The howl disappears when the reaction is increased, but the detector will not then rectify well. When the reaction is increased "hard over," another howl appears, but this latter can be shown to be due to a very different cause from that of the former. It is with the former trouble that we are more interested.

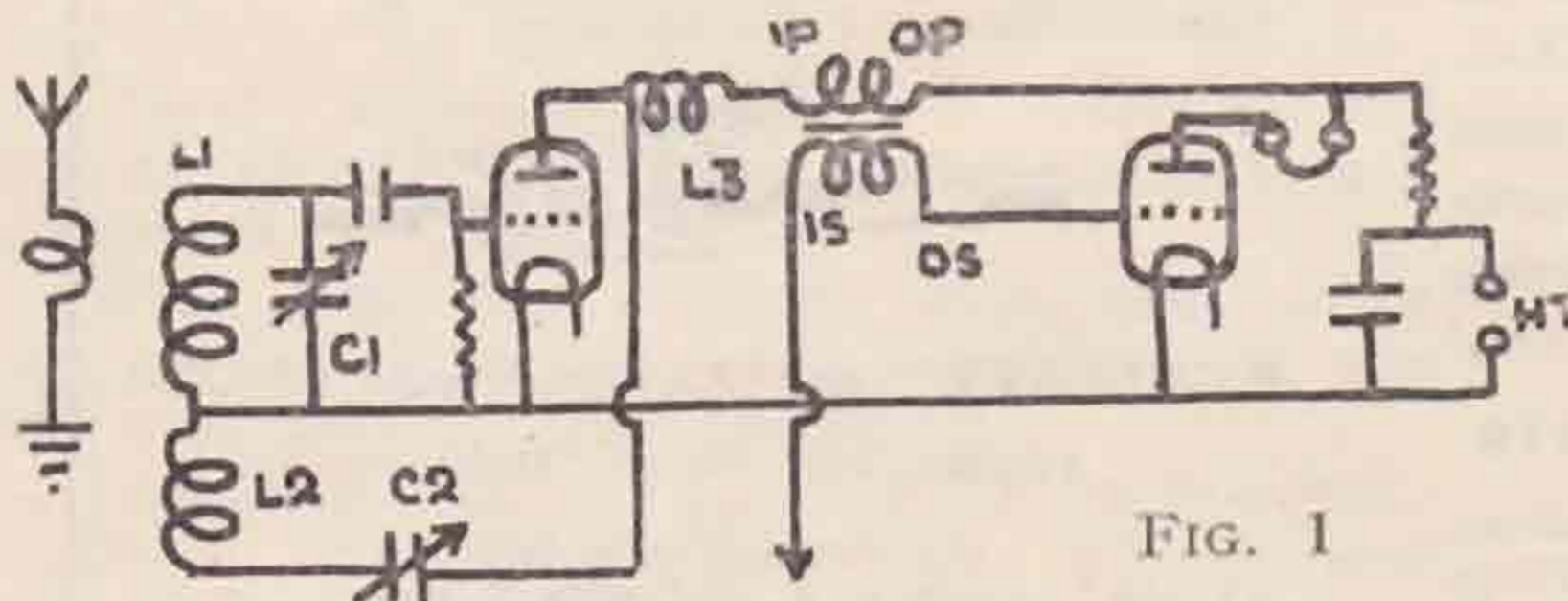

FIG. 1

Investigation brought out the following points:—

- (1) The tendency to howl is reduced by decreasing the filament voltage of the detector valve; or
- (2) The tendency to howl is increased by the use of a high-mag valve instead of one of lower amplification factor.
- (3) With two stages of L.F. amplification the tendency to howl is much greater than when one stage is used.

Now, in Fig. 1, suppose that the valve is made to just oscillate. We will assume that the choke  $L_3$  is imperfect, a justifiable assumption in nearly every case. Then there will be a H.F. current flowing through the self-capacity to the L.F. transformer primary, and also between primary and secondary through their inter-capacity, so that the grid of the L.F. valve can receive a H.F. potential. This H.F. potential will be amplified in the plate circuit and will receive the modulation of any L.F. voltage present. The H.F. currents in the plate circuit of the L.F. valve will give a voltage drop over the resistance of the H.T. battery or the microfarads across it, which will be common to the drop due to the H.F. current flowing from the plate of the detector, but in opposition of phase, owing to the reversal of phase during amplification in the L.F. valve. This voltage drop can be returned to the grid of the L.F. valve, carrying with it any L.F. modulation, and the stage can therefore generate oscillations on its own at the natural frequency of the transformer.

When reaction is increased, the effective impedance of the detector valve is increased also, and the effective voltage between the transformer I.P. and earth is decreased, and there is less tendency for the effect described to take place. In the same way decreasing the filament voltage of the detector valve lessens the effect. The use of a valve of high

amplification factor tends to make the transformer-voltage-amplification characteristic very peaky at 1,000 to 2,000 cycles, and in a better condition to go into oscillation. Two stages of L.F. is always more unstable than one, and it is reasonable to expect the threshold howl to become worse when another stage of L.F. is added to the receiver.

The cure is now easy. One simply has to stop the H.F. from getting into the L.F. It is not good enough to put a so-called H.F. choke  $L_3$  in the way, because even in the best of circles, things that deign to call themselves "H.F. Chokes" always allow *some* H.F. to get through them. No! it requires a Pukka (Hindu for F.B.) H.F. filter, such as is shown in Fig. 2, where we have two of the so-called chokes complete with bypass condensers.

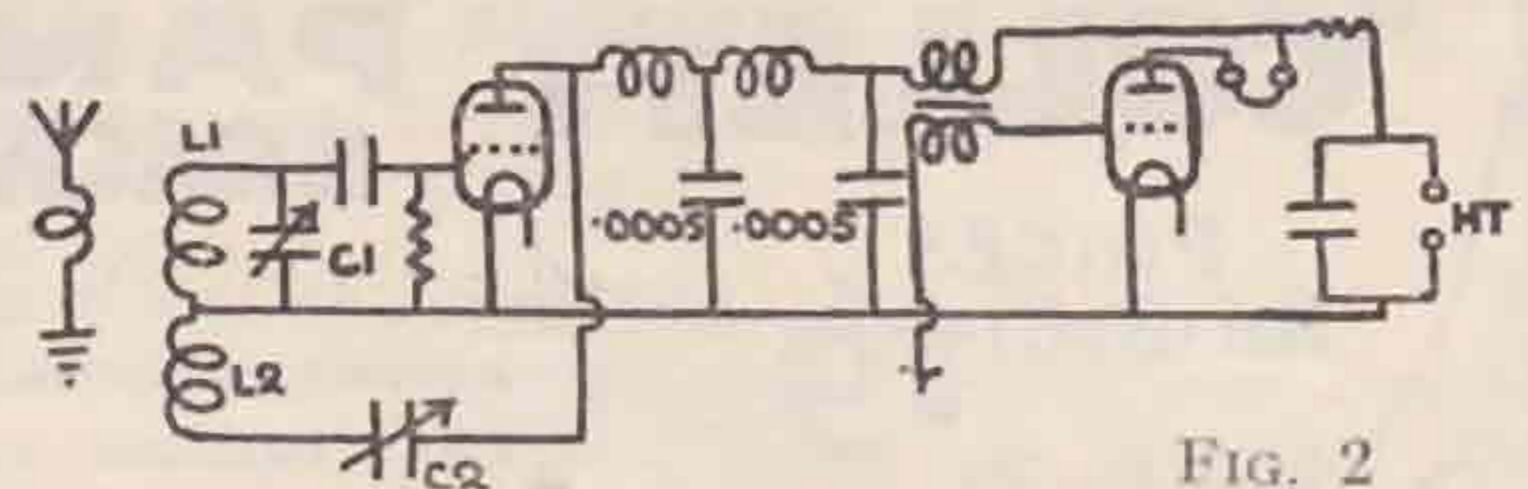

FIG. 2

The writer does not suggest that this explanation is the only one to be had, and will be glad to hear of any others which readers may have, but so far he has not previously encountered any explanation of this charming phenomenon. However, there is no doubt that the howl starts when H.F. currents start wandering around the L.F. parts of the circuit, or the batteries, where it has no business, and can be cured by warning it off these regions with the aid of a filter at the point indicated.

## CONFIDENCE!!!

Here are some reasons why firms of repute

### ADVERTISE

in the only British Wireless Journal Written and Published by Amateurs.

They know that in placing before you their various radio products they are communicating with an intelligent section of radio enthusiasts who through their intimate knowledge of radio transmission and reception are alive to the advantages of each instrument, component or accessory mentioned in their advertisement.

They are confident that even if members of the R.S.G.B. do not always need the lines they display, they are not backward in advising their less technical friends and acquaintances to purchase, because any line advertised in the T. & R. BULLETIN can be relied upon to give real satisfaction.

They pay to advertise in the T. & R. BULLETIN because they value the orders which readers send them, and, as sound business people, they want their business to go ahead and prosper just as much as you want to see advancement in the science of radio engineering.

WILL YOU STRENGTHEN THE CONFIDENCE OF THE ADVERTISERS BY PURCHASING THEIR PRODUCTS?

It will help, too, if you always mention the "T. & R." even when you only write for further details of any line advertised or when applying for Catalogues. **THANK YOU!**

*A note to those who wish to advertise—*

*Specimen Copy and Rates will be sent to all who apply to the Advertisement Managers,*

**PARRS,**  
Advertising Ltd.,  
CRAVEN HOUSE,  
KINGSWAY,  
LONDON, W C 2



## Variometer Tuning for S.W Reception.

By G5YM.

In *Wireless World*, August 12, 1925, Mr. B. R. G. Holloway described the construction of a short wave variometer. Doubtless this instrument has been tried out by some readers of the "BULL"; but as I have not heard of anyone using it I fancy I may be doing brother "hams" a service by drawing attention to its many excellencies.

The construction of the tuner is fairly simple for those with a little time and mechanical ability. I confess that I judged that it would be rather more than I could tackle, on the score of time, and asked Mr. Holloway if he could make me one. He was generous enough to let me have his original model.

The stator and rotor are of spaced, bare copper wire, mounted on good quality ebonite. Two pieces of ebonite are required, each 6 inches by 3 inches. The two pieces are bolted together by means of a 3-16ths hole through the exact centres. They are then placed in a lathe and a 2/5-16ths inch disc cut from the two pieces by means of a parting-off tool making a 1-16th cut. The discs serve to mount the rotor and the ends of the pieces the stator. Both stator and rotor consist of seven turns of No. 16 bare copper wire. Holes are drilled in the ebonite mounts through which the wire is threaded. The stator supports are mounted on dry hard wood. For full details refer to the issue of the *Wireless World* already mentioned.

The reaction coil consists of six or seven turns of No. 26 d.c.c. wire wound round the bottom of the stator mounting. It can be used either in the familiar "Reinartz" manner or with a variable capacity across the anode and H.T. negative. Both reaction inductance and capacity should be kept as small as possible to give oscillation over the complete range of the variometer.

The actual range of the tuner supplied to me is from about 18 to 40 metres; but by shunting the windings with a small air-spaced capacity of about 0.0001 microfarads the range was raised to about 25 to 50 metres—the most convenient for our ordinary working. Mr. Holloway suggested a small variable capacity; but one or two fixed condensers that can be clipped in as required enable the instrument to be roughly calibrated.

A slow moving dial is an essential. I found that an "Accratune" micrometer dial was admirable for the purpose. The scale is nicely divided, with fine lines, into 180° and the wavelength band between 43 and 46 metres is covered by just over 35°. This gives a beautifully open reading, more open than I have been able to get with any arrangement of fixed inductance and variable condenser. It is delightful to be able to separate d.c. stations that are practically on top of one another. Incidentally one gets an eyeopener as to the large amount of the frequency band taken by some of our Continental friends who pump out 50 cycles unrectified!

The aerial coupling is by means of a three turns pancake coil provided with a long ebonite handle and moving over the upper open end of the stator, pivoted on one of the stator mounts. This gives fine tuning and, save in very bad cases, allows



### RADIO CONTROL BOOKLET - Free!

Every radio amateur requires an authoritative guide to the correct electrical operation of his receiver. Here you have the opportunity of obtaining such a booklet entirely free. Just fill in and send the coupon below and a copy will be sent to you by return.

"Radio Control" has been prepared by the Weston Electrical Instrument Co., Ltd., who, for the past 30 years, have been universally acknowledged as the leading manufacturers of accurate electrical measuring instruments. Since the inception of radio the Weston Company have examined carefully every phase in its development and with each succeeding stage of progress have designed and produced appropriate instruments to assist the efforts of radio engineers.

Now the result of many years' radio experience is placed at your disposal. "Radio Control" will show you definitely how appreciable economies may be effected in the operation of radio receivers and how improved reception may be obtained at the same time.

To-day is not too soon—cut out and post the coupon now.

# WESTON

STANDARD THE WORLD OVER

Pioneers since 1888

WESTON ELECTRICAL INSTRUMENT CO., Ltd.

15, GT. SAFFRON HILL, E.C.1.

Application for free copy of booklet "Radio Control" from

NAME.....

ADDRESS.....



QSS and QSSS to be combated without touching the dials.

Altering the reaction capacity changes the frequency a little. This is useful as a means of separating stations operating very close to one another. The reaction capacity I use is 0.0002 "square law" with a slow motion dial.

The final delight of this method of tuning is that if the rotor axis rod, one end of the rotor and the metal of the dial, are all connected together they can be used as the earthed end of the tuner and all hand capacity effects are immediately banished without any resort to "remote control" devices. The whole tuner is remarkably stable and is a most efficient instrument.

## Patent Royalties and Licenses.

By H. T. P. GEE, Mem. R.S.G.B., A.M.I.R.E.,  
Patent, Trade Mark and Design Agent.  
(Copyright Reserved by the Writer.)

The grant of a British patent confers on the patentee, his agents or licensees, the exclusive right to make, use, exercise and vend the invention within the United Kingdom of Great Britain and Ireland and the Isle of Man, for the full term of sixteen years, subject to any question affecting its validity and the payment of the renewal fees, and also subject to certain provisions against any abuse of the patent monopoly.

A patentee is, therefore, at liberty to manufacture and sell the invention on his own account, or to assign his complete interest therein or to grant licences in return for the payment of agreed sums or royalties.

Licences to make, use, exercise and vend an invention may be adapted to the particular circumstances of each case, and may be General, Exclusive or Restricted.

*General Licence*.—A general licence confers on the licensee the right to "make, use, exercise and vend" the invention, subject to the agreed conditions, and does not debar the patentee from granting other licences on the same or different terms.

*Exclusive Licence*.—An exclusive licence confers on the licensee the sole right to "make, use, exercise and vend the invention," on the agreed terms, during the term of the licence, and may operate against the patentee himself using the invention, unless he reserves the right to do so. An exclusive licence is, therefore, almost equivalent to an assignment of the patent, for the period covered by the licence, as it confers on the licensee what is, in effect, a monopoly in respect of the control of the invention against competition.

*Restricted Licence*.—A restricted licence may be restricted in a variety of ways, according to the particular circumstances of each case, such, for instance, with regard to time, area or production.

It must be borne in mind that if a licensee makes, uses or sells the invention, in a way other than provided for in the licence, he renders himself liable to infringement proceedings.

In view of the complex and highly technical nature of the various points involved in connection with the payment of royalties and the granting of licences, it behoves both the patentee and the licensee to proceed very warily and to seek pro-

fessional assistance in such matters, as there are many pitfalls to be guarded against. For instance, unless the licensee stipulates, in the licence, that the licence shall terminate in the event of the patent being declared invalid, he may render himself liable to pay to the licensor the royalties payable under the licence for the full term for which the patent would have continued but for its revocation, whereas others would be at liberty to use and sell the subject of the patent without the payment of any royalties.

It is a well-settled principle of patent law that a licensee is not at liberty to question or attack the validity of the patent in respect of which he is liable for royalties, unless he has made any such provision in the licence.

It is customary and advisable for licences to provide for the payment of the agreed royalties on certain dates, and for the licensee to keep proper accounts in respect of all transactions and sales relating to the patent for inspection by the licensor at any time, and for all such particulars to be confirmed or verified by a statutory declaration, if required, and, further, for the licensor to stipulate for the termination of the licence unless the sales by the licensee are sufficient to justify the continuation of the licence or to terminate the licence in the event of the royalties not being paid, but without prejudice to his right to sue for the recovery of royalties due on any such determination of the licence.

With the object of preventing any unauthorised use of the patented article and assisting in the detection of any infringement and to facilitate the recording of sales of the licensed article, it is customary and advisable, where possible, for each patented article, made or sold under the licence, to be marked with a number or distinguishing mark.

It is very important for the licensor and the licensee to arrive at a clear understanding with regard to the payment of the renewal fees on the patent, otherwise the patent might expire, with the result that the licensee might still be held liable for the payment of the royalties, unless he took the precaution of ensuring the insertion of a proviso exempting him from the payment of any royalties after the patent had been allowed to lapse through the omission to pay the prescribed renewal fees.

In the case of *Cummings v. Stewart*, the plaintiff sought to recover royalties under a licence agreement, but failed owing to his having allowed the patents to expire, the Court holding that he was bound by the agreement to keep the patents in force, and his failure to do so released the defendant from the contract.

Conditions regarding the price at which the patented article is to be sold is also another consideration for the parties concerned, and in this respect it is necessary and advisable for the parties concerned to enter into the arrangement with a "give and take spirit," otherwise, if onerous or too restrictive conditions are imposed by either party, such, for instance, as making the price for the sale of each article unreasonably high, both are likely to suffer, mainly by reason of sales not being effected, and which otherwise might and probably would lead to a much larger turnover in the sales and consequently prove more beneficial to all concerned.

(To be concluded in our next issue.)



# Apparatus for 5-metre Work at 5MQ.

A certain amount of successful work has been accomplished on five metres at 5MQ, and it is thought that details of the apparatus in use would be of interest to those who are venturing into this interesting field for experiment.

Referring to the circuit diagram, Fig. 1, the aerial from free end to counterpoise free end is 5 metres long, and the meter shown in the counter-

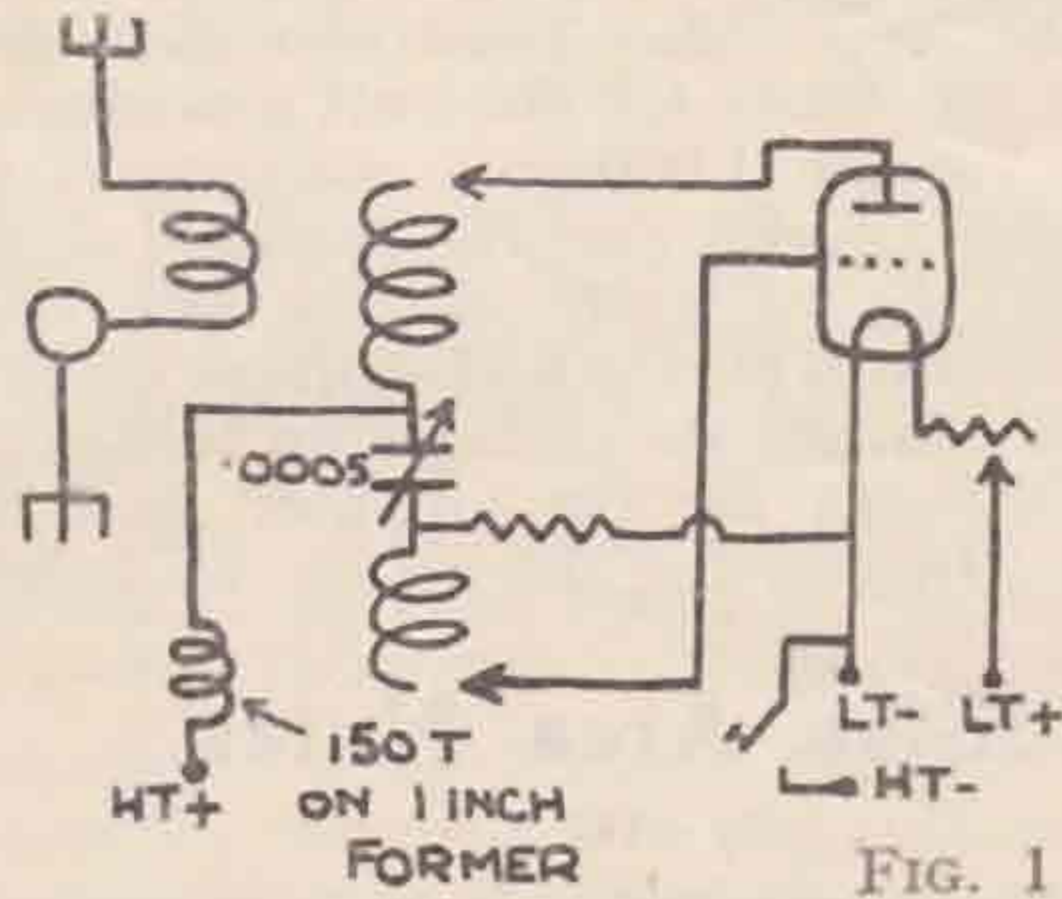

FIG. 1

poise is 1.5 metres from the end. The aerial coil consists of three turns 1.5 ins. diameter and the plate coil about five turns of a similar diameter. The grid coil is of the same diameter, but consists of as few turns as possible. The turns are reduced step by step until the input is reduced to the desired power. The coupling condenser is a .0005 variable condenser (we would here remark that this seems a trifle large, despite the fact that the large capacity helps to keep the set stable). This condenser also controls the QRH, which is, of course, obvious. The grid leak is a variable pickle jar type. The valve is an LS 5B type, and the anode voltage 300

at 8-9 watts, the aerial current being .1 at the nodal point.

Figs. 2 and 3 show the circuit diagram of the receivers which have been used, the coils being the same as those used in the transmitter. The grid tuning condenser consists of two plates, one fixed and one moving. The reaction condenser is a .0005 and the grid leak of a high value being of 8-10 megohms. The valve is a Mullard PM 1 HF.

## Strays.

Forty-four to forty-six metre morse work has recently become very difficult at the week-ends, owing to excessive 'phone activity on the narrow band. A careful perusal of their licences by many of these "'phone" experimenters would not be amiss, and would indicate in not a few cases a flagrant breach of the terms of the licence. Reference is made particularly to the clause which requires an amateur to listen on his own wavelength prior to transmitting, in order to prevent QRM, and also to the clause relating to the amount of time per hour allowed for transmission. There are several known offenders in this respect, and they would do well to take these remarks seriously to heart, lest worse befall.

GcBRS6 is willing to run late-night receiving schedules during the week-ends on 20-50 metres with any country. His QRA is A. Cross, Jun., The Manse, Muthill, Perthshire.

Mr. J. B. Henry, owner of NUICUE, Lincoln, New Hampshire, and NU6RU, 1,199, Oaklands Avenue, Pasadena, Cal., is very anxious to receive reports on his 20 and 40-metre signals, and is particularly anxious to QSO "E" stations from NU6RU.

NU1LQ has so far received only one report from Europe (de BRS6), and is anxious for further reports. His QRA is: Alton R. Anderson, 7, William Street, Ansonia, Conn.

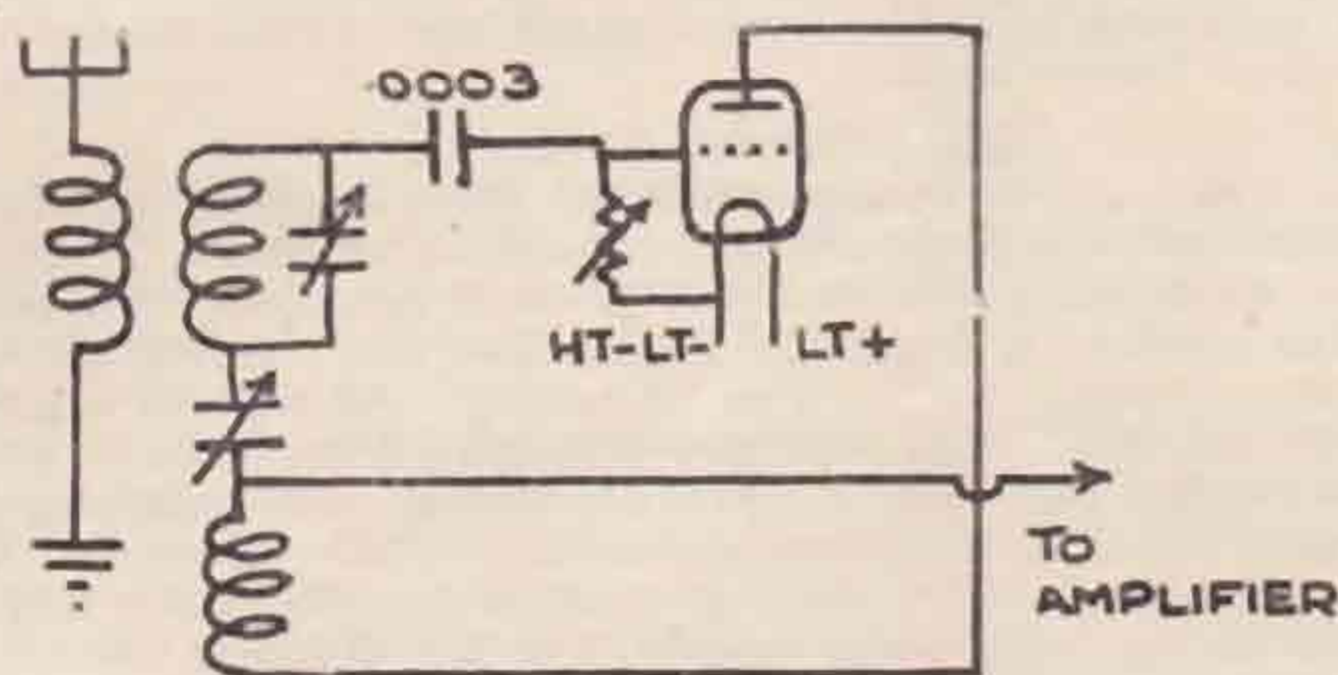

No. 2

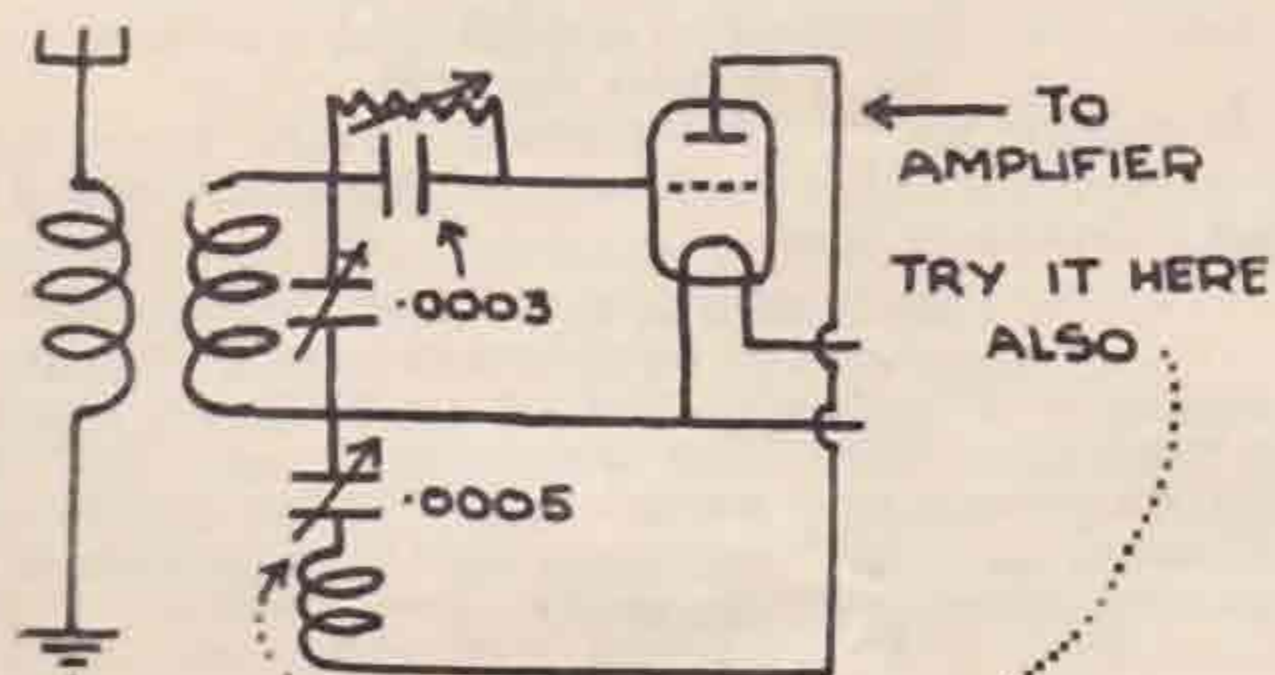

5 METRE R.X. No. 1.

FIG. 3



Static Counting at the Radio Research Board.



## Correction.

(THE VALVE IN ACTION.)

It is regretted that the text appearing under the diagrams Figs. 2 and 3, pages 12 and 13 of our October issue, became interchanges. A glance at the co-ordinates shows that an error has occurred, but the text of the article is correct.

## Stray.

A waiter in attendance at the convention dinner was heard to say "Vun Q.S.O. (Curaco?) Vun Benedictine." Obviously a case of radio conviviality.

## Copyright Warning.

It has been noted that there is a tendency to reproduce or copy the Society emblems and other matter appearing in the T. & R. BULLETIN, either for personal use or for sale.

We take this opportunity of pointing out that persons so doing render themselves liable to an action at law for infringement of copyright, which is the property of the Society.

In all cases where a member desires to copy and publish any matter appearing in the BULLETIN sanction must previously be obtained from the Hon. Secretary before so doing.

In no case should a printer, publisher or other person be encouraged to abstract, reproduce or copy any article, design or photograph appearing in the BULLETIN, and any member disregarding this warning will be dealt with according to the seriousness of the offence.

## Trade Notes.

From Messrs. Paul & Mathew, of 11, Butter Market, Bury St. Edmunds, Suffolk, we have received particulars and specimens of their QSL cards.

Their advertisement appears on page iii of this magazine, and there is no doubt that their prices are very low for really high-class work.

Messrs. Paul & Mathew also specialise in any type of radio printing, such as note headings, memorandums, shack cards, and the over-printing of members' official R.S.G.B. notepaper headings with QRA's, and tell us they are always pleased to quote competitive prices for large or small radio printing.

Samples of their QSL cards are sent post free on application, and cards to customers' own design can be set up at the shortest possible notice.

The Mullard Company have received a letter from Mr. A. S. Innes, Johannesburg (Radio FOA4E and FOA3Y), giving details of a transmission using the Mullard VO/250 transmitting valve and claiming to have established the first wireless communication between South Africa and North America during the day-time. The letter is reproduced below:—

"I have much pleasure in informing you that this afternoon, at 4.30 p.m., I used the new VO/250 Mullard valve, and was immediately replied to from Californian Radio Station 6AZS, who gave me signal strength R7. This is the first com-

munication between S.A. and North America this season at this time of day. He said signals very steady and easy to read.

"Trusting this information will be of interest to you.

"(Signed) A. S. INNES,  
"Radio FOA4E and FOA3Y."

From the M-L Magneto Syndicate we have received details of a wonderful little high tension generator which is made in accordance with the best traditions of high-grade workmanship and British thoroughness, the great characteristic of this firm. The Type "E" Generator is made for powers up to 100 watts for 600-volt machines and up to 80 watts for 1,000-volt machines. As a rotary converter transformer the machine is made to give powers of 60 watts for the low voltage machine and 50 watts for the high-voltage machines, the motor being wound for voltages up to 600 volts.

The price is right for the amateur, this being £16 10s. and £18 10s. for the rotary transformer.

## Scottish Area Notes.

By 5YG.

September seems to have been a fairly satisfactory month, although there are still some traces of holiday interference.

I much regret to announce the departure from our midst of Mr. Cross (BRS6), who has looked after the interests of No. 3 District since its inception. Mr. Cross sailed for the Federated Malay States on October 29, and I am sure takes with him our best wishes.

I am glad to say that the District will not be left without a leader, as 6KO has very kindly consented to take over from Mr. Cross. "Joe" is well known to you all, and I would ask that the support given to his predecessor be continued to him in an intensified degree. Reports will, therefore, be forwarded to 6KO by the 5th of each month. His QRA is: J. B. Sturrock, Kirkbuddo, Forfarshire.

I have to acknowledge the pleasure of visits from 5XQ and 2BRI. 2BRI is to become a T. & R. member, and I would extend to him a hearty welcome.

You will note in the October issue of the BULLETIN that station reports will, in future, take a rather different form. This information did not reach me prior to the receipt of your reports relating to September, so that, if the re-modelling of your reports to meet the new requirements in this issue does not meet with your approval I crave your forbearance.

### No. 1 District (by 2WL).

2WL.—Only a little fone work done. New Zeppelin aerial now erected, and reports from any source will be welcome. A master oscillator drive will be in use. 5XQ.—Has succeeded in working N.E. with a power of 7 watts. Transmitter and receiver are both under reconstruction for work on 23 metres. All reports welcome. 5YG.—Presently working with power ranging from 40 to 80 watts. Reports relating especially to QSB are sought, also regarding any wavelength change during transmission. 6MS.—Sailed for Australia as third Op. on a White Star boat, and consequently will not be on the air again for some months. 6NX.—Reports are desired particularly in connection with QSB change, which seems to be affected by variations in the mains. QRK of spacer also, if any. 6WL.—Continues to get across to NU, with the N-S alignment of C.F. Hertz aerial. This aerial has 60' twin feeders. Transmission takes place on 23 and 45 metres from same aerial system.

### No. 2 District (by 6IZ).

6IZ.—Nothing to report, QRW business. 6VO.—Power troubles. 2BQK.—Presently in Leeds. Desires to thank 5CX and 5JA for their kind reception of him.

### No. 3 District (by BRS6).

6KO.—Using hand generator on 45 and 23 metres. Aerial system approximating a V.F. Hertz. Twenty-three metres found very "patchy" during month. Has worked only one "G" on this band. 5JD.—Rebuilding. BRS6.—Good-bye to all old friends. By the time this is in print will be on high seas for Malaya, where it is hoped to obtain a TX licence.

### No. 4 District.

2BFQ and BRS62.—Propose to carry out tests in December to examine the effects of time, WX and moon on radio conditions, and have secured the co-operation of Blackford Hill Observatory in this connection. They are also anxious to obtain the co-operation of an amateur transmitter or transmitters who will furnish signals for observation purposes. Any offers?



## Notes and News from the Areas.

### Special Notice to Area Managers and Others.

In accordance with the unanimous decision of the Second Annual Convention of the Radio Society of Great Britain, held September 30—October 1, 1927, the following is the procedure to be followed in future when reporting for these columns:—

Each report furnished by a member will be written on one sheet of paper and shall consist of: (1) The call sign of the station reporting; (2) the programme of the station as regards lines of experiment and objects; (3) results of recent work. Special note: The total number of words is not to exceed 27 for each member, and such details as number of QSO's will no longer be published.

The object of the Notes is to keep in touch with one another members who are mutually interested in certain aspects of the work. These rules come into force with the next issue of the BULLETIN.

Those Area Managers who do not possess a typewriter are requested to write *clearly*.

### Belgian Notes.

By EB4FT.

The marking event of the season we call summer was the QSO made by 4WW of Liege with OH6BDL of the Hawaii Islands. This was confirmed to us by EF8YOR, who first got in touch with Hawaii. This QSO, states 4WW, was rather easy, and lasted more than 45 minutes. 4WW, who used to work easily with NU6 and NU7 (over fifteen of each), built a special Lévy aerial, pointed towards the North, in the aim to get Hawaii. There's no need to say that he saw with pride his efforts being crowned with success.

Our other amateurs are rather active, despite the holidays; besides, several are rebuilding; some are even designing crystal-controlled sets.

4CK, of Mons, D.M., and O.R.S., gets where he likes, and is a reliable man for relaying messages.

4CB, of Ostend, during the season receives many visits from foreign amateurs. This August saw at 4CB's, American, British, German and Danish amateurs. The shack is a fine example of what an amateur is capable.

4CO, of Ghent, a particularly scientific OM, studies the properties of the Lévy aerial. The lists of calls heard are full of his call sign.

4NN and 4ZZ are also on the air, the first in QRP from his cottage in the country; the latter is about to dominate the ether in Belgium 4WW and 4AX, of the Liege trio, work silently but surely.

4FT is returning from the States. Unhappily, he has had no time to pay a visit to the directors of Hartford, or to any amateur.

### Danish Notes.

By ed7EW.

"E.D.R.," the Danish short-wave organisation newly formed, is continuously growing, the number of members now being about 70. On September 29 we had our first meeting, at which twenty-five Copenhagen amateurs were present.

7AX has been QRW with "E.D.R." work, but has still had time for key-punching. His best QSO was NN6FB with about 38 watts. QRK was R4. FB! 7BJ is working with 5 watts c.c. on 44 and 22m., but doesn't get QSO's on 22. 7BX has been away for more than three months and will only be on occasionally, QRH 45 and 22. 7DH is now licensed as 7DU, and is one of our most active hams. He may use up to 30 watts, but is getting just the same results using 5 watts, and then his QSB is much better than with 30 watts, nearly pure DC. (I quite agree with you.—7EW.) Best DX: Morocco on 5 watts, WRK R3. 7DM has been too QRW with business to be on the air. 7EW was QSO EF8RVL, who was using an input of only 1/10th of a watt, H.T. 45 volts from a dry battery. QRK was R3, rising to R6 at the end of the QSO at 17.30 G.M.T.

He has had to take down his 32m. Hertz owing to landlord QRM. 7HP had 35 QSO's during September covering the whole of Europe with 10 watts DC from mains. He had some QRM from a neighbour BCL owing to key-clicks, but has now put the matter all right. 7JS has now returned from Iceland, where he was working as nITF3. As he now will be QRW for exams, he will not be much on the air. 7LY has had about 45 QSO's during September. He is using 18—20 watts raw A.C., but is very soon going to make a rectifier. (Glad to hear it, OB!—7EW.) 7MT has not been heard for some time, as he has been making a FB "ham journey." He has been staying in Berlin at ek4CL, and is now in London at g6CL, where he is spending a good time. 7WA is too QRW with studies to be on the air. 7ZG is now working with powers up to 85 watts, his H.T. being 620 volts derived from a motor-generator. He had a single QSO with U.S.A., QRK R3. With 15 watts he has worked all Europe. His Xmitter was exhibited on a wireless exhibition at Aalborg, and it raised considerable interest, especially the QSL crds. When the exhibition closed only one was left, hi!

### Northern Notes.

Area Manager: S. R. WRIGHT (2DR).

My first duty this month is to call attention to the new methods of sending in reports, detailed at the head of this section of the BULLETIN last month, and probably repeated this month. Will all Sub-Area Managers and members please adhere strictly to these rules, and not be frightened to let others know what line of experiment you are following, however simple those experiments may be. It is up to every member to carry out such work as he feels able to do, and to send in a report. The result will be that a considerable interchange of information should be available to readers of this section of the paper.

Requests for collaboration in any particular line of research will be published, and it behoves all hams interested in the same type of work to get together and pool their results. This not only speeds up the final result, but saves one re-doing work which has already been performed by another member.

If any members in my area have difficulties in their experiments I will gladly assist them to the best of my ability, or put them into touch with others doing similar work, or with experts who would be willing to help.

I am grateful to all hams who have re-nominated me for the area managership, and, if I am elected, will continue the good work as heretofore.

Owing to the fact that most of the reports were sent in this month in the old style, it may be necessary to "cut" one or two rather drastically, but orders are orders!

Apologies are due to 2YU and another ham whose reports were inadvertently omitted from last month's notes.

#### Yorkshire.

(Reports to 2DR by the 14th.)

600 is getting ready for more 23-metre work and is trying the C.F. Hertz as against the usual type of aerial for working U.S.A.

6DR is using 8/10 watts on 45 and has found conditions generally much better this month.

2BOQ failed to get a radiating permit, but is undaunted. Reports reception of OA-6AG's 'phone.

5KZ is starting up again after a two months' rest, and will be glad of reports on 23 and 45. C.F. Hertz experiments here.

5SZ has spent most of the month on aerial experiments, and is yet unconvinced as to the best type to use. This work is being continued.

6BR continues his work on angular propagation, and is getting some useful information together. Are you still doing 5-metre work?

5US is about to change his QRA, and is busy rebuilding for 23 and 45. Two years' results have been tabulated here, a year on each type of aerial and transmitter. I believe the C.F. Hertz is now going up for a year's test. Reports would be welcome.

6XL is also rebuilding prior to an onslaught on aerial problems. Again, reports will be welcomed.

6WD would be glad to hear from Yorkshire hams and others who are willing to attend a friendly meeting at Leeds or other convenient centre.

2DR is continuing the measurement of signal strengths and investigation of fading which he started at Giggleswick during the Eclipse. 23 metres is being operated here and comparisons of various circuits are being made.

#### Lancashire.

(Reports to 5XY by the 12th.)

5MQ as would be seen by last month's BULLETIN is busy comparing aerials in conjunction with 6YQ. This is the sort of thing we want more of, especially the results embodied into an article for the BULL.

5MS has been off the air all month.

5XY is putting up a vertical copper tube Hertz for 23 metres, and is comparing it with the horizontal type. Promises results for publication later.

2QV reports very little doing during September.



**Isle of Man.**

(Reports to 5XY by the 12th.)

5XD has spent his holidays in "ham visiting," and has benefitted considerably by the interchange of ideas.

NOTE.—Will 5XY instil a little enthusiasm into Lancashire? Surely there are more than four active men in that portion of the globe? Wake them up, OM, please.

**Northumberland, Durham, Cumberland and Westmorland.**

(Reports to 2AIZ by the 12th.)

6QT is having difficulties with 23m. on 3½ watts, and would be glad of reports. Anyone wanting to work on 8 metres should write to 6QT.

BRS44 has passed his morse test and is awaiting a full permit. Send your particulars to H.Q. and the Sub-Area Manager O.M.

6YV is trying some 23m. work and would welcome reports. Conditions are reported bad here.

**Cheshire and North Wales.**

(Reports to 6TW by the 12th.)

2SO is still going forward with angular propagation work on the C.F. Hertz, and will continue until December, when the results will be collated for the BULL.

5PO is carrying on indoor aerial work under difficulties in "digs." Any dope on this work would be welcome.

5BR is welcomed to the fold as a newcomer. Work is being done on aerials for 45m. Crystal control is being tried on 90m. and reports would be welcomed.

BRS98 reports much better conditions generally on 45m. than during the previous three months.

6TW is carrying out interesting work on the height of the aerial in relation to the angle of propagation, and good material has already been collected. Two C.F. Hertz aerials are being used for these tests.

**Derby, Notts. and Lincs.**

(Reports to 6MN by the 12th.)

5BD has suddenly found a reversal of directional effect of his aerial without apparent reason. Will BRS stations look out for him and send reports?

5OD has been QRT this month.

5QT has been at work on aerials, and finds a 3rd harmonic and counterpoise the best so far.

6MN finds the Zepp. type Hertz much better than the usual type, and an 80ft. stick offers opportunities for much experiment in aerials here.

6WO is also busy with aerial experiments, and 6MN would like to hear from him with a view to combining efforts.

6AH has got going on 45m., having just received his licence.

BRS34 would be glad to help others with tests. Write him, please.

2ABA reports good conditions this month.

2ADC on the other hand states conditions have been very bad with him.

2BPA sends his first report, and is open for schedules on 23m.

BRS97 reports good conditions on 45, but dud on 23. Will hams listen for SMUR working schedule with BRS97 every night at 1900 and report to BRS97 or direct. QRA:—Folke Bergh, Osteras, Sweden.

BRS4 has been QRT all month.

BRS103 is welcomed to the fold. Let 6MN hear from you, OM.

BRS108 is another newcomer, and would welcome dope on S/W. circuits. Will keep schedules on phone with G's on Sundays. Can I help you, OM?

5DM is changing QRA. Please inform 6MN and HQ, OM.

Failed to report 2IX, 2VQ, 5KW, and BRS45.

NOTE.—For number of reports this sub-area will take some beating, and 6MN deserves congrats. for bringing them up to scratch. Keep it up, OM's.

**Midland Notes.**

Area Manager, H. J. B. HAMPSON (6JV).

"Dixit Oraculum"—about the new style of reporting I mean—and so we must try to keep within the spirit of the Act. However, the October BULLETIN which promulgated the decree had not gone forth by the time sub-area managers were preparing their reports. Under these circumstances, there is no doubt that the ruling will not be interpreted with such rigidity as tradition has come to associate with the laws of the Medes and the Persians. There are some (among them myself) who lament the passing of the old style reporting, because this did cater for the social side of our great game, even if the matter was of little scientific value. And yet there was no alternative but to curtail these reports which had outgrown the space available. And so in asking Midlanders to accept the inevitable in all cheerfulness, I am happy to announce a little surprise which will, I hope, compensate for any possible disappointment!

The Midland Area is to have a monthly official organ of its own—or rather it is to have a page in "Q.R.W."—the new monthly journal of the Wolverhampton Society. This is by arrangement with, and kind permission of the "Q.R.W." Editorial Committee.

One final word. "Q.R.W." is complementary to and in no sense competitive with our BULLETIN. But write to the Wolverhampton Society for details. Annual subscription is 5s. to any Midland member, and—if I mistake not—the little journal will bring more than one dollar's worth of joy.

**Shropshire (reports to 5SI).**

Neither 5SI nor 6TD have been working during the month.

**Leicestershire (reports to 6WW).**

6WW is working at M.O.P.A. endeavouring to obtain stability without crystal, and finds this is only possible with still air and very loose coupling, while power loss is heavy. His eclipse transmissions are reported from Australia.

**Cambridgeshire (reports to 2XV).**

5YX has now worked all continents on 10 watts or less having worked New Zealand twice on 23 metres. (Congrats. O.M. This really is DX.—6JV.) He forwards an interesting article on R.F. chokes. (F.B. and tnx.—6JV.) 5YK has investigated directional properties of various types of aerial. He has worked New Zealand on 45 and 23 metres. 2DB has restarted, while 2HK, 5JO, and 6CR are believed to have been active but have not reported. 2XV has been moving, and has not yet settled down. Please note new QRA—117, Victoria Road, Cambridge.

**Northampton (reports to 6TR).**

2CH has done nothing, while 2QM and 5IV have been too busy to report. BRS89 has had fine results with his new single valve receiver, having logged all continents. 6TR has been reduced to one watt but has been getting R5 reports all over Europe.

**Warwickshire (reports to 5GR).**

2BCA is concentrating on 23 metres this winter. 2BNB has taken unto himself a D.C. generator. BRS2 has started again. 5CG-5PX is still working at his no aerial transmitter and promises an article for the BULLETIN. (F.B. and tnx.—6JV.) BRS3 reports better reception conditions. He noticed that several members reported reception of NU6ALS on April 3. He wrote the 6th Dist. Radio Supervisor, who states that there is no such station. BRS29 reports excellent conditions and asks for QRA's of XEP-IMA, FMAA9, AQBD.

**Coventry and District (reports to 5GR).**

5ML is working on 23metres, which he finds excellent, as many as seven NUQSO's being made at one sitting. 5YS is experimenting with modulation systems. 5SK is about to get busy on 8 metres. 6MC is probing the mysteries of A.C. as a power supply. 5GR is the new call of EX-2BPI, who expects to be on the air shortly.

**Worcestershire (reports to 6AT).**

6AT has been fixing a charging plant for L.T. and will couple up a Newton alternator to the same motor for H.T. supply. He is working out the polar curves of radiation for aerials of different lengths to be incorporated in the series of articles which he is writing for the BULLETIN.

**Staffordshire (reports to 5UW).**

2KK is working schedules with NU8EQ and trying to QSO NU6HM. 2BOC has been experimenting with crystal detector in his S/W receiver. 2OQ reports much activity on 23 metres, which wave he finds somewhat unreliable. He has received his Q.R.O. permit. He will work at "Fading." 2YV has been suffering from the effects of an accident but expects to be about again soon. 2WN is still using extreme QRP while 5AF is away from home. 5LK is rebuilding and will use "frequency doubling" on the new transmitter. 5NU is too busy to spare time for radio and 5PR is trying to solve the H.T. difficulty. 5UW is winding a new H.T. transformer. He has kept schedules with SB1AW, OATCW, OZ3AJ and 4AC. He finds 23 metres very unreliable, and has accordingly arranged DX schedules to test reliability over a definite period.

**Wolverhampton and District (reports to 5UW).**

6OH has started again on 23 metres and intends to test various aerials on this band. 6HT has been working during daylight only. 6UZ has rebuilt the transmitter and has adopted the Mesny circuit. He intends to compare Mesny and Hartley. 2AAD is rebuilding. 5NH and 6CC are welcomed as new members of this Society. Two meetings of the Society were held this month and very fine attendances were recorded.

**Norfolk (reports to 6ZJ).**

5UF has been busy using 5 watts input to TG-TP circuit. He would like to co-operate with any station desiring to investigate fading on 45 metres. 6JV will report in the new style. Hi! 6JV will use M.O.P.A. and attempt to control 100 watts to T.250 with 15W to LS5. Recent tests of optimum aerial load show coupling generally too tight. (But it took some "juggling" to do it in 27 words!)

**HELP.**

Msg from Troopship "Dorsetshire" bnd Basra and Karach. Position 200 mls West Malta.

"To G6BT. Please ask all EG hams thru the BULLETIN and Wireless World to report on my sigs. on 23 and 45 mts. during voyage to Karachi and back w/ be QRV fr QSO after service wrk 73's to G6BT. Signed Thompson ex GFR ere ex GFY op." Will members please note?



## Southern Notes.

Collected by 2ABK.

Four reports for the whole of the Southern area!! (working stations).

As it can be imagined, bricks cannot be made out of straw, and therefore you must have a short paragraph this month OM's.

The sole report from Kent is from BRS91, who rejoices in the fact he has another member in his town now and has rebuilt receiver.

2HJ reports owing to bad reports on QSB that he has QRT and is at the time of writing not yet QRV again. Five QSO's only during month.

5UY reports ND, not even his schedules being kept. He has been heard at 2ABK using fone as he hoped to do some chin-wagging when the generator could be silenced.

6WI of Colchester reports best DX Rio de Janeiro on 23 metres, and a NU has been raised on 45. He wishes to express through the medium of the T. & R. appreciation of the way the London hams entertained the provincials at the Convention.

6WQ has started up on 45.9 metres, using 2 watts C.C. and a C.F. Hertz. So far a QSO has been obtained each time the key has been pressed. No reports being under R5. A schedule with GW17C is being worked.

BRS42 reports 24 OA's and 10 OZ's on 33 metres. Fone being heard from OA7CW.

On 20 metres best DX was XNU-WNP R4 in daylight. Thirty NU's were logged including No. 6th or 7th districts. He enjoyed a visit from G6NK.

5OK is still struggling on 150-200 metres and calls in vain, and he has a F.B. note with good power, yet he can never seem to hear anyone on, and wants to know where everyone is gone.

2ABK managed to visit Convention and was pleased to have a few QSO's. Don't forget your promised reports, OM's.

2LZ has had little time for ham radio lately, and has to be congratulated on the arrival of a son and heir.

## London Area.

By G. A. EXETER (6YK).

NOTICE.—Next London Area Hamfest will be held on Wednesday, November 23, and please note that we are trying a new QRA. This one is BARNEY'S, 15, Whitcombe Street, Pall Mall East. Will all members who intend coming please notify their respective Divisional Managers immediately as the number of tickets is limited. Price of admission as usual—5s. We had forty at our last. Roll along, fellows, and see if we can make this one sixty.

### Reports.

Attention is drawn to the notices concerning reports published in these notes. Will all members please send in their reports to their Divisional Managers by the 15th of each month? Thanks, OM's.

### Western Division.

(6YK.)

2AAM has calibrated his S/W Receiver to an accuracy of 1% A 50—15 metres.

DX shows 40 countries. He is anxious to co-operate in any 8-metre scheds.

6VP has been on 23m. again and his bag of DX is too long to publish (anywhere you haven't worked OM?) He says he thinks 23m. very interesting.

5VP has been QSO most Europe. He has conducted some interesting tests with EP1BK, being reported R5-6 with 7.5-9 watts

6BB is working with 6HP on skip and fading; he has worked all Europe but has yet to get across the "pond." He says 6YW's VF aerial works best at his station.

6WN has been busy on 45, his best DX Sweden R4 with 4 watts. After a lot of work on 23m. he raised EC2UN reported R2-3. All the 23m. work was with an old DE6 valve reputed to have lost its emission. He pours flowers at our feet in connection with the Convention dinner which he says was very F.B. (we blush, OM!) and txns).

6HV has no DX to report except usual Europeans.

6YK has had a very interesting time getting 2MS to perk on 45. His best DX so far is GDKB in the Suez Canal, and NU1GA. Next to working OA's on .1 of a watt, this is the most thrilling thing we know of—making someone's station do something it hasn't done before. Extensive preparation is taking place for G.M. work in the near future.

Stn. visits.—6PG and 2MS to 6YK; 6YK to 6TN.

## Northern Division.

By G6CL.

(Reports by 15th please, OM's.)

September seems to have been a month more devoted to the social side of radio than to sheer DX. True, many interesting reports have been received and from 6CL several periods when conditions were very good were noted, but on the whole it would seem that North London has been getting acquainted with its neighbours. The inter-station visiting has proved most interesting and many useful hints have been obtained. It is hoped that shortly the North London Area will arrange weekly meetings at different ham QRA's. Many informal discussions have already taken place. In accordance with the Convention proposal reports in future will

be abridged as much as possible and every station reporting is asked to furnish some line of experimentation which will be followed up during the month in which the report will be published. This will allow co-operation to be obtained; in the event of tests on which reports are required it is suggested that the work be started from the 15th of the month—one day after the issue of the BULLETIN containing the information.

### Reports.

6PP has been on very low inputs—0.5 watts to 1.5 watts—best report SMWF (900 miles). He is now testing merits of R.A.C. over dry batteries.

6PN is now on crystal—master oscillator drive from 180 to 45. Input to last valve about eight watts. Results show an improvement over R.A.C.

5HJ has modified his transmitter to the A1-2KX (YDCR) circuit. Best QSO was EACR.

5GU has moved to 107, Chedington Road, N.15; he has rebuilt receiver to the 5YM circuit.

BRS02 has experimented with a 22½ metre single wire aerial for reception and finds it an improvement over the old 55ft. one. He is trying a telephone transformer in various positions of his Hartley receiver and comparing results. (Sa OM, 5TR requires some notes on RX; what about a few lines?).

No report again from the high power gang—5AD, 5HS and 5KU—are you all off the air?

Congrats. to BRS12 and 2AJI who have now obtained radiating licences.

BRS12 is now 6UN and will be on the air soon. QRA 45 metres.

2AJI is now 5UM and is working on 150 to 200 metres. Reports wanted from BRS.

6CL has been active with usual 2 watt input. Hungary was worked for first time. Work on R.F. chokes was continued and from results so far obtained it appears that a coil of 70 turns on a 2-inch former is best suited for 45-metre work. A series of QRP tests will be arranged between certain stations and an attempt made to find the best times for low power work at distances of 100, 200, 300, 400 and 500 miles. This test will commence on November 26 and continue for one month. Will all interested write 6CL at once?

### Station Visits (Sept. 1 to Oct. 12.)

To 6CL:—

D7MT, 2CB, 2CX, 2WR, 5XW, 5XQ, 6RB, 6BG, 6UD, 6WI.

6CL to 2AX and BRS86.

D7MT to 2AX, BRS86, 6NK, 5IV, 5AD, 5KU, 2NH, BRS42.

## East London Division.

By 6LB.

6LB is experimenting with a Zwppelin feed Hertz aerial on 45m. It is proving very satisfactory and will be used for 23m. shortly. He has been carrying out observations on the fading of S/W broadcasting and uses 2XAD as a standard. He recently had a visit from 2CS who got the Armstrong to perfection.

6UT is still trying 23m. with little success. He has been heard in the U.S.A., but has not QSO'd. He requests reports from any district on this wavelength, particularly on his QSB. On 45m. he has worked the troopship Dorsetshire when it was south of Malta.

2NU has received a report on his speech on 150m. from the Baltic Sea in daylight. Receiver used was a Superhet.

2KT has been testing a very efficient 5-valve screened BCL set which will shortly be marketed by its makers.

2BXM is still busy carrying out reception tests on 20m.

6LL is getting down to it again now that the week-end bungalow camping season is over.

A few reports from the East London Divisional stations will be very welcome.

## Southern Division.

By 6PG.

2CB had 14 QSO's during the month on 5 to 6 watts from mangle. Best DX and incidentally first contact was EC, 2YD, QRK, R4. He has been trying 2NH's circuit, as described in the September "Bull." on 45m., and finds it cleans up his QSB which is now definitely D.C.

6QB has been testing the relative merits of three different types of aerial systems, all of which can be used at a minute's notice. Working a short aerial at its fundamental appears to give stronger signals up to 200 miles and then they die off (e.g., EF-R8 and EI-R5 same night). Working at third harmonic of a longer aerial gives results more like EF-R7, EI-R7-8. He has also been testing with input of 0.3 watts. Best QSO's, FM-8VX (R5), EK-4CL (R4), and SMYU (R6). He would like to fix up schedules on 90ms. and 45ms.

6HP has been experimenting in skip distance and has found it quite easy by altering the angle of radiation both to vary the distance skipped and partially eliminate fade out. He has been comparing a DE5 with an LS5 and found that he is more QSA up to 1,000 miles on the DE5 and QRZ beyond, while with LS5, sigs. are equally QSA 2,000 miles away as 1,000 miles. He had 70 QSO's only, being QRT until the 18th of the month, best DX being FM-8RIT (QRK R9 very!)

5BQ has been caused much QRM by Cupid, but has managed to do a little useful work. Input 2 watts from accumulators (he is QRX for mains), best DX, Vienna (R6), Rome (R4), and Valencia (R5).



on 45m. Best DX on 170ms., Guildford (R4 on 0.4 watt) and R5 at Wakefield. He would like to get in touch with other QRP merchants to arrange schedules to study WX on 45ms.

2NH had 17 QSO's during the month, using 40 watts, all on 23ms. These are:—12 NU's, 1, Europe; 3 OZ's and 1 SB. Conditions were very patchy. A new receiver has been built which ED-7MT dubbed "the R9 receiver" as everything seems to come in at this strength on all waves. This is being investigated and will form an article for the "Bull." A little more work has been done on 8 metres.

5MA has now finished rebuilding and is on 45 and 23ms., using the balanced Colpitts circuit with 45 watts D.C. from B.T.H. generator and hopes to beat the old R.A.C. of the past four years.

6AP now has the mains in his new QRA, and hopes to be on the air again soon when he gets his new aerial up.

2BWR has been rebuilding his receiver and will soon commence his tests on A.A. He is going to try the TP-TG receiver described some time ago in the "Bull."

2BQH reports hearing a number of DX stations, particularly in the latter half of the month. He logged 40 OA's and OZ's, all districts NU and numerous S stations. He has now heard well over 1,800 different N.U.'s in 20 months. Jolly good, OM!

BRS50 sends his first report. Having now learnt the code he logged 15 E's, NU1, 2, 3, 4, NI and SB on O.V.2 Reinartz and later SBIIC on Schnell O.V.I. He would welcome assistance on 20m. reception as so far he has heard nothing on this wave. He would also be glad to fix up schedules with anyone requiring reports.

2CX has had little time for radio, owing to business QRM. A little work has been done on 45ms., best DX being FM, Lithuania and Latvia on 4 watts, also first QSO's with EA and EC on same power. A 20m. report has been received from NU2CC. He is now going to rebuild the transmitter in a less haywire fashion than at present.

6PG is now on the air again and has had a few QSO's including X-OIK, EA and the usual "locals." He is testing with Hertz aerials before recommencing his experiments with underground aerials. Schedules will be welcomed on 23, 45 and 90ms.

**Late Extra.**—6QB has hooked up with NE-8WG, 2nd Grenfell Stn., North West River, Labrador, using 7 watts from M-L converter at both ends. NE-8WG will look out for all EG stations on 45ms. His own wave is 47ms. for official work and 42ms. for "ham" work.

Station Visits—G12CN, G16JA, G6MS, 5BD and 5YX to 6HP. ED7MT, G5XQ, 6NK, 6QT and others to 2NH. 6PG to 6PP and 6CL.

## Irish Free State Notes.

By 11B.

This month we have to welcome two additions to the G.W. ranks. They are: 19C, G. R. S. Pennefather, 3, Adelaide Terrace, Summerhill Cork; and 11D, W. Fitzpatrick, Railway View, Naas, Co. Kildare, both of whom, I believe, are now on the air.

Now for reports.

12B, with an input of 6 watts on 45m., has been doing consistent European work and getting good reports. He has been experimenting on 23m., but so far results have been disappointing. 13B reports N.D. 14B has been carrying out transmission experiments, using an indoor aerial only 9 ft. long in conjunction with a fairly large outdoor counterpoise. Under these conditions, and with an input of about 6 watts, he has worked GW, G, and EF. His best for the month is EU08. 16B, with an input of 4.5 watts from dry cells, has worked, amongst others, FMSRIT, EU08, EI1ZA and EP1BL. He has also received a report from NU 8th dist. of reception of his sigs. some little time ago. This is F.B., OM. 18B has been experimenting with C.C. on 23m., using the harmonic of his 45m. crystal, but has not been very successful. He has now built a M.O. 23m. transmitter, and is getting out well with a good note. In the course of two evenings he worked the following N'Us between 1930 and 2100 G.M.T., viz.: 2JN, 1BYV, 1AKZ and WNP, the MacMillan Arctic Expedition. 16C has lately returned to work after an enforced retirement due to an injured hand. 17C on 45m., with an input of 4 to 5 watts, has worked EA, EB, ED, EF, EK and EP, and on 23m., with an input of 8 to 9 watts, NU1CMF, NU2ATR and NUSAXA (three times), the latter reporting him R4 C.C. Also on the same wave-length he was Q.S.O. SB1AW, being reported R6. This is, I think, the first SB worked by a G.W. Stn. 11D is only able to work at week-ends at present. He is using a hand generator on 45m., and would appreciate reports on his sigs. He has worked G, EF and EN. He expects to be on 23m. shortly. 11B has nothing special to report. He has been trying to accumulate data for the minimum working distance for 45m. after dark, which in his case appears to be about 1,000 miles, as a large number of stations have been worked at distances in excess of this after 2100 G.M.T., but practically none at appreciably shorter distances. He was down on 23m. for one day, but his note was so bad that he has reverted to 45m. until he can improve it. He had a welcome visit from 14B and a friend during the month.

The other stations have not reported.

## R.T.U. (N.I.) Notes.

The Radio Transmitters' Union (Northern Ireland) is growing steadily, as newcomers to this little patch of ether become licensed

by the P.M.G. Practically all the known transmitters in the area are now on the roll, which means that they are members of the R.S.G.B. What is quite as heartening is the enthusiasm of the gi's and the growing spirit of comradeship which is "amplified" over the monthly ham-and-eggs.

The first meeting after the summer recess was the annual general meeting on September 22, which, but for one or two unavoidable engagements, would have had a full attendance of the membership. Under the rather novel Constitution—it is so democratic that a president doesn't even exist!—an ordinary member from among those present is voted in his turn to the Chair. On this occasion Mr. W. S. Davison (5WD) ably presided.

The Committee for 1927-8 was elected as follows:—Messrs. Walsh (2IT), Allen (6YW), Megaw (6MU), Davison (5WD) and Sang (6TB). The newly-elected Committee select one of their number to act as hon. secretary, and 6TB was re-elected for 1927-8. A feature of the meeting was the allocation of the "QRM Eliminator" to the member adjudged to have the most outstanding radio achievement of the previous twelve months to his credit. By a unanimous vote this fearsome Irish shillelagh was awarded to 6YW, in recognition of his gaining first place in the T. & R. QRP tests of November, 1926. This award adds a second little silver shield to the handle, below the one recording 6MU as the previous holder of the trophy. If you aren't quite sure what a shillelagh loo—*feels* like, come and interrupt Allen in the middle of a nice new R3 QSO!

## Northern Ireland Notes.

By 5NJ.

The attention of members is particularly drawn to the special notice at the head of "Area Notes" in the October issue, and a start will be made in this issue with the new method of setting out the various reports. In the writer's opinion, this reform was much overdue, and much more space should now be available for technical articles. Please note that in future the total number of words must not exceed 27 for each individual station.

5HV.—General low power tests at present. Very consistent results in European work.

6WG.—General low-power tests. Satisfactory two-way working with U.S.A. on 8 to 10 watts, and consistently good European results.

6MU.—Aerial tests. Improved results using properly designed radiator in place of old one. Increased strength reported from Antipodes, India, Brazil, etc., and phone with Tasmania.

2CN.—Experiments to obtain pure note from hand generator, and aerial tests with current and voltage fed antennae. The note is now reported pure DC.

As these Notes are the last from the pen of the present writer, it is desired to take this opportunity of thanking all those who so kindly reported since this column was inaugurated. 73 to all.

## Indian Notes.

By AI2KX.

GENERAL.

With the departure of the monsoon, conditions have greatly improved. European signals are still scarce and weak, but FO and OA are beginning to come in strong. Reception of PCJJ is excellent throughout India, and there is general keenness to hear our old friend, G2NM.

AI2KT reports great improvement all round. Q.S.O. with FO is now a nightly affair, while OA signals are coming in strong. Up to the present, all attempts to Q.S.O. OA have failed, apparently 30-metre signals are much stronger when travelling from the dark to the light. Fone has been used and the first Q.S.O., AIFO, has been made on fone. 2KT is using the 30-metre band, and is on every week-end. The 20-metre band has been tried, but very little doing there.

AI2KX reports his return from the mountains, and ready for regular work in his old quarters in Rawalpindi. Very little work of interest has been made during the summer, but with the coming of the cold weather, 2KX will be working on 30 metres from 19.00 to 23.00 G.M.T. on Wednesdays, Saturdays and Sundays.

2BG, 2KW, 2KJ, 2JY have not reported, but are still on the air, chiefly on 30 metres. A new station will be working with a temporary call sign of FHD. His location is Central India. Q.S.L.'s via 2KX.

## German Notes.

By EK4CL—4AFA.

Recently very interesting conditions seem to have occurred. At about 2200 G.M.T., generally, EG's began to fade out completely here in Berlin, but on October 11 4AU and 4CL, independently from each other, noticed a sudden change of reception conditions, as on that date even very QRPEG's came in here at remarkable strength. 6CL was heard by 4AU R7 that day, and many more EG's at same strength by 4CL. On the other hand, neither 4AU nor 4CL raised Great Britain on that date, although attempting it several times. Did anyone in GB notice similar phenomena? Pse QSL via G6CL or DFTV.





## Don't Forget the Publications Department when next You are Stocking up Your Stationery Cupboard



Member's Notepaper headed with the Title of the Society, the paper being of the best grade. Reduced price 2s. per 100 Sheets.

Stereo Blocks of Emblem, suitable for use in overprinting your own note-heading. Price 2s. 6d. each.

Rubber Stamps of Emblem specially supplied to those members who do not desire to go to the expense of printing. Price 1s. 6d. each.

Large Enamelled Plaque of Emblem for fixing to car or door of Radio room. Price 3s. 6d. each.

Large Enamelled Emblem with own call sign inserted. Price 4s. each.

Enamelled Emblems for coat button hole. Price 2s. 6d. each.

The Handbook of Short Wave Telegraphy (Handy). Price 4s. each.

American Radio Citizens Call Book (Published September). Price 2s. 6d. each. (Amateur Section.)

All British and Foreign Books are supplied to order.

See other pages for List of Books recommended to amateurs.

*All profits derived from the Sales Section go to the working expenses of the "Bulletin" and help to defray expenses. All Members should bear this in mind when considering the purchase of books or stationery.*

We can also quote you for the supply of QSL Cards on receipt of your requirements. Lowest possible charges and the highest grade of workmanship.

Address all your inquiries to :

**THE PUBLICATIONS DEPARTMENT,  
INC. RADIO SOCIETY OF GREAT BRITAIN,  
53, Victoria Street, S.W.1.**

*Cheques and Postal Orders should be crossed and made payable to the Hon. Treasurer,  
Inc. Radio Society of Great Britain.*



Some special measurements were made by 4ACI concerning "wipe-out" in the neighbourhood, showing that troubles disappear if the near broadcast-receivers use an inductive loose-coupled aerial. 4WX (our meteorological specialist) is anxious to get in touch with EG or BRS hams, interested in the relations between reception conditions and actual WX.

On the lower band conditions seem to be very irregular. 4UAH reports that on some days he got in touch on 23 metres with FO, NU, etc., very easy, but on other days it was absolutely dud.

German hams were very pleased to hear that T. & R. Convention had such excellent success, and wish best of luck for their British comrades.

## Dutch Notes.

(Prepared by EN0CX.)

Last month there has been some reorganisation in the Dutch Section of the T.A.R.U. This society has a new name, and from now on will be called: Nederlandsche Vereeniging voor Internationaal Radio-amateurisme. The new abbreviation will, therefore, be N.V.I.R.

Also, we have at last adopted a nice emblem, coloured blue and silver. Perhaps in the next month's issue this new emblem will be printed at the top of these few lines.

Many Dutch hams have now entered the game on 20 metres, EN0GA still being the best DX-getter.

EN0PM and EN0FP are often heard in the antipodes.

Many of our Q.R.P. merchants are still punching holes in the air with their steady pure D.C. notes.

EN0FLX is getting out in fine style on Hertzian antennae, often rigged up in the garden only a few feet from the ground.

EN0PRS, is an old-timer, using this call for his portable set and can be heard on 20 metres.

EN0CX still has trouble to make his crystal work, but was able to drop a message for the convention in London in September.

## French Notes.

(By EF8PY.)

A military plane which makes tests with the French amateurs has the call-sign F12; anyone having heard its sigs. is kindly requested to QSL to assist with the tests; the more commonly used wavelength was 28 metres, and the tone a 600-cycle affair.

8FD8YOR is still QRT, owing to holidays, as many hams are.

We regret to announce that 8JN has resigned his presidential position in the R.E.F., owing to pressure of work. As 8JN's sigs. have been very scarcely heard since many months, it is quite permissible to think that the call-sign will go to another man in a short time.

8ZB is still doing excellent work on QRP; with an input of 3 to 5 watts he has been QSO OZ2AL, IAO, 4AM, the reports being R4.

SCF has been heard on 'phone FB by OZ2BG and OZ3AP, and thinks he is the first EF to have done so well with the antipodes.

IOAB, of Chelles, will do 'phone tests on 60 metres and will be glad to receive reports.

Mr. Marc Solinot, R411, 9 rue Emilio-Castelar, Paris-12°, is devoting himself to the reception of telephony, and will be glad to start schedules with British amateurs.

8DY is still experimenting on 5 metres, and will start a competition.

8KK is pounding on 4.24 metres.

8PY will do shortly new experiments under the wavelength of 1 metre; this being very QRWsome (new term, hi!), ordinary traffic on 44, 33, or 20 is very tiny little wee thing (that is not much!). When these lines appear a new QRA is found, and traffic begun already.

8FZX (old 4BM), after a move in the West, is doing very well in QRP.

We have been pleased to meet Mr. Imaoka, from AJKZB, and have had great pleasure to know the radio conditions in Japan.

## QRA Section.

I am still receiving lists of new QRA's from various countries, and am very grateful for them, though pressure of work in the Section prevents me from making any acknowledgment individually other than this.

## Q.R.A.'s Found.

EA-JI.—L. Jenny u.R. Haas, Radio Centrale, Salzburg. (Inf. BRS86.)

EA-MS.—Franz Schuldes, Auerspergstrasse, 2 Vienna 1.

EA-ZE.—E. Zemrosser, Bahustr. 33, Vöslau, Niederösterreich.

EK-4ABG.—O. A. Klotz, Fabrikant, Bergheimerstr. 159, Heidelberg.

SB-SNNI.—U.S. Naval Mission to Brazil, Rio de Janeiro. (Inf. C. D. Connerton, T. & R.)

EM-SMYU.—B. Welin, Anggardsgat 48, Gothenburg. (Inf. A. Brown, T. & R.)

EH-9XF.—M. Moret, Avenue Plantine, Lausanne. (Inf. G6YL.)

"G."

2AYB.—R. W. Hobbs, 78, Cranbrook Rise, "Beehive," Ilford.

2BNY.—C. A. Allen, The Larches, Headroomgate Road, St. Annes-on-Sea.

2BUD.—E. H. H. Young, 11, Tankerville Road, Streatham, London, S.W.16. (Inf. 2BWR.)

2FU.—H. G. Foukes, 27-29, High Street, Rhyl, Flintshire.

5AU.—D. Campbell, 19, Cranbourne Gardens, Upminster, Essex. (Inf. G5AD.)

5GA.—B. Logan, The Apex, St. Martins Hill, Canterbury.

5GR.—L. W. Gardner, 10, Ludlow Road, Coventry.

5TT.—Tottenham Wireless Society, Hon. Sec., A. G. Tucker, 42, Drayton Road, Tottenham, N.17.

5UM.—J. Hum, 17, Eastwood Road, Muswell Hill, N.10.

6BN.—A. E. Bond, "Fieldside," Groespluan, Welshpool. (Inf. G2DR.)

6CR.—A. E. Carter, 41, Parkside, Cambridge. (Inf. G6YL.)

6MG.—J. Montgomery, 147, Royal Avenue, Belfast, N. Ireland.

6NW.—J. G. Newell, "Fairlight," Waterworks Road, Eastwood, Southend-on-Sea.

6VV.—J. A. McKinnon, 22, Medway Street, Chatham.

6WB.—J. Bate, The Lodge, Stansty, Wrexham, N. Wales.

6YG.—F. W. Goff, 15, Melbourne Parade, Palmer's Green, London, N.13.

GW-11D.—Wm. Fitzpatrick, Railway View, Naas, Co. Kildare, Irish Free State.

## CHANGE OF QRA.

2AXK now Hayden House, Essex Road, Romford.

2AV now 81, Hoel Fedw, Morriston, Swansea, S. Wales.

2FD now 13, Warbreck Road, Walton, Liverpool.

2PZ now "Bourn," Ashlawn Road, Hillmorton, Rugby.

2UD now 147, High Street, Rochester.

2YP now The Grey House, Brasted, Kent.

5CD now "Queensmere," Kneeld Crescent, Hendon Central, N.W.4.

5GU now 107, Chedington Road, London, N.18.

5US now "Eastholme," Margerison Road, Ben Rhydding, Ilkley, Yorks.

6MB now 7, Mill Street, Oakham, Rutland.

6PP now 54, Purley Avenue, Cricklewood, London, N.W.2.

6SZ now 24, The Brent, Dartford, Kent.

6UC now 1, York Road, Edgbaston, Birmingham.

## CHANGE OF CALL SIGN.

2AJI now G5UM.

## BRITISH RESEARCH STATIONS.

B.R.S. III M.J. Wright, "Coveney," Valley Road, Edwalton, Notts. G6BT.

Manager, QRA SECTION,  
82, York Road, Bury, Suffolk.

## Correspondence.

### Instructions to Correspondents.

*We are always glad to hear from members. Correspondence published in these columns should be written clearly on one side of the paper and marked "For Publication."*

*All correspondence should be addressed to the Editor, T. & R. BULLETIN, who reserves the right to refrain from publishing any material which is lacking in general interest or for other reasons. Correspondence for publication will not be acknowledged.*

*Correspondence must be kept reasonably brief.*

To the Editor of T. & R. BULLETIN.

DEAR SIR,—Acting on the excellent suggestion of 2MI at the Convention, 6QT, 5MA and a number of others, including myself, have agreed to work each other on the 90-metre band every Monday evening from 20.00 G.M.T. till midnight. May I appeal, therefore, to all G's to come in with us and polish up those old 90-metre coils. After all, I am not sure that 90 metres is not preferable to 45 for



European work in winter, as all "DX Europe" comes in well right up till past midnight. In the old 90-metre days I frequently worked Sweden and Finland on less than one watt, which, I think, is more than can be done easily nowadays on 45 metres, where the terrific Q.R.M. from commercials, etc., renders low-power work spasmodic. Therefore, come back and find out for yourself what an excellent band that 90-metre desert is. Let us use it for all our inter-British work, and help to relieve the Q.R.M. on 45 metres. Don't forget, this very next Monday, take a listen up there and find out what you are missing.—Yours faithfully,

E. A. DEDMAN (G2NH).

#### FORWARDING AGENT FOR Q.S.L. CARDS FOR RUSSIA.

To the Editor of T. & R. BULLETIN.

GENTLEMEN,—We have the pleasure to inform you that our magazine, *Radiolubitel*, will now Q.S.R. Q.S.L. cards for all Russian amateurs. Q.S.L. for EU and AS please send to: *Radiolubitel*, Moscow, Centre, Ohotni riad 9, U.S.S.R.

We beg you to publish kindly this Q.R.A. for EU and AS on columns of your esteemed magazine.—Radiospectfully yours,

A. SHEVTZOV,

Editor.

V. VOSTRIAKOV (5RA),

Short-Wave Section Manager.

#### A MASTER OSCILLATOR TRANSMITTER.

To the Editor of T. & R. BULLETIN.

DEAR SIR,—Having read with interest "A Master Oscillator Transmitter" in the current BULLETIN, I should like to join issue with 5KU respecting the following:—"It is usually thought that the input to the first valve should be at least equal to if not greater than the input to the power amplifier for good control of frequency," *et seq.* I believe I know whence 5KU derived this conception. Here it was stated that it was necessary to use a valve of equal rating, not that the input power should be the same.

I have no doubt whatever that a DET1 could easily be controlled by an LS5, the point is that under these conditions the LS5 would be fully loaded and in no better condition to maintain a constant frequency than would the DET1 working self excited.

Any variations in the amplifier will be transferred to the driver and the net consequence will be that the emitted frequency will be unsteady unless the driver is capable of providing a great deal more power than is being taken from it. In other words the driver must be extremely lightly loaded.

Any variations now will have a negligible effect on the frequency of the driver.

After considerable experimental work in connection with the maintenance of a reasonably constant frequency I have come to the conclusion that provided the aerial is quite motionless and a suitable method of keying is used a good enough CW signal can be obtained with a self excited set fully loaded. If the aerial is swaying it is necessary to use some stabilising arrangement. Less power will be wasted if quartz control is used than if a self excited driver is employed and the note will be slightly better.—Yours faithfully,

A. E. WALKER.

#### REPLY OF MR. POLLOCK.

To the Editor of T. & R. BULLETIN.

DEAR SIR,—I have read Mr. Walker's very interesting letter and, I think with regard to the drive input, we should distinguish between the large valve and the large input. It is true that in a self excited circuit, using a valve running at its full input, there is trouble due to wave rise caused by the seals heating, etc., and so, for a given input to a constant frequency oscillator it is better to use a large valve running considerably under full rating.

With regard to the power ratio of the driver and power amplifier, I should like to point out that an input of, say 20 watts to the P.A. demands a definite grid swing of H.F. voltage, say 100 volts. Now it will not be disputed if I say, provided we could improve the voltage to current ratio in the drive oscillatory circuit, that we could obtain 100 v. of radio frequency E.M.F. with 5 watts input to the drive valve. If this valve is not being run near its full rating we can obtain a steady frequency. We now come to a point that has been overlooked by Mr. Walker. That is that the P.A. is neutralised and therefore any changes in the plate circuit of that valve, or the aerial circuit coupled to it will have no effect on the frequency of the drive and consequently that signal radiated is as steady as we can make the drive circuit. If the P.A. is un-neutralised we do get a coupling between the plate circuit of the P.A. and the drive circuit and also between the aerial circuit and the drive circuit and we have a system that is no steadier than the aerial tuning, etc. If Mr. Walker is at all interested in fading on 45 metres I will produce for him some beautiful effects by just swinging the aerial tuning condenser when the P.A. is neutralised and he will hear nothing but a variation in the strength of the signal.

Mr. Walker says "frequency will be unsteady unless the driver is capable of providing a great deal more power than is being taken from it. In other words the driver must be extremely lightly loaded." Well, what power is being taken from the driver? Merely that required by the small R.F. current flowing due to the grid-filament capacity of the P.A. tube plus the power represented by the grid current of the P.A. which flows against so many ohms of grid leak or against so many volts of grid bias. None of these

quantities vary. I think by the paragraph I have quoted that Mr. Walker suggests some kind of radiation load, but then, as far as that from the drive coil is concerned, we have another constant. The P.A. is neutralised and we get no load from the aerial system, and so, all things being considered, there is no variation in the load on the drive and its frequency is unaffected by variations in the aerial load on the P.A. or other variables in the P.A. plate circuit.

Mr. Walker finishes his letter by saying: "Less power will be wasted if quartz control is used than if self excited driver is employed and the note will be slightly better." Now, apart from the Goyder control system, any crystal controlled transmitter takes the form of a series of power amplifiers. The necessity for correct grid excitation for each P.A. still holds and so, if we are going to use more than 5 watts for transmission there is no difference in the number of valves or their inputs, whether the initial driving valve is quartz controlled or not. The only economy with quartz control is when the crystal controlled valve is used as the complete transmitter. After all, a quartz crystal can only produce a pure continuous wave, then why not imitate it by building up a 5-watt oscillator using D.C. supplies and following it with a neutralised P.A. system up to the power required? Apart from the advantage of flexibility there will be little to choose between the two methods in obtaining a pure-toned signal.—I remain,

Yours sincerely,

R. POLLOCK (5KU).

To the Editor of T. & R. BULLETIN.

DEAR SIR,—I was extremely interested to learn that I had worked EU05RA when perusing T. & R. BULLETIN for October! It was, indeed, the first that I knew of the matter.

I would, indeed, be very pleased to meet this gentleman who is so fond of my call; we could discuss quite a number of matters and perhaps come to some conclusions.

Meanwhile, should this meet his eye, perhaps he will take a note that the call is allotted to someone else.

So much for the grouse—may I turn my attention to something more palatable?

Let me first thank EFSPY for his comments on the Mesny circuit. It has come at an opportune moment, since it appears very suitable for 8-metre work which 5CA and I have been discussing lately. Should anything worth recording turn up there will be some "dope" for the BULL. Meanwhile, any reports on 23 metres and 45 metres Xmissions from 6CY will be appreciated and answered if O.K. with log. I might mention that I am using low power, about 2 watts as a rule, and ORB does not concern me very much.

May I also take this opportunity of commenting on the "F. B. Hamspuir" existing in 2BFA and 5MU which gave me much pleasure during my visit to Weymouth on holiday this year. It all happened before that good Editorial which recently appeared, too!

Regarding the QSL question, it seems to me that, as I believe someone else has suggested, a "Q" series or something similar might well be substituted, and I hope to develop a scheme on these lines and forward it for your perusal at an early date.

Yours sincerely,

A. STEWART CLACY,  
G6CY.

#### 4-METRE TESTS BY 4BD.

To the Editor of T. & R. BULLETIN.

DEAR SIR,—I picked up the following message to-day (October 17, 1927) at 16.15 on about 42 metres:—

"CQ DEEB-4BD. Pse qrx at 18 G.M.T. fr test on ultra short wave of 4-78 met fm stion EB4BD. Pse rppt to 4RR postal box 6, Brussels, tnx."

The message was repeated a number of times during the evening; also on a slightly higher wave-length at very slow speed. I am sending this along on the chance that it may be of some interest. Very Best 73's.

Yours sincerely,

V. G. MELLOR,  
BRS31.

P.S.—It was not stated whether the test was only for that evening or whether it was to be made every evening.

To the Editor of T. & R. BULLETIN.

DEAR SIR,—My station is now officially licensed for telegraphy only; therefore I have to change my old call EK4CL to EK4AFA. However, the old call will be kept in use also in future for some special purposes. EK4AFA will be on the air very likely during November on c.c.

Sincerely yours,

CURT LAMM, T. & R.

#### THE MASTER OSCILLATOR IN USE.

To the Editor of T. & R. BULLETIN.

DEAR SIR,—With regard to the Master oscillator on page 9. I have been using this circuit with great success on 23 metres as a drive-frequency doubler-P.A. system by the simple process of tuning the drive to 46 metres. Raising drive H.T. voltage and increasing its bias or leak until a strong harmonic on 23 metres results and then tuning the plate circuit of the P.A. to 23 metres. The result is a much steadier system than that obtained by taking



the drive oscillator down to 23 metres, and has the advantage that no adjustments are necessary to the neutralising condenser.

I should like to point out that the MOPA system is not essentially a QRO circuit; it could be used with great advantage in some of the lower powered sets one hears on the air, especially in the case of some fone stations who delight in sidebands, QSSS and other horrors. In the lower power tests last year a Mopa transmitter was used here, running 1 watt to the drive and  $4\frac{1}{2}$  to 5 watts to the PA, and although no stronger reports were received than on a self-excited set, the ease with which stations were raised was greatly improved.

Yours sincerely,  
R. POLLOCK,  
5KU.

To the Editor of T. & R. BULLETIN.

DEAR SIR,—Please put this in the BULLETIN for the benefit of those hams who so kindly tested with me in a vain attempt to get a DC note from storage HT! I discovered that the batteries really were DC and not RAC ones (hi!) as 2CB suggested, but found the trouble in a narrow spaced tuning condenser across all the coil in a Hartley circuit.

Yours for Radio,  
E. R. COOK,  
G6UO.  
M.R.S.G.B.

THANKS TO LONDON MEMBERS.

To the Editor of T. & R. BULLETIN.

SIR,—Now that the convention is over and has become a pleasant memory, it is our duty to thank the London Hams for the excellent time they gave us while we visitors were staying with them. As a visitor from the North, I must remark upon the fine spirit of those who entertained us. That real ham friendliness was in evidence everywhere, and it proves that we have friends everywhere, who are bound together by the mutual love of the game.

In every case the owner of the station visited did all he could to welcome us and make us feel at home. We provincials owe you a debt Om's.

I personally must thank G2NH and G6UO for their hospitality, and also G6PP and G5MA for their entertaining me as well while visiting them. Thanks Om's,

J. R. BROWN,  
G6QT.

To the Editor of T. & R. BULLETIN.

DEAR SIR,—I beg to inform you that I am now licensed to transmit on 8, 23, 45 and 90 metres (C.W. and telephony) using power up to 10 watts. Call sign G6UN.

With all good wishes for the continued success of the BULLETIN.

Yours very truly,  
ARTHUR E. WATTS.

To the Editor of T. & R. BULLETIN.

DEAR OM.—Enclosed I send you the "Danish Notes" for the BULLETIN. I should be very obliged to you if you would kindly publish in the BULLETIN a message from ed7ZG as follows:—

I wish to express my very best thanks for the numerous reports received from England. I regret that it is impossible for me to answer all at present.

ed-7ZG. H. Tscherning Petersen, "Fribo," Oestergade. Noerresundby, Denmark.

Thanking you in advance and wishing you every success with the BULLETIN, which I appreciate very much.

I remain sincerely yours,  
H. RAFN, ed-7EW.

#### HELP FOR ALL.

A. K. MacConaughy (NN8ZZZ) of 230, Rayne Avenue, Cuyahoga Falls, Ohio, U.S.A., writes to say that "73" means best regards, 73's best regards to ym. Also U.S. amateurs are on the air from 02.00 a.m. until about 10.00 to 13 or 14.00 p.m., G.M.T., and the best bands at present are 20, 40 metres, a few amateurs being on 80 metres and 'phone stations on 100 to 200 metres. I.C.W. stations work on 178-180 metres, broadcasting above 200 metres, commercial stations above 600 metres and government stations on 1,000 metres upwards.

That C.Q. is likely to be disregarded in U.S.A. (we thought that U.S.A. was the home of C.Q.!).

Any cards addressed to him for other U.S.A. amateurs will be promptly forwarded to their destinations and that British lists of "Calls Heard" sent to him will be forwarded to A.R.R.L.

New and changed QRA'S will be furnished by him on request, and radio magazines can be obtained from him at current prices post free to England, and that he will arrange schedules with other American stations upon request. Many thanks NN8ZZZ.

## EXCHANGE & MART.

Many amateurs are on the look-out for second-hand apparatus at a moderate figure. Look through your junk and see what you have worth selling and turn it into money. This is your best medium for disposing of your surplus experimental gear.

**A NEW RESISTANCE AND GRID LEAK FOR THE EXPERIMENTER.**—"ALWAYS" Patent Constant Resistances are supplied in all values from 1,000 ohms to 30 megohms. "ALWAYS" Resistances are guaranteed silent and constant under all tensions up to 200 volts. "ALWAYS" Resistances have been awarded Certificate of Merit by *Radio News* of New York. The "ALWAYS" Resistance is guaranteed to be within 5 per cent. of the stated value, and is guaranteed to give satisfaction. Resistance is glass-enclosed, and the retail price is 1s. 9d.

We supply all values of Resistances, and invite your inquiries.

Give the "ALWAYS" a trial and note results. Will be sent you post free from the sole distributors, ABINGDON WIRELESS SUPPLIES, 20, Lombard Street, Abingdon, Berks.

**TANTALUM.**—Tantalum metal sheet for A.C. Rectifiers.—Blackwell's Metallurgical Works, Liverpool.

**FOR SALE.**—Evershed Wireless Generator 1,000 volts, 30 milliamperes, power-driven type, perfect order: cost £11 accept £6.—G6XG, Bryn Rodyn, Colwyn Bay.

**FOR SALE.**—Compact portable self-container, S.W. transmitter, 22-93 metres, up to 40 watts. World wide qso on ten watts. Full description on request. £6. Sterling .0005 Lab. type condenser (calibrated) with chart £1.—6BR, Overdale, Ilkley, Yorks.

**SEND US** your dud valves; we guarantee to return them with their original characteristics at less than half the price of new valves.—Write for full Price List to NORTH LONDON VALVE CO., LTD., 22½, Cazenove Road, London, N.16.

**PATENTS** obtained, Trade Marks and Designs registered, British and Foreign.—GEE and Co., Patent and Trade Mark Agents (H. T. P. GEE, Member R.S.G.B., A.M.I.R.E.), 51-52, Chancery Lane, London, W.C.2. Telephone: Holborn 1525.

## Q.S.L. CARDS

We have the best range  
:: at cheapest Prices ::

100 for 5/-, 500 for 14/-, 1,000 18/-

Send for Samples.

Terms C.W.O.

**CORDWELL & EDDAS**

HIGH CLASS PRINTERS,

STANLEY RD., ST. ANNES-ON-THE SEA.



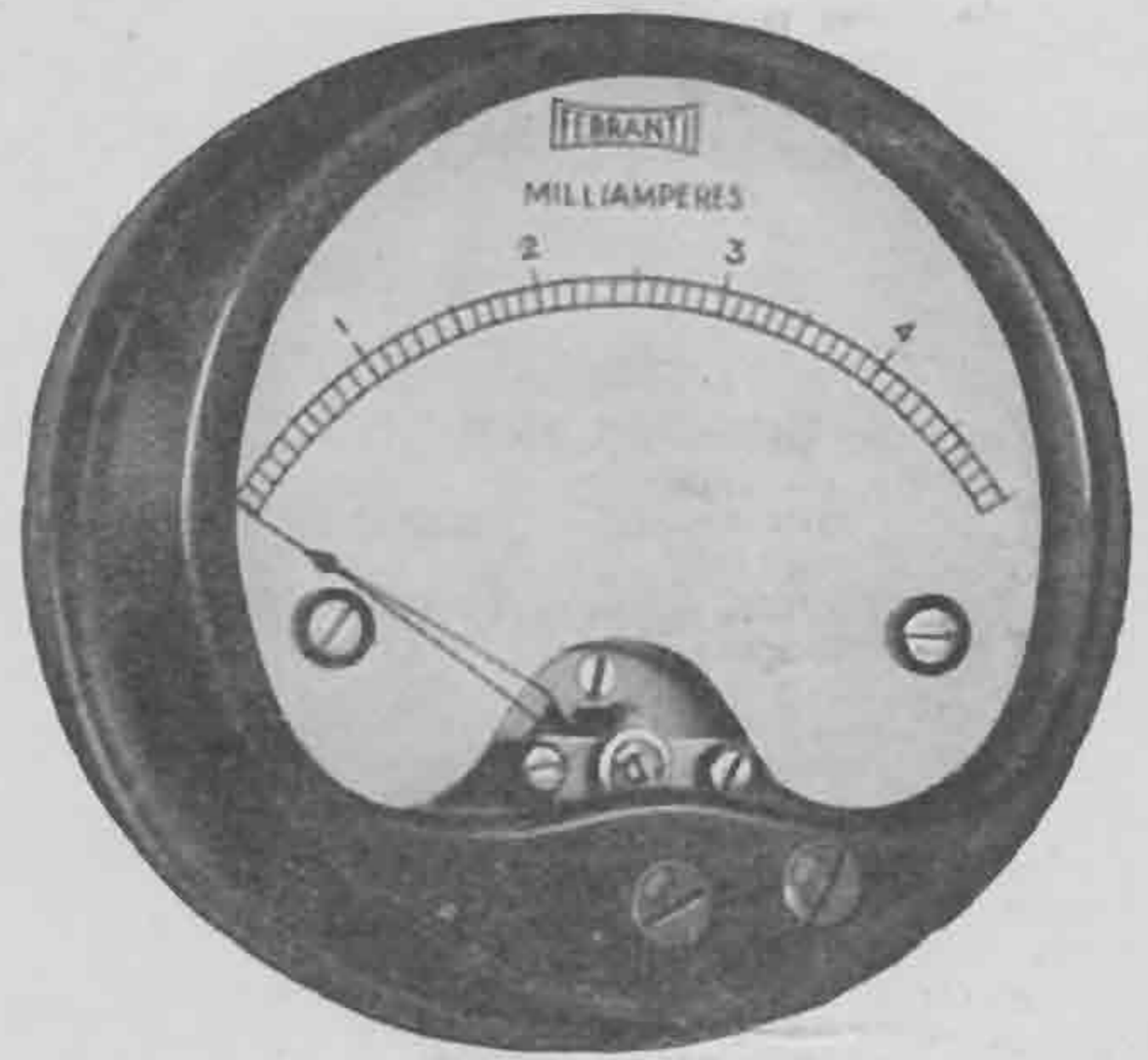
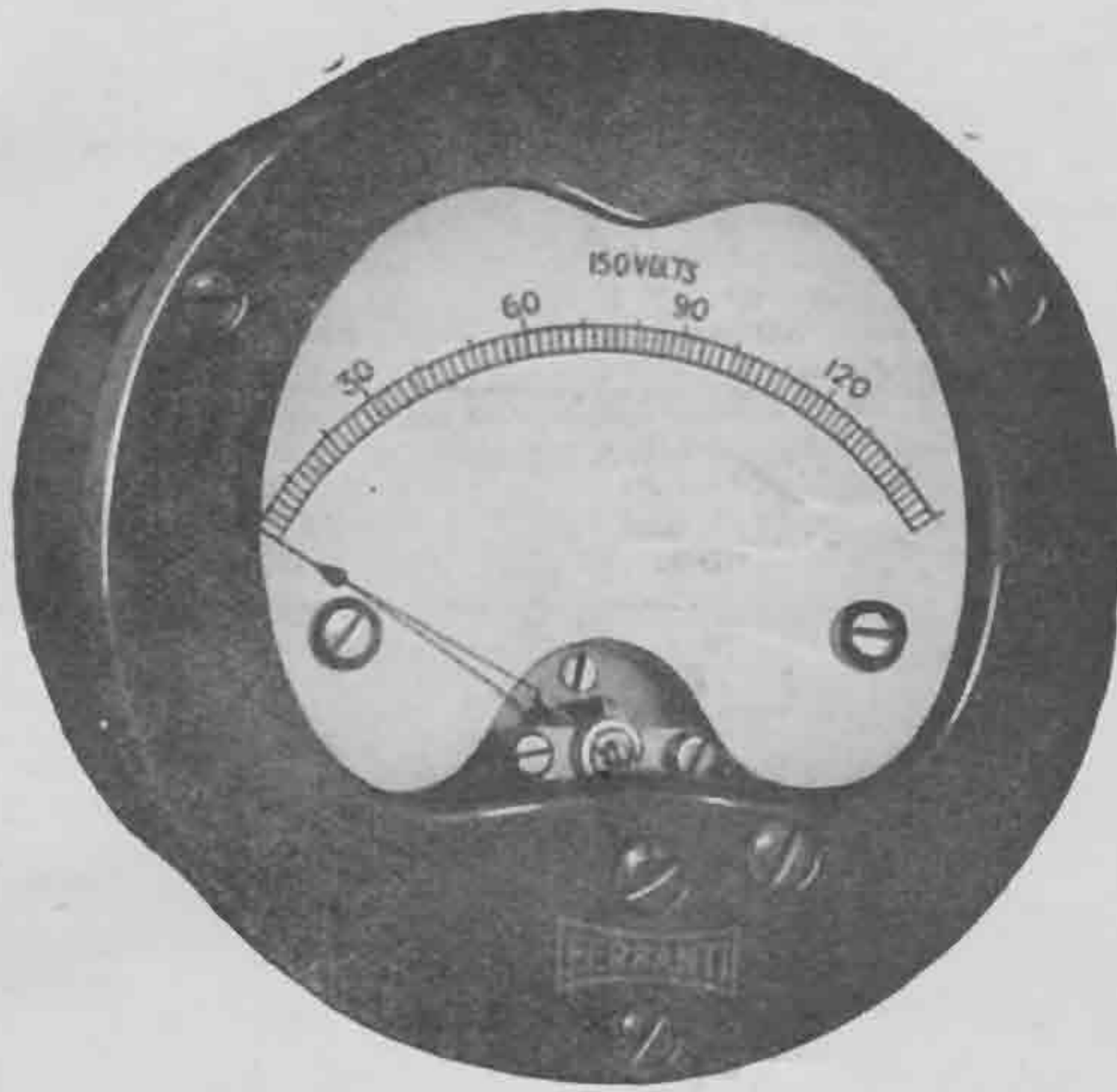

# FERRANTI

## AMMETERS & VOLTMETERS

WRITE FOR LIST W.—406.

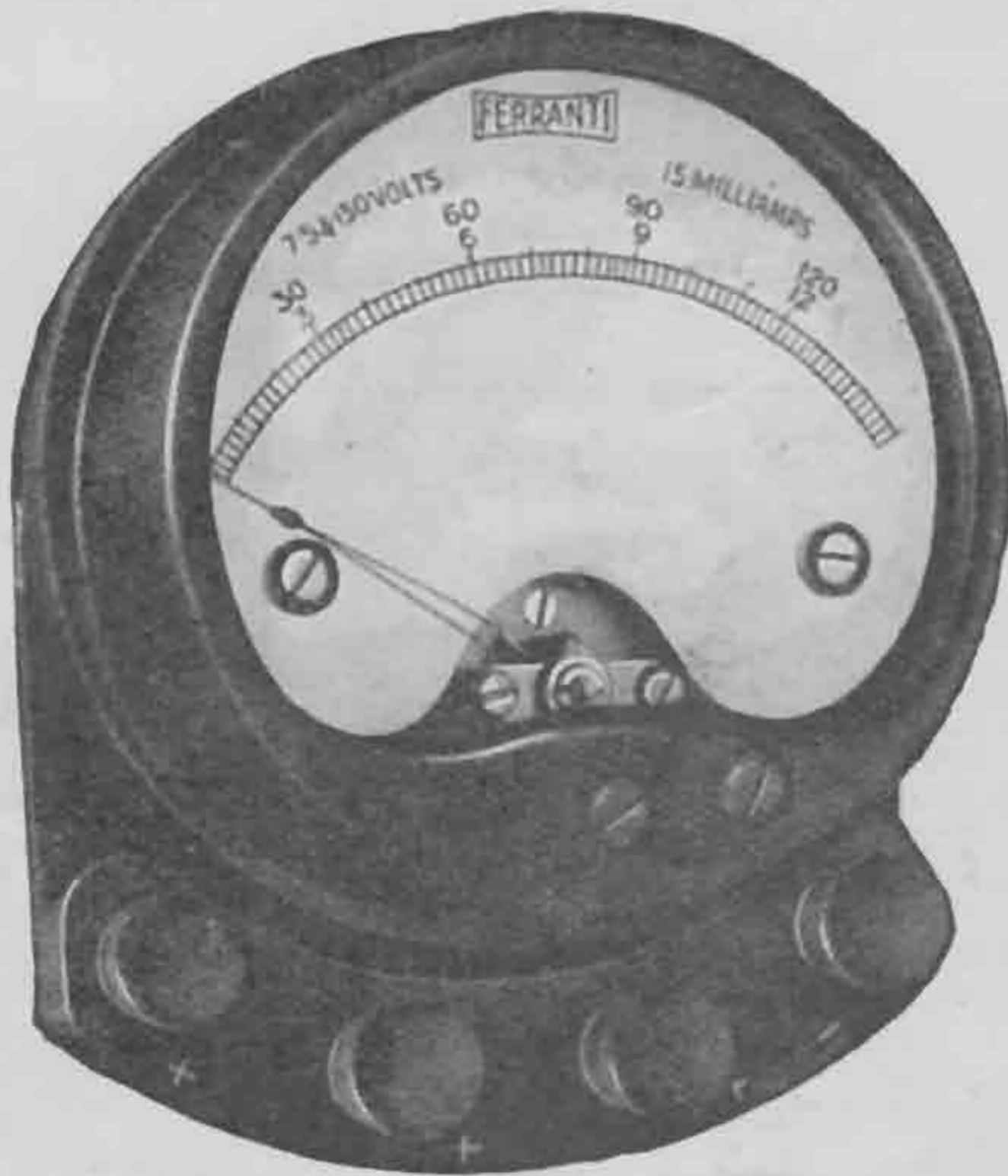

FERRANTI ELECTRIC  
LIMITED,  
TORONTO, CANADA.

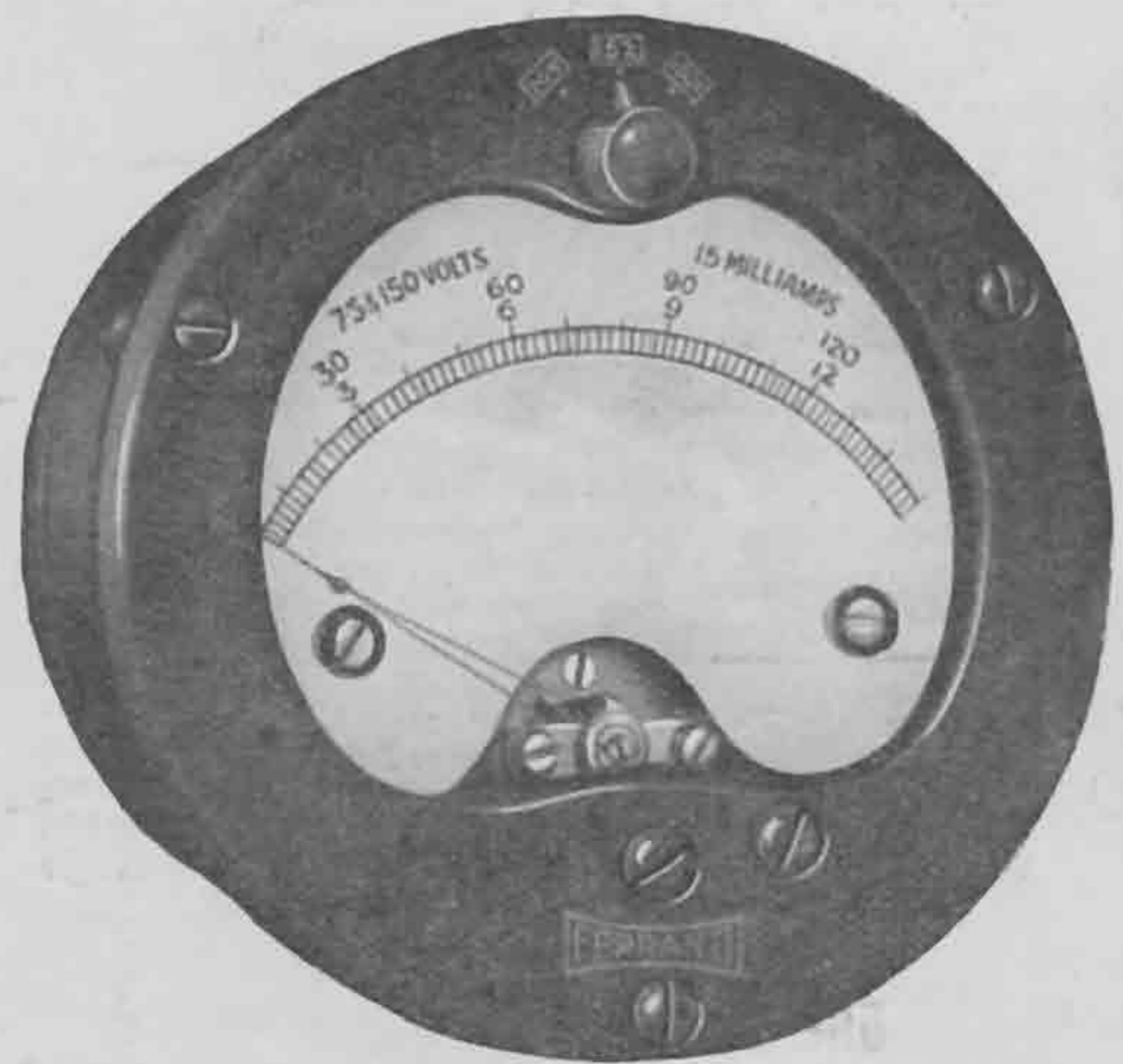

FERRANTI LTD.  
HOLLINWOOD,  
LANCASHIRE.

FERRANTI INC.  
130W 42nd STREET,  
NEW YORK.



# THE DIFFERENCE!

In this photograph the matched electrode construction of the P.M.6 is disclosed with the anode displaced. Note the great length of the wonderful P.M. Filament

The grids illustrated give a striking example of the matched electrode system in the case of only two of the series of Mullard P.M. Valves

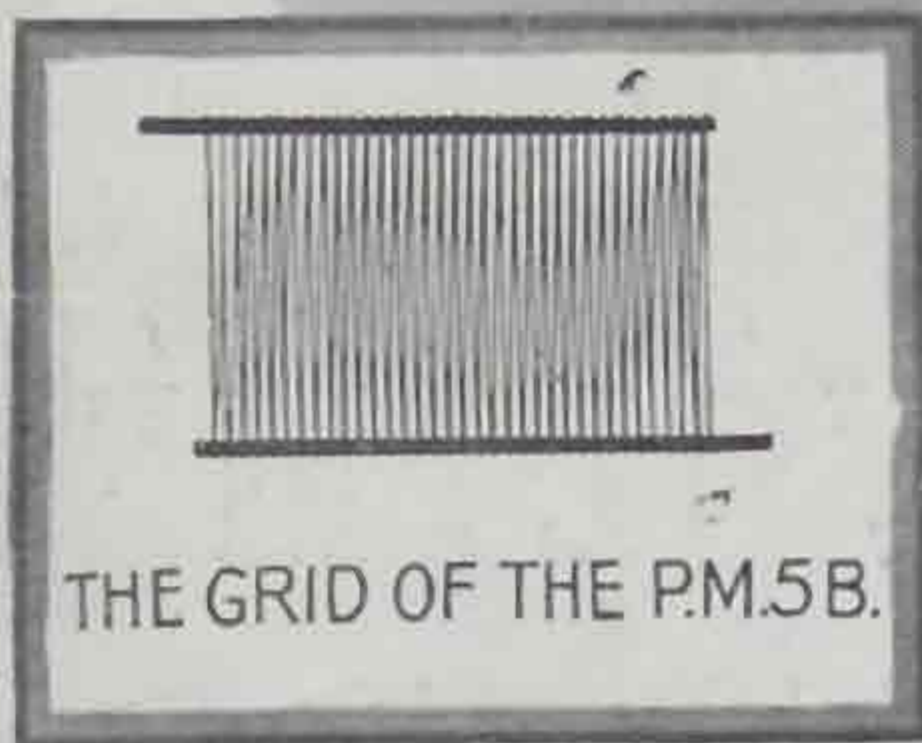

THE GRID OF THE P.M.5B.

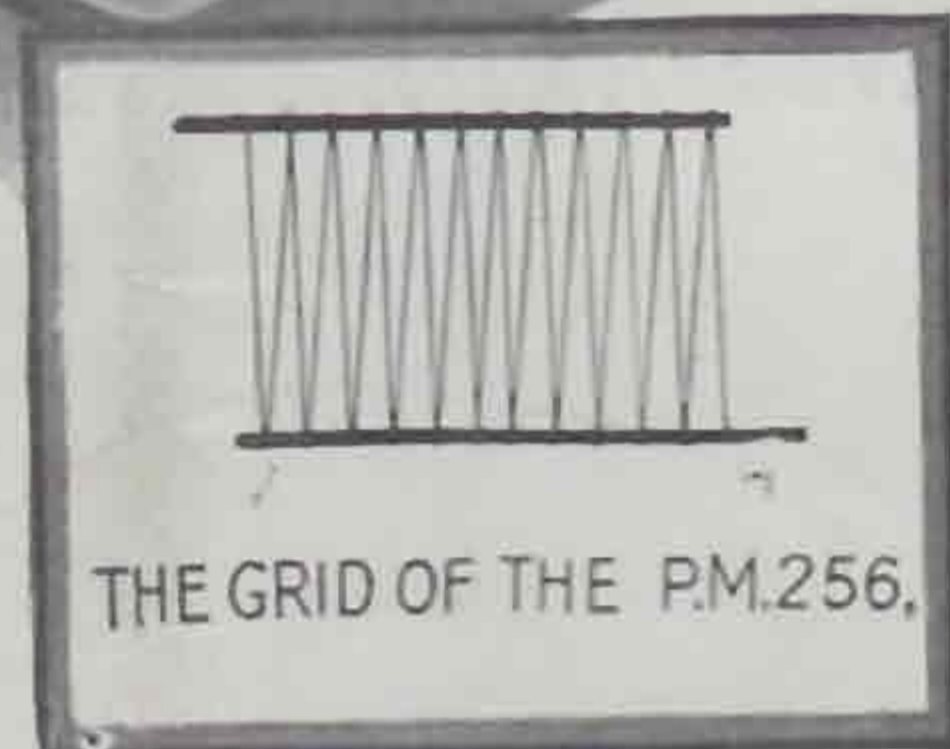

THE GRID OF THE P.M.256.

## MATCHED ELECTRODES

combined with the wonderful

## P.M. FILAMENT

MORE than a supreme filament in Mullard P.M. Valves . . . more than a master filament that has set a new standard for long life, toughness, economy and power . . . the wonderful P.M. Filament . . .

A system of matched electrodes, designed by Mullard Engineers to produce unequalled performance in every type of valve operation by completely utilising the vast energy of this master P.M. Filament to the best advantage in each case.

The result of this special P.M. construction and design is that a series of P.M. Valves has been produced from which, no matter what type of circuit you employ, positively pure and powerful amplification is assured from the first to the last stage, culminating in a final reproduction that is a delight and a revelation.

# Mullard

THE MASTER VALVE

ADVT. THE MULLARD WIRELESS SERVICE CO. LTD., MULLARD HOUSE, DENMARK STREET, W.C.2

Printed by LOXLEY BROTHERS LTD., 50, Southwark Bridge Road, S.E.1, and Published by the TRANSMITTER AND RELAY SECTION OF THE RADIO SOCIETY OF GREAT BRITAIN, 53, Victoria Street, Westminster, S.W.1.