

A NEW HIGH-POWER TELEVISION STATION

# Television

and *SHORT-WAVE WORLD*

MAY, 1938

No. 123. Vol. xi.

**AERIAL FOR  
LONG—  
DISTANCE  
TELEVISION**



**PICTURES ON  
A 31-INCH  
TUBE**

## PICTURES AT 97 MILES!

Actual Untouched Photographs of Pictures Received on

## OUR HOME-BUILT LOW-COST TELEVISOR

SEE PAGE 271

**20 OTHER  
ARTICLES  
FULLY ILLUSTRATED**



**SHORT  
WAVES**

**A T-40 TRANSMITTER  
THE DOUBLE-DOUBLET AERIAL  
AMATEUR ACTIVITIES**

BERNARD JONES PUBLICATIONS LTD.  
CHANSITOR HOUSE, CHANCERY LANE /  
LONDON W.C.2.

THE FIRST TELEVISION JOURNAL IN THE WORLD

---

# A BRITISH TRANSMITTING VALVE FOR BRITISH AMATEURS THE EDISWAN E.S.W.20



Believing that the British Amateur Transmitter would prefer to use valves of home origin the Ediswan Co. have produced the first medium power transmitting valve at a price within the reach of all pockets.

The E.S.W.20 is a 20-watt short-wave oscillator fitted with a UX base and will satisfactorily replace similar valves in Class B and Class C circuits with increased efficiency.

#### CHARACTERISTICS:

Filament Volts - - - -	7.5	Amplification - - - -	22
Filament Current - - - -	2.0 amps	Mutual Conductance	1.7 ma/V.
Max. Anode Volts - - - -	800	Impedance - - - -	12,500 ohms.
Max. Dissipation - - - -	20 watts	Base: 4-pin UX type	

## PRICE 17/6

Supplies will shortly be available from Messrs. Webb's Radio, Soho Street, W.C.2.  
Radiomart (Birmingham) Ltd., and other 'ham' suppliers.

**SUPPLIERS OF VALVES TO ALL GOVERNMENT DEPARTMENTS**

---

# EDISWAN CATHODE RAY TUBES

EDISWAN CATHODE RAY TUBES are used by leading set makers and home constructors on account of their exceptional efficiency and brilliance.

The full range now includes 9" and 12" tubes electrostatically and magnetically focussed.

*Write for full particulars to the Technical Service Department*

THE EDISON SWAN ELECTRIC CO. LTD., 155 CHARING CROSS ROAD, LONDON, W.C.2

R.M.336



# TELEVISION

## and SHORT-WAVE WORLD

### Special Features

	PAGE
New Farnsworth Pick-up Tube ...	260
World's Most Powerful Television Station ...	261
Directly-viewed Large Pictures ...	265
The Simplest Televisor ...	267
Television Sound Programmes on Your Broadcast Set ...	275
Marconi E.M.I. System ...	284
10-watt Aero Transmitter ...	294
1938 Valve Designs ...	296
Double-doublet Aerial ...	297
Dual-purpose Communication Receiver ...	301
T-40 Transmitter ...	305
Low-loss T-20 Output Stage ...	314

## COMMENT OF THE MONTH

### Small Tubes

WE publish on another page in this issue (p. 292) a letter from a reader giving a brief description of a receiver he has constructed employing a one-inch tube. A picture of such a size may seem absurd and it may be argued that it is theoretically impracticable to obtain a picture comprising 405 lines on such a small area. The fact is, however, as we have been aware for a considerable time, that the definition obtained on miniature screens leaves little to be desired. If it is remembered that the pictures obtained by scanning discs in the old 30-line days were of even smaller area and by means of simple magnification gave a considerable amount of satisfaction to many thousands of experimenters, it will be appreciated that the small tube has its possibilities.

The point we wish to stress is that with the small-tube receiver the experimenter has all the essentials of the modern cathode-ray televisor; at a comparatively small cost it is within his power to obtain valuable constructional and operating experience in addition to a reasonable amount of entertainment. In brief, he can become a viewer. Our correspondent estimates the cost of his receiver as being approximately £10; for rather more than twice this amount it is possible to employ a four-inch tube in the simple type of receiver of which constructional details have been given in recent issues. The small tube is, without doubt, the only solution of the problem of cost and is likely to remain so for a very considerable time.

### The Eiffel Tower High-power Station

ALTHOUGH this country is outside the estimated range of the new Eiffel Tower high-power transmitter which is shortly to start working on its full power of 30 kilowatts, there are grounds for believing that it may be receivable in the South of England. Normally expected ranges have constantly been exceeded in the case of the Alexandra Palace transmissions and it seems likely therefore that the distance between Paris and the South of England may be covered in view of the great increase of power and aerial height.

If reception in this country of the French transmissions is found to be possible it will no doubt provide an additional interest. Unfortunately the standards differ, but this is a practical matter in receiver design which owing to the flexibility of the cathode-ray receiver could be overcome.

### TELEVISION AND SHORT-WAVE WORLD

**Proprietors:**  
BERNARD JONES PUBLICATIONS, LTD.

**Editor-in-Chief:**  
BERNARD E. JONES.

**Editor:**  
H. CORBISHLEY, F.T.S.

**Short-Wave Editor:** KENNETH JOWERS

**Editorial, Advertising and Publishing Offices:**

Chansitor House, 38, Chancery Lane, London, W.C.2.

Telephones: Holborn 6158, 6159.

Telegrams: Beejapee, Holb., London.

Subscription Rates: Post paid to any part of the world—3 months, 3/6; 6 months, 6/9; 12 months, 13/6.

Published Monthly—1/- net. On the first day of the month).

Contributions are invited and will be promptly considered. Correspondence should be addressed according to its nature, to the Editor, the Advertisement Manager, or the Publisher, "Television and Short-wave World," Chansitor House, Chancery Lane, London, W.C.2.

#### IMPORTANT

"Television and Short-wave World" is registered at the General Post Office, London, for transmission to Canada and Newfoundland by Magazine Post. Entered as Second-class mail matter, Boston, Mass.

# A NEW FARNSWORTH "PICK-UP" TUBE AMPLIFICATION BEFORE SCANNING

*Here are details of a new camera pick-up tube that has been developed in the Farnsworth Laboratories. By reason of the fact that the image is amplified before it is scanned it is claimed that the tube is more sensitive than any of the existing types.*

*From Our American Correspondent.*

**P**HILLO T. FARNSWORTH, of Farnsworth Television Incorporated, has developed a new "pick-up" tube for use in television cameras which experiments have shown to be not only extremely sensitive to out-of-doors daylight under the most difficult conditions, but which also eliminates most—if not all—of the undesirable features that

electrically active material. In front of the image screen toward the window of the tube is placed the anode, or signal screen B. This screen is of a comparatively open mesh of fine wire, so that it is over 95 per cent. transparent.

In operation, the optical image to be transmitted is focused on the image grid A, and the light falling

element than have been available by previous means. Almost all the electrons drawn through the apertures in the image grid are collected by the anode B, although a very small part of them are collected by the photo islands and serve the function analogous to the grid leak. This amplification process results in a tremendous increase in the signal-to-noise ratio.

## Increased Sensitivity

Since the image grid is only an inch or so behind the optically clear window, it is not necessary to use a long-focus lens, and a large-aperture optical system is possible. Further, the number of stray electrons picked up by the islands may be controlled (the grid leak is variable). This enables the amount of amplification in elemental amplifiers to be conveniently adjusted to suit varying light conditions and time of response.

This tube, radically different from any other "pick-up" tube, would seem to promise a great increase in the sensitivity of television cameras.

It may be of interest to mention that the same principle has also been applied to the Farnsworth dissector tube. In this case the back of the storage screen is coated with photo-sensitive material which if flooded from a uniform source of light produces photoelectrons. These photoelectrons are subjected to the same triode action as described above. An amplified electron image is thus formed which is scanned across an aperture in the same manner as in the earlier dissector tubes.

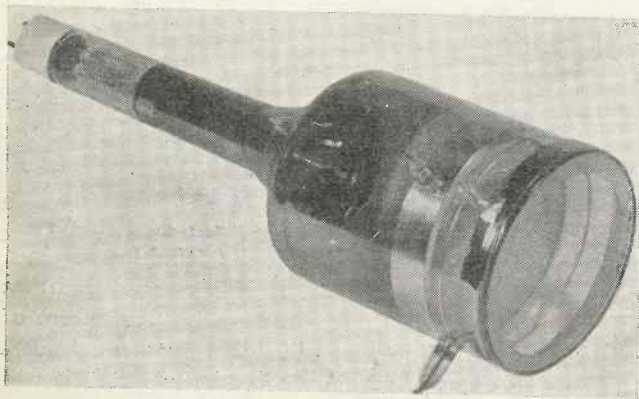

A photograph of the new Farnsworth tube.

have troubled television engineers in the design and building of tubes for this purpose.

The principle of the tube briefly is that amplification of the image is accomplished before scanning. The advantage of amplifying before the image is scanned, results from the fact that the amplifier need not respond to very high frequencies and that the effect of the light may be cumulative. The effect is accomplished by effectively embodying within the tube a million or more small triode amplifiers, the control elements of which are sensitive to light.

The new tube consists essentially of an image grid A, a signal screen B, and a cathode-ray gun C, all suitably mounted in the evacuated glass container. The glass tube has a flat window at one end, and a cathode-ray gun is in the neck.

The image grid is made up of a thin sheet of suitable metal, perforated with approximately 160,000 holes to the square inch. On the side towards the window of the tube is deposited an insulating substance, and upon this insulator are deposited numberless small islands of photo-

upon the photo-electrically sensitive islands causes the emission of electrons from individual islands proportional to the amount of light. An electrostatic charge image is thus set up on the image grid. The cathode-ray gun projects a fine high velocity beam of electrons against the metal back of this image grid and secondary electrons are produced at the point of impact of the beam.

These electrons are drawn through the apertures in the screen by the positive potential on the photo islands on the opposite side. This action represents the unique feature of this tube in that a far greater number of electrons are produced per picture

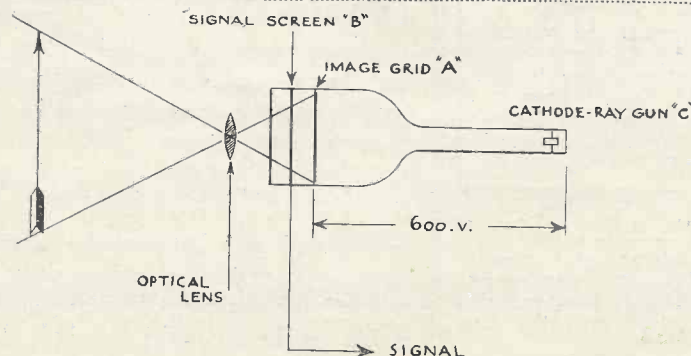

Diagram showing the principle of the tube. The beam is deflected in the usual way by electro-magnetic coils. There is a difference of 22 volts between the signal screen and image grid.

# THE WORLD'S MOST POWERFUL TELEVISION STATION

## EIFFEL TOWER SHORTLY TO START WITH A POWER OF 30 KILOWATTS

**R**ECENTLY (April 8) the Minister of the French P.T.T. invited members of the Press to inspect the new television transmitter at the Eiffel Tower. This transmitter, soon to be one of the most, if not the most powerful television broadcasting station in the world, was engineered and installed by Le Matériel Téléphonique, French licensee of the International Standard Electric Corporation of New York. The transmitter, which has been regularly operating since September, 1937, with reduced power, has recently been transmitting with a power of 15 kW and will shortly be broadcast-

port the television antenna at the height of 315 metres.

Hopes are entertained that when the Eiffel Tower transmitter comes into operation with its full power of 30 kilowatts it will be possible to receive the programmes in the South of England. This article describes the transmitter and gives details of the transmission standards that will be employed.

The design and construction of the antenna and transmitter have involved not only the solution of new

out without interfering with the elevator service of the Eiffel Tower and with full regard to stresses and strains which could be applied to the structure itself.

The French Posts, Telephones and Telegraphs Department, anxious to ensure that the programmes to be transmitted should be the best that modern technique could provide, have constructed and equipped two studios containing the most up-to-date equipment. These two studios are situated at distances of 5 and 2.5 kilometres from the transmitter to which they are connected by special equipment and cables, the contract

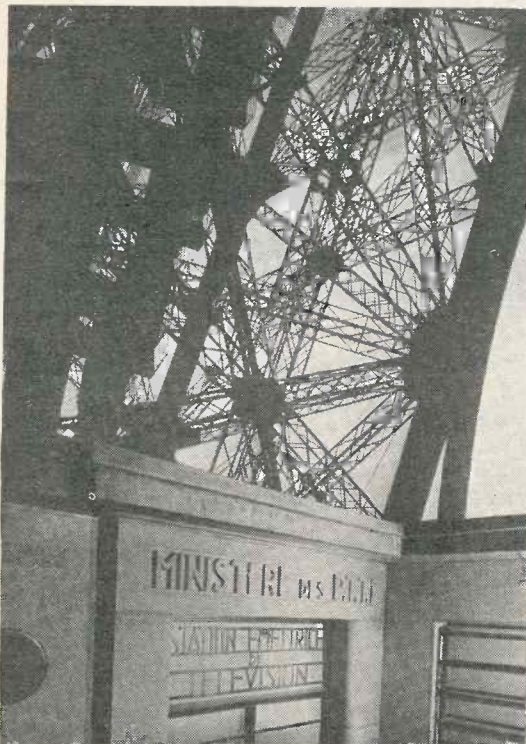

Left. The entrance to the station with the framework of the Eiffel Tower showing in the background.

Right. Installing the feeder cable which runs up the framework of the tower.



ing with a power of 30 kW peak. Already it ranks with the most powerful commercial transmitter of its kind now in operation, awaiting only the utilisation of its full 30 kW power to make it the World's most powerful station.

The transmitter is located at the base of the Eiffel Tower, and use is made of the famous structure to sup-

and difficult technical problems but the solution of many unique difficulties occasioned by the necessity of installing a feeder cable to connect the transmitter and the antenna. This cable has a total length of 380 metres, is over 5 in. in diameter and has a total weight of over 12 tons. It is the longest of its kind in the world. Installation had to be carried

for which was placed with Le Matériel Téléphonique.

### The Feeders

The cable is of the coaxial type consisting of a solid inner conductor of copper, supported within a flexible copper outer conductor. This in turn is sheathed in lead after which a fur-

## THE AERIAL FEEDER

ther protective covering of impregnated jute and of spirally wound steel wire is applied. The cable has a characteristic impedance of 71 ohms and a maximum attenuation of 4.8 db. per mile at 1 megacycle, 6.6 db. at 3 megacycles and 12.6 db. at 8 megacycles.

Perhaps the biggest problem in the development of a cable of this

carriers for transmission over the cable. For transmission of the image band a carrier frequency of 5.5 Mc. is employed, this giving a total transmitted band of 3 Mc. to 8 mgc.

### The Modulator

The equipment for modulating the

and a uniform gain from 3 to 8 megacycles.

Control equipment is provided at both studios and at the radio transmitting station for monitoring the level and form of the signal at the input and output of each unit.

The terminal equipment repeaters and control equipment are completely self-contained. All power is supplied

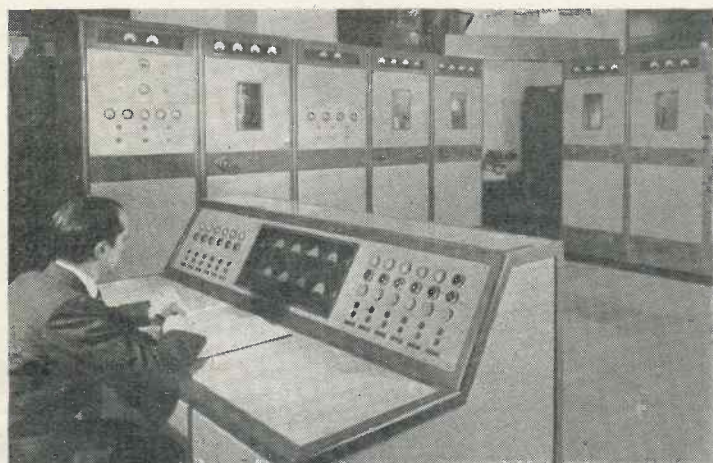

Left. A portion of the transmitter with the control desk in the foreground.

Right. Another picture showing the installation of the feeder which was a task of considerable difficulty.



type is to obtain a perfectly uniform impedance characteristic. This is more and more important as the cable becomes longer. One of the important elements to obtain this result is the outer conductor. This must be flexible, but must not be distorted when bent, and the diameter must be entirely uniform through the length. It must be self-supporting in order that the diameter will not depend on the dielectric between the inner and outer conductors. The problem has been solved by forming the outer tube of a series of interlocking copper strips having a cross section in the form of a letter "Z," as used by the Bell Laboratories in the New York-Philadelphia coaxial cable. These strips are spirally wound and are held in place by a soft steel ribbon which is wound around them. Thus, a completely self-supporting outer tube of constant diameter is obtained.

The dielectric consists of a material having very low dielectric losses at high frequency, and serves simply to centre the inner conductor.

Due to the fact that amplifiers covering wide bands beginning at very low frequencies are difficult to manufacture with satisfactory characteristics, the 5 to 2,500,000-cycle signal is impressed upon high frequency

5.5 Mc. carrier consists of a crystal controlled oscillator, a 5.5 Mc. decoupling amplifier, a balanced oscillator and two push-pull amplifiers. The television signal is supplied directly from the amplifier connected with the scanning device at a level of 50 milliwatts in 70 ohms. This is sufficient to modulate the grid of the modulated amplifier. The complete signal is then amplified in two linear stages and applied to the coaxial cable.

At the receiving end the incoming modulated carrier is amplified and then demodulated in a symmetrical circuit. The 60 milliwatts of television signal produced across the 70-ohm output is applied to the modulating amplifier of the television transmitter. In the case of the longer length of cable, a repeater is necessary to restore the level to its normal value. The repeater consists of a 3-stage amplifier having input and output impedances of 70 ohms

from the 110-volt, 50-cycle supply, the voltage of which is kept constant by means of suitable voltage regulators. In addition the individual plate voltages of the various units are highly stabilised.

The television transmitter itself comprises all the refinements made possible by recent progress in the research laboratories of Le Matériel Téléphonique and its associated companies. Not only is the power the greatest yet attempted, but the definition of the pictures transmitted is higher than that at present employed in any other country.

For several years the laboratories of Le Matériel Téléphonique have been engaged in developing high definition television scanning and transmitting equipment. The first field tests of such equipment were conducted in 1935 when transmission was effected from the laboratories to a demonstration receiver at a distance of several miles. Since then develop-

## THE MOST POWERFUL STATION

ment work has been intensified so that when tenders were made on the new Eiffel Tower transmitter it was possible to offer equipment which had, besides the qualities common to all modern transmitters, certain features believed to be unique.

Since there is as yet no definite world-wide standardisation as to the most preferable type of image scanning it was necessary that the transmitter should have sufficiently flexible characteristics to operate regardless of the type of scanning employed, provided that the modulation frequencies remain within the specified band.

### 30 Kilowatts Power

The transmitter is designed to operate on a frequency between 40 and 50 megacycles (at the moment 46 Mc. is being used) and has a peak continuous power output of 30 kW. The frequency is maintained constant within narrow limits by a quartz crystal oscillator. The quartz is cut to have a low temperature coefficient, and oscillates on the third partial of its fundamental frequency. An oven is provided which maintains the temperature of the crystal constant at  $50^{\circ}\text{C.} \pm .5^{\circ}$ . The oscillator is followed by two doubler stages which raise the frequency to the final carrier value. The doublers are followed by a single tube amplifier, two air-cooled push-pull amplifiers, and three water-cooled push-pull amplifiers, the output of the final stage being coupled to the 56-ohm transmission line to the antenna.

### Modulating Amplifier for Frequencies from 0 to 5 Cycles

Due to difficulties which are normally present in D.C. direct-coupled amplifiers, this modulator effects all the amplification at a carrier frequency on which the 0 to 5-cycle signal is impressed. The 60 mW input to the unit modulates the output of a crystal oscillator-amplifier unit operating on 3 megacycles. The modulated carrier is then amplified in five push-pull air-cooled stages to a level of 2 kW, which is rectified in a symmetrical diode circuit. The load resistance of the rectifier is connected through a low-pass filter in series with the grids of the last H.F. amplifier. The rectified carrier voltage supplies the fixed grid bias for the

H.F. amplifier, and the modulation frequencies modulate the H.F. amplifier grids. The modulation amplifier employs a large reverse feed-back which keeps the linear distortion of the amplifier at a low value.

### Modulating Amplifier for Frequencies from 25 to 2,500,000 Cycles

This amplifier receives an input of 3 volts peak in 70 ohms from the coaxial cable terminating equipment and amplifies it to a peak value of about 2,500 volts for modulation of the grid of the final radio-frequency amplifier.

The amplifier consists of four air-cooled stages followed by two water-cooled stages. A modified form of resistance-capacity coupling is used throughout. Due to the extreme limits of the band to be transmitted with small amplitude and phase distortion, care is taken to keep the capacity to ground of the active elements at a minimum. In spite of this it is essential to operate the tubes into a load circuit of comparatively low impedance in order to minimise the loss at the higher end of the amplified band.

The positive terminal of the plate supply to the final stage is earthed, the negative terminal, and hence the entire filament and grid circuit, being at a high negative potential with respect to earth. This is done in order that the plate of the modulator may be connected directly to the grids of the modulated H.F. amplifier, thus avoiding the coupling condenser and high grid resistance which would be necessary if capacity coupling were employed. Thus the D.C. drop in the modulator plate resistor furnishes the negative bias for the H.F. stage, and this bias is varied by the signal output of the modulator.

### Monitoring and Test Equipment

The monitoring equipment for a television transmitter is considerably more complicated than that for a sound broadcast station, due to the fact that the modulating wave shapes are neither sinusoidal nor symmetrical, and that in addition to controlling the frequency distortion, harmonic distortion and percentage modulation, the phase distortion must also be maintained at a very low value. At present, the easiest

method for accomplishing this is by means of the cathode-ray oscillograph. Consequently five oscillographs, with their associated equipment, are mounted on the monitoring bays. These give a rapid indication of:

- (1) The envelope of the H.F. output to the antenna.
- (2) The signal components at the input to the modulating amplifier.
- (3) The signal components from a linear rectifier coupled to the output of the transmitter.
- (4) The television image at the input to the transmitter.
- (5) The television image as received from a linear rectifier at the output of the transmitter.

These instruments give an easy and rapid check as to whether the transmitter is operating in the correct manner. For precision measurements they are, of course, supplemented by additional test equipment, which, however, does not form part of the permanent installation.

### Power Supply

The transmitter is operated directly from the 500 volt, 50 cycle, 3-phase mains and takes a maximum power of approximately 350 kVA. All direct-current supplies are furnished from either hot-cathode mercury-vapour rectifiers or selenium dry rectifiers, so that no moving machinery is used.

Due to the necessity of avoiding coupling between the various modulator stages and also between the two modulated stages of the H.F. amplifier, five separate power supplies varying from 7,500 volts 2 amperes to 14,000 volts 10 amperes are employed. These are also of the hot-cathode mercury-vapour type and are located in a room adjacent to the transmitter room. The rectifiers employ a type of construction in which the H.T. transformer, flamept transformer, and filter choke are mounted in a tank with the rectifier valves mounted directly above the tank and forming an integral part of it.

The control desk is located in the transmitter room facing the equipment and from this desk the transmitter can be set in operation. Separate push buttons, which are so interlocked that they must be operated in

the proper sequence, apply the main power supply, rectifier filaments, transmitter filaments and all H.T. which is located in the transmitter proper, and the external H.T. either together or separately. Indicating lamps show that the various units are operating.

Push buttons are also located on

the various units of the transmitter for individual application of all H.T. and the filament voltages of the water-cooled tubes.

**Water cooling Plant**

The water cooling system has a flow of 350 litres per minute and is designed to continuously dissipate

200 kW. The system is entirely closed and employs distilled water.

Each water cooled stage of the transmitter is provided with a water flow meter which indicates the flow directly in litres per minute and is provided with a contact for removing filament and H.T. voltage if the flow falls below a predetermined value.

**STANDARDS ADOPTED BY THE COMPAGNIE FRANCAISE DETELEVISION**

The picture is 450 lines, interlaced, having a frame frequency of 50 per second. The interlacing is accomplished in the following way:

whether "odd" or "even," and the displacement of the lines is produced by a phase shift of the synchronising signal during the

initial lines of the second "even" frame are superimposed on the lines of the preceding frame. The synchronising signal is then "retarded by

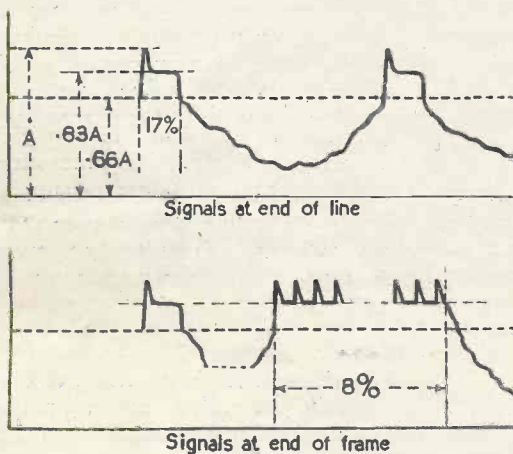
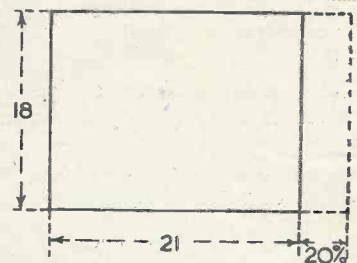

Fig. 1. (left) The synchronising signals correspond to "blacker than black" although the modulation is negative. The line impulse has a short steep front followed by a longer impulse of lower amplitude. The total duration is 17% of the line. The proportion between the amplitude of the pulse and the picture signal is shown in the figure.

The frame synchronising impulse is rectangular, lasting for 8% of the frame. The line impulses are transmitted during the frame pulse, ensuring that the first and last few lines are coincident as explained above.

Fig. 2. (right) The aspect ratio is 4.5 for the visible portion of the figure.



a small amount until the scan has dropped behind by half a line. This has the effect of producing the interlace, which is maintained until a few lines from the end of the frame when the synchronising signal is again advanced to cause the lines to be superimposed. The method is known as "interlacing by internal phasing," and the total time during which the lines are superimposed is equivalent to 30 lines.

The picture synchronising signal coincides with the line synchronising signal at the end of each frame

scanning of the frame. After the completion of one frame (the "odd" one, for example), the

**The Philco Television Camera**

On page 220 of last month's issue two drawings of camera tubes were shown, the upper, a R.C.A. tube, the power being described as a Farnsworth tube. The latter description was incorrect and the tube shown is one that has been developed by the Philco Radio and Television Corporation of Philadelphia.

The photograph here shows the camera in which this tube is employed. This new Philco television camera is electrically raised and lowered and is designed so that a single control handle rotates, tilts and focuses the camera. It forms a unit of the experimental 441-line television system operating in Philadelphia. The entire transmission sys-



The Philco Camera.

tem, as well as the receivers used in field tests, are capable of transmitting and reproducing frequencies up to 4.2 mc. The sound and vision transmitters operate in the 50-56 mc. channel. Transmitter power is 4 kW peak.

**BAIRD TELEVISION LTD. CHANGE OF ADDRESS**

Baird Television, Ltd., have now removed their offices and laboratories to new premises at Worsley Bridge Road, Lower Sydenham, S.E.26, telephone Hither Green 4600.

"Television and Short-wave World" circulates in all parts of the world.



# DIRECTLY-VIEWED LARGE PICTURES

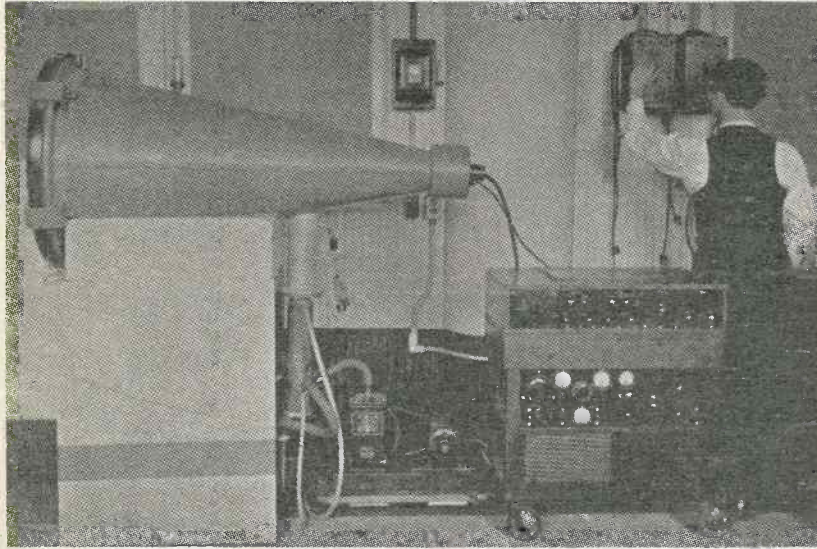

Fig. 2. Side view of tube 4½ ft. long and constructed of steel and plate glass.

MANY solutions to the problem of obtaining large television images have been proposed and several methods have been extensively explored, including projection by cathode-ray tube and also mechanical-optical methods.

An entirely new device for obtaining large bright television images of high contrast and high definition, however, has been developed at the Camden Laboratories of the R.C.A. Manufacturing Company (U.S.A.). It consists of a direct-viewing cathode-ray tube 4½ ft. long and 31 in. in diameter. It is of the continuously evacuated type and gives a picture 18 in. by 24 in. in size. The tube was built with the primary purpose of studying television pictures of large size under conditions where brightness, contrast, and definition were adequate and where the method of reproduction did not limit the performance of the system.

## Increase of Light

The most important consideration in favour of the large direct-viewing cathode-ray tube is that the total amount of light obtainable from a luminescent screen is directly proportional to the area of the screen. At present the most widely used luminescent materials for screens in cathode-ray tubes are zinc orthosilicate (willemite) and zinc sulphide. Both materials exhibit the property known as "current saturation." A current-

saturation curve of a yellow willemite screen, bombarded by 10,000-volt electrons in a developmental projection tube, is shown in Fig. 1.

Measurements show that under the conditions of normal television scanning this saturation is a function of the area of the scanning spot and not of the total scanned area. But the area of the scanning spot is necessarily a function of the total area, if

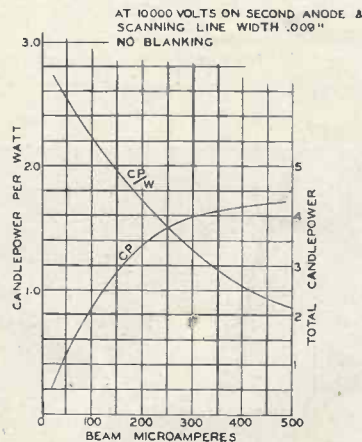

Fig. 1. Current saturation curve of yellow willemite in 3-in. tube.

the detail of the picture is to be preserved; i.e., it cannot be larger than a certain fraction of the total area

Please mention "Television and Short-wave World" when corresponding with advertisers.

## DETAILS OF THE WORLD'S LARGEST CATHODE-RAY TUBE

As mentioned last month, a cathode-ray tube has been developed by The R.C.A. Manufacturing Company which has a screen diameter of 31 inches. This article describes its construction.

scanned. In actual practice, since the luminous spot is round, a certain overlap of the scanning lines is permissible. As a limit, after which a serious loss of detail takes place, 50 per cent. overlap may be taken. The present tentative standard calls for 441 lines per frame (American standard), about 10 per cent. of which are blanked out during vertical synchronising time. The observed picture, therefore, consists of 400 horizontal lines. Allowing 50 per cent. overlap, this calls for the line width of one-half of one per cent. of the height of the reproduced picture as the limiting maximum line width.

It may be deduced from the curves of Fig. 1 that at 10,000 volts the maximum useful brightness of this particular type of luminescent screen is 0.7 candle power per sq. ft. The maximum useful beam current (while it is on) is 58  $\mu$ a. per sq. in., but when the average power over a period of one complete white frame is considered, it is only 0.80 of the product of volts and amperes (max.).

The factor of 0.80 is introduced because in actual operation the electron beam scans a given picture area for only 80 per cent. of the time since 20 per cent. of the time it is extinguished for the line and frame returns or fly-backs.

## Picture Brightness

As to the minimum required brightness of the screen, opinions vary greatly. As a measure, the brightness of a motion-picture screen is often used. A committee of the Society of Motion Picture Engineers concludes that the high-lights of the picture should have at least 11-foot lamberts or 3.5 candles per sq. ft. if

eye fatigue is to be completely avoided. The recommendation, however, is that 0.86 to 1.05 candles per sq. ft. be adopted as a temporary standard. There is very good reason to believe that a television picture should have more light than that.

The reason for low screen brightness being satisfactory for motion-picture theatres is that there is practically no stray light and the size of the image is very large. The theatre hall is devoted to the showing of pictures and everybody there is looking at the picture. The television receiver is placed in a room which is used for other purposes. It may be the living room of a residence, hotel lobby, or a restaurant. To be of maximum usefulness, a television receiver should not interfere with any other functions of the room. The willemite screen by itself at 10,000 volts is capable of giving a surface brightness as high as 100 candles per sq. ft. or 314 foot-lamberts or apparent foot-candles. For a screen 18 in. by 24 in. it would require 25 mA. at 10,000 volts. For the previously mentioned figure of 40 c.p. per sq. ft., only 6 mA. at 10,000 volts are required. The lower the current density of the luminous spot, the higher is the screen efficiency. At 2 mA. and 10,000 volts a directly bombarded luminescent willemite screen of the type described will have a brilliancy of 14.6 c.p. per sq. ft., or 46 ft. lamberts, which is nine times the upper brightness limit of the tentative S.M.P.E. standard.

### Air Pressure of 5½ tons

Last year the construction of a direct-viewing tube with screen 18 in. by 24 in. was completed at the Camden Laboratory of the R.C.A. Manufacturing Co., Inc. The tube is of the demountable continuously-evacuated type and has a metal envelope with a Pyrex sight glass. Fig. 2 shows a side view of this tube. The envelope is made of good grade steel ¼ in. thick with arc-welded seams and flanges. It has the shape of a cone, and is 4.5 ft. in length. The outside diameter of the large flange is 31 inches.

A three-stage oil-diffusion pump is directly connected to the tube through a special outlet. For fore-vacuum, a mechanical vacuum pump is connected to the diffusion pump by means of a length of rubber hose. The glass cover is convex outwards, 31 in. in diameter and, 2 in. thick.

This thickness is necessary because the total atmospheric pressure on the glass is approximately 5½ tons. A special machine was constructed for grinding and polishing both surfaces of the glass. The technique used was that of grinding telescope lenses.

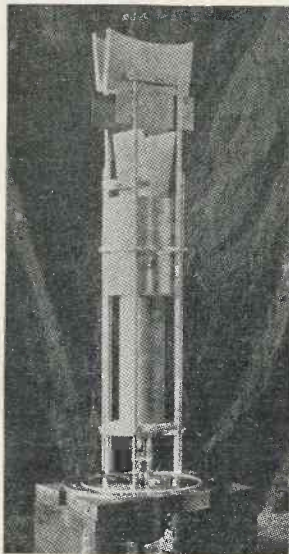

Fig. 3. The electrode assembly of the tube.

For vacuum-tight joints between the glass and metal as well as between metal flanges, pure gum rubber gaskets proved very satisfactory. The performance of the tube is quite satisfactory when vacuum of the order of 10-6 mm. Hg. is reached. Normally such a vacuum is reached after 48 hours of operation. The vacuum measurements are made by means of thermocouple and ionisation gauges attached to the sleeve

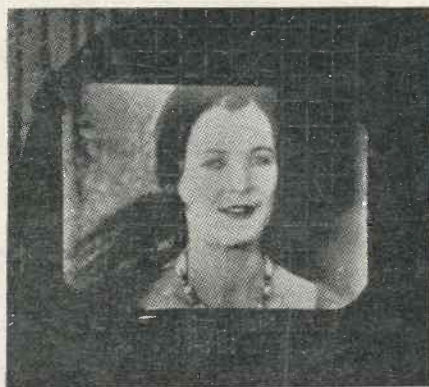

Fig. 4. An untouched photograph of a typical picture obtained on the tube.

connecting the vessel and the diffusion pump.

The tube was designed for 10,000 volts on the second anode. For safety reasons, instead of operating

the metal envelope at 10,000 volts positive, it is grounded and the cathode is raised to the same voltage, but negative. This arrangement greatly facilitates the construction of the electron gun. The electron gun used in this tube is shown by Fig. 3. It gave beam currents as high as 8 mA. at 10,000 volts with corresponding brilliancy of the high-lights. However, the best overall performance was obtained with a gun giving 2 mA. in a narrow beam with negligible focusing and with 150 volts cut-off grid voltage.

The design of the power supply and video amplifier for the demountable tube offered many difficulties. The cathodes in the last stages of the video amplifier had to be operated at minus 10,000 volts, and, of course, had to be capacity-coupled somewhere along the chain to the low-voltage stages. The two coupling condensers during the operation are charged to 10,000 volts and at the same time are required to pass low video frequency currents. All the meters and controls on the last stages of the amplifier had to be insulated for 10,000 volt. A view of the portable outfit containing the video amplifier, synchronising and deflecting circuits, and high and low-voltage supply, is shown on the right-hand side of Fig. 2.

A typical received picture is shown in Fig. 4. The signal was taken from an Iconoscope pick-up of a regular moving picture frame. The photograph has not been retouched. It will be noted from the photograph that the sides of the image are straight and there is no apparent bulging of the image. The reason for this effect is that the 2 in. thick glass disc is used only as a vacuum cover or a sight glass while the luminescent material is deposited on a flat glass sheet ⅜ mm. thick, which is fastened to the walls of the tube. The flat appearance of this type of luminescent screen is not its only advantage. The fact that it is flat greatly improves the overall contrast of the reproduced picture. On a concave screen, illuminated parts throw light directly on the blacks of the image, thereby reducing the contrast. The fact that the screen is thin improves the contrast in details by reducing the well-known "halation" or "the spurious ring" effect.

In conclusion, it may be stated that with the tube described, large, bright television images of high detail and of high contrast are obtainable.

# THE SIMPLEST HOME-BUILT TELEVISOR

Designed by S. West

## PART III. LAYOUT DIAGRAMS OF THE TIME BASE AND CONSTRUCTIONAL DETAILS OF THE POWER PACKS

*This article concludes the instructions for building the simplest television receiver yet designed. The two previous instalments dealt with the vision receiver and time base and in the following pages the construction of the power packs are described in detail.*

**I**N the two preceding articles of this series, comprehensive instructions for building the vision and time base units of this simple television receiver were given.

In conclusion of the constructional details it now remains to consider the power pack. This section of the receiver is contained on the bottom deck of the complete televisor as shown by the photograph below.

The arrangement employed actually consists of two separate power packs. One furnishes some 250 volts for the vision unit and the other approximately 1,200 volts for tube excitation and, by dissipating the excess voltage across a resistance, some 500 volts for the time base.

The circuits are quite conventional and thus will require little description.

### Vision Unit Power Pack

Dealing first with the vision unit power pack, this is comprised by the transformer T<sub>2</sub>, the condensers C<sub>37</sub>, C<sub>38</sub> and C<sub>39</sub>, and the two Varley smoothing chokes.

These are the type DP11 and their terminals are connected, according to the maker's instructions, for the series arrangement. The mains transformer, which is of Sound Sales' manufacture, has a tapped primary.

A Clix voltage selector board with fused bridge permits this primary to be adjusted to suit A.C. mains having voltages from 200-250. No additional fuse is included elsewhere for this power unit and, in view of the desirability of providing some form of safety device, it is important to specify the fused bridge type of selector board when ordering this component.

The reservoir condenser C<sub>39</sub> and the smoothing condenser C<sub>38</sub> are contained in the same "can." It is immaterial which section is used for either function.

C<sub>37</sub> is a cardboard type electrolytic and it is convenient to mount this beneath the

deck. A simple fixing bracket is entirely satisfactory.

An indirectly heated full-wave rectifying valve is employed, for this affords an opportunity for the various valves of the vision unit to acquire their normal operating temperature before application of the maximum high-tension voltage.

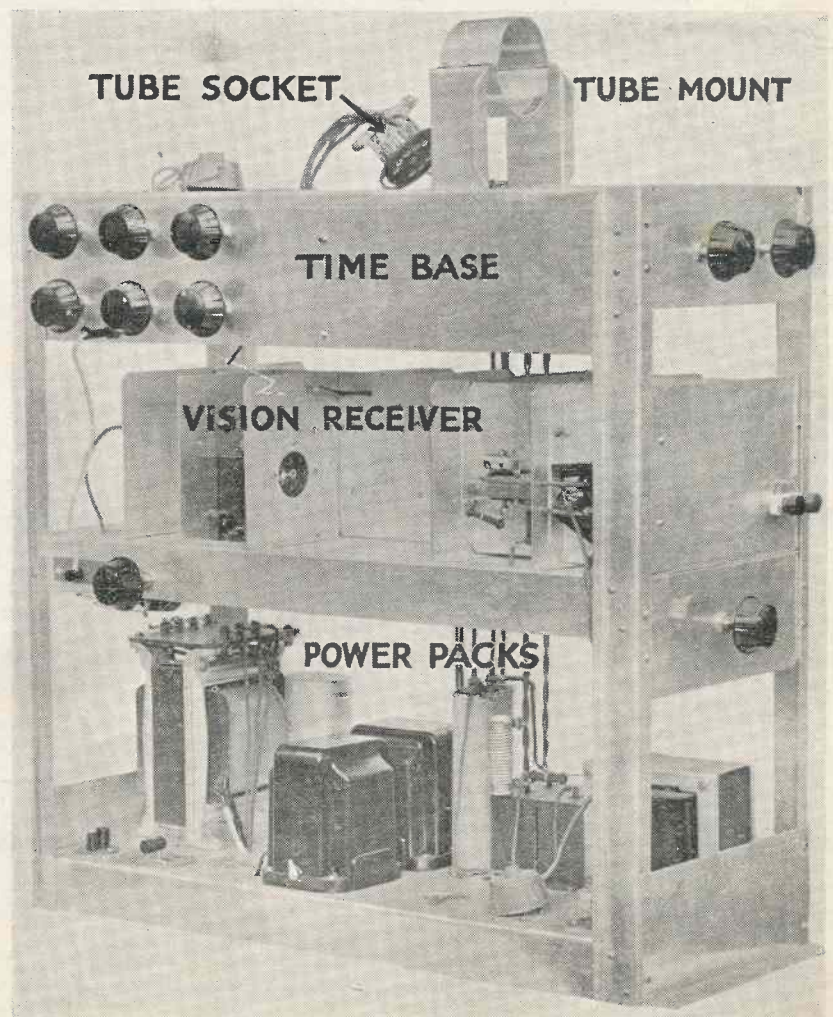

Here is a photograph of the complete televisor with the various units indicated.

## WIRING DIAGRAM OF TIME BASE

The heater and high tension voltage outputs are taken to a Bryce 10-way connecting block which is mounted at the side of the chassis.

### Tube and Time Base Power Pack

For the time base and the C.R. tube exciter voltage a half-wave mercury-vapour type rectifier is employed. The C.R. tube is operated with an earthed cathode; in consequence it is convenient to derive the time base power from the C.R. tube exciter voltage.

A potential between 1,100 and 1,200 volts is provided by the unit. As we require a little over 500 volts only for correct time base operation, the excess 600 volts is dropped across a 50,000-ohm Bulgin type PR17 power resistance.

It is strongly recommended that this type of resistance be employed as the power dissipation is approximately 8 watts.

A Dubilier 50,000-ohm resistance is included in series with the C.R. tube exciter voltage and this fulfils a dual purpose. It provides sufficient smoothing of the

tube voltage and in the event of a breakdown will restrict the rectified current flow to proportions within the rectifying valve rating. Actually this resistance together with its associated condenser is included on the time base deck.

The frame and line bases' supplies are decoupled from each other. The resistance R45, which has a value of 10,000 ohms, in conjunction with the 2 mfd. Dubilier type LEG condenser, satisfying this requirement.

A vacuum type thermal-delay switch, included in the high-voltage secondary, delays application of the high voltage until all the heaters have acquired operating temperature.

The mains transformer is a Keston. A separate voltage selector board is used to permit adjustment of the primary tapings and, as in the case of the vision unit power pack, a fused bridge is specified. Both circuits are then separately safeguarded in the event of a breakdown or short circuit occurring.

The various heater and H.T. voltages furnished by this unit are taken to the Bryce 10-way connecting block. A point concerning this connecting block has

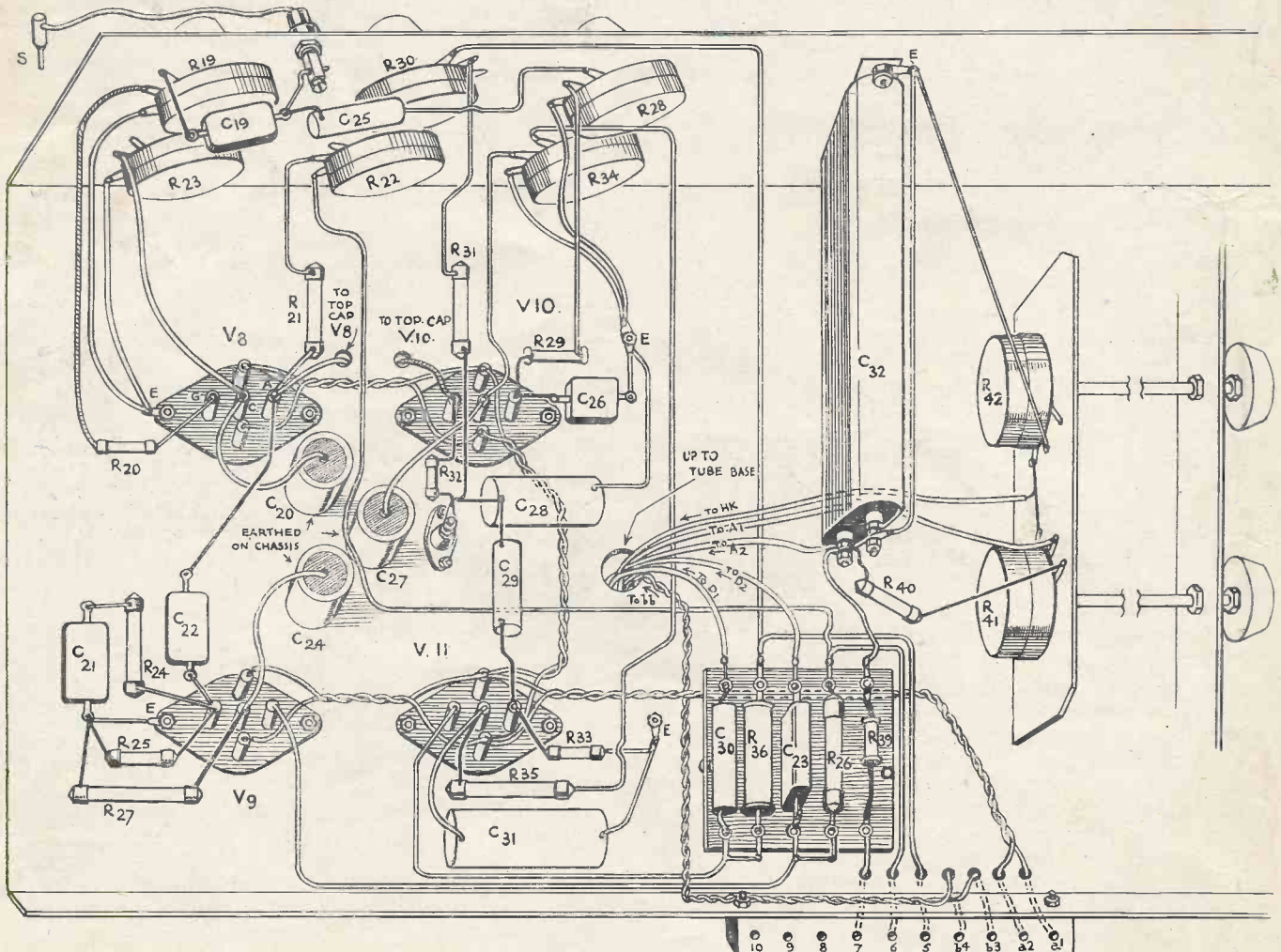

This diagram gives the details of the component assembly and wiring of the underside of the time base. The constructional information was given in last month's issue.

## THE POWER PACKS

already been mentioned but it is again repeated here. It is preferable to adhere to the same order of connection as is adopted for the original receiver. The various sockets for the complete assembly will then be correctly juxtaposed, facilitating connection and making for a neat appearance.

It is convenient to carry out the wiring in tinned

already been given. A study of the various illustrations will render the task of construction simple.

It is proposed at this juncture to consider the final assembly of the complete receiver. Unless very special reasons for departing from the original layout exist, it is strongly recommended that this arrangement be adhered to.

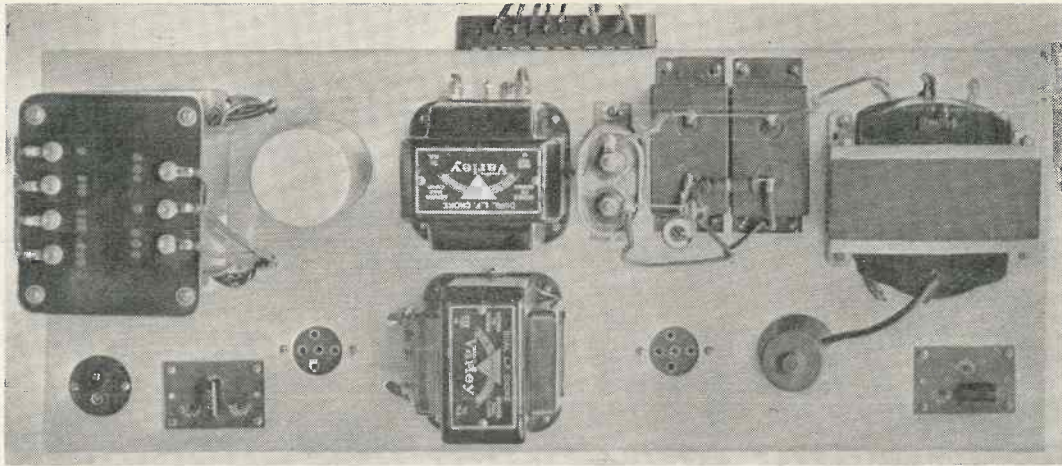

A photograph of the upper side of the power packs, from which the component assembly can be clearly seen.

copper, insulated with systoflex; or commercial slide-back wire can be used.

The usual precautions with leads carrying the full H.T. voltage must be observed; also the possibility of heater voltage drop due to employment of insufficiently heavy wire, for these leads requires to be borne in mind.

The external chassis dimensions for the unit have

The whole comprises, when completed, a compact and efficient receiver.

It will be seen from the various photographs which have been given, that metal uprights at each corner hold the three units in their correct relative positions. Two 6 B.A. bolts at each corner of the units are sufficient and ensure adequate rigidity.

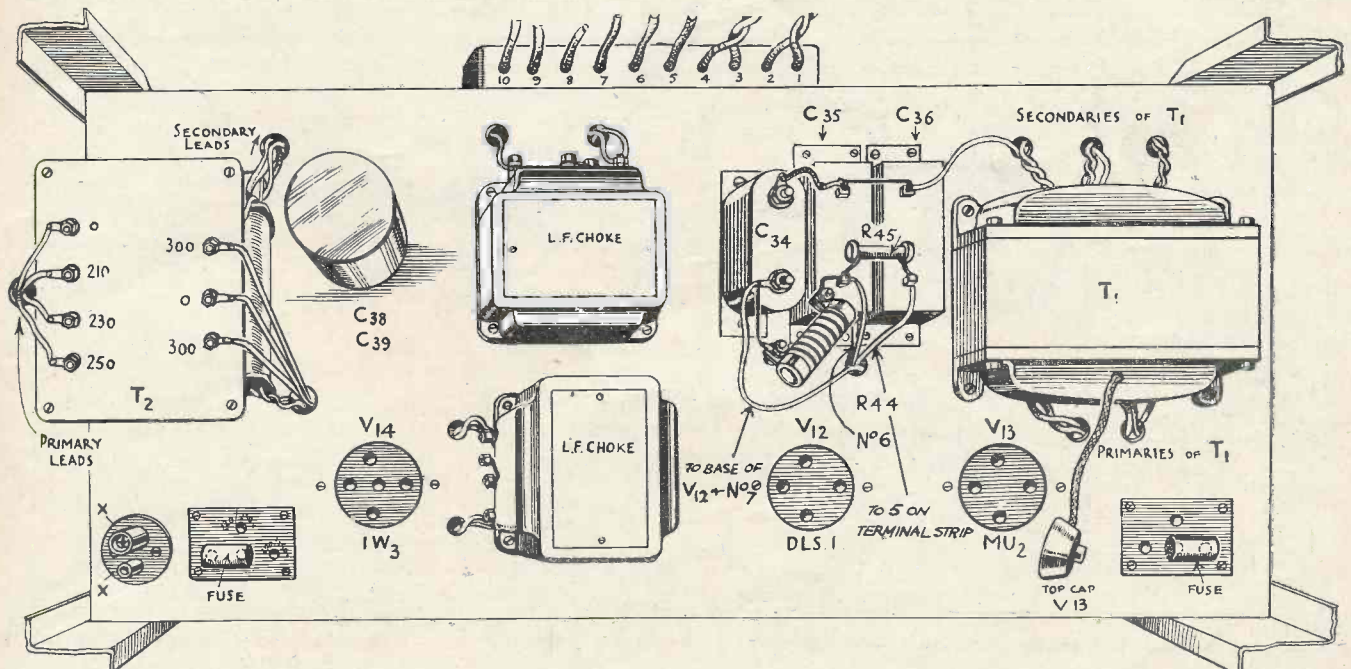

This diagram, which shows the components and wiring on the upper side of the power packs, should be studied in conjunction with the photograph above.

## ASSEMBLY

The front and rear base strengthening pieces are fitted into place when the remainder of the assembly work is completed. It is better to include them as they effectively prevent any tendency for the complete frame work to "whip."

The common earth connection between each unit is

the housing arrangements adopted for the receiver.

The concluding article in this series, which will describe very completely the adjustment and tuning procedure will be given next month.

### Correction

In the theoretical circuit for the time base which ap-

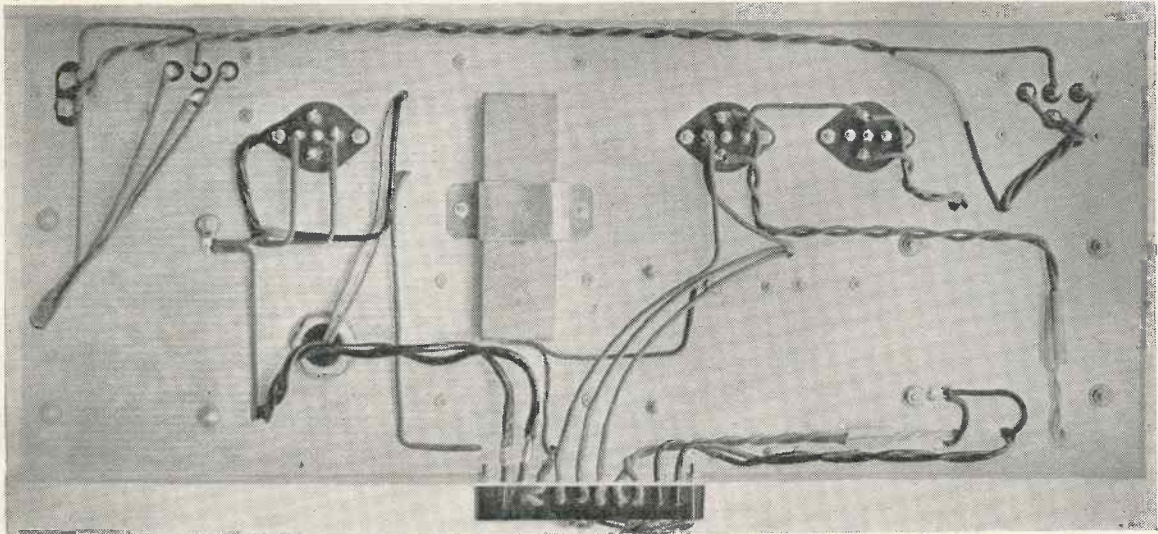

A view of the underside of the power packs showing the wiring.

made by the metal corner uprights and it is as well to ensure that a good surface contact is obtained.

It will be noted that no arrangement for switching the mains supply is included. The most convenient manner of doing this will be dictated by

peared on p. 201 of the April issue, a small error occurred. The connections to the terminals 5 and 6 of the connecting strip should be reversed, i.e., the line H.T. connects to No. 6 terminal and the frame to No. 5 terminal.

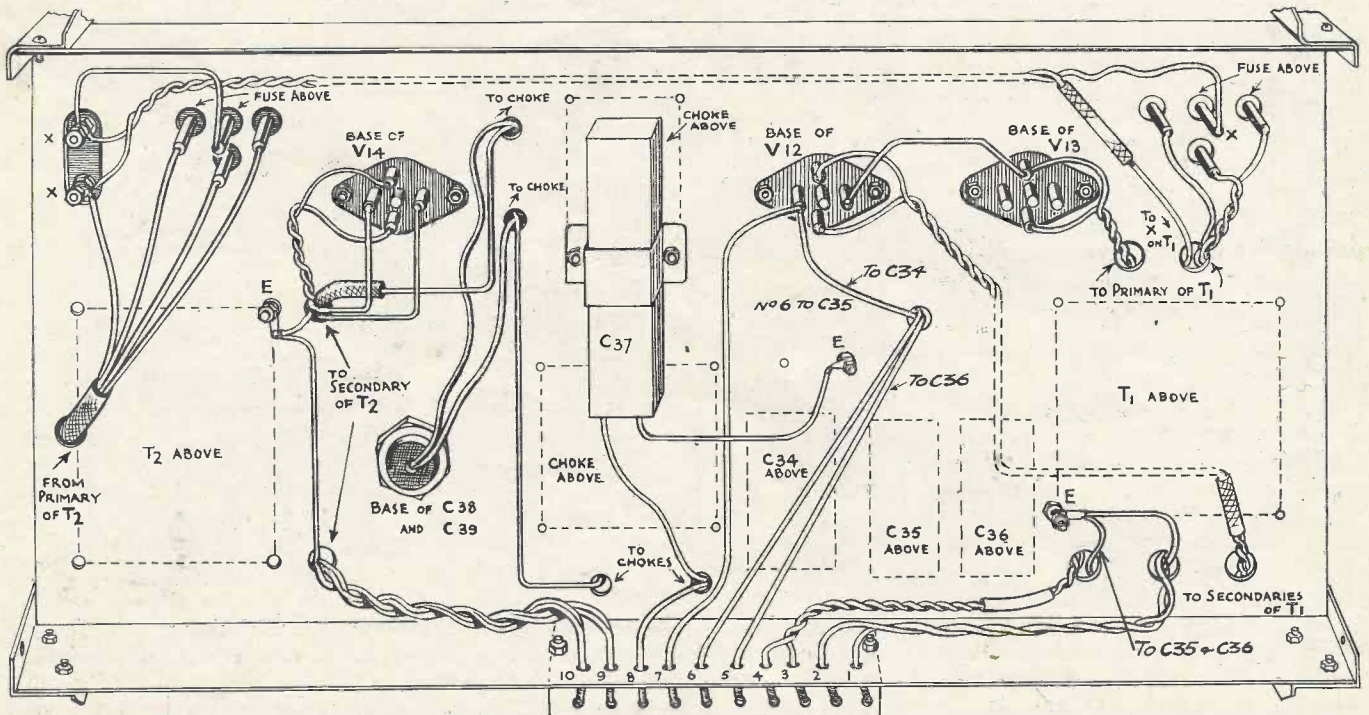

This is a detailed diagram of the wiring of the underside of the power packs as shown by the photograph at the top of this page.

# AN AERIAL FOR LONG-DISTANCE TELEVISION

By S. West.

*Here are particulars of a special type of aerial with which excellent vision reception is being consistently obtained at a distance of ninety-seven miles from the Alexandra Palace. Although it is rather more elaborate than the ordinary dipole, its construction is quite as simple.*

IT does not appear to be generally appreciated that by reason of the very short wavelengths employed for television transmission quite elaborate aerial arrays are possible even where space is limited.

The writer has observed that even where the receiving station is located at a considerable distance from the transmitter, it is general to find a simple vertical half-wave aerial with reflector comprising, what is, with-

## 100-mile Reception

During the last three months, the writer has conducted a large number of tests with different aerial arrangements at Worlingham, which is near Beccles in Suffolk, and a distance of about 100 miles from Alexandra Palace. This work is being continued and at a later date it is hoped to give a very full report of the various types

tion, though, is usually a genuine error, and the writer has himself been guilty of it. It arises from the result of confusing road and rail distance to the centre of London with the actual direct distance to Alexandra Palace, which is situated in the north of London.

Below is a fairly accurate indication of the direct distance from Alexandra Palace of several major towns.

- Nottingham, 104 miles.
- Bournemouth, 101.
- Gloucester, 98.
- Birmingham, 98.
- Norwich, 95.
- Beccles, 95.
- Salisbury, 83.
- Kings Lynn, 82.
- Rugby, 74.
- Portsmouth, 70.
- Felixstowe, 68.
- Winchester, 66.
- Ipswich, 65.
- Eastbourne, 61.
- St. Leonards & Hastings, 60.
- Canterbury, 59.
- Frinton & Walton, 62.
- Northampton, 58.
- Clacton, 57.
- Bury St. Edmunds, 57.
- Oxford, 52.
- Colchester, 49.
- Cambridge, 43.
- Brighton, 54.
- Bedford, 41.

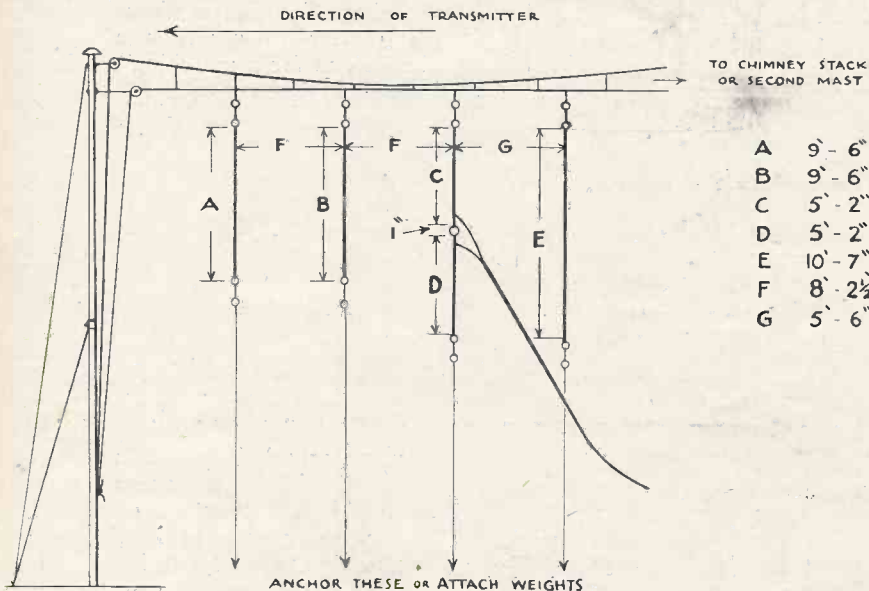

This diagram shows the detailed assembly of the aerial which is provided with reflector and two directors.

out doubt, a most important essential of the receiving outfit.

Whilst it must be admitted there is much to be said for the ease with which these simple aerials may be installed, it is by no means an arduous task to install an arrangement which has a definitely higher efficiency than the conventional arrangement and which, because of this, will mitigate to a large extent the low field strength. Furthermore, there is a considerable improvement in the signal/noise ratio than is accounted for only by the higher gain of the aerial.

of aerial tested, together with measurement data, etc.

In the meantime it is thought that particulars of an aerial which is simple to instal and is capable of providing excellent results at long distances will prove useful.

Elsewhere in this issue, photographs of actual received images are reproduced. Most of these were secured using the simple arrangement here described. (Cover illustration.)

A certain amount of exaggeration is often made in reports of long-distance reception. The exaggera-

The distances given for towns in East Anglia are perhaps more accurate than are those given for towns south of London. For the former a good ordnance survey map was available. Perhaps some person having access to large scale maps will feel inclined to make available very accurate figures.

To avoid any misunderstanding it should be mentioned that reception has not been achieved at all the locations included in this list. However, reception should be possible at all of these places and it is hoped we shall soon hear that it has been accomplished.

## AN END-FED ARRANGEMENT

### The Aerial Construction

A diagram of the aerial earlier referred to is shown. It consists of a vertical half-wave wire with reflector and two directors. This arrangement is quite directional and it is advisable accurately to determine the correct direction in which it should be oriented. Guess work to determine the correct line is to be deprecated. It is preferable, with the aid of an ordnance survey map, parallel rulers and a good compass, to decide the correct line for the aerial. In this connection observe the correction which is included on the map for the compass bearing.

It will be seen from the diagram that two horizontal rope supports are used to carry the various aerial elements. If this scheme is not adopted it will prove impossible to keep the actual aerial support rope taut and as a consequence considerable trouble will result in arranging the correct relative heights of the aerial elements.

For the halyards and aerial supports tarred ratline should be employed. Ordinary untreated ratline shrinks considerably in wet weather and some part of the arrangement is certain to break under the strain thus caused.

For the aerial elements No. 10 s.w.g. enamelled copper wire can be used.

### An End-fed Aerial

An alternative end-fed arrangement of the actual aerial element is given. In many cases this arrangement will prove more satisfactory, especially for cases where the aerial line as related to the point where the lead is to be taken into the dwelling is such as to cause this lead to run adjacent to either the reflector or directors.

The quarter-wave matching section is a conventional arrangement and is comprised of No. 10 s.w.g. copper wire spaced 2 in. Should it prove difficult to secure this gauge

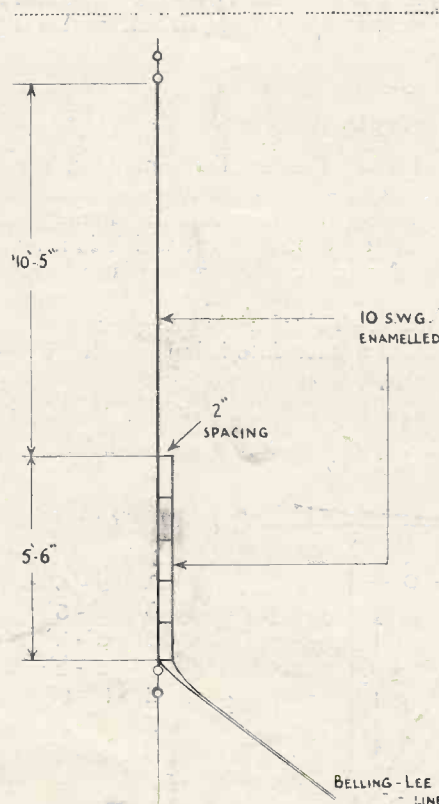

If it is desired to end-feed the aerial C and D (shown in the assembly diagram) may be constructed as above.

of wire a correct match can be obtained using the following formula.

The series impedance required for the matching section is given by the formula  $Z = \sqrt{Z_1 \times Z_2}$ , where  $Z$  is the required matching impedance,  $Z_1$  is the characteristic impedance of the feed line and  $Z_2$  is the aerial impedance.

For a half-wave aerial  $Z_2$  is approximately 2,400 ohms. Using Belling-Lee 75-ohm line  $Z = \sqrt{75 \times 2,400} = 425$  ohms approximately. The required wire size and spacing to give this impedance is derived with the following formula:

$$Z = 277 \log_{10} \frac{S}{R}$$

spacing and  $R$  = radius of the wire.

It is immaterial whether  $S$  and  $R$  are in inches or m/ms. providing the same unit of measurement is employed for each.

Converting into a form more suitable for our purpose.  $S = R$  antilog  $\frac{425}{277}$  where  $S$  and  $R$  are as above.

The following table shows the radius of typical wires. This table and the above formula renders it a simple matter to secure the spacing dimensions for a matching section.

s.w.g.	Radius in ins.
7	.176
8	.160
9	.144
10	.128
12	.104
14	.080
16	.064
18	.048

It is, of course, very desirable to erect the aerial as high as possible and to avoid as far as possible having trees or buildings in line with the transmitter. A little care in choosing the aerial site is amply repaid by the improved performance secured.

The loss occurring in the feeder line is always likely to be less than the improved gain from the aerial where a good position for the installation is located at some distance from the receiver. Therefore, in general, choose the most uninterrupted position for the aerial regardless of feeder length.

### B.B.C. Handbook for 1938

THE B.B.C. Handbook for 1938 records the most notable events and developments in the fifteenth year of the British broadcasting service and contains a great deal of standard and up-to-date information about the B.B.C. There are chapters on the Coronation broadcasts, on television, and the new foreign language broadcasts.

The year 1937 was the year of the

new Charter, of thoroughly organized television, of the first broadcasts in foreign languages, of the most extensive experiments yet made in listener research and of substantial increase in the network of Regional transmitters.

There were, it is revealed, over 100,000 hours of broadcasting from the home transmitters, a figure which includes 23,779 hours of Empire broadcasting and 1,619 hours of

television. The aggregate for 1936 was in the region of 87,000 hours.

The handbook contains licence figures and the revenue account and balance sheet for the past year, besides advice on good reception and maintenance of sets. Its price is 1s. 6d. or 1s. 10d. by post, and applications should be addressed to the B.B.C. Publications Department, 35 Marylebone High Street, London, W.1.



# A CROWD ALWAYS ASSEMBLES TO WITNESS DEMONSTRATIONS ON BAIRD RECEIVERS.

## WHY?

# BECAUSE EACH MODEL IN THE RANGE REPRESENTS THE HIGH WATER-MARK OF ACHIEVEMENT.

Among the factors contributing to the first-class performance of all Baird Television receivers are brilliant pictures, freedom from distortion, excellent detail, wide angle of vision, extremely simple operation, high fidelity sound and all-wave radio. Each television receiver incorporates a Baird "Cathovisor" Cathode Ray Tube which has the outstanding advantage of being completely electro-magnetic in operation. These tubes can be supplied separately with the necessary scan-



ning equipment where desired. Apart from manufacturing processes, stringent tests are made for electrical emission, tube characteristics, filament rating, and screen quality, and following normal picture reconstitution under service conditions, every Baird Cathode Ray Tube, on completion, is subjected to a very high external pressure test. Baird "Cathovisor" Cathode Ray Tubes are the ideal solution for high quality television pictures. Write for details.



*A small section of the daily crowd which assembled at a recent exhibition to see demonstrations on Baird receivers.*



### STOP PRESS NEWS

Model T11 Television Receiver complete with All-Wave Radio has been reduced to 55 guineas. Send for full details at once, post free on request. Price includes aerial, installation and one year's free service.

# BAIRD TELEVISION LTD.

Lower Sydenham, London, S.E.26

Telephone: HITHER GREEN 4600.

Telegrams: TELEVISOR, FOREST, LONDON.

# G.E.C.

## CATHODE RAY MONITOR TUBE

TYPE 4051

*Made in England*

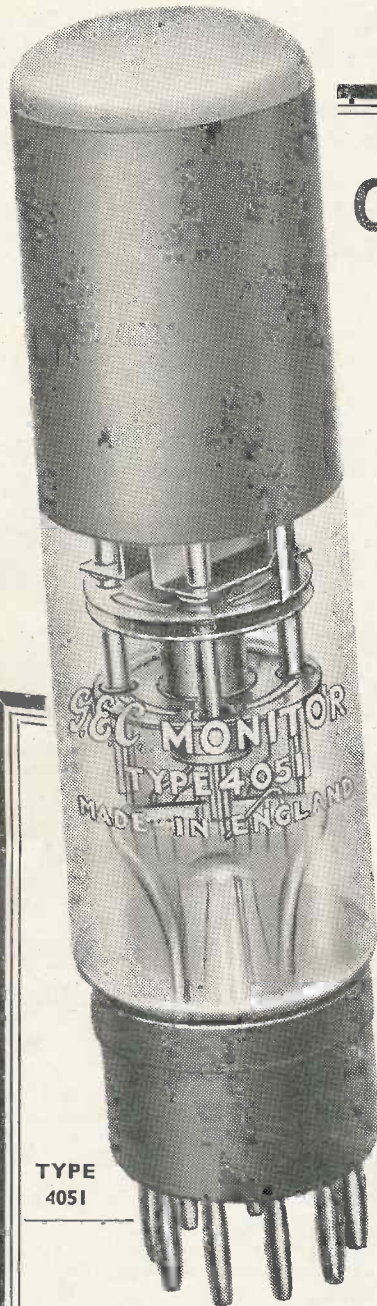

TYPE  
4051

This new tube is ideal for all purposes requiring a small, economical low-voltage cathode-ray tube. It offers the following advantages :

1. Small size (overall length about 6 inches only).
2. Low operating voltages. (The tube will operate down to 250 volts.)
3. Separate connections for the four deflector plates (allowing push-pull scan, if desired).
4. Fine focused spot, bright even down to 250 anode volts.

### RATING

Heater Voltage . . . . .	4.0 v.
Heater Current . . . . .	0.9 amp.
Accelerator Voltage (A <sub>2</sub> )	250-500 max.
Focusing Electrode (A <sub>1</sub> )	50 to 100
Modulating Electrode . . .	0 to -20
British 9-pin base	

### LIST PRICE 45/-

For all purposes requiring a rapid test on waveform, frequency measurement, modulation check, determination of amplitude of any variable quantity, etc.

### NOTE

New high slope tetrode

### OSRAM KTZ41

suitable for oscillograph and Television amplifiers.

#### CHARACTERISTICS

Heater Voltage . . . . .	4.0 volts.
Heater Current . . . . .	1.5 amp.
Anode Voltage . . . . .	250 max.
Screen Voltage . . . . .	250 max.
Mutual conductance . . . . .	7.5 mA/volt
	(measured at Ea-250, Es-250, Eg-2.5).

PRICE 15/- EACH

### ALSO

### OSRAM Gasfilled Relay GTIC for time base circuit.

This Argon filled relay is ideal for oscillograph time base circuits.

Heater Voltage . . . . .	4.0 volts minimum
Heater Current . . . . .	1.3 amp. approx.
Maximum Safe Anode Voltage . . . . .	500 volts (peak value)
Maximum Safe Anode Current . . . . .	1.0 amp. (peak value)
	0.5 (R.M.S. value)
	0.3 amp. (average value measured on a moving coil meter).

PRICE £1 5s. 0d. EACH

Advt. of The General Electric Co. Ltd., Magnet House, Kingsway, London, W.C.2.

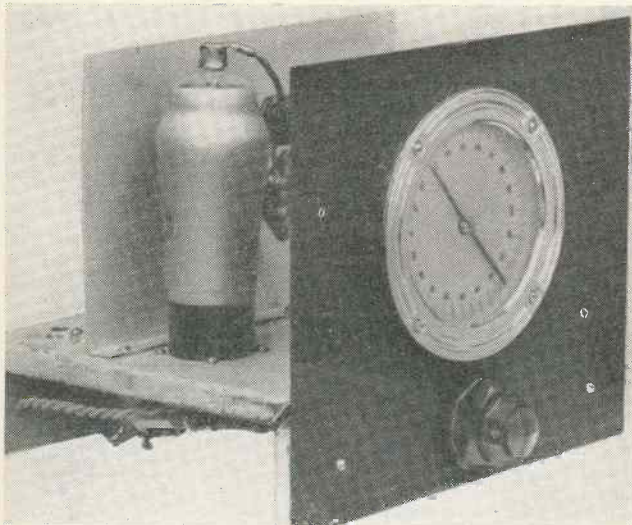

This photograph shows the simple construction of the unit. As will be seen only one valve is employed.

# TELEVISION SOUND PROGRAMMES ON YOUR BROADCAST SET

*This simple unit can be attached to any broadcast set and will enable the television sound programmes to be heard. It will be found useful in conjunction with vision receivers which have no provision for sound. The cost is very low.*

As many of the items included in television broadcasts are of a type that can be appreciated by listeners who cannot obtain the vision side, it is a great advantage to be able in a simple manner to adapt an ordinary broadcast receiver to tune-in these programmes from Alexandra Palace.

In particular programmes such as the transmission of famous dance orchestras and solo artists are of a novel type and quite different from the broadcasts normally obtained on Regional and National wavelengths. Some of the plays are also very interesting, and include famous artists whose names are not always familiar to those who rely solely on the Regional and National programmes for their entertainment.

While many modern all-wave receivers will tune down to 7 metres, the number of people who have purchased such sets is still comparatively small, while it is not to be expected that the average listener will dispense with a perfectly good receiver having only one disadvantage that it does not cover television frequencies.

It is for these listeners that we have produced a very simple super-het convertor for use with any ordinary receiver with a minimum of modification; in fact, no actual wiring alterations have to be made to the receiver.

The circuit of this simple convertor is shown on this page, from which it can be seen that it consists of a multiple valve, one section acting as a hexode detector with the triode portion as a conventional Hartley oscillator. By using this system, the

difficulties which amateurs invariably come up against in convertor design have been overcome, for the oscillator is electronically coupled to the detector by means of the electron stream flowing. Actually, the grid of the triode section is connected directly to the suppressor grid internally.

This system is a most satisfactory one, for it automatically gives the correct amount of coupling, which can never be accurately determined on paper when an inductive coupling

circuit is used with a second coil in the oscillator circuit.

For all intents and purposes, the convertor can be considered as a two-valver with both valves in one common bulb.

Refer to this theoretical circuit. It will be seen that provision has been made for a dipole aerial which is loosely coupled to the grid coil in the detector circuit. This grid coil is centre-tapped so as to reduce the damping effect, so causing greatly

Triode hexode is used as a combined detector and oscillator in Hartley circuit. Provision is made for the use of a dipole aerial

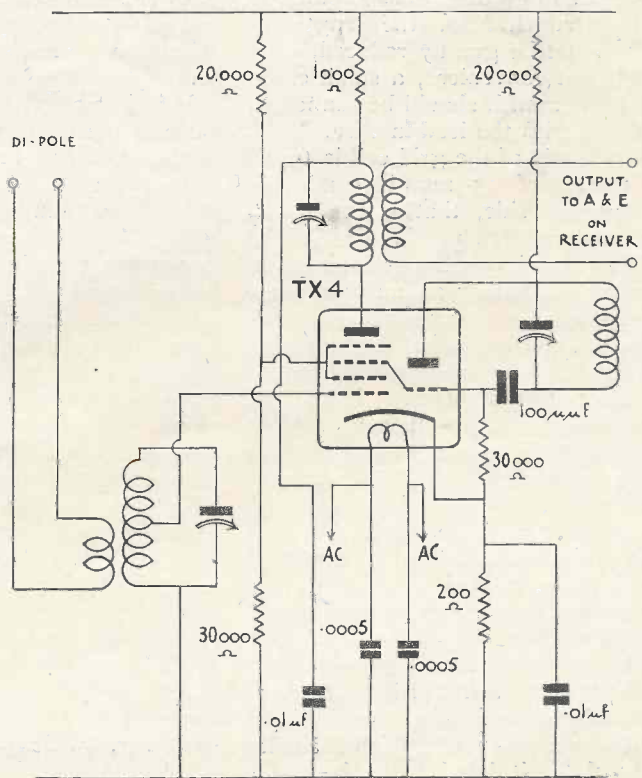

decreased amplification, and the possibility of lack of oscillation.

Should an ordinary Marconi aerial with earth connection be used, then the lower side of the aerial coupling coil is connected directly to earth with the aerial connected to the free side. This arrangement, however, causes heavy damping, and even the centre-

dividing screen by means of ebonite bushes. The grid condenser, which has a capacity of .0001 mfd., has one side connected directly to the oscillator condenser, and the other side directly to the grid of the triode section of the TX<sub>4</sub>.

In the anode of the circuit of the TX<sub>4</sub> is the conventional I.F. trans-

Connecting the unit to the parent receiver is quite a simple matter. The di-pole aerial on the main receiver is connected to the di-pole terminals on the convertor, and these can be seen actually mounted on a dividing screen between oscillator and detector sections. The secondary of the output transformer in the con-

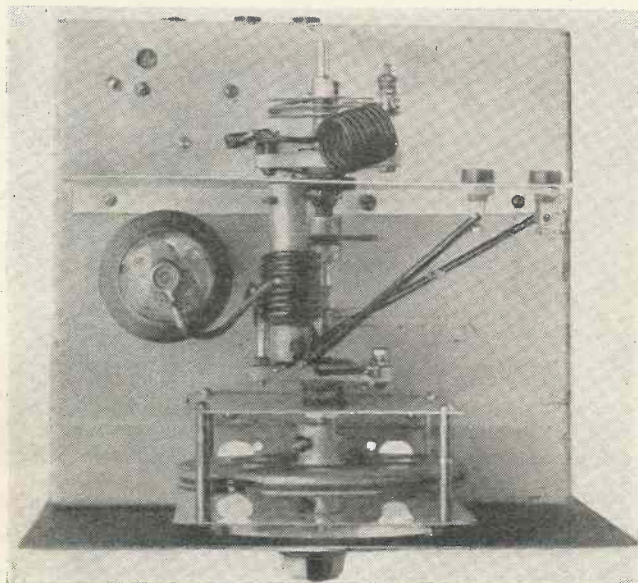

This picture shows plan view from which it will be clear that the component assembly is of the simplest

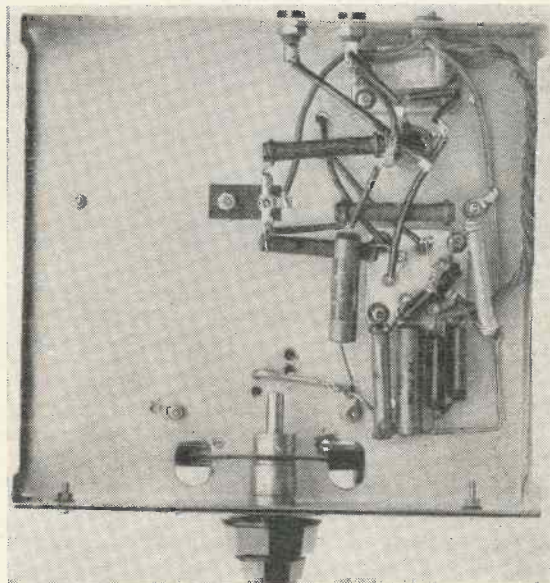

An underside view of the chassis showing the simple wiring.

tapped grid coil may not take care of the additional load, so causing the convertor to go out of oscillation. In such circumstances, the length of aerial must be greatly reduced, or if this is not convenient, a small capacity of 50 mmfd. should be connected in series with the lead-in wire.

The whole of the grid coil is tuned by means of 15 mmfd. condenser having one side, that is the rotor-plates, connected to chassis. The grid coil and coupling winding are mounted in rather an unusual way. It will be seen that the coupling coil is wound on a small half-inch paxolin former which is bolted to the dividing screen. The grid coil is wound around this former, but spaced off it approximately  $\frac{1}{4}$  in., and held in place by means of the heavy gauge-connecting wires to the rotor and stator plates of the parallel condenser. This coil consists of 8 complete turns of 1 in. diameter, with the centre tap taken directly to the top of the TX<sub>4</sub> valve.

The single oscillator coil, made up of 8 complete turns, 1 in. diameter, is soldered directly across the oscillator condenser which has its rotor plates isolated from the metal

former, having the primary tune by means of a small pre-set condenser. This can be adjusted by means of a screwdriver through the chassis, and should be arranged so that the primary is absolutely balanced.

It is important to notice that both sides of the heaters are by-passed to earth by means of .0005 mfd. condensers. This is to prevent possible modulation hum, which can be very noticeable in a convertor of this kind when used in conjunction with a high-gain receiver.

Assuming that the supply voltage from the main receiver will be approximately 230, the resistances recommended will be of the correct value. The most important resistors are those forming the fixed potential divider in the screen circuit of the TX<sub>4</sub>. In the high potential side the resistors have a value of 20,000, and in the low potential side, 30,000 ohms.

In the coupling circuit there is a resistor of 1,000 ohms, and in the oscillator anode circuit, a resistor of 20,000 ohms. A very important resistor is in the grid circuit of the oscillator, which has a value of 30,000 ohms.

vertor is then connected to the aerial and earth terminals on the main receiver, and it is immaterial which way round these wires are connected. The only point which might mystify constructors is the method of obtaining the power supply from the receiver.

First, obtain a valve socket to suit any valve in the main receiver, providing it has two external contacts to the heaters. These two terminals are then connected to two leads from the valve heater in the convertor. In that way the main receiver furnishes the heater voltage for the convertor valve.

This leaves two further leads for the high-tension supply. One is negative, the black lead, and is connected to the chassis of the main receiver, or to the earth terminal. The second lead, the red one, is for H.T. positive, and this should be joined to any high-voltage point on the main receiver. For example, the high-voltage side of the loudspeaker transformer will do excellently, and as this transformer is usually accessible, contact can be made by means of a crocodile clip.

(Continued on page 279)

# Scannings and Reflections

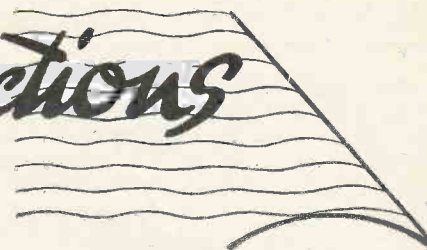

## A LONG-DISTANCE O.B.

**A**FTER the television broadcast of the Head of the River Race a telegram was received at Alexandra Palace from an Eastbourne viewer announcing reception of the broadcast. The receiver used for this was a standard Baird model, and it is claimed that this is the longest distance over which clear transmission of an outside broadcast has been reported. The B.B.C. felt this of sufficient importance to include it in their Saturday News Bulletin.

## VETERAN CARS IN TELEVISION

A gymkhana for old cars, specially staged for television by the Veteran Car Club, will be seen by viewers on May 15, when more than thirty cars, dating from 1896 to 1904, will be drawn up on the Polo Ground at Hurlingham. The television cameras will show such events as Pig Sticking, with balloons as "pigs"; an Obstacle Race, and "Musical Chairs" in which the drivers have to stop and start with a rapidity which sorely tests these ancient vehicles.

Members of the Veteran Car Club own between them more than 145 of these old-timers and it is interesting to note that the term "veteran" is applied to cars made between November 15, 1894, and December 31, 1904. The first date marked the opening of a new era when it was no longer necessary for a car to be preceded by a man carrying a red flag, and the last date marked the end of the 12-miles-an-hour limit. On January 1, 1905, cars were permitted to travel on the roads at twenty miles an hour.

Viewers will see a Benz of 1898 owned by Mr. G. J. Allday, chairman of the Club, and an Arnold motor carriage of 1896 owned by Capt. E. de W. F. Colver. Other models will include a De Dion Bouton of 1900, a Mercedes, Lanchester and Humber, all dating from 1903, and a Clement-Talbot of 1904.

## THE BOAT RACE TRANSMISSION

A workman excavating in a Muswell Hill Road almost caused a crisis

on the occasion of the boat-race transmission. Just before the transmission was due to commence he accidentally struck a telephone cable which completely cut-off Alexandra Palace from all outside communication. This meant that there could be no sound commentary accompanying the pictures of the race and it increased the difficulties of the camera operators at Mortlake because all communication had to be made by scribbled messages on paper which were held up before the camera and transmitted in picture form to Alexandra Palace.

## TELEVISION AND FILMS

According to the *Era*, the B.B.C. have absolutely denied any intention of using their film unit at Alexandra Palace to make news reel or feature-films.

When asked if it were true that the unit had been formed to make television independent of film co-operation, Gerald Cock said that such a rumour was quite unjustified. "All we expect the unit to do," he added, "is to make short film sequences that we could use as aids to background in studio productions or in outside broadcasts."

Mr. Cock, the *Era* says, further revealed that the B.B.C. had approached the Kinema Renters' Society with a suggestion that a weekly feature should be televised dealing with current or next week's films in the West End cinemas, with illustrative excerpts from the actual films. This idea was turned down by the K.R.S.

"It was intended," Mr. Cock said, "to deal with the best of the films that would be on show at the principal theatres, and we believe that it would have created a new film public."

The opinion of the *Era* is that in declining this offer from the B.B.C. the renters were probably thinking along the same lines as the exhibitors, who are concerned at the competition to the cinemas from free television shows at public houses and clubs.

## TELEVISION THE DERBY

The directors of the Epsom Grand Stand Association, Ltd., have decided to withdraw their embargo on the televising of the Derby. Sir Stephen Tallents, speaking on behalf of the B.B.C., when the decision was made known, said that it was most welcome and would, he felt sure, be appreciated by all televiewers as warmly as it was by the B.B.C.

The televising of the Derby will open with pictures on the Downs and crowd scenes which should effectively convey the atmosphere of the most famous race meeting in the world.

Three television cameras will be used; one, a super-Emitron equipped with twelve-inch telephoto lens, will, it is hoped, give a view of the start of the race from the far side of the course. Good pictures should be obtained as the horses round Tattenham Corner and come into the finish. It is hoped to show the weighing-in and saddling, and viewers will see close-ups of the owner leading in the winning horse.

Tests already conducted on Epsom Downs have yielded excellent results and it is believed that viewers will see a large part of the race just as if they were watching it through binoculars.

## M.P.'s TO VISIT ALEXANDRA PALACE

The Postmaster-General has been requested to arrange for Members of Parliament to visit Alexandra Palace and it is understood that the B.B.C. has agreed to this, but point out that it would only be possible to invite M.P.s in parties of ten owing to limitation of studio space. Invitations are therefore being issued in groups in alphabetical order.

## "CHECKMATE"

"Checkmate," the Vic-Wells ballet, which was produced at the Paris Exhibition, will be televised from Alexandra Palace on May 8, with the augmented B.B.C. Television Orchestra. The music is by Arthur Bliss, the choreography by Ninette de Valois, and the costumes and scenery by McKnight Kauffer. More

## MORE SCANNINGS

than thirty members of the Vic-Wells Company will be taking part and it is expected that the brilliant costumes of the "chessmen" in red and black will make an attractive picture on the television screen. The ballet will be preceded by a discussion by Arthur Bliss, Ninette de Valois and McKnight Kauffer, who will talk about the construction of the ballet.

### TELEVISION NEWS REEL

Officials of the Cinematograph Exhibitors' Association recently held a meeting with the chiefs of the Newsreels companies to discuss the broadcasting of newsreels. Complaints were made by the exhibitors regarding the broadcasting of newsreels, but it is understood that the chief concern was regarding the rediffusion of television programmes in public houses and other places open to the public.

### TELEVISION OUTSIDE BROADCASTS

Viewers will be able to watch several important events this summer, for plans have been made for many outside broadcasts to take place which have been made possible mainly by the perfection of the television camera with a 12 in. telephoto lens.

The Chelsea Flower Show is to be televised on May 22, 23 and 24, when Freddie Grisewood and Elizabeth Cowell will be the commentators.

Another good relay will be that of Trooping the Colour on June 9—while the experience gained in televising the Derby will be put to good advantage by the relay of the Northolt Pony Derby on June 13. All viewers will look forward to the televising of test cricket from Lords and the Oval in June and August. In the final Test Match at the Oval, some of the day's play will be televised on four separate occasions.

One of the most successful of the outside broadcasts last year was that of the tennis from Wimbledon. This year, the finals will be televised with the aid of the outside broadcasting van. Those who have not been able to watch polo will have an opportunity during the relay from Hurlingham of the match between India and the rest of the world on July 4. There is also to be a relay from the Wembley Pool of the World Swimming Championships in August.

### RADIO INTERFERENCE IN TELEVISION

It has been noticed that amateurs transmitting on the international 20-metre band are causing interference to television programmes. The third harmonic of the 20-metre signals comes in between the sound and vision frequencies, and owing to the flatness of tuning in the average television receiver considerable interference is often caused. This problem is one that will be hard to overcome, so at the present time, amateurs in certain parts of the country, such as Cambridge, have been requested to stop transmitting during the periods when viewers are using their television receivers.

### SUN-SPOT EFFECTS

Although short-wave listeners expect unusual conditions this year on the short-waves, the sun-spot effects are causing considerable difficulty to amateurs who wish to maintain consistent communication in various parts of the world. Although it is generally agreed that conditions for reception are generally poor, there are periods when freak results occur. In one instance when it was impossible to maintain communication with local countries such as Norway, stations in Peru and Japan could be received at good strength. It has also been noticed that reception of stations in India, Ceylon and that part of the globe, is now better than it has been for some time, despite the fact that transmissions are rather erratic and are inclined to fade out at a moment's notice.

### TELEVISION VALVE FOR AMATEURS

Amateurs will shortly feel the benefit of the design work which is going on with valves for use in television amplifiers. New valves are being produced very frequently, such as the new R.C.A. 1851 which has a slope of 12 mA./B. A similar valve has been produced in this country by the General Electric Company, and amateurs have been quick to realise the advantages of these high-slope valves in ordinary radio receivers. These new valves are ideal for use in radio and intermediate frequency stages, and greatly increased gain can be obtained.

It appears that most of the new components designed primarily for

use in television receivers will be also used in the ordinary short-wave receiver.

### AMATEUR TELEVISION IN AMERICA

It is very interesting to notice the different outlook of the manufacturers in America and those in this country. While television, at any rate technically, has been kept rather hush-hush in Europe, the American manufacturers are giving it all the publicity they can. In order still further to increase the interest taken by American amateurs and radio engineers in television, the R.C.A. Company have produced some tubes and necessary components complete with all data that the constructor is likely to need. They are also advertising very extensively despite the fact that there is no television service in America and little likelihood of any return for their money from the ordinary man in the street. They do, however, appreciate that the amateur, if he can obtain supplies and information, will experiment and so increase the interest amongst the ordinary listener.

### TRANSMITTING VALVES FOR AMATEURS

For many years British valve makers have refused to produce a valve of the kind suitable for the average amateur transmitter, who has been compelled to buy abroad. Even the few valves that have been produced in recent months have been far too expensive in comparison with the prices asked for valves of American and Dutch origin. However, at the present time there appears to have been a complete reversal of opinion amongst valve makers, and now there are no less than four makers all eager to market valves for the British amateur at prices very similar to that asked for American valves of a similar kind.

### SHORT-WAVE RADIO IN TRAINS

While many of the American long-distance trains have included radio communication between driver and guard this system has not taken on very well in Europe. It will be interesting to see how the goods trains on the Norwegian State Railways will find the radio service which has been put into use between engine driver and brakeman. This is quite

## AND MORE REFLECTIONS

a new idea for the Norwegian railways and if satisfactory may be included on passenger trains.

## INDOOR OR OUTDOOR AERIALS

The Huddersfield Urban Council have prohibited the erection of wireless poles on their new housing estate at Peniston, being of the opinion that indoor aerials are quite satisfactory. While this may or may not be so, they have probably forgotten that the time is not far distant when even the people in Huddersfield will have television receivers, which will certainly require external aerials. These rules and regulations are very often made without any eye to the future.

## TELEVISION PLANS FOR SYDNEY

Now that John L. Baird is in Australia and has been able to tell the authorities something about the progress of high-definition television it is expected that television in Australia will be developed in the near future.

In Sydney, however, there are several problems regarding the site for the television station for, if it is erected in the heart of the city, half of the radiation will be wasted over the Pacific Ocean.

Amateurs in Sydney have shown that by picking a high position on the Blue Mountains, it is possible to transmit a good signal into Sydney with quite low power. A station in this position would also be able to cover large towns in the north, east and south, such as Liverpool, Windsor, Penrith, Camden, Newcastle, and Parramatta.

## TELEVISION AND THE TELEPHONE

German engineers have been very keen to develop the commercial side of television where applicable to telephone use. A service has been in operation for some time between Berlin and Leipzig, a distance of 90 miles. This has proved so satisfactory that the service is being extended so that thirty telephone calls with vision can be made simultaneously.

## TELEVISION A.R.P.

A very successful transmission was that of the Territorial Army A.R.P. group on Easter Monday. The latest

type of anti-aircraft gun, and all the associated equipment was shown and fully explained to viewers. A machine gun was also televised and a gunner explained just how and why a machine gun was needed in addition to the large 3.7 in. anti-aircraft gun. During the evening transmission the searchlight was put into use and the mock air-raid was very satisfactorily televised. Actually the air-raid took the form of an imaginary attack on Alexandra Palace.

## LARGE SCREEN PICTURES

It is interesting to draw a comparison between the results obtained in large-screen picture production in this country and Germany. The power required to produce the large picture by Fernseh is of the order of 40 kW. This is controlled power. In the Scopphony picture, the highest controlled power necessary for a picture of this size is only 500 watts. The largest power used is the same as taken by the standard cinema arc.

## Price Reduction.

The Baird model T11 television receiver complete with all-wave radio has been reduced in price to 55 gns. This price includes aerial, installation and one year's free service, and represents wonderful value for a really high-class receiver of unique design.

## Crystal Bars for Frequency Meters.

One of the requirements of every amateur is a crystal controlled frequency meter, but owing to the cost of the crystal element amateurs are inclined to rely on the less effective absorption type of meter.

Messrs. Radio Clearance, of 63 High Holborn, W.C.1, have a large stock of quartz crystals ground to a frequency of 125 kc. These are priced at the extremely low figure of 4s. 6d. They can also be fitted with 125 kc I.F. transformers for crystal gate superhet work for 7s. 11d. complete.

Amateurs will find quite a lot of components of interest at Radio Clearance, such as three gang midget condensers for 2s. 6d. They also have an excellent stock of new Bryce mains transformers varying from 350 volts for 11s. 6d. up to 500 volts for 17s. 6d. Another excellent line is a 300 volt Mains transformer for 5s. Suitable chokes for use with these transformers are available from 4s. 6d. upwards.

## Inexpensive Morse Recorders

Amateurs interested in automatically recording morse signals should make a point of getting in touch with Messrs. Galpins Electrical Stores, of 75 Lee High Road, Lewisham, S.E.13. They have some excellent ex-R.A.F. morse inkers for 30s. which are extremely good value for money.

A visit to Galpins showrooms will not be a waste of time for those who are in the vicinity, for there is a whole host of items suitable for amateurs. Taken at random, there are high-resistance headphones made by B.T.H. and Western Electric for 2s. 6d., 500 mA. filter chokes for 30s. A complete range of Weston moving coil mA. meters, rotary converters of all kinds, Epoch 20-watt loudspeakers for 45s., Precision wave-meters for as low as 3s. and some really cheap high-capacity condensers. One particularly good item is an electrostatic volt meter of the quadrant type with a 2½ in. scale for 12s. 6d. Please write for the new list of these new components.

## "Television Sound Programmes on your Broadcast Set."

(Continued from page 276.)

The main receiver should be tuned to approximately 200 metres, or to a wavelength around that figure where no station is received. If an all-wave receiver is in use, then tune down to approximately 100 metres, as this will provide much more stable operation. If, however, the converter is being used at a distance from Alexandra Palace, then greater gain can be received if the receiver is tuned to approximately 500 metres.

The following components will be required.

## Components.

- 1—Chassis, panel and screen (Peto-Scott).
- 1—Coupling transformer (Peto-Scott).
- 2—15 mfd. low-loss condenser (Raymart).
- 2—.005 mfd. tubular condenser (Dubilier).
- 2—.01 mfd. tubular condenser (Dubilier).
- 1—.001 mfd. mica condenser (Dubilier).
- 1—7-pin ceramic valve holder (Clix).
- 1—TX4 metalized valve (Tungsram).
- 2—20,000-ohm 1-watt resistors (Erie).
- 2—30,000-ohm 1-watt resistors (Erie).
- 1—1,000-ohm 1-watt resistor (Erie).
- 1—200-ohm 1-watt resistor (Erie).
- 1—Slow motion tuning drive and scale (B.T.S.).
- 1—.0001 mfd. pre-set condenser (Cyldon).
- 1—4-way connecting cable (Bulgin).
- 1—Tapped valve socket (Bulgin).

We have made arrangements with Messrs. Peto-Scott, Limited, to supply readers with a converter built to this design, which is ready-wired, guaranteed and tested.

**TELEVISION IN EASY STAGES**

**III—HOW THE BEAM IS MADE TO SCAN**

The two preceding articles in this short series outlined the principles of television reception and reviewed the type of receiver employed for the reception of the vision signals. The following article ex-

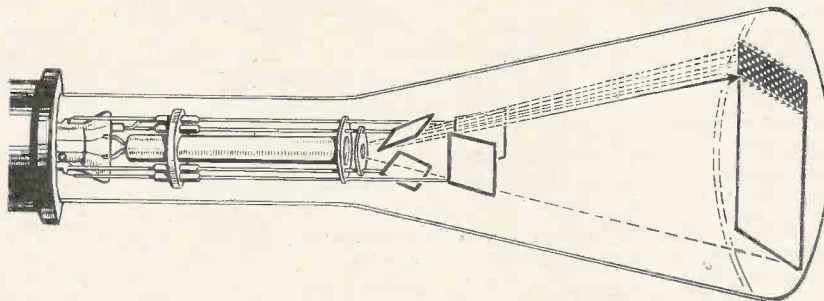

plains in a simple way how the light spot is caused to move across the screen in order to produce the "raster" or unmodulated light scan which is the basis of the picture.

**I**N the first article of this series (March issue) it was explained that the production of the light spot, from which the picture is built up, and the means to cause this spot to travel across the screen in a predetermined way is entirely a function of one unit of the receiver—that is the time base. The light spot and its movement do not concern the actual transmission except that in order to keep the spot exactly in step with the transmitter a triggering action is provided which at definite intervals has the effect of correcting any inaccuracy.

There is, therefore, the fundamental problem of making the beam move across the screen in such a way that it traces a series of lines at a definite speed and of a definite length.

It will be clear that we have to

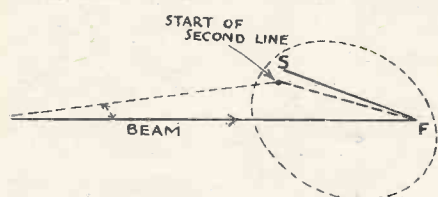

Fig. 1. Diagram showing the movement of the beam to cover the screen.

cause the cathode-ray beam to perform a to-and-fro movement to enable all the scanning lines to be drawn in the same direction in the same way as the eye follows lines of type in a book. This will be clear from Fig. 1, which shows the beam has completed one line in moving from S to F, but before it can draw a second one, it must be returned to a position in line with S and a little below. The drawing of each line is thus followed by a return stroke which places the beam in position for the next one. This return stroke

must, however, be made at such a speed as to be invisible.

For producing a complete line screen on the cathode-ray tube we have, therefore, to deal with three movements:—

- The tracing of the line at a certain speed.
- The almost instantaneous return of the beam to its original place.
- A shift of the beam in a direction at right angles to the line to produce the spacing between them.

**How the Movement is Produced**

The movement of the beam can be produced either magnetically or electrostatically. If a pair of coils is mounted on either side of the back of the tube and a current, which is caused to gradually increase in value, is passed through them, the beam will move across the screen under the influence of the field produced by the coils.

Similarly, if an increasing voltage is applied to the deflector plates of an electrostatic type of tube, the beam will move correspondingly by reason of electrostatic deflection.

The problem for either system of deflection resolves itself into the production of a varying voltage which will give the required movement of the beam. This is also the case with magnetic deflection, for the current through the coils will depend upon the applied voltage.

It is evident that the scanning line

must be drawn at a perfectly uniform speed, i.e., the beam must cover equal distances on the screen in equal intervals of time. This means that the voltage applied to the deflector plates, or coils, to move the beam must increase at a uniform rate. After the line has been drawn the beam must be returned to its initial position as quickly as possible in readiness for the next travel, and to cause this the voltage must abruptly drop to zero after it has reached a given value which has resulted in the beam moving the required distance to produce the full line.

These two voltage variations can be represented by a curve to which the name "saw-tooth" has been given because of its appearance. This is shown by Fig. 2 and it indicates the shape of the voltage wave required to draw one line and return the beam to its starting point.

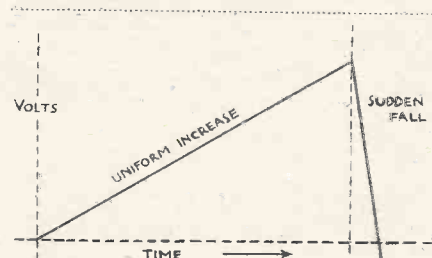

Fig. 2. Curve showing saw-tooth wave and relation of voltage and time.

Up to the present we have seen that the beam must be moved from one side to the other and then fly back practically instantaneously. There is, however, the third condition—the shifting of the beam in a direction at right angles to the line to produce the sequence of lines on the screen. This could be done by a small voltage applied to the other deflector plates at the end of each "out and back" movement of the

Ensure obtaining "Television and Short-wave World" regularly by placing an order with your newsagent.



## HOW SAW-TOOTH WAVES ARE PRODUCED

beam—a sort of ratcheting action which would move the beam by just the right amount to put the second line alongside the first.

It is more simple, however, to apply a similar type of voltage

A very satisfactory arrangement is to use a condenser connected across an H.T. supply in such a way that the voltage across it gradually rises at a rate which can be controlled.

The simplest circuit possible is

sistance  $R$ —the higher the value of  $R$  the longer will the condenser take to charge. The rate of charge can be worked out from a formula which is too complicated to give here, but there is an approximate calculation which can easily be made as follows: The time taken for the condenser voltage to reach 63 per cent. of its final value is called the "time-constant" of the circuit and is given by the product of  $C$  the capacity of the condenser in microfarads and  $R$  the resistance in megohms. So with a resistance of 5 megohms, and a capacity of 1 mfd. the condenser will take over 5 seconds to reach its final voltage. For scanning requirements, we need  $1/25$ th second for one condenser, and this could be given by .01-mfd. and about 3 megohms. For the shorter timing rate of the line scan a much smaller capacity will be required.

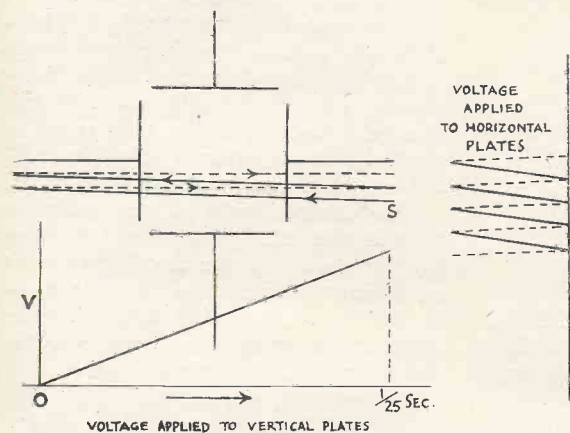

Fig. 3. The zig-zag trace produced when the two deflecting voltages are applied to the deflector plates.

wave to each pair of plates and produce the movement by a combined deflecting effect. If this is done, the beam will be acted on by both voltages during its travel along the line and will slope slightly the whole way, so that at the end of the line it will be sufficiently displaced to start the next line straightaway. The combined deflecting effect is shown in Fig. 3. The path of the beam is shown by the thick and dotted lines in the centre of the drawing and the thin lines below show the curves of voltage change applied to the deflector plates.

To consider a specific example, suppose we require to draw a 405-line screen 25 times per second. The time required to draw one line of the screen will be  $1/405 \div 25$  or  $1/10,125$  second. The voltage applied to the horizontal deflectors will, therefore, rise to its highest value in this time. If now we arrange that the voltage applied to the vertical deflectors reaches its maximum in  $1/25$  second, the beam will move from bottom to top of the screen in this time. It will be understood that the lines drawn by the beam will be slightly sloped, but this is of no consequence since the angle is so slight and the lines are so close together.

There are several ways of producing the voltage curve of Fig. 2, but the most practicable is a purely electrical circuit in which the voltage can be made to vary in the way required.

shown by Fig. 4 and as this is the fundamental circuit on which all scanning systems are based, it is worth while examining it in detail and considering its precise action with the aid of meters.

The condenser  $C$  is connected to the H.T. supply through a resistance  $R$  which can be varied. At the moment of switching on there is no potential across the condenser, and the voltmeter  $V$  will read zero. As the charging current flows into the condenser the voltage gradually rises and the needle of the meter will move across the scale until it reaches the value shown on  $V_1$ , which is connected across the H.T. terminals. The condenser is then fully charged, and the voltage across it is the same as that of the H.T. supply.

The rate at which the condenser voltage rises is controlled by the re-

Immediately the condenser has reached its maximum voltage it must be discharged as rapidly as possible to produce the second part of the voltage wave of Fig. 2. Very many circuit arrangements have been devised for giving a rapid discharge and fall in voltage, but the simplest and easiest method is to employ a gas-filled relay or thyatron.

### The Gas-filled Relay

The gas-filled relay is an ordinary triode valve in which a small quantity of inert gas such as neon or helium has been placed. The effect of the gas is as follows:

If the grid of the relay is biased to a negative value, current will only flow if the anode voltage exceeds a certain value, depending on the construction of the valve. To take a typical instance, a bias of 9 volts on the grid would mean that no current would flow from the cathode to the anode until a voltage of 160 was applied. Once the current flows a coloured glow is seen in the bulb, and then the grid has no further control over the discharge. The anode current can only be stopped by reducing the anode voltage to a very low value, and when the glow has ceased it will not start again until the anode voltage is raised to its original value of about 160. From this it will be seen that the relay can be used to discharge the condenser shown in Fig.

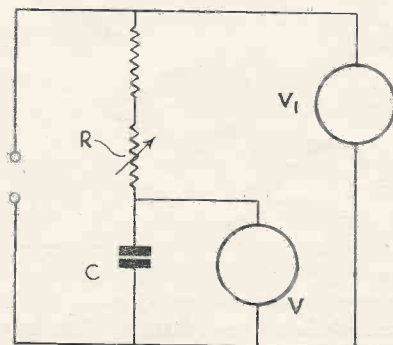

Fig. 4. Diagram showing the fundamentals of a scanning circuit.

## THE GAS-FILLED RELAY

4 instantaneously and will be satisfactory.

The valve is connected across the condenser and the grid is given a negative bias. As the voltage rises across the condenser the discharge

at an enormous speed, must, therefore, be operated at some 5,000 volts if they are of the large type and 3,000 if of the smaller type.

The distance moved by the beam on the screen for one volt of poten-

on the anode will be  $4 \times 105$  or 660. Actually, the calculation will have to be made accurately for the type of tube used and the conditions under which it is run; but the fact remains that an average figure for the deflecting potential to be applied to the beam is 500 volts or more.

Now assume that we apply a potential of 60 volts to the simple scanning circuit already described. (The condenser will charge to 500 volts, and the relay will strike at this value if the grid bias is set to a value depending on the characteristics of the relay.

The control ratio of gas relays—that is the relation between the bias on the grid and the anode potential at which the discharge commences—is specified. Assuming it is 20:1 the bias of the relay would have to be set at  $500/20$  or 25 volts to ensure striking at the correct value.

The condenser potential, however, when charged through a simple resistance as in Fig. 2 does not follow a linear law, but what is known as an exponential one. This means that the rate of increase of voltage steadily falls off as the condenser charges.

If we plot a curve of charging voltage against time we obtain the curve of Fig. 6, in which the voltage increase is shown for equal intervals of time from the commencement. (The increments get less and less as the voltage rises to 600, the full H.T. voltage. The deflection of the beam by this voltage will correspond to the rate of increase, and is shown by the dots under the base line. The beam has certainly been deflected across the screen to the required extent, but the movement is far from uniform and a hopelessly distorted picture would result if this circuit were used without any modifications.

### Necessary Modifications

The circuit must be modified, therefore, so that the increase of voltage across the condenser is uniform over the range it is desired to work. This can be done in two ways: by altering the circuit or by increasing the charging H.T., and we can now consider the advantages and disadvantages of each method.

If the resistance in Fig. 2 is replaced with a pentode, the circuit then becomes as Fig. 7. The condenser is connected in series with the anode of the valve and the screen is taken

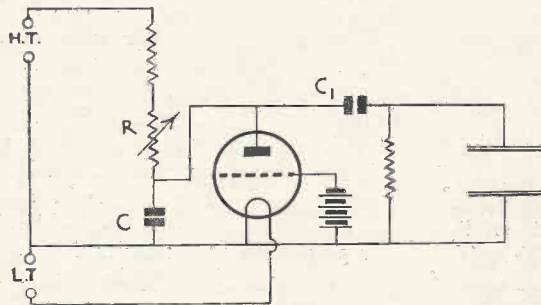

Fig. 5. Scanning circuit employing a gas-filled relay.

suddenly starts at a value determined by the grid bias, and at this point the condenser is short-circuited by the very low resistance of the glowing valve. As soon as the condenser discharges the voltage falls and the discharge ceases when the voltage has fallen to zero. The relay has now become non-conducting and the condenser can be charged again.

### A Relay Circuit

The complete arrangement of such a circuit is shown by Fig. 5. The relay is shown connected across the condenser, and the deflector plates of the tube are taken from the anode and cathode connections of the relay, i.e., across the condenser. The voltage variations of the condenser are therefore reproduced across the plates. The condenser  $C_1$ , isolates the plates from the H.T. supply. Bias is applied to the grid of the relay as shown.

For several reasons, the simple condenser circuit discharged by a gas-filled relay is not satisfactory in that form for use as a scanning circuit and in order to understand why this is so it will be best to consider the requirements. Obviously the intensity of the spot must be high in order that the image can be seen in dull light. This means that the anode voltage of the tube must be as high as possible, since the intensity is roughly proportional to the anode voltage.

Naturally, the trace on the screen appears fainter as the beam moves faster. Tubes for high-definition reproduction in which the spot travels

tial applied to the deflecting plates, or in other words the sensitivity of the tube, varies inversely as the anode voltage. For a given design of tube there is a formula from which the sensitivity can be found. This is usually given in the form Sensitivity =  $K/V$ , where  $K$  is a figure given by the makers of the tube and  $V$  is the anode voltage at which it is operated. Suppose  $K$  is 750, an average figure. Then at 1,500 volts the sensitivity is  $750/1,500$  or  $\frac{1}{2}$  mm. per volt of deflecting potential. At 3,000 volts the sensitivity will obviously be one-half of this or .25 mm. per volt.

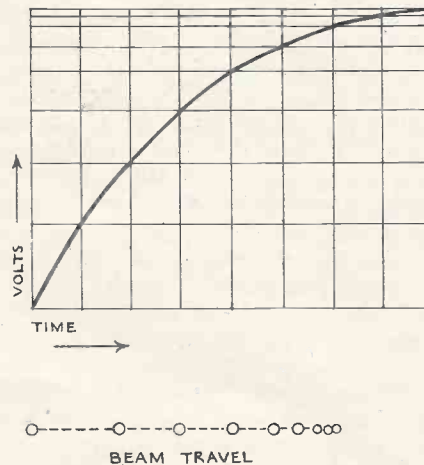

Fig. 6. Diagrams showing the effect of non-linear potential applied to the deflecting plates.

Now for the sake of example let us assume that the picture size is approximately  $6\frac{1}{2}$  in. by  $4\frac{1}{4}$  in. This means that the travel of the beam will be 165 mm. in the horizontal direction and the voltage required to deflect it this distance at 3,000 volts

## HARD-VALVE CIRCUITS

to a potentiometer connected across the H.T. supply. The characteristic of the pentode is such that the anode current remains practically constant over a very wide range of anode voltage.

When the circuit is switched on the condenser will charge at a rate which is determined by the impedance of the pentode, controlled by the screen volts. As the condenser voltage rises, the voltage across the valve falls, the sum of the two being equal to the applied H.T. But as the pentode anode voltage falls the current flowing through it remains substantially constant, enabling the condenser to charge at a constant rate. The voltage across the condenser will rise uniformly with time and the deflecting potential will give a true linear movement to the beam.

This circuit is therefore a method of overcoming the disadvantage of the one previously described and provided that the characteristic of the valve is as straight as possible there is the minimum of distortion in the scan.

An alternative to this rearrangement of circuit is the increasing of the applied H.T. from 600, our estimated figure, to over 2,000! This

The figures, therefore, become 400 and 2,000 and 50c and 2,500, and all that has been done is to magnify the whole voltage scale so that the part we wish to use is sufficiently long to give a full linear travel of the beam without distortion.

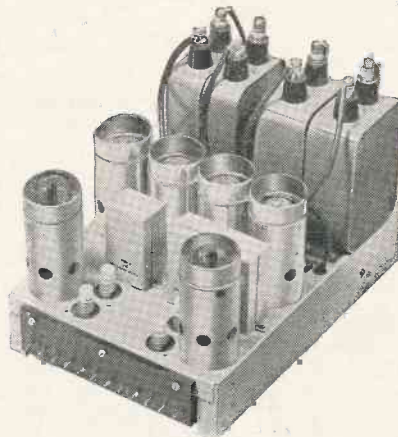

A typical time base. This is the construction employed in the G.E.C. receiver.

There are many other types of linear timing circuit. A high-vacuum valve circuit can be made to perform the same job, and be more stable in operation and in general more reliable.

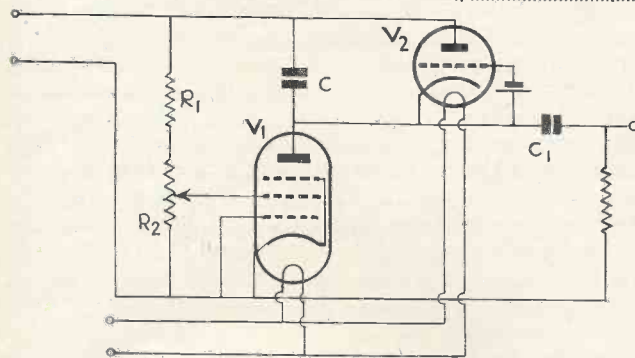

Fig. 7. Scanning circuit employing a pentode in place of the charging resistance.

seems curious at first sight but the explanation is not difficult. Referring to the curve of Fig. 6 it is seen that the first 150 volts increase takes place at a uniform rate, i.e., the condenser is charging linearly for the first small portion of its charge. If we magnified this small straight portion of about 150 volts three or four times we should get 500 volts of linear portion, which is what is required. At the same time the overall H.T. must be increased in proportion, so it must be made  $4 \times 600$  or 2,400 volts.

The principal difficulty in the design of high-vacuum valve circuits is the imitation of the "snap" discharge action of the gas relay. If an ordinary valve is biased back beyond the point at which anode current starts, an increase in anode voltage will cause a gradual rise in anode current instead of the practically instantaneous rise which we require. To accelerate the increase of current in the valve it is possible to swing the grid momentarily positive which will give a rapid flow of

current rising to a high value. If we imagine a condenser charged and connected across a valve which is normally biased to cut-off point, a sudden pulse of potential applied to the grid and swinging it positive will cause a heavy current to flow through the valve from the condenser and will discharge it in much the same way as the gas relay.

Discharge circuits of this type in which the impulse to the grid is supplied by a separate oscillator have been developed and have the advantage that the frequency of discharge can be kept within very close limits indeed, but they are outside the scope of this article which had the objective of explaining in a simple manner an outline of the means whereby the beam can be caused to travel to cover the screen.

### The Technological Institute of Great Britain

WE have received from The Technological Institute of Great Britain a prospectus entitled "The Engineer's Guide to Success," a very useful guide for those who are considering taking up any branch of engineering as a profession.

The T.I.G.B. was founded in 1917, and has enabled upwards of 25,000 men to embark upon careers in engineering through the medium of correspondence training. The tutorial service embraces the various branches of engineering and allied technology and includes a course on Television which, we understand, is particularly authoritative. These are covered most thoroughly as may be judged from the fact that the T.I.G.B. operates over 200 courses—the widest choice of engineering courses in the world.

Since its inception, the T.I.G.B. has specialised in the training of examination candidates and in order to ensure that a student shall study only for an examination which he is eligible to sit, the regulations governing admission are clearly set out. Training until successful is guaranteed to every student. The prospectus provides a fund of information on the various courses provided by the Institute and copies may be had upon application to Temple Bar House, London, E.C.4, and mention of TELEVISION AND SHORT-WAVE WORLD.

# THE MARCONI-E.M.I. TELEVISION SYSTEM

## REASONS FOR THE ADOPTION OF THE PRESENT STANDARDS

On April 21st, an important paper was read before the Institution of Electrical Engineers by Messrs. Blumein, Browne, Davis and Green, of E.M.I. Ltd., on the development of the present B.B.C. television system. We gratefully acknowledge the permission of the Institution to publish the following abstract, which will be followed next month by a similar abstract dealing with the London Television Station.

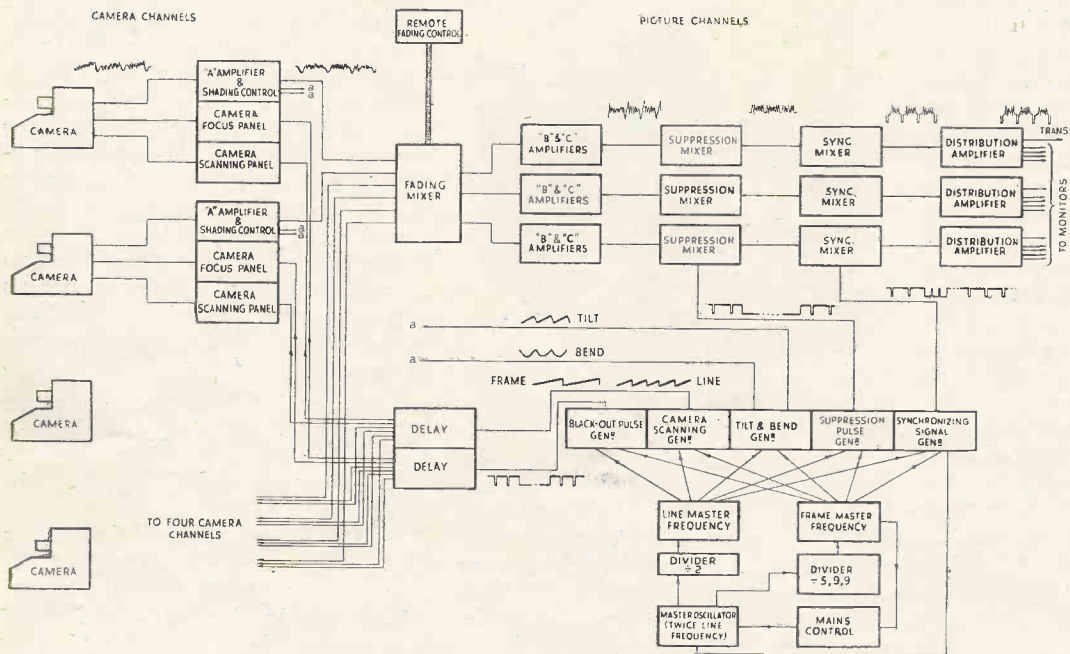

Schematic layout for control equipment of 6-camera and 3-picture channels.

THE vision signals to be transmitted represent from instant to instant the brightness of the picture being scanned, and may have any amplitude between a value representing black and a value representing the brightest part of the picture or "white." The signals may change gradually, as for a gradual shading of the picture, or very rapidly, as for a vertical edge, the ultimate rapidity of change being limited by the size of the transmitting scanning-spot and the frequency-limitations of the transmitting circuits. It should be noted that the vision signals essentially contain all frequencies down to zero and lie one side of the datum level, which is black. The signals in this respect are more akin to telegraph signals than telephone signals.

It has been considered whether better transmission could be obtained by distorting the transmitted waveform from that directly representing brightness, by distorting the frequency characteristic before transmission and correcting at the receiver. A short consideration will show that practically any frequency within the range may be produced at full black-to-white amplitude; so that, if the picture transmitted is not prescribed, any frequency distortion will reduce the transmitted level of some frequencies without enabling the level of any others to be increased. As far as possible, therefore, the vision signals are transmitted with a flat frequency characteristic.

In current cinematograph technique it is usual to increase the contrast by a factor lying between 1.5 and

2.0, presumably to make up for lack of colour. This factor is usually called  $\gamma$ , the original brightness  $A$  of any point being related to the reproduced brightness  $B$  by the relation  $B = kA$ . Since the eye is approximately logarithmic, this leads to an increase of contrast of approximately  $\gamma$ . This same effect is required in television. The question naturally arises as to whether this should be applied at the transmitter or the receiver. Now a given small change in light intensity at the picture is more noticeable in dark than in light parts of the picture. With a linear characteristic at the receiver, the dark parts of the picture are liable to suffer severely from quite slight interference.

By applying the correction at the receiver the sensitivity of the receiver is rendered lower for low light-intensities, so that slight interference is not so noticeable. It is advantageous, therefore, to transmit pictures with unity  $\gamma$  and make any correction at the receiver. This is convenient since any unidirectional control, such as the control of beam current in a cathode-ray receiving tube, is likely to be curvilinear in the required sense. Theoretically, assuming a logarithmic sensation law for the eye, a logarithmic transmitting distortion with exponential receiving characteristic is indicated, but such an arrangement is hardly considered practicable, if really desirable; and so far, despite its advantages, has seldom if ever been applied even to sound transmission.

The above arguments lead to the transmission of a signal, as far as possible undistorted in frequency or

## THE SYNCHRONISING SIGNALS

amplitude, representative of the brightness of successive elements of the picture scanned with a constant scanning velocity.

As explained above, the vision signals lie within a range limited by black and white (representing the brightest part of the picture). Synchronising signals can therefore be transmitted as signals lying beyond the black or white outside the vision signal range. Such signals may be spoken of as "blacker than black" or "infra-black" if outside the vision signal range in the black direction, or "whiter than white" or "ultra-white" if outside in the white direction. If ultra-white synchronising signals are employed it is necessary to provide special and rather complicated means at the receiver to prevent these synchronising pulses from appearing on the picture. If synchronising signals are employed in the infra-black these signals will not, with the majority of receiver types, appear on the receiver screen, since the majority of light-control devices are unaffected by a signal greater than that necessary to obscure the light. This great advantage of requiring no special synchronising signal-obscuring device at the receiver has led to the adoption of infra-black synchronising signals. In this connection it should be noted that there is a possible workable system employing ultra-white synchronising pulses extending down to zero radiated carrier, with black representing peak carrier.

This system has the merit of providing simple A.V.C. (automatic volume control) and noise suppression at the receiver, but on the other hand a comparatively complex arrangement is necessary for preventing the ultra-white signals from appearing on the screen. The infra-black system adopted can supply A.V.C. and noise suppression with no more, or even less, complex equipment than is required for pulse suppression by the above ultra-white system. Further, for a simple receiver the infra-black receiver is less complex than the ultra-white.

### Positive Modulation and 30% Synchronising Pulse

If the synchronising signals are represented by a high carrier ("negative modulation") they will be very prone to interference, which increases the amplitude and so produces at the receiver effective super-strong synchronising pulses. Such strong pulses may greatly disturb the picture-scanning. On the other hand, white being represented by a low carrier value, larger ultra-white signals than those represented by zero carrier cannot be produced, and this reduces the brightness of severe interference.

If, however, "positive modulation" is employed, in which synchronising signals are represented by a low (and, very preferably, practically zero) carrier while white is represented by a high carrier, super-strong interfering synchronising pulses cannot be experienced. This enables comparatively small synchronising signals to be employed while satisfactory synchronisation is still given. With this arrangement strong ultra-white signals can be produced by interference, but these signals are less irritating than the breaking-up of the picture produced by the interference giving super-strong synchronising pulses.

Of course, with negative modulation a carefully designed limiter could be used at the receiver to ensure that the scanning generators could only be affected by signals of the exactly correct amplitude. It is thought that such a limiter would be very difficult to adjust for all reception conditions, and if made self-adjusting would be upset by very severe interference. A similar limiter, not requiring as sensitive an adjustment, may be used for suppressing interference when positive modulation is employed.

Tests were carried out some years ago from Hayes, Middlesex, to St. John's Wood in order to compare positive- and negative-modulation reception in the presence of interference. The initial tests were made using synchronising signals equal in amplitude to the vision signals. With negative modulation the interference gave rise to breaking-up of the whole picture.

A considerable improvement was obtained by changing to positive modulation, the white flashes produced by interference being much less irritating than the breaking-up of the picture. Better results still were obtained by modulating so that the synchronising signal was represented by practically zero carrier. With this condition satisfactory synchronising under interference conditions could be obtained with synchronising signals of only one-fifth the vision amplitude. No interference can possibly produce a field strength, and so detector output, less than zero, so that by modulating down to zero carrier for synchronising signals no super-strong interfering synchronising pulses can be produced, and hence very good interference-free synchronising is obtained at the receiver.

These tests led to a definite decision to adopt a system with substantially zero carrier representing the synchronising signal and with peak carrier representing white. The diminishing return of increased vision signals produced by reducing the synchronising signal down to one-fifth the vision signal led to the adoption of a synchronising signal of three-sevenths of the vision signal.

### Intervals between Lines and Frames

The values 50 frames per sec. and 405 lines having been chosen, it was necessary to determine arbitrarily the time-intervals between successive lines and frames to which the receiver must be designed to work. These time-intervals are needed at a cathode-ray receiver for the return stroke, by which the cathode-ray beam is returned from the end of one line of frame to the beginning of the next. Actually the beam is turned off, or "blacked out" during the return stroke, nevertheless the electric or magnetic field controlling beam-deflection must be altered just as though the beam were there to perform the return stroke. Obviously such electric or magnetic fields cannot be altered instantaneously at the end of each line or frame, and thus time-intervals are necessary if some of the picture is not to be missed.

With mechanical receivers using rotating scanning means, successive lines are scanned by different mechanical elements, so that one line may be scanned from the instant the previous line-scan terminates. With such an arrangement absolutely perfect phase synchronisa-

## AUTOMATIC VOLUME CONTROL

tion would be necessary to prevent the beginning of a picture being cut off and folded round to the end of the picture. Intervals between lines and frames therefore provide a small black edge round the picture which allows for a small phase-error in the mechanical scanning.

Considering cathode-ray receivers, the total line period for a 405-line system is approximately 100 microsec. (more exactly, 98.8 microsec.), whereas a frame period is 20,000 microsec. It is therefore obvious that it is possible to reverse the scanning field (electrostatic or electromagnetic) in a shorter fraction of the frame period than the line period.

The intervals between frames may therefore be a smaller fraction of the frame period than the intervals between lines are of the line period. On the other hand, the intervals between frames should be longer than the intervals between lines, and this for two reasons. First, the frame frequency is much lower than the line frequency, so that the electrical components of the frame scanning circuit (transformers, and coupling condensers) have longer time-constants and are usually physically bigger, and thus the unwanted strays are greater than for the line-scanning circuit. This makes it more difficult to reverse the frame-scanning field quickly (say, in less than the duration of one line). Secondly, since all synchronising pulses are rectangular and of equal amplitude the frame signals are differentiated from the line signals only by the long duration of the former.

If the frame-scanning signals only are to trip the frame-scanning mechanism, some time must elapse between the end of the picture signals of one frame (which is the earliest moment that the frame-synchronising signals can conveniently be transmitted) and the beginning of the frame return stroke, in order that the long frame-synchronising signal may be transmitted and operate the receiver.

After much consideration the minimum interval between the picture signals of successive lines was fixed at 15 per cent. of the total line period (14.8 microsec.), and the minimum interval between the vision signals of successive frames was fixed at 10 lines (4.94 per cent. of the total frame period). This gives a time efficiency of 80.8 per cent. Any attempt to raise this figure to 90 per cent. would lead to very severe difficulties in connection with scanning cathode-ray receivers. As regards mechanical receivers, it appears also reasonable to give a bigger percentage interval between lines, since the scanning speed is high for lines and the phase accuracy probably more difficult to obtain.

The original specification wave-form was incomplete in one respect. As specified under minimum-interval conditions, and as shown on the drawing, the beginning of line-synchronising signals was coincident with the end of the vision signals of the line. Such coincidence with instantaneous change from white to synchronising is impossible with finite frequency band-widths. Even were such a signal radiated, it would lead to trouble in a receiver of finite band-width, inasmuch as the line synchronising would be affected by the vision signals immediately preceding the line-synchronising signal. The effect of this would be a slight distortion of vertical

edges in dependence on the signal brightness on the right-hand edge of the picture.

The specification should have contained a reference to a minimum additional interval prior to the line-synchronising signal of 0.5 per cent. of a line, making the total minimum interval between the vision signals 15.5 per cent., of which 0.5 per cent. precedes and 15 per cent. follows the beginning of the line-synchronising signal. This additional minimum interval has in fact always been present in all transmissions radiated from Alexandra Palace on the Marconi-E.M.I. system, the apparatus being set to give an interval of between 0.5 per cent. and 1 per cent. between cessation of vision signals and beginning of line synchronising. The existence of some interval between vision and synchronising signals is a practical necessity at the transmitter, so as to give a tolerance which ensures that the vision and synchronising signals do not get mixed.

### Automatic Volume Control

Before closing this discussion of the system specification it is well to consider whether the wave-form provides for facilities which may be required in the future. It has often been pointed out that an A.C. transmission system provides automatic volume control (A.V.C.) for television in the same manner as it is available for sound reception.

With an A.C. system, however, the A.V.C. must certainly operate very slowly so as to be unaffected by frame frequency, and therefore it will not be suitable for correcting variations of signal-strengths due to objects moving rapidly near an aerial. Further, the simplification of A.V.C. claimed will hardly justify the increased receiver size necessary to avoid overloads from "wandering" signals, and the reduced signal-strength due to poor use of the transmitter.

Again, it has been pointed out that a D.C. transmission with negative modulation provides simple A.V.C. by observation of the peak synchronising amplitudes. This is admittedly the case, but any simplicity of A.V.C. is, it is thought, outweighed by the complexity of the limiter necessary to suppress false synchronisation.

With the system here described, A.V.C. has not in general been found necessary on the wavelengths at present used. Were an A.V.C. required, however, the necessary control might be obtained by observing the black-level amplitude which always follows a synchronising signal.

The necessary pulse for controlling such a device can, for example, be obtained by differentiating the synchronising pulse and using the trailing edge. There are a number of circuit arrangements available, and the extra equipment involved constitutes a small addition to the multi-valve television set. Furthermore, with synchronising signals extending to zero, the arrangement can be made such that it cannot "lock" in a position of maximum receiver sensitivity, provided this maximum sensitivity is not so great as to overload the receiver completely with surface noise. If desired, a limiter may then be added to suppress interference flashes on the screen, the setting of the limiter being much less critical than in the case of the limiter which is practically a necessity for a negative-modulation system.

## "TILT" AND "BEND"

**Camera Control  
Equipment**

The camera control equipment may be divided into four main groups, comprising camera channels, picture channels, pulse generators, and supply equipment.

Each camera channel contains a unit for focusing the cathode-ray beam of the Emitron tube, by which the correct potentials may be adjusted for the electrodes. This unit also contains controls for adjusting the beam current for optimum working; a reflecting galvanometer facilitating this operation.

Another unit is included in each camera channel which accepts sawtooth signals from the pulse generator, and drives scanning currents at line and frame frequencies into the deflection coils in the camera. This unit has controls affecting the height and width of the scanned area, and for shifting the scanned area bodily.

**Tilt and  
Bend**

Apart from the distortions of the picture signals which are deliberately introduced in the head amplifier, the signals from the camera also contain spurious signals originating in the Emitron tube, of which the character depends largely upon the illumination of the scene being transmitted. These spurious signals occur during both forward and flyback periods at line and frame frequencies.

The effect of the forward-period spurious signals is generally an overall "tilt" of the picture signals in a line or frame scan, or an overall "bend," or the effect may be a mixture of both "tilt" and "bend." Further, the "tilt" and "bend" may occur in either sense. The signals photographed are typical of those produced by a scene situated in a field of very poor illumination; Fig. (a) showing the signals received from the camera after magnification in the "A," "B," and "C" amplifiers.

Fortunately, under conditions of fair illumination, the "tilt" and "bend" signals conform to a shape which can be balanced by a simple means consisting of artificial shading signals manufactured in the group of pulse generators, of which the "tilt" and "bend" components can be adjusted both in amplitude and in sense by a small number of controls. Fig. (b) shows the picture signals after the introduction of artificial shading signals containing "tilt" and "bend" components.

As the character of the spurious signals is likely to be different in the various camera channels, it is obviously necessary to provide independent shading controls. In each "A" amplifier, to which the picture signals from the appropriate camera are taken, four controls are therefore provided by which the amounts of artificial "tilt" and "bend" signals at both line and frame frequencies may be adjusted.

The spurious signals which occur in the flyback periods are of a more erratic nature, their shapes depending upon a variety of circumstances. Since the scanning currents are synchronised, however, these spurious signals may be suppressed, preparatory to the introduction of the synchronising signals, in the same manner for all camera channels.

The signals from the output of the fading mixer are amplified by a "B" amplifier having adjustable gain,

with maximum voltage-magnification of 150 times, and a "C" amplifier with fixed magnification of 20 times. Couplings between stages in these amplifiers follow transmission-line practice, in that the capacitance of the anode circuit of one stage is separated from the capacitance of the following grid circuit by a series inductance.

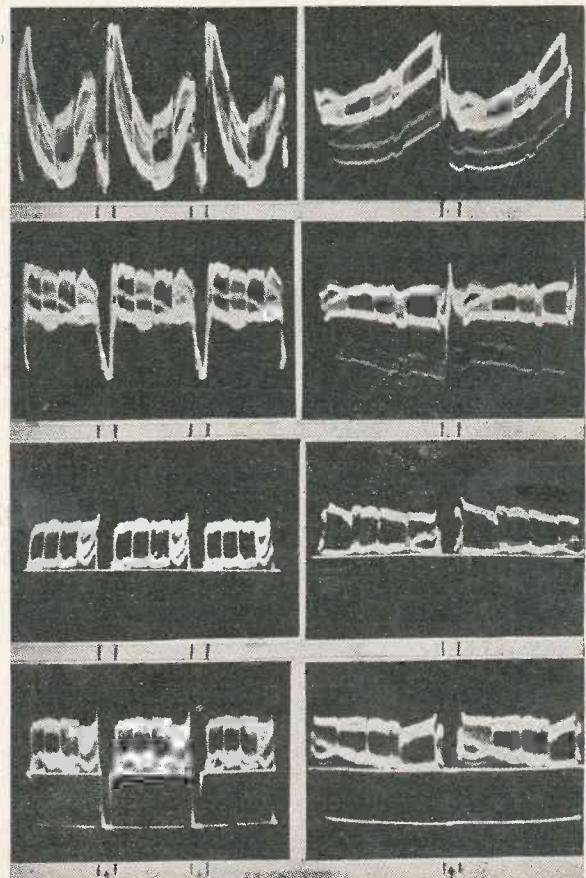

Intervals between lines (line scan)      Intervals between frames (frame scan)  
Development of television signal wave form.

Following the "C" amplifier, a unit is included in which the intervals between lines and frames are "cleaned up" in readiness for the introduction of the synchronising signals.

The picture signals having been referenced back, the spurious signals are suppressed by adding large positive pulses to the negative picture signals during the intervals between lines and frames. The pulses lift the spurious signals clear of the picture signals in the infra-black direction, and the spurious signals are removed by rectification at a subsequent valve. This valve is provided with a bias control, by which the level at which the suppression pulses are cut off can be adjusted to be the same as that of picture black. Fig. (c) shows picture signals to which this process has been applied.

The picture signals are now free from spurious signals and contain a direct component. In the following unit the synchronising signals are added to the "prepared" intervals between lines and frames, and appear as in Fig. (d). The television signals are now ready for radiation, except for the relative amplitudes of picture and synchronising signals.

# RECENT TELEVISION DEVELOPMENTS

## A RECORD OF PATENTS AND PROGRESS *Specially Compiled for this Journal*

Patentees: C. H. F. Muller Akt :: Philco Radio and Television Corporation :: The British Thomson-Houston Co. Ltd. :: M.V. Philips Gloeilampenfabrieken :: E. C. Cork and J. L. Pawsey :: V. Zeitline, A. Zeitline and V. Kliatchko :: Farnsworth Television Inc.

### Focusing the Spot

(Patent No. 476,417.)

**O**WING to slight inaccuracies in the assembly of the electrode system in a cathode-ray tube, it is usually necessary to apply a correcting voltage in order to focus the

oscillation-generator and the input valve for the synchronising signals. The object is to throw back on to the grid of the input valve a negative bias sufficiently strong to paralyse that valve immediately after it has received a synchronising signal. The time-constant of the circuit is also

the scanning action of a stream of electrons. The image so formed is stored up during the interval between successive scanings on the "Lenard phosphor" screen, and the latter is scanned by a ray of infra-red light which is synchronised with the ordinary electron stream from the cathode-ray tube. As a result, the whole of the available photo-electric energy is released and made available for signalling.—The British Thomson-Houston Co., Ltd.

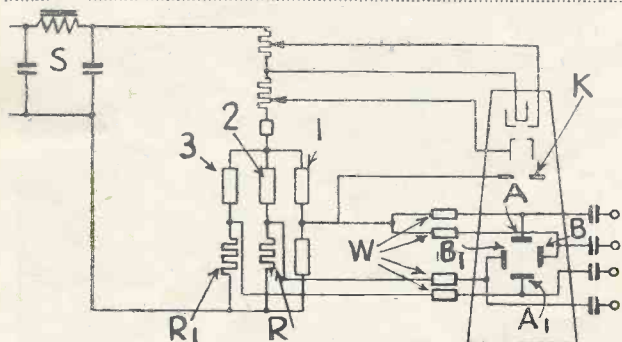

Method of centring the spot.  
Patent No. 476,417.

spot dead in the centre of the fluorescent screen. The figure shows a supply potentiometer by means of which the required correction can readily be made.

The potentiometer is shunted across the terminals of the smoothing circuits, and is divided at its lower end into three parallel branches. The first branch has a fixed ratio-tapping, and supplies the anode K, and the plates A, B of the usual deflecting system. The branch 2 contains a variable resistance R, which regulates the voltage on the deflecting plate Br. The voltage on the plate A1 is adjusted from the branch 3, which similarly includes a variable resistance R1.

The spot is centred or focused on any desired part of the fluorescent screen by adjusting the variable resistances R and R1. Fixed resistances are included in each of the supply leads as shown at W.—C. H. F. Muller Akt.

### Time-base Circuits

(Patent No. 477,038.)

A feed-back circuit is inserted between the last stage of a saw-toothed

made such that the blocking bias is operative for nearly the whole interval between one synchronising signal and the next, though not quite.

The result is that although the input valve is "released" in time to accept the next synchronising impulse, it does not respond to any static or similar interfering impulses which may arrive during the interval and which may tend to trigger the saw-toothed generator into undesired oscillation.—Philco Radio and Television Corporation.

### Photo-sensitive Screens

(Patent No. 477,216.)

The so-called "Lenard phosphors," such as zinc sulphide with a mixture of manganese, have the property, when exposed to light, of storing up the resulting photo-electric effects, and only releasing the accumulated energy when subjected to the action of infra-red rays.

This property is utilised to increase the efficiency of the type of television transmitter in which the picture is first focused on to a "mosaic cell" screen so as to set up an electric image, which is then discharged by

### Projection Tubes

(Patent No. 477,612.)

Instead of using a fluorescent screen, the picture is formed as an

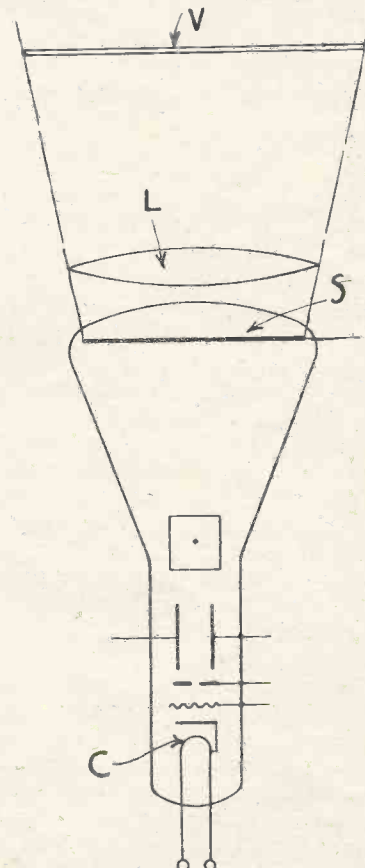

Projection tube employing a metal screen.  
Patent No. 477,612.

The information and illustrations on this page are given with permission of the Controller of H.M. Stationery Office.



incandescent image on a thin metal sheet S by the heat produced by the bombardment of the electron stream from the gun C. The sheet is made of tungsten or molybdenum and should not be more than 20 microns thick. The picture so produced is then projected on to a large viewing screen V through a magnifying lens L.

Unlike ordinary fluorescence, an incandescent picture contains all the primary colours of the original picture, so that it is possible to build up from it a picture in natural colours on the viewing screen. Three separate projection tubes may, for instance, be focused on to the same viewing screen, with a different colour filter for each. Or three different filters can be inserted, in rapid succession, between the sheet electrode S and the screen V, so that the resulting images merge into one coloured picture.—N. V. Philips Gloeilampenfabrieken.

**Transmitting Aerials**

(Patent No. 477,914.)

As shown in the drawing, the ordinary half-wave wire or rod aerial

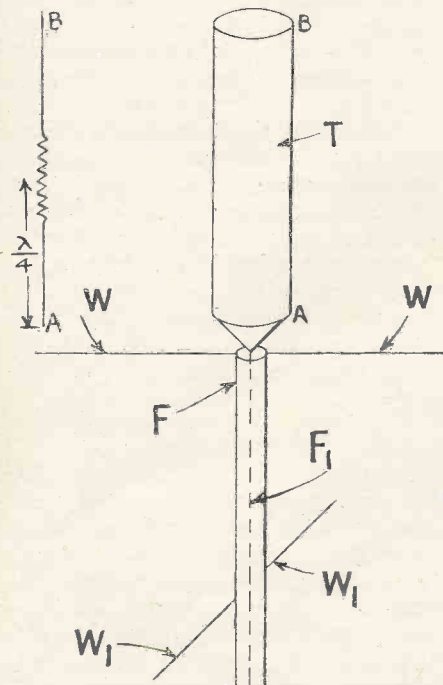

Television transmitting aerial.  
Patent No. 477,914.

used for transmitting television signals is replaced by a tube T some six or seven inches in diameter, which is directly connected at its lower end to a concentric feed-line F, F1. A transverse wire W serves to "earth"

the aerial at the working frequency (say, 6.5 metres), and another similar wire W1 helps to prevent carrier-wave leakage along the outer sheath of the feed line.

The arrangement is designed to "match" the impedance of the feed line to that of the aerial, without the necessity of using a step-up transformer coupling. The latter intro-

Transmitting tube employing fluorescent material on storage electrode.  
Patent No. 478,499.

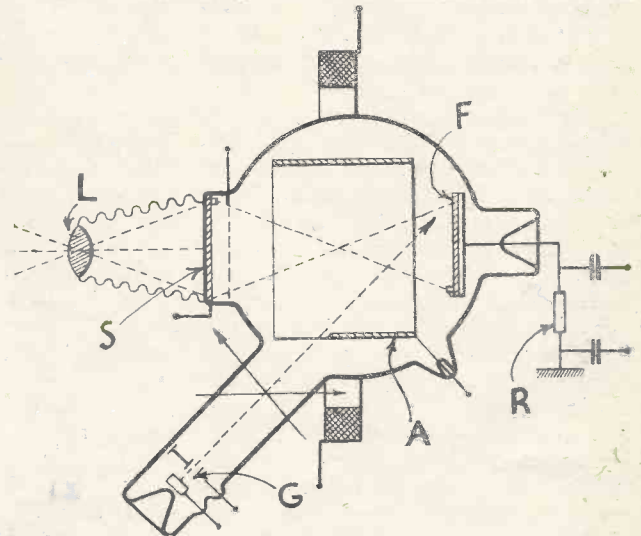

duces a certain amount of selectivity, which is objectionable because, in television, it is necessary for the aerial to radiate a wide band of signals without discriminating between the high and low frequencies.—E. C. Cork and J. L. Pawsey.

**Television Transmitters**

(Patent No. 478,499.)

It is stated that fluorescent material which emits electrons when scanned by an electron stream is also capable of acting as a "storage electrode," in the same way as the well-known mosaic-cell electrode used in an Iconoscope tube, and therefore forms a simple substitute for the latter.

As shown in the figure, the picture to be televised is projected through a lens L on to a photo-sensitive screen S. The electrons emitted are then focused upon a screen F coated with fluorescent material where, as stated above, an electron image is formed by the charges built up on each elemental area on the coating.

The image charges are swept by a scanning beam from the gun G of the tube, and the resulting currents are taken off through a resistance R and amplified. The action may be varied by causing the scanning beam to produce secondary electrons, which are collected by the anode A.

—V. Zeitline, A. Zeitline, and V. Kliatchko.

**Incandescent Screens**

(Patent No. 479,318.)

The usual fluorescent screen of a cathode-ray tube is replaced by a mesh of fine tungsten wire, on which an incandescent image, of high brilliance, is produced by the bombard-

ment of the electron stream. The metal screen is built up of individual coils of wire, 0.001 in. in diameter wound 1,200 turns to the inch. The ends of the coils are spot-welded to the frame and the assembly is held in one plane by transverse supporting wires.

The screen is first heated to a temperature just below red heat by a local current, or by means of infrared radiation, so as to reduce the amount of work which must be done by the electron stream to produce the required incandescence.—Farnsworth Television Inc.

**Summary of Other Patents**

(Patent No. 475,928.)

Cathode-ray television transmitter in which the mosaic-cell electrode produces variable secondary-emission.—Electric and Musical Industries, Ltd., and H. G. Lubszynski.

(Patent No. 475,999.)

Mechanical scanning system in which a fixed reflector coacts with a rotating mirror to cover the image in two (or more) revolutions.—R. G. Wilson and W. D. Silver.

(Patent No. 476,237.)

Cathode-ray tube fitted with a secondary emission electrode and a "storage" electrode, in addition to the usual photo-electric cathode.—W. E. Williams.

The information and illustrations on this page are given with permission of the Controller of H.M. Stationery Office.

# Telegossip

## A Causerie of Fact, Comment and Criticism

By L. Marsland Gander

**E**XPANSION of staff is going ahead rapidly at Alexandra Palace and is, in fact, the only visible sign of "Things to Come." During a visit the other day I noticed so many new faces about the studios and corridors that I asked for official figures showing the growth of personnel.

I had a surprise. There are now 280 persons employed on the television staff at the Palace, and approximately 90 are engineers. When the station opened eighteen months ago there were about 150 on the staff.

The chief accession of strength has been in producers. Originally there were exactly five producers who were expected to do everything; the strain was intolerable, the groaning and lamentation awful. Now there are sixteen; yet the hours of transmission have not been greatly increased. The only important extension of programme time since November, 1936, has been the introduction of Sunday transmissions and of outside broadcasts by means of the mobile unit.

I assume, therefore, that with three times as many producers on the job as there were eighteen months ago and only a slight increase in programme time, programmes will improve in quality out of all recognition. Among the new recruits to the producing staff three have had film experience and two stage experience. One, Mr. Fred O'Donovan, formerly manager of the Abbey Theatre, Dublin, has had both stage and film experience and also has the unusual advantage of having acted in television plays already.

Mr. Lanham Titchener, a junior producer, was assistant editor to that French film genius René Clair for two years; Mr. Stephen Harrison, another new junior, worked on such celluloid successes as "Catherine the Great," and "The Private Life of Henry Eighth."

### The New Studios

All this is the credit side. But it is now two months since I urged in these columns that the B.B.C. should push on rapidly with the provision of more studio space. Until this is done the producers are hamstrung.

*There is yet no sign of a start with the long job of reconstruction and expansion. Why?*

This problem is becoming increasingly urgent, the delay increasingly serious. I went into the old No. 2, and I found it was still being used in a lash-up state. Every programme transmitted from No. 2 is virtually an outside broadcast. The thick python-like cables coiled about the floor, a trap for the unwary visitor, are also a symptom of an inexplicable standstill order.

I am told that there is feverish activity behind the scenes, and I can only reply that "the play's the thing." The sands are running out, the three years' guarantee to potential set purchasers is dwindling away. Sixteen British manufacturers are now making sets and producing forty different models between them. No other country has even started to sell to the public. The advantage must not be frittered away because of the national characteristic to build a thing to last for twenty years when its useful life will only be three. Speed up the studio construction, B.B.C.!

### "Long-gun" Cameras

By the way, there is a sign of progress in the fact that all the six old Emitron cameras which have seen long service have now been replaced by the new "long gun" type. Have you noticed any difference in the picture? Viewers do not know what a relief to the television engineers that change meant, for some of the older cameras were near the end of their usefulness. Many a time the fate of a transmission has trembled in the balance.

**And so, B.B.C., you have got the men, you've got "long guns," you've got the money too! What are you waiting for now?**

I saw Sir Noel Ashbridge, newly returned from the Cairo carve-up of wavelengths, inspecting one of the new cameras. Sir Noel is without doubt the chief friend of television in the B.B.C. Cabinet, besides being a member of the Television Advisory Committee. He is a true enthusiast and a significant development is that on the engineering side there is no division between the vision and the

sound staffs. Thus Mr. R. H. Wood is responsible for all outside broadcasts, whether sound or vision, and Mr. R. T. B. Wynn, one of the Broadcasting House seniors, came to the rescue of the mobile unit by having the 100 ft. steel mast formerly used by 5GB transported from Daventry to Twickenham and to Mortlake.

### O.B. Interference

As I have already mentioned in these notes serious interference on the outside transmissions had been caused by interaction between the incoming waves from the mobile unit and the outgoing waves from Alexandra Palace aerial. Use of the little aerial which was specially erected on the summit of the television mast at A.P. to pick up the signals from the van has now been discontinued. Enormous improvement in the quality of reception in the home has been effected by the use of a receiving point at a garage in Swain's Lane, Highgate, about two miles from the Palace. Transmissions from the mobile unit are picked up there on a fifty-foot aerial and piped to the Palace along a balanced television feeder laid for the purpose.

Before this site was chosen B.B.C. engineers scaled the spire of St. Michael's Church, Highgate, which commands a grand view over London, and carried out reception tests in conjunction with the van. These experiments convinced them that it was necessary to establish a receiver somewhere away from the immediate vicinity of the Palace.

### Some Bad Luck

What incredible bad luck television has on occasion! A couple of years ago it was a standing joke that at every Press demonstration something went wrong. Now the vision is as reliable as the sound, and on Boat Race day it proved itself more reliable. On the morning of the race a workman put a pneumatic pick through a telephone cable in the Muswell Hill district. Result, the television station was completely cut off from the outside world. The only way Mr. Philip Dorté, in charge of the mobile unit, could communicate with the Palace was by holding up messages scribbled on paper before the camera.

## HOW THE DERBY WILL BE TELEVISED

Shortly afterwards I was at the Ideal Home Exhibition, Olympia, and Mrs. Neville Chamberlain was inspecting the exhibits. In the television studio specially built there she was to have seen a show televised under conditions identical with those at Alexandra Palace.

At the last moment when all was ready and artists from the ice spectacle at the Coliseum were waiting to begin, all the electric power failed! Mrs. Chamberlain passed through the studio in darkness. Meanwhile on the sets in the adjoining television "parade" all that could be shown was the B.B.C. morning film which daily grows more worn and more tedious. It is all very well to repeat the apology that this film is intended only for trade purposes, but hundreds of people saw it at Olympia and judged television accordingly.

Perhaps the most important fact about the Ideal Home Exhibition was that for the first time in this country television was demonstrated to the public with real showmanship, as it has been for several years both in Paris and Berlin. In some respects the demonstration was superior to any I have seen abroad because not only could the visitor see a studio in action but he could also compare the reception on more than twenty different commercial models seen side by side under anything but ideal working conditions.

There was a lesson for the organisers of the Radio Exhibition which I am glad to hear they have not been slow to learn. I understand that this year's television exhibits will eclipse anything yet attempted. Radiolympia will be the first big occasion for which the B.B.C. will have two mobile units available. The second should be ready by July and is expected to have finished all tests by August.

One unit will probably be stationed at the Zoo, as last year, and the other at Olympia for actual transmissions from a temporary studio there as from the Ideal Home Exhibition.

### The Derby

Without a doubt the chief success of the month for television has been the removal of the ban imposed by the Epsom Grand Stand Association on the televising of the Derby. The

secret history of the efforts behind the scenes to bring this about is a story on the one side of magnanimity and on the other of diplomacy.

Sir John Reith, the Director-General, himself first took a hand; but the negotiations were in the main conducted on the B.B.C. side by Sir Stephen Tallents, Controller of Public Relations, and Mr. Gerald Cock, the Television Director. In reversing its previous decision the Grand Stand Association has acted with generosity and foresight and has recognised the wider duty imposed by the fact that the Derby is a national institution. With television at its present stage of development no possible harm could come to the interests of racing—on any argument—by televising the Epsom classic.

At Epsom Mr. Dorté proposes to mount his main camera, a super-Emitron equipped with a 12-in. telephoto lens on the roof of the Royal Stand. With this he will make a gallant attempt to show the distant start. His best pictures should be those of the race from Tattenham Corner to the finish, secured with this same camera. There has already been an anxious conference to decide whether it would be safe to try a switch from this camera to another at the winning post when the horses near the finish.

It has been decided, however, that it would be too risky and the one camera will have to do the whole job. There is a chance that trying a switch-over at such a critical moment might mean that viewers would miss the one thing that matters—the actual finish and the horses flashing past the post.

### Coming O.B.'s

Viewers will also see some Derby Eve pictures on May 31 showing pictures of the Downs, the crowds, and the course. Besides the race on Derby Day itself, pictures will be shown of the saddling and weighing-in, and afterwards, of the winning owner leading in his horse. A list of coming events to be covered by the mobile unit makes impressive reading. Here it is:—

May 14.—Whitney Cup Polo match, from Hurlingham.

May 15.—Life-saving exhibition, on Judo principles, from Hurlingham pool.

May 22.—Chelsea Flower Show, final preparations.

May 23.—Chelsea Flower Show, private view conducted by C. H. Middleton, Freddie Grisewood, and Elizabeth Cowell.

May 24.—Private view for Fellows of the R.H.S.

June 9.—Trooping the Colours, from Whitehall.

June 24 and 25.—Lord's Test Match.

June 28 to July 2.—Finals Week at Wimbledon.

July 4.—India v. the World, at Hurlingham.

Aug. 6.—World's Swimming Championships, from Wembley.

Aug. 22 onwards.—Whole of the final Test Match.

### More Distance Records

More news of long distance reception. Personally, I have been told of good results in North Lancing and Malvern. Delving among B.B.C. correspondence, I found congratulatory letters from Mersea Island, King's Lynn, Eastbourne, Whitstable, Sutton (Ely), Totton (Southampton), Worthing, Rushden (Northants), Harwich, Herne Bay, and Bournemouth. A Bronley listener wrote, with reference to the Wembley International Soccer transmission: "You may be interested to know that two members of the little audience during the match remarked that the ball looked soft; it did not seem to roll properly. We laughed at the time, but read in the paper the next day that both captains complained that the ball was not fully inflated! Was this imagination or is television better than we thought?"

I saw the Head of the River race on a set at home, in Barnes; then went down to the river-bank and watched it in reality; and, finally, entered the B.B.C. television van, at Harrod's Depository, and saw Mr. Dorté wrestling with the task of making the commentary fit the pictures. He was watching two pictures, on the monitor panels, one the picture as actually being seen in the home, the other the view in the next camera waiting to be "mixed in" when the moment arrived.

# Our Readers' Views

Correspondence is invited. The Editor does not necessarily agree with views expressed by readers which are published on this page.

## Excellent Results on a One-inch Tube!

SIR,

For the past month I have been using a television receiver, designed along lines suggested by recent articles in your journal, employing the R.C.A. 1-in. tube.

I must say that the results are exceeding all expectations, complete programmes being easily followed and enjoyed. The vision receiver employs American type valves and consists of 1 H.F. and 3 I.F. (tuned anode coupling) stages and a single L.F. stage.

Synchronising impulses are separated by means of Mr. Tyers' method employing a diode, and pictures are very steady.

I can definitely advise any readers who do not wish to go to the expense of a full-sized tube, or who have limited voltage at their disposal to make up a set of this nature.

The receiver is being used on D.C. mains and a 250 volts D.C. generator, fed from a 6-volt accumulator, is used to supply the extra voltage for tune base and tube.

The approximate cost of my television receiver is as under:—

	£	s.	d.
Parts for vision set ...	1	18	0
Parts for time base ...	1	10	0
10 American valves ...	2	15	0
2 T31 Thyratrons ...	2	0	0
913 Tube .....	1	17	6

£10 0 6

Any readers in the district who would like a demonstration are welcome if they care to make an appointment for an evening session.

R. V. JANSON (Highgate).

## Aircraft and Interference

SIR,

Being ideally situated for observing the effect of aircraft on television reception, I was very interested in the paragraph devoted to it in "Scannings and Reflections." But I cannot agree that the interference is due to insufficiently screened ignition systems. In fact, I don't think that the interference has anything to do with the ignition of the aircraft. The interference takes the form of rapid fading of the whole picture—the periodicity of this fading depending

on the position of the aircraft relative to the aerial and Alexandra Palace. If it were ignition interference, it would surely be some kind of white spot effect.

Having observed several hundred instances of this interference, I have noticed that the further the plane is away, the more rapid is the fading (as long as the plane is within a certain angle of A.P. and the aerial) and this fading becomes slower and more marked until the plane has passed over the aerial and out of the angle mentioned before, when the fading ceases altogether, although the craft is nearer the aerial than when the interference was first observed. It is my belief that the whole phenomenon is due to the aircraft absorbing the signal in some way. It would be interesting to hear the opinions of some of your readers interested in this form of interference.

D. S. G. DAVIES (Hendon).

## Results with the Low-cost Telesvisor

SIR,

Many thanks for the trouble which you have taken regarding the valves. I have done as advised. I also take this opportunity of thanking you for the pleasure which has been received by all who have seen the wonderful results of your fine television receiver circuit.

W. BIRKINGER

(North Finchley, N.12).

SIR,

In the hope that they may be of interest to those of your readers who are contemplating building the television receiver described in your issues of October to January last I send you herewith a few comments on the behaviour of the set which I have just completed to that design.

The making of the set progressed without any difficulty and a satisfactory picture was obtained within a few minutes of switching on for the first time. This seems to confirm the claims which were made for its simplicity in operation and suitability for construction by those without previous experience of the building of television apparatus. The lining up of the vision circuits as described in the articles by means of phone signals was quite simple and very little further adjustment was necessary,

while the setting of the time base controls was found to be far less critical than the tuning of any ordinary short-wave receiver.

The set is being operated at a distance of rather more than twenty miles from the Alexandra Palace on a temporary aerial consisting of a plain dipole without reflector, raised only 15 ft. from the ground and badly screened by tall trees. Even with this indifferent aerial a bright and steady picture is obtained on a 12 in. tube, and the need for improving the aerial system arises from the presence of bad car interference from an adjacent main road. Actually this interference provides a good demonstration of the inherent stability of the set, since the picture remains steady without adjustment through an entire programme and even interference so intense as to obliterate the picture practically completely causes no sign of frame shift. With an improved aerial there is no doubt that it will be possible to dispense with one or possibly two of the H.F. stages.

The apparatus was built in the first instance to the original specification, the improvements described in the January issue being deferred until the set was known to be in working order. A D.C. restoring diode has since been added and has resulted in the expected improvement of picture gradation. Fitting of a correcting inductance in the output stage and modification of the H.F. grid bias arrangements are now in hand.

It is perhaps worth while pointing out that the heater winding for the MU2 rectifier required modifying, since that valve as now supplied consumes 2.5 amps. Also the D42 diode requires 0.6 amp. The tube bias resistance R40 had also to be reduced to 25,000 ohms to give the correct bias range for the tube in use.

In conclusion, may I express thanks for this very useful series of articles and satisfaction at the results obtained. The designer is to be congratulated on having produced a set the construction of which can be undertaken with confidence by anyone who is prepared to use reasonable care in following the design and who is capable of carrying out the comparatively simple constructional work involved.

It would be interesting to hear the experiences of others of your readers who have built sets to this design.

L. W. CODD (Addlestone, Surrey).

# 1938 Valve Designs

*Some interesting valve designs have appeared in the last few weeks in types suitable for amateur use. A number of these are described in this article.*

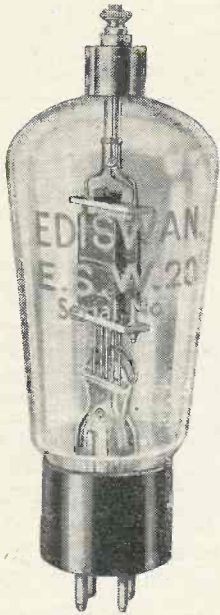

This Ediswan triode the ESW-20 is of the low capacity type suitable for high-frequency operation.

HERE appears to be quite an original note in the valve designs produced for amateurs by the British manufacturers. The Ediswan Company are now supplying a valve which is perhaps one of the first of British design to be produced specifically for amateurs at a really competitive price. This valve, the ESW-20, is a small oscillator with a UX base, suitable for a maximum anode dissipation of 20 watts. It has an impedance of 12,500 ohms and an amplification factor of 22. It is, therefore, an ideal doubler or power amplifier.

The ESW-20 also has a 7.5 volt heater, a carbonised anode and tests show that in class-B audio circuits it will provide a speech output of between 65 and 70 watts per pair of valves. This valve is priced at 17s. 6d., and of course has the top cap anode connection as is now usual with modern low-capacity triodes.

Most amateurs know of the internationally famous T-20 valve which has been very popular during the past twelve months. A slightly larger version of this valve has now been produced and appears to be ideally suitable for amateur use. T-40 has a carbon anode Isolantite base and an extremely low inter-electrode capacity. The A.C. resistance of the valve is 8,700 ohms with an amplification factor of 25. As a class-C amplifier it is possible to obtain an efficiency of 75 per cent. giving an R.F. output of 86 watts with a grid driving power of less than 10 watts. The price of this valve is approximately 24s.

A very similar valve to the T-40 is the TZ-40 with a 40 watt anode dissipation has been designed for zero bias class-B amplification or frequency doubler. A pair of these valves in class-B would provide a speech output of 175 watts with 1,000 volts H.T. supply.

A valve which we have used in many of our designs is the old Mullard T-25D.

This, of course, was superseded by the TZ05-20 which is a triode valve suitable for 20 watt anode dissipation. It is now priced at 17s. 6d., and at this figure becomes one of the most economical British valves for transmitting use. It has a 6 volt heater and is suitable for an anode voltage of 400 at 20 metres and is very conservatively rated.

Mullard, incidentally, have now a very complete range of valves suitable for amateur use. There is, for example, the TV05-15, which is very similar to the RK-23 and is priced at 27s. 6d. It has a 12 volt heater and can be used down to 5 metres. Another valve at a similar price is the TZ05-15, which has



The T-40 and TZ-40 both of which have carbon anodes and are suitable for an anode dissipation of 40-watts, are very small in dimensions, being only 2-ins. in diameter: It is, however, possible to obtain an audio output of 170-watts from a pair of TZ-40's and 85-watts carrier power from one T-40.

a 4 volt heater suitable for a minimum wavelength of 15 metres. This pentode valve has a maximum anode dissipation of 15 watts.

The popular RK-20A now has an equivalent in the Mullard range in the TV-135, the price being £4 15s. od. There is also a TZ-135, priced at £4 10s., which is equivalent of the RK-20. It is possible to obtain an efficiency of 78 per cent. with a carrier power of 21 watts when used as a class-C anode modulated radio-frequency amplifier.

We have been conducting some tests on a most interesting Mullard triode valve type TY1-50. This valve has a carbon anode, a 7.5 volt heater, an impedance of 5,250 ohms and a slope of 2 mA./V. The minimum wavelength is .85 metres, while the anode voltage at 2 metres is 1,000 volts. The maximum

anode dissipation is 50 watts. This valve is priced at £3 10s., and as a class-C R.F. amplifier will provide an efficiency of 67 per cent.

We were interested to notice that the Radio Corporation of America had produced a special tetrode valve of extremely high slope for use in television amplifiers.

This valve type 1851 is the first American valve to have more or less typical British characteristics. It is also interesting to note that the General Electric Company have had for some time a valve of this type designated the KTZ41. It has a working slope of 7.5 mA./V measured with a grid voltage of -2.5.

This tetrode has a 7-pin base with the control grid to the top cap and is priced at 15s. Another interesting valve in the Osram range is a rectifier type U52, which is a full-wave vacuum valve with a 5.0 volt heater supplying 250 mA. rectified current with 500 volts R.M.S. on each anode. It is fitted with an octal based so that it is interchangeable with the American valve of similar characteristics.

The KT32 power output tetrode is also available from the General Electric Company, and this is designed for D.C./A.C. operation having a 26.0 volt heater. It requires only 135 volts on both anode and screen, and at this voltage will provide up to 7.5 watts output in class-AB<sub>1</sub> push-pull.

Two absolutely original designs have been produced by Eimac in the KY21 and RX21 valves. KY21 is a mercury vapour grid control rectifier, particularly suitable for use in keying circuits. The RX21 is suitable for a peak anode

(Continued on page 320)



As the maximum grid driving power of this Tungram valve OS12-500 pentode is only 1/10th-watt, it is possible to construct a multi-band transmitter with one of these valves driven by a 6L6 tri-tet oscillator.

37 Mirror

# Mullard Valves

## FOR AMATEUR TRANSMITTERS

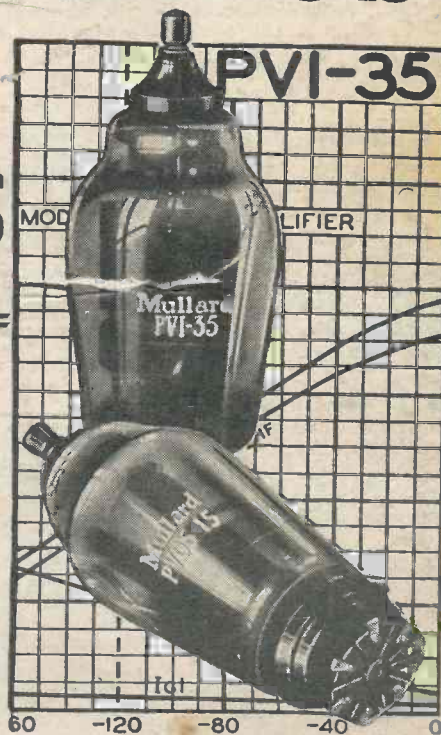

**BRITISH VALVES  
NOW AVAILABLE AT  
ATTRACTIVE PRICES:**

			s.	d.
TZ05—20	TRIODE	20w	17	6
TYI — 50	TRIODE	50w	£3 10	0
PV05—15*	PENTODE	15w	£1 7	6
PVI — 35*	PENTODE	35w	£4 15	0
PZ05—15	PENTODE	15w	£1 7	6
PZI — 35	PENTODE	35w	£4 10	0

★ INDIRECTLY HEATED CATHODES FITTED

For full data on these types send a postcard to:  
**TRANSMITTING DIVISION**

**THE MULLARD WIRELESS SERVICE CO. LTD.**  
225, TOTTENHAM COURT ROAD, LONDON, W.I.