

HOME-BUILT TELEVISION RECEIVER

Television

and *SHORT-WAVE WORLD*

JUNE 1939

No. 136 Vol. XII.

1/-

SIMPLE 22,000 R.P.M.

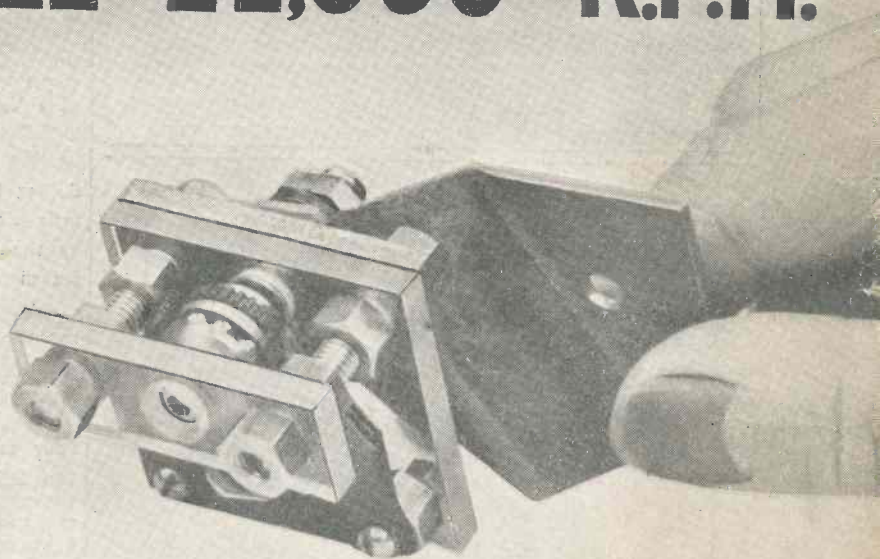

MECHANICAL SCANNER

PAGE 324

**POINTS FOR
PROSPECTIVE
VIEWERS**

**USING
LIGHT
RELAY**

**SHORT
WAVES**

**PORTABLE
DIRECTION-
FINDING
RECEIVER**

**PHONE AND C.W. MONITORS
SIMPLE LOW-POWER TRANSMITTERS**

BERNARD JONES PUBLICATIONS LTD.
CHANSITOR HOUSE, CHANCERY LANE
LONDON W.C.2.

THE FIRST TELEVISION JOURNAL IN THE WORLD

TELEVISION

and SHORT-WAVE WORLD

Special Features

	PAGE
Simple 22,000 R.P.M. Scanner ...	324
Complete Design for High-quality Television Receiver ...	325
America Makes a Start ...	330
Meissner Television Kit ...	334
The Supersonic Light Relay ...	337
Sound Equipment at Alexandra Palace	341
5-valve Portable Direction Finding Receiver ...	353
Short-wave Radio World ...	357
Building Phone and C.W. Monitors	359
Constant-voltage Power Unit ...	362
Simple Low-power Transmitters ...	368
Howard 460 Receiver ...	376

TELEVISION AND SHORT-WAVE WORLD

Proprietors:
BERNARD JONES PUBLICATIONS, LTD.

Editor-in-Chief:
BERNARD E. JONES.

Editor:
H. CORBISHLEY, F.T.S.

Short-Wave Editor: KENNETH JOWERS
Editorial, Advertising and Publishing Offices:

Chansitor House, 38, Chancery Lane,
London, W.C.2.

Telephones: Holborn 6158, 6159.

Telegrams: Beejapee, Holb., London.

Subscription Rates: Post paid to any part of the world—3 months, 3/6; 6 months, 7/-; 12 months, 14/-.

Published Monthly—1/- net.
(On the first day of the month).

Contributions are invited and will be promptly considered. Correspondence should be addressed according to its nature, to the Editor, the Advertisement Manager, or the Publisher, "Television and Short-wave World," Chansitor House, Chancery Lane, London, W.C.2.

IMPORTANT

"Television and Short-wave World" is registered at the General Post Office, London, for transmission to Canada and Newfoundland by Magazine Post. Entered as Second-class mail matter, Boston, Mass.

COMMENT OF THE MONTH

Television for the Provinces

THERE is every indication that the Government decision to institute a television service in the Birmingham area will be made almost immediately and although it appears to be improbable that the offer made by the television receiver manufacturers to the Government for the extension of television to the Provinces will be accepted, a certain amount of misconception has arisen over this matter. The manufacturers have for some time been pressing for a speedy decision and have argued that if this country is to keep the lead in television it now has, pioneer work must be pressed forward as there can now be no doubt that other countries are following hot on our heels. The answer of the Television Advisory Committee was, in effect, that while they agreed that television must eventually expand to the provinces, they were unable to make up their minds what method to adopt, i.e., by radio link or by means of the co-axial cable. The manufacturers' reply was that they did not care what method was used, so long as it worked, but it was important that some action should be taken quickly. They declared themselves in favour of the radio link method and they were so certain that it did not need any further experiments to show it would work that they were prepared to pay for any equipment that would have to be scrapped, should the method prove unsuitable.

The total cost of extending the system to the Midlands area by using the radio link method is estimated at something well under £100,000 and this would include the transmitter itself at Birmingham. The transmitter can in no sense be described as experimental, since it would be equally suitable for use with either the radio link or the co-axial cable and it will therefore be required sooner or later in any case. It will be evident that the Government are not asked to risk very much in going ahead with the radio link method, but it was to overcome any qualms that the Government may still have that the offer was put forward. It is, therefore, clear that there is no attempt by the trade to subsidise or control the transmitting side of television, nor has there been a promise of funds with which to continue provincial extension.

The offer was solely to pay for apparatus which might become useless if a wrong choice of system were made. Although no official announcement has been made of the results of experiments made by the radio link method it is understood that these are now practically complete and satisfactory, and that no outstanding technical difficulties have still to be overcome. Naturally the first practical steps in a project of this nature always bring problems which can only be answered by the kind of development work that has already given Britain its two-year lead in television.

American technicians are already convinced of the possibilities of the radio link method and France has provincial stations planned at Lyons and Lille, which it is expected will use this system.

COMPLETE DESIGN FOR HIGH-QUALITY TELEVISION RECEIVER

The designer of this receiver is Mr. S. West who has already produced several highly successful vision units. The objective for the receiver des-

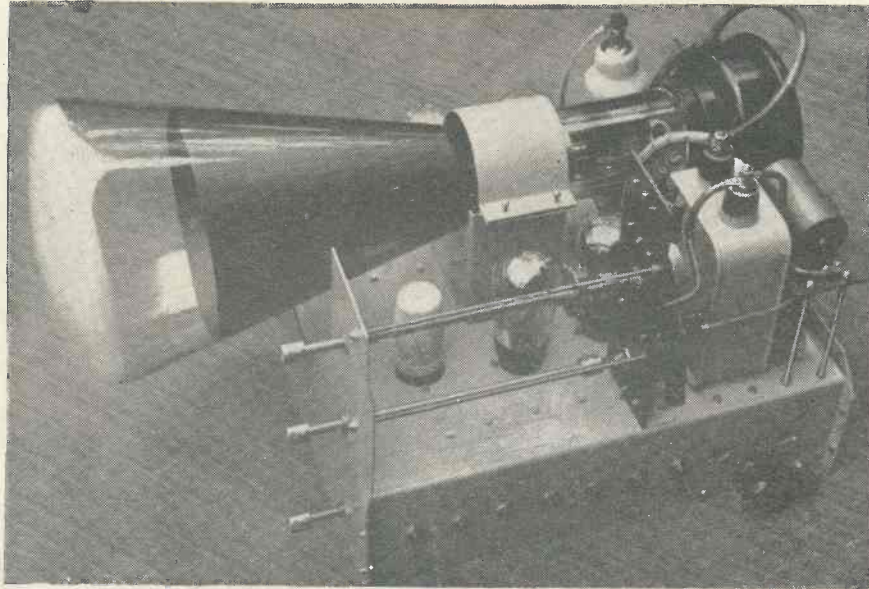

cribed in the following pages was very high quality within the ordinary service area and this has been secured.

Fig. 5. The general layout of the time base and C.R. tube circuits is well revealed in the above illustration.

IN considering the design of a television receiver there are two important factors to determine, namely, the overall gain the vision section must possess and the size of the picture desired.

The question of overall gain in the vision unit is important because there is little object in aiming at sensitivity greater than is required fully to modulate the C.R. tube having in mind the signal voltage available at the aerial feeder termination to which the receiver is to be connected, and, it is this factor that will largely determine the circuit arrangements particularly from the point of view of the number of valves. Also with a signal of reasonable amplitude, the simplicity and reduced number of stages of a tuned radio-frequency type of vision unit presents irrefutable advantages, and, with an adequate signal, such a design is excellent.

Considering the question of picture size, despite notions to the contrary, a small picture has much to commend it, indeed it can be shown that a small picture is essential for certain viewing conditions; these viewing conditions obtaining for the majority of ordinary domestic requirements.

The equipment herein described was designed for use within a 20 miles radius of Alexandra Palace, a T.R.F. circuit therefore being adopted. A quite drastic employ-

ment of the contrast control, in this case variable bias to the first R.F. stage valve, indicates the range as likely to be in excess of this estimate. A bright picture was desired and the audience would in general be restricted to not more than three persons. From a careful consideration of this requirement a C.R. tube having a 7 in. diameter screen was decided upon.

An electrostatic tube was chosen, mainly because such a tube has greater focus stability over the small magnetic types which do not in general utilise hexode focusing.

The complete equipment is entirely conventional in every respect, the

aim being throughout to ensure the very highest picture definition and good quality of sound reproduction.

It will be seen from the following description that the various units comprising the complete assembly are separately constructed but this requirement was dictated by the particular needs of this installation and obviously considerable latitude in the arrangements and grouping of the units is permissible.

The Vision Unit

The photograph, Fig. 2, shows the general arrangement of the vision

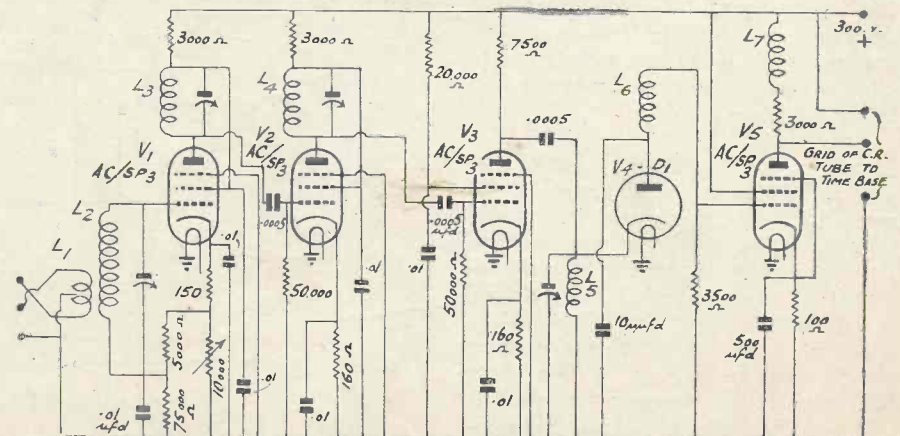

Fig. 2a. The circuit diagram of the 5-valve vision unit. The circuit values are given and any good quality components can be employed.

Furthermore, the ability to maintain a stable interlace is noticeably improved.

The two large tubular condensers that can be seen in the foreground at the left of the unit are Dubilier 0.1

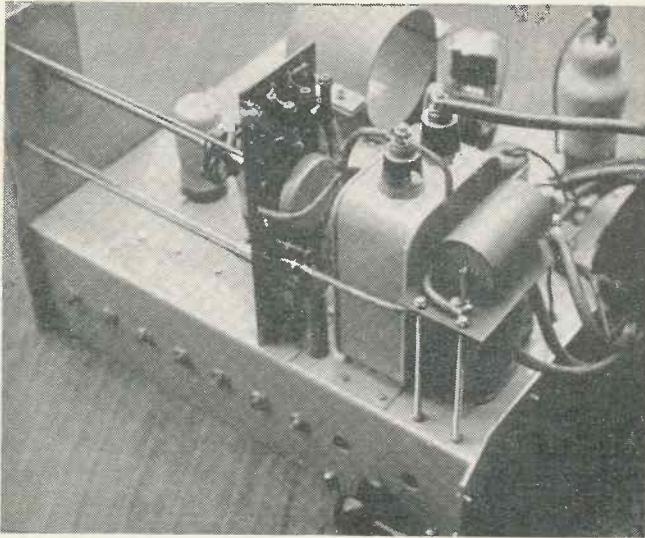

Fig. 9. The above photograph shows the arrangement of the C.R. tube's potential divider. Note the mounting of the smoothing condensers to ensure these are insulated from chassis.

smoothing condensers for the C.R. tube potentials, it is essential to insulate these when mounting, from the chassis, for, whilst the potential across them is well within their rating, the potential between them and

uFd 5,000v. intermittent working condensers. By reason of the fact that the C.R. tube is operated with the final anode some 3,000 v. above the chassis it is necessary adequately to isolate the tube deflecting plates to this D.C. potential difference.

These condensers provide connection to the vertical sweep circuits. Two similar condensers, in this case of 0.01 uFd capacity are employed for the horizontal circuits. These are mounted through a slot in the chassis and are held securely by well insulated brackets. They can just be seen to the right of the vertical feed condensers. This method of mounting was adopted to mitigate the effects of stray capacity in the horizontal circuits. Failure to give attention to this point will result in slow "flyback" with its resultant distortion or loss of the left picture edge.

The arrangement adopted for the C.R. tube electrode-potential divider and the mounting of the associated smoothing condensers is shown by Fig. 9. The panel carrying the various fixed and variable resistances is of paxolin and is secured to the front panel by means of 2 B.A. studding. The brilliance and focus controls are carried through to this front panel. In the case of the focus control, an insulated coupling breaks the control spindle, thus avoiding the possibility of shock when carrying out adjustments. It should be noted that, due to the conservative rating of the

chassis is higher than their insulation is likely to withstand.

Appendix Coil-winding Data

- L1 3 turns of 36 d.s.c. tapped at centre.
 - L2 $6\frac{1}{2}$ turns of 22 d.s.c. occupying $\frac{3}{8}$ in. winding length.
 - L3 and L4 6 turns of 22 d.s.c. wire occupying $\frac{3}{8}$ in. of winding length.
 - L5 9 turns of 22 d.s.c. occupying 1 in. of winding length.
 - L6 21 turns of 22 d.s.c. wire occupying .65 in. winding length.
 - L8 2 turns of 34 d.s.c. at earthy end of L9.
 - L9 9 turns of 20 d.s.c. wire tapped 3 turns down for grid of V15.
 - L10 9 turns as above, centre tapped.
- All the above are wound upon $\frac{1}{2}$ in. diameter paxolin coil form.
- L7 85 turns of 38 d.s.c. on $\frac{5}{8}$ in. coil form.

Valves

- V1, V2, V3 and V5 Mazda type AC/SP3.
- V4 and V7 Mazda type D.I. diodes.
- V6 and V19 Mazda type UU4 rectifiers.
- V8 Osram type MSP4 or Mazda type AC/S2.
- V9 and V12 Mazda type T.41.
- V10, V11, V13 and V14 Mazda type AC/P.

Mention of "Television and Short-wave World" when corresponding with advertisers will ensure prompt attention

Time Base and E.H.T. Transformer

- Prim. to suit main's voltage.
- Secs. 1,350 volts at 25 mA. Insulated for full voltage at inside of winding and 2x full voltage at outside end.
- 2 volts 1.6 amp.
- 2 volts 1.6 amp. Both windings insulated for 2x full voltage to frame.

Details of the sound section will be given in next month's issue.

America's First Programmes

THE National Broadcasting television programme schedule for the first week were as follows.

12.30 p.m. to 4 p.m., EDST.

President Franklin D. Roosevelt, Grover Whalen and others at opening ceremonies of New York World's Fair marking the beginning of high-definition television as an American public service. The programme was televised by the N.B.C. mobile unit and relayed to Manhattan for broadcast over Station W2XBS.

May 3 (Wednesday).

8 to 9 p.m., EDST.

Fred Waring and his Pennsylvanians; Richard Rodgers, composer, in the first studio programme of N.B.C.'s regular public television service. Hart, at the piano, accompanying Marcy Westcott, of "The Boys From Syracuse," in songs from the Rodgers and Hart Broadway hit production.

The programme also included Marjorie Clark and Earl Larimore in "The Unexpected," a dramatic sketch by Aaron Hoffman; The Three Swifts, jugglers; a relay from the New York World's Fair of 1939, and Walt Disney's cartoon comedy, "Donald's Cousin Gus."

May 5 (Friday).

8 to 9 p.m., EDST.

Mitzi Green, motion picture and stage comedienne, in a programme from the N.B.C. television studios. Also Josephine Huston in "The Choir Rehearsal," a musical piece by Clare Kummer; Roy Post, in a demonstration of his "lie detector," and The Novello Brothers, comedy whistlers.

At the bottom of the third column on page 272 of the May issue of TELEVISION, the Chairman of the Baird Company was referred to as Sir Harry Green. This, of course, should be Sir Harry Greer, and was a typographical error.

AMERICA MAKES A START

Impressions of the inauguration of a television service in the States.

TELEVISION made its formal debut in the United States on Sunday, April 30, when the National Broadcasting Company broadcast images of President Roosevelt, speaking at the opening of the New York World's Fair, to thousands of viewers scattered over the metropolitan area of New York City.

The historic broadcast was made by the system developed by the Radio Corporation of America. The N.B.C. television programmes will continue for the present with bi-weekly programmes for home viewers in and about New York.

Thousands of New Yorkers, to whom television was little more than a name, gathered in the shops of New York radio dealers and outside the windows of Manhattan department stores to witness the ceremonies at the fair grounds, eight miles distant. They saw a panorama of the fair buildings, the parade as it passed the reviewing stand and the entrances of Mayor LaGuardia, raising his hat as he advanced to the President's box.

Television viewers caught their first glimpse of the President at 2.09 p.m., when his official car, carrying several members of his bodyguard on the running boards, swept into view. Two minutes later viewers within fifty miles of the N.B.C. transmitter in the Empire State tower got an excellent view of the Chief Executive as he stood at attention in his box during the playing of the national anthem. Speakers televised, other than the President, were Mr. Whalen, Mayor LaGuardia, Governor Herbert Lehman and Sir Louis Beale, British Commissioner General to the New York World's Fair, who spoke for all the foreign nations participating in the Fair.

Those who witnessed the inaugural

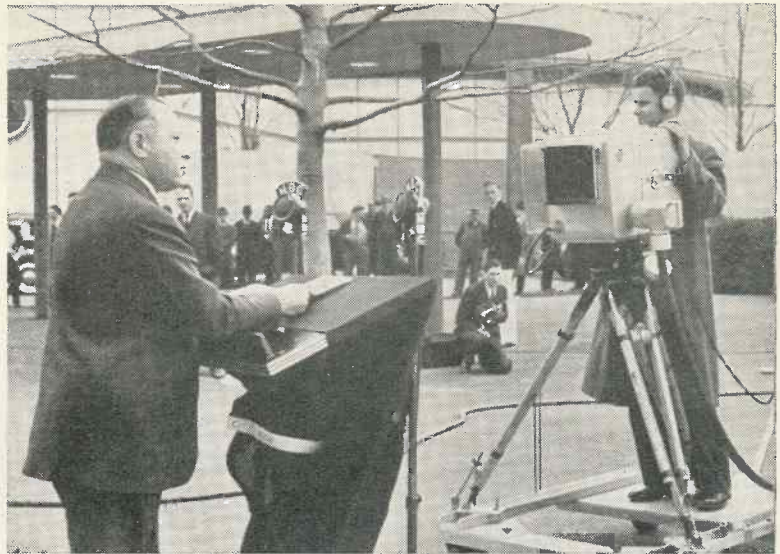

David Sarnoff, President of the Radio Corporation of America, was televised on April 20th as he delivered a speech dedicating the R.C.A. Exhibit Building at New York World's Fair. Reception was in the R.C.A. Building, Radio City, eight miles from the actual scene of events.

telecast on home receivers commented on the clarity and steadiness of the image.

Press Enthusiastic

"Amazement and then unbounded enthusiasm," reported the *New York Herald Tribune*, "marked the start of what will be a semi-weekly feature from now on. Many to whom television had been only a name admitted afterward that the demonstration exceeded anything they had thought possible. At receivers all over the city and in New Jersey representations of the Fair grounds, the images of the President and of other dignitaries at the exercises were witnessed almost as clearly as they could have been seen on the spot.

The *New York Times* said: "Reports from receiving outposts scattered throughout a fifty-mile radius of New York indicated that the spectacle by television was highly successful and that a new industry had been launched into the World of Tomorrow."

Seen 45 Miles Away

O. B. Hanson, N.B.C. vice-president and chief engineer, who looked in at his home in Westport, Connecticut, more than 45 miles from the transmitter of Station W2XBS, said the broadcast far exceeded his expectations.

Other viewers in Westchester

County and on Long Island reported "excellent images."

The first programme was televised by the N.B.C. mobile unit. The camera location was some 50 feet in front of the President's box and images were sent over coaxial cable from that point to the control van and the ultra-short wave transmitter stationed at one wing of the Federal Government Building. The transmitter van relayed the pictures on a frequency of 177 megacycles. A relay receiver at the Empire State tower, eight miles from the grounds at Flushing, Long Island, picked up the picture signals which were then put on Station W2XBS's broadcasting channel of 45.25 megacycles. Sound was broadcast on a frequency of 49.75 megacycles.

Long Preparation

The first programme marked the climax of seven months of the most intense preparation. The N.B.C. station, after several series of test transmissions last year, went off the air in August. Since that time the engineering staff has almost completely rebuilt the transmitter and studio equipment. The programme also brought to a close the strictly experimental test period that began in June, 1936. The N.B.C.-R.C.A. field tests, which have included experiment in research in both programme and engineering phases of television, have cost more than \$2,000,000.

Scannings and Reflections



TELEVISION AND AMATEUR PHOTOGRAPHERS

A TELEVISION engineer who also makes photography a major hobby, is planning to give every aid to amateur photographers in the General Electric Company's television studio at the World's Fair, New York. Visitors will be invited to take part in television programmes, and a stand will be set up with an exposure chart to show the photographer how best to picture his friend's image on the television screen and inside the television studio.

WIRELESS LICENCES

The Post Office issued 536,427 wireless receiving licences during April, 1939. This figure represents a nett decrease of 5,259 in the number of licence holders during the month after making allowance for expired licences and renewals.

The approximate total number of licences in force at the end of April, 1939, was 8,962,850 as compared with 8,604,400 at the end of April, 1938, an increase during the year of 358,450.

TELEVISION DEPUTATION TO P.M.G.

The Postmaster-General, Major Tryon, received a deputation on May 9 from the Radio Manufacturers' Association urging that television should be extended immediately to the provinces.

The deputation was headed by Mr. J. H. Thomas, of Cossor, Ltd., chairman of the Association. He was supported by Mr. C. O. Stanley, of Pye, Ltd.; Mr. J. H. Williams, of Marconiphone Co., Ltd., and Mr. M. M. Macqueen, of G.E.C., Ltd.

The deputation pointed out that as the Government had decided that the present transmission system was satisfactory, and as recent development in the London area had been rapid, a provincial station should be opened as soon as possible or Britain would lose her initial advantage in television.

The Post Office has undertaken certain experiments with radio links

between London and Birmingham to provide a means of relaying London programmes from Birmingham, and it is understood that these are now completed.

Major Tryon gave the manufacturers a sympathetic hearing and discussed the matter with them for an hour. He told them he was awaiting a report from the Television Advisory Committee on the subject.

According to well-informed sources the Television Advisory Committee is likely to recommend the Government to consent to make a grant of the necessary funds.

This grant would be made out of B.B.C. licence revenue, which is at present retained by the Exchequer. £100,000 is the figure mentioned.

SPECIAL LENS FOR DERBY BROADCAST

A special lens believed to be the largest of its type was specially made for the Derby broadcast. The lens was made at the works of Messrs. Taylor, Taylor and Hobson, Leicester. It is a 12½ in. diameter with an aperture of f1.5 and weighs 70 lb. In all there are seven glasses.

The order was executed within five weeks. It underwent thorough tests in the works laboratory and was passed as "perfect" before despatch.

B.B.C. SOUND STAFF FOR A.P.

In order to acquaint producers of sound programmes with the technique of television production, it has been decided that from time to time sound staff from Broadcasting House will be seconded to the Television Department at Alexandra Palace. Mr. Val Gielgud, Director of Features and Drama, will be temporarily transferred for six months, as from July 1 next, to the Television service. During this time Mr. Gielgud will act as a television producer, so obtaining practical studio experience.

Ensure obtaining "Television and Short-wave World" regularly by placing an order with your newsagent.

It is hoped that Mr. Gielgud will be only the first to have the opportunity of studying television production under working conditions.

DU MONT TELEVISION LICENCES

The Allen B. DuMont Labs., Inc., of Passaic, N.J., have just filed applications for additional television transmitting licences. One application covers a portable mobile transmitter to be carried on a motor truck, for picking up outside events and flashing them via ultra short wave back to the main transmitter for retransmission. Another application covers a 1 kW transmitter to be installed at the New York quarters of the DuMont organisation, on the top floor of 515 Madison Avenue. This proposed television station is for the purpose of studying programme problems and possibilities under actual working conditions. A third application covers a similar television station to be installed in the National Press Building, Washington, D.C.

"THE GREAT ADVENTURE"

Arnold Bennett's stage masterpiece, "The Great Adventure," is to be televised again on the afternoon of May 30, with D. A. Clarke Smith as Ilam Carve.

Based on Bennett's novel, "Buried Alive," this amusing comedy concerns the career of a great painter who shuns publicity. As the play opens, Shawn, his valet, is dying; Ilam Carve calls a specialist who, owing to a misunderstanding, thinks that the patient is the great Ilam Carve himself. The artist, seeing an opportunity to escape from himself, supports the illusion; the valet receives a Westminster Abbey burial and the real Carve retires into delightful anonymity for a time. But a vivacious widow, Jane Cannot (played by Marda Vanne) comes into his life. How Ilam Carve is discovered, despite his efforts to remain unknown, furnishes the material for a swift-moving comedy.

MARCONI'S AND TELEVISION

Speaking to shareholders at the annual meeting of Marconi's Wireless Telegraph Co., Ltd., on May 9,

MORE SCANNINGS

H. A. White, the chairman, dealing with the television activities of the company, said: "The development of television is still in its initial stages and will, without doubt, in the comparatively near future produce results far more striking than anything yet accomplished in this field. When the various applications of television already within sight are successfully achieved, not only in entertainment but for many other purposes, it may well prove to be comparable with the invention of the printing press in the influence which it exercises on mankind.

"No other country had, up to the end of last year, taken television beyond the limits of experimental emissions, so that England has led the world in the first practical application of television to purposes of entertainment and instruction.

"There are immense opportunities for research, including, for instance, the investigation of the lowest band of ultra-short waves from 1 to 3 metres, and of micro waves measured in centimetres and perhaps ultimately in millimetres.

BOXING AND TELEVISION

The whole question of televising boxing matches is to be discussed at the annual general meeting of the British Boxing Board of Control, which is to be held at Cardiff on Saturday, June 10, instead of May 13, as originally arranged. The chairman of the board, Colonel R. R. Myddleton, is to give full particulars of the stewards' opinion and it is expected that a decision will be made on the Board's future policy.

STUDIO EXPLOSION TELEVISED

An explosion startled viewers who were watching Mr. R. B. Bennett, former Prime Minister of Canada, in the "Speaking Personally" item in the television programme on May 9.

Mr. Bennett was seen to put his hand to his face as if to ward off a flying missile. He murmured, "Shall I go on?" and the broadcast continued.

The origin of the explosion was a studio lamp which exploded. It was near the microphone, so the explosion sounded worse to viewers than was the case.

DR. PETER C. GOLDMARK, C.B.S., CHIEF TELEVISION ENGINEER

Dr. Peter Carl Goldmark, Columbia's chief television engineer, who

is responsible for C.B.S. television activities and installation of the television station on top of the Chrysler building, was born in Budapest, Hungary, December 2, 1906.

He received his education at the University of Berlin and University of Vienna, graduating from the latter in 1931 with a B.Sc. and Ph.D. in physics. The same year he went to work for Pye Radio, Ltd., in Cambridge, England, taking charge of the concern's television activities until 1933. He then worked for several years as a consulting engineer and in 1936 joined C.B.S. to direct research on television developments. Two years later he became Columbia's chief television engineer.

SHORT - WAVE BROADCASTING FROM TRAINS

From short-wave radio equipment installed in a special studio built in one of the cars on the Union Pacific exhibition train, programmes were relayed last month for rebroadcasting by 16 major long-wave stations in cities of the United States from the Pacific to the Atlantic coast as the train travelled along on its trans-continental tour from Los Angeles to Kansas City.

This is believed to be the most extensive series of broadcasts ever attempted from a moving train. The equipment, installed by General Electric engineers, consists of a 50-watt transmitter, operating on a wavelength of 2,012 kilocycles, about 50 metres.

A 200-foot aerial was strung along the roof of three cars, projecting two feet above the roof. The signal was heard with sufficient strength for rebroadcasting for distances of 15 to 20 miles and this made it possible to originate programmes when the train was a half hour from the cities.

OPENING OF R.C.A. BUILDING AT WORLD'S FAIR TELEVISED

A preview programme of the beginning of American television broadcasting was given on the afternoon of Thursday, April 20, when the National Broadcasting Company telecast across the metropolitan area of New York, dedication ceremonies of the R.C.A. Building at the New York World's Fair of 1939.

The television images showed remarkable improvement in brilliance and detail since the N.B.C. transmitter was last on the air several months ago.

The preview programme marked the first time that pictures relayed by the N.B.C. mobile unit were rebroadcast from the transmitter on top of the Empire State Building.

Reception of the television broadcast was witnessed on the 62nd floor of the R.C.A. Building, Radio City, by reporters and invited guests. They saw and heard the dedication ceremony by David Sarnoff, president of the Radio Corporation of America.

At the conclusion of the ceremonies at the World's Fair, the audience was shown a televised boxing match, staged in the N.B.C. studios at Radio City.

RESIGNATION OF SIR LOUIS STERLING

Sir Louis Sterling, managing director of Electric and Musical Industries Ltd., has asked to be released from his duties as managing director. It is understood that Sir Louis has resigned owing to a divergence of view on a matter of internal policy. He has been prominently associated with the practical development of the Marconi and E.M.I. Television system, jointly owned by Electric and Musical Industries and Marconi's Wireless Telegraph Co.

OUTSIDE BROADCASTS IN JUNE

Both the B.B.C.'s mobile television units will be busy in June. On June 3 cameras installed in Hyde Park will show the whole of a fire-fighting and A.R.P. display organised by the London Fire Brigade and the London Auxiliary Fire Service. The Duke and Duchess of Kent will be present to inspect the four hundred men of the London Fire Brigade who can be spared from their stations. The London Fire Brigade is providing 150 vehicles, including fire engines, trailer pumps and lorries with A.R.P. appliances. The finale will be the burning of a 150-foot tower.

Trooping the Colour will be televised direct from the Horse Guards Parade on June 8, and on the same day the B.B.C.'s second mobile television unit will begin the first of three daily transmissions from Richmond Horse Show in the Old Deer Park with commentaries by Major Faudel-Phillips and Frederick Grisewood. On June 8 the main event will be coaching, June 9 will feature the Children's Jumping Contests, and on June 10 viewers will see the "Bending" competition for polo ponies. In

these the ponies have to zig-zag between closely-spaced posts, demonstrating their ability to "turn on a sixpence."

Another visit to Bull's Cross Farm is scheduled for June 14, and "Tuesday Night at the Coliseum" for June 20.

The Test Match at Lord's between West Indies and England will be televised on each of the three days, June 24, 26, and 27. Improved camera positions should give better pictures than last year, when the England-Australia match was televised. In addition to two cameras on the roof of the "Tavern," another camera alongside the commentators in the Pavilion will give close-up shots of the players.

F.C.C. TO REPORT ON TELEVISION

The U.S.A. Federal Communications Commission's television committee is expected to make its report on television within the next few days. One section believes television should be according to the standards of the RMA, while the other holds that new standards are needed.

"BEHIND THE SCHEMES"

The funny side of newspaper life will be presented in the afternoon of May 31. "Behind the Schemes" is a play about stunts and schemes to raise the circulations of rival newspapers, and the author—George H. Grimaldi—is himself a newspaper man with a Fleet Street experience of more than twenty years. The large cast also includes Laidman Browne, George Thirlwell, Hubert Woodward, and Cameron Hall, all of whom played in the first production of the play at the Richmond Theatre last year.

TELEVISION AN OPERATION

The television installation arranged by American Television Corp. at Israel Zion Hospital (Brooklyn, N. Y.) as reported last month, employed water filters to remove excess heat. Sight and sound monitor facilities in one corner of the operating room were supervised by a technician. The surgeon gave a running commentary and occasionally checked on a monitor C.R. receiving tube to see whether portions of the surgical technique were being properly picked up by the overhead pick-up tube.

MULTIPLE SCANNING SYSTEM

Radio-Amateur, of Germany, reports a new development which makes use of simultaneous transmission of a number of picture elements, giving a variation of time element in transmitting signals over the same carrier.

The pick-up tube uses five individual electron beams from as many cathodes, and each beam is caused to scan a certain area of the mosaic. The receiving tube operates in a similar manner.

TELEVISION AT RADIOLYMPIA

Television will again be an important feature of Radiolympia which this year will be open from August 23 to September 2. The R.M.A. exhibit will be a "Television Corridor" in which a number of receivers will be demonstrated. Receivers will also be in operation on individual stands though a proviso is made that these only be visible from the inside of the stands and thus avoid any obstruction of the gangways.

FOREIGN ARTISTS IN TELEVISION

The Variety Artists' Federation is concerned regarding the number of foreign artists who take part in B.B.C. television programmes. The Federation is negotiating with the

music-hall and theatre managements for a quota agreement and efforts are being made to bring the B.B.C. into this. The B.B.C., however, claims that in the television programmes four British artists to every one foreigner are employed.

CINEMA TELEVISION

The Postmaster-General received a deputation of representatives of cinema interests on May 18 to discuss the effect of the development of television on the cinema industry. The deputation included representatives of the Cinematograph Exhibitors' Association (Messrs. Hinge, Mears, Gale, Bell, Bromhead, Metcalfe, Bernstein and Fuller) and the Kinematograph Renters' Society (Messrs. Griffiths, Ditcham, Baker, Eckman, Hanbury, Dawes and Hill). At the conclusion of the discussion the deputation undertook to submit a written statement of their considered views on the subject.

The Postmaster-General promised to give full consideration to this statement, and to bring it to the notice of the Television Advisory Committee.

TELEVISION DIRECTOR RETURNING

Gerald Cock, chief of B.B.C. television is returning from America on the *Aquitania*, and it is reported that he is bringing with him a plan which will enable the B.B.C. and American Film Industries to co-operate in the matter of films for television.

40-METRE AMATEUR BANDS

With regard to the information published in our last issue under this heading, the B.B.C. inform us that certain corrections should be made to this statement. At the Cairo conference certain frequencies in this band were allocated for broadcasting and two frequencies have been chosen for use by Empire stations.

These will be GSU on 7.26 megacycles and GSW on 7.23 megacycles. In accordance with the Cairo regulations these stations will not be put into service before September 1 next and there is a restriction in their use that they should not be used for service to the Americas. They may be used for B.B.C. service to Europe, Australia and India.

The maximum carrier power permitted is 50 kilowatts so that the input power will be very much greater than 100 kilowatts.

Record for Our Long-distance Receiver

"It might be of interest to you to know that we have been receiving television programmes here since April 28. The reception has been extraordinarily good, except for occasional car interference. We might mention as being particularly good the outside broadcast of "Me and My Girl," from the Victoria Palace, on May 1. This was held for practically the entire performance.

"Since then, we have been receiving programmes every day except for yesterday morning (May 5).

"The circuit being used is the 'Long-distance Low-Cost Telesior,' 1937, by Spencer West, using 4 in. tube, with extra H.F. stage (Mullard E.F.8) added."

W. F. STEEL, Minehead.

THE MEISSNER TELEVISION KIT

AN AMERICAN PRODUCTION FOR HOME ASSEMBLY

WE have received from Messrs. Anglo-American Radio, Ltd., of Albion House, New Oxford Street, particulars of the Meissner Television Kit, Model 10-1153.

This is the first of its kind to be put on the market, and is, naturally, intended for use on the American television system. However, with one or two alterations it can be made to serve for the British system, and the design is such that it will form a useful set for the experimenter in television.

The following is the specification:

Video and sound channels combined in one compact and efficient receiver unit. 5-in cathode-ray tube to provide 3 in. by 4 in. pictures. Designed for standard 441 line scanning system. Controls include: volume (with on-off switch) focusing, background, contrast, channel selector, horizontal sweep frequency, vertical sweep frequency and centering.

A wide-band picture I.F. channel is

Fig. 1. This photograph shows the kit completely assembled.

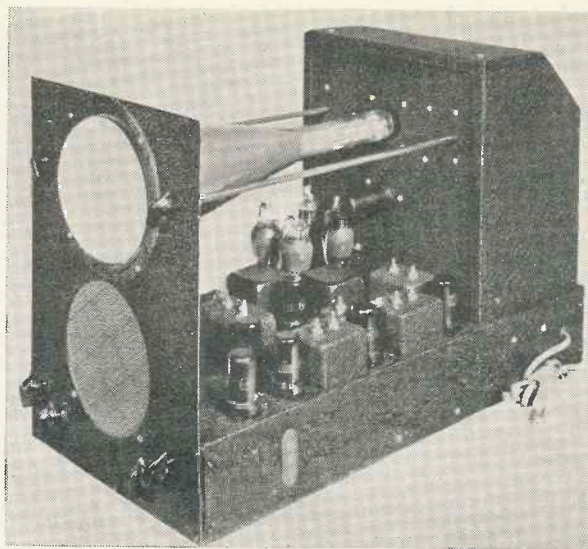

closed, and two safety switches affording extraordinary protection against accidental shock to the operator.

The dimensions are 10 $\frac{3}{4}$ in. wide by 14 $\frac{1}{4}$ in. high, and 22 in. deep.

Conversion to British Standard

In converting the circuit for use on the British system, it must be remembered that the polarity of the transmission is reversed. Accordingly, to obtain a positive picture the connections of the diode detector must be

the American system. There are no radical alterations to the scanning circuit, but the speed of scan must be reduced from 441 lines and 60 $\frac{1}{2}$ -frames to 405 and 50 $\frac{1}{2}$ -frames per second. (Note that in America, the "frame" corresponds to our "picture".) This can be done by varying the time constants of the multi-vibrator circuit slightly.

Fig. 1 shows the complete chassis assembly, and Fig. 2 the underside of the chassis. Further particulars can be obtained from the agents.

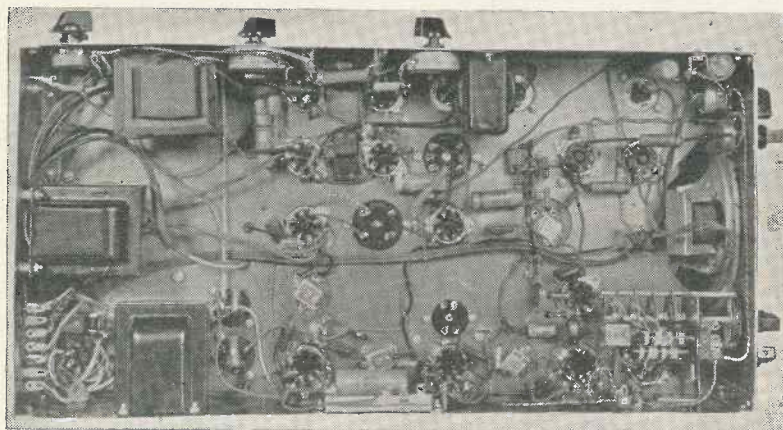

Fig. 2. An underside view of the chassis.

provided using permeability-tuned iron-core coils, thus providing excellent stability and maximum gain. The video I.F. channel permits easy adjustment with test-oscillator and output-meter for any desired combination of band-width, degree of over-coupling and sensitivity.

The high-level synchronising chain includes pre-set coils requiring no adjustments by the operator. High voltage leads and components are completely protected by suitable en-

reversed. It is usual practice in this country to directly connect the video amplifier to the diode output, and to do this the condenser coupling the diode to the 6F6 grid may be omitted, together with the leak. It will also be necessary to connect a D.C. restoring diode across the grid resistance of the tube.

The synchronising circuit will need careful re-adjustment as the amplitude of the British synchronising pulses is low compared with those of

BOOK REVIEW

PRINCIPLES AND PRACTICE OF RADIO SERVICING, H. J. Hicks, M.C. (McGraw-Hill Publishing Co., Ltd., 18s.). Radio servicing is no longer limited to the repair of simple broadcast receivers by local radio stores. Modern sets of the multi-valve type and numerous tuned circuits require complicated apparatus and also a definite system in order that the fault may be located in the minimum amount of time so that the servicing is a money-making proposition.

In America this work has been carried on consistently for many years and a service engineer has generally to pass a considerable number of examinations before he is a fully qualified man.

There are numerous books on the theory and practice of modern servicing, but few are so concise as the latest book by H. J. Hicks, M.S., the Radio Instructor of the Hadley Vocational School, St. Lewis. This book consists of 305 pages and includes not only the fundamentals of electricity and radio, but also complete chapters on valves, test equipment and set analysers, the theory of R.F. amplifiers and A.F. amplifiers and several chapters devoted to the correct methods of servicing radio receivers.

It is a book which every service engineer in this country will find of value.

POINTS FOR PROSPECTIVE VIEWERS

A BRIEF REVIEW OF TELEVISION FACTS

Although the average person is now reasonably well informed on radio matters, television with the majority of people still remains a mystery. To own and operate a television receiver does not require any technical knowledge whatever, but there are many questions which are continually being asked by those who have begun to take some interest in the subject and which probably the following notes will be useful in clearing up.

Obsolescence.—One of the greatest obsessions that the layman has is with regard to television receivers quickly becoming obsolete. Considering the rapid strides made in the early days of broadcasting this is perhaps natural. Television, as we know it to-day, has burst upon the public who almost a matter of months ago had only heard of it as a "will o' the wisp" of science which a few inventors hoped to achieve. Actually, however, there has been intensive development for the last ten years and millions of pounds have been spent on securing the results which are now possible.

Another point is that for the most part it utilises well tried radio principles which have in the last fifteen years become practically standardised and even at this comparatively early date it appears that television principles have become more or less standard.

Improvements will be made, but there is not the slightest indication that they will be other than gradual as has been the case with all other scientific developments. There is, therefore, not any prospect of modern receivers becoming obsolete, or even old fashioned, before the end of their useful life.

Bound up with this question of obsolescence there is that of useful life. Will a receiver last 2, 3, or 5 years? No receivers have been in use for much over two years so it is a point on which it is impossible to be dogmatic. A very conservative estimate of the life of a radio receiver is three years, and this with probably an average of 5 hours use per day. There is no reason why a television receiver should not function for the same total number of hours, particularly as the materials and components used are, generally speaking, of superior quality. There is, therefore, no reason why it should not function satisfactorily for five or six years. There is, however, one proviso to make and this is the probable life of the cathode-ray tube which is generally placed at 1,000 hours before it shows signs of real deterioration. This item, of course, is easily renewable.

Receiver Cost.—Price is a factor which is preventing numbers of people buying receivers and there is a general hope, and indeed, expectation that prices will be considerably reduced when the demand is greater. This would appear to be a natural sequence but it is very improbable that it will obtain for a very considerable time and the reasons are as follows: In the first place receivers at present are not being produced at an economic figure, and it is unlikely that any saving that could be effected would be passed on to the public.

Secondly, it must be remembered that a television receiver is the equivalent of three high-class broadcast sets plus the cathode-ray tube. A little calculation therefore will show that the television receiver is good value for money. Also a large proportion of the components used must of necessity be of better quality than normally used for ordinary radio receivers, which are mass produced in

the ordinary way of component manufacture and it is improbable, therefore, that any saving would be effected in this respect, as mass production will only affect certain parts of the receiver and general assembly; thus the saving is not likely to be very considerable. Altogether, therefore, any large price reduction would appear out of the question.

Picture Size.—A picture size of approximately 10 in. by 8 in. may appear to be somewhat small, but experience has shown that actually for home use this is quite adequate. Although larger screens are available, this size is the most popular choice as it provides sufficient detail and good picture value when viewed at the convenient distance that obtains in the average home. With screens that are considerably larger it is necessary to increase the viewing distance otherwise the line structure of the picture becomes evident with loss of apparent detail.

Viewing Conditions.—Pictures can be viewed in ordinary daylight but obviously they are better in subdued light or darkness, as is the case with the cinema. However, for daytime viewing the pictures are of such brightness that it is not necessary entirely to darken the room. The ordinary curtaining arrangements which are usually available are quite sufficient and, therefore, any elaborate preparation is not necessary.

Power Supply.—A supply of mains current is essential for the operation of a television receiver, and it should preferably be A.C. Direct current can be used, but this entails the use of a rotary convertor to convert the D.C. current into A.C. This method is entirely satisfactory, but the necessary equipment adds to the total cost. The use of batteries is quite impracticable and no receivers are made which will operate from batteries.

The Aerial.—A special aerial must be used for television unless reception is within about six miles from the transmitter, when any odd bit of wire will usually answer.

The aerial, termed a di-pole, is quite simple and can be used indoors or out of doors, but it must be used in

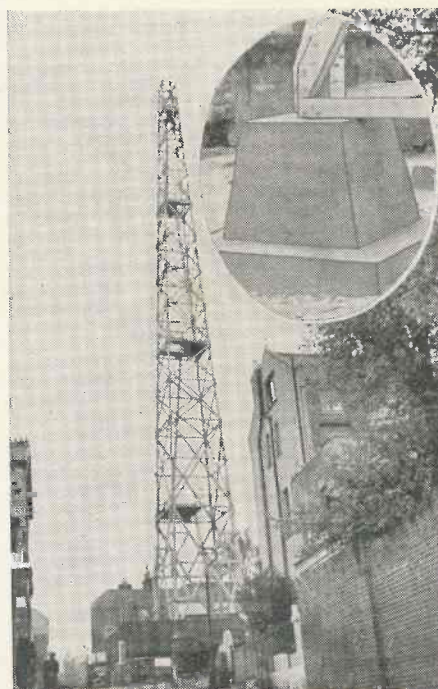

The ultra-short-wave radio link relay aerial at Swains Lane. Transmissions from the mobile unit are picked up on this for retransmission from A.P. Inset is a mast leg base.

a vertical position, and, as its height is about 11 ft., as a rule it is not easily accommodated inside a house. The best position is on a chimney stack, but it should be as far removed from motor traffic as possible on account of interference. At distances of over 12 miles it is advisable to use a reflector in conjunction with the aerial proper. This consists of a single metal tube or rod placed behind the aerial at a distance of 5 ft. 4 in. As a rule the entire assembly forms one unit and is quite easy to erect. The distance from the aerial to the receiver is quite immaterial within reasonable limits and the feeder, which must be of a special type, can be led in any convenient manner as, for example, down walls or along fences, etc.

Maintenance Costs.—The average television receiver employs from eighteen to thirty valves and it will be evident, therefore, that running costs exceed those of an ordinary broadcast receiver. An all-round power consumption figure is approximately 200 watts which means that the receiver can be run about five hours on one unit of electricity. This is about the same consumption as a bowl-type electric heater. Excluding replacement costs in case of valve breakage, etc., this is the only maintenance charge. No additional licence to the ordinary broadcast licence is required.

Reception Range.—The distance at which reception is ordinarily possible may be regarded as about 35 miles, but to some extent it depends upon local conditions. This distance can be exceeded if special arrangements are made as, for instance, the use of a high and efficient aerial and a sensitive receiver and under these conditions consistent reception has been obtained at distances rather over 100 miles, though this is by no means the limit when conditions are good.

Provincial Television.—Although no official announcement has as yet been made it appears practically certain that work will shortly be commenced upon the erection of a transmitter in the Birmingham area which would relay the Alexandra Palace programmes. Experiments have been made with two methods of relay—the ultra short-wave radio link and the coaxial cable. It is probable that the former method will be used.

Safety.—Although high voltages are used in television receivers—from 4,000 to 6,000—adequate precautions are taken by the manufacturers to

eliminate any possibility of shock. No source of high-tension supply is accessible and if the back of the receiver is removed all current supplies are automatically cut off. Any television receiver is, therefore, perfectly safe in use.

Operation.—A large number of controls are provided on a television receiver, but as a rule only four at the most are easily accessible; the remainder are the pre-set type only intended to be used when valve replacement becomes necessary.

Ordinarily, two or three controls are all that need be touched and as the effect of these is immediately noticeable on the picture, their use is very simple, in fact the control of a television receiver is more simple than a broadcast set.

Film Television.—Why is not more general use made of film in television? The chief reason is that at present the film industry is not prepared to allow films to be generally used for television and, therefore, recourse has had to be made to certain foreign and feature films. Secondly, many films are unsuitable because of the amount of detail which would be lost in the comparatively small picture of the television screen.

Colour Television.—The question of colour television is a matter which is

often raised despite the fact that even at this date the majority of films are in monochrome. Colour television is theoretically possible but in practice there are difficulties of a technical nature which at present appear to be almost insuperable, the major one being the very high frequencies that it would be necessary to use. It is improbable, therefore, that there will be any development in this direction except of an experimental character for a very long time to come.

Add-on Receivers.—There is a type of television receiver which is termed an add-on unit. This name is somewhat misleading as it seems to imply that a unit of this description can be added to an existing broadcast receiver to provide vision. Actually, receivers of this type are vision receivers only and do not provide the accompanying sound unless used in conjunction with a broadcast set. Most broadcast sets will not tune to the television sound wavelength and therefore a simple converter is provided which is included in the vision receiver cabinet and is considerably cheaper to construct than a complete sound receiver.

A saving of total cost is therefore effected, but usually this method is only adopted in the case of receivers with small screens in which even a small saving is desirable.

SEEING THE DERBY IN COMFORT

Amazing success of Baird Cinema installation

THIS year for the first time cinemas were permitted, by arrangement with the Epsom Grand Stand Association, to reproduce the B.B.C. Derby television transmission on large screens to a paying public.

Most cinemas, of course, at present are not in possession of the necessary apparatus but Baird Installations have been made at the New Victoria Cinema, The Marble Arch Pavilion, and the Tatler News Theatre in Shaftesbury Avenue.

At the first mention of cinema the screen size is 12 ft. by 15 ft. and is not noticeably smaller than the usual cinema screen. The actual apparatus used was described in the April and May issues of TELEVISION. There can be no question now that cinema television has definitely arrived, for the results obtained were but little inferior to what would ordinarily be presented by film. The picture is a

sepia colour and a little inferior in brightness, but considering the astonishing progress that has been made since last year it is not too much to expect that it will shortly practically be up to cinema standard and that cinemas will in their own interests be compelled to install equipment of this nature.

The audience at the Victoria Cinema was as enthusiastic at the conclusion of the transmission as it was at seeing the winner come in. Only once did the picture lose synchronism, and this for merely a couple of seconds. The remainder of the time it was perfectly steady. It was unfortunate that at the commencement of the race and during a period of the tracking shots the picture lost a certain amount of clarity and there was also a double image at one time, due apparently to some fault of the super emitter being used at that particular time.

WHAT VIEWERS WANT

FIRST RESULTS OF TELEVISION QUESTIONNAIRE

A PRELIMINARY analysis has now been made of the results of the Television Questionnaire. Over 4,000 viewers sent in completed forms, but to make possible a prompt review a sample of 1,200 has been made the basis of a first report. It was found that 91 per cent. of the forms had come from those who owned television sets for entertainment only and not for business.

The results are encouraging, for they show that a large majority think that the programmes provided are satisfactory and improving. Moreover, the comparative popularity of different types of programme shows that the present proportions are well in line with viewers' preference.

Plays and variety programmes direct from theatres, news reels, "Picture Page," the weekly topical magazine, the light entertainment generally are all liked by at least 90 per cent. of viewers. Outside broadcasts of sporting and other events come next, followed by full-length plays, cartoon films, demonstrations and talks.

The popularity of studio drama is a remarkable feature of television today, and the preference is for full-length rather than for short plays. Asked whether an hour and a half was too long for a television play, over 80 per cent. replied "No"; but most of them liked the practice which has lately been introduced of including occasional intervals in such plays.

Programme Time

More than half the answers affirmed that the present length of the evening programme (1½ to 2 hours) was sufficient, although they would like it to begin earlier.

Asked about men or women announcers, 44 per cent. had no marked preference; the rest showed an overwhelming preference for women. At present two women and no men are employed as announcers at Alexandra Palace.

The new and difficult job of giving television commentaries without saying too much or too little seems to have been satisfactorily tackled, judging by viewers' votes, 85 per cent. of which agree that as a rule commentators strike the happy mean.

It appears that the average number of people who watch television fairly regularly on each set is four.

A further analysis will be made in due course.

The response from viewers has been remarkable. Many of those who completed and returned forms wrote enthusiastic letters showing a keen sympathy with production problems as well as enthusiasm as viewers. It is not thought likely that any further questionnaire will be issued to viewers yet, but the B.B.C. wishes to keep the viewers' register up to date by adding the names of those new viewers who are prepared to cooperate in similar ways in the future.

Television Committee for British Kinematograph Society

DURING the past eight years the British Kinematograph Society has played an important part in solving the technical problems of the industry. At the request of the British Film Institute a committee was appointed to consider the long-period storage of film, and its recommendations form the basis upon which the National Film Library is organised. Other Committees have considered problems associated with safety film, sub-standard film and equipment, and other matters.

In matters of standardisation the Society works in close contact with the British Standards Institution and thus represents the British industry in international negotiations. Matters now under consideration include the measurement of brightness of the kinema screen, the assessing of light output of substandard projectors, and the compilation of a technical glossary.

In order that these technical activities may receive more detailed attention, the Executive Committee has now entrusted the organisation and functioning of such technical committees to a newly-formed Central Technical Committee. This Committee represents the more important technical branches of the industry.

At the request of the Cinematograph Exhibitors' Association, a committee was appointed to consider the

present position of kinema television, representatives of the leading manufacturers and of the Television Society were invited to serve.

The members of this committee are as follows:—

Mr. T. M. C. Lance, Baird Television, Ltd.

Mr. J. Siegar, Scopphony, Ltd.

Mr. D. C. Espley, The General Electric Co., Ltd.

Mr. G. S. C. Lucas, British Thomson-Houston Co., Ltd.

Mr. G. Parr, Television Society.

The organisation is at the service of the film industry, and especially of the Patron members of the Society, for the investigation of any technical matters. Any organisation encountering a technical problem is invited to submit it for the consideration of the Central Committee. All enquiries should be addressed in the first place to the Organising Secretary, Dean House, 2 Dean Street, W.1.

Television Lectures

A special course of four lectures on Television is to be given at the Polytechnic, Regent Street, on Thursdays, from 7.30 p.m. to 9.0 p.m., commencing on June 8th next.

These lectures are to be delivered by Mr. H. J. Barton-Chapple who is a recognised authority on the subject of television and demonstrations of high definition television will be given, including the reception of the B.B.C. Television Service at each lecture. The fee for the course is 6s.

We have been informed by Westinghouse Brake and Signal Co., Ltd., of 82 York Way, King's Cross, London, N.1, that their Northern representative for metal rectifiers, Mr. W. E. Wilkins, B.Sc., A.M.I.E.E., has changed his address to: Agden Lane Farm, Agden, Lymm, Warrington. Telephone: Lymm 516.

Marconi Valve—KT44

A new Marconi valve for television scanning circuits has recently been generally released. Its general characteristics are similar to the KT66, but a 4-volt 2-amp. heater is used. A 7-pin base is fitted and the anode is taken to a top cap connection. A small number of these valves were issued in television receivers under the temporary type reference A855. The list price is 15s.

TELEVISION SOUND AT ALEXANDRA PALACE

THE MARCONI-E.M.I. AUDIO-FREQUENCY EQUIPMENT AT THE LONDON TELEVISION STATION

I. L. Turnbull, T.Sc.(Eng.), and H. A. M. Clark, B.Sc.(Eng.)

The following is an abstract of a paper read before The Institution of Electrical Engineers entitled "The Marconi-E.M.I. Audio-Frequency Equipment at the London Television Station." We acknowledge the kind permission of The Institution of Electrical Engineers to publish this paper.

IN view of the fact that no previous experience was available in connection with the operation of high-definition television equipment and also that a high order of performance was necessarily demanded of many of the components in the vision apparatus, it was obviously desirable that the sound equipment should be as reliable as possible so that, in case of a vision breakdown, contact might always be retained with those receiving the programme. This require-

The outputs of all the "A" amplifiers are brought up to jack panels on the sound control desk, which incorporates arrangements for fading and mixing eight channels. These eight sets of fade-and-balance controls are divided into two banks of four, the combined output of each bank being controlled in turn by a main fader potentiometer.

The output from each of these main controls is then fed, via a special combining circuit, into two main am-

plifiers and the other to feed the loud-speaker amplifier controls. The division is accomplished in such a manner that any load may be thrown on one channel without affecting the power transferred to the other in any way. Six loud-speaker amplifiers are provided which may be jumpered to the output distributor in such a manner that they may be fed from either or both main amplifiers at will.

Suitable metering arrangements are provided at the control position so that the programme level may be monitored by the operator. As an indication that the quality of the signals being radiated is satisfactory, a check receiver, fed from the sound aerial feeder, is supplied. The output from the check receiver is divided between two circuits, one of which provides an alternative supply to the control operator's headphones in place of that from the monitor panel, and the other of which is arranged to give the correct level to feed into the loud-speaker amplifiers.

It will be noticed that by throwing a 3-position key on the control desk, the operator may listen to outputs from (a) the monitor panel, (b) the check receiver, or (c) the fader check or "pre-hear" stud. The latter position enables the operator to listen to the output of any channel before he fades it into a programme channel.

In order that the producer may give instructions to the camera operators, suitable microphones and a talk-back amplifier are supplied.

Electrical testing equipment, consisting of an oscillator and gain set, is also provided, so that routine maintenance checks of amplifier gains and levels can readily be made. Testing circuits are shown dotted in Fig. 1.

Operation

The equipment may be used in any one of five ways, depending on the type of programme which it is desired to transmit.

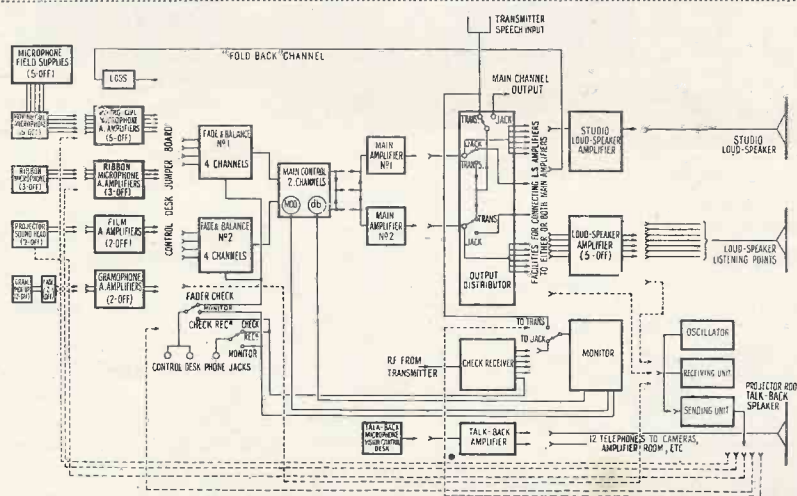

Fig. 1. Block diagram of complete system.

ment had considerable bearing on the design of the equipment.

General Arrangement

Fig. 1 gives a block schematic of the audio-frequency apparatus and shows the general arrangement of the equipment.

It will be seen that five moving-coil and three ribbon microphones, together with a similar number of associated "A" amplifiers, are provided. Two sound heads mounted on film projectors and two pick-ups associated with a gramophone desk, together with their "A" amplifiers, are also included.

plifiers which raise the signal to a level sufficiently high for it to be fed directly to the sub-sub-modulator in the transmitter. By means of the combining circuit it is possible to feed the output from either main control into either of the main amplifiers, or alternatively to feed the combined main control outputs into either or both main amplifiers.

The output from each main amplifier is fed into the output distributor, where again it is possible to select either or both outputs to be fed to the transmitter. In addition, the output distributor divides the output from each of the main amplifiers into two channels, one to feed the transmitter

Telegossip

A Causerie of Fact, Comment and Criticism

TELEVISION prospects to-day are rosier than ever before. Since last month, when I wrote about the hesitancy of the Advisory Committee and the leisurely course of Post Office experiments with the radio links to Birmingham, the situation has been transformed.

Despite the shrouds of official secrecy there can be little doubt that the Television Advisory Committee, under the chairmanship of Lord Cadman, has unanimously decided that television must be extended to the provinces with the least possible delay. A report on these lines is to be handed to the Government.

The Government may, of course, refuse the money. The committee is asking for an amount variously estimated between £100,000 and £350,000—this to come from licence revenue still diverted to the Exchequer. According to one theory the Government will decline further grants for such a frivolous purpose as television until the international situation is more settled.

Wiseacres say that the next crisis is due in September and that the Government will not budge before then. I do not believe this. On all previous occasions the Government has unhesitatingly accepted the advice of its advisory committee. The country's scientific and industrial progress cannot be held up by vague half-formed fears of the future.

Seldom has a campaign yielded such rapid results as that organised by the Radio Manufacturers' Association to press for a Birmingham station. But the most joyful surprise for the industry is yet to come, for I believe that the committee will recommend not one, but at least two, provincial stations.

The First Station

In these notes I have repeatedly urged that the first station should be built between Leeds and Manchester, and not, as generally suggested, at Birmingham. Certain members of the committee have been impressed by this argument. But if there is to be a radio or cable link with London, it must pass through the Midlands; therefore why not have a Birmingham station as well?

It is certain that if a Birmingham station alone were built the populous industrial districts of the North would immediately begin to agitate for

By *L. Marsland Gander*

another transmitter to serve them. The original plan of the committee was, of course, to have ten transmitters serving their chief areas of population. To build ten would, however, involve £1,000,000 of capital outlay and is out of the question at the moment.

I believe also that the committee will now decide that the moment is opportune for instituting a separate licence fee for television. They would be tempted to make it £1 per set, but ten shillings is a more likely figure.

Studios at A.P.

So far, so good. But what of the plans for better studio accommodation at Alexandra Palace? The old theatre is in precisely the same desolate condition as it was a year ago. I begin to think that the B.B.C. has given up all idea of developing further in London until the provincial scheme is under way.

I hear that when the King and Queen return to London on June 18 the B.B.C. will again televise pictures from whatever terminus they arrive at. Incidentally, those from Waterloo on the departure of their Majesties were the best the B.B.C. have ever transmitted from an outside event. Never have the general public had such an opportunity of seeing intimate, living portraits of the Royal Family.

Another Big Screen?

I am writing in advance of the Derby transmission but I learn that E.M.I. are to disclose big screen television apparatus which yields most impressive results.

The boys of the outside broadcasting department will be exceptionally busy this summer, apart from the unusually large number of open-air broadcasts of all kinds.

I met Mr. Gilbert Seldes, the Columbia television chief, the other day shortly before he returned to America with Mr. D. H. Munro, of the B.B.C. In Britain we have become so accustomed to looking to America for a lead in radio that even now it is hard to realise that in television the position is reversed to Cousin Sam. Mr. Seldes frankly admitted that practically everything he saw was new and educational to him. Columbia is starting off with

only one studio and half as many camera channels as the B.B.C. True the Columbia studio is very much larger than either of the boxes at Alexandra Palace, but there the advantage ends. Lack of technical facilities will make it impossible for Columbia to do any but the simplest programmes at first.

Mr. Munro took with him to America film records of B.B.C. television productions transmitted in the earlier days, when changes from one camera to another were still a haphazard affair, when long erratic tracking shots were the vogue, and when to use five different cameras for a single show was unheard of complication.

I was interested, for two reasons, in the re-appointment of Miss Olga Edwardes, the 22-years-old actress, as deputy to Miss Jasmine Bligh for the period July 31 to September. In the first place it shows that the B.B.C. prefers brunettes; in the second, it means that men announcers are definitely superseded for television purposes. The three girls, Miss Bligh, Miss Elizabeth Cowell and Miss Edwardes, will all be on duty during the Radiolympia period. Personally, I should not be surprised to see Miss Edwardes a permanent addition to the staff.

The Theatrical Garden Party

The Theatrical Garden Party at Ranelagh this year is to be televised for the first time. Television cameras will roam the gardens and side-shows on the afternoon of June 6 to give viewers the impression that they are actually attending this colourful function, which is held each year in aid of theatrical charities. The transmission will begin with the opening ceremony by Noel Coward, President of the Actors' Orphanage, and Leslie Mitchell will take viewers on a visit to the Tyrolean Beer Garden for an excerpt from the Ivor Novello show, "The Dancing Years." As Frederick Grisewood accompanies the television cameras round the side-shows fortunes will be told, and famous stage and screen stars may be persuaded to talk to the viewing audience. At the balloon stall a balloon will be bought on behalf of viewers, inflated with gas, and sent on a journey which brings a prize to the owner whose balloon descends at the greatest distance from Ranelagh.

SOME OF THE FIRST AMERICAN RECEIVERS

FIVE television receiver models, ranging from a picture receiver with sound convertor to consoles combining television and all-wave radio, have been announced for spring production by the General Electric Co. (U.S.A.), Bridgeport, Conn. For more than a year, General Electric has been designing television receivers, testing them, and building them on a production line, but these receivers are the first which will be offered for sale to the public.

HM-171 (right) picture receiver and sound convertor, table model.

HM-185 (below) television receiver, console.

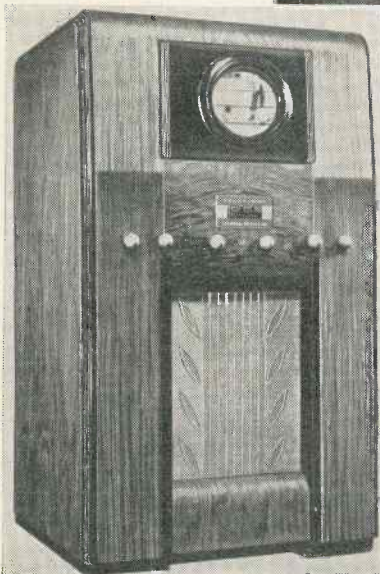

mately 18 in. deep. Controls are similar to those on the smaller set with the addition of volume and tone control.

Model HM-225 is a console-type television receiver for sight and sound employing 2 valves and a 9-in.

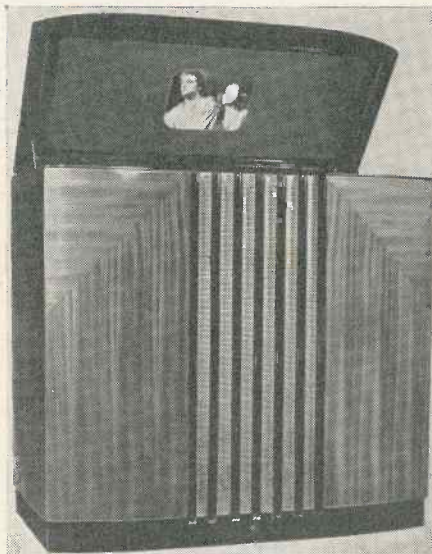

HM-275, television receiver and all-wave radio lowboy console.

tube. It has two chassis, video-sound and power, and high fidelity audio. This model is slightly larger than the HM-185.

The two remaining console models,



HM-226, television receiver, console.

the HM-226 and the HM-275, combine all-wave radio and television. The former employs 28 valves and the latter 29 valves, with a 12-in. tube. Each has a video-sound, power, and radio chassis. The approximate price range of the new television receivers is from \$250 to \$1,000.

RADIO MARKETING TRADE ANNUAL, 1939 edition. (Radio and Electrical Marketing, 5s.). All radio retailers and engineers interested in radio or television should make a point of obtaining a copy of this annual which gives all the data the average retailer is likely to require.

It consists of 192 pages of reference matter and is divided into three sections, commercial and legal, technical and directory. There are full details of radio associations and societies, an alphabetical directory of manufacturers and wholesalers, and voltage directory of the entire country, and a Who's Who of the radio industry.

A feature of this annual is a completely new servicing section occupying 22 pages, while there is also full information on automatic tuning and problems met in every-day receivers.

New Philips' Headquarters

Philips Lamps, Limited, have vacated their offices in Charing Cross Road and are now occupying an 8-storey building in Shaftesbury Avenue. From May 22 last the new address was Philips Lamps, Limited, Century House, Shaftesbury Avenue, London, W.C.2, and the phone number remains unchanged at Gerard 7777.

“TELEVISION SOUND AT ALEXANDRA PALACE” (Continued from page 344)

loss in one part of an amplifier by a corresponding gain in another part of the circuit has not been applied to any great extent. This has in turn involved what amounts to an extension of the frequency range, since the losses due to such factors as valve capacitance and the capacitance and inductance of transformers, have of necessity been made low enough to

to be obtained from ribbon microphones, etc.

The anode load of all first-stage valves is purposely kept low in order to reduce the effective input capacitance.

Intervalve coupling for balanced stages is by transformer. Particular care has been taken to prevent any sign of “in-phase” resonance of the

vision transmitters. Whilst a very small pick-up from the sound transmitter would not be important, the nature of the modulation of the vision transmitter, together with its greater power, made it necessary to take every precautionary measure against interference.

In audio-frequency amplifiers there are so many components between

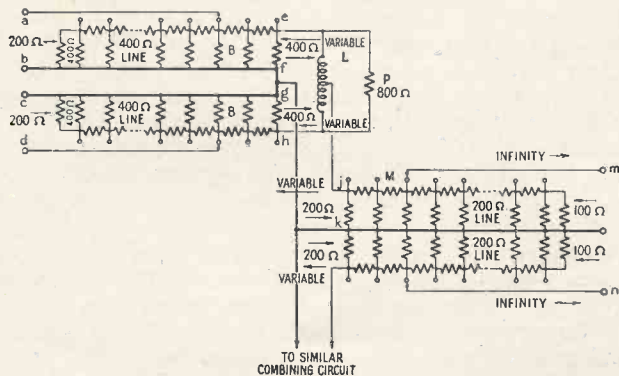
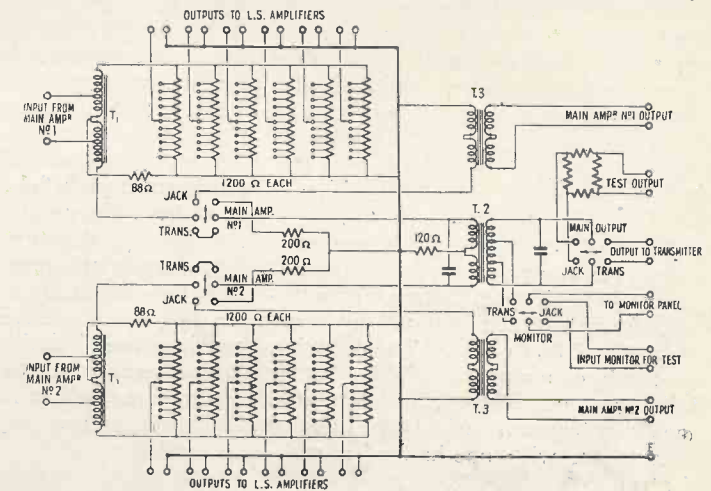

Fig. 7 (above.) Basic mixing circuit.
Fig. 8 (right.) Complete circuit of output distributor.



enable components to be changed without altering the frequency characteristic within the operating range.

As the circuits connecting the amplifiers are all of 200 ohms impedance, input and output transformers are used for all amplifiers. In the case of input transformers the secondaries are not loaded by shunt resistances. The step-up is not very great and the main inductance is made high, so that the effective input impedance to the amplifier as seen on the primary side is very high compared with 200 ohms throughout the working frequency range. A type of winding is used which enables the leakage inductance to be kept down to 1/3000 of the main inductance, with a secondary capacitance of about 30 $\mu\mu\text{F}$ when the primary is earthed. In this way the resonance of the leakage inductance and the secondary capacitance (including the input capacitance of the valve) is kept well above the working frequency range. This resonance is damped chiefly by the primary load, together with some additional series grid resistance where necessary. The substantially open-circuit input impedance which the amplifiers thus have is an important feature in the design of the control-desk circuits, and also enables the full open-circuit voltage

secondaries which would produce an unbalance of the valves at high frequencies.

Resistance coupling with fairly long time-constants is used between most single valve stages. In a few cases a very small low-frequency rise, generally not more than 0.2 db., is introduced in the anode first decoupling circuits to compensate for grid-circuit and other low-frequency losses.

R.F. Interference

Owing to the studios being in the same building as the ultra-short-

valves, such as potentiometers and switches, which require to be brought away from the chassis on leads, that it is not easy to screen completely such amplifiers. This being the case, the method employed is to screen and filter the radio-frequency (r.f.) currents thoroughly only from parts of the circuit in which modulation might occur, i.e., from the valves. In this way no attempt is made to prevent r.f. currents from flowing in the transformers, potentiometers, wiring, etc., but these currents are very carefully filtered out before the valve is reached.

Fading and Balancing Circuits

The control circuits perform two broad functions. One is the selection, level adjustment, and combining of the channels required, and the other is the adjustment of the complete programme level to a value suitable for modulating the transmitter. These two functions, referred to as “fade and balance” and “main control” respectively, take place on one control desk in this equipment.

The object of a fade-and-balance panel is to provide a fader which is used only as a fading switch,

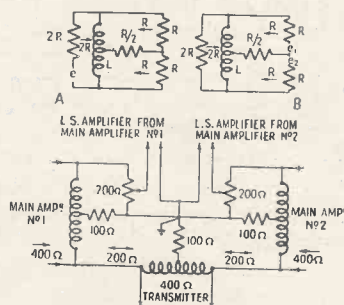

Fig. 9. Basic circuit of output distribution networks.

wave transmitters the audio-frequency amplifiers were liable to be situated in a very strong radio-frequency field from both sound and

fier, and a moving-coil meter circuit.

The meter indicating peak modulation consists of a full-wave diode peak voltmeter.

Check Radio Receiver

In order that the modulated r.f. output of the transmitter may be observed, a check receiver is provided. This consists of a diode rectifier fed through a tuned circuit directly from the transmitter output via an r.f. line coupled to the main feeder.

Loudspeaker Monitoring

The loudspeaker amplifiers are required to raise the level from the potentiometers of the output distributor or check receiver to loudspeaker level. The input transformer is of low ratio and is suitable for working from a widely varying impedance, such as is seen looking into the potentiometers, with no appreciable change in characteristic. A

low-gain first stage feeds a push-pull output stage of conventional design.

For the operation of a large loudspeaker in the studio, a similar amplifier is provided with an output stage consisting of 2 D.A.60 valves in push-pull. An audio-frequency output of 40 watts is available.

Talk-back System

In a television station the producer must be able to speak to any of the cameramen or to the film operators. This facility is provided by means of various microphones—located on the producer's desk and near the vision monitors, etc.—the output from which, after suitable amplification, supplies a distribution network. This comprises a number of keys for switching any required camera head-phone set on to the talk-back circuit. A further key closes all camera head-phone circuits simultaneously. In addition, the studio loud-speaker can be connected to the talk-back circuit to allow speaking to artists in the studio. Further, in the case of out-

door broadcasts a loud-speaker can be connected to the camera talk-back circuit, which is then fed at loud-speaker level.

Power Supply

The whole of the equipment is operated from a 50-cycle 240-volt single-phase supply, no batteries of any kind being employed. The use of large units capable of supplying a number of amplifiers has been preferred to the use of individual supply units, as being more efficient and facilitating simple stand-by arrangements.

After being in service for a period of 2 years, the equipment appears to have fulfilled the desiderata, somewhat uncertain at the outset, for a single-studio television station. All the facilities included have been of value at some time or other, whilst if there was any error in the original specification it appears to have been more in the nature of an under-estimation of the number of channels required, than the reverse.

BAIRD TELEVISION IN AMERICA

ABOUT four weeks ago Mr. Ian H. Cremieu-Javal, a director of Baird Television, Ltd., accompanied by technical experts, left for America to expedite plans for the "television invasion" of the United States.

Work is now in hand for the installation of big-screen television equipment in Broadway cinemas, and in addition standard Baird home receivers are being demonstrated in New York.

At the present moment work is proceeding with the big screen installation, and it is anticipated that this will be ready to demonstrate pictures radiated on the American standards within a very short period. In this connection it is interesting to refer to a cable by Mr. Javal from New York in the following terms—

"Interest in theatre television is increasing daily here. One of the major circuits is waiting on prices and information, and claims they will want soon a possible total of over one hundred sets. We are also receiving daily visits, and inquiries from out-of-town exhibitors.

"We have received visits from several architects who are building new theatres for their clients, asking what structural changes or

provisions they should make for television. One of New York's leading hotels is asking for the price to equip with large screen for the opening of their roof garden.

"The unions here are fighting to see who will control television employees and talent.

"Mr. Joseph Schenck has announced in an interview that Mr. Sidney Kent had been in touch with Baird representatives, and through their affiliation with G.-B., their theatres would be protected.

"Engineers are working day and night to hurry the first showing of big screen in America.

"A home set has been installed in Mr. Javal's suite, where he gave reception to friends who saw, heard and enjoyed television entertainment with perfect clarity. Another set installed in the G.-B. office thrills everyone who sees it."

The home receiving set referred to in this cable is a standard current model T.18 which gives a picture 10 in. by 8 in.

Prior to shipment to New York these home receivers were modified slightly to permit reception on the different transmission standards used in America. Although these changes

were made in England, where there is no comparable transmission to permit checks to be made, the receivers worked quite satisfactorily when installed.

Receiver Noise

As the gain of modern receivers is increasing due to improved design and high-slope valves, it becomes increasingly difficult completely to remove unwanted noise. It is absolutely essential with a modern superhet that it be wired with a heavy gauge wire and soldered at every joint. The old scheme of using a nut and bolt for connection cannot now be used, for in time, joints become loose.

Constructors should make a point of making all connections to a soldering tag with the bolt fixed to the chassis very tightly plus a shake proof washer.

Soldering the connections is quite a simple job providing an electric soldering iron is used and one that reaches its maximum temperature fairly quickly. A good iron rarely becomes dirty and makes soldering a particularly simple job and one that the rawest amateur can confidently tackle. We have always used electric irons and have found them very easy to use. An iron we can recommend is manufactured by W. T. Henley's Telegraph Work Co., Ltd., of Holborn Viaduct, E.C.1. It is sold under the name of Solon and priced at 8s. 6d. complete with solder, flex and lamp adaptor.