

Television

and SHORT-WAVE WORLD

JULY 1939

No. 137 Vol. XII.

LENSES
FOR
PROJECTION

HOME
MECHANICAL
RECEIVER

NEW
TELEVISION
SYSTEM

SHORT
WAVES

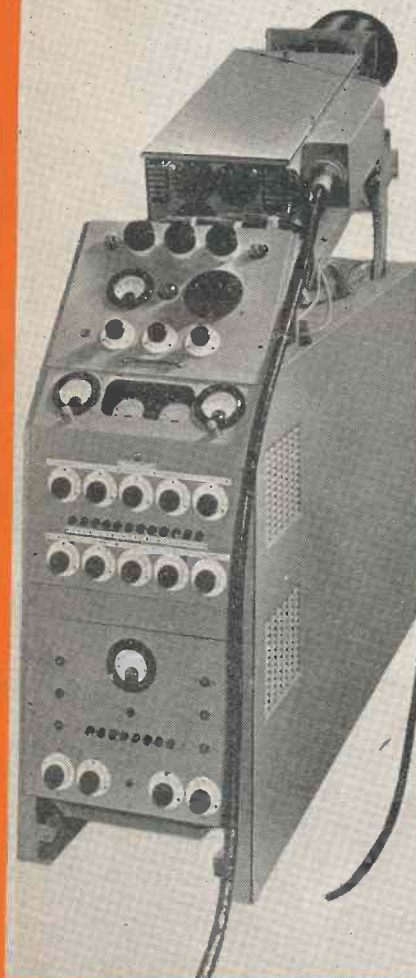

E.M.I.
CINEMA PROJECTOR
DETAILS OF SYSTEM



LONG-DISTANCE BATTERY S.-W. RECEIVER
PUSH-PULL KT8 TRANSMITTER
ONE-METRE OSCILLATOR

BERNARD JONES PUBLICATIONS LTD.
CHANSITOR HOUSE, CHANCERY LANE
LONDON W.C.2.

THE FIRST TELEVISION JOURNAL IN THE WORLD

TELEVISION

and SHORT-WAVE WORLD

Special Features

	PAGE
New G.E.C. Television Receiver ...	388
E.M.I. Cinema Projector ...	389
Lenses for Cathode-ray Projection	391
The Du Mont Television System ...	394
The Oscillograph for Television Receiver Servicing ...	397
Dipole Aerial with New Features ...	400
More Progress with Home Mechanical Receiver ...	404
Long-distance Battery S.W. Receiver	417
Beam Aerials and S.W. Programmes	420
Building a 1-metre Oscillator ...	421
Push-pull KT8 Transmitter ...	423
5 metre Crystal Exciter Unit ...	429
Frame Aerial Receiver ...	430

TELEVISION AND SHORT-WAVE WORLD

Proprietors:
BERNARD JONES PUBLICATIONS, LTD.

Editor-in-Chief:
BERNARD E. JONES.

Editor:
H. CORBISHLEY, F.T.S.

Short-Wave Editor: KENNETH JOWERS
Editorial, Advertising and Publishing Offices:

Chansitor House, 38, Chancery Lane, London, W.C.2.

Telephones: Holborn 6158, 6159.

Telegrams: Beejapee, Holb., London.

Subscription Rates: Post paid to any part of the world—3 months, 3/6; 6 months, 7/-; 12 months, 14/-.

Published Monthly—1/- net.
(On the first day of the month).

Contributions are invited and will be promptly considered. Correspondence should be addressed according to its nature, to the Editor, the Advertisement Manager, or the Publisher, "Television and Short-wave World," Chansitor House, Chancery Lane, London, W.C.2.

IMPORTANT

"Television and Short-wave World" is registered at the General Post Office, London, for transmission to Canada and Newfoundland by Magazine Post. Entered as Second-class mail matter, Boston, Mass.

COMMENT OF THE MONTH

Unreasonable Delay

QUITE a considerable number of interests are concerned about the development of television and several have sent deputations to the Postmaster-General in order to make representations regarding its effect upon their own particular sphere of activities. These have included the radio manufacturers, radio retailers, the cinema industry and theatrical professions.

The answer in each case has been that the subject is under consideration by the Television Advisory Committee and that their objections would receive sympathetic consideration when the time comes. In the meantime not the slightest indication of what is being done or when something will be done comes from the Committee. Manufacturers and trade and professional interests are wholly in the dark despite the fact that immediate decisions in view of developments that are taking place in other countries are becoming of vital importance if we are to retain the lead we now have.

Two of the matters of the most pressing importance are pronouncements on the erection of a transmitter in the Midlands and the position of the cinema with regard to television. The delay has been ascribed to various reasons, foremost of which are the international situation and finance. Nether of these, however, should be the concern of the Advisory Committee which is of a semi-technical character; its immediate problems are the technical possibilities of a station in the Midlands and the economic aspects of cinema television. The larger problems must ultimately be those of the Government.

The Popularity of Morse Code

DURING the past year or so there has been a gradual return to efficient morse code operating from the more simple and popular telephony operating.

The reasons for this change of heart by amateurs is not easy to discover for until last year speech was very rapidly taking the place of morse code. Amplifiers and all the equipment necessary for telephony operation are inexpensive.

Coincident with the crisis of last year, there was a sudden demand for morse keys, and, ever since that time this demand has remained quite steady. The change over might have been caused by very poor conditions on short waves making it more simple to communicate over long distances with morse code than with telephony. Alternatively, it may have been due to the demand of the Army, Navy and Air Force for proficient morse code operators.

At the present time the Three Services are training as many amateurs as they can induce to join their ranks, so that operating on amateur frequencies is now of a higher standard than ever before. As these Service-trained operators are being taught a definite system of procedure, they are taking a pride in operating, not only on Service frequencies, but also when inter-communicating on amateur frequencies.

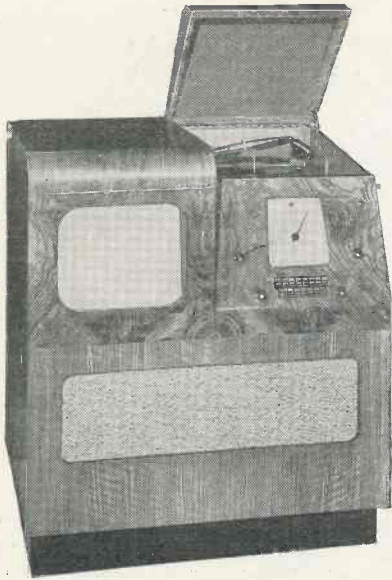

The new G.E.C. BT.0124 combined television and all-wave auto-radiogram.

A NEW G.E.C. TELEVISION RECEIVER

COMBINED TELEVISION AND ALL-WAVE AUTO-RADIOGRAM

employs a very advanced 5-valve superheterodyne all-wave circuit, embodying A.V.C. and tone compensation. Its range is almost unlimited, and in addition to the choice of any eight favourite stations that the listener can make by push-button, any other programme can, of course, be tuned in by hand. Incidentally, the selection of push-button stations can be changed as often as the user wishes in a matter of a few seconds.

Simple Control

The manually operated controls in the front on the cabinet are few and extremely simple, combining a complete control of all the functions of the instrument. The first and second vary the picture brightness and the black-to-white contrast of the television picture. The third is a volume control, and the fourth a tone control, both being operative for television, radio and gramophone reproduction.

The gramophone equipment is entirely automatic in operation and will play batches of eight 10 in. or 12 in. records consecutively; at the conclusion of the last, the mechanism is switched off, and any record may be rejected during playing.

The sensitivity of the 18-valve television chassis is of a very high order, so that the instrument can be installed in any part of the service area.

This instrument is the first of a new series of G.E.C. television receivers to be released this season. It is actually the eighth successive G.E.C. television receiver since television transmissions began. The model is known as the BT.0124.

Landmarks in Television Development

ALTHOUGH it is generally assumed that television is a 20th century development, its basic principles were known and demonstrated in the 1880's! Silhouettes and crude outlines were televised, transmitted over wires for

short distances, and finally reproduced.

For several decades thereafter, television was rather dormant. It was regarded as an interesting laboratory subject of experiment but it appeared doubtful whether it could ever be perfected.

Progress was seriously hindered by the lack of a satisfactory medium for transmitting, but in the period 1914-1918, radio developed to such an extent that shortly after it entered the home, and the old crystal sets gave way to valve receivers.

It was discovered that crude pictures could be sent through the air on radio waves, and experimenters among whom was J. L. Baird, attacked the television problem anew. In America the Radio Corporation of America, was among the first to enter the field.

Of relevant importance are the following dates and the discoveries and progress made all have their significance in development as we know it to-day.

1676—Olaus Roemer discovered that light travels at finite velocity.

1817—Berzelius discovered selenium.

1830—Joseph N. Niepce and Louis Daguerre produced the first practical system of photography.

1845—Faraday found that a ray of light polarised in a certain plane can be diverted by action of a magnet.

1857—Geissler produced the first glass vacuum tube.

1873—Light-sensitive properties of selenium discovered by a telegraph operator named May, indicating that light values could be converted into equivalent electrical values.

1878—Sir William Crookes invented the Crookes' tube, and demonstrated cathode rays.

1883—Edison discovered the "Edison effect," occurring in an incandescent lamp. An electric current was made to pass through space from a burning filament to an adjacent metallic plate.

1884—Paul Nipkow patented the television scanning disc.

(Continued on page 390.)

A NEW luxury addition has been made to the G.E.C. range of television receivers. This is a television and all-wave auto-radiogram for A.C. mains at 72 guineas. The instrument is operated almost entirely by automatic press button control, and gives the popular sized picture of 10 in. by 8 in.

Half of the cabinet face follows a straight vertical line behind which the screen of the cathode-ray tube is recessed at an angle sloped for comfortable viewing, thus providing a cabinet overhang that shelters the picture from unwanted light and reflections. The other side of the cabinet slopes evenly back, so that the gramophone deck takes up the smallest space necessary, and the radio tuning scale can be seen without stooping, with all the controls in the simplest position for operating.

In addition to eight buttons for station selection, there are seven additional buttons for purposes of control. The first button brings complete television entertainment; the second, television sound only for the special high fidelity sound broadcasts that are transmitted daily by the B.B.C.; the third brings the gramophone equipment into operation; and the fourth, fifth and sixth cover the short, medium and long sound broadcast wavebands. No matter which of these buttons is pressed first, it will automatically switch on the set, leaving the seventh and last button to switch it off.

The radio chassis incorporated

THE E.M.I. CINEMA PROJECTOR

As mentioned in last month's issue, Electrical and Musical Industries Limited have now produced cinema television equipment which was first demonstrated privately on Derby Day.

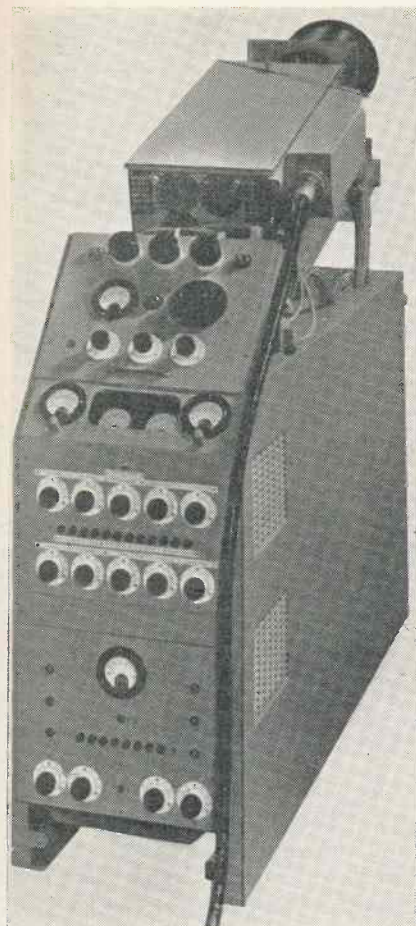

A rear view of the E.M.I. Projector showing the panels from which complete control of the equipment can be effected.

THE E.M.I. television equipment for cinemas is the third of this class which is now available in this country, and though at the present time the field of use is extremely limited it is evident that manufacturers are preparing for the time when cinema television becomes general and equipment will become essential to every well-equipped cinema.

The E.M.I. television projection equipment consists essentially of two parts: (1) the actual projection apparatus used in the auditorium, and (2) the "driving" units which can be situated in a back-stage or other convenient equipment room.

The Projector

The actual projection apparatus of which photographs are shown on this page and the cover comprises scanning and modulation amplifiers, tube unit, lens system and control panels. The extreme compactness of the projector makes it eminently suitable for installation in any theatre with little

alteration to the existing seating arrangements, particular attention having been given in this respect to the design. The usual situation of this equipment would be at the front of the auditorium, but it is of such a nature that where the design of the theatre will permit, it could alternatively be mounted on a lift on the floor of the auditorium, in much the same way as an organ console, and could, therefore, be lowered out of the way when not required.

The angle of projection can be altered so that, by suitable inclination of the screen, the best viewing conditions can easily be obtained. In order to permit of this, the tube unit and lens system of the projector are mounted on a framework hinged at the back, and with a simple raising and lowering device at the front. Although, in general, the auditorium will probably be the most convenient location for the projector, the constructional arrangements of certain cinemas may permit of alternative positions. Where, for instance, the front line of the circle is about 50 ft. or so from the screen,

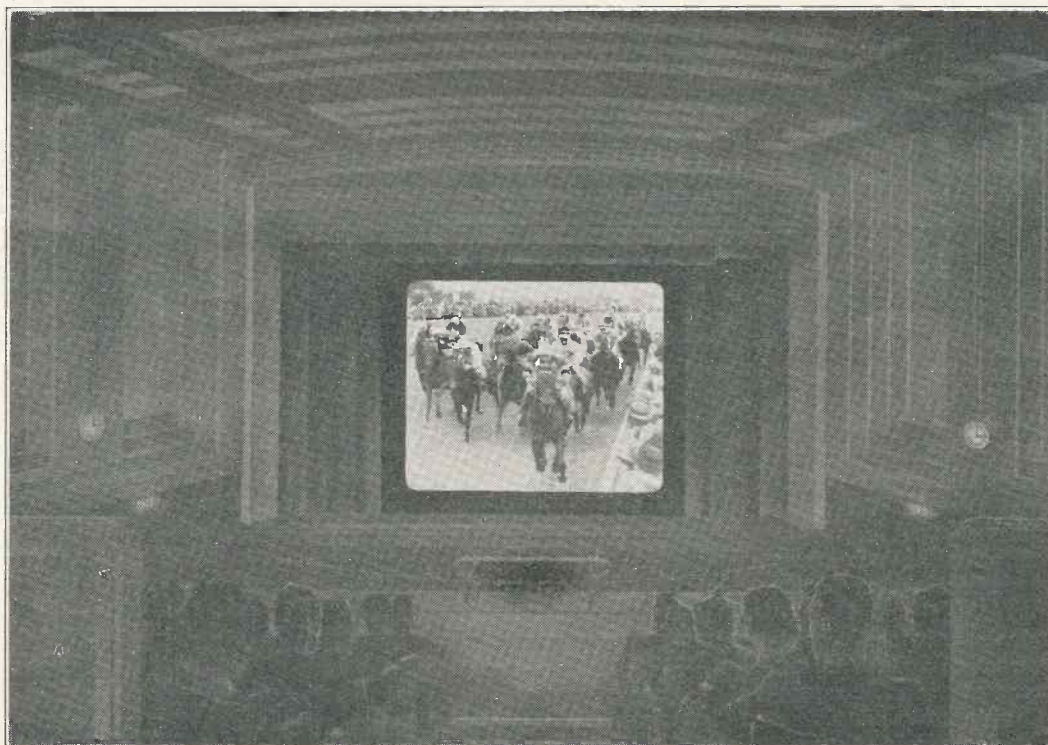

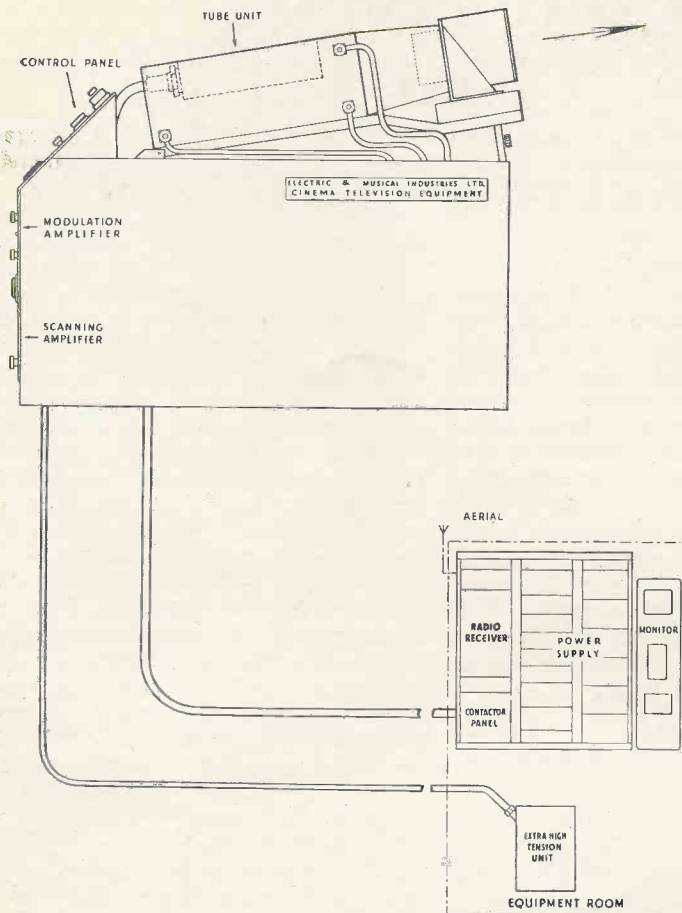

This is a schematic diagram of the arrangement of the E.M.I. cinema television equipment. The projector is in the auditorium and the drive unit in a separate room is provided with remote control.

the projector could, if preferred, be accommodated there instead of in the auditorium. Back-projection is also possible. With the projector situated approximately 50 ft. in front of the cinema screen a picture 15 ft. by 12 ft. 6 ins. is provided which is large enough for satisfactory viewing even in the largest cinemas.

Projection distance may be increased with a corresponding increase in size of pictures, still with sufficient illumination. The "drive" apparatus is operated by remote control from the projector and may, therefore, be some distance away. It comprises vertical racks, a monitor and a compact and safe high-tension unit. Included in this equipment are the vision and sound receiver and the contactor panel for remote operation of the equipment and power supply units. A special feature of the design of the contactor panel is that the circuits are interlocked in such a way as to ensure perfect safety of the equipment.

An independent monitor is provided for purposes of initial adjustment of the apparatus in the equipment room. High-tension supply for the complete equipment is obtained

from the extra high tension unit which is housed in the equipment room. This unit, which is of special design, is particularly compact and is absolutely safe in use.

The installation includes provision and erection of the aerial most suited to the particular locality in which the gear is to be used.

"Landmarks in Television Developments"

(Continued from page 388)

1888—Photoelectric cells were built.

1890—C. Francis Jenkins began experimenting with apparatus that could be used with the Nipkow scanning disc.

1906—Lee de Forest invented the three-element vacuum tube with a filament, plate and grid.

1925—C. F. Jenkins demonstrated apparatus which showed far-off, moving objects, or "shadow-graphs."

"Television and Short-wave World"
circulates in all parts of the world.

1926—J. L. Baird, publicly demonstrated television transmission by wireless and wire by sending half-tone moving pictures from point to point.

1928—First television drama, "The Queen's Messenger," broadcast from WGY's studios, Schenectady.

1929—Vladimir Zworykin, of RCA, demonstrated a non-mechanical receiver using a special cathode-ray tube called the "Kinescope."

1930—First showing of television in a theatre. The programme was broadcast from the General Electric Laboratories to Proctor's Theatre, Schenectady.

1933—After 10 years of work Zworykin announced success of his "Iconoscope," the modern television camera tube.

1934—New television camera tube demonstrated by P. T. Farnsworth, in Philadelphia.

1935—New type of wire line, the coaxial cable, capable of transmitting television signals, announced by Bell Telephone Laboratories.

Back Issues Wanted

A correspondent, who wishes to complete his volumes of TELEVISION requires the following issues which are now out of print. If any reader has copies of these for disposal we shall be glad to receive a postcard stating which are available.

- 1931. September, October.
- 1932. April.
- 1933. March, October, November, December.
- 1934. January, April.
- 1935. March, June, October.
- 1936. January, February, March, April, May, July.
- 1937. April, December.
- 1938. January.

Television Interference

A new publication has recently been issued by the British Standard Institution devoted to radio interference suppression for automobiles and stationary internal combustion engines, which is the result of work carried out with the co-operation of the Society of Motor Manufacturers and Traders, the B.B.C., the Electrical Research Association and the G.P.O.

This will be of interest to all who suffer from interference not only with their television receivers, but also on short-waves generally. The specification (B.S. 833/1939) is priced 2s. 2d., post free.

and the others that are important at wide apertures, have led to various more or less standardised types of lenses. Naturally the type depends on the use to which it is to be put.

Two types of lenses are available for use in projecting cathode-ray images. These are projection lenses and anastigmats.

The prototype of the projection lens is the Petzval lens. Designed

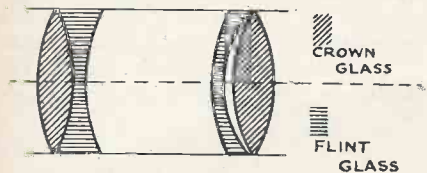

Fig. 5. Petzval-type lens.

about 1845 it is still in vogue to-day with certain modifications.

The Petzval lens consists of two pairs of lenses, each pair comprising a crown glass and a flint glass. These pairs are mounted in a tube at a relatively large separation. The modifications introduced consist mainly in changing the order of crown and flint glasses, in cementing or leaving them uncemented, and in using glasses developed comparatively recently. This lens can be made with quite large apertures, F/2 and F/3 being not unusual.

The construction is of a simple form. The central definition is frequently superb. The aperture is what is needed to have a large light-gathering power. The defect of this type of lens is that only a small field is covered.

An excellent example of the Petzval type is an Aldis lens designed for cinema projection work. This lens has an aperture of F/2.2 and with a focal length of 4 in. gives superb projection from a circle 1.2 in. in diameter. This result may be taken as a general rough guide. A projection lens will give excellent projection, at this aperture, from a circle of diameter not greater than one-third of the focal length. Naturally some lenses may have a larger covering power, but this result is true of the general run.

An anastigmat lens can best be described as comprising a number of component lenses packed together comparatively closely. The quality of definition given by modern anastigmats is astoundingly good over quite large fields even at large apertures. Designs have been patented for anastigmats working at about F/2, which claim to cover a field of diameter about twice the focal length.

The more normal type tends to be simpler and cheaper in construction than wide-angle, wide-aperture anastigmats, and this factor may be of considerable importance in the manufacture of television sets for the million.

An economical anastigmat is, for example, the Aldis 2 in. F/3 lens. Fig. 6 shows the construction.

This lens will give excellent definition over a circle of diameter about 1 1/4 in. to 2 in. Again, this result may be taken as typical of anastigmats, that are not specifically stated to be wide-angle lenses. A very good

guide is to assume that an anastigmat will give good projection from a field whose diameter is equal to the focal length of the lens. The exact field covered, after this guide has indicated the approximate focal length of the lens required, may be found from the makers' catalogues.

The advantage of the anastigmat over the projection lens is that for a given cathode-ray image and given

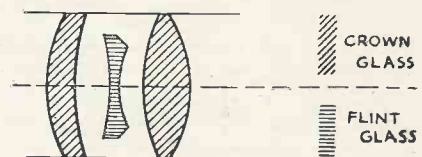

Fig. 6. 2-in. F/3 anastigmat.

magnification, there is a much smaller overall length, since a smaller focus lens may be used to cover the tube image. The disadvantage is that to obtain a lens working at the same aperture, and giving the same definition all over the field as a projection lens, may necessitate a rather more costly lens, such as those used in miniature cameras.

Only the user can decide, in each individual case, whether for a given cost, the light-gathering power outweighs the disadvantages of the larger throw of a projection lens; or whether, for a given light-gathering power, the increased cost of an anastigmat is justified. In most cases a good compromise would be to use an F/3 lens of the type shown by Fig. 6, which is not unduly costly and has a reasonably large aperture.

Television Receivers are Quite Safe

ONE of the earliest criticisms of the cathode-ray receiver when it became known that voltages of 3,000-6,000 were employed was the possibility of fatal accidents by shock. Voltages of this order were unknown in domestic use with the exception of certain apparatus of a quasi-medical nature which was known to be harmless.

An initial problem of designers therefore was to make the instrument quite safe in ordinary use and this was quite easily accomplished by making the interior or any live part accessible without first disconnecting from the mains. Of course, no piece of apparatus can be made proof

against deliberate interference, but the chances of shock to the ordinary user of a television receiver is certainly much less than with a vacuum cleaner and the results would in all probability be less dangerous.

Voltage is not the dangerous factor. Frequencies and the amount of current available are of much greater importance, providing the voltage is sufficient to force the current through the body. For example the voltage generated by the average car ignition system is of the order of 15,000 volts,

and yet nobody regards such a system as dangerous although it can give an unpleasant shock.

Comparatively low frequencies are the most dangerous and with these the body will only tolerate a small amount of current compared with extremely high frequencies. For example 50 mA. at 50 to 200 cycles can be dangerous, whereas 750 mA. at 100,000 cycles can be tolerated without injurious results.

The real danger points are the secondaries of the high-voltage power transformers and it is probable that it is only from these that any real harm would result except under exceptional conditions. Condenser discharge, generally speaking, is not dangerous, but it is capable of giving a most unpleasant shock.

Mention of "Television and Short-wave World" when corresponding with advertisers will ensure prompt attention.

THE DUMONT TELEVISION SYSTEM

EMPLOYING TRANSMITTED SCANNING IMPULSES

REASONING that it is desirable to provide for extension to pictures of even higher definition than are now accepted as standard without the necessity of rendering existing apparatus obsolete either at the transmitting or receiving end, the DuMont laboratories have evolved a television system which solves many of the problems entailed. Conversely, it is claimed that high-definition apparatus of this type can

synchronising and sweep-frequency controls are therefore unnecessary.

At first it may appear that the addition of these two sweep signals on two new channels seriously complicates the methods, but advantages result therefrom which more than offset the complication. Receiver control is simplified considerably and the design will permit of reception from numerous stations of differing degrees of definition.

receiver and there simply amplified to utilise directly for the scanning.

In this way the receiver will follow even quite radical changes in the scanning raster. The problem of maintaining synchronism no longer exists as no synchronising pulses are utilised at the receiver and there is no need for the complicated system of synchronising pulses with their provision for causing the interlace of scanning.

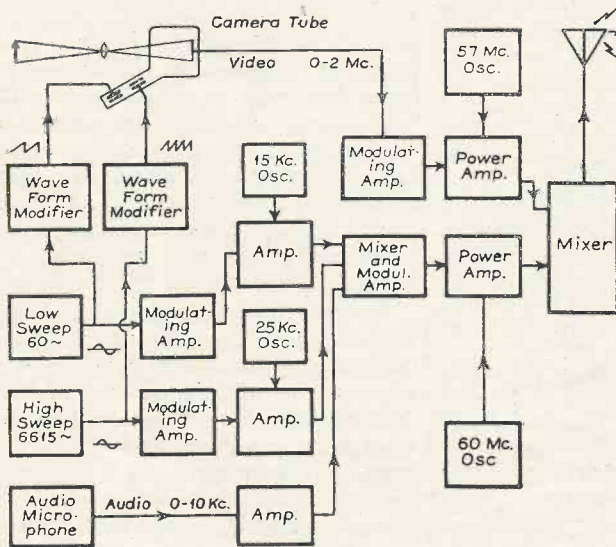

Fig. 1. Double carrier transmitter for four independent signals.

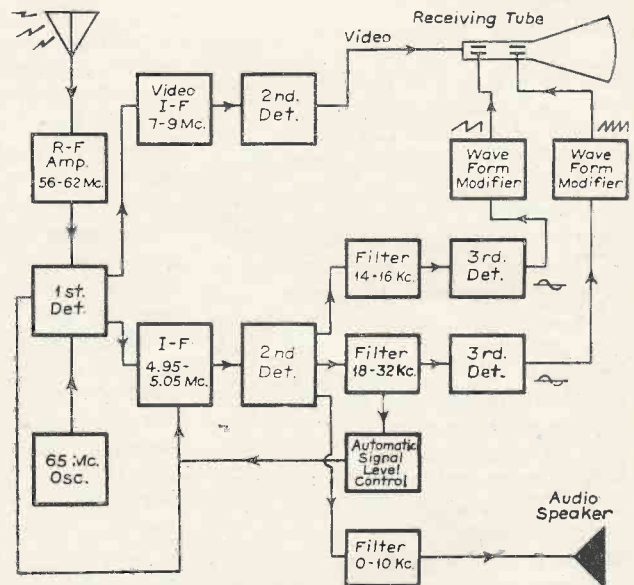

Fig. 2. Double carrier receiver.

be used for a lower definition without radical alteration.

Transmitted Scanning Impulses

The DuMont television system employs the actual transmission of the entire scanning signals for both horizontal and vertical deflection in addition to the conventional vision modulating signals and the associated audio-channel signals. The deflection signals are generated exclusively at the transmitting station and sent by means of a suitably designed carrier methods as independent signals to the receiver, thus simplifying the receiver considerably by making it unnecessary to employ local sweep oscillators for each receiver. Local

Details of this system were given in a paper read before The Institute of Radio Engineers, New York, by Thomas L. Goldsmith. We are indebted to "Communications," New York, for the information.

The complex equipment in any transmission system rightly belongs to the transmitter, leaving the receiver very simple to operate and free from critical circuits which might require frequent attention. It may be seen presently how many of these advantages are possible when utilising this new system.

In the DuMont system instead of the conventional practice of having a set of sweep-generating oscillators at the transmitter controlled by synchronising pulses, and having another set of sweep oscillators in each receiving unit, these synchronised by pulses sent out from the transmitter and filtered from the vision signals, one carefully controlled set of sweep generators is employed at the transmitting station. These sweep wave-form voltages are used to modulate auxiliary carriers in the transmission system, enabling the actual sweep wave forms to be picked up at the

Two-to-one interlaced scanning has been achieved quite acceptably with the synchronising pulse method although the receiving equipment is thereby complicated, but it is not very likely that higher interlace ratios can be employed by this method of remote control of oscillating circuits.

On the other hand, when the sweep oscillators of the master transmitter of this system have once been adjusted to the proper frequencies, interlace ratios of four or six are entirely practical, as the deflection circuits at the receiver are essentially connected directly with the transmitter oscillators and automatically remain in step with whatever system of scanning is being employed at the transmitter.

Four Signal Channels

The receiver has four signal channels, each of which is quite like

ordinary radio channels, though employing unique frequency characteristics. These channels require no adjustment after installation other than proper tuning for satisfactory audio reception whereupon the remaining signal channels are at once in adjustment. There may, of course, be necessity for brilliance controls associated with the cathode-ray tube, but in general the set will not be much more complicated to operate than the average broadcast receiver.

A primary advantage of the system is the practical possibility of using four-to-one or even six-to-one interlace, still maintaining sixty fields or fractional scans per second

sinusoidal wave shapes and are then modified to the rather conventional saw-tooth signals by means of a simple filter network at the receiver. A cathode-ray tube is desirable employing electrostatic deflection which very readily follows changes in the scanning system since electrostatic deflection plates have practically no frequency discriminating characteristics.

Fig. 1 shows a double-carrier transmitter for the necessary four independent signals. This system utilizes two separate ultra-high-frequency carriers to transmit the signals.

The two carriers are in adjacent

will be desirable to provide black levels on the picture signals to eliminate undesirable portions of the return traces, but these blanking pulses need not be of greater height than just sufficient to cause extinction of the beam, for there is no need of their use for synchronising pulses, with the complex amplitude and frequency filtering at the receiver. With such a vision signal it is feasible to utilise full hundred per cent. modulation of the ultra-high-frequency carrier with efficient picture producing signal. It is unnecessary to sacrifice 20 to 25 per cent. of this very broad channel for the purpose of synchronising pulses.

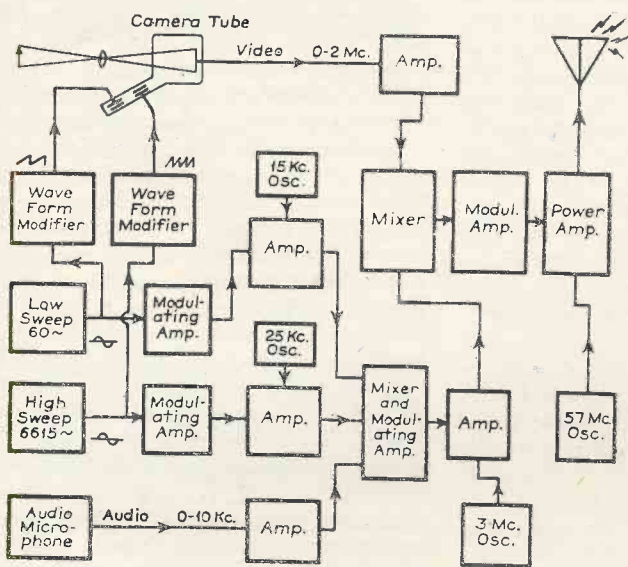

Fig. 3. Single carrier transmitter for four independent signals.

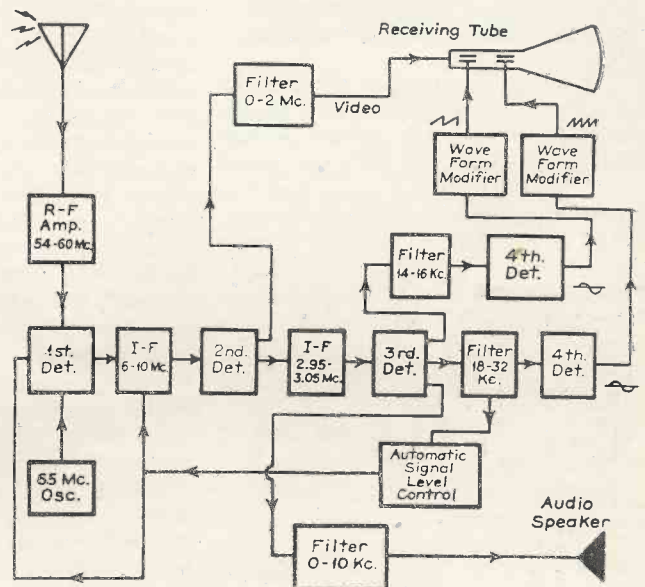

Fig. 4. Single carrier receiver.

in order to insure absence of flicker, but utilising a correspondingly lower frame or picture repetition frequency, by means of which a great reduction in signal band width is possible. Even including the extra bands required for the transmission of the independent sweep signals, the entire band necessary for a complete television transmission is reduced to one-half or less of the band width required for 441-line pictures utilising the two-to-one interlace of to-day with the tentative line and field frequencies being used, because of the reduction in the band width of video modulating signals.

The general system may best be illustrated by a specific example. In order to maintain simple frequency discriminating circuits, the sweep signals are transmitted in the form of

ultra-high-frequency channels to facilitate dual handling at the receiver. One carrier is modulated by the vision signal alone, and the other one is modulated by the three remaining signals, the sweeps and the audio in distinct narrow channels. These three signals are kept distinct from one another by the use of appropriate subcarriers.

The camera tube for converting the pictures into the so-called vision signals may assume several conventional forms, though very promising results have been obtained with the use of a special type of photoelectric mosaic tube employing electrostatic deflection. This type of deflection is considerably more desirable where it is planned to vary the style of scanning raster.

With certain types of scanning it

The sweep signal generators shown provide sinusoidal wave shapes of 60 cycles per second and 6,615 cycles per second respectively for the vertical and horizontal scanning. This type of signal is rather easily handled in selective-filter circuits, and can be modified by a simple resistance-capacity rectifier network into the more conventional saw-tooth waveform which is very efficient in accomplishing uniform coverage of the screen area.

It is necessary to provide a suitable and simple means of transmitting the sweep signals and the audio voltages independently. The low sweep is used to modulate the output of a 15-kilocycle oscillator. The high sweep in turn is used to modulate the output of a 25-kilocycle oscillator.

The audio signals, generated in a

Scannings and Reflections

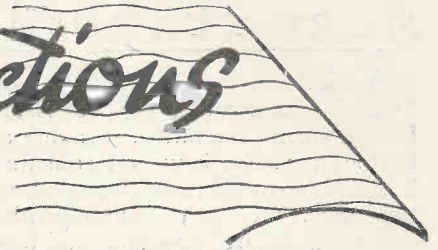

THE NEWSREELS

OPPPOSITION by cinema interests to the televising of the newsreels is increasing, and at a meeting of the Northern Branch of the Cinema Exhibitors' Association a recommendation to the General Council was passed that diffusion of the newsreels concerned should not be permitted.

TELEVISION AND LIGHT "GATES"

Following the Roderick-Armstrong fight for the world's welterweight championship at Harringay Arena, the question of allowing the televising of boxing matches has been raised again. Less than 5,000 went to see this fight, and according to Brig.-Gen. A. C. Critchley, the promoters lost about £8,000.

Opinion, however, among promoters differs and not all attribute the poor attendance on that occasion to broadcasting and television.

THE SCOPHONY BIG SCREEN

It is stated that Odeon Theatres, Ltd., have placed an order with Scophony, Ltd., for the equipment of all Odeon cinemas with television receiving apparatus. Sixty cinemas in London will be the first to be equipped, and it is understood that this will take from about 18 months to complete. There are about 300 Odeon theatres but, of course, there would be no point in equipping those until there was a local television service.

The chairman of Odeon Theatres, Ltd., Mr. Oscar Deutsch, is also a director of Scophony, Ltd.

ACTORS AND VISION

All members of the Actors' Equity Association of America are now required to submit offers and terms for television appearances for approval before appearing before the television camera.

AMERICAN RESPONSE

General Electric (U.S.A.) television engineers have been amazed at the popular response to the television

demonstrations in the G.E. exhibit building at the New York World's Fair.

The G.E. demonstration consists of a small studio, into which visitors are invited to be interviewed before a television camera, and a half a dozen receivers in darkened booths across the auditorium. People crowd in lines six deep in front of the glass window of the studio. Comments in the booths of the television receivers reveal that when visitors see their friends televised they have an urge to talk back to them—as though they were standing face to face.

PHONE LINES FOR TRANSMISSION

A telephone wire from Madison Square Garden, New York, where bicycle races were in progress, to the N.B.C. studios in Radio City, a distance of just over a mile, was experimented with by engineers of the National Broadcasting Co. recently for television transmission. It is stated that at this distance the results obtained were quite good. Use of telephone lines for short distances has, of course, been made by the B.B.C.

YORKSHIRE CINEMA TELEVISION

Arrangements have been made for the installation of television in a number of cinemas in Yorkshire.

These include the Yorkshire kinemas of Gaumont-British. In all probability, the New Victoria at Bradford will be the first of the halls owned by this group to be fitted.

WIMBLEDON TENNIS TOURNAMENT

Improved camera positions should give even better television pictures from the centre court at Wimbledon this year than in 1938 and 1937. Formerly the "shots" have been made from an oblique angle, but this time a "square on" view will be obtainable from a point opposite the Royal Box. In previous years one camera, used for occasional long shots, has been left unattended, but this year all the cameras will be

manned and will be brought frequently into circuit with rapid changes of lenses.

Television from Wimbledon will begin on July 1 and, as the all-important Finals Week proceeds, more and more play will be televised. On the last two days, July 7 and 8, cameras will be in continuous operation from 2.30 to 5 p.m. The finals to be televised will include the men's and ladies' singles, and the men's doubles.

DEPUTATION TO P.M.G.

Representations asking for the limitation of the transmission of television programmes constituted of dramatic, variety, music and singing items to prevent big screen production in public establishments were made to the Postmaster General last month by a deputation representing stage interests. The plea was unfair competition generally detrimental to the maintenance of the variety, theatrical and concert professions.

FILMS FOR A.P.

According to the *Motion Picture Herald* (U.S.A.) (May 20), the television director of the B.B.C. talked with various of the major distributors' executives to obtain from them permission to use some of their features. He had sought arrangements through the Motion Picture Producers and Distributors of America, which referred him to individual executives of member companies. Progress, if any, was not disclosed.

CROSLY TELEVISION

The Crosley Corporation (U.S.A.) has leased the entire 48th floor of Cincinnati's Carew Tower for construction of television studios. Carew Tower, 574 ft. high, will have an estimated service radius of 25 miles. The transmitter is rated at 1,000 watts, and work is progressing rapidly.

EMPIRE TOWER FOR TELEVISION?

Tower of Empire at Bellahouston Park, Glasgow, has been suggested

MORE SCANNINGS

as a television station. Mr. C. O. Stanley, chairman of the Television Development Committee, speaking at Peebles recently, however, said that it would be 10 years or thereabout if the present attitude of the authorities continued before Scotland had television. It was his personal opinion that the obstruction to provincial television was coming from the Post Office. He thought the Post Office had contracted a new disease—"cablitis."

MISS RADIOLYMPIA, 1939

A contest has been organised by the Radio Manufacturers' Association to select the girl with the perfect radio and television personality to appear at Radiolympia—August 23 to September 2, 1939. The heats of this contest are being conducted at the leading seaside resorts, one night each week, from week commencing July 10 to week commencing August 14. The girl will be chosen for appearance, personality and microphone voice.

At the completion of the local heats, semi-finals will be held in large centres of population, such as London and Birmingham, to select twelve semi-finalists who will appear in London for final judging. The semi-finals and finals will be judged by a Committee of radio critics, film, stage and radio stars, and other well-known personalities.

DuMONT TELEVISION

Two new DuMont television transmitters are being finally tuned up to take the air shortly with experimental transmissions, while down in the spacious basement two television studios and a control room are rapidly taking definite form so that suitable programme material may be available to the DuMont television station, which was recently granted an experimental licence to operate within the 42,000-56,000 kc. band.

One studio is being devoted to direct pick-up programmes, and the second film pick-ups.

Two transmitters are available for simultaneous transmission within the allotted frequency band, permitting the handling of vision and sound components of a single programme, or the transmission of the same vision pick-up by the standard R.M.A. system and the DuMont system, for a direct comparison. Demonstrations will be available shortly, so that the

relative merits of these two systems may be ascertained under actual operating conditions. The DuMont system, which is described on another page in this issue, eliminates the need for sweep circuits at the receiving end.

The DuMont Laboratories, last month, filed application for three additional television transmitters. No. 1—A 50-watt mobile transmitter on 60-86 mc.; No. 2—A 1-kw. unit for 515 Madison Avenue (top floor), N.Y.C., on 60-86 mc.; No. 3—a 1-kw. unit for the National Press Buildings, Washington, D. C., on 42-56 mc. and 60-86 mc.

"HOME" TELEVISION ?

The *Milwaukee Journal* has applied to the Federal Communications Commission for permission to inaugurate an experimental television service to the public. The Journal Company's application is the *first-application* for the establishment of an experimental programme service for reception in the home as distinct from fundamental research or technical experiment. The Commission has previously issued a number of licences for technical experiment only.

NATIONAL SERVICE UNITS TO BE TELEVISED

Television cameras will pay a return visit to Hyde Park on July 2 for the march past of National Service units before His Majesty the King. The members of the parade will have come from all parts of the British Isles and will include detachments of the Army, Navy, Air Force, A.R.P. services, the Auxiliary Police and Nursing services. Incidentally, the parade will be His Majesty's first important public engagement after his return from America.

MUSIC BEE FOR TELEVISION

A Musical Bee is planned for the evening television programme on July 10 when two teams, part professional, part amateur, will be matched. With women ranged against the men, the contest will develop on the lines of a general musical knowledge bee in which competitors will not only have to guess tunes but identify strange instruments, translate obscure musical terms, recognise records played backwards, and solve other problems which

should not be too difficult to people who have a little more than a nodding acquaintance with music. The whole programme will be strongly visual in appeal, and even viewers who have no knowledge of music will, it is believed, extract a lot of enjoyment from this unusual programme.

TROOPING THE COLOUR BROADCAST

Five London cinemas reproduced the Trooping the Colour broadcast. The New Victoria, Marble Arch Pavilion and Tatler used Baird apparatus, and the Odeon, Leicester Square, and Monseigneur, Oxford Street, Scopphony. All had audiences somewhat larger than usually attend. It has been generally conceded that the quality of the reproduction was the best ever on big screens, largely due to ideal weather conditions.

FOOTBALL TELEVISION

At the annual dinner of the Football League Secretaries' and Managers' Association Mr. Stanley R. Rous, secretary of the Football Association, declared that it would be a mistake for football people to stand against television and broadcasting. This may be an indication that some arrangement will be made to televise matches next season.

SCHOOL LESSONS BY TELEVISION

At Hurst House School, Staplehurst, Kent, the scholars are being given lessons with the assistance of a television receiver. News reels and the televising of events like "Trooping the Colour" and the departure of the King and Queen for Canada provide the subject matter for general knowledge teaching. These special lessons have been started by the headmaster, Mr. H. Farrington.

MR. GERALD COCK BACK FROM U.S.A.

Mr. Gerald Cock, B.B.C. Director of Television, who has returned from the U.S.A., where he has been inspecting the progress of television, addressing a gathering of the Radio Manufacturers' Association on his return, said: "England still leads the world in television, but American interests are watching us. The National Broadcasting Company, Columbia, the Film Industry, the New Deal itself, all these organisations with their vast resources are

AND MORE REFLECTIONS

waiting to take up television at the point to which we have brought it.

"It behoves this country to move forward in the television field at such a pace that we still continue to maintain our lead. If only this country will go on developing television, the rest of the world will come to us for television equipment, not only for receivers, but for transmission equipment itself. In every country of the world, except England, television is in the experimental stage. In this country it is already a practical proposition. We know we have a three years' lead on the others. It is up to nations with the object of helping us to maintain this lead while offering the results of our experience to other them to enjoy the facilities we already possess."

SANDOWN PARK

At the moment there does not appear to be any chance of the Eclipse Stakes being televised from Sandown Park on July 14 as was previously announced. The Jockey Club Stewards have refused permission for the race to be televised despite the fact that B.B.C. engineers had already surveyed the course and obtained permission from the Sandown Park authorities to instal the necessary equipment and cameras.

The attitude of the Jockey Club Stewards is to be deplored, as surely it cannot have any effect on the attendance at the race meeting, while from a technical aspect the transmission would have been highly successful as the course is a short one and lends itself to a complete transmission of the race without difficulty.

TELEVISION IN BLACKBURN

Philips' engineers at the new Blackburn factory are very optimistic about receiving television pictures there. If it is possible for them to erect an aerial 250 ft. above ground level and with directors and reflectors they feel there is a very good chance of satisfactory pictures being received. Their results are awaited with interest by readers who live considerably beyond the service area.

TELEVISION AT THE NEW YORK WORLD'S FAIR

American television was given quite a boost by the transmission of pictures of the King and Queen when

they visited the World's Fair. A commentator talking over one of the American short-wave stations was very optimistic regarding the possibilities of a rapid advance in American television and was using the King and Queen's visit to prove how important it is that television should be in every home in order that the ordinary viewer could be kept acquainted as to what was going on even if they were not able to see the events themselves.

LONG-DISTANCE AMERICAN TELEVISION

Contrary to the theory that television programmes can only be received at a limited distance from the transmitter, General Electric engineers in Schenectady using a standard console receiver picked the complete two-hour programme "teletcast" by N.B.C. from the Empire State Building. Both picture and sound were received exceptionally well despite the fact that the distance from the transmitter was 130 miles and the receiver was located approximately 8,000 ft. below "line of sight." This is believed to be an American record for reception of a regular broadcast television programme, although in this country and elsewhere, distances considerably in excess of 130 miles have been spanned. The test was made on May 26 and a group of engineers erected a temporary diamond directive aerial array. It was suspended from four masts, with the plane of a diamond parallel to and about 40 ft. above the ground. The aerial occupied a space on ground of about 300 by 600 ft. Tests were conducted close to the location chosen for the new high-power General Electric television station which is being put up in the Helderberg mountains, 12 miles from Schenectady.

GENERAL ELECTRIC U.S.A. RADIO-TELEVISION ACTIVITIES

A new department of the General Electric Company which will consolidate for the first time all radio, television, and related activities, has been established with headquarters at Bridgeport, Conn., effective immediately. Dr. W. R. G. Baker, for many years associated with G.E. activities in the radio field and until now chairman of the radio manage-

ment committee, has been named manager of the new unit, to be known as the radio and television department.

ANOTHER DEPUTATION

A deputation of radio dealers organised by the Radio and Television Traders' Federation met the Postmaster-General to explain the retailers' case for a new station at Birmingham and in other important provincial centres. It is hoped that the various deputations putting their views before the Postmaster-General will ultimately have the desired effect.

"A Dipole Aerial with New Features"

(continued from Page 400)

Except for the aerial and reflector members and the insulators the entire construction is in heavily galvanised iron and the assembly should be proof against weather conditions for a very long time. As clamps are used both for the mast supports and the mast cap directional setting is quite an easy matter. The electrical design conforms to accepted standards and the aerial may therefore be relied upon to be electrically efficient. As it is essential that the mast should fit the sockets this is included as part of the kit, its length being 12 ft.

"Du Mont Television System"

(continued from Page 396)

frequency of sixty and reducing the frame frequency to fifteen instead of thirty, as with the 441-line two-to-one interlaced pictures, the video frequency band is halved without sacrifice in either horizontal or vertical definition.

Use of single-side-band transmission is, of course, possible with this system which will reduce the required frequency band on the air to one-quarter of that of existing systems.

Another advantage is the assurance of synchronism if signals are received at all. There is no local adjustment of auxiliary controls. Furthermore, the receivers are capable of responding to several scanning systems in turn from different transmitting stations.

It is realised that this system can only stand on the merits of results of extensive field trials which are under way. DuMont laboratory tests have indicated that the system is entirely feasible.

THE SLOW-SPEED SCANNER

The impression was unintentionally given, last month, that this motor might be home-constructed. Owing to the accuracy in certain details involved, and certain other technical points, that is hardly feasible even for the skilled amateur, without an unreasonable amount of preliminary work, and it is not proposed to give any directions for such attempts. The author is arranging for the manufacture of these motors, and they will be available through H. E. Sanders and Co. as mentioned last month. They are being supplied, for the mechanical set, on a bracket mounting for fixing, by a single bolt, to the optical frame described in the January, 1939, issue of this journal, in place of the mains-driven 67½ ball scanner and motor there specified.

Slow-speed Scanner

The slow scanner-motor is also illustrated with a four-sided plastic block scanner, of the type described in previous issues, for producing a 4-in. 135-line interlaced picture. It is of very simple construction, but the amateur worker is not likely to want to go to the trouble of fitting up the arrangements for producing the plastic block scanner. The motor part, however, comprises a rotor consisting of an eight-tooth wheel, 1 in. in diameter, cut out of 1/16 in. thick iron sheet, and pole-pieces made by bending up a length of 3/8 in. by 3/32 in. iron as shown in the picture, with windings of No. 32 enamelled wire (for operation off the 8 volt 50 cycle supply used to light the lamp).

There is only one point that is really important for success with this motor: there must be either a spring coupling of some sort between the rotor and the scanner, or between, at least, some two parts of the rotating system as a whole, or else a part of some sort running free, with a suitable degree of friction, on the rotating system. This is necessary to damp out disturbing impulses that would otherwise stimulate hunting or even throw the scanner out of synchronism. This point was explained in the August, 1938, issue of this journal. In the form now illustrated there is a free running brass disc, with a moment of inertia of the same order as that of the scanner block, which effectively keeps the system running smoothly.

Chance for Serious Experiment

With the availability of these two scanning units and the necessary lenses, the way has been opened for the experimenter to work seriously on mechanical television reception. The author does not wish to give the impression that he has offered here a finished and complete alternative to the cathode-ray tube type of receiver; it is not feasible, with individual work on an experimental scale, to offer the certainty of trouble-free, perfect results that has been achieved, with the cathode-ray type of receiver by years of research by many big companies. It is assumed, therefore, that anyone who merely wants a trouble-free television receiver will not bother with mechanical arrangements at all, until, if ever, the big companies have led the way with cheap mechanical sets. The experimenter, however, is in a different class; he wants interesting developments, and the chance to do a bit of research on his own, and it has been that desire that has stimulated the author to suggest the present arrangements. He is fairly well satisfied that they are actually practical means of receiving television programmes, and is going ahead to develop them further.

It is hoped, in the course of this development, to give shortly constructional details for a set using the scanners now developed, and the vision receiver, lenses and optical

frame previously described, but with the details of design cleaned up and the overall size cut down. The picture size of this set would be four inches, and care would be taken to provide for acceptable picture quality; not merely, as so far, for the simplest arrangement that will do the job at all.

As has already been stated, this idea has from the beginning been kept in mind, and the components described are such that improvements in quality are possible with them by slight additions and modifications. The only big departure that was necessary from the original scheme outlined a year ago has already been made, viz., the substitution of the new nine-ball synchronised scanner for the simple mains-driven type. The reduction in over-all size of the set is made possible by partly cutting the web B (see previous articles) of the optical bench, and bending this so that the lamp is brought nearer in and nearer the front; a mirror is then needed to reflect the light round this bend, to the light control, and in introducing this the opportunity will be taken to insert a small prismatic device for utilising the diffracted, instead of the direct beam, as hitherto, from the light relay, thus giving better contrast and gradation in the simplest possible manner. At the same time this will bring the picture closer to the centre of the receiver, improving the appearance considerably. None of these alterations will be difficult or expensive.

The Television Image

DR. F. SCHROETER, in discussing the acceptability of television pictures in *Telefunken Hausmitteilungen*, from the points of view of physics, physiology, and psychology formulates the following conclusions:

Psychologically and aesthetically absolute image size is not a decisive factor in combined television and sound broadcast reception.

Home television screen dimensions, for a 441 line interlaced image, should not exceed 12.4 in. by 10.4 in.

With the present number of scanning lines, large images are of value only in large rooms and in connection with proportionately extended viewing distances.

The normal contrast range satisfies all requirements, provided that stray light is excluded from the vicinity of the screen. Where stray light interferes, the brightness level in interlaced images is limited by flicker.

In rooms with interference from the lighting system the most satisfactory tone colour is produced by screens which fluoresce with strong white and some blue.

Television calls for high fidelity acoustical reproduction to be acceptable, just as do sound motion pictures.

Television is significant primarily for extending ordinary optical limits and thus enabling audiences to witness distant events as they are taking place.

Tuning in the case of the sound receiver is quite easily achieved. A trimmer is fitted to permit the tuning condenser to be ganged, but it is not really necessary, as it is a simple matter when only a single station is to be received to free the spindle coupling and adjust individually the two condensers when the coupling can be tightened. Should it not prove possible to secure oscillation, the capacity of the regeneration condenser

cerned, will largely depend upon the adjustment of the regeneration condenser. Accordingly, no more feedback than will provide sufficient volume and discrimination against the vision channel should be employed.

The circuit diagram of the vision unit power supply is given by Fig. 2b (May issue). It comprises a 250 volt H.T. supply for the vision and synchronising section. It will be obvious

a separately smoothed tapping from the H.T. circuit being the only additions necessary.

Aerial

It is perfectly feasible to employ a common aerial for sound and vision. The aerial terminals can be connected in series or in parallel depending upon the arrangement and layout of the units. Alternatively, quarter-wave matching sections isolating the units from one another can be used. These sections can conveniently consist of adjusted inductances if desired. As a further alternative small transformers can be employed. In general, such additional complications are unnecessary, and it is entirely satisfactory to connect the aerial terminals in series. Also in the vision unit's circuit diagram (p. 325, Fig. 2a) there is shown a resistance between L7 and the 7,500 ohms resistance. The inclusion of this item in the diagram is an error and no resistance is required in this position.

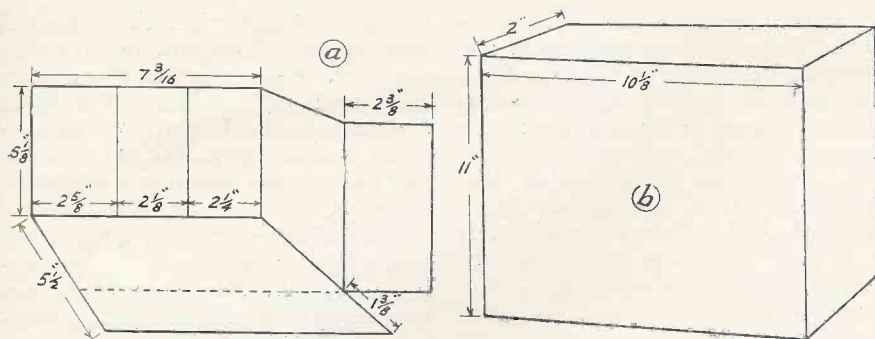

Fig. 15. Details of chassis construction.

can be increased. Again, for reception of a fixed frequency station it is convenient, should such a course be necessary, to parallel a small trimmer across the regeneration condenser. It should be observed, however, that the quality of reproduction, as far as the treble response at any rate is con-

that where an existing sound amplifier or a B.C.L. receiver is to be employed, in conjunction with the small signal receiving unit, that the power supply for this small unit can conveniently be provided by this supply unit an additional centre tapped L.T. winding for heater operation and

CORRECTION

It is regretted that a small error occurred in last month's article in this series. The terminal marked 'mod' in Fig. 6a should not be directly connected to the output terminal of the vision unit but should be isolated with a condenser of 0.5 uFd. capacity connected in series.

A NEW STUDIO LIGHTING SYSTEM

A NEW system of television studio lights has been installed in the N.B.C. Radio City television studios which does away with the necessity of using the heavy, heat-giving movie type "suns," "spots" and "broads." A complete pre-set system of lighting units, that formerly required the service of three men for several hours, can now be accomplished by one man in less than ten minutes.

Basically, the new system consists of many remotely controlled lighting units, suspended from the ceiling of the television studio. Each unit, of a bank of six lamps, may be raised and lowered, or tilted through a considerable angle, and swung through nearly a complete circle. Light may thus be focused on any desired spot in the studio. Remote control from the lighting engineer's desk at one end of the studio enables him to change the lighting set-up at any time during an actual broadcast without interfering with camera movement.

The new lighting units have effected a reduction in electrical load and a corresponding reduction in studio temperature.

One of the problems of studio lighting has been the supply of sufficient overall, illumination for the scenic sets used in a television show. Previously, television has followed a modified motion picture practice of setting individual light units in fixed overhead positions.

Provides Light "Flow"

The resulting compromises in distributing the available overall lighting made this system inadequate for television. Motion pictures are pro-

duced piecemeal and the film as finally released is assembled in the cutting room. A flexible lighting system is, therefore, not of great importance to the cinema industry. Television, however, follows stage and radio practice; the action flows continuously from beginning to end and the accompanying illumination must flow with it if acceptable photographic effects are to be achieved. The new N.B.C. system provides this necessary "flow" in the light accompaniment.

Light from the studio floor and from the sides of sets, used to "erase" undesirable shadows created by an overhead lighting system, is now supplied by lightweight and movable floor units, each supporting a bank of inside silvered lamps. A small lighting "dolly," mounted on wheels and bearing several lamps, furnishes the flexible element in this "modeling" illumination. Less than two feet in height, this dolly may be moved to within a few feet of an actor without appearing in the pictures.

Ensure obtaining "Television and Short-wave World" regularly by placing an order with your newsagent.

RECENT TELEVISION DEVELOPMENTS

A RECORD OF PATENTS AND PROGRESS
Specially Compiled for this Journal

Standard Telephones and Cables Ltd. :: *Telefunken Ges für drahtlose Telegraphie m.b.h* ::
F. J. G. van den Bosch :: *A. Carpmael and H. R. C. Van de Velde* :: *Baird Television Ltd.,*
and E. G. O. Anderson :: *J. D. McGee* :: *W. D. Wright*

Transmitting Tubes (Patent No. 501,375.)

THE "mosaic-cell" screen of a television transmitter of the Iconoscope type is replaced by a photo-sensitive electrode consisting of a pair of thin metal sheets, placed back to back, with an intervening layer of insulating material. The sheets are perforated uniformly, one side being coated with a photo-sensitive substance, and the other with a layer of highly-resistant material.

The electrode is placed midway along the length of a cathode-ray tube, and the image to be televised is focused on to the photo-sensitive surface, which is then scanned by an electron stream from one end of the tube. The liberated electrons are projected on to an electron-multiplier arrangement at the other end of the tube, where they are amplified by secondary emission before passing out to the transmitter.—*Standard Telephones and Cables, Ltd.*

Television Cabinets (Patent No. 501,532.)

Relates to a cathode-ray television receiver in which the picture on the fluorescent screen of the tube T is reflected by a mirror M so that it is

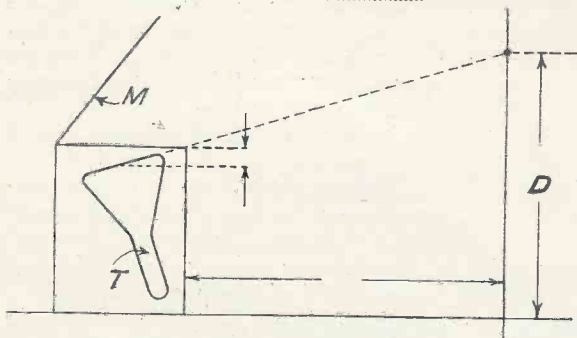

viewed indirectly. Although the inclination of the mirror can be varied, it is normally kept at a fixed angle when the set is in operation. The person using the set should not, of course, be able to see the fluorescent

Arrangement of tube in cabinet. Patent No. 501,532.

screen at the same time as the reflected picture, since this would distract his attention. This, in turn, sets a limit to the height of the observer's eyes when looking at the received picture.

According to the invention, the cathode-ray tube, instead of being mounted vertically in the cabinet, is "set back" at the angle shown. For a cabinet of given height, this increases the viewing-area or elevation D over which the picture can be seen in the mirror without interference from the direct light of the fluorescent screen.—*Telefunken Ges für drahtlose Telegraphie m.b.h.*

Transparent Screens (Patent No. 501,816.)

Instead of the usual fluorescent screen a cathode-ray television receiver is fitted with a screen of zinc sulphide, on which the scanning-beam acts to set up local charges corresponding to the light-and-shade values

of the received picture. Mounted next to the screen is a flat disc-like chamber, containing iron particles suspended in paraffin. The light from a powerful lamp, mounted outside the tube, is focused through the zinc sulphide screen on to the paraffin chamber.

Normally the iron particles in the paraffin set themselves "higgledy-piggledy," so that they block out practically all the light from the lamp. But the static charges formed on the zinc sulphide by the action of the scanning-beam cause each of the iron particles to swing round and set themselves "end on" so as to afford free passage for the light. In other words the transparency of the paraffin chamber is varied locally, according to the picture intensity. Light from the lamp can therefore pass through and project an image of the picture on to a large viewing-screen mounted outside the cathode-ray tube.—*F. J. G. van den Bosch.*

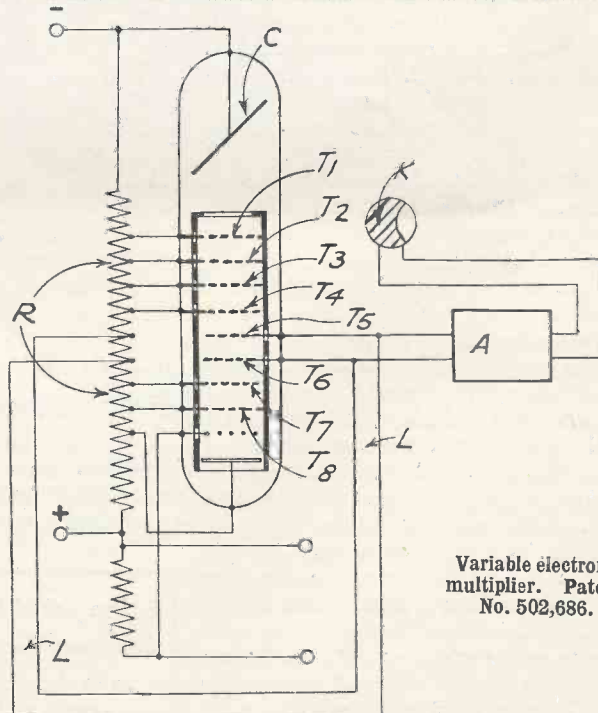

Variable electron multiplier. Patent No. 502,686.

The information and illustrations on this page are given with permission of the Controller of H.M. Stationery Office.

Television in Colour

(Patent No. 502,358.)

To produce television pictures in colour, the light from a powerful arc lamp is passed through three different "light-valves," set side by side, and provided with red, yellow and blue filters respectively. Each cell is of the "supersonic" type in which a peizo-electric crystal creates high-frequency waves in a liquid, which then causes interference fringes to be

shown. In parallel with the leads L is an amplifier A, which amplifies the light picked up by a cell K arranged to respond to the "background intensity" of the scene being televised. The effect of the auxiliary potential, so applied from the cell K to the electrodes T₅, T₆, automatically regulates the final output from the multiplier in the manner desired.—*Baird Television, Ltd., and E. G. O. Anderson.*

optical system consists of a lens L for producing an image in the plane P, P, and a diverging lens L₁ placed in the plane P', so that the combination produces an accurately-focused image on the convex surfaces which can then be placed directly in contact with the similarly-shaped surface of the photo-sensitive cathode.—*W. D. Wright.*

(Patent No. 501,966)

Television system in which signals from different scanning points can be mixed together.—*A. D. Blumlein.*

(Patent No. 502,696)

Construction of stationary mirroring, for scanning, in which all the mirror elements are held in position by pressure applied to the two end mirrors.—*E. Traub.*

Patent No. 502,830)

Circuit for producing saw-toothed oscillations for use in scanning.—*Marconi's Wireless Telegraph Co., Ltd.*

(Patent No. 501,058)

Clear-cut focusing of the electron stream of a cathode-ray tube.—*C. S. Bull.*

(Patent No. 501,535)

Cathode ray television receiver in which a "flooding beam" of electrons is used in combination with the usual scanning-stream.—*Baird Television, Ltd., and T. C. Nuttall.*

(Patent No. 501,741)

Means for treating luminescent screen material so as to increase its resistance to burning.—*Marconi's Wireless Telegraph Co., Ltd.*

(Patent No. 501,919)

Electron-multiplier in which a "mirror action" is used to produce successive impacts of the main discharge-stream.—*H. G. Lubszynski and W. S. Brown.*

(Patent No. 501,931)

Magnetic lens system for focusing the electron stream in a cathode-ray tube.—*The British Thomson-Houston Co., Ltd.*

Patent No. 494,145.

Cathode-ray receiver in which a grid electrode is scanned by an electron stream proportional to the intensity of the received signal, and controls the passage of a second electron stream on to a fluorescent surface.—*Radio-Akt. D. S. Loewe.*

Patent No. 495,331.

Method of offsetting the inherent time-delay of circuits used in deriving synchronising-impulses from A.C. mains.—*Baird Television, Ltd., and V. A. Jones.*

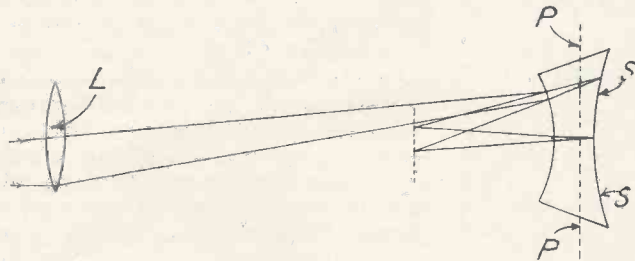

Method of avoiding loss of focus. Patent No. 502,975

set up in the path of the ray of light.

The three light cells are controlled in turn, so as to give what is, in effect, "interlaced" scanning for each of the primary colours. For this purpose a special type of a cathode-ray tube is used, in which the electron beam is continually swept over three different sections of a common anode.

Each of the three sections controls an amplifier to which the incoming signals are applied, so that these are fed in rapid succession first to the red, next to the yellow, and then to the blue "light valve." The different "scans" are finally reassembled on the viewing-screen by two rotating mirror-drums set at right-angles to each other.—*A. Carpmael and H. R. C. Van de Velde.*

"Variable" Electron - multiplier

(Patent No. 502,686.)

The Figure shows an electron-multiplier arranged for amplifying television signals. More particularly it allows the degree of amplification to be varied from time to time, in order, for example, to follow any slow changes that may occur in the average light-intensity of the "background" of the scene being televised.

Light from the picture is focused on the photo-sensitive cathode C of the electron-multiplier, the resulting stream being amplified by secondary emission from each of the "target" electrodes T₁ . . . T₈. Each of these carries a gradually-increasing positive voltage which is tapped off from a potentiometer R. The voltage on the two electrodes T₅, T₆ is, however, reversed by means of the leads L as

Multiple-spot Scanning

(Patent No. 502,796.)

A cathode-ray television receiver is arranged to produce several electron-streams, each separately controlled, so as to scan the screen in regular sequence, one after the other. The cathode or "gun" of the tube consists of a number of separate and mutually insulated strips, each acting as the source of one stream. The strips are arranged along the outside of a cylindrical heating-element with a filament running axially inside. A wire is connected to each strip through which separate control potentials are applied, to bring each into action in turn. Separate control grids may also be arranged in front of each emitter, so as to ensure that the screen is scanned by each of the streams in regular succession.—*J. D. McGee.*

Optical Focusing

(Patent No. 502,975.)

In certain forms of television transmitter tubes the electron-emitting surface is made curved, instead of flat, in order to avoid distortion of the image. In such cases the sensitised surface is usually transparent, and the optical image is projected on to its convex surface. The resulting electron emission, of course, takes place from the inner or convex surface.

This type of tube calls for an optical lens system of special design if the whole image—and not merely the axial rays—is to be truly focused. According to the invention, the

Telegossip

A Causerie of Fact, Comment and Criticism

THOSE seven hundred viewers who applied to the B.B.C. for invitation to the free Television Tea Party (which will have taken place at Broadcasting House by the time these words are read) may be interested to hear how Mr. Gerald Cock, the Television Director, chose the 150 guests. He placed all the letters in a waste paper basket, had them well stirred and then picked at random.

One of the most interesting applicants was a man who declared that he had been an invalid for thirteen years and during that time had never been able to go out to a cinema or theatre. Television is a God-send to such unfortunates. He proposed going to Broadcasting House in his invalid chair.

20,000 Receivers

There are now about 20,000 television set owners, according to semi-official estimates. So approximately one in thirty asked to go to the B.B.C. party, a very high proportion. The television audience is still to some extent a big family and viewers take a personal interest in the programmes, the staff and the problems of production. It was precisely the same among pioneer listeners in the 'twenties, but the broadcasting audience quickly grew to unmanageable proportions, whereas television moves slowly.

Curioser and curioser grows the situation regarding a Birmingham station. Last month, writing on excellent authority, I indicated that a favourable decision might be expected soon. Since then the Postmaster-General, who was greatly impressed by the arguments put before him by the Radio Manufacturers' deputation, has seen three other deputations representing the theatrical and cinema industries, putting the case for the opposition. It is reported that this has given him pause and that there will be no provincial television station without suitable safeguards for rival entertainments.

But I cannot believe that this is the real cause for deferring a decision. The Television Advisory Committee exists to advance television not to raise difficulties. A prominent leader of the music hall industry told me that every new entertainment affected theatre attendances at first,

but that eventually, when the novelty had worn off, people flowed back to the music halls in increased numbers. Every new type of entertainment seems to whet the appetite afresh and to stimulate the public demand to be amused. Mr. George Black, director of the General Theatre Corporation, was for years a strong opponent of broadcasting. Now he is an enthusiastic believer in its public value.

I believe that the reasons for delay have nothing to do with the clash of interests. The gear for the radio television link experiments, ordered by the Post Office from E.M.I., has not yet been delivered, and, I understand, is not expected to be ready before the end of the year. The fact is that the Post Office has such a vast amount of work on hand for the Defence Forces and the A.R.P. organisation that television has definitely taken a back seat. The Radio Manufacturers' Association should now press their campaign with renewed vigour. Peace-time development cannot be entirely submerged by preparation for war. In the so-called bloodless "war of nerves" nebulous fears should not be allowed to produce that creeping paralysis of the nation's life which our enemies would rejoice to see.

A.P. Staff

Nor has the financial difficulty been properly resolved. The R.M.A. "offer" to put up £100,000 "if the projected station were not a success" was couched in such vague terms as to be held valueless by official circles. The Advisory Committee, I believe, is much exercised over the possibility that Midland and Northern viewers may not be satisfied to draw all their programmes from London and may demand separate studios and Regional programmes. Now the staff of Alexandra Palace was recently increased to 450. In other words, for the present strictly limited service one-eighth of the total staff of the B.B.C. is employed. Roughly ten times as many employees are required for a television programme as for its equivalent in sound.

But the service must be allowed to grow and a review of the difficulties does not advance matters much. Officialdom must cease to boggle and act courageously and decisively.

Meanwhile staff expansion goes on. The B.B.C. has just recruited four new assistant studio managers and an outside broadcasting assistant. The assistant studio managers are Paul Chesterton, Peter Henschel, T. M. Jenkins, and Campbell Logan, and the new O.B. manager is G. dell Strother. All have had film and stage experience. Mr. dell Strother was an assistant director to Alexander Korda for four years.

D. H. Munro, just returned from New York, where he has been advising the Columbia television staff on their new service, is reticent about his visit because he says he does not want to seem patronising or discourteous to his late hosts. But the fact is that, as always at the start, organisation was at a very primitive stage. Columbia had two cameras and two telecine channels, but had omitted to make any provision for sound! However, that was soon corrected, and Mr. Munro produced one or two specimen programmes on a closed circuit. Regular programmes have not yet been started by Columbia.

Big-screen Developments

One of my most interesting television experiences this month was the big screen reproduction of Trooping the Colour. This I saw at the New Victoria which is only a short walking distance from the Horse Guards Parade. Some hundreds of people preferred to watch the television version at cinema prices rather than stand in the crowd and endure the June heat. I imagined at one time that television was playing tricks by making the long straight line of Guardsmen into a crescent. But Mr. Philip Dorté vigorously defended his transmission and he must really have it out with the Brigade of Guards, for I decline to take sides.

I thought I was used to big screen shows, but once again I was most impressed with this Baird achievement. On entering the theatre I felt that the most important improvement necessary is more light, and then, from the back of the theatre it would to the eye be almost indistinguishable from a cinema picture.

I am told that even big screen development is held up by the Advisory Committee's procrastination over a Birmingham station.

NARROW BAND PICTURE TRANSMISSION

A METHOD of transmission and reproduction of line images which do not necessitate great detail has been the subject of experiment in the U.S.A. with the object of using a comparatively narrow band width. Tests have shown that a drawing of a woman's head could be reproduced in outline with an equivalent total band width of approximately 2,600 cycles. This is made up of two bands, each 1,300 cycles wide. Analysis of a more complex image, such as that of an animated cartoon shows that such material could be transmitted and reproduced by the method within a total band width of 10 kc.

The illustrations shown by the author in explaining the system are each in the form of a closed loop in which the spot on the cathode-ray tube is made to traverse by applying simultaneously the proper voltages to the horizontal and vertical deflecting plates. The voltages are, of course, directly proportional to the x and y coordinates of the point of the drawing, taken along the path of the spot in the direction in which it moves.

The system therefore essentially resolves itself into the problem of making line drawings, determining the x and y coordinates for each point on this line, generating deflection voltages proportional to the x and y coordinates, and transmitting the two voltages simultaneously.

At the receiver they are re-assembled in such a manner that x and y displacement voltages are applied to the horizontal and vertical plates of the cathode-ray tube for the reproduction of the image.

The primary advantage of this method is that it enables certain types of drawings to be reproduced with much less band width than is necessary at the present time with the usual scanning method of television operation.

The two kinds of detail which will suffer most are straight portions and sharp bends. The overall shape and form of the image and the larger details are dependent on the lower frequencies which are present in the transmission band, and these frequencies are therefore the most important ones. If the bands include enough harmonic to reproduce the small detail, even in approximate

form, the larger details of general form will be reproduced with good fidelity.

The total band width necessary for satisfactory reproduction of a Walt Disney cartoon was judged to be 10,000 cycles, this total being made up of 5,000 cycles each for the x and y deflecting potentials.

A total band width of 10,000 cycles

is also adequate for about seven words of handwriting. The total band width for script is proportional to the total number of letters and spaces, or to the number of words of average length.

The type of images which are capable of transmission by this method include drawings, diagrams and maps, either with or without animation, animated cartoons, and script.

TELEVISION STUDIO TECHNIQUE

Lessons of Seven Years' Experience in the Don Lee Studios

IT has been found that real properties invariably televise satisfactorily, although suitable illumination may be required for emphasis. In painted properties, such as background, windows and fireplaces, the delineation of the object from the general tone of the background should be sharp, and the width of lines comprising the structures bold. A certain amount of defocusing is usually obtained on the background, often for the purpose of centring attention on the principal characters, who are in sharp focus, as is utilised in cinematography. The background properties are therefore televised in subdued tones as desired.

For multi-character scenes, the long shot is often used with complete settings, such as a room, which may assist in the story. If small items of interest are to be displayed, however, the scene may be modified from what would normally be a long shot to one showing only half or two-thirds of the principals involved. One scene may be changed into the other by moving the camera, or by moving the principals. On many scenes, a rather high camera is utilised, that is, the lens 4 or 5 feet from the floor. Changes from long shot to close-up may be made once or twice during an episode. Changes of scene are usually accomplished by panning, under which conditions, two sets are established on opposite sides of the general stage area.

Lighting

The technique of lighting for television appears to be one of the most fruitful in creating pleasing artistic effects. So-called "flat lighting" will give television pictures, but ones which have little interest and sparkle compared to those televised with more elaborate lighting. By flat lighting, of course, is meant that nearly all the light to illuminate the

scene comes from the front of the set and perhaps also from the top of the set at the front.

The advance technique appears to be only limited by the number of lighting units available, and the possibility of manoeuvring them as required for the changing conditions brought about by motion of the performers on the set. This problem is complicated by the fact that in television, illumination must be continuous for the total duration of the act. In motion picture technique, each portion of action may be made as a separate take and ample time allowed for skilful placement of the lights.

In the Don Lee studio, a portable switching panel is installed which gives control of individual or limited groups of all the lights utilised. With this device the lighting supervisor can vary the lighting considerably without touching any unit. This control is usually supplemented by changing diffusers, changing the angle of the unit, and/or change of position of mobile units by lighting assistants. A considerable number of the lighting units are fixed in position near the ceiling, each in the proper direction for usual action as has been determined by experiment. A few mobile floor units are utilised.

Hard back lighting has been found to be a very desirable component. This must be supplied by lens-reflector units. General lighting is properly supplied by lamps in dull finish reflectors and modeling lights for the face must be diffused with one or more diffusing screens.

The camera photo-electric tube suffers a form of overload similar to over-exposure, if the illumination on the subjects is too great. This usually occurs first on the faces of the performers and gives a "washed-out" effect, in which the sharpness of

the features are lost. This condition is eliminated by either reducing the amount or hardness of the light, or stopping down the lens aperture. Make-up is also a factor in this effect, and lighting, camera aperture and make-up must be correlated in order to achieve desirable results. It has further been found that the spectral characteristic of the light exercises an important effect on the resulting image. A pure white light is the ideal.

Use of Models

Cognisance is taken of the fact that large and elaborate sets are beyond the present scope of television economically, if not otherwise, and that physically impossible actions must not be imposed upon the cast. Through the use of miniatures, however, otherwise impossible action has been televised. In a recent episode, a considerable portion of the action took place in close shot with the characters in an aeroplane. Running out of petrol they go into a tail spin and crash on land. The first scene was taken with the characters and life-size properties. The nose dive was made by means of a miniature airplane, handled by wires, and the crash scene, previously set up on another set, was occupied by the characters during the transition through the miniature.

Sound Pick-up

Two methods of microphoning have been evolved, first, the boom or moving microphone method, wherein a comparatively light microphone boom is utilised and moved to keep the microphone reasonably close to the performers. The usual microphone position is overhead and in front of the performers and as close as possible without appearing in the picture.

The second method utilises up to four stationary microphones. These are arranged at strategic points on the scene of action, and the electrical change-over from one to another is accomplished by fader operation by the sound monitor supervisor. This method does not require production assistants for moving the microphone boom.

Make-up

Make-up is most important in long shots. In close-ups, street make-up is sufficient, although accentuated make-up may be utilised by increasing

the light intensity on the subject.

A base paint is utilised as a start. Eyebrows are accentuated with black or dark brown liner. Lipstick of a brownish-violet shade is applied. This colour has been found desirable after considerable tests in performance to the red lipstick, because the camera tube exhibits increased sensitivity in the red region of the spectrum, and because red light energy is particularly predominant in the incandescent illumination utilised.

Overall supervision of all the processes of television operation and production can be exercised by a suitably trained director, who observes the programme at a sight-sound television receiver located at a representative point in the service area of the

television station. He talks by telephone to the television studio supervisor, television transmitter control operator and possibly to other members of the operating staff. Defects in lighting, camera technique, microphoning or television control or transmitter adjustments are thus instantly apparent. Monitors are provided in the studio and also at the transmitter, the latter operating from an input which has been radiated. Following the complete broadcast, a written report is prepared by the director. This includes tabulation of various technical readings, the artistic observations on the merit of the camera shots and lighting, and a summary of the merit of the broadcast as a whole.

SPONSORED PROGRAMMES IN U.S.A.

WHILE it is expected that television will become an advertising medium in the U.S.A., the Federal Communications Commission has not yet licensed any television broadcasting station to operate commercially. The National Broadcasting Co. has not as yet planned any immediate sale of its time, but, of course, will expect eventually to make available certain hours of sponsored television programmes. In the meantime, it is following the policy of creating as much programme variety as possible in order to build up a fund of experience which will be of value to advertisers when the time comes for sponsored programmes.

Programme material already tried has included drama, variety and music and novelty, including ping-pong, fencing and animal acts. Full-length films, newsreels, and short films were also tried. In the field of education, programmes have been included embodying the microscope through which the "family life" of minute organisms was watched by the television audience and described by specialists on the subject, travelogues through various parts of the world, book reviews, dancing lessons, and science demonstrations. Experiments have been made with a mobile out-

door pick-up unit at various times to determine what may be done in the way of providing broadcasts of current events and outdoor athletic contests.

There has been collaboration with those industries whose products appear to lend themselves most readily to television exploitation. Experimental programmes have been worked out with advertisers in many of the major industries, including cars, fashions, jewelry, foods, steel, drugs, oil, tobacco and others.

Special observers have been employed whose task it has been to watch and chart the development of television in relation to its possibilities as an advertising medium. These men have developed exhaustive files of information on all phases of the medium and have explored its future possibilities from the economic and from the practical advertising standpoints, have made preliminary plans for the maintenance of proper statistical records, the measurement of reception conditions and a study of the psychological aspects of television advertising. They are also carefully studying the application of television programme technique to such problems as package design, commercial announcements, and dramatisations of the uses of products. Analysis has been made of the types of industries which may be expected to be able to use television most effectively and the functions to be performed by all those concerned in the production of commercial television programmes have been studied.

Mention of "Television and Short-wave World" when corresponding with advertisers will ensure prompt attention.

JULY, 1939

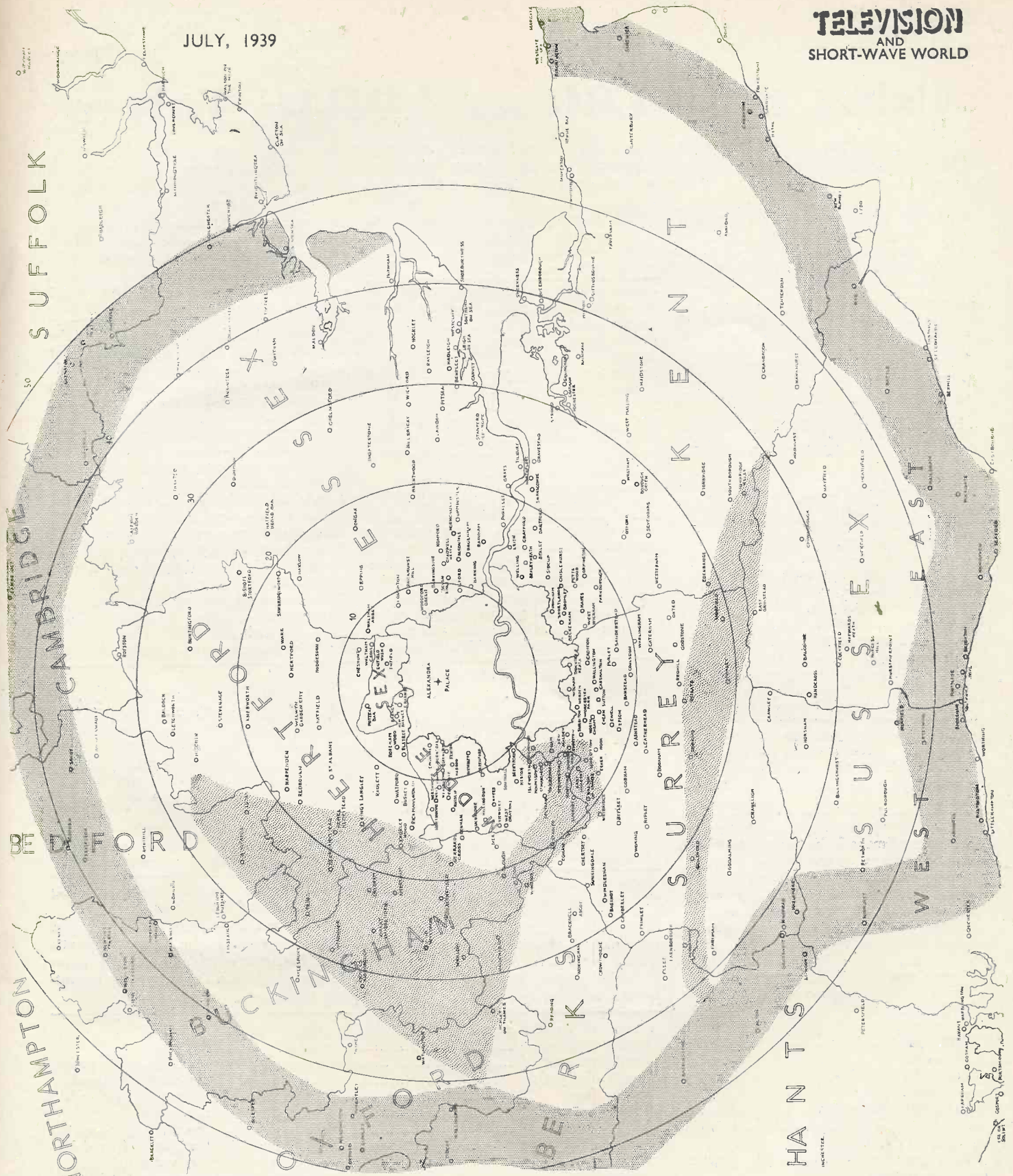

GOOD AND BAD PICTURE AREAS

This map, showing the area in which reliable reception can be obtained from the Alexandra Palace television station, has been compiled by the R.M.A. from exhaustive information supplied by television receiver manufacturers. Effective radius of the station is 40 miles.

It is, of course, impossible to lay down a hard and fast line between the area where reception is satisfactory and that where it is unsatisfactory. The outer shading (fine) is the approximate boundary of the area in which consistently reliable reception is usually obtained. In exceptional circumstances reception is possible outside the area, particularly in favourable locations with very efficient aerial systems. The shading represents an area roughly five miles wide.

Within the inner shaded portion (coarse) reception is usually satisfactory, but difficulties may be experienced due to local conditions.

In localities of heavy road traffic, interference may be of sufficient strength to spoil otherwise satisfactory reception.

Large-size copies of this map (31 ins. by 28 ins.) can be obtained, price 2s. 6d., from the Radio Manufacturers' Association, 59, Russell Square, London, W.C.1.



The finest key in the world at the price. Heavy cast parts. Balanced arm. Solid silver contacts. Ideal for the fast sender, 11/8.

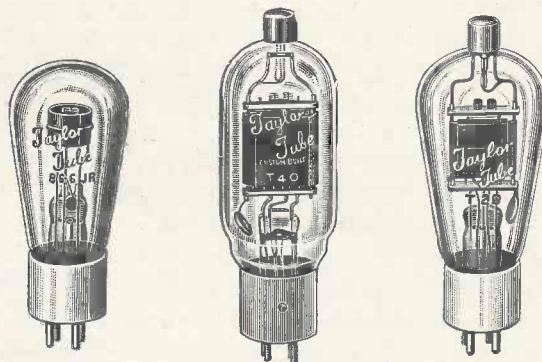

TAYLOR TUBES.

866 Jr. Mercury Rectifier ...	7/-	T40	24/-	T20	17/6
		TZ40	24/-	TZ20	17/6

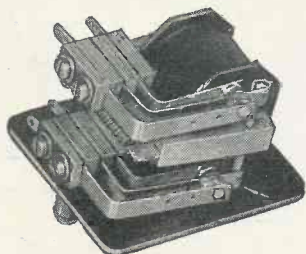

GUARDIAN RELAYS.

B100. Break-in relay. Coil for 230-volt operation. As illustrated, 33/-.	K100. Keying relay. Will handle 2,000 v. at 60 w.p.m., 24/-.	R100. R.F. relay. Useful for switching coils, crystals, etc. 13/-.
--	--	--

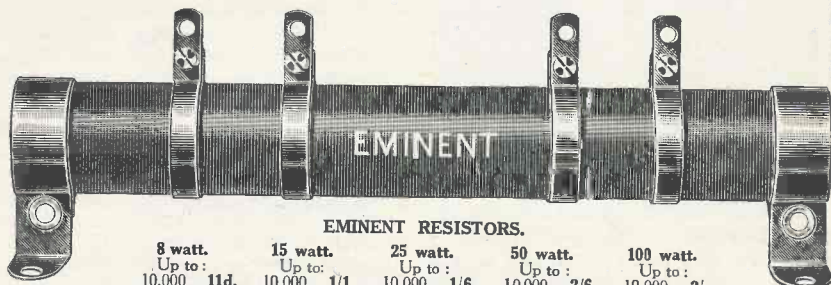

EMINENT RESISTORS.

8 watt.	15 watt.	25 watt.	50 watt.	100 watt.
Up to:	Up to:	Up to:	Up to:	Up to:
10,000 11d.	10,000 1/1	10,000 1/6	10,000 2/6	10,000 3/-
20,000 1/1	20,000 1/4	20,000 1/9	20,000 2/9	20,000 3/5
50,000 1/4	50,000 1/6	30,000 1/11	30,000 2/11	30,000 3/8
		40,000 2/1	40,000 3/-	40,000 4/-
		50,000 2/3	50,000 3/2	50,000 4/6

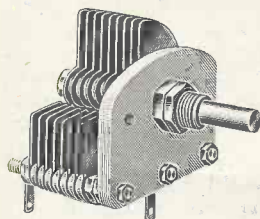

Frequentia ended, single end plate type. No. 275.

50 mmfd. ...	2/8
100 mmfd. ...	2/11
150 mmfd. ...	3/7

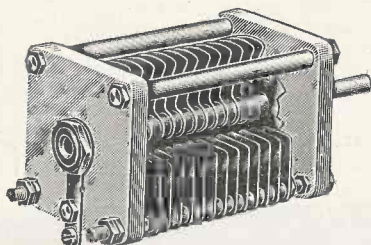

No. 370. As illustration. Silvered vanes. Working volts, 1,000.

25 mmfd. ...	4/9
50 mmfd. ...	5/-
100 mmfd. ...	5/11
150 mmfd. ...	6/10
200 mmfd. ...	10/-

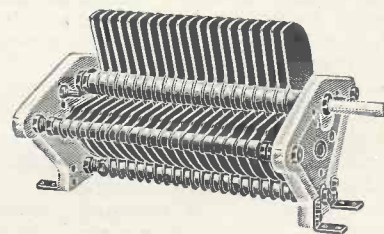

No. 400. The highest grade transmitting condenser on the market. Working volts 3,000. Extremely solid Frequentia ends. Frequentia extendible shafts.

150 mmfd. ...	28/-
250 mmfd. ...	33/-

We have stocks of Ham goods in immense variety. Most types of Raytheon RK types in actual stock. 1851's, 1852, 1853. Practically all Raytheon, Yale, Sylvania & Impex types also in stock. Sleeveings. Trolitul sheet and rod. Coil formers, Keys, Ceramic and Paxolin valveholders. Black crackle paint that works. Transformers, Chokes, Aerial wires in enamelled copper and copperweld. Thousands of small lines such as plugs, sockets, clips, washers, etc. Eidsons 7 Mc. crystals 10/6d. Eidsons ceramic crystal holders 7/6d. Electrolytic and paper condensers at the right prices. Send a penny stamp for June list. Good discounts to genuine traders.

HAMRAD WHOLESALE LTD., 32 ST. LAWRENCE TERRACE, W.10
LADbroke: 1166

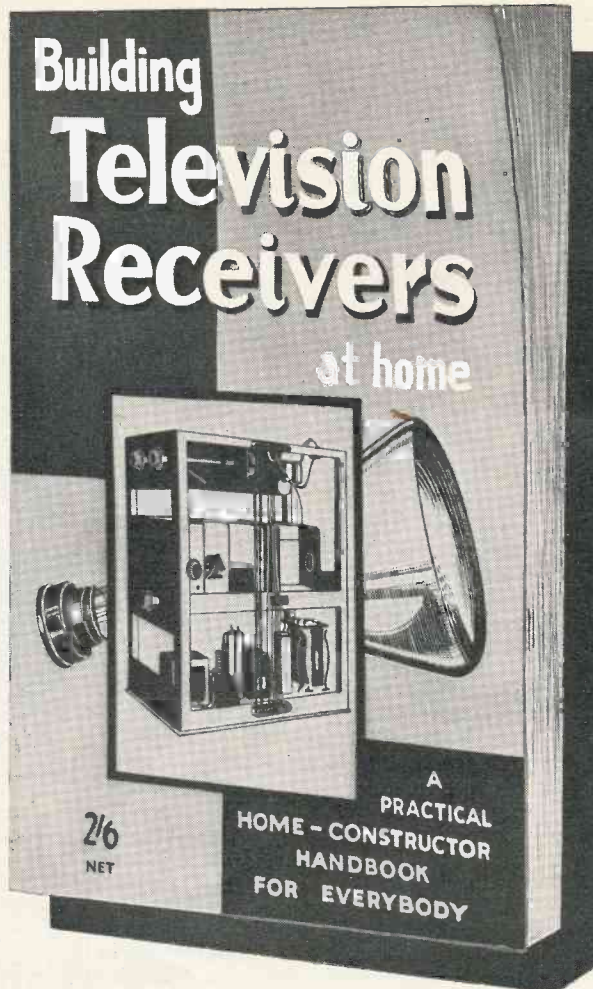

**A Simple &
Practical
Handbook**

**For the
Amateur Home
Constructor**

"Building Television Receivers at Home"

Is a practical handbook giving precise instructions that will enable any amateur to build a Television Receiver guaranteed to produce pictures of present-day standards both as regards definition and brightness. Three designs are provided with a wide range of picture size and the constructional information and illustrations are in such simple detail that they can be understood and carried out quite easily by the average wireless amateur. Results are assured.

CONTENTS INCLUDE :

How a Television Receiver works
Receiver giving pictures up to 12 inches
The Time Base, Cathode-Ray Tube network and Receiver Power Unit
Adjusting the Vision Receiver, the Tube and Time Base Power Unit
Adjusting the Time Base
Adding refinements

Small-picture Receivers
Receiver giving a 4-inch picture. The simplest Home-Built Televisor
Time Base for 4-inch Tube Receiver
The Power Units of the 4-inch Tube Receiver
Long Distance Reception
Simplified Receiver using a 1-inch Cathode-Ray Tube

100 ILLUSTRATIONS

112 PAGES

2/6 net

OR

2/9 post paid

FROM ALL BOOKSELLERS

FROM THE PUBLISHERS

BERNARD JONES PUBLICATIONS LIMITED,

CHANSITOR HOUSE, CHANCERY LANE, LONDON, W.C.2

(Proprietors of "TELEVISION AND SHORT-WAVE WORLD")