

# Electronic Engineering

INCORPORATING ELECTRONICS, TELEVISION AND SHORT WAVE WORLD

## PRINCIPAL CONTENTS

The Measurement of 'Q'.

The Synchronisation of Oscillators — Part 2.

Amplifying and Recording Technique in Electro-Biology.

Wave Analysis — Part 3.

Data Sheets — Choke Coupled Amplifiers at Audio  
Frequencies.

**2/- APR., 1943**

# Inspection ..

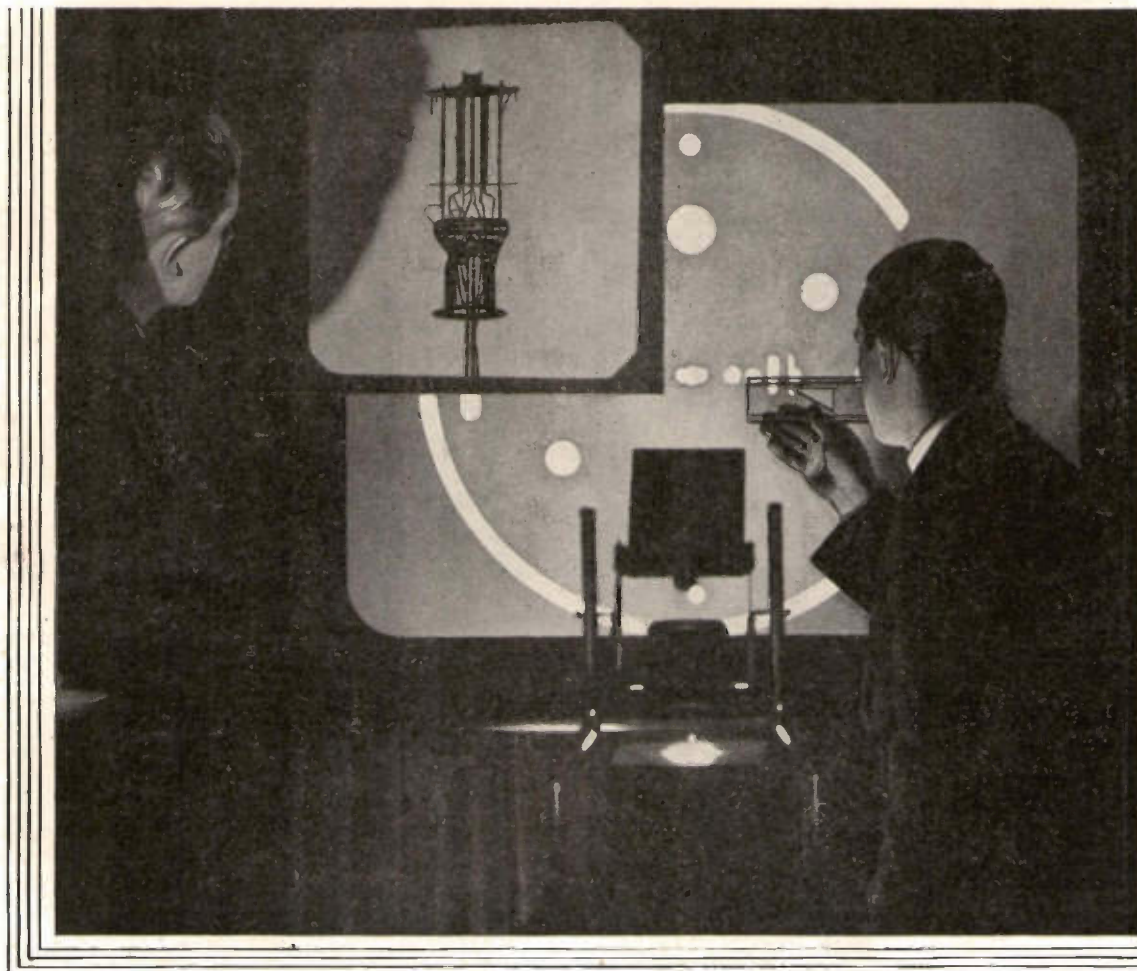

**B**Y means of the epidiascope, accurate and speedy inspection is facilitated. Our illustration shows greatly enlarged images of a top mica and partially assembled beam tetrode. Another example of the care which characterises every phase in the manufacture of Brimar Valves.

**BRIMAR**  
**BVA**  
**VALVES**

**STANDARD TELEPHONES AND CABLES LIMITED, FOOTSCRAY, SIDCUP.**

The fact that goods made of raw materials in short supply owing to war conditions are advertised in this magazine should not be taken as an indication that they are necessarily available for export.

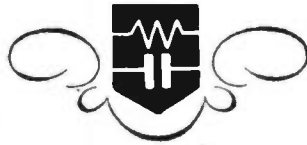

**T H E R E   I S   N O   S U B S T I T U T E  
F O R  
E N G I N E E R I N G   E X P E R I E N C E**



*And this is obviously a matter of extent, intensity and time.*

Take Electrical condensers for instance—simple in conception maybe—but demanding infinite experience and skill, to satisfy the exacting operating conditions of modern requirements. The fulfilment of these has meant the whole time occupation of highly skilled specialists, working at high pressure, in this way to earn, along with their countrymen in other spheres, the right of survival.

What a wealth of experience and technical excellence will be available to all, when happier times arrive; and nowhere more than in Dubilier Condensers.

**DUBILIER**  
CONDENSER CO. (1925) LTD.



***Value proven  
by long service***

**Osram  
Valves**

MADE IN  
ENGLAND

*for*

INDUSTRIAL APPLICATIONS

ELECTRO MEDICAL  
EQUIPMENT

THERMIONIC INSTRUMENTS  
and TEST GEAR

VITAL COMMUNICATIONS  
and WARNING SYSTEMS  
ETC.

THE GENERAL ELECTRIC CO. LTD.  
Magnet House, Kingsway, London, W.C.2

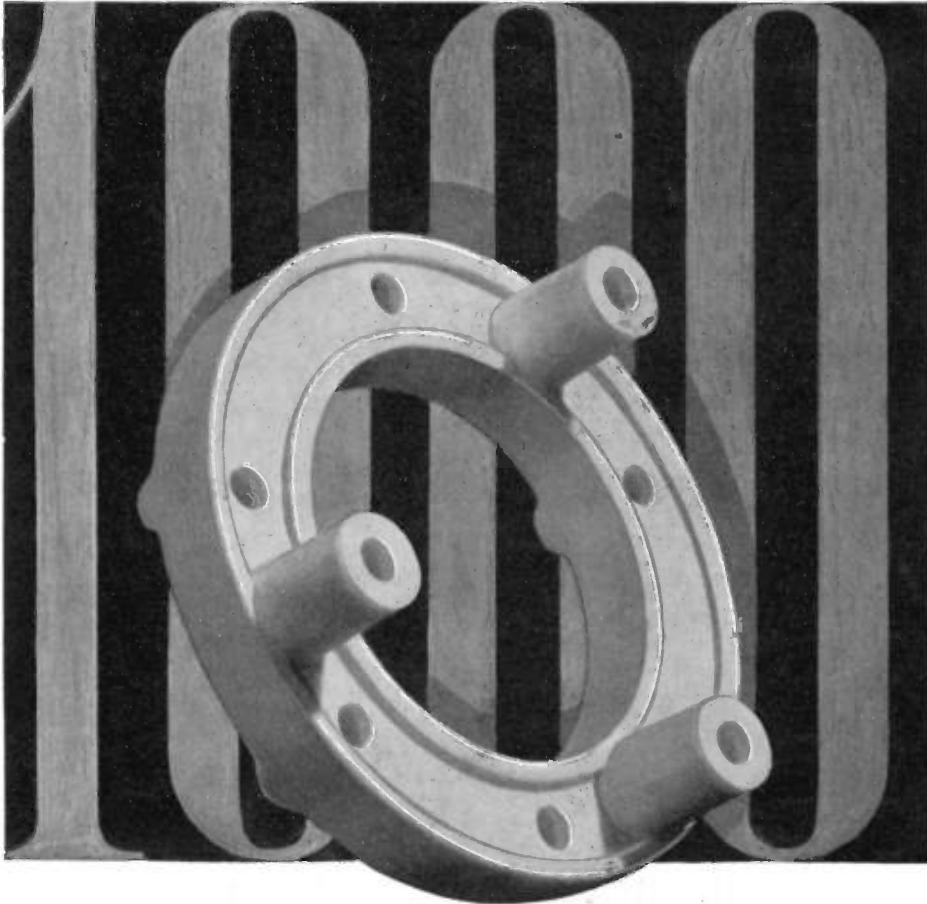

## ONE IN A THOUSAND

Ten years ago we introduced the first British-made low-loss ceramic. To-day the range of FREQUENTITE components covers more than a thousand pieces of every shape and size.

With such a store of manufacturing experience we are able to offer advice backed by practical knowledge on your insulation problem. Please consult us before you finalize your design.



## STEATITE & PORCELAIN PRODUCTS LIMITED

Head Office: Stourport-on-Severn, Worcs. Telephone: Stourport 111. Telegrams: Steatins, Stourport.

S.P.17



## A date with Destiny

These two modern weapons of battle ... the electronic tube and the bombing plane ... have an important date with post-war industry. In the days to come Eimac tubes, like the airplane, will help achieve the better way of life for the common man.

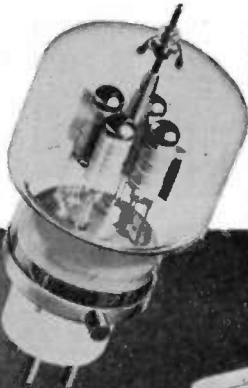

**Eimac**  
VALVES

*"First in Peace, First in War." First in the important new developments in the field of electronics*

OFFICIAL PHOTO U. S. NAVY

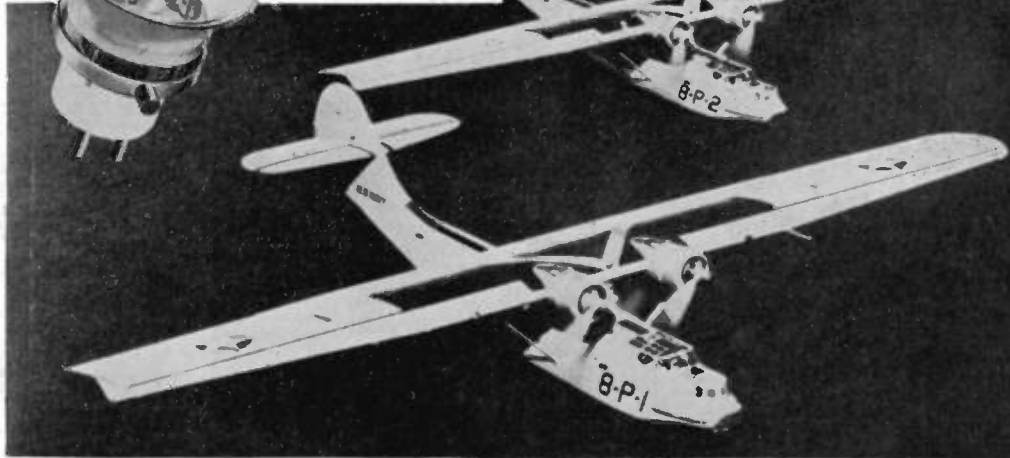

For high achievement in the production of war material ... the joint Army-Navy "E" awarded September 4, 1942.



**EITEL-McCULLOUGH, INC.**  
SAN BRUNO • CALIFORNIA U. S. A.

Export Agents: FRAZAR & CO., LTD.  
201 Front Street, San Francisco, California, U. S. A.

# The Synchronisation of Oscillators

By D. G. TUCKER, B.Sc. (Eng.), A.M.I.E.E. \*

Part II.—The Synchronisation of Types of Oscillator other than the Simple Inductance-Capacitance-Tuned Feedback Circuit

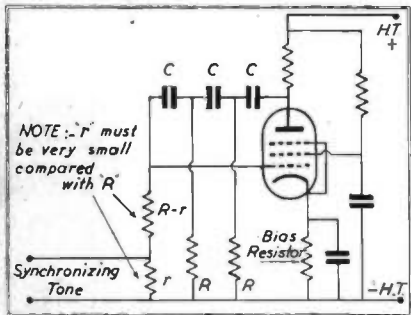

Fig. 1. Basic Circuit of "Phase-Shift" R.C. tuned Oscillator.

## I. Introduction

IN Part I the synchronisation of the simple inductance - capacitance tuned oscillator with resistance-controlled feedback was investigated in some detail. This type of oscillator (particularly with some of its modern refinements added) is the most commonly used for ordinary purposes, for instance, as the carrier generator in carrier telephone systems, and it is very frequently necessary to apply synchronisation to it. Other types of oscillator, developed as a rule for their special features of cheapness, or stability or suitability for extreme frequencies, do occasionally require synchronisation, however, and it is proposed to describe a few types in this part of the article, from the point of view of synchronisation by injection of a control tone into a suitable point of the circuit. The types considered are

- (a) The "Phase-Shift" RC-tuned oscillator.
- (b) An R.C. oscillator of the Muirhead-Wigan type.
- (c) The beat-tone oscillator.
- (d) The bridge-stabilised oscillator.

The first two are simply varieties of the feedback oscillator described in Part I, and are dealt with in the same way; their chief advantage is their suitability for very low frequencies, and type (a) can also be made very cheaply. The synchronised beat-tone oscillator has the very important feature of extreme phase stability, firstly, because it permits of a better inherent frequency stability than a straight oscillator with the same output frequency, and secondly, because phase variations in the two main oscillators largely cancel out in the difference frequency. The synchronised

bridge-stabilised oscillator also has the advantage of a good phase stability, if required, because of its natural frequency stability. It is important, too, in throwing light on the physical nature of synchronisation.

## 2. The Synchronisation of a "Phase-Shift" RC-tuned Oscillator

The "phase-shift" oscillator is a type of RC tuned oscillator that can be operated with only one valve. The basic circuit is shown in Fig. 1, where a pentode valve and a 3-section phase-shift network are used, although a network with more sections can be used if desired. A discussion of the principle of operation of this circuit has been published elsewhere; it is basically the same as for a feedback LC-tuned oscillator. The valve gives 180° phase-shift, and consequently 180° phase-shift is needed in the feedback circuit in order that oscillations may be possible—the gain of the valve must, of course, be greater than the loss in the feedback circuit. In the LC-tuned oscillator the 180° phase-shift is obtained (by means of the coupling mutual inductance) only near the resonance of the tuned circuit, and thus the oscillator can oscillate only at a certain frequency. In the RC-tuned oscillator, the 180° phase-shift is obtained by means of the phase-shift network, which gives the required phase-shift at one frequency only, and thus controls the frequency of oscillation.

A very important distinction between the two types of oscillator must be made, however. In the LC-tuned

case, as the frequency applied to the tuned circuit changes, so the phase-shift departs very rapidly from the required value, the rapidity of the variation being roughly proportional to the Q of the coil. But in the RC-tuned case, the phase-shift departs from the required value very slowly, and the extent of the change is determined only by the number of sections in the phase-shift network. Fig. 2 shows a graph of the variation of phase-shift with frequency, about the nominal value required for oscillation, for a 3-section RC network and for a tuned circuit with a Q of only 10 (which is a very low value).

It will be seen that the tuned circuit characteristic is approximately 20 times as steep as that of the RC network.

This distinction between the two types of oscillator causes an enormous difference between their locking characteristics. It will be seen from Appendix 2, which gives the equations to the phase-shift network in full, or from an inspection of Fig. 2, that the law of the phase network is given (for frequencies near that at which 180° phase-shift is obtained) by

$$\tan \beta = \frac{\omega - \omega_0}{\omega_0} \text{ approximately}$$

Since the graphical explanation of the synchronised feedback oscillator (see Fig. 3 of Part I and associated text) applies as far as general principles are concerned equally to the LC and RC-tuned types,  $\tan \beta$  in the above equation has the same significance as  $\tan \phi$  in equation (1) of

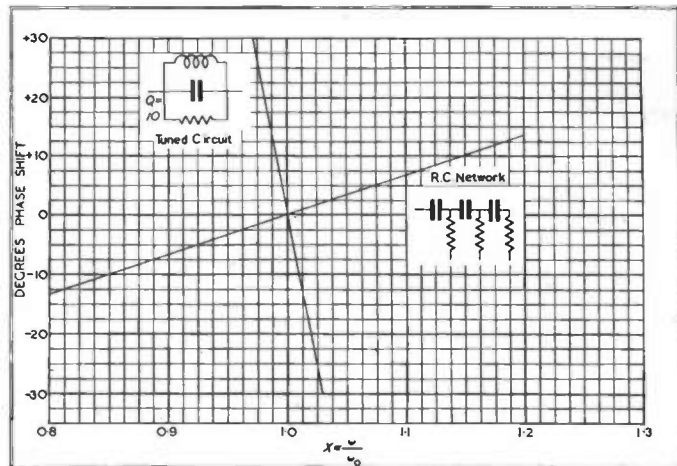

Fig. 2. Phase characteristics of tuned circuit and R.C. network near the oscillation frequency

\* P.O. Research Station

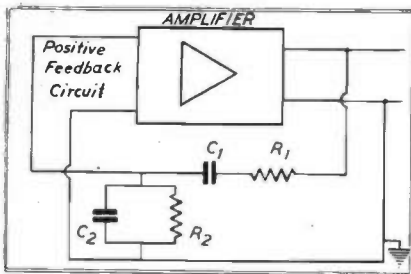

Fig. 4. Principle of Muirhead-Wigan oscillator

Part 1, i.e.,  $E_{syn-1}/E_E = \tan \phi$ .

We thus obtain the equation

$$E_{syn-1} = E_E \cdot \frac{\omega_{syn} - \omega_0}{\omega_0} \dots (1)$$

for the synchronisation of the RC-tuned oscillator.

It can now be observed that the voltage of locking signal required to lock the RC-tuned oscillator from a given frequency difference is very much smaller than in the case of any practicable LC-tuned oscillator. Fig. 3 shows the measured locking characteristic of an RC-tuned phase-shift oscillator using valve type SP41 (Mazda), the gain being adjusted so that oscillation takes place with only a very small margin. This characteristic may be compared with the results shown for an LC-tuned oscillator in Fig. 10 of Part I, provided that it is noted that whereas in that figure the magnitude of  $E_E$  was about 1 volt, in Fig. 3 it was only about 0.35 volt. The table below compares values of locking range for  $E_{syn-1}/E_E = 0.025$  in all cases.

Type of Oscillator	Q value in case of LC Oscillator	Percentage frequency difference for locking, i.e. $\frac{\omega_{syn} - \omega_0}{\omega_0} \times 100$
LC	40	.025
	20	.05
	10	.098
RC	—	3.5

### 3. Synchronisation of Muirhead-Wigan Type of Resistance-Capacitance-Tuned Feedback Oscillator

It will have been noticed above that, in order to obtain  $180^\circ$  phase-shift in the network of the oscillator of Fig. 1, at least three resistances and three condensers are required. A circuit\* designed to reduce the number to two is shown in schematic form in Fig. 4, and is used in the Muirhead-Wigan oscillator, previously described in this journal.<sup>2</sup> Instead of requiring  $180^\circ$  phase-shift in the network at the oscillation frequency, zero phase-shift is required since the feedback is here in

the positive sense. The amplifier must be designed, of course, to give  $2n\pi$  radians phase-shift ( $n$  being 0, 1, 2 etc.) and in the commercial design referred to above has three valves with considerable negative feedback (to give stability), and the input to the network is taken from the cathode resistance of the last valve.

Such an oscillator may be synchronised by a tone injected into the valve circuits, for example, injected across a low resistance in one of the grid circuits. If there are several valves, the locking voltage for a given locking range will be different for different points of injection, according to the total grid voltage developed on the different valves. An equation corresponding to equation (1) derived for the previous type of RC oscillator may be obtained in a similar manner. It is shown in Appendix 3 that if  $R_1 = R_2$  and  $C_1 = C_2$ , then for frequencies near the oscillation frequency the phase-shift is given by

$$\tan \beta = \frac{2}{3} \cdot \frac{\omega - \omega_0}{\omega_0} \text{ approximately}$$

and so

$$E_{syn-1} = \frac{2}{3} \cdot E_E \cdot \frac{\omega_{syn} - \omega_0}{\omega_0} \quad (2)$$

Since on the first valve the voltage  $E_E$  may be very low (the limiting action taking place on one of the other valves), it will be clear that a very small voltage of a frequency near the natural frequency will lock the oscillator to it, and if the synchronisation is not intentional, for instance, if the

locking voltage is actually only cross-talk or pick-up, the effect is very troublesome. In a test oscillator, it was found that a locking range of 0.2 per cent, was obtained with a locking voltage on the first valve 100 db. below one volt, i.e.  $10^{-5}$  volt.

### 4. The Synchronisation of Beat-Tone Oscillators

As a general rule, beat-tone oscillators are used as variable-frequency oscillators, and therefore are unlikely to require synchronisation. However, a fixed-frequency beat-tone oscillator can be synchronised to an external tone, and offers one or two important advantages over simpler schemes. The most useful of these advantages is probably the fact that phase variations between locking tone and oscillator output can be reduced to very small values, as will be shown later.

#### 4.1. The Simplest Method of Synchronisation

A simple beat-tone oscillator is shown in block schematic form in the full-line portion of Fig. 5. A and B are two simple oscillators generating frequencies  $f_1$  and  $f_2$  and C is a frequency changer which intermodulates these tones to give products including the difference frequency ( $f_1 - f_2$ ). D is a low-pass filter which removes all the frequencies leaving C with the exception of  $f_1 - f_2$ . E is an output amplifier. The first step in applying synchronisation to this oscillator is to ensure that the natural frequencies of oscillators A and B are approximately harmonically related to the difference frequency, i.e.,

$$f_1 \doteq n(f_1 - f_2) \text{ and } f_2 \doteq (n - 1)(f_1 - f_2)$$

Then synchronisation can be effected as shown in the dotted lines in Fig. 5 (the amplifier F being omitted at this stage) by taking the control tone ( $f_0$ ) at a suitable amplitude into a harmonic generator G, following which are two tuned circuits, H and J, selecting frequencies  $nf_0$  and  $(n - 1)f_0$  respectively; the outputs from these

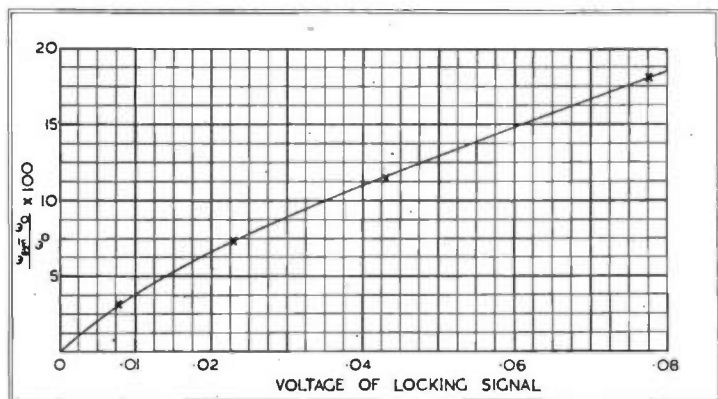

Fig. 3. Locking characteristics of "Phase-Shift" oscillator.

\* Originating in America. See refs. 5a and 5b. at end of article.



(amplified if necessary) are injected into the simple oscillators, A and B, as locking signals. It is clear that if the various amplitudes are correct and if the natural frequencies of the oscillators A and B are very nearly harmonics of the difference frequency, then the whole system will be locked, so that  $f_1$  is exactly the  $n$ th harmonic and  $f_2$  exactly the  $(n-1)$ th harmonic of the output frequency  $f_1 - f_2$ , which will now be equal to  $f_0$ . The selectivity of the tuned circuits H and J need not be great; provided that the wanted harmonic is given a few decibels discrimination against the adjacent harmonics, the oscillator will lock to the correct frequency and will give a considerable suppression to the other frequencies so that they are unlikely to cause trouble elsewhere in the circuit. Suitable amplitudes for the injected frequencies can be determined from the equations given in Part 1, according to the expected stability of the oscillators. If  $n$  is fairly large (as it usually will be) the best type of harmonic generator is the saturated inductor (electro-magnetic) type, described in a previous article in this journal.<sup>3</sup>

#### 4.2. "Self-Synchronisation" and Another Method of External Control

Before proceeding further, it is of interest to note that a kind of "self-synchronised" or harmonic beat-tone oscillator without external control can now be obtained which may be in itself more stable than the simple beat-tone oscillator. All that is required is to connect the oscillator output into the harmonic generator, preferably via an amplifier, F (see Fig. 5) to prevent unwanted signals and distortion products getting back into the oscillator output and to provide the necessary power to drive the harmonic generator. Then, in the absence of the locking tone, the main oscillators A and B will be so controlled that  $f_1$  and  $f_2$  are exactly the  $n$ th and  $(n-1)$ th harmonics of the difference frequency. This property is sometimes useful, and if the circuit is suitably designed an improved stability of frequency can be obtained. One necessary condition is that any change of supply voltage or temperature should affect both oscillators A and B in the same direction. The oscillator in this condition can still be synchronised to an external locking tone by connecting this latter also to the input of the harmonic generator, as before, so that we have now the complete scheme of Fig. 5. Of course, a much smaller amplitude of control tone would be sufficient if it were injected into the input of amplifier, F, but in this case, any stray signals mixed with the control tone would be injected directly into

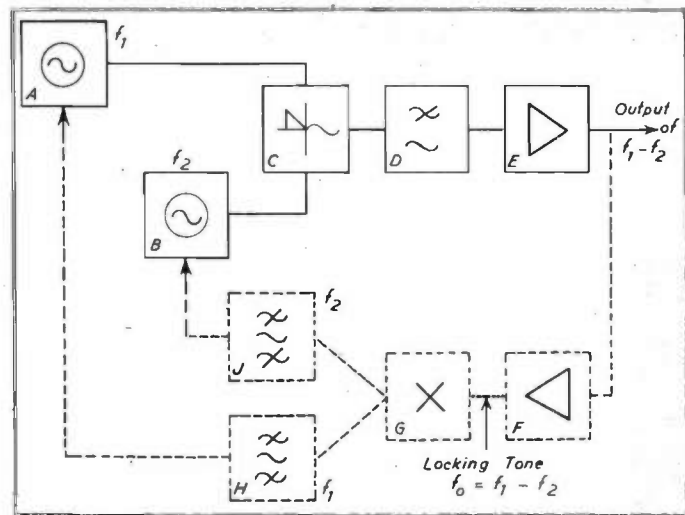

Fig. 5. Synchronisation of beat-tone oscillator.

the output circuit. If the amplitude of the control tone is adequate, the whole oscillator will synchronise with an output frequency equal to the control frequency. As a first approximation the injected voltage should bear the same relation to the total signal at the point of injection as obtains in the individual oscillators A and B.

#### 4.3. Suppression of Unwanted Signals

In the first and simpler case of synchronisation described, the suppression of unwanted signals mixed with the control signal is the same as in the case of a single oscillator with a Q value the same as in oscillators A and B, except in so far as the selective circuits D, H and J provide extra suppression. In the second and slightly more complicated system of synchronisation, the suppression may be considerably improved owing to the fact that a relatively smaller amplitude of locking signal (and therefore of interfering signal also) can be used.

#### 4.4. Phase Stability

The way in which an improved phase stability is obtained can be readily seen by considering first the ideal case in which we have that (a) when the natural frequency of oscillator A is the same as its locking frequency, the natural frequency of oscillator B is also the same as its locking frequency; (b) all the variations of natural frequency of both oscillators are cyclic, *i.e.*, there are no irregular or permanent changes of frequency due to such causes as slipping of clamps, etc., in the inductors and condensers which will affect only one oscillator frequency; (c) changes in temperature and supply voltage are the same for

both oscillators; and (d) the amount of locking tone injected into the two oscillators is so adjusted that both have exactly the same percentage locking frequency-range.

In this ideal case it is evident that any difference between the locking and natural frequencies will result in identical phase changes in both oscillators A and B, so that in the difference frequency the phase variations will exactly cancel out, and there will be no phase change in the output frequency.

In cases other than the ideal one, there will evidently be a phase variation of magnitude depending on the degree of departure from the ideal conditions.

#### 4.5. An Example

A synchronised beat-tone oscillator was made to the complete scheme of Fig. 5, and the oscillators A and B were of simple feedback type with pentode valves (Mazda SP41) and Q values of about 80. In each of these oscillators the total grid voltage ( $E_g$ ) was about 1 volt, and the voltage of injected signal ( $E_{syn}$ ) about 0.1 volt. The ratio  $n$  was 15, and the overall locking range was about 0.25 per cent. of the output frequency with an external locking voltage of any value between 1/5th and four times the voltage normally existing at the point of injection. Below the value 1/5th, the external locking voltage begins to control the locking range, and for very small values, the locking range depends almost entirely on the external voltage and is consequently independent of the voltage injected into oscillators A and B. No great difficulty was experienced in reducing the phase variation over the locking range to only a few degrees,

As regards the suppression of unwanted signals, a tone of any frequency not very close to (*i.e.*, not within a few per cent. of) the control frequency could be injected with the control tone and at an equal level and yet be too low to detect in the output of the oscillator, *i.e.*, at least 50 db. below the oscillator output. The ratio of control voltage to the normal voltage at the point of injection was about  $\frac{1}{4}$  in this test.

**5. Synchronisation of the Bridge-Stabilised Oscillator**

The bridge-stabilised oscillator consists fundamentally of an amplifier, the input and output of which are connected to the conjugate points of a bridge circuit, as shown in Fig. 6. One arm of the bridge is a series-tuned circuit controlling the frequency of oscillation; the opposite arm contains a resistance which varies with the power dissipated in it—a metal-filament lamp is generally used for this arm. The other two arms are ordinary linear resistances. If the lamp has a negative temperature-coefficient of resistance (*e.g.*, a carbon filament) it must be connected in an arm of the bridge adjacent instead of opposite to the tuned circuit. The principles of operation of this oscillator have been fully discussed by Meacham,<sup>4</sup> but the main points are briefly as follows:—The bridge is so set up initially that a small unbalance exists; the loss between the input and output should be approximately equal to the gain of the amplifier, and the unbalance should be in such a direction that the attenuation is increased (*i.e.*, the balance is improved) if the power in the circuit increases. Then it is clear that if the oscillation tends to increase in amplitude, due, say, to an increase in gain in the amplifier, the bridge loss increases and so reduces the loop gain, thus causing the amplitude to decrease. In this way, the amplitude is maintained almost constant in spite of variations in the amplifier, and the limitation of amplitude is not effected by valve non-linearity; in consequence it is possible to work the valves in the amplifier at very low power levels, with very little non-linearity. The lamp forms the non-linear amplitude control, but as it has a very slow response to variations, relative to the period of the oscillation, we may regard the oscillator as essentially linear, if operated at a very low power level. Bridge-stabilisation has other important properties, such, for instance, as the fact that phase variations in the amplifier have little effect on the frequency; all these contribute to make this type of oscillator exceptionally stable.

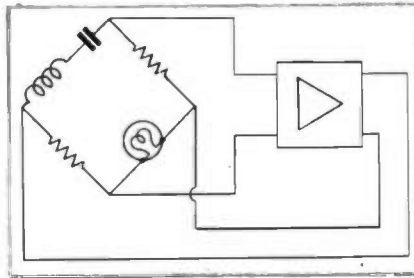

Fig. 6. The bridge-stabilised oscillator.

The synchronisation of the oscillator is effected by injecting the control tone into the grid circuit of a valve, exactly as in the case of other oscillators. The circuit relationships for the synchronised state are rather more complex than in the case of the simple feedback oscillator, but the magnitudes of locking voltage, total grid voltage and locking frequency-range have a relationship of the same order as in the simple case. This is demonstrated by the following experimental result:—A 1,000 c/s bridge-stabilised oscillator was set up with an output power of only 1 mW from a valve which under the same conditions could handle 250 mW. The tuned circuit had a Q value of about 25. With a ratio  $\frac{\text{locking voltage}}{\text{total grid voltage}}$  of  $\frac{1}{100}$ , the half locking range  $\left(\frac{\omega_{syn} - \omega_0}{\omega_0}\right)$  was

0.00018 (*i.e.*, 0.018 per cent.). With a ratio of 1/3.2 the half locking range was 0.0033 (*i.e.*, 0.33 per cent.). If these values are substituted in the equation for the simple feedback oscillator (Part I, equation (2)), it will be seen that the first result agrees almost exactly, although the second one is considerably out, due to the fact that the locking characteristic is not a straight line.

This process of synchronisation of the bridge-stabilised oscillator is another demonstration of the truth of the theory put forward in Appendix (1). Synchronisation clearly does not depend on any non-linearity during the cycle of the oscillation; it depends entirely on the ability of the forced oscillation at the control frequency to suppress the free oscillation by means of the long-period non-linearity. In this particular case, the amplitude of the forced oscillation is sufficient, within the locking range, to reduce the unbalance of the bridge so that the loop circuit has a loss instead of an initial gain, thus preventing the occurrence of the free oscillation.

**Appendix I.**

**A Simplified Mathematical Treatment of the Synchronised Feedback Oscillator**

The work of paragraphs 2 and 5 of Part I and 5 of Part II supports the following theory of the mechanism of synchronisation:—

At the injected frequency, which is very near the resonant frequency of the tuned circuit, a very large amount of positive feedback is obtained, and this causes the grid voltage  $E_{g \cdot syn}$  at the injected frequency to be very large compared with  $E_{syn}$ . Owing to the non-linearity of the valve, this large amplitude so reduces the amplification available for the natural oscillation that this is unable to take place, and only the locking frequency is present. We may say that the forced oscillation suppresses the free. As  $\omega_{syn}$  departs more and more from the natural angular frequency  $\omega_0$ , the amount of positive feedback becomes smaller, and so  $E_{g \cdot syn}$  becomes smaller. At a certain critical frequency,  $E_{g \cdot syn}$  is no longer large enough to suppress the natural oscillation, so that what we have termed "pull-out" occurs.

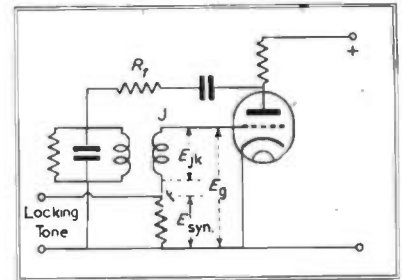

Fig. 7.

The mathematical treatment of this theory is quite simple. If the valve characteristic is expressed by

$$E_{jk} = \alpha E_g - \beta E_g^2 - \gamma E_g^3$$

(referring to Fig. 7) then assume the presence of a free oscillation of grid amplitude  $E_{gr}$  and substitute  $E_g = E_{g \cdot syn} \sin \omega_{syn} t + E_{gr} \sin \omega_0 t$ . We are interested at present in the terms of fundamental frequency only, and it is readily seen on expanding the square and cube terms that, neglecting all but fundamental terms in the expansion,

$$E_{jk} = \dots (1) \\ (a - \frac{3}{2}\gamma E_{g \cdot syn}^2 - \frac{3}{2}\beta E_{gr}^2) E_{g \cdot syn} \sin \omega_{syn} t + (a - \frac{3}{2}\gamma E_{gr}^2 - \frac{3}{2}\beta E_{g \cdot syn}^2) E_{gr} \sin \omega_0 t$$

Therefore, for free oscillation to occur in the presence of the injected frequency, we have the condition

$$a - \frac{3}{2}\gamma E_{gr}^2 - 3/2\beta E_{g \cdot syn}^2 \geq 1$$

The condition for "pull-in" to occur, *i.e.*, for the free oscillation to cease, is evidently

$$a - \frac{3}{2}\beta E_{g \cdot syn}^2 = 1 \dots (2)$$

The term in  $E_{gr}$  is omitted, because it is zero at this point. Also,  $\alpha$  and  $\gamma$

are conveniently related to the amplitude of the natural oscillation by the requirements of the free oscillation when  $\omega_{syn}$  is absent. For if  $E_{g0}$  is the grid amplitude of the natural oscillation, we have

$$\alpha - \frac{3}{4}\gamma E_{g0}^2 = 1$$

so that

$$E_{g \cdot syn \cdot 1}^2 = \frac{1}{2} E_{g0}^2 \text{ or } \frac{E_{g0}}{E_{g \cdot syn \cdot 1}} = \sqrt{2} \quad (3)$$

which relates the grid amplitude at pull-out to the unsynchronised amplitude.

To relate these conditions to the angular frequency  $\omega_{syn}$  we must consider the positive feedback circuit in more detail. It is convenient to consider the circuit as shown in Fig. 7; we assume the two windings of the coil to be tightly coupled and to have a ratio 1:1.

The impedance of the tuned circuit, relative to its impedance at resonance, is

$$x \cdot \frac{1 + jQ(1 - x^2)}{1 + Q^2(1 - x^2)^2} \text{ where } x = \frac{\omega_{syn}}{\omega_0}$$

If  $R_r$  is large compared with the tuned circuit impedance, the voltage fed back,  $E_{jk}$ , is

$$x \cdot \frac{1 + jQ(1 - x^2)}{1 + Q^2(1 - x^2)^2} \left[ \alpha - \frac{3}{4}\gamma E_{g \cdot syn \cdot 1}^2 \right] E_{g \cdot syn}$$

from the first term of equation (1) And we have

$$E_{g \cdot syn} = E_{syn} + E_{jk}$$

Now if we substitute for  $E_{jk}$  from the expression above, we obtain an equation which is too complicated for easy solution. But the assumption of a linear characteristic at this stage leads to little error. If we also assume for the linear case that  $\alpha = 1$  (the necessary condition for free oscillation in the absence of  $\omega_{syn}$ ), we obtain

$$\frac{E_{g \cdot syn}}{E_{syn}} = 1 \left/ \left[ 1 - x \frac{1 + jQ(1 - x^2)}{1 + Q^2(1 - x^2)^2} \right] \right.$$

and dealing only with magnitudes, the modulus

$$\left| \frac{E_{g \cdot syn}}{E_{syn}} \right| = \sqrt{\frac{1 + Q^2(1 - x^2)^2}{(1 - x)^2 + Q^2(1 - x^2)^2}}$$

Now, since  $\omega_0$  and  $\omega_{syn}$  are nearly equal,

$$(1 - x)^2 \ll Q^2(1 - x^2)^2$$

and  $\frac{Q^2(1 - x^2)^2}{Q^2(1 - x^2)^2} \ll 1$  (for normal values of  $Q$ ) so that

$$\left| \frac{E_{g \cdot syn}}{E_{syn}} \right| = \frac{1}{Q(1 - x^2)} = \frac{1}{2Q(1 - x)}$$

Therefore, at pull-out,

$$E_{syn \cdot 1} = 2QE_{g \cdot syn \cdot 1} \frac{(1 - x)}{\omega_0 - \omega_{syn}} \dots (4)$$

$$= 2Q \frac{E_{g \cdot syn \cdot 1}}{\omega_0} \dots (4)$$

which is the same as equation (2) of paragraph 5.

We may also write this, perhaps more conveniently, as

$$E_{syn \cdot 1} = \sqrt{2} \cdot QE_{g0} \cdot \frac{\omega_0 - \omega_{syn}}{\omega_0} \quad (5)$$

The justification for the assumption of a linear valve law for determining the pull-out relationship of equations (4) and (5) is that the amplitudes concerned at pull-out are reasonably small. The linear law is useless for determining the behaviour (e.g., the phase characteristic) inside the locking range, because it suggests an infinite amplitude of  $E_{g \cdot syn}$  at  $\omega_0 = \omega_{syn}$ .

**Appendix 2. (See Fig. 1.)**

**The 3-Section RC Phase-Shift Network**

It can be shown by a number of algebraic or analytical processes that the ratio of input voltage (anode side) to output voltage (grid side) is

$$\frac{V_1}{V_2} = \frac{-5\omega CR + \omega^3 C^3 R^3 + j(1 - 6\omega^2 C^2 R^2)}{\omega^3 C^3 R^3} \quad (1)$$

so that the phase-shift  $\beta$  is given by

$$\tan \beta = \frac{1 - 6\omega^2 C^2 R^2}{-5\omega CR + \omega^3 C^3 R^3} \quad (2)$$

At the oscillation frequency  $\omega_0/2\pi$ ,  $\beta$  must be  $180^\circ$ , i.e.,  $\tan \beta = 0$ .

$$\therefore 1 - 6\omega_0^2 C^2 R^2 = 0$$

$$\text{or } \omega_0 = \frac{1}{\sqrt{6} \cdot CR} \dots (3)$$

Substituting this result in equation (2),

$$\tan \beta = \frac{1 - \left(\frac{\omega}{\omega_0}\right)^2}{-\frac{5}{\sqrt{6}} \frac{\omega}{\omega_0} + \frac{1}{6\sqrt{6}} \left(\frac{\omega}{\omega_0}\right)^3} \quad (4)$$

which is a very useful form. Making small numerical approximations

$$\tan \beta = \frac{1 - \left(\frac{\omega}{\omega_0}\right)^2}{-2 \cdot \frac{\omega}{\omega_0} + \frac{1}{15} \left(\frac{\omega}{\omega_0}\right)^3}$$

and near  $\omega_0$  we may say that

$$\tan \beta = \frac{1 - \left(\frac{\omega}{\omega_0}\right)^2}{-2} = \frac{\omega}{\omega_0} - 1$$

$$= \frac{\omega - \omega_0}{\omega_0} \text{ approximately} \quad (5)$$

**Appendix 3 (See Fig. 4.)**

**The Single-Section RC Phase-Shift Network**

Equations corresponding to those in Appendix 2 are:—

$$\frac{V_1/V_2 = \omega(C_1 R_1 + C_2 R_2 + C_1 R_2) - j(1 - \omega^2 C_1 R_1 C_2 R_2)}{\omega C_1 R_2 (1 - \omega^2 C_1 R_1 C_2 R_2)}$$

so that  $\tan \beta = \frac{\omega(C_1 R_1 + C_2 R_2 + C_1 R_2)}{1 - \omega^2 C_1 R_1 C_2 R_2}$

If  $C_1 = C_2$  and  $R_1 = R_2$ , then

$$\tan \beta = \frac{3\omega CR}{1 - \omega^2 C^2 R^2}$$

and since  $\omega CR = 1$  at the oscillation frequency  $\omega_0/2\pi$  we may say that near the natural frequency

$$\tan \beta = \frac{1}{3} \left[ x = \left(\frac{\omega}{\omega_0}\right)^2 \omega_0^2 C^2 R^2 \right]$$

$$\text{or } \tan \beta = \frac{2}{3} \frac{\omega - \omega_0}{\omega_0} \text{ approximately}$$

**BIBLIOGRAPHY**

- 1 (a) E. L. Ginzton and L. M. Hollingsworth, "Phase-Shift Oscillators," *Proc. I.R.E.*, February, 1941, p. 43.
- 1 (b) W. Bacon, "A Simple R.C. Oscillator," *Electronic Engineering*, April, 1942, p. 707.
- 1 (c) D. G. Tucker, "A Note on R.C. Oscillators," *Electronic Engineering*, May, 1942, p. 752.
- 2 "A New Frequency Generator," *Electronic Engineering*, June, 1941, p. 246.
- 3 D. G. Tucker, "The Generation of Groups of Harmonics," *Electronic Engineering*, November, 1942, p. 232.
- 4 L. A. Meacham, "Bridge-Stabilized Oscillators," *Proc. I.R.E.*, October, 1938, p. 1,278.
- 5 (a) H. H. Scott, "A new type of selective circuit and some applications," *Proc. I.R.E.*, February, 1938, p. 226.
- 5 (b) F. E. Terman *et al.* "Some applications of Negative Feedback," *Proc. I.R.E.*, October, 1939, p. 649.

**Corrections to Part I.**

Para. 5.1. page 415.

The 3rd and 4th lines should read:

$$\tan \phi_0 = \frac{\omega_0 L - 1/\omega_0 C}{R}$$

where  $\omega_0/2\pi$  is the . . . etc. End of centre column Equation should read:  $\tan \phi = \text{etc.}$

Equation (1) should read:

$$\tan \phi = \frac{Q(\omega_{syn} - \omega_0)}{\omega_0 L} (2L)$$

$$= \frac{2Q(\omega_{syn} - \omega_0)}{\omega_0} \dots (1)$$

The caption to Fig. 4 should read:  $Q = 50$ , and  $E_g = 2$  volts.

# Amplifying and Recording Technique in Electro-Biology

## With Special Reference to the Electrical Activity of the Human Brain

A paper read before the Wireless Section of the Institution of Electrical Engineers, March 3rd. 1943

By G. PARR, A.M.I.E.E.,\* and W. GREY WALTER, M.A.†

### Nature of Phenomena to be investigated

ONE of the fundamental properties of the living cell is the production of an e.m.f. Not only are potential differences inseparable from the elaborate chemical reactions which constantly occur in vital processes, but many essential functions of living tissue are mediated by the small currents which the cells generate.

These currents usually precede in point of time the more obvious signs of life, such as muscular action, nervous conduction, and glandular secretion.

The basic phenomenon underlying this electrical activity is the maintenance of the interior of every living cell at a steady potential difference with respect to the outside world.

For example, if a small electrode is inserted into a muscle cell, the interior is found to be at a potential of about 50 mV. negative to the outside. If the surface of a nerve or muscle is injured, a similar potential difference will be found to exist between the injured and intact surfaces, since the injury has exposed the inside of the cell by breaking down the cell wall.

This e.m.f., termed the "injury potential," can be found in all living cells, plant or animal, though its magnitude varies with different types of cell, as does also the capacity of the cell to maintain it.

When a cell is stimulated to activity, changes occur in the cell wall which in most cases result in the active region becoming negative to the inactive, and a flow of current—the "action current"—results. In tissue which is specialised for the conduction of impulses (such as nerve, muscle, and certain kinds of sensitive plant) the region of activity travels down the conductor away from the point of origin and can be detected as a moving patch of "negativity," or negative impulse.

This travelling of the impulse is usually ascribed to the breakdown of a polarised membrane enclosing the nerve, with a resulting migration of ions to the injured region from the

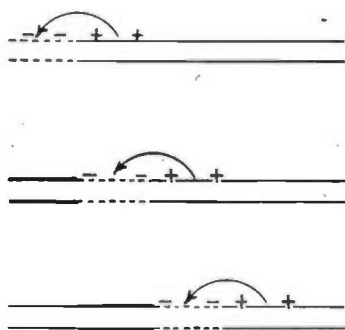

Refractory Active Resting  
Fig. 1. Mechanism of propagation of impulse along a nerve. (After Adrian).

part immediately above it. The restoration of the injured surface leaves the portion of nerve ahead depolarised, and this in turn is restored, with the result that an impulse is propagated throughout the length of the nerve. The newly restored surface of the nerve is temporarily refractory, i.e., it is insensitive to a second stimulus until a definite interval of time has elapsed. (Fig. 1).

A simple model has been made to show how an impulse can be propagated (Lillie<sup>1</sup>). If a length of iron wire is inserted in a glass tube filled with strong nitric acid the immediate action is quickly suppressed by the formation of a thin film of oxide on the surface, and the wire remains quiescent. If, however, the oxide film is broken down by scratching the surface lightly, local action takes place with the formation of hydrogen bubbles at the point of injury, and this active region then travels down the wire to the end, its passage being marked by a trail of rapidly forming

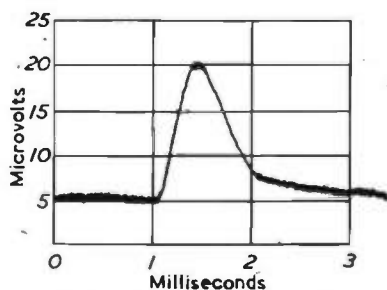

Fig. 2. Single impulse in a nerve fibre.

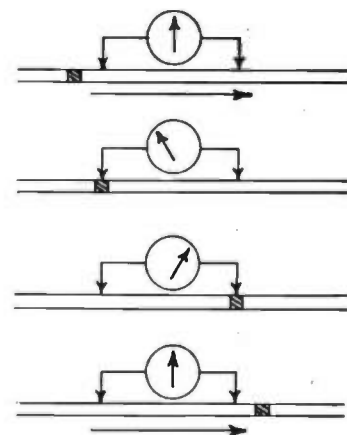

Fig. 3. Production of diphasic wave by travelling impulse.

and dispersing bubbles, after which the wire returns to its inactive condition.

Impulses may be evoked in a nerve fibre by touching the end organ with which it is connected, e.g., in the skin, or by exciting it in specialised ways, as by the action of light on the retina.

The brain can also excite the nerve fibres by initiating a voluntary movement.

In experimental work the nerve is usually excited by an electric shock, as this can be accurately controlled in magnitude and duration. In general it may be said that any change in environment will excite a nerve, provided that the change is sufficiently large and takes place at a sufficiently rapid rate.

The mathematics of excitability of

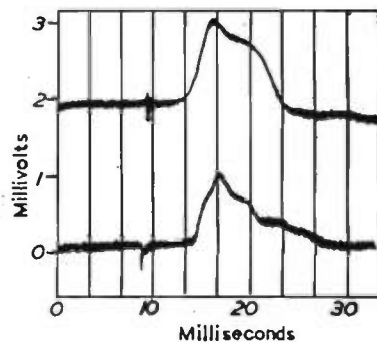

Fig. 5. Wave form of muscle action potential.

\* Editor: *Electronic Engineering*  
† The Burden Neurological Institute, Bristol.

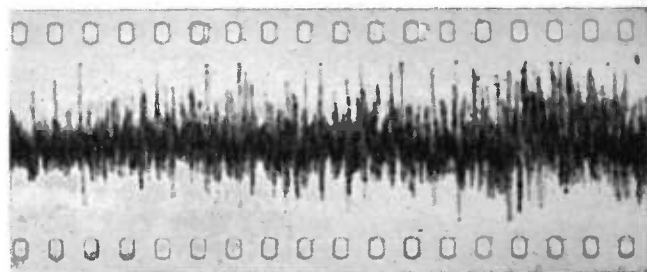
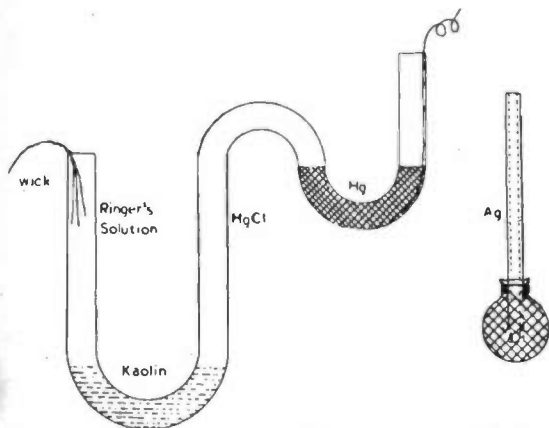

Fig. 4. Burst of impulses in a nerve trunk.

Fig. 6. Two types of non-polarisable electrode (left) calomel (right) silver-silver chloride.

nervous tissue in terms of the potential difference produced, the sign, duration, and rate of change, have all been worked out in detail and form a coherent set of expressions.

Once the impulse has been initiated in a nerve, it is "all or none"—the rate of travel and magnitude are independent of the strength of the stimulus and depend only on the state of the nerve at the point under consideration. When an impulse reaches the end of the nerve it in turn stimulates the related tissue (*e.g.*, muscle) into activity, which again is "all or none."

Degrees of activity are only obtained by a variation in the number of units engaged in the propagation of the message and the frequency with which the impulses are transmitted. The size, duration, and rate of conduction of the impulse vary over a wide range from plants to mammals, but are consistent and characteristic for each tissue under standard conditions.

In the human body the impulses have a peak potential of about 1.0 mV. and last for 1.0 millisecond. The rate of travel is 50 m/sec. and the impulse thus occupies about 5.0 cm. of the nerve at one time. This may be considered its "wavelength."

Fig. 2 shows the potential waveform recorded from a single point with respect to the inside of an isolated nerve fibre, which takes the form of a steep-fronted transient with a gradual decline. Such an impulse, obtained from a single electrode (earthy) resting on the nerve with a second electrode placed at the end, is unidirectional and is referred to physiologically as "monophasic."

If two electrodes are placed a little distance apart on the nerve (wider, however, than the wavelength of the impulse), the passage of the impulse will be marked by a reversal of potential as it travels under first one electrode and then the other (Fig. 3) and the resulting waveform will be alternating, or "diphasic."

Owing to the refractory period which occurs in the nerve after stimulation, a limit is set to the rapidity with which a succession of stimuli will produce discrete impulses in the nerve.

From the foregoing data, this limit is about 1,000 per sec. and may be considered as the limit to maximum effort, rarely reached under normal conditions.

In the nerve trunk, which contains thousands of fibres of varying types and sizes, records show a complex series of transients as difficult to analyse as a series of code signals received simultaneously from a thousand different stations. (Fig. 4).

Since each transient contains in effect many different frequencies it is not possible to use a tuned amplifier to discriminate between one kind of activity and another, and elaborate dissection technique is usually necessary to separate a single nerve fibre or stimulate a single end organ.

The action potentials of muscle fibre are similar in shape to those of nerve fibres, but are larger and slower (Fig. 5). The best known example of muscle action potential is that of the heart, known as the electrocardiogram, which was demonstrated before the Institution in 1937<sup>2</sup>, and again recently.

#### Electroencephalography

The fact that electrical potentials were produced in the brain itself, as distinct from those originating the conduction of impulses to the brain, was first demonstrated by Caton in 1875, and Berger<sup>3</sup> is credited with the first records of the electrical activity of the human brain.

These records were simply taken with a galvanometer connected to points on the unopened skull and, on account of the crudity of the apparatus, were inconclusive. In 1932 Berger published improved records taken with an amplifier and oscillograph which were more convincing, and their significance was confirmed by Adrian & Matthews in 1935.

As soon as it was realised that the electrical phenomena associated with the brain could be observed with less trouble than in the case of nerve action potentials, the study of the human electro-encephalogram (as it is termed) proceeded very rapidly with important and striking results which are discussed fully in the latter part of the paper.

#### Method of Recording Biological Potentials

Although the amplification of bioelectric potentials presents fundamentally the same problems as encountered in radio practice, there are several difficulties peculiar to the nature of the material worked on which necessitate special adaptations of the circuit if reliable results are to be obtained.

An example of these difficulties, the nerve fibre has poor regulation, and the connexion of an amplifier to the nerve must not impose a load on it. Such a connexion may also have to be made through an electrolyte, since there is a permanent phase boundary between the moist nerve in its normal state and the "dry" amplifier.

#### Electrodes

If contact is made with a nerve or muscle by means of inert metal electrodes, such as platinum, the passage of the unidirectional current is accompanied by ionic migration and the well-known polarisation effects. These effects can be reduced by the use of an electrode consisting of a metal in contact with a solution of one of its own salts. The salt solution can then be brought into contact with the tissue and body fluids through an intermediate physiological fluid such as normal saline or Ringer's solution\* and the indeterminate boundary between the liquids does not occasion any appreciable polarisation.

\* A solution of alkaline salts found empirically by Ringer to be isotonic with mammalian blood. Its approximate composition is NaCl 0.65; KCl 0.014; CaCl<sub>2</sub> 0.012; NaHCO<sub>3</sub> 0.02; NaH<sub>2</sub>PO<sub>4</sub> 0.001 and water to 100 parts by weight.

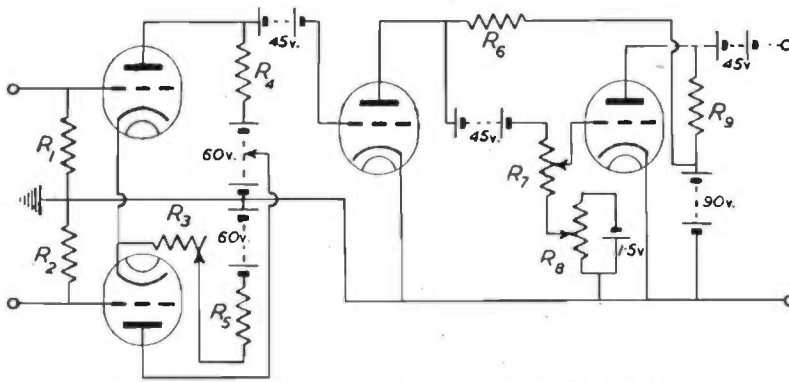

Fig. 8. Matthews direct coupled amplifier. Amplification 60,000.

The two types of non-polarisable electrode commonly in use for bioelectric recording are (a) the calomel electrode, and (b) the silver-silver chloride electrode. Sketches of these are shown in Fig. 6. The calomel electrode in one form consists of a U-tube containing in one limb a layer of mercury into which the lead from the amplifier is dipped. A porous plug separates the solution of mercurous chloride which fills one limb of the tube from the layer of Ringer's solution, into which a wick is inserted to act as a conductor from the nerve.

The silver-silver chloride electrode is simpler in construction and use and consists of a silver wire, tube or plate coated with silver chloride by electrolysis in a solution of common salt with a platinum cathode. The silver chloride forms a thin black film on the surface of the wire which is not easily dissolved by biological fluids. The chlorided metal can thus be placed in direct contact with the moist living cell or tissue. Silver tubes covered with a gauze pad are also convenient for application to the skin or scalp (Fig. 6).

The magnitude of polarisation effects is, of course, diminished by using high resistance input circuits and the effect can be still further reduced by using as large an effective area of electrode as possible, to reduce the current density. In cases where a large area electrode is permissible, such as in cardiographic work, it is usual to use a zinc or silver electrode plate with a layer of "electrode jelly" between it and the skin to reduce the resistance.

One advantage which the large electrode confers is in the reduction of resistance variations caused by movement of the tissue under the electrode. Contact resistance is an important factor in the measurement of potentials which may undergo momentary fluctuations and an increased area of electrode reduces it correspondingly.

**The Input Circuit**

A review of the main types of balanced input circuit has already appeared in this journal. (M. G. Saunders).<sup>7</sup> The description of the Tönnies circuit which follows has therefore only been included in the present article for the sake of completeness. See also Bibliography, references<sup>8</sup> and<sup>12</sup>.

A form of differential input circuit devised in 1938 by Matthews,<sup>9</sup> and independently by Tönnies,<sup>10</sup> is shown in Fig. 7. There is a common cathode resistance  $R_c$  and an anode resistance in one valve  $R_p$ . In order to balance the circuit the valves are selected to have approximately the same characteristic and the anode current in each valve is adjusted to the same value by tapping the anode of  $V_1$  to a lower point on the H.T. battery. Final adjustment of the anode current is made by varying part of  $R_c$ , the total value of  $R_c$  being approximately equal to  $R_p$ .

It will be seen that  $V_1$  is operating as a cathode follower, and a signal applied to the grid will appear across the cathode resistance in the same phase. A signal applied to  $V_2$  appears partly across  $R_c$  in phase and partly across  $R_p$ , 180° out of phase.

The circuit thus acts as a discriminator between in-phase and out-of-phase signals, and Debski<sup>11</sup> has shown that the ratio

Amplification of in-phase voltages for triodes

$$= 1 + 2k \frac{(1 + \mu_1)}{\mu_1}$$

where  $k = \frac{R_c \mu}{R_1 + R_p}$  and  $\mu_1$  and  $R_1$  the amplification factor and internal resistance of the valve, respectively.

This circuit has been found particularly useful for biological recording as it is simple to adjust, operates from a single 120 v. battery and does not require a push-pull arrangement of the succeeding stage, although the use of push-pull throughout is popular in American practice.

**Amplifiers**

If it is required to amplify the full range of frequencies met in bioelectrical work, from 1 - 10,000 c/s. the possibility of using a direct coupled amplifier is usually first considered. Such amplifiers have been successfully used by Matthews,<sup>14</sup> Forbes and Grass,<sup>15</sup> and in a later form the Matthews amplifier is shown in Fig. 8. This had an amplification of 60,000 using AC/2HL valves and could be increased to 10<sup>6</sup> by the use of pentodes.

On the other hand, it usually happens that the research is confined to a portion of the frequency spectrum less than the full range quoted previously, and in this case the conventional resistance coupled amplifier with the time constants suitably designed for the frequency range is usually satisfactory.

A form of universal biological amplifier used in America and designed by A. M. Grass shown in Fig. 9. The circuit is balanced throughout, the first three stages being battery operated to minimise A.C. interference.

A two-way switch enables the input to be changed from single grid (G) to push-pull (PP) and a low resistance is inserted in one of the grid leads to provide a calibrating potential by means of a known current passed through it from the 1½ v. battery.

The amplifier is divided into two main sections—the "head amplifier" (the first three stages shown) and the power amplifier which operates a pen recorder which will be described later.

(Continued on p. 469).

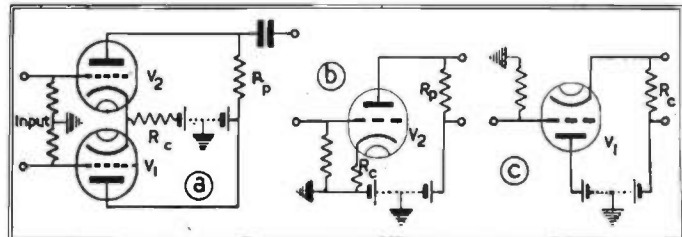

Fig. 7. Tönnies' Input Circuit (a) and its analysis into two sections (b) and (c) (See Bibliography<sup>7</sup>).

# DATA SHEETS XLVII, XLVIII AND XLIX

**C**HOKE coupled amplifiers are used in the audio frequency range for one of the following two purposes: (a) to obtain an increase in power output or voltage output by largely eliminating the voltage drop present in the anode coupling resistance of the normal R.C.C. Amplifier (b) to obtain a rising gain versus frequency response for tone correction or frequency response equalisation, etc. This will be normally achieved by an anode coupling network consisting of a resistance and inductance in series.

The circuit of Fig. 1 shows the most general arrangement where  $L$  represents the inductance and  $r_1$  the resistance of the choke.  $r_2$  represents any additional series resistance included to provide the required frequency response. The self capacity of the choke is indicated by  $C_1$  and the total anode to earth capacity by  $C_2$ , plus  $C_4$  in series with  $C_3$ . For the purpose of this analysis the magnitudes of  $C_1$ ,  $C_3$  and  $C_4$  will be assumed to be sufficiently small to have a negligible effect on the performance, also the resistance of  $R_2$  is assumed very large compared with  $\sqrt{R^2 + \omega^2 L^2}$  and  $1/\omega C_2$ . (The special case of appreciable capacity loading will be dealt with in a separate Data Sheet.

With these assumptions the circuit simplifies to that shown on the Data Sheets where  $R = r_1 + r_2$ , and the output voltage  $E_2$  is given by

$$E_2 = \mu E_1 \frac{R + j\omega L}{R + R_a + j\omega L} \quad (1)$$

where  $\mu$  is the amplification factor.

In order to plot a universally applicable family of response curves suitable for the design of tone correcting stages, we have to use the gain at very low frequency as our reference value, and we therefore rewrite (1) in the following form:—

$$\frac{E_2}{E_1} = g \cdot \frac{R R_a}{R + R_a} \frac{\sqrt{\left[1 + \left(\frac{\omega L}{R}\right)^2 \left(\frac{1}{1 + \frac{R_a}{R}}\right)^2\right] + \left[\frac{\omega L}{R} \left(\frac{1}{1 + \frac{R_a}{R}}\right)\right]^2}}{1 + \left[\frac{\omega L}{R} \left(\frac{1}{1 + \frac{R_a}{R}}\right)\right]^2} \angle \theta \quad (2)$$

where

$$\theta = \tan^{-1} \frac{\frac{\omega L}{R} \frac{R_a}{R}}{1 + \frac{R_a}{R} + \left(\frac{\omega L}{R}\right)^2} \quad (3)$$

If we designate by the "Relative Gain"  $M$ , the ratio of the gain at any frequency  $f = \omega/2\pi$ , to the gain at a very low frequency given by

$$g \frac{R R_a}{R + R_a}$$

then:

$$(M_1)_{in \ ab} = 20 \log_{10} \frac{\sqrt{\left[1 + a^2 \left(\frac{1}{1+b}\right)^2\right] + a^2 \left(\frac{b}{1+b}\right)^2}}{1 + a^2 \left(\frac{1}{1+b}\right)^2} \angle \theta \quad (4)$$

and the angle  $\theta$  by which  $E_2$  leads  $E_1$  is

$$\theta = \tan^{-1} \left[ \frac{ab}{1 + b + a^2} \right] \quad (5)$$

where for convenience we have written

$$a = \frac{\omega L}{R} \quad \text{and} \quad b = \frac{R_a}{R}$$

Equations (4) and (5) have been plotted on Data Sheets 47 and 49.

When dealing with normal non-frequency-correcting amplifiers it is usually more convenient to express the "Relative Gain"  $M$ , as the ratio of the gain at any low frequency  $f = \omega/2\pi$  to that at a frequency sufficiently high to have reached a gain sensibly equal to the asymptotic value of  $\mu$ . With this definition we have

$$(M_2)_{in \ ab} = 20 \log_{10} \frac{\left(\frac{b}{1+b}\right)^2 \sqrt{\left(\frac{1+b}{b^2} + d^2\right)^2 + d^2}}{1 + \left(\frac{b}{1+b}\right)^2} \quad (6)$$

(see Data Sheet 48).

where the frequency dependent parameter has now been changed to  $d = \omega L/R_a$  and  $b = R_a/R$  as before.

## Choke Coupled Amplifiers at Audio Frequencies

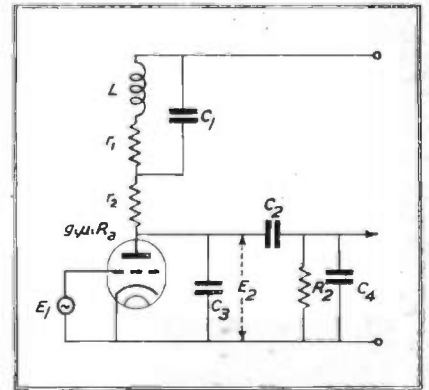

Fig. 1. Comprehensive circuit of choke-coupled stage.

### Effect of $R_2$ and $C_2$

For the above analysis the coupling network  $R_2 C_2$  was assumed to have a negligible effect on the amplification. If the impedance of  $R_2$  and  $C_2$  in series is large compared to the impedance of  $(R + j\omega L)$  in parallel with  $R_a$  then any additional attenuation due to the finite value of  $C_2$  may be calculated separately as shown in last month's Data Sheet No. 46. At the higher frequencies where the reactance of  $C_2$  is very small compared with  $R_2$ , the limitation of the magnitude of  $R_2$  will have the effect of reducing the maximum gain obtainable while at the same time also reducing the frequency at which the response curve tends to flatten out to its final gain value. This is due to the fact that the effective anode load controlling the stage gain at the higher frequencies consists of  $R_2 + j\omega L$  in parallel with  $R_a$ .

THE RESPONSE OF A CHOKE COUPLED L.F. AMPLIFIER

DATA SHEET 47

**Electronic**  
Engineering

$$M_1 \text{ in db.} = 20 \log_{10} \sqrt{\left[1 + \frac{\omega^2 L^2}{R^2} \left(\frac{1}{1+R_a/R}\right)\right]^2 + \left[\frac{\omega L}{R} \left(\frac{1}{1+R/R_a}\right)\right]^2} \cdot \frac{1}{1 + \left[\frac{\omega L}{R} \cdot \frac{1}{1+R_a/R}\right]^2}$$

GAIN AT 0 db. =  $20 \log_{10} \left[ \frac{R R_a}{g R + R_a} \right]$

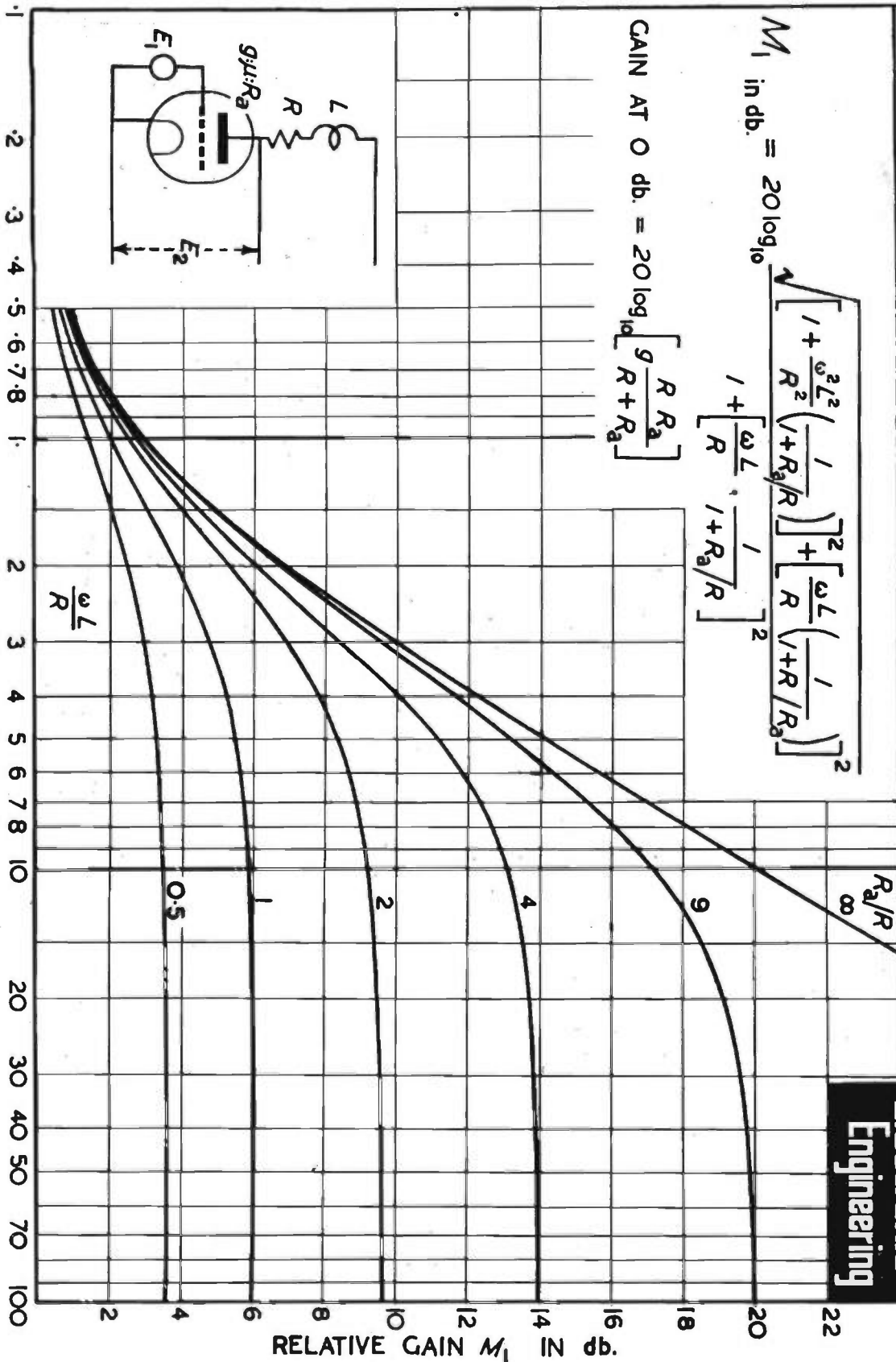
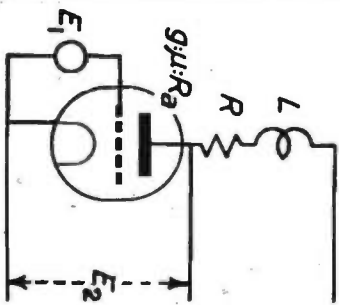



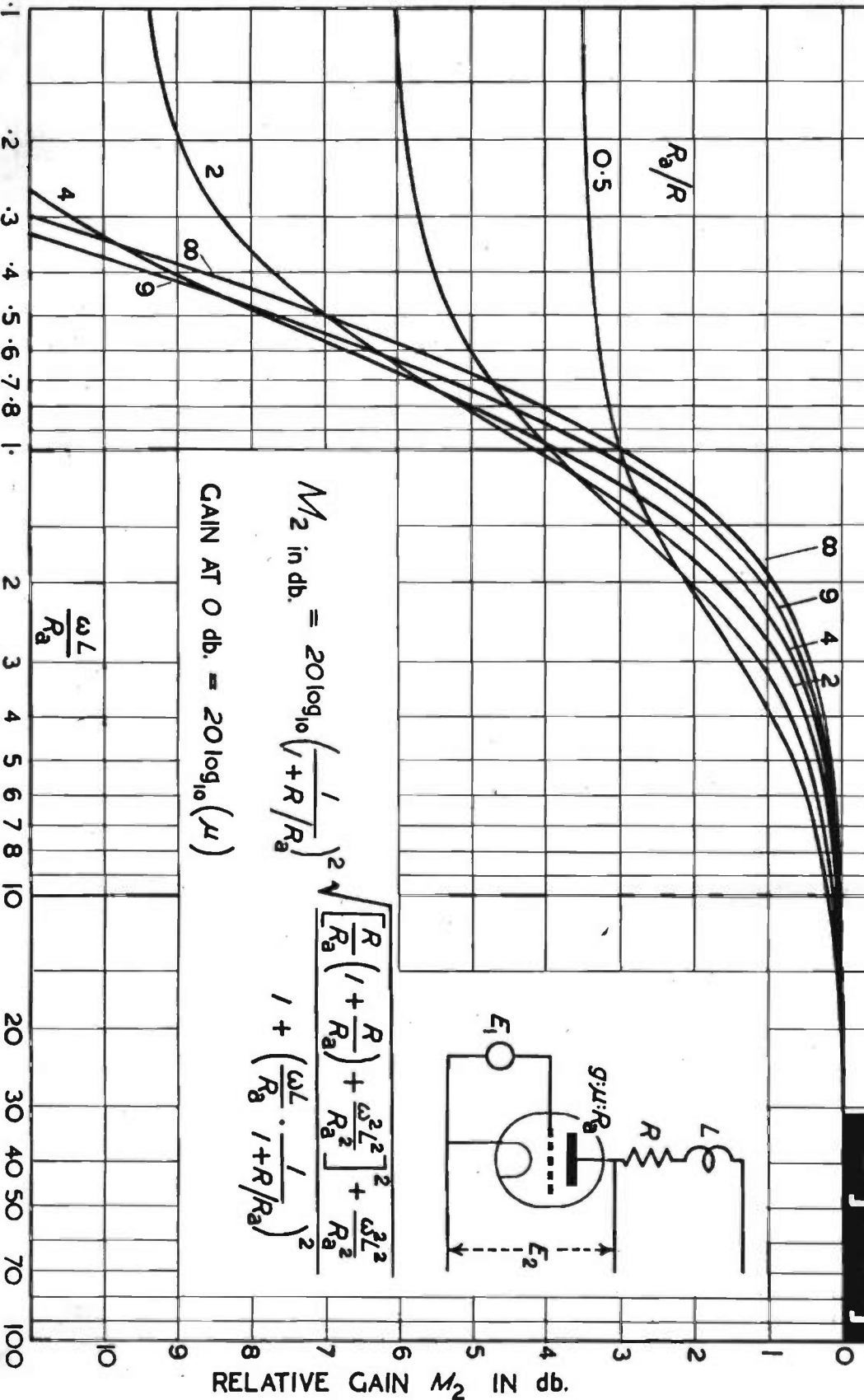

$$M_2 \text{ in db.} = 20 \log_{10} \left( \frac{1}{1 + R/R_a} \right)^2 \sqrt{ \left[ \frac{R}{R_a} \left( 1 + \frac{R}{R_a} \right) + \frac{\omega^2 L^2}{R_a^2} \right]^2 + \frac{\omega^2 L^2}{R_a^2} } + \frac{\omega^2 L^2}{R_a^2}$$

$$\text{GAIN AT 0 db.} = 20 \log_{10} (\mu)$$

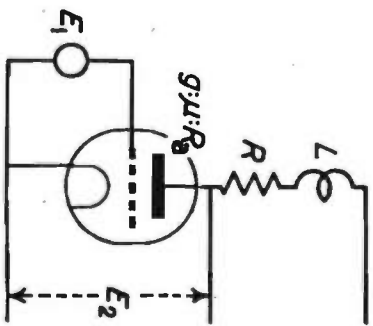

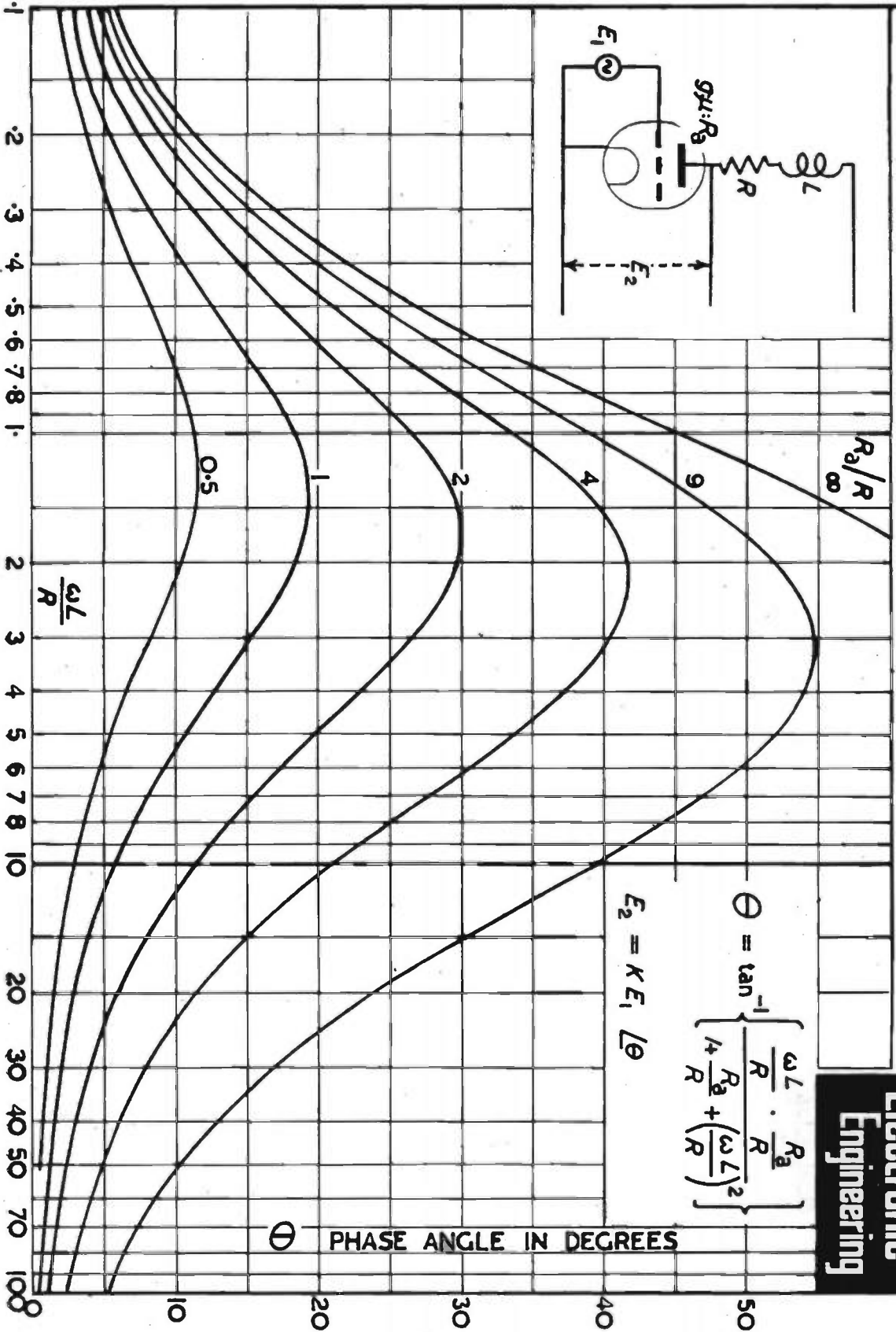
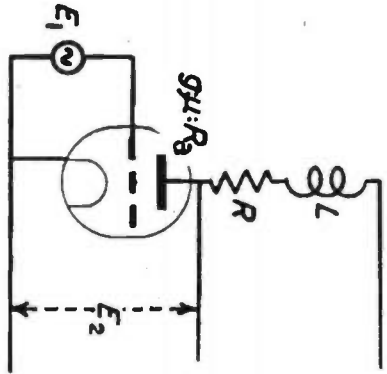

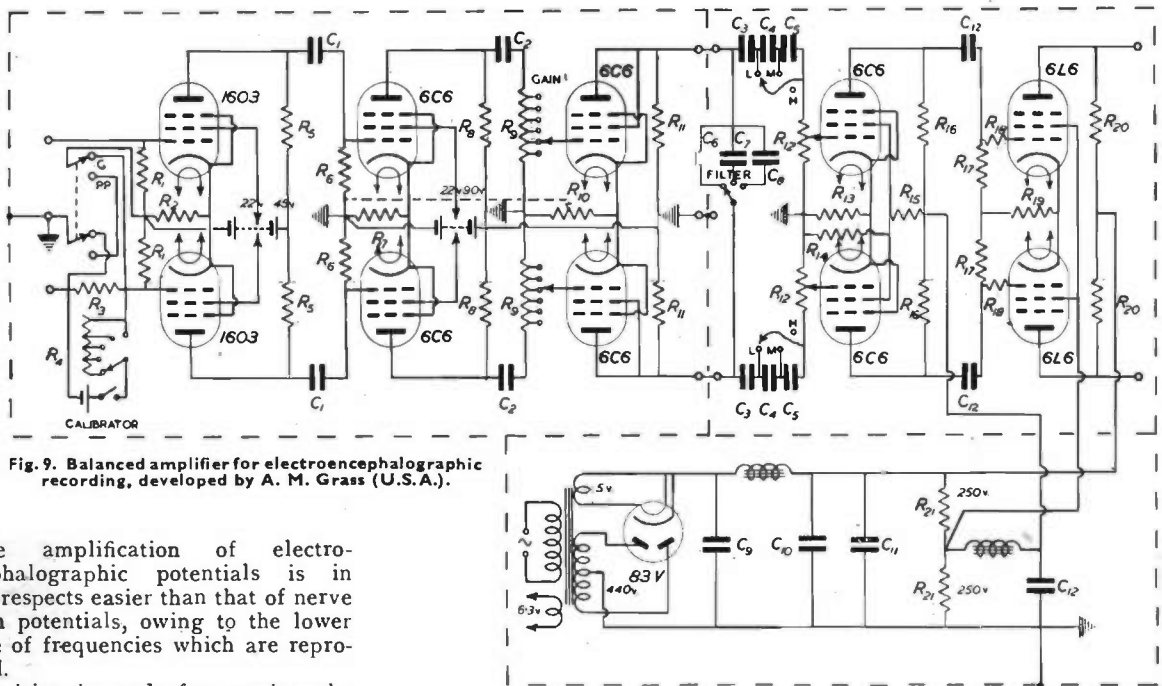

Fig. 9. Balanced amplifier for electroencephalographic recording, developed by A. M. Grass (U.S.A.).

The amplification of electroencephalographic potentials is in some respects easier than that of nerve action potentials, owing to the lower range of frequencies which are reproduced.

Provision is made for varying the time constant of the coupling between the stages at the input to the power amplifier, and in addition there is a filter circuit for higher audio frequencies.

Assuming that the shape of occasional transient waves (known as "spikes") is to be preserved with reasonable fidelity, a frequency range

covering the tenth harmonic of the highest normal frequency is satisfactory, and this corresponds to a range of 1 - 2,000 c/s.

Limiting the range of the amplifier in this way enables a record to be obtained free from background, and a simple form of by-pass filter is usually satisfactory.

An amplifier circuit used by one of the authors for electroencephalographic recording is shown in Fig. 10. With the exception of the first two stages, which are battery operated, the H.T. supply is obtained from a stabilised mains rectifier unit of conventional type. The input is normally of such a low value that

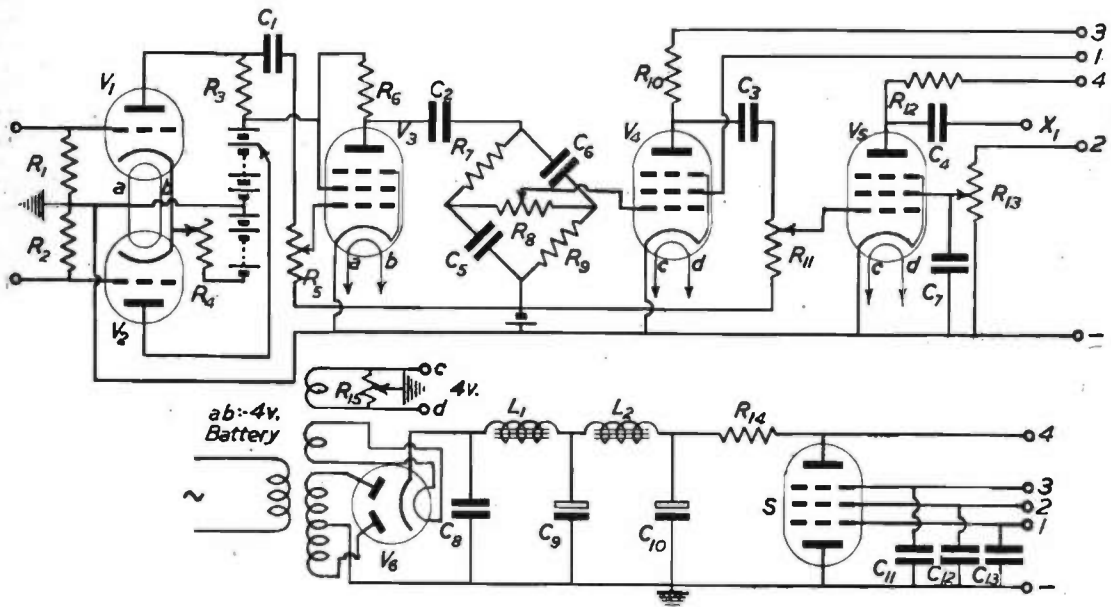

Fig. 10. Amplifier with balanced input used by one of the authors for electroencephalographic recording.

Values of Components

R <sub>1</sub> , R <sub>2</sub>	1.0 megohm
R <sub>3</sub>	50,000 ohms
R <sub>4</sub>	100,000 ohms
R <sub>5</sub>	1.0 megohm
R <sub>6</sub>	50,000 ohms
R <sub>7</sub> , R <sub>9</sub>	60,000 ohms

R <sub>8</sub>	0.25 megohm
R <sub>10</sub>	50,000 ohms
R <sub>11</sub>	1.0 megohm
R <sub>12</sub>	50,000 ohms
R <sub>13</sub>	50,000 ohms
R <sub>14</sub>	5,000 ohms

C <sub>1</sub> , C <sub>2</sub> , C <sub>3</sub> , C <sub>4</sub>	4.0 μF.
C <sub>5</sub> , C <sub>6</sub>	0.25 μF.
C <sub>7</sub>	4.0 μF.
C <sub>8</sub> , C <sub>9</sub> , C <sub>10</sub>	10 μF.
C <sub>11</sub> , C <sub>12</sub> , C <sub>13</sub>	4 μF.

L <sub>1</sub> , L <sub>2</sub>	50 H.
V <sub>1</sub> , V <sub>2</sub>	V 312 (Mazda)
V <sub>3</sub> , V <sub>4</sub> , V <sub>5</sub>	AC/SP3. (Mazda)
V <sub>6</sub>	U2 Rectifier
S	Stabilovolt

there is little advantage in using push-pull circuits and the balanced input stages (Tönnies) is coupled to three stages of A.C. mains H.F. pentodes, the over-all gain being approximately  $10^7$ .

A form of filter circuit suggested by the G.E. Co., of America, has been used with very satisfactory results. This is shown between stages 2 and 3, and the values of the components have been chosen so that at the centre of the potentiometer  $R_3$  the response is flat from 1 c/s. to  $10^3$  c/s. This amplifier is primarily intended for oscillographic recording, but is used with a pen recorder through an additional power amplifier stage.

As might be expected, all amplifiers having time constants of the order of 2-4 seconds are subject to "blocking" by stray signals which exceed the normal signal input in magnitude. For example, in an amplifier in which the successive stage gains are 30, 100, 100, a transient impulse of 1.0 mV becomes 30 volts when applied to the grid of the succeeding valve, resulting in prolonged cut-off of anode current while the charge in the coupling condenser leaks away, or in excessive grid current. It has been suggested that a diode connected across the grid leak will tend to minimise the blocking effect, but the additional complication to the circuit is hardly worth making when it is possible to avoid the surges by turning down the gain control when making adjustments to the input circuit.

#### Recording Apparatus

The cathode-ray tube suggests technique in Electro-Biology. FOUR self as the most convenient form of recording apparatus, but its use in biological research is by no means universal, and it is being replaced in special cases by ink writing recorders.

No single recording device can be considered satisfactory over the whole range of potentials and frequencies examined and the choice of instrument is determined by the special characteristics of the research.

The comparison between three types of recording device, the mirror oscillograph, cathode-ray tube, and pen writer, can be summarised as follows:

#### Mirror Oscillograph.

Satisfactory at frequencies up to 2,000 c/s.

Requires appreciable deflecting power.

Can only be used in conjunction with mirror time scale or recording camera.

For several simultaneous records the equipment is costly and bulky. Maintenance cost is low.

#### Cathode-ray Oscillograph.

A low voltage small tube is satisfactory at all frequencies.

No deflecting power required.

A long afterglow screen gives it advantage for observing transient phenomena.

Requires recording camera.

Several simultaneous records can be made by multiple-beam tubes or electronic switching.

Maintenance cost appreciable.

#### Pen Writer.

Limited to recording frequencies below 100 c/s.

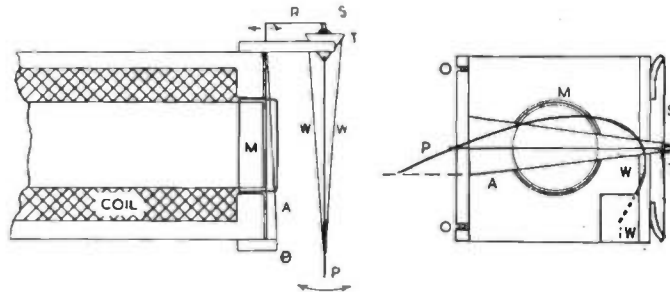

Fig. 12. A. M. Grass' Pen Writer showing the system for magnifying the coil movement.

Requires appreciable power to operate.

The record is instantaneously available.

Simultaneous records can be made with corresponding increase in bulk and cost.

Maintenance cost is low.

The cathode-ray oscillograph is too well-known to need detailed description, but attention is drawn to the practicability of obtaining four independent traces on the screen by the use of an electronic switch (such as Clothier's<sup>10</sup>) in conjunction with a double-beam tube.

A tube with a long afterglow screen is essential for most biological recording, and the time base circuit should be capable of sweep frequencies as low as 0.1/sec. without loss of linearity.

Gas-focused tubes have been found particularly useful on account of their sensitivity and no difficulty is experienced in obtaining sharp photographic traces with modern sensitised paper at voltages as low as 500.

The difficulties of photographing continuous traces lasting for perhaps twenty minutes, and the expense of a special recording camera have led to the development of ink writers suitable for recording low frequencies up to 100 c/s. The obvious advantage of ink records is that the phenomenon is under continuous observation while it is being recorded and identification marks can easily be made on the record. The use of ink writers is at present confined to electroencephalo-

graphic records, in which the frequencies lie within the range quoted, but there is a need for a light inexpensive ink writer with a wide frequency range.

A form of moving-coil writer which has given very satisfactory results is that developed by A. M. Grass, shown in Figure 12. The moving coil M is attached to a hinged arm A which extends across the coil and field system to connect on to a short coupling arm R which actuates the pen P. This is a steel tube of .02 in. internal diameter reduced at the tip to .005 in., which is soldered to a triangular

plate T and braced by two wires WW to prevent whipping. The restoring tension for the pen is provided by a steel spring strip S, stretched vertically between the brass supports, the triangular plate being attached to its centre. The end of the pen tube is curved to dip into the inkwell IW containing a 2 per cent. solution of methylene blue.

The recording paper (indicated by a dotted line) is pulled under the pen by a friction roller driven from a synchronous motor, giving three speeds of travel (an average figure is 30 mm/sec.).

The frequency response of the pen is flat from 0 to 100 c/s, the response at the upper limit being affected by the friction of the pen on the paper. The total amplitude is 7-8 mm. on each side of the base-line.

(Part II of the paper, dealing with the electrical activity of the human brain, will appear in next month's issue.)

#### REFERENCES

- 1 Lillie *Protoplasmic Action and Nervous Action* (Chicago) 1923.
- 2 Robertson, *J.I.E.E.*, Vol. 81, p. 497, 1937.
- 3 Berger, *Ark. Psych. Neurol.*, 87, p. 527, 1929.
- 4 Adrian, *Jour. Physiol.*, 61, p. 49, 1926.
- 5 Forbes, *Am. Jour. Physiol.*, 52, p. 409, 1920.
- 6 Casser and Erlanger, *Am. Jour. Physiol.*, 62, p. 496, 1922.
- 7 Saunders, *Electronic Engineering*, 14, p. 760, 1942.
- 8 Adrian and Matthews, *Jour. Physiol.*, 81, pp. 286 and 440, 1934.
- 9 Matthews, *Jour. Physiol.*, 93, p. 25, 1938.
- 10 Tönnies, *Rev. Sci. Inst.*, 9, p. 95, 1938.
- 11 Debski, *Electronic Engineering*, 15, p. 80, 1942.
- 12 Offner, *Rev. Sci. Inst.*, 8, p. 20, 1937.
- 13 Schmitt, *Jour. Sci. Inst.*, 15, p. 100, 1938.
- 14 Matthews, *Proc. Phys. Soc.*, May, 1938.
- 15 Forbes and Grass, *Jour. Physiol.*, 91, p. 31, 1937.
- 16 Clothier, *Jour. Sci. Inst.*, p. 235, 1939.

# T I M I N G T I M E

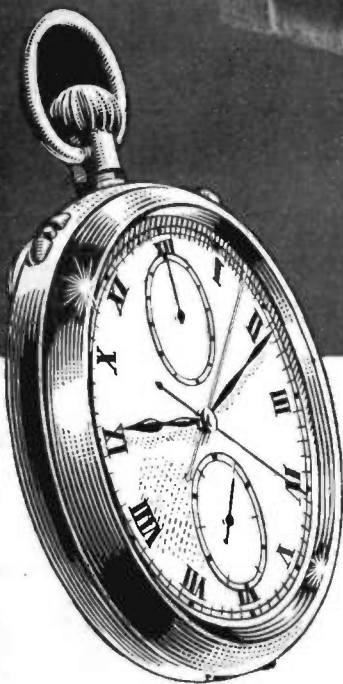

The accurate timing of watches and clocks is normally a lengthy procedure and involves keeping the instrument under observation for a considerable period.

The development of the Thermionic Valve and Cathode Ray Tube have made possible the design of special apparatus by means of which any timepiece can be regulated with great precision in a matter of minutes.

This is yet another example of the important part which the valve plays in solving specialised problems of control which arise in almost every industry.

COMMERCIAL  
INDUSTRIAL  
SCIENTIFIC  
MEDICAL  
EXPERIMENTAL  
DOMESTIC

## MULLARD

THE MASTER VALVE

*A Valve for Every Purpose*

# Wave Analysis

## Part III—Analysis of Periodic Wave-Forms

By K. BOURNE\*

THE methods of analysis described in a previous article (Part II)† for use in dealing with semi-periodic wave-forms, had of necessity to sacrifice many desirable properties—sensitivity, convenience, and resolving power—to attain the speed required to analyse a rapidly changing wave-form. Very many of the tones met with in acoustics, however, can be considered as periodic during a time of several seconds, or even much longer in the cases of persistent noise and automatically-played musical instruments; whilst in many cases, an electrical wave-form can be kept constant over a period of several hours, so that speed, however desirable from the standpoint of general convenience, is fundamentally of very slight importance. Thus it remains to obtain the desired sensitivity and selectivity in as convenient a form as

sufficiently sensitive and selective indicator, which need not be of constant or known characteristics over the frequency band required. The only important requirement is that any amplification or modulation before the selective element shall be linear. The indicating apparatus is tuned to the harmonic or component required, and adjusted to give a convenient reading: the wave-form under examination is then removed, and the output of a local oscillator applied, through a suitable controlling device, and adjusted until the reading is the same as before. A knowledge of the oscillator level applied then evidently gives the amplitude of the component of the wave-form being analysed. A suitable schematic is given in Fig. 1; from the reading on the meter *V* and the attenuation in the attenuator *A*, the amplitude is known to a very con-

to the required value, is applied through the apparatus under test and an attenuator *A* to the selective indicator, and a suitable reading obtained: the output is then switched through attenuator *B*, which is adjusted to obtain the same reading as before. The oscillator is then again applied to the apparatus to be tested, and the indicator tuned to the harmonic which is to be measured, and a suitable reading obtained. The oscillator is adjusted to the frequency of the harmonic, the level as indicated by voltmeter *C* being maintained constant, and switched through *B*; the attenuation which has to be inserted into *B* to obtain the reference reading on the indicator is evidently the amount the harmonic is below the level of the fundamental, and does not depend upon the exact characteristic of the indicator, nor upon the calibration of

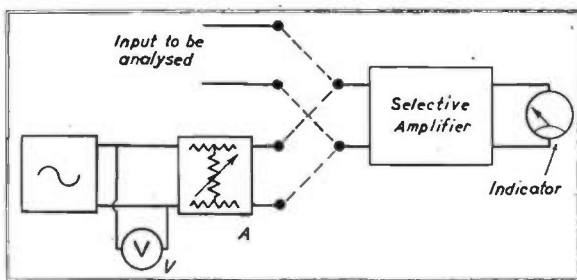
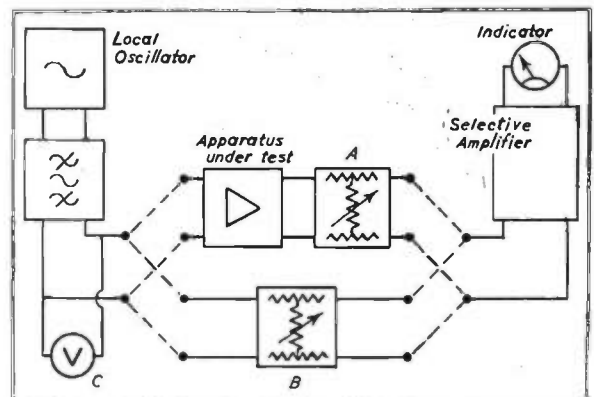

Fig. 1 (above). Substitution method, using a local oscillator, and Fig. 2 (right). Substitution method used for testing apparatus.



possible. The major part of this article will consider the methods developed for this purpose, dealing first with devices using a variable-frequency resonating element, and subsequently with the utilisation of the heterodyne principle with a fixed-frequency element. The few miscellaneous methods coming under neither of these heads will be briefly mentioned at the end.

Before considering in detail the resonance and heterodyne analysers, mention must be made of a very straightforward and accurate method, which can be used either for routine measurement, or as a standardising or calibrating device for an existing direct-reading analyser. This is the Substitution Method, and the special apparatus required consists only of a

considerable degree of accuracy. The auxiliary oscillator needs only the barest frequency calibration unless it is desired to identify the components of the analysis by the oscillator frequency; (in which case, the selective amplifier needs no calibration), and its harmonic content need not be extremely low; in the worst case, when using a peak voltmeter, the error cannot exceed the percentage total harmonic present, and if a square-law instrument (*e.g.*, a thermo-couple meter) be used, no appreciable error is likely to occur.

A useful modification of the above method is often used for the measurement of the harmonic production of amplifiers, filters, etc., this is shown in Fig. 2. In this case, the oscillator must be followed by tuned circuits or a band-pass filter to obtain a very pure output. The oscillator level, adjusted

the voltmeter (except that this must be constant with frequency). This indirect method can be used with many of the analysers subsequently described, either as a normal system, or where extra accuracy may be needed; it is also evidently suitable for the initial calibration of a direct-reading instrument.

### 1. Methods using Variable-frequency Resonators

These methods have been used from the early days of electric power for the measurement of harmonics on power circuits, but the introduction of the thermionic valve has radically enlarged their possibilities. The simplest circuit is that shown in Fig. 3, showing an inductor of value *L* with effective resistance *R*, and a condenser of a capacitance *C* which can be normally considered as loss-free. The

\* Post Office Research Station.  
† *Electronic Engineering*, Dec. 1942, p. 280.

voltage across the meter  $M$  (which must be of high impedance) will be :

$$V = E \left\{ \frac{R + j\omega L}{R + j\omega L + 1/j\omega C} \right\}$$

This expression, simplified by the substitution below, reduces to :

$$|V| = E \sqrt{\frac{1}{1 + Q^2 x^2}}$$

where  $\omega = 2\pi f$   
 $x = \omega/\omega_0$   
 $\omega_0 = 1/LC$   
 $Q = \omega_0 L/R$

and if the voltage at resonance (*i.e.*, when  $x = 1$ ) is  $V_0$ , then from above  $|V_0| = E \sqrt{1 + Q^2}$ . Thus if  $x$  is somewhat different from one, and is not very small, and  $Q$  is large (this must be so if the circuit is to be of any use), then since  $Q^2 x^2$  and  $Q^2(x - 1/x)^2$  will be very much greater than 1,  $|V| \approx \pm E/(1 - 1/x^2)$  and  $|V_0| \approx EQ$ ; so the suppression at a frequency of  $x$  times the resonant frequency will be  $|V_0/V| \approx Q(1 - 1/x^2)$ , the sign being chosen so as to make the expression positive. It is seen that for measurement of the second harmonic, the suppression of the fundamental will be  $3Q$  (since  $x = 1/2$ ); thus if 1 per cent. accuracy is required, so that the fundamental must be reduced to 10 per cent. of the harmonic amplitude when a square law meter is used (and if  $Q = 100$ ), the harmonic must not be less than  $3\frac{1}{2}$  per cent. of the fundamental. A  $Q$  value of 100 in a reasonable size is rather a lot to expect at power frequencies (though it is the  $Q$  at the harmonic frequency which must be considered); however, in power work it is quite usually only odd harmonics which are concerned, and it is seen that for the third harmonic the situation is considerably improved: the suppression of the fundamental is approximately  $8Q$  and the effective  $Q$  value higher, since  $Q = \omega L/R$  and the higher the harmonic the higher is the value of  $\omega$ .

The circuit shown (or slight modifications of it) has been extensively used in investigations on power supply wave-forms, and has been treated in considerable detail by Morgan and others.<sup>1,2</sup> (*see* bibliography). The need for higher values of  $Q$  has, however, led to the use of very large and heavy inductors (some interesting details in this respect are given by Morgan). As early as 1924, the thermionic valve had been pressed into service by Wegel and Moore<sup>3</sup> in the construction of an elaborate recording analyser, a brief schematic of which is shown in Fig. 4. Two ranges of 20-1,250 c/s and 80-5,000 c/s were provided by altering the inductance  $L$ , while the capacitance  $C$  was variable in small

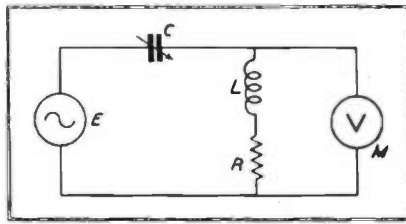

Fig. 3. The Resonance method of analysis.

steps to provide a semi-continuous frequency variation over the range. The condenser switching (linked to the recording meter drive) and other minor functions were performed by a pneumatic mechanism (modified from standard player-piano parts), and a complete record was obtained in five minutes. Such an instrument has two primary disadvantages: first, a single resonant circuit can give only a very limited selectivity; second, a straightforward rectifier system feeding a D.C. meter will normally give a linear amplitude scale, and, if it departs from linearity, does so in the direction of a square law, thus giving an even more cramped scale at low levels. This is not so important where the instrument has additional amplitude

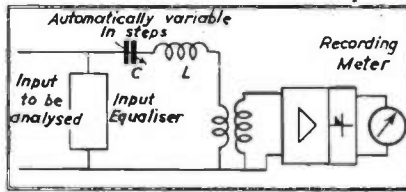

Fig. 4. The recording analyser of Wegel & Moore

controls, though even then it is a nuisance; but for a recording instrument, where a wide range of levels have to be registered on the same scale, a logarithmic response is essential if any attempt is to be made to record small amounts of harmonic.

The first disadvantage mentioned above can be tackled in four ways. First, the " $Q$ " of the tuned circuit used can be raised by the use of lower power-factor elements. It is quite practicable to use high-quality dust-core inductors at frequencies above some 10 Kc/s., and obtain " $Q$ " values of 300 or over, but below 10 Kc/s., this becomes increasingly im-

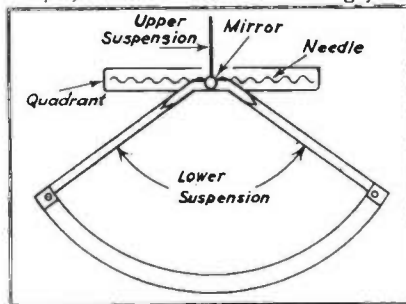

Fig. 5. Resonant system of electrometer analyser

practicable as the physical size needed increases rapidly. In any case, the power-factor cannot be reduced sufficiently to measure very small harmonic percentages, and the situation may be much worse when measuring waves containing components not harmonically related. It is possible, however, to use a mechanical resonator, which may have an effective " $Q$ " of several thousand. Any mechanical resonator which can be efficiently coupled to an electrical circuit, and have its resonant frequency varied over a considerable range, is however, likely to be unsatisfactory mechanically. The method has been used by Delsasso<sup>4</sup> in the analysis of aeroplane noise; his range was restricted to comparatively low frequencies (20-550 c/s.) though this is not the maximum attainable, and from his results there should be little difficulty in extending it to several thousand cycles per second. The instrument used is in effect a quadrant electrometer, with a resonant suspended system of low damping, whose frequency can be varied over a considerable range. The upper suspension of the electrometer needle is a single strand of fine tungsten wire, connected to a micrometer tension head: the lower suspension is bifilar, connected to adjustable radius arms, so that the angle between the suspension strands can be readily varied. This bifilar suspension produces a considerable restoring torque on the needle system, and a moderately high resonant frequency is obtained, variable by alteration of the angle of the suspension. The equivalent " $Q$ " of the system is of the order of 400 to 500, giving a very sharp resonance. The wave-form to be analysed, after amplification, is applied to the electrometer quadrants: the amplitude of the needle vibration is measured by a normal lamp and scale device, thus giving the amplitude of the components as the frequency of the suspension is varied by a micrometer controlling the angle of the radius arms. A somewhat similar modification to a vibration galvanometer would presumably be quite possible: but such instruments have rather evident disadvantages in regard to lack of robustness.

A second means of obtaining higher selectivity is to reduce the damping of the selective element by the addition of an external negative resistance. This is normally a dynatron connected across a parallel tuned circuit. This method is used by Piddington,<sup>5</sup> whose circuit is shown in Fig. 6. In setting up this circuit,  $R_2$  is adjusted so that the dynatron and parallel tuned circuit (which is tuned to the fundamental) are just below the threshold of

oscillation; under this condition, the tuned circuit is a very high impedance to the fundamental, and almost all the fundamental volts are dropped across it. Any other components appear mainly across  $R_1$  (which is normally some 5 to 10 thousand ohms) and are amplified and shown on an oscillograph or measured by a valve voltmeter. Apart from a more ready adjustment and greater flexibility, this is a similar result to that obtained by a frequency dependent bridge (such as the Wien bridge) which can be used to remove the fundamental; it has the same disadvantage that it gives only the total harmonic, unless a number of such circuits are used to remove successive harmonics. The same principle is used, however, by Barnard,<sup>8</sup> who employs a tuned circuit with a dynatron as above, but arranged to pass only its resonant frequency (see Fig. 7). A "Q" value of several thousand can be obtained before the adjustment becomes too critical; this is sufficient for most harmonic measurements, and for many cases where non-harmonic components in close proximity have to be separated. Such a device is not very easy to keep in accurate calibration, however. It has a very wide frequency range, up to several megacycles, but it not well suited for use below about 100 c/s.

A third method is more adaptable to low frequencies, though it gives much less selectivity. It has been used by Scott<sup>7</sup> and employs a bridge or "parallel T" network in the feedback circuit of a negative feedback amplifier. Such a network has infinite attenuation at one frequency, and can be designed to have a fairly low attenuation at other frequencies. By placing it in the feedback circuit, the negative feedback is removed at the point of infinite attenuation, so that the amplifier gives its full gain, whilst at other frequencies, the amplifier gain is low. The simplest forms of network are shown in Fig. 8a (a "parallel T" network) and Fig. 8b (the Wien bridge, well known as a frequency bridge). The relations given between the components lead to a simple formula for the frequency, and the variable components can be ganged. The parallel T network is used by Scott, with ganged variable resistors, the bridge circuit allows the use of normal ganged condensers, which is advantageous at high frequencies. As stated above, the selectivity is not high, but the percentage selectivity is constant throughout the range, which is an advantage for many purposes, and the circuit obviates the use of large and costly inductances at low frequencies. A minor advantage is that a large fre-

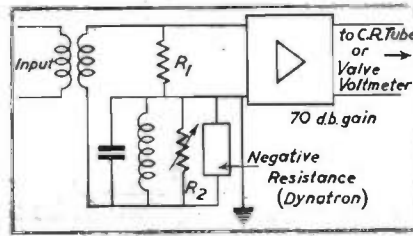

Fig. 6. Piddington's method.

quency ratio can be covered on a single dial.

A fourth method of obtaining high selectivity is, of course, to use several resonant circuits.<sup>9</sup> This is not so attractive at very low frequencies, since the tuned circuits, even if of low efficiency, become cumbersome and ganging is difficult: but for audio frequencies upwards to several megacycles, it is entirely practicable, since ordinary ganged condensers can be used and several tuned circuits cascaded, either loosely coupled or separated by valves. The selectivity thus obtained will be sufficient for all purposes of harmonic analysis, and in many cases for the separation of non-harmonic components. A disadvantage is that constant sensitivity is difficult to obtain; this is of no conse-

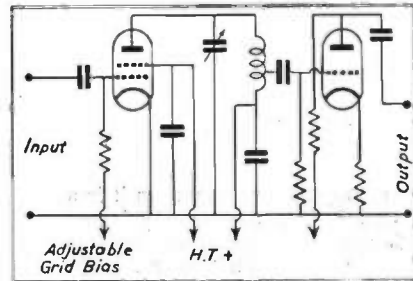

Fig. 7. The use of a dynatron to increase selectivity.

quence if the substitution method of measurement is used. A calibration for sensitivity can be made and corrections applied; this is simple enough, but apt to be a nuisance in practice: calibrations are easily mislaid. To cover a wide frequency band

many ranges will need to be provided (three to one is about the limit for each range): this disadvantage is largely outweighed by the straightforward character of the circuits involved. If, however, constant sensitivity, wide frequency range at a single sweep, and very high selectivity are required, a heterodyne analyser is essential.

A second disadvantage mentioned above in connexion with Wegel and Moore's apparatus, which applies to many others, is the scale-shape of the indicating instrument. In the case of a non-recording device, this is not of great importance, though a square-law instrument (e.g., a thermo-couple meter or anode-bend valve-voltmeter) is undesirable, since it greatly limits the amplitude range over which accurate readings can be taken without changing the instrument sensitivity. A linear-law meter (e.g., a metal rectifier meter, diode valve-voltmeter) supplemented by sufficient range multipliers, is convenient and accurate. When, however, a recorded result is required, and thus only a single range possible, a square-law response gives very poor results, and a linear-law instrument is not sufficient for many purposes. Thus it would be difficult to note the existence of a component of a few per cent. of the fundamental when recorded on a linear scale (bearing in mind the inherent limitations of any recording instrument) and an accurate estimation of the value would be impossible. This difficulty is accentuated by the tendency of most A.C. meters to approximate a square law at the lower end of their range. Evidently an indicating instrument following a logarithmic law is necessary. This is not so with a non-recording method, since the best logarithmic voltmeter is not so accurate as a linear meter; but since great accuracy is not normally obtainable or even necessary with recording analysers, the need for a constant percentage accuracy at all parts of the scale is paramount. Several methods have been developed

whereby this can be attained and mention may be made of the methods of Ballantine,<sup>9</sup> Ryall,<sup>10</sup> Payne and Story<sup>11</sup> and Hunt,<sup>12</sup> among others. The method of Hunt gives the widest range.

(To be concluded).

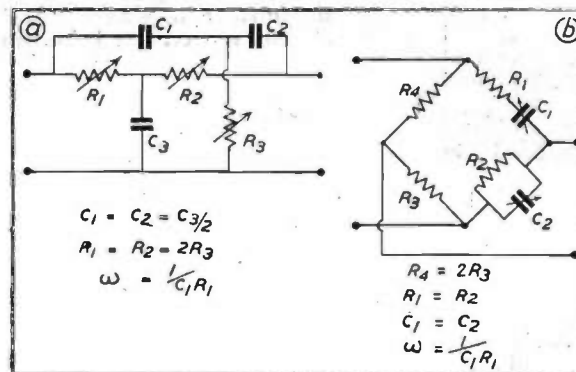

Fig. 8. Use of parallel-T or bridge networks for analysis.

$$C_1 = C_2 = C_3/2$$

$$R_1 = R_2 = 2R_3$$

$$\omega = \frac{1}{C_1 R_1}$$

$$R_4 = 2R_3$$

$$R_1 = R_2$$

$$C_1 = C_2$$

$$\omega = \frac{1}{C_1 R_1}$$





## on ne passe pas

**T**HOUGH Custom may cry Halt, the order of the day is Forward. In modern industry, men and women of imagination, undeterred by the doubts of the timid, are pressing on towards new ideas and methods.

Of this dynamic spirit Simmonds Aerocessories is at once the symbol and the servant. The Simmonds Organization is geared to the achievement of maximum output without loss in quality; the Simmonds products in all fields are fulfilling a high vocation in conserving the Nation's time, material and man-power. Let Simmonds be your ally in the great advance.

# S I M M O N D S

*The Creative Impulse in*  
**AERONAUTICAL, INDUSTRIAL & MARINE**  
*Construction*

THE SIMMONDS NUT · PINNACLE NUT · SPIRE NUT  
 SIMMONDS GAUGES, INSTRUMENTS AND CONTROLS  
 FRAM OIL & ENGINE CLEANER

SIMMONDS AEROCESSORIES LTD.  
 GREAT WEST ROAD, LONDON

A COMPANY OF THE SIMMONDS GROUP

LONDON, MELBOURNE, PARIS, NEW YORK.

# A Method of Demonstrating the Action of the Multivibrator

By B. HALLETT\*

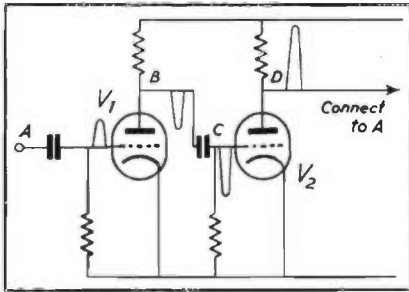

Fig. 1. R.C. coupled amplifier showing how positive feedback is applied.

It has been found difficult to explain to students the voltage waveforms at the anodes and grids of the symmetrical multivibrator, as shown on the Cathode-Ray Oscilloscope. That such a circuit can produce the positive "feed-back" necessary for the maintenance of oscillations is easily demonstrated by explaining the phase changes which take place in a two stage resistance-capacity coupled amplifier, as shown in Fig. 1. When the output lead is taken close to the input grid circuit oscillations are produced, and if connexion is made via a coupling condenser from the output anode to the input grid, oscillations of larger amplitude and lower frequency are produced. Alteration of the circuit diagram from Fig. 1 to Fig. 2 makes it obvious that the multivibrator is only a two-stage R.C.C. amplifier "fed-back" on itself.

Observations of the voltage waveforms at the anodes and grids of a symmetrical multivibrator, with a frequency of oscillation of about 1,000

\* S.W. Essex Technical College.

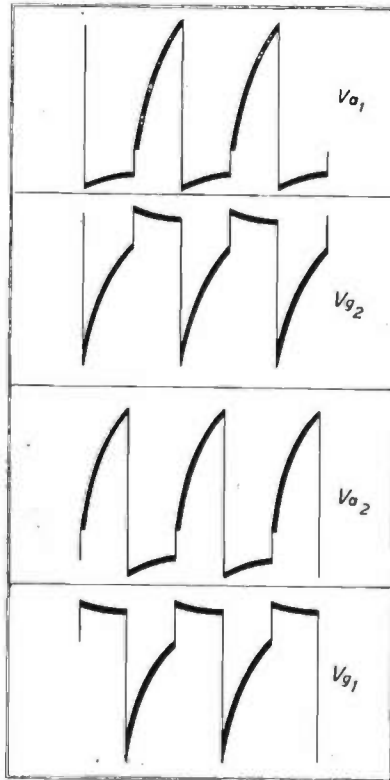

Fig. 3. Waveforms in the multivibrator circuit. The 'thin' vertical lines represent where both valves are working. The thicker lines show where one valve is 'cut-off' and the system is relaxed.

c/s, are made on the C.R.O. These waveforms are carefully observed since they are the basic waveforms of both types of multivibrator.

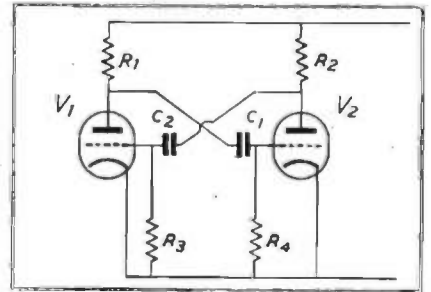

Fig. 2. The fundamental circuit of the multivibrator obtained from the circuit of Fig. 1.

Study of the waveforms in Fig. 3 reveals the fact that each valve "cuts off" in turn and the condensers  $C_1$  and  $C_2$  in Fig. 2 charge and discharge alternately. However, in order to obtain a clearer picture of the action during the "relaxation" periods, it is necessary to have a knowledge of the anode and grid currents flowing.

It is fairly simple to arrange such a circuit to oscillate at so low a frequency that normal D.C. meters can be inserted at the anodes and grids of both valves, and readings taken of the voltage and current variations. Graphs of these variations can be plotted against time.

If the grid condensers are of high capacity and grid and anode resistors made large, the circuit will oscillate only once every few seconds. The frequency is given by:—

$$f \approx (R_1 C_1 + R_2 C_2)^{-1}$$

The values can be arranged to suit the components available.

The circuit in Fig. 4 was set up so that an increase in ratio up to 43:1

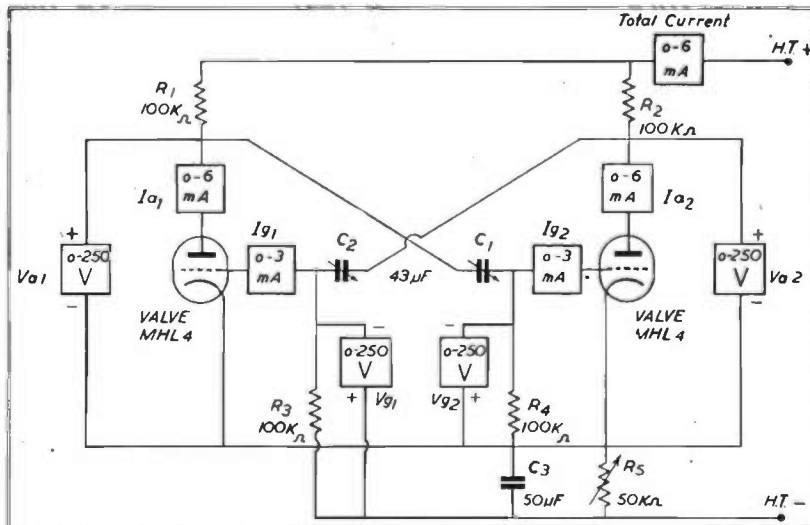
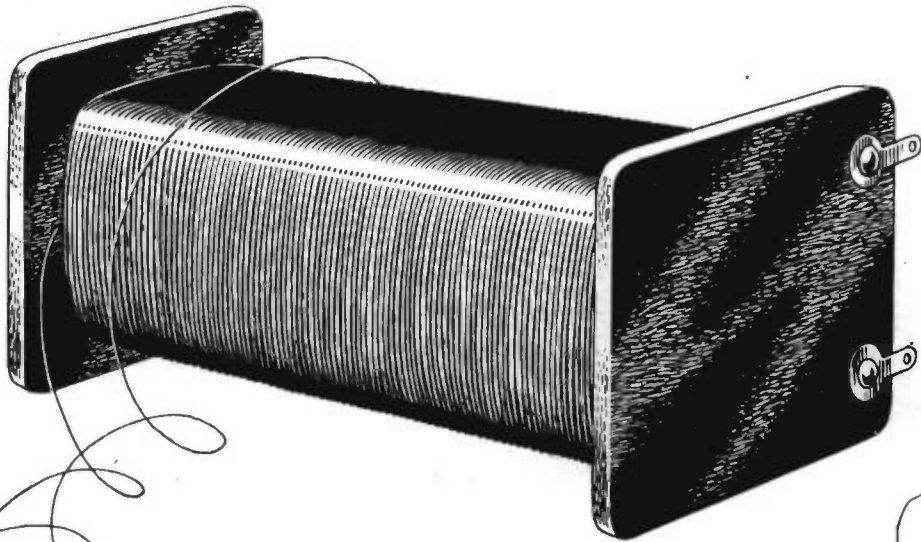



Fig. 4. Circuit diagram of experimental multivibrator.



## BAKELITE VARNISH

# V11105

— the latest phenolic stoving varnish for insulated wires can be safely used with enamelled wire, cellulose acetate, silk, cotton, 'Viscose' and 'Formvar'. Write for samples and detailed information to Bakelite Limited, 18 Grosvenor Gardens, London, S.W.1. Telephone: SLOane 9911

TREFOIL  
**BAKELITE**  **PLASTICS**  
REGD. TRADE MARKS

*Pioneers in the Plastics World*

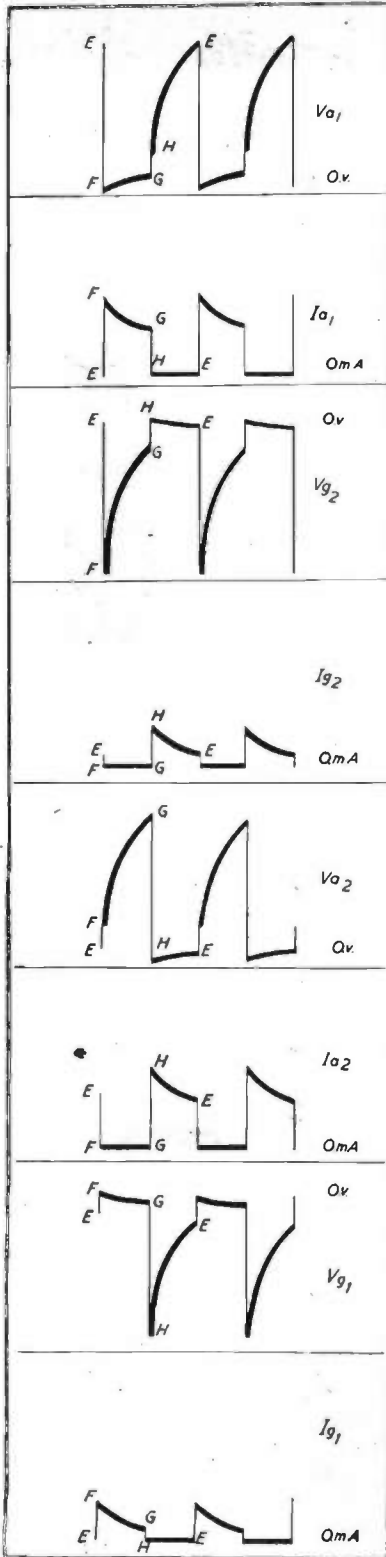

Fig. 5. Waveforms for experimental readings. The thin vertical lines represent where both valves are working. The thicker lines show where one valve is "cut-off" and the system is relaxed.

between the time constants of the grid condenser-leak combinations could be made in  $1 \mu F$  steps.

The anode voltmeters must be the best type obtainable. Since all meters must be "dead-beat" it is impossible to use electrostatic voltmeters. However, so long as those used are not less than  $1,000 \Omega$  per volt, the effect on the voltage variations is small. For the grid voltmeters it is necessary to set "zero" at 10 volts so that positive, as well as negative, readings can be taken. In the circuit in Fig. 4,  $R_5$  and  $C_5$  are included so that it can be converted into a Kipp Relay. For use as a normal multivibrator  $R_5$  is short-circuited. It is preferable to arrange all the meters, each labelled boldly, in a row behind the circuit board.

When the circuit is set up with each condenser at maximum capacity, readings are taken from each meter in turn. Note very carefully the readings at points marked E, F, G, H, on the waveforms of Fig. 5. Plot the eight graphs in a single column so that the relations in time can be studied, and a careful analysis of the action made. The heavy anode currents at F on the  $I_{a1}$  waveform and at H on the  $I_{a2}$  waveform, are very interesting. In the circuit of Fig. 4 the current at these points is 5mA. The drop in  $V_a$  is 155 volts, the anode load is  $100,000 \Omega$  so that the current supplied from the H.T. supply is 1.55 mA. The remainder of the  $I_a$  is due to the discharge of the condenser. This illustrates the action of the valve as a switching device. The grid currents during the periods HE in the  $I_{g2}$  waveform, and FG in the  $I_{g1}$  waveform, are equivalent to introducing a comparatively low resistance in parallel with the grid leak during that period of time during which the grid is positive. Since the grid voltages are those developed across the grid leaks, then, during the periods HE in the  $V_{g2}$  waveform, FG in the  $V_{g1}$  waveform, there can be little variation since the effective resistance between grid and cathode is low. When the grids are driven negative however, no grid current flows and the voltages are developed across the full value of grid leak and, hence, are large.

A close approximation to the anode and grid voltage waveforms can be obtained by using two switches instead of valves, as shown in Fig. 6. Switch  $S_1$  is equivalent to anode to cathode of V in Fig. 2. Switch S is equivalent to grid to cathode of  $V_2$  when C, Fig. 6, is equivalent to  $C_1$  in Fig. 2. Since the charge and discharge of C can be made very slow,  $V_1$  in Fig. 6 can be an electrostatic voltmeter  $V_2$  can be a normal instrument with an "off-set"

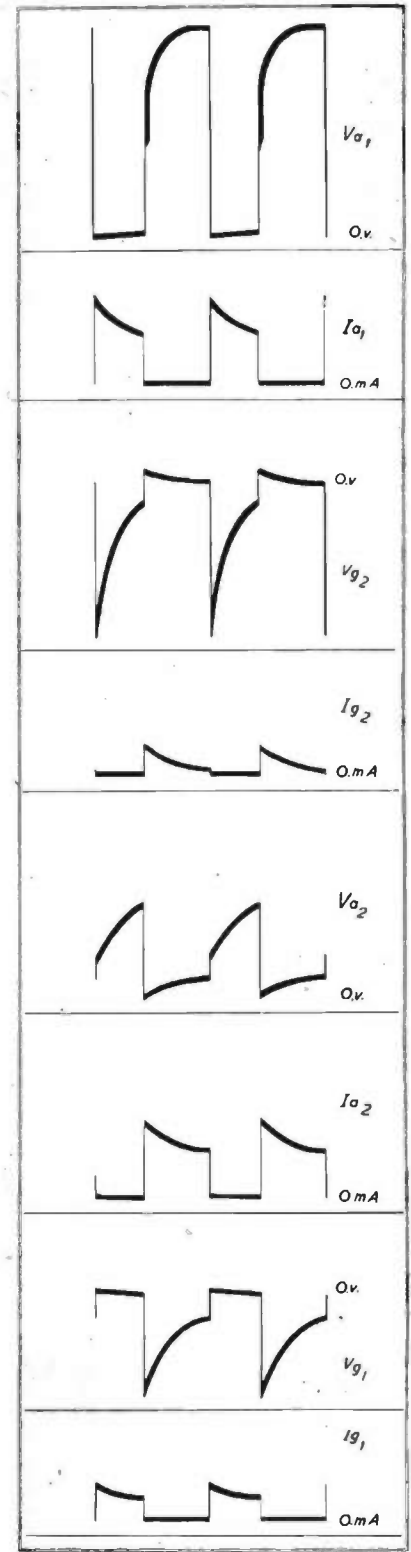

Fig. 9. Waveforms of asymmetrical multivibrator with unequal relaxation periods—compare with Fig. 5.

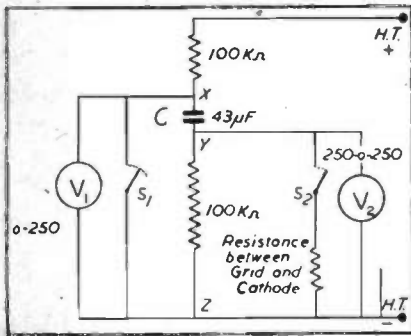

Fig. 6. The use of two switches to replace the valves in Fig. 2.

zero. The resistance between grid and cathode can be calculated from the figures for grid voltage and current obtained previously.

With  $S_1$  and  $S_2$  open, switch on H.T. supply and observe the voltage variations between X and Z during the charging of C. Discharge C. Repeat the charging process and observe  $V_{yz}$  variations. Discharge C again. With  $S_1$  open and  $S_2$  closed, observe the new  $V_{yz}$  variations during the charging of C. The difference in these two variations clearly illustrates the effect of grid current in the multivibrator. When C is fully charged open  $S_2$ , close  $S_1$  and observe  $V_{yz}$  variations. Plot the graphs as shown in Fig. 7. The process can be repeated with  $S_1$  open and  $S_2$  closed during charge;  $S_2$  open  $S_1$  closed during discharge; the "change-over" taking place before C is fully charged. This gives a much closer approximation to normal symmetrical multivibrator waveforms. The action of the valves as switches can be emphasised, and the differences in the waveforms explained.

The circuit in Fig. 4 can also be used to observe the voltage and current waveforms of the asymmetrical multivibrator, see Fig. 8. To understand these waveforms it is essential to realise that the action of both types

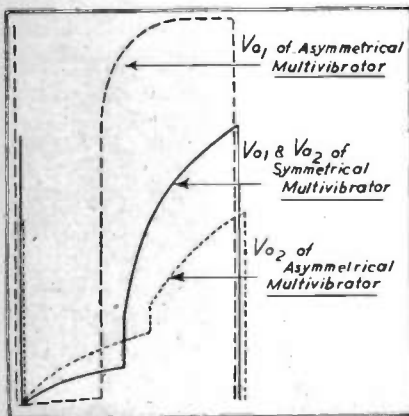

Fig. 10. Superposition of symmetrical and asymmetrical vibrator waveforms.

of multivibrator is the same, the great difference in output waveforms being due to the asymmetry of circuit constants. The reason these waveforms are so different is more easily understood if it is remembered that the time during which the small condenser charges is determined by the large condenser, and the time during which the larger condenser charges is determined by the small condenser. Hence, the small condenser can charge up almost completely, and the anode of  $V_1$  rise to a high potential, whereas the large condenser only partly charges and the anode of  $V_2$  does not rise to such a high potential as the anode of  $V_1$ . If the waveforms in Fig. 9 are compared with those in Fig. 5 the great differences can be observed. It will be seen that both types are similar, but whereas in Fig. 5 grid voltage and anode voltage waveforms and periods of relaxation are equal for both valves,

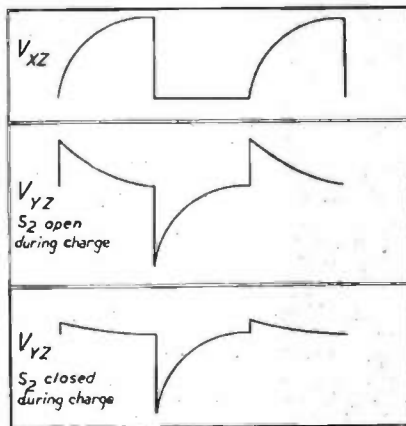

Fig. 7. Waveforms plotted from observations on the circuit of Fig. 6.

in Fig. 9 they are unequal. In Fig. 10 the three anode waveforms have been superimposed on one another to illustrate this.

The change between the two circuits can be studied by decreasing  $C_1$  in Fig. 4 by  $1 \mu F$  steps and plotting waveforms for each change. Thus the increase in asymmetry can be observed up to the maximum ratio of 43:1.

Finally, by increasing  $R_1$  till the circuit becomes quiescent with  $V_1$  cut-off and  $V_2$  heavily conducting, the circuit becomes a Kipp Relay. A single short negative "trigger" pulse at the anode of  $V_1$  will cause the circuit to execute one cycle before coming quiescent again. It is intriguing and instructive to observe all the meters "turn-over" once in response to a triggering pulse which is effected here by a flick of the moistened finger at the anode of  $V_1$ .

The duration and amplitude of the

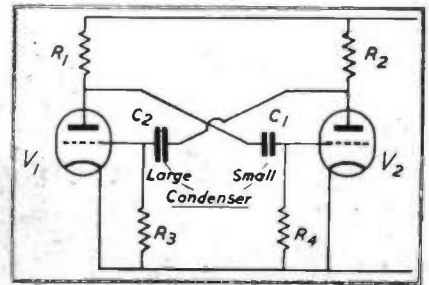

Fig. 8. Asymmetrical multivibrator circuit.

output pulse is determined by the circuit constants of the relay and not by the input pulse. This is shown by selecting different condenser combinations, the input pulse remaining the same. The differences in amplitude and duration can be measured.

Comparison between the waveforms obtained for the three circuits in "slow-motion" and for normal circuits can be made. These emphasise the fact that, though the frequencies are very different, the action during each cycle is the same.

### Cameras and Contacts

There was once a camera manufacturer who had a lot of trouble because his customers oiled the shutters. This gummed them up so they would not work. The instructions said not to oil the shutter, but nobody read instructions. They tried to make the shutter so that it couldn't be oiled, but there is no thwarting a man with an oil can. Finally, so the story goes, a meek little draughtsman in the engineering department asked timidly if he might try his remedy. He put a little hole in the top of the shutter marked "OIL" and ran a small pipe from it to the outside of the camera. This worked fine, for the oil never reached anything except the user's fingers.

This story may not be true, but it certainly is timely. Some receivers have suffered severely at the hands of well-intentioned men who believed "a drop of oil will fix it."

Contact trouble seems to be the cause of the oil can. A dirty contact is noisy, and oiling the contact reduces the noise for a little while. The remedy for a dirty contact is to clean it with carbon tetrachloride. After drying, it may be lubricated with a very small amount of petroleum jelly or vaseline. Do not use much, and never use oil. Oil creeps over the chassis, attacking rubber insulation and gathering dust. We have seen receivers with enough oil on the chassis to drown ants in.

Dick Gentry, Q.S.T., Dec., 1942.

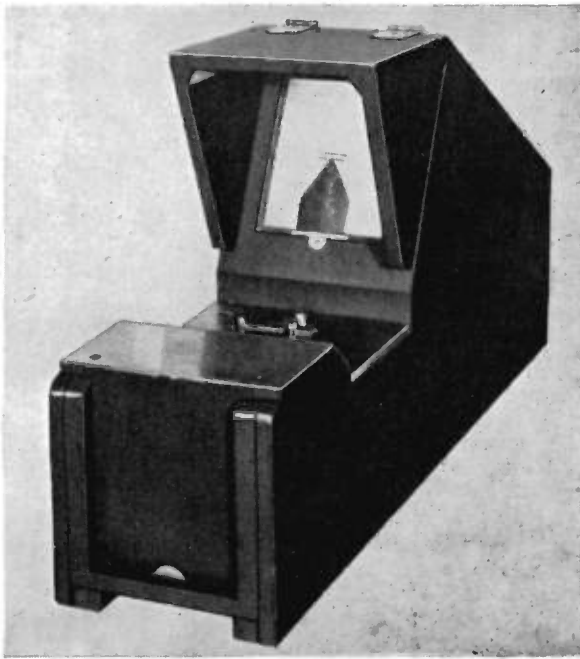

The "Lumigage"

The "Lumigage" is a new optical indicator recently developed and introduced by Hoover Limited of Perivale.

It can be used by semi-skilled or unskilled labour for the rapid inspection of small components—a projector type of instrument, it can be used both for checking dimension and form.

The apparatus comprises a cabinet—see accompanying illustration—having a table to accommodate the adaptors for the various components to be checked. With the cabinet, a light from a 25 watt lamp passes through a condenser system and the component undergoing inspection is inserted within the beam of light so produced. The beam then passes through a projection lens on to a mirror: thence it is reflected on to a viewing ground glass screen on which the shadow can be examined at a magnification of approximately 25 times.

Where it is not possible to insert the component into the light beam by reason of its construction, an indicating stylus is employed which extends into the beam and has its position influenced by the measurement of the component.

Substantial economies of cost, time and upkeep can be affected by its use. Hoover Limited are prepared to assist users by supplying sketches of the necessary fittings required for checking their components.

The cost of the device is 10 guineas. Further details will be supplied on request.

# NOTES FROM THE INDUSTRY

## B.S.I. Glossary of Terms used in Electrical Engineering

In a recent issue of this journal, the B.S.I. announced the publication of Part 1 of the "Glossary of Terms used in Electrical Engineering" Section 1. "General."

Part 2 of this series, Section 2 covering Machines and Transformers is now available and copies may be obtained from the British Standards Institution, 28 Victoria Street, Westminster, S.W.1; price 2s. net.

## Cheltenham College Fund for Educating Sons of Engineers

A fund has been registered under the War Charities Act, 1940, for educating at Cheltenham College the sons of engineers who lose their lives as a direct result of the war, whether they are in the services or are civilians.

Although the purpose of the fund is to give a general education preparatory for any profession, it may be of interest to engineers to know that:

- (a) The Engineering Foundation of Cheltenham College dates back to 1841, and many eminent engineers have been educated there.
- (b) Engineering facilities include twelve laboratories, engineering workshops and a modern drawing office. Mechanical drawing is a College subject for School Certificate purposes.

Donations, large and small, will be gratefully received, and donations over a period of seven years can be arranged under a covenant.

## British Insulated Cables, Ltd.

British Insulated Cables, Ltd., announce that the following have been appointed Assistant Home Sales Managers:—

Mr. O. W. Minshull, B.Sc., M.I.E., M.Inst.W., formerly Manager, Birmingham Office.

Mr. C. H. Hampson, formerly Joint Sales Manager.

Mr. A. H. Layne, formerly Sales Representative in Newcastle/Tyne

It is also announced that Mr. F. W. Leake, A.M.I.E.E., Manager, Manchester Office, has been transferred to Head Office (Estimating Department) and has been succeeded at Manchester by Mr. J. Anderson, M.Inst.C.E., who was manager in South Africa.

## Radio Industries Club

Owing to the present-day difficulties in catering for large luncheon meetings, the Committee of the Radio Industries Club have reluctantly decided that for the time being they cannot entertain any further applications for membership of the club.

The total membership now stands at well over 300, and at several recent luncheons the attendance has been in the region of 250.

The committee propose, however, to establish a waiting list from which any vacancies that may arise in future will be filled.

## Institution of Electronics

At the annual general meeting it was decided to set up a North-Western Committee to deal with the increasing activities of the Institution in that area. This section will hold its meetings at various intervals in the Manchester district. Inquiries regarding activities and the conditions of membership of this section should be addressed to Mr. L. F. Berry, The Institution of Electronics, 14 Heywood Avenue, Austerlands, Oldham.

## EEL Selenium Cells

Messrs. Evans Electro Selenium, Ltd., have issued a catalogue of "EEL" selenium photo-cells giving their characteristics and results of tests. An interesting point mentioned is that a number of cells which have been returned to the manufacturers as faulty have been found to be badly mounted. It is recommended that a reasonably strong spring contact should be used and no attempt should be made to solder on contact wires. Screw contacts are deprecated. The prices of the cells range from 17s. 6d. (unmounted) to £3 5s. od. for a large (67 mm.) circular cell. Copies of the catalogue can be obtained from Evans Electro Selenium, Westminster Bank Chambers, Bishops Stortford, Herts.

## MOULDED TODAY ARE THE DESTINIES OF TOMORROW . . .

Upon the shape of events to-day, and every day, depend the fortunes of the future. Through to-day's endeavour in research and industry already are discerned new and greater benefits for the coming era.

The name Marconi, since the earliest days of Radio, stands foremost in the field of communication; and Marconi Instruments Ltd., in the specialised work of instrument production, maintain this pride of place.

Over the horizon we see a golden age for scientist and technician. As always to the fore—but in who knows what new guise?—will be the name Marconi;—accuracy and reliability, then as now, the standard by which we judge ourselves.

Meanwhile, we concentrate on the business of to-day and endeavour to meet fully all requirements.

COMMUNICATION TESTING EQUIPMENT • INDUSTRIAL, MEDICAL AND LABORATORY APPARATUS

**MARCONI INSTRUMENTS LIMITED**

ST. ALBANS • HERTS • Phone 4323

# PERMALI

ELECTRICAL  
**INSULATION**  
to DCD WT 1000

*The* **NEW INSULATION CO., LTD.**

Telephone:  
Glos. 4419.  
Write for publication  
No. 31.

**BRISTOL ROAD, GLOUCESTER**  
London Office: 40, BROADWAY, S.W.1.

Telegrams:  
"Nico, Gloucester."  
Telephone:  
ABBey 6494.

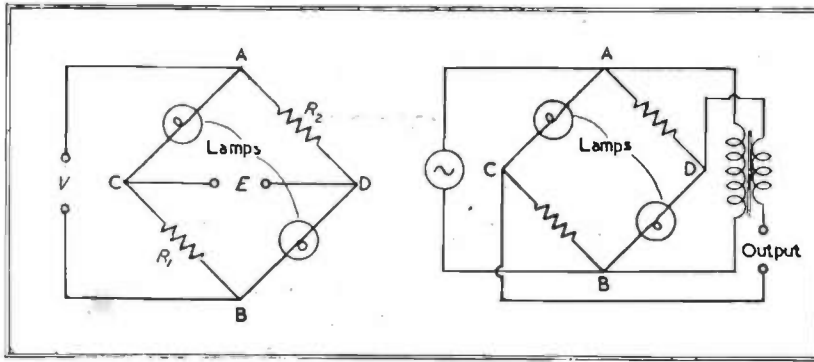

Figs. 1 and 2 (above) Fig. 3 (right).

It is well known that the resistance of a metal-filament lamp increases with the applied voltage. Therefore, considering a bridge circuit of the form show in Fig. 1, in which two metal-filament lamps and two resistors of low temperature coefficient are connected together there will be some voltage which, applied to the terminals AB, will result in zero voltage at CD. An increase in the voltage at AB increases the lamp resistances and causes a voltage to appear at CD, D being positive with respect to C; whilst a reduction in the applied voltage reverses the voltage at CD.

With a view to mathematical analysis the voltage/current characteristics of a number of lamps were measured and, by plotting to logarithmic coordinates, it was found that the relationship between voltage and current could be expressed with considerable accuracy between 30 per cent. and 100 per cent. of the rated voltage by the formula  $v = ki^n$ . For vacuum lamps the index,  $n$ , is about 1.65, and for gasfilled lamps it is 2.0.

It occurred to the author that this bridge circuit might be a means of producing a steady voltage for testing a.c. instruments, and Fig. 2 shows a circuit based on this idea. The output voltage of the bridge of lamps is added to the secondary voltage of the transformer, which has a ratio of  $(n + 1)/(n - 1)$ . A 1 per cent. increase in the supply voltage produced a voltage at CD of

$$\frac{n - 1}{n + 1} \times \frac{V}{100}$$

At the same time the secondary voltage of the transformer increased by the same amount. The two increments cancel each other, and a steady output voltage is the result.

The principal defect of this simple stabiliser is that, owing to the high resistance of the bridge, little power is available. It has, however, been successfully used to measure, continuously, the a.c. resistance of an electrolyte.

The author attempted to amplify, by means of valves, the a.c. output voltage of the bridge and to obtain, from the secondary terminals of an output transformer connected to the power valve of the amplifier, an output which would be of the correct magnitude and phase to neutralise the fluctuations in the supply voltage, and so to yield a steady voltage output. It was found, however, that no adjustment of the input voltage to the bridge would reduce the output voltage to zero, there being a residual minimum voltage.

Oscillograph records of the bridge output due to input voltages which differed by 1 per cent. indicate that changes in output voltage due to variations in the supply voltage of 1 per cent. are small compared with the minimum voltage. It follows that third-harmonic and quadrature voltages will overload the amplifier, particularly the power stage, and will prevent the required (sine) component from being properly amplified.

After many unsuccessful attempts to eliminate these unwanted voltages by filter circuits in the amplifier, the differential bridge shown in Fig. 3 was developed. The "indicator" bridge network may be regarded as consisting of two four-arm bridges with one pair in common. The two bridges develop e.m.f.'s of equal magnitude which consist of sine, cosine

## A Differential Electronic Stabiliser for Alternating Voltages

(An abstract of a paper by A. Glynne, M.A., read before the Measurement Section of the Institution of Electrical Engineers)

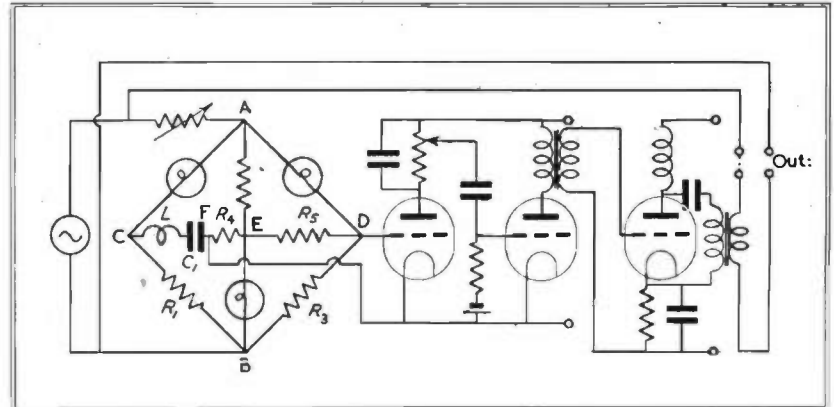

and third-harmonic components. The load connected to the left-hand bridge is a series choke, condenser and resistance circuit which is tuned to the third harmonic. The third-harmonic voltage of the terminals of the resistor  $R_4$  is in phase with the third-harmonic e.m.f. and hence in phase with the third-harmonic voltage at the terminals of  $R_5$ . The net third-harmonic voltage between the points F and D can therefore be reduced to zero by adjustment of  $R_5$ . The quadrature component in the e.m.f. of the left-hand bridge produces a voltage in  $R_4$  which, owing to the presence of condenser  $C_1$ , leads the e.m.f. and can therefore be balanced by some of the sine component of voltage in the right-hand bridge. Again, a sine component in the e.m.f. of the left-hand bridge creates a quadrature component of voltage in resistor  $R_4$ , and it can therefore be adjusted to neutralise the unwanted quadrature-component voltage in the right-hand bridge.

To obtain the proper setting of the "indicator" it is first necessary to tune the series circuit by adjustment of either L or C, then to adjust  $R_6$  to equalise the third-harmonic voltages in  $R_4$  and  $R_5$ , and finally to adjust  $R_1$  and  $R_2$ , until, at the desired operating voltage, the indicator output voltage is zero. The cathode-ray oscillograph is of great assistance in making these adjustments.



Fig. 3 also shows the circuit of the amplifier, which consists of two triode valves, the first resistance-coupled and the second transformer-coupled to the output valve (L.S.6a), the output of which passes to the output transformer through the choke-condenser coupling. This arrangement was found to be necessary to ensure that the output should be proportional to the variations in the supply voltage.

The stabiliser, as constructed by the author, when supplied from the public mains is capable of giving a steady power output of some hundreds of watts and of dealing with variations of  $\pm 2$  per cent. in the supply voltage. If the output voltage is measured with a precision voltmeter fitted with a knife-edge pointer, it is impossible to detect any fluctuation when the supply voltage is varying over a range of  $\pm 1$  per cent.

## Freon

IN a paper presented before the I.A.I.E.E. Convention, New York, H. H. Skilling and W. C. Brenner\* describe studies on the electrical strength of nitrogen and the gas dichlorodifluoromethane ( $\text{CCl}_2\text{F}_2$ ).

This gas, which is commonly known as Freon F-12, has an unusually high electric strength and will withstand  $2\frac{1}{2}$  times the voltage of air or nitrogen under the same conditions.

It cannot be used at pressures above about 70 pounds per square inch, as that is its approximate vapour pressure at ordinary temperatures.

Mixtures of freon and nitrogen are intermediate in characteristics between the two gases used alone. The most interesting characteristic of mixtures is the large increase in electric strength produced by a very small amount of freon in nitrogen.

The greatest advantage in the utilisation of freon between smooth surfaces is where the pressure of gas that may be used is limited by mechanical considerations. For most purposes, nitrogen at 300 pounds per square inch pressure is superior to freon, for it has as great an electric strength, is more consistent in behaviour, and does not become corrosive in the presence of electric discharge. But if the gas pressure is limited by mechanical design to 150 pounds per square inch, or less, the possible use of freon should be carefully considered.

The possibility of adding a small percentage of freon to nitrogen, and thereby increasing its electric strength by 15 to 25% appears to be a practical consideration.

## Solubility of Metals in Mercury

C. H. Prescott

**M**OST metals dissolve slightly in mercury and they also react chemically with it to form intermetallic compounds. Platinum, the classical metal for contact with mercury, deteriorates slightly with age and becomes brittle with long exposure to it. Iron and tungsten seem inert, but this may be due in part to the protection of adherent surface films of oxide. Lead, tin, zinc, and cadmium are sufficiently soluble to alter the properties of the mercury which makes them unsuitable for use in contact with it in mechanical devices. Silver, copper, nickel, and platinum are but slightly soluble.

The solubility of silver was found to be 0.0018 gram per gram of mercury and that of copper was tenfold less, i.e., 0.00013 gram per gram.

The solubility of nickel was  $1.4 \times 10^{-7}$  gm./gm. or one part in seven million. That of platinum was thirty times less,  $4.6 \times 10^{-9}$  gm./gm.

With iron and stainless steel, the boilers were perfectly clean after eight months. Washings gave a spectroscopic test for iron with indicated solubilities of about  $5 \times 10^{-11}$  gm./gm. or one part in twenty billion.

The surfaces of silver, copper, nickel, and platinum are easily wet and remain covered with a fluid film of mercury. At the surface of contact there forms a layer of solid amalgam, an intermetallic compound of the metal with mercury. Silver amalgam forms readily; copper, soaked in mercury for a few months at 100 degrees C., disintegrates completely into crystals of copper amalgam. The surfaces of nickel, which has been submerged a few days and platinum, a few months, become rough and granular.

It thus appears that the material in equilibrium with mercury in these solubility experiments is not the metal itself, but this layer of solid amalgam. Actually the metal must be somewhat more soluble than the amalgam. Thus as it slowly dissolves, it is reprecipitated as an intermetallic compound which covers the surface and retards further attack. The free metal is essentially unstable in the presence of mercury, and this change into solid amalgam is one form of disintegration suffered by silver, copper, nickel, and platinum.

The solubilities of nickel and platinum are below the limit of a spectroscopic test on the mercury in equilibrium with the metal and the quantity of metal actually in the mercury, at any instant, is negligible.

—*Bell Laboratories Record*, Vol. 21, No. 4, December, 1942, p. 104.

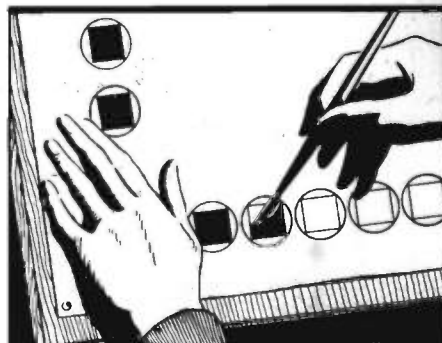

## SQUARE PEGS IN ROUND HOLES

Easy for our draughtsman perhaps, but what's the use of them? Unfortunately we have reason to suppose that there are still some about! This does not apply to RELIANCE, however, for our entire capacity is fully occupied with the War Effort, but when Victory is achieved, our many years' experience of Variable Resistors will again be at your service.

### RELIANCE

Manufacturing Co. (Southwark) Ltd.  
Sutherland Road, Higham Hill,  
Walthamstow. E. 17.  
Telephone—Larkswood 3245

## RADIO BOOKS

### SHORT WAVE RADIO

By J. H. Reyner, B.Sc. (Hons.), etc. This book deals with the developments and progress in the field of short wave radio telegraphy, giving comprehensive data and practical methods of application. Has been quoted as being "one of the finest short wave treatises available." 10s. 6d. net.

### PROBLEMS IN RADIO ENGINEERING

By E. T. A. Rapson. A classified collection of examination questions set from time to time by some of the more important examining bodies in Radio Communication, together with some useful notes and formulae. Fifth Edition. 5s. net.

### EXPERIMENTAL RADIO ENGINEERING

By E. T. A. Rapson, assisted by E. G. Ackermann. Eminently suitable as a textbook for a three or four years' course in radio engineering at a technical college. Contains a number of experiments and methods of measurement, the majority of which may be carried out with standard laboratory equipment. 8s. 6d. net.

39 PARKER STREET, KINGSWAY

# PITMAN

# ABSTRACTS OF ELECTRONIC LITERATURE

## MEASUREMENT

### Device for Measuring Tip Force and Current in Spot Welding (H. Wolfe, R. W. Powell)

Spot weld electrode force and current measuring devices are described. In the force-measuring apparatus use is made of four temperature-compensated, wire-type strain gauges which form the arms of a Wheatstone bridge. The power source is a 2,000 cycle oscillator and the rectified out-of-balance current is observed with a cathode-ray oscillograph. The electrode current is determined from the potential developed across a manganin disc of the same cross-section as the electrode holder and silver-solder brazed between two parts of the electrode. 60 cycle current is used.

—*Weld. J.*, June, 1942, page 293.\*

### An Electronic Potentiometer (M. A. Honnell)

A direct current, degenerative, slide-back vacuum tube voltmeter employing standard potentiometer design principles is described. The voltmeter is completely self calibrated upon construction. By adjusting the voltmeter to the same reference balance condition for all voltage measurements, the grid current is readily reduced to less than  $10^{-9}$  ampere. Voltages in the range from 1 to 100 volts are read to four significant figures in the experimental model of the voltmeter.

—*Proc. I.R.E.*, Vol. 30, No. 10 (1942), page 433.

### Temperature Measurement and Control by Electronics (C. Walsh)

Electronics has played a conspicuous role in the development of temperature measurement and control instruments during the past several years. This is a review article with some background of temperature measurement and control in general and a description of several electronic instruments.

—*Electronics*, Vol. 15, No. 10 (1942), page 56.

### The Q-Meter and its Theory (V. V. L. Rao)

The ratio of the reactance to resistance of a coil or condenser may be expressed as its Q. Direct reading instruments for this measurement are commercially available. The theory of their operation is given and includes corrections to increase the accuracy of the results of the measurements.

—*Proc. I.R.E.*, Vol. 30, No. 11 (1942), page 502.

## INDUSTRY

### A Concise Report on a High-Speed Camera for Simultaneous Photographic and Oscillographic Records (H. W. Baxter)

A high-speed camera of the (optical compensator) type is described, which is capable of recording simultaneously on the same film a high-speed photograph and the traces from several cathode-ray tubes. It is simple, compact, comparatively light and inexpensive. The camera can be operated at any speed up to its maximum. Photographs at speeds corresponding to 1,000 pictures per sec. have been obtained with good definition, but the instrument is capable of higher speeds.

—*Jour. Sci. Inst.*, Vol. 19, No. 12 (1942), page 183.

## RADIO

### On Radiation from Antennas (S. A. Schelkionoff)

This paper presents some theoretical remarks and experimental data relating to applications of the transmission-line theory of antennas. It is emphasised that the voltage, the current and the charge are affected by radiation in different ways, a fact which should be considered in any adaptation of line equations to antennas. It is shown experimentally and theoretically that in an antenna of length equal to an integral number of half wavelengths, which is energised at a current antinode, the effect of radiation on the current and on the charge (but not on the voltage) can roughly be represented by adding to the resistance of the wires another fairly simple term.

—*Proc. I.R.E.*, Vol. 30, No. 11 (1942), page 511.

## CIRCUITS

### Some Characteristics of a Stable Negative Resistance (C. Brunetti and L. Greenough)

By exploring positive feedback in a two stage amplifier it is possible to obtain an input impedance which is equal to the impedance in the feedback circuit multiplied by a negative constant.

For a resistance-capacitive feedback circuit the input impedance becomes a negative resistance in series with a negative capacitance. With the proper choice of circuit constants, the negative impedance can be made to

approximate closely a pure negative resistance over any given frequency range. In the apparatus described high stability is secured by the use of inverse feedback in addition to the positive feedback loop.

—*Proc. I.R.E.*, Vol. 30, No. 12, page 542.

## THEORY

### Formulae for the Inductance of Rectangular Tubular Conductors (T. J. Higgins)

Utilising a function  $H(x)$  defined by G. Stein formulae are derived for the inductance per unit length of rectangular tubular conductors. An example illustrates use of these formulae. A table of Stein's function is given for values of the argument  $x$  between 0 and 1 at intervals of 0.01.

—*Jour. App. Physics*, Vol. 13, No. 11 (1942), page 712.

### Some Aspects of Coupled and Resonant Circuits (J. B. Sherman)

An analysis is presented of the coupled impedance and its components in the two-mesh inductively coupled circuit with a tuned secondary. A similar analysis is made of the impedance and its components in the parallel-resonant circuit having dissipation in the inductive branch.

—*Proc. I.R.E.*, Vol. 30, No. 11 (1942), page 504.

### Performance Curves for $m$ -Derived Filters (W. J. Cunningham)

For a composite filter made up of several  $m$ -derived sections the greatest discrimination will be obtained if the values of the design parameter  $m$  for the various parts of the filter are chosen so that successive minima of insertion loss in the attenuation band are all the same.

Many different low pass structures were set up and adjusted experimentally to show this type of performance. The necessary values of  $m$  and the resulting discrimination for each network have been plotted on curves, which give information also about the sharpness of cut-off. These curves are useful for the most economical design of low-pass or high pass composite filters to meet definite requirements.

—*Jour. App. Physics*, Vol. 13, No. 12 (1942), page 768.

\* Supplied by the courtesy of Metropolitan-Vickers Electrical Co., Ltd., Trafford Park, Manchester.

# The National Interest Standardisation

These "Standard Values" cover every

Resistance Value from 10 ohms to 10 Meg.

In the Fixed Composition Resistor Field  
**"STANDARD VALUES" is the Solution**

For a long time now the range of values demanded in Fixed Composition Resistors has been increasing until it has now reached an uneconomic and wasteful figure exceeding 800. This position has produced unavoidable delays in delivery because of the time expended in special sorting and colour-coding, and the consequential hold-ups in the manufacture and servicing of important equipment. In order to regularise the position the Services, the Manufacturers, their Engineers and Laboratories have co-operated in rationalising the range to the 255 STANDARD VALUES, listed in the accompanying table, without any loss of efficiency. Tolerance  $\pm 20\%$  should be used wherever possible;  $\pm 10\%$  should be used only where essential; whilst for (1)  $\pm 5\%$  prior authorisation is required and should be sought by the Development Authority through the appropriate Supply Department Design Authority. The schedule applies only to new development projects, and not to existing contracts, spares for same or repeat orders for either. Your co-operation in using only STANDARD VALUES of resistance is vital if your demands are to be met on time.

$\pm 20\%$	$\pm 10\%$	$\pm 5\%$	$\pm 20\%$	$\pm 10\%$	$\pm 5\%$	$\pm 20\%$	$\pm 10\%$	$\pm 5\%$
10	10	10	1000	1000	1000	100000	100000	100000
15	12	11	1200	1200	1100	120000	120000	110000
22	15	13	1500	1500	1300	150000	150000	130000
33	18	16	1800	1800	1600	180000	180000	160000
47	20	18	2000	2000	1800	200000	200000	180000
68	22	20	2200	2200	2000	220000	220000	200000
82	24	22	2400	2400	2200	240000	240000	220000
100	27	24	2700	2700	2400	270000	270000	240000
150	33	30	3300	3300	3000	330000	330000	300000
220	39	36	3900	3900	3600	390000	390000	360000
330	47	43	4700	4700	4300	470000	470000	430000
470	56	51	5600	5600	5100	560000	560000	510000
680	68	62	6800	6800	6200	680000	680000	620000
820	82	75	8200	8200	7500	820000	820000	750000
910	91	82	91000	91000	82000	910000	910000	820000

## "STANDARD VALUES"

- Increased Production
- Quicker Delivery
- Speedy Servicing
- Valuable Raw Materials
- Labour
- Dangerous Delays

A limited number of "Quick Reference" STANDARD VALUES charts at 3d. each is available from manufacturers of Fixed Composition Resistors to those engaged in work of National Importance.

Issued under the Authority of

**INTER-SERVICE COMPONENT MANUFACTURERS' COUNCIL**

59, Russell Square, W.C.1.

Tel: MUSEum 4031-2

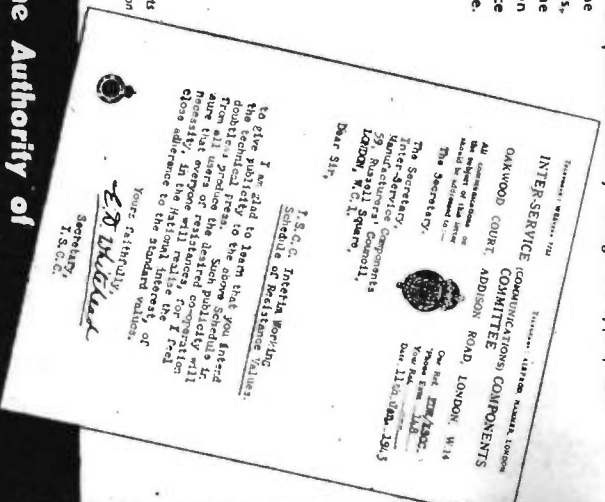

★ See note (1) in Text

# A Multi-Range D.C. Meter Circuit

From a paper by  
G. E. ROTH, M.Ph., in *Jour. Sci. Inst.*, Jan. 1943.

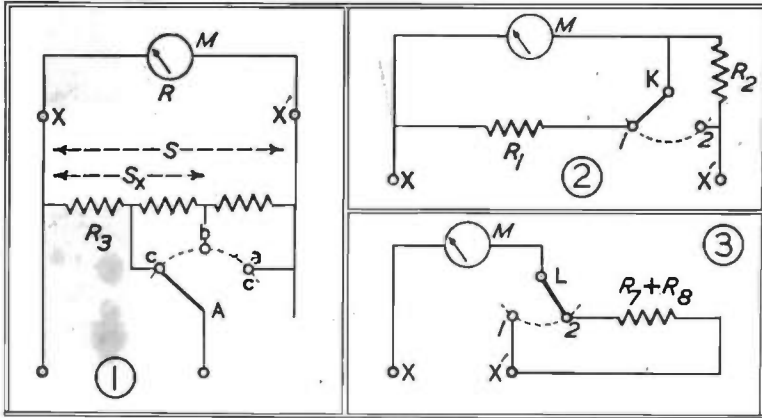

FIG. 1 shows a conventional universal-shunt circuit for an instrument  $M$  having an internal resistance of  $R$  ohms. Without any shunt, a current of  $I$  amperes will cause a full-scale deflection of  $M$ . In the circuit of Fig. 1 the current required to cause a full-scale deflection of  $M$  is  $F \times I$ , where the multiplying factor  $F$  is given by the well-known formula.

$$F = (R + S)/S_x \quad \dots (1)$$

e.g., for  $S = 0.11 R$ ,  $R_2 = 0.001 S$ , and switch  $A$  in position  $\alpha$ ,  $F = 10,000$ .

If the instrument  $M$  is disconnected at the points  $X$  and  $X'$  (Fig. 1) and the circuit arrangement of Fig. 2 is substituted, with the switch  $K$  in position 1, the current giving full-scale deflection of  $M$  will be determined by the current range selected with switch  $A$ . If  $K$  is put in position 2 any of the current ranges selected by  $A$  will be multiplied by a factor  $F'$  such that

tion 1, the current giving full-scale deflection of  $M$  will be determined by the current range selected with switch  $A$ . If  $K$  is put in position 2 any of the current ranges selected by  $A$  will be multiplied by a factor  $F'$  such that

$$F' = R/R_1 + 1 \quad \dots (2)$$

$R_2$  must satisfy the equation

$$R_2 = R - \frac{R_1 R}{R_1 + R} = R - \frac{R}{F'} \quad \dots (3)$$

while  $R_1$  is given from equation (2) as

$$R_1 = \frac{R}{F' - 1} \quad \dots (4)$$

If instead of the circuit arrangement of Fig. 2 the circuit of Fig. 3 is connected between the points  $X$  and  $X'$  in Fig. 1, with switch  $L$  in position 1, the current required for a full-scale deflection of the instrument  $M$  will be determined by the current range selected with switch  $A$ . If  $L$  is put in position 2 any of the current ranges selected by  $A$  will be multiplied by a factor

$$F'' = \frac{R_7 + R_8}{R + S} + 1 \quad \dots (5)$$

from which

$$R_7 + R_8 = (F'' - 1) \cdot (R + S) \quad (6)$$

follows.

From this elementary discussion of the effect of combining the circuits of Figs. 1, 2 and 3 it follows that the combination of the basic universal-shunt circuit of Fig. 1 with (a) either a single resistor in the circuit of Fig. 3 or (b) with two resistors in the circuit of Fig. 2, makes possible a doubling of the total number of ranges selected by switch  $A$  while retaining the advantageous situation of the switch  $A$  in the line circuit.

**SILVERED CERAMIC  
FIXED CONDENSERS**

PEARL TYPE •  
0.5pF to 5pF.

Max. Dimensions 7 x 9mm.  
Test Voltage 1500V. D.C.  
Loss Factor - 20 x 10<sup>-4</sup>

Mechanical and electrical stability  
whatever the climatic conditions.

Type approved

**MULTUM IN PARVO**



**UNITED INSULATOR CO. LTD**

12-20 LAYSTALL STREET, LONDON, E.C.1.

Phone: TERminus 7383

Grams: Calanel, Smith, London.

*The Pioneers  
of Low-Loss  
Ceramics*

# MYCALEX

[REGD. TRADE MARK]

*The All-Round Insulator  
with many Virtues  
and no Vices*

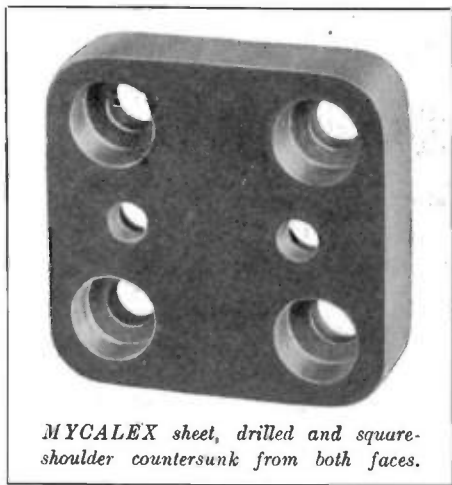

*MYCALEX sheet, drilled and square-shoulder countersunk from both faces.*

**N**O designer should be without up-to-date data relating to the properties and performance of MYCALEX. They offer many opportunities for improved design. Special characteristics are :

- Consistent in temperatures up to 400 degrees centigrade.
- Tough and unaffected by gas or oil.
- Readily machined to fine limits.
- Can be combined with metal parts as in the example below.



## MYCALEX METAL MOULDINGS

*with and without metal inserts.*

If you are interested, write for particulars and send drawings.

**MYCALEX LTD., CIRENCESTER, GLOS.**

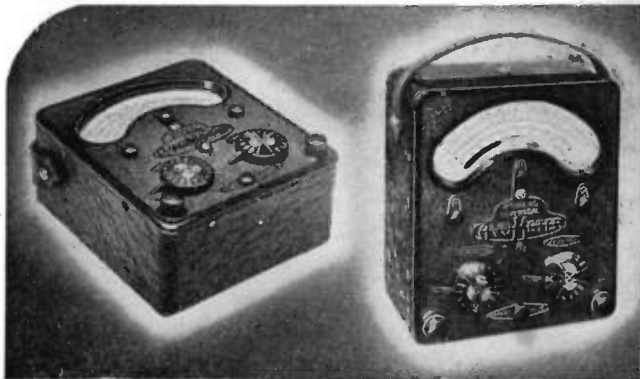

46-range Model 7  
Universal AvoMeter

40-range Model 40  
Universal AvoMeter



Regd. Trade Mark

## ELECTRICAL MEASURING INSTRUMENTS

**F**ROM years of intensive research in the design and manufacture of electrical testing equipment has grown the range of world-famous "AVO" Instruments. To-day, wherever rapid precision testing is demanded, there will be found the meters that matter— "AVO" Meters.

Some delay in delivery of Trade Orders is inevitable, but we shall continue to do our best to fulfill your requirements as promptly as possible.

Write for literature fully descriptive of any "AVO" Instrument in which you are interested.

Sole Proprietors and Manufacturers :

**THE AUTOMATIC COIL WINDER & ELECTRICAL EQUIPMENT Co. Ltd.**  
Winder House, Douglas Street, London, S.W.1 Phone : VICTORIA 3404-7

Universal AvoMinor

D.C. AvoMinor

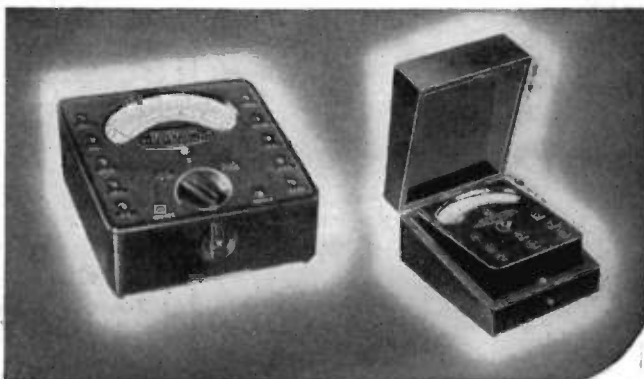

## To PROFESSIONAL ENGINEERS and TECHNICIANS

An abbreviated version of the original thesis by Dr. Norman Partridge on

### HARMONIC DISTORTION IN AUDIO FREQUENCY TRANSFORMERS

is now available in booklet form. This has been reprinted from the September, October and November issues of "The Wireless Engineer." The subject is treated technically, at length, and from an essentially practical viewpoint.

Copies can be obtained free of charge by professional engineers and technicians upon request. The shortage of paper prohibits distribution to interested amateurs.

# N. Partridge

Ph.D. B.Sc., M.B.A.I.R.E., M.I.E.E.

King's Bldgs., Dean Stanley Street,  
LONDON, S.W.1. Phone: VICTORIA 5035

## ELECTRADIX BARGAINS



**LIGHT RAY CELLS.** Selenium Bridge, in bakelite case. Raycraft Model, 21/- Electro-cell, self generating, light meter type, 35/- Raycraft Ray Set, with relay, 42/- Gas-filled Photo Cells, W.E. type, for sound on film, 70/- Relay enclosed, 10,000 ohm tele-type, 22/6. For other Relays see special leaflet, 2d.

**MAGNETS.** The Wonder Midget 2-oz. Permanent Magnet. Discs of Alni Steel. Tremendous magnetic force and only 1.3/16in. dia. x 3/16in. thick, with soft centre for drilling. One leaps off the table to meet another. Uses: Any magnetic duty, metal separation, magnetic chucks and lifters. Cut-out core, polariser, solenoid cores, headphone re-magnetisers, etc., 2/6 each, or 4/6 pair. A.C./D.C. Mains Magnets, 2 wound poles, 110 or 220 volts, 7 lb. lift, 5/6. Small 12-volt solenoids 2in. x 3/16in. plunger, 6/6. Transformers, 220 volts 50 cycle to 4,000 volts, C.T. 150 m/a. L.T. winding, approx. 7 volts 8 amps., 70/-

**DYNAMO BARGAINS.** We have a large stock of all sizes. Special Rotax 6 to 12 volts, 8 amps. D.C., 3rd brush, 8in. long, 4 1/2in. dia., weight 11 lbs., Unused, 17/6. L.T.-H.T. Double-current G.E.C. Dynamos, D.C. 6 volts and 600 volts, 2 coms., 17 lbs., 27/6. Carriage paid England and Wales.

Motor Generators and Rotary Convertors for radio, in stock.

**PANEL SWITCH RHEOSTATS.** "Off" and 0 to 1 ohm, 3 amps. 6 volts. Dimmers Charger Sub-circuit Regulators, Model Speed control, etc., 1 hole fixing and extra bracket for rack. Hollow knob has base for min. bulb to glow when "on." Makers, Aetna Co., U.S.A. New for 2/6, worth 5/-

**40 AMP. RHEOSTATS.** Large ironclad grid type with heavy 10-stud switch, drops 25 volt mains to 50 volts. Size, 3 1/2in. x 16in. 14in. x 15 1/2in., H0 volt ditto, size 16in. x 14in. x 16in. £2 10s. Tanks, etc. Open water tanks for engines, storage, fire, 14in. by 5ft., with fittings, 45/- Welded steel bottles for any pressure, pint size 8 1/2in. x 2 1/2in., new from works, 3/6.

Vee Pulleys, turned steel for 3/16in. belt, 4in. outside, 4/6. Endless Belts, rubberized, 7/6.

### ELECTRADIX RADIOS

19, Broughton Street, Queenstown Road,  
Battersea, S.W.8.  
Telephone: Macaulay 2159, Nearest Rly. Station,  
Queen's Road, S. Rly.

## Classified Announcements

The charge for miscellaneous advertisements on this page is 12 words or less 3/-, and 3d. for every additional word. Single-column inch rate displayed, £1. All advertisements must be accompanied by remittance. Cheques and Postal Orders should be made payable to Hulton Press, Ltd., and crossed, and should reach this office, 43, Shoe Lane, London, E.C.4, not later than the 15th of the month previous to date of issue.

### CAPACITY AVAILABLE

CAPACITY will be available at well established engineers for production and assembly or part assemblies of light Electrical Equipment and Apparatus. Essential work only. "Electronic Engineering," Box No. 651.

### FOR SALE

IN STOCK, Rectifiers, Accumulator Chargers, Rotary Convertors, P.A. Amplifiers, Mikes, Mains Transformers, Speakers of most types, Test Meters, etc., Special Transformers quoted for.—University Radio, Ltd., 238, Euston Road, London, N.W.1. Ger. 4447.

200 G.E.C., P.M. SPEAKERS with Transformer in stock, complete in metal cabinets, £2 5s. each, c.w.o. plus 1/- carriage and packing. Brand new in maker's carton. A. Imhof Ltd., 112 New Oxford Street, W.C.1.

### LITERATURE

7,000 MEMBERS of the Scientific Book Club believe that Knowledge is Power. Are you a member? Particulars from 121, Charing Cross Road, London, W.C.2.

### LOUDSPEAKERS

3,000 SPEAKERS P.M. and energised 4" to 14" including several Epoch 18". Sinclair Speakers' 170, Copenhagen Street, N.1.

LOUDSPEAKER repairs, British, American, any make, 24-hour service; moderate prices.—Sinclair Speakers, 170, Copenhagen Street, N.1.

### MISCELLANEOUS

WE WILL BUY at your price used radios, amplifiers, converters, test meters, motors, pick-ups, speakers, etc., radio and electrical accessories. Write, phone or call, University Radio Ltd., 238, Euston Road, London, N.W.1. Ger. 4447.

### MORSE EQUIPMENT

FULL range of Transmitting Keys, practice sets and other equipment for Morse training.—Webb's Radio, 14, Soho Street, London, W.1. Phone: GERrard 2089.

### RADIO MAP

WEBB'S Radio Map of the World enables you to locate any station heard. Size 40" by 30" 2 colour heavy Art Paper, 4/6, post 6d. Limited supply on Linen, 10/6, post 6d.—Webb's Radio, 14, Soho Street, London' W.1 Phone: GERrard 2089.

### WANTED

WE OFFER cash for good modern Communication and all-wave Receivers.—A.C.S. Radio, 44, Widmore Road, Bromley.

**DIRECTOR OF RESEARCH** and development, to take complete charge of these departments, required by a London firm of Electrical Engineers manufacturing radio frequency, acoustic and electrical instruments. First class qualifications in Physics or Electrical Engineering essential, coupled with wide industrial experience. Write, stating full particulars, to "Electronic Engineering," Box No. 652.

**CHIEF DESIGNER** (mechanical) required for development department of a firm of Communication Engineers. Good experience in the design of electrical instruments and apparatus essential. Write giving full details to "Electronic Engineering," Box No. 653.

**HANK BUSHES** and screws to your specifications (Repetition Work). Quick deliveries. D.T.Co., "Electronic Engineering," Box No. 654.

**ASSISTANT RESEARCH ENGINEER** required by London firm engaged on essential work for development of radio frequency and/or audio frequency apparatus. Training to B.Sc. standard in Physics or Electrical Engineering. Some experience desirable but not essential. Write stating full particulars to "Electronic Engineering," Box No. 656.

## TECHNICAL BOOKS

English and American Books on Radio and Electrical Engineering supplied from stock or obtained to order.

Please mention interest when writing

**LENDING LIBRARY**

Annual Subscription from One Guinea.

Details post free on request.

**H. K. LEWIS & Co. Ltd.**

136 Gower Street, London, W.C.1

Telephone: EUSton 4282 (5 lines)

Wartime installations  
show more conclusively  
than ever that  
you can

trust  
**TRIX**  
Quality SOUND Equipment

To priority order only



30-watt Amplifier with Radio.  
There are TRIX amplifiers  
from 5-500  
watts.

TRIX ELECTRICAL CO. LTD., 65, Bolsover St.,  
London, W.1. Phone EUS 5471/2  
Grams: Trixradio, Wesdo, London.

## GALPINS ELECTRICAL STORES

"Fairview" London Road, Wrotham, Kent.

PLEASE NOTE CHANGE OF ADDRESS

This business is now transferred permanently to the above address where all mail orders will receive strict personal attention.

TERMS: Cash with order. No C.O.D.

(Ire and Northern Ireland orders cannot be accepted.)

**HEADPHONES**, 120 ohm, Secondhand, complete with headband and cords, in perfect working order. Price 7/6 per pair, post free.

**INSTRUMENT METAL RECTIFIERS**, by famous makers, 10 M/A full load working. Price 15/- each, post free.

**TUNGSTEN CONTACTS**, 3/16 in. dia., a pair mounted on spring blades also two high quality pure silver contacts, 3/16 ins. dia., also on spring blades, fit for heavy duty, new and unused, there is enough base to remove for other work. Price the set of four Contacts, 5/-, post free.

**POST OFFICE RELAYS**, Small type high resistance, twin blade, very low milliamperes operation, as new Price 7/6 each, post free.

**ELECTRIC LIGHT CHECK METERS**, well-known makers, first-class condition, electrically guaranteed, for A.C. mains 200/250 volts 50-cy. 1 phase 5 amp. load 10/- each; 10 amp. load, 12/6, carriage 1/-.

**I.K.W. FIRE ELEMENTS**, mounted, size 16 x 1 1/2 x 1 ins., for 220 volts A.C. or D.C., as new 6/-, post free.

**ROTARY CONVERTOR**, D.C. to D.C., Input 12 volts; Output 1,100 volts at 30 M/A, Ex R.A.F., new. Price 50/-, carriage paid.

**LOUD RINGING BELLS**, working on 100 volts D.C., 8 in. dia. gong (bell metal), plated, waterproof, absolutely as new. Price 30/-, carriage 2/-.

**HEAVY DUTY CABLE**, V.I.R., and braided, in first-class condition, size 37/13, lengths 30 to 40 yards. Price by the length 6/- per yard, or 8/- per yard for short lengths, carriage paid.

**1/2 WATT WIRE END RESISTANCES**, new and unused, assorted sizes (our assortment), 6/6 per doz., post free.

**DYNAMO**, output 20 volts, 15 amps., shunt wound slow speed, ball bearing, condition as new. Price £3 10s. 0d., carriage paid.

**POWER PACKS** for smoothing, etc., consisting of two 300 ohm Choker and two 2 MF Condensers. Price 8/6, post free.

# HIVAC

THE SCIENTIFIC VALVE

BRITISH

MADE

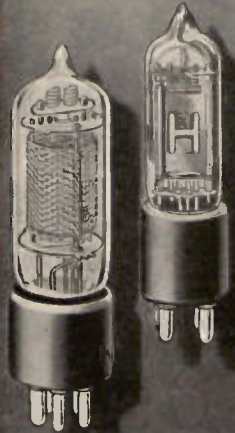

*Specialists in*

## MIDGET VALVES

**HIVAC LIMITED**  
Greenhill Crescent,  
Harrow on the Hill, Middx.

Telephone: Harrow 0895.

*Precisely!*



for accurate testing it must be

# TAYLOR METERS

Write for complete details to

TAYLOR ELECTRICAL INSTRUMENTS, Ltd., MONTROSE AV., SLOUGH, BUCKS.  
Telephone: Slough 21381.

Greenwood

# YOU

can trust Ardux because others trust their lives to it. Ardux has been used for joining stress-carrying aircraft structures. Ardux is, of course, officially approved for aircraft use. Here is an independent test report from a well-known aircraft firm :-

"Of the many adhesives on which we have carried out tests of mechanical strength Ardux is to date the only one in which there was no failure of the adhesive layer. In addition Ardux proved equally good with either a smooth or rough surface of sheet, thus showing it to be an adhesive in the true sense. Fatigue tests suggest that there is no weakening of the bond under vibration."

**AERO RESEARCH LTD., DUXFORD, CAMBRIDGE**

Telephone: Sawston 167-8

## "AFTER THE WAR" TELEVISION

With the coming of Peace, and backed by the Technical advances that have resulted from the war years, TELEVISION will again spring to life and offer opportunities, as never before, to the trained man.

Now is the time to prepare for this new "market." Our Home-study "Television" Course is comprehensive, up-to-date and suitable both for the amateur and experienced Radio Engineer.

We definitely guarantee

**"SATISFACTION—OR REFUND OF FEE"**

You are advised to send for details of this special Television Course immediately, to Investigate its possibilities. Details will also gladly be sent of A.M.I.E.E. and A.M.Brit.I.R.E., Examinations and other courses in all branches of WIRELESS ENGINEERING, including particulars of our special SHORT WAVE and RADIO SERVICING COURSES which are in such demand—Free.

**BRITISH INSTITUTE OF ENGINEERING TECHNOLOGY**

Principal: Prof. A. M. Low.

337, Shakespeare House, 17/19, Stratford Place, London, W.1

## BASICALLY BETTER...



*Air Insulation*  
is the basic principle of

**CO-AX**  
LOW LOSS CABLES  
*Unequaled*  
H.F. PROPERTIES

TRANSRADIO LTD. Inc. TELEQUIPMENT CO. 16 HIGHWAY, BEACONSFIELD.

Great Possibilities for

## TECHNICALLY QUALIFIED ENGINEERS KEY MEN IN WARTIME AND AFTERWARDS

The finest posts and the majority of posts in this war are technical and when the war is over, the immense increase in technique and mechanisation created for war purposes will be applied to reconstruction and commerce. An age of great possibilities for qualified engineers is here. Study at home with The T.I.G.B. and take a Recognised Engineering Qualification such as C. & G., A.F.R.Ae.S., A.M.I.Mech.E., A.M.I.E.E., etc. in which examinations T.I.G.B. Students have gained 32 FIRST PLACES and hundreds of passes. Write now for "The Engineer's Guide to Success" — 200 Courses — covering all branches — Aeronautical, Tele-communication, Mechanical, Electrical, Chemical, etc.



World's best choice of Courses in Engineering

**THE TECHNOLOGICAL INSTITUTE OF GREAT BRITAIN**  
160, Temple Bar House, London, E.C.4.

# EDDYSTONE

## COMMUNICATION RECEIVER

# 358x

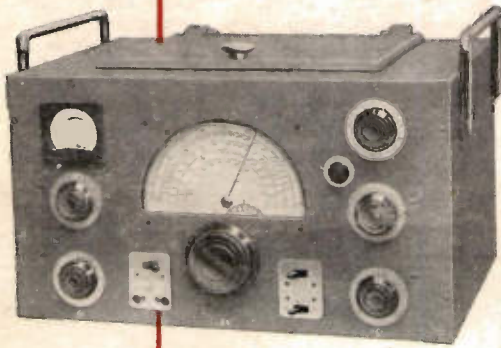

In the 358X version of this famous receiver a Band-pass Crystal circuit is employed giving high selectivity and complete rejection of unwanted adjacent signals. Furthermore the double crystal circuit avoids the extreme "peaked" effect of the conventional crystal gate, allowing easier tuning and accommodating some frequency drift of the wanted signal. These advantages are readily appreciated by operators familiar with the hair-breadth tuning of the normal filter.

The "358X" may be inspected at 14, Soho Street, preferably by appointment.

**EDDYSTONE COMMUNICATION RECEIVERS ARE AVAILABLE ON PRIORITY ORDER ONLY.**

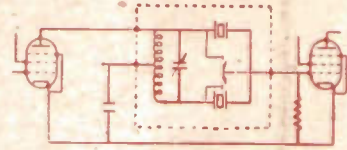

### BAND-PASS FILTER CIRCUIT

Above is shown the fundamental circuit similar to that employed in the Eddystone 358X receiver. When in circuit the band-width is 300 c/s, front panel control allowing optional use of normal I.F. selectivity, band-width 5 Kc/s.

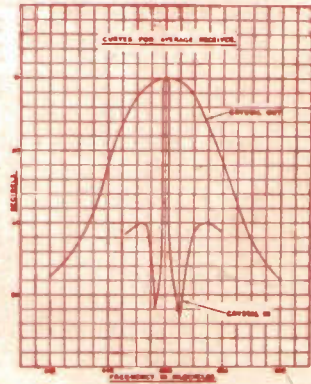

### SELECTIVITY CURVE "A"

shows the steep sides and flattened top response curve of the Band-pass Filter. Compare the normal crystal gate (Curve B) with its typical sharp peak necessitating constant tuning adjustment with the slightest signal frequency variation. Note the symmetrical rejection given by Curve "A" as opposed to the uneven tail effect of curve "B."

# WEBB'S

## RADIO

Hours of Business 10 a.m.—4 p.m. Saturdays 10 a.m.—12 noon.

14, SOHO ST. OXFORD ST. LONDON, W. I. Telephone. GERRARD 2089